

UNCLASSIFIED

AD NUMBER

AD107148

LIMITATION CHANGES

TO:

Approved for public release; distribution is unlimited.

FROM:

Distribution authorized to U.S. Gov't. agencies and their contractors;
Administrative/Operational Use; SEP 1956. Other requests shall be referred to National Aeronautics and Space Administration, Washington, DC.

AUTHORITY

NASA TR Server website

THIS PAGE IS UNCLASSIFIED

0107

NACA TN 3767

TECH LIBRARY KAFB, NM
0066688

NATIONAL ADVISORY COMMITTEE FOR AERONAUTICS

TECHNICAL NOTE 3767

THE USE OF PERFORATED INLETS FOR EFFICIENT
SUPERSONIC DIFFUSION

By John C. Evvard and John W. Blakey

Lewis Flight Propulsion Laboratory
Cleveland, Ohio



Washington
September 1956

AFMDC
TECHNICAL LIBRARY
SEP 1956



NATIONAL ADVISORY COMMITTEE FOR AERONAUTICS

TECHNICAL NOTE 3767

THE USE OF PERFORATED INLETS FOR EFFICIENT
SUPERSONIC DIFFUSION¹

By John C. Evvard and John W. Blakey

SUMMARY

The use of wall perforations on supersonic diffusers to avoid the internal contraction-ratio limitation is described. Experimental results at a Mach number of 1.85 on a preliminary model of a perforated diffuser having a geometric internal contraction ratio of 1.49 (the isentropic value) are presented. A theoretical discussion of the flow coefficients as well as the size and the spacing of the perforations is also included. At angles of attack of 0° , 3° , and 5° , total-pressure recoveries of 0.931, 0.920, and 0.906, respectively, were obtained.

INTRODUCTION

Supersonic diffusion may be most easily accomplished by means of a normal shock. Associated with this discontinuous process is a progressive decrease in the total-pressure recovery ratio as the Mach number is increased. The losses in total pressure across the shock may be minimized, however, by decelerating the supersonic stream by means of stream contraction to a low supersonic Mach number before the shock occurs.

The usable stream contraction and the amount of stream deceleration is limited on some types of supersonic diffuser. If the internal contraction ratio (the entrance area divided by the throat area) of the diffuser is made too large, the entrance mass flow will not pass through the throat of the diffuser, choking will occur, and a normal shock and bow wave configuration will form ahead of the inlet. The shock will not be swallowed again by the diffuser until the internal contraction allows the subsonic stream behind the normal shock to be accelerated to a Mach number of unity at the throat. This value of the contraction ratio is less than required for isentropic supersonic

¹Supersedes recently declassified NACA Research Memorandum E51B10 by John C. Evvard and John W. Blakey, 1951.

diffusion. In the design of a supersonic diffuser, either a loss in total pressure must therefore be accepted or some means must be provided to prevent choking.

One method to prevent choking that has been effectively applied is to accomplish the supersonic diffusion ahead of the inlet (such as on a conical shock diffuser). During the starting operation, the subsonic mass flow behind the normal shock, which will not pass through the throat of the diffuser, spills over the edge. Investigations of shock or spike diffusers have been reported in references 1 to 5. Although the pressure recoveries that may be obtained with the spike diffusers are very satisfactory, the external wave drag of this type diffuser is likely to be large unless the position of the shocks is carefully controlled. Furthermore, the high recoveries of total pressure may be obtained only on single units because, if the diffuser is operated in cascade (such as on a supersonic compressor) or if the diffuser is confined as a second throat in a supersonic tunnel, the flow spillage that allows the diffuser to start may be prevented.

The convergent-divergent type diffuser investigated by Kantrowitz and Donaldson (ref. 6) and by Wyatt and Hunczak (ref. 7) need not have a shock in the vicinity of the entrance. This diffuser should therefore be less critical with respect to external wave drag than the shock diffuser. Because no spillage is required for starting, the diffuser may be operated at the design Mach number in cascade or as the second throat of a supersonic wind tunnel. The main disadvantage of the convergent-divergent diffuser investigated heretofore is that the contraction ratio on the supersonic portion must be less than the contraction ratio required to decelerate the free stream isentropically to unity because of starting difficulties. This diffuser then inherently accepts a loss in total pressure. In addition, the normal shock must be located near the throat of the diffuser for optimum pressure recovery and, consequently, a slight increase in back pressure can cause the shock to jump irreversibly ahead of the inlet, which leads to a discontinuity of mass flow and pressure recovery.

A simple modification that may be made to the convergent-divergent diffuser, which removes the contraction-ratio limitation established by Kantrowitz and Donaldson (ref. 6) is described. Results obtained during November, 1946, with a preliminary experimental model at a Mach number of 1.85 are also included.

FUNCTION OF PERFORATIONS

751 ,
CO-1 back

If diffusion is attempted by means of a reversed de Laval nozzle, a normal shock will form ahead of the inlet as required by the theory of reference 6 and the supersonic diffusion process will not be established. Under this condition a high pressure differential will exist between the inner and outer surfaces of the convergent portion of the diffuser. If a succession of holes or perforations are drilled in the diffuser, part of the subsonic mass flow entering the inlet will pass through the perforations, the flow spilled over the inlet will decrease, and the shock will move nearer to the inlet (fig. 1(a)). If a sufficient number of holes is drilled in the diffuser, the normal shock will pass through the inlet as in figures 1(b) and 1(c).

As the shock is swallowed by the diffuser, supersonic flow will be established in the convergent inlet. The density and the static pressure will then have low values corresponding to the local supersonic Mach number and a low pressure differential will exist across the orifices. Likewise, the orifices become less effective as the Mach number is increased because the high-speed air has less time to swerve and pass through the holes. Each of these factors tends to reduce the loss of mass flow through the perforations as compared with the subsonic regime. The perforations thus act as automatic valves, which are open during the starting process and partly closed (in terms of mass flow rate) during operation. The contraction ratio of the convergent-divergent diffuser may then be extended beyond the limit originally described in reference 6. In fact, if additional entrance area is included to account for the mass flow lost through the holes in the supersonic regime, compression to a Mach number near unity at the throat may be achieved. A theoretical treatment of the area distribution of the perforations and the diffuser cross-sectional area distribution as a function of Mach number is presented in the appendix.

If the area of the perforations is uniformly increased beyond the minimum value required for shock entrance, the shock may be located at any station in the convergent portion of the diffuser and the flow through the throat of the diffuser will be subsonic. Under these conditions, the mass flow rate will be continuous through the diffuser and in fact, if a transient pressure disturbance should force the shock ahead of the inlet, the shock would again be swallowed by the diffuser as soon as the disturbance ceased. The irreversible discontinuity in performance associated with operation of the usual convergent-divergent diffuser is thus eliminated. The action of the perforations in the control of the boundary layer should also be noted.

APPARATUS AND PROCEDURE

A preliminary model of a perforated supersonic diffuser was built for an investigation at a Mach number of 1.85 in the 18- by 18-inch supersonic tunnel at the NACA Lewis laboratory. This model, machined of plastic (fig. 2(a)), consists of a converging inlet having an internal geometric contraction ratio of 1.49, the isentropic value for Mach number of 1.85. The inlet was attached to the 5° conical subsonic diffuser diagrammed in figure 2(b). The flow through the diffuser was controlled by a 90° conical damper at the diffuser exit.

The subsonic portion of the diffuser was thoroughly instrumented for static-pressure distributions; total- and static-pressure distributions at the diffuser exit were obtained with the rake shown in figure 2(c). The free-stream total pressures were obtained as described in reference 7. All pressures were photographically recorded on a multiple-tube mercury manometer board.

Because the diffuser as first installed in the supersonic tunnel had an insufficient number of perforations, the normal shock would not enter the inlet. A multiplicity of randomly spaced holes was then drilled by a trail procedure until the shock entered the inlet. A photograph of the final configuration is shown in figure 2(a). The performance of the diffuser at angles of attack of 0°, 3°, and 5° was determined for a Mach number of 1.85.

RESULTS AND DISCUSSION

The total-pressure recovery ratio obtained with the preliminary model of the perforated supersonic diffuser is plotted against the ratio of plenum-chamber outlet area to diffuser throat area in figure 3. The portion of the curve at area ratios greater than about 1.2 is approximately a rectangular hyperbola. (See ref. 7.) In this region, the mass flow rate through the diffuser is constant. It is therefore of interest to note that the point giving the highest total-pressure recovery ratio at all measured angles of attack falls to the left of the hyperbolic portion of the curve, which indicates that the mass flow rate through the throat of the diffuser has already decreased and that the shock is stabilized in the convergent portion of the diffuser. This stabilization is a result of the perforations near the throat. The portion of the curve at area ratios less than about 1.2 corresponds to progressive movement of the shock toward the inlet until the normal shock emerges from the inlet (area ratios less than about 0.60).

Contrary to the performance obtained with the usual convergent-divergent diffuser (refs. 6 and 7), the perforated diffuser may approach the peak total-pressure recovery from either branch of the curve (fig. 3). The pressure recovery need not be double valued as a function of the area ratio, nor need there be a discontinuity in the mass flow through the diffuser. The irreversible performance of the perforated diffuser will simplify the control problems of internal contraction inlets for application to supersonic aircraft. (On the preliminary model shown in fig. 2(a), the shock moved into the inlet in discrete steps rather than continuously. This phenomenon was probably caused by local variations of the perforated-area distribution.)

The maximum total-pressure recovery ratio obtained with the perforated diffuser was 0.931. This value may be compared with the value of 0.838 obtained on the convergent-divergent diffuser of reference 8. The theoretical maximum allowed in reference 6 for the convergent-divergent diffuser is 0.89. Thus the perforated diffuser has experimentally demonstrated that the contraction-ratio limitation established in reference 6 may be avoided.

The sensitivity of the perforated diffuser to changes in angle of attack (fig. 3) is less than the sensitivity of the convergent-divergent type diffuser (ref. 7), but greater than that of the single conical shock diffusers (ref. 3). For angles of attack of 0° , 3° , and 5° , the perforated diffuser gave total-pressure recovery ratios of 0.931, 0.920, and 0.906, respectively. The pressure-recovery ratio of the double-shock cones (ref. 4) was more sensitive than was the perforated diffuser to angles of attack.

The static-pressure distributions along the wall of the divergent portion of the diffuser are shown in figure 4 for angles of attack of 0° , 3° , and 5° . These curves are useful in locating the normal shock as the outlet area is varied. Apparently on the perforated diffuser, even with angles of attack, the shock may be located forward of the coordinate 0.32 throat diameter. No instrumentation was included in the throat nor in the supersonic portion of the diffuser, inasmuch as the inlet was constructed of plastic.

Static- and total-pressure distributions across the diffuser outlet are presented in figures 5 and 6, respectively, for angles of attack of 0° , 3° , and 5° . As was expected from the results of reference 8, the static pressures were nearly constant across the plenum chamber. The variations in the total pressure therefore indicate the Mach number distribution in the plenum chamber.

It should be emphasized that the results presented for the perforated diffuser were obtained on the first preliminary model, which for the sake of expediency was not carefully designed. Refinements are clearly feasible.

POTENTIAL APPLICATIONS OF PERFORATED DIFFUSER

The use of perforations to increase the performance of supersonic arrangements that involve a stream contraction has many potential applications. A few examples are shown in figure 7. By a combination of the perforated and the shock diffusers, a minimum number of perforations would be required and the shocks would still be internally confined. Other considerations may require that the diffuser be short. A compact perforated diffuser may be built simply by placing a group of smaller perforated diffusers adjacent to each other. Such an arrangement may also yield a more favorable velocity distribution for some purposes than would be possible with a single diffuser of the same exit area. Similarly, the perforated diffuser may be operated in cascade, as in the design of supersonic compressors. A perforated diffuser should also operate when confined in a passage and may therefore find application as the second throat of a supersonic wind tunnel. In this type of arrangement, a detonation wave could probably be stabilized in a tube. The use of perforations may even be applied to eliminate the starting difficulties of the Busemann biplane. Each of these potential applications requires further research to achieve perfection.

SUMMARY OF RESULTS

A short preliminary investigation of a perforated supersonic diffuser at a Mach number of 1.85 for angles of attack, 0° , 3° , and 5° gave the following results:

1. Perforations were applied to increase the allowable contraction ratio of a convergent-divergent supersonic diffuser. A total-pressure recovery ratio of 0.931 was obtained with a perforated diffuser as compared with 0.838 for the convergent-divergent diffuser.

2. The perforated supersonic diffuser was relatively insensitive to changes in angle of attack. Total-pressure recovery ratios of 0.931, 0.920, and 0.906 were obtained at angles of attack of 0° , 3° , and 5° , respectively.

CONCLUSION

The use of perforations may be applied to eliminate the starting difficulties of supersonic passages that include an internal contraction; hence, the contraction ratio may be increased or the operating Mach number range may be extended.

Lewis Flight Propulsion Laboratory
National Advisory Committee for Aeronautics
Cleveland, Ohio, February 1, 1951

APPENDIX - METHOD FOR ESTIMATING SIZE AND
SPACING OF PERFORATIONS

Estimation of flow coefficients. - In order to start the diffusion process, the normal shock must be able to enter the diffuser and move toward the throat. This entrance will be permitted if the perforations (including the throat) downstream of the shock are large enough to accommodate the subsonic mass flow behind the shock. The limiting condition occurs when the flow through the holes reaches sonic velocity. Under this condition, the mass flow rate per unit area for perforations downstream of the shock becomes

$$\frac{dm}{dA} = Q_a P \sqrt{\frac{\gamma}{RT} \left(\frac{2}{\gamma+1}\right)^{\frac{\gamma+1}{\gamma-1}}} = Q_a B P \quad (1)$$

where

- m mass rate of flow through holes downstream of shock
- A perforated area
- Q_a ratio effective to actual area of perforations downstream of normal shock
- P total or stagnation pressure downstream of normal shock
- γ ratio of specific heats
- R gas constant
- T total temperature of fluid

$$B = \sqrt{\frac{\gamma}{RT} \left(\frac{2}{\gamma+1}\right)^{\frac{\gamma+1}{\gamma-1}}}$$

The total pressure P is a function of the Mach number M at which the normal shock occurs and is given in terms of the free-stream total pressure P_0 and the supersonic shock Mach number M as

731

$$\frac{P}{P_0} = \left(\frac{\gamma + 1}{2\gamma M^2 - \gamma + 1} \right)^{\frac{1}{\gamma-1}} \left[\frac{(\gamma+1) M^2}{2(1 + \frac{\gamma-1}{2} M^2)} \right]^{\frac{\gamma}{\gamma-1}} \quad (2)$$

If isentropic diffusion is desired, the entrance of the diffuser must be enlarged somewhat to account for the loss of mass flow through the perforations upstream of the normal shock. The flow rate through the perforations in the supersonic portion of the diffuser may be estimated by means of the Prandtl-Meyer theory (ref. 8) for flow around a corner. If free-stream static pressure is assumed at the perforation or hole exit, the pressure differential across the hole is just sufficient to accelerate the flow to the original free-stream Mach number. The flow will turn in the vicinity of the hole or corner until the free-stream Mach number is reached and will then proceed without further deflection until it either passes through the hole or is straightened by the diffuser wall with the formation of a shock. The limiting streamline denoted by the coordinates r and φ is shown in the following sketch: (In some cases, the final Mach line becomes tangent to or drops below the wall surface. The limiting streamline then depends only on the local Mach number and the perforation width.)

CO-2

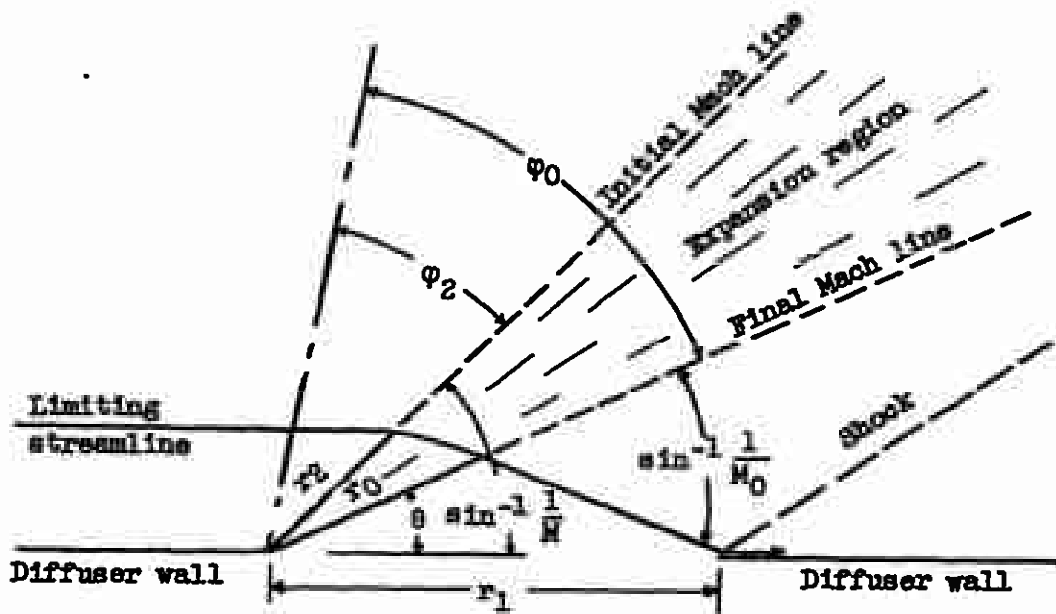

The shock caused by the flow straightening will intersect the final Mach line and mutual cancellation of shock and expansion waves will occur. Because the extension of the shock depends on the size of r_1 , this distance should be small to minimize internal shock losses.

The coordinate angle φ of the Prandtl-Meyer theory is a function of the Mach number and may be computed from the equation

$$M^2 = \frac{1}{k^2} \tan^2 k\varphi + 1 \quad (3)$$

where

$$k^2 \equiv \frac{\gamma-1}{\gamma+1} \quad (4)$$

From the equation of a streamline in the expansion region bounded by the two Mach lines, the ratio of the radii may be obtained as

$$\frac{r_2}{r_0} = \left(\frac{\cos k\varphi_0}{\cos k\varphi_2} \right)^{\frac{1}{k^2}} \quad (5)$$

Also from the geometry

$$\frac{r_0}{r_1} = \frac{1}{\cos \theta + \sin \theta \cot \left(\sin^{-1} \frac{1}{M_0} - \theta \right)} \quad (6)$$

The angle θ between the final Mach line and the diffuser wall is

$$\theta = \sin^{-1} \frac{1}{M} - (\varphi_0 - \varphi_2)$$

or, with the aid of equation (3),

$$\theta = \sin^{-1} \frac{1}{M} - \frac{1}{k} \left[\tan^{-1} \left(k \sqrt{M_0^2 - 1} \right) - \tan^{-1} \left(k \sqrt{M^2 - 1} \right) \right] \quad (7)$$

The effective flow area dA' is given as

$$dA' = \frac{r_2}{Mr_1} dA = \frac{dA}{M} \frac{r_2}{r_0} \frac{r_0}{r_1} \quad (8)$$

Combination of equations (3), (5), (6), and (8) thus yields

$$dA' = \frac{dA}{M} \left[\frac{k^2(M^2-1)+1}{k^2(M_0^2-1)+1} \right]^{\frac{1}{2k^2}} \left[\frac{1}{\cos \theta + \sin \theta \cot \left(\sin^{-1} \frac{1}{M_0} - \theta \right)} \right] = Q_b dA \quad (9)$$

where the effective area ratio upstream of the normal shock Q_b is given by use of equation (9) as

$$Q_b = \frac{1}{M} \left[\frac{k^2(M^2-1)+1}{k^2(M_0^2-1)+1} \right]^{\frac{1}{2k^2}} \left[\frac{1}{\cos \theta + \sin \theta \cot \left(\sin^{-1} \frac{1}{M_0} - \theta \right)} \right] \quad (10)$$

The mass flow coefficient through the holes in the supersonic portion of the diffuser will then be

$$\frac{dm_b}{dA} = \rho v Q_b \quad (11)$$

The product of the density and the velocity ρv is given by

731

CO-2. back

$$\rho v = \sqrt{\frac{\gamma}{RT}} \left[\frac{MP_0}{\left(1 + \frac{\gamma-1}{2} M^2\right)^{\frac{\gamma+1}{2(\gamma-1)}}} \right] \quad (12)$$

It should be emphasized that in the derivation of the effective area ratio Q_b , the external pressure was assumed to be equal to the free-stream static pressure. If some other static pressure persists, the coordinate angle φ_0' of the final Mach line may be obtained from the equation

$$\left(\frac{p}{p_0}\right)^{\frac{\gamma-1}{\gamma}} = (1-k^2) \cos^2 k\varphi_0' \quad (13)$$

Any flow through the holes will, of course, curve the external streamlines in the vicinity of the perforation and form a light shock. As a result, the hole-exit static pressure will increase and the mass flow rate through the perforations in the supersonic regime will be further decreased.

An indication of the relative effectiveness of the holes in the supersonic and subsonic regime may be gained from figure 8. The quantity $\frac{\rho v Q_b}{Q_a B P_{a,0}}$, where $P_{a,0}$ is the total pressure behind a free-stream normal shock, has been plotted as a function of local Mach number and represents the supersonic mass flow rate through a perforation divided by the mass flow rate with the normal shock ahead of the inlet when Q_a is 1.0 and 0.6. The fact that the quantity $\frac{\rho v Q_b}{Q_a B P_{a,0}}$ is generally less than unity assures the action of the perforations as automatic valves, allowing the diffuser to start at low effective contraction ratio and to operate at a high effective contraction ratio.

Estimation of cross-sectional and perforation area distribution. - The area of the perforations A and the cross-sectional area B may be measured positively from the throat of the diffuser (see sketch).

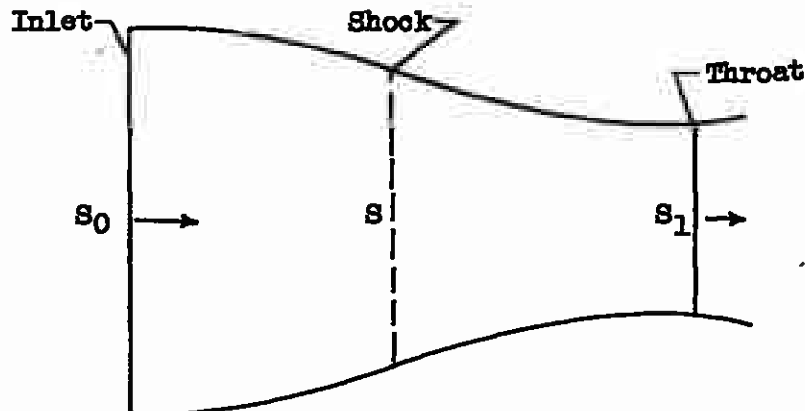

The subscripts 0 and 1 refer to the entrance and the throat of the diffuser, respectively. Now the mass flow rate through the area S_0 must be equal to the flow through the perforations upstream and downstream of the normal shock, plus the flow through the throat.

Because the walls of a diffuser may be gently curved, the effective subsonic area ratio Q_a of the throat will be read by unity. On the other hand, the wall perforations may be regarded as sharp-edged orifices and Q_a for the wall perforations will be less than 1. Accordingly for a fixed shock position the mass flow rate through the inlet will be

$$m = \int_A^{A_0} \rho v Q_b dA + BP \int_0^A Q_a dA + BPS_1 \quad (14)$$

Because the shock is temporarily stationary, P was considered constant in equation (14) and was therefore taken outside the integral sign. The quantity Q_a will generally depend upon the Mach number near the local perforation dA particularly for Mach numbers near unity. In the absence of experimental determinations of Q_a for tangential orifices and in the interest of simplicity, Q_a is assumed constant in the present analysis. Equation (14) may then be written

$$m = \int_A^{A_0} \rho v Q_b dA + BP(Q_a A + S_1) \quad (15)$$

But the rate of mass flow through the area S_0 is independent of the position of the shock and the shock may be moved to a new position without changing m . The total pressures P and $\rho v Q_b$ then become functions of the shock Mach number. Differentiation of equation (15) with respect to the shock Mach number yields

$$\frac{d\left(\frac{A}{S_1}\right)}{\frac{A}{S_1} + \frac{1}{Q_a}} = \frac{-\frac{1}{P} \frac{dP}{dM} dM}{1 - \frac{\rho v Q_b}{BP Q_a}} \quad (16)$$

Equation (16) may be simply integrated numerically by summing the differentials, or it may be integrated explicitly to give

$$\log\left(Q_a \frac{A}{S_1} + 1\right) = \int_{M=1}^M \frac{-\frac{1}{P} \frac{dP}{dM} dM}{1 - \frac{\rho v Q_b}{BP Q_a}} \quad (17)$$

The quantity $\frac{1}{P} \frac{dP}{dM}$ of equation (17) is given from equation (2) as

$$\frac{1}{P} \frac{dP}{dM} = \frac{-2\gamma(M^2 - 1)^2}{M(2\gamma M^2 - \gamma + 1)\left(1 + \frac{\gamma-1}{2} M^2\right)} \quad (18)$$

The quantity $\frac{\rho v Q_b}{BP Q_a}$ may be computed with the aid of equations (12), (10), (7), (1), and (2).

The assumption that Q_a is a constant now appears as a workable approximation; in the neighborhood of $M = 1$, where Q_a would be expected to vary most rapidly, $\frac{1}{P} \frac{dP}{dM}$ has a zero of second order.

From equation (16), $\Delta \left(\frac{A}{S_1} \right)$ is then nearly zero in the vicinity of $M = 1$ regardless of the value of Q_a if Q_a does not approach Q_b in such a manner as to give a zero of the same order in the denominator.

Equation (16) was solved numerically for an M_0 of 1.85 for values of $Q_a = 1, 0.6,$ and 0.5 . The resulting plot of A/S_1 as a function of Mach number is presented in figure 9. The approximate perforated-area distribution of this experimental model is also included on figure 9. For this curve, the loss of mass flow through the holes in the supersonic regime was neglected and one-dimensional flow equations were assumed to calculate the Mach number. Although the experimental curve indicates the approximate value of Q_a , the holes were so crudely drilled in the preliminary model that the perforated area is probably larger than necessary.

In order to obtain the hole-area distribution A as a function of the cross-sectional area S , a relation is required between S and M . This relation will depend on the particular design of the diffuser. If one-dimensional flow applies, the contraction ratio corrected for the mass flow through the perforations in the supersonic portion is given by the equation

$$\left(m - \int_A^{A_0} \rho v Q_b dA \right) \frac{S_0}{m} = \frac{\rho v}{\rho_0 v_0} S \quad (19)$$

Because $m = \rho_0 v_0 S_0$, equation (19) becomes

$$\rho_0 v_0 S_0 - \int_A^{A_0} \rho v Q_b dA = \rho v S \quad (20)$$

For conditions at the throat, equation (20) becomes

$$\rho_0 v_0 S_0 - \int_0^{A_0} \rho v Q_b dA = (\rho v)_1 S_1 \quad (21)$$

Subtraction and rearrangement of equations (20) and (21) give

$$\frac{S}{S_1} = \frac{(\rho v)_1}{\rho v} + \frac{1}{\rho v} \int_0^A \rho v Q_b d\left(\frac{A}{S_1}\right) \quad (22)$$

Equation (22) was solved numerically in conjunction with equation (16) for an initial Mach number of 1.85 and values of $Q_a = 1, 0.6,$ and 0.5 . The resulting plot of S/S_1 as a function of Mach number is presented in figure 10. The value of S/S_1 at the free-stream Mach number 1.85 is the geometric contraction ratio required to decelerate the supersonic stream to a Mach number of unity at the throat. By a comparison of this value with the isentropic contraction ratio, the mass flow lost through the holes may be estimated. For a value Q_a of 0.6, the percentage mass flow lost is

$$\frac{1.57 - 1.495}{1.495} \times 100 = 5 \text{ percent.}$$

REFERENCES

1. Oswatitsch, Kl.: Der Druckrückgewinn bei Geschossen mit Ruckstossantrieb bei hohen Überschallgeschwindigkeiten (Der Wirkungsgrad von Stossdiffusoren). Ber. Nr. 1005, Forschungen und Entwicklungen des Heereswaffenamtes, Kaiser Wilhelm-Inst. f. Strömungsforschung, Göttingen, Jan. 1944. (The Pressure Recovery of Projectiles with Jet Propulsion at High Supersonic Speeds (The Efficiency of Thrust Diffusers). Trans. by Douglas Aircraft Co., Inc., 1946.) (Available in English translation as NACA TM 1140.)
2. Oswatitsch, and Böhm: Air Forces and Flow Phenomena on Self Propelled Missiles. Rep. No. 1010/2, Kaiser Wilhelm Inst. Aero. Res., Oct. 1944. (Trans. by Curtiss-Wright Corp., Oct. 1945.)

- 731
3. Moeckel, W. E., Comors, J. F., and Schroeder, A. H.: Investigation of Shock Diffusers at Mach Number 1.85. I - Projecting Single-Shock Cones. NACA RM E6K27, 1947.
 4. Moeckel, W. E., Comors, J. F., and Schroeder, A. H.: Investigation of Shock Diffusers at Mach Number 1.85. II - Projecting Double-Shock Cones. NACA RM E6L13, 1947.
 5. Ferri, Antonio, and Nucci, Louis M.: Preliminary Investigation of a New Type of Supersonic Inlet. NACA Rep. 1104, 1952. (Supersedes NACA TN 2286.)
 6. Kantrowitz, Arthur, and Donaldson, Coleman duP.: Preliminary Investigation of Supersonic Diffusers. NACA WR I-713, 1945. (Supersedes NACA ACR L5D20.)
 7. Wyatt, DeMarquis D., and Hunczak, Henry R.: An Investigation of Convergent-Divergent Diffusers at Mach Number 1.85. NACA RM E5OKO7, 1951.
 8. Taylor, G. I., and Maccoll, J. W.: The Two-Dimensional Flow Around a Corner; Two-Dimensional Flow Past a Curved Surface. Vol. III of Aerodynamic Theory, div. H, ch. IV, secs. 5-6, W. F. Durand, ed., Julius Springer (Berlin), 1935, pp. 243-249. (Reprinted, C.I.T., Jan. 1943.)

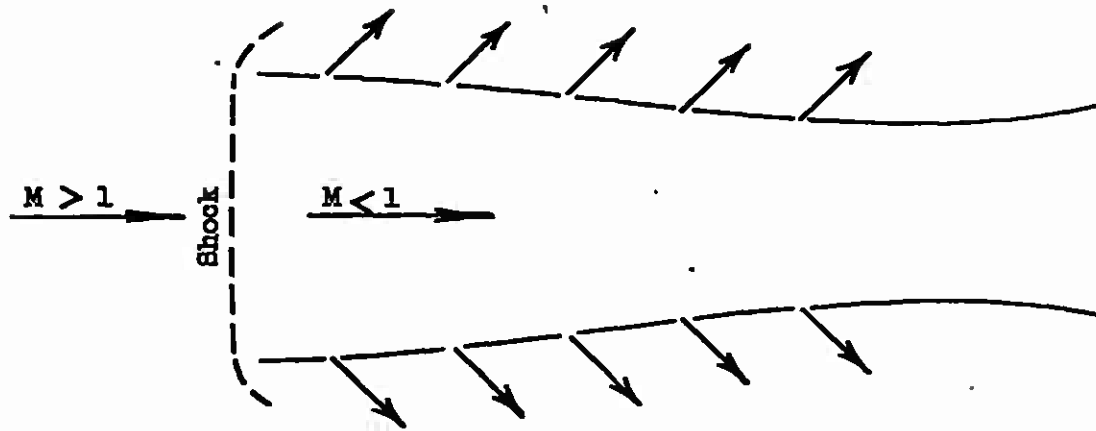

(a) Normal shock ahead of inlet.

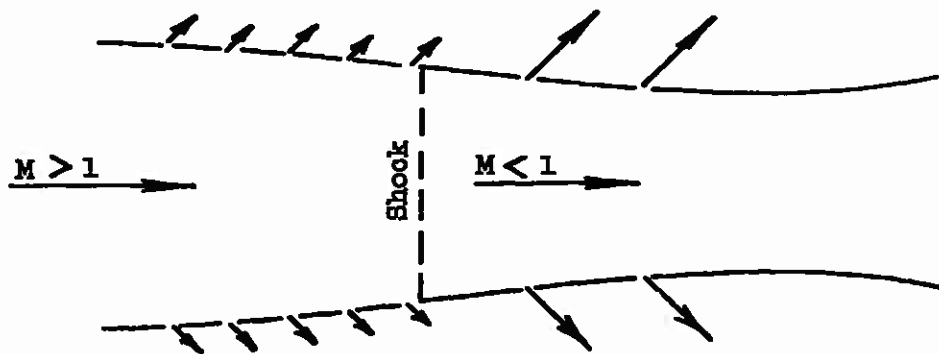

(b) Normal shock partly swallowed.

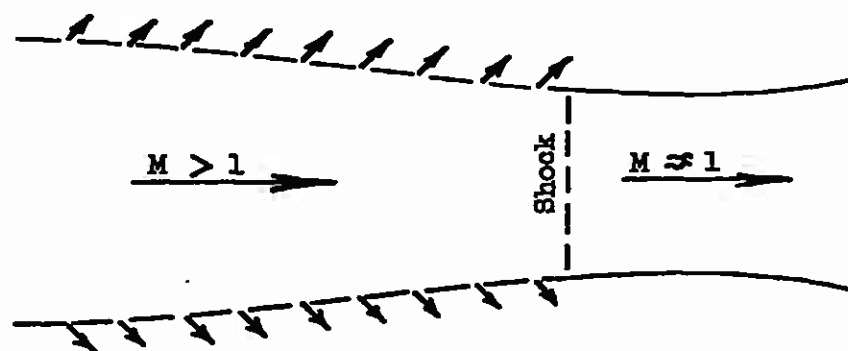

(c) Normal shock near throat.

Figure 1. - Schematic progression of shock as perforated area is increased.

751

CO-3 back



(a) Plastic perforated inlet.
Figure 2. - Preliminary test model of perforated supersonic diffuser.

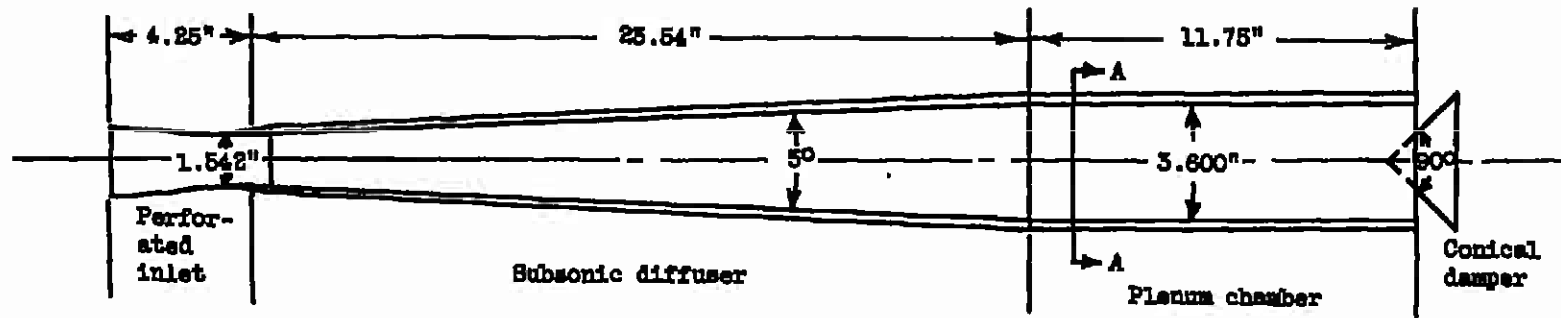

(b) Schematic drawing of perforated inlet, subsonic diffuser, and plenum chamber.

Figure 2. - Continued. Preliminary test model of perforated supersonic diffuser.

751

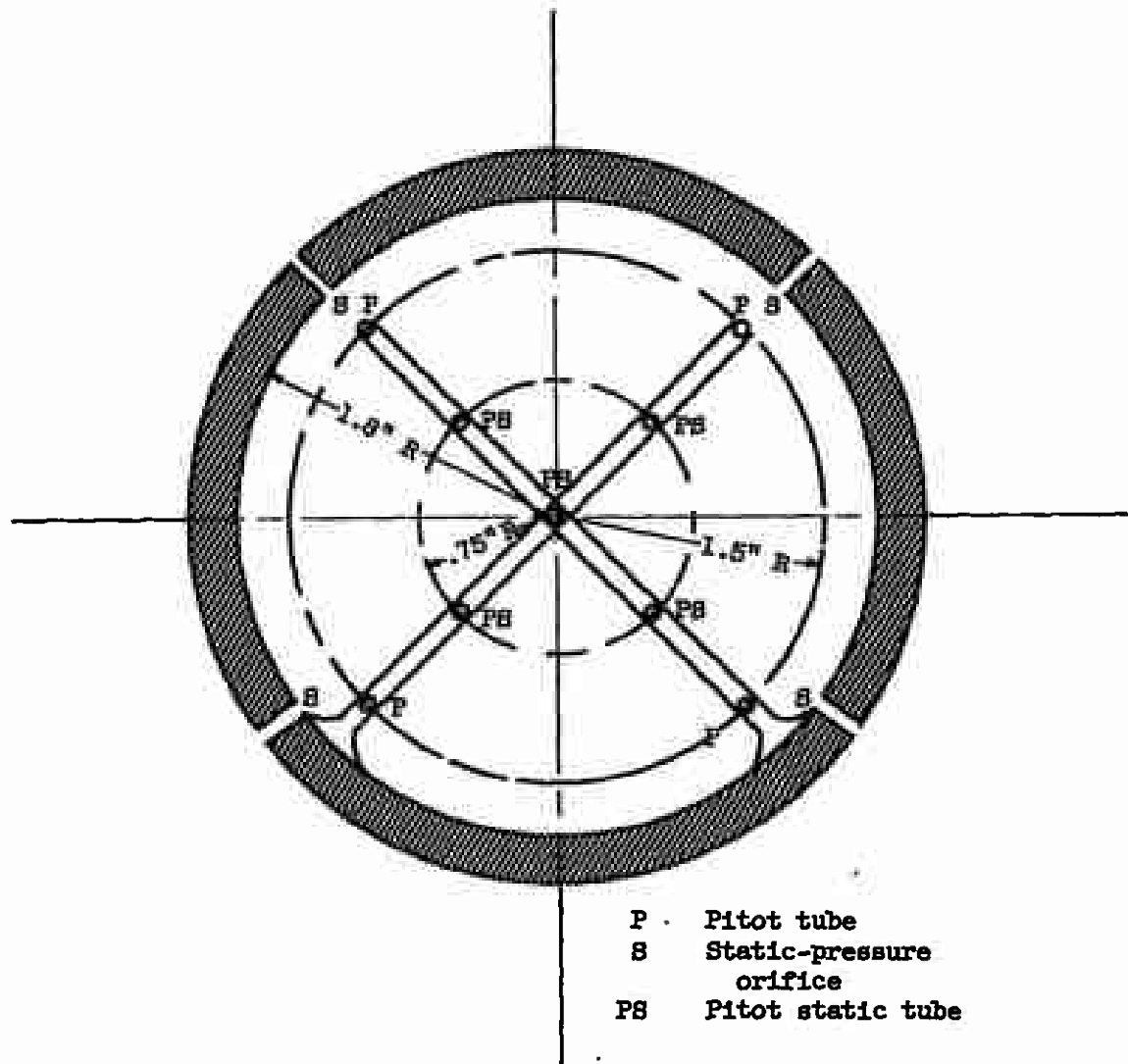

Cross section at A-A (fig. 2(b))

(c) Schematic drawing of pressure instrumentation at diffuser outlet.

Figure 2. - Concluded. Preliminary test model of perforated supersonic diffuser.

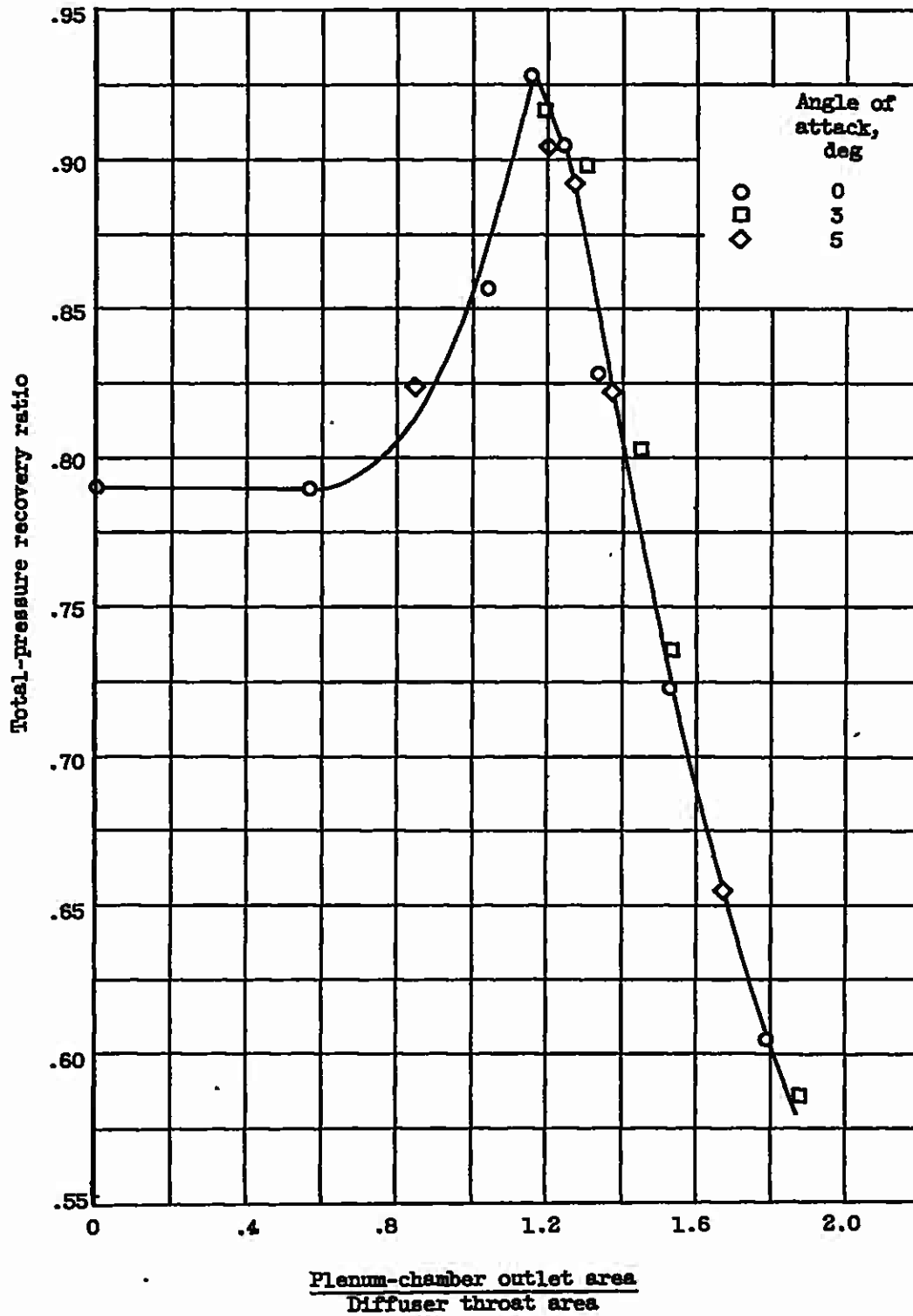

Figure 3. - Total-pressure recovery of perforated supersonic diffuser. Free-stream Mach number, 1.85.

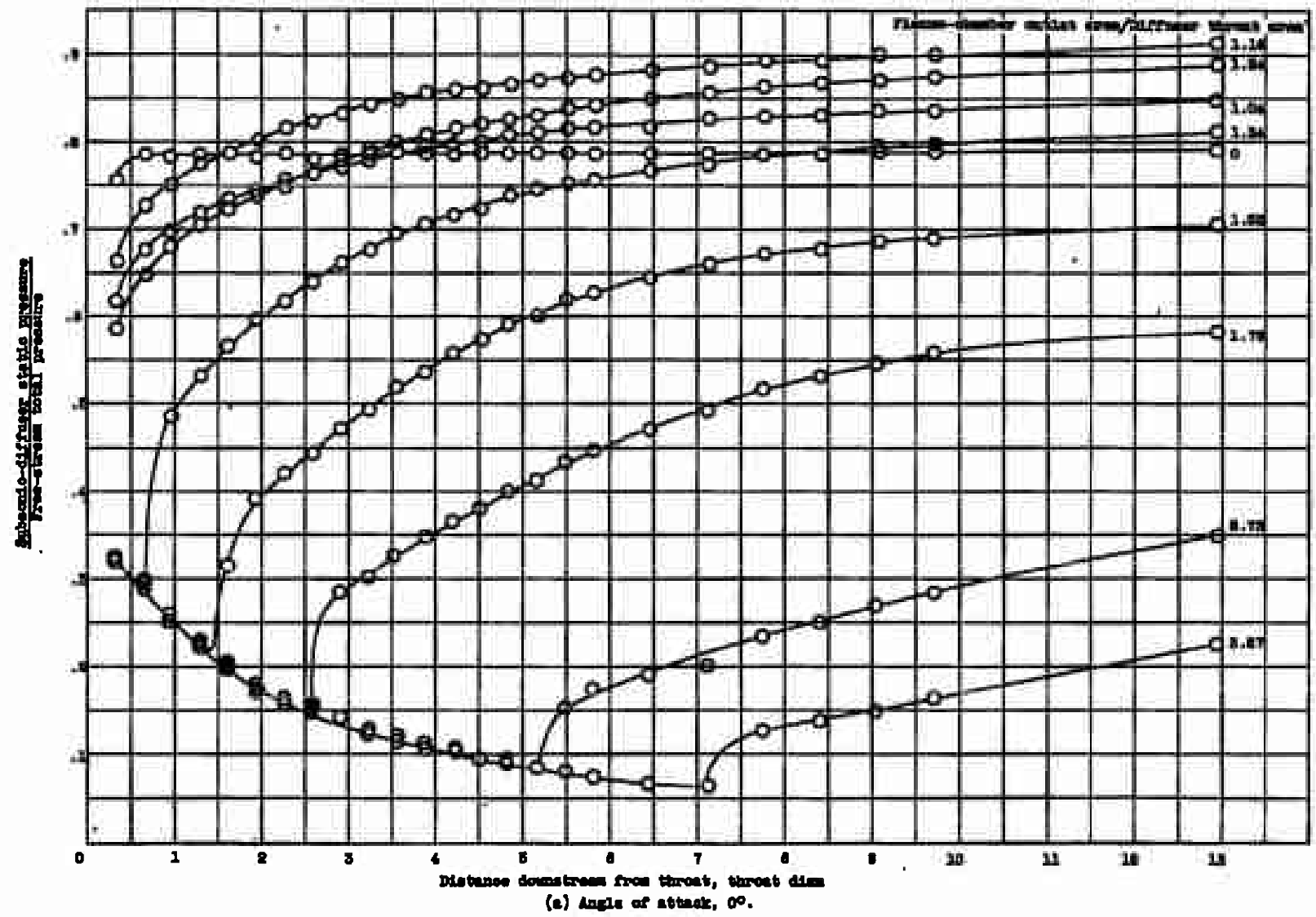

Figure 4. - Static-pressure distribution along subsonic diffuser. Free-stream Mach number, 1.00.

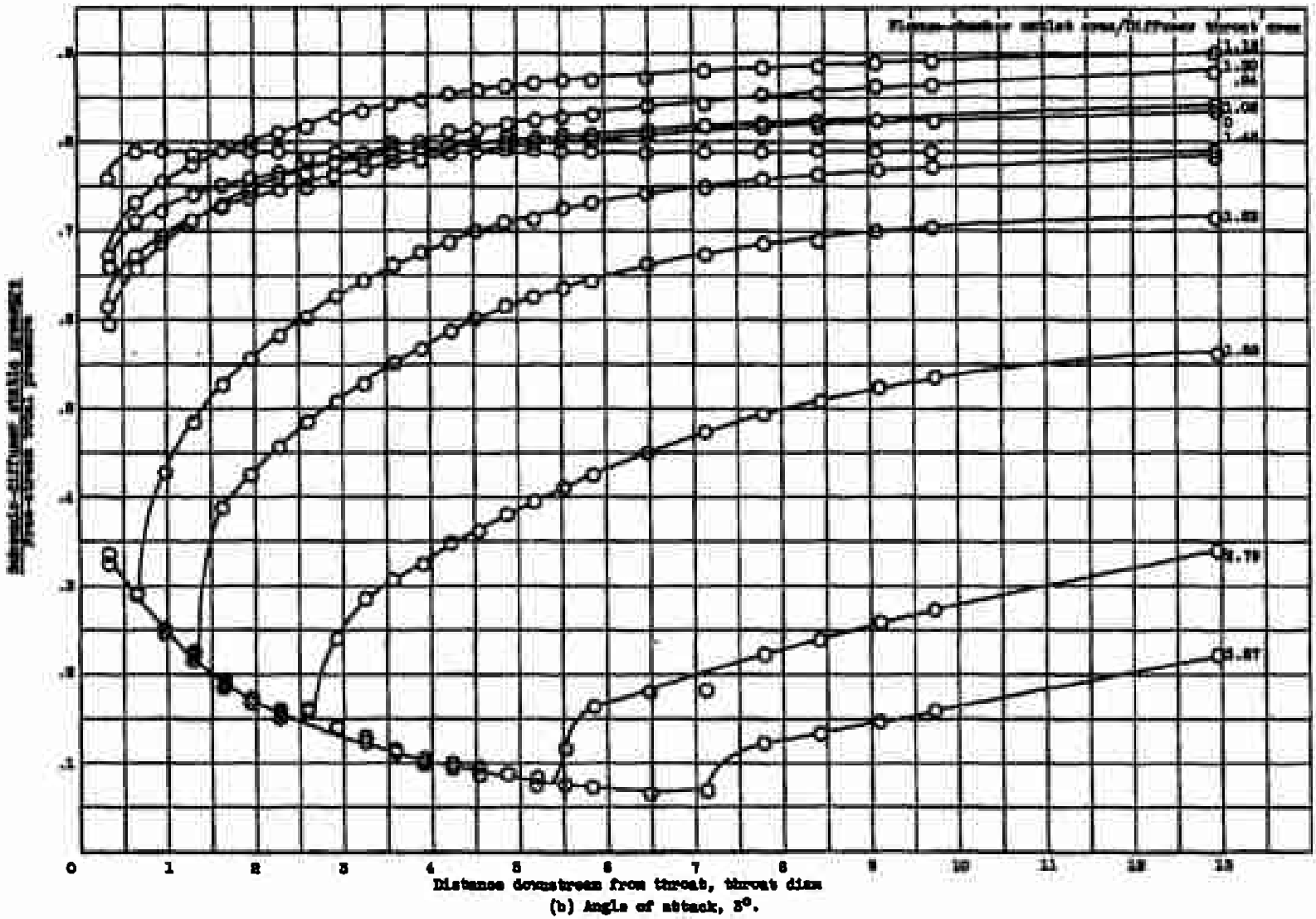

Figure 4. - Continued. Static-pressure distribution along subsonic diffuser. Free-stream Mach number, 1.05.

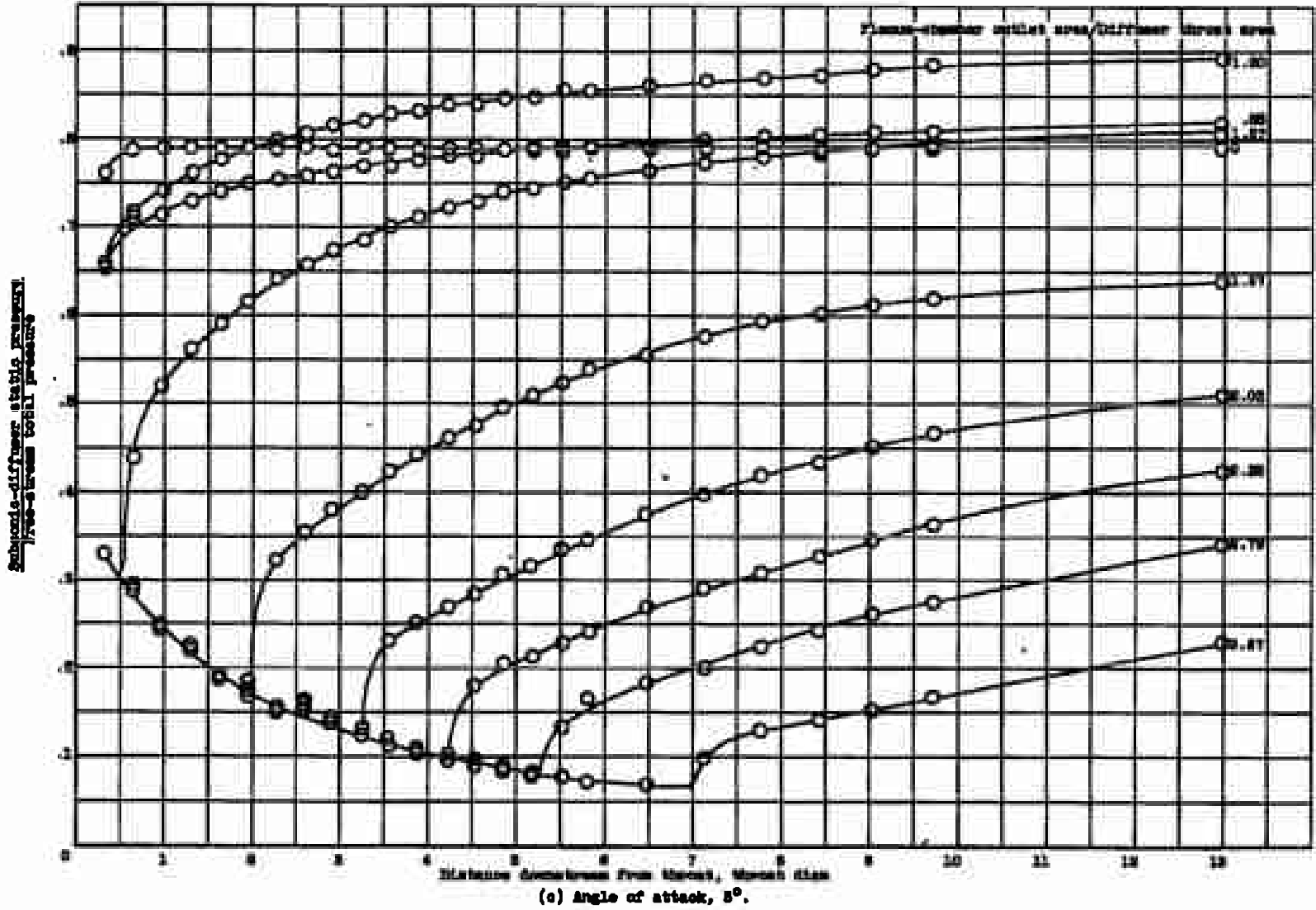

Figure 4. - Concluded. Static-pressure distribution along subsonic diffuser. Free-stream Mach number, 1.05.

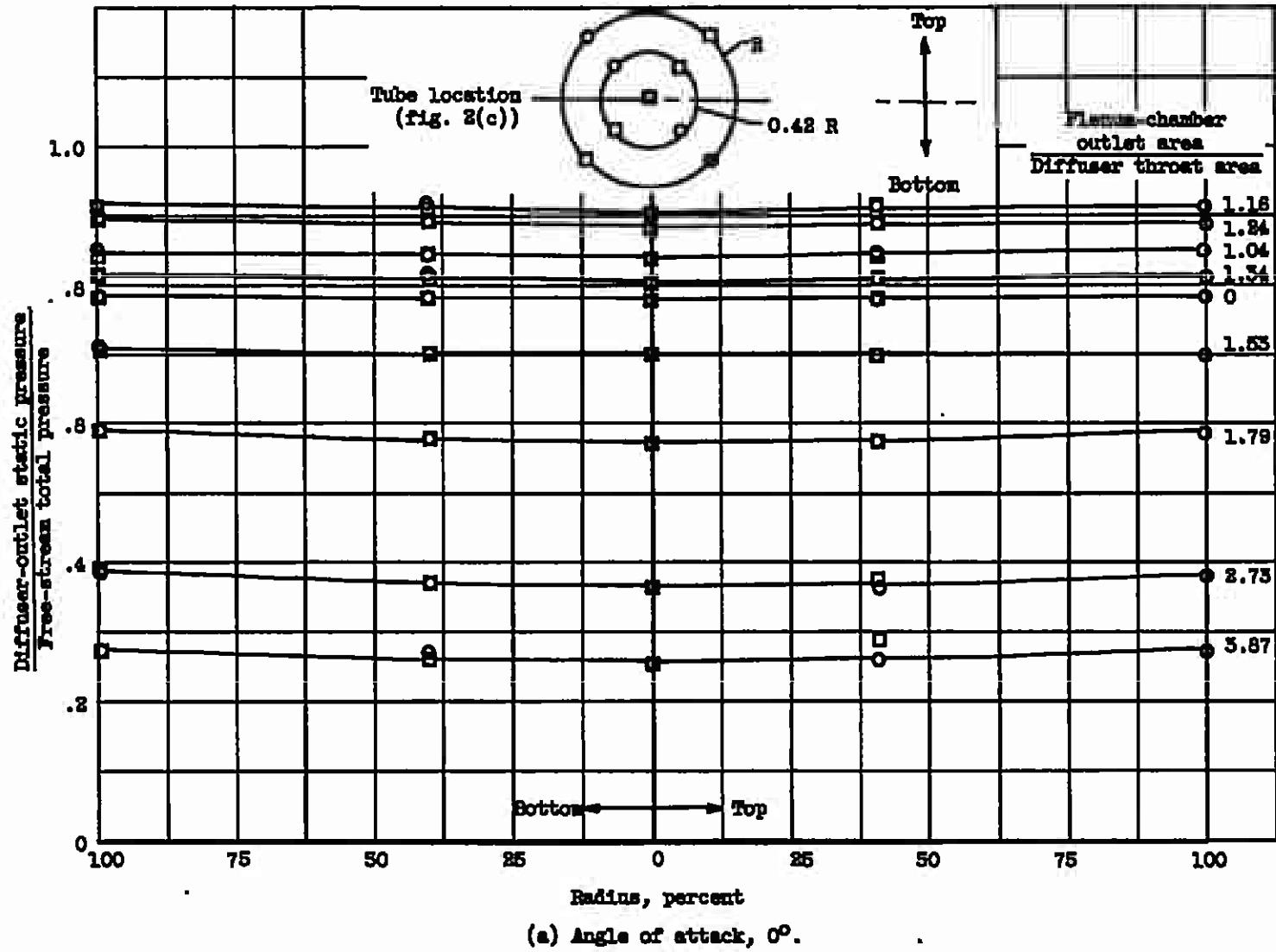
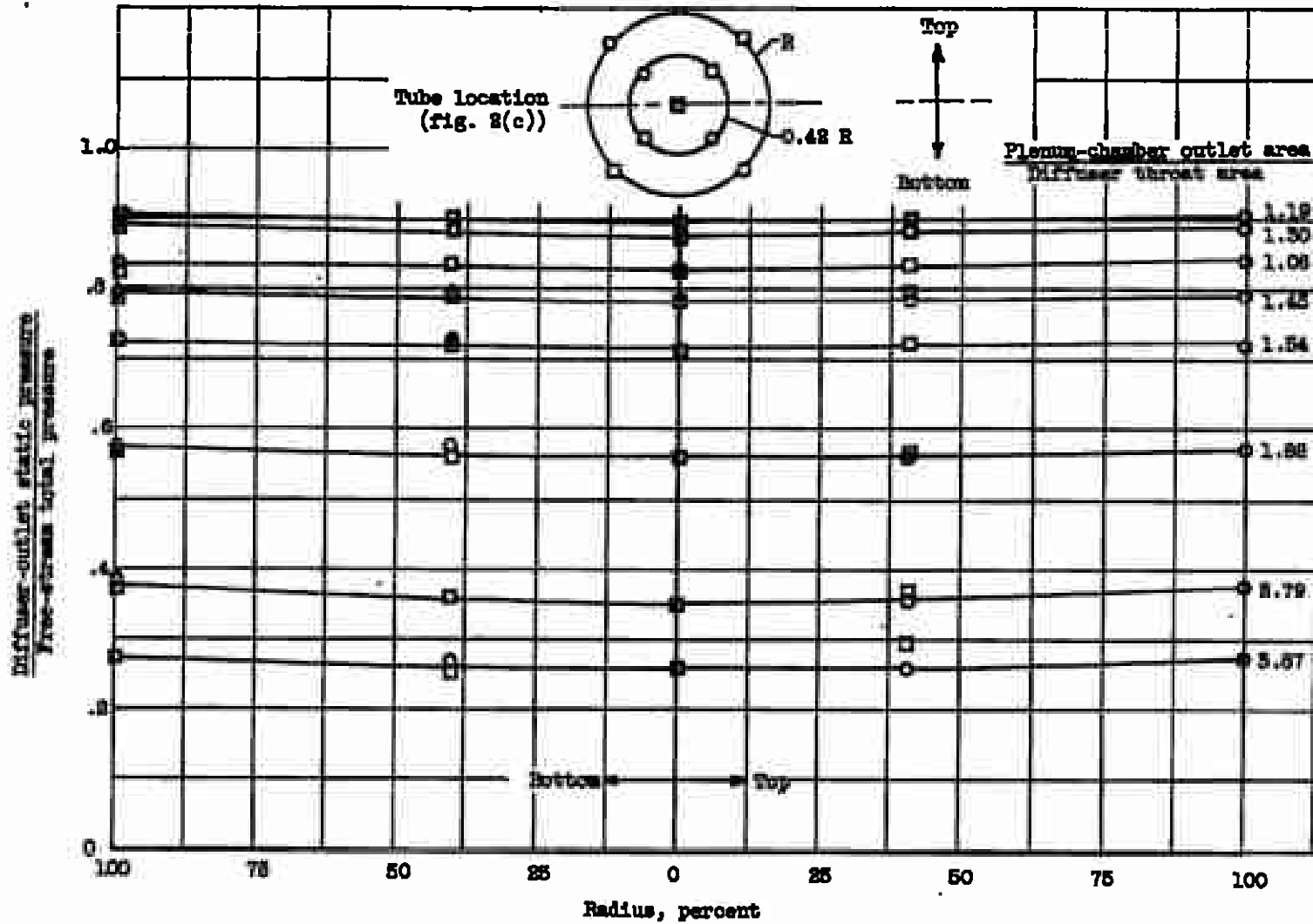

Figure 5. - Static-pressure distribution across diffuser outlet. Free-stream Mach number, 1.85.



(b) Angle of attack, 5°.

Figure 5. - Continued. Static-pressure distribution across diffuser outlet. Free-stream Mach number, 1.65.

NACA TN 5767

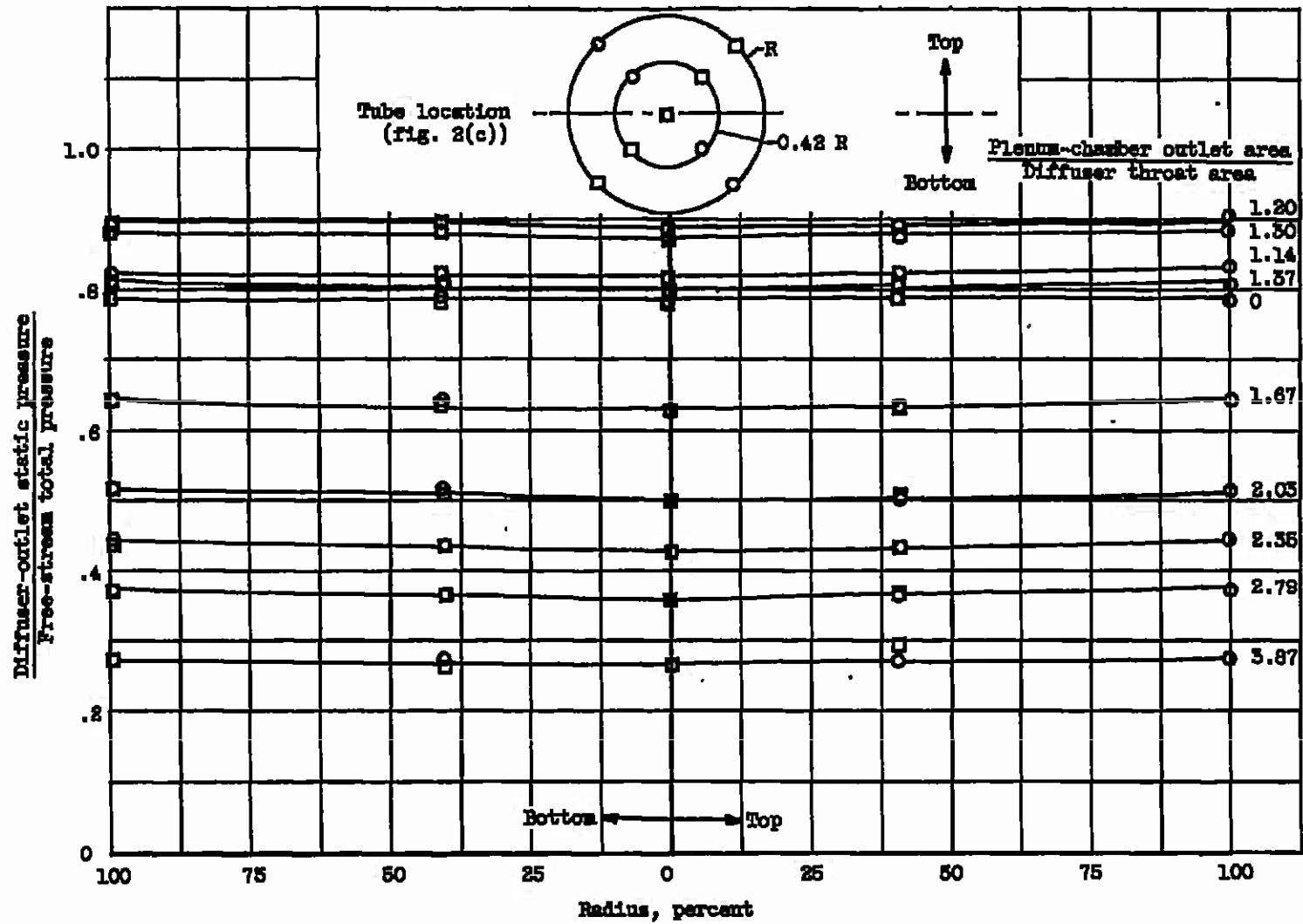

(c) Angle of attack, 5° .

Figure 5. - Concluded. Static-pressure distribution across diffuser outlet. Free-stream Mach number, 1.85.

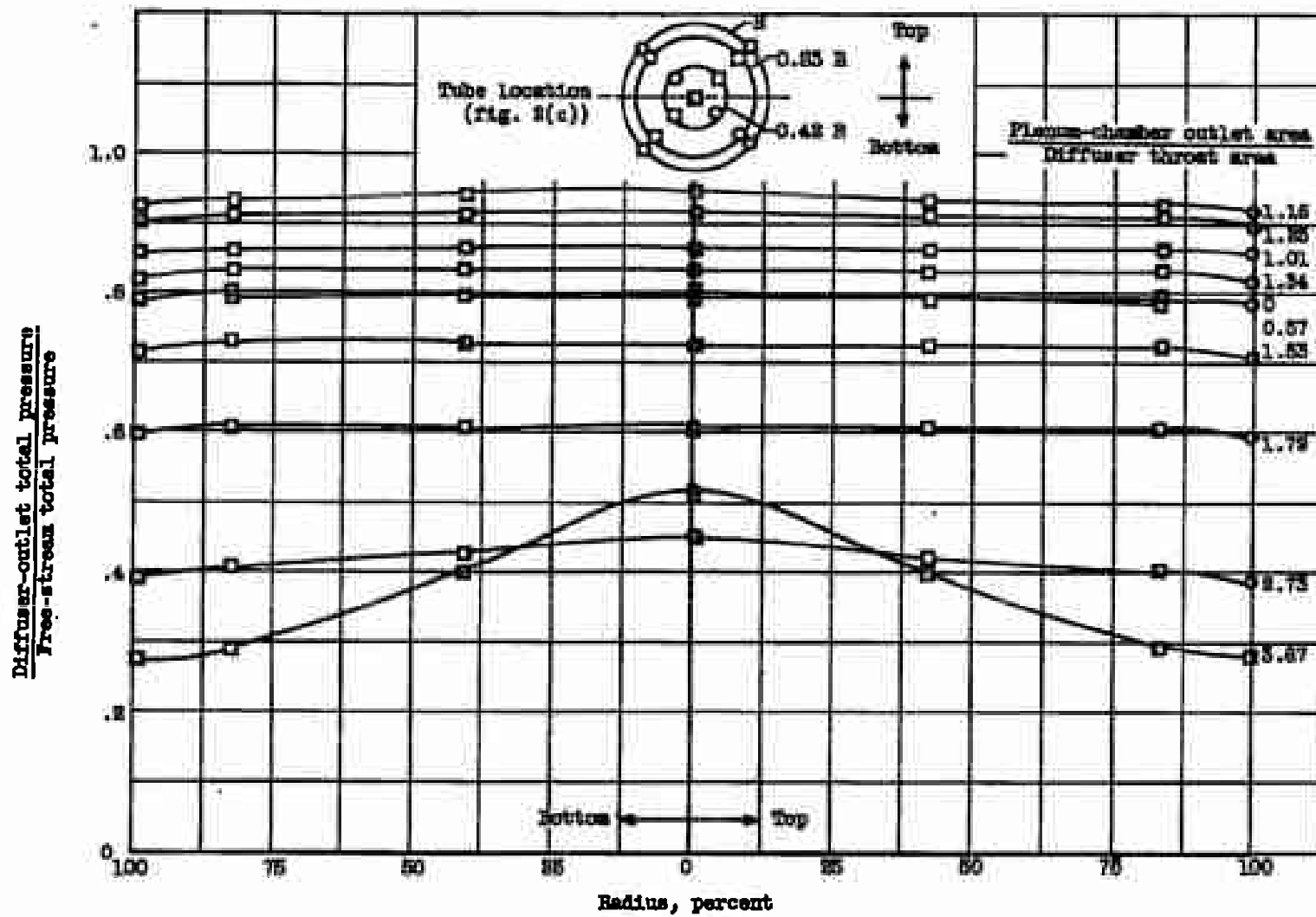

(a) Angle of attack, 0° .

Figure 8. - Total-pressure distribution across diffuser outlet. Free-stream Mach number, 1.85.

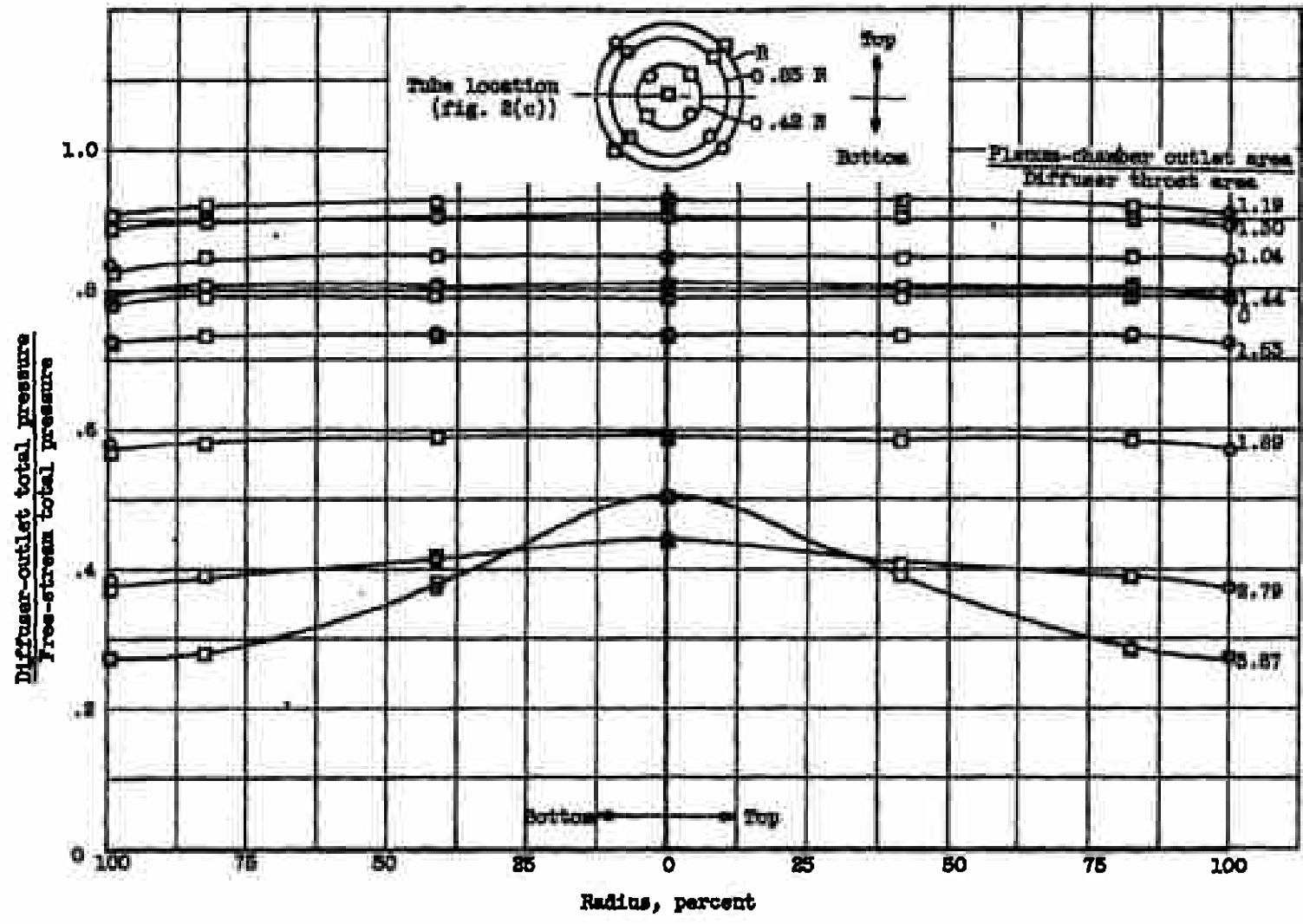

(b) Angle of attack, 3°

Figure 8. - Continued. Total-pressure distribution across diffuser outlet. Free-stream Mach number, 1.85.

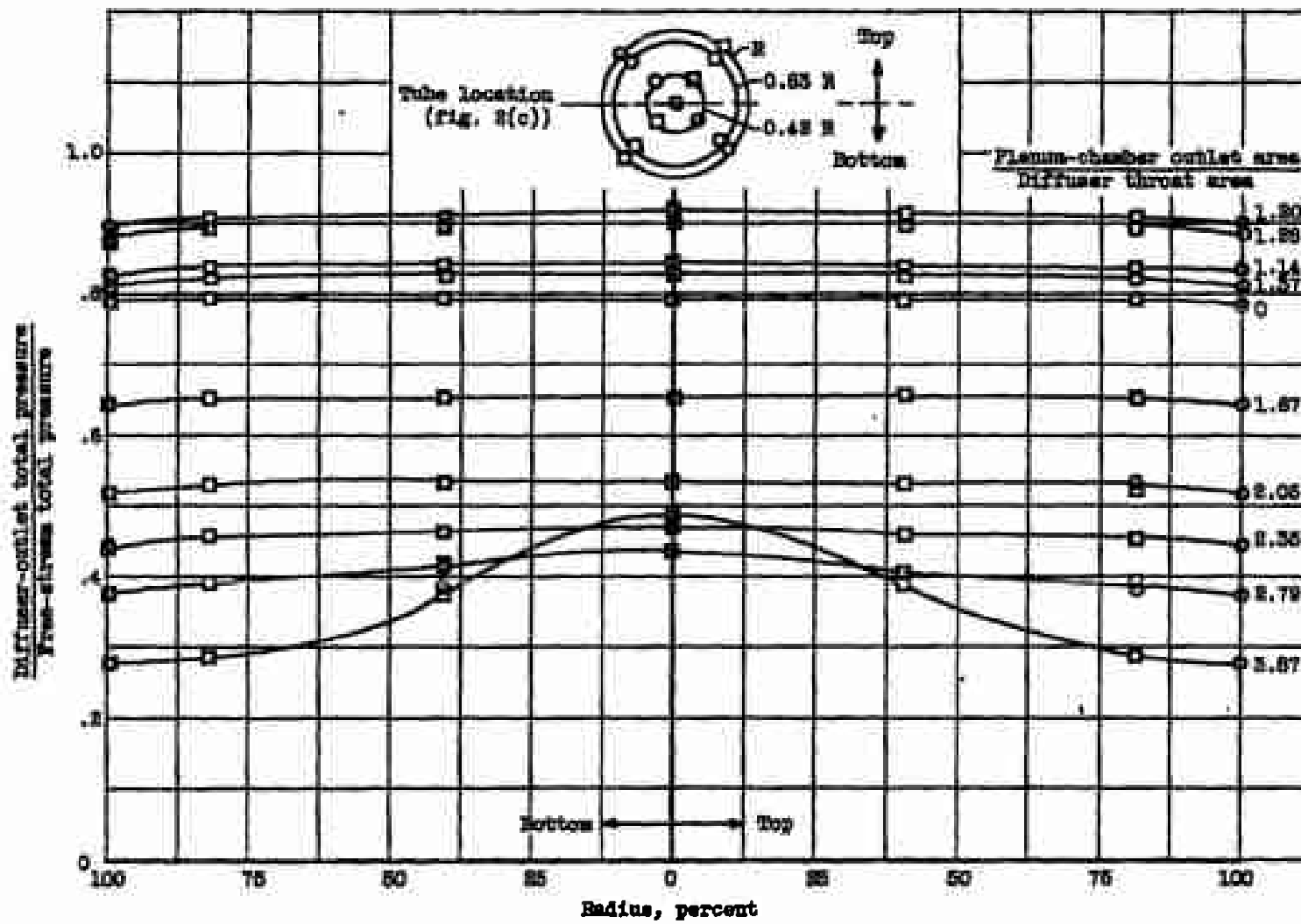

(c) Angle of attack, 5°.

Figure 8. - Concluded. Total-pressure distribution across diffuser outlet. Free-stream Mach number, 1.85.

731



Oblique shock diffuser

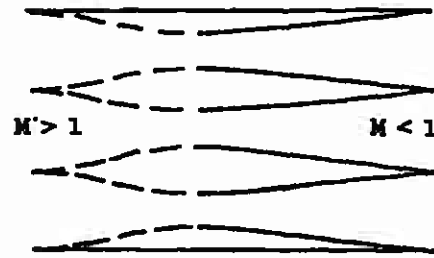

Group operation



Cascade operation

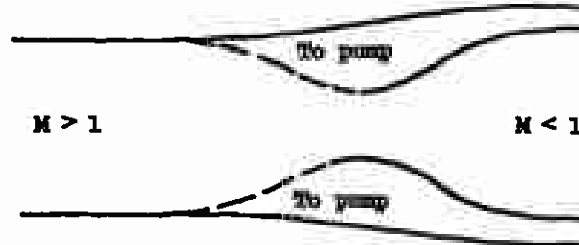

Second throat of supersonic wind tunnel

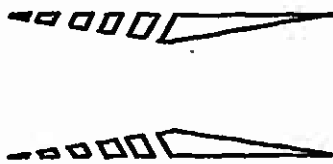

Busemann biplane

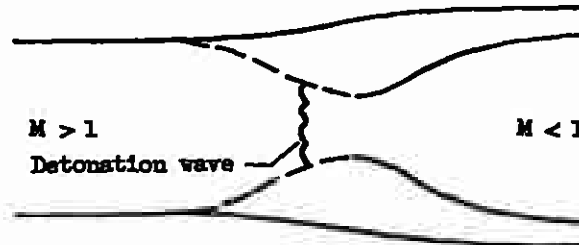

Stable location of detonation wave

Figure 7. - Schematic diagrams of several potential applications of perforated supersonic diffuser.

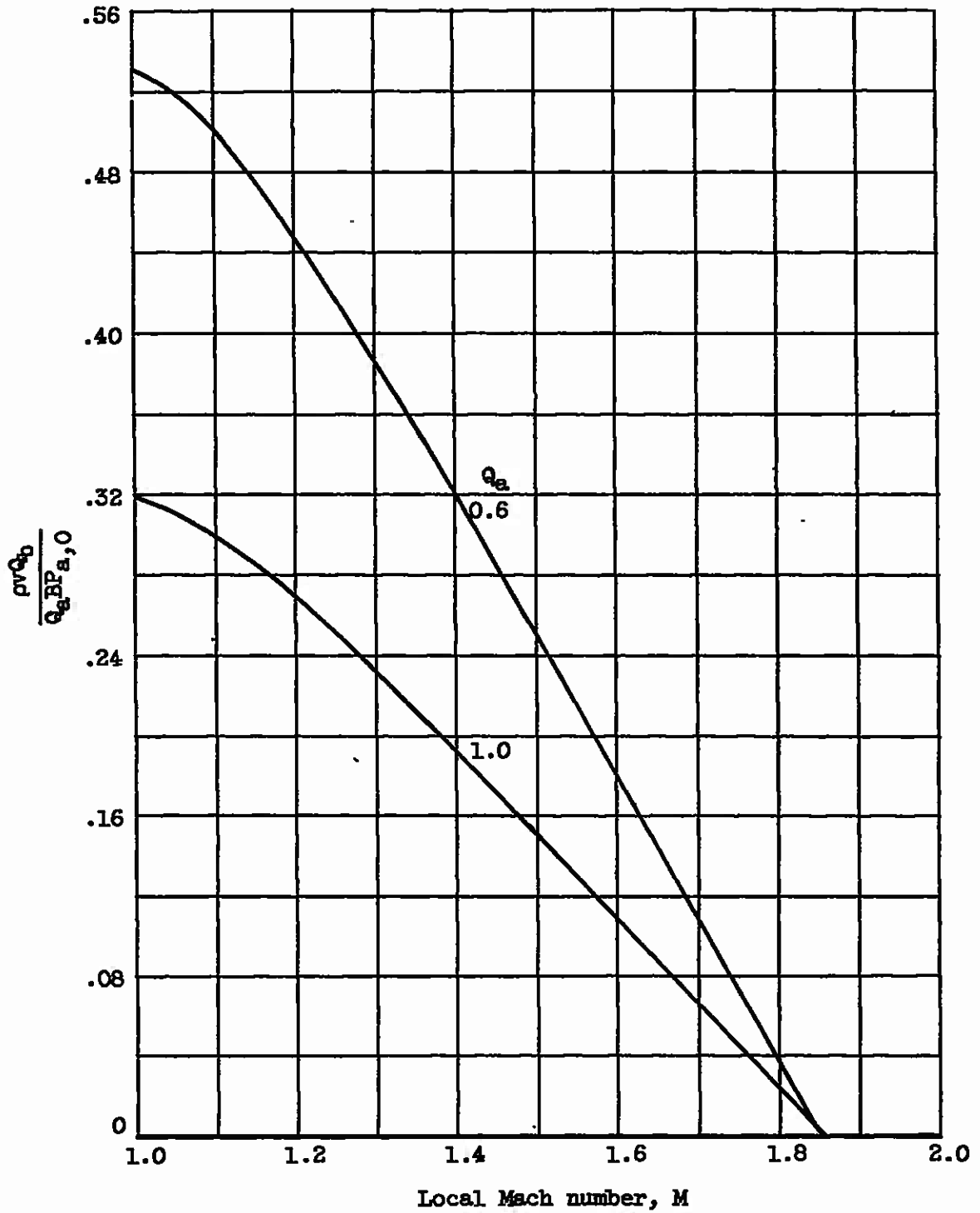

Figure 8. - Ratio of mass flow through perforation with normal shock at throat and ahead of inlet. Free-stream Mach number, 1.85

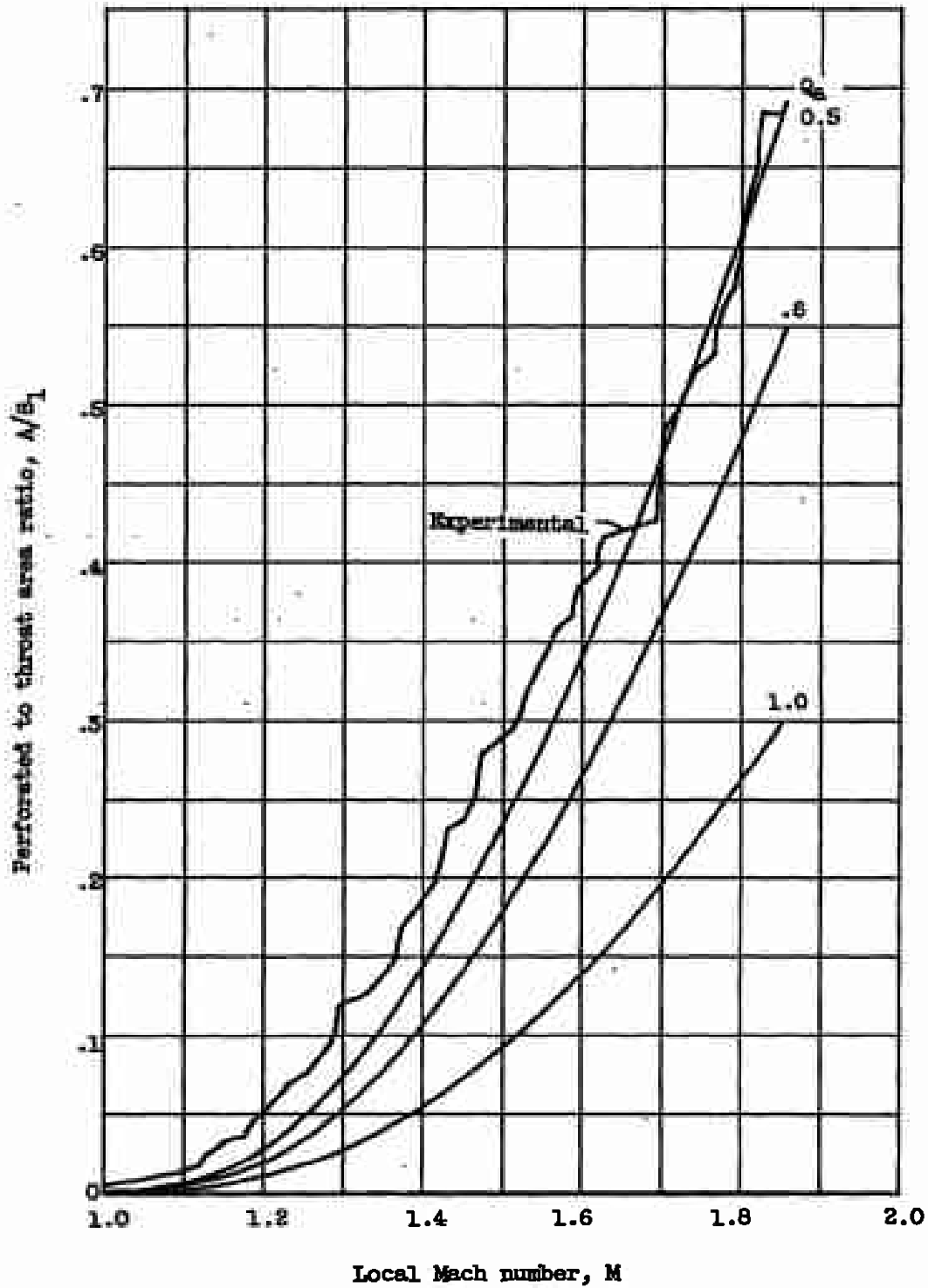

Figure 9. - Distribution of perforated area. Free-stream Mach number, 1.85. Theoretical curves calculated by use of equation (17).

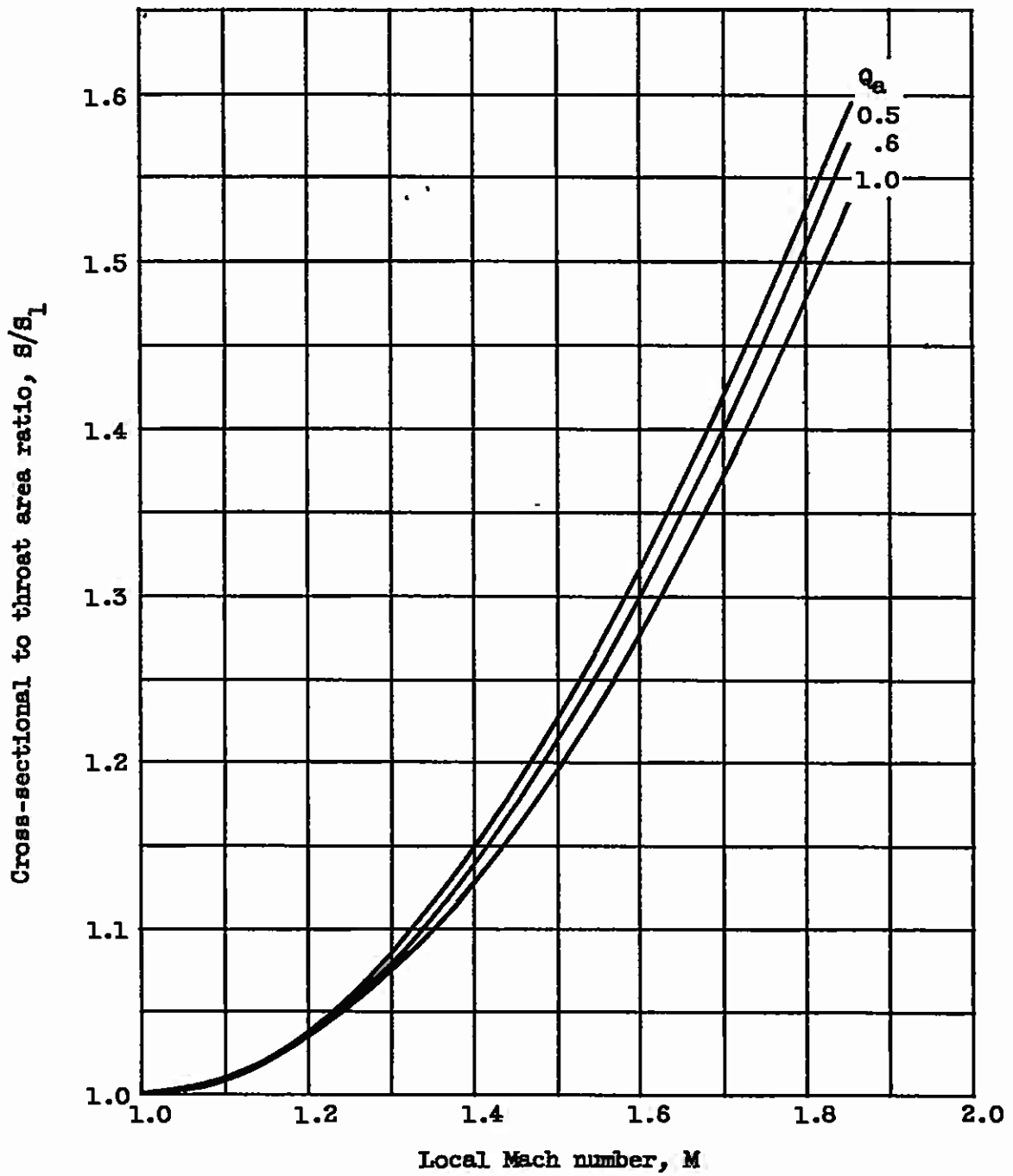

Figure 10. - Variation of cross-sectional area with local Mach number. Free-stream Mach number, 1.85.