

UNCLASSIFIED

AD NUMBER

AD116274

CLASSIFICATION CHANGES

TO: UNCLASSIFIED

FROM: CONFIDENTIAL

LIMITATION CHANGES

TO:  
Approved for public release; distribution is unlimited. Document partially illegible.

FROM:  
Distribution authorized to U.S. Gov't. agencies and their contractors;  
Administrative/Operational Use; 30 NOV 1956.  
Other requests shall be referred to Department of Defense, ATTN: Public Affairs Office, Washington, DC 20301. Document partially illegible.

AUTHORITY

DARPA ltr dtd 7 Oct 1993; DARPA ltr dtd 7 Oct 1993

**UNCLASSIFIED**

---

---

**AD** \_\_\_\_\_

*Reproduced  
by the*

**ARMED SERVICES TECHNICAL INFORMATION AGENCY  
ARLINGTON HALL STATION  
ARLINGTON 12, VIRGINIA**



DECLASSIFIED  
DOD DIR 5200.9

---

---

---

**UNCLASSIFIED**

# AD 16274

## Armed Services Technical Information Agency

Reproduced by

**DOCUMENT SERVICE CENTER**

**KNOTT BUILDING, DAYTON, 2, OHIO**

This document is the property of the United States Government. It is furnished for the duration of the contract and shall be returned when no longer required, or upon recall by ASTIA to the following address: Armed Services Technical Information Agency, Document Service Center, Knott Building, Dayton 2, Ohio.

**NOTICE: WHEN GOVERNMENT OR OTHER DRAWINGS, SPECIFICATIONS OR OTHER DATA ARE USED FOR ANY PURPOSE OTHER THAN IN CONNECTION WITH A DEFINITELY RELATED GOVERNMENT PROCUREMENT OPERATION, THE U. S. GOVERNMENT THEREBY INCURS NO RESPONSIBILITY, NOR ANY OBLIGATION WHATSOEVER; AND THE FACT THAT THE GOVERNMENT MAY HAVE FORMULATED, FURNISHED, OR IN ANY WAY SUPPLIED THE SAID DRAWINGS, SPECIFICATIONS, OR OTHER DATA IS NOT TO BE REGARDED BY IMPLICATION OR OTHERWISE AS IN ANY MANNER LICENSING THE HOLDER OR ANY OTHER PERSON OR CORPORATION, OR CONVEYING ANY RIGHTS OR PERMISSION TO MANUFACTURE, USE OR SELL ANY PATENTED INVENTION THAT MAY IN ANY WAY BE RELATED THERETO.**

# DISCLAIMER NOTICE

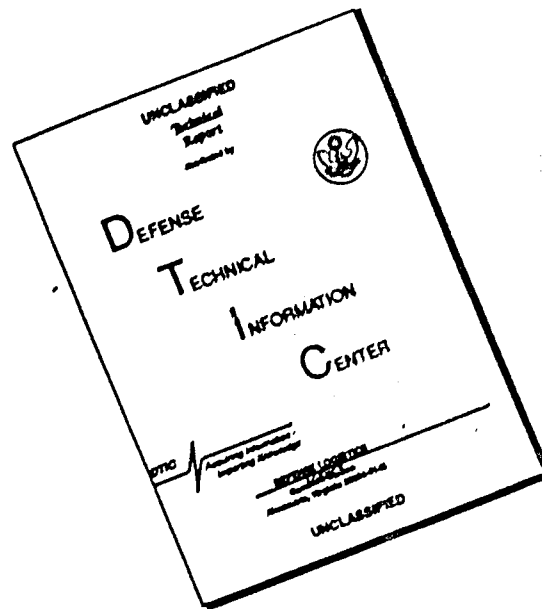

THIS DOCUMENT IS BEST QUALITY AVAILABLE. THE COPY FURNISHED TO DTIC CONTAINED A SIGNIFICANT NUMBER OF PAGES WHICH DO NOT REPRODUCE LEGIBLY.

AD No. 16-274  
ASTIA FILE COPY

CONFIDENTIAL

FC

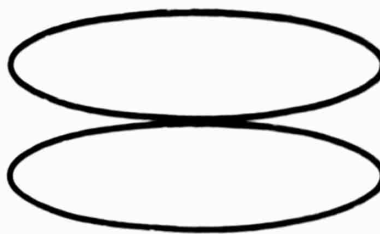

ENGINEERING REPORT NO.

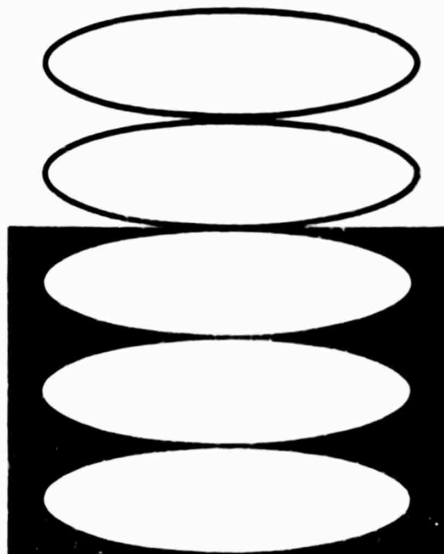

AERODYNAMICS OF DUCTED PROPELLERS  
AS APPLIED TO THE PLATFORM PRINCIPLE

CONFIDENTIAL



5611

60508

1649

**NOTICE: THIS DOCUMENT CONTAINS INFORMATION AFFECTING THE  
NATIONAL DEFENSE OF THE UNITED STATES WITHIN THE MEANING  
OF THE ESPIONAGE LAWS, TITLE 18, U.S.C., SECTIONS 793 and 794.  
THE TRANSMISSION OR THE REVELATION OF ITS CONTENTS IN  
ANY MANNER TO AN UNAUTHORIZED PERSON IS PROHIBITED BY LAW.**



PREPARED	NAME A. Morse	DATE 11/30/56	HILLER HELICOPTERS	PAGE 1
CHECKED			TITLE: Aerodynamics of Ducted Propellers As Applied to the Platform Principle	MODEL 1031-A
APPROVED				REPORT NO. 50-106

C O N F I D E N T I A L

TABLE OF CONTENTS

	<u>Page No.</u>
List of Symbols . . . . .	ii
I Summary . . . . .	v
II Introduction . . . . .	1
III Analysis . . . . .	2
IV Power Required . . . . .	11
V Propeller Efficiency . . . . .	14
VI Blade Design . . . . .	14
VII Variation of Tip Speed with Duct Exit Velocity for Fixed Pitch Propellers . . . . .	15
VIII Pitching Moment . . . . .	19
IX Platform Hover Ceiling . . . . .	21
X Propeller Tip Clearance . . . . .	22
XI Activity Factor for Ducted Propellers . . . . .	22
XII Control Moment . . . . .	25

List of Figures

1 Sign Conventions . . . . .	5a
2 Equilibrium Performance at Forward Speed . . . . .	28
3 Tilt Angle Required for Horizontal Equilibrium . . . . .	29
4 Non Dimensional Moment Coefficients . . . . .	30
5 Thrust Variation with Altitude for Piston Engine . . . . .	31
6 Effect of Tip Clearance on Duct Thrust . . . . .	32
7 Blade Activity Factor . . . . .	33
8 Parasite Power Function . . . . .	34
References . . . . .	35

C O N F I D E N T I A L

PREPARED	NAME A. Morse	DATE 11/30/56	HILLER HELICOPTERS	PAGE ia
CHECKED			TITLE Aerodynamics of Ducted Propellers As Applied to the Platform Principle	MODEL 1031-A
APPROVED				REPORT NO. 56-108

C O N F I D E N T I A L

TABLE OF CONTENTS  
(Continued)

List of Appendices

- I Comparison of Theoretical and Experimental Data for Hiller Model 1031-A Platform.
- II Aerodynamic Considerations of Platform Control Problem.
- III Platform Control.
- IV Stability and Control
- V Preliminary Aerodynamic Analysis

C O N F I D E N T I A L

PREPARED	NAME A. Morse	DATE 11/30/56	HILLER HELICOPTERS	PAGE ii
CHECKED			TITLE: Aerodynamics of Ducted Propellers As Applied to the Platform Principle	MODEL 1031-A
APPROVED				REPORT NO. 56-108

C O N F I D E N T I A L

SYMBOLS

A	Flow area $\sim \text{ft}^2$
AF	Activity factor
a	Lift curve slope $\sim dC_L/d\alpha$
b	Number of blades
$C_{D0}$	Zero lift drag coefficient
$C_{L0}$	Lift coefficient at $\alpha = 0$
$C_L$	Lift coefficient
$C_m$	Moment coefficient
D	Duct or propeller diameter $\sim \text{ft}$
F	Force $\sim$ Pounds
f	Ratio of equivalent internal flat plate drag area to flow area
HP	Horsepower
h	Clearance between blade tip and duct
K	$(1 + f)$
$K'$	Function of $V_2/V_T$
L	Lift $\sim$ Pounds
M	Moment $\sim$ foot pounds
m	Mass rate of flow $\sim$ slugs/second
P	Power $\sim \frac{\text{ft.-lbs.}}{\text{sec.}}$
p	Pressure $\sim \text{lbs./ft.}^2$
q	Dynamic pressure $\sim \text{lbs./ft.}^2$

C O N F I D E N T I A L

PREPARED	NAME A. Morse	DATE 11/30/56	HILLER HELICOPTERS	PAGE 11
CHECKED			TITLE: Aerodynamics of Ducted Propellers As Applied to the Platform Principle	MODEL 131-A
APPROVED				REPORT NO. 50-1 A

C O N F I D E N T I A L

SYMBOLS  
(Continued)

R      Duct or propeller radius ~ ft

r      Propeller station radius ~ ft

SHP    Shaft horsepower input

T      Thrust ~ lbs

V      Velocity ~ ft/sec

W<sub>G</sub>    Gross weight ~ lbs

w      Disk loading ~ lbs/ft<sup>2</sup>

α      Duct aerodynamic angle of attack (β - θ)

β      Angle between the horizontal and duct centerline

η<sub>p</sub>    Propeller efficiency

θ      Angle between the horizontal and the free stream flow

ρ      Mass density

μ      Ratio of induced velocity to blade rotational velocity  $\mu = \frac{V_o}{\Omega r}$

φ      Inflow angle

ψ      Flow coefficient

Ω      Angular velocity rad./sec.

C O N F I D E N T I A L

PREPARED	NAME A. Morse	DATE 11/30/56	HILLER HELICOPTERS	PAGE iv
CHECKED			TITLE: Aerodynamics of Ducted Propellers As Applied to the Platform Principle	MODEL 1031-A
APPROVED				REPORT NO. 56-106

C O N F I D E N T I A L

SYMBOLS  
(Continued)

Subscripts

0	Free stream
1	Duct inlet
2	Propeller inlet
3	Propeller exit
4	Duct exit
5	Wake, far behind 4
D	Duct or drag
H	Hover
INT	Internal
N	Net
P	Propeller
R	Resultant
S.L.	Sea Level
S	Shroud

C O N F I D E N T I A L

PREPARED	NAME A. Morse	DATE 11/30/56	HILLER HELICOPTERS	PAGE V
CHECKED			TITLE: Aerodynamics of Ducted Propellers As Applied to the Platform Principle	MODEL 1031-A
APPROVED				REPORT NO. 56-108

C O N F I D E N T I A L

### I. SUMMARY

This report is intended to provide analytical means of predicting the performance spectrum for ducted propeller aircraft that maintain an equilibrium of forces by adjusting the angle between the vertical and the exit stream tube. Equations are derived relating the tilt angle, free stream velocity, propeller characteristics, and available power, to the net force produced by the platform and to the direction of this force. Particular emphasis has been placed on the relation between the duct exit velocity and propeller tip speed for fixed pitch propellers, because this variation determines the relation between the power available and the power required.

It is impossible to determine the accuracy of the individual relations without further test data, because they must be combined to determine the overall performance, and the overall performance - not individual performance contributions - was all that was obtained by test. The net force calculated for the condition indicating the greatest difference between theory and test ( $V = 45$  knots, tilt angle =  $31^\circ$ , and 100% power) produced a net thrust of 515 pounds directed  $8.05^\circ$  aft of the vertical.

The test data of Reference 3 for the same conditions of tilt angle and velocity indicate a net thrust of 624 pounds directed aft  $12^\circ$ . The difference between the theoretical net thrust and test net thrust is 17.5%. This is rather poor correlation, but the error cannot be completely attributed to the theory, because the net thrust is dependent upon the square root of the available power cubed. The test was conducted at full power, and it is not apparent exactly how the power available varied with RPM or what effect tilting the engines had on power output. The expressions for the moment are empirical and involve non dimensional parameters which were determined from the truck test data of Reference 3; therefore the moment equation cannot be checked against the experimental data to determine their accuracy.

C O N F I D E N T I A L

PREPARED	NAME A. Morse	DATE 11/30/56	HILLER HELICOPTERS	PAGE 1
CHECKED			TITLE: Aerodynamics of Ducted Propellers As Applied to the Platform Principle	MODEL 1031-A
APPROVED				REPORT NO. 56-108

C O N F I D E N T I A L

### INTRODUCTION

This analysis is complete for coaxial fixed pitch propellers, but not necessarily limited to exclude other types of propeller configurations. The procedure for calculating the performance will be outlined. Curves are presented which allow rapid estimation of tilt angles and power required for all disk loadings and power loadings. All information is based on the assumption that the flow does not separate from the duct lip. The flow will actually separate from the forward lip at a high duct angle of attack ( $\alpha$ ) (Figure 1) and large free stream velocity, but the lip shapes and disk loadings currently in use have shown no tendency toward separation.

The advantage of good internal aerodynamic design is obvious from Figure 2 and the definition of the quantity  $[1 + (A_1/A_2)^2 f]$ . It can also be seen that high values of disk loading will require lower tilt angles for a given forward speed. Figure 2 indicates a minimum cruise power for platforms designed to cruise where  $V_0(\rho/wD_H)^{1/2} = .8$  to 1.0. If a platform is to be designed in this region, particular attention should be given to the moment, both from a standpoint of magnitude and the possibilities of the rate of change of the moment with velocity becoming negative.

#### A. Procedure for Performance Calculations

The conditions of altitude and temperature under which the platform must hover are used as a starting point. The required flow area and velocity are determined, and the propeller blade design is straight forward once the actual diameter and internal drag has been determined. The power required under these conditions is readily determined, since the flow velocity, areas, and tip speed are known. Figure 2 may be used to determine the relation between tilt angle and velocity. The external drag is very small compared to the lift; therefore the assumption that  $T/L \sin \beta$  is zero (Equation 1.15) will be valid and will allow the determination of  $V_0/V_5$ , consequently  $\psi$ , and an estimation of the pitching moment may be made. An indication of the hover ceiling and power required can be obtained from the curves by assuming that the propeller efficiency does not change.

If the performance obtained thus far is desirable, the relation between  $V_5/V_T$  and  $V_0/V_5$ , given by Equation (4.01) or (4.02) should be determined. This information can then be used in Equation (2.07) of Section 2. Equation (2.07) should be plotted against  $V_0/V_5$ ; this holds for all conditions and with Equation (1.04) relates the actual shaft power input to  $V_5$  and  $V_0$ . The power required along

C O N F I D E N T I A L

PREPARED	NAME A. Morse	DATE 11/30/56	HILLER HELICOPTERS	PAGE 2
CHECKED			TITLE Aerodynamics of Ducted Propellers as Applied to the Platform Principle	MODEL 1031-A
APPROVED				REPORT NO. 56-108

C O N F I D E N T I A L

the flight equilibrium line can now be calculated as  $V_0/V_5$  and thus  $\eta_p$  are known.

Sufficient information is available for the calculation of performance for conditions other than flight equilibrium.

The effect of tip clearance on power loading for the shrouded propeller of Reference 4 is given in Figure 5. If the velocity over the lip increases or the lip is made sharper, the tendency toward flow separation is increased and the tip clearance must be held to closer tolerances.

The product of the number of blades and the activity factor is used in most propeller weight equations; of interest here is the design value of  $b(AF)$  which may be calculated using the velocity and tip speed under the same conditions used to design the propeller. The method outlined in Section 8 is straight forward. The assumption of constant taper is put into the equation, but an ideal taper blade will actually have a  $b(AF)$  slightly lower than the calculated value; therefore the assumption is conservative.

ANALYSIS

A. Aerodynamics of Ducted Propellers with Particular Application to Platforms

The general equations relating power and thrust will be calculated using the conservation of energy and the momentum equation.

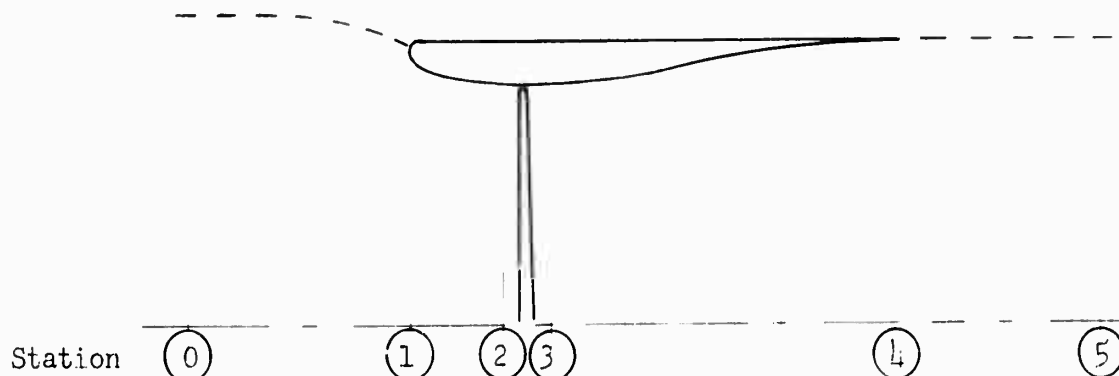

C O N F I D E N T I A L

PREPARED	NAME A. Morse	DATE 11/30/50	HILLER HELICOPTERS	PAGE 3
CHECKED			TITLE: Aerodynamics of Ducted Propellers as Applied to the Platform Principle	MODEL 1031-A
APPROVED				REPORT NO. 58-108

C O N F I D E N T I A L

The equation for the net thrust is obtained immediately by the use of the momentum equation between stations (0) and (5)

$$T_N = mV_5 - mV_0 + p_5A_5 - p_0A_0 - p_0(A_5 - A_0)$$

A pressure equilibrium exists between the jet stream and the surrounding air at station 5; therefore  $p_5 = p_0$ .

$$T_N = mV_5 (1 - V_0/V_5) \quad (1.01)$$

The change in kinetic energy is equal to the power put into the air stream.

$$P = KE(5) - KE(0) + \Delta KE(0) - (5)$$

$$P = \frac{m}{2} \left( V_5^2 - V_0^2 + \frac{2\Delta KE(0) - (5)}{m} \right)$$

The energy lost by the air in passing from station (0) to (5) is equal to the integral of the product of the drag and velocity from station (0) to station (5).

If the conservative assumption is made that the internal drag is acting at station (2) where the velocity is the greatest, the evaluation of  $\Delta KE(0) - (5)$  is simplified.

$$\Delta KE(0) - (5) = DV_2$$

and

$$D = C_D A_{REF} \rho_2$$

By definition

$$f = \frac{C_D A_{REF}}{A_2} \quad (1.02)$$

$$D = f \rho_2 A_2 = \frac{m}{2} f V_2$$

$$\Delta KE(0) - (5) = \frac{mV_5^2}{2} \left( \frac{A_1}{A_2} \right)^2 f$$

$$P = \frac{m}{2} \left[ V_5^2 + V_5^2 \left( \frac{A_1}{A_2} \right)^2 f - V_0^2 \right]$$

C O N F I D E N T I A L

PREPARED	NAME A. Morse	DATE 11/30/56	HILLER HELICOPTERS	PAGE 4
CHECKED			TITLE: Aerodynamics of Ducted Propellers as Applied to the Platform Principle	MODEL 1031-A
APPROVED				REPORT NO. 56-108

C O N F I D E N T I A L

$$P = \frac{\rho V_5^2}{2} \left[ 1 + \left( \frac{A_1}{A_2} \right)^2 f - \frac{V_0^2}{V_5^2} \right]$$

but

$$1 + \left( \frac{A_1}{A_2} \right)^2 f = K$$

by definition

$$P = \frac{\rho V_5^2}{2} K \left[ 1 - \left( \frac{V_0}{V_5} \right)^2 \frac{1}{K} \right] \quad (1.03)$$

The term defined as "K" has a large influence on the total power required; the definition of f, Equation (1.02), shows that the equivalent flat plate drag area ( $C_{D,REF}$ ) must be kept small. When the platform is hovering, the velocity diminishes rapidly as the distance is traversed from station (1) to station (0). Therefore, if there is an appreciable amount of drag area a large distance above the duct lip, this drag area should not be included in calculating the value of "K". Instead it should be included in the external drag, since the velocity in this region is more nearly that of the free stream.

The power put into the shaft is greater than the power input to the air by the parasite power and induced drag power.

$$\eta_P = \frac{\text{horsepower input to air}}{\text{horsepower input to shaft}}$$

$$\eta_P = \frac{SHP - (HP_o + HP_i)}{SHP}$$

$$\eta_P = 1 - \frac{HP_o + HP_i}{SHP}$$

$$SHP = \frac{\rho V_5^2}{1100 \eta_P} \left[ K - \left( \frac{V_0}{V_5} \right)^2 \right] \quad (1.04)$$

The power input to the air is equal to the product of the propeller thrust and the velocity of the air through the propeller disk.

$$T_{PG} \frac{V_2}{550} = SHP \eta_P$$

but

$$V_2 = \frac{A_1}{A_2} V_5$$

C O N F I D E N T I A L

PREPARED	NAME A. Morse	DATE 11/30/56	HILLER HELICOPTERS	PAGE 5
CHECKED			TITLE: Aerodynamics of Ducted Propellers As Applied to the Platform Principle	MODEL 1031-A
APPROVED				REPORT NO. 56-108

C O N F I D E N T I A L

$$T_{PG} = SHP \eta_P \frac{550}{V_5} \frac{A_2}{A_L}$$

$$T_{PG} = \frac{\pi V_5}{2} \frac{A_2}{A_L} \left[ K - \left( \frac{V_0}{V_5} \right)^2 \right] \quad (1.05)$$

This gross propeller thrust is actually the thrust that the propeller is producing; however part of this thrust is required to draw the air through the shroud, and the net propeller thrust is all that is actually lifting the platform.

$$T_{PG} - D = T_{PN}$$

$$T_{PN} = \frac{\pi V_5}{2} \frac{A_2}{A_L} \left[ 1 - \left( \frac{V_0}{V_5} \right)^2 \right] \quad (1.06)$$

When  $V_0 = 0$

$$T_N = \pi V_5^2 \quad \text{from (1.01)}$$

$$SHP = \frac{\pi V_5^2 K}{1100 \eta_P}$$

$$SHP = \frac{T_N}{1100 \eta_P} \left( \frac{T_N}{\rho A_L} \right)^{1/2} K \quad (1.07)$$

$$SHP = \frac{(T_N)^{3/2}}{(\rho/\rho_{S.L.} A_L)^{1/2}} 1.865(10)^{-2} \frac{K}{\eta_P} \quad (1.08)$$

$$T_N = 14.22 (\rho/\rho_{S.L.} A_L)^{1/3} \left( \frac{SHP \eta_P}{K} \right)^{2/3} \quad (1.09)$$

when  $V_0 \neq 0$

The equations for thrust involve both velocity and direction; therefore it will be necessary to express the equations in terms of their components in the directions of lift and thrust so that the equations for equilibrium flight can be shown explicitly. Defining the angles, as shown in Figure 1, and assuming that  $V_5$  is parallel to the centerline of the duct, the equations for lift and thrust become:

C O N F I D E N T I A L

PREPARED	NAME A. Morse	DATE 11/30/56	HILLER HELICOPTERS	PAGE 5a
CHECKED			TITLE: Aerodynamics of Ducted Propellers As Applied to the Platform Principle	MODEL 1031-A
APPROVED				REPORT NO. 56-108

CONFIDENTIAL

SIGN CONVENTIONS

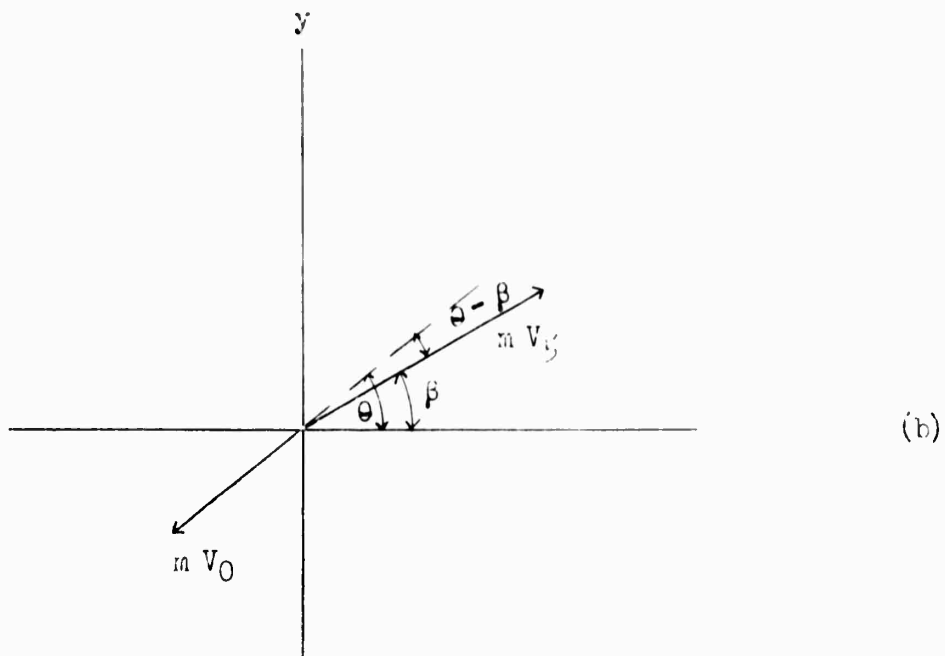
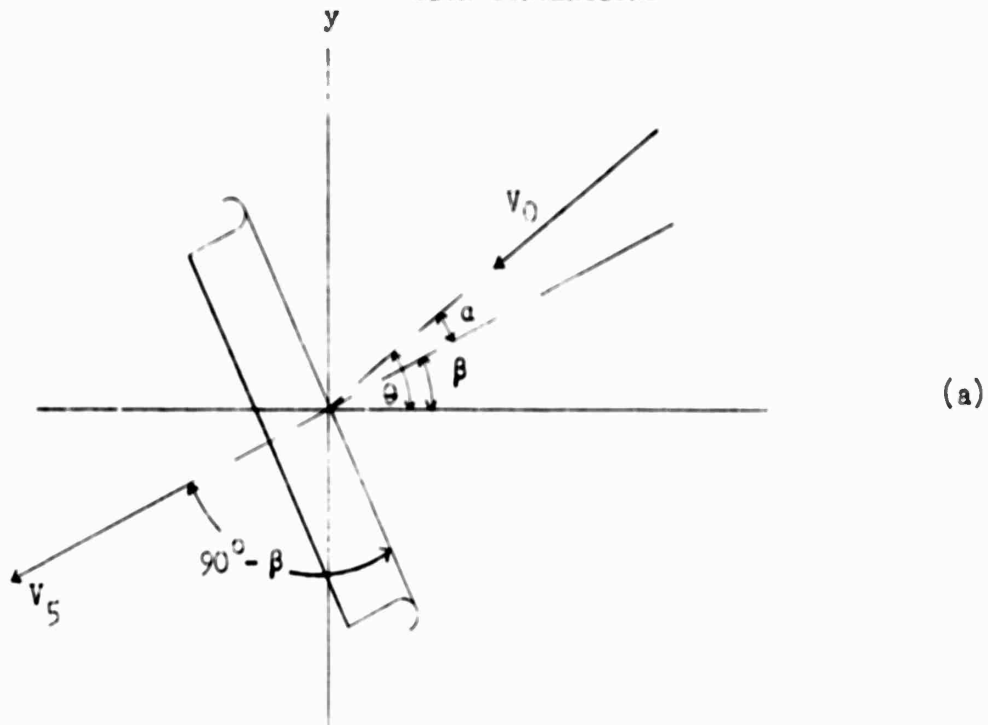

CONFIDENTIAL

FIG. 1

PREPARED	NAME A. Morse	DATE 11/30/56	HILLER HELICOPTERS	PAGE 6
DESIGNED			TITLE: Aerodynamics of Ducted Propellers As Applied to the Platform Principle	MODEL 1031-A
APPROVED				REPORT NO. 60-100

CONFIDENTIAL

$$\Sigma F_y = L$$

$$L = m (V_5 \sin \beta - V_0 \sin \theta)$$

$$V_0 \sin \theta = V_5 \sin \beta - \frac{L}{m}$$

$$\sin^2 \theta = \left( \frac{V_5}{V_0} \sin \beta - \frac{L}{mV_0} \right)^2$$

$$\Sigma F_x = T$$

$$T = m (V_5 \cos \beta - V_0 \cos \theta)$$

$$\cos^2 \theta = \left( \frac{V_5}{V_0} \cos \beta - \frac{T}{mV_0} \right)^2$$

$$\text{but } \sin^2 \theta + \cos^2 \theta = 1.0$$

$$\left( \frac{V_5}{V_0} \right)^2 \sin^2 \beta + \left( \frac{V_5}{V_0} \right)^2 \cos^2 \beta + \left( \frac{L}{mV_0} \right)^2 + \left( \frac{T}{mV_0} \right)^2 = \frac{2L \sin \beta}{\rho A_4 V_0^2} + \frac{2T \cos \beta}{\rho A_4 V_0^2} + 1$$

$$\left( \frac{V_5}{V_0} \right)^2 + \left( \frac{L}{mV_0} \right)^2 \left[ 1 + \left( \frac{T}{L} \right)^2 \right] = \frac{2L}{\rho A_4 V_0^2} \left( \sin \beta + \frac{T}{L} \cos \beta \right) + 1$$

$$V_5^4 + \left( \frac{L}{\rho A_4} \right)^2 \left[ 1 + \left( \frac{T}{L} \right)^2 \right] = \frac{2L V_5^2}{\rho A_5} \left( \sin \beta + \frac{T}{L} \cos \beta \right) + (V_5 V_0)^2$$

$$V_5^4 - V_5^2 \frac{2L}{\rho A_4} \left( \sin \beta + \frac{T}{L} \cos \beta + \frac{\rho A_4 V_0^2}{2L} \right) + \left( \frac{L}{\rho A_4} \right)^2 \left[ 1 + \left( \frac{T}{L} \right)^2 \right] = 0$$

(1.12)

CONFIDENTIAL

PREPARED	NAME A. Morse	DATE 11/30/46	HILLER HELICOPTERS	PAGE
CHECKED			TITLE: Aerodynamics of Ducted Propellers As Applied to the Platform Principle	MODEL 1031-A
APPROVED				REPORT NO. 56-108

CONFIDENTIAL

$$\begin{aligned}
 v_5^2 &= \frac{L}{\rho A_h} \left( \sin \beta + \frac{T}{L} \cos \beta + \frac{\rho A_h v_0^2}{2L} \right) \\
 &= \left\{ \left[ \frac{L}{\rho A_h} \left( \sin \beta + \frac{T}{L} \cos \beta + \frac{\rho A_h v_0^2}{2L} \right) \right]^2 - \left( \frac{L}{\rho A_h} \right)^2 \left[ 1 + \left( \frac{T}{L} \right)^2 \right] \right\}^{\frac{1}{2}}
 \end{aligned}
 \tag{1.13}$$

Equation (1.13) is very cumbersome. If  $\theta = 0^\circ$  which is the actual case for equilibrium flight, the solution is greatly simplified.

$$\theta = 0^\circ$$

$$v_0 \sin \theta = v_5 \sin \beta - \frac{L}{m}$$

$$v_5 \sin \beta = \frac{L}{\rho A_h v_5}$$

$$v_5 = \frac{\left( \frac{L}{\rho A_h} \right)^{\frac{1}{2}}}{\sin^{\frac{1}{2}} \beta} \tag{1.14}$$

$$v_0 \cos \theta = v_5 \cos \beta - \frac{T}{m}$$

$$\cos \theta = 1.0$$

$$v_0 = v_5 \cos \beta - \frac{T}{\rho A_h v_5}$$

$$\frac{v_0}{v_5} = \cos \beta - \frac{T}{\rho A_h v_5^2}$$

but

$$v_5^2 = \frac{L}{\rho A_h \sin \beta}$$

$$\frac{v_0}{v_5} = \cos \beta - \frac{T}{L} \sin \beta \tag{1.15}$$

CONFIDENTIAL

PREPARED	NAME A. Morse	DATE 11/30/56	HILLER HELICOPTERS	PAGE 6
CHECKED			TITLE: Aerodynamics of Dusted Propellers As Applied to the Platform Principle	MODEL 101-A
APPROVED				REPORT NO. 56-167

CONFIDENTIAL

$$\text{but SHP} = \frac{\rho V^2}{1100 \eta_P} \left[ K - \left( \frac{V_C}{V} \right)^2 \right] \text{ Equation (1.07)}$$

$$\text{SHP} = \frac{V^2}{1100 \eta_P} \left[ K - \left( \cos \beta - \frac{T}{L} \sin \beta \right)^2 \right]$$

$$\text{SHP} = \frac{\rho A_L}{1100 \eta_P} \left( \frac{L}{\rho A_L} \right)^{3/2} \frac{1}{\sin^{3/2} \beta} \left[ K - \left( \cos \beta - \frac{T}{L} \sin \beta \right)^2 \right]$$

$$\text{SHP} = \frac{L^{3/2}}{1100 \eta_P} \frac{K}{(\rho A_L)^{1/2} \sin^{3/2} \beta} \left[ 1 - \frac{(\cos \beta - T/L \sin \beta)^2}{K} \right] \quad (1.16)$$

Equation (1.16) gives the horsepower required to produce a given lift and thrust when  $\theta = 0^\circ$  and  $\beta$  is the angle defined. For  $L = W_G$  Equation (1.07) becomes:

$$\text{SHP}_H = \frac{L^{3/2} K}{1100 \eta_P (\rho A_L)^{1/2}}$$

and Equation (1.16) becomes:

$$\frac{\text{SHP}}{\text{SHP}_H} = \frac{\eta_P}{\eta_{PH}} \frac{1}{\sin^{3/2} \beta} \left[ 1 - \frac{(\cos \beta - T/L \sin \beta)^2}{K} \right] \quad (1.17)$$

$$\frac{\eta_P \text{SHP}}{\eta_{PH} \text{SHP}_H} = \frac{1}{\sin^{3/2} \beta} \left[ 1 - \frac{(\cos \beta - T/L \sin \beta)^2}{K} \right] \quad (1.18)$$

Figure 2 is a graphical representation of Equation (1.18). Another equation is required to determine what free stream velocity is associated with the different tilt angles ( $90 - \beta$ ).

The equations obtained from summing the forces in the directions of L and T with the assumption of  $\theta = 0$  will provide the necessary relation. This is equation 1.19 which is also shown on Figure 2.

CONFIDENTIAL

PREPARED	NAME A. MORSE	DATE 11/30/53	HILLER HELICOPTERS	PAGE 7
CHECKED			TITLE: Aerodynamics of Ducted Propellers As Applied to the Platform Principle	MODEL 1031-1
APPROVED				REPORT NO. 56-108

CONFIDENTIAL

$$L = \rho A_l V_5 \sin \beta$$

$$V_5^2 = \frac{L}{\rho A_l \sin \beta}$$

and

$$T = \rho A_l (V_5 \cos \beta - V_0)$$

$$V_5 \cos \beta - \frac{T}{\rho A_l V_5} = V_0$$

$$\frac{V_0}{V_5} = \cos \beta - \frac{T}{\rho A_l V_5^2}$$

$$\frac{V_0}{V_5} = \cos \beta - \frac{T}{L} \sin \beta$$

but

$$w_{DH} = \frac{L}{A_l}$$

$$V_0 = \left( \frac{L}{\rho A_l} \right)^{\frac{1}{2}} \frac{1}{\sin^{\frac{1}{2}} \beta} \left( \cos \beta - \frac{T}{L} \sin \beta \right)$$

$$V_0 \left( \frac{\rho}{w_{DH}} \right)^{\frac{1}{2}} = \frac{1}{\sin^{\frac{1}{2}} \beta} \left( \cos \beta - \frac{T}{L} \sin \beta \right) \quad (1.1')$$

From Figure 1 the exit velocity is directed  $\beta$  degrees from the horizontal, and the assumption was made that the platform was tilted to an angle  $(90^\circ - \beta)$ . If it is assumed that the platform tilt angle remains zero ( $\beta = 90^\circ$ ) and only the exit stream is turned through the angle  $(90^\circ - \beta)$ , the force diagram remains the same. Therefore, the tilt angle  $(90^\circ - \beta)$ , shown in Figure 2, can be interpreted as the angle through which the exit stream is turned. The moment produced by a platform propelled by turning the exit stream, rather than tilting the platform, will be affected to a large extent. This can be seen if the equations for the thrust

CONFIDENTIAL

PREPARED	NAME A. Morse	DATE 11/30/50	HILLER HELICOPTERS	PAGE 15
CHECKED			TITLE: Aerodynamics of Ducted Propellers As Applied to the Platform Principle	MODEL 1031-A
APPROVED				REPORT NO. 50-106

C O N F I D E N T I A L

produced by the duct are found. This can be accomplished by taking the equations obtained for L and T and subtracting the components of the propeller net thrust

$$T_{PN} = \frac{\pi V_5}{2} \frac{A_2}{A_L} \left[ 1 - \left( \frac{V_0}{V_5} \right)^2 \right]$$

$$L = \pi (V_5 \sin \beta - V_0 \sin \theta)$$

$$T = \pi (V_5 \cos \beta - V_0 \cos \theta)$$

$$T_{DL} = \pi V_5 \left( \sin \beta - \frac{V_0}{V_5} \sin \theta \right) - \frac{\pi V_5}{2} \frac{A_2}{A_L} \sin \beta \left[ 1 - \left( \frac{V_0}{V_5} \right)^2 \right]$$

$$T_{DL} = \pi V_5 \sin \beta \left\{ 1 - \frac{A_2}{2A_L} \left[ 1 - \left( \frac{V_0}{V_5} \right)^2 \right] - \frac{V_0 \sin \theta}{V_5 \sin \beta} \right\}$$

$$T_{DL} = \pi V_5 \sin \beta \left\{ 1 - \frac{A_2}{2A_L} + \frac{A_2}{2A_L} \left( \frac{V_0}{V_5} \right)^2 - \frac{V_0 \sin \theta}{V_5 \sin \beta} \right\} \quad (1.20)$$

$$T_{DT} = \pi V_5 \left( \cos \beta - \frac{V_0}{V_5} \cos \theta \right) - \frac{\pi V_5}{2} \frac{A_2}{A_L} \cos \beta \left[ 1 - \left( \frac{V_0}{V_5} \right)^2 \right]$$

$$T_{DT} = \pi V_5 \cos \beta \left\{ 1 - \frac{A_2}{2A_L} + \frac{A_2}{2A_L} \left( \frac{V_0}{V_5} \right)^2 - \frac{V_0 \cos \theta}{V_5 \cos \beta} \right\} \quad (1.21)$$

Examination of Equations (1.20) and (1.21) indicate an increase in the total duct force when  $\theta = 0^\circ$  and  $V_0/V_5$  is increased. The point of application of the resultant duct lift moves forward as  $V_0/V_5$  increases and the duct lift becomes larger; therefore the moment will increase rapidly with  $V_0/V_5$  when the tilt angle ( $90^\circ - \beta$ ) is small.

The drag to lift ratio is difficult to determine, because the direction of the streamlines over the external surfaces are not easily determined. If Equation (1.15) is plotted ( $V_0/V_5$  VS  $\beta$ ) for  $T/L = 0$ ,  $\theta = 0$  and the truck test data for the platform model 1031 is corrected so as to keep the lift equal to a constant (Figure 3)

C O N F I D E N T I A L

PREPARED	NAME A. horse	DATE 11/30/56	HILLER HELICOPTERS	PAGE 11
CHECKED			TITLE Aerodynamics of Ducted Propellers As Applied to the Platform Principle	MODEL 1691-A
APPROVED				REPORT NO. 50-177

C O N F I D E N T I A L

reasonably good agreement between test and theory is found. This indicates that the drag component in the direction of flight is very small and can be neglected. The method used to correct the test data and an example calculation is shown in Appendix A.

POWER REQUIRED

The term  $\eta_p$  has appeared frequently with no mention of how it is to be obtained. To do this, it will be necessary to determine where the total power put into the propeller shaft is consumed.

The total power required is the sum of the induced power, the blade profile power, the shroud profile power, and the induced drag power.

The induced drag power ( $P_L$ ) is the power necessary to overcome the torque caused by the component of lift in the plane of rotation.

The shroud profile power ( $P_{0S}$ ) is the power necessary to overcome the resistance to flow caused by the shroud and internal objects in the flow field. Because the propeller thrust must overcome the shroud profile power, the product of propeller thrust and velocity through the propeller is equal to the sum of the shroud profile power and the induced power.

$$P_i + P_{0S} = T_p V_2 = T_p V_5 \frac{A_L}{A_2}$$

but

$$T_p = \frac{\rho V_5^2}{2} \left[ K - \left( \frac{V_0}{V_5} \right)^2 \right]$$

$$P_i + P_{0S} = \frac{\rho V_5^2}{2} \frac{A_L}{A_2} \left[ K - \left( \frac{V_0}{V_5} \right)^2 \right] \quad (2.01)$$

A. Induced Drag Power

$$dQ = \frac{\rho}{2} V_R^2 c r C_L \sin \phi dr$$

$$\text{but } V_R = \frac{V_2}{\sin \phi}$$

$$dQ = \frac{\rho}{2} \frac{V_2^2 c C_L}{\sin \phi} r dr$$

$$\text{and } \sin \phi = \tan \phi = \frac{V_2}{\Omega r}$$

C O N F I D E N T I A L

PREPARED	NAME A. Morse	DATE 11/30/56	HILLER HELICOPTERS	PAGE 12
CHECKED			TITLE: Aerodynamics of Ducted Propellers As Applied to the Platform Principle	MODEL 1031-A
APPROVED				REPORT NO. 56-108

C O N F I D E N T I A L

$$dQ = \frac{\rho}{2} V_2 c C_L \omega r r dr$$

$$dP_L = \frac{\rho}{2} V_2 \omega \int_0^R C_L c r^2 dr \quad \text{for one blade}$$

$$dP_L = \frac{b\rho}{2} V_2 \omega \int_0^R C_L c r^2 dr \quad \text{for } b \text{ blades}$$

The induced drag power is small compared to the induced power and shroud profile power; therefore the assumption of constant  $C_L$  and  $c$  will be adequate.

$$\therefore P_L = \frac{\rho b c R}{6} C_L V_2 V_T R$$

$$P_L = \frac{\rho b c R}{6} C_L V_T^2 \frac{V_2}{V_T} R \quad (2.02)$$

Expressing the propeller thrust in terms of the propeller blade section characteristics, and making use of the assumption of uniform chord and lift coefficient, the induced drag power can be related to the propeller thrust.

$$T_P = \int_0^R \frac{\rho}{2} (\omega r)^2 C_L b c dr$$

$$T_P = \frac{\rho b c R C_L}{6} V_T^2$$

$$P_L = T_P \frac{V_2}{V_T} R \quad (2.03)$$

#### B. Propeller Profile Power

$$P_O = \frac{b c R \rho C_{D0}}{8} V_T^3 K' \quad (\text{Reference 1})$$

where  $K' = \frac{V_2}{V_T}$  by definition (Figure 8)

$$P_O = \frac{\rho b c R C_L V_T^2}{6} \frac{3}{4} V_T K' \frac{C_{D0}}{C_L}$$

C O N F I D E N T I A L

PREPARED	NAME A. Morse	DATE 11/30/56	HILLER HELICOPTERS	PAGE 13
CHECKED			TITLE: Aerodynamics of Ducted Propellers As Applied to the Platform Principle	MODEL 1031-A
APPROVED				REPORT NO. 56-108

C O N F I D E N T I A L

$$P_0 = \frac{3}{4} T_P V_T K' \frac{C_{D0}}{C_L} \quad (2.04)$$

$$P_0 + P_L = T_P \left[ \frac{3}{4} V_T K' \frac{C_{D0}}{C_L} + \frac{V_2 R}{V_T} \right] \quad (2.05)$$

but  $T_{P_G} = \frac{m V_5}{2} \frac{A_2}{A_L} \left[ K - \left( \frac{V_0}{V_5} \right)^2 \right]$  from equation (1.05)

$$T_{P_G} = \frac{\rho A_L V_5^2}{2} \frac{A_2}{A_L} \left[ K - \left( \frac{V_0}{V_5} \right)^2 \right]$$

C. Summation of Power Required

$$P_R = P_i + P_{O_5} + P_0 + P_D$$

$$P_R = \frac{m V_5^2}{2} \left[ K - \left( \frac{V_0}{V_5} \right)^2 \right] + \frac{m V_5}{2} \frac{A_2}{A_L} \left[ K - \left( \frac{V_0}{V_5} \right)^2 \right]$$

$$\left[ \frac{3}{4} V_T K' \frac{C_{D0}}{C_L} + \frac{V_2 R}{V_T} \right]$$

$$P_R = \frac{m V_5^2}{2} \left[ K - \left( \frac{V_0}{V_5} \right)^2 \right] \left\{ 1 + \frac{A_2}{A_L} \left[ \frac{3}{4} \frac{V_T}{V_5} K' \frac{C_{D0}}{C_L} + \frac{A_L R}{A_2 V_T} \right] \right\}$$

when  $V_0 = 0$

$$T = m V_5 = \rho A_L V_5^2$$

$$V_5 = \left( \frac{T}{\rho A_L} \right)^{\frac{1}{2}}$$

$$P_R = \frac{T^{3/2} K}{2 \sqrt{\rho A_L}} \left\{ 1 + \left[ \frac{3}{4} \frac{A_2}{A_L} V_T \left( \frac{\rho A_L}{T} \right)^{\frac{1}{2}} K' \frac{C_{D0}}{C_L} + \frac{R}{V_T} \right] \right\}$$

$$HP_R = \frac{T^{3/2} K}{1100 \sqrt{\rho A_L}} \left\{ 1 + \left[ \frac{3}{4} \frac{A_2}{A_L} V_T \left( \frac{\rho A_L}{T} \right)^{\frac{1}{2}} K' \frac{C_{D0}}{C_L} + \frac{R}{V_T} \right] \right\} \quad (2.06)$$

C O N F I D E N T I A L

PREPARED	NAME A. Morse	DATE 11/20/50	HILLER HELICOPTERS	PAGE 14
CHECKED			TITLE Aerodynamics of Ducted Propellers As Applied to the Platform Principle	MODEL 2031-A
APPROVED				REPORT NO. 56-108

C O N F I D E N T I A L

$$\text{where } K = \left[ 1 + \left( \frac{A_4}{A_2} \right)^2 f \right]$$

D. Propeller Efficiency

$$\eta_P = \frac{\text{horsepower input to air}}{\text{horsepower input to shaft}} = 1 - \frac{HP_O + HP_D}{SHP}$$

$$HP_O + HP_D = \frac{\pi V_5^2 A_2}{1100 A_4} \left[ K - \left( \frac{V_O}{V_5} \right)^2 \right] \left[ \frac{3}{4} V_T K' \frac{C_{D_O}}{C_L} + \frac{V_2 R}{V_T} \right]$$

$$SHP = \frac{\pi V_5^2}{1100 \eta_P} \left[ K - \left( \frac{V_O}{V_5} \right)^2 \right] \text{ from equation (1.04)}$$

$$\eta_P = 1 - \frac{A_2}{A_4} \eta_P \left[ \frac{3}{4} \frac{V_T}{V_5} K' \frac{C_{D_O}}{C_L} + \frac{V_2 R}{V_5 V_T} \right]$$

$$\frac{1}{\eta_P} = 1 + \frac{A_2}{A_4} \left[ \frac{3}{4} \frac{V_T}{V_5} K' \frac{C_{D_O}}{C_L} + \frac{A_4 R}{A_2 V_T} \right]$$

but  $\frac{A_4 R}{A_2 V_T} \ll 1.0$

Therefore, the approximation of  $R/V_T = R/V_{T_H}$  will be good, particularly in view of the fact that  $V_T$  was found to vary very little when the five foot Hiller platform was truck tested. This data was not published.

$$\frac{1}{\eta_P} = 1 + \left[ \frac{3}{4} \frac{V_T}{V_5} K' \frac{C_{D_O}}{C_L} \frac{A_2}{A_4} + \frac{R}{V_{T_H}} \right] \quad (2.07)$$

BLADE DESIGN

This analysis is concerned only with counter-rotating coaxial blades. The method of analysis given in Reference 2 has been shown to give good results, provided the substitution of  $C_L = (a \alpha + C_{L_0})$  is made rather than  $C_L = a \alpha$ . The above

C O N F I D E N T I A L

PREPARED	NAME A. Horse	DATE 11/30/56	HILLER HELICOPTERS	PAGE 15
CHECKED			TITLE: Aerodynamics of Ducted Propellers As Applied to the Platform Principle	MODEL 1031-A
APPROVED				REPORT NO. 56-108

CONFIDENTIAL

substitution was necessary to generalize the equations for use with other than symmetrical airfoil sections. This effects only Equation (10) and (11) of Reference 2.

If no substitution is used for  $C_L$  but  $b$  is used as defined in this report and Equations (10) and (11) of Reference 2 are solved for the chord, the resulting equations can be used to determine the variation of chord with radius.

$$c_1 = \frac{2 R K \pi (r/R) \mu \sin \phi_1}{C_L b}$$

similarly for the lower propeller.

$$c_2 = \frac{2 R K \pi (r/R) \mu \sin \phi_2}{C_L b}$$

The optimum propeller design is one which has a maximum lift to drag ratio at all blade stations ( $C_L = \text{constant}$ ).

If the required performance is known,  $V_2$  can be calculated from Section 1; a tip speed and number of blades can be chosen, thus giving all the information necessary to compute the variation of the chord with radius. Blade angles are then computed in accordance with Reference (2). When design requirements dictate a constant taper, proceed as above and approximate the optimum chord versus  $r/R$  curve with a straight line and use the constant taper variation of chord with radius to determine the blade angle settings as per Reference (2).

VARIATION OF TIP SPEED WITH DUCT EXIT VELOCITY

FOR FIXED PITCH PROPELLERS

The variation of propeller efficiency with forward velocity is dependent upon the variation of the duct exit velocity and propeller tip speed (Equation 2.07).

CONFIDENTIAL

PREPARED	NAME A. Morse	DATE 11/30/56	HILLER HELICOPTERS	PAGE 16
CHECKED			TITLE: Aerodynamics of Ducted Propellers As Applied to the Platform Principle	MODEL 1051-A
APPROVED				REPORT NO. 55-103

CONFIDENTIAL

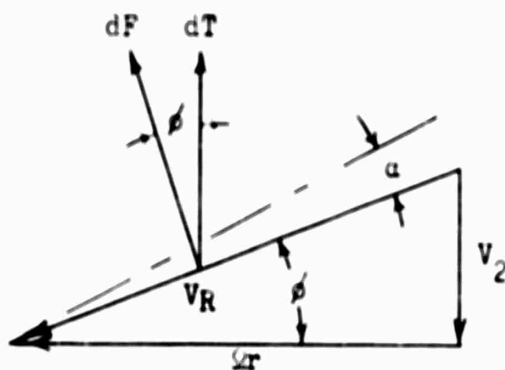

$$dF = C_L \frac{\rho}{2} V_R^2 da$$

$$dA = b c dr$$

$$dF \cos \beta = dT$$

$$V_R^2 = \bar{\Omega}r^2 + V_2^2$$

$$dT = \frac{\rho}{2} C_L (\bar{\Omega}r^2 + V_2^2) b c dr \cos \beta$$

$$\cos \beta = \frac{\bar{\Omega}r}{(\bar{\Omega}r^2 + V_2^2)^{\frac{1}{2}}}$$

$$dT = \frac{\rho}{2} C_L \frac{(\bar{\Omega}r^2 + V_2^2)}{(\bar{\Omega}r^2 + V_2^2)^{\frac{1}{2}}} \bar{\Omega}r b c dr$$

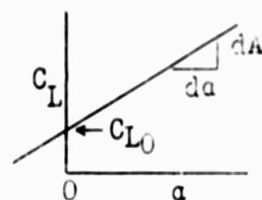

$$dT = \frac{\rho}{2} C_L \bar{\Omega}r (\bar{\Omega}r^2 + V_2^2)^{\frac{1}{2}} b c dr$$

$$dT = \frac{\rho}{2} \bar{\Omega}r^2 \left( \frac{dC_L}{da} a + C_{L0} \right) \left[ 1 + \left( \frac{V_2}{\bar{\Omega}r} \right)^2 \right]^{\frac{1}{2}} b c dr$$

$$C_L = C_{L0} + \frac{dC_L}{da} a$$

$$= C_{L0} + a$$

$$a = (\beta - \phi) = (\beta - \tan^{-1} \frac{V_2}{\bar{\Omega}r})$$

$$dT = \frac{\rho}{2} \bar{\Omega}r^2 \left[ a (\beta - \tan^{-1} \frac{V_2}{\bar{\Omega}r}) + C_{L0} \right] \left[ 1 + \left( \frac{V_2}{\bar{\Omega}r} \right)^2 \right]^{\frac{1}{2}} b c dr$$

but, for small angles

$$\tan^{-1} \frac{V_2}{\bar{\Omega}r} = \frac{V_2}{\bar{\Omega}r}$$

CONFIDENTIAL

PREPARED	NAME A. Morse	DATE 11/30/56	HILLER HELICOPTERS	PAGE 17
CHECKED			TITLE: Aerodynamics of Ducted Propellers As Applied to the Platform Principle	MODEL 1031-A
APPROVED				REPORT NO. 46-108

CONFIDENTIAL

$$\text{and} \quad \left[ 1 + \left( \frac{v_2}{\Omega r} \right)^2 \right]^{\frac{1}{2}} = \left[ 1 + \frac{1}{2} \left( \frac{v_2}{\Omega r} \right)^2 \right]$$

$$dT = \frac{\rho}{2} \Omega^2 r^2 \left[ a\beta - a \frac{v_2}{\Omega r} + C_{L0} \right] \left[ 1 + \frac{1}{2} \left( \frac{v_2}{\Omega r} \right)^2 \right] b c dr$$

$$dT = \frac{\rho}{2} \Omega^2 r^2 \left[ a\beta - a \frac{v_2}{\Omega r} + C_{L0} + \frac{a\beta}{2} \left( \frac{v_2}{\Omega r} \right)^2 - \frac{a}{2} \left( \frac{v_2}{\Omega r} \right)^3 + \frac{3C_{L0}}{2} \left( \frac{v_2}{\Omega r} \right)^2 \right] b c dr$$

The last three terms in the bracket are small compared to the first three.

$$dT = \frac{\rho}{2} \Omega^2 r^2 \left( \beta - \frac{v_2}{\Omega r} + \frac{C_{L0}}{a} \right) b c dr$$

$$r = R \frac{r}{R}$$

$$dr = R d \left( \frac{r}{R} \right)$$

$$dT = \frac{a}{2} \rho V_T^2 R \left( \beta - \frac{v_2}{V_T \left( \frac{r}{R} \right)} + \frac{C_{L0}}{a} \right) b c \left( \frac{r}{R} \right)^2 d \left( \frac{r}{R} \right)$$

This element of force summed over  $r/R$  must equal the propeller thrust. It must be remembered that blockage and the necessary fairing of the blade near the root will alter the flow in that area. In practice, then, it will be necessary to account for this during summation. Perhaps the simplest method would be to assume ideal blade conditions down to some minimum radius, producing uniform inflow beyond and zero velocity inside this radius.

$$T_P = \int_{\left(\frac{r}{R}\right)_{\min}}^{1.0} dT = \frac{\rho}{2} a V_T^2 R \int_{\left(\frac{r}{R}\right)_{\min}}^{1.0} \left( \beta - \frac{v_2}{V_T \left(\frac{r}{R}\right)} + \frac{C_{L0}}{a} \right) b c \left(\frac{r}{R}\right)^2 d \left(\frac{r}{R}\right)$$

CONFIDENTIAL

PREPARED	NAME A. Morse	DATE 11/30/56	HILLER HELICOPTERS	PAGE 18
CHECKED			TITLE: Aerodynamics of Ducted Propellers As Applied to the Platform Principle	MODEL 1031-A
APPROVED				REPORT NO. 56-108

CONFIDENTIAL

$$\frac{2 T_p}{ab \rho V_T^2 R} = \int_{\left(\frac{r}{R}\right)_{\min}}^{1.0} \rho c \left(\frac{r}{R}\right)^2 d\left(\frac{r}{R}\right) - \frac{V_2}{V_T} \int_{\left(\frac{r}{R}\right)_{\min}}^{1.0} c \left(\frac{r}{R}\right) d\left(\frac{r}{R}\right)$$

$$+ \frac{C_{L0}}{a} \int_{\left(\frac{r}{R}\right)_{\min}}^{1.0} c \left(\frac{r}{R}\right)^2 d\left(\frac{r}{R}\right)$$

$$C_1 = \int_{\left(\frac{r}{R}\right)_{\min}}^{1.0} \rho c \left(\frac{r}{R}\right)^2 d\left(\frac{r}{R}\right)$$

$$C_2 = \int_{\left(\frac{r}{R}\right)_{\min}}^{1.0} c \left(\frac{r}{R}\right) d\left(\frac{r}{R}\right)$$

$$C_3 = \int_{\left(\frac{r}{R}\right)_{\min}}^{1.0} \frac{C_{L0}}{a} c \left(\frac{r}{R}\right)^2 d\left(\frac{r}{R}\right)$$

$$\frac{2 T_p}{ab \rho V_T^2 R} = C_1 - \frac{V_2}{V_T} C_2 + C_3$$

$$\frac{2 T_p}{ab \rho V_T^2 R} + \frac{V_2}{V_T} C_2 - (C_1 + C_3) = 0 \quad (4.01)$$

CONFIDENTIAL

PREPARED	NAME A. Morse	DATE 11/30/50	HILLER HELICOPTERS	PAGE 19
DESIGNED			TITLE: Aerodynamics of Ducted Propellers As Applied to the Platform Principle	MODEL 1031-A
APPROVED				REPORT NO. 50-102

C O N F I D E N T I A L

From Section 1:

$$T_P = \frac{\rho V_5 A_2}{2} \left[ 1 + \left( \frac{A_1}{A_2} \right)^2 - \left( \frac{V_0}{V_5} \right)^2 \right] \quad \text{Equation (1.05)}$$

Now define:

$$C_L = \frac{A_2}{A_1} \left[ 1 + \left( \frac{A_1}{A_2} \right)^2 - \left( \frac{V_0}{V_5} \right)^2 \right]$$

$$T_P = \rho A_5 V_5^2 C_L$$

By continuity

$$V_2 = V_5 \frac{A_4}{A_2}$$

Equation 4.01 now reads

$$\left( \frac{V_5}{V_T} \right)^2 \frac{2A_5 C_L}{abR} + \frac{V_5 A_4}{V_T A_2} C_2 - (C_1 + C_3) = 0$$

$$\frac{V_5}{V_T} = \frac{abR C_2}{2A_2 C_L} \left\{ \left[ \frac{A(C_1 + C_3) A_4}{abR C_2^2} \left( \frac{A_2}{A_4} \right)^2 C_L + 1 \right]^{1/2} - 1 \right\}$$

$$\frac{V_5}{V_T} = \frac{abR C_2}{2A_2 C_L} \left\{ \left[ C_5 C_L + 1 \right]^{1/2} - 1 \right\} \quad \text{Equation 4.02}$$

where

$$C_5 = \frac{A(C_1 + C_3) A_4}{abR C_2^2} \left( \frac{A_2}{A_4} \right)^2$$

#### PITCHING MOMENT

The variation of the pitching moment with free stream velocity is very important from the standpoint of its effect on stability and maximum forward speed. The maximum moment can become very large, particularly with low thrust per unit area.

C O N F I D E N T I A L

PREPARED	NAME A. For	DATE 11/30/56	HILLER HELICOPTERS	PAGE 16
CHECKED			TITLE: Aerodynamics of Ducted Propellers As Applied to the Platform Principle	MODEL 1031-A
APPROVED				REPORT NO. 56-10P

CONFIDENTIAL

The three dimensional character of the flow about a platform and non-symmetric flow at large angles of attack makes it impossible to calculate the pitching moment by a simplified two dimensional approach.

The only information available on pitching moment is data obtained from a duct of large length to diameter ratio and the data obtained by Hiller. The model used was a five foot duct (Reference 3). This report has measurements of moment, lift, thrust, and a small amount of pressure survey data. Using the pressure survey data to determine the moment contributed by the duct the following results were obtained.

At 1° tilt angle without duty and 35 knot forward speed

Calculated moment	161 ft.-lbs.
Measured moment	170 ft.-lbs.

At 31° tilt angle without duty and 36 knots

Calculated moment	301 ft.-lbs.
Measured moment	312 ft.-lbs.

The calculated moments are in very good agreement with the measured values, particularly in view of the fact that the pressure survey included only four stations: front lip, rear lip, 45° and 90° lip positions.

The conclusion drawn from this data is that the total moment is produced by the duct. This does not solve the problem of determining the moment to be expected from any arbitrary ducted propeller, but it does shed some light on the problem.

The force producing the moment is the integral of the pressure as the velocity increases from the free stream value to the duct exit value. If the flow does not separate from the duct surface, a total turning angle is defined by the duct lip shape.

The tilt angle and the ratio of free stream to exit velocity is an indication of the turning angle.

$$T_p = A_5 V_5 (V_5 - V_0) \quad \text{From Equation 1.01}$$

$$\frac{T_p}{\rho C_0 A_1} = \frac{V_5}{V_0} \left( \frac{V_5}{V_0} - 1 \right) = \psi \quad \text{1.01}$$

CONFIDENTIAL

PREPARED	NAME A. Morse	DATE 11/30/56	HILLER HELICOPTERS	PAGE 21
DESIGNED			TITLE: Aerodynamics of Ducted Propellers As Applied to the Platform Principle	MODEL 1031-A
APPROVED				REPORT NO. 56-102

C O N F I D E N T I A L

This non-dimensional parameter ( $\psi$ ) has been taken as a representation of the flow field. The moment must increase directly with the diameter and with the square of the velocity over the lip, but at the same value of  $V_0/V_5$  this is proportional to the square of the free stream velocity. For this reason the moment coefficient has been taken as:

$$C_m = \frac{M}{2q_0 D A_L} \quad (5.02)$$

The five foot platform truck test data has been plotted in coefficient form (Figure 4).

It has previously been mentioned that the only moment data available is from one configuration, but it is believed that the use of Figure 4 will at least give the order of magnitude and trend of the moment to be expected from an arbitrary selected ducted propeller.

PLATFORM HOVER CEILING

Equation 1.08 indicates that the power required varies with the reciprocal of the density ratio. The power available is also a function of the density ratio; therefore to eliminate trial on error the equations have been combined.

The variation of power available with density ratio is given in reference 4 as:

$$SHP_{ALT} = SHP_{SL} (1.132 \rho / \rho_{SL} - .132) \quad (6.01)$$

By combining Equation 1.09 and Equation 6.01 the variation of thrust with altitude becomes:

$$T_{ALT} = 14.22 (\rho / \rho_{SL} A_L)^{1/3} \left[ \frac{SHP_{ALT} \eta_{P_{ALT}}}{K} \right]^{2/3} \quad \text{Equation 1.09}$$

$$T_{SL} = 14.22 (A_L)^{1/3} \left[ \frac{SHP_{SL} \eta_{P_{SL}}}{K} \right]^{2/3} \quad (6.02)$$

$$\therefore \frac{T_{ALT}}{T_{SL}} = \left( \frac{\eta_{P_{ALT}}}{\eta_{P_{SL}}} \right)^{2/3} \left( \frac{\rho_{ALT}}{\rho_{SL}} \right)^{1/3} (1.132 \rho / \rho_{SL} - .132)^{2/3} \quad (6.03)$$

C O N F I D E N T I A L

PREPARED	NAME A. Morse	DATE 11/30/56	HILLER HELICOPTERS	PAGE 22
CHECKED			TITLE: Aerodynamics of Ducted Propellers As Applied to the Platform Principle	MODEL 1031-A
APPROVED				REPORT NO. 56-108

C O N F I D E N T I A L

$$\frac{T_{ALT}}{T_{SL}} \left( \frac{\eta_{PALT}}{\eta_{PSL}} \right)^{2/3} = \left( \frac{\rho}{\rho_{SL}} \right)^{1/3} (1.132 \rho/\rho_{SL} - .132)^{2/3} \quad (6.04)$$

For convenience Equation 6.04 is plotted in Figure 5. To determine the thrust at a given altitude, the thrust for a corresponding power setting is calculated at sea level. The product of the ratio of propeller efficiencies and the function of density ratios read from the curve gives the correction factor to be applied to the sea level thrust to obtain the thrust at altitude. To determine the maximum hover altitude the gross weight is divided by the maximum sea level thrust; the propeller efficiency ratio is assumed equal to 1.0 and an altitude is read from the curve. The actual propeller efficiency ratio is then calculated and the altitude is again determined. The propeller efficiency does not change rapidly with altitude and the second altitude is normally very accurate.

#### PROPELLER TIP CLEARANCE

The effect of tip clearance on trust and power does not lend itself to calculation; therefore test data must be used to determine the magnitude of the losses. The test data of reference 5 has been re-plotted so as to reflect the variation of shroud thrust to horsepower with tip clearance to diameter ratio (Figure 6).

#### ACTIVITY FACTOR FOR DUCTED PROPELLERS

The thrust required to hover and the lift that must be maintained at forward speeds are dependent upon the gross weight. The loads acting on the duct have been given in equation form, and the weight can be estimated. Equations for the propeller thrust have also been given, but most propeller weight equations involve terms containing  $b$  and  $AF$ ; therefore the ducted propeller has been analyzed to facilitate calculation of the quantity  $b \times AF$ .

C O N F I D E N T I A L

PREPARED	NAME A. Morse	DATE 11/30/56	HILLER HELICOPTERS	PAGE 23
CHECKED			TITLE: Aerodynamics of Ducted Propellers As Applied to the Platform Principle	MODEL 1031-A
APPROVED				REPORT NO. 56-102

CONFIDENTIAL

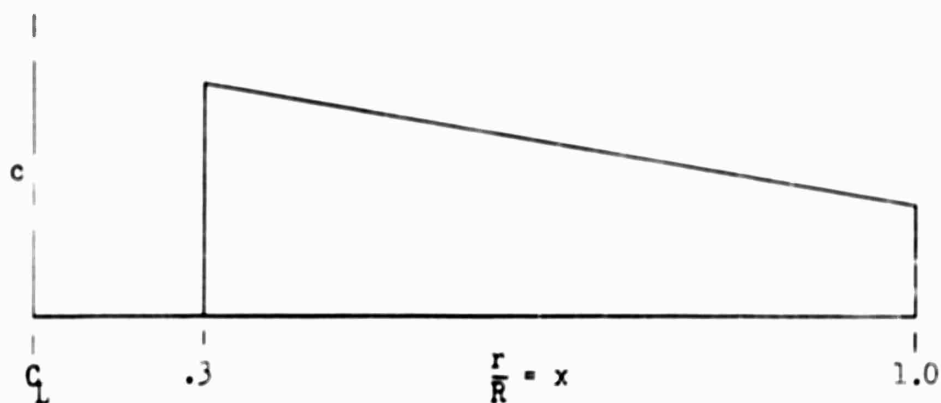

Assume Constant Slope

$$AF = \frac{10^5}{16} \int_{.3}^{1.0} x^3 \left(\frac{c}{D}\right) dx = \frac{10^5}{16D} \int_{.3}^{1.0} x^3 c dx$$

$$c = m(x - .3) + c_{.3} \quad \text{where } m = \text{slope} = \frac{c_{1.0} - c_{.3}}{(1 - .3)}$$

$$m = 1.43 (c_{1.0} - c_{.3})$$

$$16D(AF)(10)^{-5} = \int_{.3}^{1.0} x^3 [mx - .3m + c_{.3}] dx$$

$$16D(AF)(10)^{-5} = m \int_{.3}^{1.0} x^4 dx + \int_{.3}^{1.0} (c_{.3} - .3m) x^3 dx$$

$$= \frac{m}{5} x^5 \Big|_{.3}^{1.0} + (c_{.3} - .3m) \frac{x^4}{4} \Big|_{.3}^{1.0}$$

$$16D(AF)(10)^{-5} = \frac{m}{5} (1 - .3^5) + \frac{1}{4} (c_{.3} - .3m) (1 - .3^4)$$

CONFIDENTIAL

PREPARED	NAME A. Morse	DATE 11/30/56	HILLER HELICOPTERS	PAGE 24
CHECKED			TITLE: Aerodynamics of Ducted Propellers As Applied to the Platform Principle	MODEL 1031-A
APPROVED				REPORT NO. 56-108

C O N F I D E N T I A L

$$\begin{aligned}
 16(10)^{-5} D(AF) &= .196m \cdot .21^{\circ} C_{.3} - .0745m \\
 &= .1751m \cdot .21^{\circ} C_{.3} \quad \text{but } m = 1.43(C_{1.0} - C_{.3}) \\
 &= .1789C_{1.0} - .1789C_{.3} + .21^{\circ} C_{.3} \\
 &= .1789C_{1.0} + .0691C_{.3} \\
 &= .0691(2.59C_{1.0} + C_{.3})
 \end{aligned}$$

$$\begin{aligned}
 AF &= \frac{.0691}{16D} (10)^5 (2.59C_{1.0} + C_{.3}) \\
 &= \frac{4.31(10)^2}{5} (2.59C_{1.0} + C_{.3})
 \end{aligned}$$

$$a' = \frac{\pi(1+f) \mu \sin \phi_r}{\frac{\Delta C_L}{\Delta c} \frac{b}{2} \frac{c}{r}} \quad \text{but} \quad \frac{\Delta C_L}{\Delta c} = \frac{C_L}{a'} \quad c_0 + \Delta a = a'$$

$$\begin{aligned}
 c_r &= \frac{2r}{C_L b} \pi(1+f) \mu \sin \phi_r \quad \text{and} \quad \mu = \frac{V_2}{2r} \\
 &= \frac{2\pi}{C_L b} (1+f) \frac{V_2}{2} \sin \phi_r = \frac{2\pi}{C_L b} (1+f) \frac{V_2 R}{V_T} \sin \phi_r \quad R = \frac{D}{2}
 \end{aligned}$$

$$c_r = \frac{2\pi V_2 (1+f) D}{2C_L b V_T} \sin \phi_r \quad \text{and} \quad \sin \phi_r = \frac{2 V_2}{\left[ \left( V_T \frac{r}{R} \right)^2 + V_2^2 \right]^{\frac{1}{2}}}$$

$$c_r = \frac{2\pi V_2^2 (1+f) D}{2C_L b V_T^2} \frac{1}{\left[ \left( \frac{r}{R} \right)^2 + \left( \frac{V_2}{V_T} \right)^2 \right]^{\frac{1}{2}}}$$

C O N F I D E N T I A L

PREPARED	NAME A. Morse	DATE 11/30/56	HILLER HELICOPTERS	PAGE 25
CHECKED			TITLE: Aerodynamics of Ducted Propellers As Applied to the Platform Principle	MODEL 1031-A
APPROVED				REPORT NO. 56-108

CONFIDENTIAL

$$AF = \frac{2 \cdot 4.31 (10)^2 \pi V_2^2 (1 + f) D}{D \cdot 2C_L V_T^2 b} \left[ \frac{2.59}{\left[1 + \left(\frac{V_2}{V_T}\right)^2\right]^{\frac{1}{2}}} + \frac{1}{\left[.09 + \left(\frac{V_2}{V_T}\right)^2\right]^{\frac{1}{2}}}\right]$$

$$T = \rho A_5 V_5^2 \quad \text{or} \quad V_5^2 = \frac{1}{\rho} \frac{T}{A_5} = \frac{1}{\rho} w_D$$

$$\rho A_5 V_5 = \rho A_2 V_2 \quad V_2^2 = \left(\frac{A_5 V_5}{A_2}\right)^2 = \frac{1}{\rho} w_D \left(\frac{A_5}{A_2}\right)^2$$

$$b(AF) = \frac{1355 \cdot (1 + f) w_D}{C_L V_T^2 \rho} \left(\frac{A_5}{A_2}\right)^2 \left[ \frac{2.59}{\left[1 + \left(\frac{V_2}{V_T}\right)^2\right]^{\frac{1}{2}}} + \frac{1}{\left[.09 + \left(\frac{V_2}{V_T}\right)^2\right]^{\frac{1}{2}}}\right] \quad (8.01)$$

A typical curve obtained from Equation (8.01) is shown on Figure 7.

#### CONTROL MOMENT

When a ducted propeller is placed in a flow field with the propeller axis parallel to the flow, the propeller thrust is acting along the axis, and the duct forces form a cone, the apex of which is on the propeller axis some distance above the duct lip. When the axis of the ducted propeller is at some angle with respect to the free stream, the propeller thrust continues to act along the axis of rotation, but the apex of the cone formed by the duct forces moves upstream. The apex of this cone will continue to move upstream until the angle between the propeller axis and free stream reaches 90 degrees; as the angle is increased, the apex of the cone will move back until it again lies on the axis of rotation of the propeller at 180 degrees. The platform maintains an equilibrium of forces by tilting the axis of rotation of the propeller into the free stream velocity and the center of aerodynamic forces is continually changing as the free stream velocity is increased. The center of gravity of the entire mass can be moved, within limits, by the operator while in flight. However, when the mass

CONFIDENTIAL

PREPARED	NAME A. Morse	DATE 11/30/56	HILLER HELICOPTERS	PAGE 26
DESIGNED			TITLE: Aerodynamics of Ducted Propellers As Applied to the Platform Principle	MODEL 1031-A
APPROVED				REPORT NO. 56-108

C O N F I D E N T I A L

of the pilot is small compared to the total mass, the distance through which the total center of gravity can be moved diminishes, and insufficient control results. The duct produces approximately one half of the total lift; therefore, if the total lift remains constant, but the diameter of the duct is increased, the moment arm and thus the moment will increase and again insufficient control results. The necessity of additional control forces is obvious. Several methods have been considered and are included in this report.

The method used to calculate the performance of a ducted propeller outlined in Appendix II of this report has been superseded by this report. However, the differences are small and the description of the forces and moments are not affected. As indicated, the use of duct exit guide vanes for creating nose down pitching moments are not advisable, unless exceptionally large distances between the exit vanes and C.G. location are possible. The maximum moment obtainable from a means of propeller tip clearance control (see Appendix II) such as boundary layer removal at the blade tip, can quickly be estimated.

If the test data shown in Figure 6 of this report can be extrapolated, a tip clearance to diameter ratio of .005 will decrease the duct thrust 16.5 percent. The model 1031-A has a duct thrust of approximately 250 lbs.; therefore the loss due to this tip clearance is 41.3 lbs. If it is assumed that the clearance is reduced to zero over one half the duct, an additional force of 20.6 lbs. would be created, and the moment arm would be approximately  $.7R = 1.75'$ . The maximum moment would be 36 ft-lbs. The propeller tip clearance should be kept at a minimum value to minimize losses, but any attempt to cause a cyclic variation in tip clearance to produce a control moment will be non-rewarding.

The third means of producing a control moment, discussed in Appendix II, and also in Appendix IX of this report, has to do with the control of the duct lip forces through the boundary layer. The natural circulation due to a differential lift would probably not reduce the moment to a large degree. If a powered system were used to direct the flow field, the moment would be significantly reduced and at the same time additional lift would be produced. This appears to be a promising means of reducing the moment to the point where kinesthetic control would be adequate.

An analysis has been presented, Appendix III of this report, which indicates promising values of moment obtained from duct inlet lip vanes. This information is believed to be misleading in that the forces calculated would be cancelled by opposite forces originating due to the

C O N F I D E N T I A L

PREPARED	NAME A. Morse	DATE 11/30/56	HILLER HELICOPTERS	PAGE 7
CHECKED			TITLE: Aerodynamics of Ducted Propellers As Applied to the Platform Principle	MODEL 1031-A
APPROVED				REPORT NO. 56-100

C O N F I D E N T I A L

interference between the lip and vane. The calculated thrust, assuming 100 percent inlet diffuser efficiency, shows very good agreement with test data. Therefore, additional inlet guide vanes cannot improve the performance of the inlet diffuser to a large extent, and the moment calculated must be in error.

A cyclic pitch change can be effected by changing the inflow direction. This means of producing a pitching moment was investigated, Appendix V of this report, and found capable of producing approximately one tenth of the required moment with essentially no loss in performance. It would be necessary to increase the propeller strength, but this type of system should show good reliability due to simplicity of the mechanism.

C O N C L U S I O N

The maximum nose down pitching moment developed by the control surfaces discussed are of the order of 20 percent of the total nose up moment. For this reason, it would appear that attempts to decrease the moment by changes in lip configuration might be more rewarding than attempts to overpower the nose up moment. The powered boundary layer would appear to have the greatest possibility of controlling the moment in that it can be used either to increase or decrease the moment by working on the small quantity of air within the boundary layer, which in turn alters the entire flow field.

C O N F I D E N T I A L

PREPARED	NAME A. Morse	DATE 11/30/56	HILLER HELICOPTERS	PAGE 28
CHECKED			TITLE Aerodynamics of Ducted Propellers As Applied to the Platform Principle	MODEL 1031-A
APPROVED				REPORT NO 56-108

EQUILIBRIUM PERFORMANCE

AT FORWARD SPEED

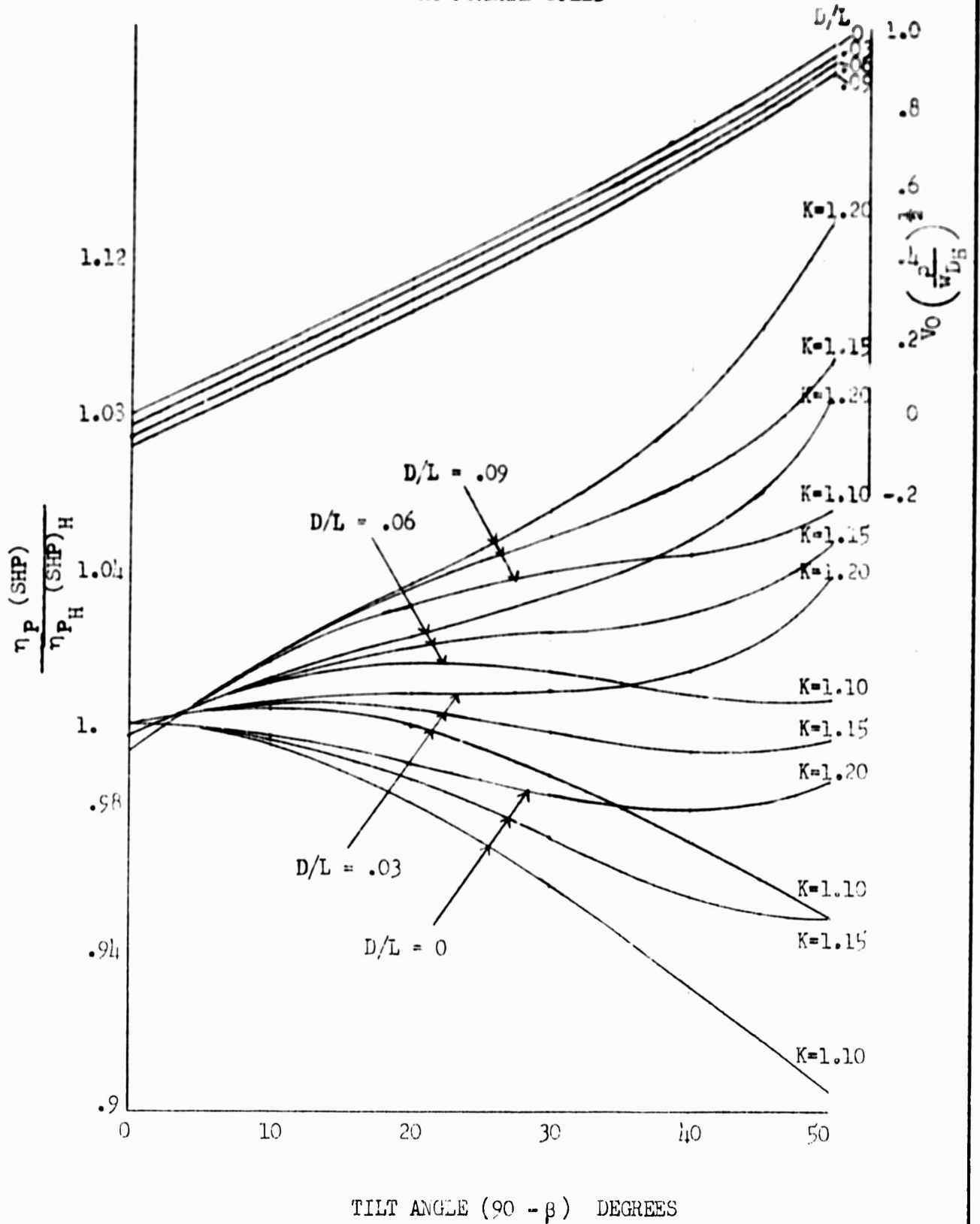

FIG. 2

CONFIDENTIAL

PREPARED	NAME F. Hall	DATE 11/30/56	HILLER HELICOPTERS	PAGE 29
CHECKED			TITLE Aerodynamics for Ducted Propellers As Applied to the Platform Principle	MODEL 1031-A
APPROVED				REPORT NO. 56-108

C O N F I D E N T I A L

TILT ANGLE REQUIRED  
FOR HORIZONTAL EQUILIBRIUM

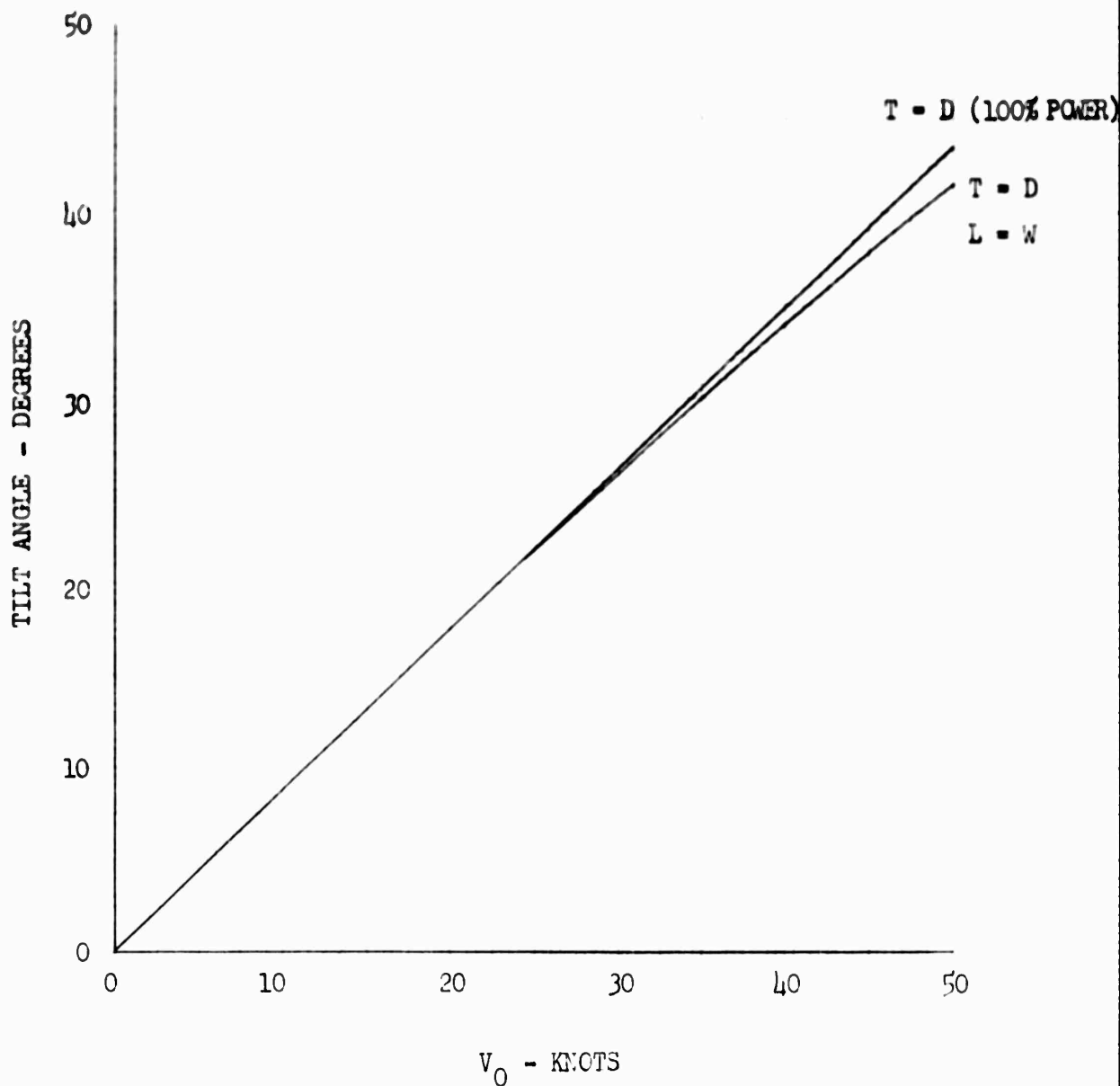

FIG. 3

C O N F I D E N T I A L

PREPARED	NAME A. Morse	DATE 11/30/56	HILLER HELICOPTERS	PAGE 30
CHECKED			TITLE Aerodynamics of Ducted Propellers As Applied to the Platform Principle	MODEL 1031-A
APPROVED				REPORT NO 56-108

CONFIDENTIAL

NON DIMENSIONAL MOMENT COEFFICIENTS

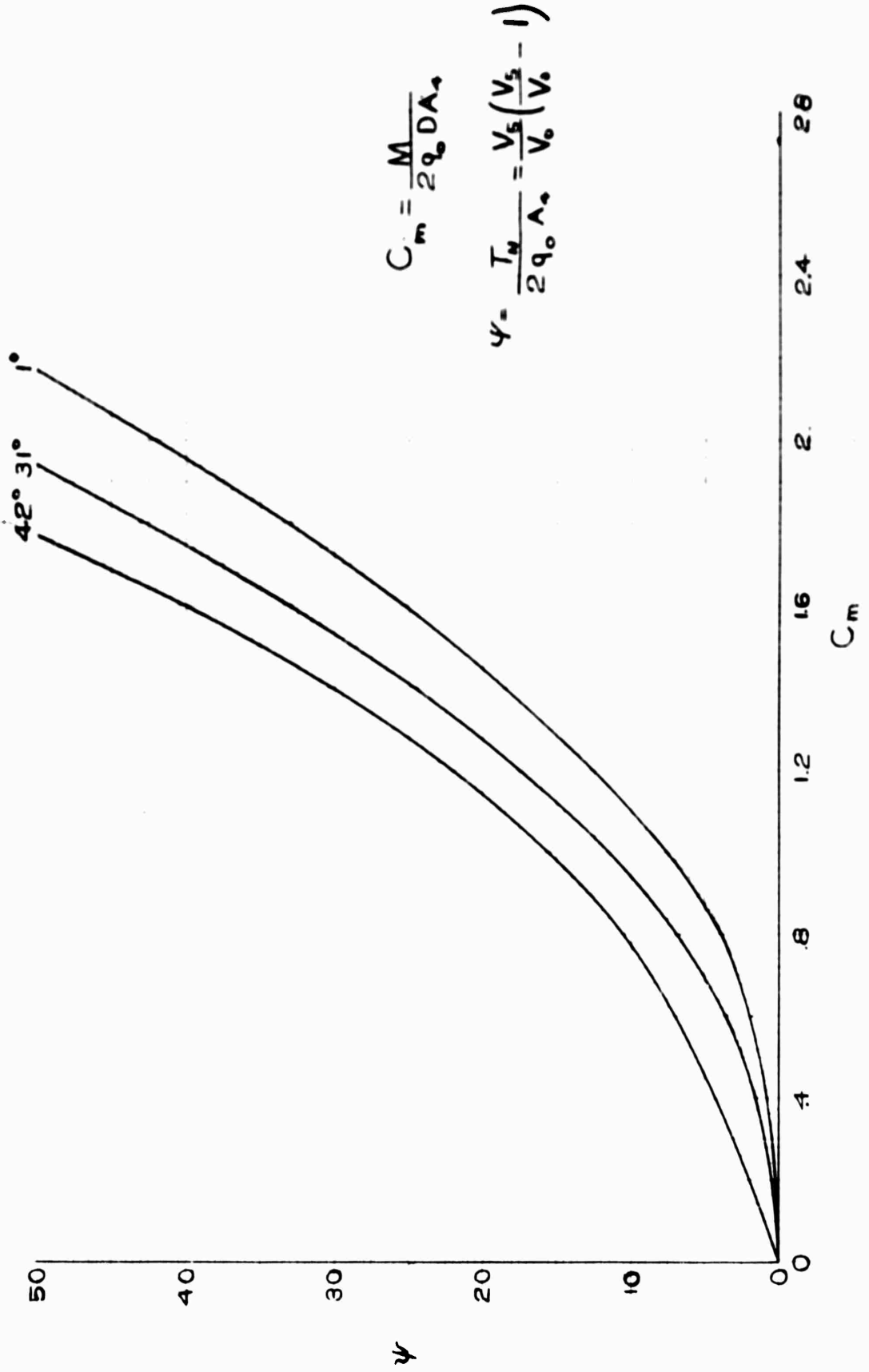

CONFIDENTIAL

FIG 4

PREPARED	NAME A. Morse	DATE 11/30/56	HILLER HELICOPTERS	PAGE 31
CHECKED			TITLE Aerodynamics of Ducted Propellers As Applied to the Platform Principle	MODEL 1031-A
APPROVED				REPORT NO. 56-108

CONFIDENTIAL

THRUST VARIATION WITH  
ALTITUDE FOR PISTON ENGINE

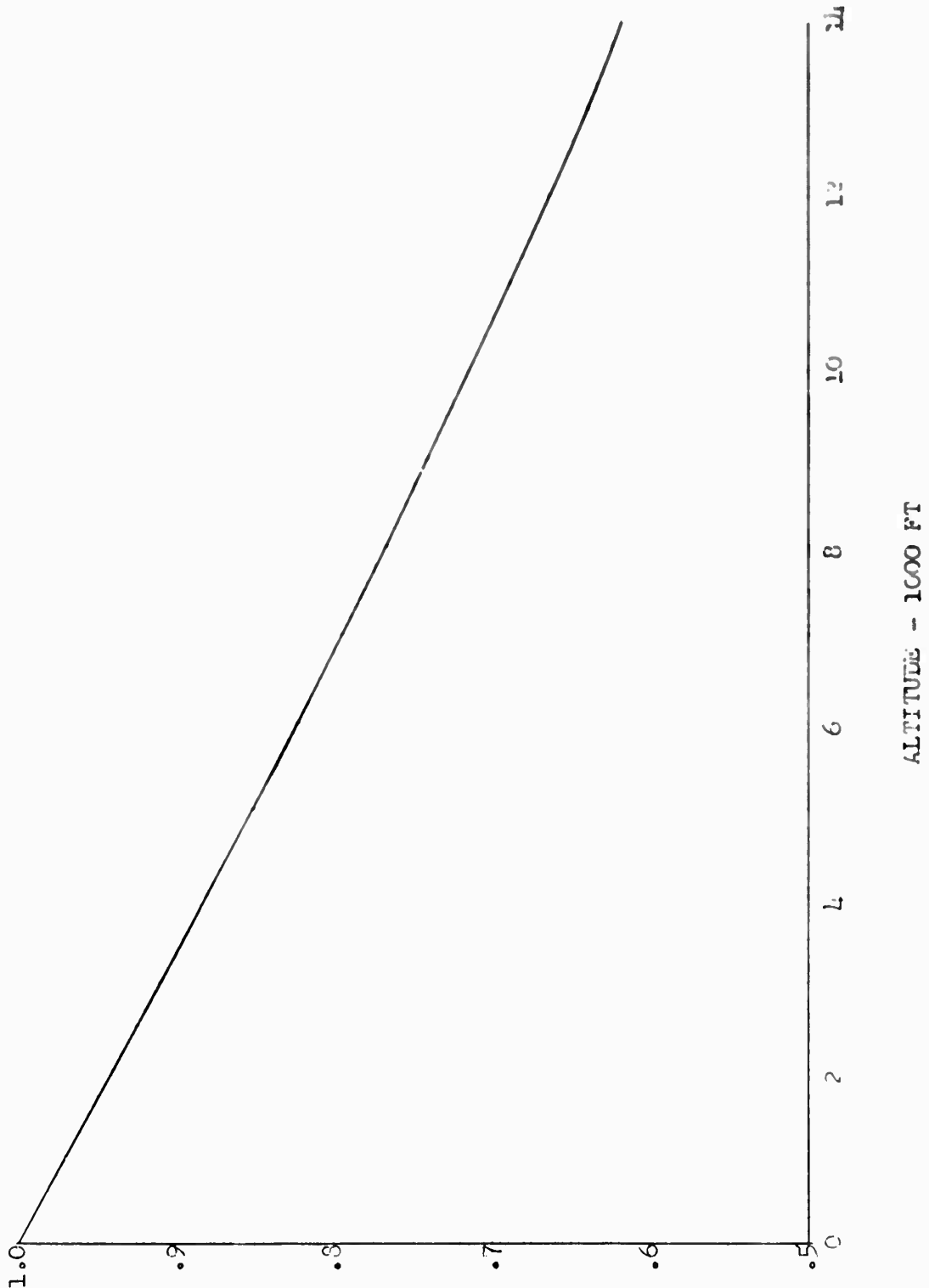

$$\frac{\text{THRUST AT ALTITUDE}}{\text{THRUST AT S.L.}} = \left( \frac{P_{d,ALT}}{P_{d,S.L.}} \right)^{2/3}$$

FIG. 5

CONFIDENTIAL

PREPARED	NAME A. Morse	DATE 11/30/56	HILLER HELICOPTERS	PAGE 32
CHECKED			TITLE Aerodynamics of Ducted Propellers As Applied to the Platform Principle	MODEL 1031-A
APPROVED				REPORT NO. 56-108

C O N F I D E N T I A L

EFFECT OF TIP CLEARANCE ON DUCT THRUST

Reference - NACA 2224  
Propeller at .4 Chord (Shroud)

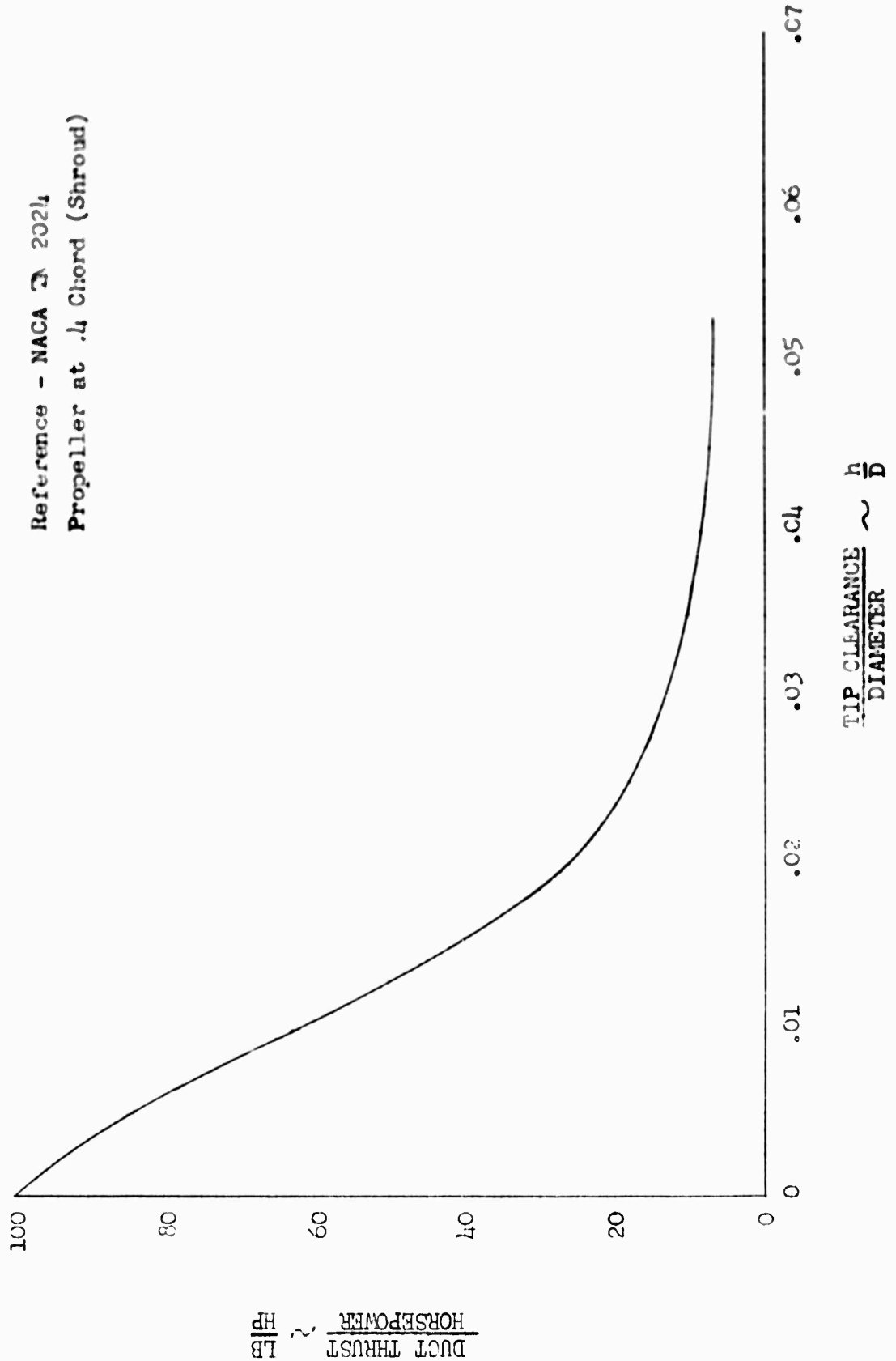

FIG. 6

C O N F I D E N T I A L

PREPARED	NAME A. Morse	DATE 11/30/56	HILLER HELICOPTERS	PAGE 33
CHECKED			TITLE Aerodynamics of Ducted Propellers As Applied to the Platform Principle	MODEL 1031-A
APPROVED				REPORT NO 56-108

C O N F I D E N T I A L

BLADE ACTIVITY FACTOR

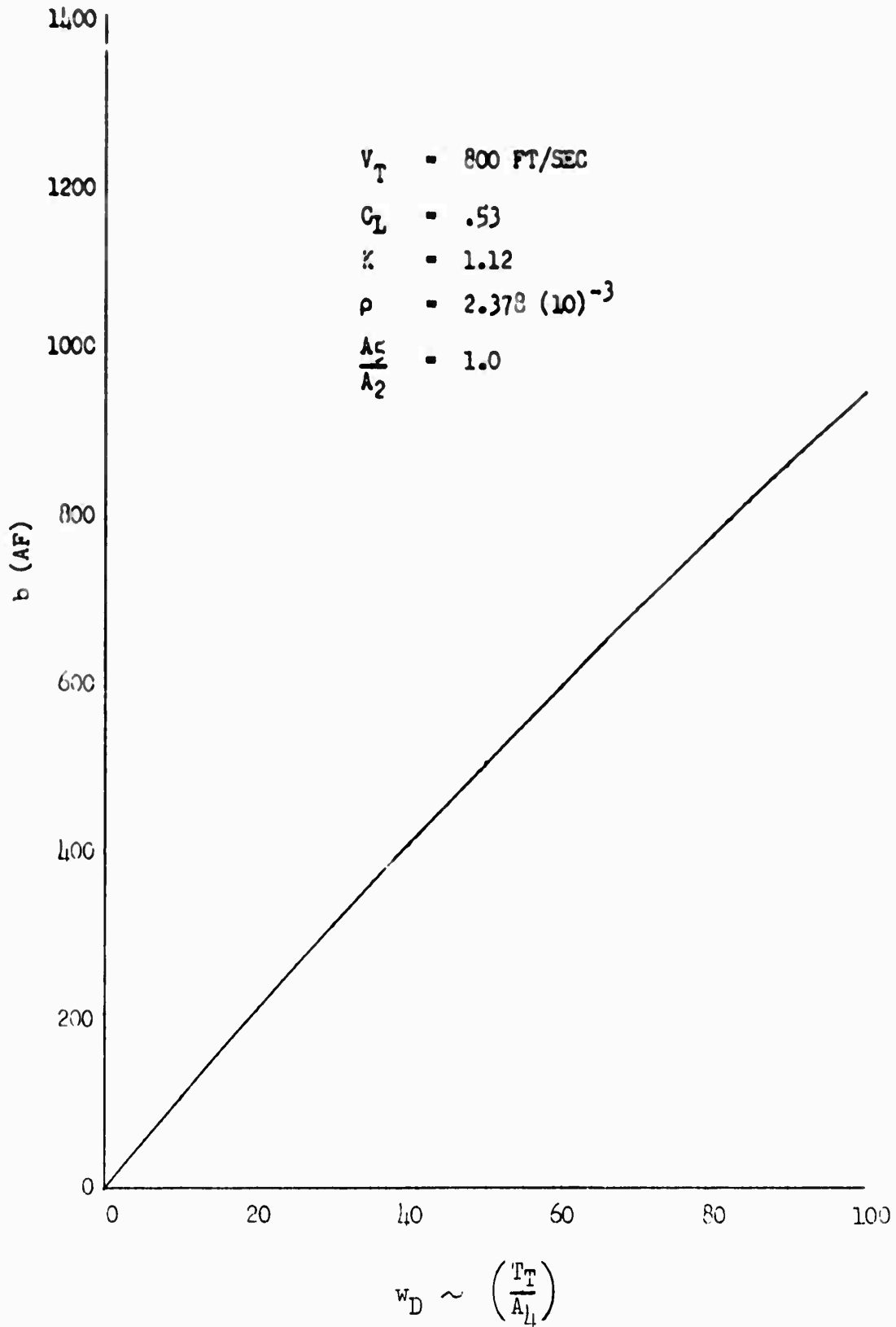

FIG. 7

C O N F I D E N T I A L

PREPARED	NAME A. Morse	DATE 11/30/56	HILLER HELICOPTERS	PAGE 34
CHECKED			TITLE Aerodynamics of Ducted Propellers As Applied to the Platform Principle	MODEL 1031-A
APPROVED				REPORT NO 56-108

CONFIDENTIAL

PARASITE POWER FUNCTION

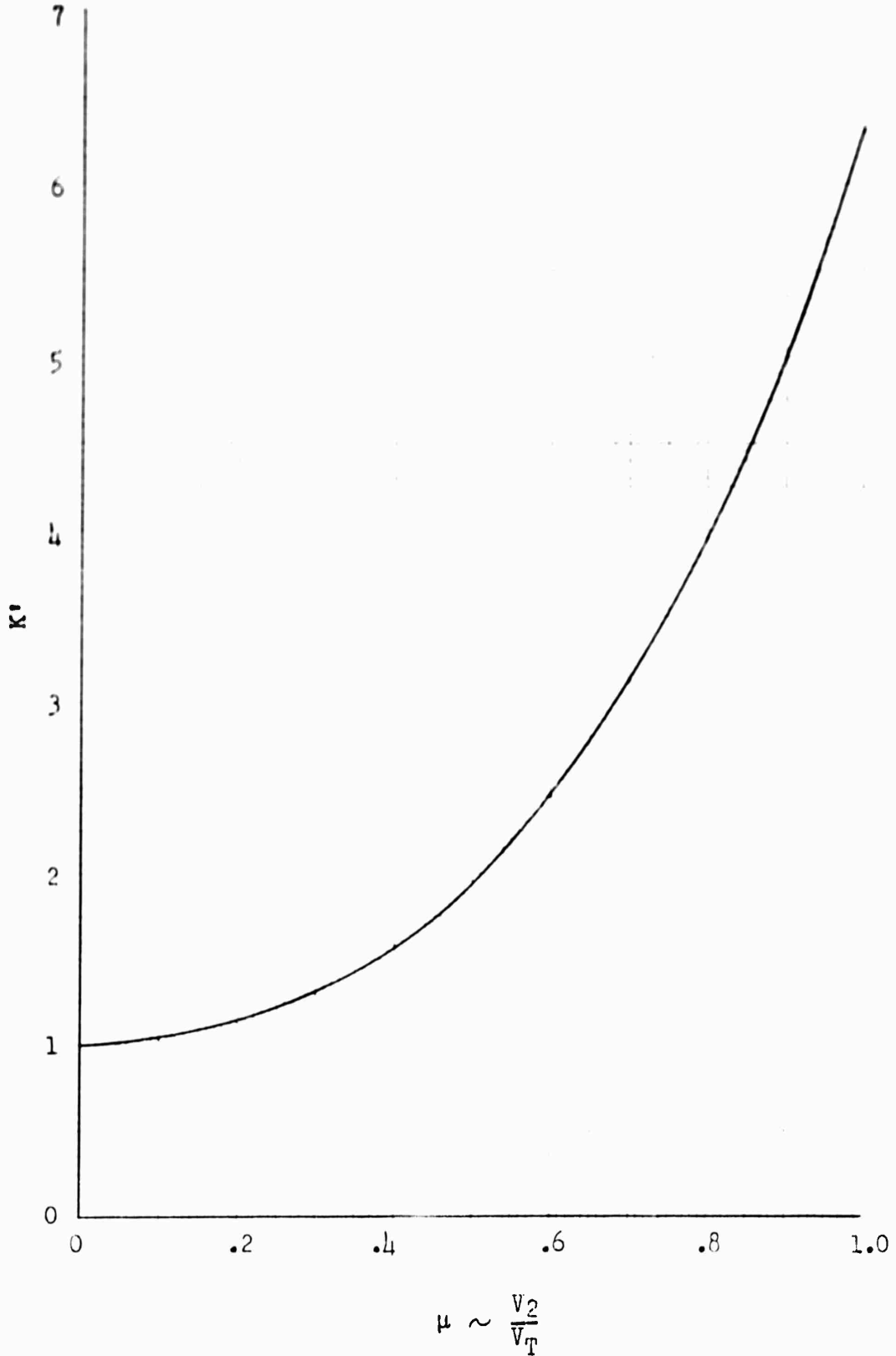

FIG. 8

CONFIDENTIAL

PREPARED	NAME A. Morse	DATE 11/30/56	HILLER HELICOPTERS	PAGE 35
CHECKED			TITLE: Aerodynamics of Ducted Propellers As Applied to the Platform Principle	MODEL 1031-A
APPROVED				REPORT NO. 5-10

CONFIDENTIAL

REFERENCES

1. "Aerodynamic Analysis report for Two-Place, High Performance Observation and Reconnaissance Aircraft, Contract NOa(s) 55-944", Hiller Report No. 114.4, Appendix B, December, 1955.
2. "Ducted Coaxial Propeller Blade Angle Settings", Hiller Report No. 120.3, March, 1954.
3. "Truck Test Stand Tests of Hiller Airborne Personnel Platform - Phase II", Hiller Report No. 600.2, September, 1955.
4. Dwinell, James H., Principles of Aerodynamics.
5. Hubbard, Harvey H., "Sound Measurements for Five Shrouded Propellers at Static Conditions", NACA TR-2024.

CONFIDENTIAL

PREPARED	NAME F. Hall	DATE 11/30/56	HILLER HELICOPTERS	PAGE A-3
CHECKED			TITLE: Aerodynamics of Ducted Propellers As Applied to the Platform Principle	MODEL 1031-A
APPROVED				REPORT NO. 56-108

C O N F I D E N T I A L

APPENDIX I

COMPARISON OF THEORETICAL AND EXPERIMENTAL DATA

FOR HILLER MODEL 1031-A PLATFORM

C O N F I D E N T I A L

PREPARED	NAME F. Hall	DATE 11/30/56	HILLER HELICOPTERS	PAGE 1-1
ENGINEERED			TITLE: Aerodynamics of Ducted Propellers As Applied to the Platform Principle	MODEL 1031-A
APPROVED				REPORT NO. 56-108

C O N F I D E N T I A L

COMPARISON OF THEORETICAL AND EXPERIMENTAL DATA  
FOR HILLER MODEL 1031-A PLATFORM

The detailed analysis found in Section 4 of Hiller Report No. 56-108 has produced the relation between tip speed and exit velocity.

$$\frac{V_5}{V_T} = \frac{a b R C_2}{2A_2 C_4} \left\{ [C_4 C_5 + 1]^{\frac{1}{2}} - 1 \right\} \quad \text{Equation 4.02}$$

where  $C_1 = \int \rho c \left(\frac{r}{R}\right)^2 d\left(\frac{r}{R}\right) = .01746$

$$C_2 = \int c \left(\frac{r}{R}\right) d\left(\frac{r}{R}\right) = .1149$$

$$C_3 = \int \frac{C_{L0}}{a} c \left(\frac{r}{R}\right)^2 d\left(\frac{r}{R}\right) = .003485$$

$$C_4 = 1 + \left(\frac{A_4}{A_2}\right)^2 \left[ 1 - \left(\frac{V_0}{V_5}\right)^2 \right] = 1.203 - \left(\frac{V_0}{V_5}\right)^2$$

$$C_5 = \frac{4(C_1 + C_3) A_4}{a b R C_2^2} \left(\frac{A_2}{A_4}\right)^2 = 3.168$$

Constants  $C_1$ ,  $C_2$ , and  $C_3$  were integrated graphically.

The simultaneous solution of Equations (4.02 and 2.07) of Report No. 56-108 allows the computation of propeller efficiency, power required, etc. To do this it is necessary to use only the hover tip speed from test data. This analysis, then, is functionally independent of the test data, and is numerically dependent only upon this one value.

$$\frac{1}{\eta_P} = 1 + \frac{3}{4} \frac{V_T}{V_5} K' \frac{C_{D0}}{C_L} \frac{A_2}{A_4} + \frac{R}{V_{TH}} \quad \text{Equation (2.07)}$$

This was calculated over the range of  $V_0/V_5$  from 0 to .7 which is well over the maximum forward velocity attainable. The value varied only from 1.240 at hover to 1.219 at high speed; the value at hover may be taken over the entire range, giving a small margin of surplus efficiency in the upper speed ranges.

C O N F I D E N T I A L

PREPARED	NAME F. Hall	DATE 11/30/56	HILLER HELICOPTERS	PAGE A-2
CHECKED			TITLE: Aerodynamics of Ducted Propellers As Applied to the Platform Principle	MODEL 1031-A
APPROVED				REPORT NO. 56-108

CONFIDENTIAL

The power required may be written in the form:

$$P_R = \frac{\rho A V_G^3}{1100 \eta_P} \left[ 1 + f - \left( \frac{V_0}{V_G} \right)^2 \right] = \frac{\rho A V_G^3}{1100 \eta_P} C_L$$

Values of  $C_L$  and  $V_G$  at hover ( $V_G$  obtained from the momentum equation) were substituted as a cross check, yielding a value equal to the available power. To determine the range of  $V_G$ ,  $V_T$ , and available horsepower, the assumed RPM was increased from 3800 to 3810. When the corresponding values were substituted, it was found that the power required decreased with increasing  $V_G$ . In this range, the term  $K - (V_0/V_G)^2$  controls in spite of the fact that  $V_G$  is cubed. This means that not even this small increase in available power can be absorbed, and this, in turn, shows that the horsepower and RPM are constant regardless of the value of  $V_G$  in the operating range. Experimental data definitely confirms this.

The qualitative interpretation of these data is that, as forward speed increases, more and more thrust is shifted from the propeller to the duct. Figure 1 shows the predicted decrease in power required; this curve appeared as the  $D/L = 0$ ,  $1 + f = 1.2$  curve of Figure 2, Hiller Report No. 56-108. During the truck tests, however, the power was not allowed to decrease. As should be expected, the propeller produced a  $V_G$  greater than that required for lift. In Figure 7 of Hiller Report 680.2 the lift curve for drag-thrust equilibrium reflects the decrease in power required for equilibrium, having the peak lift just short of the bucket of the power curve and decreasing to lift equilibrium again just short of required power equal to hover power.

The test data contain lift, thrust, and thrust equilibrium curves for full power. A curve of  $V_G/V_T$  versus  $V_0/V_G$  has already been calculated. Now it is possible to draw a curve of  $V_G$  versus  $V_0$ , since  $V_T$  is a constant for full power operation. This is done in Figure 2.

The forces on the platform may be found by momentum theory.

$$L = \rho A V_G^2 \cos \alpha$$

$$T = \rho A V_G (V_G \sin \alpha - V_0)$$

CONFIDENTIAL

PREPARED	NAME F Hall	DATE 11/30/56	HILLER HELICOPTERS	PAGE A-3
CHECKED			TITLE: Aerodynamics of Ducted Propeller As Applied to the Platform Principle	MODEL 1031-A
APPROVED				REPORT NO. 56-10A

C O N F I D E N T I A L

These curves are plotted in Figures 3 and 4. Experimental curves may be found in Figures 7 and 8, Hiller Report No. 680.2.

A thrust equilibrium curve may be drawn in two ways. First, the thrust equation may be equated to zero, reducing the condition of equilibrium to:

$$V_G \sin \alpha = V_0$$

This curve is plotted in Figure 5. As a check, a cross plot of the intersection of each thrust curve with the  $V_0$  axis may be used. These points deviated by a small amount, confirming the calculations leading to the lift and thrust curves.

The condition described above does not constitute a true equilibrium since the vertical forces are not balanced. In fact, no such equilibrium is possible at full power except at a single  $V_0$  already excluded by other limitation and, of course, at hover. Equilibrium can occur only along the  $(BHP)_V / (BHP)_H$  curve of Figure 1. It is more easily and directly done by simply equating forces. This curve also appears in Figure 5.

In order to check the propeller operation, it is necessary to compare the design and test values for  $V_G$ ,  $V_T$ , T, and  $P_R$ .

	Design	Test	Error
$V_G$	112.7 ft./sec.	110.5 ft./sec.	2%
$\frac{V_G}{V_T}$	$\frac{112.7}{707} = .1594$	$\frac{110.5}{675} = .1637$	2.7%
T	483 lb.	500 lb.	3.5%

No direct and definite information as to either power available or power actually expended is available. However, the design estimation of power required left but a small margin from the maximum output of the engines. Therefore, since the expected  $V_G$  and T were obtained at full power, the estimation was reasonably good.

It is safe to conclude that the propeller was properly designed, for a slightly larger than predicted amount of power was absorbed producing the predicted thrust.

C O N F I D E N T I A L

PREPARED	NAME F. Hall	DATE 11/30/56	HILLER HELICOPTERS	PAGE 1-1
CHECKED			TITLE Aerodynamics of Ducted Propeller As Applied to the Platform Principle	MODEL 1031-A
APPROVED				REPORT NO 56-108

CONFIDENTIAL

POWER REQUIRED (EQUILIBRIUM)  
AND LIFT AT FORWARD SPEED

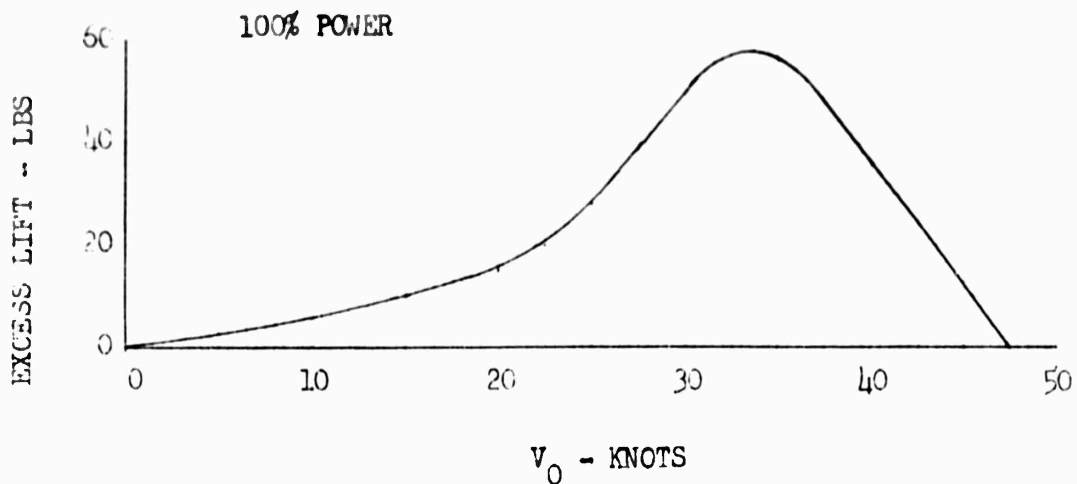
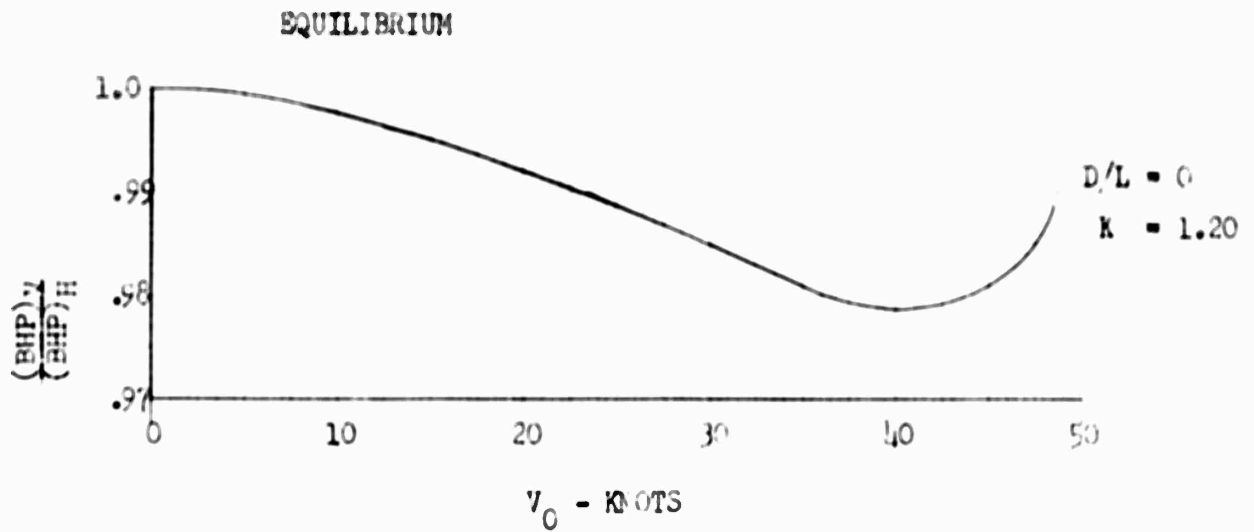

FIG. A-1

CONFIDENTIAL

PREPARED	NAME P. J. H.	DATE 11/30/50	HILLER HELICOPTERS	PAGE ...
CHECKED			TITLE A ... .. Digital Project ... As Applied to ... Platform Project ...	MODEL 1-11-1
APPROVED				REPORT NO ...-100

CONFIDENTIAL

EXIT VELOCITY AT FORWARD SPEED  
100% POWER

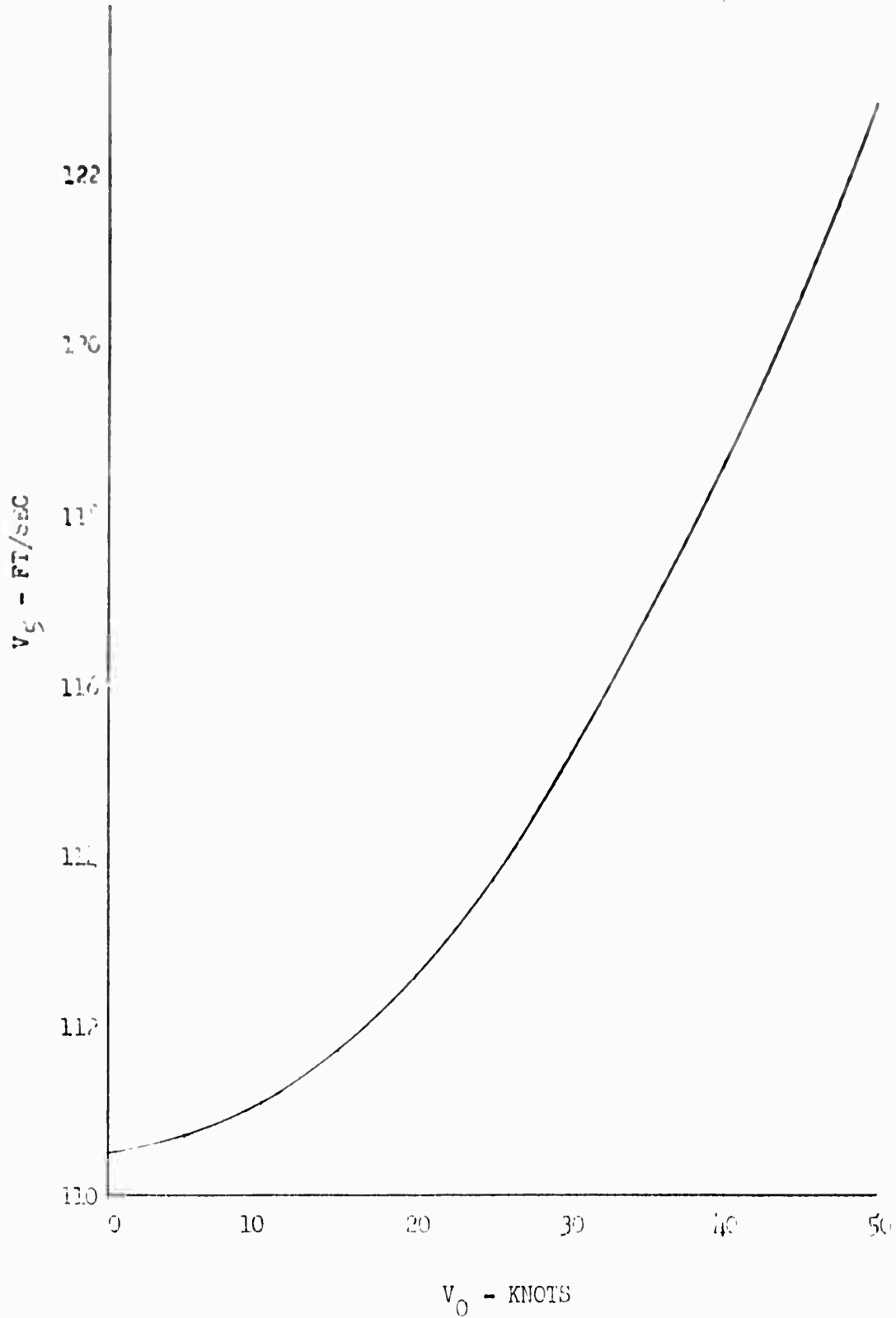

$V_0$  - KNOTS

FIG. A-2

CONFIDENTIAL

PREPARED	NAME F. H-11	DATE 11/30/56	HILLER HELICOPTERS	PAGE A-6
CHECKED			TITLE Aerodynamics of Ducted Propellers As Applied to the Platform Principle	MODEL 1031-A
APPROVED				REPORT NO 56-108

CONFIDENTIAL

LIFT AT FORWARD SPEED

100% POWER

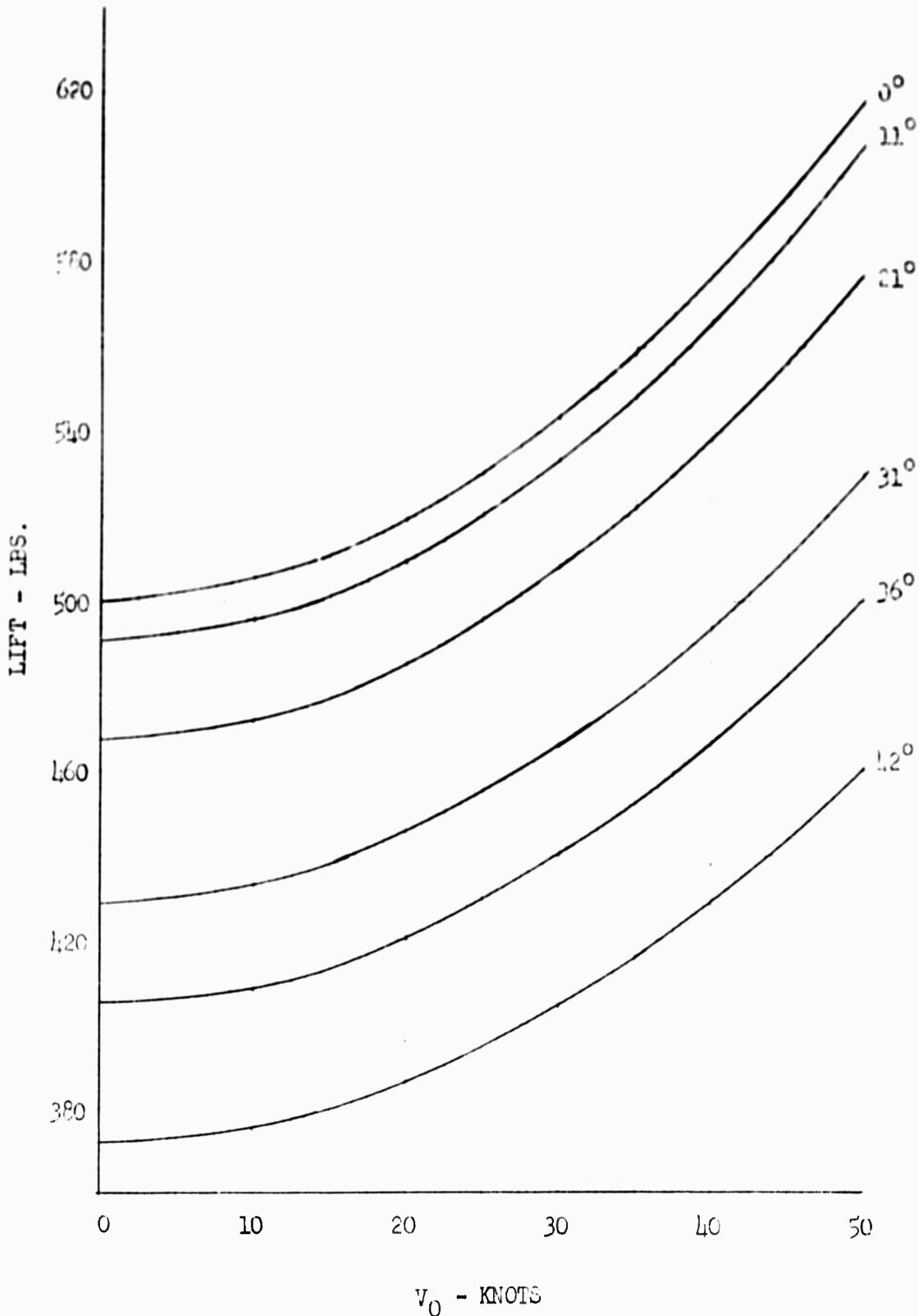

CONFIDENTIAL

FIG. A-3

PREPARED	NAME F. Hall	DATE 11/30/56	HILLER HELICOPTERS	PAGE A-7
CHECKED			TITLE Aerodynamics of Ducted Propellers As Applied to the Platform Principle	MODEL 1031-A
APPROVED				REPORT NO 56-108

CONFIDENTIAL

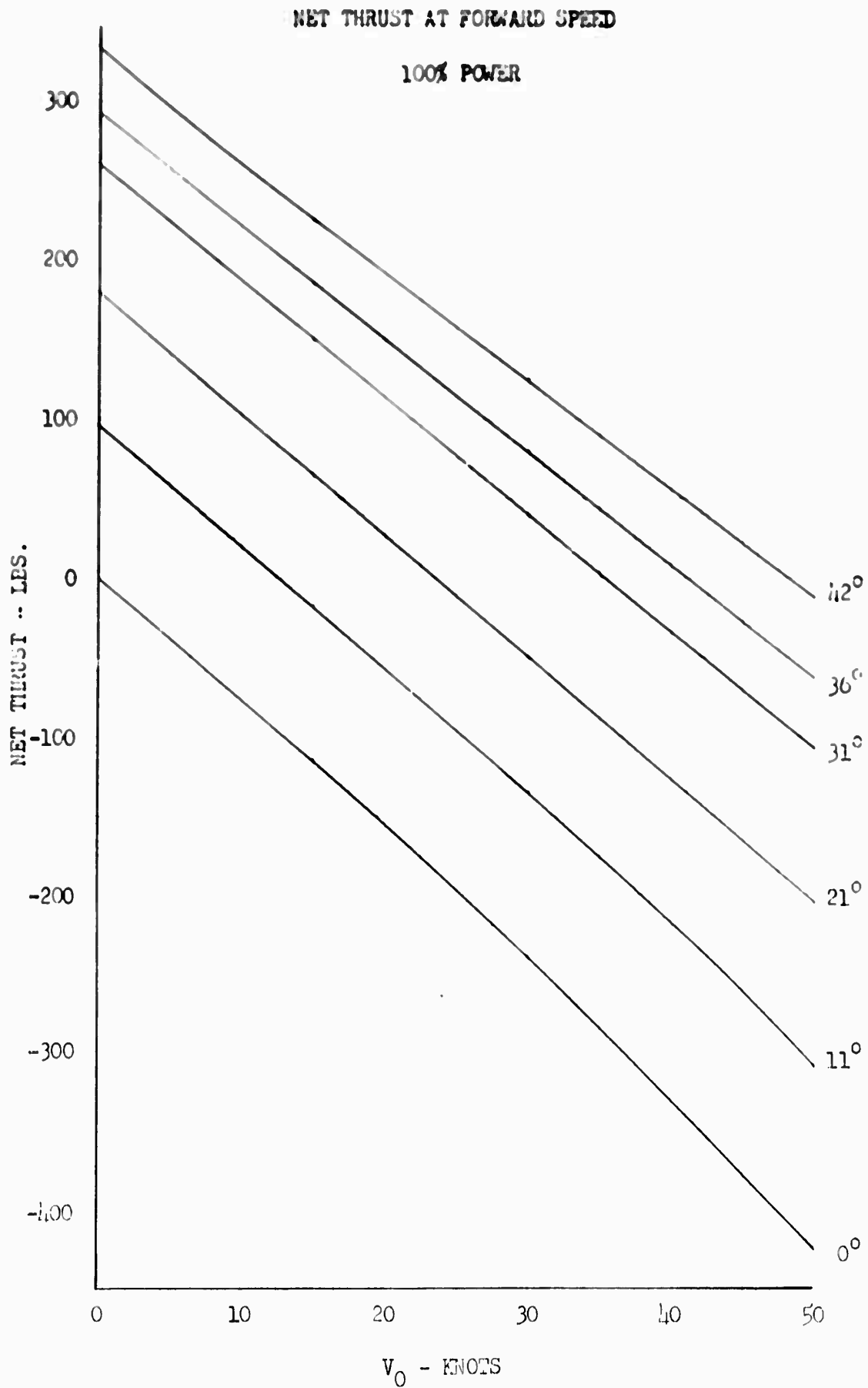

CONFIDENTIAL

FIG. A-4

PREPARED	NAME F. Hall	DATE 11/30/56	HILLER HELICOPTERS	PAGE A-8
CHECKED			TITLE Aerodynamics for Ducted Propellers As Applied to the Platform Principle	MODEL 1031-A
APPROVED				REPORT NO 56-108

C O N F I D E N T I A L

TILT ANGLE REQUIRED  
FOR HORIZONTAL EQUILIBRIUM

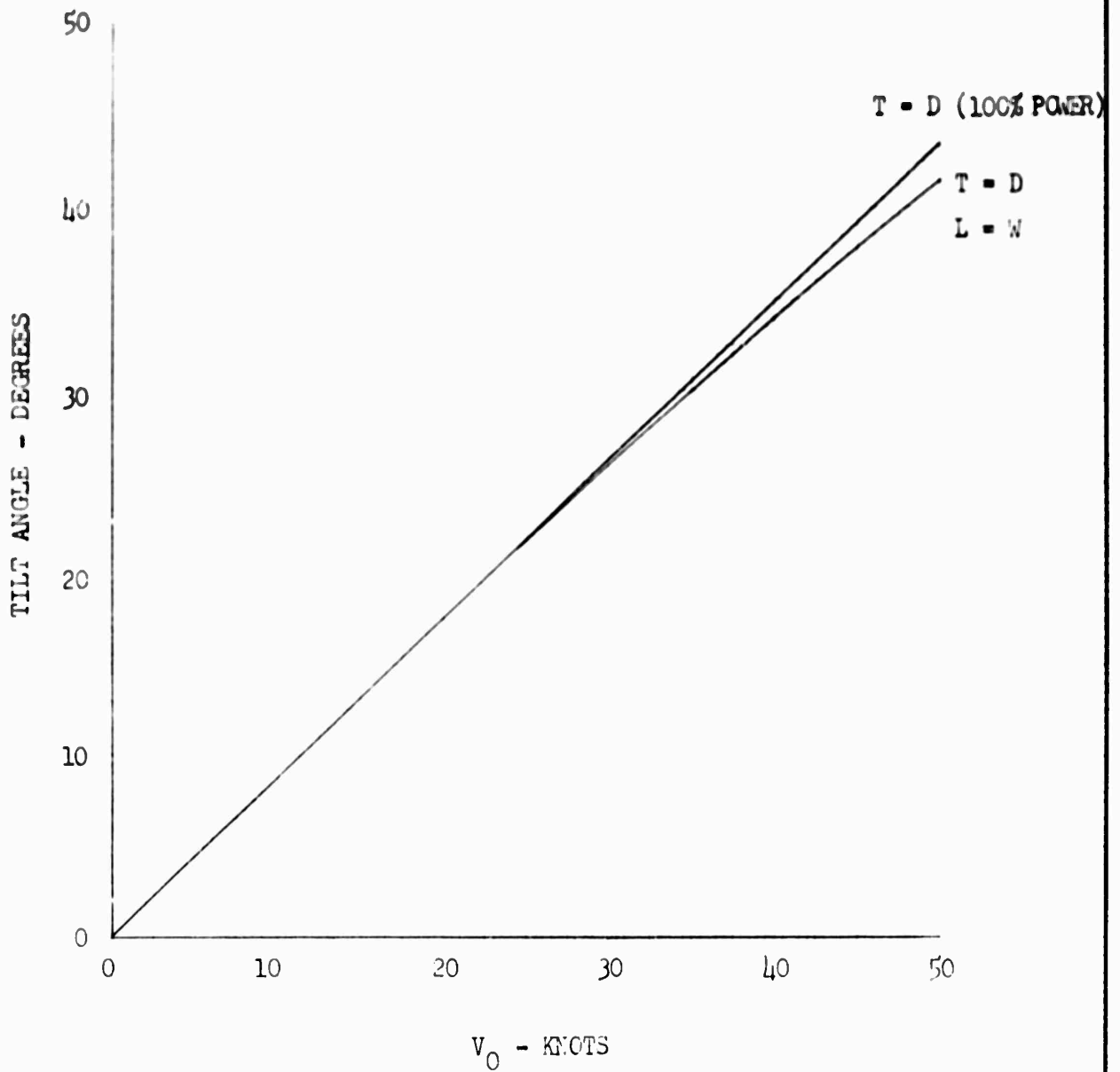

FIG. A-5

C O N F I D E N T I A L

PREPARED	NAME A. Morse	DATE 11/30/56	HILLER HELICOPTERS	PAGE AII-1
CHECKED			TITLE Aerodynamics of Ducted Propellers As Applied to the Platform Principle	MODEL 1031-A
APPROVED				REPORT NO 56-108

**CONFIDENTIAL**

APPENDIX II

AERODYNAMIC CONSIDERATIONS OF PLATFORM CONTROL PROBLEM

(Previously submitted as Appendix I of Airborne  
Platform Progress Report dated March, 1956)

**CONFIDENTIAL**

**I. DISCUSSION:**

Before the merits or disadvantages of a control system can be determined, it is necessary to understand how the basic forces produce lift and thrust. Figure 1 shows these forces in hovering and forward flight, and the accompanying diagrams illustrate how Hiller Report 120.5 is used to calculate the net force ( $F_G$ ) and its direction. If this method is applied correctly, very good agreement between theory and test results are obtained. The assumptions essential to apply this theory to ducts at forward speed and angle of attack are:

1. The net force is in a direction opposite to the flow through the duct.
2. The direction of the flow through the duct is the vector sum of the free stream velocity and a vector (X) parallel to the duct axis.
3. The magnitude of the vector (X) is the vector sum of the free stream velocity ( $V_0$ ) and the duct exit velocity ( $V_5$ ).

Returning now to Figure 1, first, we must define the terms used.

$F_G$	Net Aerodynamic Force
$F_C$	Control Force
L	(Vertical) Component of F
T	Horizontal Component of F
$W_G$	Gross Weight
V	Induced Velocity
$V_0$	Free Stream Velocity
$V_5$	Duct Exit Velocity
P	A Point on the $Q_L$ of the Duct
$M_a$	Aerodynamic Moment
$M_C$	Control Moment
$\alpha$	Duct Angle of Attack (Figure 16)
$\phi$	(Angle of) Inclination of the Net Thrust ( $F_G$ )
$\beta$	Angle Between the Vectors X and $V_5$



I. DISCUSSION (Continued)

It will be noted from Figure 1, (c) and (d), that a platform hovering in still air subjected to a gust will develop a drag force in the direction of the gust and simultaneously a variation in lift along the duct lip, creating a moment  $M_A$  which rotates the duct and tips the vector  $F_G$ ; because there is only a small translation ( $V_0 = 0$ )  $\delta \approx \alpha$  and a force  $T + D$  is produced in the direction of the gust. The translation velocity is increased, but the moment  $M_A$  will not vanish until the translation velocity reaches the velocity of the gust. At this point  $M_A = 0$ , but there is no restoring moment. However, if the translation velocity exceeds the gust velocity a restoring moment will develop which will stabilise the platform approximately at the speed of the gust if sufficient time is allowed.

Now that the direction of the aerodynamic forces can be found, it is possible to see how a platform may be controlled by a shift in the center of gravity.

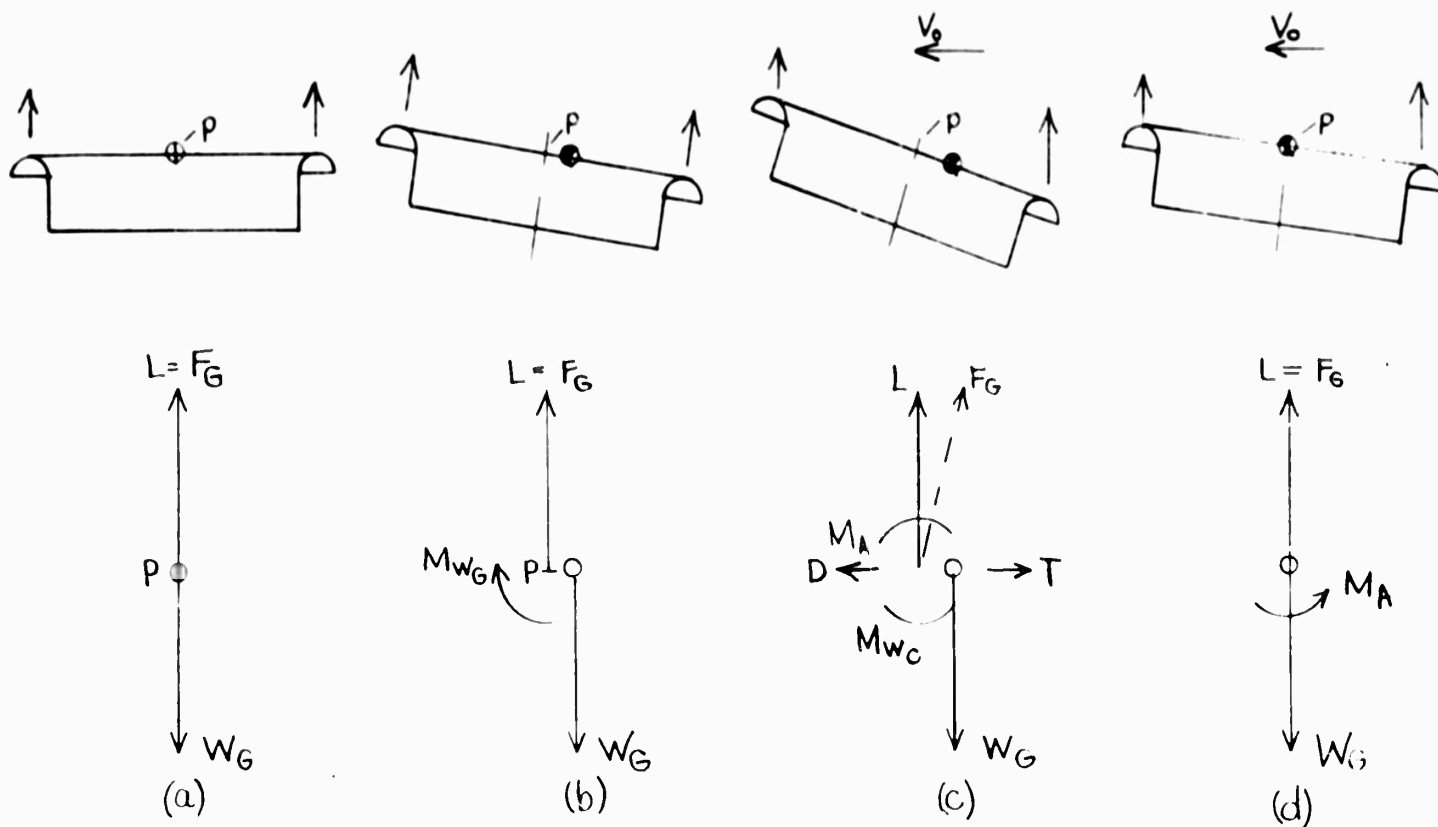

FIGURE 2

I. DISCUSSION (Continued)

Figure 2(a) shows a hovering platform; all forces are in equilibrium, and no moment exists. In Figure 2(b) the c.g. has suddenly been displaced, and a moment appears due to the shift in weight with no corresponding shift in lift. If this c.g. position is maintained, the velocity is increased, and the lift on the leading duct lip becomes sufficiently larger than that on the trailing edge to produce an aerodynamic moment equal to the weight moment. At this point, the thrust vector ( $F_0$ ) is inclined at the angle  $\phi$  and  $F_0 \sin \phi = \text{drag}$ . The entire system is in equilibrium, Figure 2(c). If the c.g. is returned to its original position, Figure 2(d), the aerodynamic moment restores the platform to the horizontal position, and  $\phi$  decreases to zero; thus the thrust ( $F_0$ ) is again equal to the weight and equilibrium is again attained as in Figure 2(a).

Now let's examine the platform with exit vane control.

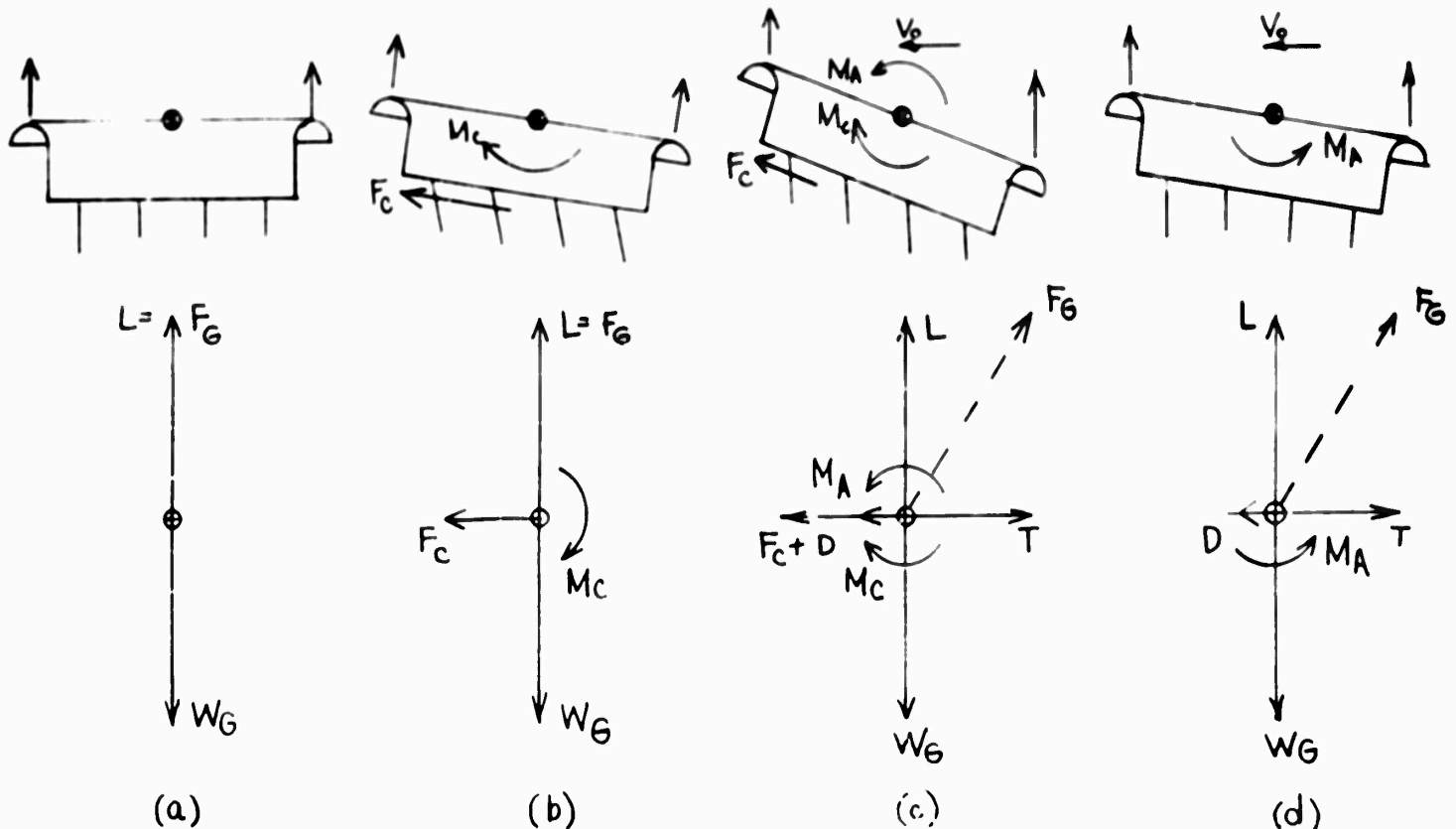

FIGURE 3

In Figure 3(a), the situation is the same as in Figure 2(a). In Figure 3(b), the operator has initiated a force intended to roll the machine clockwise, but in so doing he has created an unbalanced control force  $F_c$ , which starts to move the platform backward. If a constant control setting is maintained, the entire machine will rotate so that  $\phi$  increases, and a component of thrust overcomes the control force and forward motion is initiated. Eventually, an equilibrium point will be found, Figure 3(c), where the control moment and aerodynamic moment are of equal magnitude but opposite in direction, and at the same time the control force and drag are equal and opposite to the thrust ( $T$ ) and  $F_0$  is still sufficient to maintain a lift force equal to the weight.

I. DISCUSSION (Continued)

When the controls are returned to neutral, there is an aerodynamic moment tending to return the platform to the upright position, but the balance of the horizontal forces has been destroyed, and the thrust is greater than the drag, Figure 3(d), and the platform will accelerate. If the controls are maintained, the machine will begin to decrease its angle of attack.  $\delta$  and consequently  $T$  will reduce, and again it will return to a balanced position, Figure 3(a).

If we examine Figure 3(c) in light of the test results of the present platform, we find that the control moment is very large. Miller Report 545.91 indicates an equilibrium at approximately 25 degree tilt angle and 30 knots forward speed. The moment that must be overcome is 380 foot-pounds. If we assume that the exit fins are located 3.8 feet below the c.g.,  $F_C$ , Figure 3(c) has a magnitude of 100 pounds. Now  $T = F_C + D$  for equilibrium. This additional 100 pounds must come from  $F_C$ ; therefore the tilt angle must increase considerably as well as the magnitude of  $F_C$ . Therefore, the forward speed for any tilt angle will decrease, and consequently the maximum forward speed will be reduced by a considerable amount.

The larger the distance between the c.g. and the control fin, the smaller  $F_C$  required to overcome the moment. For instance, if the distance between the c.g. and control fin were 10 feet,  $F_C$  would be 38 pounds or about twice as large as the drag force  $D$ .

In practice when the control force is applied and the machine commences to respond in the opposite direction, more control is applied and by this time the angular acceleration has produced sufficient tilt angle so that the horizontal component of  $F_C$ , that is  $T$ , has become predominant and forward motion is increasing. The reaction is to decrease the vane deflection which increases  $T - (F_C + D)$  and the forward acceleration increases. In brief, though not unstable, it is a difficult means of control.

II. METHODS OF CONTROL:

If spoilers are used to control the platform, a control force will be associated with a decrease in thrust. If suction is applied to the duct lip, a stable machine results with the opposite effect on required power as the spoiler; however, the tendency to follow a gust is not alleviated.

How, then, can a platform be controlled satisfactorily?

A plenum chamber connected to the duct lip and vented through the lip will reduce its natural stability as will be shown. Figure 4(a) shows the hovering duct.

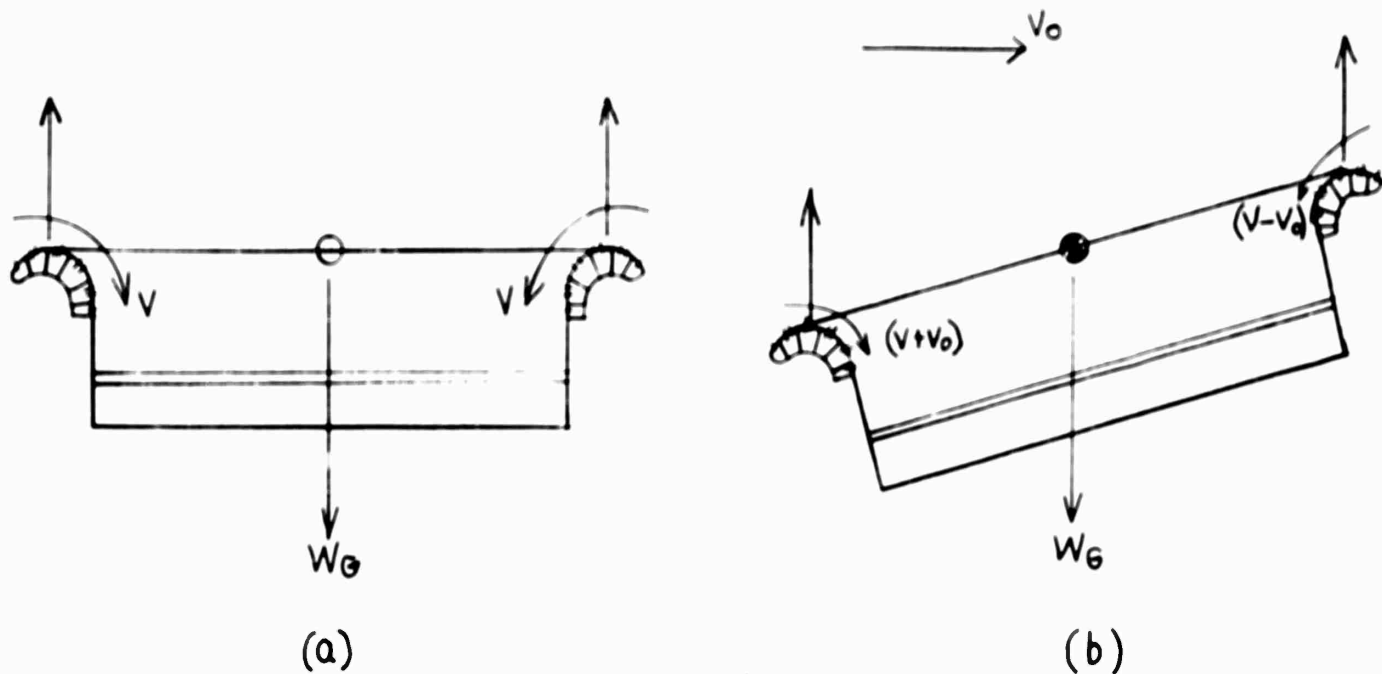

FIGURE 4

II. METHODS OF CONTROL (Continued)

There is no flow because all portions of the duct are lifting uniformly. When the duct is subjected to a gust or forward flight, as in Figure 4(b), the velocity over the duct lip increases on the up stream side and decreases on the opposite side. A relatively high pressure will develop on the side with the low velocity, while reduced pressure will prevail on the upwind side. Thus a flow will be developed in the plenum chamber from the high to the low pressure side. The boundary layer will be forced into the plenum chamber on the side where the velocity is  $V - V_0$  and the low energy air will be forced into the boundary layer on the opposite side. This will tend to neutralize the lift and moment; however, there will always be a restoring moment, which is less than the non-vented platform.

This, then, is not a means of control but rather a means of reducing the stability. The control force need not be as large with the vented lip, but exit vanes below the c.g. will still produce undesirable forces. Therefore, a spoiler or other means must be employed to produce the control force or moment. If vanes are desirable, they must be placed in a stream of high energy air, both in hovering and forward flight. Vanes placed above the c.g. in the inlet stream would produce both a favorable force and moment but would probably be ineffective in hover due to the low velocity. If vanes are placed in the vicinity of the duct lip, the vane on the down wind side can be used to produce additional lift and a desirable moment at low forward speeds. At high forward speeds the velocity over the down stream lip is insufficient to produce the necessary lift; therefore, a vane on the leading duct lip must produce the same moment and force change as spoilers. We find ourselves reverting to c.g. change or boundary layer control for the control force, if we do not wish to accept a means of reducing lift, such as, spoilers. The change in c.g. location is good, and with a vented lip should give adequate control. Boundary layer control with the vented lip should be adequate, but the vented lip is in reality a boundary layer control, and at high forward flight speeds where  $V_0$  approaches  $V$ , suction on the rearward lip would become ineffective.

II. METHODS OF CONTROL (Continued)

It is known that the propeller tip clearance is quite critical in producing duct lift. This, then, is a possible means of control.

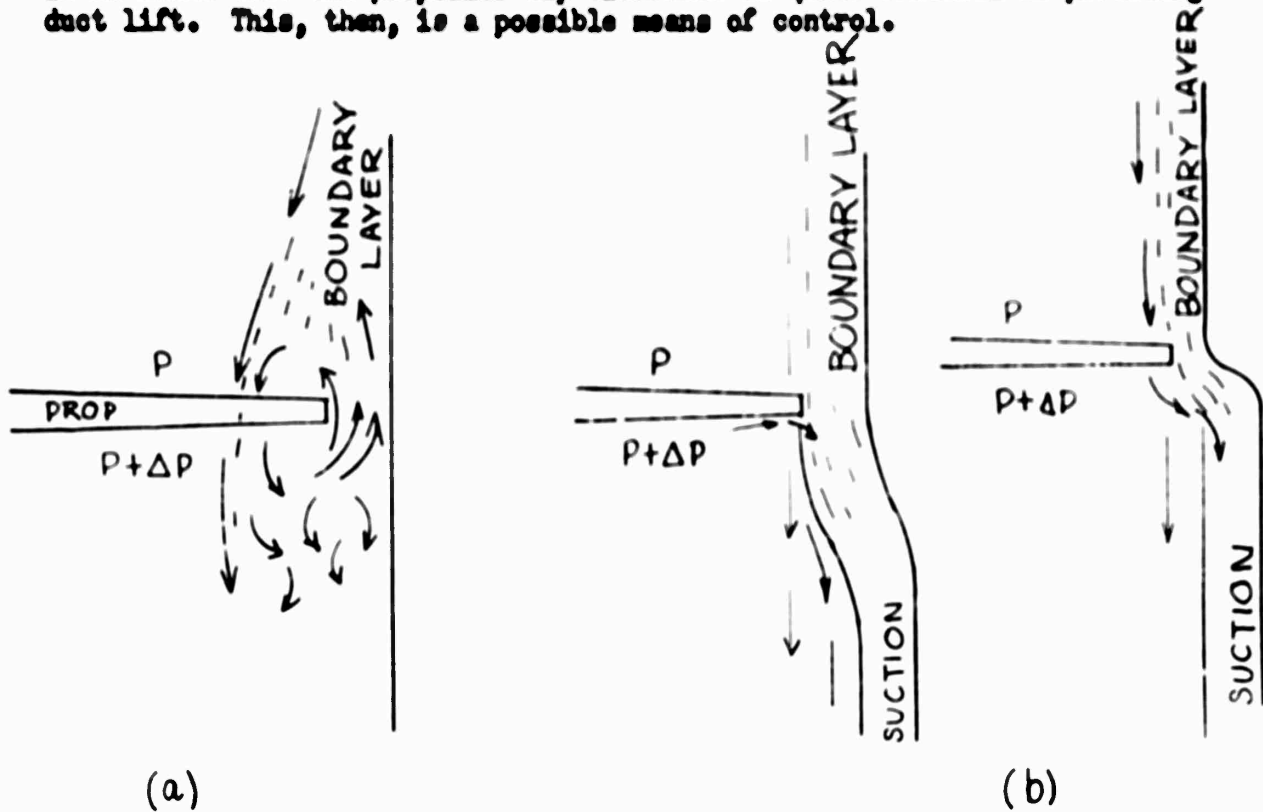

FIGURE 5

Figure 5(a) shows what is happening at the propeller tip. The higher pressure air at the down stream side flows over the blade tip, causing separation ahead of the propeller. Figure 5(b) shows possibilities of local control, which would cause a cyclic lift. The first method may not be possible, due to the bending of the blade, but, if possible, should result in a smaller quantity of air to be removed. The duct lip is an extremely handy source of low pressure, which could be used to supply the suction. This could be accomplished with only a small overall loss in thrust, because the duct lip thrust is reduced but the propeller thrust is increased.

PREPARED	NAME A. Morse	DATE 11/30/56	HILLER HELICOPTERS	PAGE AIII-1
CHECKED			TITLE: Aerodynamics of Ducted Propellers As Applied to the Platform Principle	MODEL 1031-A
APPROVED				REPORT NO 56-108

CONFIDENTIAL

APPENDIX III

PLATFORM CONTROL

CONFIDENTIAL

PREPARED	NAME A. Morse	DATE 11/30/50	HILLER HELICOPTERS	PAGE A-III-1
CHECKED			TITLE Aerodynamics of Ducted Propellers As Applied to the Platform Principle	MODEL H-31-A
APPROVED				REPORT NO. 75-178

CONFIDENTIAL

PLATFORM CONTROL

Memorandum (C) E-56-159

A. Introduction

An inlet guide vane control has been suggested as a means of platform control. The vane would be located in the vicinity of the duct lip, either on the forward side, the rearward side, or both. If both fore and aft vanes are used, they would act in opposite directions; that is, the forward vane would cause a decrease in lift on the forward duct lip and a negative vane lift, and the aft vane would increase the lift on the aft portion of the duct and produce a lifting force on the vane.

This analysis is not intended to give absolute values, but an indication of the forces and the feasibility of such a means of control, either for gust stability or forward flight.

B. Hover Analysis

Tests were conducted to determine the velocity profile in a vertical direction above the duct lip. The test was run in ground effect with the duct exit approximately one foot above the paved surface. The velocities obtained were converted to dynamic pressure ( $q$ ) and plotted against the distance above the lip in inches ( $h$ ), Figure 1.

The variation of dynamic pressure along the surface of the duct is shown in Figure 2. The values of dynamic pressure for a tilt angle of  $0^\circ$  and forward velocity of 0 knots are probably quite accurate; however the values for a forward speed of 38 knots and a tilt angle of  $30^\circ$  are somewhat in error, due to the assumption that the total pressure is equal to the static pressure. In reality, the total pressure is slightly higher than static; however the velocities are probably of the general order of magnitude.

The test results are duct lip pressure below ambient pressure. This was assumed to be the same as static to total pressure in determining the values of dynamic pressure. Actually the total pressure on the aft lip is above ambient as evidenced by the fact that a pressure of one inch of water above ambient was measured at  $h = 0$  on the aft duct lip for the conditions of 38 knots forward speed and a tilt angle of  $30^\circ$ .

Because it is a vertical force, that is, desired from the inlet guide vane, it has been assumed that the maximum chord is of the order of six inches. This assumption enables one to evaluate the

CONFIDENTIAL

CONFIDENTIAL

the lift from a given vane length from the expression:

$$L = C_L q A$$

If it is further assumed that a lift coefficient of one can be obtained and that the duct will contribute an additional force equal to the force produced by the vane, the total lift becomes:

$$L_T = 2qA$$

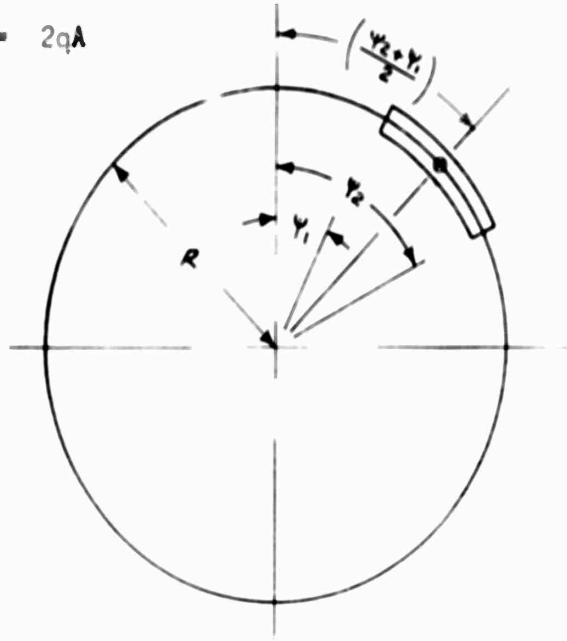

If we define  $\psi$  as in the accompanying diagram,  $q$  is independent of  $\psi$  for hover.

$$\text{Circumference} = \pi D$$

$$\text{The length of the control vane} = \frac{\pi D}{360} (\psi_2 - \psi_1)$$

where  $\psi$  is in degrees.

If the lift is considered at the center of the area, the moment arm can be computed.

$$\text{Moment Arm} = R \cos \left( \frac{\psi_2 - \psi_1}{2} \right)$$

The moment in foot pounds is:

$$\begin{aligned}
 M &= R \cos \left( \frac{\psi_2 - \psi_1}{2} \right) L_T = 2 R \cos \left( \frac{\psi_2 - \psi_1}{2} \right) q A \\
 &= d_1 A \cos \left( \frac{\psi_2 - \psi_1}{2} \right)
 \end{aligned}$$

PREPARED	NAME A. Moore	DATE 11/27/50	HILLER HELICOPTERS	PAGE	A-III-3
CHECKED		TITLE		MODEL	1771-A
APPROVED				REPORT NO.	60-1771

CONFIDENTIAL

The maximum vane chord has been assumed as . . . feet.

$$A = \frac{\pi D}{360} (\psi_2 - \psi_1)$$

$$h = \frac{D^2}{2(360)} (\psi_2 - \psi_1) \cos \left( \frac{\psi_2 - \psi_1}{2} \right)$$

because we are interested in the . . . for the least weight, we can assume  $\psi_1 = 0^\circ$ ; the vane is on both sides of the  $\psi = 0^\circ$  radius.

$$h_{max} = \frac{D^2}{360} \psi_2 \cos \left( \frac{\psi_2}{2} \right)$$

and

$$\frac{h}{A} = .213 \psi_2 \cos \left( \frac{\psi_2}{2} \right)$$

Values of  $h/A$  obtained from this equation are plotted against  $\psi$  in Figure 3.

An average value of  $q$  can be estimated from Figure 1 and 2. The average  $q_{av}$  for  $x$  between  $-2$  and  $+2$  is about 10 from Figure 2. Starting at  $x = 0$  on Figure 1 and going up to 2 inches above the lip, the average  $q$  is approximately 9. Assuming  $120^\circ$  of arc covered by the control vane, then from Figure 3,  $M/q = 11.3$ . The maximum moment available is  $9(11.3) = 101.7$  ft.-lbs.

If one vane is installed on the front end and a second of equal size on the rear lip, the moment would be approximately 203.4 ft.-lbs. or twice the value of a single vane.

### C. Forward Flight Analysis

The accompanying sketch is the same as the corresponding one for the hovering analysis; however  $q$  now varies with  $\psi$ . Assume that the variation is of the form:

CONFIDENTIAL



PREPARED	NAME A. Morse	DATE 11/30/48	HILLER HELICOPTERS	PAGE A-III-5
CHECKED			TITLE Analysis of Ducted Propellers As Applied to the Platform Principle	MODEL K-11-1
APPROVED				REPORT NO. 50-100

CONFIDENTIAL

$$\frac{M}{q_H} = \frac{1.25(1+\psi_2)}{(\psi_2 - \psi_1)} \left[ .02390 (\psi_2 - \psi_1) + (\cos \psi_2 - \sin \psi_1) \right]$$

$$\text{but area x moment arm} = \frac{(\pi D)}{(2\pi)} (\psi_2 - \psi_1) \cos \left( \frac{\psi_2 + \psi_1}{2} \right)$$

$$M = q_H \frac{1.25 D^2}{4} \cos \left( \frac{\psi_2 + \psi_1}{2} \right) \left[ .02390 (\psi_2 - \psi_1) + (\cos \psi_2 - \sin \psi_1) \right]$$

$$\frac{M}{q_H} = \frac{1.25 D^2}{4} \cos \left( \frac{\psi_2 + \psi_1}{2} \right) \left[ .02390 (\psi_2 - \psi_1) + (\cos \psi_2 - \sin \psi_1) \right]$$

Again, assuming the vane extends on both sides of  $\psi_1 = 0$  of the leading duct edge, the above expression becomes:

Forward vane,  $D = 3'$

$$\frac{M}{q_H} = 15.61 \cos \frac{\psi_2}{2} \cdot .02390 \psi_2 + \sin \psi_2$$

Trailing lip vane

$$\frac{M}{q_H} = 15.61 \cos \frac{180 - \psi_1}{2} \cdot .02390 (180 - \psi_1) + \sin \psi_1$$

Figure 4 indicates the magnitude of the moment available at forward speed. To find the moment proceed as in the previous example. Assuming the same location of the vane, we have an average  $q$  of 9. From Figure 4,  $120^\circ$  of arc covered by the vane on the forward lip yields  $M/q_H = 30$  and the moment will be  $M = 30 \times 9 = 270$  ft.-lbs. If an additional vane covering  $120^\circ$  of the aft lip is used, it will have  $M/q = 7.5$ . This will produce an additional moment of  $7.5 \times 9 = 67.5$  ft.-lbs., making the total moment  $270 + 67.5 = 337.5$  ft.-lbs. Figure 5 indicates the moment required at a tilt angle of  $30^\circ$  and 38 knots forward speed to be 400 ft.-lbs. It would, therefore, be necessary for the pilot to supply approximately 100 ft.-lbs. In this condition the net force due to the vane would be approximately 125 lbs. down on the forward lip and 11 lbs. additional lift on the aft lip.

CONFIDENTIAL

PREPARED	NAME A. Morse	DATE 11/30/56	HILLER HELICOPTERS	PAGE A-III-6
CHECKED			TITLE Aerodynamics of Ducted Propeller As Applied to the Platform Principle	MODEL 1031-A
APPROVED				REPORT NO. 56-108

DYNAMIC PRESSURE PROFILE

(C) E-56-159

CONFIDENTIAL

100% POWER

IN GROUND EFFECT

0° TILT ANGLE

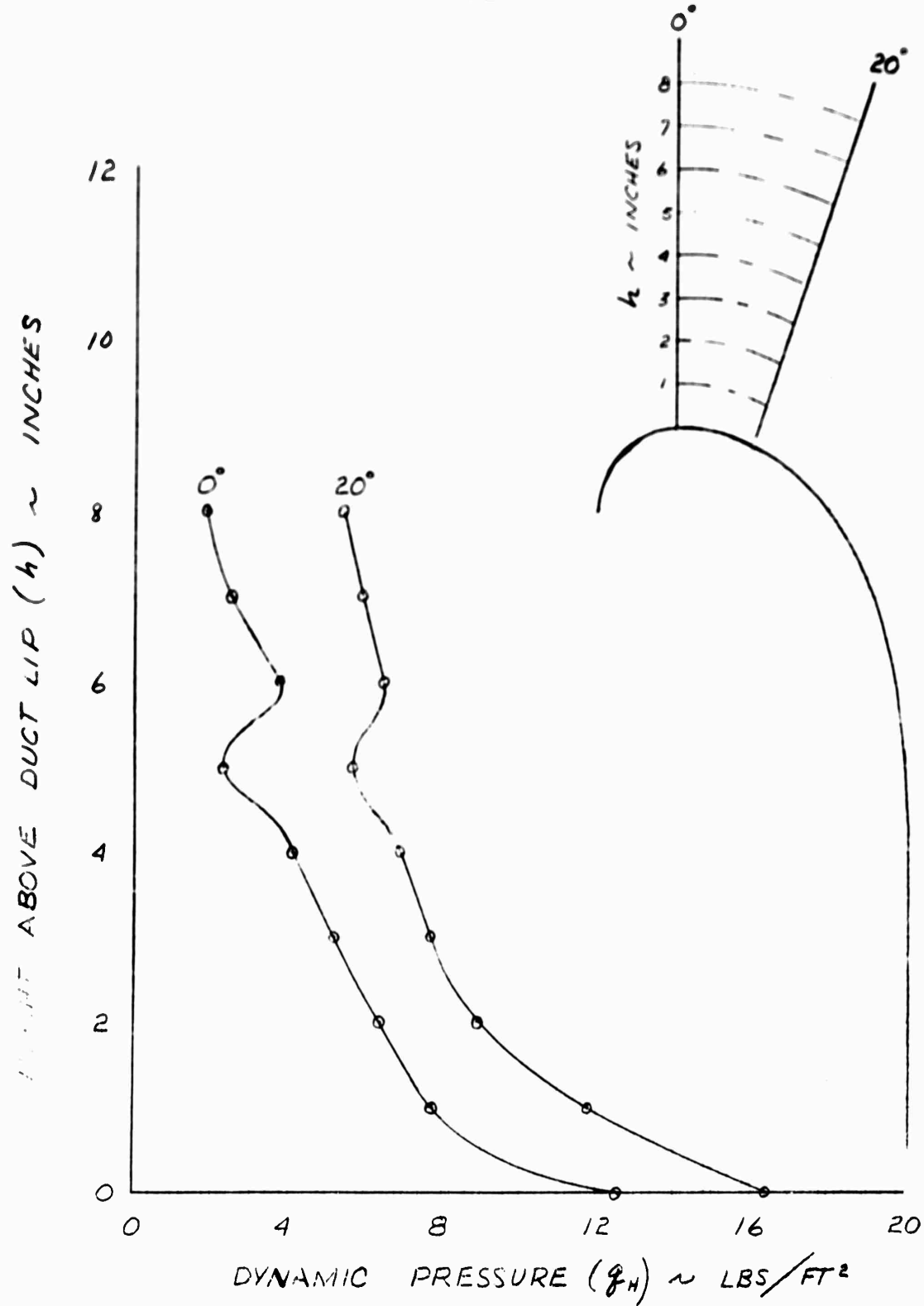

CONFIDENTIAL

FIGURE 1

PREPARED	NAME A. Morse	DATE 12/30/54	HILLER HELICOPTERS	PAGE A-III-7
CHECKED			TITLE Aerodynamics of Ducted Propellers As Applied to the Platform Principle	MODEL 10J-A
APPROVED				REPORT NO. 56-108

CONFIDENTIAL  
(C) 56-108

### DYNAMIC PRESSURE ON THE DUCT SURFACE

100% POWER

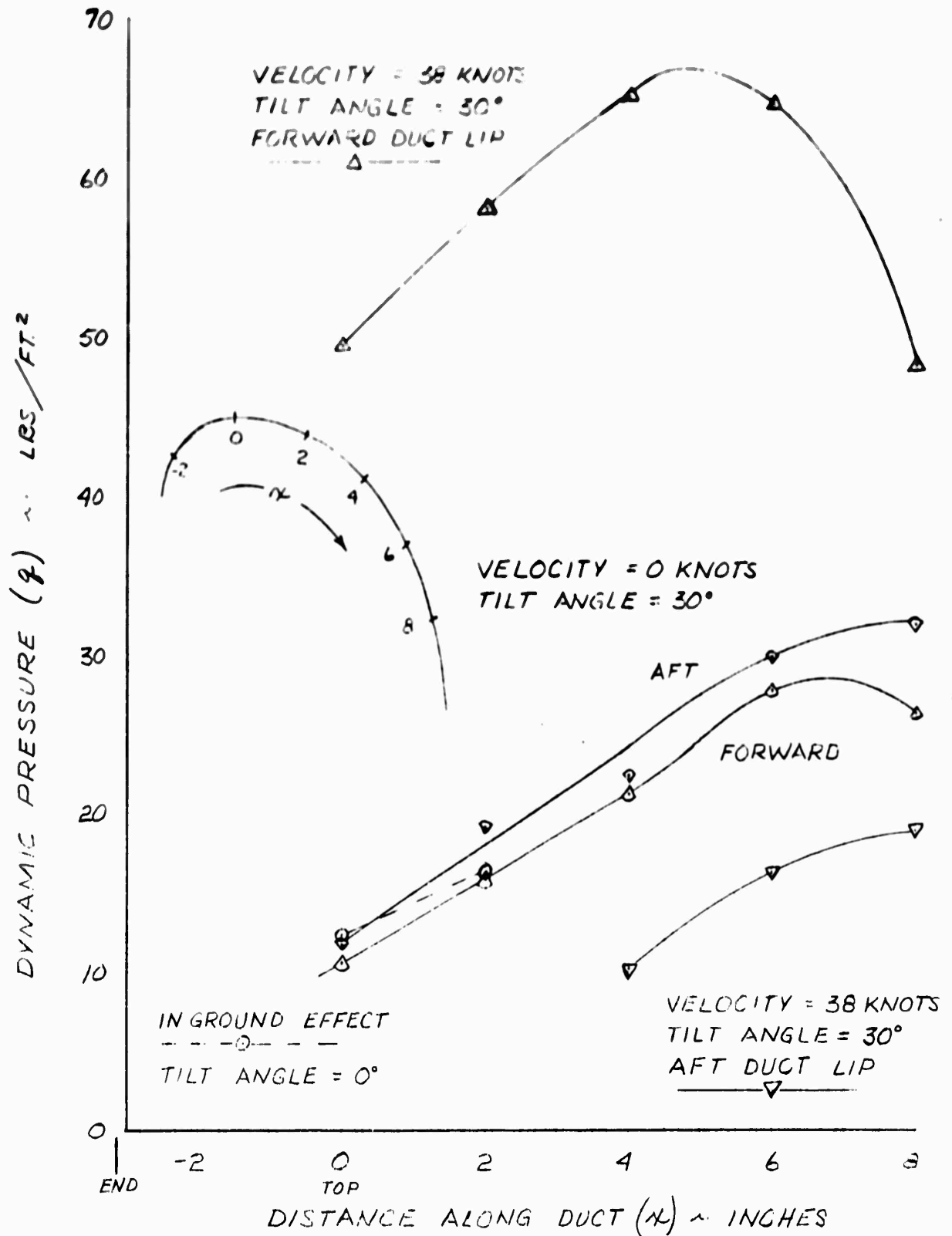

PREPARED	NAME A. Morse	DATE 11/30/56	HILLER HELICOPTERS	PAGE A-III-8
CHECKED			TITLE Aerodynamics of Ducted Propellers As Applied to the Platform Principle	MODEL 1031-A
APPROVED				REPORT NO. 56-108

CONFIDENTIAL  
(C) E-56-159

### INLET GUIDE VANE EFFECIVENESS IN HOVER

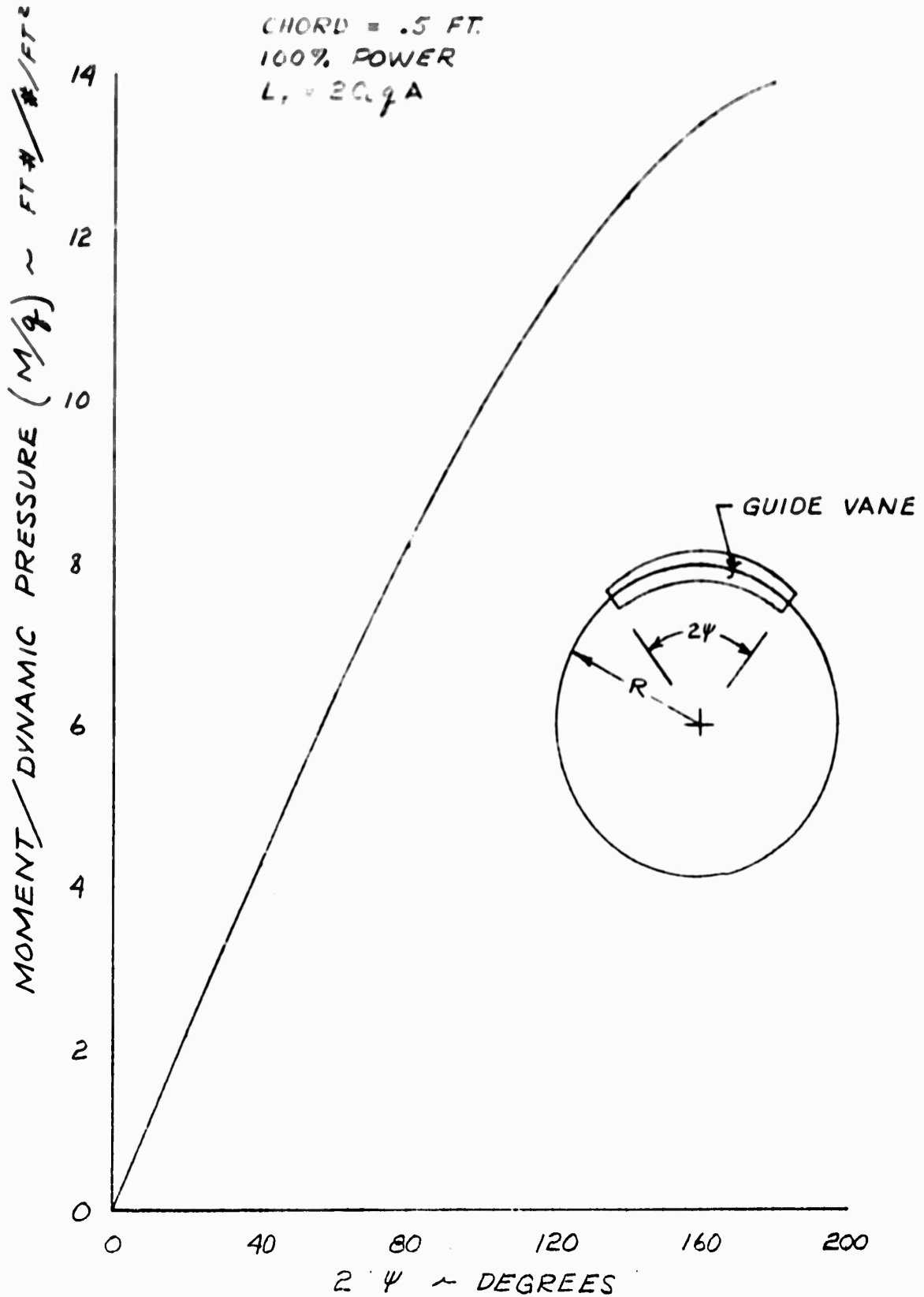

CONFIDENTIAL

FIGURE 3

PREPARED	NAME A. MORSE	DATE 11/30/56	HILLER HELICOPTERS	PAGE A-III-9
CHECKED			TITLE Aerodynamics of Ducted Propeller As Applied to the Platform Principle	MODEL 1031-A
APPROVED				REPORT NO. 56-108

CONFIDENTIAL  
(C) 5-56-159

INNER GUIDE VANE EFFECTIVENESS AT FORWARD SPEED

100% POWER  
CHORD = .5 FT.  
L = 2 C. 9 A

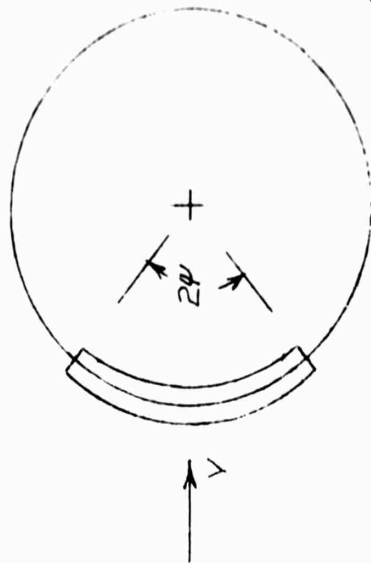

MOMENT/DYNAMIC PRESSURE (N/2)

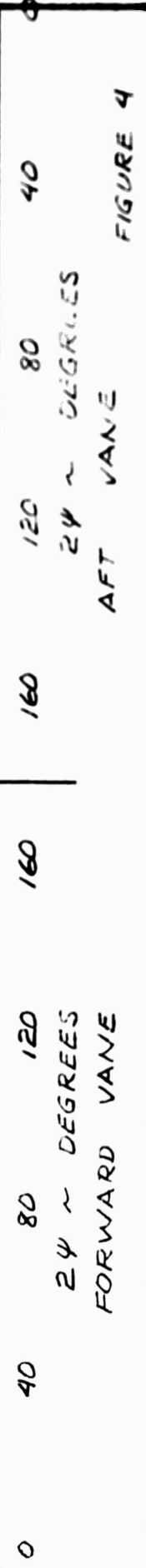

24 ~ DEGREES  
FORWARD VANE

24 ~ DEGREES  
AFT VANE

FIGURE 4

PREPARED	NAME A. Morse	DATE 11/30/56	HILLER HELICOPTERS	PAGE A-III-10
CHECKED			TITLE Aerodynamics of Ducted Propellers As Applied to the Platform Principle	MODEL 1071 A
APPROVED				REPORT NO. 60-228

CONFIDENTIAL

(S) 60-228

FITCHING MOMENT PRODUCED  
BY PLATFORM

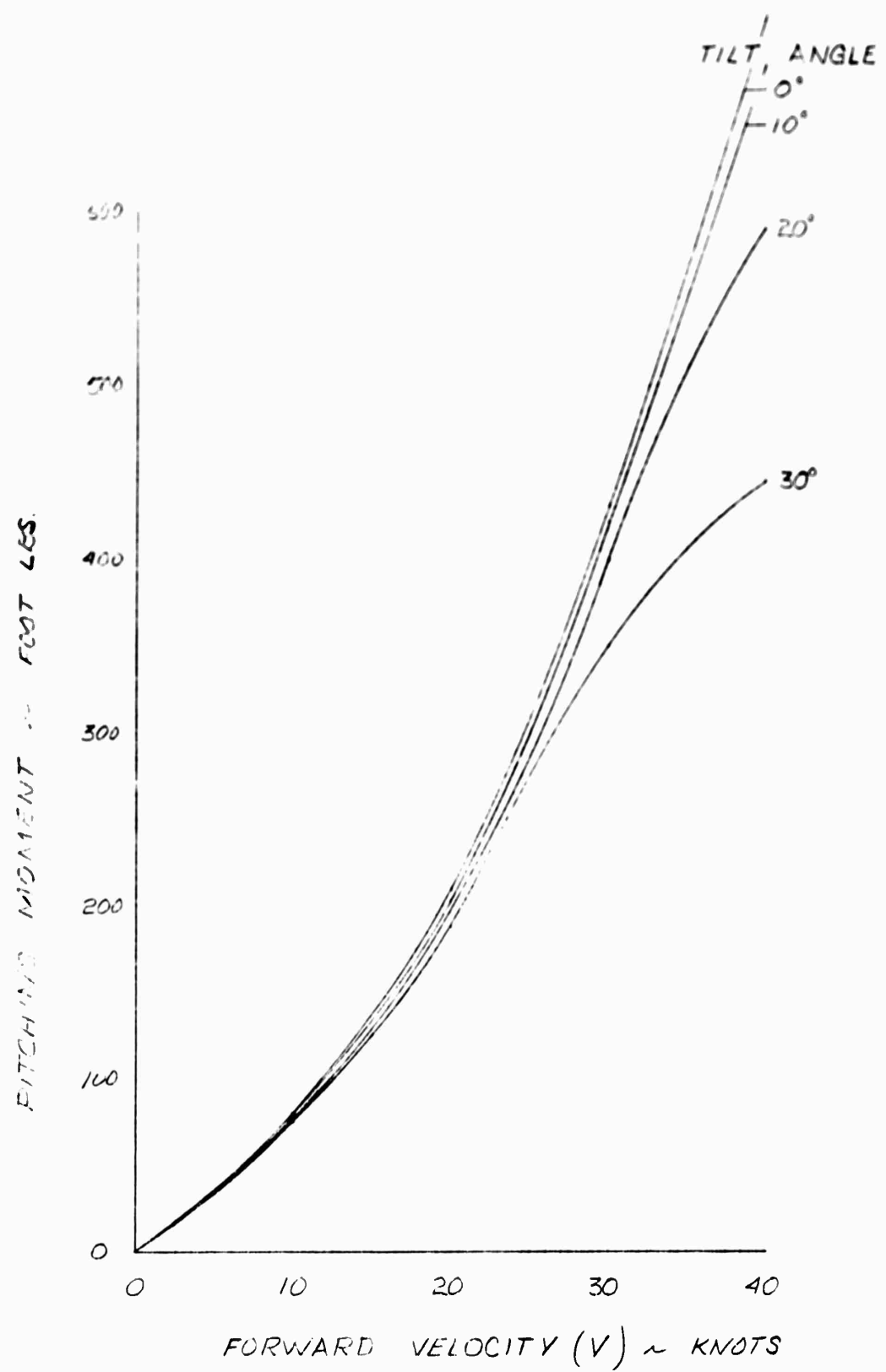

CONFIDENTIAL

FIGURE 5

PREPARED	NAME A. Morse	DATE 11/30/56	HILLER HELICOPTERS	PAGE AIV-1
CHECKED			TITLE: Aerodynamics of Ducted Propellers As Applied to the Platform Principle	MODEL 1031-A
APPROVED				REPORT NO. 56-108

C O N F I D E N T I A L

APPENDIX IV

STABILITY AND CONTROL

C O N F I D E N T I A L

PREPARED	NAME J. Nichols	DATE 11/30 56	HILLER HELICOPTERS	PAGE A-IV-2
CHECKED			TITLE Aerodynamics of Ducted Propellers As Applied to the Platform Principle	MODEL 1031-A
APPROVED				REPORT NO. 56-108

CONFIDENTIAL

STABILITY AND CONTROL

Memorandum E-56-504

A. Introduction

One of the methods proposed for reducing the large pitchup moment on the platform in forward flight is BLC - venting and interconnecting the duct lips to equalize the pressures.

It is the considered opinion of the writer that this method will not work. The following qualitative analysis is offered in support of this opinion.

B. Analysis

Consider a "two dimensional" duct (i.e., a longitudinal cross section). Furthermore, consider the lip edges carried around to the trailing edge to complete the airfoil.

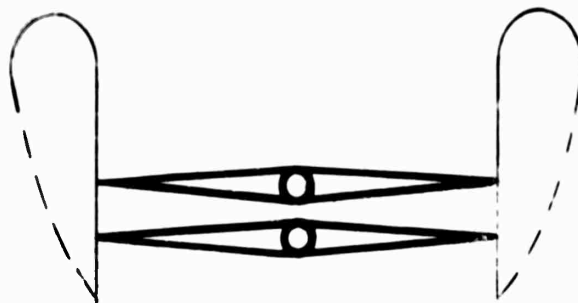

Figure 1

CONFIDENTIAL

PREPARED	NAME A. Morse	DATE 11/30/56	HILLER HELICOPTERS	PAGE A-IV-3
CHECKED			TITLE: Aerodynamics of Ducted Propeller As Applied to the Platform Principle	MODEL 1031-A
APPROVED				REPORT NO. 56-108

C O N F I D E N T I A L

In hovering flight the air enters symmetrically over both "airfoils".

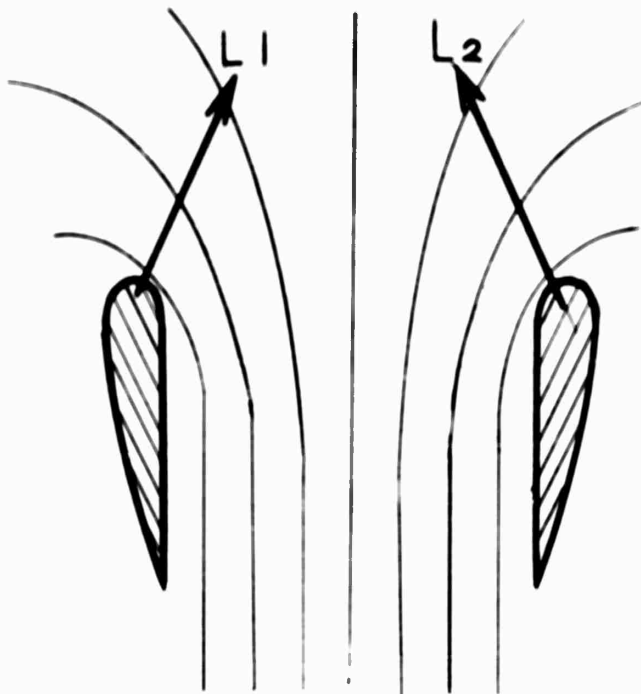

Figure 2

Lift,  $L_1$ , equals lift,  $L_2$ , and if we consider that the lift is generated by a circulation about the two airfoils, we can see that the fan is generating the velocity and the circulation about both airfoils, but the circulation is in the opposite sense on each airfoil.

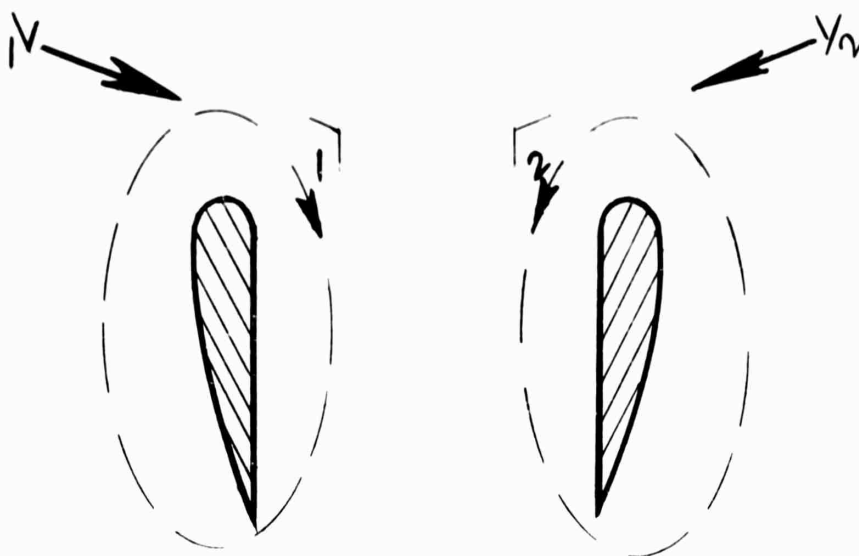

Figure 3

C O N F I D E N T I A L

PREPARED	NAME J. Nichols	DATE 11/25/56	HILLER HELICOPTERS	PAGE A-IV-4
CHECKED			TITLE: Aerodynamics of Ducted Propellers As Applied to the Platform Principle	MODEL 1031-A
APPROVED				REPORT NO. 60-108

CONFIDENTIAL

Now let us tilt the duct and translate it at a lateral velocity  $V_H$ .

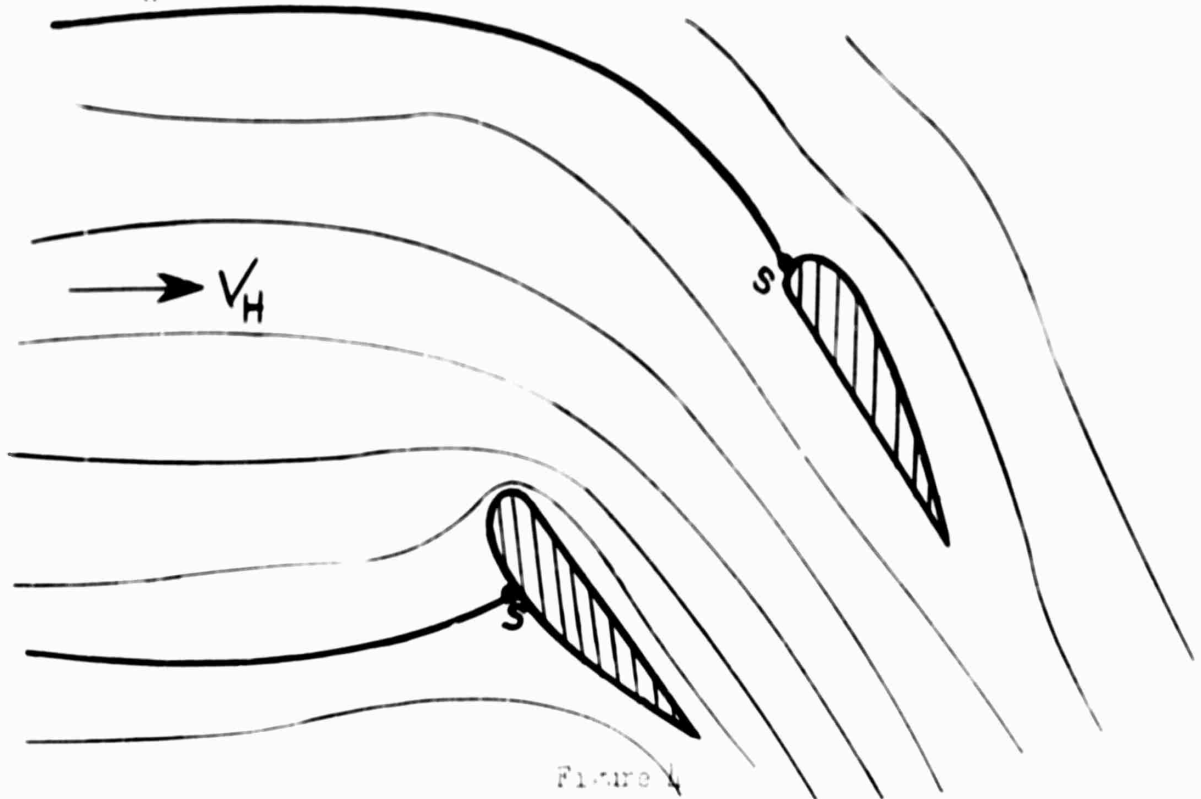

Figure 4

In essence the airflow sees two airfoils (i.e., a biplane) at an extremely high angle of attack. If the fan were not operating, the air would prefer to flow around the airfoils as follows:

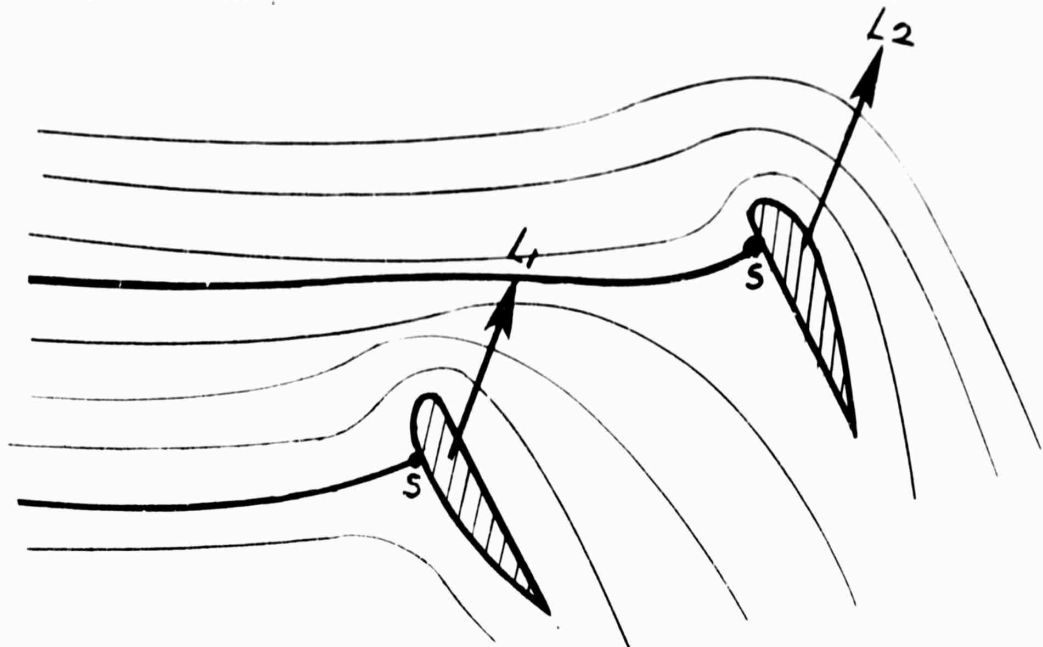

Figure 5

CONFIDENTIAL

PREPARED	NAME J. Nichols	DATE 11/30/56	HILLER HELICOPTERS	PAGE A-IV-5
CHECKED			TITLE Aerodynamics of Ducted Propellers As Applied to the Platform Principle	MODEL 1031-A
APPROVED				REPORT NO. 56-17

CONFIDENTIAL

The circulation over the aft airfoil is in the OPPOSITE DIRECTION as that set up by the fan in hovering flight, and the circulation is now in the same sense as for the forward airfoil.



Figure 6

Now we see that the fan "backs" the "normal" circulation buildup, or conversely the forward velocity "backs" the circulation set up by the fan.

Now if we want to maintain the symmetrical lift over the two airfoils, we must maintain the same symmetrical flow pattern as occurs in hovering.

Our moment would be eliminated if the flow pattern looked like Figure 7 below rather than like Figure 6.

CONFIDENTIAL

PREPARED	NAME J. L. Litch	DATE 11/30/56	HILLER HELICOPTERS	PAGE A-IV-6
CHECKED			TITLE: Aerodynamics of Ducted Propellers As Applied to the Platform Principle	MODEL 1031-A
APPROVED				REPORT NO. 60-108

CONFIDENTIAL

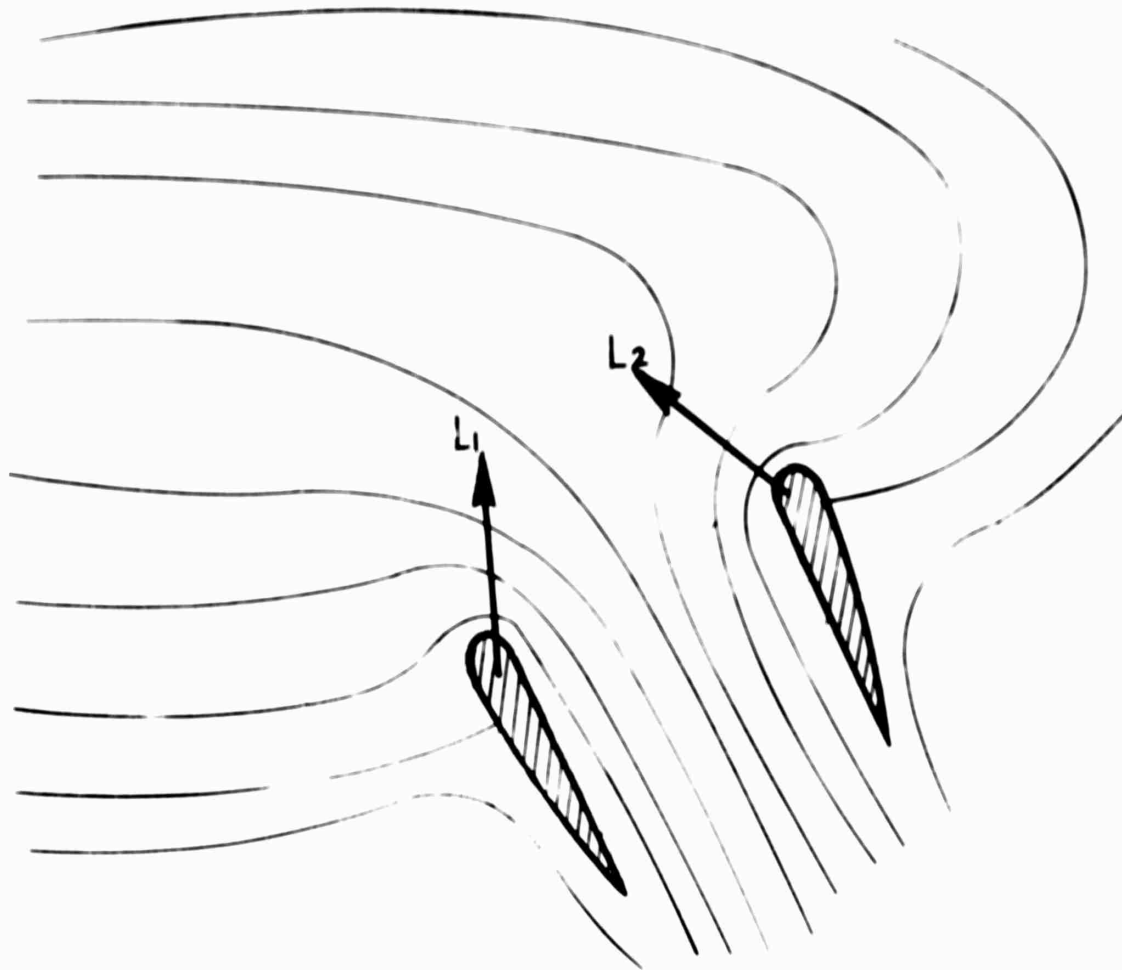

Figure 2

Now we can see that we are asking the lip vent BLC system to do an awful lot if we have to displace the flow pattern as drastically as shown, with a larger mass of air actually making a reverse bend in order to flow over the rear lip in the correct manner.

The primary duct lift is obtained from the rapid acceleration of the mass of air around the lip, causing a low pressure region.

SUCTION HOLES ON the rear lip will not provide a low pressure region unless the suction is enough to change the general flow pattern.

This can be demonstrated by showing the pressure pattern around an airfoil:

CONFIDENTIAL

PREPARED	NAME J. Nichols	DATE 11/30/56	HILLER HELICOPTERS	PAGE A-IV-7
CHECKED			TITLE: Aerodynamics of Ducted Propellers As Applied to the Platform Principle	MODEL 1001-A
APPROVED				REPORT NO. 56-108

C O N F I D E N T I A L

a) Without BLC

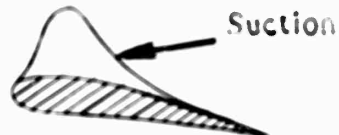

b) If suction is applied, the pressure does not decrease near the suction hole, thus:



c) But the entire pressure (and flow) distribution is changed thus:

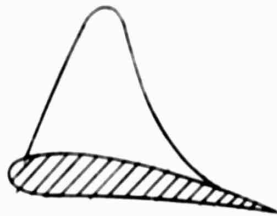

In order to do what we propose, we have to put in a large amount of power to change the flow field.

If we bleed from the front lip, we will destroy the lift on the front without materially increasing the lift on the rear, and we will have to put more power into the platform. So we see we are still left with the conclusion that we will have to pay a power price for moment control, IF WE CONSIDER EQUALIZING THE MOMENTS BY flow alteration around the duct.

If, on the other hand, we reduce the power put into the "forward" air to keep  $L_1$  constant as forward speed is increased, then we can put that power into the "aft" air to keep  $L_2$  high.

C O N F I D E N T I A L

PREPARED	NAME J. Nichols	DATE 11/1/69	HILLER HELICOPTERS	PAGE A-17
CHECKED			TITLE: Development of Control Program As Applied to the Platform Project, etc.	MODEL
APPROVED				REPORT NO.

CONFIDENTIAL

This power can be transferred from the "head" air to the "rear" air by employing cyclic blades or by transferring the power to a powered PLC system for the rear of the platform.

The former approach leads to the utilization of cyclic pitch mechanisms, the latter approach to the use of electric motor blowers.

CONFIDENTIAL

PREPARED	NAME A. Morse	DATE 12/30/56	HILLER HELICOPTERS	PAGE AV-1
CHECKED			TITLE Aerodynamics of Ducted Propellers As Applied to the Platform Principle	MODEL 1031-A
APPROVED				REPORT NO 56-108

C O N F I D E N T I A L

APPENDIX V

PRELIMINARY AERODYNAMIC ANALYSIS

C O N F I D E N T I A L

**CONFIDENTIAL**

**HILLER HELICOPTERS**  
PALO ALTO, CALIFORNIA

**ENGINEERING REPORT**

REPORT NO. 111.9

MODEL NO. 1031A

TITLE PRELIMINARY AERODYNAMIC ANALYSIS

NO. OF PAGES 22

DATE June 15, 1956

BY A. H. Morse  
A. H. Morse

CHECKED R. Heida  
R. Heida

APPROVED C. Dessin  
C. Dessin

APPROVED for W. A. Wagner  
for W. A. Wagner

**REVISIONS**

DATE	PAGE NUMBER

**CONFIDENTIAL**

PREPARED	NAME A. MORSE	DATE 6-15-56	TITLE HILLER HELICOPTERS	PAGE 1
CHECKED				MODEL 1031A
APPROVED	<i>W</i>		PRELIMINARY AERODYNAMIC ANALYSIS	GROUP NO 114.9

**CONFIDENTIAL**

INDEX

	<u>Page No.</u>
INTRODUCTION . . . . .	1
SUMMARY . . . . .	2
I. MOMENT APPLIED TO THE PROPELLER BY CHANGING THE INFLOW DIRECTION . . . . .	3
II. ADDITIONAL MOMENT DUE TO INCREASED INFLOW VELOCITY OVER THE DUCT LIP . . . . .	10
III. CHANGE IN PROPELLER BLADE LIFT COEFFICIENT . . . . .	14
IV. DECREASE IN HOVER PERFORMANCE DUE TO INSTALLATION OF PROPELLER INLET GUIDE VANES . . . . .	17
V. INCREASE IN PARASITE POWER DUE TO DEFLECTION OF PROPELLER INLET GUIDE VANES . . . . .	21

**CONFIDENTIAL**

PREPARED	NAME A. Morse	DATE 6-15-56	HILLER HELICOPTERS	PAGE 1
CHECKED			TITLE PRELIMINARY AERODYNAMIC ANALYSIS	MODEL 1031-A
APPROVED				REPORT NO 114.9

**CONFIDENTIAL**

INTRODUCTION

This is a preliminary issue of the final aerodynamic report to be submitted in satisfaction of Phase III of Contract Nonr-1357(00).

The present content of this report covers only the analysis of the radial inlet vane control of pitching moment.

**CONFIDENTIAL**

PREPARED	NAME A. Morse	DATE 6-15-56	TITLE HILLER HELICOPTERS	PAGE 2
CHECKED				MODEL 103L <sub>A</sub>
APPROVED			PRELIMINARY AERODYNAMIC ANALYSIS	REPORT NO 114.9

**CONFIDENTIAL**

SUMMARY

It has been suggested that propeller inlet guide vanes, or stator vanes, be used to direct the induced velocity into or opposite from the direction of rotation of the propeller blade, and thus change the angle of attack and lift coefficient of the propeller. This will again change the inflow velocity and, in turn, the lift of the duct lip.

According to the analysis, an optimum configuration is reached when the area covered by the inlet guide vanes is a circular segment of approximately  $160^\circ$  on the front and another equal segment on the rear portion of the duct. If it is assumed that the propeller inlet guide vanes are capable of turning the flow through an angle of  $25^\circ$ , the moment from the propeller will be 20.6 ft.lbs, and the additional moment will be 67.6 ft.lbs, or a total of 88.3 ft.lbs. The thrust divided by brake horsepower in the hovering condition will be reduced by .156.

If the machine develops 475 lbs. of thrust with the consumption of 77 BHP without propeller inlet guide vanes, the addition of guide vanes would require an increase in horsepower to 79 BHP for the same performance. When the vanes are deflected to achieve  $25^\circ$  of turning, the maximum blade lift coefficient (assumed to occur at  $r/R = .5$ ) will be increased by approximately 0.5. This increase in lift coefficient is associated with an increase in drag coefficient. The increase in brake horsepower required was calculated and found to be negligible.

**CONFIDENTIAL**

PREPARED	NAME A. Morse	DATE 6-25-50	TITLE HILLER HELICOPTERS	PAGE 3
CHECKED				MODEL 1031A
APPROVED			PRELIMINARY AERODYNAMIC ANALYSIS	REPORT NO 114.9

**CONFIDENTIAL**

I. MOMENT APPLIED TO THE PROPELLER BY CHANGING THE INFLOW DIRECTION



$$\tan \phi' = \frac{V_1 \sin(90 - \epsilon)}{52r - V_1 \cos(90 - \epsilon)}$$

$$\tan \phi'' = \frac{V_1 \sin(90 + \epsilon)}{52r - V_1 \cos(90 + \epsilon)}$$

but  $\beta_{\max} = 23^\circ$   $\therefore \epsilon < 23^\circ$  and  $\tan \phi' \approx \phi'$

$$\tan \phi' = \frac{V_1 \sin(90 - \epsilon)}{52r - V_1 \cos(90 - \epsilon)}$$

but  $\sin(90 - \epsilon) = \cos \epsilon$

and  $\cos(90 - \epsilon) = \sin \epsilon$

$$\tan \phi' = \frac{V_1 \cos \epsilon}{52r - V_1 \sin \epsilon} = \phi'$$

**CONFIDENTIAL**

PREPARED	NAME A. Morse	DATE 6-5-56	HILLER HELICOPTERS	PAGE 4
CHECKED			TITLE PRELIMINARY AERODYNAMIC ANALYSIS	MODEL 2032A
APPROVED				REPORT NO 114.9

**CONFIDENTIAL**

$$\tan \phi^n = \frac{V_1 \sin(90 + \epsilon)}{\Omega r - V_1 \cos(90 + \epsilon)}$$

and

$$\sin(90 + \epsilon) = \cos \epsilon$$

$$\cos(90 + \epsilon) = -\sin \epsilon$$

$$\tan \phi^n = \frac{V_1 \cos \epsilon}{\Omega r + V_1 \sin \epsilon} = \phi^n$$

$$\phi^i - \phi^n = V_1 \cos \epsilon \left[ \frac{1}{\Omega r - V_1 \sin \epsilon} - \frac{1}{\Omega r + V_1 \sin \epsilon} \right]$$

$$\Delta \phi = V_1 \cos \epsilon \left[ \frac{1}{\Omega r \left( 1 - \frac{V_1 \sin \epsilon}{\Omega r} \right)} - \frac{1}{\Omega r \left( 1 + \frac{V_1 \sin \epsilon}{\Omega r} \right)} \right]$$

$$= \frac{V_1 \cos \epsilon}{\Omega r} \left[ \frac{1}{\left( 1 - \frac{V_1 \sin \epsilon}{\Omega r} \right)} - \frac{1}{\left( 1 + \frac{V_1 \sin \epsilon}{\Omega r} \right)} \right]$$

but

$$\frac{\sin \epsilon}{\Omega r} \ll 1.0$$

$$\begin{aligned} \Delta \phi &= \frac{V_1 \cos \epsilon}{\Omega r} \left[ \left( 1 - \frac{V_1 \sin \epsilon}{\Omega r} \right)^{-1} - \left( 1 + \frac{V_1 \sin \epsilon}{\Omega r} \right)^{-1} \right] \\ &= \frac{V_1 \cos \epsilon}{\Omega r} \left[ \left( 1 + \frac{V_1 \sin \epsilon}{\Omega r} \right) - \left( 1 - \frac{V_1 \sin \epsilon}{\Omega r} \right) \right] \end{aligned}$$

**CONFIDENTIAL**

PREPARED	NAME A. Morse	DATE 6-15-56	HILLER HELICOPTERS	PAGE 5
CHECKED			TITLE PRELIMINARY AERODYNAMIC ANALYSIS	MODEL 1031A
APPROVED				REPORT NO 114.9

**CONFIDENTIAL**

$$\Delta \phi = \frac{V_1^2 \cos \epsilon \sin \epsilon}{\Omega r^2} = \frac{2 V_1^2 \cos \epsilon \sin \epsilon}{(\Omega r)^2}$$

but  $\Delta \phi = \Delta \alpha = d\alpha$

and  $\frac{dC_L}{d\alpha} = 5.73/\text{rad.}$

$\therefore \frac{dC_L}{d\alpha} (d\alpha) = dC_L$

$$dC_L = \frac{5.73(2V_1^2 \cos \epsilon \sin \epsilon)}{(\Omega r)^2}$$

$$dC_L = \frac{11.46 V_1^2 \cos \epsilon \sin \epsilon}{(\Omega r)^2}$$

$$dC_L = \frac{5.73 V_1^2 (2 \sin \epsilon \cos \epsilon)}{(\Omega r)^2} = \frac{5.73 (V_1^2 \sin 2\epsilon)}{(\Omega r)^2}$$

and  $L = C_L q A_{\text{blade}}$

but  $q = \frac{1}{2} \rho V_{\text{blade}}^2$

and  $V_{\text{blade}}^2 = V_0^2 + (\Omega r)^2$

$\therefore \Delta L = \frac{5.73 V_1^2 \sin 2\epsilon}{(\Omega r)^2} \left[ V_1^2 + (\Omega r)^2 \right] A_{\text{blade}} \frac{\rho}{2}$

**CONFIDENTIAL**

PREPARED	NAME A. Morse	DATE 6-15-50	HILLER HELICOPTERS	PAGE 6
CHECKED			TITLE PRELIMINARY AERODYNAMIC ANALYSIS	MODEL 1031A
APPROVED				REPORT NO 124.9

**CONFIDENTIAL**

If radial inlet guide vanes extending from the duct to the hub are used, a relatively large blade area experiences the new angle of attack instantaneously; therefore, it has been suggested that vanes extending from the circumference to a chord line be used.



The area of the blade experiencing the changed angle of attack will vary with azimuth position.

$l$  = length of blade influenced by vanes.

$$\sin\psi = \frac{R \cos\theta}{R-l}$$

$$R-l = \frac{R \cos\theta}{\sin\psi}$$

$$l = R \left( 1 - \frac{\cos\theta}{\sin\psi} \right)$$

$$A_{\text{blade}} = \text{chord}(C)(\text{length}) = C l$$

$$A_B = CR \left( 1 - \frac{\cos\theta}{\sin\psi} \right)$$

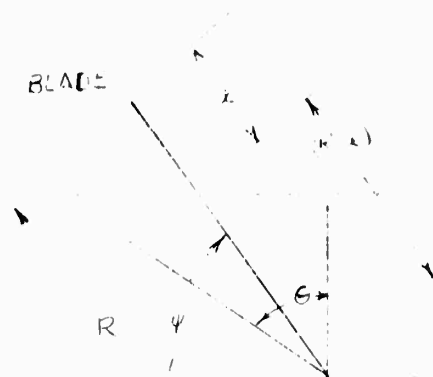

**CONFIDENTIAL**

PREPARED	NAME A. Morse	DATE 6-15-56	HILLER HELICOPTERS	PAGE 7
CHECKED			TITLE PRELIMINARY AERODYNAMIC ANALYSIS	MODEL 1031A
APPROVED				REPORT NO. 11.9

**CONFIDENTIAL**

$$\text{Now: } \Delta L = \frac{2.865 V_1^2 \rho \sin^2 \epsilon (CR)}{(\Omega r)^2} \left[ V_1^2 + (\Omega r)^2 \right] 1 - \frac{\cos \theta}{\sin \psi}$$

$$\text{At } \psi = 0; \quad r = R$$

$$\text{and at } \psi = 90^\circ; \quad r = R \cos \theta$$

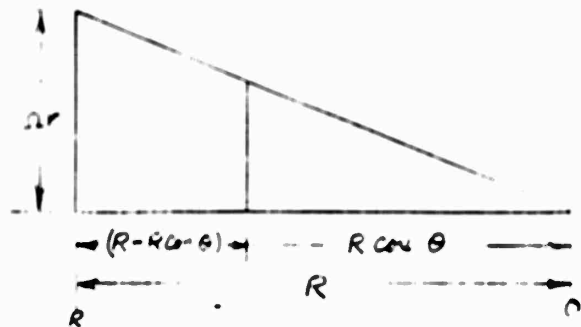

The average value of  $r$  should be closer to  $R$  than to  $R \cos \theta$ .

For simplification, assume that the average value of  $r$  is obtained  $2/3$  of the way between  $R \cos \theta$  and  $R$ .

$$r_{\text{av}} = R \cos \theta + \frac{2}{3} (R - R \cos \theta) = \frac{2}{3} R + \frac{R}{3} \cos \theta$$

$$r_{\text{av}} = \frac{R}{3} (2 + \cos \theta)$$

$$\therefore \Omega r_{\text{av}} = \frac{\Omega R}{3} (2 + \cos \theta)$$

$$\text{and } (\Omega r_{\text{av}})^2 = \frac{\Omega R^2}{9} (2 + \cos \theta)^2$$

$$\left( \frac{\Omega r_{\text{av}}}{V_1} \right)^2 = \left( \frac{\Omega R}{3V_1} \right)^2 (2 + \cos \theta)^2$$

The blade chord decreases linearly with radius from  $R = r$  to  $.4R = r$ .

$$r/R = 1.0, \quad c = .2 \text{ ft.}$$

$$r/R = .4, \quad c = .3182 \text{ ft.}$$

$$\therefore c = m \frac{r}{R} + b$$

Evaluating the constants,

$$C_{\text{av}} = .397 \left[ 1 - .1653(2 + \cos \theta) \right] = .2657(1 - .2475 \cos \theta)$$

**CONFIDENTIAL**

PREPARED	NAME A. Morse	DATE 6-15-56	HILLER HELICOPTERS	PAGE 8
CHECKED			TITLE PRELIMINARY AERODYNAMIC ANALYSIS	MODEL 1031A
APPROVED				REPORT NO 114.9

**CONFIDENTIAL**

but 
$$r_{av} = \frac{R}{3} (2 + \cos\theta)$$

$$\therefore \frac{r_{av}}{R} = \frac{1}{3} (2 + \cos\theta)$$

and 
$$C_{av} = .397 [1 - .1653(2 + \cos\theta)] = .2657(1 - .2475 \cos\theta)$$

The moment arm (h) is the distance from the center of lift ( $\Delta L$ ) to the axis  $\psi = 0$ ,  $\psi = 180^\circ$ . If the center of lift ( $\Delta L$ ) is assumed to be 1/3 of the distance  $l$  from the tip;

$$h = R \cos\theta + 2/3 l \sin\psi$$

but 
$$l = R \left(1 - \frac{\cos\theta}{\sin\psi}\right)$$

$$\begin{aligned} h &= R \left[ \cos\theta + \frac{2}{3} \sin\psi \left(1 - \frac{\cos\theta}{\sin\psi}\right) \right] \\ &= R \left[ \cos\theta + \frac{2}{3} \sin\psi - \frac{2}{3} \cos\theta \right] \\ h &= \frac{R}{3} \left[ \cos\theta + 2 \sin\psi \right] \end{aligned}$$

$$\Delta L = 5.73 \frac{\rho V_1^2 cR}{2} \left(\frac{V_1}{\Omega r}\right)^2 \sin 2\epsilon \left[1 + \left(\frac{\Omega r}{V_1}\right)^2\right] \left(1 - \frac{\cos\theta}{\sin\psi}\right)$$

but 
$$\left(\frac{V_1}{\Omega r_{av}}\right)^2 = \left(\frac{3V_1}{\Omega R}\right)^2 \frac{1}{(2 + \cos\theta)^2}$$

$$\therefore \Delta L = \frac{5.73 \rho V_1^2}{2} cR \left(\frac{3V_1}{\Omega R}\right)^2 \frac{\sin 2\epsilon}{(2 + \cos\theta)^2} \left[1 + \left(\frac{\Omega R}{3V_1}\right)^2 (2 + \cos\theta)^2\right] \left(1 - \frac{\cos\theta}{\sin\psi}\right)$$

**CONFIDENTIAL**

PREPARED	NAME A. Mors	DATE 6-5-56	HILLER HELICOPTERS	PAGE 9
CHECKED			FILE PRELIMINARY AERODYNAMIC ANALYSIS	MODEL 103.A
APPROVED				REPORT NO 114.9

**CONFIDENTIAL**

but 
$$c_{av} = .2657(1 - .2475 \cos\theta)$$

$$\Delta L(h) = \Delta M \quad \text{and} \quad h = \frac{R}{3} [\cos\theta + 2 \sin\psi]$$

$$\Delta M = .2536\rho V_1^2 \left(\frac{3V_1}{R}\right)^2 \frac{\sin^2\epsilon}{(2 + \cos\theta)^2} \left[1 + \left(\frac{QR}{3V_1}\right)^2 (2 + \cos\theta)^2\right] (1 - .2475 \cos\theta) (\cos\theta + 2 \sin\psi) \left(1 - \frac{\cos\theta}{\sin\psi}\right)$$

Constants:

$$k = 283 \left(\frac{1.48}{1.533}\right) = 273$$

$$\rho = .002378$$

$$V_1 = 113$$

$$R = 2.5'$$

$$\Delta M = \frac{11.87 \sin^2\epsilon}{(2 + \cos\theta)^2} \left[1 + 2.013(2 + \cos\theta)^2\right] (1 - .2475 \cos\theta) (\cos\theta + 2 \sin\psi) \left(1 - \frac{\cos\theta}{\sin\psi}\right)$$

**CONFIDENTIAL**

PREPARED	NAME A. MORSE	DATE 6-25-50	HILLER HELICOPTERS	PAGE
CHECKED			TITLE PRELIMINARY AERODYNAMIC ANALYSIS	MODEL 1031A
APPROVED				REPORT NO 114.9

CONFIDENTIAL

PROPELLER MOMENT

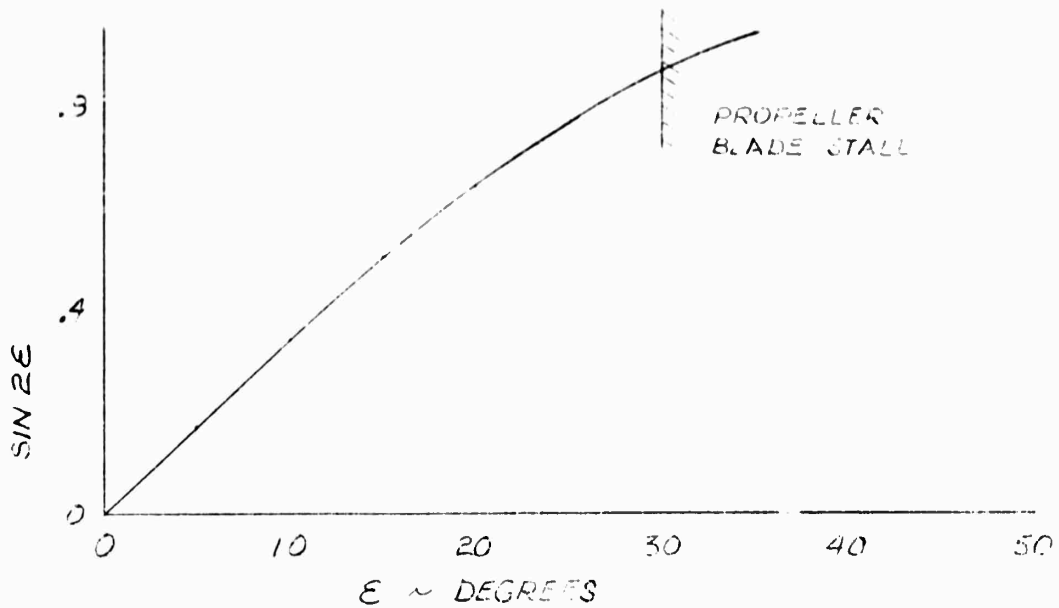
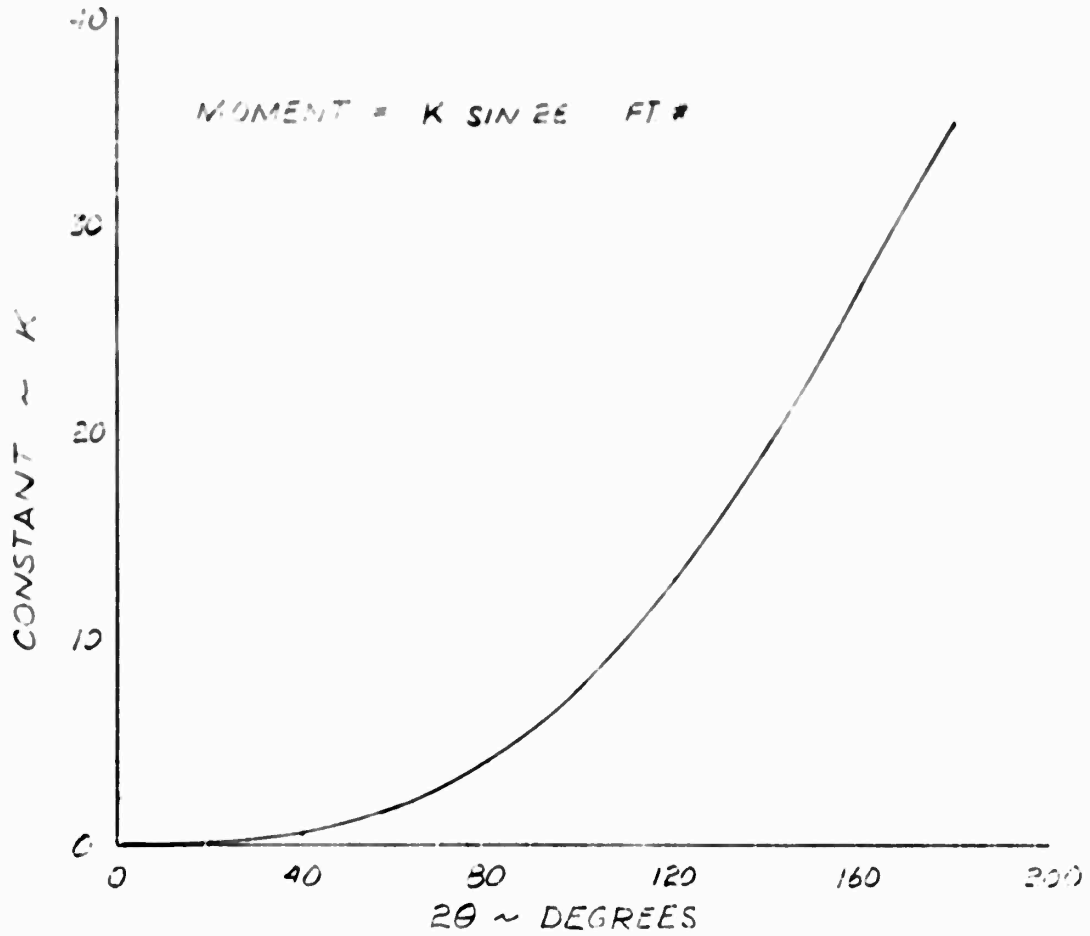

CONFIDENTIAL

PREPARED	NAME A. Morse	DATE 6-15-56	HILLER HELICOPTERS	PAGE 10
CHECKED			TITLE PRELIMINARY AERODYNAMIC ANALYSIS	MODEL 1031A
APPROVED				REPORT NO 114.9

**CONFIDENTIAL**

II. ADDITIONAL MOMENT DUE TO INCREASED VELOCITY ON THE DUCT LIP

$$L = C_L q_R A_R$$

$$L = (P_2 - P_1) A_{\text{disk}}$$

$$\therefore (P_2 - P_1) = C_L q_R \frac{A_{\text{blade}}}{A_{\text{disk}}}$$

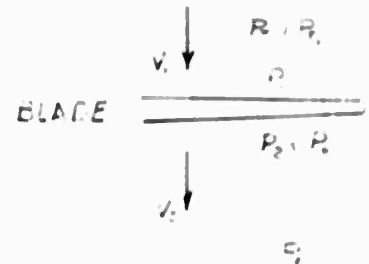

Now:

$$P_{T1} = P_1 + q_1$$

but  $P_{T1} = P_{T0} = P_0$

$$\therefore (P_0 - P_1) = q_1$$

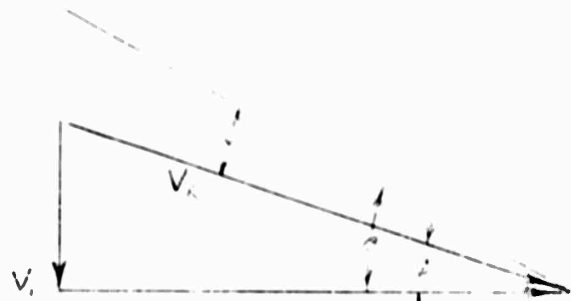

but  $\rho AV = \text{const.}$

$$\rho \doteq \text{const.}; \quad A \doteq \text{const.}; \quad \therefore V \doteq \text{const.}$$

$$P_{T1} \doteq P_{T_{\text{wake}}} \quad \therefore P_2 + q_2 \doteq P_{\text{wake}} + q_{\text{wake}}$$

and  $q_{\text{wake}} \doteq q_2 \quad \therefore P_2 \doteq P_0$

$$q_1 = C_L q_R \frac{A_{\text{blade}}}{A_{\text{disk}}}$$

**CONFIDENTIAL**

PREPARED	A. Morse	6-15-56	HILLER HELICOPTERS	PAGE	11
CHECKED			TITLE	MODEL	103A
APPROVED			PRELIMINARY AERODYNAMIC ANALYSIS	REPORT NO	114.9

**CONFIDENTIAL**

but

$$\frac{\lambda_{\text{blade}}}{\lambda_{\text{disk}}} = 0$$

$$v_1^2 = C_L v_R^2 \sigma \quad \text{but } v_R^2 = (\omega r)^2 + v_1^2$$

$$v_1^2 = C_L \sigma \left[ (\omega r)^2 + v_1^2 \right] = C_L \sigma (\omega r)^2 + C_L \sigma v_1^2$$

$$v_1^2 = \frac{C_L \sigma (\omega r)^2}{(1 - C_L \sigma)}$$

The blade chord,  $C$ , =  $C_3 - \left( \frac{C_3 - C_1}{.7R} \right) (r - .3R)$

$$C_3 = .275, \quad C_1 = .200, \quad .75R = 1.75, \quad .3R = .75$$

$$C = .275 - \left( \frac{.275 - .200}{1.75} \right) (r - .75) = .275 - .0428r + .0321$$

If one rotor disk is used,

$$v_1 = \frac{\omega r}{\left( \frac{2}{C_L \sigma} - 1 \right)^{1/2}} \quad \therefore \quad v_1 = \frac{\omega r}{\left( \frac{2}{\Delta C_L \sigma} - 1 \right)^{1/2}}$$

$$\Delta v_1 = \frac{\omega r}{\left( \frac{2}{\Delta C_L (.1475)} - 1 \right)^{1/2}}$$

**CONFIDENTIAL**

PREPARED	NAME A. Morse	DATE 6-15-56	HILLER HELICOPTERS	PAGE 12
CHECKED			FILE	MODEL 1031A
APPROVED			PRELIMINARY AERODYNAMIC ANALYSIS	REPORT NO 111.9

**CONFIDENTIAL**

Because of inlet losses and boundary layer effects, the  $V_1$  obtained from the equation does not agree with test data. The closest test point is about 7" above the blade tip. It will be necessary to use this point and assume that there will be no change in boundary layer or tip losses due to the increase or decrease in inlet velocity.

$$\Delta C_L = \frac{5.73V_1}{\Omega R} \left[ 1 - \cos \epsilon \pm \frac{V_1 \sin 2\epsilon}{2\Omega R} \right] \quad \text{from determination of maximum blade lift coefficient.}$$

We are interested in the change in inflow over the duct lip,  $\therefore$  it is the tip radius we are to consider.

$$\Delta C_L = \frac{5.73V_1}{\Omega R} \left[ 1 - \cos \epsilon \pm \frac{V_1 \sin 2\epsilon}{2\Omega R} \right]$$

Assume  $V_1 = 140$  ft/sec.,  $\Omega R = 683$  and  $R = 2.5$  ft.

$$\Delta V_1 = \frac{683}{\left[ \frac{11.56}{(1 - \cos \epsilon \pm .1025 \sin 2\epsilon)} - 1 \right]^{1/2}}$$

The duct lift  $L_D = \Delta P A$ , where  $\Delta P = P_T - P$

and  $P_T = P + q$

$\therefore P_T - P = q = \Delta P$

$$A = \pi D \left( \frac{2\theta}{360} \right) (b)(1) = \frac{\pi (.75\theta)}{36} = .0655\theta$$

$$\text{Moment arm} = \left[ \left( R + \frac{b}{2} \right) + \left( R + \frac{b}{2} \right) \cos \theta \right] \frac{1}{2}$$

$$b = 8" = .75' \quad R = 2.5'$$

$$A = .0655\theta \quad (\theta \text{ in degrees})$$

$$\text{Moment arm} = 1.4375(1 + \cos \theta)$$

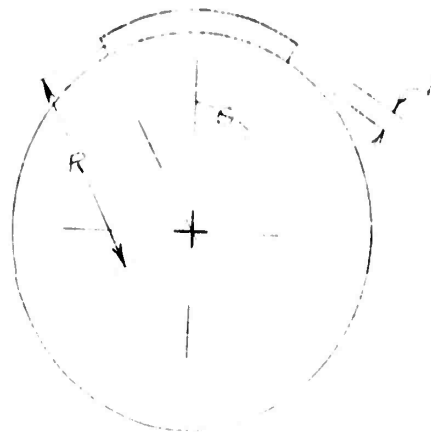

**CONFIDENTIAL**

PREPARED	NAME A. Morse	DATE 6-15-56	HILLER HELICOPTERS	PAGE 13
CHECKED			TITLE PRELIMINARY AERODYNAMIC ANALYSIS	MODEL 1031A
APPROVED				REPORT NO 114.9

**CONFIDENTIAL**

$$\Delta M = .0942 \Delta q \theta (1 + \cos \theta) = .0942 \Delta q \theta (1 + \cos \theta) \quad (\theta \text{ in degrees})$$

$$\Delta q = \rho/2 \Delta v_1^2 = 1.189 \Delta v_1^2 (10^{-3}) \quad \text{Sea Level}$$

**CONFIDENTIAL**

PREPARED	NAME A. Morse	DATE 6-15-56	HILLER HELICOPTERS	PAGE 14
CHECKED			TITLE PRELIMINARY AERODYNAMIC ANALYSIS	MODEL 1031A
APPROVED				REPORT NO 114.9

**CONFIDENTIAL**

III. CHANGE IN PROPELLER BLADE LIFT COEFFICIENT

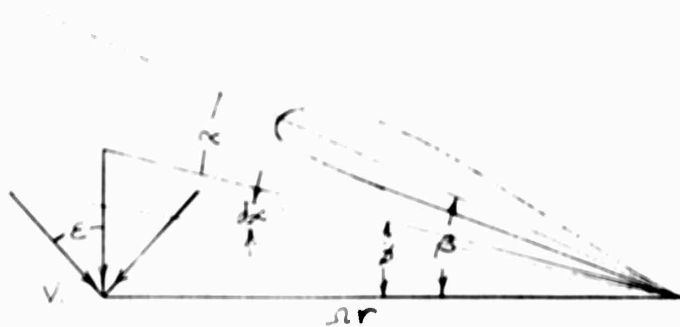

$$\tan \phi = \frac{V_1}{\Omega r}$$

$$\tan \phi - d\alpha = \frac{V_1 \sin(90 + \epsilon)}{\Omega r - V_1 \cos(90 + \epsilon)}$$

$$\therefore -d\alpha = \tan \phi - d\alpha - \tan \phi = \frac{V_1 \sin(90 + \epsilon)}{\Omega r - V_1 \cos(90 + \epsilon)} - \frac{V_1}{\Omega r}$$

$$\begin{aligned} d\alpha &= \frac{V_1}{\Omega r} - \frac{V_1 \sin(90 + \epsilon)}{\Omega r - V_1 \cos(90 + \epsilon)} = \frac{V_1}{\Omega r} \left[ \frac{V_1 \sin(90 + \epsilon)}{\Omega r \left[ 1 - \frac{V_1}{\Omega r} \cos(90 + \epsilon) \right]} \right] \\ &= \frac{V_1}{\Omega r} \left\{ 1 - \frac{\sin(90 + \epsilon)}{\left[ 1 - \frac{V_1}{\Omega r} \cos(90 + \epsilon) \right]} \right\} \end{aligned}$$

but  $\sin(90 + \epsilon) = +\cos \epsilon$

and  $\cos(90 + \epsilon) = -\sin \epsilon$

**CONFIDENTIAL**

PREPARED	NAME A. Morse	DATE 6-15-56	HILLER HELICOPTERS	PAGE 15
CHECKED			TITLE: PRELIMINARY AERODYNAMIC ANALYSIS	MODEL 1031A
APPROVED				REPORT NO 111.9

**CONFIDENTIAL**

$$da = \frac{V_1}{\Omega r} \left[ 1 - \frac{\cos \epsilon}{\left(1 + \frac{V_1}{\Omega r} \sin \epsilon\right)} \right]$$

$$\frac{dC_L}{da} = 5.73 \quad da \left( \frac{dC_L}{da} \right) = dC_L$$

$$dC_L = \frac{5.73V_1}{\Omega r} \left[ 1 - \frac{\cos \epsilon}{\left(1 + \frac{V_1}{\Omega r} \sin \epsilon\right)} \right]$$

but  $\frac{V_1}{\Omega r} \sin \epsilon \ll 1.0$

$$\therefore dC_L = \frac{5.73V_1}{\Omega r} \left[ 1 - \cos \epsilon \left( 1 + \frac{V_1}{\Omega r} \sin \epsilon \right) \right]$$

$$dC_L = \frac{5.73V_1}{\Omega r} \left[ 1 - \cos \epsilon + \frac{V_1}{2\Omega r} \sin 2\epsilon \right]$$

The maximum change in  $C_L$  will be at the radius where  $V_1/\Omega r$  is a maximum; but

$$V_1 = \frac{\Omega r}{\left(\frac{1}{C_L \sigma} - 1\right)^{1/2}}$$

$$\therefore \frac{V_1}{\Omega r} = \frac{1}{\left(\frac{1}{C_L \sigma} - 1\right)^{1/2}}$$

**CONFIDENTIAL**

PREPARED	NAME A. Morse	DATE 6-15-56	HILLER HELICOPTERS	PAGE
CHECKED			TITLE PRELIMINARY AERODYNAMIC ANALYSIS	MODEL 1031A
APPROVED				REPORT NO. 111.9

CONFIDENTIAL

DUCT MOMENT

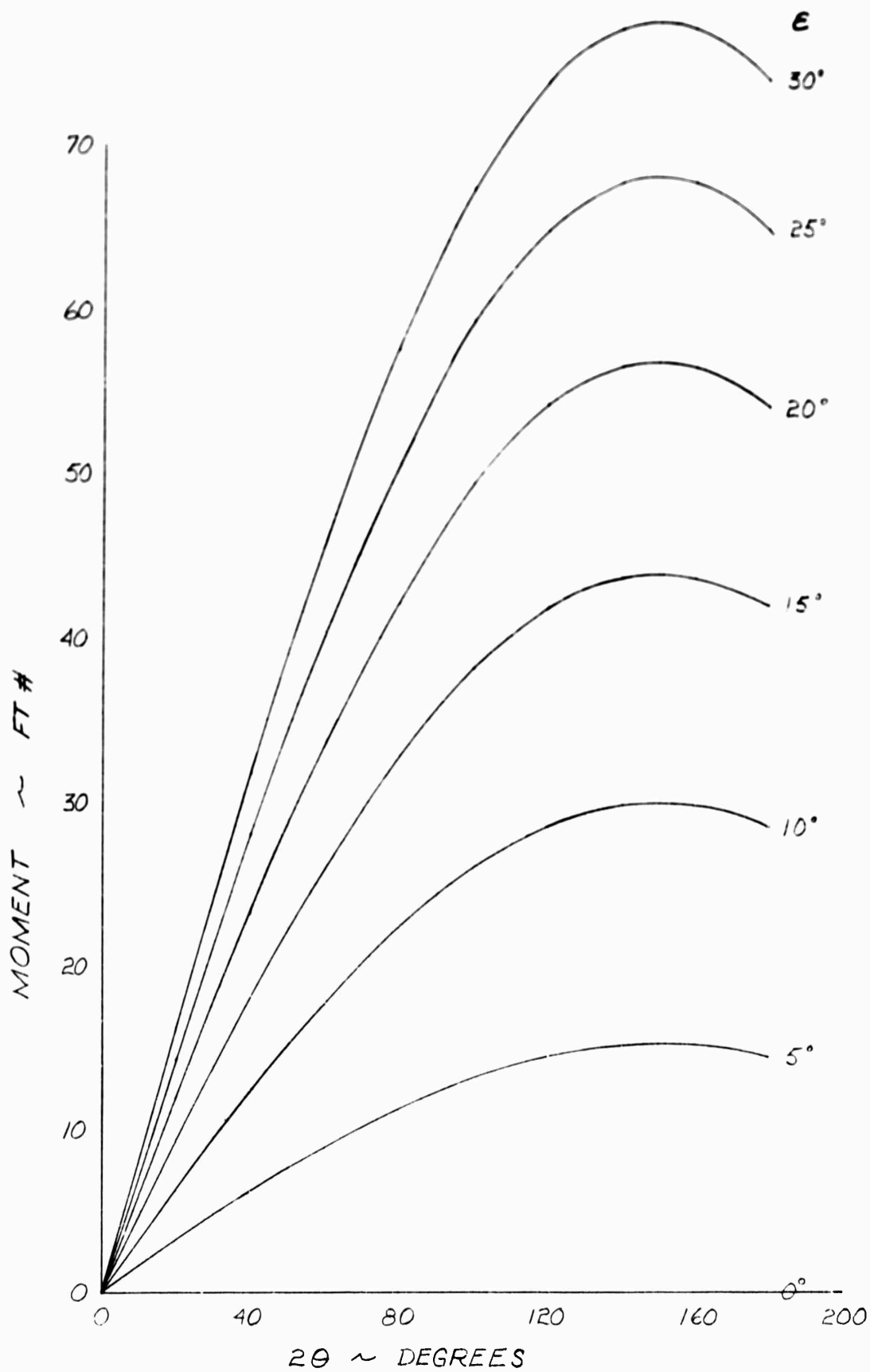

PREPARED	NAME A. Morse	DATE 6-15-56	HILLER HELICOPTERS	PAGE 16
CHECKED			TITLE PRELIMINARY AERODYNAMIC ANALYSIS	MODEL 1032A
APPROVED				REPORT NO 114.9

**CONFIDENTIAL**

At  $r/R = .5$ ,  $C_L$  reaches a maximum value of  $C_{L5} = .76$ .

$$\therefore \frac{V_1}{V_2} = \frac{1}{.5 \left( \frac{6.78}{C_L} - 1 \right)^2} = \frac{1}{(8.92 - 1)^2} = \frac{1}{7.815} = .365$$

$$dC_L = 5.73(.365) \left( 1 - \cos \epsilon \pm \frac{.365}{2} \sin 2\epsilon \right)$$

and  $C_L + dC_L = 1.2_{\max}$

$$\therefore dC_L = 1.2 - .76 = .44_{\max}$$

$$.44 = 5.73(.365) \left( 1 - \cos \epsilon \pm .1825 \sin 2\epsilon \right)$$

$$.2105 = \left( 1 - \cos \epsilon \pm .1825 \sin 2\epsilon \right)$$

$$-.7895 = -\cos \epsilon \pm .1825 \sin 2\epsilon$$

**CONFIDENTIAL**

PREPARED	NAME A. Morse	DATE 6-15-56	HILLER HELICOPTERS	PAGE 17
CHECKED			TITLE PRELIMINARY AERODYNAMIC ANALYSIS	MODEL 1031A
APPROVED				REPORT NO 114.9

**CONFIDENTIAL**

IV. DECREASE IN HOVER PERFORMANCE DUE TO INSTALLATION  
OF PROPELLER INLET GUIDE VANES



$$L = C_L q A_s$$

$$L = F \quad \text{and} \quad A_s = ch$$

$$F = W/g dV = W/g V_1 \sin \epsilon$$

$$\frac{W}{g} V_1 \sin \epsilon = \rho V_1^2 A_s \sin \epsilon = \rho V_1^2 l h \sin \epsilon$$

$$C_L q A_s = \frac{C_L}{2} \rho V_1^2 ch$$

$$\frac{C_L}{2} \rho V_1^2 ch = \rho V_1^2 l h \sin \epsilon$$

$$l = \frac{C_L c}{2 \sin \epsilon}$$

$$\frac{l}{c} = \frac{C_L}{2 \sin \epsilon}$$

**CONFIDENTIAL**

PREPARED	NAME A. Morse	DATE 6-15-56	HILLER HELICOPTERS	PAGE 18
CHECKED			TITLE PRELIMINARY AERODYNAMIC ANALYSIS	MODEL 1031A
APPROVED				REPORT NO 114.9

**CONFIDENTIAL**

The total vane area required can be found from the force produced.

$$F = \frac{\rho V_1^2 D^2 \sin \epsilon}{2} \left( \theta - \frac{\sin 2\theta}{2} \right)$$

but

$$F = L = \frac{C_L \rho V_1^2 A_s}{2}$$

$$\therefore A_s = \frac{D^2 \sin \epsilon}{C_L} \left( \theta - \frac{\sin 2\theta}{2} \right)$$

This is the vane area required when the maximum  $C_L$  and  $\sin \epsilon$  are used. To this the supporting strut will have to be added, which has a length of  $4R \sin \theta$ . If a chord length for the supporting strut of  $4/12$  foot is assumed:

$$A_s = \frac{D^2 \sin \epsilon}{C_L} \left( \theta - \frac{\sin 2\theta}{2} \right) + 1.333 R \sin \theta$$

$$\Delta f = \frac{C_D A}{\pi D^2 / 4} = \frac{C_D A}{\pi R^2}$$

$$\Delta f = \frac{4 C_D \sin \epsilon}{C_L \pi} \left( \theta - \frac{\sin 2\theta}{2} \right) + \frac{1.333 C_D \sin \theta}{\pi R}$$

$$\Delta f = \frac{4 C_D}{\pi} \left[ \frac{\sin \epsilon}{C_L} \left( \theta - \frac{\sin 2\theta}{2} \right) + \frac{.334 \sin \theta}{R} \right]$$

**CONFIDENTIAL**

PREPARED	NAME A. Morse	DATE 6-15-56	HILLER HELICOPTERS	PAGE 19
CHECKED			TITLE PRELIMINARY AERODYNAMIC ANALYSIS	MODEL 1031A
APPROVED				REPORT NO 114.9

**CONFIDENTIAL**

From Hiller Report 120.5 and the condition of zero forward speed.

$$l_p = \frac{4.92 \eta_p^2}{W_p (1+f)^2}$$

$$w_D = \frac{29.18 P_o \eta_p W_p}{T_o (1+f)}$$

$$\therefore l_p = \frac{26.6 \eta_p}{(1+f)} \left( \frac{P_o}{T_o w_D} \right)^{\frac{1}{2}}$$

and 
$$\Delta l_p = 26.6 \eta_p \left( \frac{P_o}{T_o w_D} \right)^{\frac{1}{2}} \left[ \frac{1}{(1+f_2)} - \frac{1}{(1+f_1)} \right]$$

but 
$$1+f_1 = 1.05 \quad \text{and} \quad (1+f_2) = (1+f_1 + \Delta f)$$

$$\therefore f_1 \text{ and } f_2 \ll 1.0$$

$$\Delta l_p = 26.6 \eta_p \left( \frac{P_o}{T_o w_D} \right)^{\frac{1}{2}} \left[ (1-f_1 - \Delta f) - (1-f_1) \right]$$

$$\Delta l_p = 26.6 \eta_p \left( \frac{P_o}{T_o w_D} \right)^{\frac{1}{2}} (-\Delta f)$$

$$\Delta l_p = -26.6 \eta_p \left( \frac{P_o}{T_o w_D} \right)^{\frac{1}{2}} \frac{4C_D}{\pi} \left[ \frac{\sin \epsilon}{C_L} \left( \theta - \frac{\sin 2\theta}{2} \right) + \frac{.334}{R} \sin \theta \right]$$

**CONFIDENTIAL**

PREPARED	NAME A. Morse	DATE 6-15-56	HILLER HELICOPTERS	PAGE 20
CHECKED			TITLE PRELIMINARY AERODYNAMIC ANALYSIS	MODEL 1031A
APPROVED				REPORT NO 114.9

**CONFIDENTIAL**

Constants used:

$$\begin{aligned} \eta_p &= .75 \\ w_D &= 29.0 \\ P_o/T_o &= 4.075 \\ C_D &= .015 + \text{interference} \\ &= .028 \\ C_{L_{max}} &= 1.10 \end{aligned}$$

$$\Delta l_p = -.2665 \left[ \frac{\sin \epsilon}{C_L} \left( \theta - \frac{\sin 2\theta}{2} \right) - .0356 \sin \theta \right]$$

$$\Delta l_p = -.2425 \sin \epsilon \left( \theta - \frac{\sin 2\theta}{2} \right) - .0356 \sin \theta$$

**CONFIDENTIAL**

PREPARED	NAME A. Morse	DATE 6-15-56	HILLER HELICOPTERS	PAGE
CHECKED			TITLE PRELIMINARY AERODYNAMIC ANALYSIS	MODEL 1031A
APPROVED				REPORT NO 114.9

CONFIDENTIAL

VANE CAPABILITY AS A  
FUNCTION OF HOVER  
REVERSE ANGLE

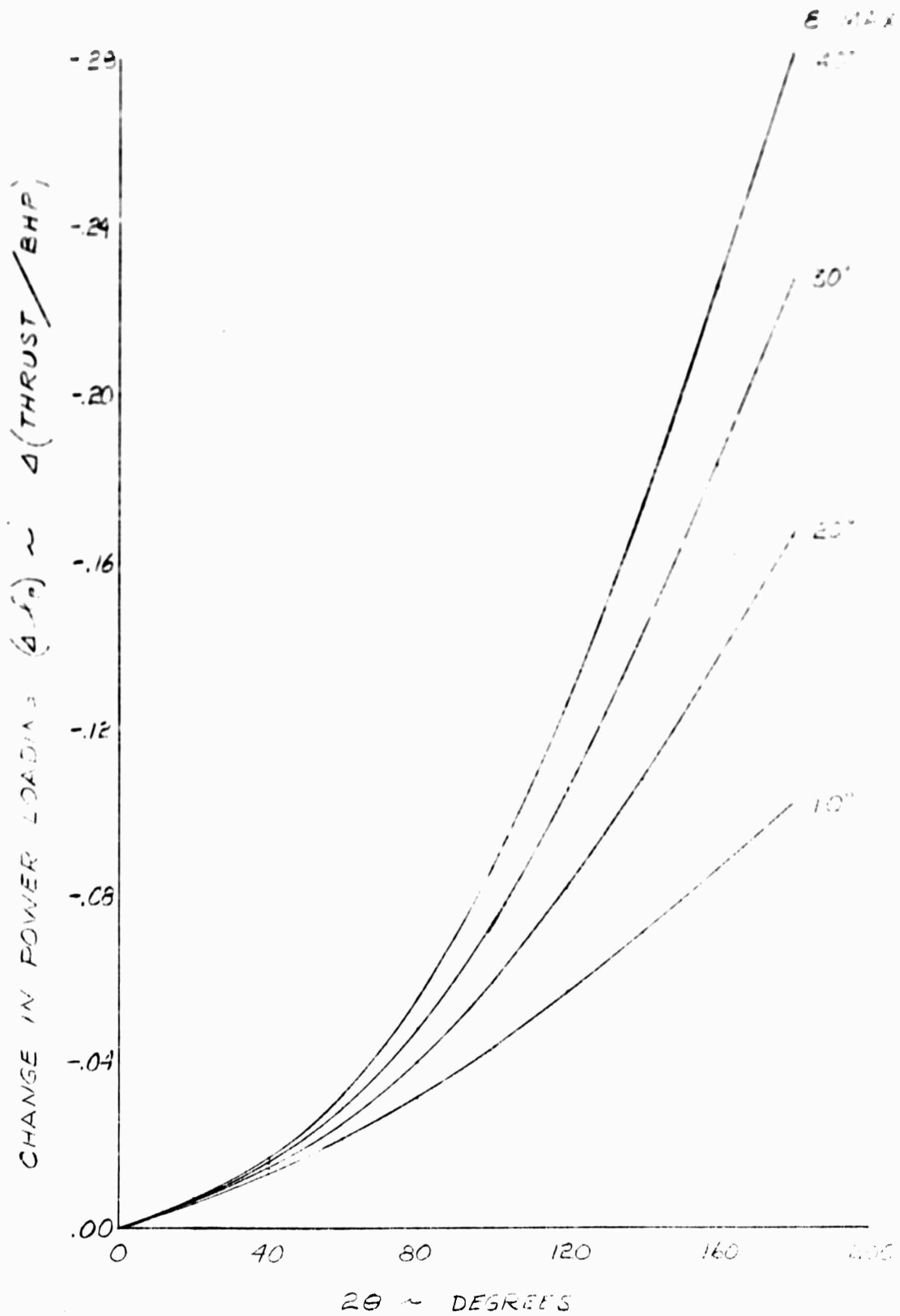

CONFIDENTIAL

PREPARED	NAME A. Morse	DATE 6-15-56	HILLER HELICOPTERS	PAGE 21
DESIGNED			TITLE PRELIMINARY AERODYNAMIC ANALYSIS	MODEL 1031A
APPROVED				REPORT NO 114.9

**CONFIDENTIAL**

V. INCREASE IN PARASITE POWER DUE TO DEFLECTION OF  
PROPELLER INLET GUIDE VANES

$$rhp = \left[ \frac{\sigma A_F \rho C_{D_0} V_T^3}{4400} \right] K = \frac{\sigma A_F \rho V_T^3 K C_{D_0}}{4400}$$

There is a change in drag coefficient associated with the change in lift coefficient.

$$C_{D_0} = \delta_0 + \delta_2 a_r^2 \quad \text{and} \quad da_r = \frac{dC_L}{a} = \frac{dC_L}{5.73}$$

$$C_{D_0} = \delta_0 + \frac{\delta_2 dC_L^2}{32.85}$$

$$\therefore drhp = \frac{\sigma A_F \rho V_T^3 K}{4400} \left( \frac{\delta_2 dC_L^2}{32.85} \right) \quad \delta_2 = .3$$

$$drhp = \frac{\sigma A_F \rho V_T^3 K}{4400} (.9125 \times 10^{-2} dC_L^2)$$

From the determination of the blade lift coefficient -

$$\begin{aligned} dC_L &= \frac{5.73 V_1}{\Omega r} \left[ 1 - \cos \epsilon \pm \frac{V_1}{2\Omega r} \sin 2\epsilon \right] \\ &= \frac{5.73}{\left( \frac{1}{C_L \sigma} - 1 \right)} \left[ 1 - \cos \epsilon \pm \frac{1}{2 \left( \frac{1}{C_L \sigma} - 1 \right)} \sin 2\epsilon \right] \end{aligned}$$

**CONFIDENTIAL**

PREPARED	NAME A. Morse	DATE 6-15-56	HILLER HELICOPTERS	PAGE 22
CHECKED			TITLE PRELIMINARY AERODYNAMIC ANALYSIS	WORD 1031A
APPROVED				REPORT NO 114.9

**CONFIDENTIAL**

$$dC_L^2 = \frac{32.85}{\left(\frac{1}{C_L \sigma} - 1\right)} \left[ 1 - \cos \epsilon \pm \frac{\sin 2\epsilon}{2\left(\frac{1}{C_L \sigma} - 1\right)^{3/2}} \right]^2$$

$$drhp = \frac{0.3 \lambda_P \rho V_T^3 K}{4400} \cdot \frac{32.85}{\left(\frac{1}{C_L \sigma} - 1\right)} \left[ 1 - \cos \epsilon \pm \frac{\sin 2\epsilon}{2\left(\frac{1}{C_L \sigma} - 1\right)^{3/2}} \right]^2$$

$$= \frac{.30 \lambda_P \rho V_T^3 K}{4400 \frac{1}{C_L \sigma} - 1} \left[ 1 - \cos \epsilon \pm \frac{\sin 2\epsilon}{2\left(\frac{1}{C_L \sigma} - 1\right)^{3/2}} \right]^2$$

Constants: (existing platform)

$$\sigma = .1475$$

$$C_{L_{av}} = .55$$

$$A. = 17.22$$

$$K = 1.05$$

$$\rho = 2.378(10^{-3})$$

$$\left(\frac{1}{C_L \sigma} - 1\right) = 11.33$$

$$V_T = 683$$

$$V_T^3 = 3.185(10^8)$$

$$d(rhp) = 12.13 \left[ 1 - \cos \epsilon \pm \frac{\sin 2\epsilon}{6.725} \right]^2$$

**CONFIDENTIAL**