

UNCLASSIFIED

AD NUMBER

AD119366

LIMITATION CHANGES

TO:

Approved for public release; distribution is unlimited.

FROM:

Distribution authorized to U.S. Gov't. agencies and their contractors;
Administrative/Operational Use; 31 DEC 1956.
Other requests shall be referred to Office of Naval Research, Arlington, VA 22203.

AUTHORITY

ONR ltr 28 Jul 1977

THIS PAGE IS UNCLASSIFIED

**THIS REPORT HAS BEEN DELIMITED
AND CLEARED FOR PUBLIC RELEASE
UNDER DOD DIRECTIVE 5200.20 AND
NO RESTRICTIONS ARE IMPOSED UPON
ITS USE AND DISCLOSURE.**

DISTRIBUTION STATEMENT A

**APPROVED FOR PUBLIC RELEASE;
DISTRIBUTION UNLIMITED.**

UNCLASSIFIED

AD 119366

Armed Services Technical Information Agen

Reproduced by

DOCUMENT SERVICE CENTER

KNOTT BUILDING, DAYTON, 2, OHIO

This document is the property of the United States Government. It is furnished for the duration of the contract and shall be returned when no longer required, or upon recall by ASTIA to the following address: Armed Services Technical Information Agency, Document Service Center, Knott Building, Dayton 2, Ohio.

NOTICE: WHEN GOVERNMENT OR OTHER DRAWINGS, SPECIFICATIONS OR OTHER DATA ARE USED FOR ANY PURPOSE OTHER THAN IN CONNECTION WITH A DEFINITELY RELATED GOVERNMENT PROCUREMENT OPERATION, THE U. S. GOVERNMENT THEREBY INCURS NO RESPONSIBILITY, NOR ANY OBLIGATION WHATSOEVER; AND THE FACT THAT THE GOVERNMENT MAY HAVE FORMULATED, FURNISHED, OR IN ANY WAY SUPPLIED THE SAID DRAWINGS, SPECIFICATIONS, OR OTHER DATA IS NOT TO BE REGARDED BY IMPLICATION OR OTHERWISE AS IN ANY MANNER LICENSING THE HOLDER OR ANY OTHER PERSON OR CORPORATION, OR CONVEYING ANY RIGHTS OR PERMISSION TO MANUFACTURE OR SELL ANY PATENTED INVENTION THAT MAY IN ANY WAY BE RELATED THERETO.

UNCLASSIFIED

AD No 119366
ASTIA FILE COPY

STRATO-LAB DEVELOPMENT

FEDERAL BUREAU OF INVESTIGATION

MAY, 1954

CONTRACT NO. N6-119366

GENERAL MILLS, INC.
MECHANICAL DIVISION

Headquarters: 1000 ...
... ..

Mechanical Division of
GENERAL MILLS, INC.
Engineering, Research and Development
2003 East Hennepin Avenue
Minneapolis 13, Minnesota

STRATO-LAB DEVELOPMENT

by

R. L. Schwoebel

FINAL TECHNICAL REPORT
Contract No. NONR 1589(06)
May 4, 1955 to November 12, 1956

"Reproduction in whole or in part is permitted for
any purpose of the United States Government"

Submitted by H. E. Froehlich
H. E. Froehlich
Head, Geophysics Section

Approved by O. M. Stuetzer
O. M. Stuetzer, Manager
Physics and Chemistry Research

Report No. 1648
Date: 31 December 1956
Project: 85031

ABSTRACT

A theoretical study of currently used polyethylene film balloon types was made to evaluate their possible use for Project Strato-Lab. The study showed that the use of any of the general class of polyethylene cylinder balloons for gross loads exceeding 2,000 lb is not completely satisfactory due to the presence of high film stresses in upper areas of the cell. The use of Mylar as a balloon barrier film extends the load capabilities of cylinder-type balloons, but its use in this application is dependent on the development of refined fabrication techniques. A tape-reinforced balloon, investigated in the course of this study as a possible heavy load vehicle, is discussed.

The scientific value of the Strato-Lab System hinged on the provision of an environment which did not impede the normal functions of the gondola occupants. Accordingly, a pressurized gondola was chosen to provide an artificial atmosphere. A desiccant system utilizing LiCl and LiOH was developed to provide a partial pressure of carbon dioxide not exceeding 6 mm of Hg and a relative humidity not exceeding 50 per cent at a temperature of 50°F. An oxygen supply and gondola pressure maintenance system was designed to maintain a minimum pressure of 380 mm of Hg and a minimum oxygen partial pressure of 110 mm of Hg. The operating characteristics of this atmospheric maintenance system were evaluated by a series of five chamber tests.

The gondola was equipped with instrumentation to indicate and/or record such flight data as altitude, gondola pressure, oxygen and carbon dioxide partial pressure and the vertical speed of the balloon. Included also was a specially designed multi-channel communications link capable of receiving on 6.7005, 6.425, 122.8 and 121.5 megacycles and of voice transmissions on 1.724, 1.742, 122.8 and 121.5 megacycles.

To determine the characteristic vertical dynamics of the Strato-Lab system in the stratosphere, two radio-controlled balloon flights were conducted. Data obtained from these flights do not agree with the theoretical prediction of the variance of descent speed with the fractional heaviness of the system.

A cargo type parachute, utilized as an alternate mode of descent, was released at an altitude of 38,500 ft loaded with an equivalent gondola mass. The resultant deceleration of this mass was recorded graphically and indicated, as did data from other experiments at different altitudes, that the peak deceleration never exceeded 3.5 g's and that this force was apparently independent of altitude.

The culminating effort of this development was a personnel flight to a maximum altitude of 76,000 ft. The flight was prematurely terminated by a malfunctioning balloon valve.

TABLE OF CONTENTS

	<u>Page</u>
INTRODUCTION	1
STRATO-LAB SYSTEM CONCEPT	2
STRATO-LAB SYSTEM COMPONENTS	4
Balloon	4
The 128TT Balloon	4
New Balloon Designs	16
A Method of Reinforcement	21
Mylar Balloons	29
Selection and Modification of the 128TT Balloon	32
Balloon Construction and Subsequent Inflation Tests	34
Balloon Gas Valve	37
Parachute	47
Gondola	53
Atmospheric Requirements	53
Aeroembolism	61
Summary	61
Description of the Atmospheric Maintenance System	63
Pressure	63
Oxygen Supply	65
Measurement and Recording of Oxygen Level	72
Carbon Dioxide Removal System	76
Measurement and Recording of Carbon Dioxide Level	78
Water Vapor Removal System	81
Test of the Atmospheric Maintenance System	83
Preliminary Chamber Test	87

TABLE OF CONTENTS (CONT.)

	<u>Page</u>
Sea Level Test	88
Final Chamber Tests	93
Gondola Electrical Systems	110
Power Sources	110
Control Panels	112
Climate Controls	114
Balloon Valve System	115
Ballast Valve System	118
Data Panel	120
Camera and Flash Tube	120
Thermistor System	121
Flight Termination System	121
Communications Systems	125
Intercom System	125
VHF Unit	126
LF-HF Unit	129
Recommendations for Future Electrical and Communications Systems	131
FLIGHT SIMULATION	142
Radio Control Flights	142
Parachute Test Flight	148
"Programmer" Flights	148
FIRST STRATO-LAB PERSONNEL FLIGHT	153
Strato-Bowl, Rapid City, South Dakota	153
Pre-flight Preparations	155

TABLE OF CONTENTS (CONT.)

	<u>Page</u>
Launching of the Strato-Lab Flight	155
Strato-Lab Flight Data	159
REFERENCES	165
ACKNOWLEDGEMENTS	167
APPENDIX	

LIST OF ILLUSTRATIONS

<u>Figure</u>		<u>Page</u>
1	Launching of Project Stratolab Personnel Flight, 11/8/56	5
2	Natural Shape Balloon Profile	8
3	Calculated Stress Distribution for 128TT Balloon for Two Gross Loads	10
4	Maximum Film Stress for 128TT While in a Vertical Position at Sea Level as a Function of Gross Lift	12
5	Film Stress as a Function of Relative Pressure at Balloon's Base	13
6	Platform Bubble Gore Length	15
7	Relative Stress in Polyethylene Cylinder Balloons	17
8	Pictorial Indicating the Tendency of Tapes to Separate from Balloon Wall at Low Relative Volumes	19
9	Calculated Film Stress in Two Natural Shaped Polyethylene Balloons Without Excess Material or Reinforcing Members	20
10	Plot of a Derived Curve Compared to a Parabola & Catenary	26
11	Method for Utilization of Reinforcing Technique in Upper Section of Balloon	27
12	Fraction of Ultimate Strength Obtainable from a Plastic Sheet Which Has a Section of Width, W, Shortened by a Factor	33
13	Modified Top Fitting Installed in 128TT Balloon Prior to Test Inflation	35
14	Orientation of Modified Top Fitting During the Low Stages of Balloon Inflation	36
15	128TT Balloon Inflated to Relative Volume of Approximately 0.3	38
16	128TT Balloon Just Prior to Burst	39
17	Fail Safe Helium Valve	41
18	Model EV-13 Electric Valve	42
19	Model Orifice Used to Determine Discharge Coefficients	43
20	Lift Gross Curve for 128TT Balloon with EV-13 Valve-Balloon Wt. 555 lbs.	46

LIST OF ILLUSTRATIONS (CONT.)

<u>Figure</u>		<u>Page</u>
21	Lift Gross Curve for 128TT Balloon With EV-13 Valve-Balloon Wt. 555 Lbs.	49
22	Descent Rate in Thousands of Feet per Minute	51
23	Approximate Free Fall Characteristics of Strato-Lab Gondola	52
24	Required Oxygen Partial Pressure in Alevolar Air	55
25	Oxygen Required Expressed as a Percent of the Inspired Air	57
26	Heat Loss by Radiation and Convection for Average Man	59
27	Evaporative Heat Loss for Average Man	60
28	Pictorial Drawing of Controller Valve	64
29	Controller and Toggle Valves	66
30	Pictorial Diagram of Pressurization-Oxygen System	67
31	Boiling of Oxygen from Open Mouthed Dewar	69
32	Complete Oxygen Pressurization Supply with Controlling and Monitoring Equipment	71
33	Pictorial of Recording Oximeter	74
34	Automatic Monitoring and Recording Oxymeter	75
35	Trays Containing LiOH (Left) and Sponges Carrying LiCl (Right)	77
36	Pictorial of Desiccant Container	79
37	Absorption of CO ₂ by LiOH	80
38	Thermco CO ₂ Analyzer Calibrations for Three Ambient Pressures	82
39	Mass of H ₂ O Absorbed per Unit Mass of Absorbent Per Unit Time at 50% Relative Humidity and 70-74°F	84
40	Comparison of Two Similar H ₂ O Removing Systems	85
41	LiCl Absorption of H ₂ O 75% Relative Humidity 18°C	86
42	Chamber Flight Test, Inyokern, California, 29 June 1956	89
43	Chamber Flight Test, Inyokern, California, 29 June 1956	90

LIST OF ILLUSTRATIONS (CONT.)

<u>Figure</u>		<u>Page</u>
21	Lift Gross Curve for 128TT Balloon With EV-13 Valve-Balloon Wt. 555 Lbs.	49
22	Descent Rate in Thousands of Feet per Minute	51
23	Approximate Free Fall Characteristics of Strato-Lab Gondola	52
24	Required Oxygen Partial Pressure in Alevolar Air	55
25	Oxygen Required Expressed as a Percent of the Inspired Air	57
26	Heat Loss by Radiation and Convection for Average Man	59
27	Evaporative Heat Loss for Average Man	60
28	Pictorial Drawing of Controller Valve	64
29	Controller and Toggle Valves	66
30	Pictorial Diagram of Pressurization-Oxygen System	67
31	Boiling of Oxygen from Open Mouthed Dewar	69
32	Complete Oxygen Pressurization Supply with Controlling and Monitoring Equipment	71
33	Pictorial of Recording Oximeter	74
34	Automatic Monitoring and Recording Oxymeter	75
35	Trays Containing LiOH (Left) and Sponges Carrying LiCl (Right)	77
36	Pictorial of Desiccant Container	79
37	Absorption of CO ₂ by LiOH	80
38	Thermco CO ₂ Analyzer Calibrations for Three Ambient Pressures	82
39	Mass of H ₂ O Absorbed per Unit Mass of Absorbent Per Unit Time at 50% Relative Humidity and 70-74°F	84
40	Comparison of Two Similar H ₂ O Removing Systems	85
41	LiCl Absorption of H ₂ O 75% Relative Humidity 18°C	86
42	Chamber Flight Test, Inyokern, California, 29 June 1956	89
43	Chamber Flight Test, Inyokern, California, 29 June 1956	90

LIST OF ILLUSTRATIONS (CONT.)

<u>Figure</u>		<u>Page</u>
		91
44	Sea Level Test 11 Oct. 1956	92
45	Sea Level Test 11 Oct. 1956	96
46	Hydrostatic Chamber Test I, 8 October 1956	97
47	Hydrostatic Chamber Test I, 8 October 1956	102
48	Hydrostatic Chamber Test II - 16 Oct. 1956	103
49	Hydrostatic Chamber Test II - 16 Oct. 1956	104
50	Hydrostatic Chamber Test - 16 Oct. 1956	107
51	Hydrostatic Chamber Test III - 26 Oct. 1956	108
52	Hydrostatic Chamber Test III - 26 Oct. 1956	111
53	Main Power Supply in Mounted Position Under Observer Seat	113
54	Pilot and Observer Control Panels	116
55	Cooling and Warming Fans	117
56	Gas Valve Circuit	119
57	Data Panel	122
58	Equipment Mounted Over Observer Panel	123
59	External Thermistor Wiring Diagram	124
60	Thermistor Wand and Mounting - Pressure Tight Electrical Fitting in Top of Gondola	127
61	Intercom and Communications Amplifier (Under Observer's Panel)	128
62	Intercommunications Amplifier Mounted Beneath Panel - VHF Skycrafters Transmitting-Receive	130
63	Battery Pack and Cable for VHF Unit - Schematic D	132
64	External & Internal View of Lf-HF Transceiver	133
65	Battery Pack and Cable for 6 _{Mc} Receivers - Schematic B	134
66	Composite Wiring Diagram	136
67	Rigid Support System	

LIST OF ILLUSTRATIONS (CONT.)

<u>Figure</u>		<u>Page</u>
44	Sea Level Test 11 Oct. 1956	91
45	Sea Level Test 11 Oct. 1956	92
46	Hydrostatic Chamber Test I, 8 October 1956	96
47	Hydrostatic Chamber Test I, 8 October 1956	97
48	Hydrostatic Chamber Test II - 16 Oct. 1956	102
49	Hydrostatic Chamber Test II - 16 Oct. 1956	103
50	Hydrostatic Chamber Test - 16 Oct. 1956	104
51	Hydrostatic Chamber Test III - 26 Oct. 1956	107
52	Hydrostatic Chamber Test III - 26 Oct. 1956	108
53	Main Power Supply in Mounted Position Under Observer Seat	111
54	Pilot and Observer Control Panels	113
55	Cooling and Warming Fans	116
56	Gas Valve Circuit	117
57	Data Panel	119
58	Equipment Mounted Over Observer Panel	122
59	External Thermistor Wiring Diagram	123
60	Thermistor Wand and Mounting - Pressure Tight Electrical Fitting in Top of Gondola	124
61	Intercom and Communications Amplifier (Under Observer's Panel)	127
62	Intercommunications Amplifier Mounted Beneath Panel - VHF Skycrafters Transmitting-Receive	128
63	Battery Pack and Cable for VHF Unit - Schematic D	130
64	External & Internal View of Lf-HF Transceiver	132
65	Battery Pack and Cable for 6 _{Mc} Receivers - Schematic B	133
66	Composite Wiring Diagram	134
67	Rigid Support System	136

LIST OF ILLUSTRATIONS (CONT.)

<u>Figure</u>		<u>Page</u>
68	Gondola Suspension Network	137
69	Perfect Shock Absorber Thickness Vs the Maximum Permissible Deceleration (in g units)	140
70	Radio Control Test Flight I	143
71	Experimental and Theoretical Comparison of Descent Rate	145
72	Radio Control Test Flight II	147
73	Parachute Test Flight	149
74	Automatic Flight Programmer	150
75	Strato-Bowl, Rapid City, S. D.	154
76	Surface Chart for 1230Z - November 8, 1956	157
77	Strato-Lab Personnel Flight I	161
78	The Strato-Bowl As Seen From the Eastern Edge	169
79	Lt. Cdr. M. L. Lewis and M. D. Ross with Strato-Lab Gondola -	170
80	The Vertically Inflated 128TT Prior to Launching the Strato-Lab System	171
81	The Strato-Lab Gondola at Its Landing Site	172

LIST OF TABLES

<u>Table</u>		<u>Page</u>
I	Weight Comparison of Taped and Tailored Tapeless Balloons for Two Hypothetical Designs	28
II	Comparison of the Mechanical Properties of Polyethylene and Mylar at 15°C	29
III	Physiological Reaction to Various Partial Pressures of Carbon Dioxide	58
IV	Human Output and Consumption of Oxygen, Carbon Dioxide and Water Vapor	62
V	Remarks on Hydrostatic Chamber Test I Conducted 8 October 1956	98
VI	Remarks on Hydrostatic Chamber Test II Conducted 16 October 1956	105
VII	Mass of Carbon Dioxide and Water Vapor Absorbed by Desiccants During Chamber Tests	109
VIII	Weight Summary for Strato-Lab Personnel Flight, 8 November 1956	156

INTRODUCTION

The purpose of this report is to record the technical progress on the Strato-Lab program within the General Mills' group.

General Mills, Inc. was initially contracted to "conduct research on the design, development, construction and flight testing of single and/or clusters of constant level balloons capable of carrying personnel or simulated loads of 1500 pounds or more into the stratosphere for extended periods." This research was to include the launching and descent of balloons, incorporating hangar and field tests with personnel or simulated loads. This work commenced on 15 April 1955.

During April, 1956, General Mills, Inc. began work to 'automate' the atmospheric maintenance system within the gondola. The project scope was further enlarged in July, 1956, when work concerning all phases of gondola function and design was initiated.

This work culminated in a personnel flight launched 8 November 1956 from the Strato-Bowl, Rapid City, South Dakota. This flight, piloted by Mr. M. D. Ross and Lt. Cdr. M. L. Lewis, attained a maximum altitude of 76,000 feet.

The work that took place during each phase of the Strato-Lab program overlaps to the extent that a chronological record of program progress would not be entirely satisfactory. Consequently this report is composed of separate discussions of the individual problem areas.

STRATO-LAB SYSTEM CONCEPT

The objective of the Strato-Lab Program was to provide a safe and convenient vehicle to carry scientists into the upper atmosphere. Because of the altitude and stability requirements of many of the experiments planned, a balloon was selected as the supporting device.

Balloons had been used on many occasions before for this type of scientific ascent. The first such ascents by scientific personnel were made shortly after construction of the first hot air balloons by the Montgolfiers in 1781. These flights were, of course, limited to lower altitudes.

Use of rubberized fabrics greatly extended balloon utility, and many manned flights were made with systems using the new fabrics. In 1935 the Explorer II, using rubberized cotton cloth as the balloon fabric, ascended to an altitude of approximately 72,000 feet. No manned stratospheric balloon flights were made after the Explorer II flight up to the time of the Strato-Lab flight.

In the early post-war years the Office of Naval Research initiated a program of plastic film balloon development. Its continued sponsorship, as well as that of the Air Force, of this activity brought about rapid changes in the whole concept of ballooning. Modern balloon technology has since extended altitude, payload and duration capabilities considerably beyond points long considered virtual limits. As a direct result of these newly extended capabilities the modern plastic balloon has found wide application in many phases of atmospheric physics. As new techniques of design, control and utilization are developed, many new applications are continually being found.

The Office of Naval Research, feeling that reliability and understanding of the plastic film balloon had been sufficiently advanced, planned an ex-

tended series of personnel flights well into the stratosphere. It was first planned to develop an intermediate altitude system to float at approximately 80,000 feet. This altitude was selected because it was well into the stratosphere and was within the reach of currently used balloon vehicles.

A project with similar objectives had been initiated in June, 1946 by the Office of Naval Research with Dr. Jean Piccard serving as principal scientist.¹ Plastic balloon technology had not advanced sufficiently at that time, however, to permit carrying out project plans. Work was terminated in April, 1947. Much was accomplished in the course of this program, however. One major accomplishment was the design and construction of an aluminum sphere to serve as the gondola. When work on this project was halted, the gondola shell was stored at Lakehurst, New Jersey. Following initiation of work on Project Strato-Lab, this gondola was selected as the vehicle for the first series of flights.

STRATO-LAB SYSTEM COMPONENTS

The Strato-Lab system consists of three basic components: (1) balloon; (2) parachute; and (3) gondola. Each of these components will be described in detail in succeeding sections of this report. The entire flight train may be seen in Figure 1, a photograph of the launching, 8 November 1956.

Balloon

Selection of a balloon for a given task depends on several factors. Two of these factors are: (1) desired altitude and (2) payload. Since Strato-Lab requirements called for an altitude of no less than 75,000 ft on the initial feasibility flight, and since payload weight was estimated to be approximately 1,800 lb, a minimum balloon size of approximately 700,000 to 800,000 cubic feet was necessary.

Although balloons of this volume and payload capacity were being fabricated and were in routine use at that time, it was felt initially that other balloon designs should be investigated in order to provide greater safety factors. A study was begun to survey this problem and to develop a suitable design for a heavy load vehicle. A new balloon design was not utilized, however. Choice of a balloon vehicle was made based primarily on its past flight record. This balloon was the 128TT balloon. It is discussed in some detail in succeeding paragraphs.

The 128TT Balloon - The 128TT balloon had been used on many flights up to the time of Strato-Lab and had proved to be on a comparative basis a fairly reliable balloon. The numeral "128" in its name is the diameter of the balloon in feet, and the "TT" signifies "tailored tapeless", simply a description of balloon style. The tailored tapeless balloon is a modification of the cylinder type balloon, in which part of the excess material in the



LAUNCHING OF PROJECT STRATOLAB
PERSONNEL FLIGHT, 8 NOVEMBER 1956

FIGURE 1

upper and lower sections of the balloon is removed and the central section is actually "tailored" to the fully inflated shape.² This particular construction is shown graphically in the gore pattern found in Table I in the Appendix. Information on duct size and location, inflation tube, balloon weight, dimensions, etc., is found in Table II in the Appendix.

The most important balloon parameters are, of course, the stresses placed on the film during the various phases of flight, i.e., inflation, launch, ascent, float and descent. Probably the simplest of these stresses to describe are those existing during the period when the system is floating at its ceiling altitude.

The shape of the balloon described by the shape factor, Σ , is determined by the following relation:

$$\Sigma = \left(\frac{2\pi}{L} \right)^{1/3} \frac{w}{(G/V)^{2/3}} \quad (1)$$

where:

- L = load on the balloon
- w = balloon material weight/unit area
- G = total weight of the entire system
- V = volume of the balloon

It is recognized, of course, that $V = f(\Sigma)$ and that a series of approximations must be made to arrive at the true value of Σ . It must also be noted that this Σ will be for a perfectly tailored balloon, which is not precisely the case here. The true value may be approximated if "w" is altered such that it corresponds to the total balloon weight divided by the tailored surface area. This will give a somewhat larger factor for "w" than the actual material weight.

The profile of the balloon shape for the particular case where:

$$L = 1800 \text{ lb}$$

$$w = 0.0139$$

$$G = 2400 \text{ lb}$$

$$V = 757,000 \text{ cu ft}$$

$$\Sigma = 0.098$$

is given in Figure 2. In Figure 2 it may be seen that the force being transmitted to the base of the balloon will be given by

$$F = L \sec \theta/2$$

or the force/unit length of material in the base of the balloon will be given by

$$f = \frac{L}{\ell} \sec \theta/2 \quad (2)$$

where ℓ is the circumferential length of material used in the lower apex.

Assuming for a moment that the balloon material is weightless, it can be stated that the total load going into the upper apex will be the same as that going into the lower. Since the balloon is not weightless, however, the load going into the upper apex will be greater by a factor involving the balloon weight. This can be described by the relation:

$$f = \frac{L \sec \theta/2 + p (G-L)}{2 \pi R} \quad (3)$$

where:

L = payload weight

p = dimensionless fraction describing the fraction of balloon weight below a point designated by the radius, R

R = radius of material at a given point

G = gross weight of entire system

θ = cone angle at base of balloon

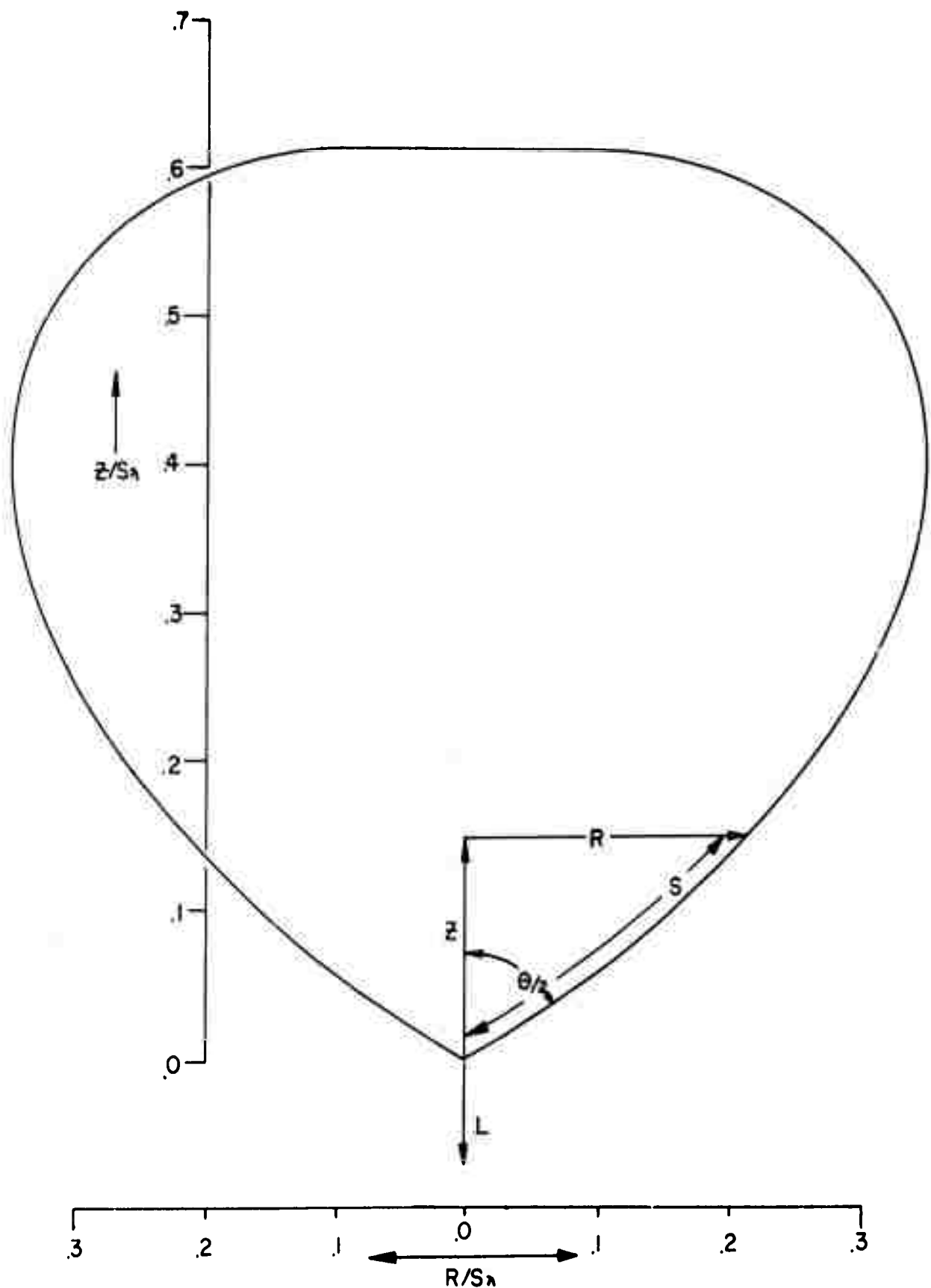
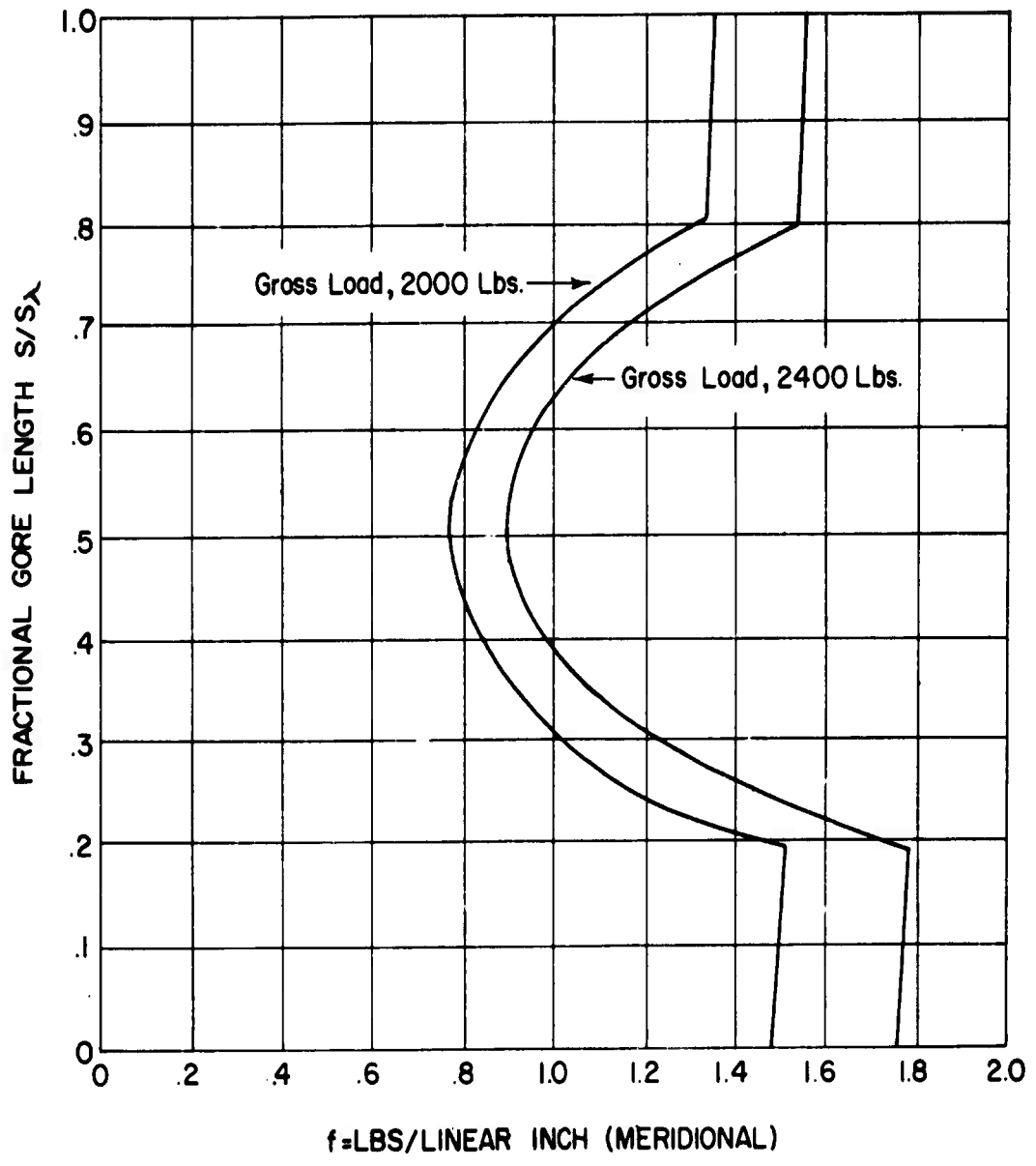

FIGURE - 2.
 NATURAL SHAPE BALLOON
 PROFILE : $\Sigma = .15$
 WHERE $S_{\lambda} = .1000$
 $\theta/2 = 57^{\circ}$
 FOR 128 TT $S_{\lambda} = 179$ FT.

It is recognized that this relation is only an approximation of the true case. Plotting this relation for the completely filled balloon, we have the curve shown in Figure 3. It can be seen from Figure 3 that this balloon with the intended gross load (~ 2,200 lb) would not go beyond the proportional limit of the material (see Table III). It is important to note, however, that this applies only to the case where the balloon is floating at its ceiling altitude and is completely inflated. Thus far only the completely inflated case has been considered. Let us now investigate the case of minimum volume, i.e., the inflated balloon at sea level. Since under this condition the total amount of material utilized in constraining the lifting gas is at a minimum, the stress over certain areas of the balloon is at a maximum.

When the balloon is filled with the proper amount of lifting gas, its occupied volume is significantly less than when it is at its ceiling altitude. In this particular case, the gas expands to roughly twenty-five times its original volume while expanding to its lowest pressure. Since the relative volume of the lifting gas is very small at sea level, it can be seen that certain areas of the balloon could be stressed to a greater degree than in the fully inflated case. With regard to the balloon at a relative volume of less than one, it has been postulated that only a fraction of the total material sustains this load, and, moreover, that the fraction of material is determined by the size of the bubble of gas within the balloon. There are many obvious arguments against the exactness of such a hypothesis, although it certainly can be used to express a lower limit of the amount of loaded material in the balloon wall. It might also be noted that calculations based on this hypothesis with regard to balloon failures during static inflations have been quite reliable.³



CALCULATED STRESS DISTRIBUTION FOR
I28TT BALLOON FOR TWO GROSS LOADS

FIGURE 3

It appears that the worst condition, from a stress standpoint, occurs when the balloon is at its lowest stage of relative inflation, or, in other words, just as it leaves the ground with something over 2,000 lb of gross lift. It is not inferred that this is generally true, but in this particular case the stress appears to be a maximum in specific areas of the balloon. Not only is the gross lift concentrated in a small volume, but the lift is accentuated slightly by the specified amount of free lift. In Figure 5 it can be seen that the stress factor (which is proportional to $\frac{\sec \theta/2}{R}$) is at a maximum when the pressure at the lower apex of the balloon is at its largest negative value. Theoretically, the pressure head at the balloon base for gross lifts ranging from 2,000 to 2,800 lb varies within about 5 per cent of -0.8 of the gore length. Assuming that the hypothesis is approximately correct, it can be seen that this is, indeed, the worst case. It should be borne in mind, however, that the temperatures encountered at sea level differ appreciably from those encountered by a completely inflated balloon in the stratosphere. Polyethylene does, of course, exhibit marked differences in elasticity at these two temperatures and one might expect some greater degree of plastic deformation and redistribution of the load while the balloon is at the higher temperatures in the troposphere.⁴

The computation of the film stresses while the balloon is in this particular orientation gives the result indicated in Figure 4. This result was obtained by assuming that (1) the gas bubble approximates a sphere and (2) the geometric circumference of the sphere is equivalent to the amount of gas sustaining the gross lift. Mathematically, this may be expressed as:

$$f = \frac{2}{3} (\beta)^{1/3} \left(\frac{3G}{4\pi} \right)^{2/3} \quad (4)$$

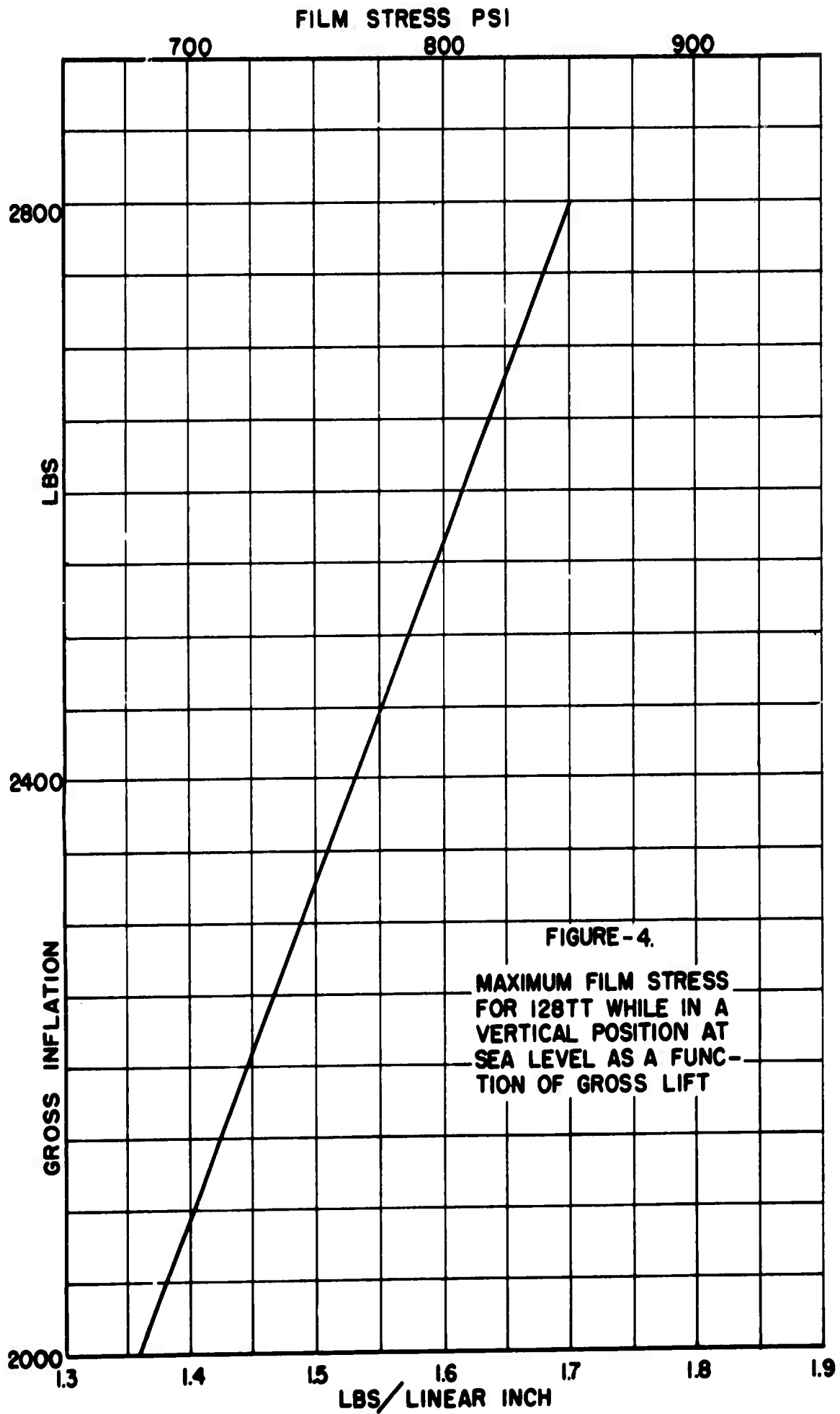
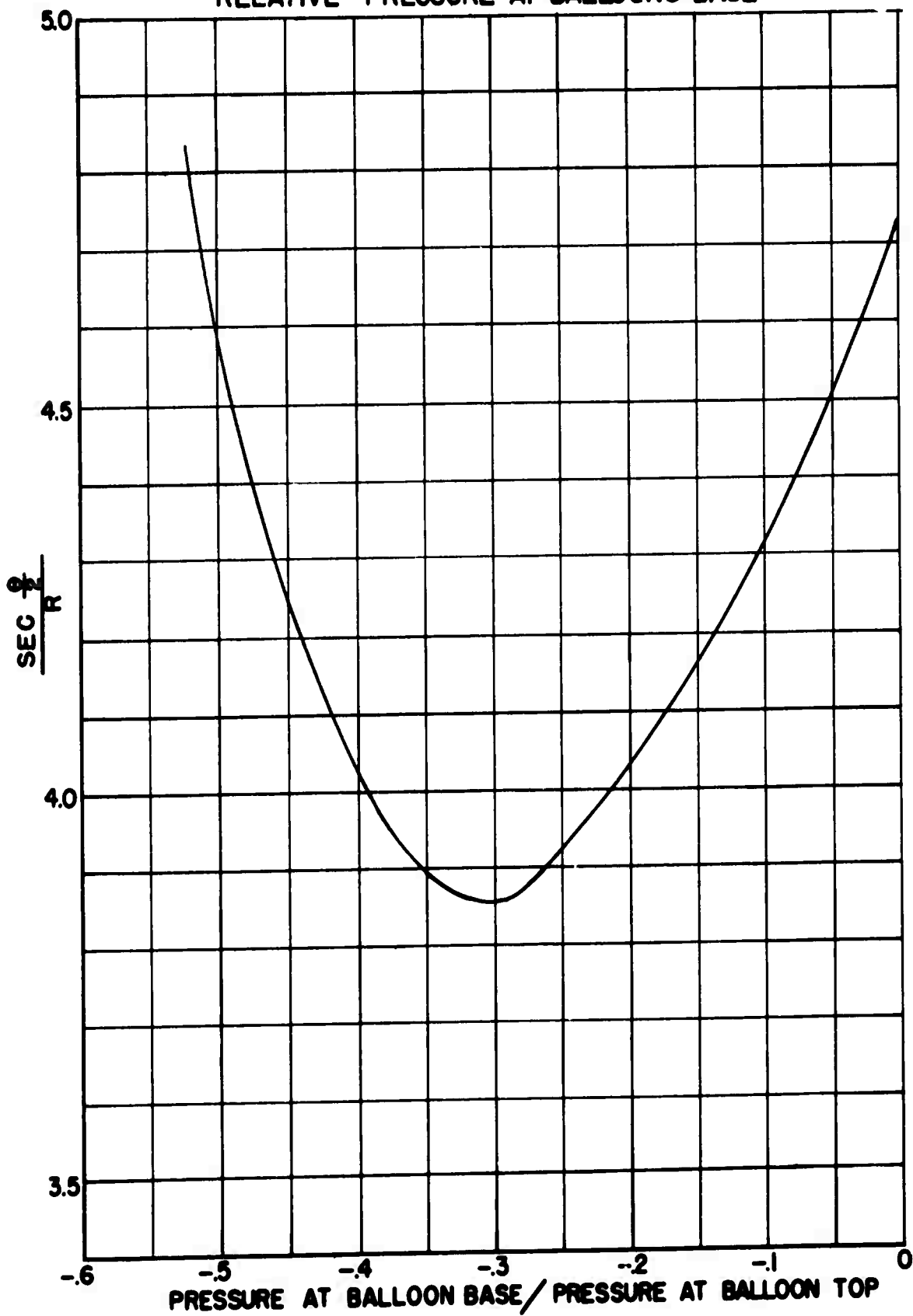

FIGURE - 4.

MAXIMUM FILM STRESS
FOR 128TT WHILE IN A
VERTICAL POSITION AT
SEA LEVEL AS A FUNC-
TION OF GROSS LIFT

FIGURE-5.
FILM STRESS AS A FUNCTION OF
RELATIVE PRESSURE AT BALLOON'S BASE



where: β = lift of the inflation gas in lb/cu ft at the altitude of launch site

G = gross lift of gas within the balloon

f = load in lb/ft of balloon material surrounding the bubble of gas

Another case in which the stresses should be defined is that related to the launch of a balloon with a platform system. One immediate problem in such a consideration is the configuration of the balloon within the constraining device. Since the constraint is a variable, in that the balloon can be located in any position in the platform, there must be an optimum location where stresses within the bubble are minimized.

Referring to Equation 3, and noting that G and L are constant, it can be seen that the quantity, $\frac{\sec \theta/2}{R}$, can be minimized to reduce, f , to its minimum value. Plotting this quantity as a function of the negative pressure head gives a result as shown in Figure 5. Figure 5 shows a minimum value occurring at a pressure head of -0.3 .² This means that a balloon is under a minimum meridional stress for a given inflation when the pressure at the balloon base is equivalent to -0.3 of the total head. For a platform-launched system the balloon should be oriented such that this condition is satisfied. It should be recognized, however, that this is true for an idealized case. No consideration has been given to such things as wind, etc. A plot showing the correct location of the balloon oriented in the platform to satisfy these conditions is shown in Figure 6.

It can be seen from the above that this particular balloon is not a completely satisfactory vehicle. Moreover, it can be shown that even this general class of current polyethylene cylinder balloons, whatever its ramification, i.e., tailored tapeless, is not wholly satisfactory regardless of

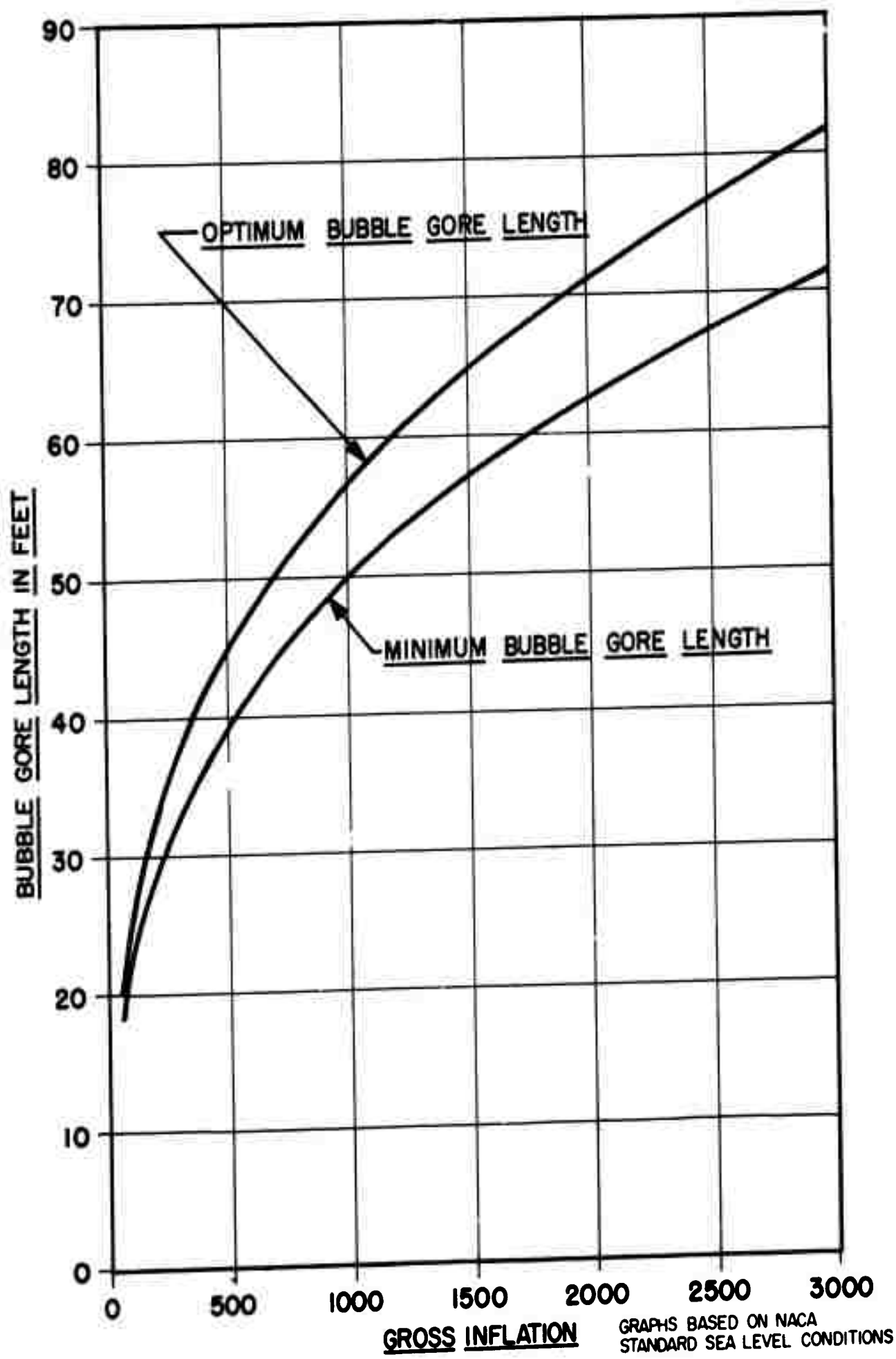

PLATFORM BUBBLE GORE LENGTH
 FIGURE-6.

the thickness of material used to provide strength. This can be demonstrated by considering Equation 4 and rewriting it as

$$G = \frac{4\pi}{3} \left(\frac{3f}{2\beta^{1/3}} \right)^{3/2} \quad (5)$$

Since f was defined as the load in pounds per linear foot of material, we can express this in terms of film stress, σ , and thickness, t . Doing this, we have:

$$G = \frac{4}{3}\pi \left(\frac{18\sigma t}{\beta^{1/3}} \right)^{3/2} \quad (6)$$

where:

σ = film stress in lb/in²

t = film thickness in inches

Using a value for β equivalent to the lift of one cubic foot of He at an altitude of 1,000 ft,⁴ we obtain

$$G = 1260 (\sigma t)^{3/2} \quad (7)$$

which has been expressed in Figure 7 for 1, 1.5 and 2 mil polyethylene material. Although the stresses, as determined by these methods, do not necessarily exceed the capabilities of polyethylene, they are sufficient to justify close consideration of other designs possibly more suitable for this particular application. General Mills began a study, therefore, of other designs which might provide a greater margin of safety for the maximum gross load.

New Balloon Designs - One of the most attractive designs for heavy load vehicles has always been one version or another of a taped balloon. The taped balloon is essentially a tailored natural shaped balloon that sustains its payload by means of reinforcing filament tapes that run longitudinally

FIGURE-7.

$$G = \frac{4}{3} \pi \left(\frac{18 \sigma t}{B \sqrt{3}} \right)^{\frac{3}{2}}$$

RELATIVE STRESS IN POLYETHYLENE CYLINDER BALLOONS

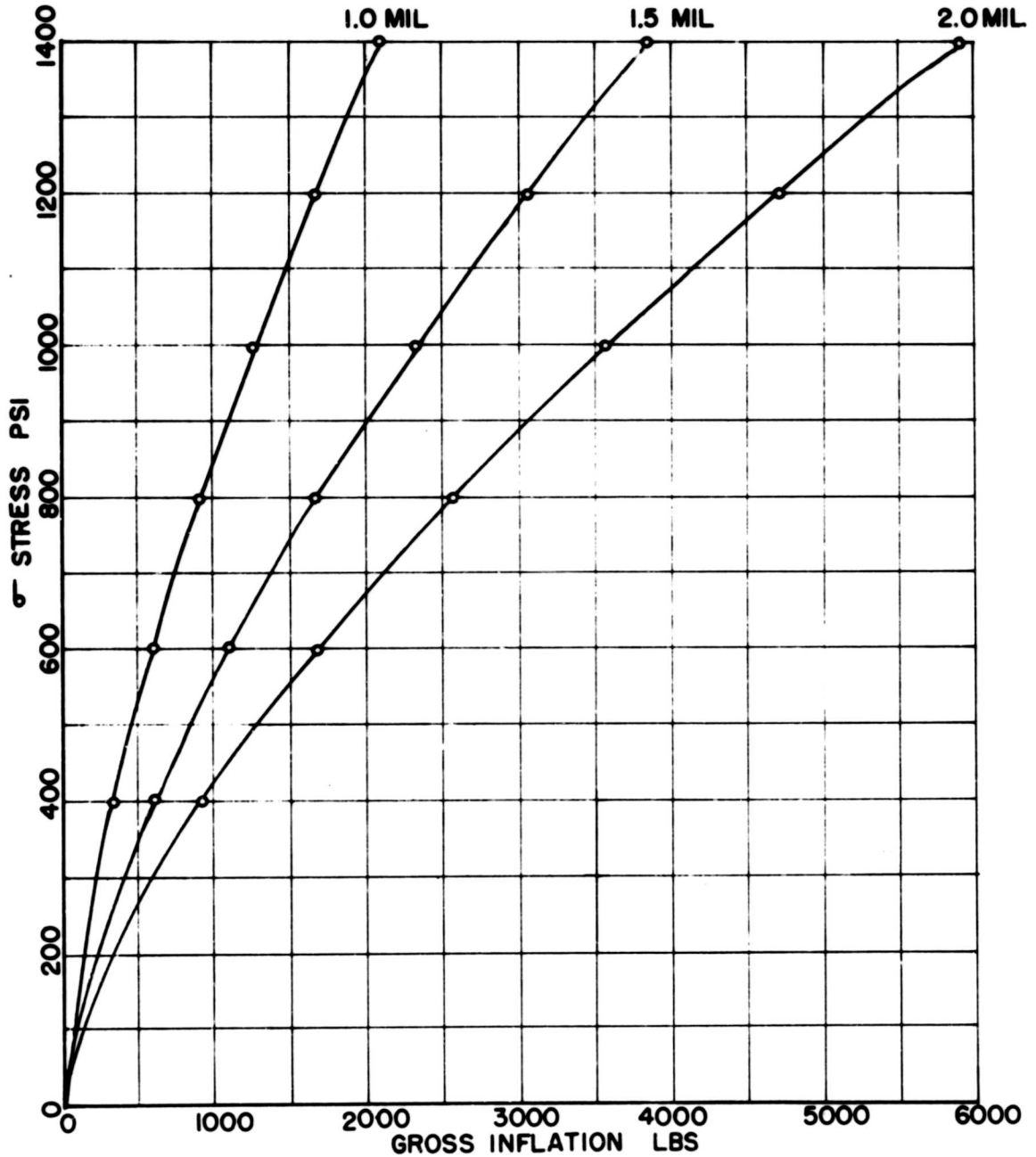

along the balloon. This type of balloon has a greatly diminished gross weight because no excess material is needed to support the load. It is also true that the strength of the balloon is comparatively higher because of the use of higher strength-to-weight materials in the reinforcing tapes.

The ultimate strength of a taped balloon requires consideration beyond simply that of noting the ultimate strength of the tapes. Tapes have a tendency to pull away from the gas barrier material when the volume of the balloon is less than its ultimate capacity. This tendency is demonstrated graphically in Figure 8. It is difficult to calculate these separation forces, due to the complexity of the balloon configuration. Observation of such a balloon at a low stage of inflation will, however, make the existence of such forces obvious. For this reason, we believe the design of a high capacity vehicle involves more than simply the addition of a number of tapes or the use of a stronger tape.

It is also pertinent to note that in most cases only a portion of the balloon needs to be reinforced. Usually the portion of the balloon adjacent to its maximum diameter contains enough gas barrier material so that no reinforcement is required. This can be demonstrated by considering the examples of a 10^6 cubic foot balloon and a 3×10^6 cubic foot balloon constructed of 2 mil and 1.5 mil polyethylene respectively. Consider only the perfectly tailored shapes in which there is no excess of material in either upper or lower parts of the cells. The stress pattern as given by Equation 3 gives the result shown in Figure 9. Note that at the upper and lower apexes the stresses approach infinity as the total amount of material approaches zero. It can be seen that additional strengthening is usually necessary only in the upper and lower-most areas of the balloon. The areas to which this re-

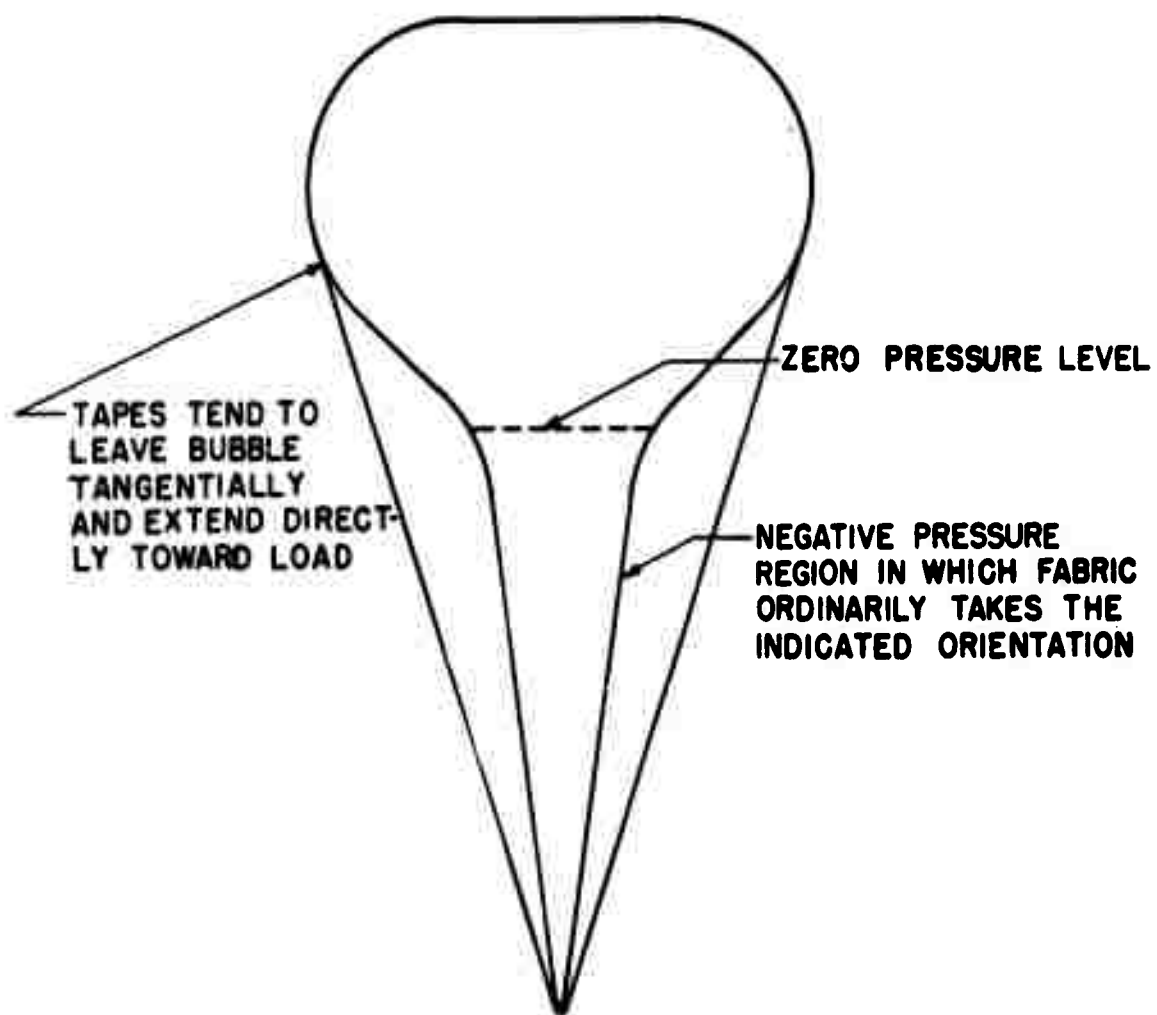

PICTORIAL INDICATING THE TENDENCY OF TAPES TO SEPARATE FROM BALLOON WALL AT LOW RELATIVE VOLUMES

FIGURE-8.

CALCULATED FILM STRESS IN TWO NATURAL SHAPED POLYETHYLENE BALLOONS WITHOUT EXCESS MATERIAL OR REINFORCING MEMBERS

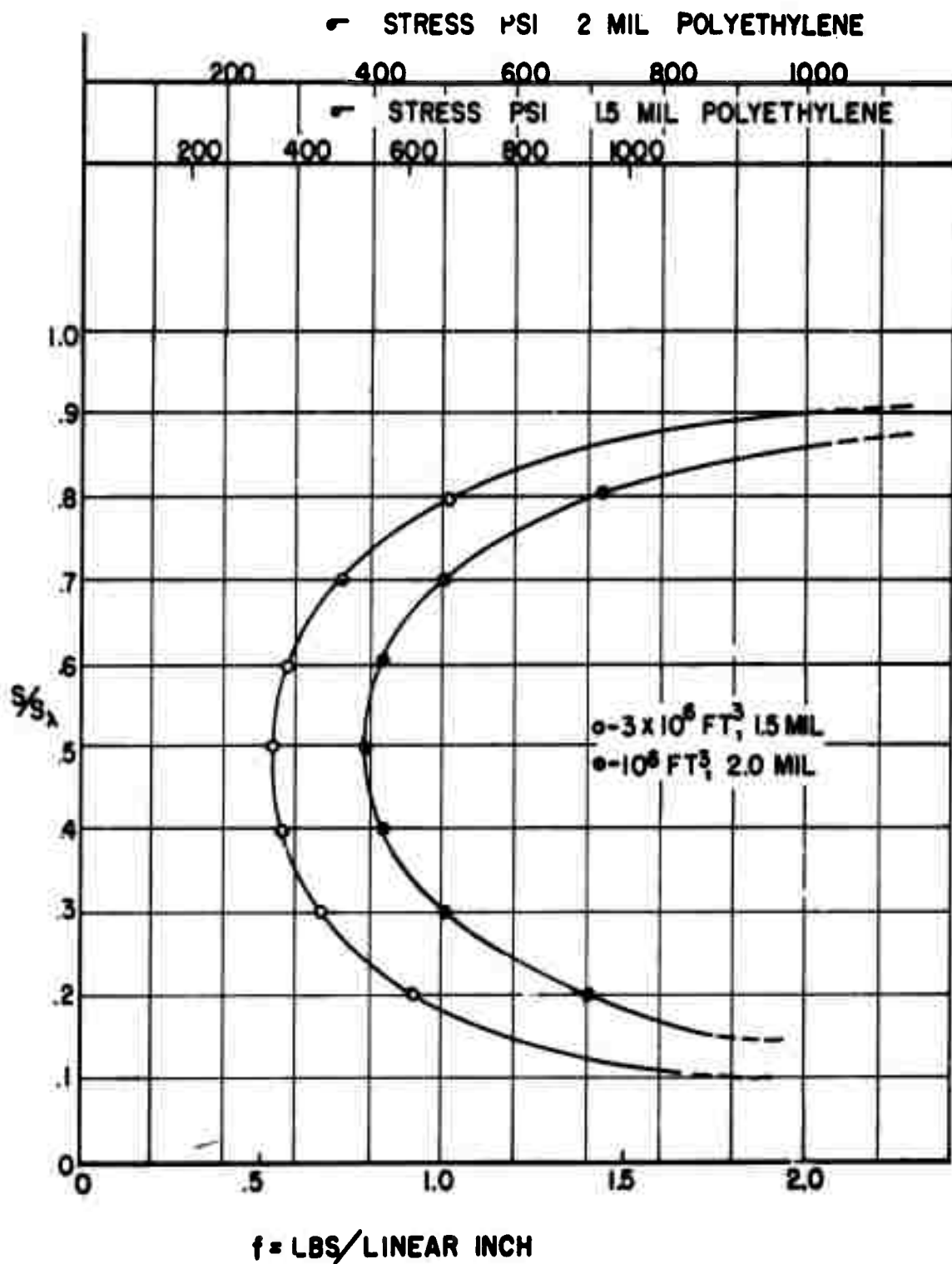

FIGURE-9.

inforcement must extend along the balloon are determined wholly by the stress levels it is desirable not to exceed. The corresponding stress for each material is indicated along the abscissa.

It was suggested above that one solution to this problem would be simply to reinforce these areas alone in order to bring the material stresses below their critical values. If such a method were feasible, it can be seen that the disadvantage of continuously reinforced systems might be avoided.

Methods of accomplishing this include:

(a) Constructing the top and bottom of the balloon with thicker material to reduce material stresses in those areas

(b) Laminating a stronger material, e.g., Mylar, to the polyethylene in the highly stressed area

(c) Providing some system, e.g., tapes or other strengthening members, in these areas which do not extend into the intermediate areas and result in some finite separation force.

Method (a) is not currently feasible within the scope of current plastic technology. Method (b) is possible but the process of laminating polyethylene to Mylar is not sufficiently advanced to prevent delamination under slight straining. Method (c) does, however, hold some possibilities which were explored to a limited degree and which will be described below.

A Method of Reinforcement - Although it may be entirely possible to reinforce the upper and lower balloon areas by a system of tapes terminated in "finger patches", it was felt that a more desirable solution was possible.

In order to distribute the load in the tapes uniformly into the film, it was felt that some type of suspension system of filament tapes could be used. This suspension system might be similar to a catenary in shape and

purpose. It can be understood, however, that a catenary would not be the theoretical shape, since one of its initial boundary conditions specifies the load per unit length along the curve as a constant. In this case, we must solve the case in which the load per unit length along the projected horizontal axis is a constant. This is, in effect, the solution of the figure described by a non-uniform string.

Considering the equilibrium case of a string attached between two points, where m_1 , m_2 and m_3 are beads of equivalent mass attached along that string, and where T_{12} is the tension between m_1 and m_2 , we have:

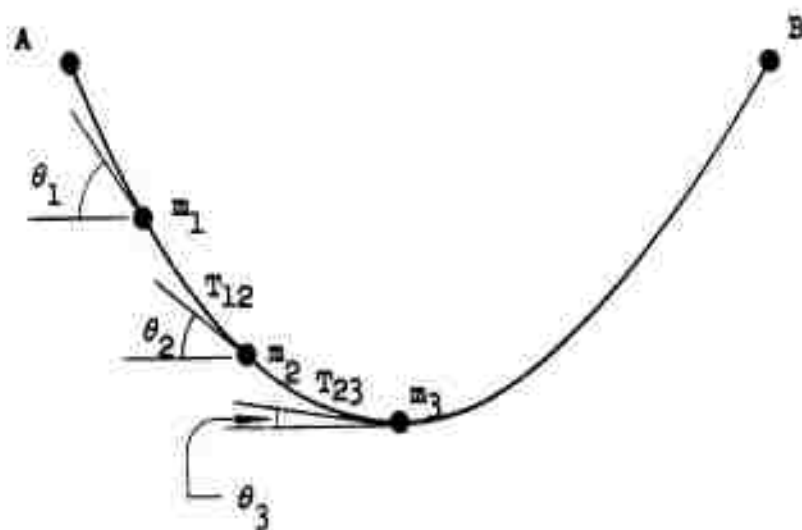

The sum of the vertical forces acting on m_2 is identically zero for the equilibrium condition. Therefore, the horizontal and vertical components are also zero and are written as:

$$\text{Vertical: } -mg - T_{23} \sin \theta_3 + T_{12} \sin \theta_2 = 0 \quad (8)$$

$$\text{Horizontal: } T_{12} \cos \theta_2 - T_{23} \cos \theta_3 = 0 \quad (9)$$

The horizontal component about m_1 can also be written as:

$$T_{01} \cos \theta_2 - T_{12} \cos \theta_2 = 0 \quad (10)$$

From (9) and (10) we can write:

$$T_{01} \cos \theta_1 = T_{13} \cos \theta_2 = \dots = T_{(n)(n+1)} \cos \theta_{n+1} = T_H$$

or that:

$$T_{01} = T_H \sec \theta_1$$

$$T_{12} = T_H \sec \theta_3$$

⋮

$$T_{(n)(n+1)} = T_H \sec \theta_{n+1}$$

We can now rewrite Equation 9 and its associated equation as:

$$-mg + T_H \sec \theta_2 \sin \theta_2 - T_H \sec \theta_3 \sin \theta_3 = 0$$

$$-mg + T_H \sec \theta_3 \sin \theta_3 - T_H \sec \theta_4 \sin \theta_4 = 0$$

⋮

$$-mg + T_H \sec \theta_n \sin \theta_n - T_H \sec \theta_{n+1} \sin \theta_{n+1} = 0$$

which can again be rewritten as:

$$-mg + T_H \tan \theta_2 - T_H \tan \theta_2 = 0$$

⋮

$$-mg + T_H \tan \theta_n - T_H \tan \theta_{n+1} = 0$$

Now if we let θ_{n+1} represent the lowest point:

$$\theta_{n+1} = 0$$

Therefore:

$$-mg + T_H \tan \theta_n = 0$$

or:

$$\tan \theta_n = mg/T_H$$

$$\tan \theta_{n-1} = 2mg/T_H$$

⋮

$$\tan \theta_1 = nmg/T_H$$

Now let us impose the condition that the horizontal spacing between the beads is everywhere the same, or that $x_1 = x_2 = x_3 = \dots = x_n$

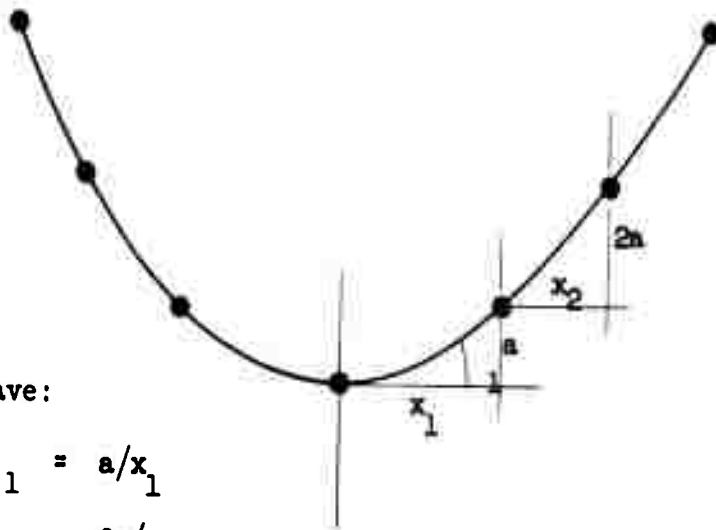

Therefore we have:

$$\tan \theta_1 = a/x_1$$

$$\tan \theta_2 = 2a/x_1$$

⋮

$$\tan \theta_n = na/x_1$$

Therefore, the coordinates of the points are:

$$\begin{aligned} P_1 & (0, 0) \\ P_2 & (x_1, a) \\ P_3 & (2x_1, 3a) \\ P_4 & (3x_1, 6a) \\ & \vdots \\ & \vdots \\ & \vdots \\ P_n & \left[(n-1)x_1, \frac{(n-1)n}{2} a \right] \end{aligned} \quad (11)$$

A plot of these coordinates is presented in Figure 10. Note that it is somewhat similar to a parabola or a catenary.

A suspension system such as that shown in Figure 11, where either or both upper and lower sections are reinforced in this manner, might be used.

The advantage of taped balloons, whether reinforced in this manner or not, is apparent from Table I. Design specifications for a one million cubic foot balloon and a three million cubic foot balloon are stated. The second column gives the shape factor compatible with the present estimated gondola weight. The fifth column gives the required gore length. The sixth column represents the tailored weight, or, in other words, the weight of material used in constructing the final shape where no provision has been made for extra material. If a cylindrical top and bottom section are utilized, their approximate additional weight is given in the seventh and eighth columns of Table I.

It is evident from these data that it is desirable to investigate taped balloon systems. Although cylinder-type balloons have proved to be reliable vehicles, their limitations must be recognized, particularly with regard to

————— $y = a \left[\cosh\left(\frac{x}{a}\right) - 1 \right], a = 4.75$

- - - - - $x^2 = 4fy, f = 1.66 \dots$

————— $P_n \left[(n-1)x, \frac{(n-1)n}{2} a \right] a = 2y$

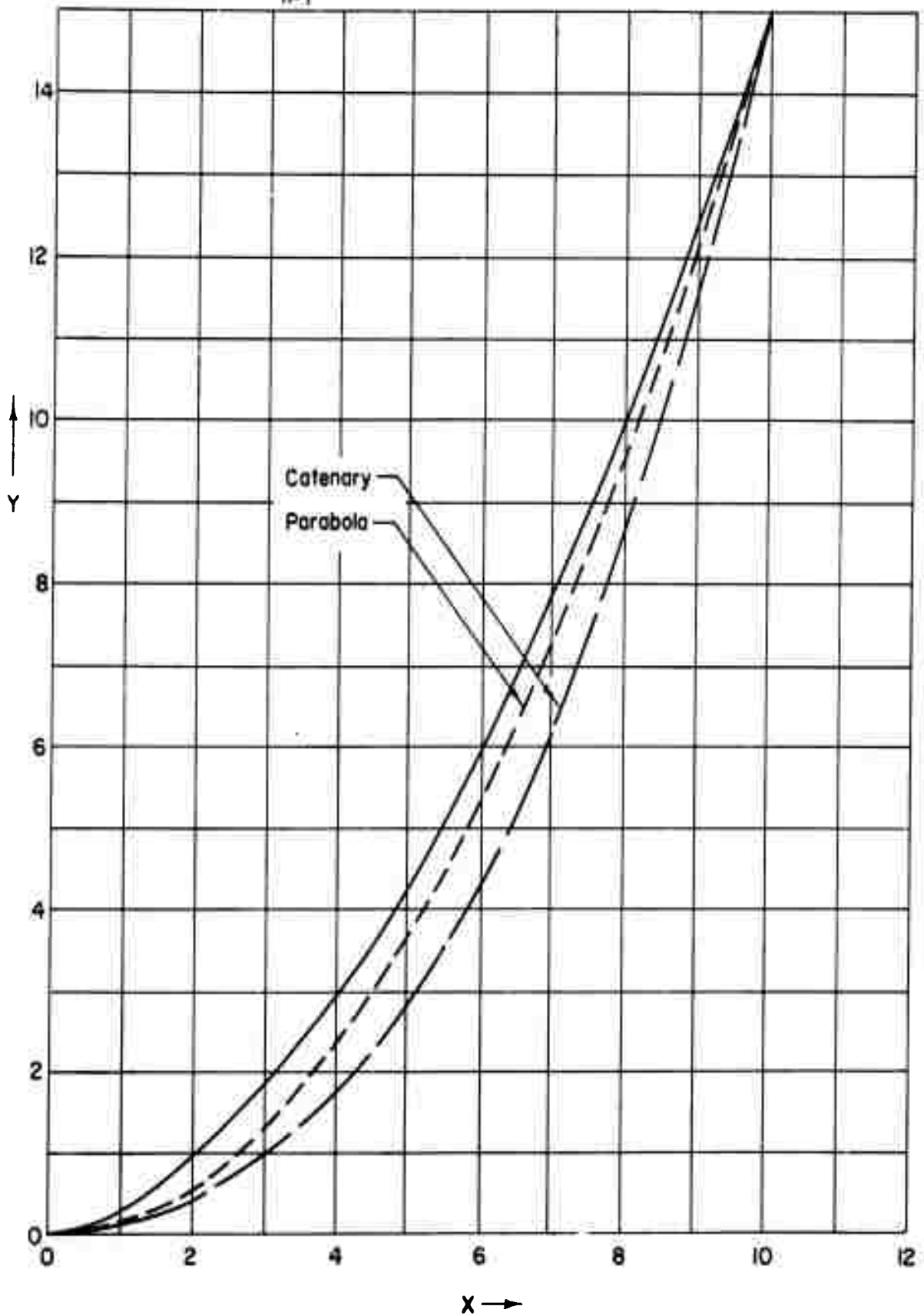

PLOT OF DERIVED CURVE COMPARED
TO A PARABOLA AND CATENARY

FIGURE 10

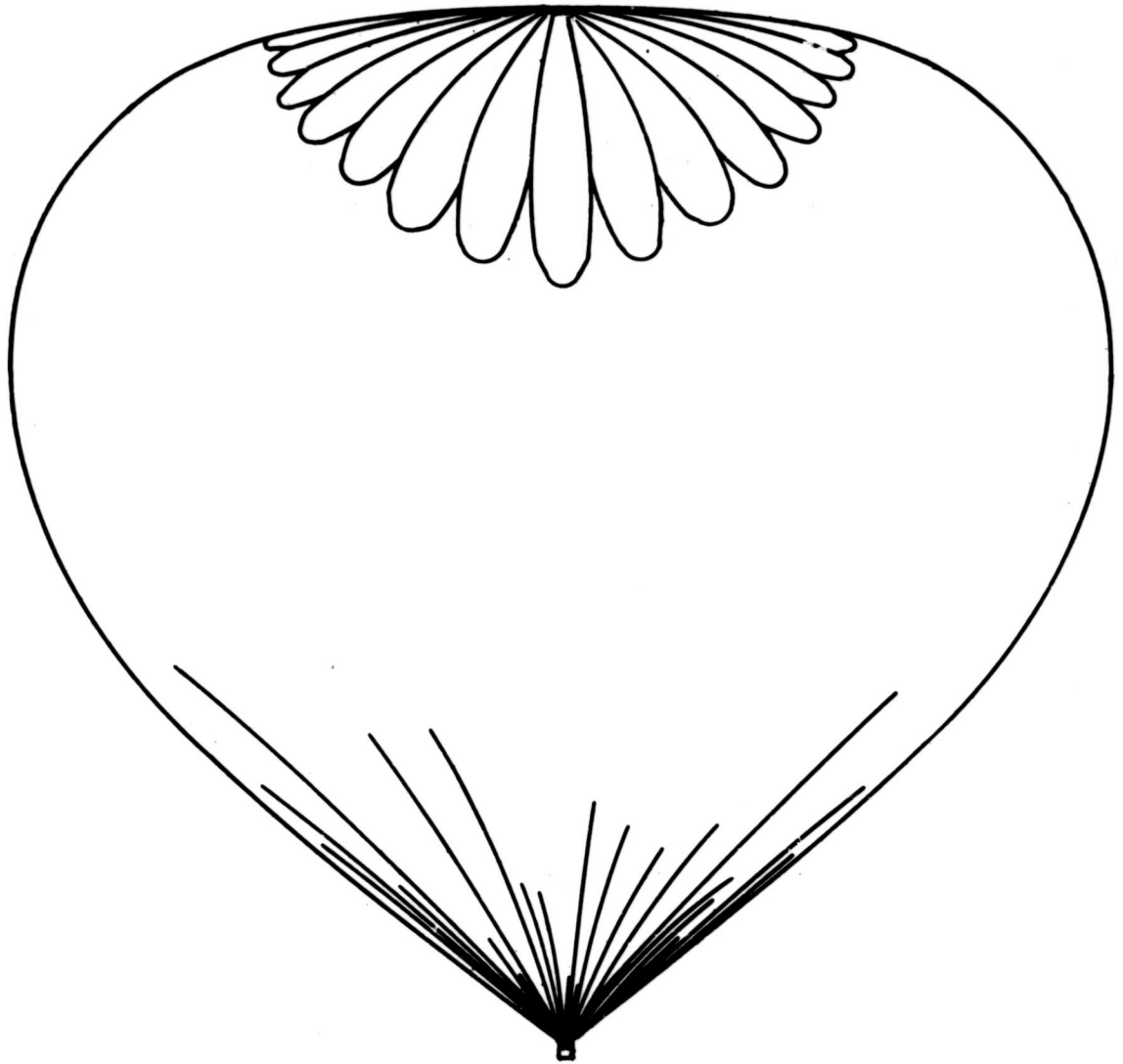

FIGURE 11

**METHOD FOR UTILIZATION OF REINFORCING
TECHNIQUE IN UPPER SECTION OF BALLOON**

TABLE I

WEIGHT COMPARISON OF TAPED AND TAILORED TAPELESS BALLOONS
FOR TWO HYPOTHETICAL DESIGNS

<u>Size</u>	<u>Σ</u>	<u>Number of Gores</u>	<u>Duct Size</u>	<u>Gore Length</u>	<u>Tailored Weight</u>	<u>Additional Weight of Cylindrical Bottom Section</u>	<u>Additional Weight of Cylindrical Top Section</u>
10^6 cu ft	0.10	50	33 ft ²	196 ft	506 lb	89 lb	101 lb
3×10^6 cu ft	0.15	72	76 ft ²	281 ft	776 lb	137 lb	155 lb

the use of polyethylene as a gas barrier for gross loads greater than 2,000 lb. Other materials, e.g., Mylar, which are inherently stronger than polyethylene have been considered. The use of Mylar as a balloon film is briefly discussed below.

Mylar Balloons - Use of Mylar greatly enhances the extension of cylinder balloons with respect to maximum permissible gross load. The obvious drawback to the use of Mylar is, of course, its comparatively high modulus of elasticity and low tear resistance. A comparison is shown in Table II which demonstrates the differences of the two materials at room temperature.

TABLE II
COMPARISON OF THE MECHANICAL PROPERTIES OF
POLYETHYLENE AND MYLAR AT 15°C

<u>Material</u>	<u>Ultimate Tensile Strength</u>	<u>Elastic Modulus</u>	<u>Average % Elongation to Ultimate</u>
Polyethylene	28,000 psi	28,000 psi	500%
Mylar	350,000 psi	350,000 psi	60%

These data are representative of those taken at a temperature of 15°C.⁵ As may be seen above, Mylar is relatively non-extensible in comparison to polyethylene. Due to this high modulus of elasticity, Mylar balloon construction would seem to be somewhat critical. Meridional dimensional errors in a Mylar cell would be serious, since a non-uniform loading could cause high local stresses and eventual failure at a small fraction of the total strength.

An idealized situation is considered below to note the relation between meridional dimensional errors and the fraction of the ultimate tensile strength that might be reached.

First, consider a rectangular sheet of material of dimensions x , y , t . This sheet shall be stressed along a vertical axis. The load will then be:

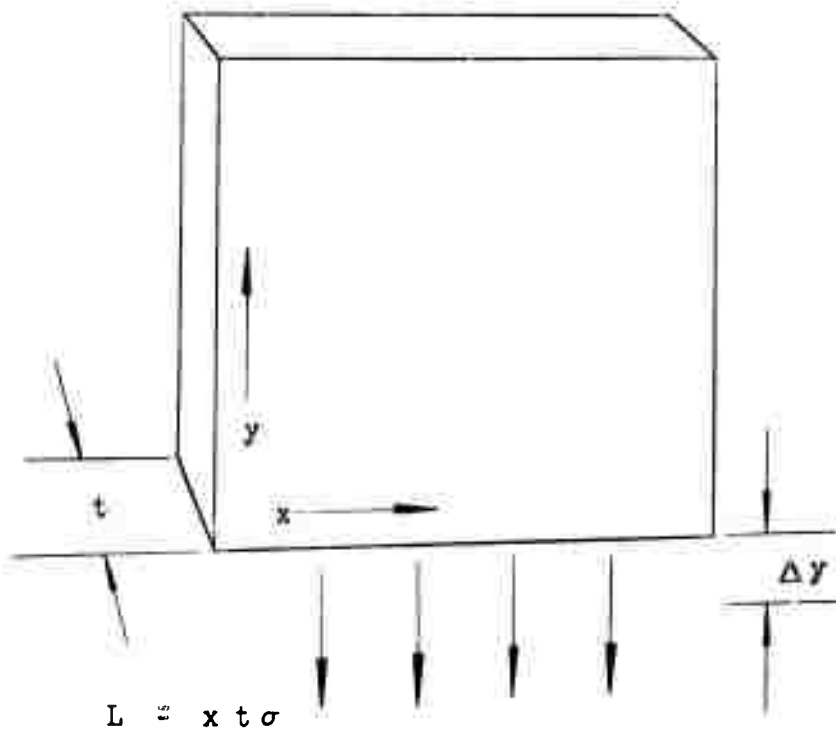

where:

- L = load in lb
- x = width of sheet in inches
- t = thickness of sheet in inches
- σ = stress in psi

Also, we have:

$$\sigma = \frac{\Delta y}{y} e$$

where:

- Δy = strain in inches
- y = height of sheet in inches
- e = elastic modulus

Therefore:

$$L = \frac{\Delta y}{y} \text{ ext} \quad (12)$$

Now, if we consider a similar sheet imperfectly located in the loading mechanism, we can determine the relative loading efficiency. In other words, consider a section of width, w , which is located in error along a vertical axis by a factor, Δl .

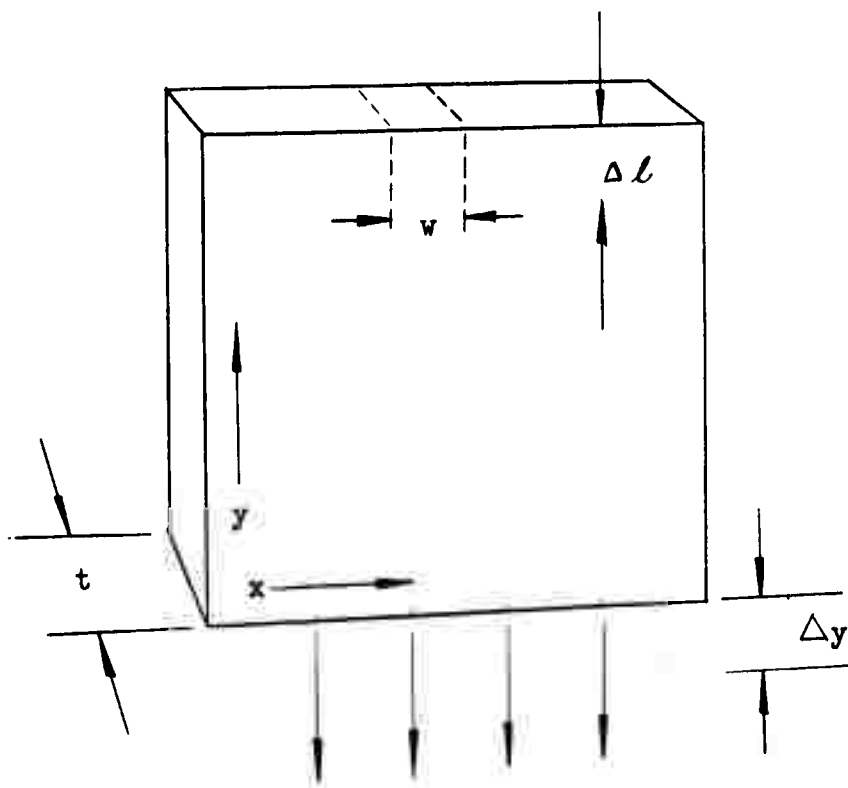

The point of failure will then presumably occur within the region, w , width. It will be assumed that, if part of the sheet fails, the whole sheet will fail without an increase in load. The question is then what fraction of the ultimate strength will the sheet attain.

The load on the error section will be:

$$L_w = \frac{\Delta y}{(y - \Delta l)} \text{ ext} \quad (13)$$

The remaining part of the sheet will sustain a load of:

$$L_R = \frac{\Delta y - \Delta l}{y} e (x - w) t \quad (14)$$

where L_R is significant only when positive.

The total load is then given by:

$$L_T = L_W + L_R \quad (15)$$

and the fraction of ultimate strength attained by any combination of parameters is given by:

$$f = \frac{L_T}{L} \quad (16)$$

Plotting this result for various values of w/x and $\Delta l / \Delta y$ gives the hyperbolics shown in Figure 12.

It should be noted that Δy is the ultimate strain of a specified length of plastic sheet.

This is an obviously simplified case since any such erroneous orientation will, of course, occur more generally in each end of the sheet. It is interesting to note that this simplified case might be generalized by considering the fact that $w\Delta l$ represents an area in error.

The important consideration is basically that since the ultimate strain of a Mylar sample is significantly less than a similar polyethylene sample, the Mylar sample must be oriented proportionately more precisely in order to utilize an equivalent degree of the ultimate strength. Basically, then, this is a construction difficulty and has been borne out to some degree by Mylar balloon experience.

Selection and Modification of the 128TT - This balloon was finally

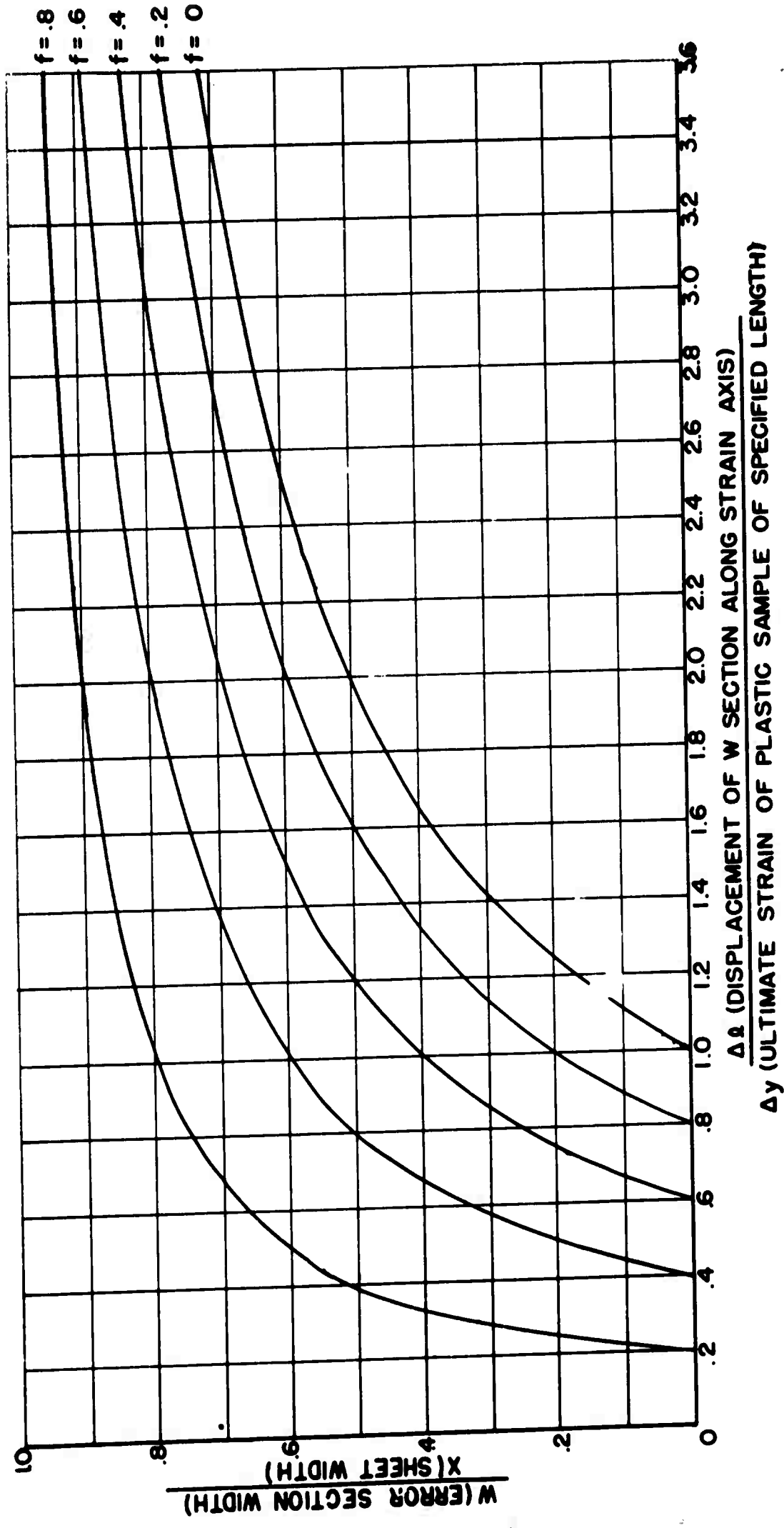

FRACTION OF ULTIMATE STRENGTH OBTAINABLE FROM A PLASTIC SHEET WHICH HAS A SECTION OF WIDTH, W, SHORTENED BY A FACTOR $\Delta\Delta$

FIGURE 12

selected by the advisory panel of the Office of Naval Research as the cell to be used on the initial feasibility flight on the basis of its past record with similar gross loads. Although other designs may have held some promise from the standpoint of film stress, it was decided that a new balloon design and flight testing were beyond the scope of this project.

Since this balloon was not ordinarily fitted with a controlling valve, a new top fitting was designed such that a valve opening equivalent to an orifice of approximately one foot in diameter could be accommodated.* In order to evaluate this upper fitting visually, a unit was installed in a test balloon (see Figure 13) and inspected for any obvious defects.⁶ The large orifice within the fitting was sealed with a plate and loaded so as to simulate the weight of the valve. The asymmetric orientation of this fitting while the balloon was at a low stage of inflation (during a launching condition) was anticipated as is shown in Figure 14. No adverse effects were apparent in the inspection of the fitting proper.

Apart from the installation of the top fitting, only one other modification of the balloon was necessary, i.e., the installation of electric cables to control and power the valve. These cables were encased in a polyethylene envelope heat sealed to the balloon wall.

Balloon Construction and Subsequent Inflation Tests - Four 128TT balloons were constructed and modified in the manner described. The material in each unit was tested thoroughly in accordance with existing standards and every effort was made to inspect the entire balloon surface for any abnormalities.

One balloon was used in a series of inflation tests conducted in an LTA

*See Figure I-A, Appendix.

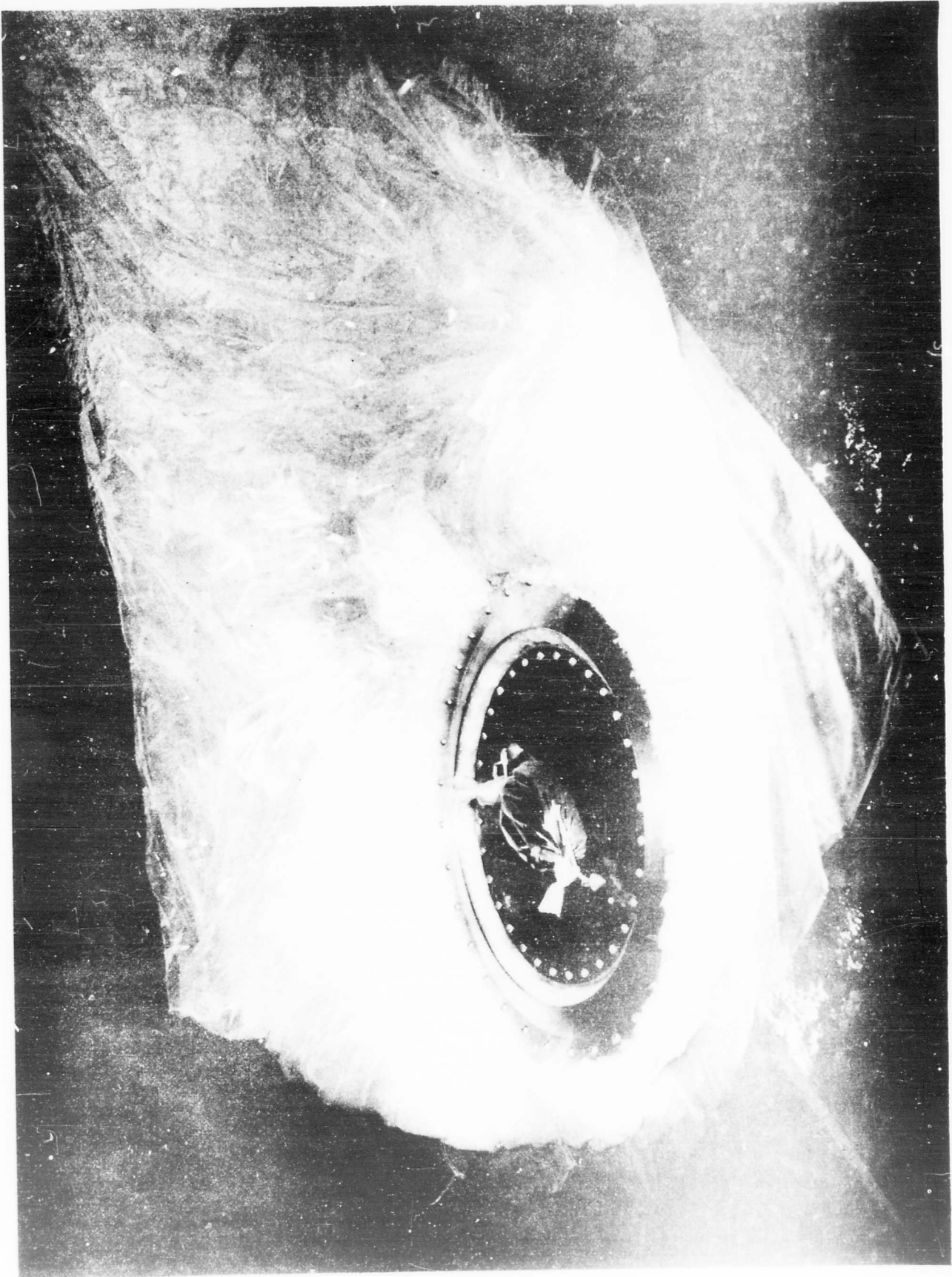

MODIFIED TOP FITTING INSTALLED IN
I28TT BALLOON PRIOR TO TEST INFLATION

FIGURE 13

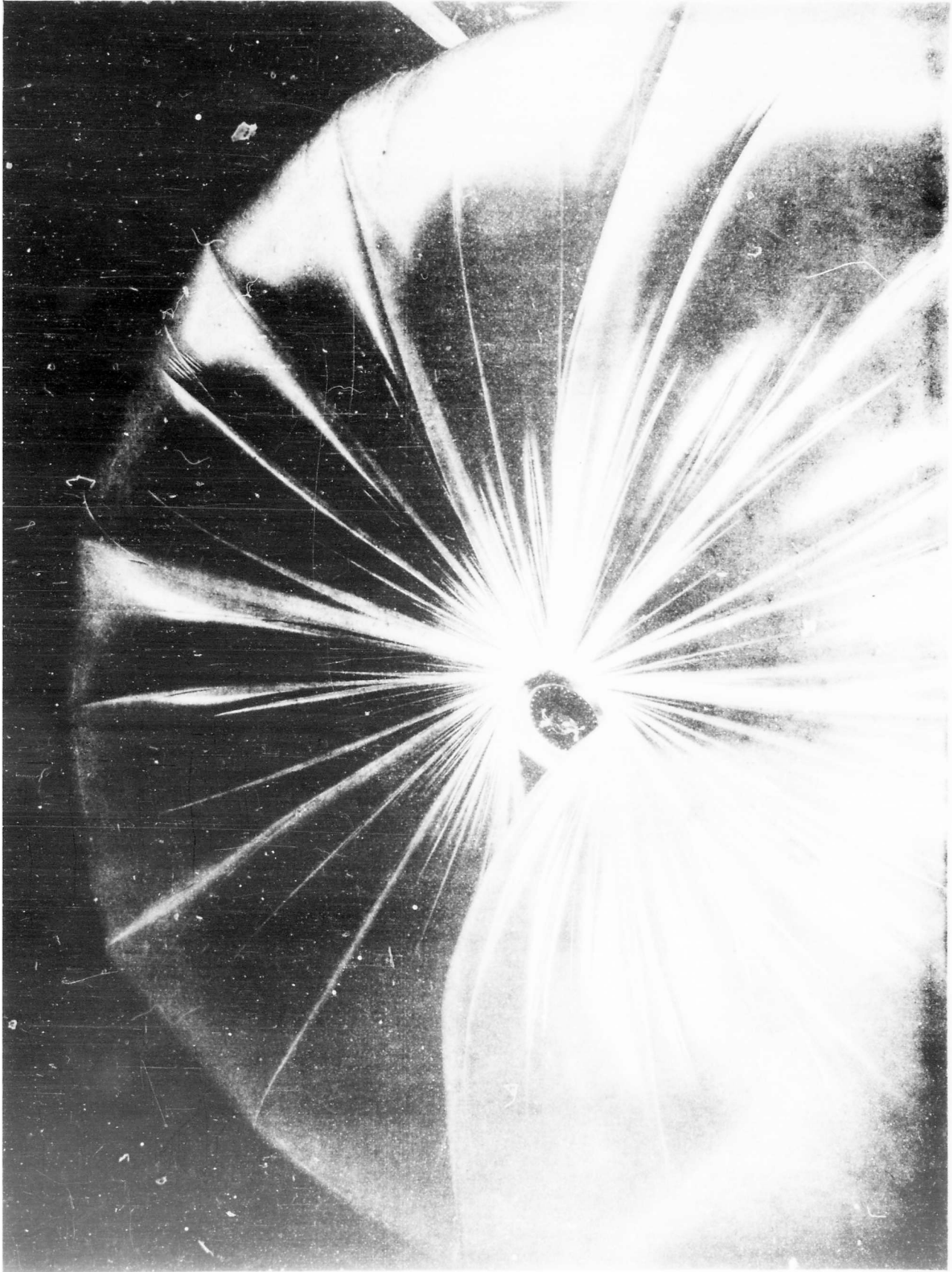

ORIENTATION OF MODIFIED TOP FITTING
DURING THE LOW STAGES OF
BALLOON INFLATION

hangar at Weymouth, New Jersey.² The balloon was first inflated to approximately full volume by means of a carbureting system (see Figure 15). The carburetor mixed helium and air in proper proportion to permit simulation of the balloon shape at its equivalent ceiling altitude. The balloon was inspected visually for any defects such as loosened tapes, duct orientation, etc., and deflated by means of the valve in the upper apex.

This same balloon was then inflated to destruction with pure helium. Figure 16 shows the configuration immediately prior to burst. Prior to destruction inflation, we had calculated from Equation 3 that a gross inflation of 5,000 lb appeared to be a reasonable burst value. We had also calculated that a gross inflation of 6,000 lb appeared to be a real outside limit. The burst actually occurred at 5,220 lb gross inflation. Refer to Figure 7 for a comparison of these data with the various film stress values.

Balloon Gas Valve - Before work on the design of a valve was begun, calculations were made to determine the approximate size of such a unit. The criterion for the size requirement was that for adequate control it should be possible to release about 200 lb of lift in 30 minutes. Using nominal coefficients of discharge, it was determined that such a valve might be equivalent to an orifice approximately one foot in diameter.

One initial requirement was a "fail-safe" valve, i.e., a valve which would close in the event of a power or mechanical failure. This requirement virtually specified some type of mechanically loaded valve, whether achieved by a gravity, spring or clutch-type system. The GMI initial design was mechanically simple, the main moving part being a crank which moved a spring-loaded cover along a vertical axis. The coupling of the drive motor to the crank was made with an electric clutch which, in the event of power failure,

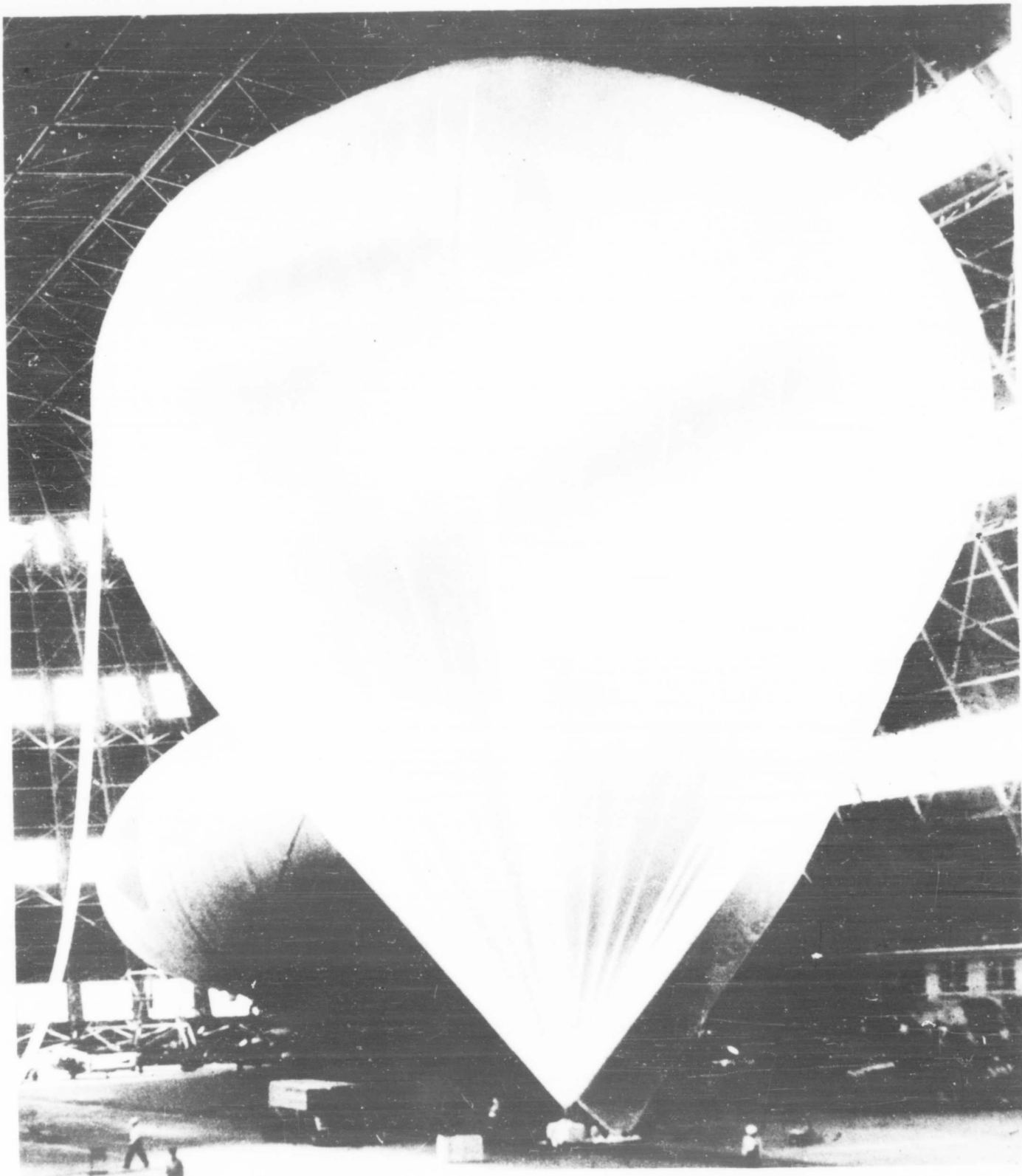

128TT BALLOON INFLATED TO RELATIVE
VOLUME OF APPROXIMATELY 0.3

FIGURE 15

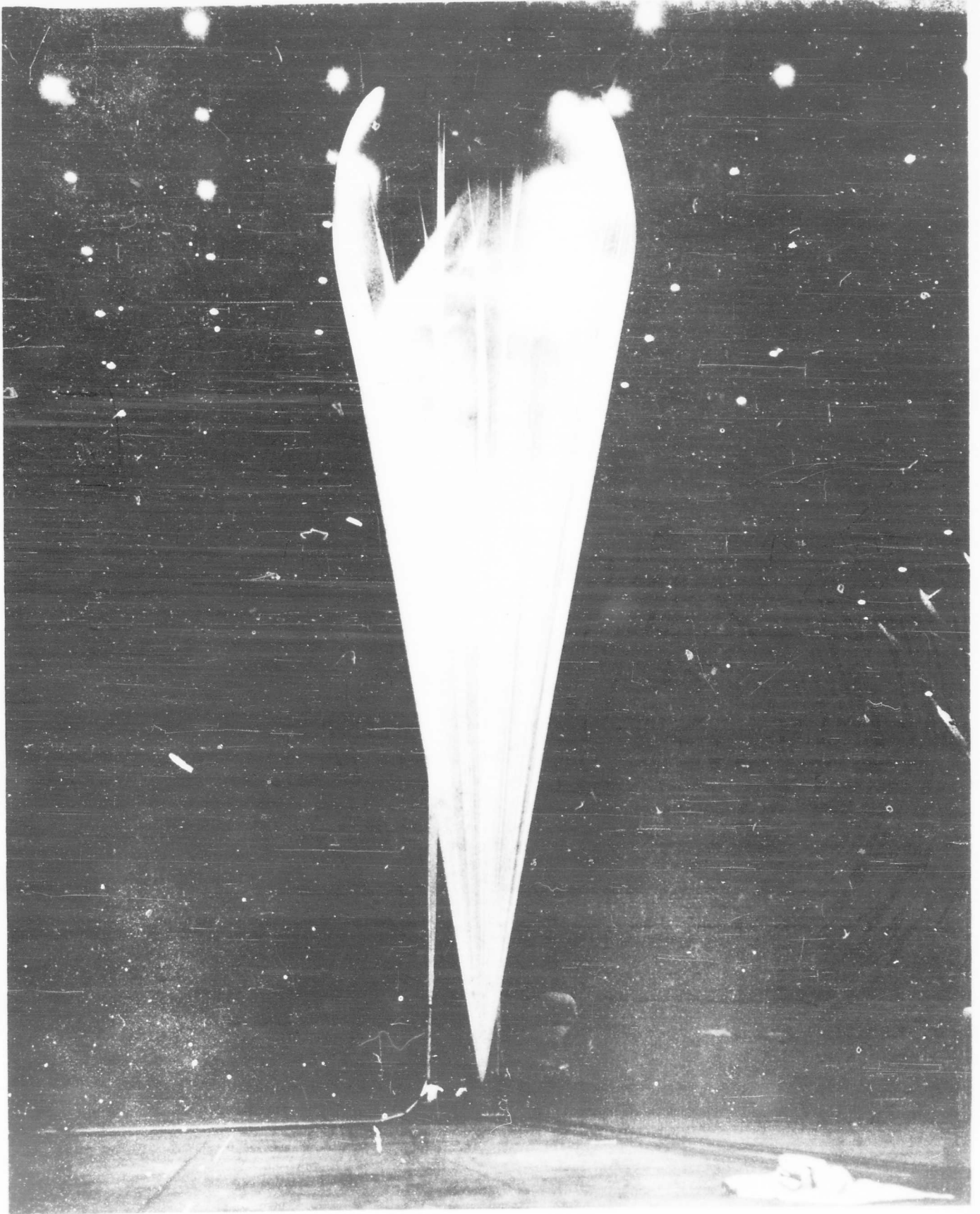

128TT BALLOON JUST PRIOR TO BURST
(GROSS LIFT APPROXIMATELY 5200 LBS)

FIGURE 16

would permit the spring-loaded cover to return to its closed position.

A complete duplicate of this system was included in the actual construction, i.e., two motors and two clutches were coupled to the crank mechanism.

Figure 17 shows a complete unit.

A greatly simplified valve was designed which did not include any "fail-safe" or back-up devices. This valve, although having a slightly greater discharge capacity, weighed only 5 lb, whereas the old style weighed approximately 15 lb. Its simplicity (see Figure 18), in addition to its light weight and reliability, caused it to be selected for special personnel flights prior to the Strato-Lab flight. It was later selected as the valving mechanism for the Strato-Lab ascent. Since the orifice geometry of this unit was similar to that of the previous valve, a similar discharge coefficient was assigned to it.

The discharge coefficient for this type of geometry was determined by a model valve whose orifice diameter was 0.75 inch (see Figure 19).

It can be shown that the loss of lift through an orifice is given by the relation:

$$L = \frac{60}{144} UCA \sqrt{2g h_f} \quad (17)$$

where:

L = loss of lift of He (lb/min)

U = lift of He at the specific altitude (lb/ft³)

C = coefficient of discharge (dimensionless)

A = area of orifice (in.²)

g = gravitational constant

h_f = head of fluid (ft)

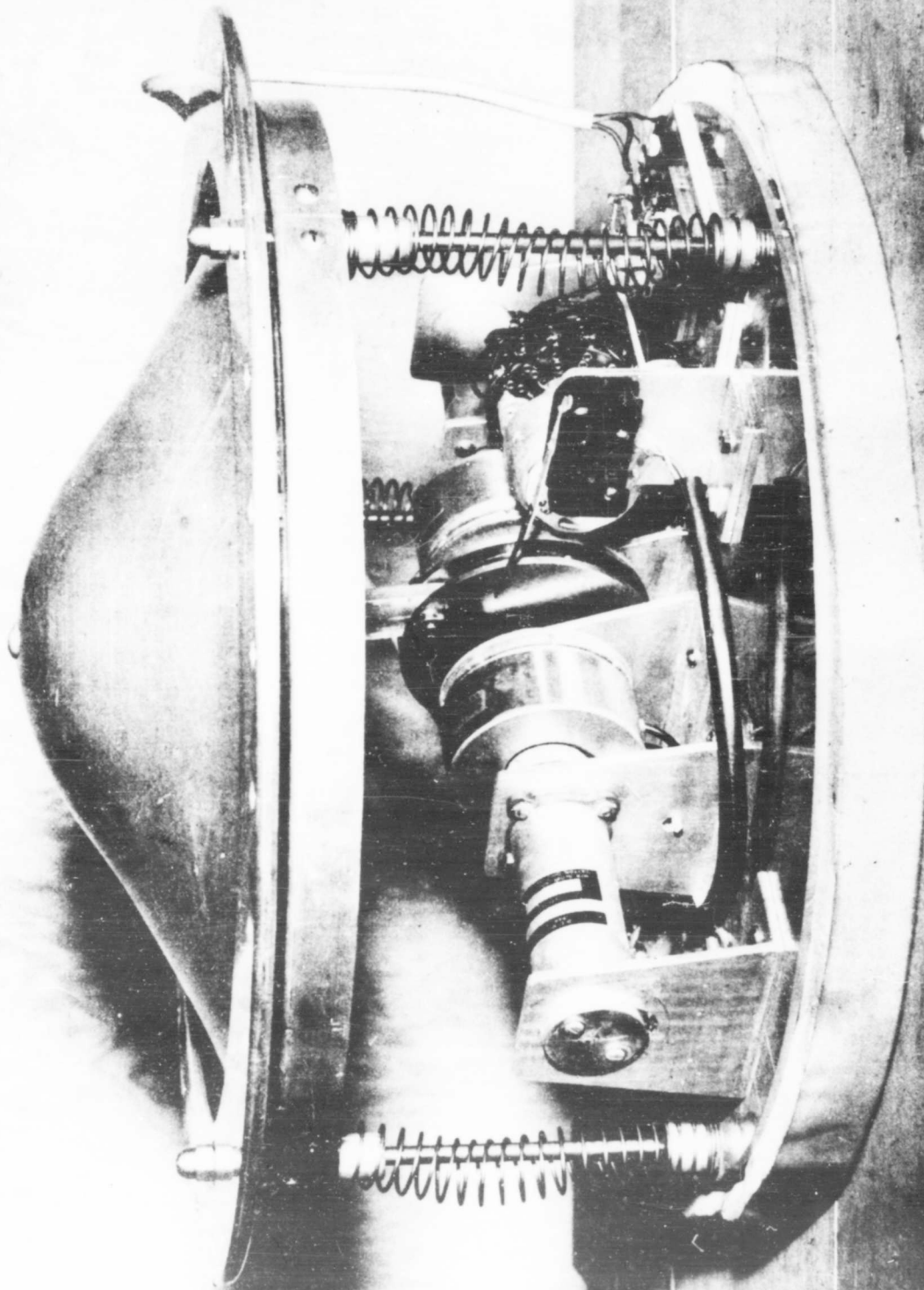

FAIL SAFE HELIUM VALVE
FIGURE 17

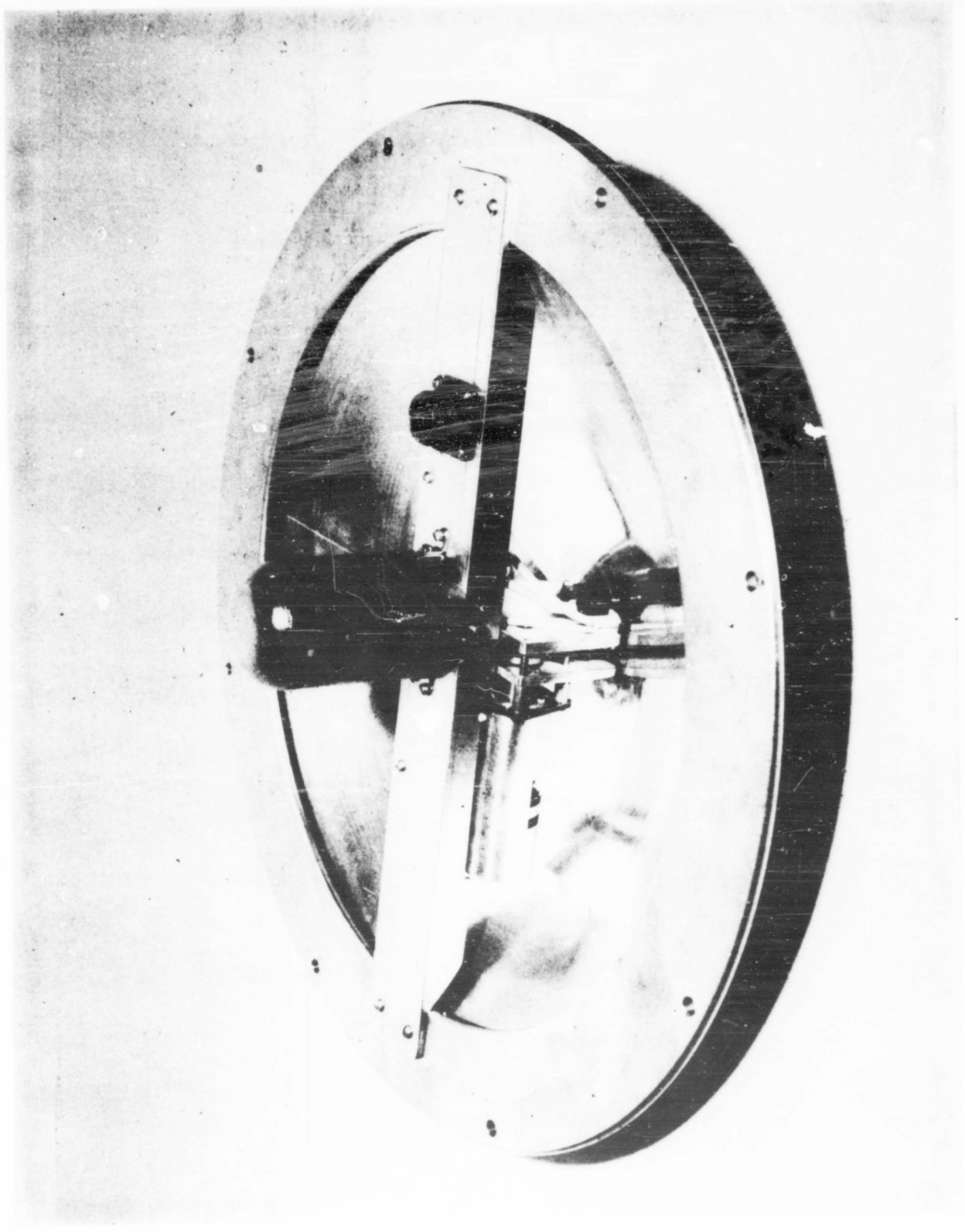

MODEL EV-13 ELECTRIC VALVE

FIGURE 18

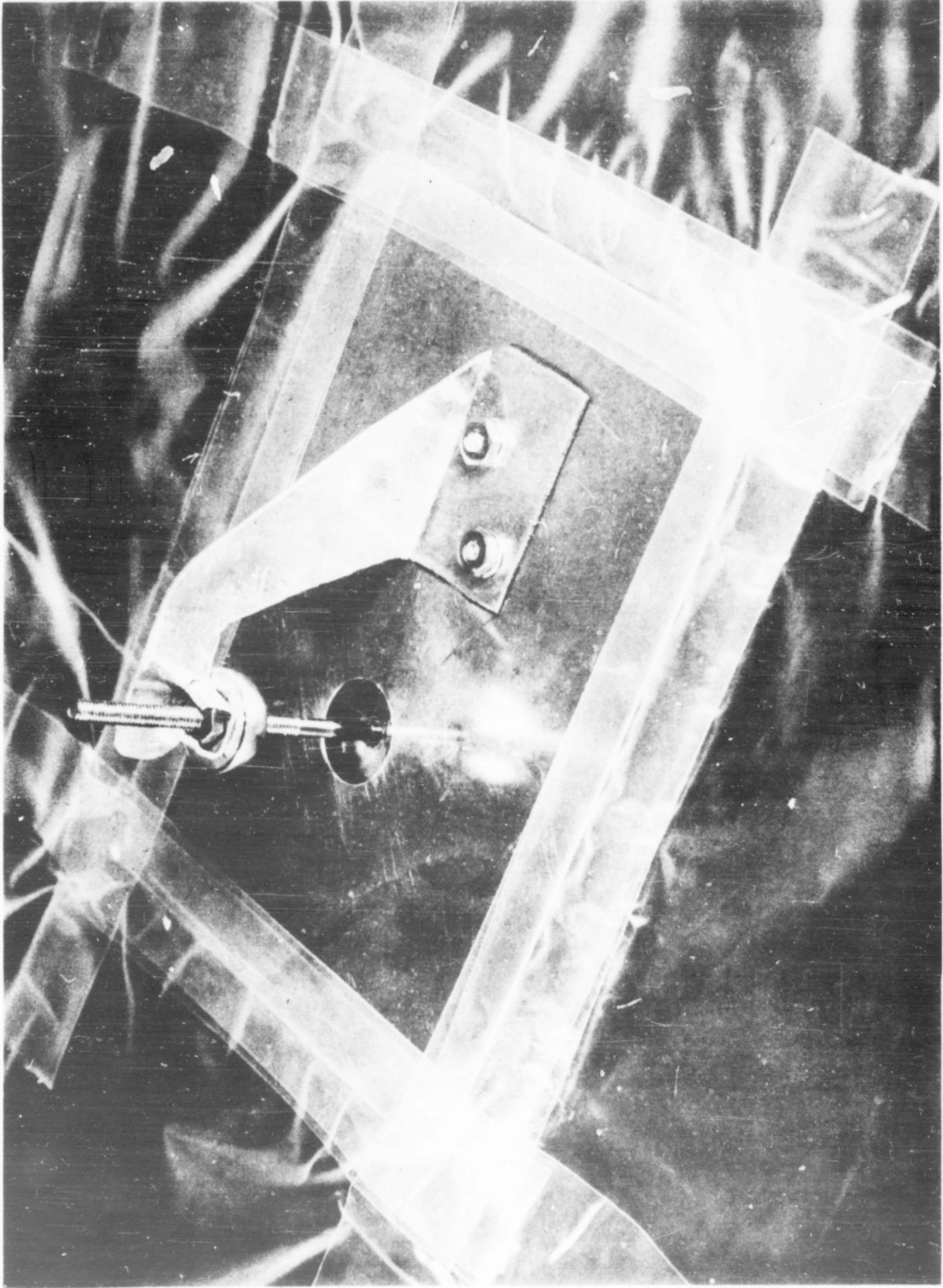

MODEL ORIFICE USED TO DETERMINE
DISCHARGE COEFFICIENTS

Since, in this case, the densities of the two fluids, air and helium, are comparable, we must alter the value of h_f by considering the differential above and below the orifice

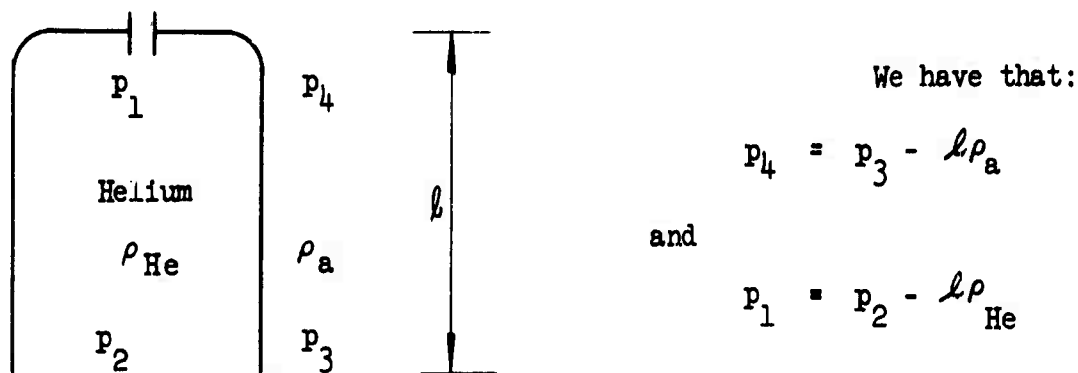

Therefore, the pressure differential across the orifice is:

$$\Delta p = p_1 - p_4 = p_2 - l\rho_{He} - p_3 + l\rho_a$$

since $p_2 = p_3$ we can rewrite Δp as:

$$\Delta p = l(\rho_a - \rho_{He})$$

But, since Δp also equals $h_f \rho_{He}$, we have:

$$h_f = \left(\frac{\rho_a - \rho_{He}}{\rho_{He}} \right) l \quad (18)$$

or:

$$L = \frac{60}{144} \text{UCA} \sqrt{2gl \left(\frac{\rho_a - \rho_{He}}{\rho_{He}} \right)} \quad (19)$$

The coefficient of discharge in this equation was determined by inserting the small model orifice in the upper portion of a vertical plastic tube approximately 3 feet in diameter. This tube was filled with helium and the lift loss measured as a function of time. In conjunction with this, the effective head of fluid was noted by observing the negative pressure region

on the plastic tube.

Three different models were used. The first of these was a plain hole and was used for comparison purposes as well as a test of the method of measurement. The second type of orifice consisted of the 0.75 inch hole with a thin disk of slightly larger diameter located 0.2 inch beneath the hole. The third type was of a similar in geometry to the second, except that a cone was used in place of the disk. The cone base was located 0.2 inch below the hole, the apex being in the plane of the hole. These orifice types were selected, since a moving member as large as was indicated by the initial calculations virtually eliminates any trap door type valve.

The results were as follows:

<u>Type</u>	<u>C</u>
1. Hole, 0.75 inch diameter	0.54
2. Hole, 0.75 inch diameter	0.55
3. Hole, with disk	0.37
4. Hole, with disk	0.40
5. Hole, with cone	0.33
6. Hole, with cone	0.41

Using a value for $C = 0.37$, we can then describe the valve's discharge characteristics as shown in Figure 20.

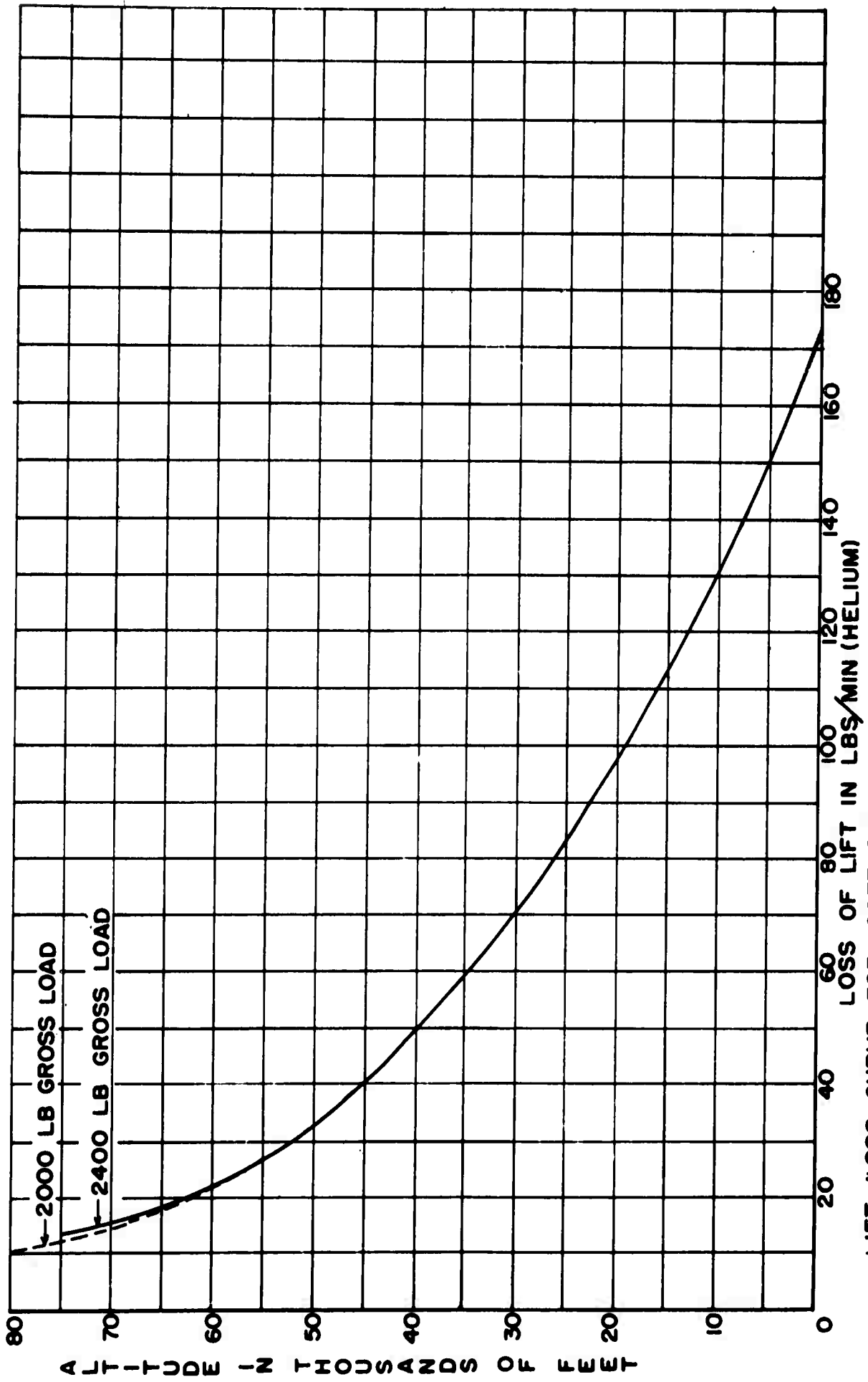

LIFT LOSS CURVE FOR 128TT BALLOON WITH EV-13 VALVE-BALLOON WT. 555 LBS.
 FIGURE 20

Parachute

Recognizing that a balloon failure is always possible, a parachute was selected as the first alternate method of descent. Fortunately, a cargo type parachute with a 64-ft canopy had been utilized many times with comparable loads at similar altitudes. Because this particular parachute had functioned so well on these flights, it was selected as a part of the Strato-Lab system.

High altitude balloon experience with parachutes has indicated some practices which should be avoided. It has been found, for example, that parachutes used to drop loads from high levels are very successful if they are not packed in the usual manner but are extended along the flight train. Apparently, the low air density will not fully extend the parachute in its proper orientation for opening until the velocity of the whole system is sufficient to cause the parachute to "squid". Using an extended chute significantly decreases the length of time required for the system to reach a velocity at which ρV^2 is large enough to open the parachute. It has also been found that parachutes which carry a portion of their total load on the top are prone to failure. Both of these pitfalls were avoided in this system.

In order to determine the opening shock characteristics of this parachute, several tests were conducted in which the maximum force on the gondola during the parachute opening was measured. Brinnell accelerometers were placed in the form of links in the shroud lines of the parachute and measured the maximum force occurring along the axis of that particular shroud. The result of the drops, which occurred at altitudes of 2,000 feet, 38,000 feet and 76,000 feet, was that in each case the deceleration of the simulated gondola mass was equivalent to slightly over 3 g's.

The drop from an altitude of 38,000 feet also utilized a Ryan Flight Recorder to record the time-force relationship graphically.^{6,7} Excellent results were obtained from this flight. The actual trace, greatly enlarged, is shown in Figure 21 with a scale overlay to indicate the force or "g" ordinate. Note that:

(1) Approximately 4.7 seconds were required before the maximum acceleration (3.22 g) was encountered.

(2) The duration of this force (that corresponding to one greater than 1 g) is about 1.4 seconds.

(3) By calculation, the gondola fell approximately 232 feet before the parachute began to load over 1 g and the maximum downward speed was approximately 116 ft/sec.

Looking at the fine structure of the curve indicates that:

(1) The initial variations in acceleration during the "free fall" period may be due to individual parachute risers elongating to sustain the parachute drag and applying short duration forces to the gondola.

(2) The somewhat regular wave form after the opening shock may be the force-time expression of the oscillatory "breathing" of the chute. This oscillatory pattern continued for most of the descent but in a decreased magnitude.

(3) The general tendency for the forces to be greater than 1 g following the opening shock would be expected, since the terminal velocity diminishes due to the increasing density of the air.

The Brinell accelerometers (on four of the eight risers) indicated maximum forces of 550, 680, 810 and 710 lb. This results in a maximum deceleration equivalent to 3.2 g which is in good agreement with the maximum

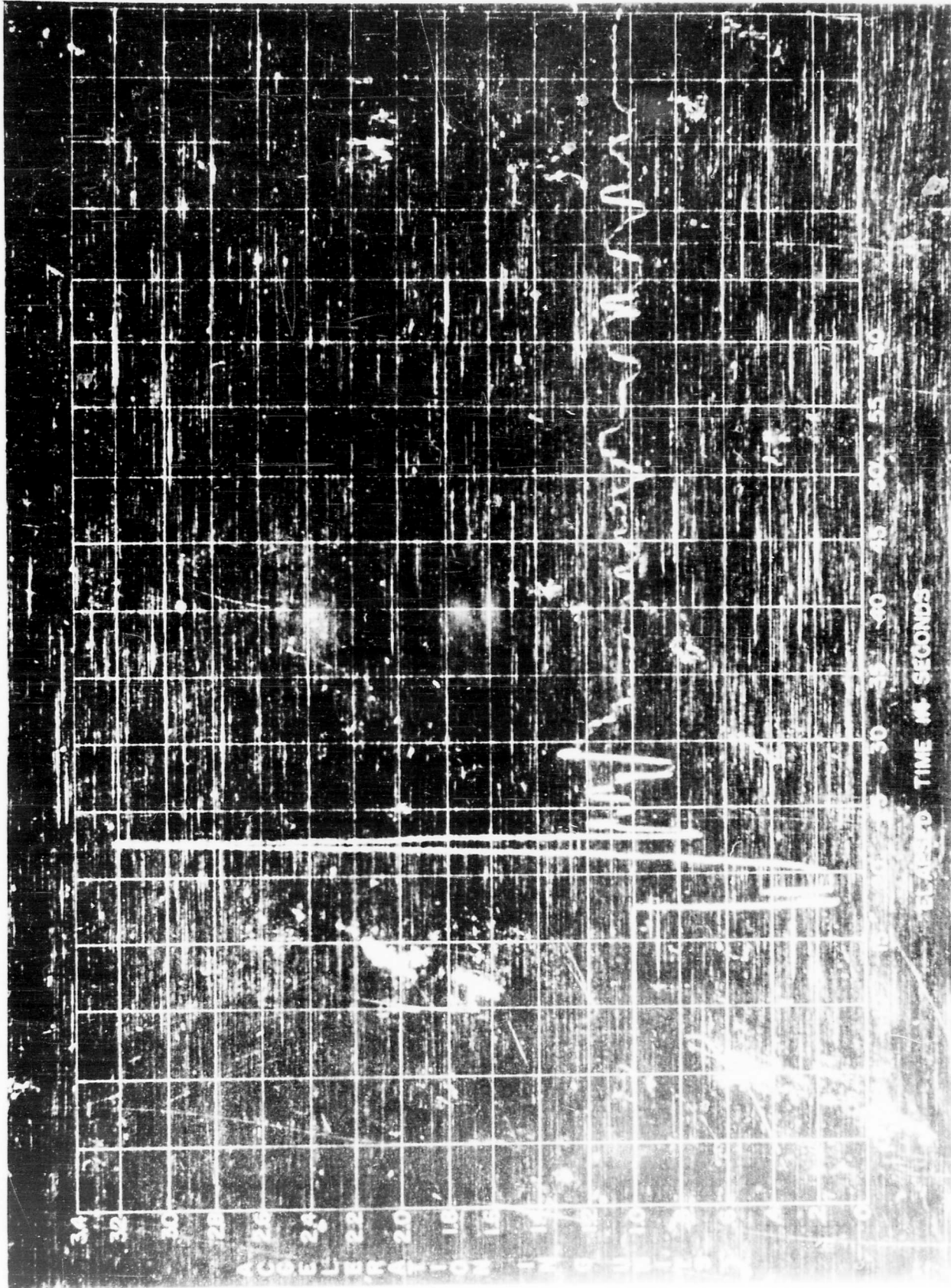

PARACHUTE OPENING SHOCK AS
RECORDED BY RYAN FLIGHT RECORDER

FIGURE 21

Flight Recorder indications.

For a load of 1,600 lb, the descent rate as a function of altitude is expressed in Figure 22. This curve has been calculated using a coefficient of drag of 1.32 which is a standard value for flat type parachutes.

This curve is the graphical presentation of the equation:

$$D = 1/2 C_D \rho S U^2 \quad (20)$$

where:

D = drag (lb)

C_D = coefficient of drag

ρ = density of atmosphere ($\frac{\text{lb} \cdot \text{sec}^2}{\text{ft}^4}$)

S = protected surface of parachute (ft^2)

U = descent speed (ft/sec)

In contrast to these descent rates as shown in Figure 22, it is of value to determine the terminal velocity of the gondola falling freely.⁸ Figure 23 shows this relationship and the necessity for well defined emergency procedures in the event of parachute failure.

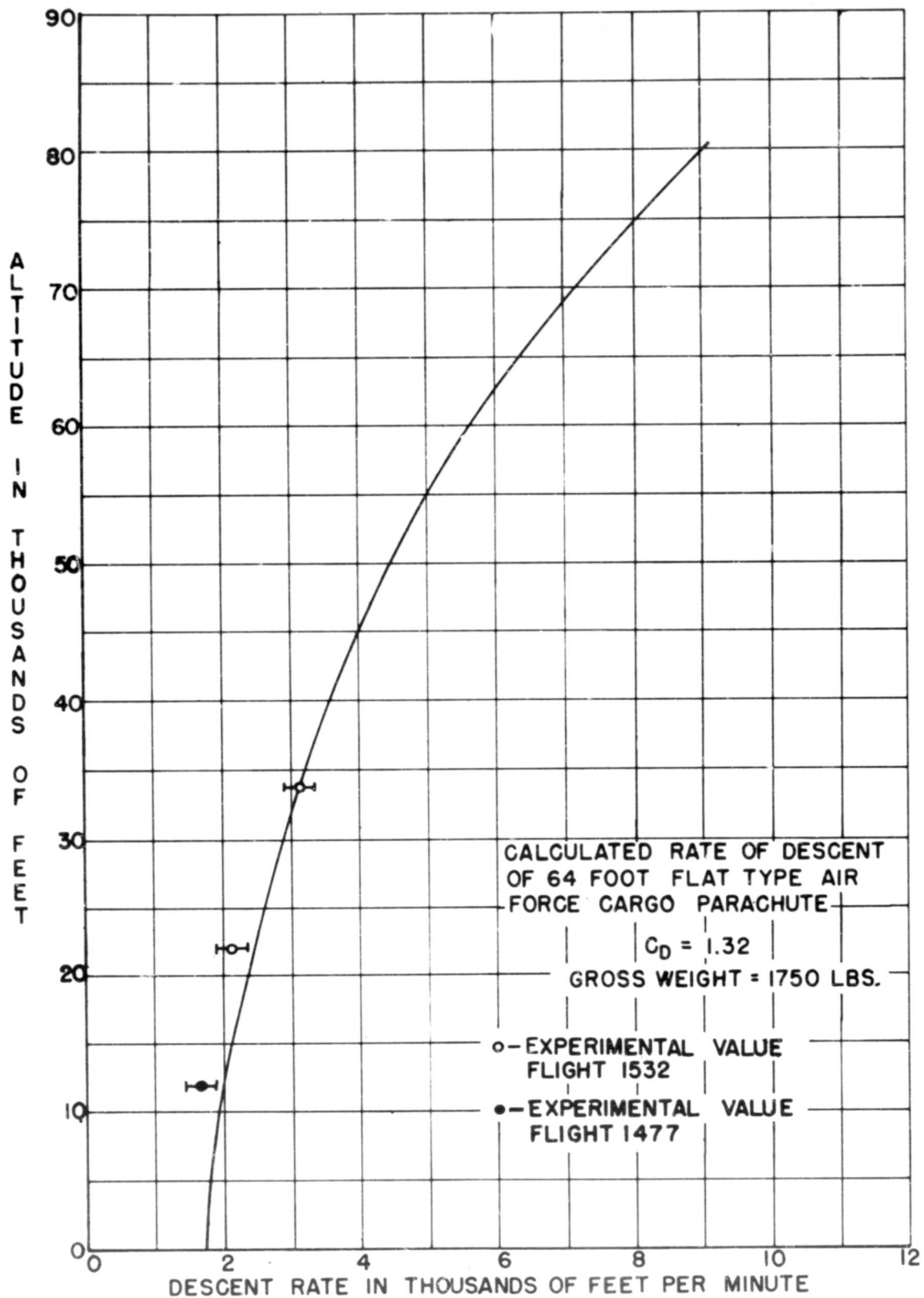

FIGURE-22.

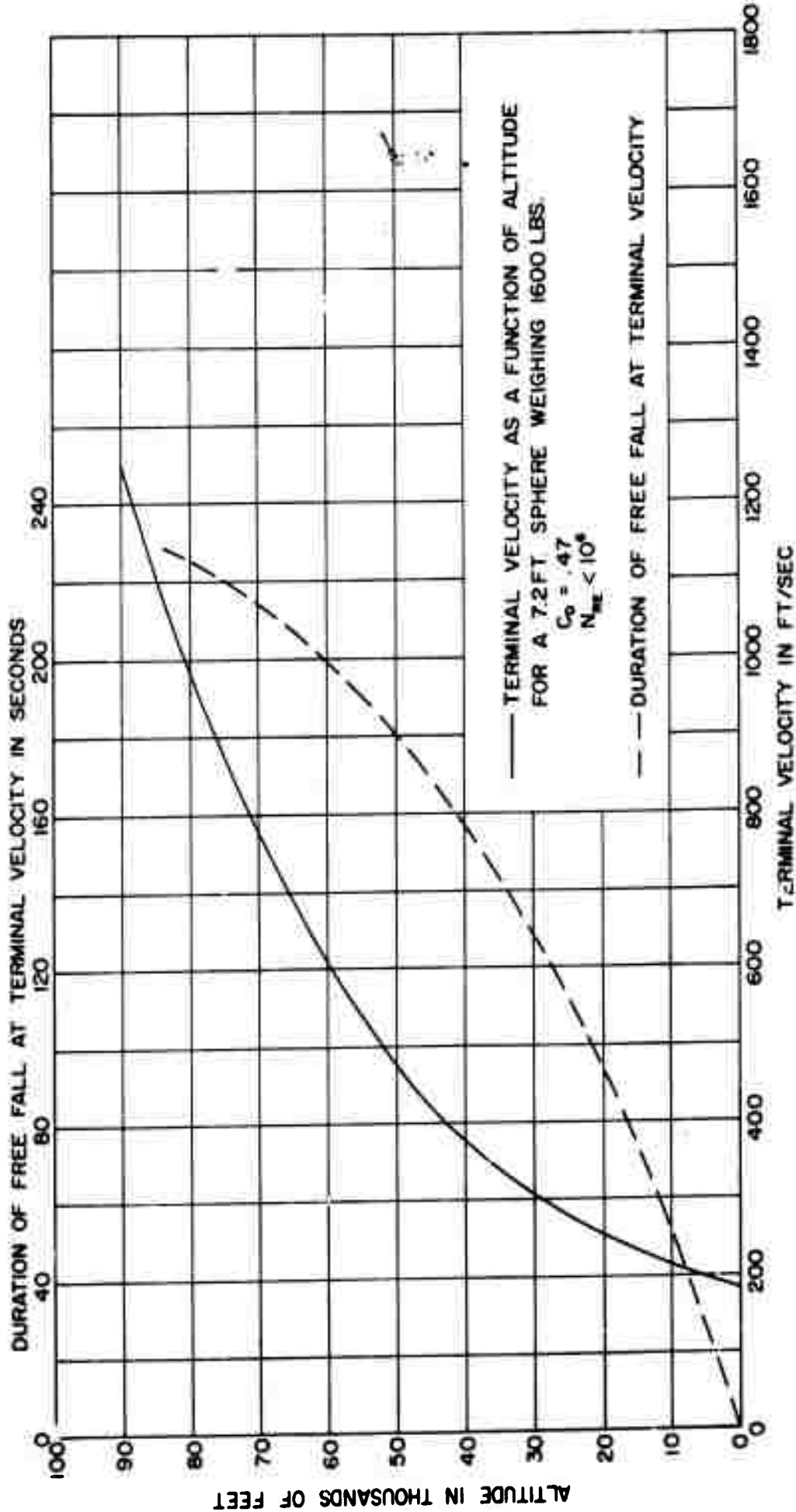

FIGURE - 23.

APPROXIMATE FREE FALL CHARACTERISTICS OF STRATO-LAB GONDOLA

Gondola

Atmospheric Requirements - The purpose of the closed gondola is to maintain an atmosphere at a pressure suitable for carrying out normal human functions. The composition of this atmosphere is also important. Certain maximum and minimum values of oxygen, carbon dioxide and water vapor must be maintained at all times. With regard to these physiological requirements, various inquiries were made in order to set down these values. The results of these inquiries are summarized in the following paragraphs.

The air inspired by a person at sea level includes a partial pressure of oxygen of 158 mm of Hg and a partial pressure of carbon dioxide of about 0.3 mm of Hg. The expired gas contains a partial pressure of oxygen of 116 mm of Hg, 28 mm of Hg of carbon dioxide and 47 mm of Hg of water vapor. This exchange is accomplished by means of the mechanical mixing and the diffusion of the inspired air with that within the lungs, the so-called alveolar air. The approximate composition of the alveolar air is 116 mm of Hg of oxygen, 28 mm of Hg of carbon dioxide and 47 mm of Hg of water vapor. The purpose, then, of any oxygen system is to maintain these levels in suitable zones such that normal physiological processes may continue.⁹

The requirements of a given oxygen system are determined not only by the maintenance of a set of partial pressures but also by the very nature of the system itself. This can be most easily exemplified if two distinct examples are considered, e.g., the so-called "open" and "closed" systems.

The "open" system is one in which all expired air is removed. An effective analogy would be that of a person wearing a mask and subjected to ambient pressure. Since a resting man inspires roughly 500 cubic centimeters per breath, and since he will take 10 to 14 breaths per minute, his total con-

sumption will be about 6 liters per minute. This inspired gas must, of course, be enriched with oxygen depending on the ambient pressure. The enrichment can only be carried so far, however, since there is an altitude limit which humans cannot safely exceed without artificial pressurization.

A "closed" system does not discard expired air, but simply removes carbon dioxide and excess moisture to permit re-use of the residual oxygen. From data presented earlier in this report it can be calculated that the actual consumption of oxygen by a resting man is about 300 cubic centimeters per minute. Therefore, in a system of this type it is only necessary to supply that oxygen required for metabolic consumption.

The two examples given above demonstrate the major difference between the two systems. The advantages and capabilities of one compared to another must not be evaluated on this basis alone, however. Such other factors as anticipated altitude, flight duration, necessary humidity control, etc. must also be considered.

Regardless of the system selected, the proper levels of the various gases must be maintained in the inspired air. Consider first the required densities of oxygen. Figure 24 shows the per cent saturation of hemoglobin as a function of the partial pressure of oxygen in the alveolar air. Since the partial pressure of carbon dioxide and water vapor within the lungs is 40 mm of Hg and 47 mm of Hg, respectively, the minimum necessary partial pressure of oxygen can be determined.* In Figure 24 it may be noted that the minimum partial pressure of oxygen required in the lung corresponds to about 55 mm of Hg. This means that the total pressure must never be lower

* Values obtained from Dr. Vail, Aero-Medical Research Section, WADC, Dayton, Ohio

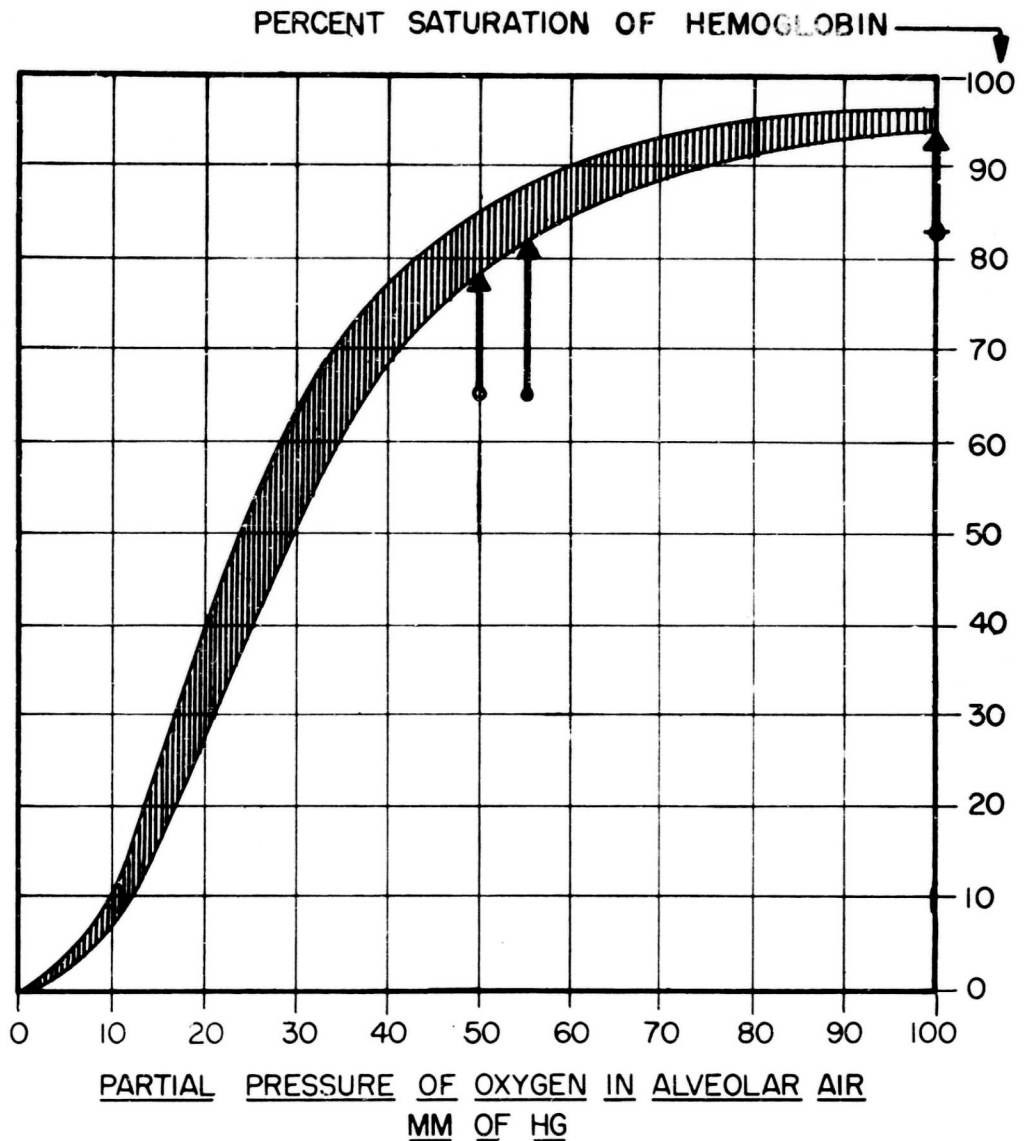

THIS CURVE HAS BEEN REPRODUCED FROM "PHYSIOLOGICAL BASIS OF MEDICAL PRACTICE" BY BEST-TAYLOR.

THE NOTES AT CRITICAL PARTIAL PRESSURES WERE OBTAINED FROM REFERENCE

- NO LONGER CAPABLE OF DOING TASKS
MINIMUM PARTIAL PRESSURE NECESSARY FOR NORMAL SUBJECT ACTIVITY
- ◆ PERSONNEL FUNCTION PROPERLY

REQUIRED OXYGEN PARTIAL PRESSURE IN ALVEOLAR AIR

FIGURE 24

than 40 mm +47 mm +55 mm = 142 mm of Hg. This value corresponds to an altitude of approximately 40,000 ft and is the limit to which humans should be exposed without artificial pressurization. Note that it is necessary to provide a supply of pure oxygen in order to provide sufficient quantities of oxygen to the body at this maximum altitude. A plot of the percentage of oxygen required in the inspired air as a function of altitude is shown in Figure 25.

The maximum permissible amount of carbon dioxide in an atmosphere extends over a range of values, some of which are presented in Table III. Certain investigators contend that the important consideration with regard to carbon dioxide concentration is the per cent of the ambient atmosphere and not the partial pressure. Others believe that the partial pressure is the determining factor, as is the case with oxygen.

Some question may exist regarding the maximum permissible partial pressure of oxygen. There are really two separate considerations here: (1) the physiological toxicity of high partial pressures of oxygen, and (2) the more rapid combustion of any flammable items in an atmosphere of increased oxygen density. One source indicates that 760 mm of Hg of oxygen can definitely be toxic when used over long periods of time.* The same source stated that a partial pressure of 500 mm of Hg can be tolerated for periods of time extending to 8 or 12 hours while a partial pressure of 300 mm of Hg could be tolerated for periods in the order of 24 hours. A Naval authority felt that an upper limit of 300 mm of Hg of oxygen was reasonable when considering both the toxicity and the added fire hazard.**

* Dr. Nello Pace, Department of Physiology, University of California, Berkeley, California

** Dr. Norman Barr, Director of Aviation Medicine and Research, USN Medical Center, Bethesda, Maryland.

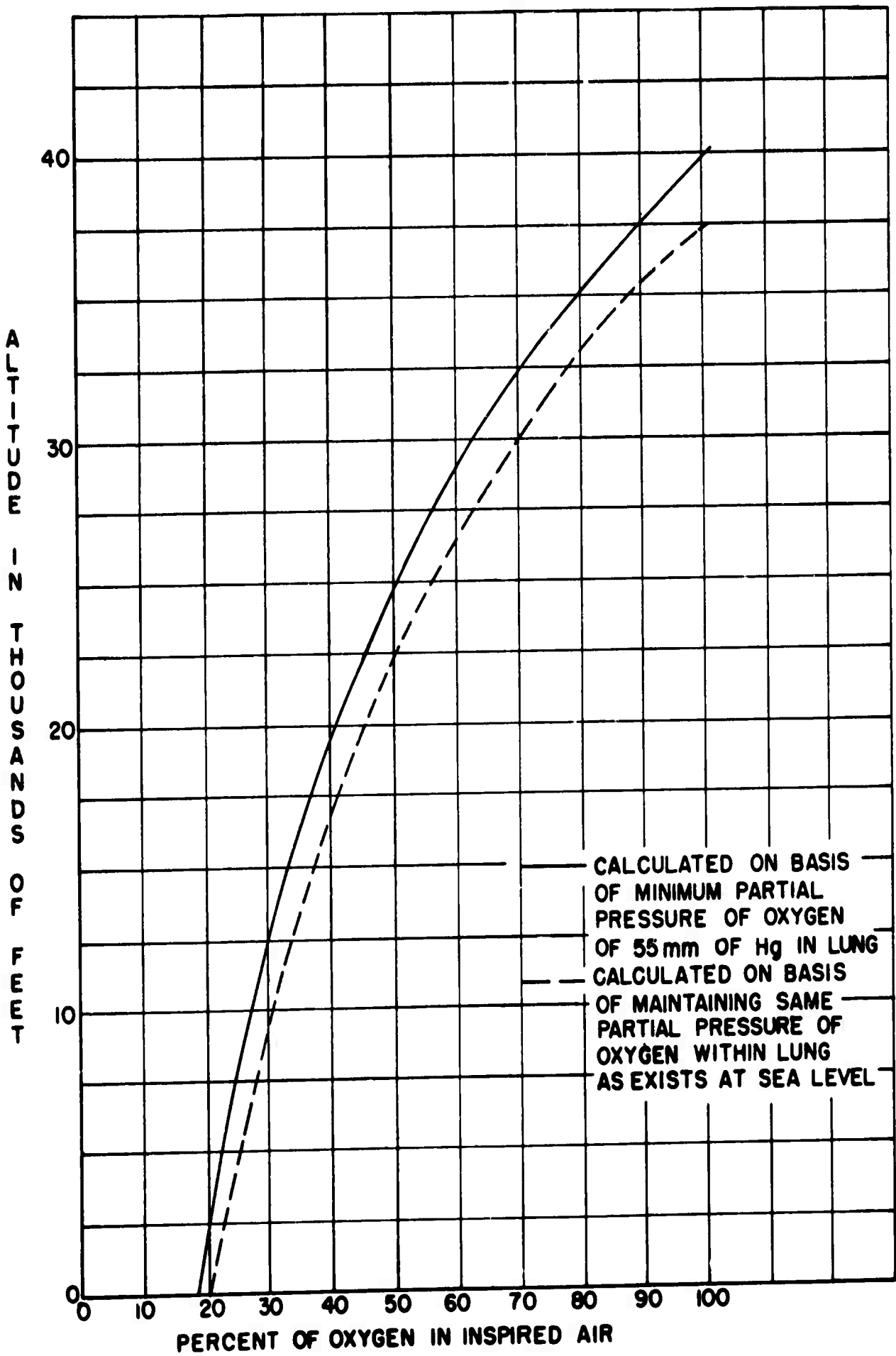

FIGURE-25
 OXYGEN REQUIRED EXPRESSED AS A
 PERCENT OF THE INSPIRED AIR

TABLE III

PHYSIOLOGICAL REACTION TO VARIOUS PARTIAL PRESSURES
OF CARBON DIOXIDE

Dr. Norman Barr, Director of
Aviation Medicine and Research,
USN Medical Center, Bethesda,
Maryland.

Should not exceed 0.6 per cent of gondola
atmosphere but could go up to 3 per cent
for very short periods or at end of
flight.*

Dr. Nello Pace, Department of
Physiology, University of
California, Berkeley, California

10 mm of Hg of carbon dioxide will stimu-
late respiration. 40 mm of Hg has been
tolerated by men in submarines for periods
up to 35 hours in emergencies. 55 mm of
Hg can be tolerated for a few hours with-
out causing 'unique' physical effects.
76 mm of Hg is dangerous.

Dr. F. Helmholtz, Medical and
Sciences Building, Mayo Clinic,
Rochester, Minnesota

Up to approximately 5 mm of Hg of carbon
dioxide causes no undue reaction. 7-10
mm of Hg will cause the subject to no-
ticeably over-ventilate. 20-30 mm of Hg
will cause the subject to become definitely
apprehensive.

Explorer II Report

0.5 per cent is maximum permissible level.
5 per cent will become dangerous in 30
to 60 minutes. 10 per cent is rapidly
fatal.**

"Air Pollution" by McCabe

5 per cent causes very labored breathing.
12 15 per cent is dangerous.**

"Physics and Medicine of Upper
Atmosphere", Chapter XI, by
H. Specht.

Level should not accumulate to over 2 per
cent of atmosphere.**

* With the selected gondola absolute pressure of approximately 387 mm of Hg
these values correspond to 1.93 mm of Hg and 11.6 mm of Hg of carbon
dioxide.

** These per cent values are presumed to be used at a full atmosphere of
760 mm of Hg rather than of the gondola atmosphere.

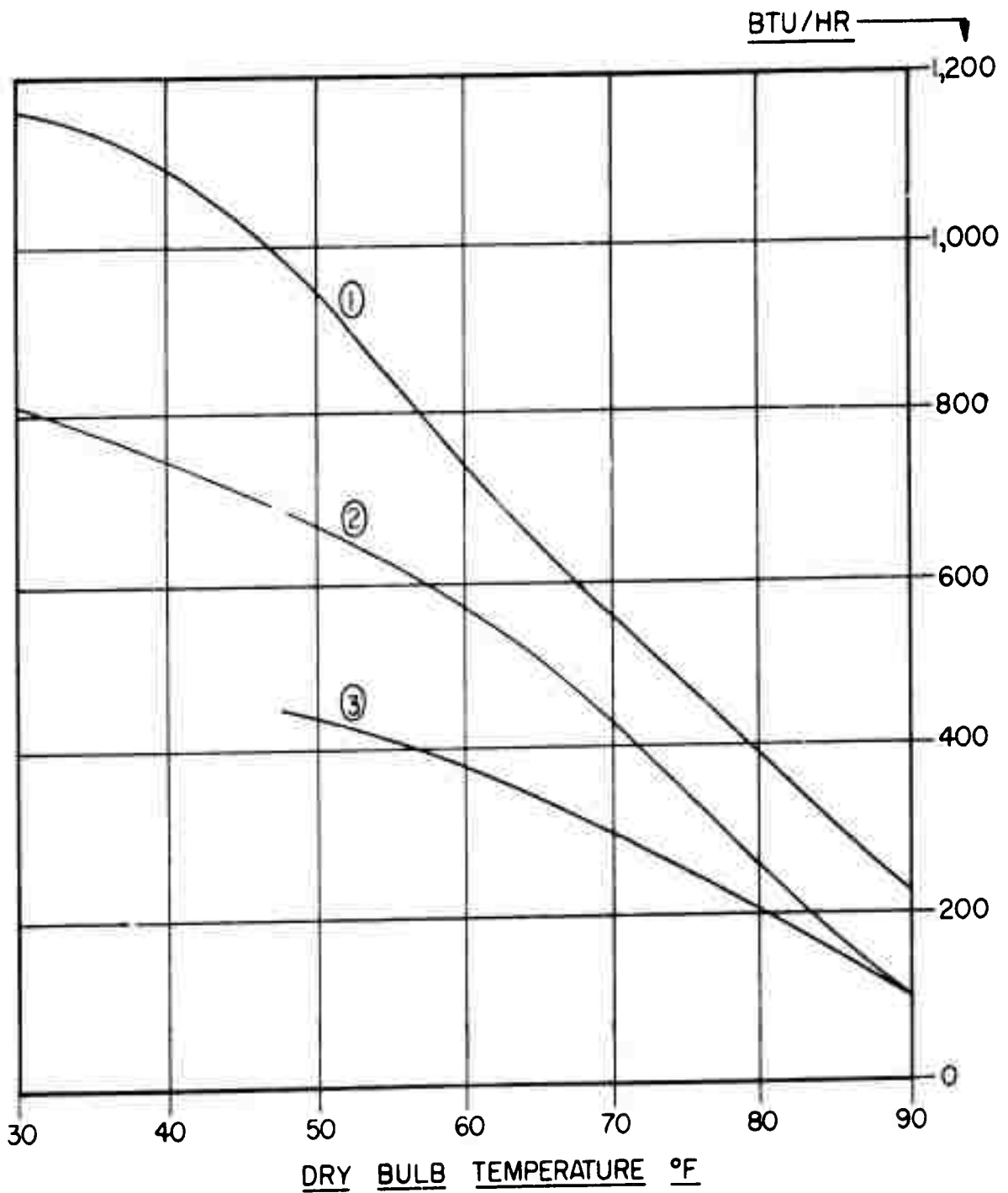

- ① PERSON WORKING, METABOLIC RATE 1300 BTU/HR
- ② " " " " 850 BTU/HR
- ③ PERSON SEATED AT REST, METABOLIC RATE OF 400 BTU/HR

Reproduced from HEATING AND VENTILATING GUIDE

FIGURE — 26.

HEAT LOSS BY RADIATION AND CONVECTION
FOR AVERAGE MAN

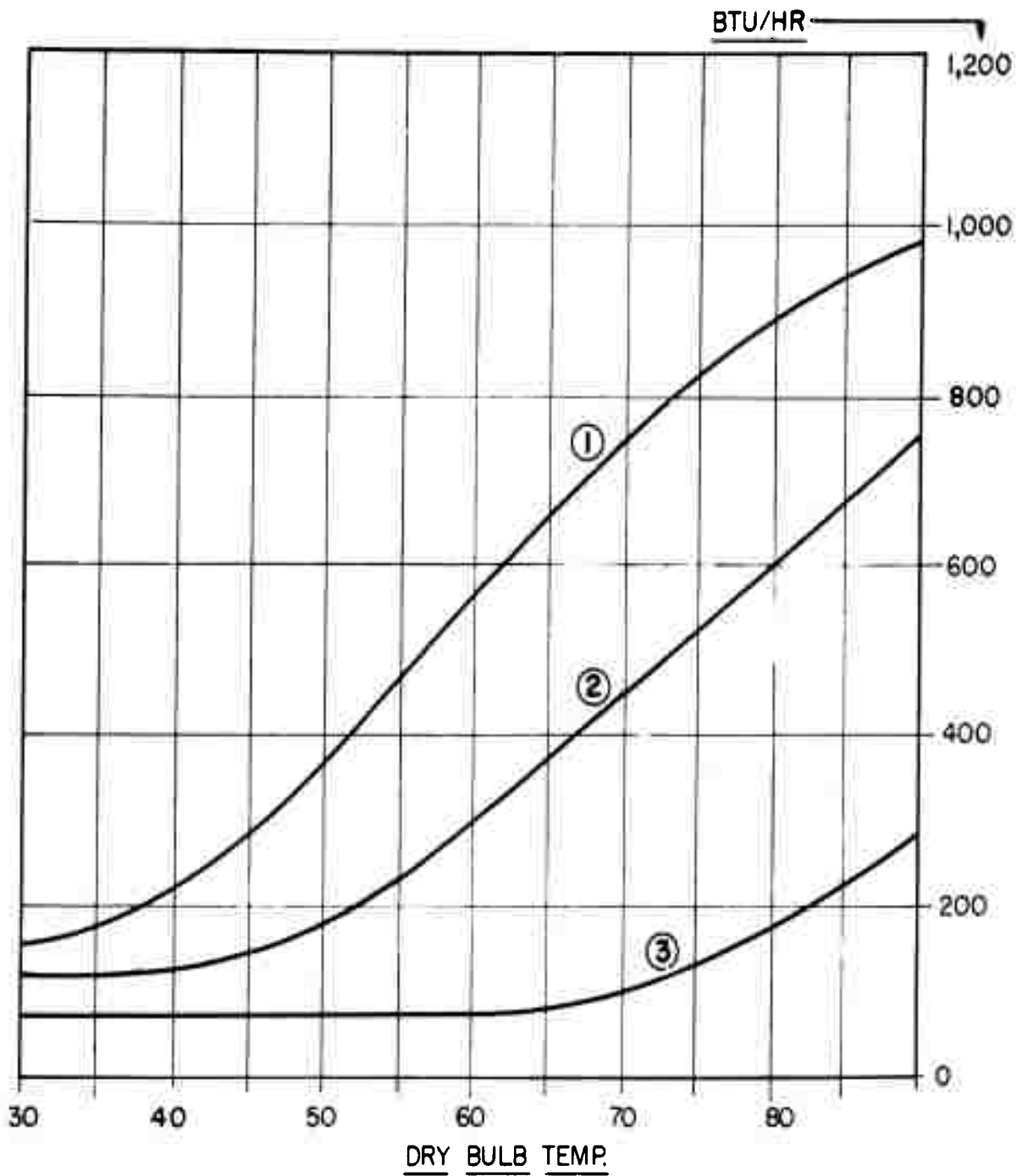

- 1 PERSON WORKING, METABOLIC RATE 1310 BTU/HR
- 2 " " " " 850 BTU/HR
- 3 PERSON SEATED AT REST METABOLIC RATE OF 400 BTU/HR

Reproduced from HEATING AND VENTILATING GUIDE
FIGURE - 27

**EVAPORATIVE HEAT
LOSS FOR AVERAGE MAN**

Fundamental in the consideration of the "closed" system are the human output and consumption rates of carbon dioxide, oxygen and water vapor. A survey of the information is presented in Table IV.

Aeroembolism - Aeroembolism, more commonly referred to as "bends", results when the rate of change of pressure on a human subject is higher than the bodily elimination of gases absorbed by the blood stream and certain tissues. The result is that nitrogen bubbles may form and cause disturbing effects in the subject. This is particularly true of the fatty tissues, which have a high affinity for nitrogen. A rapid change of pressure will cause nitrogen bubbles to form in these tissues and press against sensory nerves causing pain. This pain is usually centered at large body joints or may be evidenced by itching of the skin or sensations of heat or cold.

Pre-breathing of pure oxygen and slow decompression will help prevent bends. Once encountered, the bends may be alleviated by descent to a lower altitude. A more complete description of these effects may be found in any physiology textbook.

Summary - Certain of the basic information necessary to specify present requirements for a given system is now at hand. Since the maximum altitude will be significantly above 40,000 ft, it will be necessary here to pressurize the observers. Pressurization can be accomplished in either one of two ways, i.e., by use of a pressure suit or by use of a sealed chamber.

An original Strato-Lab concept expressed the desire for an environment which would in no way impede an experiment or scientific observations by an observer. Since full pressure suit technology had not been advanced to a point compatible with Strato-Lab requirements, a closed gondola system was selected. This gondola is a 7 ft-2 inch sphere constructed of 350 aluminum

TABLE IV

HUMAN OUTPUT AND CONSUMPTION OF OXYGEN, CARBON DIOXIDE AND WATER VAPOR

<u>Source</u>	<u>Carbon Dioxide Output</u>	<u>Oxygen Consumption</u>	<u>Water Vapor Output</u>
Dr. Vail, WADC, Dayton, Ohio	3.5 to 4 per cent of expired air or about 180 cm ³ /min for resting man at sea level	4 per cent of the inspired air is actually consumed (metabolic consumption); this amounts to approximately 300 cm ³ /min for a resting man at sea level	.6 to 1.8 lbs/day-man from the skin and about 1.7 lb/day-man from breath with ambient temperature of 80°F and relative humidity of 30 per cent
Explorer II Report	Approximately 680 cm ³ /min during normal exertion at 0°C, 760 mm of Hg	Approximately 1170 cm ³ /min during normal exertion at 0°C, 760 mm of Hg	Approximately 5.9 lbs/day-man
"Physics and Medicine of Upper Atmosphere", Chapter XI, H. Specht.	370 cm ³ /min for non-strenuous activity at 760 mm of Hg	Approximately 630 to 890 cm ³ /min for non-strenuous activity at 760 mm of Hg	-----
A. S. H. V. E. Research Report No. 908, "Heat and Moisture Losses from Men at Work and their Application to Air Conditioning Problems"	-----	-----	See Figures 26 and 27
General Mills, Inc., GMI Report 1648, See Section "Sea Level Test"	-----	Average of 275 cm ³ /min for each of two resting men for a period of 150 minutes (metabolic consumption)	-----

approximately 1/8 inch thick. It has been equipped with an atmospheric maintenance system designed to satisfy the above conditions for a period up to 12 hours.

Description of the Atmospheric Maintenance System

Pressure - In order to maintain the correct absolute pressure within the gondola a control valve was used which is ordinarily utilized in a current type of pressure suit. This valve uses oxygen gas from a liquid converter to maintain pressure at the proper level. It can be seen that controlling the internal pressure in this manner requires the knowledge of the "natural leak" of the gondola such that the oxygen partial pressure is well defined at all times. This particular aspect will be discussed later.

A pictorial diagram of the controller valve is shown in Figure 28. The oxygen converter is connected to the valve in the lower portion of the diagram. The oxygen, in a gaseous state, flows through the metering orifice into the control section and out the overboard vent beneath the absolute pressure control. As the absolute pressure decreases (gondola ascending), the absolute pressure control will expand and seal off the small overboard vent. This will cause a pressure increase in the control section, which will close the valve between the gondola and the large overboard vent. This increase in pressure is also large enough to cause the absolute pressure control to open slightly. The absolute pressure control, therefore, seeks an equilibrium position which will allow the metered gas to continue going overboard, but will cause a finite pressure drop in passing through the control section. The gondola is "sealed" in this manner at an altitude determined by the absolute pressure control. If the pressure within the gondola begins to decrease due to a leak, the diaphragm in the demand section is pushed down by the pressure

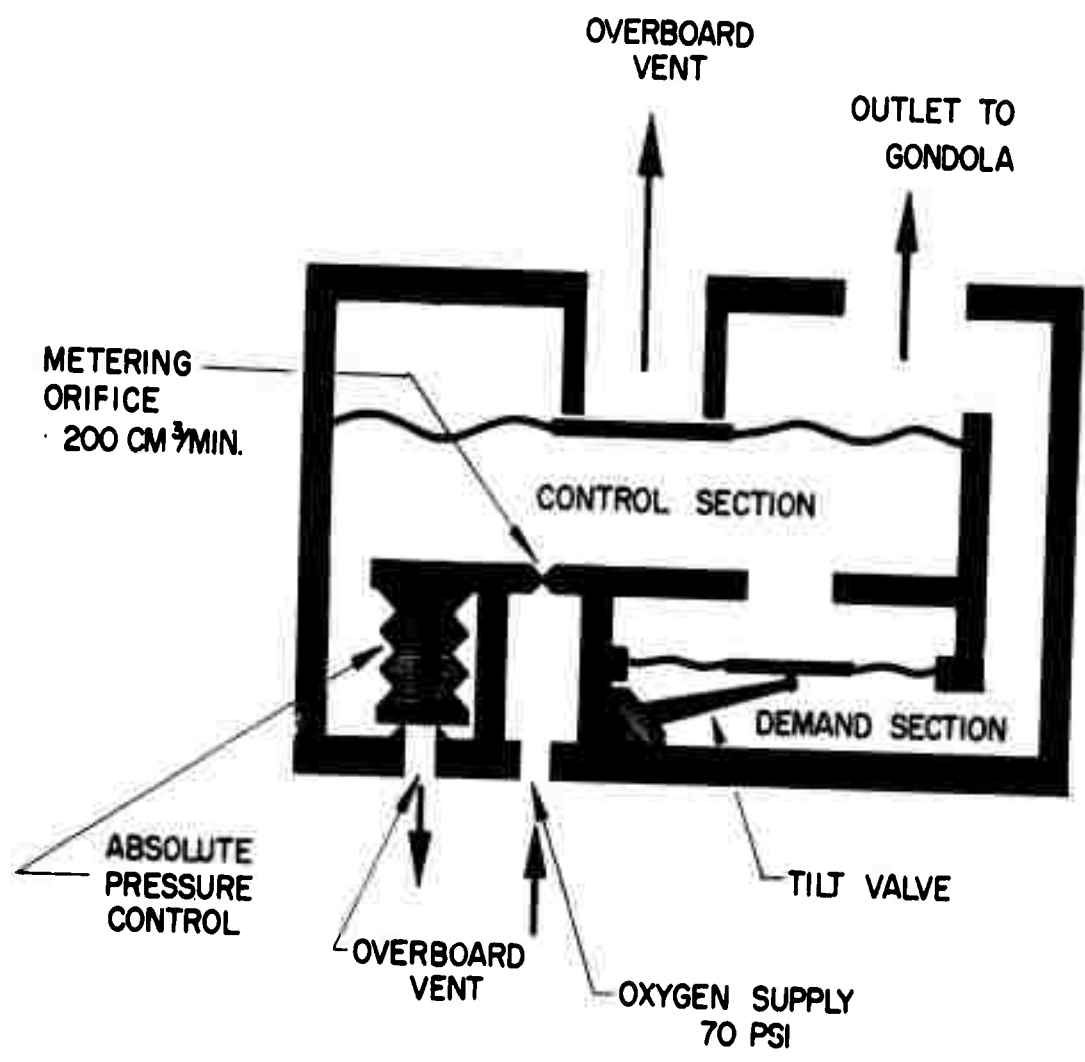

FIGURE —28.

**PICTORIAL DRAWING
OF CONTROLLER VALVE**

MANUFACTURED BY
FIREWEL INC.
BUFFALO, N.Y.

in the control section and the tilt valve spills gas into the demand section, building up pressure within the gondola. This valve is shown in Figure 29. Figure 29 also shows the manually operated toggle valves which connect the controller valve to the system. These three units are used to isolate the controller valve in the event of its failure or if it is desired to control the gondola's equivalent altitude at any desired value. In the gondola, the valves were located directly under the oxygen converter. Figure 30 is a schematic of the pressurization-oxygen system.

Oxygen Supply - The oxygen supply is in the liquid state in order to reduce the over-all equivalent weight. For a 5 liter liquid oxygen converter, we have available approximately 4,150 liters of oxygen STP. Such a system weighs approximately 36 lb with all of its associated equipment. Therefore, we have roughly 115 liters of oxygen STP per pound of weight. An ordinary oxygen cylinder weighs about 135 lb and contains 5,720 liters of oxygen STP. The cylinder then provides 42.4 liters of oxygen STP per pound of weight, about 37 per cent of the 5 liter liquid system. It is recognized that the weight penalty of a gaseous system increases as the requirements are increased. The only reason in making this comparison is to demonstrate the relative massiveness of small liquid oxygen systems. Since the weight of the dry 5 liter system is slightly more than twice the weight of the oxygen it contains, it seemed worthwhile to investigate to some extent an unpressurized, lightweight type converter.

The simplest, lightest form of an unpressurized oxygen converter is probably a Dewar flask, which exposes the surface of the liquid to the ambient atmosphere. The liquid will boil off slowly at a rate approximately proportional to the area of this surface and at a rate independent

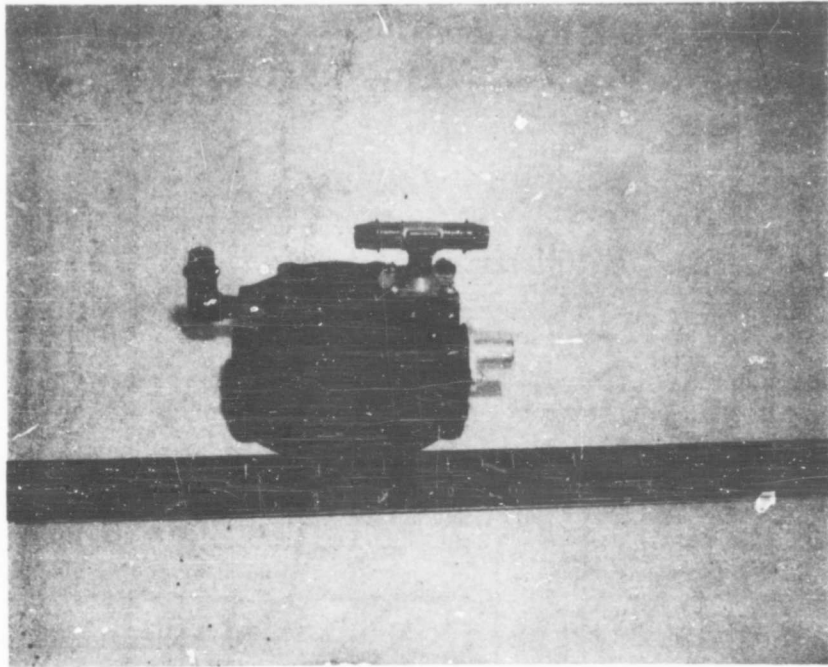

CONTROLLER VALVE, MANUFACTURED BY
FIREWELL INC., BUFFALO, N.Y.

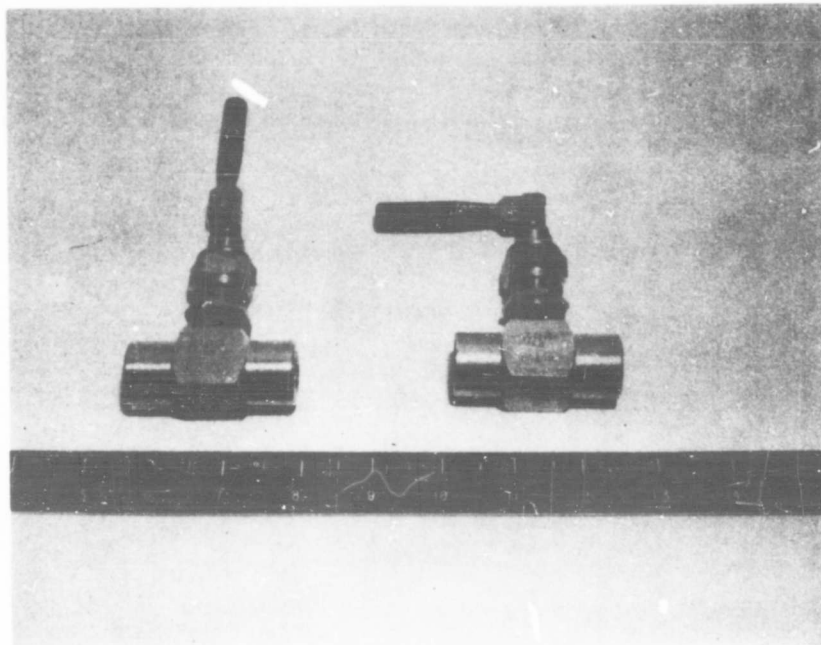

TOGGLE VALVES, MANUFACTURED BY
HOKE INC., ENGLEWOOD, N.J.(PART #PS492)

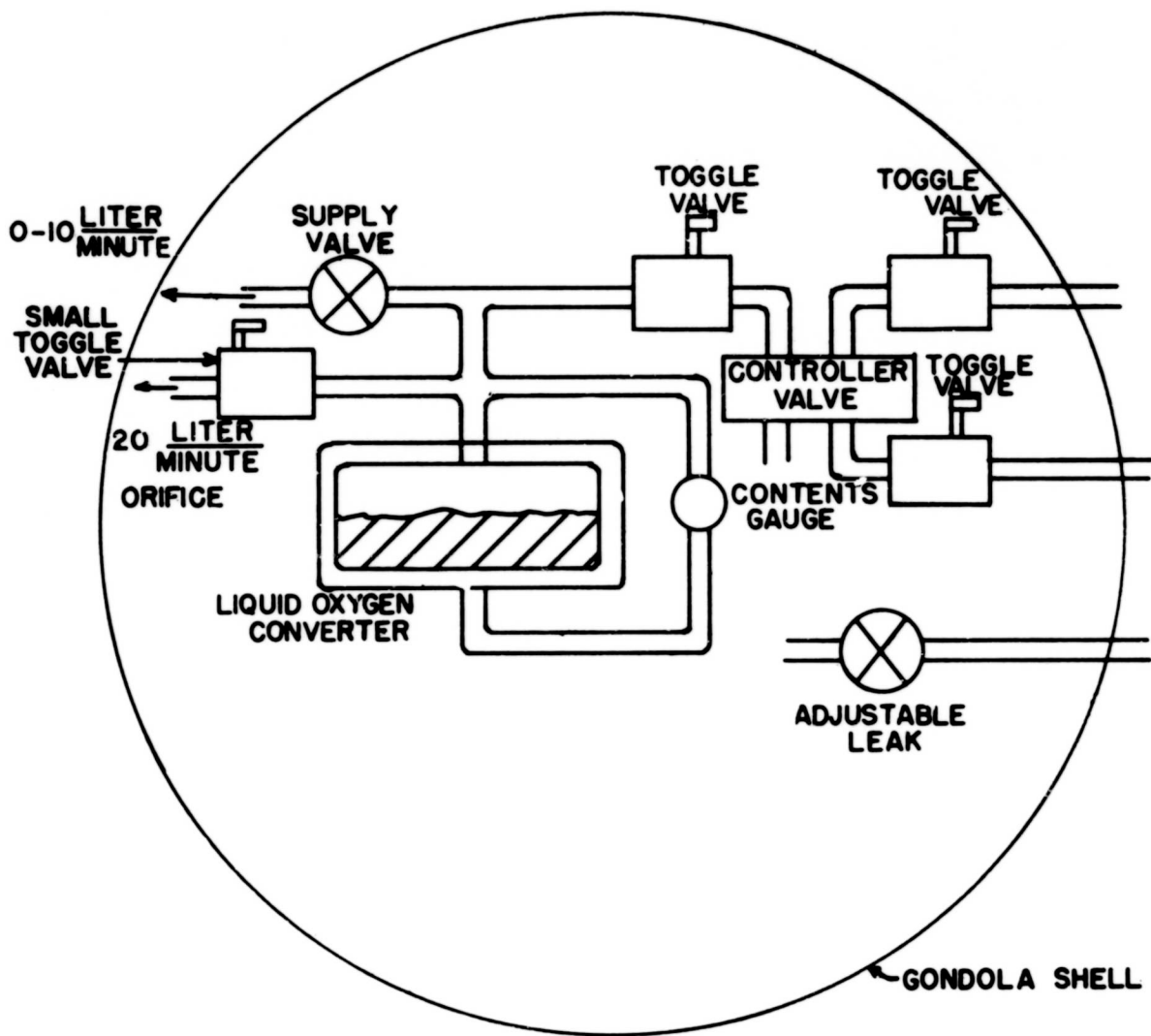

PICTORIAL DIAGRAM OF PRESSURIZATION-OXYGEN SYSTEM
 FIGURE-30.

of the ambient pressure. Data have been collected from such a system which support these two statements (see Figure 31). The most significant fact demonstrated by this curve is that heat exchange is accomplished primarily through radiation, and that, therefore, the boiling rate is almost independent of ambient pressure.

One other interesting point demonstrated by this curve is the initial period during the test conducted at an ambient pressure of 375 millibars. Note that the initial rate here is significantly faster than its later rate. This is due to the necessary lowering of the boiling point of oxygen during the reduction of ambient pressure. The amount boiled off in lowering the temperature of the liquid may be calculated approximately as follows:

$$\begin{array}{l} \text{Heat to be removed to} \\ \text{lower temperature of} \\ \text{liquid} \end{array} = \begin{array}{l} \text{Heat lost by} \\ \text{boiling liquid} \end{array}$$

or:

$$m_o K (T_o - T) = m_L L$$

where:

- m_o = total mass of liquid (gm)
- K = specific heat
- T_o = boiling point at atmospheric pressure ($^{\circ}K$)
- T = boiling point at reduced pressure ($^{\circ}K$)
- m_L = mass of liquid lost in boiling
- L = heat of vaporization (cal/gm)

The percentage loss in the process of pressure reduction is approximately:

$$\frac{m_o}{m_L} = \frac{L}{K(T_o - T)} \quad (1)$$

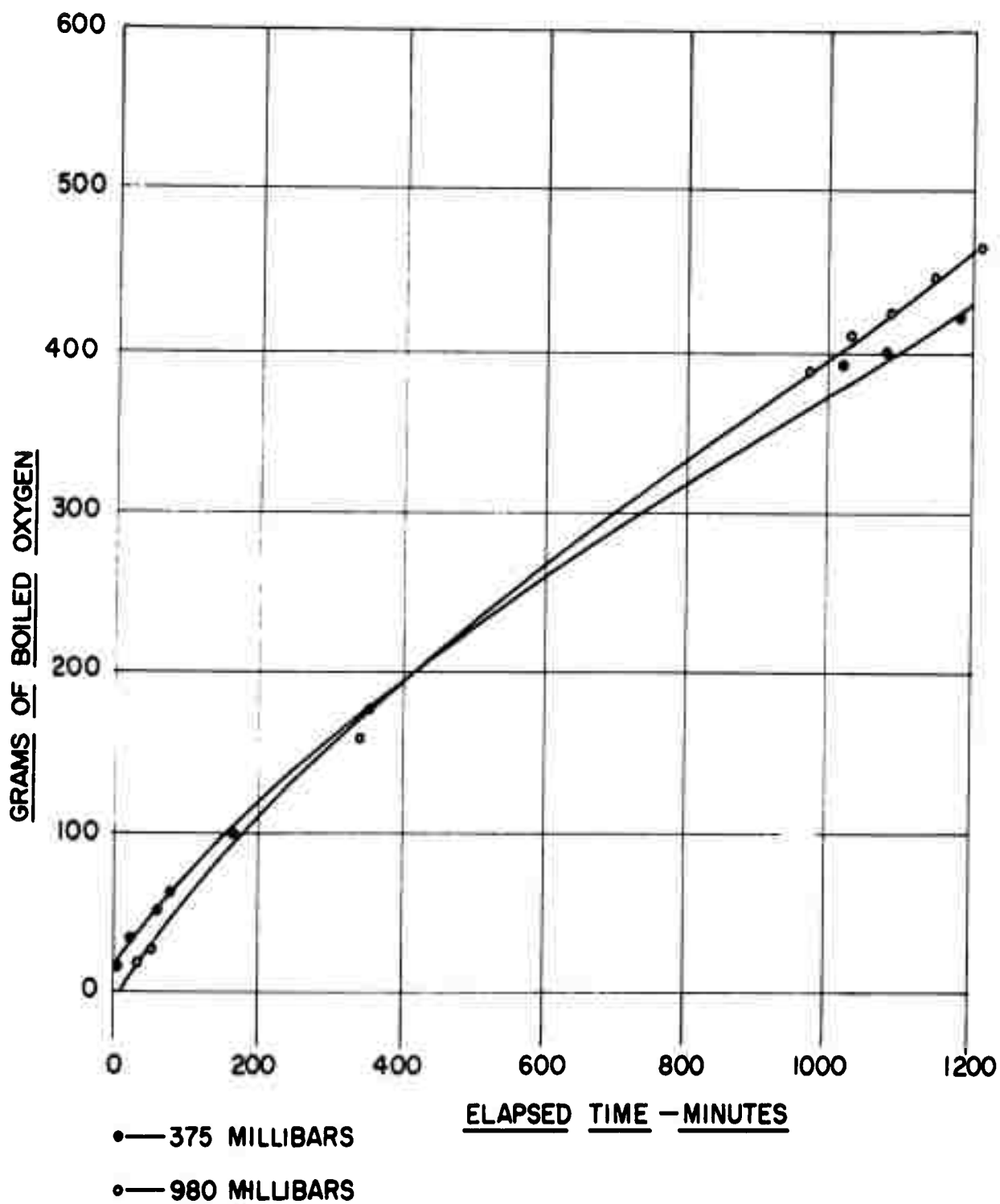

FIGURE — 31.

BOILING OF OXYGEN FROM OPEN MOUTHED DEWAR

The boiling point of oxygen as a function of pressure may be found in any handbook.

The control of such a converter can be achieved in any one of a number of simple ways. One of these is to provide a variable conducting surface to insert into the liquid. Another would be to provide an electrically controlled heater which boils oxygen off at the desired rate. Such a system could have a net dry weight of no more than 20 per cent of the liquid weight. The whole unit could be very simple, compact, light, and could be utilized on a vehicle with the high stability of a balloon.

Since the pressure controller utilized by the gondola required a source of finite pressure relative to ambient, a commercially available 5 liter converter was utilized. This converter and associated equipment was built into a compact unit complete in itself. Appropriate manifolds were provided such that any number of conceivable systems could be supplied by this unit.

The complete converter system is shown in Figure 32. The control at the upper right is the variable orifice which discharges oxygen at the desired rate. The gauge at lower right indicates the amount of liquid remaining in the converter. The control located at the panel top center is a toggle-type valve which opens a comparatively fast discharge orifice. This orifice stops the decrease of the oxygen partial pressure at any desired level during the gondola ascent. The orifice is a No. 50 hole and has a calibrated discharge rate of about 20 liters per minute at the converter operating pressure of 70 psi. The gauge in the lower portion of the panel indicates the operating pressure of the converter. The control in the lower left is the "build up and vent" valve which opens or seals the converter from the ambient

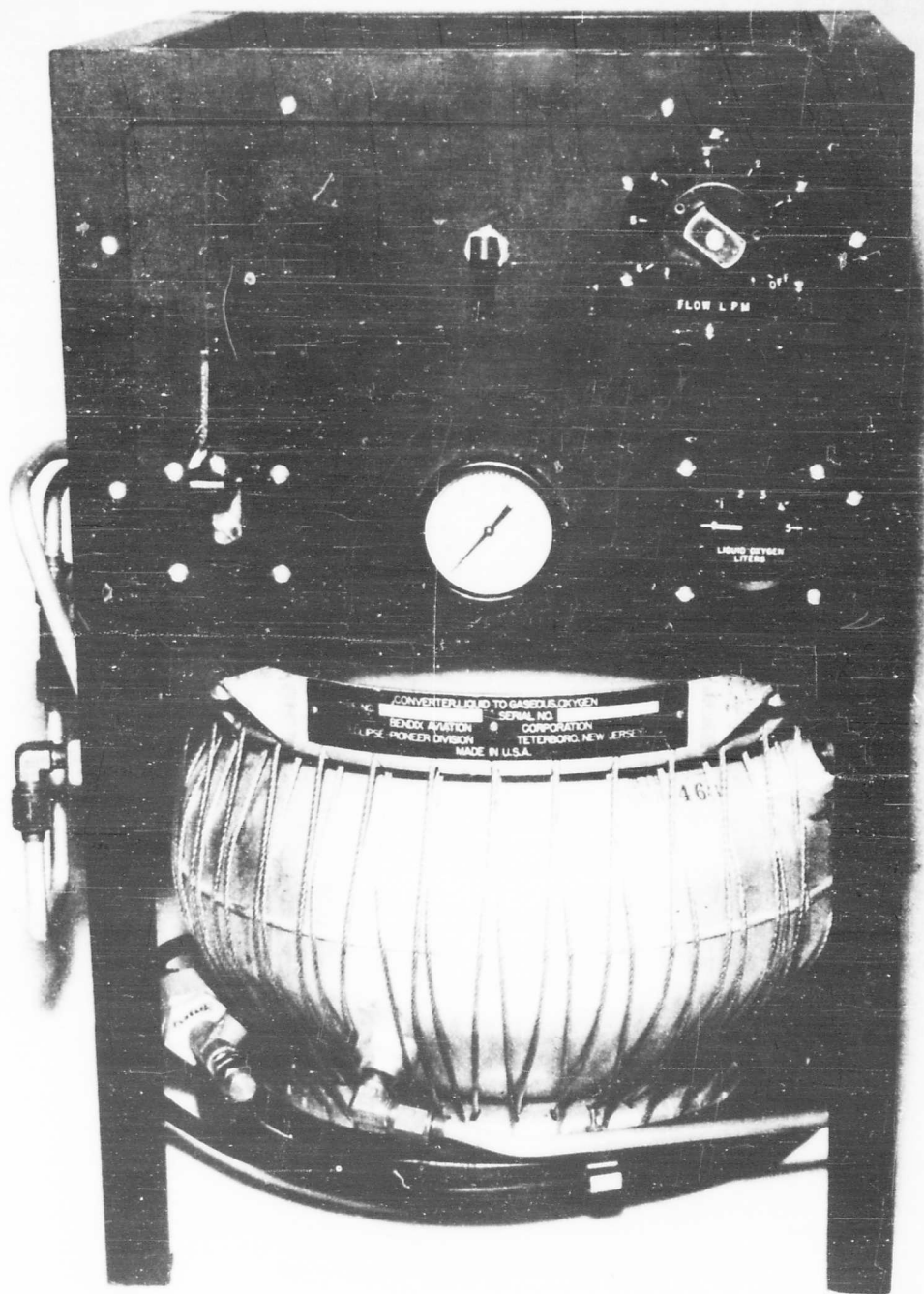

COMPLETE OXYGEN PRESSURIZATION
SUPPLY WITH CONTROLLING AND
MONITORING EQUIPMENT

FIGURE 32

atmosphere during the filling and operating periods. This unit weighs 34.7 lb; another similar unit weighed 35.7 lb.

Pressurized and unpressurized "no flow" tests were made on each of these converter systems. Results showed that (1) when pressurized (but with both orifices closed), the loss of liquid was 7.02 lb/day for each of the converters, and (2) when unpressurized, the loss was 1.8 and 2.5 lb/day. This is a measure of the heat exchange occurring in each case and is within the limitations prescribed by the manufacturer.

Each of the contents gauges were calibrated for dial reading as a function of head of fluid. The gauges were found to be fairly accurate (± 0.1 liter) over their entire range at room temperature. Readings did, however, vary significantly when the converters were discharged rapidly or the equilibrium pressure above the liquid was in some way disturbed. Accuracy was restored when the equilibrium conditions were again attained.

Some question may exist as to the output capacity of this type converter under low temperature and low ambient air density conditions. It was calculated that, even if the unit were in a vacuum, the purely radiative heat exchange between the boiling coil and the surroundings (assumed to be at -40°C) could supply about 100 watts of power to the coil. This would be more than ample for the requirements of the system.

Measurement and Recording of Oxygen Level - The oxygen partial pressure within the gondola was determined by two Beckman oxygen analyzers. The Beckman unit operates on the paramagnetic property of oxygen. A dumbbell-shaped glass container of lower magnetic susceptibility than oxygen is suspended between the two poles of a permanent magnet whose field is non-uniform. An increase of oxygen density around this dumbbell will cause it to rotate

into an area of lower flux density, thus moving a mirror attached to its suspension. The instrument is read in the same way as laboratory-type galvanometers.

Two of these devices were used, one operated manually by an observer and the other operated automatically. The automatic unit was designed by General Mills. The heart of this unit is a Beckman analyzer, but certain modifications were necessary to enable it to take its own air sample and record the corresponding partial pressure. An illuminated dial gives continuous indication of the partial pressure at all times. A pictorial of this unit is shown in Figure 33 and a photograph of the unit in Figure 34. Note in the pictorial that the light beam is divided by the glass plate, the reflected beam moving vertically to a camera which continuously advances film and records the oxygen level.

At one time in the gondola development, it was thought desirable to "automate" the partial pressure of oxygen within the gondola. This was the actual purpose of this automatic oximeter, and it was constructed for that operation. Instead of using an illuminated dial to indicate the present partial pressure of oxygen, four photocells located along this dial were stimulated by the reflected light beam as it passed certain specified points. The output of each photocell was amplified by a one-stage amplifier fed into a relay network. This network actuated a servo system which drove an oxygen valve to certain pre-set discharge rates. Since the "natural leak" and human oxygen consumption were well enough defined, however, it was not necessary to automate this control. The servo link in the gondola was removed, but the oximeter remained to record the oxygen partial pressure continuously.

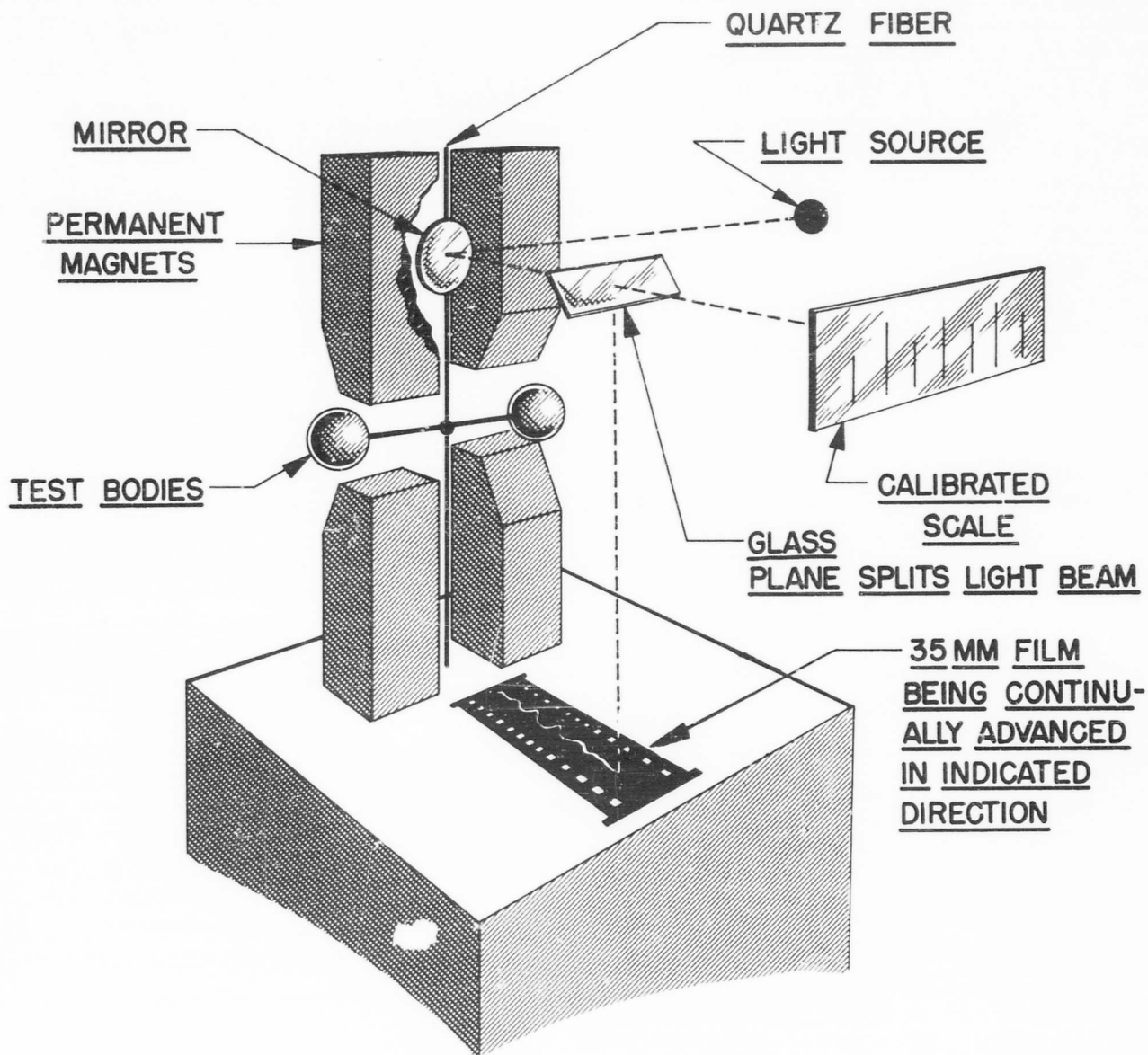
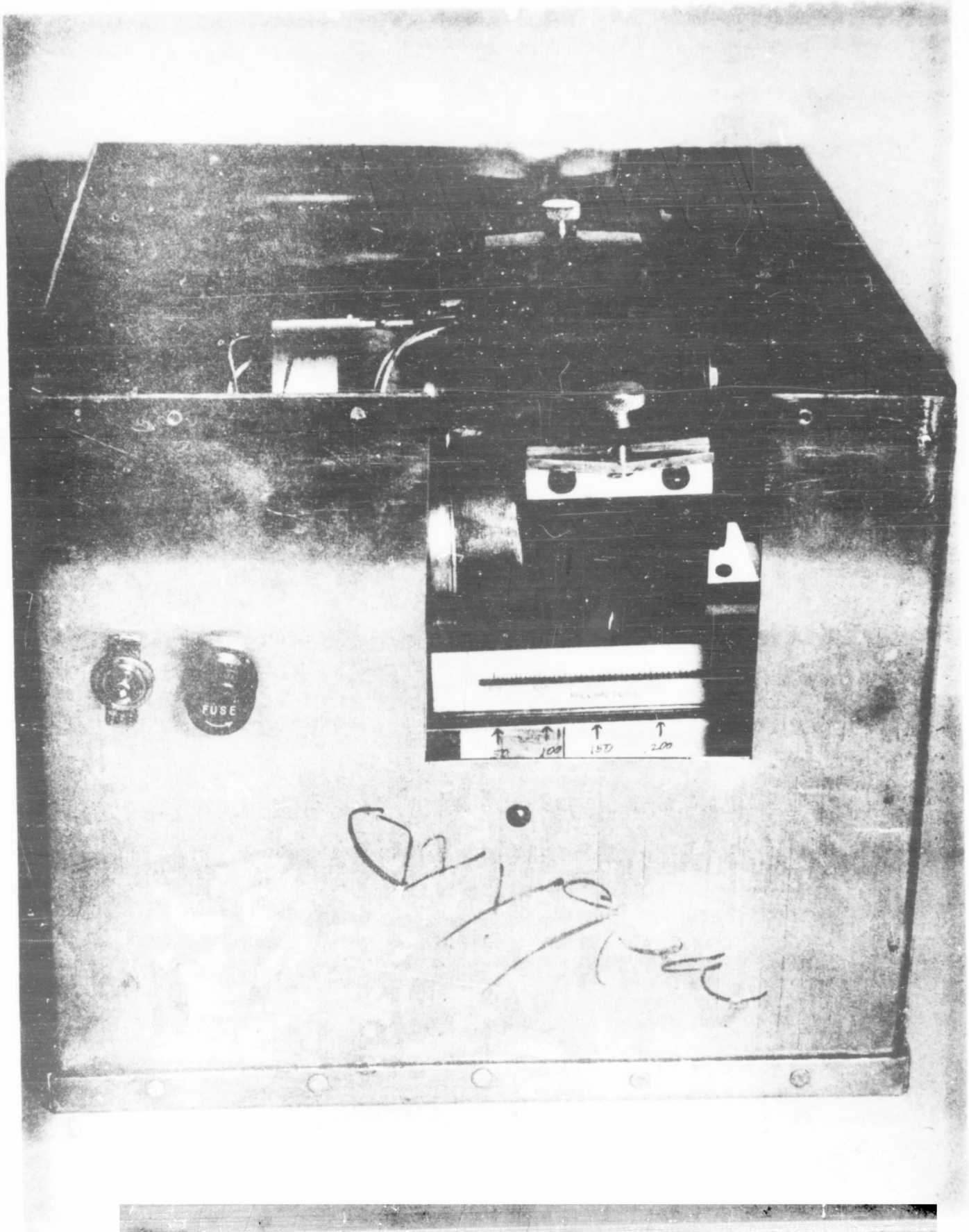

FIGURE - 33.

PICTORIAL OF RECORDING OXIMETER



AUTOMATIC MONITORING AND RECORDING OXYMETER
FIGURE 34

11

Carbon Dioxide Removal System - Carbon dioxide may be removed from

an enclosed area, e.g., a cabin, in a number of ways: (1) a liquefied gas (e.g., the liquid oxygen supply) may be used to condense the carbon dioxide; (2) the carbon dioxide may be absorbed by using scrubbers or packed towers; or, (3) removal of carbon dioxide may be accomplished by use of solid absorbents.

The second system seemed generally undesirable for airborne use. The first system was not evaluated but seems to have some real possibilities for high altitude balloon flights and deserves careful consideration, not only for carbon dioxide removal, but for water vapor removal. A solid absorbent system had been selected for this purpose before General Mills began work on this program, and time did not permit a re-evaluation of this selection. Lithium hydroxide was selected because it has the best theoretical capacity for carbon dioxide of any absorbent now available, i.e., 1.08 lb/lb of carbon dioxide. Its capacity is virtually independent of the partial pressure of carbon dioxide and it is the only absorbent which retains its full activity at temperatures as low as 35°F. Since it will react both physically and chemically with water, the chemical was kept separate from the moisture removal system.

Lithium hydroxide (LiOH) is a fine powder and will dust. The dust is very irritating to mucous membranes and can be avoided by using filters. In this case, the powder was placed in open bottom trays and enclosed by layers of cloth and a large mesh screen. A stiff layer of screen was laid in the tray, supported by the edge, then a layer of cloth, about 0.25 inch of lithium hydroxide, a layer of cloth and the heavy screen on top. A complete tray is shown in Figure 35. Four such trays, each containing approximately

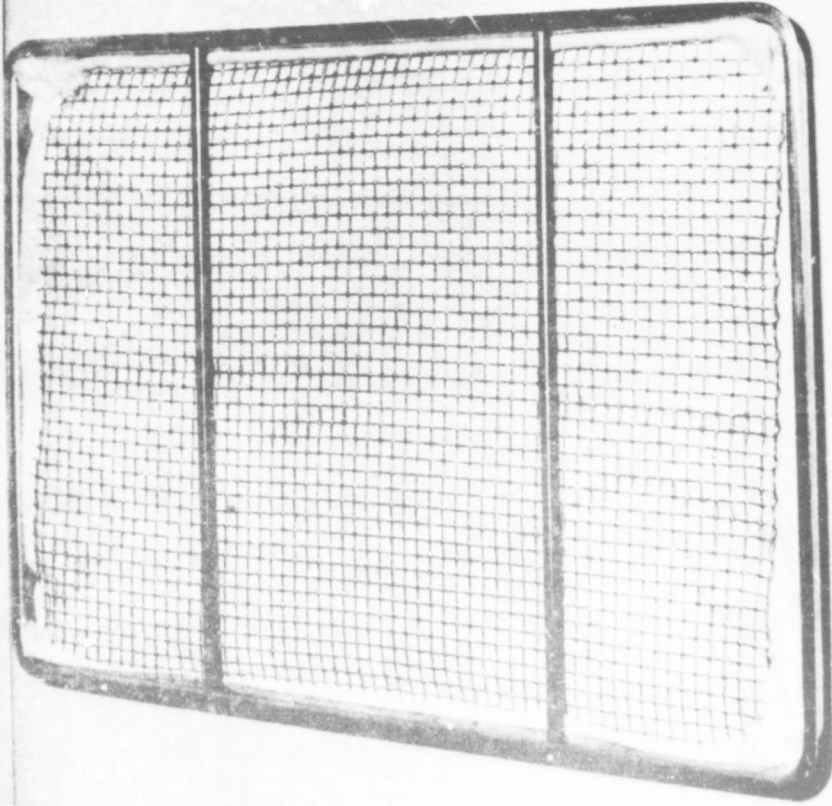
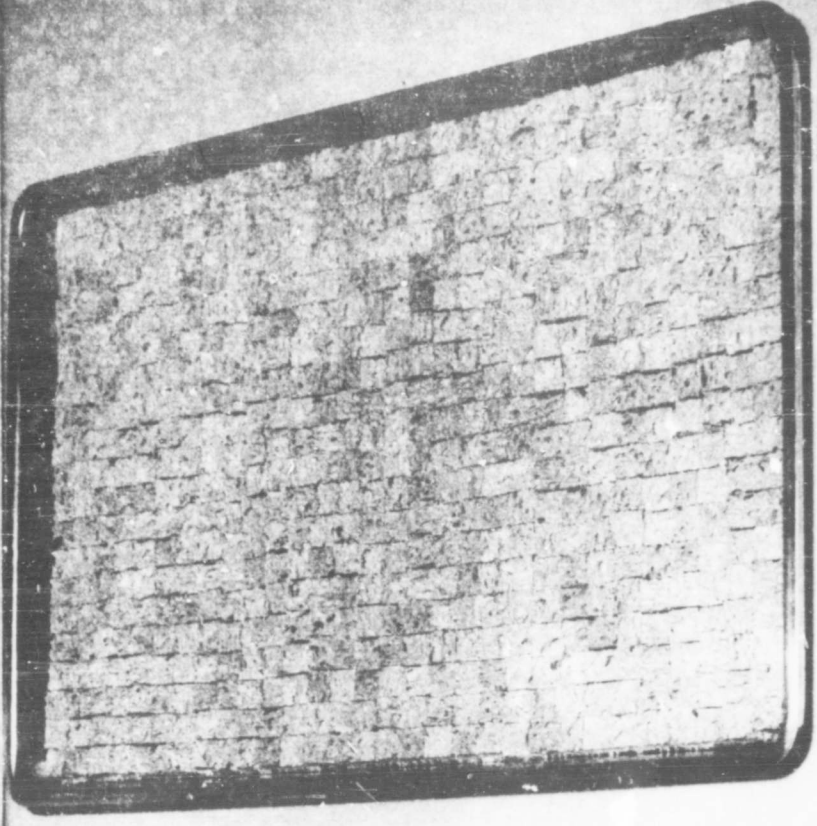

TRAYS CONTAINING LiOH (LEFT) AND
SPONGES CARRYING LiCl (RIGHT)

650 grams of lithium hydroxide were used to keep the carbon dioxide level within the required limits. The dimensions of the tray are 1 inch x 15.5 inches x 10.5 inches. The four trays containing lithium hydroxide along with trays containing the water vapor desiccant were located in a 0.25 inch plywood box. A centrifugal fan mounted on top of this container circulated the gondola air over the staggered trays with a volume flow of approximately 20 cubic feet per minute. A pictorial of this unit is shown in Figure 36. Since the absolute pressure within the gondola had not yet been selected, we chose to determine the approximate relative efficiency of lithium hydroxide at a reduced pressure in relation to that at sea level. This effect is shown in Figure 37. The curve labeled lithium hydroxide pellets was made to compare the relative efficiency of both pellet and powder forms.

Measurement and Recording of Carbon Dioxide Level - A survey of advertising literature on carbon dioxide analyzers was made with initial emphasis on infrared detection of carbon dioxide. Commercially available systems for infrared detection of carbon dioxide were ruled out because of excessive weight and large power requirements. Since the development of a unit specifically for this job was beyond the scope of this project, an alternative was sought.

Thermco Company, Michigan City, Indiana proposed to build a carbon dioxide analyzer operating on the principle of the measurement of differential heat conduction through two gas samples. Since such a unit already existed and the main problem was the design of more sensitive associated circuitry, this job was undertaken by Thermco Company.

This instrument is a Wheatstone bridge using thermistors for two of the arms. A voltage applied to the bridge raises the temperature of the

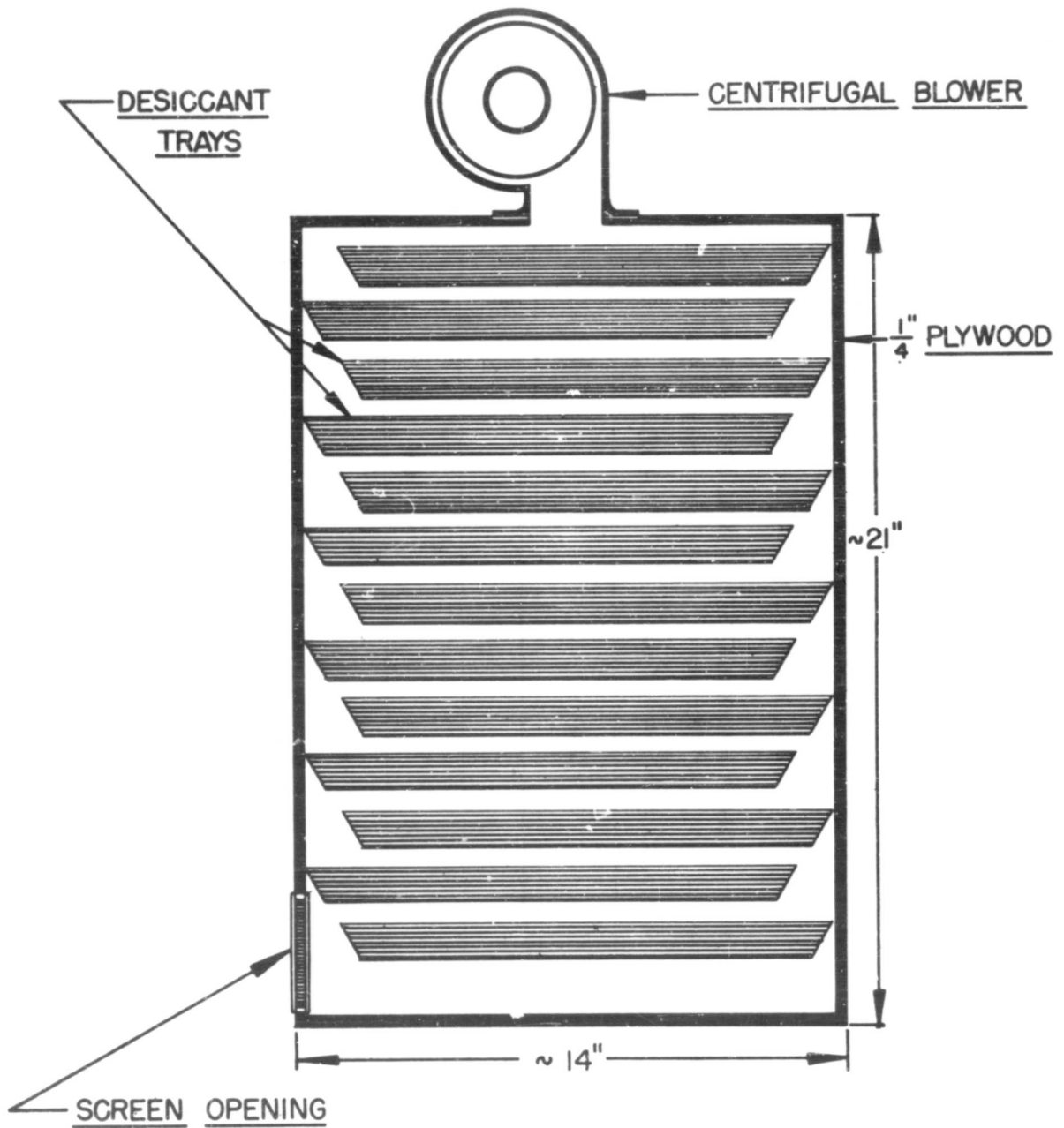

FIGURE—36.
PICTORIAL OF DESICCANT CONTAINER

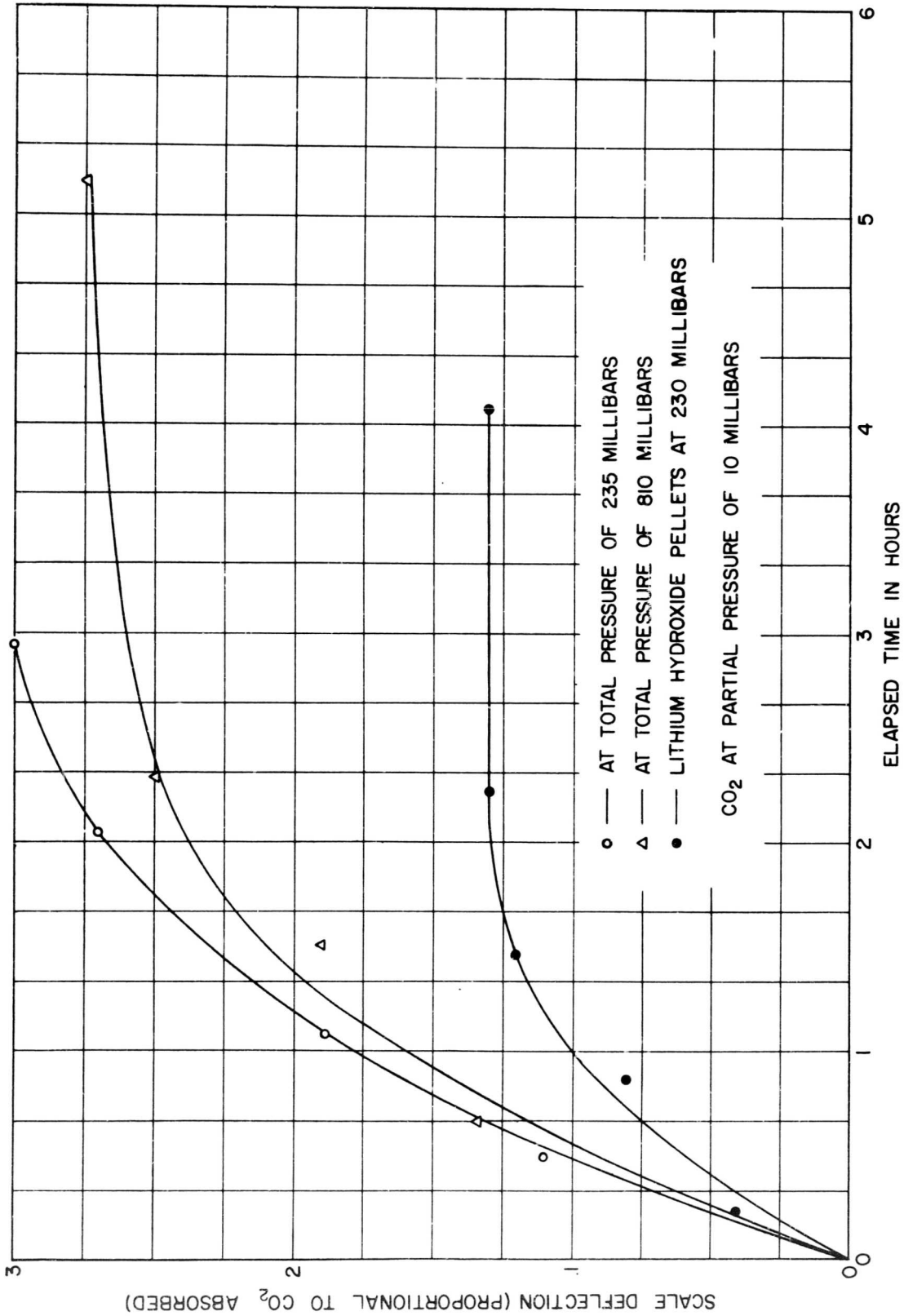

FIGURE - 37.

ABSORPTION OF CO₂ BY LiOH

arms. The air to be sampled diffuses through desiccant tubes to the two thermistors. The reference thermistor desiccant tube contains both water desiccant and carbon dioxide desiccant. The sampling thermistor desiccant tube contains only a water vapor desiccant. The two thermistors are therefore exposed to different gas mixtures which will conduct heat away from them at different rates. The result is an unbalanced bridge due to changes in resistance. The resultant unbalance is measured by a milliammeter which is calibrated in units of carbon dioxide partial pressure. This meter reading is photographed by the recording camera and is visible to both gondola observers. The calibration is shown in Figure 38 and the entire assembly can be seen in the lower left section of the instrument panel in Figure 57.

Water Vapor Removal System¹¹ - The moisture removal system had also been selected prior to our beginning work on this gondola. This, too, involved the use of an absorbent, LiCl (lithium chloride). Here again, many possible methods of removing excess moisture exist. One of the most attractive of these methods involves some type of condensing system. Such a system could seemingly operate quite efficiently for high altitude balloon flights because of the low ambient air temperature. Unfortunately, we were not able to evaluate this type system completely with relation to the desiccant system. Any future design work should, however, consider this possibility carefully.

The absorption of water takes place through the hydration of LiCl to $\text{LiCl}\cdot\text{H}_2\text{O}$. Usually the LiCl is located in a bed over which the air to be dried is passed. In this case, the LiCl was dissolved in water to form a saturated solution. This solution was then soaked into O-Cel-O sponges which were dried in vacuum ovens. It was found that about 8 to 10 grams of LiCl per gram of sponge would absorb more water per unit time. This is a broad

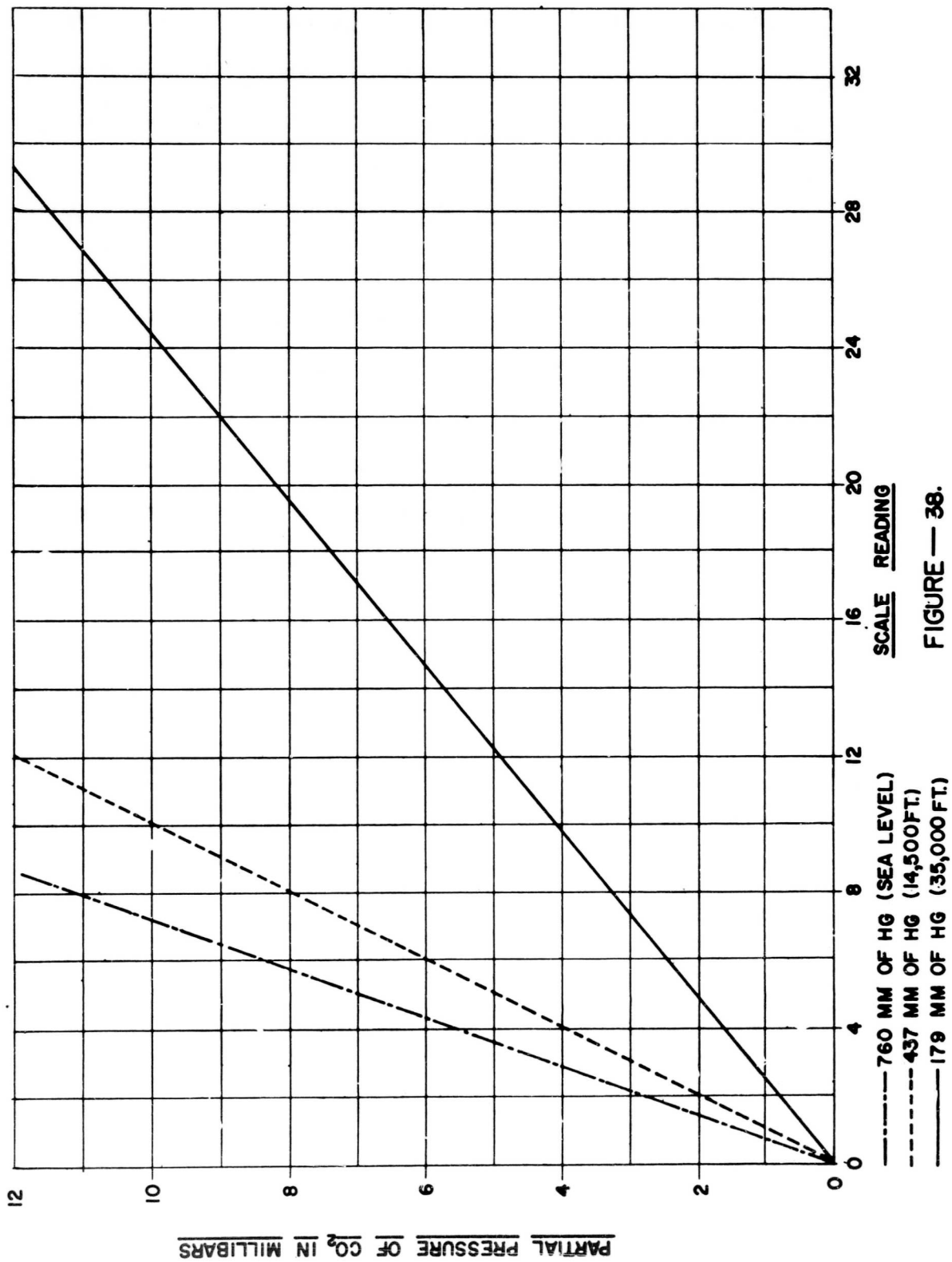

FIGURE — 38.

THERMCO CO₂ ANALYZER CALIBRATIONS FOR THREE AMBIENT PRESSURES

maximum, however.

It was also found that for this particular system there was an optimum sponge size. Various sizes were tried, and the experimental results are shown in Figure 39. Sponges 1/2 inch on an edge were used for this purpose. The resulting increase in efficiency by selection of these optimum parameters is further demonstrated in Figure 40. In a test run of the system, optimum sponges were in the even numbered trays and assorted sponges used previously were in odd numbered trays. The net amount of water absorbed by the two sets for a given weight of LiCl differs by a factor varying from a minimum of 3 to an over-all average of 7. It is interesting to note that provision of a physical carrier for LiCl in this manner will allow it to absorb approximately 0.6 lb of water per pound of desiccant (including carrier), which is excellent when compared to other absorbents at exit humidities of approximately 30 per cent.¹¹

It was necessary to determine the relative efficiency of this desiccant at other ambient pressures as before. The relative efficiency was determined at an ambient pressure of 237 millibars, and the results are shown in Figure 41.

As with lithium hydroxide powder, the sponges carrying lithium chloride were placed in trays located within a 14 inch x 21 inch x 17 inch plywood container (see Figures 35 and 36). A centrifugal blower delivered approximately 20 cubic feet per minute through this system continuously throughout the test flight period.

Test of the Atmospheric Maintenance System - In order to verify the operating characteristics of this system, it was necessary to subject the gondola to a series of chamber studies. The following paragraphs will describe four chamber experiments and the corresponding data will be presented.

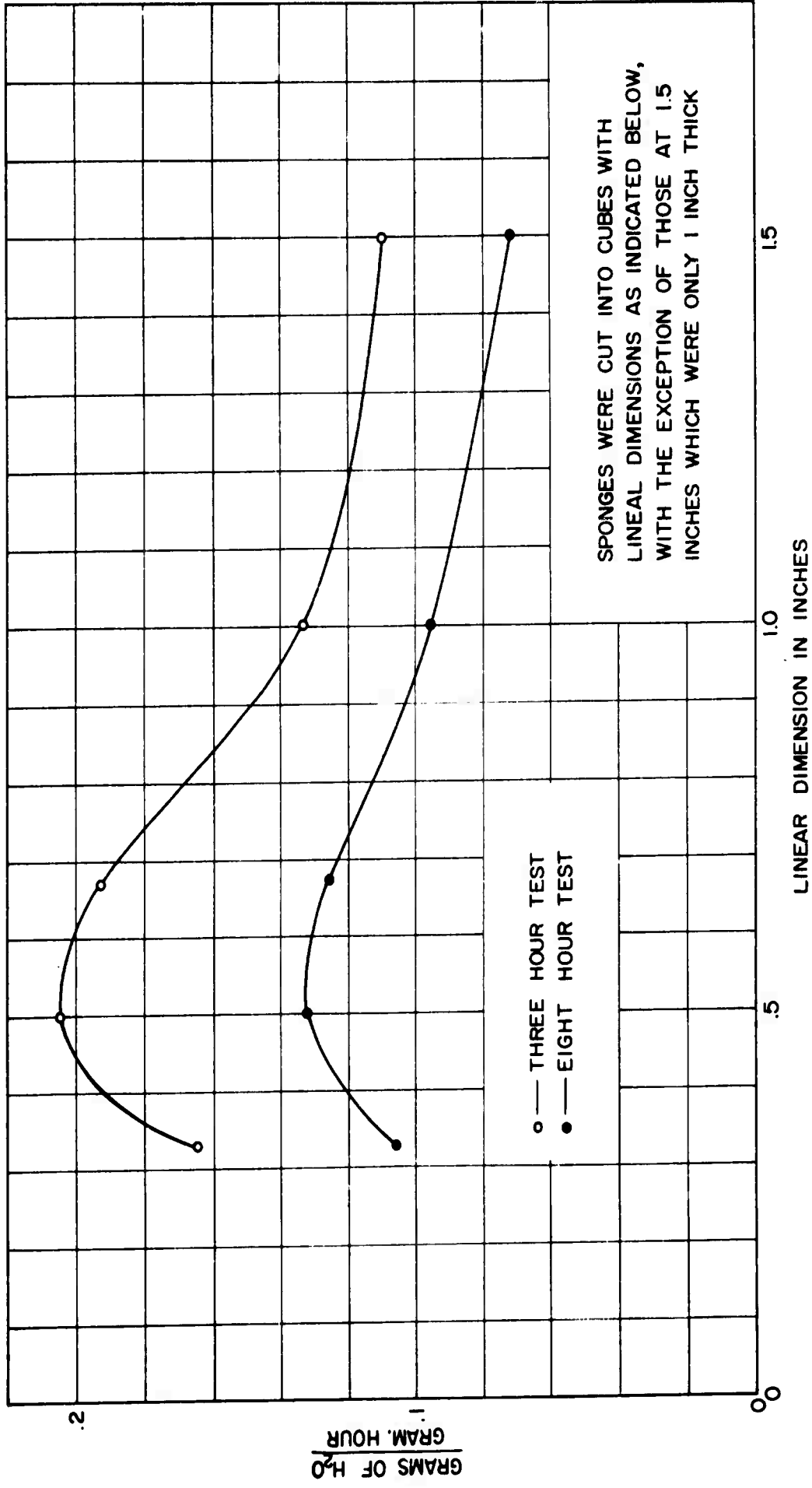
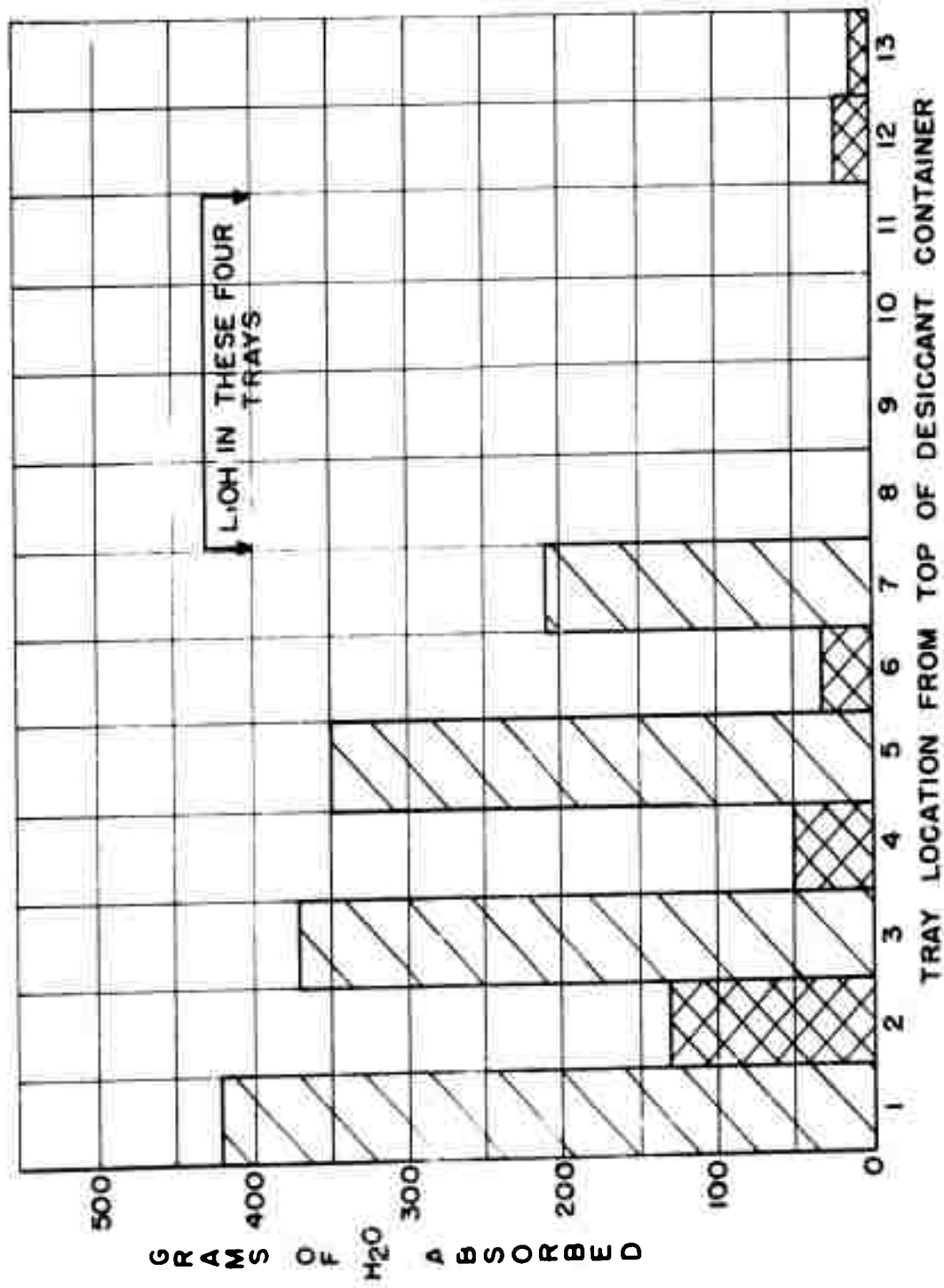

FIGURE -39.
 MASS OF H₂O ABSORBED PER UNIT MASS OF ABSORBENT
 PER UNIT TIME AT 50% RELATIVE HUMIDITY AND 70-74°F

1) TRAYS NUMBERED 1,3,5, AND 7 CONTAINED 1600 GRAMS OF LiOH IN OPTIMUM SPONGES AND REMOVED 1350 GRAMS OF H₂O OR .845 gm H₂O/gm LiOH

2) TRAYS NUMBERED 2,4,6,12, AND 13 CONTAINED 2000 GRAMS OF LiOH IN OLD STYLE SPONGES AND REMOVED 240 GRAMS OF H₂O OR .12gm H₂O/gm LiOH

THIS DATA TAKEN FROM RESULTS OF HYDRO STATIC CHAMBER TEST II



COMPARISON OF TWO SIMILAR H₂O REMOVING SYSTEMS
FIGURE - 40.

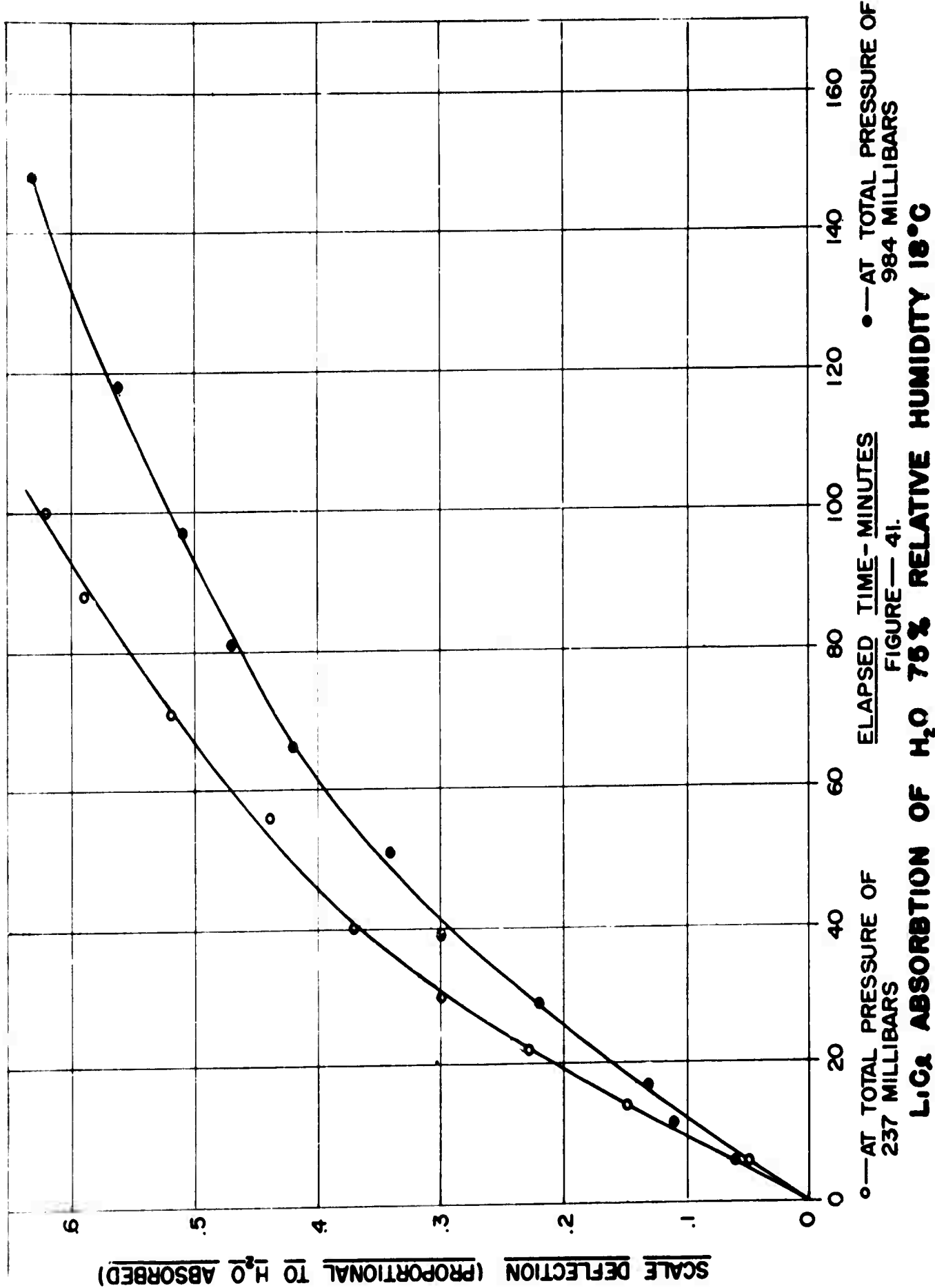

The first two chamber tests were of a preliminary nature and designed to establish a base line of operation of the atmosphere maintenance equipment.

The two final chamber tests were almost identical in all respects and were generally representative of the expected results in the actual Strato-Lab flight.

Preliminary Chamber Test - The gondola, in an incompleated state, was taken to NOTS (Naval Ordnance Test Station) at Inyokern, China Lake, California, for a preliminary series of tests. Test objectives included:

(1) Evaluation of the general atmosphere regeneration philosophy and capabilities under both decreased pressure and temperature conditions.

(2) Determination of further requirements necessary to successful gondola operation.

(3) Observation of any effects, from a medical standpoint, which might be important in the over-all flight consideration.*

Preparations involved in readying the gondola, insofar as possible, for such a series of tests pointed out many obvious defects and system incongruities. These were noted and the gondola was placed in an altitude chamber at Mickelson Laboratory, NOTS, Inyokern, California.

It had been planned originally to use Navy-type full pressure suits as an emergency pressure sustaining device. It was found, however, that this would be virtually impossible, since the physical discomfort imposed by the uninflated suits would not allow them to be worn for periods of up to ten hours.

* A report on medical considerations of such a flight may be found in the Appendix written by Dr. Nello Pace, Department of Physiology, University of California.

The gondola had been pressurized in earlier tests, and it was felt to be quite safe to proceed with a personnel test. Mr. M. D. Ross and Lt. Cdr. M. L. Lewis, the two pilots, made this test on 29 June 1956.

Data collected in this personnel test are presented in Figures 42 and 43. Since these tests were the principal tests at China Lake, these data alone are presented here. This series of tests at Inyokern indicated that the system philosophy was generally sound with regard to the air regeneration and oxygen supply equipment. There were, of course, areas in which it was felt that improvement should definitely be made. Various simplifications in the system also seemed desirable and these were noted.

It was decided to attempt to increase the effective capacity of the two desiccants through further development work.

There were certain parameters pertinent to the oxygen partial pressure that were not known for this series of tests. These dealt primarily with the gondola's "natural leak" and the controller valve's oxygen consumption. This particular information was later determined and is discussed elsewhere in this report.

The gondola was returned to Minneapolis for modification and final completion. This work progressed quite rapidly, and a series of conclusive tests followed this completion.

Sea Level Test - After completion of several experiments on the effectiveness of each of the desiccants as a function of absolute pressure, a sea level test, designed to indicate the over-all usability of the revised system was conducted. This test took place on 11 October 1956 and lasted slightly over six hours. Data collected during this period are presented in Figures 44 and 45. Note that (1) the carbon dioxide level was held to a

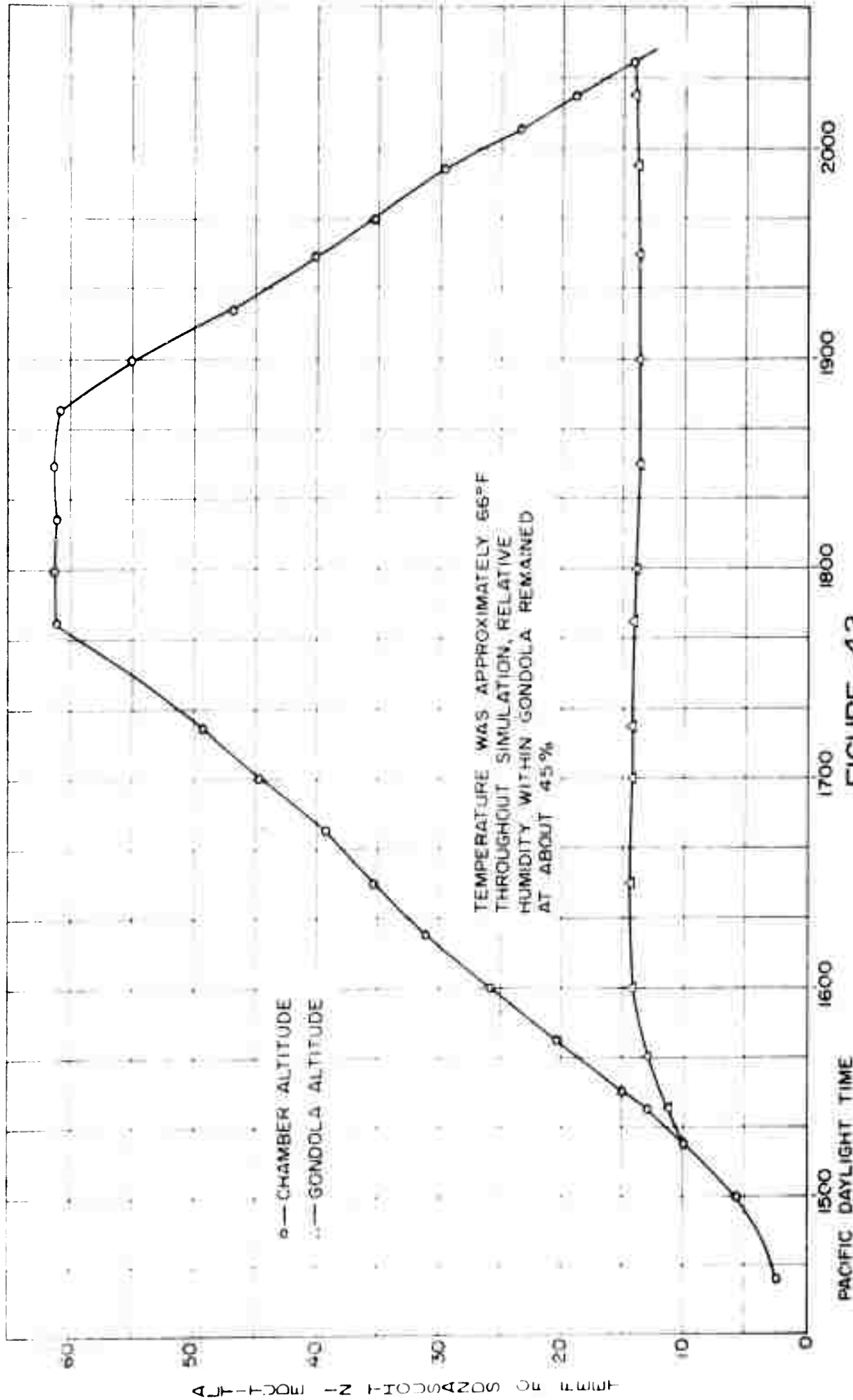

FIGURE - 42.

CHAMBER FLIGHT TEST, INYOKERN, CALIFORNIA, 29 JUNE 1956

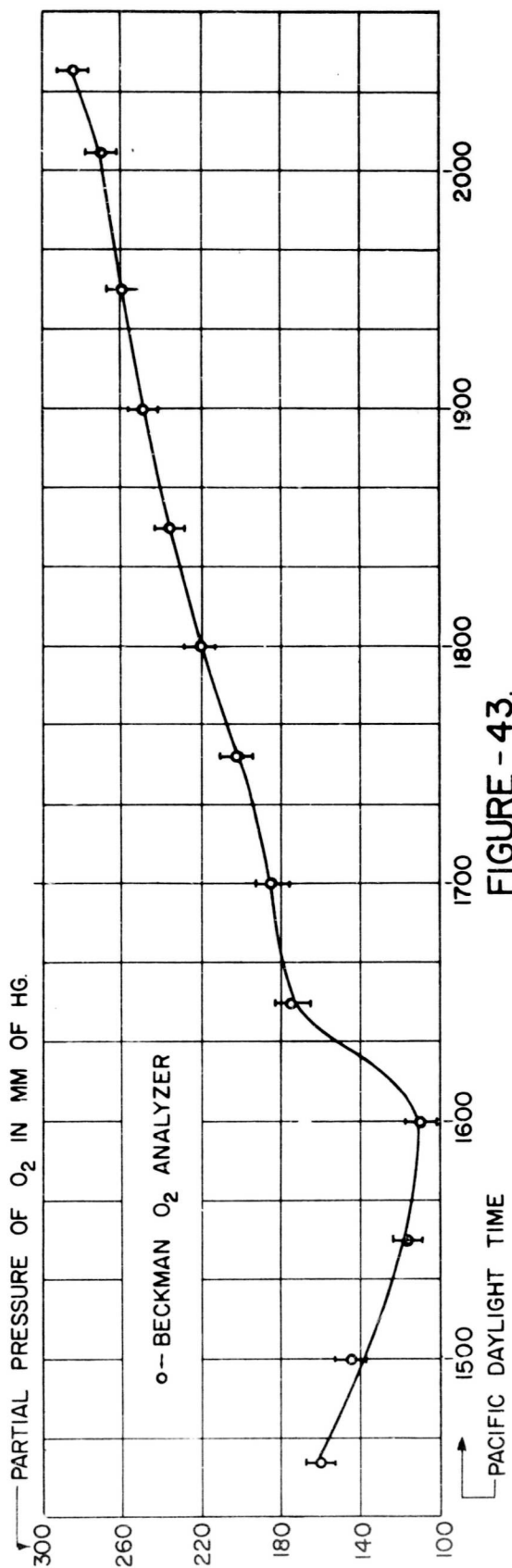
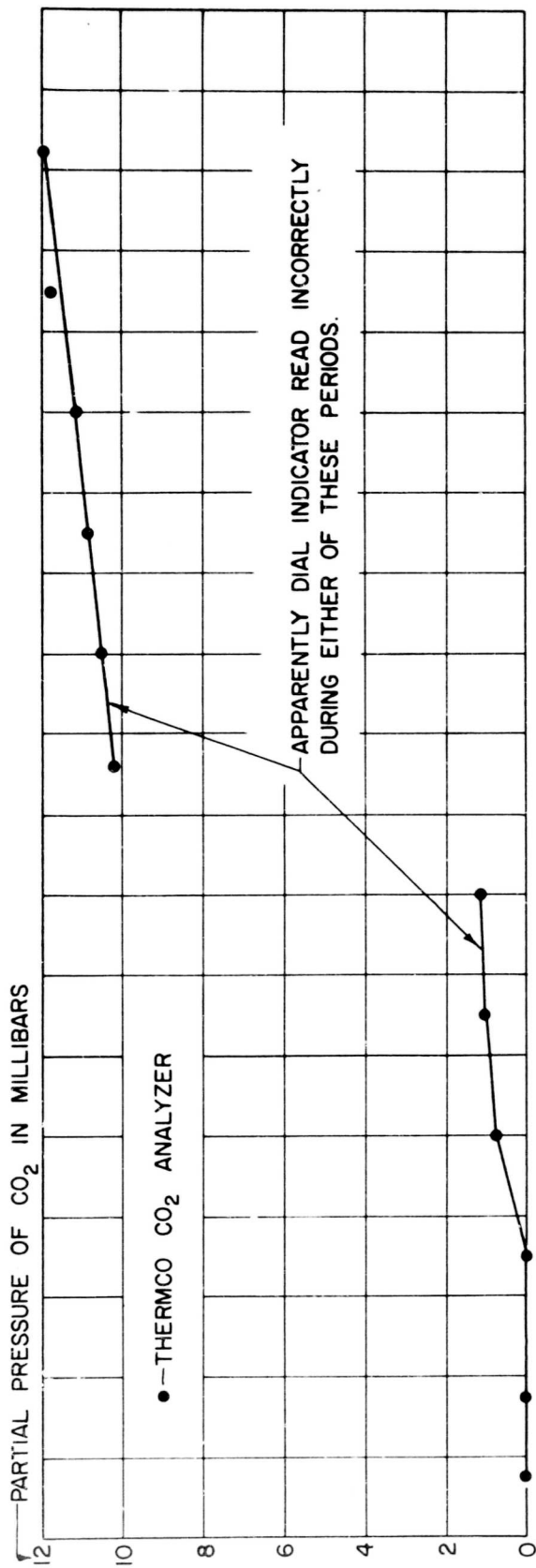
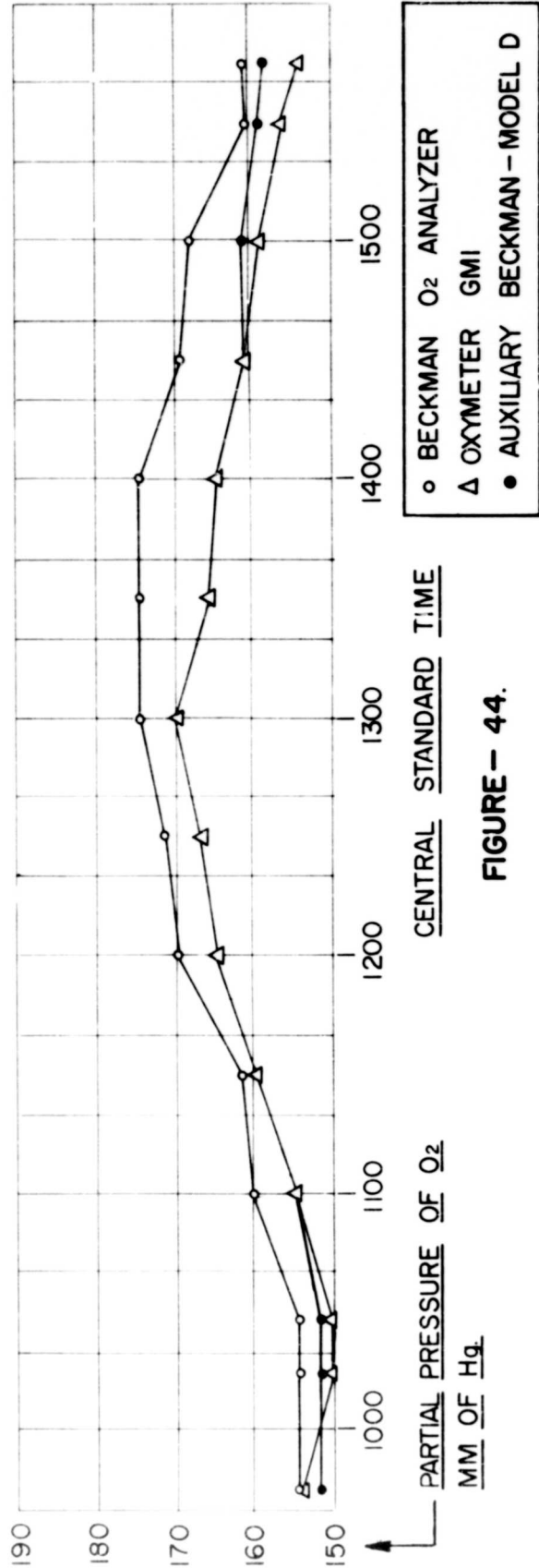
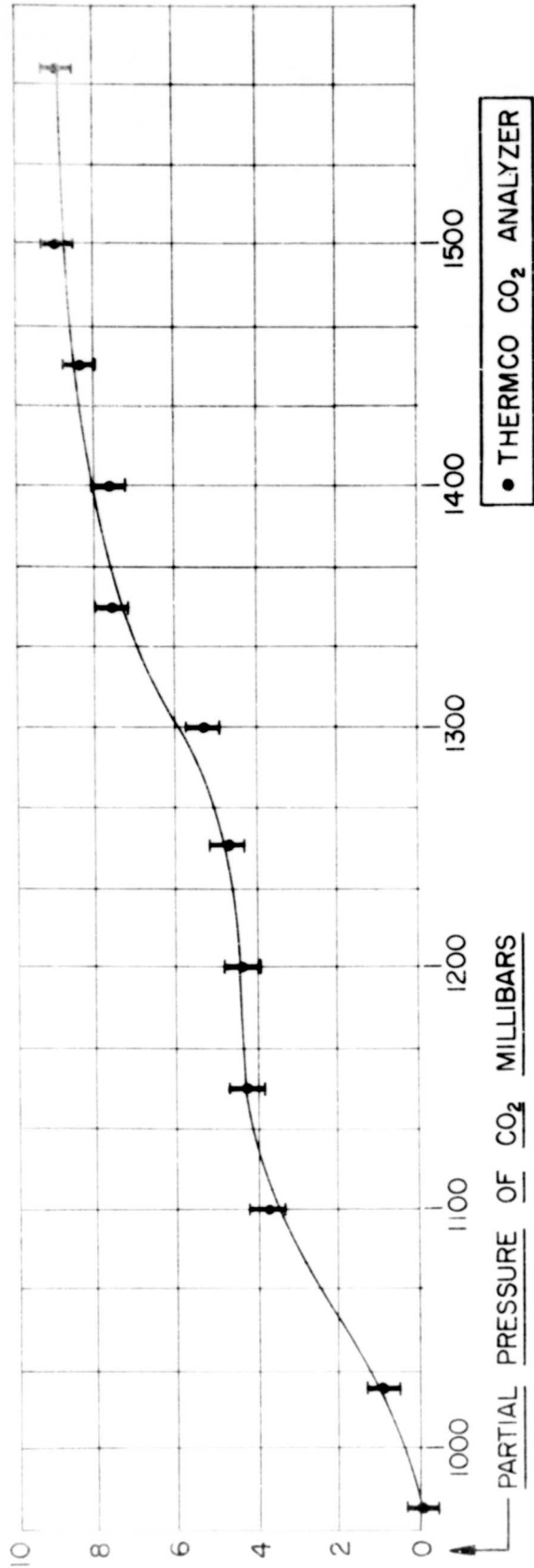

FIGURE - 43.

CHAMBER FLIGHT TEST, INYOKERN, CALIFORNIA, 29 JUNE 1956



O₂ OUTPUT FROM CONVERTER
 2L/M FROM 1028 TO 1145
 1L/M FROM 1145 TO 1300

FIGURE - 44.

SEA LEVEL TEST 11 OCT 1956

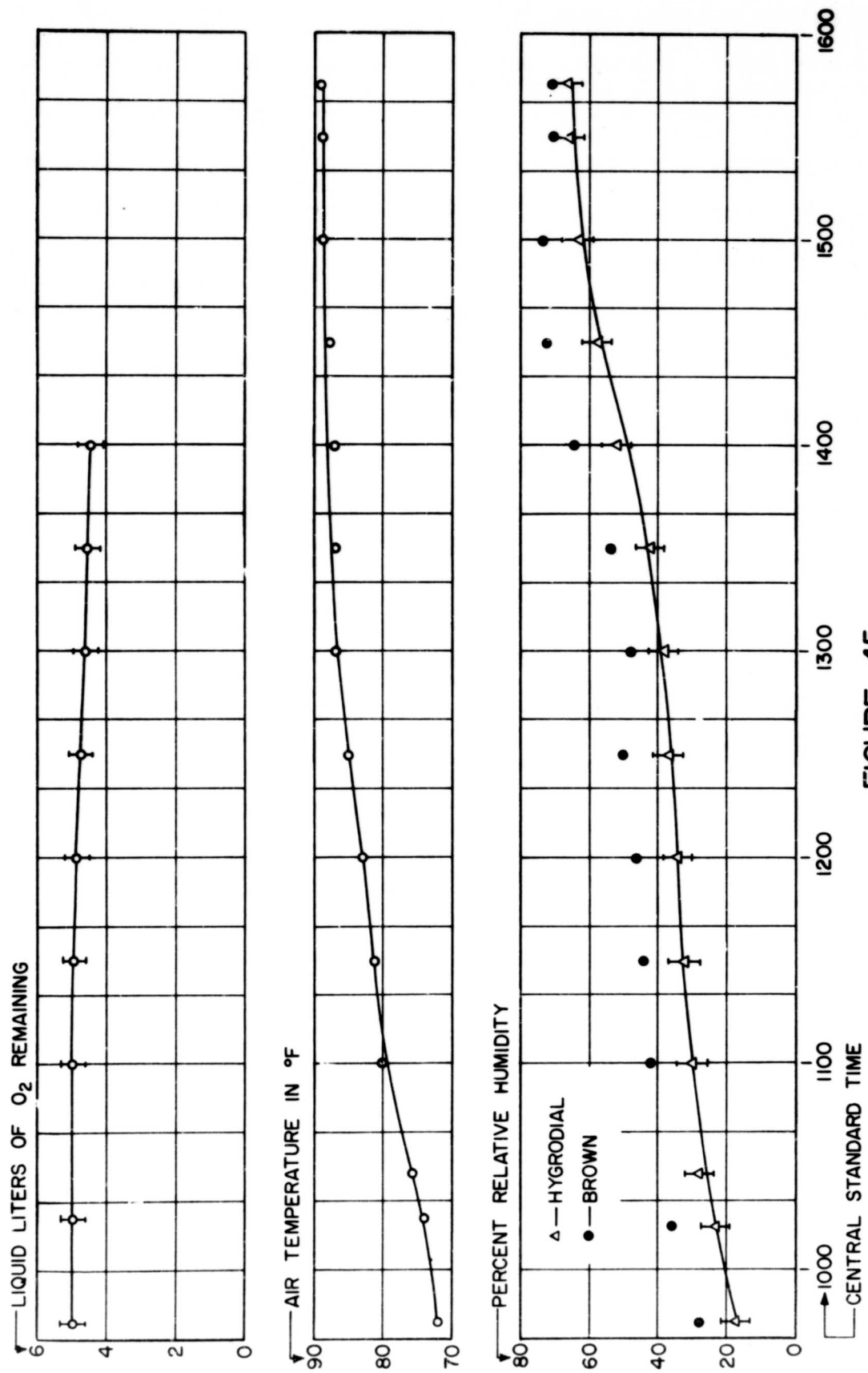

FIGURE - 45.
SEA LEVEL TEST 11 OCT 1956

moderately low value throughout this period, never exceeding approximately 9 millibars or 6.7 mm Hg; and (2) the relative humidity climbed to a value of approximately 70 per cent, although this rise was prompted by a marked rise in the internal air temperature. The increased air temperature caused an increase of moisture output by the two subjects (see Figures 26 and 27). This moisture removed by the desiccant resulted in a significant increase in the exit temperature of the air from the desiccant chamber, which in turn contributed to a higher internal gondola temperature. It was determined, however, that under reduced temperature conditions a low equilibrium level would be reached and this conclusion was borne out by subsequent tests.

During this sea level test the oxygen partial pressure was allowed to rise above that normally occurring at that absolute pressure. Since the gondola was essentially sealed from the outside, the oxygen converter was turned off to note the decreasing density of oxygen and from this to compute the average metabolic consumption of the two observers. Since the converter was turned off from 1300 CST (see graph) to 1530 CST and since the oxygen partial pressure decreased from an average value of 172 mm to 157 mm of Hg, the metabolic consumption by the two observers was calculated to be in the order of 550 cubic centimeters per minute, or an average of 275 cubic centimeters per minute for each person. This is in excellent agreement with previously obtained values (see Table IV).

Final Chamber Tests - Noting that General Mills, Inc. had been conducting pressure tests of hydrostatic equipment to pressures of 300 psi, the possibility of utilizing this chamber for evacuation purposes was investigated. The size and strength of this chamber were entirely compatible with Strato Lab requirements and arrangements were made for use of this

chamber.

It can be shown that the pressure within the chamber expressed as a function of time is:

$$p_c = p_o e^{-Kt/V}$$

where:

p_c = absolute pressure of chamber

p_o = initial pressure of chamber

K = pumping speed of vacuum pumps

V = volume of chamber

t = pumping time.

From this relation the pumping speed, K , can be determined by using a value of p_c/p_o . This fraction is related to a rate of rise value and thereby one can simulate the balloon ascent. Two valves permitted variation of ascent and descent rates as well as maintenance of any specified altitude equivalent.

After several unmanned test runs had been performed to familiarize personnel with relative pumping speeds, the controller valve operation, etc., a manned run was made 8 October 1956. The purpose of this test was to evaluate desiccant and oxygen systems with a simulated flight of six to eight hours with an internal gondola altitude of approximately 35,000 ft. In order to evaluate the moisture removal system more precisely, one ton of crushed ice was placed in the bottom of the chamber before the gondola was lowered inside. The purpose of this was to keep the moisture output of the two subjects at moderate levels by keeping the temperature at a reduced level (see Figures 26 and 27).

Various parameters were recorded as a function of time and the entire plot of these data can be found in Figures 46 and 47. A log of the remarks of the gondola occupants during the test may be found in Table V.

The two gondola occupants were Mr. H. E. Froehlich and Mr. K. M. Lang, both of General Mills, Inc. Mr. Froehlich had made several balloon ascents, the majority of which had not been to altitudes requiring an oxygen system. He had experienced one chamber test prior to this at the Mayo Clinic, Rochester, Minnesota. Mr. Lang had made one balloon ascent prior to this experiment. He had also participated in the same chamber test with Mr. Froehlich at Mayo Clinic, Rochester, Minnesota.

Approximately two weeks before this experiment, both of these men had made a balloon ascent to an altitude of 41,000 feet in an open gondola.

Prior to this test, both subjects breathed pure oxygen for a period of approximately 80 minutes to avoid aeroembolism. Both subjects had previously experienced the bends and were acquainted with the necessary precautionary measures.

The results of this test showed:

- (1) Oxygen partial pressure did not decrease below a value of 150 mm Hg.
- (2) Carbon dioxide partial pressure was slightly greater than 1 mm of Hg at 1133 CST.
- (3) Absolute pressures within the gondola were never lower than 187 mm of Hg.

From this information, it may be difficult to see, from a physiological standpoint, why one of the subjects experienced the particular set

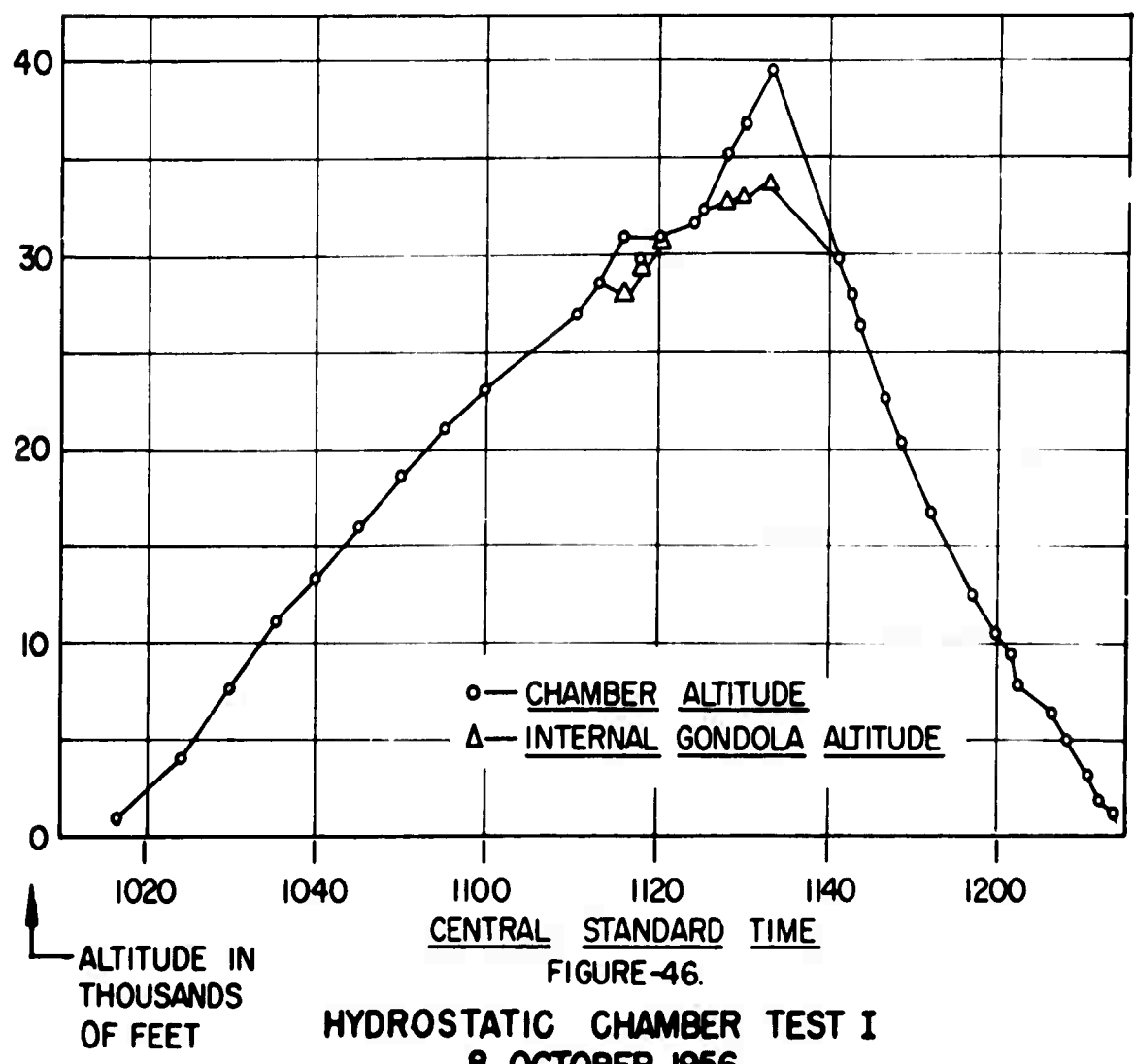
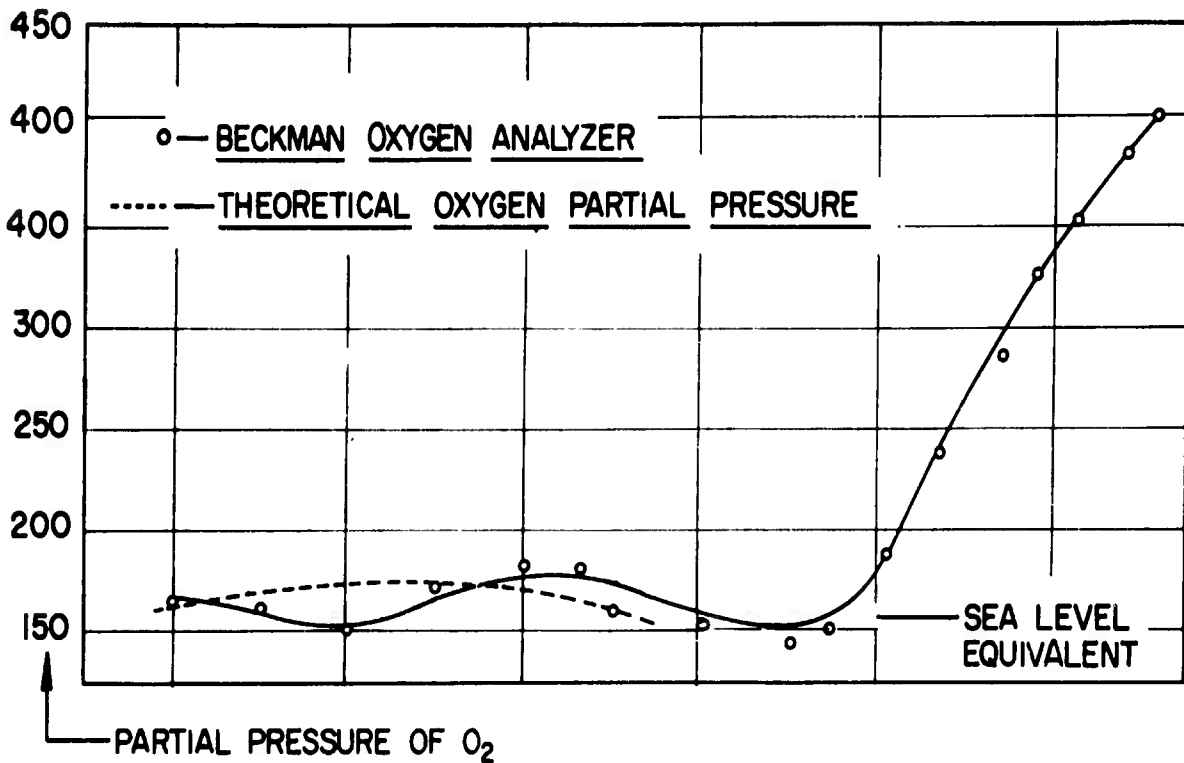

FIGURE-46.
 HYDROSTATIC CHAMBER TEST I
 8 OCTOBER 1956

HYDROSTATIC CHAMBER TEST I - 8 OCTOBER 1956

FIGURE 47

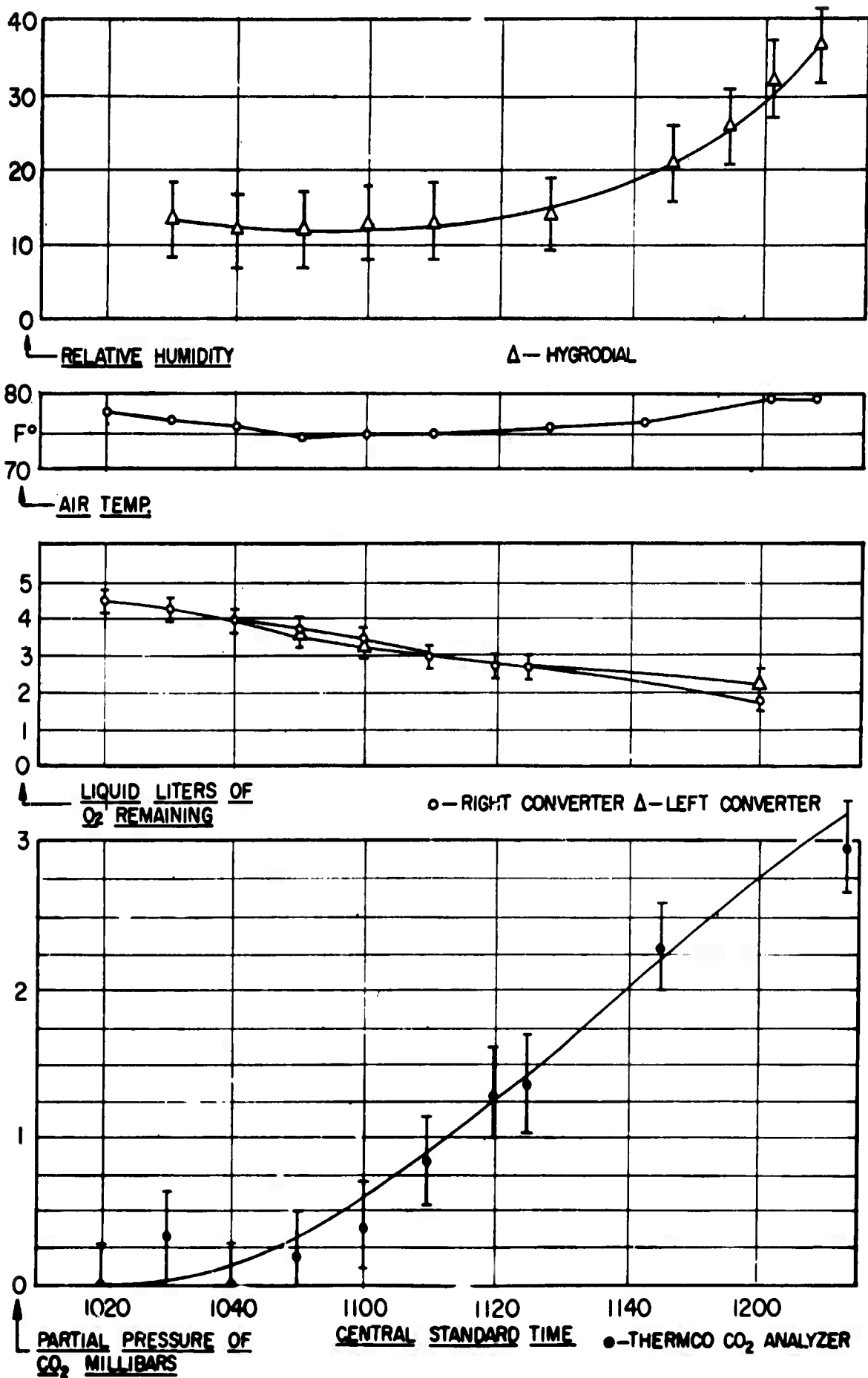

TABLE V

REMARKS ON HYDROSTATIC CHAMBER TEST I CONDUCTED 8 OCTOBER 1956

<u>Time</u>	<u>Gondola Altitude</u>	
1014	Ground	2 liters/minute orifices started on each converter.
1016	Ground	Vacuum pumps on.
1045	16,000 ft	Both converters turned to 4 liters/minute.
1055	23,000 ft	Moved portable Beckman oxygen analyzer around gondola. Apparently no striation of gas.
1113	28,500 ft	Decompression valve closed.
1116	28,000 ft	H. E. Froehlich noticed that his face felt warm.
1118	29,000 ft	Decompression valve opened.
1125	32,000 ft	Cool fan turned on. Converter orifices turned off. Decompression valve closed.
1128	33,000 ft	H. E. Froehlich again noticed warm sensation around face and neck.
1133	33,000 ft	K. M. Lang felt faint, slightly dizzy. He noted increase in heart beat rate; face was warm, sensitive. He started 20 liters/min. orifice and directed into his breathing area and felt better immediately.
1155	12,500 ft	H. E. Froehlich noticed slight pain in knee.
1158	11,000 ft	K. M. Lang turned off 20 liters/min. leak.

of reactions noted in the remarks on Chamber Test I. Some authorities pointed out that this may have been a reaction to a carbon dioxide level actually greater than that recorded. By calculation, however, it can be shown that even if all carbon dioxide produced by the two observers had remained in the gondola in a free state the level would have been about 2.9 per cent of the interior atmosphere, which corresponds to a partial pressure of about 5.3 mm of Hg. Also, there was no reason to doubt the efficiency of the desiccant because of its adequate performance in the sea level test (see Figure 44) and because the desiccant's efficiency actually increased slightly with reduced pressures (see Figure 37).

One argument against the calculation of a carbon dioxide pressure of 5.3 mm of Hg is the possibility of incomplete mixing of the gases. It is conceivable, then, that a number of breaths may be taken in an area, the carbon dioxide concentration of which might be relatively high. This seems improbable, however, since the movement of air within the gondola due to observer movements, breathing, etc., would accomplish some mixing.

It is conceivable that these particular reactions may have been the result of an induced nervous state in the individual. Ordinarily when personnel encounter such altitudes, either in chambers or in aircraft, they are equipped with oxygen masks and associated apparatus. In this case, however, each of the observers was free to note such effects as the differences in sound propagation when talking and the "lightness" of each breath due to the low density of the surrounding atmosphere. If ordinary oxygen equipment had been utilized, such effects might have been more difficult to observe and the observers might then not have been overly aware of their environment. This is, of course, speculation.

One function of the Strato-Lab system is to provide an atmosphere in which one observer can carry out functions without the acclimation to special environmental conditions. Because of this consideration, it was felt necessary to lower the equivalent altitude of the gondola significantly. The choice of this new altitude was based on two factors: (1) the provision of a comfortable altitude for observers, and (2) the choice of an altitude such that no undue fire hazard could exist in the event that the gondola atmosphere would be pure oxygen. By purely qualitative tests, it had been determined that the oxygen partial pressure should not exceed approximately 300 mm of Hg. Because of this and because the controller valves were conveniently adjusted to maintain an altitude equivalent of 17,500 ft, this level was chosen.

A second chamber test was conducted on 16 October 1956. This experiment utilized a significantly lower altitude within the gondola. This altitude was equivalent to approximately 17,000 ft initially and about 14,000 ft thereafter for a period of over five hours. Again, the primary purpose of this test was to demonstrate the effectiveness of the desiccant system as well as to verify certain oxygen partial pressure predictions.

Again, approximately 2,000 lb of cubed ice was packed around the gondola base such that the moisture output of the two observers would be within reasonable limits.

The two observers were Mr. H. E. Froehlich and Mr. Thomas Olson, both of General Mills, Inc. Mr. Froehlich's personal experience in such matters has already been outlined. It was Mr. Olson's first chamber experience, and he had made no balloon flights prior to this time.

The duration of the test exceeded six hours and was terminated only

because no unusual data were being recorded. These data are presented in Figures 48, 49 and 50.

Some points worthy of mention are that:

(1) Even though the controller valve was not used for gondola internal altitude control, satisfactory control was easily obtained through use of the adjustable leak valve.

(2) For the entire six hour period, no more than two liquid liters of oxygen, or 40 per cent of the capacity of one converter was used.

(3) The practicality of a pure oxygen converter system was nicely borne out by the oxygen partial pressure relationship expressed as a function of time.

(4) The relative humidity rapidly reached and maintained an equilibrium value of 40 per cent for the duration of the test.

(5) The carbon dioxide level was very low throughout the entire test, never exceeding a partial pressure of 3.3 millibars of Hg.

(6) The rise in oxygen partial pressure was expected but exceeded calculated values; this excess partial pressure, however, never exceeded the upper limit (300 mm Hg) and was attributed primarily to the unused converter building up in pressure and venting directly into the gondola.

Both observers were quite comfortable throughout the test period and experienced no unusual or unexplainable reactions.

The third and final chamber test took place 26 October 1956. This test was designed primarily to indoctrinate the pilots, Mr. M. D. Ross and Lt. Cdr. M. L. Lewis, in the use of the atmospheric maintenance equipment in the gondola. This final test was conducted in essentially the same manner as the preceding test with the exception that the controller valve was used to

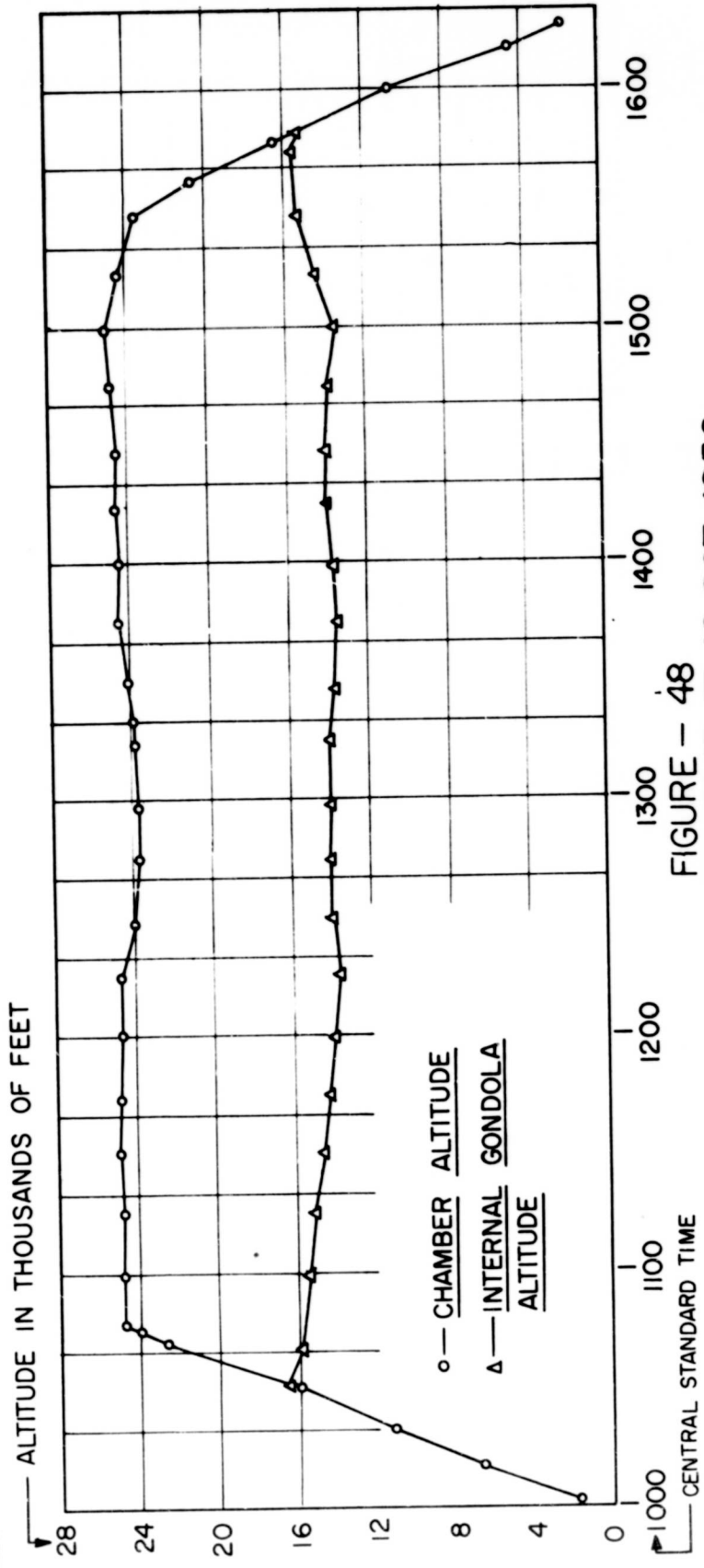
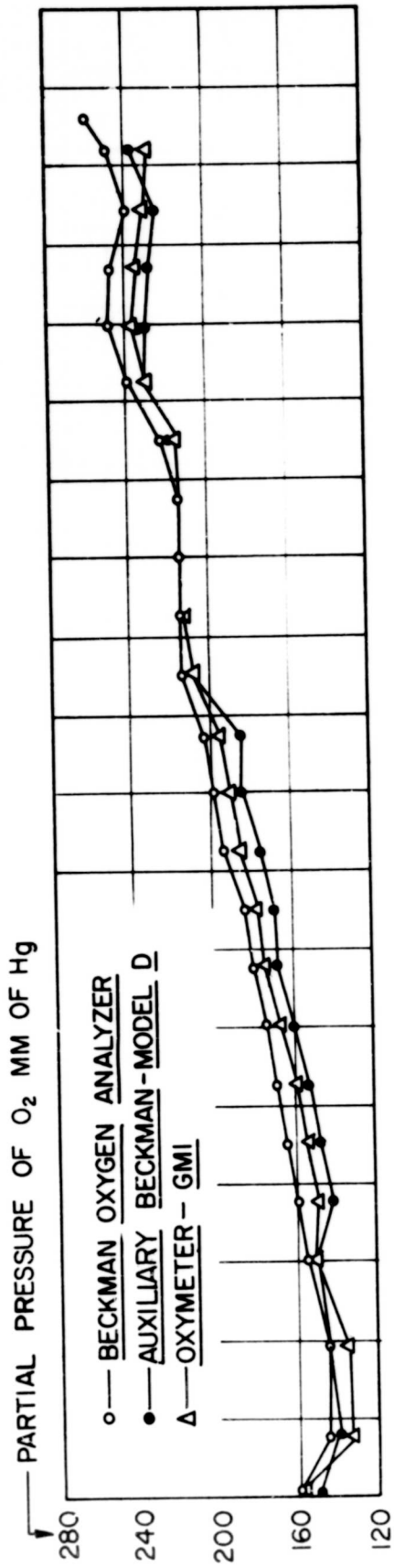

FIGURE - 48
 HYDROSTATIC CHAMBER TEST II-16 OCT 1956

CENTRAL STANDARD TIME

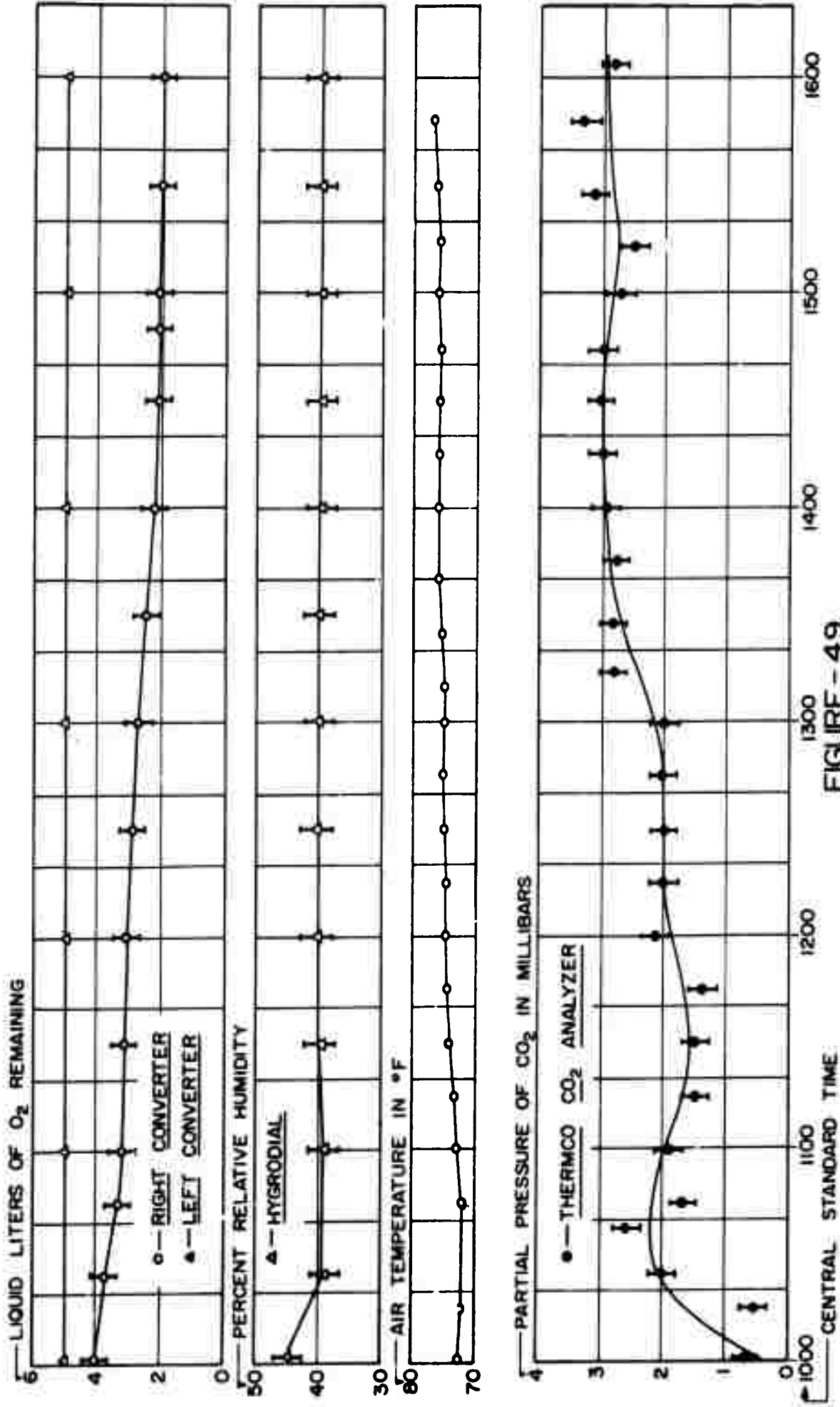

FIGURE - 49.
HYDROSTATIC CHAMBER TEST II 16 OCT 1956

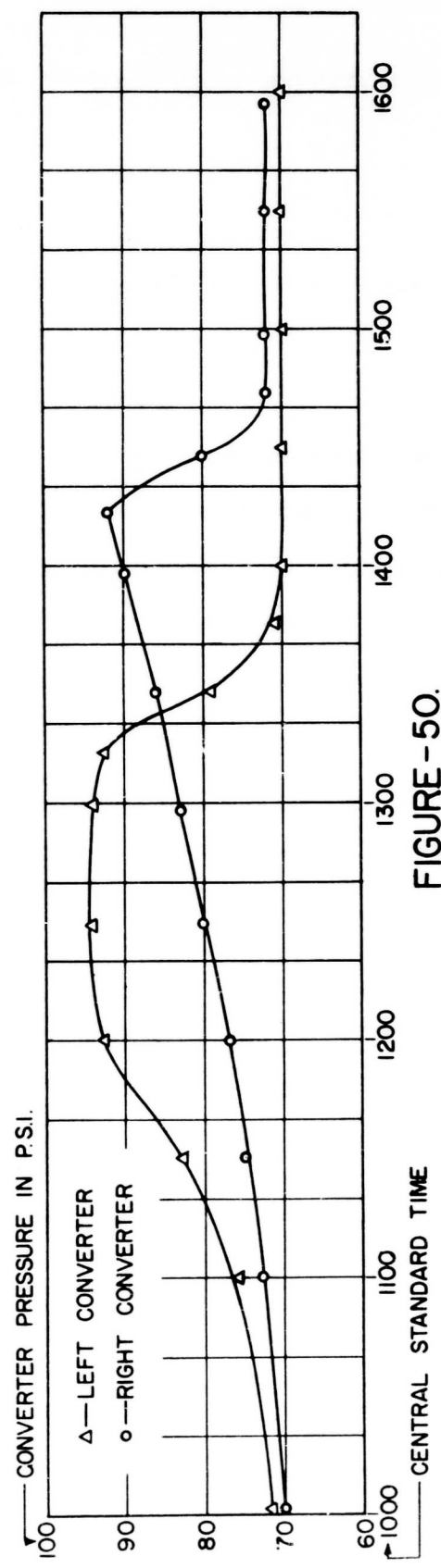
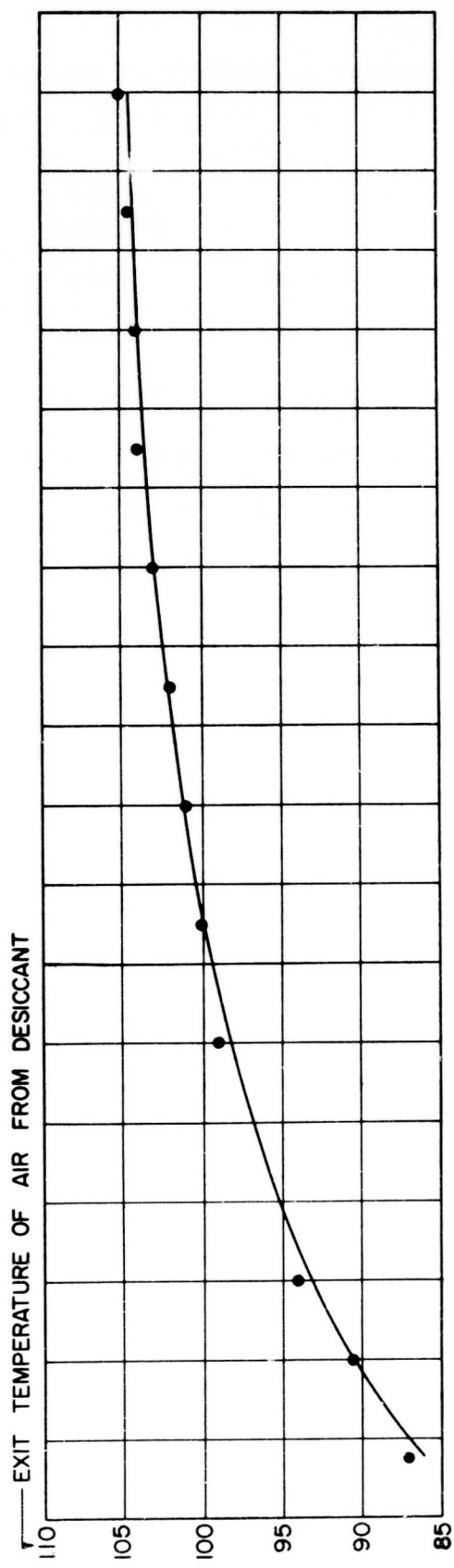

FIGURE - 50.
HYDROSTATIC CHAMBER TEST 16 OCT 1956

TABLE VI
REMARKS ON HYDROSTATIC CHAMBER TEST II CONDUCTED 16 OCTOBER 1956

<u>Time</u>	<u>Gondola Altitude</u>	
0958	Ground	Chamber sealed and oxygen orifice on at 4 liters/minute
0958.5	Ground	Vacuum pumps on.
1013.5	6,000 ft	20 liters/min leak turned on.
1027.5	16,800 ft	Decompression valve closed, 20 liters/min leak turned off
1053	15,500 ft	Orifice turned down from 5 liters/min to 2 liters/min
1216	13,800 ft	Manual altitude control valve opened, 1/2 turn.
1223	14,000 ft	Manual valve closed to 1/4 turn open.
1318	14,000 ft	Converter orifice turned off. Manual valve closed.
1334	13,800	Manual valve opened 1/4 turn.
1433	14,000 ft	Heat fan turned on.
1436.5	14,000 ft	Heat fan turned off, cool fan turned on.
1440	14,000 ft	Cool fan turned off.
1504	13,800 ft	Manual valve turned from 1/4 to 1/2 turn open.
1532	15,500 ft	Manual valve turned from 1/2 to 1/4 turn open.
1549	15,000 ft	Decompression valve opened.

control internal altitude of the gondola.

This final test also verified calculations of the expression of oxygen partial pressure as a function of time. At the time simulating the launching of the system, the 2 liters/min orifice was opened. When the gondola reached an internal altitude of 10,000 ft, the high discharge orifice (20 liters/min) was opened and was not closed until the internal altitude came to its equilibrium value. The purpose of this high discharge orifice was, as has been pointed out previously, to halt the decrease of oxygen partial pressure at the 10,000 ft altitude equivalent (about 110 mm Hg). This is demonstrated by the corresponding curve in Figures 51 and 52.

Here again, note that the relative humidity and carbon dioxide partial pressure were held to very low values throughout the entire test. Also, note that one oxygen converter alone easily supplied the test requirements.

This chamber test concluded the series of tests conducted on the atmospheric maintenance system. The effect of the desiccant on the internal atmosphere has been presented in each of the appropriate data presentations. The amount of desiccant used and the net amounts of carbon dioxide and water vapor absorbed during each test are listed in the following table.

It should be noted that the carbon dioxide desiccant, LiOH, took up an undetermined amount of water while it was also removing carbon dioxide. The RQ (respiratory quotient) has an average value of 0.85, which means that the volume output of carbon dioxide of an individual will be about 0.85 times the volume of oxygen consumed metabolically. Therefore, since the resting body consumes approximately 160 grams of oxygen in a six-hour period, the carbon dioxide output should be about 195 grams in the course of this same

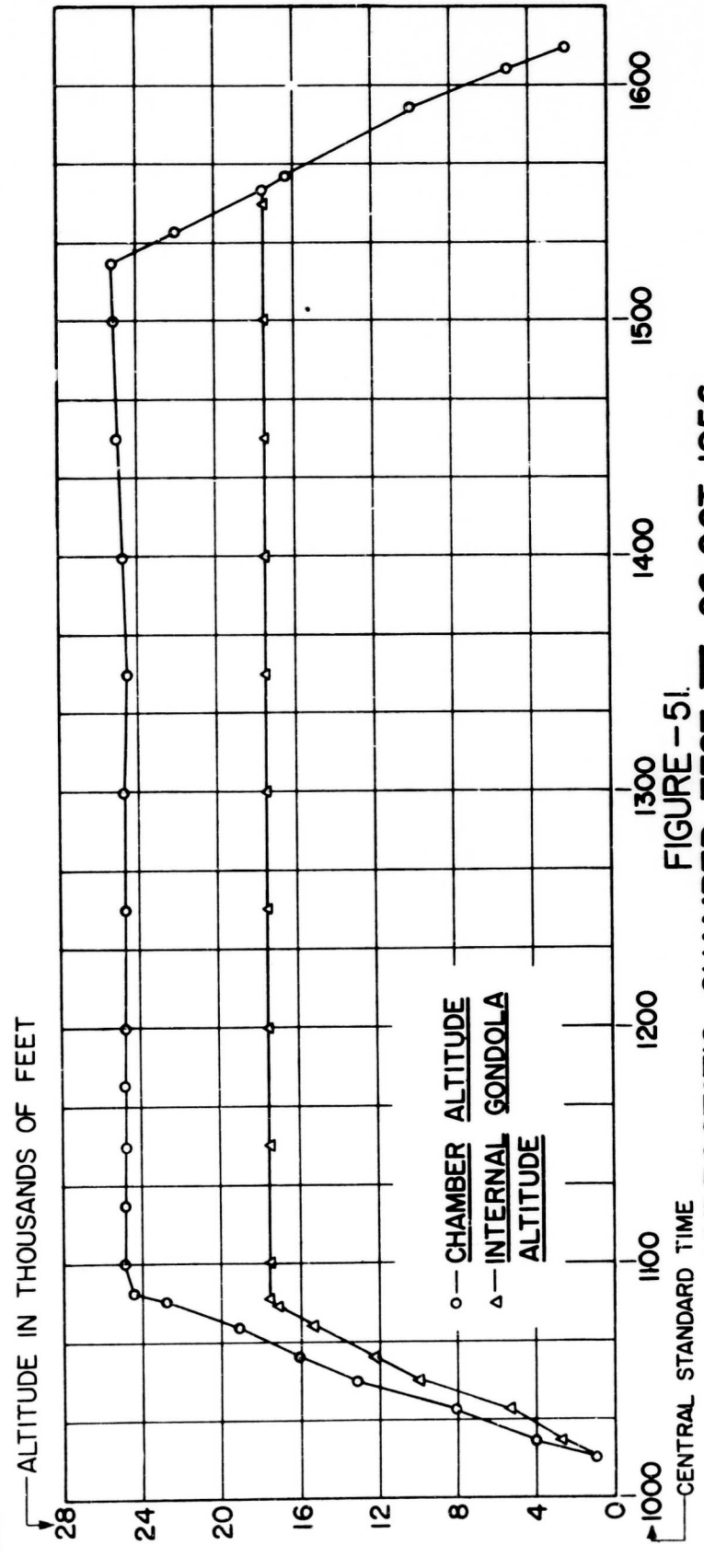
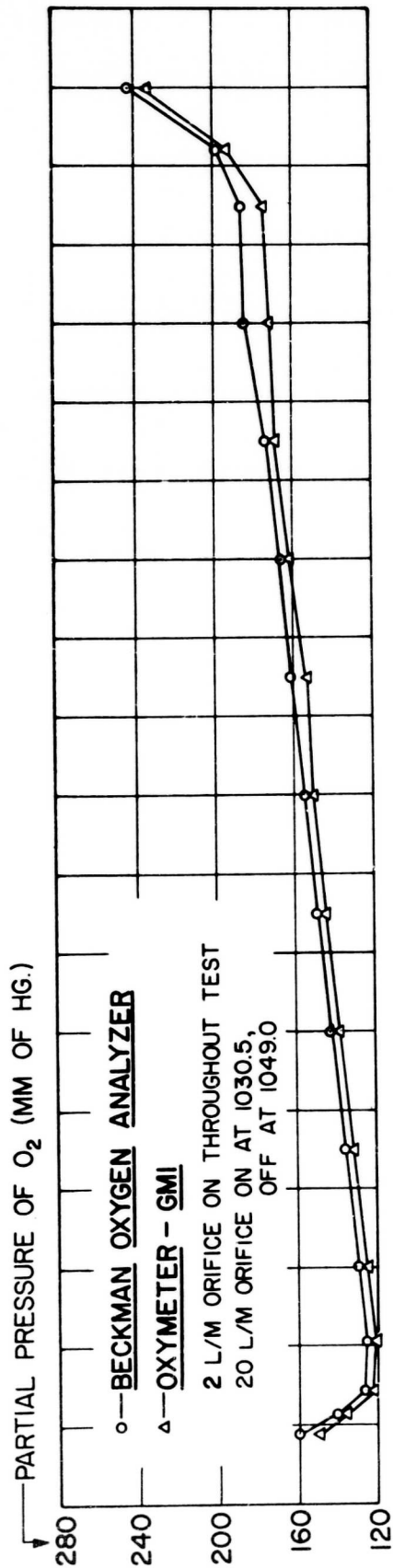

FIGURE -51.
 HYDROSTATIC CHAMBER TEST III 26 OCT 1956

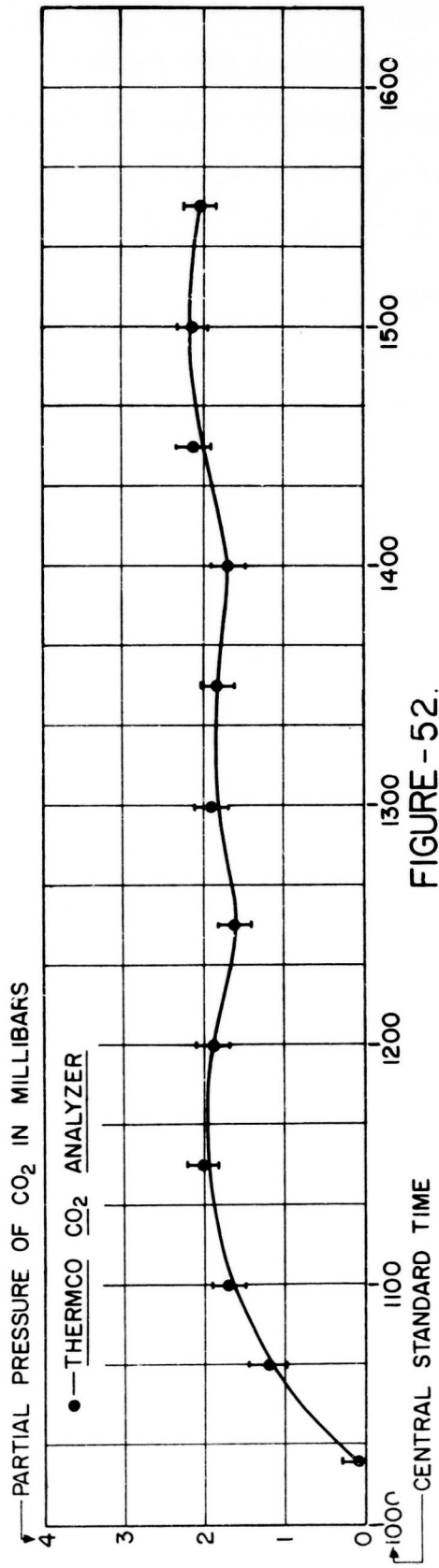
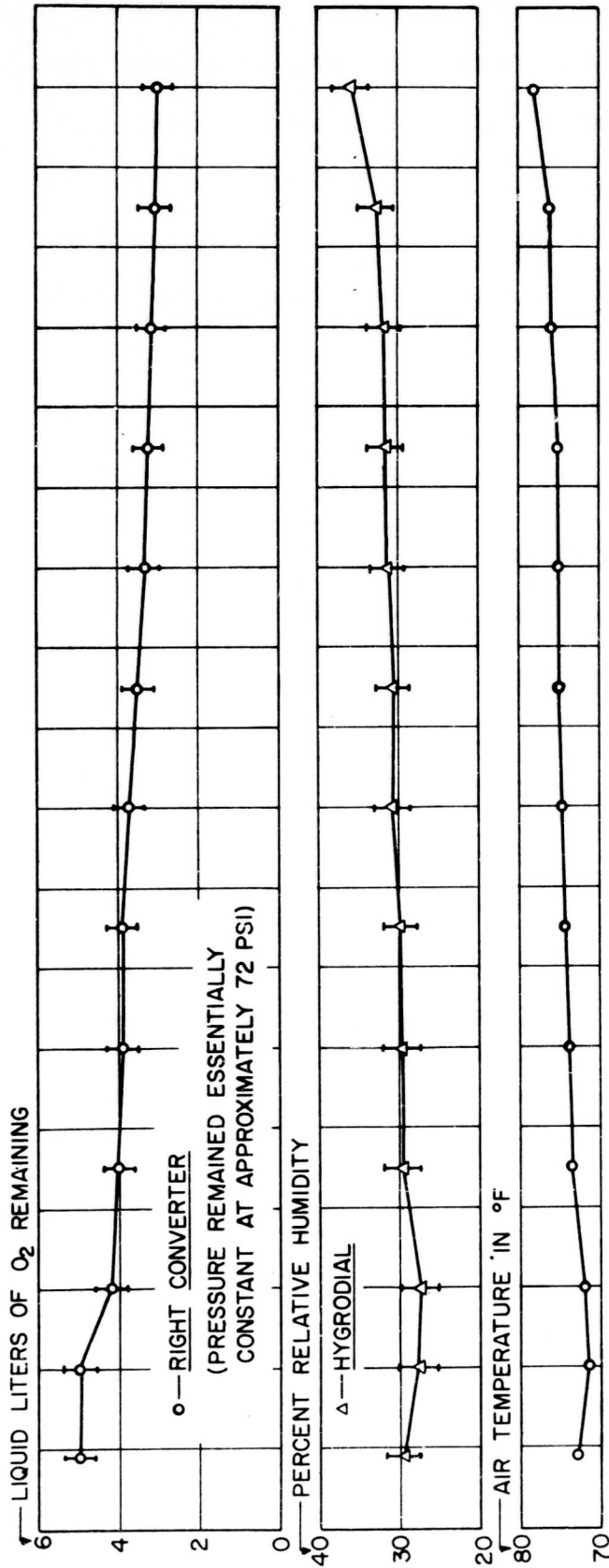

FIGURE -52.
 HYDROSTATIC CHAMBER TEST III 26 OCT 1956

interval of time. This value compares fairly well with the results of the last three tests given in Table VII below. The first test (Inyokern), however, yields a value significantly higher than this and is probably reasonable when one considers that a major portion of the LiOH for this test was not located in the low humidity region of the desiccant box. It was exposed directly to the ambient air within the gondola. Since the carbon dioxide level during the Inyokern test also rose to a high value, this test shows the necessity of locating the carbon dioxide desiccant in an area void of high water vapor concentration.

TABLE VII

MASS OF CARBON DIOXIDE AND WATER VAPOR ABSORBED BY
DESICCANTS DURING CHAMBER TESTS

<u>Test</u>	<u>LiCl</u> <u>gm</u>	<u>LiOH</u> <u>gm</u>	<u>H₂O</u> <u>Absorbed</u> <u>gm</u>	<u>CO₂</u> <u>Absorbed</u> <u>gm</u>	<u>Total Enclosed</u> <u>Time</u>
Inyokern	1397	4327	804	538*	6 hours
Chamber Test I	--	--	--	--	--
Sea Level Test	2210	2830	1020	160	6 hours
Chamber Test II	3600	2600	1590	191	6 hr 20 min
Chamber Test III	2045	2320	530	265	6 hours

* Include some H₂O.

Gondola Electrical Systems

Power Sources - Most of the electrical apparatus operated on 6 volts. The main 6-volt supply consisted of a pack of eighty RM42 R-2T Mallory mercury cells. Sixteen groups of cells were connected in parallel, each group consisting of five cells in series. Total weight of the assemblage, including the base plate and mounting components, was 35 lb. At the manufacturer's rating of 14,000 milliampere hours per cell, total capacity of the battery supply was 224 ampere-hours. The battery supply is shown in its rigidly-mounted position underneath the observer's seat in Figure 53. A pair of parallel, 40-ampere circuit breakers was connected in series with the main 6-volt lead to allow either circuit breaker to be used individually, in case one or the other should develop faulty contacts or holding tendencies. The circuit breakers were located under a floor panel.

An auxiliary 6-volt supply, consisting of thirty-five RM42 R-2T mercury cells, was mounted under the pilot's control panel. By means of a switch on the pilot's control panel, it was possible to operate the more vital electrical apparatus from the auxiliary supply.

The helium valve required a 24-volt supply. Because of the length of the leads in the valve circuit, it was considered best to avoid the use of high current. There was a main, as well as an auxiliary, 24-volt battery supply for the helium valve. The main supply consisted of two parallel groups of twenty RM12 R-2T cells in series. The auxiliary supply consisted of a single group of 20 cells in series. The current requirement of the valve motor was 150 milliamperes. In the case of the more vital electrical apparatus, it was considered essential to use parallel cells, at least in the main supply, particularly where a number of cells were to be used in series

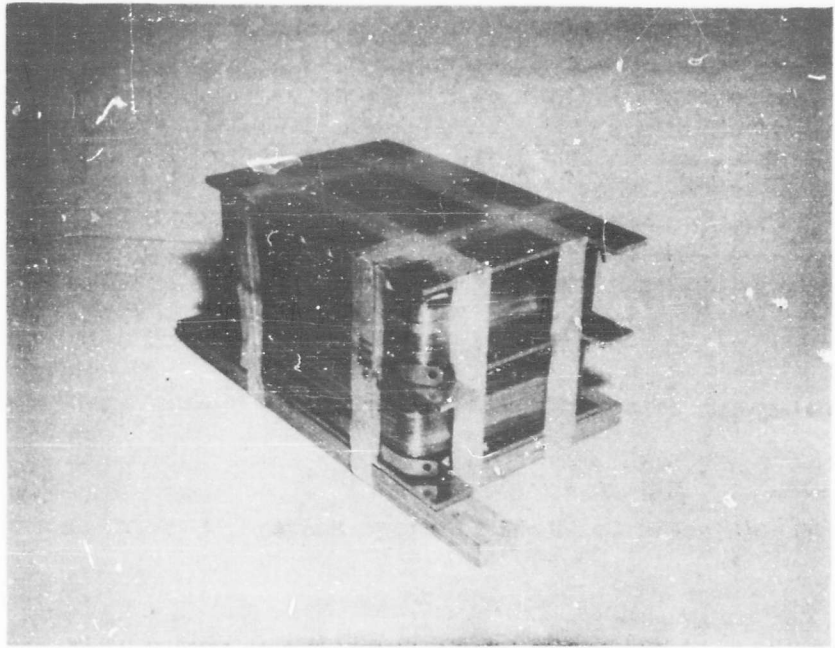

MAIN 6 VOLT POWER SUPPLY

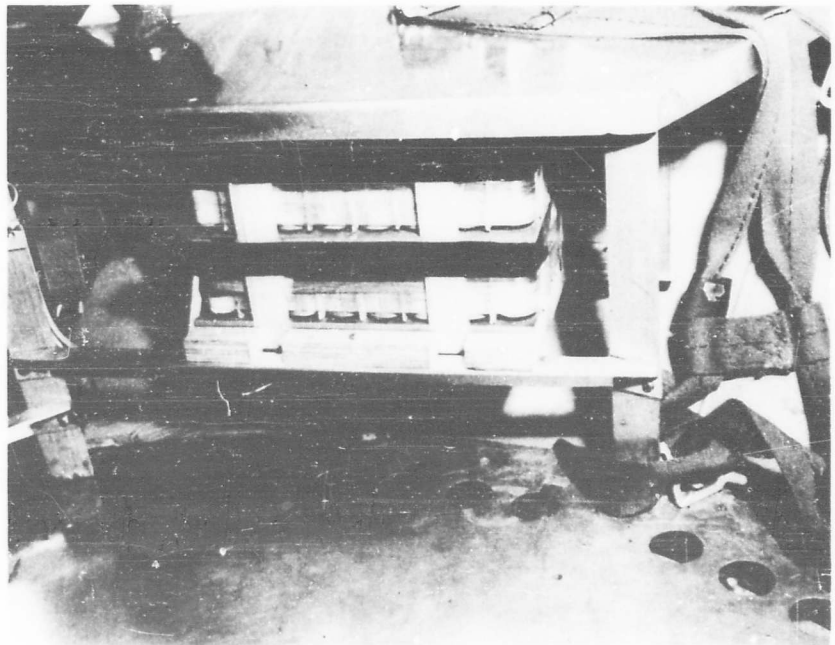

MAIN POWER SUPPLY IN MOUNTED
POSITION UNDER OBSERVER SEAT

FIGURE 53

to obtain the required voltage, since in this case there is an increased probability of a faulty cell, any one of which would render the entire series chain useless. Therefore, a parallel chain was used. Either the main or the auxiliary 24-volt supply for the helium valve could be selected by means of a switch on the pilot's control panel. The auxiliary 6-volt supply and both 24-volt supplies were packaged and mounted together under the pilot's control panel.

The radio and intercom systems operated from individual battery packs.

Control Panels - With a few exceptions, the electrical devices were controlled from one or both of the two control panels. One panel was located on the right side of the pilot's position and the other was located on the right side of the observer's position. The panels, which were made of 0.125-inch 24ST aluminum and were hinged on one edge to allow access to the wiring and components, are shown in Figure 54.

The pilot's panel contained the following items:

1. Switch for oximeter, carbon dioxide analyzer and dome light
2. Switch for jettisoning ballast
3. Switch for ballast flow
4. Switch for energizing cut-down squibs
5. Switch for voice radio transmission
6. Switch for opening helium valve
7. Switch for main or auxiliary 6-volt supply
8. Switch for main or auxiliary 24-volt supply
9. Indicator for ballast expended
10. Microphone and receiver jacks

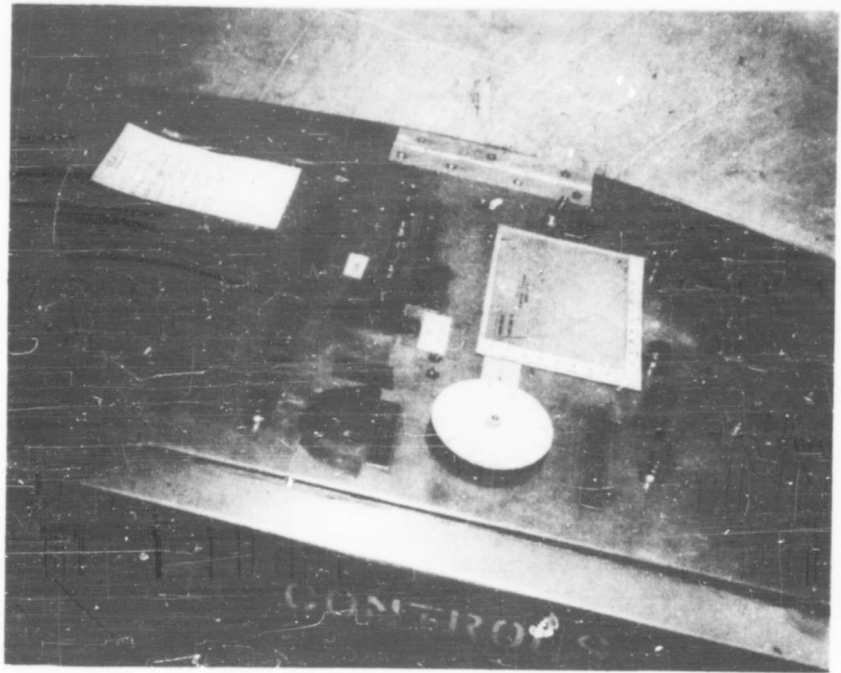

PILOT CONTROL PANEL



OBSERVER CONTROL PANEL
FIGURE 54

11. Pilot lights and fuses
12. Altimeter
13. Clock.

The observer's panel contained the following items:

1. Switch for desiccant fan
2. Switch for warming fan
3. Switch for cooling fan
4. Switch for data recording camera
5. Switch for thermistor wand and zero motors
6. Switch for energizing cut-down squibs
7. Switch for voice radio transmission
8. Switch for HF-VHF receiver selection
9. Altimeter for gondola internal altitude
10. Microphone and receiver jacks
11. Pilot lights and fuses.

Wires leading to and from the panels were connected to terminal strips on the panels. Interpanel wiring was cabled underneath the gondola deck.

Climate Controls - The component parts of the climate control system were the cooling fan, the warming fan and the desiccant fan.

The external surface of the upper hemisphere of the gondola, which was painted white, was regarded as a "cold" reservoir. Cooling was accomplished by energizing a fan mounted above the instrument panel at a "latitude" of approximately 40° . The axial fan directed a stream of air upward across the cold inner surface of the upper hemisphere. The fan was controlled by a center-off switch on the observer's panel and could be energized manually

by throwing the switch in the "manual" direction. By throwing the switch in the "auto" position, a thermostatic switch was included in the circuit and the cooling fan was automatically energized when the temperature reached a pre-set level. The thermostat unit consisted of a bi-metal spiral and a mercury switch mounted beneath the observer's seat.

The external surface of the lower hemisphere of the gondola was painted black to create a "heat" reservoir. Heating was accomplished by energizing a fan in the center of the circular deck. The centrifugal fan directed a radial flow outward along the warm inner surface of the lower hemisphere. The air rose through a ring of 1-1/4 inch holes in the outer edge of the deck. The control switch was located on the observer's panel and the manual-auto system was identical with that of the cooling system. The warming thermostat was similarly mounted beneath the observer's seat. Each temperature fan drew 4.6 amperes. The cooling and warming fans are shown in Figure 55.

The desiccant fan was a centrifugal blower which constantly directed a stream of air through the air regeneration box. The fan was located on top of the box and directed air downward. The fan switch was located on the observer's panel. A blue pilot light on the data panel was energized by the fan voltage. The current requirement was 3.9 amperes. It was possible to operate this unit from the auxiliary power supply.

Balloon Valve System - Helium was expelled from the top of the balloon by a mechanical valve which was operated by a 24-volt motor. The dimensions and capacity of the valve are discussed elsewhere. The electric circuit for the valve system is shown in Figure 56. The valve was energized by throwing the spring return switch on the pilot's panel. This applied

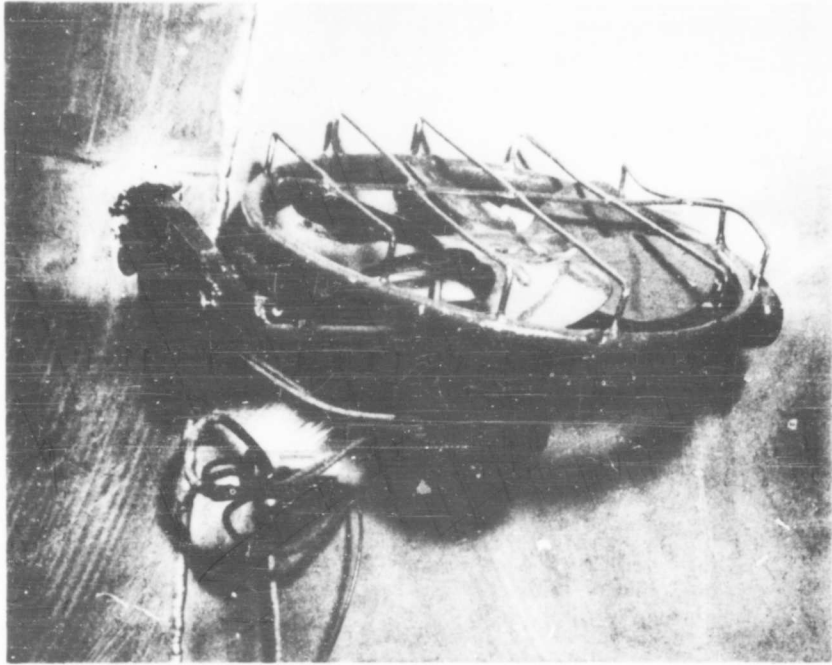

COOLING FAN

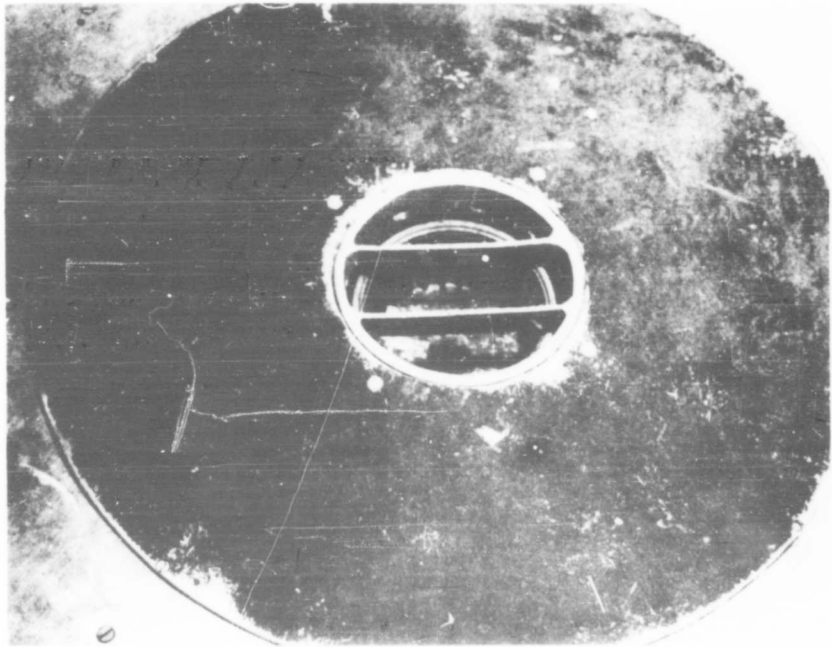

WARMING FAN
FIGURE 55

**GAS VALVE CIRCUIT
FIGURE 56**

VALVE OPENS: \uparrow C \bar{A}
VALVE CLOSES: \bar{B} A

**BOTH MICROSWITCHES HELD
IN TRIPPED POSITION WHEN
VALVE IS CLOSED**

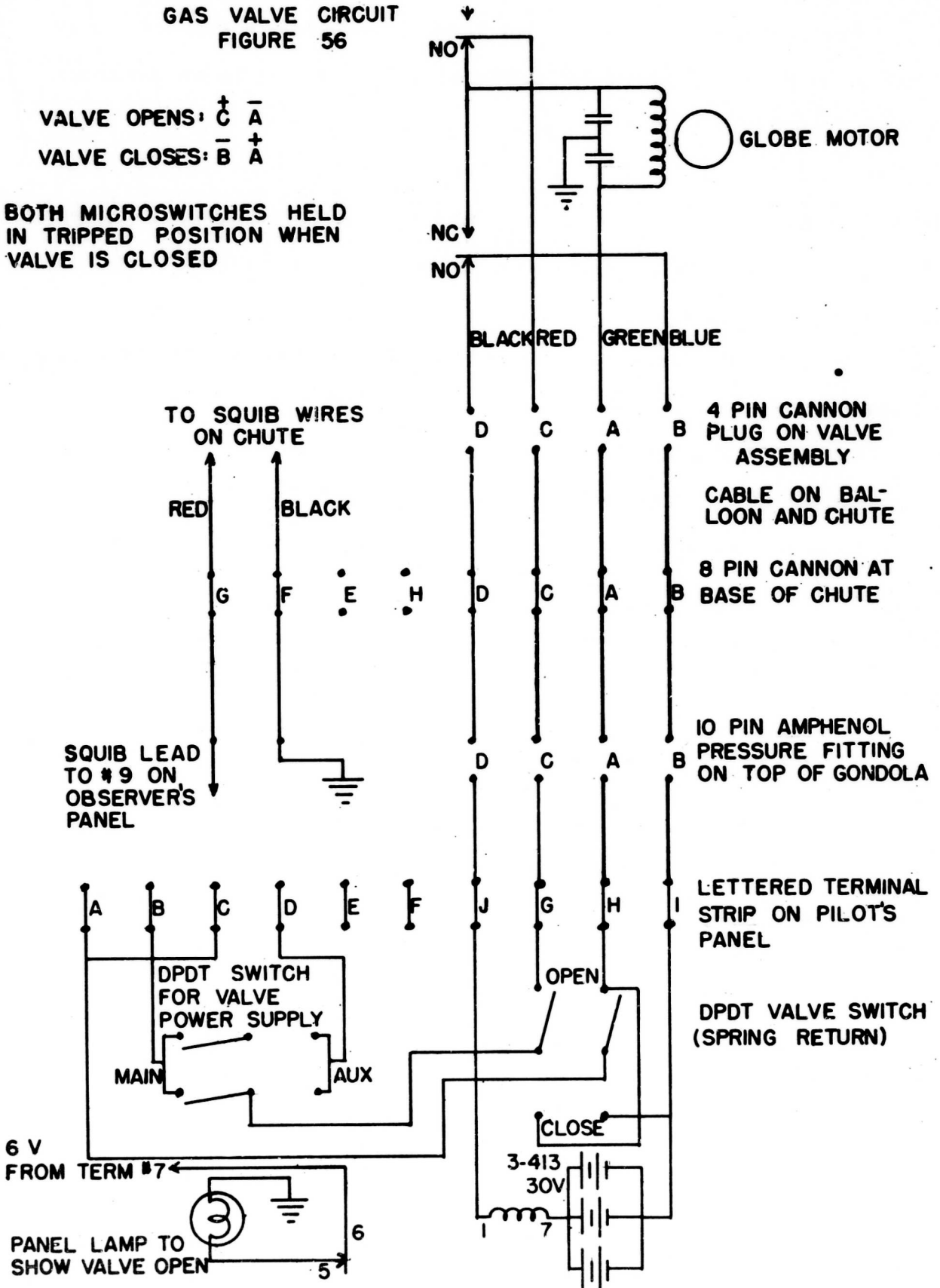

24 volts of polarity to the proper opening wires and the valve commenced to open. The spring return switch was held "on" in order for the valve to reach the end of its travel. At this time the opening limit switch on the valve mechanism was tripped and the opening circuit was interrupted. The valve remained open until the control switch on the pilot's panel was released; this applied reversing polarity to the closing circuit and the valve closed. When the closed position was reached, the closing limit switch interrupted the circuit. If during the opening cycle the control switch were released, the valve closed again. The otherwise unused contact on the closing limit switch was connected in series with a relay coil on the pilot's panel. When the valve opened, the relay coil was de-energized and the indicator panel light was energized from the back-contact of the relay. Thus, the valve indicator light was on when the valve was in any position but closed. The valve is shown in Figure 18.

Ballast Valve System - The two ballast containers were mounted approximately at the equator of the gondola at diametrically opposite points. The ballast material was 110-grade iron shot. The ballast valves were of the usual magnetic type and were "plugged" by the field from a circular permanent magnet. Ballast was made to flow by energizing the 500-ohm bucking coil with 12 volts. It was necessary to mount a pair of type 724 parallel batteries beneath the pilot's control panel for an additional 6 volts, since this size valve is not reliable on 6 volts alone. Thus, the ballast valve operated on a 12-volt supply. Operation of the spring-return ballast switch on the pilot's panel caused ballast to flow from both hoppers. The falling ballast impacted small discs which were coupled to micro-switches. The micro-switches energized flow-indicator lights on the pilot's panel. Each hopper had an indicator light associated with it. In addition, a constant speed



DATA PANEL
FIGURE 57

motor was connected across the indicator light of one of the ballast hoppers. The geared output of the motor shaft drove a calibrated disc which indicated the total ballast remaining. The flow rate from each valve was 15 lb/min. It was possible to jettison the ballast by throwing a switch on the pilot's panel. This switch, which was equipped with a safety cover, energized explosive squibs located inside blow-out patches at the bottom of each hopper. The wiring of the ballast circuit is included in Figure 66. The ballast system could be operated from the auxiliary power supply.

Data Panel - An instrument data panel was mounted on the inner wall of the gondola above the pilot's control panel. This panel allowed centralized viewing of the various flight instruments by the pilot and observer and by the recording camera on the opposite side of the gondola. The data panel shown in Figure 57 contained the following instruments:

1. Low altitude altimeter (external)
2. High altitude altimeter (external)
3. Rate of rise indicator
4. Clock
5. Ohmmeters for the external thermistors
6. Thermometer
7. Voltmeter for a 6-volt supply
8. Indicator light for vent fan
9. Internal gondola altimeter
10. Carbon dioxide analyzer
11. Hygrometer

Camera and Flashtube - A 35-mm recording camera was mounted on the bottom of the air regeneration box above the observer's control panel. The camera was motor-driven to wind one frame per minute, at which time the shutter

contacts triggered a flashtube. The camera motor was energized by a switch on the observer's panel. The camera and flashtube are visible in Figure 58.

Thermistor System - A pair of thermistors, one black and one white, were used to obtain external temperature data. Each thermistor was connected to an ohmmeter on the data panel. The thermistor circuit is shown in Figure 59. In order to minimize radiation effects, the thermistors were mounted on the end of a wand propelled in a circular path by a small electric motor. This put the thermistor in an artificially-convective atmosphere equivalent to 18.5 ft/sec. A motor-driven switch located behind the data panel short-circuited both thermistors periodically, allowing the meters to be zeroed. The switch for energizing both motors was located in the observer's control panel. The wand mounting is shown in Figure 60.

Flight Termination System - The circuitry for the main terminating system is shown in Figure 66. The termination switches on both instrument panels were wired in series, making it necessary for both switches to be thrown in order to energize the cut-down squibs. The energizing wires from the control panels were connected to a pressure-tight electrical fitting in the top of the gondola. This fitting, a 10-pin cannon-type connector, the internal side of which is shown in Figure 60, served as the feed-through for the four helium-valve wires. The valve and termination wires shared a common cable along the parachute. At the base of the balloon the squib wires were separated and a four-wire cable continued to the top of the balloon to the helium valve.

The electrical outlet and the connecting cable were vital circuit elements. Any damage to them could result in the inability to descend by means of the parachute or by the helium valve. For this reason, an auxiliary

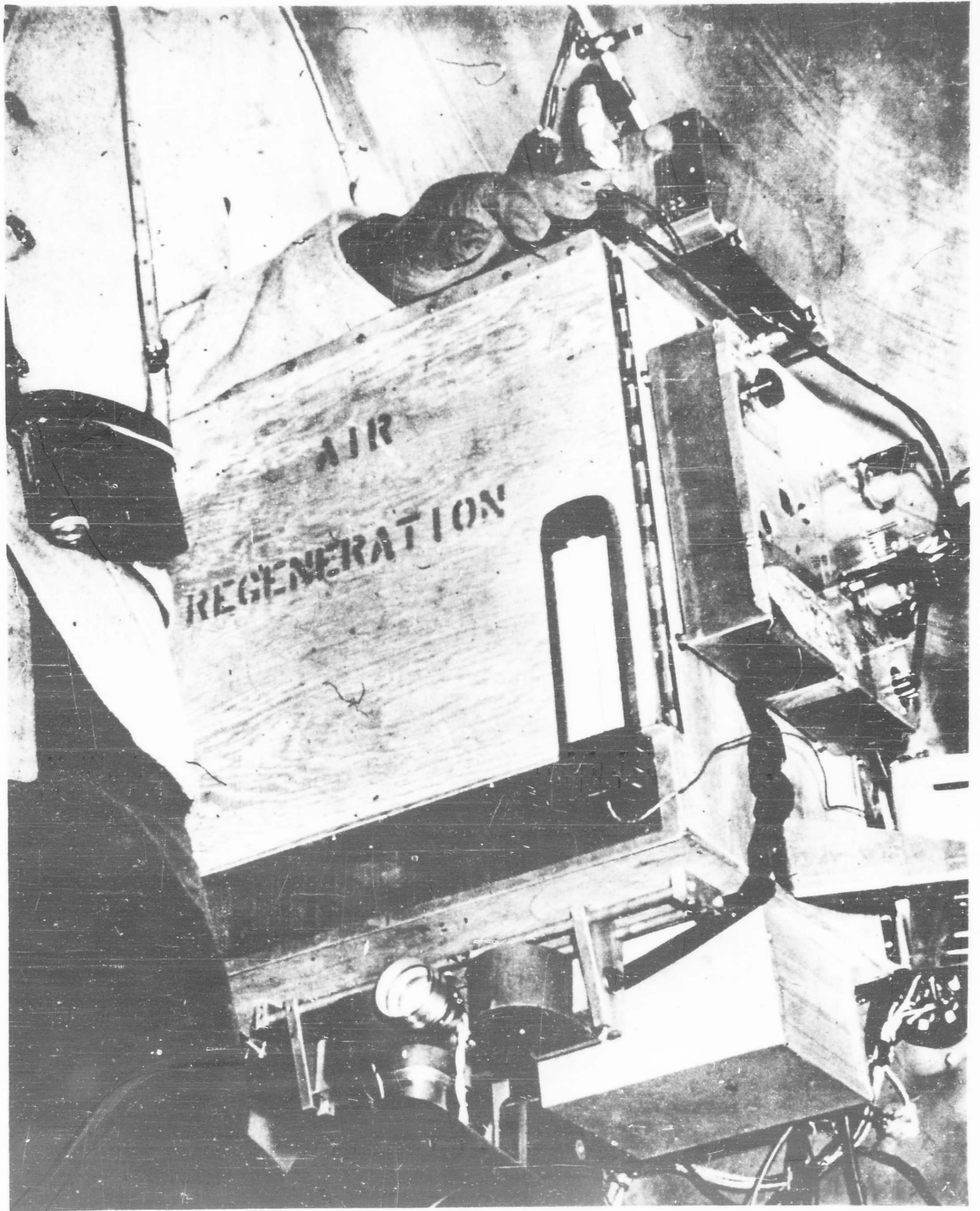

EQUIPMENT MOUNTED OVER OBSERVER PANEL

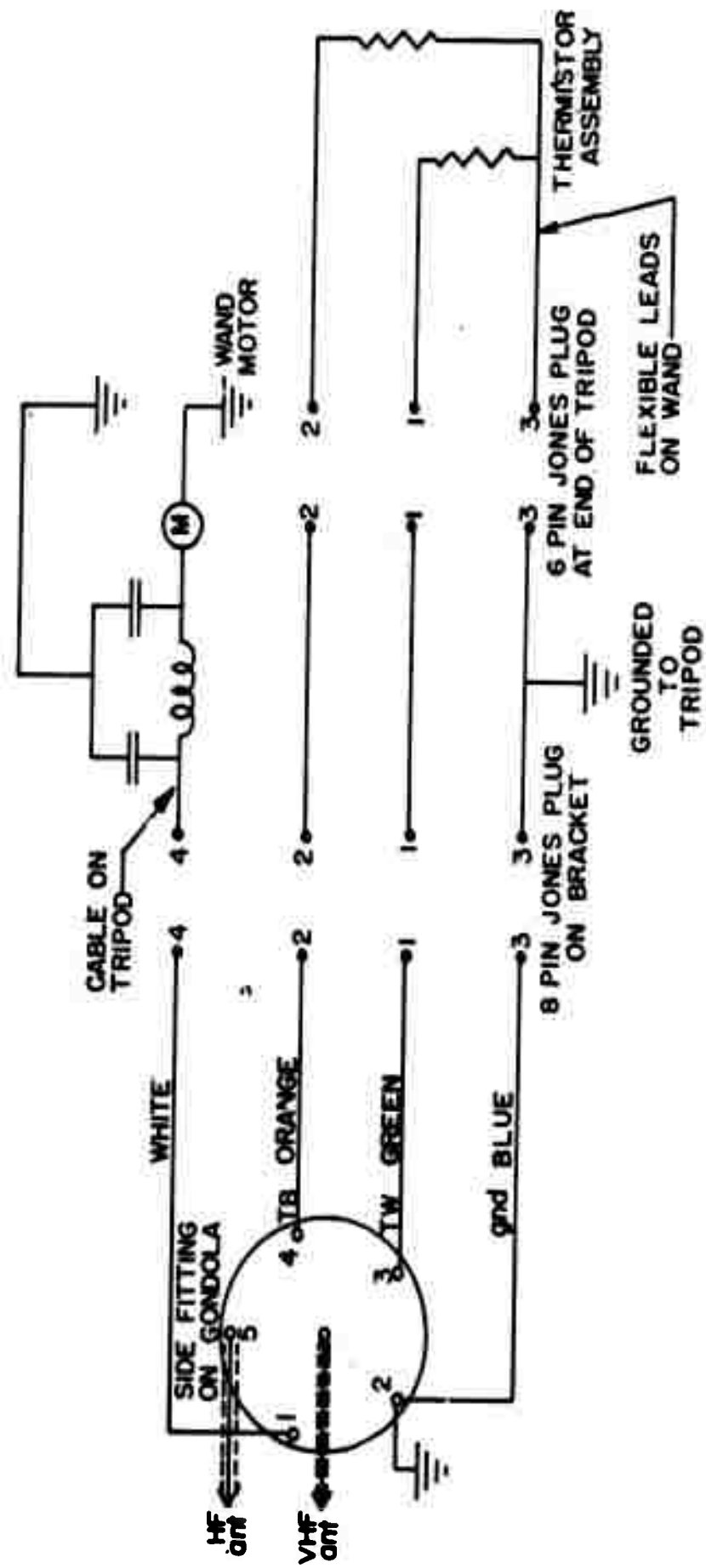

EXTERNAL THERMISTOR WIRING DIAGRAM

FIGURE 59



THERMISTOR WAND AND MOUNTING

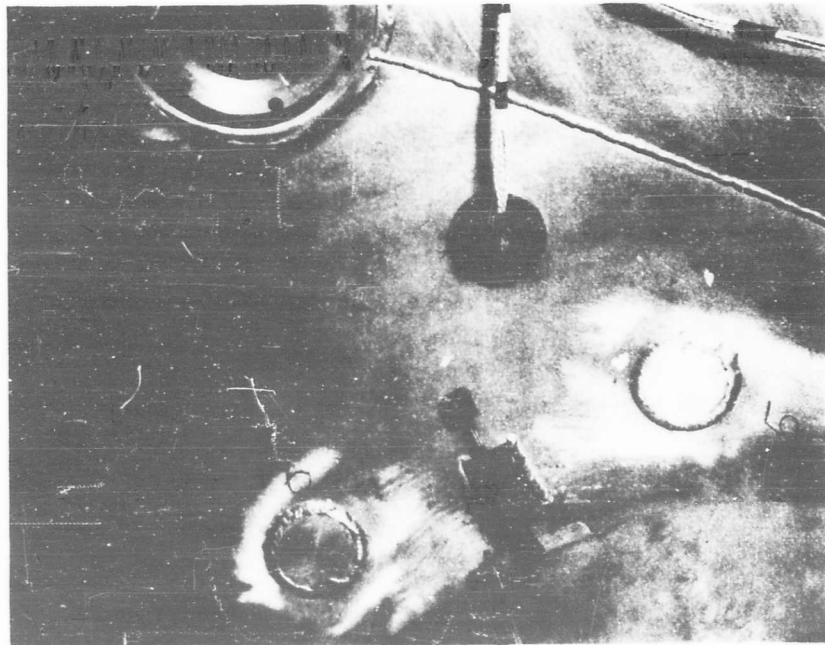

PRESSURE TIGHT ELECTRICAL FITTING
IN TOP OF GONDOLA
FIGURE 60

termination circuit was added. An additional set of squibs was included in the nylon attachment at the balloon and an additional pair of wires was attached along the parachute opposite the main cable. This pair of wires was connected to an otherwise unused electrical feed-through in a different area of the gondola top, the intent being to devise an independent descent system having a high probability of escaping damage by any occurrence that might harm the main cable or fitting. The auxiliary leads were not wired to the control panels; one lead was terminated at a ground lug near the fitting, and a length of coiled wire being attached to the remaining lead. To ignite the auxiliary squibs, it was only necessary to draw the free end of the coiled wire to any "hot" terminal after slipping off the insulated sleeving from its end.

Communications Systems - A small vacuum tube amplifier was used for both intercom and radio communication amplification. There were two separate pieces of radio apparatus, one a VHF transmitter-receiver, and the other a combination LF-HF unit. An additional telemetering transmitter was installed by an agency of the Navy; its details are not a subject of this report.

Intercom System - A microphone and a pair of earphones were integral parts of the head pieces worn by the observers. It was found necessary to change the microphones from a type giving a very low output voltage to a type having a more suitable output. Subsequently, a pair of magnetic hearing-aid microphones were substituted which produced medium output and very good voice quality. The microphones were operated in parallel and were connected to the 300-ohm section of the input transformer. The headphones, connected in parallel, were each of 10-ohms impedance, making a 5-ohm load on the output transformer. The slight additional audio load of the two transmitters brought the total load reasonably close to the 3.5 ohm rated output of the

transformer secondary.

Inasmuch as the intercom system was continually energized, the operators could converse freely through the system without pressing buttons or switches. The output of the desired type of communication was superimposed on the intercom system, enabling operators to hear themselves being called at any time. In order to broadcast, it was only necessary to push the spring-return transmit switch on either panel. This applied voice modulation to the LF carrier and switched "on" the VHF voice transmitter. The receiver channel was cut out by this action but left the intercom undisturbed, as can be seen from the circuit diagram of the intercom amplifier, Figure 61. The amplifier consisted of a triode-connected 1L4 voltage amplifier followed by a 1S4 power-amplifier with transformer coupling. The amplifier was mounted under the observer's control panel as shown in Figure 62. The batteries were mounted underneath the observer's panel along with the radio batteries.

VHF Unit - A commercial, lightweight VHF transmitter-receiver, manufactured by Skycrafters, Inc. was mounted on top of the air regeneration box. This unit was capable of delivering one watt of rf output and is shown in Figure 62. A switch on the front panel selected either 122.8 mc or 121.5 mc as the operating frequency. This unit, operating on 122.8 mc, served as the principal means of radio communication. The receiver output was wired to the receiver selector-switch on the observer's panel, permitting either this or the HF receiver to be heard. The output of the intercom amplifier was connected through a relay to the microphone input of the VHF transmitter. The transmitter carrier was energized by operating the "push to transmit" switch on either panel. This operation also cut out the receiver.

A ground-plane vertical antenna suspended downward was used for the VHF system. The antenna lead from the unit was connected to the elec-

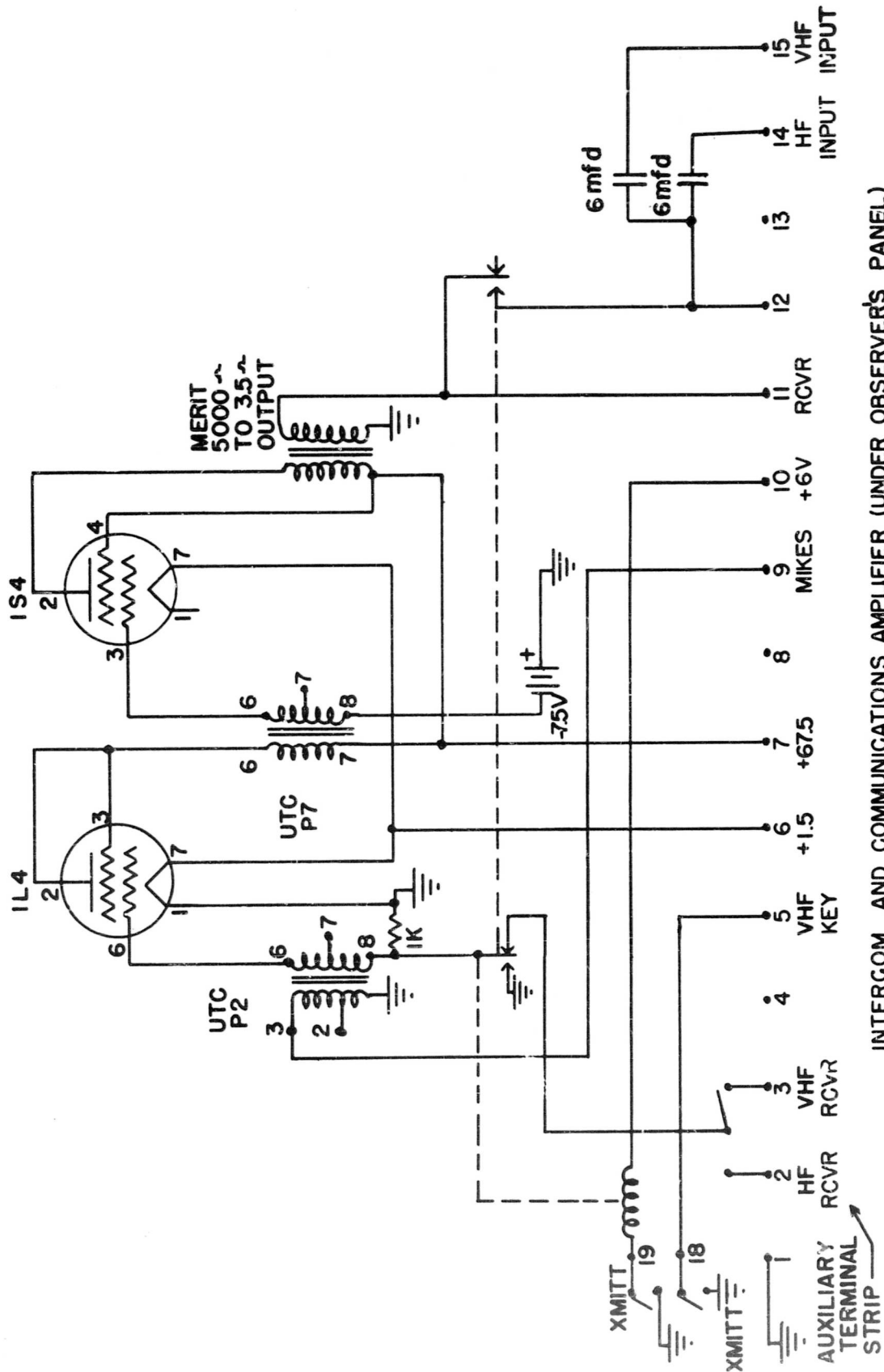

INTERCOM AND COMMUNICATIONS AMPLIFIER (UNDER OBSERVER'S PANEL)
 FIGURE 61

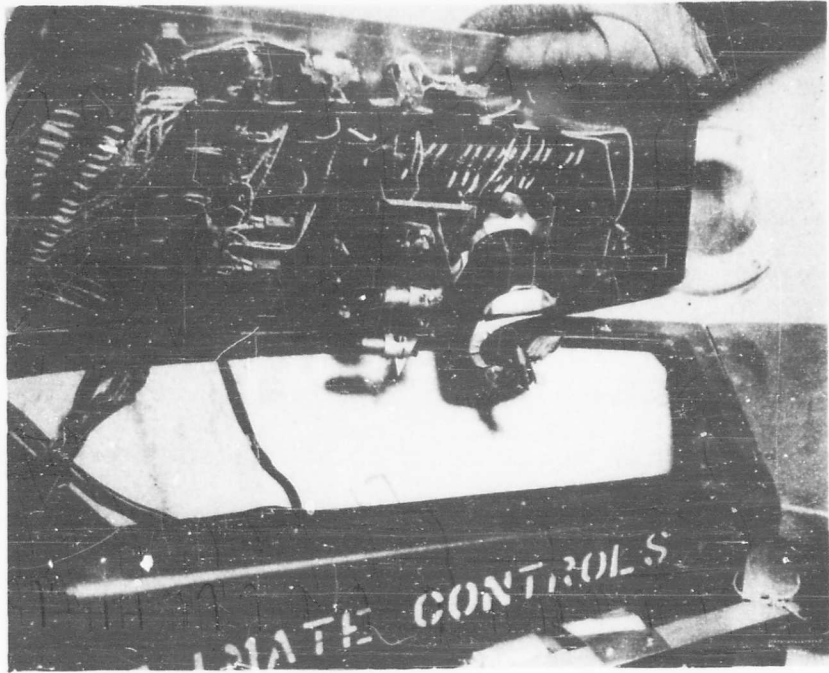

INTERCOMMUNICATIONS AMPLIFIER
MOUNTED BENEATH PANEL

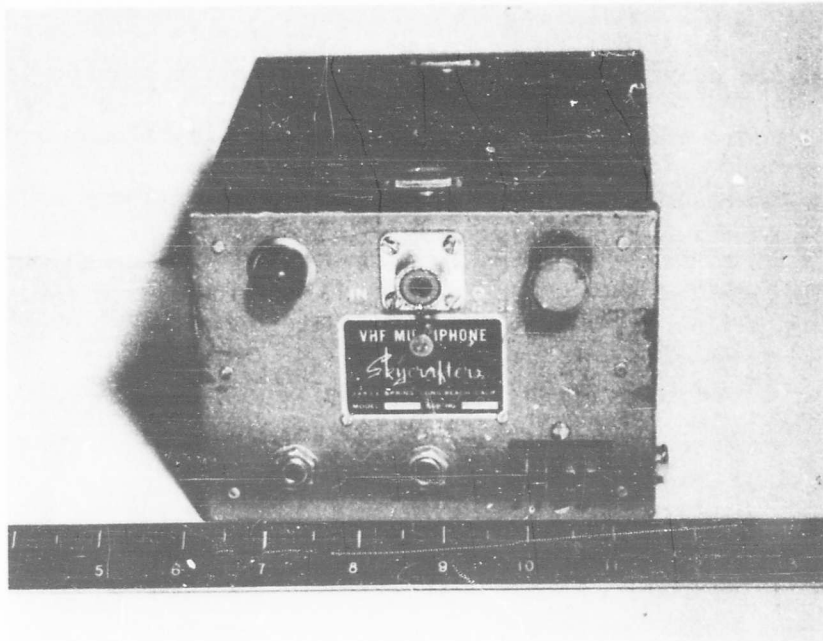

VHF SKYRAFTERS TRANSMITTER-RECEIVE
FIGURE 62

trical fitting located at the equator of the gondola, near the air regeneration box. Externally, the lead connected to a coaxial fitting mounted on a bracket. The lead to the HF receiving antenna was brought out to an additional coaxial fitting in the same manner. The HF receiving antenna was a two-turn loop wound on a horizontal disc of 2-inch Styrofoam, 11 inches in diameter. The suspended coaxial cable from the ground-plane VHF antenna passed through the center of the HF loop antenna. From this point upward, both coaxial feeders were in physical contact.

LF-HF Unit - A low-frequency beacon transmitter was considered essential for generating a homing signal for monitoring by tracking aircraft and ground vehicles. Also, since the weight of such equipment was almost entirely in the power supply and not in the transmitter itself, it was advisable to be able to switch to an alternate beacon on a slightly different frequency in case of breakdown or radio interference. The two LF transmitters in this unit operated on 1724 KC and 1742 KC. In addition, since so little energy was required for screen grid modulation, a screen modulator was added to each LF transmitter, thus allowing all of the voice transmissions to appear on the tracking carrier as well as on VHF. The desired transmitter was selected by moving a center-off switch to the left or right. This switch was located on the front panel of the unit.

A simple HF receiver was devised using subminiature components. The power requirements were low enough that a 1.5-lb battery pack would operate the unit for 20 hours*. Two such receivers were included in the same container to serve as dual beacon transmitters. One operated on the 6425 KC and the other operated on 6700.5 KC. Selection was made by moving a center-off switch either to the left or to the right. The antenna for these re-

* See Figure 63.

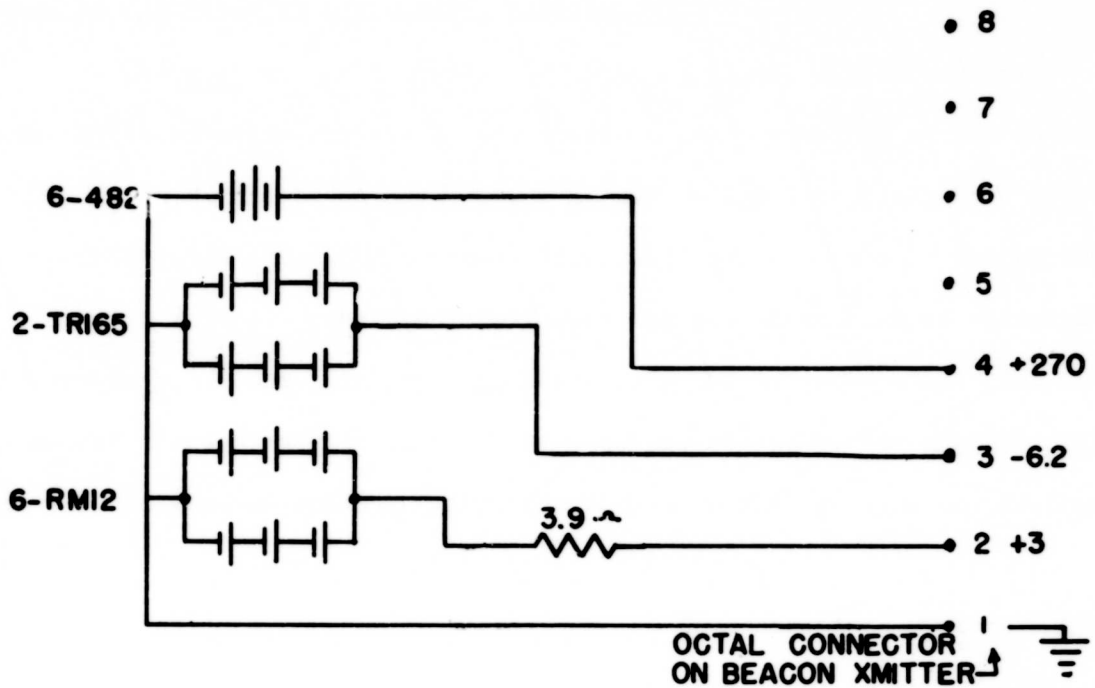

BATTERY PACK AND CABLE FOR LOW FREQUENCY TRACKING BEACONS
SCHEMATIC C

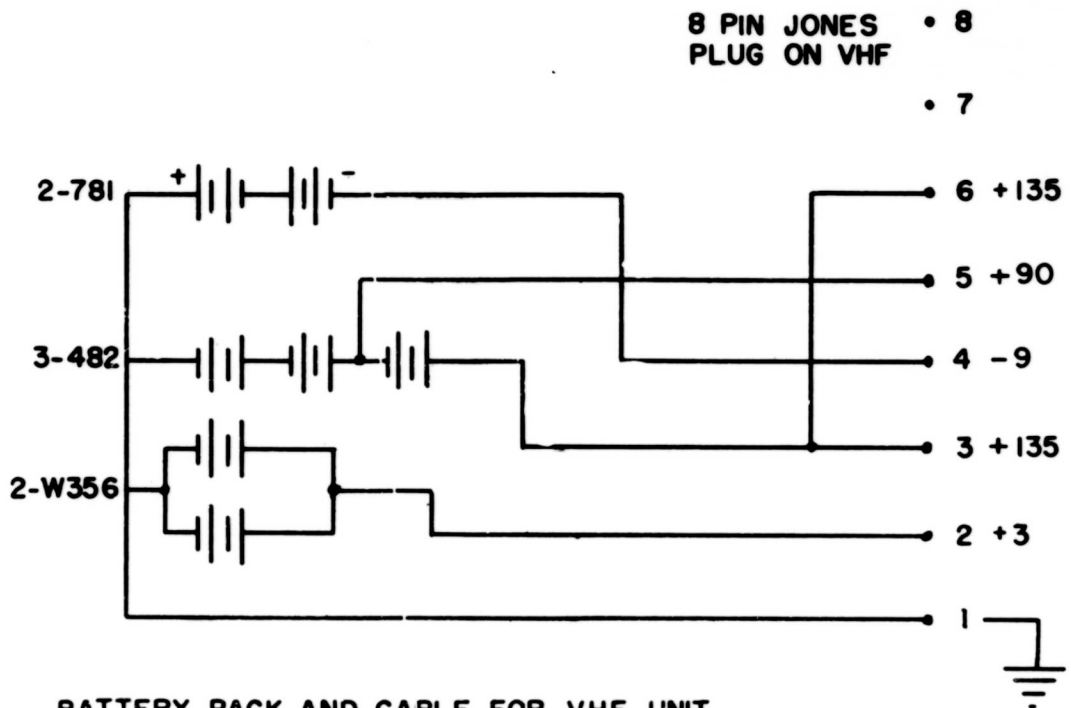

BATTERY PACK AND CABLE FOR VHF UNIT
SCHEMATIC D
FIGURE 63

ceivers is described in a preceding section.

In the dual unit, all transfer of antenna input, output and power was accomplished automatically by the single selector-switch. The entire unit, shown in Figure 64 with its power supply, weighed only slightly more than a conventional tracking beacon. The power output of the LF transmitters was 1.5 watts into a conventional half-wave end-fed antenna, consisting of a quarter-wave, 72-ohm twin lead, followed by a quarter-wave wire. The output was fed through an electrical fitting in the bottom of the gondola. The battery packs for the radio and intercom apparatus were mounted on the framework beneath the observer's control panel (see Figure 65).

Recommendations for Future Electrical and Communications Systems - The use of a 12-volt or 24-volt basic electrical system might be more practical than the 6-volt system presently utilized. This would allow the helium valve to operate from the main supply instead of from a special supply, and the ballast valves could operate directly from the main supply instead of requiring a booster battery. Also, a selection of aircraft motors would be available for blowers, etc. These are of lighter weight and higher quality than the 6-volt apparatus used presently.

The ballast hoppers should be redesigned to eliminate residual ballast that fails to flow. They should also be designed to fit closer to the gondola and to hold much more ballast. The ballast control and indicator system was satisfactory.

Use of low-power transmitters was made necessary by weight limitations. The one-watt power level appeared fairly effective for communicating with ground stations at substantial ranges, provided the range was within the electrical horizon. This communication arrangement has been tried in con-

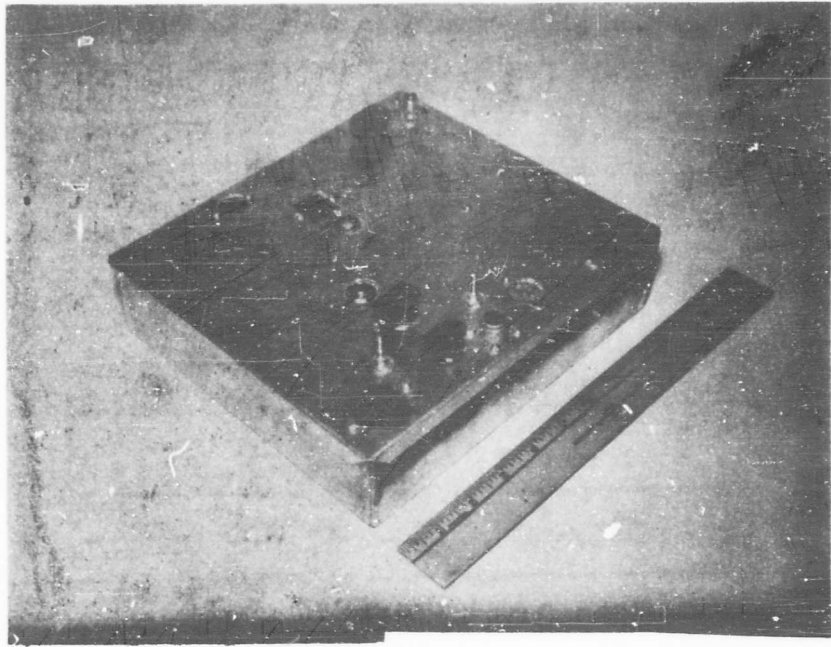

EXTERNAL VIEW OF LF-HF TRANSCEIVER

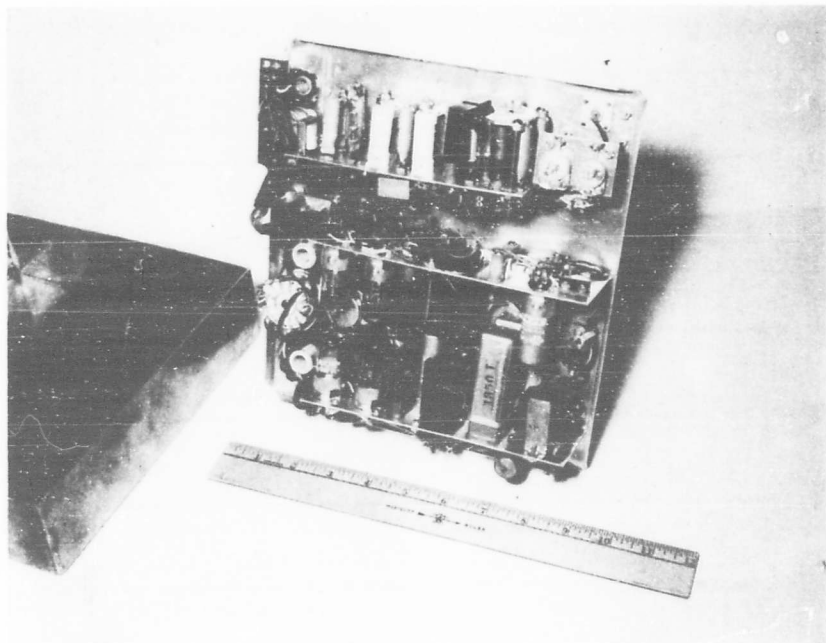

INTERNAL VIEW OF LF-HF TRANSCEIVER
FIGURE 64

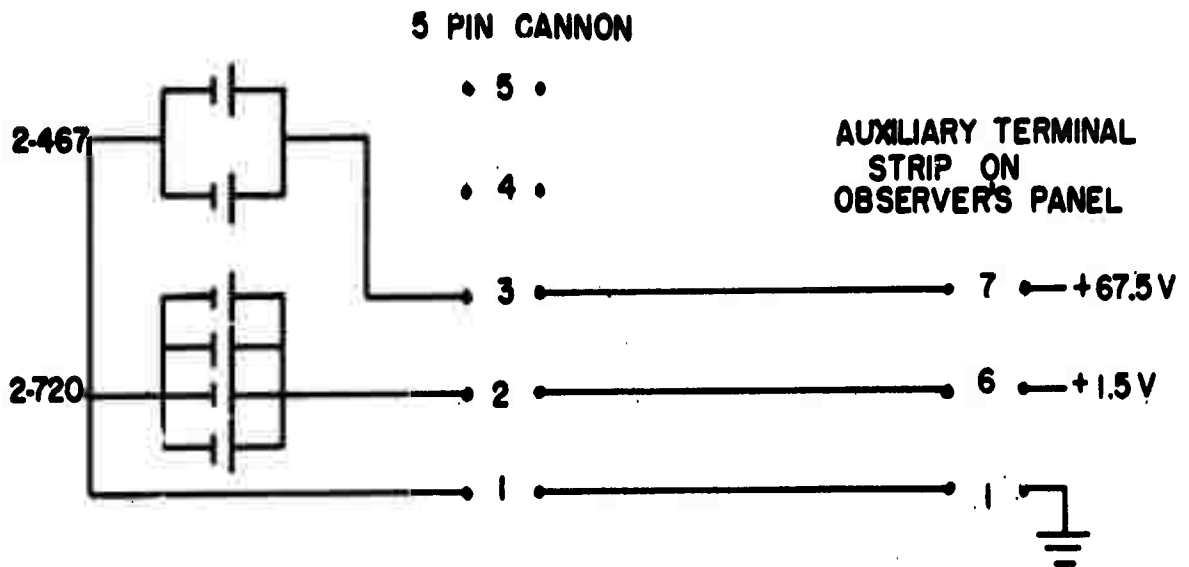

**BATTERY PACK AND CABLE FOR INTERCOM AND COMMUNICATIONS AMPLIFIER
SCHEMATIC A**

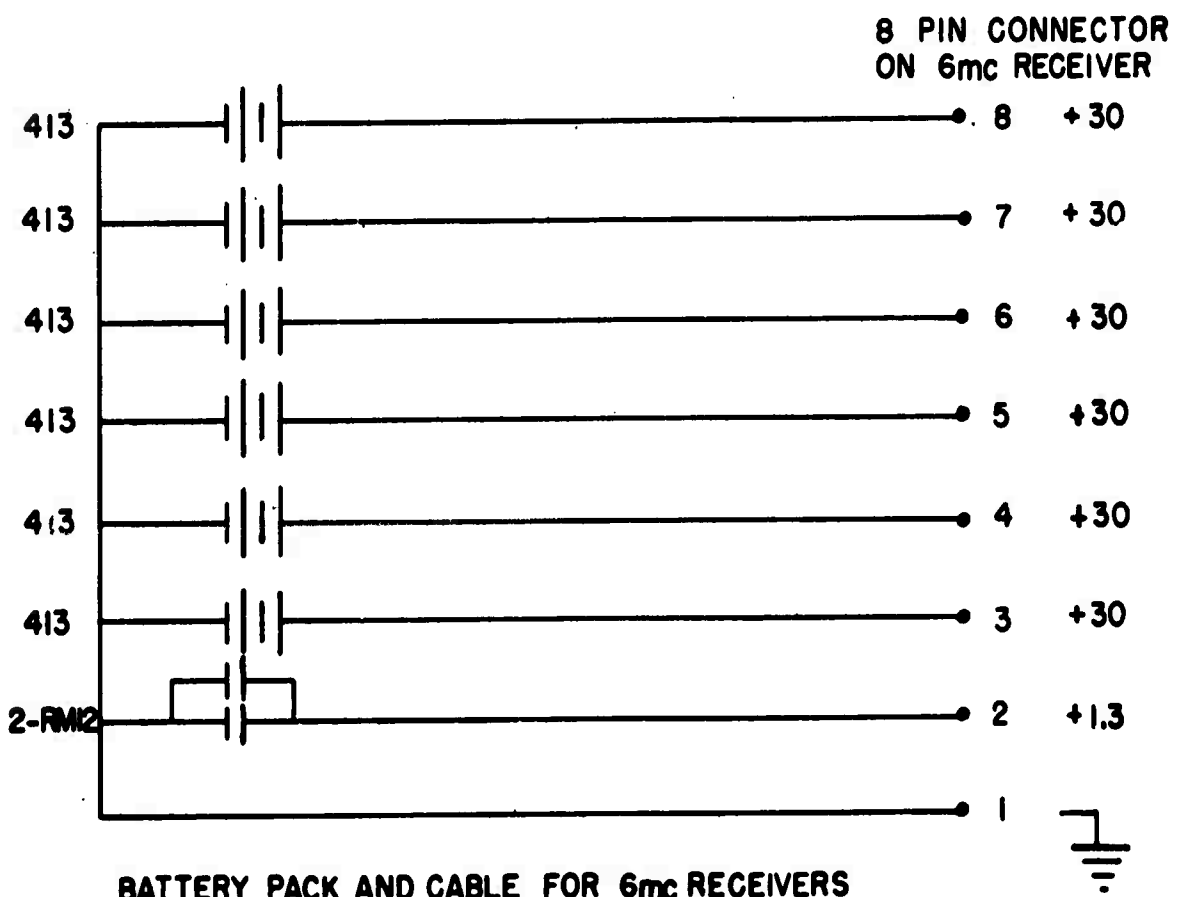

**BATTERY PACK AND CABLE FOR 6mc RECEIVERS
SCHEMATIC B**

FIGURE 65

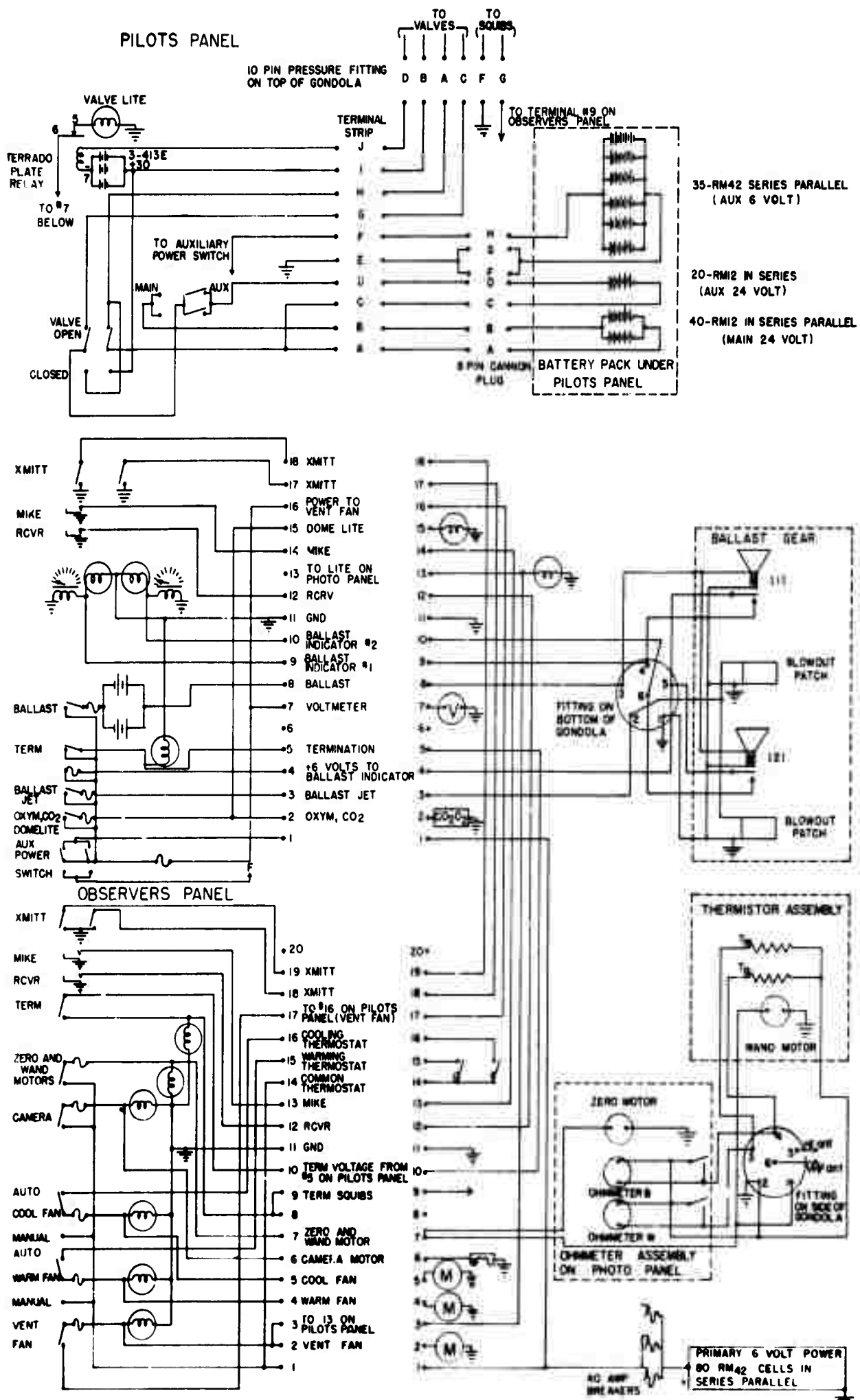

COMPOSITE WIRING DIAGRAM
FIGURE 66

nection with three different aircraft, and in only one case was the balloon-borne equipment satisfactory for voice transmitting to the tracking aircraft, and this on VHF only. In spite of the shorter ranges to the tracking aircraft, wing static and electrical noise create a noise level in the average aircraft which makes reception of low-power signals difficult or impossible. A 5 or 10-watt transmitter should be included in the gondola if possible. Also, the aircraft gear should be critically maintained; this includes minimizing and carefully aligning RF and IF sections of radio receivers used.

Gondola Suspension - Several methods of suspending the gondola were considered. Among these, two were most feasible. The first involved a series of long aluminum tubes extending through the gondola, top and bottom, as shown in Figure 67. In effect, these six tubes would form a cylinder capable of withstanding tensile shock loads applied to the top as well as landing loads applied to the bottom. Inasmuch as possible, the weight of interior components would be borne by these tubes, leaving the spherical shell free to serve only as a pressure-maintaining device, for which it is more than adequate. Six rods were convenient from an interior arrangement standpoint. Two rods would straddle each port and each occupant seat. In these positions the rods would give the balloonists handy guide rails for use in moving about internally, leaving the gondola, or for support during landing or any emergency situation. Such an arrangement would result in a safe gondola which could withstand very high abnormal loads and would be servicable for many flights. This method, however, was not used because the additional weight of 56 lb was undesirable from a balloon load-carrying standpoint.

The second method of suspending the gondola (the method used on the first flight) is shown in Figure 68. This method, in effect, suspends the spherical pressure shell in a network of nylon webbing. A series of eight,

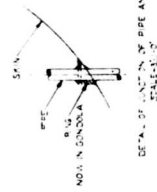
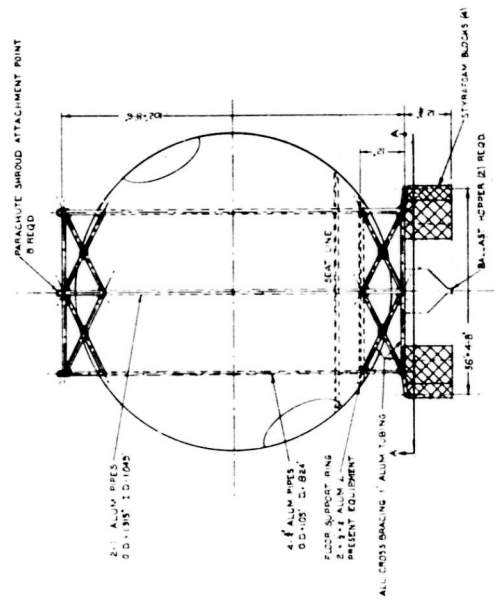
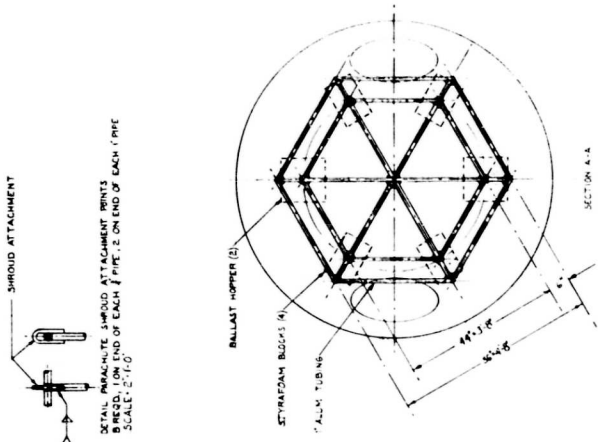

DETAIL OF JUNCTION OF PIPE AND ELBOW SUPPORT RING
SCALE: 1/5

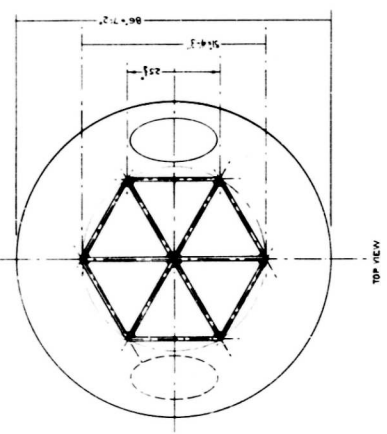

TOP VIEW

RIGID SUPPORT SYSTEM
FIGURE 67

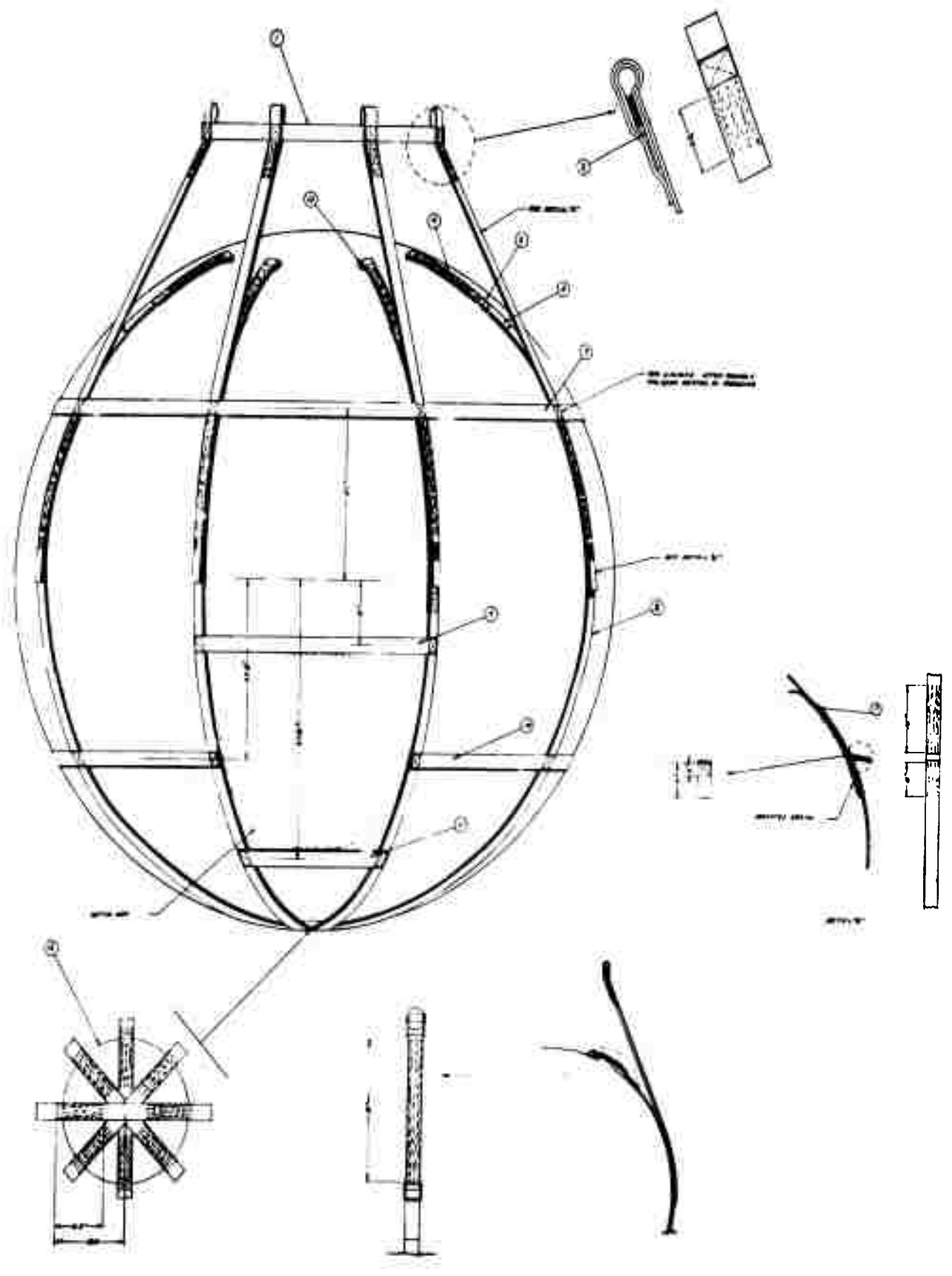

GONDOLA SUSPENSION NETWORK
 FIGURE 68

double, vertical straps of 6,000 lb strength each, or 96,000 lb total, supports the gondola. The nylon network is held in place principally by eight padeyes welded to the skin near the top of the gondola. The eight padeyes are located equidistant along the circumference of a 3-ft diameter circle in the upper hemisphere of the gondola.

The arrangement was designed to allow pre-stressing of the harness with respect to the gondola. Applied loads tending to shift the harness would be absorbed principally in static friction between the shell and the nylon webbing, with the residual force taken up by a tangential load on the padeye. The straps of the harness also passed between a bottom aluminum ring and the shell, as well as between the lugs used to hold the ring in place. This feature insured that each of the eight, double, nylon webbings would occupy only a definite given area. A top circumferential band was made a part of the harness to keep the nylon webbings oriented when supported by an opened parachute. Two horizontal bands were used to keep the bands evenly spaced.

The harness assembly was tested to an equivalent of 4 g's by supporting the gondola on one-half of the straps and loading the gondola to one-half of the expected maximum load of 6,400 lb.

Landing Shock Absorber - Since, under conditions of a parachute descent, the descent velocity could reach 1,700 ft/min, it was necessary to provide some type of impact absorbing device to cushion this deceleration.

Various means have been devised to minimize this deceleration. It can be seen readily that, even if some perfect absorber were used, its thickness would be related by the equation:

$$S = \frac{v^2}{2a} \quad (2)$$

where:

S = distance over which the shock absorber is effective

v = descent velocity

a = the maximum desired deceleration

Assuming a descent rate of approximately 1,700 ft/min, the curve shown in Figure 69 indicates the necessary thickness of some perfect absorber for a specified deceleration. In reality, any shock absorber must have a thickness greater than this, i.e., the point of operation will generally lie some point above from this curve.

It was highly important to land the gondola with maximum safety provided for the occupants and with minimum damage to the gondola (to permit its re-use on future flights). Two requirements were paramount:

1. To provide a low center of gravity to prevent tipping and subsequent rolling on impact, with possible injury to the pilots
2. To provide shock absorber pad of sufficient thickness to decelerate the gondola within reasonable limits.

Unfortunately, the simultaneous solutions of these two requirements were in conflict, and a compromise was necessary. General Mills chose to compromise in favor of (1) above, with the expectation that a balloon landing would be made, and that, therefore, it was more important to prevent tipping and rolling upon impact than it was to prevent damage to the bottom of the sphere as would be the case if a parachute landing were necessary.

In accordance with the above, a base was designed to keep the center of gravity as low as possible and to provide the greatest possible padding thickness. An annular Styrofoam base was selected. This allowed 14 inches of crushable material around the bottom of the gondola, but kept the gondola

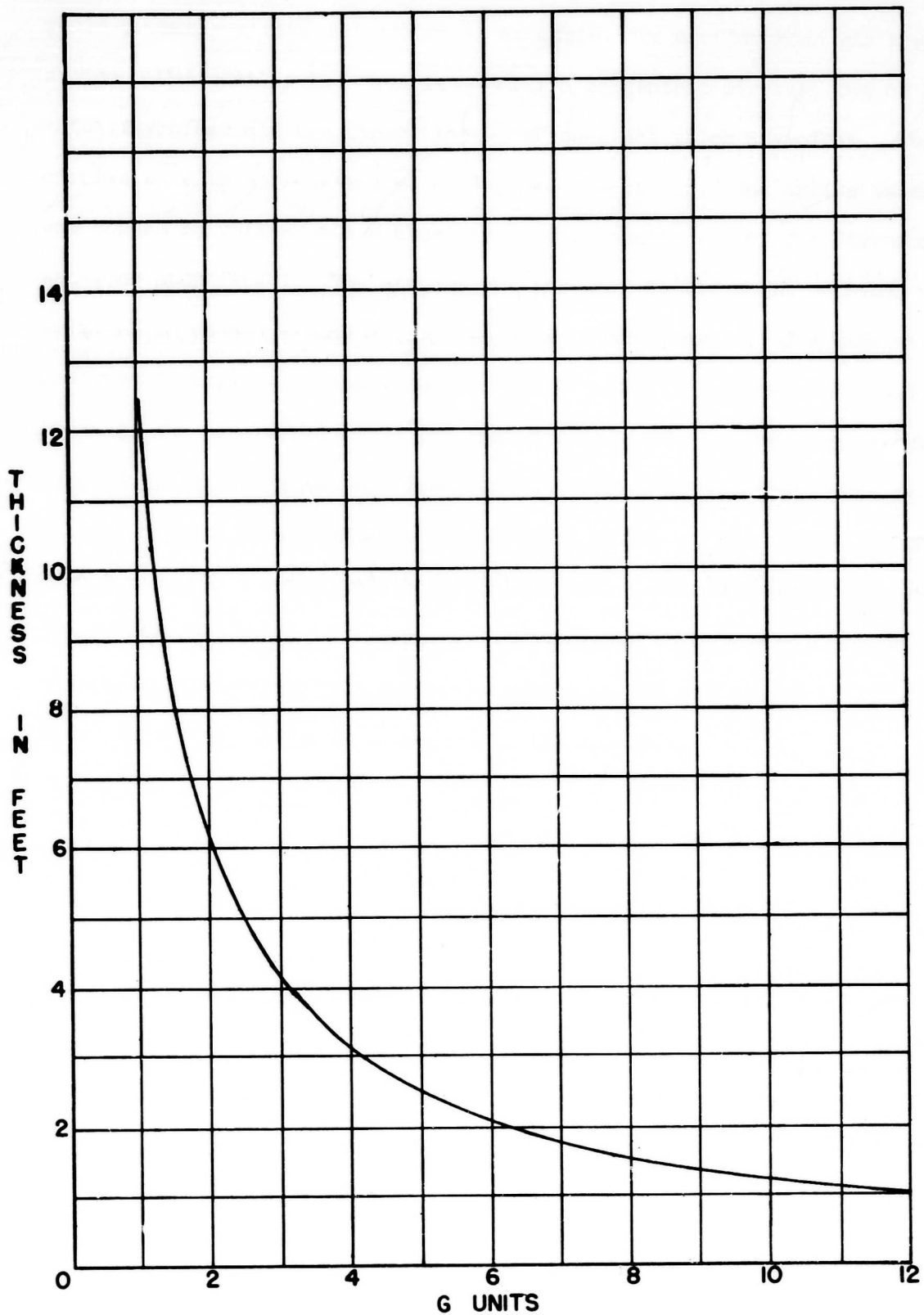

PERFECT SHOCK ABSORBER THICKNESS VS THE MAXIMUM PERMISSIBLE DECELERATION (IN G UNITS)

FIGURE 69

well within 5 inches of the ground at the bottom center. Since the gondola would probably strike the ground at an angle, the annular base was a good choice. The annular base consisted of two concentric circles, one of 2-inch thick Styrofoam and the other (inner) of one-inch thick Styrofoam. The two circles were then cross-braced by Styrofoam sections. The entire assembly was housed in thin aluminum sheet to prevent scattering of the Styrofoam sections upon impact. The annulus was fastened to the shell by bands of metal which passed around a ring attached to the gondola. The base was designed to begin yielding with an evenly applied 5.7 g load. At 20.5 g loading, the base would be 75 per cent crushed. The entire base assembly weighed 30 lb. As a further deterrent to rolling after impact, the two ballast hoppers were mounted at the gondola equator. The hoppers weighed approximately 5 lb each and therefore did not appreciably raise the center of gravity, but would be effective in stopping a roll on a moderate slope. A detailed analysis of the stresses imposed on the gondola shell by this shock absorbing system is contained in the Appendix.

FLIGHT SIMULATION

Radio Control Flights

One important consideration in any controlled balloon flight is the amount of ballast necessary to check a specified descent rate and subsequently permit a safe landing. Since the proposed feasibility flight called for certain approximate rates of ascent and descent during various portions of the flight, it was desirable to attempt to simulate the ballast problem completely. By noting the acceleration of the balloon as it entered the troposphere, it could be determined, from experimentation, what ballast requirements would be necessary to slow that descent. Such a flight simulation would also provide the two observers with the required valving times needed to initiate some specified descent rate.

Two radio-controlled flights were conducted in which useful information was obtained. The first (Flight 1477) took place 31 August 1955. The time-altitude curve of this flight is seen in Figure 70.

The basic objectives of this flight were:

1. To control the ascent rate at approximately 400 ft/min to ceiling
2. To float for two hours
3. To establish a 200 ft/min descent in the stratosphere
4. To note the resulting tropospheric descent rate and check by ballasting
5. If possible, to obtain more data by driving system back to ceiling and repeating.

The results of the experiment were:

1. The ascent rate was radio-controlled to an average rate of approximately 360 ft/min
2. The system was allowed to float at its theoretical ceiling for a period of two hours and 10 minutes

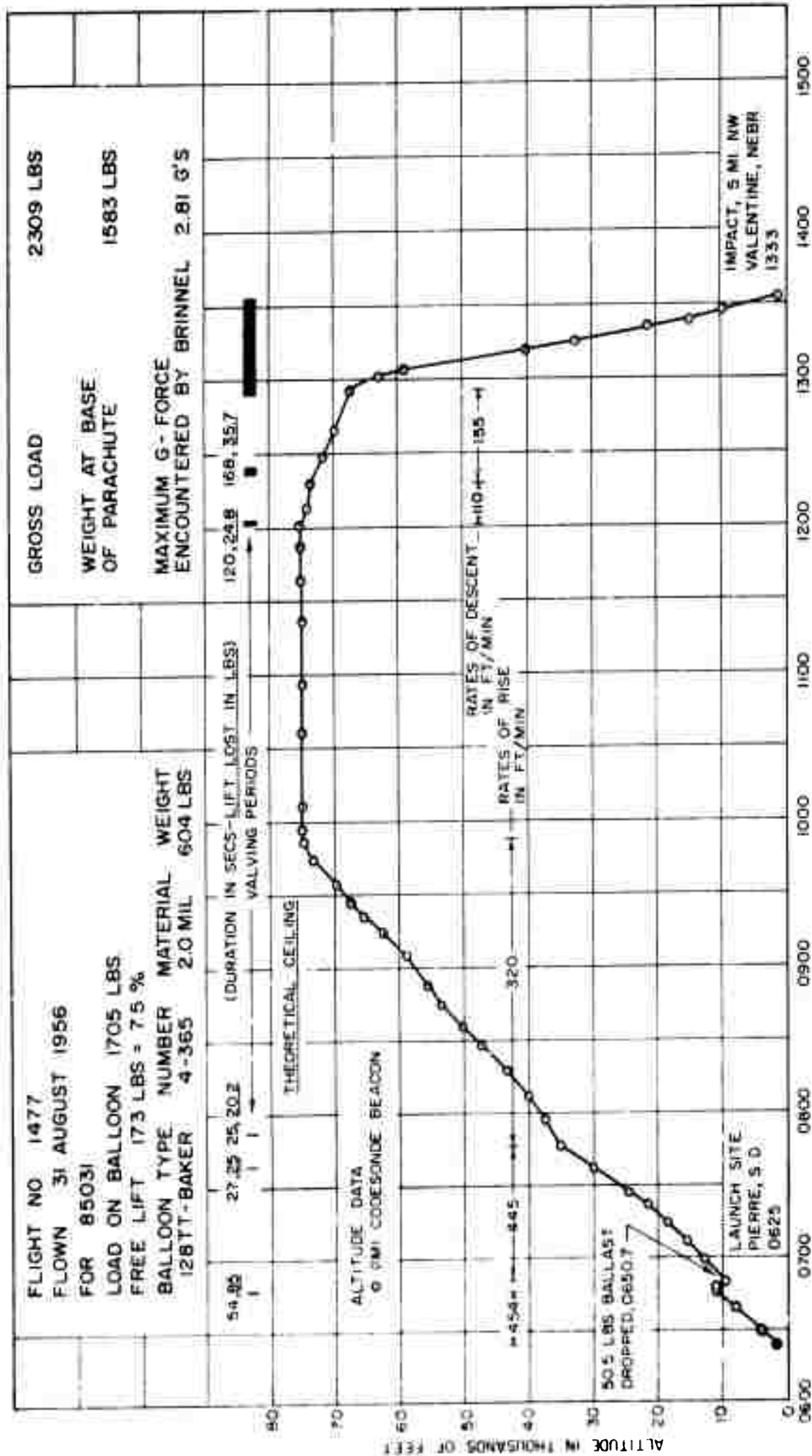

RADIO CONTROL TEST FLIGHT I
 FIGURE 70

3. The descent was initiated by 2.0 minutes of valving, which produced a descent rate of 110 ft/min; the system was accelerated to a descent rate of 155 ft/min by valving again for 2.8 minutes.

Since it was desired to establish the 200 ft/min descent rate more previously, valving was begun again. Unfortunately, just after the valve opened, the controlling airplane's electrical system failed to operate correctly and it was not possible to close the valve.

Important data was obtained, however, from this flight regarding required valving periods to produce a given rate. The time required for the system to reach an equilibrium downward speed was also determined. Inasmuch as the balloon ruptured during the ensuing rapid descent, information was also obtained concerning the parachute's opening shock (2.8 g) at this altitude.

Using the above data, a crude calculation of the dependence of the descent speed on the fractional heaviness can be made.

If we assume that:

$$f = Kv^n$$

where:

f = fractional amount that system is "heavy"

K = some constant for this system at this altitude

v = descent rate (ft/min)

then n is approximately 5/2 when using the data from this flight. The constant, K, is, of course, dependent in some way on the gross load, the ambient density of the atmosphere and the lapse rate. For this particular case, however, each of these factors remain essentially constant and thus have been lumped together in a constant. These two points have been plotted in Figure 71, as have two other points from Flight 1594. Note that they fall fairly closely on the $v^{5/2}$ curve. The dashed curve represents the theoretical

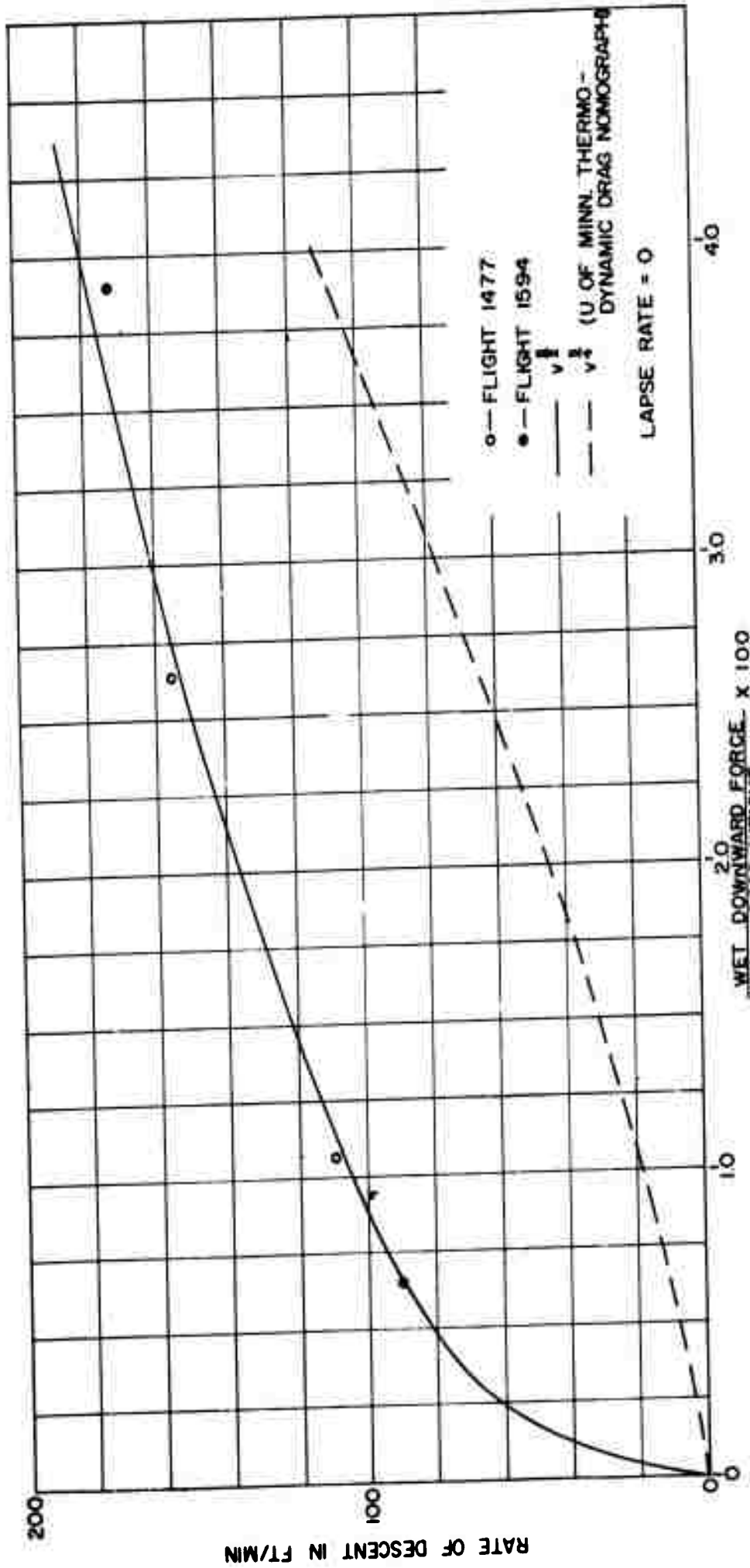

EXPERIMENTAL AND THEORETICAL COMPARISON OF DESCENT RATE
 FIGURE 71

thermodynamic drag predicted by the University of Minnesota.² The dashed curve is plotted on the basis of a gross load of 2,300 lb and a zero lapse rate. In order for this curve to correspond to the points collected from these two flights, a lapse rate of -3.5° would be necessary according to the theoretical relation. The actual lapse rate was significantly less than this and is shown in Figure 70. Needless to say, the aerodynamic drag of this particular system is negligible in the above consideration at these descent rates. It appears that it would be possible to conduct a series of flights with the purpose of determining empirically the thermodynamic drag relations by separation of variables.

The second radio-controlled flight (Flight 1594) was conducted 30 November 1955 and was an attempt to supplement the information already obtained from Flight 1477. The time-altitude curve is shown in Figure 72. As mentioned previously, the stratospheric descent rates have been plotted in Figure 71. This flight provided additional data concerning the increase of descent rate as this system passed from the stratosphere into the troposphere. The stratospheric descent rate averaged 172 ft/min, and the tropospheric rate averaged 456 ft/min from 35,000 ft to 30,000 ft, an increase by a factor of approximately 2.65. At an altitude of 30,000 ft, 72 lb of ballast was discharged by radio control. This caused a decrease in the average descent rate of 269 ft/min from an altitude of 30,000 ft to 16,500 ft. At this time approximately 140 lb of ballast was dropped, which halted the descent and caused the system to begin ascending at a rate of 535 ft/min. As it developed, this rate of ascent decreased gradually and the system came to equilibrium at the base of the stratosphere, significantly below its theoretical ceiling as shown by the time-altitude curve. From this infor-

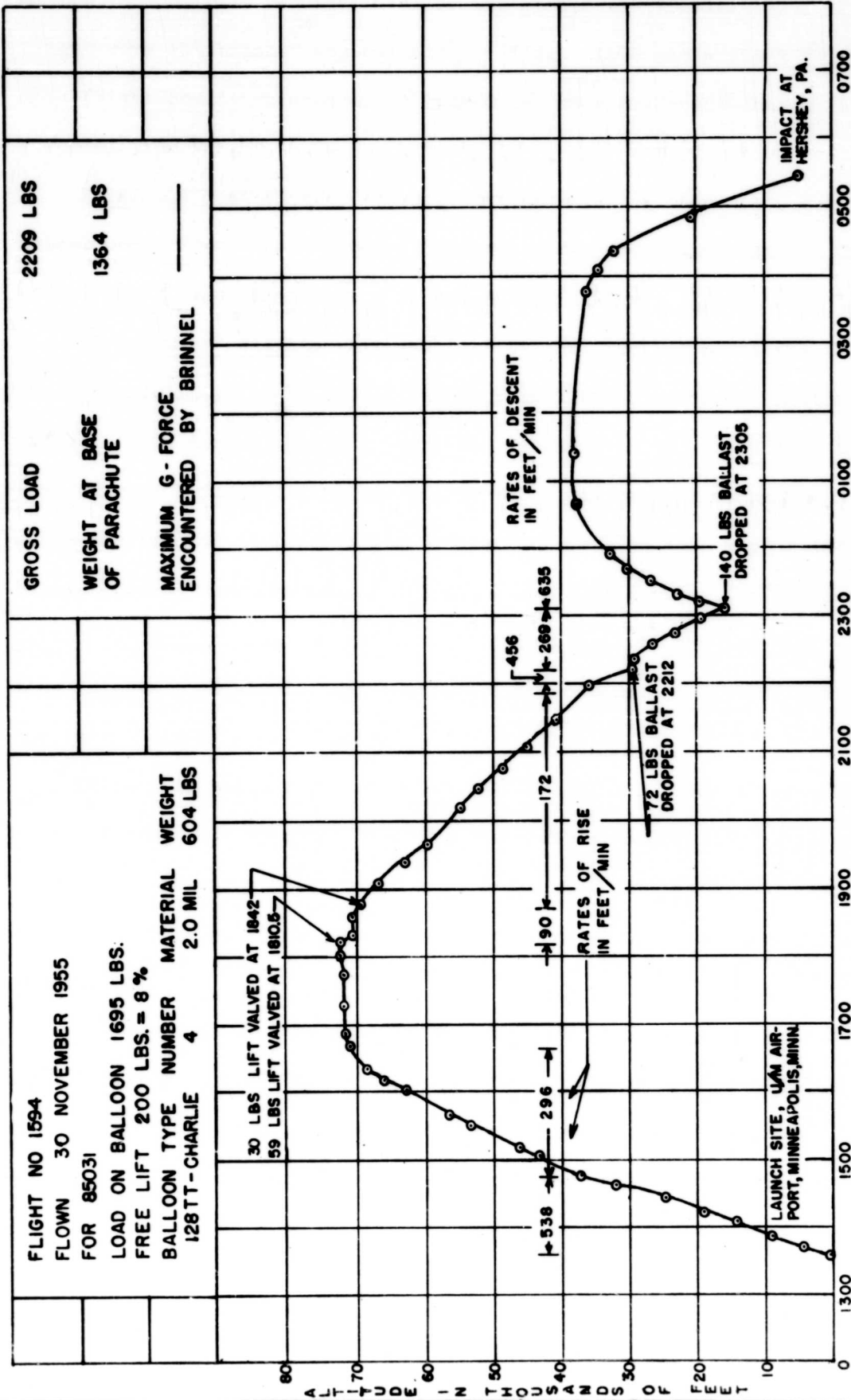

CENTRAL STANDARD TIME

RADIO CONTROL TEST FLIGHT II

FIGURE 72

mation, the ballast requirements for the Strato-Lab feasibility flight were established approximately. Flight 1594 was a night flight, and this flight condition apparently introduced no significant change in data recorded from Flight 1477.

Parachute Test Flight - This flight has already been discussed to some extent under Strato-Lab System Components - Parachute above and in GMI Report 1471. The time-altitude curve is presented in Figure 73.

"Programmer" Flights - It was felt by the steering committee that the first feasibility flight should be programmed by an automatic controlling device. This device should control the ascent rate to within some specified rate of rise by controlling the helium valve and ballast mechanism. It should allow the balloon to rise to its theoretical ceiling and appropriately ballast the balloon, by use of a "follow-up" type device, for any pre-set period of time in order to maintain this ceiling. At the conclusion of this time interval, it should then initiate a pre-determined descent rate and bring the entire system back to earth.

This instrument, referred to as the "programmer," was constructed for a test flight. It operated on a time base which specified a particular altitude zone within which the balloon must operate. If the balloon system was not within this zone, the gas or ballast valve would be actuated, whichever was appropriate.

This was achieved by plating the entire surface of a dielectric circular disc with a conducting material except for a path of finite width curving from the outside edge to the center (see Figure 74). This disc was then given a slow constant angular velocity by means of a chronometric DC motor. A contact arm moved over the face of the disc and along one of its radii

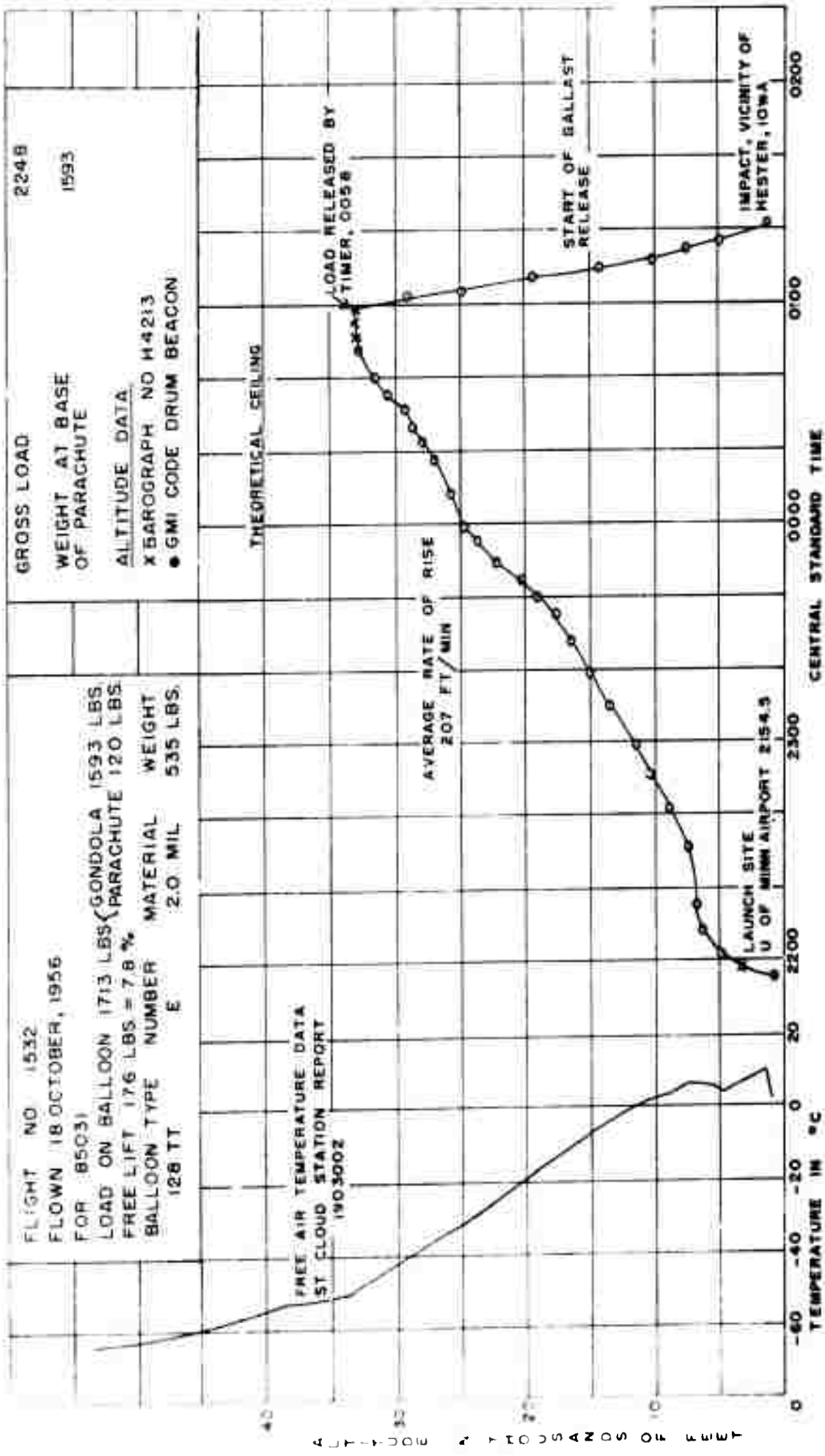

PARACHUTE TEST FLIGHT
 FIGURE 73

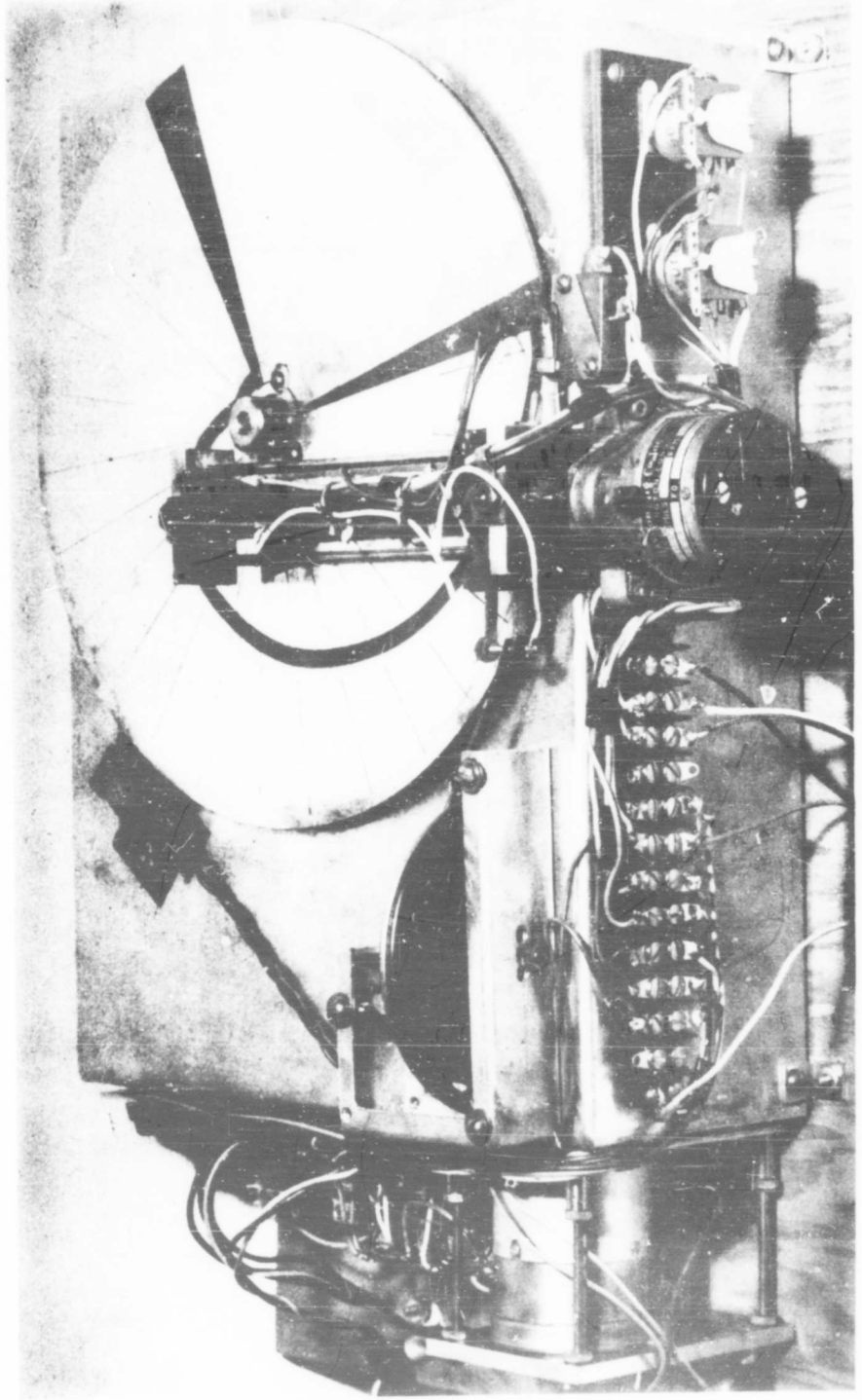

AUTOMATIC FLIGHT PROGRAMMER

FIGURE 74

by means of another chronometric motor when the motor circuit was actuated by a bellows system. It can be seen, for example, that if the balloon system ascended too rapidly or too slowly, the contact arm would move out of the non-conductive path on the disc and onto either one or the other conductive areas. Each of these areas acted as a series link in either the valve or the ballast circuit. When the bellows system stopped expanding (ceiling altitude), the rotation of the disc was stopped and a "follow-up" switch maintained the system at that particular altitude. Reaching the ceiling altitude also started a timer which specified the time interval the balloon system would maintain its ceiling altitude. At the conclusion of this interval, the disc began to rotate again, but in the reverse direction. The contact arm would then move over into the "valve" area, which would open the valve and initiate the descent. The average descent rate would then be approximately the same as the ascent rate.

Various refinements of such a design are probably desirable. For example, it may be desirable to have a different ascent and descent rate. This and other ramifications of the basic design are possible. However, a fairly simple "program" was chosen since additional complexities would have greatly extended design and construction time.

The "programmer" had an altitude interval approximately equivalent to 5000 feet. This interval is, of course, represented by the width of the dielectric path.

Two attempts were made to fly this instrument on experimental balloon flights to test its operation. Unfortunately, both of these attempted flights were unsuccessful. Neither of these failures, however, was due to the "programmer" but, rather to local weather conditions.

The first attempted flight took place on 21 August 1956. The general weather conditions were satisfactory throughout the preparation and inflation of the balloon. During the launching period, however, the local winds became somewhat excessive and buffeted the instrument gondola rather severely. This buffeting disturbed the adjustment of the ballast valve. Other than this unnoticed maladjustment, the launching was difficult but successful. Because of a low level temperature inversion, the balloon ascended to an approximate level of 2000 ft and floated for a period of 100 minutes. At this time the "safety switch" terminated the flight. Obviously, the "programmer" would have demanded ballast in order to pass the balloon through this inversion. On inspection of the recovered equipment, it was found that the programmer and associated equipment was still functioning properly and was still demanding ballast flow. Unfortunately, the disturbed ballast valve adjustment would not permit the ballast to flow from the hopper.

A second attempt to test this instrument took place 11 October 1956. After inflation and other preparations, it was found that the system would not ascend even though the prescribed amount of helium had been used to inflate the balloon. The launching procedure was halted and the balloon allowed to valve the remaining helium. The inflation tube was found to have torn a sizeable hole around its attachment area on the balloon wall. This balloon was replaced by the manufacturer; however, no further flights of this instrument have since been attempted.

FIRST STRATO-LAB PERSONNEL FLIGHT

Strato-Bowl, Rapid City, South Dakota - Early in this program it established that vertical inflation and launching would be most suitable for this project. Although several feasible launching schemes were proposed, it became obvious that none provided the neat and clear-cut method of vertical launching.

Desirable as this method of launching is, it can also, even under "normal" circumstances, be extremely difficult. A wind of 5 to 7 knots will cause the extra material in the balloon to "sail" and, in general, endanger the entire launching. If, however, the proper synoptic condition prevails and proper precaution is observed, a vertical inflation and launching can easily be carried forward.

Such an ideal synoptic condition is somewhat unusual. The condition generally exists when a high pressure cell is centered directly over the launching site at dawn or dusk. Since it is important to time the launching to coincide with this condition, it is desirable to extend this interval of calm winds by seeking some type of shelter. The Strato-Bowl, a natural depression near Rapid City, South Dakota, and scene of the launching of the Explorer and Explorer II balloon flights, provides such a shelter.

Some of the physical characteristics of the geological formation are indicated in Figure 75. The various radials indicate the distance out to prominences, the heights of which are shown adjacent to the indicated points. See Figure 1 also.

A number of experimental launchings of small balloons from the Strato-Bowl were made prior to its final selection as the launch site. A 73-ft diameter balloon was also inflated vertically and launched after observing effects of the existing wind on the balloon at various levels within the bowl.

These tests indicated that the probability of obtaining proper launching conditions with the bowl was approximately three times greater



ENCLOSED AREA REPRESENTS
FLAT SECTION

+ REPRESENTS POINTS TAKEN
BY THEODOLITES AT ⊙

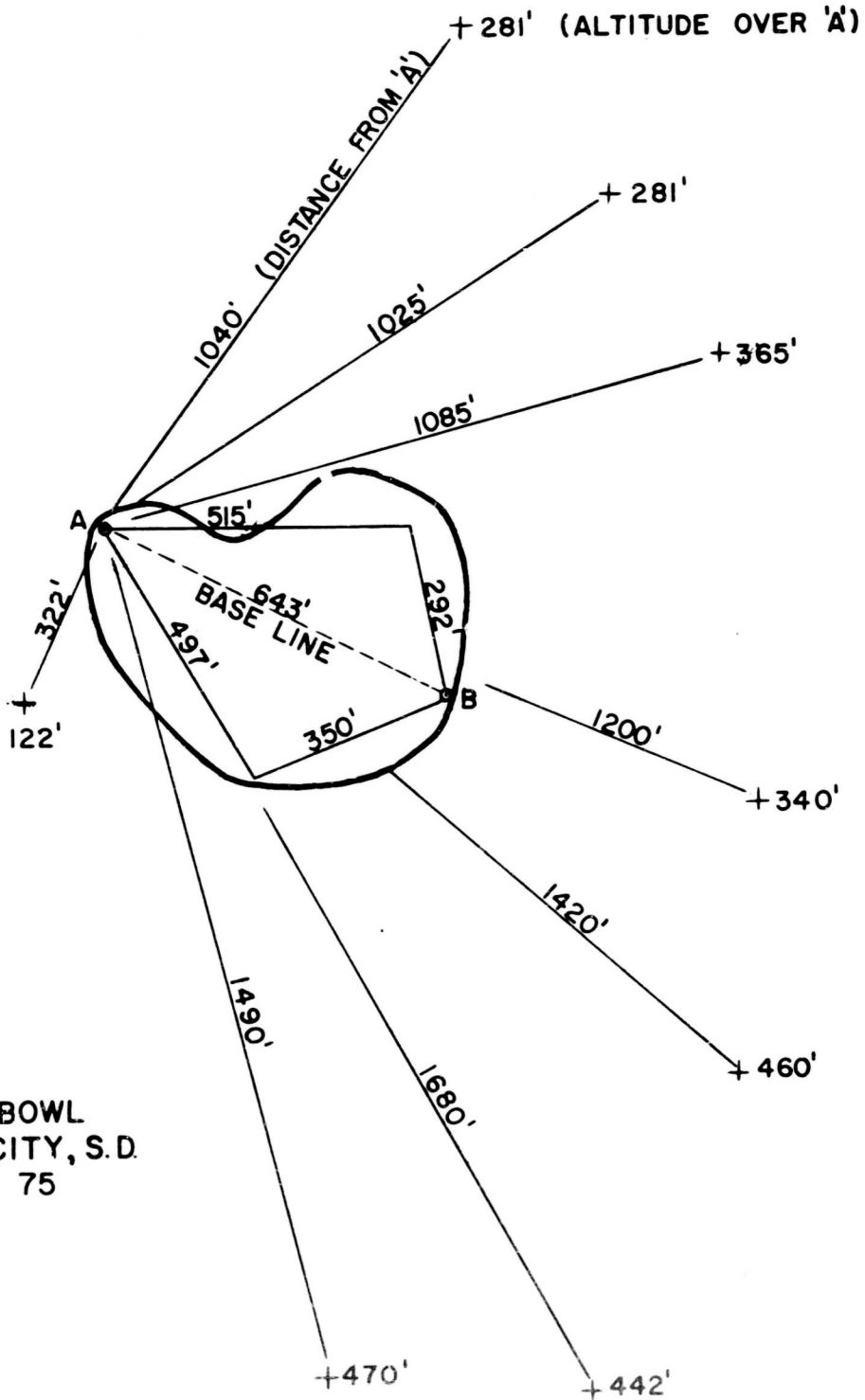

STRATOBOWL
RAPID CITY, S.D.
FIGURE 75

than in an exposed area. It was also felt that the bowl would provide added protection against most unpredictable wind conditions during the inflation period as well as providing a favorable trajectory.

Pre-Flight Preparations - Following the arrival of the balloon, parachute, gondola and auxiliary launching equipment, certain pre-flight preparations and tests were made. Communications equipment, flight control components, converter system, etc., were checked to insure good operating condition. The gondola was pressurized and checked for leaks. The natural leakage of the gondola was determined to be not in excess of 100 cubic centimeters per minute while pressurized at approximately 7.3 psi in excess of the ambient pressure for a period of approximately eight hours.

Telemetry equipment to transmit cardiac activity was also installed and checked by Navy personnel.

The shock absorbing base was installed and the gondola, complete with personnel and all equipment, was found to weigh 1637 lb. An approximate weight breakdown is shown in Table VIII.

Launching of the Strato-Lab Flight - The synoptic conditions for early morning 8 November 1956 are shown in Figure 76. The balloon was inflated in the usual manner and the parachute and gondola attached to the lower apex.

The balloon was allowed to rise on the restraining line until the gondola lifted from the three-wheel cart. It was found that the system had a measured net lift of approximately 80 lb instead of the desired 300 lb. It had also been noted previously that the net lift at the bottom of the balloon was approximately 1,975 lb. This value decreased to approximately 1,920 lb during a 25 minute period and remained at this value until the

TABLE VIII

WEIGHT SUMMARY FOR STRATO-LAB PERSONNEL FLIGHT
8 NOVEMBER 1956

BALLOON	595 lbs
PARACHUTE	135
GONDOLA	1,637

Approximate Weight of Some of the Gondola Components:

Aero-Medical Equipment	10 lbs
Air Regeneration System	26
Antennae	5
Barograph	4
Ballast, Iron Shot	345
Binoculars	4
Cameras	15
Liecas	5 lbs
Movie	5
Recording	5
Carbon Dioxide Analyzer	20
Clothing	15
Control Panels	30
Desiccants	20
Fans	10
Firewel	3
Flashlights	2
Gondola Shell	230
Harness, Suspension	17
Hatches	44
Instrument Panel	25
Knives	1
Lunch	7
Oxygen Analyzer	2
Oxygen Converter	38
Parachutes (2)	25
Personnel	280
Ross	150 lbs
Lewis	130
Power Sources	81
Main 6 Volt	36
Aux. 6 Volt	13
Main 24 Volt	4
Aux. 24 Volt	2
Communications	24
Intercom	2
Pressure Suits (2)	38
Seat Packs (2)	20
Shock Absorber	30
Tools	5
Transceiver	31
VHF and HF Unit	10

GROSS WEIGHT - 2,367 lbs

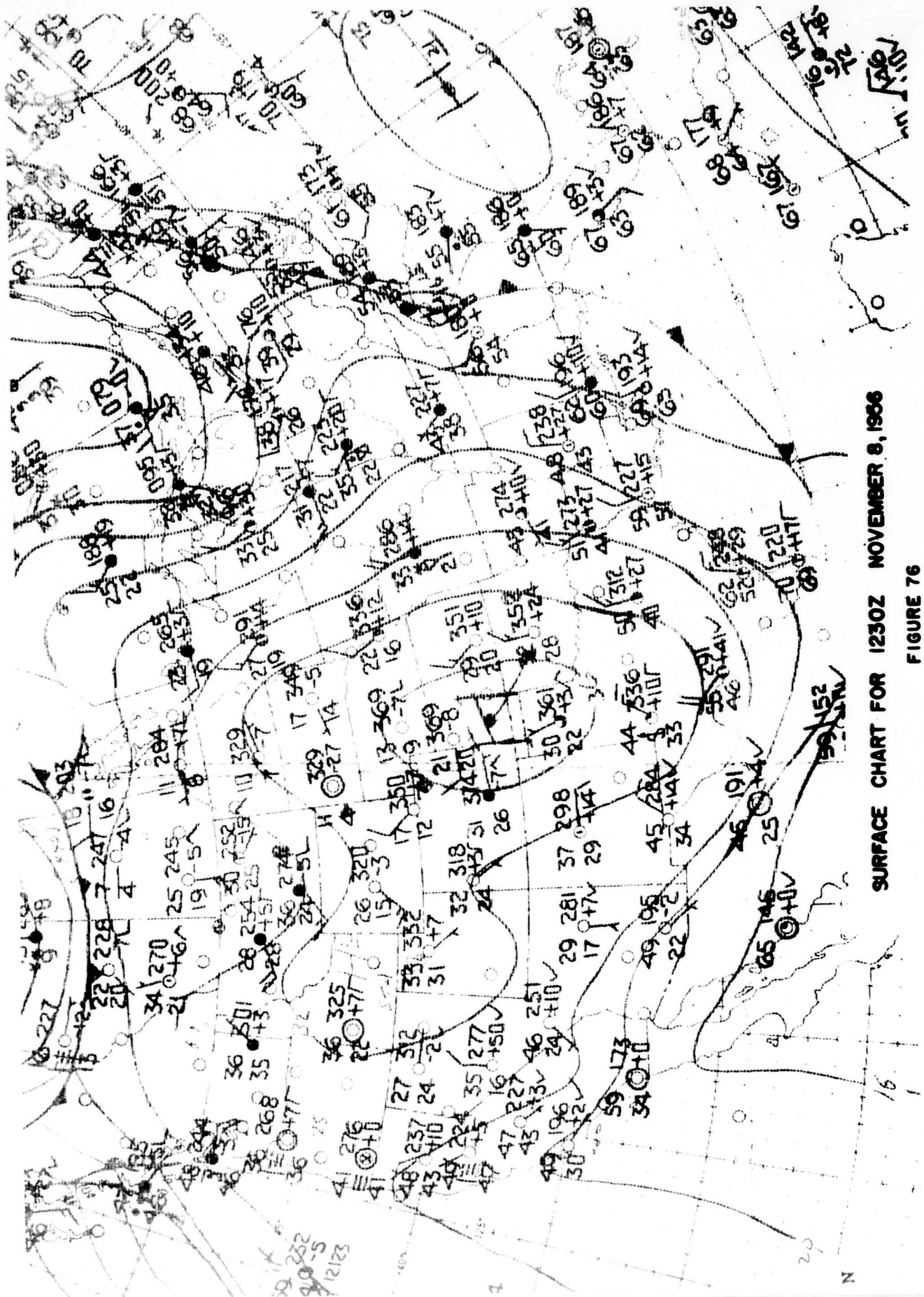

SURFACE CHART FOR 1230Z NOVEMBER 8, 1966

FIGURE 76

parachute and gondola were attached. Since the balloon weight was approximately 595 lb, this indicated that the gross lift was approximately 2,515 lb. The gross weight of the system was about 2427 lb, which indicated a free lift of 88 lb, a figure agreeing well with the measured value.

Although dynamometer readings have never been regarded as an accurate source of information when applied for this purpose, their readings would be expected to be more reliable under very low wind conditions. The wind was virtually calm and the two dynamometer readings of free lift were in good agreement.

To facilitate a safe launching, approximately 60 lb of extraneous gondola equipment were removed, which reduced the gross load to 2,367 lb and increased the free lift to approximately 140 lb. The Strato-Lab system was then launched without difficulty and rose almost vertically from the bow.

A number of conceivable explanations exist for the inadequately measured free lift of the system. Certain of these include:

1. Escape of helium from the balloon through a hole or holes, or through the valve.
2. Malfunction of one or more valves on the helium trailer bottles
3. An error in metering the helium from the high pressure tanks
4. An error or omission in the gross weight calculation.

It is, of course, possible that the prescribed amount of lift was within the balloon and that the dynamometer readings were influenced by some other effect or combination of effects. The gas temperature figure can be questioned and could be responsible for some part of the discrepancy. In order to account for the ten per cent discrepancy entirely, however, the balloon gas would necessarily have been about 45° colder than the surrounding air.

Escape of helium through a hole (or holes) or through the valve does not seem likely, since the dynamometer was observed to give a constant reading for a long period of time. Also, the balloon has since been inspected thoroughly and no unexplainable openings have been found. The valve itself remained closed throughout the flight and, by inspection both prior to and following the flight, would have allowed the escape of only a negligible amount of helium.

The possibility of malfunction of a trailer valve seems remote since each of the helium bottles was checked at the launching site and no faulty valves were found.

Possibility of errors mentioned in (3) and (4) above have been thoroughly checked. The system's gross weight calculations appear to be correct. Similarly, the lift computations are correct for each bottle of gas as specified by its recorded temperature and pressure. It is conceivable, however, that the temperature or, more likely, the bottle pressures were incorrectly obtained or misread. This error has occurred previously in other balloon flights.

The error, or combination of errors, resulting in deficit free lift cannot be attributed positively to any specific cause. Any specific conclusions are pure speculation.

Strato-Lab Flight Data - Following the launching, there were a number of duties carried out by observers in readying the gondola for the ascent.

The long (270 ft) 2-megacycle antenna was thrown overboard and allowed to unroll from its spherical configuration. Communications were established immediately on both channels and were completely satisfactory.

The gondola hatches were sealed carefully after noting that the "0"

ring facings were clean and free from any wire, lines, clothing, etc. When the internal gondola altitude was equivalent to 10,000 ft, the high-discharge orifice (20 liters/min) was started and allowed to continue until the internal altitude was equivalent to approximately 17,000 ft. At this altitude the controller valve automatically sealed the gondola from the external atmosphere. At this time, the internal atmosphere was essentially established and no further attention was required of the observers. Throughout this period of "establishing the atmosphere," data was regularly transmitted by the observers at 5 minute intervals in order that such data could be compared with calculations of previous chamber tests. By plotting this data over copies of the chamber tests, it could be readily seen that all was going as planned. As determined previously, the key to the detection of an undesirable gondola leak was in the rate of increase of the oxygen partial pressure, since the converter system was used to maintain the proper gondola pressure. By noting the slope of the oxygen partial pressure, the relative leak could be determined and appropriate steps taken. In this case, the oxygen partial pressure duplicated almost exactly the calculations obtained from earlier chamber tests and previous theoretical analysis.

The balloon continued to rise uneventfully but with a decreasing rate of ascent as it entered the stratosphere. The balloon did not stop ascending at its theoretical ceiling of 73,800 ft, but continued to rise to an altitude of approximately 76,000 ft. At this time the balloon lost part of its lifting gas through improper functioning of a valving device, and the entire system began to descend at a rate of approximately 3,800 ft/min (see Figure 77).

This descent rate was reduced by the increasing aerodynamic drag of the lower altitudes, as well as through reduction of the gross load of the system.

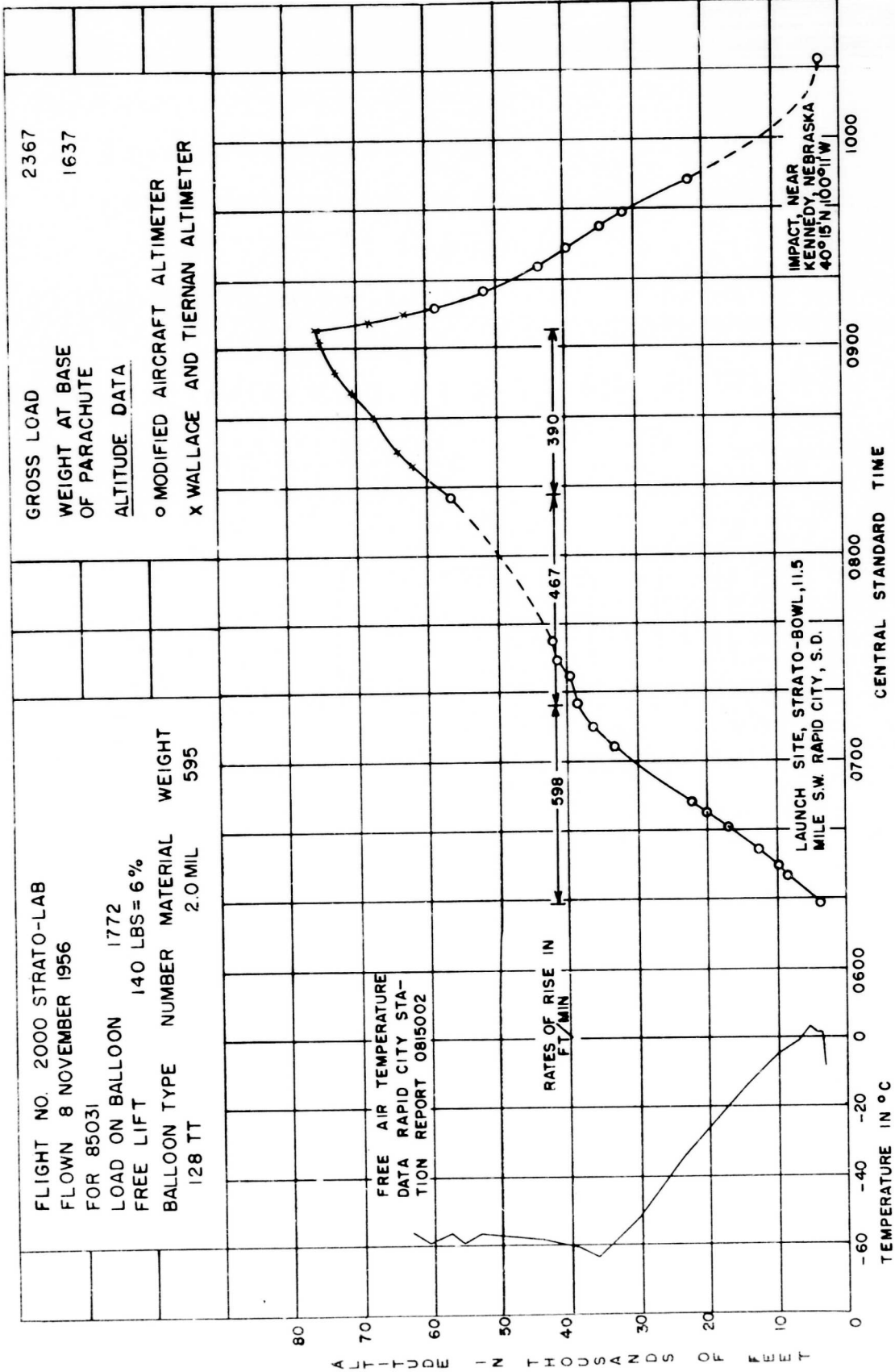

STRATO-LAB PERSONNEL FLIGHT I
 FIGURE 77

The observers dropped all ballast and, when the system was at a sufficiently low altitude, opened the gondola hatches and jettisoned some of the internal equipment.

A relatively soft landing was made with no visual damage to the gondola.

A composite of recordings and notes of the observer's remarks throughout the flight is presented in the Appendix.

A further analysis of the faulty operation of the balloon valving device is included in GMI Report 1651.

SUMMARY

A theoretical study of currently used polyethylene cylinder balloons indicated that they were not satisfactory in all regards for Strato-Lab program purposes. As a possible alternative to the cylinder balloon, a hypothetical tape reinforced vehicle was investigated and a comparison made with various cylinder balloon types. The decision was made, however, that a new balloon design was beyond the scope of this project, and, accordingly, the 128TT balloon was chosen, on the basis of its past flight record, for use on the feasibility flight.

Two experimental balloon flights were conducted to determine empirically the Strato-Lab system's response to gas and ballast discharge. In particular, it was necessary to determine the valving time required to establish a specified descent rate in the stratosphere. This was determined, as was the quantity of ballast required to stop the corresponding tropospheric descent rate. These data were employed to specify suitable system ballast capabilities as well as to provide a general flight prognosis of the personnel ascent and descent.

A large cargo-type parachute was incorporated in the Strato-Lab system as an alternate descent method. To test the compatibility of this parachute with the Strato-Lab system, it was released with a simulated load from a balloon at an altitude of approximately 38,000 feet. The opening shock characteristics of this parachute were recorded by a Ryan Flight Recorder. Information from this experiment, plus that from similar experiments conducted at different altitudes, indicated that the main parachute opening force never exceeded 3.5 g's and was apparently independent of altitude.

The gondola, a 7 ft-2 in. aluminum sphere, was equipped to maintain an

internal atmosphere at a pressure equivalent to an altitude of approximately 17,000 ft. The proper composition of this atmosphere was maintained by a chemical desiccant system which removed excess carbon dioxide and water vapor. A liquid oxygen converter controlled the internal gondola pressure and provided oxygen to the observers. Five altitude chamber tests were conducted in order to examine the operating characteristics of this system.

The gondola was also equipped with instrumentation to control the vertical motion of the balloon system, and with a multi-channel communications system. The main component of the communications system was a transceiver utilized both as a tracking beacon and as a voice communications link.

It was first thought that a type of automatic pilot should be incorporated in the Strato-Lab system and linked directly to the gas and valve discharge controls. This device would "program" the entire flight, making manual control, exclusive of landing, un-necessary. A "programmer" was constructed to perform this function. Two attempts to flight-test the "programmer" were unsuccessful, however, due to local synoptic conditions, and plans for its incorporation were temporarily abandoned.

The first Strato-Lab feasibility flight was launched from the Strato-Bowl, Rapid City, South Dakota, 8 November 1956. The launching and ascent of the system were satisfactory, the system ascending to a maximum altitude of 76,000 ft. At this altitude the flight plan was interrupted by malfunction of the balloon's valving mechanism and the balloon began a premature descent. A satisfactory landing of the Strato-Lab system was made and the gondola shell suffered no damage.

Figures 78, 79, 80 and 81 are views taken at the time of the first Strato-Lab feasibility flight.

REFERENCES

1. Project "Helios" ONR Contract N6ONR-251, Task Order 1. GMI No. A102.
2. Minnesota, University. Department of Physics. Progress report on research and development in the field of high altitude plastic balloons, vol 5. Contract Nonr-710(01). (June 15-Dec. 22, 1952). Confidential.
3. General Mills, Inc. Mechanical. Engineering Res. and Dev. Dept. Rept. no. 1457. Weymouth inflation tests, by R. L. Schwoebel (Sept. 12, 1955). Confidential.
4. General Mills, Inc. Mechanical Div. Engineering, Research and Development. Rept. no. 1525. Balloon barrier materials, by A. A. Anderson, E. C. Gear and G. L. Morfitt. Contract AF 19(604)-1393. Final Tech. Rept. (April 1, 1955-March 14, 1956). (Also known as Air Force Cambridge Research Center. TR-56-292).
5. General Mills, Inc. Mechanical Div. Engineering Res. and Dev. Dept. Report no. 1441. 128TT hangar inflation, by R. L. Schwoebel. Contract Nonr 1589(06). (Aug. 3, 1955). Confidential.
6. General Mills, Inc. Mechanical Div. General Mills flight recorder, designed by James J. Ryan (1955).
7. General Mills, Inc. Mechanical Div. Engineering Res. and Dev. Dept. Rept. no. 1471. Flight 1532, parachute test flight, by R. L. Schwoebel. Contract Nonr 1489(06). (Oct. 25, 1955). Confidential.

8. Hoerner, S. F. Aerodynamic drag. Midland Park, N. J., 1952.
9. Best, C. H. and N. B. Taylor. The physiological basis of medical practice. 5th ed. Baltimore, Williams and Wilkins, pp. 16-31, 1950.
10. Best, C. H. and N. B. Taylor. The physiological basis of medical practice. 5th Ed. Baltimore, Williams and Wilkins, p. 426, 1950.
11. Ohio State University Research Foundation. Study of cabin atmosphere conditioning systems for high altitude aircraft (1955). (Also known as Wright Air Development Center. TR-55-353).

ACKNOWLEDGEMENTS

Many people have contributed to the development of the Strato-Lab system. Although it is not possible to acknowledge all contributors, those who have made major contributions to the success of this program are indicated below.

Mr. H. E. Froehlich, Head, Geophysics Research Section, General Mills, Inc. assumed technical and scientific responsibility for the program. Other important GMI contributors include:

D. L. Bookout

D. A. Church

J. L. Cramer

R. A. Kizzek

R. J. Krieg

C. P. Merrell

A. P. Schumann

R. V. Stuart

In order to provide a satisfactory atmosphere within the gondola, it was necessary to gather information pertaining to human physiological requirements. This information could not have been collected and utilized without the helpful counsel of the following:

Dr. Norman Barr, U. S. Navy Medical Center, Bethesda, Md.

Dr. Nello Pace, Department of Physiology, University of Calif.

Mr. Donald Rosenbaum, Aeromedical Research Section, WADC

Dr. Edward Vail, Aeromedical Research Section, WADC

Commander Robert Cochran, local U. S. Navy Office of Research representative, has made significant contributions in logistics, experimental flight tracking, meteorological analysis and has provided general support

and understanding of General Mills' problems as contractor.

Mr. M. D. Ross and Lt. Cdr. M. L. Lewis deserve major credit for providing the initial impetus to this program and for the growth and continuance of this scientific endeavor.

Chief Richard Miles from the Minneapolis Naval Air Station made many contributions to the program. He inspected and checked all parachutes used. He helped design and fabricated the gondola suspension harness, and assisted in numerous other capacities.

Dr. Bleich, Director of Airplane Structures, Columbia University, served as a structural consultant with respect to the gondola suspension method.



THE STRATO-BOWL AS SEEN FROM
THE EASTERN EDGE

FIGURE 78



LT. CDR. M.L. LEWIS AND M.D. ROSS
WITH STRATO-LAB GONDOLA

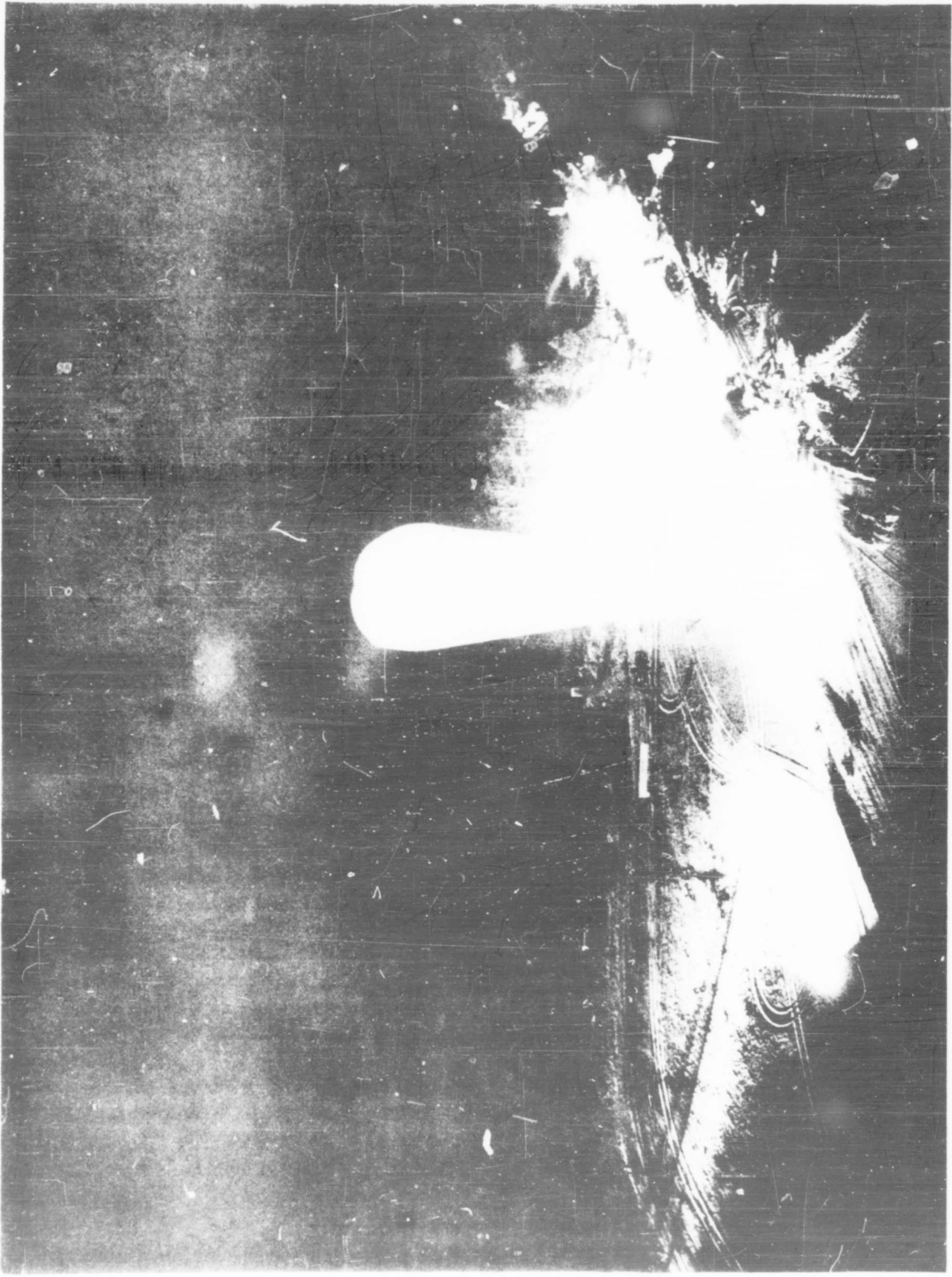

THE VERTICALLY INFLATED I28TT PRIOR TO
LAUNCHING THE STRATO-LAB SYSTEM

FIGURE 80

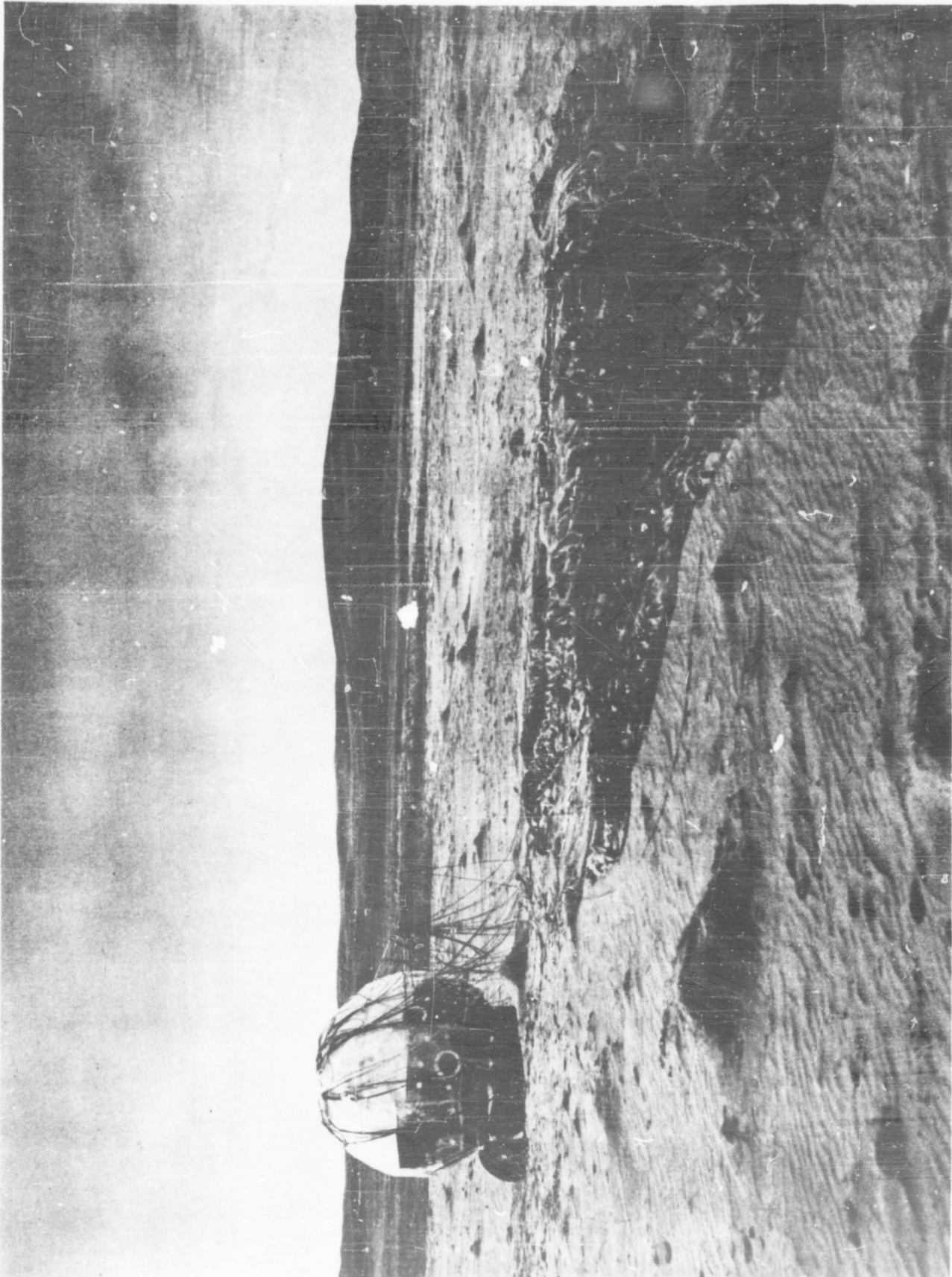

THE STRATO-LAB GONDOLA AT ITS LANDING SITE

APPENDIX

TABLES

TABLE I
GORE PATTERN FOR 128TT BALLOON

<u>Gore Width in Inches</u>		<u>Distance from Lower Apex Along Balloon Wall in Feet</u>
50.0) Lower Cylindrical Section	0.0
50.0		29.0
64.3		44.8
81.2		58.7
95.4		73.0
104.5		89.3
103.4		102.6
92.6		117.7
74.3		132.6
64.0) Upper Cylindrical Section	143.3
64.0		176.5

TABLE II
PHYSICAL CHARACTERISTICS OF 128TT BALLOON

Shape Factor	0.25
Core Length	176.5 feet
Approximate Volume	803,000 cubic feet
Inflate Height	106 feet
Number of Gores	46
Approximate Surface Area	43,200 square feet
Location of Inflation Tube	25 feet from upper apex
Length of Inflation Tube	180 feet
Duct Location (Attached Style)	30 feet from upper apex
Elliptical Area	20 square feet
Approximate Balloon Weight (2 mil polyethylene)	550 pounds exclusive of special fittings

FIGURE I-A

PACE'S MEMO: PHYSIOLOGICAL FINDINGS DURING
STRATOLAB TEST AT THE U. S. NAVAL ORDNANCE
TEST STATION, INYOKERN, CALIFORNIA, 27-29
JUNE 1956

PHYSIOLOGICAL FINDINGS DURING STRATOLAB TEST AT THE
U. S. NAVAL ORDNANCE TEST STATION, INYOKERN, CALIFORNIA, 27-29 JUNE 1956
Nello Pace, University of California, Berkeley

2 January 1957

Physiological tests, representing base line data for the first manned Stratolab flight into the upper atmosphere, were performed on the two balloonists, LCDR M. L. Lewis and Mr. M. D. Ross, in the course of carrying out a simulated flight of the Stratolab gondola in the low pressure chamber at the U. S. Naval Ordnance Test Station, Inyokern, California in June of 1956. The physiological tests were directed at establishing the metabolic profile of the two aeronauts, through chemical analysis of blood and urine specimens, with particular respect to estimation of the degree of physiological stress that might develop as a result of the ascent.

The blood and urine constituents examined were those reflecting primarily the activity of the adrenal cortex gland, which plays an important role in enabling individuals to adapt to environmental stressors. Both adrenocortical hormone levels and the levels of metabolites reflecting secondary hormone effects were measured. Thus in the urine the excretion rate of the following electrolytes was determined: sodium, potassium, chloride and phosphate. The excretion rate of the nitrogenous urinary constituents, ammonia, urea, uric acid and creatinine was determined. Urinary glucose excretion rate was measured. The excretion rate of the 17-ketosteroids was obtained, together with the excretion rate of the glycotropic hormones, the 17-hydroxycorticoids. In the blood the level

of sodium, chloride, glucose, urea and 17-hydroxycorticoids was also determined.

The procedures and analytical technics employed were essentially those described by Pace et al.¹ The analyses were carried out in the Department of Physiology, University of California, Berkeley by the following individuals: Dr. P. S. Timiras, J. A. Guldenzopf, C. Hwang, W. H. Haertle and E. Fava. The samples were frozen shortly after being collected at Inyokern and were kept frozen until analysis was performed in Berkeley, using thymol in addition as a preservative.

The two aeronauts were white males in good health with age, height and weight as shown in Table I.

TABLE I

Age, height and weight of the subjects.

<u>Name</u>	<u>Symbol</u>	<u>Age</u> (yrs.)	<u>Height</u> (ins.)	<u>Weight</u> (lbs.)
M. L. Lewis	LEW	43	67	130
M. D. Ross	ROS	37	69	143

¹Physiological Studies on Infantrymen in Combat by N. Pace, F. L. Schaffer, F. Elmadjian, D. Minard, S. W. Davis, J. H. Kilbuck, E. L. Walker, M. E. Johnston, A. Zilinsky, R. W. Gerard, P. H. Forsham and J. G. Taylor. University of California Publ. Physiol., 10: 1-47, 1956.

The test group arrived at Inyokern on 26 June 1957 when outside shade temperatures were running as high at 110°F. Even though the Michelson Laboratory where the tests were conducted was air conditioned, exposure to the high temperatures was unavoidable, particularly outside of working hours. On 27 July quantitative urine collections were begun at 0910 from LEW and ROS and a 12 hour day collection was made. This was followed by an overnight 13 hour collection, and then by successive 4 hour and 5 hour collections during the day on 28 June. During the last named 5 hour period the aeronauts were dressed in full pressure Navy flying suits awaiting the simulated flight, which eventually was aborted. The final urine collection period was the 6.5 hours in the afternoon of 29 June when the manned test flight of the gondola was made in the pressure chamber. The men were unsuited and in a cool, comfortable ambient temperature environment during this entire period. A summary of the urine collection periods and data obtained at Inyokern follows:

TABLE II

Urine collection data during Inyokern test period, 27-29 June 1956.

Sample No.	Date	Start Time	End Time	Elapsed Time (hrs.)	Total Vol. (ml)	Output Rate (ml/hr)	Spec. Grav.	pH
LEW-1	27 June 56	0910	2115	12.1	615	51	1.025	5.5
ROS-1	27 June 56	0910	2120	12.2	434	36	1.027	5.5
LEW-2	27-28 June	2115	1015	13.0	600	46	1.025	5.0
ROS-2	27-28 June	2120	1015	12.9	398	31	1.022	5.2
LEW-3	28 June 56	1015	1435	4.3	230	54	1.019	5.7
ROS-3	28 June 56	1015	1440	4.4	191	43	1.027	6.5
LEW-4	28 June 56	1435	1940	5.1	232	46	1.025	5.0
ROS-4	28 June 56	1440	1935	4.9	100	20	1.032	5.2
LEW-5	29 June 56	1410	2040	6.5	329	51	1.020	6.0
ROS-5	29 June 56	1410	2045	6.6	481	73	1.014	6.8

A fasting, 20 ml venous blood sample was obtained in a heparinized syringe at 0800 before breakfast from LEW and ROS on 28 June and the plasma was separated immediately by centrifugation. After the addition of a crystal of thymol the plasma was frozen until the chemical analyses were performed in Berkeley. The plasma levels of the constituents measured are given in Table III.

TABLE III

Plasma levels of various constituents in fasting blood from LEW and ROS taken at 0800 on 28 June 1956.

Sub- ject	Chloride		Sodium		Urea		Glucose		17-OH	
	(meq/l)	(% of nor- mal)	(meq/l)	(% of nor- mal)	(mg N%)	(% of nor- mal)	(mg %)	(% of nor- mal)	(mg %)	(% of nor- mal)
LEW	110	105	145	104	18.9	144	68	82	21	162
ROS	118	112	147	105	18.9	144	76	92	19	146

The simulated flight with the two aeronauts in the gondola was made on the afternoon of 29 June 1956. The men voided at 1410 and the altitude run in the chamber was started at 1450. By 1510 a pressure altitude of 10,000 feet was reached with the gondola open. The gondola was sealed at 1515 and put on automatic control. Pumping of the main chamber was resumed at 1517. By 1540 the internal gondola pressure altitude had leveled off at 14,300 feet and the chamber pressure altitude had reached 20,000 feet. The gondola pressure altitude was maintained at approximately 14,000 feet for the remainder of the test while oxygen was continuously bled into the gondola atmosphere to maintain a partial pressure of oxygen of 200 to 270 mm Hg. CO₂ was simultaneously removed to maintain a pCO₂ of 10 to 12 mm Hg throughout. At 1740 the external

chamber pressure altitude reached 62,000 feet, where it was maintained for one hour. The descent was started at 1845, and at 2022 when the chamber and gondola pressure altitudes were equal at 13,800 feet the gondola was opened. Sea level pressure was reached at 2035, and urine samples were collected immediately and designed LEW-5 and ROS-5. Table IV gives the simulated flight data.

TABLE IV

Simulated flight of Stratolab gondola to 62,000 feet in Inyokern Chamber on 29 June 1956, manned by LEW and ROS.

<u>Time</u>	<u>Chamber Pressure Alt. (feet)</u>	<u>Gondola Pressure Alt. (feet)</u>	<u>Gondola Air Temp. (°F)</u>	<u>Gondola Relative Humidity (%)</u>	<u>Gondola Atmosphere pO₂ (mm Hg)</u>	<u>Gondola Atmosphere pCO₂ (mm Hg)</u>	<u>Remarks</u>
1450	2,450	2,450	-	-	-	-	Started ascent.
1510	10,000	10,000	-	-	-	-	Gondola sealed
1540	20,000	14,300	-	-	110	-	
1610	30,000	14,500	-	-	140	-	
1620	33,000	14,500	-	-	-	-	
1710	50,000	14,250	66 (mid)	40	195	9.5	
1740	62,000	14,110	66 "	44	210	10.0	Leveled off
1800	62,000	14,000	66 "	45	220	10.5	
1820	62,000	13,900	66 "	45	225	10.5	
1830	62,000	13,870	66 "	45	235	10.9	
1840	62,000	13,770	66 "	44	245	11.0	Started down
1900	53,000	13,740	57(deck)	44	250	11.1	
1920	44,500	13,760	57 "	44	235	11.5	
1940	35,250	13,880	56 "	44	260	12.0	
1950	29,500	13,980	56 "	44	265	12.0	
2005	23,500	14,060	56 "	44	270	12.0	
2015	19,000	14,120	56 "	44	275	12.0	
2022	13,800	13,800	-	-	-	-	Gondola opened
2035	2,450	2,450	-	-	-	-	On the ground

The results of the chemical analyses on all of the urine samples are given in Table V. In order to simplify comparison, the results have been plotted as bar diagrams using the per cent value of the mean for the normal population of

TABLE V

Excretion rates of various urinary constituents during Inyokern test period 27-29 June 1956.

Urine No.	HPO ₄ ³⁻ (meq/hr)	Cl ⁻ (meq/hr)	Na (meq/hr)	K (meq/hr)	Na/K	NH ₄ (meq/hr)	Urea (gm N/hr)	Uric Acid (mg/hr)	Creatinine (mg/hr)	Glucose (mg/hr)	17-K (mg/hr)	17-OH (mg/hr)
LEW-1	1.9	10.2	8.6	4.6	1.9	1.32	0.35	14	64	27	0.40	0.23
ROS-1	1.9	7.4	6.4	4.2	1.5	1.14	0.21	24	69	47	0.32	0.29
LEW-2	2.1	8.4	8.4	2.5	3.4	1.48	0.39	23	60	35	0.37	0.49
ROS-2	1.7	8.3	2.3	1.8	1.3	2.84	0.27	20	52	30	0.33	0.40
LEW-3	3.3	10.7	10.1	3.2	3.2	1.07	0.34	22	59	43	0.36	0.50
ROS-3	3.2	9.2	9.5	5.0	1.9	0.78	0.33	33	81	60	0.35	0.37
LEW-4	3.0	9.1	9.3	2.5	3.7	1.50	0.37	25	75	42	0.30	0.46
ROS-4	2.4	3.0	3.3	2.0	1.7	1.08	0.14	-	-	50	0.21	0.36
LEW-5	2.6	11.3	11.0	4.2	2.6	1.27	0.37	28	77	29	0.42	0.48
ROS-5	1.3	9.5	10.3	2.7	3.8	1.02	0.52	31	79	40	0.34	0.27

each urinary constituent. Figure 1 shows the mean metabolic profile for the two subjects (LEW-1 and ROS-1) during the first day at Inyokern, 27 June 1956, and during the simulated flight to 62,000 feet in the chamber on 29 June 1956 (LEW-5 and ROS-5). The individual values are also designated on the diagrams. LEW showed a somewhat elevated excretion rate of 17-hydroxycorticoids during the chamber run; however, the remainder of his pattern was quite normal, as was that of ROS. It is of interest to note that the metabolic profile of both men during the "control" period on 27 June shows evidence of dehydration and some salt deficiency, probably as a consequence of the summer desert heat at Inyokern. Otherwise the control pattern was not unusual except for low 17-ketosteroid excretion rates in both subjects. This low excretion rate persisted throughout the period of observation, but its physiological significance is not clear.

Figure 2 shows the mean metabolic profile for the subjects during the two periods on 28 June 1956 when the chamber runs were aborted (LEW-3 and ROS-3, LEW-4 and ROS-4). It is of further interest that some indication of stress may be seen in the metabolic profiles for the two periods examined during 28 June. The 17-hydroxycorticoid and glucose excretion rates for both subjects were slightly elevated. During this time the two subjects also showed evidence of dehydration and salt depletion as on 27 June. They had had relatively little sleep the night before, together with having the responsibility for numerous decisions concerning the proposed flight plan. During 28 June additional serious questions arose concerning the structural strength of the gondola, and then the actual dressing in the full pressure suits involved no little heat stress. Altogether, the patterns seen in Figure 2 in all probability

represent the effects of both an anticipatory stress and a physical stress from several sources, all at a relatively moderate physiological level.

The time sequence may be seen conveniently for each urinary constituent in Figure 3 and the results may be summarized as follows: Both subjects showed evidence of heat stress during the first two days at Inyokern before the chamber run. There was also evidence of an anticipatory response on the second day, but the metabolic profiles were essentially normal during the simulated flight to 62,000 feet on 29 June.

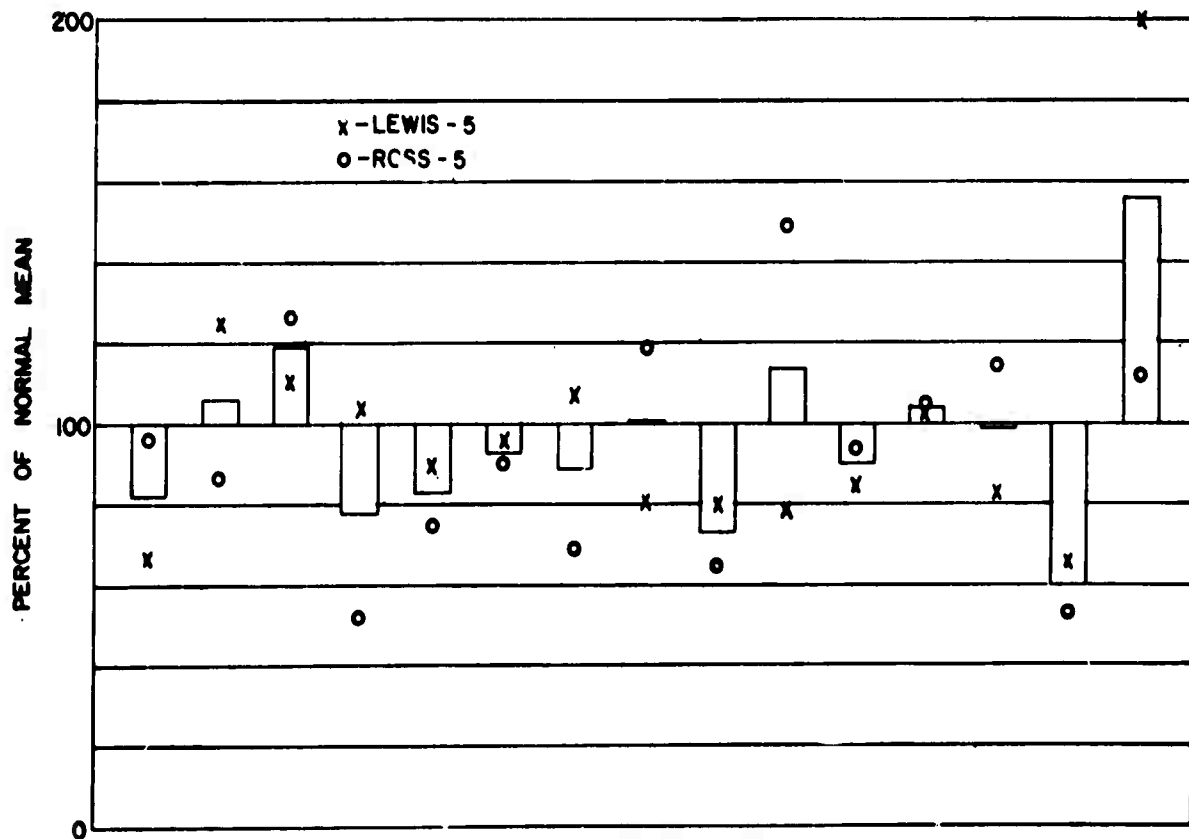
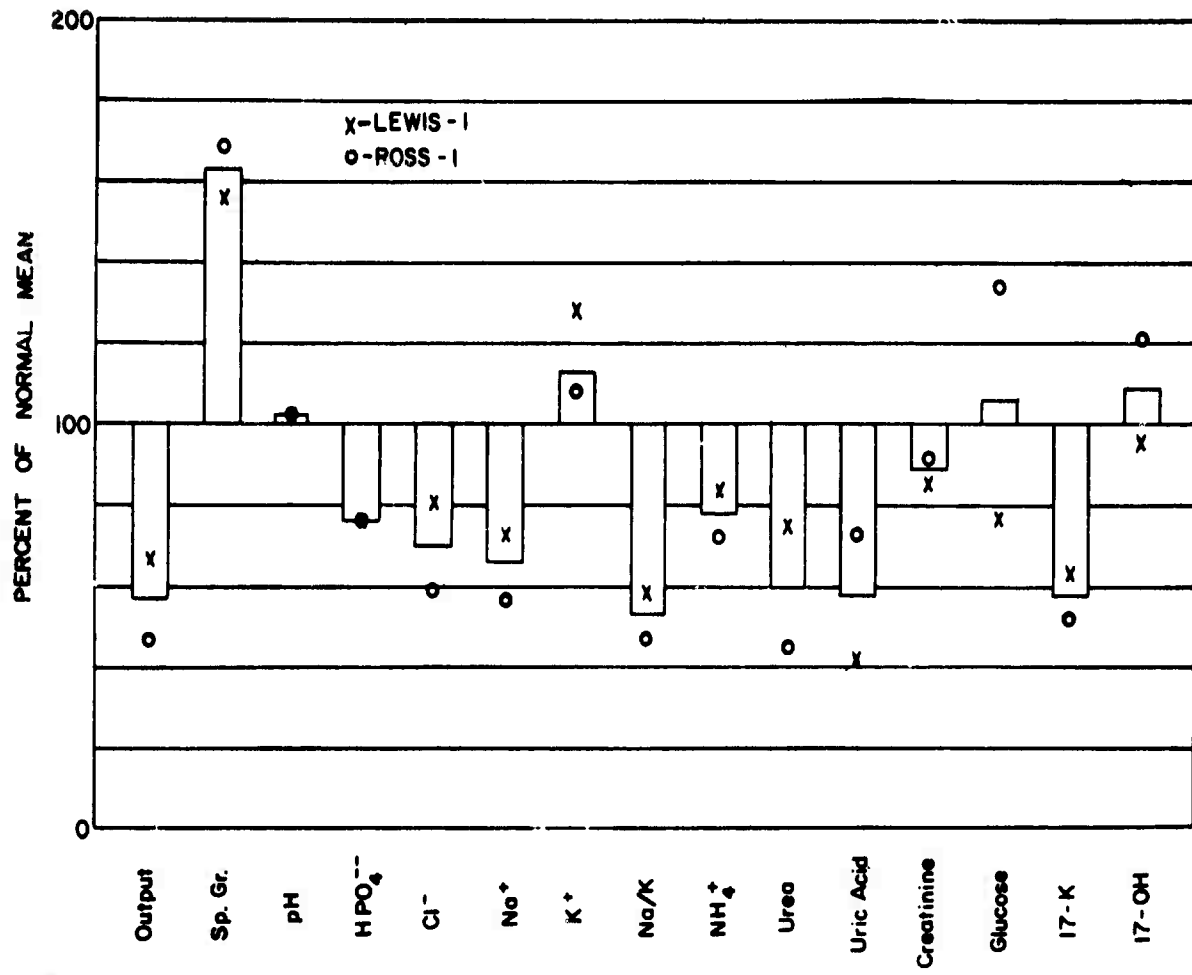

URINARY EXCRETION RATES, 0910-2120 ON 27 JUNE 1956,
 AND DURING SIMULATED FLIGHT, 1410-2040 ON 29 JUNE 1956

Figure 1

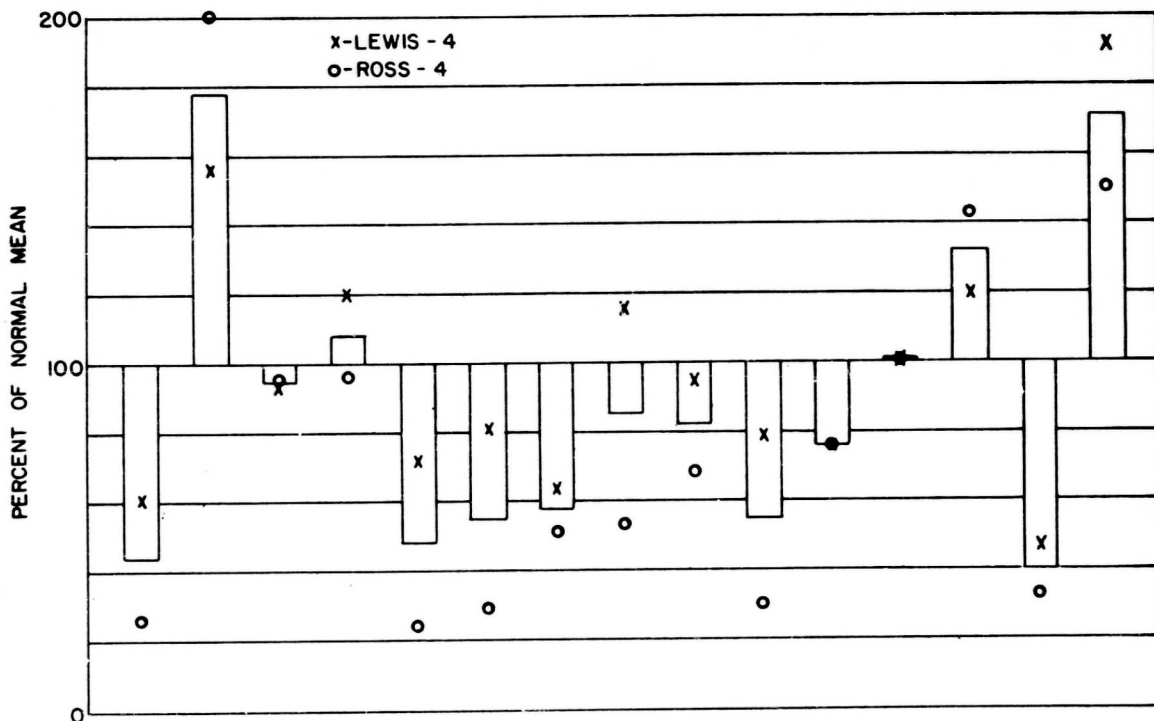
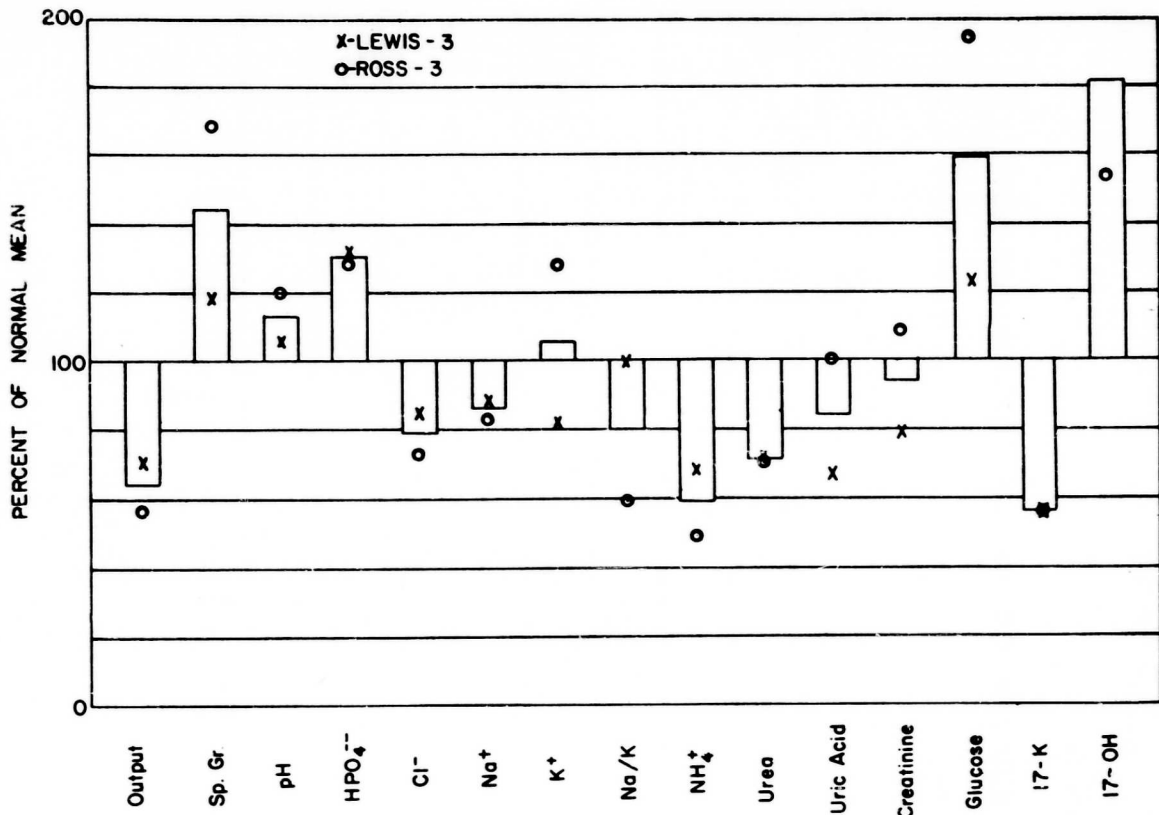

URINARY EXCRETION RATES DURING TWO PERIODS
 (1015-1435 AND 1435-1935) ON 28 JUNE 1956

Figure 2

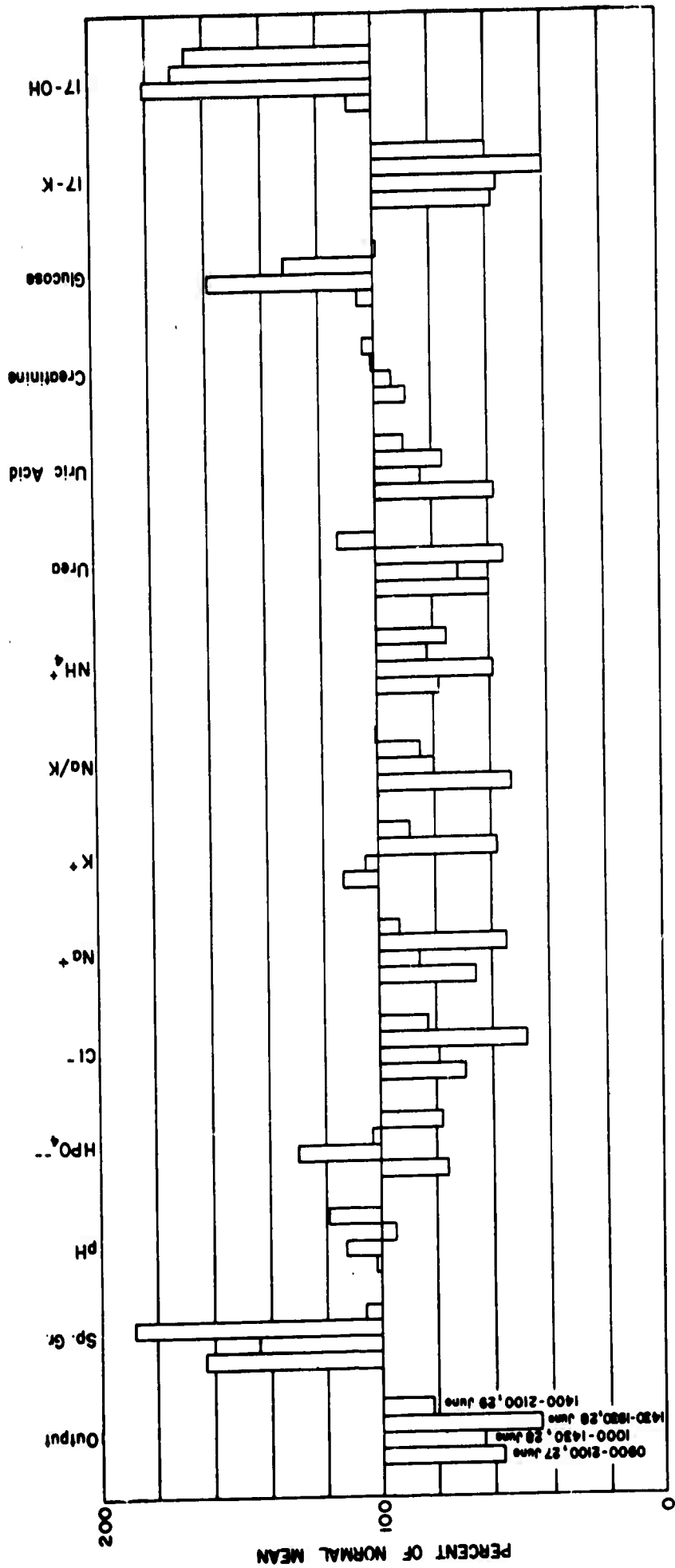

COMPOSITE URINARY EXCRETION RATES FOR FOUR DAYTIME PERIODS STUDIED 27-29 JUNE 1956

Figure 3

VERBAL TRANSMISSIONS FROM STRATO-LAB

GONDOLA 8 NOVEMBER 1956

VERBAL TRANSMISSIONS FROM STRATO-LAB GONDOLA 8 NOVEMBER 1956

Time	External Altitude	Internal Altitude	R. H.	°F	CO ₂	Beckman O ₂	Liters Remaining	Converter Pressure	Rate of Rise	Remarks
	6,500								500	Close top hatch.
	7,000								500	
0627	8,500								500	
0629	9,500						4.0		300	Bottom hatch is secure.
0630	10,000									
0631	10,400		25%	32°	0	125	4.8	72	500	Calm, confident.
	11,700	9,900								
										68-70 milliamps
A 0635	12,600								400	Sun shining through top hatch, illuminating panels; very cloudy.
0637	13,760	10,200	30%	32°	off scale	135	4.6	72	500	
	15,000								600	Parachute very cumbersome.
	15,660								650	
	16,000									
0641	16,800	13,000	31%	32°	off scale	140	4.3	72	600	Approximately 64 milliamps on the CO ₂ scale.
0645.5	20,000	15,200	31%	32°	off scale	140	4.2	72	550-600	

(INITIAL DATA RECORDED AT STRATO-BOWL)

VERBAL TRANSMISSIONS FROM STRATO-LAB GONDOLA 8 NOVEMBER 1956

Time	External Altitude	Internal Altitude	R.H.	°F	CO ₂	Beckman Liters O ₂ Remaining	Converter Pressure	Rate of Rise	Remarks
0647	21,000								Feel well; rotating slowly.
0648.5	22,000	16,400	32%	31°		140 4.1	72.8		
0650		17,200							Closing 20 liter leak.
0706.8	26,000	17,700	30%	30°		135 4.0	73		Upper ports frosted, still in clouds.
		17,730 (holding constant)							Released lugs on lower hatch.
0704.5	33,000	17,750				135 4.0	73		Feel well.
0707	34,500	17,710	33%	27°		140 4.0	73		Sun shining through upper port.
0710	36,000	17,700	32%	26°		140 4.0	73		Spinning a little, rotating.
	36,500 (entering tropopause)								Appear to have stabilized well.
0718	37,750	17,600	32%	26°		140 4.0	73		
	38,100		32%						
	38,500								
0718	38,600	17,550	33%	25°		140 4.0	73		
0719	39,000								

VERBAL TRANSMISSIONS FROM STRATO-LAB GONDOLA 8 NOVEMBER 1956

Time	External Altitude	Internal Altitude	R.H.	Of	CO ₂	Beckman O ₂ Liters Remaining	Converter Pressure	Rate of Rise	Remarks
0720	39,400								May be coming down. We are coming down.
0723									Ascension rate varies. Rate of climb shows -250, then zero. Altimeter increasing slightly, climbing slightly. Apparently in inversion. Will take time to climb. Don't wish to dump ballast; will force our way through.
0724	39,600								
0725	39,840	17,350	33%	25°	145	4.0	73		
0729	41,000								
0730	41,500		32%	25°	145	3.9	73		Light frost on top and bottom of gondola interior. Internal altitude going up very, very slowly.
0735	42,300			25°					
0826	62,000								Now using Wallace & Tiernan gauge.
0830	64,000	16,850			160	3.5	73		Gondola pressure climbing slowly.
0836									Earth almost entirely obscured by cirrus cloud deck. Occasionally see mountainous country. Upper part of gondola frosted to considerable extent, lower part quite clear. All machinery in gondola functioning quite well, except CO ₂ analyzer, which is apparently out.

VERBAL TRANSMISSIONS FROM STRATO-LAB GONDOLA 8 NOVEMBER 1956

Time	External Altitude	Internal Altitude	R.H.	OF	CO ₂	Beckman Liters O ₂ Remaining	Converter Pressure	Rate of Rise	Remarks
		Almost solid layer of cirrus under us; looking out side ports, horizon almost white, overhead sky is almost black, blue-black.							
0840	67,400								
0847	70,500		60%	38°		165	73	3.5	Approaching ceiling, time limited, power supply down to 4.2 volts on transmitter.
0849		71,400							
0853.5	73,000								
0902	75,000								
0906.4	74,000								
	72,000								Gondola beginning to rotate, strapped in seat belts, face masks open. Emergency. Hit 76,000, descending rapidly. Strapped in, no shoulder harness, face mask on but not down. Passing 70,000, elevator feeling.
0907.8	68,000								Rate of descent 1,000 feet per minute or greater
	67,000								
0908.5	66,000								
0910	63,000								
0910.8	62,000								
		165							Gondola continues to rotate. Emergency situation. What kind of terrain are we over? Flat land?
								1,100	

VERBAL TRANSMISSIONS FROM STRATO-LAB GONDOLA 8 NOVEMBER 1956

Time	External Altitude	Internal Altitude	R.H.	OF	CO ₂	O ₂	Beckman Liters Remaining	Converter Pressure	Rate of Rise	Remarks
0912	58,400									Dropped 60 lb ballast in an attempt to slow descent; want to slow balloon down before cutting balloon loose. Do not consider it feasible to come all the way down on balloon. In stratosphere rate of descent approximately 1,200 ft/min; troposphere will make easily 2,400 to 3,000 or 4,000 ft/min, which is excessive. We, therefore, desire to slow descent to maximum possible and will cut balloon loose and descend by parachute. Over.
0915.6										Balloon out of control; descending at 1,200 ft/min.
0917.4	51,500									We are not going to bail out. We are going to cut gondola away from balloon and descend on cargo chute. We will not bail out unless essential, only in the event of cargo chute failure.
0918										We are still in stratosphere; our rate of descent will increase markedly in troposphere.
0920	43,500									Dropped 60 lb ballast. We are dropping another 60 lb ballast.
										Dumping ballast. Our rate of descent has not decreased. Rate of descent approximately 1,200 ft/min. Mildly perturbed; very unusual experience. Were just about to photograph panel with isopan film when we started down. It was very lovely up there.
0924.4										Negative, Dr. Barr. Our rate of descent has not changed. We have approximately 115 lb ballast left. We have dumped approximately 160 lb ballast. This has not influenced our rate of descent. We are still coming down at about 1,200 and have not yet entered the troposphere. We are standing by to take such action as may be indicated.
0926										We are again ballasting.

VERBAL TRANSMISSIONS FROM STRATO-LAB CONDOLA 8 NOVEMBER 1956

Time	External Altitude	Internal Altitude	R.H.	Of	CO ₂	O ₂	Beckman Liters Remaining	Converter Pressure	Rate of Rise	Remarks
	39,500									We have slowed our descent to about 800 at our current altitude. We are approaching the troposphere, if we are not already in it. We have very little ballast remaining. We will stay with balloon as long as we can. We are cool, calm and collected.
0929.6										Our altitude is now about 39,000, still holding steady. Our rate of climb indicator is about 800. Have about 40 lbs ballast remaining. Should start accelerating very soon when we hit troposphere.
										Roger, we will attempt to comply with it. This is standard procedure. We're standing by to see what will happen in troposphere.
0931.3										There is very, very little hope of being able to float; we have expended almost all of our ballast; we are still descending at 800. We are at 38,000 ft. We have virtually no hope of bringing the balloon to a floating condition.
	37,500									Looks like our rate of descent is starting to increase again. About 900.
0932.6	37,000									A closer check on our rate of descent, please.
0933.8										We are expending the rest of the ballast. We will not blow out the residual ballast, however; but we will drain down all ballast to that point. We are doing this in an attempt to slow our descent while we are still at a high level in high velocity winds.
0935.5	34,750									Our rate of climb indicator indicates 1,000.
0936.1										
0936.5	34,000									
0938										We are doing fine; we are going to get into our shoulder straps right now. Dr. Barr, we're doing a little over 1,000 right now.
0939.5										Affirmative, Dr. Barr. Rate of descent has now passed 1,000. We are indicating about 1,100. Current altitude 31,500. Over.
										We are indicating 1,100 descent.

VERBAL TRANSMISSIONS FROM STRATO-LAB GONDOLA 8 NOVEMBER 1956

Time	External Altitude	Internal Altitude	R.H.	Of	CO ₂	O ₂	Beckman Liters Remaining	Converter Pressure	Rate of Rise	Remarks
0942										We are experiencing a little more stress than anticipated. We are now at 28,500. We are standing by to blow the remainder of the ballast.
0943										
0945										
0946.2										We will jettison to see if we can slow down our descent. If we can, we will stay with the balloon. If not, we will leave it. What is height of terrain beneath us? Are we above something of about 3,000 above sea level?
0949										Roger, Captain Barr. We're making about 1,300.

22,200

SHOCK ABSORBER LOADING ANALYSIS

SHOCK ABSORBER LOADING ANALYSIS

An analysis of the stresses imposed on the gondola shell by this shock absorbing system was performed by Mr. F. Bollag of General Mills, Inc.

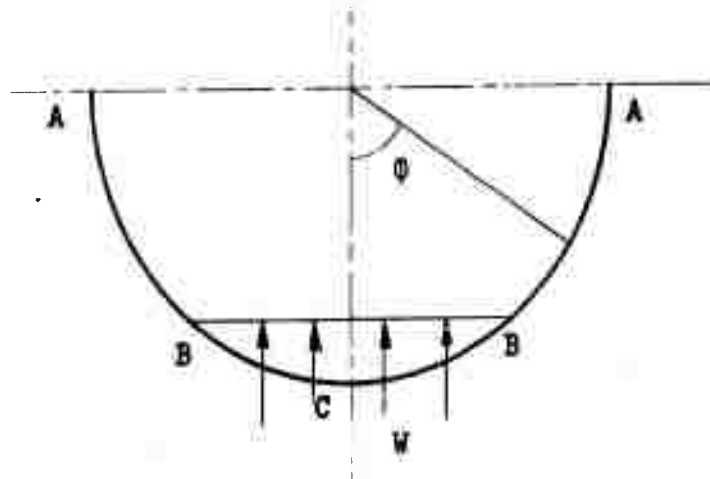

The landing load is transmitted to the shell by the lower structure along a circular line load. A sketch of this is shown above and indicates the circular line loading concentric to the vertical axis of the gondola. The point of critical stress is at the point of load application, B.

The basic method of the analysis is an approximate method but gives good accuracy for thin shells^(1,2). The problem consists of dividing the sphere into regions of continuity and matching the boundary conditions at the points where the regions intersect. This produces a different set of constants for each region. The problem is divided into two regions, the first region between points B and C and the second region between A and B. The boundary between these regions is at the point of load application.

Upon solution of the equations as stated in the reference, shear per linear inch is:

$$Q = \frac{2\lambda^2 D}{a^2} \left[C_{1i} e^{\lambda\phi} \cos \lambda\phi + C_{2i} e^{\lambda\phi} \sin \lambda\phi + C_{3i} e^{-\lambda\phi} \cos \lambda\phi - C_{4i} e^{-\lambda\phi} \sin \lambda\phi \right]$$

where $i = A, B, C$.

(1) Timoshenko, S., "Theory of Plates and Shells", 1st Ed. (1940), p. 467

(2) Malkin, I., "Stress Analysis of a Hemispherical Pressure Vessel Head Under Concentric Line Loads", J. Franklin Inst., 251, 2, pp. 247-261, Feb. 1951.

The rotation is:

$$V = C_{11} e^{\lambda\phi} \cos \lambda\phi + C_{21} e^{\lambda\phi} \sin \lambda\phi + C_{31} e^{-\lambda\phi} \cos \lambda\phi + C_{41} e^{-\lambda\phi} \sin \lambda\phi$$

The moment per linear inch is:

$$M_{\phi} = \frac{-D\lambda}{a} \left[C_{11} e^{+\lambda\phi} (\cos \lambda\phi - \sin \lambda\phi) + C_{21} e^{\lambda\phi} (\sin \lambda\phi + \cos \lambda\phi) - C_{31} e^{-\lambda\phi} (\sin \lambda\phi + \cos \lambda\phi) - C_{41} e^{-\lambda\phi} (\sin \lambda\phi - \cos \lambda\phi) \right]$$

and the deflection is:

$$\delta = -\frac{a}{2\lambda} \left[C_{11} e^{\lambda\phi} (\sin \lambda\phi + \cos \lambda\phi) + C_{21} e^{\lambda\phi} (\sin \lambda\phi - \cos \lambda\phi) + C_{31} e^{-\lambda\phi} (\sin \lambda\phi - \cos \lambda\phi) - C_{41} e^{-\lambda\phi} (\sin \lambda\phi + \cos \lambda\phi) + \frac{(1+\nu)\lambda}{Eh} \frac{W}{\pi a} \right]$$

where,

$$\lambda = \left[3(1-\nu) \left(\frac{a}{h} \right)^2 \right]^{1/4}$$

and,

$$D = \frac{Eh^3}{12(1-\nu^2)}$$

where:

D = flexural rigidity

a = radius of sphere

h = thickness of sphere

ν = Poisson's ratio

$C_{11}, C_{21}, C_{31}, C_{41}$ = unknown constants ("1" refers to the first or second area)

E = modulus of elasticity

W = external applied load.

These equations present eight unknown constants which must be satisfied by the boundary conditions. At $\phi = 0$, or at point C, the shear Q, and the rotation, V, are zero. Therefore, C_{3A} and C_{4A} may be set equal to zero. At point B the boundary conditions are matched and four equations are obtained. The conditions indicate that the shear across B must be equal to the applied load:

$$Q_B^+ - Q_B^- = \frac{W}{2\pi a \tan \theta}$$

where $\phi = \theta$ at point B.

The rotation across B must be equal to zero, or:

$$V_B^+ - V_B^- = 0$$

The moment across B must be equal to zero, or:

$$M_\theta^+ - M_\theta^- = 0.$$

The last two boundary conditions are obtained by assuming no bending at A or where $\phi = \frac{\pi}{2}$. From this assumption the boundary conditions are that the moment is zero and the deflection is equal to:

$$\delta = \frac{a^2 \gamma}{hE} (1 + \nu)$$

where γ = weight of material per square inch of shell multiplied by the g loading.

Substituting the values,

$$a = 43.5 \text{ inches}$$

$$h = .125 \text{ inches}$$

$$\nu = .3$$

$$E = 10.5 \times 10^6 \text{ lb/in}^2$$

$$\gamma = .125 \text{ lb/in}^2$$

$$\lambda = 23.98$$

$$D = 1880$$

into the equations and allowing a 10 g loading, the solutions for the eight constants are:

$$C_{1c} = -.605 \times 10^{-12}$$

$$C_{2c} = .764 \times 10^{-12}$$

$$C_{3c} = 0$$

$$C_{4c} = 0$$

$$C_{1B} = 0$$

$$C_{2B} = 0$$

$$C_{3B} = -2.84$$

$$C_{4B} = 3.57$$

Using these values in the equations, it is found that the moment and deflections are insignificant.

UNCLASSIFIED

AD 1936

Armed Services Technical Information Agency

Reproduced by

DOCUMENT SERVICE CENTER

KNOTT BUILDING, DAYTON, 2, OHIO

This document is the property of the United States Government. It is furnished for the execution of the contract and shall be returned when no longer required, or upon recall by ASSTC to the following address: Armed Services Technical Information Agency, Document Service Center, Knott Building, Dayton 2, Ohio.

NOTICE: WHEN GOVERNMENT OR OTHER DRAWINGS, SPECIFICATIONS OR OTHER DATA ARE USED FOR ANY PURPOSE OTHER THAN IN CONNECTION WITH A DEFINITELY RECORDED GOVERNMENT PROCUREMENT OPERATION, THE U. S. GOVERNMENT THEREBY INCURS NO RESPONSIBILITY, NOR ANY OBLIGATION WHATSOEVER; AND THE FACT THAT THE GOVERNMENT MAY HAVE FORMULATED, FURNISHED, OR IN ANY WAY SUPPLIED THE SAID DRAWINGS, SPECIFICATIONS, OR OTHER DATA IS NOT TO BE REGARDED BY IMPLICATION OR OTHERWISE AS IN ANY MANNER LICENSING THE HOLDER OR ANY PERSON OR CORPORATION, OR CONVEYING ANY RIGHTS OR PERMISSION TO MANUFACTURE OR SELL ANY PATENTED INVENTION THAT MAY IN ANY WAY BE RELATED THEREBY.

UNCLASSIFIED