

UNCLASSIFIED

149926

Armed Services Technical Information Agency

ARLINGTON HALL STATION  
ARLINGTON 12 VIRGINIA

FOR  
MICRO-CARD  
CONTROL ONLY

1 OF 4

NOTICE: WHEN GOVERNMENT OR OTHER DRAWINGS, SPECIFICATIONS OR OTHER DATA ARE USED FOR ANY PURPOSE OTHER THAN IN CONNECTION WITH A DEFINITELY RELATED GOVERNMENT PROCUREMENT OPERATION, THE U.S. GOVERNMENT THEREBY INCURS NO RESPONSIBILITY, NOR ANY OBLIGATION WHATSOEVER, AND THE FACT THAT THE GOVERNMENT MAY HAVE FORMULATED, FURNISHED OR IN ANY WAY SUPPLIED THE SAID DRAWINGS, SPECIFICATIONS, OR OTHER DATA IS NOT TO BE REGARDED BY IMPLICATION OR OTHERWISE AS IN ANY MANNER LICENSING THE HOLDER OR ANY OTHER PERSON OR CORPORATION, OR CONVEYING ANY RIGHTS OR PERMISSION TO MANUFACTURE, USE OR SELL ANY PATENTED INVENTION THAT MAY IN ANY WAY BE RELATED THERETO.

UNCLASSIFIED

149926

ASIA FILE COPY

FINAL REPORT

Feasibility and Preliminary Design  
Study for a  
Hydrofoil Amphibious Tracked Vehicle  
November 30, 1957

*Hawaii Shipbuilding Corporation*

**BEST**

**AVAILABLE**

**COPY**

MIAMI SHIPBUILDING CORPORATION  
615 S. W. SECOND AVENUE  
MIAMI 36, FLORIDA

**FC**

FINAL REPORT

FEASIBILITY AND PRELIMINARY DESIGN STUDY  
FOR  
A HYDROFOIL, AMPHIBIOUS TRACKED VEHICLE

for the  
OFFICE OF NAVAL RESEARCH

Surface Branch

Contract Nour 2307

Prepared by

Edwin L. Rose  
Robert J. Johnston

30 November 1957

## TABLE OF CONTENTS

<u>Subject</u>	<u>Page</u>
Summary and Conclusions	aa
Preliminary Design Characteristics	
A. Physical Specifications:	
1. Vehicle, Flying Configuration	a
2. Vehicle, Boating Configuration	a
3. Vehicle, Land Operation Configuration	b
4. Vehicle, Shipping Configuration	b
B. Performance Specifications:	
1. Vehicle, Flying Configuration	b
2. Vehicle, Boating Configuration	c
3. Vehicle, Land Operation Configuration	c
C. Fuel Capacity	c
D. Ramp Dimensions	c
E. Cargo Compartment Dimensions	c
I. Introduction	1
A. Objectives	1
B. History	2
C. General Results of Study	25
II. Characteristics of Craft When Water-Borne	30
A. Stability	30
B. Planing Characteristics of Hull	31
C. Flying Characteristics	36
III. Characteristics of Vehicle on Land	41
IV. General Arrangement of Vehicle	49
V. Structural and Mechanical Features	53
A. Hull	53
B. Front Foil Assembly	55
C. Rear Foil and Propulsion Unit	66
D. Power Plant	67
E. Track System	70
F. Weight	72
Appendix A	75

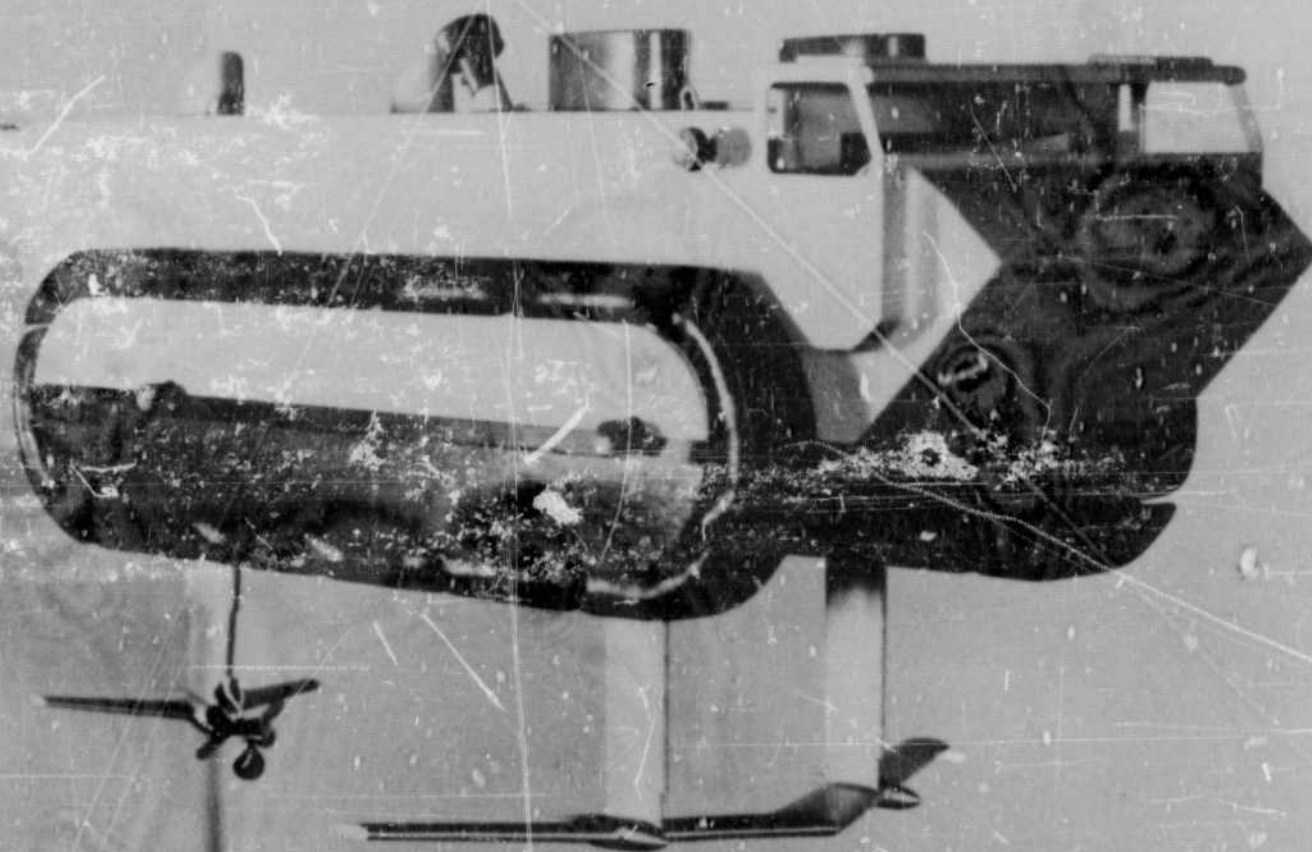

MODEL OF HATV  
HYDROFOIL AMPHIBIOUS TRACKED VEHICLE  
UPPER - FLYING CONFIGURATION  
LOWER - LAND CONFIGURATION

## SUMMARY AND CONCLUSIONS

A study has been made of the feasibility of designing a tracked amphibious vehicle with surface boating characteristics adapted to permit takeoff for flight on hydrofoils suited to high speed flight with an available power plant of reasonable capacity.

It has been found that this objective can be attained with a vehicle having a good cruising range on land and at sea. Speeds of 45 knots at sea and 60 m. p. h. on land appear attainable. A photograph of the model of one conception of such a craft is shown on the opposite page. Other attainable characteristics are summarized on the following pages.

The primary problems involved in the development of such a vehicle have been found to be concerned with design of a hull of reasonable weight to resist dynamical loading pressures and with the design of a track having clean contours (hydrodynamically) and adapted to high speed operation on land. Preliminary designs of essential elements have been outlined.

PRELIMINARY DESIGNED CHARACTERISTICS  
HYDROFOIL AMPHIBIOUS TRACKED VEHICLE POWERED  
BY T-58 GAS TURBINE

---

A. Physical Specifications

1. Vehicle, Flying Configuration

Length, overall	35 ft. 7 in.
Width, overall	18 ft. 3 in.
Height	17 ft. 10 in.
Crew	2
Passenger capacity (250#/each)	32
Cargo capacity	8000 lbs.
Weight:	
Bare	22,805 lbs.
Loaded (fuel, crew and cargo)	36,000 lbs.
Draft	3 ft. 1 in.
Hull to water clearance	3 ft.

2. Vehicle, Boating Configuration

Length overall	35 ft. 7 in.
Length, waterline	21 ft.
Width, overall	12 ft. 6 in.
Height	12 ft. 6 in.
Draft, foils down	9 ft. 8 in.
Draft, foils retracted	3 ft. 6 in.
Metacentric Height (full loaded), GM	3 ft. 5 in.
Metacentric Height (light load), GM	5 ft. 9 in.

### 3. Vehicle, Land Operation Configuration

Length, overall	35 ft. 7 in.
Width, overall	12 ft. 6 in.
Height	10 ft. 4 in.
Ground clearance	18 in.
Ground pressure	4.0 p. s. i.
Vertical center of gravity above ground full load	4.4 ft.

### 4. Vehicle, Shipping Configuration

#### a. Hull:

Length, overall	35 ft. 7 in.
Beam	10 ft. 2 in.
Height	8 ft. 10 in.
Weight	14,353 lbs.

#### b. Side Sponsons (each)

Length	24 ft. 9 in.
Width	1 ft. 10 in.
Height	6 ft. 10 in.
Weight	4,226 lbs.

## B. Performance Specification

### 1. Vehicle - Flying

#### Speed:

Cruising (max. range)	25 knots
Maximum	45 knots

Range (with 200 mi. land reserve)	200 miles
Fuel Consumption:	
Cruising	300 lb./hr.
Maximum	700 lb./hr.
2. Vehicle Boating	
Speed	11 knots
Range	55 miles
Fuel consumption	700 lb./hr.
3. Vehicle - Land Operation	
Speed (max.)	60 m.p.h.
Range (with 200 mi. sea reserve)	200 mi.
Fuel Consumption (15 m.p.h.)	1.5 g./mi.
Grade Ascending ability (forward slope)	70%
Grade Ascending ability (side slope)	60%
Obstacle Ability:	
Solid vertical wall	2 ft. 6 in.
Trench span	8 ft.
Angle of approach	48°
Angle of departure	35°
<u>C. Fuel Capacity</u>	
Diesel Fuel	640 gals.
<u>D. Ramp</u>	
Width of opening	7 ft.
Height of opening (minimum)	6 ft. 2 in.

E. Cargo Compartment

Width of Cargo Hatch	5 ft.
Length of Cargo Hatch	8 ft. 4 in.
Height (minimum)	6 ft. 8 in.
Width (minimum)	7 ft. 6 in.
Length (minimum)	14 ft.
Cubic space	700 cu. ft.

## I. INTRODUCTION

This report is the final report on a combined feasibility and preliminary design study for an amphibious tracked vehicle equipped with hydrofoils to provide high speed at sea, in a moderately heavy seaway. In order to broaden the usefulness of the report, only essential conclusions are presented, together with such alternatives of choice as appear to warrant further consideration.

Technical discussion is avoided with the thought in mind that it tends to obscure the broader picture and technical answers can be supplied, on inquiry, to any interested parties.

### A. Objectives.

The prime objective of this undertaking is to determine the feasibility of development of an amphibious vehicle capable of high speed on water, in a moderately heavy sea and on land over moderately rough terrain. A further objective is the simultaneous provision of capacity for transporting a military pay load at least 25% of its gross loaded weight. Other specific desirable characteristics of such a vehicle are summarized in Table I.

In pursuing these specific objectives, there has also been an effort to incorporate such other features and characteristics as may result in maximum practicable versatility and utility of the resulting vehicle.

TABLE I

Desirable Characteristics  
of a  
Hydrofoil Amphibious Tracked Vehicle

Land speed capability, at least	60 m. p. h.
Water speed capability, at least	45 knots
Cargo capacity, at least	8,000 lbs.
Hill climbing ability, at least	70% grade
Stable side hill operation, at least	60% grade
Cruising range at sea, at least	200 mi.
Cruising range on land, at least	200 mi.
Trafficability over dry light beach sand and over maximum practicable range of other terrain.	
Dimensional limits to permit rail and air shipment and operation at sea from an L. S. T.	

## B. History.

For some years, there has been a well-recognized need for an amphibious vehicle adapted to various military uses and capable of high speed operation on land and at sea. One of the early efforts in the direction of rendering such a craft available was the development of the DUKW. However, while amphibious and capable of moderately high speed on land, this vehicle left much to be desired as regards high speed operation at sea. Although useable over most beaches, it was also limited in its trafficability over more difficult forms of terrain by the load bearing and tractional characteristics of wheels of practical size.

In 1956, in an effort to overcome the water speed limitations of the DUKW the Miami Shipbuilding Corporation, under sub-contract with AVCO as prime contractors for the United States Army, undertook to remove the water speed limitations of the DUKW by applying hydrofoils thereto. At the inception of the undertaking, an important question was whether the DUKW could attain sufficient surface speed, with a useable power plant, to takeoff on foils of small enough area to permit attainment of a desirable flying speed, with that same power plant.

In order to establish a preliminary answer to that question, under a feasibility-type contract, arrangements were made with the United States Navy to tow a DUKW at sea and to measure the drag at estimated takeoff speed. The results of

these tests showed a very high drag, but indicated the possibility of takeoff and flying, provided powering was by gas turbine, or other equally light-weight power plant.

After undertaking the contract, two groups of model tests at one-tenth scale were conducted. One group was performed at the Experimental Towing Tank of the Stevens Institute of Technology. The other was by the Miami Shipbuilding Corporation. In general, these tests confirmed the results of the full-scale towing tests. Minor improvements were then effected by slight bow modifications, but these results still left much to be desired in the way of drag reduction. This experience provided the stimulant for active thinking at Miami Shipbuilding Corporation regarding steps that might be undertaken by way of modification of an amphibious vehicle to materially reduce its drag during takeoff and, perhaps, simultaneously to improve its land-going trafficability and versatility.

The unfavorable takeoff characteristics of the DUKW are due to a number of factors. Hull contour, the presence of wheel pockets and the tunnelling for the propeller combine to affect planing characteristics very adversely. Unit speed length ratio is attained at less than 4 knots so that high drag is reached at relatively low speed. The useful planing speed is very much higher than this, substantially out of reach for any feasible power plant. The wheels, wheel pockets, axles and other hull

irregularities and appendages combine to produce very high friction drag. These are not eliminated by planing. The bow shape and high planing speed combine to cause production of a high bow wave at all but very low speeds so that wave drag is high. The drag producing appendages and the adverse hull configuration will be recognized by reference to Figure 4.

To avoid the adverse features of the underwater system of the DUKW, it is necessary:

- (1) To provide a clean hull, avoiding all pockets, cavities or protrusions or alternatively to provide means for covering pockets and cavities and for retracting protrusions when boating.
- (2) To avoid the use of propeller tunnels or, if such are required for shallow water navigation, to provide arrangements for covering them during takeoff and flying operations by foldable squat boards.
- (3) To avoid use of numerous large appendages, like wheels, axles, etc., or to provide for their retraction and covering.
- (4) To establish hull form and lines adapted to planing so as to minimize drag at speed length ratios greater than unity and to avoid the development of negative lift at high speed through "Bernoulli Effects" on submerged curved contours and in propeller tunnels.

Careful consideration shows that, while means for meeting requirements with a wheeled vehicle are conceivable, this can be provided only at the cost of structural and mechanical complexity and with difficulty. The necessary provision of retraction and covering of wheels and axles leads to great mechanical complication. Without careful and reliable sealing, the space taken up by housed appendages is subtracted from flotation displacement, increasing the draft or rendering difficult the attainment of static, roll stability with reasonable draft.

On the contrary, the attainment of most of these design objectives is relatively easy with a properly design tracked vehicle. Still, there are two areas of difficulty. The geometry of track, bogey mechanism and suspension are such as to produce high friction drag. The space consumed by these components subtracts from flotation lift and their weight combines therewith to increase draft. The location of these negative displacement areas tends to reduce roll stability.

This problem has not, normally, hampered design of tracked amphibious vehicles since they have generally been heavy with deep draft and low center of gravity. The effect of track space volume in lowering metacentric height has hence not been serious. On the other hand, if high speed is to be attained, design must be for shallow draft to encourage planing. This raises the center of gravity and renders essential the provision

of a broad effective beam to produce high meta-center for a suitable stability moment. This is not easy with conventional track and with a stringent limitation on beam. However, stability is attainable and its attainment is facilitated by a suitable choice and design of track and thereby is more readily accomplished than in the case of a wheeled vehicle.

After due consideration of these various aspects of the problem of design of an amphibious vehicle for high speed on land and water, the conclusion was reached, at Miami Shipbuilding Corporation, that the potentialities offered by a hydrofoil-equipped, tracked amphibious vehicle were such as to justify a more careful study for the purpose of determining just what difficulties the accomplishment might present and whether satisfactory solutions therefor were recognizable. This conclusion was based on the following general observations:

- (1) The hull design for a tracked vehicle can be made comparatively clean and can readily be adapted to planing.
- (2) While track, bogey and suspension system offer high resistance, this can be at least partially offset by motorizing the track at a suitable speed during boating and takeoff. Furthermore, a suitably designed special track can present clean lines and when motored, may have negligible drag.

(3) If the hydrodynamic problems which they present can be solved, use of conventional tracks is preferred, but other track systems are possible and some are particularly well adapted to reducing drag by motoring.

Having reached this conclusion, Miami Shipbuilding Corporation submitted a formal proposal for a feasibility and preliminary design study of a Hydrofoil Amphibious Tracked Vehicle to the Office of Naval Research on 27 December 1956. The present contract resulted from that proposal.

The basic features of the vehicle proposed are shown in Figures 1 and 2. For the sake of brevity and for the purposes of this report only, we shall henceforth refer to this vehicle as the H. A. T. V.

As originally conceived, the H. A. T. V. was gas turbine-powered. It was provided with conventional track, suspension and bogey system except that provisions were made to retract this assembly to the point where the bearing face of the track was flush with the bottom of the hull, in boating and flying. Arrangements were contemplated for covering the bottom track face with a smooth belt, during boating, in order to cut down drag. As originally conceived, the beam of this assembly was contemplated to be broad enough to meet both planing and roll stability requirements.

LAT.	ALTERATION	BY	DATE	APP.

BELT REEL WITH  
SPRING-LOADED  
RECOIL

ACCESS HATCH P&S.



RUBBER-COVERED CANVAS  
BELT FOR REDUCING DRAG  
ON TRACKS WHEN RETRACTED.

FIGURE 1

ITEM	DESCRIPTION	QTY.	MATERIAL	SIZE	REMARKS
<b>BILL OF MATERIAL</b>					
FINISH		CALC. WT.		ACT. WT.	
SCALE	PROPOSED METHOD OF REDUCING				
DATE	TRACK DRAG IN FLIGHT				
DRAWN	AMPHIBIOUS TRACK VEHICLE				
TRACES	MIAMI SHIPBUILDING CORPORATION				
CHECKED	MIAMI, FLORIDA, U.S.A.				
				03765	ALT.

LET. 98LEO BY DATE APP.

ALTERATION

TRANSMISSION BOX:  
REDUCTION GEAR & CLUTCH  
LAND-MACHINE DEVICES &  
REVERSE GEAR

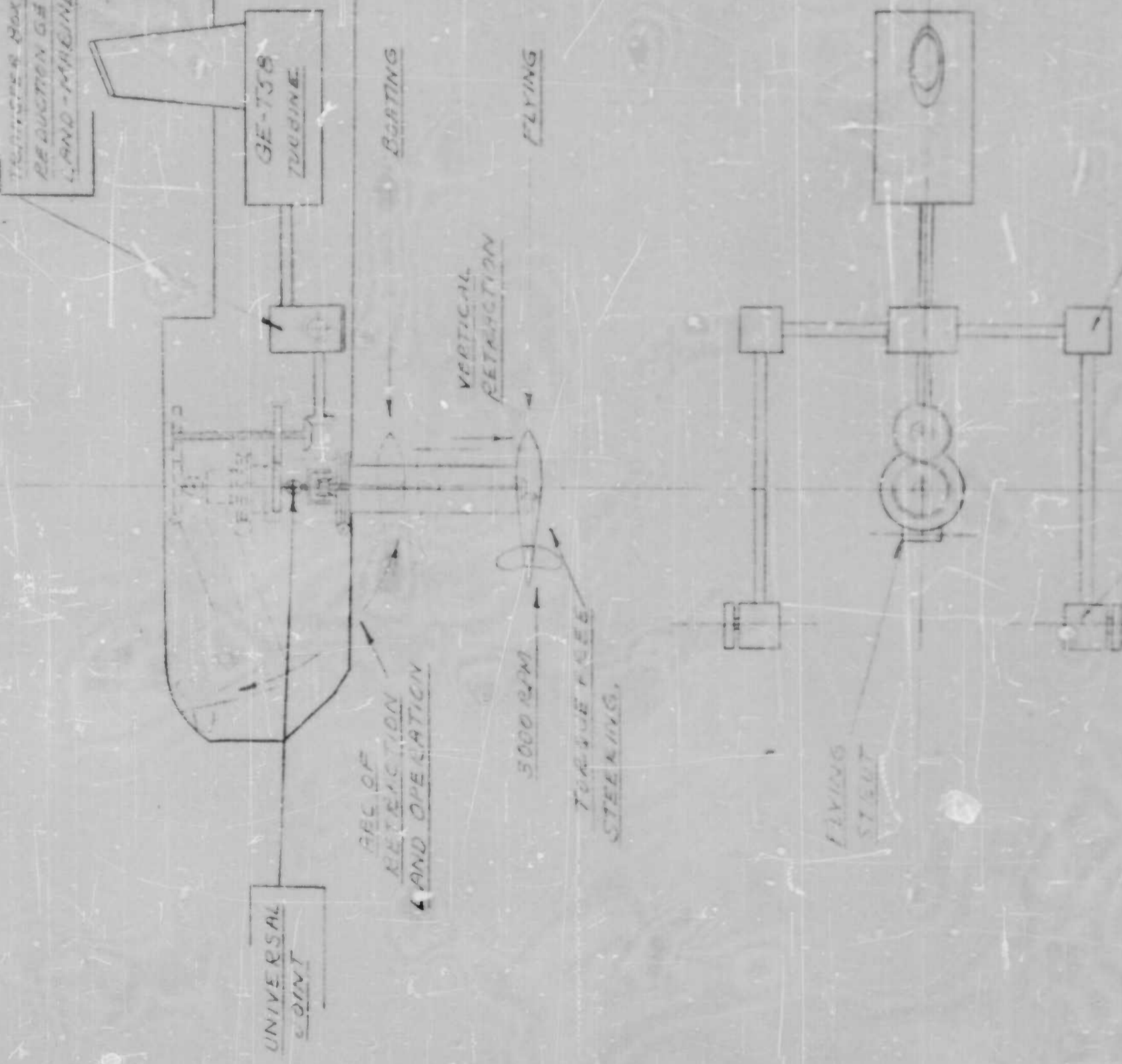

ITEM	DESCRIPTION	QTY.	MATERIAL	SIZE	REMARKS
BILL OF MATERIAL					
FINISH				CALL. WT.	ACT. WT.
SCALE	1/4" = 1"				MAJOR ASSEMBLY
DATE	10/15/58				NEXT ASSEM.
DRAWN	J.A.				NO. PER NEXT ASSEM.
TRACED					
CHECKED					
MIAMI SHIPBUILDING CORPORATION MIAMI, FLORIDA, U.S.A.					03786

TRANSMISSION & RETRACTION  
SYSTEM -- TRACKED  
AMPHIBIOUS VEHICLE

FIGURE 2

Shortly after the contract got under way, conferences with Navy and Marine Corps personnel established the fact that it was essential to restrict the beam. An initial figure of 15 feet maximum was ultimately reduced to a working figure of 12-1/2 feet.

A one-tenth scale model of the resulting craft, when tested, showed a rather high drag, though somewhat lower than that of the DUKW. This model is shown in Figure 3. Since it simulated the track and bogey assembly with a smooth contoured dummy, drag characteristics were not strictly representative. However, a further and more serious difficulty developed. When the track and suspension housing portions of the model were properly vented to produce something approaching the true displacement picture, the roll stability proved to be inadequate. This started a new search for configurations meeting stability requirements while preserving the balance of desired performance.

Various arrangements considered for providing track retraction and meeting the stability problem are shown in Figures 6-a, b, c. One approach was the use of a "catamaran" type configuration, Figure 6-c, in which the entire track system was placed below the hull with as much as possible of it enclosed. The two track assemblies were located along opposite edges of the hull and when viewed from bow or stern, the craft presented

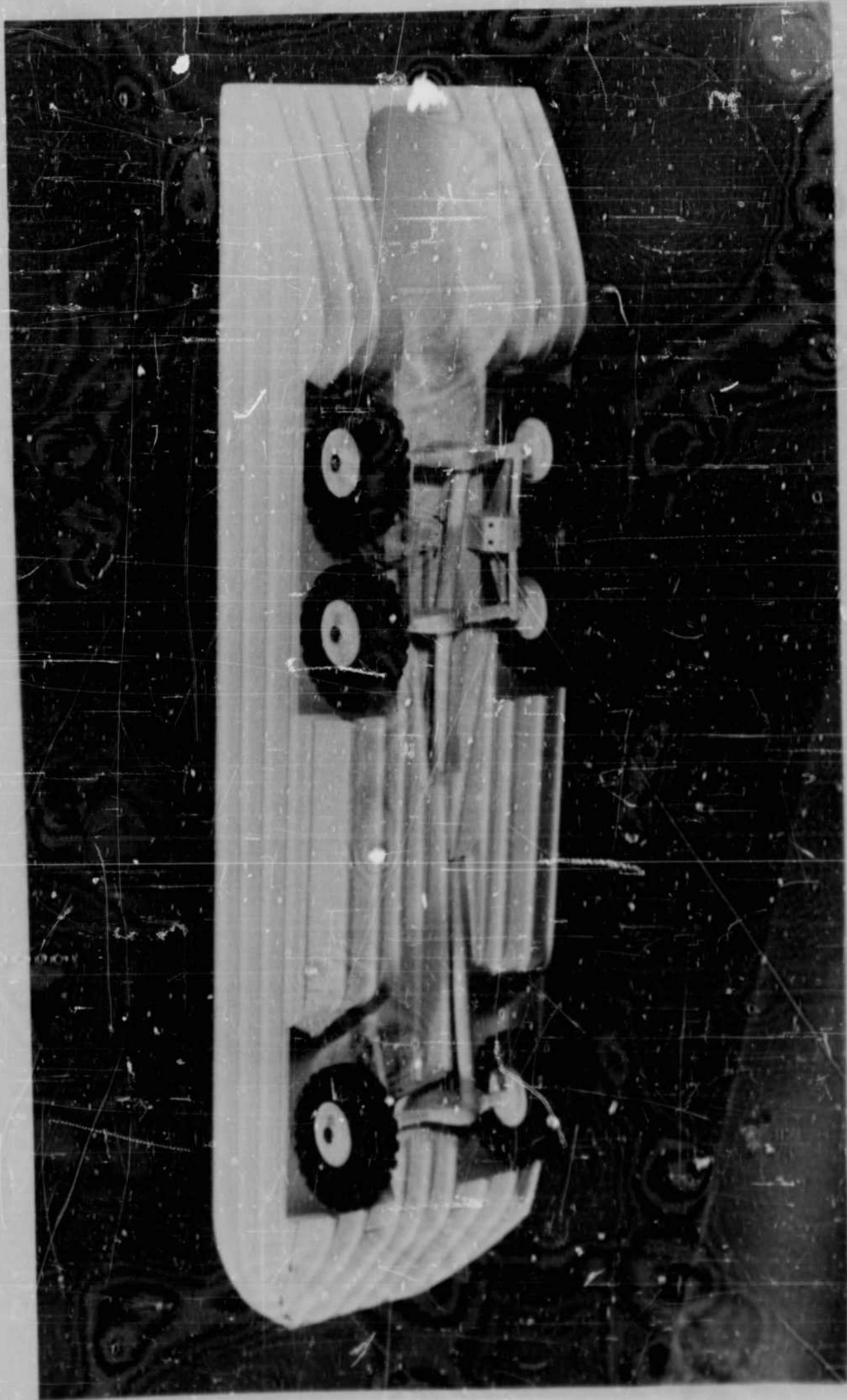

UNDER VIEW OF DUKW MODEL

FIGURE 4



FIRST MODEL OF HATV

FIGURE 3

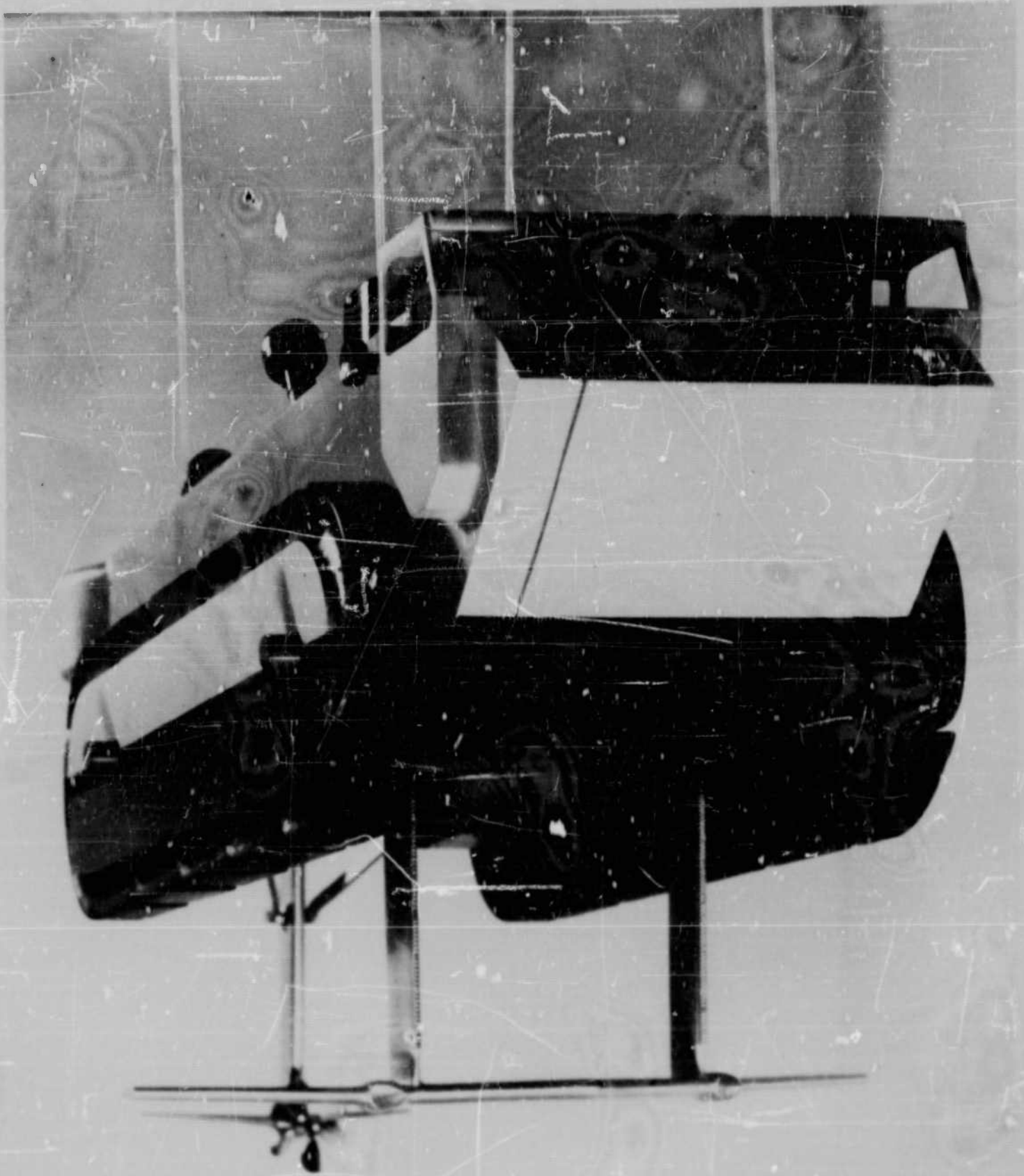

UNDER VIEW OF HATV FINAL MODEL  
FIGURE 5



FIGURE '6A

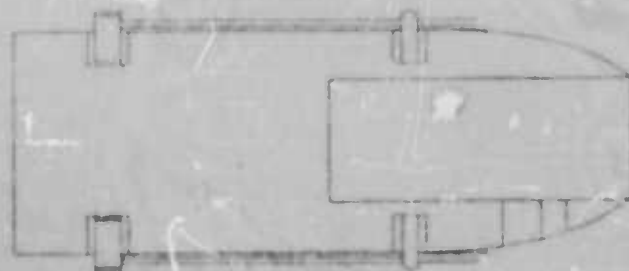

FIGURE '6B

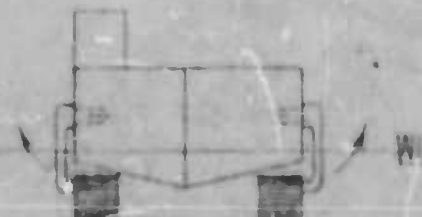
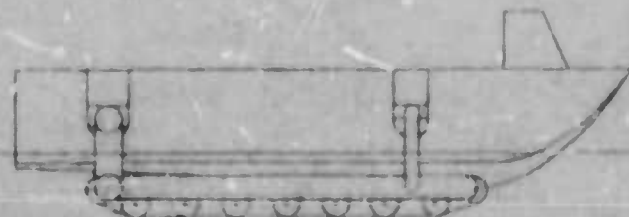
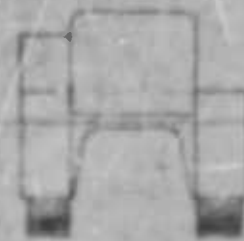

FIGURE '6C



the appearance of a crude catamaran. Such a configuration can be given a broad effective beam without excessive width and its center of gravity can be kept reasonably low relative to the metacenter. It presents two serious disadvantages. The foil struts must be excessively long in order to provide a suitable flying clearance and an excessive amount of track, bogey, suspension and other parasitic equipment, having a high friction coefficient, is immersed in water and remains immersed until the vehicle is well off the water in flight. A general development of this configuration with retractable front foils is shown in Figure 7.

The takeoff drag characteristics of this vehicle are not good, and it requires excessively heavy struts in order to safely support the craft on foils during turning.

At the time these aspects of the problem were under discussion, a visit was made to the laboratory of Col. Bekker at Detroit Arsenal for the purpose of discussing the problems and capabilities of spaced link tracks. At these discussions, it was decided that spaced link track presented more problems than advantages in the present application. As an alternate, Col. Bekker suggested consideration of use of his ground ski system. This system has the very definite advantage of producing a continuous and uniformly distributed ground pressure. It thus presents the best attainable bearing capability on soft terrain. It is also well adapted to design for reasonable friction drag.

MIAMI SHIPBUILDING CORPORATION

BY TRR DATE \_\_\_\_\_

SUBJECT \_\_\_\_\_

SHEET # \_\_\_\_\_ OF \_\_\_\_\_

CHKD. BY \_\_\_\_\_ DATE \_\_\_\_\_

JOB # \_\_\_\_\_

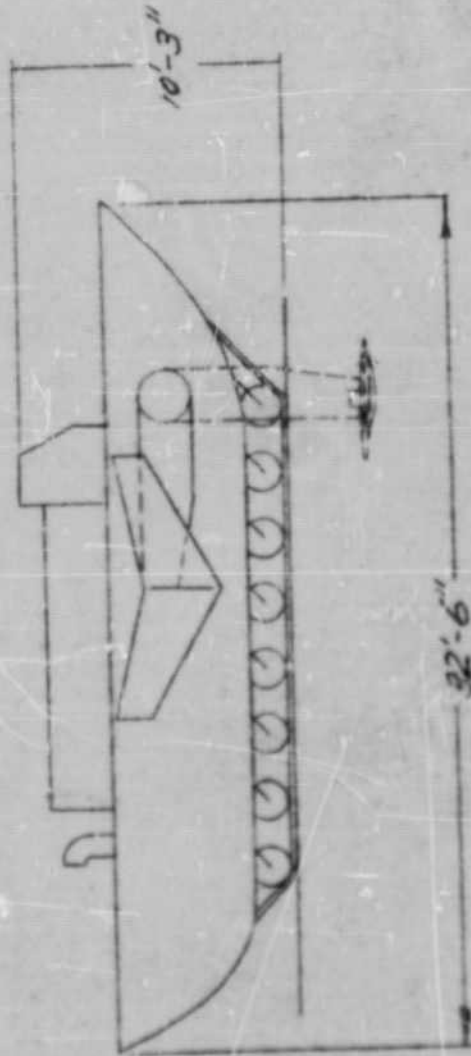
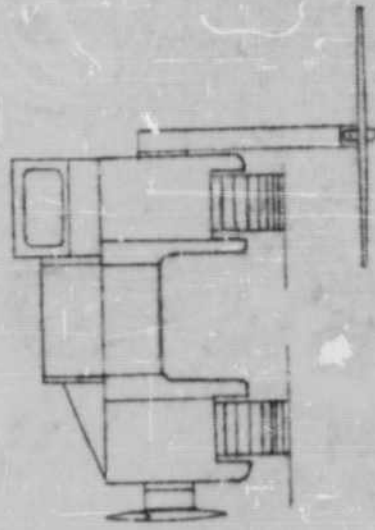
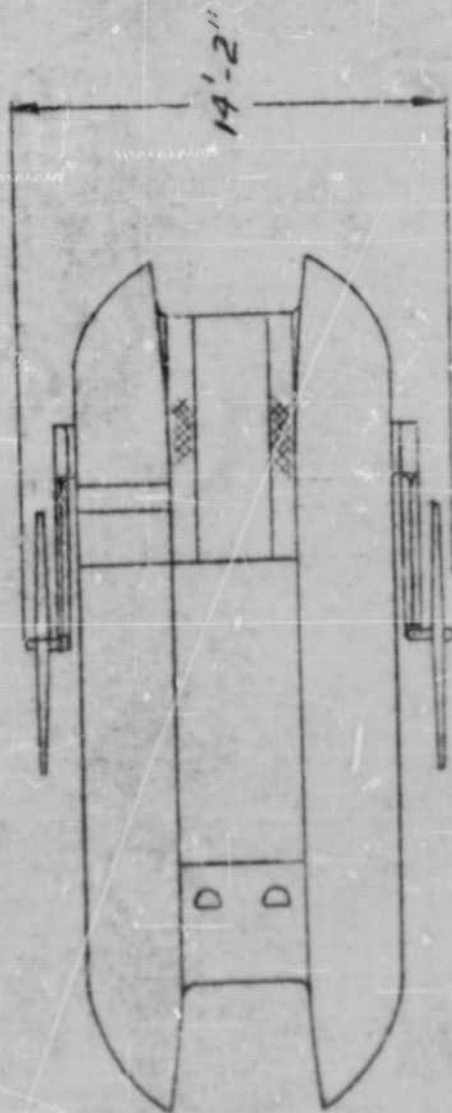

SCALE:  $\frac{1}{8}'' = 1' \pm$

FIG. 7  
CATAMARAN CONFIGURATION

FIG 7

5042E:8 = 112

Figure 8 illustrates an application of this track to the H. A. T. V. Because the guide problem of a belted track such as this is difficult, articulated steering is used in place of differential track steering.

While the ground ski has some very advantageous characteristics, it presents some serious design difficulties. The most difficult of these results from the necessity of tightly sealing the enclosure within the belt in order to avoid wear and to maintain lubrication. Furthermore, the necessity for use of articulated steering greatly increases the complexity of the drive system. In recognition of these problems, a continuing search for a useable track system was now pursued with the purpose of endeavoring to attain as many as possible of the advantages of the ground ski, while avoiding its design difficulties.

A study was made of the possibilities of producing a segmental pneumatic belt. While such a belt would necessarily run on guide rails and rollers and hence require seals, the sealing does not have to flex with the belt and hence presents less serious difficulties. These seals will be much farther above ground than in the ground ski. Furthermore, a turbo-blower can be used to maintain air pressure within the sealed space to keep out dust and water. Tightness of the seal is then less important and seal wear can be minimized. The general concept of a segment of such a belt is indicated in Figure 9. Its application to a form of H. A. T. V. is shown in Figure 10.

MIAMI SHIPBUILDING CORPORATION

BY JAG DATE \_\_\_\_\_

SUBJECT \_\_\_\_\_

SHEET # \_\_\_\_\_ OF \_\_\_\_\_

CHKD. BY \_\_\_\_\_ DATE \_\_\_\_\_

JOB # \_\_\_\_\_

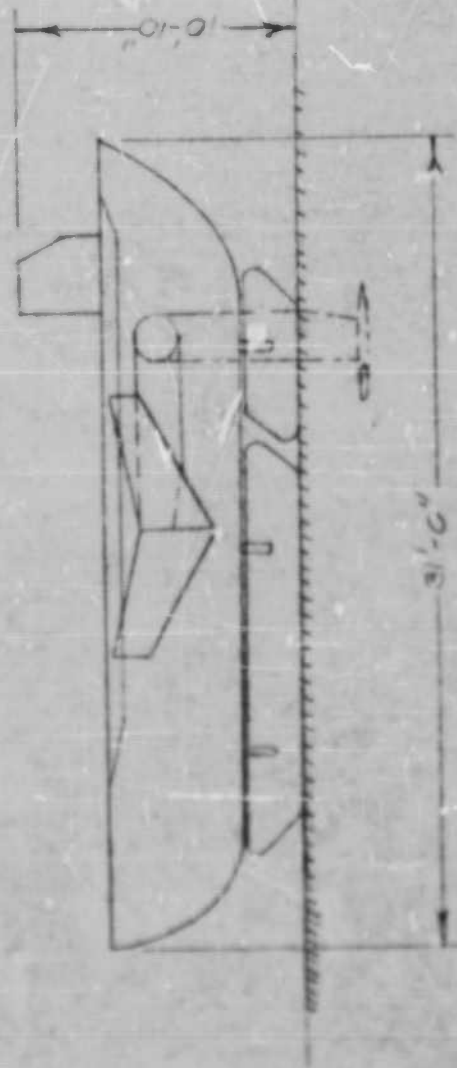
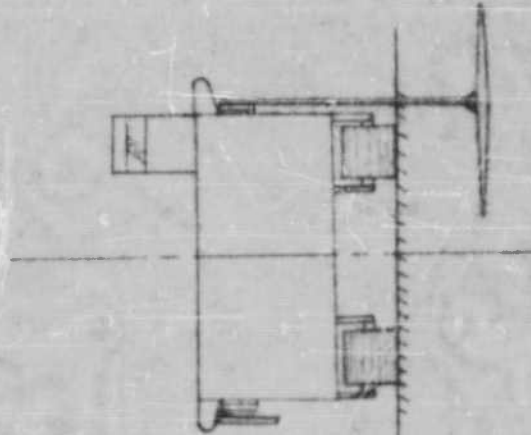
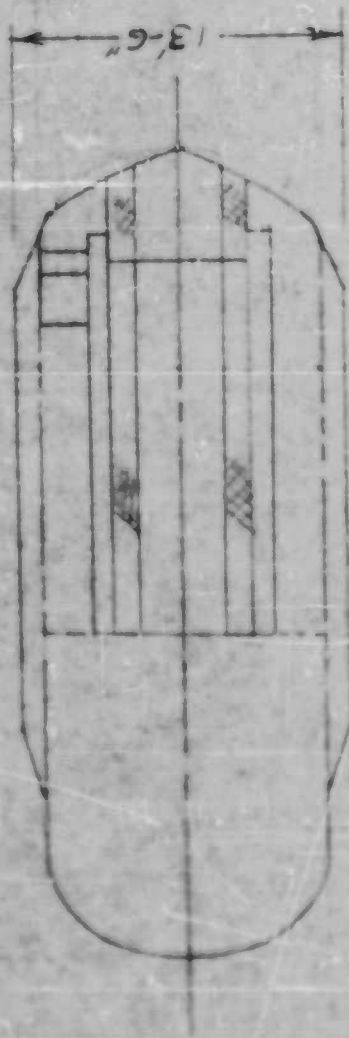
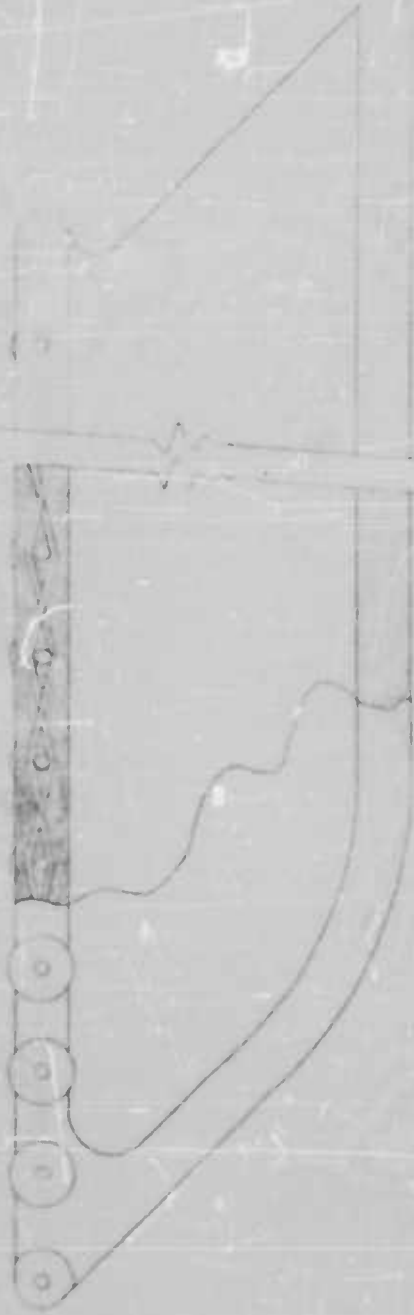
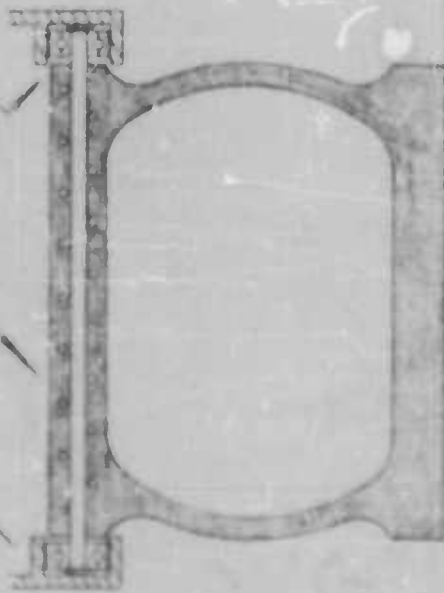

FIG. 8

—GUIDE CHANNELS

—REINFORCING CABLES

—BALL BEG ROLLERS



—FIG. 169—

SEGMENT NO. 108114

TRACK BELT

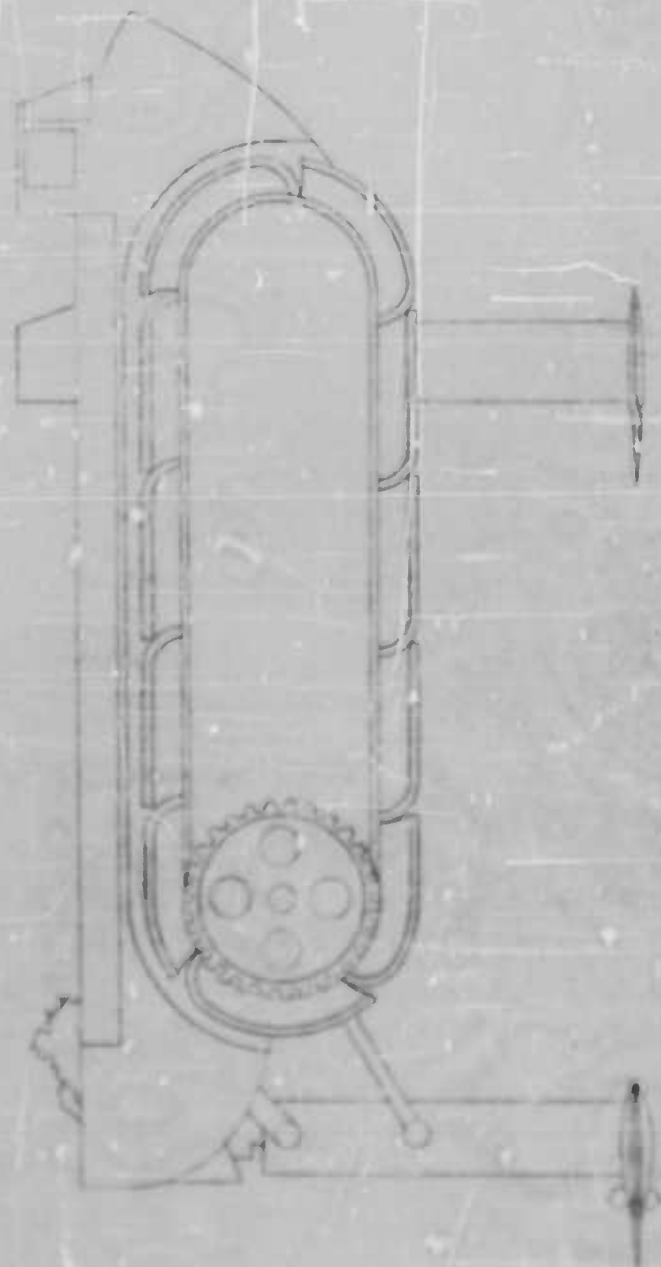
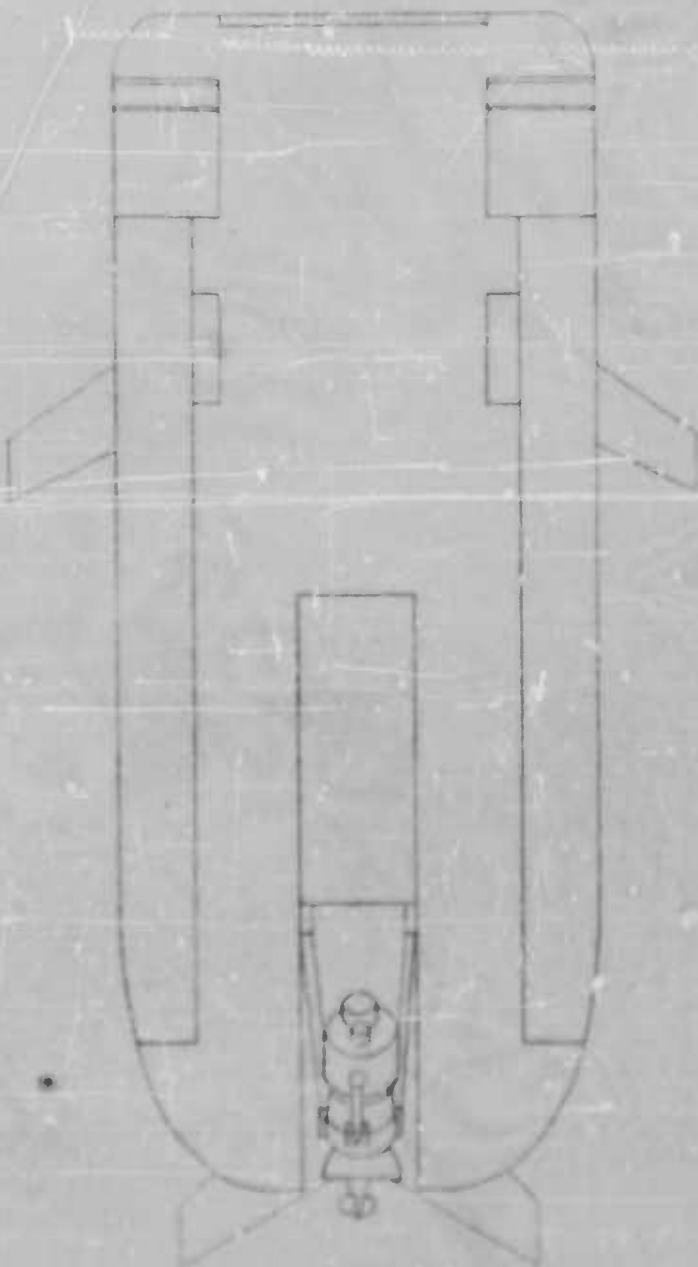
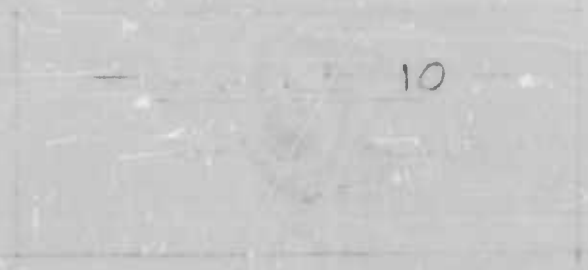

Early conceptions of the H. A. T. V. had the foils mounted on the outside of the hull. In this location, they were vulnerable to damage. In developing a configuration for the pneumatic track arrangement, a simultaneous effort was made to get the retracted foils inside the hull. A new concept of a front foil system, comprising a single swept back foil spanning the craft and mounted on two struts, with foldable foil tips extending beyond the struts, resulted. This also is shown in Figure 10. Figure 11 shows an early concept of this foil retraction arrangement. The foil tips fold up against the struts and struts and foil tips retract into wells inside the hull.

A tentative hull form is shown in Figure 12. The hull is completely decked over with a hatch provided for crane loading. A bow door permits loading and offloading of men and vehicles at ground level. Figure 13 shows a retractable rear foil and propulsion assembly with gas turbine mounted on the unit.

Since evolution of the conceptions illustrated in Figures 9 to 13, inclusive, there has been more detailed study of power plants, drive gearing, control mechanism, hull structure, foil structure and hull configuration. Various retraction systems were investigated. Steering arrangements were investigated. Some potential advantages were found in the possible use of a high pressure steam boiler and engine.

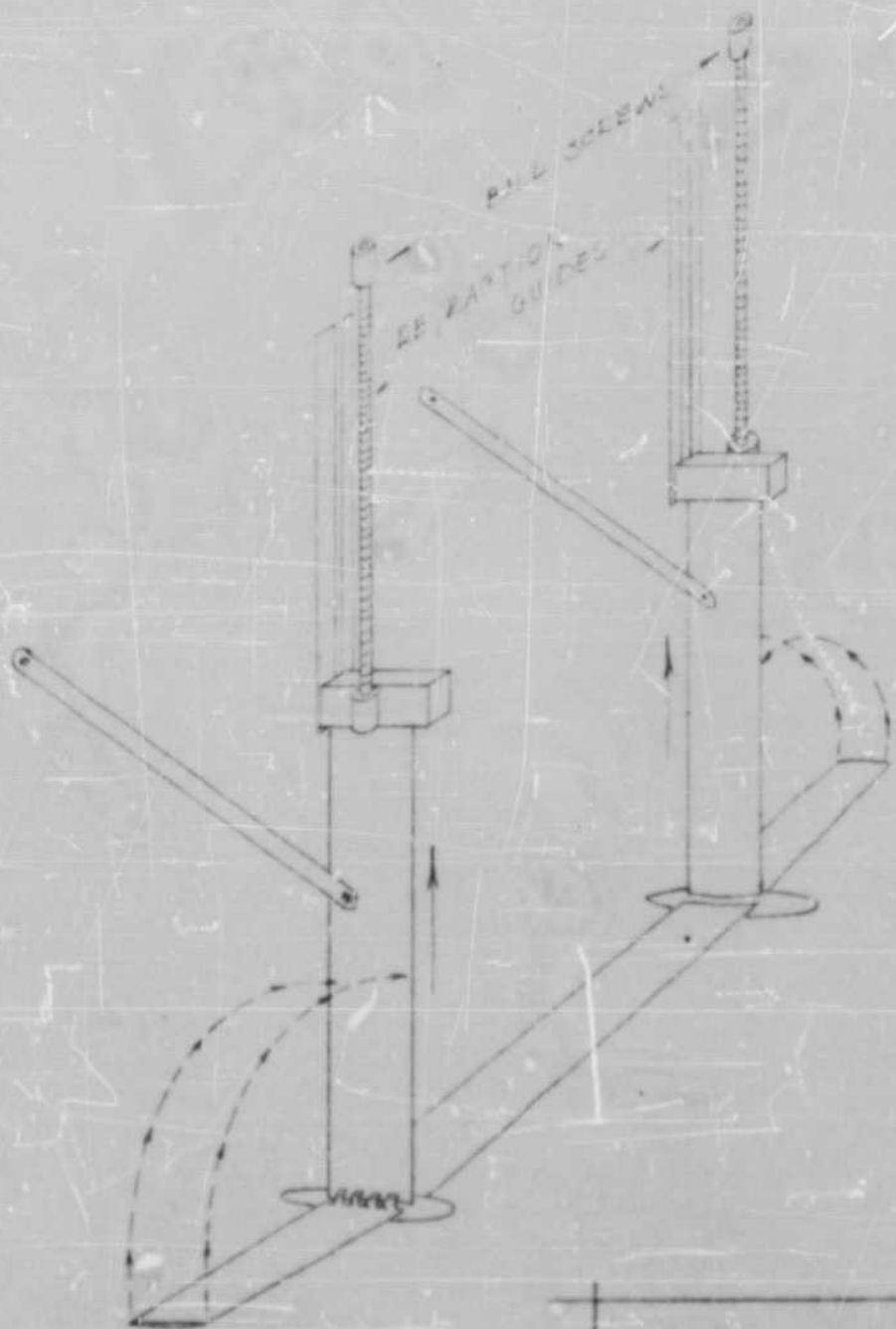
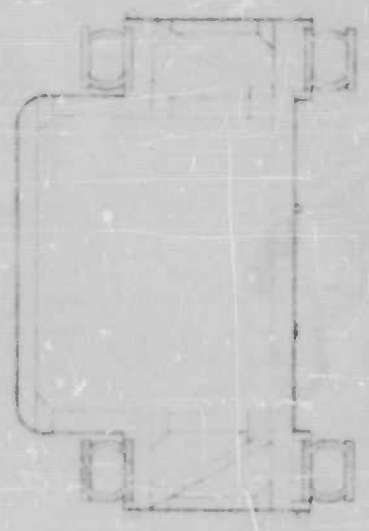
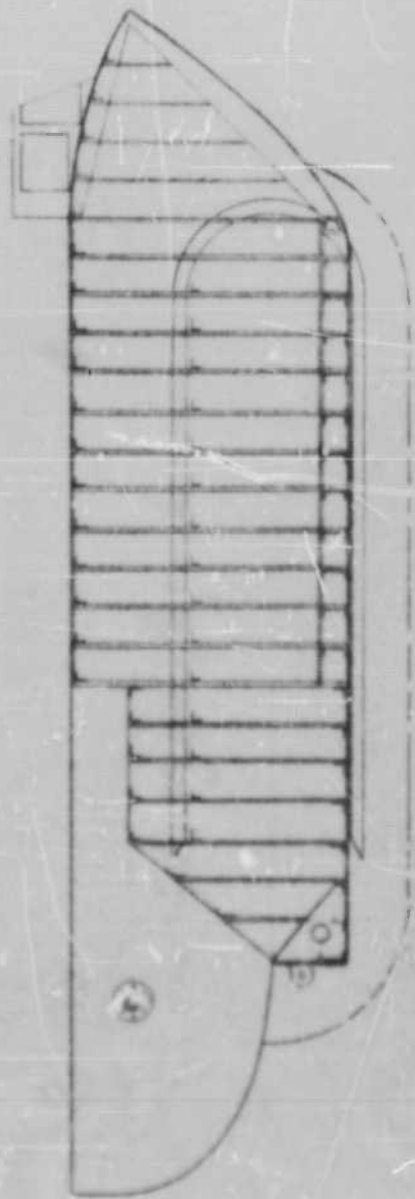
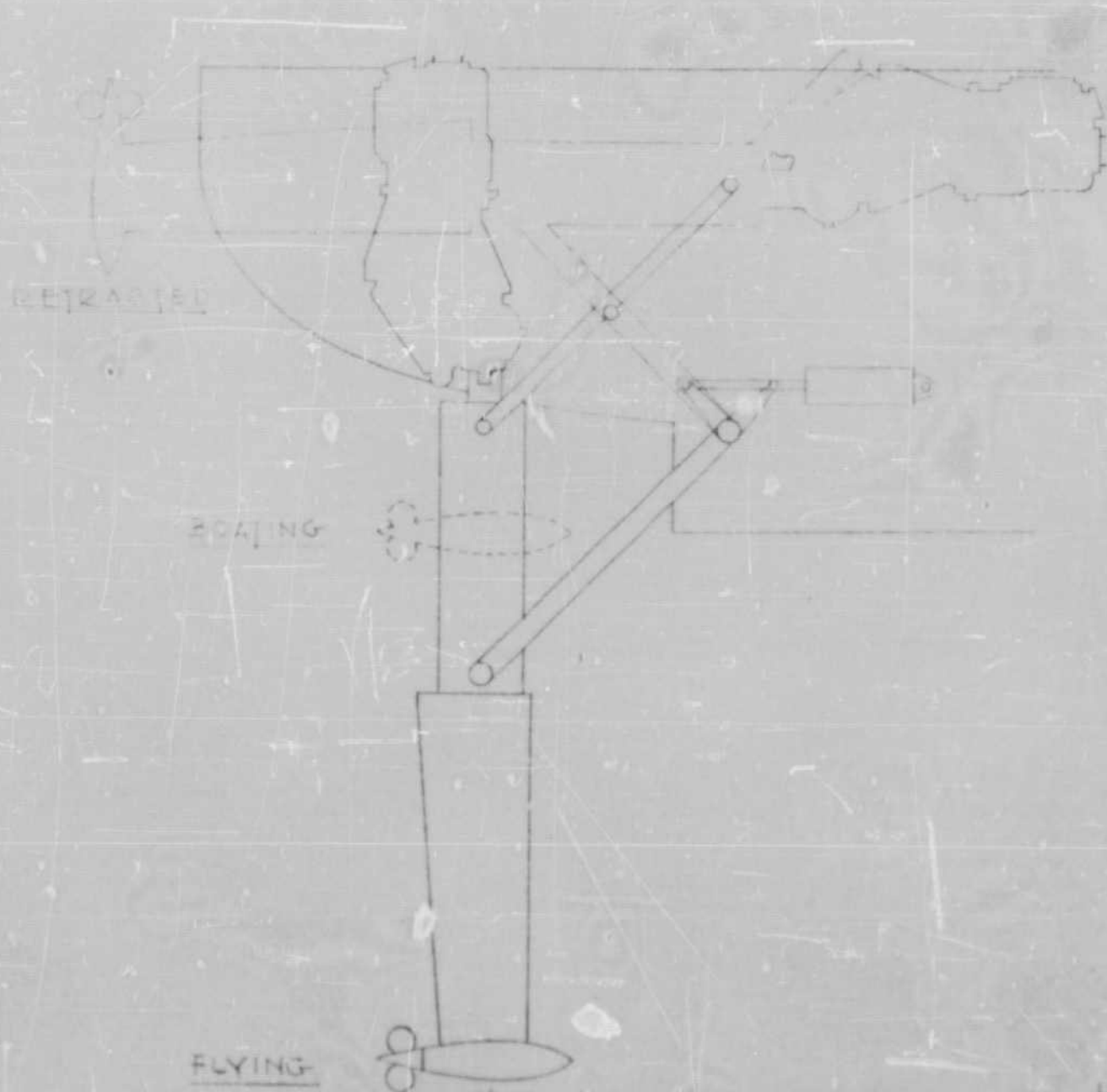

FIGURE 11  
ALTERNATE  
FOIL ASSEMBLY



— FIGURE 12 —

CROSS SECTION OF  
SECTION OF  
DECKED OVER



— FIGURE 13 —

RETRACTABLE PROPULSION  
ASSEMBLY

In the case of the steam engine, special advantages derive from use of separate propeller drive and track drive. With an engine on each track, steering can be by differential throttle control, eliminating steering clutches and brakes. The torque speed characteristics of the steam engine are very favorable.

The hull has presented certain problems. Initially, an effort was made to give shape to the bow and dead rise to the bottom, to keep shock loading down. It was found that shaping the bow adequately interfered with its utilization as a ramp. It was also found that the fence effect of the tracks, extending along the "chines" nullifies most of the shock reduction effect of dead rise and may actually increase shock under some conditions.

The craft appears to have excess power available during takeoff and takes off at a moderate speed. It was hence decided that the danger of shock damage could be minimized by a quick, full power takeoff which can apparently be accomplished in about 120 to 150 feet, or four to five lengths. The main requirement is then to provide hull strength for moderate shock and bow strength to resist shock of a high speed dive. The bow shape is such as to minimize this insofar as possible with a flat-bottomed hull.

#### C. General Results of Study.

The frontispiece of this report presents a photographic

views of a model constructed to the general arrangement and resulting configuration of the design resulting from the conceptions outlined above. Opposite this illustration is a tabulation of the principal dimensions and characteristics. The total gross weight on this first go around is in excess of that established as a tentative objective. However, this is the result of a generally conservative approach to the preliminary design of principal components. It is certain that with proper research into essential loadings, utilization of high strength materials and careful refinement of detail, the desired weight can be closely approached and possibly bettered.

Such weight reduction is desirable from the standpoint of economy, but the present weight does not interfere with performance. Ground pressure is down to the neighborhood of 4.4 psi, and the craft can attain 45 knots at sea with its intended power plant. It has a large margin of power at takeoff. Re-design of foils can take advantage of the favorable planing characteristics and the consequent practicability of a takeoff at higher speed. The resulting reduction of foil area will raise the flying speed to 50 knots, or higher if desired, or reduce the power requirement at 45 knots, permitting the use of a smaller power plant.

The thrust margin at takeoff is such that cargo weight could be very materially increased. The foil induced drag is so low that this would have substantially negligible effect on flying

speed. As a matter of fact, this craft could take off with another 9000 lbs. of cargo weight and would still fly at close to 45 knots.

These potentialities derive mainly from the high aspect ratio front foil and from the clean-up of hull contours permitted by the track system. Figure 5 showed a partial under-view of the resulting hull bottom. Comparison with Figure 4 reveals the obvious advantages of the tracked configuration over the wheeled.

This study has not produced complete preliminary designs. It has shown that it is practicable to produce a vehicle capable of a water speed of 45 knots and a land speed of 60 m. p. h. Both speeds will be attainable under moderately rough conditions. A number of attractive alternative arrangements for propulsion and steering have been found. Preliminary design layouts and calculations have been carried to the point of establishing conservative weights, space requirements and power.

One of the important conclusions of the study is that with a suitable track, a tracked vehicle has many advantages at sea and on land. At the same time, it has been found that the choice and design of a suitable track provides the key to accomplishment of the desired ends. The segmental pneumatic belt track has the most favorable characteristics so far attainable, to insure the desired performance. At the same time, it presents many design difficulties. Solutions to these difficulties are recognizable, but extensive competent development work is necessary for their accomplishment.

With the limited time and funds available for this study, it has not been possible to exhaust the entire list of possible track or roller-wheel systems. It is recognized that there may be other systems which meet the traction and load-carrying requirements of the desired vehicle and which may simultaneously meet hydrodynamic requirements at sea. So far, no such system has been recognized.

## II. CHARACTERISTICS OF CRAFT WHEN WATER-BORNE

### A. Stability

Design studies have been carried far enough to establish the fact that satisfactory roll stability is attainable, though careful development of the final design will be necessary to produce a satisfactory margin. In the present state of design, the G-M is approximate 3.4 feet. A value of 5 to 7 would be more desirable. The easiest way to produce it would be to broaden the beam, but this interferes with air and rail shipment. Adding 2-1/2 feet would still permit passing through the L. S. T. door, but would leave a width of 12 feet for the dismantled unit. At the same time, it would raise the G-M to about 11 feet, which would be very satisfactory.

Corresponding improvement could be accomplished by ballasting. Since there is adequate takeoff capability and flying speed would not be seriously affected, this is a possibility. Water ballast could be utilized when boating and dumped on landing or when flying. A studied re-arrangement of machinery could produce some benefit. However, with these changes, the improvement is no so rapid as that with increased beam. It appears that, in a more detailed study, it may prove advantageous to accept an increase in beam at the cost of sacrificing less important objectives or to investigate the possibility of use of retractable sponsons as a means for producing an adjustable effective beam. These could take

the form of tanks located above the tracks and hinged to drop down, outboard of the tracks, when boating. Such tanks would dismount with the tracks for shipment and could be kept within the lines of the track when retracted. Figure 14 shows a sketch of such an arrangement.

The proposed use of aileron control on the foils reduces the available lift moment for roll control relative to that with which we have experience. It has been found that if the main lift requirement is met by trim control of foil angle of attack, the transient requirements can be met by flap control. It appears that an adequate margin for stability can be provided by this means. Cruising lift will be met by foil camber and built-in angle of attack. Increase lift coefficient during takeoff can be provided by trimming the craft to a suitable planing angle. During flight, control of altitude can be provided transiently by flap control while steady state speed changes are compensated by micrometer adjustment of angle of attack or trim.

#### B. Planing Characteristics of Hull.

A planing body has the essential characteristics of a foil of the same aspect ratio, but with roughly half the lift coefficient. Departures from foil characteristics are due mainly to the build-up of a forward projected jet, at the surface, ahead of the stagnation point. The main effect of this is to modify lift slightly, but to substantially increase induced drag. For purposes of rough

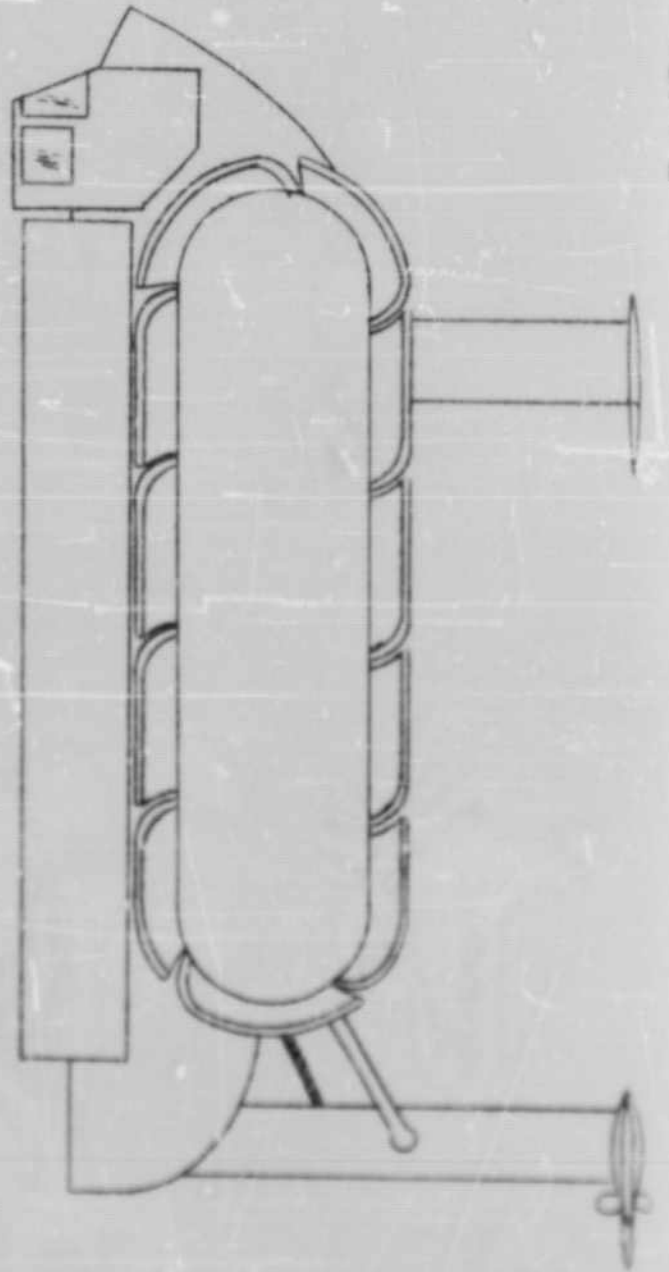
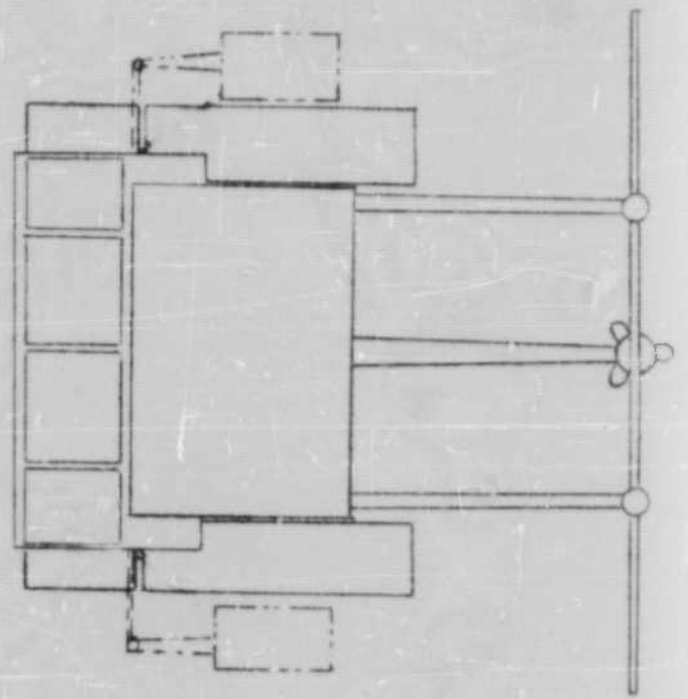
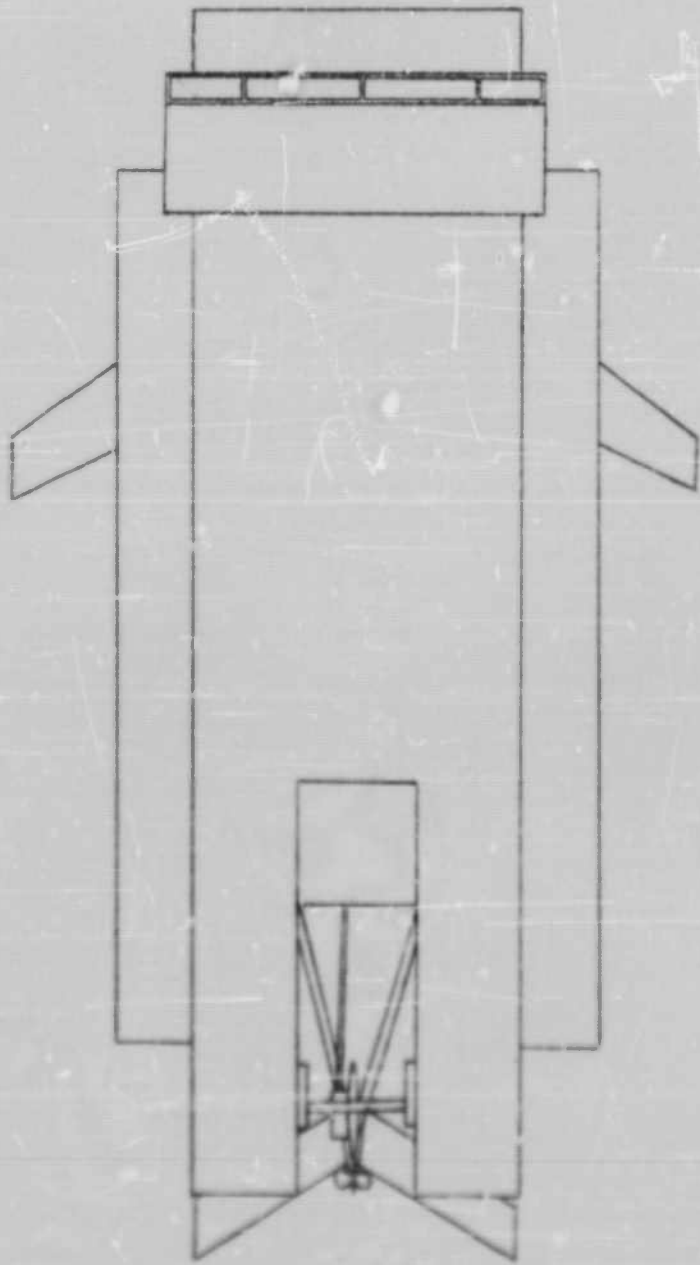

FIGURE 14

computation, the planing lift can be estimated by

$$L = 0.85 \pi \alpha \frac{A_e}{2 + A_e} b^2 q / A \quad (1)$$

where  $L$  is planing lift,  $\alpha$  = geometrical angle of attack in radians,

$A_e$  = effective aspect ratio of wetted surface,  $A$  = geometrical aspect ratio,  $b$  = beam in feet and  $q$  is the dynamical pressure in lbs/sq. ft. corresponding to the speed of advance. This relation maps the area of extensive NACA tests within 5% to 10% and is here used for rough estimating of planing characteristics.

The tracks on the H. A. T. V. behave as fences along the edges of the hull and increase the effective aspect ratio in a manner similar to the behavior of tip plates on airfoils and hydrofoils. Also, for small aspect ratios, there is a secondary effect of angle of attack on lift coefficient which can be approximated by a correction to aspect ratio. For purposes of approximation, the effective aspect ratio is given

$$\begin{aligned} A_e &= A + 4 \frac{h}{b} + \alpha \\ &= \frac{\ell}{b} + 4 \frac{h}{b} + \alpha \end{aligned} \quad (2)$$

where  $h$  is the height from base of track to bottom of hull,  $b$  is the overall beam and  $\ell$  is the wetted length. The effective lift coefficient of the planing H. A. T. V. is substantially increased over that of a conventional hull of equal beam length ratio, by the presence of the solid wall presented by the profile of the track. For

this reason, the H. A. T. V. will plane at a lower speed than a conventional hull, if trim is properly controlled.

The tracks themselves present an irregular surface which offers a high resistance. This resistance is estimated for a coefficient of 0.015. The coefficient for the balance of the hull will be normal and is estimated at 0.005. With tracks stationary, the drag of the H. A. T. V. in boating will be high. However, by motoring the tracks at a linear speed a little above boating speed, their contribution to this resistance can be reduced to zero or made negative. The main drag contribution of the track will then be that of its planing and wave-making action.

It is necessary to add a displacement increment to planing lift which is negligible at high speeds, but not during the low-speed, boating regime. The flow separates from the transom at relatively low speed so that base drag becomes constant and the displacement lift makes a pseudo "induced" drag contribution along with the planing lift. The induced drag of a flat planing surface is essentially the total lift times the tangent of the angle of attack or effective trim, except at very low speeds.

With this information and the calculated foil characteristics, the takeoff drag curve of the H. A. T. V. has been calculated for comparison with other hydrofoil craft and is presented as a part of the H. A. T. V. characteristics shown in Figure 15. Calculated drags are in fair agreement with model tests, but model test results

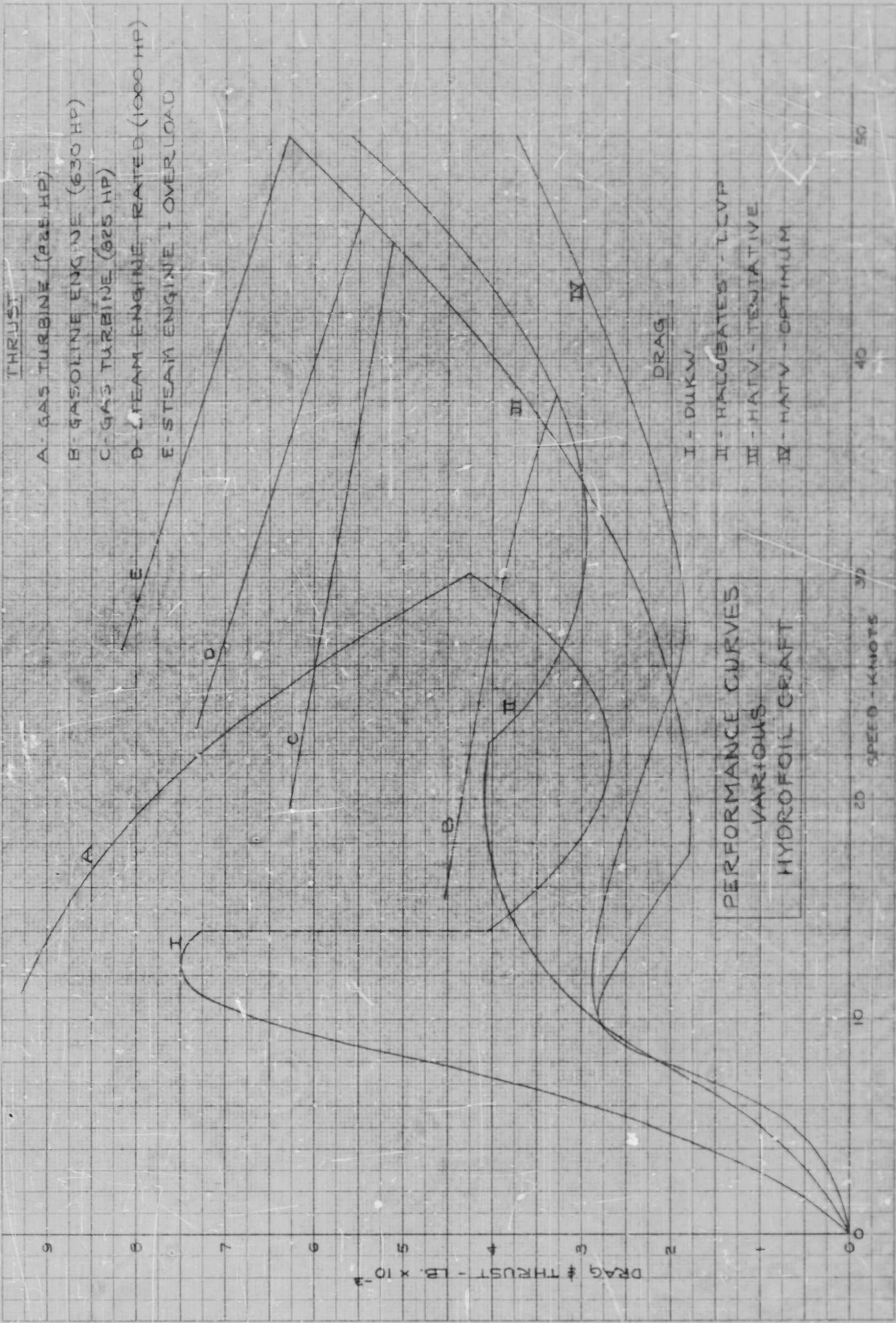

PERFORMANCE CURVES  
VARIOUS  
HYDROFOIL CRAFT

THRUST

A - GAS TURBINE (225 HP)  
 B - GASOLINE ENGINE (630 HP)  
 C - GAS TURBINE (825 HP)  
 D - STEAM ENGINE - RATED (1000 HP)  
 E - STEAM ENGINE - OVERLOAD

DRAG

I - DUKW  
 II - HALCUBATES - LCVP  
 III - HATV - TENTATIVE  
 IV - HATV - OPTIMUM

ENGRING 854-3, 10 X 12 THE HALF INCH  
 WHEN ORDERING STATE DESIGN SYMBOL OR SCALE IN CASES  
 100% GAS PAPER

accumulated are inadequate for determination of the complete characteristic.

### C. Flying Characteristics.

The front foil of the tentative H. A. T. V. design has a high aspect ratio, about 11.6 and a large area, about 25.6 square feet. So far as hydrodynamic requirements go, the area could be smaller. For a takeoff speed equal to that of the hydrofoil-supported LCVP, "Halobates", it could be about 15 square feet. No attempt has been made to develop the optimum design since this involves a rather elaborate stress analysis and is beyond the scope of this report. Such analysis is worthwhile for it can greatly reduce high speed drag and thereby raise attainable speed or reduce cruising power requirements. It should have an important place in a detailed design development program.

The takeoff characteristics have been calculated for a foil lift coefficient of one. For this condition, the total drag coefficient of the tentative foil and strut system, plus wind resistance, is 0.085 referred to the front foil area. After takeoff, the friction drag coefficient is approximately 0.0332 on the same basis. The corresponding induced drag coefficient is  $C_{Di} = 0.047/V^4$  where  $V$  is the ratio of flying speed to takeoff speed. For the optimum foil system, takeoff speed will change from 17.2 knots to about 23 knots, and the two drag coefficients will be reduced by a

factor of approximately 0.55.

In Figure 15 have been plotted the takeoff and flying characteristics of the hydrofoil-supported LCVP, "Halobates", DUKW, the H. A. T. V. with tentative foil system and of the H. A. T. V. with an estimated optimum foil system. There are also plotted available thrust curves for these three craft, respectively powered by a 615 HP gasoline engine with a 26" x 22" propeller and an 825 HP gas turbine with a 33" x 22" propeller and a 24" x 32" propeller. In the case of the H. A. T. V., consideration has also been given to an alternative 1000 HP steam engine. This particular steam power plant is attractive because its specific fuel rate at rated power is roughly equal to that of the turbine, while that at reduced power is much better. Furthermore, its available torque at reduced speed is substantially greater than that of the turbine. With such an engine, gear shifting on land can be eliminated and takeoff can be accomplished in a very short run (about 4 to 5 lengths) at sea.

In calculating the takeoff curves of the H. A. T. V., the track has been considered as motoring. Also, the curves of Figure 15 have been estimated for 30,000 lbs. designed total weight. At the present stage, the estimated weight is 36,000 lbs. To show the effect of increased weight, Figure 16 has been prepared showing performance with the tentative foil for 36,000 lb. weight and 45,000 lb. weight. A takeoff curve with track

# DRAG CURVES

I	30,000	LBS	TOTAL WT	- TAKE OFF & FLIGHT
II	36,000	"	"	" " " "
II <sub>A</sub>	36,000	"	"	TRACKS FIXED
III	45,000	"	"	TAKE OFF & FLIGHT
IV	60,000	"	"	" " " "
V	36,000	"	"	- BOATING -

FOILS RETRACTED - TRACKS MOTORING -  
OPTIMUM TRIM ADJUSTED BY  
REAR FOIL

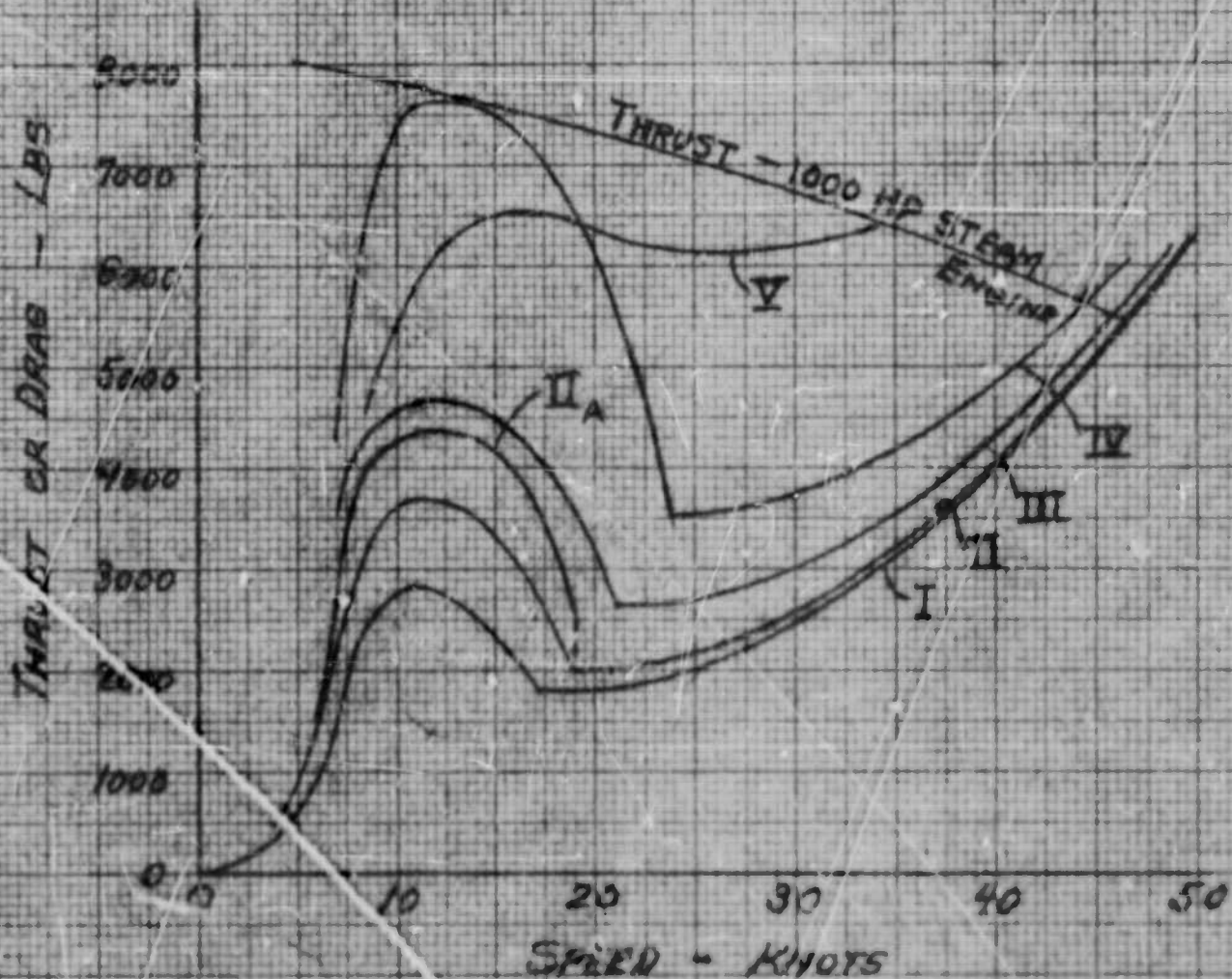

HATV. LOAD CHARACTERISTICS

FIGURE 10

stationary is also shown.

It is to be noted that the tentative design of H. A. T. V. shows less drag during takeoff and low speed flight than does "Halobates". However the characteristics cross at about 35 knots. Thereafter, the H. A. T. V. drag is higher. With the optimum foil system, the H. A. T. V. drag is lower than that of Halobates at all speeds and substantially lower at high speed. It is considered that the foil design producing this performance is realizable, structurally, by careful design and fabrication, including use of high strength materials.

The estimated drag of the H. A. T. V. with stationary track is less than that of the DUKW, during takeoff. The reduction of effective drag to the value obtaining on the lower curve is the result of motoring the track. The power required for this is relatively minor compared with the drag power. Motoring a suitably designed track is effective in reducing overall drag. On the other hand, tests conducted on the DUKW showed that motoring the wheels had no measurable effect on drag. With a suitable track, hull contours can be kept clean and drag producing appendages can be avoided. The one unavoidable appendage (the track) can be motored in a manner adapted to keep its drag down.

To accomplish an equivalent result with a wheeled vehicle required retraction of all appendages into wells in the

hull and covering these wells with shells fitted to the hull lines. The wells reduce displacement and stabilizing moment unless the covers are water-tight. The multiplicity of retraction and covering arrangements greatly increases mechanical complexity.

In coming through a surf, it is desirable to be able to pick up speed rapidly and to reach a speed in excess of that of an approaching wave, so as to keep out of its way at the time it breaks. For this reason, it is important to know the speed capabilities of the craft in boating. To cover this situation, an estimated boating drag curve has been plotted on Figure 16. It appears that the attainable planing speed is in excess of the need. Being calculated, this curve is, of course, quite approximate and merely indicative of possibilities.

### III. CHARACTERISTICS OF VEHICLE ON LAND

As previously indicated, purposes of this undertaking have been the development of a vehicle capable of high speed on land, as well as at sea, and further to provide satisfactory trafficability over the maximum range of likely terrains to be encountered in service. In a conventional mechanical track mechanism, as in all mechanisms involving frictional wear, the wear rate increases very, very rapidly with speed. Life, in both hours and miles, decreases accordingly. The same is true when parts are of rubber. But the resiliency and shock reducing capability of rubber are such that with proper application and design, the diminution of shock loads and resistance to gritty abrasion combine to cause a less rapid rate of increase of wear with speed. Thus, as in the case of the pneumatic vehicle tire, a good life can be realized at speeds far beyond the equivalent performance of steel.

When the rubber is used in a pneumatic element, the shock reduction capability is increased and may be carried to the point where other shock absorbing mechanisms can be eliminated. In working out the concept of a pneumatic rubber track, an effort has been made to utilize to the maximum this shock reducing capability. At the same time, the further effort has been to produce a continuous track bearing pattern with uniform unit loading. The advantage of uniform ground bearing is indicated

in Figure 17, taken from an illustration of Dr. Bekker. Regardless of their arrangement or of the flexible belt or chain with which they are covered, the localized loading pattern of the bogeys carries through to the bearing on the ground. No matter how tightly they are stretched, belts and chains deflect more rapidly than the ground on which they bear until the shear developed by non-uniform loading produces a flow to redistribute pressure. Once this flow starts, the ground break-up is under way and the depth of its penetration increases with each passage of a vehicle.

With a pneumatic support by a flexible pneumatic casing, the ground pressure is substantially uniform over the bearing area. In the case of a tire, deflection of the casing produces such bearing over an elliptical flattened area at the point of contact. With the allowable deflections, the major diameter of this area is of the order of one-fifth to one-third of the tire diameter. A linear pneumatic bearing element thus is equivalent to a pneumatic wheel of diameter three to five times the length of the pneumatic unit. This situation is illustrated graphically in Figure 18, also an illustration of Dr. Bekker's.

In the case of the H. A. T. V. segmental pneumatic track, the bearing pressure has been kept down to approximately 4.4 psi. With this pressure, the vehicle will traverse the landward, light dry sand of almost any known beach or other sandy

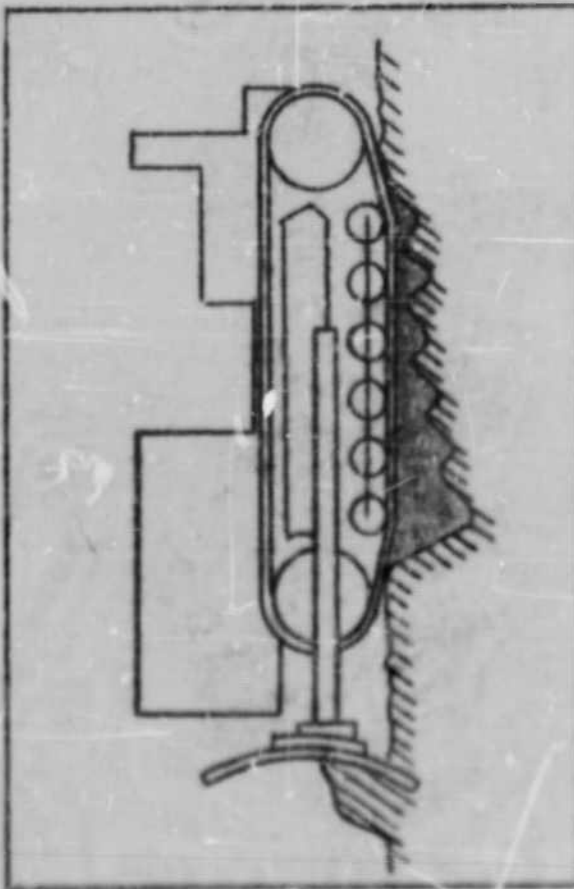
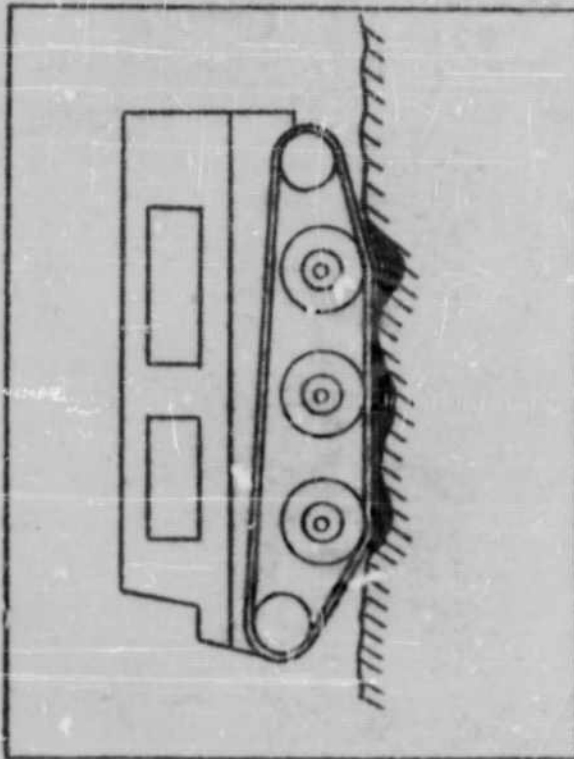
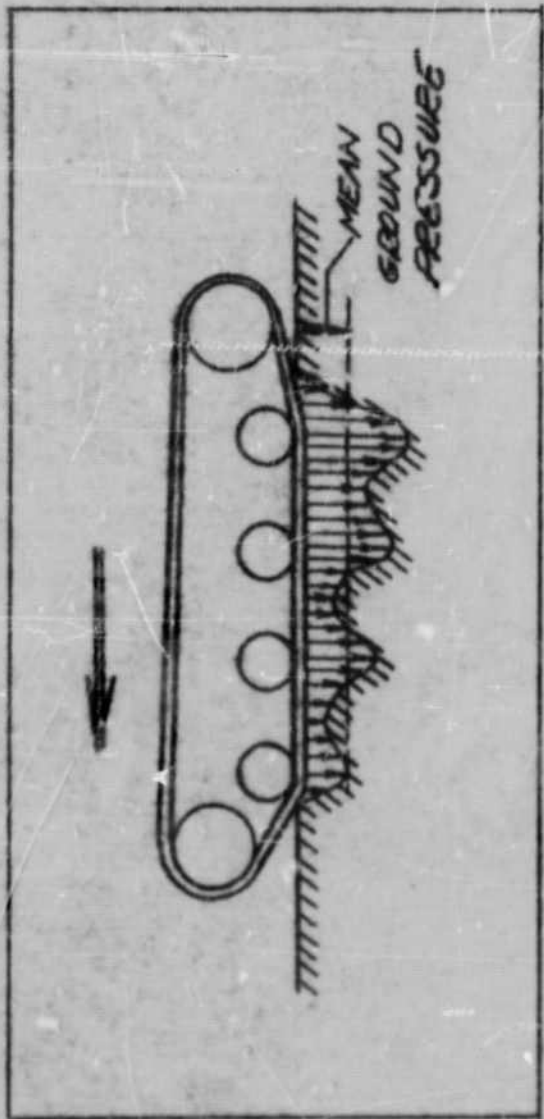

GROUND PRESSURE DISTRIBUTION UNDER TYPICAL TRACK VEHICLES  
(after Bekker.)

FIG. 17

MIAMI SHIPBUILDING CORPORATION

BY TRE DATE \_\_\_\_\_

SUBJECT \_\_\_\_\_

SHEET # \_\_\_\_\_ OF \_\_\_\_\_

CHKD. BY \_\_\_\_\_ DATE \_\_\_\_\_

JOB # \_\_\_\_\_

"EQUIVALENT  
WHEEL" TO GET  
SAME EFFECT OF  
GROUND SKI.

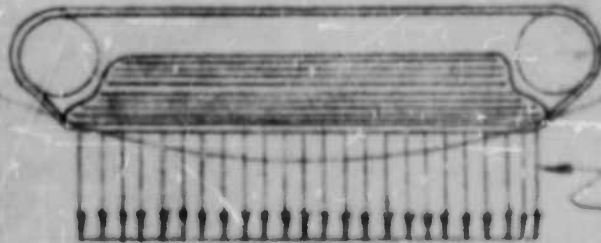

UNIFORM LOAD

FIG. 18

FIG. 18

area with substantially zero penetration; certainly less than 3 inches in almost any case. Lack of adequate information on the specific numerical terrain parameters has precluded a detailed analysis of performance on other likely terrain.

While the pneumatic track has a depth of 15 inches, its tread is 22 inches and its equivalent section diameter is about 21 inches. Due to its construction, it deflects little under initial loading so the side wall fatigue under periodic loading will be less than for a normally loaded conventional tire. Figure 19 shows a diagrammatic section of the tire. The configuration, when loaded, is indicated by the solid outline. With an internal pressure of 10 psi, the configuration with a bearing load of 4 psi is indicated by the broken outline. When the vehicle is operating on a 60% side slope with the existing c. g. location, the configuration is as indicated by the dash-dot outline. The lateral deflection of 2-1/4" over a tread length of 17 feet is such that only a very modest yaw will be necessary to compensate the resultant down-hull drift. This will almost certainly be less than the compensation for earth movement unless the slope is paved.

While this pneumatic track will be fairly stiff when deflected as a whole, it will be quite soft in its deformation by local obstructions. Surface irregularities of wave length less than 17 feet will produce no appreciable vertical movement of the vehicle. For ground waves in the neighborhood of 34 feet wave length, less than

MIAMI SHIPBUILDING CORPORATION

BY \_\_\_\_\_ DATE \_\_\_\_\_ SUBJECT \_\_\_\_\_ SHEET # \_\_\_\_\_ OF \_\_\_\_\_  
 CHKD. BY \_\_\_\_\_ DATE \_\_\_\_\_ JOB # \_\_\_\_\_

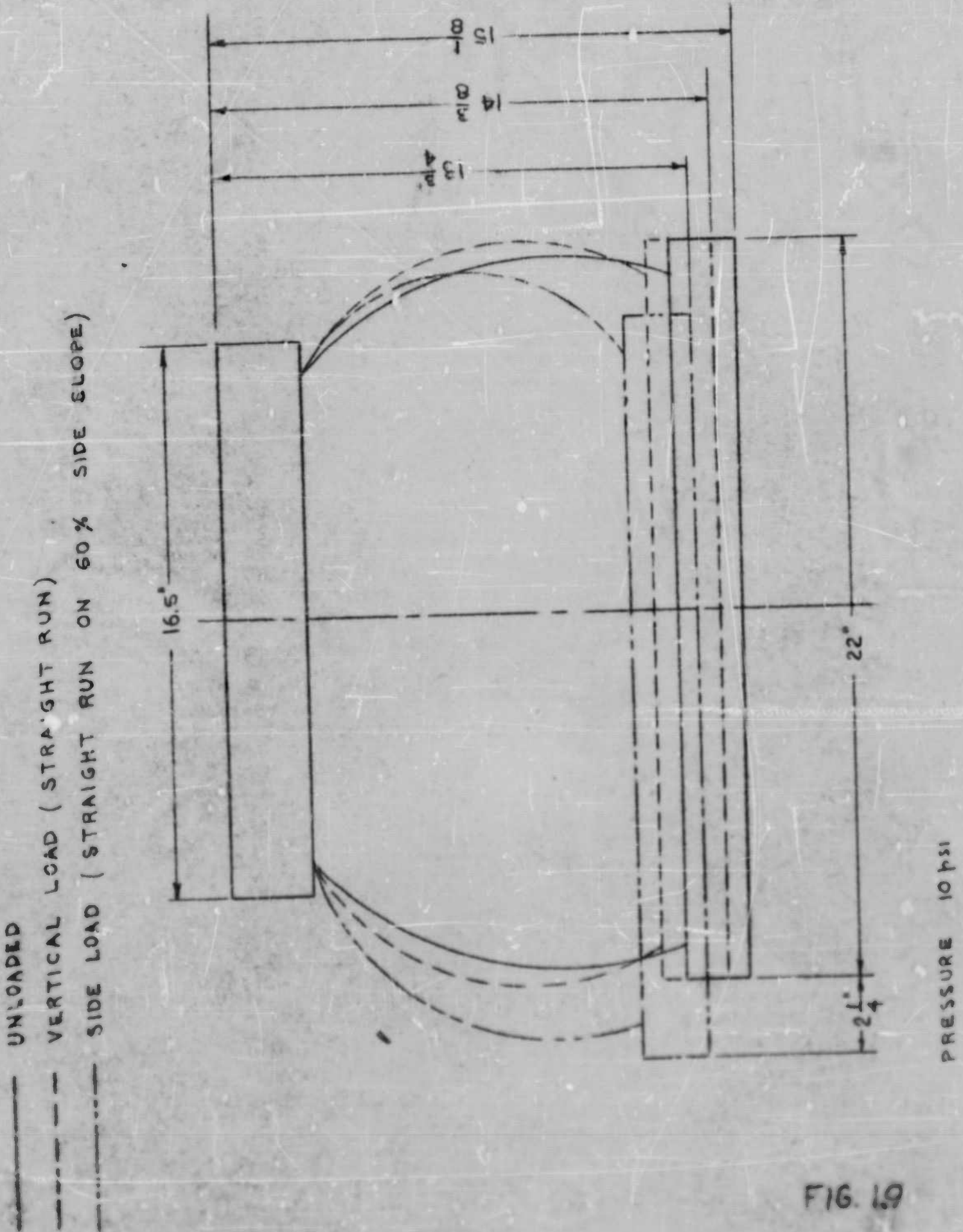

FIG. 19

1 ft. high, the vertical movement will be roughly half the wave height. For longer waves, it will approach the full height. The natural frequency of the vehicle on its pneumatic track in heave will be about 3.6 cycles per second and about 1.9 cycles in pitch. This is a little high for high speed driving. The average automobile runs about 2 cycles in heave and about 1.2 cycles in pitch. Trucks run higher, up to the neighborhood of 1-3/4 to 2 cycles in pitch. For high speed operation in flat areas where there is no danger of having to negotiate steep side hills, the tire pressure could be maintained as low as 6 psi. This would drop the frequency to less than 3 cycles in heave and 1.6 cycles in pitch. This high suspension frequency presents the main obstacles to be overcome in seeking good riding at high land speeds.

The powering of the vehicle is adequate for very high speed on land. While friction characteristics have not been accurately estimated, a rough evaluation indicates a capability of 110 mph on pavement. No attempt has been made to realize this in present designs. Gear ratios and other mechanical equipment have been designed for a maximum land speed of 60 mph at rated turbine speed. This provides good hill climbing ability with minimum gear shifting, while still affording a top speed on land well in excess of that of any existing equivalent vehicle.

Ultimate realization of this high speed will depend upon careful engineering of the track design. Even then, the high speed

use will be limited to comparatively flat and smooth terrain. But it will be available for emergency use under conditions where riding qualities are not the sole criteria determining speed limits. With the use of seat belts by all personnel, the speed will be realizable on what otherwise might be considered quite rough terrain.

#### IV. GENERAL ARRANGEMENT OF VEHICLE

The general appearance of the proposed vehicle is shown by the frontispiece and by Drawings 04149 and 04142. The frontispiece is a photograph of a model. Drawing 04149 shows the configuration for boating and land operation, and Drawing 04142 shows the water-borne flying configuration.

Drawing 04140 presents the overall general arrangement. The vehicle comprises a hull section having a rear engine compartment and a forward cargo compartment, a pair of demountable sponsons carrying the track assembly, a retractable forward foil assembly, a rear, retractable foil and propeller assembly, and an inboard power plant. In addition, there are clutches, brakes and other gear for steering on land and water. A three-speed automatic transmission delivers power to the tracks and the propeller to meet hill climbing and accelerated takeoff requirements.

Control is from a pilot house located over the bow. Dual control can be provided by locating a pilot cockpit station on each side. The cockpits are so arranged as to have adequate passage-way through the bow for loading and unloading a jeep.

The cargo compartment is large enough to accommodate at least a jeep and 10 men or, alternatively, 32 fully equipped men. The hull is completely decked over to add strength and to protect against swamping in a following surf.

Cargo weight capacity is in excess of 8000 lbs.

Two wells on either side of the cargo compartment house the front foil struts and strut retraction mechanism. The tips of the front foil fold up against the struts and on retraction, the bridge of the foil draws up into a pocket in the bottom of the hull, for protection on land.

The stern propulsion unit is retractable into an upper operating position for boating operation and into a fully retracted horizontal position for land operation. In the latter position, the assembly is largely contained by a slot in the stern of the hull and the protruding portions are protected by a guard structure extending from the stern.

Steering on the water is by directed thrust of the propeller, aided by the rudder action of the lower portion of the streamlined strut. At high speed, rudder steering dominates, but at low speed, the contribution of propeller thrust is major. This is particularly important for maneuvering in a surf and alongside a dock or ship.

The main design study has revolved around use of a gas turbine. Some study has been given a flash boiler steam plant which appears to offer some advantages. This is particularly true when separate engines, directly connected, are used for the propeller and for the two track drives.

For the turbine drive, a single unit is used. It supplies power to an automatic three-speed transmission having ratios of 1/1, 1.7/1 and 3/1. Drive from the transmission to the propeller is through a clutch and through retractable articulated shafting and gear trains in the propulsion unit assembly. Dual, counter-rotating tractor propellers are provided to eliminate torque reaction on steering and to provide high efficiency. Consideration has been given to use of a single propeller with torque compensating gearing. The latter is complex, adds weight and is less efficient.

Controls are coordinated so that rudder and tracks steer from the same wheel, alternatively or simultaneously. Push button controls effect the change from one control regime to another, and interlocks prevent damaging operation when the stern unit is stowed for land travel.

While no details have been developed for presentation, it is contemplated that roll stabilization, when flying, will be by automatic gyro-pilot mechanism controlling ailerons on the front foil tips. It is also anticipated that flight altitude and pitch control will be by joint action of the gyro-pilot and water surface sensing means located on the front struts. This removes all obstructions on the bow end, leaving a clear opening for the bow door. Since the basic arrangements of this control equipment

are developed in a separate undertaking, they are omitted here.

The principal dimensions and general characteristics of the vehicle are summarized in Table I at the front of this report.

The detailed weights are presented in Appendix A.

## V. STRUCTURAL AND MECHANICAL FEATURES

### A. Hull.

The static loading on the bottom hull surface is roughly one pound per square inch. Design has been based on a localized dynamical loading of 20 psi for determining skin thickness and a mean loading of 10 psi for structural design of bow and bottom. Stressing under these loads is at half the yield point of the material. The hull will hence have a good fatigue life under the designed loading. It can accept localized dynamical loading to 40 psi or general loading of 20 psi permanent without deformation. Pressures of 50 psi and 25 psi, respectively, would be necessary to cause breakage.

Little information is available to provide a sound basis for structural design of hulls for dynamical loading under the anticipated operating conditions. If too conservative a basis is adopted, weights become excessive. On the other hand, the occurrence of substantial dynamical loading cannot be ignored. Verbal reports of extremely high pressures have been received, but the published information is meager. Some NACA reports indicate dynamical lift coefficients approaching 2 in heavy seas. Such results have been observed in the laboratory under rather extreme conditions simulating those encountered by hydroplanes during landing in a seaway. The simulated landing conditions are much more severe than would be encountered by any surface craft.

It would appear that an average lift coefficient of  $1/2$  to 1 would be reasonable for a surface craft. This is four to ten times the normal planing lift coefficient. For the 17.2 knot takeoff speed of the present craft and using the extreme value, 2, for the dynamical lift coefficient, the dynamical pressure would be 1690 pounds per square foot, or 11.8 psi. The fatigue strength is hence obviously adequate for any likely frequently repeated loading, and the structural capacity for infrequent loads of this extremity is also adequate. The ultimate skin strength is four times this value.

The main question remaining open is as to the adequacy of the skin for absorbing high localized pressures. The 40 psi strength is greater than the maximum measured value of 36 psi of which we have any direct knowledge. Higher values may have been observed, but their frequency is apparently not great enough to have resulted in publication.

Most published pressure data are for bottoms with dead rise. The plane bottom will experience higher localized loading under some conditions, but there are other conditions under which the dead rise may not reduce pressure loading. These depend on the direction of approach and shape of a wave. In the absence of more complete experience data, it would appear that the selected skin is adequate.

Drawing 04141 shows the main details of hull construction.

## B. Front Foil Assembly.

Beside its design for structural adequacy, the front foil assembly presents two important design problems. One is in regard to retraction arrangements; the other is in the structure of the hinge for the foil tips. This hinge assembly must provide for folding and locking the foil and, in addition, must house mechanism for actuating the tip ailerons.

The general configuration of this foil assembly is illustrated in Figure 11. Drawing 04148 shows one form of hinge assembly. In this, the foil tip is locked in flying position by forward movement actuated by the hydraulic piston. Lugs on the tip portion engage seats on the strut portion to cooperate with the hinge pin in carrying the bending load.

A lever, mounted on the aileron and provided with a ball coupling to a vertical actuating bar, controls the aileron. The ball coupling permits universal movement. When the foil tip is folded, the aileron automatically assumes mid-position regardless of control position.

Figures 20, 21 and 22 present alternative latching arrangements which present structural and machining advantages over the earlier design. Figure 20 shows a pin locking arrangement. Segmental pins of length equal to the width of hinge lug are cascaded in holes running the length of the hinge. In one position, the pin ends match the lug faces. In the other, the lug faces are in the middle of the pins and the pins lock the assembly.

BY	DATE	APP.
ALTERNATION		
LCT.		

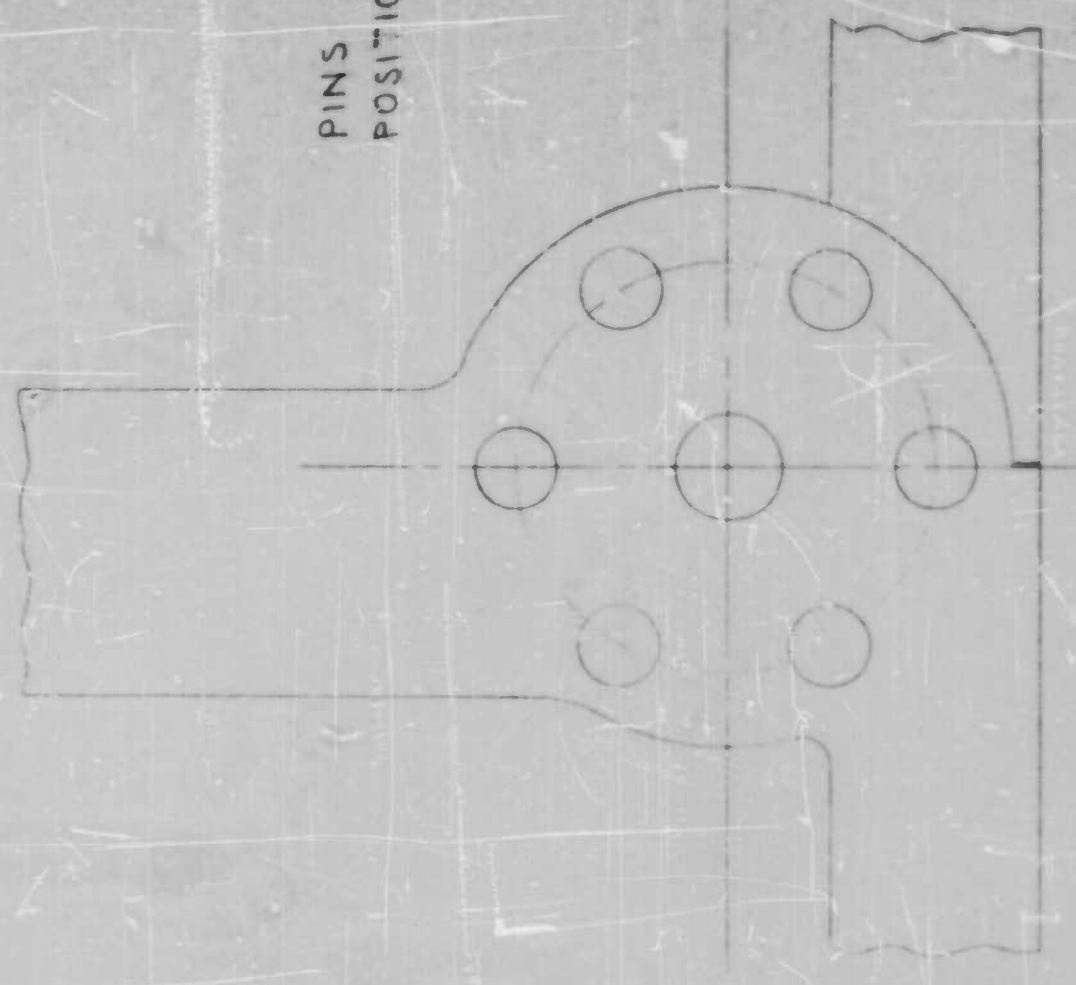

PINS IN UNLATCHED POSITION

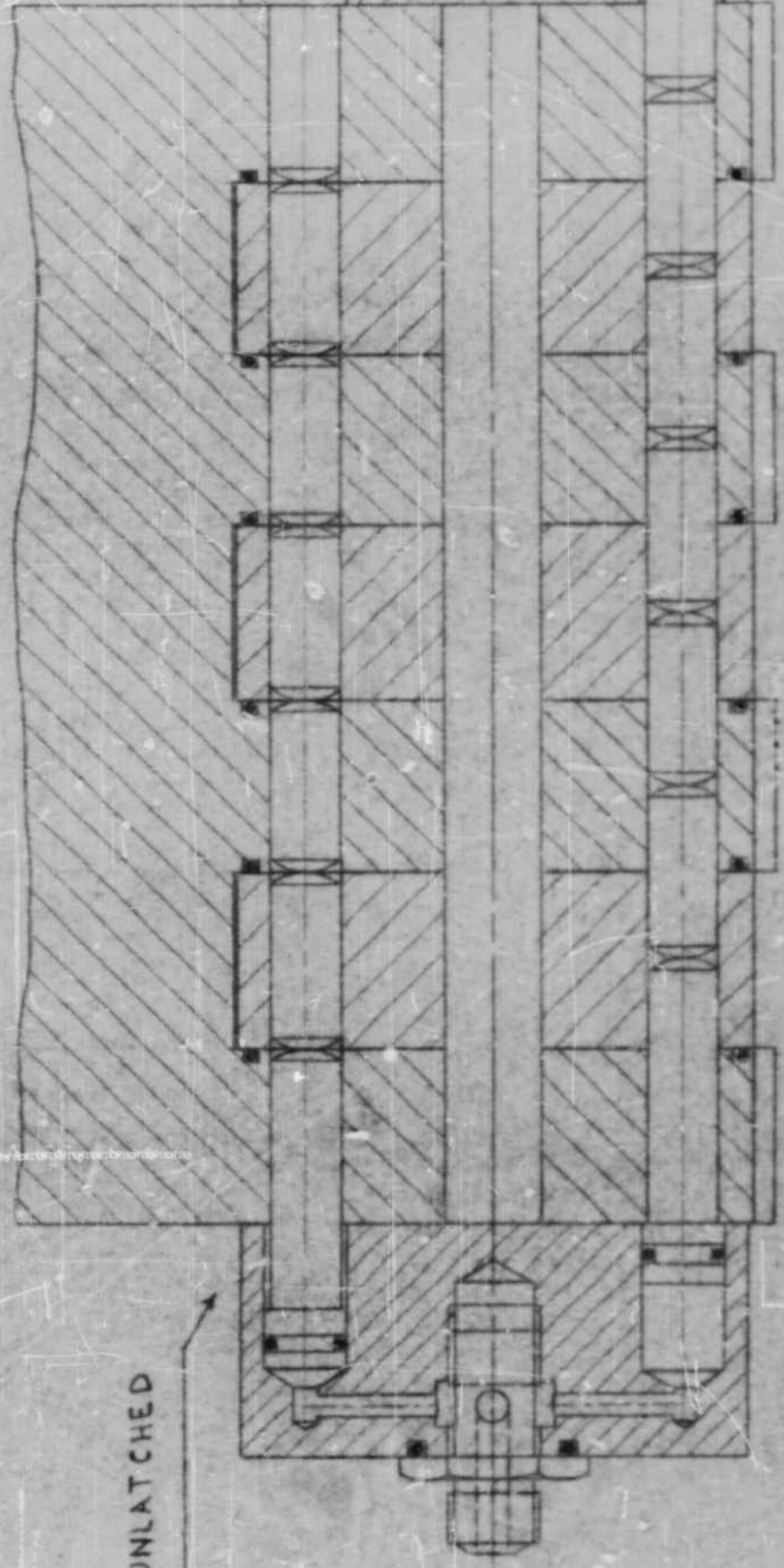

PINS IN LATCHED POSITION

ITEM	DESCRIPTION	QTY.	MATERIAL	SIZE	REMARKS
<b>BILL OF MATERIAL</b>					
FIGURE					
SCALE	HALF				ACT. WT.
DATE	11-29-57				MAJOR ASSEMBLY
DESIGN	O.C.F.				NEXT ASSEM.
TRACED					NO. FEB 1957 ASS'Y
CHECKED					
MIAMI SHIPBUILDING CORPORATION MIAMI, FLORIDA, U.S.A.					FIG 20

ALT. NO.	BY	DATE	APP.

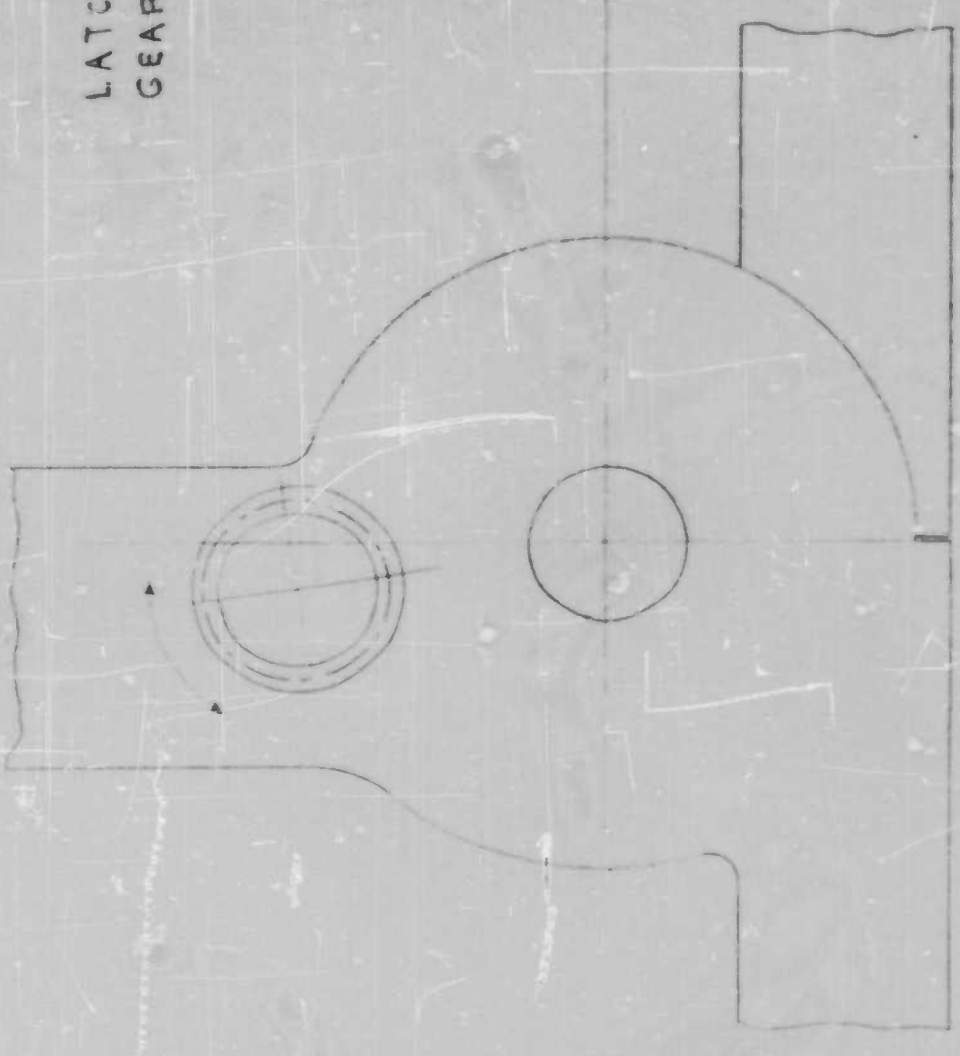
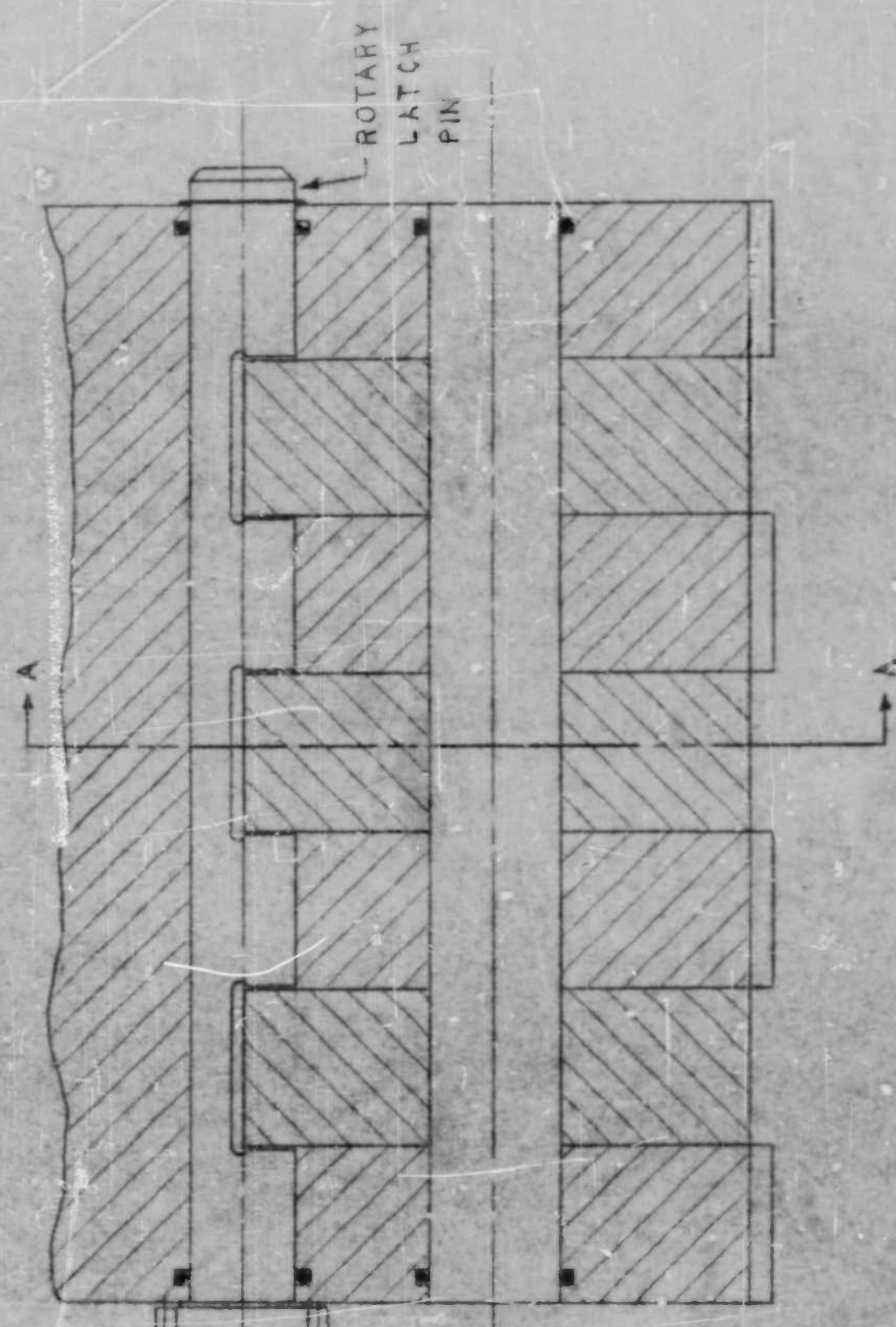

b) LATCHED POSITION  
(NOTCHES UP)

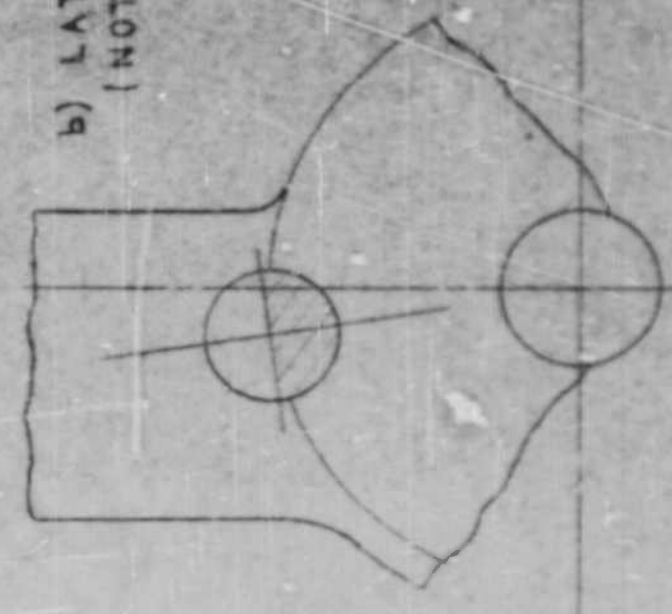

a) UNLATCHED POSITION  
(NOTCHES DOWN)

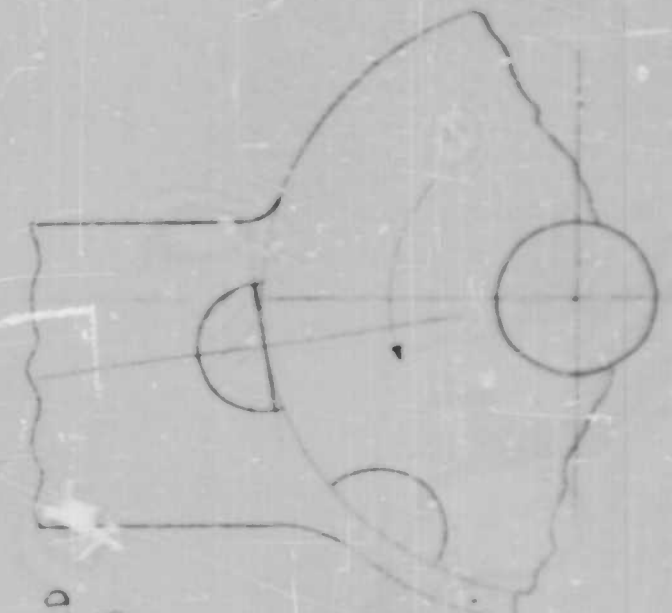

ITEM	DESCRIPTION	REQ.	MATERIAL	SIZE	REMARKS
<b>BILL OF MATERIAL</b>					
FINISH	SCALE	DATE	DRAWN	CHECKED	ACT. WT.
	HALF	12-2-57	O.C.P.		MAJOR ASSEMBLY
					NEXT ASSEMB.
					NO. PER NEXT ASSEMB.
FWD. FOIL HINGE LATCH					ALT. N. 2
MIAMI SHIPBUILDING CORPORATION					FIG. 21
MIAMI, FLORIDA, U. S. A.					ALT.

SECT. A-A

LET.	ALTERATION	BY	DATE	APP.

SECT. A-A

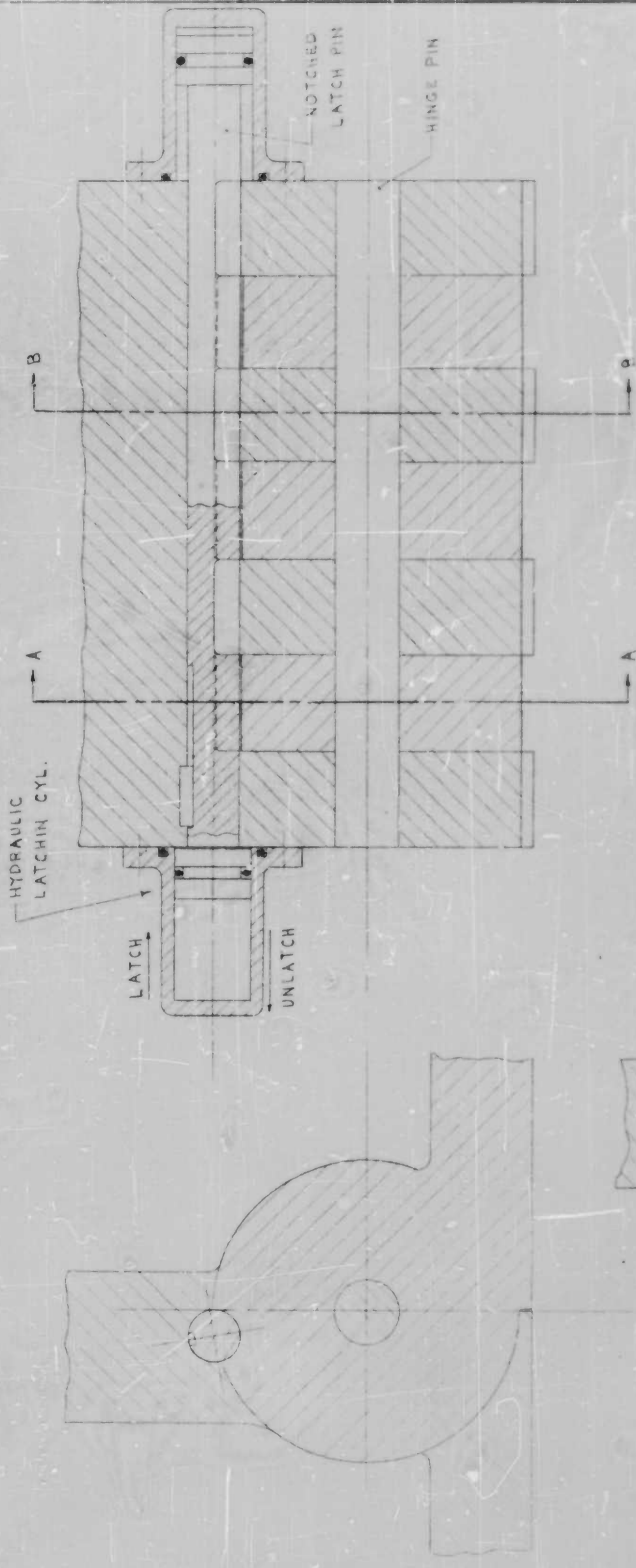

SECT. B-B

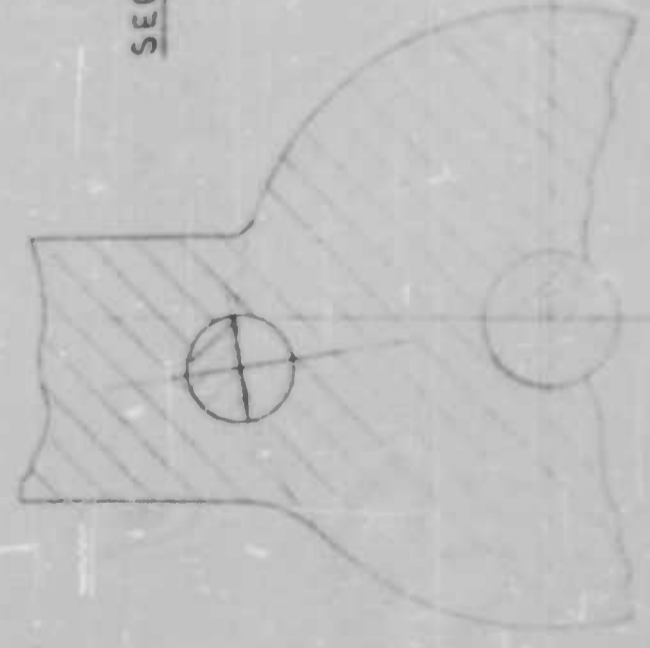

ITEM	DESCRIPTION	QTY	MATERIAL	SIZE	REMARKS
BILL OF MATERIAL					
FINISH					
SCALE	HALF				
DATE	12-2-57				
DESIGN	O.C.P.				
TOLERANCES					
CHECKER					
FWD FOIL HINGE LATCH					
ALT. N. 1					
MIAMI SHIPBUILDING CORPORATION MIAMI, FLORIDA, U.S.A.					
					FIG. 2.2

The pins resist the tip bending moment by shear, at the pitch circle. This design can be very strong and construction is inexpensive.

Hydraulic pistons at the ends of the assembly move the pins between the two extreme positions. The foil can be locked in both retracted and flying positions with proper pin spacing. Locking pin hole alignment can be assured by boring and reaming at assembly.

In Figure 21, the locking arrangement involves a rotatable pin in a bored hole, centered on the periphery of the hinge lugs. The pin is notched to its mid-point with gaps matching the width of the tip lugs. When rotated to position, the notches inward, the hinge can be rotated freely. When the pin is rotated 180 degrees from this position (notches outward), the hinge is locked. Rotation is possible only with the hinge in locking position. Again, locking can be accomplished in both folded and flying position.

The latch of Figure 22 is similar to that of Figure 16 except that locking and unlocking are accomplished by sliding the latch pin end-wise. Actuation is by hydraulic cylinder.

The main problem with foil retraction is to provide an adequately strong retractable mounting arrangement which does not encroach too much on cargo space through enlarging the size of the retraction wells. Various schemes have been studied

Figure 23 shows an arrangement in which the strut is steadied by a bent link hinged at the base of the hull and attached to the strut at a point well above the flying water line. In the flying position, the top of the strut is steadied by wedging into a socket attached to the hull, under the forcing action of the retraction screw.

Figure 24 shows a similar arrangement except that the link is straight and pivoted to a horizontally moving cross-head, to permit vertical retraction without swinging of the foil assembly. In flying position, the cross-head is locked by hydraulic, screw or other means capable of remote control.

Figure 25 is similar to Figure 24 except that the link is telescoping. Hydraulic means lock the link in extended position in flight.

Figure 26 shows another arrangement for rectilinear retraction in which a stabilizing bracket rigidly attached to the top of the foil carries a cross-head guide member. This member is rigidly locked in place in the flying position by remotely controlled means.

Figure 27 shows an evolutionary form of the design of Figure 26 in which both the steady bracket and the strut are driven by screws. The screws are geared together and cooperate in raising and lowering the foil assembly. In flight, the screws jam

LET.	ALTERATION	BY	DATE	APP.

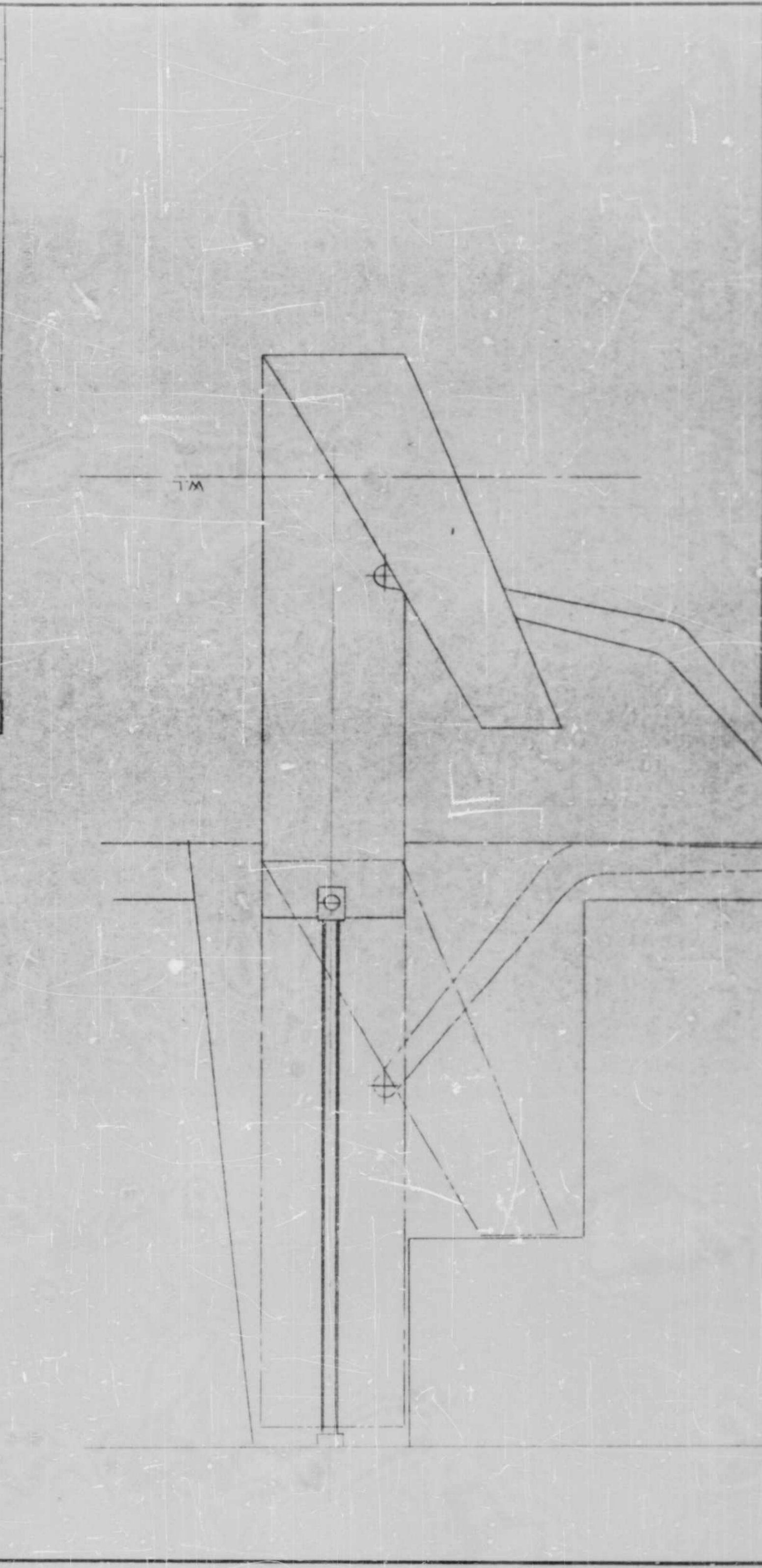

ITEM	DESCRIPTION	REQ.	MATERIAL	SIZE	REMARKS
<b>BILL OF MATERIAL</b>					
FINISH				CALC. W.	ACT. WT.
SCALE	3/4" = 1'-0"				MAJOR ASSEMBLY
DATE	11-9-57				NEXT ASSEM.
DRAWN	O. C. P.				NO. PER NEXT ASSEM.
TRACED					
CHECKED					

FWD. FOIL RETRACTION  
SCHEME 1

MIAMI SHIPBUILDING CORPORATION  
MIAMI, FLORIDA, U. S. A.

ALT. **FIGURE 23**

LET.	ALTERNATION	BY	DATE	APP.

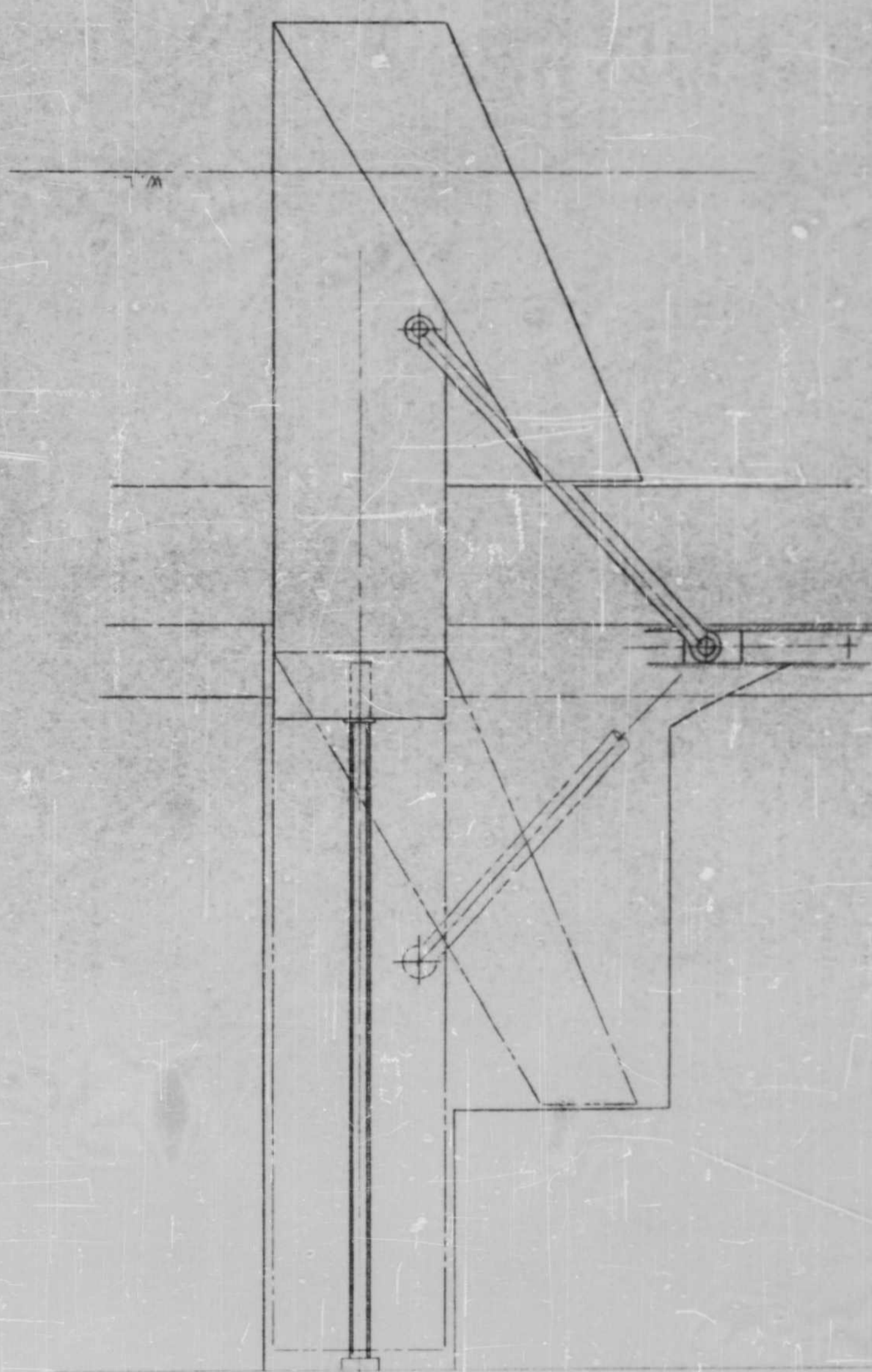

ITEM	DESCRIPTION	REQ.	MATERIAL	SIZE	REMARKS
<b>BILL OF MATERIAL</b>					
FINISH					ACT. WT.
SCALE	1/4" = 1'-0"				MAJOR ASSEMBLY
DATE	11-18-57				NEXT ASSEMB.
DESIGN	G.C.P.				NO. PER NEXT ASSEMB.
TRACED					
CHECKED					
FWD. FOIL RETRACTION SCHEME 2					
MIAMI SHIPBUILDING CORPORATION MIAMI, FLORIDA, U. S. A.					FIGURE 24

LET.	ALTERNATION	BY	DATE	APP.

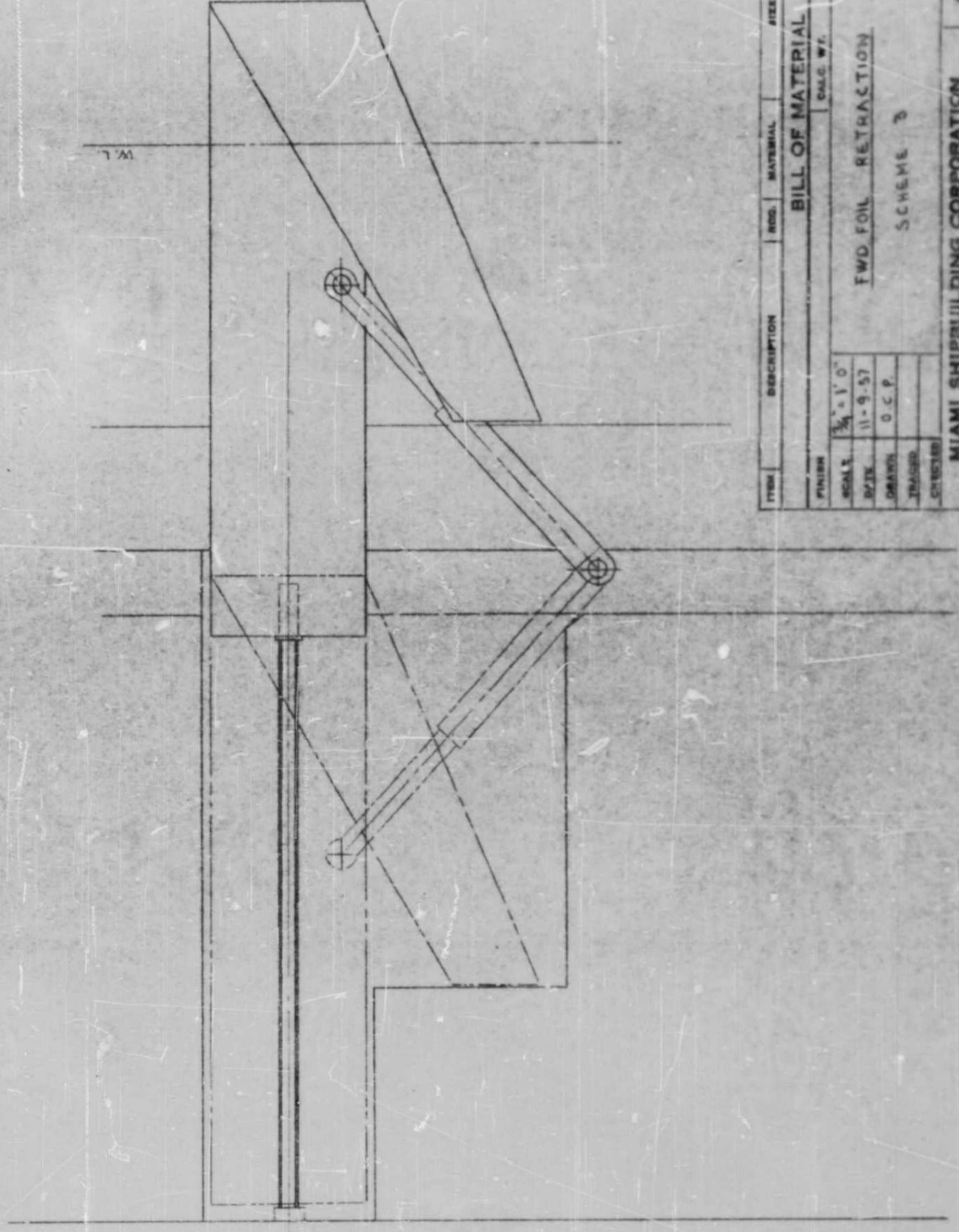

ITEM	DESCRIPTION	QTY.	MATERIAL	SIZE	REMARKS
<b>BILL OF MATERIAL</b>					
FINISH		CALC. WT.		ACT. WT.	
SCALE	$\frac{3}{4}'' = 1' 0''$	MAJOR ASSEMBLY			
DATE	11-9-57	NEXT ASSEM.			
DRAWN	O.C.P.	NO. FOR NEXT ASSEM.			
TRACED					
CHECKED					
FWD FOIL RETRACTION SCHEME 3					ALT.
MIAMI SHIPBUILDING CORPORATION MIAMI, FLORIDA, U. S. A.					<b>FIGURE 25</b>

LEFT	ALTERNATION	BY	DATE	APP.

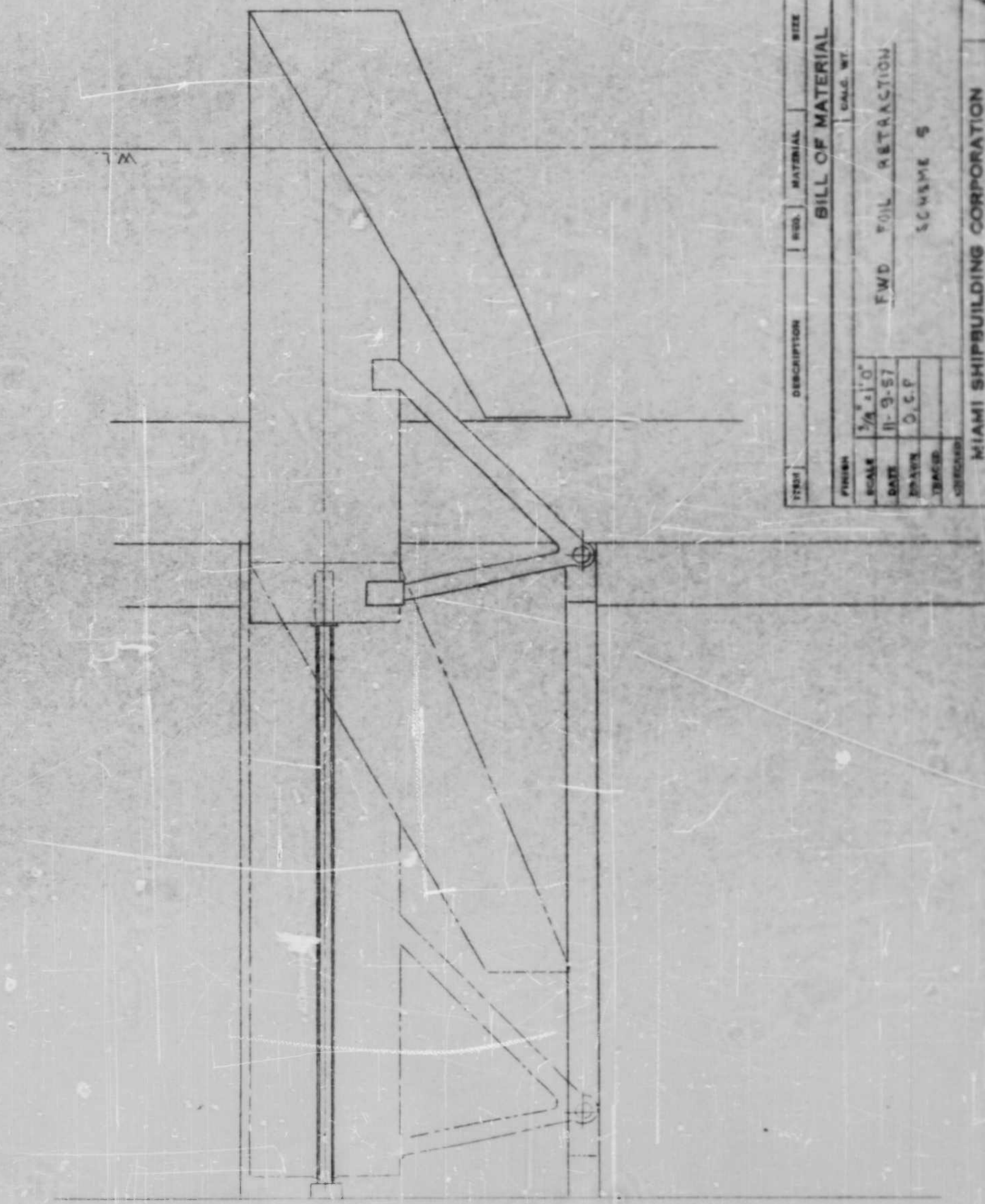

ITEM	DESCRIPTION	REQ.	MATERIAL	SIZE	REMARKS
<b>BILL OF MATERIAL</b>					
FWD FOIL RETRACTION					
SCHEME 5					
SCALE	3/8" = 1" O				
DATE	11-9-57				
DESIGN	D. C. P.				
ISSUED					
CHECKED					
ACT. WT.					MAJOR ASSEMBLY
CALC. WT.					NEET ASSEM
					NO. PER NEET ASSEM.
MIAMI SHIPBUILDING CORPORATION					ALT.
MIAMI, FLORIDA, U. S. A.					<b>FIGURE 26</b>

7654

U. S. NAVY

U. S. NAVAL CORPUS

LET.

BY

DATE

APP.

ALTERATION

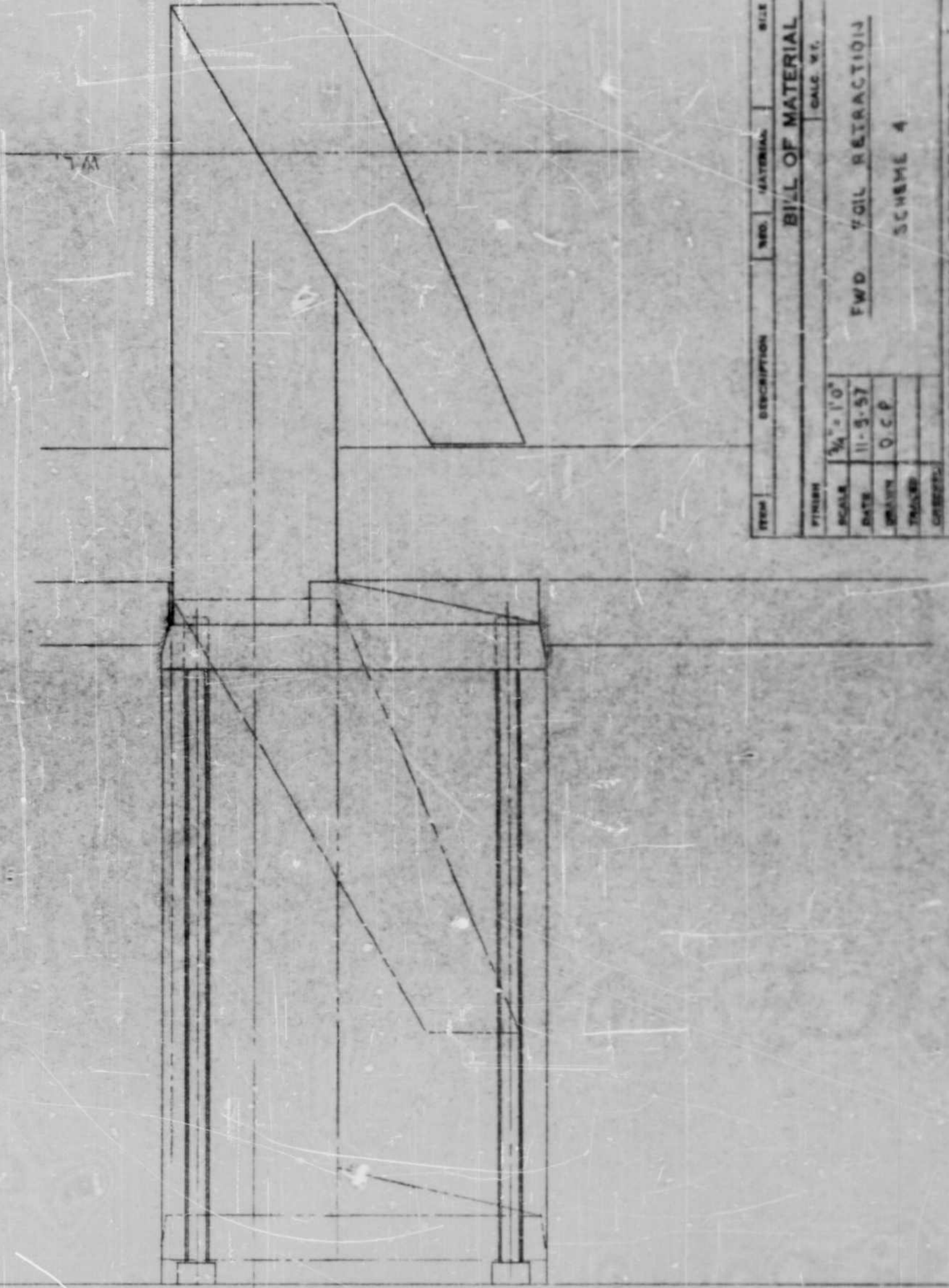

ITEM	DESCRIPTION	REQ.	MATERIAL	SIZE	REMARKS
<b>BILL OF MATERIAL</b>					
FITNESS		CALC. WT.		ACT. WT.	
SCALE	1/4" = 1'-0"	FWD FOIL RETRACTION		MAJOR ASSEMBLY	
DATE	11-9-57	SCHEME A		NEXT ASSEMB.	
DESIGN	O.C.P.			NO. PER NEXT ASSEMB.	
DRAWN					
CHECKED					
MIAMI SHIPBUILDING CORPORATION MIAMI, FLORIDA, U.S.A.				<b>FIGURE 27</b>	

MIAMI SHIPBUILDING CORPORATION  
MIAMI, FLORIDA, U.S.A.

FIGURE 27

the support members into wedging sockets to rigidly support the top of the strut. This is probably the most satisfactory of all designs.

#### C. Rear Foil and Propulsion Unit.

This unit is retractably mounted in a slot in the stern of the hull. This arrangement is illustrated in Drawing 04147. It follows the general design of the propulsion unit of "Halobates" except that the retraction arrangements are modified to permit folding inside the hull slot for land operation and that dual, counter-rotating propellers are used.

The counter-rotating propellers are mounted on a nacelle at the bottom of the strut. This nacelle also mounts the rear foils and houses bevel gearing. The counter-rotating propellers are driven through separate gear trains by concentric vertical shafts. This arrangement neutralizes propeller torque providing torque-free steering.

The retractable drive from inboard engine to the propulsion unit is similar to that of "Halobates", but requires a splined sliding coupling in the drive shaft to permit the movement into a horizontal position for stowing on land.

There are various possible alternative arrangements of the retraction linkage for mounting. The slotted track shown provides a convenient means for powering this action, but screws or hydraulic cylinders may be used alternatively with minor alterations.

In the boating position, the propeller falls behind the transom. It is hence necessary to provide a tunnel in the bottom of the hull. To favor planing at takeoff, this tunnel is closed by a squat board which is hydraulically actuated for movement between its extreme positions.

Use of the tractor propellers improves efficiency by avoiding placing the propeller in the wake of the strut. It greatly reduces the danger of ventilation of the propeller by air drawn down the strut. It further retards the development of propeller cavitation by avoiding the strut wake effects thereon. Experience with "Halobates" has indicated the desirability of this change. Tests conducted in Italy by Cabi-Cattaneo have demonstrated the efficiency improvement by the tractor arrangement.

#### D. Power Plant.

Three power plant and drive systems have been studied. Most layouts have been developed around the 825 HP, T-58 gas turbine. These arrangements are illustrated in Drawing 04143.

The gas turbine has a rather poor fuel rate at reduced power. The specific fuel consumption increases about 50% at half load over that at full load. A steam power plant, along the lines of the Bessler design operating at 900 psi, develops close to the same fuel rate as the turbine with atmospheric exhaust pressure. It is practicable to maintain this exhaust with an air condenser.

Furthermore, the specific fuel consumption changes relatively little with output. The steam engine can develop high low speed torque without gear shifting. Furthermore, the use of a subdivided engine arrangement with a common boiler permits direct driving of the propeller and each track, eliminating speed change transmissions and much other gearing.

In view of the attractive features of the steam plant, preliminary designs were prepared on a single, 1000 HP steam engine replacing the gas turbine and on a second arrangement with a 1000 HP steam engine mounted directly on the outboard retractable propulsion unit and with two additional 200 HP engines, each directly connected to a reduction gear driving a track drive sprocket. These arrangements are shown respectively in Drawings 04144 and 04145.

In the gas turbine arrangement, the turbine drives through a three-speed automatic transmission unit having ratios 1/1, 1.7/1 and 3/1. Power from the transmission is transmitted to the propeller unit through a disconnect clutch and an articulated drive shaft. The output of the transmission is also geared to a cross shaft. Power from the cross shaft is transmitted to track sprocket drive gears through controllable fluid couplings. The torque of these couplings is controllable by a scoop which controls the fluid level in the coupling. Brakes on the output shafts of these couplings are hydraulically controlled and automatically

coordinated with the draining and filling of the couplings. Differential controls actuated by the steering wheel actuate these brakes and couplings to control track speed differentially for steering purposes.

In the case of the single engine steam drive, the arrangements are essentially the same except for the addition of the boiler and condenser. However, the high torque capacity of the steam engine permits elimination of the speed change gear. The saving in weight thereby offsets the increased weight of the steam power plant over the turbine so that very little weight change results.

When the three engine drive is used, steering brakes and couplings can be eliminated, as well as the speed change gear. The articulated drive train and disconnect clutch to the water propulsion unit are also eliminated. Again the weight savings balance increases with little net change.

The main problem presented by the steam plant is condensing for land operation. The air condensers are bulky and require considerable air. However, they can be accommodated if their capacity is limited to the reduced power demand on land. At sea, it will be desirable to supplement the air condenser with a water condenser.

If air condensers can be mounted above deck, the deck closure can be maintained. This would be desirable. If not practicable, the large air ducts for condensing can be closed at

sea and water condensing used exclusively.

In further consideration of alternative power arrangements, consideration was given to a separate, 225 HP diesel or turbine power plant for land use. It was found that the extra weight of this power plant was considerably greater than that of the extra fuel required by use of the main engine on land. This was true whether a diesel engine or a regenerative gas turbine was used. In view of the weight advantage and reduction of first cost, the availability of the extra power for higher speed was considered to out-weigh the economic cost in fuel consumption. For the life of the vehicle, the possible fuel cost savings just about balance the cost of an extra turbine power plant of smaller size.

#### E. Track System.

No attempt has been made to develop a detailed design of track. This is a major undertaking. However, in respect to the pneumatic track discussed, sufficient consideration has been given the design and manufacture to determine that a produceable, structurally sound, pneumatic track segment can be devised. Figure 28 shows a section that incorporates the essential features.

Transverse high strength reinforcements provide the means of supporting the inner pressure by the flat belt and tread areas. Longitudinal wires at the corners provide the means for supporting the cords at the bends. Use of a "trapezoidal" sectional

LET.	BY	DATE	APP.
ALTERATION			

UNLOADED  
 VERTICAL LOAD (STRAIGHT RUN)  
 VERTICAL AND SIDE LOAD (STRAIGHT RUN  
 ON 60% SIDE SLOPE)

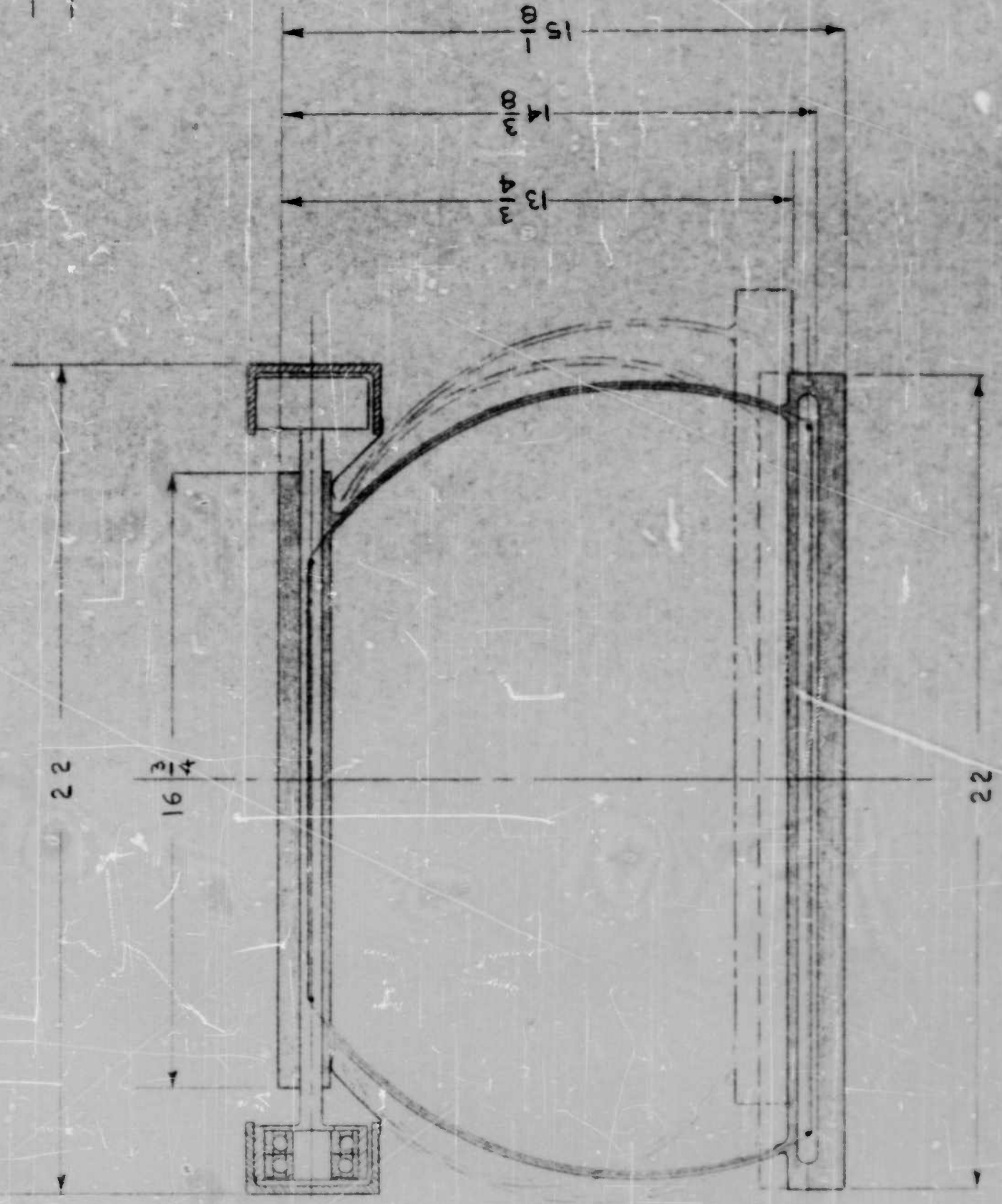

ITEM	DESCRIPTION	REQ.	MATERIAL	SIZE	REMARKS
<b>BILL OF MATERIAL</b>					
TRACK CROSS SECTION					
ACT. WT.					
MAJOR ASSEMBLY					
NEXT ASSEM.					
NO. PER NEXT ASSEM.					
MIAMI SHIPBUILDING CORPORATION MIAMI, FLORIDA, U. S. A.					ALT. <b>FIGURE 28</b>

form provides the means of supporting transverse load, on a side hill and in turning. The reinforcing rods also provide the axles for rollers guiding the belt section.

In the figure, the solid section shows the track inflated but unloaded. In the dotted sections, its configuration under vertical load and on a 60% side slope is shown.

The guide rails run the length of the sponsons surrounded by the track and curved around the forward end to form the return path. The drive sprocket is located at the rear end mounted on sealed anti-friction bearings supported by brackets secured to the sponson. The drive sprocket is shown in Drawing 04146. The sprocket is driven by roller chain extending forward to a sprocket pin also mounted in bearings bracketed to the sponson. Since the sponson is demountable, this drive pinion is coupled to the drive gear mounted in the side of the hull by a double-ended splined shaft. When sponsons are removed for rail shipment, these splined shafts are removed, leaving faces on the sides of the hull free of projections.

#### F. Weight.

In setting tentative objectives, the total weight aimed at was 30,000 lbs., fully loaded, of which 8,000 lbs. was established as pay load. In the preliminary design study, a weight of 36,000 lbs. has been calculated. As pointed out earlier, this

is based on a relatively conservative tentative approach. The weight breakdown is summarized in Appendix A. There is now little doubt that the original objective can be met by careful attention to detail in preparing a final design. The payload objective can be preserved in so doing.

In preparing a final design, careful investigation must be carried out in setting the design criteria for foils and hull. Here a considerable weight penalty must be paid as the price of conservatism in the absence of explicit dynamical loading data.

While the preliminary weight runs higher than planned, the boating and flying characteristics are such that this extra loading and more can be carried with ease. Thus, even though structural weight is ultimately reduced, it may be advantageous to increase the cargo rating for dense cargo to bring the gross weight to 45,000 lbs.

There is nothing sacred about the particular gross weight and cargo capacities set as objective. Craft of the proposed type can be built to any desired scale. In a particular case, the size would ultimately be set by the capacities and weights of available power plants in the neighborhood of the size established by the vehicle necessary to perform a specified task. The latitude of sea and land performance available from a given

vehicle allows plenty of room for compromise in order to take care of special situations.

APPENDIX A

ESTIMATE OF WEIGHT FOR BOATS WORK SHEET

NAVP-17-1-45 (REV. 1-1-53)

U.S.S. H.A.T.V. - SUMMARY -

758 POWER PLANT, BOATING

PAGE 21 OF

DATE

DESCRIPTION	WEIGHT (Pounds)	ABOVE BASE	MOMENTS	CENTER OF GRAVITY	
				REFLECTED TO FORE-AND-AFT	HEIGHT
<u>HULL STRUCTURE</u>					
<u>FRAMING</u>	4467.6		21627.6	1986.8	8984.5
<u>SHELL</u>	3361.4		17162.7		
<u>PROPULSION</u>					
<u>POWER PLANT AND TRANSMISSION</u>	3495.0		16092.5		37056.5
<u>DRIVE TRAIN (MACHINES)</u>	150.0		1020.0		1740.0
<u>DRIVE TRAIN (TRACKS)</u>	925.0		3740.0		8311.5
<u>FOILS AND STREETS</u>	3490.0		12977.4		15781.1
<u>TRACKS</u>	6916.0		23514.4		29906.8
<u>LIGHT CONDITION</u>	22805.0	4.43	101134.6		4.18 95,393.6
<u>CREW</u>	400.0	1.5	3400.0	10	4000.0
<u>FUEL</u>	4500.0	3.4	15300.0	0	0
<u>PAYLOAD</u>	8000.0	4.2	33600.0	1.0	8000.0
<u>MARGIN</u>	295.0	4.4	1298.0	0	
<u>Full Load Condition</u>	36000.0	4.30	159732.6		2.32 83,393.6

DESCRIPTION	WEIGHT (Pounds)	ABOVE BASE	MOMENTS	CENTER OF GRAVITY		
				REFERRED TO BASE	APPROXIMATE	MIDSHIP
HULL STRUCTURE						
FRAMING	4467.6		21627.6		1386.8	
SHELL	3361.4		17162.7			8984.5
PROPULSION						
POWER PLANT & TRANSMISSION	3495.0		16092.5			37056.5
DRIVE TRAIN - (MARINE)	150.0		840.0			1710.0
DRIVE TRAIN (TRACK)	925.0		3740.0			7741.5
FOILS & STRUTS	3490.0		21652.9			15547.1
TRACKS	6936.0		23514.4			24906.8
LIGHT CONDITION	22805.0	4.59	104630.1		1386.8	95906.4
CREW	400.0	8.5	3400.0	10.0	4000.0	
FUEL, LUBRICATING OIL, WATER	4500.0	3.4	15300.0	0.0	0.0	
PAY LOAD	8000.0	4.2	33600.0	1.0	8000.0	
MARGIN	295.0	4.6	1357.0	0.0	0.0	
FULL LOAD CONDITION	36,000.0	4.4	158287.1			2.29 57,619.8

ESTIMATE OF WEIGHT FOR BOATS WORK SHEET

NAVY (13-15)

B.S.B. HATY SUMMARY T58 POWER PLANT - FLYING

DESCRIPTION	WEIGHT (Pounds)	ABOVE BASE	MOMENTS	CENTER OF GRAVITY	
				FEET	INCHES
HULL STRUCTURE					
FAMING	4467.6		21627.6		
SHELL	3361.4		17162.7		8984.5
PROPULSION					
POWER PLANT AND TRANSMISSION	3495.0		16092.5		37056.5
DRIVE TRAIN (MARINE)	150.0		480.0		1905.0
DRIVE TRAIN (TRACK)	925.0		3740.0		8311.5
FOILS AND STRUTS	3490.0		-1313.2		19635.5
TRACKS	6916.0		23514.4		24906.8
LIGHT CONDITION	22805.0	3.57	81304.0		99413.0
CREW	400.0	8.5	3400.0	10.0	4000.0
FUEL	4500.0	3.4	15300.0	0.0	0.0
PAYLOAD	8000.0	4.2	33600.0	1.0	8000.0
MARGIN	295.0	4.36	1298.0	0.0	0.0
FULL LOAD CONDITION	36000.0	3.71	134902.0		87413.0

U.S.S. HATV. SUMMARY THREE BESLER STEAM ENGINES - FLYING

DESCRIPTION	WEIGHT (Pounds)	ABOVE BASE	MOMENTS	CENTER OF GRAVITY		MIDSHIP
				REFERRED TO	HEIGHTS	
HULL STRUCTURE	4467.6		21627.6			
FRAMING	3361.4		17162.7		1386.8	8784.5
SHELL						
PROPULSION						
POWER PLANT AND TRANSMISSION	3968.0		22944.0			43941.0
DRIVE TRAIN (MARINE)	1760.0		9472.0			24736.0
DRIVE TRAIN (TRACK)	925.0		3740.0			7741.0
FOILS AND STRUTS	3490.0		-1313.2			19635.5
TRACKS	6916.0		23514.4			24906.8
LIGHT CONDITION	24088.0	3.90	97147.5			5.17 128558.0
CREW	400.0	8.5	3400.0	100	4000.0	
FUEL	2500.0	3.4	15300.0	0.0	0.0	
PAYLOAD	8000.0	4.2	33600.0	1.0	8000.0	
MARGIN	212.0	3.9	826.8	0.0	0.0	
FULL LOAD CONDITION	36000.0	4.17	150274.3			3.24 116558.0

U.S.S. H.A.T.V. SUMMARY SINGLE BESLER STEAM ENGINE - FLYING

DESCRIPTION	WEIGHT (Pounds)	ABOVE BASE	MOMENTS	CENTER OF GRAVITY		
				FT	INCHES	REFERRED TO MARKING NO.
HULL STRUCTURE						MIDSHIP
FRAMING	4467.6		21627.6		1386.8	
SHELL	3361.4		17162.7			8984.5
PROPULSION						
POWER PLANT & TRANSMISSION	5682.0		30903.0			60226.0
DRIVE TRAIN (MARINE)	150.0		480.0			1908.0
DRIVE TRAIN (TRACK)	925.0		3740.0			7741.6
FOILS & STRUTS	3490.0		- 1313.2			19685.5
TRACKS	6916.0		23514.4			24906.8
LIGHT CONDITION	24992.0	3.85	96114.5			4.90 122412.5
CREW	400.0	8.5	3400.0	10	4000.0	
FUEL	2500.0	3.4	15300.0	0	0.0	
PAY LOAD	80000	4.2	336000.0	1.0	80000.0	
MARGIN	108.0	3.8	410.4	0	0.0	
FULL LOAD CONDITION	360000.0	4.13	148824.9			3.07 110412.5

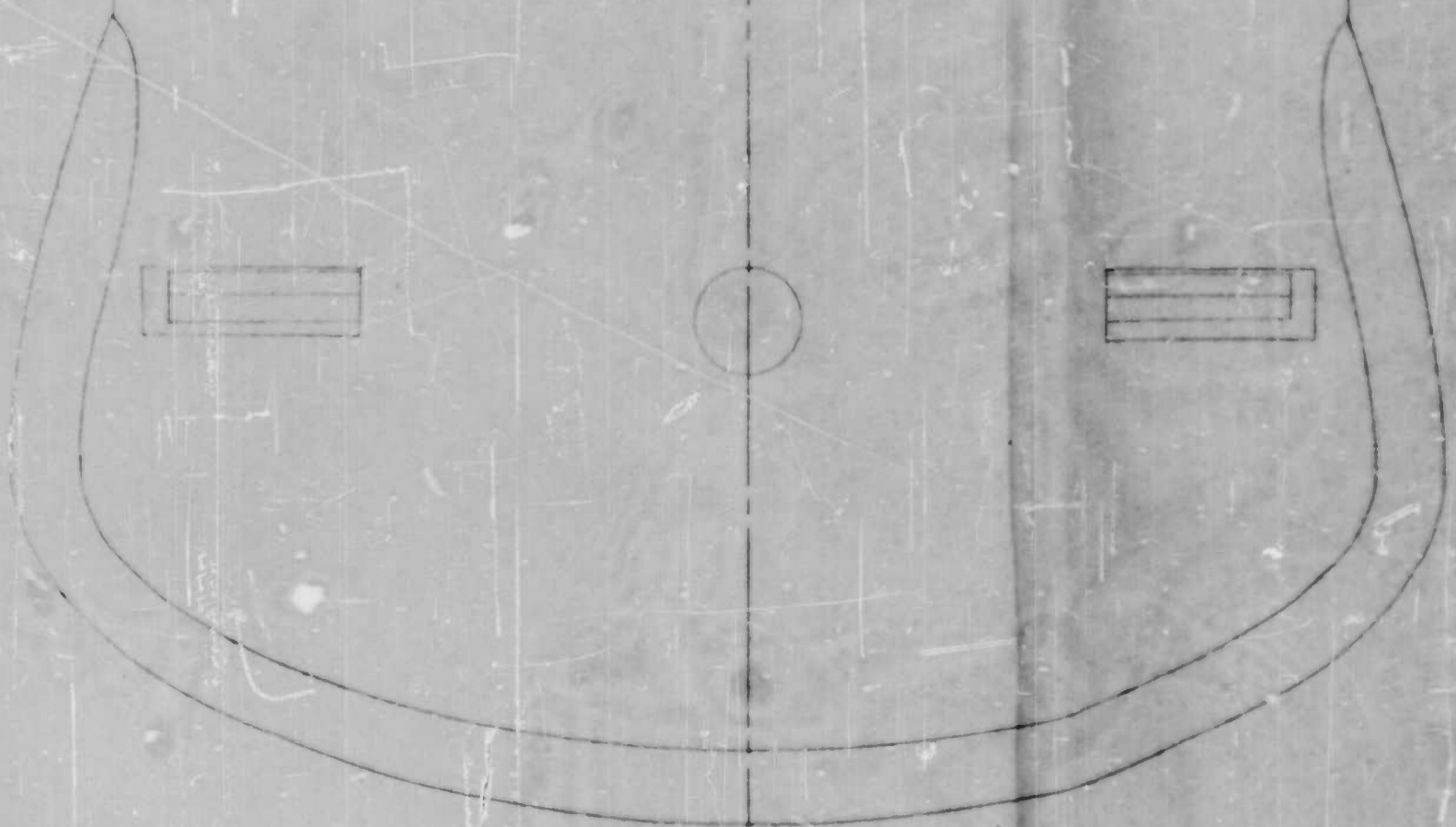
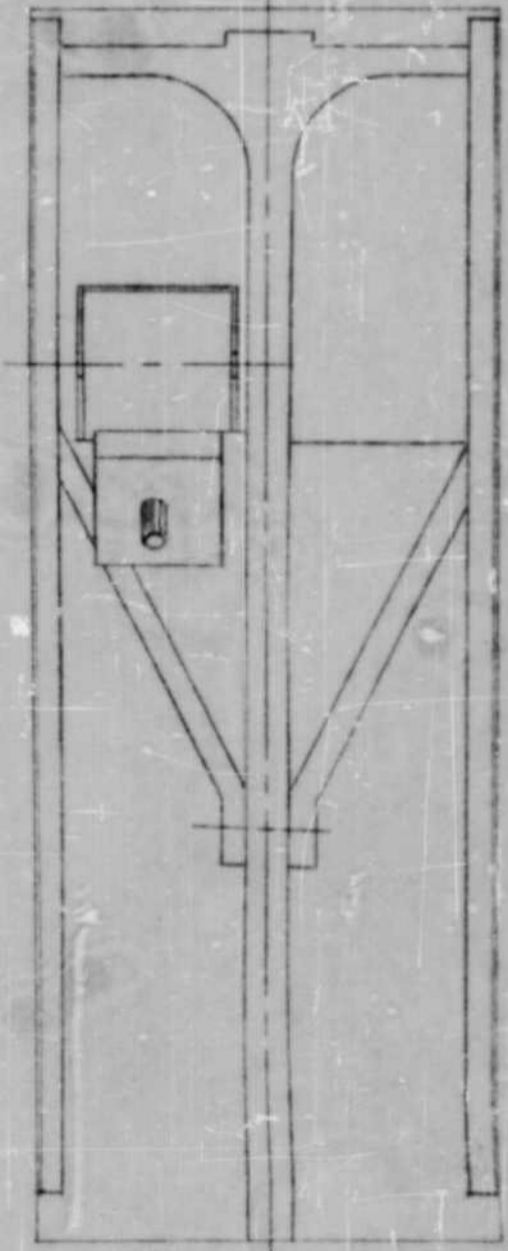
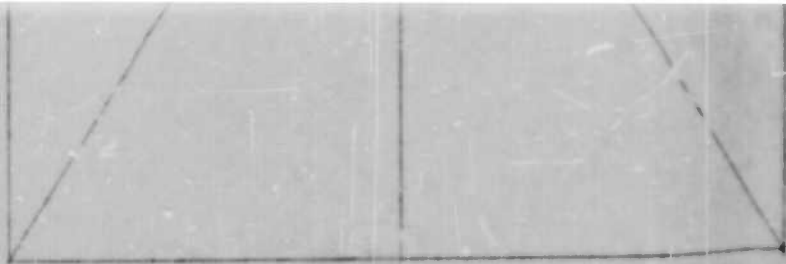

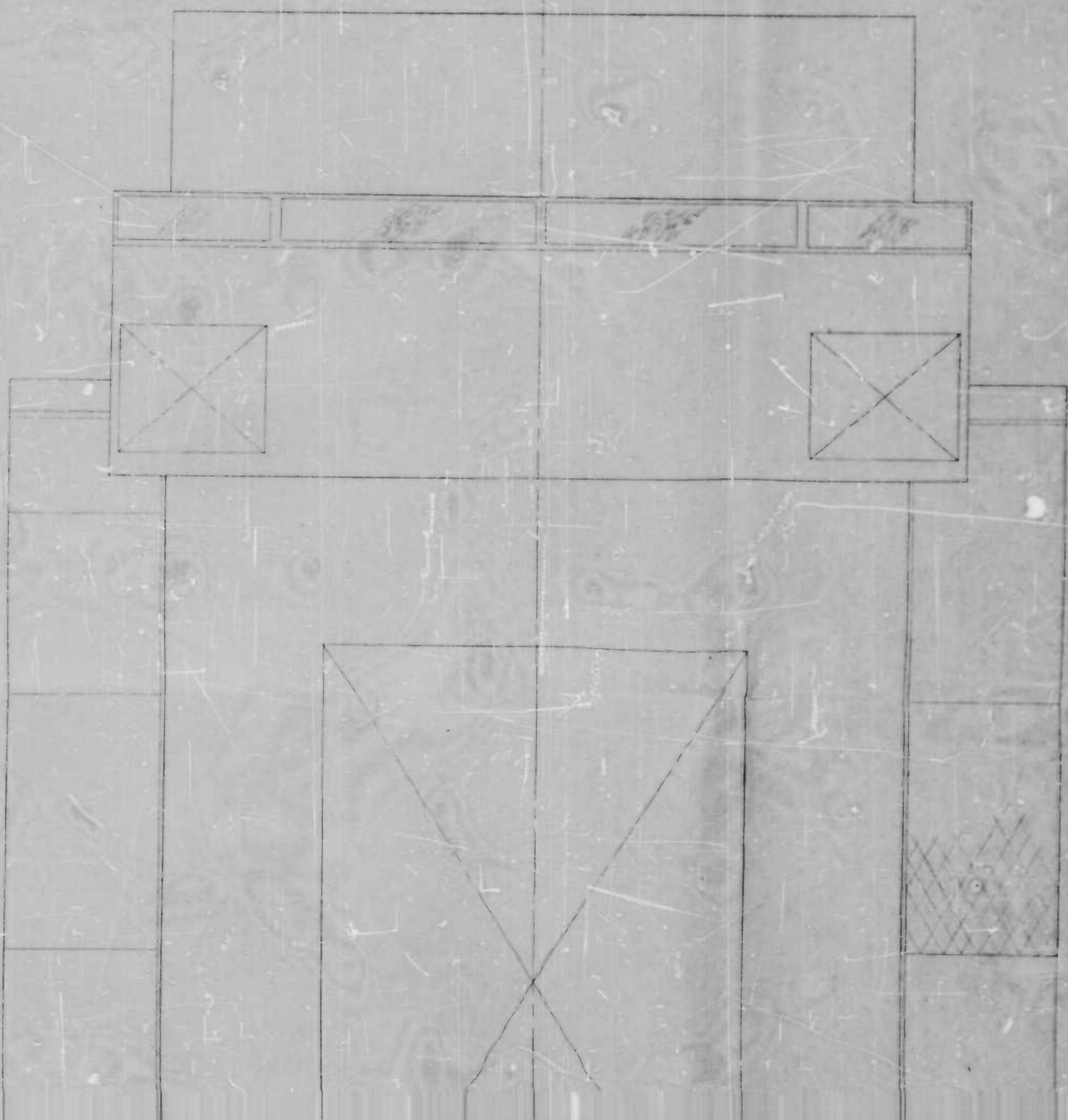

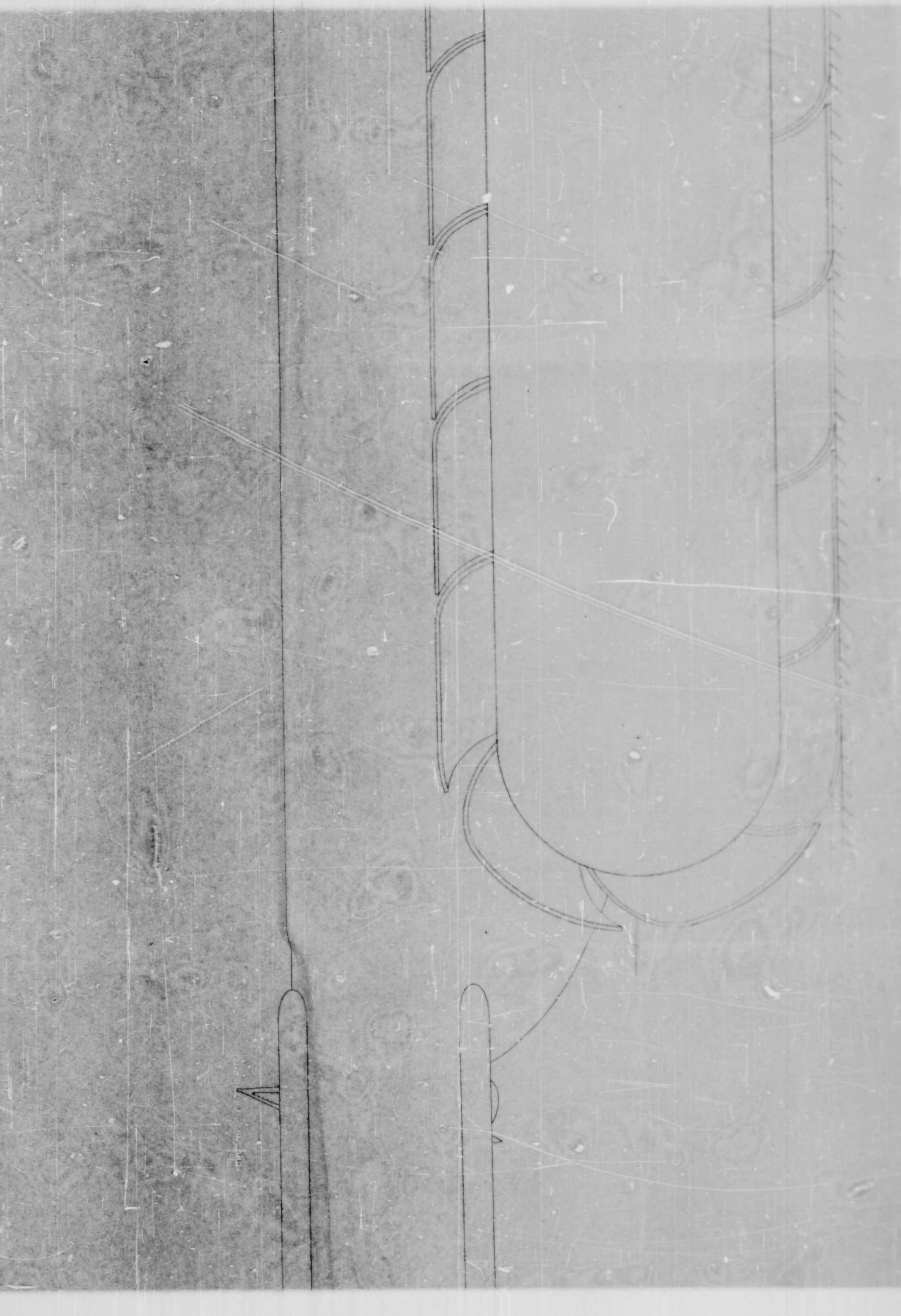

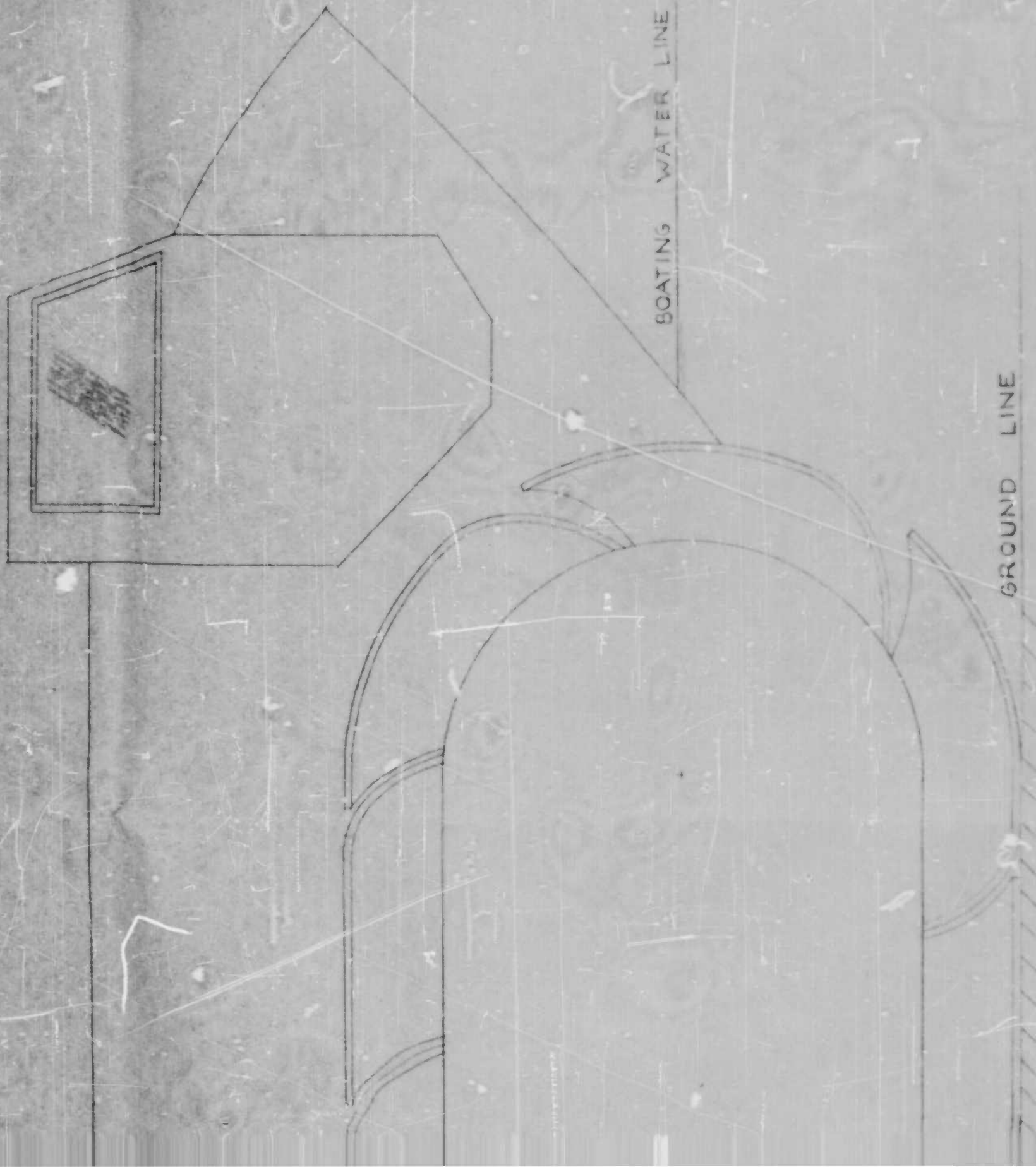

SCALE	3/4" = 1'	H.I.A.T. V.
DATE	11-12-57	OUTBOARD PLAN & PROFILE
DESIGNER	J.A.G.	GROUND POSITION
		C 4149

TO OPERATE ELEVON

THE CONTROL ROD IS RAISED OR LOWERED IN ACCORDANCE WITH DESIRED ELEVON MOVEMENT. THIS ROTATES THE ELEVON CONTROL ARM AND ELEVON ABOUT THE  $\xi$  OF ELEVON HINGE.

THE UNIBALL JOINT AND CONTROL ARM PIN ALLOW THE ELEVON TO BE IN ANY POSITION BEFORE RETRACTION. WITH THE CONTROL ROD HELD IN PLACE DURING RETRACTION, THE ELEVON GRADUALLY MOVES TOWARD ITS NEUTRAL POSITION AND REACHES ITS NEUTRAL POSITION WHEN THE TIP REACHES ITS FULLY RETRACTED POSITION.

$\xi$  OF ELEVON HINGE

ELEVON

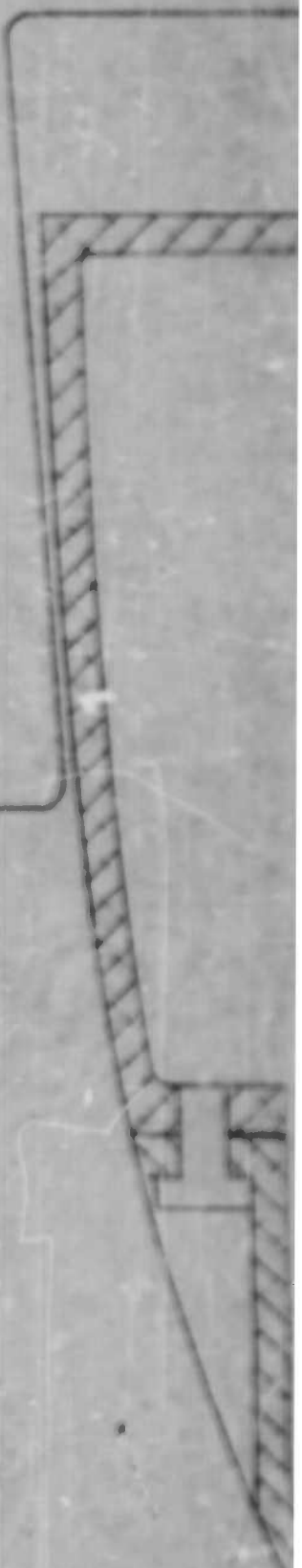

HOW TO RETRACT FOIL TIP

PRESSURE IS APPLIED TO THE HYDRAULIC CYLINDER. THE HYDRAULIC PISTON MOVES THE RETRACTION SHAFT AFT WHICH IN TURN MOVES THE FOIL TIP LOCKING LUG INTO THE CLEARANCE SPACE. TENSION APPLIED TO WIRE ROPE C<sub>1</sub> (SECTION C-C) ROTATES THE RETRACTION SHEAVE COUNTER CLOCKWISE FOLDING THE FOIL TIP UPWARD TO ITS RETRACTED POSITION ALONGSIDE THE STRUT.

FOIL TIP

FOIL TIP LOCKING LUG

CLEARANCE SPACE

RETRACTION SHAFT

HYDRAULIC CYLINDER

HYDRAULIC PISTON

C

B

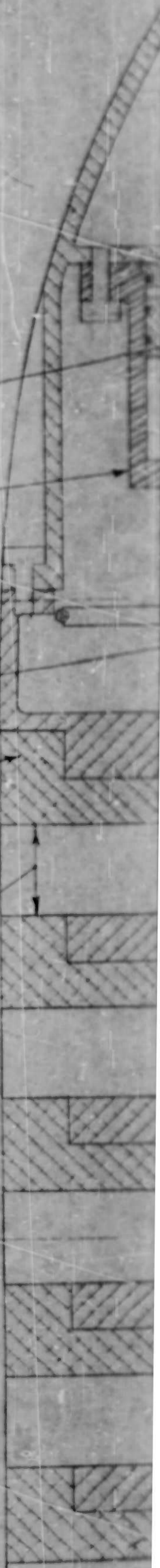

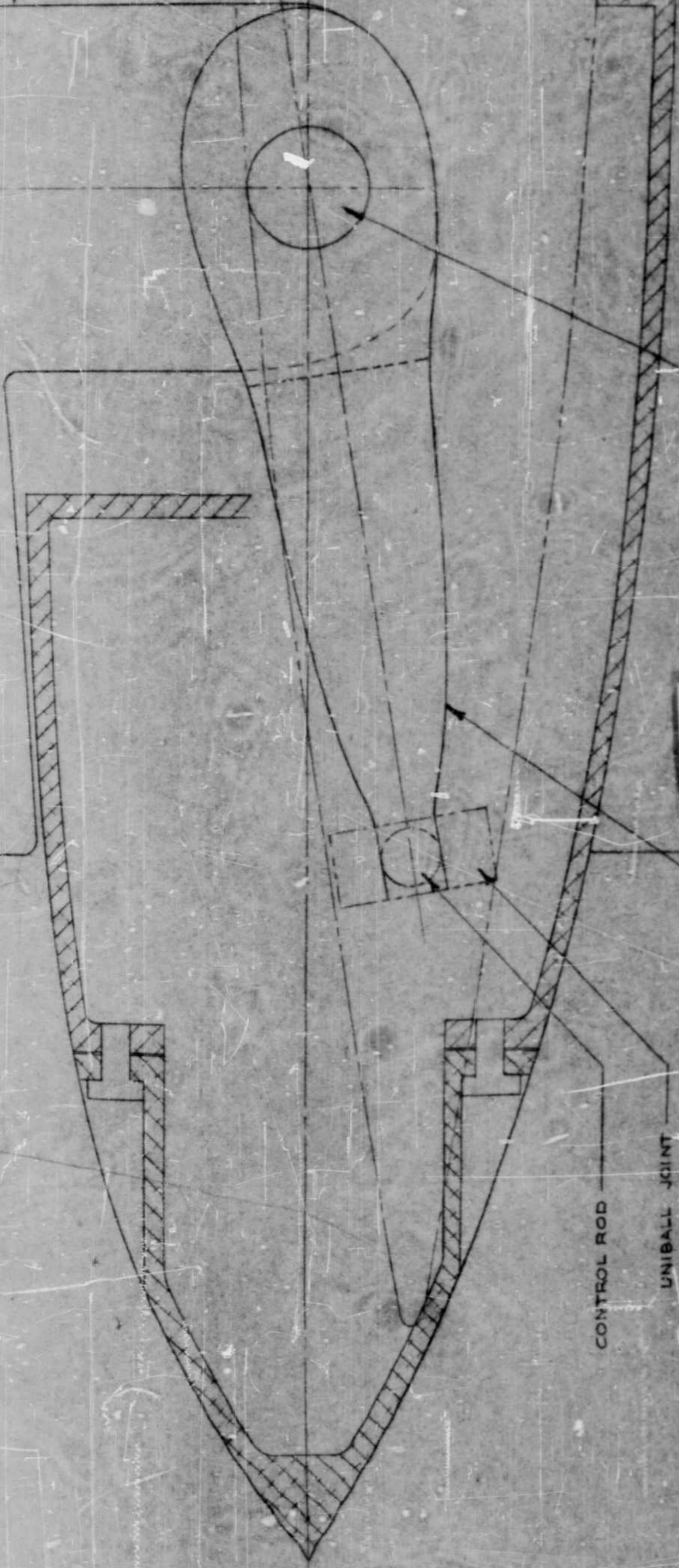
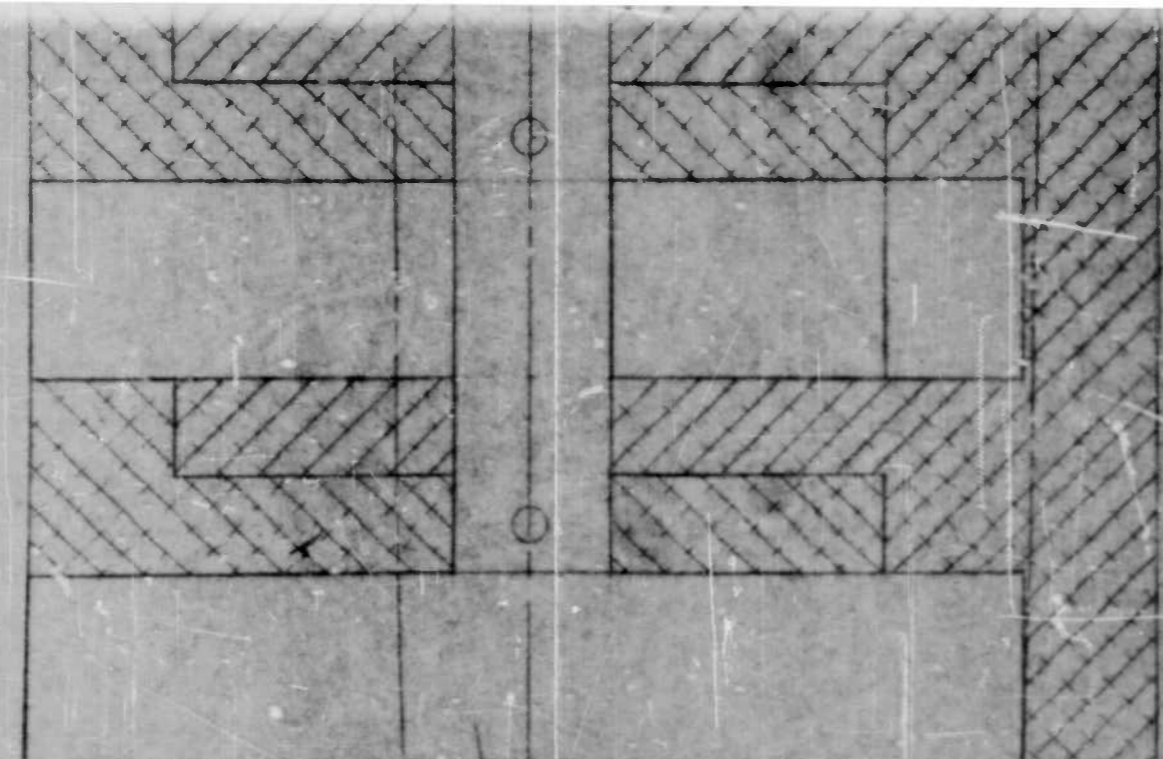

CONTROL ROD

UNIBALL JOINT

ELEVON CONTROL ARM

CONTROL ARM PIN

3

FOIL TIP LOCKING LUG

CLEARANCE SPACE

RETRACTION SHAFT

HYDRAULIC CYLINDER

HYDRAULIC PISTON

RETRACTION SHEAVE

WIRE ROPE

OUTLINE OF STRUT

4

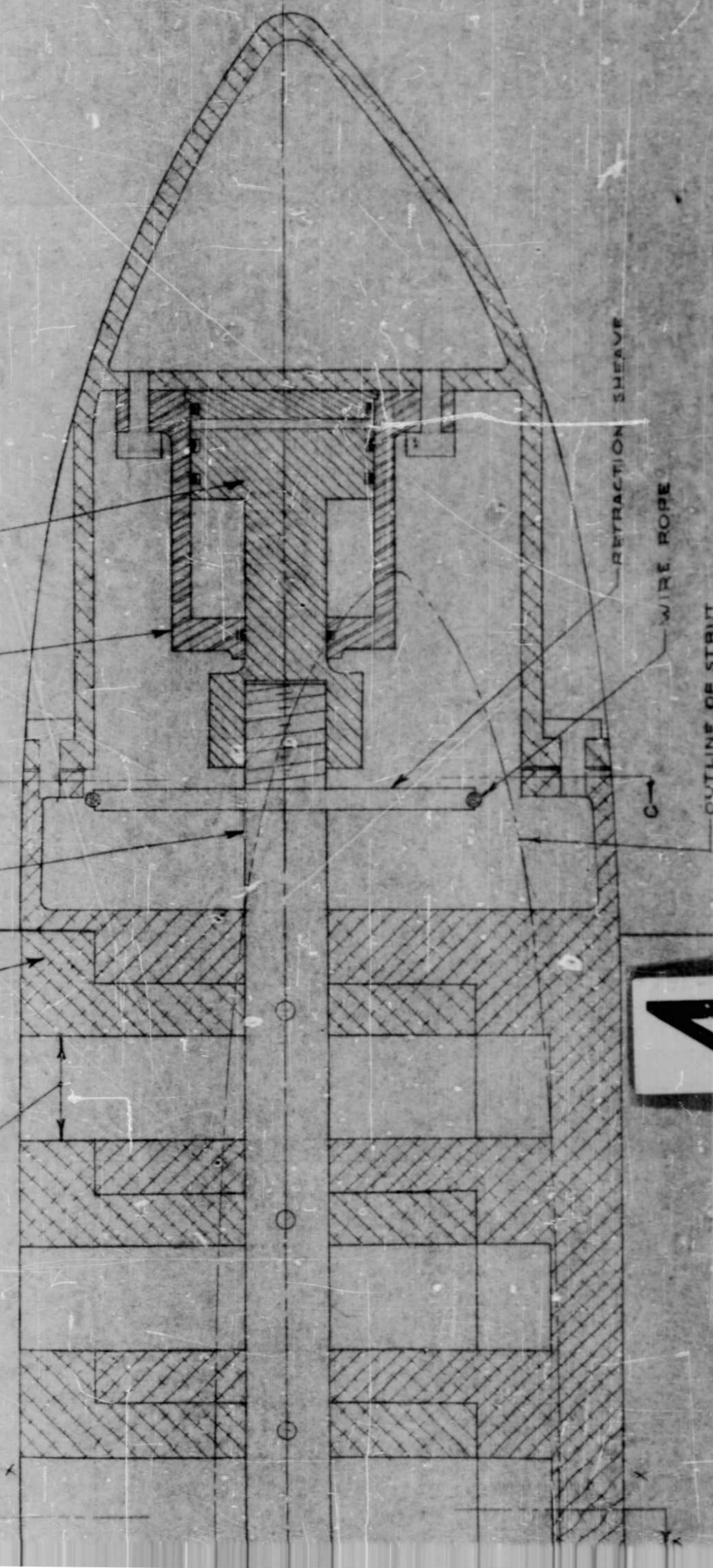

5

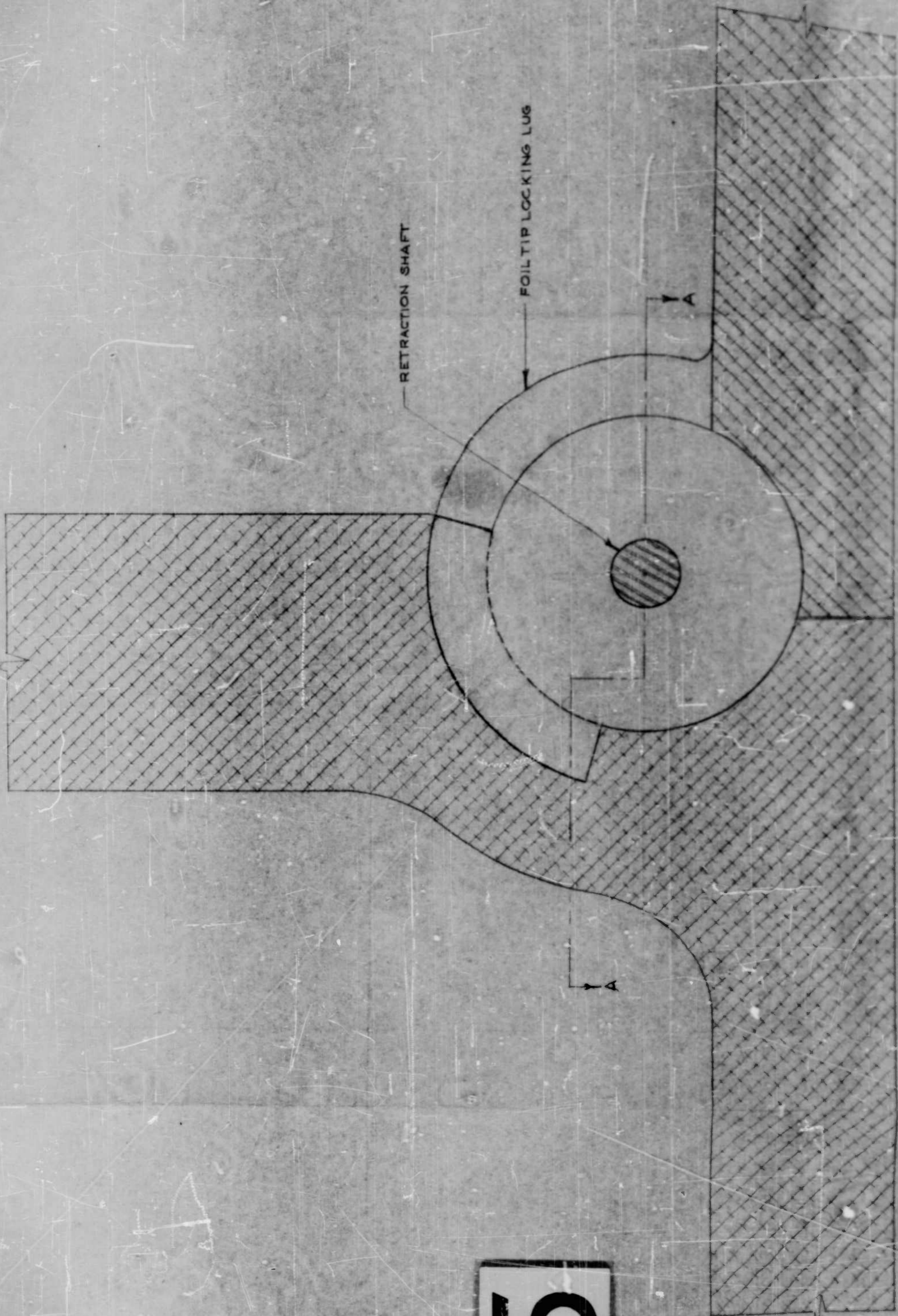

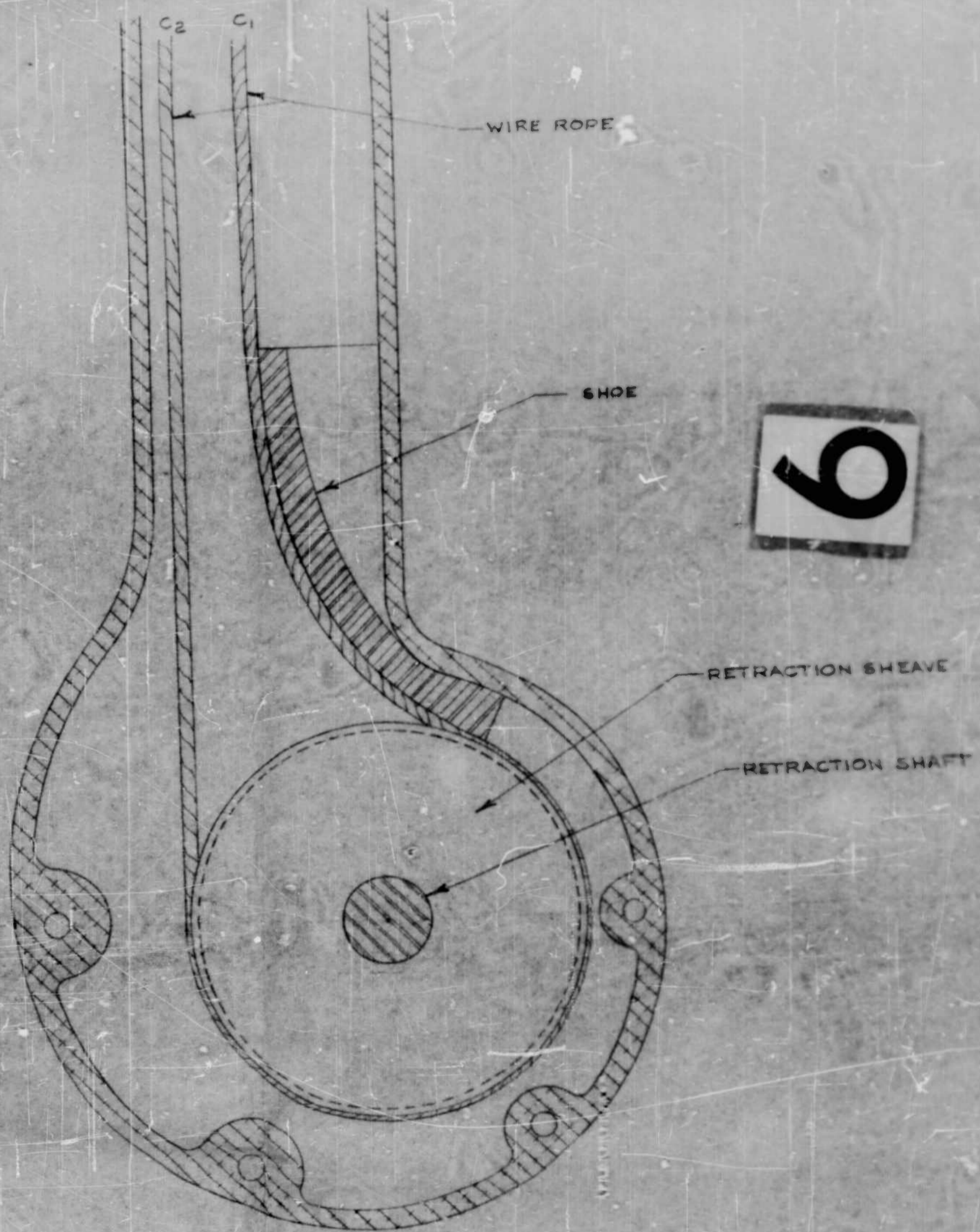

6

SECTION C-C



CONTROL ARM PIN

B-X

CENTER SPAN OF FOIL



SECTION A-A  
PLAN VIEW

8

ITEM	DESCRIPTION	QTY	UNIT	SIZE	REMARKS
BILL OF MATERIAL					
SCALE	F.S.	H.A.T. V.			
DATE	11-15-57	FRONT FOIL HINGE			
DRAWN	JAG	04148			
CHKD	<i>W</i>	H.A.T. V. Corporation M.F.V. FLORIDA, U.S.A.			

LET	ALTERNATION	BY	DATE	APP.

1

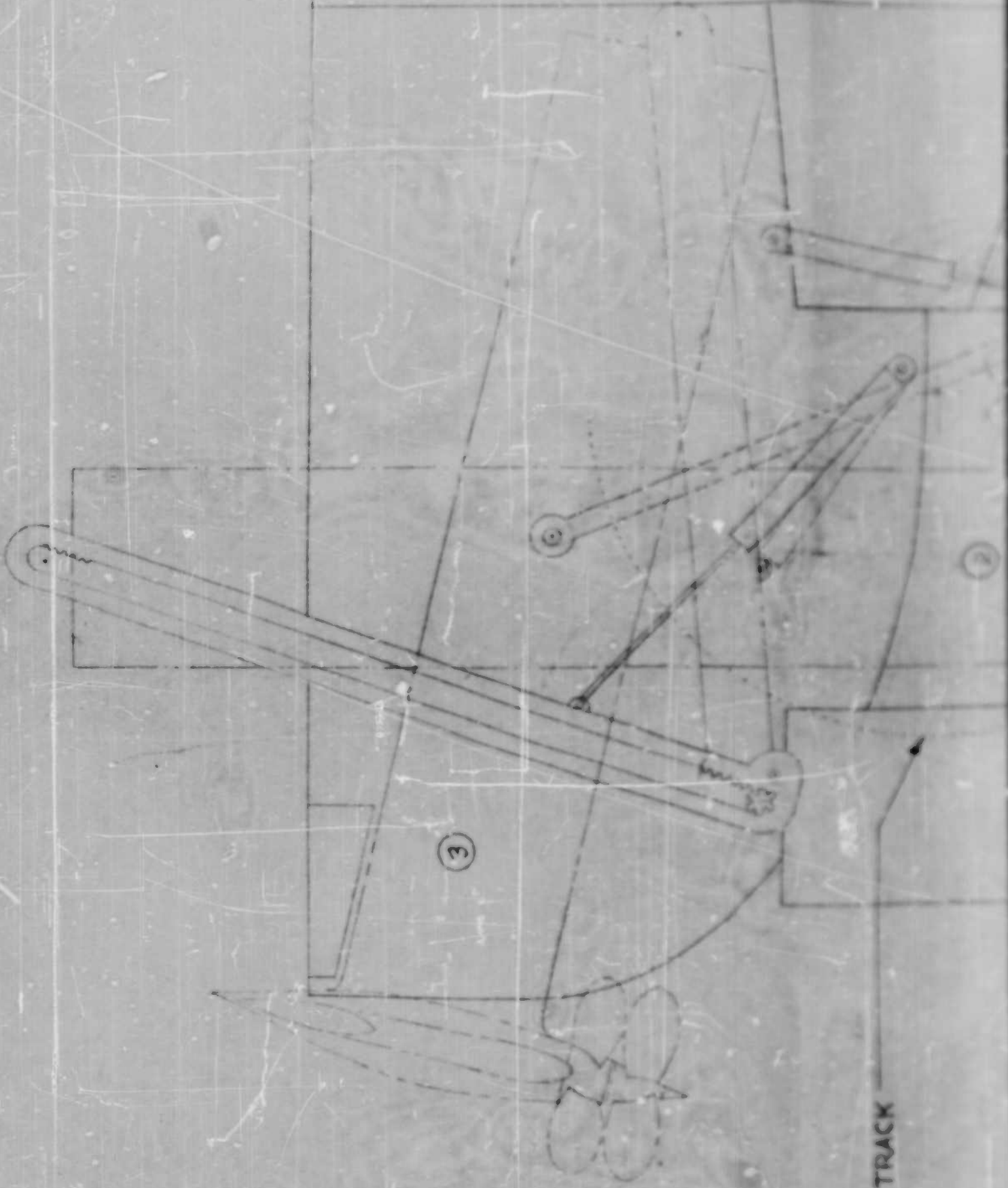

OUTLINE OF TRACK

OUTLINE OF TRACK

SQUAT BOARD

GROUND LINE

- NOTE
- ① FLYING POSITION
  - ② BOATING POSITION
  - ③ LAND POSITION

2

ITEM	DESCRIPTION	REQ.	MATERIAL	SIZE	REMARKS
BILL OF MATERIAL					
H.A.T. V.					
RETRACTABLE					
PROPULSION UNIT					
FINISH				CALL WT	
SCALE	3/4" = 1'				
DATE	11-20-57				
DRAWN	JAG				
TRACED					
CHECKED	JM				
MIAMI SHIPBUILDING CORPORATION MIAMI, FLORIDA, U.S.A.					ALT 04147

1

SUPPORT BRACKETS

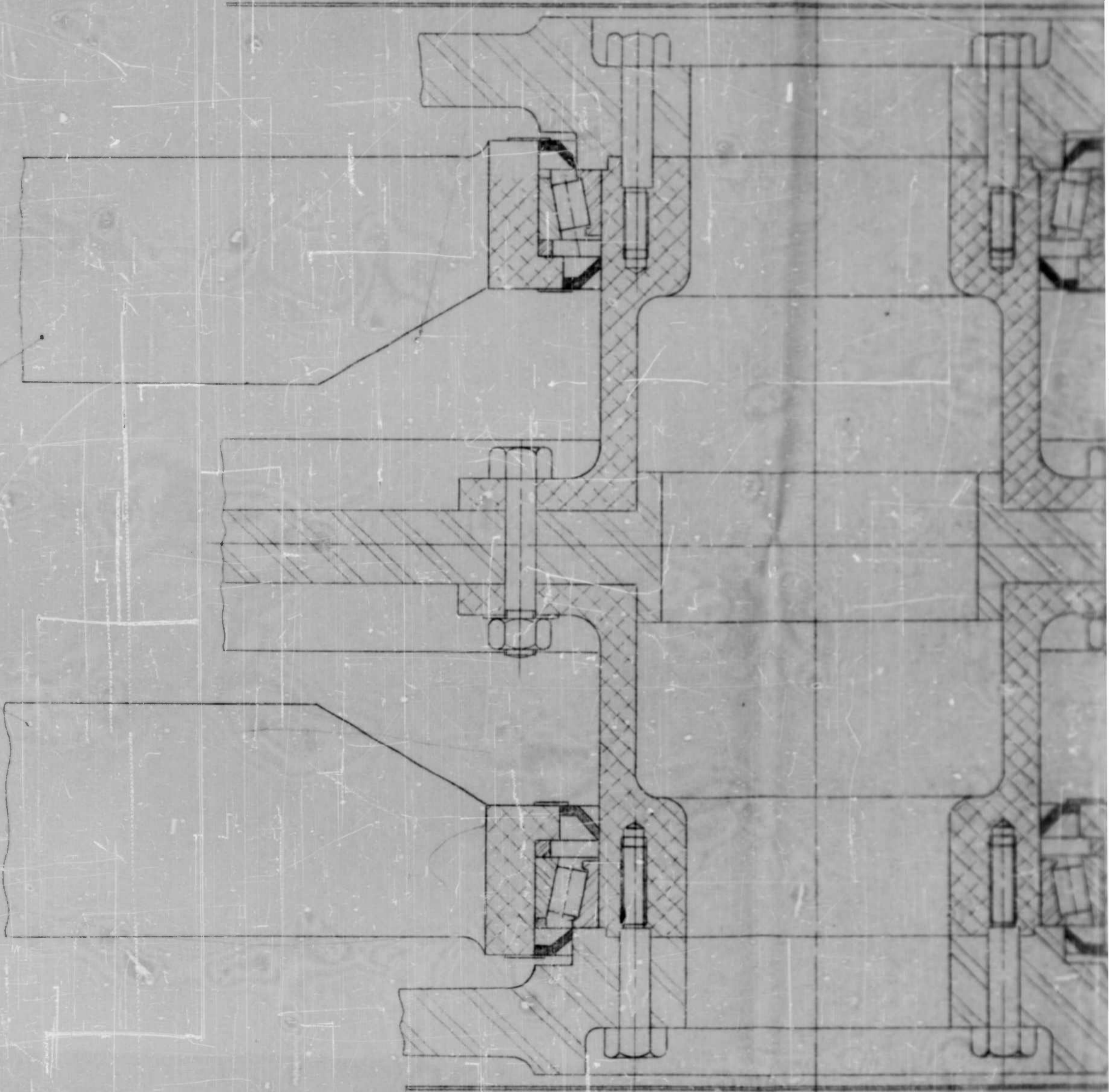

2

FWD



SIDE PLATING

SUPPORT BEARING

3

DRIVE SPROCKET

TRACK SPROCKET

TRACK INNER  
BELT

TRACK ROLLER  
SUPPORT SHAFT

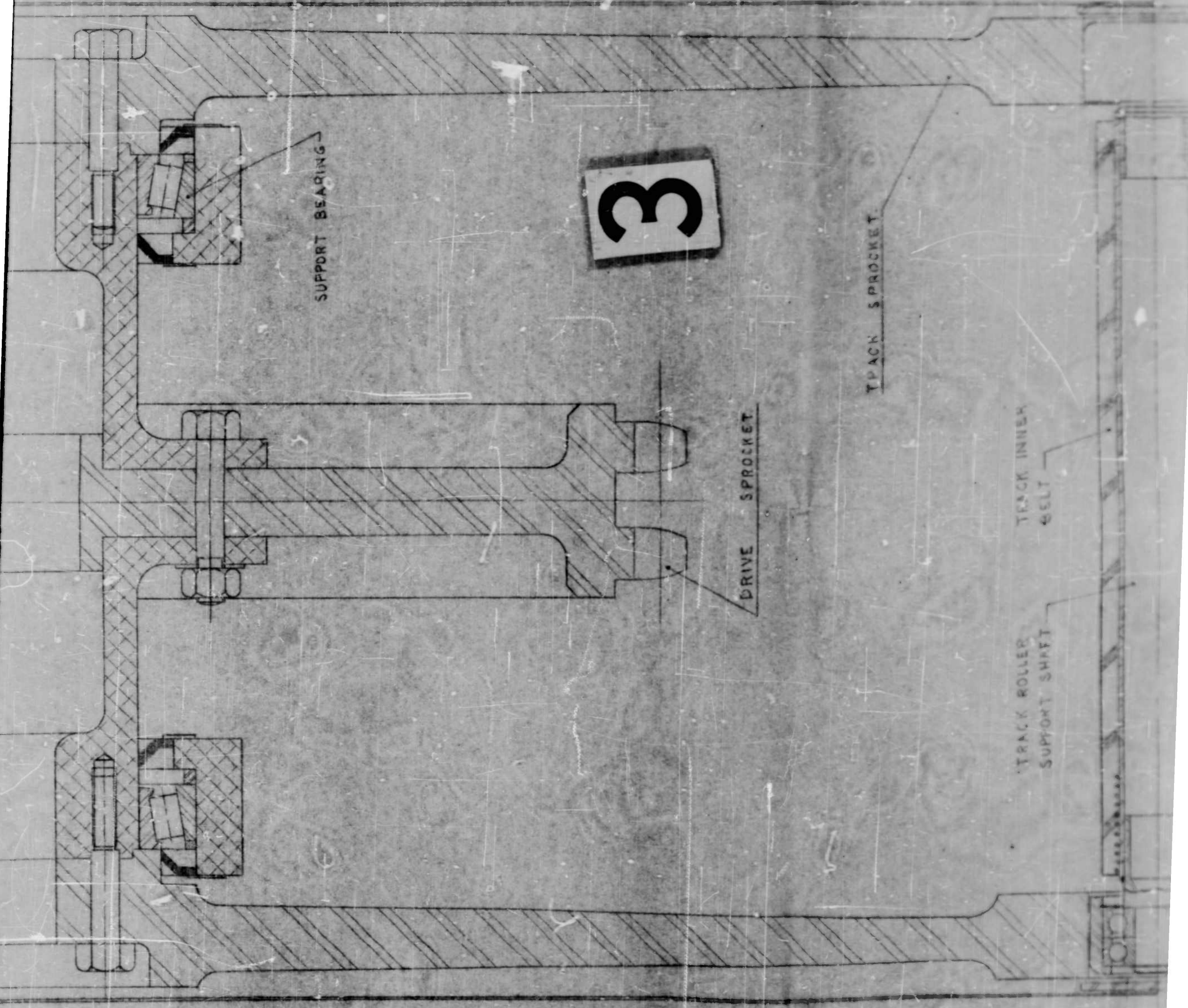

4

TRACK SPROCKET

HORIZONTAL E

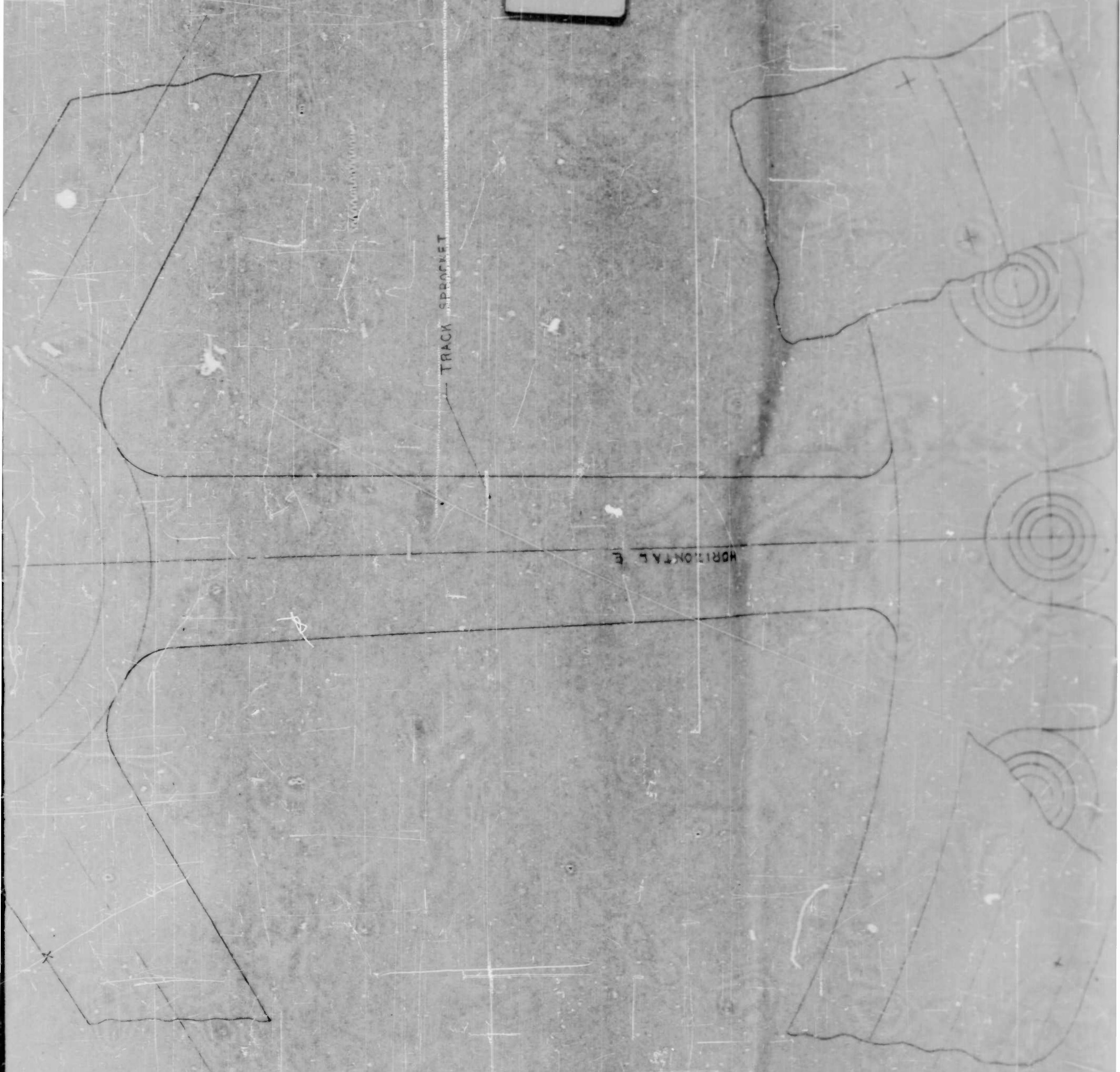

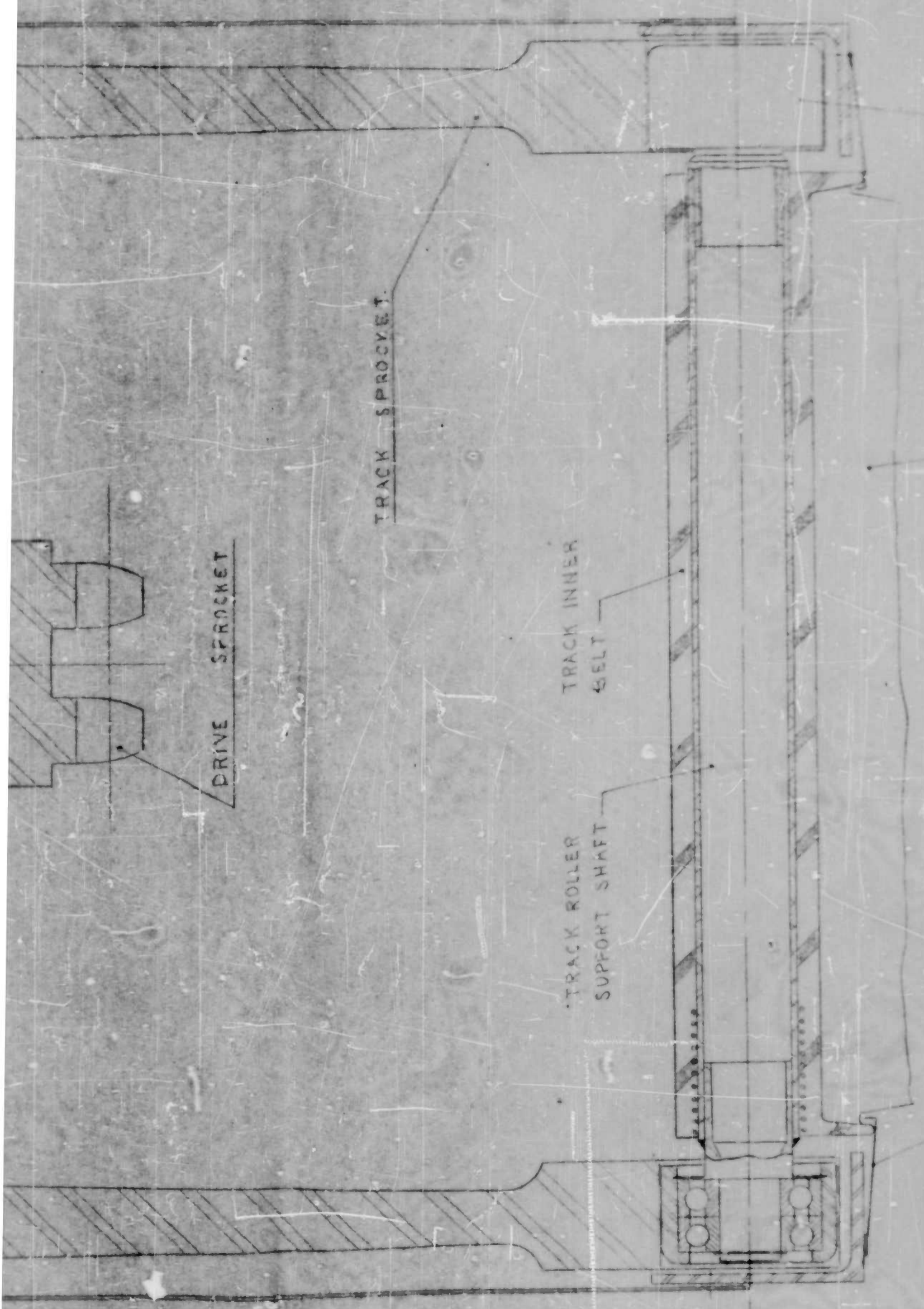

DRIVE SPROCKET

TRACK SPROCKET

TRACK INNER BELT

TRACK ROLLER SUPPORT SHAFT

SEAL

5

TRACK ROLLER

TRACK

6

TRACK ROLLER -

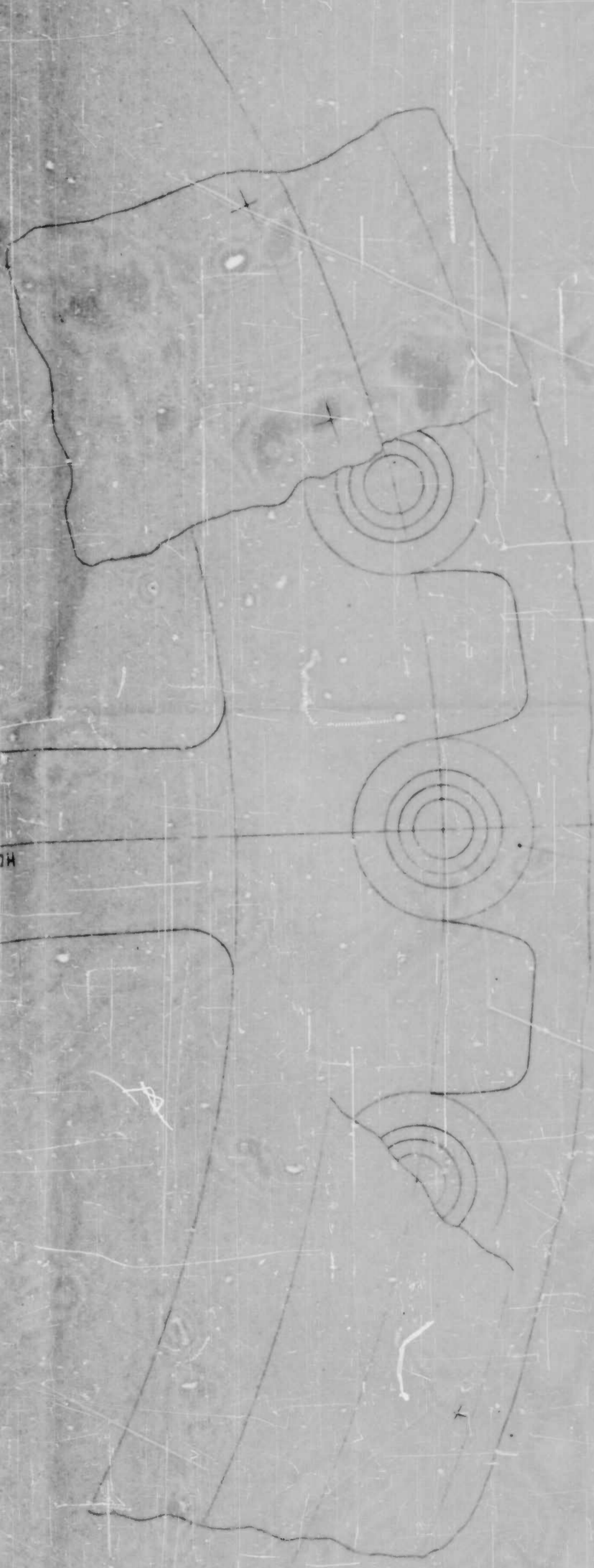

HORIZONTAL E

ITEM NO.	QUANTITY	DESCRIPTION	UNIT
1	1	TRACK ROLLER ASSEMBLY	
H. A. T. V. TRACK SPROCKET ASSEMBLY 04146			
SCALE	DATE	DESIGNED BY	CHECKED BY
1-14-52		OSP	EMC

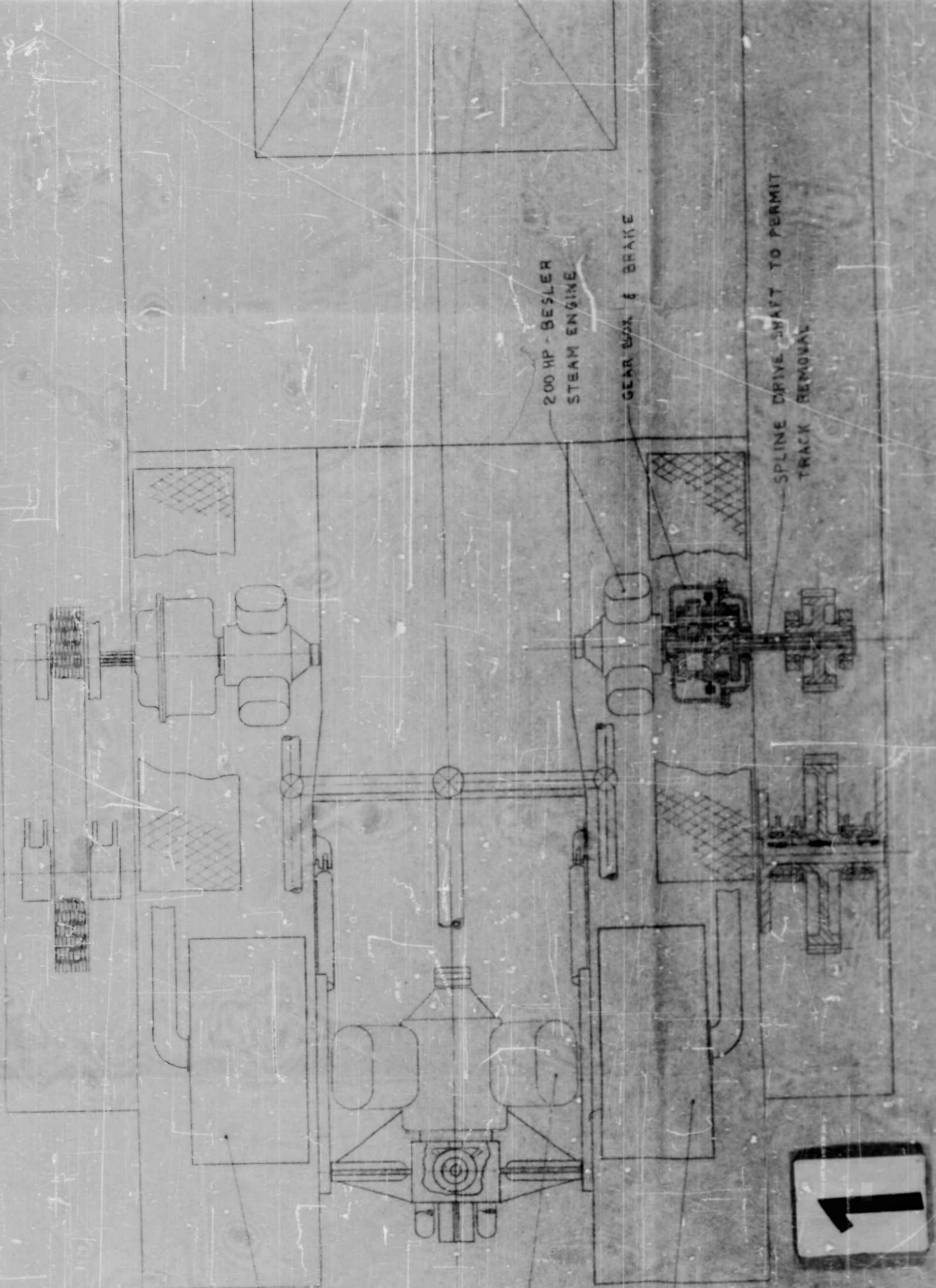

1

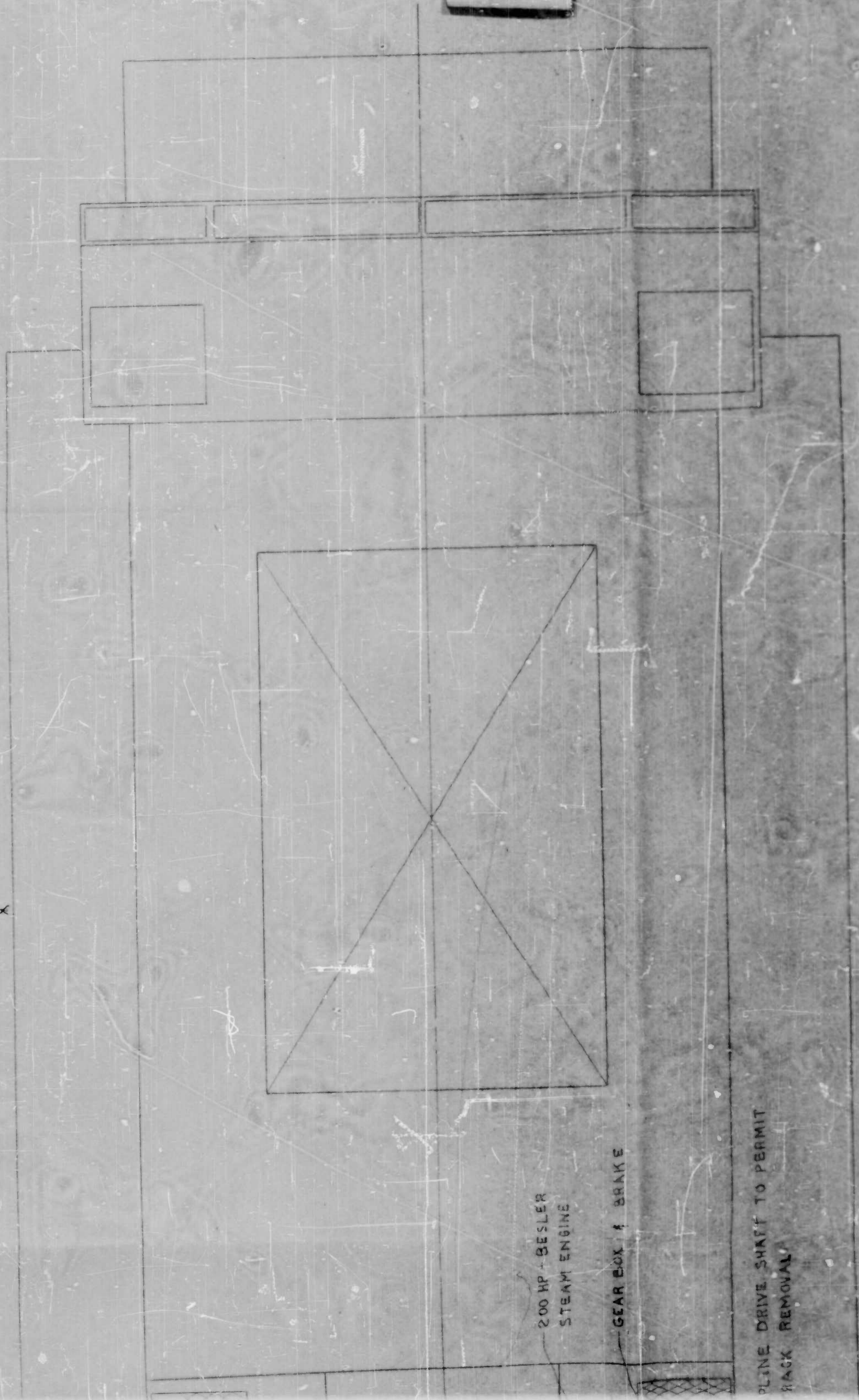

200 HP - BESLER  
STEAM ENGINE

GEAR BOX & BRAKE

REMOVE DRIVE SHAFT TO PERMIT  
RACK REMOVAL

AIR COOLED CONDENSER  
USE DURING LAND TRAVEL

200 HP BESLER  
STEAM ENGINE

3

200 HP - BESLER  
STEAM ENGINE

STEERING GEAR

WATER COOLED CONDENSER  
USE DURING SEA OPERATION

STEAM PIPES

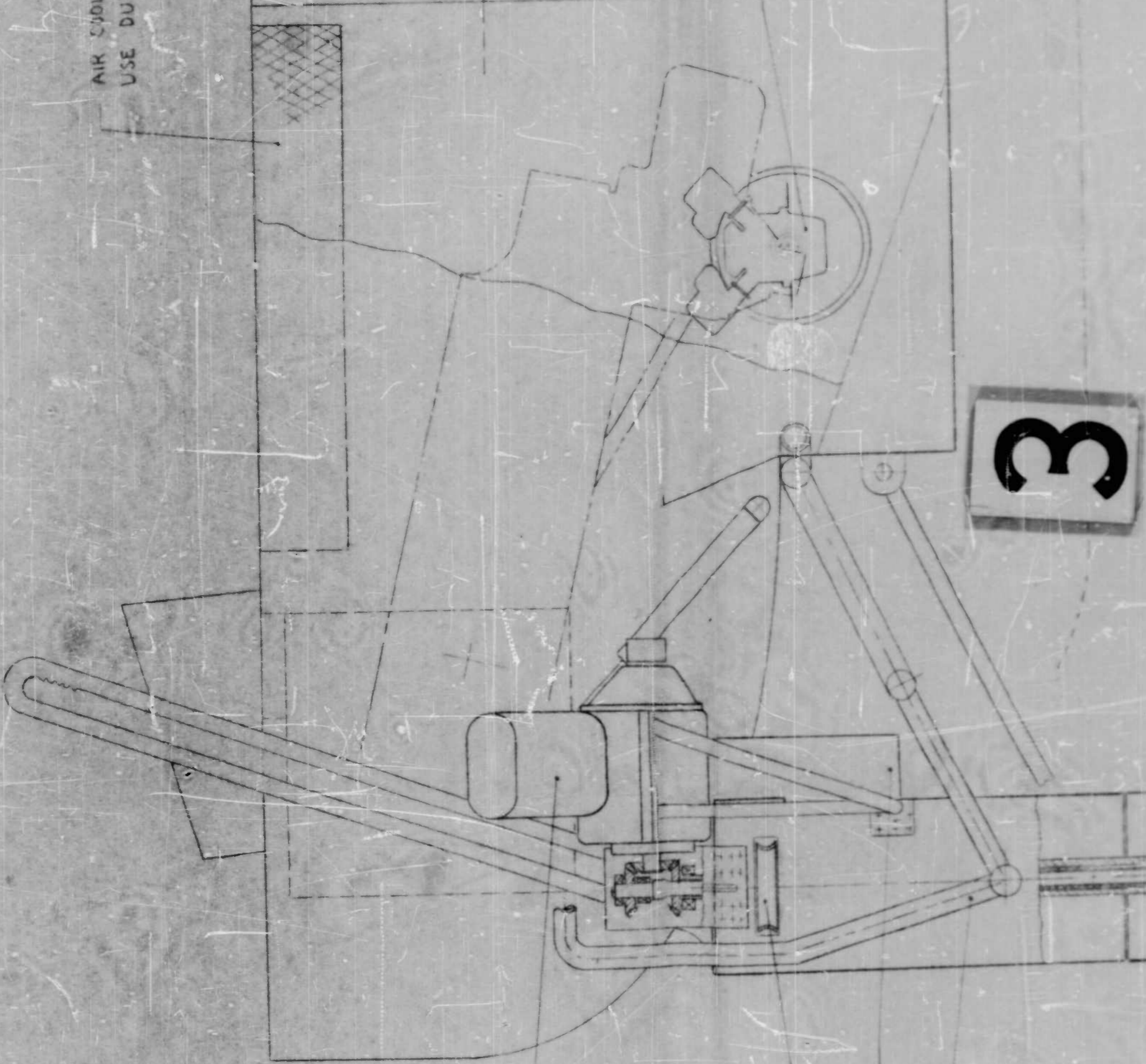

USER  
TRAVEL

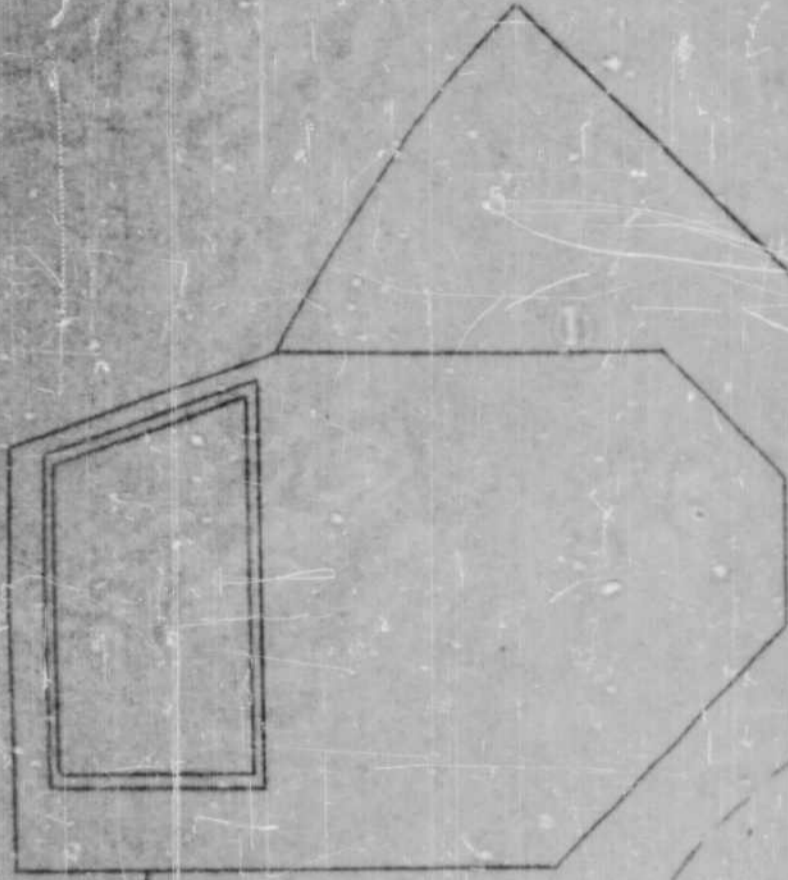

BESLER  
ENGINE

4

GROUND LINE

ITEM	DESCRIPTION	REQ.	QTY.	UNIT	REMARKS
BILL OF MATERIAL					
H.A.T.V.					
POWER PLANT ARRANGEMENT					
3 BESLER STEAM ENGINES					
NO.	DESCRIPTION	REQ.	QTY.	UNIT	REMARKS
1	W-110				
2	11-6-57				
3	O.C.P.				
4	6W				
H.A.T.V. PROJECT HAWAIIAN ISLANDS HONOLULU, HAWAII HAWAII, U.S.A.					
					04145

1000 HP - BESLER  
STEAM ENGINE

200 HP  
STEAM

STEERING GEAR

WATER COOLED CONDENSER  
USE DURING SEA OPERATION

STEAM PIPES

W.L.

5

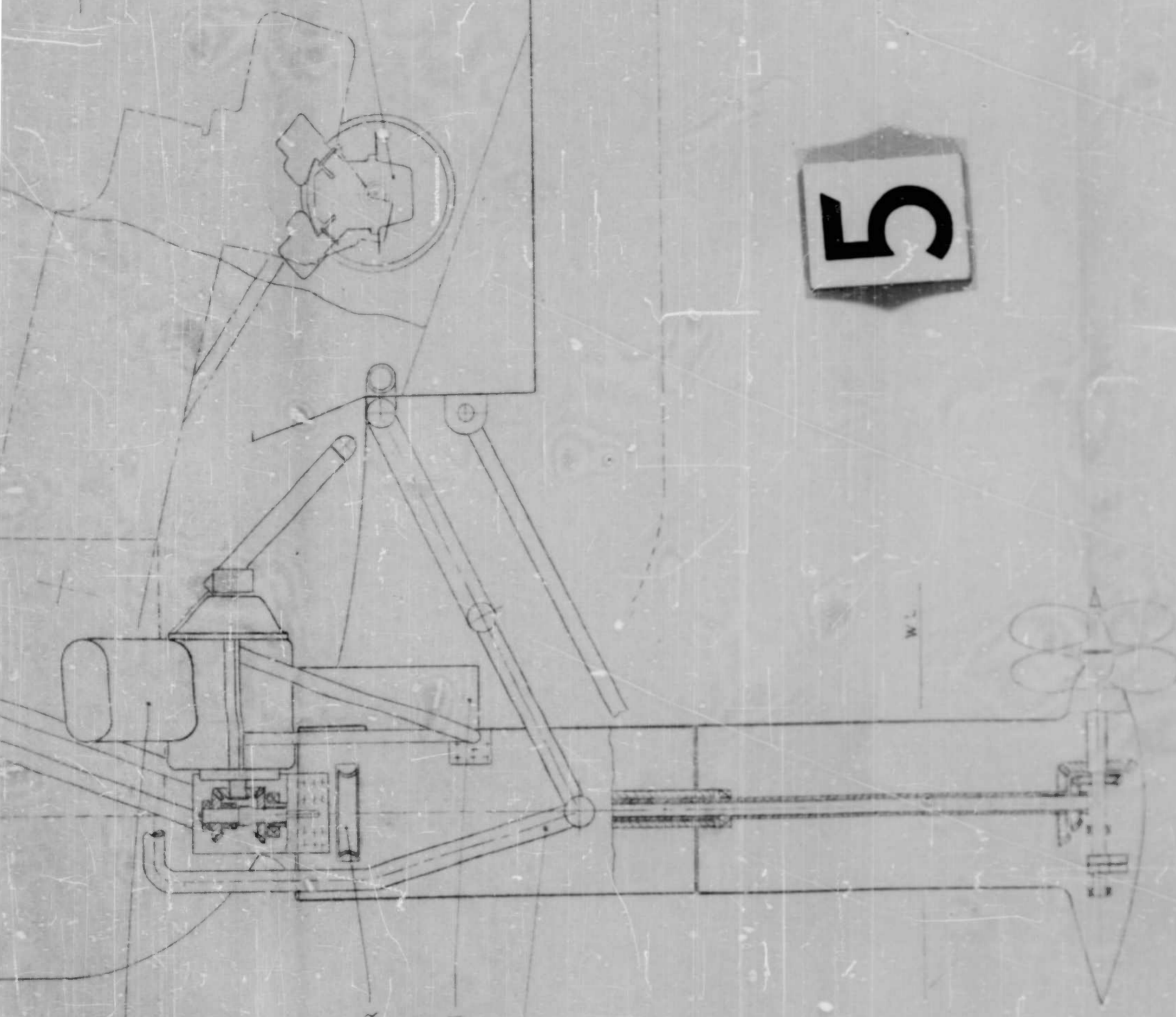

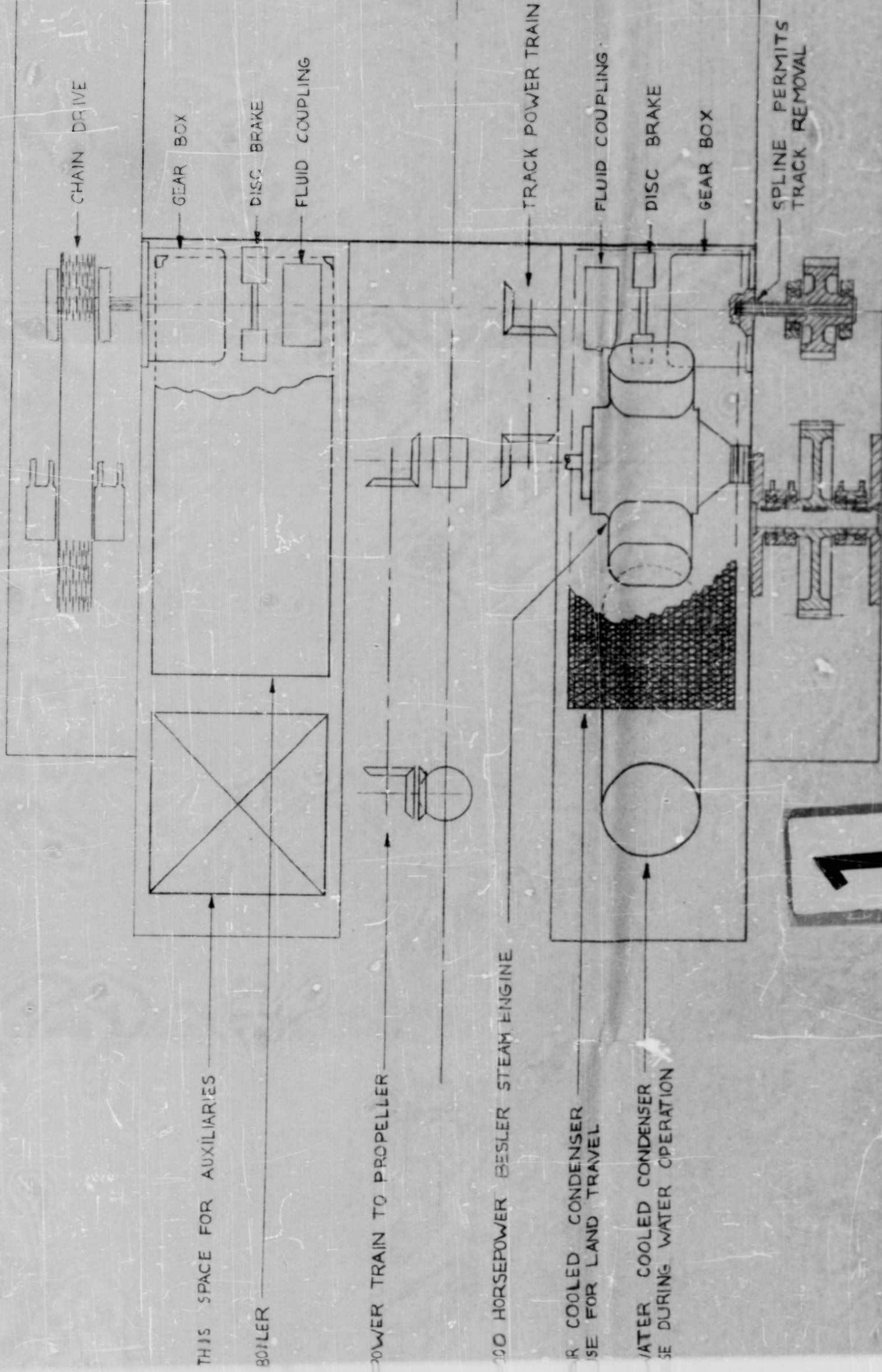

DECK PLAN

2

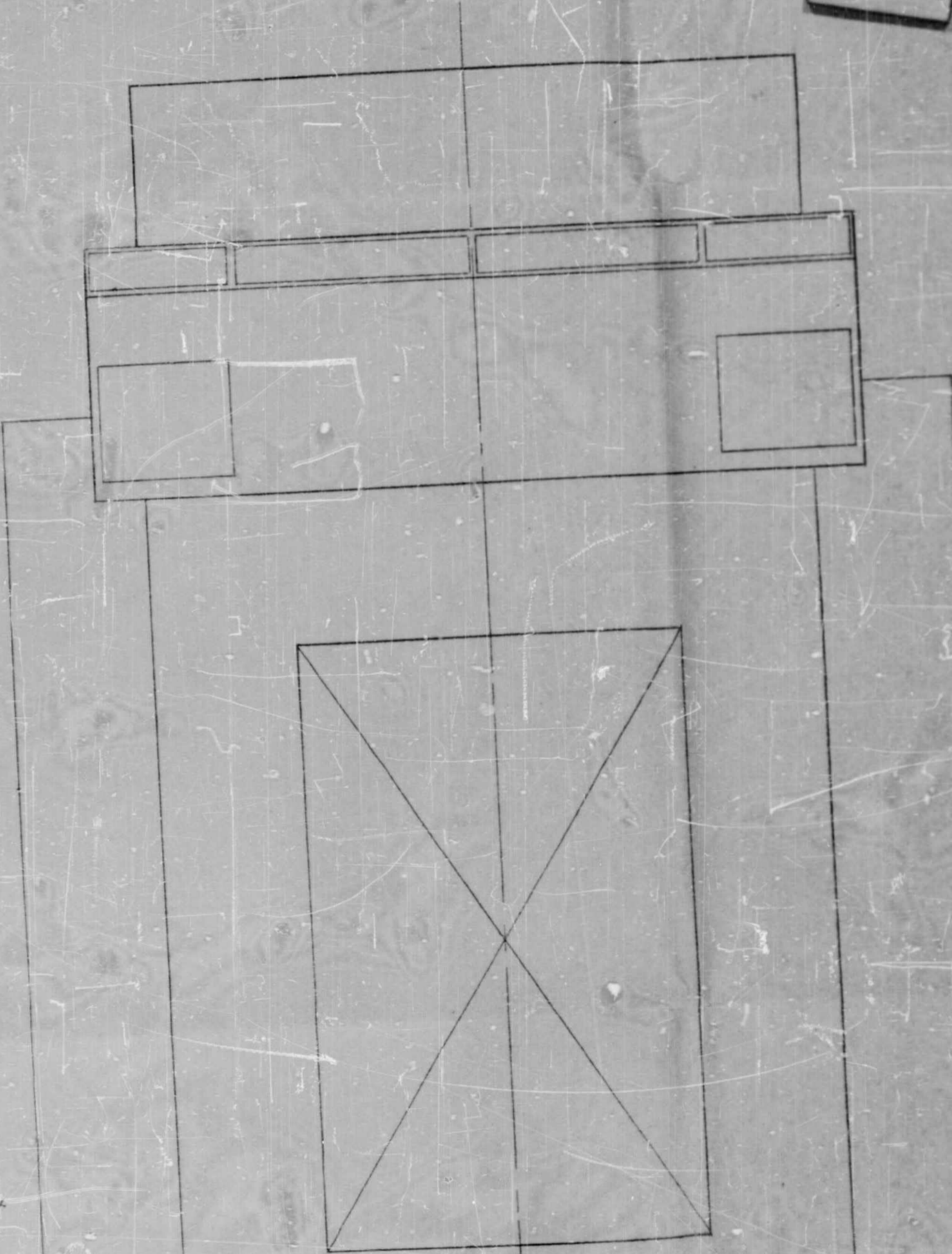

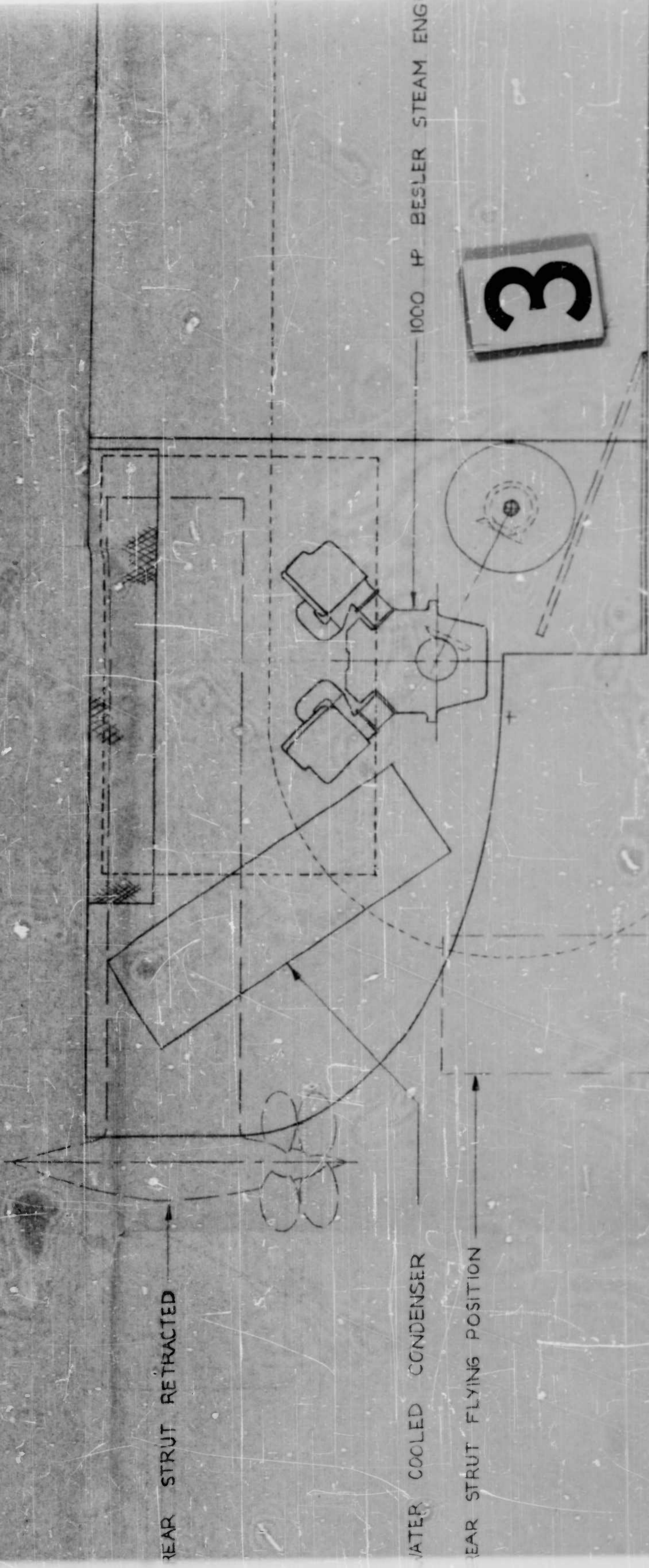

1000 HP BESLER STEAM ENGINE

3

REAR STRUT RETRACTED

WATER COOLED CONDENSER

REAR STRUT FLYING POSITION

INBOARD PROFIL

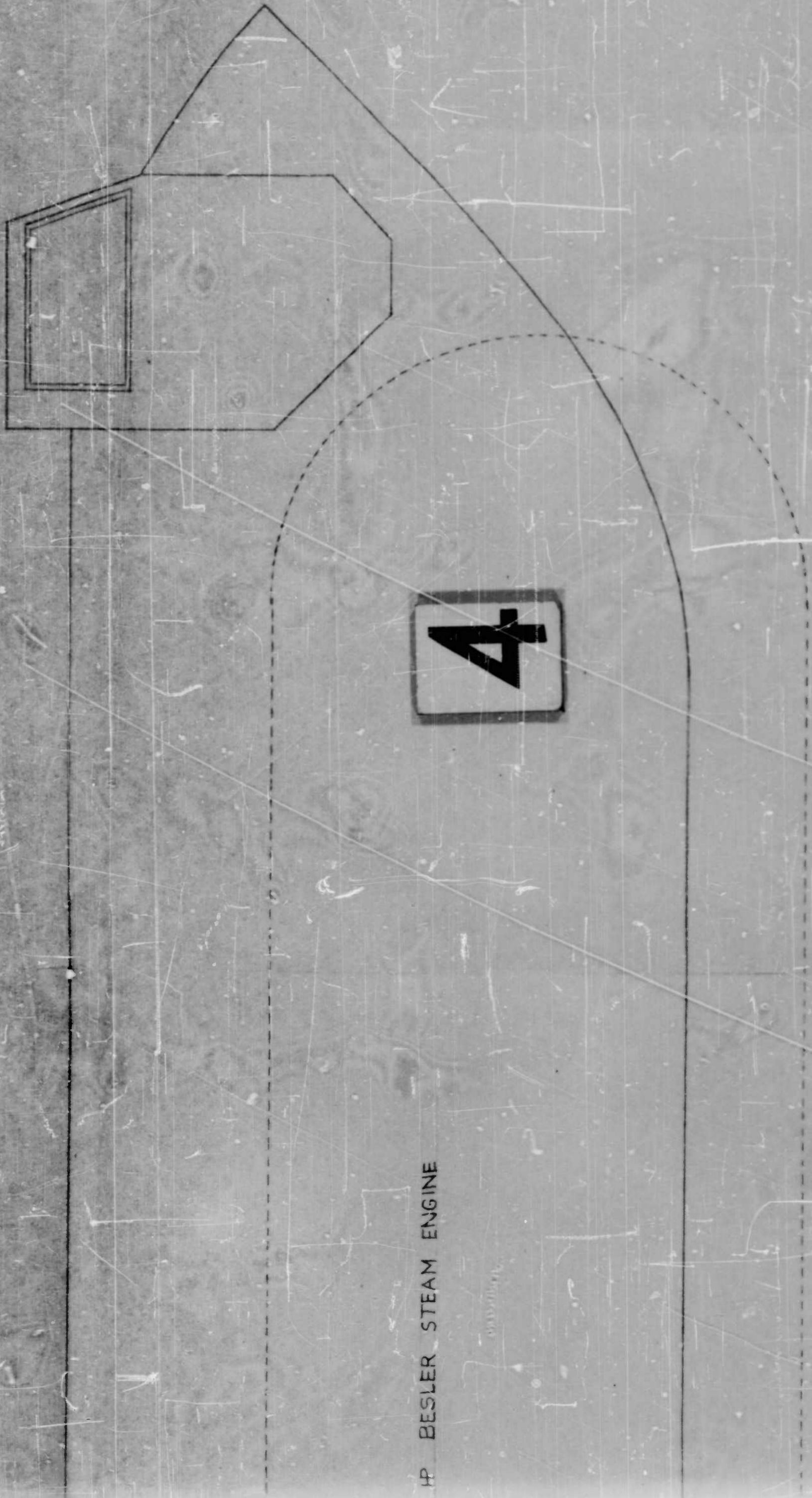

HP BESLER STEAM ENGINE

INBOARD PROFILE

5

ITEM	DESCRIPTION	QTY	MATERIAL	SIZE	REMARKS
<b>BILL OF MATERIAL</b>					
FINISH		H. A. T. V.			
SCALE	3/4" = 1'-0"	1000 HP BESLER STEAM			
DATE	11-20-57	ENGINE INSTALLATION			
DRAWN	G K P	ACT. WT			
TRACED		MAJOR ASSEM.			
CHECKED		NET ASSEM.			
		NO. PER MAJ. ASSEM.			
MIAMI SHIPBUILDING CORP.		04144		AMT.	
MIAMI, FLORIDA U. S. A.					

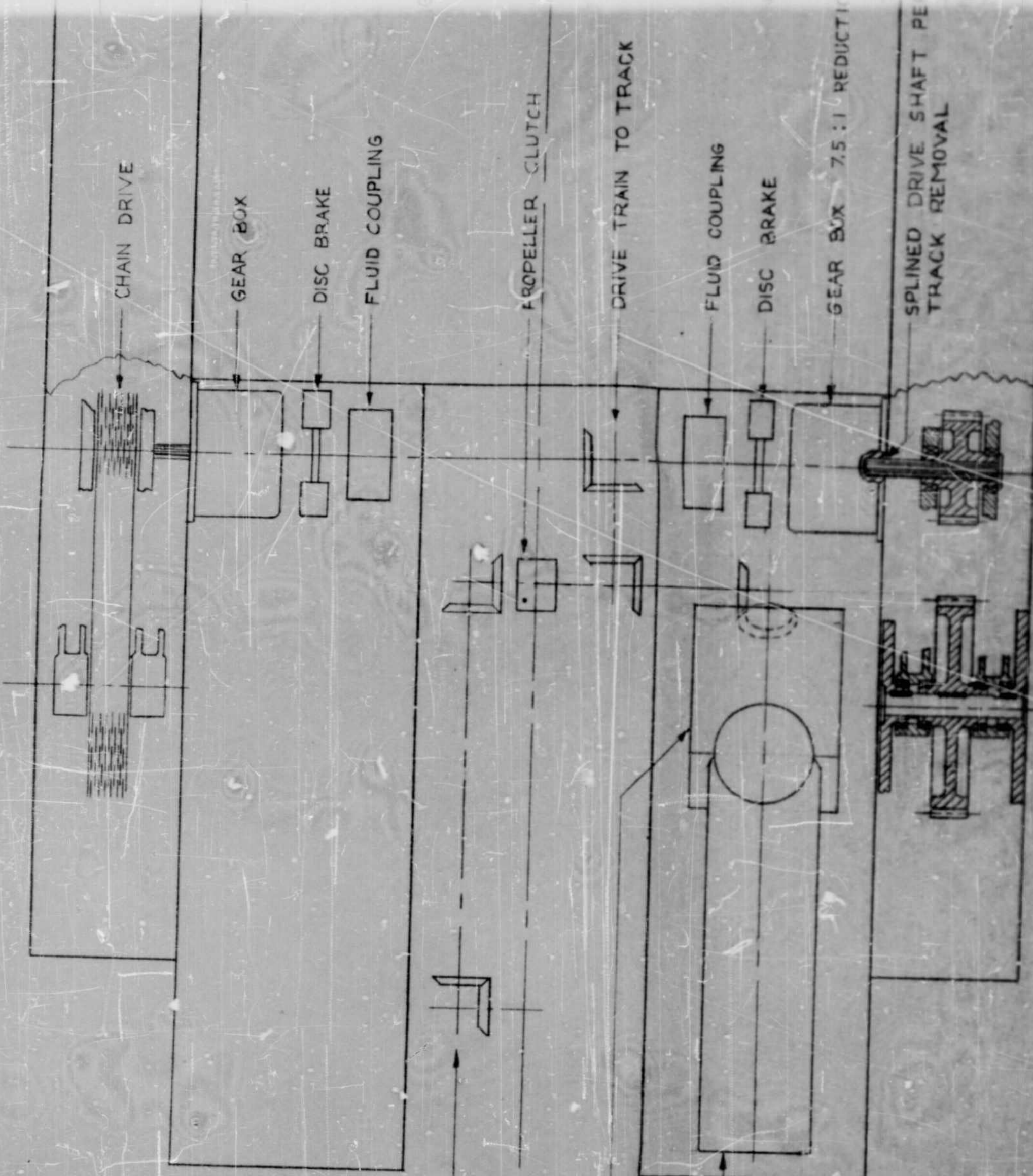

DRIVE TRAIN TO PROPELLER

TRANSMISSION 3 SPEED & REVERSE

GENERATOR TURBINE 825 HP  
GENERAL ELECTRIC T 58

1

DECK

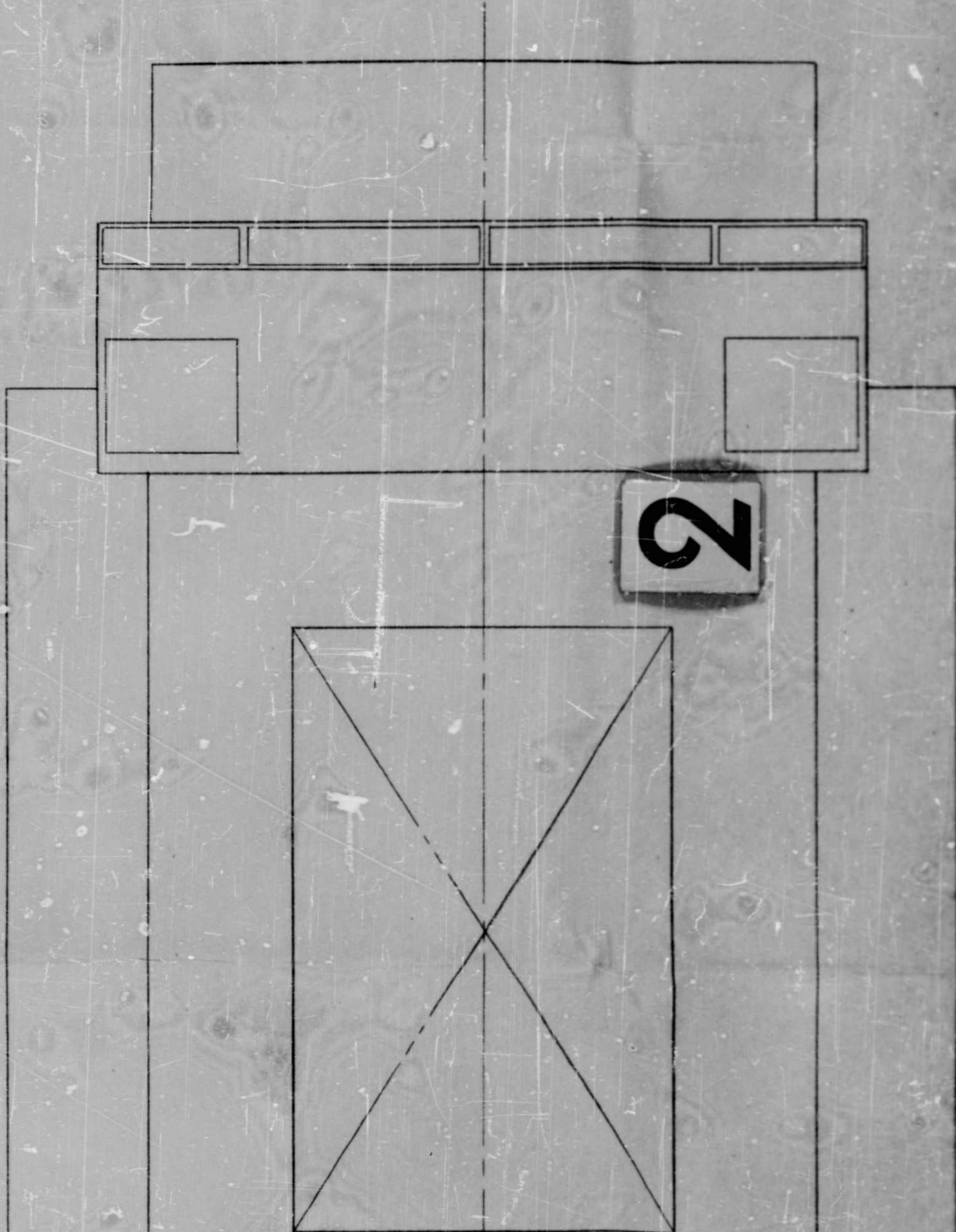

x

ACK

REDUCTION

HAFT PERMITS

DECK PLAN

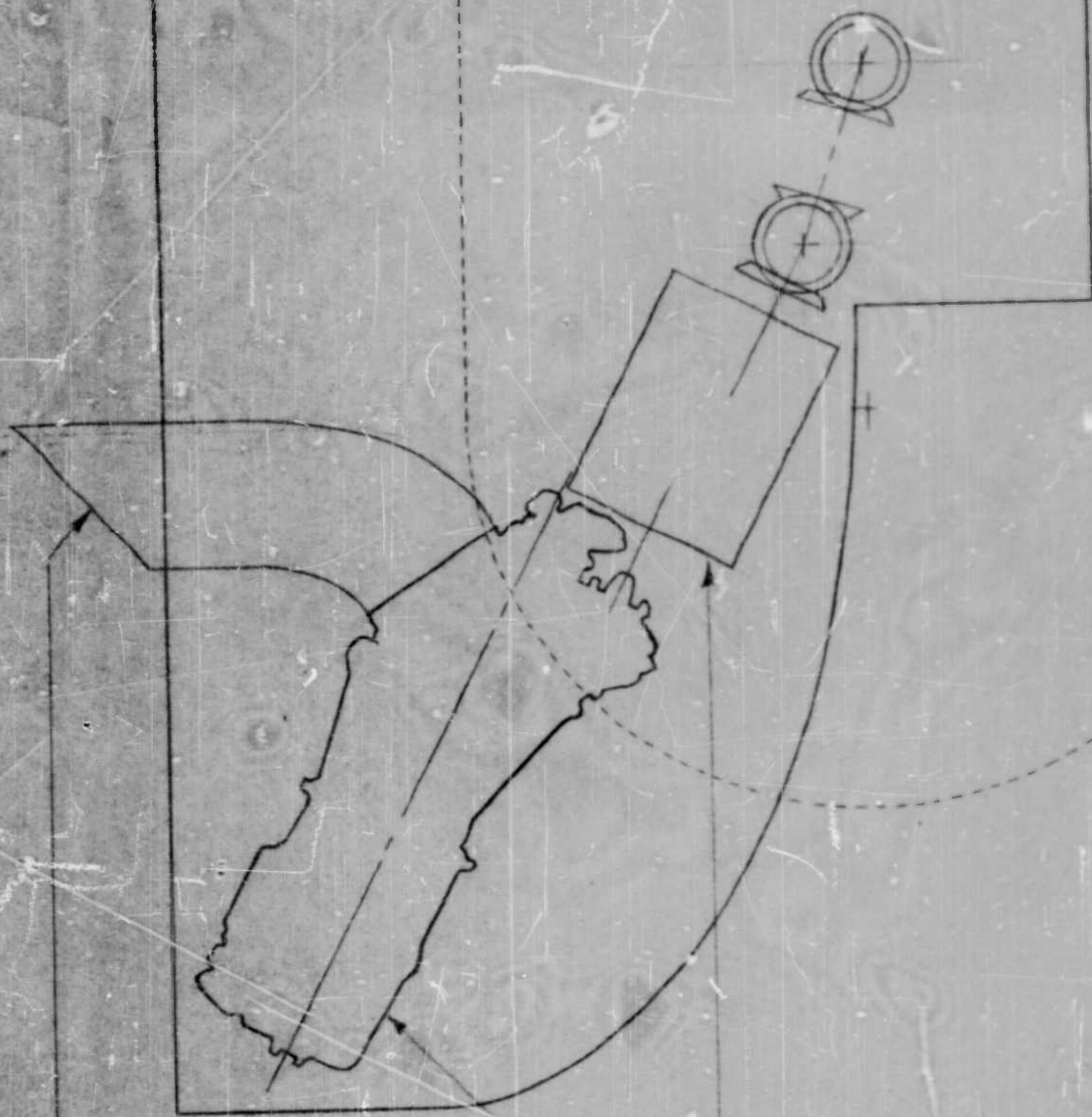

— EXHAUST —

— TURBINE AIR INLET —

— TRANSMISSION —

3

INBOARD



4

INBOARD PROFILE

5

ITEM	DESCRIPTION	REQ.	MATERIAL	SIZE	REMARKS
<b>BILL OF MATERIAL</b>					
FINISH					ACT. WT.
SCALE	3/4" = 1'-0"				MAJOR ASSEM.
DATE	11-20-57				MEET. ASSEM.
DRAWN	G K P				NO. PER PROJ. ASSEM.
TRACED					
CHECKED	S J V				
H. A. T. V. 825 HP GE GAS TURBINE ENGINE INSTALLATION				04143	ALT.
Miami Shipbuilding Corporation MIAMI, FLORIDA, U. S. A.					

35'-7"

1

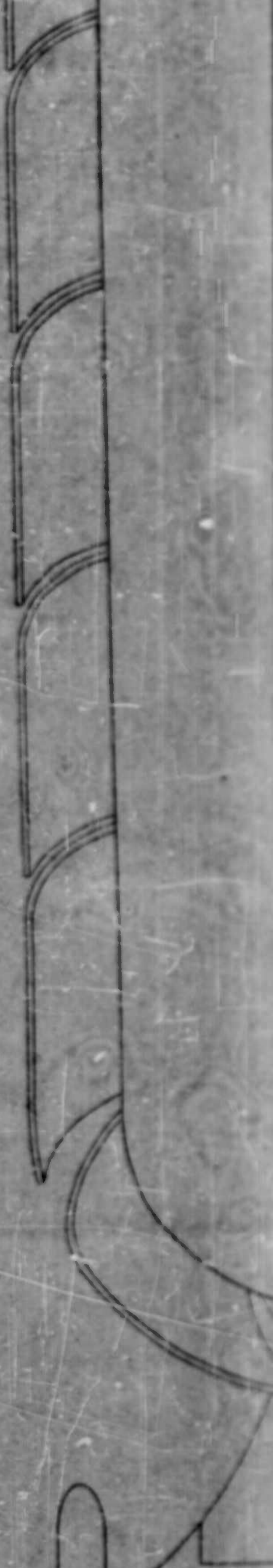

2

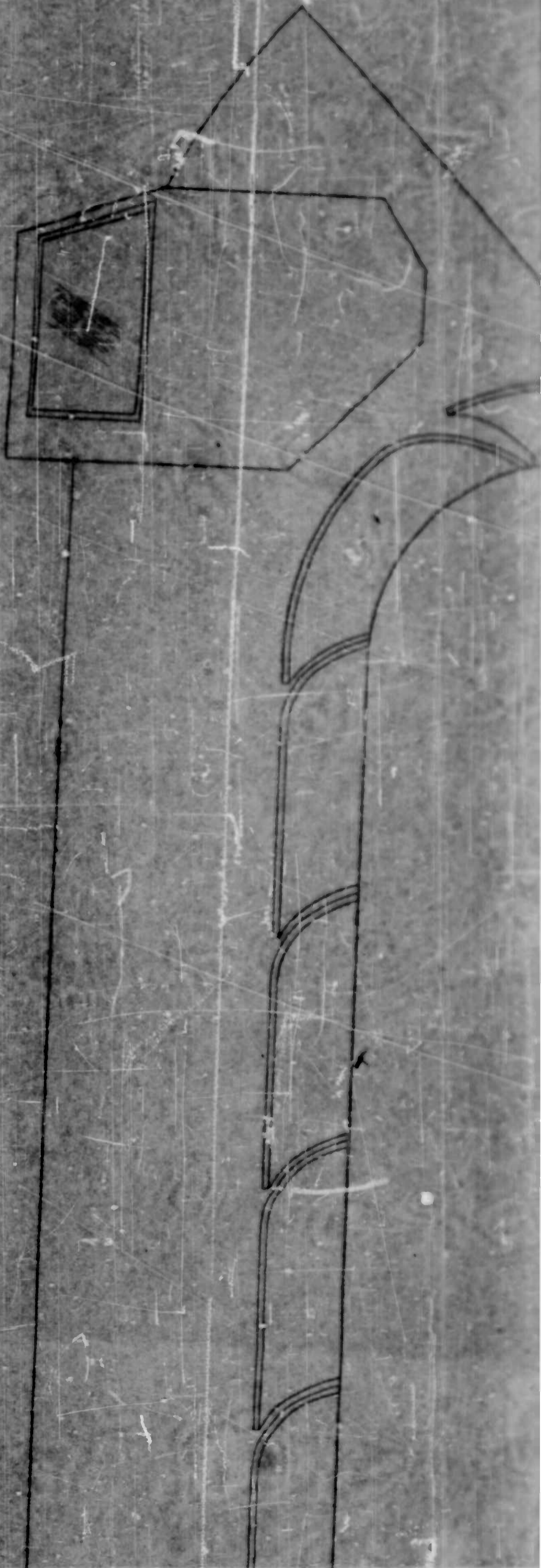

3

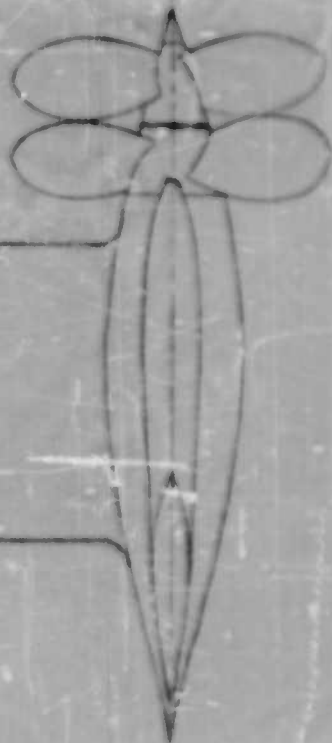

BOATING WATER LINE

FLYING WATER LINE

4

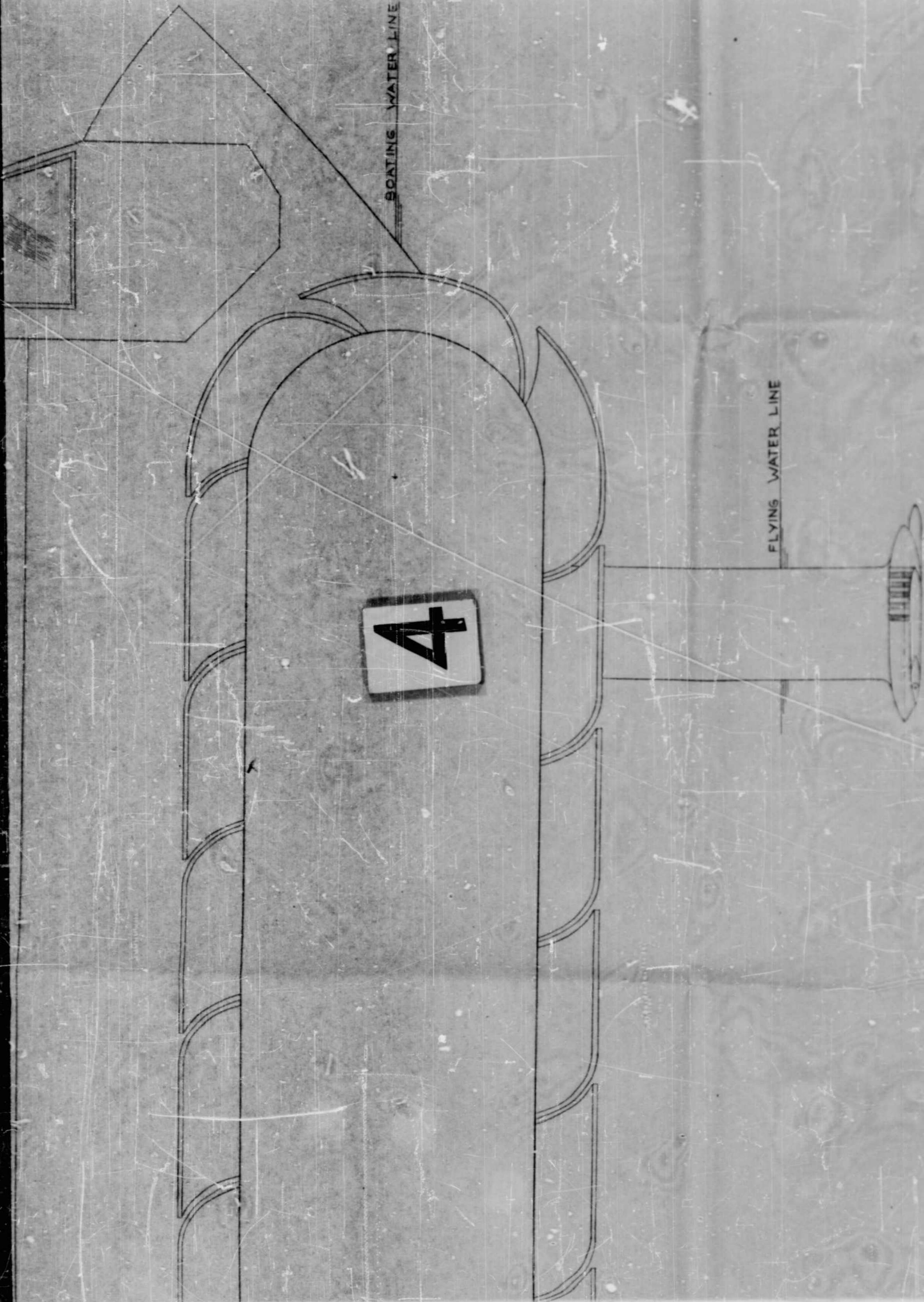

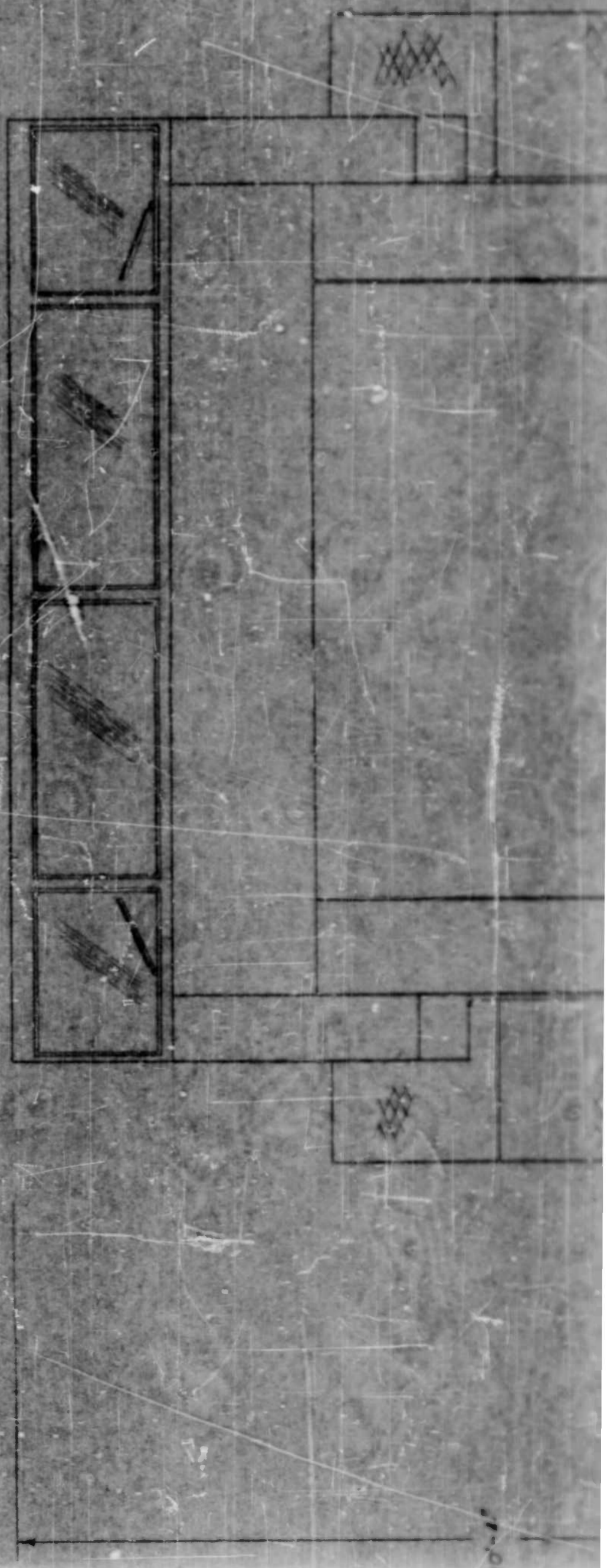

6

3'-6"

5'-0"

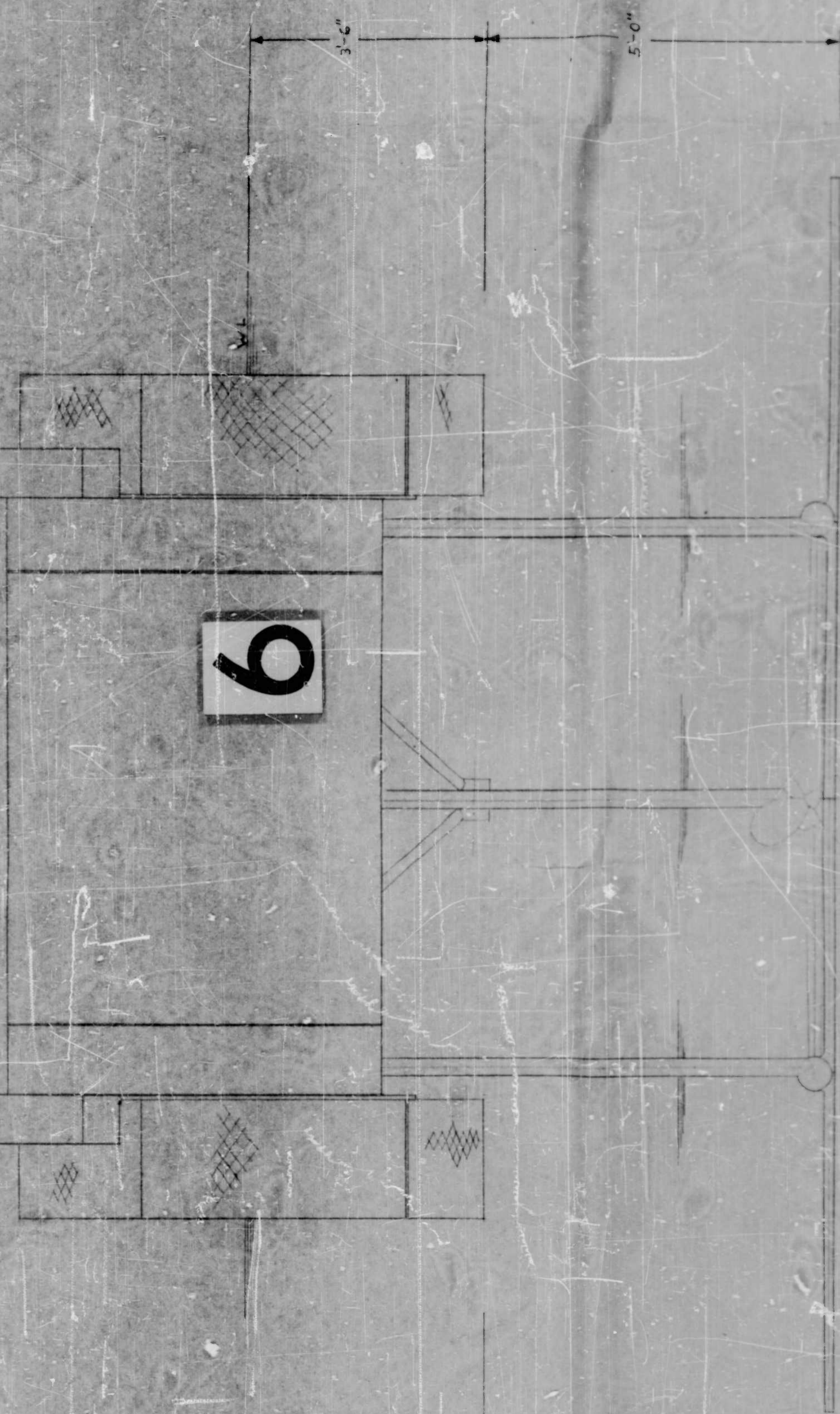

5'-0"



7

ITEM	DESCRIPTION	REQ	DATE	REMARKS
BILL OF MATERIALS				
H.A.T.V.				
FLYING POSITION				
FINISH	3/8" x 1/2"			
SCALE	1/4" = 1"			
DATE	11-13-57			
DESIGN	JAG			
BY	ELN			
CHECKED				
NEW SUPPLYING COMPANY				
MIAMI, FLORIDA, U.S.A.				
				04142
				04142

3' x 3" x 3/16" L GUNWALE

INTERMEDIATE DECK BEAMS 3' x 2 1/2"

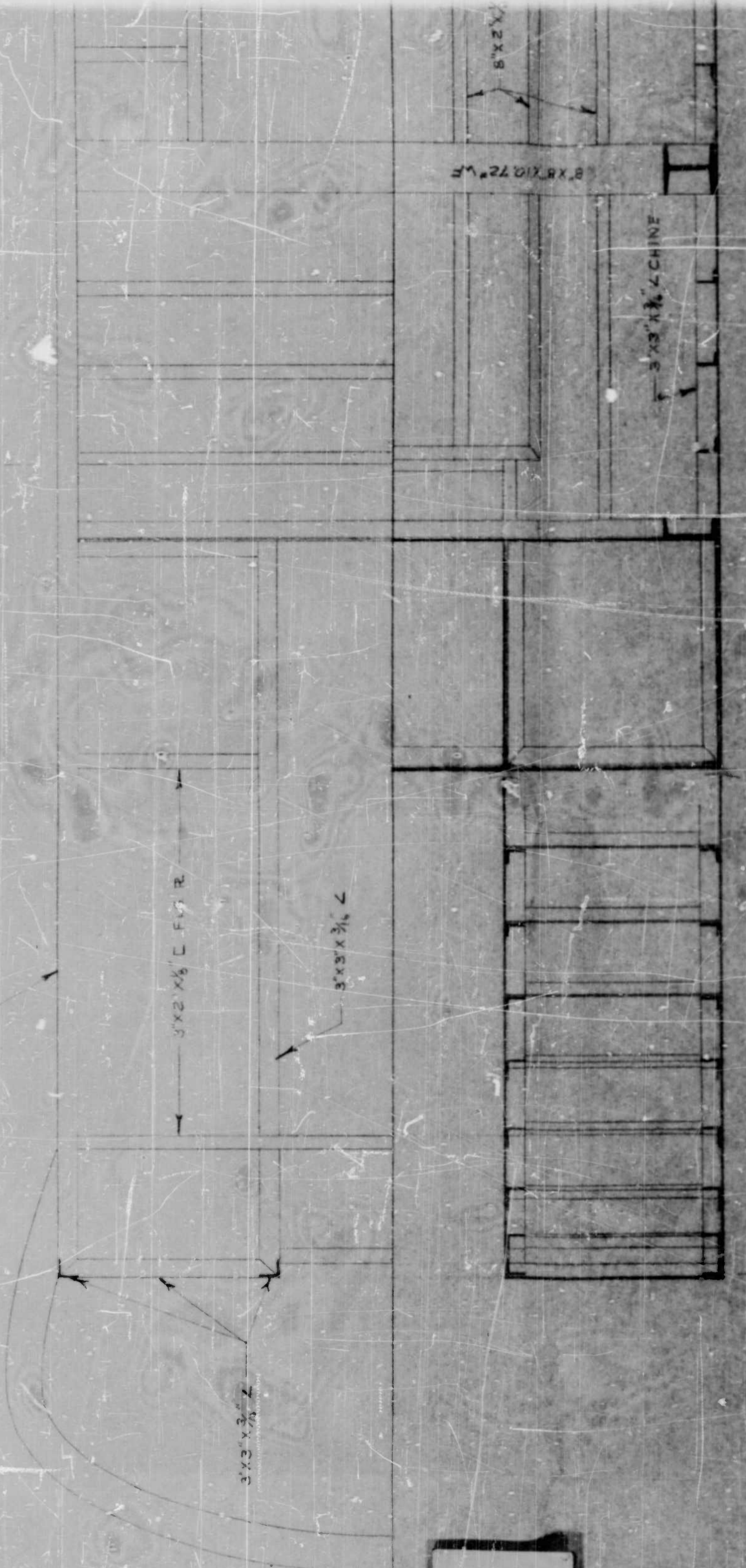

1

2

4" X 5" X 1/2" BOX FRAME

2 1/2" X 5" X 1/2" BOX FRAME

DECK FRAMING  
BOTTOM FRAMING

8" X 8" X 12 9/16" W.F.

8" X 8" X 12 9/16" W.F.

2" X 2" X 1/4" (FLG R)

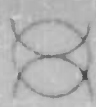

2" X 2" X 1/4"



3

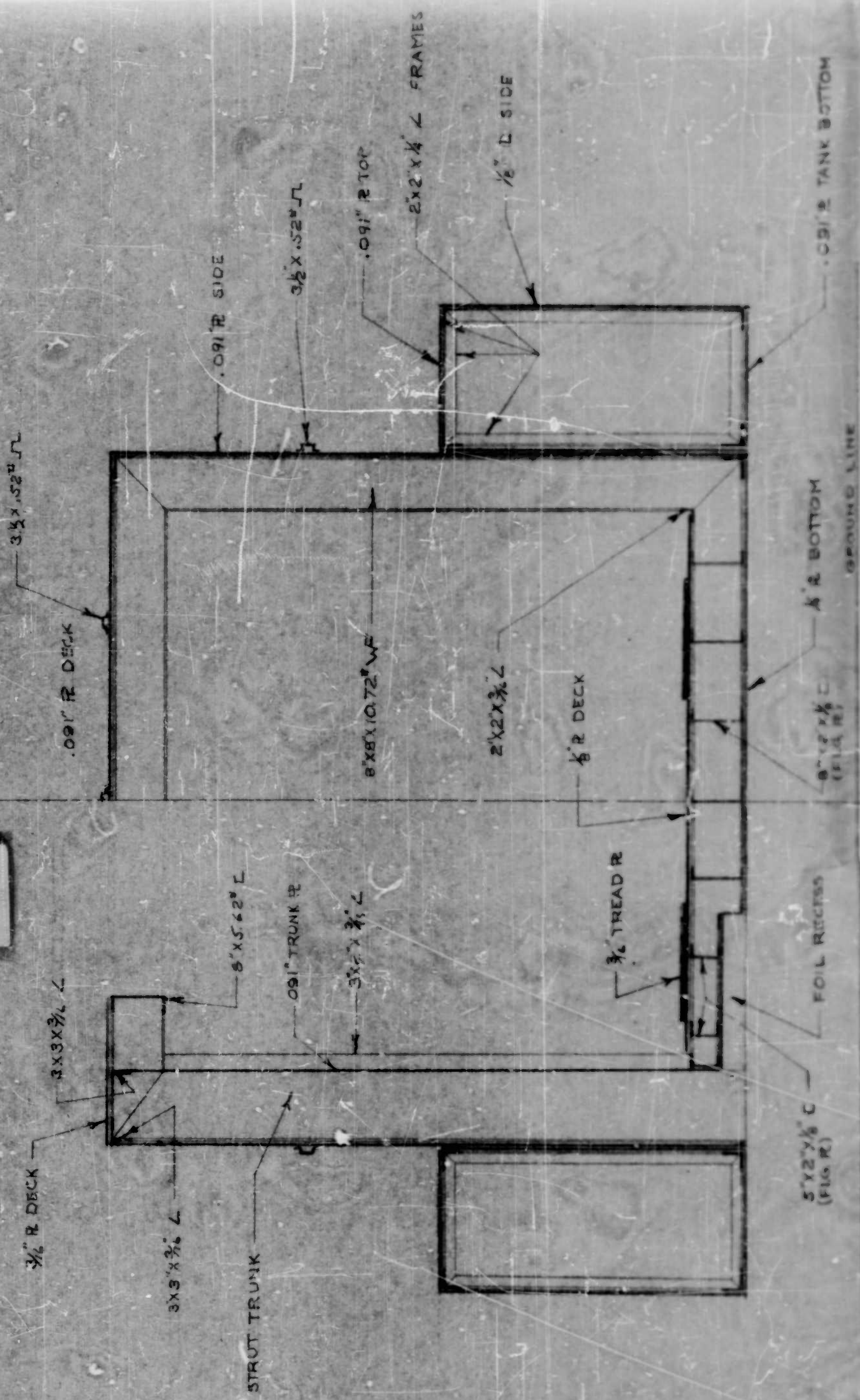

SECTION AFT OF HATCH  
LOOKING FWD.

SECTION THROUGH HATCH  
AND STRUT TRUNK - LOOKING AFT.

4

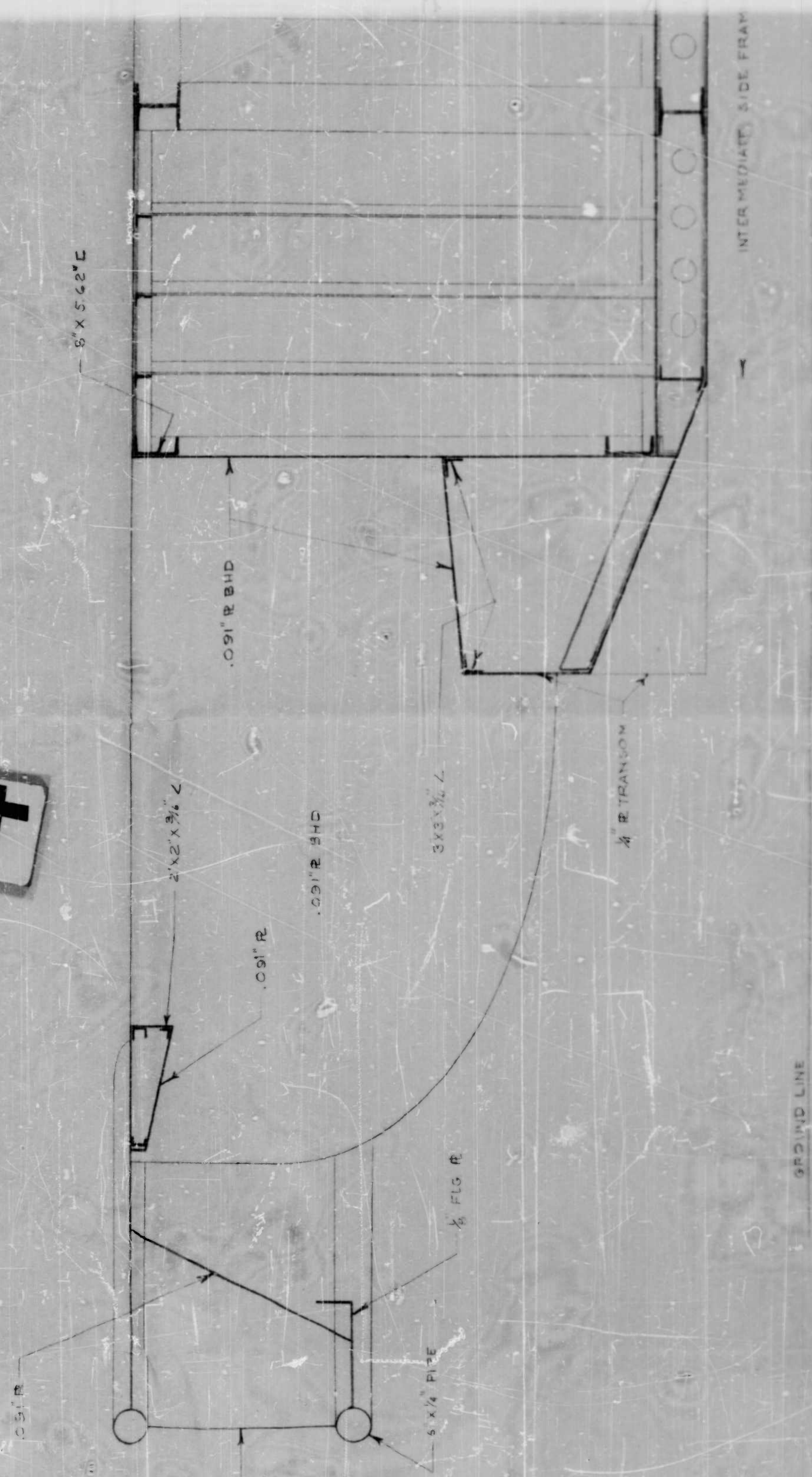

2x2 x 3/8" L

0.01 E

8" x 5.62" C

5 x 3.11" C

5

1/2" FLG R. CONTIN.

1/2" FLG R. INTERCITAL

HINGE  
FOIL RECESS

INTERMEDIATE SIDE FRAMING 3x2x3/2

GROUND LINE

1

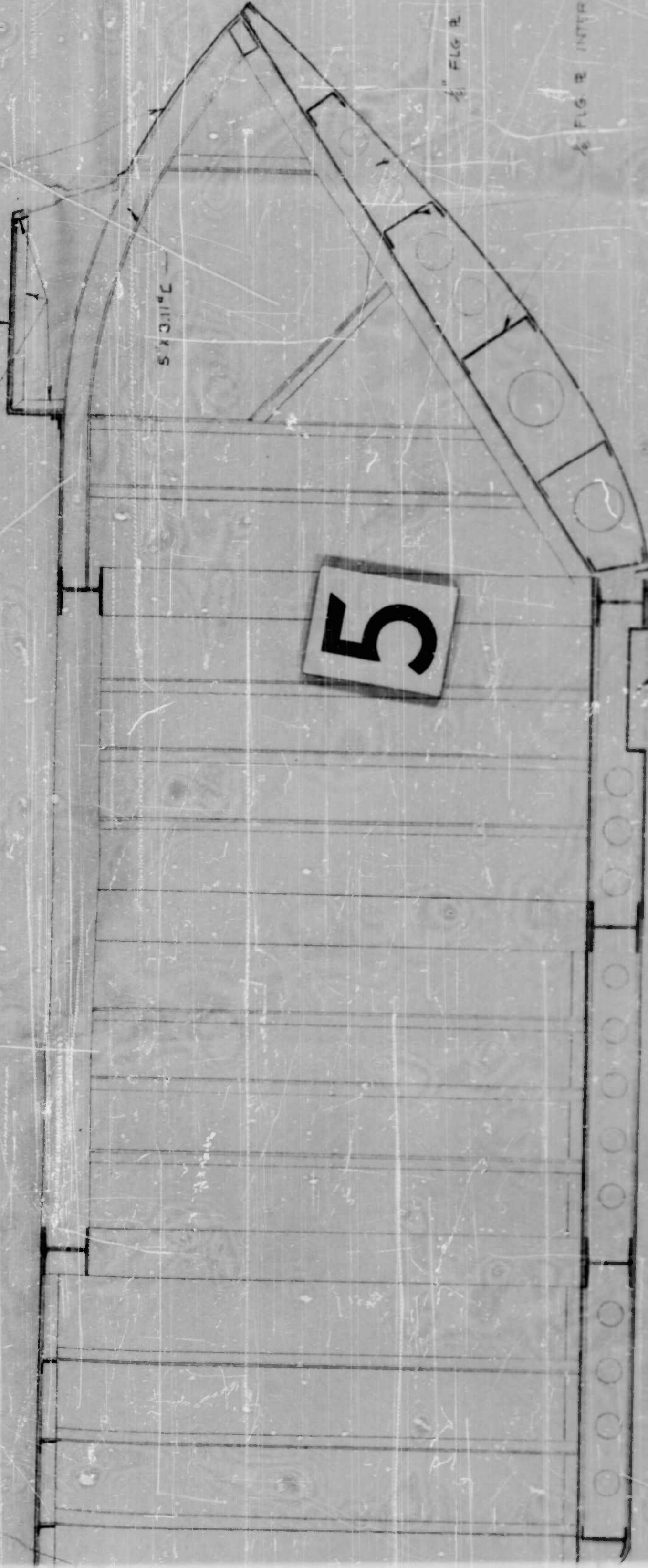

6

DATE	14 MAR 50
TIME	11-21-57
BY	WZ
REMARKS	WZ
TYPE OF OBSERVATION	LINE
LOCATION	U.S. V.
DESCRIPTION	HULL STRUCTURE
SCALE	0.4/41
NO.	7

1

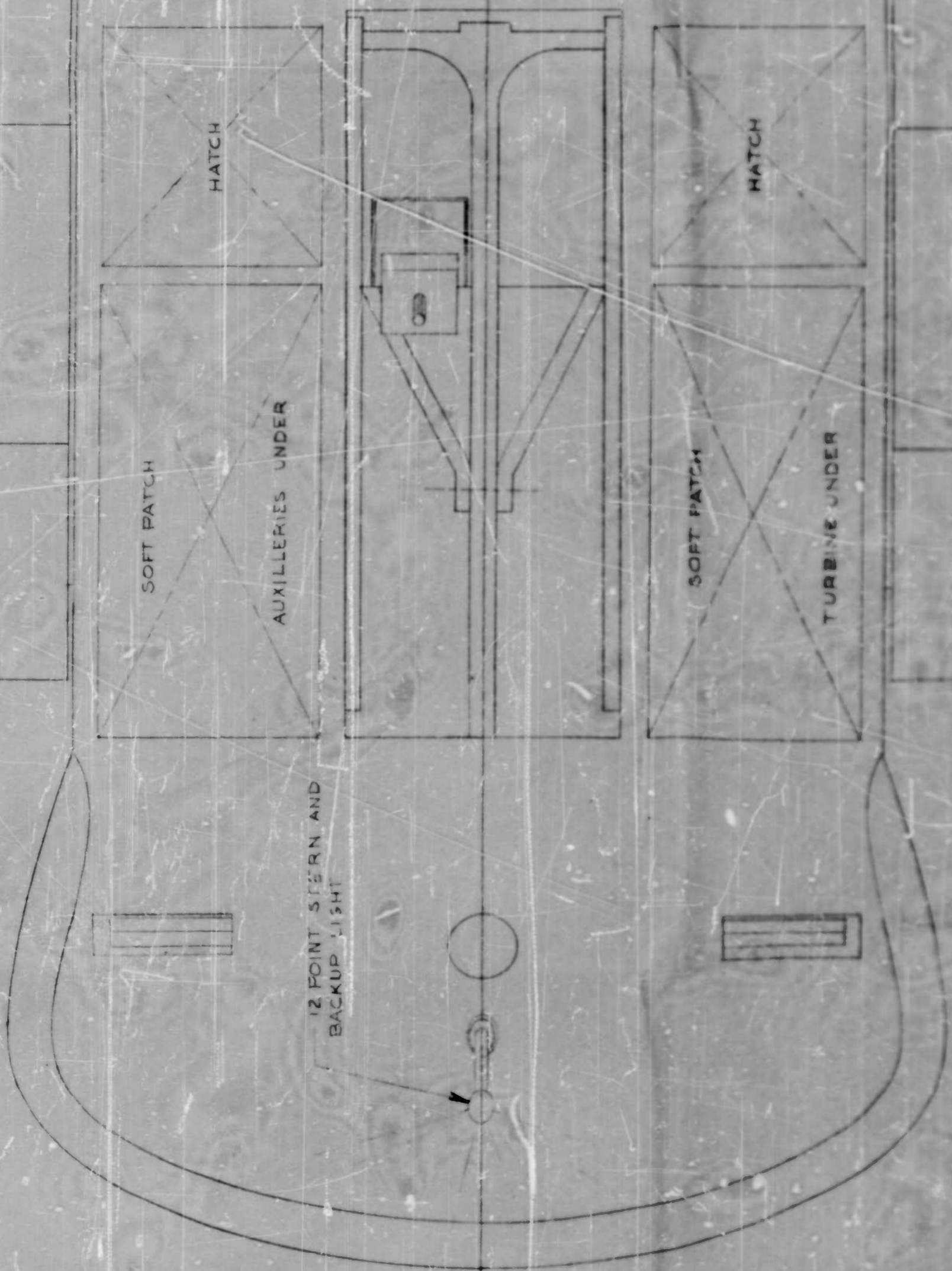

RED PORT LIGHT - 10 POINTS

WHITE BOW LIGHT - 20 POINTS

GREEN STARBOARD LIGHT - 10 POINTS

2

HATCH

HATCH

CARGO HATCH

8'4" X 5'0"

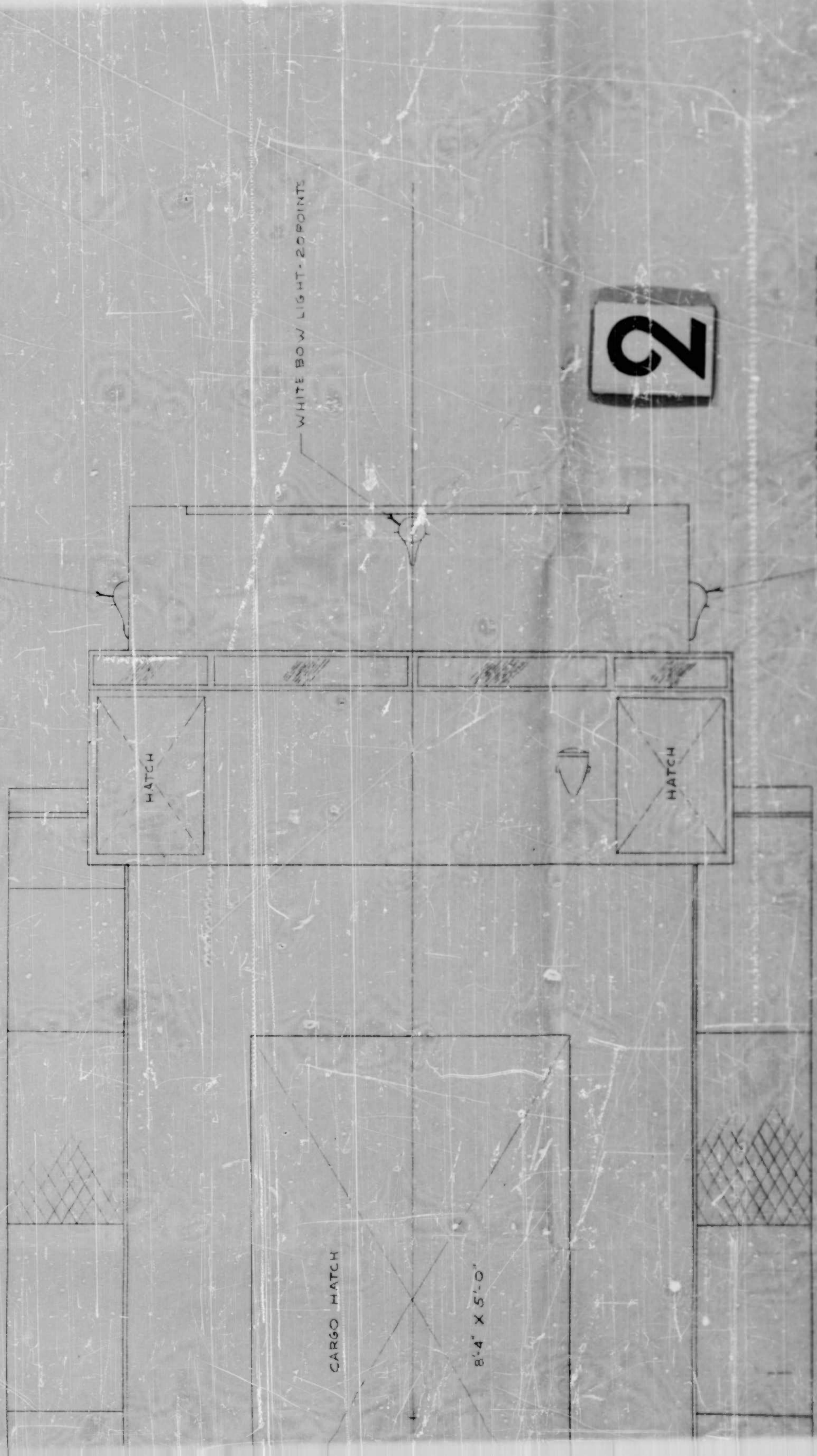

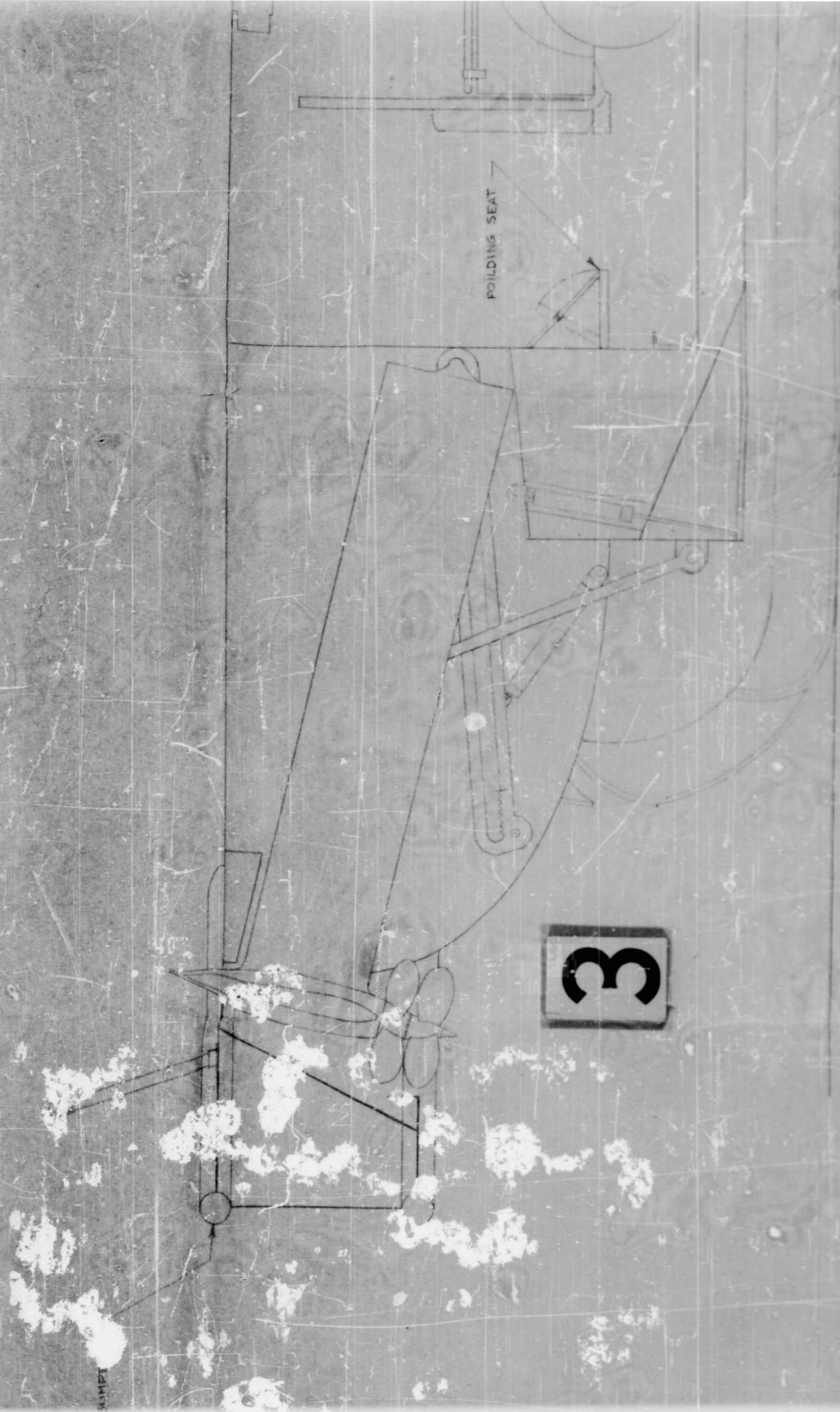

FOLDING SEAT

3

31111

SEARCHLIGHT - 3/4 MILE

BOW DOOR HOISTING WINCH

RECESSED HEAD LIGHT

4

CARGO HATCH

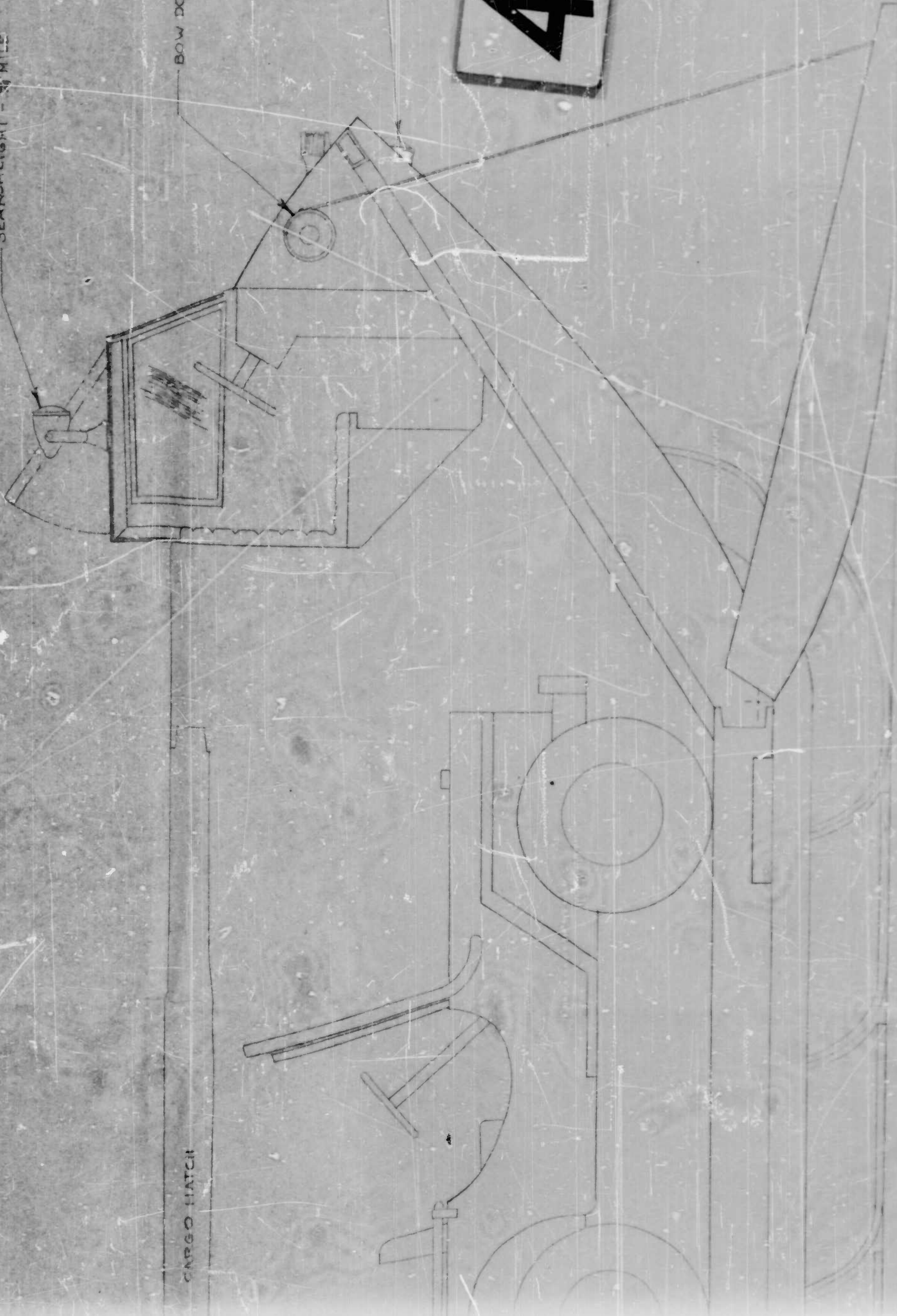



**UNCLASSIFIED**

**A  
D  
149926**

**Armed Services Technical Information Agency**

**ARLINGTON HALL STATION  
ARLINGTON 12 VIRGINIA**

**FOR  
MICRO-CARD  
CONTROL ONLY.**

**4 OF 4**

**NOTICE: WHEN GOVERNMENT OR OTHER DRAWINGS, SPECIFICATIONS OR OTHER DATA ARE USED FOR ANY PURPOSE OTHER THAN IN CONNECTION WITH A DEFINITELY RELATED GOVERNMENT PROCUREMENT OPERATION, THE U. S. GOVERNMENT THEREBY INCURS NO RESPONSIBILITY, NOR ANY OBLIGATION WHATSOEVER, AND THE FACT THAT THE GOVERNMENT MAY HAVE FORMULATED, FURNISHED, OR IN ANY WAY SUPPLIED THE SAID DRAWINGS, SPECIFICATIONS, OR OTHER DATA IS NOT TO BE REGARDED BY IMPLICATION OR OTHERWISE AS IN ANY MANNER LICENSING THE HOLDER OR ANY OTHER PERSON OR CORPORATION, OR CONVEYING ANY RIGHTS OR PERMISSION TO MANUFACTURE, USE OR SELL ANY PATENTED INVENTION THAT MAY IN ANY WAY BE RELATED THERETO.**

**UNCLASSIFIED**