

UNCLASSIFIED

<b>AD NUMBER</b>	
<b>AD157180</b>	
<b>CLASSIFICATION CHANGES</b>	
<b>TO:</b>	<b>unclassified</b>
<b>FROM:</b>	<b>confidential</b>
<b>LIMITATION CHANGES</b>	
<b>TO:</b>	<b>Approved for public release, distribution unlimited</b>
<b>FROM:</b>	<b>Distribution authorized to U.S. Gov't. agencies and their contractors; Administrative/Operational Use; FEB 1958. Other requests shall be referred to Army Armament Research and Development Center, Dover, NJ.</b>
<b>AUTHORITY</b>	
<b>ARRADCOM ltr 8 Jul 1982; ARRADCOM ltr 8 Jul 1982</b>	

THIS PAGE IS UNCLASSIFIED

THIS REPORT HAS BEEN DELIMITED  
AND CLEARED FOR PUBLIC RELEASE  
UNDER DOD DIRECTIVE 5200.20 AND  
NO RESTRICTIONS ARE IMPOSED UPON  
ITS USE AND DISCLOSURE.

DISTRIBUTION STATEMENT A

APPROVED FOR PUBLIC RELEASE;  
DISTRIBUTION UNLIMITED.

UNCLASSIFIED

AD 157180

CLASSIFICATION CHANGED  
TO: UNCLASSIFIED  
FROM: CONFIDENTIAL  
AUTHORITY:

A.R.R.A.D. 17

14 Jul 72



UNCLASSIFIED

**CONFIDENTIAL**

**AD 157180**

# Armed Services Technical Information Agency

ARLINGTON HALL STATION  
ARLINGTON 12 VIRGINIA

FOR  
MICRO-CARD  
CONTROL ONLY

**1 OF 1**

**NOTICE: WHEN GOVERNMENT OR OTHER DRAWINGS, SPECIFICATIONS OR OTHER DATA ARE USED FOR ANY PURPOSE OTHER THAN IN CONNECTION WITH A DEFINITELY RELATED GOVERNMENT PROCUREMENT OPERATION, THE U. S. GOVERNMENT THEREBY INCURS NO RESPONSIBILITY, NOR ANY OBLIGATION WHATSOEVER; AND THE FACT THAT THE GOVERNMENT MAY HAVE FORMULATED, FURNISHED, OR IN ANY WAY SUPPLIED THE SAID DRAWINGS, SPECIFICATIONS, OR OTHER DATA IS NOT TO BE REGARDED BY IMPLICATION OR OTHERWISE AS IN ANY MANNER LICENSING THE HOLDER OR ANY OTHER PERSON OR CORPORATION, OR CONFERRING ANY RIGHTS OR PERMISSION TO MANUFACTURE, USE OR SELL ANY PATENTED INVENTION THAT MAY IN ANY WAY BE RELATED THERETO.**

**CONFIDENTIAL**

AD No. 157180  
ASTIA FILE COPY

# NORTHERN

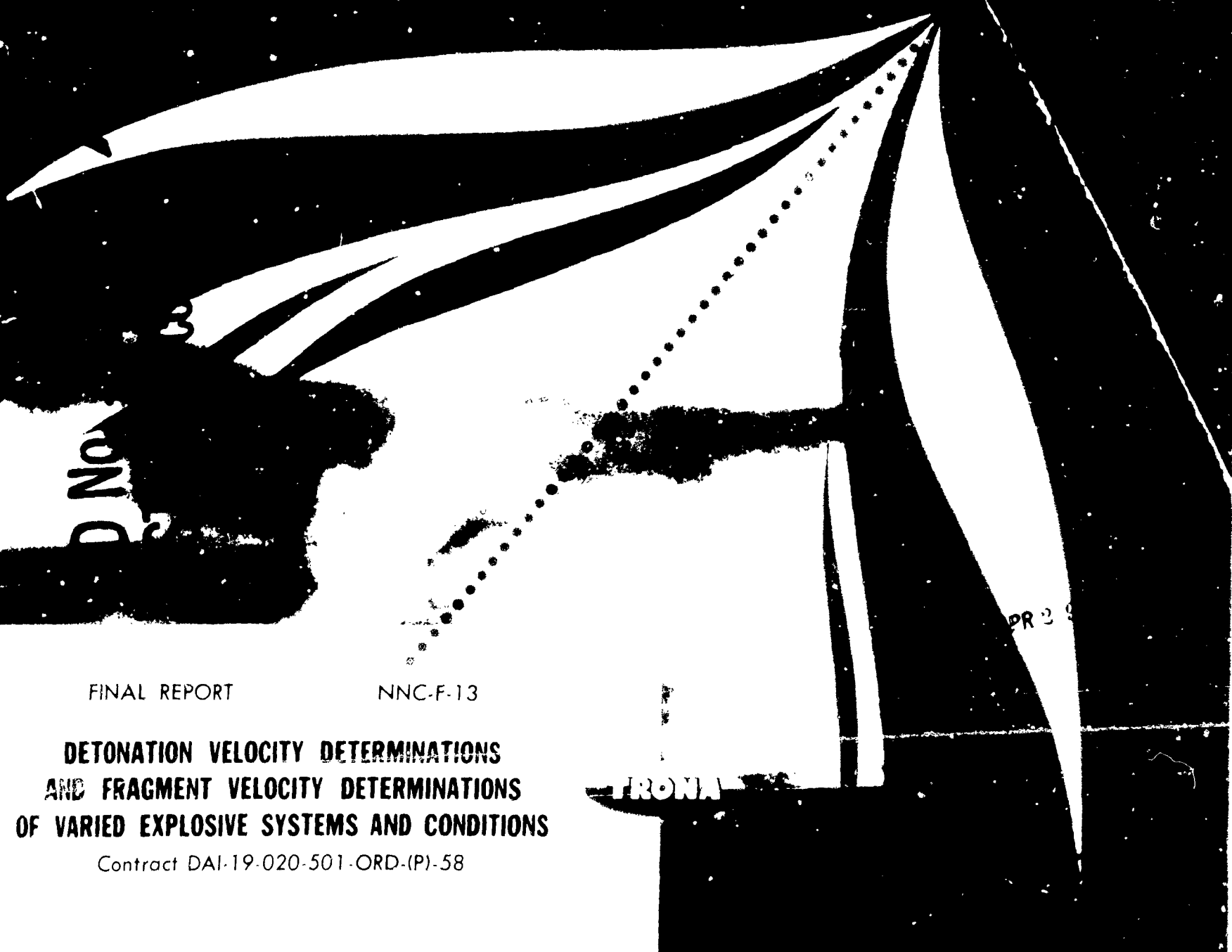

FINAL REPORT

NNC-F-13

**DETONATION VELOCITY DETERMINATIONS  
AND FRAGMENT VELOCITY DETERMINATIONS  
OF VARIED EXPLOSIVE SYSTEMS AND CONDITIONS**

Contract DAI-19-020-501-ORD-(P)-58

**CONFIDENTIAL**

This document is the property of the United States Government. It is furnished for the duration of the contract and shall be returned when no longer required, or upon recall by ASTIA to the following address:  
Armed Services Technical Information Agency, Arlington Hall Station  
Arlington 12, Virginia

**NOTICE: THIS DOCUMENT CONTAINS INFORMATION AFFECTING THE NATIONAL DEFENSE OF THE UNITED STATES WITHIN THE MEANING OF THE ESPIONAGE LAWS, TITLE 18, U.S.C., SECTIONS 793 and 794. THE TRANSMISSION OR THE REVELATION OF ITS CONTENTS IN ANY MANNER TO AN UNAUTHORIZED PERSON IS PROHIBITED BY LAW.**

Confidential

NATIONAL NORTHERN CORPORATION

West Hanover, Massachusetts

DETONATION VELOCITY DETERMINATIONS  
AND FRAGMENT VELOCITY DETERMINATIONS  
OF VARIED EXPLOSIVE SYSTEMS AND CONDITIONS

FINAL SUMMARY REPORT

Contract DAI-19-020-501-ORD-(P)-58

NNC-F-13

February 1958

Submitted by:

Arthur W. O'Brien, Jr.  
Charles W. Plummer  
Robert P. Woodburn  
Vasil Philipchuk

Approved by:

  
S. J. Porter

Vice President and General Manager

**NOTICE:** This document contains information affecting the National Defense of the United States within the meaning of the Espionage Laws, Title 18, U. S. Code, Sections 793 and 794. Its transmission or the revelation of its contents in any manner to unauthorized persons is prohibited by law.

Confidential

Confidential

DETONATION VELOCITY DETERMINATIONS  
AND FRAGMENT VELOCITY DETERMINATIONS  
OF VARIED EXPLOSIVE SYSTEMS AND CONDITIONS

Contract DAI-19-020-501-ORD-(P)-58

FINAL SUMMARY REPORT

NNC-F-13

February 1958

Copy No. 22

NATIONAL NORTHERN CORPORATION

West Hanover, Massachusetts

A Subsidiary of American Potash and Chemical Corporation

Confidential

TABLE OF CONTENTS

	<u>Page No.</u>
1.0 INTRODUCTION	1
2.0 OBJECT OF TESTS	1
3.0 CHARGE DATA	1
4.0 TEST EQUIPMENT	2
4.1 Detonation Velocity	2
4.2 Fragment Velocity	3
5.0 TEST RESULTS	6
5.1 Detonation Velocity	6
5.1.1 RDX-TNT 70/30	6
5.1.2 HMX-TNT 70/30	10
5.1.3 H-6	14
5.1.4 TNT	18
5.1.5 MOX 2B	22
5.2 Fragment Velocity	23
5.2.1 Velocities at Various Altitudes	23
6.0 DISCUSSION	25
6.1 Detonation Velocity	25
6.2 Fragment Velocity	30
7.0 CONCLUSIONS	32
7.1 Detonation Velocity Determinations	32
7.2 Fragment Velocity Determinations	34

Confidential

TABLE OF CONTENTS (Cont'd)

	<u>Page No.</u>
8.0 APPENDIX A	35
8.1 A Method of Measuring Detonation Velocity in a Continuous Manner	A-1
9.0 APPENDIX B	36
9.1 Distribution List	B-1

Confidential

## 1.0 INTRODUCTION

This is a Summary Report of the testing completed during the period June 1957 through February 1958. This work was sponsored by Picatinny Arsenal under Contract DAI-19-020-501-ORD-(P)-58 and Supplements.

We gratefully acknowledge the guidance and assistance of Picatinny Arsenal engineers and scientists in this investigation.

## 2.0 OBJECT OF TESTS

The task assigned under this contract, as supplemented, is an investigation of the effect of simulated altitude on various explosive systems.

Parameters studied included detonation velocity and fragmentation characteristics. In addition to changes in simulated altitude, charge diameter and degree of confinement were varied.

## 3.0 CHARGE DATA

Specific conditions of simulated altitude, charge diameter, and charge confinement were selected for the measurement of the velocity of detonation and the velocity of fragments. The compositions selected for test were detonated in two charge diameters, one and two inches, and were fired (1) without confinement and (2) in one-quarter-inch-thick steel tubing (AISI 1015 seamless). The one-inch diameter explosive charges were eighteen inches long and the two-inch diameter explosive charges were seven inches long. These limits were imposed by the dimensions of the simulated-altitude test-chamber. In each test, a 26 gm. tetryl booster was used to initiate the charge.

3.1 The explosive systems tested under these conditions were TNT, RDX/TNT (70/30), HMX/TNT (70/30), H-6 and MOX-2B.

3.2 These systems were detonated for measurements at ambient pressures of 760, 226, 60 and 13 mm of mercury, corresponding to simulated altitudes of ground, 30,000, 60,000 and 90,000 feet respectively.

#### 4.0 TEST EQUIPMENT

##### 4.1 Detonation Velocity Determinations

4.1.1 The average velocity of detonation is determined by measuring the time required for the detonation reaction to travel a known distance. "Average" velocity implies that the reaction may proceed at varying rates between measured points, and that the total distance divided by the total time taken provides an "average" velocity. Electrical probes are inserted in the detonating column at two points, a known distance apart (Figure No. 1, page 4). The probes consist of open pairs of conductors, which are closed by the ion concentration in the media surrounding them, due to the passage of the detonation reaction.

This switch action of the probe initiates a sharp electrical pulse which, in turn, operates the start or stop circuit of an electronic counter-chronograph. The counter is a Potter Model 471, operating at 8 megacycles.

4.1.2 Tests at simulated altitude were performed in our large vacuum chamber. A photograph that depicts the chamber layout is included in Appendix A. The chamber has approximate inside dimensions of 12 x 14 x 9 feet and may be evacuated to a simulated altitude of 120,000 feet (3 mm Hg) by a Kinney DK-780 vacuum pump run by a forty-horsepower electric motor. The tests performed at "ground" pressure were conducted at our Halifax range.

Confidential

## **4.2 Fragment Velocity Determinations**

**4.2.1** Fragment velocities were obtained by counter chronograph. The start circuit was 1" from the charge and the stop circuit was 6 feet from the start switch (Figure No. 1, page 4 ).

**4.2.2** The start switch was an aluminum foil make switch and the stop switch was a wire grid-type switch which stopped the chronograph when the circuit wire was broken by fragments.

**4.2.3** This method was found the most satisfactory for obtaining velocities at altitudes. However, many velocities were lost due to a phenomenon caused by the gas cloud of the combustion products. At altitude, a gas cloud from large explosive charges expands more rapidly than at ground level. The mean velocity of this gas cloud (measured over a 6' distance) is higher than the mean velocity of the fragments being measured. This gas cloud being ionized would, at times, keep the stop circuit closed even though it was physically opened by a fragment, thereby nullifying the test.

Confidential

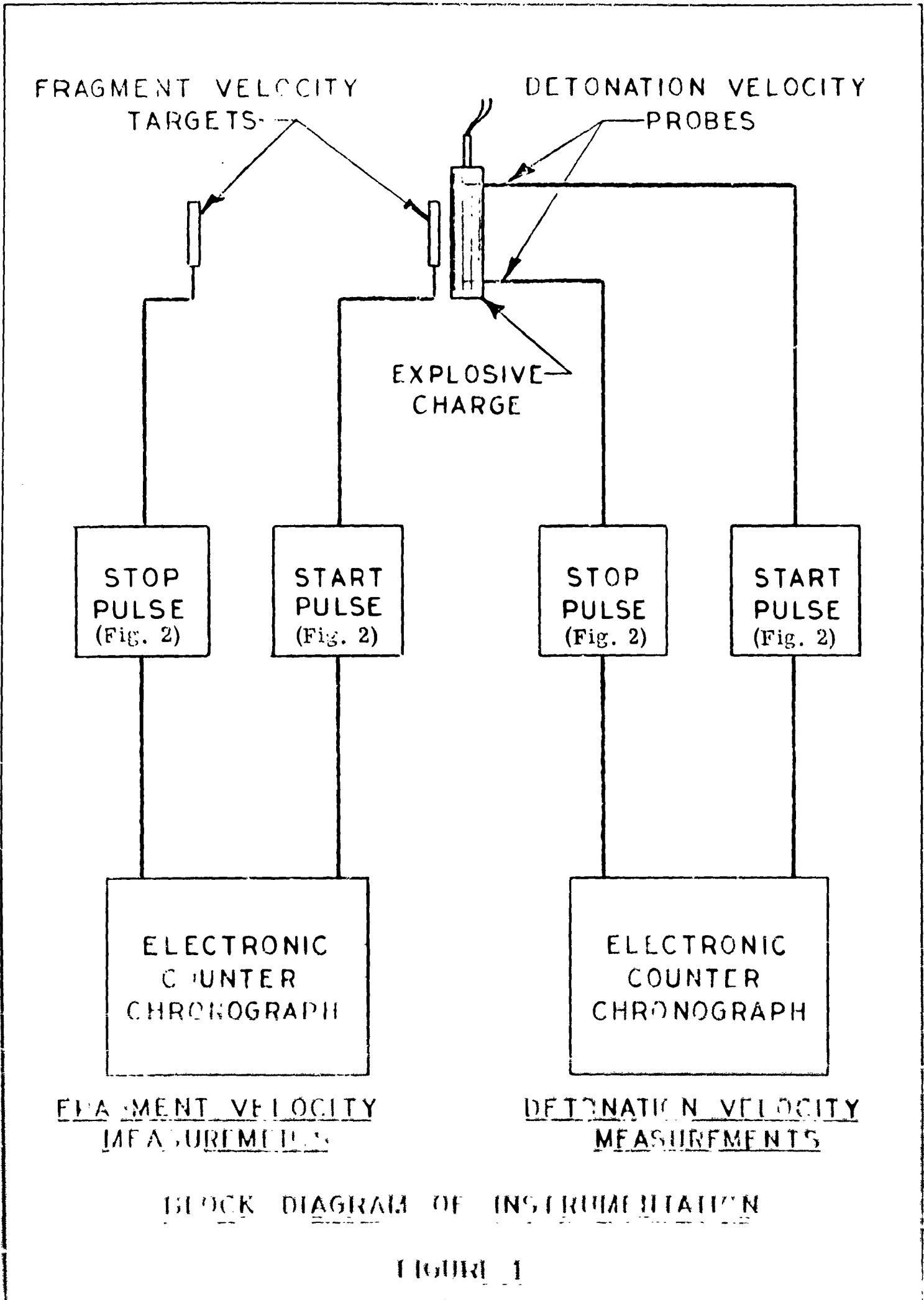
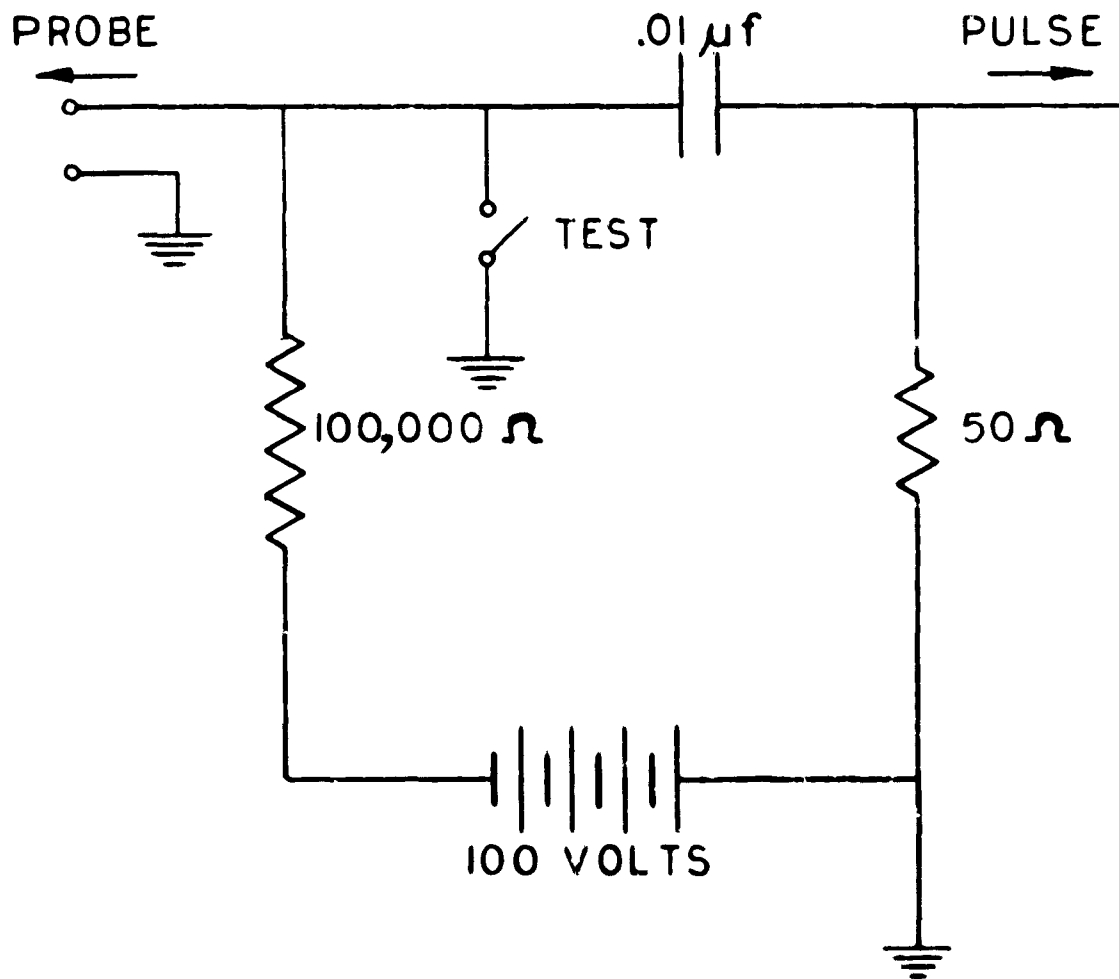

FIGURE 1



FOUR USED IN INSTRUMENTATION

PULSING CIRCUIT

FIGURE 2

## 5.0 TEST RESULTS

### 5.1 Detonation Velocity

#### 5.1.1 RDX-TNT 70/30

<u>Altitude (feet)</u>	<u>Measured Segment (meters)</u>	<u>Measured Time (microseconds)</u>	<u>Velocity of Detonation (meters-second)</u>
----------------------------	--	---	---

#### 5.1.1.1 RDX-TNT 70/30 Unconfined in a one inch diameter column.

<u>Ground</u>	.305	38.1	8000
	.302	36.1	8360
	.305	37.6	8110
	.302	38.0	7950
	.303	37.6	8060
<u>30,000</u>	.306	37.9	8070
	.305	36.0	8470
	.302	38.0	7950
	.305	37.9	8050
	.305	37.8	8070
<u>60,000</u>	.302	37.5	8050
	.305	37.8	8070
	.302	37.2	8120
	.305	36.5	8360
	.305	37.7	8090
<u>90,000</u>	.305	38.1	8000
	.305	38.0	8030
	.302	37.9	7970
	.305	38.4	7940
	.302	37.9	7970

5.1.1.2 RDX-TNT 70/30 Confined in 1/4 inch thick steel tubing, one inch diameter column.

<u>Measured Segment (meters)</u>	<u>Measured Time (microseconds)</u>	<u>Velocity of Detonation (meters-second)</u>
.305	38.3	7960
.305	38.0	8030
.305	38.1	8010
.305	38.4	7940
.305	38.0	8030
.302	37.9	7960
.305	38.1	7990
.305	38.0	8020
.305	37.6	8100
.305	37.9	8050
.305	37.9	8050
.305	38.0	8020
.305	37.8	8070
.305	38.0	8020
.305	37.9	8050
.307	37.9	8100
.306	37.9	8070
.305	38.0	8020
.305	37.9	8050
.305	37.9	8050

5.1.1.3 RDX-TNT 70/30 Unconfined in a two inch diameter column.

<u>Altitude (feet)</u>	<u>Measured Segment (meters)</u>	<u>Measured Time (microseconds)</u>	<u>Velocity of Detonation (meters-second)</u>
<u>Ground</u>	.102	12.6	8050
	.102	12.6	8050
	.102	12.8	7970
	.102	12.6	8050
	.102	12.6	8050
30,000	.103	13.0	7920
	.099	13.2	7500
	.099	12.2	8110
	.102	13.0	7850
	.102	13.4	7610
60,000	.099	12.6	7860
	.103	12.9	7980
	.102	12.8	7960
	.102	12.6	8010
	.099	12.5	7920
90,000	.102	13.2	7730
	.099	12.5	7920
	.099	12.6	7860
	.099	12.6	7860
	.096	13.4	7160

5.1.1.4 RDX-TNT 70/30 Confined in 1/4 inch thick steel tubing, two inch diameter column.

<u>Altitude (feet)</u>	<u>Measured Segment (meters)</u>	<u>Measured Time (microseconds)</u>	<u>Velocity of Detonation (meters-second)</u>
<u>Ground</u>	.102	13.2	7730
	.102	13.1	7790
	.101	13.0	7770
	.102	13.9	7340
<u>30,000</u>	.102	12.8	7970
	.102	12.6	8100
	.102	13.5	7560
	.102	12.8	7970
<u>60,000</u>	.102	12.6	8090
	.102	12.5	8160
	.102	12.6	8090
	.102	12.9	7910
	.102	13.1	7790
<u>90,000</u>	.102	12.8	7970
	.102	12.6	8100
	.102	12.6	8100
	.102	13.0	7850
	.102	12.7	8030

5.1.2 HMX-TNT 70/30

<u>Altitude (feet)</u>	<u>Measured Segment (meters)</u>	<u>Measured Time (microseconds)</u>	<u>Velocity of Detonation (meters-second)</u>
5.1.2.1 <u>HMX-TNT 70/30</u> Unconfined in a one inch diameter column.			
<u>Ground</u>	.305	39.0	7810
	.302	38.3	7900
	.305	38.3	7970
	.305	38.5	7920
<u>30,000</u>	.305	38.1	7990
	.305	38.0	8020
	.303	38.1	7950
	.305	37.3	8180
	.305	37.4	8150
<u>60,000</u>	.302	38.4	7860
	.305	38.0	8020
	.306	38.5	7950
	.305	38.4	7940
	.308	39.1	7870
<u>90,000</u>	.305	38.4	7940
	.302	39.0	7750
	.305	39.0	7810
	.305	37.5	8130
	.305	36.4	8380

5.1.2.2 HMX-TNT 70/30 Confined in 1/4 inch thick steel tubing, one inch diameter column.

<u>Altitude (feet)</u>	<u>Measured Segment (meters)</u>	<u>Measured Time (microseconds)</u>	<u>Velocity of Detonation (meters-second)</u>
<u>Ground</u>	.305	38.4	7940
	.305	38.1	7990
	.305	38.1	7990
	.305	38.4	7940
	.305	38.4	7940
<u>30,000</u>	.303	37.8	8030
	.305	37.9	8050
	.305	37.9	8050
	.305	37.8	8070
	.305	37.9	8050
<u>60,000</u>	.305	37.9	8050
	.305	38.1	7990
	.305	38.0	8020
	.305	38.3	7970
	.305	37.8	8070
<u>90,000</u>	.303	38.3	7930
	.303	38.0	7980
	.305	38.5	7920
	.303	38.1	7950
	.303	38.0	7980

5.1.2.3 HMX-TNT 70/30 Unconfined in a two inch diameter column.

<u>Altitude (feet)</u>	<u>Measured Segment (meters)</u>	<u>Measured Time (microseconds)</u>	<u>Velocity of Detonation (meters-second)</u>
<u>Ground</u>	.098	13.5	7290
	.100	13.1	7620
	.102	12.9	7890
	.102	13.1	7740
<u>30,000</u>	.102	13.2	7730
	.102	13.5	7560
	.102	13.1	7790
	.102	13.2	7730
	.102	13.2	7730
<u>60,000</u>	.099	13.1	7560
	.102	13.6	7500
	.099	13.2	7500
	.102	13.1	7790
	.102	12.9	7910
<u>90,000</u>	.102	14.9	7240
	.102	12.9	7910
	.102	13.0	7850
	.102	12.8	7970
	.099	13.6	7280

5.1.2.4. HMX-TNT 70/30 Confined in 1/4 inch thick steel tubing, two inch diameter column.

<u>Altitude (feet)</u>	<u>Measured Segment (meters)</u>	<u>Measured Time (microseconds)</u>	<u>Velocity of Detonation (meters-second)</u>
<u>Ground</u>	.102	12.8	7970
	.102	13.1	7790
	.102	13.2	7730
	.103	13.1	7860
	.103	12.9	8010
<u>30,000</u>	.102	13.1	7790
	.102	12.6	8100
	.102	12.8	7970
	.102	13.0	7850
	.127	16.0	7940
<u>60,000</u>	.102	13.1	7790
	.103	12.6	8170
	.102	12.8	7970
	.102	13.1	7790
	.102	13.2	7730
<u>90,000</u>	.127	16.0	7940
	.103	12.6	8170
	.102	13.2	7730
	.102	12.7	8030
	.102	13.0	7850

5.1.3 H-6

<u>Altitude</u> (feet)	<u>Measured</u> <u>Segment</u> (meters)	<u>Measured</u> <u>Time</u> (microseconds)	<u>Velocity</u> <u>of</u> <u>Detonation</u> (meters-second)
5.1.3.1 <u>H-6</u> Unconfined in a one inch column.			
<u>Ground</u>	.302	41.1	7350
	.295	41.1	7180
	.303	40.9	7410
	.305	40.9	7460
	.303	41.1	7370
<u>30,000</u>	.305	40.6	7510
	.302	41.2	7330
	.302	40.9	7380
	.305	40.9	7460
	.305	40.9	7460
<u>60,000</u>	.302	39.2	7700
	.305	40.6	7510
	.302	40.4	7480
	.303	41.1	7370
	.300	40.5	7410
<u>90,000</u>	.302	41.0	7360
	.302	41.0	7360
	.302	42.1	7170
	.303	40.6	7470
	.290	41.4	7000

Confidential

5.1.3.2 H-6 Confined in 1/4 inch thick steel tubing, one  
inch diameter column.

<u>Altitude (feet)</u>	<u>Measured Segment (meters)</u>	<u>Measured Time (microseconds)</u>	<u>Velocity of Detonation (meters-second)</u>
<u>Ground</u>	.305	42.0	7260
	.305	42.0	7260
	.303	42.0	7210
	.305	43.3	7050
	.303	42.3	7180
<u>30,000</u>	.305	42.1	7230
	.305	41.4	7370
<u>60,000</u>	.302	41.5	7280
	.305	41.3	7390
	.305	41.5	7340
	.305	42.0	7260
	.305	42.6	7150
<u>90,000</u>	.302	41.6	7260
	.305	41.8	7300
	.302	41.3	7330

Confidential

5.1.3.3 H-0 Unconfined in a two inch diameter column.

<u>Altitude (feet)</u>	<u>Measured Segment (meters)</u>	<u>Measured Time (microseconds)</u>	<u>Velocity of Detonation (meters-second)</u>
<u>Ground</u>	.099	14.0	7070
	.100	14.5	6900
	.102	14.8	6890
	.102	15.1	6750
	.100	14.8	6760
<u>30,000</u>	.099	14.0	7070
	.099	14.2	6970
	.102	15.0	6800
	.102	14.7	6940
	.102	14.3	7130
<u>60,000</u>	.102	14.4	7080
	.099	14.1	7020
	.102	14.9	6840
	.102	14.5	7030
	.102	14.4	7080
<u>90,000</u>	.099	14.2	6970
	.102	14.6	6990
	.099	14.0	6640
	.102	14.1	7230
	.102	14.2	7180

5.1.3.4 H-6 Confined in 1/4 inch thick steel tubing, two inch diameter column.

<u>Altitude (feet)</u>	<u>Measured Segment (meters)</u>	<u>Measured Time (microseconds)</u>	<u>Velocity of Detonation (meters-second)</u>
<u>Ground</u>	.102	13.9	7340
	.102	13.9	7340
	.102	14.4	7080
	.102	13.6	7500
	.102	13.7	7450
<u>30,000</u>	.103	13.8	7500
	.102	14.0	7260
	.103	13.9	7430
	.102	14.0	7260
	.103	14.0	7370
<u>60,000</u>	.103	12.4	8330
	.103	13.8	7500
	.103	14.1	7300
	.103	14.1	7300
	.103	14.1	7300
<u>90,000</u>	.103	14.0	7370
	.102	13.6	7460
	.102	13.8	7390
	.103	13.1	7860
	.103	13.9	7430

5.1.4 TNT

5.1.4.1 Difficulty was encountered in completely detonating an unconfined column of TNT, regardless of the diameter of the column.

<u>Altitude (feet)</u>	<u>Measured Segment (meters)</u>	<u>Measured Time (microseconds)</u>	<u>Velocity of Detonation (meters-second)</u>
----------------------------	--	---	---

5.1.4.2 TNT Unconfined in a one inch diameter column.

<u>Ground</u>	.305	45.1	6750
	.305	42.5	7170
	.305	45.4	6720
	.305	48.4	6300
	.305	45.8	6660
<u>30,000</u>	.305	42.3	7210
	.305	45.9	6640
<u>60,000</u>	"no data obtained"		
90,000	.305	46.4	6570
	.305	45.6	6680
	.305	44.4	6870
	.305	45.9	6640
	.305	44.5	6850

5.1.4.3 Confined in 1/4 inch thick steel tubing, one inch diameter column.

<u>Altitude (feet)</u>	<u>Measured Segment (meters)</u>	<u>Measured Time (microseconds)</u>	<u>Velocity of Detonation (meters-second)</u>
<u>Ground</u>	.305	44.7	6820
	.305	45.5	6850
	.303	44.7	6780
	.304	44.7	6800
	.305	44.5	6850
<u>30,000</u>	.305	46.9	6500
	.305	46.9	6500
	.305	45.4	6720
	.305	45.4	6720
	.305	44.4	6870
<u>60,000</u>	.305	44.8	6810
	.305	44.6	6830
	.305	44.9	6790
	.305	45.4	6720
	.305	44.5	6850
<u>90,000</u>	.305	44.8	6810
	.305	44.7	6820
	.305	44.7	6820
	.305	44.8	6810
	.305	44.8	6810

5.1.4.4 TNT Unconfined in a two inch diameter column.

<u>Altitude (feet)</u>	<u>Measured Segment (meters)</u>	<u>Measured Time (microseconds)</u>	<u>Velocity of Detonation (meters-second)</u>
<u>Ground</u>	.100	19.5	5130
	.102	19.9	5110
	.102	18.5	5500
	.100	19.3	5200
	.103	19.0	5430
<u>30,000</u>	.102	14.4	7070
	.102	14.9	6830
	.102	16.0	6350
	.102	15.0	6770
<u>60,000</u>	.102	15.3	6660
	.102	16.0	6350
	.102	18.6	5450
	.102	14.3	7130
<u>90,000</u>	.102	15.4	6610

5.1.4.5 TNT Confined in 1/4 inch thick steel tubing, two  
inch diameter column.

<u>Altitude</u> <u>(feet)</u>	<u>Measured</u> <u>Segment</u> <u>(meters)</u>	<u>Measured</u> <u>Time</u> <u>(microseconds)</u>	<u>Velocity</u> <u>of</u> <u>Detonation</u> <u>(meters-second)</u>
<u>Ground</u>	.102	15.4	6620
	.103	15.2	6780
	.102	15.2	6710
	.102	15.2	6710
	.102	15.5	6550
<u>30,000</u>	.102	15.1	6720
	.102	15.6	6500
	.102	15.4	6610
	.102	15.4	6610
	.102	15.4	6610
<u>60,000</u>	.102	15.8	6460
	.102	15.9	6420
	.102	15.6	6540
	.102	15.4	6620
	.102	15.5	6580
<u>90,000</u>	.102	15.6	6540
	.102	15.6	6540
	.102	15.6	6540
	.102	15.6	6540
	.102	15.5	6580

## Confidential

5.1.5 MOX 2B

5.1.5.1 The two inch diameter, confined column of MOX-2B was the only MOX-2B system which would completely propagate.

<u>Altitude (feet)</u>	<u>Measured Segment (meters)</u>	<u>Measured Time (microseconds)</u>	<u>Velocity of Detonation (meters-second)</u>
----------------------------	--	---	---

5.1.5.2 MOX-2B Confined in 1/4 inch thick steel tubing, two inch diameter column.

<u>Ground</u>	.105	22.3	4630
	.103	20.9	4940
	.102	22.1	4590
	.103	22.1	4660
	.103	21.4	4820
<u>30,000</u>	.103	22.4	4540
	.103	23.9	4260
	.103	21.4	4750
<u>60,000</u>	.103	22.8	4470
	.103	22.0	4620
	.103	22.9	4440
	.103	23.6	4300
	.103	23.5	4320
<u>90,000</u>	.103	26.0	3910
	.103	21.6	4700
	.103	24.0	4230
	.103	23.6	4300

Confidential

5.2 Fragment Velocity5.2.1 Velocities at Various Altitudes

Composition	Charge Diameter	Case Wall Thickness	Ground	30,000	60,000	90,000
H-6	1"	1/4"	3412	3438	3206	3634
			3368	3412	3435	3636
			3445	3445	3623	3419
			3539	3323	3781	
			3540		3250	
H-6	2"	1/4"	4420	4890	5326	4455
			4558	4539	5390	4755
			4563	4600	5184	
			4871	4676	4708	
					4762	
TNT	1"	1/4"	2904	2903	3030	2993
			2976	3109	3112	3309
			2879	2975	3203	2642
			3000	2977	3218	2862
					2995	2534
TNT	2"	1/4"	3620	4214	5172	4591
			3694	4111	5145	5411
			3556	4235	4807	5640
				4229	5134	4622
				4149		5128
70/30 RDX/TNT	1"	1/4"	3315	3762	3687	3831
			3065	3561	3579	3712
			3609	3553	3915	3753
			3531	3785	3587	3529
			3556	3709	3561	3601
	3728					
	3609					

Confidential

5.2.1 Velocities at Various Altitudes (Cont'd)

Composition	Charge Diameter	Case Wall Thickness	Ground	30,000	60,000	90,000
70/30 RDX/TNT	2"	1/4"	4604	5357	5220	5919
			4741	5200	5369	6206
			4589	5018	5120	5908
			4653			
70/30 HMX/TNT	1"	1/4"	3380	3828	4003	3656
			3179	3691	3837	3462
			3314	3578	4068	3810
			3376	3618	4101	3407
			3490	3653	4061	3750
			3492	3715		
			3317			
			3427			
70/30 HMX/TNT	2"	1/4"	4708	5298	6080	6312
			4681	5286	6291	6287
			4467	5549	5897	6320
			4786	5660	6088	5787
			4871	5527		5847
MOX-2B	1"	1/4"	2012	*	*	*
MCX-2B	2"	1/4"	3402	3482	3605	*
			3239	3699	3245	*
			3354	3473	2908	*
			3452		3230	*
			3116			*
			3321	*		

\* Did not detonate

Confidential

## 6.0 DISCUSSION

### 6.1 Detonation Velocity

6.1.1 The data provided necessarily requires statistical treatment for the indication of significant differences in detonation velocity with differences in ambient pressure (simulated altitude), charge confinement or charge diameter. Although the sample groups are small in population, usually five samples for each set of conditions, some indication of variation can be ascertained by this statistical treatment.

6.1.2 We have chosen variance analysis, the statistical F-test, to determine the significance of the data for the RDX/TNT, 70/30 system. In the presentation of our tables and calculations, we use the following notations:

$X$	sample data
$X_T$	sample data totals
$X_A$	altitude data
$X_{A8}$	ground (one atmosphere ambient pressure)
$X_{A3}$	30,000 feet (226 mm Hg ambient pressure)
$X_{A6}$	60,000 feet (60 mm Hg ambient pressure)
$X_{A9}$	90,000 feet (13 mm Hg ambient pressure)
$X_1$	one-inch diameter charges
$X_2$	two-inch diameter charges
$X_a$	confined charges
$X_b$	unconfined charges
$X_C$	$(X_{1a} \neq X_{2a}) \neq (X_{1b} \neq X_{2b})$
$X_D$	$(X_{1a} \neq X_{1b}) \neq (X_{2a} \neq X_{2b})$
$\bar{X}$	sample mean
$n$	number of samples
$S(X),$ $S$	estimated standard deviation from finite data

$S^2$	variance
$S(\bar{X})$	estimated standard deviation of the mean
d.f.	degrees of freedom (n-1)
t	comparison coefficient of significance between sample means
F	comparison coefficient of variances.

6.1.3 Our calculations for the RDX/TNT 70/30 series, made from tables 6.1.4 and 6.1.5, are as follows:

$$\begin{aligned}
 \Sigma X = X_T &= 637580 \\
 (\Sigma X)^2 &= 406508256400 \\
 C = \frac{(\Sigma X)^2}{n} &= \frac{(\Sigma X)^2}{80} = 5081353205 \\
 \Sigma X^2 &= 5085265000 \\
 \Sigma X_{Ag} &= 158910 \\
 \Sigma X_{A3} &= 159220 \\
 \Sigma X_{A6} &= 160670 \\
 \Sigma X_{A9} &= 158780 \\
 \Sigma X_{1a} &= 160590 \\
 \Sigma X_{1b} &= 161690 \\
 \Sigma X_{2a} &= 157880 \\
 \Sigma X_{2b} &= 157420 \\
 \\
 \frac{\Sigma(X_D)^2}{n_D} &= \frac{(\Sigma X_{1a} + \Sigma X_{1b})^2}{n_D} + \frac{(\Sigma X_{2a} + \Sigma X_{2b})^2}{n_D} \\
 &= \frac{(322280)^2 + (315300)^2}{40} \\
 &= 5031932210
 \end{aligned}$$

$$\begin{aligned} \frac{\Sigma(X_C)^2}{n_C} &= \frac{(\Sigma X_{1a} + \Sigma X_{2a})^2}{n_C} + \frac{(\Sigma X_{1b} + \Sigma X_{2b})^2}{n_C} \\ &= \frac{(318470)^2 + (319110)^2}{40} \\ &= 5081358325 \end{aligned}$$

$$\begin{aligned} \frac{\Sigma(X_A)^2}{n_A} &= \frac{(158910)^2 + (159220)^2 + (160670)^2 + (158780)^2}{20} \\ &= 5081466690 \end{aligned}$$

TABLE 6.1.4 WITHIN-SET MEANS FOR  
DETONATION VELOCITY DATA

<u>Explosive</u>	<u>Simulated Altitude</u> (mm Hg)	<u>One-Inch Columns</u>		<u>Two-Inch Columns</u>		<u><math>\bar{X}_A</math></u>
		<u>confined</u>	<u>unconfined</u>	<u>confined</u>	<u>unconfined</u>	
RDX/TNT 70/30	760	7990	8100	7660	8030	7945
	226	8020	8120	7900 (4)	7800	7960
	60	8040	8140	8010	7950	8035
	13	8060	7980	8010	7710	7940
$\bar{X}_{C,D}$		8028	8085	7895	7873	
HMX/TNT 70/30	760	7960	7900 (4)	7870	7640 (4)	7843
	226	8050	8060	7930	7710	7938
	60	8020	7930	7890	7650	7873
	13	7950	8000	7940	7650	7885
$\bar{X}_{C,D}$		7995	7973	7908	7883	
H-6	760	7190	7350	7340	6870	7163
	226	7300 (2)	7430	7360	7980	7518
	60	7280	7490	7550	7010	7308
	13	7300 (3)	7270	7500	7000	7268
$\bar{X}_{C,D}$		7268	7385	7438	7215	
TNT	760	6820	6720	6670	5270	6370
	226	6660	6930(2)	6610	6760 (4)	6740
	60	6800	--	6520	6400 (4)	6573
	13	6810	6720	6550	6610 (1)	6673
$\bar{X}_{C,D}$		6798	6790	6588	6260	
MOX-2B	760			4730		
	226			4530 (3)		
	60			4430		
	13			4290		
$\bar{X}$				4495		

Note: All means were determined from sets of five values, unless otherwise indicated by parenthesis.

**TABLE 6.1.5 SUMMATION OF DATA FOR  
RDX/TNT, 70/30, SERIES**

	$(X_{1a})$	$(X_{1a})^2$	$(X_{1b})$	$(X_{1b})^2$	$(X_{2a})$	$(X_{2a})^2$	$(X_{2b})$	$(X_{2b})^2$
$(X_{Ag})$	7960	63361600	8000	64000000	7730	59752900	8050	64802500
	8030	64430900	8360	69889600	7790	60684100	8050	64802500
	8010	64160100	8110	65772100	7770	60372900	7970	63520900
	7940	63043600	7950	63202500	7340	53875600	8050	64802500
	8030	64480900	8060	64963600	(7660)	58675600	8050	64802500
	<u>39970</u>	<u>319527100</u>	<u>40480</u>	<u>327827800</u>	<u>38290</u>	<u>293361100</u>	<u>40170</u>	<u>322730900</u>
$(X_{A3})$	7960	63361600	8070	65124900	7970	63520900	7920	62726400
	7990	63840100	8470	71740900	8100	65610000	7500	56250000
	8020	64320400	7950	63202500	7560	57153600	8110	65772100
	8100	65610000	8050	64802500	7970	63520900	7850	61622500
	8050	64802500	8070	65124900	(7900)	62410000	7610	57912100
	<u>40120</u>	<u>321934600</u>	<u>40610</u>	<u>329995700</u>	<u>39500</u>	<u>312215400</u>	<u>38990</u>	<u>304233100</u>
$(X_{A6})$	8050	64802500	8050	64802500	8090	65448100	7860	61779600
	8020	64320400	8070	65124900	8160	66585600	7980	63680400
	8070	65124900	8120	65934400	8090	65448100	7960	63361600
	8020	64320400	8360	69889600	7910	62568100	8010	64160100
	8050	64802500	8090	65448100	7790	60684100	7920	62726400
	<u>40210</u>	<u>324370700</u>	<u>40690</u>	<u>331199500</u>	<u>40040</u>	<u>320734000</u>	<u>39730</u>	<u>315708100</u>
$(X_{A9})$	8100	65610000	8000	64000000	7970	63520900	7730	59752900
	8070	65124900	8030	64480900	8100	65610000	7920	62726400
	8020	64320400	7970	63520900	8100	65610000	7860	61779600
	8050	64802500	7940	63043600	7850	60612500	7860	61779600
	8050	64802500	7970	63520900	8030	64480900	7160	51265600
	<u>40290</u>	<u>324660300</u>	<u>39910</u>	<u>318566300</u>	<u>40050</u>	<u>320844300</u>	<u>38530</u>	<u>297306100</u>

Note: Values in parenthesis are the approximate means from four preceding values. They were inserted to complete rows and columns for variance analysis.

6.1.6 Variance analysis is tabulated as follows:

Source of Variance	d.f.	Sum of Squares (s. s.)	Mean Square (s <sup>2</sup> )	F
Means	no. of means-1	$\frac{\Sigma(X \text{ means})^2 - C}{n \text{ means}}$	$\frac{s. s. (\text{means})}{d. f. (\text{means})}$	$\frac{s^2 (\text{means})}{\bar{s}^2 (\text{means})}$
Within Sets	total d.f. - $\Sigma$ mean d.f.	total s. s. - $\Sigma$ s. s. means	$\frac{s. s. \text{ within sets}}{d. f. \text{ within sets}}$	
Total	$n_T - 1$	$\Sigma X^2 - C$		
Altitude	3	113485	37828	.885
Confinement	1	5120	5120	.120
Diameter	1	629005	629005	14.71
Within Sets	74	3164185	42759	
Total	79	3911795		

## 6.2 Fragment Velocity

6.2.1 On all 1" diameter charges, except HMX/TNT and MOX-2B, there was essentially no effect on velocity up to 90,000 feet altitude. The 1" diameter MOX-2B would not detonate and the 1" diameter HMX/TNT increased in velocity with altitude to a peak at 60,000 feet (by 20%) and then decreased at 90,000 feet to a velocity approximately 7% faster than that at ground.

6.2.2 Generally, on all 2" diameter charges, except MOX-2B, there was an increase in velocity to 90,000 feet altitude. The MOX-2B charges tended to remain the same at altitudes up to 60,000 feet, and above that altitude, 2" diameter MOX-2B failed to detonate.

6.2.3 The table in 6.3 lists the average fragment velocities of the compositions tested. The table in 6.4 (page 32 ) lists their average weights and average densities.

6.3 TABLE OF AVERAGE FRAGMENT VELOCITIES AT VARIOUS ALTITUDES

<u>Composition</u>	<u>Charge Diameter</u>	<u>Case Wall Thickness</u>	<u>Ground</u>	<u>30,000</u>	<u>60,000</u>	<u>90,000</u>
H-6	1"	1/4"	3461	3405	3467	3563
"	2"	"	4603	4726	4998	5288
TNT	1"	"	2940	2991	3119	2868
"	2"	"	3623	4191	5077	4980
RDX/TNT	1"	"	3415	3672	3666	3635
"	2"	"	4647	5192	5236	6011
HMX/TNT	1"	"	3366	3680	4014	3617
"	2"	"	4703	5464	6089	6111
MOX-2B	1"	"	2012	-	-	-
"	2"	"	3314	3351	3247	-

6.4 WEIGHT AND DENSITY TABLES

OD = 1.545      ID = .990      Length = 18"

<u>Composition</u>	<u>Avg. Wt. gms.</u>	<u>Avg. Vol. c.c.</u>	<u>Avg. Density</u>
H-6	382.87	227.0	1.69
TNT	362.27	"	1.59
RDX/TNT	368.42	"	1.62
HMX/TNT	365.46	"	1.61
MOX-2B	472.16	"	2.08

OD = 2.54      ID = 2.04      Length 7"

<u>Composition</u>	<u>Avg. Wt. gms.</u>	<u>Avg. Vol. c.c.</u>	<u>Avg. Density</u>
H-6	640.05	375.0	1.71
TNT	567.45	"	1.51
RDX/TNT	616.68	"	1.64
HMX/TNT	611.86	"	1.63
MOX-2B	776.25	"	2.07

7.0 CONCLUSIONS7.1 Detonation Velocity Determinations

7.1.1 The F value for the diameter variance shows better than 99% probability of a real variation of detonation velocity between one and two inch diameter charges.

7.1.2 The F value for the altitude and confinement variances shows no real variation of detonation velocity between altitudes or confinement conditions of our testing of RDX/TNT, 70/30 charges.

7.1.3 Our precision of measurement is shown to be

$$\pm t \sqrt{s^2} \text{ (within sets)}$$

where t is 2.00 for 95% probability and 74 degrees of freedom.

$$\begin{aligned} \text{precision} &= \pm 2.00 \sqrt{42759} \\ &= \pm (2.00) (207) \\ &= \pm 414 \text{ meters/second} \end{aligned}$$

This indicates a precision of approximately 5%. This represents the combination of errors due to density variations within charges, time and distance measurements, and insufficient "run-up" time on the charges. This "run-up" time is that time, or length of column, allowed for the detonation reaction to reach a steady state. Should any variation in velocity exist due to confinement differences or to difference in ambient pressure, (simulated altitude), it is certainly less than 5%.

7.1.4 Our larger diameter charges show a mean velocity of detonation of 7838 meters/second compared with 8057 meters/second for the smaller diameter. This is in apparent disagreement with all other studies showing larger velocities for larger diameters, but we assign this apparent discrepancy entirely to the short "run-up" column of our seven-inch long charge measured over the last four inches of detonating column. The detonation reaction apparently proceeds at an average rate lower than that at steady-state, over this seven inch column.

7.1.5 National has recently shown a feasible method for indicating detonation velocity on a continuous basis. By this method, large variations in detonation velocity were shown to occur over the first few inches of a one-inch diameter column of Composition B, 80/20 RDX/TNT. The method used and a typical result are shown in Appendix A.

7.1.6 Variance analysis was not performed on the other explosive systems for two reasons. The other systems have less complete data and, secondly, show more variation within sets, by simple inspection of data.

## 7.2 Fragment Velocity Determinations

7.2.1 The altitude effect on fragment velocities of 2" diameter cased charges was such that fragment velocities increased with increased altitude. This is attributed to the lower air drag on the fragments at high altitudes. The percentage increase with altitude would be dependent on the fragment mass, i.e., the velocity of larger fragment sizes (as is the case with MOX-2B) would not change as much as the velocity of the smaller fragment sizes. The greatest increase in fragment velocity with increased altitude would be from the explosive giving the smallest mean fragment mass.

7.2.2 Data on 1" cased charges indicated very little increase of velocity with altitude. This is attributed to the larger mean fragment mass of the 1" cased charges compared to that of the 2" cased charges. Both charge sizes, 1" and 2", had 1/4" wall thicknesses.

8.0 APPENDIX A

## 8.1 A METHOD OF MEASURING DETONATION VELOCITY IN A CONTINUOUS MANNER

### INTRODUCTION

Electrical methods of measuring the passage of the reaction zone in a detonating explosive column, or in a strand of burning propellant, depend upon the concentration of ions in the reaction zone. A probe, usually a pair of open-end conductors, acts as a switch. The passage of the reaction zone and its high content of ions provide the electrical conductor that closes the switch. This switch, in turn, ordinarily operates some sort of pulsing and recording system. One of the usual types of pulsing and recording systems is a counter chronograph operated by a differentiating circuit. In this manner, the time taken for the reaction zone to traverse any measured segment of the explosive column or propellant strand is determined, and the average velocity of the reaction zone may be obtained. Any number of segments may be measured by the insertion of the necessary number of probes and adequate pulsing and recording equipment.

### THE CONTINUOUS METHOD

As the segment measurements, above, are discontinuous in the sense that only the average velocity between any two points may be determined, the method here proposed is continuous in the sense that the single probe inserted is a infinite number of points along the path of detonation or burning.

Again, the ion concentration is depended upon for switching, except that it is not simply an "off-on" type of switch. The "probe" consists of a closed resistance loop. The effect of the ion concentration in the reaction zone is that of the slide on a slide wire potentiometer. The reaction zone decreases the resistance in the loop remaining and at a rate equal to its own velocity. This effect is readily measured and

by relatively simple electrical circuitry.

### THE EXPERIMENTAL EQUIPMENT

Our preliminary equipment is shown schematically in Figure 3, page A-4. The resistance loop consisted of approximately three feet of chromel wire, .015 inches in diameter. The resistance was measured at approximately eleven ohms. This resistance loop was mounted in a fifteen-inch length of one-inch diameter pipe, before the pipe was loaded. The bottom half of the column was cast TNT and the upper half was cast Composition B. A twenty-gram tetryl booster was placed at the top of the column and the column initiated with a #8 electric blasting cap. The "off-on" type of probe was utilized to trigger the sweep on the oscillograph. This probe was inserted between the blasting cap and the tetryl booster.

The resistance loop was connected in a series circuit with a three-volt dry cell and an external resistance. The voltage change across the external resistance during detonation was monitored by an oscillograph and the sweep recorded by camera.

### THE ELECTRICAL CIRCUIT

The electrical considerations in our preliminary circuit are simple and require only an application of Ohm's Law in its elemental form:

$$E = IR,$$

The voltage shown across any resistor in the circuit is the product of the current and resistance. Our circuit is essentially two series resistors and a source of constant voltage. This is shown on the accompanying simplified schematic diagram (Figure 3, page A-4). As the resistance of the probe decreases, the current in the whole series circuit increases. This current increase requires that the voltage found across the external resistance increases. The oscillograph records this voltage in time.

## DISCUSSION OF RESULT

As is outlined above, the voltage found at any time across the external resistance is dependent upon the amount of resistance remaining in the probe loop. Our record, (Figure 4, page A-5), a graph of voltage and time, can be seen to be, indirectly, a measure of the changing resistance of the probe loop in time and, further, a measure of the position of the reaction zone in time. Thus, the velocity of the zone becomes the slope of the curve, and changes in velocity, acceleration, or deceleration, are indicated by positive and negative changes in the slope of the curve. No accurate determinations of length were made in this first effort, so that no accurate determinations of instantaneous velocity can be made. We do have adequate timing marks, however, and the overall velocity of fifteen inches of explosive column can be approximated at 7600 meters/second, a reasonable figure for this combination of TNT and Composition B.

It is interesting to note that two stable slopes, or velocities, are indicated, one each for the two explosives. Both of the slopes follow a short period of unstable detonation. The Composition B was apparently over its stable detonation rate and slowed down over the first ten microseconds. This is reasonable because of the effect of the tetryl booster. At the interface of Composition B and TNT, the detonation zone again searched for a stable velocity and settled down after starting too rapidly. Again, this occurred in about ten microseconds.

## APPLICATIONS

This method of measurement may be applied where knowledge of the behavior of the reaction zone velocity is useful. In explosives, this includes effects of boosters, the diameter effects on propagation of the detonation, indirect measurement of the power of the explosive, the effects of additives for desensitizing or catalysis, etc. Again, the measurements here proposed have value where the point-to-point changes in the velocity are important in precise measurements on explosives or propellants.

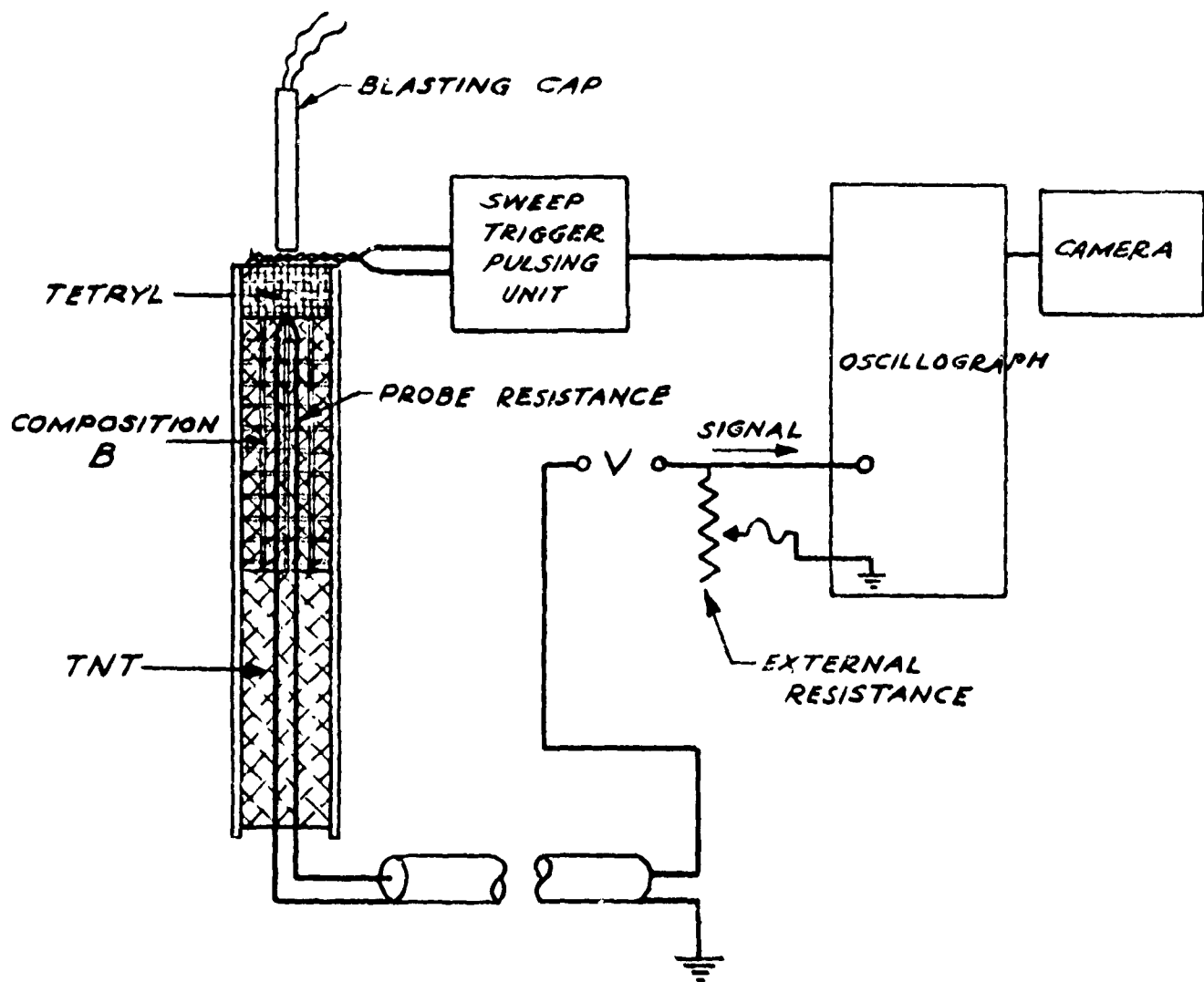

PRELIMINARY INSTRUMENTATION SCHEMATIC

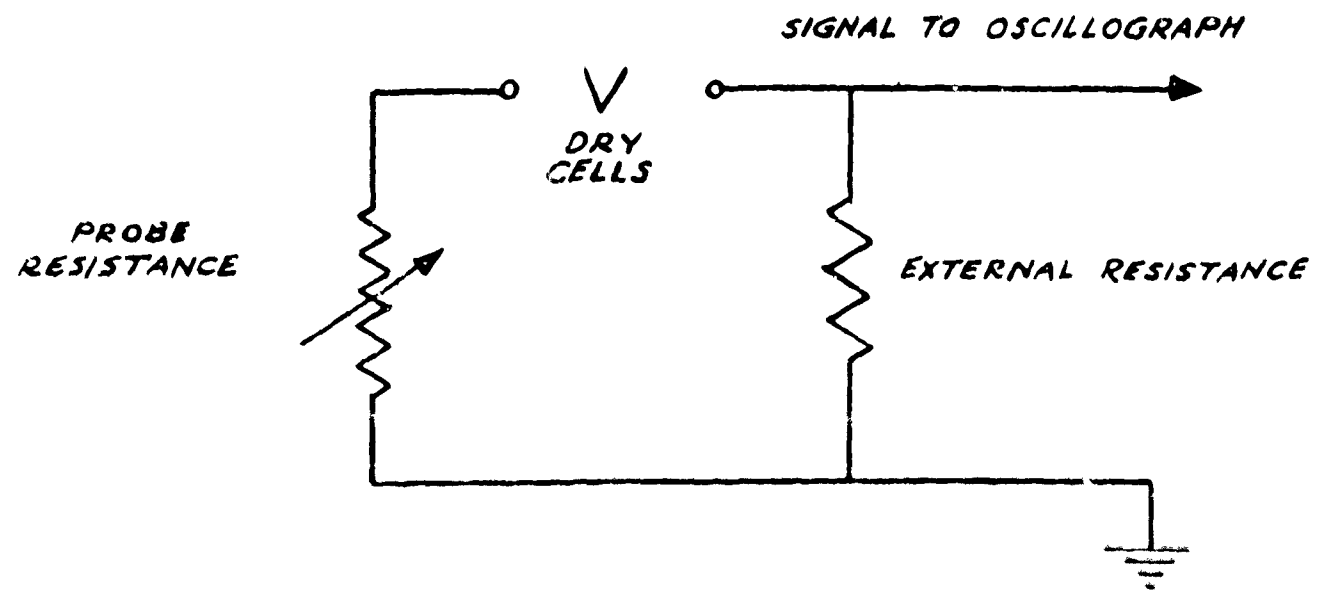

SIMPLIFIED SCHEMATIC DIAGRAM

FIGURE 3

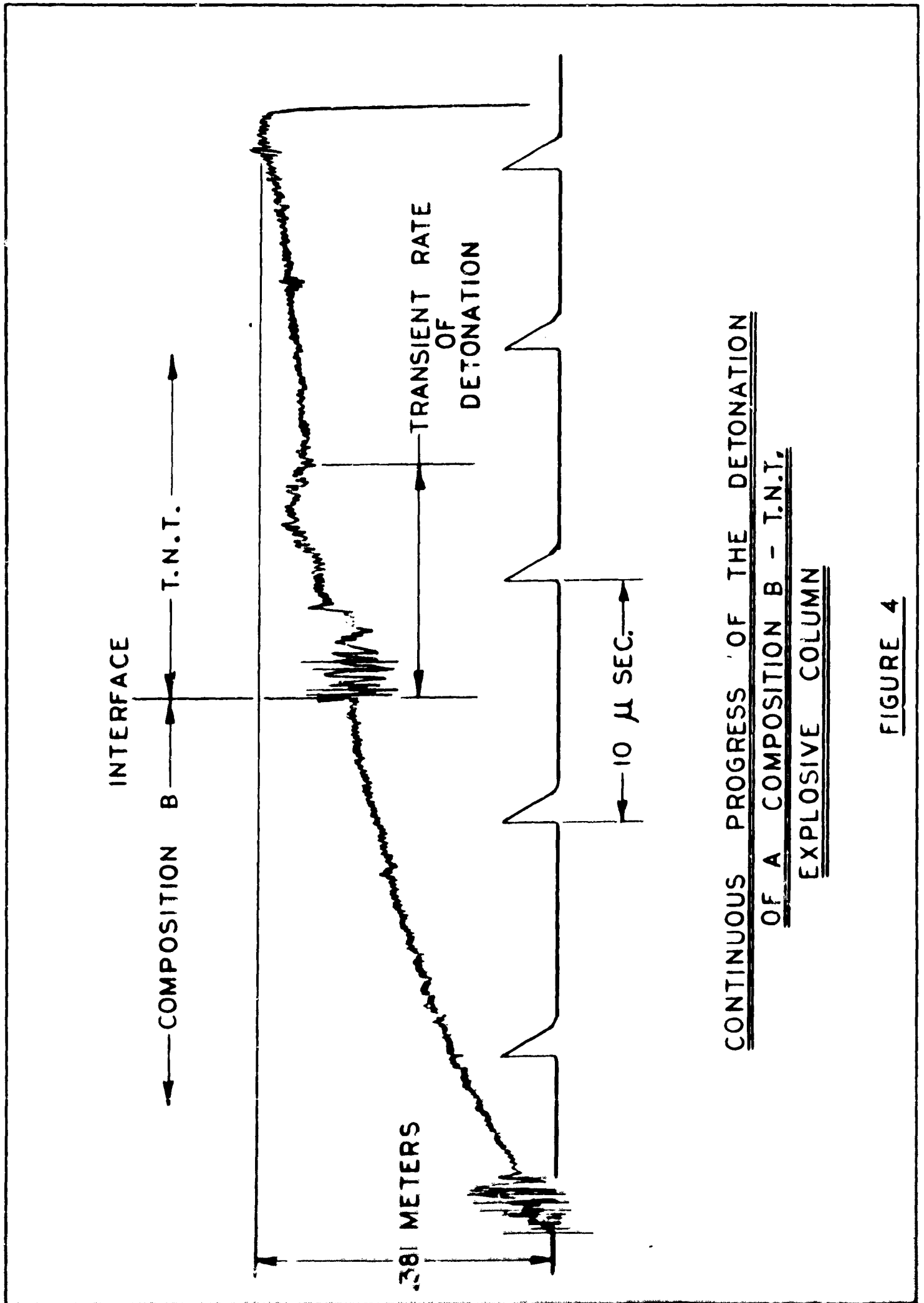

CONTINUOUS PROGRESS OF THE DETONATION  
OF A COMPOSITION B - T.N.T.  
EXPLOSIVE COLUMN

FIGURE 4



9.0 APPENDIX B

DISTRIBUTION LIST