

BR 00804

AD-200 804

This document has been approved
for public release and sale; its
distribution is unlimited.

REGRADED UNCLASSIFIED ORDER SEC ARMY BY
TAG PER J 205213

UNCLASSIFIED

**DECLASSIFIED
DOD DIR 6300.9**

**SUMMARY TECHNICAL REPORT
OF THE
NATIONAL DEFENSE RESEARCH COMMITTEE**

19961127 102

This document contains information affecting the national defense of the United States within the meaning of the Espionage Act, 50 U.S.C., 31 and 32, as amended. Its transmission or the revelation of its contents in any manner to an unauthorized person is prohibited by law.

This volume is classified RESTRICTED in accordance with security regulations of the War and Navy Departments because certain chapters contain material which was RESTRICTED at the date of printing. Other chapters may have had a lower classification or none. The reader is advised to consult the War and Navy agencies listed on the reverse of this page for the current classification of any material.

UNCLASSIFIED

DTIC QUALITY INSPECTED 3

RESTRICTED

UNCLASSIFIED

Manuscript and illustrations for this volume were prepared for publication by the Summary Reports Group of the Columbia University Division of War Research under contract OEMsr-1131 with the Office of Scientific Research and Development. This volume was printed and bound by the Columbia University Press.

Distributions of the Summary Technical Report of NDRC has been made by the War and Navy Departments. Inquiries concerning the availability and distribution of the Summary Technical Report volumes and microfilmed and other reference material should be addressed to the War Department Library, Room 1A-522, The Pentagon, Washington 25, D. C., or to the Office of Naval Research, Navy Department, Attention: Reports and Documents Section, Washington 25, D. C.

Copy No.

69

This volume, like the seventy others of the Summary Technical Report of NDRC, has been written, edited, and printed under great pressure. Inevitably there are errors which have slipped past Division readers and proofreaders. There may be errors of fact not known at time of printing. The author has not been able to follow through his writing to the final page proof.

Please report errors to:

JOINT RESEARCH AND DEVELOPMENT BOARD
PROGRAMS DIVISION (STR ERRATA)
WASHINGTON 25, D. C.

A master errata sheet will be compiled from these reports and sent to recipients of the volume. Your help will make this book more useful to other readers and will be of great value in preparing any revisions.

UNCLASSIFIED

UNCLASSIFIED

SUMMARY TECHNICAL REPORT OF DIVISION 16, NDRC

VOLUME 4

IMAGE FORMING INFRARED

OFFICE OF SCIENTIFIC RESEARCH AND DEVELOPMENT
VANNEVAR BUSH, DIRECTOR

NATIONAL DEFENSE RESEARCH COMMITTEE
JAMES B. CONANT, CHAIRMAN

DIVISION 16
GEORGE R. HARRISON, CHIEF

WASHINGTON, D. C., 1946

UNCLASSIFIED

RESTRICTED

NATIONAL DEFENSE RESEARCH COMMITTEE

James B. Conant, *Chairman*

Richard C. Tolman, *Vice Chairman*

Roger Adams Army Representative¹

Frank B. Jewett Navy Representative²

Karl T. Compton Commissioner of Patents³

Irvin Stewart, *Executive Secretary*

¹*Army representatives in order of service:*

Maj. Gen. G. V. Strong Col. L. A. Denson
Maj. Gen. R. C. Moore Col. P. R. Faymonville
Maj. Gen. C. C. Williams Brig. Gen. E. A. Regnier
Brig. Gen. W. A. Wood, Jr. Col. M. M. Irvine
Col. E. A. Routheau

²*Navy representatives in order of service:*

Rear Adm. H. G. Bowen Rear Adm. J. A. Furer
Capt. Lybrand P. Smith Rear Adm. A. H. Van Keuren
Commodore H. A. Schade

³*Commissioners of Patents in order of service:*

Conway P. Coe Casper W. Ooms

NOTES ON THE ORGANIZATION OF NDRC

The duties of the National Defense Research Committee were (1) to recommend to the Director of OSRD suitable projects and research programs on the instrumentalities of warfare, together with contract facilities for carrying out these projects and programs, and (2) to administer the technical and scientific work of the contracts. More specifically, NDRC functioned by initiating research projects on requests from the Army or the Navy, or on requests from an allied government transmitted through the Liaison Office of OSRD, or on its own considered initiative as a result of the experience of its members. Proposals prepared by the Division, Panel, or Committee for research contracts for performance of the work involved in such projects were first reviewed by NDRC, and if approved, recommended to the Director of OSRD. Upon approval of a proposal by the Director, a contract permitting maximum flexibility of scientific effort was arranged. The business aspects of the contract, including such matters as materials, clearances, vouchers, patents, priorities, legal matters, and administration of patent matters were handled by the Executive Secretary of OSRD.

Originally NDRC administered its work through five divisions, each headed by one of the NDRC members. These were:

Division A—Armor and Ordnance
Division B—Bombs, Fuels, Gases, & Chemical Problems
Division C—Communication and Transportation
Division D—Detection, Controls, and Instruments
Division E—Patents and Inventions

In a reorganization in the fall of 1942, twenty-three administrative divisions, panels, or committees were created, each with a chief selected on the basis of his outstanding work in the particular field. The NDRC members then became a reviewing and advisory group to the Director of OSRD. The final organization was as follows:

Division 1—Ballistic Research
Division 2—Effects of Impact and Explosion
Division 3—Rocket Ordnance
Division 4—Ordnance Accessories
Division 5—New Missiles
Division 6—Sub-Surface Warfare
Division 7—Fire Control
Division 8—Explosives
Division 9—Chemistry
Division 10—Absorbents and Aerosols
Division 11—Chemical Engineering
Division 12—Transportation
Division 13—Electrical Communication
Division 14—Radar
Division 15—Radio Coordination
Division 16—Optics and Camouflage
Division 17—Physics
Division 18—War Metallurgy
Division 19—Miscellaneous
Applied Mathematics Panel
Applied Psychology Panel
Committee on Propagation
Tropical Deterioration Administrative Committee

NDRC FOREWORD

AS EVENTS of the years preceding 1940 revealed more and more clearly the seriousness of the world situation, many scientists in this country came to realize the need of organizing scientific research for service in a national emergency. Recommendations which they made to the White House were given careful and sympathetic attention, and as a result the National Defense Research Committee [NDRC] was formed by Executive Order of the President in the summer of 1940. The members of NDRC, appointed by the President, were instructed to supplement the work of the Army and the Navy in the development of the instrumentalities of war. A year later, upon the establishment of the Office of Scientific Research and Development [OSRD], NDRC became one of its units.

The Summary Technical Report of NDRC is a conscientious effort on the part of NDRC to summarize and evaluate its work and to present it in a useful and permanent form. It comprises some seventy volumes broken into groups corresponding to the NDRC Divisions, Panels, and Committees.

The Summary Technical Report of each Division, Panel, or Committee is an integral survey of the work of that group. The first volume of each group's report contains a summary of the report, stating the problems presented and the philosophy of attacking them, and summarizing the results of the research, development, and training activities undertaken. Some volumes may be "state of the art" treatises covering subjects to which various research groups have contributed information. Others may contain descriptions of devices developed in the laboratories. A master index of all these divisional, panel, and committee reports which together constitute the Summary Technical Report of NDRC is contained in a separate volume, which also includes the index of a microfilm record of pertinent technical laboratory reports and reference material.

Some of the NDRC-sponsored researches which had been declassified by the end of 1945 were of sufficient popular interest that it was found desirable to report them in the form of monographs, such as the series on radar by Division 14 and the monograph on sampling inspection by the Applied Mathematics Panel.

Since the material treated in them is not duplicated in the Summary Technical Report of NDRC, the monographs are an important part of the story of these aspects of NDRC research.

In contrast to the information on radar, which is of widespread interest and much of which is released to the public, the research on subsurface warfare is largely classified and is of general interest to a more restricted group. As a consequence, the report of Division 6 is found almost entirely in its Summary Technical Report, which runs to over twenty volumes. The extent of the work of a division cannot therefore be judged solely by the number of volumes devoted to it in the Summary Technical Report of NDRC: account must be taken of the monographs and available reports published elsewhere.

Division 16 carried out a broad program in the fields of light and optics. Among the studies undertaken were a number involving the principles and techniques of camouflage, and perhaps the outstanding success achieved in this field was the development of the "black widow" finish for night-flying aircraft. Significant improvements were made in aerial mapping and photography. Devices depending on the use of infrared light were developed for the detection of enemy craft, the recognition of friendly ones, and for intercommunication by voice and code. The sniperscope, using image-forming infrared rays, was a spectacular weapon which enabled our troops to fire accurately on an enemy 100 yards away in utter darkness.

The Division 16 Summary Technical Report, prepared under the direction of the Division Chief, George R. Harrison, describes the technical achievements of the Division personnel and its contractors, and is a record of their skill, integrity, and loyal cooperation. To all of them, we extend our grateful praise.

VANNEVAR BUSH, Director
Office of Scientific Research and Development

J. B. CONANT, Chairman
National Defense Research Committee

FOREWORD

AT THE TIME of its formation late in 1942, Division 16, the Optics Division of NDRC, was assigned both the general task of stimulating and supervising OSRD research in optics and the immediate problem of overseeing a large number of contracts which had previously been initiated by the Instruments Section. Inasmuch as the new Division consisted to a large extent of personnel associated with the Instruments Section during 1940 and 1941, the reorganization involved few important changes.

The present Summary Technical Report describes the accomplishments of both Division 16 and Section D-3, and covers the principal developments in optics made in America during World War II. This report should be considered as intermediate in character between the detailed contractors' reports of Division 16, to which reference is frequently made herein which are complete scientific reports of the investigations carried on, and the historical volume entitled *Optics and Applied Physics in World War II*, which presents in less technical form the accomplishments of the Division and its contractors, and assigns credit to those who took part.

The contents of the present volume demonstrate impressively the great contribution made by the optical industry of America and the university optical laboratories to the war effort. While less glamorous than some of the newer fields brought into existence during the war, optics nevertheless made significant contributions which were by no means confined to mere extension or application of optical methods or apparatus previously in use. The stress of the emergency produced many new optical de-

velopments, and the genesis of a large proportion of these will be found recorded in the following pages.

The science of optics and the optical industry have both benefited greatly by the intensive research which took place during the war. Many of the new devices developed under emergency conditions have contributed and will contribute more to our fundamental understanding of optics, and many of them will have peacetime applications. New lines along which optical research should be directed have been made apparent. In particular, the infrared field has benefited greatly, and the art of infrared phosphor development and utilization has been elevated to an entirely new level.

Consideration of the developments in optics, as in other fields, emphasizes that, once adequate immediate defense has been insured, more important than having weapons for a possible future war is having available a large body of trained personnel who can step into any breach that occurs and be available to produce the new devices that may be needed.

The Optics Division of NDRC is especially indebted to the chiefs and members of its Sections, whose names are listed at the end of this volume. They have provided the essential leadership, combined with scientific knowledge, without which the work of the Division could not have been planned or completed.

GEORGE R. HARRISON
Chief, Division 16

CONTENTS

CHAPTER		PAGE
1	Introduction and Summary by <i>W. E. Forsythe</i> . . .	1
2	Infrared Image Tubes and Electron Telescopes by <i>Charles A. Federer, Jr.</i>	4
3	Metascopes by <i>Mary Banning</i>	35
4	Infrared-Sensitive Phosphors by <i>Franz Urbach</i> and <i>Mary Banning</i>	54
5	Survey of Infrared Sources by <i>George E. Meese</i> . . .	70
6	Ultraviolet Sources and Filters by <i>Charles A. Federer, Jr.</i>	91
7	Autocollimators by <i>Mary Banning</i>	110
8	Antiglare Devices by <i>Mary Banning</i>	120
9	Miscellaneous Optical Developments by <i>Mary Banning</i>	127
	Glossary	135
	Bibliography	137
	OSRD Appointees	141
	Contract Numbers	143
	Service Project Numbers	145
	Index	146

Chapter 1

INTRODUCTION AND SUMMARY

By *W. E. Forsythe*^a

SECTION 16.5, National Defense Research Committee [NDRC], and the sections that preceded it in this work, which were the Illumination Committee of the National Research Council, and Section C-6, Section 12.1, and Section 16.2 of NDRC, had as their main problems methods of seeing road markings and of signaling without the use of radiation within the visible spectrum. This means that ways were sought by which either ultraviolet [UV] radiation or infrared [IR] radiation—each as far beyond the limits of the visible spectrum as possible—were to be used. The idea back of this was, of course, to find some method that would enable troops, convoys, boats, or airplanes to find their way along darked-out roads, shores, or runways without the enemies being able to see them.

Two devices by which this could be done by the use of infrared radiation had been experimented with even before the formation of the Illumination Committee in 1940. These were the two infrared telescopes: the electronic telescope developed by some of the engineers of the Radio Corporation of America [RCA] Laboratories, and the metascope developed by the physicists of the Institute of Optics of the University of Rochester. Later, special reflecting devices were developed for use in marking out roads, lanes, runways, or shores; such devices became visible under irradiation by ultraviolet radiation. Similar devices were developed that could be used for this same purpose when irradiated by infrared radiation. These several devices will be taken up in turn, first the electronic telescope. This device is fully described in Chapter 2 of this report, but here some of its uses will be touched upon.

The first use of the infrared telescope was to enable the operator of a truck to see his way along a darked-out road. It was demonstrated at Fort Belvoir late in 1942 that a truck could be driven along a dark road, or through a dark lane through a woods, without the truck or its lights being visible to an observer 50 to 100 yards directly in front of the truck; this infrared telescope was used by the driver to "see" the road. Like demonstrations were made at several other Army camps.

The use of this infrared telescope for moving tanks under blackout conditions was demonstrated, and it was shown that this could be done even under complete darkness. Neither the lamp nor the infrared source could be seen even when the tank was so near to an observer that the heat from the tank and the infrared sources was quite evident.

Boats were brought to the shore or back to the mother ship under dark-out conditions with the only means of seeing the shore or the ship being the infrared telescope.

Several demonstrations were made of the use of this instrument to pilot a locomotive along a track where the engineer depended upon the infrared telescope to see his signals.

There were two criticisms of this device. It was difficult to hold the telescope so that good use could be made of it and it was felt that too much wattage was required for the infrared sources. As time went on, the sensitivity of this infrared telescope was greatly increased, and better sources of the infrared radiation were produced. Later, a binocular electronic telescope was developed that could be carried on the head of the user. With this head-borne instrument, the engineers at Fort Belvoir demonstrated that trucks or jeeps equipped with special infrared headlights could be driven along roadways that were completely dark with safety and at a speed at least 25 miles per hour.

With the use of this head-borne instrument it was also demonstrated that a pilot could land an airplane on a runway that was marked out with infrared sources that could not be seen at all unless the pilot had a device of this general type. This was done at Lancaster, Pennsylvania, in tests held for the Navy and later by some officers of the Navy at the Charleston Navy Air Base in Rhode Island.

By the use of this telescope it was shown, at the request of the Army, that a target could be seen at a distance of about 800 yards in complete dark-out. To do this, however, required for the source of infrared radiation two 60-inch searchlights, each equipped with a 3,000-watt tungsten lamp. In front of these searchlights was an infrared filter of such density and wavelength limit that these searchlights

^aNela Park Laboratories, General Electric Company.

were not visible even for a person directly in front of them and about 100 to 150 yards away. An infrared telescope with a Schmidt mirror about 12 inches in diameter was used for this job.

The most popular use that was made of the electronic telescope was in the devices called the snooper-scope and the sniperscope. With the snooper-scope, which, with its power pack, source of radiation, and infrared telescope, weighed only 20 pounds, the observer could see a man at a distance of about 100 yards. The sniperscope consisted of a special infrared telescope and a lamp mounted on a carbine and a source of power carried on the user's back, with a total weight of 20 to 25 pounds. With such a device, a man could be seen at about 100 yards in complete darkness and good use made of the carbine. Some very good reports were received for the uses of the sniperscope in the field, particularly in the Okinawa campaign.

A source of infrared radiation, which in general consisted of a tungsten lamp in a reflector bulb with a filter in front of it, so that it was not visible even to a person directly in the line of sight for more than 50 to 100 yards, could be seen for a very long distance (several miles) by the use of this telescope. Thus this infrared telescope would enable a pilot in an airplane or on a boat to find a position marked with infrared sources, even in complete darkness without being seen himself.

The metascope enables an observer to see an infrared source at a distance of several thousand feet, and thus it can be used either for locating positions marked with infrared sources or for signaling. One great advantage of this instrument over the electronic telescope is that it needs only a very simple power source and also it is not so fragile. It is thus lighter and more portable. However, it is much less sensitive than the electronic telescope. Because of their different characteristics, these two infrared telescopes supplement each other very well.

A plan to enable paratroopers to find their jump area and then to assemble by the use of these infrared telescopes was worked out and demonstrated at Camp Mackall, North Carolina. The pilot located a previously erected infrared source by the use of the electronic telescope; then, after the paratroopers had landed, their leader held a flashlight with an infrared filter over it to present a source of infrared radiation that could be located by the men by the use of a special very small metascope (Type K).

There are some devices that will return light al-

most along the same path by which it reached the device. One such device is the triple mirror, an arrangement familiar to many persons as the common roadside reflector button used to mark out the limit of the road. Some of these were used in World War I. Methods were worked out by the Mount Wilson Observatory staff for making triple mirrors. A large number were made and used for signal- and range-finding work.

When triple mirrors are employed, the observer simply holds a light source near his eye and sees an answering beam returned to him by the triple mirror. For the return beam to be seen from an ideal triple, the eye should be as close to the source as possible and not farther away than the diameter of the mirror.

Triple mirrors were used to mark out the runway on a landing made using a light source near the eye of the observer. The light source was composed only of 2- or 3-candlepower lamps covered with red cellophane. This enabled the pilot to see returned beams from the triple-mirror runway markers as much as 7,000 feet away.

Triple mirrors are only one type of autocollimator, or retrodirective, reflector. Another type employs a Schmidt optical system, with a mirror (convex) as the focal surface if visible light is used. For security and use with ultraviolet light, the surface is coated with a phosphor which emits light when excited by ultraviolet radiation. With modification, this system may also be used with infrared phosphors. These autocollimators will return light in any direction, over a wide range of incidence angles, and should prove very valuable to the Armed Forces for either signaling or marking the limit of roads or paths through the woods. They can also be used to mark out landing beaches. Many of these devices were made and tried out for various marking and identification purposes.

Section 16.5 had contracts with a number of laboratories to help produce better parts for the above-mentioned instruments and light sources. Engineers in some of these laboratories helped to equip several vehicles with special sources of infrared radiation; in some cases, they installed special power equipment so that sources of radiation could be used consuming more wattage than produced by the vehicle's power supply. Also, special light sources were devised and built, sometimes on short notice, for various tests. These engineers and scientists also acted as consultants to the Armed Forces and devised some apparatus which has not been listed in this summary.

Contracts were made with six laboratories to do

special work in an attempt to produce better infrared phosphors than were available at the start of World War II. Not only was the work done in Europe reproduced in this country for the first time, but a new and extraordinary series of very sensitive infrared phosphors was developed, and the sensitivities and ranges of metasopes employing these new phosphors were thereby increased substantially.

In both ultraviolet and infrared detection, communication, and ranging systems, optical filters play an important part. Contractors for both Sections 16.4 and 16.5 tested and explored filter materials of many kinds, and resultant improvements in filters for both ultraviolet and infrared increased the security and ranges of many source-receiver combinations.

Among the several special problems undertaken by Section 16.5 and its predecessors, that of observing an airplane when it is almost directly in line with the sun and the eye of the observer deserves special mention. Direct observations were, of course, out of the question. Several devices were made and tried out for this purpose, but they proved ineffective or too difficult to operate. Finally, a phosphorescent material that has an upper-limit brightness response after being excited by the sun's rays was employed in a device resembling a metascope. This instrument, called the Icaroscope, makes it possible to look directly at the sun and see an airplane even if it were directly in line with the sun and the observer. Several models of this device were made and tested.

Chapter 2

INFRARED IMAGE TUBES AND ELECTRON TELESCOPES

By Charles A. Federer, Jr.^a

2.1 INTRODUCTION

FOR THEIR APPLICATION in signaling, night firing, reconnaissance on land and sea, infrared driving, airborne operations, and the like, Section 16.5 undertook the investigation of infrared image tubes and electron telescopes. Chief contractor for this work was RCA Laboratories at Princeton, New Jersey, where the infrared telescope had already been studied, so the research described herein was carried on to develop the image tube and telescope to the point where they would have military usefulness. In the actual application of the infrared electron telescope to military problems, cooperative work was carried on among RCA Laboratories, Contract OEMsr-440; the University of Pennsylvania, Johnson Foundation, Contract OEMsr-1075; and the General Electric Company, Nela Park, Contract OEMsr-423.

As applied to military problems, the infrared-sensitive telescope operates in the spectral regions from 0.8 to 1.0 micron and slightly beyond—that is,

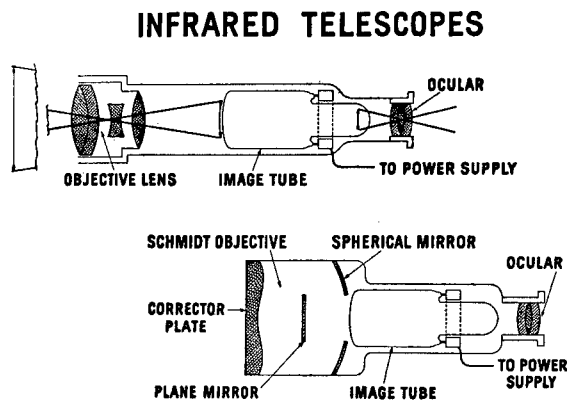

FIGURE 1. Two forms of the infrared telescope, one employing a refracting objective and the other a Schmidt system.

in the near infrared. Basically, the instrument consists of an objective for forming an infrared image of the scene being viewed upon the sensitive cathode of an image tube, the image tube itself, and an ocular for viewing the image (in visible light) formed on the

^aHarvard College Observatory. The material in this chapter has been prepared and extracted from reference 1.

fluorescent screen of this image tube. As auxiliary equipment, a high-voltage power supply is used to actuate the image tube. Figure 1 is a schematic diagram of such a telescope, in two forms, one with a refracting objective and the other with a Schmidt system.

The essential element is the electron image tube, of which Figure 2 is a schematic diagram. The cathode, on the end of the glass envelope, consists of a semi-

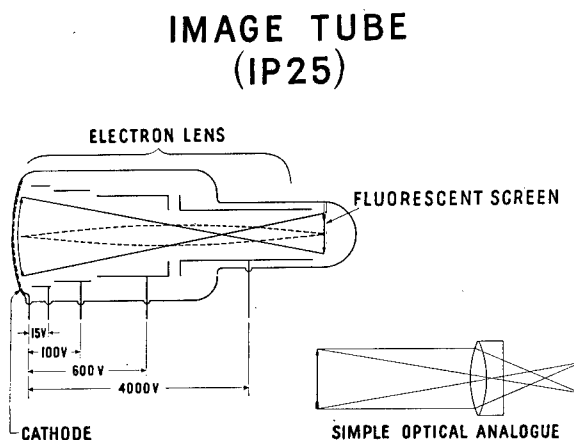

FIGURE 2. Schematic diagram of the standardized image tube.

transparent layer of silver which has been treated with oxygen and cesium. Electrons which leave the cathode when radiation strikes that surface are accelerated through an electron lens system which focuses them on the phosphor coating on the other end of the tube. Here fluorescence produces the visible image.

As a result of a long series of investigations on various types of image tubes, a tube was finally developed and put into production as the 1P25 which was satisfactory for general infrared work. It was manufactured and used in fairly large quantities during the latter part of the war. At the close of the war, a high-voltage tube with improved performance characteristics had been developed and was being put into pilot production (see Section 2.3.3). A number of other new image tubes showing considerable promise had been developed (see Section 2.3.2).

Telescopes using the 1P25 were developed for many military purposes. A signaling telescope, Type C₃, was put into production, as was a gun-aiming instrument. Several other telescopes were in production or on order, but in smaller quantities. Instruments for the improved image tubes were also developed.

Because of the use of image tubes in television pick-up devices, serious work on electron imaging began at the RCA Laboratories in the early thirties. Initially, magnetic electron optical systems were employed, but it was soon found that excellent results could be obtained with electrostatic lenses. By the end of 1935, it was possible to demonstrate an operative infrared telescope² with excellent image quality, quite comparable to that of a modern image tube such as the 1P25. However, the image brightness relative to the incident radiation was only 1/500 to 1/1,000 of that obtained with the modern tube. A number of these early telescopes were built and tested in scientific and other applications and their value in maintaining military security demonstrated. It was conclusively shown that the device could not be used for seeing through fog.

By 1938-1939, the sensitivity had been so increased that a car equipped for infrared night driving was used in a great many experimental field tests, and was demonstrated at Aberdeen Proving Ground. While this particular equipment was inadequate, it was clearly shown that driving in absolute visual darkness was possible. Simultaneously, two filtered searchlights with telescopes mounted on them were built for and delivered to the Navy for experiments in infrared signaling. This equipment was the forerunner of the Type C₃ instrument later developed under Contract OEMsr-440 and put into production for the Navy.

Further development of these and other military projects will be discussed (see Section 2.5) after the technical details of the development of infrared image tubes and telescopes and their auxiliary apparatus, including some of the problems in designing production models, have been reviewed.

2.2 THE INFRARED IMAGE TUBE

2.2.1 A Standardized Tube

As the image tube would only be of value during the war if it could be produced quickly and in quantity, it was necessary to choose a single type of relatively simple construction and to make it possible for use in a wide range of devices and situations.

Type of Tube. There were three general types of tube to choose from:

1. The first type has a *uniform field* between cathode and screen, which requires close spacing between them in order to obtain high definition. Unity magnification is inherent, a high field is required, and the image is erect (leaving final image inverted because of the inversion of objective).

2. A *magnetic lens* system is capable of producing a sharp true image, but it is in general rotated with respect to the image on the photocathode. The magnetic lens system is in general heavy and bulky.

3. The *electrostatic lens* system is the type chosen for development, for it has the following advantages: inverted image (erecting the objective image); any desired field strength at the cathode; adjustable magnification. When used with a Schmidt system a curved photocathode is naturally provided. One disadvantage is that with a refracting objective lens system, an optical field corrector must be used to produce the proper curvature for the photocathode (see below).

Magnification. In the image tube, the brightness of the reproduced image varies inversely with the square of the magnification. This results from the increase in the concentration of electrons when the magnification is small; it is better, therefore, to use low magnification in the image tube (such as 1/2 instead of 1) and to make up the difference in the power of the eyepiece (such as 10 instead of 5). However, although special purpose image tubes might be made, therefore, with very small fractional magnifications, various factors pointed to 1/2 as the best magnification for an all-purpose image tube. This magnification does not give maximum possible brightness, but does insure such results as filling the pupil of the dark-adapted eye or furnishing an especially large exit pupil when needed for military operations.

The standardized tube, then, was set at between 1 1/2 and 2 inches in diameter, 4 to 5 inches long, about 5,000 volts, magnification 1/2 by an electrostatic lens.

2.2.2 Electron Optical Considerations

In its simplest form, the image tube consists of a uniform field between the cathode and main lens, a fairly strong main lens, and a constant potential between the lens and the fluorescent screen. For a magnification of 1/2 the main lens should be halfway between the cathode and screen.

A rather complete analysis of the electron optics of the electrostatic image tube³ had been made prior

to the date of the NDRC contracts. While such an analysis can by no means give a complete solution to the design problem of the image tube, nor can it predict completely the performance of a specific image tube structure, it is nevertheless helpful in indicating the course along which the development should proceed. Some of the conclusions are briefly discussed here.

Curvature of the Image Field. When a flat cathode is employed, curvature of the field is inherent. Together with astigmatism, it limits the off-axis defini-

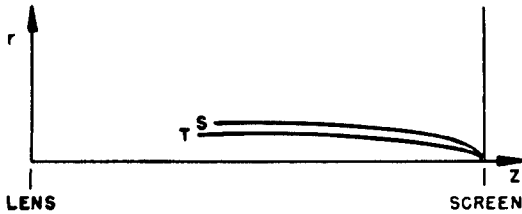

FIGURE 3. Sagittal and tangential image planes.

tion. Figure 3 illustrates the shape of the sagittal and tangential image planes.

Curvature can be reduced by a suitable selection of weak correcting lenses between the cathode and main lens, but the field can be completely flattened only by properly curving the cathode. However, as has been mentioned, a curved cathode introduces optical complications with a refracting objective. Therefore, the cathode curvature adopted for the standardized tube (1P25) is a compromise between light optical and electron optical considerations. The radius of curvature selected was 2.38 inches. With this radius, there is still a perceptible loss of definition at the edges of the field and some pincushion distortion, but both very small in a perfect tube.

Astigmatism. Astigmatism is reduced somewhat by the curvature of the cathode, but with the curvature used in the 1P25, neither the sagittal nor the tangential image plane is flat. However, the depth of focus at the image is quite large because of the very small aperture angles of the imaging pencils.

Associated with this type of aberration are image defects which result from mechanical errors in tube construction or assembly. Misalignment of the cylinders and apertures or a departure from roundness of some electrodes most commonly cause the lens to act as a slightly cylindrical system instead of as a truly spherical one. Then the image of a point on the cathode is an ellipse with its minor axis in one direction for one voltage setting, and at right angles to this direction for a second setting. Figure 4 illustrates

this condition, in which readjusting the voltage to sharply focus one set of lines blurs those at right angles. However, as manufacturing procedures continue to improve, tubes with electron optical defects are becoming rarer.

Chromatic Aberration. This is due to the spread of initial velocities of the photoelectrons, and establishes the limit of resolution at the center of the image field. If D is the diameter of the circle of confusion, the following approximate equation applies:

$$D = \pm 2m \frac{V}{E},$$

where m is the image magnification, V the initial velocity in electron volts, and E the field strength at the cathode. Thus E is the primary factor determining definition.

On this basis, the apertures forming the main lens should be small, and the limiting resolution obtained with the electron lens system arranged as shown in Figure 5A is better than that shown in Figure 5B. The main lens in the 1P25 is half the diameter of the cathode, which is not the smallest size that could be used. The limit to size is set by the point at which

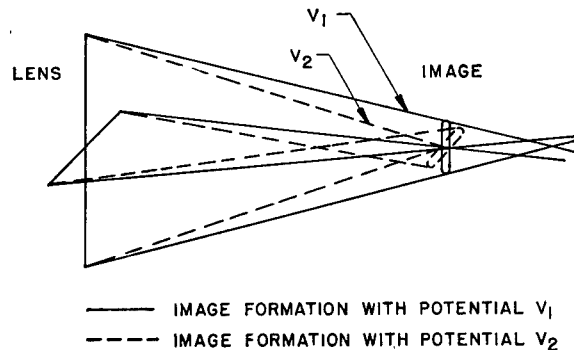

FIGURE 4. The elliptical image effect.

the main lens acts as a field stop, but the size in the 1P25 is a practical value considering alignment and insulation problems of tube production.

Spherical aberration and *coma* play a negligible part in limiting the definition.

ELECTRODE DESIGN OF THE 1P25

A preliminary analysis of the first-order imaging properties of a simplified electron optical system of the general type suitable for the image tube suffices to establish an outline for the design. This simplified system consists of a uniform field between the cathode and main lens, a fairly strong main lens, and a constant potential between the lens and screen. It is

found that the main lens should be located halfway between the cathode and screen for a magnification of $\frac{1}{2}$. Furthermore, the range of aperture-cylinder

diameters for the main lens and corresponding field strength for the secondary lens can be estimated.

With this as a basis, more realistic models of electron optical systems can be laid out, their potential distributions calculated, or measured in an electrolytic plotting tank, and ray paths traced through the systems. In this way, the fundamental form of the image tube can be derived.

The exact dimensions and arrangement of the electrodes of the 1P25 are shown in Figure 6. Where the overall voltage differs from that indicated, the given voltage ratios must be maintained. In production, in

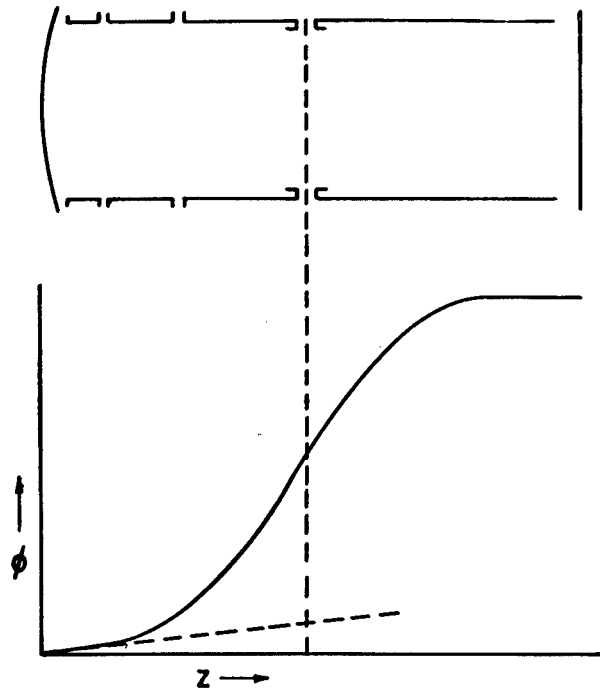

A

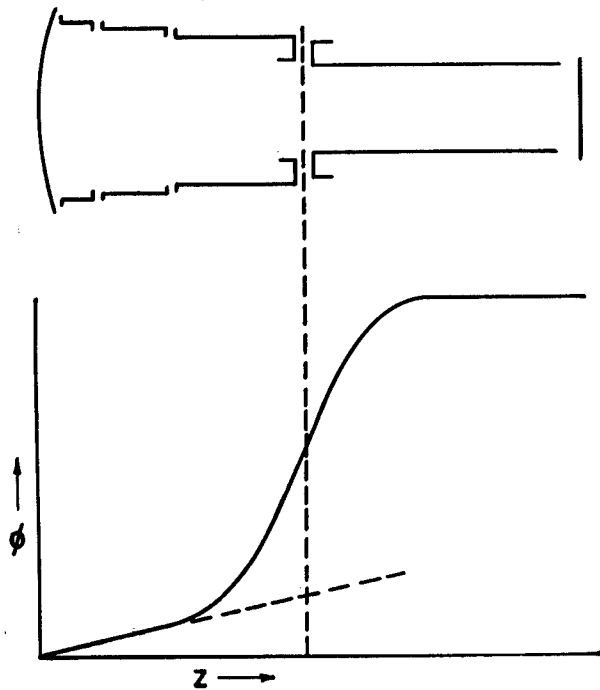

B

FIGURE 5. Large and small aperture lens systems.

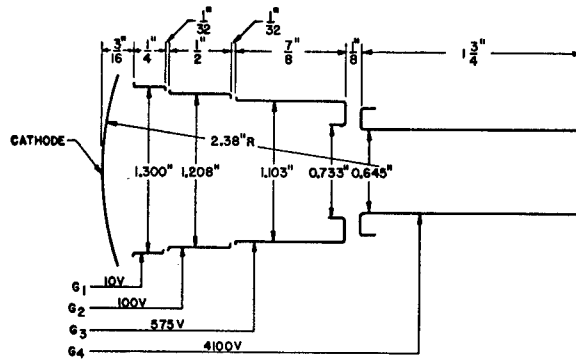

1P25 ELECTRODE DIMENSIONS AND VOLTAGES

FIGURE 6. Electrode design of 1P25 image tube.

general, the length and diameter of each electrode can be held quite close to these dimensions. There is, however, some variation in spacing, principally in that between the cathode and electrode G_1 . If the potentials to the four electrodes between the anode are readjusted, the effect of this variation is in general negligible. It is, however, customary in telescope design to fix all but one potential, either G_2 or G_3 . Because of this, the least incorrect spacing will result in incorrect magnification and enhanced off-axis aberrations. The potential distribution and electron paths for 2 electrons, (1) off axis with zero initial velocity, (2) on axis having initial velocity, are shown in Figure 7.

2.2.3 Photoelectric Cathode Problems

Photoemission serves as the source of the electrons which are imaged by the electron lens system. Therefore, the success of an image tube depends upon obtaining an efficient photocathode.

Work on photocathodes during the NDRC contract period was divided into two parts: investigation of methods to improve cesium-on-oxygen-on-silver cath-

odes for infrared use and to better their reproducibility; a search for a new photoemitting surface of superior characteristics. The second program was without significant success, although a wide range of materials was studied.^{1a}

With respect to the first line of investigation, a threefold increase in the maximum response to radi-

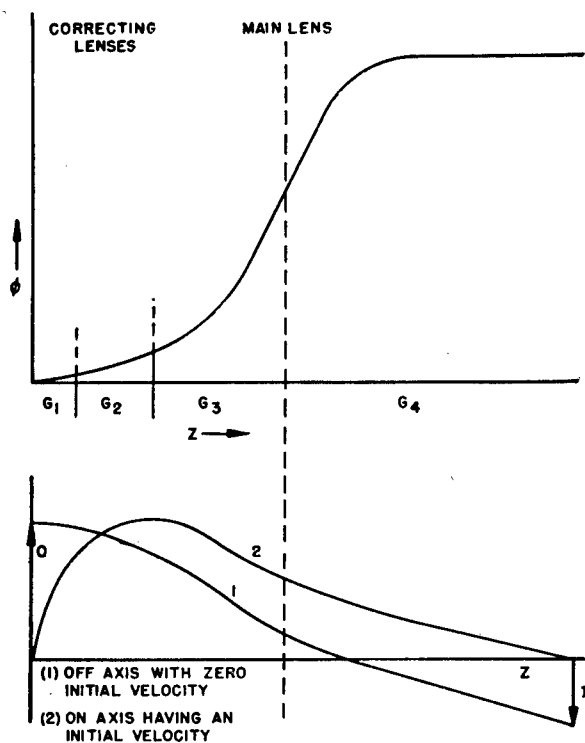

FIGURE 7. Potential design and electron paths in 1P25 image tube.

ation at about 0.9 to 1.0 micron was effected. Furthermore, whereas originally one good surface out of four was considered reasonable, the present advance finds the experienced laboratory operator capable of producing nine good surfaces in ten attempts. The contractor's report^{1a} describes causes of failure in activating surfaces and explains the detection of contamination by the color of the treated cathode surface.

THE CESIUM-ON-OXYGEN-ON-SILVER SURFACE

The Alkali Metals. The alkali metals form the basis of all the best photoemitters known. In general, the long wavelength limit of response increases with the atomic weight in the alkali series, and cesium is therefore used for surfaces of high infrared sensitivity. In spite of years of research, which include study of most of the known elements, no material has been found which gives better results, either from the

standpoint of a longer wavelength limit or of increased magnitude of the infrared response.

The pure alkali metals, however, are relatively poor photoemitters compared with the same metals used to activate complex surfaces of silver and oxygen. However, the emission becomes selective, and the response curve has several maxima and minima. For the present application, the only portion of the cesium-on-oxygen-on-silver response curve which is important is the peak which rises from a minimum in the neighborhood of 0.55 micron to a maximum between 0.8 and 0.9 and drops gradually to zero at 1.2 microns or even longer (see Figure 8).

Preparation of the Surface. Basically, surfaces of this type are prepared by forming on a silver surface a thin layer of silver oxide, then exposing the surface to cesium vapor, and subjecting the system to heat treatment, during which the cesium reacts with the silver oxide to form cesium oxide and free silver. The final surface then consists of silver, a layer of mixed silver and cesium oxide with metallic silver interspersed in it, and a bound layer of cesium. The cesium itself probably acts as the active centers of

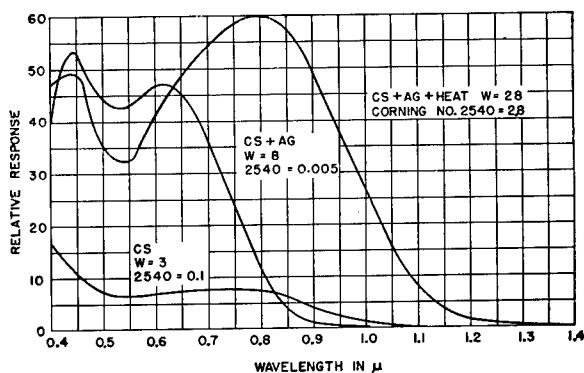

FIGURE 8. Spectral response characteristics of cesium-oxygen-silver photoemitter.

photoemission, and the underlying layer serves to provide a suitable environment for binding the cesium and also serves to supply replacement electrons for those emitted. At present, a satisfactory theory of the mechanism of operation of this type of surface is lacking, so that attempts to improve the basic surface must proceed on an empirical basis.

Thermionic Emission. Thermionic emission is an indication of the state of activation and can be used as such during the processing. Some work has been done along the line of reducing thermionic emission, inasmuch as it is the principal source of background

glow in a well-made tube. The order of magnitude of the current density for room temperature is 10^{-12} ampere per square centimeter, and this current increases by a factor of 10 for every 20-degree rise in temperature. There is some evidence that there

ure 9 gives the emission spectra of Willemite and zinc-cadmium-sulfide.

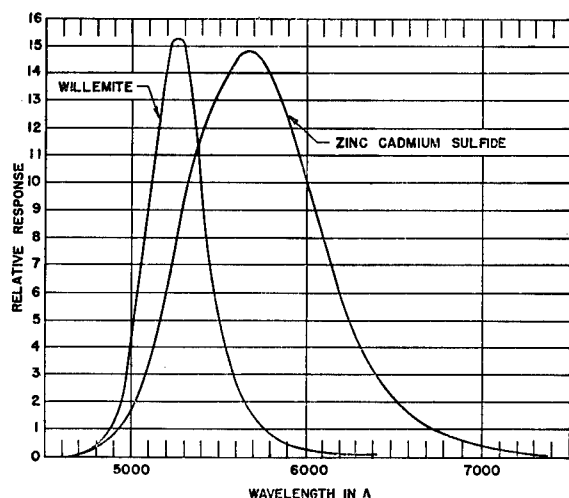

FIGURE 9. Emission spectra of the two phosphors used in image tubes.

is a limit below which the thermionic emission cannot be reduced for a tube having a given infrared response. It is also known that by decreasing the response above 1.0 micron the thermionic emission can be lowered.

Spectral Sensitivity. A well-sensitized infrared cathode has a spectral response as shown in Figure 8, but some deviation from this curve, particularly at the long wavelengths, can be expected in production tubes. The absolute response of these surfaces to whole light from an incandescent source with a color temperature of 2870 K can be as high as 50 microamperes per lumen, but usually runs between 25 and 35. If 1 lumen of light from this source is filtered with Wratten 87, the response is cut to about $\frac{1}{3}$ and, when filtered with 4 millimeters of Corning 2540 heat transmitting glass, it is about $\frac{1}{10}$ the whole light response.

2.2.4 Fluorescent Screen Problems

Of the fairly large class of phosphor materials which might be used for the fluorescent screen in the image tube, only two have high efficiency along with the other characteristics required to make their use practical. These are Willemite, which has a very low sensitivity to contamination by cesium vapor, and the sulfide phosphors, which are very sensitive to cesium contamination and must be protected by a film. Fig-

ure 9 gives the emission spectra of Willemite and zinc-cadmium-sulfide. Both phosphors have been used in image tubes, Willemite for the 1P25, and zinc-cadmium-sulfide for high-voltage tubes (see Section 2.3.3). Many other phosphors have been tested in the course of image tube development, including zinc oxide, the tungstates, and others, but none has been entirely satisfactory. A perfect phosphor for image tubes would:

1. Be suitable for vacuum conditions;
2. Be insensitive to cesium contamination;
3. Have high efficiency at low current density;
4. Operate in the voltage range 3,000 to 6,000 volts and higher;
5. Form a fine-grain, high-resolution screen;
6. Have a rapid decay time;
7. Emit light suitable for scotopic vision (not red).

Willemite has been used for 1P25 image tubes as most nearly fulfilling these conditions. Its luminous efficiency is from 1 to 3 candles per watt at the voltages employed. Of great importance is its low sensitivity to cesium-vapor contamination. It easily makes a fine-grain screen, and its color is green or yellow-green. But its time-lag characteristics are such as to interfere appreciably with signaling speed where an instrument is used for this purpose; this same factor also reduces definition of rapidly moving extended objects. The build-up to maximum value requires 0.04 second; brightness falls to 10 per cent of its initial value 0.04 second after excitation is discontinued; and the luminescent decay follows an exponential curve so that residual glow remains visible a long time after intense excitation.^{1c} Signaling speed cannot be much more than five words per minute.

The sulfide phosphors are somewhat more efficient than Willemite, although at 1P25 voltages the difference is unimportant. When contaminated, sulfide phosphors lose most of their efficiency; protecting aluminum or other metallic films absorb a large percentage of the bombarding electrons at low voltages, but at high voltages this protective film is very satisfactory. Various shutters and removable protective barriers have been tried to reduce contamination but without practicable success.

The phosphors are prepared as extremely fine powders with particle sizes of the order of 1 micron. Preparation is described in the contractor's report.^{1d} For Willemite used at 5,000 volts, the screen density is about 1 milligram per square centimeter; for 20,000 volts, it is $2\frac{1}{2}$. A sulfide screen should have about the same density.

2.2.5 Construction of the 1P25

The contractor's report^{1e} outlines the construction and activation procedure in sufficient detail to permit an experienced laboratory worker actually to build an image tube which would be a laboratory version of

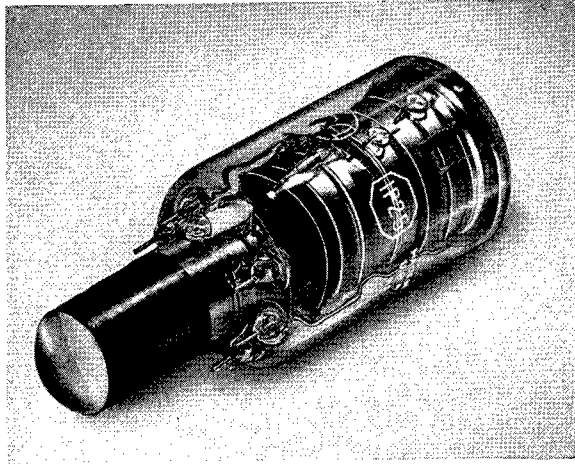

FIGURE 10. The 1P25 image tube.

the production 1P25. The procedure outlines would not, of course, be feasible for production purposes.

Cleanliness is the most important single factor contributing to the success or failure of the image tube. All the parts must be thoroughly cleaned before assembly and kept clean through all subsequent operations.

Figure 10 is a photograph of the complete image tube; Figure 11 shows its component parts; and Figure 12, its dimensions.

2.2.6 Performance of the Image Tube

RESOLUTION

In rating experimental tubes for television, it is the practice to specify the definition as the maximum number of black and white horizontal lines which can be resolved in a rectangle with a 3x4 aspect ratio whose diagonal is equal to the diameter of the image area. Ambiguity exists in that the percentage contrast between the black and white lines is not specified, and the minimum detectable contrast by eye depends upon the brightness of the image. Under brightness conditions giving approximately maximum resolution, however, the results are fairly reproducible. Under these conditions, a difference in brightness of 1 or 2 percent is usually taken as the limiting value at which the lines can be resolved. The method gives a conven-

ient and rapid way of rating tubes by simply projecting a pattern of calibrated wedges made up of bundles of lines onto the photocathode and observing the re-produced image.

Occasionally, the definition is specified in terms of the total number of black lines which can be resolved along a diagonal. If N is the resolution by the rating procedure outlined above, the definition n_1 in terms of black lines along a diameter is

$$n_1 = \frac{N}{2} \cdot \frac{5}{3} = 0.83N.$$

Sometimes it is convenient to specify the number of lines per millimeter n_2 which can be resolved at the photocathode. For the 1P25, the conversion in this case is

$$n_2 = \frac{N}{2} \cdot \frac{5}{3} \cdot \frac{1}{28} = 0.03N.$$

For experimental image tubes, a resolution of $N = 450$ has been generally considered as acceptable. Actually a well-constructed tube, correctly focused and shielded from external fields, will give better than twice this resolution. The limiting definition as determined by the chromatic aberration for a tube of this type is around $N = 2,000$ or 2,500 for an infrared

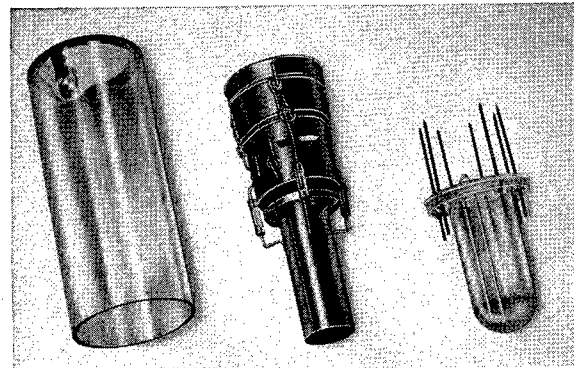

FIGURE 11. Components of the 1P25 image tube.

image near threshold. A whole light image will give a much lower limiting resolution because of the higher initial velocities of the emitted electrons.

For viewing an extended object, $N = 450$ gives nearly all the resolution that can be perceived with the dark-adapted eye, when combined with a reasonably high-powered eyepiece (e.g., $\times 8$ to $\times 10$) and a practical infrared illuminator. Where the tube is used in a signaling instrument close to threshold, the definition may be much lower without impairing the usefulness of the instrument.

Curvature of the Focal Surface. The resolution, in general, will not be uniform over the cathode area because of the curvature of the image field. The circle of maximum definition can be shifted by the focusing voltage. With a well-constructed image tube, the volt-

fraction of the screen that is in optical contact, and it adds approximately two-power to the ocular without appreciably reducing the practical eye aperture of the system.

Voltage Focusing. The resolution will, of course, be lowered if improper focusing voltages are applied. Figure 13 shows the effect on resolution of a departure from the optimum focusing voltage. Curve No. 1 is for G_2 used as the focusing electrode and curve No. 2 for focusing with G_3 . In each case, the voltages on the remaining electrodes are assumed constant. For any value of G_2 over a considerable range, G_3 can be re-adjusted to obtain sharp focus at the center. However, unless G_2 and G_3 are correctly adjusted, the magnification will be incorrect and the off-axis aberrations large.

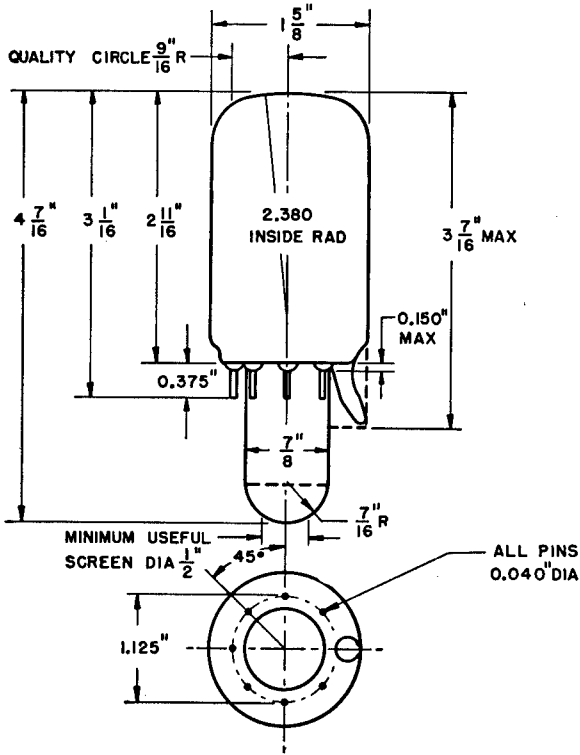

FIGURE 12. Glass envelope of the 1P25 image tube.

age is usually adjusted so that the circle of maximum definition has a diameter of perhaps a quarter of an inch. Under these conditions, if the definition at the center is $N = 450$ lines, the definition at the edge (i.e., a circle 1 inch in diameter) will be about 300 to 350 lines. However, if the lens dimensions are incorrect, or the voltages not properly chosen, the definition may be much poorer at the edges even though it is sharp in the center.

A correctly built and adjusted image tube will show very little distortion, usually only a slight amount of pincushion distortion being noticeable at the edges of the image. Like loss of definition at the edge of the image, distortion increases rapidly with incorrect electrode spacings or incorrect electrode voltages.

The hemisphere on the screen end of the image tube (Figure 10) tends to correct pincushion distortion when used with a low-power eyepiece. This is only one of the functions of this hemisphere. In addition, it increases the effective brightness of the image for the

SENSITIVITY

The ratio of the amount of whole light on the cathode to that emitted by the screen is a measure of the sensitivity of the image tube; "conversion" has been adopted to express this sensitivity. Conversion is defined as the ratio of the number of lumens emitted by the fluorescent screen on the side from which the im-

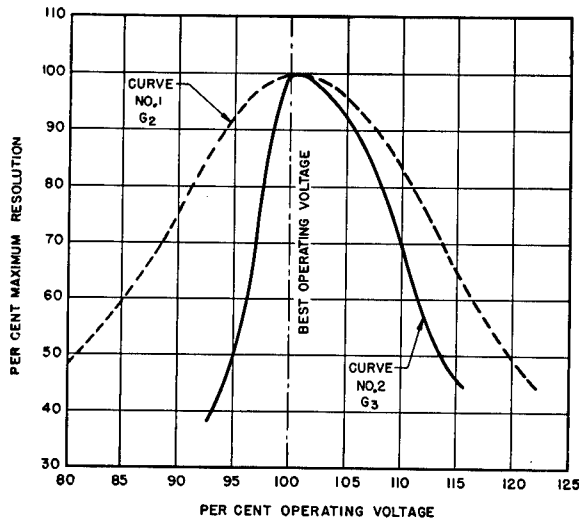

FIGURE 13. Resolution versus electrode voltage setting.

age is viewed, to the number of lumens falling on the cathode. The output from the screen is measured with a photronic cell having a response characteristic approximating that of the eye. The cathode is illuminated by an incandescent source with a color temperature of 2870 K. The conversion is easily measured inasmuch as it is independent of the area of cathode illuminated and the magnification of the image tube.

The conversion deals with total light flux to and from the tube. However, inasmuch as the fluorescent screen closely follows Lambert's law, a knowledge of the magnification is all that is necessary to transform conversion into units of brightness and intensity. For the 1P25, where the magnification is $\frac{1}{2}$, the brightness of the screen B in candles per square foot in terms of foot-candles incident on the photocathode is

$$B = \frac{4}{\pi} IC,$$

where C is the conversion.

Infrared Conversion. An exact statement of performance in the infrared is difficult as it involves an integration of the product of the spectral response curve and the radiation distribution curve. However, there are a number of approximate methods which can be used which are satisfactory from a practical standpoint. One method is to specify the measured whole light conversion and a filter factor giving the amount by which the response is reduced by the filter in question. The disadvantage of this procedure is that small differences in the long wavelength response between image tubes cause the filter factor defined in this way to vary widely from tube to tube.

A more practical specification is to determine the filter factor giving an attenuation in the neighborhood of 10, either by direct measurement with an image tube having a standard spectral distribution curve or by computing it from the filter transmission curve and the standard response curve. Using this filter, the luminous flux output from the image tube being tested is measured with a source delivering 1 lumen (unfiltered). This value is then multiplied by the filter factor giving a nominal whole light conversion. The nominal whole light conversion will equal the measured whole light conversion if the tube has a nearly standard spectral response, but may differ considerably in many cases. However, it has been found experimentally (over the range of practically useful filter factors—from 5 to 15) that in nearly every case the nominal whole light conversion divided by the filter factor will give a good approximation to the tube performance.

The expected conversion can be easily computed from the data on photocathodes and the performance of the fluorescent screen. For the purpose of making this estimate, assume that the photosensitivity is 20 microamperes per lumen and the screen efficiency 8 lumens per watt. One lumen on the cathode will produce 0.08 watt at 4,000 volts. The luminous output,

and hence the conversion, will therefore be 0.64. Measured conversions for useful tubes run between 0.25 and 1.5 lumens/lumen.

The light output from the image tube is closely proportional to the light on the photocathode over the useful range of the tube. At very high light levels, the

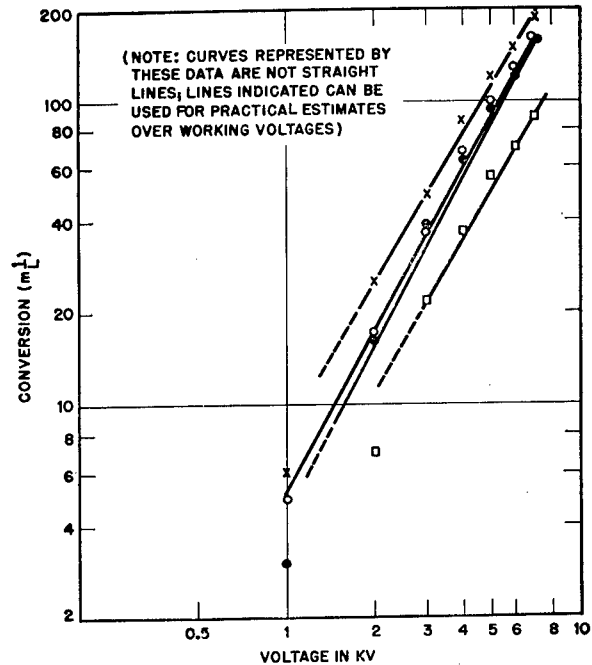

FIGURE 14. Conversion versus voltage.

phosphor begins to saturate and the light output ceases to increase as rapidly as the incident light.

The conversion is a function of the overall voltage on the tube. The variation of conversion with voltage for a number of image tubes is shown in Figure 14. With Willemite screen, the increase in conversion is approximately proportional to $V^{1.4}$.

CONTRAST

The contrast in the reproduced image depends upon a large number of factors. Leaving out such effects as optical scattering in the objective and ocular as not pertinent to a discussion of the image tube itself, there are other possible optical effects: scattered light in the electron lens structure being reflected back onto the cathode, regeneration between fluorescent screen and cathode, and internal reflections in the hemisphere. Tests show that reflection back to the cathode from the internal structure and optical feedback between screen and cathode are quite small. Internal reflection in the hemisphere is not negligible

and several per cent of the light from the screen may be returned to other points on the screen. A non-reflecting coating would avoid this loss in contrast. At low light levels, the background due to two types of electrical effects is by far the greatest cause of loss of contrast.

Thermionic Emission. As already described, thermionic emission amounts to 10^{-12} ampere per square centimeter at room temperature. The screen brightness due to this current is sufficient to be observable with the well dark-adapted eye. However, in the practical operation of the infrared telescope, it only interferes with contrast when the image brightness is extremely low, close to visual threshold. With the present method of measuring the sensitivity of signaling instruments, thermionic background can be an important factor. Where the voltage is higher or the magnification lower than that used in a 1P25, the thermionic background becomes a matter of prime importance. The thermionic background varies considerably among different tubes, even when the spectral responses are quite similar. There is some evidence which indicates that the minimum thermionic background for tubes which have a high response at long wavelengths will be higher than for those which have a smaller response, even though the whole light response of the two classes of tubes are the same.

Field Emission. When there is a high potential gradient at a metal surface, electrons will be drawn out of the material even when its temperature is too low for any appreciable thermionic emission. This field emission or cold discharge increases exponentially with the field strength, and increases as the work function decreases. Since cesium is used in the cathode activation, the work function of the metal surfaces of the electrodes in the tube is reduced by its presence; accentuating the tendency for field emission from them. Furthermore, if there is any roughness of the metal surfaces, high field strengths will exist at points, high places, and sharp edges.

Because of field emission, the metals used in an image tube must be such that, even in the presence of cesium, they will have as high a work function as possible. The free cesium left in the tube after activation should be reduced to a minimum. The spacing between electrodes, particularly those having a large potential difference between them, should be as great as is consistent with the electron optical design. All metal surfaces should be smooth, preferably polished, and sharp edges must be avoided.

The highest gradient in the 1P25 is at the main

lens, between electrodes G_3 and G_4 . Therefore, these are formed in such a way that the metal edges are turned back away from the high-field region. The secondary lenses which are formed by the other electrodes do not require as large potential differences, and the cylinder edges of G_1 , G_2 , and G_3 do not cause trouble. These edges are smoothed and rounded as much as possible. In the case of the experimental 1P25's built during the contract period at the RCA Laboratories, the entire structure was polished electrolytically.

Even with these precautions, cold discharge is not eliminated and it sets an upper limit to the voltage which may be employed. Figure 15 shows the variation of background with voltage for a number of typical experimental tubes. It will be noticed that the tubes differ quite markedly in their performance in this respect. By selecting tubes, those can be found which can be operated much above their present rating, even to overall voltages of 10,000 or 15,000 volts.

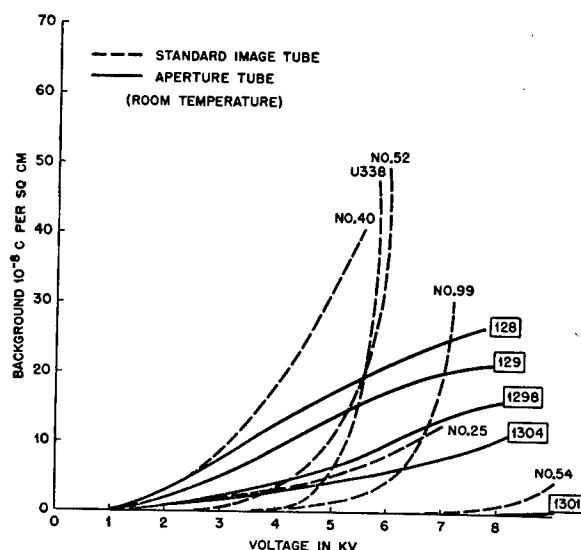

FIGURE 15. Background glow versus voltage for 1P25 and aperture image tube.

This, in general, is not advisable because even these selected tubes may develop cold discharge in the course of their life.

Dust or particles settling on the electrodes during construction and assembly of the tube can completely nullify the care taken in smoothing and polishing the electrodes. Such particles will constitute points about which the field strength will be high, and therefore cold discharge is likely to originate from them. When a completed tube shows bad cold discharge upon initial test, it can frequently be greatly improved by running it at considerably over voltage for a short period.

An investigation was made of the effect of a small aperture placed beyond the main lens at the point of minimum diameter of the electron ray bundles. The effect of such an aperture is shown in Figure 15. It will be seen that while the rate of rise of background is reduced at higher voltage, the background level is still high. Nevertheless an aperture of this type may be of advantage for some applications of the image tube (such as the sniperscope) but not for others (threshold-point source sensitivity).

2.3 EXPERIMENTAL IMAGE TUBES

2.3.1 Single-Voltage Tubes

One of the objects of the work under Contract OEMsr-440 was to develop a series of lightweight telescopes having a long operating life. The multiple voltage of the 1P25 limited the reduction in size because of the consequent requirement of a voltage divider load on the power supply. Therefore, considerable work done on single-voltage image tubes.

To insure maximum usefulness, the design was based on a tube of the same external size and shape as the 1P25, so it could be substituted for it in the

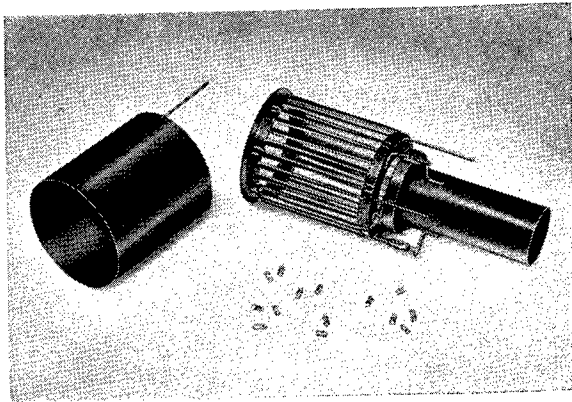

FIGURE 16. Components of the single-voltage image tube (Type U-41).

then existing telescopes, and could be used in new instruments with smaller, longer-lived power supplies.

Where the requirements of $\frac{1}{2}$ magnification and particular size have to be met, the electrons have to be accelerated by secondary lenses before the main lens, not only to correct for distortion and field curvature, but also to obtain a focus. A series of *unit* lenses, consisting of pairs of coaxial cylinders at cathode potential with positive cylinders surrounding the spaces between them, gave good images in laboratory

models, but were entirely unsuited for production because of very close tolerances.

THE U-41 TUBE

The method finally adopted involves a radically new type of electron lens structure, although the main lens is essentially the same as the lens in the 1P25. As shown in Figure 16, the secondary system is formed by the field between a structure of tapered lateral strips and a surrounding positive cylinder. The dimensions of this tube (U-41) are given in Figure 17. The inner and outer electrodes are self-supporting

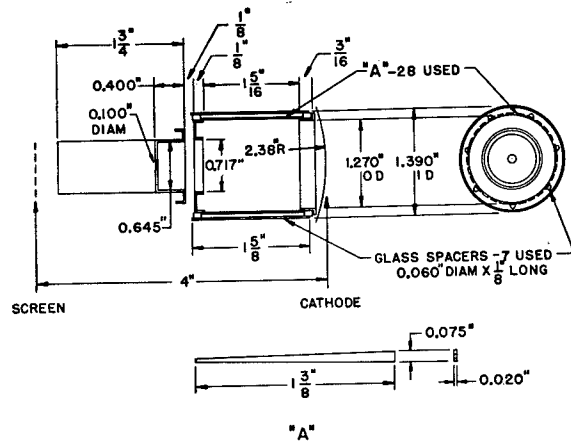

UNPOTENTIAL IMAGE TUBE-ELECTRODE ARRANGEMENT AND DIMENSIONS

FIGURE 17. Electrode design of the U-41 image tube.

units requiring insulating beads only at the ends of the cylinders to space them.

A field plot of the potential distribution in planes which include the tube axis is shown in Figure 18. The dotted equipotentials show the distribution between the strips and the solid lines show that at the center of the strips. It is evident that the two distributions do not differ significantly, except close to the electrodes, well outside of the electron paths. The aberration produced by the difference is well below the other aberrations of the electron optical system and does not produce a measurable degradation of the image.

Since these tubes are designed for a low-power, high-voltage supply, the avoidance of electrical leakage is very important. Leakage may take one of two forms, either due to conductivity over the insulating beads or cold discharge between the inner and outer electrodes. Both of these are reduced by keeping the structure and components clean, and by keeping free cesium in the tube to a minimum. The metal elec-

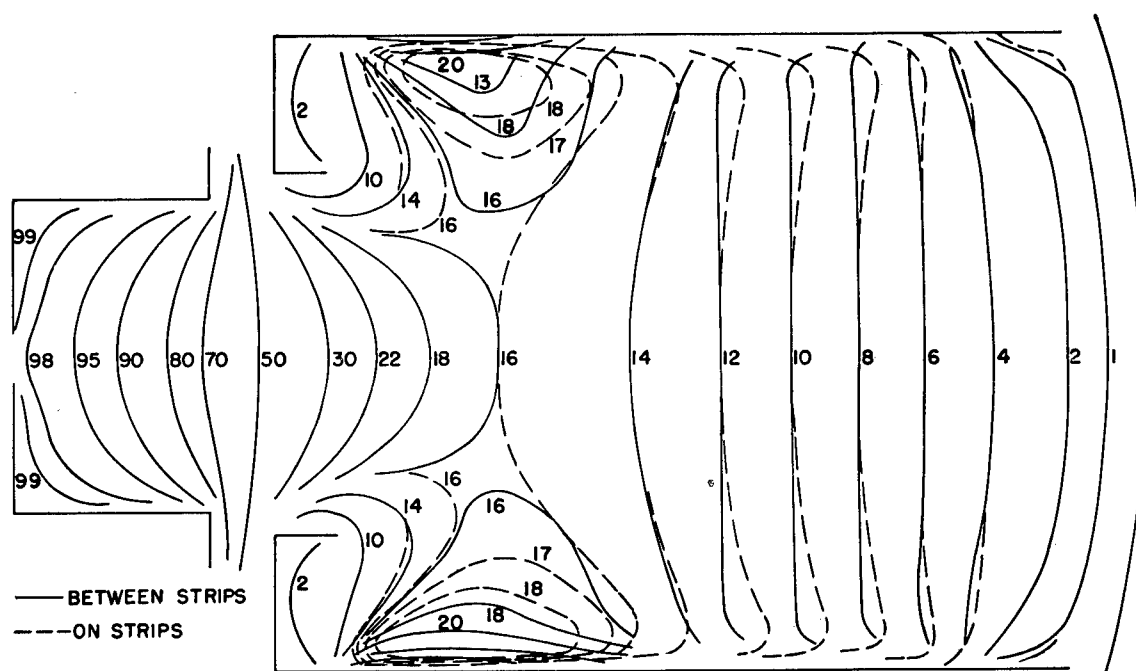

FIGURE 18. Potential distribution of the single-voltage image tube (U-41).

trodes should also be polished. By proper attention to these details, it was found possible to build experimental tubes with an effective resistance as high as 100,000 megohms at the operating voltage, 4,000.

A number of these tubes were built in the laboratory and used in single-voltage telescopes. The U-41 tube was not put into production.

THE SU-2 TUBE

Another, very simple single-voltage image tube was designed to be used in converting the Type A metascop (Chapter 3) into an electron telescope. This tube employed unity magnification and its length-to-diameter ratio was so chosen that a simple two-cylinder lens in conjunction with a cathode having suitable curvature would yield an image sufficiently free from distortion and curvature to be useful. A number of samples were built, but the tube was not put into production.

2.3.2 Low-Magnification Tubes

In addition to the $\frac{1}{2}$ magnification of the 1P25, two other ranges of magnification, about $\frac{1}{8}$ and $\frac{1}{50}$, were investigated. As already pointed out, the brightness of the reproduced image of a given object increases inversely with the square of the magnification. This method of increasing the brightness can be continued until the aperture ratio of the electrons

leaving the main lens becomes so large that spherical aberration makes the image unusable. However, the design of the infrared telescope sets a practical limit to the magnification which is much higher than this fundamental limiting value.

Tubes of $\frac{1}{50}$ Magnification. Some tubes with 3-inch cathodes and $\frac{1}{50}$ magnification were experimented with and found to produce fair images but with definition of only about 100 lines. It was, of course, essential to cool the cathode to a low temperature to reduce thermionic emission, but even then the background was fairly high. After work on several tubes of this type, it was decided to concentrate on tubes of higher magnification.

Tubes of $\frac{1}{8}$ Magnification. A series of tubes having the same cathode size as the 1P25 but with magnifications of $\frac{1}{6}$ to $\frac{1}{8}$ was constructed, and images resolving 300 lines obtained. With dry-ice cooling of the cathode, the screen was reasonably dark with no incident light, and the expected gain in brightness over the 1P25 was obtained. This type of tube, however, was superseded by a high-voltage, low-magnification tube, which was built in a larger blank having a 3-inch cathode (see below).

2.3.3 High-Voltage Tubes

The lowering of the portability requirements for certain types of instruments, and improvements in

power-supply design brought much higher voltages into the range of practicability. For a Willemite screen, the light output varies approximately with $V^{1.4}$, and for the sulfide phosphors nearly as V^2 . Figure 19 shows the screen efficiency in millilumens per microampere for a number of image tubes with screens of each type. In high-voltage tubes, sulfide phosphors may be employed, for the 2,000 to 4,000 volts lost in an aluminum film of sufficient thickness to protect the screen is more than offset by the efficiency gain in using the sulfide phosphor and due to the light reflected back by the metal film.

High voltage also results in improved resolution, due in part to increased field strength at the cathode (reducing chromatic aberration), and in part to the greater depth of focus.

THE MA-4 TUBE

Although the electrodes and assembly of the 1P25 might have been redesigned to stand the higher voltage, it was decided to expedite getting the high-volt-

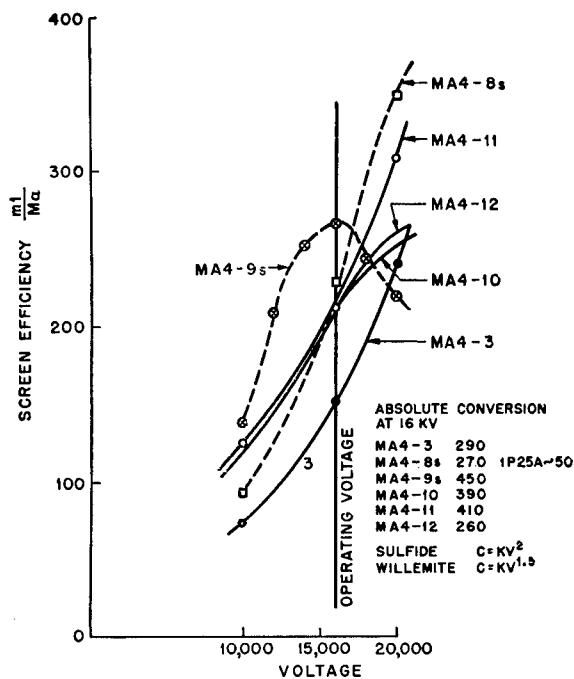

FIGURE 19. Screen efficiency versus voltage (Type MA-4 image tube).

age tube into production by using an initial lens system identical with the 1P25, supplemented by a series of anode lenses over which the high voltage is distributed. As shown in Figure 20, the structure and blank up to and including the pin circle were made identical to the 1P25, and the multiple-anode lenses

take the form of flanged cylinders sealed into a tubular neck carrying the fluorescent screen.

Electron optically, the multiple-anode image tube behaves somewhat differently from the 1P25. The weak lenses form a real electron image of a virtual object, the latter being the image formed by the main

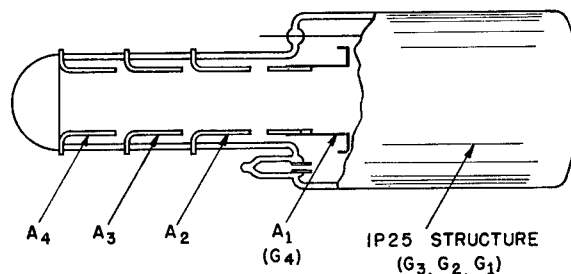

FIGURE 20. Electrode design of Type MA-4 image tube.

lens. In order to bring the real image into focus, electrode G_3 must be somewhat more positive than in the 1P25. The magnification of $\frac{1}{2}$ is maintained in spite of the increased anode length; pincushion distortion is reduced, while increased field curvature is compensated by greater depth of focus. Willemite fluorescent screens may be used in these tubes, but considerable advantage is gained if a sulfide is employed.

Operating Voltages. The operating voltages used on the MA-4 are: Cathode, 0; G_1 , 10; G_2 , 100; G_3 , 800 to 1,000, adjustable; A_1 , 4,000; A_2 , 8,000; A_3 , 12,000; A_4 , 16,000. As with the 1P25, the cold-discharge points must be removed by overvoltages before the tube can be successfully operated.

The Type MA-4 tubes give a useful conversion factor from 5 to 8 times that of the 1P25, and a number of these tubes were built and used in experimental instruments. At the close of the war, a procurement order for a quantity of these tubes had been placed by the Armed Forces.

LOW-MAGNIFICATION TUBE

As mentioned in Section 2.3.2, a high-voltage, low-magnification tube was developed. It employed the multiple-anode structure, made of aluminum, carefully smoothed and polished (Figure 21). The fluorescent screen is an aluminum-protected layer of zinc-cadmium-sulfide. Instead of 5,000 volts, 20,000 were used, and an excellent image, high definition, and a brightness gain of 50 to 100 times over the 1P25 was obtained. Work with this type of tube (MA-6) and a telescope incorporating it was in progress as the contract terminated. When this tube was used in

conjunction with a large Schmidt optical system, it was possible to exceed the sensitivity of the dark-adapted eye when whole light from an incandescent source was employed.

2.3.4 Image Tube Research

Lines along which further work might well be done include:

1. Photocathodes may eventually be improved, but independent research over a number of years, on the

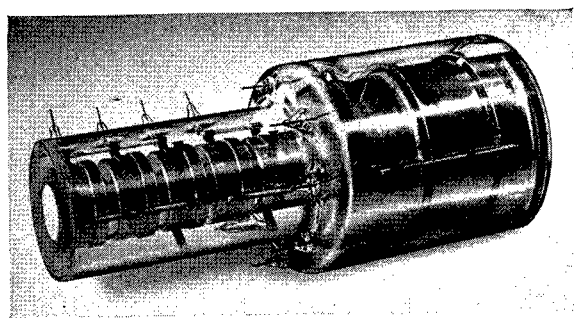

FIGURE 21. High-voltage low-magnification image tube (Type MA-6).

part of the British, the Germans, and ourselves, has produced cathodes almost identical both in spectral response and in sensitivity.

2. For the low-voltage tube, a high-efficiency phosphor with a short persistence time, insensitive to cesium contamination, is badly needed. The fluorescent screens used now in high-voltage tubes leave much to be desired with respect to particle or aggregate size, uniformity, and resolution. There are many known phosphors which might be suitable for image tube work, but which have not been studied because of insufficient time.

3. Revision of the basic electron optical design of the 1P25 should aim toward elimination of cold discharge and to permit more accurate construction and alignment.

4. The question of retaining the multiple anode on high-voltage tubes should be considered—higher field strength at the cathode resulting from omission of the multiple anode would reduce chromatic aberration. On the other hand, such an increase in field at the cathode may add to background glow.

5. Much remains to be done as far as image brightness is concerned. It is felt that by increased magnification, with high voltage and an antimony photocathode, it might be possible to build an instrument which is much more sensitive than the eye for night

vision. Other methods of increasing brightness, such as phosphors, photocathode cascading, secondary emission multiplication, and the image amplifier, should be thoroughly explored.

6. The military applications of image tubes employing the middle infrared and far infrared regions are numerous. It has not yet been possible to extend the sensitivity of photoemitters beyond 1.4 or 1.5 microns, and there is no evidence to indicate that they can be extended appreciably into the infrared. Therefore, an image tube operating in the intermediate or far infrared must be based on something other than the external photoelectric effect. Thermal and far-infrared imaging, in particular using a "velocity selection" tube, may become very important. These proposals are discussed in the concluding portion of the contractor's report.¹¹

2.4 IMAGE TUBE POWER SUPPLIES

All of the electron image tubes described in this chapter require a power supply giving a rather high-voltage output. Portability requirements necessitated small batteries with a minimum operating life if the instrument was to be practical. Fortunately, at 4,000 to 6,000 volts, the current demand is very small—the

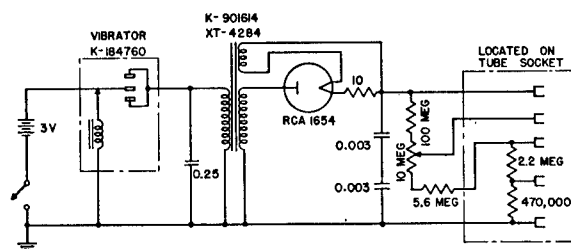

FIGURE 22. Basic circuit of vibrator power supply.

image tube itself requires only a fraction of a microampere, while the voltage divider needed to supply the various focusing electrodes of the 1P25 uses under 50 microamperes. The power output, therefore, is of the order of $\frac{1}{10}$ of a watt.

2.4.1

Component Parts

THE CONVERTER UNIT

The only practically available means for converting the low battery voltage is a vibrator-transformer-rectifier combination, such as illustrated in Figure 22. It differs from the conventional vibrator power units used in battery-operated radios in that the transformer is resonated by tuning the primary, so that a

very high voltage appears across the primary each time the vibrator interrupts the current. A corresponding voltage peak is thereby induced across the secondary. A filter with the time constant $R \times C$ large compared to the vibration period in the output circuit smooths out the voltage pulses after rectification. Where the divider load is, for example, 100 megohms, the capacity required is about 100 μf .

Vibrator. Due to the rather stringent requirements of load, size, and weight, special consideration had to be given to the selection of components. For ease of procurement, a standard type of vibrator was used, one which required minimum power, of the order of 0.2 to 0.3 watt. The rate was 100 interruptions per second, with "on" time approximately equal to "off" time.

Transformer design makes use of the relatively high-voltage peaks across the transformer due to the sudden collapse of the magnetic field when the primary circuit is broken. A rough approximation of the rate of collapse was based on the assumption of 100 vibrations per second, 0.005-second time of contact, 3-volt battery voltage, 3-ampere peak current, 4,000-volt peak voltage. The contractor's report²⁵ explains the method of concluding that the primary should have 100 turns and the secondary 13,000 turns. Higher voltage can be obtained by increasing the primary flux—by increasing the core size. However, a compromise in transformer size had to be adopted for each particular instrument design. The S-4 transformer, complete with filament winding for the rectifier, weighs 3 ounces.

Rectifier. This presented a difficult problem for portable units because of the lack of a rectifier suitable from the standpoint of physical size and filament current. Consequently, it was necessary to develop new rectifiers for the purpose. The first type is a thermionic rectifier which requires a heater current of 50 milliamperes at 1.5 volts and will deliver up to 100 microamperes at 5,000 volts. This tube was designed to use standard miniature receiving tube parts as far as possible and to present a minimum of manufacturing problems. It has since been put in rather large production with the designation, RCA 1654.

A second type of rectifier, the KR31 (Figure 23), was developed for this contract for use primarily with the single-voltage image tube. It is designed to occupy essentially the same space as the RCA 1654, but differs from the latter in that it requires no heater current. This greatly reduces the load on the primary batteries when the rectifier is used intermittently, as

in the case of the impulse-power supply described later, and simplifies the insulation problem in the case of the voltage multiplier, also to be described.

The rectifier depends for its action upon a gas discharge in helium at approximately 0.5 millimeter pressure. (Other gases such as neon may be used.) The cathode is simply an aluminum cup or disk. The anode is a nickel rod or tubing, over which is fitted a woven Fiberglas sleeve. The Fiberglas is heated to remove the organic lubricant with which it is impregnated. The entire nickel wire must be covered with the Fiberglas; the sleeve fitting down over the Dumet wire seal on one end and closed by fusing the glass at the free end of the rod.

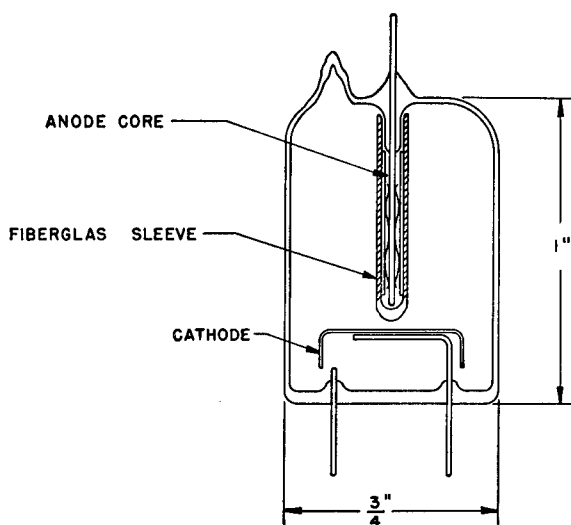

FIGURE 23. Rectifier Type KR31.

The peak inverse voltage of the KR31 is 6,000 volts and the forward breakdown voltage between 300 and 600 volts. The current-carrying capacity depends upon the operating conditions. In the application for which it was designed, the average current is under 10 microamperes, but the peak current may be several milliamperes. Under these conditions, the tube has a long operating life. Complete life tests have not been made, but tubes have been operated for periods of 100 hours with no observable change in performance.

THE VOLTAGE DIVIDER

A high degree of stability of the overall voltage is not essential but the ratio of voltages on the various electrodes must be maintained, as was pointed out in the section on image tubes. Since the overall voltage varies considerably as the batteries discharge and since the instruments may be subjected to wide ranges of temperature, behavior of the components of the volt-

age divider as regards temperature and voltage was a matter of considerable concern. As it is not always possible to maintain the proper voltage ratios over the range of temperature and voltage encountered in the field, occasional refocusing is necessary. The variations can be greatly reduced, however, by proper

+60 C. Divider No. 2 remains in focus from -40 C to +75 C. Therefore, using storage battery supply and selected components for the voltage divider, it is possible to build an instrument which will not require electrical focusing in the field under the range of conditions usually encountered.

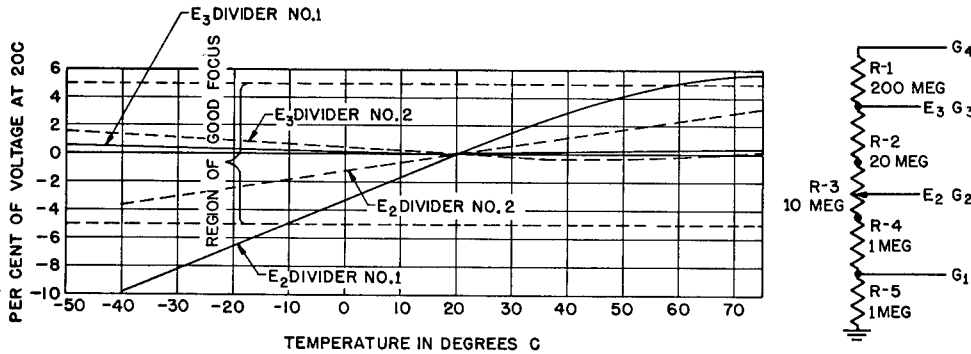

FIGURE 24. Temperature characteristics of composite voltage dividers.

choice of components in order to balance the characteristics of the components.

All of the available high resistances (50 megohms or more) show considerable change of resistance with voltage. Using dry cells as a source of power, a 2 to 1 change in overall voltage may be encountered from start to end point. Under these conditions, it is impossible to maintain focus without adjustment since a 50 per cent change in voltage represents a change of about 5 per cent in resistance of the best resistor. Therefore, unless compensation could be provided, it is necessary to refocus as the batteries deteriorate. In the case of storage battery supply, about 10 per cent change in voltage may be expected over the operating life. This produces a negligible change in resistance of the IRC Type MV resistor and no refocusing is necessary.

Most resistors have a high temperature coefficient, so it is necessary to select components which either have the same coefficient so that the ratio remains the same over the temperature range, or which have coefficients which tend to compensate for each other.

In making up a divider, many combinations of resistors tending to compensate are possible. Figure 24 shows the characteristics of two combinations. In both cases, the G_3 voltage remains essentially constant over the entire temperature range, the small variations being in such a direction as to compensate for the variation in G_2 . With divider No. 1 adjusted for focus at 20 C, the voltage on G_2 remains in the region of good focus over the range from -10 C to

2.4.2

Power Supply Units

S-4 Power Supply. This power unit was used with the Type Z binocular, the Type L monocular, and other general uses. It was required to deliver 4,000 volts to a 100-megohm divider, with a drain of 1 watt from a 2-volt battery. It employed essentially the converter unit already described and its transformer weighed only 3 ounces, as already mentioned.

S-3 Power Supply. Figure 25 shows this interesting modification of the vibrator power supply. This ar-

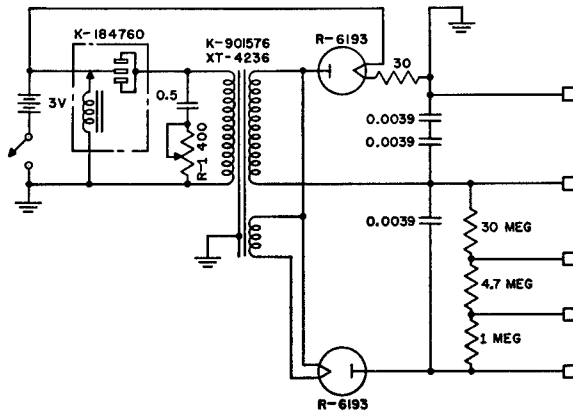

FIGURE 25. Voltage-doubler power supply.

angement is similar to the conventional voltage-doubler circuit except that the two halves of the doubler are brought out separately. In this way, it is possible to place a voltage divider across one side without disturbing the other. In the vibrator supplies,

the a-c wave is nonsymmetrical, being in the nature of a damped oscillation, so that in the circuit shown, the voltage across the high-voltage section, which is determined by the first loop of the wave, is about 4,000 volts while the voltage in the opposite section, determined by the second or negative loop is about 1,000 volts. Therefore, by putting the voltage divider

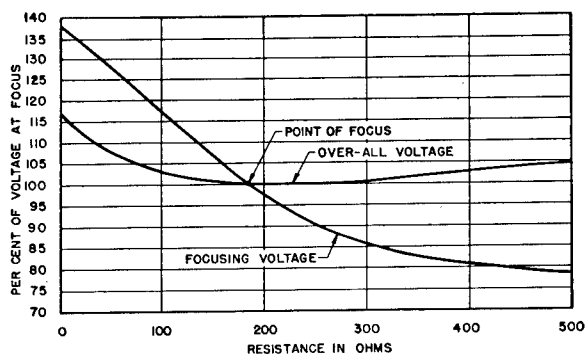

FIGURE 26. Voltage control of Type S-2 power supply.

across only the low-voltage section, the desired low voltages may be obtained without loading down the high-voltage section.

S-2 Power Supply. Another very interesting feature of this circuit is the fact that by introducing resistance in the tuned primary circuit, the damping of the circuit is increased, which tends to decrease the second or negative loops and thus the low voltage without appreciably affecting the high voltage. This action is shown in the curves in Figure 26. Thus, we have a means of varying the focusing voltage by an element in the primary circuit, which is a great advantage from the standpoint of electrical design. This circuit was used in the preliminary C_3 telescopes.

Impulse-Power Supply. In the single-voltage tube, the only load on the power supply is the actual photocurrent and leakage. By careful design, the entire load resistance can be made as high as 10^{10} ohms. Using a relatively large capacity on the output, the time constant of the circuit can be made several seconds so that a quite infrequent charging of the circuit is required. For this purpose, an interrupter was designed consisting of an electrically driven balance wheel having a period of about $\frac{1}{2}$ second. The design was such that the transformer primary is open most of the time and is closed for a short time to allow the current to build up and immediately open. In this way, the drain on the battery is extremely small, the supply operating for as long as 50 hours on a single size-D flashlight cell. The interrupter, the 1-ounce

transformer designed for the purpose, and the KR31 rectifier are shown in Figure 27.

S-5 Power Supply. The Type MA-4, high-voltage image tube brought up some special problems in power-supply design. The overall voltage required is in the range of 15 to 20 kilovolts and in addition, voltages of 10, 200, 1,000, 4,000, 8,000, and 12,000 are required. These intermediate voltages, particularly the 4,000 volts and over, are difficult to obtain efficiently by conventional means because of the relatively large power which would be wasted in a voltage divider of sufficiently low resistance to be stable. Also, as was pointed out before, it is possible to obtain higher voltages from the previously described power supplies only by increasing the flux in the transformer. This in turn can be accomplished only by increasing the primary power, necessitating larger transformers and batteries. Lastly, if a conventional power supply is used, a rectifier tube capable of withstanding 20 to 30 kilovolts inverse voltage would be necessary. This type of rectifier is not available in small size and low filament power. Consequently, a cascade-type (voltage adding) power supply was designed which

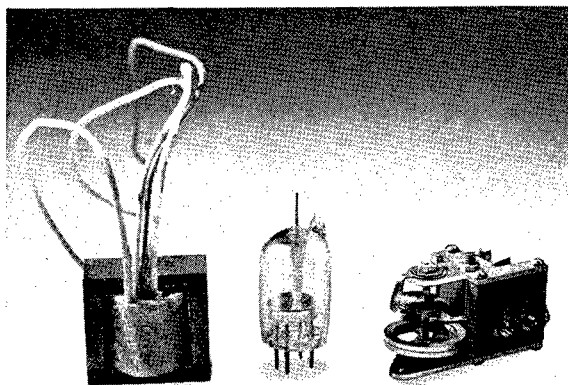

FIGURE 27. Components of impulse-power supply.

overcame most of the objections and automatically provided the necessary four steps of high voltage without a voltage divider.

A schematic diagram of the S-5 power supply making use of this circuit is shown in Figure 28; a photograph of the S-5 unit is Figure 29. As can be seen, this supply is made up of four rectifiers which are essentially in parallel for alternating current. The d-c voltages developed across the rectifiers, however, are added by means of the resistors which connect the cathode of one rectifier to the plate of the next and

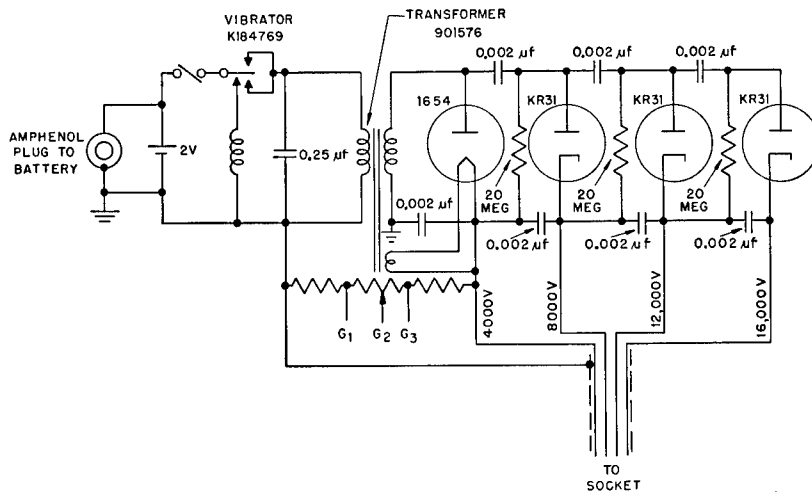

FIGURE 28. Circuit of voltage-quadrupler power supply (Type S-5).

thus place all the rectifiers in series for direct current. These resistors offer much higher impedance to the alternating current than do the capacitors so they do not affect the parallel a-c connection. Any number of stages may be cascaded in this manner, provided, of

course, that the transformer will deliver the proper voltage to all the rectifiers in parallel. Four stages were chosen in this case because four steps of voltage are necessary for operation of the MA-4 tube. The lower voltages required for the tube are obtained in the

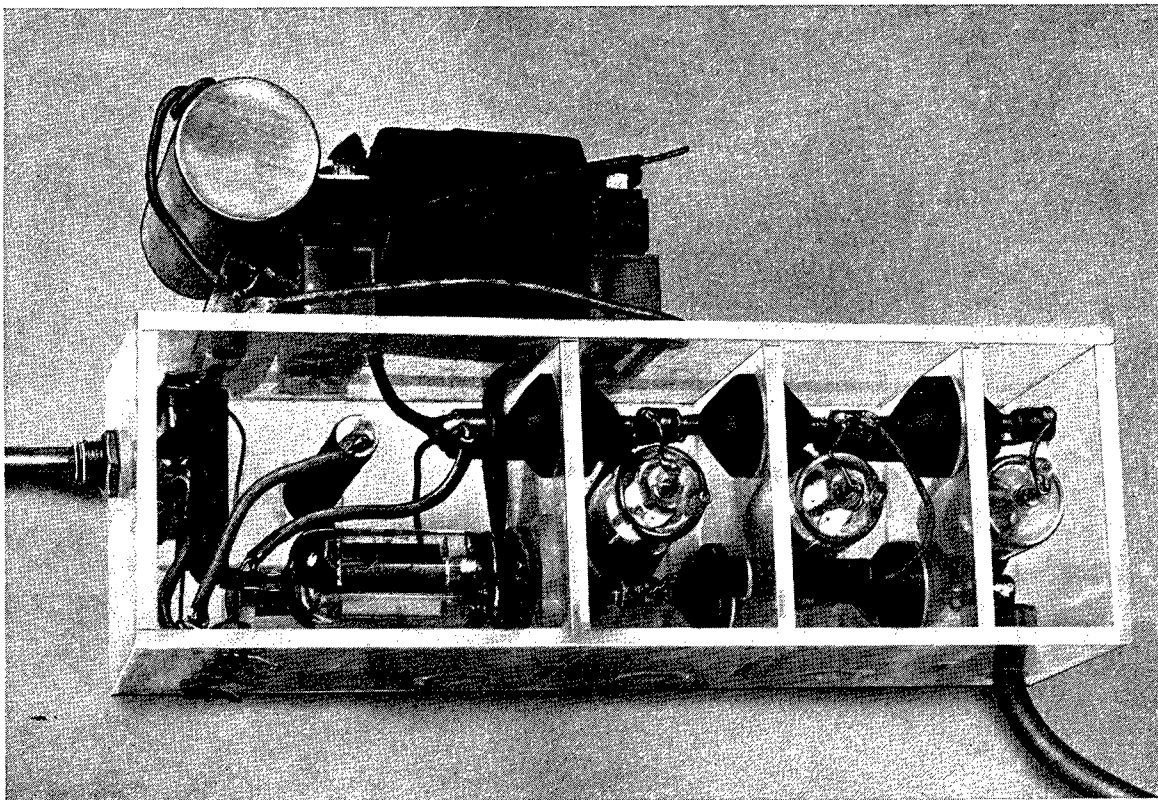

FIGURE 29. Components of Type S-5 power supply.

RESTRICTED

usual way by a voltage divider across the first section of the power supply. A thermionic rectifier (RCA 1654) is used in this stage in order to supply the divider current, but the following stages make use of KR31 gas rectifiers, thus eliminating the need for filament-supply circuits with a high degree of voltage insulation. The current drain at the high voltages is very low so that the voltages shown are obtained with a total battery current of only 0.4 ampere at 2 volts.

The chief problems in connection with this supply are leakage and corona. These must both be kept to a minimum since the internal resistance of the power supply is quite high. Leakage can be minimized by use of high-quality insulation and protection from humidity. Corona can be prevented by eliminating all sharp edges at the high-voltage connections or by coating with a closely adhering insulating material like wax.

2.5 INFRARED TELESCOPES

2.5.1 Telescope Performance

In general, there are two types of application for infrared telescopes which require somewhat different theoretical and practical considerations when the sensitivity and resolution of the telescope are to be predicted or measured. The first is where the telescope is used for signaling or to observe marker lights, and the second is where reconnaissance and the viewing of extended objects is involved. In the first case, the object may be considered a point source, which is obviously not true in the second case.

Point-Source Sensitivity. When the distance of a source is so great that the spot of light cannot be resolved by the eye, the eye responds to the total light flux entering the pupil rather than to the surface brightness of the source. As the distance is increased, the visual threshold is reached, and the sensitivity of a given telescope is usually expressed in terms of the radiation required to produce this threshold response. For a given filter, this sensitivity is usually expressed in terms of the mile-candlepower of the unfiltered source.

The threshold sensitivity of the eye may be taken as that of the light of a sixth-magnitude star, or, in some instances, as that of a fourth-magnitude star. Consequently, a source having a luminous intensity of 1 mile- (statute) candle corresponds to a 1.84-magnitude star. A fourth-magnitude star would be 0.14 mile-candle and a sixth-magnitude star, 0.21 mile-candle (0.028 nautical-mile-candle).

The contractor's report^{1h} derives the following expression for the optical efficiency factor for infrared telescopes:

$$E_F = \frac{1}{400} m^2 d_1^2 \frac{AC}{K},$$

where E_F is the optical efficiency factor for the telescope viewing a filtered infrared source with filter factor K ; m is the magnification of the eyepiece (ocular); d_1 is the diameter of the objective; A is the optical transmission factor representing light losses due to absorption and reflections; and C is the conversion of the image tube in lumens emitted per lumen incident.

One other factor must be considered: the "brightness" of the spot on the screen required to produce threshold response in the eye increases with the background glow. The background factor B is the number of times the "brightness" of the spot must be increased as a result of a given background glow, over the "brightness" which would be required for threshold if the screen were completely black. B varies among observers, and it applies only close to absolute threshold. If a brightness corresponding to I is assumed as a threshold, the threshold of the telescope in mile-candles—its sensitivity S_F —will be

$$S_F = \frac{IB}{E_F}.$$

Thus, in terms of image-tube characteristics for a given source and telescope:

$$S_F = k \frac{B}{C},$$

where k stands for the constant factors in the equation for E_F above. Under actual conditions of use, for example in signaling, the "brightness" of the spot has to be considerably above threshold in order to obtain reliability, and the background factor becomes much less important. A universal sensitivity rating probably lies between S_F and a rating which omits the background factor. At present, rating of production image tubes for signaling is primarily based on S_F , but a lower limit has been set for C .

Sensitivity for Extended Objects. For an extended image, the magnification of the eyepiece has no effect on the brightness of the image seen, as long as the exit pupil of the ocular is larger than the pupil diameter of the eye. The illumination on the photocathode is inversely proportional to the F -number of the objective, so that in this application the sensitivity does not depend upon objective diameter alone. Finally, the brightness conversion of the image tube

rather than conversion alone is the determining factor for extended objects.

The ratio of brightness B of the image seen on the fluorescent screen to the object brightness B_o is therefore:

$$\frac{B}{B_o} = \frac{C}{4m^2F^2}$$

where m is the magnification of the image tube, C its conversion for the radiation in question, and F is the F -number of the objective of the telescope. The absorption factor, taking into account light losses due to absorption and reflection in the optical system, has not been included. About 5 per cent loss should be allowed for each noncoated surface and 15 per cent for each mirror reflection. Nonreflecting films on the optical surfaces will greatly reduce losses in a complicated optical system, but these films must be adjusted to the wavelength of the radiation involved. In general, the transmission will be between 25 and 35 per cent for telescopes of the type employed in this work.

Where a searchlight or spotlight is used to illuminate the object, the requirements for the illuminator can be calculated in much the same way as in an ordinary lighting problem. If the beam candlepower of the source is P , the object is at a distance D (feet) and of reflectivity r , its brightness as seen through the telescope will be

$$B = \frac{PCr}{4\pi m^2 F^2 D^2} .$$

The expressions derived above are sufficient to permit an estimate of practical lighting requirements.

Resolving Power. The resolution requirements for a reconnaissance telescope are in general more severe than for a signaling instrument. Visual acuity of the human eye for a well-illuminated object corresponds to about 1 minute of arc. As the brightness of the object decreases, the visual acuity also decreases and corresponds to perhaps 10 minutes when the illumination reaches 10^{-2} to 10^{-3} foot-candle (assuming good contrast and a high reflection coefficient for the bright portions of the object). In this range of brightness, scotopic or rod vision begins to predominate. Experiment indicates that this order of brightness is convenient for work with the infrared instruments, in that fatigue is not too serious and at the same time it is not wasteful of illuminator power.

If the operating visual acuity is assumed to be 10 minutes, this means about 1.4 lines per millimeter at a 10-inch viewing distance. Therefore, if the image

tube has a resolution of $N = 450$ lines, the image can be viewed with an eyepiece power as high as 20 before instrumental definition limits the performance of the telescope. Because these instruments are frequently used under conditions which give somewhat better eye performance, and also because the definition of the objective-image tube combination may not give full 450-line definition, the most practical ocular magnification has been found to be 10 to 12. Other factors, such as the size of the exit pupil, also are taken into consideration.

The resolving power of the instrument must be considered in terms of the type of target being observed. No increase in range can be obtained by increasing the illumination if the essential detail of the target is below the instrumental limit of resolution.

For example, to recognize a man against anything but the simplest background, the definition in the object plane must be 6 inches or better. Assuming Type C₂ optics with a 3.5-inch focal length objective, the resolution required to give the required 6-inch definition in the object plane at 200 feet is 150 lines. With a 10-power ocular, this represents about 15 minutes of arc. The object is, therefore, within the limits of both visual and instrumental definition.

With a 2.5-inch focal length objective, such as is used in the Type B binocular, the angle at the eye becomes 11 minutes and is, therefore, close to the limit of visual acuity at these light levels. Where a 6-power ocular is employed, the definition would not be adequate.

Expected Ranges. The group of reconnaissance instruments to be described, namely, Types C₂, B, D, and K, all employ $F/2$ objectives. The sensitivity and performance of these telescopes can be estimated from the equations derived above. Assuming a conversion $C = 1$, a magnification $m = 1/2$, and a transmission $A = 0.35$, the brightness ratio $B/B_o = 0.09$. In other words, the object must be 11 times as bright to produce the same sensation through the telescope as would be obtained without the instrument. If an infrared filter with a filter factor of 10 is used, the ratio becomes $B/B_o = 0.009$.

It is of interest to determine the ranges that might be expected from various illuminators with such telescopes. First, consider a 30-watt concentrated source with a beam candlepower of 50,000. Taking 0.01 foot-candle illumination with visible light as the minimum for reasonably good "seeing," the above estimate indicates that the filtered source to be used with the telescope must be large enough to produce 1.0 foot-

candle without the filter. Therefore, the range of the source in question is

$$D = \sqrt{50,000} = 220 \text{ feet or } 75 \text{ yards.}$$

Employing a 600-watt airplane landing light with a beam candlepower of 500,000, the range becomes 700 feet. Finally, if a searchlight with a beam candle-

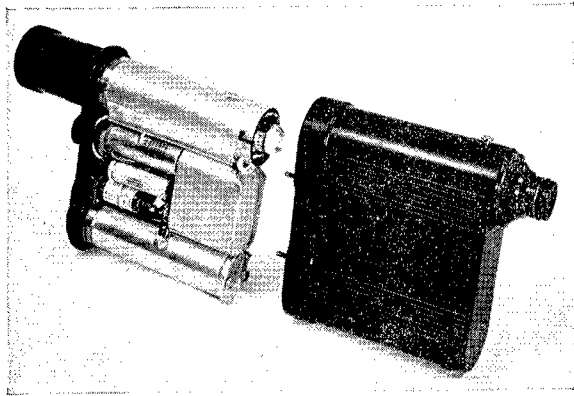

FIGURE 30. Components of Type C_2 telescope.

power of 20 million is used, the range should be 4,500 feet. These ranges are fairly well substantiated by experimental observations, but backscattering from dust and water particles in the air and absorption tends to reduce the larger range values, particularly if the telescope is close to the searchlight.

Image brightness is only one of the factors which must be taken into account in estimating the working range. Object reflectivity and contrast are important. In general, under field conditions, poor contrast and the like will reduce the working range to 60 or 70 per cent of the values given above.

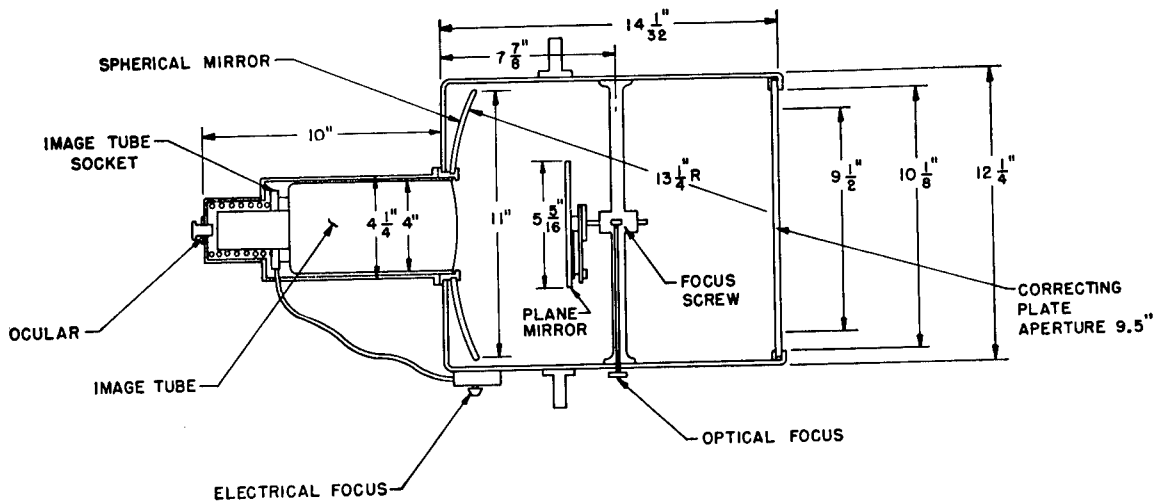

FIGURE 32. Infrared Schmidt telescope—Type C_F .

2.5.2

Infrared Telescope Types

SIGNALING AND MARKER DETECTORS

The widest and perhaps the most exacting use of the electron telescope is for observing infrared signal and marker lights. These lights may be used to mark important positions such as landing or assembling points, ships, airplanes, or airfield locations. The source lights may be equipped with shutters or other keying mechanism and used for transmitting messages

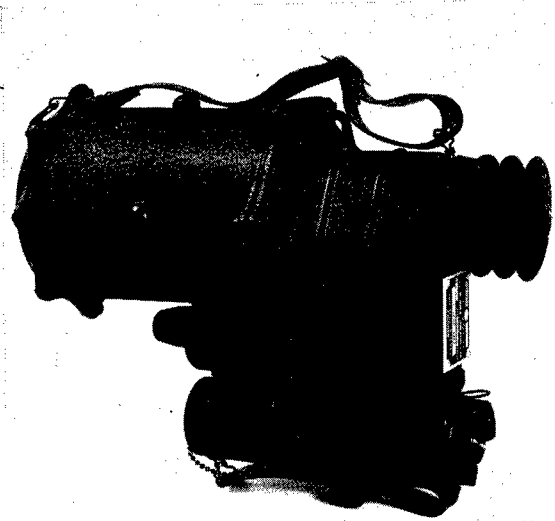

FIGURE 31. Type C_3 telescope—production instrument.

in code. The lights may be arranged in patterns for the transmission of information.

Type C_2 . This telescope (Figure 30) was one of the first to use the 1P25 in any quantity in the laboratory; about 30 were built, some on Contract OEMsr-440,

the others on separate contracts with the Armed Services who wished to continue tests with them along lines initiated by the NDRC project.

This type operates from two size-D flashlight batteries, and has a continuous operating life of about 1 hour per set of batteries. The objective is an $F/2$, $3\frac{1}{2}$ -inch-focus Cinephor, and the instrument is optically focused by rotating the threaded lens mount. The eyepiece is a $9\times$ triplet which, in conjunction with the hemisphere, gives an overall ocular magnification of 11. This instrument has an angular field of 18 degrees and an absolute threshold sensitivity of $S_F = 0.26$ for a sixth-magnitude star, and 1.3 for a fourth-magnitude star.

Type C₃. As a signaling instrument, Type C₂ had a somewhat narrow angular field. This could be improved by a shorter focal length in the objective, but would result in an impractically small F -number. By the Schmidt system, however, the focal length can be decreased and the objective diameter increased. Type C₃ was eventually evolved, reengineered for manufacture, and put into production employing plastic optics.^b It was used in the fleet in very large numbers before the end of the war.

The C₃ optical system has a focal length of 2.38 inches and an effective aperture of $F/0.9$ or better; its angular field was about 25 degrees. Assuming an optical efficiency factor of 25 per cent, the sensitivity is 0.16 for a sixth-magnitude star (nautical) and 0.8 for a fourth-magnitude star (statute).

The complete weight of the C₃ instrument in production form (Figure 31) was 7 pounds, somewhat greater than desirable for a hand-held unit. However, since the majority of the instruments were used with a signaling searchlight to which they could be attached, the weight was not objectionable.

Some reconnaissance tests were made with Type C₃, but the lack of depth of focus, the difficulty of adjustment, and the short focal length made it unsatisfactory for this purpose in spite of the increased brightness.

Type C_F. In order to test the value of a really large absolute aperture, the Type F (C_F) was evolved. Originally, this telescope was built around a large image tube with a 3-inch diameter cathode but was later redesigned to use the 1P25. The objective was a Schmidt system with a 9.4-inch aperture and a 7-inch focal length. Figure 32 is a schematic drawing of this telescope and Figure 33 shows it mounted for use. A variety of eye lenses permit magnifications from 4 to 10.

^bSee STR Division 16, Volume 1, Section 8.5.

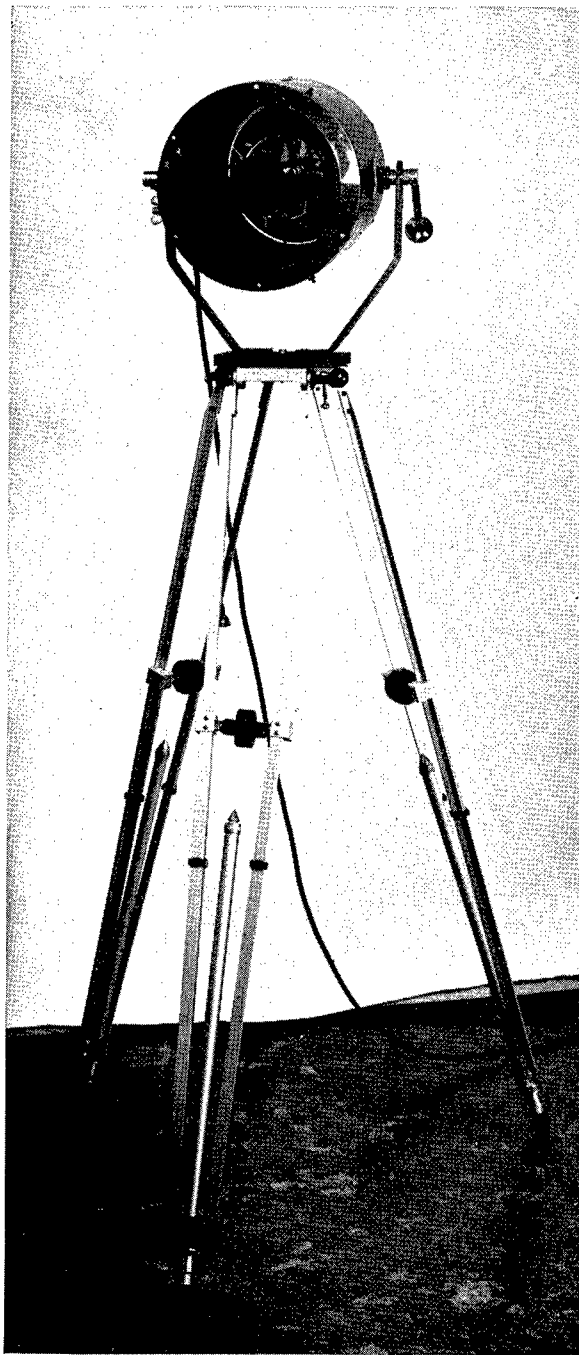

FIGURE 33. Type C_F mounted for use in signaling or reconnaissance.

Maximum sensitivity is obtained with the highest power eyepiece, and for signaling the resultant loss of field is not too serious considering the gain in sensitivity. After preliminary tests with the laboratory instrument, the Navy negotiated the procurement of 50 instruments of this type.

Even higher signaling sensitivity is possible with the high-voltage MA-4 tube, and an instrument of this type, using the 7-inch focal length Schmidt system, was built, but only preliminary tests were made before termination of the contract.

Later Portable Telescopes. Two very portable laboratory instruments, Types L and P, useful both for signaling and reconnaissance, were built. The Type L followed the general style of the Type C₂ but operated

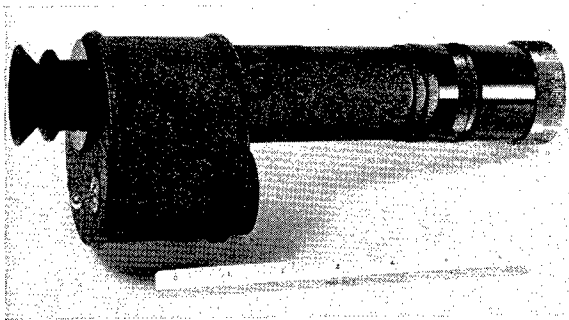

FIGURE 34. Type T telescope, with single-voltage image tube.

from a single flashlight-size storage battery Type BB-200/u. The power-supply components were also considerably smaller than in the C₂. Type P used a power supply identical with Type L, but was assembled in a different form for convenience of handling.

The Type T telescope illustrated in Figure 34 was designed around the single-voltage tube. Instead of the usual vibrator, an impulse-power supply controlled by a balance wheel was employed. This power supply, operated from a single size-D flashlight battery, gives, instead of the 1- to 2-hour running life of the conventional instrument, more than 25 hours continuous operation.

Following along the lines of the Type T, a very compact version of the impulse-power supply was built which, together with the small single-voltage image tube (Section 2.3.1), was used to convert a Type A metascope (Chapter 3) into an electron telescope. This change was carried out in such a way that the Schmidt objective and eyepiece of the Type A could be used without modification, and that almost no changes were required on the housing. Only one of these instruments was built, and is shown in Figure 35.

The image obtained with the instrument was quite good and its performance seemed satisfactory. Sensitivity measurements were made on it at the Naval Research Laboratory, Anacostia, where its threshold was found to be 1.5 mile-candles. However, it is doubt-

ful that it was working properly when these measurements were made since tube performance and optical considerations indicate that the threshold should be better than this by a factor of at least two or three.

RECONNAISSANCE TELESCOPES

The reconnaissance possibilities of the infrared telescope combined with a searchlight were recognized early in the work and the development of this aspect was carried on throughout the contract. Three general procedures were followed: first the use of a large searchlight and a relatively long focal length telescope, second, the use of large searchlights at some distance from the objects being viewed with hand-held instruments carried by observers moving up close to the object, and finally the employment of small hand-held telescopes and a portable hand spotlight.^{10,15}

Type C_F. As already mentioned, the *F*-number of this instrument is about 0.9. Therefore, the brightness ratio for whole light is $B/B_o = 0.3$, assuming an optical transmission of 25 per cent. With a filter factor of 10, the ratio becomes 0.03. The field of view is about 9 degrees; angular definition is approximately 2.2 minutes, which is sufficient to distinguish a man at about 800 feet with lighting corresponding to 0.01 foot-candle.

For the first type of procedure mentioned above, the Type C_F telescope was mounted close to a pair of 3-kilowatt searchlights and a special generator pro-

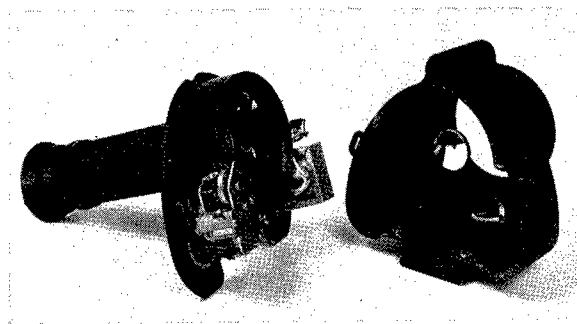

FIGURE 35. Components of converted Type A metascope.

vided by General Electric Company [GE]. The complete unit is shown in Figure 17, Chapter 5, of this volume. This application was shown at the demonstration at Solomon's Island on August 25, 1942. The ranges obtained then were rather small, but improved techniques eventually made it possible to see a shoreline and buildings along a coast up to a distance of a mile, and to detect (but not to identify) trucks, tanks, and other large vehicles at 700 yards. When the instru-

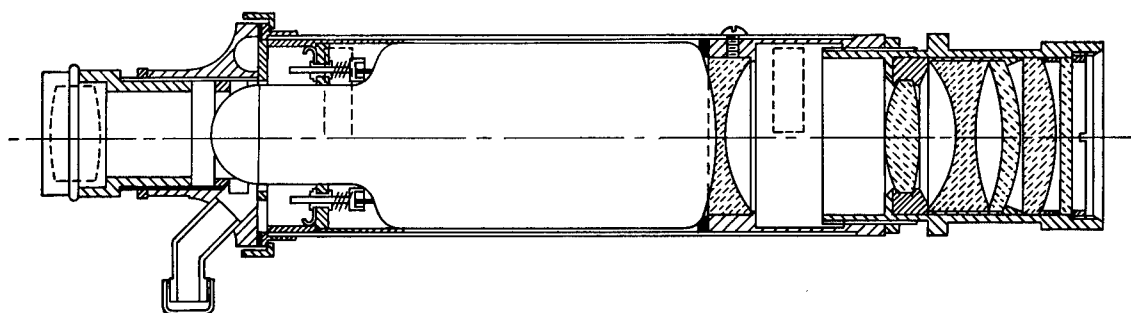

FIGURE 36. Assembly drawing of Type D telescope.

ment and searchlights are carried in a large boat and used to pick up prominent objects along a coast, portable instruments carried in small boats using the illumination from the searchlights for close-up inspection are of considerable aid. The combination of marker and signal lights to guide the overall operation with these

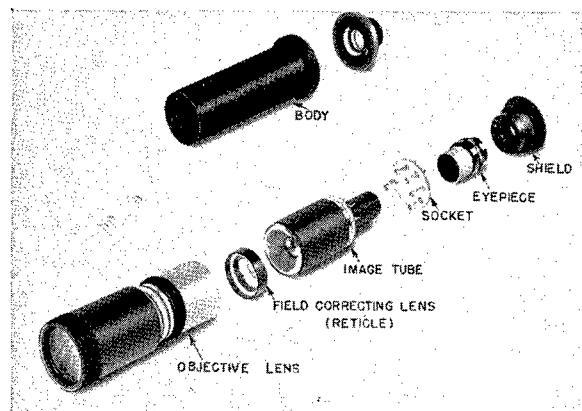

FIGURE 37. Components of Type D telescope.

two forms of reconnaissance should make a very powerful team for certain types of amphibious operations against an opponent not equipped with counterinstruments.

Type C₂. This instrument, which has already been described for its use in signaling, was also employed for reconnaissance, although the types described below superseded it.

Types B and D. Both the Types B and D instruments are based on the telescope shown in Figures 36 and 37 (Type D), and Type B is shown in Figure 38. Type D consists of a single telescope barrel; Type B is a pair of these mounted to form a binocular. The image-tube barrel is of 30-mil mu-metal which provides magnetic shielding against external fields. The objective is an $F/2$ plastic lens of 2.5 inches focus. A field-corrector lens matches the image to the curvature of the photocathode.

The cable from the instrument goes to a small battery-operated power supply held in a plastic case. One or two focus controls are provided, depending on whether for monocular or binocular. This power supply, S-1 and S-3, has already been discussed.

Type D proved to be a very useful instrument. Frequently, it was used by an observer accompanying the driver in night-driving operations. The observer was able to walk about (including in front of the vehicle) to inspect suspicious objects. In addition to general reconnaissance, Type D was used as a signal receiver. An instrument very similar to Type D, the C₄, with an improved power supply (S-4), was ordered in quantity by the Navy, but deliveries were only starting when the war ended.

Type B also proved to be very useful, but it was not put into production. The hinge between the barrels allows interpupillary adjustment, and eccentric loca-

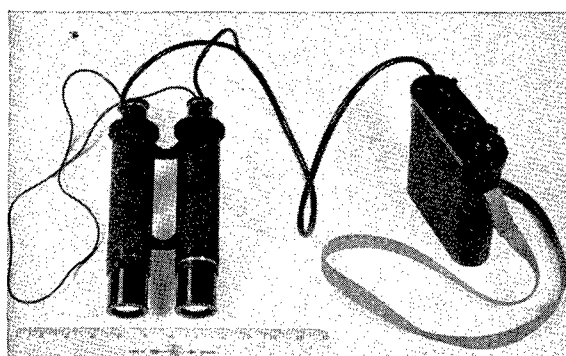

FIGURE 38. Type B binocular unit.

tion of the eyepieces with reference to the axis of rotation of the mount permits registering and fusing the two images in both vertical and horizontal directions. Since these instruments were designed for night driving, the majority of them were provided with 2.5-inch objectives and 8× oculars, giving an overall magnification of unity. Some, however, had 3.5-inch

objectives and $1\times$ eyepieces, giving a magnification of 2.1. The angular field of the former was about 25 degrees, and of the latter about 18 degrees.

Type K—Snooperoscope and Sniperscope. The most effective application of the small reconnaissance telescopes was in the Type K instruments, the snooperoscope and sniperscope. These are illustrated in Figures 39 and 40. Both of these instruments were based on the Type D telescopes, but used 3.5-inch objectives.

In the case of the snooperoscope, the telescope and 30-watt sealed-beam lamp (see Chapter 5) were

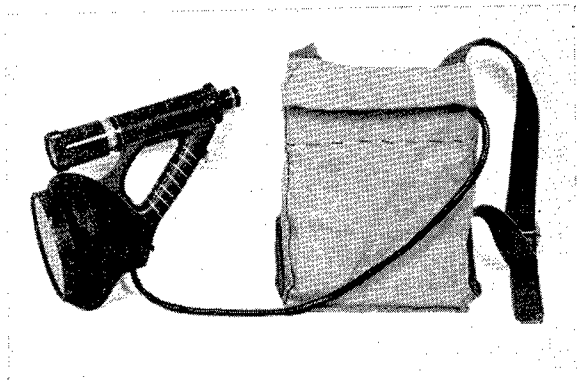

FIGURE 39. The snooperoscope.

mounted on a light handle, the unit weighing about 6 pounds. The power supply and batteries for the lamp were carried in a knapsack which weighed 13 pounds. The batteries were sufficient for $3\frac{1}{2}$ to 4 hours' continuous operation.

The same telescope, lamp, and power supply were used for the sniperscope. The lamp and telescope were mounted on a carbine, as shown in the photographs, and added about 5 pounds to the weight of the gun. An opaque chevron recticle was applied to the field-corrector lens on the side in contact with the image tube to cast a shadow on the photocathode. It was accurately aligned with the optics of the telescope and served as gunsight. With this unit, it is possible to hit a target the size of a man against an average background at a distance of 75 yards, and at a greater distance against special backgrounds. The Army placed procurement orders for a fairly large number of these two types of instruments, and a quantity (2,000 to 3,000) were used in the latter stages of the Pacific campaign.¹⁷

Experience with the sniperscopes showed that there would be an advantage in mounting the telescope on heavier rifles, or even on machine guns. The use of larger separate sources may be advisable, and a more

sensitive telescope using a high-voltage image tube would be desirable.

NIGHT-DRIVING INSTRUMENTS

Early Instruments. The first type of instrument used to any extent for night driving after the Aberdeen test (Section 2.1) employed an image tube with a 3-inch photocathode and a magnification of $\frac{1}{2}$. It is interesting to note that the German night-driving equipment which they were about to put into operation when the war ended was very similar to this unit. With the reduction in size of the image tube, first to the 6-inch size and then to the $4\frac{1}{2}$ -inch 1P25, it was possible to reduce the size of the telescope and to develop stereoscopic binoculars.

For tank driving, a "protectoscope" was designed to fit into the viewing hatch, with the infrared telescope occupying about one third of the visual channel. The tests made with this unit seemed to indicate that it was a fairly practical solution to night operation and fighting with tanks with closed armor. Another instrument—a helmet unit—was designed to be used as a tank periscope, but was too heavy to be worn without undue fatigue. Tests at Aberdeen on August 12, 1942, demonstrated the complete feasibility of driving tanks in full darkness, and of operating them by infrared when closed for combat.

When periscopic binoculars were designed with 6-inch image tubes, they gave better results than any

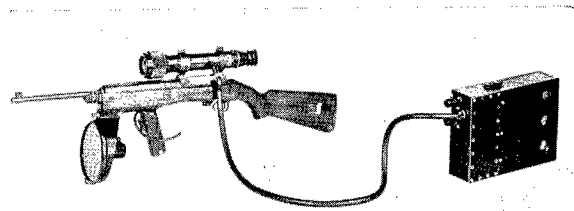

FIGURE 40. The sniperscope.

of the previous instruments, but they were too complicated in design and very difficult to keep in correct adjustment.

Type B. Mounted in jeeps, ducks, tanks, Type B binoculars had all the advantages of the periscopic instruments yet were simple enough to readily remain in adjustment. With these instruments, ordinary headlights with infrared filters permitted an average driving speed of 8 to 10 miles an hour; with 150-watt lights, the speed could reach 30 miles per hour; and if 500 to 1,000 watts were used, it was possible to

drive fully as well as with ordinary visible night-driving lights. The installation on a jeep is shown in Figure 41, and in Chapter 5, Figures 11 and 12 show the installations on an amphibian and a tank.

Infrared illuminators are an important part of night-driving development. After the initial experiments, this problem was handled by GE under Contract OEMsr-423, because of their experience with road lighting and headlights, and the sources used are described in Chapter 5 of this volume.

Type Z—Helmet Instruments. The Type B binoculars overcame most of the difficulties of the earlier night-driving systems. However, when used on rough roads at high speeds the motion of the eye relative to the ocular of the instrument became somewhat objectionable, and further work was done in trying to stabilize the binocular mounting.

However, the final step in the night-driving development was the helmet unit shown at the right in Figure 42. This unit was worked out under Contract OEMsr-1075 with the Johnson Foundation of the



FIGURE 41. Jeep equipped for night driving with infrared.

University of Pennsylvania, using telescope practice developed by RCA and the large amount of experience in general helmet design on the part of the staff of the Johnson Foundation.¹³ The general arrangement of the components can be seen at the left of the figure. With the exception of the ocular magnifiers, plastic optics were used throughout. The objectives had a 2½-inch focal length and a numerical aperture

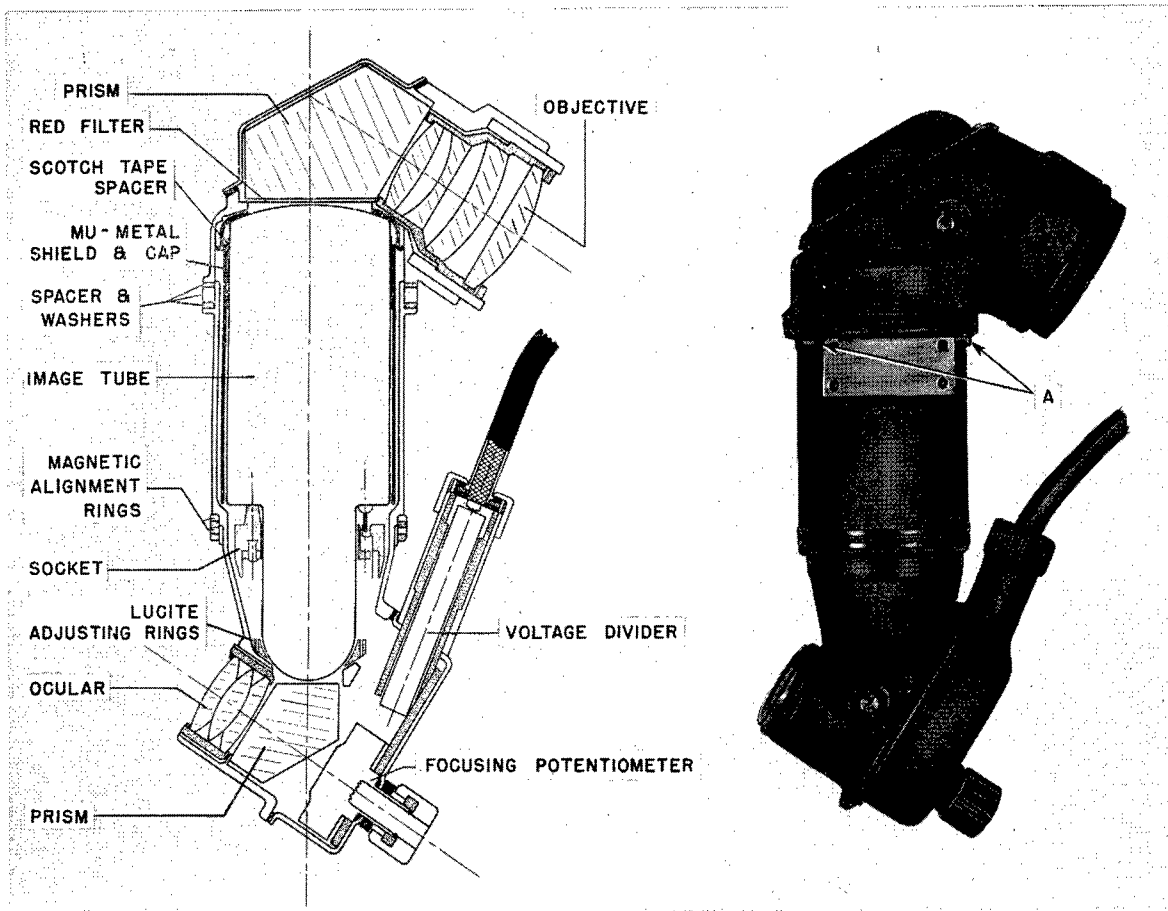

FIGURE 42. Telescope unit for Type Z binocular.

$F/2$. The overall magnification was unity. The general design of the telescope followed the practice already described, except for detail. A somewhat different method of obtaining register of the two images

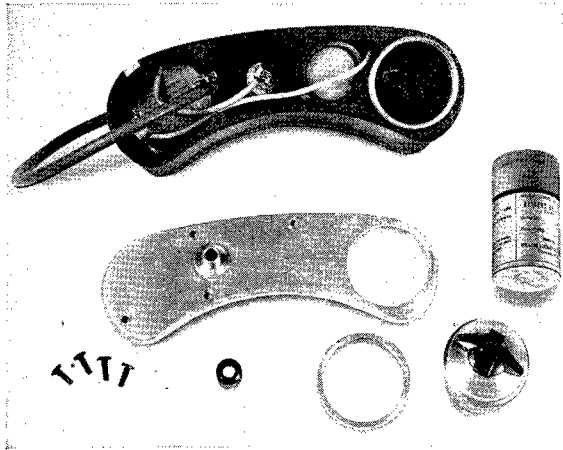

FIGURE 43. Power supply (S-4) for helmet binocular.

was employed than for the in-line binoculars. Two steel rings which were magnetized so as to produce magnetic fields across a diameter were placed around the telescope barrel just below the mu-metal shield. By rotating these two rings independently, the electron image in the 1P25's could be moved into any desired position. Type S-4 power supplies shown in Figure 43 were employed.

The pair of telescopes and head harness weighs $2\frac{1}{2}$ to 3 pounds while the power supply weighs $2\frac{1}{2}$ pounds. When mounted on a steel helmet as shown in Figure 44, with the power supply acting as a counterbalance to the binocular, the additional five pounds on the driver's head was quite unobjectionable.

Twenty of the helmet binoculars were built under Contract OEMsr-440, twelve for test on night driving and eight for night flying. Just before the end of the war, as a result of tests by the Engineer Board at Fort Belvoir, the Army was negotiating the procurement of 100 instruments as a preliminary to placing production orders.

INSTRUMENTS FOR AIRBORNE OPERATIONS

Tests showed that the near infrared telescopes were not satisfactory for detecting planes by their own radiation, except where the plane had a long length of exposed exhaust pipe or other hot surface. Consequently this application was not pursued further, but there are several other applications of infrared telescopes to airborne operations.

Glider Towing and Landing. This problem requires an infrared telescope through which lights on the tow-plane may be observed. The telescope should, in general, be fixed to the glider and have in it a visible reference index with respect to which the marker lights may be aligned. The tow-plane should carry wing tip and tail lights.

Two large telescopes similar to those made initially for driving were built and mounted on gliders. These instruments employed a projection reticle which gave a frame of reference fixed with respect to the glider. Like the driving instruments, these telescopes were nonstereoscopic, but allowed binocular vision, and were arranged so that the pilot did not have to hold his head close to the instrument. These instruments were used both for flying and landing, and were in general fairly satisfactory (Wright Field, Dayton, Ohio, May 5 to 21, 1943).⁹

Inasmuch as the units just described were quite large, and it was found that the pilot preferred to view the ocular from the closest possible distance, it was decided that the Type B₁ binocular might form the basis of a more satisfactory instrument. Conse-



FIGURE 44. Combat helmet binocular (Type Z).

quently, the unit shown in Figure 45 was constructed, consisting of binoculars which clipped into a cradle which carried a headrest and the projection reticle. The binoculars were used in this cradle for towing or landing operations, but could be removed and used as a hand instrument for locating landing fields or marking light, checking identification, etc. This instrument was turned over to Wright Field for further tests.

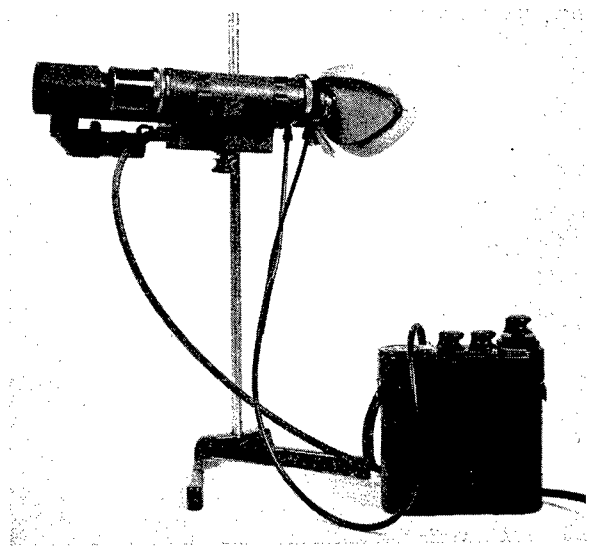

FIGURE 45. Binoculars mounted for use in glider towing and landing.

Identification—Type R. One of the problems of night flying is the identification of friendly planes to avoid their being accidentally shot down. A possible solution is to equip planes with infrared identification lights and telescopes. The telescopes for this purpose must be small and placed so as not to interfere with the plane's operation. They also must be easily viewed, both from a distance and near by.

The barrel and objective of the instrument developed for this purpose is the same as that used in the Type D. The eyepiece is, however, special, being a 4-power magnifier with a diameter of about 2 inches, which in combination with the hemisphere of the image tube forms a 6-power ocular. The latter is adjusted so that the virtual image is at infinity so that the image may be viewed from a distance up to about 15 to 20 inches without change of sensitivity of the instrument. The eye lens permits monocular vision only.

A second eye lens made from a Mark VIII gunsight ocular was also investigated. This system was proposed by the staff of Naval Research Laboratory. When adjusted so that the virtual image is 10 inches in front of the ocular, it permits binocular vision. It suffers, however, from two disadvantages. The sensitivity of the telescope decreases by a factor of 80 when the observer moves from close to the instrument to a point 20 inches back of the ocular. Furthermore, the image is very seriously barrel-distorted. For these reasons, the first described eye lens is considered more satisfactory.

B-29 Tailsight Telescope. A somewhat more com-

plicated identification telescope is shown in Figure 46. This was designed to be used on the computing gunsight in the tail of a B-29. The eye lens, telescope barrel, and objective are similar to the previously described instrument. Ahead of the objective, there is a periscopic section which transfers the observer's eye-point to the center line of the sight. This is necessary since one of the requirements of the telescope was that it have the same angle of view through the rear window as the sight itself. A projection reticle was arranged to project index marks on the cathode. These marks indicate the position of the image of lights on the wing tips of a B-29 a specified distance behind the observing plane.

This telescope was sent to Wright Field for test, where only a very small amount of work was done with it.

Night-Landing Telescopes. The landing of aircraft on blacked-out airfields, or carrier decks, can be accomplished by means of infrared telescopes. Preliminary tests indicated that a fixed instrument, such as

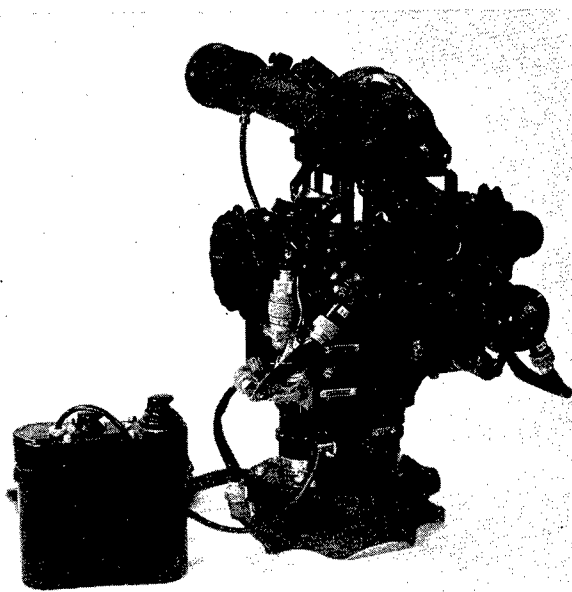

FIGURE 46. Type R telescope on B-29 tail gunsight.

the glider-type telescope, would not, in general, be suitable. Further tests with a lightweight periscopic monocular (Type H) mounted on a helmet showed that similarly mounted binoculars, if correctly designed, could be used for night landings.

Although the head harness required for the flying instrument is very different from that for driving,

the folded Type Z telescopes can be the same, and the development of the units undertaken by the Johnson Foundation, as has already been mentioned, was for both purposes.

The telescopes themselves have already been described in connection with the driving application. The head harness (Figure 47) is arranged so that the telescopes can be removed or replaced readily with one hand, while the harness is in place on the head. When the telescopes are attached, they can be pulled down over the eyes in the viewing position, or tilted back out of the way. When in viewing position, the harness is tight around the head to hold the instruments ac-



FIGURE 47. Type Z helmet binocular for night flying.

curately in place, but the tension is released on tilting them back. The binoculars are so arranged that they can be worn over standard flying goggles. The ocular ends are small enough so that the user can readily see his instrument panel under them. When the binoculars are removed, the weight of the harness is negligible and it can be worn for long periods without discomfort. The complete unit in operating position does not produce serious discomfort and can be worn without difficulty for periods many times longer than would be required in practice. The harness weighs under 1 pound and the binocular about 2 pounds.

A great many landing tests were made without accident or mishap. These included work with a civilian plane by members of the Johnson Foundation staff and with military aircraft by both Army and Navy. It was concluded that the instrument provided a fairly

satisfactory means of night landing where a complete blackout is required. It was found that it was perfectly possible to make carrier landings with these instruments where the carrier deck was marked with infrared runway lights, and the signal man used infrared luminous wands. Further details on the solution of this problem, including a description of the lighting, will be found in reports by GE¹⁹ and the Johnson Foundation.¹⁸

Paratroop Assembly Operations. Here the infrared telescope is used to pick out marker lights placed by a scouting group to identify the landing or assembly location. Since the marker light must be as small as possible (see Chapter 5), Type C₃ telescope was selected as having the high sensitivity required by the pilot of the plane in discerning the marker. This type of operation was tested and found to be very feasible.

Once the area is located, the men who make the jump may carry small, lightweight telescopes and infrared flashlights. The instruments may be either metascopes or small infrared telescopes with which they can locate the assembly beacon. This type of operation was tested and also found very feasible.

It is suggested that sniperscopes and snooperscopes carried by a number of the men would be of value. Because of the danger of any of these instruments falling into enemy hands, they should be made self-destructing after a certain interval of time.

2.5.3

Special Telescopes

In order to accommodate the special tubes, type MA-4 and the high-voltage low-magnification tube, special telescopes were designed.

Type W. A telescope using a Type MA-4 image tube retained the general shape of Type C₂, but was somewhat larger in order to accommodate the high-voltage power supply. The instrument is made in such a way that alternative objectives could be used. One objective is a 3.5-inch focal length $F/2$ Cinephor; the other, a projection lens with a 4.75-inch focal length and a relative aperture $F/1.4$.

The internal arrangement of the instrument can be seen in Figure 48. The power supply delivers a total of 16 kilovolts to the image tube. Because of the high voltage employed, great care has to be taken in insulating various of the components. A 2-volt storage battery (flashlight battery size) operates the instrument, with a continuous running life of 1½ to 2 hours. Provision was made for operating the unit from an external 2-volt battery if desired.

The performance of the instrument was excellent, its conversion being about 8 times that of an instrument using 1P25, so it gives a much brighter picture. Its definition is somewhat better than that of the con-

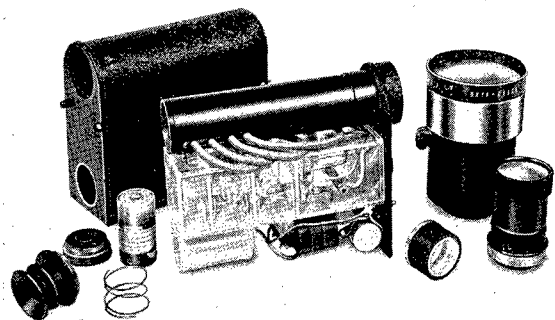

FIGURE 48. Components of Type W telescope.

ventional telescope, and, because of the sulfide screen used in the MA-4, it has no observable time lag.

A telescope based on the Schmidt system used for the Type C_F was also built incorporating the MA-4. The optics for this telescope were obtained from the Bureau of Ships and tests were made by it with fairly satisfactory results. However, the optics of this instrument could have been improved so as to take full advantage of the capabilities of the Type MA-4 image tube.

High-Voltage, Low-Magnification Telescope. The high-voltage, low-magnification tube is by far the most sensitive image tube developed during the contract. It offers a possible means of being able to see under conditions of illumination below that required by the unaided eye. Tests made with an experimental telescope employing this tube proved that it was possible to see objects illuminated by whole light from an incandescent source when the light level was too low to see them with the naked eye.

As was pointed out in the discussion of low-magnification tubes, there are limitations to the increase in brightness that can be obtained in this way. These limitations are characteristic of the telescope rather than the tube. The brightness of the observed image only continues to increase as long as the exit pupil of the ocular exceeds the diameter of the pupil of the observer's eye. The diameter of the pupil of the dark-adapted eye is about 6 millimeters. Therefore, the practical limit to the magnification of the ocular if a compound microscope is employed is about 100, while the limit for a simple magnifier is about 30.

It is easily shown¹¹ that B/B_0 may reach 1,500. Ac-

tually, it will be some time before any such gain can be realized, because there are many practical difficulties both of telescope and image tube which must be overcome.

As has already been mentioned, the most practical high-voltage, low-magnification image tube developed under the contract had a magnification $\frac{1}{6}$ to $\frac{1}{8}$. The tube operated with an overall voltage of 20 kilovolts and had a conversion of about 3. It was used in a telescope with Schmidt objective of 7-inch focal length and an f -number, $F/0.9$. Various oculars were used with this instrument ranging from $10\times$ to $15\times$. Because of the high brightness conversion of the tube, it was necessary to cool the photocathode. This was accomplished by means of a small liquid-air container arranged to blow cold air against the photocathode. Precautions had to be taken to prevent the condensation of moisture on the optical parts. With the $15\times$ eyepiece, the magnification is 1.3 and the brightness ratio, 15. All of this gain was not realizable because of loss of contrast and the like, but there was a definite gain over direct vision when incandescent lights were used. This line of development was considered one of the most promising and should be continued, both as applied to visible light and infrared radiation.

2.6

SUMMARY^c

Early in World War II, it was decided to exploit the possibilities of the infrared-electron telescope for nocturnal vision. Section 16.5 undertook the development of the necessary image tubes and instruments and investigated various applications. Before the close of the war several thousands of these telescopes had been put in service by the Navy, primarily for nighttime communications, and a similar number in the form of sniperscopes and snooperscopes were in use by the Army in the Pacific campaign. Other instruments in smaller number had seen service for a variety of purposes.

The image tube is the essential element in the infrared-electron telescope and serves to convert an invisible infrared image into a visible image. The tube consists of a semitransparent photocathode sensitive to the radiation in question, an electrostatic electron lens system, and fluorescent screen. An infrared image on the photocathode causes electrons to be released in conformity with the image. These electrons are accelerated and focused, by the electron optical system,

^c Taken from bibliographical reference 1, with changes in style only.

onto the fluorescent screen where a visible reproduction of the original image is formed.

Work on the image tube was started before the war. Under the NDRC contracts, the tube was developed to the point where in 1942 it could be put into production as the 1P25. The investigation then continued along the lines of improving the 1P25, developing a replacement single-voltage tube, working out a small high-voltage tube and studying special tubes. A single-voltage tube was designed so that it could be used as a replacement for the 1P25 in the then existing instrument and in new instruments which were much smaller and longer lived because of simpler, lower power supplies. A very satisfactory multiple-anode, high-voltage image tube was developed which was at the point of going into production at the close of World War II. The study of special tubes included the following: (1) work on a high-voltage, low-magnification infrared image tube which, when used in a

Basically, the infrared telescope consists of an objective which images the scene being viewed onto the photocathode of the image tube, and an ocular arrangement for viewing the reproduced image.

An electrical power supply furnishing 4,000 to 6,000 volts is required to actuate the image tube. The obtaining of the required high voltage from a small lightweight unit presented some rather special design problems. A combination of vibrator, transformer, and rectifier was developed which gave excellent results. Two new rectifiers were developed, one of which (RCA 1654) is finding wide usage in other applications.

A large number of different types of telescopes were designed and built to meet the needs of various applications, such as signaling, night driving, night flying and landing of airplanes and gliders, airplane identification, reconnaissance, and gun aiming. Some of the instruments developed for these operations are:

Type	Optics	Power Supply	Application
C ₂	<i>F</i> /4 refractive	Self-contained	Signaling and general purpose
C ₃	2.4 Schmidt	Self-contained	Signaling
D (forerunner of C ₄)	<i>F</i> /2 refractive	Separate	General purpose
B (binoculars)	Separate	Reconnaissance and general purpose
R	Special ocular	Separate	Plane-to-plane identification
K ₁ (sniperscope)	Gun aiming
K ₂ (snooperscope)	Reconnaissance
Z (helmet-mounted binoculars)	Night driving and flying
C _F	7-inch Schmidt	Separate	Signaling and reconnaissance
L	Refractive	Small self-contained	Signaling and reconnaissance
T	Refractive	Impulse	Signaling
CW	Refractive	High voltage	General purpose
CV (low magnification)	7-inch Schmidt	High voltage	General purpose

suitable telescope, gives promise of exceeding the eye in sensitivity even for ordinary visible light; (2) an investigation of image tubes for the intermediate and far infrared portions of the spectrum; (3) image tubes having special electron optics, phosphors, or photocathodes.

In addition to the development of image tubes themselves, detailed studies were made of the various components going to make up these tubes, including photocathodes, electron lenses, and fluorescent screens.

Many other instruments were built and used in the course of the tests.

Continued research in this field should include further work on high-voltage tubes and instruments for near infrared application, continued investigation of high-voltage, low-magnification image tubes with a view toward achieving an instrument which will permit vision at visible light levels below which the unaided eye is operative, and the development of a far infrared-imaging device.

Chapter 3

METASCOPIES

By *Mary Banning*^a

3.1

INTRODUCTION

A SERIES of image-forming infrared receivers which convert infrared to visible light have been developed at the Institute of Optics, University of Rochester, under NDRC Contracts OEMsr-510 and OEMsr-1219. With these instruments, a source of infrared radiation, or objects illuminated by it (see Chapter 1), can be seen by an observer in much the same manner as objects emitting or illuminated by visible light can be seen with an ordinary telescope. These infrared receivers depend for their performance upon special phosphors converting infrared to visible light and upon specially efficient optical systems. The phosphors will be described in Chapter 4. At the request of the Navy Bureau of Ships for a descriptive, yet concealing term for this class of infrared receivers, the name *metascope* has been applied.

A metascope consists essentially of a high-aperture optical system which forms an image of distant objects upon the surface of an infrared-sensitive phosphor. This image covers a useful field of 25 to 45 degrees, depending upon the particular style of instrument. A second optical system is provided for viewing the phosphor surface, which emits visible light on *stimulation* by the incoming infrared. Since the operation of the metascope depends on the phosphor's emitting visible light of a shorter wavelength than the infrared, it is necessary to provide extra energy by *exciting* or *charging* the phosphor prior to its use. This excitation may be accomplished by visible or ultraviolet light or by radium, all three methods having been applied successfully. In each case, the exciting means are so provided that the metascope is entirely self-contained. Several forms of these instruments were put into production by the Army and Navy, for operational use in both the European and Pacific theaters. They were used by the Navy for signaling and identification and by the Army for signaling, especially applied to the assembly of airborne troops in a drop zone at night. The weights of the production instruments range from about 4 pounds for the heaviest instrument developed to about 3 ounces for the lightest.

^aInstitute of Optics, University of Rochester, Rochester, New York.

Optical Design. All metascoopes have the same fundamental optical design, and make use of the large relative aperture of the *Kellner-Schmidt* [K-S] system. In essence, the K-S system is as shown in Figure 1. Here *M* is a spherical mirror, *C* is an aspheric plate placed at the center of curvature of the mirror to correct for spherical aberration, and *F* is the focal surface. In the metascope, the phosphor is coated on or otherwise formed to occupy this focal surface. The

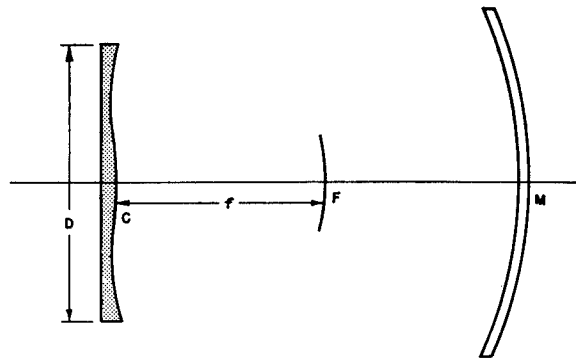

FIGURE 1. Sectional view of Kellner-Schmidt system: *M*, spherical mirror; *F*, focal surface; *C*, corrector plate; *D*, aperture; *f*, focal length.

most important characteristics of the K-S system are its great simplicity and its wide field of definition, combined with large aperture-ratio.

Infrared radiation entering through the corrector plate is reflected by the mirror to form an inverted real image on the phosphor. The brightness of this image is directly proportional to the flux gathered. In the case of a point source, it is proportional to the square of the aperture *D*. If the source is an extended area, it is also inversely proportional to the square of the focal length *f*, that is, it also depends on the size of the image formed. For maximum image brightness of an extended source, therefore, the aperture-ratio should be as great as possible; the brightness of an extended image on the phosphor is thus determined only by the speed of the primary system, not by the size of the aperture. The immersion of this primary system in a medium of refractive index *n*, higher than that of air, will increase the illumination on the phosphor of an extended image but will not affect the intensity of a point image.

The intensity of the visible image emitted by the phosphor is usually a linear function of the stimulating radiation, and is determined by the rules given above. The intensity of a point image as seen by the eye, on the other hand, will depend on the amount of

system and the resolving power of the phosphor itself. It is thus dependent on the size of the system.

Methods of viewing the visible image differ in the various metascopes models and will be described in the next section.

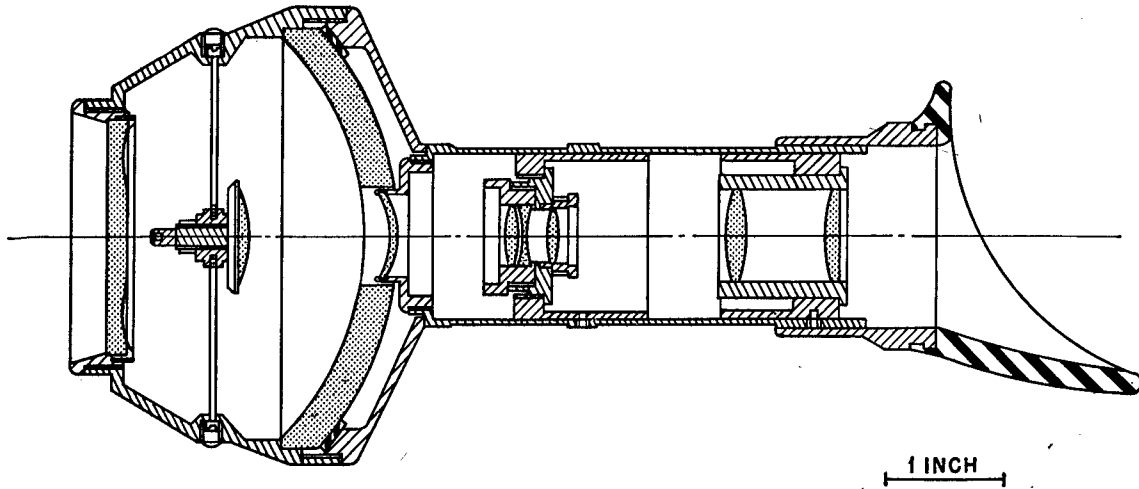

FIGURE 2. Two-inch ultraviolet telescope, assembly drawing.

flux received by the eye from the phosphor, or on the solid angle subtended by the pupil of the eye at the phosphor.

In an air system, the solid angle utilized increases inversely with the square of the focal length f' of the viewing system, since if it is properly designed the limiting aperture is the pupil of the eye, and thus the apparent intensity of a point source varies as $1/f'^2$. An extended source, however, will not change its apparent brightness with a change in focal length, since the gain in flux is counteracted by the magnification of the image. If the viewing system is immersed in a medium of high index, there will be no change in the apparent intensity of a point source, but an extended source will be magnified without a compensating flux gain and will appear less bright.

Considering both primary and viewing systems together, with unit magnification ($f = f'$), both the apparent brightness of an extended source and the apparent intensity of a point source will vary with $(D/f)^2$. In neither case is the size of the system important, but only the relative aperture. Immersion in a high index will not affect the point source, and neither will it affect the apparent brightness of an extended source since the gain in the primary system is compensated by the loss in the viewing system.

The resolving power of such a K-S phosphor system is determined by the focal length of the primary

3.2 DEVELOPMENT OF INSTRUMENTS

3.2.1

Type A

Early in 1941, an ultraviolet telescope provided with a high-sensitivity ultraviolet phosphor was designed using a K-S optical system. Figure 2 shows a scale drawing, and Figure 3 a photograph of the instrument.

In this prototype, the visible image emitted by the phosphor is viewed through a central hole in the mirror by means of a lens-erecting system and an eye-

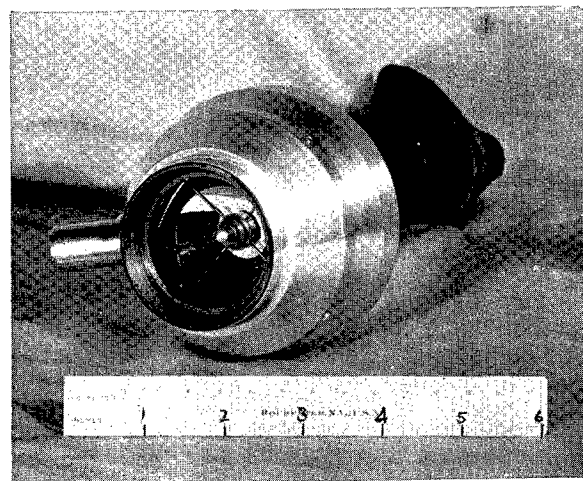

FIGURE 3. Two-inch ultraviolet telescope.

piece. Lens erection was chosen to give exact unity magnification by final adjustment of the lens separations. The diameter of the K-S housing chamber was made small enough to permit using the instrument as a monocular and at the same time to allow unobstructed vision straight ahead with the unaided eye. Any object seen through the telescope then appears the same size and in the same position as when seen with the unaided eye, independent of the motion of the telescope. This permits use in a fast-moving vehicle and also allows an observer to locate the source of invisible radiation in its proper place against a dimly visible landscape.

This ultraviolet instrument has an aperture of approximately 2 inches and works at a speed of $f/0.55$. The K-S plate corrects for all rays striking the phosphor up to an angle of 68 degrees. The corrector plate was ground and polished by hand methods, from Corning glass No. 791.

An infrared phosphor coated on the focal surface was the only change necessary to convert the instrument for infrared use, although a redesign of the corrector plate for the longer wavelength is necessary for optimum image quality.

Since the infrared phosphors, unlike those for the ultraviolet, require excitation prior to use, it was desirable to provide some means for excitation inside the instrument. An outside attachment would have been too bulky. Fortunately, previous work with the ultraviolet telescope had shown that there is a location between the corrector plate and mirror at which a point source will give approximately uniform illumination over the focal surface, and mechanical provision for this had been made in the prototype. A small light, provided with suitable filters, can thus be placed in the proper position for exciting the phosphor. This method of excitation is satisfactory, except that when in use the viewing of an infrared source must be interrupted during excitation.

In May 1942, a request came from the Bureau of Ships [BuShips] through NDRC for a compact and lightweight infrared system capable of receiving signals over a range of 5 to 10 miles and covering as large an angular field as possible. It was decided to design a 2-inch telescope like that described above, but with a built-in exciting system that would permit continuous observation. The final design used the same optics as the ultraviolet telescope, with the dimensions slightly altered. Figures 4A and 4B show this first metascope, Type A. It has a clear aperture of $2\frac{1}{4}$ inches, a field of 36 degrees and a speed of

$f/0.55$; the image is erect and the magnification, unity.

The phosphor used in Type A is *Standard VI*, described later in this chapter. Standard VI emits orange light, and is stimulated by radiation of wavelengths from 0.75 to 1.3 microns with a well-defined maximum at 1.025 microns. It is excited with a tungsten source filtered by Corning light blue-green glass



FIGURE 4. A. Front view of Type A metascope. B. Side view.

No. 428 plus Corning medium aklo infrared absorbing glass. Ten to 30 seconds' exposure of the phosphor to this source is sufficient for charging. Immediately thereafter the phosphor shows a bright afterglow which soon dies down. The greatest phosphor sensitivity is 5 to 10 minutes after charging, and recharging should be done every few hours.

Provision for Continuous Viewing. Two extension pockets were added on either side of the chamber carrying the K-S system, and two independent focal surfaces coated with phosphor were provided, mounted on the arms of a rigid, two-tined fork. The fork is pivoted in such a way that throwing a lever on the front of the instrument brings one phosphor into the focal position and puts the other in a side pocket. Each pocket is equipped with a small lamp, suitably filtered. On the fork carrying the phosphors is a switch which automatically connects only the lamp in the

side pocket occupied by a phosphor. The battery circuit can then be closed by a small push button in the rear of the case.

A semicircular guard around each focal surface allows the operator to excite a phosphor in a side pocket without visible radiation escaping from the instrument. He can then use the metascope with one phosphor surface while exciting the other and without disclosing himself to an enemy, or, more important, without interfering with his view. Thus, continuous viewing is provided. The power supply for the lamps consists of two "penlite" dry cells mounted in the base. At the top of the base is a small cylindrical compartment containing a drying agent, silica gel, to prevent decomposition of the phosphor by moisture.

Except for a small breather hole to the outside air through the drying chamber, the entire instrument is sealed. It can be used under severe conditions of rain and sea spray, and at the same time can be carried to high altitudes without danger of rupture of the corrector plate. Moisture will not even deposit inside a cold instrument upon sudden exposure to warm humid air. This last advantage is particularly important when the metascope is used in aircraft.

A sample instrument weighing 1.8 pounds, including batteries, was submitted to BuShips. As a result of tests made by the Navy in September 1942, a procurement order for 10,000 was placed with the Samson United Corporation of Rochester, New York.

PRODUCTION-MODEL PROBLEMS

Although the Type A metascope was compact and rugged, it was not designed primarily for production. Modification of the design to permit large-scale production was undertaken by Eastman Kodak Company under Contract OEMsr-1100, and production drawings were furnished to Samson United Corporation.

The Navy has specified that a red filter be built in over the corrector plate, to reduce interference with the observer's vision by moonlight or a bright night sky. This also eliminates autocollimator action which returns visible light in the direction of any infrared or visible source viewed with the metascope. A red, not an infrared, filter is used to allow final adjustments inside the metascope to be made easily, looking through the filter with visible light. This filter cuts the incoming infrared to approximately 80 per cent of its true value, but to the dark-adapted eye its visible transmission is quite low.

Most of the production Type A instruments were supplied with phosphor powder from the Brooklyn

Polytechnic Institute, which, under Contract OEMsr-982, has improved Standard VI and has also made several improvements in the method of production. Sensitivities of Standard VI samples increased during the production of Type A, as did the method of forming the "button," the focal surface coated with phosphor. Therefore, the average sensitivity of the instruments increased. The first instruments had threshold sensitivities of 100 nautical-mile-candles and the final ones averaged 20 to 25 nautical-mile-candles.

This order of sensitivity rating was set up by BuShips as a practical standard of performance. An instrument of 1 nautical-mile-candle sensitivity is one with which a fully dark-adapted observer can just detect one nautical mile away a specially filtered source of 2800 K color temperature (tungsten lamp) which has an intensity of 1 candlepower before filter-

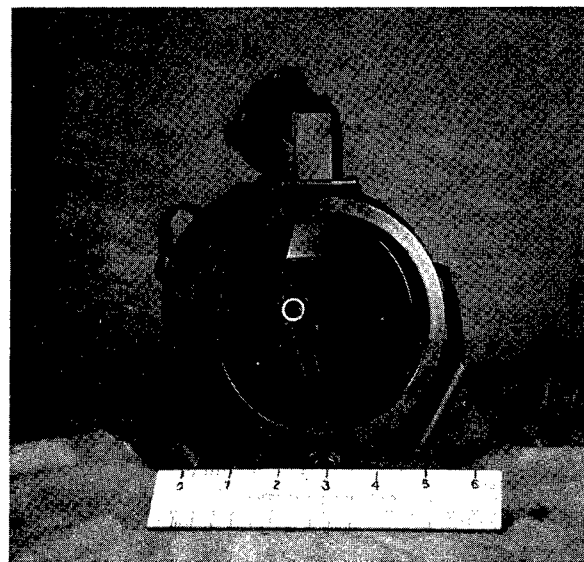

FIGURE 5. Type B metascope, front view.

ing. The filter used is an XRX7 type made by the Polaroid Corporation, specially selected by BuShips for such test work.

Resolving-power tests show that the Type A metascope can resolve one part in 150, or about 7 mils.

3.2.2

Type B

A 4½-inch aperture ultraviolet telescope of approximately three-power was developed at the same time as the 2-inch instrument. Comparison of the sensitivities and resolving powers of these two indicated that there would be a use for a larger instrument than Type A. Accordingly, a metascope was designed in

November 1942 with approximately twice the linear aperture and twice the weight of the A unit, with two-power magnification. This Type B is shown in Figure 5, with a scale drawing of the optics in Figure 6. It has a clear aperture of $4\frac{3}{4}$ inches, as com-

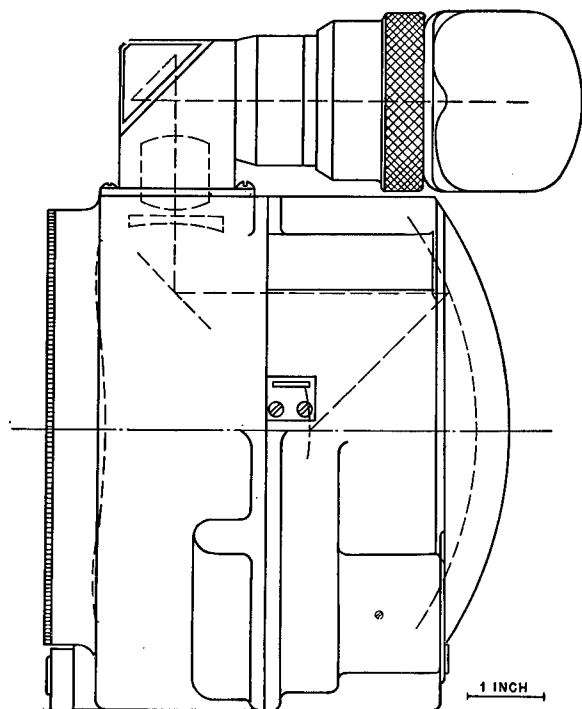

FIGURE 6. Type B metascope, optical system.

pared to $2\frac{1}{4}$ inches in Type A, a magnifying power of 2.12 and 24-degree field. Like Type A, it operates at a speed of $f/0.55$ and gives an erect image. It weighs approximately 4.6 pounds.

As in Type A, two focal surfaces are mounted on a swinging fork, so that one can be excited in a side pocket while the other is used for viewing. The side pockets are each provided with batteries and a filtered light source. Standard VI phosphor is regularly used in Type B, but another phosphor, *B-1*, developed at Brooklyn Polytechnic Institute, has also been tested in this instrument. As seen in Figure 5, two silica gel chambers, one with a breather hole, are attached diagonally across the exciting pockets. The weight of the Type B metascope is so distributed that it may be held in one or both hands, using the lower side grips over the battery cases shown in the figure. As with Type A, unobstructed vision is provided for the unaided eye.

In the Type B instrument, however, the viewing system is quite different from that used in A, since that kind of viewing system would be too cumbersome

for this larger size. Visible light emitted by the phosphor is reflected by the spherical mirror to a diagonal mirror, thence through a section of a corrector plate, which in this case should be calculated for visible light, and finally through the viewing telescope. Erection of the image is obtained by a second diagonal reflection through a pentaprism in the viewer. This gives an extremely compact instrument for one of such a large aperture.

The magnification in Type B should give an increase in the apparent intensity of a point source of $4\frac{1}{2}$ times that of Type A. However, five metallic reflections take place in the B and part of the aperture is lost because of the diagonal mirror; the total theoretical gain is thus about $3\frac{1}{2}$. The magnification will produce no change in the apparent brightness of an extended source and, due to the many reflections, it will actually appear less bright.

Tests of the range of the Type B were made at the contractor's laboratory. When a tungsten source of 400,000 beam candlepower was filtered through 6 millimeters of Corning No. 2540 glass, a well-dark-adapted observer could pick it up with the metascope 10 miles away on a dark night and 5 miles away in the bright moonlight. If a deep red or thin infrared filter were used to cut out the visible light, a well-shielded observer could find the lamp at 10 miles in bright moonlight.

An average sensitivity of 7 to 10 nautical-mile-candles was obtained in the Type B with Standard VI phosphor, approximately three times that of the A. It has a resolving power of about 1 in 350, or 3 mils.

BuShips ordered 5,000 Type B metascopes from Eastman Kodak Company, which altered the design for production under Contract OEMsr-1100. A red filter with a bayonet attachment to fit over the corrector plate is supplied with the instrument. Production started in 1943 and was completed early in 1944.

3.2.3

Types O and M

Two miniature metascopes, Types O and M, were developed next, using a K-S system of $1\frac{5}{16}$ -inch entrance aperture. The O instrument was designed at the request of the Office of Strategic Services; and the M, which differs from the O only in that it contains batteries and a self-exciting system, was produced for BuShips. These were meant to be used as pocket instruments in cases where extreme range was not desired but lightweight and small size were important.

A single, rigidly mounted surface with Standard VI phosphor is used in both types. Both instruments use a viewing system similar to Type A but with no erecting lenses. The phosphor was observed with a two-element eyepiece through a hole in the spherical mirror. Type O is excited by either daylight or an incandescent lamp through the eyepiece, which is provided with a removable filter of Corning glasses No. 428 and medium aklo, for this purpose. Type M has a built-in exciting system, using a fixed light source placed between the K-S corrector plate and mirror, as described for the ultraviolet prototype. For emergency use, daylight excitation as in Type O is also provided. With both O and M metascopes, therefore, observation must be interrupted for excitation. It was expected, however, that the excitation could be done shortly before use, and that the period of observation would be short enough not to require recharging.

In both types, provision is made for an infrared filter to be screwed over the corrector plate, and such filters are supplied with the instruments. Silica gel is not used in these metascopes, for they can be pressure-sealed because of the absence of moving parts. This also makes the small metascopes more rugged than the Types A and B, and less likely to come out of adjustment.

The sensitivity of these small metascopes is approximately half that of Type A, giving a threshold value of about 40 nautical-mile-candles. Both instruments have the serious disadvantage of an inverted image. Types O and M weigh 4 and 6 ounces, respectively.

These small instruments, especially Type M, aroused considerable interest, but it was felt that a better metascopie should be made which would give an erect image of good quality and have greater sensitivity.

3.2.4

Type A-M

A metascopie was designed in the early summer of 1943 to incorporate the advantages of the miniature models with those of the larger types; it was designated Type A-M (A modified). It employs a single, rigidly mounted surface with Standard VI phosphor, with a built-in exciting source. The first A-M used the same size K-S optical system as the Type A, giving similar sensitivity and resolving power.

The method of viewing the phosphor results in a better image than in any of the previous types. Light emitted by it is reflected by the large spherical mirror through a small high-index roof prism and a small

element of a K-S plate in the side of the instrument case. There is no eye lens, since the bundles of rays are collimated by the spherical mirror and the visible image appears at infinity.

If the Schmidt correcting segment were placed at the same optical distance from the mirror as is the

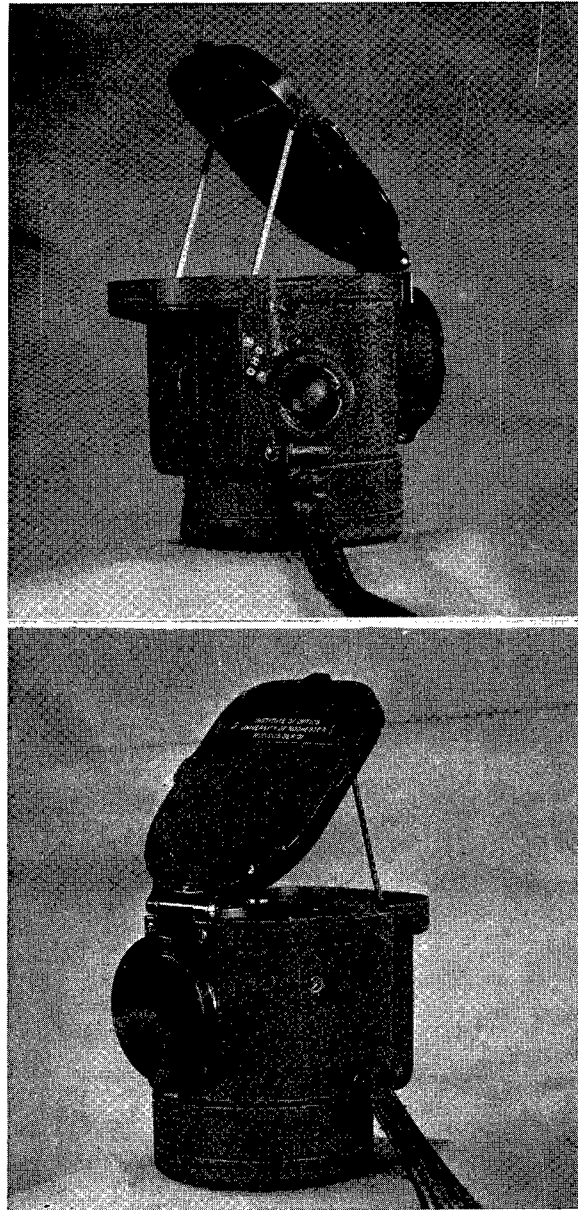

FIGURE 7. Type F metascopie, front view and rear view.

large corrector plate (allowing for the change in optical path introduced by the roof prism), the whole optical system would be completely symmetrical, and many aberrations would be eliminated. However, under these conditions the entire available field, as

limited by the aperture and size of the focal surface, cannot be seen by the eye, since there is not room for a prism large enough to take advantage of the whole field. Therefore, to keep the same field in the A-M as in the A, the eyepoint is moved closer in by making the prism of dense glass and placing the segment closer to the mirror. This makes aberrations in the image, for the segment is no longer in the proper position and off-axis rays traverse the wrong parts of the segment correcting curve. Nevertheless, the image thus formed is very satisfactory and far better than the image in any previous metascope. Erection of the image in one plane is taken care of by the roof prism and in the other by an external diagonal mirror, which folds to form the cover of the instrument. The roof prism need not be made with high optical precision as there is no magnification of the image.

Type A-M weighs about half as much as Type A, and takes up only half the space. It, too, is excited by internal batteries, but like the M has only one phosphor surface, or button. A metal shutter is provided over the eyepiece so that the instrument may be completely closed and carried without a case, if necessary. Since it has no internal moving parts, the A-M can be pressure-sealed, though a compartment for silica gel is also provided. The instrument is quite rugged. Except for damage to the shutter or to the arm or hinge supporting the diagonal mirror, or actual breakage of the corrector plate, little harm can be done to the A-M.

This metascope was seriously considered for production. In the meantime, however, the development of a new phosphor, *Standard VII* (see Chapter 4), and a new means of exciting it rendered the instrument, although not the essential design, obsolete.

3.2.5

Type A-1

A new phosphor material, B-1, which is more sensitive than Standard VI, was developed (see Chapter 4). In order to take advantage of this, a new pressure-sealed metascope, Type A-1, was designed and produced by Samson United Corporation. This uses the optical parts of Type A, but copies the original prototype using a single button and a fixed source. The sensitivity of this instrument is about 4 to 8 nautical-mile-candles. The Navy ordered 5,000 of these instruments, and delivery has been completed.

3.2.6

Type F

In May 1943, a very different phosphor was made available, which proved to be three times as sensitive

as Standard VI when excited with ultraviolet light. Later experiments showed that this phosphor, which gives a visible green response on exposure to infrared radiation, can also be excited by alpha particles and

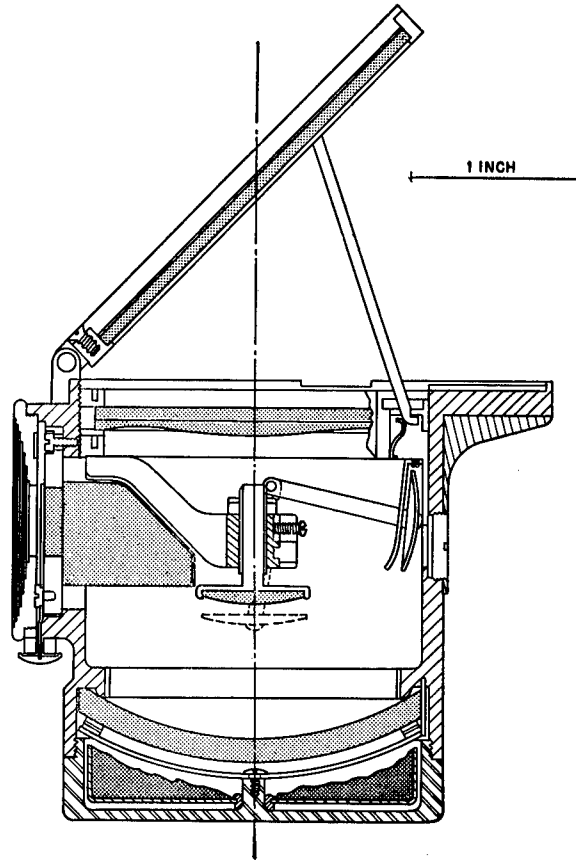

FIGURE 8. Assembly drawing of Type F.

is then six or more times as sensitive as Standard VI. This phosphor has been called Standard VII (see Chapter 4).

It is interesting to note that provision for this type of excitation had been made in the original prototype telescope, and early experiments had been made with a radium source fused into porcelain.

Because of this new development, another metascope, Type F, was designed to be used with Standard VII. It is $\frac{8}{10}$ the linear dimensions of the Type A-M and uses the radium method of excitation. One of the production instruments is shown in Figure 7. Figure 8 is a scale drawing. Type F was originally provided with a removable infrared filter, which was screwed into the back of the instrument when not in use. This was intended for use on bright nights to exclude visible light and enable easier detection of the infrared. A later model uses a red filter cemented to the main

corrector plate. The production instrument weighs 0.7 pound, with outside dimensions approximately $2\frac{1}{4} \times 2\frac{1}{2} \times 3$ inches. The optical arrangement is exactly the same as for Type A-M.

Excitation Arrangement. Alpha-particle excitation is supplied in Type F by mounting a small disk of radioactive gold foil, which is usually referred to as blitz, upon a lightweight swinging arm within the instrument. The radium is contained within, rather than on, the surface of the gold, and special precautions have been taken to minimize the escape of radon, which produces objectionable scintillations on the surface of the phosphor. For excitation, the arm can be swung so as to place the blitz about 1 millimeter in front of the phosphor surface, or it may be swung out of the way behind a barrier in the instrument case when the metascope is in use. Even with the blitz in the latter position, beta rays will continually strike the phosphor, acting as a *trickle charge* to keep it excited. Once excited, Standard VII will hold its excitation for many days even in the absence of the trickle charge, provided, of course, that the instrument is kept closed. Since unfiltered daylight quickly exhausts the excitation of Standard VII, it is very important to keep the instrument closed.

The phosphor may be used immediately after swinging the exciting arm away, although it continues to glow spontaneously for some time. Maximum threshold sensitivity is obtained after this afterglow has been allowed to die down. One hour after excitation, or any longer period up to at least 2 days, gives the best results. For example, if the average Type F is fully excited, the threshold sensitivity is 40 nautical-mile-candles 5 minutes after excitation, and 6 nautical-mile-candles or better 1 hour later. The best Type F shows a sensitivity of 2 nautical-mile-candles after 1 hour.

After a phosphor has been exposed to a strong infrared source for a long time, it becomes exhausted and loses sensitivity. For instance, if a surface of Standard VII has been exhausted to half sensitivity by continuous use during night operations, 1 hour of recharging is necessary to bring it up to full sensitivity again. However, 10 minutes of recharging will bring it back to 80 per cent maximum sensitivity. In both cases, maximum sensitivity is not obtained until an hour after the excitation is removed.

Length of Use Before Recharging. It is important to determine how long the instrument may be used under average operating conditions without interrupting its use for a recharging period. The bulk of operational use is expected to be conducted at 5 to 10

times threshold. However, as a precautionary measure, a test was set up with a Type F metascope and an infrared source 100 times the instrument threshold. The instrument was clamped in position so that the image of the distant source remained fixed on the phosphor surface and thus exhausted a very small area of about $1/200$ of a square millimeter. It was found that under this condition, 70 minutes of exposure were necessary to exhaust this area to one-half sensitivity. Under any operating conditions the instrument is, of course, moved, and while most of the use is confined to the central areas of the phosphor surface, this still involves working areas of as great as 50 or more square millimeters. Thus, it is probable that under any ordinary operating use the phosphor cannot be seriously exhausted even by a full night of continuous service. Practical experience in the field and under combat conditions has borne this out.

Pressure-Sealing Method. The Type A and B metascope were not sealed, but supplied with breather holes as already mentioned, because of the fear of rupturing the corrector plate by atmospheric pressure changes and also because of sealing difficulties connected with moving the fork holding the focal surfaces. Subsequent tests showed that the corrector plates could withstand pressures up to 25 pounds per square inch, so that with the F instrument the only thing that prevented pressure-sealing was the movement of the blitz arm by an outside lever. This was overcome by using a sealed push button to release a catch holding the blitz arm. When the instrument is tilted and the button pressed, the arm falls into position by gravity and is pinned in this position when the button is released. All production instruments are thus pressure-sealed. Silica gel is inserted in the doughnut-shaped cavity behind the spherical mirror.

All the advantages of Type A-M, good image quality, compactness, and lightweight, are included in Type F. Two arms are used to support the diagonal mirror, making the instrument more rugged than the Type A-M, which has only one, but still subject to damage while being opened or when left in the open position. In view of the fact that the front diagonal mirror, which forms the hinged cover of the metascope, might be injured in operation under conditions when the need for the instrument would be critical, the design provides a deliberate weak point in the arms which normally serve as stops and braces for the mirror in the operating position. Thus, if the mirror has been broken or injured in any way, it is only necessary to rip the supporting arms from their stops without

doing other damage. This folds the mirror entirely out of the way so that the metascope can be used in the fashion of a reflex camera, that is, by looking down into the eyepiece while the corrector-plate portion of the instrument points forward. The sensitivity is not impaired (although the convenience of an erect image straight ahead is lost), and the instrument may thus be kept in operation under very severe conditions of combat service.

The Type F metascope, with its high sensitivity and good image quality, aroused considerable interest. The Army Engineer Board placed a total order for 55,000 instruments with Samson United Corporation and with Electronics Laboratories of Indianapolis. Each company has designed its own production model; these differ slightly from each other and from the original model, but both production instruments are satisfactory.

3.2.7

Type J

The Type F metascope is difficult to open with one hand and thus cannot easily be used under some circumstances, as, for example, by the pilot of a single-seater fighter plane. For this reason, the Type J was developed at the request of the Navy Bureau of Aeronautics, differing from the F only in having a stationary diagonal mirror, with a filter and a cover that can be flipped down with one finger. It was submitted to the Navy but has never been put in production.

3.2.8

Type H

Although the F metascope is very compact and so can be used in cases where there is no room for a straight-through viewing system such as the Type A, and although it gives excellent image quality, it is somewhat difficult for inexperienced observers to use because of the offset optical axis. For this reason, another metascope was designed for BuShips at the same time as the F, called Type H (Figure 9). However, it is known by the Navy as Type A-M because the designation of the earlier Type A-M had already become fixed in certain authorizations. It is also sometimes referred to as the Type H-AM.

Type H uses the straight-through optical system originally used in Type A, but with linear dimensions of the primary K-S system $\frac{8}{10}$ those of the A, as in the F instruments. It is excited by alpha particles in the same manner as the F and has the same average sensitivity, but not quite the off-axis image quality, since it uses a lens-erecting and viewing system. Type

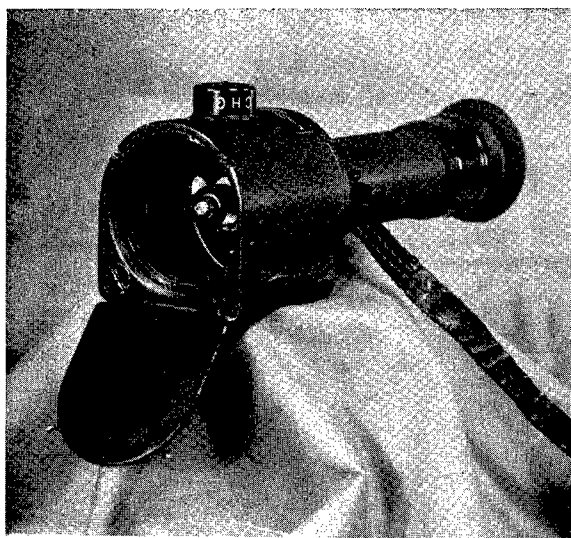

FIGURE 9. Type H metascope, front view and side view.

H is pressure-sealed, with 2 silica gel chambers on the side of the case. The cover can be flipped open, and it folds under the instrument with a retaining catch. A red filter is cemented over the corrector plate.

Smaller than the A instrument and with about half its 2-pound weight, Type H has four times the sensitivity, and thus can be used to advantage in any application where the A instrument has been successful.

Because of the unit magnification, the position of

the image is independent of the motion of the telescope, and thus two systems can be linked together to form a binocular (Figure 10), with no critical alignment necessary. This necessitates good adjustment of the magnification, however, or one image might be larger than the other and the two would then

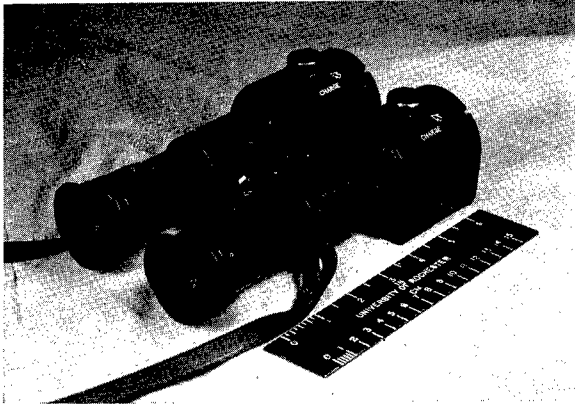

FIGURE 10. Type H metascopes used as binoculars.

be difficult to fuse. A binocular attachment is provided with the instruments, so that they can be put together in the field in a few minutes.

BuShips has received 21,000 Type H metascopes, and has made an additional postwar request for more. The production model in this case is identical with the contractor's original design.

3.2.9

Type K

On request from OSRD observers in the European area, a small, compact metascopé was developed which could be attached to the back of a G. I. flashlight for use with airborne troops. The first of these, Type K, was taken to the European theater in August 1944.

With the Type K and its successor, Type L, a new principle as applied in metascopes is used, that of a solid dielectric optical system. The maximum speed that can be obtained in air with a K-S system is $f/0.50$. If a medium of high refractive index n is used, the speed is theoretically increased by a factor of n , but if the magnification is kept at unity, the sensitivity of the instrument remains the same. Increasing the speed of the system means that the slope of the K-S corrector plate must be steeper by the same factor, and this is difficult to accomplish. Therefore, to cut off the steepest portions of the curve, the aperture diameter of this solid system is made slightly smaller than that of an air system. Type K has a speed of $f/0.36$ when glass of index 1.532 is used.

The great advantages of a solid system are that it can be treated very roughly, since the assembly is extremely rugged, that smaller sized units can be made than are feasible with an air system, and that perfect optical symmetry can be obtained, resulting in an image with no aberrations for axial rays.

Solid K-S systems had been used with ultraviolet phosphors in 1941, but not applied to the infrared until the need arose. The optical parts of the first such metascopé, Type K, consist of three cemented glass elements and an eyepiece. The back element has two spherical curves, one of which is polished and aluminized to serve as the spherical mirror. The other has a ground surface in the focal position. To this is cemented a thin *separator plate* with a hole in the center, of the same diameter as the focal surface, to facilitate coating this with phosphor material. After the phosphor has been applied, the *front element*, which has the aspheric correction curve on the outside, is cemented on. The back surface is aluminized except for a small hole in the center, through which the phosphor is viewed by means of a three-element eyepiece.

This metascopé gives an inverted image of rather good quality over most of the field; however, it has all the distortion of the Type O and M units, and the eyepiece aberrations and backward curving field make the image very bad at the extreme edge. When mounted in an aluminum case, it is about $1\frac{1}{4}$ inches in depth and $1\frac{1}{2}$ inches in diameter. It has never been considered for production because of the far superior quality of Type L.

3.2.10

Type L

A solid form of metascopé giving an erect, nondistorted image was achieved in the spring of 1945 in the Type L unit, developed to meet the specific requirements of extreme compactness with erect image prescribed by the Army Engineer Board, Fort Belvoir, Virginia. Photographs of this instrument are shown in Figures 11A and 11B, and a scale drawing in Figure 12.

In the Type L metascopé, the front element is divided into two parts, as shown in the drawing. When cemented together, parts *B* and *E* act as in the Type K, correcting for spherical aberration in the infrared image cast on the phosphor. The back element *D* and the separator plate *C* have the same function as before. The method of viewing the phosphor, however, uses somewhat the same principle as does Type F. A 45-degree wedge is cut out of the front element and in

its place a viewing segment E is cemented. This segment is a portion of another front element, and has an aluminized ellipse on its hypotenuse face. This acts as a diagonal mirror to reflect the visible light coming from the spherical mirror to the eye; the exit

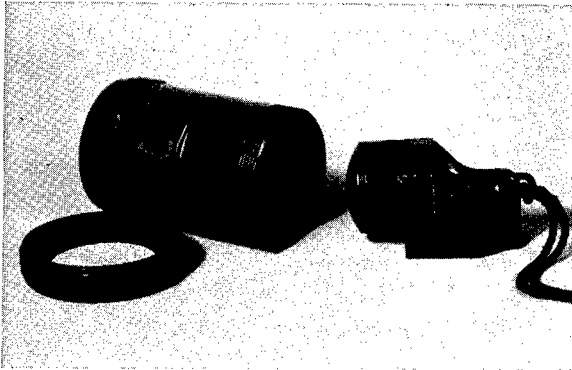

FIGURE 11A. Type L metascope with carrying case.

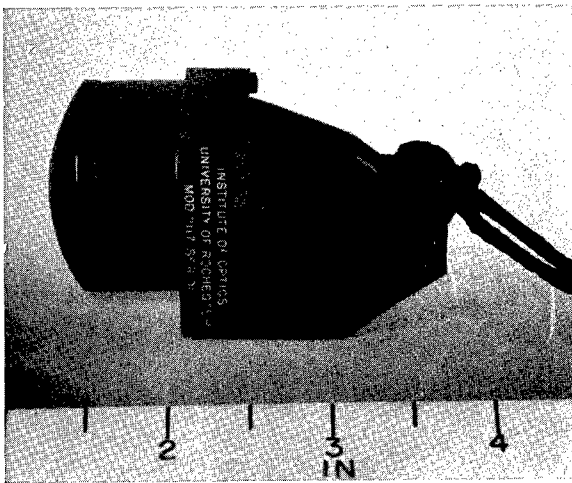

FIGURE 11B. Close up of Type L, showing roof prism.

face of the segment corrects for spherical aberration.

Complete erection of the image is obtained by means of a roof prism, A , mounted separately from the rest of the system to receive the incident light. A red filter F is placed between the roof prism and the K-S system.

Type L has a threshold sensitivity of 5 to 6 nautical-mile-candles, comparable to the 5 nautical-mile-candles for the average F and H. It has no axial aberrations in its image; the correcting surface of the eyepiece segment is in its proper position, and the system is completely symmetrical. Due to refraction in the glass, an extremely wide field of 45 degrees is obtained. It has an aperture of 23 millimeters and a

weight of 3 ounces, compared to 12 ounces in the size F. The carrying case is designed to screw directly onto a G. I. flashlight. Both the housing and carrying case are made of Lucite.

Standard VII-b phosphor is used in the Type L, and was developed expressly for this service. VII-b is very similar to VII in most respects, but differs in permitting regeneration in powder form without loss of sensitivity. It also permits a sensitivity on ultraviolet excitation which is substantially that obtainable by Standard VII on radium excitation. This makes possible the excitation of the instrument by daylight, and a suitable ultraviolet transmitting filter is mounted in the carrying case of the instrument to accomplish this. By careful attention to the character of the filter, which is so positioned in the case that it always registers with the eyepiece of the instrument, it has been found possible to get full excitation of the instrument in about 5 minutes' exposure to average blue sky light, while 20 to 30 minutes' exposure is required with a very dark overcast sky. Prolonged excitation has no known deleterious effect, so that the instrument can be left exposed all day if so desired.

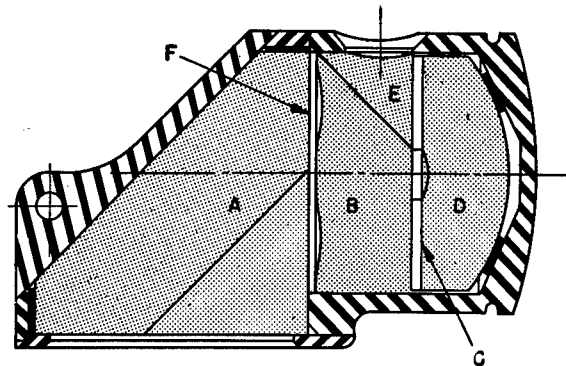

FIGURE 12. Assembly of Type L; A , roof prism; B , front element; C , separator plate; D , back element; E , eyepiece segment; F , red filter.

Standard VII-b phosphor has the same fortunate properties of Standard VII in retaining its excitation for many days and in storing a sufficient amount of energy to permit all-night use without recharging.

Although the prototypes of the Type L instrument have been made in glass, the Polaroid Corporation undertook to investigate the possibilities of plastic construction. Using a drop-molding process similar to that developed for the Kellner-Schmidt glass corrector plates (Section 3.4.1), the University of Roch-

ester produced glass molds to permit polymerization casting of the aspheric front element for the Type L, and these molds have been furnished to the Polaroid Corporation. The latter has applied this method very successfully, and the Army Engineer Board placed an initial contract for manufacture of a few instruments by that company. The Engineer Board has also placed a parallel contract for manufacture of the glass version by the Eastman Kodak Company.

3.2.11 Stadiameter Attachments

A stadiametric device for the Type A metascopes has been designed to enable an observer to determine the range as well as the direction of an infrared source. The stadiameter is shown schematically in Figure 13 and photographs of the assembled instrument in Figure 14.

Two mirrors, *A* and *B*, are mounted over the metascopes aperture with mirror *B* obscuring half of the aperture. If *A* and *B* are parallel, the light received by the metascopes through the mirror system will be parallel to that received through the unobstructed aperture, and a single image will result. If, however, *A* is slightly tilted with respect to *B*, a double image will appear. Conversely, by tilting *A*, two separated images can be brought into coincidence, and, if the horizontal separation of these sources is known, their distance can be determined by the angle through which the mirror must be moved. A calibrated screw, provided with a small, dark-red light source and batteries to enable reading at night, gives the angular displacement of mirror *A*.

Although the resolving power of the Type A metascopes is only 5 mils, the stadia setting can be made to an accuracy of approximately 1 mil. This is because one mirror can be slightly tipped by means of a cam

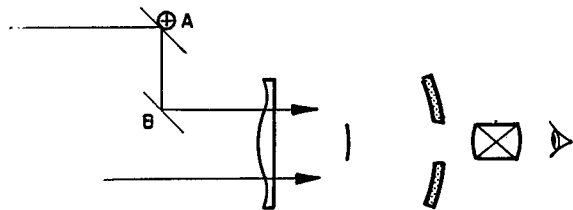

FIGURE 13. Stadiameter for Type A, schematic drawing.

so that instead of the images being brought into coincidence, they are lined up one above the other and their center lines matched.

Since the stadiameter is attached on the outside of the metascopes, it is unaffected by any distortion due to the metascopes itself, although the instrument should,

of course, be kept in focus. When set at zero, the stadia attachment is neutralized, giving 95 per cent of full image brightness. The stadiameter weighs 0.8 pound, including the battery. It can be attached or removed in the field in less than 5 seconds by means of a bayonet clamp.

A similar attachment on the Type B metascopes would be far too bulky. However, since the Type B

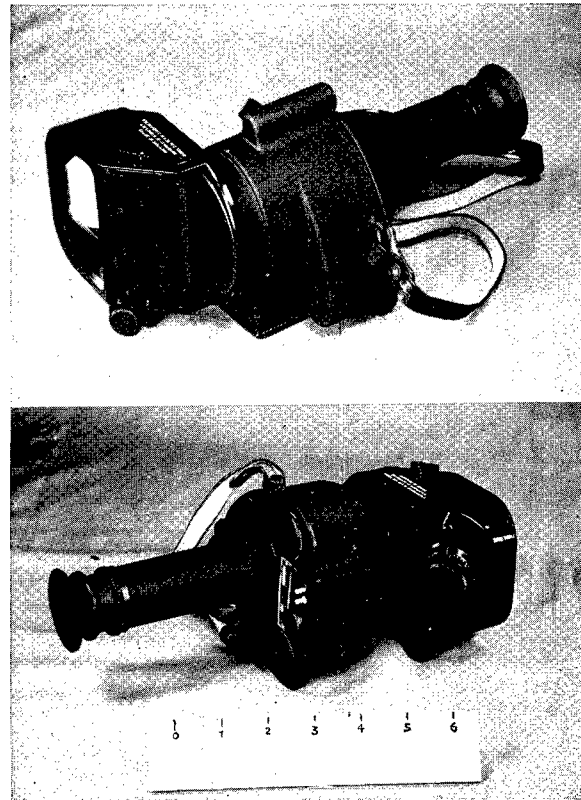

FIGURE 14. Stadiameter for Type A, front view and rear view.

has a completely symmetrical optical system, up to the two-power telescope, the stadiameter can be incorporated within the instrument without fear of sacrificing accuracy. By splitting the cemented doublet of the telescope into two halves and moving these parallel to their cut surface, one image may be split into two parts, or two images brought into coincidence. As in the Type A stadiameter, allowance is made for displacing the images vertically to allow greater accuracy of setting. The Type B metascopes, complete with stadiameter, is shown in Figures 15A and 15B. The scale is made of Lucite and lighted by pressing a button on the side. Type A stadia attachments have been put into production, but not the attachment for the Type B.



FIGURE 15A. Stadiometer for Type B, attached to metascoper.

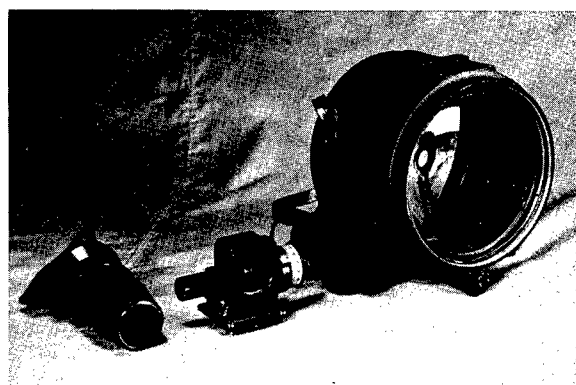

FIGURE 15B. Stadiometer for Type B, disassembled parts.

3.3 APPLICATION OF PHOSPHORS TO METASCOPIES

Infrared-sensitive phosphors are thoroughly described in Chapter 4. A brief discussion of the properties as applied to use in metascopes will be given here. At present it is by no means possible to predict and control all the desired phosphor properties. A wide variety of *emission spectra* has been made available, because of the preparation and study of many thousands of phosphors. *Stimulation spectra* have been obtained with maxima out to 1.3 microns, and it is desirable to push the stimulation to still longer wavelengths, or greater intensities at the 1.3 micron limit. The *excitation spectra*, *afterglow*, *spontaneous decay*, and *quantum efficiency* are controllable only in part; *resolving power* can be partially controlled by the grain size and thickness of the phosphor layer.

3.3.1 Optical Properties of Standards

Starting in July 1941, research was undertaken at the Institute of Optics in the development and production of high-sensitivity infrared phosphors. Originally, the purpose was to reproduce two types of phosphors that had been made by Urbach and Kunz in Vienna in the 1930's. This was virtually accomplished by the beginning of 1942, and since then new phosphors have been made which are either more sensitive or more adaptable for use.

All these phosphors are composed of a *basic material*, a *flux* and one or more *activators*. After preparation, a phosphor may be regarded as containing a matrix of base and flux in which is embedded a very small amount, about one part in ten thousand, of activating impurities. The energy levels of the matrix and activators are mutually perturbed, and quasi-stable states are produced which provide traps for excited electrons. Upon infrared stimulation, the electron receives enough energy to release it from the trap and falls back to the ground state with the emission of visible light.

Standard VI, the phosphor used in Types A and B metascopes, uses a strontium sulfide base and equal amounts of samarium and europium activators. Standard VII has the same base, but cerium and samarium activators. The B-1 phosphor, developed at Brooklyn Polytechnic Institute, uses samarium and europium activators, as in Standard VI, but a strontium selenide-strontium sulfide base.

A careful study of two-activator phosphors has been made, and as early as May 1942 several facts became evident. Of the two activators, one, the *dominant*, determines the color of emission while the other, the *auxiliary*, determines the stimulation spectrum. Changing the basic material, although in most cases secondary to changing the activators, will also cause a shift in both emission and stimulation spectra. Although the excitation spectrum is primarily determined by the dominant activator, it will also change with the basic material and possibly with the flux used.

The threshold sensitivity of a phosphor at a given time will depend not only on the color of emission but also on the brightness of the afterglow and the *stimulability* at that time. Stimulability is a measure of the efficiency of conversion of infrared radiation into visible light. Since these two factors change with time, good sensitivity will occur when the background is sufficiently low and the stimulability still sufficiently

great. Standard VI decays to practically no background in 10 minutes after excitation, while Standard VII shows an observable background after 18 hours. However, Standard VI loses much of its stimulability in a few minutes, and Standard VII shows little loss of sensitivity a week after excitation. In spite of its background, Standard VII is far preferable to Standard VI after a period of 2 minutes or more. While the B-1 is much better than VI, it is considerably less sensitive than radium-excited Standard VII. Neither B-1 nor Standard VI shows good sensitivity when radium-excited.

The dominant factor determining the threshold sensitivity is the quantum efficiency of a phosphor. This depends upon the amount of light the phosphor absorbs and the ability of the phosphor to turn infrared energy into emitted visible light. It is quite possible for one phosphor to absorb less infrared energy than another, but to make more efficient use of it. For example, although Standard VII absorbs only 4 to 6 per cent of incident infrared when excited, it is much better than Standard VI, which absorbs 50 per cent.

3.3.2 Physical Properties of Standards

It is a common property of all phosphors that they lose sensitivity when subjected to grinding. Thus, some form of *regeneration* must be undertaken. The first method was successive pulverization and reheating to just below the sintering temperature. It was later found that a single heating at a lower temperature for a longer time will produce the same results. The addition of magnesium oxide to the phosphor before baking, suggested by the New Jersey Zinc Company, results in a much softer cake, which can be crumbled into a powder with less destruction of luminosity. If extremely fine powders are desired, the magnesium oxide combination can be ground, then regenerated, and the final powder sprayed or painted on the desired surface.

Even after obtaining a fine powder, difficulties were sometimes still encountered in trying to apply the powder to a focal surface. Spraying the regenerated phosphor on focal surfaces resulted in irregular spots and thicknesses at first, although the powder obtained by the magnesium oxide method can be sprayed. An attempt to mold buttons and machine them to the proper thickness was successful in the case of Standard VI, while Standard VII is sprayed on a ground back and regenerated in place.

Carbon has been chosen as the backing substance for buttons, because it combines many essential qualities. It does not warp or react with the phosphor even at high temperatures; it is easily machined and it will absorb, not reflect, any light that reaches it, thus increasing the resolving power.

The phosphors as now formed on buttons are not injured by extreme changes in temperature, and they withstand any shock that the metascopes themselves will stand. However, they must be protected from water vapor, which causes marked deterioration of the sulfide by hydrolysis. For this reason silica gel is supplied in all instruments except the solid systems, and in every case possible the instruments are pressure-sealed.

3.3.3

Methods of Excitation

Excitation filters should be chosen with great care to exclude any radiation that may stimulate or quench the phosphor. Standard VII was first found to be excitable by the ultraviolet, with such an exhaustion band occurring in the region of maximum excitation. This causes the phosphor to be partially exhausted

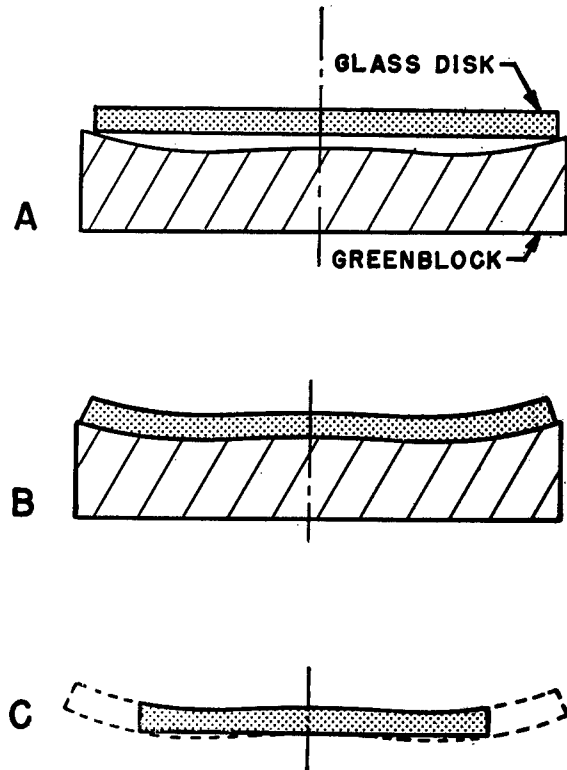

FIGURE 16. A. Sectional view of mold and blank before heating. B. Appearance after temperature cycle. C. Finished plate edged to diameter, lower surface ground and polished flat.

during excitation, resulting in values of stimulability less than saturation. Alpha-particle excitation, on the other hand, does not exhaust the phosphor nearly as much, for reasons still not understood.

The scintillations produced by alpha particles from radon and its decay products, however, are a problem when blitz excitation is used. Such scintillations are confusing to an observer because they are hard to distinguish from small distant light sources. The problem in this case was solved by keeping the radon within the foil by a coating of fused silver chloride.

Exposure of the phosphor to too long and too intense a source of radium causes a marked deterioration of the phosphor. For this reason the radium content of the blitz foil must be carefully regulated. Suitable protection must be given by the housing to shield the person using the metascope from harmful radiation. This is easily accomplished in the case of alpha and beta particles, and the gamma radiation from the small amount of radium present in any one instrument is of too low intensity to be a hazard under ordinary operational use.

3.4 PRODUCTION OF ASPHERIC CORRECTOR PLATES

The aspheric surface required on the Kellner-Schmidt corrector plate cannot be produced by ordinary production optical grinding and polishing techniques, so that in the past the only method of making such plates was to grind and polish the surface by hand. This is a very laborious and time-consuming operation that requires a highly skilled optician and renders the method unsuitable for mass production. Late in 1941, a study was begun of the possibility of producing corrector plates by the process known as *dropping*. Essentially, this method consists of heating a plane-parallel glass disk, which is optically polished on the upper surface, until it becomes sufficiently plastic to sag or drop into a mold of predetermined form. Parabolic reflectors of searchlight quality have been produced in this fashion for many years, but the process was not refined to the point where aspheric surfaces approaching ophthalmic quality could be obtained.

3.4.1 The Dropping Process

From the outset, the molds have been made from a refractory material called *greenblock*, manufactured by the American Optical Company. This greenblock ma-

terial is somewhat abrasive and difficult to machine, but has the desirable properties of not warping in the required temperature range and of lasting for 100 or more firings.

The aspheric curve on the greenblock was first cut on a lathe in a series of steps, from a table of coordinate data giving the depth, Y , at equally spaced increments, Δx of radius x . Δx was chosen to be a millimeter or less so that successive values of Y did not differ by more than 0.1 millimeter in any region of the curve. These steps were then smoothed out by hand with emery paper until the tool marks almost disappeared. Later in this development, the molds were cut on one of two contouring lathes specifically designed to reproduce the curve from a precision metal template, described in Section 3.4.2.

Considerable experimentation was required to determine the proper heating cycle. It was found that too high a temperature caused devitrification of the polished glass surface, while too low a temperature did not permit the glass to sag completely into the mold, even when the maximum temperature phase of the heating cycle was greatly prolonged. The difference in temperatures producing a good or bad surface amounted to about 30 C. Figure 16 shows the steps required to obtain a corrector plate from the original disk of glass. It should be noted that no work is done on the polished side after dropping; once a plate is dropped, it is only necessary to grind and polish the back flat and edge it to the proper diameter. All dropping has been done in electric furnaces provided with precision temperature controls. A new glass, developed by the American Optical Company and manufactured by the Pittsburg Plate Glass Company, called 1045x, was adopted in 1943 and is now the standard glass used for this purpose.

Suction Molding. Gravity dropping did not always insure positive enough contact between the plate and the mold, and tangential flow of the glass was difficult to control. In 1943, it was decided to try a partial vacuum between the two. Therefore eight No. 46 holes were drilled through the mold around the zone where the glass touches last. The mold was then placed on an Inconel platform, inside the furnace, which was connected to an ordinary domestic vacuum cleaner outside. The platform made from this heat and corrosion-resistant alloy was designed so that vacuum connections could be made with several molds simultaneously, for multiple dropping. With this arrangement, as shown in Figure 17, a pressure differential of 48 mm Hg was produced between the mold and

upper glass surface; the large capacity of the vacuum cleaner, even when operated below rated speed, is adequate to handle the very small amount of leakage.

Suction molding greatly reduces the total time for a heating cycle. Whereas with gravity dropping, the

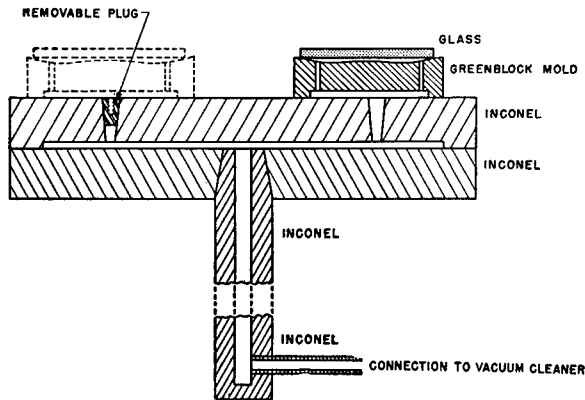

FIGURE 17. Inconel fixture in furnace for multiple dropping.

glass had to be kept at maximum temperature for an 8-hour period, only 25 minutes at maximum temperature are required under vacuum; the first 15 allow for the equalization of temperatures throughout the furnace, and the vacuum is turned on for the remaining 10 minutes. Electric time clocks turn the vacuum on and off at the proper times. This cycle has been

1045x glass now used lengthens the heating cycle about one hour.

CORRECTOR-PLATE TESTING

A dropped plate can be tested in one of two ways: by a direct measurement of its coordinates, or by an examination of its optical performance in the final system. Both procedures take about the same amount of time, but the second is employed because it is by far the more accurate and has the advantage of providing information about image quality directly.

The testing unit shown in Figure 18 consists of a spherical mirror and a smooth, diffusing focal surface which is viewed by a microscope equipped with a micrometer eyepiece. The plate is positioned at the mirror's center of curvature and the entire unit placed to receive light from a point source either at infinity or a finite distance, depending upon the particular application. Before proceeding with the testing, the plate is centered with respect to the mirror by moving it in its own plane. When this adjustment is correct, the out-of-focus image formed on the focal surface is a bright concentric circular pattern usually containing one or more bright rings caused by zonal errors. Any departure from concentricity which cannot be eliminated by recentering indicates that the plate is not a true surface of revolution.

The next step is to cover the entire plate except for

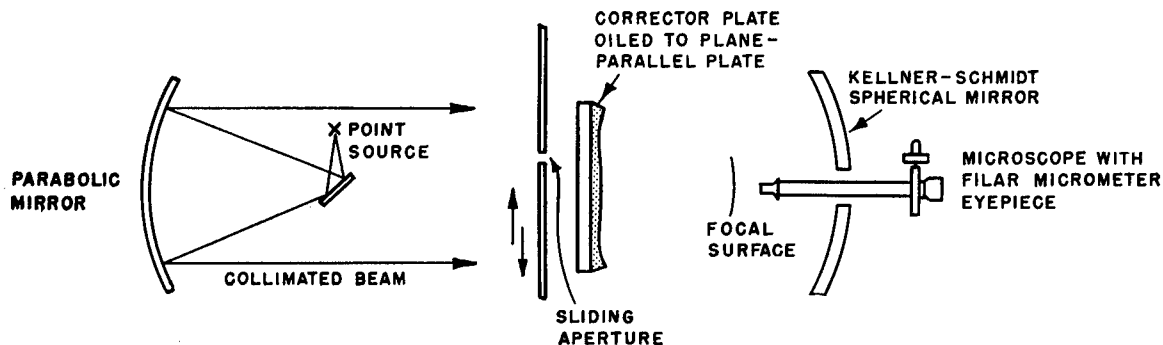

FIGURE 18. Kellner-Schmidt testing unit.

adopted as standard except for variations in the maximum temperature to suit the type of glass. Even with the same type, however, the maximum temperature is selected with a 10-degree C range, depending upon the maximum slope and second derivative of the particular mold curve. In all cases, the lowest possible temperature is used which produces barely visible markings of the suction holes on the back of a dropped plate. Except for plate diameters above 5 inches, no annealing of the glass is performed. Annealing the

a small aperture which can move in front of the plate along a diameter in the manner of a Hartmann test. A perfect plate would focus all rays at the same point and, consequently, no image displacement would be noted as the aperture is moved. Any displacement which appears is almost exactly proportional to the error in slope at the zone under investigation. These displacements are measured at small intervals and averaged for corresponding zones equidistant from the center. This visual scanning is usually performed with

light in the sodium D line region. If the plate is to be used in some other spectral region, the data are adjusted to that region by adding a displacement correction proportional to the slope at each zone to compensate for dispersion. The corrected displacements are numerically integrated from the center to edge and the error in sag, ΔY , at any zone, X , is found by multiplying the integral at that zone by a factor which depends chiefly upon the focal length of the system and the index of the plate, and to a much smaller extent upon the slope of the surface. For practical purposes it can be considered a constant.

MOLD-SURFACE CURVES

No mention has yet been made about the shape of the curve on the corrector plate with respect to that on the mold. Because of the finite thickness of the glass and unequal expansion coefficients of glass and greenblock, the two curves are not the same. No fundamental study of the difference in the curves has been undertaken; instead, the first approximation in making a corrector plate is to cut the desired curve on the greenblock. In the first dropping, the gross differences ΔY between the plate and mold curves appear and are determined from an optical scanning test. The values of ΔY are usually a small fraction of the total sag Y and vary so slowly across the plate that modifying the mold curve directly by ΔY results in very nearly the same changes in the sag of the plate. After five or six trials, the method of successive approximations yields plates of a quality approaching the reproducibility of the dropping process.

Extensive experience in developing mold curves proves that the zone having the maximum curvature is the most difficult to control. In the case of K-S corrector plates, this region is generally at the edge of the clear aperture, which further increases the difficulty since a definite *edge effect* is noticed due to the boundary. Whenever possible, to counteract the edge effect, a glass plate considerably larger in diameter than the clear aperture needed is dropped.

SIZES MADE BY DROPPING

K-S corrector plates have been made by dropping in a variety of sizes from 0.9 inch to 9.5 inches in diameter. Two of the designs are used as projection systems of slower speed than the metasopes (Section 7.2.1 in Chapter 7). Angular resolution of the $f/0.55$ systems is roughly $\frac{1}{5}$ as good as with the slower types. This limitation is undoubtedly due to the fact that the maximum plate slope for the $f/0.55$

is of the order of 0.17, whereas it is only 0.03 for speeds around $f/0.8$.

The dropping process was also applied to produce reverse Schmidt curves out of glass, which in turn served as molds for making plastic corrector plates by a casting process. In this work, the glass curve was developed until it closely approximated the coordinates given in the original optical calculations. From that point, scanning tests performed upon plastic castings were used to make the final corrections to the greenblock curve.

3.4.2 Cutting Greenblock Curves

As the extent and importance of the aspheric-plate-dropping program developed, it became necessary to design and construct contouring machines for cutting greenblocks. One of these uses a 1-to-1 ratio between template and duplicate. It is capable of turning disks as large as 13 inches in diameter and of reproducing templates with sags as great as 2 inches. Design work on this machine began in the last month of 1942, and the first trial cuts were made in February 1944. Another machine, with a 5-to-1 ratio between template and work, was constructed before the 1-to-1, and is used for all work less than 3 inches in diameter.

1-TO-1 CONTOURING MACHINE

The contouring machines must be able to cut the extremely abrasive greenblock material as well as ferrous and nonferrous metals; it is still possible, however, to use a stationary tool and not an abrasive grinder as would be necessary for glass. In order to take full advantage of the highly accurate aspheric metal templates available, the system must be one of high inherent accuracy and the entire construction extremely rigid and precise. In addition, some type of template corrector mechanism is desirable to improve the accuracy of the master template where necessary, to eliminate constant but predictable machine errors such as wear of the tool, and to allow a small amount of curve alteration to be carried out during work with experimental templates.

Figures 19A and 19B show the 1-to-1 contouring machine as finally constructed. A standard bench-lathe is used as a base, supplied with raising blocks to allow a diametral capacity of $13\frac{1}{2}$ inches. The drive is equipped with a speed-selector unit to allow a range of spindle speeds from 30 to 300 rpm.

The tool-carriage system consists of a parallelogram with two parallel movable arms anchored at one end,

by means of preloaded self-aligning ball bearings, to a heavy duty *cross slide*. At the other end, the arms are attached in an identical manner to a *traveler head*, which carries the cutting tool and the *template-*

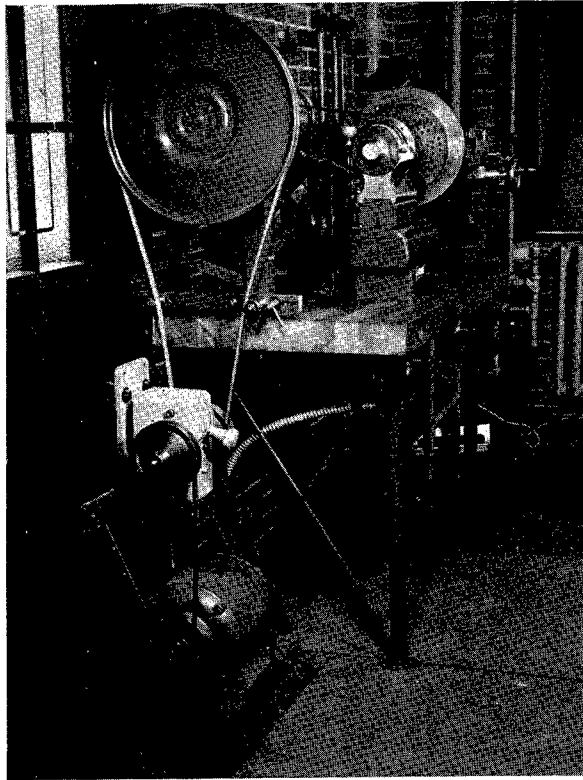

FIGURE 19A. 1-to-1 aspheric contouring machine. Side view.

follower mechanism at opposite extremities. The movement of the cross slide carries the traveler head across the master template, causing the cutting tool to trace the template curve across the face of the work mounted in the spindle. The cross slide is provided with an automatic variable-speed power feed to insure smooth surface cuts on any material.

The geometry of the system and the character of the aspheric surface generated require that the tool and follower both be sections of circles of identical radius. The follower was made in the shape of a hemisphere of 0.250-inch radius and mounted on a long finely threaded screw fitted with a calibrated dial to allow accurate feeds to be obtained. Since the tool was then required to also have a 0.250-inch radius cutting form, it was decided that a circular tool of 0.5000-inch diameter, mounted on a vertical axis, would fulfill the form requirements and could be rotated to present a new cutting surface when necessary. A tool of this

type, constructed out of tough steel with a Carboloy disk brazed on to form the cutting edge, was found to be entirely satisfactory.

In order to provide continuous corrections to the master template curve during the generation of a surface, provision was made in the machine for mounting a second metal template next to the axis of the follower adjustment screw. As the traveler head moves across the work, it traverses the two templates at the same time. The accuracy of this secondary template need not be very great, as the demagnification of the correction applied by it is 200 to 1. The range of sag correction supplied by this mechanism is plus or minus 0.010 in. With corrector templates, the various approximations to the proper greenblock curve can be made as described above. In case the master template is not quite accurately centered, the corrector template can be cut to correct this; the corrector also provides for gradual wear of the tool during the cut. Both the master and corrector templates are cut from hard $\frac{1}{8}$ -inch sheet-aluminum alloy and the two types are uniform in size and reference surfaces.

Greenblock chucks for this contouring machine were constructed in such a manner as to allow the

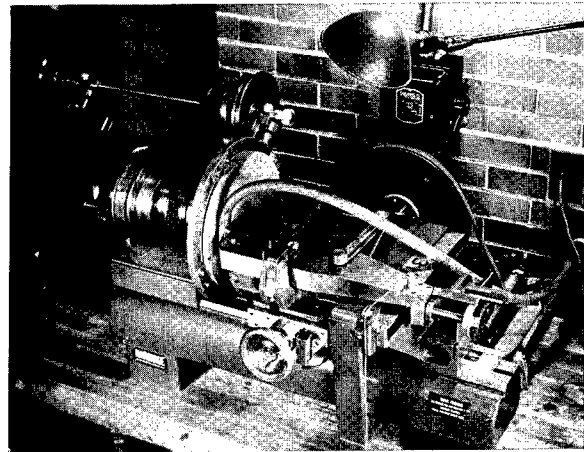

FIGURE 19B. 1-to-1 aspheric contouring machine. Top view.

blocks to be quickly mounted or dismounted and also to permit accurate centering.

Some 200 greenblocks in sizes up to 12 inches in diameter, a great number of metal test blocks, and several Lucite corrector plates have been cut on this machine and all proved to be of acceptable quality. Measurements of all these curves indicated that the machine has a systematic error or departure from the

curve desired of less than 0.001 inch, and that it will duplicate curves to better than 0.0001 inch for any size of template within the capacity of the machine.

5-TO-1 CONTOURING MACHINE

The 5-to-1 contouring machine, used for cutting all greenblocks less than 3 inches in diameter, uses a different system than that of the 1-to-1. A long, 40-inch arm is anchored at one end in crossed pivots so that it is free to swing in any direction about this pivot point, but is prevented from rotating about its own axis. At the opposite end of the arm is the template follower, with the cutter at an intermediate point. The work revolves continually, at speeds up to 3,000 rpm. As with the 1-to-1 machine, if a spherical cutter is used the follower must also be a segment of a sphere.

The same tool as used in the 1-to-1 machine has also proved successful here.

In operation, the arm is so counterweighted that the follower rests lightly but firmly on the template. As the arm is swung through a horizontal arc across the template, it also swings through a small vertical arc as the sag of the template surface increases and decreases. The cutting wheel traces out a reduced replica of the path of the follower and, as the work revolves, cuts a reduced replica of the template surface on the greenblock. No corrector template is necessary.

By October 1943, the machine was capable of cutting greenblocks to a total error spread of 0.008 millimeter or 0.0003 inch. Since then approximately 150 greenblocks have been cut on the 5-to-1 machine.

Chapter 4

INFRARED-SENSITIVE PHOSPHORS

By *Franz Urbach* and *Mary Banning*^a

4.1

INTRODUCTION

THE DEVELOPMENT of infrared-sensitive phosphors capable of emitting visible light when exposed to infrared radiation was undertaken by a number of laboratories under OSRD contract from 1941 through August 1945. All the various contractors worked closely together during this period and were kept well-informed of the progress made in each division. Since the advances made in one laboratory were often chiefly due to a suggestion coming from another, there will be no attempt made in this chapter to separate the work of the several laboratories. In July 1941, development started at the University of Rochester under Contract OEMsr-81, and in 1943 other groups joined the investigation from the Polytechnic Institute of Brooklyn (OEMsr-982), the General Electric Company (OEMsr-1155), the New Jersey Zinc Company (OEMsr-740), and the Radio Corporation of America (OEMsr-440).

Early attempts to use phosphors for the detection of infrared signals were confined to the use of materials with a high phosphorescent *afterglow* that was extinguished when exposed to infrared radiation. This necessitated frequent re-excitation or the continual motion of the phosphor surface. Until 1934 no phosphor showed sufficient sensitivity of emission upon infrared *stimulation* to be used for any practical purpose. The first practical infrared-stimulable [IRS] phosphors were made by a group of Viennese scientists during the 1930's. They developed two kinds of phosphors, one for use at dry-ice temperature with a green emission, and one for room temperature use with a red emission. These two phosphors were the background for the greater part of OSRD work in this field.

Every IRS phosphor is composed of a *basic material*, a *flux*, and a very small amount of one or more *activators*. Variations in any one of these or in the method of preparation of the phosphor will change the characteristics of the resulting material. The remain-

der of this section is devoted to the definition and discussion of the desirable phosphor characteristics. In Section 4.2, the general development and properties of the most important phosphors are given and the relationship of the various components discussed. Section 4.3 deals with the chemical methods of preparation and mechanical means of forming smooth, precisely shaped surfaces, and Section 4.4 with the methods of observing phosphor characteristics. Section 4.5 is a brief summary of the theory of such IRS phosphors.

4.1.1

Properties of IRS Phosphors

In the field of phosphorescence, no strict definitions or terminology have ever been agreed upon, so the following definitions are inserted to make the succeeding discussion clear.

An infrared-sensitive phosphor, unlike the more common ultraviolet type, requires *excitation* prior to use. Exciting radiation, which may be visible, ultraviolet, X rays, cathode rays, or alpha particles, lifts electrons within the phosphor from some ground state to a higher level. Some electrons immediately return to the ground state, causing *luminescence*, while others fall into various traps; the phosphor is then said to contain excited states. Part of these trapped electrons will spontaneously return to the ground state with time; this *spontaneous emission* occurring after excitation is called the *afterglow* or *background*. This return to the ground state is temperature dependent and in some cases can be accelerated by infrared radiation, in which case it is called *stimulation*, appearing as a flare-up of the emission of the excited phosphor.

The total amount of light energy which an excited phosphor is capable of emitting is called its *light sum*. Both the brightness of the emission and the rate of decay of a phosphor are determined by the rate of release of this stored energy. In many cases some infrared or other radiation diminishes the brightness of a phosphor without accelerating the emission, and is called *quenching*. *Extinction*, the net result of loss

^aBoth of the University of Rochester until December 1945, when Dr. Urbach joined the staff of the Eastman Kodak Company.

of brightness by either stimulation or quenching, is distinguished from *exhaustion*, which is due to stimulation alone. The ratio of stimulated brightness to the intensity of the stimulating radiation is called the *stimulability* of the phosphor. A gradual growth of stimulated brightness during constant infrared irradiation is called the *inertia* of stimulation, while a persistence of emission after the end of stimulation is called the *time lag*.

In order to be suitable for military applications, particularly for infrared detection, a phosphor must fulfill a complex set of conditions, some essential, some desirable, depending on its use. Of primary importance is that the phosphor have a high *quantum efficiency*, i.e., that as much as possible of the incident energy is turned into visible emitted energy. This requires that the absorption of infrared by the phosphor be high and at the same time that the most efficient use be made of the amount absorbed. Some phosphors may absorb a large amount of infrared but make inefficient use of it, while others absorb little but use almost all of this.

The background or afterglow at the time of use should be low, but for many purposes a faint background is desirable. The emission spectrum should match the sensitivity curve of the dark-adapted (scotopic) eye as closely as possible, while the stimulating infrared spectrum should extend to as long wavelengths as possible to avoid detection by image tubes or other devices used by the enemy. Excitation should be accomplished by daylight or an easily available and portable source permitting the attainment of maximum sensitivity within a short time.

Sensitivity to infrared radiation should persist for a long period after excitation, requiring that the spontaneous return of the trapped electrons to the ground state be slow. In order that sensitivity be exhausted slowly when in use, the useful amount of energy stored, the light sum, should be large. Both the inertia and the time lag should be small in order to permit the detection of fast signals and moving objects.

Physically, the phosphor should be capable of being formed into smooth precise surfaces as for the *but-tons*, described in Chapter 3. Its resolving power should be high to enable the detection of closely spaced multiple lights or the details in a scene. The surfaces should withstand severe mechanical shock, high humidity, and sudden changes in temperature. Finally, the infrared sensitivity of the phosphor should be constant over all possible temperatures of use.

4.2 PHOSPHOR DEVELOPMENT

4.2.1 Early Phosphors, Standards I through V

By the end of 1941, the two Viennese phosphors had been reproduced successfully under OSRD contract. The "cold" phosphor, consisting of a strontium sulfide-calcium sulfide base with a lead activator, was called *Standard I*, while the room-temperature phosphor, using the same base but a mixture of rare-earth activators, samarium, gadolinium, and europium, was *Standard II*. Although Standard I, emitting in the green, was more sensitive than the red-emitting Standard II, the difficulty of using a cold phosphor in the field caused its further development to lapse in favor of the rare-earth phosphor.

Several factors prevented the immediate use of Standard II. Its sensitivity needed to be increased; this could be done by shifting the color of emission to shorter wavelengths and also by reducing the background. The grain size needed to be reduced to permit greater resolving power. Improvement in the methods of synthesis was necessary to insure a uniform and reproducible phosphor. A detailed knowledge of spectral properties as well as of the decay of sensitivity in storage and in use had to be secured in order to determine the best operating conditions.

Standards III, IV, and V were further developments of Standard II; increasing proportions of strontium sulfide over calcium sulfide in the basic material were used with each type, Standard V using no calcium sulfide at all. This change in base shifted both the emission and stimulation spectra to shorter wavelengths (see Figure 1), thus increasing the sensitivity for the scotopic eye. Because of this and other improvements, Standard V showed a 10-fold increase in sensitivity over Standard III.

In addition to varying the basic materials, different fluxes were tried. Pure strontium sulfide bases at first appeared to have the inherent disadvantages of possessing a very strong afterglow. However, careful variation of fluxes and firing conditions finally led to a suppression of the background sufficient to allow the use of pure strontium sulfide as a base. This was achieved with Standard V.

4.2.2 Standard VI

Simultaneously with the development work on Standards III through V, attempts were made to create new types of infrared-sensitive phosphors by

changing the activators. This led to the observation that the rare-earth phosphor was one of a large class in which two main activators interact to produce a sensitivity to stimulation by infrared light which neither of the activators would produce if used alone. Although interaction of activators was known before, it had never been found to produce infrared stimutable phosphors. It was found that an emission spectrum produced by the presence of one activator, the *dominant*, could be sensitized for the stimulating

as to the ease of excitation with incandescent light. And no auxiliary activator was found that gave longer wavelength stimulation than samarium in alkaline earth sulfides. *Standard VI*, the first IRS phosphor used in service, was therefore composed of a strontium sulfide base like that of *Standard V*, and a samarium-europium activator combination proportioned for maximum sensitivity.

Several problems arose at this time in regard to the mechanical properties of the phosphors. Calcium fluor-

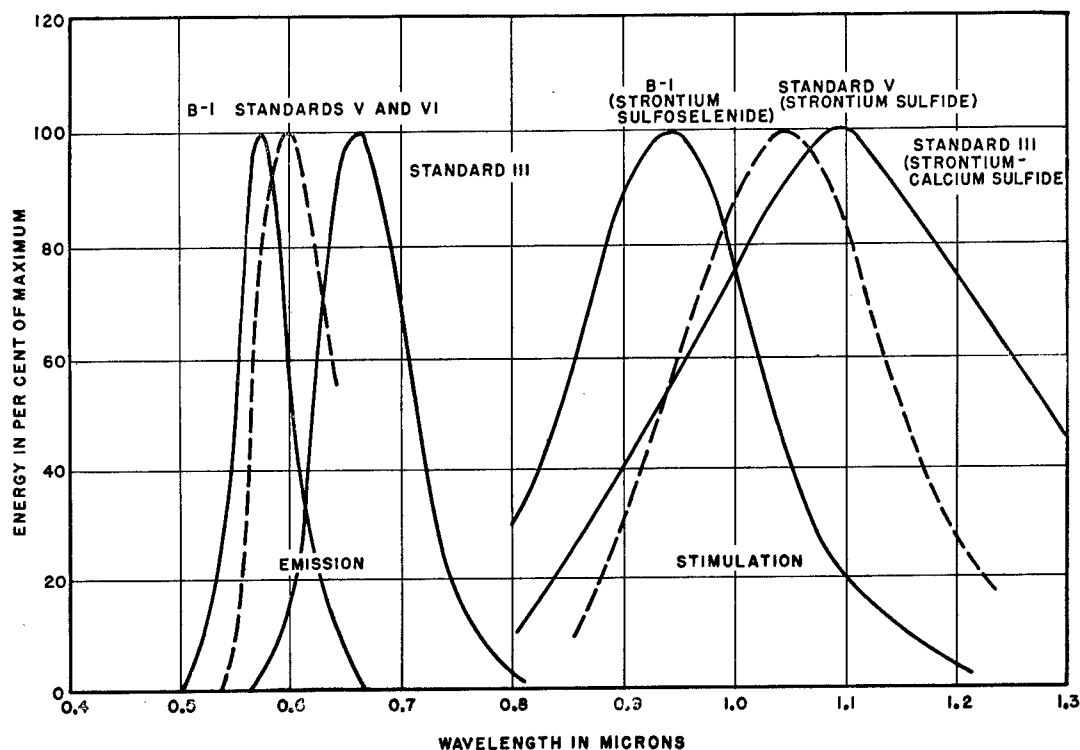

FIGURE 1. Spectral characteristics of phosphors with same activators but with different bases.

action of infrared radiation by the presence of a second *auxiliary* activator. While the spectrum emitted upon stimulation is determined by the dominant, the spectral distribution of sensitivity to stimulation is in most cases controlled by the auxiliary activator. Figure 2 is an illustration of this effect, showing emission and stimulation spectra of three phosphors with the same base and same auxiliary activator, samarium, but with three different dominant activators, cerium, manganese, and europium.

Since it would take many years to investigate all the possible activator combinations, a systematic search for the best possible pair was out of the question. No dominant activator was in prospect and none was found thereafter which could match europium

ide fluxes produced particularly hard phosphor cake whose luminescence was nearly destroyed, however, when the cake was ground to a fine powder. Whether *regenerated* by cautious reheating of the powder, or regenerated in place on the desired support, no satisfactory results on sensitivity were obtained and the resolving power of the surfaces was poor.

Buttons made from the original powdered cake under fairly high pressure were reheated beyond the softening temperature to cause the grains to coalesce and form a smooth surface. Thus, since not as much light was lost by scattering from cracks and fissures, more radiation could penetrate the phosphor and more sensitivity could be gained, as well as a greater resolving power. This process introduced some new

difficulties. Bubbles or cracks in the surface appeared, mainly because of a carbonate content in the phosphor. Spots showing a disturbingly bright afterglow were also seen; these turned out to be caused by traces of copper and were eliminated by extreme caution in the

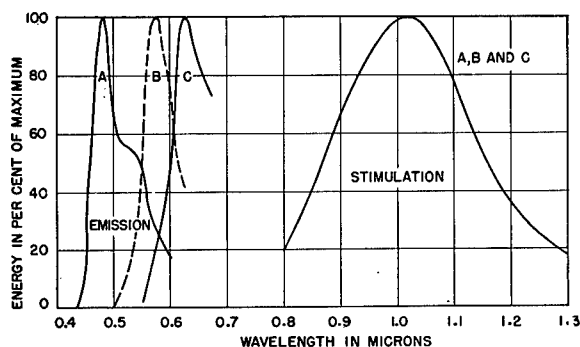

FIGURE 2. Spectra of three phosphors with same base and auxiliary activator. A. Standard VII, dominant activator cerium. B. Dominant activator manganese. C. Standard VI, dominant activator europium.

preparation and handling of the materials. Another problem was that the buttons appeared to contract during heating, so that the desired precision surfaces could not be obtained. Initially, wet grinding with alcohol and acid was used to compensate for this, and later a dry grinding procedure was devised.

After a great deal of trial and error, smooth precise buttons of a brightness comparable to that of the original phosphor cake, or even better, were obtained. The resolving power of these grainless surfaces, however, was still poor. The reasons for the low resolving power seem to be quite complex and have never been satisfactorily explained. It was assumed that the sharpness would be improved if the formation of the image was confined to a thinner layer, and appreciable gain in resolving power was obtained when this was accomplished. This was the last essential change in the formulation of Standard VI.

Threshold sensitivity and resolving powers were the main problems in the development of Standard VI. The peak of the emission band, still at an unfavorably long wavelength, was the best that could be obtained with this type of phosphor. The peak of excitation around 5,000 Å made it possible to excite with a filtered incandescent light, and the infrared sensitivity with peak about 1.02 microns, gradually tapering off towards longer wavelengths permitted the use of infrared filters excluding all visible light but at the same time making full use of the infrared sensitivity of the phosphor. Figure 2 shows the emission and

stimulation spectra and Figure 3 the excitation spectrum of Standard VI compared to those of some other phosphors.

The infrared sensitivity of Standard VI, as determined by threshold measurements, reaches a maximum a few minutes after the excitation is removed, due to the fast decay of the background and the relatively slow decay of the stimulability (see Figure 4). After a maximum is reached, the threshold sensitivity decreases slowly, as shown in Figure 5, with the stimulability obtained after one-half hour being still more than half that obtained after one minute. The best surfaces showed maximum sensitivity of 10 nautical-mile-candles⁸ (defined in Chapter 3). The rate of exhaustion by infrared light is relatively slow, with the useful light sum one or two microlambert hours.

In selecting a suitable combination of filters for excitation of Standard VI, it was necessary to cut out radiation below 0.44 micron, which increases the background, and above about 0.55 micron, which decreases the sensitivity because of a stimulating effect. Although the quantity of light required for the excitation

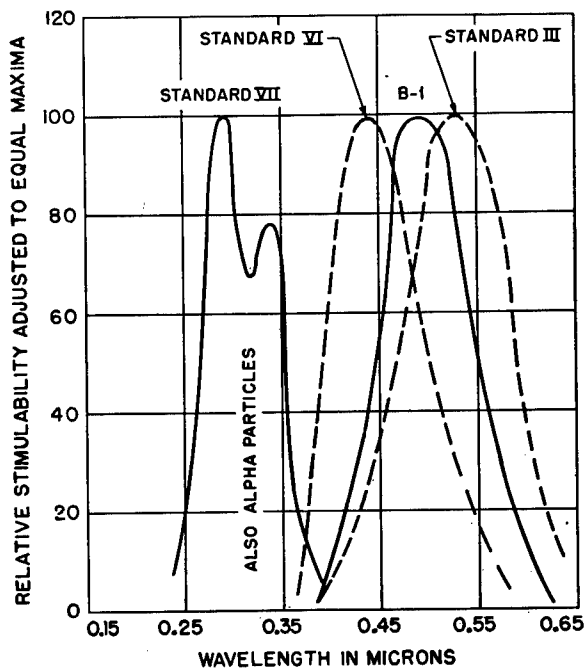

FIGURE 3. Excitation spectra of several phosphors. The curve for B-1 is a very rough approximation.

of a fully exhausted sample is quite large, the amount needed to re-excite a partially exhausted sample is small. This is further discussed in Section 4.5. Preliminary measurements showed that both the inertia and time lag of Standard VI were negligible. Me-

chanical properties were satisfactory, although the phosphor had to be protected from moist air by enclosure in a chamber containing a drying agent, silica gel. Quantum efficiency, which should be one in a perfect phosphor, was low in Standard VI since of every

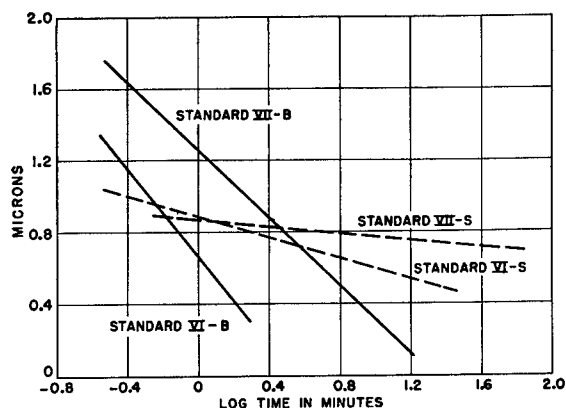

FIGURE 4. Comparative decay of background and stimulability with time. B, background; S, stimulability. The decay of stimulability and background of B-1 lies between VI and VII.

300 incident infrared quanta, only one was converted into visible light. This was a great improvement over Standard III, however, which has a $1/700$ ratio.

Tentative studies of zinc sulfide phosphors with copper and manganese activators were made, and a few tests of the alkali halides conducted. An attempt to excite both pure and activated alkali halides by X rays, cathode rays, and ultraviolet-spark sources showed cases of fair sensitivity to infrared, but none was regarded as promising enough to warrant further investigation. The results were not wholly discouraging because the threshold sensitivity of some potassium chloride and sodium bromide preparations was of the same order of magnitude as that of a fair europium samarium sulfide phosphor, although the total light sum was very small. Other attempts made with barium or magnesium sulfide showed little success.

4.2.3

Standard VII

The next phosphor to be successfully developed was Standard VII. Since samarium seemed to be by far the most satisfactory auxiliary activator in the strontium sulfide base, giving a strong sensitivity at the longest wavelength (tin and bismuth are very effective in producing stimulation, but the wavelength is too short), it was retained. The choice of the dominant activator was made on the basis of numerous experiments which tried to match most closely the emission spectrum with the spectral sensitivity of the scotopic

eye. Cerium was chosen because of its very suitable green emission (Figure 2). The cerium samarium phosphor thus produced proved to be about ten times more sensitive than Standard VI if excited with ultraviolet light and if a sufficiently long period was allowed between excitation and stimulation (Figure 5). More important, it was found that Standard VII was also excitable with alpha particles from radium, a comparatively rare occurrence in a phosphor of this type, becoming then even more sensitive than with ultraviolet excitation, and allowing a source to be inserted in the same chamber as the phosphor. If suitable filters are provided, daylight excitation is another promising possibility.

It was necessary to find a new technique for making buttons, since that used with Standard VI was not suitable for the new phosphor, which is chemically much

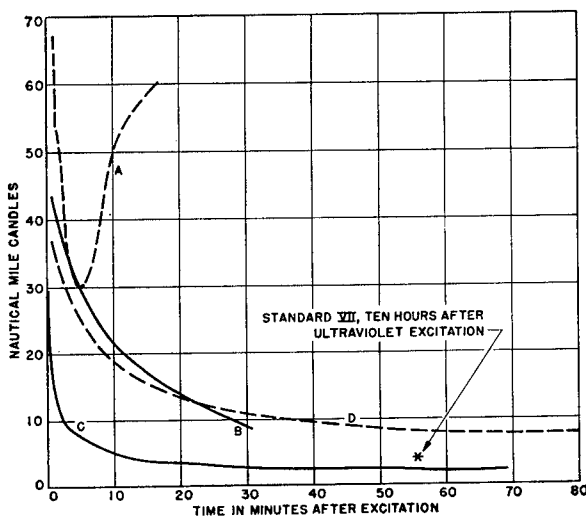

FIGURE 5. Threshold sensitivities of various phosphors in Type A metascope. A. Early sample of Standard VII. B. Standard VII, ultraviolet-excited. C. Standard VII, radium-excited. D. B-1.

more sensitive. A method of spraying a crushed powder on a carbon backing and regenerating in place was developed for Standard VII.

The properties of Standard VII are much more favorable than those of Standard VI. Although the background of VII is very strong immediately after excitation, it decays within a few hours to a suitable level, while the infrared sensitivity decays very slowly during this time. Figures 4 and 5 show this effect for several phosphors, with threshold sensitivities defined in terms of nautical-mile-candles (nmc). The best surfaces showed sensitivities of 0.6 nmc.⁸ A very large light sum is obtained; under infrared illumination

the phosphor emits several microlambert hours before its sensitivity drops to one-half of its initial value. Quantum efficiency is about 1/300 after ultraviolet excitation. Resolving powers obtained with Standard VII surfaces are better than those of Standard VI. Again, the phosphor is sensitive to humidity and must be protected with silica gel. The infrared sensitivity of Standard VII is nearly independent of temperature from -70 to 85 C; at temperatures greater than this it drops rapidly.

A third activator added to cerium and samarium showed no improvement, although perhaps the addition of lead makes it easier to obtain reproducibility.

To suit a particular application, an attempt was made to obtain fine powders of good sensitivity. The addition of magnesium carbonate or magnesium oxide combined with a regeneration process yielded fine powders that could easily be painted on any surface. In such a form the phosphor is called Standard VII-b, and sensitivities reached with this powdered phosphor excited by daylight are comparable to those found with radium-excited molded buttons.

4.2.4 Selenide Phosphors

It was suggested that selenides, or a combination of sulfides and selenides, would make satisfactory basic materials. Two laboratories started work on this problem after the development of Standard VI, using the activator combination of that phosphor: europium and samarium. Emission peaks were found to shift into the yellow when a combination sulfoselenide was used, but for some time the sensitivity was unsatisfactory compared with that of Standard VI. If the mixture contained a sufficient predominance of sulfide, the sensitivity was about that of Standard VI, but the red color of emission was also approximately the same, and there was no net gain in sensitivity. Further work, however, showed that a phosphor of remarkably high sensitivity (B-1) could be made when the proportion of selenide was greater than 80 per cent, with a favorable yellow emission.

Although many other activator pairs were tried, none came even near to the high infrared sensitivity of the europium-samarium combination. Bismuth was second to samarium as an auxiliary, showing less shift to shorter wavelengths in a sulfoselenide than in a pure sulfide base. In a bismuth-samarium combination, it appears that bismuth largely determines the stimulation in both sulfide and selenide bases.

An investigation of a group of bases containing the

four ions of calcium, strontium, selenium, and sulfur was carried out, confirming the hypothesis that the combination containing mainly strontium selenide is the most favorable.

As in the transition from Standard II to Standard VI, the transition from VI to the selenide phosphor B-1 involves a change of base and achieves an advantage of a further shift of emission toward shorter wavelength (Figure 1), accompanied by a shift of the stimulation

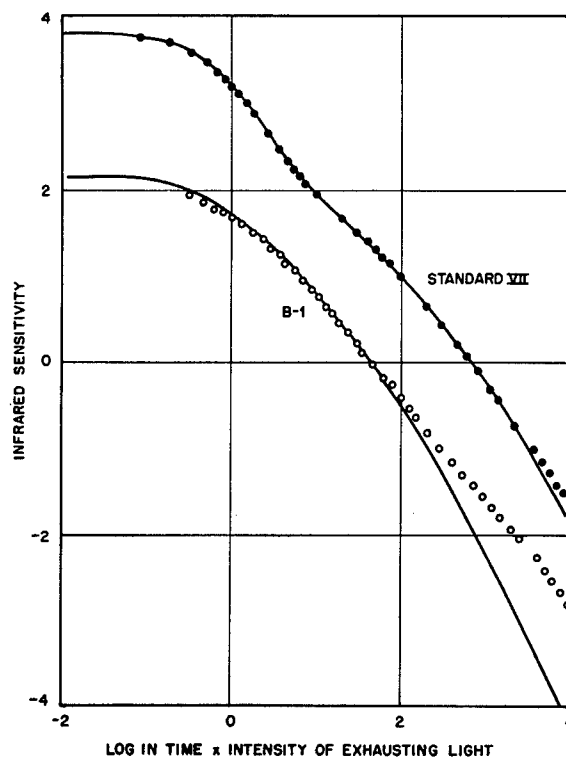

FIGURE 6. Phosphor decay with exhaustion. Dots, experimental points; solid line, calculated curve.

and excitation bands to shorter wavelength in an unfavorable direction, though not seriously so. The B-1 phosphor, like Standard VII, has a rather high background which becomes negligible after about one-half hour, more slowly than Standard VI but more quickly than Standard VII. The sensitivity is stored for periods of days and the useful light sum is very large (Figure 5). Best surfaces showed sensitivities of 1.5 nautical-mile-candle.

Figure 6 is a graph of the exhaustion curves, or the decrease of sensitivity with the amount of infrared stimulation of the practically important standard phosphors. The fact that in both Standard VII and B-1 useful light sums of several microlambert hours are available is one of the most important features of

the infrared phosphor development. These large light sums permit long-continued use with intensities occurring in signaling; even accidental strong over-exposures will affect the performance only in exceptional cases.

Excitation of B-1 is effected by a broad band in the visible and very near the ultraviolet. It extends from about 4,200 to 5,400 Å and is practically zero at 3,800 and 6,200 Å. The total amount of incandescent light needed to produce full excitation is somewhat larger than that for Standard VI, but the danger of "over-exposure" by too high exciting intensities that exists with VI is negligible in B-1. The stimulation of B-1 has a peak at 0.93 micron with a half-width of about 0.2 micron, and the emission peak at 0.57 micron is in a favorable position. If equal numbers of emitted quanta are considered, an evaluation of the emission bands in terms of scotopic vision yields relative values of 1, 10, and 25 for Standard VI, B-1, and Standard VII, respectively. Quantum efficiency is roughly the same as in Standards VI and VII.

B-1 has one serious disadvantage. Preparing, handling, and protecting the selenides from the atmosphere is much more difficult than with the sulfides; the finished surfaces must be protected with a ceresin wax coating. This may contribute to the relatively low resolving power of B-1. In addition, there is a considerable inertia of the infrared response at low infrared intensities.

The threshold sensitivity reached with the B-1 phosphors was much higher than that obtained with Standard VI, but did not quite reach that obtained with Standard VII.

4.2.5 Zinc Sulfide Phosphors

An extensive search for stimuable phosphors sensitive to longer infrared wavelengths yielded no useful results as far as field use was concerned. Even if the stimulation peak was pushed to the desired longer wavelengths, the sensitivity at that wavelength was still less than that of Standard VII.

Preliminary observations of several thousand zinc sulfide phosphors showed that the most sensitive ones were those activated with copper and manganese. An infrared-sensitive phosphor with copper and terbium as activators has a red stimulated emission; in both the copper-terbium and copper-manganese types the color of the afterglow is different from that of the stimulated emission, and the latter is less favorable to the scotopic eye.

However, more promising results were obtained when a large amount (as much as 6 per cent) of the single activator, lead, was used. The emission is blue-green and very favorable for scotopic vision. Second to lead, lanthanum and gadolinium produced good sensitivity. In no case did the sensitivities of these zinc sulfides reach that of Standard VI. If a very small amount of another activator, copper, manganese, lanthanum, or gadolinium, was added as an auxiliary to

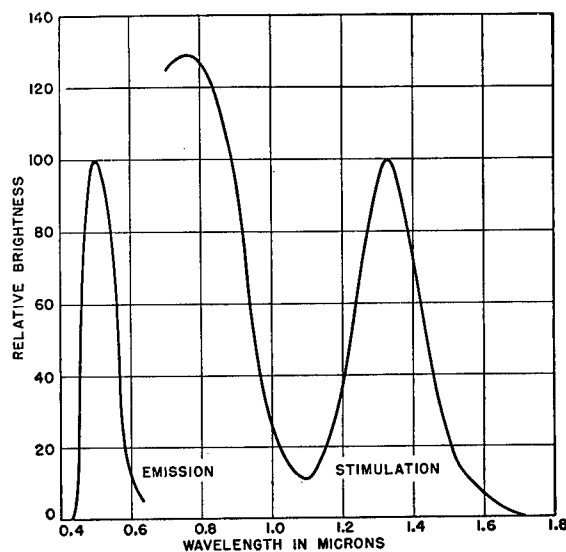

FIGURE 7. Emission and stimulation spectra of zinc sulfide copper lead phosphor.

the dominant lead, better phosphors were obtained. With the best zinc sulfide materials, careful preparation, and appropriate heating cycles, an optimum of sensitivity was found with 4 to 7 per cent lead sulfate and 1 to 10 micrograms of copper per gram of zinc sulfide. Figure 7 shows the emission and stimulation spectra of a typical zinc sulfide lead phosphor.

The optimal copper concentration depends on the use to which the phosphor is put; if observation shortly after excitation is desired, the lower copper concentrations are more favorable. Highest threshold sensitivities were obtained with concentrations of 3-10 ppm of copper and waiting periods of several hours after excitation, to allow the very bright background to decay. Under these conditions thresholds comparable to those of Standard VI were obtained, so that these phosphors were suggested for use in practical tests. Results of these tests were very disappointing and by no means confirmed the laboratory data. The discrepancy was explained by the fact that in the field a moving instrument was used, while in the laboratory

everything was stationary. These phosphors show a strong inertia to stimulation which naturally affects the field tests more unfavorably. This effect becomes more and more pronounced the longer the waiting period after excitation.

These phosphors were so near to practical usefulness that more complicated procedures were tried for their operation in the field. One method was to heat the phosphors immediately after excitation so as to remove the background in a short time, but this produced the same inertia effect as waiting. Operating the phosphor at low temperature did not yield any particular improvement. An important experiment was made that showed promise: If a sample is excited at the temperature of liquid nitrogen and stimulated at that temperature with radiation beyond 1.0 micron and then warmed to room temperature, the sample shows no appreciable background while its sensitivity is as high and its light sum as favorable as that obtained with normal excitation. However, this has the same obvious objection for field use as that which applied to Standard I.

The stimulation spectra in zinc sulfide phosphors are very different from those in the strontium sulfide or selenide groups. All zinc sulfide phosphors seem to show infrared sensitivity with one stimulation peak between 0.6 and 0.8 micron, and many of them show a band with a peak at 1.32 microns, which is the one desired. It has been found that numerous manganese phosphors show only the first of these bands and that the addition of cadmium sulfide decreases the sensitivity of the long wavelength band. Magnesium chloride and lithium fluoride fluxes used with heating temperatures less than 1000 C also suppress long wavelength stimulation while zinc orthophosphate and high muffling temperatures develop it. In addition, there are some indications that the long wavelength band has something to do with the presence of copper.

At low temperatures, the stimulation spectrum of zinc sulfide phosphors seems to change considerably; the two bands are replaced by one broad band with the peak between the two room-temperature peaks but extending less far into the infrared than does the separate 1.32-micron band.

Other interesting effects have been noted with the zinc sulfide phosphors. While the spontaneous emission or afterglow of the zinc sulfide copper-lead phosphors can be represented by a straight line in a log-log plot, the stimulated emission yields a straight line on a semilog plot, indicating an exponential monomolecular decay. The spontaneous emission is mainly

determined by the copper, and the stimulated emission by the lead.

Simple theoretical considerations indicate the possibility of obtaining response at much longer wavelengths by reducing the temperature; therefore a comprehensive survey was made with several hundreds of phosphors. While peaks of infrared response were found up to 1.8 microns and appreciable tails to at least 2.5 microns, the absolute sensitivities were so low that even the most efficient cold phosphors, particularly the selenides, were less efficient up to 1.4 microns than any good standard infrared phosphor. Beyond this limit, the sensitivities may be better with the cold phosphors, but they are still far too low for military use.

A search for new bases achieved little success. Lanthanum oxysulfide phosphors showed infrared sensitivity with lead-europium and indium-lead pairs; zinc germanate activated by the addition of tin and manganese oxides showed quite high stimulability but very bright backgrounds. Zinc orthophosphate phosphors with lead, and magnesium and barium silicate phosphors with europium and samarium were also investigated, but none of these seemed promising enough to warrant further development at the time.

4.3 CHEMICAL AND MECHANICAL PREPARATION OF PHOSPHORS

4.3.1 Purity of Materials

If phosphors of long duration are desired, and particularly if attention is given to details of their light storage (response to infrared radiation), the requirements on the purity of the materials which make up the phosphors are even higher than those for fluorescent and cathode-luminescent materials.

Thus far, the only phosphors of practical value for infrared detection have been prepared with alkaline-earth sulfides and selenides as bases. Nearly the only information on the synthesis of highly sensitive phosphors of this type is that contained in the papers of Lenard and his pupils. In these papers, the prescriptions given for the synthesis of a particular phosphor very often contradict one another and often are not repeatable by another group. Nor are some general statements made by the Lenard group to be trusted as final and absolute. For example, there is the statement that in sulfide phosphors the presence of sulfate in quantities as high as 80 per cent is not significant. This was shown to be false before the present work

began and has become more evident as the work continued. Cationic as well as anionic impurities are of the greatest importance, as they may act as additional activators and change the whole characteristics of the phosphor.

By proper purification and handling, it is possible to free a phosphor material from impurities to a higher degree than even spectroscopic methods can discern. This is necessary because anionic impurities may influence results in quantities as small as 100 ppm, and cationic impurities in quantities of 10^{-2} ppm. Details of purification of the materials used are not given here, but can be found in references 8 and 9 in the bibliography.

4.3.2 Influence of Fluxes

One important purpose of a flux in a phosphor is to allow the basic material to flow into a definite matrix in which the activators are embedded in a certain crystal structure. It has been found, however, that the chemical reactions that take place between the base and flux can also be of the greatest importance.

Previous mention has already been made about the influence of flux and heating cycle on the background. Further advances were made at the very beginning of the investigation of the selenide phosphors. The first preparations used a selenide base that had been obtained from the reduction of selenite, and fluxed with strontium sulfate and calcium fluoride. It was found that, when the sulfate in the flux was replaced by sulfite, better results were obtained. The sulfite apparently formed some sulfide as well as an oxygen ion and free selenium. The selenium was not desirable, but evaporated at the fluxing temperatures used, while the presence of strontium oxide and strontium sulfide in small amounts materially increased the sensitivity of the phosphor. It was finally found that the addition of both sulfide and sulfate to the flux produced the necessary ions and the best resulting matrix. Addition of the sulfate also makes the material adhere more strongly to a graphite base and increases the absorptivity of the phosphor film.

4.3.3 Preparation of Standard Phosphors

STANDARD VI

The first infrared-sensitive phosphor to be used extensively was prepared by methods much cruder than those used for the later production of Standards VII and B-1.

Strontium carbonate is slurried with water, dosed with solutions of samarium and europium to yield concentrations of approximately 200 ppm of each gram of strontium carbonate, and dried. The carbonate is mixed with $\frac{3}{8}$ of its weight of distilled sulfur, placed in a 120-150 ml covered platinum dish and heated in a gas furnace at 1200 to 1250 C. This charge is heated for 12 to 15 minutes depending on its size, with a stream of hydrogen sulfide or nitrogen laden with carbon disulfide vapor continually passing into the furnace.

To flux, a mixture of 100 parts of the now activated strontium sulfide, 40 parts distilled sulfur, and 6 parts of chemically pure calcium fluoride, is fired as before at 1000 C for 30 minutes. The phosphor product is then ground to pass a 60-mesh silk screen and stored until needed.

A button is made by first grinding the fluxed phosphor to pass a 200-mesh screen. Then the requisite amount of material is pressed into a capsule to form a cone-shaped heap, and the capsule is tapped to distribute the powder in a symmetrical mound which is molded to the desired shape by an iron mold. This is placed in a cold gas furnace and heated to 990 C. The furnace is allowed to cool to 250 C and the capsules removed; a stream of nitrogen is passed through the furnace during both heating and cooling. Buttons so formed are further processed by lapping to precise shape by means of a ground-glass mold and dilute acid. An extension of this method made use of mechanical grinding on a lathe with an Alundum grinding wheel of proper curvature.

This method of forming buttons has been superseded by the high-pressure technique used with B-1 and Standard VII, and finally by the use of regenerated fine powders of high sensitivity painted onto the desired surfaces.

B-1

One thousand grams of strontium selenide, 75 grams of activated calcium fluoride, 75 grams of strontium sulfate, and 50 grams of strontium sulfide are screened through 150-mesh silk, mixed in a mortar and milled for 2 hours in a ball mill. This mixture is then stored in paraffin-stoppered bottles until ready for use.

The B-1 powder mixture is molded in a Loomis hydraulic press at 16,000 to 20,000 pounds. This mold is made of a pressure-molded slab of ignited chemically pure magnesia, so constructed that when fired the button conforms to the dimensions required for use. The molded button is finally fired in a quartz

tube in oxygen-free nitrogen for exactly 10 minutes. Protection of the button is achieved by dipping in ceresin wax.

STANDARD VII

Two hundred and eighty grams of strontium sulfide, 28 grams of chemically pure magnesia (ignited in air at 1050 C), 13.4 grams of activated lithium fluoride, and 28.5 grams of strontium sulfate are screened through 150-mesh silk, mixed in a mortar and milled for an hour and a half. The powder mixture is placed in covered platinum boats of 80 to 85 grams capacity and fired in pure nitrogen at 1050 C for 30 minutes; cooling is also accomplished in the nitrogen atmosphere. The product, after inspection for abnormalities, is ground in a porcelain mortar to about 16 mesh and then milled for 2 hours. After screening through a 300-mesh silk, the powder is bottled and stored in a desiccator.

A thin coating of Standard VII powder is applied to a graphite button (grade C-15, National Carbon Company) of the proper radius of curvature, by first suspending the phosphor powder in a solution of methyl methacrylate in ethylene chloride and then paint-spraying the suspension onto the graphite buttons. After drying, the buttons are fired in an air-free nitrogen atmosphere; they are placed on steel trays and inserted into a quartz muffle, heated to 860 C and kept at this temperature for 20 minutes. They are cooled under nitrogen and then inspected for faults.

4.4 METHODS OF MEASURING PHOSPHOR CHARACTERISTICS

In order to secure complete information about a particular phosphor, many different quantities must be measured. Of these the most important are (1) the stimulability; (2) the infrared *sensitivity*, defined as the reciprocal of the infrared illumination required to produce a just detectable bright spot on the phosphor, or threshold sensitivity; (3) the background or afterglow; (4) the spectral characteristics; (5) the resolving power; and (6) the inertia and time lag.

4.4.1 Qualitative Observations

For nearly every phosphor the most important measurement is that of stimulability. Such a test gives at once a good idea of the value of the phosphor for infrared detection, and in many cases a direct measure of its infrared sensitivity. In most cases a qualitative

inspection under an incandescent lamp with various infrared filters was made, varying the intensity of infrared by the distance from the lamp, and using various waiting times after excitation. When enough intensity and duration of infrared illumination was used, indications of the brightness and behavior of the afterglow and of the useful light sum were also obtained. These qualitative tests were usually made in conjunction with some standard; very frequently a whole set of preparations, differing in one well-defined respect such as flux, activator concentration, or heating cycle, were observed simultaneously. Crude threshold comparisons were made with a weak infrared illumination if preparations of strongly differing background were compared.

If more than usual importance was attributed to some preparation and if its reproducibility was regarded as well-defined, its infrared stimulability was quantitatively measured, as later described.

In many cases, it was necessary to obtain a general idea of the spectral distributions of emission, excitation, and stimulation of a phosphor as well as of the quenching spectrum. Emission spectra could be observed either visually or photographically with a high-aperture spectroscope. This was particularly useful for the recognition of different coexistent bands, or line emission superimposed on broad emission bands.

Excitation spectra are very important since knowledge of these must be obtained before proper excitation of the phosphor for infrared sensitivity tests can be accomplished. The standard arrangement for this purpose consisted of a spectroscopic device, projecting the spectrum of a suitable light source (carbon arc, spark, mercury arc) on a phosphor spread in the horizontal plane of the spectrum. An infrared light source was frequently arranged above the phosphor and in some cases a small direct-vision spectroscope was used so that the emission spectra produced by different exciting wavelengths could be observed. Experiments made with the phosphor spread on a heating tray, so as to permit observation at different temperatures, gave perhaps the most comprehensive information available with qualitative observations.

Stimulation spectra and quenching in the visible and infrared region were also observed by means of a spectrum projected on a phosphor. Although infrared stimulation was desired throughout this work the stimulation bands were by no means confined to this region. In order to make the extinguishing effects (stimulation or quenching) of various wavelengths plain, an infrared light source was arranged so as to

make possible an even flooding of the phosphor with infrared light after an exposure to the spectrum. This is in many cases the most sensitive means for detecting weak stimulation or quenching.

4.4.2 Measurements

THRESHOLD

Much time was spent in the development of a method of measuring threshold which would give

exhaustion, and absorption spectra, and, with slight modifications, for nearly any determination that required high precision or monochromatic light. Many of these measurements had to be carried out at very low intensity levels, since it was necessary to maintain the phosphor in very nearly the same state of excitation throughout a series of measurements. In the determination of a stimulation spectrum, for example, it is permissible to measure the whole spectrum with

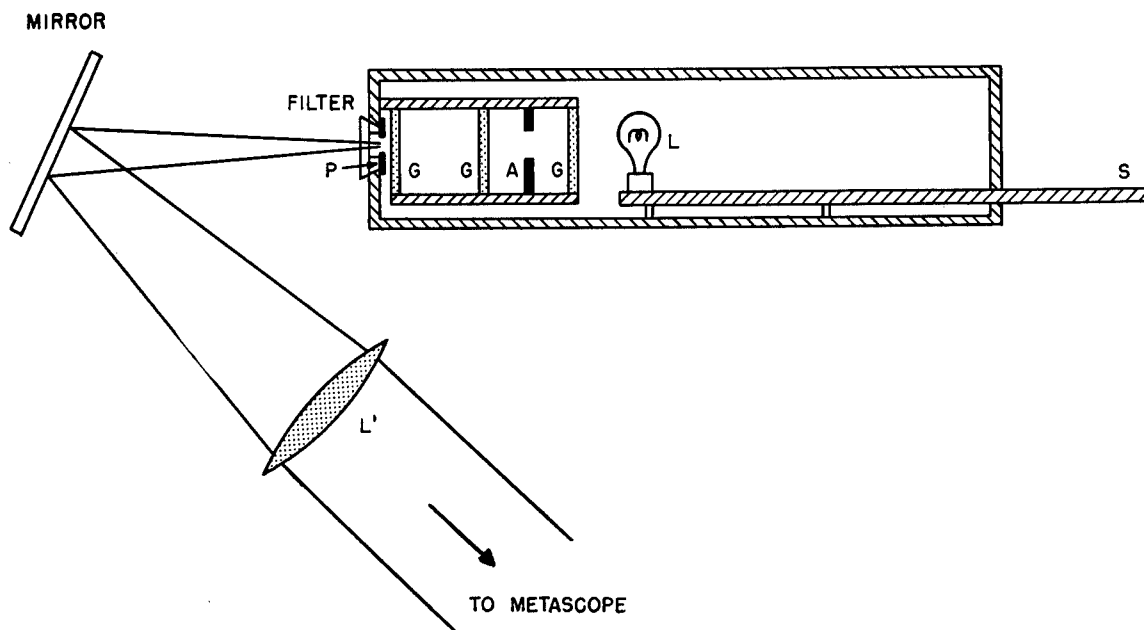

FIGURE 8. Light source for threshold measurements. *P*, metal plate with set of calibrated pinholes; *L*, 10-watt lamp; *G*, ground glass; *A*, aperture; *S*, movable meter stick.

reasonably consistent results and would agree with tests made under the conditions of practical use. None of the arrangements developed was considered by all workers as wholly satisfactory. Much of the difficulty was caused by the fact that a device with an aperture similar to that of the Kellner-Schmidt system (see Chapter 3) was desirable. In such a device the focusing is very critical, and the thresholds obtained are sensitive to the focusing. Since threshold determinations are necessary for all phosphors which are seriously considered for practical use, and are therefore obtainable in button form, the use of a metascope (Chapter 3) and a properly illuminated pinhole is very helpful. This device is shown schematically in Figure 8.

SPECTRAL MEASUREMENTS

Figure 9 shows the method that was used for the determination of excitation and stimulation spectra,

one single excitation only if the first measurement can be repeated at the end of the series with the same result as at the beginning. Another reason for the need for highest sensitivity is the desire to make the measurements at the intensity level at which threshold observations take place. Thus the sensitivity of the measuring arrangement should be such that a just detectable brightness of a fairly small phosphor sample can be measured without great difficulty.

The desired sensitivity was achieved by using a photocell in conjunction with the FP54 electrometer tube amplifier. A current sensitivity of 10^{-17} ampere was used in extreme cases with fair stability. High-aperture mirrors collected the light from the phosphor and cast it on the photocell; in the most favorable arrangements, more than 50 per cent of the light flux emitted by the phosphor was collected on the photosensitive surface. By these means, the emission of a phosphor of any color could be measured conveniently,

although it might be absolutely invisible to a well-dark-adapted observer.

With the exception of extreme cases, sufficient sensitivity could be reached by the use of multiplier phototubes. For measurements in the red and infrared regions, cesium phototubes were used with a Vance amplifier.

Direct absorption measurements on the phosphor powders by determination of their transmissions are difficult to carry out and not simple in their significance. Measurements were therefore made of diffuse reflectance, permitting the calculation of the ratio of the coefficients of absorption and scattering. Within the wavelength ranges concerned, the scattering is regarded as constant, and thus the ratio is proportional to the absorption coefficient.

Monochromator-photocell arrangements were again used for emission spectra measurements, with provision made for alternating excitation and stimulation while measuring the stimulated emissions. Photo-

RESOLVING POWER

For practical reasons it was necessary to make some kind of resolving power tests. Initial experiences showed that a really thorough investigation of this problem would require very much effort and manpower, for simple procedures proved to be extremely unreliable.

A statistical method was used at one of the laboratories with good success. The objects to be resolved were two pinholes illuminated in a manner similar to that used for the pinhole in the threshold-measuring apparatus. A set of small brass plates, each with a pair of small pinholes, was constructed with the distances between holes chosen so as to make the corresponding values of the angular separation go from 10 to 30 minutes of an arc in steps of 2 minutes. To this set was added a few similar plates which had only one pinhole. All of the pinholes in the plates were of the same size. To make a measurement, the plates were shuffled to give a random order and then placed

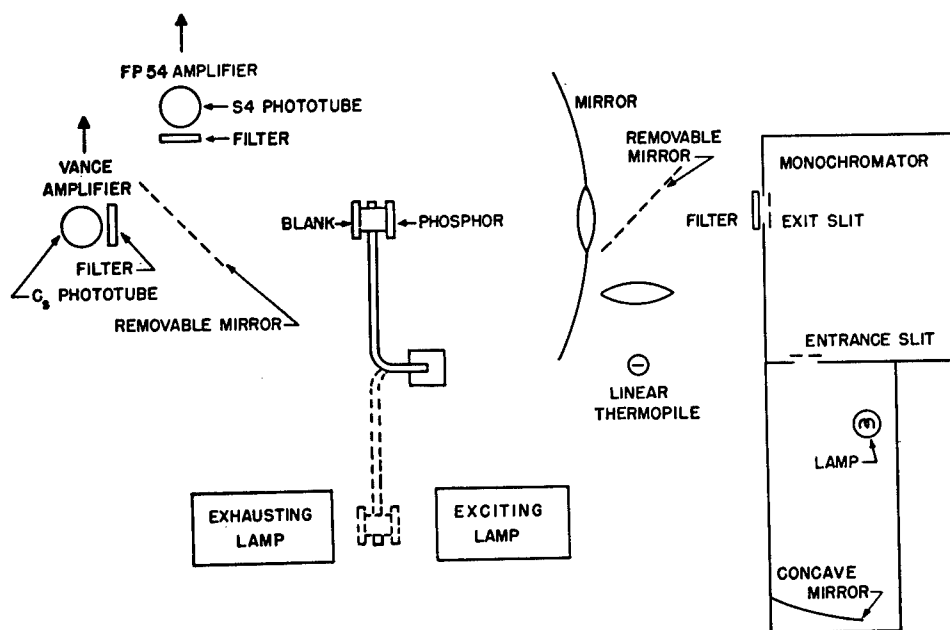

FIGURE 9. Monochromator and FP54 setup.

graphic methods for quantitative determination of emission spectra with the usual methods of photographic spectrophotometry were also used for this purpose. With both of these methods, the emission spectra of background as well as those of stimulated emission were investigated, the photographic method proving superior for weakest emissions.

in position and observed (with the placing of the plates done by someone other than the observer whenever possible). The observer then described the image as single or double as it appeared to him. If he called all plates above a certain separation double and all below it single, the measurement was considered valid and the separation recorded as the limit of resolution.

A photographic method was used to determine graininess as well as resolving power. An infrared image of an evenly illuminated slit 1 millimeter wide and 100 millimeters long was projected on a phosphor through an infrared-corrected microscope objective by means of a vertical illuminator. The visible light emitted by the phosphor was projected by the same microscope onto a photographic plate sensitive to the phosphor emission but not to infrared. This image, which should be geometrically identical with that of the original slit, was quite diffuse and showed the graininess of the early phosphors very well. In order to obtain a measure of the sharpness independent of the exposure time, a steep neutral wedge was placed in contact with the photographic plate with its maximum gradient parallel to the slit image. With weak and short infrared exposures and re-excitation between exposures, photographs were obtained showing an approximately triangular isodensity contour. The steepness of the triangle is a measure of the sharpness or resolving power, and allows quite small differences in resolving power to be detected. Unfortunately, the correlation of these measurements with practical resolving powers has not been investigated.

SENSITIVITY

The gradual decrease of sensitivity under continuous infrared illumination has been investigated for both its practical and theoretical importance. Although the obvious subject to investigate is the brightness as a function of time under constant infrared illumination, such a measurement is difficult because of the very large ranges of sensitivities to be covered with most phosphors if anything approaching full exhaustion is to be reached. Since it was thus desirable to change the infrared intensity during the progress of exhaustion, an investigation was carried out that showed that a reciprocity law for the effect of time and intensity of infrared radiation holds, making possible the piecing together of sections taken at different infrared intensities into a single exhaustion curve.

In these measurements the infrared emission was obtained and plotted as a function of time representing the law of exhaustion. For theoretical reasons, it was also desirable to obtain the plot of infrared sensitivity against the light sum or against absorption. If the exhaustion is carried out properly, this plot can easily be obtained from experimental data. In some of these experiments, the effective intensity was increased gradually in a known manner; and sometimes

a simultaneous measurement of infrared reflectivity of the phosphor and the visible emission was carried out while the exhaustion was proceeding.

Along with these quantitative investigations of the processes of stimulation, a quantitative study was made on the release of stored light by thermal energy. The measurement of emitted brightness during a gradual increase in temperature was carried out for a number of cases, with automatic recording of the brightness and temperature. Spectral sensitivity of the photocell used for brightness measurement was flattened to such an extent that it could be regarded as an energy-measuring device. For the comparison of stimulated and thermoluminescent emission, the two experiments were carried out on the same apparatus.

TIME LAG

Delays in the visible response of an IRS phosphor to an abrupt beginning or ending of a period of infrared illumination are closely connected, and if they are too long they become an important setback to the practical use of the phosphor. These delays are disastrous in the zinc sulfide copper lead phosphors, quite pronounced in B-1, and still observable in Standard VII. Measurements on Standard VII have been made by four methods: (1) the observation of the flicker limit obtainable; (2) an oscillographic investigation; (3) a series of phosphoroscopic investigations; (4) direct decay measurements of the slow component of the time lag. With B-1 some direct measurements of the inertia were carried out. The complexity of this part of the subject is so great that no attempt will be made to describe it further here; details may be obtained from the contractors' reports listed in the bibliography.

4.5 GENERAL THEORY AND ITS APPLICATION TO PRACTICAL PHOSPHORS

Although the theory of IRS phosphors is still in its infancy, it is necessary for further development to understand at least the simplest parts of the proposed theories. This section is included for the purpose of making clear the fundamental reactions that are responsible for the characteristics of phosphors, as far as they are known at present.

4.5.1 Exhaustion Curves

From a theoretical point of view, probably no single piece of information on the IRS phosphors is as interesting as are the exhaustion curves. Since it had

been assumed that the exhaustion was a bimolecular process, it was thought that a function representing the superposition of several second-order decays could be constructed to follow the phosphor exhaustion (see the solid curves of Figure 6). Although this succeeded

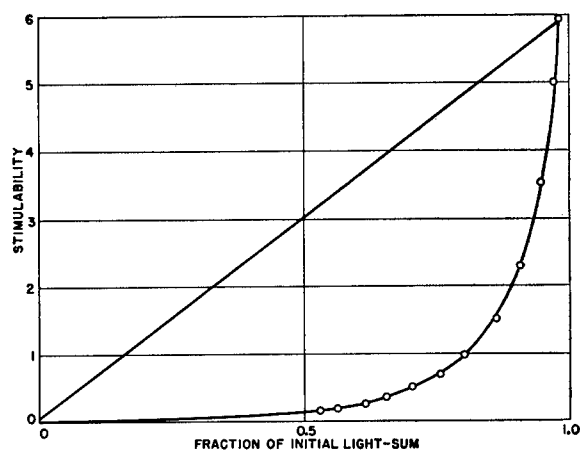

FIGURE 10. Stimulability against fraction of initial light sum.

fairly well with Standard VII, the exhaustion of B-1 could not be fitted over any considerable range. Recently, after the expiration of NDRC contracts, the B-1 curve was fitted with a single second-order decay using a correction for absorption in the phosphor.

In addition to plotting the brightness against the time of exhaustion, it is useful to represent sensitivity as a function of the light sum still contained in the phosphor (Figure 10). The general shape of an exhaustion curve of this sort, beginning with strong, quickly decaying emission and tapering off into an apparently endless *tail* with very slow diminution of the still appreciable brightness, suggests immediately that excited states of very different sensitivities must be present initially in a fully excited phosphor. Here the brightness represents the rate of return to the ground state while the light sum represents the remaining number of useful excited states.

Curves like that of Figure 10 may also be used to make an estimate of the order of magnitude of the absolute sensitivities of the few highly sensitive states which, upon stimulation, return first to the ground state. When calculated in relation to the number of infrared quanta absorbed, the quantum efficiency for the most sensitive states turns out to be about one-fifth in Standard VI and very nearly unity in Standard VII. The relatively low practical efficiency of these two phosphors is mainly due to the still large reflect-

ance of the excited phosphors in the region of their stimulation maximum, and to the presence of a relatively large number of excited states of low sensitivities compared to a small number of highly sensitive ones. Standard VII, which absorbs only about 4 per cent of the incident infrared, is mainly affected by the first characteristic while Standard VI is affected mainly by the second.

A third method of plotting the exhaustion is to represent the number of excited states (or stimulability) as a function of the absorption coefficient of the stimulation peak. This is shown in Figure 11. If the same sensitivity is produced by partial excitation and by complete excitation with partial exhaustion, the absorption and light sum of the two states may be very different. Conversely, the same light sum or absorption may be accompanied by very different sensitivities. This is easily explained by again assuming the coexistence of excited states of different sensitivities. Part of the difference should be due to the finite depth and the absorption of the phosphor layers.

Another approach to the problem of efficiencies was made by correlating the constants in the second-order equation, fitting the decay curve of Standard VII with the number of excited states and the intrinsic

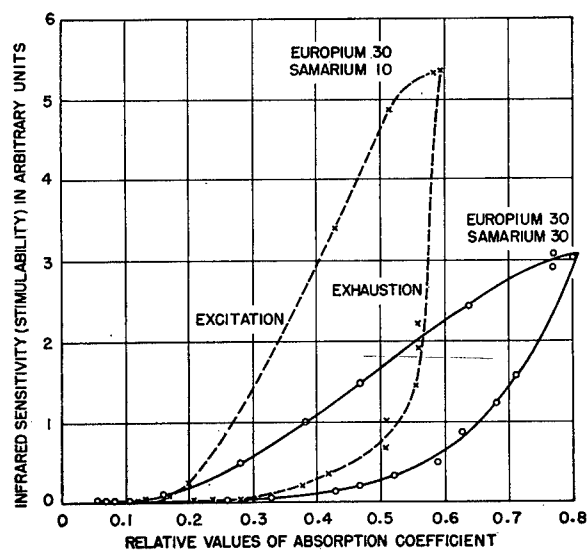

FIGURE 11. Sensitivity against absorption during excitation and exhaustion.

efficiency of the most sensitive states. The results found by using different cerium-samarium phosphors of various samarium content showed that while the efficiency of such a group remained nearly constant, the number of excited electrons varied considerably.

4.5.2 Excitation after Partial Exhaustion

The amount of light needed to excite a fully exhausted Standard VI or B-1 phosphor is considerable, but if the phosphor has once been fully excited and has lost only part of its sensitivity by stimulation or by spontaneous decay, the restoration of full sensitivity requires very much less exciting light. For example, if 40 per cent of the full sensitivity of Stand-

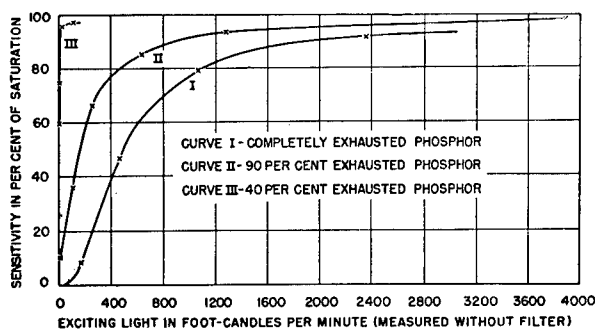

FIGURE 12. Sensitivity in per cent of saturation.

ard VI is lost by exhaustion, only a few per cent of the amount of light originally necessary is required to bring it back to full sensitivity. See Figure 12. As in the preceding paragraphs, the explanation of this is probably that excitation of a fully exhausted phosphor produces many excited states. Of these, exhaustion removes selectively only the most sensitive states, so that a considerable drop in sensitivity means only a small reduction in the total number of excited states. This loss is easily replaced by re-excitation, since now the only states that are free are those of high sensitivity. Although the re-excitation phenomenon is not pronounced with ultraviolet excitation of Standard VII, it is quite distinct with radium excitation.

4.5.3 Thermal and Stimulated Emission

Figure 13 shows typical examples of glow curves, or the gradual release of light by an excited phosphor as its temperature is raised. Lenard had previously stated a rule that the total light sum emitted on stimulation was always small compared to the amount emitted on heating. However, in phosphors with high infrared sensitivity, cases are found where the opposite holds true, such as with Standard VII, which emits much more light upon stimulation than upon heating, and with B-1, where the ratio is as large as 100. In Standard VII, the color of the light stimulated by infrared is distinctly different from that emitted by heat; the first is probably due to cerium and the second to samarium bands. At first this was thought to have something to do with the light sum

discrepancy, but the same anomalous effect was found in Standard VI and in manganese-samarium phosphors where the two colors are equal.

4.5.4

Saturation

After the initial stages of excitation, when the sensitivity of the phosphor increases, usually with the square of the amount of exciting light, the sensitivity reaches an equilibrium saturation value. The rate at which this process takes place and the saturation value obtained depend on the intensity of the exciting light and its wavelength, and these two factors are different for different phosphors. In many cases, there is little dependence if the intensity is so high that the building up of sensitivity is fast compared with the spontaneous decay, and the saturation value reached in such cases is not determined by an equilibrium between the decay and the rate of excitation. Thus the saturation must be due in part to an exhausting effect of the exciting light itself, especially important in Standard VI, where too high exciting intensities must not be used if greatest sensitivity is desired.

4.5.5

Decay Phenomena

There is a distinct relationship between the stimulability σ , the infrared threshold sensitivity S , and the background G , of a phosphor. Up to a limiting

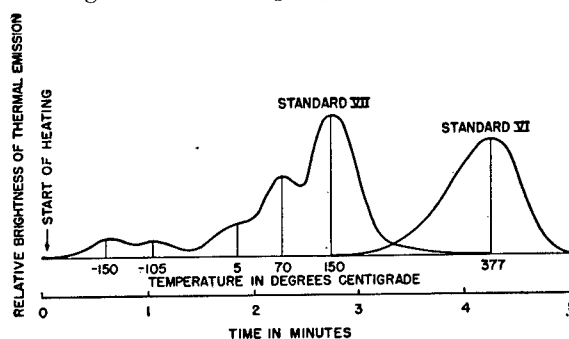

FIGURE 13. Glow curves for Standards VI and VII.

background G^* , the sensitivity is not influenced by the background. Any afterglow less than this will not appreciably affect the sensitivity and S , in appropriate units, will be the same as σ ; at the same time this faint background may be of great help in locating the proper eyepoint in an instrument. With a stronger background, the relation can be fairly well represented by the following equation.

$$S = \sigma \left(\frac{G}{G^*} \right)^{-n},$$

or

$$\log S = \log \sigma - n \log G + n \log G^*.$$

For practical purposes, G^* is of the order of 10 micro-millilamberts and n is roughly 0.5. Thus, if the stimulability and afterglow are known as functions of time, the sensitivity at any time can be calculated without the need of making threshold measurements.

If the decay of stimulability is very slow compared to that of the background, the threshold sensitivity will increase until the background has dropped below the limiting value G^* and then will decrease slowly as the stimulability drops. For most good standard phosphors, this is a fair approximation and thus a simple measurement of stimulability will give a measure of the threshold. Standard I, however, with a single activator, acts in quite another manner and seems to be typical of most singly activated phosphors. Its stimulability, remarkably high immediately after excitation, drops seriously with the slowly decaying strong background and becomes very low when G is less than G^* .

A reasonably general formulation may be given by using a Becquerel-type formula for phosphor decay. This yields simplified expressions sufficient for values of t that are not too small:

$$\log \sigma = c_1 - m_1 \log t,$$

$$\log G = c_2 - m_2 \log t.$$

In most cases, m_2 is very near to one while m_1 is considerably smaller, and the sensitivity formula can be simplified.

$$\log S = C + (nm_2 - m_1) \log t.$$

Thus the condition necessary for improvement of threshold on waiting after the end of excitation is simply that m_2 must be greater than m_1 . Table 1 shows values of m_1 and m_2 for some important cases;

TABLE 1. Decay constants of several phosphors.

	m_1	m_2
Standard VI	0.28	1.14
Standard VII	0.10	1.10
Zinc sulfide lead	0.26	1.18
Strontium sulfide copper	0.20	0.96

in all of them the above condition is met by a considerable margin. The physical meaning of the difference between m_2 and m_1 depends upon whether there exists a connection between thermal instability and infrared sensitivity of the excited states. If the two quantities are equal there is complete parallelism, and if their difference is 1 there is complete independence. In the first case, waiting after excitation would be of no value since reduction of the thermal background would reduce the stimulability proportionately. In the second case, the thermally most unstable states are lost by waiting, but if they are only a small fraction of all excited states, the stimulability is little impaired and the threshold improved.

Knowledge of these decay properties is of great importance for developing methods of operating the phosphors. The very slow spontaneous decay of sensitivity in Standard VII, for example, makes it possible to use very slow excitation from a weak radium preparation; the same good storage permits use throughout a whole night without re-excitation. Daylight excitation (a weak source) is not sufficient to excite the fast-decaying Standard VI. The relatively small difference in the decay constants of the strontium sulfoselenide copper phosphor shown in Table 1 is enough to make this phosphor, which has a promisingly long wavelength stimulation at 1.4 microns, show little threshold sensitivity at any time.

Chapter 5

SURVEY OF INFRARED SOURCES

By George E. Meese^a

5.1

INTRODUCTION

THIS CHAPTER has been prepared to record the development and/or application of the various infrared sources in projects of Section 16.5, NDRC.

Information is given on three general types of sources: incandescent filament lamps, standard arc lamps, and special gas-discharge lamps. Wherever possible, a brief description of the type of associated electrical and optical equipment employed with each lamp has been included.

The types of applications for which radiation sources have found actual or potential military use are quite numerous. In general, incandescent filament lamps have been employed in systems of detection and recognition, aircraft position indicators, signaling and other communication, reconnaissance, and nocturnal vehicular movement. Carbon-arc lamps have been used principally in reconnaissance work; mercury-vapor lamps for ultra high-speed photography, target seeking, and several ultraviolet projects; and special gas-discharge sources for modulated communication work. Because of security requirements, most of the projects falling under the categories just mentioned have involved infrared sources, though ultraviolet radiation has been used in certain cases. A discussion of all receivers and a detailed treatment of filters are beyond the scope of this chapter.

5.2 INCANDESCENT FILAMENT LAMPS

The incandescent tungsten filament lamp has been used to a greater extent as a radiation source in projects covered by this report than any other type of lamp. There are several reasons for this: (1) the tungsten lamp is the most efficient producer of near infrared; (2) at higher filament temperatures, some ultraviolet is produced; (3) all the radiation and electrical characteristics of tungsten are well-known; (4) incandescent lamp design and production facilities are readily available.

^aProject Engineer, NDRC Contract OEMsr-423, Nela Park Lamp Development Division, General Electric Company.

5.2.1

General Characteristics

The general nature of tungsten filament lamps is universally known. Basically, all such lamps are similar—variations in bulb size and shape, base, and filament form are shown in the Design and Construction section following and keyed to particular lamps listed in Table 1.

Many of the filament lamps listed in this report were originally developed for military service; certain others are standard lamps available before the war. All were developed and manufactured by the Lamp Department, General Electric Company [GE] (Contract OEMsr-423). The military applications are indicated in the right-hand column of the tables.

DESIGN AND CONSTRUCTION

The specific physical details of all tungsten filament lamps are expressed in terms of bulb size and shape, base, filament form and shielding, and lamp length.

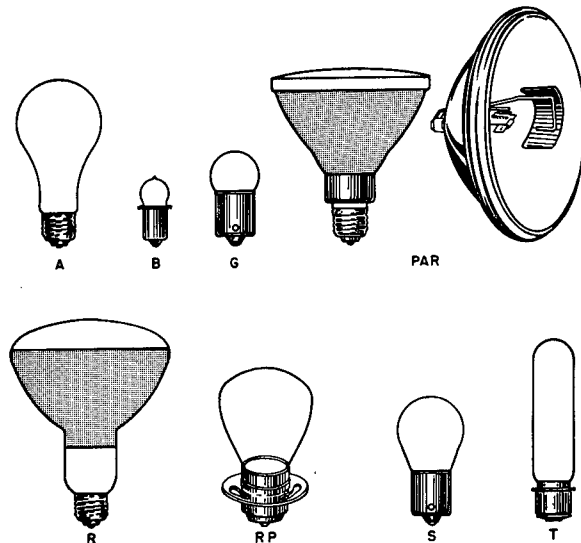

FIGURE 1. Bulbs used in incandescent and conventional mercury lamps described in this chapter.

Bulb shapes are indicated by one or more letters which designate the particular type of bulb involved. These types are shown in Figure 1. The numerical portion of the bulb designation indicates the nominal

TABLE 1. Filament lamps.

Lamp No.	Watts	Volts	Amp	Rated life, hours	Bulb	Base	Max overall length, inches	Filament form	Shield	Approx. max cp	Approx. spread to 50% max		Approx. color temp volts °K	Application
											H	V		
4560	600	24	25	25	PAR-64	Flex. lug.	4	C-13	A	600,000	7° x 4½°	24 3250 22 3150 20 3050 18 2950	Automotive housing—8-in. diam, 5-7-mm Corning No. 2540 laminated filter. IR spotlight for tank, DUKW and other vehicles. Figs. 11 and 12. Bibliography Nos. 1, 4, and 5.	
4560	600	28	21.4	25	PAR-64	Screw term.	4	C-13	A	600,000	7° x 4½°	28 3350	New lamp design. Supersedes 24-volt No. 4560. Also used with IR filter XRX7D as metascope source for BuShips. Figs. 11 and 12.	
4561	250	13	19.2	25	PAR-64	Screw term.	4	C-2V	A	500,000	4½° x 2¼°	13 3350	Automotive housing—8-in. diam, 5-7-mm Corning No. 2540 laminated filter. Landing boat IR spotlight Norfolk tests. Bibliography No. 2.	
4562	250	28	8.9	25	PAR-64	Screw term.	4	C-13	A	450,000	5½° x 3°	28 3300	Automotive housing—8-in. diam, 5-7-mm Corning No. 2540 laminated filter. IR driving tests. Bibliography Nos. 1, 4, and 5.	
4541	450	24	18.75	25	PAR-56	Flex. lug.	4½	C-13	D	425,000	7° x 4°	24 3400	Automotive housing—6½-in. diam, 5-7-mm Corning No. 2540 laminated filter. Jeep, amphibious jeep, misc. IR headlighting, and signaling. Figs. 11 and 12. Bibliography Nos. 1, 4, and 5.	
4541	450	28	16.1	25	PAR-56	Screw term.	4½	C-13	D	450,000	7° x 4°	28 3300 26 3250 24 3150 22 3050	New lamp design. Supersedes 24-volt, No. 4541. Also used with XRX7D filter as metascope source for BuShips. Figs. 11 and 12.	
4540	450	13	34.6	25	PAR-56	Screw term.	4½	C-2V	D	500,000	6½° x 5½°	13 3350 12 3250 11 3150 10 3050	Automotive housing—6½-in. diam, 5-7-mm Corning No. 2540 laminated filter. For 2½-ton truck headlighting misc. spot and marker applications. Bibliography Nos. 4 and 5. Also used in XRX7D filter as metascope source for BuShips (spreader reduced beam cp to 50%).	
4543	100	12.5	8	50	PAR-56	Screw term.	4½	C-6	None	300,000	2° x 3½°	12.5 3100	Airborne Beacon-Air Corps-Kopp IR170 glass. Figs. 13 and 14. Bibliography No. 13.	
4522	250	13	19.2	25	PAR-46	Screw term.	3¾	C-2V	A	250,000	5½° x 4°	13 3350	Marker application for BuShips. Bibliography No. 2.	
4523	250	28	8.9	25	PAR-46	Screw term.	3¾	C-13	A	225,000	7° x 5°	24 3100 28 3300	Used with XRX7D filter as metascope source for BuShips and with No. 2540 for IR driving. Fig. 11. Bibliography Nos. 4 and 5.	

TABLE 1. Filament lamps (continued).

Lamp No.	Watts	Volts	Amp	Rated life, hours	Bulb	Base	Max overall length, inches	Fila-ment form	Shield	Approx. max cp	Approx. spread to 50% max H V	Approx. color temp volts °K	Application
4030	40-30 40 30	6-8 6.4 6.4	6.2 4.7	120 200 at 7 v	PAR-56	3 Cont. lug.	5½	C-6 C-6	None	30,000 20,000	7° x 2°	6.4 2900 7.4 3050 6.4 2950 7.4 3100	Automotive housing—6½-in. diam, approx. 8-mm Corning No. 2550 and 5874 filters. Head-lamp adapters for 2½-ton truck, amphibian (DUKW) and other vehicles. UV and IR night driving. Fig. 11. Bibliography Nos. 4, 5, 6, and 9.
2400 *	45-35 45 35	6-8 6.4 6.4	7.0 7.5	120 200		3l Cont. lug.	5½	C-6 C-6	None	30,000 20,000	7° x 2°	6.4 2800 6.4 2950	5½-in. composite metal-glass head lamp. 6-in. diam, approx. 8-mm Corning No. 2550 and 5874 filters. Head lamp adapters for jeep and amphibious jeep. UV and IR night driving. Bibliography Nos. 4, 5, 6, and 9.
4011	30	6-8 6.2	4.8	300	PAR-46	Screw term.	4	C-6	C	35,000	5½° x 2¼°	6.2 2900	Automotive housing—Polaroid IR plastic filter. Boat marker at Norfolk tests. Bibliography No. 2.
4015	30	6-8 6.2	4.8	300	PAR-46	Screw term.	2½	C-6	C	8,000	22° x 2°	6.2 3000	Automotive housing—6½-in. diam, 5-mm Corning No. 2540 filter. Landing boat identification. Norfolk tests. Also used for UV driving. Fig. 15. Bibliography Nos. 2, 6, and 9.
4013	25	6-8 6.2		300	PAR-46	Screw term.	4	C-6	None	1,000	38° x 16°	6.2 2950 6.2 2950	Exp. marker—glider landing. Bibliography No. 15.
4524		6.0	4.75	400	PAR-46	Screw term.	4	C-6	None	80,000	3¼° x 1¼°	6.0 3050	RCA Laboratories—experimental snooper scope. Bibliography No. 15.
Spec.	30	6.0	5.0	300	PAR-36 (clear cover)	Screw term.	2½	C-8	None	80,000	5° x 3°	6.0 3150	RCA Laboratories—experimental snooper scope. Bibliography No. 15.
Spec.	30	6.2	4.75	25	PAR-36 (clear cover)	Screw term.	2½	C-6	None	50,000	7° x 3°	6.2 3050	RCA Laboratories—experimental snooper scope, Bibliography No. 15.
4501		26	5.3	50	PAR-36	Screw term.	2½	4CC-8	None	50,000	6½° x 6½°	26 3000	Experimental tow-plane identification. Glider towing. Bibliography No. 15.
Spec.	250	28	8.8	25	PAR-36 (frosted cover)	Screw term.	2½	C-13	None	7,000	26° x 27°	28 3300	Experimental tow-plane identification. Glider towing. Bibliography No. 15.
Spec.	5.6	4.5	1.25	75	PAR-36	Screw term.	2½	C-6 (Vert.)	None	1,500 at 5.1 v on 4 dry cells	22° x 2½°	4.5 3000	6½-in. diam, 8-mm Corning No. 2550 filter. Portable battery-operated IR beach markers. Fig. 16. Norfolk tests. Portable IR runway markers. Glider landing. IR driving. Bibliography Nos. 2, 4, 5, and 15.
Spec.	150	12.8	11.7	200	PAR-56	Screw term.	4½	C-6	None	130,000	7½° x 3½°	12.8 3100	Vehicle head lamps—Polaroid filter. Jeeps and misc. trucks for Eng. Bd. IR driving. Bibliography No. 15.

*Lamp bulb is not separately replaceable but is soldered into reflector of composite unit.

RESTRICTED

TABLE 1. Filament lamps (continued).

Lamp No.	Watts	Volts	Amp	Rated life, hours	Bulb	Base	Max overall length, inches	Fila-ment form	Light center length, inches	Approx. max cp	Approx. color temp volts °K	Application
	2,500	65	38.5	50	T-24	Mog. bipost	11½	C-13D	4		65 3300 70 3400	24- and 36-in. searchlights. IR reconnaissance and locomotive driving. Fig. 17. Bibliography Nos. 3, 7, and 8.
	4,000	110	36.4	50	T-32	Mog. bipost	14	C-13D	4		110 3300	Navy types exp. searchlights. IR shoreline reconnaissance. Bibliography No. 11.
	1,800	28	64.3	10	T-20	Mog. bipost	9½	C-8 curved	6½		28 3400	See Sections 5.3.1 and 9.3.1.
	1,000	115	8.7	25	T-20	Mog. bipost	9½	C-13D	4	2,850 Perpendicular to plane of filament	115 3050	24-in. GE searchlight gold-plated reflector. 2 layers 8 mm each Corning No. 2550 filter. IR reconnaissance and locomotive driving. Bibliography No. 3.
	250	115	2.2	200	G-30	Med. screw	5½	C-5	2¾	400	115 2850	360 markers for Naval Aircraft Factory—IR homing beacon for carrier landing—IR lacquer filter. Bibliography No. 15.
	240	24	10	100	A-19	Med. pref.	4½	C-2V	1½			Portable IR beacon for airborne landings. 360° Fresnel lens. Fig. 18. Bibliography No. 15.
	150	110	1.4	25	T-8	D.C. Bay.	3½	2CC-8	1½	300 Approx. spherical	100 3100	Motor-driven revolving beacon glider landing—IR lacquer. Fig. 19. Bibliography No. 15.
	100	115	0.87	1,000	R-40	Med. screw	6½	C-11		1,275	115 2800 125 2900	IR runway marker for aircraft carriers. Approx. 8-mm Corning No. 2550 filter. Fig. 20.
	85	10.6	8	100	A-17	Med. pref.	3½	4C-8	1¼		10.6 2950	Airborne marker—A.G.F. Eng. Bd. Used in 360° Fresnel—Polaroid. Bibliography Nos. 13 and 15.
	75	115	6.5	1,000	T-12	Med. screw	11½	C-8		63	115 2500	IR wands for deck officer aircraft carrier landing. IR lacquer filter. Figs. 21 and 22. Bibliography No. 15.
	cp or watts											
	40	115		1,000	T-8	Med. screw	11½	C-8		32	115 2500	Wands for deck officer aircraft carrier landing. IR lacquer filter. Figs. 27 and 28. Bibliography No. 15.
1196	50 cp	12-16	3.46	300	RP-11	D.C. Bay.	2¼	C-2V	1¼	50—Spherical 4,000-in. reflector 75°x4°	12.5 3000	Portable battery-operated revolving beacon. Glider landing IR lacquer filter. Bibliography No. 15.
310		28	0.91	300	S-11	D.C. Bay.	2¼	C-2V	1¼	32	28 2950	Beacon runway marker for aircraft landing. 4 with lacquer filter per marker. Figs. 23 and 24. Bibliography Nos. 10 and 12.
1045	30	5.9	5.1	30	RP-11	S.C. Bay. pref.	2¼	C-6	¼	5,300 in gold parabola	5.9 3300	Snooper-sniperscope production model. Bibliography No. 15.
63	3 cp	7	0.64	500	G-6	S.C. Bay.	1¾	C-2R	¼	63-360° Horizontal band in cylindrical Fresnel lens		Portable battery-operated runway marker. 360° Fresnel lens. Glider landing. IR lacquer filter. Fig. 25. Bibliography No. 15.
1524	21/6 cp	28		300/1,200	GG-10	S.C. Bay. Indexing.	2¾	CC-6/CC6		21-6	28 2800	Cowl flood and wing-tip marker lacquer filter. Aircraft landing—BuAer. Bibliography Nos. 10 and 12.

TABLE 1. Filament lamps (continued).

Lamp No.	CP or watts	Volts	Amp	Rated life, hours	Bulb	Base	Max overall length, inches	Fila-ment form	Light center length, inches	Approx. max ep	Approx. color temp volts °K	Application
14		2.5	0.30	15	G-3½	Min. screw	15/16	C-2R	23/32	½ spherical ep		Used in flashlights for IR signaling and airborne operations. Fig. 26.
51	1 cp	6-8 7.5	0.22	1,000	G-3½	Min. Bay.	15/16	C-2R	½	1 spherical ep		Used in flashlights for ground assembly, etc., on airborne operations. Fig. 26. Bibliography Nos. 13 and 15.
53	1 cp	12-16 14.4	0.10	1,000	G-3½	Min. Bay.	15/16	C-2V	7/16	1 spherical ep		Used in flashlights for ground assembly, etc., on airborne operations. Fig. 26. Bibliography Nos. 13 and 14.
PR2		2.4	0.50	15	B-3½	S.C. min. flanged	1¼	C-2R	¼	¼ spherical ep		Used in flashlights for IR signaling.
PR3		3.6	0.50	15	B-3½	S.C. min. flanged	1¼	C-2R	¼	1¼ spherical ep	3.57 2805	Used in flashlights for IR signaling.

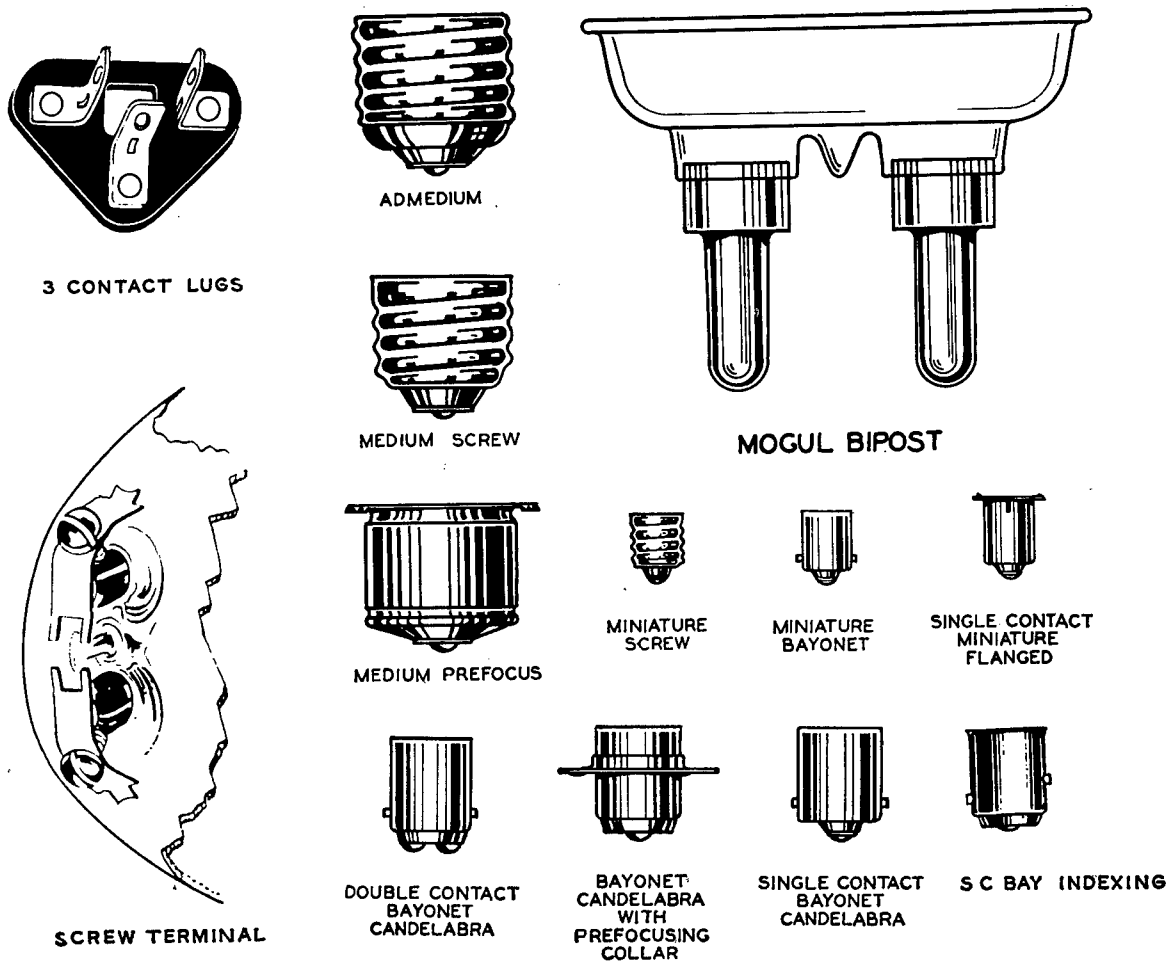

FIGURE 2. Bases used on incandescent and conventional mercury lamps described in this chapter.

diameter in eighths of an inch. In the case of PAR type lamps, the reflector is an integral part of the lamp. On occasion, filter materials (lacquers) have been applied directly to the bulbs of certain lamps, as indicated in the Application column of the lamp tables.

Base designations are given in Figure 2. The *light center length* gives the distance from the center of the light source to the point indicated in the list below, depending on the base used:

Type of base	Point for measure
All screw bases	Bottom-base contact
Medium and mogul prefocus	Top of base fin
Mogul bipost	Shoulder of post
Medium bipost	Bottom of bulb (base end)
Prong	Nut, washer or shoulder of base prong
Bayonet candelabra	Top of base pins
Medium bayonet	Top of base pins
SC or DC prefocus	Plane of locating bosses of pre-focusing collar
Miniature flanged	Plane of locating bosses

The filament designation consists of a prefix letter to indicate whether a wire is straight or coiled, and a number to indicate the arrangement of the filament on the supports. Prefix letters include: *S* (straight), wire is straight or slightly corrugated; *C* (coiled),

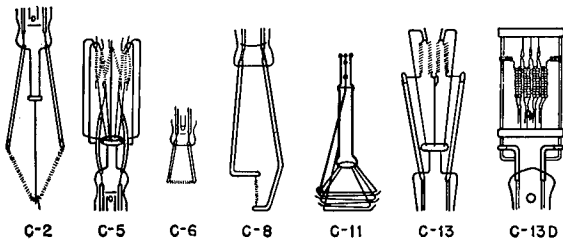

FIGURE 3. Filament forms used in incandescent lamps described in this chapter.

wire is wound into a helical coil; *CC* (coiled coil), wire is wound into a helical coil and this coiled wire is again wound into a helical coil. The shapes of filaments are shown in Figure 3.

OPERATING CHARACTERISTICS

Power Supply. Tungsten filament lamps can be operated from either a-c or d-c, except for certain restrictions where carrier-wave detection and current modulation are involved. The power supply for the sources listed in Table 1 depends on the military application, and is determined by the work cycle involved for the particular source, the voltage and current required, and the type of available power for other electrical equipment. Sources for use on aircraft are designed to operate from the standard electrical power supply of the plane; sources used in airborne operations are usually powered from batteries; and large sources for reconnaissance operations have been operated from mobile engine-generator sets.

Modulating Equipment. Filament lamps were not used for current-modulated communication.

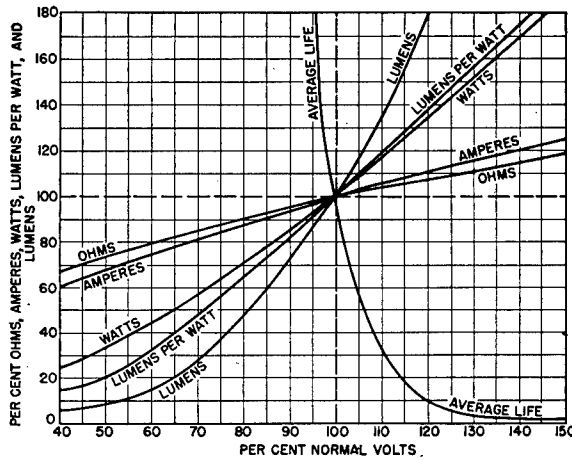

FIGURE 4. Characteristic curves for large gas-filled tungsten filament lamps.

Electrical Characteristics. The electrical characteristics of filament lamps are determined by the filament, which is designed to operate at a particular temperature and give acceptable life for service under definite conditions of voltage, vibration, shock, etc. Candlepower, current, wattage, color temperature, and life values for the rated voltage of each lamp are given in Table 1. Values of resistance, current, light output, wattage, and efficiency for operation at other than the rated voltage of a large gas-filled tungsten lamp are shown in Figure 4. The *average* effect of voltage on life is also indicated. It should be remembered, however, that this *life curve* cannot be expected to apply with great accuracy to a single lamp or a

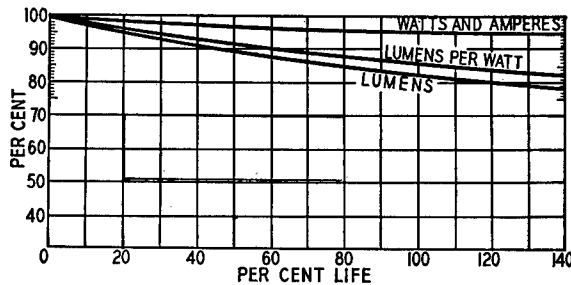

FIGURE 5. Depreciation throughout life for a 115-volt, 1.7 ampere, general service, tungsten filament lamp.

small group of lamps, because normal probability functions apply just as they do to lamps operated at rated voltage.

The electrical characteristics change some throughout the life of a tungsten filament lamp. Because of gradual evaporation, the filament becomes thinner and thus has a higher resistance, thereby using less current and wattage. The radiant energy output de-

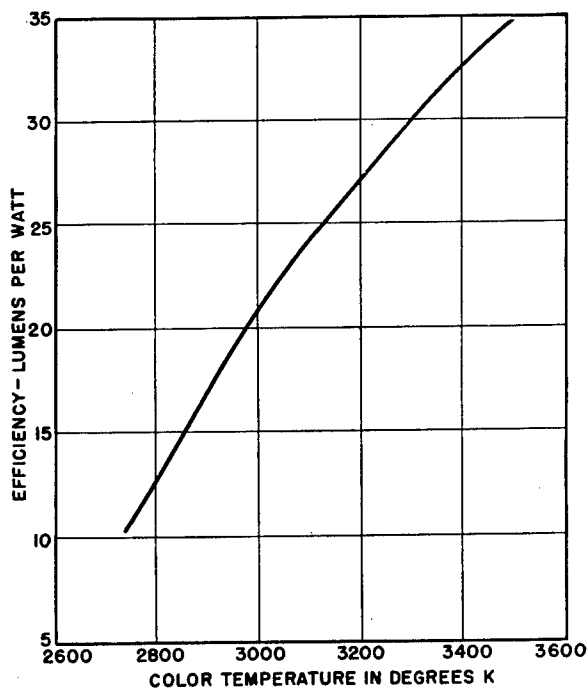

FIGURE 6. The visible output efficiency versus filament color temperature.

increases during life because of lowering filament temperature and bulb blackening, at a rate which depends on the temperature at which the filament is operated and the ratio of watts per unit internal volume of the lamp. Certain relatively low wattage PAR type lamps have almost the same light output at the end

of rated life as when they are first placed in service. This is due to an early gain in efficiency because of filament seasoning. Figure 5 shows the depreciation curves for a 750-hour rated life, 1.7-ampere filament in a PS-30 bulb.

RADIATION CHARACTERISTICS

Spectral Distribution. The spectral distribution of incandescent tungsten filament lamps is continuous and, in general, has the shape of the familiar black-body radiation curve. Within the visible spectrum, the distribution corresponds closely to that from a black body at the color temperature of the lamp.

The luminous efficiency of a filament lamp increases as the temperature is raised. Figure 6 shows the efficiency in lumens per watt for a group of different lamps ranging in color temperature from 2750 K to 3475 K. This relationship can be expected to hold for most clear or frosted-bulb tungsten lamps. The candlepower in a given direction will increase at the same rate for a given type of lamp and filament construction. Figure 7 gives the spectral radiant intensity per 1,000 candles for five color temperatures. Approximate values for other color temperatures can be obtained by interpolation. The color temperature is fairly close to the actual filament temperature. The approximate color temperature for the various lamps used in NDRC projects is given in Table 1.

Brightness. The filament brightness of an incandescent lamp depends on its temperature, the latter being

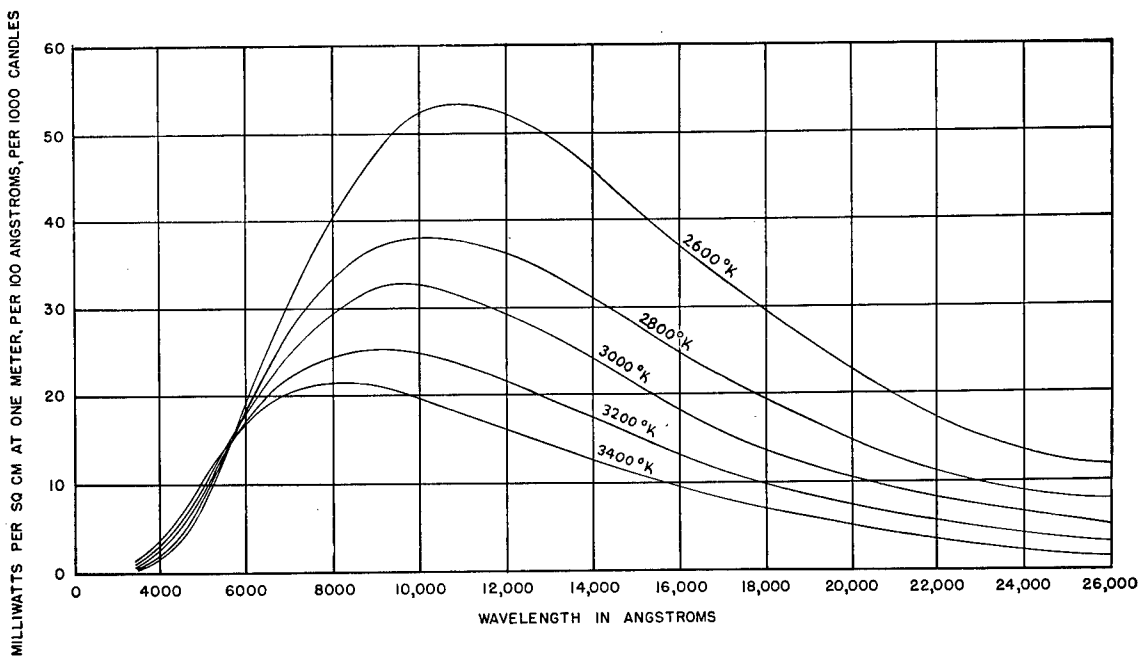

FIGURE 7. Spectral distribution curves for tungsten filament lamps at five color temperatures.

RESTRICTED

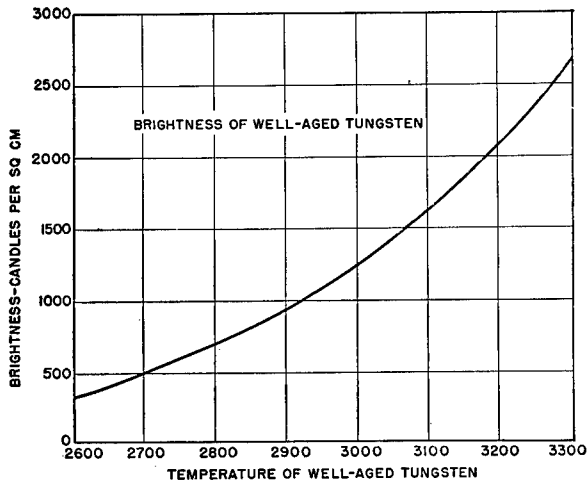

FIGURE 8. Brightness versus temperature for well-aged tungsten.

selected by the lamp designer to give the desired life for the service intended. Figure 8 gives the brightness of well-aged tungsten at various temperatures, and can be used to indicate the approximate brightness of coiled filaments, particularly in the range 2700 to 3000 K. Of course, the brightness of the filament will be less near a support wire or lead, because such

members drain heat from the filament by conduction. In the case of inside frosted, enameled, or colored glass bulbs, the brightness is much less than that of the filament.

Spatial Distribution. The energy distribution in space about filament lamps depends on the bulb shape and finish, and the filament construction. The beam dimensions of PAR type lamps are indicated in the tabular data; such lamps have different horizontal and vertical distributions because of the flutes on the lens or cover plate and the use of a *bar* filament. Projection, airway beacon, and similar lamps used in NDRC projects have maximum output perpendicular to the plane of the filament.

RADIATION CHARACTERISTICS IN ASSOCIATED OPTICS

Spectral Energy Distribution. Applications of filament lamps for the utilization of *white* light result in spectral distributions fairly similar to those for the light source, because the reflector and lens systems used in such applications are reasonably nonselective in reflectance and transmission. The distribution of the output of ultraviolet [UV] and infrared [IR]

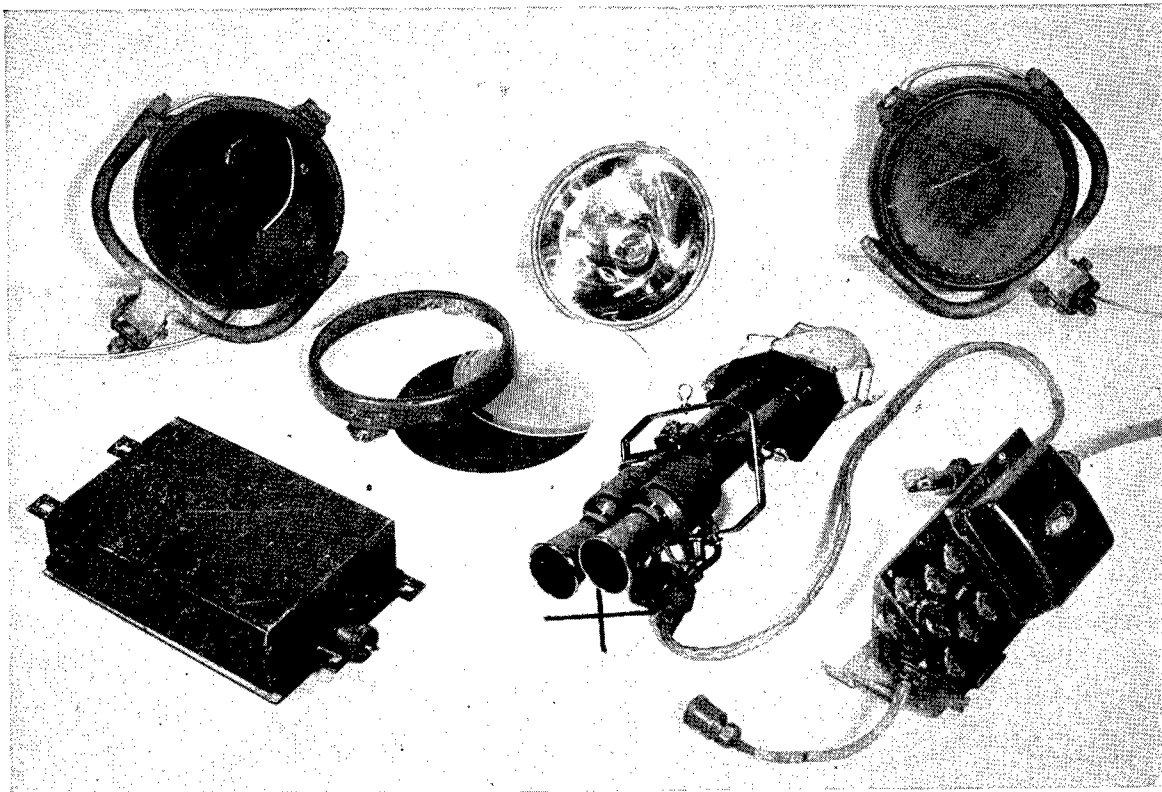

FIGURE 9. British source and telescope equipment for infrared night driving.



FIGURE 10. The equipment of Figure 9 mounted on $\frac{1}{4}$ -ton truck. There are four 36-watt projectors; binocular image tubes mounted on springs in frame suspended from windshield frame and front bow. Binoculars are fastened to driver's head with web harness. The power source is a 12-volt battery strapped on the left sponson.

units can be calculated from the spectral transmission curve of the filters employed. Beam dimensions of filtered outputs are comparable to those given for the light source in the case of PAR lamps, because filters with little diffusion have been employed in most applications of UV and IR projected beams.

5.2.2 Miscellaneous Filament Sources

A Kellner-Schmidt projector (design 3A) was developed by the Institute of Optics, University of Rochester (Contract OEMsr-1219), as a visible or infrared source for aerial photography work by the AAF, Wright Field. The 1,800-watt lamp has a single filament curved to fit the optical requirements of the

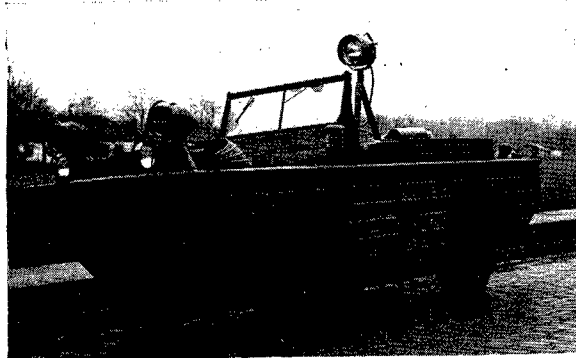

FIGURE 11. $\frac{1}{4}$ -ton 4x4 amphibian with 450-watt infrared head lamps, 600-watt spot lamp (filter removed) and low-wattage running lights.

Kellner-Schmidt system (see Table 1 and Section 9.3.1 for other details). The mirror has a radius of 8 inches, clear aperture $8\frac{3}{8}$ inches, focal length 4.42 inches, aperture ratio $f/0.53$. The output is 800,000 beam candlepower in a solid angle 1.5 by 25 degrees. Astigmatism is introduced into the corrector plate to smear the image of the coiled filament.

A British infrared beacon has also been used as a metascope source at the Engineer Board, Fort Belvoir. The beacon employs a 200-watt, 12-volt lamp and is operated from lightweight storage batteries. The IR

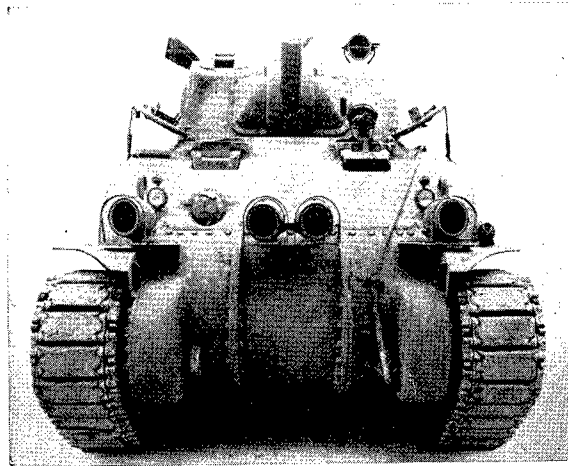

FIGURE 12. Infrared equipment on a medium tank, consisting of four 450-watt IR projectors on the front and one 600-watt IR searchlight on left top of turret. Binocular image tubes are mounted in a socket welded to the driver's direct-vision slot visor. Source of power is Waukesha multi-fuel model $2\frac{1}{2}$ T.G.U. engine generator mounted in left rear sponson.

filter is incorporated in polyvinyl alcohol. British IR driving equipment (Figures 9 and 10), using 36-watt, 12-volt lamps in headlight reflectors, was tested by the General Electric Company. These sources also have polyvinyl alcohol filters.⁵

Sources used in the triple-mirror development for Army aircraft landing include a special 3-ampere tungsten lamp with 225 candlepower, and the small grain-of-wheat lamp giving 0.29–0.35 candlepower at 3 volts (color temperature 2510 K).

Photographs of many incandescent lamp applications are given in Figures 11 through 26.

5.2.3 Recommended Filament Lamps for Various Military Projects

The lamps listed in Table 1 are not necessarily the best sources for the projects indicated. In some cases, several lamps were tried (and are listed) before the

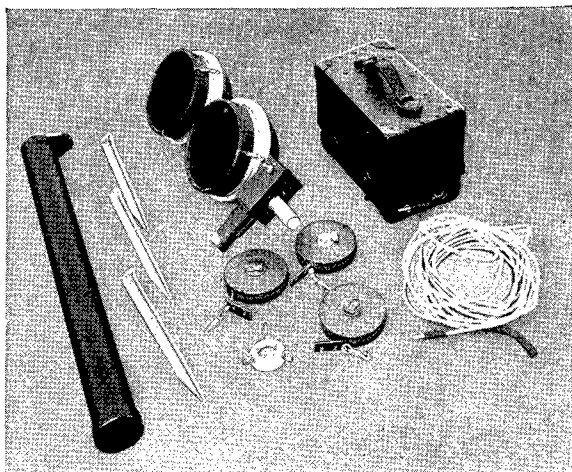

FIGURE 13. Components of airborne beacon, including collapsible mast, stakes, gey wires, and twin sources.

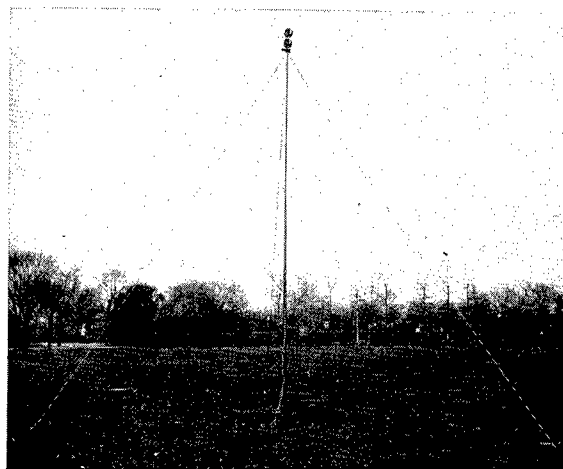

FIGURE 14. A daytime view of the airborne beacon assembled from the parts of Figure 1.

best lamp or combination was selected. Also, improvement in infrared filter and receivers (such as the recent high-voltage RCA model) should make certain previous recommendations obsolete.

1. *Infrared Night Driving.*^{1,4,5,15}

Head lamps: Two 150-watt, PAR-56 special lamps, with beam pattern similar to automotive practice. Filtered with three layers of XR7X25. Spotlight: One No. 4522 or 4523 250-watt, PAR-46, 13-volt or 28-volt lamp filtered with three layers of XR7X25.

2. *Ultraviolet Night Driving with Autocollimating Fluorescent Reflector Buttons.*^{6,9}

Head lamp: One No. 4015, with 586 and 587 glass filter mounted on top of windshield just above driver's line of vision.

3. *Night Shore Reconnaissance.*^{2,11}

Source: Two 4,000-watt, 115-volt T-32 lamps, each in 24-inch reflector with OSU or Polaroid filter. (Both the twin 24-inch carbon-arc searchlights and the 60-inch antiaircraft arc searchlight were used for shore reconnaissance, but the contract was terminated before the relative merits of arc-lamp and filament-lamp searchlights were completely established.)

4. *Nocturnal Gun Ranging.*⁵

Source: Same as for Night Shore Reconnaissance.

5. *Night Towing and Landing of Gliders.*^{15a}

Markers for Tow-Plane: Three special PAR-36, 250-watt, 13-volt or 28-volt wide conical distribution lamps and infrared filter. Used to locate tow plane for glider pilot.

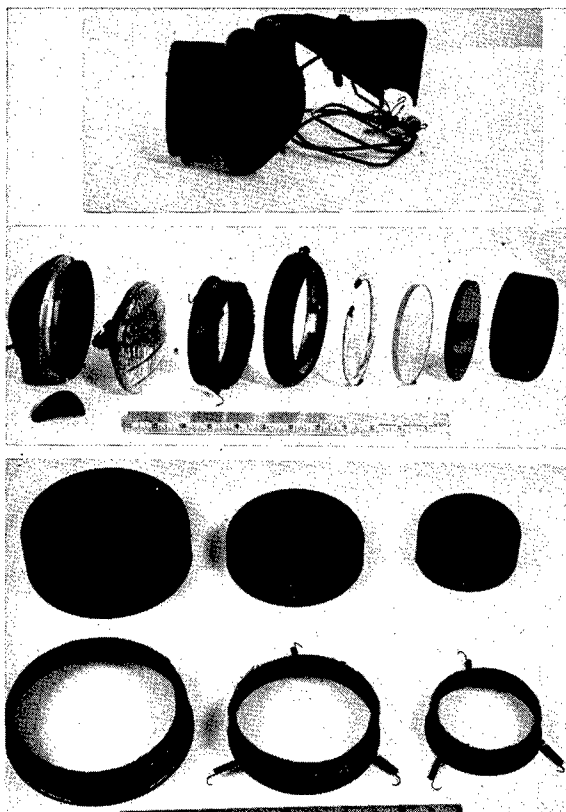

FIGURE 15. The No. 4015 lamp and filter (in various sizes) used for night driving with ultraviolet radiation.

Landing Location Markers: B-9 airborne beacons using lamp No. 4543 and infrared filter.

Markers for Landing Strip: Had not been established.

6. *Night Railway Operation.*^{3,7,8}

Head lamp: One 2,500-watt, 65-volt lamp, in 24-

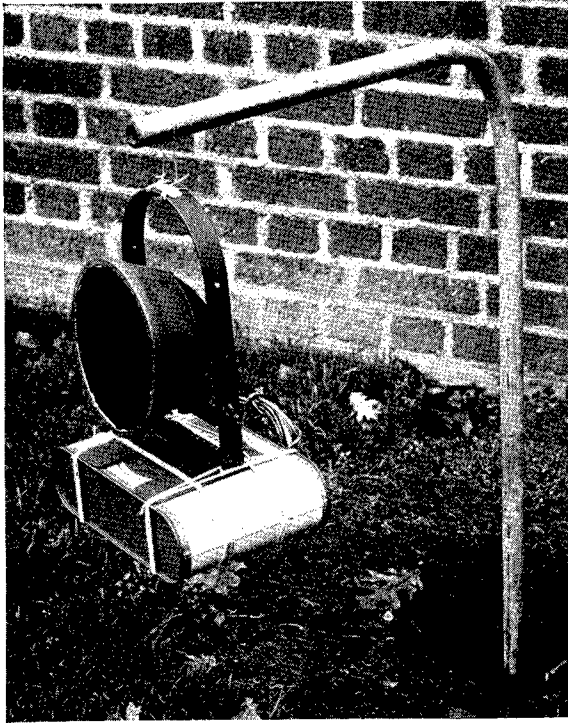

FIGURE 16. Improvised IR beach marker for reconnaissance test using PAR-36 4.5-volt, 1.5-ampere special lamp and Corning No. 2540 filter.



FIGURE 17. The 36-inch IR searchlights and 12-inch Schmidt receiver.

inch reflector and infrared filter for locomotive headlamp.

7. *Night Landing of Carrier Aircraft.*^{10,12}

Runway Markers: Pattern of 4 No. 310 filtered lamps, one at each corner of a 2-foot square.

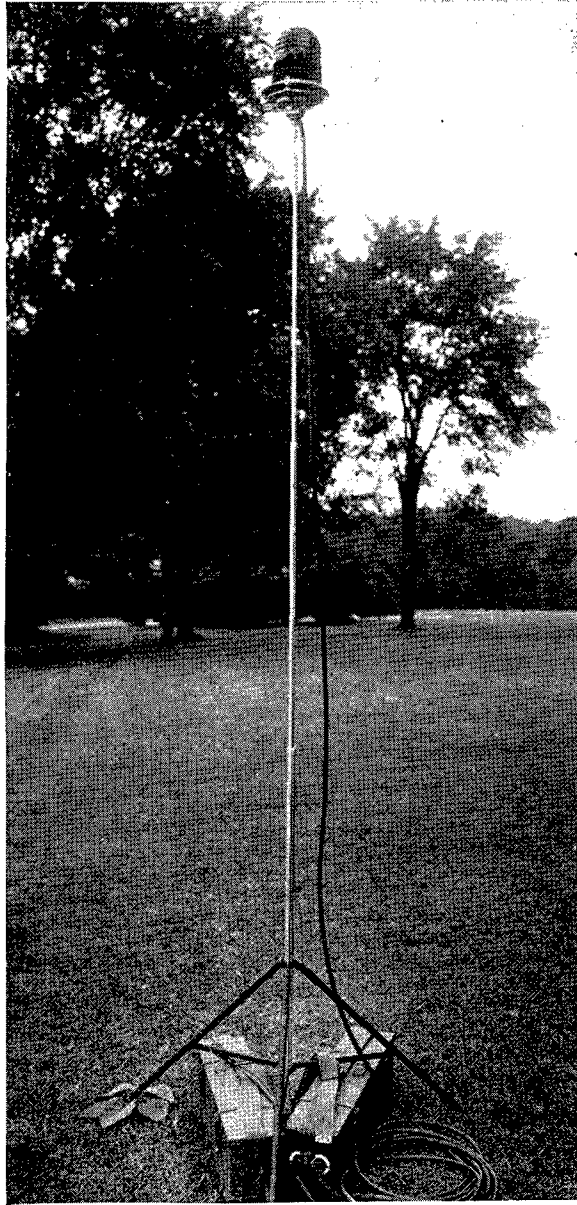

FIGURE 18. Experimental airborne beacon on 8-foot mast built for ETO.

Markers spaced on 100-foot centers down the sides of a 100x600-foot runway.

LSO "Wands:" 15-cp coated lamps spaced along each of two light metal *wands* for hand signaling. One similar strip suspended vertically from Landing Signal Officer's neck for orientation. Navigation Lamps on Plane: Existing lights, filtered.

Cowl Illumination Lamp: One No. 1524 GG-10 lamp and filtered globe to illuminate cowl of plane for pilot orientation.

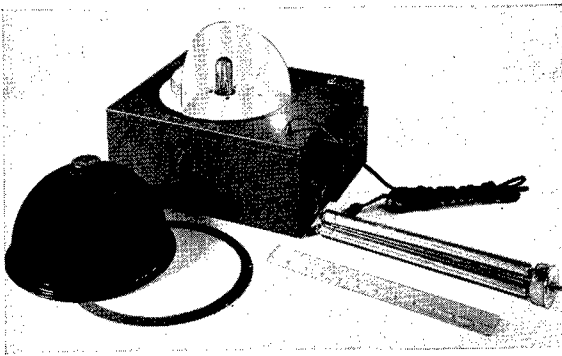

FIGURE 19. Experimental rotating IR beacon using 115-volt, 150-watt lamp for glider landing project.

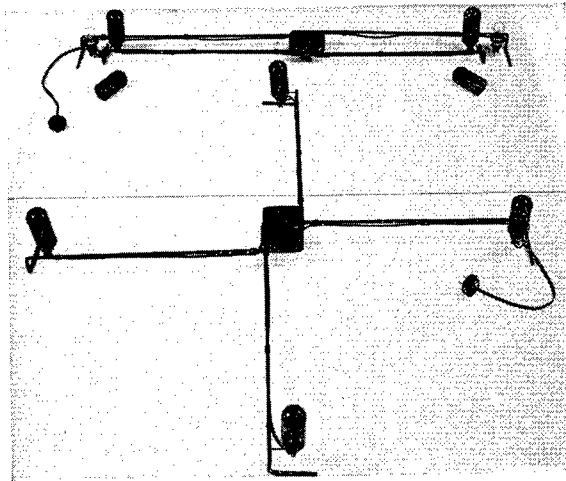

FIGURE 23. A wire-frame multiple-source beacon to mark runways for IR night landing of aircraft.

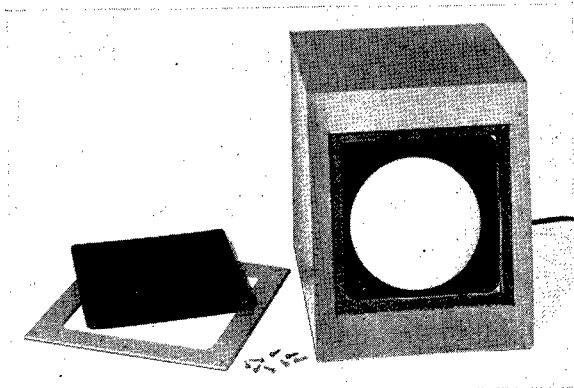

FIGURE 20. Infrared marker using 115-volt, 150-watt R-40 lamp for carrier landing project.

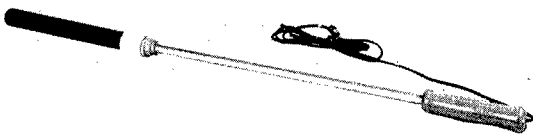

FIGURE 21. The first experimental IR "wand" for use by the Landing Signal Officer.



FIGURE 22. The second type of IR "wand" for the Landing Signal Officer.

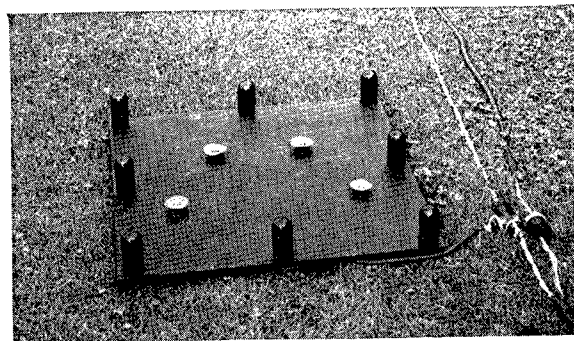

FIGURE 24. Same as Figure 23 except extra sockets on wood panel permit flexibility of source pattern.

Approach or Altitude Lamp: Two 21-cp bar filament lamps in fixture developed by the Johnson Foundation, University of Pennsylvania, under NDRC Contract OEMsr-1075.

8. *Snooperscope-Sniperscope*.^{15b}

Source: No. 1045 lamp in 5-inch gold-plated reflector and Polaroid filter.

9. *Airborne Beacon*.¹³

Two No. 4543 100-watt, 12.5-volt PAR-56 spot lamps with infrared filter.

10. *Hidden Japanese Defenses*.¹⁴

At the single trial of this project, one 1,500-watt, 32-volt, T-24 filament lamp was used in a 24-inch searchlight with OSU filters.

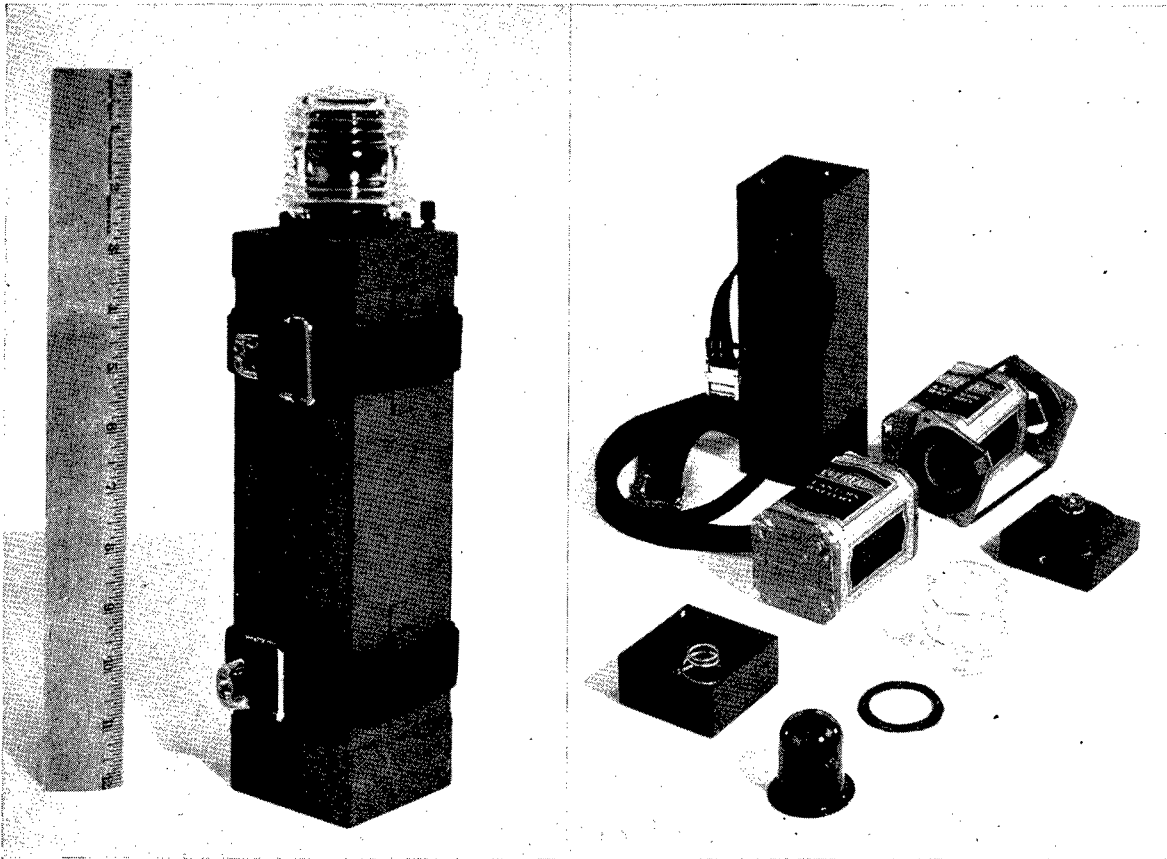

FIGURE 25. Experimental battery-operated infrared runway marker for glider landing.

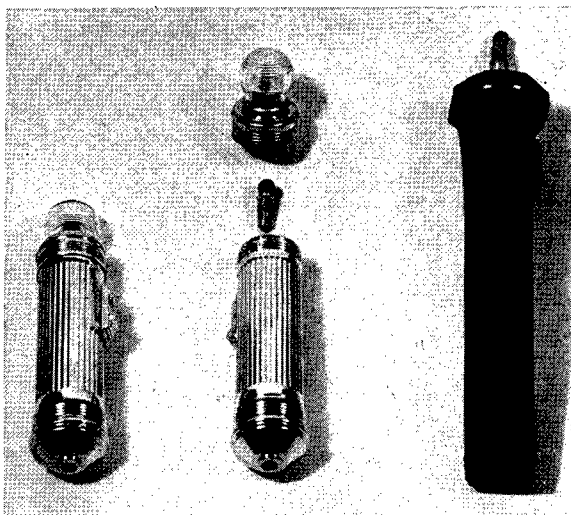

FIGURE 26. *Left and center*, 360-degree hand infrared source; *right*, filter-coated lamp with output adjustable by resistor head of battery case.

5.3 CONVENTIONAL ARC LAMPS

5.3.1 Carbon-Arc Lamps

GENERAL CHARACTERISTICS

The conventional carbon arc has been used by Section 16.5 both as a visible source and as a concentrated source for long-range projection of IR. The general designations, manufacturers, and military applications are given in Table 2.

The two visible light sources were used by the Institute of Optics, University of Rochester. The Simplex arc lamp was employed in an 11-inch reflector; the Westinghouse carbon-arc assembly, in an 18-inch parabolic reflector mounted in a nacelle for aircraft installation and with remote control.

The 24-inch arc IR unit was adapted from the standard Navy searchlight of the same size. Two such searchlights were mounted in tandem on a single base, with mechanism for directing the pair simultaneously for azimuth and elevation (Figure 27). The operator's

seat and the manual aiming controls are located in the center behind the two searchlight drums. A resistance box was located at the rear of each searchlight

TABLE 2. Carbon-arc lamps.

Source designation	Development auspices	Where developed	Mfd. by	Military application
Simplex arc lamp	BuAer	Simplex Co.	Simplex	Visible light for sea search
Westinghouse carbon-arc assembly	BuAer	WE	WE	Visible light for sea search
24-in. carbon-arc searchlight	BuShips	GE	GE	IR reconnaissance
60-in. carbon-arc searchlight	BuShips	GE	GE	IR reconnaissance

and turned in azimuth with the units. Mounting was also provided for an infrared telescope conveniently located for the seated operator. Eleven-millimeter high-intensity carbons (made by National Carbon Company) were employed.¹¹

The 60-inch arc IR unit consisted of a standard anti-aircraft searchlight of this size modified by application of Polaroid IR filter material to the inside of the cover glass. The unit was used with the standard remote control station, the latter changed to accept an infrared telescope. The control station was interconnected electrically with the searchlight to correlate its aim with that of the telescope. High-intensity carbons made by National Carbon Company were employed; the positive carbon was 16 millimeters in diameter, the negative 11 millimeters. The normal arrangement of power plant, searchlight, and control station is shown in Figure 28.¹¹

OPERATING CHARACTERISTICS

Power Supply. The Simplex arc lamp was powered from a d-c generator. Both the 24-inch and the 60-inch carbon-arc IR units were run (but not simultaneously) from the mobile d-c engine-generator set which is standard equipment for the 60-inch anti-aircraft searchlight (see Figure 28, left).

Modulating Equipment. None was employed with these conventional arc lamps.

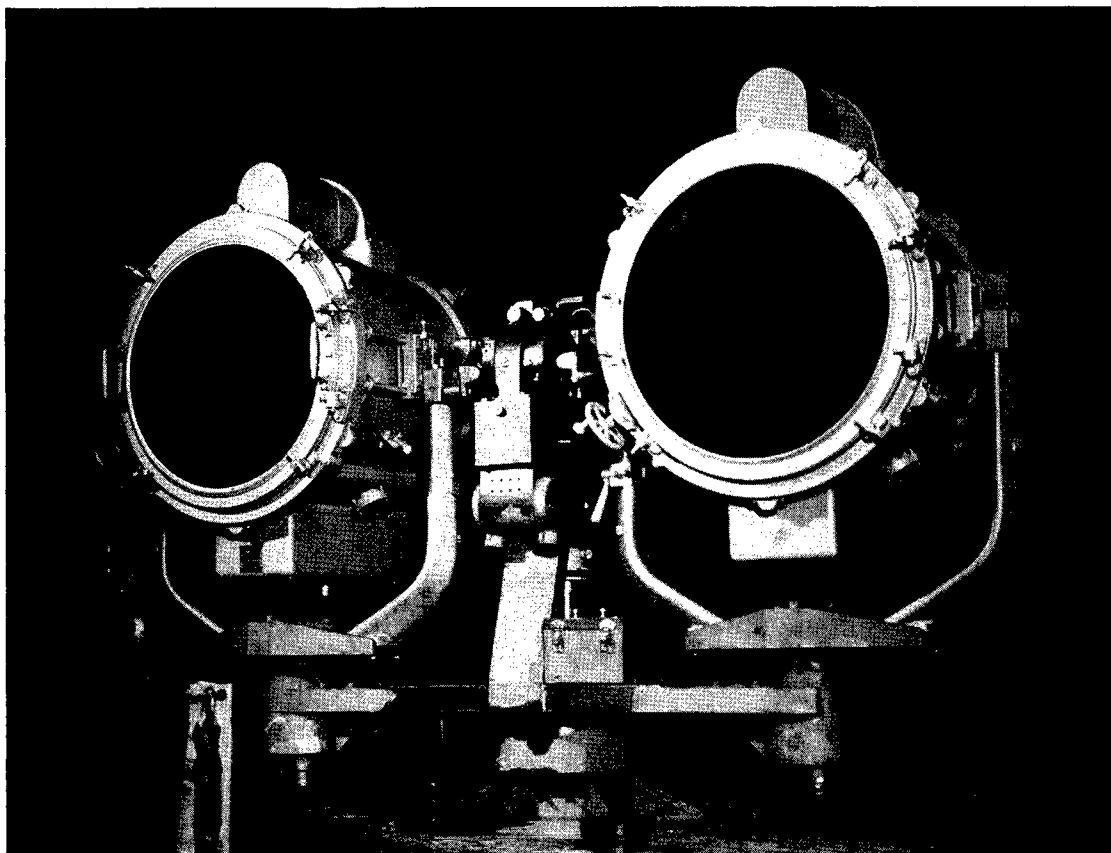

FIGURE 27. Twin 24-inch IR searchlights used with filament and arc lamps for shoreline reconnaissance.

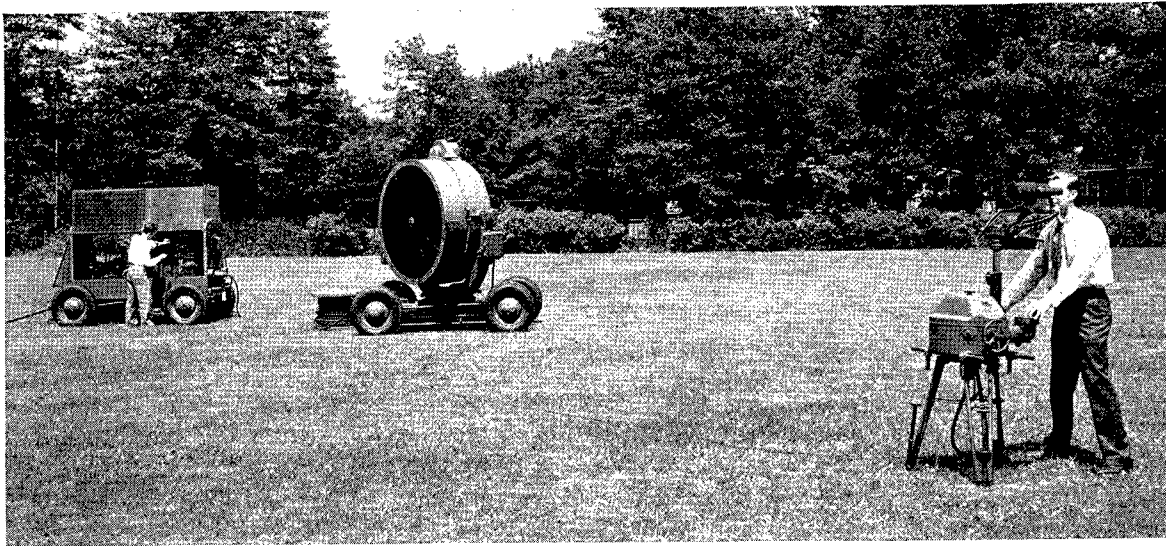

FIGURE 28. (Left to right) The power plant, 60-inch IR arc searchlight, and control station employed for nocturnal shoreline reconnaissance.

Electrical Characteristics. The well-known characteristics of arc lamps (change of current with voltage, etc.) apply to these sources (Table 3). Characteristics of this nature, for the particular IR arc searchlights employed, have not been obtained because they have always been operated at rated voltage and current.

TABLE 3. Arc-lamp characteristics.

Source	Volts	Amperes
Simplex arc lamp
Westinghouse carbon-arc assembly	27	45
24-in. arc searchlight (each unit)	65 to 70	75 to 80
60-in. arc searchlight	80	150

RADIATION CHARACTERISTICS

Spectral Distribution. The approximate spectral distribution curves for the high-intensity arcs employed in the 24-inch and 60-inch IR searchlights are given in Figures 29 and 30. The output is a combination of line, band, and continuous spectra. Since the carbons are replaced as consumed and the reflectors are periodically cleaned, there is no change in spectral quality during the normal life of the searchlight (see Table 4 for other characteristics).

5.3.2 Mercury-Vapor Lamps

GENERAL CHARACTERISTICS

A mercury-vapor lamp is one in which light and other radiation is produced by the excitation and ion-

ization of mercury atoms. Thus the lamp consists of an envelope to contain the mercury vapor and two or more electrodes to deliver power for starting and maintaining the arc discharge. Mercury-vapor lamps are versatile as a type of light source. As will be pointed out later, variations in the design of the lamp (vapor pressure, current, voltage, and the like) can be used to help control the distribution of energy.

Standard mercury lamps are designated by a letter-number combination. Lamps having the same numer-

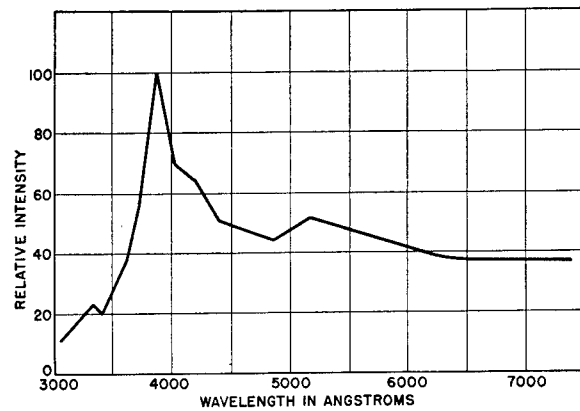

FIGURE 29. The approximate spectral distribution of the carbon-arc lamp in the 24-inch searchlight.

ical designation have identical voltage, current, and power requirements, and therefore each can be employed with a given design of transformer. For example, C-H4 and E-H4 lamps can each be operated from the same transformer, because all mercury lamps

TABLE 4. Radiation characteristics in associated optics.

Source	Candlepower millions	Beam spread to 50 per cent maximum	Filter	Half-beam candlepower	Visual range yards
Simplex arc	7 - 10.5	3°x3°	Used as visible source	...
Westinghouse carbon-arc assembly	30	3°x3°	Used as visible source	...
24-in. twin IR searchlight (both units)	130	1°x1°	4 layers XR7X25	1,550,000	475
60-in. IR searchlight	700	¾°x¾°	7 layers XR7X25	1,200,000	125

with a "4" in their designation have identical mercury-arc elements. The initial letter simply indicates modifications for different bulb shapes, burning positions, or type of outer glass employed.

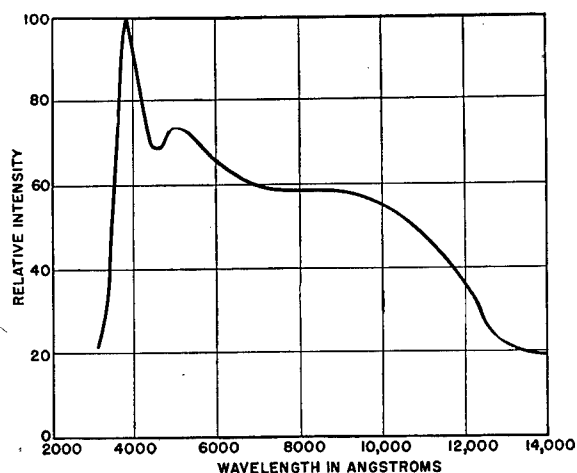

FIGURE 30. The approximate spectral distribution of the carbon-arc lamp in the 60-inch searchlight.

Each mercury lamp must have auxiliary equipment, which often consists simply of the proper size and type of transformer to provide the required electrical values for lamp starting and operation. Separate windings for two lamps are sometimes located on the same core, but provision must be made to ballast each lamp because of the negative volt-ampere characteristics of all discharge sources.

Illustrations of the bulbs and bases listed in Tables 5 and 6 are among those given earlier in this report, except that details of the positioning of the mercury element in the J-H4 are shown in Figure 31. The 4-watt germicidal lamp has a bent-tube construction which makes the lamp approximately 1 inch in width; it has a radio-type 4-prong base.

OPERATING CHARACTERISTICS

Power Supply. Because all mercury lamps have a negative resistance characteristic, each lamp must be provided with suitable ballast equipment to prevent the arc current from reaching destructive values. In

TABLE 5. Development and manufacturing data on mercury-vapor lamps.

Source	Auspices for NDRC project	Development* institution	Original purpose	Military applications	Mfd. by
C-H4	Army and Navy	GE	Near UV spotlight	Night driving Night landing	GE
E-H4	Army and Navy	GE	Near UV floodlight	Night driving Night landing	GE
J-H4	Army and Navy	GE	Night landing	Night driving Night landing	GE
A-H6	BuAer	GE	Photochemical and general lighting	Sea search	GE
A-H10	Army and Navy	GE	Night landing	Night landing	GE
B-H10	Army and Navy	GE	Night landing	Night landing	GE
4-W Germicidal	BuShips	GE	Germicidal source	Metascope source	GE

*All but night driving are NDRC development projects by Institute of Optics, University of Rochester; night-driving project by RCA (instruments) and from GE.

TABLE 6. Design and construction of mercury-vapor lamps.

Source	Bulb	Base	M.O.L. (in.)	Number of electrodes
C-H4	PAR-38	Admedium screw	$5\frac{7}{8}$	3
E-H4	PAR-38	Admedium screw	$5\frac{7}{8}$	3
J-H4	PAR-56	Screw terminal	$4\frac{1}{2}$	3
A-H6	T-2	$\frac{3}{16}$ -in. sleeve	$3\frac{1}{4}$	2
A-H10	PAR-56	Screw terminal	$3\frac{3}{8}$	2
B-H10	PAR-56	Screw terminal	$5\frac{1}{4}$	2
4W Germicidal	T-4	Radio 4-terminal	$5\frac{3}{8}$	2

most cases, this type of control can be achieved by employing a transformer specifically designed for high reactance, with sufficient open-circuit voltage to initiate the discharge and a reduced value when the arc current builds up to the proper value. Where standard voltage a-c power supplies (115 or 230 volts, 60-cycle) are available, standard transformers can be employed. Special designs must be used for other voltage and frequency installations. High-pressure mercury sources (all the lamps discussed in this section except the 4-watt germicidal lamp) do not give best

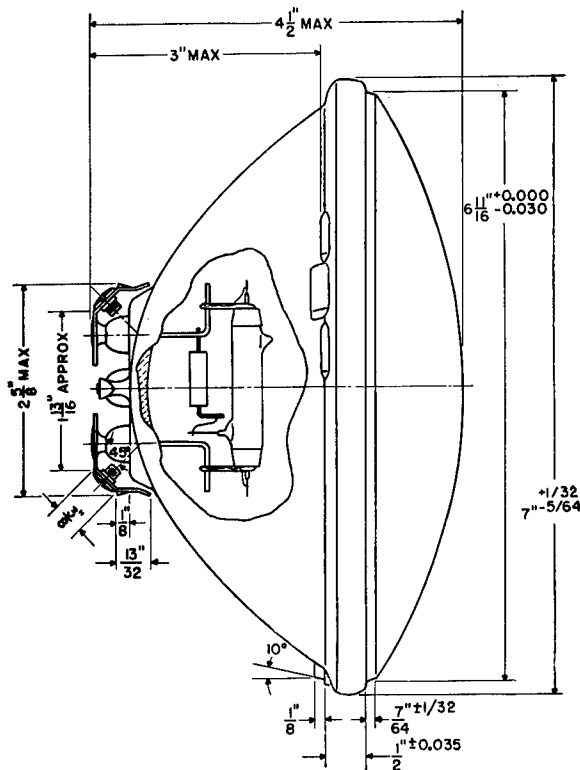

FIGURE 31. Construction details of the 100-watt J-H4 mercury lamp.

performance on d-c power supplies because of the reduction in overall efficiency due to higher wattage losses in the resistance ballast circuit. Too, the difficulty of providing the open-circuit voltage necessary for starting often rules out the use of ordinary mercury-vapor lamps on direct current.

The starting of C-H4, E-H4, and J-H4 lamps is accomplished by a third or starting electrode close to one of the main electrodes and connected to the other main electrode by a small resistor. The A-H6 is a 2-

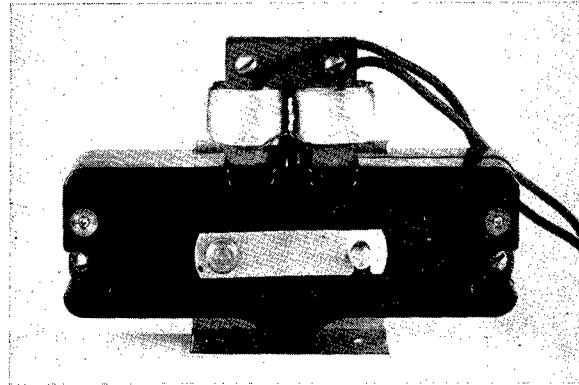

FIGURE 32. The Z-12146 magnetic starter used for the A-H10 and B-H10 mercury lamps.

electrode lamp and is started by applying 1,200 volts (the open-circuit value) across the electrodes. The discharge in A-H10 and B-H10 lamps is initiated by the use of a magnetic starter shown in Figure 32. The starter (GE Catalog No. Z-12146) is connected as in Figure 33.

The voltage surge across the lamp when the starter contacts open starts the discharge, and the lamp current is sufficient thereafter to hold the contacts open magnetically. The 4-watt germicidal lamp can be

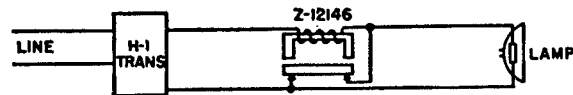

FIGURE 33. Diagram of magnetic starter connection.

started with a push button arrangement or standard FS-5 fluorescent starter to provide the cathode preheat time required. The standard 115-volt, 60-cycle ballast for this lamp carries the GE Catalog No. 58G-825; the ballast is designed to supply the proper cathode current during the short preheat interval.

Because the 1,000-watt, A-H6 lamp has such a small volume, it is necessary that water be passed over the lamp with sufficient velocity to prevent the formation of steam bubbles on the surface of the quartz tube.

TABLE 7. Electrical characteristics of mercury-vapor lamps.

Lamp	Lamp watts	Overall watts (std trans)	Rated life* (hours)	Open circuit volts from trans (sec)	Lamp (volts)	Lamp starting (amp)	Lamp operating (amp)	Starting time to full output
C-H4 E-H4 J-H4	100	123	1,000	245	130	1.3	0.9	3-8 min
A-H6	1,000	1,095	75	1,200	840	2.5	1.4	4 sec
A-H10 B-H10	400	450	20	220	137	5.0	3.2
4-W Germicidal	4	5	1,000	Line values	58	0.8

*Under specified test conditions as to frequency of starting, voltage, auxiliary equipment, and so forth.

TABLE 8. Spectral distribution of radiation from 100-watt C-H4 and E-H4 mercury projector lamps.*

Wavelength (center of band) (Angstroms)	Microwatts per sq cm at 10 ft from front of lamp	
	C-H4	E-H4
2,972	0.007
3,022	0.097
3,075	0.081	0.007
3,131	4.23	0.931
3,192	0.85	0.222
3,255	1.31	0.375
3,322	7.41	2.05
3,394	2.89	0.863
3,472	2.85	0.894
3,556	3.43	1.03
3,648	150.	42.4
3,745	8.01	2.28
3,852	5.39	1.53
3,931	5.49	1.575
4,049	69.0	19.4
4,175	8.04	2.31
4,358	124.	34.9
4,560	6.56	1.85
4,742	6.31	1.79
4,947	7.84	2.19
5,188	7.52	2.07
5,461	156.	43.5
5,780	149.	40.4
6,143	13.0	3.48
6,587	13.5	3.63
7,105	18.4	4.85

C-H4 running at 131.7 lamp-volts and 0.855 lamp-ampere.

E-H4 running at 135.3 lamp-volts and 0.843 lamp-ampere.

Data by B. T. Barnes, Lamp Development Laboratory, GE, Nela Park, Cleveland. From pages 62, 63, Book 58.

*NOTE: These two lamps use the same type of mercury element and the spectral characteristics of each should be quite similar. Since intensities were measured on the axis, the lack of data for the E-H4 at 2972 and 3022 Angstroms is due to cell sensitivity rather than absence of radiation.

The spectral characteristics of the J-H4 should also be very similar to the C-H4 and E-H4. Candlepower of C-H4 17,550, of E-H4 4,830.

This is accomplished by using a glass or quartz water jacket around the lamp, with a very small radial clearance to restrict the water flow. In approved designs, enough velocity results with a flow of about 3 quarts per minute to prevent steam formation.

Modulating Equipment. The mercury-vapor lamps described in this section of the report have not been used by Section 16.5 with modulating equipment for communication purposes.

Lamp Lives. The life of most mercury lamps is increased as the hours of burning per start become greater. In the case of C-H4 and E-H4 lamps, the rated life given in Table 7 is based on specified test conditions with the lamps turned on and restarted no oftener than once every 5 burning hours. The A-H6 life rating is based on tests employing 25-minute burning periods. With the lower ratio of total burning hours per start found in many military applications, the life will be less. In the case of the A-H6, the life may not be more than 25 hours on very short burning periods, such as 3 to 5 minutes.

RADIATION CHARACTERISTICS

Spectral Distribution. Light and radiant energy result from mercury-vapor lamps because of energy transitions (electron displacements) in the ionized mercury atoms. Radiation of particular wavelengths is produced which corresponds to the resonant frequency of the atom, which in turn is dependent on the degree of electron displacement. At low pressures, such as found in the 4-watt germicidal lamp, the radiation output appears almost entirely as energy concentrated at these various resonant wavelengths, giving a line spectrum. At high pressures, such as the 110 atmospheres in the A-H6 when lighted, the radi-

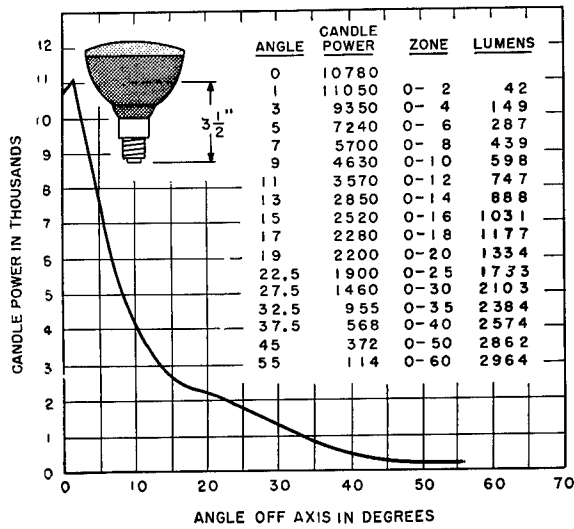

FIGURE 34. Candlepower distribution of a GE Mercury Mazda C-H4 projector spotlight, lamp operating with 115-volts, 60 c a-c on input side of auxiliary; lamp rotating. Bulb is PAR-38 inside aluminized, stippled lens; No. 2 photometer at 25 feet.

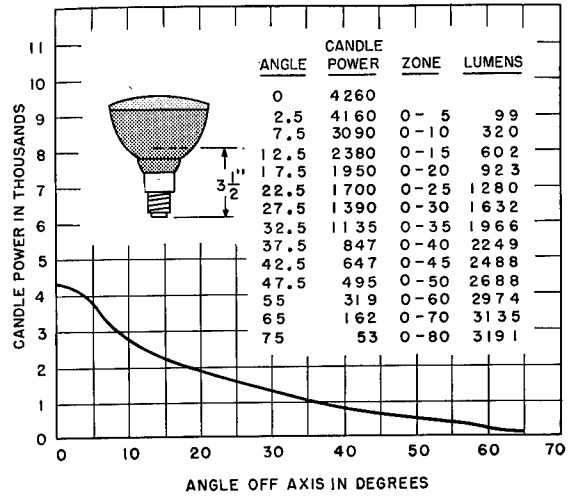

FIGURE 35. Candlepower distribution of a GE Mercury Mazda E-H4 projector floodlight, lamp operating with 115-volts, 60 c a-c on input side of auxiliary; lamp rotating. Bulb is PAR-38 inside aluminized, cross-hatched lens; No. 2 photometer at 15 feet.

TABLE 9. Spectral distribution of radiation from type H-6 water-cooled capillary lamp.

Wavelength band (Angstroms)	Microwatts per cm ² at 1 meter		Wavelength band (Angstroms)	Microwatts per cm ² at 1 meter		Wavelength band (Angstroms)	Microwatts per cm ² at 1 meter	
	quartz jacket	glass jacket		quartz jacket	glass jacket		quartz jacket	glass jacket
2216-2233	0.003		3291-3360	94.	44.5	7250-7610	62.0	61.3
2233-2250	0.020		3360-3434	65.6	36.5	7610-8000	63.1	61.5
2250-2268	0.077		3434-3514	52.6	35.2	8000-8450	65.4	64.0
2271-2289	0.385		3514-3601	48.1	36.8	8450-8900	70.4	67.8
2293-2312	1.32		3601-3696	300.	251.	8900-9390	71.3	67.8
2313-2333	2.06		3696-3798	175.	150.	9390-9880	74.4	61.6
2328-2348	1.24		3798-3902	95.	87.	9880-10410	130.	111.
2343-2364	3.10		3902-3960		40.8	10410-10960	77.6	69.8
2367-2389	10.8		3960-4019		46.3	10960-11560	95.3	74.2
2388-2410	12.8		4019-4079		193.	11560-12170	65.2	35.3
2411-2434	14.3		4079-4142		99.	12170-12800	58.6	32.3
2435-2459	15.3		4142-4209		65.	12800-13440	57.1	24.2
2452-2477	21.2		4209-4280		78.	13440-14060	60.0	8.7
2470-2496	27.4		4280-4354		159.	14060-14550	13.3	
2498-2524	23.6		4354-4431		281.	14550-15130	13.7	
2524-2550	9.5		4431-4516		93.	15130-15710	25.0	
2550-2578	0.033		4516-4605		62.6	15710-16290	24.8	
2578-2607	0.80		4605-4696		51.6	16290-16850	28.0	
2607-2638	7.36		4696-4789		56.6	16850-17390	38.1	
2638-2671	19.1		4789-4892		60.4	17390-17920	23.4	
2671-2705	28.9		4892-5002		45.5	17920-18430	18.9	
2705-2741	34.6		5002-5123		35.6	18430-18930	8.9	
2741-2780	41.4		5123-5252		35.9	18930-19420	0.3	
2780-2820	48.8		5252-5388		55.0			
2820-2861	48.0		5388-5536		396.	20350-20810	2.7	
2861-2904	57.6		5536-5691		134.			
2904-2949	48.3		5691-5863		273.	21650-22080	6.1	
2949-2998	106.	3.1	5863-6043		92.			
2998-3050	116.	6.8	6043-6245		54.4	22910-23320	3.9	
3050-3106	76.	7.7	6245-6470		50.5			
3106-3165	173.	31.5	6470-6705		51.5	24190-24570	0.85	
3165-3226	117.	29.1	6705-6960		55.9			
3226-3291	76.	26.5	6960-7250		59.4			

ation tends to become continuous, or the line spectrum is superimposed on a continuous spectrum.

Spectral distribution data are given in Tables 8 through 11 for the mercury-vapor lamps described in this report. In the case of projector-type lamps (PAR-38 and PAR-56) used for visible applications, the

values given represent the output of a complete unit. For ultraviolet and infrared energy applications, the lamp output must be modified by the spectral transmission characteristics of the filter.

Brightness. The maximum brightness of conventional mercury lamps is in the direction perpendicular

TABLE 10. Spectral intensities perpendicular to axis of 400-watt, ribbon-seal, air-blast cooled mercury-vapor lamp.

Primary volts = 115
 Primary watts = 450
 Lamp amp = 3.6
 Lamp volts = 120
 Lamp watts = 400
 E-vitons per steradian = 283,000

Candlepower = 1,660
 Lumens = 17,100
 Brightness = 64 candles per mm²
 Color coord.: X = .324 Y = .365
 Color temp = 5870 K + 38 m.p.c.d.

Wavelength band	Principal lines	Milliwatts per steradian	Wavelength band	Principal lines	Milliwatts per steradian
2198-2214	49	4431-4516	48
2214-2230	67	4516-4605	34
2230-2246	85	4605-4696	32
2246-2262	2259-61	101	4696-4789	35
2262-2279	110	4789-4892	45
2279-2298	116	4892-5002	4916	56
2298-2317	2302-04	130	5002-5123	33
2317-2337	2323	110	5123-5252	34
2337-2358	2353-54	129	5252-5388	60
2358-2379	128	5388-5536	5461	1,070
2379-2401	2399-401	149	5536-5691	110
2401-2424	98	5691-5863	5770-91	1,410
2424-2448	2447	65	5863-6043	94
2448-2472	2464	107	6043-6245	6234	64
2472-2498	2482-84	290	6245-6470	65
2498-2524	126	6470-6705	70
2524-2550	2535-39	340	6705-6960	6716	96
2550-2578	2576	450	6960-7250	7082-92	95
2578-2607	280	7250-7580	88
2607-2638	200	7580-7950	7606-729	97
2638-2671	2652-55	550	7950-8350	101
2671-2705	2697-701	182	8350-9040	168
2705-2741	93	9040-9710	183
2741-2780	2753	135	9710-10480	10140	580
2780-2820	2800-07	310	10480-11360	11187-290	340
2820-2861	84	11360-12280	11890-2130	280
2861-2904	2894	170	12280-13200	167
2904-2949	2925	82	13200-14100	13570-955	400
2949-2998	2967	460	14100-14980	133
2998-3050	3021-27	730	14980-15850	15300	174
3050-3106	91	15850-16700	118
3106-3165	3126-32	1,200	16700-17520	16900,17100	330
3165-3226	93	17520-18300	106
3226-3291	51	18300-19040	81
3291-3360	3341	200	19040-19740	75
3360-3434	55	19740-20420	69
3434-3514	35	20420-21080	61
3514-3601	55	21080-21720	57
3601-3696	3650-63	1,900	21720-22340	50
3696-3798	170	22340-22970	50
3798-3909	3902-3906	100	22970-23590	52
3909-3960	34	23590-24200	42
3960-4019	43	24200-24800	39
4019-4079	4047-78	550	24800-25390	39
4079-4142	82	25390-25960	36
4142-4209	34	25960-26530	29
4209-4280	45	26530-27080	27
4280-4431	4339-58	1,140			

TABLE 11. Spectral distribution of radiation from 4-watt germicidal lamp.*

Wavelength Angstroms	Total output milliwatts	Wavelength Angstroms	Total output milliwatts
2436	0.40	3255	0.15
2460	0.37	3322	0.34
2485	0.36	3394	0.19
2511	1.6	3472	0.22
2537	600	3556	0.26
2564	1.1	3648	9.0
2592	0.25	3745	0.40
2622	0.0	3852	0.0
2655	0.86	3931	0.55
2689	0.0	4049	11.4
2725	0.0	4175	0.42
2760	0.17	4358	25.6
2800	0.16	4560	0.19
2840	0.16	4742	0.16
2881	0.59	4947	0.21
2925	0.14	5188	0.33
2972	1.9	5461	15.1
3022	1.2	5773	3.9
3075	0.0	6143	0.26
3131	9.0	6587	0.20
3192	0.14	7105	0.24

*Based on rated output of 0.6 watt, 2537 A at 100 hours life. Initial outputs will be approximately 25 per cent higher. The average output throughout life is approximately 0.5 watt at 2537 A.

to the axis of the arc tube. This brightness for the A-H4 lamp (which uses the same basic 100-watt element as the C-H4, E-H4, and J-H4) is 8 candles per square millimeter. For the three PAR lamps using this mercury element, the brightness would be somewhat less, and its spatial distribution would depend on the accuracy of positioning the arc tube in the reflector and the type of cover glass employed. Figures 34 and 35 give the candlepower distribution for typical C-H4 and E-H4 lamps.

The brightness of the 1,000-watt water-cooled A-H6 is approximately 300 candles per square millimeter and the A-H10 and B-H10 have element brightnesses

TABLE 12. A-H10 beam output.

Beam candlepower	With reflector	Without reflector
7-inch	490,000	2,070
8-inch	509,000	2,360
Beam spread to half maximum	Vertical	Horizontal
7-inch	1°42'	6°6'
8-inch	2°42'	7°29'

of approximately 65 candles per square millimeter. As in the case of the C-H4 and E-H4, the unit (complete lamp) brightness is lower because of the reflection factor of the built-in reflector. The candlepower distribution curve of an A-H10 lamp is given in Figure 36. It will be noted that the spread to half-

maximum is somewhat different than obtained by tests at Rochester (see Table 12).

Beam Output and Distribution In Specific Optics. The distribution curves (Figures 34 to 36) indicate the maximum unfiltered candlepower for all the projector-type mercury sources covered in this report except the J-H4. The latter was employed by the Institute of Optics, University of Rochester for UV night landing. Experimental lamps using the H-4

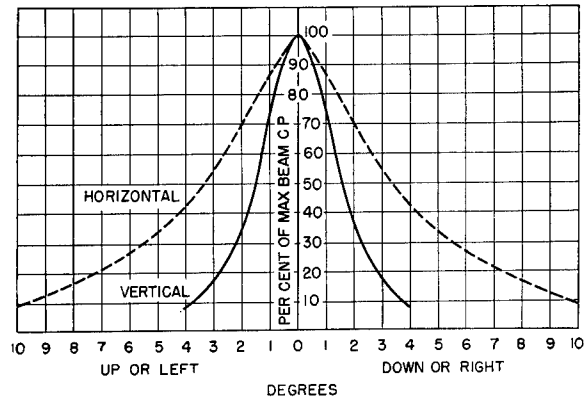

FIGURE 36. Percentage candlepower distribution for the 7-inch 400-watt A-H10 mercury lamp, maximum candlepower 600,000.

mercury element were mounted both horizontally and in the end-on position within the parabolic reflector. No data on outputs are available.

The A-H6 lamp employed in the sea-search project (Section 9.5) had a candlepower of 5,300 with 120 volts on the primary of the transformer. In the 24-inch parabola (10-inch focus, reflection factor 0.91, arc area 0.25 square centimeter), the beam candlepower was 52,700,000, with beam spread of $\frac{1}{3}$ degree to half-maximum.

The A-H10 UV source gave the outputs and distribution at the Institute of Optics shown in Table 12.

Filters. For ultraviolet uses, the filters shown in Table 13 were employed.

TABLE 13. UV filters with mercury-vapor lamps.

Source	Filter
J-H4	UV filter 3 mm #5874 plus 3 mm #5860
A-H10, B-H10	UV filter 3 mm #587 plus 3 mm #586
4-watt germicidal lamp	UV filter 1.78 (10 mm) molar N-Cl and 5.3 mm of Corning # 9863 (Wavelengths transmitted, 2537 A group and 3130 A group—90 per cent in 2537 A group).

Chapter 6

ULTRAVIOLET SOURCES AND FILTERS

By Charles A. Federer, Jr.^a

6.1 INTRODUCTION

IN THE COURSE OF NDRC investigations of optical methods of military communication and recognition, ultraviolet [UV] radiation has been given considerable attention, for under certain circumstances it furnishes relatively high security and satisfactory ranges. Chief contractors for this work have been the University of California (Department of Physics), OEMsr-1073; the University of Rochester (Institute of Optics), OEMsr-1219; and the New Jersey Zinc Company, OEMsr-740.

Perhaps the chief contribution to the progress of UV communication has been the invention of the gallium lamp, described in Section 6.2.3, as a result of work at the University of California. This lamp produces radiation of wavelengths invisible to the scotopic (dark-adapted) eye, thereby overcoming the objection to such sources as the high-pressure mercury arc, which can be seen several miles away on a dark night, even though the source is well-filtered.

Although developments in optical communication by infrared means have outstripped those in the ultraviolet, principally because of the objection to ultraviolet visibility just mentioned, UV can often be used by day when infrared is impractical.

REGIONS OF THE ULTRAVIOLET

The ultraviolet may be considered as extending from 0.4 micron to 0.3 for the *near ultraviolet* [NUV], from 0.3 to 0.2 for the *middle ultraviolet* [MUV], and shorter than 0.2 micron for the *far ultraviolet* [FUV]. The NUV can pass through the eye lens and cause fluorescence of the retina; the FUV suffers rapid atmospheric extinction; consequently, only the MUV is practical for military security. Even at 0.2 micron, however, the atmospheric transparency is practically zero, and the most useful portion of the MUV is from 0.3 to 0.25 micron.

The region of the MUV most suitable for military use is further narrowed by the factors illustrated in

^aHarvard College Observatory. The material in this chapter has been prepared principally from the report¹ on ultraviolet communication written by Dr. Harvey White, of the Department of Physics, University of California at Berkeley.

Figure 1, so that a desirable UV source is one which emits strongly and efficiently in the region 0.270 to 0.295 micron, with as little radiation as possible at longer wavelengths.

RANGES OF THE ULTRAVIOLET

On an average clear day, the atmospheric transmission for the visible region of the spectrum is about 60 per cent per mile. At this same time, in the 0.270-0.295-micron band, the transmission is about 40 per cent

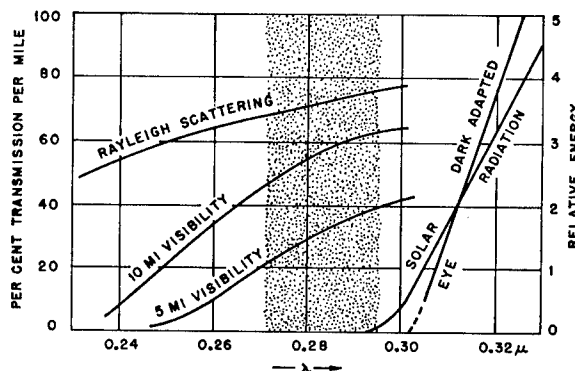

FIGURE 1. Graphs of factors affecting transmission and operation in the ultraviolet region.

per mile, and this latter is taken arbitrarily as the practical value to be expected under this condition. If R_0 is defined as the maximum distance in miles between light source and receiver at which satisfactory operation could be maintained if atmospheric transmission were 100 per cent, R is the actual range in miles of a source and receiver, and T is the atmospheric transmission per mile, then: $R = R_0(T)^{R/2}$.

Figure 2 is a graph of this equation, and shows clearly the ranges to be expected in the field. The values of R_0 have been determined from laboratory measurements in which the light path is through only a few feet of air. For example, the curve labeled $R_0 = 20$ miles is used for a source-receiver system which has a vacuum range of 20 miles, as measured in the laboratory. On an average clear day when the visibility range is 10 miles, the UV transmission T is taken as 40 per cent per mile; the practical field range is 3.6 miles, or about 6,300 yards.

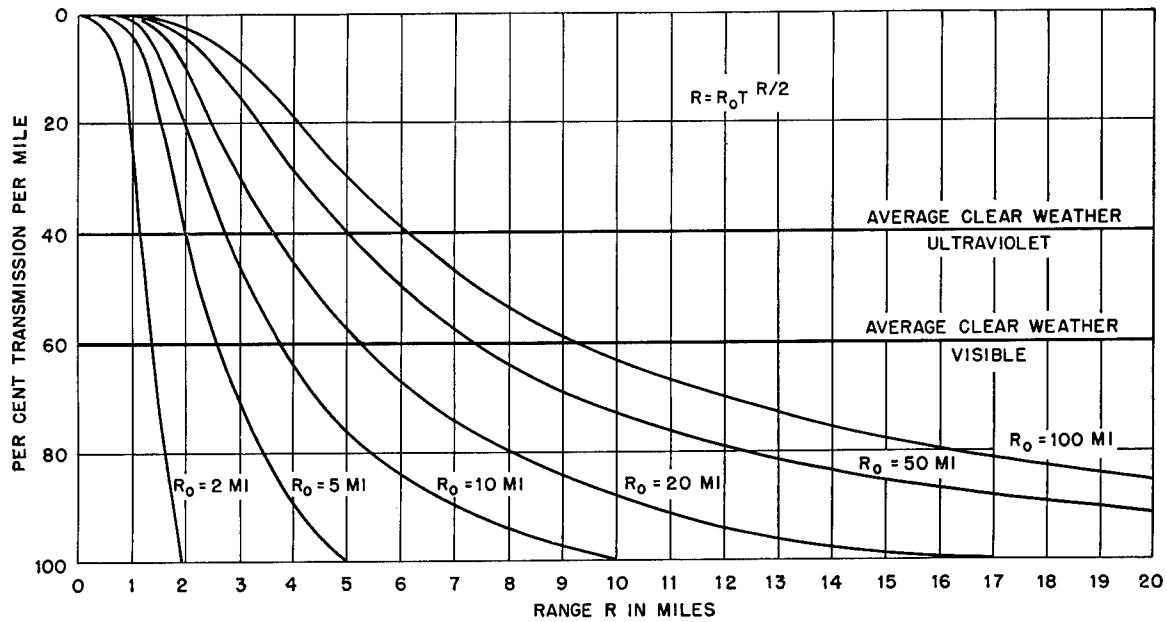

FIGURE 2. Graphs giving actual range R to be expected in the field, as they depend upon laboratory-measured vacuum range R_0 and the existing atmospheric transmission T .

TABLE 1. Field ranges attained with invisible ultraviolet sources of radiation. (Values are given in yards and are limiting ranges determined for $\lambda = 0.280\mu$ and an atmospheric transmission of 40 per cent per mile.)

Receiver		Source	High-pressure mercury arc 400 watt 4°x10° beam	Low-pressure mercury arc 25 watt 360° beam	Gallium lamp 50 watt 15°x25° beam	Magnesium spark 250 watt 6°x6° beam	Carbon arc d-c 65 amp 2°x2° beam	Carbon arc d-c 65 amp grid-modulated 6°x6° beam	Flame arc 50 amp 500 c 360° beam
Phosphor metascope for visual perception	Day				200				
	Night	8,500			2,000	>2,000			
Autocollimators seen with unaided eyes	Day								
	Night	3,500			750	1,000			
1,000-c source signal and 2°x2° photomultiplier receiver	Day			1,600		5,000	11,000		6,200
	Night								
2°x2° photomultiplier voice receiver	Day			800	800			4,500	
	Night				5,000			>9,000	
Quartz triple-chopped return and multiplier receiver	Day						>1,400		
	Night								
Geiger-Mueller tube counter 10° receiver	Day				200				
	Night				>>1,000				
Quartz triple return and metascope	Day				30				
	Night				200				

Table 1 gives the practical ranges, R , of various ultraviolet sources with different receivers. Spaces not filled in are not considered practical either because of visual insecurity or shortness of range.

ULTRAVIOLET FLUORESCENCE

More substances fluoresce under NUV radiation than under MUV, but some substances fluoresce under the shorter wavelengths and not at all under the longer, and vice versa. The spectacles of an unknowing observer in the path of UV light may fluoresce, and similar action within the eye itself results in the *visibility* of ultraviolet sources at great distances. The eye lens is opaque, however, to MUV radiation. Binoculars of ordinary glass are also opaque to UV.

The fluorescence with spectacles led to the testing of the coverings of aircraft taken from captured enemy planes. It was hoped that the plastics used in the cabin cowlings of such planes would fluoresce under ultraviolet light, thereby cutting off the pilot's vision through to the outside. Many samples were tried, with disappointing results because the fluorescence is far too weak to have any significant effect.

6.1.1 Results of NDRC Studies

The following are the principal results of work by NDRC on ultraviolet recognition and communication systems.

1. The high-pressure mercury-arc source was studied and its use abandoned because as a source it was not entirely invisible, and some of its surroundings gave visible fluorescence (see Section 6.2.1).

2. Two new types of UV sources, the gallium lamp (see Section 6.2.3) and the magnesium spark lamp (see Section 6.2.4), were developed to meet the security requirements for night operation. Both lamps give usable ranges when employed as identification markers or for communication with International Morse Code.

3. The gallium lamp can be voice-modulated and speech-transmitted through it with 100 per cent intelligibility for 5,000 yards on an average clear night.

4. Carbon arcs can be used as sources of ultraviolet radiation in the daytime, with usable ranges for both signal and voice communication. A grid-modulated carbon-arc source has been made that gives good voice communication at 4,500 yards by day.

5. A flame arc, without any reflector, gives 360-degree coverage, and can be picked up in the daytime

at 6,000 yards. This source could be voice-modulated for a 3,500-yard range on an average clear day.

6. Table 1 gives the field ranges attained in tests with the UV systems developed by NDRC.

6.2 ULTRAVIOLET SOURCES

6.2.1 High-Pressure Mercury Arcs

The high-pressure mercury arc was invented some years ago by Bol, and is considered one of the strongest of light sources, its intrinsic surface brightness being comparable to that of the sun. The radiation of this lamp is very high in the NUV, but relatively weak in the MUV. Most systems employing mercury arcs for UV radiation use part of the NUV, as described below. If only the MUV is used, the radiation is weak and very small ranges are obtained.

Nevertheless, in the fall of 1941 and the first half of 1942, extensive experiments were performed under NDRC Contract OEMsr-1219, in which various sizes and styles of these arcs were studied. The most effective unit developed employed a 400-watt air-cooled GE mercury arc mounted at the focus of a 6-inch parabolic mirror and equipped with either one of two filters.

With the Corex 9863 filter (see Section 6.4.1), the above source showed no visible light, but wavelengths 0.366 micron and 0.313 micron were strongly emitted. With the nickel filter (see Section 6.4.2), 0.366 micron was cut off, and only 0.313 was visible, but even this caused significant fluorescence in the naked eye of an observer a mile away.

On an average clear night, these sources can be readily located and observed by means of an ultraviolet phosphor metascope (see Chapter 3) at 5 or 10 miles. Field tests with autocollimators (see Chapter 7), set up at distant points and viewed with the unaided eyes of the observer at the source, gave ranges almost identical with the visibility of the source itself to the unobstructed eye, 2 miles with filter 9863 and 1 mile with the nickel filter.

A number of successful airborne tests were performed with high-pressure mercury-arc sources on a plane and with rows of autocollimators lining the runway of a landing field. The runway was first seen at about 2 miles; good approaches and landings were made on all trials. The general results of various other field tests were all satisfactory, but the lack of security ruled out further development.

For daytime use, although the mercury arc gives a strong NUV radiation, sunlight and sky radiation are so strong that receivers covering any appreciable angular field are overloaded. The MUV radiation is too weak for use by day, so on this count, also, the high-pressure mercury arc is ruled out.

6.2.2 Low-Pressure Mercury Arcs

On numerous occasions, low-pressure mercury discharge tubes have been tested as sources of ultraviolet, using their strong radiation at 0.2537 micron. (High-pressure mercury arcs do not emit this wavelength because such light is strongly absorbed by the surrounding mercury vapor.)

While the efficiency of the low-pressure mercury-arc discharge is higher for 0.2537 micron than is the gallium lamp for 0.290 micron, the atmospheric attenuation is considerably greater. As a consequence, the ranges obtained on average clear days are comparable to gallium, and are therefore inadequate for daytime use. Since mercury tubes are widely manufactured in long straight designs, it appears feasible to mount a considerable number of tubes in a cylinder

arc spectrum offered interesting possibilities as a source of invisible ultraviolet radiation. Preliminary attempts to substitute gallium for mercury in commercial quartz lamps failed until further effort was expended in the purification of the gallium. A lamp consisting of a pool of gallium with a tungsten anode and filled with argon operated successfully but with low brilliance even at dull-red heat. Another attempt to substitute gallium for mercury in the Bol high-pressure mercury arc produced a very bright source but the life was only long enough to obtain spectrograms showing typical gallium lines.

Other experiments with potassium chloride, gallium chloride, bromide, and finally iodide, showed that it was necessary to use one of the volatile compounds of gallium to obtain reasonable brightness at conveniently controlled temperatures. Only gallium iodide was free of objectionable lines in the NUV region. (At the time of this development, optical filters isolating the NUV from the MUV were not considered practical.)

Table 2 gives the spectral distribution of the gallium iodide discharge lamp, as determined from one

TABLE 2. Emission spectrum of the gallium lamp (microns).

Wavelength band	Milliwatts steradian	Wavelength band	Milliwatts steradian	Wavelength band	Milliwatts steradian	Wavelength band	Milliwatts steradian
.2448-.2472	0.3	.2705-.2741	0.07	.3696-.3798	0.02	.5232-.5512	0.07
.2472-.2498	0.1	.2741-.2854	0.0	.3798-.3909	1.2	.5512-.5835	0.02
.2498-.2524	0.5	.2854-.2897	4.75835-.6215	0.0
.2524-.2550	1.5	.2897-.2921	0.2	.3876-.3989	6.1	.6215-.6672	0.07
.2550-.2607	0.0	.2921-.2968	9.1	.3989-.4110	19.1	.6672-.7210	0.05
.2607-.2638	0.8	.2968-.3018	0.03	.4110-.4244	18.1
.2638-.2671	0.5	.3018-.3601	0.0	.4244-.4391	0.08	.7105-.7760	0.2
.2671-.2705	0.04	.3601-.3696	0.07	.4391-.5232	0.0	.7760-.8545	0.6
						.8545-.9415	0.5

and to obtain a 360-degree distribution with considerable range. Voice modulation of the tubes is not difficult, so that they could be used for general voice communication.

It is difficult to filter properly the low-pressure mercury arcs for nighttime security. This is due largely to the emission of light in the NUV. The gallium lamp does not present this problem and is therefore considerably more effective for night work.

6.2.3 The Gallium Lamp

INTRODUCTION

A systematic survey of the spectra of all the chemical elements led to the conclusion that the gallium-

lamp sent to the General Electric Lamp Works, Nela Park, Contract OEMsr-423.

Because a filter must be used over the receiver phototube or the metascope to cut out solar radiation, daytime ranges are only one-third as great as those obtained at night, and daytime use of the gallium lamp is not promising.

Compared with the high-pressure mercury arc, this lamp is very easy on the eyes. No ill effects have been experienced by any workers operating for many hours day after day. The peak gallium-lamp radiation is absorbed by the cornea of the eye and never reaches the retina.

LAMP CONSTRUCTION

Details of the construction of the gallium iodide lamp are given in the contractor's report.¹ After preliminary work with lamps of different sizes and shapes, a final design was developed to be used with a 6-inch reflector for portable service (Type 6GS6). The discharge tube itself is shown in Figure 3, lamp and reflector in Figure 4, and portable assembly in Figure 5.

The Discharge Tube. This fused-quartz tube is held mechanically in a fused-quartz jacket. The tube is made by bending a suitable length of 6-millimeter fused-quartz tubing into the shape of a U. The finished U-tube is about 7 centimeters long and 1.7 centimeters wide. An oxide-coated tungsten wire is wound into a close helix 3 to 4 millimeters long and 1 millimeter in diameter and is sealed at the end of each

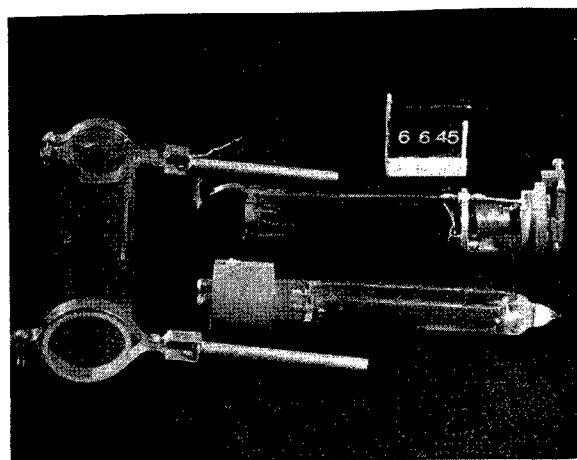
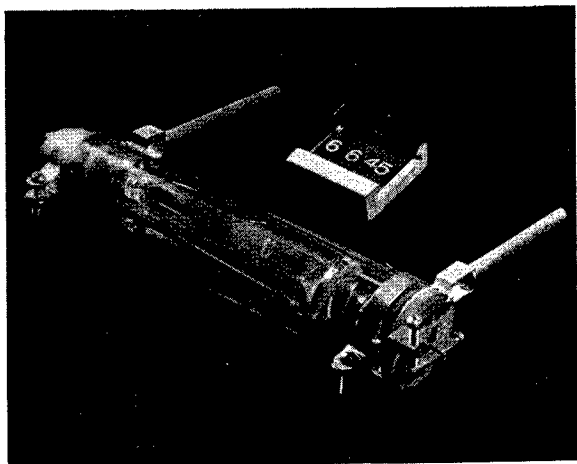

FIGURE 3. Gallium lamp. *Upper*—Discharge tube assembly. *Lower*—Disassembled unit showing discharge tube, thermostat and jacket.

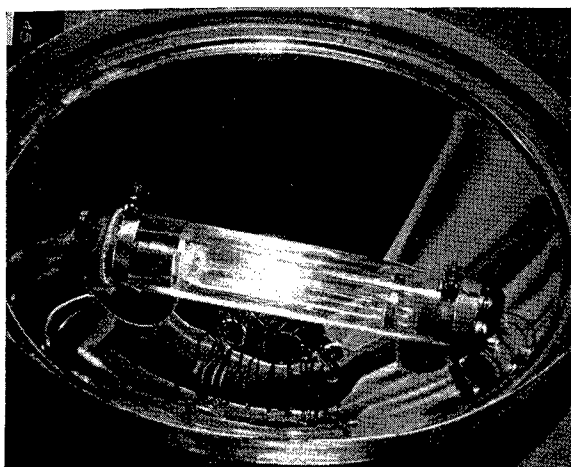
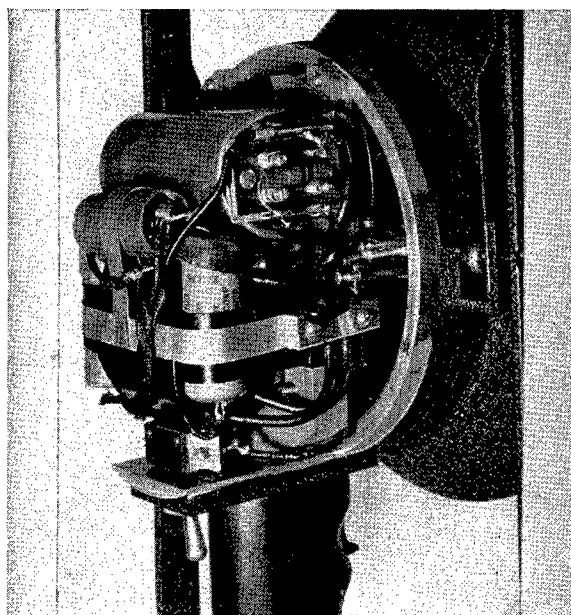

FIGURE 4. Gallium lamp and reflector. *Upper*—Rear view with housing removed to show electrical parts and assembly. *Lower*—Front view with filter removed to show mounting of discharge tube.

leg of the U. Each electrode is separated from the main discharge space by a 1-millimeter section of fused-quartz capillary selected to fit into the 6-millimeter tubing. A seal-off tube is provided at the bend, and used for evacuating and finally filling the tube with pure gallium iodide and a mixture of gas consisting of 20 millimeters of argon and 5 millimeters of neon. This tip serves finally as a reservoir for the gallium iodide and is thrust through a metal shield so as to be in immediate contact with a bimetallic thermoregulator.

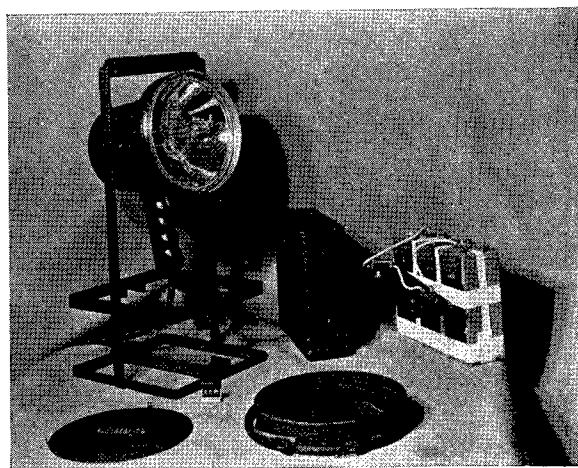
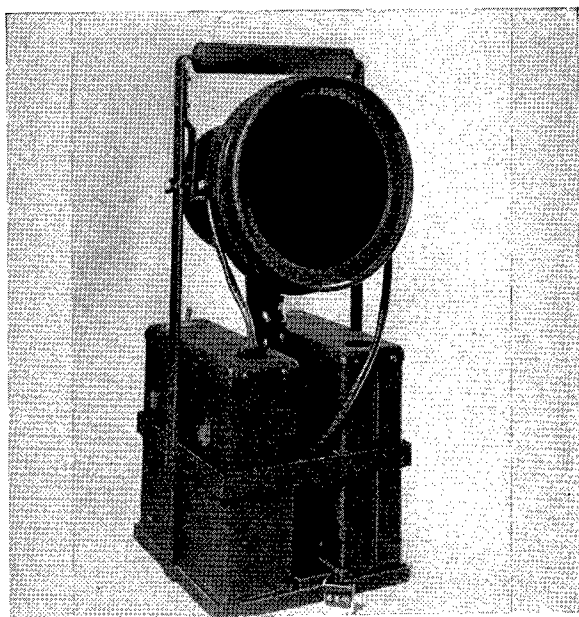

FIGURE 5. Gallium lamp portable assembly. *Upper*—Assembled, complete with batteries and carrying stand. Lamp and one battery when removed form one complete unit for code communication. Spare battery is for prolonged operation. *Lower*—Disassembled unit showing component parts.

The gallium was purified by several chemical methods, all of which proved wasteful or time-consuming. The method of purification finally adopted consisted first of sealing a sample of the metal in a fused-quartz tube, evacuating and heating so as to distill off the volatile constituents and leave the gallium plus nonvolatile constituents behind. The distillation was performed at red heat (650 C) and the residue cooled with solid carbon dioxide and then transferred to a solution of dilute sulfuric acid (about 0.1 to 0.01 M). The acid was warmed until the gallium melted; then

ice was used to cool the solution gently while at the same time a platinum wire dipped alternately into the pool of liquid metal and then into a crack in a piece of ice. This process brought about a slow growth of gallium crystals.

When completed, the mass of crystals was made the anode of an electrolytic cell using a platinum cathode in the same acid solution. Very low current accomplished the electrolysis, and the surface of the crystal became etched or tarnished. The process of recrystallization was repeated several times until the gallium no longer tarnished in the electrolysis. The final product was so pure that concentrated nitric acid did not attack it. Several methods of preparing small individual crystals to be used in lamp making were developed. Individual vials of gallium iodide 2 to 3 millimeters in diameter and 10 to 20 millimeters long were also prepared. Each had a fragile capillary tip which could be broken by shaking the vial about in a larger tube containing a short section of rod to serve as a hammer.

Filling and Stabilizing the Discharge Tube. Two lamps were sealed to a fused-quartz tube containing one of the vials and the mechanism for breaking it. The system was evacuated, thoroughly heated, and then filled with argon and operated while still on the vacuum line. The argon was changed several times until the electrodes formed and the argon showed the proper pinkish color. The final gas mixture of 20 millimeters of argon and 5 millimeters of neon was then introduced into the system and the tube containing the vial of gallium iodide, together with the lamps, was sealed off the line. The vial was then broken and the gallium iodide distilled into the lamps. The lamps were again operated by using a neon-sign transformer at a current of about 30 milliamperes. When each tube seemed to reach the proper operating conditions, it was sealed off individually and the tube containing the vial was cleaned and made ready to be used for another lamp.

If the operating temperature of the tube is too low, no gallium lines appear; if the tube is too hot, an extremely high voltage is required to produce any discharge at all. For efficient operation, the temperature gradient in the tube must be carefully adjusted so that the solid gallium iodide collects and remains in the small cool pocket made by the seal-off tube. Before operating the lamp, it is necessary to distill most of the gallium iodide into this position by heat alone. The tube is then connected to the terminals of a current-limiting transformer capable of giving 40 or 50

milliamperes at a voltage sufficient to operate the tube.

The operating voltage is a function of the temperature and of the condition of the electrodes. Individual lamps may vary in operation from 250 to 450 volts. A higher voltage means the lamp is either too hot or that all of the gallium iodide has not been distilled away from the electrode region. Newly made tubes should operate at about 40 or 50 milliamperes at the start, and then at between 25 to 30 milliamperes. Should the lamp fail to stabilize, it is often necessary to turn off the current and use heat alone to distill more gallium iodide.

THE PORTABLE LAMP UNIT (6GS6)

This unit is illustrated in Figure 5, and the electrical circuit for operation from a 6-volt storage battery is given in Figure 6. This is essentially a conventional vibrator power-pack assembly using a special transformer with an open-circuit voltage of about 1,500 volts. The function of the resistor R_1 inserted into the primary circuit is to limit the operating current through the lamp to about 25 milliamperes.

Figure 7 shows the electrical circuit for modulating the gallium lamp for voice communication. The rectifier tube in the secondary circuit is important to

The entire portable source housing, 6 inches in diameter and weighing 6 pounds, is mounted between the uprights of a frame carrying two 6-volt, light-weight storage batteries. The complete unit, with all necessary gear, weighs 32 pounds.

Operation and Visibility of the Portable Unit. As a marker on the ground, or carried and hand-oper-

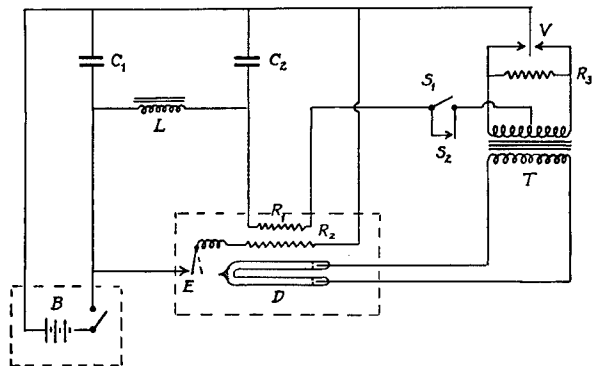

FIGURE 6. Circuit diagram for portable gallium lamp (6GS6). B , 6-volt storage battery; C_1 and C_2 , 0.5- μ f paper condensers; D , discharge tube; E , thermo-regulating element; L , radio frequency choke; R_1 , 0.35-ohm coil of heavy resistance wire mounted in the lamp reflector; R_2 , 1.2-ohm heating element inside jacket; R_3 , 50-ohm resistor; S_1 , toggle switch for "stand-by" condition; S_2 , signaling trigger switch; T , transformer, Gardner No. 4600; V , Radiart vibrator No. 5334.

prevent distortion due to frequency doubling. This circuit, adapted from existing equipment, is not necessarily the best or the most efficient arrangement. Field tests show no difficulty in obtaining 100 per cent intelligibility.

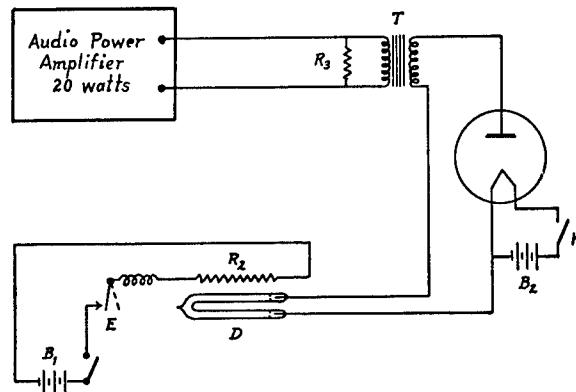

FIGURE 7. Circuit diagram for speech modulation of the portable gallium lamp (6GS6). B_1 and B_2 , 6-volt batteries; D , discharge tube; E , thermo-regulating element; K , rectifier tube HK24-K; R_2 , heating element inside jacket; R_3 , 50-ohm resistor.

ated for signaling, the unit can maintain continuous operation for 2 hours. The beam angle is 25 degrees horizontally and 15 degrees vertically, considering the limits at half the intensity of the central maximum. On moonless nights, the unaided eye cannot see the radiating source beyond 5 to 10 yards. The ground and objects in front of the lamp fluoresce very faintly, but are not visible beyond some several yards.

A 2-inch and a 5-inch metascope (see Chapter 3) with UV phosphor buttons and corrector plates that will transmit UV have been used to observe the gallium source. At 1 mile, it is easily seen with either instrument; 2 miles is probably the limit on average clear nights (transmission 40 per cent per mile). With phosphor metasopes equipped with corrector plates made especially for UV, twice this range can be expected, but none have been made. Hand-held image tubes could be made that should enable these lamps to be seen at from 3 to 5 miles on average clear nights. It is evident that the gallium lamp development brings UV more nearly on a par with infrared as a means for night signaling with high military security.

As a Signaling Lamp. The lamp and one light-weight battery can be hand-held for signaling, a trigger on the lamp handle being used for coding. This unit has a weight of 17 pounds, will operate on code

for 1½ hours, and has the same range as given above for continuous beacons.

Voice Transmission. By directly modulating the current input to the discharge tube, voice transmission is readily accomplished. A newly developed photomultiplier tube (RCA 1P28—see Chapter 2) was mounted at the focus of a 10-inch $f/1$ mirror and used as a receiver. On an average clear night, the voice range of this combination, with 100 per cent intelligibility, is about 3 miles (vacuum range 15 miles). Several gallium discharge tubes in a 12-inch reflector should give a 25 per cent increase in range with an equally wide beam angle.

Use with Autocollimators. Five-inch UV autocollimators were made by BuAer for use with gallium lamps. At 600 yards, these markers accept UV radiation and return it as visible light to a circular field about 2 feet in radius around the source as a center. Thus, an observer within 2 feet of the source sees the returned beam, whereas it is otherwise invisible. The autocollimators cover a field of about 45 degrees horizontally and 30 degrees vertically.

The range for a single autocollimator is 600 yards, but a cluster of three of them can be seen at 750 yards in average clear weather. Twice this range is obtained with 7x50 binoculars, and 10 per cent greater range when single or triple clusters are lined up in rows, as they were when used to line the runway of a landing field.

6.2.4 The Magnesium Spark

INTRODUCTION

The magnesium spark involves essentially an electrical spark discharge from condensers between magnesium electrodes operating on high voltage direct or alternating current. The UV radiation consists of four very strong lines from ionized magnesium atoms. Their wavelengths, 0.2791, 0.2796, 0.2798, and 0.2803 micron, lie exactly in the more desirable region of the spectrum. Radiation of very low intensity from neutral magnesium is also present at wavelengths 0.2852, 0.3097, 0.3337, and 0.3838, but if the potential across the spark gap is high and the spark is quickly quenched, this neutral radiation can be kept insignificant.

The spark itself is intensely bright, measures about ½x¼ inch, and gives a fairly narrow beam when mounted in a 6-inch parabolic reflector. It cannot be modulated for voice, but does respond perfectly to code signaling.

ELECTRICAL CIRCUITS

For the magnesium source to be practical, the auxiliary electrical equipment must not be too heavy, the radiation must be of high efficiency, and filters must suppress undesirable wavelengths of radiation. Several types of circuits have been found suitable, and these are described in the contractor's report.¹

One method employs high-frequency excitation by charging a condenser placed across the secondary of a transformer, and discharging it through a spark gap, as shown in the upper part of Figure 8. Spark lines, rather than arc lines, are produced as the voltage drops very rapidly because of the high-frequency oscillation of the discharge. The number of sparks per

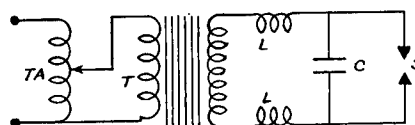

TA - AUTO TRANSFORMER
L - 100 mH CHOKE COILS
S - SPARK GAP

(A) (B)

T - 1 KVA-25000 volt-TRANSFORMER - ¼ KVA-8000 volt
C - 0.008 μf - 25 KV-CONDENSER - 0.003 μf - 10 KV

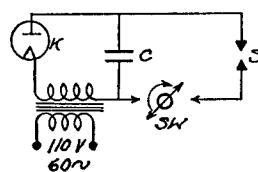

S - SPARK GAP
SW - SYNCHRONOUS SWITCH
K - KENOTRON
C - CONDENSER

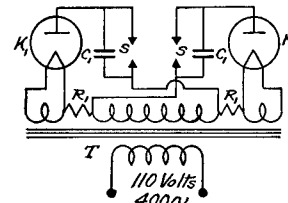

S - SPARK GAP
C - 0.002-0.004 μf
K - HK-24-K
R₁ - 5 × 10⁴ Ω, 20 W RESISTOR
T - GARDNER - 7000 volt.
500 VA,
400 ~ TRANSFORMER

FIGURE 8. Diagrams of circuits used with magnesium spark.

half cycle depends on the gap length, capacity of condenser, and charging voltage. It is found that the intensity of the spark lines is increased by increasing the breakdown voltage and the number of sparks per second, optimum values being chosen by trial.

In a second method, the condenser across the spark gap may be charged continuously with high-voltage direct current, as shown in the lower left of Figure

8. Resonant charging conditions are then absent, providing complete control of the spark frequency by means of a synchronous gap. Very rapid rise and fall of the voltage results in enhancement of spark-line intensities, but the apparatus is bulky.

The first method mentioned above is difficult to use with power-line frequencies higher than 60 cycles since the condenser reactance becomes so low. To obviate this difficulty, the rectifier circuit shown at the lower right in Figure 8 was devised. Two spark gaps operate in parallel, one on one half of the cycle and the other on the other half. The transformer has a filament winding at each end of the secondary for heating the kenotron cathodes. This arrangement has been found quite suitable for operation from a 0.5-kilo-volt-ampere, 400-cycle airplane inverter, and could presumably be operated just as well from an 800-cycle one.

Spark Intensities. In order to increase the sharpness of gap breakdown, various types of series multiple gaps were tried; they all enhanced the spark lines and might well be adapted to certain applications. Gap length and atmospheric pressure also increase the voltage at breakdown. The intensity of the 0.28-micron emission was determined as a function of the gas atmosphere in which it occurred. Atmospheres of air, nitrogen, hydrogen, helium, argon, and carbon dioxide were tried; argon appeared best, but impractical. Air works quite well, although carbon dioxide is perhaps a little better and might be practical in some cases.

To prevent the sputtering of magnesium on the reflector, it is necessary that the gap be surrounded by a fused-quartz jacket in which there is a rapid flow of gas. This is readily accomplished by using a high-pressure atmosphere in the jacket with a small amount continuously bled out. Bleeder holes in the electrode centers resulted in more rapid quenching. A satisfactory spark and jacket design is shown in Figure 10.

LARGE MAGNESIUM SOURCE

The lamp in Figure 9 is the large source usually mounted on a tripod for field operations. Figure 10 shows the construction and design of this lamp. A vacuum-cleaner unit is used with it to pull air through the spark and remove the sputtered magnesium powder from the quartz jacket.

All field tests on which ranges for this and the portable source have been quoted were carried out with a single spark gap mounted coaxially in a parabolic glass reflector. In the case of the 1-kilovolt-am-

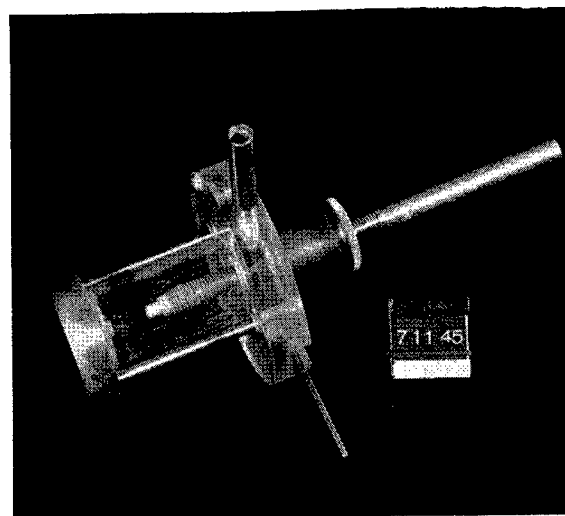
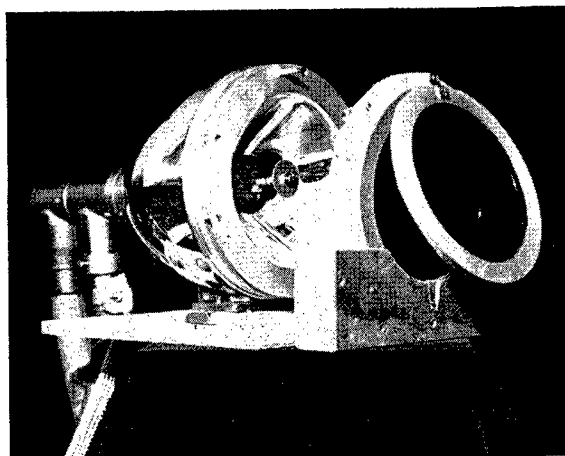

FIGURE 9. Magnesium lamp. *Upper*—Front view of large lamp with filters removed. *Lower*—Special fused-quartz jacket for magnesium spark.

pere source, this reflector is 6 inches in diameter by 1-inch focal length and front aluminized. Some six-field tests were made with the large source, using 5-inch autocollimators and a 5-inch metascope as receivers. With a 6 by 6 degree beam and 250-watt circuit, a range of 2,000 yards was achieved with phosphor metasopes. With a photomultiplier tube as a receiver, the range may be increased to about 4,400 yards (see "Radar Principles" below). Autocollimator ranges are about 1,000 yards in average clear weather.

When this source is turned on, fluorescence of spectacle lenses is observed not farther than 50 yards from the source; at 440 yards, a slight fluorescence is discernible, but an unknowing observer could not tell the source of the radiation.

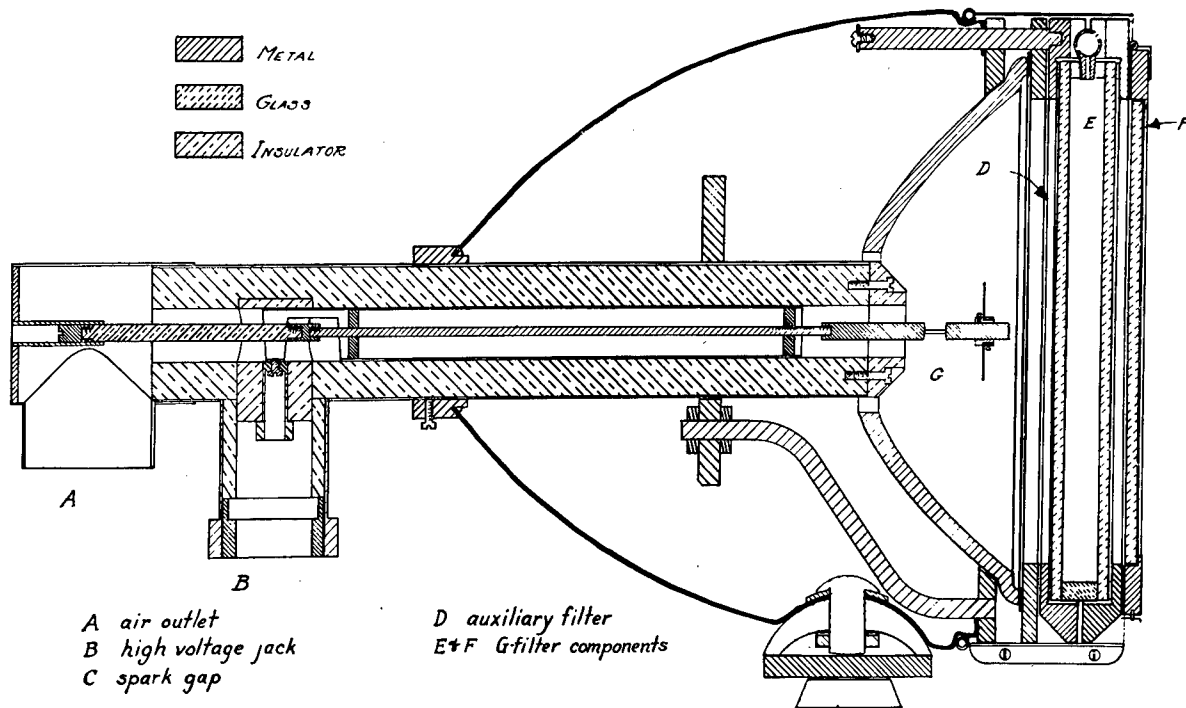

FIGURE 10. Large magnesium lamp.

HAND-HELD MAGNESIUM SOURCE

For a hand-held unit of about 60 volt-amperes capacity, the reflector is of 4 inches diameter and 1-inch focal length, the entire unit weighing less than 4 pounds. The power pack, of about 15 pounds, contains a 25-ampere-hour, 6-volt storage battery, a small 2,000-volt step-up transformer, and a standard 60-watt vibrator unit.

With a suitable filter in front of the source, this lamp can be used on the darkest night without being seen. Suitable electrical filtering is provided, particularly for code signaling. The range for satisfactory communication on an average clear night is about 1,000 yards.

RADAR PRINCIPLES

Due to the nature of the electrical discharge, the usable ultraviolet radiation is emitted in pulses of about 1 to 2 microseconds duration. Because of the consequent brightness of the pulses, the distance at which the signals can be picked up by a receiver with phototube and amplifier is very great. The pulse response of such a receiver depends on the pulse intensity and not upon the time average over a succession of pulses as is the case with any viewing device.

IRRAD or radar principles^b are therefore suggested

^b See STR Division 16, Volume 3, Chapter 6.

as highly promising when applied day or night to the magnesium spark as a source of radiation. A fused-quartz triple prism used to return the light toward the source presents an excellent opportunity for many short-ranging problems. This problem was not investigated to any extent.

6.2.5 High-Intensity Carbon-Arc Sources

INTRODUCTION

In Chapter 5 these sources have been described in detail as to their general construction and operating characteristics. Carbon arcs cannot be used for security in night communications, because filters are not available to remove their very strong NUV, but in the daytime they are secure, as far as visibility is concerned, and give sufficiently strong radiation in the MUV for practical use.

National Carbon Company's U-carbon was chosen as best for UV work. With 50 volts and 60-ampere current, such an arc is known as a "high-intensity flame arc." The increased brilliancy as compared with that of a low-intensity arc is produced by radiation from the flame materials within the confines of the arc center.

THE 24-INCH SEARCHLIGHT

In the experiments here reported, these arcs were run in a Navy 24-inch searchlight similar to those

described in Chapter 5. In most cases, U-carbons were used as the rotating positive carbons. Slight modifications in the automatic feed circuit were required for these carbons. With an 11-millimeter positive and an 8-millimeter negative carbon, the arc drew a current of 60 amperes with an arc drop of 38 volts. The usable UV from this arc consists principally of two peaks between 0.25 and 0.29 micron; filters must cut out all wavelengths longer than this. In some cases, Corex 9863 glass, made up of 6-inch squares mounted in a cell-like structure, was used to cut out visible light. For complete security a G-filter, described later, should have been used, but there was no time to make one of suitable size. In the actual tests, inasmuch as the Corex filter affected the range only slightly, it was often not used at all.

The beam from the searchlight was chopped by two slotted wheels to obtain 1,000 cycles per second to suit the electrical filter already available for the receiver. One of the wheels remained stationary while the other rotated. A frequency of 90 to 100 cycles is recommended, however, if mechanical chopping is used at the source.

A receiver, consisting of an RCA photomultiplier tube (1P28), an ultraviolet light filter, a high-gain tube amplifier, a 1,000-cycle electrical filter, and earphones, was used. The phototube was mounted in a small, light-tight box and located at the focus of a 10-inch diameter, 10-inch focus mirror, as shown in Figure 11. The field angle taken in by this receiver was approximately 1 degree horizontally by 4 degrees vertically.

With the source mounted high on the top of a building and the beam chopped at 1,000 cycles, the receiver was taken to various distant vantage points and the signal picked up by listening for the 1,000-cycle note in the earphones. On one exceptionally clear day, a strong signal was picked up at 13 miles. Since in the laboratory this source and receiver have a measured vacuum range R_0 of 130 miles, the atmospheric transmission for that one test was the highest ever measured by this group, about 70 per cent per mile. On an average clear day when the visibility is only 10 miles, the ultraviolet transmission of the atmosphere will be about 40 per cent per mile ($T = 0.40$), and the actual usable range of 6 to 7 miles will be achieved.

With only the Corex filter in front of the source and the 2 by 2 degree searchlight beam turned on the receiver, observers at the receiver can see the source as a red light. Though a large G-filter was not available at the time, such a filter can be made, and meas-

urements already at hand show that the above ranges would not be decreased by more than 10 to 15 per cent by its use.

THE TRIPLE-PRISM RETURN

Several fused-quartz triple prisms, 3 inches in aperture, were made by the Mount Wilson Observatory

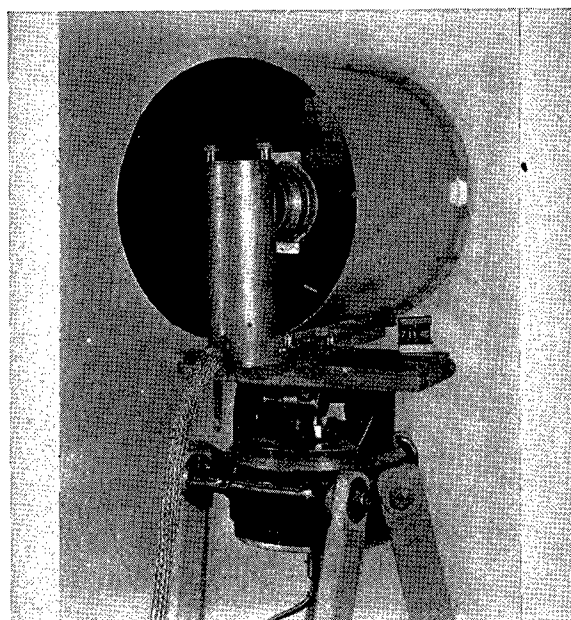

FIGURE 11. Photomultiplier receiver. *Upper*—Receiver assembled, mounted on tripod for field use. Seven-inch collecting mirror. Amplifier and power supply not shown. *Lower*—Receiver disassembled to show component parts.

optical shop. The chopper was removed from the 24-inch searchlight, and the receiver phototube and mirror mounted at the center of the beam where the chopper motor had previously stood. The triple prism was

carried to a distant vantage point and a chopper placed in front of it. On an average clear day, the return signal was picked up at 0.8 mile. Several prisms in a cluster should increase this range to 1 mile. It is worthy of note that in this system the source itself cannot be chopped without overloading the receiver with backscattered light.

CURRENT-MODULATED FLAME ARC

To produce a daytime communication system with a 360-degree beam, large-sized special cored carbons (16 to 22 millimeters in diameter) were mounted vertically with no reflector. A 50-ampere current produces a conically shaped flame about 1 inch high and 1 inch wide at the top. With a Corex filter, such a flame is invisible to the unaided eye beyond 100 feet; the filter transmits about 70 per cent at 0.28 micron, and a voice range of at least 2 miles is assured on an average clear day.

However, because of the large current required and the shortness of time available for development, a voice-modulation system was not used. In its place, a 500-cycle generator was used, causing the flame to dim at each half-cycle, or 1,000 times a second.

This bare arc flame was picked up in the daytime at $3\frac{1}{2}$ miles by means of the photomultiplier tube already mentioned and described below. This appears to be the usable range of the open flame arc when the UV transmission is 40 per cent per mile—a remarkable result when the 360-degree distribution of the radiation is considered. At the focus of a reflector restricting the beam to about 20×20 degrees, this source should give a range of from 5 to 7 miles.

This system was not tested at night, but the range curves and field measurements with other sources and receivers show that nearly twice the daytime ranges are assured. Proper filters should be fairly easy to produce because of the relatively low emission of visible and NUV.

GRID-MODULATED CARBON ARC

Figure 12 gives the circuit and optical system of a means for modulating radiation from a high-intensity flame arc for voice communication by day or night. The system has complete visual security in the daytime, and might be made to have reasonable security at night.

A 12-inch diameter elliptical mirror E focuses the light from the source S on the mirror M_V , which is spherical. The light passes through the uncoated strip

spaces of the concave mirror M_R , made of fused quartz, with its radius of curvature twice the distance M_R to M_V . Thus mirror M_V focuses an image of the grid itself, and as M_V rocks back and forth, owing to voice modulation, the grid image moves back and forth, thus reflecting more or less light in a parallel beam into space. The beam is about 6 by 6 degrees, with fairly sharp edges.

Modulation is accomplished by vibrating mirror M_V so that the grid lines move half their width. The grid mirror is 8 inches in diameter, and its strips of evaporated aluminum are $\frac{1}{10}$ of an inch wide with spaces of equal width. The vibrating mirror M_V is $1\frac{1}{2}$ inches in diameter.

In this system, a moving-picture projector is used as a source. It consists of a high-intensity automatic arc with reflector (Figure 13). With special U-carbons (9-millimeter positive carbon) a current of 60 amperes is maintained with 50 volts across the arc. The standard ellipsoidal mirror is used to focus an image of the positive carbon on the vibrating mirror located at the position ordinarily occupied by the film gate.

The vibrating mirror is attached to a coil in a magnetic field, somewhat like the arrangement of a ballistic galvanometer. The resonant frequency of the coil support is about 500 cycles per second, and damping is provided by a small amount of silicone stopcock grease between the coil and the pole piece. The maximum displacement of the vibrating mirror is about 0.072 degree radian. The driving amplifier is of conventional design except that the coupling condensers are of much smaller capacity than usual; this helps to give the mirror a constant response for all used audio frequencies.

In principle, this system can be used to modulate any kind of radiation. It uses very little power for even the strongest sources; it is very compact and the optical system consists almost entirely of reflecting surfaces.

Field tests were made with RCA photomultiplier tube receivers. These comprise a UV filter, a high-gain tube amplifier, an electrical filter with high-frequency cutoff, and earphones. The usable range by day was $2\frac{1}{2}$ to 3 miles, and twice this distance at night. The daytime range is lessened because of the need for a heavy light filter to shield the receiver from sky radiation by day.

Smaller vibrating-mirror elements used for sound-recording equipment could also be used for modulating UV sources.

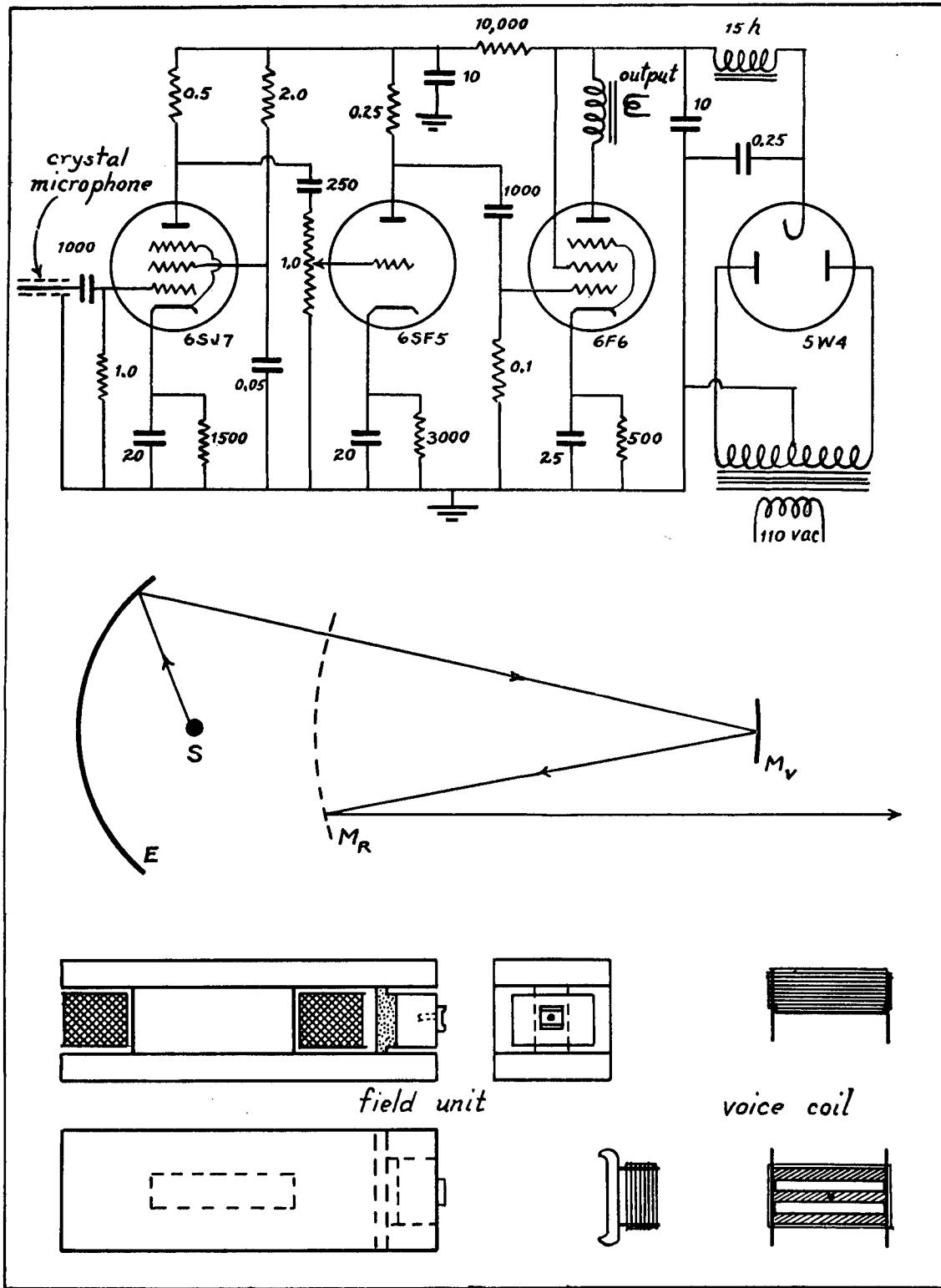

FIGURE 12. Mechanical-optical modulator. Upper—Circuit diagram. Middle—Optical system. Lower—Voice coil and magnet design.

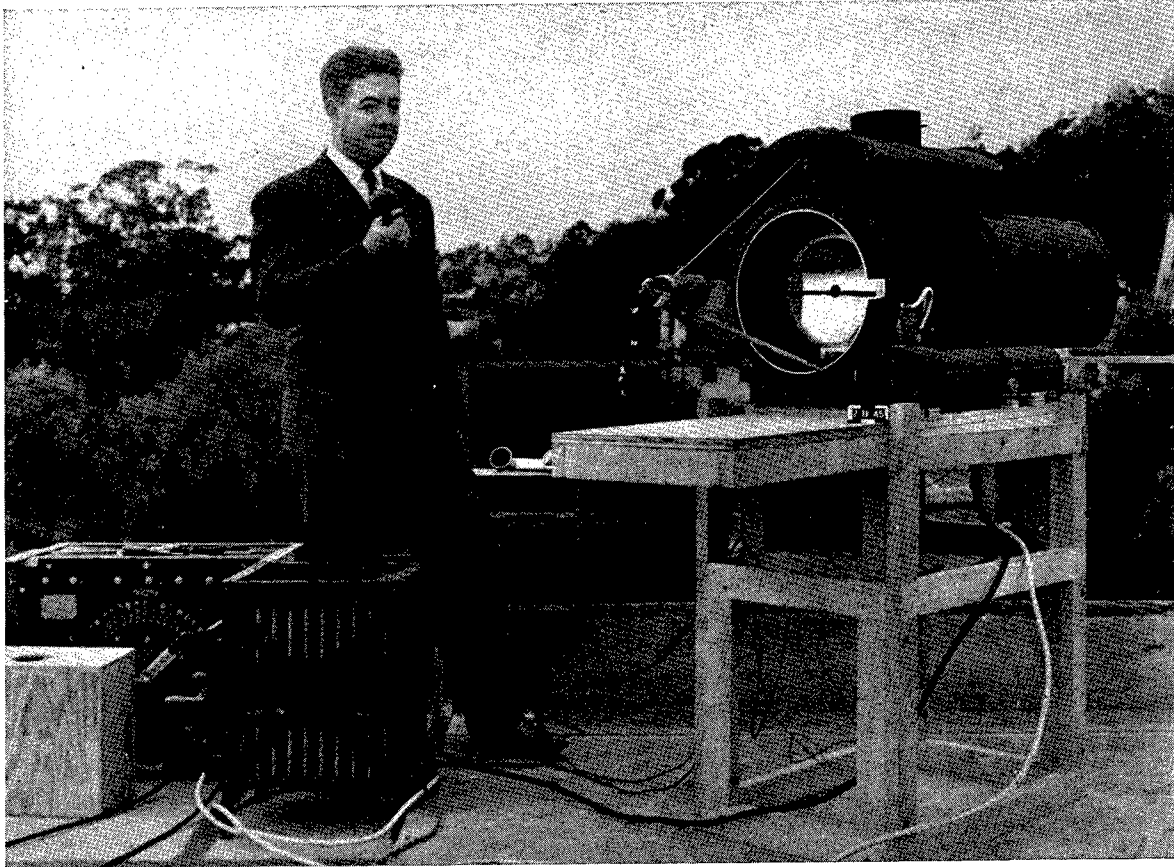

FIGURE 13. Voice-modulated carbon-arc transmitter. No filter is shown here.

6.3 ULTRAVIOLET RECEIVERS AND AUTOCOLLIMATORS

6.3.1 Metascopes

Instruments of this general type are described in Chapter 3 of this volume, their use being chiefly for the detection of infrared radiation. Nevertheless, the first metascopes employed UV-sensitive phosphors. No UV metascopes have gone into the production stage, but several types have been used in field tests of UV communication systems.

In the UV metascope, radiation enters through a corrector plate, and after reflection by the spherical primary mirror is brought to a focus on a phosphor-coated spherical screen. The visible light emitted by the phosphor passes through the perforation in the primary mirror to be viewed by an eyepiece. Usually, the magnification is unity.

UV phosphors do not require precharging as do those sensitive to infrared. However, it is believed that greater sensitivity can be obtained from UV-sensitive

image tubes, but the construction of such instruments has only been contemplated. Future work on UV communication should give this proposal full consideration. Meanwhile, the most sensitive UV receivers have been photomultiplier tubes.

6.3.2 Photoelectric Receivers

Prior to the war, existing receivers for detecting UV below 0.3 micron were inadequate both in type and sensitivity, so it was decided to develop a photoelectric receiver of high sensitivity to modulated beams of such radiation. With modulated beams, the receivers could be used with fairly high background light (daytime), they could detect voice- and code-modulated radiation, and the detection would be audible rather than visual.

Each such receiver is an assembly of several components: (1) a suitably sensitive photocell; (2) a light collector; (3) an optical filter; (4) a suitable amplifier combined with an electrical filter for rejecting unused energy-frequencies (noise).

As a result of the current amplification attainable with secondary electron emission, vacuum photocells extremely sensitive to UV have recently become available. The RCA photomultiplier tube 1P28 amplifies the original photocurrent 10^5 or more. This tube was used in spherical-mirror light collectors, one of 10-inch aperture and 20-inch focus, the other of 7-inch focal length and 7-inch diameter. The latter is more usable as the photocell has a sensitive surface, $\frac{1}{4}$ inch wide by 1 inch long. Thus, the cell placed at the focus of the mirror has an angular aperture of 2 by 8 degrees, and by diaphragming this can be reduced to 2 by 2 degrees or less.

The amplifier is a 3-tube, battery-operated voltage amplifier designed to cut off frequencies below about 600 cycles. It is combined with a low-pass filter having a cutoff at 3,000 cycles for receiving noise. The amplifier is coupled to a 1,000-henry choke in the anode circuit of the 1P28. Other methods of coupling may also be used. Dry batteries were used for convenience.

In case a single-frequency signal is used as a source of radiation, a band-pass filter having strong attenuation at all frequencies except the signal frequency is substituted for the low-pass filter mentioned above. This increases the signal-to-noise ratio.

Figure 11 shows the complete receiver with the 7-inch mirror in place. In order to measure the range of this receiver with a 24-inch Navy searchlight, it was necessary to modulate the beam with the two slotted disks already mentioned. This signal was found to have a range of 22,000 yards in daylight on an unusually clear day, using the above described receiver with the 10-inch reflector and a Navy-type 1020-cycle band-pass filter.

Other ranges achieved with photomultiplier tubes are shown in Table 1.

6.3.3

Autocollimators

As described in Chapter 7, autocollimators may be made with the usual Kellner-Schmidt system, and if the focal surface is coated with UV phosphors, the autocollimator will return visible light after illumination by a UV source. Instruments of this type were developed by the University of Rochester in 1940-1941.

If the corrector plate is corrected for spherical aberration in the UV, it is not corrected for the returning visible light, and vice versa. As a consequence, a compromise had to be made in the 17 special 5-inch autocollimators made by Navy BuAer for field tests by

the University of California. This resulted in the visible return beam having a slightly increased spread, reducing the maximum range of each device but permitting mounting of the source several feet from the observer.

As explained in Chapter 7, the intensity of the returned beam of an autocollimator is inversely proportional to the fourth power of the distance. When atmospheric attenuation is taken into account, to double the limiting range of any one autocollimator-source system, the source beam must be intensified about 100 times.

6.3.4

Triple Mirrors of Fused Quartz

Four fused-quartz triple mirrors (prisms), to be used as autocollimators for UV field tests by the University of California, were made by the Mount Wilson Observatory. These prisms, with apertures of about $3\frac{1}{2}$ inches, are in principle the same as glass triples commonly used with visible and infrared light (see Chapter 7).

The manufacturing time for quartz is about the same as for glass, but inhomogeneity of the fused quartz results in a wider return beam than usual with ordinary glass triples. The quartz prisms return a beam within a cone of about 40 seconds of arc (1 foot in a mile), as against from 2 to 5 seconds of arc for visible light with optical glass. In some respects, however, the wider return beam is an advantage.

6.3.5

Photoglow Tubes

An investigation of the use of copper-electrode photoglow tubes has established the fact that discharges can be initiated in neon at 25 millimeters pressure by very faint invisible ultraviolet radiation. It was determined from laboratory measurements that a 6-inch Kellner-Schmidt optical system, 1 mile away from the gallium lamp described in this report, would collect sufficient radiation to control these photoglow tubes. Furthermore, it was demonstrated by field measurements that such a neon discharge placed at the focal plane of a Kellner-Schmidt optical system is visible at a distance of over 1 mile.

The actual work of developing a mosaic of photoglow cells to replace the phosphor surface of the ultraviolet autocollimator has not been undertaken. However, there is good evidence that such a mosaic could be perfected and that it would greatly increase the range of the present ultraviolet autocollimators.

Before planning the actual investigation of a photoglow mosaic, one alternative device seemed to deserve

investigation. This would be an electron image tube in which a relatively high potential is applied between two parallel screens no more than 1 millimeter apart. One screen should be a semitransparent photosurface, and the other a fluorescent surface. Photoelectrons, emitted by the ultraviolet-sensitive photosurface, should be drawn directly across the gap to impinge upon the fluorescent screen and give rise to a bright spot of visible light. Such an image tube, placed in the focal plane of a Kellner-Schmidt optical system, would make of it a longer-range ultraviolet autocollimator.

6.3.6 Geiger-Counter Receiver

A copper Geiger counter, as described in published literature, was built and used in conjunction with a quenching circuit and an electronic relay. The tube was mounted at the focus of a 6-inch spherical reflector having a focal length of $2\frac{1}{2}$ inches. This unit was mounted on the top of a building with the relay connected to an ordinary light bulb for indicating to a distant observer the reception of a signal.

A gallium lamp was carried at night to distant vantage points where the beam was directed back toward the receiver. Triggering the gallium lamp source as in code signaling caused the Geiger-counter receiver to operate and to turn on the white light.

The tests showed that extremely faint ultraviolet radiation can be made to operate a relay. A nighttime range with this first tube was found to be 1 mile. The daytime range is considerably less at the present time because of the filter that must be used around the counter tube. Further work on the chemical purification of the copper surface and on the selection of other metals to replace copper shows promise of greater daytime ranges.

The filter consisted of NAT (Section 6.4.4) in cellulose acetate. Since this detector is not sensitive to light in the visible, it is necessary to eliminate only the near ultraviolet from 0.31 micron up. This is accomplished sufficiently well by the NAT alone.

6.4 FILTERS FOR ULTRAVIOLET SOURCES AND RECEIVERS

INTRODUCTION

Filters for UV play an important part in maintaining the visual security of signaling and communication systems. The choice of a suitable filter depends on such factors as the relative intensity of the emis-

sion of the source in the NUV and the MUV, the use of modulated beams, and the distance at which complete security is required.

In January 1945, it was first suggested that UV radiation might well be used in the daytime, and considerable effort was made to reinvestigate all UV sources. In daylight, the eye is not sensitive to the UV, and all filtering problems of a source are simpler, when compared to the problems for night security. Laboratory and field tests have shown that such sources as the gallium lamp and the magnesium spark, which work so well in darkness, are too weak to hope for any long daytime ranges. This is due principally to the relatively low ultraviolet transmission of the filter that must be placed in front of any receiver. A receiver filter must cut out all visible and near ultraviolet light down to 0.295 microns. Though exceptionally good filters for this purpose have been made, their transmission in the desired region, 0.275-0.295 micron, is only 10 to 27 per cent at best. (See Figure 14, dot-dash curve labeled G + PDAA + PDAB.)

Fortunately, carbon arcs using carbons especially cored to give strong ultraviolet radiation of the desired wavelengths are very powerful sources, thereby compensating for the loss in sensitivity at the receiver.

6.4.1 The Corex 9863 Filter

This is Corning glass filter No. 9863, and has been found to be the best filter for cutting out most of the visible light emitted by an ultraviolet source. Its transmission curve is included in Figure 14 (long dashes); note its infrared transmission, and its opacity for radiation below 0.250 micron.

Corex 9863 filters can be obtained only in sizes up to $6\frac{1}{2}$ inches square; both sides should be cloth-polished and 3 to 5 millimeters thick. Long exposure to sunlight or strong UV should be avoided, shields being used during daylight operation.

6.4.2 The Nickel Filter

This filter was developed to produce a semisolid filter that would not require a cell structure for support, that would not leak (as may liquid filters), and would not easily break. Its principal absorbing agents are nickel chloride and nickel sulfate. Its absorption curve is shown by short dashes in Figure 14; note that it cuts off at 0.36 instead of 0.41 micron as does Corex. When combined with the Corex filter, the nickel filter becomes the G-filter, shown by the solid

curve in Figure 14. Further details of the G-filter are given in the next section.

Prior to this NDRC project, the nearest that anyone had come to obtaining such a filter was a liquid filter containing nickel chloride or nickel sulfate in solution.

6.4.3 The G-Filter for the Gallium Lamp

This filter consists of a sandwich of nickel sulfate-sorbitol complex between a plate of polished fused silica and a plate of Corex 9863. A thickness of 3.5

gallium arc has virtually no radiation in this region.

The nickel sulfate-sorbitol complex was developed in order to obtain a solid filter that has essentially the same absorption characteristics as nickel sulfate in water. Many compounds including glycerol, ethylene glycol, propylene glycol, erythritol, inositol, pentaerythritol, and mannitol were tried separately and in various combinations. None except sorbitol was satisfactory, owing to either crystallization or poor transmission characteristics. The nickel sulfate-sorbitol complex has sat-

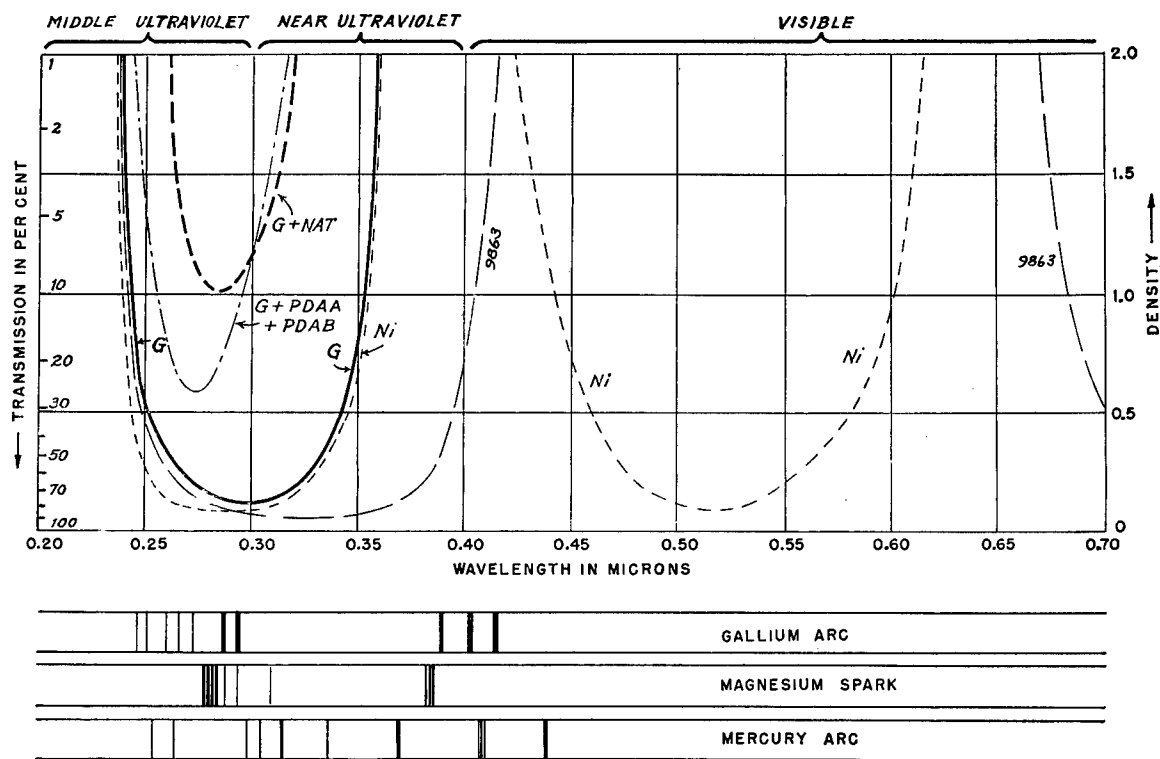

FIGURE 14. Density and transmission curves for G-filter alone, components of G-filter, and G-filter plus NAT filter. Spectra of sources to show radiation in ultraviolet region.

millimeters of the complex and 3.5 millimeters of the Corex makes the gallium lamp invisible at 50 feet to a dark-adapted observer. The filter has good transmission in the region 0.26-0.35 micron, as seen in Figure 14. In the region of the strong gallium lines (0.28-0.30 micron), its overall transmission is remarkably high, from 65 to 74 per cent.

The variation in transmission at 0.28-0.30 micron is due to the Corex 9863 filters. Different batches of these seem to differ considerably.

While the filter transmission from 0.31-0.35 micron would be objectionable for many ultraviolet sources because of the resulting fluorescence of the retina of the eye, it is of little consequence here because the

is satisfactory transmission in the desired region only if it is prepared under vacuum at a temperature of 60 C or less. Details of the procedure for making the G-filter are given in the contractor's report.¹

The finished filter complex is a very sticky mass that does not pour but flows under pressure. The overall transmission of the filter, consisting of 4-millimeter Corex 9863, 3.5-4.0-millimeter nickel-sorbitol complex, 3.5-4.0-millimeter quartz, is 69-74 per cent at 0.28-0.29 micron. Hence, since the Corex by itself has about 80 per cent transmission here, the complex absorbs very little in this region. The filter can stand the low temperature of solid carbon dioxide and can be heated to 70 C for several hours without any per-

ceptible change, but it will not stand long heating at higher temperatures. It stops practically all the radiation from the gallium lamp except that in the region 0.25-0.30 microns. It satisfactorily eliminates all the visible except for a small amount in the extreme red and violet regions (see Figure 14).

6.4.4 Filter for the Magnesium Spark

This filter consists of the same "sandwich" used with the gallium lamp plus a film of polyvinyl butral or cellulose acetate containing a compound that will transmit in the region 0.28-0.30 micron and absorb from 0.305 to 0.35 micron.

Many materials were investigated for making the films. These include polyvinyl chloride, methyl methacrylate, cellophane, polyvinyl butral, and cellulose acetate. Only the last three had suitable transmission in the desired region. Of these the polyvinyl butral (Butvar) and cellulose acetate (Hercules Powder Company special) had superior transmission to the cellophane (Dupont unlacquered), as shown in Figure 15. Polyvinyl butral has slightly better transmission than cellulose acetate but the difference is not critical. However, films of cellulose acetate are more easily made with good optical properties and are also removed more readily from the glass plates.

The compounds investigated for cutting out the region 0.305-0.35 micron include anthranilic acid (ONH_2), *p*-dimethylaminobenzaldehyde (PDAB), picric acid, auramine O, *p*-dimethylaminoacetophenone (PDAA), 5-nitro-2-aminotoluene (NAT), Michler's ketone, *p*-nitroaniline (PNA), *p*-nitrodimethylaniline (PNDA), diphenyloctatetraene, α , α' -dichlorocamphor, methyl anthranilate, and methyl-*m*-amino benzoate. The absorption curves for some of these compounds are given in Figure 14. The most suitable compound is 5-nitro-2-aminotoluene, referred to as NAT in this chapter. Anthranilic acid has fairly good absorption characteristics, but it fluoresces and is decomposed by ultraviolet light. *p*-Dimethylaminobenzaldehyde also has good absorption in the desired region, but it has a tendency to escape from the film and is also decomposed by radiation.

6.4.5 Photomultiplier-Tube Receiver Filter

This filter consists of the nickel sulfate-sorbital sandwich with a 6-millimeter thickness of Corex plus a fairly concentrated film of NAT in cellulose acetate. The problem here is to eliminate the daylight radiation in the visible and near ultraviolet and still to have transmission of radiation from 0.30 micron down,

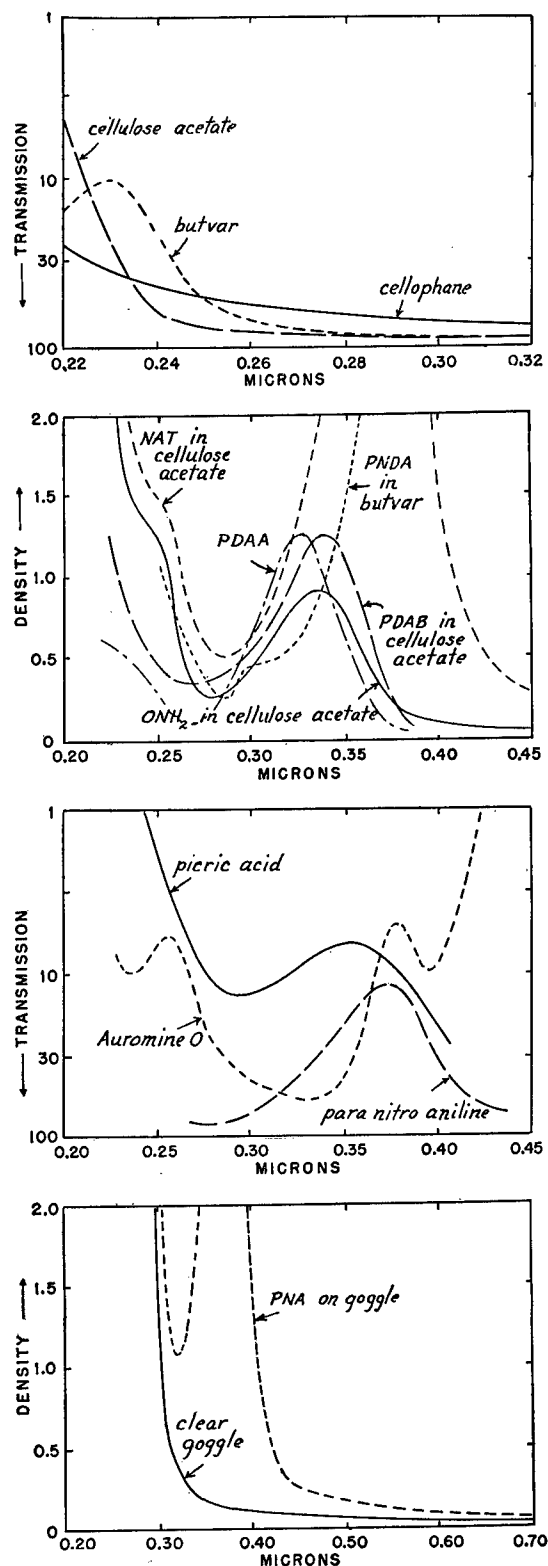

FIGURE 15. Density and transmission curves for compounds and film materials.

preferably as low as 0.25 micron. However, since the cellulose acetate or polyvinyl butral absorbs appreciably at 0.23 micron and the NAT compound absorbs fairly strongly from 0.26 micron down, the radiation effectively used is from 0.265 to 0.30 micron. The absorption curve of the filter that is most suitable in this case is given in Figure 15. This particular filter had a transmission of about 5 per cent at 0.28 micron. Its preparation is described in the contractor's report.¹

A BETTER FILTER

Last-minute tests with a combination of PDAH and PDAB compounds in a Butvar film proved to be considerably more effective as a phototube receiver filter than the NAT filter described above. It is to be noted in Figure 14 that the G + NAT filter reaches maximum transmission of about 10 per cent while that of G + DDAA + DDAB goes up to nearly three times this with an equally sharp cutoff of the higher wavelengths.

6.4.6 Goggle-Filter for a Mercury Arc

During the past two years, high-pressure mercury arcs have been used to illuminate the fluorescent clothing worn by Landing Signal Officers [LSO] on

night-carrier landings. Each lamp is located on the deck a few feet from the LSO. A "black" filter passes red and violet light and UV down to 0.36 micron; the lamps appear purple and the eyes of the LSO fluoresce. NDRC was requested to eliminate the visible light and to protect the eyes from fluorescing.

First, a Corning 9840 filter was placed in front of each mercury lamp. This green filter cuts out the red light, but passes UV. To protect the eyes of the LSO, Navy Polaroid clear-vision plastic goggle lenses were impregnated with *p*-nitroaniline. After thorough cleaning, each lens was moistened with alcohol and dipped for 2 minutes in a 0.5 per cent solution of *p*-nitroaniline in 85 per cent alcohol and 15 per cent acetone. After drying for 20 or 30 minutes, each treated lens was ready for use.

The absorption curves of these goggle-filters are given in Figure 15, lower right. Compared with goggles commercially manufactured later to do this same job, the NDRC filters have a more complete cutoff of the violet and, at the same time, fluoresce by a lesser amount, thus giving a more transparent goggle and a clearer vision. The NDRC filters were successfully used on trial runs, and subsequently a number of the Corning filters and dyed goggles were furnished LSO's on several carriers.

Chapter 7

AUTOCOLLIMATORS

By *Mary Banning*^a

7.1

INTRODUCTION

AN AUTOCOLLIMATOR is a device that returns incident radiation from a distant source back to this source in a narrow cone. This enables an observer near the source to see the return beam, while an observer located off the line between the source and autocollimator can see nothing. The more perfect the optical system of the autocollimator, the more accurately this is true. Two types of these devices have been developed under Section 16.5 of NDRC for military applications where high security is required.

The *Kellner-Schmidt* [K-S] system makes use of a phosphor to convert incident ultraviolet or infrared into a return beam of visible light. This type had been proposed and partially developed for peacetime applications prior to the formation of NDRC. Specific development of ultraviolet conversion autocollimators for military use started in the spring of 1941 at the University of Rochester and continued under Contracts OEMsr-69, OEMsr-427, and OEMsr-725. The Eastman Kodak Company, OEMsr-994, undertook the manufacture of a number of small glass units; the Rochester Button Company, OEMsr-932, developed plastic units; and the Bausch and Lomb Optical Company, OEMsr-495, studied methods of molding and supplied molds for both glass and plastic units. Infrared conversion autocollimators, or *metaflectors*, were developed at the University of Rochester under Contract OEMsr-1000.

A second type of autocollimator, the *triple mirror*, uses either visible or infrared radiation but is not of the conversion type. This device has been known for a long time and was even used in World War I. Quantity-production methods for making a precision glass form were developed at the Mount Wilson Observatory under Contract OEMsr-698. Various applications of these were studied and developed at the University of Rochester, OEMsr-1219.

7.2 KELLNER-SCHMIDT AUTOCOLLIMATORS

7.2.1 Ultraviolet Autocollimators

The principles and advantages of the Kellner-Schmidt system have already been described in Chap-

ter 3, as used in *metascopes*. When used as an autocollimator, not as a telescope, the system is a great deal simpler since no viewing system need be used. Invisible radiation entering through the *corrector plate* comes to a focus on the phosphor which then emits visible light which is returned to the source over the identical path of the incident radiation. Ultraviolet-conversion autocollimators have been applied to problems of road-marking for traffic operating under blackout conditions, to problems of night identification, and to the night landing of aircraft when the airfield is completely blacked out. Limited procurement of two sizes of these ultraviolet autocollimators has been made by the Navy Bureau of Aeronautics. However, the devices have not gone into general use because of changes in operational needs during the progress of the war.

Since the rigid requirements of very high resolving power necessary for metascopes did not need to be met in autocollimators, an $f/0.52$ system was used. In the first instruments, shown in Figures 1A and 1B, the phosphor was coated on the convex surface of a metal mount which was suspended in the focal position of the autocollimator by a rigid spider. These instruments have a clear aperture of $4\frac{1}{2}$ inches; later models were made on the same principle with $2\frac{1}{4}$ - and $1\frac{1}{4}$ -inch aperture. Solid K-S autocollimators, made in the same way as the solid metascopes, have been developed and produced on a larger scale in both glass and plastic. Considerable development work was carried on for the mass production of such units.^{12,13,14} Several thousand plastic units and a few hundred glass units were supplied to the Navy for test work.

Ranges obtained with the various kinds of autocollimators vary with the observer and the atmospheric conditions. An average production instrument gives only about 40 per cent of the range of a similar precision model. If atmospheric attenuation of the radiation is negligible, the range follows an inverse fourth power law, so that to double any range, 16 times as many autocollimators must be used, a source 16 times as bright, or a K-S system of twice the aperture. A General Electric high-pressure mercury arc was developed for this purpose which was 1 inch long, used

^a Institute of Optics, University of Rochester.

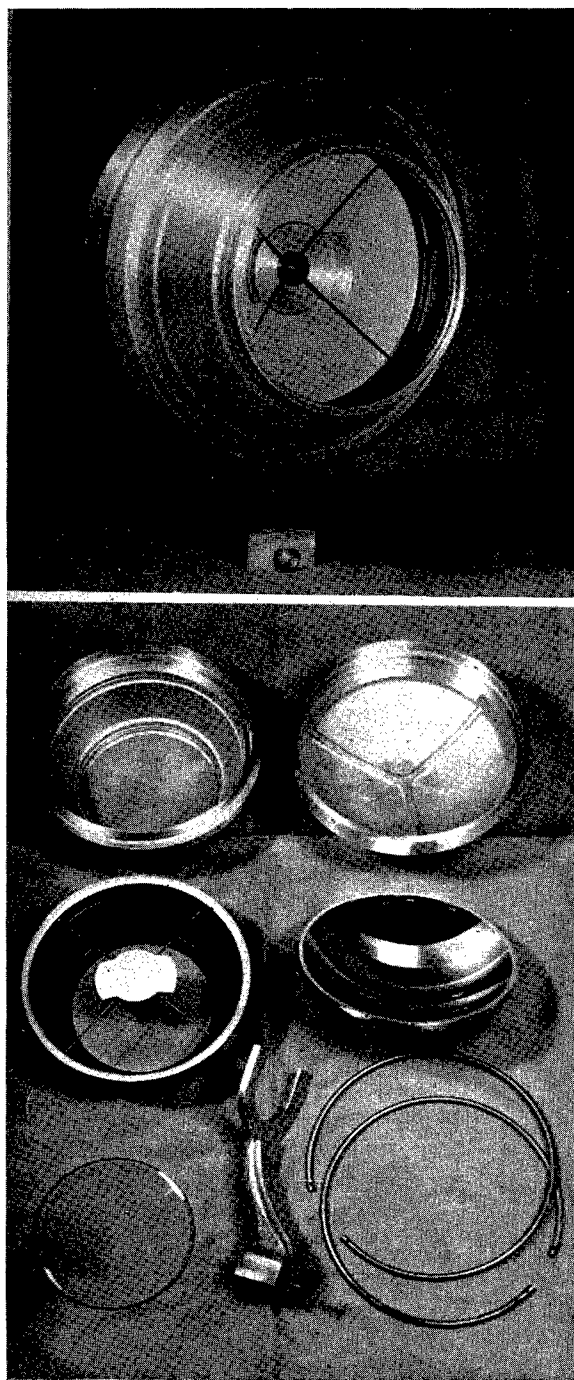

FIGURE 1. $4\frac{1}{2}$ -inch ultraviolet autocollimator.
A. Upper—assembled. B. Lower—disassembled.

400 watts, and operated at 30 atmospheres pressure. It was mounted in a standard 7-inch automobile sealed-beam reflector. It is described more fully in Chapter 5. Using the 3650 Å radiation and a $4\frac{1}{2}$ -inch autocollimator equipped with a URN-1 phosphor described

below, an average range for foveal vision of about 1.2 miles can be attained.

PHOSPHORS

As with the metascope phosphors (Chapter 4), the most important requirement in an ultraviolet K-S autocollimator is that of high efficiency; i.e., it must transform as much as possible of the ultraviolet energy into visible light, and this light should be of the wavelength to which the eye is most sensitive. Also, the phosphor should come up to full brilliance as soon as the ultraviolet light falls upon it, with as little delay before full emission as possible. Fortunately, a short delay usually means an *afterglow* of short duration. Signals may then be picked up immediately, with no confusion caused by a lingering glow in a region which has been previously illuminated. Another important phosphor requirement is that it endure long exposure to sunlight with impunity.

Since at low levels of illumination, the sensitivity of the eye has a maximum at about 5,100 Å, the best visual efficiency for a given energy efficiency in a phosphor is accomplished when the emitted light has an overall greenish blue color. If other colors are desired for identification purposes, it is necessary to sacrifice some visual efficiency. Of course, an individual phosphor is usually more sensitive to some ultraviolet wavelengths than to others and this, as well as the difficulty in making the phosphor and its availability, must be taken into account for practical applications.

One of the most useful phosphors for the present purpose is a green-emitting cadmium platino-cyanide. It was first described many years ago, but its properties were fully recognized by personnel of the Physical Optics Division of the Naval Research Laboratory. It has been further refined at Rochester under Contract OEMsr-81. It is most sensitive to ultraviolet radiation at 3,650 Å, but in the later form (URN-1) is satisfactory for use around 3,000 Å as well as below. Potassium uranyl sulfate, also emitting in the green, is only about half as efficient as the URN-1 at 3,650 Å, but it increases in relative efficiency at shorter wavelengths. It is very soluble in water, however, and must be protected from moisture. Another phosphor, developed by the Continental Lithograph Corporation, Cleveland (P-63), has a yellow emission and is used when distinction from the green phosphors is necessary.

FILTERS

Contrary to general belief, not all the ultraviolet spectrum is invisible to the unaided eye, and advan-

tage is taken of this fact in the ultraviolet autocollimators. From 3,200 to 3,800 Å there is surprisingly little change in eye sensitivity, with the color sensation produced in this range an unsaturated blue-violet. By utilizing light filters which transmit only the strong lines of the mercury spectrum in the neighborhood of 3,650 Å, it is possible to insure enough visibility of an approaching source for friendly observers to detect it, while an enemy observer not in the direct beam can see nothing.

In general, the filter giving the best transmission in the 3,650 Å region is a combination of Nos. 586 and 587, or 586 and 984 Corning glasses. For best transmission in the 3,130 Å region, it is necessary to use a liquid filter of nickel chloride solution combined with Corning No. 9863. Even with this last combination, the lamp source is still visible to the unaided eye, and if still shorter wavelengths are used, the absorption by the oxygen in the air begins to seriously cut down the range.

NIGHT LANDING OF AIRCRAFT^{1,2,5}

One of the first problems at the beginning of the war was that of landing aircraft at night with high security. To meet the necessary specifications of secrecy, light weight, moderate power requirements, and ranges of at least a mile, it was proposed that an ultraviolet autocollimating system be used, with the plane carrying the source and the autocollimators lining the runway. In such a plan, the security of the ultraviolet autocollimator system is quite high; the light beam is returned in such a narrow cone that it is visible only from the cockpit of the plane carrying the source and not from any enemy plane no matter how close it may be. At the same time, the visibility of the source is very low or negligible except to observers on or near the landing strip and within the beam of the source. Moreover, the pilot is not encumbered by any special equipment and makes his approach and landing as though the runway were marked out with visible light sources.

Throughout 1941 and 1942, many field tests were made of the range of various autocollimators with several ultraviolet light sources and filter combinations and with both moving and stationary sources. As a result of these tests, the equipment was prepared for demonstration to the Armed Forces. The first actual landings were made in Rochester in June 1942, and soon thereafter demonstrated to both Army and Navy personnel. Several glide-path indicators were tried and discarded, either because the range was too small or

because the system required manual operation in the field.

In August 1942, an official demonstration was held for representatives of the Army and Navy at Wright Field. The 4½-inch autocollimators were set up 400 feet apart in two rows, marking a runway 400 feet wide; a group of three on each side marked the beginning of the runway, followed by 9 single ones on each side, giving a total length of 3,600 feet. Two ultraviolet lamps were mounted in front of the plane. Approaches were successfully made from a direction of 45 degrees off the center of the runway, with the markers becoming visible at a range slightly over 1 mile. The only objections to the system were the difficulty in finding the field from a distance and the trouble necessary to install the equipment. It was agreed upon by all present that the equipment demonstrated had performed in a perfectly satisfactory manner, and had done all that was claimed for it.

A further test demonstration was held at the Naval Air Station at Norfolk in a DC-5 and a fighter F4U4, to simulate carrier landings. Here again, the only difficulty encountered was the failure to see the autocollimators from the sharp angle of approach necessary under these conditions. A final test at the Philadelphia Navy Yard, in the spring of 1943, proved that when proper alignment of the lamps and autocollimators was accomplished, the field of use could be greatly extended. Small autocollimators placed on the wings of the approaching plane were observed by a signal officer on the ground, using an ultraviolet source. Ranges with these small autocollimators were unsatisfactory, however.

Night-landing tests with autocollimators were discontinued at this time due to the relatively greater efficiency of the triple-mirror landing system described later.

FURTHER ULTRAVIOLET SYSTEMS

A similar system, also developed at Rochester, used ultraviolet autocollimators in identifying surface vessels from aircraft. It was proposed to facilitate *sea search* by providing friendly ships with autocollimators and searching bombers with mercury searchlights.⁷

Although a searching plane is able by means of radar equipment to find and approach a ship by night, the bombardier is not able to differentiate between small friendly ships and enemy submarines until the plane has approached too close to the ship to bomb it. Before a second bombing run can be made, a sub-

marine has time to submerge. Maintenance of light sources or moving parts of instruments on the friendly ships was not desired. A range of approximately 2,000 feet was considered essential, and also the bombardier should be able to identify the ship without using any optical aid, as the limiting time between identification and possible bombing is only a few seconds.

In the fall of 1942, sea search tests were conducted in Chesapeake Bay and at the Norfolk Air Station. Sixteen 4½-inch autocollimators were mounted on a 190-foot trawler, and ranges of 5,000 feet were obtained consistently.

A third use for ultraviolet autocollimators was for the landing of small boats on hostile islands at night.⁴ Tests conducted at Solomon's Island, Virginia, showed that small solid autocollimators mounted on the masts of landing boats enabled one boat to follow another with ease. On the flag deck of the mother ship carrying the small boats, two 4½-inch autocollimators were placed, oriented in such a way that they could be viewed very readily from the shore side of the ship; an additional unit was hung on a board over the ship's side near the stern, and two more placed on shore. A small landing boat was equipped with a 400-watt mercury-arc lamp filtered to transmit 3,100 Å and shorter. Ranges of 1 mile were easily obtained, both going to shore and returning.

7.2.2 Infrared Autocollimators, or Metaflectors¹⁵

Work on an infrared autocollimating system, paralleling the ultraviolet, started in 1943. These instruments have been called metaflectors to distinguish them from the ultraviolet autocollimators and from the infrared viewing systems, or metasopes. They operate basically in the same manner as the ultraviolet autocollimators. A high aperture K-S system forms an infrared image upon a previously excited phosphor sensitive to infrared. Upon this stimulation, visible light is emitted which returns through the optical system along the path of the incident infrared. Thus a distant observer sees the autocollimator emitting visible light when he illuminates it with an infrared source. The emission of visible light is only in the direction of the source wherever that source may be in the whole field of the autocollimator. Since it is unnecessary for the observer to use any type of viewing device, this system has certain advantages in applications where it is important that the observer's view be entirely unobstructed.

NECESSITY FOR CHARGING

An important difference between the infrared and ultraviolet autocollimators lies in the necessity for excitation of the infrared phosphor before use. In contrast to the ultraviolet, which utilizes only the energy of the incoming radiation to produce and return visible light to the observer, the infrared phosphor must be excited by ultraviolet radiation or by alpha particles and store this energy of excitation until exposure to infrared. This may be accomplished in two ways. The phosphor may be excited while in the focal position and the high background allowed to die down before use, or provision may be made for exciting the phosphor in one part of the instrument and transporting it into the working field after excitation. The latter method has the advantage that the bright fluorescence of the phosphor occurs in a completely shielded part of the device, while only the phosphorescent afterglow occurs during the time the phosphor is in the working position. Thus, for applications where only occasional use is required, and that for a short time, the first method is most suitable; but for any application requiring continuous use, or any use where the image of a distant source might remain focused for a time long enough to exhaust the phosphor within that small area, the moving phosphor surface is to be preferred.

FEATHERWEIGHT UNIT

The smallest metaflector designed was intended for hand-held operation on a signaling wand for the night landing of aircraft. It has an aperture of 1.8 inches and is externally excited. An ultraviolet source is contained in the holder into which the wand supporting the small units is thrust when not in use. Each unit weighs approximately two ounces and, when used with a 12-volt, 450-watt aircraft-landing lamp of 100,000 to 200,000 beam candlepower and filtered with 6 millimeters of Corning No. 2540 glass, gives a useful range of about 1,800 feet. The phosphor used on the focal surface in this smallest type, as in succeeding instruments, is Standard VII, described in Chapter 4. The unit is pressure-sealed but, as an added precaution, a small silica gel chamber is placed in back of the mirror to keep the phosphor dry.

4¾-INCH METAFLECTOR

A larger metaflector of the size of the Type B metascope, with a clear aperture of 4¾ inches, was next developed, intended primarily as a test model for still larger instruments to be used as runway markers. This uses the moving phosphor type of excitation. The

phosphor-coated surface is a segment of a sphere of radius equal to the focal length of the K-S system, with the chord of the segment approximately twice as long as that required by the working field of the instrument. The spherical segment is mounted with its axis of symmetry, and that of rotation, so tilted that the angle made with the optical axis of the autocollimator is equal to half the vertical working field, or slightly more than 15 degrees. The spherical button is rotated at the rate of two turns per minute by a belt drive and appropriate gearing from a 2-watt motor. Since it is necessary to use electric power for the ultraviolet excitation, a motor is used rather than a clock-work mechanism.

A field width of 50 degrees is obtained by exposing one third the area of the phosphor segment in the focal surface of the autocollimator, while the remaining two thirds is enclosed in a small housing containing the exciting source. Ultraviolet, instead of alpha-particle excitation, is preferred in the metalector, because the amount of radium necessary to completely charge the phosphor every 30 seconds would be excessive. During rotation, the phosphor is charged by a 2-watt mercury-arc lamp, in combination with a Corning No. 9863 filter. With this instrument, it is possible to obtain a range of approximately one-half mile when using the 12-volt source and filter described above.

8-INCH METAFLECTOR

After successful demonstration of the 4 $\frac{3}{4}$ -inch instrument, a larger metalector was made to obtain greater range. This has a clear aperture of 8 $\frac{3}{8}$ inches, and is excited in the same manner as the smaller model. When used with the same source as the feather-weight unit, it has a useful range of the order of 1 nautical mile. As in all devices of this class, the range varies with the fourth root of the beam candlepower of the source. The return beam of the instrument is very narrow, only a few minutes of arc in width, although its working field is approximately 30 degrees in height by 50 degrees in width.

The 8-inch metalector has two marked advantages over the 5-inch size. First, the exciting source and rotating motor with its gear mechanism are no larger and no more complicated than for the smaller type. Second, the visible light returned by the metalectors varies as the fourth power of the diameter of the entrance aperture, if the aberrations of the optical system are smaller than the beam spread due to scatter of light within the phosphor. Thus, doubling the linear aperture of the autocollimator is the equivalent of

increasing the beam candlepower of the illuminating infrared source by 16-fold, and should double the range. Actual field tests confirm this relation within the unavoidable errors of field measurement.

At present, one instrument has been assembled, photographs of which are shown in Figures 2A and 2B. Complete with motor and a sheet-aluminum case, this instrument weighs 14 $\frac{1}{2}$ pounds. In a completely waterproof form for shipboard use, a heavy cast shell of aluminum houses the assembly. At the close of the war, the Navy was still desirous of obtaining 20 of the 8-inch metalectors for experimental tests.

7.3

TRIPLE MIRRORS

7.3.1

General Properties

If three plane mirrors are set mutually perpendicular to each other, the system possesses the property of returning a beam of light back to the source without requiring any particular orientation of the mirrors to the source. Such devices have been in use for many years, including a form in which the three mirror reflections occur internally in a block of glass or other transparent material. The latter form permits high accuracy in positioning the reflecting faces, resulting in high efficiency for the device and a long range of operation. These solid forms will be referred to as triple mirrors, or triples. Quantity-production methods for this precision glass form were developed at the Mount Wilson Observatory (OEMsr-698), while various applications for military use were worked out at the University of Rochester (OEMsr-1219). Several of the applications to military and naval problems have been very successful and have resulted in substantial service production of triple mirrors and accessories.

A triple mirror is an excellent means of identification and signaling. The observer simply holds a light source next to his eye and sees an answering beam returned to him by the distant mirror. If the back of the triple is silvered, the field is increased from approximately 40 to more than 90 degrees, although in this case the intensity of the reflected light is reduced by three metallic reflections instead of three substantially perfect total reflections. However, an aluminum coating greatly reduces the polarizing effects found with clear glass and the resulting image is improved. An ideal triple will spread the return beam over about 4 seconds of arc; production triples are now of sufficient quality to concentrate the light inside a beam of approximately 8 seconds.

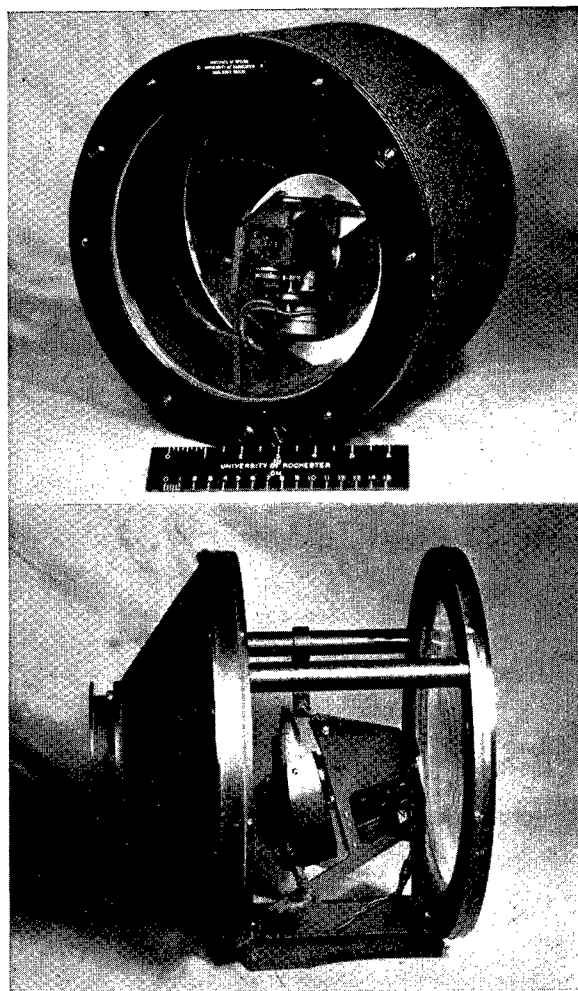

FIGURE 2. Eight-inch metalector. A. *Upper*—front view. B. *Lower*—side view.

When observed from the position of the illuminating source, the ideal triple acts as a diaphragm through which the light appears to come from a point at twice the distance from the source to the mirror. Thus, if the observer is standing at a point source and can barely see a triple at a distance x , the source can just be seen at a distance $2x$. This ratio of 2 to 1 in range between the visibility of the source and that of the detector is very desirable, and better than most other systems using visible light. However, variable refraction in the atmosphere seldom allows this minimum ratio to hold for long distances.

If the triple is of high optical quality, an observer can see this virtual source as long as his eye is at the real source. The freedom of movement of his eye is confined to an area twice the size of the mirror if a point source is used. With a large source, the area

is twice the size of the mirror plus the size of the source. As the observer and source move away from the mirror along the normal to the entrance face, the intensity of the reflected image diminishes according to the inverse square law applied to twice the distance from source to triple. Vignetting occurs when off axis. There is a distance away from the triple, however, where diffraction begins to "spill" the light over the edges of the geometrical return beam, and then the light is no longer confined to an area twice the aperture of the triple and the apparent brightness no longer obeys the inverse square law. For a 2-inch triple of very high quality, in the absence of atmospheric disturbances, this spilling occurs at about 1 mile; increasing the size of the mirror increases this limiting range.

In order to get the best possible performance from a triple mirror, the wave surface should not be distorted by more than a quarter wavelength by reflection at each surface. The reflecting planes must also be mutually perpendicular to within a few seconds of arc. If one of these angles departs from 90 degrees, there is a doubling in the return beam. An angular error in the prism is multiplied by about 5.3 in the return beam.

Owing to the small weight and permanence of adjustment of a triple, it can be used in many cases where other equipment, although perhaps better from a security point of view, is banned because of clumsiness or weight. Many such applications have already arisen. Figure 3 shows the triples used in the demonstrations described below. At least 6,000 of the size A were ordered from Mount Wilson Observatory by the Navy Bureau of Aeronautics, and an authorization for 60,000 of the size A' (size A edged round) was given just before the close of World War II.

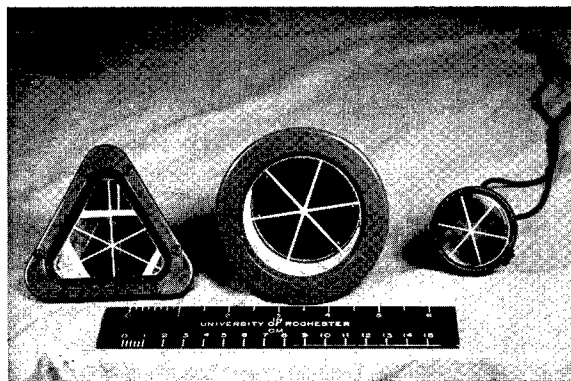

FIGURE 3. Triple mirrors. Left to right: size A (2 inch), size B (3 inch), size A' (size A edged round).

7.3.2 **Production of Triple Mirrors**¹⁷

The manufacture of triple mirrors on a production scale was undertaken at the Mount Wilson Observatory in 1942. Since the basic aim was to develop a simple method of production and not necessarily a new one, this subject was treated as an engineering rather than a research problem. Particular attention was given to the various phases of manufacture in order to eliminate as far as possible any laborious hand-correcting operations. One part of the process, that of forming the rough shape by diamond milling, was strictly a machining operation adapted to optical work. Here the physical shape of the triple was utilized; it was made the corner of a cube and its edges milled parallel to those of the cube. It was then removed from the cube and processed by normal optical shop techniques.

A model production line was set up so that the final process could be tried out on a limited production scale and appropriate time studies could be made. By the end of January 1943, nine people were working on the contract, four of them full time. One of the primary purposes of the project was to train people who were totally unfamiliar with optical work and to record their progress, which was surprisingly rapid.

EQUIPMENT

The following equipment was installed.

1. Two Blanchard No. 11 grinding machines.
2. One Norton vertical spindle grinder, for small lots.
3. One Covel grinder, used primarily as a saw.
4. Three 2-spindle 12-inch grinding and polishing machines.
5. Five 5-spindle 8-inch grinding and polishing machines.
6. Two 6-spindle 8-inch grinding and polishing machines.

The 10-multiple spindle machines were designed and constructed in the Mount Wilson instrument shop, along with auxiliary equipment, such as collimators and jigs.

PRODUCTION

By the end of March 1943, more than 200 triple mirrors had been finished and the production time had been reduced from over 20 to about 6 man-hours per unit. During 1943, about 1,000 triples of various sizes (1½-, 2-, 2½-, 3-, and 6-inch aperture) were completed, and the production time reduced to 3 man-

hours apiece. In April 1943, the working tolerances were reduced from 2 seconds to 1 second of arc without materially increasing the production time. The average glass blank was not good enough to warrant such accuracy, however, and internal errors due to the quality of the glass gave an error corresponding to an angular error of approximately 2 seconds.

At least one manufacturer (Penn Optical Company¹⁸) had attained satisfactory production by the middle of 1944, using the general method developed at Mount Wilson; this left the Mount Wilson group free to devote more time to purely experimental work and less to producing triples in quantity. Glass blanks of superior quality were produced by the Hayward Optical Glass Company of Los Angeles, and the resulting triples showed extremely small errors.

Considerable evidence was found that the finished triples are subject to a gradual change in shape. These changes do not appear in all mirrors and usually require several weeks or even months to become appreciable. Accumulated data indicate that "creep" actually occurs, but it cannot be traced to any one manufacturing process. Very often the error due to creep amounts to as much as a quarter wavelength.

An experimental triple mirror, utilizing three triangular plane mirrors mounted in an adjustable metal frame, was completed in order to avoid using an excessively thick block of optical glass. This device had a clear aperture of 6 inches. Although not particularly successful as an optical instrument, it showed that the extremely accurate mechanical devices necessary for adjustment could be made.

PROCESS OF MANUFACTURE

The milling procedure is divided into two operations: the shaping of the entrance face, and the shaping of the three side faces. With comparatively small lots of glass, say 200 blanks each, about 4½ minutes per triple are required to mill them completely to shape. Several minor changes were made in the Blanchard grinder to reduce the need of constantly attending the machine during milling. The choice of a suitable diamond wheel depends largely on the area of the individual triples. For small ones, metal-bonded diamond wheels are very satisfactory and have the advantage of long life; for the larger mirrors, a resinoid-bonded diamond wheel was found to be the most efficient type, since such a wheel wears just fast enough to cut freely. The feed cycle is arranged for the 2½- and 3-inch triples so that the first or roughing cut is made at 0.060 inch per minute and reduced

to 0.006 inch per minute for the last few thousandths. Surfaces produced in this manner are satisfactory for further processing, and chipping of the edges is eliminated.

Two types of jigs are necessary. For milling the entrance face, a diamond-shaped jig is used, with eight sockets shaped to fit the triangular pyramidal end of the blank. For milling the reflecting faces, the triples are waxed into place on the truncated corner of a cube-shaped jig. This jig must be made with great accuracy. The waxing is performed with both triples and jig preheated to obtain the greatest wax strength possible. A special fixture of two accurately aligned sockets to fit both jig and glass was made to permit accurate location of the blanks on the jigs.

A production rate of 350 2½-inch milled triples per day is easily maintained. The milling procedure holds the angles within 15 seconds of arc and the dimensions within a few thousandths of an inch.

Many attempts have been made to produce a milled surface sufficiently good to allow polishing without the necessity of intermediate fine grinding. These attempts have been unsuccessful in general, because of random marks probably caused by abrasive particles carried in the milling coolant.

Two of the four triple faces are fine-ground and polished in plaster blocks. The most important departures from the usual finishing technique are the use of rather heavy iron rings around the blocks, which are left in place while polishing, and a method of driving the block with an adjustable spider on the back. The entrance face and one of the reflecting sides are finished in this manner, with approximately 0.005 inch of glass removed from each surface by fine grinding.

The next step is to mount the triple in a cage for polishing and final angle-correction. The face to be finished is set into a hole in a glass plate, which forms the front of the cage and which is held in place by means of plaster; the other faces are left unobstructed for testing purposes. During the fine grinding, the greater part of the correction for angle is completed. As soon as the cage and triple face have been ground to a common level, the prism is tested for angle; any corrections found necessary are brought about during the grinding by clamping weights on a raised metal rim of the cage or by inserting the driving pin of the machine into one of the several eccentrically placed sockets in the top of the cage. It is possible to correct angles in this manner to well within 4 seconds of arc. During the polishing operation, the angles are corrected to within the final degree of tolerance.

The last reflecting face of the triple presents the greatest difficulty, for in this case two angles must be corrected, and it is necessary to test them both at frequent intervals. Mounting in cages, fine grinding, polishing and angle correction can be accomplished in about 1 man-hour per surface.

The last operation on a given triple is to verify its quality by means of an autocollimator. This instrument consists of a 9-foot-focus telescope with a specially constructed compound eyepiece. A boxlike housing at the eyepiece of the telescope contains a very thin plane-parallel glass acting as a beam splitter, which can be rotated so that the returning image can either be visually examined or can be photographed. The equivalent focus of the combination is 135 feet, enabling the diffraction pattern of the triple to be studied. This instrument has proved most useful both for final inspection and for providing photographic records of the performance of the individual triples.

7.3.3 Applications to Special Problems^{9,10}

SPECIAL NIGHT LANDING

In December 1942, the Office of Strategic Services presented NDRC with a high-urgency specialized problem involving the landing at night of a small plane of the Cub type in unfriendly territory. The plan was to have a man previously go to the spot on foot, prepare a landing strip, and place along it markers for the pilot. It was stated that the pilot would have no difficulty in locating the general area because of certain prominent landmarks. Because of the ease of carrying triple mirrors, their simplicity and ruggedness, they were an obvious solution to the problem.

Several tests were run at the Rochester Municipal Airport, to determine the kind of source necessary and the best grouping of the triplets. Four selected triples were set 1 foot apart on each side of the beginning of the runway, and 5 more on the left side 200 feet apart to outline the rest of the strip. A headset consisting of two 3-candlepower lamps, covered by red cellophane to provide minimum impairment of dark adaptation and minimum visibility to distant observers, was worn by the pilot. The lamps were restricted to a forward beam, reducing the glare on the eye and the backscatter from windshield and cockpit. With this equipment in a Stinson 105 plane, it was easy to locate and hold the runway at 5,000 feet looking through the windshield and at 7,000 feet looking through an open window.

These results were communicated to the Office of Strategic Services and 2 headsets and 14 triples supplied to them.

NIGHT LANDING GROUND-BASED PLANES

At the request of the Air Force Equipment Board, which had been informed of the application of triple mirrors to night landing as just described, demonstrations were conducted at the Kissimmee Air Base, Florida, during April and May 1943. These demonstrations used a P-70 airplane. After many tests, it was decided to abandon the headsets altogether, because of the large amount of scattered light and the relatively short range obtainable, and to substitute a 4-inch 50-candlepower lamp. This was made as small as possible to avoid obstructing the pilot's vision, and was mounted directly above his eyes; a handle was attached to the lamp so that it could be rotated to scan the field.

For the final demonstration, with both American and English observers, the runway was arranged with ten triples placed on the ground extending about 600 feet beyond the near end of the runway, as well as additional triples at stations 300 feet apart to line the sides of the runway itself. The P-70 plane (landing speed of 115 mph) was successfully landed, with the pilot reporting that the runway was visible for at least 2 miles despite bad weather conditions and looked brighter than when the usual portable small incandescent lamps (B-2) were used.

NIGHT LANDING CARRIER-BASED PLANES

While the ultraviolet autocollimator night-landing equipment was being demonstrated at the Philadelphia Navy Yard for use with Navy carrier planes (Section 7.2.1), it was decided to show the triple method also. Approaches were made in a TBD-1 but no landing was attempted; the pilot was very enthusiastic about this method and reported the triples showed up excellently. As a result of this demonstration and the failure of other landing systems to perform satisfactorily, the BuAer requested that the triple method of landing at night be further investigated. Triple-mirror equipment, including light sources, has been furnished and tests have been conducted by the Navy at Patuxent River Naval Air Station. Figure 4 shows a simplified drawing of the landing scheme, with the path of the plane traced around the carrier.

A bright signal, visible from any direction, must be placed on the carrier so that it can be located by a

returning pilot and inform him whether or not to attempt a landing. For these two purposes a cluster of 12 size-B triples, arranged in six groups around a vertical cylinder, has been designed. A shutter with six openings is rotated around the triples so that the mirrors appear to blink, to be constantly visible or invisible, at the signal officer's discretion. The cluster is located on top of the island at *A*.

If the pilot receives the signal to land, he circles the carrier in the manner shown and lines up in the

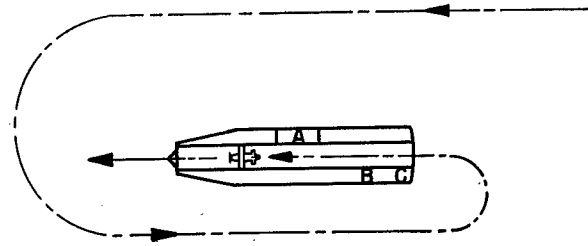

FIGURE 4. Schematic representation of night carrier landing by triple mirrors. *A*, bright cluster of twelve triples on island; *B*, several bright clusters to indicate turning point; *C*, signal officer.

proper direction by means of several bright clusters of triples placed in the neighborhood of *B*, where he begins to make his turn. The signal officer stands at *C* to direct the final approach. For the actual landing, single triples are observed by the pilot along the port side of the deck, with a few scattered ones on the starboard side.

This project was still being developed at the close of World War II, and the Navy has indicated a desire to carry it to a conclusion.

GLIDER LANDINGS

The problem of landing glider troops in enemy territory at night was the subject of a series of conferences at Wright Field in August 1943. It was assumed that paratroopers would land first, clear a landing strip and set up markers for glider landings. Because paratroopers could easily carry them down and no auxiliary equipment was necessary, triple mirrors seemed a good solution.

In a test conducted at Wright Field, the tow plane carried an 80,000-beam candlepower spotlight, while the glider had a 2,000-beam candlepower spotlight mounted at the pilot's left side for searching purposes, and a 200-beam candlepower lamp fixed on the front of the glider for actual landing. The triples were placed on the ground in units of two, wired together with one pointing directly up and the other in the conventional manner along the runway. A triple

was also placed on each wing tip of the tow plane, facing back.

The glider was released at 6,800 feet. At an angle of 45 degrees, the runway was visible with the 2,000-beam candlepower light at any altitude less than this; the usual range later proved to be 1.5 miles at 1,200 feet. The two triples on the tow plane were easily visible to the glider pilot. Both tow plane and glider made successful landings.

PLANE-TO-PLANE IDENTIFICATION

In July 1944, a request came from the Army Air Force for some system of plane-to-plane identification of B-29's. In bombing attacks over Germany, our planes had been disturbed by the infiltration of enemy night fighters. It was desired to install some system by which the tail gunner of a B-29 could identify a plane as friend or foe before that plane had closed in to less than 3,000 feet.

It was proposed that every B-29 carry a triple on each wing tip, facing forward. The tail gunner's compartment would be equipped with a 6-candlepower source and a small beam projector, boresighted with the gunsight. He would pick up a trailing plane by radar and wait until it approached to a known range as determined by an APG-15 unit. The reticle pattern of the sight would be roughly set (because of the great difference between the B-29 wingspread and that of any other plane) at the proper separation for the apparent wingspread of a B-29 at this range. As soon as the range was reached, the gunner would momentarily energize the small projector. If no return beams were seen, or if they did not fit the reticle, he would fire.

In Wright Field tests with Type-A triples, an easy range of 1.2 miles was established, and with Type B a great deal more light was obtained. In all, six B-29's were equipped with triples and projectors. The system has not gone into general use, however, as theater operational requirements changed and no further follow-up was requested.

NIGHT TORPEDO BOMBING TRAINING

Another triple-mirror application was for training pilots for night torpedo bombing. In this training, a

pilot makes successive radar approaches on a friendly ship on a very dark night. It had heretofore been impossible for the pilot or for watchers on the ship to tell how well the approach had been made. Two or more triple mirrors were mounted on the target at widely spaced locations of known separation, and a light source and continuously recording camera mounted close together on one wing of the bomber. These were boresighted with the axis of the plane and had sufficiently wide field to more than cover the target. Since the pilot could not see the return beam from the triples, he was unprejudiced in his flying. The film record proved of great use to both the pilot and his instructors.

NIGHT LANDING WITH TRIPLES ON PLANE

In many cases when a plane returns to its carrier, it is badly damaged, and, although the pilot may think his landing gear is down, it sometimes is not. It was suggested that triples mounted on the retractible wheels, flaps, and tail hook of a carrier plane would enable the signal officer to determine whether or not the wheels were down; he could then signal the pilot whether it would be safe to attempt a landing.

In this case, triples of size A' are used. The signal officer is provided with binoculars upon which are mounted one or more small restricted-beam light sources. Watertight mountings have been designed and water-repellent coatings used on the entrance face of the triples. The system can be used either with or without the triple system placed on the carrier, described above. It was for this use that the 60,000 triples were desired by the Navy.

NIGHT AIR-SEA RESCUE

The Equipment and Matériel Branch, BuAer, requested assistance on the application of triples for the rescue at night of men down at sea and supported either by a life raft or a vest. To enable rescues to be made at night as well as by day, triples, which can easily be seen by a searching plane, are mounted on the heads of the men. Recent extensive air-sea rescue tests of this system have been conducted by the Navy in the Caribbean, with very gratifying results.

Chapter 8

ANTI GLARE DEVICES

By *Mary Banning*^a

SEVERAL ANTI GLARE devices for special purposes were developed under Section 16.5. Graded-density goggles, to be worn by pilots while flying under conditions of extreme glare, were designed by the Bausch and Lomb Optical Company [B&L] (OEMsr-989). Three contracts were respectively assigned to Harvard University (OEMsr-571), Eastman Kodak Company (OEMsr-996), and the University of Rochester (OEMsr-1219) for the development of special instruments as aids in defense against aircraft attacking from the general direction of the sun.

8.1 GRADED GOGGLES¹

In the early spring of 1943, at a meeting of the Sub-Committee on Visual Problems of the National Research Council Committee on Aviation Medicine, Dr. Walter Miles, a member, emphasized the need for better sun goggles. Among the samples he exhibited was a graded-density goggle he had obtained in England; it was believed to be of Zeiss origin and a visitor present at the meeting said that he knew such goggles were marketed commercially by Zeiss. They apparently consisted of two pieces of glass, one clear and one of an unsaturated greenish color, which had been ground and polished in a wedge shape so that the thickness of the absorbing glass varied linearly from the tip to the base of the wedge. Thus, an observer looking straight ahead would have the entrance pupil for his eyes cut practically in half by the tip of the neutral wedge. Looking above this point, the density would increase in approximately a linear manner with angular elevation of the eyes. The sample exhibited, however, was of much too low density to be of any practical value for military work under bad glare conditions.

It was learned that B&L had made a few samples after the Zeiss pattern, and one such pair was tried under a variety of glare conditions in California desert country during April of 1943. Evidently the graded goggles had possibilities, but the gradation in density proved to be uncomfortably rapid near the center of the visual field, while not rapid enough

well above the center to provide proper protection in flying or driving into a low sun. The gradation in density at the center had the unpleasant effect that in either rough air or in driving a car over rough roads the unavoidable bouncing of the head caused a sufficient change in light transmission to produce a flicker effect which was very disturbing. It was also observed on these tests that for use in desert country, flying above a dense overcast, or driving over snow some protection was needed for glare from below.

A contract was arranged with B&L (OEMsr-989) under Section 16.2, NDRC, to develop graded-density goggles. It was contemplated at the time that the goggles would be of the Zeiss form, but that perhaps glass of stronger absorption would be used and possibly other modifications made which might improve them.

It was suggested by the section that the solution to the flicker effect and the protection from glare from below could be accomplished by a single change in design. Instead of a wedge, a concave cylindrical lens of absorbing glass could be fused to a convex cylindrical lens of clear glass. If the two glasses have the same refractive index, and their external surfaces the same radius of curvature, such a combination introduces no magnification or distortion. By placing the axes of the cylinders horizontally, the region of minimum density lies across the center of the field with the density increasing either above or below. The gradation in density in this case varies as the square of the displacement from the center, and not in a linear fashion. This has the advantage of a small variation in the center so that head movement and jerks are not troublesome, yet a rapid increase in density takes place near the top and bottom.

A sample of this scheme was immediately constructed by the contractor and tested in the summer of 1943. It proved to have a very great advantage over the original Zeiss type, and was also better than the original B&L sample, but it was rather difficult to manufacture. As a result, the contractor undertook to produce an equivalent change in optical density over the surface of the lens by evaporating a hard film of nickel-chromium alloy onto the surface of either

^aInstitute of Optics, University of Rochester.

a clear or tinted glass of uniform thickness. Such a metallic coating gives an almost perfect "neutral" density. The gradation is accomplished by evaporating through a rotating mask which alternately exposes and protects the glass from the stream of distilling atoms. By properly shaping the contour of the mask, any desired gradient in optical density can be secured.

The evaporated-film goggles were just as satisfactory to use as the cemented or fused glass combination, and B&L found them much easier to make. The slight disadvantage of a mirror surface on one side of the glass could be overcome by forming the goggles from two pieces of neutral absorbing glass, with the evaporated film on the interface between them. Thus, any light reflected from the mirror surface would have to undergo double passage through the neutral glass and would be considerably attenuated. It was believed that this might be necessary in close hand-to-hand fighting such as in jungle warfare, but for aircraft or for most desert operations it was considered that the glint of sunlight on the goggles would not be sufficiently conspicuous to an enemy to warrant the trouble of adding the cover glass.

In some cases, it is advantageous to have the graded-density film only on the top half of the goggles. When flying an open cockpit airplane or one with a military canopy, there appears to be advantage in a graded density below the center line only when looking out over a bright overcast. In the case of a closed automobile or plane, there is a distinct disadvantage in having absorption below the center line because there is not usually sufficient light within the car or plane to render the instrument panel properly visible through a graded density.

Samples of both forms were presented to the Air Forces and to a number of other agencies for test and trial. Acceptance was quite enthusiastic, with a request from the Eighth Air Force in England for immediate procurement. This resulted from samples which had been sent to the OSRD Liaison Officer in London. Substantial numbers of those with graded density above the center line only have been procured by the Air Force, together with a few hundred of the type with graded density in both directions. Although the goggles are not a cure-all for every sun-glare condition, they appear to cope with a much wider range of conditions than any form hitherto proposed.

Development and manufacture of these goggles were classified until early in November 1945 when the Air Force authorized B&L to announce that the goggles had been made for the Armed Forces.

8.2

DETECTION OF AIRCRAFT AGAINST SUN GLARE

In order to keep in view an object approaching from the direction of the sun, it is necessary to be able to see the object against the sky background in the neighborhood of the sun, and also against the brilliant background of the sun itself, which is between 10^4 and 10^5 times brighter. It is impossible to select any single smoked-glass or light filter which will permit an airplane silhouette to be seen clearly both against the sun's disk and against the adjacent sky. If the filter is made sufficiently dense so that the sun is not dazzling, the surrounding sky is completely blacked out, whereas if it is made suitable for observing the sky, the solar image will be so bright that only an airplane very near at hand will be recognizable against it.

This fact is so well known that planes always approach an enemy target from the direction of the sun whenever possible, in order to avoid visual detection. In 1942, a device to counteract the glare of the sun by occulting the solar image with a high-density disk just large enough to cover the sun's image was proposed by the Harvard College Observatory. A similar but unsuccessful device was developed by the Eastman Kodak Company. Later, a completely different device, an *Icaroscope*, was developed and was in production at the close of the war.

8.2.1

Occulting-Disk Method^{2,3}

If a translucent disk is interposed between the sun and the eye of an observer, of a size such that the solar disk is just obscured and of a density such that the intensity of the solar image is reduced to that of the sky, any object between the viewing instrument and the sun can be seen equally well against the sun's disk or against the surrounding sky. Such a disk may be used with a telescope, and placed to block the solar image either in the exact position of the sun's image or beyond the objective lens. Preliminary experiments at Harvard Observatory showed that best results were obtained with a disk with a central portion of density 3 occulting the sun and a surrounding region graded in density from 3 to zero. The diameter of the complete disk was three times the diameter of the central portion, with the ideal gradation from center section to edge lying somewhere between a linear density and a linear transmission. Automatic positioning of this disk so that it always centered on the sun could be

most readily controlled by means of a photoelectric mechanism.

TYPE 1

The first such instrument, developed under Contract OEMsr-571 with Harvard University, involved a sighting unit, designed for tripod mounting, comprised of a telescope with a movable glass plate suspended in the focal plane of the primary objective. This plate had an occulting area of high density at its center, which could be moved to any point within the field of view, or to any part of a circumferential area surrounding the field of view. Rigidly attached to this plate is a photocell holder so positioned that when the occulting disk intercepts the sun's image in the viewing system, the center of the photocell is directly behind another image of the sun formed on a ground-glass plate at the focal plane of an auxiliary guiding telescope. Two electric motors, with their applied forces mutually perpendicular and controlled by the photocell, direct the position of the occulting disk. Motors, disk, and photocell are mounted in a sheet-metal housing measuring $7\frac{1}{2} \times 9 \times 12$ inches. The two telescopes are attached to the 9×12 -inch front face, and the eyepiece to the rear face.

The photocell, made by RCA, has four cathodes, each an equal portion of a conical surface. Opposing pairs of cathodes are coupled to the input of balanced feedback amplifiers each of which in turn regulates the firing of a pair of thyatron tubes. Each thyatron of one pair has one field of a split-field motor connected in series with its anode. Unbalanced illumination of an opposed pair of photocell cathodes unbalances the amplifier, causing one thyatron to fire and thus controls the direction of rotation of one of the motors. In this manner, successive unbalancing of the image on the photocell acts as a drive to regain balance.

The instrument was first demonstrated for Navy and OSRD personnel at the Naval Observatory in Washington on February 2, 1943. With the telescope pointing in the direction of the sun at noon, the horizontal position of the occulting disk was corrected at the rate of approximately 45 times per minute, corresponding to an image displacement of 20 seconds of arc per correction. The time required for the occulting disk to traverse the entire diameter of the field was approximately 0.5 second.

Conclusions based on this test were that a sensitivity able to correct for an image displacement of 30 seconds of arc is sufficient, but that the time re-

quired for the disk to traverse the diameter of the field should not exceed 0.1 second, in order to prevent a blinding flash in the eye of the observer. Accuracy with this instrument averaged less than 15 minutes of arc, whereas an accuracy within 30 seconds of arc was desired.

TYPE 2

Another type of device was also proposed, with the occulting disk outside the objective of the viewing telescope. In this case, the disk must be supported by an arm having theoretically a length in feet approximately 10 times the diameter of the lens in inches. Construction of a unit carrying a 10-foot arm was instituted at Harvard University. The unit was later redesigned to employ an open sight of zero power which would allow a shorter arm. The disk was mounted on a turntable and controlled by a photocell and thyatron system as in Type 1.

8.2.2

Shutter Method⁴

Two methods somewhat similar to the Harvard device were developed by the Eastman Kodak Company during 1943, under Contract OEMsr-996; one of these was a photoelectric and mechanical process and the other one photographic.

PHOTOELECTRIC PROCESS

The photoelectric process uses an opaque disk in a telescope to cover the image of the sun, but differs from the Harvard instrument in that a shutter is employed to prevent observation unless the disk is in the occulting position. Since a barrier-layer photocell generates about 10 milliamperes of current when exposed to the light of the sun's image, it was hoped that the energy obtained from such a cell would be capable of operating a small shutter near the exit pupil of the eyepiece. A photocell, whose sensitive surface is cut away to leave only a wheel-like section with sensitive spokes, is rotated rapidly about an axis such that the spokes traverse the field lens of the telescope. As a spoke intercepts the sun's image, the current rises to a value sufficient to open the eye shutter. To avoid objectionable flicker and to allow the telescope to be used for reasonably fast tracking, the rate of interruption must be about 30 cycles or more per second. This development was unsuccessful, since it was found to be impossible to produce a shutter that would operate at the required frequency with the available current input.

PHOTOGRAPHIC PROCESS

The photographic method consisted of running a film through the focal plane of the telescope, allowing the sun to produce a dense image of itself which would act as the occulting disk. The first method tried was that of the *printing-out process* in which no development is necessary, but the density obtained in this

images of the sun and surrounding sky upon a strip of 35-mm film coated with the special emulsion. The beam passing through A_1 is offset by the prism B so that the image formed on the film at C will be optically identical to the image formed by A_2 at D . Similar points in images C and D are 0.75 inch apart, which is the separation of the standard 35-mm film

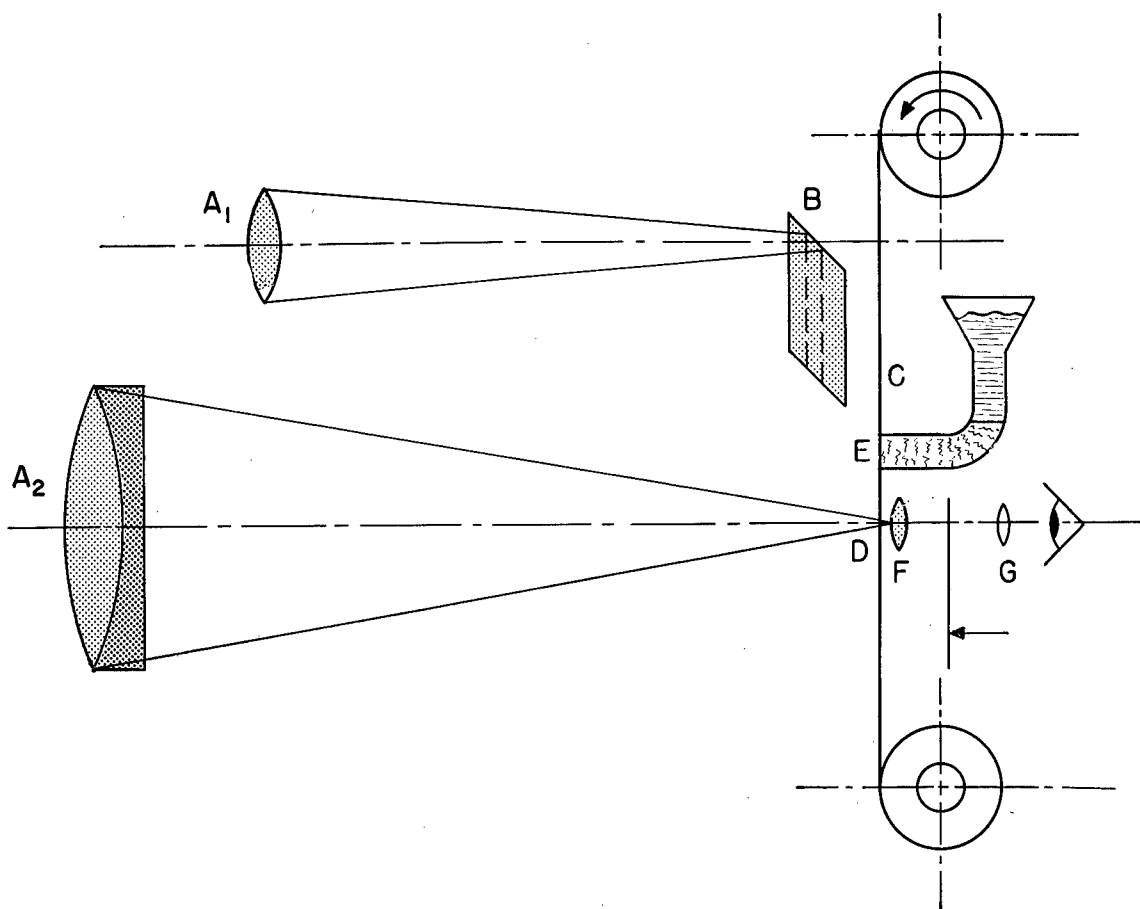

FIGURE 1. Optical system of photographic antiglare device.

fashion was only about one tenth of what was needed.

Another solution was the use of a special emulsion, amply sensitive to the intense light present in the sun's image, but low enough in sensitivity to prevent exposure from the surrounding sky. The emulsion is sufficiently transparent so that its presence in the image plane is not objectionable. Such a material may be developed by wetting with a special solution; the development may be made to proceed very rapidly, but whether or not it would be rapid enough was problematical.

Two 14-inch objectives, A_1 and A_2 , as shown in Figure 1, are mounted with parallel axes to form

frame. The film is moved intermittently by a standard camera pulldown so that a picture exposed at C moves next into position D . Between frames C and D is a wick, E ; this is pushed in contact with the emulsion face of the film and wet with a developing solution. The solution is intended to develop the latent image formed at C during its transport to the frame D . So if in any part of the first frame there is formed a latent image of the sun's disk, that image after transport and development will be in exact register with the image formed by A_2 .

Lens F acts as a field lens close to the plane of D , and G is an eye lens. Between F and G , a sector shut-

ter synchronized with the film movement covers the eye lens until the film comes to rest.

The trial of this apparatus was disappointing. Development time was too long to produce an image of sufficient density at the rate at which the film had to move.

8.2.3

Icaroscope Method⁵

In 1943, a method of using an afterglow phosphor was worked out at the University of Rochester, independently of NDRC contract, and found to be

if any brighter than that exposed only to sky light.

This principle of phosphorescent saturation is here utilized in a telescopic device for viewing the sun and surrounding sky. An image is formed on a phosphor screen by means of a suitable objective lens, and a rotating shutter between lens and screen intermittently exposes the phosphor to the incident radiation. A second rotating shutter, connected to the first, exposes the phosphor to view only at such times as the shutter in the illumination beam is closed, so that the phosphor screen becomes visible only by virtue

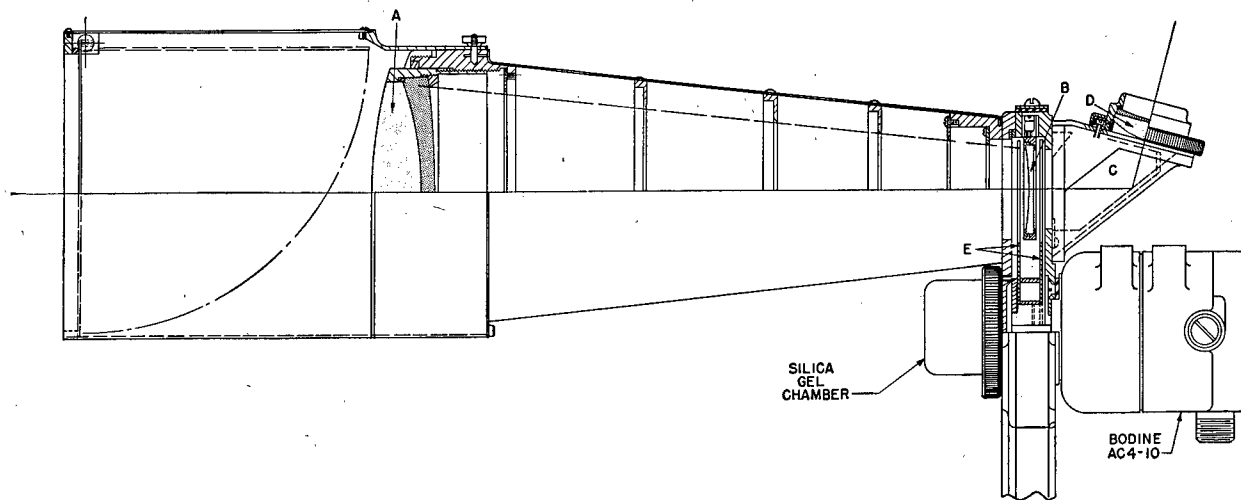

FIGURE 2. Assembly drawing of Type 1 Icaroscope.

practical, but no further work was done at the time since there was no pressing Service need for such an instrument. By the summer of 1944, however, it developed that this device, code-named Icaroscope, could be of use to the Services, and further refining of the instrument was done at the request of Section 16.5 under existing Contracts OEMsr-81 and OEMsr-1219. The image of the sun in the Icaroscope is but 20- to 50-fold brighter than the image of the surrounding sky. Two sizes of the instrument were designed, constructed, and submitted to the Navy Department. These permit spotting an airplane under ordinary sky conditions at distances well over 25,000 feet.

The operation of these instruments is based on a property observed in many commercially available afterglow phosphors; i.e., the apparent fluorescence varies approximately as the intensity of the exciting radiation, but the phosphorescent afterglow exhibits a phenomenon of saturation. Thus, if two areas of the same sample are exposed to sky light and direct sunlight and then removed to the dark, the phosphorescent afterglow of the area exposed to the sun is little

of its phosphorescent afterglow. With the phosphor used, the image of the clear blue sky is 1 to 2 millilamberts in brightness while that of the sun is 50.

TYPE 1 ICAROSCOPE

A request for the development of a service type of sun telescope was made by Lt. Comdr. R. E. Burroughs of the Readiness Section, COMINCH, in the summer of 1944. An assembly drawing of the first production prototype Icaroscope, Type 1, is shown in Figure 2. A cemented doublet of 4-inch clear aperture and 12-inch focal length forms the objective, giving an image on the phosphor screen, *B*. The image of a 10-foot diameter circle (airplane cross section) 25,000 feet away is approximately 0.005 inch in diameter. On each side of the screen is a rotating shutter *E*, so arranged that the excitation and viewing of the phosphor take place at different times. The screen itself is slightly concave toward the objective, to secure the best image quality possible.

Because of the necessity of a very long working distance for the eyepiece, which must function as a

simple magnifier, a special aspheric doublet, *D*, of 2-inch focal lengths is used. It has a clear aperture of 30 millimeters, to provide comfortable eye relief. This allows room for an erecting prism, *C*, between the eyepiece and phosphor screen, consisting of a special roof prism which deviates the axis by 75 rather than the usual 90 degrees. This particular deviation has been chosen to provide maximum comfort in viewing objects anywhere between the horizon and zenith. The combination of eyepiece and erector gives an erect image of 6-power magnification with a real field of 7 degrees.

Elimination of all scattered light is most important in this instrument, because of the tremendous difference in brightness of the sun and the sky. Scattering by the objective has been cut until 75 per cent of the residual scattered light is due to diffraction. Scattering by the housing tube and exciting shutter have also been cut to a minimum. In order to avoid scattering due to exciting light reflected from the back surface of the phosphor screen, a glass backing has been chosen that transmits the green-yellow emission but absorbs the blue, violet, and ultraviolet radiation which excites the phosphor.

Shutter speeds of approximately 2,000 rpm give good results. The relative length of time for viewing and exciting the phosphor is not critical; however, the shutter cannot be made of equal open and closed quadrants. This is because the phosphor screen is circular and the illumination sector must be completely closed over the whole surface of the phosphor before the viewing sector opens, otherwise scattered light from a small illuminated area will fog the whole field. Thus some shutter space is necessarily wasted.

The final instrument developed weighs but 9 pounds complete with motor, and can be used either hand-held or in a simple altitude-azimuth swivel mount. Operation from a portable storage battery or dry batteries is quite feasible since the input requirement of the motor, a Bodine AC 4-10, is only 10 watts. In the production design of the instrument, a silica gel compartment is provided to keep moisture away from the phosphor. A contract was placed by the Navy Department with the Universal Camera Corporation for the production of several hundred of these Icaroscopes. Photographs of the production prototype are shown in Figure 3.

TYPE 2

The design of a smaller, lightweight Icaroscope, Type 2, was started in January 1945. It is essentially



FIGURE 3. Type 1 Icaroscope, assembled; disassembled, front view and rear view.

the same as Type 1, but with an 8-inch focal length, 2.67-inch aperture, magnification of 4, and a weight of 4.3 pounds. In order to save space, two conical rotating sectors are used in the smaller model. This brings the axis of rotation closer to the phosphor screen and even more of the sector is wasted than in Type 1. For this reason a single aperture is used in each section, and dynamic balance is obtained by thinning a portion of the sector opposite the aperture. The motor, a 28-volt DC Eastern Air Devices model,

RESTRICTED

has twice the speed of Type 1, or approximately 4,000 rpm, which makes up for the single opening. The instrument is easily held in the hand.

A sample Type 2, which is shown in Figure 4, was delivered to the Navy in July 1945. Not shown in the photograph is an auxiliary finder, which also deviates the beam by 75 degrees and has a density of about 3. This operates at unity magnification, has

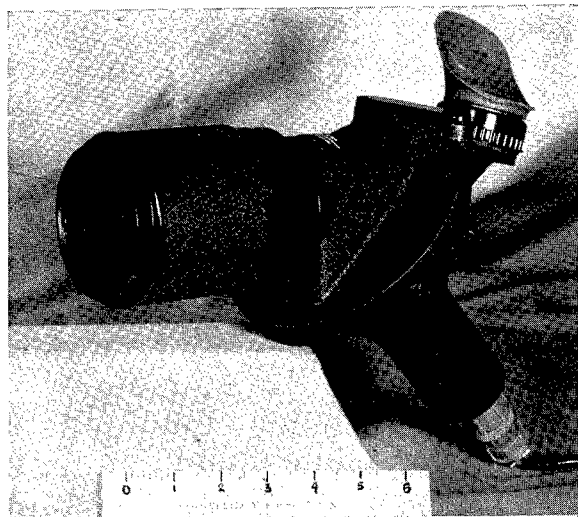

FIGURE 4. Type 2 Icaroscope, assembled.

a wider field than the Icaroscope itself, and is used to prevent the operator from following his natural impulse of first looking directly at the sun before using the telescope.

PHOSPHOR REQUIREMENTS

In order to perform satisfactorily in an Icaroscope, the band of wavelengths emitted by the phosphor must be well separated from those wavelengths which excite it. This permits the use of a glass backing for the screen that will cut off the exciting light while letting through the emission. The phosphor must be in the form of a fine-grained powder with the best possible resolution, for the image of a distant airplane cast on the phosphor is very small, and to be well resolved this image must fall upon a number of grains.

Also, the phosphorescent saturation point must be at neither too high nor too low an intensity level. If too high, the image of the sun will be blinding to the eye, and if too low, no contrast will be seen between sky and sun. Finally, the time constants of phosphorescence must be adjusted; if the decay is too slow an image of the sun will remain on the phosphor for too long a time and leave a trail as the instrument is moved, while if the reaction is too fast the image will not have sufficient intensity.

The phosphor finally developed under Contract OEMsr-81 (see Chapter 4) for the Icaroscope consists of a zinc sulfide - cadmium sulfide *base* with a silver *activator* and a sodium iodide *flux*. All zinc and cadmium sulfide phosphors undergo photolytic decomposition, which is accelerated by moisture and flux. This is prevented by carefully washing the phosphor with acetic acid to remove the flux, and by providing silica gel to absorb the moisture.

FORMATION OF SCREENS

After the phosphor has been prepared in the form of a powder of suitable particle size, it is necessary to deposit it on a screen in a uniform layer approximately 25 microns thick. This is done by first removing the larger grains by elutriation, and then allowing the fine particles to settle on a glass disk immersed in a liquid. Amyl acetate is used for the process, since it does not react with the phosphor powder. The elutriation column is adjusted to retain particle sizes from about 3 to 8 microns, or about half of the original material. This fine powder is then dispersed in ethyl acetate and allowed to settle out on a glass disk. After the proper thickness has been deposited, the disk is very carefully raised through the liquid. It has been found that there is an optimum thickness of the phosphor that gives best results, and this is controlled by weighing the amount of powder before introduction into the settling column.

Screens formed in this way have approximately a 17-micron resolving power, under optimum conditions of contrast, when used in the Icaroscope with 12-inch focal length lens.

Chapter 9

MISCELLANEOUS OPTICAL DEVELOPMENTS

By *Mary Banning*^a

9.1 INTRODUCTION

SEVERAL OPTICAL devices have been developed under Section 16.5 of NDRC that are not concerned either with infrared or ultraviolet systems. One of these, the so-called *flash metascope*, uses a Type B metascope described in Chapter 3 with a phosphor sensitive to visible, not infrared, radiation. Another, the *Kellner-Schmidt [K-S] strip projector*, uses a K-S optical system (also described in Chapter 3) for projection, but with a filament in place of the phosphor. The third uses an optical system of projection and reception designed specially for the Navy *Cadillac-2* project and has no relation to other optical devices developed under Section 16.5. All three devices were being successfully tested at the close of war. Another development was completed in the fall of 1943 involving the identification of surface vessels from aircraft equipped with linked searchlights and anti-oscillation mounted binoculars; this succeeded the ultraviolet method described in Chapter 7.

9.2 FLASH METASCOPE^{7c}

In October 1944, a group of representatives of the Army and of Division 16 met to discuss various methods of night aerial reconnaissance. Of the several methods proposed, that involving the use of flares appeared the most promising. At the request of the Army, the Institute of Optics (under Contract OEMsr-1219) started the development of a system using a flash afterglow metascope (*flash metascope*) for observation purposes.

Flash metascope were first tried in the spring of 1941, in connection with the ultraviolet developments described in Chapter 7. For the present application, the Type B production metascope with 4.75-inch aperture has been modified with an afterglow phosphor selected for the purpose. The reconnaissance scene is illuminated with a photoflash lamp or small charge of flash powder, which produces an afterglow picture on the phosphor surface. This can be viewed and studied for a period of 10 to 20 seconds following

the flash, after which the image dies away to brightness levels too low to be useful. The metascope has been mounted in a specially designed sweep mechanism to fit the nose of a B-25 or A-26 airplane in such a manner as to be used by the bombardier. Tests have been made to determine the proper ground illumination necessary, using a scale model simulating actual ground conditions.

9.2.1 Metascope Modification

The use of the metascope for this special application involves a change of the phosphor used on the focal surface. Commercial phosphors supplied by the U. S. Radium Company were first tried, and later replaced by one which has a much better resolving power. The best sample consists of a zinc-cadmium sulfide *base* with copper and manganese as *activators*; this is quickly excited, has a usable afterglow of 10 to 20 seconds, and a grain size of 3 to 4 microns. Tests with the Type B metascope show that a much brighter image can be obtained if the phosphor is pre-excited by white or ultraviolet illumination, causing it to show an appreciable afterglow. Provision for pre-excitation in the metascope is supplied by the light source already incorporated in it for infrared use.

In order to illustrate the effect of using the Type B as a flash metascope, and to determine the amount and distribution of illumination necessary, a small-scale landscape traversed by a simulated convoy was set up on the ninth floor of the Rush Rhees Library tower, at the University of Rochester. This model was shown to Army and OSRD representatives in December 1944. Observations with the flash equipment were made from the thirteenth level with scale models such that the equivalent altitude was about 1,200 feet, and flash lamps were set off at an equivalent altitude of 400 feet. The metascope was pointed directly at the scene to be viewed. Eyes were closed while the flash was set off and then immediately opened to inspect the phosphorescent image seen on the focal surface of the metascope. The image showed a useful duration of about 20 seconds.

Flash equipment for local tests was received from the Army, and during the winter of 1944-45 several

^aInstitute of Optics, University of Rochester.

tests were made. However, with the equipment that was furnished, insufficient ground illumination was obtained. It was calculated from the model that a ground illumination of 0.2-foot-candle-second would be necessary and that sharp shadows were essential.

9.2.2 Sweep Mechanism

At the end of December 1944, a conference was held at the Army Air Forces Board, Orlando, Florida, on this project. It was decided there to build a *sweep mount* for the metascope, to be fitted into the nose of a B-29, providing a total sweep from 45 degrees to the vertical, and controlled by a spring and air dashpot mechanism to give a constant projected velocity at a fixed distance. Such an instrument has been constructed, with controls that change the sweep acceleration to allow for various combinations of altitude and ground speed of the plane.

Because of airplane vibration, as well as the size of the instrument and other moving parts, the mounting frame is made from heavy aluminum angles and mounted on a plate which in turn can be fastened to the bombsight platform. Tapered mounting ways are provided to hold the Type B metascope, or, if desired, a small camera.

The design of the headrest comprised a good portion of the design problem. Since the instrument moves through a sizable angle, it would be impractical for the observer to follow it during its sweep. Therefore, a fixed headrest is used, into which the eyepiece of the instrument swings, and the observer keeps his head in position throughout the sweep to be ready the instant the eyepiece comes into view. Since he does not have anything to look at while waiting for

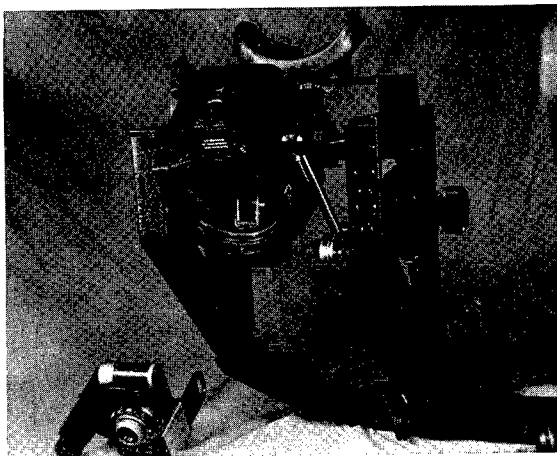

FIGURE 1. The flash metascope in its sweep mount with the camera below.

the instrument to appear, a fixation point is provided to keep the observer's eye from wandering and to maintain the focus at infinity. This fixation point is a cross-hair reticle, projected into the headrest from

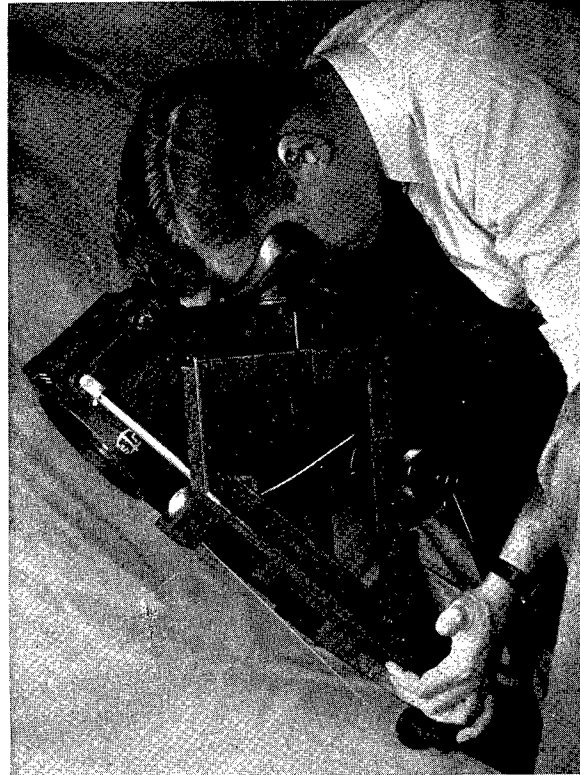

FIGURE 2. Method of viewing with flash metascope.

the side and upward to the eye by a small right-angle prism which snaps quickly and completely out of the field the instant the eyepiece comes into position.

Figure 1 shows the Type B metascope in its sweep mount, with a Kodak 35-mm camera below; the camera can be used in the same mount and has a special back permitting quick developing of the photographs taken.

Figure 2 shows the method of viewing with the flash metascope.

9.3 STRIP PROJECTOR^{3,4,5,7a}

To meet the need for low-altitude aerial photography at night, using *strip cameras* such as the Sonne S-6 and S-7, some form of lightweight high-intensity projector is required. Because a much higher beam candlepower is possible in a given size of projector when a stigmatic image of a line source is used, this type was decided upon rather than a concentrated

source image such as a carbon arc with the addition of a beam-spreader to the projector mirror. A very compact projector, with an outside case diameter of about 11 inches, has been developed using a K-S type of optical system.

Initially, the project was undertaken with the expectation of using only visible light for photography. However, as a result of the high efficiency of the projector plus the high-sensitivity infrared films recently developed by the Eastman Kodak Company, it has been possible to use infrared radiation and thereby to obtain much greater security. Photographs have

aperture, reduced only by the transmission and reflection losses in the optical system. Because of this high efficiency, an 8-inch aperture K-S projector without a beam-spreader yields the same beam-candlepower which is produced by a carbon-arc system with a beam-spreader and an 18-inch parabola.

A series of filaments for this system was specially developed for the purpose by the Lamp Development Laboratory of the General Electric Company, under Contract OEMsr-423. Finally used was a 28-volt, 1,800-watt filament of 37-mil tungsten wire with 18 turns per inch and 2 inches long (see Section 5.3.2).

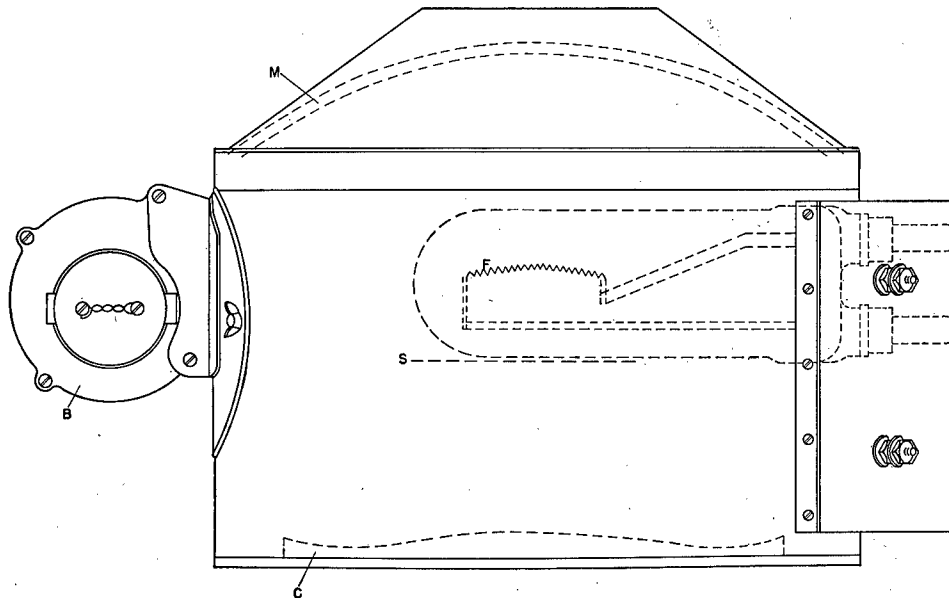

FIGURE 3. The optical system of the K-S projector.

been successfully made at altitudes as great as 1,000 feet, although best results thus far have been obtained at altitudes of about 500 feet.

9.3.1 Development of the K-S Projector

In the spring of 1944, the Chief of the Photographic Laboratory at Wright Field informally requested the development of a system of strip projection. Preliminary investigations showed that a beam of light approximately 1.5 by 25 degrees was necessary. A K-S projection system was decided upon, consisting of a spherical mirror corrected for spherical aberration by an aspheric *corrector plate* placed at its center of curvature, and a long tungsten coil curved to follow the focal surface. Light from the filament is reflected by the spherical mirror out through the corrector plate. Such a system requires no beam-spreader, and the beam candlepower is equal to the brightness of the source multiplied by the area of the projector

Figure 3 shows the optical system of the $f/0.53$ K-S strip projector. *M* is a spherical mirror of 8-inch radius, *C* the aspheric corrector plate, *F* the tungsten filament, and *S* a shield to prevent direct light from the filament from leaving the projector. The clear aperture of the system is 8.375 inches, and the focal length is 4.42 inches. The optical system is mounted in a lightweight aluminum housing with forced-draft cooling provided by a miniature 27-volt blower *B*, built into the projector. Including blower, the total weight of the finished projector is approximately 11 pounds. When the filament is operated at a color temperature of 3400 K, the beam candlepower is about 800,000 over a solid angle approximately 1.5 by 25 degrees.

9.3.2 Use of K-S Strip Projector

The final unit used is shown in Figures 4A and 4B. This consists of two projectors mounted with an S-7 Sonne camera, equipped with an $f/1.5$ lens of 8-inch

aperture which covers a 40-degree field. It was proposed to use two of these units together, or four projectors in all, to make a photographic record of a 70-degree strip on the ground. Preliminary tests with the two strip projectors were so satisfactory that (as mentioned above) it was decided to use infrared illumination for the final demonstration. A cylindrical surface was superimposed on the aspheric corrector

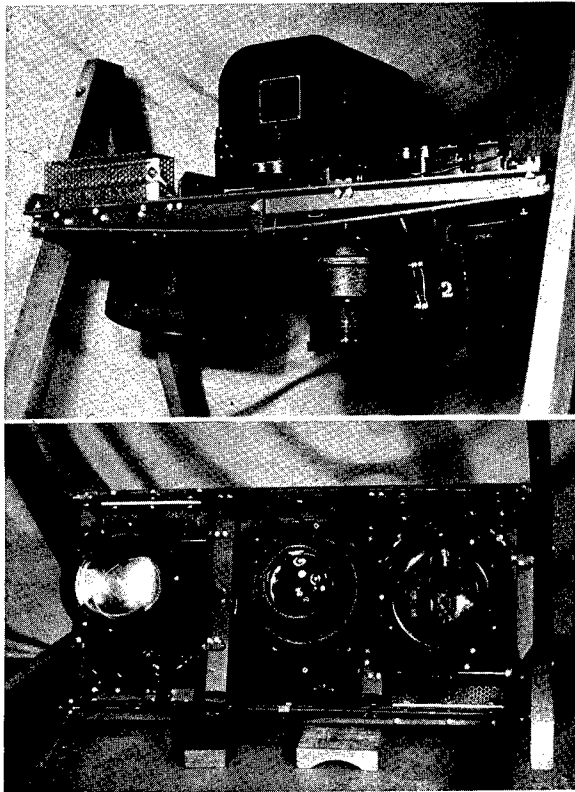

FIGURE 4. A. Upper—Two strip projectors mounted with camera, side view. B. Lower—Strip projectors, bottom view.

plate, to astigmatize slightly the projected image. This was to prevent too accurate focusing of the filament on the ground, which causes uneven illumination. The two projectors were arranged with a slight overlap to cover a field from approximately 5 degrees on one side of the vertical to 35 degrees on the other. The slit of the camera was opened wide, since the sharp projected strip of light on the ground acted as the slit itself. This made the most efficient use of the light and eliminated critical alignment between the camera and projector.

In July 1945, tests were made in a B-25 airplane at Wright Field of the projector system using a new film developed by the Eastman Kodak Company called Kxx. The two projectors were covered with Wrat-

ten No. 88 infrared filters. Observers on the ground being photographed reported that no scattered light at all was visible, and that it was impossible to detect the projected light except during the 0.1 second that they were in the direct beam and then only if they happened to look up at the instant the airplane passed overhead. In this case, only a faint deep red light is seen for this fraction of a second, and extremely high security is thus obtained.

Successful exposures were made up to altitudes of 1,000 feet. Figure 5 is a sample photograph taken at 500 feet at an airspeed of 200 mph on Kxx film with a slit width of 0.400 inch. The vignetting at the top of the picture can be reduced when the unit is tested in an A-26, for which it was designed; the bomb bay of the B-25 cuts in on the edge of the oblique beam. The camera used was a Sonne S-7 with an $f/1.5$, 8-inch lens. Unfortunately, it was still set for visible focus when the picture was taken, a fact not known until after development, and produced an out-of-focus infrared image. Much better results are obtained when the proper focus is used.

At the close of the war, the Army was desirous of obtaining the complete set of four projectors for further testing.

9.4

CADILLAC-2^{7b}

On June 14, 1945, Section 16.5 was asked to assist in a top-priority project, *Cadillac-2*, by BuAer.

In large fleet operations, *Combat Information Centers* [CIC] are placed aboard major fleet units to pick up information on enemy movements by means of radar (AEW) equipment, and to maintain a correlated picture of the disposal of all units. For this purpose a large screen is used, on which is drawn a general geographical map of the area, together with temporary positions of friendly and enemy sea and aircraft as determined by radar. Watching the changes on the screen enables coordinating officers to transmit proper directions to individual units. However, low-flying attacks are difficult to detect by shipboard radar, and to provide protection against these it was proposed to place a CIC unit in a specially constructed room in the bomb bay of a B-17 airplane, from which all enemy movements could be detected.

Whereas a ship has a relatively low speed throughout such an area, an airplane moves so rapidly that the coordinates of its position are continually changing with respect to the map. This requires that some

RESTRICTED



FIGURE 5. Infrared photograph taken with strip projector (see text).

method be provided of superimposing the changing position of the CIC airplane on the screen map.

A moving grid of polar coordinates, with the B-17 at the origin, must be projected on a screen which also has temporary markings of unit positions and fixed markings of geographical points. The maximum size allowed for the screen was a circle 4 feet in diameter, and the greatest possible projection distance was 81 inches. It was found that the projector could be placed on the forward bulkhead, and that the screen could be slightly tilted so that a line from the projector to the center of the screen would be perpendicular to the screen and enable a 20-degree half field to be used. Optical specifications of a projection system and the form of screen to be used were requested by the Navy, with the deadline placed at July 1, 1945.

As planned, the CIC room has a scribe sitting in a doorway of the aft bulkhead (No. 5), receiving information as to the disposition of enemy and friendly aircraft from two radar observers stationed behind him outside of the room; he plots this information on the screen. The projector is mounted outside the room on the starboard side of the forward bulkhead (No. 4), in such a position that the beam of light passes

just over the head of one of the four coordinating officers.

9.4.1

Screen Specifications

After several attempts with fluorescent screens and ultraviolet illumination, these were discarded as giving too faint a response for use and it was decided to use visible projected light. Since this will only show up against a diffusing surface, one side of the screen must be ground or made otherwise diffusing. This prevents edge illumination of the screen, and so it was decided to make the screen of two pieces mounted close together. As finally recommended, the main plotting screen consisted of two layers of Plexiglas, both polygonal to facilitate mounting, with a minimum of 8 sides and a 48-inch diagonal. The front surface of the layer facing the projector is ground, and the whole illuminated with ultraviolet light. Geographical markings can then be written on the ground surface with a phosphor pencil, and the moving grid can be projected on this surface with visible light. In order that the scribe on the opposite side may not be confused by ultraviolet-induced fluorescence of his eyes, this first layer was made of an ultraviolet ab-

RESTRICTED

sorbing Plexiglas No. 106 with the back surface polished. The recommended thickness is preferably $\frac{1}{16}$, but possibly $\frac{1}{8}$ inch.

In close mechanical but not optical contact with the first layer is a second of $\frac{1}{8}$ -inch clear Plexiglas. This is polished on both surfaces and edge illuminated, with care being taken to shield the first layer from the illumination. The scribe writes with a grease pencil on this back plate. Cementing the two layers together, even with cement of the lowest refractive index obtainable, is not recommended because of the scattering of light from high-index points. Stress is placed on the necessity of using as thin plates as possible to avoid diffusion of the writing

photographed the coordinate grid G on a lantern slide plate, with lines which when projected on the screen are $\frac{1}{8}$ -inch wide (magnification, 40 times). Automatic motion of the slide keeps the center of coordinates projected on the screen in the geographical area corresponding to the position of the CIC plane. In order to cover the field of the screen, the slide may shift 1.2 inches in the two coordinates in its own plane.

A General Electric 250-watt T-10 projector lamp, P , is used as a source; it operates at 25-28 volts, and can be provided with a dimming rheostat adjustable to suit the observers. The lamp is sufficiently rugged for use in a vibrating plane, and it is strongly recom-

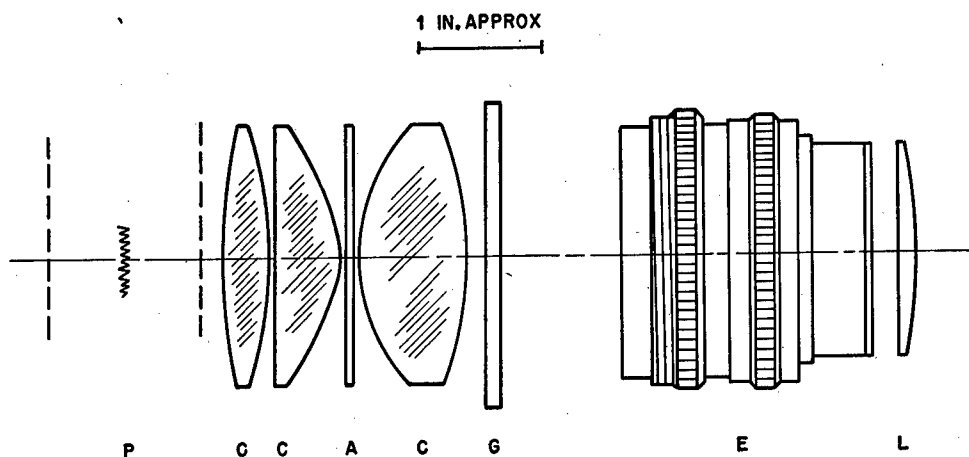

FIGURE 6. Optical design of projector system; P , projector lamp; C , Condensing lenses; A , aklo filter; G , moving grid; E , Ektar lens; L , auxiliary lens.

on the back plate due to the ground surface of the first. The Rohm and Haas Company, Philadelphia, supplies the Plexiglas.

The scale used is 12 inches to 100 miles, so that the total excursion of the screen is plus or minus 200 miles.

9.4.2

Projector Specifications

The requirements for the projector were not as difficult to fill as those for the screen. Since the full field was set at 40 degrees, the only problem left was that of finding a high-speed objective having this field, and one quickly available. Figure 6 shows the optical design recommended. E is an Eastman Kodak Ektar lens, No. 23700, of 50-mm focal length and speed of $f/1.9$, used as the objective. The condensing lenses, C , are also obtainable from Eastman Kodak. A heat-absorbing glass, A (Corning Dark Aklo), is used in the condensing system.

The Photo Science Laboratory, Navy Department,

mended that no antishock mounting be used for the projector for fear of blurring the image.

Since the distance from screen to projector may vary slightly in different planes, the projectors are equipped with a set of auxiliary lenses. The lens, L in Figure 6, needed to obtain the exact magnification of 40, is selected from a set of spectacle lenses in $\frac{1}{4}$ -diopter steps up to plus or minus 2 diopters, obtainable from B&L. It is placed $\frac{1}{4}$ inch in front of the objective.

The preceding specifications and recommendations were reported to the Naval Research Laboratory and the Special Devices Division of the Navy, in June 1945.

9.5

SEA SEARCH^{1,2,6}

The problem of identification of surface vessels from aircraft at night has already been discussed in Chapter 7. Both methods described there, the use of

Stimsonite with visible illumination, and ultraviolet autocollimators with ultraviolet illumination, require identifying devices on friendly ships. To eliminate the need for these, another method was proposed. This involves a 6-power or 10-power binocular with large exit pupil, mounted to avoid oscillation. The mounting in the airplane must be such that it may be directed toward the position indicated by radar and a searchlight is attached to move with the binocular. Illumination of the target by the searchlight and magnification by the binocular allows identification at ranges over one mile.

The use of searchlights mounted on airplanes for identification purposes was not a new idea, and was regarded with skepticism for several reasons. The weight of the searchlight usually necessitates a material reduction in the bomb load that may be carried; the position of the aircraft is immediately apparent when the light is turned on; the glare of scattered light obscures the target and blinds the pilot; and the probability of finding the target with the searchlight beam is relatively small in the time available for search.

Elimination of glare by the use of crossed Polaroids over the searchlight and binoculars was unsuccessful; backscatter was greatly reduced, but this was far outweighed by the loss of target brightness. By keeping the observer as far away from the searchlight as possible, and using a light with a very narrow beam, difficulties encountered with scattered light were cut to a workable minimum.

A test was held in a PBV-5A airplane over Long Island Sound, with a submarine for a target. It was found that antioscillation-mounted binoculars were better than the unaided eye in locating and viewing the submarine, and that a 10x50 binocular was definitely better than a 6x40.

Various searchlights were tested at the University of Rochester. A bank of six 450-watt, 24-volt aircraft landing lights did not give enough illumination for use, although the total beam candlepower was about three million. Both carbon-arc and mercury-arc searchlights with very narrow beams were next tried, and although both appeared to be usable, the final demonstration was conducted with the mercury light because of its long narrow beam. It is described below.

In October 1943, a ground demonstration was held in Rochester for representatives of BuAer. A small, dark gray surface craft was easily identified at a range of $1\frac{1}{4}$ miles under conditions simulating those en-

countered in sea search. An 18-inch parabolic searchlight, with a 1,000-watt high-intensity General Electric water-cooled mercury capsule (Chapter 5) was used for a source. This gave a beam of approximately 25 million beam candlepower about $\frac{1}{3}$ degree wide and 6 degrees high. The searchlight was mounted on a rotating table, and connected by synchros to a 6-power binocular 50 feet away in such a manner that the axis of the searchlight and that of the binocular remained parallel. It could be turned on and off rapidly, and could be rotated at various speeds in either direction about a vertical axis. Radar was not used to detect the small boat, but an infrared source aboard the boat was observed through a Type A metascope (Chapter 3), so that the function of the radar was adequately simulated.

An observer was able to point the binocular and searchlight in the general direction of the boat by observation with the infrared viewing system. The searchlight was then turned on and the final adjustment of direction of the binocular-searchlight combination was made. Because of the shape of the beam it was unnecessary to adjust the altitude of the searchlight, which effectively reduced the searching problem to one dimension, and the probability of finding the target was greatly increased. The remote control for the searchlight, including the shutter and arc, was operated by the observer stationed at the binocular. An illuminated reticle in the eyepiece of the binocular aided in centering the target and also showed the exact direction of the searchlight beam.

No effort was made to make the apparatus demonstrated usable in airplanes, other than to choose that which, with straightforward engineering, could be so adapted. When the equipment was turned over to the Navy for further development, the following points had been established to the satisfaction of the contractor:

1. The binocular-searchlight combination is practical for sea search.
2. Magnification is essential. Ten-power binoculars are preferred to 6-power.
3. The searchlight should have a narrow sharp-edged beam; it should go on and off quickly with a maximum lag of 4 seconds, and it should be as far away from the observer as possible.
4. The linkage between the radar and the binoculars and that between the binoculars and searchlight must be accurate and fast.

GLOSSARY

- ACTIVATOR.** A component of a phosphor, present in small quantities only, which may control the emission, excitation, or stimulation spectrum.
- ACTIVATOR, AUXILIARY.** An activator that controls the stimulation spectrum.
- ACTIVATOR, DOMINANT.** An activator that controls the emission spectrum.
- AFTERGLOW (BACKGROUND).** Spontaneous emission of a phosphor after excitation ceases.
- ASPHERIC.** Any surface which is neither plane nor spherical.
- ATMOSPHERIC ATTENUATION.** The decrease in radiant flux produced by absorption and scattering during traversal of a given atmospheric path.
- ATTENUATION COEFFICIENT.** The logarithm of the ratio of the intensities of a parallel beam of radiation incident on and emergent from, respectively, unit length of attenuation path.
- BACKGROUND.** See afterglow.
- BASIC MATERIAL.** The component of the phosphor present in largest quantity.
- BEAM CANDLEPOWER.** The candlepower of a source in a given direction, when the source is at such a distance that the inverse square law applies.
- BLITZ.** Radium-impregnated gold foil used for exciting phosphors.
- BUTTON.** The focal surface of a Kellner-Schmidt system coated with phosphor.
- CAM.** Cloud attenuation meter.
- CONTRAST.** The ratio of the difference in brightness of two objects to the brightness of the more brilliant object.
- CORRECTOR PLATE.** An aspheric surface in a Kellner-Schmidt system that corrects for spherical aberration of the mirror.
- DIRECTIONAL INDICATING SYSTEM.** A system which indicates the orientation of a given line through an object with respect to a reference direction in space.
- DROPPING.** A glass-molding process wherein the glass is heated sufficiently to drop into a mold, by gravity or with suction.
- EXCITATION.** The irradiation of a phosphor which causes it to emit radiant energy, or, in the case of infrared phosphors, to store it for emission at a later time.
- EXHAUSTION.** The decrease in sensitivity of a phosphor due to infrared stimulation.
- EXTINCTION.** The decrease in sensitivity of a phosphor due to both infrared stimulation and quenching.
- FLUX.** A chemical material which, added to the basic material in a phosphor, causes the formation of a definite matrix and improves the luminescence.
- GPI.** Glider position indicator.
- GREENBLOCK.** A refractive material used in the dropping process as a mold for corrector plates.
- KELLNER-SCHMIDT.** K-S system—a wide-aperture optical system with an aspheric corrector plate placed at the center of curvature of a spherical mirror.
- INERTIA.** The delay of maximum emission over stimulation.
- LUMINESCENCE.** Emission of a phosphor during excitation.
- METASCOPE.** An infrared-viewing device making use of a K-S system and an infrared sensitive phosphor at the focal surface.
- PHOTOCONDUCTIVE CELL.** A radiation-sensitive detector, the conductivity of which increases upon exposure to radiation within a restricted wavelength region.
- POSITIONAL INDICATING SYSTEM.** A system which indicates the position of an object with respect to a reference position in a two-dimensional space field.
- QUENCHING.** The decrease of sensitivity of a phosphor due to some radiation and without the emission of visible light.
- REGENERATION.** Restoration to a phosphor of sensitivity which has been lost by pulverization or shearing stresses.
- SPONTANEOUS EMISSION.** Emission without stimulation or quenching, after excitation.
- STIMULABILITY.** Any arbitrary measure of sensitivity to stimulation proportional to the quantum efficiency with respect to incident light.
- STIMULATION.** Release of radiant energy through irradiation of an excited phosphor by means of any radiation which is not interpreted as being due to excitation. Usually, in this report, release of light from an excited phosphor by infrared radiation.
- THALOFIDE CELL.** A photoconductive cell in which the radiation-sensitive surface is prepared from thallosulfide.
- THRESHOLD CONTRAST.** The smallest value of the contrast which may be detected by the eye.
- THRESHOLD SENSITIVITY.** The value in nautical-mile candles for which the image in a given metascope just disappears extra-foveally; in phosphors, the reciprocal of the radiant flux or radiant energy causing a just perceptible emission of a given phosphor under given conditions.
- TIME-LAG.** The delay of emission after stimulation has ceased.
- VISUAL RANGE.** The limiting range at which a large black object may be seen on the horizon.

BIBLIOGRAPHY

Numbers such as Div. 16-421-M3 indicate that the document listed has been microfilmed and that its title appears in the microfilm index printed in a separate volume. For access to the index volume and to the microfilm, consult the Army or Navy agency listed on the reverse of the half-title page.

Chapter 2

INFRARED IMAGE TUBES AND ELECTRON TELESCOPES

1. *Infrared Image Tubes and Electron Telescopes*, G. A. Morton, OSRD 5653, OEMsr-440, Service Projects CE-34, NS-172, and others, Final Report 16.5-123, RCA Laboratories, Nov. 30, 1945. Div. 16-421-M3
 - 1a. *Ibid.*, p. 56.
 - 1b. *Ibid.*, p. 53.
 - 1c. *Ibid.*, p. 81.
 - 1d. *Ibid.*, pp. 60, 93-95.
 - 1e. *Ibid.*, pp. 63-68.
 - 1f. *Ibid.*, pp. 177-182.
 - 1g. *Ibid.*, p. 159.
 - 1h. *Ibid.*, pp. 101-103.
 - 1i. *Ibid.*, pp. 154-155.
2. "Applied Electron Optics," V. K. Zworykin and G. A. Morton, *Journal of the Optical Society of America*, Vol. 26, No. 4, April 1936.
3. "Electron Optics of an Image Tube," G. A. Morton and E. G. Ramberg, *Physics*, Vol. 7, December 1936, pp. 181-189.
4. *Development of Infrared Telescope*, G. A. Morton, OSRD 744, OEMsr-440, Research Project PDRC-269, RCA Manufacturing Co., Inc., June 22, 1942. Div. 16-421-M1
5. *Night Landing Operations with the Aid of Infrared Lights and Viewing Equipment*, G. A. Morton, OSRD 1046C, OEMsr-440, Research Project PDRC-269, RCA, November 1942. Div. 16-434.1-M2
6. *Night Driving by Means of Infrared Telescopes* ([Part] I), G. A. Morton, OSRD 1909, OEMsr-440, RCA, July 1943. Div. 16-431.1-M1
7. *Infrared Identification Systems Using Electron Telescopes*, G. A. Morton, OSRD 1910, OEMsr-440, RCA, July 1943. Div. 16-440-M1
8. *Application of Infrared Radiation in Gun Ranging and Vehicle Driving under Cover of Darkness, Field Trials at Princeton, N. J., on March 27, 1943, and at Fort Knox, Ky., April 13 and 14, 1943*, G. E. Meese, OEMsr-423, Research Project PDRC-403, Interim Report 16.5-47, General Electric Co., Aug. 17, 1943. Div. 16-431.1-M2
9. *Application of Infrared Telescopes to Glider and Airplane Operation* ([Part] III), G. A. Morton, OSRD 1877, OEMsr-440, RCA, July 1943. Div. 16-433-M1
10. *Reconnaissance and Observation of Extended Objects with Infrared Telescopes*, G. A. Morton, OSRD 1854, OEMsr-440, Progress Report V, RCA, August 1943. Div. 16-460-M1
11. *Headmounts for Infrared Telescope for Aircraft and Vehicle Use*, OSRD 3310, OEMsr-1075, Progress Report 16.5-68, University of Pennsylvania, Feb. 15, 1944. Div. 16-421.11-M1
12. *Driving Test of Red Headlights*, OSRD 3336, OEMsr-1075 and OEMcmr-209, Progress Report 16.5-69, University of Pennsylvania. Div. 16-431.3-M1
13. *Use of Head-Mounted Infrared Binoculars in the Landing of Aircraft*, OSRD 4092, OEMsr-1075, Progress Report 16.5-91, University of Pennsylvania, Aug. 18, 1944. Div. 16-433.1-M6
14. *Night Landing of Aircraft with Infrared Radiation, Demonstration at Lancaster, Pa., on June 7, 1944*, G. E. Meese, OSRD 4945, OEMsr-423, Interim Report 16.5-103, General Electric Co., June 1944. Div. 16-433.1-M5
15. *Nocturnal Shoreline Reconnaissance with Infrared Radiation, Tests at Cape Henlopen, Delaware, March 16 to 17, 1945 [and at] Fort Pierce, Florida, April 14 to 20, 1945*, C. L. Amick and G. E. Meese, OSRD 5376, OEMsr-423, Service Projects AC-226, CE-34, and NA-175, Progress Report 16.5-113, General Electric Co., Aug. 15, 1945. Div. 16-434.2-M1
16. *Infrared Radiation as an Aid in Nocturnal Airborne Operations, Wright Field, Stout Field, and Camp Mackall, N. C., Three Chronological Reports Covering Development of the Airborne Beacon, Aug. 10 to 19, 1944, Oct. 20 to 24, 1944, Dec. 5, 1944*, G. E. Meese, OSRD 5650, OEMsr-423, Service Projects CE-34 and NA-175, Progress Report 16.5-120, General Electric Co., Sept. 5, 1945. Div. 16-433.2-M1
17. *Trial of Infrared Devices in the Detection of Hidden Japanese Defenses*, [Tests at] Fort Knox, Kentucky [on] July 9 to 11, 1945, G. E. Meese, OSRD 5920, OEMsr-423, Service Projects CE-34 and NA-175, Progress Report 16.5-121, General Electric Co., Sept. 17, 1945. Div. 16-460-M2
18. *Development of a Head-Mounted Infrared Binocular Telescope for Vehicle Driving and for Landing Airplanes*, D. W. Bronk, H. K. Hartline, and others, OSRD 5654, OEMsr-1075, Service Project CE-34, Final Report 16.5-124, University of Pennsylvania, Sept. 30, 1945. Div. 16-421.11-M2
19. *Activities under Contract OEMsr-423*, G. E. Meese, OSRD 5651, OEMsr-423, Service Projects AC-226, CE-34, and NA-175, Final Report 16.5-127, General Electric Co., Sept. 25, 1945. Div. 16-430-M1

Chapter 3

METASCOPIES

1. *Development of Kellner-Schmidt Optical Systems (Parts I and II)*, OEMsr-510, Interim Reports 16.5-16, and 16.5-17, University of Rochester, June 30, 1943. Div. 16-421.21-M1
2. *Outline of Metascope Infrared Telescope Development*, OEMsr-81, and OEMsr-510, Report 16.5-22, University of Rochester. Div. 16-421.2-M3
3. *Development of Infrared Telescopes Utilizing Infrared-Sensitive Phosphors*, OSRD 3129, OEMsr-81, and OEMsr-510, Report 16.5-55, University of Rochester, June 15, 1943. Div. 16-421.2-M1
4. *Development of Infrared-Sensitive Phosphors* [covering period from] *January 1, 1943, to August 31, 1943*, OSRD 3134, OEMsr-81, Report 16.5-57, University of Rochester, Aug. 31, 1943. Div. 16-411.1-M1
5. *The Type F Metascope*, OSRD 3266, OEMsr-81, and OEMsr-510, Report 16.5-65, University of Rochester, Jan. 1, 1944. Div. 16-421.23-M1
6. *Metascopes*, OSRD 3400, OEMsr-1100, Problem DD-2510C, Report 16.5-73, Eastman Kodak Co., Sept. 22, 1943. Div. 16-421.2-M2

7. *Development of Optical Device, Type B, formerly Metascope, Model B* [covering period from] *June 8, 1943 to February 1, 1944*, OSRD 3408, OEMSr-1100, Problem 25.10C, Report 16.5-76, Eastman Kodak Co., Feb. 1, 1944. Div. 16-421.22-M1
8. *Special Optical Devices*, OSRD 5656, OEMSr-1219, Service Projects AC-225, NS-172, and others, Report 16.5-126, University of Rochester, Nov. 1, 1945. Div. 16-420-M1

Chapter 4

1. *Preparation of Infrared Phosphors*, [covering the period from] *March 1, 1943 to August 31, 1943*, OSRD 3140, OEMSr-982, Report 16.5-56, Polytechnic Institute of Brooklyn, Aug. 31, 1943. Div. 16-411.1-M2
2. *Development of Infrared Sensitive Phosphors*, [covering the period from] *January 1, 1943 to August 31, 1943*, OSRD 3134, OEMSr-81, Report 16.5-57, University of Rochester, Aug. 31, 1943. Div. 16-411.1-M1
3. *Preparation of Stimulated Zinc Sulfide Phosphors, Report II, Characteristics*, G. R. Fonda, OSRD 3371, OEMSr-1155, Report 16.5-70, General Electric Co., Dec. 7, 1943. Div. 16-411.11-M1
4. *Survey of Zinc Sulfide Phosphors Capable of Stimulation*, G. R. Fonda, OSRD 3947, OEMSr-1155, Progress Report 16.5-84, General Electric Co., July 7, 1944. Div. 16-411.11-M2
5. *Stimulation and Phosphorescence of Zinc Sulfide Phosphors*, G. R. Fonda, OSRD 4587, OEMSr-1155, Progress Report 16.5-99, General Electric Co., Dec. 2, 1944. Div. 16-411.11-M3
6. *Preparation and Characteristics of Zinc Sulfide Phosphors Stimulated by Infrared*, G. R. Fonda, OSRD 5377, OEMSr-1155, Service Project NS-172, Final Report 16.5-11, General Electric Co., July 20, 1945. Div. 16-411.11-M4
7. *Infrared Stimulation of Phosphors*, [covering period from] *August 1, 1943 to June 30, 1945*, N. F. Miller, OSRD 5360, OEMSr-740, Service Projects CE-11, and NS-172, Final Report 16.5-114, New Jersey Zinc Co., June 1945. Div. 16-411.1-M3
8. *Preparation of Infrared Phosphors*, [covering the period from] *September 1, 1943 to August 31, 1945*, Roland Ward, OSRD 5643, OEMSr-982, Service Project NS-172, Progress Report 16.5-119, Polytechnic Institute of Brooklyn, Sept. 1, 1945. Div. 16-411.1-M4
9. *Phosphors*, OSRD 5655, OEMSr-81, Service Projects CE-11, NS-172, and NS-282, Final Report 16.5-125, University of Rochester, Sept. 24, 1945. Div. 16-411.1-M5
10. *Infrared Phosphors*, OSRD 6057, OEMSr-440, Radio Corporation of America, Nov. 30, 1945.
4. *Application of Infrared Equipment to Night Amphibious Operations, Part I, Field Demonstration in the Vicinity of Fort Storey, Virginia, on the Night of February 7, 1943; Part II, Field Demonstration at Camp Edwards, Massachusetts, on the Night of February 23, 1943*, G. E. Meese, OSRD 2017, OEMSr-423, Research Project PDRC-403 (Division 12, Report 165-72-824E), Report 12, General Electric Co., Apr. 16, 1943. Div. 16-434.1-M3
5. *Application of Infrared Radiation in Gun Ranging and Vehicle Driving under Cover of Darkness*, G. E. Meese, OEMSr-423, Research Project PDRC-403, Interim Report 16.5-47, General Electric Co., Aug. 17, 1943. Div. 16-431.1-M2
6. *Blackout Driving, Ultraviolet System, as Demonstrated at Palmerton, Pa., on September 27, 1943*, [covering period from] *July 1 to October 1, 1943* (Joint Report), OSRD 3208, OEMSr-423, and OEMSr-740, Report 16.5-61, New Jersey Zinc Co. and General Electric Co., December 1943. Div. 16-431.2-M1
7. *Application of Infrared Radiation in the Operation of Railway Locomotives under Blackout Conditions, Field Trials Conducted on the Evenings of October 2, 3, 4, and 23, 1943 at Camp Claiborne, Louisiana, (Camp Claiborne Test)*, G. E. Meese, OSRD 3319, OEMSr-423, Research Project PDRC-403, Supplementary Report 16.5-66, General Electric Co., Feb. 2, 1944. Div. 16-432-M2
8. *Application of Infrared Radiation in the Operation of Railway Locomotives under Blackout Conditions, Demonstration to Representatives of the Transportation Corps, U. S. Army at the Engineer Board, February 22, 1944, (Engineer Board Tests)*, G. E. Meese, OSRD 3946, OEMSr-423, Research Project PDRC-403, Supplementary Report to 16.5-85, General Electric Co., June 30, 1944. Div. 16-432-M3
9. *Road Delineation and Nocturnal Vehicular Driving with Ultraviolet Radiation*, G. E. Meese, OSRD 3945, OEMSr-423, Research Project PDRC-403, Final Report 16.5-86, General Electric Co., Apr. 18, 1944. Div. 16-431.2-M2
10. *Night Landing of Aircraft with Infrared Radiation, Demonstration at Lancaster, Pa., [on] June 7, 1944*, G. E. Meese, OSRD 4945, OEMSr-423, Interim Report 16.5-103, General Electric Co., June 1944. Div. 16-433.1-M5
11. *Nocturnal Shoreline Reconnaissance with Infrared Radiation*, C. L. Amick, and G. E. Meese, OSRD 5376, OEMSr-423, Service Projects AC-226, CE-34, and NA-175, Progress Report 16.5-113, General Electric Co., Aug. 15, 1945. Div. 16-434.2-M1
12. *Night Landing of Aircraft with NAN Markers, Tests at NAAF, Charlestown, R.I., May 12 [to] June 14, 1945*, C. L. Amick and G. E. Meese, OSRD 5564, OEMSr-423, Service Projects CE-34 and NA-175, Final Report 16.5-118, General Electric Co., Sept. 7, 1945. Div. 16-433.1-M7
13. *Infrared Radiation as an Aid in Nocturnal Airborne Operations*, G. E. Meese, OSRD 5650, OEMSr-423, Service Projects CE-34 and NA-175, Progress Report 16.5-120, General Electric Co., Sept. 5, 1945. Div. 16-433.2-M1
14. *Trial of Infrared Devices in the Detection of Hidden Japanese Defenses, [Tests at] Fort Knox, Kentucky [on] July 9, 10, and 11, 1945*, G. E. Meese, OSRD 5920, OEMSr-423, Service Projects CE-34 and NA-175, Progress Report 16.5-121, General Electric Co., Sept. 17, 1945. Div. 16-460-M2
15. *Activities Conducted under Contract OEMSr-423*, G. E. Meese, OSRD 5651, OEMSr-423, Service Projects AC-226, CE-34, and NA-175, Final Report 16.5-127, Engineering Division, Lamp Department, General Electric Co., Sept. 25, 1945. Div. 16-430-M1

Chapter 5

1. *Infrared Equipment for Night Operation of Tanks*, V. J. Roper and G. E. Meese, OEMSr-423, Research Project PDRC-403, Progress Report 16.5-9, General Electric Co., Sept. 4, 1942. Div. 16-431-M1
2. *A Field Demonstration of Infrared Equipment in the Vicinity of Solomon's Island, Virginia*, OEMSr-427, Report 16.5-10, University of Rochester, Aug. 25, 1942. Div. 16-434.1-M1
3. *Application of Infrared Radiation in the Operation of Railway Locomotives under Blackout Conditions*, G. E. Meese, OSRD 2033, OEMSr-423, Research Project PDRC-403 (Division 12, Report 165-72-825E), Report 11, General Electric Co., July 23, 1943. Div. 16-432-M1
- 15a. *Ibid.*, p. 49.
- 15b. *Ibid.*, p. 69.

Chapter 6

1. *Visual Thresholds at Low Brightnesses*, [covering period from March 1 to October 6, 1943, L. J. Reimert, OEMSr-740, Final Report 16.5-79, New Jersey Zinc Co., Oct. 12, 1943. Div. 16-470-M1
2. *Evaluation of Ultraviolet Telescope*, [covering report from May 7 to October 27, 1943, L. J. Reimert, OEMSr-740, New Jersey Zinc Co., Oct. 27, 1943. Div. 16-421-M2
3. *Visibility of Ultraviolet Light Sources and Ranges of Fluorescent Retrodirectional Autocollimating Devices*, [covering period from March 12 to April 12, 1943, L. J. Reimert, OEMSr-740, Progress Report 16.5-44, New Jersey Zinc Co., Apr. 13, 1943. Div. 16-422.2-M2
4. [Visibility of ultraviolet light sources and ranges of autocollimating reflectors], OEMSr-740, Report 16.5-44, University of Rochester, March 30, 1943. Div. 16-422.2-M1
5. *A Special Radiation Filter Opaque to the Eye, Transmissive for Waves Shorter than 3,000 Angstroms*, C. G. Abbot and L. B. Aldrich, OSRD 4169, OEMSr-1015, Final Report 16.5-930, Smithsonian Institution. Div. 16-424-M1
6. *Development of an Invisible Ultraviolet Light Source*, OEMSr-1073, Progress Report 16.5-78, University of California, Mar. 1, 1944. Div. 16-412-M1
7. *Communication by Non-Visible Ultraviolet Radiation*, Harvey E. White, OSRD 5378, OEMSr-1073, Service Projects NS-370 and NS-371, Final Report 16.5-112, University of California, Oct. 15, 1945. Div. 16-450-M1
9. *Aircraft Night Landing*, [Part] IV, *Visual Light Supplement*, OEMSr-69, University of Rochester, Feb. 1, 1943. Div. 16-433.1-M3
10. *Autocollimator Buttons*, R. A. Woodson, OSRD 3370, OEMSr-994, Progress Report 16.5-64, covering period from July 1, 1943, to December 1, 1943, Eastman Kodak Co., Dec. 13, 1943. Div. 16-422.1-M1
11. *Schmidt Autocollimator Unit*, OSRD 3136, OEMSr-495, Report 16.5-60, Bausch and Lomb Optical Co., Dec. 10, 1943. Div. 16-422-M1
12. *The Manufacture of Autocollimating Lens Units*, OSRD 3948, OEMSr-932, Progress Report 16.5-87, Rochester Button Co., July 18, 1944. Div. 16-422.1-M2
13. *Fluorescent Retrodirectional Autocollimating Buttons, covering period [from] December 1, 1943 to August 31, 1944*, Reginald T. Lamb and John H. McLeod, OSRD 4318, OEMSr-994, Final Report 16.5-96, Eastman Kodak Co., Sept. 27, 1944. Div. 16-422.1-M3
14. *Schmidt Autocollimator Units*, OSRD 5158, OEMSr-495, Service Project CE-11, Final Report 16.5-107, Bausch and Lomb Optical Co., June 30, 1945. Div. 16-422-M2
15. *Metaflectors*, OSRD 6213, OEMSr-1000, Service Projects AC-225, NS-172, and others, Final Report 16.5-130, University of Rochester, Oct. 4, 1945. Div. 16-422-M3
16. *Special Optical Devices*, OSRD 5656, OEMSr-1219, Service Projects AC-225, NS-172, and others, Final Report 16.5-126, University of Rochester, Nov. 1, 1945. Div. 16-420-M1
17. *Manufacture of Trihedral (Triple Mirror) Prisms*, OSRD 5652, OEMSr-698, Service Project AC-65, Final Report 16.5-122, Mount Wilson Observatory, Sept. 30, 1945. Div. 16-422.3-M3
18. *Triple Mirrors*, W. V. Penfold, OEMSr-1319, Final Report 16.5-110, Penn Optical and Instrument Co., June 1, 1945. Div. 16-422.3-M2

Chapter 7

AUTOCOLLIMATORS

1. *A System for Night Landing of Aircraft under Conditions of Blackout and Radio Silence*, OSRD 741, OEMSr-69, University of Rochester, July 24, 1942. Div. 16-433.1-M1
2. *A Demonstration Test of the Institute of Optics, Night Landing System at Wright Field*, Supplementary Report to OSRD 741, OEMSr-69, University of Rochester, Aug. 10, 1942. Div. 16-433.1-M2
3. *A Visual Method for the Identification of Surface Vessels from Aircraft, Field Demonstration [at] Langley Field, Virginia, and Norfolk, Virginia, September 19 to October 6, 1942*, OSRD 985, University of Rochester, Oct. 6, 1942. Div. 16-441-M1
4. *A Field Demonstration Held for the Benefit of the Amphibious Forces in the Vicinity of Solomon's Island, Virginia. Field Demonstration of Special Equipment for Night Landing Operations*, OEMSr-427, Report 16.5-10, University of Rochester, Aug. 22 to 25, 1942. Div. 16-434.1-M1
5. *Methods of Making Triple Mirrors*, Theodore Dunham, Jr., Walter S. Adams, and others, OSRD 3138, OEMSr-698, First Progress Report 16.5-52, Mount Wilson Observatory, February 1943. Div. 16-422.3-M1
6. *Methods of Making Triple Mirrors*, Theodore Dunham, Jr., Walter S. Adams, and others, OSRD 3139, OEMSr-698, Second Progress Report 16.5-53, Mount Wilson Observatory, Mar. 31, 1943. Div. 16-422.3-M1
7. *Air [to] Surface Vessel Identification System [Parts] II and III*, OSRD 1598, OEMSr-725, Reports 16.5-13 and 16.5-14, University of Rochester, Mar. 1, 1943. Div. 16-441-M2-M3
8. *Aircraft Night Landing System*, [Part] III, OSRD 1596, OEMSr-69, Interim Report 16.5-36, University of Rochester, June 30, 1943. Div. 16-433.1-M4

Chapter 8

ANTI GLARE DEVICES

1. *Gradient Density Sun Glasses*, OSRD 5177, OEMSr-989, Service Project QMC-37, Final Report 16.5-109, Bausch & Lomb Optical Co., Nov. 15, 1945. Div. 16-423-M4
2. *The Development of a Sight in Which the Solar Glare Is Eliminated*, Donald H. Menzel, OEMSr-571, Progress Report 16.5-39, Harvard University, Dec. 31, 1942. Div. 16-423-M1
3. *An Investigation of Sun-Occulting Devices*, James R. Balsley and Harlow Shapley, OSRD 4097, OEMSr-571, Final Report 16.5-90, Harvard University, July 3, 1944. Div. 16-423-M3
4. *Telescope Shutter, Sun-Obscuring Device*, C. M. Tuttle, OSRD 3404, OEMSr-996, Problem DD-2528, Progress Report 16.5-75, Eastman Kodak Co., Feb. 14, 1944. Div. 16-423-M2
5. *Special Optical Devices*, OSRD 5656, OEMSr-1219, Service Projects AC-225, NS-172, and others, Final Report 16.5-126, University of Rochester, Nov. 1, 1945, Volume 4, *Development of the Icaroscope*. Div. 16-420-M1

Chapter 9

MISCELLANEOUS OPTICAL DEVELOPMENTS

1. *Air [to] Surface Vessel Identification System [Part] II*, OSRD 1598, OEMSr-725, Report 16.5-13, University of Rochester, Mar. 1, 1943. Div. 16-441-M2

2. *Air [to] Surface Vessel Identification System [Part] III, Special Equipment Developed for Identification of Surface Vessels from the Air*, OEMsr-725, Report 16.5-14, University of Rochester, Mar. 1, 1943. Div. 16-441-M3
 3. *Development of Kellner-Schmidt Optical Systems [Part] I*, OEMsr-510, Interim Report 16.5-16, University of Rochester, June 30, 1943. Div. 16-421.21-M1
 4. *Development of Kellner-Schmidt Optical Systems [Part] II*, OEMsr-510, Interim Report 16.5-17, University of Rochester, Aug. 15, 1943. Div. 16-421.21-M1
 5. *Wide-Aperture Kellner-Schmidt Optical Systems*, OEMsr-510, Progress Report 16.5-24, University of Rochester, Aug. 15, 1943. Div. 16-421.21-M2
 6. *Air [to] Surface Vessel Identification System [Part] IV, The Identification of Surface Vessels from Aircraft Equipped with Linked Searchlight and Antioscillation Mounted Binoculars*, OSRD 3128, OEMsr-725, Report 16.5-59, University of Rochester, Oct. 15, 1943. Div. 16-441-M4
 7. *Special Optical Devices*, OSRD 5656, OEMsr-1219, Service Projects AC-225, NS-172, and others, Final Report 16.5-126, University of Rochester, Nov. 1, 1945. Div. 16-420-M1
- 7a. *Ibid.*, Vol. 1, *Kellner-Schmidt Strip Projector*.
7b. *Ibid.*, Vol. 2, *Cadillac-2*.
7c. *Ibid.*, Vol. 3, *Flash Metascope*.

OSRD APPOINTEES

DIVISION 16

Chief

GEORGE R. HARRISON

Deputy Chiefs

PAUL E. KLOPSTEG

RICHARD C. LORD

Consultants

HERBERT E. IVES

F. E. TUTTLE

Technical Aides

H. R. CLARK

RICHARD C. LORD

J. S. COLEMAN

H. K. STEPHENSON

Members

O. S. DUFFENDACK

ARTHUR C. HARDY

THEODORE DUNHAM, JR.

HERBERT E. IVES

E. A. ECKHARDT

PAUL E. KLOPSTEG

HARVEY FLETCHER

BRIAN O'BRIEN

W. E. FORSYTHE

F. E. TUTTLE

SECTION 16.1

Chief

THEODORE DUNHAM, JR.

Consultants

G. W. MOREY

H. F. MARK

F. L. JONES

H. F. WEAVER

Technical Aides

LILLIAN ELVEBACK

S. W. McCUSKEY

H. F. WEAVER

Members

IRA S. BOWEN

R. R. McMATH

W. V. HOUSTON

G. W. MOREY

F. E. WRIGHT

SECTION 16.2

Chief

BRIAN O'BRIEN

Consultants

W. R. BRODE

V. K. ZWORYKIN

Technical Aide

CHAS. E. WARING

Members

W. E. FORSYTHE

JULIAN H. WEBB

HARVEY E. WHITE

RESTRICTED

OSRD APPOINTEES (Continued)

SECTION 16.3

Chief

ARTHUR C. HARDY

Consultants

LEWIS KNUDSON

PARRY H. MOON

EDWARD R. SCHWARZ

Technical Aides

S. Q. DUNTLEY

ARTHUR W. KENNEY

ERNEST T. LARSON

Members

EDWIN G. BORING

L. A. JONES

F. C. WHITMORE

SECTION 16.4

Chief

O. S. DUFFENDACK

Consultants

W. L. ENFIELD

H. G. HOUGHTON, JR

W. H. RADFORD

Technical Aides

H. S. BULL

WINSTON L. HOLE

JAMES S. OWENS

Members

ALAN C. BEMIS

H. G. HOUGHTON, JR

SAUL DUSHMAN

GEORGE A. MORTON

SECTION 16.5

Chiefs

W. E. FORSYTHE

HERBERT E. IVES

Deputy Chiefs

W. E. FORSYTHE

BRIAN O'BRIEN

Consultants

E. Q. ADAMS

A. C. DOWNES

Technical Aides

WILLIAM HERRIOTT

JOHN T. REMEY

VAL E. SAUERWEIN

Members

D. W. BRONK

W. B. RAYTON

A. C. HARDY

A. B. SIMMONS

THEODORE MATSON

G. F. A. STUTZ

A. H. PFUND

HARVEY E. WHITE

V. K. ZWORYKIN

RESTRICTED

CONTRACT NUMBERS, CONTRACTORS, AND SUBJECTS OF CONTRACTS

<i>Contract Number</i>	<i>Name and Address of Contractor</i>	<i>Subject</i>
NDCrc-19	Precision Castings Company, Inc. Syracuse, New York	Producing metallic mirrors by a metal-spraying process.
NDCrc-202	University of Rochester Rochester, New York	Apparatus for improvement of night vision.
OEMsr-69	University of Rochester Rochester, New York	Night landing of aircraft.
OEMsr-81	University of Rochester Rochester, New York	Development of infrared phosphors.
OEMsr-115	Carnegie Institution of Washington Washington, D. C.	Investigations in connection with night sky-scanning.
OEMsr-169	Radio Corporation of America RCA Victor Division Camden, New Jersey	Construction of 2 infrared viewing tubes—infrared (light sources: 1 + TRA-115 gasoline driven generator).
OEMsr-188	The Johns Hopkins University Baltimore, Maryland	Infrared penetration of gases and vapors.
OEMsr-249	Precision Castings Company, Inc. Syracuse, New York	Search-light mirrors using sprayed metal backs.
OEMsr-265	University of Rochester Rochester, New York	Brightness of night sky.
OEMsr-303	University of Rochester Rochester, New York	Development of an aspheric molding machine for luminescent traffic markers.
OEMsr-427	University of Rochester Rochester, New York	Investigation of night markers for harbors and beaches.
OEMsr-440	Radio Corporation of America RCA Victor Division Camden, New Jersey	Special purpose image tubes and infrared phosphors.
OEMsr-472	University of Rochester Rochester, New York	Field lens for use in connection with the Navy-RCA "Block Project 135."
OEMsr-623	Eastman Kodak Company Rochester, New York	Triplet projection lens in plastics.
OEMsr-698	Carnegie Institution of Washington Washington, D. C.	Development of triple mirrors.
OEMsr-740	The New Jersey Zinc Company (of Pa.) New York, New York	Luminescent markers and IR phosphors.
OEMsr-766	Western Electric Company, Incorporated New York, New York	Night surveying and signaling by infrared.
OEMsr-951	Radio Corporation of America RCA Victor Division Camden, New Jersey	Special purpose infrared viewing equipment.
OEMsr-982	Polytechnic Institute of Brooklyn Brooklyn, New York	Development of phosphors and basic phosphor material.
OEMsr-987	Ohio State University Research Foundation Columbus, Ohio	Infrared transmitting filter development.
OEMsr-996	Eastman Kodak Company Rochester, New York	Sun scanning devices.
OEMsr-1000	University of Rochester Rochester, New York	Infrared auto-collimators.

CONTRACT NUMBERS, CONTRACTORS, AND SUBJECTS OF CONTRACTS (Continued)

<i>Contract Number</i>	<i>Name and Address of Contractor</i>	<i>Subject</i>
OEMsr-1031	Radio Corporation of America RCA Victor Division Camden, New Jersey	Crystal light source.
OEMsr-1041	Eastman Kodak Company Rochester, New York	Sprayed metal mirrors.
OEMsr-1073	The Regents of the University of California Berkeley, California	Sources of ultraviolet radiation.
OEMsr-1075	The Trustees of the University of Pennsylvania Philadelphia, Pennsylvania	Mounts for infrared driving telescopes.
OEMsr-1100	Eastman Kodak Company Rochester, New York	Metascope design.
OEMsr-1155	General Electric Company Schenectady, New York	Infrared phosphors.
OEMsr-1219	University of Rochester Rochester, New York	Special optical devices.
OEMsr-1319	Penn Optical & Instrument Company Pasadena, California	Fabrication of high precision triple mirrors.

SERVICE PROJECT NUMBERS

The projects listed below were transmitted to the Executive Secretary, National Defense Research Committee [NDRC], from the War or Navy Department through either the War Department Liaison Officer for NDRC or the Office of Research and Inventions (formerly the Coordinator of Research and Development), Navy Department.

<i>Service Project Number</i>	<i>Subject</i>
AC-15	Night landing ultra-violet light with minimum enemy observation.
AC-15, Ext.	Development of light source producing ultra-violet light of sufficient intensity for illuminating instrument boards.
AC-37	Development of an aircraft window suitable for photographic purposes.
AC-64	Phosphor light sources.
AC-65	Triple mirrors.
AC-66	Night identification.
AC-103	Identification for B-29 aircraft.
AC-104	Infrared radiation from exhaust systems.
CE-7	Mirrors of stainless steel or metal other than copper.
CE-11	Luminous material to replace radio-active substances.
CE-11, Ext.	Ultra-violet reflector buttons.
CE-11, Ext.	Development of a phosphorescent material.
CE-34	Image forming IR equipment.
CE-34, Ext.	Infrared filters.
CWS-8	Generation of colored smokes.
N-103	Development of air-surface identification equipment.
NA-175	Minimum visibility aids to aircraft carrier landings.
NR-108	Night vision adaptometer—phosphorescence warning and quenching.
NS-158	Development of range finding attachment for infrared radiation receivers.
NS-172	Infrared phosphors.
NS-279	Radioactive luminous markers for shipboard use.
NS-282	Determination of time response characteristics of electron image tubes and phosphor type image forming.
NS-350	Development of a large aperture Kellner-Schmidt system for the large type of infrared receiver, etc.
NS-370	Development and improvement of invisible ultra-violet sources.
QMC-37	Graded sun glasses.
SOS-5	Means for locating bunkers.
OD-16	Blackout lighting.
OD-150	Apparatus for measuring the integrated intensity and the time variation of the intensity of muzzle flash.
SC-21	Photography of anti-aircraft shell bursts.
SC-122	Infrared coating of lenses.

INDEX

The subject indexes of all STR volumes are combined in a master index printed in a separate volume. For access to the index volume consult the Army or Navy Agency listed on the reverse of the half-title page.

- Activators
 dominant and auxiliary phosphors, 47
 infrared sensitive phosphors, 55-57
Aerial photography at night with strip projectors, 128-130
Afterglow in phosphors, definition, 54
Airplane identification with infrared, 31
Airplane landing triple mirror device, 78
Airplane operations infrared instruments
 B-29 tailsight telescope, 31
 paratroop assembly systems, 32
 telescope for night landing, 31-32
Airplane runway markers
 high-pressure mercury arc sources, 93-94
 metaflector, 112, 113
 triple mirror autocollimators, 2, 118
 ultraviolet autocollimators, 112-113
Alkali metals as photoemitters, 8
Alpha particle excitation
 exhaustion of phosphor, 48
 phosphors, 41-42
 scintillations produced by particles, 49
American Optical Company, greenblock manufacture, 49
Anode lenses for image tubes, 16
Antiglare devices, 120-126
 for aircraft detection, 121-126
 graded-density goggles, 120-121
 icaruscope method, 124-126
 occluding disk method, 121-122
 shutter method, 122-124
Arc lamps, 82-90
 carbon-arc lamps, 82-84
 mercury-vapor lamps, 84-90
Aspheric corrector plates, dropping process, 49-51
 greenblock, refractory material, 49
 mold surface curves, 51
 plate testing, 50-51
 production, 49
 size of plates, 51
 suction molding, 49-50
Aspheric corrector plates, greenblock cutting, 51-53
 1 to 1 contour machine, 51-53
 5 to 1 contour machine, 53
Aspheric corrector plates, metasopes, 49-53
 construction, 49-53
 dropping process of production, 49-51
 greenblock curves, cutting, 51-53
Astigmatism with image tube, 6
Autocollimators, 110-119
 construction, 105
 gallium lamp use, 98
 general description, 2
 Kellner-Schmidt autocollimators, 110-114
 metaflectors, 113-114
 principles of operation, 110
 range, 98
 triple mirror autocollimators, 114-119
 ultraviolet autocollimators, 110-113
B-1 phosphor
 preparation, 62-63
 time-lag and inertia measurement, 37
 selenide content, 59-60
B-17 airplane, CIC unit in bomb bay, 130-131
B-29 airplane
 sweep mount for metascope, 128
 tailsight telescope, 31
 triple-mirror autocollimator, 119
Background of phosphors (afterglow), 54
Bausch and Lomb Optical Company
 autocollimator molds, 110
 graded-density goggles, 120-121
Binoculars
 night aerial identification of vessels, 132-133
 night-driving instruments, 28
 periscopic, 28
Brightness
 incandescent filament lamp, 76
 mercury-vapor lamps, 89-90
 target brightness at night with glare elimination, 133
British infrared beacon, 78
Brooklyn Polytechnic Institute, phosphor powders for type A metascope, 38
Buttons in phosphors
 definition, 55
 early production, 56-57
 formation, with Standard VI phosphor, 62-63
Butvar as a magnesium spark filter component, 108-109
Cadillac-2, CIC screen and projector, 130-132
 B-17 installation, 130-131
 projector specifications, 132
 screen specifications, 131-132
Carbon-arc, high intensity ultraviolet source, 100-102
 current-modulated flame arc, 102
 grid-modulated carbon arc, 102
 searchlight, 24 inch, 100-102
 triple-prism return, 101-102
Carbon-arc lamps, 82-85
 electrical characteristics, 84
 manufacturers, 83
 military applications, 83
 radiation characteristics, 84, 85
Cerium as a phosphor activator, 58
Cesium surfaced photocathodes, preparation, 8
Chromatic aberrations in image tube, 6
CIC installed in B-17 airplane, 130-131
Color temperature, incandescent filament lamps, 76
Continental Lithograph Corporation, phosphor for ultraviolet autocollimators, 111
Contour machines for greenblock cutting, 51-53
Contrast effect, image tubes, 12-14
Conversion, infrared, 11-12
Corex 9863 filter, 100-101
Corning filters for metasopes
 No. 428, light blue green, 37
 No. 2450; 39
 anklo infrared absorbing, 37
 removable, 39
Corona in power supply units, 22
Current-modulated flame arc, 102
Curvature of image field lens, 5-6, 10-11
Decay phenomena, phosphors, 68-69
Eastman Kodak Company
 autocollimator manufacture, 110
 graded-density goggles, 120
 Kxx film for K-S strip projector, 130
 type A metascope production, 38
 type B metascope production, 39
Electron optical considerations, infrared image tube, 5-7
Electronics Laboratories of Indianapolis, metascope production, 43
Electrostatic lens, 5
Emission spectrum
 gallium lamp, 96
 phosphors, 47
Evaporated film goggles, 120-121
Excitation of phosphors
 after partial exhaustion, 68
 definition, 54
 measurement, 63
 methods of excitation, 48-49
 within instrument, 37
Exhaustion of phosphors
 curves, 66-67
 definition, 55
Extinction in phosphors, definition, 54-55
Field emission, cold discharge of infrared telescope, 13
Filament lamps, incandescent
 see Incandescent filament lamps
Filament sources, incandescent lamps, 78
Film evaporation on glass surface, 120-121
Filters
 anti-sun glare, for aircraft detection, 121

- Corex 9863; 100-101, 106
 goggle filters for high pressure mercury arcs, 109
 magnesium spark, 108
 mercury-vapor lamps, 90
 standard VI phosphor, 57-58
 ultraviolet autocollimators, 111
 ultraviolet sources and receivers, 106-109
 ultraviolet with type L metascope, 45
 Wratten No. 88 for strip projector, 130
- Filters, metascope, 37-40
 Corning No. 428; 37
 Corning No. 2540; 39
 Corning anklo infrared absorbing, 37
 Corning removable, 39
 excitation, 48-49
 infrared, 40
 red for type A, 38
 XRX7; 38
- Filters, ultraviolet sources and receivers, 106-109
 G-filter for gallium lamp, 106-108
 goggle filter for mercury arc, 109
 magnesium spark, 108
 nickel, 106
 photomultiplier-tube receiver, 108-109
 security measures, 106
- Flash metascope, 127-128
 phosphors used, 127
 sweep mechanism, 128
- Fluorescence, ultraviolet, 93
 Fluorescent screen phosphors, 9
 Fluxes used with phosphors, 55, 62
 Focal surface curvature in image tubes, 5-6, 10-11
- Formulas
 chromatic aberration, 6
 decay phenomena, phosphors, 68-69
 image tube sensitivity, 12
 resolution of image tubes, 10
 telescope sensitivity, 22, 23
 ultraviolet range, 91-93
- FP54 electrometer tube amplifiers, phosphor characteristics measurement, 64
- Fused-quartz triple mirrors, 105
- Gallium lamp, 94-98
 Autocollimator use, 98
 construction, 95-97
 development, 94
 discharge tube, 95-97
 emission spectrum, 96
 portable unit, 97-98
 purification of gallium, 96
 range, 94
 signalling use, 97
 visibility, 97
 voice transmission, 98
- Geiger-counter receiver, 105-106
- General Electric Company
 filament lamps, 70
 gallium lamp testing, 94
 infrared-sensitive phosphor development, 54-69
- infrared telescope, 4
 German listening gear, 229
 Germicidal lamp, 86, 90
 G-filter for gallium lamp, 107-108
 Glare elimination, night aerial identification of vessels, 133
 Glide landings, triple-mirror autocollimators, 118-119
 Glider telescopes for towing and landing, 30, 31
 Goggle-filter for a mercury arc, 109
 Goggles, graded density, 120-121
 design, 120
 evaporated film, 120-121
- Grid-modulated carbon arc, 102
- Harvard University
 antiglare devices, 122
 graded-density goggles, 120
- Hayward Optical Glass Company, triple mirror production, 116
- High pressure mercury arcs, 93-94
- Icaroscope, antiglare device, 124-126
 formation of screens, 126
 general description, 3
 phosphor requirements, 126
 phosphorescent saturation, 124
 type 1 icaroscope, sun telescope, 124-125
 type 2 icaroscope, lightweight, 125
- Image field lens, curvature, 5-6, 10-11
- Image tube development, 33, 34
- Image tubes, infrared
see Infrared image tubes
- Image-forming infrared receivers
see Metascopes
- Incandescent filament lamps, 71-81
 applications, 71-74
 brightness, 76
 design and construction, 70-75
 electrical characteristics, 71-76
 lamp life, 71-74
 luminous efficiency, 76
 miscellaneous filament sources, 78
 modulating equipment, 75
 operating characteristics, 75-76
 power supply, 71-76
 radiation characteristics, 76-77
 recommended lamps for military projects, 78-81
 spatial distribution, 77
 spectral distribution, 71-76
 tungsten lamps, 70-78
- Inertia in phosphors, definition, 55
- Infrared autocollimators
see Metafactors, infrared autocollimators
- Infrared beacon, 78
- Infrared image tubes, 4-22
 basic components, 4
 electron optical consideration, 5-7
 fluorescent screen phosphors, 9
 1P25; 4-14, 24
 photocathodes, 7-9
 production, 4
 research recommendations, 17, 34
 standardized type, 5
- Infrared image tubes, experimental types, 14-17
 high voltage tubes, 15-16
 low-magnification tubes, 15-16
 single voltage tubes, 14-16
- Infrared image tubes, performance, 10-14
 contrast, 12-14
 conversion, 11-12
 resolution, 10-11
 sensitivity, 11-12
- Infrared image tubes, power supplies, 17-22
 converter unit, 17, 18
 power units, 19-22
 voltage divider, 18, 19
- Infrared receivers
see Metascopes
- Infrared sources, 70-90
 applications, 70
 arc lamps, 82-90
 incandescent filament lamps, 70-81
- Infrared telescope, 22-34
 basic components, 4
 construction, 33-34
 production, 5
 use, 1, 33-34
- Infrared telescope performance, 22-24
 expected range, 23-24
 resolving power, 23
 sensitivity, 22-23
- Infrared telescope types, 23-33
 airborne operations instruments, 30-32
 night-driving instruments, 28-30
 reconnaissance type, 26-28
 signaling and marker detectors, 23-26
 special types, 32-33
- Institute of Optics, University of Rochester
 infrared phosphors, 47
 K-S projector for infrared visibility, 78
 metascope development, 35
 ultraviolet radiation, 91
- Jeep movement at night, infrared telescope, 1
- Kellner-Schmidt
 corrector plates produced by dropping process, 51
 metafactors, infrared autocollimators, 113-114
 optic system, 35-36
 solid optic system, 44
 ultraviolet autocollimators, 110-113
- Kellner-Schmidt strip projector, 78, 128-130
 design, 129
 development, 129
 low-altitude aerial photography at night, 128
 optical system, 129
 performance, 129-130
 use, 129-130

- Kodak film for strip projector, 129-130
KR31 rectifier, 18, 20
- Lamp life, incandescent filament lamps, 71-74
- Leakage in image tubes, 14
- Leakage in power supply units, 22
- Lenard, research on sulfide phosphors, 62
- Lens structure of image tubes, 14
- Light-sun, energy emitted by a phosphor, 54
- Low-altitude aerial photography at night, strip projector, 128-130
- Low-pressure mercury arcs, 94
- Lucite, metascope cases, 44
- Luminescence in phosphors, definition, 54
- Luminous efficiency, incandescent filament lamps, 76
- Magnesium spark, 98-100
description, 98
electrical circuits, 98-99
filter, 108
hand held magnesium source, 100
large magnesium source, 99
radar principles, 100
spark intensities, 99
- Magnetic lens, 5
- Magnification in image tube, 5
- Mark VIII gunsight, 31
- Marker and signaling detectors, 23-26
early telescopes, 24, 25
portable telescopes, 26
- Mercury arcs, high pressure, 93-94
- Mercury arcs, low pressure, 94
- Mercury-vapor lamps, 84-90
air-blast cooled, 89
applications, 85
design and construction, 86
electrical characteristics, 87
general characteristics, 84
source lamps, 85
- Mercury-vapor lamps, operating characteristics
lamp life, 87
modulating equipment, 87
- Mercury-vapor lamps, radiation, 87-90
beam output, 90
brightness, 89-90
filters, 90
spectral distribution, 87-90
- Metaflectors, infrared autocollimators, 113-114
4½-inch metalector, 112-113
4¾-inch metalector, 113-114
8-inch metalector, 114
airplane runway markers, 112
charging requirements, 113
featherweight unit, 113
small boat landing, 112-113
- Metascopes, 35-53
aspheric corrector plates, 49-53
basic construction, 35-36
basic principle, 35
flash metascope, sensitive to visible radiation, not infrared, 127-128
optical design, 35, 36
phosphor application, 47-49
pressure-sealing, 42
stadimeter attachments, 46
ultraviolet, 104
use, 2
- Metascopes, types, 38-46
A, 36-38
A1, pressure-sealed, 41
A-M, modified type A, 40, 41
B, 38-39
F, radium excited, 41-43
H, 43, 44
J, single hand operation, 43
K, solid system, 44
L, 44-46
M and O miniature, 39, 40
- Mold surface curves in aspheric corrector plates, 51-53
- Mount Wilson Observatory
fused-quartz triple mirrors, 105
fused-quartz triple prisms, 101-102
triple mirror autocollimators, 110
triple mirror glass, 114
triple mirror production, 116
- National Carbon Company
carbon for arc-lamps, 82-83
ultraviolet carbon, 100
- Navy searchlight, infrared, 82
- New Jersey Zinc Company
infrared-sensitive phosphor development, 54-69
ultraviolet radiation, 91
- Nickel filter, semisolid, 106
- Nickel-chromium film on glass surface, 120-121
- Night aerial identification of vessels, 132-133
apparatus specifications, 133
binoculars, 133
glare elimination, 133
searchlights, 133
- Night aerial photography at low altitudes with strip-projectors, 128-130
- Night aerial reconnaissance with flash metascopes, 127
- Night air-sea rescue with triple-mirror autocollimators, 119
- Night torpedo bombing training with triple-mirror autocollimators, 119
- Night-driving instruments, 28-30
binoculars, 28
helmet instruments, 28
incandescent filament lamps, 78-79
periscopic binoculars, 28
protectoscope, 28
- Night-landing aircraft recommended lamps, 80
telescopes, 31, 32
triple-mirror autocollimators, 117-119
ultraviolet autocollimators, 112-113
- Norway-vapor lamps, operating characteristics, 85-87
- Occulting-disk, antiglare device, 121-122
principle, 121-122
type 1 instrument, disk inside telescope, 122
type 2 instrument, disk outside telescope, 122
- 1P25 image tube
construction, 10
electrode design, 6-7, 13
infrared telescope use, 24
manufacture and use, 4
multiple voltage, 14
phosphor materials, 9
- Optical devices sensitive to visible light, 127-133
Cadillac-2, CIC screen and projector, 131
flash metascope, 127-128
for night aerial identification of vessels, 132-133
K-S strip projector, 128-130
- P-70 airplane, night landing, 118
- Paratroop equipment
infrared telescope, 2, 32
triple-mirror autocollimators, 118-119
- Penn Optical Company, triple-mirror production, 116
- Phosphor
activators, 47, 56-57
composition, 54
definitions of terminology, 54-55
fluorescent screen use, 9
icarscope antiglare device, 124-126
metascope use, 47-49
ultraviolet autocollimator use, 111
- Phosphor characteristics, measurement, 63-66
excitation, 63
resolving power, 65-66
sensitivity, 66
spectral measurements, 64-65
stimulability, 63-64
threshold, 64
time-lag, 66
- Phosphor pencil, 131
- Phosphor preparation, 61-63
fluxes, influence on preparation, 62
purity of materials, 61-62
standard phosphors, 62-63
- Phosphor properties
alpha-particle excitation, 41-42
definitions, 54-55
emission spectra, 47
excitation, 37, 48-49
exhaustion, 42, 54
maximum sensitivity, 42
optical properties of standards, 47-48
physical properties of standards, 48
stimulation spectra, 47
- Phosphor terminology, 54-55
- Phosphor theory, 66-69
decay phenomena, 68-69
excitation after partial exhaustion, 68
exhaustion curves, 66-67
saturation, 68
thermal and stimulated emission, 68

- Phosphor types, 55-61
 standards I through V, early phosphors, 55
 selenide phosphors, 59-60
 standard VI, 55-58
 standard VII, 58-59
 zinc-sulfide phosphors, 60-61
- Phosphorescent saturation principle, 124
- Photocathodes, 6-9
 cesium surface, 8
 spectral sensitivity, 9
 thermionic emission, 8
- Photoelectric receivers, 104-105
- Photoglow tubes, 105-106
- Photographic film, Eastman Kxx for K-S strip projector, 129-130
- Photomultiplier-tube, receiver filter, 108-109
- Pittsburgh Plate Glass Co., 1045X glass, 49
- Plane-to-plane identification with triple-mirror autocollimators, 119
- Plexiglas, Cadillac-2 screen, 131
- Point-source sensitivity with infrared telescope, 22
- Polaroid Corporation
 metascope filters, 38
 metascopes, plastic construction, 45
- Polytechnic Institute of Brooklyn, infrared-sensitive phosphor development, 54-69
- Pressure-sealing, metascopes, 42
- Prisms, fused-quartz triple, 105
- Protectoscope (night tank driving instrument), 28
- Quantum efficiency of phosphors, 48, 55
- Quenching phosphors, 54
- Radar principles, magnesium spark applications, 100
- Radio Corporation of America
 infrared-sensitive phosphor development, 54-69
 Princeton laboratories, 4
- Radium excited metascope, 41-43
- Range of the ultraviolet, 91-93
- RCA 1P28, gallium lamp receiver, 98
- RCA 1654, thermionic rectifier, 18-20
- RCA tube 1P28, photoelectric receiver construction, 104
- Receivers, image-forming infrared
see Metascopes
- Receivers, ultraviolet
see Ultraviolet receivers
- Reconnaissance telescopes, 26-28
 early, experimental, 26-27
 snooperscope and sniperscope, 28
- Rectifier in image tube power supplies, 17, 18
- Regeneration of phosphors, 48
- Research recommendations for infrared image tubes, 17, 34
- Resolving power
 image tube, 10-11
 infrared telescopes, 23
 phosphors, 65-66
- Rochester Button Company, autocollimator development, 110
- Rohm and Haas Company, Philadelphia, plexiglas manufacture, 132
- Samson United Corporation, metascope production, 38, 41, 43
- Saturation, phosphors, 68
- Searchlights
 Navy 24-inch searchlight, 100-101
 night aerial identification of vessels, 132-133
 source of infrared radiation, 1
- Selenide phosphors, 59-60
- Sensitivity
 infrared image tube, 11-12
 phosphor measurement methods, 66
 rating in metascopes, 38
- Shutter antiglare device, 122-124
 photoelectric process, 122
 photographic process, 123-124
- Signaling and marker detectors, 23-26
 early experimental telescopes, 24-25
 portable telescopes, 26
- Single band operation metascope, 43
- Sniperscope
 construction, 28
 filament lamp-recommendation, 81
 reconnaissance use, 28
- Snooperscope
 filament lamp-recommendation, 81
 general description, 2, 28
 paratroop use, 32
 reconnaissance use, 28
- Solid system metascope, 44
- Sonne camera, S-6 and S-7, 128-130
- Spatial distribution, filament lamps, 77
- Spectral distribution
 filament lamps, 71-74, 76-78
 mercury-vapor lamps, 87-90
- Spectral sensitivity, photocathodes, 9
- Spontaneous emission in phosphors, definition, 54
- Stadiometer attachments, metascopes, 46
- Stimulability of phosphors
 definition, 55
 factors effecting, 47
 measurement, 63
- Stimulation of phosphors
 definition, 54
 spectra, 47
- Strip camera projectors, 128-130
- Suction molding, aspheric corrector plate, 49-50
- Surface vessel identification with ultraviolet autocollimators, 112-113
- Sweep mount for metascope, 128
- Tank movements at night
 infrared telescope, 1
 protectoscope, night driving instrument, 28
- TBD-1 airplane, autocollimator testing, 118
- Telescopes
 glider applications, 30
 reconnaissance use, 26-28
- tailsight telescope for B-29; 31
 ultraviolet, 36-38
- Telescopes, infrared
see Infrared telescope
- Television, image tube in pick-up device, 5
- Thermionic emission
 infrared telescope, 13
 phosphors, 68
 photocathodes, 8
- Thermionic rectifier, RCA 1654; 18-20
- Threshold sensitivity
 phosphors, 48, 64
 standard VI phosphor, 57-58
- Time lag, phosphors
 definition, 55
 methods of measurement, 66
- Triple mirror autocollimators, applications, 117-119
 glider landings, 118-119
 night air-sea rescue, 119
 night landing, carrier-based planes, 118, 119
 night landing, enemy territory, 117-118
 night landing, ground based planes, 118
 night torpedo bombing training, 119
 plane-to-plane identification, 119
- Triple mirror autocollimators, manufacturing process, 116-117
 milling, 116-117
 mounting, 117
 production results, 116
 quality verification, 117
- Triple mirror autocollimators, properties, 114-115
- Triple mirror devices
 autocollimators, 114-119
 fused quartz, 105
 general description, 2
- Triple-prism return, carbon arc source, 101-102
- Tubes, image
see Image tubes
- Tungsten lamps, incandescent filament, 70-78
- 24-inch searchlight, 100-102
- Ultraviolet autocollimators, 105-106, 110-113
 construction, 110
 filters, 111-112
 phosphors, 111
 photoglow tubes, 105-106
 range, 110-111
 triple mirrors of fused quartz, 105
- Ultraviolet autocollimators, applications, 112-113
 night landing of aircraft, 112-113
 sea-search, 112-113
 small boat landings, 112-113
- Ultraviolet carbon, 100
- Ultraviolet radiation, 91-93
 fluorescence, 93
 range, 91-93, 108-109
 regions, 91

- Ultraviolet receivers, 104-106
 Geiger-counter receiver, 105-106
 metascopes, 104
 photoelectric receivers, 104-105
- Ultraviolet sources, 93-102
 carbon-arc, high intensity, 100-102
 filters, 106-109
 gallium lamp, 94-98
 magnesium spark, 98-100
 mercury arcs, high pressure, 93-94
 mercury arcs, low pressure, 94
- Ultraviolet spectrum, visibility to naked eye, 111-112
- Ultraviolet telescope, metascope fore-runner, 36-38
- United States Radium Company, flash metascope phosphor, 127
- University of California
 autocollimator development, 105
 ultraviolet radiation, 91
- University of Pennsylvania, Johnson Foundation, 4
- University of Rochester
 autocollimator research, 105, 110-111
 glass mold production, 45
 graded-density goggles, 120
 icaruscope development, 124
 infrared-sensitive phosphor development, 54-69
 triple mirror research, 114
 ultraviolet autocollimators, 112
- Vance amplifier, phosphor characteristic measurement, 65
- Vibrator in image tube power supplies, 17, 18
- Visible light, optical developments
 see Optical devices sensitive to visible light
- Voice transmission of gallium lamp, 98
- Voltage focusing, infrared image tube, 11
- Water-cooled capillary lamp, 88
- Willemite screen
 conversion, 12
 fluorescent screens, 9
 light output, 15
- XR7 filter, metascope use, 38
- Zeiss graded density goggles, 120
- Zinc-sulfide phosphors, 60-61
 bases, 61
 emission, 61
 operations, 61
 stimulation, 61

TITLE: Image Forming Infrared

ATI-23244

AUTHOR(S): Forsythe, W. E.; Federer, C. A.; Banning, M.; and others

REVISION

(None)

ORIGINATING AGENCY: Office of Scientific Research and Development, Washington, D. C.

ORIG. AGENCY NO.

VOL 4 STR

PUBLISHED BY: (Same)

PUBLISHING AGENCY NO.

Div 16

DATE	DOC. CLASS.	COUNTRY	LANGUAGE	PAGES	ILLUSTRATIONS
1946		U.S.	Eng.	159	photos, tables, diagrs, graphs

ABSTRACT:

The accomplishments in the field of infrared and optics in America during World War II are described. Devices depending on the use of infrared developed for the detection of enemy craft, the recognition of friendly craft and intercommunication by voice and code are discussed. The sniperscope, using infrared image-forming rays, is described as a spectacular weapon which enables troops to fire accurately on an enemy 100 yd away, in utter darkness. Other subjects discussed are: Infrared-image tubes and electron telescopes, metasopes, infrared sensitive phosphores, infrared sources and filters, auto-collimators, antiglare devices and other miscellaneous optical developments.

DISTRIBUTION: Copies of this report obtainable from Air Documents Division; Attn: MCIDXD

DIVISION: Ordnance and Armament (22)

SECTION: Fire Control (4)

SUBJECT HEADINGS: Infrared devices - Development (51905.21); Communication systems, Infrared (23992.845); Infrared, Detectors (51905.3); Filters, Infrared (36564)

ATI SHEET NO.: R-22-4-71

Central Air Documents Office
Wright-Patterson Air Force Base, Dayton, Ohio

AIR TECHNICAL INDEX

TITLE: Image Forming Infrared

ATI- 26114

AUTHOR(S): Banning, Mary; Federer, Charles A.; Forsythe, W. E.; and others

REVISION

(None)

ORIGINATING AGENCY: Office of Scientific Research and Development, NDRC, Div. 16

ORIG. AGENCY NO.

V-4

PUBLISHED BY: (Same)

(Washington, D. C.)

PUBLISHING AGENCY NO.

DATE	DOC. CLASS.	COUNTRY	LANGUAGE	PAGES	ILLUSTRATIONS
1946		U.S.	Eng.	157	photos, tables, diagrs, graphs

ABSTRACT:

In the technical report of NDRC, Division 16, the following are discussed: infrared image tubes and electron telescopes, metasopes, infrared-sensitive phosphors, infrared sources, ultraviolet sources and filters, autocollimators, antiglare devices, and miscellaneous optical developments. The infrared-sensitive telescope consists of an objective for forming an infrared image of the scene being viewed upon the sensitive cathode of an image tube, the image tube itself, and an ocular for viewing the image (in visible light) formed on the fluorescent screen of this image tube. A metascope consists essentially of a high-aperture optical system which forms an image of distant objects upon the surface of an infrared-sensitive phosphor. This image covers a useful field of 25° to 45°, depending upon the particular style of instrument.

DISTRIBUTION: Copies of this report obtainable from Air Documents Division; Attn: MCIDXD

DIVISION: Sciences, General (33)

SECTION: Physics (2)

SUBJECT HEADINGS: Infrared devices - Development
(51905.21)

ATI SHEET NO.: R-33-2-3

Air Documents Division, Intelligence Department
Air Materiel Command

AIR TECHNICAL INDEX

Wright-Patterson Air Force Base
Dayton, Ohio