

UNCLASSIFIED

AD

200 809

Reproduced

Armed Services Technical Information Agency

ARLINGTON HALL STATION; ARLINGTON 12 VIRGINIA

NOTICE: WHEN GOVERNMENT OR OTHER DRAWINGS, SPECIFICATIONS OR OTHER DATA ARE USED FOR ANY PURPOSE OTHER THAN IN CONNECTION WITH A DEFINITELY RELATED GOVERNMENT PROCUREMENT OPERATION, THE U. S. GOVERNMENT THEREBY INCURS NO RESPONSIBILITY, NOR ANY OBLIGATION WHATSOEVER; AND THE FACT THAT THE GOVERNMENT MAY HAVE FORMULATED, FURNISHED, OR IN ANY WAY SUPPLIED THE SAID DRAWINGS, SPECIFICATIONS, OR OTHER DATA IS NOT TO BE REGARDED BY IMPLICATION OR OTHERWISE AS IN ANY MANNER LICENSING THE HOLDER OR ANY OTHER PERSON OR CORPORATION, OR CONVEYING ANY RIGHTS OR PERMISSION TO MANUFACTURE, USE OR SELL ANY PATENTED INVENTION THAT MAY IN ANY WAY BE RELATED THERETO.

UNCLASSIFIED

**Best
Available
Copy**

Summary
Technical
Report
of NTRC

APP
Vol 2

1
2
3
4
5
6
7
8
9
10
11
12
13
14
15
16
17
18
19
20
21
22
23
24
25
26
27
28
29
30
31
32
33
34
35
36
37
38
39
40
41
42
43
44
45
46
47
48
49
50
51
52
53
54
55
56
57
58
59
60
61
62
63
64
65
66
67
68
69
70
71
72
73
74
75
76
77
78
79
80
81
82
83
84
85
86
87
88
89
90
91
92
93
94
95
96
97
98
99
100

FILE COPY

Return to
ASTIA
ARLINGTON HALL STATION
ARLINGTON 12, VIRGINIA
Attn: TISS

OSRD

CLASSIFICATION CHANGED TO
~~CONFIDENTIAL~~
AUTHORITY

58462

CLASSIFICATION CHANGED TO
UNCLASSIFIED
AUTHORITY *Sec. 1.1 by TAC*
per J204313
DA Ltr 23 Apr 58

FC

~~UPGRADED~~
~~CLASSIFICATION CHANGED TO~~
~~UNCLASSIFIED~~
AUTHORITY *1.1* Initials *79*
Date *3/27/79*

CLASSIFICATION CHANGED TO
~~CONFIDENTIAL~~
AUTHORITY

SUMMARY TECHNICAL REPORT
OF THE
NATIONAL DEFENSE RESEARCH COMMITTEE

This document contains information affecting the national defense of the United States within the meaning of the Espionage Act, 50 U. S. C., 31 and 32, as amended. Its transmission or the revelation of its contents in any manner to an unauthorized person is prohibited by law.

This volume is classified RESTRICTED in accordance with security regulations of the War and Navy Departments because certain chapters contain material which was RESTRICTED at the date of printing. Other chapters may have had a lower classification or none. The reader is advised to consult the War and Navy agencies listed on the reverse of this page for the current classification of any material.

CLASSIFICATION CHANGED TO
~~RESTRICTED~~
UNCLASSIFIED
AUTHORITY

Manuscript and illustrations for this volume were prepared for publication by the Summary Reports Group of the Columbia University Division of War Research under contract OEMsr-1131 with the Office of Scientific Research and Development. This volume was printed and bound by the Columbia University Press.

Distribution of the Summary Technical Report of NDRC has been made by the War and Navy Departments. Inquiries concerning the availability and distribution of the Summary Technical Report volumes and microfilmed and other reference material should be addressed to the War Department Library, Room 1A-522, The Pentagon, Washington 25, D. C., or to the Office of Naval Research, Navy Department, Attention: Reports and Documents Section, Washington 25, D. C.

Copy No.

30

This volume, like the seventy others of the Summary Technical Report of NDRC, has been written, edited, and printed under great pressure. Inevitably there are errors which have slipped past Division readers and proofreaders. There may be errors of fact not known at time of printing. The author has not been able to follow through his writing to the final page proof.

Please report errors to:

JOINT RESEARCH AND DEVELOPMENT BOARD
PROGRAMS DIVISION (STR ERRATA)
WASHINGTON 25, D. C.

A master errata sheet will be compiled from these reports and sent to recipients of the volume. Your help will make this book more useful to other readers and will be of great value in preparing any revisions.

CLASSIFICATION CHANGED TO
~~RESTRICTED~~ UNCLASSIFIED
AUTHORITY

SUMMARY TECHNICAL REPORT OF THE
APPLIED PSYCHOLOGY PANEL, NDRC

VOLUME 2

**HUMAN FACTORS IN
MILITARY EFFICIENCY**
TRAINING AND EQUIPMENT

OFFICE OF SCIENTIFIC RESEARCH AND DEVELOPMENT
VANNEVAR BUSH, DIRECTOR

NATIONAL DEFENSE RESEARCH COMMITTEE
JAMES B. CONANT, CHAIRMAN

APPLIED PSYCHOLOGY PANEL
CHARLES W. BRAY, CHIEF

WASHINGTON, D. C., 1946

CLASSIFICATION CHANGED TO
~~SECRET~~
UNCLASSIFIED
AUTHORITY

NATIONAL DEFENSE RESEARCH COMMITTEE

James B. Conant, *Chairman*

Richard C. Tolman, *Vice Chairman*

Roger Adams Army Representative¹

Frank B. Jewett Navy Representative²

Karl T. Compton Commissioner of Patents³

Irvin Stewart, *Executive Secretary*

¹ Army representatives in order of service:

Maj. Gen. G. V. Strong Col. L. A. Denson
Maj. Gen. R. C. Moore Col. P. R. Faymonville
Maj. Gen. C. C. Williams Brig. Gen. E. A. Regnier
Brig. Gen. W. A. Wood, Jr. Col. M. M. Irvine
 Col. E. A. Routheau

² Navy representatives in order of service:

Rear Adm. H. G. Bowen Rear Adm. J. A. Furer
Capt. Lybrand P. Smith Rear Adm. A. H. Van Keuren
 Commodore H. A. Schade

³ Commissioners of Patents in order of service:

Conway P. Coe Casper W. Ooms

NOTES ON THE ORGANIZATION OF NDRC

The duties of the National Defense Research Committee were (1) to recommend to the Director of OSRD suitable projects and research programs on the instrumentalities of warfare, together with contract facilities for carrying out these projects and programs, and (2) to administer the technical and scientific work of the contracts. More specifically, NDRC functioned by initiating research projects on requests from the Army or the Navy, or on requests from an allied government transmitted through the Liaison Office of OSRD, or on its own considered initiative as a result of the experience of its members. Proposals prepared by the Division, Panel, or Committee for research contracts for performance of the work involved in such projects were first reviewed by NDRC, and if approved, recommended to the Director of OSRD. Upon approval of a proposal by the Director, a contract permitting maximum flexibility of scientific effort was arranged. The business aspects of the contract, including such matters as materials, clearances, vouchers, patents, priorities, legal matters, and administration of patent matters were handled by the Executive Secretary of OSRD.

Originally NDRC administered its work through five divisions, each headed by one of the NDRC members. These were:

Division A—Armor and Ordnance
Division B—Bombs, Fuels, Gases, & Chemical Problems
Division C—Communication and Transportation
Division D—Detection, Controls, and Instruments
Division E—Patents and Inventions

In a reorganization in the fall of 1942, twenty-three administrative divisions, panels, or committees were created, each with a chief selected on the basis of his outstanding work in the particular field. The NDRC members then became a reviewing and advisory group to the Director of OSRD. The final organization was as follows:

Division 1—Ballistic Research
Division 2—Effects of Impact and Explosion
Division 3—Rocket Ordnance
Division 4—Ordnance Accessories
Division 5—New Missiles
Division 6—Sub-Surface Warfare
Division 7—Fire Control
Division 8—Explosives
Division 9—Chemistry
Division 10—Absorbents and Aerosols
Division 11—Chemical Engineering
Division 12—Transportation
Division 13—Electrical Communication
Division 14—Radar
Division 15—Radio Coordination
Division 16—Optics and Camouflage
Division 17—Physics
Division 18—War Metallurgy
Division 19—Miscellaneous
Applied Mathematics Panel
Applied Psychology Panel
Committee on Propagation
Tropical Deterioration Administrative Committee

NDRC FOREWORD

AS EVENTS of the years preceding 1940 revealed more and more clearly the seriousness of the world situation, many scientists in this country came to realize the need of organizing scientific research for service in a national emergency. Recommendations which they made to the White House were given careful and sympathetic attention, and as a result the National Defense Research Committee [NDRC] was formed by Executive Order of the President in the summer of 1940. The members of NDRC, appointed by the President, were instructed to supplement the work of the Army and the Navy in the development of the instrumentalities of war. A year later, upon the establishment of the Office of Scientific Research and Development [OSRD], NDRC became one of its units.

The Summary Technical Report of NDRC is a conscientious effort on the part of NDRC to summarize and evaluate its work and to present it in a useful and permanent form. It comprises some seventy volumes broken into groups corresponding to the NDRC Divisions, Panels, and Committees.

The Summary Technical Report of each Division, Panel, or Committee is an integral survey of the work of that group. The first volume of each group's report contains a summary of the report, stating the problems presented and the philosophy of attacking them, and summarizing the results of the research, development, and training activities undertaken. Some volumes may be "state of the art" treatises covering subjects to which various research groups have contributed information. Others may contain descriptions of devices developed in the laboratories. A master index of all these divisional, panel, and committee reports which together constitute the Summary Technical Report of NDRC is contained in a separate volume, which also includes the index of a microfilm record of pertinent technical laboratory reports and reference material.

Some of the NDRC-sponsored researches which had been declassified by the end of 1945 were of sufficient popular interest that it was found desirable to report them in the form of monographs, such as the series on radar by Division 14 and the monograph on sampling inspection by the Applied Mathematics Panel. Since the material treated in them is not duplicated in the Summary Technical Report of NDRC, the monographs are an important part

of the story of these aspects of NDRC research.

In contrast to the information on radar, which is of widespread interest and much of which is released to the public, the research on subsurface warfare is largely classified and is of general interest to a more restricted group. As a consequence, the report of Division 6 is found almost entirely in its Summary Technical Report, which runs to over twenty volumes. The extent of the work of a Division cannot therefore be judged solely by the number of volumes devoted to it in the Summary Technical Report of NDRC: account must be taken of the monographs and available reports published elsewhere.

The Applied Psychology Panel, under the direction first of W. S. Hunter and later of C. W. Bray, comprised a small group of psychologists and personnel specialists whose responsibility was to aid in refining and standardizing Army and Navy personnel procedures. The Panel devised selection and classification tests; it developed training methods; it improved the design of much equipment. The work of the Panel proved that it is as important to get the right man for a military job as it is to get the right ammunition for his gun.

The achievements of the Applied Psychology Panel cannot be measured in quantitative terms. But one can, for example, estimate with certainty that the tests devised to eliminate the emotionally unfit from induction prevented the wrecking of many lives and the fruitless expenditure of much time, effort, and money; and one can know surely that many lives were saved as the result of the one study alone which showed that the best night lookouts at sea were four times as proficient as the poorest.

The Summary Technical Report of the Panel, prepared under the direction of the Panel Chief and authorized by him for publication, is a record of scientific accomplishment and of zealous effort by able men working to increase the effectiveness of the nation's military manpower in time of national peril. The members of the Panel have our gratitude.

VANNEVAR BUSH, Director
Office of Scientific Research and Development

J. B. CONANT, Chairman
National Defense Research Committee

RESTRICTED

v

FOREWORD

THE APPLIED PSYCHOLOGY PANEL of NDRC was organized in June 1942 in order to mobilize civilian assistance for a program of application of psychology to military problems. Outstanding at the time was the problem of assigning men to duty in terms of aptitude. Aptitude testing was the primary contribution of psychology to military efficiency in World War I. In World War II, psychologists were engaged at an early date to apply this specialty to the problems of mass classification.

In the peacetime years between the two wars, many research studies of human learning were conducted. The principles of learning developed in the laboratory, and their application to mass training of industrial personnel, were obviously relevant to military training. Hence, when the Applied Psychology Panel was formed, it was asked to assist in military training as well as in aptitude testing.

With the extraordinary freedom permitted to scientists by the NDRC organization, the psychologists of the Applied Psychology Panel branched into a third field: the design and operation of military equipment. Matériel must be operated by men. In wartime it must be operated by half-trained men, by men who are not confident of themselves, by men who make mistakes. Hence the design and operation of equipment is not a problem of matériel alone. It is a problem of man and machine in combination. To this problem the psychologists of the Applied Psychology Panel made contributions.

As the war progressed, the Panel's work on aptitude, on training, and on equipment became more unified. If aptitude tests were improved, the men sent to a given school could be more readily trained; operating procedures and equipment could be more complex. As training became more specific, general verbal ability tests became less useful and special aptitude tests more necessary. With high quality training, complex matériel was more often used and less often misused. When matériel was designed in terms of the needs of the average soldier or sailor, operation became simpler and the requirements for selection and training were reduced.

Not only were the problems of aptitude, training, and equipment seen to be interrelated, but the same research method was found to be useful in each of the three problems. In all three cases, objective measures of human performance were necessary as criteria to use in evaluating alternative procedures. Such criteria were needed to measure the knowledge and skill of men who were selected by alternative aptitude tests, of men who were trained on different synthetic devices, of men who were following opposed doctrines of use of equipment, or of men who were serving as human guinea pigs in the comparison of alternative designs of equipment. Thus the projects of the Applied Psychology Panel tended to become centers for a coordinated approach to the problems of using the devices of war.

The results of these coordinated studies of the problems of military psychology are described in the APP Summary Technical Report under the general title, *Human Factors in Military Efficiency*. Volume 1 is subtitled *Aptitude and Classification*. This volume is subtitled *Training and Equipment*. The first half of this volume describes the research on the training of various specialists. The second half describes research on the design and operation of the equipment for which training was necessary.

The research reported in the Summary Technical Report resulted in an increase in the proficiency of soldiers and sailors in combat. The application of psychological techniques increased the speed, for example, with which messages were sent over radio and interphone in the noisy conditions of combat. The accuracy of antiaircraft gunners was raised. The ability of radar operators to read the position and range of enemy targets became greater. Amphibious personnel were better able to recognize beach markers.

Yet the positive values of psychological research were limited in World War II by conditions which can now be corrected. Greater value could have been obtained if research studies had been activated earlier. In many cases psychological research began too late to be of maximal effectiveness. Several examples may

be mentioned from the experience of the Applied Psychology Panel.

In the early years of the war in Europe, at Pearl Harbor, and in the further reaches of the Pacific, the need for antiaircraft defense was made obvious. But not until 1942 and 1943 was the Panel asked to help improve the efficiency of antiaircraft gunners. In 1942 and 1943 the priority of ground warfare increased. But it was 1944 before a project on human errors in the use of field artillery was activated. It was 1945, after the B-29 airplane had seen combat, before psychological research was requested in order to help formulate military requirements for aerial gunnery equipment. In each instance months were required to obtain useful results. In each instance significant research results were obtained. In each instance these results would have had greater military value if the need had been anticipated and the research requested before instead of after that need became acute.

In the future, new devices must be considered in terms of personnel requirements before production begins. New devices always impose a strain on personnel. Officers in training camps or in the field cannot be expected to produce efficient fighting teams when the officers themselves are unfamiliar with the new devices

which must be used. The psychological problems can be anticipated, and many military problems eliminated before they occur, if qualified psychologists are encouraged to study new devices which are at the blueprint, the mock-up, or the reproduction stage of development.

If psychological research on selection, training, and equipment is concentrated on preproduction models, the results will appear in time to be of maximal usefulness. Standard operating procedures will be worked out by the time the new equipment is ready for distribution. Training plans can be developed before actual training begins. Selection requirements will be known before men are selected for training on the new equipment.

Postponing psychological studies until after general use has demonstrated the shortcomings or difficulties of a piece of equipment can accomplish only corrective measures. Anticipating those shortcomings by subjecting equipment to psychological study during its early development will lead to better selection, better training, better operating procedures, and better equipment.

CHARLES W. BRAY
Chief, Applied Psychology Panel

PREFACE

THE APP SUMMARY TECHNICAL REPORT is a systematic account of the work done under the direction of the Applied Psychology Panel of the National Defense Research Committee. It includes work done before the Panel's formation when the same projects and personnel were under the supervision of the National Research Council's Committee on Service Personnel—Selection and Training. Volume 1 describes selection and classification of military personnel; Volume 2 describes military training and the human factors involved in the design and operation of military equipment. In each of these three fields—selection and classification, training, and the design and operation of military equipment—the work actually done and the effects of that work on military practice are described.

Chapter 1 summarizes this volume. The remaining chapters can conveniently be divided into four groups: Chapters 2 to 12 relate the specific efforts of Applied Psychology Panel projects to improve the training given to a number of different types of military specialists. Chapters 13 to 17 discuss the psychological principles and the methods employed in organizing mass instruction, developing instructional aids, evaluating synthetic trainers, and measuring the achievement of men in training. Chapters 18 to 23 describe the work done by Panel projects on improving the design and operational procedures for a number of types of military equipment. Chapters 24 and 25 present psychological principles for designing military equipment and for developing the most efficient operating procedures for that equipment.

As was true of Volume 1, cross references are given by means of section numbers, for example 11.3.5, in which the 11 refers to the chapter, 3 to the third major division of Chapter 11, and 5 to the fifth section of the third division of Chapter 11. Commonly used abbreviations are explained in a glossary at the end of the volume.

In writing this final summary a few tables were recalculated from the original reports. In no case were the changes large enough to alter conclusions or recommendations.

The Applied Psychology Panel has had help from many sources in preparing this final account of its work. To each of these we express our thanks.

The Army, the Navy, and the Applied Psychology Panel Contractors have provided photographs to illustrate many of the devices and procedures discussed.

The author of each chapter is named in the table of contents and at the beginning of the chapter. Though all chapters are based upon the original reports prepared by the contractors,^a many of them were finally written by the editor. Approximately half of the chapters were written by men who spent the war years in the field, working on problems their chapters summarize. The Panel and the editor are very appreciative of the time and effort devoted by these men to writing first-hand accounts of their work. We are particularly indebted to William E. Kappauf, Jr., who wrote seven of the chapters in this volume.

As in Volume 1, credit is not given to the individual psychologists who actually made the contributions here reported. Their specific contributions can be discovered only by studying the original reports listed in the bibliographies. The Applied Psychology Panel expresses its sincere appreciation to these men for their individual contributions and for their effective teamwork. These two volumes record their achievement.

DAEL WOLFLE
Editor

^a A complete bibliography of reports prepared by Applied Psychology Panel contractors is contained in *Final Report and Bibliography of the Applied Psychology Panel*, Charles W. Bray, OSRD 6668, June 30, 1946. This report gives the title and other identifying data of each report.

CONTENTS

CHAPTER	PAGE
1 Summary by <i>Dael Wolfe</i>	1
<i>PART I</i> <i>TRAINING OF SPECIALIZED MILITARY PERSONNEL</i>	
2 Search-Radar and Bombing-Radar Operators by <i>Donald B. Lindsley</i>	8
3 Training Trackers for Antiaircraft Fire Control by <i>William C. Biel</i> and <i>William E. Kappauf, Jr.</i>	19
4 Training Personnel in Range Determination by <i>William E. Kappauf, Jr.</i>	41
5 Training the B-29 Gunner by <i>Charles W. Bray</i>	57
6 Night Lookouts by <i>Dael Wolfe</i>	63
7 Training Navy Gunners and Engine Room Crews by <i>Bernard J. Covner</i>	79
8 Training Winch Operators by <i>Dael Wolfe</i>	83
9 Training Amphibious Craft Crews by <i>Dael Wolfe</i>	86
10 Training Navy Telephone Talkers by <i>Dael Wolfe</i>	90
11 Voice Communication Training in the Army Air Forces by <i>Dael Wolfe</i>	98
12 Training Radio Operators by <i>Dael Wolfe</i>	106
<i>PART II</i> <i>PSYCHOLOGICAL PRINCIPLES IN MILITARY TRAINING</i>	
13 Psychological Principles in Military Training by <i>Dael Wolfe</i>	124
14 Job Analysis of Duties to Be Learned by <i>Bernard J. Covner</i>	127
15 Course Outlines and Lesson Plans by <i>Bernard J. Covner</i>	132
16 The Use and Design of Synthetic Trainers for Military Training by <i>Dael Wolfe</i>	140
17 Measuring the Effects of Training by <i>Norman Frederiksen</i>	155

CHAPTER	PAGE
<i>PART III</i>	
<i>THE DESIGN AND OPERATION OF SPECIAL TYPES OF MILITARY EQUIPMENT</i>	
18 Antiaircraft Directors and Guns by <i>William E. Kappauf, Jr.</i>	179
19 Field Artillery Equipment by <i>William E. Kappauf, Jr.</i>	206
20 The Design and Operation of B-29 Gunsights by <i>Charles W. Bray</i>	219
21 The Operation of Radar Equipment by <i>Donald B. Lindsley</i>	234
22 Stereoscopic Rangefinders and Heightfinders by <i>William E. Kappauf, Jr.</i>	251
23 Standard Procedures in Voice Communication by <i>Dael Wolfe</i>	270
<i>PART IV</i>	
<i>GUIDING PRINCIPLES FOR FUTURE EQUIPMENT DEVELOPMENT</i>	
24 Principles of Good Equipment Design by <i>William E. Kappauf, Jr.</i>	284
25 The Development of Standard Operating Procedures by <i>William E. Kappauf, Jr.</i>	296
Glossary	321
Bibliography	323
OSRD Appointees	349
Contract Numbers	351
Service Project Numbers	353
Index	355

Chapter 1

SUMMARY

By Dael Wolfe

1.1 INTRODUCTION

THIS CHAPTER is a summary of the work of the Applied Psychology Panel, NDRC, on problems of military training and equipment, the work reported in the remaining chapters of this volume. This summary is divided into four sections which parallel the four major divisions of the volume. Section 1.2 summarizes specific studies of military training. Section 1.3 outlines the psychological principles of learning and general methods of improving training. Section 1.4 describes specific studies directed toward improving the design of military equipment and the development of better operating procedures for such equipment. Section 1.5 briefly reviews the psychological principles involved in equipment design and operation.

The subtitles of the following sections include the numbers of the chapters summarized in each. A rapid reading will give the location and plan of organization of the main research findings of the entire volume.

1.2 TRAINING OF SPECIALIZED MILITARY PERSONNEL

Chapters 2 to 13 deal with the application of general psychological principles to specific learning situations and pieces of equipment. In each case, work was directed toward the achievement of one or more of three objectives: to make the training more specifically directed toward the actual duties to be performed; to include better measures of progress and achievement; and to make fuller use of established principles of learning.

1.2.1 Training Search-Radar and Bombing-Radar Operators (Chapter 2)

Surveys of radar operator training schools led to a number of specific suggestions for improving the instruction given.

The task of the search-radar operator is in general the same, even though there are wide

differences in equipment and in special procedures. Common elements in the task were studied: the tactical use of radar equipment; specific procedures, such as calibration and tuning; manipulation of controls; interpretation of scope phenomena; and the reading of ranges and bearings. These studies resulted in the development of synthetic trainers, achievement measures, and instructional aids, including the following examples: several mechanical-optical *plan position indicator* [PPI] trainers to aid in the training of search-radar operators; a flash-reading method to train men in the rapid identification and interpretation of scope phenomena; an H2X film trainer and radar scope movies for ground training and for use in briefing radar bombing operators for training missions.

Reductions in average bombing errors of from 1,000 to 1,500 feet were secured by giving trained bombardiers an additional 150 hours of practice in operation of the main scope.

1.2.2 Training Trackers for Antiaircraft Fire Control (Chapter 3)

Checksights were developed for use on a number of different guns. It was demonstrated that trackers learn more rapidly when trained with checksights than when trained without them. Checksights were found to be the most generally useful objective measure of the tracker's skill. A phototube scoring device to replace the checksight observer was developed too late in the war to be used. Its reliability and effectiveness were, however, demonstrated.

Learning records showed that once men were adequately trained in tracking they needed refresher drills no more often than once a month.

Three on-target tracking trainers were developed: a trainer which simulated the task of optical tracking with the stereoscopic heightfinder; a trainer which simulated the two-man tracking task in the gun director Mark 37; and a trainer which simulated the two-man tracking task on the director M7. The

last one became known as the Tufts tracking trainer. It had validity as both a selection device and a training device.

Several manuals giving instructions for the use of gunnery trainers and the operation of fire-control equipment were written.

1.2.3 Training Personnel in Range Determination (Chapter 4)

Projects of the Applied Psychology Panel prepared training manuals for instructing Army personnel in heightfinder operation. The same material was in large part adapted for the training of Navy personnel in rangefinder operation. A number of training aids were developed for both Services.

The rate of improvement during training in heightfinder and rangefinder operation was studied in a variety of situations. About 2,700 trials were found necessary on the M2 trainer and about 3,200 on the Eastman trainer before men reached a plateau. Men who had had this amount of practice on a trainer reached a plateau in their ability to range on aerial targets in about 500 trials.

Unaided estimation of the opening range for 20 mm fire, 1,700 yards, was found to be superior to stadiametric ranging with the gunsight Mark 14. Training on the firing line with the reticle of the gunsight Mark 14 was found to be superior to training on the mirror range estimation trainer device 5C-4 in learning stadiametric ranging.

Practice in aerial target range estimation increased the percentage of estimates within 15 per cent of true range from about 25 to about 45 per cent. Relatively frequent refresher drills were found necessary, however, to keep men at this level of performance.

The accuracy of estimating the range of aerial targets is approximately the same as the accuracy of estimating the range of ground targets.

1.2.4 Training the B-29 Gunner (Chapter 5)

Applied Psychology Panel project personnel studied the scoring of gun camera film, a checksight for B-29 gunners, and the effects of

coaching in a training program. A new scoring method for gun camera film was developed which required less than one-third as many man hours as the standard Army method. The checksight provided unreliable scoring but probably motivated the men to better performance. The data of the coaching experiment indicated that gunners tended to over-range at the beginning and to under-range at the end of an attack.

1.2.5 Night Lookouts (Chapter 6)

A shipboard study of the performance of night lookouts on duty in an Atlantic convoy provided specific information on the average ability and the variation in ability of night lookouts to spot targets. The best lookouts were able to see a ship nearly four times as far away as the poorest ones. These differences were not due to differences in night vision as measured by the adaptometer.

Two night vision trainers and a training exercise in the use of binoculars at night were constructed and submitted to the Navy. Assistance was given in the preparation of literature for the training of lookouts.

1.2.6 Training Navy Operating Crews (Chapters 7 and 8)

Lesson plans, course outlines, and instructional manuals were written for the .50 caliber machine gun, for the 20 mm, 40 mm, 3"/50, 4"/50, and 5"/38 guns, and for the main battery of large ships. Similar teaching aids were written for the instruction of operating engineers in training for duty aboard a number of types of Navy ships.

Paralleling the work on lesson plans for gunnery instruction was a series of studies on gunnery trainers and lesson plan materials for their use.

Courses entitled *How to Teach Gunnery* and *How to Teach Engineering* were developed and given to a number of classes of instructors.

A trainer consisting of a miniature electric winch was constructed to help train hatchmen and winchmen for duty on APA's and AKA's.

1.2.7 Training Amphibious Craft Crews (Chapter 9)

Project personnel assisted the Amphibious Training Command in the development and improvement of training courses for the crews of amphibious craft.

Job analyses were made of amphibious enlisted billets and a questionnaire was administered to personnel returning from combat zones in order to secure information about the effectiveness of various methods of training, classification, or ship performance in actual combat.

The training studies and the curricula developed were organized into a systematic overall program described in the Amphibious Training Command *Training Manual*.

1.2.8 Voice Communication Training (Chapters 10 and 11)

The high noise levels encountered in military airplanes and aboard ship frequently made normal speech unintelligible over telephone and other communication circuits. Special training courses were developed in order to increase intelligibility.

A *Telephone Talkers' Manual*, a manual for instructors, and phonograph records were developed for Navy telephone talkers. Experimental investigations of the best methods of instruction and of the value of various parts of the course and a survey of the training given to telephone talkers in a number of installations led to improved standardized instruction. The training ashore was integrated with subsequent training on board ship.

Three courses were developed for the submarine service: a basic course to teach general skills; an intermediate course to give each man proficiency in the use of the phraseology required by his assignment aboard ship; and an advanced course to drill the entire crew as a combat team in the coordinated use of the communication circuits.

In the Army Air Force, training methods were devised and instructors' handbooks and students' manuals written for courses designed to teach personnel to speak so that their mes-

sages would be more intelligible. Special courses were written for the training of each type of aircrew specialist and for the training of formed crews of heavy and very heavy bombers.

1.2.9 Training Radio Operators (Chapter 12)

The code-voice method of teaching basic code was developed on the basis of established principles of learning. It was shown to be superior to former methods and was adopted by the Army.

Four hours of daily drill were shown to produce as rapid learning as 7. The distribution of these 4 hours within a day was found to be unimportant. Increasing the variety of drill materials produced more rapid learning and decreased boredom in both students and instructors. One hour a day of practice in copying hand-sent clear-text practice material produced a small improvement in ability to copy cipher accurately. Giving men practice in copying code through various types of interfering noises did not diminish their ability to copy clear code and led to a moderate improvement in ability to copy code through interference.

A trainer to aid men in learning to send correctly was developed. It consisted of a typewriter which was controlled by electronic circuits in such a way that Morse code characters were transcribed by the typewriter as ordinary letters. Correct sending appeared immediately on the typewriter as correct copy. Errors in sending appeared as errors and informed the student immediately of the nature of the mistake he had made.

A monograph on code speeds was prepared to provide instructors and others with an understanding of the various bases for computing code speed and with instructions for cutting tapes which would have the exact speed desired.

Two studies were made of errors, one of errors in receiving and one of errors in sending. In both cases the order of difficulty of the numbers and letters was found to be highly constant for students of different levels of ability.

Standardized tests of ability to receive code at different speeds were constructed. The prog-

ress of several hundred code students was recorded and tabulated. These data provide information on average rate of learning and upon variability of rate in learning for students ranging in level from beginners to men able to receive at 25 groups per minute.

1.3 PSYCHOLOGICAL PRINCIPLES IN MILITARY TRAINING

1.3.1 Improving Instruction (Chapters 13 and 14)

The general operating procedure followed by Applied Psychology Panel projects working on training problems was:

1. In the time available, getting as complete a knowledge as possible of the duties men were being trained to perform. This knowledge was obtained by conducting a job analysis, by taking the course, or through observation and by discussions with experienced personnel.

2. Studying the training procedures in use to determine where and just how improvements could be made. These improvements usually involved the application of one or more of the following psychological principles.

- a. Improve the distribution of practice.
- b. Secure active participation of the trainee.
- c. Vary the practice material.
- d. Develop accurate performance records.
- e. Give the men an immediate knowledge of the results of their practice.
- f. Write clear, detailed plans for the instructor.

3. Putting the improvements into effect. This step sometimes involved the writing of lesson plans. Sometimes it consisted of designing a new trainer or improving an existing one. Frequently it included the development of better methods of measuring the achievement of men in training.

1.3.2 Lesson Plans (Chapter 15)

Lesson plans furnish an instructor with a detailed statement of the topics to be covered

in a course and the time and method of teaching each topic. With inexperienced instructors, lesson plans make better teaching possible and provide a basis for more standardized instruction.

Lesson plans were written for many of the special types of training covered in Chapters 2 to 12. The details of writing lesson plans are described in Chapter 15.

1.3.3 The Use and Design of Synthetic Trainers for Military Training (Chapter 16)

A good trainer has three essential characteristics: practice on it leads to substantial improvement on the equipment the men are being trained to operate; it provides reliable information on the quality of the men's performance; and, mechanically and electrically, it is as simple as possible.

It is necessary to plan carefully an instructional program using a trainer. Simply telling men to practice for a while sometimes results in a loss of skill instead of a gain. Instructions for the proper use of a trainer should be prepared as the trainer is being developed, and distributed with the trainer.

Trainers possess some advantages over real equipment for practice: they are generally safer, more economical, and more readily available. On a trainer it is possible to break up a complex task into simpler elements. It is usually easier to give men exact information about their errors and successes on a trainer than on real equipment.

1.3.4 Measuring the Effects of Training (Chapter 17)

Good tests of the amount of skill acquired by men undergoing training improve the training program in several respects.

1. They increase the amount the trainees learn, both by motivating the trainees and by showing the instructor where his instruction is good and where it is poor.

2. They provide measures of actual achieve-

ment which are useful in advanced classification.

3. They provide better criteria than do ordinary school grades for evaluating selection procedures.

4. They make possible more uniform instruction in different classes and different schools.

5. They provide quality control officers with continuous checks on the success of training programs.

1.4 THE DESIGN AND OPERATION OF SPECIAL TYPES OF MILITARY EQUIPMENT

Psychological studies of the best methods of operating military equipment, as distinct from the best methods of training, grew to be a more and more significant part of the work of the Applied Psychology Panel as World War II progressed. Studies of operating procedures led in some instances to modifications in design in order to produce equipment better adapted to the abilities and limitations which characterized the average soldier or sailor.

1.4.1 Antiaircraft Directors and Guns (Chapter 18)

The accuracy of antiaircraft firing was in need of improvement. Applied Psychology Panel projects studied problems related to the operation and design of antiaircraft equipment. They studied tracking controls; telescopes and sights; operating, maintenance, calibration, and adjustment procedures; and training features for antiaircraft equipment which determine its accuracy. In each case the work was aimed at making operation by the average gunner easier and more accurate.

These studies led to a number of specific improvements in operational procedures and to some design changes.

It was demonstrated, for example, that tracking through large changes in elevation is made easier by gearing the gunsight in such a way that the line of sight of the system will elevate through 90 degrees while the exit pupil of the telescope moves through a smaller (45 to 60 degrees) arc.

1.4.2 Field Artillery Equipment (Chapter 19)

An analysis of errors in the operation of field artillery equipment led to the conclusion that two types of studies were desirable. The first study analyzed the scales used for panoramic telescopes and resulted in the development of an odometer type of scale which reduced greatly the number of errors made in reading the scale.

The second study resulted in the development of remote indicating equipment which recorded the entire action of a field artillery battery.

The project was terminated before either study was complete, and before its work could affect actual firing practice. The methods and equipment are available. They should be employed in a continuing study by the field artillery in order to decrease the number of firing errors.

1.4.3 B-29 Gunsights (Chapter 20)

An experimental test apparatus was developed for the study of the B-29 gunner in relation to his equipment. This apparatus provided for ground and airborne scoring of performance against synthetic targets. A ground and an airborne synthetic trainer were developed from the experimental apparatus.

Experimental studies indicated that triggering the B-29 gunsight occurred semirhythmically and independently of the accuracy of fire. Continuous firing was recommended. A set of simplified hand controls for the B-29 gunsight was developed. They proved to be superior to the standard controls. A study of slewing methods indicated the need for attention to slewing in training and in the design of equipment. Viscous damping of the B-29 gunsight was shown to be superior to friction damping.

1.4.4 Radar Equipment (Chapter 21)

A number of experimental studies were made of radar operating procedures and of types of oscilloscope presentation. Desirable levels of trace brightness and scope illumination and

desirable periods of scope observation were determined. Alternative presentations were compared in terms of accuracy of determination of target position and range. Procedures for minimizing calibration and operating errors were recommended. It was demonstrated that continued scope operation did not have a harmful effect on vision.

1.4.5 Stereoscopic Rangefinders and Heightfinders (Chapter 22)

Records of stereoscopic rangefinder and heightfinder performance made it apparent that the actual ranging accuracy of the best observers did not approach the predicted, or theoretical, accuracy of the instrument. A number of operating procedures and devices to improve performance on the existing equipment were developed.

1. An interpupillometer and template to ensure that the initial interpupillary setting of the instrument is adequately accurate.
2. Operation of the instrument at reduced aperture whenever possible.
3. An improved calibrating procedure and an improved record form for use in calibration.
4. Special training in making the height-of-image adjustment.

1.4.6 Standard Procedures in Voice Communication (Chapter 23)

Experimental studies were conducted to aid in the development of courses of instruction in voice communication procedures for AAF personnel. The following facts were established relative to the best methods of speaking and the best ways of using airplane interphone and radio telephone equipment in the presence of intense noise.

1. The most important factor in the use of the voice itself is loudness. In order to secure maximal intelligibility, the speaker should talk in such a way as to produce a good loud side tone in his earphones.
2. The second most important factor is articulation. One hour of instruction produces

enough improvement in articulation to increase intelligibility significantly.

3. Message forms should be standardized. Message content should be standardized. Each type of message should be as unique as possible.

4. The T-17 (hand-held) microphone should be held lightly touching the speaker's lips and parallel to the plane of the face.

5. The T-30 (throat) microphone should be worn on or slightly above the Adam's apple, never below it.

6. Gain control should remain inoperative on the interphone.

1.5 GUIDING PRINCIPLES FOR FUTURE EQUIPMENT DEVELOPMENT

1.5.1 Principles of Good Equipment Design (Chapter 24)

If an instrument design is well suited to the human operator, it permits many men to qualify as operators, it permits qualified men to operate with efficiency, it permits easy training, and it is acceptable to operators.

The general procedure in evaluating the psychological efficiency of a design is described. A first attempt at providing a check list for use in evaluating new designs is presented.

1.5.2 The Development of Standard Operating Procedures (Chapter 25)

The satisfactory and efficient analysis of operating methods requires the understanding of the military problems involved in the use of the equipment under consideration, in their mechanical, mathematical, psychological, and tactical aspects. The specific steps to be taken in achieving this understanding and developing the operating procedures are the following.

1. Study the equipment. Learn what it is supposed to do and how it works.
2. Determine all the tasks which have to be done in adjusting and operating the equipment.
3. Determine what the standards of accuracy of instrument operation should be and how limitations or approximations in the design of the equipment influence these standards.

4. Determine how each unit task should be done in order to achieve the greatest efficiency in time and accuracy.

5. Determine the proper sequence of actions.

6. Examine the sequence for short cuts.

7. Try out the procedure or compare alternative procedures if more than one has been developed.

8. Evaluate operator acceptance of the procedure.

9. Standardize the procedure finally established.

These steps should culminate in the preparation of a manual of standard operating pro-

cedures to accompany a new piece of equipment as it is distributed for use.

1.6 FUTURE RESEARCH ON TRAINING AND EQUIPMENT DESIGN

The Applied Psychology Panel's recommendations for future research on problems of military psychology are contained in the foreword to Volume 1 of the Summary Technical Report by this Panel. That foreword also outlines the type of research organization which the Panel believes most likely to lead to continued successful research in military psychology.

RESTRICTED

Chapter 2

SEARCH-RADAR AND BOMBING-RADAR OPERATORS

By Donald B. Lindsley^a

SUMMARY

THE TRAINING of search-radar and bombing-radar operators is described. Surveys of radar operator training schools led to a number of specific suggestions for improving the instruction given.

The task of the search-radar operator is in general the same, even though there are wide differences in equipment and in special procedures. Common elements in the task include the tactical use of radar equipment, specific procedures such as calibration and tuning, manipulation of controls, interpretation of scope phenomena, and the reading of ranges and bearings. The types of knowledge necessary for each of these frequently occurring tasks are discussed.

Several mechanical-optical plan position indicator [PPI] trainers were developed to aid in the training of radar operators. A flash-reading method was developed to train men in the rapid identification and interpretation of scope phenomena.

Studies were conducted of the training of radar bombing operators. An H2X film trainer and radar scope movies were developed for ground training and for use in briefing men for training missions.

An experimental study of improvements in bombing accuracy showed that the addition of 150 hours of main scope operating time produced reductions in average bombing error of from 1,000 to 1,500 feet.

2.1 INTRODUCTION

The training of the radar operator can be discussed only in relation to the special tasks he has to perform in connection with the operation of specific kinds of gear. Therefore a particular radar program representing Navy

search radar and another representing Army bombing radar will be reviewed. To discuss these programs meaningfully requires the presentation of an outline sketch of the training together with specific criticisms and suggestions directed toward the weaknesses of the programs.

Each program will be followed by general suggestions or the reports of further experiments bearing on factors which facilitate training and enhance final proficiency of the radar operator. The emphasis is on search-radar operations.

The selection of radar operators is considered in Volume 1, Chapter 6, the Summary Technical Report of the Applied Psychology Panel, and the general questions of the design of radar equipment in Chapter 21.

2.2 SEARCH RADAR

2.2.1 Training the Search-Radar Operator in the Navy

The sudden and large demand for radar operators, both in the Army and in the Navy, meant the rapid establishment of radar operator schools, the selection of instructors from relatively inexperienced personnel, the securing and setting up of new equipment for demonstration and training purposes, and the graduation of large numbers of operators required to meet quotas. Typical of the emergency training school were two set up by the Navy for training search-radar operators, one at Virginia Beach, Virginia, and another at Point Loma, San Diego, California. About one year after these schools began training operators, the Training Division, Bureau of Personnel, requested Project SC-70, NS-146, Applied Psychology Panel, NDRC, to visit these schools and analyze the training programs. The results of these investigations^{6, 8} will be summarized as a basis for further discussion of the problem of search-radar operator training.

^a This chapter is based on the work of Project SC-70, NS-146.

LENGTH OF COURSE AND TRAINING LOAD

The length of the course in both schools was 3 weeks, during which time the trainee was expected to become familiar with the operation of several types of radar gear. In addition to learning to operate each type of gear, the operator was required to know something about target detection and interpretation, interference, jamming, anti-jamming, CIC, fighter direction, navigation, dead-reckoning tracking, plotting, and intercommunication procedures. Obviously only a smattering of knowledge on any of these topics could be acquired in the time available for training.

The training load at Virginia Beach at the time of the investigation consisted of 120 men each week, making a total of 360 men in three stages of training at a time. At Point Loma the weekly quota was 200 men, with 600 in training at a time. Only 300 could be handled at a time in the latter school, necessitating two shifts.

ANALYSIS OF TRAINING PROGRAMS

In both schools the total training time during the 3-week period averaged about 105 hours. The percentages of this time devoted to specific aspects of training were as follows: lectures, 20 per cent; laboratory, 50 per cent; study periods, 13 per cent; quizzes and reviews, 10 per cent; and instructional films, 7 per cent. For a course 3 weeks in length, this was an acceptable distribution of time. The content of the lectures and laboratory periods was of greater importance. Lectures consisted of radar theory, 55 to 60 per cent; radar usage, 25 to 30 per cent; plotting, 15 to 20 per cent. Laboratory periods were composed of demonstrations and operation of gear, 70 to 75 per cent; plotting, 15 to 25 per cent; trainers and communication, 5 to 10 per cent.

CRITICISMS AND SUGGESTIONS

The following comments were made on course content and laboratory training.

1. The lectures and the operator's handbook should place more emphasis on practical and functional aspects of operation and operator skills. Many instructors had the misguided notion that an operator had to have radar theory

and maintenance training, much as a radar mechanic would be trained.

2. Laboratory and operational procedures should have adequate supervision. Students were assigned to operate equipment with insufficient knowledge of correct operating procedures. Thus much valuable time assigned to search watches and operation was wasted by trial-and-error procedures which often resulted in poor habits of operation.

3. Laboratory work should take up one kind of equipment at a time. Operators were shifted from one gear to another before completely mastering any one. This led to confusion and failure to assimilate any specific procedure.

4. Plotting and operating periods should be organized with specific problems in mind rather than relying on rote memory procedures and random operation. The problems should stress tactical and functional uses of the gear.

5. Greater emphasis should be placed upon speed and accuracy in operation. The correct procedure should be taught and the methods of greatest accuracy stressed. When an operator has mastered the procedure, gradual increase in speed of operation should become the goal.

6. An operator should be taught that calibration and tuning are basic to efficient operation and that the greatest care must be observed in carrying out these procedures.

7. Greater recognition should be given to the fact that radar operation is a *skill* which may be developed to a high degree. Knowledge of the operating procedures is not enough. Skill comes only with practice in the job. Therefore every opportunity should be afforded for the trainee to exercise his knowledge by operating the gear. In all practice he should work for correctness, accuracy, and speed. The timing and posting of operational scores is a good way to foster competition and provide motivation to work harder at the task of improving skill and speed.

8. With better information concerning eventual assignment of men to ships, based upon production and commissioning schedules, it should be possible to determine the type of equipment for proper training. This would reduce to a minimum the number of different types of gear upon which an individual operator

RESTRICTED

would be given training. By concentrating on one or two types much greater proficiency could be attained.

9. Greater use should be made of training aids, especially visual aids. Models, wall diagrams, illustrations, slides, and movies are indispensable for demonstrating the correct procedures or the basic principles behind operating procedures. These should be coordinated with assignments, lectures, and demonstrations.

10. More time and attention should be given to target interpretation and the dynamic aspects of scope viewing and reading. All conceivable types of targets, land masses, fading, and other phenomena which may occur during operation should be illustrated. Operating procedures for all possible exigencies should be practiced. The basic principles of scope interpretation, distortion, and interference should be explained not as theory but as practical working concepts.

11. Greater use should be made of radar trainers and similar devices by which operating problems may be presented, specific components of operating procedures may be illustrated and practiced, and quantitative scores on performance may be obtained.

12. More attention should be given to the development of objective measures of proficiency. These should emphasize particularly the performance aspects of operation and the solving of "real" operating problems.

13. Fleet operational requirements were constantly changing to meet the demands of new tactics. Many small and frequently some major changes in operational procedures were introduced in the fleet. In order that the training in the schools might be kept up to date, it was recommended that instructors be selected for a period of sea duty, rotating with men who have had shipborne operational experience. Not only would this system bring the latest operational procedures into the schools, but it would bolster the morale of the trainees.

2.2.2 Functions of the Navy Search-Radar Operator

There are two principal types of search radar in the Navy, surface search and air search.

The different radars that function in these capacities often vary considerably in appearance and physical layout. The scope presentations, the controls, and the operating procedures vary according to the specific uses of the equipment. The radar operator's task in general is the same, although there may be wide differences in complexity of operation, speed required, and special procedures. It is difficult to specify procedures for any radar set in a hard and fast way since particular tactical situations or maneuvers may call for variations. Thus it is that an operator, whether of surface-search or air-search radar, must be trained in the tactical uses of his equipment as well as in the specific procedures, such as calibration and tuning, manipulation of controls, interpretation of scope phenomena, and the reading of ranges and bearings. The following uses of the equipment will serve to illustrate some of the problems of operation which depend upon specific training and experience.

TYPE OF SEARCH FUNCTION

Surface-search radar requires that a constant 360-degree search be maintained, unless radars in other ships of the formation are assigned specific sectors. The search function is further subdivided into long-range search and short-range search. The former is for the purpose of picking up large surface targets and requires the use of appropriate range scales and proper adjustment of gain controls. In the case of distant surface targets, speed is not so essential as for close-range targets or air targets, and therefore more liberty may be taken in connection with the speed of antenna rotation, stopping of antenna rotation for study of target composition, and tracking in order to determine relative motion. The operator should remember, however, the need to make frequent 360-degree scans for possible targets in other sectors. With bearing and range determined accurately for a target, continuous search may be resumed, but a plot of the target should be maintained. An operator should be skillful enough to read ranges and bearings without stopping the rotation of the antenna. This is an aspect of performance which is often not stressed sufficiently in training.

RESTRICTED

Short-range surface search is for the purpose of detecting submarines and small craft or, in the case of offshore operations, for the detection of possible coral reefs or other obstacles to navigation. Sometimes the short range is used for keeping a ship in position in a formation, especially during severe maneuvers. Because the antenna must be tilted down during short-range search, the problem of balancing sea return against possible targets requires constant manipulation of gain controls. The use of surface-search radar for navigation along coastlines demands not only a thorough knowledge of scope interpretation and familiarity with the geographical features of the area but

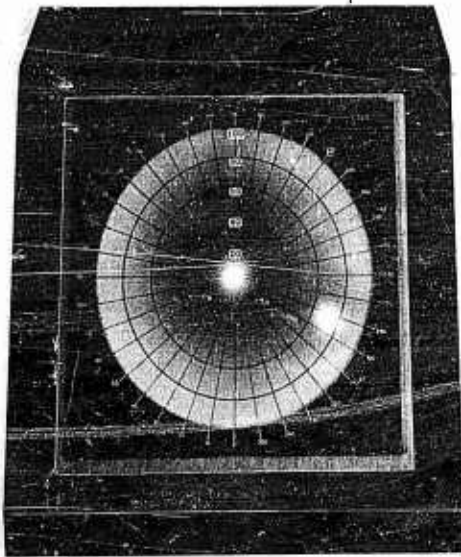

FIGURE 1. Close-up of repeater unit of PPI flash-reading radar trainer, showing illuminated center splash and target complex consisting of fine blips. (The bearing scale in this photograph is inverted.)

an understanding of the characteristics of the radar, such as beam width and pulse length, which contribute to distortion in the mapping of land areas. In short-range operations the operator should be especially careful not to overlook the matter of constant search for possible attack from another quarter. Having detected a target at short range, it may be necessary to turn it over immediately to fire-control radar and continue full search operations.

These are tactical operating problems which

are difficult to teach in training but which can often be made vivid and real by means of trainers which produce synthetic targets on the actual gear and which allow not only maneuvering of targets but also make provisions for scoring the performance of the operator. A PPI flash-reading radar trainer is shown in Figure 1. The trainer was used to teach students to read the bearing and range of blips quickly and accurately. The trainer consists of a master timing unit and five repeater scopes. Targets may be presented in any desired order and position and with varying persistence.^{12, 16}

A mechanical PPI tracking trainer¹⁷ is shown in Figures 2 and 3. Figure 2 shows the simulated scope face; Figure 3 the mechanical controls of the target trace. Two flashlight-like projector tubes ride on range cams and are geared to bearing cams. Light from the projectors is focused on a persistence screen and is interrupted by a rotating sector disk. The continuous movement of the projectors and the interruption of the lights by the sector disk simulate the PPI presentation of two aerial targets. The courses may be altered by changing cams.

Another teaching possibility is the presentation of tactical problems by means of a series of successive pencil-and-paper test diagrams which may be used as proficiency measures. A surprising degree of dynamic simulation, as well as difficult problems requiring the operator to think through the solution, may be worked out in this way. Examples of this kind of functional and tactical problem may be found in tests,^{9, 19} workbooks,^{10, 11} and manuals¹³ developed by Project SC-70, NS-146, for the Services.

Operating air-search radar is usually more difficult than operating sea-search radar. The greater difficulty is due to the speed of search and tracking and the complexity of identifying and keeping a plot of friendly and enemy planes. Long-range air search is, of course, for the purpose of detecting and identifying enemy planes at maximum range. The nature of the pip or blip must be studied carefully in order to determine the number, type, and movement, if possible, of the attacking force. Interceptors, if available, must be alerted and vectored to the attacking force. Throughout these activities the

RESTRICTED

operator must remain alert to the possibility of attack from other quarters, which means that scanning of the entire area must continue. In short-range air search, speed is even more important. Rotation of the antenna must be more rapid, target location and identification must be made more quickly, and reports must be communicated continuously.

From the foregoing brief account of the operator's task in surface-search and air-search

proper operational and tactical procedures were taught in the schools. Knowledge of proper procedures depends upon close liaison between the fleet and the schools; the introduction of these methods in training requires careful planning of the school program so that tactical procedures will dovetail with basic operations of the equipment. In general, more consideration should be given to the step-by-step advancement through the various stages of training. Whenever possible, those phases of operation which require more practice and skill than others may be separated, as components from the whole task, and given special attention.

CALIBRATION AND TUNING

Calibration and tuning can usually be accomplished by two or three alternative methods, and since an operator may be forced to use any one of them he should know them all perfectly. Not only should the operator know the methods; he should have opportunity to practice them so that all the steps become automatic and habitual. If opportunity to see the alternative tuning methods function is limited with land-based equipment, an attempt should be made to provide synthetic signals simulating the kinds of returns the operator will be forced to use. Emphasis should be placed upon the fact that an adequate warm-up period for the equipment must be allowed before calibration and tuning may be accomplished accurately.

KNOWLEDGE OF AND USE OF CONTROLS

The operator not only must know the functions and limitations of all controls but must be able to manipulate them skillfully and rapidly. The discrete function of each control is only part of the total function, and much must be learned by experience with regard to the refinements which may be accomplished by delicate adjustments of two or more controls simultaneously. For example, it is sometimes necessary to attain a delicate balance by manipulating intensity, focus, and receiver gain controls in order to bring out a target echo clearly. The operator should know the exact location of all controls so that he can reach for them without removing his gaze from the radar scope. This type of tactual-kinesthetic adjustment is ac-

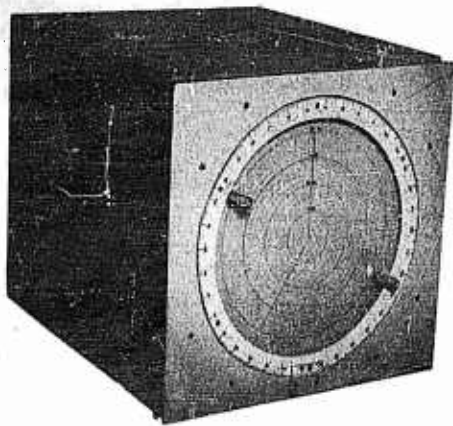

FIGURE 2. Mechanical PPI tracking trainer, scope face.

operations it may readily be seen that the complexity of the task depends upon the situation. Much more is required of training than that it teach the fundamentals of operation. Although the elements of operation are essential, there must be superimposed upon and integrated with that kind of training the complete gamut of tactical operations. The latter will of course become refined and most highly efficient only with extensive experience in the fleet, but it is essential that practice in such operations begins early and is integrated with elementary operator training. This is important in order to avoid the bad habits which invariably become associated with operator training when it is not properly oriented toward the final goal of achievement. Too frequently it was reported from operational sources that habits of operation learned in basic training had to be unlearned and new ones substituted. This should not have been necessary if from the start the

RESTRICTED

quired only with extensive practice with the actual gear. Even though an operator has access to the gear, frequently he may have little opportunity to make the required adjustments because of lack of target situations, unless some type of synthetic signal generator (radar

his position, course, speed, type, and strength, if composed of more than one ship or plane. His position is obtained by range and bearing. His course and speed may be determined by plotting a series of positions as a function of time. His type and strength, as well as other

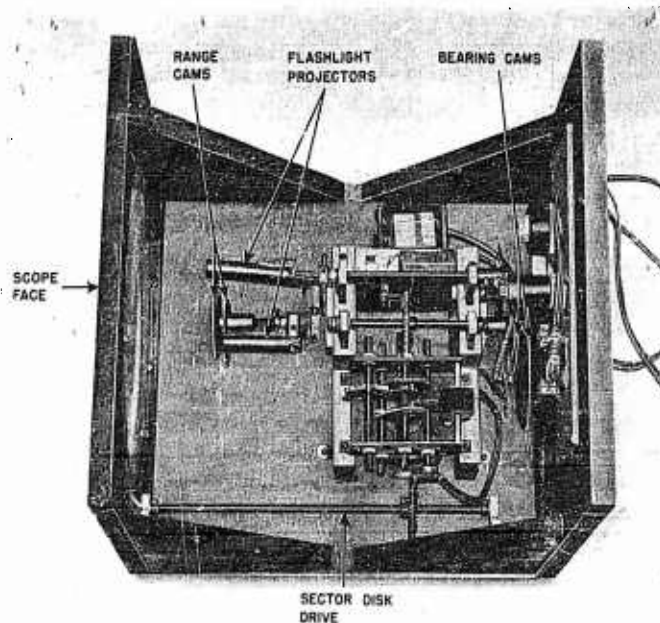

FIGURE 3. Mechanical PPI tracking trainer, controls.

trainer) is available for feeding targets in under a variety of conditions.

TARGET IDENTIFICATION AND INTERPRETATION

Less than half of an operator's knowledge and skill are complete when he has mastered start-stop procedures, calibration and tuning, manipulation of controls, and the finding of the bearing and range of a target. Screen interpretation and the ability to analyze an echo in terms of its composition are the critical aspects of successful operation. First of all a target echo must be recognized as friend or enemy. This involves knowledge of *information friend or foe* [IFF] procedures and the recognition and interpretation of the coded signals which appear on the scope and are the basis for such recognition. If the contact is established as an enemy, the next step is to secure as much information as possible about him, including

possible characteristics, may be determined by piecing together a number of bits of information, some of which are dependent upon knowledge of set characteristics, some upon range and bearing information, but principally from the size, form, and dynamic aspects of the target echo on the screen. For example, the nature and amount of bobbing or fluctuation of the pip on an A scope is sometimes a cue to the distinguishing of a single or multiple plane target. A single pip may sometimes show by its breadth and by multiple peaks that a contact is composed of a large number of planes. To recognize a single blip on a PPI scope as a single large target, or as two or more small targets, depends upon knowledge of range and bearing resolution, distortion due to pulse length and beam width, and other factors.

Although the theory of target analysis may be taught, the use of such knowledge is depend-

RESTRICTED

ent upon actual practice with a variety of target conditions. These can seldom be supplied in a land-based school due to the sparsity of targets and lack of variety of target situations. In order to make the time during which an operator is practicing on the actual gear maximally useful, a radar trainer or other simulating device for feeding in synthetic signals should be used. Such trainers must provide good simulation of the types of target conditions which are needed for practice in target identification. If electronic signal generators are not available for this purpose, some simpler type of mechanical-optical^{12, 15, 17} device should be developed for presenting the target situations on a mock-up scope. In fact this type of device might well supplement the use of the electronic simulator. Another way in which practice in the study and interpretation of target composition may be made possible is through the use of a series of photographs, or better, a movie¹⁸ of actual scopes during the kinds of target situations which it is desired to study. Such pictures may be taken on board ship during actual missions or during experimental cruises. The still pictures may be arranged in a problem series requiring the trainee to work out a solution. The movies may be presented on a mock-up radar scope with provision for reversal and detailed study of characteristics.

2.2.3 Trainers and Training Situations

Three studies^{4, 5, 7} have shown that electronic trainers can be used effectively to develop proficiency in certain aspects of a radar operator's task. This is especially true if a means of measuring performance is associated with the trainer so that the student's score can be made available immediately. Learning curves may be plotted for individuals and for the group of trainees and in this way the optimal period of time to spend in practice on a particular task may be determined. In all three of the above studies, typical learning curves were found. These showed progressive improvement with practice up to a point where the curves leveled off, indicating that maximal efficiency in that function had been attained.

One of the major weaknesses found among Navy search-radar operators was the inability to read target locations (range and bearing) rapidly and accurately. In order to provide practice in this task, a mechanical-optical trainer¹² was developed, together with a flash-reading method of training. The trainer consisted of a timing unit which controlled the timing and location of a series of blips which appeared on the mock-up scopes of several scope-reading positions (see Figure 1). Multiple or single blips could be presented at varying rates of speed. The position of each blip was known so that the accuracy of the student's readings could be immediately checked and his results posted for comparison with the speed and accuracy attained by other students. This not only provided a measure of proficiency by which an instructor could gauge progress but it served as a motivating device to encourage students to work harder to improve their skill in reading range and bearing of target echoes. Trainers of this type were used successfully at the Virginia Beach and Fort Lauderdale training schools, where they were coupled with reporting procedures and the use of sound-powered phones. During the training period, records of battle noises were played in order to provide some degree of operational reality. The method of training and some preliminary results obtained at Fort Lauderdale have been described.¹⁶ An important feature of this method of training was that simple targets and a slow rate of presentation were given initially until an operator had the habit of reading blip position accurately; then the rate of speed was stepped up and the number and complexity of the echoes were increased.

It should be strongly emphasized that practice on a trainer which does not provide a measure of performance so that the student can appreciate his progress is likely to be a waste of time. In one study¹ where knowledge of results was not made available to the student, it was demonstrated that accuracy of performance got worse instead of better with increased practice. Training by means of trainers must be closely supervised to ensure that students develop the correct habits of operation; otherwise the training may prove detrimental.

RESTRICTED

2.2.4 Final Achievement Examinations for Search-Radar Operators

As mentioned previously in connection with the survey of training programs in search-radar operator schools, there was found to be a definite need for improvement of the examination methods. In particular, it was deemed advisable to develop objective-type examinations as measures of final achievement for use at the end of the training period. As a result of a conference called by the Bureau of Naval Personnel which included representatives from the three mainland operator schools and the Fleet School, Pearl Harbor, it was recommended that Project SC-70, NS-146 prepare a series of final achievement examinations for use in the mainland schools.

This study¹⁴ required extensive work with each school and the preparation of objective examinations covering the operation of a number of different types of radar gear. Nineteen experimental tests were made and tried out in the schools. An item analysis was made to rule out items which did not contribute significantly to the total examination. Finally, three radar operator final achievement batteries²⁰ of two forms each were prepared and submitted to the Bureau of Naval Personnel for reproduction and use in the schools. Each examination included sections on basic radar, two or more types of radar gear, DRT plotting, relative motion, navigation, air plotting, and surface plotting.

2.3 RADAR BOMBING

2.3.1 Army Training of Radar Bombing Operators

The second type of radar training program was for bombers. Initially, enlisted men were trained as airborne radar operators. Later, when navigational and bombing procedures became intimately associated with the use of radar, navigators and bombardiers were trained to operate the radar equipment. For the most part the training of the radar observer (bombardment) [ROB] or the training of the

radar operator for high-altitude radar bombing allowed adequate time and provided a well-balanced course. There were, from time to time, changes in the length and content of the course, but for the most part these changes were consistent with improvement of the course of training and in line with recommendations from the theater of operations. The principal difficulties encountered in training were in adjusting training schedules and quotas to new demands made by higher headquarters. There were constant shifts in the plans as to who would be trained, what equipment they would be trained on, and what operation procedures would be followed. These variables made it almost impossible to standardize the course of training and to apply the necessary proficiency measures, although despite the constant changes considerable progress was made in these areas.

Briefly, the course of training, which was 10 weeks in length, consisted of radar ground training, 360 hours; flying training, 80 hours; and miscellaneous training, 85 hours. Ground training for ROB consisted of navigation review; bombing review; basic radar theory; fundamentals of one specific type of radar bombing equipment, including component parts, calibration and tuning, controls, and trouble shooting; accessory equipment; radar navigation; radar intelligence, consisting primarily of scope interpretation and target study; radar bombing methods and procedures; briefing and critiques; and supersonic trainers. Flying training required at least 35 hours of operation of the main scope and 30 hours of observation of an auxiliary scope. Miscellaneous training included instruction in the use of personal equipment, such as parachutes, oxygen masks, oxygen equipment, and emergency equipment; military training; physical training; war orientation; and chemical warfare training.

Deserving of special comment is the fact that radar theory was rightfully given a relatively small amount of time and that scope interpretation and target analysis were given an adequate proportion of time. A large amount of detailed procedure was necessary under radar bombing and radar navigation, but, since these procedures all came in for varying amounts of practice during flight training and in the use

of supersonic trainers, it appears that the amount of time assigned to them in lectures and demonstrations was adequate. The most outstanding weaknesses of the program were in briefing procedures, use of supersonic trainers, and scope interpretation. The time devoted to briefing and critiques of missions was minimal but probably adequate. Pre-mission briefing frequently consisted of weather reports, a hasty survey of the route of the mission, and a brief discussion of some possible difficulties to be encountered in navigating to the target area. A great deal more could have been accomplished by way of showing movies and stop-frame pictures of the radar scope taken especially for briefing of the route to be followed, so that the radar scope navigation problems

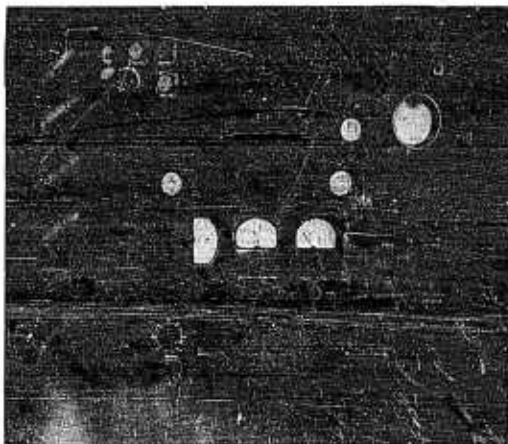

FIGURE 4. H2X film trainer, front view.

could have been studied and digested in relation to the maps. A preliminary study of scope movies or photographs of the target area would have greatly improved the efficiency of the training on bombing runs. In navigating, finding the initial point, and finding the aiming point, the radar operator frequently became confused due to unfamiliarity with the region and the type of scope returns. Although the ability of an operator to find his way on blind missions was important and should have been emphasized toward the end of operational training, the uncertainties of navigation and target identification should not have been allowed to become a distraction detrimental to

the development of specific operational skills. This could have been remedied by careful and complete briefing. The H2X film trainer¹⁵ and the radar scope movies¹⁸ developed by Project SC-70, NS-146 were prepared with the facilitation of the briefing task in mind, although the trainer and the films could also be used to good advantage in scope interpretation studies.

The H2X film trainer¹⁵ is shown in Figures 4 and 5. Figure 4 shows the front view of a photographic mock-up of an AN/APS-15 receiver-indicator unit. A repeater projector, mounted as shown in Figure 5, projects 16-mm movies by means of a mirror system upon the rear projection screen in the scope opening. Scope movies taken on actual navigation and bombing missions are projected. The realistic effect is useful in familiarizing the student with the scope presentation as seen in the air, in teaching scope interpretation, and in briefing men for practice missions.

2.3.2 Phase Checks and Final Proficiency Measures

Because of the length of the period of training and the diversity, there was a serious need for systematic evaluation of progress by phases. Also as in all other training programs, there was a need for some means of final evaluation of proficiency in order that an operator might be classified and assigned, as well as that the school might know when an operator had reached a given level of proficiency. Without some valid measure of proficiency it was impossible for the school to set a criterion of final proficiency and thus scale its training program to meet this requirement.

In the summer of 1943, Project SC-70, NS-146 began work on a group of final proficiency measures for operators of air surface vessel [ASV] radar. These measures² and the method³ of construction have been described. Later with the introduction of radar bombing equipment other measures of proficiency were constructed¹⁰ for specific equipments. In the fall of 1944, the Air Surgeon's Office assigned a group of men from the Psychological Research

RESTRICTED

Division to work specifically on the development of proficiency measures for radar bombing equipment. This group, known as the Psychological Research Project (Radar), did an excellent job in attempting to provide systematic phase checks and final proficiency measures for the constantly changing radar bombing program. Their work was instrumental in helping to standardize the training program in the various schools.

2.3.3 An Experiment on Training and the Analysis of Radar Bombing Errors

When radar observers (bombardment) began to reach the active theaters there were numerous complaints that the accuracy of bombing by radar was not satisfactory. It was not known whether this was due to the type of equipment being used, to inadequacy of training, or to insufficient length of operational flying training. In order to solve this problem the AAF Training Command, Fort Worth, decided to set up an extended training experiment at the AAF Training School at Victorville, California. Project SC-70. NS-146 was asked to supervise and report upon the results of this experiment.²¹

The study was carried out during the period from April to July 1945. During this time 20 graduates of the regular course in radar bombardment, including 10 bombardier-trained operators and 10 navigator-trained operators, were given 150 hours of main scope operating time. This was in addition to the 35 hours of main scope time during the regular training course. Since the method of synchronous bombing was used throughout, 20 experienced bombardiers returned from combat were assigned to operate the bombsights. Each bombardier was teamed with a radar operator for the duration of the experiment. Eleven different target areas were used throughout the training and at intervals a four-target test mission was flown. Bombing proficiency was scored by the photo-bomb-scoring method and a detailed analysis of the sources of error was made. The components of error for which analysis was made included drift error, final point deflection error, radar altitude range error, radar range error, final

point bombsight range error, ground-speed range error, and time-of-fall range error.

The experiment showed that the amount of additional training required to reach peak efficiency was 85 hours, over and above that regularly given, when the total group of operators was considered. It was interesting to note that the navigator-trained operators required only 35 hours of additional training to reach peak

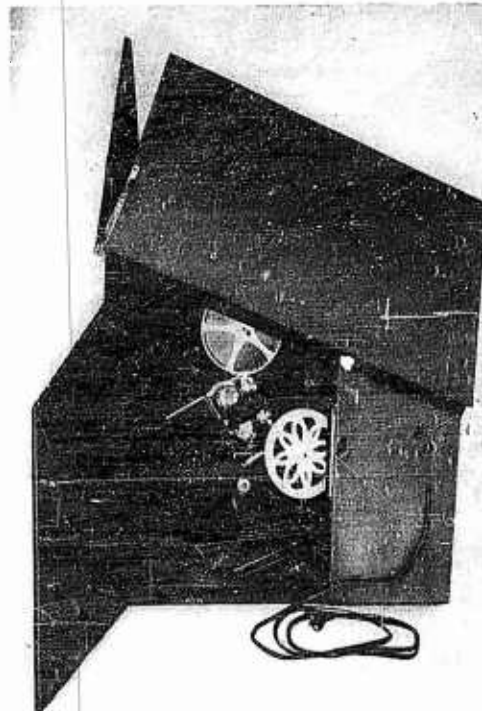

FIGURE 5. H2X film trainer, projector mounting.

efficiency, thus raising the question concerning the selection of men to be trained as radar observer (bombardment).

The analysis of type of error showed that the two largest sources of error were the final point deflection error and the radar range error. Both of these indicate inaccuracy in localizing the precise aiming point during the bombing run. This result shows that scope interpretation was largely at fault and that considerably more emphasis should be placed upon training in target analysis and scope interpretation. The third most important source of error was the radar

altitude range error, much of which was due to improper calibration. Thus emphasis should also be placed upon set calibration.

During the course of the additional training there was a consistent reduction in the circular error, range error, and deflection error. These reductions from the first 25 hours to the last 25 hours of the training period were approxi-

mately 1,500 feet, 1,000 feet, and 1,000 feet, respectively. The results of the experiment provided information on the general level of bombing accuracy which could be expected with the particular kind of equipment used and clearly indicated that with additional training of the operational type much greater proficiency could be attained.

RESTRICTED

Chapter 3

TRAINING TRACKERS FOR ANTI-AIRCRAFT FIRE CONTROL

By *William C. Biel* and *William E. Kappauf, Jr.*^a

SUMMARY

THE PROBLEMS found in the training of trackers include those of obtaining objective measures of the tracker's skill, of his learning speed, and of the nature of his learning task. Since the tracker uses complicated, expensive equipment, the problem of designing supplementary trainers is important.

Objective measures of the tracker's skill are more reliable and useful than instructor's ratings; ratings are unreliable and do not agree with accurate methods of scoring performance. Checksights, found to be the most generally useful objective measure, were developed for use on various guns. Checksight scores may be obtained by observing whether the tracker is on target at certain instants, such as once every 2 seconds, or observing the tracker at pre-selected bearing points. A phototube scoring device to replace the checksight observer was developed too late in the war to be used. Its reliability and effectiveness were, however, demonstrated.

Trackers in general learn more rapidly when trained with checksights than when checksights are not used. The learning curves demonstrate the time when improvement ceases and thus make it possible to judge when the training program should end.

Standards for daily improvement can be set up for each tracking device and the conditions for its use. These standards serve as a guide for both instructors and trainees. Learning records show that, once men are adequately trained in tracking, they need refresher drills no more often than once a month.

Three on-target tracking trainers (trainer means a supplementary device for use in training) were developed: a trainer which simulated the task of optical tracking with the stereoscopic heightfinder; a trainer which simulated the two-man tracking task in the gun director Mark 37; and a trainer which simulated the

two-man tracking task on the director M7. The last one became known as the Tufts tracking trainer. It has validity as both a selection device and a training device.

Several manuals giving instructions for the use of gunnery trainers and the operations of fire-control equipment were written.

3.1 VARIETY IN TRACKING TASKS

The task of tracking, broadly defined, may be stated as the operation of advancing the position of a sighting system or a gun so that it continually points in a direction which bears some required relation to the position of the target. Some of the complication of this definition arises from the fact that the name "tracking" is applied to two similar operating jobs in which the point of aim is different. These are on-target tracking and lead tracking.

In on-target tracking, the tracker keeps a line of sight on the target: he keeps the target as near as possible to the center of the reticle or ring sight which establishes the line of sight. In lead tracking, which is used only by gunners and only in some modes of gun operation, the tracker keeps the target off center in the reticle or sight; he keeps the target displaced in a direction and to an amount which he estimates to be necessary for the gun to aim at the place where the target is going to be by the time the projectiles reach it. Thus, lead tracking involves lead determination. On-target tracking, on the other hand, is tracking per se, and is used when leads are established by auxiliary fire control or computing systems. In on-target tracking, the tracker's function is to establish the train and/or elevation position of the target relative to the battery and the rates at which that position is changing. Most of the wartime research work on the training of trackers concerned on-target training.

The tracking job on any particular piece of equipment is not completely specified until it

^a This chapter is based primarily on the work of the Applied Psychology Panel projects listed in the chapter.

is further described in terms of the mechanics, perceptual tasks, and controls involved. For purposes of orientation, a review of these descriptive terms and tracking variables follows.

Tracking may be classified as direct line-of-sight tracking or disturbed line-of-sight tracking. In the former, the line of sight of the tracking system is fixed relative to the sight or telescope mount. The line of sight always moves with the mount and through the same angles as the mount is moved. In disturbed line-of-sight tracking, the line of sight of the tracking system is offset relative to the mount axes by a computing system which functions to determine the angular leads for firing. When the line of sight is on the target, the mount is aimed in the direction in which the guns should fire. Motion of the mount does not produce an identical motion of the line of sight, because the position of the line of sight is affected not only by the tracking movements but also by the action of the computer.

Another classification of tracking contrasts optical tracking and radar tracking. The tracking function is the same in both cases. Either the optical line of sight or the radar line of sight is kept on target. The main difference between the two forms of operation is found in the kind of visual presentation which the tracker views.

Distinction is also made between the types of tracking control. Tracking may be by direct control, as when handle bars or handwheels are attached or geared directly to the tracking structure. This is sometimes called position tracking. It is contrasted with the form of tracking known as rate tracking or velocity tracking. In this case, the tracker adjusts the speed of a power drive and thereby regulates the rate of motion of the tracking structure. Both these forms are different from rate control, also known as aided tracking. In this case, the tracking movement controls the position of the line of sight at the moment but also varies the rate of motion of the line of sight as controlled by a power drive.

Another set of tracking variables, which runs through most of the above classifications, concerns the specific form of the control mechanism which the tracker uses, be it handwheel,

handle bar, handle grip, joy stick, or the like. Any of these controls may be adapted to single or to two-man tracking situations.

The variety in tracking tasks indicated by this discussion makes it apparent that no war-time research program on training methods could hope to examine the specific training problems met within each set of tracking conditions. Only selected training problems were dealt with. Those which were investigated by the Applied Psychology Panel, in particular, were for the most part problems proposed by the Services. The Panel cooperated by undertaking direct research in training methods, by developing training instruments and methods of using them, and by preparing training materials, lesson plans, and the like. Contributing to this work were the following projects: the Height Finder Project, N-105, N-111, N-114, NS-146, SC-70, SOS-6, and AC-94. In the last-named project the tracking task was complicated by the fact that the personnel not only tracked but simultaneously ranged on a target. The work of Project AC-94 is described in Chapters 5 and 20. In this chapter will be considered the research on tasks involving tracking only.

3.2 MEASURING TRACKING SKILL

Methods of scoring trackers attract the interest of the instructors for at least three reasons. First, they want to know when their men are adequately trained. Second, they want to know which men in a group are the best trackers. Further, if they have had some introduction to the psychology of learning, they want to provide their men with tracking scores during their training to improve their rate of learning and their final level of tracking proficiency.

The paragraphs which follow discuss and evaluate various methods, devices, and schemes for scoring trackers or measuring tracking skill.

3.2.1 Inadequacy of Qualitative Observational Methods

Many gunnery and fire-control instructors accept as obvious their ability to rate trackers

RESTRICTED

and to know when a man is tracking well. They judge tracking skill on the basis of how a man grasps the tracking handwheel, how he turns the handwheel, or how smoothly he moves the director or the gun. Attractive as these qualitative scoring methods may seem, experimental evaluation indicates that they have little practical usefulness. A study by Project SOS-6 of the Applied Psychology Panel demonstrated this by comparing judgments of tracking made by qualified antiaircraft officers with actual checksighting scores.²³

Three officers observed and scored the tracking of 30 trackers. Each of the men was scored on two courses in azimuth and two courses in elevation. The men were rotated in such a way that when a man had tracked two courses on one side of the gun, he did not track his two courses on the other side of the gun until some eight courses later. This minimized the possibility that the judges would generalize from azimuth to elevation ratings and vice versa. The target was an AT-11, flying a crossing course, average speed 160 mph, altitude about 1,000 feet, minimum range about 1,200 yards.

The three officer observers were instructed to watch the tracking as carefully as possible and to use all the tricks or cues they knew in evaluating the tracking. For each pair of courses by a given tracker, each judge was to record the course on which the tracking had been the better. At the end of the test, each judge was to rate the men in order of tracking ability, using, in his ratings, notes taken during the tracking runs. All judgments were made separately for azimuth and elevation tracking.

The scores and ratings provided by the officers were compared with the checksight scores obtained for the same courses and periods of tracking. The method of checksighting used was that of observing whether the tracker was on target at certain times; the method is described in Section 3.2.4.

The results were these: of the 30 pairs of courses tracked in azimuth by the 30 men, 28 were such that the checksight scores on the first and second runs of the pair were different. These 28 paired courses, judged by the three officers, yielded a total of 84 judged comparisons. Of these, 48.8 per cent were in agreement

with the checksight score differences and 51.2 per cent were in disagreement. In elevation, 24 paired courses yielded checksight score differences. These netted 72 judged comparisons, of which 45.8 per cent were correct and 54.2 per cent were incorrect. Thus the officer observers were just as often wrong as they were right in deciding which of two *immediately successive* courses represented the better tracking.

When the rankings of the 30 men as determined by the checksight scores were correlated with the rankings provided by each of the officers, none of the correlations was reliably different from zero. The judges had only 25 per cent success in picking out the worst or the best man of the group and only about 31 per cent success in picking out the men in the top or bottom 10 per cent of the group.

The generalization of these results for 40 mm gun tracking is that qualitative methods of assessing tracking are not accurate. True, some of the rating factors used by the officers might have been employed more systematically if incorporated in a carefully developed check list, but other similar studies show that these methods, when perfected, will not be as accurate as objective and quantitative checksight methods.

3.2.2

Recording Cameras

Recording cameras, which have seen wide use in gunnery and director tests and on aerial combat missions, provide very precise records of tracking. Depending on the degree of detail wished for in the analysis, the cameras may be operated at many frames per second or controlled to take one photograph every second or two. Two Applied Psychology Panel projects were interested in the development and use of recording cameras for analyzing tracking with lead-computing gunsights.

Project N-105 worked on a camera for the gunsight Mark 14. It is shown in Figure 1.²⁹ The gunsight Mark 14 has a disturbed line of sight and uses an illuminated, reflected reticle. In order to photograph both target and reticle, Project N-105 mounted the camera on top of the gunsight where it was directed down at the

RESTRICTED

elevation mirror in the sight. With this arrangement, the reticle was not disturbed in elevation, as far as the camera was concerned, but it was disturbed in traverse. Since the target and reticle stayed within the camera field only when the traverse lead stayed below 5

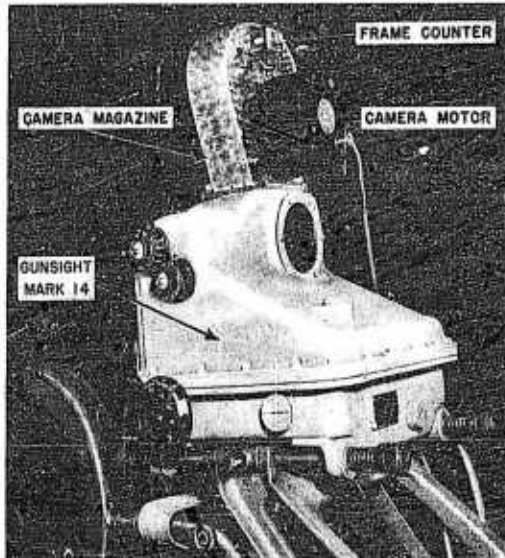

FIGURE 1. Gunsight Mark 14 with camera attached, front view.

degrees, tracking errors could be scored from the camera film only when the traverse lead was less than 5 degrees. This was a limitation in the camera design, although one which was not serious for incoming courses. Improvement would appear to depend upon an extension of the effective field of the camera or the elimination of the disturbed traverse condition by the use of a compensating traverse mirror in the recording system.

Project N-111 assisted the Bureau of Ordnance in the development of a recording camera for use with the gunsight Mark 15. This camera is mounted so that it aims into a semi-reflecting prism on the eyepiece of the gunsight. It photographs the fixed telescopic reticle in the gunsight, the image of the target, and when used on the gun director Mark 63, the radar tracking dot. The installation is known as test equipment Mark 1, Model 1.

These cameras are of great usefulness in recording tracking and firing results for ex-

perimental analysis or for instruction during the final stages of the training of director teams. They can hardly be considered as day-by-day training devices, however, because scoring of the tracking performance from the films takes too long. For this reason, whenever conditions permit, checksights are used instead of cameras for scoring trackers during training.

3.2.3

Checksights

For use on the 40 mm gun, Project SOS-6 devised two forms of checksight, one made from the 4-power elbow telescope M1A1¹¹ and another less elaborate one called the Plexiglas checksight.²⁴ Either of these sights can be attached temporarily to the automatic loader of the gun or permanently to the telescope of the computing sight M7. Both sights have demonstrated value when used for scoring the performance of men undergoing training, but the Plexiglas checksight is less accurate and of lower reliability than the elbow telescope checksight.

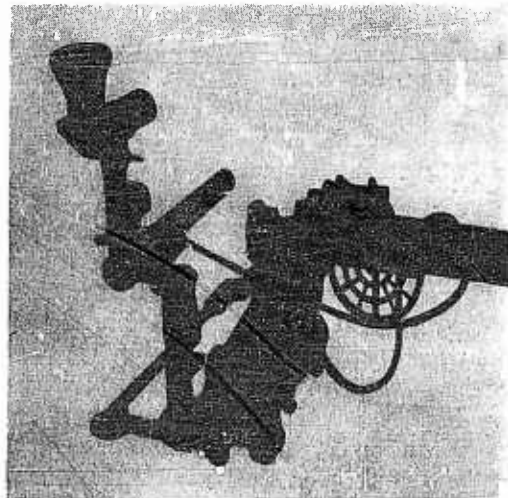

FIGURE 2. Checksight made from elbow telescope M1A1 attached by bracket to elevation telescope of computing sight M7 on a 40 mm gun.

Figure 2 shows the elbow telescope M1A1 mounted on the elevation telescope of the computing sight M7. Figure 3 shows the checksight in use. The reticle pattern which the

RESTRICTED

checksight operator sees in the telescope is shown in Figure 4. Graduations are in 5-mil steps. The central open area extends 2 mils from center in all directions.



FIGURE 3. Elevation telescope bracket and elbow telescope M1A1 mounted on the M7 telescope on the elevation side of the gun. If a check on tracking during firing is desired, this arrangement is recommended.

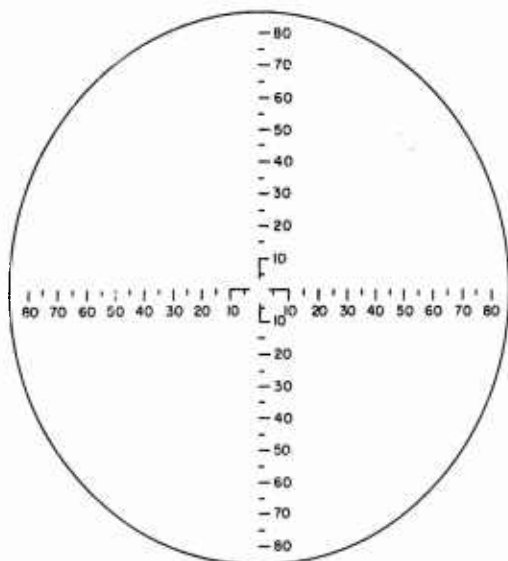

FIGURE 4. Reticle pattern in elbow telescope M1A1. Reticle numbers indicate mils.

The Plexiglas checksight is shown in diagram in Figure 5. It was developed for the special purpose of having a device which could be made in the field and which would be applic-

able on a wide variety of tracking devices. Figure 6 shows it in use on an M55 turret. It can be used for evaluating either on-target tracking or lead tracking.

For use on the gun director Mark 37, Project N-114 installed a telescope Mark 79 on the left end of the rangefinder tube about 18 inches outside the director housing. The telescope was collimated with the director. For purposes of

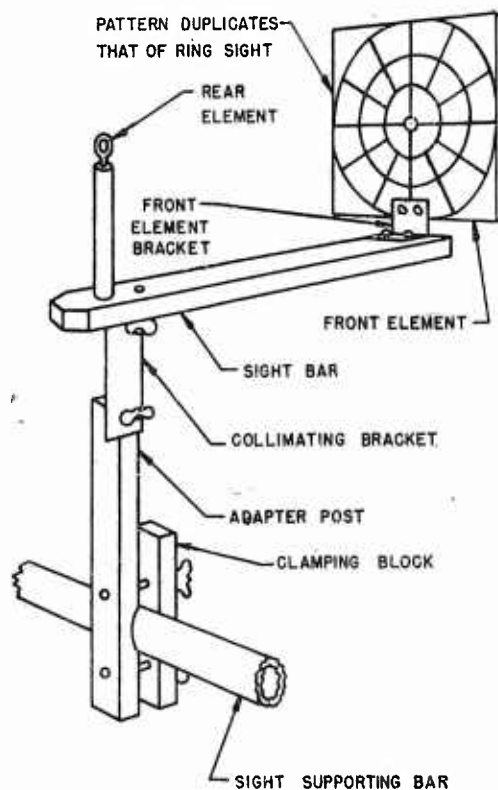

FIGURE 5. Plexiglas checksight.

scoring tracking performance, either optical or radar, the reticle in the standard Mark 79 was replaced by one graduated in 2- and in 5-mil steps (see Figure 7).¹²

For use with the gunsight Mark 15, Project N-111 assisted the Bureau of Ordnance in developing and testing a checksight, now known as test equipment Mark 1, Model O.^{33, 38} The checksight equipment includes a special reflecting prism and mount which clamps over the eyepiece lens of the gunsight; a bracket which attaches to the director; and a unit-power telescope which mounts on the bracket and is

RESTRICTED

directed at the prism. The telescope is attached to the director as shown in Figure 8 so that anyone looking through the telescope can see exactly what the tracker sees as he tracks. The reticle pattern in the checksight telescope must



FIGURE 6. A checksight observer using a Plexiglas checksight to observe tracking on the M55 turret.

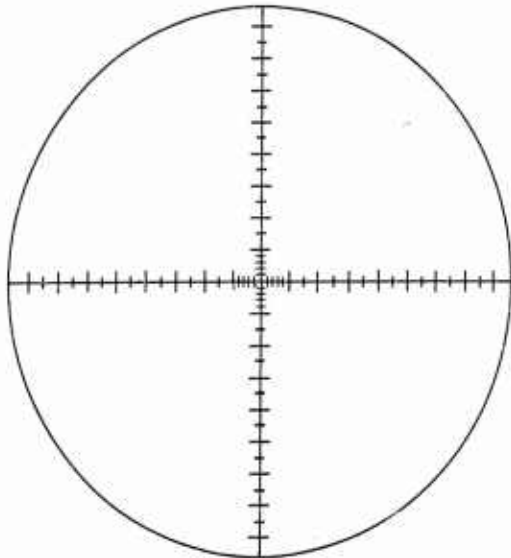

FIGURE 7. Reticle pattern in telescope Mark 79 used as a checksight on the gun director Mark 37. The scale is calibrated in 2-mil steps from the center to 10 mils, then in 5-mil steps to the edge of the field.

be aligned with the gunsight reticle. It includes crosslines and a series of circles as shown in Figure 9. The center open area of the reticle represents a circle which is $3\frac{1}{2}$ mils in diameter in terms of the gunsight field.

An interesting use of this checksight for the gunsight Mark 15 is its use in checking the

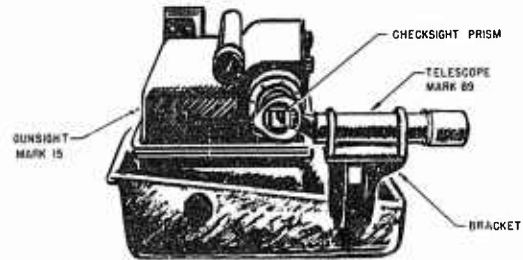

FIGURE 8. Test equipment Mark 1, Model 0.

accuracy of blind tracking with the gunsight on the gun director Mark 63. On clear days, the radar dot and the visible target are normally seen together in the gunsight field, but by the use of mutually exclusive red and green

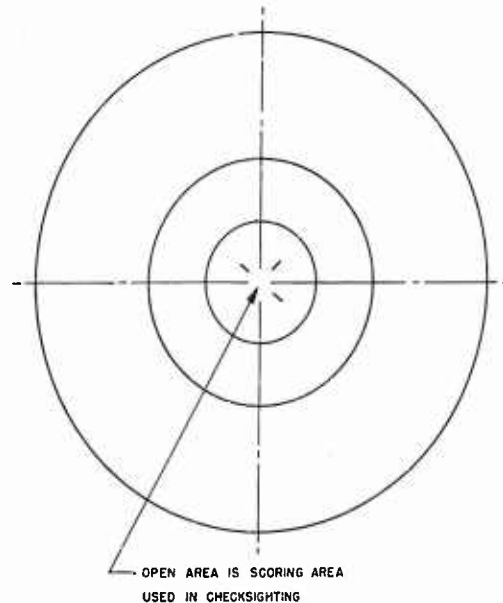

FIGURE 9. Reticle in telescope shown in Figure 8.

filters (red over the front window of the gunsight and green in front of the tracker's eye) the tracker is allowed a view of the radar dot only, while the checksight operator can see the target itself and observe how well the tracker is following it.

RESTRICTED

3.2.4 Checksight Scoring Methods

There are a variety of ways in which the reticle shown in the accompanying figures may be used in scoring tracking performance by checksight observation. These methods require a timing device or a performance sampling scheme of some sort. Projects under the Applied Psychology Panel collected data by five different methods. They are the following.

PER CENT OF TIME ON TARGET

This method involves a continuous time-clock or stop-watch record of the per cent of time that a given point of the target (the aiming point) is within a specified distance of the center of the reticle. Two clocks are needed, one to measure the duration of the course, the other to be operated by the checksight observer whenever the tracker is on target according to the agreed-upon criterion. Project SOS-6 used this method of scoring with the elbow telescope M1A1 as a checksight.¹¹ For scoring 40 mm gun tracking with the computing sight M7, the method was found to deliver scores on individual courses which correlated $+0.92$ with similar per cent time-on-target scores obtained from camera records of the tracking for those courses. When two observers scored the same course using two collimated checksights mounted on the same gun, the correlation of the scores which they obtained was $+0.84$. Project N-111 tested the precision and accuracy of this same scoring method by having a group of four observers score a series of 30-second tracking runs presented by motion picture. It was found, in agreement with the results from Project SOS-6, that the scores obtained by an individual course differed from frame-to-frame motion picture scoring by only 8 per cent on the average. Both the reliability and the accuracy of these checksight scores are, of course, improved if scores are obtained and averaged for a number of courses. Thus, if a tracker is scored for five short courses, the data indicate that the average checksight score obtained for him would be in error, as compared with photographic frame-by-frame scoring, by approximately 4 per cent.¹⁰

PER CENT OF OBSERVATION INSTANTS WHEN ON TARGET

This method is essentially the same as the one just described except that it does not require the use of a continuous timing mechanism. The checksight operator observes whether the tracker is on target at certain instants, perhaps once per second or once every 2 seconds. He receives observing signals from an assistant and merely counts the number of times that the tracker is on target when the signal comes. At the end of the course, the tally is expressed as a per cent of the total number of signals or observing instants which were called. This method is just as accurate as the continuous timing method and is probably more reliable.¹⁶

ESTIMATED (NOT MEASURED) TIME ON TARGET

By this method, a checksight operator merely estimates the per cent of the time that the tracker is on target. How closely he tries to estimate is optional, but in one study by Project SOS-6 the estimate was made to the nearest 25 per cent, i.e., scores were given as 0, 25 per cent, 50 per cent, 75 per cent, or 100 per cent for each course. Correlation of these scores with scores obtained by continuous timing (method 1 above) was $+0.79$ when obtained by a group of three observers for a group of 25 trackers of varying ability. Reliability of the method for a group of 24 courses tracked by one man was about $+0.50$, a value which would probably have been higher if the variation in tracking of this one subject from course to course had been as great as the variation between different trackers.¹⁹ A follow-up study indicated that the method is quite satisfactory for use with the Plexiglas checksight in the rough assessment of tracking performance on short-range crossing courses.²⁶ In such courses trackers vary widely.

AVERAGE TRACKING ERROR

A measure of average tracking error is impossible to obtain by direct visual observation unless the error is estimated at specific intervals. Such spaced estimates, one every 10 seconds, were made in a series of checksight scoring experiments by Project N-114.²⁷ Er-

RESTRICTED

rors, observed in elevation and in train separately, were estimated to the nearest mil. When checksight operator estimates were compared with photographic records of the errors, the average error of a single estimate was about 0.4 mil when the director was being tracked optically and about 0.7 mil when the director was being tracked by radar. This reliability is certainly sufficient to assure dependable scores for radar tracking with the Mark 37 director where average tracking errors are about 10 to 20 mils. The method is inadequate, however, for the evaluation of Mark 37 optical tracking where average tracking errors may be less than 1 mil.

Although this study demonstrates that it is impractical to try to obtain direct average error scores for optical tracking, it should be pointed out that reliable average error scores can be predicted or estimated from time scores obtained by methods 1 or 2 above. Project N-111 evaluated this prediction procedure and compared predicted average error scores with the average of frame-by-frame measured errors. The predicted average errors had a probable error of only 0.1 mil for cases where a per cent time-on-target score had been obtained for a series of five courses and where the checksight scoring circle had been one of 3 mils diameter.¹⁶

Prediction is made on the basis of the formula:

$$\text{Per cent of time inside circle} = 1 - e^{-\frac{\pi r^2}{4m^2}}$$

where e = the base of the natural logarithm,
 r = scoring circle radius, and
 m = average miss or radial error.

This formula assumes that tracking errors in traverse (or train) and elevation are normally distributed with the same standard deviation. That the assumption is justified for tracking with the gunsight Mark 15, at least, is demonstrated by the accuracy of prediction reported above.

AVERAGE ERROR AT SELECTED BEARING POINTS

For the evaluation of tracking on crossing courses, Project SOS-6 tested the efficiency of

getting an average tracking error score based on observed tracking errors at five preselected bearing points.¹⁹ (Obviously this method can be used only where the target is flying a prescribed course and the bearing points have some meaning in relation to the course being flown.) The correlation of scores obtained by this method with scores obtained by the timing method was +.84 for a series of azimuth courses by 25 different trackers. Reliability coefficients, when two men scored the same course by the method, were approximately +.80. This is exceptionally good reliability and validity for a method as simple as this. At each of the five observation points, the checksight operators merely reported whether there was a zero error (if the radial error was less than 2 mils), a 2-mil error (if between 2 and 5 mils), a 5-mil error (if between 5 and 10 mils), or a 10-mil error (if over 10 mils). The five numbers for each course were averaged to obtain the score for the course.

Given any particular training task for trackers, at least one of the above methods of checksight scoring should be applicable. So that the training of personnel will no longer be based on unreliable, qualitative methods of rating trackers, the standardization of these or comparable checksighting methods by the Services is of great practical importance.

3.2.5 A Phototube Scoring Device

An instrument which would replace the checksight observer and obtain a time-on-target score mechanically is a phototube scoring device which was tested and improved for the Bureau of Ordnance by the Applied Psychology Panel.³⁰ This device puts a lens, a scoring aperture, and a phototube in place of the checksight operator's eye. A modulated light source of small area is mounted on the target. As the tracker tracks the target, the mechanism scores whenever the image of the light source falls within the scoring aperture and excites the phototube.

Light intensity considerations require that the light source on the target be in a reflector and that the beam of light be directed at the

RESTRICTED

tracking device on the ground or ship. The source therefore has to be controlled by someone in the plane who tracks, with no great precision (± 10 degrees), the place where the director or gun is located. If properly stabilized and operated, the device has remarkable range and sensitivity. Scoring should proceed satisfactorily out to ranges of 4,000 yards and may extend to 8,000 or 10,000 yards on clear days. Reliability of scoring with the device closely approximates the theoretical limit based on the change of effective light intensity from the searchlight with change of target range.

This device was brought to its present stage of development only in the last days of the war and was not field tested. Nevertheless it deserves very serious consideration as a training device for regular use on those sights and directors where the addition of the small weight and bulk of the recording unit can be tolerated. For disturbed line-of-sight directors, the phototube unit and lens must be coupled to a checksight system and aimed at the target through the gunsight. For direct line-of-sight directors, the phototube unit can be attached to the tracking head in any convenient spot. The operation of aligning the phototube aperture with the center of the tracker's reticle is the same for either type of director system.

Like checksight scoring, scoring with this phototube device has the advantage of providing the tracker with a score immediately at the conclusion of each target run. The device may also be used to provide a signal during the run whenever the tracker is on the target. Such a signal can be an important aid in the training of trackers.

3.3 EXPERIMENTS IN THE TRAINING OF TRACKERS

Although much has been said in the preceding paragraphs about ways of scoring tracking performance during training, no demonstration has yet been offered in this chapter of the specific value of such scoring in a training program. Experiments which provide this demonstration were performed by Project SOS-6¹³, ²⁴ and Project N-114.¹²

3.3.1 How Knowledge of Performance Aids Learning

The effect of providing trackers with information concerning the accuracy of their tracking during training was first studied in an experiment where the checksight observer used an electric buzzer which he sounded whenever the tracker was off the tracking point by more than 2 mils.¹³ Six men trained under these conditions were found to improve significantly more rapidly than six men trained without coaching. The conditions under which the "no coaching" group was trained resembled the conditions under which trackers frequently practice. The men took turns practicing on the

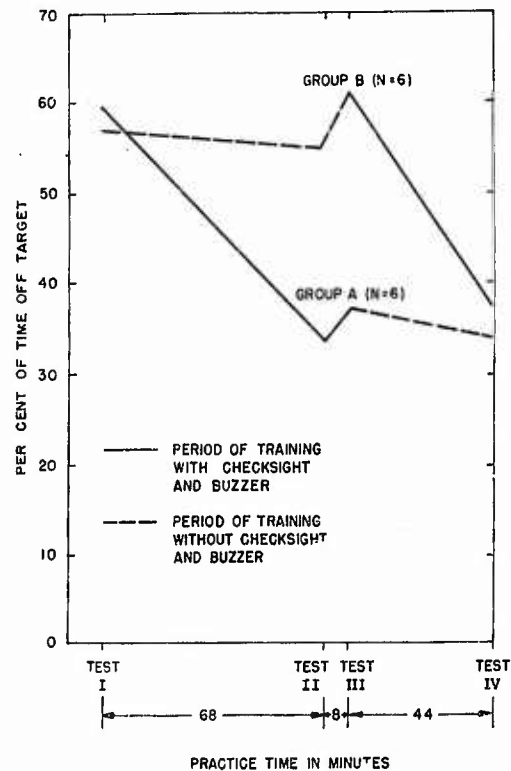

FIGURE 10. Effect of buzzer coaching technique on tracking learning with the 40 mm gun. Scores are mean per cent of time off target on each of four tests.

40 mm gun using the computing sight M7 and no particular checks were made of their tracking accuracy or of the adequacy of their drilling. The results of the experiment are presented

RESTRICTED

in Figure 10. It can be seen in the figure that the group trained under the "no coaching" condition showed little or no improvement between Test I and Test II, whereas the group trained with checksight and buzzer coaching showed rapid improvement. After Test II, the training conditions for the two groups were reversed. The group which before had "just practiced," was now trained with the checksight and buzzer. The men in the group showed prompt improvement and soon performed approximately as well as the group first trained with the buzzer. It may be noted that the effect of the special training with the buzzer persisted for the first group for the duration of the experiment even though scoring was stopped for these men after Test II. These data thus show that the buzzer-training technique is effective in speeding up tracking learning.

In a later experiment, the buzzer-training technique was compared with two other methods occasionally used in training 40 mm gun

comments before, during, and after each man's practice on the gun. In the other method, the co-tracker guidance method, one of the gun pointers serves as instructor or coach as well as tracker, and calls "Off" whenever the other tracker makes errors. The results of this experiment are shown in Figure 11. It can be seen that the checksight and buzzer method of training, which provides the more immediate and more accurate tracking information to the gun pointer, leads to the best tracking.

A similar experiment in radar tracking was not quite so successful as the two foregoing studies in showing the advantages of checksight scoring.¹² The experiment was run by Project N-114 at NTS, Fort Lauderdale, and concerned tracking with the radar Mark 4. The checksight used was that described in Section 3.2.3 for the gun director Mark 37. The scoring method was the method of average error outlined in Section 3.2.4.

Two groups of subjects were compared. One group was a control group. It consisted of four pointers and four trainers^b who practiced but received no special training or coaching during approximately 8 hours of work on the Mark 4 (30 to 33 runs). Checksight scores were taken by the experimenters throughout the practice periods but were never reported to the men. The second group of subjects also consisted of four pointers and four trainers. These men were coached by checksight data for 12 runs and were then allowed to practice for 12 to 15 noncoached runs. Each session of noncoached runs, however, was begun with one coached run.

During their practice, the men in the control or noncoached group showed only slight evidence of learning. There was little demonstrable increase in the tracking accuracy of the pointers and a greater, but still unreliable, increase in the tracking accuracy of the trainers.

In the second group, the men trained as pointers became more accurate than the control group and improved in their tracking as long as coaching was continued. On removal of coaching, their scores became worse at first but

^b In Section 3.3.1 the word trainer is used to mean a man who tracks in train.

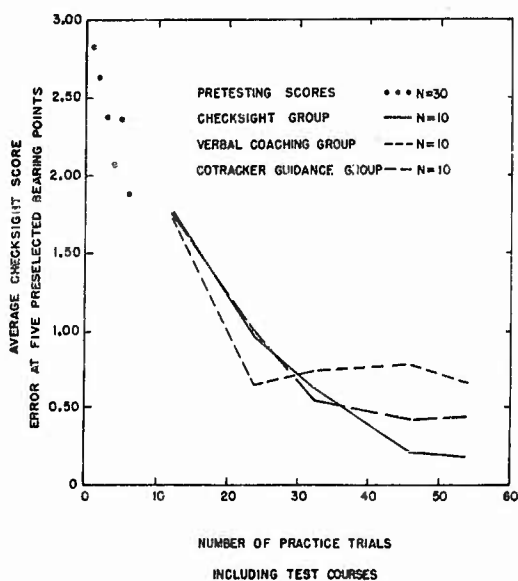

FIGURE 11. Improvement in azimuth tracking performance in three groups of men trained by different methods on the 40 mm gun.

pointers to track on target with the computing sight M7.²² One of these methods, called the verbal coaching method, involves coaching by the officer in charge. He makes suggestions and

RESTRICTED

by the end of the sequence of noncoached runs had improved considerably again. The trainers in this group, however, never became significantly better than the trainers in the uncoached group.

For the Mark 4 pointers, the experimenters believed the training effects of the checksight scoring to be real. For the trainers, they attributed their failure to obtain more significant training effects to poor equipment maintenance, evidenced by generally large radar tracking errors observed during the tests. The study therefore points, as do many others, to the need for satisfactory equipment supervision as a prerequisite to research on other variables.

of four men trained to track with the gun sight Mark 15 on the handle bar controlled gun director Mark 52.¹⁷ Their learning curves are shown in Figure 12. Each training period included some eight to ten courses. If an average curve for the group were drawn in the figure, it would show a plateau after about five training periods.

Actually, however, the data as shown in Figure 12 are somewhat deceptive. Learning is not complete in five training periods. If performance is considered as a function of range to target, it is found that the men were improving in their ability to track close-in targets right to the end of the training program. A breakdown of average tracking performance for course sections when the targets were at different ranges is given in Figure 13. These data

3.3.2 Time Required in Learning to Track

The data in Figures 10 and 11 provide some information on the time required to reach a probable final level of proficiency in tracking with the 40 mm gun. This is shown to be about

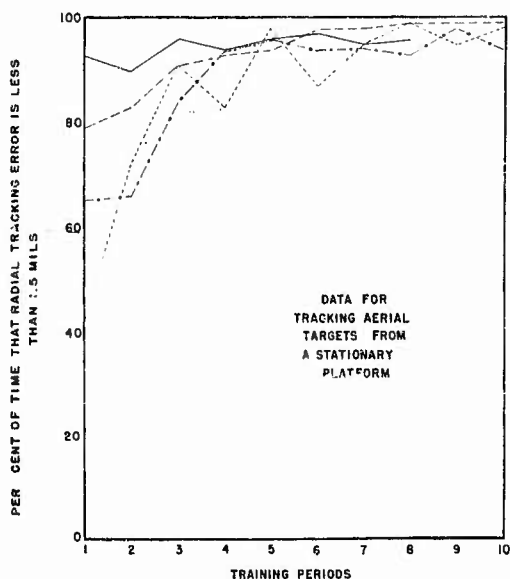

FIGURE 12. Individual learning curves for four trackers on the gunsight Mark 15.

50 or 60 courses if each course is of about 1 minute's duration.

Comparable data were obtained for a group

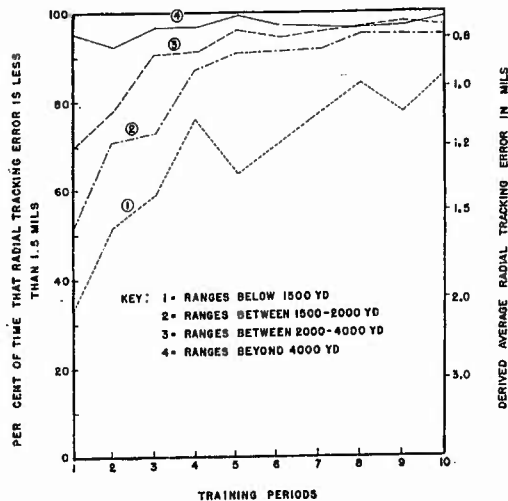

FIGURE 13. Variation in tracking accuracy with target range. Data averaged for four men tracking aerial targets from a stationary platform using the gunsight Mark 15.

suggest that about two weeks of training, ten courses per day, would be required to train men to the point where they stay on target (within 1.5 mils) more than 90 per cent of the time for targets at short range. This refers to tracking from a stable platform. Tracking from a rolling deck is more difficult, and data paralleling the above indicate that about 200 courses of aerial

target tracking drill are needed to bring trackers to their learning plateau for operation on a rolling deck.

3.4 FACTORS TO CONSIDER IN THE TRAINING OF TRACKERS

This discussion of the training problems of trackers would not be complete without raising some questions relative to a number of training principles which may well determine the pattern for and the success of later training programs.

3.4.1 Selection of Personnel

The selection of personnel to be trained as trackers, as for any type of job, can be expected to reduce training time and improve the final level of operator performance.

For some tasks, it is efficient to use performance on early trials with the equipment itself as a means of selection or screening. This is probably true of tracking. One indication of the success of this selection procedure for tracking is found in the report of one of the Foxboro Laboratory studies.⁷ Average performance scores over successive ten-trial training periods were obtained for each subject. Correlations between scores on each of the earlier sets of trials with scores for the sixth set of ten trials were determined. These correlations are shown in Table 1. The correlation of $+0.68$ between the scores on the first block of trials (I) and those on the sixth (VI) indicates that in the training of these subjects useful judgments could have been made from

TABLE 1. Rank order correlations between average scores for groups of trials during pointer matching training (20 subjects).

I* and VI	II and VI	III and VI	IV and VI	V and VI
+0.68	+0.77	+0.85	+0.87	+0.92

* All Roman numerals refer to blocks of ten trials except the number I. In this block only seven trials are included, since the first three trials were considered practice.

early trials as to which men were likely to be superior at the close of training. Similar implications for the predictive value of early

training trials are found in test data which showed that the Tufts tracking trainer was a good selection device for M7 director trackers.⁹

Thus, for optical tracking at least, it appears that a working method of selecting operators would be to use checksights to administer preliminary tracking tests to those men who are available for assignment as trackers.

3.4.2 Training Goals

When men have been selected and are undergoing training as trackers, it is important that certain goals in tracking performance be set and that the men check daily on how they are progressing toward those goals. Inasmuch as tracking accuracy varies with so many conditions (target range and angular rate of motion, roll and pitch of the deck, the director or gun in use, the kind of tracking control, etc.) it is obviously necessary that these training goals be made specific for each tracking device and for the conditions under which it is used. One attempt at setting such tracking standards based on assembled tracking data was made in a report by Project N-111.¹⁷ The data, applicable to the gunsight Mark 15, are reproduced in Table 2. Reprinted in several operat-

TABLE 2. Acceptable tracking proficiency after 2 weeks of tracking training with the gunsight Mark 15.

For tracking at ranges between 4,500 and 1,500 and under 40° elevation	Per cent of time with tracking error less than 1.5 mils	Approximate average error equivalent (mils)
Tracking aerial targets from a stable deck	90-95	0.9-0.8
Tracking surface targets from a rolling and pitching deck (5° to 10° motion)	70-80	1.2-1.0
Tracking aerial targets from a rolling and pitching deck (5° to 10° motion)	50-60	1.6-1.4

ing pamphlets, these standards serve as a guide to those officers who are responsible for training men and as a performance goal for the men in training.

RESTRICTED

3.4.3 How Well Is Tracking Skill Retained?

Data on the retention of tracking skills are important in determining the need for refresher drills and tracking exercises. Some research reports contribute information on this point.

Two groups of men trained in azimuth tracking on the 40 mm gun under conditions of checksight and buzzer training were tested after an interval of no practice to measure the skill they retained.²⁵ These data are summarized in Figure 14. It can be seen that the par-

curacy after from 16 to 29 days of no practice.⁷

Pending the accumulation of additional data, the conclusion seems indicated that once men are adequately trained in tracking they need refresher drills no more often than once a month.

3.4.4 Is Tracking Skill a General Skill?

The Services have occasionally expressed interest in the design and construction of a gen-

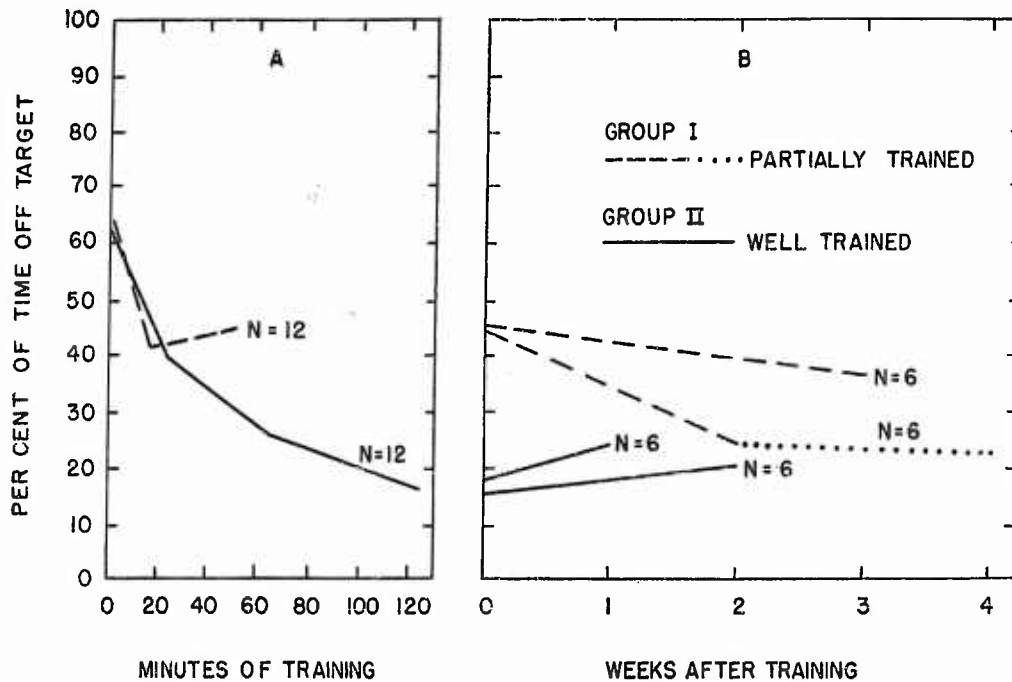

FIGURE 14. Curves showing (A) the improvement in tracking performance and (B) the retention of tracking skill in groups of 40 mm gun pointers.

tially trained trackers, the men of Group 1, showed no decrement but actually showed some improvement when part of the group was tested after two, three, and four weeks of no practice. In the case of the highly trained men, Group 2, six of whom were tested after one week and six after 2 weeks with no practice, some but little loss in performance was observed. A Foxboro Laboratory experiment presents similar data indicating no loss but actually some improvement in tracking ac-

erualized tracking trainer, an instrument which could be used to train trackers for all or many types of tracking tasks. This suggestion raises a more fundamental question, however, as to whether tracking skills are specific to particular devices or whether they are general. If they are general, then men may be transferred from one tracking job to another with no doubt as to their ability to do the second job as well as the first. A general trainer would be feasible. But if tracking skills are specific to particular

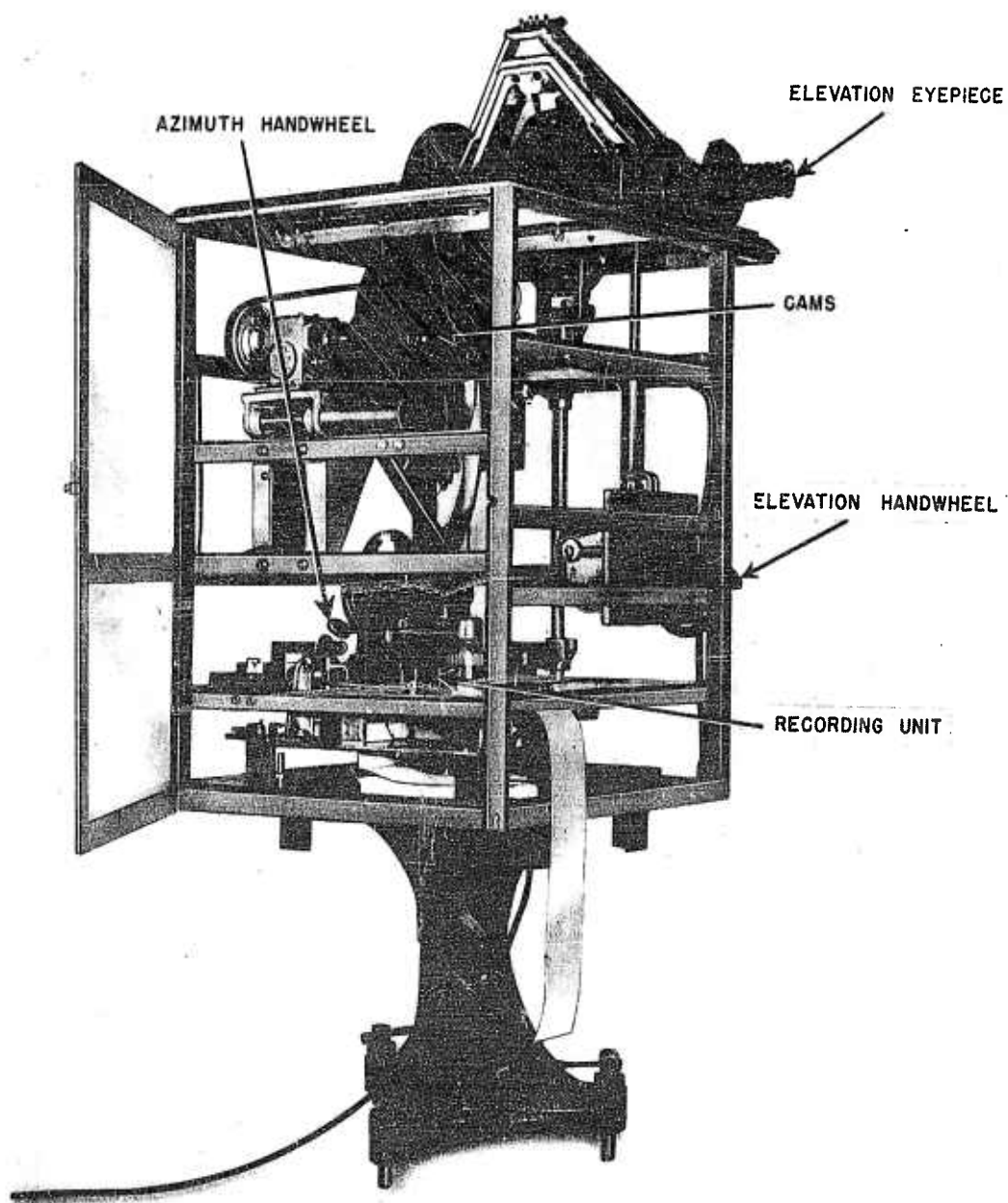

FIGURE 15. Tufts tracking trainer with housing removed, front view.

RESTRICTED

instruments, men must be trained for each tracking job in a particular way and on a reasonably specific trainer.

An approach to this problem was made in an experiment by Project SOS-6.¹⁵ The project recruited six small groups of trackers who had learned on-target tracking. The groups comprised men who had been trained, respectively, on the director M7, director M5, Tufts tracking trainer, heightfinder, radar SCR-268, and the 40 mm gun. The groups were all given a short test for tracking skill on the Tufts (director M7) tracking trainer. Except for the groups trained on the director M7 and the tracking trainer itself, none of the groups were superior to a group of untrained men tested on the same instrument. These data argue against the notion of generality and suggest that training on one tracking task does not necessarily provide skill in another tracking task. However, other data show that as long as a man continues to work at the same instrument there is a high degree of carryover of skill from tracking one course to tracking another with similar components⁷ and from tracking with one form of control to tracking with another.²⁸

Either of two explanations is possible for these data. Either the degree of transfer of tracking skill from one tracking device to another depends specifically on the resemblance between the two tasks and the number of identical coordinations they involve, or the study by Project SOS-6 concealed a general skill factor by failing to follow the men long enough to see how they would have compared in ability once they had become completely familiar with the new job.

It is important that the Services know which of these alternatives is correct; the answer governs a number of important decisions with respect to training and the assignment of personnel.

3.5 TRAINING AIDS FOR OPTICAL TRACKING

The role of trainers in a program of training men to track aerial targets can be a significant one because of the flying time, fuel, and general

operational costs which are saved and the independence of weather conditions which is gained if the training of trackers can be carried out without having to have a target plane in the sky.

Several Applied Psychology Panel projects assisted in the trainer phase of the optical-tracking jobs, in the experimental evaluation of trainers, and in the preparation of instruc-

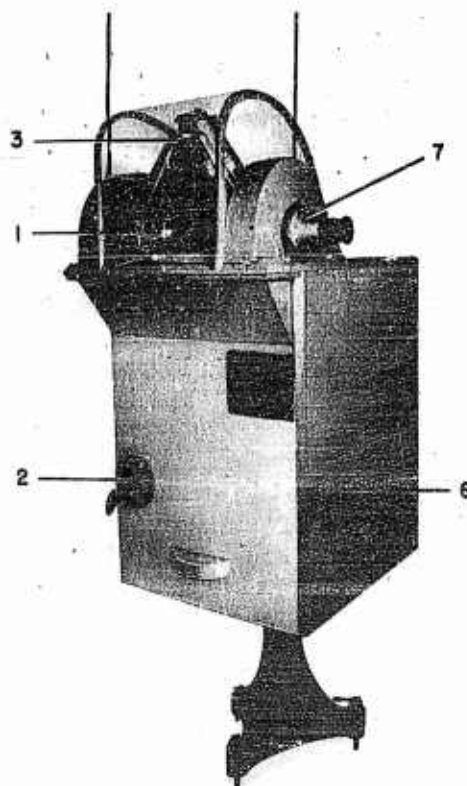

FIGURE 16. Tufts tracking trainer, rear view.

tion guides and lesson plans to be used with standard trainers.

3.5.1 The Development of Optical Trainers

Three on-target tracking trainers were developed by Panel projects. These were a trainer which simulated the task of optical tracking found on the stereoscopic heightfinder,² a trainer which simulated the two-man tracking task in the gun director Mark 37,²⁰ and a trainer simulating the two-man tracking task

RESTRICTED

on the director M7.⁶ All these trainers were similar in principle in that they scored by recording differentially the cam-controlled motion of the target and the tracking input of the operator. A discussion of the M7 trainer only is included here because this trainer was the most elaborate of the three devices and the one which was evaluated most systematically. Built by Project SOS-6, under a Tufts College contract, it became known as the Tufts tracking trainer.

In size and in general appearance (with the exception of the added target units) the Tufts tracking trainer resembles the director M7 very closely. The critical factors of tracking—telescope position and handwheel position, size, torque, etc., match those of the director M7. The azimuth and the elevation tracker use direct handwheel tracking to keep the reticle crossline in the telescope on the tracking point of the target.

The trainer is shown in Figures 15 and 16. When the azimuth handwheel is turned, the whole trainer turns on the pedestal, as would the director itself. When the elevation handwheel is turned, the telescope tubes in the target unit move in the same way that the tracking telescopes elevate or depress on the director. The target is presented on a Kodachrome slide. Courses are regulated by large cams installed in the body of the trainer. A recording unit produces a graphic record of tracking accuracy. A "time-off-target score" or a "per cent of time-off-target score" can also be obtained for each course.

3.5.2 The Experimental Evaluation of Trainers

The Tufts trainer was tested⁹ for validity as a training device and, in a preliminary way, for validity as a selection device (Section 3.4.1). Thirty-two enlisted men were used in the training experiment. After a preliminary tracking test on the Tufts trainer, the men were divided equally into two groups so that the groups were similar in tracking skill. One of these groups was trained in tracking on the trainer while the other was trained on the director M7 itself. The men being trained on

the trainer learned after each trial how well they had tracked. They were told what amount of time they had been off target by two mils or more and were given a graphic record of their tracking performance. The men trained on the director tracked airplane targets and were put through standard tracking practice sessions (without checksight scoring) for an amount of time equivalent to that devoted by the other men on the trainer. After approximately 2½ hours of actual tracking practice per man, the two groups were tested for their skill in tracking on the director M7 itself. The director which was used was equipped with a recording camera, and tracking photographs were taken, one per second, during the test. In order to permit a further comparison of the groups, all the men were given a post-training test on the trainer.

The results of these tests are presented in Table 3. The data show that the group trained on the trainer performed somewhat better on the director in the post-training test than did the group trained on the director. The difference between the groups in director-tracking skill approached statistical significance (it might have occurred by chance about one time out of ten). The records for the final test on the trainer confirmed this group difference. The observed superiority of the trainer group in the post-training tests is probably to be attributed to the greater information concerning errors received by this group and to the basic similarity of the trainer to the director in those characteristics essential to the tracking operations.

Although the Tufts tracking trainer was shown by these results to accomplish a real training job, it was not adopted for regular Army use because it was not ready until too late in World War II. The trainer will probably be of continuing interest to the Services, however, because it solves a number of mechanical problems not dealt with successfully in other trainers. Among these is the problem of presenting the target in such a way that the men are required to walk around with the trainer while tracking in azimuth, just as they do when tracking a real target with actual director equipment.

RESTRICTED

One aspect of trainer evaluation relates to the difficulty of the trainer task in terms of learning time. Learning curves for the Tufts trainer, obtained for the trainer group in the

that reached by the same men in tracking similar courses on the director itself. Learning time on the trainer was similar to that for tracking with the gunsight Mark 15 from a

TABLE 3. Results of training test using the Tufts tracking trainer. Scores are given as average errors in mils.

Tests	Mean score for men trained on the M7	Mean score for men trained on the trainer	Difference in mils	Probability of the difference occurring by chance
Pre-training test on trainer (basis on which groups were matched)	2.86	2.85	0.01	50/100 ($t = 0.02$)
Post-training test on trainer (same test as pre-test)	1.48	1.20	0.28	9/100 ($t = 1.40$)
Difference: pre-training test vs final test post-training	1.38 ($t = 4.81$)	1.65 ($t = 4.44$)		
Post-training test on director. Azimuth scores				
Trial 1	1.12	0.79	0.33	
Trial 3	1.08	0.95	0.13	12/100 ($t = 1.19$)
Total 1 + 3	1.10	0.86	0.24	
Elevation scores				
Trial 1	0.86	0.71	0.15	
Trial 3	1.22	0.91	0.31	
Total 1 + 3	1.03	0.81	0.22	9/100 ($t = 1.36$)

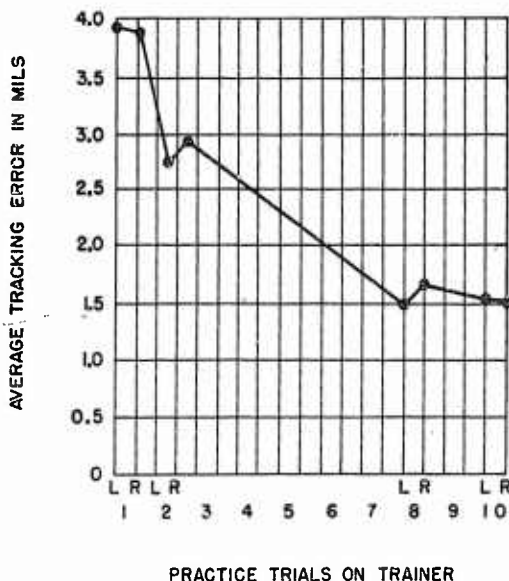

FIGURE 17. Average tracking error for azimuth practice trials of 16 men trained on Tufts tracking trainer.

test just described, are shown in Figure 17. They reached a plateau in about 2 hours of actual tracking practice spaced over a 2-week period. The average tracking error score reached on the trainer was slightly lower than

stable platform (Section 3.3.2). It was similar also to the times indicated in Figure 18, based on two studies of pointer-matching training performed at the Foxboro Laboratory.^{7, 8} The curves in Figure 18 indicate that 35 to 40 trials are required to reach a performance plateau at this job. This turns out to be about 150 minutes of actual practice time.

A second optical tracking trainer which was studied experimentally was the gunnery trainer Mark 5 designed for use on the gunsight Mark 14. When this instrument was in pilot-model form, the Bureau of Ordnance requested Project N-111 to carry out an evaluation study. Early tests made by the project indicated that the scoring device incorporated in the trainer was too unreliable to provide meaningful training scores, so the investigation turned to a study of ways of improving the scoring system. The source of unreliability was found to be in the phototube system and was compensated for by increasing the intensity of the target image on the phototube and increasing the effective sensitivity of the "target image in phototube aperture" system.³⁹ The changes required by these improvements were made in subsequent production models of the trainer. Tests of a

number of the latter have shown that scoring in units coming "off the line" is dependable. Because of the delays which a thorough validation study would have introduced in the production program, the gunnery trainer Mark 5 was

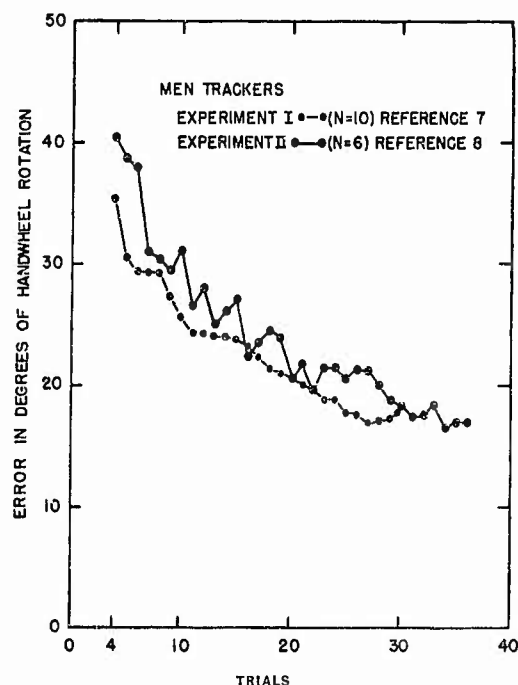

FIGURE 18. Learning pointer matching, a plot of tracking error in degrees handwheel rotation by trials.

ordered into production on its face validity alone. Now that a recording camera is available for use on the gunsight Mark 14 (Section 3.2.2 above), the validation study of the gunnery trainer Mark 5 should be undertaken.

3.5.3 Preparation of Instruction Guides and Lesson Plans for Use in Trainer Programs

There were a number of optical-tracking trainers, among them several lead-tracking trainers, which were adopted by the Services early in the war and which were put into regular use at training stations throughout the country. In order to make training with these devices as effective as possible, Project N-105 assumed the job of preparing instruction

guides, lesson plans, and drill outlines for work with these devices.^{21, 31, 35}

In the preparation of the drills an effort was made to (1) maximize time available for drill and minimize time spent in lectures and discussion; (2) minimize "dead" time when men were not profitably employed; (3) provide for standardized and adequate coaching; (4) utilize charts, diagrams, etc., as illustrative teaching devices; and (5) introduce drills with moving targets as early as possible in the training programs.

A sample of one of the drills is shown in Figure 19. The sample is for the panoramic trainer, Mark 12. Other trainers for which lesson plans and drills were prepared included the portable aiming teacher, the multiple forward area sight trainer, the Mark I trainer (polaroid, machine gun trainer), the Mark III trainer, Model 1 (for forward area sight training), and the Mark VI trainer (fixed gunnery deflection trainer).

3.6 RADAR TRACKING TRAINERS

Work with radar tracking trainers was undertaken by Projects SC-70, N-111 and N-114. SC-70 and N-114 contributed to the development and testing of trainers which simulated the pip-matching tracking task of the radar Mark 4. Projects N-111 and N-114 designed devices to simulate tracking with a radar which provides a T and E dot.

3.6.1 The Development and Evaluation of Two Pip-Matching Radar Trainers

The Foxboro trainer (BC-968-A) is a device for training men to track by pip matching. It is an electronic-mechanical unit which feeds synthetic target echoes into an indicator unit for SCR-268 radar equipment or other equipment types using pip matching. All scope controls are reproduced, and as the operator tracks on a cam-controlled course a Veeder counter score and a tape record of his tracking performance are taken.

In one evaluation test for this trainer,⁴ 25

- I PURPOSE: To give practice in maintaining skill in use of forward area sight on combat targets.
- II CONDUCTED BY: Enlisted instructor.
- III PREPARATION

Materials needed:
Three Mark IV trainers per crew.

- A. Lecture (2 min). Know contents A, part IV.
- B. Drill: See that trainer is in running order.
- IV PRESENTATION

- A. Lecture (2 min): Nature of this drill.
 - 1. The purpose of this drill is to give the men practice in keeping up their skill in the use of the forward area sight on combat targets.

Tell men Mark IV trainer is commonly known as panoramic.

- 2. The men will fire a 20 mm gun at moving targets.
 - a. The gunner will be strapped to the shoulder bars.
 - b. He will put his head into the eyepiece and using both eyes he will see
 - (1) motion pictures of planes going through combat maneuvers,
 - (2) a forward area sight which can be moved,
 - (3) a red flash when a hit is scored.
 - c. The gunner will have to track the target and to sight the target correctly.
 - d. A trunnion operator will raise and lower the column for the gunner.
- 3. The gunner will fire by squeezing trigger on left handgrip as follows:

Point out trigger.

- a. Open fire as soon as plane appears.
- b. Fire in bursts until hits are made.
- c. Fire continuously thereafter until plane flies off screen.
- 4. The speed of the plane will be between 200 and 300 knots.
- 5. The number of hits will be recorded automatically.

Number of rounds fired is also recorded but don't tell crew.

- 6. The film will stop automatically.
- B. Drill
 - 1. Assign the men as follows:
 - a. First man is gunner.
 - b. Second man is trunnion operator.
 - c. When firing is finished men reverse positions.
 - d. When first pair finishes, a second pair takes positions.
 - 2. Coaching
 - a. Stance
 - (1) See that feet are placed well forward.
 - (2) See that gunner is balanced on both feet.
 - (3) See that gunner walks with gun.
 - b. Firing
 - (1) Remind gunner that lead is constantly changing except for zero approach angles.
 - (2) Don't allow long periods to go by without the gunner firing.
 - c. See that trunnion operator works column quickly and smoothly to keep gunner's knees slightly bent.
 - d. Scoring.
 - (1) Tell gunner and rest of crew number of hits made but not number of rounds fired.
 - (2) Record number of hits and number of rounds fired.
 - 3. Before dismissing men look over the scores and comment on the men's performances and difficulties.

FIGURE 19. Mark IV (3A-11) trainer, one drill, forward area sight, combat targets.

RESTRICTED

enlisted men with no previous experience in radar tracking were given 9 minutes and 36 seconds of practice per day (three runs of 3 minutes 12 seconds each) for 12 successive days. One week following their last training trial, they were tested to see how much skill they had retained.

Curves showing the improvement that took place in the average performance of the men during the training days are shown in Figure 20. It can be seen that by the twelfth day, after

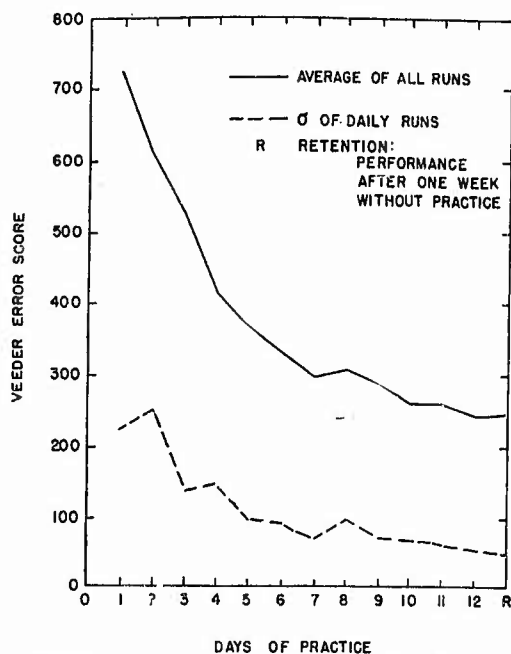

FIGURE 20. Learning curve showing development of proficiency with daily practice on Foxboro trainer ($N = 25$).

approximately 115 minutes of practice, the curve had begun to level off into a plateau. Variability of performance from trial to trial as measured by the standard deviation on each day decreased continuously, as shown by the dotted curve. There is little change in either accuracy or variability after one week without practice.

In a later experiment,¹⁴ one of these Foxboro trainers was modified so that the tracking controls resembled the tracking handwheels in the gun director Mark 37 and so that the scope face was in the same position relative to the tracker as in the Mark 37. The instrument was then evaluated for its efficiency in training

men for Mark 4 radar tracking. The experiment was run at the Naval Training School, Fort Lauderdale, Florida, by Project N-114.

Concurrently, a test was made of the validity of an optical-mechanical pip-matching trainer designed jointly by Projects SC-70 and N-114.¹⁸ In this device, the scope presentation is accomplished by passing light through two pip-pattern slits and green filters and having the light fall on a ground glass surface which simulates the scope face. The remainder of the apparatus consists of (1) a cam device to unbalance the pips (i.e., to make one higher or lower than the other) in a manner resembling pip variation when a target is flying crossing courses; (2) handwheels, whereby the operator can offset the tendency of the course cam to unbalance the pips and thus keep them matched in height; (3) a jiggle mechanism, which causes movement of the light source to produce a complex bobbing of the pips, thereby increasing the difficulty of the task and introducing a factor found in tracking with Mark 4 radar; and (4) a scoring device, which provides both a graphic record and an integrated number score indicative of the proficiency of tracking.

In an experiment to evaluate the two trainers, 36 men previously untrained in radar tracking were used. At the outset, they were given a pretest in tracking aerial targets (pointing and training) with the radar Mark 4 in the gun director Mark 37. On the basis of their pretest scores they were divided into three matched groups. One group of 12 men was trained for 12 days on the Foxboro trainer (three trials daily, each trial of 3 minutes duration). The second group of 12 was trained for 12 days on the optical-mechanical pip-matching trainer (three trials daily, each trial of 2 minutes 15 seconds duration). The third group was given no radar tracking practice during the 12-day period. For the groups trained on the two trainers, daily progress was recorded on a posted score-sheet, so that subjects could compare their daily performance with their past records and with the performance of other subjects. This contributed toward keeping motivation high in the two experimental groups.

RESTRICTED

Analysis of the learning curves for the men trained on the Foxboro trainer confirmed the conclusion drawn from Figure 18 above, namely, that performance on the trainer reaches a plateau in about 12 days of practice. For the optical-mechanical pip-matching trainer, however, almost all improvement in performance occurred during the first 3 days of practice, with slight improvement continuing until the eighth day.

TABLE 4. Radar tracking training with two pip-matching trainers. Comparison of combined pointing and training average error scores for experimental and control groups in tests for tracking on the director itself.

	Group trained on Foxboro (N=12)	Control group (N=12)	Group trained on optical-mechanical trainer (N=12)
Pre-test group mean	16.6 mils	16.7 mils	16.6 mils
Post-test group mean	13.2 mils	18.4 mils	13.4 mils
Experimental post-test vs control post-test	$M_{diff} = 5.2$ mils $t = 3.8$ $p = .003$		$M_{diff} = 5.0$ mils $t = 3.9$ $p = .002$

At the end of the training period, the three groups were again tested (pointing and training) in the gun director for their ability to track aerial targets with the Mark 4. In these post-training tests, the two groups trained on the trainers tracked with greater accuracy than did the control group which had had no training. When pointing and training scores were combined, the performance differences in favor of the trainer groups were statistically significant for both trainers. These data are presented in Tables 4 and 5.

The experimental data show, therefore, that both the Foxboro instrument and the optical-mechanical pip-matching device are valid trainers for the operations of tracking with the radar Mark 4. The Foxboro trainer, in production early in World War II, was already in use at many training stations. To aid the Services in obtaining effective training with this trainer, Project SC-70 prepared a special report summarizing the methods and training tech-

niques which should be employed with the device.⁵

TABLE 5. Radar tracking training with two pip-matching trainers. Statistical comparison of experimental and control groups when pointing and training during post-tests are considered separately.

	Pre-test	Post-test	Experimental post-test vs control post-test		
			M_{diff}	t	p
Foxboro trainer:					
Pointers	18.4	15.5	7.2	3.6	.004
Trainers	14.7	10.9	3.4	2.1	.06
Control:					
Pointers	18.9	22.7			
Trainers	14.5	14.2			
Optical-mechanical trainer:					
Pointers	20.5	17.3	5.4	2.5	.03
Trainers	12.6	9.8	4.4	3.4	.006

3.6.2 The Development of Two T and E Type Radar Trainers

Two other radar training devices which the projects worked on were devices which simulated T and E type radar tracking.

The first was a mock-up of the dot tracking job on the radar Mark 12. This tracking presentation was incorporated in the optical tracking trainer for the gun director Mark 37 (Section 3.5.1 above), built by Project N-114.⁴⁵ In an experiment to determine the validity of this instrument as a tracking trainer for the radar Mark 12, practice was found to result in significant improvement in tracking on the trainer, but men so trained showed no superiority on the Mark 12 itself over a control group which had received no training of any sort. The device, therefore, had no validity as a trainer for the radar Mark 12. These results should serve to emphasize the caution with which one must regard proposed trainers. Practice on a device which has a good amount of face validity and which results in a large amount of improvement in performance on the device itself *does not necessarily transfer* to the real job on combat equipment.

Accepting the view that a trainer does not merit the name until it has been proved valid

for training, Project N-111 called the instrument which it developed a *radar tracking demonstrator*.⁴⁰ The instrument is a device which generates a dot type of radar signal and simulates the presentation on the pedestal-type, radar-equipped gun directors, the Marks 57, 60, and 63. The synthetic radar signal, which reproduces the appearance of an actual signal with considerable fidelity, is fed to a T and E scope mounted on the tracking head of a standard pedestal director. In tracking, the man moves around the director and performs all the operations required in following a real target with the real radar system. The signal generating unit, with cams to control courses and a scoring system to register performance, may be mounted on the director in place of the gunsight normally positioned on the tracking head, or it may be located away from the director and used to feed signals to the regular T and E scope in the standard gunsight on the director.

This demonstrator was completed just at the close of the war and is now undergoing further test and development at the Naval Research Laboratory.

3.7 TRAINING AIDS AND TRAINING MATERIALS

In addition to preparing trainers and studying training methods, several of the projects

under the Applied Psychology Panel gave further assistance in the general program of training trackers by developing training aids and training materials of various sorts. Their work included assistance in planning courses of instruction for gunners, trackers, and director operators, the preparation of course outlines, lesson plans, and drill outlines, and the writing of pamphlets on operating technique and theory. Illustrative of this work are the following.

Lesson plans for courses of instruction in 20 mm gunnery,¹ 40 mm gunnery,^{3, 32} and in the operation of the gun directors Mark 37,¹⁰ Mark 57,⁴⁴ and Mark 63.⁴²

Drill manuals for the use of gunnery trainers.^{21, 31, 35}

Operational pamphlets, discussing tracking in relation to the general operation of pedestal-type Navy gun directors.^{30, 40, 41, 46}

Achievement test items for courses of instruction in director operation.^{37, 43}

Material on fire control nomenclature³⁴ and monographs on training theory and methods⁴⁷ and on the theory of lead computing systems.⁴⁸

These instructional aids were useful in improving the training of trackers, in increasing their understanding of the work they performed, and in developing standardized methods of operation.

Chapter 4

TRAINING PERSONNEL IN RANGE DETERMINATION

By William E. Kappauf, Jr.^a

SUMMARY

THE RANGE to a target may be *measured* stereoscopically or by radar, or it may be *estimated* either with or without the use of a stadiametric aid.

Projects of the Applied Psychology Panel suggested a few improvements in stereoscopic trainers, but their major contribution was in the preparation of training manuals for instructing Army personnel in heightfinder operation. The same material was in large part adapted for the training of Navy personnel in rangefinder operation. To improve training further, a number of training aids and teaching aids were developed.

The rate of improvement during training in heightfinder and rangefinder operation was studied in a variety of situations. About 2,700 trials were found necessary on the M2 trainer and about 3,200 on the Eastman trainer before men reached a plateau. Men who had this amount of training on the trainer reached a plateau in their ability to range on aerial targets in about 500 trials.

Men completing heightfinder or rangefinder training showed a mean deviation of about 2.5 units of error [UOE] in aerial target height readings and a mean deviation of from four to five UOE in range readings on aerial targets.

Training on the firing line with the reticle of the gunsight Mark 14 was found to be superior to training on the mirror range estimation trainer device 5C-4 for learning stadiametric ranging.

Unaided estimation of the opening range for 20 mm fire, 1,700 yards, was found to be superior to stadiametric ranging with the gunsight Mark 14.

Practice in aerial target range estimation for ranges up to 8,000 yards increases the per cent of estimates within 15 per cent of true range from about 25 per cent to 40 or 45 per

cent. Relatively frequent refresher drills are necessary, however, to keep men to this level of performance.

The accuracy of estimating the range of aerial targets is approximately the same as the accuracy of estimating range of ground targets.

4.1 METHODS OF RANGE DETERMINATION

In the operation of anti-aircraft batteries, range to the target is determined by any one of four methods: radar, rangefinder, some type of visual stadiametric device, or estimation. Precision of the methods of determining range decreases in the order given. The fact that the last two methods are less accurate than the first two does not mean that they are any the less important. A number of fire-control systems, directors, or sights, used at short range or delivering only approximate solutions to the firing problem, regularly depend on stadiametric or estimated ranges in standard operating procedure.

The Applied Psychology Panel was called upon to assist in the training of operators for the most precise and highly developed of the Army and Navy director systems as well as to assist in the training of gunners and gunsight operators who used less refined range data. Panel projects contributed training aids, trainers, lesson plans, course outlines, and examinations. They also conducted experiments to evaluate the efficiency of particular training methods and to determine the standards of proficiency to be expected of range men in a battery or at a gun.

The selection of rangefinder personnel is described in Volume 1, Chapter 8, the Summary Technical Report of the Applied Psychology Panel, and the general procedures of ranging in Chapter 22 of this volume. Radar training and radar operation are described in Chapters 2 and 21 respectively. The selection of radar operators is covered in Chapter 7 of Volume 1.

^a This chapter is based on work by NDRC Projects N-105, N-111, N-114, and the Height Finder Project and on earlier work by NDRC Division 7.

4.2 THE TRAINING OF STEREOSCOPIC RANGEFINDER AND HEIGHTFINDER OPERATORS

4.2.1 The Development of Stereoscopic Trainers

The need for a stereoscopic training instrument was recognized a good many years ago. Under Army and Navy contracts, the stereoscopic trainer M2 (or Mark 2 in Navy terminology) was developed. This is a relatively simple trainer and does little more than present the target and reticle patterns in a viewer resembling a stereoscope. Provision is made for changing the target silhouette. It is also possible to introduce changes of target range and of its azimuth and elevation positions, so that the operator experiences some of the difficulties of ranging on an aerial target.

A more versatile and realistic trainer was developed by the Princeton University group.¹ Known originally as the Eastman trainer, this device uses Kodachrome target slides, introduces tracking errors and range changes by cams, and makes a record of the observer's errors in ranging.

The Princeton University group tested these two instruments to determine their validity as trainers.¹ A class of 36 students at the Height Finder School, Fort Monroe, was divided into three sections. One section was trained by the usual methods on the heightfinder, one section was trained on the M2 trainer (modified to include a motor range device), and the third was trained on the Eastman trainer. Both trainers proved to be valid. When the men of all sections were tested on the heightfinder at the end of 4 weeks, 7 weeks, and 10 weeks of training, their performance as measured by a variability or precision score was equivalent. The men who had had 7 weeks of work out of 10 on the trainers made readings which were no more variable than the readings of the men who had practiced through the entire course on the heightfinders.

The Height Finder Project and Project N-114 of the Applied Psychology Panel entered this field after the above developments were complete. Its trainer contributions to the stereo-

scopic training program were limited to the following. (1) A simplified motor drive was designed to control an automatic range input on the stereoscopic trainer M2.⁴ (2) A method was developed for controlling both range and tracking errors by motor drive on the Navy trainer Mark 2.¹⁶ (3) Some preliminary work was done on stereoscopic spotting trainers. Many such trainers have been built for the purpose of teaching rangefinder operators how to spot burst errors in range, but few, if any, have ever been validated. At the request of the Navy Bureau of Ordnance, Applied Psychology Panel projects submitted a design for a better spotting trainer³ and submitted criticism of a proposed polaroid spotting trainer.²⁸ What seemed to be needed most in handling the spotting problem, however, was not a trainer for the present spotting job but a way of introducing range spots in UOE instead of in yards. Until this instrument development is achieved, stereoscopic spotting will always be inaccurate because of its dependence on an estimate of the absolute range of the target.

4.2.2 The Preparation of Training Manuals

A manual on the theory, operation, and maintenance of heightfinders was prepared for use at the Height Finder School, Camp Davis, North Carolina.^{6, 7, 9} The manual was first distributed in mimeographed form. Later the principal chapters of the manual appeared in a new Army pamphlet on the heightfinder,³⁸ while other parts were incorporated in field manuals and ordnance manuals.^{32, 33, 34}

The manual was written so that the new heightfinder operating procedures developed by Division 7 and the Height Finder Project would be available to heightfinder operators. Important among the procedures established in the manual were the following suggestions.

1. That the interpupillary adjustment be made with the aid of an interpupillary template.

2. That the height-of-image adjustment be made on a target at a range greater than 2,000 yards and with the measuring scale set to more than 2,000 yards.

3. That the internal adjustment, when made

on the internal target, be made at 650 mils elevation and with the height range lever in height.

4. That the internal adjustment, when made on a star or on the moon, be made with the height range lever in height.

5. That the calibration correction be computed on the basis of combined data for the fixed target, aerial target, and celestial target readings, omitting data on any targets at ranges shorter than 2,000 yards.

6. That the wedge check be carried out with the elevation tracking telescope on a carefully surveyed "level point."

7. That the wedge check be carried out at height-900 yards instead of height-550 yards. This recommendation simplifies the wedge check procedure and is in line with the new manufacturer's inspection procedure.

8. That the wedge adjustment be considered satisfactory when the difference between range-infinity readings and height-infinity readings does not exceed two UOE and when the difference between range-infinity readings and height-900 readings does not exceed one UOE.

9. That regular measurements be made of the amount of backlash between the main bearing race and the bevel pinion and that ordnance repairs be made to reduce it.

10. That vertical slot-shaped end-window stops be used for observing at 24 power except when the illumination is too low to permit it.

When Project N-114 was set up at NTS, Fort Lauderdale, members of the project assisted the school staff in adapting parts of the Army pamphlet to Navy use. Most operating and training procedures, except those specific to the Army heightfinder, were carried over. Later, members of the project assisted in writing a revision of the ordnance pamphlet on the care, adjustment, and operation of stereoscopic rangefinders.²³

^{1.2.3} The Development of Training Aids and Teaching Aids

A considerable number of training aids and teaching aids were developed by the Applied Psychology Panel for use in the training of

stereoscopic rangefinder and heightfinder operators. Some of these required background research, but most of them were prepared and recommended for school adoption on the grounds that they represented good teaching technique in the eyes of the project staff. A list of these training aids follows.

1. Simplified record forms for observers to use in scoring their performance, in computing their calibration correction, in checking the zero mils adjustment of the heightfinder, and in noting what maintenance work is done on their instruments.⁷

2. A short pamphlet of arithmetic instruction, later included in the heightfinder manual.⁷

3. A series of classroom wall charts on the construction of the heightfinder and rangefinder.¹⁴

4. A detailed course outline for a 12 weeks' course of instruction in the operation and maintenance of the heightfinder.⁹

5. A series of worksheets to parallel the chapters in the new heightfinder manual.¹⁴

6. Simplified models of the optics of the heightfinder⁵ and rangefinder.²³

7. An interpupillometer for the accurate measurement of interpupillary distance.¹⁵

8. Interpupillary templates to be used in making interpupillary distance settings on a rangefinder or heightfinder.¹⁴

9. A range correction computer for determining a parallax correction for the range to the target from each of a series of rangefinders used in a row at a training station.¹²

10. A rangefinder slide rule, which was a simplified rule for computing rangefinder errors in units of error.¹³

11. A set of achievement test questions and performance test items for operators of Navy fire-control equipment.²⁰

12. A set of lesson plans for an officers' course on the selection and training of rangefinder operators.¹⁷

13. A set of instructions and suggestions to heightfinder instructors.⁹

^{1.2.4} Special Suggestions for Training

The specific importance of a good calibration correction procedure for aerial target read-

ings,¹⁰ and of a precise height-of-image adjustment for taking infinity readings on stars,⁸ was shown experimentally. These two matters are discussed in detail in connection with the development of better heightfinder operating procedures in Chapter 22. Their implications for a training program are these: students need to be thoroughly trained in the techniques of calibration which they may have to use when they are in the field. They should be drilled in infinity-target readings and ground-target readings until they can get a calibration by these methods which is just as satisfactory as a correction based on aerial target readings. They should also be drilled in height-of-image adjustment technique until they can make this adjustment with a precision (spread less than 1 mil of apparent field) which does not destroy the accuracy of infinity readings on stars.

A further test result of importance to training was the demonstration that Mark 10 radar ranges on targets beyond 6,000 yards were satisfactory reference ranges for use in scoring student operators or in calibrating rangefinders.²¹ The method requires, of course, an accurately calibrated radar but it has the great advantage that it lends itself to use aboard ship and in the field where calibration data are usually hard to obtain.

4.2.5

Learning Rates

There are five studies from which learning data may be drawn in an analysis of the time required to train stereoscopic operators.^{1, 2, 16, 20, 27}

Two measures of student performance were used in these studies: the UOE score and the variability score. Both are measures of the variability of observer readings. The UOE score is the mean deviation of the readings expressed in units of error; a unit of error is a disparity of 12 seconds of arc at the observer's eye between the right and left eye field of view. The variability score is a measure of the spread of the readings. It is based on the median errors of sets of three consecutive readings. The variability score turns out to be between 2 and 2.5 times as large as the UOE score, so the scales

on the graphs which follow are corrected by a factor of 2 wherever variability scores are used.

Curves showing the decrease in the variability of student readings with practice on the heightfinder are shown in Figures 1 and 2.

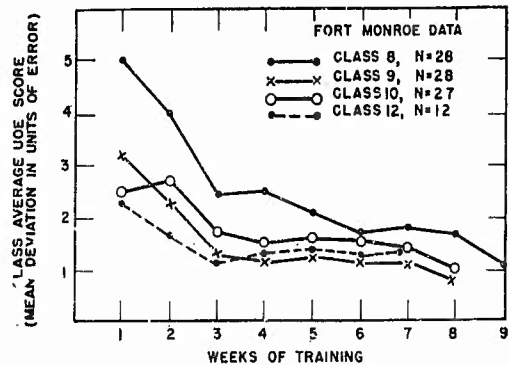

FIGURE 1. Learning curves showing decrease in variability of fixed target readings on the heightfinder. (Classes had no previous training on the trainer.)¹

None of the classes represented in these data had any previous or concurrent training on stereoscopic trainers. Figure 1 indicates that 3 weeks of training in ranging on fixed targets is sufficient to bring the students to their best

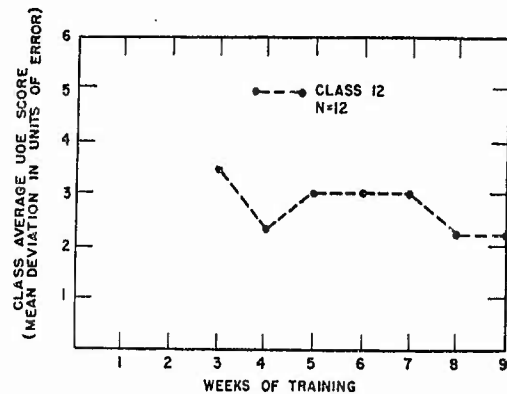

FIGURE 2. Learning curve showing variability in aerial target altitude readings on the heightfinder. (The class had no previous training on the trainer.)^{1, 27}

level of performance. Though the data in Figure 2 are based on the records of a very few students, they show that the typical UOE score for height measurements by graduating student observers is between 2 and 2.5 UOE.

Since most of the heightfinder and range-finder operators trained in schools during the war received their initial stereoscopic training on synthetic devices, Figures 3 and 4 are of interest. In the heightfinder training program, the first few classes trained on trainers were required to make a great many trainer readings on both fixed and moving targets. Learning records for these classes were analyzed to determine how many practice readings were needed before the classes reached their learning plateau.² Some of the results (the learning curves for fixed target trainer readings) are shown in Figure 3. The two curves represent

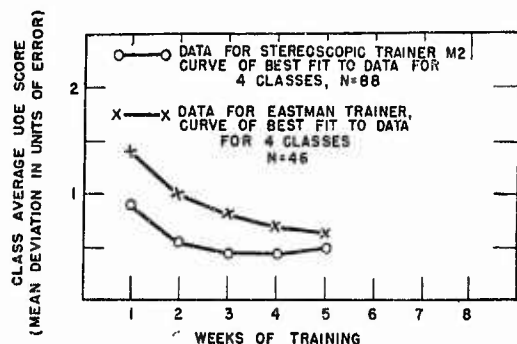

FIGURE 3. Learning curves showing decrease in variability of fixed target readings on stereoscopic trainers.² (Scale of error is expanded in comparison with Figures 1 and 2.)

the records of men trained on M2 trainers and of those trained on Eastman trainers. Both curves show a learning plateau after about 2½ weeks. Learning curves for moving target readings made by the same men parallel the present curves. The M2 trainer men took about 2,700 trials to reach a plateau, and the Eastman trainer men about 3,200 trials.

When the rangefinder training program was set up at NTS, Fort Lauderdale, a similar analysis of the trainer learning curves was made for 87 students in one class.¹⁶ The records for these men are summarized in Figure 4. The 8 weeks of training represented in the figure combine training on fixed targets and on moving targets, as indicated at the bottom of the graph. Throughout the training period, a total of 2,900 readings was made by each man. The learning plateau for this class was reached

at about the end of the seventh week, which means that the number of trials to reach the plateau agreed very closely with that found in the heightfinder study.

Data on the rate of learning to range on aerial targets after training on stereoscopic

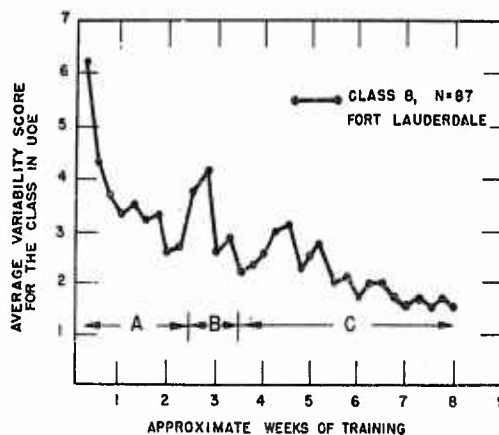

FIGURE 4. Learning curve showing decrease in variability of readings on stereoscopic trainer M2.¹⁶ (Variability score scale adjusted to be roughly equal to UOE score scale in Figure 3.)

trainers is shown in Figure 5. The curves are for two classes of students at NTS, Fort Lauderdale.²⁰ Statistical analysis of these curves indicates that there is no significant improvement in performance after the first quarter or third of the training program. This confirms the results of an earlier study of heightfinder observers in which it was found that men with previous experience on the trainer needed only about 500 readings on aerial targets on the heightfinder itself to complete their training.¹ The figure 500 corresponds very closely to a third of the training readings (1,700 total) represented in Figure 5.

In summary of the present learning data, the following conclusions can be drawn.

1. Students reach a plateau in trainer learning in terms of the variability of their observations after about 2,500 trials.
2. Students, even those previously untrained on trainers, need no more than two weeks of training in fixed target ranging on the rangefinder or heightfinder before they reach a plateau.
3. Following practice on a trainer, some 500

trials of aerial target readings bring variability close to the learning plateau.

It will be noted, however, that these data leave some important questions about rangefinder learning unanswered. In the first place, all the records presented here are in terms of

the absolute sense. As a matter of fact, the trainer validation study itself used variability scores as the validating criterion. If one were to insist on completely refined experimentation, the validation study should be repeated to determine how much practice on trainers can be substituted for practice on rangefinders or heightfinders in a program which has *accuracy* of readings as its primary objective.

In the second place, the value of overtraining on the trainer (or on the rangefinder) is not known. Even though a student reaches his learning plateau on the trainer in some 2,500 trials, it is possible that the skills which he transfers to the rangefinder or heightfinder continue to develop through 3,500 or 4,500 trainer trials; these extra trials would be called 1,000 or 2,000 trials of overlearning. Conversely, it is possible that students profit only from their first 1,000 trials on the trainer even though they have not reached their trainer learning plateau in this time.

Thus, if the stereoscopic method of ranging continues, there is still need for further research.

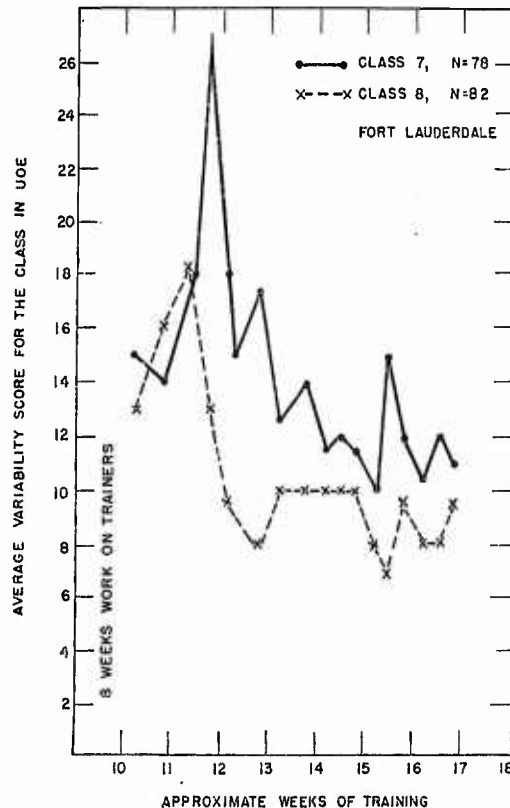

FIGURE 5. Learning curves showing decrease in variability of aerial target range readings on the rangefinder.

The classes had had 8 weeks of work on stereoscopic trainers and had surface target and fixed target training paralleling this aerial target work. The men made about 100 aerial range readings per day, or a total of about 1,700 per man. The variability score scale has been adjusted to be roughly equal to the UOE score scale in Figures 1 and 2.

variability of range or height observation, not in terms of absolute accuracy. Although there is a good correlation between the variability and accuracy of readings of men who have been given many hundreds of trials on the heightfinder, it is not established that 500 trials of aerial target reading are sufficient to train men in reliable calibration, i.e., in getting readings which are satisfactorily accurate in

4.2.6

Proficiency Data

Some information on the proficiency of stereoscopic operators can be drawn from the learning data presented in this section.

Performance on the stereoscopic trainers is far superior to performance on either the rangefinder or heightfinder. This appears to be due to the fact that the target is always clearly seen in the trainer without atmospheric disturbances to trouble the observer and to the fact that instrument variance is practically absent in the case of the trainer. The latter factor is largely unknown, particularly in aerial target readings on the rangefinder or heightfinder.

The mean deviation of the stereoscopic settings of the average student on a trainer should approach 0.5 to 0.7 UOE after training in fixed target readings and should approach 0.8 to 1.0 UOE after training on moving target readings with tracking errors. The range in these figures allows for differences between the M2

RESTRICTED

trainer and the Eastman type trainers.

The mean deviation of the heightfinder students' aerial target height readings is about 2.5 UOE and of range readings is probably about 4.0 (estimated from data in Chapter 22). In general, student performance on the range-finders at NTS, Fort Lauderdale (mean deviation of about 5 UOE, see Figure 5) was poorer than would have been predicted from these Army data. This difference was attributable in part to poor instrument maintenance and to inconvenient and mechanically irregular tracking gear on the range-finders in use.

4.3 TRAINING IN STADIAMETRIC RANGING

Stadiametric ranging is the method of ranging in which range is determined from the angular size of the target. In this method, the target must first be recognized as a plane with a known wingspan or as a tank of a known width or length. Its range is then inferred from its size in the visual field of a telescope or sight. Size judgments are made with reference to the known dimensions of the telescope or sight reticle pattern. To facilitate ranging by this method, many telescope reticles contain graduated mil scales. A target which is 1 yard wide is at 1,000 yards range if it fills a space of 1 mil on the reticle. An attacking airplane with a wingspan of 12 yards is at a range of 2,000 yards when the wing-tip to wing-tip silhouette fills 6 mils of the reticle pattern and is at 1,000 yards when it fills 12 mils of the pattern.

For field artillery operation this is not a difficult ranging method in view of the fact that the target is generally stationary or moving at a very slow rate. Measuring the angular size of the target is accomplished by adjusting the position of the telescope or sight until the reticle crosses the target in some convenient way.

For antiaircraft firing, however, stadiametric ranging is more difficult. There are at least three reasons why this is so. (1) The man who must do the ranging is often a tracker and hence he has more than one job to do. (2) The target moves around in the visual

field according to the tracking errors which are made. (3) The gunsight reticle, chosen for its usefulness in tracking, is not necessarily graduated or designed for ease of ranging. The shifting target pattern must therefore be judged relative to some dimension of the reticle: one-half, two-thirds, or some other fraction of an area or distance represented in the reticle. A typical example is found in anti-aircraft gunsights which use a reticle pattern with a 15-mil or 25-mil diameter circle. At ranges where gunners should open fire, targets may subtend angles of only 7 to 10 mils. Thus, to the other sources of error in stadiametric ranging, there is often added the observer's inability to estimate fractional parts of reticle spaces with accuracy and consistency.

4.3.1 Preparation of Training Manual Material

It had generally been assumed that a gunner who was viewing the target through a tracking telescope could make a better judgment of when to open fire if he determined range by stadiametric methods than if he made a free, unaided estimate. On the basis of this assumption, a number of manuals for gunners and director teams had included diagrams to show how stadiametric range estimates could be made in terms of the relative size of target and reticle. Typical manuals which had carried this information included the following Navy publications: *Gunners' Bulletin No. 2, Use of the Gunsight Mark 14, Operating Instruction for Use of the Gun Director Mark 51, Model 3, and Operating Instructions: Gun Director Mark 52.*

For purposes of simplifying the stadiametric task for the gunner or tracker, enemy planes were classified into three groups: those with wingspans approximating 36 feet, those with wingspans approximating 50 feet, and those with wingspans approximating 75 feet. Most single-engined fighter planes, carrier-based bombers, and two-engined bombers fall respectively into these three classes. Classification of targets could be simplified to this degree because wingspan variation within these three plane types was small in relation to errors in

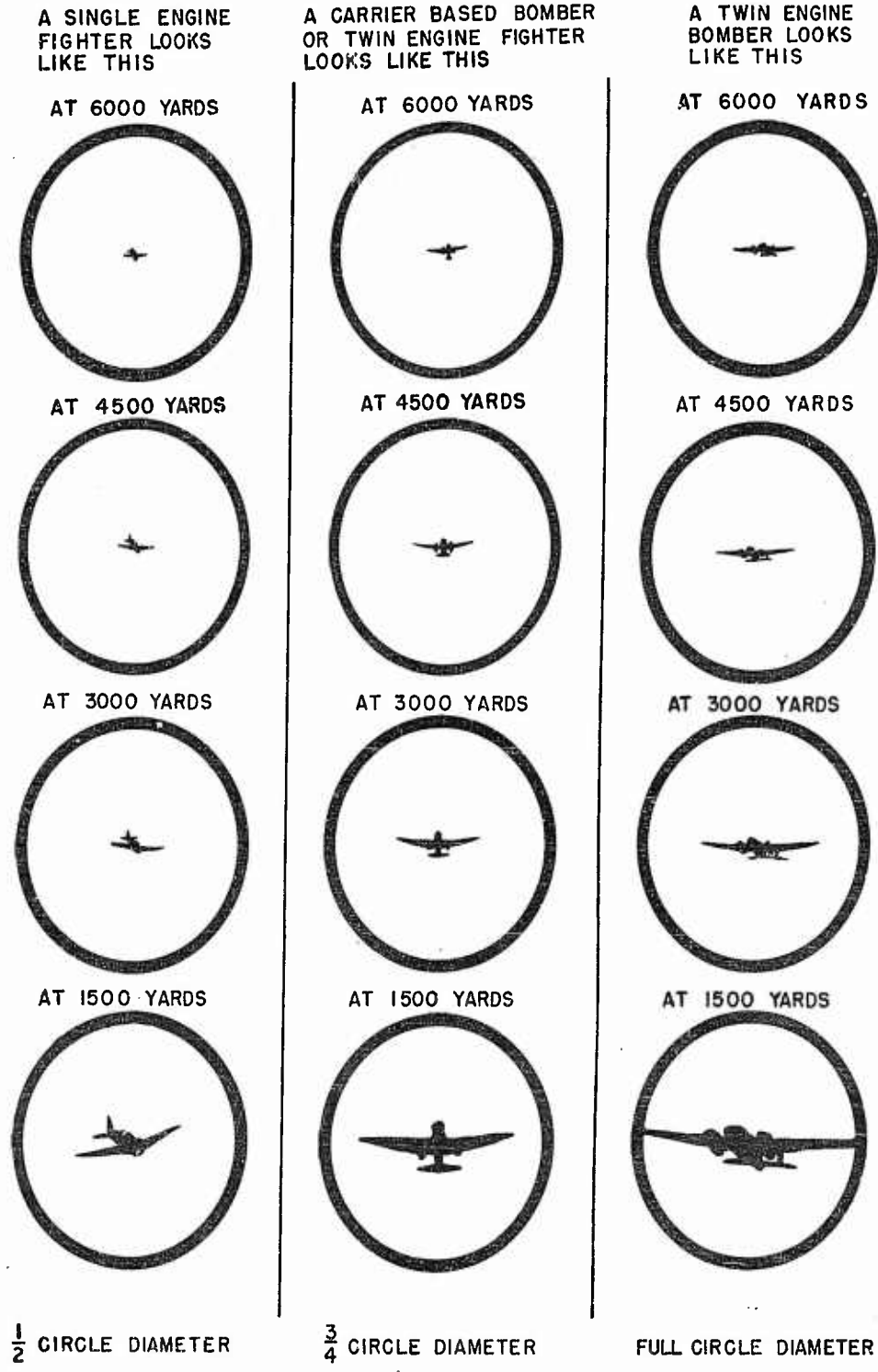

FIGURE 6. Appearance of aerial targets at different ranges as seen through the gunsight Mark 15.

RESTRICTED

stadia metric observation. Once the tracker or gunner identified the target and its class, his ranging job became one of observing when the target filled a specified fraction of the reticle. Diagrams illustrating how the three classes of target appeared at different ranges through the gunsight Mark 15 are shown in Figure 6, taken from *Operating Instructions: Gun Director Mark 52*.

4.3.2 Proficiency of Ranging with the Reticle in the Gunsight Mark 14

In connection with a study of procedures for operating the gunsight Mark 14 on the 20 mm gun, Project N-105 compared the proficiency of free range estimation and stadia metric estimation using the reticle pattern in the gunsight.

Groups of 18 men each were trained in stadia metric observations and were then tested to determine how well they could judge when the target was at 1,700 yards, i.e., when they would open fire. At this range, the target wingspan filled about one-third the diameter of the smaller of the reticle circles in the gunsight. The judgments made by each group on each trial were assembled into separate distributions. The means of these distributions deviated 229 yards on the average from the required 1,700 yard range. The average standard deviation of the distributions (18 judgments each) was 411 yards.

4.3.3 Methods of Training Men in Ranging with the Mark 14 Reticle

In an experiment to determine the relative efficiency of different methods of training gunners in stadia metric ranging with the gunsight Mark 14, Project N-105 compared four methods of training. These were method 1, a 10-minute period of indoctrination or instruction, with the aid of wall charts, in the use of the reticle in the estimation of target range; method 2, indoctrination as in method 1 plus two 1-hour periods of estimation and training on the mirror range estimation trainer, device

5C-4; method 3, indoctrination as in method 1 plus about ten training trials on the firing line; method 4, indoctrination and training on the 5C-4 as in method 2 plus about ten training trials on the firing line using the actual gunsight and a real target. One day after training, each group was tested for its accuracy in stadia metric range determination using the gunsight Mark 14 on the firing line.

The mirror range estimation trainer, device 5C-4, is an instrument designed by the Special Devices Division, Bureau of Aeronautics. It permits eight men to observe simultaneously the approach or withdrawal of an airplane model and to estimate the portion of an illuminated reticle pattern which it fills. On instructional trials, the apparent range of the target, in terms of the visual angle which the model subtends, is announced at intervals and the men observe target size relative to reticle size. On test or drill trials, the target is brought in from long range and men record (by marking a moving paper disk) when they believe that the target has reached the desired angular size or opening fire range. Upward of 50 drill trials comprised the two-day experimental training program on this instrument.

In training on the firing line, the men tracked an approaching target with the gunsight Mark 14 mounted on a 20 mm gun. On instructional trials, an instructor announced radar-measured ranges to the target at 5,000, 4,000, 2,500, 1,700, and 1,000 yards. Three such trials were interspersed with drill trials in which the men indicated when they thought the plane was at 1,700 yards and were advised of their errors. The procedure for having the men indicate the range at which they would open fire was as follows: The instructor who had access to radar-measured ranges called successive letters of the alphabet for each 200-yard point on the target's incoming run. Thus at 4,000 yards he might call "A," at 3,800 "B," at 3,600 yards "C," etc. Each gunner remembered the letter which was called at the time or just prior to the time at which he thought the range was 1,700 yards. Later he was told which the correct letter was. In this way he knew whether his estimate was short, long, or just right. Since the first letter called varied from trial to trial

RESTRICTED

and was called when the target was at varied ranges, the correct letter was different on each run. Seven drill trials plus three trials of announced ranges completed the program of firing line training.

The ranging test which was given to all groups of men consisted of six trials similar to the firing line drill trials described above, except that information on estimation accuracy was withheld. Three runs for each man were with the target flying at an altitude of 2,000 feet, and the remaining runs were with the target making a simulated torpedo attack. The relative performance of the four training groups is shown in Table 1.

From these results it is concluded that firing line training is, at the moment, the most satisfactory method of training men in stadiametric ranging with the gunsight Mark 14. The device 5C-4 is useful only in those situations where it is impossible or impractical to train on the firing line in the real tracking situation.

4.4 TRAINING IN RANGE ESTIMATION

Range is obtained by estimate in the casualty operation of most fire-control systems and in the standard mode of operation for a number of specific anti-aircraft and tank fire-control

TABLE 1. The effectiveness of different methods of training men in stadiametric ranging with the reticle of the gunsight Mark 14.

Experimental group	Number of men in group	Type of target run	Number of observations by the whole group	Mean target range in yards when it was judged to be 1,700 yards	Per cent of men whose mean judgment was within 200 yards of 1,700 yards
I Indoctrination only	82	Torpedo Med. alt. All	246	2,187	23
			156	2,501	17
			402	2,309	21
II Indoctrination plus 5C-4 training for 2 hours	82	Torpedo Med. alt. All	246	2,080	39
			156	2,364	20
			402	2,191	32
III Indoctrination plus firing line training for 45 minutes	47*	Torpedo Med. alt. All	141	1,710	52
			141	1,918	44
			282	1,814	48
IV Indoctrination plus 5C-4 plus firing line training for 45 minutes	31†	Torpedo Med. alt. All	93	1,775	43
			93	1,799	56
			186	1,787	49

* Drawn from Group I.

† Drawn from Group II.

An inspection of the data in the last two columns of Table 1 shows that method 2 (training on the device 5C-4 plus indoctrination) was more effective than method 1 (10-minute indoctrination lecture). It tended to bring the mean point of range judgment closer to 1,700 yards and increased the number of men whose mean judgment was within 200 yards of 1,700. On the other hand, 5C-4 training was less effective than a short period of ranging on the firing line. Furthermore, since method 4, which included both 5C-4 training and firing line training, did not excel method 3, it appeared that training on the 5C-4 did not add to the skill obtained from firing line training.

systems. In the interest of either application it is appropriate to make experimental inquiry into the adequacy of free, unaided range estimation and of various training methods.

The wartime need for studying range estimation for tank gunnery was recognized somewhat earlier than the need for the experimental investigation of the accuracy of range estimation for anti-aircraft firing. This was probably due to the early importance of tank warfare as well as to the possibility open to many AA batteries of getting range data from a nearby unit by telephone. Among those research agencies which studied range estimation for ground targets and tank objectives were various

RESTRICTED

British research groups,^{31, 35, 37} Division 7 of NDRC,¹¹ and the Princeton Branch of the Frankford Arsenal Fire Control Design Division.^{30, 36} Projects N-105 and N-111 of the Applied Psychology Panel later investigated the accuracy of range estimation for aerial targets.

Range estimation in antiaircraft firing is needed in situations of two types: for opening fire with automatic weapons and for setting range into directors or gunsights when they are operated for barrage or fly-through firing. The only difference between the two estimating problems is a difference in the range at which the estimates must be made.

4.4.1 Training for Estimation at Short Range

It is common observation that 20 mm gunners open fire too soon; that is, they underestimate the range of their targets. Experimentally, it turns out that this is true whether the men are actually at their guns or whether they are simply standing by for the express purpose of estimating ranges.¹⁹ Thus the tendency, at short ranges at least, to underestimate the range of rapidly approaching aerial targets is a very real one. It may be exaggerated by, but it is not caused entirely by, the stress and emotion of combat. It is a wasteful tendency, but, what is more, it often leaves a gunner with an empty magazine by the time the target gets within good hitting range.

It is not difficult to demonstrate that this tendency to underestimate the range of attacking planes can be overcome by a very short training program.¹⁹ In fact, no more than three trials may be required in order to bring a group of gunners to the point where their *average* estimate of the opening fire range is in error by a very small amount.

The training procedure used in the experiment was this: The plane flying on the special training mission, a TBF, was instructed to make simulated torpedo runs on the firing line where the gunners were stationed. The men had a clear, unobstructed view of the target coming in from over the ocean at an altitude of between 50 and 150 feet. During the series of three training trials, an instructor who had

access to radar-measured ranges called the range of the target at 500-yard intervals from 4,000 yards in to 500 yards.

Test trials to determine how accurately the men in the group could estimate a 1,500-yard opening-fire range were carried out before and after the training trials. The method of testing was the same as that described in Section 4.3.3 above, except that the men viewed the target directly, not through a gunsight. The instructor called (over a PA system) successive letters of the alphabet at 200-yard intervals during the target's approach. The men recorded the letter which was called or had just been called when they judged the target to be at 1,500 yards range. The judgments were scored later by the research group. Thus, throughout the experiment the men were ignorant of how well or how poorly they were doing.

A group of 151 subjects participated. Their pre-training test performance and post-training test performance are summarized in Table 2. The table shows a significant increase in the number of judgments which are close to the desired 1,500-yard opening range (last column). This increase results from the shift of the mean judgment for the group toward 1,500 yards (middle column of table) and an attendant reduction in the variation between the judgments of different men. The short program of training was successful.

TABLE 2. Improvement of range estimation as the result of three instruction trials on the firing line. The task: to estimate 1,500 yards range for 20 mm firing.

		Average range in yards of target when men thought it to be 1,500 yards	Per cent of men whose estimates were within 15 per cent of true range*
Pre-training trials	1	2,374	9
	2	2,134	15
	3	2,174	17
Post-training trials	1	1,612	42
	2	1,382	63
	3	1,554	60

* The last column of the table was derived from Table IV, page 6, reference 19, and conforms with the data to be presented in Table 3.

This training method, of course, does not differ significantly from that regularly in use in the fleet. The importance of the experiment

was that it demonstrated how effective the method could be. In order that the facts revealed by the experiment would become known to the fleet and the method applied more widely, the method and test results were described in a short pamphlet, prepared jointly by Project N-105 of the Applied Psychology Panel and the Antiaircraft Training and Test Center, Dam Neck, Virginia, *Instruction in Range Estimation on the Firing Line*.³⁸

Project N-105 also evaluated the mirror range estimation trainer, device 5C-4, for use in training men in free range estimation.¹⁸ It was found that 1 or 2 hours of drill⁴⁵ on the 5C-4 in no way improved the accuracy of range estimation by the experimental group. When these men were tested on the firing line they performed just as poorly as men who had had no training in range estimation whatsoever. Thus, although the 5C-4 is useful to a degree in the training of men in stadiametric ranging (Section 4.3.3), it is of no value in free range estimation training.

4.4.2 Training for Estimation at Medium Range

The accuracy of aerial target range estimation at medium and short ranges was studied by Project N-111 of the Applied Psychology Panel.²² Data were collected for ranges between 1,500 and 8,000 yards, the range in which estimates are needed for target designation and in the use of directors operating without ranging systems.

The experiment sought to determine and compare the accuracy of estimates made by trained and untrained men. Although the number of subjects in the experiment was not very large, the results for several parts of the experiment were sufficiently consistent to indicate that the data are dependable. Four groups of men, totaling 18 in all, participated.

TRAINING METHODS

The training which each of the four groups had varied considerably.

Group A consisted of five fire controlmen. They were tested before and after a 1-month

period of training in the operation of the gun director Mark 52. Work with this director involved some estimation of ranges, usually followed by a radar operator's report of the actual range to the target. Although this range estimation training was informal and a by-product of work with the director, the men improved significantly in their ability to estimate target ranges.

Group B consisted of three fire controlmen who participated in a training study. Their initial estimating ability was measured in a test extending over 3 days before training began. Training sessions ran for 6 days. The training procedure was as follows. As the men observed a designated target, the radar operator gave instructions by loudspeaker, "Ready. . . Estimate." Each observer recorded his estimate on a prepared record form and then looked up to watch the plane as the radar operator announced the range of the target when its range was 200 yards and then 400 yards different from range at the time of estimation. Three estimates at well-spaced ranges were usually made on a single target. About 150 training observations were included in the 6-day period. Then a 2-day post-training test was conducted. Although the men were poorly motivated during the experiment, their records showed considerable improvement in accuracy of estimation as a result of the training.

Group C consisted of seven officers, three of whom had had no sea experience at all and four of whom had had sea experience in fire control or gunnery. These men were given no training as part of the experiment, but they were given a 2-day test to compare the abilities of experienced and inexperienced groups. The group with sea experience, and with such incidental or formal range estimation training as that provides, were significantly better estimators than the non-sea-experience group.

Group D included three research men who were drilled in range estimation. Training began with a procedure identical to that for Group B, with the men making three estimates on each target, but later shifted to a routine in which the men made a single estimate on each target and were then advised by loudspeaker of the range of the target at every

RESTRICTED

500-yard point as long as it was practical to follow the target. Training continued for 10 days, spaced over a four-week period, during which time each man made about 250 estimates followed by range information. Each man in the group became significantly less variable in his judgments and the accuracy of the group became the best of any of the groups studied.

TESTING PROCEDURE FOR ESTIMATION EXPERIMENTS

The observers stood in an enclosure 15 feet square and 6 feet 4 inches high. The walls of the enclosure obscured all land objects, so that the aerial targets were always seen against a free expanse of sky. Each observer recorded his range estimates on a record form which listed ranges from 800 yards to 10,000 yards. Ranges between 800 yards and 2,000 yards were listed by 100-yard intervals, ranges between 2,000 and 5,000 yards by 200-yard intervals, and ranges between 5,000 and 10,000 yards by 500-yard intervals. These recording intervals represented range steps which varied between 5 per cent and 10 per cent of range. Previous records of range estimation for ground targets^{30, 31, 37} indicated that these recording intervals would be below the observers' limit of accuracy for aerial target range estimation.

Estimates were made on "targets of opportunity"—targets on any course, at any altitude, of any size, and observed in weather varying from clear to hazy. No data were secured on days when visibility was below 5,000 yards. Although the record form indicated ranges from 800 to 10,000 yards, estimates were never called for when a target was under 1,500 yards or over 8,000 yards. Since the observers were not advised of this, the response scale was "open" at both ends.

Target ranges were measured with a radar Mark 26 mounted on a gun director Mark 52. The experimenter selected a target, pointed to it, and called its bearing. When the director and radar were "on target," and when all observers reported that they could see it, a series of three estimates on that target was begun. To signal each estimate, the radar operator called, "Ready. . . Estimate," over a portable loud-

speaker system. Each signal was called when the target range was exactly equal to one of the ranges listed on the record form. After the first signal, each observer put a number 1 opposite the listed range corresponding to his estimate. A second and a third estimate were called for at later points in the target's course when range had changed. Each man marked his new estimates on the record form as number 2 and number 3. Twelve runs, three estimates per run, generally constituted a day's test. The radar operator so varied the ranges at which estimates were called for that at the end of each day's test there were about the same number of observations in each of five predetermined and logarithmically equal range zones (1,500 to 2,000, 2,100 to 2,900, 3,000 to 4,000, 4,200 to 5,000, 6,000 to 8,000 yards).

DATA ANALYSIS

The data were analyzed on logarithmic charts. Figure 7 illustrates the plotting pro-

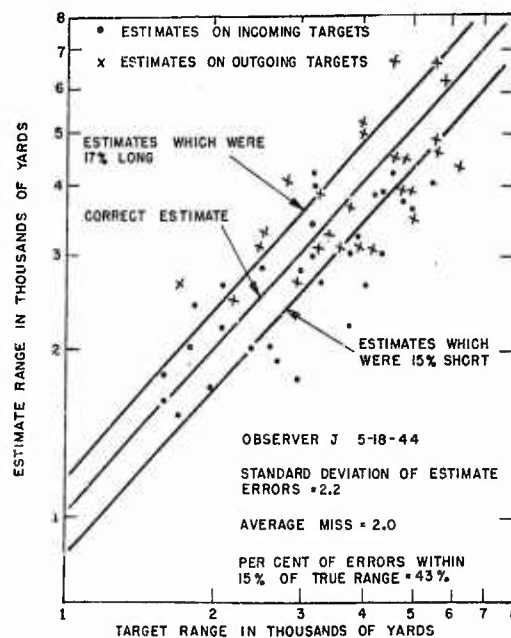

FIGURE 7. Estimates of aerial target ranges.

cedure. Target ranges are given on the logarithmic horizontal axis, range estimates on the logarithmic vertical axis. The central diagonal line represents estimates which are equal to

true range. The two diagonals either side of the correct estimate line are error lines representing a logarithmic error of 0.07. These side diagonals mark a band which includes all estimates from those which are 15 per cent shorter than true range to those which are 17 per cent longer than true range.

On a log-log plot, the pattern of the plotted estimates provides a direct clue to the way in which estimate errors change with range. If the pattern of points is equally wide at all ranges, it may be concluded that variable errors of estimate increase linearly with range. If the pattern of points departs from the central diagonals, the observer has a bias toward underestimation or overestimation. When the scatter of points in Figure 7 is examined, it is seen to be of about equal width at all ranges and to reveal little general bias. The observations made on incoming targets and those made on outgoing targets showed a shift in bias, however, the circles on the average being lower on the chart than the corresponding crosses.

Once the estimates for a given man on a given day had been plotted, his errors from true range were tallied to form a frequency distribution. This tally was made directly from the graph using a logarithmic collection interval corresponding to a 10 per cent range decrement (that is, a logarithmic step of 0.046). Such a logarithmic unit is convenient for measuring systematic estimate errors and variable estimate errors since it gives the same weight to equivalent relative errors at all ranges. To interpret these logarithmic error scores for any observer, it is sufficiently accurate to multiply the score by ten and consider the result as an error measured in per cent of true range.

Three measures of observer performance were used, two measures of error and one measure of successful estimation.

1. Standard deviation of estimate errors. After a frequency distribution of estimate errors (in log steps) had been tallied from the log-log charts, the standard deviation of that distribution was determined. For the estimates plotted in Figure 7, the standard deviation is 2.2 (interpreted as about 22 per cent of true range).

2. Average miss, or average error from true range. From the frequency distribution of estimate errors (in log steps), the average error, neglecting algebraic sign, was determined. For the estimates plotted in Figure 7, the average miss was 2.0 (interpreted as about 20 per cent of true range).

3. Per cent of estimates within 15 per cent of true range. This was based on a count of the number of estimates falling within the central diagonal zone on the log-log chart—the estimates which fell within 1.5 logarithmic error units of true range. Forty-three per cent of the estimates plotted in Figure 7 fell within the 15 per cent zone.

RESULTS

The results for the four groups of subjects are summarized in Table 3. All the observations by the men in any one of the groups were massed in a single distribution for purposes of this final summary. The data in the table indicate what can be said about the accuracy of single observations taking into account the variability of estimates for any one man, the variability of estimates from man to man, the variability introduced by changes in weather and visibility conditions from day to day, and the variability introduced by changes in target size and target course.

It will be observed from an inspection of the table that the per cent of estimates which fell within 15 per cent of true range for each of the trained groups was about the same. These figures, in excess of 40 per cent, are smaller than those presented in Table 2, Section 4.4.1 above, for the case of estimating the range to a target on a torpedo run. Although the training was very brief in the case of the latter study, the excellence of the estimates in terms of the per cent of individual judgments within 15 per cent of true range is to be accounted for most probably in terms of the simplicity and constancy of the observation situation from trial to trial during training and test. The combined results of the two studies suggest that gunners who are trained especially to estimate opening range for 20 mm firing can be expected to cluster their observations closer (on a per cent of range basis) to the desired range

RESTRICTED

than director operators who must estimate ranges over a wide variety of conditions and ranges.

Table 3 shows that practice in aerial target range estimation increases the per cent of observations within 15 per cent of true range from about 25 per cent to about 40 or 45 per cent. At the same time the average error of a single range estimate drops from about 33 per cent of true range to about 22 per cent of true range. These values represent general averages for the four groups of subjects. All forms of

men should participate actively by recording their observations. Their performance should be scored promptly in some way, so that the men learn quickly of their errors. Until other data are forthcoming, the data cited in this chapter can be used as standards against which to compare the scored performance of Service groups in training.

The tendency to underestimation which is so prevalent within 20 mm gun range was not observed in estimates at longer range.²² This may mean that estimates are seriously influ-

TABLE 3. Training data: aerial target range estimation at medium ranges.

	Total number of estimates made by the group	Standard deviation of estimate errors	Average miss or error from true range	Per cent of estimates within 15% of true range
Group A: 5 fire controlmen				
1-day test before work on Mark 52	150	3.3*	3.6	25
1-day test after 1 month of work with Mark 52	493	2.4 <i>p</i> < 1%†	2.3	41
Group B: 3 fire controlmen				
3-day test before range estimation training	400	3.4	3.0	30
2-day test after 6 days of range estimation training	153	2.9 <i>p</i> = 2%†	2.5	41
Group C: 7 officers				
3 officers without sea experience (2-day test)	185	3.2	3.2	23
4 officers with fire-control and gunnery experience (2-day test)	186	2.6 <i>p</i> < 1%†	2.1	42
Group D: 3 laboratory men				
Data for 6 days after 10 days of training (about 250 reinforcements)	400	2.1	1.9	45

* Multiply by 10 in order to interpret as per cent of range. See text.

† Probability that difference between the above pair of figures could have been due to chance factors alone.

training represented in the experiment were effective, but the best range estimation performance was obtained with the most interested group of subjects, Group D, which was given the most formal and longest training.

4.4.3 General Conclusions on Range Estimation Training

Relatively short periods of training and drill in situations resembling combat situations and involving actual airplane targets can be very effective in reducing range estimation errors. In such training, the gunners or fire control-

enced by the observer's "set" and that "to open fire" establishes a different set than "to put range in a director." More research on this problem is in order.

Relatively frequent refresher drills, perhaps one every 2 or 3 weeks, may be required to keep men up to par in their estimating skill. Not many data were gathered on the subject of the retention of range estimation skill in the course of the wartime studies, so this is a field which still requires careful investigation. The only pertinent data which can be cited are the following. In the estimation of opening range for 20 mm operation, there is some decrement in estimation accuracy 11 days after

training, but there is still a significant amount of skill retained.²⁰ In the experiment on medium range estimation, each of the Group D men was just as consistent in his judgments 60 days after training as he had been at the end of training, but he was no longer as accurate. Biases appeared in their observations. This corresponds to a loss of calibration, if you will. Short and frequent periods of drill on friendly targets would overcome this trend toward inaccuracy by permitting each man to reestablish his calibration and bring his estimation scale once more in line with the scale of true ranges.

The foregoing data on the estimation of

range to aerial targets are in agreement with the general results on the estimation of range to ground targets for artillery and tank firing. Average range estimation errors increase in an essentially linear way with range. This finding, confirmed for aerial target range estimation, parallels the data on sensory discrimination which are subsumed under the Weber-Fechner law of discrimination—that the ratio of observation error to the magnitude observed is a constant. Thus, unaided visual range estimation resembles, in its quantitative characteristics, other more completely analyzed and more commonly studied forms of human perception.

RESTRICTED

Chapter 5

TRAINING THE B-29 GUNNER

By Charles W. Bray^a

SUMMARY

IN CONNECTION with other research on B-29 gunnery, Project AC-94 of the Applied Psychology Panel studied the scoring of gun camera film, a checksight for B-29 gunners, and the effects of coaching in a training program. A new scoring method was developed which required less than one-third the number of man-hours of the standard Army method. The checksight provided unreliable scoring but probably motivated the men to better performance. Coaching had less effect than expected on the basis of general psychological experience. The data of the coaching experiment indicated that gunners adopted a standard pattern of ranging, tending to over-range at the beginning and to under-range at the end of an attack.

5.1

INTRODUCTION

In connection with a program of research on psychological problems in the design and operation of the B-29 gunsight as described in Chapter 20, the training of the B-29 gunner was studied by Project AC-94 of the Applied Psychology Panel. Research problems of design and operation can be solved only by the development of adequate methods of measurement of gunner performance and by studies of the ability of the average gunner to learn to use his equipment. Thus research on design furnished by-products in the form of contributions to training problems.

The B-29 gunner had to track and to range simultaneously. In all studies conducted by Project AC-94, the gunsight (Figure 1, Chapter 20) required position tracking through an optical sight; a spot of light in the center of the field of view of the sight was held on the target. Around this spot were a varying number of illuminated diamond-shaped dots out-

lining a circle. The diameter of the circle was controlled by the gunner, giving a measure of target range when the apparent distance from wing tip to wing tip just equaled the diameter (adjustment for variation in target size was made in advance of an actual attack).

The gunner's task was difficult and complex. He was required to track skillfully (the problems of tracking without simultaneous ranging are considered in Chapter 3). Accurate ranging required that the wing tips be framed by the reticle. Inadequate tracking required a change in the method of ranging from the relatively simple process of framing to the more difficult process of comparison of two dimensions. When the target approached at an angle other than head-on the gunner had to correct for the effects of perspective on wing length. In addition, since the reticle circle was defined only by eight to twelve discontinuous dots, it was seen by some gunners as a polygon rather than a circle. Also, the central dot, which should have helped to define a diameter, was frequently disregarded as the gunner's attention shifted from tracking to ranging. Thus the gunner sometimes chose a chord rather than a diameter as the critical dimension. Finally, the attacks were very short in duration because of the high speed of the B-29 airplane.

In view of the difficulty of the task, the success of the B-29 gunners is worthy of remark. The data given below and in Chapter 20 show that he could track with an accuracy approaching 5 mils and that the average error of ranging could be reduced to about 10 per cent of range. These figures were by no means typical of standard Army results in B-29 gunnery. They were achieved after special training on a few types of attack and only on the ground. Nevertheless they were achieved by standard Army personnel. The objective of the research of the Applied Psychology Panel, in collaboration with the Research Division, Laredo Army Air Field, was to attain similar results under all conditions.

Contributions were made by Project AC-94

^a This chapter is based on the work of Project AC-94.

in three phases of the training program: (1) the measurement of gunner performance, (2) training methods, and (3) the development of synthetic trainers. Because the last topic is so closely related to the program of evaluation of B-29 gunnery equipment, it is discussed in Chapter 20 rather than in this chapter. Certain technical questions relative to the measurement of gunner performance are also treated in that chapter. In the discussion which follows it is assumed that the reader is familiar with Chapter 3, Training Trackers for Antiaircraft Fire Control.

5.2 THE MEASUREMENT OF GUNNER PERFORMANCE

A basic need in any training program is to measure the performance of the trainee. The instructor needs to know men's scores to determine which need coaching and which have achieved a level satisfactory for "graduation." If a score is furnished the trainee, he will compete with others and with his own past performance. For both instructor and trainee there is need for a valid, reliable, and informative score that will be available immediately or as soon after the performance as possible.

In the fall of 1944 the training of B-29 gunners was accomplished in three ways: on the ground through use of synthetic targets, in the air through use of simulated attacks on a bomber by pursuit planes, or in a mixed situation by simulated attacks of a real plane on a ground mock-up of a bomber. In all phases a contribution was made to the measurement of performance. The development of scoring with synthetic targets is described in Chapter 20.

5.2.1 Scoring Gun Camera Film

In air-to-air and mixed practice, the gun camera was in standard use. The gun camera, attached to the sight and photographing the sight reticle and target, furnished a film record of gunner performance. At the completion of practice the film was developed and errors were measured. Frequently the film was also

shown to the gunner to indicate the quality of his performance. Since thousands of gunners were under training, use of the gun camera was a major undertaking. Photographic development, alone, was a difficult problem. Scoring required over 6 man hours for about 6 minutes of "firing." These 6 minutes included about 50 representative attacks.

METHOD OF SCORING

The standard method of scoring was to measure every tenth frame of the projected film. The size of errors in tracking and framing was stated in terms of millimeters. This unit was relatively meaningless to the gunner. Thus the method provided less information than was desirable, it was arduous, and the information was given the gunner long after the performance. Nevertheless, when time permitted its use, it provided the only quantitative information received by the gunner.

The project simplified¹ the scoring of gun camera film by an adaptation of the checksight method, per cent of observation instants on target, described in Chapter 3. The method developed for the gun camera was named the on-target method.

In on-target scoring, each frame of projected film was judged to be on the target in tracking if the center dot of the reticle touched a part of the target fuselage forward of the trailing edge of the wings. It was judged on the target in ranging if the diameter of the reticle circle was within ± 5 per cent of the distance from wing tip to wing tip.

The on-target score consisted of the percentage of all film frames in which the gunner was within the tolerances for tracking and ranging simultaneously. This score seemed more meaningful to the gunner than the arbitrary millimeter score used in the standard procedure.

Normally the scorers estimated whether the film met the tolerances, but they checked themselves by measurement in case sequences of doubtful frames occurred. A method of training observers in making the estimate was developed. Observers should be given refresher training from time to time to check any tendency toward a shift in the tolerances.

RESTRICTED

From the same data two other scores were derived, the computer-on-target score and the hits-on-target score. The computer-on-target score was developed in order to remind the gunner that the B-29 computer does not instantaneously solve the problem of integrating the input from the gunsight. After the gunsight has moved, there is a delay before the effect of the sight movement is fully realized in gun movement. The length of the delay varies but a standard delay of $\frac{1}{2}$ second was arbitrarily assumed to be accurate enough for training purposes. On this assumption the gunner had to be on target in tracking and ranging for $\frac{1}{2}$ second before the computer drove the guns into proper firing position. The computer-on-target score, therefore, was calculated by subtracting eight frames ($\frac{1}{2}$ second) from the number of frames in each sequence of on-target frames. The remaining frames in the sequence were computer-on-target frames. The sum of these expressed as a percentage of the total number of frames for the attack was the computer-on-target score. The hits-on-target score was based on computer-on-target frames occurring when the gunner pressed the trigger.

The hits-on-target score was not evaluated in the work of the project, and the computer-on-target score was evaluated only for the ground mock-up. The tolerances for air-to-air firing, as will be shown below, were set too narrowly in the Panel's studies, and computer-on-target scores were usually zero in aerial practice.

EVALUATION OF SCORING ACCURACY

To evaluate the on-target scoring system a group of 20 experienced gun camera film scorers from all Air Forces training centers was assembled. Over a period of 5 days these enlisted men were trained in the use of the new method and given refresher training in the old by scoring and rescoring film for 50 attacks. A different set of 50 attacks of ground mock-up film and 40 attacks of air-to-air film were then scored twice by each method (orders of scoring counterbalanced).

In Table 1 are stated the general level of ability and the variability of performance shown by the sample films used in the experiment.

For these films, originally thought to be representative of gunners in operating training, the mean on-target scores were 29 per cent for the mock-up and 13 per cent for air-to-air attacks. It will be shown below that these figures give too high an estimate of the ability of the gunners at this stage of training. Since the most effective on-target scoring system gives mean scores of 50 per cent, it must be concluded that the tolerance limits within which the gunners were judged on target were set too narrowly. Nevertheless enough variability existed in the sample films to warrant a preliminary correlation analysis of the reliability of the method.

TABLE 1. Average performance in gun camera practice when scored by various methods.

Score	50 Mock-up attacks		40 Air-to-air attacks	
	Average at-track scores	σ distribution	Average at-track scores	σ distribution
On target	29.11%	23.48%	13.28%	15.37%
Computer on target	14.11%	16.74%	1.64%	4.30%
Measured tracking error	5.54 mm	3.32 mm	11.39 mm	5.40 mm
Measured ranging error	12.81 mm	11.07 mm	12.99 mm	9.89 mm

In Table 2 the consistency of the individual scorers is shown by the mean reliability coefficient for first and second scorings by each method. Ranging error is more precisely determined by the measuring method of scoring, but the obtained reliability of the on-target method is adequate. The data may be expressed in another way by the statement that the average difference from first to second scoring was roughly 1 to 8 per cent for the various conditions and scores by the on-target method, and roughly 1 to 2 mm by the measuring method.

A study of inter-scorer differences gave the same conclusion. Throughout all comparisons, measured framing error was the most reliable and objective score, but the on-target method was reasonably satisfactory.

The correlations of the two kinds of score with measured accuracy on every frame of the film were calculated. The correlation of meas-

ured accuracy in ranging on every tenth frame with measured accuracy on every frame for 29 of the attacks was .999, the average difference being only 0.2 mm. For the on-target score, however, the correlation with measured accuracy on every frame in ranging was only .68, and 12.7 per cent of all frames were incorrectly

TABLE 2. Mean of 20 score-rescore reliability correlations of gun camera film by various scoring methods.

Score	Mean <i>r</i> for 50 mock-up attacks	Mean <i>r</i> for 40 air-to-air attacks
On target	.86	.84
Computer on target	.81	*
Measured tracking error	.88	.82
Measured ranging error	.97	.93

* Such a high proportion of air-to-air computer-on-target scores were zero that this correlation coefficient would be meaningless.

judged as being on or off target as defined above. The data indicated that the scorers were generally too strict.

Although the measurement method showed some superiority in reliability (for ranging) and in accuracy, it required 3.3 times as many man-hours to score the film by it as by the new on-target method.

These results of the comparison of scoring methods show a very small loss of reliability when estimation replaces measurement. The lack of a greater difference between the two methods is understandable if one considers the details of the measurement method actually used on gun camera film. For tracking, the scorer judges the center of the target's nose and measures the distance of the reticle dot from this judged center. The judgment may vary considerably. In the case of ranging, the wing tips are often poorly defined on the projected image. In addition, the time required to make measurements permits the film to heat and expand between measurements of reticle and target sizes.

The on-target method was applied in a follow-up study⁴ to the film of 250 gunners who received, on the average, three sessions each of mock-up training and air-to-air training during the period March to July 1945. The number of sessions varied considerably for the individual gunners. Much of the film could not

be scored because of poor photographic quality. The results of the follow-up experiment indicated that the performance of these gunners was very poor. Their on-target scores are shown in Table 3. The table indicates a low level of achievement in this training which just preceded combat. The distributions are J-shaped with a preponderance (50 to 72 per cent) of zero scores. A study of the 28 gunners who had scorable film for successive sessions gave small evidence of improvement as training progressed.

TABLE 3. Distribution of on-target scores in scorable gun camera film of 250 B-29 gunners during operational training, March to July 1945. The units for table entries are single attacks.

On-target score	Session 1	Session 2	Session 3	Session 4
Manipulation tower				
0	188	136	108	55
1-10	38	32	31	9
11-20	14	14	13	4
21-30	10	9	7	3
31-40	6	2	5	3
41-50	2	4	4	2
51-60	2	0		
61-70		1		
Total	260	198	168	76
Air-to-air				
0	209	175	87	33
1-10	83	63	31	19
11-20	25	26	17	9
21-30	17	23	10	3
31-40	2	3	4	2
41-50	5	3	2	
51-60	1	3	1	
61-70	0			
71-80	0			
81-90	1			
Total	343	296	152	66

5.2.2 A Checksight for Scoring B-29 Gunners

The many defects of the gun camera were obvious. At best it provided a score or permitted coaching long after the completion of a particular practice session. In addition, it was very expensive. A substitute method was desirable.

On synthetic motion picture trainers Army instructors often modified the optics of the gun-sight so that the reticle was projected on the screen. Thus the instructor could see the results

of the gunner's efforts and have a basis for coaching him. It was recognized that the instructor's judgments were relatively unreliable in this situation, but it seemed possible that the unreliability was due in considerable part to the poor definition of film targets. Hence, in the summer of 1945, an Army technician developed a checksight for use on real targets. This checksight was a hand-held telescope in which reticle size was controlled by a repeater from the gunsight.

Project AC-94 undertook the evaluation of the checksight.² With it, the instructor tracked the target and observed the gunner's ranging. At one-second intervals the instructor informed the gunner that he was "over," "under," or "good" in ranging. The judgments were recorded and later compared with gun camera film. The accuracy of judgment was low. However, the performance of the gunners in the experiment was very good. It seemed possible that the checksight, despite its inaccuracy, served as a motivating device. Additional studies of the device were planned, but the closing of the project prevented further research.

5.3 AN EXPERIMENT IN TRAINING B-29 GUNNERS

A single, preliminary study in training methods for B-29 gunners was carried out under Project AC-94.⁴ The primary purpose of the study was to compare a training program in which the gunner's faults and successes were analyzed and explained to him immediately after his practice with a program in which no such coaching occurred.

The analysis and explanation of the gunner's faults and successes were made possible by recording tracking, ranging, and triggering on a moving-paper kymograph. The movements of the appropriate sight controls were transmitted mechanically to the kymograph pens (Chapter 20). A modified E-14 trainer provided a motion picture target.

Two groups of 12 inexperienced gunners each and a third group of 10 graduates from a basic school for B-29 gunners served as subjects. The

two groups of inexperienced gunners were balanced for GCT score. They were also equated for original proficiency on one attack, but it was discovered later that this did not serve to equate them on all attacks.

One group of inexperienced gunners was coached over the 20 days of the experiment and one was not. The graduate group was uncoached for the first 8 days and then coached until their training ceased on the fourteenth day. Coaching consisted of analyzing, with the aid of the gunner, two of six recorded attacks out of a total of 16 attacks for each man on each day of the experiment. The 16 attacks were those on the training film P-7, which gave beam attacks of fairly high speed.

Every man in the experiment received a daily score on his ranging performance. This score was the mean (regardless of sign) measured ranging error at $\frac{1}{3}$ -second intervals throughout one of the recorded attacks. Use of this error score as a motivating device distinguished the training of all gunners in the experiment from standard Army training.

The results on the main experiment may be stated in terms of framing error on five of the recorded attacks. Mean performance of each of the three groups for all five attacks is shown in Figure 1. The coached group was slightly superior to the uncoached group. The superiority appeared throughout the experiment. The difference persisted at a confidence level of .06 when the original superiority of the coached group was taken into account. Thus the difference between the groups was in the direction expected on the basis of other psychological studies, but the magnitude of the difference was too small to be accepted with confidence.

The experiment also showed that the graduate gunners were no better at the beginning than the inexperienced men. Nor did the graduates improve more rapidly. It is evident that standard Army training was essentially ineffective, at least as far as ranging accuracy was concerned. It is also evident from the data that training which includes a motivating score is effective in improving performance, not only for inexperienced men but for experienced men as well. An average error in ranging of around

10 per cent of range is a satisfactory performance relative to the 20 per cent error, which was typical of all groups at the beginning of the experiment.

That the final performance level of all groups was satisfactory is also suggested by a follow-up in air-to-air firing. The study used the firing error indicator, which is an acoustic device mounted in a towed glider to provide a measure of the accuracy of actual fire on a target.

Against 18 crossing-over attacks for each man the gunners of the experiment fired a total of 15,000 rounds. According to the firing error indicator 5.7 per cent of all rounds were within 2.5 yards, 7 per cent were within 2.5 to 5.0 yards, and 18.6 per cent were within 5 to 10

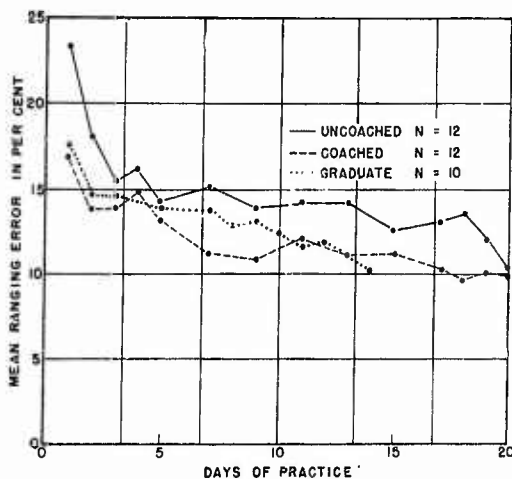

FIGURE 1. The effects of coaching on mean ranging error for 20 days of practice. The group of graduate gunners was uncoached for the first 8 days and coached thereafter.

yards of the target. If such accuracy were attained against real targets there would be

no question of the adequacy of the training given the men. There were no differences among the three groups of the experiment. Unfortunately, comparable data for men trained only by Army standard methods were not secured before the war's end.

Perhaps the most interesting result of the ground experiment was the indication that ranging errors show systematic variation in the E-14 trainer situation. On all five attacks, there was a tendency toward overframing of the target at the beginning of the course and underframing as the target closed. The tendency persisted despite an overall constant error of underframing on a fast attack and of overframing on a slow attack. The data suggest that the gunners tended to adopt a pattern of ranging which was independent of the target movement. Any further experimentation on this subject should consider at least the following: the poor definition of motion picture targets; the relatively large size, at long ranges, of the dots defining the reticle circle; and the overall complexity of the gunner's task which may lead him into a series of more or less automatic and nondiscriminating reactions (Chapter 20).

5.4

CONCLUSION

The Panel's studies of the training of B-29 gunners demonstrated that time could be saved in the scoring of gunner performance for training purposes and that improvement in training methods was possible. In addition, they suggested that systematic experimentation on training might yield some understanding of the limitations on gunner performance which the difficulty and complexity of the task impose.

Chapter 6

NIGHT LOOKOUTS

By Dael Wolfe^a

SUMMARY

A SHIPBOARD STUDY of the performance of night lookouts on duty in an Atlantic convoy provided specific information on the average ability and the variation in ability of night lookouts to spot targets. The best lookout was able to see a ship nearly four times as far away as the poorest one. This difference was not due to differences in night vision as measured by the adaptometer.

Two night vision trainers and a training exercise in the use of binoculars at night were constructed and submitted to the Navy. Assistance was given in the preparation of literature for the training of lookouts.

6.1

INTRODUCTION

The lookouts, the "eyes of the ship," have always played an important role in naval operations. They watch for other ships, friendly or enemy, or for lights, smoke, or debris that may indicate the presence of another ship. They help in navigation as well as in combat. In more recent years submarines, periscopes, torpedoes, and airplanes have been added to the list of things to watch for and report.

In one sense the task of the lookout is a very simple one. He merely scans his sector of the sea or sky and reports what he sees. But in another sense his difficulties are fairly great. Looking steadily at a sector of the sea with nothing in sight but the sea is not conducive to a wide-awake alertness. So questions of fatigue and of motivation are added to the obvious visual aspects of the lookout's job. Airplanes approach with such high speed that systematic and rapid scanning becomes necessary. At night the lookout must learn to acquire and maintain dark adaptation and must learn how to use his eyes most effectively in the dark if he is to pick up targets in time for appropriate

^aThis chapter is primarily based on the work of the staff of Project N-115.

action to be taken. In order to make accurate estimates or readings of the range, position angle, target angle, and relative bearing of a target, he must learn a number of special techniques and must learn how to use the equipment supplied him. In order to increase his range of vision he must learn how to adjust and use binoculars. All of these requirements add to the difficulties of the lookout's task and create problems of proper selection and adequate training.

The Navy, well aware of these problems and aware also of the rather low prestige of the lookout's job, a prestige which made it difficult to assign good men to this job, asked the Applied Psychology Panel to make "an analysis of the duties and successes of officers and enlisted personnel in various night lookout assignments with reference to the specific abilities required for successful duty" and to suggest improvements in the training of night lookouts. The work was assigned by the Applied Psychology Panel to Project N-115, Princeton University. The major work of this project was an effort to obtain reliable, quantitative information on the performance of night lookouts under actual wartime shipboard conditions. In order to secure this information, arrangements were made by the Navy for two members of the project staff to conduct a study aboard a cruiser engaged in convoy duty.

6.2

THE PERFORMANCE OF NIGHT LOOKOUTS ABOARD SHIP

At sea, in a convoy, studies² were conducted on the ability of the ship's regularly assigned lookouts to spot targets visually at night. The subjects for this study were the ship's regular lookouts. They had been chosen for their duties by their respective division officers and were under the supervision of a lookout officer and an assistant lookout officer for purposes of organization and training. Most of the men were seamen 2/C and all were unrated. Con-

siderable evidence indicated that these men were typical of those who may be found generally throughout the fleet performing lookout duty.

6.2.1

Collection of Data

Observations were, of course, made only during the hours of darkness. One of the investigators stood on the open deck at the level of the forward-sky-lookouts. He made frequent qualitative and quantitative records of weather conditions and visibility. The second investigator was stationed in the combat information center [CIC]. Both were in direct communication with all lookouts and with each other on the regular lookout [JL] circuit of the ship's sound-powered telephone system.

The investigator in CIC called each lookout in turn on the JL phones, asked for the bearing of the most distant ship he could see in his sector, recorded the bearing of the target as reported by the lookout, and obtained the range of that target from the duty radar operator. At the same time he recorded the name and station of the lookout, the date, and the time. Weather, sky, and sea brightness conditions were obtained by phone from the investigator on the open deck and also recorded. The type of ship sighted (transport, tanker, destroyer escort, etc.) was obtained later from a chart of the convoy.

At the beginning of each watch men came directly from compartments lighted only by dim red light. Furthermore, testing did not begin until the men had been on watch for 15 minutes or more. All men were therefore dark-adapted before being asked to make any report.

All tests were made when the lookout was using standard Navy 7 × 50 binoculars.

With few exceptions all bearings were read from alidades. When the alidade could not be read, the bearing was estimated by the lookout. The investigator in CIC then got from radar the range of the nearest ship in the vicinity of the estimated bearing.

On most nights it was possible to secure reports during only one watch. Moonlight and the short hours of summer darkness prevented

a longer observation period. The cruiser was usually in the first or last line of the convoy formation. In either case all visible targets were therefore within a 180-degree sector. Consequently, it was usually possible to secure reports from only part of the 14-man watch. On some nights the destroyer escort [DE] screen could be seen, making it possible to secure reports from all lookouts on duty.

The raw data of this experiment consisted of bearings and ranges of the most distant ships visible to lookouts when they were asked for a report. In their original form, these data provided no means of comparing lookouts directly. The size and distance of the target ship, the angle to the target, the illumination, and the height of the lookout all varied. It was therefore necessary to introduce a considerable number of corrections to make the reports comparable. Two main types of correction were necessary, those for purely geometrical features of the situation and those for differences in illumination.

GEOMETRICAL CORRECTIONS

The visible area of a target is reduced when the ship is foreshortened as a result of the angle at which it is sighted (target angle). The area of the image thrown on the observer's eye varies inversely as the square of the range at which the object is seen. And the actual size of the ship is a variable that obviously has to be taken into account. These three corrections could be made easily and with a reasonable degree of accuracy.

Target Angle. The corrections for the foreshortening effect were read from Table 1 which provided an approximation to the sines of the target angles. Seven discrete steps were used instead of a continuous function. This table gives the visible percentage of a ship's length with satisfactory accuracy for present purposes.

In making use of Table 1, the target angles for most ships were found directly from the bearing, since their course was always that of the ship from which the sighting took place. The DE's, however, constantly changed their course with respect to that of the convoy, so that no simple relationship existed between

RESTRICTED

angle of sighting and target angle. It was necessary, as a consequence, to choose some arbitrary figure, and since 40 degrees was assumed to be on the safe side, the "visible length" of a DE was always taken to be 200 feet except for those cruising directly forward or astern of the lookout. Since these latter also changed course somewhat, they had to be rated at a visibility above what would be offered by their beam alone. A standard of 90 feet was used in all the calculations involving these ships.

Range to Target. Corrections for range were made by using a distance of 1,000 yards as a point of reference and dividing all areas by the quantity $(R/1,000)^2$, where R is the actual range in yards obtained from the radar operator at the time of the report. Thus all rec-

TABLE 1. Corrections of target length for angle of sighting.

Angle between the lookout's line of sight and the course of the target ship, degrees)	Visible fraction of total length (per cent)
90-65	100
64-55	85
54-45	75
44-35	65
34-25	50
24-15	30
14- 0	20

ords are given in terms of equivalent square feet [ESF] or as the visual equivalent of a given area at the standard distance of 1,000 yards.

Target Size. Even when the true dimensions of a target ship are known, the fact that all vessels have highly irregular profiles makes it impossible to do more than estimate the area of a visible silhouette. The type of ship (i.e., transport, cargo ship, tanker, or DE) was always known and average dimensions for these ships were available.⁵

The height used in calculating target area was measured from a point low enough on the ship so that masses large enough for spotting could be found at that level, since masts, funnels, and the like are rarely, if ever, of much use in picking up a target under night conditions. This practice necessitated the introduction of an arbitrary figure for each type. Transports were rated at height 50 feet, length 550

feet; cargo ships, height 30 feet, length 450 feet; tankers, height 20 feet, length 450 feet; and DE's, height 30 feet, length 300 feet.

CORRECTIONS FOR ILLUMINATION

Since visual acuity varies with illumination, it was necessary to correct all reports in terms of the light available for seeing. The final value of "equivalent square feet" therefore involved not only a standard range but also a standard brightness. The standard used in these calculations was 0.05 foot-lambert, which is about the brightness of the sky in bright moonlight and is in the neighborhood of the brightest illumination recorded on the cruise.

It is difficult to arrive at a precise method of correcting for illumination, since there are no perfectly satisfactory tables showing the relationship between small changes in brightness and human visual acuity. Two sources of information were, however, available. Very accurate data secured by König almost 50 years ago give the relationship for light varying from very low values to very high ones, and the lower portion of König's curve approximates a simple relationship such that a tenfold increase in brightness produces a twofold increase in acuity. Recent data from the night training manual of the Royal Canadian Air Force show the relationship between acuity and the brightness of the sky against which planes are viewed.

The RCAF figures, compiled by Evelyn, are more nearly comparable to the present situation, and while only four points are shown the agreement between these data and König's is good. Figure 1 shows that the curves from these two sources tend to be parallel, though they diverge somewhat at higher values.

In the present study, corrections for illumination were made by dividing the visible area of each target by the square of a value which varies continuously from 1 at 0.05 foot-lambert through 8 at 0.00005 foot-lambert, doubling with each tenfold decrease in brightness. The resulting quotient is the area of a hypothetical target illuminated by 0.05 foot-lambert and having a visibility equivalent to the one actually sighted.

The difference in contrast for a given ship

between the situation in which it has sea for a background and that in which it has sky is sometimes very great. Consequently it was necessary to divide the total area of each ship into two parts: that part seen against a sea background and that seen against the sky. Determining the size of each of the two parts was a straightforward geometrical problem. The height of each lookout station was known, and the distance to the horizon from each height could be computed from the formula $1.15 \sqrt{h} = \text{distance to horizon in nautical}$

of the target appearing against sky and sea, the level of brightness, and the range of the target.

For example, one of the after-sky-lookouts sighted a freighter at a relative bearing of 225 degrees. The freighter was 450 feet long, and its average visible height was 30 feet. But at the target angle at which the lookout spotted the vessel (45 degrees), only 75 per cent of its length was visible. The 450 feet was consequently reduced to 337.5 feet. The lookout's station was 30 feet above the water and his horizon 12,770 yards away. At 5,000 yards (the range of the freighter) his line of sight to his horizon was 18 feet above the water. In other words, 18 feet of the target ship's 30 feet of height were seen by the lookout silhouetted against the sea, giving an area of 6,075 square feet (337.5×18 feet). The measured brightness of the sea was 0.000028 foot-lambert, at which level acuity is only $1/9.3$ as great as at the arbitrarily chosen standard illumination. The area of that portion of the ship viewed against the sea was, therefore, again adjusted as follows: $6,075 / (9.3)^2 = 70.2$ square feet. The brightness of the sky, against which the other 12 feet of the target's height were seen, was 0.0005 foot-lambert, and the divisor for acuity at that brightness is 8.0. Thus $[337.5 / (8.0)^2] 12$ feet or 63.4 square feet was the computed equivalent of the portion of the target ship seen above the horizon. The sum of these two terms gives the total visible area corrected for brightness: $70.2 + 63.4 = 134$ square feet. It was still necessary to take account of the range at which the target was sighted and to reduce the area of 134 square feet to the area which would be visibly equivalent at a standard range of 1,000 yards. Thus 134 was divided by the quantity $(5,000/1,000)^2$ giving $134/25$ or 5.36 ESF.

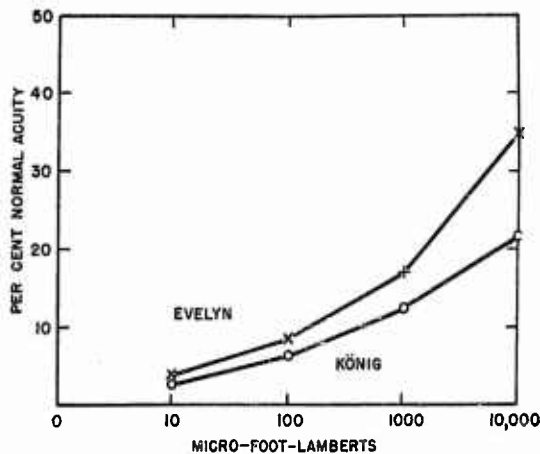

FIGURE 1. Relation between level of illumination and visual acuity.

miles, where $h =$ lookout's height above water in feet. The lookout's line of sight to his horizon cuts the target ship at a height depending on the distance between the lookout and his target. That height could be calculated by simple trigonometric means and used for determining the area of sea-contrast. The area of sky-contrast equals the length of the ship times the remainder of its height.

SUMMARY OF TREATMENT OF DATA

Each ship reported by a lookout was reduced to the number of equivalent square feet [ESF] representing a hypothetical target (equivalent to the one actually seen) silhouetted against a sky of 0.05 foot-lambert brightness at a distance of 1,000 yards. This reduction was accomplished by correcting each raw report for size of ship, angle of appearance, proportions

6.2.2

Possible Sources of Error

The five corrections illustrated above are subject to varying degrees of error. Some ships were undoubtedly longer or shorter, higher or lower, and more or less visible than they were rated. Some errors were inevitable in the meter readings, and the curve by which those read-

RESTRICTED

ings were translated into equivalent visibilities was only an approximation to the true function relating brightness and acuity. In spite of these possibilities for error in the ESF unit, it was stable enough to give meaningful results in the present study, for the scores showed far greater ranges than could possibly be attributed to fluctuations in the measuring instrument.

Another possibly significant variable was contrast. On clear moonlight nights the contrast of the target would vary depending upon the position of the moon relative to the observer and the target. The influence of contrast was greatly diminished in the present study by limiting the observation to cases where the target ship appeared as a dark object

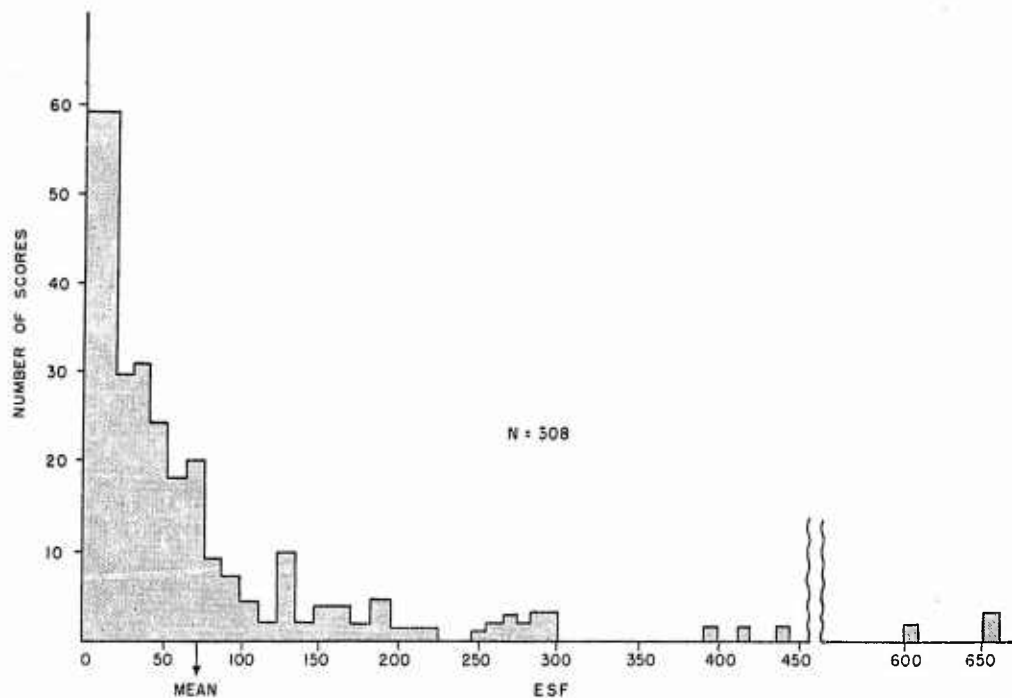

FIGURE 2. Distribution of single ESF measures.

In addition to these defects three other factors deserve comment. Haze is a factor of potential seriousness in this type of study. Unfortunately no method was available for measuring haze accurately. Its presence was recorded at the appropriate times but no way of quantifying its effect was found.

Performance on hazy nights was later compared with performance on clear nights. By several methods of comparison it was shown that haze increased the minimum size a target must possess in order to be seen at a given distance under any specified light conditions. The amount of this effect is, of course, dependent upon the amount of haze. Since haze was not measured quantitatively, quantitative statements of its effect cannot be made.

against a lighter background and by the fact that the angles of view of the lookouts probably did not differ sufficiently to allow important variations in contrast to appear. Under other operating conditions, however, differences in contrast could be quite important.

The possibility of errors due to the use of binoculars must also be considered. Such a possibility results from two facts. First, although all lookouts had been instructed in methods of setting their glasses properly, it is difficult to reset glasses in the dark after another man has been using them, and the investigators had no way of checking on the adequacy of any man's setting at the time of his test. Second, possible damage to binoculars was similarly beyond the control of the experimenters. In

RESTRICTED

at least one case a pair was demonstrated to be faulty, but there was no way of discovering for how long lookouts' reports from that station had been so handicapped.

6.2.3 Interpretation of the Data

The data which were gathered and treated according to the procedures outlined above provide tentative answers to three questions. The

with extreme scores running up to very high values. The mean of these scores was 60 ESF. The range was from a best score of 3 ESF to a worst one of 650 ESF.

When each man's scores were averaged, the nature of the distribution changed only slightly. The extreme values dropped out as they were counterbalanced by more moderate scores, and the range narrowed to 5 to 316 ESF. The mean was practically unchanged, but the mode moved up to the region between 25 and 30 ESF, giving

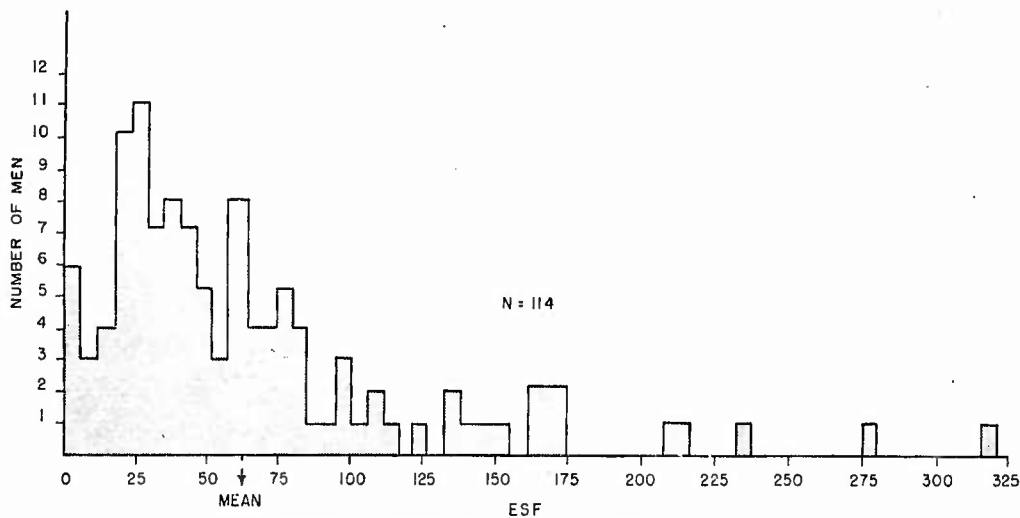

FIGURE 3. Distribution of average ESF measures.

answers are tentative because of the limitations of the study. Nevertheless they are believed to be the best answers now available to these three questions:

1. What can the average lookout see at night?

2. How much difference exists between a good night lookout and a poor one?

3. How consistent are lookouts?

After records taken on certain nights had been discarded because of faulty operation of the low-brightness meter or for other technical reasons, there remained 308 usable records. These records were of reports made by 114 different men, some of whom had been tested only once, others as often as seven times. Figure 2 gives the distribution of the 308 scores. The distribution was extremely skewed with a modal region between 10 and 20 ESF and

the distribution a slightly more normal appearance. By and large, however, the distribution of single scores and the distribution of average scores do not differ greatly. Figure 3 displays the latter distribution.

WHAT CAN THE AVERAGE LOOKOUT SEE AT NIGHT?

Those concerned with the problem of selecting and training lookouts have often been handicapped by a lack of standards by which to judge the performance of their men. On the basis of the present study, it now seems feasible to estimate what an average lookout can do in the way of spotting ships at night.

The average score of the men studied was very stable. The means of the total group and of all the subgroups examined fell between 59 and 65 ESF. It seems reasonable to accept, for

use as a practical yardstick, a median figure of about 60 ESF as typical of the main body of lookouts on the ship studied, though it should be borne in mind that there was considerable variability about this norm.

This score of 60 ESF means that the typical lookout, when stationed low enough for good contrast, can see a target of 60 square feet at 1,000 yards against a brightly moonlit sky. At the same distance in clear starlight, the same man requires a target to be almost 1,000 square feet. At 2,000 yards in starlight, he requires a target of about 3,800 square feet, or something like a PC seen broadside. At 2,500 yards in starlight, he would have trouble seeing a small cargo ship. At the same distance on an overcast night with no moon, he would require a ship the size of a very large freighter. On a really dark night, his maximum useful range is not much over 3,000 yards for even the largest ship.

All these figures are, of course, subject to modification by weather, the lookout's condition, etc., and all will depend somewhat on the height of the lookout. Men higher up have a better chance of seeing the bow wave or wake of fast moving ships, but the men lower down will get the greatest advantage from contrast against the sky; the typical lookout, whose effectiveness is exhausted at about 3,000 yards anyway, will only be handicapped on dark nights by being stationed high above the water in order to increase the distance of his horizon.

HOW MUCH DIFFERENCE EXISTS BETWEEN A GOOD NIGHT LOOKOUT AND A POOR ONE?

The range was very great. The 308 individual measures scattered from 3 ESF to 784 ESF. The range of average measures for the 114 men was naturally somewhat smaller, but was still considerable. If only those men who were tested five or more times are considered, thus limiting the population to the fairly reliable measures, the averages ranged from 210 ESF for the poorest man to 14 ESF for the best. This pair of figures means that the best man, using 7×50 binoculars, should be able to see a target of only 14 square feet at a distance of 1,000 yards in bright moonlight, while the worst one would require a target about 15

times as large, or 210 square feet in size, under the same conditions.

In terms of distance, this difference means that the better of these two men can see a ship nearly four times as far away as can the poorer one.

Table 2 gives some comparative areas for the best, average, and poorest lookouts under different conditions of brightness and distance. For the purpose of translating these areas into ship sizes, the typical areas used in this study for different types of ship viewed broadside may be useful: large transports, 30,000 square feet; cargo ships, 12,000 to 20,000 square feet; tankers, 4,000 to 9,000 square feet; DE, 8,000 to 9,000 square feet. In practice, of course, certain types of ship are more easily visible than others of the same area.

TABLE 2. The performance of lookouts.*

Range in yards	Illumination of sky, in ESF		
	Overcast starlight	Clear starlight	Bright moonlight
10,000	22,400	1,400
	6,000
	21,000
5,000	22,400	5,600	350
	24,000	1,500
	5,250
2,000	3,584	896	56
	15,360	3,840	240
	53,750*	13,440	840
1,000	896	224	14
	3,840	960	60
	13,440	3,360	210

* All values are in equivalent square feet (see text). The first value in each cell is for the best lookout studied, the second for the average lookout, and the third for the poorest lookout. A line of dots in place of a figure indicates a value far too large for any existing ship. The asterisk indicates a value greater than any but the very largest passenger liners.

A study of the comparisons offered in Table 2 should make it abundantly clear that there are very significant differences between the very poor night lookout and the expert. The differences obtained in this investigation, moreover, may not have been maximal, for there was reason to believe that even the best of the lookouts tested had not been as thoroughly or as carefully trained as possible.

With differences as large as those reported here, the care used in selecting and training of lookouts could be multiplied many times before

there would be any question of seriously diminishing returns. If a good selection and training program could bring the entire lookout watch from the level of the average man reported here to that of the best, it would increase the range of the "eyes of the ship" to more than double its present range. Success in bringing the poorest men up to the present average would have an even larger comparative effect.

HOW CONSISTENT ARE LOOKOUTS?

Thirty of the subjects of this experiment were tested four or more times. With such a group, the comparison of two random samples of measures for the same men gives a fair estimate of the consistency with which the subjects performed. The correlation coefficient was cal-

instance to take the logarithm of the ESF scores.

The logarithm of each ESF score was taken and the average log ESF computed for each individual. Figure 4 is the frequency polygon constructed from these data. The distribution is much more normal in appearance than the distribution of arithmetic scores shown in Figure 3. It has a mean at 1.49 log ESF and a standard deviation of 0.40 log ESF.

An even more striking change in the size of the reliability coefficient takes place when a logarithmic scale is used. The logarithm of each ESF measure was computed for the 30 men on whom four or more measures were obtained. The average logarithm of the odd-numbered measures was then correlated with the average

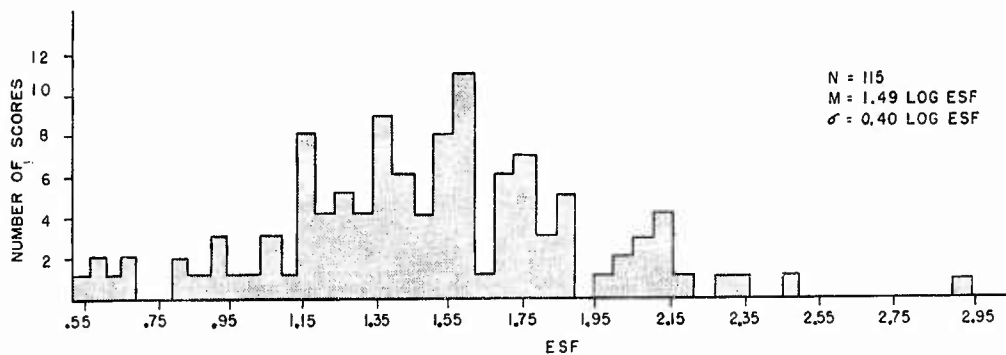

FIGURE 4. Distribution of average log ESF measures.

culated for the odd versus the even measures on the 30 men with four or more records. The coefficient was positive but low, $r = .27$. The rank difference correlation was .59. With a group as small as thirty men, there is always, however, the possibility that a correlation coefficient may be too high or too low as a result of chance fluctuations, and the usual techniques of measuring the probable error of the coefficient are not applicable to distributions that depart so widely from the normal.

It is evident that this study dealt with what was essentially a psychophysical problem, namely, just-perceptible visual stimuli. Since there is a wealth of evidence indicating that sensory intensity is linearly related to the logarithm of the stimulus over a wide range of stimulus values, it is justifiable in the present

algorithm of the even-numbered ones. The result is a product moment r of .67, illustrated in the scatter diagram of Figure 5. When corrected by the Spearman-Brown prophecy formula, this correlation becomes .80. In other words, if a logarithmic scale is used, the reliability of the data is shown to be fairly high. It should be noted that since the measures on which this correlation is based were obtained on different nights, the value of .80 is more nearly comparable with test-retest reliabilities than with odd-even reliabilities obtained from a single test.

Another method of estimating the consistency of individual lookouts was obtained by comparing the range of an individual's scores with the range of the averages for all subjects. When the range of scores was calculated for

each of the 93 men who had reported on two or more occasions, the average range was found to be 100 ESF. In terms of the total distribution, this value means that a lookout who is neither more nor less variable than the average might, on one occasion, score as low as any man tested and, on another, score just above the average of all records. Or again, another man might score around the average of the distribution at one time and higher than 90 per cent of the men at another. Briefly, this result is to be interpreted in much the same way as the co-

has had a good average record will continue to be good. This statement, however, *does not* by any means imply that the good lookout may not occasionally miss fairly easy targets nor that the man who is very poor on the average may not occasionally spot a difficult one. It certainly does not mean that a poor lookout cannot improve with proper training.

6.3 EQUIPMENT FOR THE TRAINING OF NIGHT LOOKOUTS

6.3.1 Night Lookout Trainer—Model A

Experience on shipboard and conferences with lookout officers revealed the desirability of a simple portable trainer which could be used aboard ship as a basis for systematic training in night vision.³

Two models of such a trainer were constructed. Model A was designed for use with groups of 16 men, in a room which could be completely darkened. Model B was planned for use by one or two men, in a partially darkened room.

Basically, the trainer unit of both models consisted of three parts: a radium plaque, a test plaque, and a plaque holder. The test plaque is a strip of translucent plastic on which test objects of various kinds are imprinted. It rests in the holder 1 inch in front of the radium plaque and is viewed at a distance of 10 inches.

Figure 6 shows the holder of Model A with the two plaques in position. The end of the wooden strip which extends toward the subject is held against the chin. It sets the test distance at 10 inches. Both plaques are 6 inches high and cover a total arc of 71 degrees at radii of 10 and 11 inches respectively. Allowing for the ends inserted into the grooves of the holder, the working visual field is about 66 degrees by 34 degrees.

It is necessary to protect the radium plaque in Model A from light, as well as to have a place to store it when it is not in use. Figures 7 and 8 illustrate how several of the trainers, with accessories, can be assembled into a single small packing box. A set of eight trainers would permit the training officer to conduct

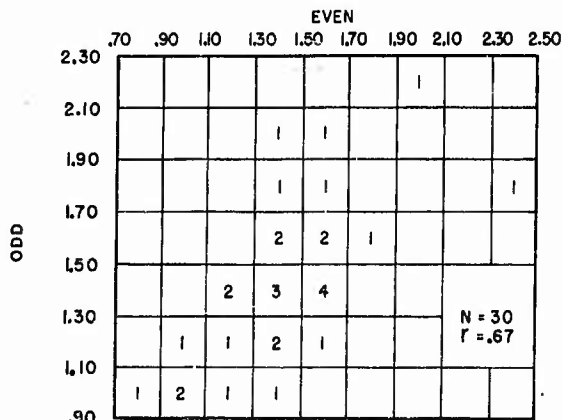

FIGURE 5. Scatter diagram showing the mean of the odd-numbered measures plotted against the mean of the even-numbered measures in terms of log ESF.

efficient of correlation discussed above. One may expect a lookout who has shown himself to belong in the upper half of the distribution to stay in that half most of the time. A lookout who is poorer than the average on one occasion will probably remain poorer than the average.

The practical problem in judging lookouts is whether or not the lookout who is good today can also be expected to be good tomorrow. The data reported here allow a qualified answer. Knowing the rank order of a group of lookouts as a result of having studied or measured a reasonable sample of their night performance (five to ten reports apiece), one can be moderately satisfied that another such sample taken on a different night will not give a widely divergent rank order. Lookout officers would be wise to assume that the man who

classes of 16 men per period, since the men work in pairs on each unit.

The storage box shown in Figure 8 is divided into two sections by means of a door which

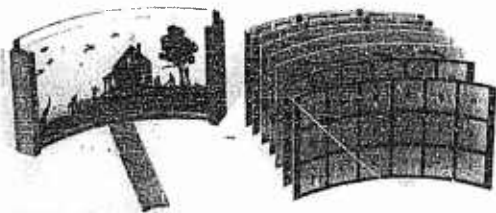

FIGURE 6. Holder with plaque 1 in place and the other seven plaques to one side.

closes off a back compartment where the holders and plaques are housed. This compartment is virtually lightproof. In the small front compartment are stored all the accessories needed for using the trainer, including a set of directions, a sample viewer and blank plaques for demonstration to the trainees, red goggles, a red flashlight, recording pads, and pencils.

THE DISTANCE OF THE TEST FIELD

The close range of 10 inches is not an ideal distance. It was finally selected for three rea-

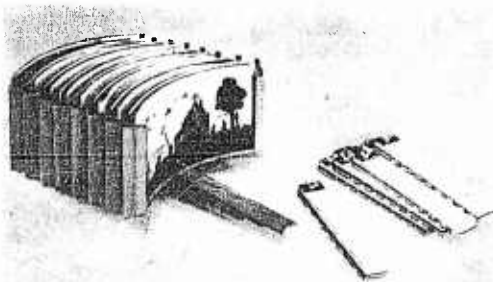

FIGURE 7. Assembly of eight holders with plaques in "storage" position. Eight darkroom recording pads.

sons: (1) lower cost, especially of the radium illuminant; (2) economy in space required for shipping and storing; and (3) the desire to keep the weight to a minimum, in order that

the viewer might be held comfortably before the eyes for a considerable period of time.

In laboratory tests the close range has not proved a serious handicap. Far-sighted individuals would certainly have considerable difficulty with some of the acuity problems. But since form vision in the periphery of the eye is relatively poor anyway, this difficulty may be much less serious here than it would be at photopic levels. Among Navy personnel, no serious departure from normal visual acuity is likely to be encountered anyway. Other individuals could wear whatever optical correction they require. In trial use, no difficulty was found in demonstrating the phenomena of night vision with the device.

THE SOURCE AND LEVEL OF ILLUMINATION

Considerations of convenience and relative stability over fairly long periods of time deter-

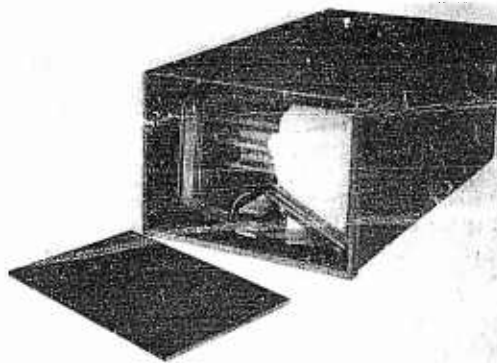

FIGURE 8. Packing box showing accessories in opened front compartment.

mined the choice of the radioactive material as an illuminant. The U. S. Radium Corporation cooperated in the considerable amount of experimentation involved in determining the proper concentration of radium salt and in devising the means of spreading the material over the Vinylite plaque.

The brightness level is approximately 4.45 log micromicro-lamberts, as measured at the surface of the test plaque. This value is toward the lower limit of night sky brightness, according to O'Brien's measurements. (See Division 16 Summary Technical Report.) After many tests at various levels within the range for

RESTRICTED

starlit nights, the lower limit was chosen because it looked more like normal night brightness.

The surface of the radium plaque at this low intensity does not present a uniformly illuminated appearance. There is a sparkling effect

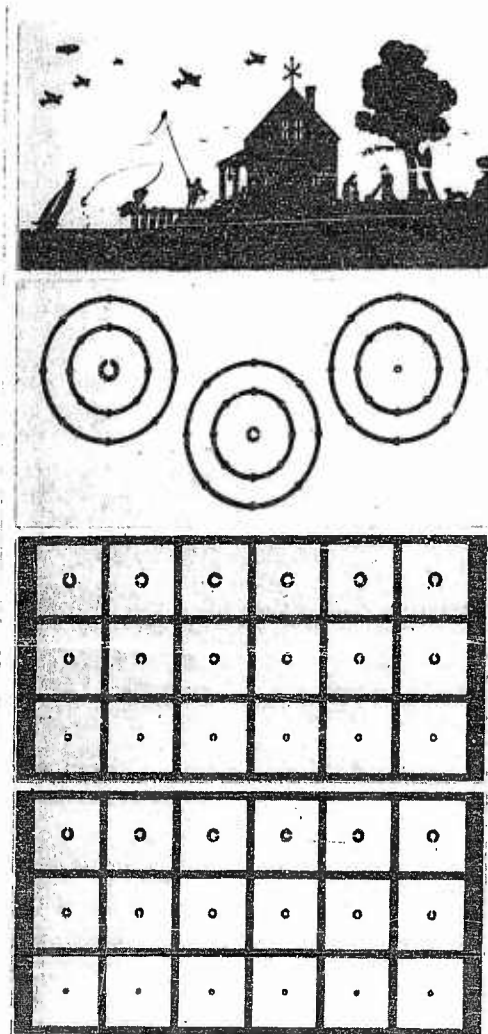

FIGURE 9. Four plaques for night lookout trainer.

which is somewhat distracting and which seems to vary irregularly in brightness. It is necessary, therefore, to diffuse the light in order to secure a uniform test field. To accomplish this diffusion an opalescent or mat finish was used on the test plaque.

THE TEST PLAQUE

Each of the eight test plaques was printed on a strip of translucent Vinylite by means of a photoengraving process. The imprint was made upon a piece 0.01 inch in thickness and then additional layers were laminated over the ground strip to give a total thickness of 0.03 inch. In this way the test figures were inside the plaque and could not chip off. The plaque was then heated for one minute in a hot-air oven at 220 F and pressed over a form of the proper curvature.

Eight plaques were developed. They are shown in Figures 9 and 10.

Landscape Silhouette—Plaque 1. This scene was used to demonstrate the progressive increase in visual acuity during dark adaptation. The demonstration was similar in purpose to that of Squadron Leader Evelyn's RCAF initial exercise.

Off-Center Vision Training Plaque—Plaque 2. Landolt rings 3, 2, and 1 degrees in diameter (at 10 inches from the eye) and of Snellen dimensions were used for systematic instruction in off-center vision. The landmarks about the concentric circles were illustrative fixation points, and the subject practiced until he found his optimal off-center fixation point. The inner circle was 6 degrees and the outer circle 10 degrees from the center of the Landolt ring.

Landolt Ring Test I—Plaque 3. This plaque provided additional systematic practice in the off-center principle introduced in the preceding plaque. The diameters of the rings in the three rows were 2, 1.5, and 1 degree, respectively, with the break equal to 20 per cent of the diameter. The squares enclosing each ring were approximately 10 degrees in size and the partitions 1 degree in width. With proper precautions, this plaque could also be used as a night vision test, if better calibrated adaptometers are not available.

Landolt Ring Test II—Plaque 4. The rings in the three rows were 1.75, 1.25, and 0.75 degree in diameter respectively. A more difficult test than plaque 3, it was designed for a subsequent training period.

Night Vision "Dice" Game I—Plaque 5. The dots on the dice varied from 1 degree in diameter to 0.125 degree. Laboratory tests

RESTRICTED

showed that this range provided sizes which at the upper limit could be seen by all subjects and at the lower limit could hardly be seen by any subject. There were five sizes in all, 1, 0.75, 0.5, 0.25, and 0.125 degree. The subjects were

Ship Silhouettes I, Detection—Plaque 7. Six silhouettes of warships were shown on each of three horizontal bands which represented surfaces of the sea. All the main classes of U.S. naval fighting craft were shown in varying sizes. The photographs were made from the simplified silhouettes in the *Recognition Pictorial Manual of Naval Vessels*. They were then reduced to four sizes: 1 inch, $\frac{3}{4}$ inch, $\frac{1}{2}$ inch, and $\frac{1}{4}$ inch. At a 10-inch distance, one inch equals 5.73 degrees. The subject was asked to call bearings for all ships sighted and to recognize them if possible.

Ship Silhouettes II, Recognition—Plaque 8. The 12 ships in this plaque ranged in length from 1 inch to $2\frac{1}{2}$ inches. The products of length by height of superstructure varied from about 30 square degrees to about 8 square degrees. This plaque could provide a basis for experimental work on recognition at night. Modifications of this plaque, as well as additional ones, could be made as desired.

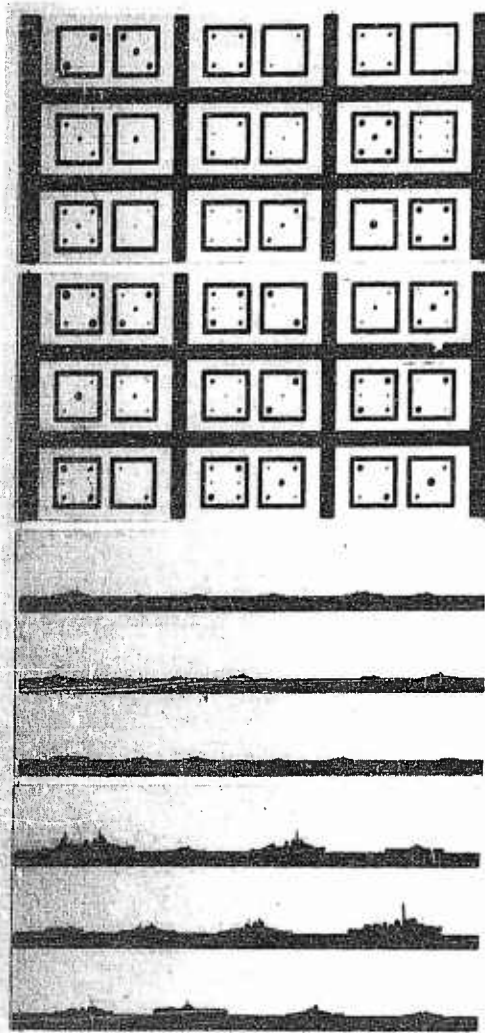

FIGURE 10. Four more plaques for night lookout trainer.

asked to use off-center vision and to report the number of dots seen.

Night Vision "Dice" Game II—Plaque 6. This test differed from the preceding one in that the sizes of dots for a single die were heterogeneous. It therefore presented a more difficult task.

6.3.2 Night Lookout Trainer—Model B

In order to do any really effective instruction in night vision it is necessary to produce and maintain reasonably good dark adaptation in the trainee. The fact that on many ships it is not possible to secure a large dark room presents a difficult problem for the lookout training officer. However, on many ships a small room which can be made reasonably dark is available.

In an effort to produce a trainer which would be useful under these conditions, a second model of the shipboard night lookout trainer was constructed. It can be used by two men at a time in a room not totally dark. This model, called Model B, is shown in Figure 11. Instructions accompanying Model B make it possible for the men to train themselves.

The principal differences between Model A and Model B are that in Model B (1) the holder and the plaques are housed in a light plywood box; (2) a viewing frame of black plastic is mounted in the front of the box, with a heavy piece of black cloth fastened about it and attached to the interior surface of the box; (3)

RESTRICTED

the viewing frame is fitted with prismatic lenses to make the plaque seem to be at an infinite distance from the eye; (4) an opaque plastic plaque is inserted into the test plaque holder when it is not in use, to keep light from falling on the self-luminous material.

The overall size of the box is $13\frac{3}{8} \times 14\frac{1}{4} \times 6\frac{7}{8}$ inches. A front door slides upward, exposing the viewing frame, and a smaller door on one side can be opened to remove the test plaques, directions, and accessories. If Model B were to be provided in large quantities, it is suggested that the box be made of 22-gauge steel, which would entail some changes in design. The sliding doors would become hinged doors.

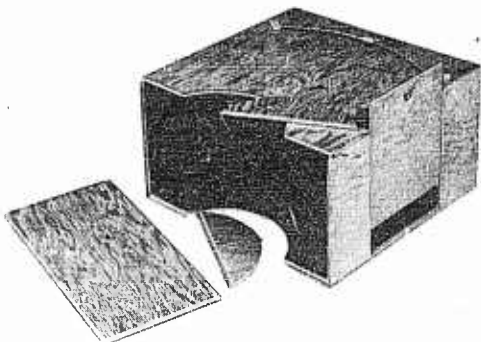

FIGURE 11. Night lookout trainer, Model B.

The box would be shortened and the viewer so constructed that after opening the box it could be pulled out on a slide to the proper viewing position. This change would eliminate the need for semicircular inserts to accommodate the head which are shown in the pilot model illustrated in Figure 11. It would also decrease the size of the box as well as the cost.

If Model B is used in a room not totally dark, the subject must wear red dark-adaptation goggles when he is not looking at the plaques. By closing the eyes, sliding the goggles upward onto the forehead, and quickly putting the face up to the viewing frame, it is possible to keep fairly well dark-adapted. The room should, of course, be made as dark as practicable, and the subject should face the darkest part of the room. Care should also be taken to protect the radium plaque from direct light. The special directions furnished with the pilot models gave

detailed instructions on the proper use of this model of the trainer.

6.3.3 Navy Evaluation of Night Lookout Trainers

Model A of the night lookout trainer was transferred to the Training Aids Division, BuPers, for evaluation. Model B was evaluated by the Medical Research Laboratory, Submarine Base, New London, Connecticut. That laboratory recommended on November 24, 1944, to BuPers that the "trainer be produced and supplied to all ships of destroyer escort class and larger, in numbers 3 for BB and CV, 2 for CA, CL, CVL, and CVE, and 1 for DD, DE, AK, etc."

As a basis for this recommendation the Submarine Base reported, "Subject trainer is designed to serve as a lookout trainer for shipboard use. It may be used informally as a self-trainer in a compartment used for dark adaptation or for more formal instruction. In either case, it provides excellent night vision training.

"Cost of subject trainer will be approximately \$35.00 each supplied in quantities in excess of one thousand.

"Attention is invited to the fact that this device will supply an inexpensive training device that can be made readily available to ships of the fleet."

The Training Aids Division took no action on this recommendation.

6.3.4 Training Exercise in the Use of Binoculars at Night

Much disagreement exists concerning the value of binoculars for night lookout duty.³ Interviews with lookout officers, with lookouts, and with other naval officers have revealed a variety of attitudes and practices. Some officers do not require any use of binoculars at night. Others instruct the men to scan with the naked eye and to use binoculars when an object is sighted. Still others insist upon the use of binoculars under all circumstances.

The scientific evidence seems to show fairly conclusively that binoculars greatly increase the range at which objects can be detected at night, except in rain or very dense fog. Observations made by members of Project N-115 confirm British reports of the superiority of 7×50 binoculars over the naked eye for virtually all brightness levels likely to be encountered at night. One study conducted by the National Physical Laboratory for the Admiralty indi-

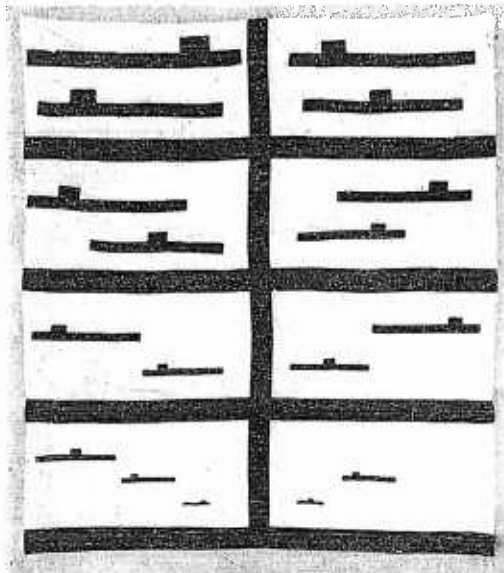

FIGURE 12. Training exercise in the use of binoculars at night.

cated, for example, an increase in range from about 1,100 yards with the naked eye to more than 5,000 yards with 7×50 binoculars, for a bright starlit night. These values were secured with silhouettes of a trawler 100 feet in length. For a very dark night the naked eye had an estimated range of approximately 500 feet, while 7×50 binoculars gave about 1,000. Differences in atmospheric transmission would make laboratory visibility better than that at sea, but the general lesson is clear.

In training lookouts it is desirable first of all to provide a convincing demonstration of the value of night binoculars. As a means of providing a standardized training aid for this purpose, a set of simplified ship silhouettes was

arranged on a piece of white cloth. This cloth is placed in a bag and inserted into either the Model A or Model B night lookout training units described above. Figure 12 shows the arrangement of the silhouettes, which represent different ranges of a highly schematic DE. The test is arranged for use on the open deck of a ship at a distance of 50 feet on a starlit night. The subject is asked to locate the ships within each section and to give the position of the superstructure. The figures range in size from 2 down to 0.25 degrees, as shown in Table 3.

TABLE 3. Lengths and ranges of the simplified silhouettes (for 300-foot DE viewed at 50 feet).

Length of silhouette (inches)	Length of silhouette (degrees)	Equivalent range (yards)
20.94	2.00	2,865
18.36	1.75	3,581
15.72	1.50	4,298
13.08	1.25	5,014
10.49	1.00	5,730
7.86	0.75	7,163
5.22	0.50	11,460
2.61	0.25	22,920

This binoculars test is highly artificial but its lesson is unequivocal. Even the largest silhouette is scarcely visible in reflected starlight with the naked eye, using off-center vision. On the other hand, with 7×50 Navy binoculars some subjects can locate the superstructure on the 0.5-degree size and can detect the 0.25 size.

This demonstration of the value of binoculars should be part of a systematic training session. Once the man can see how greatly his vision is improved, his instruction in correct adjustment and in the method of scanning with binoculars at night can proceed.

Instructions for the use of this training exercise were furnished with the sample models submitted to the Navy.

6.3.5

Training Literature

The Applied Psychology Panel contributed to the training of men for night duty by writing or assisting in the writing of four publications.

RESTRICTED

The first was a short pamphlet, *The Best Way to Use Your Eyes at Night*.⁴ This pamphlet was published by Science Service on the basis of material furnished by the NRC (Committee on Service Personnel, Selection and Training). It was reprinted by a number of war journals and was also published by the Infantry Journal for the Division of Training of the War Shipping Administration. A total of over 400,000 copies was distributed. The pamphlet includes a popular discussion of the differences between day and night vision; various methods, such as red light and goggles, of securing dark adaptation; off-center vision and scanning; and the use of night glasses. Directions are also included for several games which give practice in proper use of the eyes for night vision.

Assistance was given to officers in the U. S. Navy in writing the Navy's *Lookout Manual*.⁷

Lesson plans for the use of the night lookout trainer were written.

A manual for lookout officers was written in cooperation with representatives of the Bureau of Naval Personnel, the Interior Control Board, the Medical Research Laboratory, Submarine Base, New London, and representatives of NDRC Division 6. This manual contains a general discussion of night vision, a series of carefully planned and detailed lesson outlines for the instruction of night lookouts, and a list of available training aids. The manual was published by the Bureau of Naval Personnel.⁶

6.4 GENERAL RECOMMENDATIONS CONCERNING LOOKOUTS

The experience of the project in dealing with lookouts and lookout problems at sea and conferences with lookout officers led to the writing of a memorandum summarizing the project's recommendations concerning lookouts.¹

This memorandum was written because problems of lookout organization and the motivation of lookouts seemed to be of much greater practical importance in improving lookout performance than were purely visual problems.

Consequently, the memorandum discussed the problem of lookout organization, the prestige of lookout duty, the training of both the lookout and the lookout officer, and the possibility of a periodic inspection of lookout procedures. It described the existing situation, pointed out its faults, and suggested directions in which improvements should be made as well as methods by which those improvements could be accomplished. The memorandum concluded:

1. Lookout duty has a very low position in the hierarchy of duties aboard ship. Both officers and men complain of the low prestige of the lookout and lookout officer.

2. Lookout duty is not usually regarded as a task requiring specialized skill and knowledge.

3. There is a strong tendency to discount the value of the lookout because of the development of radar and other instruments.

4. There is a natural disposition for officers to concern themselves with the complex devices employed on many other jobs while neglecting the lookout who has no imposing apparatus to use.

5. There is disagreement over the function of the lookout and his place in the ship's organization. Some believe that all lookouts should be responsible to the navigator; others that all should be under the gunnery department; and still others that the responsibility for lookouts should be divided between these two departments.

6. In the training of lookout officers, too much attention has been given to teaching recognition, and not enough effort has been directed toward teaching how to organize, train, and manage lookouts.

7. In the training of lookouts themselves, the emphasis has been on recognition rather than on the duties of the lookout. Lookout training at one stage of the seaman's development has not been coordinated with that at another, resulting in much repetition of material.

The remedies suggested were:

1. A specific form of lookout organization should be established for each type of ship.

2. The prestige of the lookout should be raised so that the lookout will be regarded aboard ship as the equal of men performing

RESTRICTED

other duties which require special skill and training.

3. The entire program of lookout training should be revised to eliminate repetition and to provide an orderly progression from introductory verbal material to more complex subjects. It should involve practice in actually doing the job. The training of the apprentice seaman should emphasize lookout duty. Recognition training should be reserved for the seaman who has become an expert lookout.

4. Lookout officers should be taught to organize, train, and manage lookouts and should be convinced that their primary duty aboard ship is to achieve an efficient lookout organization. They should be provided with a comprehensive teaching manual, and should be urged to keep records of lookout performance.

5. All officers aboard ship and prospective officers in Naval officers' training schools, particularly the U. S. Naval Academy, should be indoctrinated in the importance of lookouts.

6. The inclusion of an inspection of lookout procedures in the checkoff list of Inspection and Shakedown Boards is suggested as a method of continuous evaluation of lookout practices. If this device is not appropriate some other system of formal report or inspection should be adopted.

These recommendations with the supporting discussion contained in the memorandum were transmitted through OSRD and the Coordinator of Research and Development to the Commander-in-Chief, U. S. Navy, and the Chief of the Bureau of Naval Personnel. As far as is known, no resulting action was taken.

6.5 RECOMMENDATIONS FOR FUTURE WORK ON LOOKOUTS

Future work on night lookout training can well be concentrated for some time to come on the application of what is already known to be desirable instruction. It is probable that greater immediate practical gain can be secured through applying the principles and methods described in the lookout officers' manual⁶ than is likely to come from any research studies in the near future.

The selection of lookouts is in a quite different stage of development. The present methods of selecting men for night lookout duty in terms of visual qualification have been shown to be uniformly poor (see the Summary Technical Report of the Applied Psychology Panel, Volume 1, Chapter 9). There is room for a great deal of fundamental work on the improvement of visual tests and the development of other types of tests for selecting night lookouts.

The most important problem which the Navy faces in handling its night lookouts is an administrative one rather than a research one. The organization of lookouts aboard ship, motivating them to work as well as possible, and enhancing the prestige of the lookout will result in much more rapid improvement in lookout performance than will any research studies on the visual factors in the night lookout's task. Further research work will have little opportunity to bring about significant improvements until the solution of the administrative problems has been undertaken by the Navy.

RESTRICTED

Chapter 7

TRAINING NAVY GUNNERS AND ENGINE ROOM CREWS

By Bernard J. Covner^a

SUMMARY

LESSON PLANS, course outlines, and instructional manuals were written for the .50 caliber machine gun, for the 20 mm, 40 mm, 3"/50, 4"/50, and 5"/38 guns, and for the main battery of large ships. Similar teaching aids were written for the instruction of operating engineers in training for duty aboard a number of types of Navy ships.

Paralleling the work on lesson plans for gunnery instruction was a series of studies on gunnery trainers and lesson plan material for their use.

Courses on *How to Teach Gunnery* and *How to Teach Engineering* were developed and given to a number of classes of instructors.

Assistance was given to Project N-112 on problems of aerial free gunnery. Later in 1943 a request was made to render similar assistance in the training of Navy engineering operating personnel. Project NR-106 was established for this purpose. All three projects were assigned to the University of Pennsylvania.

To determine how and where these projects could help the various programs with which they were concerned, the basic procedure of job analysis² of duties as performed on ships operating in nearby areas was used. Additional procedures included discussions with supervisory and teaching personnel, cruises, class visits, questionnaires,^{20, 31} and study of curriculum outlines, supplemented by reading of manufacturers' pamphlets and standard Navy publications.

These procedures gave the project staffs a broad, general picture of the training program under consideration, as well as specific information concerning the nature of the jobs for which students were being trained, the physical conditions of instruction, the availability of training equipment, and so on. With this information as a background, project members, in collaboration with naval personnel, developed methods and materials for use in the improvement of gunnery and engineering instruction.

The work was always done in close liaison with operating personnel. Project members lived and worked at the Naval Operating Base, Norfolk, Virginia; the Naval Training Station, Newport, Rhode Island; the Operational Training Center, Treasure Island, California; the Escort Carrier Precommissioning School, Bremerton, Washington; the Gunnery Schools aboard the USS *Wyoming* and USS *New York*; and other places where large-scale training was being given.

Emphasis throughout the program was on the immediate improvement of mass instruction. Specific accomplishments typically eventuated in the preparation of an outline of instruction, a set of lesson plans, a detailed breakdown of duties, a training aid, or instruc-

7.1

INTRODUCTION

In the peacetime Navy before World War II, much training was done by the apprenticeship method. Men were assigned to duty aboard ship; there they gradually acquired the knowledge and skills of a particular specialty.

The great expansion of World War II made the apprenticeship system impossible. Experienced men were too few and had to be spread too thinly through the fleet to be able to instruct all the green hands. Many special schools were established on shore to cope with the situation, but here also problems arose. Experienced instructors were too few. Standardized course outlines did not exist to aid new instructors in giving mass instruction.

Special sections were created in the Bureau of Naval Personnel to train instructors for this emergency. Lesson plans, training aids, and course outlines were prepared. The Navy also called upon NDRC for help. The first request, in 1942, asked the Committee on Service Personnel to aid in improving gunnery instruction. Project N-105 was established for that purpose.

^a This chapter is based upon the work of NDRC Projects N-105, N-112, and NR-106.

tions for the use of a synthetic trainer. Research studies were conducted on a number of points, but the principal effort consisted of applying already established psychological principles and practices to the immediate problems of Navy training.

This chapter lists the training manuals produced by Projects N-105 and NR-106 for use in gunnery and engineering instruction. In the references to the chapter will be found the specific training schedules and plans for each gun or type of activity with which these projects dealt. Microfilm copies of several of the manuals^{11, 13, 32, 36, 37} are included with this volume in order to provide detailed examples of effective planning of mass instruction.

The procedure followed in writing lesson plans are described in Chapter 15. Job analysis procedures, regularly employed to determine what should be taught in a particular course, are discussed in Chapter 14. The lesson plans put to practical effect the principles of learning discussed in Chapter 13.

7.2 TRAINING NAVY GUNNERS

7.2.1 Curricula for Gunnery Instruction

Lesson plans, course outlines, and guides for gunnery instructors were prepared for guns ranging in size from the .50 caliber machine gun: up to the main battery: .50 caliber machine gun, reference 13; 20 mm, references 1, 4, 10; 40 mm, references 5, 6, 7; 3"/50, reference 12; 4"/50, reference 10; 5"/38, reference 10; main battery, reference 21.

In addition to writing manuals for specific guns, assistance was given in the general organization of gunnery instruction,⁴³ in the training of gun crews for different types of ships,^{12, 24} and in conducting general quarters drill on APA's and AKA's.²⁸

Project personnel cooperated with other NDRC and Navy personnel in preparing instructional material for the position firing

method in aerial free gunnery.¹⁶

7.2.2 Operating Procedures

The references listed above necessarily included some information on operating pro-

cedures. In addition a special memorandum on the operation of the 5"/38 twin mount⁴⁸ was written and a micromotion analysis of the service of the 3"/50 gun conducted.⁴⁵ Results of this analysis are discussed in Chapter 25.

7.2.3 Gunnery Trainers and Training Aids

Many different training aids and synthetic trainers were used in gunnery instruction. Project personnel developed some,^{3, 15} studied the value and characteristics of others, wrote training manuals to help secure greater value from some, and described the psychological characteristics of good gunnery trainers.²³

The range estimation trainer, BuAir device 5C-4, was studied experimentally.^{18, 40} Its value was found to be very small. Nevertheless, suggestions⁴² were made for its use when better methods of instruction in range estimation were not available.

A manual for instruction on the machine gun trainer Mark 1 was written¹⁴ and a study of the scoring characteristics of that trainer conducted.⁴¹ Drill manuals were written or started for several models of the Mark 3 gunnery trainers: Model 2,⁴⁷ Model 3,⁴⁷ Model 5,⁵⁰ and Model 6.⁵⁰ Suggestions were made for improved target films³³ and for the operation and use⁴⁹ of this trainer. Lesson plans for the gunnery trainer Mark 7 were written.⁴⁴

A drill manual²⁵ was prepared to serve as a guide to the coordinated use of several gunnery trainers and to provide specific instructions for conducting drills on each one.

7.3 TRAINING OPERATING ENGINEERS

7.3.1 Curricula for Engineering Instruction

Project work in engineering training was started at Norfolk shortly after the initiation of the destroyer escort [DE] program. Crews had been instructed largely by chief petty officers who, although experienced in operating the engineering plants of many types of naval vessels, were relatively unfamiliar with the detailed fireroom operating procedures for the new DE's. In addition, these instructors were handicapped by the absence of functioning

RESTRICTED

equipment to be used in drill for trainees.

This situation clearly demonstrated the necessity for a detailed knowledge of step-by-step procedures for operating DE fireroom equipment. The analysis was directed primarily toward the isolation of specific steps of performance, with emphasis placed upon *operation* as contrasted with theoretical knowledge of equipment. On the basis of this analysis a manual⁸ on fireroom operating procedures for DE's was written. It was used by instructors to help familiarize themselves with the details of the fireroom operating procedures and as a teaching guide. It was used by men in training as a text or study guide.

A manual similar in design and purpose to the DE fireroom manual was written for instruction and operation of the DD and DE distilling plant.⁹

Project personnel helped prepare lesson plans for the various units of a progressive engineering course divided into three stages. Stage I included study of the basic units of a ship's power plant and information on the ship's construction and organization.²⁰ During Stage II men were divided according to the engineering division for which they were being trained. Men in each division were given separate courses.^{22, 29} In Stage III training was given in watch-standing either in the operational training building or on a training ship.^{30, 37}

Several miscellaneous training manuals provided material for instruction on the Welin gravity davits,²⁷ for balance of crew training for APA's,³⁰ and for some special engineering training programs.³⁹

Most of the materials referred to above were developed in the course of work done on DE's and DD's for the Operational Training Command, U. S. Atlantic Fleet. When emphasis shifted to the Pacific, project personnel moved to the Operational Training Command, U. S. Pacific Fleet. Work there was primarily on APA's, AKA's, and escort carriers [CVE's]. Work with these new types of ships required developing some new course materials but consisted in large part of adapting the previously constructed course outlines and lesson plans.^{24, 28, 30, 35, 38, 39, 46}

7.3.2

Training Aids

Several training aids were developed^{32, 34} and instructions were prepared for the most effective use of training aids.¹⁹ Two types of drill material were devised. The first consisted of drill-board mock-ups of such units as the distilling plant or the refrigeration system. These drill boards simulated both individual units and larger systems of equipment. They provided an opportunity for drill on operating procedures where neither the shipboard equipment nor models of that equipment were available. The mock-ups were used in instruction on theory as well as for drill in operating procedures.

A further development was the operational drill chart. This type of training aid was applicable to a large variety of engineering equipment systems. It consisted of a diagrammatic representation of engineering equipment on which operating controls were identified, and it illustrated what happened when those controls were manipulated. Operational drill charts were prepared for use in teaching the operation of the Soloshell distilling plant.³² Drill charts of this nature may be used (1) for familiarizing the trainee with operating procedures prior to actual drill; (2) for following the progress of a drill on a mock-up or on actual equipment; and (3) as a basis for discussion of operating steps.

7.4

INSTRUCTOR TRAINING

The course outlines, lesson plans, and training aids listed above were all developed to assist the instructor in giving more effective instruction. In addition to these aids, a need was felt for more careful training of the instructor himself. Courses on *How to Teach Gunnery*¹¹ and *How to Teach Engineering*¹⁷ were developed for this purpose.

Each of these courses was given to classes made up of Navy instructors. Each course was accompanied by a kit of training aids and by recorded samples of lectures, explanations, and drills which illustrated good and bad teaching technique. These samples were played to classes

RESTRICTED

of instructors and used as a basis for their discussion and criticism.

The two courses were much alike, but the illustrations and examples of principles were specific in each to the field of instruction for which it was intended. The course for gunnery instructors can illustrate both. It consisted of five sessions, each 1½ hours long.

Lesson 1 gave the background and purpose of the course and developed 11 principles of good instruction.

Lesson 2 gave an opportunity for rating instruction recordings in terms of the principles of good instruction developed in the first lesson. These ratings were analyzed and discussed by the group. The remainder of the lesson was devoted to the use of lesson plans, preparation of charts, models, and other equipment, and other problems of planning a class session.

Lesson 3 was devoted entirely to a discussion of the problems centering around instruction itself. The use of instructional aids, the value and use of questions, use of summaries, the importance of job analysis, and how to conduct a demonstration were discussed.

Lesson 4 was a discussion of the problems encountered in conducting practice and drill sessions.

Lesson 5 was a review of the course. Recordings of instruction by members of the group which had been obtained well in advance of this lesson were played and analyzed. A check list outline of how to teach gunnery was used to point out good and poor features of instruction and to summarize and evaluate the course. It also furnished a method for the instructor to use in auditing and evaluating his instruction at a later time.

A small pamphlet, *Is Your Teaching Effec-*

tive,¹⁷ provided a basis for self-rating on the points emphasized in the two courses for instructors.

7.5

CONCLUSION

Throughout their work, project personnel sought to improve gunnery instruction and engineering instruction. The principal features of this work were:

1. Basing instruction on an analysis of the actual operating jobs. Job analysis of operating procedures provided the basic information for writing any set of lesson plans.

2. Separating instruction levels so that separate and appropriate attention and emphasis could be given to (a) general information on the equipment to be used, (b) detailed study of specific operations, (c) drill on separate procedures, and (d) drill as part of an entire team or watch.

3. Using mock-ups, drill boards, models, trainers, and any other available device to help prepare the trainee for his actual operating duties.

4. Emphasizing operational drill rather than theory.

5. The lesson plans and course outlines were written to make effective use of motivation, repetition, drill, and other principles and techniques of good instruction.

The training manuals were generally useful. Some were reproduced by the Bureau of Naval Personnel. Others were printed by the Operational Training Commands. Eleven of them were distributed by the Navy to the fleet, to operational training and antiaircraft centers, and to all new ships at the time of commissioning.

Chapter 8

TRAINING WINCH OPERATORS

By Dael Wolfle^a

SUMMARY

A TRAINER consisting of a miniature electric winch was constructed to help train hatchmen and winchmen for duty on APA's and AKA's.

written with the University of Southern California under NDRC Project N-116. Work began in July 1944 and continued through February 1945. By that time most of the AKA's and APA's were commissioned.

8.1

INTRODUCTION

At the request of the Commander, Operational Training Command, U. S. Pacific Fleet [COTCPac] a project was established to improve the selection and training of hatchmen and winchmen specialist teams assigned to duty on *assault personnel auxiliary* [APA] and *assault cargo auxiliary* [AKA] ships. Research

8.2 THE ELECTRIC WINCH TRAINER

Project personnel designed an experimental model of an electric winch trainer¹ in which the controls were of the same dimension as the ones found on electric winches being installed at that time on AKA's and APA's. The winches were otherwise miniature in size, speed, and lifting power. They were used in conjunction with miniature booms and rigged yard and stay.

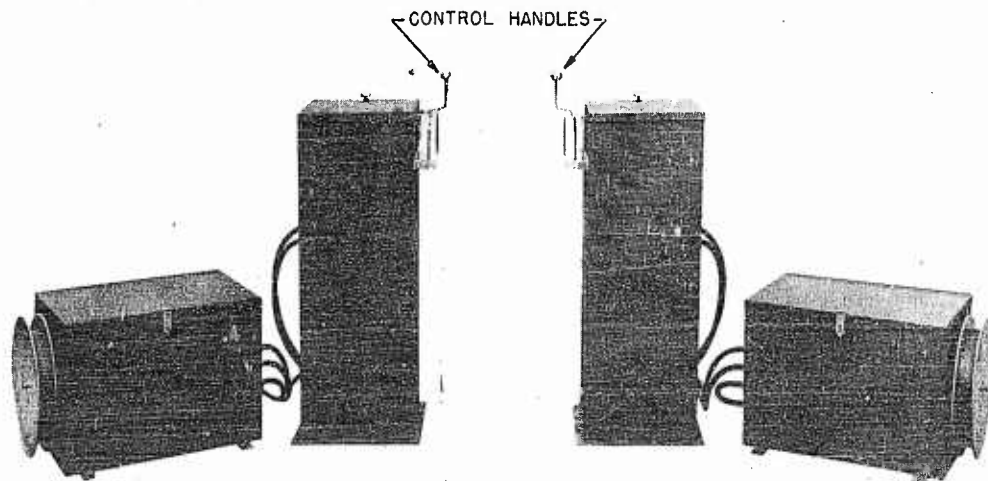

FIGURE 1. The electric winch trainer, controls.

studies on hatchmen and winchmen were considered urgent by COTCPac because of the large number of AKA's and APA's being built for duty in the Pacific and the small number of available men with civilian experience in handling winches. A contract for the work was

^a This chapter is based on the work of NDRC Project N-116.

The miniature electric winch trainer is shown in Figures 1 and 2.

This equipment was tried out at the Small Craft Training Center Seamanship School on Roosevelt Base, Terminal Island, Cal. Following this trial use, a manual for instructors was developed.¹ The manual contained a tested set of six lectures and practice drills arranged

according to the part-progressive method of instruction. The manual included a winch operation test and an objective rating scale for the use of the instructor. It also described the construction and maintenance of the entire rig.

Several attempts were made to conduct vali-

trained men and details of untrained men who could be made available at the time an AKA or APA was available.

A suggestive study was finally completed in which 13 trained men and 14 untrained men were compared in their first attempts to master

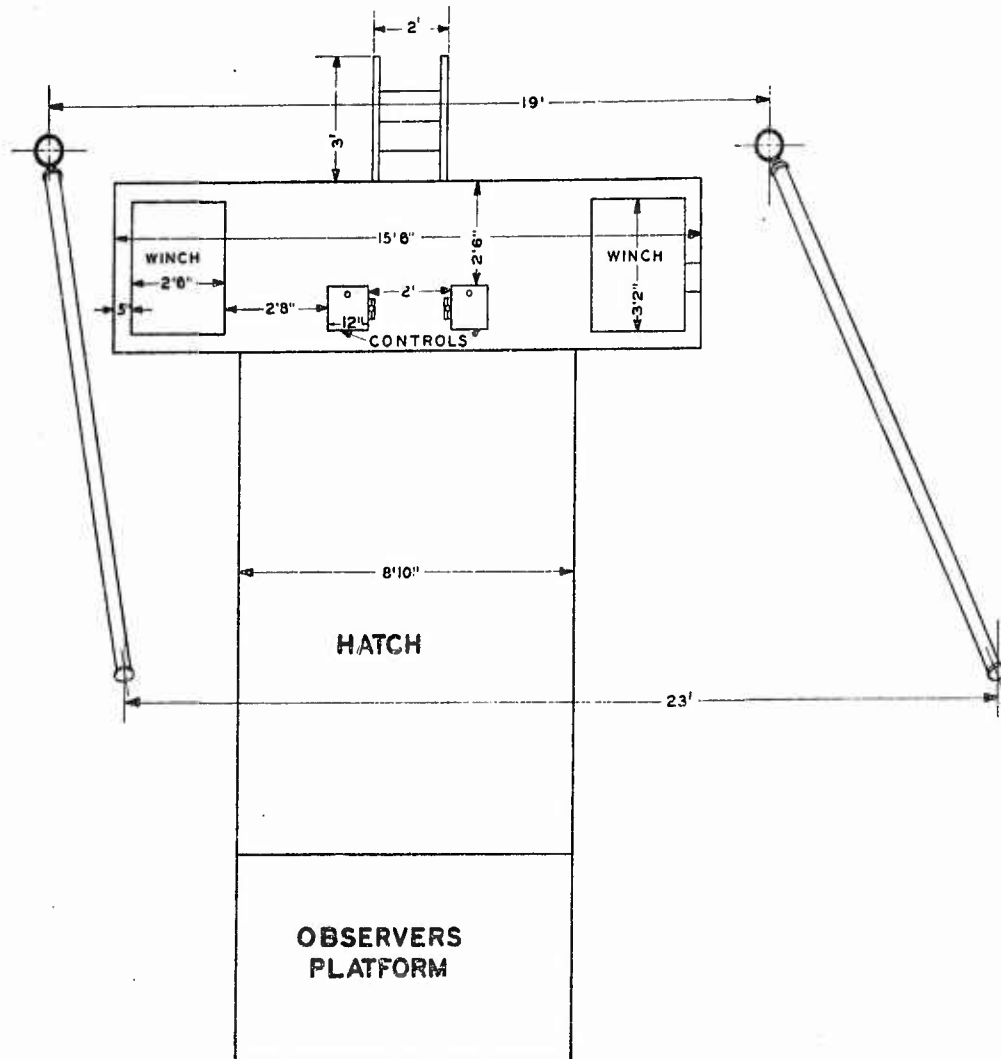

FIGURE 2. The electric winch trainer in operation.

dation experiments. All but one of these encountered scheduling difficulties. Validation of the trainer required testing the ability to handle standard winches on board ship of men who had had experience on the miniature trainer and of other men who had not had that experience. Thus it was necessary to find details of

the operation of standard electric winches aboard ship.² The miniature-trained group was superior to the untrained group to a degree which was, despite the small number of cases, significant at the 1 per cent confidence level. The distributions of ratings³ given to trained and untrained groups are shown in Table 1.

RESTRICTED

TABLE 1. Distribution of proficiency ratings.

Proficiency rating	13 trained men (Number of ratings)	14 untrained men (Number of ratings)
5.0	5	
4.5	3	4
4.0	10	5
3.5	6	4
3.0	11	7
2.5	4	6
2.0		8
1.5		4
1.0		1
0.5		1
0.0		2
Median	3.9	2.9
Mean	3.7	2.7

In this table a comparison is given of the ability of 13 trained and 14 untrained men to handle a full-sized electric winch on an assault cargo auxiliary ship. The trained men had received their instruction on an electric winch trainer.

Three judges made independent proficiency ratings of each man. The judges did not know until after the ratings were completed which of the 27 men had had prior training on the miniature electric winch trainer. Correlations of ratings by the different judges were 0.81, 0.83, and 0.89.

Two additional trainers were built for installation and use at COTCPac training stations.

Chapter 9

TRAINING AMPHIBIOUS CRAFT CREWS

By Dael Wolfe^a

SUMMARY

ASSISTANCE was given to the Amphibious Training Command in the development and improvement of training courses for the crews of amphibious craft. The work was of two types, development of specific courses of instruction and collection of relevant information in order to improve instruction.

Training courses were developed:

1. To instruct amphibious training base instructors in effective teaching methods.
2. To train instructors in methods of measuring student achievement.
3. To instruct a specially selected group of classification specialists in the elements of personality analysis, in order to improve the processing of atypical cases such as psychiatric cases, illiterates, and billet misassignments.
4. To train attack boat personnel in gas defense and piloting.

Two related programs provided information with which to improve instruction:

1. A questionnaire was administered to personnel returning from combat zones in order to secure information about the effectiveness of various methods of training, classification, or ship performance in actual combat.
2. A job analysis was made of the amphibious enlisted billets.

The training studies and the varied curricula were organized into a systematic overall program described in the Amphibious Training Command *Training Manual*.

9.1 INTRODUCTION

At the request of the Commander, Amphibious Training Command, U. S. Atlantic Fleet, NDRC Project N-117 was established on February 1, 1944, to aid the Command in the development of its personnel program.

World War II necessitated the development

^a This chapter is based primarily upon the work of NDRC Project N-117.

of amphibious operations on a much larger scale than ever before; new ships, new tactics, new duties all produced new problems. The Amphibious Training Command was established to solve these problems and to train crews for the amphibious forces. The request to NDRC was for help in this undertaking.

Speed was even more necessary than usual in this case. Preparations were being made and crews being trained for Atlantic and Pacific landings. The time schedule permitted very little research. Practically all the project's efforts consisted of immediate application of ideas and techniques worked out at earlier times.

The project was established at Amphibious Training Command headquarters but also worked at the amphibious training bases [ATB]. In addition to work on billet analysis and instruction described in this chapter, project personnel cooperated with Amphibious Training Command and Bureau of Naval Personnel officers in developing standardized classification procedures for officers and enlisted men (see the Summary Technical Report of the Applied Psychology Panel, Volume 1, Chapters 11 and 13).

9.2 TRAINING COURSES FOR AMPHIBIOUS TRAINING COMMAND

Special training courses were developed in four fields, each of which is briefly described below.

9.2.1 The Training of Amphibious Training Base Instructors

With the cooperation of NDRC Projects N-105 and NR-106 and the instructor training staff of the Bureau of Naval Personnel, a course on effective instruction was developed. The course was modeled after the course *How to Teach Gunnery*, described in Chapter 7, but

was specifically adapted to the problems encountered by ATB instructors. The course consisted of ten lessons of from 1 to 2 hours in length. It was given to over 700 instructors of the Amphibious Training Command.

The instructor training staff of the Bureau of Naval Personnel performed most of the work in this program with the administrative cooperation of Project N-117. After the course was developed and had been taught to several groups of instructors, the project withdrew. The program was carried on by the instructor training staff.

This course was but one phase of a larger program for improvement of instruction. The whole program included voice recording of actual periods of instruction with subsequent analysis of the presentation by the instructor and a member of the instructor training staff, joint action with the base training aids officer to effect full utilization of existing training materials and to develop new aids, and periodic conferences with the base instructional staff.

9.2.2 Achievement Testing in the Amphibious Training Bases

In cooperation with the training staff at each base, an achievement testing program for officers and men in training was initiated at ATB, Camp Bradford, Virginia, and at ATB, Little Creek, Virginia. A board of senior instructors from each of the training divisions was appointed to supervise the construction and administration of achievement tests throughout the base. At the outset, a series of weekly conferences with this board was held by members of the project staff. The discussion covered specific examination problems of the various training divisions. The purpose of the conferences was to agree upon standard examination procedures and to construct tests of known and appropriate difficulty which would adequately cover the subject matter. The participants constructed specimen examinations in their subject fields which were analyzed and evaluated by the group. The manual, *Measuring the Achievement of the Trainee*,² served as the basis for much of this conference work.

The base training officer and the board of senior instructors continued to supervise examination procedures at each base after project personnel withdrew from this activity.

The adoption of standardized achievement tests increased the motivation of instructors and trainees and improved measurement of knowledge of course content and operational achievement.²

At the request of the Standards and Curriculum Division of the Bureau of Naval Personnel, a representative of Project N-106 assisted in the development of an achievement testing program at ATB, Coronado, California.¹⁰ Fourteen minimum essentials achievement tests were prepared in order to evaluate the success of the training program. Eleven of the tests were for use in the ship-to-shore training, two were gunnery tests, and one was for use in the boat training division. Reliabilities of seven of the tests were computed. The coefficients varied from .74 to .94.

Distributions of scores were made for examinations administered after 4 weeks' training. The distributions indicated that practically all students failed to attain the minimal essentials prescribed by the curriculum for blinker receiving and compass-and-steering. Achievement was best on semaphore sending, maneuvering signal (semaphore), and beach marker tests. In general, the achievement of students was poorer than had been anticipated in view of the ease of the material taught and the average ability of the students.

The difficulty of each item in the 14 tests was determined by finding the percentage of students who passed it. The results indicated specific areas where instruction was poor. Suggestions were made for the improvement of teaching in some of these areas.

9.2.3 Course in Personality Analysis

Early in the classification of enlisted personnel at the ATB's, a need was felt for specialized processing of atypical cases, such as illiterates, billet misassignments, and men suspected of being psychiatric cases. Accordingly, Project N-117 in cooperation with the force surgeon

developed and administered a course of instruction for selected specialists (C), intended to provide each classification office with at least one classification interviewer particularly trained to screen out such cases for further consideration.⁷ Nine specialists (C), drawn from the four Atlantic Coast training bases, were given a course in personality analysis at the ATB, Camp Bradford, Virginia. The course included elementary instruction in the nature of psychology, individual differences, emotions, personality, the measurement of intelligence and other traits, Navy tests, and psychiatry. Instruction in psychiatry was given by the base medical officer and the staff of the Portsmouth U. S. Naval Hospital; it included clinical observation of maladjusted and combat fatigue cases. Instruction in the other topics was given by project personnel.

Upon completing the course, the specialists (C) were designated as special case-technicians by the Amphibious Training Command and were assigned to the mobile classification unit and to the ATB classification offices. They were provided with interviewing rooms, reference libraries, and special psychological testing equipment to aid them in screening atypical cases for referral to the base medical officers for further consideration.

Accurate evaluation of the work of the special case technicians would have necessitated a study in which the base medical officer would have diagnosed both those cases which the technicians suspected of having emotional maladjustments and so referred to him for interview and those processed by the technicians but not so referred. Such a study would have made it possible to determine what percentage of referred cases was correctly referred and what percentage of nonreferred cases should have been referred. Owing to the heavy case loads of the base medical staffs, the study was not possible. However, for two of the training bases and for the mobile classification unit, determinations were made of the percentages of psychiatric referrals which the base medical officer also diagnosed as emotionally disqualified. The figures are presented below.

At two establishments over 60 per cent of men referred to the base medical officers were

diagnosed as emotionally disqualified. At the third establishment 36 per cent were disqualified. These results indicated that the special case technicians did a reasonably accurate job of screening possible psychiatric cases for referral. The special training given them seemed justified.

	Enlisted men processed by special case technicians	Psychiatric referrals by special case technicians	Psychiatric referrals disqualified by medical officers
ATB, Camp Bradford	5,443	570	354 (62.1%)
ATB, Little Creek	5,119	1,400	512 (36.6%)
Mobile classification unit	1,574	1,259	816 (64.8%)

At the request of the Commander, Training Command, Amphibious Force, U. S. Pacific Fleet, the course in *Personality Analysis for Specialists (C)*, *Special Case Technicians* was administered by the project to a group of five specialists (C) at ATB, Coronado, California, during November 1944.

9.2.4 Courses in Gas Defense and Piloting

The project staff cooperated with the training officer, ATB, Fort Pierce, Florida, in the construction of courses in gas defense and piloting specifically designed for the training of attack boat personnel.⁵ The courses featured active participation by the trainees, largely through the use of drills and problem work sheets.

9.3 INFORMATION TO IMPROVE INSTRUCTION

Two types of work were undertaken in order to secure information for improving the classification and training programs of the Amphibious Training Command.

1. A questionnaire was administered to personnel returning from combat zones.
2. A job analysis was made of the billets on amphibious craft.

Each is briefly described below.

RESTRICTED

9.3.1 Questionnaire for Personnel Returning from Combat Zones

As one means of obtaining information which might prove of value in the amphibious training program, the project, in cooperation with the Amphibious Training Command, constructed and administered a questionnaire of 93 items for personnel returning from combat zones.⁴ The project analyzed the replies made by 511 enlisted men and 141 officers returning from amphibious duty and by 164 enlisted men returning from nonamphibious duty. Tabulation of the responses gave information regarding the men's experience and opinions in respect to training, classification, ship performance, morale, gear, supplies, etc.

Most of the officers and an even larger fraction of the enlisted men considered their training satisfactory for the duties they were assigned aboard ship. Some dissatisfaction was revealed, however, over the way in which training time was used. For example, half the officers and about 40 per cent of the men reported inadequate instruction in the handling of perishable supplies.

The tabulated results, the individual questionnaire forms, and specific suggestions for improvements which were made by many of the men were furnished to administrative officers of the Amphibious Training Command. These data were useful in indicating ways in which amphibious training could be made more satisfactory.

9.3.2 Analysis of Amphibious Enlisted Billets

The project, at the request of the Amphibious Training Command, undertook to analyze the duties of amphibious enlisted billets on four types of ships:⁶ *landing ship tank* [LST]; *landing ship medium* [LSM]; *landing craft infantry* [LCI]; and *attack boats*. The Com-

mand assigned four officers to work with the project in making the billet analyses.

The analysis form consisted of a summary of billet duties and an activity analysis. The analyses indicated the functions which were considered necessary to insure successful performance of billet duties but did not provide detailed instructions for carrying out those duties. The analyses were used in the development and revision of courses and in some cases of the watch, quarter, and station bills. They proved particularly useful in planning instruction whenever a base had to start training personnel for ships or craft which were new to that base.

9.4 THE AMPHIBIOUS TRAINING COMMAND TRAINING MANUAL

The training studies and the varied curricula of the Amphibious Training Command, U. S. Atlantic Fleet, were organized into a systematic overall program described in the Amphibious Training Command *Training Manual*.³

The training manual consisted of two parts. Part II outlined the curricula themselves in order to effect standardized training in the several ATB's. Part I of the training manual was prepared cooperatively by Amphibious Training Command officers and project personnel. It provided a statement of the objectives of the training program and the means of achieving those objectives. It complemented the *Manual of Classification Procedures for Amphibious Training Bases*,¹ also cooperatively developed by Amphibious Training Command and project personnel, and utilized the results of the project's extensive study, *The Effectiveness of Classification Data in Predicting Billet Performance in Training in the Amphibious Force*.⁸ It incorporated the studies reported in this chapter into the organization and administration of the whole training program.

Chapter 10

TRAINING NAVY TELEPHONE TALKERS

By Dael Wolfe^a

SUMMARY

THE HIGH NOISE LEVELS encountered aboard ship frequently made normal speech unintelligible over shipboard telephone circuits. Special training courses were developed in order to increase the intelligibility of telephone communications.

A telephone talkers' manual, a manual for instructors, and phonograph records were developed for use in a course for telephone talkers.

Experimental investigations of the best methods of instruction and of the value of various parts of the course and a survey of the training given to telephone talkers in a number of installations led to improved standardized instruction. The training ashore was integrated with subsequent training on board ship.

Three courses were developed for the submarine service: a basic course to teach general skills; an intermediate course to give each man proficiency in the use of the phraseology required by his assignment aboard ship; and an advanced course to drill the entire crew as a combat team in the coordinated use of the communication circuits.

10.1

INTRODUCTION

Speaking over a telephone is a relatively simple and commonplace activity. Yet special training in the use of shipboard telephone equipment was necessary. There were two reasons. One was the fact that shipboard phones were sound-powered, depending entirely upon the energy of the speaker's voice to get a message through. The second reason was the high noise level in which talking was necessary. The different equipment and the difficult conditions both meant that normal telephone speaking habits had to be overcome. Hence special training courses were a necessity.

At higher noise levels, the intelligibility of

^a This chapter is based upon the work of NDRC Project N-109.

speech over sound-powered phones drops very sharply. This drop in intelligibility was clearly shown in an experiment⁹ in which trained talkers read lists of familiar words over sound-powered phones to trained listeners. A noise approximately the same as diesel noise in quality was used as interference. The results are shown below. At a noise level of 110 decibels, such as exists in a submarine engine room with both diesels running, 73 per cent of the words were missed. These results, obtained with expert talkers and expert listeners, make obvious the difficulty of passing messages on board ship under comparable circumstances.

Noise (db)	Words correct (%)	Words missed (%)
None	91	9
90	77	23
100	60	40
110	27	73
120	13	87

Recognizing the difficulties involved in voice communication aboard ship, the Navy requested NDRC help in solving those problems. The request was accepted and assigned as Project N-109 to the Psychological Corporation for study. Work on the selection and training of shipboard telephone talkers was started early in 1943. Chronologically, the work was divided into three fairly separate phases.

The first phase was largely exploratory and covered both selection and training.^{1, 3, 4} The speech interview, developed to aid in selecting Navy telephone talkers, is described in the Summary Technical Report of the Applied Psychology Panel, Volume 1, Chapter 10. The initial work on training resulted in the development of a short course of instruction for telephone talkers and several manuals and training aids. These are described in Section 10.2 of this chapter.

The second phase consisted of extending and adapting for submarine use the techniques already developed for training talkers on surface ships. This work is described in Section 10.5.

The final phase (with surface ships) con-

sisted primarily of improving and standardizing the many telephone talker courses which had grown up largely as a result of the work done in the first phase. Because of the logical relation to the first work, these developments are discussed, out of chronological order, in Sections 10.2.3, 10.3, and 10.4.

In general, the manner of speaking and the way of using communication equipment found most satisfactory on shipboard were the same as those found most satisfactory in airplanes. Since these procedures are discussed in detail in Chapter 23, they will not be considered here.

10.2 TRAINING TELEPHONE TALKERS

10.2.1 Experimental Comparison of Methods of Instruction

Preliminary trials¹ indicated that short periods of training sometimes produced marked improvements in intelligibility over sound-powered phones. A more comprehensive experiment was therefore conducted to determine, if possible, the relative value of various methods for training recruits to speak intelligibly over sound-powered telephone circuits.²

Fourteen methods of instruction were tried out. They were of four general types: (1) instruction through materials which the recruit read silently; (2) instruction by means of phonograph recordings; (3) instruction by teachers over phones; and (4) instruction in a teacher-classroom or face-to-face situation. In addition, control groups were used to check the relative effectiveness of the training methods.

The procedure followed was to select 17 recruits as a listening panel and to divide the remaining recruits into two groups of speakers. The 17 men in the panel were given instruction over the sound-powered phones, all phones being in parallel so that the entire panel could be instructed at the same time. After hearing these instructions, the listening panel was divided into two groups, one panel listening to one group of speakers, the other to the second group.

Each speaker read from one of a series of nine cards. Each card contained 36 randomly selected digits, arranged in 12 series of three. Alternate series followed the words "bearing"

and "range." These words were used merely to give the listeners time to write the digits, for example, "Bearing 6 3 1, range 9 4 2."

The listening panels recorded the digits as they heard them, using a mimeographed blank prepared for this purpose.

Both listening panel members and speakers were recruits at the Naval Training Station, Bainbridge, Maryland.

Experiments were normally divided into three parts: (1) an intelligibility test, (2) instruction, and (3) another intelligibility test. In the pretest, instruction for the speaker was kept at a minimum. He was shown how to put on the earphones, told to talk with his mouth $\frac{1}{2}$ inch from the transmitter, and instructed to read the words and numbers in a loud, clear voice. The only coaching given was to move the transmitter closer to the speaker's mouth and to caution him to read more slowly in case such directions were needed.

During the second, or instruction, period different training methods were introduced for different groups of subjects.

The retest period involved a repetition of the pretest procedure, the purpose being to determine the effectiveness of the instruction in increasing intelligibility.

The increases in intelligibility resulting from the different training methods were compared individually by the *t*-statistic to determine the relative reliability of the differences found. A control series, consisting of a pretest and retest with no intervening training, was used as a standard for evaluating all methods.

All methods of instruction, including the control series, resulted in definite improvement in intelligibility. The instructional method which produced the greatest improvement was one called "mass drill." It was therefore adopted as the basic classroom procedure for the telephone talker course. The brief directions given the instructor, his introduction to a new class, and the start of the drill itself are quoted below.

Note to the Instructor

The following drill is to be read to the men in a lively spirited fashion, looking at them as much as possible. Soon you will have memorized the drill, which should give you a better contact with your audience than you had while reading the drill.

The class must participate. If they don't follow you at first, have them try the drill sentence again until you are satisfied.

This drill has been used with a large number of recruits. Properly administered it becomes a successful teaching device.

Mass Drill

Every ship has at least two phone circuits. Large ships have as many as a small city. These phone circuits connect every part of the ship. On each circuit are a number of *telephone talkers*, whose important job is to pass orders and information to different stations. The outcome of a sea battle depends in part on the ability of these talkers. *Poor* talkers who make "repeats" necessary may *sink* a ship. *Good* talkers may *save* a ship and help in sinking enemy craft.

Sound-powered phones are used in the Navy. The good talker on a sound-powered phone must be *alert* in listening to and repeating commands. He must be able to *remember* orders so that he can repeat them correctly. And very important, he must speak clearly, as time during action at sea is too valuable to allow for "repeats."

Now the question is, What makes a *good telephone talker*?

First of all, the good speaker is *loud*, because a sound-powered phone gets its power *from the voice alone*. If you talk over the sound-powered phone as you might to a friend standing next to you, your voice might not be heard at all. "The louder the better" is a good rule in this case.

Let us see for the moment how loudly some of you speak. All of you say after me:

"One, two, thu-ree, four, fi-ive, six, seven, eight, niner." Now say, only much louder,

"Range four . . . fi-ive . . . oh . . . double . . . oh." (Pick out various individuals to say this.)

Don't worry about talking too loud! Very few men talk too loudly over sound-powered phones. There is little or none of the blasting or fuzzing effect you hear on battery phones.

In the *second* place, *loudness control* is important in good telephone talkers. By loudness control, we mean that the loudness of the voice is continuous, rather than trailing off at the end of a phrase or sentence. If the listener cannot hear the last word of a message, the whole message may have to be repeated!

Do not speak this way, with the last part of the message almost unintelligible,

"Control from sky lookout, plane sighted off starboard bow." (Let voice trail off.)

Instead, try to say it this way, with sustained loudness,

"Control from sky lookout, plane sighted off starboard bow."

Now all together. Now you over there. (Point out a few men and have them repeat after you.)

10.2.2 Training Manuals and Training Aids

TELEPHONE TALKERS' MANUAL

Project personnel cooperated with officers from a number of Navy offices interested in communication problems (COMINCH, COTCLANT, BuPers, and the Interior Control Board) in the production of a telephone talkers' manual for the U. S. Fleet.¹¹ The manual was put in final form in cooperation with the Training Aids Division, BuPers, and was issued as a publication of the Headquarters of the Commander-in-Chief, U. S. Fleet, dated November 19, 1943.

The manual was prepared in quantity by the Bureau of Naval Personnel and was distributed widely to the fleet and to shore stations. A revised edition embodying some minor changes but keeping the general content and format of the original manual was prepared and distributed later by the Bureau of Naval Personnel.

INSTRUCTORS' GUIDE

The U. S. Fleet Telephone Talkers' Manual provided the basic information necessary for effective communication over sound-powered telephone circuits; it did not provide course outlines, drill materials, or exercises. There was obviously a need for such supplementary material. Accordingly, when the DE Gunnery School, Naval Operating Base, Norfolk, Virginia, requested special drill materials for 3-inch and 5-inch guns, preparation of this requested material developed into the *Supplement to Fleet Telephone Talkers' Manual, I: A Guide for the Training of Instructors with Methods of Instruction for Telephone Talkers*.⁶

The supplement contained a plan for a telephone talker classroom, suggestions for shipboard training, lesson plans for a 4-hour, a 3-hour, and a briefer talker course, practice materials in special digit drill, language used in docking and paravanning, language used in damage control, gunnery drills for 3"/50, 5"/38, and 1.175 guns, instruction on phrasing commands, and drill on difficult sounds. It had limited distribution as an OSRD report,⁶ but was immediately reproduced by the Navy and distributed in considerable numbers to various training centers. A revised copy, somewhat changed in

RESTRICTED

organization and containing a number of photographs, was later distributed by the Bureau of Naval Personnel.¹⁴ The Bureau of Naval Personnel also prepared a guide for shipboard instruction of telephone talkers.¹²

TRAINING AIDS

At the beginning of its work, Project N-109 was asked to assist in the preparation of phonograph recordings useful for training purposes. A script for a series of training records was prepared and given to writers of the Columbia Broadcasting System for revision. The project assisted the Columbia Broadcasting System in the production of the records. Three were produced: *The Importance of Battle Phone Talking* (NavPers No. 11390 RA and RB), *How to Speak over Battle Phones* (NavPers No. 11391 RA and RB), and *Standard Battle Phone Procedures and Command* (NavPers No. 11392 RA and RB).

These records were produced in quantity for the Bureau of Naval Personnel and widely distributed to ships and training centers.¹⁰

GLOSSARY OF NAVAL TERMS

Project N-109 did some work on a glossary of naval terms and commands. Work on the glossary was stopped when the material was classified confidential and thus made practically useless for talker training purposes.¹⁰

10.2.3 Studies of Telephone Talker Training

Telephone talker classes, based upon the *Telephone Talkers' Manual*¹¹ and the supplement^{6, 12} for instructors, were established and taught at many training stations. Project personnel were asked to appraise these courses by conducting an experimental determination of their effectiveness in increasing ability to use sound-powered phones.

The work was carried out at the DE Gunnery School, Naval Operating Base, Norfolk, Virginia. Training methods and materials used in the DE Gunnery School were substantially those outlined in *Supplement to Fleet Telephone Talk-*

*ers' Manual, I.*⁶ These methods and materials were tested individually and as a whole to determine their effects upon intelligibility over sound-powered telephones.^{5, 7} Features of the instruction are here listed in order of effectiveness as shown by the superiority of experimental over matched control groups.

1. There was a high average improvement in intelligibility resulting from the course as a whole.

2. Training record NavPers 11391 RA and RB, *How to Speak Over Battle Phones*, produced a statistically significant improvement in intelligibility.

3. The mass drill technique of instruction for improvement in intelligibility yielded a statistically significant increment.

4. The test procedure itself, that is, the reading of digits against a background of noise, proved to be an effective instructional device.

5. A half hour of drill on phones in which the subjects repeated standard commands and were criticized over the phone system by an instructor did not result in statistically significant improvement in intelligibility.

Training records NavPers 11390 RA and RB, *Importance of Battle Phone Talking*, and NavPers 11392 RA and RB, *Standard Battle Phone Procedures and Commands*, were found to be relatively ineffective as teaching aids but to have some usefulness in securing motivation and in presenting general background information.

The Telephone Talkers' Manual was found to be a satisfactory outline for instructors. It contained useful supplementary and reference material but was not a satisfactory substitute for lectures or demonstrations in class. It substantially aided class instruction if read outside of class hours.

The drills contained in *Supplement to Fleet Telephone Talkers' Manual, I.*⁶ were found to be most useful as material for practice in standard procedures and commands and less useful as drill material for improving intelligibility. Simplified procedure in which fewer men were required to read and more men to repeat heard commands was recommended.

Most of the changes suggested by these findings were made in telephone talker instruction.

SURVEY OF TELEPHONE TALKER TRAINING UNDER COTCPAC

Telephone talker courses, patterned after the one described in Section 10.2.1, were developed by the Bureau of Naval Personnel and the Operational Training Commands of the Atlantic and Pacific Fleets. They were taught at boot camp, school, precommissioning, and afloat levels. The rapid development of these courses in geographically widely separated regions naturally led to a considerable lack of standardization. In an effort to improve and standardize instruction in COTCPac training installations, the project director was asked to survey all instruction in telephone talking being given under that Command.

The initial directive¹⁰ given to the project director might well serve as a model in any similar situation in which a civilian consultant is called upon to go into a number of Service installations and recommend such changes and improvements as he thinks desirable. The directive read:

Subject: Duties and Status

1. You are designated as COTCPac assistant for telephone talker training. As such, you are responsible for observing telephone talking training and standardizing methods to improve the training at the precommissioning training schools under this command.
2. You will visit each of the below-listed activities in succession for a period of approximately 10 days for the purpose set forth in paragraph one (1) above.
 APA Precommissioning School, Seattle, Washington
 CVE Precommissioning School, Puget Sound Navy Yard, Bremerton, Washington
 Precommissioning Training Center, Treasure Island, San Francisco, California
 Small Craft Training Center, San Pedro, California
3. When you are in agreement with the Commanding Officer of any of the above activities as to the desirability of a change which will aid in improving the course in telephone talking instruction at that activity, the change will be effected immediately. If the Commanding Officer is not in agreement as to the desirability of a recommended change, you will submit a report in the premises, with copy to the Commanding Officer, who will make a separate report to this command. Decision will then be made by COTCPac.
4. As soon as the date of completion of each period

at an activity can be anticipated, you will inform the Commanding Officer who will in turn notify this command.

5. Upon completion of your period at each activity you will submit to COTCPac, via the Commanding Officer, an informal report of your work at that activity. This report will include:
 - a. Your observations of telephone talking at the activity as regards quality and duration of instruction.
 - b. Improvements made in instructional methods as a result of your visit.
 - c. Suggested changes not yet effected.
 - d. Any further recommended changes.
 - e. Any specific or general observations relative to telephone talker instruction, instructors, or trainees which might reflect the status of the instruction at the activity or improve the overall results of the instruction.
6. There is no intent in these instructions to detract from the authority or responsibility of the Commanding Officer of any of the above activities. Your duty is primarily that of liaison between COTCPac and the various activities.
7. By copy of this letter, the Commanding Officer of each activity listed in paragraph two (2) is directed to arrange the requisite priority and transportation to facilitate your travel between activities.

The recommendations which were made for all the activities visited indicated the chief faults located by this survey.

1. Use synthetic noise in the training rooms so that talkers become accustomed to speaking and listening in interfering noise.
2. Place more emphasis on how to speak over sound-powered phones.
3. Make sure that every man under training actually handles and speaks over the phones in each scheduled drill period.
4. Have men use the standard methods of breaking out and securing the phones as described in the *U. S. Fleet Telephone Talkers' Manual*.
5. Require the use of the standard pronunciation of numerals given in the *Manual*.
6. Make use of available visual training aids.
7. Introduce more realistic material into the messages used in drills, so that talkers will become familiar with station names and typical messages used aboard ship.
8. At schools where such action has not already been taken, assign an officer to be responsible for all talker instruction.

RESTRICTED

All these recommendations were adopted and put into effect by COTCPac.

A final survey¹⁰ some months later consisted chiefly of the exchange of recent information and experience. The effect of the NDRC work could be seen in improved physical equipment, improved instruction, more nearly uniform instructional methods, and more carefully organized course outlines and drill materials. Increased recognition of the importance of training in interior voice communications was evidenced by greater length of courses and by the talker courses for officers.

10.3 TRAINING TELEPHONE TALKER INSTRUCTORS

To meet the requirements of standardized methods of talker instruction throughout COTCPac, the organization of a central course for telephone talker instructors at a centrally located training activity was agreed upon.¹⁰ From January 7, 1945, until June 20, 1945, Project N-109 assisted COTCPac in organizing a course for telephone talker instructors, preparing course materials, selecting training space and equipment, teaching experimental and demonstration classes, and in indoctrinating naval personnel to continue the instruction.

A 10-day course for talker instructors was first developed, recommended, and approved by COTCPac. When quotas of trainees for the course proved to be small, the course length was reduced. A week's course was developed, tried out, approved by COTCPac, and turned over to the Navy staff for routine administration.

10.4 COORDINATION OF TRAINING ASHORE AND AFLOAT

Early in the work on telephone talker training, it was observed that much of the ultimate effect of shore training was determined by the attitude of ship's officers and petty officers toward the necessity and importance of that training and toward the principles and techniques taught in the shore school. Unless the standards taught on shore were also required

on board ship and unless there was close coordination between what was taught in the classroom and what was seen and heard in actual practice, the effect of the shore training soon became negligible.

The project recommended that each ship appoint an interior communications officer to be responsible for the quality of interior communications on his ship. It was suggested that this officer become thoroughly acquainted with the problems of interior communications and the methods being taught as a solution of those problems; and that he act as a coordinator between shore instruction and ship's talker practice. Classes for officers were recommended in order to acquaint them with the problems of the talker. It was suggested that whenever possible the ship's talker officer should observe the training of his men on shore.

With the assistance of the project the following method of operation was evolved in the San Diego shakedown group.¹⁰

When a ship arrived for shakedown, an arrival inspection was given to determine the state of training of the officers and enlisted talkers and the condition of circuits, telephones, and stowage facilities. The percentage of talkers (officers and men) who had had shore-based training was determined. If no suitable training program was in effect for the ship's company, one was suggested to the telephone talker officer of the ship. Assistance was rendered in the procurement of training aids and materials.

An officer from the interior communications department went aboard the ship as an underway instructor for several days at the beginning of the shakedown training and again for several days near the end of the shakedown period. He taught standard circuit procedures and the proper method of making up and stowing the telephones.

The final exercise for ships undergoing shakedown training consisted of a battle problem. During the battle problem officers of the interior communications department of the shakedown group monitored and recorded the traffic on the most important battle telephone circuits. The recordings were played back to the officers and, if possible, to the talkers. At the critique which was held after the conclusion of the

battle problem, the head of the interior communications department made a report on the telephone talking, pointed out the excellences and the deficiencies observed, and suggested ways and means to improve use of the ship's interior communications equipment. Transcriptions of the battle problem recordings were made and sent to the ship for use in further training.

10.5 VOICE COMMUNICATION TRAINING FOR THE SUBMARINE SERVICE

10.5.1 Cooperative Program with NDRC Divisions 6 and 17

Many submarine commanders testified that errors and confusion in interior communications had cost them targets and jeopardized the safety of their ships. Recordings made from battle circuits during attacks confirmed this testimony. The recordings showed that some commands had to be repeated several times before they were understood. Some were misunderstood, but the error was not detected. Some never got through at all.

Four main factors accounted for these difficulties in voice communications aboard a submarine: (1) limitations of the equipment; (2) noise interference; (3) unstandardized procedures and phraseology; and (4) untrained personnel.

In April 1944 the laboratory of the Columbia University Division of War Research [CUDWR] at New London was asked by Commander Submarines, Atlantic [ComSubsLant] to assist in standardizing submarine voice procedures and phraseology and in developing a comprehensive voice communications training program. The request stated that the work was considered vitally urgent. After consultation among the NDRC groups working in the field of voice communication, the following plan was agreed upon. The Harvard Psycho-Acoustic Laboratory, Section 17.3, and Project N-109, Applied Psychology Panel, would furnish personnel to work at the Submarine Base, New London; CUDWR would make available the

general facilities of the laboratory and would coordinate the activities of the groups concerned.

10.5.2

Courses Developed^{8, 9}

It was generally agreed by submarine officers that a comprehensive training program in voice communication was needed for both officers and enlisted men. Late in June 1944, ComSubsLant approved a proposed submarine interior communications program, which recommended that the training be given at three levels.

1. A basic course to teach general skills in the use of equipment, ability to talk intelligibly in noise, and observance of correct voice procedures and circuit discipline.

2. An intermediate course to give each man proficiency in the use of the particular phraseology required by his assignments aboard ship.

3. An advanced course to drill the crew as a combat team in the coordinated use of the communication circuits.

Plans for the layout of a training room were developed and the necessary equipment designed. A text, *Submarine Telephone Talkers' Manual*,¹³ and an instructor's manual¹⁰ for the basic course were prepared. After establishing the training program at the New Construction Training School and the Basic School at the Submarine Base in New London, it was extended to eight outlying activities. Kits for completely equipping training rooms at these activities were prepared and tested by NDRC personnel, who also supervised the installations in some cases and aided in the training of instructors to take charge of the training.

10.5.3

Standardized Procedure and Phraseology

The work on standardization of submarine voice procedures and phraseology followed the general pattern described in Chapter 23. Results are given in detail in reference 9 and in summary in the Summary Technical Reports of Divisions 6 and 17.

In the program of standardizing phraseology,

RESTRICTED

a systematic catalogue was first made of alternative forms of all commands in common use. Experimental tests were then conducted to determine the intelligibility over sound-powered phones in the presence of noise of alternative station names and of key words frequently used in messages. Based on these tests and upon conformity with submarine usage, detailed uniform voice procedures and specific wordings for all important submarine commands were prepared and submitted for criticism to officers throughout the submarine service. The material was published by ComSubsLant under the title *Standard Submarine Phraseology*.¹⁵

10.6

CONCLUSION

Substantial improvement in the intelligibility of shipboard telephone communication was

made possible by the work on telephone talker training. Standardized use of words and names of relatively high intelligibility, training aids, training manuals, courses of instruction for telephone talkers and for those who had to teach telephone talkers, all contributed to this result.

A great many other new courses of instruction and new requirements of personnel also became necessary during World War II. Under the pressure of many duties, it was not possible for every ship and every training base to give full attention to or take full advantage of the telephone talker or any other specific training program. Whenever the results of the work described in this chapter could be carefully put into effect, more intelligible communication was the result.

Chapter 11

VOICE COMMUNICATION TRAINING IN THE ARMY AIR FORCES

By Dael Wolfe^a

SUMMARY

THE INTENSE NOISE LEVELS of a military airplane make voice communication over radio or interphone very difficult. Training methods were devised and instructors' handbooks and students' manuals written for courses designed to teach aircrew personnel to speak so that their messages would be more intelligible. The training received in these courses resulted in an increase of approximately 25 per cent in the number of words heard correctly over airplane communication equipment in the presence of intense noise.

Special courses were written for the training of each type of aircrew specialist and for the training of formed crews of heavy and very heavy bombers.

11.1 THE PROBLEM OF VOICE COMMUNICATION IN THE AIR FORCES

Most of the communication among the members of an airplane crew is by means of an interphone system consisting of microphones, headsets, and an amplifier. Communication between planes or between a plane and a ground station is normally by radio telephone [R/T]. Intelligibility over both interphone and R/T is handicapped to some extent by the acoustical limitations of the equipment and to a large extent by the high noise levels found in military airplanes.

In interphone communication both speaker and listener are surrounded by a constant noise which at best is about 85 decibels [db] and at worst about 125 decibels. This noise enters the communication system at two points. The microphone picks up the airplane noise as well as the speaker's voice. The listener finds that his earphone cushions do not provide a perfect seal, so noise enters his ear along with the message he is

^a This chapter is based upon the work of NDRC Project SC-67.

trying to understand. Communication under these conditions is very difficult. Information and orders must be understood in spite of the difficulties.

The Army Air Forces requested the NRC Committee on Service Personnel (which became the Applied Psychology Panel) to investigate methods for improving communications under these necessarily very noisy conditions. The request was accepted and assigned, as Project SC-67, to the Psychological Corporation.

The work of the project was of three types.

1. The development of training courses to teach aircrew personnel the best methods of voice communication in noise.

2. Experimental studies of the optimal methods of using existing voice communication equipment and the voice itself.

3. The development and experimental testing of standardized names and messages.

Work in the first of these three fields is described in this chapter on training. Work in the second and third is described in Chapter 23.

11.2 SPEECH TRAINING COURSES FOR THE AAF

Most members of the staff of the Voice Communication Project were experienced teachers borrowed for the war period from college speech departments. On the basis of their collective experience, and with the cooperation of AAF instructors, they outlined a speech training course, which they then taught to a group of Air Force cadets. At the end of the course the cadet students were no more intelligible than a control group which had not been trained. The training course itself was a complete failure.²⁰

After this first attempt failed, new courses which were based upon the research findings discussed in Chapter 23 were developed. They proved highly effective in improving intelligibility over airplane communication equipment. These courses are described below.

11.2.1 The Criterion of Intelligibility

Measuring the effectiveness of instruction in speech communication required the development of a test of intelligibility. For practical reasons the test had to be short and of a type which could be administered to groups or classes of students. Most important, it had to be a test of intelligibility in noise.

TESTING PROCEDURE

The testing process that was developed operated as follows.^{5, 18, 19} From 8 to 12 students were stationed on a party-line network over which they could talk and listen to each other through airplane intercommunication equipment. High-level, airplane-type noise filled the testing room.^{1, 7, 10} Each student read a list of words in the manner, "Number one is *fog*. Number two is *dashboard*," and the remaining persons on the line wrote what they heard the test words to be. The introductory phrase tended to make the reading of the words sufficiently slow for the listeners to keep up. The members of the party line rotated as speakers, each using a different test list. The speaker's intelligibility score was the proportion of correct responses made by all the listeners.

DEVELOPMENT OF INTELLIGIBILITY TESTS

The first step in the development of intelligibility tests was to select test words, and the second to combine them into tests of equal difficulty. The following criteria were followed as closely as was practicable in the selection of words.

1. Use of one- and two-syllable words.
2. Use of words with Thorndike ratings of 10 or less.
3. Use of words that in trial tests were pronounced correctly by at least 90 per cent of AAF cadets.
4. Use of words that on trial tests were between 20 and 80 per cent intelligible. (The intelligibility value of a word is the proportion of times that it is heard correctly when spoken by many speakers.)
5. Avoidance of homonyms.
6. Avoidance of words with alternative stress patterns.

The final tests were drawn from 5,000 words that were used in trials.

In combining the words into test lists, the items were assigned to make the lists equal in mean intelligibility values and approximately equal in standard deviation. Repetitions of initial sounds and suffixes within a list were generally avoided.

In general, experimental work was conducted with lists of 24 words; 48 equivalent lists were constructed. Later, for use in training classes, these lists were refined and the words regrouped into 24 lists of 12 words each. Standardization for all the tests was based on a minimum of 50 speakers and 450 listeners, all from the AAF population for which the tests were constructed.

In administering the tests, each member of a class served in rotation as a speaker while his classmates constituted a panel of listeners. Other researchers have used constant panels of listeners. The employment of a single speaker-listener panel of 8 to 12 members, however, turned out satisfactorily. In actual measurements, panels of 4 and of 7 listeners showed reliabilities of .68 and .83 respectively. The predicted reliability for different numbers of listeners is as follows (Spearman-Brown).

Number of listeners	Reliability	Number of listeners	Reliability
4	.68	10	.84
6	.76	12	.86
7	.79	16	.89
8	.81	20	.91

Revisions and extensions of the word tests continued throughout the duration of the project and culminated in a set of multiple-choice tests¹⁹ in which the listener choices represented the four most common error-substitutions on the part of listeners who took the write-down tests. However, the experimental results described in this chapter and in Chapter 23 were derived from write-down tests.^{5, 18} One sample list includes fog, dashboard, cold, flight, headwind, roll, missile, course, binding, practice, socket, impulse.

STATISTICAL CHARACTERISTICS

The following indexes relate to the adequacy of the tests. The mean intelligibility score for a

RESTRICTED

sample of 169 untrained speakers under laboratory conditions was 50.0, σ , 12.0. Split-half correlations, corrected for length, of the measures of individual speakers were .86 to .94. Relative intelligibility values of test items as determined at different training centers correlated .86 to .92. No significant differences were found (F tests) among the mean scores on different word lists; $F = 0.26$ when 1.61 = 5 per cent level of confidence. (An assumption in an analysis of variance is that the variation in all subdivisions is the same. L was computed, and it showed satisfactorily uniform variance among the tests.)

type noise. Students spoke and listened, using standard airplane communication equipment.

VOICE COMMUNICATION TRAINER

The voice communication trainer consisted of 48 positions or stations for students. Each station contained jackbox, headset, and the two most commonly used microphones (hand-held and throat). Stations were connected to make four separate circuits or party lines. The 12 stations on each circuit were spaced about a single table and separated by dividing boards that extended approximately 12 inches above table level. The four circuits were wired into an

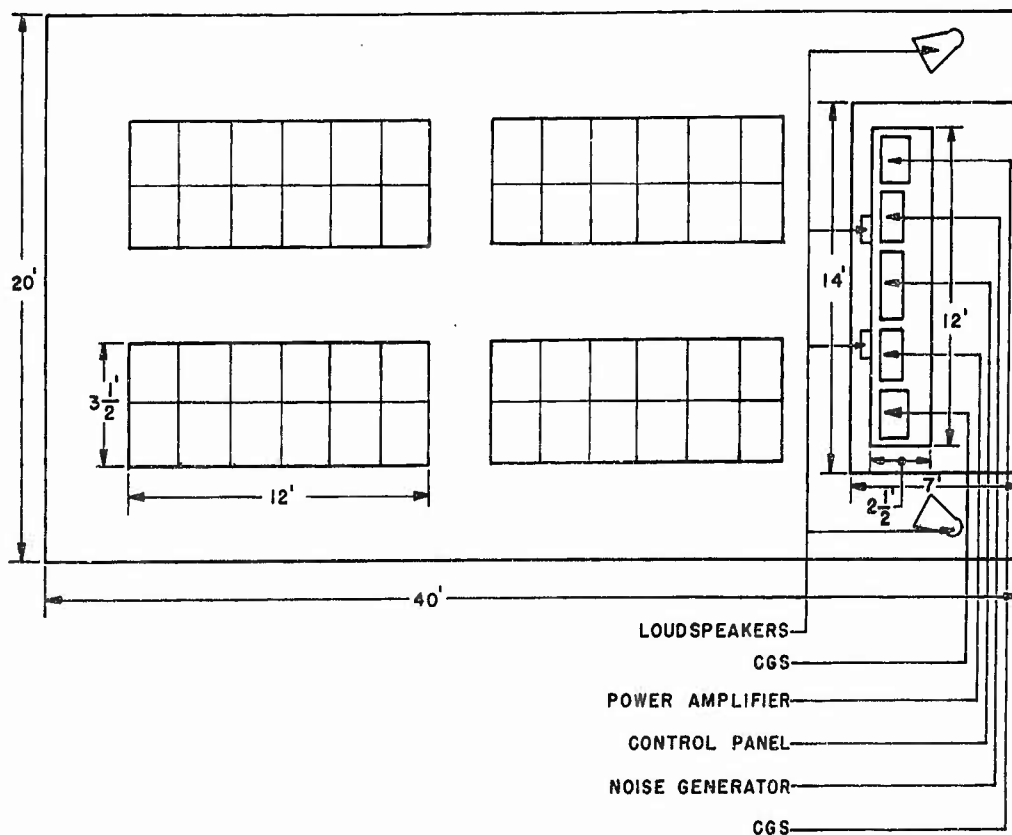

FIGURE 1. Diagram of recommended classroom.

11.2.2

Training Procedures

The classes in voice communication were conducted in especially prepared classrooms. A voice communication trainer filled the room with an intense (100 to 110 decibels) airplane-

especially designed control panel, the central piece of equipment at the instructor's table.⁷

The instructor occupied a fifth table. His equipment included, in addition to the control unit, an airplane-type noise generator, a 50-watt amplifier connected between the generator and

RESTRICTED

four loudspeakers that were spaced about the room, two voice recorders, and two decibel meters. This equipment operated flexibly through the control panel with patch cords and switches so that the instructor could listen and talk to any station or record and play back any message. He could also read from the meters the effective loudness level of any student's transmission.

Figure 1 shows the recommended classroom arrangement. Figure 2 shows a section of a

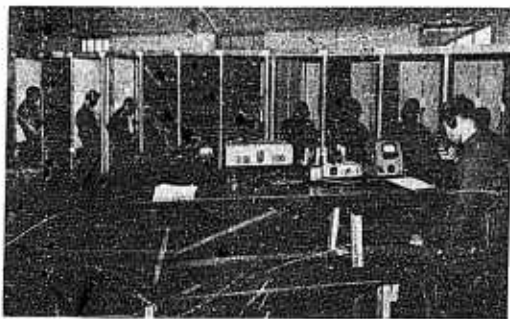

FIGURE 2. Voice communication training class.

slightly different classroom and the equipment at the instructor's table.

METHOD OF INSTRUCTION

The role of the instructor was largely to keep students talking and listening over the inter-phone equipment, that is, to keep voice drills going. Instead of lecturing about how to use the microphone or how loudly to talk, he listened to the drills, interrupting the speaker with a request to talk louder or slower, to hold the microphone differently, or to change the message phraseology to conform to standard forms. Phonograph records did most of the lecturing; manuals and instruction sheets outlined the drills.

The courses given in various training environments were similar, but not identical. Approximately 20 curricula were drawn up to provide each air specialist with materials that as closely as possible represented the voice messages and communication skills that he would use in his job (Section 11.2.3). These courses were usually 4 hours long.

Testing and instruction during the 4 hours was organized somewhat as follows:

Hour I. Intelligibility test; demonstration recording, loudness; loudness drill.

Hour II. Continued loudness drill; demonstration recording, rate; rate drill.

Hour III. Demonstration recording, articulation; articulation drill.

Hour IV. Demonstration recording, accustomed patterns of speaking; procedure review drill; intelligibility test.

The first 30 to 40 minutes of the training were devoted to a 12-word write-down or a 24-word multiple-choice intelligibility test. The tests were graded, with the class participating, so that each member learned immediately his score and his standing in his class. At the very start, the student thus experienced the problem of communicating in noise, received a measure of his proficiency, and was usually motivated for the remainder of the short course.

Following the test in the first period and at the outset of each remaining class period, the students heard a 5-minute demonstration recording played to them through their headsets. These recordings explained, largely through examples of good and poor usages, the principles of speaking for intelligibility. They were partially dramatized with dialogue and sound effects. The demonstration recordings both standardized content and saved time while providing exemplary messages pertinent to the voice drills for the hour.

A typical class hour is exemplified in Hour III of a course for bombardiers. In Part III of the outline, the left-hand column describes the lesson procedure in a time sequence; the second column shows the time allotted to each procedure; the third gives directions for the instructor; and the fourth tells him where to find the drill materials in manuals that he has.

Third Hour (Bombardiers)

- | | |
|---|---|
| I Objectives. At the conclusion of this lesson each student should (a) know the importance of slow, clear speech; (b) have practiced slow, clear speech; (c) have practiced using inter-phone messages. | II Instructional aids
A. Demonstration recordings. "Rate" and "Pronunciation" (nonpilot).
B. Prepared sheets for drill 2, items 1 to 12.
C. Prepared sheets for drill 5. |
|---|---|

RESTRICTED

III Lesson procedure	Time	Play demonstration recordings, "Rate" and "Articulation" (nonpilot).	Vol. I, Sec. V for scripts.
A. Demonstration	10	Use T-30 microphones. Student monitor on each circuit to time messages.	Drill 2, items 1 to 12.
B. Drill	40	Record and play back portions.	Drill 5.
1. Voice, rate.			
2. Interphone messages, aircrew members.			

In the speaking exercises students on each party line worked as a unit. In most cases the sequence of messages in an exercise made an entity, for example the radio and/or interphone messages of a simulated flight. As one person spoke, the others on the line listened. Frequently the message designated which listener should respond. Each exercise had a dual purpose, to establish habits for intelligibility and to establish habitual use of routinized message forms.

The following excerpt from a drill shows how some of the materials were given to the instructor. He, in turn, reproduced them in usable form for the individual stations.

Drill 25: R/T Position Reports

This drill is a simulated airway flight. Plane No. 3459 is cruising at 200 miles per hour. Each position report should include, in order, call, position relative to check point, time, altitude, flight conditions, E^TA next check point or destination.

Example:

Station 1: Memphis Radio, this is Army 3459, over.

Station 7: Army 3459, this is Memphis Radio, over.

Station 1: Memphis Radio, this is Army 3459, 15 miles northeast Memphis, time 0935 at 4000 on instruments, estimate Texarkana time 1055, over.

Station 7: Army 3459, Roger, out.

Station acting as plane	Station acting as range	Range station	En route	Additional information
1	7	Memphis	Nashville to Dallas	260 miles to Texarkana
2	8	Texarkana		100 miles to Dallas
3	9	Dallas		Request permission to contact Love Tower

During the last half-hour of the course, as during the first, an intelligibility test was given.

This test was similar to the earlier one in type and difficulty.

The training called for maximal student performance and made the instructor's chief function that of being an alert critic. For this role he was guided largely by objective criteria. For example, if the meter showed low voice level, the cause was insufficient loudness, poor microphone position, or more than one open microphone on the circuit. It was easy for the instructor to make an appropriate comment.

In summary, the training procedures in voice communication were characterized by directed drill over service equipment in the presence of high-level noise. Realism in course content and training environment was approached. The equipment, drill manuals, and organization made it possible to give the course in a reasonably standardized manner even though the instructors (AAF officers) varied widely in training and experience.

11.2.3 List of Training Courses for Aircrew Specialists

All training courses followed the basic pattern described in Section 11.2.2. The drills included in each course were specifically designed to give practice in using the message forms that the particular specialist would use in actual flight. In some cases the scheduling requirements necessitated a departure from the usual 4-hour course length. Instructional manuals written were:

Students' Manual and Instructors' Syllabus for Basic (Pilot) Course in Communication.^{2,3}

*Instructors' Handbook for a Course in Voice Communication for Pilot Instructors (4 Hours).*¹²

*Indoctrination in Voice Communication for Instructors in Primary Flying Schools.*¹³

*Instructors' Syllabi for Courses in Interphone Communication for Navigators and Bombardiers.*¹¹

*Instructors' Syllabus for a Radio Operator-Mechanic Course in Voice Communication.*⁹

*Students' Workbook, Radio Communications, Basic.*²³

*Instructors' Handbook: Basic Radio Communications.*²⁴

RESTRICTED

*Manuals for Instruction in Voice Communication for Aerial Gunnery.*⁴

*Students' Manual for a Basic Course in Interphone Communication in Flexible Gunnery Schools.*²²

*Instructors' Handbook for a Course in Voice Communication for Control Tower Operators (8 Hours).*¹⁴

In addition to these, special drills in voice communication procedure were written for special purposes, such as bombing through overcast,²⁶ night fighter operations,¹⁰ and the Far East Air Forces¹⁰; and sections were written for various aircrew information files, such as pilots information file and radio operators information file.

One of the final tasks of the Voice Communication Project was to revise these training manuals and instructors' handbooks and to bring both methods and contents up to date (July 1945). The various manuals were combined into a single handbook for instructors and a set of specialized drills for different members of the aircrew.¹⁹ This task was completed a few days before World War II ended; the new combined manual was therefore not printed. The manuscript copy was given to the Assistant Chief of Air Staff-3 for use by the AAF Training Command. This new manual, rather than the various earlier ones named above, is reproduced on microfilm to accompany the Applied Psychology Panel's Summary Technical Report.

11.2.4

Crew Training

In order to provide materials for training the crews of large bombers in interphone procedure, the project developed an interphone crew trainer¹⁷ and special drills for crew training.¹⁶ Each Crew Commander²⁵ conducted the training course for his own crew. In most respects this course was very similar to those described in Section 11.2.2.

11.2.5 Effects of Voice Communication Training

The measured effect of voice communication training was increased intelligibility. There were other effects—better handling of equip-

ment and use of standardized message forms—but their extent was not measured. Tests given at the beginning and end of each course regularly demonstrated increased intelligibility.

EFFECT OF SPEECH DRILL

The increase in intelligibility was in all probability due more to improvements in speaking ability than to improvements in listening ability.^{8, 20}

Furthermore, the improvement resulted from the training course itself and not from unsupervised practice in the use of communication equipment. The effects of experience alone in changing speaking ability are shown in Table 1. Groups of instructors whose jobs necessitated teaching in the air, combat returnees, students in training, and men awaiting training (all stationed at one center) were tested for intelligibility under the same circumstances. Their experience in flight and, consequently, in using communication equipment ranged from none to the large amounts represented by long periods instructing in an airplane or by completion of a tour of combat duty followed by reassignment to this country. In spite of these differences in experience, no significant differences in intelligibility were found among the groups. The cadets in training were on the average as intelligible as the men who had returned from combat.

TABLE 1. Intelligibility scores for instructors, combat returnees, cadets, and preflight student navigators.

Group	N	Mean	
		intelligibility score*	σ_m
Instructors	27	67.9	2.1
Combat returnees	20	60.2	2.6
Cadets	78	58.7	1.8
Preflight students	38	60.3	1.9
Total	163	60.7	

* The noise level in the classroom in which these scores were obtained was somewhat below the recommended 100 to 110 decibel level. The mean intelligibility scores were therefore all substantially above 50. This fact does not invalidate comparisons among the groups.

A survey of the frequency with which interphone messages had to be repeated in order to be understood further supports the idea that experience alone did not provide adequate voice communication skill. Among aircrews who had

RESTRICTED

not had voice communication drill, but who were in other respects fully trained and ready to be sent to combat theaters, it was found that 40 per cent of interphone messages were repeated one or more times. Many more were never acknowledged as received.

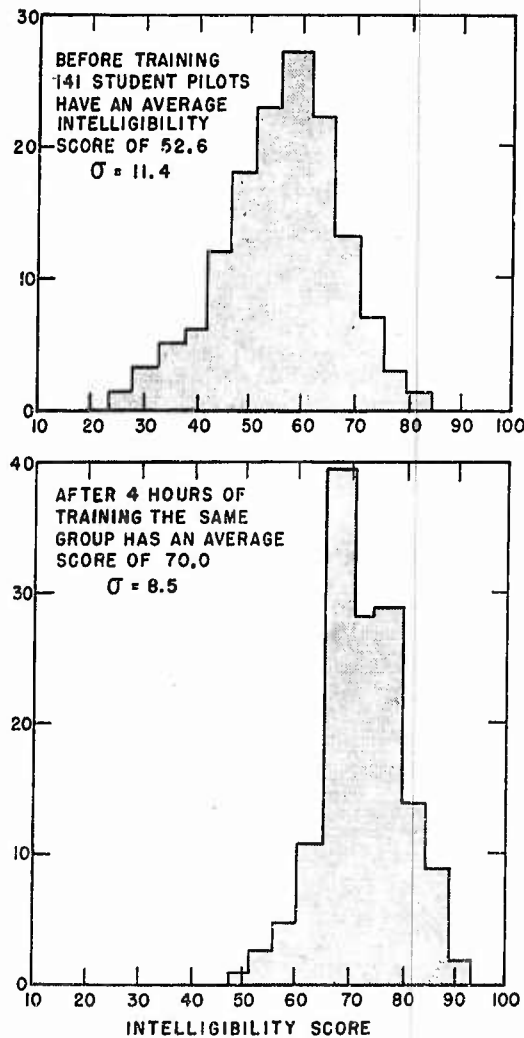

FIGURE 3. Effect of 4 hours of speech training on intelligibility over airplane communication equipment.

Specific training in voice communication was necessary to improve message intelligibility.

RETENTION OF INCREASED INTELLIGIBILITY

Another aspect of the effectiveness of training is retention of the acquired skill. Follow-up

tests were given to two classes 30 days after they were trained in voice communication. In each class a small but statistically significant improvement in mean intelligibility scores was found. The improvement may have been due to experience with the test itself, but it is clear that the improvement which results from training was retained without loss for at least a month.

EFFECT OF INSTRUCTOR

Figure 3 typifies the results of laboratory training conducted by speech teachers. If the program was to be of value it had to operate under the direction of Army instructors. Table 2 shows that the results obtained in field use by teachers who had little speech training other than 1 week's indoctrination given by project personnel were about equally satisfactory. Although only five centers were surveyed thoroughly, they appeared to represent what was happening generally in basic training installations.

TABLE 2. Intelligibility scores of speakers trained in voice communication at five AAF centers.

Type of training center	N	Untrained mean	Trained mean	Mean gain
Pilot	329	49.3	67.1	17.8
Pilot	128	59.6	76.7	17.1
Gunner	543	67.7	81.7	14.0
Navigator	229	65.9	85.4	19.5
Bombardier	78	68.6	84.7	16.1

BRINGING ALL MEN TO APPROXIMATELY EQUAL INTELLIGIBILITY

The effectiveness of the training program with regard to intelligibility is illustrated in an analysis of a representative class of 141 student pilots. Before training, the class had a mean intelligibility score of 52.6 (σ , 11.4). After four hours of training the mean score was 70.0 (σ , 8.5). Table 3 shows the gain of the class by deciles, divided according to pre-training intelligibility scores, and it also illustrates the decrease in variability that accompanied training. This training made the men more intelligible and made them more alike in intelligibility.

RESTRICTED

TABLE 3. Effects of voice communication training upon speakers of different pre-training ability.

Decile	Initial score	Final score	Gain
1	70.21	74.93	4.72
2	63.64	72.71	9.07
3	60.57	71.00	10.43
4	57.21	72.14	14.93
5	54.86	68.57	13.71
6	51.71	73.00	21.29
7	48.50	69.57	21.07
8	43.64	69.86	26.32
9	39.93	64.71	24.78
10	30.07	65.86	35.79
Total	52.6	70.0	17.4

11.3

CONCLUSION

The importance attached by the AAF to the project's success in improving voice communication training was demonstrated by a letter from Brig. Gen. F. C. Meade, USA, Director

of Plans and Operations Division, written to the Chief Signal Officer. General Meade wrote, "The Voice Communication Laboratory, located at Waco Army Air Field, and operated under NDRC Project SC-67, has developed training methods by means of which intelligibility over the inter-phone and radio telephone may be increased on the average by as much as 25 per cent. . . . It should be indicated that an average increase of 25 per cent in intelligibility is greater than the increase that has been obtained in recent months through costly changes in equipment" (SPSOO 334, June 7, 1944, 3rd Ind., June 26, 1944).

After the results reported in this chapter were made known, AAF directives required all aircrew personnel undergoing training in the United States to take a voice communication course.

Chapter 12

TRAINING RADIO OPERATORS

By Dael Wolfe^a

SUMMARY

IMPROVEMENTS were made in all phases of training radio code operators: initial learning of the code characters; acquiring receiving speed; learning to send; measuring both receiving and sending speed and skill; and the standardization of code speeds.

The code-voice method of teaching basic code was developed on the basis of established principles of learning. It was shown to be superior to former methods and was adopted by the Army.

During the weeks when receiving speed is being acquired, 4 hours of daily drill were shown to produce as rapid learning as 7. The distribution of these 4 hours within a day was found to be unimportant. Increasing the variety of drill materials was shown to produce more rapid learning and to decrease boredom in both students and instructors. One hour a day of practice in copying hand-sent, clear-text practice material produced a small improvement in ability to copy cipher accurately. Giving men practice in copying code through various types of interfering noises did not diminish their ability to copy clear code and led to a moderate improvement in ability to copy code through interference.

Work with high-speed operators consisted of an evaluation of two devices which had been suggested as ways of helping men to attain speeds of 25 words per minute. Both were shown to be without value.

The introduction of sending practice early in the course was shown to have no detrimental effect upon the speed with which men learned to receive code. Since the earlier introduction allowed more practice in sending, this schedule was recommended.

A trainer to aid men in learning to send correctly was developed. It consisted of a typewriter which was controlled by electronic circuits in such a way that Morse code characters

were transcribed by the typewriter as ordinary letters. Correct sending appeared immediately on the typewriter as correct copy. Errors in sending appeared as errors and usually informed the student immediately of the nature of the mistake he had made.

A monograph on code speeds was prepared to provide instructors and others with an understanding of the various bases for computing code speed and with instructions for cutting tapes which would have the exact speed desired.

Two studies were made of errors, one of errors in receiving and one of errors in sending. In both cases the order of difficulty of the characters was found to be highly constant for students of different levels of ability and advancement. Practice material, both for receiving and for sending, in which difficult characters appeared more frequently than easy ones was suggested as a plausible method of improving learning. Neither suggestion had been adequately tested at the time NDRC's work on code learning ended.

The progress of several hundred students learning to receive code was recorded and tabulated. Tables and curves based on these data provided information on average rate of learning and upon variability of rate in learning for students ranging in level from beginners to men able to receive at 25 groups per minute.

Standardized tests of ability to receive code at different speeds were constructed. They were used in research studies and in Navy schools.

12.1

INTRODUCTION

One of the very first requests made of the Committee on Service Personnel was to assist the Navy in improving methods of selecting and training radio code operators. The request was answered by establishing Project N-107. Later, two other radio code projects were activated: Project SC-88 worked on methods of training

^a This chapter is based primarily upon the work of NDRC Projects N-107, SC-88, and NS-366.

Army operators; Project NS-366 developed a Morse-code-actuated typewriter for use in improving sending skill.

Code learning is an activity of considerable psychological interest for it provides an opportunity to study a practically important kind of learning which is rather easily subjected to experimental study. There was, in consequence, a fair background of civilian research for these projects to draw upon.

The first assignment for Project N-107 was to get acquainted with procedures being followed in 1942 in selecting, training, dismissing, and rating radio operator students. A survey was made of the practices followed in some twenty Army and Navy schools.¹ Great diversity was found in organization, methods, and standards. For example, the 20 schools followed 11 different systems in introducing the individual characters and lesson groups. In one school all characters were introduced in the first 2 or 3 days; in another the men were in school for 6 weeks before encountering all 36 characters. Proficiency tests were given as frequently as once or twice a day and as infrequently as once a week. Despite a large amount of past experience, there were no generally accepted requirements, methods, or standards for training code operators. The radio code projects of NDRC undertook to determine the best methods in order that they might become standard practice.

Work on selection of radio operators is described in Chapter 6 of Volume 1 of the Summary Technical Report of the Applied Psychology Panel. It culminated in the adoption by both Army and Navy of the NDRC-developed Speed of Response Test of Code Aptitude.

Work on training is described in this chapter. It culminated in the adoption by the Army of a new manual²⁵ on the training of code operators, a manual putting into standard use improved methods developed by project personnel.

12.2 TRAINING MEN TO RECEIVE INTERNATIONAL MORSE CODE

Code training consists of two phases. In the first, recognition of the characters representing

the 36 letters and numbers must be learned. In the second, speed and skill must be acquired in recognizing the characters and in sending them.

12.2.1 Learning the Characters

THE CODE-VOICE METHOD

The first task in learning code is to learn to identify each of the 36 sound patterns (dots and dashes) which represent the 36 letters and digits. Various methods have been used to produce this learning. All consist essentially of helping the student to associate the sound of each character with its more familiar English equivalent. Thus when the pattern ·- is sounded, the student may be told that it represents A (or Able), he may search through a printed list until he finds the correct letter, or he may have to wait until he has heard a number of such patterns before he is informed of the equivalent of each.

On the basis of general learning principles, it appeared likely that learning would proceed most rapidly if the learner was told immediately after hearing each character just what that character was. In order to provide him with an opportunity to recognize the characters for himself, a pause of about three seconds was introduced between sending the character and naming it. In order to allow a fairly large number of correct responses, the characters were frequently sent in "doubles," for example: ·-, pause, "Able," pause, ·-, pause, "Able." Then another character was sent, named, repeated, etc. This was called the code-voice method of teaching code.^{15, 23, 25}

Again on the basis of general learning principles, it appeared likely that learning would proceed more rapidly if all 36 characters were learned than if they were broken up into groups, as had previously been common practice. "Whole learning" of all 36 characters at once was therefore included as a feature of the code-voice method.

In order to provide the student with a record of his progress and at the same time to give him a standard method of scoring his own work, special record sheets were prepared. Each line

consisted of a double row of squares, like this:

R	R	M	N	--	C														
		N	C																

When a character was sent, the student wrote it, or wrote what he thought it to be, in the upper row, for example R in the first box. When the instructor announced the character, the student learned he was correct, wrote nothing in the lower row, and could respond accurately when R was repeated. When an error was made, as in the third box, or the student did not recognize the character at all, as in the fifth, the instructor's naming it allowed immediate correction. When the missed character was repeated, a correct identification was almost always possible.

Counting the entries in the lower row of squares quickly gave the total number of errors. Plotting these error scores gave an easily made and easily understood learning curve.

The code-voice method combined the psychological advantages of immediate knowledge of results, whole learning, meaningful scores, a running record of improvement, and the opportunity to compete with one's own past record.

EXPERIMENTAL TESTS OF THE CODE-VOICE METHOD

Inexperienced students of three beginning code classes were trained with standard Z-tape procedure, the usual Army method. Progress in code receiving was measured in terms of the number of hours required to learn to receive 5 words per minute [wpm] correctly and in terms of the percentage of men who qualified at 5 wpm or above by the end of the seventh day of training.

Inexperienced students in the succeeding three entering classes were given code-voice training for 6 days and moved to the 5 wpm tape on the seventh day. No student, however proficient at the code-voice level, was permitted to practice on tape until the morning of the seventh day. Progress was measured by the same criteria used with the preceding three classes.

There were 87 men in the Z-tape group and 262 in the code-voice group. The two groups were equal in general ability as measured by

the Army General Classification Test and in code ability as measured by the Army Radio Operator Aptitude Test [ROA].

The mean number of hours for 74 Z-tape students to qualify at 5 wpm was 35. The corresponding value for 253 code-voice students was 27. The percentage of Z-tape students who qualified at 5 wpm by noon of the seventh day of instruction was 29; for code-voice students, the mean was 50. Both differences were highly significant statistically, and in each case the superiority of the code-voice method was demonstrated. The data are summarized in Table 1. This demonstration led to the immediate adoption of the code-voice method at the Central Signal Corps School, Camp Crowder, Missouri, where the experiment was conducted.

TABLE 1. Comparison of code-voice and Z-tape methods of teaching International Morse Code.

Training method	Tape standard	Number of men	Hours required to pass 5 wpm		Per cent who failed to pass 5 wpm
			Mean	σ	
Code-voice	Paris	253	26.57	7.93	3.4
Code-voice	Codez	258	25.66	14.59	
Z-tape	Paris	74	34.78	15.47	15.0
Z-tape	Paris	446	40.87	22.78	

CODE-VOICE TRAINING MANUAL

Following the adoption of the code-voice method at Camp Crowder, project personnel cooperated with the radio training section in preparing an instructors' manual for the method²³; an introductory pamphlet and explanation for the student²⁴; and a WD manual, TM 11-459,²⁵ which gave the code-voice method formal Army approval and made it a standard training method.

VARIANTS OF THE CODE-VOICE METHOD

Situations occurred in which code learning could not be taught in regular classes or in which limited practice time, such as an hour a day, was available. A simplified code-voice procedure was worked out for situations of this kind. An experimental test was made of the speed of learning of 77 soldiers taught 1 hour a day by this simplified method.¹⁵ In terms of

actual hours of practice, they learned slightly more rapidly than a normal school group taught by the standard code-voice procedure.

The Office of the Chief Signal Officer and the Infantry School, Fort Benning, Georgia, produced a *Basic Radio Code* course for the Armed Forces Institute. This course used the code-voice technique as its basic method. The course was recorded on phonograph records, making its use possible by students working without an instructor.

An experimental evaluation of the *Basic Radio Code* course was attempted. Various difficulties arose to interfere with the experiment, but the results indicated that the method was satisfactory and that the course could be recommended for use.⁶

12.2.2 Intermediate Stages of Learning

Following the learning of the individual characters making up the International Morse Code, the would-be operator must learn to identify the characters as they are sent to him at faster and faster rates. Acquiring this skill takes up most of the time spent in code school. It is a relatively slow and sometimes tedious process.

Several experimental studies were directed toward improving the training given during this period. These studies covered four general fields: an evaluation of a method comparable to the code-voice method described in the preceding section but adapted to use at higher code speeds; studies of the most effective distribution of practice; the development and experimental test of methods of introducing variety into practice materials; and an analysis of the errors made by student operators.

THE CALL-BACK METHOD

The success of the code-voice method in the early stage of training suggested that an adaptation of it might be advantageous at more advanced stages. The call-back method was therefore developed for use with practice materials which consisted of continuous messages or series of code groups.

The call-back method systematized the frequent practice of reading to the students a

series of characters that they had just copied and allowing them to correct their own copy. Daily records of the number of errors made in 100 consecutive characters allowed each man to plot his own learning curve.

The method was evaluated experimentally by comparing the progress of two groups of subjects, one taught by the call-back method and the other by a method as similar as possible in all respects except for the omission of the call-back feature.¹²

The call-back procedure, at levels of 7 wpm and up, did not increase the student's rate of progress. Neither did it enable him to achieve a higher level of final proficiency. On the other hand, it did not hamper achievement. The occasional use of the call-back method as a variety device to reduce the monotony of receiving practice and as a means of satisfying those who want some knowledge of their progress was recommended.

DISTRIBUTION OF PRACTICE IN CODE LEARNING

In an effort to force students to attain higher operating speeds, men in the code school at Camp Crowder were given 7 hours a day of code instruction. It seemed likely that this schedule was accomplishing no more than could be accomplished in fewer hours per day. In a variety of previous studies it had been shown that increasing the daily hours of drill or work beyond an optimum does not lead to increased learning or increased output. An experimental comparison of the effect of different numbers of hours per day for code practice was therefore agreed upon.¹⁴

Several preliminary experiments were conducted with small groups. Five hours a day appeared to be at least as good as 7. Four hours per day was as good as 5. Three hours per day showed only a slight loss. Two hours per day could not be tried out because that schedule would have violated an order specifying the minimum total number of hours of code training required of the men.

On the basis of these preliminary experiments the project and the radio training section agreed to study a 4-hour-a-day schedule more intensively.

The men were actually available for instruc-

tion for 8 weeks. In the normal schedule they spent 7 hours a day, 5 days a week, and 4 hours a day on Saturday for 5 of these weeks in code school. The final 3 weeks were devoted to other topics. Code learning in a group of 355 men working on this schedule was compared with that of 165 men who had their training spread over the entire 8 weeks on a 4 hours per day, 6 days a week schedule. The same instructors were used with the two groups; the same criteria of mastery were employed at the different

parison, the superiority of the shorter daily practice period is even more obvious. This comparison is given in Table 2.

TABLE 2. Code speeds attained with 4 and with 7 hours of daily drill.

Highest speed passed	Seven hours per day for 5 weeks		Four hours per day for 8 weeks	
	No. of men	Per cent	No. of men	Per cent
7 wpm	15	4.23		
10 wpm	58	16.34	3	1.82
12 wpm	151	42.53	22	13.33
15 wpm	112	31.55	71	43.03
18 wpm	16	4.51	36	21.82
20 wpm	3	0.84	33	20.00
Total	355	100.00	165	100.00

$\chi^2 = 155.11$ $p = .97$

Median speed at end of training	Seven hours per day for 5 weeks	Four hours per day for 8 weeks
	13 wpm	15 - 16 wpm

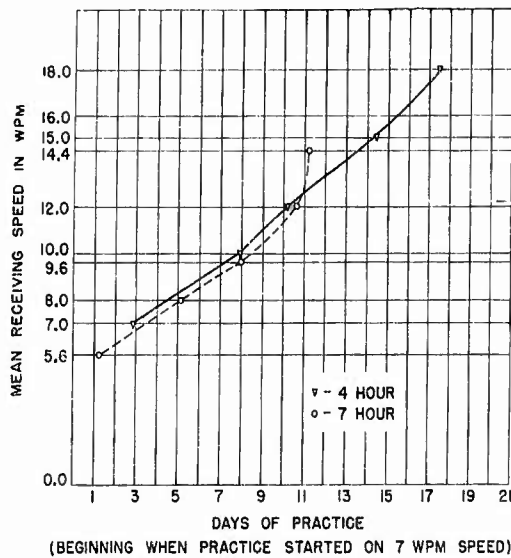

FIGURE 1. Comparison of 4 and 7 hours per day of code practice in terms of mean receiving speed attained. A "day of practice" meant 4 hours of drill for one group and 7 hours of drill for the other.

speed levels studied; and other training conditions were kept as alike as possible. The men of both groups were without previous code experience. No significant difference existed between the two groups in code aptitude or general intelligence as indicated by Radio Operator Aptitude and Army General Classification Test scores.

The results are shown in Figure 1. This figure shows clearly that 4 hours a day of practice produced just as rapid learning as did 7 hours a day. If the total training period (5 weeks for the 7-hour-a-day group and 8 weeks for the 4-hour-a-day group) is used as a basis of com-

parison, the conclusion from this experiment was unquestionable: 4 hours per day of drill was just as effective as 7 hours per day. The schedule was changed at Camp Crowder to put this finding into effect. The change had desirable by-products in addition to the principal advantage of saving time. Fewer men failed and morale immediately improved.

A comparison was made of two code-teaching schedules as they affected the progress of 165 men in three successive classes throughout a 10-week period of observation.¹³ One group (74 men), the massed-practice group, was taught code during the first 4 hours of each 7-hour school day; another group (91 men), the spaced-practice group, was given instruction during the first, second, fourth, and seventh hours of the day. Progress was measured in terms of (1) hours required to pass successive code speeds, (2) number of men passing each speed, (3) performance on the Code Receiving Test (see Section 12.2.4) at the end of the training period, and (4) the highest speed at which students were able to receive their own sending (their operating speeds).

Results of these comparisons indicated no significant difference in the progress of the two groups. In so far as the arrangement of

4 code hours within a school day was concerned, one schedule was as effective as the other.

VARIETY OF PRACTICE MATERIALS IN CODE DRILL

A general complaint from students in radio code schools was that their many daily hours of copying code became very monotonous. This complaint was especially acute in the stretch of weeks after the code alphabet had been mastered and before the student was competent to handle real communications equipment and to work on simulated nets. The existence of monotony was recognized by officers and instructors who persistently asked for ideas for reducing the deadly sameness of hour-by-hour copying of code.

It was common in most code schools, during the middle weeks of the course, for the students to copy for several periods a day automatically transmitted code. The automatic transmissions were occasionally relieved by the instructor's hand sending. In some schools the content of the drill was almost all of one kind; in others, the tapes were composed of messages more or less varied in nature. The pitch of the signals was usually the same, week in and week out. The instructors' duties were chiefly those of room clerks, supervisors of discipline, and test administrators. Some schools had tried a few innovations aimed to enliven the course. Some had short intervals of music or broadcasts of news and information in the middle of the periods. But no school, as far as the project could learn, had set up a comprehensive, systematic program aimed to reduce monotony by employing a variety of activities which were designed to induce positive motivation to learning.

Therefore, the project staff decided to try out the effects of a program in which the activities in each code period were continuously and systematically varied.⁸ It was agreed that in a 50-minute code period there should never be more than 15 minutes of continuous activity on any one particular kind of material and that usually there should be at least four separate activity-units in each period.

Four principles governed the selection of activities to be included in the program.

1. The activities should pertain to code. Monotony was not to be relieved by stories, music, or other noncode activities.

2. The activities were to be adapted to large classes and mass education.

3. Each of the activities included was to be educationally useful in and of itself.

4. The activities should be made as interesting as possible.

A variety of activities meeting these criteria can be found in reference 9.

The value of this variety, or antimonotony, program was tested in two code schools. In each school the progress of students taught by the methods regularly employed was compared with the progress of students taught by the variety techniques. The experiment was a rigorous test of the variety technique, for the two schools chosen for the study were the two in which students normally made faster progress than in any other schools with which the project had had experience.

Results differed in the two schools. In one, normally the best school known to the project, the classes taught by the regular procedures progressed just as rapidly as did those taught by the variety methods. The program of this school already included more variety than usual; the systematic addition of still more variety did not improve learning. In the other school, the second best normally, the variety classes learned more rapidly than the regular classes. From the eighth week on, the average man in the variety group could copy correctly from $1\frac{1}{2}$ to 2 groups per minute [gpm] faster than the average man in the regular classes.

The results from both schools and including only men in the two groups who were matched initially in terms of code aptitude were combined. The results obtained are shown in Table 3. The variety of activities led to better learning.⁸

In addition to improvement in code speed, several other positive values were reported from the variety experiment. Both students and instructors were better motivated. Both had to work harder, but the work was more interesting. The bored, lackadaisical attitude of the students and instructors gave way to one of alert interest.

USE OF HAND-SENT CLEAR TEXT AS PRACTICE MATERIAL

Most practice material was in the form of five-letter code groups such as BDXMC, IATNB. Most of the practice material was machine sent. In a few schools the men were given occasional practice in copying hand-sent material. Occasionally part of the practice material was in plain English text, for example from newspapers, bulletins, or announcements.

There was considerable disagreement over

TABLE 3. Comparison of code learning under normal and variety schedules.

Test number	Regular classes, gpm	Variety classes, gpm
1	4.6	5.0
2	6.4	6.5
3	7.5	8.0
4	8.5	9.4
5	10.0	11.0

the value of clear-text material. It was argued that the context of plain English helped the student to acquire confidence and speed. On the other hand, it was argued that plain-text practice material led to carelessness; a code group CHM26 might have been C5M26, but in plain English SHIRT could not possibly have been S5IRT. In receiving clear text, four or five dots had to be H; in code groups more accurate discrimination was necessary. So the argument went, without any very definite evidence to support either side.

An experimental study was therefore made of the effect of receiving hand-sent plain-language material upon the progress of code students in receiving machine-sent cipher material.¹⁶ In this study, clear-text training was begun for 28 students at the 10 gpm level, for 31 students at 12 gpm, and for 32 students at 15 gpm. The men were paired with the members of a control group on the basis of the time required for them to pass the speeds preceding the one on which plain English practice began.

The plain English practice material used in the experiment consisted of items of general information, humor, current events, and Signal Corps history, arranged for the most part

in short sentences. After each item was transmitted, the instructor read it aloud to his students in order that they might correct their copy. The amount of material transmitted in a practice hour varied with the speed level employed; at the 15 gpm level, about a page and a half of typewritten text was used.

The data summarized in Table 4 justified several generalizations.

1. Under the schedule employed in this school, a daily hour of receiving hand-sent clear text, at any speed or speeds, did *not* retard progress in learning to copy cipher material.

2. The use of hand-sent clear text may actually accelerate the progress of students in receiving cipher. This was definitely true of those students who received clear text at both 12 and 15 gpm.

3. When clear text was used at one speed only, there was no significant difference between the groups; when used at two speeds,

TABLE 4. Effect of one hour a day of practice with plain English on ability to receive cipher material.

Receiving speeds	Hours of practice work					
	Control group (cipher material only)		Experimental group (1 hour per day of plain English)		Differences between means	Critical ratio
	Mean	σ	Mean	σ		
10 gpm (N:28)	31.0	9.03	30.5	9.78	0.5	0.20
12 gpm (N:31)	19.3	9.82	19.6	7.48	-0.3	0.14
15 gpm (N:32)	34.7	14.11	31.6	12.93	3.1	0.92
10 & 12 gpm (N:9)	47.8	15.46	41.0	14.42	6.8	0.96
12 & 15 gpm (N:25)	52.5	16.66	40.4	10.62	12.1	3.06
10, 12, & 15 gpm (N:9)	75.4	17.11	59.5	12.75	15.9	2.24

the difference between means was considerably greater; and when used at three speeds it was greatest of all.

There was no way of determining from these data whether clear text or hand sending played the greater part in producing the effect observed, but it would seem that the clear text was probably the more important, since the passing of any speed was based solely on performance with machine-sent material. The

value accruing from experience with hand-sent code would presumably show itself in other connections, for example, in ability to copy the sending of other students.

Although it was impossible, in this experiment, to measure the improvement in ability to copy hand-sent clear text itself, it was nevertheless apparent to all concerned that, after an initial stage of confusion in spacing words (due to the habit of five-letter grouping which carried over from practice with cipher), progress in clear-text copying was rapid and steady, often leading to a high degree of skill.

TRAINING TO COPY THROUGH INTERFERENCE

In teaching about equipment, the schools introduced the actual equipment the men would use later. Similarly, the responsibilities of watch-standing and of log-keeping were taught under conditions which simulated future work reasonably well. However, most of the students' radio code reception was with the clear, well-controlled signals of the classroom. Stable circuits in the code rooms, good oscillators, uniform frequency of tone signal, standard conditions of reasonable quietness, and an emphasis on speed were characteristic. In the advanced phases, some schools were fortunate enough to have watch-rooms, airbase towers, mobile field units, and other devices to simulate field conditions, but many schools lacked these features. As a result word frequently came back from combat areas that newly assigned radio operators often lacked skill in copying under difficult conditions.

An experiment was conducted to study the influence of giving men practice in copying code through interference.⁵ The specific aims were to determine the effect of such practice upon the ability of the men to copy both with and without interference. At the same time it was possible to evaluate a set of seven albums of 16-inch records which had been prepared by project personnel in cooperation with the Training Aids Section of the Bureau of Naval Personnel (NavPers 11150P). These records had been specifically designed for practice in copying code through several types of interference: room noises, battle noises, atmospheric, precipitation static, motor noises, radar interfer-

ence, bagpipe jamming, beam jamming, and interfering code signals.

The learning records of the two groups (one with part of their practice given under conditions of interference, the other matched in ability and in other conditions but not experiencing the interference records) were compared. Both groups were tested on speed of copying without interference and on speed of copying with two types of interference, motor noises and beam jamming, neither of which had been heard before by either the experimental or the control groups. Comparisons of the records led to the following conclusions.

1. The two groups were about equal in their ability to copy clear code.
2. The experimental group was moderately better in its ability to copy through interference.
3. The range of ability of the experimental group became greater after 5 weeks of interference than that of the control group after 5 weeks of regular instruction. The superior students became relatively more superior under conditions of interference. The poorer students became relatively poorer. Thus, the interference training served to identify the marginal students who could either be eliminated or given special instruction.

It was recommended that interference training be included in daily code instruction of students who had attained a receiving speed of about 10 or 12 wpm. The NavPers interference records were recommended as satisfactory for this purpose.

ANALYSIS OF ERRORS IN COPYING CODE

As part of other research activities reported in this chapter, classes of students in a number of code schools were tested periodically. The resulting data were analyzed to determine the frequency of various errors and the frequency with which one character was confused with another.⁷ The analysis was made in response to a demand from code schools for authentic and comprehensive answers to such questions as: "What is the order of difficulty of the 36 characters of the International Morse Code?" or "What characters are confused with each other and to what degree?"

Analyses were made of errors occurring after 2, 4, 8, and 12 weeks of instruction. The total number of classes studied at each of these four periods varied from two to six. The total number of students' records analyzed varied from 251 to 993.

Undoubtedly both the total number of errors and the specific substitutions and confusions which occurred most frequently depended upon the type of material used in the tests. In this study, all errors were made on periodic administrations of the Code Receiving Tests² described in Section 12.2.4. In these tests all 36 characters occurred in equal frequency. The characters were presented in random order in five-character groups. Any group might contain all letters, all numbers, or both letters and numbers. Mixed groups of this kind are more difficult than are groups made up entirely either of letters or numbers.

A second factor determining the general nature of the results was the selection of which errors to count, or of which students to include in the count. This selection was necessary because some kind of preliminary answer had to be made to the question: Is an error made very frequently by a poor student to be counted more heavily than another error made occasionally by a number of good students? If the simple total number of errors had been used as a basis of comparison, one poor student would have carried more weight in determining the final results than would several good students.

Any class of radio code students contains, at any stage of training, a quite wide range of proficiency. Any analysis of errors which included all students tested at a given speed would have been primarily representative of the errors of the poorest students tested.

In order to eliminate from the count errors made by students tested at inappropriately difficult levels for them, the analyses were based solely upon copying which was 80 per cent or above in accuracy.

Because good students might have a different order of difficulty and different types of confusions than average students, they were divided as follows: *Good students* were defined as those who had 10 per cent or fewer errors on the 4 gpm test; *average students* were defined

as those who had from 10 to 20 per cent errors on the test.

A different analysis was necessary for advanced students. It was decided to divide the classes into fourths in terms of code speeds.

TABLE 5. Order of difficulty in receiving code characters. Percentage difficulty determined by dividing number of times each character was missed by number of times it was transmitted. The order in the first column is the rank order for the second week.

	Second week		Fourth week		Eighth week		Twelfth week	
	%	Rank	%	Rank	%	Rank	%	Rank
V	19.3	1	18.7	2	12.1	6	14.0	5
H	17.9	2	19.0	1	16.9	2	19.5	1
4	17.6	3	18.1	3	17.4	1	16.9	2
6	17.1	4	15.0	4	16.5	3	14.2	3
B	12.3	5	11.4	6	13.3	4	12.4	6
1	11.3	6	13.1	5	9.7	8	9.5	8
5	11.2	7	9.4	8	11.5	7	12.3	7
2	10.9	8	9.5	7	6.1	13	4.8	16
3	10.8	9	9.3	9	8.3	10	7.7	11
J	9.9	10	8.1	11	12.2	5	14.0	4
Y	9.6	11	6.0	17	2.2	31	2.8	24
8	8.8	12	6.4	15	6.4	11	6.0	13
P	7.9	13	6.5	14	2.8	22	3.3	20
L	7.6	14	4.1	25	1.8	33	2.0	30
7	7.6	15	7.3	12	6.3	12	7.9	10
U	7.2	16	6.0	16	2.7	25	3.2	23
C	7.0	17	5.8	18	2.8	21	1.3	36
Z	6.9	18	8.7	10	8.4	9	9.5	9
F	6.7	19	4.1	24	3.9	16	4.9	15
W	6.4	20	5.4	20	2.9	20	2.5	26
D	6.3	21	6.8	13	4.9	15	5.1	14
S	6.0	22	4.5	23	5.2	14	6.3	12
X	5.7	23	4.7	22	2.6	27	2.3	28
R	5.6	24	3.6	27	2.4	28	3.2	22
Q	4.5	25	5.8	19	2.7	24	2.0	29
G	4.4	26	2.2	33	2.7	23	2.7	25
A	4.3	27	2.8	32	2.2	30	1.6	35
K	4.0	28	2.9	31	1.8	34	1.7	34
I	3.8	29	3.5	28	2.9	19	3.9	18
9	3.5	30	3.0	30	3.2	17	3.3	21
M	3.2	31	3.2	29	2.0	32	1.9	31
0	2.9	32	5.0	21	3.0	18	3.8	19
T	2.7	33	2.2	34	1.1	36	1.8	32
O	2.4	34	3.9	26	2.6	26	1.8	33
N	2.0	35	1.3	35	1.2	35	2.3	27
E	1.7	36	0.5	36	2.2	29	4.0	17
Number of errors								
	16,520		3,733		4,510		4,516	
Number of men								
	993		251		363		348	

RESTRICTED

The poorest quarter of the men were omitted from further study. The paper of each man in the upper three quarters was then analyzed by counting and identifying the errors he made on the highest speed which he passed. On the Code Receiving Tests, passing was defined as having 90 per cent correct responses to the 216 signals in the test. These men thus had from 1 to 21 errors in their highest passing speed.

A sample of the final results of the analysis is given in Table 5. Principal findings of the analyses were:

1. The characters V, H, 4, 6, and B were among the six most difficult characters at all four periods (after 2, 4, 8, and 12 weeks of instruction).

2. In general, the ten characters with most errors at 2 weeks were also the most difficult later.

3. The most difficult characters were typically long signals composed of strings of dots and dashes.

4. Some of the most difficult characters were those which were mutually confused. For example, B and 6 were frequently confused with each other. Detailed analysis of such reciprocal errors is included in reference 7.

5. The complex characters with four elements, such as C, F, L, P, Q, X, Y, and Z, were typically of medium difficulty.

6. Contrary to popular opinion, numbers were difficult. At all times, five or six of the ten numerals were among the ten most difficult characters.

7. Some simple characters, such as E and I, became relatively more difficult as time went on.

8. For each of the four stages, there were two to four characters which were considerably harder than those next in rank. For the second week these were V, H, 4, and 6. For the fourth week, they were the same. For the eighth week, 4, H, and 6 were distinctly more difficult than the next character, B. At the twelfth week, H and 4 were most difficult.

The method of analysis employed made it possible to report separately the relative order of difficulty of the 36 characters for three groups of students, the top fourth, the second fourth, and the third fourth. The data for the eighth week are shown in Table 6. The order of

difficulty was practically the same for all three subgroups.

TABLE 6. Order of difficulty of code characters at end of eighth week for students of different ability levels. Percentage difficulty determined by dividing number of times each character was missed by number of times it was transmitted. Errors on Code Receiving Tests made by men in upper three quarters of their classes in two code schools.

Order of characters	Upper quarter students (%)	Second quarter students (%)	Third quarter students (%)	All three groups (%)
4	10.7	20.5	22.2	17.4
H	10.8	18.8	22.5	16.9
6	15.0	16.8	18.2	16.5
B	14.8	12.8	12.0	13.3
J	12.1	11.9	12.9	12.2
V	8.4	13.0	15.8	12.1
5	9.9	13.8	10.3	11.5
1	5.5	11.7	12.5	9.7
Z	6.9	10.0	8.4	8.4
3	5.9	9.9	9.5	8.3
8	5.6	7.5	5.8	6.4
7	5.2	7.3	6.4	6.3
2	4.2	7.0	7.4	6.1
S	4.7	5.4	5.7	5.2
D	6.0	5.3	2.9	4.9
F	4.2	3.3	4.5	3.9
9	2.3	4.3	2.9	3.2
0	2.8	3.2	3.1	3.0
I	3.4	2.5	2.9	2.9
W	1.8	3.1	4.1	2.9
C	2.4	3.2	2.9	2.8
P	1.9	3.0	3.6	2.8
G	3.4	2.2	2.4	2.7
Q	0.8	3.3	4.5	2.7
U	2.4	2.8	2.9	2.7
O	2.3	3.2	2.2	2.6
X	2.3	2.7	2.7	2.6
R	2.9	2.3	1.7	2.4
E	4.1	1.0	1.5	2.2
A	2.5	2.2	1.5	2.2
Y	1.9	3.1	1.2	2.2
M	2.8	1.9	1.2	2.0
L	1.3	1.7	2.7	1.8
K	1.8	1.9	1.7	1.8
N	1.3	1.4	0.9	1.2
T	1.1	1.4	0.5	1.1
Number of errors	1,378	1,826	1,306	4,510
Number of men	131	135	97	363

The constancy of difficulty for students at different levels of ability, after different amounts of training, and in different schools was relatively great. Table 7 shows typical correlations.

TABLE 7. The constancy of difficulty of code characters.

Groups correlated	Correlation
Second vs fourth week	.95
Second vs twelfth week	.86
Eighth vs twelfth week	.97
Good students vs average students after 2 weeks' instruction	.94
Students in one school vs students in another school after 2 weeks of instruction (median of six <i>r</i> 's)	.88

Detailed analyses of the specific errors, substitutions, and omissions at each of the four periods studied were also made and are presented in reference 7.

The results of this analysis of errors led to several recommendations for code teaching.

1. The order of difficulty is relatively constant and can be used in planning classroom activities. The number of schools, men, and errors included were sufficient to show the stability of results. The orders of difficulty were much the same from school to school even though different methods of teaching were used and even though the schools differed considerably in quality of training.

2. The order of difficulty remained rather stable through at least 12 weeks of the course. Differences among the orders of difficulty in the second, fourth, eighth, and twelfth weeks were rather minor.

It was suggested that if the difficult characters were stressed more in the early weeks, a reduction of errors on difficult characters at a faster rate might result. That is, by paying more attention to the characters which account for most of the errors, the overall rate of acquiring speed on the whole code alphabet might be increased.

3. Differences in order of difficulty between good and average students were negligible, and therefore the same practice materials could be used for all students. The good and average students made practically the same kinds of

errors; the average students just made more of them.

4. The characters which were most difficult were those which were highly interconfused. It may be that the most effective way to reduce errors on difficult characters is to teach them in relation to the characters with which they are primarily confused.

On the basis of these findings, it seemed reasonable to assume that improvement in rate of code learning could be attained by emphasizing the characters which cause a disproportionate number of errors. If students could be given drills which would reduce the errors on these characters more rapidly, the overall rate of learning might increase.

It was therefore recommended that special drills be used in order to give the students relatively more practice on the difficult characters. Sample practice materials of this type were constructed. The 36 characters were included in each drill in approximate proportion to the order of difficulty for the second week of the code course. Each drill included characters in the frequencies shown below.

Times to be presented	Characters
11	V
10	H, 4, 6
7	B, 1, 5
6	2, 3, J, Y
5	8, P, L, 7, U, C
4	Z, F, W, D, S, X, R
3	Q, G, A, K, I, 9, M
2	0, T, O, N, E

No experimental test of this type of drill material was made. The suggestion that learning would be more rapid if drill material was weighted for difficulty is a plausible one, but the suggestion should be tried out experimentally before it is adopted. An experimental test was planned by the Signal Corps, but a change in the school quotas and in the basis of selection of students sent to code schools just as the experiment was being started made the collection of useful data impossible.

12.2.3

High-Speed Operators

The only work done on the training of high-speed operators was to try out experimentally

two remedial methods suggested as possible aids to enable students to achieve a 25 gpm speed.¹⁸ All subjects in both experiments were men who had made satisfactory progress up to 20 gpm but who had experienced more than usual difficulty in passing 25 gpm tests. In each experiment men were paired into experimental and control groups. In each experimental group one of the 4 daily hours was devoted to practice on specially prepared remedial tapes.

One remedial device consisted of an adaptation of the recommendation made in the previous section that practice material should be weighted for difficulty. Part of the special practice tapes consisted of characters given at random but with frequency of occurrence determined by difficulty. The other type of special practice material consisted of 5-character groups in which frequently confused characters were presented together, for example: RLLR, RLRL, LLRL, LRLL.

The other remedial device consisted of tapes in which groups of less than 5 characters each were used. Three arrangements were used: 3-character groups with normal spacing between groups; 4-character groups with triple spacing between groups; and 4-character groups with normal spacing between groups.

Neither of the special drills was shown to be of value. With each device, when training was continued for more than 2 weeks, it appeared that the students' progress was actually retarded. On the basis of these results, it seems advisable to submit to experimental evaluation any remedial device proposed to facilitate learning of higher code speeds, regardless of the apparent reasonableness of the suggestion.

12.2.4 Measurement of Code Receiving Speed

THE CODE RECEIVING TESTS

In order to evaluate the effectiveness of radio code selection and training methods, it was necessary to have uniform tests for the measurement of proficiency in receiving code. In 1942 there was no existing series of proficiency tests which could be used satisfactorily for research purposes. It was, consequently, decided

to prepare a sequence of measures of ability to receive code.²

The tests were designed to measure the basic ability of the radio code operator, the speed and accuracy with which he could copy the alphabet and numbers of the International Morse Code. They were not intended to cover the other abilities required for graduation from code schools. The tests consisted of five-letter mixed-code groups in which all 36 characters appeared with equal frequency. Each test was 216 characters in length plus practice and identifying characters which brought the total to 245. The material, including directions, was placed upon phonograph records to ensure uniformity of presentation and accurate control of speed. Collectively, these tests were named the Code Receiving Tests.

A test was constructed for every even-numbered speed from 4 through 24 gpm; this was equivalent in tone content to a range of from 5.5 to 34.1 wpm of plain English.

The material in all tests at all speeds was identical in signal content, except that the order of characters differed in each case. At every speed the 26 letters and 10 numbers were randomly mixed, and each character appeared six times. There were two forms of the test for each speed. The two forms were identical in arrangement and difficulty but differed in letter arrangement.

Under normal school conditions the test had a reliability (first half versus second half, Spearman-Brown corrected) of from .93 to .96.

A description of the materials and equipment needed and detailed directions for administering and scoring the Code Receiving Tests are given in the *Instructor's Manual for the Code Receiving Tests*.²

The Code Receiving Tests were widely used as a research tool. For this purpose they were excellent. They were not widely used as regular school examinations. There was one strong and continuous objection to their use for that purpose: letters and numbers were mixed at random within the same code groups. Mixed-code groups do occur, but most transmission is in five-letter groups, or, less frequently, five-number groups. Consequently most training was with unmixed groups. Using mixed groups

as test material added new confusion and greatly increased the difficulty of the test material over the normal practice material. The Code Receiving Tests were therefore never adopted for routine use as school achievement tests.

COMPARISON AMONG NAVY RADIO SCHOOLS

At the request of the Bureau of Naval Personnel, special mixed-code tests were prepared

for its own use. In general, these locally produced tests were intended to determine which men should fail the course, which should pass it, and which should pass with good enough performance to justify a recommendation that they be given ratings of radioman, third class.

Great differences were found among the schools in the percentages passed and rated, in the percentages passing each of the 14 and 18 gpm mixed-code tests, and in the relations be-

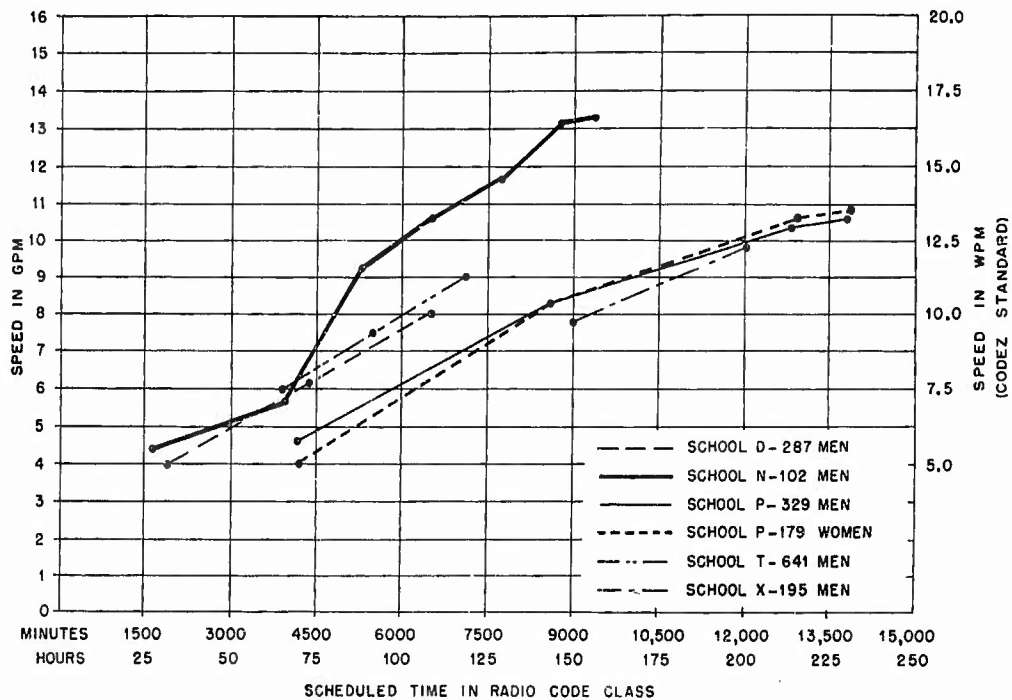

FIGURE 2. Differences in code speeds attained after equal amounts of practice by students in different schools.

Scale on left shows the average speed in gpm at which mixed code was received with 90 per cent accuracy. Scale on right shows equivalent speed in wpm on CODEZ standard.

at speeds of 14 and 18 gpm.¹⁰ These tests were administered during the sixteenth week of training to graduating classes in eight Navy schools. Data were available from two classes in each of seven of these schools and from one class in the eighth school. Comparisons were made among the schools by recording the number of men in each who failed the 14 gpm test, the number who passed the 14 but failed the 18 gpm test, and the number who passed the 18 gpm test. Further comparisons were made between performance on these standard tests and upon those made up locally by each school

tween the standardized mixed-code tests and the local examinations. The principal comparisons are given in reference 10.

The speeds of 14 and 18 gpm were slightly too high. It was recommended that mixed-code tests be constructed at speeds of 13 gpm and 16 gpm, 13 gpm to qualify men for graduating and 16 gpm to qualify men for consideration for a rating. Such tests would provide a uniform standard to apply to men being trained in all radio schools. If men assigned to the different schools were selected on the same basis, the tests would provide a means of com-

RESTRICTED

paring the schools themselves in terms of quality of instruction.

RADIO CODE RECEIVING EXAMINATIONS

The recommendation that standardized code-receiving examinations be prepared was followed, but the form of test material used differed considerably from the mixed-code tests discussed above. At the request of the Bureau of Naval Personnel, Project N-106 constructed these tests.

The battery of *Radio Code Receiving Examinations*²¹ consisted of four equated forms of a

amount of instruction is clearly evident in Figure 2. The five schools included in this figure varied so widely that the average student in the best school reached in 75 hours a speed that the average student in the poorest school required 150 hours to attain.²² Speed of learning depends upon the aptitude of the men in training and the quality of the instruction given them. Where these factors vary, as they did in the five schools included in Figure 2, the rates of learning are bound to vary. Yet reasonably reliable normative data on rate of code learning would be useful on many occasions. In order to secure

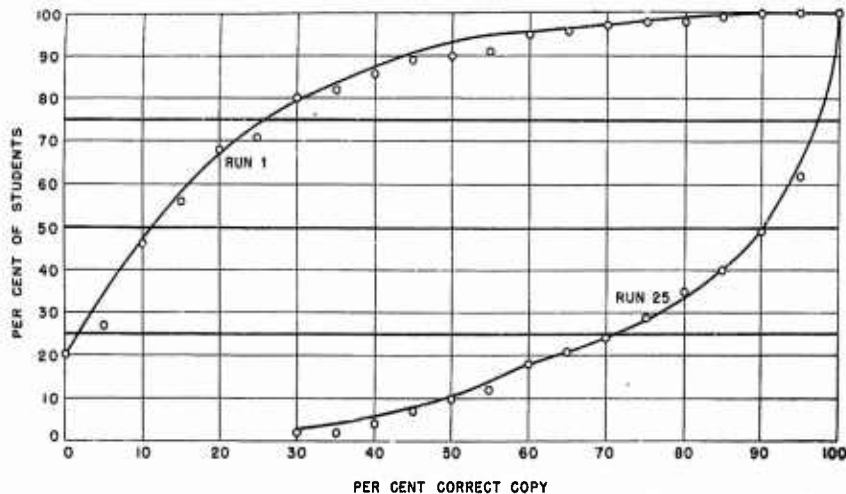

FIGURE 3. Variability of performance in basic code as shown by the percentage of students having a given percentage of correct copy on the first and twenty-fifth runs of their code-voice training.

message test and eight equated forms of a plain-language test. Directions to the trainees, practice tests, and the tests themselves were all recorded on four 16-inch phonograph records. It was intended that one form of each of these tests would suffice as a final achievement test in code school or as a qualifying test for radioman 3/c. The total time needed to administer such an examination was approximately 70 minutes. The tests were distributed by the Bureau of Naval Personnel (NavPers 16798).

THE RATE OF LEARNING TO RECEIVE INTERNATIONAL MORSE CODE

That different schools varied widely in the speed which students attained after a given

such data, records were kept of the progress of several hundred code students at Camp Crowder, Missouri. Selection of these students was in accordance with normal Signal Corps practice of 1944-1945. Training was of better than average quality.

Average learning curves for three stages of progress were drawn.¹⁹

1. Progress in basic code for a group of 342 students without previous code experience. Progress was expressed in terms of the relative frequency with which the members of this group equaled or exceeded various error scores at several different times during their first week of code practice.

2. Progress through practice speeds of 5, 7,

10, 12, and 15 gpm for low-speed operators. The low-speed criterion group consisted of 200 men who qualified as low-speed operators (SN-776) with 8 weeks of training and who during this interval achieved a receiving speed of at least 15 gpm.

3. Progress through speeds of 16, 18, 20, 22, and 25 gpm for high-speed operators. The criterion group consisted of 200 men who qualified as high-speed operators (SN-766 or SN-777).

Progress for groups 2 and 3 was expressed in terms of the number of hours required to pass the several practice speeds concerned. The

12.3 STANDARDIZATION OF CODE SPEEDS

Radio operators have traditionally been rated in terms of the number of words per minute that they can receive or send. But this measure is a flexible one which has varied widely in actual meaning. It varies first in the definition of a word, for tests may be given using plain English, code words, or various kinds of ciphers. It varies in the amount of material included, for a wpm score can be computed from 1 minute of transmission or from a much longer transmission. Finally, variation has been great in

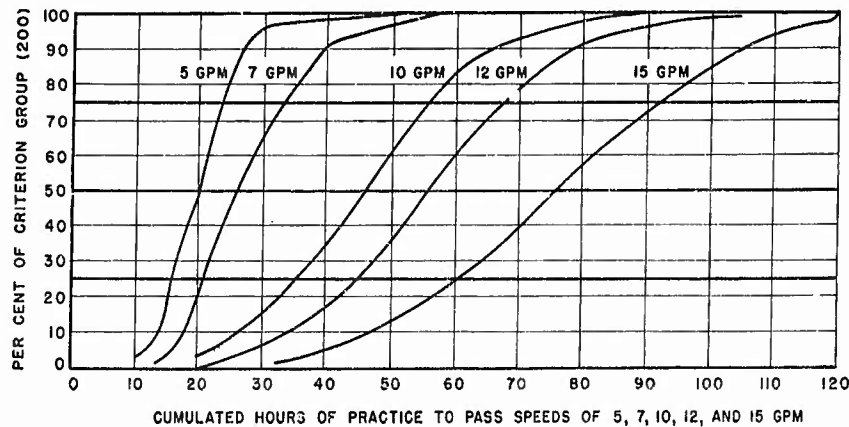

FIGURE 4. Percentage of the criterion group who passed practice speeds of 5, 7, 10, 12, and 15 gpm after various amounts of practice.

The time limits on the base line refer to the total number of hours of code practice required before passing the speeds indicated. Quartile limits of the groups are shown by heavy horizontal lines.

relative frequency of passing in various time intervals was taken as the basis for evaluating individual progress and assigning grades. Data of this nature were plotted for each of the practice speeds separately, so that progress could be evaluated on each speed independent of previous progress. Similar data were plotted for each speed in terms of the cumulated or total number of practice hours required for passing.

Sample progress charts or learning curves to illustrate the type of norms available are presented in Figures 3, 4, and 5. Additional curves, for both low- and high-speed operators, are given in reference 19.

The Army has reproduced and distributed these curves in TM 11-459.²⁵ They may be used as guides for appraising the progress of other code students.

the accuracy of transcription required before a student is said to have "passed" a test. In five schools studied in 1943, accuracy required for passing a test ranged from 60 per cent to 100 per cent.¹ The range was even greater than that indicated, for the custom prevailed in some schools of giving a bonus for perfect copy. Thus if a student copied with perfect accuracy a test given at 16 wpm speed he was credited with being a 17 wpm operator. The combined effect of these three variables was tremendous. At the greatest extremes, one man might be credited with being able to receive at 15 wpm if he got 60 per cent of the characters correct in a 1-minute test consisting of plain English text. At another school, a man credited at 15 wpm might have to copy, without error for several minutes, material consisting of the

RESTRICTED

much more difficult mixture of letters and numbers in 5-character groups.

How greatly these different message contents vary in terms of actual number of tone units is shown below. The unit of measurement is the baud, the length of a single dot.

Plain language (Paris, Pride, Worn, or Boise, each 48 bauds long, are used to define the typical word)	48 bauds per word
Letters and numbers in equal frequency	68.2 bauds per group
Letters only in equal frequency	60 bauds per group
Numbers only in equal frequency	89 bauds per group

verting speeds computed in terms of one set of conditions into equivalent speeds under other conditions are included.

12.1 TRAINING MEN TO SEND INTERNATIONAL MORSE CODE

Much more attention has been given in most code schools to the problems involved in training men to receive code than to those of training them to send it. Many instructors have considered sending an easier process than receiving. Corresponding to this emphasis, less attention has been given in research studies to the problems of sending than to those of receiving code. Nevertheless, three of the Applied Psychology

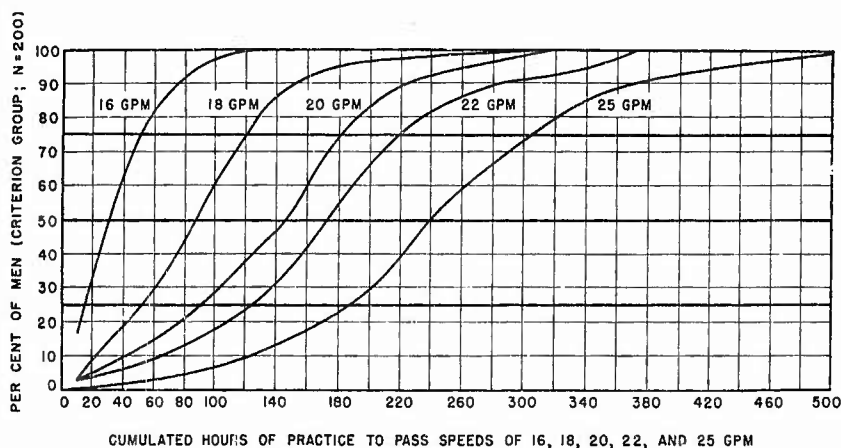

FIGURE 5. Percentage of the criterion group who passed practice speeds of 16, 18, 20, 22, and 25 gpm after various amounts of practice. The time limits on the base line refer to the total number of hours of code practice required after beginning practice on 16 gpm and before passing the speeds indicated. Quartile limits of the group are shown by heavy horizontal lines.

No text book or monograph on code speed or the bases for standardization of code speed existed. Project N-107 therefore wrote one³ which brought together for the first time the various concepts involved in determining code speed. The monograph was written for the guidance of instructors and others who have responsibility for preparing instructional material, speed tests, drills, and any other transmissions for which an accurate measure of speed is desirable. Detailed instructions for preparing Wheatstone tapes are given, and tables for con-

Panel's investigations dealt with problems of learning to send radio code.

12.1.1 Effect of Early Introduction of Sending upon Learning to Receive

After students have learned the code and while they are gaining speed in receiving it, they must begin to learn to send the code characters. The time at which practice in sending is started varied from quite early to relatively

late in the course. Introducing sending practice later in the course was generally more common than early introduction.

Three classes in a naval radio code training school were studied to determine the effect of the time of introducing instruction in code sending upon the rate of progress in learning to receive code.⁴ Standardized code receiving tests were given at the end of 4, 5, 8, and 12 weeks, after code-sending instruction had been introduced to an early-sending class in the first week, to an intermediate-sending class in the third week, and to a deferred-sending class in the seventh week. The men in the three groups were equated on the basis of their scores on an intelligence test and the Speed of Response Code Aptitude Test.

The experiment showed that instruction in sending code, regardless of when it was introduced, did not interfere with the rate of learning to receive. Progress in receiving was not retarded by devoting part of each period to sending code. On the basis of these results, it was recommended that sending instruction be introduced early in the radio code course.

12.4.2 Order of Difficulty of Characters in Sending Code

Ten judges rated the quality of code signals transmitted by 459 code-school students at Camp Crowder.¹⁷ The students were distributed in operating speed (defined as the maximal speed at which each student could correctly read tape recordings of his own hand sending) from 0 gpm to 13 gpm.

The rank-order correlations of the difficulty of sending the 36 characters as computed between the different operating speeds were all .90 or above. The order of difficulty, therefore, remained very constant for students sending at different speeds up to a speed of 13 gpm.

The order of difficulty for students of different ability levels and the errors most commonly made in attempting to transmit each character are tabulated in reference 17. Table 8 shows the relative difficulty of the characters for the total group. The rank difference correlation between the order shown in this table and the order of

difficulty in receiving shown in the first column of Table 5 is .76. In general, characters which are difficult to receive correctly are also difficult to send.

TABLE 8. Order of difficulty in transmitting signals.

	All speeds				All speeds		
	No. good	Per cent good	Rank		No. good	Per cent good	Rank
A	1,953	95.5	33.0	S	1,872	91.5	27.0
B	1,802	88.4	21.0	T	1,994	97.7	35.0
C	1,631	80.5	5.0				
D	1,920	94.2	32.0	U	1,855	91.2	26.0
E	1,999	98.0	36.0	V	1,714	84.4	10.0
				W	1,853	90.9	25.0
F	1,759	86.8	20.0	X	1,722	84.6	11.0
G	1,829	89.7	23.5	Y	1,682	83.4	9.0
H	1,653	81.7	7.0	Z	1,828	89.7	23.5
I	1,903	93.1	29.0				
J	1,744	86.0	16.0	1	1,625	80.4	4.0
				2	1,662	81.5	6.0
K	1,824	89.6	22.0	3	1,452	72.3	1.5
L	1,732	85.8	15.0	4	1,452	72.3	1.5
M	1,966	96.0	34.0	5	1,661	82.2	8.0
N	1,913	93.8	30.0				
O	1,921	94.0	31.0	6	1,532	75.7	3.0
				7	1,763	86.7	19.0
P	1,763	86.5	17.0	8	1,724	85.4	12.5
Q	1,750	85.7	14.0	9	1,763	86.6	18.0
R	1,871	91.8	28.0	0	1,735	85.4	12.5

The data presented in Table 8 could be used to construct practice material in which the characters would occur with frequencies weighted in terms of their difficulty. Such practice material might well be advantageous. The assumption seems plausible since it would give the students most practice on those characters which they find most difficult. However, the assumption should be tested experimentally before weighted frequency drills in sending practice are recommended for standard practice. This experimental test has not yet been made.

12.4.3 The Morse-Code-Actuated Printer

One of the difficulties of radio communication is poor sending. One of the less well-handled aspects of code training is the rating of quality of sending. A technique frequently employed in code schools is to require a man to send copy

which is recorded on an inked tape. He is then required to read his own sending as it is played back to him. In other schools, the instructors or fellow students read the students' sending. Both techniques involve variable standards of excellence. An A may be understood as such even though the dash is drawn out to greater than normal length. A 5 may be understood as such even though it contains six or seven or eight dots instead of the correct five. In plain English copy the context helps the receiver greatly so that perfect sending is not always necessary. The fact that less than perfect sending can frequently be understood means that

cial error sign. With most incorrect sending, however, the nature of the typed character or characters indicates the nature of the error made. If, for example, in attempting to send the character H, the student sends five dots instead of four, the typewriter prints 5. If the final dot is prolonged into a dash, the typewriter prints V. If the pause between the first and second dots is made too long, the typewriter prints ES. In each case, if an error is made, the nature of the printed record gives both student

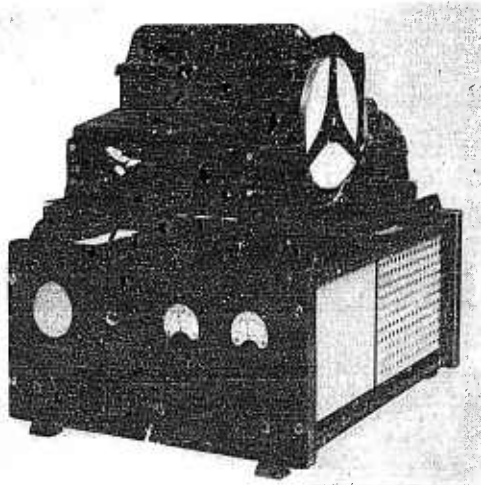

FIGURE 6. The Morse-code-actuated printer.

perfect sending is frequently never acquired.

Applied Psychology Panel personnel working on problems of code training agreed that a trainer which would give an objective record of the quality of a student's sending would be an aid to instruction. Such a trainer was built. It consists of an electromatic typewriter which is controlled by discriminator and analyzer circuits in such a way that radio code signals fed into the device are printed as ordinary type characters on the typewriter.²² The instrument is shown in Figure 6.

The Morse-code-actuated printer was designed primarily as a trainer. If a man sends a letter correctly, he immediately sees that letter printed by the typewriter. If he sends an impossible character, the typewriter prints a spe-

URGENT BA49 R 49 U URGENT 0933 R 0933

NEWLEAD SANFRANCISCO TOKYO RADIO SAID EARLY TODAY

THAT JAPAN IN NAME HIROHITO READY ACCEPT TERMS

ALLIED POTSDAM SURRENDER DECLARATION BROADCAST

IN MORSE TELEGRAPHIC CODE HALTED MYSTERIOUSLY

WITHOUT COMPLETING WHAT PURPORTELY WAS

OFFICIAL ANNOUNCEMENT TWO HOURS LATER

TOKYO STILL NOT RETURNED AIR

FIGURE 7. Radio code message printed by the Morse-code-actuated printer. This instrument automatically converts radio code messages into typescript.

and instructor an immediate indication of the nature of that error. If the sending is perfect, within adjustable tolerance limits, the student has the satisfaction of seeing perfect copy appear on the typewriter. Operators with long experience have tried out the trainer. Their usual comment after a few trials is that it cleans up their sending better than anything they have ever seen.

The Morse-code-actuated printer may also be used to monitor circuits or as part of a communication net. It has an operating speed of up to 100 wpm. The instrument was nearing completion just at the time of the Japanese surrender. At that time its ability to copy off the air was being tested. Figure 7 shows a message caught from the air at that time.

Three different models of the printer were constructed and turned over to the Navy Bureau of Ships for service trials.

RESTRICTED

Chapter 13

PSYCHOLOGICAL PRINCIPLES IN MILITARY TRAINING

By Dael Wolfe

SUMMARY

SUCCESSFUL ATTEMPTS by psychologists to improve military training usually involved the application of one or more of the following well-established principles of learning.

1. Improve the distribution of practice.
2. Secure active participation of the trainee.
3. Vary the practice material.
4. Develop accurate performance records.
5. Give the men an immediate knowledge of the results of their practice.
6. Write clear detailed plans for the instructor.

13.1

INTRODUCTION

A striking fact about the successful application of psychological principles to the training of military specialists in World War II was that very substantial help was given by systematically applying only a very few of the principles of learning. Some learning principles were irrelevant to the problems of military training. Others were already well-accepted parts of military training doctrine. Between these extremes lay a half dozen or so important principles which were frequently neglected. By altering training programs and methods to comply with these few principles, psychologists employed on a number of Applied Psychology Panel projects improved materially the training of radio operators, gunners, and other military specialists. Many of the topics traditionally included in a textbook on the psychology of learning are of little practical value in military situations. Opportunities are rare to improve military training by applying our knowledge of the relation between learning ability and chronological age or by what is known about nonsense syllables, remote associations, or serial relations. The reasons for the uselessness of some of these topics are obvious. In an age range restricted to men at the peak of physical vitality there is little room for any relation between age and learning ability to appear or to be important. Such topics

as nonsense syllables, remote associations, and serial relations are unimportant in military training, for memorizing word lists is seldom required.

A number of important principles of learning are already entrenched in military training doctrine. The usefulness of overlearning was recognized by many officers, although its application in World War II varied. The speed required in training men frequently prevented even a close approach to overlearning. In other cases, the enthusiasm of an officer or the necessity of keeping men busy produced an overdose of the principle. A second generally recognized point was that skill is lost during periods without practice. Review and refresher courses were established to prevent or repair this loss. A third principle is the policy of making training situations as much like combat situations as possible. This principle has appealed to the military authorities with the result that men went through some very realistic battle practice and combat maneuvers. Finally, military thinking long ago accepted the doctrine that one learns by doing, and systematic drill has long been required of all recruits.

13.2

PRINCIPLES OF LEARNING IMPORTANT IN MILITARY TRAINING

The principles which were most immediately useful in helping to improve military training, but which had not in 1942 become standard parts of military doctrine, were those which improved the organization and presentation of the material to be learned and hence improved the motivation of the men in training. Application of these principles has been illustrated in the detailed accounts of Chapters 2 to 12. It is the purpose of this chapter to point out the chief ones involved.

13.2.1

Distribution of Practice

In wartime men must be trained quickly. There is an understandable temptation to crowd

practice into a few days or weeks and to give the men long hours of drill in order to develop quickly the skills necessary for combat. But this massing of practice is not always necessary. It was sometimes possible, by rearranging a training schedule, to spread practice on an important skill over a greater number of days without increasing the total length of the training period. Neither are the long hours of drill always necessary. It was sometimes possible to reduce the number of hours of drill without loss in the amount learned. The best example is from the studies of code learning reported in Chapter 12. Men being trained as radio operators were drilled 7 hours a day on radio code. Reducing the schedule from 7 to 4 hours a day allowed the men to learn just as rapidly, freed time for other activities, and greatly improved their morale.

13.2.2 Active Participation

Active participation by the learner has generally been found superior to passive receptivity. The emphasis on more active drill in training radar operators (Chapter 2), the range-estimation drills on the firing line (Chapter 4), the interphone and R/T procedure drills (Chapter 11), and the emphasis given to realistic practice periods in setting up achievement examinations (Chapter 17) were all based on the established principle that men learn faster through actual practice of a skill than they do through hearing, reading, or talking about how it should be done.

13.2.3 Variation of Material

Failure to vary the training material sufficiently was an easily corrected fault. Some radio schools, for example, repeated the same drill material so frequently that the men partially or completely memorized a particular sequence of characters instead of mastering the individual characters well enough to recognize them in any sequence. The remedy was obvious, and radio code training was improved in a number of schools by the relatively simple

method of increasing the amount and variety of practice material given the learner (Chapter 12).

The same general principle was applied, with beneficial results, to other types of military drill. A group of radar operators, for example, was found being given such monotonous and unvaried instruction that they became less accurate in locating targets than they were at the start of training (Chapter 2). Varying the drills and giving the men better knowledge of the results of their practice made them improve with practice instead of getting worse.

Greater variation in drill material also helped to improve motivation. Requiring men to perform the same task in the same way day after day can quickly lead to complete boredom. Having a number of cams to simulate different courses in the training of trackers (Chapters 3 and 16) and the antimonotony techniques in training radio operators (Chapter 12) illustrate the general principle that varying the activity of the men in training helps maintain their interest and enthusiasm and thereby speeds their learning.

13.2.4 Accurate Records of Progress

Accurate progress records are useful in two ways. They aid the instructor in coaching the trainee to mastery of his task. And they provide better motivation for the men in training. More accurate records of performance were obtained in a variety of ways: by developing simple and usable forms for recording a man's performance, by improving the kinds of scores which were recorded, and by designing and building scoring attachments for training equipment which was originally built without any. The most extensive work in this field was the whole program of developing achievement tests described in Chapters 9 and 17. Other illustrations are the record forms for heightfinder operators (Chapter 3), the scoring attachment for the radar trainer BC-1070-A (Master) (Chapter 2), the intelligibility tests for aircrew personnel (Chapter 11), and the improved gun camera scoring method for the B-29 gunner (Chapter 5). In all these cases the improved

scores provided better measures of progress and better checks on the quality of training.

Improved performance records also helped to motivate the men. Posting scores, keeping individual learning curves, and competition between groups or individuals are all good motivational devices. The effectiveness of each depends upon accurate performance records. By improving scoring systems and by making better use of scores, the psychologist contributed to more effective military training.

13.2.5

Knowledge of Results

Giving the men in training an immediate knowledge of the results of their trials was one of the most useful single contributions the psychologist made to military training. Instances occurred where men, presumably learning to operate a radar set, were simply told to "practice for a while," without being given any information on the results of their practice or the quality of their performance. In some of these cases the men got worse and worse instead of improving with practice. Again the remedy was obvious to one who knew the literature of learning studies: Inform each man, as soon as possible after each trial, how he has done. If well, tell him so. If wrong, tell him where.

Examples of the application of this principle occurred in the development of the code-voice method of teaching men to receive and the code-actuated typewriter for teaching them to send radio code (Chapter 12), the checksight-and-buzzer method used in the training of trackers (Chapter 3), and the method of training men in range estimation on the firing line (Chapter 4).

In all these examples men learned immedi-

ately whether their performance was good or poor. It is very generally true that giving men that knowledge makes them learn faster.

13.3

SYSTEMATIC LESSON PLANS

Putting these principles into practice required the training of instructors and the writing of lesson plans. Good instruction can be obtained from relatively inexperienced teachers if they are told in detail how to proceed. Industrial psychologists and some verbally facile "apparatus men" wrote effective, detailed, and vivid plans in which the material to be learned was organized in simple logical form. Lesson plans of this type are described in detail in Chapter 15. They state the objective of each lesson and the methods of reaching it, present the simpler material first, the complex later. They tell the instructor when and how to use questions, reviews, examinations, and appropriate teaching aids. By doing these things they solve many of the problems which puzzle inexperienced teachers. They make for better standardized instruction. And they give every trainee some benefit of the knowledge and skill of the expert who wrote the lesson plans.

13.4

CONCLUSION

The principles outlined above are very general ones. Their application, however, to specific problems of military training must in each case be specially designed for the particular type of training involved. The examples cited above were successful because the men responsible were acquainted both with military training situations and with the principles of learning.

Chapter 14

JOB ANALYSIS OF DUTIES TO BE LEARNED

By Bernard J. Covner^a

SUMMARY

A JOB ANALYSIS is a detailed description of the operations involved in a job. It suggests what skills are called for. The information resulting from job analyses is used as a basis for establishing training programs, for determining selection requirements, and for identifying jobs which demand similar skills and which therefore serve as a source for securing replacement personnel. The job analysis material provides suggestions for valid examinations because of its definiteness and comprehensiveness.

14.1

INTRODUCTION

The training of personnel for specific duties such as radar operators, gun pointers, or fire controlmen is a major concern of training programs in the Armed Forces. In the process of preparing and administering such training programs, first consideration must be given to an analysis of the specific duties or tasks which are required of a man assigned to a particular job.

Few people will differ with this point of view. However, when it comes to determining what constitutes a consideration of the specific tasks which a specific job calls for, there is a variety of opinion. For some, the duties of a particular job are what an individual or his friends think they are. For others, such duties are what they recollect them to be from performing them at a particular location a long time ago. Still another type of variation in opinion is the tendency to think in terms of broad categories of jobs rather than specific jobs involving specific equipment and specific situations. For example, potential gunners may be given gunnery training, and "gunnery" may mean general theory or it may mean the operation of a particular type of gun.

There have been many instances in World War II in which such variation in interpreta-

^a This chapter is based primarily on the work of the staffs of NDRC Projects N-105 and NR-106.

tion concerning the nature of a particular job has resulted in lack of close relationship between the content of training courses and actual job duties. Evidence for this condition is the frequently heard comment of officers, "The men they send me have been taught anything except what they need to know for this job," and the comment of men, "Why didn't they teach us about this job in our training course instead of all that theoretical stuff?"

Job analysis of duties to be learned can do much toward preventing such complaints. Making studies of what duties are actually performed on a particular job, and of what knowledge and skills are called for, and then using this material as a basis for a course of instruction will increase the appropriateness of training courses. Such application of job analysis material will also help standardize instruction and thereby facilitate interchange on a replacement basis of personnel trained at different times and places. Applications of job analysis findings to problems of test construction are discussed in the Summary Technical Report of the Applied Psychology Panel, Volume 1, Chapter 14, and to the development of operating procedures, in Chapter 25 of this volume.

Job analysis procedures were widely used in World War II, by NDRC, by the Billet Analysis Section of the Bureau of Naval Personnel, by the Army, and by the United States Employment Service. The information which resulted was used as a basis for establishing training programs, for determining selection requirements, and for identifying jobs which demanded similar skills and could therefore serve as a source for securing replacement personnel.

Many examples of the training courses and training manuals which were based on job analysis information are given in the bibliographies for Chapters 7 and 9.

14.2 ANALYZING JOBS AND PRESENTING THE FINDINGS¹

A job analysis is best conducted by a team of two or more persons, a job analyst, who may

have no previous familiarity with the job being analyzed, and one or more experts in the job itself. The job analyst plans the analysis and is generally responsible for it. He is trained to observe and record what he sees, as well as to describe to others what he has seen or done. Having the purpose of the analysis in mind, he asks certain questions and checks carefully on points which might otherwise not be considered.

The man who is highly skilled in performing a certain job is trained to do the job rather than to describe it. Working with the job analyst, however, he can provide much useful information and can serve as a critic of the job analyst's descriptions.

The actual procedure for analyzing a job will vary, depending upon the job being analyzed and the purpose for which the analysis is made. As a rule, the more detailed the analysis, the greater the use to which the findings may be put.

During World War II, job analyses for training purposes were made of a large variety of service men's jobs. For example, one project concerned with improving the training of Navy gunners made analyses of the duties performed by every crew member of practically every type of antiaircraft gun in use. In making these analyses the following types of information were obtained.

1. Job title.
2. Alternate title.
3. Description of equipment used.
4. Summary of duties.
5. Supervision received or given.
6. Relation to other jobs.
7. Surroundings and conditions.
8. Estimated time necessary to reach acceptable performance.
9. Nature of training given.
10. Stated qualifications for job.
11. Tools and materials used.
12. Detailed description of duties.

The first four items in this list give a brief analysis of the job; the last eight a more detailed analysis.

The information included in items 4 and 8 provides a valuable starting point for constructing lesson plans and organizing drills.

11.2.1

Summary of Duties

The summary of duties is based upon the entire analysis and gives an overall view of the job. Such a summary, written for the position of third loader in a 40 mm gun crew, follows.²

Keeps second loader supplied with a continuous train of full clips so that second loader can pass them on to first loader. Takes clips from ready service rack on side of splinter shield, one at a time; turns clips so that they will arrive at gun with clip edges facing first loader; and passes to second loader. At conclusion of firing replaces unused loaded clips in racks. May perform additional duties at the direction of gun captain.

A similar type of summary follows for the job of burner man in a destroyer escort fire-room.³

Primarily: Regulates steam pressure in boiler by turning oil regulator (micrometer) valve and/or needle valve to change rate of flow of oil to burners, by turning register handles to adjust flow of air to burners, by installing burners, lighting off, securing, and replacing them to alter heat in firebox; maintains constant watch on drum steam pressure gauge, oil pressure gauge, peep sights, and periscope to determine what adjustments are necessary.

In addition: May increase or decrease blower speed to alter air flow to burners by turning blower reach rod; may test safety valves by spinning hand lifting gears; may adjust temperature of fuel oil heater by turning reach rod; may start and secure fuel oil service pump; may open and close various superheater and steam line valves; may secure auxiliary feed pump; may assist in adjusting level of water in steam drum; may assist in miscellaneous repair and maintenance work; may take over duties of check man or water tender-in-charge.

Is supervised by: water tender-in-charge and/or chief water tender.

RESTRICTED

14.2.2 Detailed Description of Duties

This material gives a fairly complete account of the step-by-step procedure involved in carrying out the job. In setting up such material for training purposes, it is customary, in addition to the actual operations themselves, to include supplementary information concerning how and why the operations are performed. This type of arrangement is illustrated in Figure 1 in an excerpt⁴ from the detailed procedures for preparing a shipboard distilling plant for operation.

Main Steps for Operating Distilling Plant
on
DE Steam Vessel
A. Starting the Plant

1. Lines up circulating water circuit for cooling purposes and starts circulating water and fresh water pumps.
2. Lines up evaporator feed water circuit.
3. Lines up air removal circuit and starts air ejector.
4. Lines up generating steam and vapor circuits.
5. Tests salinity of condensate in air ejector condenser drain line.
6. Tests salinity of condensate in first effect tube nest drain line.
7. Regulates air vent cocks of evaporator tube nests.

WHAT HE DOES	HOW HE DOES IT	WHY HE DOES IT
3. <i>Lines up air removal circuit and starts air ejector.*</i>		
(a) Opens drain valve from air ejector condenser to drain collecting system.	(a) Fully.	(a) To allow accumulated air ejector condensate to drain off into drain collecting tank.
(b) Checks to see that air vents on air ejector condenser are free from obstructions.	(b) Visually.	(b) To allow air and noncondensable vapors to escape.
(c) Opens steam root valve to air ejector.	(c) Slowly and fully.	(c) To allow exhaust steam to enter throttle valve of air ejector.
(d) Opens exhaust steam throttle valve.	(d) Slightly (about $\frac{1}{4}$ turn).	(d) To force out any accumulated condensate and to allow air ejector to warm up slowly.
(e) Opens throttle valve farther.	(e) Turns valve to left enough to bring steam pressure up to 150 lb.	(e) So that ejector may remove air and noncondensable vapors and also maintain a low pressure in the plant.
(f) Opens suction valve from distilling condenser.	(f) Slowly and fully.	(f) To allow air ejector to draw vapor from distilling condenser and thus cause a low pressure vacuum in the plant.
When vacuum gauge shows 16" in second effect evaporator shell.		
4. <i>Lines up generating steam and vapor circuits.</i>		
(a) Opens exhaust steam root valve.	(a) Slowly and fully.	(a) To allow exhaust steam to enter first effect tube nest and heat feed water in first effect shell.

*There is a stand-by air ejector for use in case of emergency.

FIGURE 1. Excerpt from description of duties of evaporator man in preparing distilling plant for operation.¹

A useful condensation of the detailed description of duties is the *list of main steps* for performing a detailed series of operations. Such a list is particularly helpful in introducing or reviewing extremely long operating procedures. One example⁴ illustrates the type of information contained.

8. Lines up fresh water circuit and starts condensate and brine discharge overboard pumps.
9. Tests salinity of condensate in second effect tube nest drain line.
10. Makes chemical salinity test at test tank, if so ordered by CWT, CMM, or chief engineer.
11. Tests (electrically) salinity of condensate in test tank.

RESTRICTED

12. Routes fresh water to reserve feed or fresh water tanks.

13. Adjusts control valve of second effect feed regulator.

14. Makes certain that first and second effect feed valves are properly adjusted.

15. Tests brine density of evaporator shells.

16. If density is too high, adjusts brine density of evaporator shells.

17. Keeps a constant check on functioning of distilling plant.

18. At intervals designated by the chief engineer, makes chemical salinity test of fresh water being made.

14.3 THE USE OF JOB ANALYSIS MATERIAL IN THE TRAINING PROGRAM

As indicated above, there are several ways in which job analysis material may be employed in the training program. In general, such material provides a wealth of information around which a course may be built, as well as a point of orientation for the instructor who in most instances is neither a trained teacher nor skilled in the job he teaches and is therefore in need of all the help he can get. By calling attention to the knowledge and skills which the job calls for, job analysis material does much toward keeping course material relevant. Some of the specific applications of job analysis information are considered below.

14.3.1 Information on Equipment

A frequently overlooked aspect of job analysis data is the descriptive information it gives about equipment with which personnel will be concerned. All too often during World War II courses of instruction were based upon equipment lists with the result that students were taught about one type of equipment only to find another type in use on their assignments. Also, it was noticed that even though a particular unit of equipment was installed at a particular location, this fact was no guarantee that it was used. It was only through analysis of the job that such information was frequently discovered.

14.3.2 Data on Personnel Requirements

Frequently much information concerning the personnel requirements of the job is revealed by the job analysis. Here one can find out not only how many men are required and what each does but what their job relationships are. Such information is important not only for teaching normal procedure but for teaching casualty procedure as well. For example, on some types of jobs it may be discovered that certain positions are more necessary than others or that little or no supervision is necessary.

The job analysis also calls attention to knacks and skills necessary for successful performance of certain duties. Such ideas may be used as a basis for subjective criteria for selecting men for the job, as well as a guide for the development of selection research. Here the job analysis serves as a point of articulation between coordinated programs of selection, classification, and training.

14.3.3 How Job Analysis Aids Training Programs

The detailed information of the job analysis provides many suggestions for establishing a course of instruction. From such material the job analyst can obtain ideas for formulating course objectives, for deciding upon subjects to be taught, for devising novel methods of examination, and so on. In addition he can decide upon the relative stress to be given various subjects. The important aspects of a job as revealed by a job analysis often differ considerably from the impressions obtained in talking to experts or reading about jobs.

Sometimes highly complicated equipment may be simple to operate. Frequently well-trained personnel is available for servicing if repairs are needed. The question arises as to the nature of the training which should be given to the man who will operate this equipment.

The job analysis helps provide an answer to this question. If the operator spends most of his time in simple lever pushing or valve turning, it is important that he be given instruction

on these routine operations. If trained personnel is always available to handle repairs to the equipment there is no need for the operator to learn about its maintenance and mechanical functioning. All too often, however, the practice has been to give men who are headed for routine operating jobs considerable training in maintenance and mechanical functioning of equipment, and little training, if any, in the operation of the equipment.

Another type of information that is obtained from the job analysis concerns the relative ease or difficulty of various aspects of the job. People who have acquired certain skills and have over-learned them to a considerable degree are often unaware of the difficulties the beginner has in acquiring these skills. In watching performance on the job and in performing the job himself the job analyst often sees in quite clear relief the relative ease or difficulty of learning the various aspects of the task. This information allows him to plan a training program in which the easier tasks are learned first and in which more drill is given on the harder ones.

Closely related to the use that is made of job analysis material in providing suggestions for setting up curricula is the use that can be made of it in setting up standard drills as a part of the training course. First of all, the analysis may indicate the amount of drill required to bring necessary skills up to the desired level of proficiency. Next, the analysis may give suggestions for breaking up various aspects of the job into drill units which are both convenient and natural. Frequently, job analysis material

may be set up in check list form and used as a guide for instructors in conducting drills and for students in following drills.

14.3.4

Examination Data

Another application of job analysis material is its use as a source of examination questions. The definiteness of the material suggests questions on specific points of operation. Its comprehensiveness provides a check list for ensuring that all important aspects of the job have been covered. The following multiple-choice questions which have been used in various standardized training courses are representative of operational procedure questions taken from job analyses.

When firing in local control, the gun pointer at the command, "Stand by":

- a. Checks to see that ammunition racks are loaded.
- b. Places safe and fire lever on safe.
- c. Takes place in pointer's seat.
- d. Fires gun with foot firing pedal.

The hand operating lever on 40 mm antiaircraft gun is usually operated by the

- a. Second loader.
- b. Director pointer.
- c. Gun captain.
- d. First loader.

In starting the plant, the evaporator man does not cut in the generating steam until he

- a. Checks the vacuum of the second effect shell.
- b. Checks the temperature of the feed water in the first effect shell.
- c. Starts the brine overboard discharge pump.
- d. Determines the salinity in the first effect tube nest drain line.

Chapter 15

COURSE OUTLINES AND LESSON PLANS

By *Bernard J. Covner*^a

SUMMARY

LESSON PLANS furnish an instructor with a detailed statement of the topics to be covered in a course and the time and method of teaching each topic. With inexperienced instructors, lesson plans make better teaching possible and provide a basis for more standardized instruction.

Course outlines have the same objectives as lesson plans but are much briefer and leave more to the initiative and judgment of the individual instructor.

Much of the training described in Chapters 2 to 12 depended upon the writing of course outlines and lesson plans. This chapter describes these teaching aids and discusses their planning and preparation.

15.1 INTRODUCTION

Large numbers of instructors, many of them inexperienced, necessarily characterized the training programs of the wartime Army and Navy. Such instructors inevitably taught differently, and some of them taught poorly. To help them teach better and to help make the teaching of one more nearly like that of another, a number of projects of the Applied Psychology Panel cooperated with Army and Navy training officers in developing standardized course outlines and lesson plans.

Much of the work on training described in Chapters 2 to 12 depended upon the development of lesson plans. Lesson plans were written for courses given to heightfinder operators and fire controlmen (Chapter 3), Navy gunners and engine room crews (Chapter 7), attack boat pilots (Chapter 9), telephone talkers (Chapter 10), air crews (Chapter 11), and radio operators (Chapter 12). This chapter describes and illustrates course outlines and lesson plans and discusses their principal features and advantages.

^a This chapter is based primarily upon the work of NDRC Projects N-105 and NR-106.

Like job analysis, course outlines and lesson plans are a help in making training effective. Job analysis is primarily concerned with determining the nature of the task to be performed and what skill is involved in performing it, lesson plans and course outlines are primarily concerned with how the information and skill necessary for a particular job can be taught most effectively.

15.2 WRITING COURSE OUTLINES AND LESSON PLANS

Writing a lesson plan involves three major steps. First, it is necessary to agree upon the detailed objectives of the course. Second, the course must be outlined as a whole and divided into separate class sessions or teaching units. Finally, the details of each lesson must be decided upon and complete directions for teaching each lesson written.

15.2.1 Establishing Course Objectives

The starting point for writing a lesson plan is agreement upon training objectives. The training objectives serve as a goal toward which instructors and trainees alike should aim. They help to make the training specific and realistic. And they determine the kind of achievement examinations and proficiency measures which should be developed for the course. Losing sight of the objectives frequently results in a course becoming too theoretical, too easy, too difficult, too concentrated on a few aspects of the total job, or in some other way getting out of line with its fundamental purpose.

As an example, the following objectives were established for a course for training operating engineers in the Navy.⁴ The primary objectives were to teach each man to:

1. Start, operate, and secure equipment of his own division under the supervision of experienced personnel; and to

2. Perform simple maintenance tasks in his own division.

In order to enable him to perform these duties each trainee was expected at the conclusion of the course to know:

1. The location, purpose, and services of the engineering plant.

2. In an elementary way, how the plant works.

3. The appearance, use, gross construction, and elementary operation of the major units of equipment.

4. Nomenclature and purpose of each major piping or wiring system.

5. The organization and general duties of the engineering department personnel.

6. His specific duties in the division of his assignment.

7. Symptoms, causes, and procedures for handling the most common casualties to equipment of his own division.

8. Safety precautions to be followed in engineering spaces generally and in the operation of equipment of his own division.

8. What training aids will help the students to understand, and what trainers will help them to acquire the necessary skill?

9. How much practice on the trainers is effective in producing increased skill?

10. How can this drill be most effectively distributed in time?

11. How frequently, and when in the course, can examinations, reviews, proficiency tests, or ratings of performance be most effectively used?

12. What adjustments should be made to take account of the fact that men of widely different experience and knowledge may be assigned to the same class?

The most important question of all should be kept constantly in mind as all details are decided upon: What are the essential objectives which the men are supposed to learn in this course?

There are no standard answers to the questions listed above. In planning each course it is necessary to draw upon the psychological principles of learning, particularly those discussed in Chapter 13, to adapt them to the specific training to be given, to make tentative judgments, to try them out, and to make changes where indicated by the results of examinations or other measures of the success of the training.

Writing a course outline requires a knowledge of the skills to be taught. Course outlines are trustworthy only when based upon the information gained from such sources as job analysis, experience in teaching the course, participation in the course as a trainee, field trips and visits to training stations, discussion with supervisory, teaching, and operating personnel, and continuous study of the performance of men in training.

After the course is outlined, it may be necessary to modify it in terms of the particular conditions existing at a given training establishment. As long as guard duty, housekeeping requirements, and haircuts have priority over class attendance, numerous adjustments of schedule will be required. These adjustments will have to be made, but the course outline should be originally planned in terms of most effective learning, not in terms of fitting into a schedule. Sometimes the schedule can be modi-

15.2.2

Outlining the Course

With the objective clearly in mind, the course outline can be written. The general aim of the outline is to establish a series of teaching units which will cover all the material to be taught in a given course and to give appropriate time and emphasis to each part or topic. The following questions illustrate the kind of points which have to be considered.

1. How much time is required to teach the necessary knowledge and skills to an average class of trainees?

2. Which topics are of greatest importance?

3. Which topics are of greatest difficulty for the average trainee?

4. In what order can the topics be most easily learned?

5. How much time should be devoted to each topic?

6. How much time should be devoted to theory and how much to practice?

7. What motivational devices will aid the students to learn?

fied if that will help men to learn their duties faster and better.

The outline of a 4-day course in 20 mm gunnery¹ which was developed early in World War II is given below. This outline illustrates the way in which the foregoing questions were answered for one course. Note the variation in the times allotted to different topics, the alternation of theoretical instruction and practical drill, and the introduction of related material after the men have had some firing drill.

Outline of Dam Neck AATTC
4-Day Course in 20 mm Gunnery

Lesson 1	General introduction	¾ hr
Lesson 2	Principles in AA firing	1 hr
Lesson 3	Orientation to tracer control firing	1 hr
Lesson 4	First operating instruction and drill period on firing line	1 hr
Lesson 5	First firing and observation of firing	1¼ hr
Lesson 6	First stripping and cleaning	1 hr
Lesson 7	Practice on machine gun trainer Mark 1	½ hr
Lesson 8	Review of previous day's firing, and machine gun trainer Mark 1 firing	¼ hr
Lesson 9	20 mm machine gun mechanism and operation (Part I)	1½ hr
Lesson 10	Second operating instruction and drill period on firing line	1 hr
Lesson 11	Orientation to tracer firing assisted by ring sight (Part I)	1 hr
Lesson 12	Second firing and observation of firing	1¼ hr
Lesson 13	Second stripping and cleaning	½ hr
Lesson 14	Ammunition, magazine mechanism, and loading	½ hr
Lesson 15	20 mm machine gun mechanism and operation (Part II)	1¾ hr
Lesson 16	Orientation to tracer firing assisted by ring sight, Part II, drill on the ring sight trainer	1 hr
Lesson 17	Third operating instruction and drill period on firing line	1 hr
Lesson 18	Plane sighting and plane bearing	½ hr
Lesson 19	Range estimation	½ hr
Lesson 20	Third firing and observation of firing	1¼ hr
Lesson 21	Third stripping and cleaning	½ hr
Lesson 22	Use of the Mark 14 sight	¼ hr
Lesson 23	Second period on machine gun trainer Mark 1	½ hr
Lesson 24	20 mm machine gun operation and mechanism (Part III)	2 hr
Lesson 25	Plane identification	1 hr
Lesson 26	Fourth operating instruction and drill period on firing line	1 hr

Lesson 27	Ammunition, magazine mechanism, loading (Part II) drill	½ hr
Lesson 28	Review of gun mechanism and operation	½ hr
Lesson 29	Plane identification (Part II)	½ hr
Lesson 30	Fourth firing and observation of firing	1¼ hr
Lesson 31	Fourth stripping and cleaning	½ hr
Lesson 32	Night lookout	1½ hr
Lesson 33	Check list of information	1½ hr

A course outline of the type just given can be used as a general guide for an instructor to follow. It presents a plan for the broad outlines of a course, but the details of actual class instruction are left entirely to the initiative of the instructor.

The instructor can be given more help by writing the outline in a little more detail. The term *curriculum unit* is sometimes used for the type of slightly expanded outline illustrated below.

Operation VIII Lube Oil Purifier

Lesson M-19 (1½ hour)

A. Purpose: To acquaint the student with the operation of the lube oil purifier.

B. Topics:

1. Survey of lesson topics.
2. Lube oil purifier:
 - a. Review of operating controls.
 - b. Operation under various conditions.
 - c. Operating procedure:
 - (1) Steps for starting.
 - (2) Steps for proper running after starting.
 - (3) Steps for securing.

15.2.3 Writing Detailed Lesson Plans²

A lesson plan is an organized, written outline of the details of one lesson. It gives the instructor information on all the points he will need to know in order to teach that lesson.

The details of a lesson plan depend upon the purpose and nature of the lesson. The lesson may be largely lecture or demonstration. It may consist primarily of instructions for conducting a drill. It may be made up mostly of review questions to be used as a basis for class discussion. The lesson plan itself should be or-

RESTRICTED

ganized and written in terms of the purpose of the lesson. To help the instructor accomplish that purpose it should provide him with a reasonably complete statement of everything he should say and do in teaching a particular class session.

A typical lesson plan is organized into five sections.

1. *Purpose.* This section states the objective of the lesson. These objectives should be as specific as possible: What knowledge and what skill should the trainee have at the end of the lesson that he did not have before?

2. *Preparation.* In this section the instructor is told what he must do beforehand in order to be properly prepared for the class. It lists training aids, pictures, charts, blackboard, and any other materials that should be prepared in advance. In writing a lesson plan, this section is not worked out until after the next step, *presentation*, is completed.

3. *Presentation.* This section is the principal part of any lesson primarily devoted to giving information to the trainees. If the lesson is primarily devoted to drill, the section on presentation should be much shorter, serving merely as an introduction to the drill period.

Questions such as the following serve as a check list in planning the presentation section of a lesson plan:

- a. What type of introduction should be provided?
- b. What technical terms should the trainees be expected to learn?
- c. In what order and how should these technical terms be taught?
- d. How much straight lecture material should be used?
- e. At what points in the presentation could training aids be used to add interest or to make things more understandable?
- f. How will those aids be used?
- g. Where can questions add to the effectiveness of the presentation?
- h. What type of questions should be used, those calling for one-word answers or those demanding explanations of general principles? Can thought questions which require the trainee to tie to-

gether parts of the presentation be used to advantage?

It is well to provide questions, and their answers, in the printed lesson plan. Such questions are probably better than those made up on the spur of the moment. The classroom situation should be allowed to determine which ones will be used, but supplying the instructor with a good set of questions is frequently a valuable service to him.

- i. What allowances should be made for differences in the background of groups to be taught? For example, if a particular group is already acquainted with the subject matter, which sections of the material should be omitted, and what should be substituted?
- j. How much time should be given to a review of the last lesson, to a preview of this one, to showing the relation between this lesson and other parts of the course?

4. *Practice.* In this section of the lesson plan, provision should be made for actual practice or drill in order to give the trainees an opportunity to display what they have learned. Participation or drill may take the form of discussion or explanation by various members of the class concerning important topics they have studied; explanation or discussion involving the use of charts, diagrams, or models in the classroom; or practice or drill in equipment operation.

Questions such as the following ought to be considered in planning practice or drill periods.

- a. How much time should be allowed for practice with the various methods suggested?
- b. How can variety, novelty, or competition be used to maintain interest during a long drill period?
- c. How frequently should trainees be shifted from one activity to another? Should rest periods be used?
- d. What degree of skill will be required of trainees?

5. *Review and summary.* Whenever possible, the lesson plan should provide for a review or summary of material covered in that lesson, and

TABLE 1. Excerpt from lesson plan for first lesson on .50 caliber machine gun.³

LESSON TITLE: Caliber .50 Machine Gun, General Characteristics & Field Stripping
 TYPE: Conference DAY: Monday TIME: 0900-1000

PLACE: Machine Gun Laboratory NUMBER OF INSTRUCTORS: 1

PREPARATION:

VISUAL AND AUDITORY AIDS

Have General Motors charts ready for exhibition.

PRINTED MATERIAL

Have nomenclature lists ready for distribution.

TOOLS AND EQUIPMENT

Have ready for use or demonstration the following:

- (1) Link belt of dummy cartridges.
- (2) Browning caliber .50 machine gun, WC type.
- (3) Stripping punch.
- (4) Several fiber buffer discs.

REFERENCES:

- (1) TM 9-1225 (15 April 1943), pages 38-45.
- (2) TM 9-226 (2 August 1943), pages 83-91.
- (3) General Motors Training Manual FGA, Caliber .50, M2 Browning Machine Gun Aircraft Basic, page 40 (summary of field stripping and reassembly).
- (4) FM 4-155 (4 October 1943), pages 30-56, 83.

TOPICAL OUTLINE:

- I 5 minutes—General Characteristics of the Gun.
- II 10 minutes—General Specifications of the Water-Cooled and Heavy-Barrel Types.
- III 5 minutes—Summary.
- IV 30 minutes—Field Stripping.
 .10 minutes—BREAK.

I. GENERAL CHARACTERISTICS OF THE GUN

TIME: 5 minutes.

PURPOSE: To outline the important general characteristics of the gun.

- A. The name of the gun is the Browning Machine Gun, Caliber .50, M2.
 Q.: What does "caliber .50" mean?
 Ans.: The diameter of the bore is .50 inch.
 - B. The gun is a recoil-operated, belt-fed, alternate-feed gun.
 1. "Recoil-operated" indicates that the gun is cocked and made ready for firing the next round by its own recoil and counter-recoil.
 2. "Belt-fed" indicates that each round is fed into the gun by means of a belt.
 - a. The belt may be made either of cloth or of metal links.
 - b. The link belt is in more general use.
- Exhibit a link belt of dummy cartridges and show how the links are held together by the cartridges.
3. Since the gun may be fed from either the right or the left side, it is known as an "alternate feed" gun.
 - C. There are three types of Browning caliber .50 machine guns in widespread use at the present time:
 1. The aircraft basic.
 - a. Used in aircraft.
 - b. Air-cooled.
 2. The heavy barrel.
 - a. Used in the M45 turret, on either the M51 trailer unit or M16 half-track.
 - b. This type is also air-cooled, but the barrel is much heavier than the barrel of the aircraft basic type.
 3. The water-cooled, which the class see before them.
 - a. Used on various mounts by all branches of the services as a basic anti-aircraft weapon.
 - b. This type is water-cooled, as the name indicates.
 - (1) A water jacket surrounds the barrel.

RESTRICTED

Point out the water jacket.

- (2) There is also an auxiliary water chest.
- (3) Water is kept in circulation within the jacket and chest by means of a hand pump. . .

Q.: Which would you think is more effective, water-cooling or air-cooling?

Ans.: (Given directly below.)

D. Importance of water-cooling.

- 1. The heavy barrel type is capable of sustained effective firing for about 300 rounds, on the basis of observations made at the firing range of the AAA School. After 300 rounds, the barrel is overheated and the trajectory is no longer "true."
- 2. The water-cooled type is capable of sustained effective firing for about 1000 rounds, after which the water must be changed. This figure was also obtained from observations at the School firing range.

II. GENERAL SPECIFICATIONS OF THE WATER-COOLED AND HEAVY-BARREL TYPES

TIME: 10 minutes.

PURPOSE: To present the most important figures and measurements of the gun.

A. Except for a very few differences, both types are almost identically constructed, and have approximately the same characteristics.

B. Important dimensions of the gun:

- 1. Weight.
 - a. Heavy barrel—about 80 lbs.
 - b. Water-cooled:
 - (1) Without water—about 100 lbs.
 - (2) With water—about 120 lbs.

Give weights to round numbers. Avoid giving precise figures unless precision is important. To state less important figures precisely leads the student to place undue importance on them.

- c. Either type normally requires two men to carry it, owing to the shape, and distribution of weight.
 - 2. Length of barrel.
 - a. The length of the barrel of both the heavy-barrel and water-cooled types is 45 inches.
 - b. There are still in use some water-cooled guns having a 36-inch barrel, but these are being replaced.
 - 3. Capacity of the water jacket is 10 quarts.
 - 4. Capacity of the auxiliary water chest is about 8 gallons.
- C. Important firing characteristics.
- 1. Rate of fire.
 - a. Water-cooled type: 500 to 650 rounds per minute.
 - b. Heavy barrel type: 400 to 500 rounds per minute.
 - 2. Muzzle velocity.

Q.: What does the term "muzzle velocity" mean?

Ans.: The velocity of the projectile at the moment it leaves the muzzle.

- a. For a new gun of either type, the muzzle velocity is about 2900 feet per second, or about 2000 miles per hour.
- b. As is the case with all guns, muzzle velocity decreases with use, improper care, and with overheating of the barrel.
- 3. Range.
 - a. The maximum range, which is the same for both types, is about 7500 yards, or 4.25 miles.
 - (1) The gun will rarely, if ever, be employed against targets at ranges even approaching the maximum range.
 - (2) Students should remember the maximum range, however, as it is important in laying out firing ranges, planning firing practice, defining safety zones, etc.
 - b. The tracer burn-out range, that is, the distance at which the tracer burns out and is no longer visible, is about 1850 yards.
 - c. The effective range is usually given as about 500-600 yards.

Q.: Does this mean that if you hit a plane at range greater than 600 yards, the hit is ineffective?

Ans.: No.

RESTRICTED

something of material covered in earlier lessons. This section should include:

- a. A review of the major points covered.
- b. An evaluation of the progress of the group. What were the major difficulties encountered? What parts of the material need further study, or what procedures need further practice?
- c. A brief statement of the next lesson, showing how it is related to the present one.

The physical layout of the lesson plan should be designed to make its use as easy as possible. Anything which the instructor is expected to read should be clearly printed and easily found. Enclosed boxes or other emphasizing marks can be used to remind him of points of classroom procedure, visual aids to be used, or, in general, to differentiate material telling him what he is supposed to do from material telling him what he is supposed to say.

An excerpt from a lesson plan on the .50 caliber machine gun³ is shown in Table 1. This excerpt illustrates the final product resulting from the steps described above.

15.3 THE CLASSROOM USE OF LESSON PLANS

A lesson plan may be written by one instructor for his own use or may be prepared for use by many instructors all of whom teach a particular course. If an individual instructor writes his own lesson plans, he will follow them as closely as he sees fit and modify them when and as he likes. If they are prepared for many instructors, several problems concerning their classroom use arise.

The most general question is: How closely is each instructor expected to follow the plans given to him? The answer to this question depends upon the quality of the lesson plan, how it was developed, the skill and experience of the instructor, and the administrative policy of the school in which he is teaching.

In general, an instructor is more likely to follow a lesson plan closely if he finds it satisfactory. This is most likely to be the case if the plan was developed cooperatively by several

experienced teachers working with an educational expert. Whenever lesson plans are to be used by teachers in several schools, it is recommended that representatives of each of those schools prepare the plans together. That cooperation will bring a wider range of experience into the initial preparation of the plans. It will ensure consideration of different points of view and different teaching problems.

Good lesson plans present the instructor with a pattern to follow in handling each class session. The pattern has been carefully thought out; it is probably better than the average instructor would develop for himself; and it ought to be followed by all instructors. But each individual instructor will have had different experience and may have his own illustrations. He should make use of these differences to make the lesson *his* lesson. The more experienced and skillful the instructor is, the more individuality he can give to his interpretation of the lesson plan. Yet the purpose of the plan is to provide standardized instruction in order that men trained by one instructor will acquire the same skill and knowledge as men trained by another. In order to achieve that standardization, it is necessary for the instructor, no matter how good he individually is, to follow the pattern set by the plan.

Lesson plans are sometimes criticized as keeping instruction from being changed when new conditions require change. This is true only if the instructor or training officer makes it so. As changes in subject matter occur, new material can be incorporated into the lesson plan as a substitute for or supplement to older material.

Sometimes lesson plans are criticized as making instruction stereotyped and mechanical. The criticism applies, not to the lesson plan, but to the quality of the instructor's preparing or using it. As a matter of fact, when teaching material is organized into lesson plan form, its relative strengths and weaknesses become apparent, and ideas for improvement suggest themselves readily. New ideas for teaching are always acceptable. If they appear while the lesson plans are being written, they may be incorporated for the benefit of all users; if they occur to an instructor using the plans, he

may introduce them into his classes without departing from the general pattern laid down by the original plans.

Considerable time is necessary for the original preparation of lesson plans, but once this initial work is done they save much time in preparing for individual classes and in running classes. Instead of wondering what to do in class

and how to do it, the instructor can review the lesson plan and be prepared in a relatively short time. Instead of wandering around in class and losing time over trifles, the instructor knows just what he wants to accomplish and how he is supposed to accomplish it. These are characteristic of good instruction and lesson plans help the inexperienced instructor to achieve them.

Chapter 16

THE USE AND DESIGN OF SYNTHETIC TRAINERS FOR MILITARY TRAINING

By Dael Wolfe^a

SUMMARY

AS THE ENGINEER succeeds in developing ever more precise and complicated weapons of war, more and more problems arise in training men to use the new equipment properly. Synthetic trainers have frequently aided in the solution of these problems. Improvements in the design and use of trainers will therefore contribute to the more efficient use of military equipment.

A good trainer has three essential characteristics: (1) practice on it leads to substantial improvement on the equipment the men are being trained to operate; (2) it provides reliable information on the quality of the men's performance; and (3) mechanically and electrically, it is as simple and rugged as possible.

It is necessary to plan carefully an instructional program using a trainer. Simply telling men to practice for a while sometimes results in a loss of skill instead of a gain. The factors to be controlled in a trainer program are:

1. The men being trained should be informed of the meaning of their task.
2. Difficulty of practice should be controlled.
3. The amount of improvement possible on the trainer should be considered.
4. A variety of practice materials should be available.
5. Practice on the trainer should be coordinated with the rest of the training program.
6. Practice should be properly distributed in time.
7. Practice should be carefully supervised.
8. Scoring records should be used to motivate the men and to help in coaching them.
9. The men should want to learn the task.

Instructions for the proper use of a trainer should be prepared as the trainer is being developed and distributed with the trainer.

Trainers possess some advantages over real

equipment for practice. (1) They are generally safer, more economical, and more readily available. (2) On a trainer it is possible to break up a complex task into simpler elements. (3) It is usually easier to give men exact information about their errors and successes on a trainer than on real equipment.

The steps to follow in developing a new trainer or in evaluating an existing one are outlined.

16.1

INTRODUCTION

16.1.1

Need for Trainers

Complicated equipment was so characteristic of World War II that the conflict was frequently called a physicist's war or an engineer's war. The equipment was costly to procure and its initial distribution was slow; but above all it posed a difficult problem for the men who had to operate it in combat. As the engineer succeeded in developing ever more advanced and precise tools of war, more and more psychological problems arose in the adaptation of men and machines for successful operational procedures.

The operational problem created a training problem, for men had to be taught how to use their complicated weapons. Synthetic trainers had been extensively used as one solution of this problem (see Section 16.6). These devices presented simulated tasks which could be mastered during the training period and in the training area. If the synthetic trainers were good, they enabled men to develop skill which could be quickly transferred to the operation of real equipment under combat conditions.

During the early months of World War II the pace of training was so rapid and the demand for speed so great that many synthetic trainers had to be produced and operated with little or no opportunity for careful evaluation of their contribution to operational skill.

^a This chapter is based upon a report³⁰ prepared by the Applied Psychology Panel to summarize the work of different projects on synthetic trainers.

In the postwar period, new weapons will continue to be devised. New synthetic trainers will be produced as convenient and efficient aids to the operational mastery of the new equipment. These trainers should be designed with careful regard for the capacities of the men who must use them. They should not be accepted merely because they appear to be useful. They should be planned in terms of sound psychological and engineering principles, and *their true value should be experimentally determined*. If these things are not done, production facilities and many man-hours will be wasted with little or no benefit to the training program.

16.1.2

Definitions

A synthetic trainer is a device which provides an opportunity for practice that can be substituted for practice in an actual operational situation. The Link instrument trainer is a familiar example. It gives a pilot practice in instrument flying without requiring a real plane and with no danger to the pilot. Other trainers give men practice in gunnery, in the operation of radar sets, or in the use of various other kinds of military equipment. These devices vary from simple training aids which teach the prospective users something about the equipment they will later use to devices as complex and expensive as the equipment itself. There is no sharp line separating training aids from synthetic trainers. In this chapter any device used to give a student information about a piece of equipment or a process will be called a training aid. Cut-away models, wall charts, and motion pictures are examples. In contrast, a device on which a man can actually build up skill will be called a trainer. The emphasis will be on trainers, not on training aids.

16.1.3

Uses of a Trainer

A trainer may have any one of three purposes: (1) to teach the student something *about* a particular piece of equipment,¹³ in which case the trainer is being used as a training aid; (2) to develop basic skills and general

habits which will later be applied in handling the equipment itself; and finally (3) to give practice in the specific coordinations and habits necessary to operate the equipment.

Synthetic trainers may be used to train individual operators or to train a crew of operators in the teamwork necessary for the skillful handling of their equipment.

16.1.4

Types of Trainers

The design of trainers may be along any of the three following lines.

1. Some trainers are completely synthetic. The Link instrument trainer and the gunnery trainer Mark 1 are examples. So also are the Navy stereoscopic trainers, Marks 2, 6, and 7, and the Army stereoscopic trainers M2, M4, and M5. These contain no airplanes, guns, nor rangefinders, but each reproduces important psychological features required for operation of the corresponding equipment.

2. A trainer may consist in part of real equipment used under artificial practice conditions. Some gunnery trainers, for example, deliver synthetic targets to an actual gun or gun sight. The BuOrd gunnery trainers Marks 3 and 5 are examples. Similarly, the use of a field telephone network under simulated combat conditions is an artificial situation but one which uses real equipment in training.

3. Finally, a piece of operational equipment can be called a trainer if men are given practice on it to prepare them to use another similar weapon. Practice on an available radar set in order to develop skill in the use of another less accessible set is an illustration.

16.2

THE CHARACTERISTICS OF GOOD TRAINERS

Any good trainer has these three essential characteristics: It is valid. It gives the men information about the success of their trials. It possesses satisfactory mechanical details.

16.2.1

Validity

The first essential characteristic is validity. Unless practice on the trainer results in sub-

stantial improvement in operational skill, the device is not a valid trainer. Conversely, the faster that performance in the operational situation improves as a result of practice on the trainer, the better, or more valid, that device is as a trainer.

METHOD OF DETERMINING VALIDITY

The ideal method of determining the validity of a trainer requires three groups of subjects equal at the start in ability to handle the real equipment involved. One of these three groups is then given practice on the trainer—enough to allow the men to approach the best performance they can demonstrate. A second group is given comparable practice on the real equipment. A third group is given no practice on either trainer or equipment. The members of all three groups should be tested on the real equipment at the start of the experiment and again at its conclusion. The group which had practice on the actual equipment can normally be expected to show considerable improvement between the first and last tests. The group which had no practice on either trainer or equipment will normally be expected to show little improvement. These two groups are used as a basis for evaluating any improvement shown by the group trained on the trainer. If the trainer group improves as much as the real equipment group, the trainer is as valuable for training as the equipment itself. If the trainer group shows no more improvement than the control group, the uselessness of the trainer is demonstrated. If the improvement shown by the trainer group is somewhere in between that exhibited by the control group and that shown by the group trained on the real equipment, the trainer has some value. This third possibility is the one which is usually found. There is a fourth possibility, that the trainer group shows greater improvement than the equipment group. This sometimes happens. It means either that the trainer group had better instruction or that the trainer is actually superior to the equipment itself for practice at that stage of training. In all four cases the value of the trainer is determined by comparing the performance, on real equipment, of men who practiced on the trainer with that of other men who

practiced on the equipment and with that of still others who had no practice on either equipment or trainer.

The description of this experiment has been greatly oversimplified. The proper conduct of the experiment requires a knowledge of how many men to include, how to equate the groups at the start, and how to measure their improvement. The interpretation of the results depends upon a statistical analysis of the data to determine whether or not the three groups were properly chosen and whether final differences could confidently be expected to recur or must be attributed to chance. Furthermore, it is sometimes impossible to plan the experiment in exactly the fashion outlined above. Sometimes performance on the equipment cannot be measured with sufficient reliability to justify using that as a basis for matching the groups at the start. Because of these difficulties and complications, a validation study must be planned and supervised by someone well acquainted with experimental problems and methods. Otherwise the results may be untrustworthy.

Service conditions may make it difficult to conduct an experiment along the lines indicated. Sometimes the complexities of the operational situation make it practically impossible to obtain an accurate measure of operational skill. In such situations, a substitute method of appraising a trainer may be useful. For example, a group of men already known to be proficient, or at least experienced, on the real equipment can be compared with a group of new men in terms of their performance on the trainer. Ordinarily, the experienced men should do better on the trainer than the green ones, but this will not always be true, for experience alone does not necessarily bring improvement. As an example, a study by Applied Psychology Panel Project SC-67 showed that experienced flight instructors and men returned from combat were no more intelligible in speaking over an airplane intercommunication system than were inexperienced cadets. Experience in a plane does not teach men to speak better. Practice over the voice communication basic trainer²⁰ does. In this case comparing an experienced with an inexperienced group would give no in-

RESTRICTED

formation on the validity of the voice communication basic trainer.

DANGERS OF FACE VALIDITY

The true validity of a trainer as determined experimentally should not be confused with what is called face validity. Face validity means the apparent or superficial similarity of the trainer to the real equipment. For example, in the mirror range estimation trainer, BuAer device 5C-4, the subject sees a model airplane against a painted sky background. The appearance is fairly realistic, so the face validity is reasonably good; but the improvement which it brings about in ability to estimate ranges on the firing line is too small to be significant. True validity of this instrument (when used without a stadiametric sight) is practically zero.²⁴ Results are shown in Figure 1.

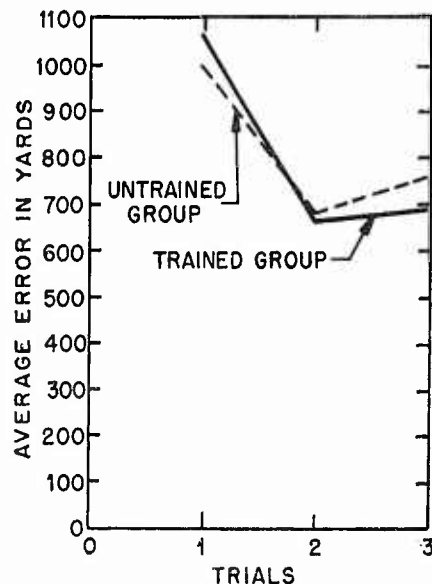

FIGURE 1. Ability to estimate ranges of aerial targets on the firing line by men with previous training on the mirror range estimation trainer and by men without previous practice on the trainer.

The mirror range estimation trainer illustrates a fault which must always be guarded against in trainers: that of allowing men to gain proficiency on the trainer by responding to cues which will never be present in the real situation. Training in range estimation has

sometimes been given on this device without using a stadiametric sight. When used in this way men may learn to estimate the apparent range of a model plane by responding to such irrelevant cues as position of the target in the observation port, changes in the clarity of the painted sky backdrop, or appearance and disappearance in the field of view of parts of the carriage mechanism. The men may or may not be aware of their use of these secondary cues. Obviously none of these factors are present with real planes against a real sky. Improvement on the trainer which results from their use indicates nothing of a man's ability to estimate ranges under operating conditions.²⁴

A second example illustrates the fact that physically identical parts of a trainer and real equipment may produce some but not perfect transfer. A Mark 14 sight on a BuOrd Mark 3 trainer is physically identical with one on a 20 mm gun, but they represent different psychological situations since only a portion of the habits required for using the Mark 14 sight on the 20 mm gun can be obtained from practice with that identical sight on the Mark 3 trainer.

NECESSARY SIMILARITY BETWEEN TRAINER AND REAL EQUIPMENT

While face validity is never enough and sometimes is definitely misleading, obvious resemblance of a trainer to the actual equipment is desirable. It is likely to give the student a greater feeling of realism. It helps to improve his motivation and the seriousness with which he attacks the learning problem. Controls, dials, spatial relations, sizes, etc., which are included on the trainer should, whenever possible, duplicate the corresponding features of the equipment. But these features should not be included at all if they detract from the true validity of the trainer.

Of much greater importance than superficial similarity is similarity in terms of the psychological processes and the skills required for proficiency. A device may show some very obvious differences from the corresponding equipment and still prove to be a good trainer. A comparison of two radar trainers illustrates this point. The Foxboro trainer (BC-968-A) is a complex electronic device designed to give pip-

matching training. It gives preliminary training for the operation of some radar sets, for example the Navy's Mark 4, which requires the operator to keep pips matched in height on the oscilloscope screen. The Foxboro trainer is an excellent device of demonstrated value in giving this kind of training.^{31, 32} Apparently equally valuable, however, for giving some of the training which can be given on the Foxboro is a much simpler mechanical pip-matching trainer. In this device a light shining through a template cut out to resemble a pip is cast on a ground glass plate. Two such images are kept unbalanced by a mechanical lever system. This system can be counteracted and the two pips matched with controls similar to those used on the Mark 4 radar. Two groups of enlisted operator trainees, one given practice on the Foxboro trainer and one on the mechanical pip-matching trainer, showed essentially equal transfer to operation of the Mark 4 radar.^{32, 33} The results are shown in Figure 2.

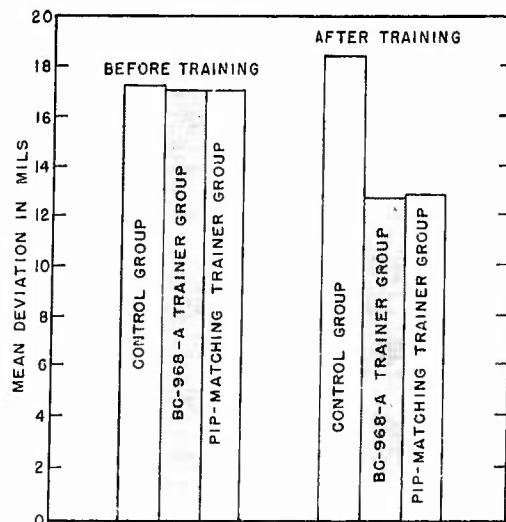

FIGURE 2. Comparison of modified BC-968-A trainer and mechanical pip-matching trainer in producing improvement in ability to track aerial targets with Mark 4 radar in the gun director Mark 37.

These two trainers differ greatly in their component parts. One is an electronic device, in many respects resembling a real radar set; the other is a mechanical-optical device. One makes use of an oscilloscope trace; the other

casts a light image on a ground glass plate. These are large differences. The task of the operator, however, is essentially the same on the two devices, and the improvement which the devices can bring in matching pips on radar equipment is likewise similar.

Another example of gross mechanical and electrical differences from the original equipment is furnished by a mechanical-optical *plan position indicator* [PPI] trainer. This trainer simulates the PPI oscilloscope found on many radar sets. The simulation is provided by small light bulbs flashing behind a ground glass plate to represent the blips which appear on the PPI screen. This device is highly reliable and on the basis of the available evidence appears to be a valid trainer.^{27, 35}

TRANSFER OF SKILL

The value of any trainer depends upon the extent to which skill acquired in practice on it transfers to performance on the real equipment. The transfer may involve a general orientation to the problem; it may involve general principles of operation; or it may involve specific skills which are identical with those required for the real task. It is easy to overestimate the probable amount of this transfer. Therefore, the amount of transfer should be a problem for special study for each trainer.

It is, in summary, always necessary to ask concerning any trainer, "Does practice on this device improve performance on the real equipment?" The answer can be given most confidently if the trainer is evaluated experimentally by the method described above. If the results of this experiment indicate that practice on the trainer significantly improves performance on the real equipment, then validity of the trainer has been demonstrated.

16.2.2

Knowledge of Results

The second essential feature of a good trainer is the incorporation of a means of informing each man whether or not his performance is correct. If men are to learn rapidly, their errors and their successes must be pointed out. As an illustration of this fact, Figure 10 of Chapter 3

RESTRICTED

summarizes a study of tracking with the Army computing sight M7. The dotted lines show the slow improvement made under ordinary training conditions; the solid lines show the much more rapid improvement produced by sounding a buzzer whenever the tracker was off the tracking point by 2 mils or more. By having an instructor look through a checksight and sound the buzzer when the tracker got too far off target, each man knew when his tracking was satisfactory and when it was not. This knowledge of results produced a very substantial increase in the rate of learning to track accurately.

Sometimes a knowledge of results comes as an inherent part of a training situation. If a man in parachute school breaks his leg on a practice jump, he knows the jump was unsatisfactory. Sometimes the knowledge comes from the remarks of the instructor. In a synthetic trainer it frequently comes from a scoring device.

OBJECTIVE SCORING SYSTEMS

If a scoring device is used, and it is recommended for most trainers, it is important that the score accurately reflects the student's skill. This means that the score should measure the appropriate aspect of the performance and that it should be reliable. If scores are unreliable men will lose confidence in the device, for they quickly learn that the same quality of performance does not always lead to the same score.

The easiest single step in securing reliable scores is to have objective scores. Counter readings, ink tape records, or number of hits are objective scores and can be distinguished from subjective scores such as general opinions or estimates of the quality of performance. Objective scores may measure either qualitative or quantitative aspects of performance. An ink tape record of tracking shows in its deviations from the target path a measure of the smoothness or quality of tracking. A record of the number of hits made with a gunnery trainer is a quantitative measure of the gunner's skill. Sometimes it is well to have both kinds of scores on the same performance, as is possible on the Foxboro radar trainer (BC-968-A), which provides both a Veeder counter score and an ink tape record. Both quantitative and qualitative

scores are desirable. Either may be useful in motivating the student or in helping the instructor to coach him.

UNRELIABILITY OF SCORES

Objectivity of scores is not enough to ensure their reliability. Some features of trainers which have sometimes made objective scores unreliable are voltage variations; variations in amplifier characteristics; variations in film densities which may become progressively greater and greater with increasing age; failure to allow sufficient time for equipment to get completely warmed up; time changes in sensitivity of photoelectric cells used in recording; and mechanical wear in the recording system.

With some scoring devices it is impossible to get satisfactory scores. Even though the system functions perfectly in a purely mechanical sense, the scores may not be meaningful. Examples are as follows. In recording tracking in gunnery trainers there is sometimes a failure to distinguish between performance on relatively easy approach angle shots and those involving more difficult targets with rapidly changing approach angles. High scores can be made on some gunnery trainers with jerky tracking when smooth tracking is required for efficient operation of the gun and should be demanded on the trainer. Individuals who miss widely and those who are only a little off make identical scores with some scoring systems. In these cases the scores themselves may be objective but of little value in training.

Finally, unreliability of the subject himself will appear. Even with perfectly reliable scoring devices, men themselves are not always consistent. Learning is usually marked by progressive improvement. But frequently the learner will not do so well on one day as he did the day before. Fluctuations of the kind shown in Figure 3 must be expected. While they will lower the overall reliability of the records, they should never be used as an excuse for accepting a scoring system less reliable than the best which can be designed and maintained.

SCORING DIFFICULTY

Associated with the question of reliability is one of difficulty. If everyone gets perfect scores

or zero scores there is no way of telling good men from poor ones or of showing a man's improvement with practice. The most reliable scores can be obtained if the system is adjusted

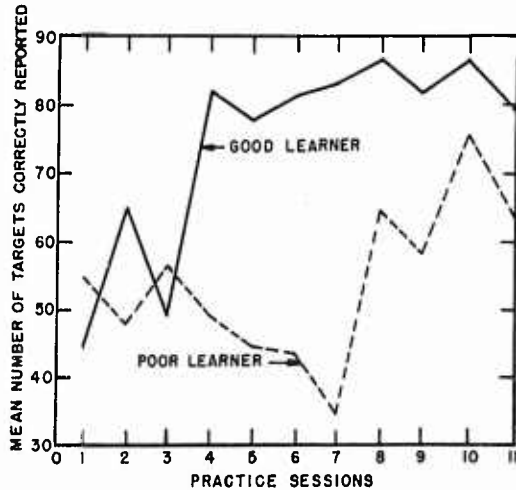

FIGURE 3. Individual learning curves in indicating azimuth on the trainer BC-1070-A (Master).

to give the average man a score in the middle of the range of possible scores. With a wide range of possible scores it is easier to demonstrate improvement with practice or to show up the differences between men of different ability levels.

In order to secure a satisfactory range of scores it may be necessary to sacrifice realism. Some gunnery instructors set the machine gun trainer Mark 1 to allow only 2 or 3 per cent hits. Such low scores correspond fairly closely to what can be expected under battle conditions. Instructors recommend them for this reason and also because they believe that low scores will keep the gunner from becoming overconfident. While these statements are true, a somewhat higher hit percentage need not lead to overconfidence and should still provide good motivation. More important, it would permit better discrimination between good and poor trainees. In general it is more important for a trainer to provide reliable scores than to maintain absolute realism of scores.

PURPOSE OF SCORES

In considering any scoring device, it should be remembered that the primary purpose is to in-

form the student of his progress. If it fails to do that, it has no training value.

As a general principle, men should always be informed of the results of their practice. This information sometimes comes immediately, as it does when the buzzer sounds as soon as a man gets 2 mils off target (Figure 10 of Chapter 3). Sometimes it is delayed, as it is when the instructor shows the student an ink tape record of his tracking on the Foxboro radar trainer (BC-968-A) at the end of a practice period. Knowledge of results which is delayed provides motivation. It is useful in plotting learning curves and in keeping accurate progress records, and it can be used to analyze the kind of errors being made. Knowledge of results which comes immediately can be used for all these purposes and has the additional advantage of providing an immediate check on performance. Many studies have shown that learning is faster when knowledge of results comes immediately after practice than it is when that knowledge is delayed. Whenever possible, men should be given immediate knowledge of results, but whether that knowledge comes immediately or after a delay, men in training should always have it.

16.2.3 Physical Features of Trainers

The third essential feature of a good trainer is that it have satisfactory physical characteristics and be free of maintenance difficulties. If all trainers were ideal they would require no maintenance crews, no special buildings or wiring, and would never break down. Practically, each trainer should be as simple as possible while still doing the training job for which it was intended.

Sometimes the training job requires a complicated trainer. The Link celestial navigation trainer and the BuAer operational flight trainers are complex and involve many special requirements. The complications seem necessary to accomplish the training job and are, therefore, justified. What is not justified is the addition of complications that do not increase the trainer's validity.

In designing a trainer a compromise between

desirable features may be necessary. A very valid trainer so complicated and delicate that it is never in operating condition is obviously useless. So is a simple rugged trainer of no validity. In practice, the first emphasis should be on validity and on giving the student a knowledge of results. After making certain that the trainer is satisfactory on these points, every effort should be taken to make it as simple and rugged as possible.

16.3 THE USE OF TRAINERS

No trainer is any better than the instruction which goes with it. No trainer is a useful substitute for a well-planned instructional program. With unsupervised or poor practice on a trainer men may even get worse instead of better.

16.3.1 Necessity for Good Instruction

Figure 4 shows the learning records of two groups of enlisted men given training on the Philco trainer (trainer box BC-1070-a), designed for training men to operate the radar set SCR-270-71.^{7,8} The lower curve in this figure shows the steady improvement of a group of men trained at one Army base. These men were given 30 minutes practice on each of 6 days. The practice and training were carefully planned. Each day the average error was less than on the day before. The upper curve in the figure shows the record of another group. These men were trained 20 minutes a day for 6 days but in a poorly controlled training program. Their average error became greater and greater as practice went on. The main faults of the poor training program were: The schedule was dull and monotonous. No great effort was made to interest the men in trying to improve their performance. There was inadequate variation in the training program; the same target course was used over and over again. The men were not told how well they were performing. Poor teaching here led to worse instead of better performance.

The effects of badly planned training are

seldom as marked as these. Poor teaching can, however, frequently be shown to result in little if any gain. An illustration comes from the evaluation of the Mirrophone for voice communication training. The Mirrophone is a magnetic tape recorder which plays back immedi-

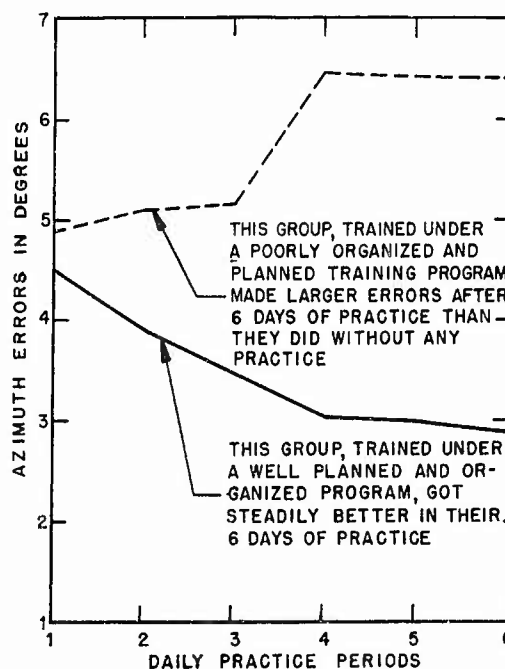

FIGURE 4. Learning curves for two groups of subjects trained for 6 days on Philco trainer.

ately anything spoken into it. Three groups of subjects practiced on the Mirrophone in the presence of simulated airplane noise. One of these groups was given supervised voice drill by a trained instructor. The men in this group showed substantial improvement in the intelligibility of their speech. A second comparable group practiced in the presence of an officer who did not serve as an instructor. The men in this group showed a small amount of improvement. A third group comparable to the first two was given unsupervised drill with no officer present. The men in this group improved not at all. The importance of careful supervision in the use of this trainer is obvious.

In planning a program for a trainer, attention should be given to the order of drills or practice, amount of time for each drill, frequency of practice periods, types of scores, and

methods of correcting errors. It may even be more important to consider these factors carefully in planning a trainer program than in planning a program in which real equipment is used. Work with a trainer is more artificial, and motivation may be poorer. In spite of a generally good war morale, men frequently lack interest in the many details which make up a program of military training. It is never safe to assume that men are so anxious to learn that a well-planned training program is unnecessary.

A violation of the above principles is illustrated by directions which were written for the guidance of instructors teaching pilots ground-controlled interception [GCI] procedure. Pilots using Link instrument trainers were given flight directions from an officer assuming the role of the ground control interception operator. The instructors were informed that "The pupils not actually taking part in the exercises can be placed in the operations room and at other advantageous points, so that they can hear and note the correct and incorrect messages as relayed over the loud speakers. They should be encouraged to point out mistakes."⁴⁷

The pupils not actually taking part in the exercise could learn much more about proper communications procedure in a well-planned course on communications than in such casual and unorganized observation of part of what is going on in the GCI training course.

The careful application of good principles of instruction is illustrated by a trainer developed to teach a number of students to operate sound-locating equipment. An important feature of this trainer is a central control station for the instructor from which he can set up a problem and can constantly monitor the performance of each operator. He is able to detect errors immediately and can coach each operator on his own individual errors over a communication system. The central location of the instructor makes it easier for him to control and direct the class. The fact that problems are designed so that the instructor must give information to the students at intervals and must receive and record their reports forces him to take an active part in all drills. As a result of these arrangements the instructor, even the inexperienced instructor, has a better opportunity to teach,

and the students a better opportunity to learn than they do under less well-planned conditions (see Summary Technical Report of NDRC, Division 6, Volume 4).

16.3.2 Characteristics of Good Instruction

Any plan for instruction on a trainer should include attention to the following points.

MEANING OF THE JOB

The student should be told not only what he is doing mechanically but also what this means in terms of operation of the real equipment for which he is being trained. It is frequently impossible to give men complete information about the part their work plays in the whole war picture, but it is desirable to give as full information as one can. Failure to do so may lead to a mechanical, uninterested, and unadaptive performance instead of an enthusiastic and intelligent adaptation of skill to changing requirements.

DIFFICULTY OF PRACTICE

The difficulty of practice should be controlled. Many tracking trainers come equipped with several cams, each simulating a different target course. These usually vary in difficulty. Generally speaking the easier ones should be given first. More difficult target courses can be saved for practice after some skill has been developed. In testing and sometimes in training, it is desirable to keep difficulty constant. On tracking trainers using cams, this can be done by using different starting points for a given cam. By starting at different points in the target course (different points on the cam) it is unlikely that a student will memorize the course. At the same time, the total difficulty of the entire course will remain constant from day to day or from subject to subject.

AMOUNT OF IMPROVEMENT POSSIBLE

A second aspect of difficulty demanding attention is overall range of improvement possible on the trainer. An expensive apparatus is not economical if men reach their top level of skill in a few trials requiring a few minutes. In

RESTRICTED

spite of its expense, it may be necessary if no other type of practice is feasible. The general principle is that the training device should require enough practice so that the required skill will be retained for later stages of learning and in the real operational situation.

VARIETY OF PRACTICE

Practice should be provided on a variety of courses or in a variety of situations to the end that the men do not learn to do a good job on only one or a few situations or on only one or a few kinds of courses. A variety of courses is required if a man is to learn to track any kind of course. A variety of conditions of radar operation must be simulated if a man is to learn to operate a radar set under all sorts of conditions. To achieve this variety, a larger number of target films or course cams than is usually provided should be available. Most of these films or cams could be used to add variety to the training. Some could be used to provide examination or test runs different from those on which the men had practiced.

PLACE OF TRAINING IN WHOLE TRAINING PROGRAM

The place of the trainer in the whole training program should be carefully planned. Trainers are generally most useful in the early stages of learning although some have been specially designed for refresher training. Generally speaking, trainers which most nearly duplicate the whole operational task can be used with profit throughout the greater part of an entire training program. Trainers which duplicate only part of the whole task should ordinarily be used during the early stages of learning. The Army director trainer M8 and antiaircraft machine gun trainer M9 are considered useful for several hours of practice because certain principles of firing and certain operations on the part of the gunner can be illustrated. More extended practice on these devices is probably not valuable since it is thought that little, if any, real skill in firing or fire control can be developed on them.

Several trainers may be used in succession, each serving to increase a man's skill. In antiaircraft gunnery training at the Armed Guard School, Shelton, Virginia, such a program is

followed. Prospective gunners are first given three drills on the portable aiming teacher to teach them the general principles of lead. Six drills on the multiple forward area sight trainer allow the men to attain greater speed and certainty in setting in the proper lead. The Mark 6 trainer, for three drills, introduces moving targets but does not require real tracking. Four drills on the Mark 3, Model 1 trainer develop skill in tracking. At later times drill on the Mark 4 trainer serves as a refresher course to keep a man from losing skill.

DISTRIBUTION OF PRACTICE

Practice should be distributed. Many short practice periods are almost always better than a few long ones. If training must be concentrated into a few days, two half-hour periods will usually be better than one hour-long period of practice.

SUPERVISION OF PRACTICE AND INSTRUCTION

Practice on trainers should be carefully supervised. In many cases it is desirable to have one instructor responsible for each trainer. Each student will then have a new instructor on each trainer. But each of these instructors can become an expert on one particular trainer. The instructor should serve as a tutor, correcting mistakes as they are made, making suggestions for improvement, and otherwise coaching the student toward mastery of the skill required. Teaching as good as that described requires regular and careful supervision of the instructors, for most of them will have to learn to teach effectively. One device for helping the instructors to maintain the students' point of view is to require periodic checkouts on the trainer by every instructor.

The trainer should never be used as a plaything or as a time filler. It should never be turned over to the student with the instruction, "Practice for a while." The effects of violating this recommendation are, frequently, that nothing useful is learned.

USE OF PERFORMANCE SCORES

Immediate use should be made of the scoring records obtained during practice. If counter or numerical scores are obtained, they should be

given to the student immediately and compared with the scores made in past practice periods. If a graphic record is obtained, the graph should be shown and explained to the student at the end of each practice session. The particular kinds of errors made by each student should be carefully pointed out as soon after practice as possible. An Army Air Forces study of methods of training men to recognize friendly and enemy aircraft by slides and films demonstrates the value of this recommendation. Learning was 40 per cent greater in a group required to make responses which were either corrected or confirmed immediately than in a comparable group which simply saw the planes and heard the names the same number of times.

Recording scores daily allows both student and instructor to keep track of the student's improvement and to compare each student with the expected standards. If the amount of time spent on a trainer is flexible, a learning curve is useful in deciding when further training is no longer profitable. If the trainer is desirable at all, men should practice on it until an appre-

obviously uneconomical. An experimental study will determine useful limits on the amount of time which can profitably be spent on any trainer.

MOTIVATION

Finally, the men should want to learn the task. Any available device for motivating the student should be used. Posting learning curves or progress charts is one good method. Sometimes it pays to have each man post his own score. Friendly competition between individual students or groups of students aids learning. Formally recognizing progress to a higher level of training serves to motivate men. So does an explanation of the ultimate purpose of the training. Lastly, students should be praised. Correcting errors and reprimanding men for failure help learning but are more effective if good performance is also pointed out and rewarded.

16.3.3

Lesson Plans

A carefully prepared set of lesson plans is the best way of making certain that these nine principles will be followed. The most competent and experienced instructors available should prepare these plans. Less experienced instructors can follow them even though they are not able to originate the training plans. In this way the best instructor talent can be stretched to cover all the men, and all men will get more nearly the same course. A good example of a well-planned course of instruction is to be found in reference 10. This memorandum outlines a course of instruction for using the Foxboro trainer (BC-968-A) in training operators of the SCR-268 radar set. A second good illustration is found in reference 34, which outlines a number of drills for using antiaircraft gunnery trainers in an armed guard school. Samples are given in Chapter 15.

16.3.4

Preparation of Lesson Plans

Sometimes the agency best able to prepare the lesson plans for a trainer is the one which developed the trainer. This agency may also be

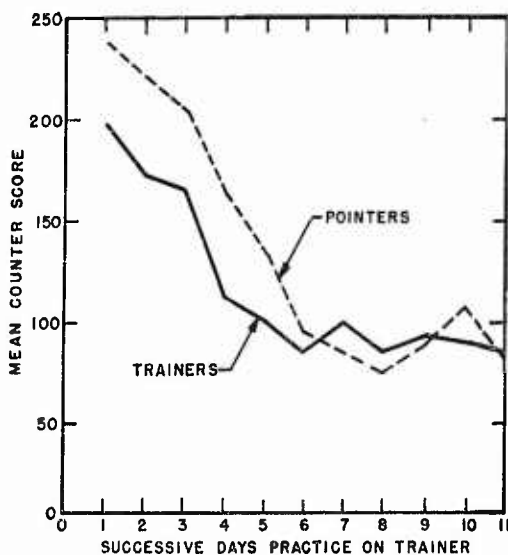

FIGURE 5. Experimental determination of amount of practice on a trainer that is beneficial.

ciable amount of skill is developed. But practice should not continue after the men are no longer showing significant amounts of improvement. An example is given in Figure 5. On this particular trainer, practice after the eighth day is

RESTRICTED

made responsible for indoctrinating the officers who will later be in charge of the instruction on the trainer.

An example of such a program is furnished by NDRC Project N-118 working at the Submarine Base, New London, Connecticut. This project standardized submarine telephone terminology, developed an appropriate trainer to produce artificially the difficulties of communication in a submarine, wrote a manual for distribution to the men (*Submarine Telephone Talkers Manual*, prepared by National Defense Research Committee and Bureau of Naval Personnel, NavPers 16171), and wrote the lesson plans for the courses of instruction in submarine communication.⁴⁸ Each of the submarine bases which planned to give telephone talker training then sent an officer to New London on temporary duty. These officers were taught by the project staff to use and maintain the trainer properly and to give the already outlined course of training (see STR of Division 6, Volume 14).

A similar program has been followed in the development of speech training courses and equipment for the Army Air Forces by NDRC Project SC-67 (Chapter 11). In both cases the plans for instruction were drawn up and the prospective instructors trained by the same group which developed the trainer. In a program of this nature, close cooperation is necessary between the military officials responsible for administering a training program and the agency which develops the trainer and the plans for its use. Adaptation of the instructional plans to local needs is frequently necessary. The new instructors must be taught their job and must then be supervised until they have demonstrated their ability to teach effectively. Arrangements must be made for maintenance of the trainer. These problems are best solved cooperatively. When they are solved, a program of this kind can go a long way toward insuring proper and uniform instruction on a trainer.

A trainer should help men learn to use real weapons and equipment. This help should not be lost through poor teaching. The benefit men get from trainers can be great. Careful planning and good teaching are required to see that the men actually get these benefits.

16.4 ADVANTAGES OF A TRAINER OVER REAL EQUIPMENT

Trainers are usually thought of as substitutes for real equipment. How useful they are as substitutes depends on the degree to which practice on the trainer improves performance on the real equipment. Even when the transfer is far from perfect, a trainer may have some advantages. The chief advantages are economy, availability, safety, the possibility of isolating part of the task and giving special training on that part, and the greater ease with which a student can be given information on the exact nature of the errors he is making.

16.4.1

Economy

Practice on a trainer is frequently more economical in time and money than is practice with real equipment. In training aircrew members to use intercommunication equipment the presence of a loud noise similar to that found in an airplane is highly desirable. The training could be given in an airplane. It can be given much more economically in a classroom. If the classroom is equipped with an airplane-type noise generator the difficulties of communicating in an airplane are satisfactorily reproduced (Chapter 11).

16.4.2

Availability

Trainers are sometimes more easily available than real equipment. When new equipment is first introduced, field and operating use sometimes gets first call on a limited output. Trainers are especially important then to prepare men to operate the new equipment they will find on board ship or in the field.

In a different sense also a trainer may be more available. In training gun crews or radar operators, actual targets flying prescribed courses may be rare. Trainers can simulate such courses at any time and under any weather conditions. The easier availability of trainers means that they can save a good deal of training time (Chapter 2).

16.4.3

Safety

Allowing unpracticed men to use real equipment may be dangerous to the men and the equipment. The Link instrument trainer gives pilots experience in instrument flying in perfect safety. The BuAer flight engineer's panels allow the engineer to practice all the controls and adjustments necessary to keep a heavy bomber operating. In the trainer, the flight engineer gets this practice with no danger to himself or an expensive plane.

Sometimes a real situation is too dangerous to set up merely for training purposes. In these situations the only possible practice is that which can be provided by a trainer. An example is the B-29 ditching mock-up which enables flight crews to practice escape from a B-29 without requiring a plane to land on the water.

16.4.4 **Control of Difficulty of Practice**

The job for which a man is being trained is sometimes extremely complex. A trainer may isolate important elements of this job and allow a man to learn those elements before the complications are added. The Foxboro (BC-968-A) radar trainer and the radar set SCR-268 illustrate this possibility. In operating the SCR-268, it is necessary to keep two pips on the oscilloscope screen equal in height. Under operating conditions this task is quite difficult. The pips bob up and down and are frequently partly hidden by interfering patterns, called grass, on the oscilloscope screen. The Foxboro has separate bobbing, interference, and grass controls so that these may be introduced singly or together, or all three may be eliminated. Eventually the operator must learn to keep the pips matched in spite of bobbing, interference, and grass. Whether these complications should be introduced gradually or should all be present from the beginning is an experimental question. The answer depends on which procedure leads to more rapid development of skill in using the SCR-268. An identical question can be asked about a number of other trainers. If the evidence demonstrates the desirability of introducing the complicating elements gradually, the

trainer has an advantage which the real equipment cannot match.

16.4.5

Knowledge of Results

A trainer frequently gives a man immediate knowledge of results and of exactly what errors are being made. This information is much rarer with real equipment. The most completely satisfactory evidence of good shooting by an anti-aircraft gun crew is to see an enemy plane hit and explode in the air. If a hit was not made, however, the crew rarely knows what errors were made. A trainer, on the other hand, can give immediate knowledge of results and can also be designed to tell just what was done wrong. The best example is found in a device designed to train men to send radio code properly. What the man sends with this device is immediately printed by a typewriter. Properly sent at any speed the letter *A* in the International Morse Code consists of a dot, a pause equal in length to the dot, and a dash three times as long as the dot ($\cdot-$). With this training device if a man sends an *A* properly the typewriter prints *A*; if the initial dot is too long, the typewriter prints *M* ($--$). If the pause between the dot and dash is too long, the typewriter prints the two separate characters *E* (\cdot) and *T* ($-$). If the final dash is too short, the typewriter prints *I* ($\cdot\cdot$). If the dot and dash are reversed the typewriter prints *N* ($- \cdot$). These are examples to demonstrate how precisely the typewriter record shows the type of error. The man has the immediate satisfaction of seeing the correct letters printed only when his pauses, dots, and dashes are quite correct. The immediate knowledge of just what is right and wrong is a good teaching principle to incorporate in any trainer.⁴⁶

As a result of such advantages men sometimes learn faster on trainers than they do on real equipment. One study showed that men learned to track on the gun director M7 as fast or faster when trained on the Tufts tracking trainer as when trained on the director itself.¹⁸ The results are shown in Figure 6. When men learn faster on a trainer than they do on real equipment, one should look for better motiva-

RESTRICTED

tion, better planned instruction, better records of performance, etc., on the trainer than on real equipment. These factors plus the advantages of a trainer just described sometimes make a trainer a better instrument for training than is the real equipment itself.

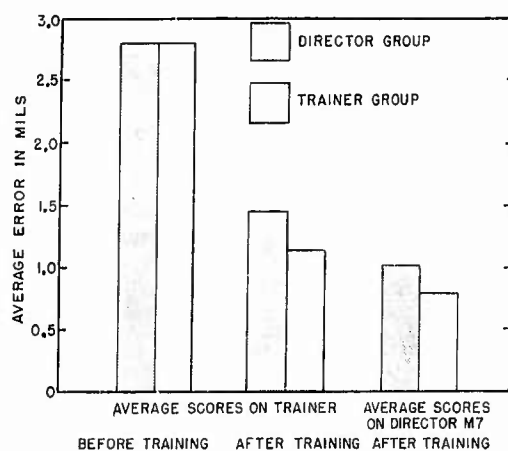

FIGURE 6. Comparison of two groups of men, one trained on the gun director M7 and one trained on the Tufts tracking trainer.

16.5

CONCLUSION

The foregoing discussion is summarized by two check lists, one for evaluating a completed trainer, the other for planning and designing a new trainer.

16.5.1 The Evaluation of a Trainer

Any trainer should be carefully evaluated before it is accepted for regular use. The evaluation should cover the following six points:

1. *Intended purpose.* Is it planned as a team trainer or for individual practice? Is it intended to be used for basic training or is it capable of providing a higher level of skill and thus suitable for advanced training? Will it be useful for refresher training?

2. *Description.* The description should include photographs, wiring diagrams, size, weight, material specifications, and statements of any special requirements such as special buildings and wiring.

3. *Scoring system.* What kind of scoring sys-

tem does it have? How reliable are the scores? If there is no special scoring system, what provision is made for informing the men of their progress?

4. *Validity.* How well does it accomplish its intended purpose? This question can always be best answered by using the experimental method described in Section 16.2.1.

5. *Amount of improvement possible.* For how many hours of actual practice will men continue to improve their performance on the trainer? A trainer may be uneconomical if it can be used advantageously for only a short period or if the necessary skill can be quickly developed in other ways.

6. *Comparison with similar trainers.* How does it compare with other trainers intended for the same general purpose? This comparison should cover scoring reliability, variety of material, validity, cost, availability, maintenance troubles, and special requirements.

If a training agency has the information called for under these six points it will not have to guess about the usefulness of a trainer. It will know whether the trainer will be useful and how it can best be used.

16.5.2 Planning and Designing a Trainer

These eight steps should be followed in planning and designing a synthetic trainer:

1. *Training schedule.* It is first necessary to know whether the real equipment will continue to be used or will quickly be superseded by newer models. If the equipment will continue in use, it is then pertinent to ask whether the doctrine determining *how* it is used will remain unaltered or will be changed materially. An estimate should then be made of the time required for the development of the trainer and the initial engineering work necessary to get it into production. Development of a new trainer is not justified unless it will have a real opportunity to be useful. This is most likely to be the case if the trainer is developed along with the corresponding equipment. Ideally the two should be planned together, tested together, and put into use at the same time.

2. *Analysis of the job.* If the time schedule

RESTRICTED

indicates that a trainer is likely to be useful, the second step can be taken: a careful analysis of the job for which training is to be given. This analysis should include attention to the difficulty of the job involved. In some cases the job can be learned so quickly that a trainer is unnecessary. In others, where more prolonged practice is necessary, a trainer can be useful. The job analysis should also provide the basis for deciding which of the several aspects of the total task will be emphasized in the trainer.

3. *Purpose of the trainer.* On the basis of the job analysis, decisions should be made on the purpose of the trainer. Is it to be used for elementary or advanced training? Is it to be used for individual or crew training?

4. *Design.* The previous decisions are preparatory to the actual design of the trainer itself. The problem of design should be attacked from two standpoints. From an engineering point of view it should be designed for ease of production and maintenance. From a psychological point of view it should be designed for maximum validity and in terms of the physical and mental capacity of the men who will have to use it.

5. *Pilot model.* Construct a pilot model of the trainer.

6. *Validity.* Determine the validity of the trainer by the experimental method described in Section 16.2.1 and determine the minimum and maximum number of hours it can profitably be used.

7. *Improved design.* Make any changes in the design of the trainer which appear to be desirable in terms of the experience with the pilot model and the results of the validity study.

8. *Plans for instruction.* Prepare lesson plans and an instructional manual to accompany the trainer when it is introduced into field use. Examples of such instructional manuals are found in Chapter 25.

In planning and designing any trainer it is desirable to follow, in order, the eight steps listed. In peacetime this should always be possible. In wartime it may be necessary to allow some overlapping of the eight steps. For example, after the pilot model is constructed, it may be desirable to start production. Validation should still be carried out, however, for the

contract can be cancelled if the device proves to be of too little value to justify its use. If it is valuable, time will have been saved in getting it into production.

Trainers have in the past been of varying quality, ranging from some very good ones to some which have been almost worthless. If these eight steps are uniformly followed, the trainers which are actually put into use will be of high quality. The great potential value of synthetic trainers in military training can then be fully realized.

16.6 TRAINERS DESIGNED AND BUILT BY PROJECTS OF THE APP, NDRC

Gun Director and Tracking Trainers

1. The Tufts director (M7) tracking trainer¹⁴
2. Director tracking trainer²³
3. Multiple forward area sight trainer¹
4. Phototube scoring device for tracking trainers³⁷

Aerial Gunnery Trainers

1. Remote control aerial gunnery trainer⁴²
2. B-29 ground trainer³⁸
3. Airborne synthetic gunnery trainer⁴⁴
4. Remotely controlled test device for the analysis of gunner performance on flexible gunnery equipment⁴⁵

Radar Trainers

1. H2X film trainer³¹
2. PPI trainer^{22, 35}
3. Pip-matching trainer³³
4. Recording device for Philco trainer (BC-1070-A)^{16, 23}
5. Mark 12 radar tracking trainer³⁰
6. Radar air-search tracking trainer⁴⁰
7. Mechanical PPI tracking trainer⁴¹

Communication Trainers

1. Voice communication basic trainer²⁰
2. Crew interphone trainer (no OSRD report; described in *Army Air Forces Manual* 50-19, March 1945)
3. Radio code sending trainer⁴⁶

Night Vision Trainer

1. Night lookout trainer²⁵

Cargo Handling Trainer

1. Electric winch trainer³⁰

Landing Craft Trainer

1. Coxswain trainer (no OSRD report)

RESTRICTED

Chapter 17

MEASURING THE EFFECTS OF TRAINING

By *Norman Frederiksen*^a

SUMMARY

GOOD TESTS of the amount of skill acquired by men undergoing training improve the training program in several respects.

1. They increase the amount the trainees learn, both by motivating the trainees and by showing the instructor where his instruction is good and where it is poor.

2. They provide measures of actual achievement which are useful in advanced classification.

3. They provide better criteria than do ordinary school grades for evaluating selection procedures.

4. They make possible more uniform instruction in different classes and different schools.

5. They provide quality control officers with continuous checks on the success of training programs.

Specific examples of these advantages, descriptions of several types of achievement tests, and information on the development of such tests are given.

17.1

INTRODUCTION

The most obvious reason for attempting to measure the effects of training is to obtain an evaluation of the success of the training program—to determine whether or not the trainees are actually learning the things which the school was organized to teach. There are, however, other equally important advantages which grow out of the organization of a good achievement testing program. Achievement itself increases; the tests supply data which are extremely useful in the subsequent assignment of trainees to specific billets; and the tests make possible better evaluation of selection methods.

The Applied Psychology Panel, working in close cooperation with members of the Achievement Test Unit, Standards and Curriculum Sec-

^a This chapter is based on the work of a number of Applied Psychology Panel projects.

tion of the Bureau of Naval Personnel, devised a large number of tests for measuring the proficiency of trainees in various training activities of the Navy. In most cases Navy Service schools already had in operation testing programs which stressed the use of pencil-and-paper tests and failed in many cases to evaluate adequately the proficiency of trainees in practical work. The efforts of the Panel were accordingly bent in the direction of providing tests for measuring the skill of students in performing such tasks as receiving radio code, wiring circuits, tuning transmitters, and repairing and adjusting mechanical equipment.

17.1.1 Achievement Tests Increase the Amount of Learning

One of the most important reasons for conducting an achievement testing program is that testing is practically always associated with improved achievement on the part of the students. It is not difficult to divine the reasons why students learn more when they expect to be tested than when they do not. The expectation of tests puts the students on their mettle, partly because of an appeal to ego motives and partly because the possibility of slipping through the course without lack of application being noticed is much reduced. This use of tests to supply motivation is particularly important in schools where most students have little intrinsic interest in the materials taught, which is, unfortunately, the case in many Service schools.

When achievement tests are used in this manner to supply motivation, it becomes particularly important to build tests which measure exactly the ability which it is desired that the trainees learn. If the skills required by the test are equivalent to those required on the job for which men are being trained, the efforts of the trainees will be bent in the right direction. If, on the other hand, the tests measure only academic knowledge which is of limited practical

use, the efforts of the students are likely to be oriented to some extent in the wrong direction.

The use of achievement tests tends to improve the motivation not only of the students but also of the instructors. It is found in practice that instructors become extremely interested in test results for successive classes and strive to overcome the deficiencies that may be revealed by the first use of achievement tests. Well-designed achievement tests owe much of their value to the fact that they enable the instructor to diagnose his weak and his strong points. The tests should be divided into specific areas to show the instructor where he has failed to teach his men adequately and in what areas he is most successful.

17.1.2 Achievement Tests Improve Advanced Classification

The achievement test scores assigned to the men in a given school should, if the tests are carefully prepared and administered, furnish valuable information for the later assignment of men to specific billets. Present practices in Navy classification centers call for assignment of men largely on the basis of rate, plus other information (including Basic Classification Test Battery scores) which is recorded on the Q-card. More valuable information would be the actual proficiency of men in various skills. In balancing crews for a number of destroyers, for example, it would be extremely helpful to know the number of errors made by radiomen in receiving message-type material at 22 words per minute. This is exactly the type of information that is provided by good achievement tests.

17.1.3 Achievement Tests Aid in Validating Recruit Classification Procedures

Those individuals whose responsibility it is to devise methods of selecting recruits for assignment to the various Service schools have faced a difficult problem: how to evaluate the success of their methods of selection. It is possible that selection was sometimes better than the correlation with Service school success

showed it to be; because Service school success was sometimes based on one type of examination measuring only part of the abilities the school was interested in developing. More often, methods of selection were not as good as they appeared, because the criterion was the same type of pencil-and-paper test which had been used several months previously as the method of selection.

The work in recruit classification was often handicapped by the lack of good achievement tests to use as a criterion measure. Adequate achievement testing procedures to use as the basis of Service school grades would greatly further the work on evaluation of recruit classification methods.

17.1.4 Achievement Tests Make Instruction More Uniform

The use of achievement tests furnishes an opportunity for a general evaluation of the success of the training program. How well the aims of a curriculum are being satisfied can be determined only by putting the trainees in standardized situations in which they are required to demonstrate unequivocally the extent to which they possess the knowledge and skills which the course was organized to teach.

Standardized tests of achievement are particularly useful in determining whether or not various schools of similar type are giving uniform training. When schools are widely separated geographically, it is difficult to tell, unless standardized achievement tests are used, whether all the schools are issuing graduates who are equally well qualified for a particular assignment. In the mass production of skilled workmen for military jobs, it is just as important that the products be standardized as in the production of interchangeable parts of automobiles. Achievement tests furnish a basic technique of evaluation which aids in bringing all schools of a certain type up to a uniform standard of achievement.

By means of tests it is possible to evaluate not only the success of the teaching methods but also, provided the tests are developed from the point of view of proficiency in the duty for

which the men are being trained, the adequacy of the curriculum itself. An achievement testing program is thus seen to be essential for evaluation, and without continuing evaluation a training program is likely to succeed only within limits which are set by the personal idiosyncrasies of the individual instructors.

17.2 THE DEVELOPMENT OF ACHIEVEMENT TESTS

17.2.1 Types of Achievement Tests

The effects of training can best be measured by placing each trainee in a situation in which he will eventually have to work and there requiring him to demonstrate his ability to perform the tasks required in his eventual assignment. Methods by which his performance in that situation can be objectively and reliably measured have to be devised. It is further necessary that the testing methods be adapted to whatever limitations are imposed by such practical factors as time and availability of physical equipment.

The Applied Psychology Panel assisted in the development of achievement tests for such diverse schools as torpedoman, electrical, signalman, radioman, gunnery, and landing craft schools. The types of measures which were developed include pencil-and-paper tests, identification tests, product ratings, ratings of performance, and performance tests. This section concerns the procedures involved in test construction and includes a number of illustrations of the specific tests which resulted and the techniques which were found to be successful in handling problems of various types.

PENCIL-AND-PAPER TESTS^{16, 21, 22}

When the subject of achievement tests is introduced, everyone first thinks of the subject matter examinations so universally used in schools and colleges. Tests of this type are definitely limited in their usefulness in military training, where the aim is generally to teach *skills* rather than verbal knowledge. There are a few situations in which they are appropriate.

The conventional procedures for developing pencil-and-paper tests were ordinarily followed, the most common type of item being the multiple-choice with five choices. The procedure in general parallels that described in detail in the Summary Technical Report of the Applied Psychology Panel, Volume 1, Chapter 14, although in practice the need to get out a test rapidly sometimes precluded the possibility of performing as thorough and careful a job as would be possible in peacetime.

The first task in developing a test, whether it be pencil-and-paper or any other type, is to make a careful preliminary survey of the curriculum and the duties involved in the job for which men are being trained, as well as of the pertinent aspects of the testing situation. After the test specialist has a good understanding of what should be measured, he is ready to prepare test items for an experimental form of the test. The content of the item should be chosen particularly from the point of view of its contribution to the validity of the test. If a test is being developed for torpedomen, items of information which are of importance in the actual assembly and adjustment of torpedoes would be chosen. For example, knowledge of the tolerances used in adjusting bearings would be included rather than information on the composition of alloys used in torpedo parts. The distractors should be carefully considered to avoid ambiguities and to test distinctions that are important and of suitable difficulty.

In working with Service school instructors, it is frequently found that they prefer true-false and completion items because these types are comparatively easy to make up; and they tend to dislike multiple-choice items because they consider them too easy. The type of item chosen should of course depend upon the merits of the particular situation; but in many cases multiple-choice items are preferable because they can be scored more accurately and reliably than completion items and because they are less affected by chance factors than the true-false. In a comparative study of item types in a signalman school it was shown that the multiple-choice items were not necessarily easier than completion items and the chance factors were less important than the instructors had

thought. This finding resulted in a more favorable attitude toward the multiple-choice form. Good results were also obtained with matching items.

The experimental test should be tried out on a sample representative of the population for which it is intended, and a revision then made on the basis of a statistical study of the data obtained. After the revised form of the test has been tried out and found satisfactory, norms can be developed and the test put into general use.

Ordinarily several forms of a test are needed in order to prevent students from passing on to following classes the specific content of the examination. As an aid to the development of alternative forms of examinations, it is recommended that item files be prepared. The items can be typed on cards, together with information on the difficulty and validity of each item. After a sufficient number of items has been collected, new equivalent forms of the test can easily be prepared by selecting items which have the proper distribution of difficulty values, a satisfactory correlation with the total-test score, and equivalent coverage of the topics of the course.

IDENTIFICATION TESTS^{2-6, 16, 17, 22}

A type of achievement test which is somewhat similar to a written test is called an identification test. This type of test is appropriate for use in training situations where it is important for men to have a good understanding of the principles of operation and the nomenclature of a piece of equipment. In administering an identification test, various parts of the equipment are laid out on tables about the testing room, and a card is placed near each part. Each card contains a list of part names and a list of statements describing possible uses or functions of the parts in the operation of the equipment. The trainees are then required to go to each such station and choose from the first list the correct name of the part and from the second list the statement which correctly describes the use or function of the part. Such a method permits the testing of a large number of men simultaneously on a considerable amount of material in a relatively short time,

and it has the advantage over a pencil-and-paper test that the actual parts are at hand where they can be picked up and examined by the trainees.

The first step in the development of an identification test is to choose 25 to 50 parts of a piece of equipment which are important in that their names and functions should be familiar to trainees. Usually parts are chosen which can be removed from the equipment; but sometimes it is preferable or necessary to leave the parts installed and to identify them with tags.

After the parts have been chosen, the next step is to make up the lists for the test. One list pertains to the name of the part and the other to its function. It is of course possible to use more than two lists. Other lists might pertain to methods of adjustment, methods of making repairs, or to the type of equipment from which the part was taken. The main problem in making up these lists is to choose suitable distractors, so that the student is required to make important distinctions in choosing his answer. It is recommended that two or three extra distractors be used in experimental tryouts of the test, so that the best distractors can be chosen on the basis of a statistical study of the results. The procedures to be followed in developing and revising an identification test would in general parallel those described in the Summary Technical Report of the Applied Psychology Panel, Volume 1, Chapter 14.

As many men can be tested at one time with an identification test as there are items in the test. If it is necessary to test more men at once, duplicate sets of equipment must be prepared. In administering the test, the parts are laid out in a continuous pattern on tables. A man is stationed at each part and the test begins, each man starting the test with the item where he happens to be stationed. About 1 minute is allowed to record the answers, and then all the men move to the next item. To reduce opportunities for cheating, it has been found advisable to lay out the parts and cards so that each man must move to the *second* station to his right in order to reach the next consecutively numbered item; then the men on each side of any student are working on a part of the test which he will not reach until the second round

of the tables. The only requirement for this scheme to work successfully is that there be an odd number of items, so that by answering the questions at every other station the test is completed after two rounds of the tables.

A typical identification test card with the associated gun parts pictured in Figure 1. Figure 2 shows students taking an identification test based on the parts of a 40 mm gun.

PRODUCT RATINGS¹³

In some Service schools, men are trained to make objects, usually of metal, to certain specifications. In such cases it is appropriate to measure proficiency on the basis of the quality of the products turned out by the trainees. In class P engineering schools, for example, considerable attention was given to training in the use of hand and machine tools. The shop work involved the construction of samplers, which were metal objects constructed to specifications. Good proficiency was indicated by samplers which conformed to these specifications. The grading was based on such factors as accuracy of layout and workmanship, eccentricity of curved surfaces, flatness of flat surfaces, and the relationships among the parts of the piece.

The evaluations of the samplers by instructors, using combination squares, were found to result in scores of very limited range and of low reliability.¹³ The application of analysis-of-variance techniques to the ratings of one set of samplers by four instructors indicated that the variance due to variation among the instructors was almost twice as large as that due to variation among the samplers. The correlations between ratings made by different instructors ranged from $-.11$ to $.55$. Obviously some standard procedure for rating the samplers was needed in order to measure proficiency reliably and in order to yield scores of a great enough range to represent adequately the range in ability of the group.

After trying out several mechanical devices for measuring the important variables of the samplers and investigating their reliability, it was found that a set of taper gauges was most successful. One of these gauges, with the sampler which is being rated, is shown in Fig-

ure 3. In this case the gauge is tapered to measure the hole in the sampler. A taper of $\frac{1}{8}$ inch per foot was used, and calibrations were placed to yield unit differences in score for each 0.05-inch variation. When samplers were rated by means of a set of four such gauges, the intercorrelations between ratings made by different instructors went up to $.93$ and $.94$.¹³ Correlations between ratings made by the same instructor, 10 days apart, varied from $.97$ to $.98$. The spread of scores was greatly increased over the original method in use by the school. The gauges thus yielded scores of high reliability and satisfactory spread. The instructors felt that the ratings were valid in that important aspects of the skill were being measured. Furthermore, the ratings could be made more quickly with the gauges than with the older methods.

Other types of gauges were also developed. One (shown in Figure 4) is a type of caliper gauge; the movable pointer indicates on the scale the extent to which the distance between shoulders on a turned rod departs from specifications.

RATINGS OF PERFORMANCE^{15, 22}

In the case of some skills taught in Service schools, there is no tangible product which can be rated, or the quality of the performance itself is of greater significance for evaluation than is the final product. In such cases, methods have been worked out by which an observer can evaluate the performance while it is going on. By means of special rating forms and procedures, the ratings obtained are more valid and reliable than those based merely on a casual overall judgment. Ratings of performance were infrequently used by Panel projects as measures of achievement, since it was felt that performance tests (which will be discussed next) were generally preferable. Ratings were used in a few cases where practical considerations made it difficult to administer performance tests.

In deciding what specifically is to be evaluated in the performance ratings, the psychologist is guided by the same considerations as were described for other tests: the objectives of the curriculum and knowledge of the duties

involved in the billets for which men are being trained. The performance rating is simply a device to aid in objectifying judgments of the quality of performance on the job. The trainee

rately, as described in the items of the rating scale.

In planning the rating scale, the psychologist selects separate traits for rating which will

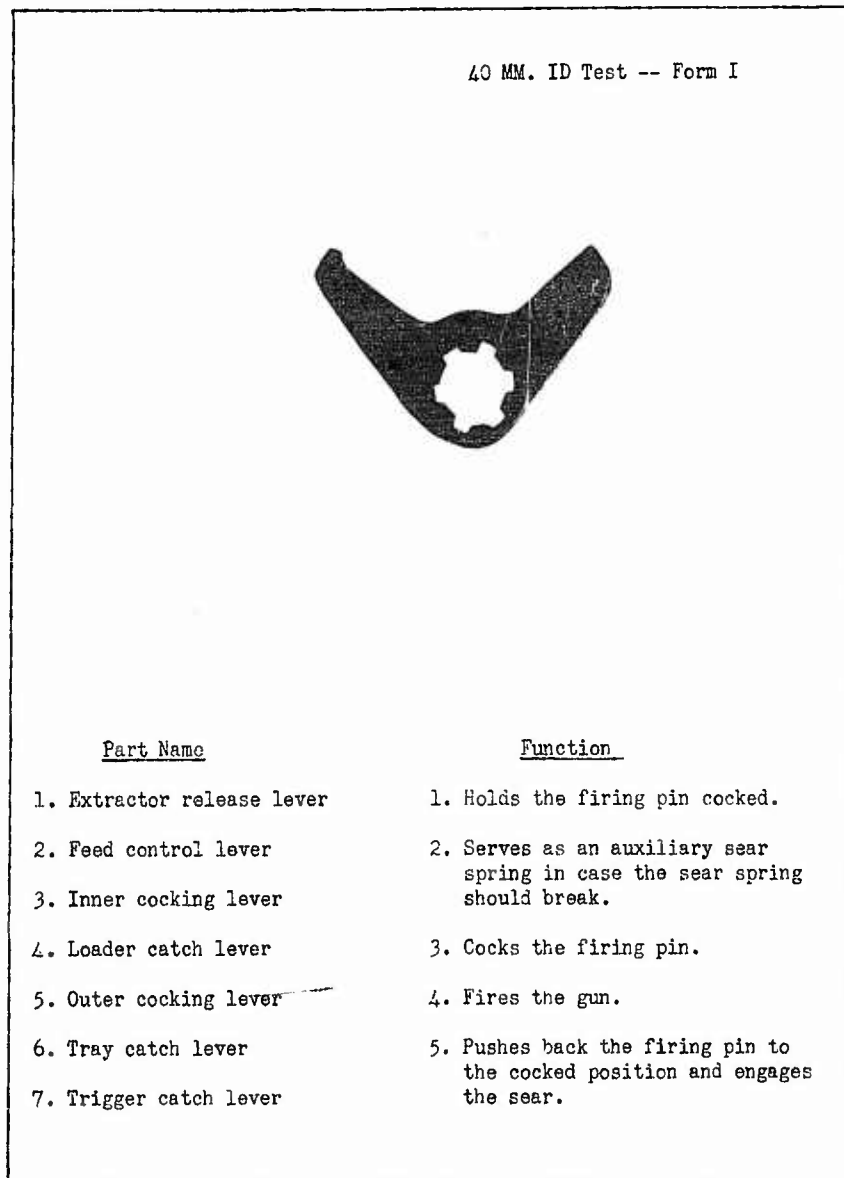

FIGURE 1. Identification test card.

should be observed at work under conditions which are as far as possible standardized. Various aspects of his behavior are evaluated sepa-

not only lead to valid measurement but which are also as objective as possible. Each trait is carefully defined for the rater. Probably a

RESTRICTED

graphic rating scale, on which certain points are defined by descriptive statements, is in general most satisfactory. Each trait should, as far as possible, refer to an independent aspect of proficiency.

It is equally important that the raters be

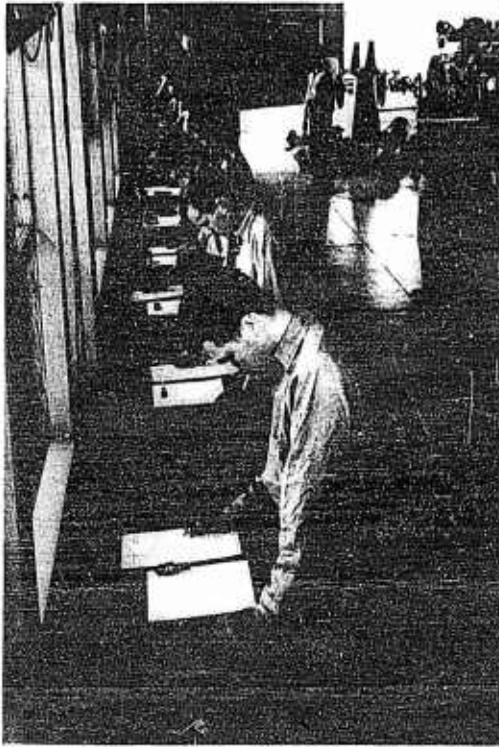

FIGURE 2. Class taking an identification test.

adequately trained before their ratings are accepted for reporting school grades. The common errors in rating are well enough known without discussing them in detail. The training of raters should include cautioning against such errors as halo effect and leniency and discussions of the distributions of abilities, overrating, and prejudice. The scale itself should be explained carefully. Without such training of raters and follow-up studies of their ratings, the use of this technique of evaluation is of limited value. Each trainee should be rated by five or more instructors in order to improve reliability of ratings. The score is then based on an average rather than on the opinion of any one instructor.

A different approach was used by one of the

Panel projects in developing a rating scale.¹⁵ The problem was to develop a criterion for evaluating proficiency of LCVP coxswains; the rating device was of course suitable also as a measure of achievement in the landing craft school where it was developed. The evaluation of coxswain proficiency by means of a test was not considered practicable because of the difficulty of standardizing test conditions. Variability in mechanical efficiency of boats, in smoothness of the beach, and in direction, level, and roughness of the surf made it impossible to give a performance test under standard conditions.

The rating scale that was developed is shown in Figure 5. The scale value of each item was obtained by a method similar to that used by Thurstone in constructing attitude scales. The score is obtained by averaging the scale values

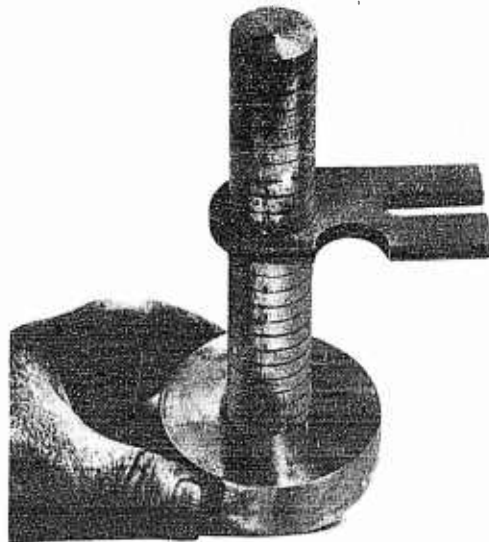

FIGURE 3. A taper gauge in use. The accuracy of the sampler is determined by inserting the taper gauge into the hole in the sampler.

of the statements which the rater indicates are true of the coxswain being judged.

In actual use, the form shown in Figure 5 was filled out by a trained rater who rode in the boat with the coxswain. Ratings were made each day that observations could be made, and later the raters summarized their reports on a summary sheet which was similar to the one

shown. This summary sheet was the one which was actually scored.

It was found that the reliability of the scale, as measured by the correlation between ratings made independently by two raters, was only .60 when the ratings were based on only one

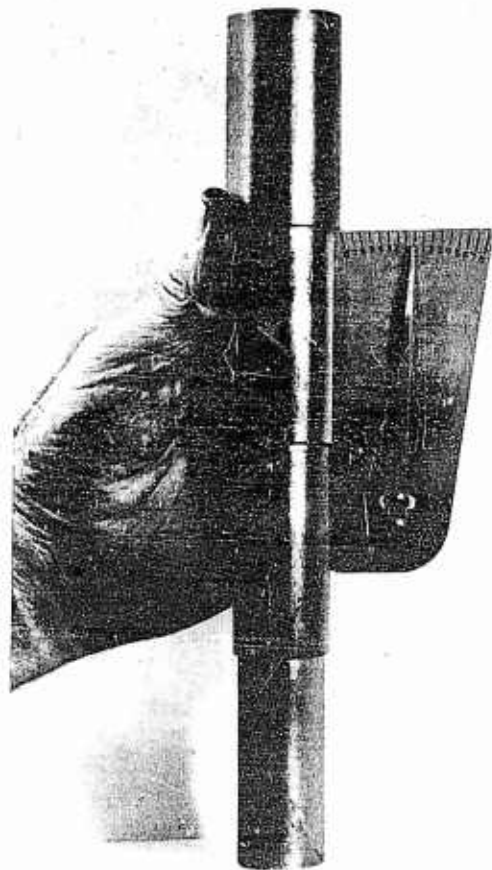

FIGURE 4. A caliper gauge in use. The accuracy of the spacing between shoulders on the sampler is being measured.

observation. However, when ratings were made on the basis of two daily observations, the reliability went up to .83. With more daily observations, it would be expected that reliabilities approaching .90 or even higher could be obtained.

PERFORMANCE TESTS^{7-11, 16, 18, 19, 22-29}

The most important technique for evaluating proficiency in many military training activities

is the performance test. Here the trainee is required to carry out under standard conditions a task typical of those he will be required to do in his later assignment. The trainee's score depends upon success or failure in each of various parts of the total task or upon other objective indications of proficiency. Some typical performance tests devised by Panel projects measure proficiency in disassembly, assembly, and adjustment of a .50 caliber Browning machine gun; lighting off a searchlight; calibrating the depth control mechanism of a torpedo; and steering assigned magnetic courses, using a magnetic compass and a deviation card.

Performance tests would usually be expected to yield the most valid type of evaluation in military training, where the objectives are most commonly to develop skills rather than to teach facts. The tests should be designed to measure proficiency in those duties which are most important in determining success or failure in the jobs to which the trainees are to be assigned.

After the job to be tested has been decided upon, the next problems are to devise ways and means of presenting that task to students under standard conditions and to devise methods of objectively determining the degree of proficiency shown in performing the task.

Certain difficulties are commonly encountered in developing performance tests.^{16, 22} One common handicap is lack of sufficient equipment; another difficulty, which is obviously related to the first, is the limitation on amount of time available for testing. It is also found that instructors sometimes object to testing one man at a time when the jobs are more commonly performed by teams. All these difficulties and others can usually be overcome by exercise of a little ingenuity and by carefully analyzing the jobs.

The problem of scarcity of equipment can in some situations be overcome by breaking a large piece of equipment down into sub-assemblies. A gunners mate school might not have more than two 5"/38 guns for a class of 50 students, which would seem to limit the testing to two students at a time. However, more students can be accommodated by removing subassemblies such as the firing mechanism

RESTRICTED

and the breechblock.⁷ Two students can work at the firing mechanisms, two at the breechblocks, and at least two on other parts of the two guns. This permits eight instead of two students to work at one time, and by having the men rotate from station to station the same jobs can be performed by all the men.

Time is saved through using subassemblies, since more students can be tested at once.

total job can be used in testing different classes, so that each class must be prepared for any portion of it.

Some jobs require teamwork because the parts to be moved are too heavy for one man to handle. In some such cases the job can still be presented as an individual test by using a job sample that includes all the task except the actual lifting of the heavy part. For ex-

Project N-117b
COXSWAIN PERFORMANCE CHECK LIST

NAME _____ SERVICE NO. _____ RATE _____
Fill out one of these sheets for each coxswain during each day of the observational experience. Try to observe each man on each point in the list. For each point that you observe to be *TRUE* about a man, circle "T" after the statement. For each point that you observe to be *NOT TRUE* about a man, circle the "NT." If you have not had a chance to observe a man on a point, or if you are completely unsure concerning a coxswain's performance on a point, circle the "?."

COMING ALONGSIDE

- 1. Placed boat in proper position under net T NT ?
- 2. Used too much speed in coming alongside T NT ?
- 3. Judged speed and distance well T NT ?
- 4. Coordinated use of wheel and throttle well T NT ?
- 5. Approached ship at incorrect angle T NT ?

BEACHING AND RETRACTING

- 1. Overrode breakers T NT ?
- 2. Changed course of boat inside breaker line T NT ?
- 3. Failed to hit the beach hard enough T NT ?
- 4. Raced motor when boat was grounded with little water astern T NT ?
- 5. Timed application of power so as to take advantage of incoming waves, while retracting T NT ?
- 6. In retracting, tried to turn boat while still inside the breaker line T NT ?
- 7. Backed at too high a speed after flotation was gained T NT ?
- 8. Controlled swing of bow well while retracting T NT ?
- 9. Regulated speed of boat well so as to avoid full impact of breakers, while retracting T NT ?
- 10. Tended to overcontrol with the wheel T NT ?

GENERAL

- 1. Failed to react quickly when some action had to be taken T NT ?
- 2. Is throttle happy T NT ?
- 3. Has the feel of the boat T NT ?
- 4. Tended to make errors in which he had previously been corrected T NT ?
- 5. Tended to freeze controls in emergency T NT ?
- 6. Failed to take wind and sea into consideration in maneuvering boat T NT ?
- 7. Seemed afraid of heavy surf T NT ?
- 8. Made an error or errors in keeping proper distance in formation T NT ?
- 9. Judged relative speed in formation poorly T NT ?
- 10. Became upset and handled boat poorly in tight spots T NT ?

ADDITIONAL COMMENTS

FIGURE 5. Check list for evaluating proficiency of LCVP coxswains.

Further time can be saved by eliminating much of the routine assembly of nuts and bolts, which will often not be the significant part of the job. Time can also be saved by selecting *samples* of the total job. If the job is a long continuous operation, such as the overhaul and assembly of the main engine of a steam torpedo, separate jobs requiring about 10 minutes each can be selected as samples. Different samples of the

ample, one man can *prepare* to remove the barrel of a 40 mm gun; this involves all the crucial parts of the task, without the necessity of actually lifting out the barrel. In other cases it is possible to have a test proctor or a student assistant ready to help on those steps that one man cannot perform alone.

The actual evaluation of proficiency in the task usually involves the use of some sort of

check list which is filled out by a proctor who observes the work of the trainee. In some cases it is found that advanced students can, after suitable indoctrination, perform satisfactorily the duties of the proctors. This expedient must together with space in which the proctor can indicate success or failure on each step. When appropriate, time may also be used as a factor in scoring the test. In some cases differential weights are assigned to check-list items on the

RECORD SHEET

		Raw Score	Navy Grade
20 MM PERFORMANCE TEST			
NAME _____		CLASS _____ BILLET No. _____	
			TIME
<i>STATION A</i>			
Proctor's Initials	1. Remove trigger plunger and spacer.	1. Yes	No
	2. Reassemble the trigger mechanism.	2. Yes	No
	3. Remove magazine interlock carrier spring.	3. Yes	No
	4. Reassemble magazine interlock mechanism	4. Yes	No
	5. Remove the D. L. S. lever spring.	5. Yes	No
	6. Reassemble the D. L. S. mechanism.	6. Yes	No
<i>STATION B</i>			
Proctor's Initials	7. Remove the barrel from the gun.	7. Yes	No
	8. Replace the barrel.	8. Yes	No
	9. Remove the breech face piece.	9. Yes	No
	10. Replace the face piece.	10. Yes	No
	11. Cock the gun.	11. Yes	No
	12. Uncock the gun.	12. Yes	No
	13. Place a magazine on the gun.	13. Yes	No
	14. Remove the magazine from the gun	14. Yes	No
<i>STATION C</i>			
Proctor's Initials	15. Remove parallelogram spring box.	15. Yes	No
	16. Remove parallelogram.	16. Yes	No
	17. Remove trigger hook & trigger hook holder.	17. Yes	No
	18. Reassemble the whole group.	18. Yes	No
	19. Remove hammer.	19. Yes	No
	20. Remove striker pin.	20. Yes	No
	21. Remove breech face piece.	21. Yes	No
	22. Reassemble the gun.	22. Yes	No
Number of No's circled			
		Total Time	
3 times number of No's circled			

FIGURE 6. Record sheet for 20 mm performance test.

sometimes be resorted to when the number of available instructors is too small. When student proctors are used, they should be carefully trained and supervised by instructors.

The check list itself is usually a list of the operations which the trainee should perform correctly in completing the task assigned him,

basis of their importance as judged by competent authorities.

In developing a performance test, it is usually desirable to try out the first version on a few students in order to test the feasibility of the plan, determine time allowances, and check the adequacy of the directions and check list. If

necessary, revisions are made, and the new test tried out on a whole class. The test may then be studied statistically to determine its reliability and the distribution of scores. When the test has reached a state of development such that no immediate revisions are contemplated, a manual of directions for administering and scoring the test should be prepared, to ensure standard procedures when given by dif-

. . . Reassemble the trigger mechanism. . . . Remove the magazine interlock carrier spring. . . . Reassemble the magazine interlock mechanism. . . . Remove the double-loading stop lever spring. . . . Reassemble the double-loading stop mechanism." These jobs are all performed at one station. The student then moves to two other stations where he performs other jobs. The record sheet on which the proctor records

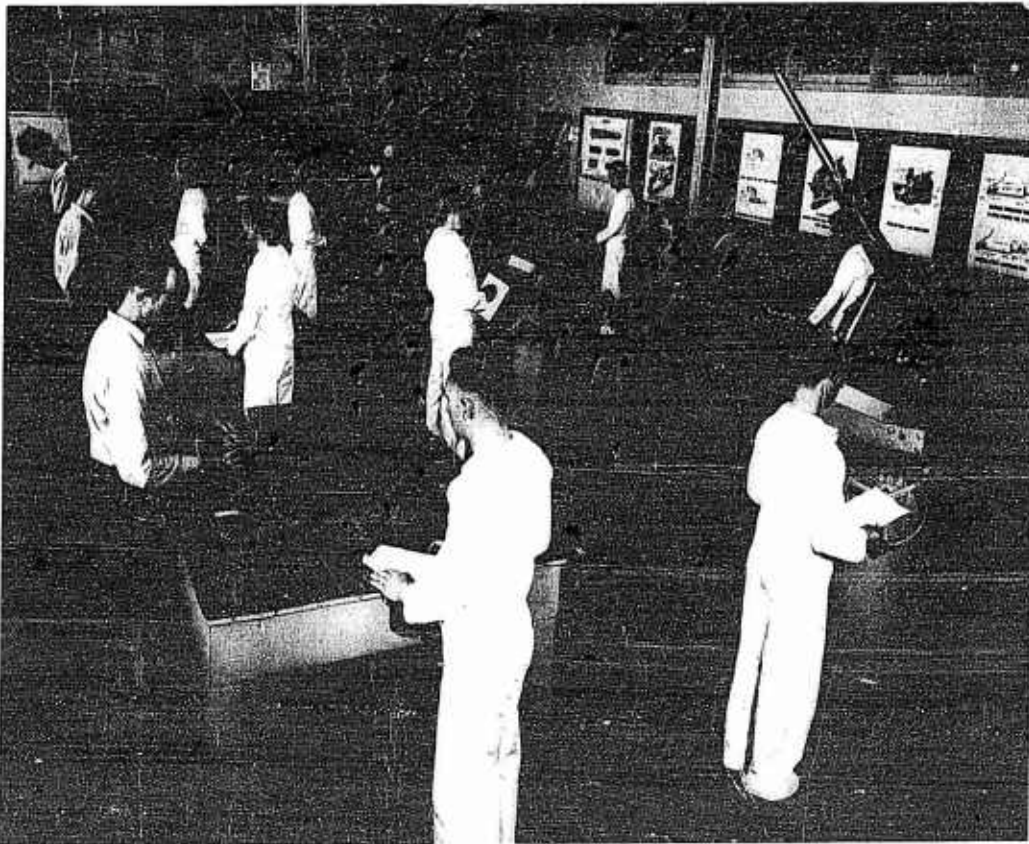

FIGURE 7. Class taking 20 mm performance test.

ferent instructors and to aid in its introduction at other schools of a similar type.

In order to illustrate the types of tasks which have been included in performance tests for various types of schools, some of the tests are described briefly below.

In a gunners mate school, a student is stationed at a 20 mm gun which is off the mount.²⁰ He is assigned the following jobs by the proctor: "Remove the trigger plunger and spacer.

his observations is shown in Figure 6. Figure 7 shows this test being given in a gunners mate school.

In an electrical school, one of the tasks is to light off a searchlight.²¹ The searchlight has previously been prepared by throwing it out of adjustment in various specified ways. The proctor tells the student, "Check to make sure the searchlight is ready for operation, then light it off." The complexity of the job is indicated

RESTRICTED

by the record sheet for this test, which is shown in Figure 8.

A typical record sheet for a torpedo performance test is shown in Figure 9.¹⁸ A Mark 13 main engine, ready for the installation of the number two turbine, is placed on a stand. The student is given directions: "Install the number two turbine and adjust the clearances between the turbines."

17.2.2 Developing Efficient Procedures for Test Administration^{16, 22}

An achievement testing program, to be effectively used, must not only result in evaluations of proficiency which are valid and reliable but must also fit in well with instructional schedules. For efficient use, the measures should be capable of administration in a relatively short time without the necessity for large numbers of trainees standing by awaiting their turn to be tested. Considerable attention must therefore be given to problems of developing efficient procedures for test administration.

Adequate planning of the testing schedule well before the time of test administration will help considerably in avoiding undue interference with teaching activities. If arrangements can be made well in advance, it is usually possible to make sure that the necessary equipment will not be needed for teaching during the time of the examination. Similarly, it should be possible to avoid conflicts with regard to space for testing by suitable rearrangement of teaching schedules when necessary.

Another problem is how often tests should be given. The solution will depend upon the nature of the situation involved. In torpedoman schools it was decided that "period" tests should be given covering the work of successive 4-week periods, and a final test should be given at the end of the course.²² Examinations of three types were used: pencil-and-paper, identification, and performance. In gunners mate schools, tests of all three types were given at the end of each week during which instruction was given on a particular gun, and final tests of all three types were given at the end of the course, covering all the guns studied.¹⁰

Achievement tests, particularly performance tests, have considerable instructional value. In some types of training a very large proportion of the time, perhaps as much as 90 per cent, could well be spent in testing. In typing classes, for example, testing and drill are easily combined to good advantage. In a landing craft school it was recommended that tests be given several times a week in such subjects as flag hoist, identification of buoys, and maneuvering signals.

In a gunners mate school, considerable time was actually saved in test administration while providing a superior testing program.¹⁶ The weekly tests previously in use by the school consisted of a written test and a so-called practical test. The practical test was given by an instructor to students in a group gathered about a piece of equipment. He would point to a part of the gun and ask some student to name it and describe its function, then do the same for other students, pointing to different parts. From a half to a whole day would be spent in this way, during which each student might be asked only eight or ten questions. The questions differed from student to student and there was no objective way of recording or evaluating the responses. In addition to this practical test, all of Saturday morning was reserved for a written examination. From 1 to 1½ days were thus devoted to testing on the material taught during the remainder of the week, and the testing methods were of a sort which had neither great instructional value nor reliability.

When the work of the Panel project was completed in the same school, all the testing was done on Saturday morning. Three tests were given on each gun: a pencil and paper, an identification, and a performance test. The administration of the tests was coordinated in such a manner that students were kept busy nearly all the time. The scheme which was introduced is illustrated in Figure 10. Under this procedure, the entire class assembled and half the class was sent to another room for the identification test. The rest of the class worked on the written test, and meanwhile small groups, of a size which could be accommodated by the performance test, were sent out one

after another to take the performance test. When the identification test was finished, the students returned and began work on the written test, and the same students were later sent out in groups to take the performance test. In addition to saving considerable time, the new tests were more reliable and permitted a more thorough coverage of the material than was possible under the old method. Schemes of this type can easily be devised to permit the

RECORD SHEET

Test DC-9

Raw Score

LIGHTING OFF A SEARCHLIGHT

Navy Grade

NAME _____ SECTION _____ BILLET No. _____

"CHECK TO MAKE SURE THE SEARCHLIGHT IS READY FOR OPERATION; THEN LIGHT IT OFF."

- | | | |
|--|-----|----|
| 1. Secured the training stowing lock before opening rear door | YES | NO |
| 2. Secured the elevation stowing lock before opening rear door | YES | NO |
| 3. Opened rear door. (Do not permit student to open rear door until stowing locks are secured.) | YES | NO |
| 4. Loosened hand clamps nearest hinge first | YES | NO |
| 5. Locked rear door in open position | YES | NO |
| 6. Adjusted positive carbon to project about 1/2" before closing rear door | YES | NO |
| 7. Adjusted negative carbon for an arc length of about 1" before closing rear door | YES | NO |
| 8. Engaged feed rollers on positive carbon before closing rear door | YES | NO |
| 9. Engaged feed rollers on negative carbon before closing rear door | YES | NO |
| 10. Checked positive and negative terminals on lamp before closing rear door | YES | NO |
| 11. Brushed dust from the magnifying glass before closing rear door | YES | NO |
| 12. Brushed dust from glass on top of control box before closing rear door | YES | NO |
| 13. Checked holding key which secures lamp in drum before closing rear door | YES | NO |
| 14. Secured rear door. (Do not permit student to secure rear door until feed rollers are engaged and carbons are properly adjusted.) | YES | NO |
| 15. Secured hand screw clamps opposite hinge first | YES | NO |
| 16. Opened door on arc image screen before closing arc switch | YES | NO |
| 17. Opened door on peep sight before closing arc switch | YES | NO |
| 18. Closed iris shutter before closing arc switch | YES | NO |
| 19. Closed arc switch. (Do not permit student to close arc switch until doors on arc image screen and peep sight are opened and iris shutter is closed.) | YES | NO |
| 20. Removed lamp mechanism cover | YES | NO |
| 21. Adjusted spring tension on negative carbon control | YES | NO |
| 22. Disengaged positive feed rod | YES | NO |
| 23. Adjusted lamp to focus arc | YES | NO |

"SECURE THE SEARCHLIGHT."

- | | | |
|---------------------------------|-----|----|
| 24. Opened arc switch | YES | NO |
|---------------------------------|-----|----|

(Raw score = number of YES's which have been circled.)

Proctor's
Initials

FIGURE 8. Record sheet for lighting off a searchlight.

The men who did not take the identification test were later sent to take that test, having in the meantime completed the written and performance tests. The interruptions of the written test were not important since the test was of the objective type. simultaneous administration of tests of various types. The general principle is to provide a pool of men engaged in some activity from which men can be drawn as needed for the shorter test which cannot be given to all men at once. Sometimes men are taken singly or in

RESTRICTED

E 5. Performance Check List.

Score

INSTALLATION OF No. 2 TURBINE SPINDLE

CLASS _____ BILLET No. _____ NAME _____

Proctor _____

Mark 13 main engine, supported in stand, ready for installation of No. 2 turbine. Turbine wheel secured on No. 2 spindle, and wheel alignment correct. Tools and other engine parts laid out on convenient bench or tool rack.

Tools: 54, 227, 228, 229, 231, two 424's, 454, WE 5, grease, extra balls.

Scoring: When two items in a line are to be scored separately, two numbers are printed in the column at the right

If item is correct, circle the corresponding number in the score column (e. g. ①).

If item is incorrect or omitted, cross out the number, (✕).

DIRECTIONS TO STUDENT: "INSTALL THE NUMBER TWO TURBINE AND ADJUST THE CLEARANCES BETWEEN THE TURBINES. OMIT OILING PARTS EXCEPT WHERE IT WILL HELP TO HOLD BALLS IN PLACE."

Steps		Score
		A B
A. Insert No. 2 turbine spindle through No. 1 spindle and casing		1
A. Place holding clip over turbines without dropping one		1
A. Press pinion tight on shaft	B. Punch marks aligned	1 1
A. Loosen A-frame holding screws	B. Insert wedge in casing	1 1
A. Insert upper thrust washer before inserting balls		1
A. Insert spacer	B. Before inserting balls	1 1
A. Grease and insert balls	B. Knows correct number (12)	1 1
A. Position balls skillfully		1
A. Put in lower bearing race	B. Start threads carefully	1 1
A. Screw in only until turbines spread slightly		2
A. Insert 12 balls		1
A. Place outer thrust washer	B. Brass washer	1 1
A. Put on oil pump worm		1
A. "Mike" both 424's	B. Correct measure .060	1 1
A. Insert two 424's between turbines	B. Opposite one another	1 1
A. Adjust lower bearing race	B. Feel 424's for slight drag	1 1
A. Align nearest notch on race	B. By backing off bearing race	1 1
A. Remove 424's	B. Remove wedge	1 1
A. Lock lower bearing with locking lever and clamp bolt		2
"TO SAVE TIME, DON'T TIGHTEN THE BOLT."		
A. Tighten A-frame screws. (Stop man after first screw.)		1
"THAT'S ENOUGH. NOW DISASSEMBLE IT."		

(Proctor check disassembly before next testee arrives.)

FIGURE 9. Check list for installation of No. 2 turbine spindle.

RESTRICTED

groups from shop work instead of from a written test.

17.2.3 Characteristics of a Good Examination

Before embarking on a project of test development for measuring the effects of training, not only is it necessary to have some understanding of the general principles and techniques of testing but it is even more important to have a thorough knowledge of the duties involved in the billets for which men are being trained and of the curriculum of the training

the aims of the curriculum actually in use by the school. Such a method, however, can be successful only to the extent that the school curriculum has been well planned and successfully put into operation. A better procedure is to keep constantly in mind the ultimate goal of all military training—success in combat—and to choose tests which measure proficiency in the duties involved in the billets for which the men are being trained. If those duties involve, for example, maintenance of a gun during combat, the test had better be a performance test in which trainees are required to analyze casualties and repair them rather than a written examination dealing with such topics as muzzle velocity and weight of projectiles. If a man is being trained as a range setter on a 20 mm gun, he should be tested on his ability to estimate range of targets actually in the air rather than on his knowledge of such things as the number of yards at which the gun is effective. Knowing the number of yards is by no means equivalent to being able to estimate actual distances of targets. On the other hand, some shipboard jobs involve duties which can be tested most adequately by means of pencil-and-paper tests; for example, a signalman's knowledge of procedure can readily be measured by means of objective written examinations.

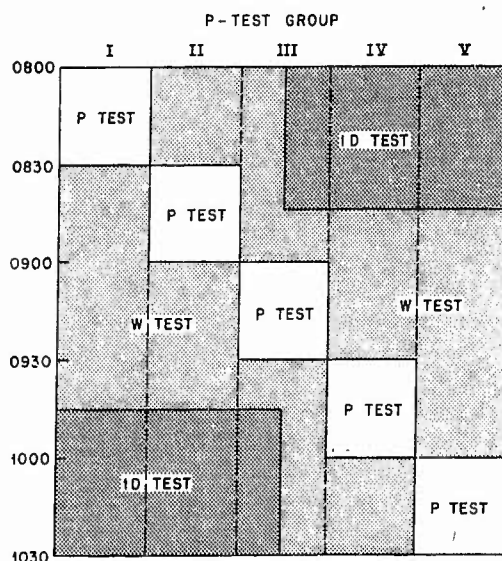

FIGURE 10. Plan for coordinating the simultaneous administration of written, identification, and performance tests to a class.

activity. After mastery of such essential background information has been acquired, one is ready to consider the specific problems involved in choosing the type of test which is to be used.

VALIDITY

The most important consideration is that the proposed achievement test be *valid*, that it measure the degree of proficiency attained by each trainee in performing the tasks which the school was designed to teach. In deciding whether or not a proposed test is likely to be valid, the test expert might use as his criterion

The validity of an achievement test can ultimately be checked only by investigating the relationship between the test scores and some measure of proficiency on the job to which the men are eventually assigned. The introduction of the tests in a school need not wait for this final statistical evaluation of validity, however. Initially the psychologist should trust his judgment as to the validity of a test, and if the judgment is based on adequate information concerning the duties for which men are being trained, he will ordinarily be able to produce tests which are superior to tests made up without careful consideration of the problem of validity.

FACE VALIDITY

The test should not only be valid in the strict sense of the word, but it should also *look* valid. One of the important reasons for using achieve-

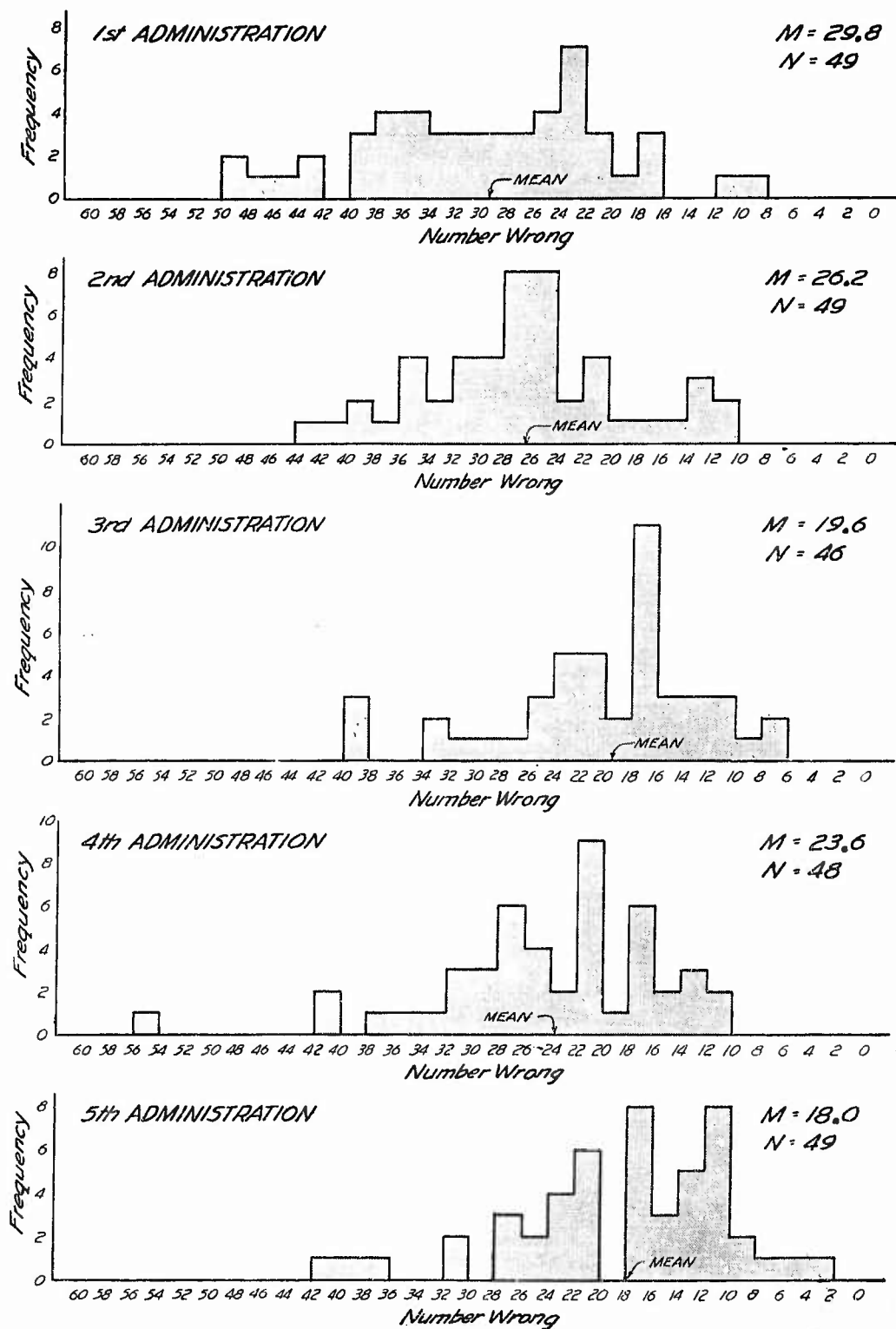

FIGURE 11. Improvement on small arms identification test.

RESTRICTED

ment tests is to supply motivation both for trainees and instructors. The test will better serve as an incentive if, in the eyes of students and teachers, it appears to measure abilities which are important in the performance of duties in combat situations. This appearance of validity is what is meant by face validity. It is worthwhile, therefore, to give some consideration to the possibility of setting up testing situations which simulate the actual problems and working conditions which will be encountered in combat.

RELIABILITY

Other things being equal, one would always choose a reliable test rather than an unreliable one, a reliable test being one which consistently yields the same scores when the measurements are repeated.

In practice it has been found that performance tests tend to be less reliable than most of the other types of tests.¹⁶ If enough items are included, pencil-and-paper and identification tests of acceptable reliability can quite easily be prepared. Product ratings of high reliability have been developed through the use of specially designed gauges.

The reliability of performance tests has usually been estimated by correlating random halves of the test. This method is not the most appropriate, since it really gives a measure of the homogeneity of the test. Test-retest correlations would be more appropriate, except that in most school situations the first test furnishes a significant amount of additional practice which influences the retest results. Subsequent discussions of the test by students also affect the retest performance. No entirely satisfactory method of ascertaining the reliability of performance tests has yet been devised.

The generally low reliability of performance tests, based on the correlation between halves, is partly the fault of the type of test and partly the fault of the training situation. Performance tests are generally made up of relatively few separately scorable units, and low reliability is a characteristic of any test made up of few, even though lengthy, items. The relatively low reliabilities of performance tests which have been observed are also a function

of variability in instructional procedures. A common practice in schools is to give precedence to military duties over school attendance; consequently trainees frequently miss a part of their instruction because of interruptions for guard duty. Pay day and even haircuts also are allowed to interfere with teaching at some schools. Other irregularities in the teaching program often occur because of losing or shifting instructors, inconsistencies in procedures from week to week, and laxity of supervision. Such irregularities are likely to influence one of the halves in the split-half correlation and not the other, thus lowering reliability. These factors may contribute to the unreliability of any test; but performance tests are particularly susceptible because they are made up of relatively few items.

It is recommended that the unreliability of performance tests should not be given too much weight in choosing types of tests. In many situations the other advantages of performance tests outweigh the disadvantage of lower reliability. Furthermore, with the improved instruction which is likely to result from the use of a program for evaluating teaching, some of the factors in the school which contribute to low reliability may be overcome. With careful developmental work accompanying studies of performance tests in use, it is then entirely feasible to improve the tests to the point where their reliability reaches a satisfactory level.

17.3 STUDIES OF ACHIEVEMENT TESTS

The extent to which the various achievement testing programs developed by the Panel have actually been successful in achieving the objectives stated in Section 17.1 has been studied in many of the training activities involved. The remainder of this chapter is devoted to a summary of the findings.

17.3.1 How Achievement Tests Increase Learning

The introduction of good achievement tests results in increased achievement. Tests moti-

vate the students to make increased effort, and they motivate the instructor by supplying him with information on the areas where improvement is particularly needed. An example is given from a gunners mate school.

When a performance test was planned for the 40 mm gun, one of the tasks considered for inclusion was that of replacing extractors, since a broken extractor is a common casualty on this weapon. The instructors objected, however, on the grounds that it was a job which

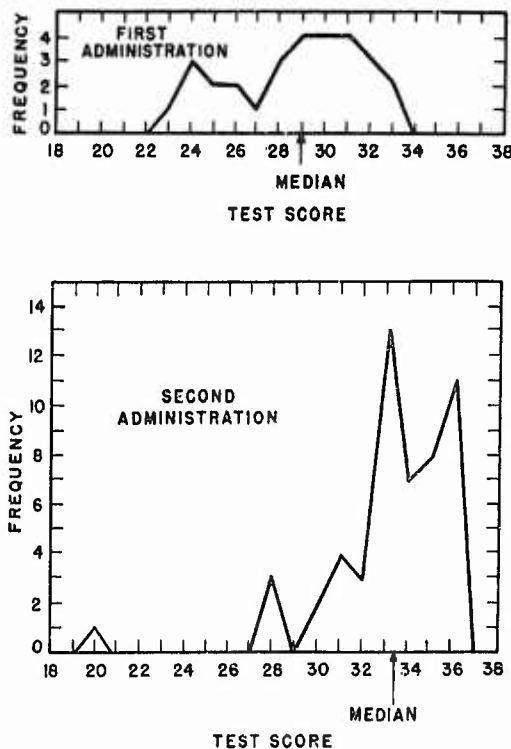

FIGURE 12. Frequency distribution of scores for first and second administration of a performance test on assembling turbine bulkhead leads. (Perfect score = 36.)

required several men and which would take too long to be feasible as a part of the test. The test was tried out, with a tentative 5-minute time allowance, and, as the instructors predicted, most students failed to complete it. The job was nevertheless included in the test, since it was considered an important one, and within a few weeks the majority of the men in a class could complete the job in the time allowed. The men in successive classes practiced until

the time required was reduced still more; some students completed the entire job in less than 2 minutes. Time was a factor in scoring the test, in spite of the objections of some of the instructors that the job should not be done rapidly. It was found that a speed score, being

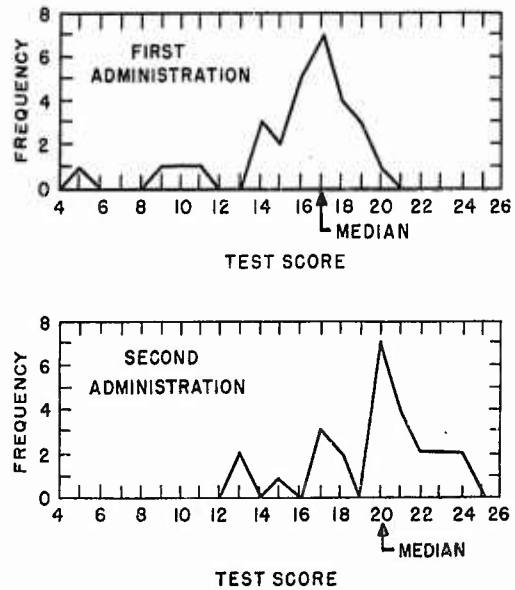

FIGURE 13. Frequency distribution of scores for first and second administration of a performance test on centering the depth steering line. (Perfect score = 24.)

an extremely objective measure of proficiency, served as an excellent incentive for students, and the competition that ensued resulted in a tremendous increase in amount of practice.

Many examples of this anecdotal type might be cited as evidence that the introduction of a good testing program results in improved achievement. The result is shown more conclusively, however, by data which were collected at various schools.

When achievement tests were introduced in one gunners mate school, it was found that scores on small arms tests were particularly low. A survey of the teaching methods showed that students were getting too many hours of lecture in proportion to the amount of time spent in disassembly and assembly of equipment. The school officers accordingly made plans for more effective use of equipment; one classroom was transformed into a shop. The

scores on the small arms identification tests for the first five administrations reflect the changed attitudes of instructors and students (see Figure 11).¹⁰ It will be noticed that the mean raw score (number of errors) was reduced from 29.2 for the first class that took the test to 18.0 for the fifth class. Since the two forms of the test were used on alternate weeks, the decrease in number of errors can hardly be attributed to students passing on to other students information about specific test items.

Figures 12 and 13 show the considerable amount of improvement that took place between the first and second administrations of torpedo performance tests.²² In the torpedoman school, various work samples were used as the basis for the performance tests, so that a particular test might not be given oftener than once a month. Thus several weeks intervened between the two administrations of each of these tests, during which different forms were used. The improvement is striking, and since even the instructors did not know the form of the test to be given on a particular week it undoubtedly reflects a general improvement in the quality of instruction.

Results similar to those cited are typically found in schools when an achievement testing program is introduced. School officers and instructors have frequently testified that tests have a high motivational value and that their use has improved instruction considerably. There seems little doubt that the use of achievement tests is justified solely on the grounds of their effect on achievement.

17.3.2 Effects of Achievement Testing on Validity of Selection Tests

The attempts to devise valid methods for predicting success in Service schools has been handicapped by lack of a good criterion of Service school success. Service school grades have frequently been based almost entirely on a composite of written tests and instructors' judgments of ability, petty officer qualifications, neatness, military bearing, and the like. Since the ratings frequently have smaller variability than the written tests, they were weighted less

than written tests in determining final school grade. It is therefore not surprising to discover that tests such as Reading and Arithmetical Reasoning predict school grades better than the mechanical tests even in such schools as gunners mate, basic engineering, and aviation ordnance. The criterion used may, therefore, actually contribute to the use of the wrong test for selection and the consequent selection of men for training who are not well qualified. The use of achievement tests provides a more trustworthy criterion for validating selection tests.

A comparison of the validity of the Basic Battery tests, using various criteria, can be made on the basis of the correlations reported in Table 1, which were obtained at a torpedoman school.²² When no standard achievement tests were used, the best tests for predicting final grades in torpedoman school were the General Classification Test [GCT] and the Arith-

TABLE 1. Validity of Basic Battery tests in a torpedoman school, using various criteria.

Criterion	GCT	R	AR	MAT	MK-MMK-E	
Final grades, classes having no standard achievement tests	.29	.26	.30	.21	.26	.18
Identification test scores	.18	.22	.24	.39	.53	.48
Performance test scores	.10	.23	.06	.34	.53	.42

metical Reasoning Test [AR]. These two selection tests in general correlated much lower with identification and performance tests, however; the best tests for predicting grades after the introduction of the achievement tests were the two mechanical knowledge tests. The correlations reported are average correlations for from six to nine classes. The choice of a test for predicting success in torpedoman school would clearly depend a great deal on the type of criterion used.

Unfortunately no before-and-after data are available which clearly show the effects of achievement testing on the pattern of validity

coefficients. However, the validities for Form 1 and Form 2 of the Basic Battery have been obtained separately for large samples, and it happens that Form 1 went into disuse before work was begun on achievement testing to any great extent. The data for Form 2 were obtained while achievement tests were being introduced, and the correlations were no doubt influenced to some extent by the achievement testing work. Table 2 gives the mean validity coefficients, corrected for range of talent (see Chapter 2), for basic engineering, electrical, gunners mate, and torpedoman schools. For these four schools, in which most of the

during which Form 1 was used was AR. When the new achievement tests went into use, the best test, as shown by the Form 2 validity coefficients, was MK-E, and the validity of AR dropped considerably.

With the grading methods which were in use during the time the Form 1 data were obtained, the mechanical tests were only slightly better than such tests as GCT, Reading, and AR for predicting grades in gunners mate and torpedoman schools. When the improved methods of measuring proficiency went into use, the superiority of the mechanical tests was considerably increased. These differences between Form 1 and Form 2 validity coefficients, which seem to be due mainly to the improved testing and grading procedures, have considerable significance with respect to the methods used in the selection of naval personnel.

TABLE 2. Mean validity coefficients, corrected for range of talent, for Form 1 and Form 2 of the Basic Battery.*

		GCT	Reading	AR	MAT	MK-M	MK-E	N
Basic engineering	Form 1	.52	.52	.63	.52	.46	.39	1,480
	Form 2	.58	.42	.50	.52	.62	.50	1,176
Electrical	Form 1	.52	.52	.59	.44	.35	.49	1,747
	Form 2	.48	.37	.49	.48	.36	.62	1,062
Gunners mate	Form 1	.38	.39	.31	.28	.40	.43	1,677
	Form 2	.38	.32	.31	.50	.56	.54	809
Torpedoman	Form 1	.32	.35	.28	.27	.39	.35	880
	Form 2	.29	.26	.24	.33	.54	.39	786

* The means were computed by transmuting each correct r to s and weighting on the basis of N .

achievement test work was done, the general pattern of change is a decrease in the validity of reading and arithmetical reasoning tests and an increase in the validity of one or more of the mechanical tests.

The case of basic engineering has been previously mentioned; because fairly good mathematics tests are relatively easy for instructors to make up, mathematics was found to determine in large degree the final grade. For Form 1 the highest correlation was between basic engineering grades and AR; for Form 2, the highest correlation was between basic engineering grades and MK-M, which seems much more reasonable from the standpoint of the curriculum. This increase in validity of MK-M seemed to be due mainly to the influence of the new performance tests and rating methods on Service school grades.

The results from electrical schools follow a similar pattern. The best test for the period

17.3.3 Using Achievement Tests for Quality Control

The records of well-constructed achievement tests provide a quality control section with the best available information on which to base judgments concerning the effectiveness of the training being given in Service schools. Achievement tests are reliable. They can be constructed to cover all major aspects of a training course. Results depend upon the work of the entire course. They are therefore much more satisfactory than the subjective impressions gained on a quick inspection tour.

Continuous records of the results of standardized achievement tests given to successive classes in a group of similar schools would provide reliable comparisons among the schools and objective evidence of any changes in the quality of graduates.

The following examples illustrate the type of information that good achievement tests can furnish a quality control officer.

MEASURING THE QUALITY OF TRAINING IN A LANDING CRAFT SCHOOL²⁸

Prior to the participation of a Panel project in developing achievement tests for the Land-

ing Craft School at the Amphibious Training Base, Coronado, California, no systematic methods of evaluation were in use. The training officer resorted to subjective judgments reported to him by his subordinates. In some cases these judgments led to erroneous conclusions.

The first 4 weeks of training at the school were given at Fort Emory, located a short distance away from the amphibious training base [ATB]; the students were stationed at ATB for the continuation of their training. Among the subjects taught was a course known as "ship to shore"; this included such topics as beach markers, buoys, flag hoist, maneuvering signals, and seamanship. The officer in charge of ship-to-shore training at ATB complained to the training officer that the trainees came to him from Fort Emory poorly prepared; they could not identify the beach markers, buoys, etc. Simple tests were later developed by the Panel representative for measuring achievement in these subjects. In the beach marker test, for example, each marker was exhibited and the student was required to choose from a list the meaning of that marker. The use of these tests disclosed that achievement was poorer after two weeks of "advanced" training at ATB than it had been at the end of the 4 weeks at Fort Emory.²⁸ The poor achievement that the ATB officer had complained about was apparently due to the type of training given at ATB rather than at Fort Emory.

A study of the situation revealed that the teaching consisted of giving essentially the same lecture to trainees at each class meeting. This resulted in fair achievement after 4 weeks; but when the students were sent to ATB, expecting advanced training, and found that they were given more repetitions of the same monotonous lecture, they apparently reacted negatively to the situation. At any rate, their achievement was markedly poorer. The solution which was suggested was to improve teaching during the first few weeks by such means as using tests as drill material, and then reducing the time spent on the subjects, giving only refresher drills a couple of times each week.

The test results showed that some sub-

jects, especially semaphore sending, were being taught effectively, while the teaching of other subjects failed almost completely. No student was found who could actually use a deviation card and magnetic compass to put a boat on a prescribed magnetic course. No student could receive simple messages by flashing light at the prescribed rate of four words per minute. These facts were not previously known by the training officer. Without achievement tests as a means of measuring the effects of training, it was impossible for the training officer to take the appropriate steps to ensure the production of uniform, well-trained crews of LCVP's. The number of men lost in amphibious assaults because the members of a boat crew failed to identify correctly a maneuvering signal or a landing point marker will never be known.

MEASURING THE PROFICIENCY OF RADIOMEN

The achievement tests devised by the Panel for use in radio schools were of two types: tests of proficiency in receiving plain language and message-type material at a prescribed rate²⁹ and performance tests for measuring proficiency in such tasks as tuning transmitters and receivers and operating direction finders. In addition, considerable assistance was rendered the schools in preparing pencil-and-paper tests dealing mainly with procedure.

In one of the Navy's class A radioman schools, students were required to stand several 4-hour watches in a room equipped with five different types of radio receivers.²⁰ The purpose of the installation was to train students to tune receivers; they were required to go from one type of receiver to another, tuning in stations and making the necessary adjustments to bring in the signals clearly. The school officers had surveyed this training situation and were apparently quite proud of it. A performance test on tuning each type of receiver was developed by the Panel. Tests were administered for the first time to students who had stood two 4-hour watches in the room. Each student was permitted to choose the receiver on which he had had the most practice. Of the 25 students tested, 16 failed the test completely; when required to tune in a particular station, they were completely ignorant of

the proper procedure. Apparently during their watches students had been merely turning dials until by chance a signal came in clearly. The procedures for tuning in a particular station were, in the opinion of the instructor, so easy and well known that it was not necessary to teach them. The situation had apparently existed for some time, and without the use of performance tests it might have persisted much longer, while the officers went on assuming that the students were being given adequate training.

At another radio school it was found, when performance tests were introduced, that students had never touched a direction finder set; at another, trainees were proficient in tuning the large-ship-type transmitters but had no idea how to tune the Navy's more widely used ultra-high-frequency crystal set. Sometimes the deficiencies were due to lack of equipment, but more often the equipment was not being utilized most effectively. The most common fault in instruction was for instructors to assume that men could do a job after a lecture on theory and a demonstration. The performance tests were extremely effective in pointing out the instances where men were inadequately trained in actually performing the important jobs of their later assignments.

EVALUATION OF TEACHERS

The evaluation of the effectiveness of different instructors is impossible when each makes up his own examination. The use of standardized tests therefore provides a means by which a school officer can evaluate his instructors, provided each instructor is responsible for the teaching of particular classes.

In a torpedoman school, one particular class made exceptionally low scores on one of the identification tests.²² The school officer suspected poor teaching, but the instructors insisted it was just a stupid class. Since the mechanical score of the Mechanical Knowledge Test [MK-M] was known to be the best predictor of identification test scores, a plot was made of identification test scores against MK-M scores for the "stupid" class and also for another class which had made much higher identification test scores. Figure 14 is a simplification

of the plot which was obtained; in Figure 14 the average identification test score is given for each MK-M score interval. The range of aptitude scores is the same for both classes, but the best-fitting regression line shows that men of a given level of aptitude made better scores if they were in one class rather than

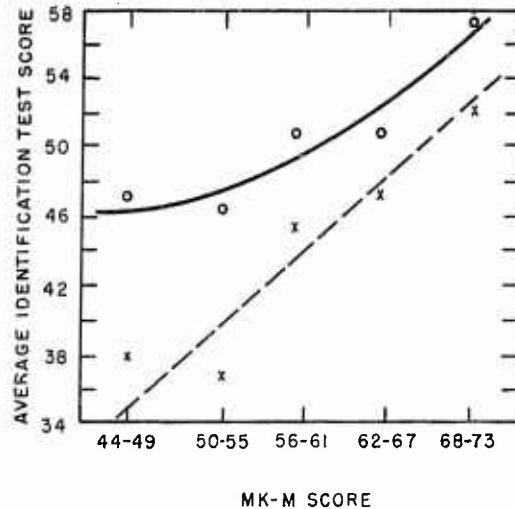

FIGURE 14. Plot of identification test score and scores on MK-M test for two different classes. Letter o = class with higher achievement scores. Letter x = class with lower achievement scores.

the other. The obvious conclusion is that instruction for one class was considerably better than for the other. Such a means of teacher evaluation has obvious implications regarding the training of instructors or the transfer of exceptionally poor teachers to other duty.

The use of an aptitude measure in the comparison of classes, as illustrated above, is necessary when small samples are involved. If data are available for a large number of classes, it can usually be assumed that large differences in aptitude are unlikely, and a comparison of mean scores should be sufficient to indicate which instructors are doing the best and which the poorest job of teaching.

IMPROVEMENT OF SERVICE SCHOOL GRADES¹

It is important for various reasons that the final Service school grades reflect as fairly as possible the extent to which each student has acquired the various skills and information

taught in a particular school. When school grades fairly represent the achievement of each student, student morale is likely to improve, the grades aid in making billet assignments, they can be used as a basis for comparing schools, and they become more useful as criteria for evaluating success of selection methods. The application of careful achievement testing methods makes possible the improvement of Service school grades so that such objectives may be attained.

A common fault of final grades in many Service schools prior to the introduction of improved achievement measures was that they depended too much on written examinations. These written examinations were in general more reliable and yielded a greater dispersion of scores than the measures of practical ability which were being used at that time. The result was that the written examinations were more highly weighted in the final grades than were the practical ability tests. A study of grades in a basic engineering school will illustrate this point.¹³

TABLE 3. Means and standard deviations of grades in mathematics, mechanical drawing, and shop and their correlation with final school grades.

	Mean		Standard deviation		<i>r</i>	
	Class 1	Class 2	Class 1	Class 2	Class 1	Class 2
Mathematics	83.6	83.4	7.7	8.5	.86	.88
Mechanical drawing	89.1	87.7	4.1	4.1	.74	.72
Shop	84.0	83.5	2.5	2.6	.48	.60

In the basic engineering school, four-sevenths of the time was spent in shop work, and the rest of the time was spent in classroom work, which included mathematics, mechanical drawing, and shop theory. A study was made of the grades of the men in two classes, a total of 690 students. Table 3 shows the means, standard deviations, and correlations with final school grade of the grades in mathematics, mechanical drawing, and shop. These statistics are given separately for the two classes. It will be noticed that mathematics grades had the largest standard deviations and that they have

the highest correlations with final school grades. The mathematics grades, which are based on only about one-seventh of the work, contribute a great deal more to the final grade

TABLE 4. Intercorrelations of written, identification, and performance tests and Service school grades* in class A NTS (gunners mate), Bainbridge, Maryland.

	Test	Identi- fication	Per- formance	Final school grade
Written	Browning machine gun	.36	.21	.61
	20 mm gun		.35	.75
	40 mm gun	.47	.25	.72
	5"/38 gun	.54	.14	.70
Identification	Browning machine gun		.30	.52
	40 mm gun		.21	.61
	5"/38 gun		.12	.68
Performance	Browning machine gun			.43
	20 mm gun			.42
	40 mm gun			.34
	5"/38 gun			.21

* For Browning machine gun, $N = 133$;
For 20 mm gun, $N = 125$;
For 40 mm gun, $N = 127$;
For 5"/38 gun, $N = 82$.

than do shop grades, which are based on four-sevenths of the work. This small contribution of shop grades to final grade is the result of the unreliability of shop grades as well as their small variability. The final grades so obtained not only are of little use in evaluating selection methods or as an aid to classification but are likely to lead to wrong conclusions.

To correct the situation, the attempt was made to develop more adequate methods of assessing proficiency in shop work. The development of gauges for rating samplers, with the resultant increase in reliability and spread of shop grades, has already been described (Section 17.3.1). A number of identification and performance tests were also developed for measuring familiarity with naval machinery and proficiency in assembling, adjusting, and operating the various types of equipment.

It is often assumed by school officers that written tests can be substituted for performance tests, that the same results will be obtained by testing the trainees' ability to answer

questions about the assembly and operation of equipment as by testing his ability with performance tests. The correlations between performance tests and written tests indicate, however, that the tests measure different abilities.¹⁰ Table 4 shows the intercorrelations of written, identification, and performance tests in a gunners mate school and their correlations with final grade. The correlations between written and performance tests are low, and identification tests appear to resemble written more than they do performance tests. In order for final grades to reflect practical ability adequately, it would seem that attention must be paid to development of performance tests for measuring proficiency in handling equipment.

Chapter 18

ANTIAIRCRAFT DIRECTORS AND GUNS

By William E. Kappauf, Jr.^a

SUMMARY

THE ACCURACY of antiaircraft firing was in need of improvement. Applied Psychology Panel projects studied problems related to the operation and design of new anti-aircraft equipment as well as the improvement of methods of operating the older types. They studied tracking controls; telescopes and sights; operating, maintenance, calibration, and adjustment procedures; and training features for antiaircraft equipment which determine its accuracy. In each case the work was aimed at making operation by the average gunner easier and more accurate. The studies were conducted during operational and school training. Similar studies should be conducted under conditions simulating actual combat as closely as possible.

Illustrative findings and recommendations were:

1. A double handwheel or double handcrank is approximately 25 per cent more accurate for pointer matching than a single handwheel with the handle facing the operator.
2. In pointer matching, accuracy is best with a handwheel rotation speed of about 100 rpm.
3. Aided tracking is superior to velocity tracking.
4. To avoid obscuration in tracking, the center of the reticle field should have a clear area of at least 10 mils of apparent field.
5. For accuracy of tracking, the optimal level of magnification is the greatest that can be tolerated in terms of amount of vibration, construction difficulties, size of the telescope, and the like.
6. In general, free estimation of target range is more accurate than stadiametric ranging with the reticle of the gunsight Mark 14.
7. Tracking through large changes in elevation is made easier by gearing the gunsight in such a way that the line of sight of the system will elevate through 90 degrees while the exit

^a This chapter is based primarily upon the work of Projects N-111, N-114, SOS-6, and the Height Finder Project.

pupil of the telescope moves through a smaller (45 to 60 degree) arc.

Studies such as those summarized in this chapter provided the basic information necessary for improving equipment design in terms of operating efficiency (Chapter 24) and developing standard operating procedures (Chapter 25).

18.1 PROBLEMS IN THE DESIGN AND OPERATION OF ANTIAIRCRAFT BATTERIES

The activity of an antiaircraft battery engaging a target includes the operations of target detection by a searching or warning group, target designation, target pickup by the director and gun crews, tracking, ranging, and whatever additional control operations may be necessary to establish leads and fuze settings. Most of the operator tasks involve visual-motor coordination. The complexity of these tasks varies with the type of equipment being used and with the amount of teamwork which is required between different members or groups in the combat unit.

The need for improved accuracy of antiaircraft firing became apparent very early in the war. To meet this need, physicists and engineers pooled efforts in the development of more precise computers, directors, and radars. This developmental research touched every level of fire control from automatic-weapons gunnery to full automatic director control, and, at every level, accuracy was improved. In general, the unit operating tasks became simpler as new devices were evolved, but this was usually accomplished at the expense of increasing the number of things one man had to do, or increasing the size of the crew, or complicating the teamwork demanded of the crew, or multiplying the problems of maintenance.

The study of problems related to the operation and design of this new equipment, as well as the improvement of methods of operating the equipment already in use, was handled by

special research projects requested by the Services. A number of these projects, staffed principally by psychologists, were organized under the Applied Psychology Panel. They included (1) Project SOS-6, which studied operating procedures and training problems and procedures for all types of Army antiaircraft equipment, (2) Project N-105, which analyzed the tasks involved in the effective operation of various types of Navy guns and also assisted in the gunnery training program, (3) Project N-111, which dealt with psychological problems in the operation of antiaircraft lead computing sights and directors, and (4) Project N-114, which undertook research on the selection and training of rangefinder and radar operators. Other groups working on related operational and design problems included various research and test centers set up by the Services and various laboratory projects organized under other divisions of NDRC.

As the Applied Psychology Panel projects proceeded in their work, they concentrated most on operational problems in tracking. They contributed to the improvement of operating design of various types of antiaircraft equipment and to the development of training devices for use on antiaircraft equipment. They investigated almost all forms and types of antiaircraft fire control in studies ranging from those of firing automatic weapons by ring sight control, to those of organizational problems in target designation and director control aboard ships carrying many directors.

18.2 STUDIES OF TRACKING CONTROLS

The research on tracking controls included a series of laboratory studies on handwheel characteristics and a series of field studies comparing various types of tracking controls for the 40 mm gun and the director M5.

18.2.1 Handwheel Design for Pointer-Matching Operations

Basic experiments on the design of handwheels for pointer-matching operations were

carried out by the Foxboro Company under a Division 7 contract.⁷⁻⁹ The variables which were investigated included handwheel position, handwheel size, inertia, friction, required speed of turning, and single versus two-hand control. The subject's job was to keep a movable pointer opposite a fixed pointer. The movable pointer was always under the dual control of the subject's handwheel and a course-generating system. Performance measures were taken as each of the experimental variables was changed systematically. The handwheel sizes examined did not exceed 9 inches diameter; inertias did not exceed that for a wheel weighing 9 pounds; and friction did not exceed 7 pounds; but the

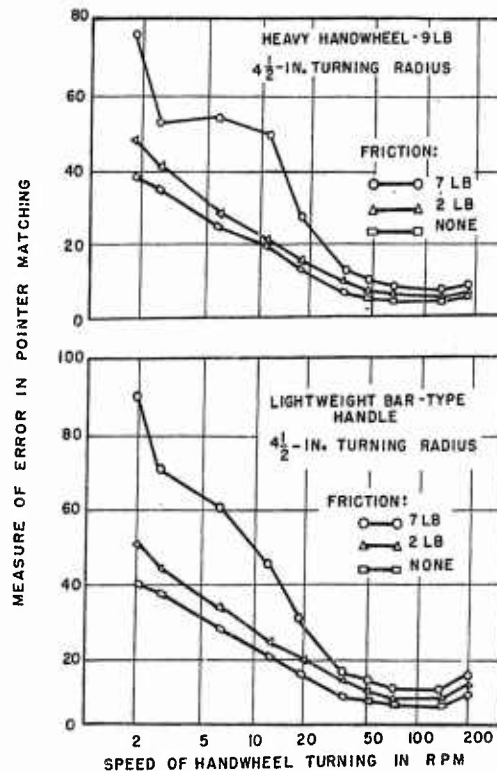

FIGURE 1. Data on handwheel characteristics for pointer matching.

Note. Errors decrease with increased speed of handwheel rotation. Errors increase with friction. Errors are smaller for heavier handwheel (upper set of curves).

results are of special interest because they were sufficiently extensive and systematic to permit representation in families of curves. Similar sets of curves for other tracking situations can

be counted upon to give a similarly complete picture of the effect of situation variables, acting singly and in combination, on tracking performance.

Figure 1 is an illustration of the type of data obtained in these pointer-matching studies. Matching errors decrease with the speed of handwheel rotation and speeds in the neighborhood of 100 rpm are the best. Errors become fewer as friction decreases (compare the curves within either graph) and are fewer for the heavier handwheel (compare the curves in the upper graph with those in the lower).

A result of further interest from the Division 7 studies is that the accuracy of pointer matching where two hands are used on a double handwheel or double handcrank is approximately 25 per cent better than that where only one hand is used on a single handwheel with the handle facing the operator. Similarly, pointer matching with a single handwheel having the handle and axis at right angles to the direction in which the operator is facing is about 15 per cent more accurate than that with a single handwheel having its handle facing the operator.⁹

18.2.2 Aided Tracking and Velocity Tracking

Laboratory investigations of the relative efficiency of aided and velocity tracking uniformly agree that aided tracking is the better.⁴ The consistency and magnitude of this difference is indicated in one study of simulated turret operation. Aided tracking (time constants 0.4 to 1.7 seconds) was superior to velocity tracking from the very start of training, and the difference between tracking with the two mechanisms was far greater than differences between operators.

When the Army was considering the use of velocity tracking or aided tracking with its 40 mm gun power drive, it conducted field tests on pilot models of both types of control, comparing both with handwheel tracking. Tests of the velocity tracking control indicated that the gun tracking obtained with this control operated by one man was inferior to standard handwheel

tracking (position tracking) by two men.³⁰ Learning to use the velocity mechanism was difficult and slow. Coordination of elevation and train movements appeared to be a serious problem. Aided tracking on the same gun, however, proved to be just as good as handwheel tracking.³¹ Thus the superiority of aided over velocity tracking was again demonstrated. Project SOS-6 assisted in these tests.

On the subject of the relative efficiency of different time constants, some data were obtained for the director M5.² This director, like much other military equipment, underwent a series of modifications during the war. When two late experimental models, the M5A2 and the M5A2E1, were developed with aided tracking constants, comparative field trial data²⁰ were examined for possible dependence of tracking and prediction errors on the time constant value. In azimuth tracking, the M5A2 with time constant 0.14 second had a slightly lower variable tracking error (0.58 mil as compared with 0.66 for the M5A2E1), while in elevation tracking the M5A2E1 with a time constant of 0.5 second had the lower variable error (0.29 mil as compared with 0.39 for the M5A2). From the standpoint of prediction errors, i.e., probable gun errors, the M5A2E1 was the better by a slight but statistically significant amount.

Only indicative and far from final, this study of the field operation of the director M5 with different time constants should be extended. General theory of aiding, as well as such experimental results as are available, suggests that time constants under 1 second are desirable, but exactly what value is best or whether the value must vary for different types of equipment has not been established. One specific study has shown that for handwheel or handlebar tracking an aiding constant of about 0.3 second is best.³⁶ Data for more devices and situations are needed.

18.2.3 Variable Speed Controls

In at least one previous paper³⁸ it has been suggested that azimuth tracking might be simplified and improved by the use of a gear ratio or a time constant which might be changed to suit changing tracking conditions during a

course. For crossing courses, the azimuth rate of the target changes considerably: it is very slow when the target is at long range but becomes very rapid as the target approaches and passes the gun position. Two possible solutions have been proposed to the tracker's problem of staying on target and tracking well in spite of this change in rate of relative target motion: (1) the tracking gear ratio might be under the operator's control and varied by him in such a way that his handwheel turning rate would not change so widely during each course; or (2) the aided tracking constant (for a power drive control) might be variable so that the operator could set it and get more rapid changes of rate when the target is in those parts of its run where angular acceleration in azimuth is a maximum. It has been assumed that under either of these special conditions the operator would probably raise his tracking accuracy throughout the entire target course.

During World War II, one device incorporating the principle of a changing-gear ratio was developed for test on the 40 mm gun. It was a hydraulic device which permitted the azimuth tracker to change the effective ratio between tracking handwheel and gun drive by depressing a foot pedal. The results of preliminary tests, made by Project SOS-6,²⁷ showed that tracking performance with the device was clearly superior to tracking with the standard gear mechanism. Further analysis, however, revealed that this superiority of tracking performance was not to be attributed solely to the variable gear feature of the hydraulic mechanism. The new device required a higher handcrank torque than did the standard mechanism, and its operation was smoother. Thus, when the hydraulic system was locked at the point where it provided the same gear ratio between handwheel and gun mount as the standard gun drive, tracking was still superior to that with the standard drive.

The results of the above tests suggest that research should turn next to a series of tests of simple hydraulic 40 mm gun controls using fixed gear ratios. When the efficiency of these simple hydraulic systems is understood, the variable speed drive will merit further testing in and of itself.

18.3 STUDIES OF TELESCOPES AND SIGHTS

In the design of telescopes and sights, the designer may exercise choice over the type of sight, the nature of the reticle pattern which it should contain, and the amount of magnification which it should provide. All these variables may be and have been subjected to experimental investigation. These experiments recognize that sight design may well vary with the use to which the unit is to be put. The principal uses to be considered are for slewing on or rough aiming as compared with careful tracking, for on-target tracking as compared with lead tracking, and for daytime operation as compared with nighttime operation.

18.3.1 Type of Sight

Results of a Division 7 laboratory experiment on slewing indicate that the Polaroid ring sight is superior to the illuminated sight Mark 7 for slewing speed.¹⁷ For tracking, however, the Polaroid sight is inferior to the illuminated sight and also to the reflector sight made by the American Cystoscope Company. The latter two sights are nearly equivalent for tracking performance.³⁵

18.3.2 Reticle Pattern

When the illuminated sight Mark 7 was tested with several different reticles, it was found that tracking was better if the radial lines normally present in the reticle were omitted. The remaining reticle pattern, consisting of two circles of 100 mils and 200 mils in diameter, is improved by the addition of a central dot. Errors in central, on-target tracking with a reticle having the dot were 64 per cent less than errors made when tracking with a reticle lacking the dot.³⁵

The latter result may be restated by saying that tracking with a reticle circle as large as 100 mils of apparent field is not as precise as tracking with a reticle pattern which more accurately defines the point of aim.

RESTRICTED

This is in agreement with the findings in an earlier field study of tracking with the gunsight Mark 15.¹⁸ The reticle chosen for original (production) installation in this gunsight was one of 15 mils real field diameter. When viewed through the 6-power telescope used in the gunsight, this reticle subtended 90 mils of apparent

mils real field diameter. Reticle 2 was the standard crossline pattern used in other sights. Reticle 3 was a test reticle with a circle of 3 mils real field diameter at the center. The general results, summarized in Figure 3, indicated that the original 15-mil reticle was inferior to either of the test reticles under a variety of tracking conditions. The test reticles were about equally satisfactory. The details of the experiment follow.

The results are limited by the fact that a very small number of subjects, only four, participated. The three reticles were compared in a series of four tests. In Test A, the target flew a level crossing approach course, while in Test B it flew a diving direct approach course. The director on which the gunsight was mounted for these tests was an experimental model of the gun director Mark 52. It was set up on a steady platform. In Test C, the target again flew level crossing approach courses, while in D, the subjects tracked a stationary surface target. For these tests, the director used was a production model Mark 52 mounted on a rocking platform (with a single axis of motion). Photographic records of the tracking were taken at one frame per second as each of the four subjects tracked. Simultaneous, synchronized photographs were taken of the range input to the gunsight. The range input was controlled as in normal director operation in Tests A, B, and C, but for Test D it was artificially controlled at —100 yards per second. The reticles were tested in a rotating, balanced order.

The tracking errors were measured on the films to the nearest mil. Average radial tracking errors were computed for each 10-second interval of every course. These scores were collected by range intervals. Averages of the scores for all the trackers are plotted as a function of range in Figure 3. Reticle 1, the 15-mil circle, was inferior in Tests B, C, and D. Statistical analysis of the data showed that for the men who served in the experiment the differences between the reticles in each of Tests B, C, and D would not be expected to occur by chance alone more than one time in a hundred. In Test A, the ordering of the reticles was different and the interreticle differences were not quite so marked. The net result of the entire set of tests

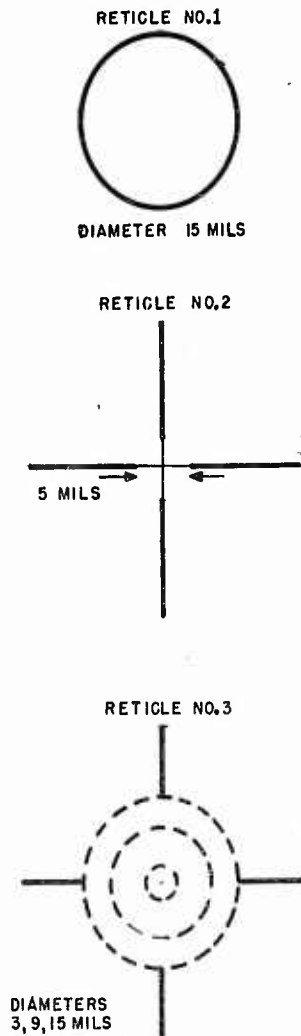

FIGURE 2. Reticle patterns tested for use in the gunsight Mark 15.

field. Working on the hunch that this pattern might not be as satisfactory as a pattern which located the center of the field more precisely, Project N-111 made a comparative test of the three reticles shown in Figure 2. Reticle 1, the original production reticle, had a circle of 15

RESTRICTED

was a confirmation of the initial hunch that a reticle which defined the center more precisely (either reticle 2 or 3) would permit tracking with a smaller average error. Analysis of the data showed that there was no reason to believe that the spectrum of tracking errors would be different with the several reticles. This means that the measured average tracking errors could be taken as an index of the expected average gun errors, or that reticle preference based on

might cause obscuration of targets near the center unless the fine lines across the central 5-mil (real field) area were eliminated.

At night when a telescope reticle is illuminated and appears as a bright pattern of lines against a dark background, the phenomenon of glare, which is physiological and psychological in nature, reduces the tracker's ability to detect very dim targets in the vicinity of the reticle. The amount of glare, as well as the likelihood

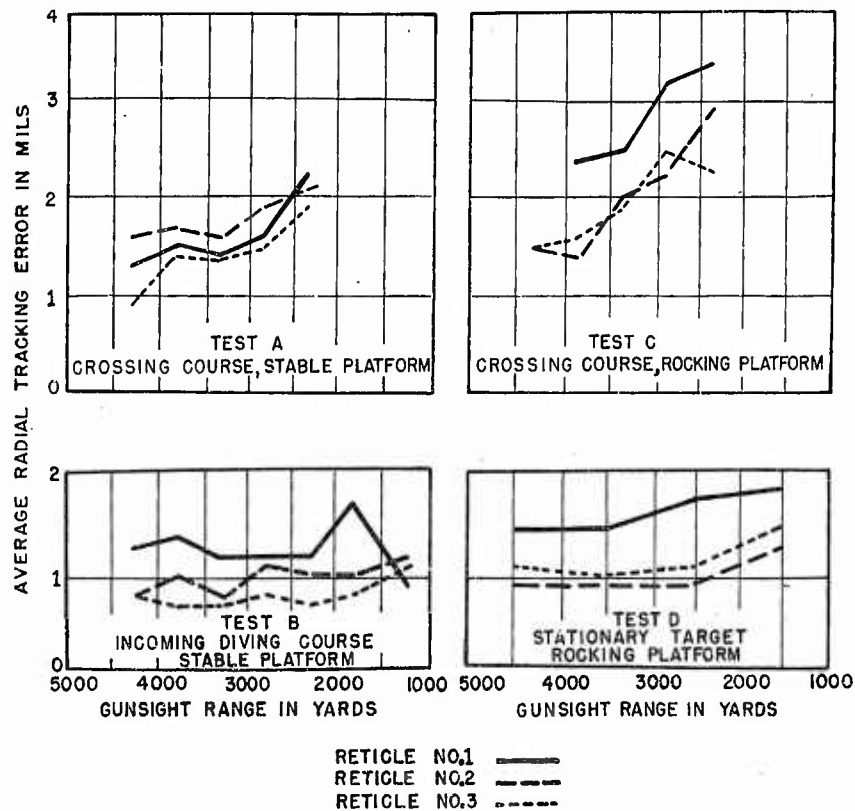

FIGURE 3. Tracking accuracy with three different reticles in the gunsight Mark 15. (Curves show average tracking error for all men.)

gun errors would be the same as that based on tracking error data.

To be satisfactory, a reticle must be so designed that it does not obscure or wash out the target when the target is small or when its contrast with the background is low. Reticles 1 and 3 of Figure 2 meet this condition. Reticle 3, having a 3-mil (real field) circle, satisfies this requirement because the magnification in the gunsight is 6 power, bringing the apparent field covered by the reticle circle to 18 mils. Reticle 2

of a target being masked by glare, varies with the reticle contour, the reticle brightness, and the nearness of the target to a part of the reticle.

Although further reticle tests under a greater variety of target conditions are needed, it is possible to speculate about the kind of reticle pattern which would satisfy all the foregoing experimentally established requirements. Among the best patterns suggested is a reticle with two circles of 100-mil apparent field diam-

RESTRICTED

eter and 20-mil apparent field diameter, so prepared that only the 100-mil circle is illuminated for night tracking. Such a reticle, though difficult to make, should be tested as part of future reticle research programs.

18.3.3

Magnification

The role of telescope magnification in the determination of tracking or pointer-matching accuracy was investigated by the Foxboro Instrument Company, Division 7, NDRC.²⁵ In an aided tracking system using handlebars, where the subject was required to keep a pointer on a fixed index, his average tracking error was reduced from 0.82 mil to 0.30 mil when a 6-power monocular telescope was substituted for an open viewing tube. For a further increase in magnification from 6 to 20 power, the average tracking error dropped to 0.26 mil, a statistically significant decrease. This indicates that the optimal level of magnification certainly is above that at which the target, reticle, and tracking error seem clearly visible. Similar results were obtained in experiments where the pointer and index were viewed at unit power but where the amount of motion of the pointer was mechanically magnified.

Explanation for these results seems to run as follows. With greater magnification, tracking errors (in mils of real field) are perceived and responded to sooner, while rates of target motion can be observed more accurately. There may also be a tendency for the operator to set his own level of accuracy and to try to reach this level in terms of target motion in the apparent or visual field regardless of magnification. Thus he may work more precisely when he sees his errors under greater magnification, since he tries to keep his error within the relatively narrow limits which he has set for himself.

The Services, of course, find that limits to useful magnification are often imposed by requirements or conditions related to size of field, overall size of the telescope, vibration, and the like. The usual tracking telescope has been constructed with 6 or 8 power, a magnification which does not restrict the field unduly nor

raise vibration to a disturbing degree. Studies like the one cited above demonstrate that from the point of view of an uncomplicated tracking job, there is justification in seeking the greatest tolerable amount of magnification.

18.4 ANATOMICAL REQUIREMENTS IN DIRECTOR DESIGN

The preceding sections of this chapter have dealt with functional and mechanical ways of fitting equipment to a human operator in terms of the physiological and psychological characteristics absolutely demanded by the task. If equipment is to be perfectly suited to the operator, however, designers must recognize also the importance of more general anatomical features which influence performance. The human frame and its normal types of motion must be considered in equipment designs. Thus, seats on guns and in tanks or director turrets should be so designed and capable of such adjustments that men of widely varying size can look through the sighting system without being uncomfortable, can grasp the tracking controls without reaching or assuming unnatural postures, and can operate foot pedals with maximal thrust and speed. Director stations where operators stand at their jobs should be arranged with similar considerations in mind. The distance between a sighting-system eyepiece and the deck on which the operator stands should be adjustable in terms of his eye height. The position of elbow rests and shoulder rests should be adjustable in separation and in height in accordance with anthropometric data. The throw of handlebar controls should be regulated by available data on arm length variation among men of military age.

These matters have been discussed with special reference to particular guns, directors, and searching sights in a variety of reports.^{41, 44, 47} For the most part, the assumption has been made a priori that operators will be more successful at their jobs if equipment is "anatomically right" than if it is not. Little experimental evidence has been gathered on the merits of anatomical design, but the principle needs little experimental support in view of its thorough-

going application by enlisted and officer personnel alike in their evaluation and criticism of new gear. They report liking this or that device because they "find it comfortable." They doubt how useful some other device will be because it seems awkward or almost impossible to operate under this condition or that. These attitudes occasionally go so far as to produce actual refusal to use a device at all or refusal to use it in a prescribed manner. Such reactions by Service personnel have, in fact, been important cues to psychologists and others that the design of particular instruments needed further study. The rejection of a device or its neglect during combat negates the entire developmental program on that device. It is therefore important to apply anatomical criteria in evaluating new equipment.

A great many of the anatomical problems of design can be handled by consulting an appropriate table of anthropometric data. Others require the collection of new anatomical data on the specific aspect of human build or motor function which is under consideration. One illustration of such a case requiring the collection of research data will suffice. It concerns the proper arc of motion of a telescope, a problem which arises in several situations: the design of gunsight arrangements in aircraft turrets, the design of a sight mount to be used by lookouts aboard ship while scanning the sky, and the design of manually operated, handlebar, pedestal-type directors.

What is the proper arc of motion of a sight or telescope as it moves in elevation from some angle of depression, perhaps about -30 degrees, to an angle of elevation approaching 90 degrees? Any randomly chosen pivoting mechanism for elevating the sight will probably not move the sight in a way which will allow the operator to look through it comfortably through more than a limited part of the arc in elevation. Since anthropometric data did not describe the normal track of the eyes in elevation as the head and eyes were elevated and lowered, it was necessary to make a specific study to find the most desired elevation movement for the optical system. This study had to be carried out under the conditions of body posture and tonus which would prevail during the operation of the equip-

ment for which the sight mount was being designed.

The problem was investigated by Project N-111 as it applied to the design of handlebar, pedestal directors.⁴⁷ The data show that no simple, single pivoting mechanism existed which could move a sight through a path satisfactorily matching the track of the eyes in elevation. To provide a satisfactory match, the displacement of the eyepiece per degree of elevation motion of the line of sight of the system had to be increased and accelerated when elevation exceeded 50 or 60 degrees. Beyond 50 or 60 degrees, motion of the shoulders carried the head back and stepped up the absolute amount of displacement or motion of the eyes in space.

This whole design question may be clarified by reference to the specific study made by Project N-111. That the matter of the design of tracking heads should be investigated became apparent to the project when successive new directors of the pedestal type were built with continually different, but not necessarily continually better, tracking head arrangements. At least two variables in design were important: the location of the elevating axis, and the radius of rotation of the exit pupil of the eyepiece. Gun directors Mark 51 and Mark 63 varied in both these respects as shown in Figure 4. In order to determine the path through which the exit pupil should move in elevation if comfortable sighting by the human operator was to be achieved, the project made measurements of the path of eye movement for 25 men as they fixated points from 45 degrees below horizontal to 90 degrees above. The fixation points were spaced at intervals of $22\frac{1}{2}$ degrees and were about 20 feet from the subjects' eyes. The men ranged in height from 62.5 to 72.5 inches. The position of their eye pupils, projected into a plane parallel to the medial plane through the body, was determined by the experimenter, using a cylindrical sight which he moved perpendicularly over the surface of a wire window screen located at the subject's left side and parallel to the medial plane of the subject's body. The position of the experimenter's cylindrical sight at the point where the subject's eye pupil was centered in the sight represented the medial plane projection of the pupil position.

RESTRICTED

A complete series of observations through all the elevation points would therefore describe the path of eye motion projected into the medial plane or into any plane perpendicular to the elevation axis of the tracking head. So that there would be a fixed and constant reference point for all the measurements, the subjects leaned against and were strapped to a body rest

circle. The curves for individual men, though more irregular, bear this out. But the most important feature of the data is that the full range of 135 degrees of change in target (from -45 degrees to 90 degrees) is represented by a segment of only 90 degrees on the arc or path of eye movement. Similarly, a 45-degree segment of the circle of best fit covers the range

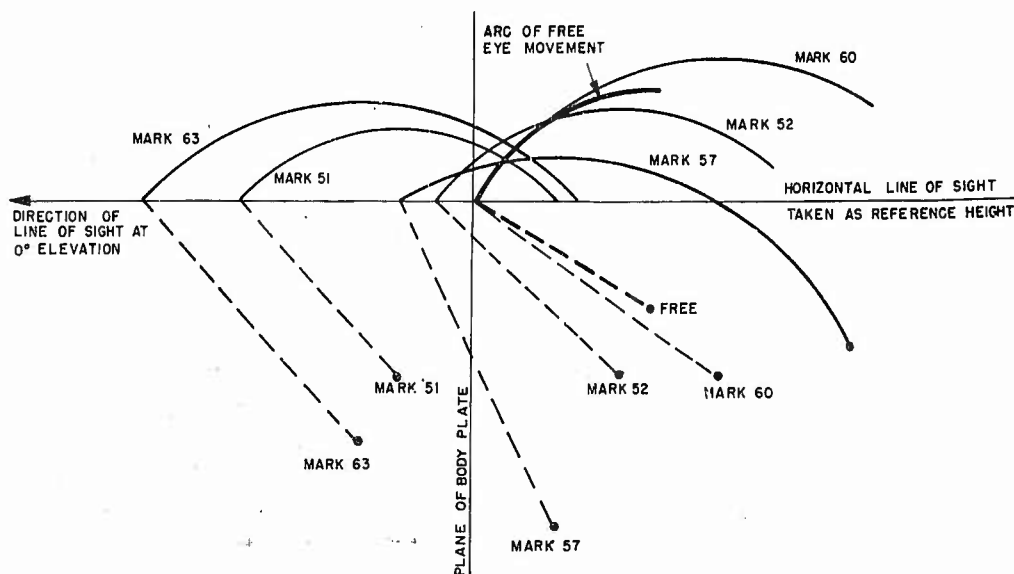

FIGURE 4. Comparison of the arc of free eye movement with the arc of eye movement required on the various pedestal directors when elevating from 0 to 90 degrees. Fixed points of reference common to all arcs are position of body plate and height of eye at 0-degree elevation of the line of sight. Large dots show location of the elevation axes for the different systems.

which was at waist level. Each subject was asked to assume whatever position was natural and most comfortable when viewing each of the fixation points. This direct measurement technique, justified in terms of its greater speed, may not have provided data as precise as could have been obtained using motion picture photography (as in a parallel British study). In any continuation of the work precision would demand photographs.

When the pupil position for each man had been determined at each elevation angle, the data were averaged by elevation angle and plotted as a curve. This curve, representing the path of eye movement when head movement is free and not restricted by the use of optical equipment, is shown in Figure 5. One feature of the plot of points is immediately apparent: the points are fitted very well by the arc of a

of points from the -45 degrees to the +45 degrees elevation of the line of sight. In other words, when the line of sight moves through 90 degrees, the eye pupils move along a path which is a 45-degree arc. The points from 0 elevation to 90 degree elevation of the line of sight fall on an arc which is about 60 degrees long. In Figure 4 the arc of eye movement determined as normal in this experiment is compared with arc of motion of the gunsight exit pupils for each of the standard Navy pedestal-type directors. It will be seen that existing instruments do not match the normal path of eye movement. The result is that trackers have to assume very awkward tracking postures at high angles of elevation.

The type of tracking head mechanism which seems to be demanded by the foregoing experimental data is shown in mock-up in Figure 6.

RESTRICTED

In this mock-up, the bracket holding the gun-sight is mounted on a spider gear which rotates about a fixed gear on the elevation axis. This arrangement causes the line of sight of the

symmetrically located mass attached to the rear spider gear.

The gears used in the mock-up moved the exit pupil through a 45-degree arc in a 90-degree elevation change. Preliminary tests indicated that this arrangement was not completely satisfactory and that a different ratio of sight movement would probably be better. A more satisfactory tracking movement will probably be achieved when gearing is such that the exit pupil moves through 60 degrees, rather than 45, as the line of sight moves up to 90 degrees.

When NDRC work on this mock-up was concluded, the device was turned over to the Naval Research Laboratory for further study and development in relation to the design of the gun director Mark 64. In all pedestal-type directors, starting with the Mark 51, the position of the tracking head must be transmitted to a computer or to the gun by selsyn. This makes it most practical to use direct gearing rather than cams to control gunsight position. But where selsyn transmission is not needed, cams are desirable since they can be designed to match the exact path of eye movement. Actually, cams were used in the design of the searcher sights finally developed by the British.

If a gear-controlled tracking head fails to

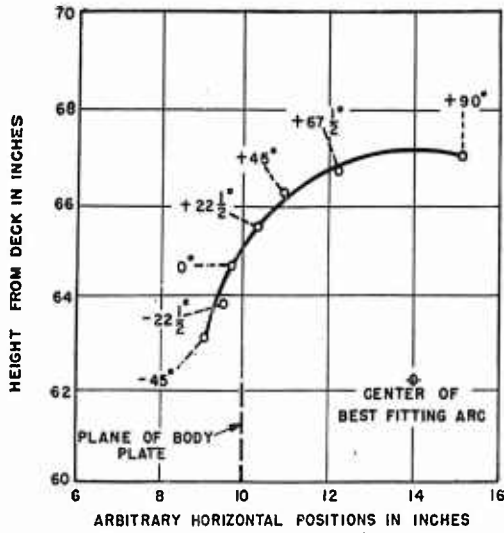

FIGURE 5. Average eye position of 25 men when the line of sight assumed was that indicated by the dotted line.

system to elevate rapidly while the exit pupil of the telescope moves through a smaller arc. Counterweighting of the sight is provided by a

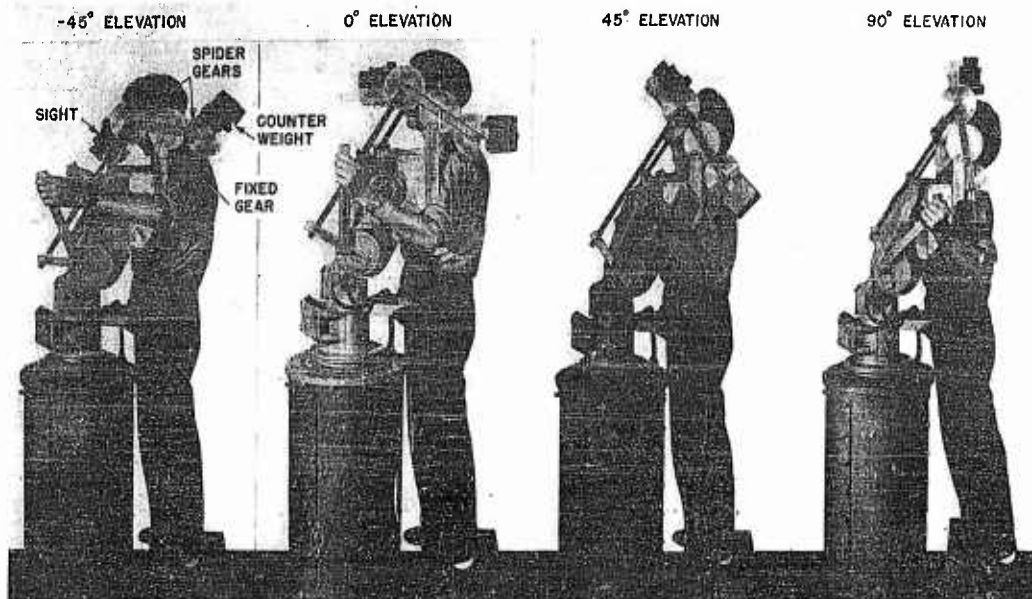

FIGURE 6. Mock-up of experimental tracking head design to satisfy data shown in Figure 4.

provide comfortable tracking at high angles of elevation, a possible solution exists in a modification of the sight design so that the tracker's line of sight, when looking through the eyepiece, is offset some 20 or 30 degrees from the line of sight of the gunsight telescope. If the tracker looks down, say 20 degrees, when sighting on a target on the horizon, he would look up at only 70 degrees when the target is dead

One involves an experimental comparison and evaluation of design features, exemplified in the work reviewed in the preceding parts of this chapter. The other involves an application, after a few empirical checks, of existing knowledge and psychological principles to the criticism of certain design features and the endorsement of others. Frequently both of these approaches are employed concurrently; and, as new design

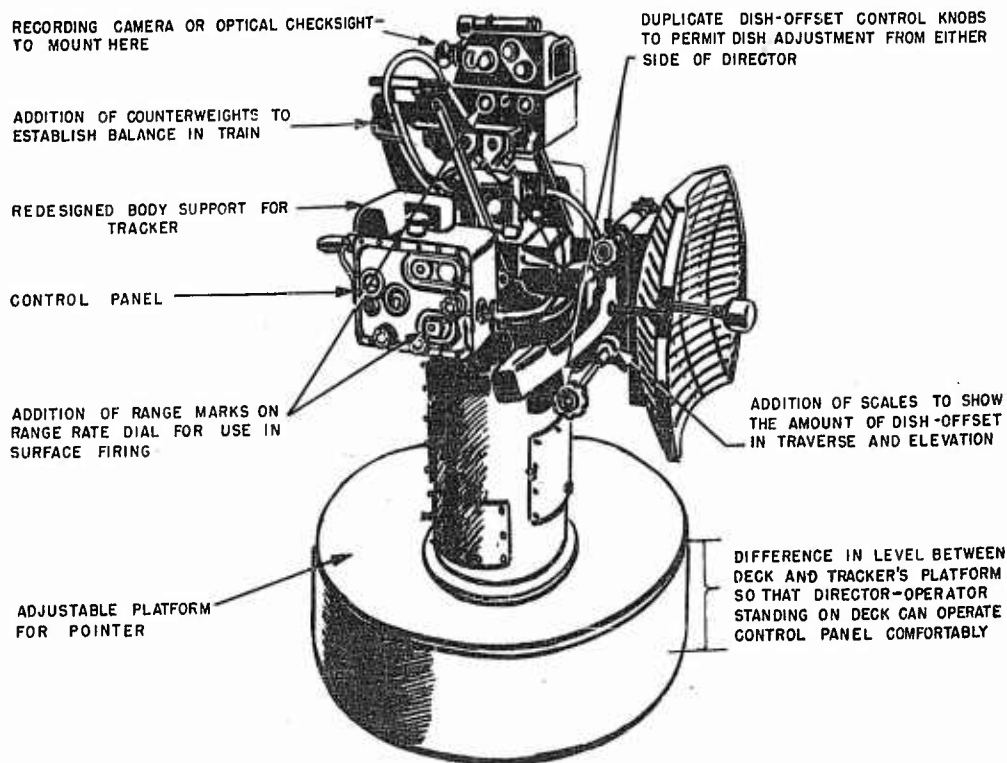

FIGURE 7. Design changes suggested and incorporated in the gun director Mark 52.

overhead. Such an offset, achieved optically within the gunsight, should make for comfortable tracking at all angles of elevation. This suggestion for tracking head design is also under consideration and study by the Naval Research Laboratory.

18.5 EMPIRICAL ANALYSIS OF OPERATING FEATURES

Evident in the reports of the various psychological research groups are two approaches to the solution of equipment design problems.

problems arise, the efficiency of a research group is measured by its ability to discriminate between those which must be handled experimentally and those which can be settled satisfactorily on the basis of existing knowledge and past experience.

During World War II psychologists were the only research people who as a group were consistently interested in ways of simplifying equipment operation and operator training. They were, therefore, frequently invited to witness and participate in the testing of new equipment. When the speedy solution of design

RESTRICTED

problems precluded the running of thorough experiments, as it often did, psychologists dealt with them in an advisory, empirical, but non-experimental way, devoting a relatively short period to practical work with and study of the equipment.

In the case of anti-aircraft equipment, a great deal of this type of design work was done in connection with the development of the pedestal-type gun directors considered in Section 18.4 above. These design suggestions of Project N-111 were reviewed in a series of reports.^{37, 41, 44} Typical of the suggestions and recommendations are those which appear in Figure 7. The changes proposed for the gun director Mark 52 were adopted and made in all the most recent production models. A more representative picture of the range of design comments made by the project are the selected recommendations which appear in the following list. They refer to a number of different directors.

1. That a time motor switch be incorporated in the integrator circuit of the computer Mark 13 so that equipment checks might be run more easily.

2. That the drag of slip clutches in the gun director Mark 52 be reduced as much as possible to permit smooth control when operation requires driving through the clutches.

3. That the range control handwheel on the computer Mark 13 be counterbalanced.

4. That the gun director Mark 52 be more satisfactorily counterbalanced in train and in elevation.

5. That the slewing telescope arrangement on the gunsight Mark 15 be modified to permit the tracker to wear a standard helmet while tracking.

6. That the radar and optical tracking systems be combined into a single telescopic tracking unit on the gun director Mark 57, to simplify both operation and training.

7. That the initial velocity [IV] control on the gun director Mark 63 be modified to allow easier access, positive locking, and a more appropriate range of IV values.

8. That dials or scales on a number of devices be made more legible from the operator's position.

In line with this work, Project N-111 assisted

the Navy Bureau of Ordnance in determining working circle provisions, in planning the most convenient layout of equipment (Figure 8), in developing telephone circuits, and in approval-testing of various attachments and items of equipment designed for use with the directors.

This program of work on anti-aircraft equipment finds exact parallels in work which was done by British psychologists and anatomists on the design of gunnery and director equipment for the British Navy and by psychologists working in this country on aerial gunnery design problems (Chapter 20).

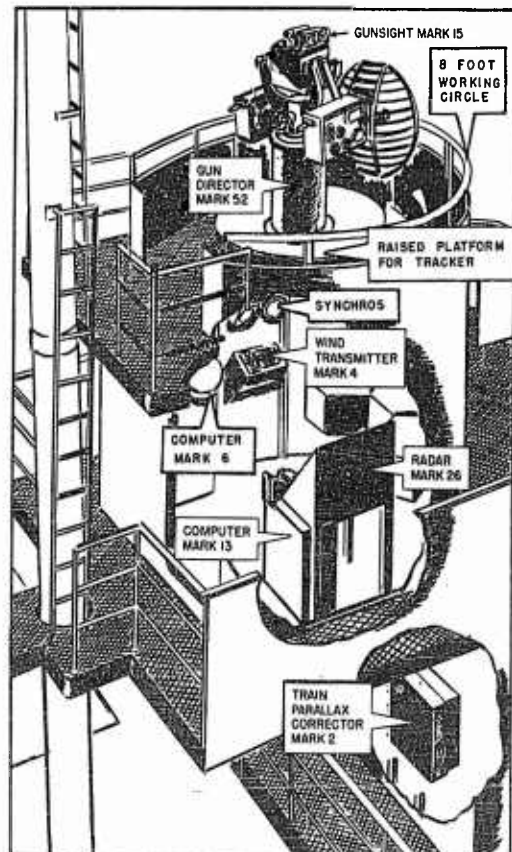

FIGURE 8. System arrangement for the gun director Mark 52 and associated equipment. Arrangement planned after operating procedures had been completely worked out.

18.6

STUDIES OF OPERATING PROCEDURES

The Applied Psychology Panel supervised the work of a number of projects which were con-

RESTRICTED

cerned with the analysis and development of operating procedures for anti-aircraft [AA] equipment. The work covered a variety of operating problems, among which are the gun and director problems considered below. Range-finder operation, however, is given special treatment in Chapter 22.

18.6.1 Navy Gun Crew Procedures

Project N-105 of the Applied Psychology Panel was organized at the request of the Navy to assist in the standardization of gunnery procedures and methods of gunnery instruction. Although most of the work of the project dealt specifically with the gunnery training program and is summarized elsewhere, one aspect of the work of this project falls in the category of procedure analysis. When the project undertook, by standard job analysis methods,¹ to prepare detailed instructions for training in the operation of the 3"/50 caliber gun, wide differences in operating technique were observed at different training stations. Clearly standardization could not proceed until an experiment had been carried out to compare the several methods and determine which was the most satisfactory. Accordingly, a detailed micromotion analysis of the operation of the 3"/50 gun was made.^{33, 34a}

With the cooperation of the Commander, Fleet Operational Training Command, Atlantic Fleet [COTCLant] and with the assistance of local officers, motion picture records were taken of the procedures and operations involved in servicing the 3"/50 caliber gun at a number of installations: at the Naval Training Station, Norfolk; at the AATTC, Dam Neck, Virginia; aboard the USS *New York*, the USS *Wyoming*, and the USS *Reuben Jones*. The primary interest of the study lay in an analysis of the loading operation. Pictures were taken under a variety of conditions: during AA firing, during surface firing, and during drills on loading machines.

The detailed analysis of the films was carried out at the New York University Motion and Time Study Laboratory. The analysis was made with the aid of a slow motion projector built so that it could be operated at any desired speed and stopped, started, and reversed at will. Each action or action sequence in the firing of

the gun was timed by referring to a clock photograph which appeared in every picture. Clock times could be read to 1/2,000 of a minute. Although the study was principally an exploratory one and although variation in the conditions observed limited the amount of data obtained for operating situations, the following conclusions were drawn.

1. The performance of the first loader is the most important aspect of the total loading operation in determining the rate of fire of the gun.

2. When firing at an elevation angle of less than about 50 degrees, the first loader should use the palm of his hand rather than his knuckles or fist for ramming the round into the breech of the gun.

3. The first loader should stand as close to the breech of the gun as possible.

4. The ammunition should be passed to the first loader at an angle approximately that of the elevation of the gun.

5. A standard method of grasping the round by each of the loaders should be adopted and consistently followed. When using preset ammunition, the even-numbered loaders should grasp the round in the middle, and the odd-numbered loaders should grasp the collar of the round with the left hand and the base with the right hand.

6. The first loader should not pivot when loading the gun.

7. When using preset ammunition, the second loader should stand facing in the same direction as the first loader rather than in the opposite direction.

8. Aboard ships of the DE type, the ammunition ready-boxes should be placed so that they face inboard rather than forward, space permitting.

9. When using a fuze pot, the second loader rather than the first loader should remove the round from the fuze pot.

10. When using a fuze pot, the second loader passes the rounds to the first loader around his left side, rather than around his back and right side.

11. The third loader should place the round in the fuze pot.

12. When using the fuze pot there should be at least four loaders in the loading line.

These conclusions are presented to show the possibilities of a detailed job analysis of gunnery procedures.

18.6.2 Comparison of Speed Ring Methods in 40 mm Firing

The speed ring method of lead tracking and firing is the commonest in 40 mm operation, used when all other methods of control have failed or are not available. Although training schools and instructors will readily agree that speed ring methods of operation must be taught to 40 mm gunners, there is little agreement as to the preferred method of teaching speed ring tracking. An attempt at answering this question is found in an experiment carried out by Project SOS-6 of the Applied Psychology Panel, working in cooperation with Antiaircraft Artillery Board, Fort Bliss, Texas.²⁸ The results of the study were reasonable if only preliminary; the end of World War II prevented a more complete study.

The particular speed ring which was investigated is a standard one in which the forward element contains three concentric rings representing correct midpoint leads for targets which are traveling at 100, 200, and 300 mph, respectively. The rear element is a metal ring of approximately 1/2-inch diameter. The azimuth tracker establishes lead on crossing courses, the elevation tracker on overhead courses, by carrying the target to various radial distances from the center of the forward element. The other tracker keeps the shots on the line of the target's course by tracking so that the target always appears to be flying toward the center of the sight.

Three methods of speed ring firing were investigated. They may be designated as the constant lead method, the method of stepwise changing leads, and the method of continuously changing leads.

By the constant lead method, the lead tracker is instructed to hold zero lead until the approach angle of the target is 15 degrees. He then changes his lead to three-fourths of the estimated speed of the target and holds this

lead through the course until target angle is 15 degrees on the receding leg. This method guarantees two fly-through points, one at a point on the approaching leg and one at a point on the receding leg at those times when, for brief intervals, the lead happens to be exactly right.

By the method of stepwise changing leads, the lead tracker is instructed to make six changes of lead throughout the course, three on the incoming leg and three on the receding leg. These changes are made in the interest of increasing the number of fly-through points. Lead is varied as a function of the angle of approach of the target in the following way.

Angle of Approach of Target, in Degrees	Fraction of Estimated Speed or Fraction of Lead at Midpoint
0 to at least 5	0
5 to at least 30	1/2
30 to at least 45	3/4
45 to at least 90	Full
90 to at least 45 on receding leg	3/4
45 to at least 30	1/2
30 to at least 5	0

By the method of continuously changing leads, the lead tracker is instructed to vary his lead in a continuous manner so that he leads by the amounts indicated in the above table for the approach angles given at the end of each interval. His lead should always be equal to estimated speed times the sine of the angle of approach.

The study was divided into three phases: practice tracking, practice firing, and test firing. The entire program extended over a period of 6 weeks. The men who served as trackers were 18 lieutenants who had had no previous experience with automatic weapons. In a preliminary on-target tracking test, all the men were scored for tracking ability and on the basis of these scores nine crews were made up. Of the nine crews, a good crew, a crew of medium ability, and a poor crew were given initial training by each of the three methods of firing. Preliminary tracking practice continued until the end of the second week. Two days of practice firing preceded the test firing. After the first firing tests, six of the crews were shifted to firing methods other than the one

RESTRICTED

they had started with. Later, another similar shift was made. Thus, the men in six of the crews eventually used all three methods, while the men in the remaining three crews stayed at their original methods throughout the tests.

Three types of target courses were used: (1) flag towed on a level crossing course, (2) flag towed on a diving crossing course, and (3)

radial distance but was also broken down in terms of its components along and across the target course.

The results are summarized in Table 1. None of the differences shown in the table is large enough to be statistically significant except the difference in "along course errors" between the constant and the continuous methods on

TABLE 1. Accuracy of 40 mm firing by speed ring control. This comparison of the three methods was obtained by averaging data for all crews.

Course	Performance measure	Constant lead method	Stepwise changing lead	Continuously changing lead
B-26, 20' x 4' flag, crossing course, 1,000 ft alt, 180-200 mph, average minimum slant range 659 yd (data based on about 30 rounds per crew)	Average error along course	19.7 yd	19.8 yd	19.3 yd
	Average error across course	9.4 yd	10.0 yd	10.3 yd
	Average radial error	23.5 yd	24.3 yd	23.9 yd
	% of rounds in hit area*	6.6%	5.6%	5.0%
B-26, 20' x 4' flag, crossing diving course, 240-285 mph, average minimum slant range 744 yd (data based on about 15 rounds per crew)	Average error along course	38.3 yd	30.2 yd	29.0 yd
	Average error across course	11.9 yd	11.6 yd	13.2 yd
	Average radial error	41.6 yd	35.2 yd	33.7 yd
	% of rounds in hit area	0%	0%	1.9%
OQ-3, radio controlled, on approaching turn-receding run, altitude 500 ft or more, average min slant range 287 yd, speed 80-100 mph (data based on about 15 rounds per crew)	Average error along course	6.7 yd	7.7 yd	7.8 yd
	Average error across course	8.7 yd	6.6 yd	6.3 yd
	Average radial error	11.5 yd	11.0 yd	11.0 yd
	% of rounds in hit area	15%	12.7%	13.2%

*Hit area defined as an across-course miss of less than 3 yards and an along-course miss of less than 13 yards.

radio-controlled plane (PQ and OQ) on an incoming turning and crossing course.

During the 6 weeks of the experiment, each crew averaged a total of 115 practice tracking courses and 77 firing courses (including practice and test). Firing was by single fire at the rate of 60 to 80 rounds per minute. The crews averaged 1,058 rounds each.

During the firing, phototheodolite records were taken from two instruments on a 60-foot vertical base line. From the paired photographs, the miss distance for each projectile was determined. This distance was measured as a

the crossing diving course (5 per cent level).

This absence of demonstrable difference between the three methods is further shown in Figure 9, which presents the average radial firing error for each of the methods as a function of the average minimum range to the target. The average firing error is the same linear function of minimum slant range for all three methods of speed ring tracking.

Unfortunately, these data cannot be considered as a final answer to the speed ring problem. The study just reported had a number of significant limitations. The number of men was

RESTRICTED

small. Not many good, high-speed courses were obtained. The fastest target, a B-26, was restricted to an altitude of 1,000 feet minimum, a fact which eliminated fast low-altitude courses. The theodolites could not track satisfactorily on fast close-in courses. The angle of the field of fire was too small, thereby limiting the number of rounds per course which could be fired. There was no perfect check on whether the trackers consistently used the method they were told to use, whether they at

made between the efficiency of firing when the trackers use speed ring methods and when leads are set by an operator using the computing sight M7¹¹. When the latter device is in use, the trackers always track on target. Four crews of trackers participated in the study. After preliminary on-target tracking tests, teams were made up and were trained by a buzzer checksight technique.¹² One sight setter was used with all four crews. He was an experienced man at this job. For the purpose of this ex-

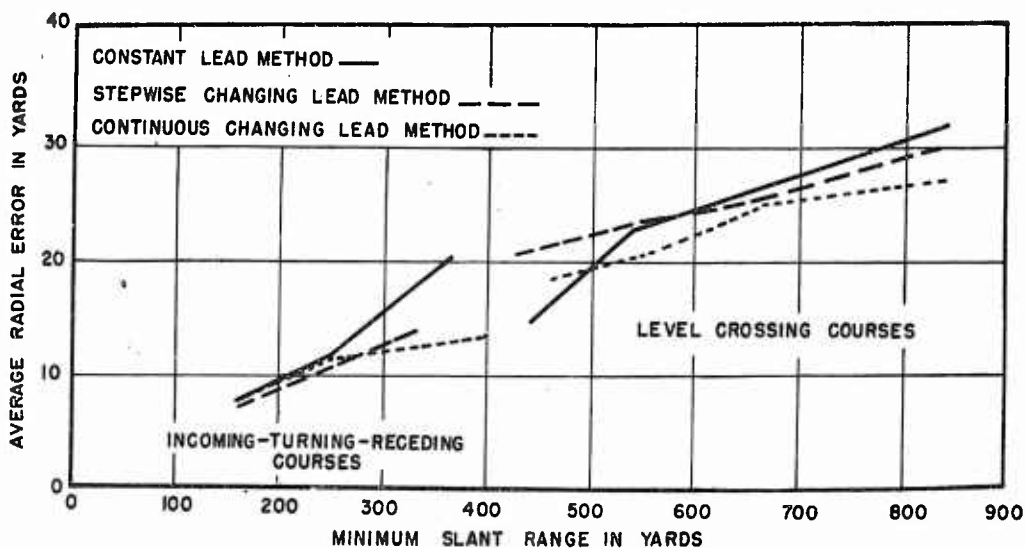

FIGURE 9. Effect of minimum slant range upon average radial firing error: A comparison of three speed ring methods for 40 mm operation.

times adopted other methods, or whether they sometimes reverted to adjusting their fire on the basis of tracer observation.

Within the limitations of the experiment, however, no method was superior to the others. Should the result be confirmed for other firing conditions, choice between speed ring methods can be made on the basis of teachability alone. On this basis, choice would undoubtedly rest with the constant lead method.

18.6.3 Comparison of 40 mm Gun Control with Speed Rings and with the Computing Sight M7

In conjunction with the experiment reported in the previous section,²⁸ a comparison was

performed he wore green glasses (observation glasses, Type 4) to reduce the assistance he would get from tracer observation.

The results showed that the firing with the computing sight M7 was unquestionably superior to firing with ring sight methods of lead determination. Greatest superiority was found on the crossing level and the crossing diving courses. On the courses flown by radio-controlled planes, the M7 firing had about the same average errors as speed ring firing, but in terms of the percentage of shots placed within the effective hitting area it was again the more effective. Table 2 presents data analogous to those in Table 1. A comparison of the two tables shows the gain which is realized by using the computing sight M7 instead of ring sight lead tracking.

RESTRICTED

18.6.4 Methods of Correcting Tracking Errors

When a man tracking with a director makes a tracking error, allowing the reticle or sight to move off the target, he may correct that error in one of two ways: he may get back on

TABLE 2. Accuracy of 40 mm firing controlled by computing sight M7. Data averaged for 4 crews.

Course	Performance Measure	Average performance with M7*
B-26, 20' x 4' flag, crossing course, 1,000 ft alt, 180-200 mph, average minimum slant range 659 yd (data based on about 75 rounds per crew)	Average error along course	10.2 yd
	Average error across course	4.4 yd
	Average radial error	11.8 yd
	% of rounds in hit area	27.5%
B-26, 20' x 4' flag, crossing diving course, 240-285 mph, average minimum slant range 744 yd (data based on about 25 rounds per crew)	Average error along course	12.5 yd
	Average error across course	5.7 yd
	Average radial error	14.7 yd
	% of rounds in hit area	14.9%
OQ-3, radio controlled, on approach-turn-receding run, altitude 500 ft, or more, average min slant range 287 yd, speed 80-100 mph (data based on about 45 rounds per crew)	Average error along course	6.7 yd
	Average error across course	4.9 yd
	Average radial error	9.3 yd
	% of rounds in hit area	35.4%

*Comparable to data in Table 1.

target as quickly as possible, or he may get back by a gradual change of tracking rate, so that the return movement is smooth. In general, when the time constants in the prediction mechanism of the director are small, smoothness of tracking is desired so that the amplification ratio (the ratio of prediction errors or gun errors to tracking errors) will be small. This ratio increases with the tracking error frequency; hence slow, correcting movements will be amplified less in the gun errors.

Although their importance would be considerable, no controlled experiments have been conducted to find out how differently men will

track if they are instructed, "Track smoothly," or if they are instructed, "Correct all tracking errors as quickly as possible." Some, but relatively few, studies have been carried out on the characteristics of corrective movements following tracking errors when the tracking controls are of different sorts. For the most part, the frequency characteristics of the human operator under different instructions and with different control mechanisms are not well known. Until they are known, there are two ways of arriving at recommendations on tracking methods: (1) to base the recommendations for operation solely on the director time constant values; or (2) to run tests on specific directors and to analyze the tracking data with a view toward determining whether smoothness is in fact an important characteristic of the tracking as far as prediction or gun errors are concerned.

Project SOS-6 conducted a series of such tests on the directors M5 and M7 used by the Army.^{14, 20} Tracking photographs were taken at 1-second or at half-second intervals during specific parts of these tests. The magnitude of the tracking errors was evaluated in terms of the average deviation of the line of sight from the prescribed tracking point on the target (tracking average error) and in terms of the average deviation of the line of sight about its average position relative to the target (tracking variable error). Smoothness of the tracking was measured in terms of the average picture-to-picture change in the tracking error. For both studies there was a high relation between the average tracking error and the smoothness measure. The specific correlations for the study on the M5 were as follows.

Correlation with Rate of Change of Tracking Error

Tracking average error (deviation from target)	Lateral tracking	M5A2	+0.53
	Lateral tracking	M5A2E1	+0.47
	Elevation tracking	M5A2	+0.59
Tracking variable error (deviation from mean point)	Elevation tracking	M5A2E1	+0.08
	Lateral tracking	M5A2	+0.65
	Lateral tracking	M5A2E1	+0.77
	Elevation tracking	M5A2	+0.56
	Elevation tracking	M5A2E1	+0.61

These data have interesting implications. If, for every tracker, the correlation between average tracking error and smoothness is positive

RESTRICTED

over the universe of courses and performances, then but one tracking instruction is indicated, namely, "Track smoothly." If, however, the correlation should be negative for some trackers, further investigation would be required in order to find out whether these men should also be instructed to track smoothly or whether some other set, determined by the instructions given, would have a less adverse effect on the magnitude of the prediction errors. Of course, the number of men for whom the correlation might be negative would be important for a training and/or selection program. Finally, if it should turn out that the correlation between average tracking error and smoothness is reversed for particular types of tracking controls or for particular courses, the data would bear on instrument design and operating problems.

Thus, a considerable amount of research is needed to check and extend the correlational data which Project SOS-6 obtained.

Part of the new research should be an attempt to find out what men do when they are instructed to track in certain ways. As indicated above, nothing is known on this matter. Tracking training to date seems to have proceeded on the assumption that it is sufficient to tell a man: "Do your best to stay on the target. Don't change rates too rapidly." But it may be that handwheel tracking as studied on the directors M5 and M7 by Project SOS-6 is a special case where rates are fairly easy to gauge in a kinesthetic way. It may be that similar instructions would lead to less satisfactory tracking with handlebar controlled directors operated on a rolling and pitching deck. It may be that no matter what the tracking system, a man instructed to do his best and to keep his errors small naturally tracks with all the smoothness of which he is capable, making it unnecessary to refer to smoothness in training instructions. It may be that special emphasis on smoothness would cause some men to go to the extreme, disregarding errors until they became large and then correcting them in a leisurely way.

Answers to these questions, particularly the latter, will go far in demonstrating how typical or how specialized were the results of the experiments of Project SOS-6.

18.6.5 Comparison of Simple Methods of Range Determination

For many forms of antiaircraft fire control, it is not necessary to use long-base optical rangefinders or to employ radar because the method of solving the fire control problem permits the use of relatively crude range data. Similarly in the determination of the range at which to open fire with automatic weapons, good approximations to the proper range are sufficient. Simple methods of range determination are acceptable.

Simple range determination methods, at least for the purposes of this discussion, include range estimation, stadiametric range determination, and the use of hand-held ranging devices. They are characterized by the fact that they require no more than portable equipment and no more than a single operator.

If personnel familiar with fire control problems rate these simple ranging methods in order of expected precision and accuracy, they usually put range estimation in the category of the crudest of the methods and ranging with special hand-held devices in the category of the best. This order receives no support from the experimental data.

In one experiment conducted by the Antiaircraft Artillery Board,⁴⁸ three hand-held devices were compared for their accuracy in determining ranges under 3,000 yards on a target flying a crossing course with a minimum slant range of about 800 yards. The instruments tested included an Eastman 15-inch base coincidence rangefinder, a Weiss tangent-type rangefinder, and the Navy range indicator Mark 1. A full-field coincidence setting was required in the Eastman instrument. A setting of tangency of the wing tips of a pair of target images was required in the Weiss finder. Framing the wing tips with a pair of fine vertical wires was required in the operation of the range indicator. Both of the latter instruments required a knowledge of target wingspan, and this was given to the operators. Five hundred readings through 19 courses were taken with each instrument. Although the data presented in the report are given in a form which is difficult to interpret, they show that the Navy range

RESTRICTED

indicator was superior to the two other instruments. It had the lowest systematic errors (bias as a function of range) and the lowest probable error (the specific measure in this case being ambiguous). Static errors in the Weiss finder and perhaps the awkwardness of the Eastman hand-held instrument weighed against these devices.

The Navy range indicator is light, simple, and easy to use. It consists of a small frame held 24 inches from the eye. Within the frame are two vertical wires, the separation of which is adjustable. The operator judges when the target wingspan fills a separation of the wires preset by range, or he fits the wires to the wingspan and reads the range. A strict requirement to ensure accuracy of operation is that the distance of the frame from the eye be 24 inches. A cord fastened to the indicator and looped around the operator's neck holds this distance reasonably constant. As in other stadiametric ranging (Chapter 4), use of the Mark 1 assumes that targets can be classified by wingspan into a limited group of classes, in this case four. Simplicity of operation, plus the trend of the experimental data, led to the recommendation by the Antiaircraft Artillery Board that the Navy range indicator Mark 1 be adopted for the determination of opening range for automatic weapons.

Although the Navy had issued the Mark 1 to all fleet units, its use with 20 mm gun teams using the gunsight Mark 14 was never widespread. A question in which these teams were interested, however, was whether the range setter for the gunsight (the man who stands beside the gun and views the target directly) or the gunner (the one who tracks the target through the gunsight) can determine more accurately the range at which to open fire. When a range setter determines opening range he does so by free, unaided estimation. When a gunner decides on the range, he does so by stadiametric means in terms of the known mil size of the reticle (Chapter 4). This question of the relative efficiency of free range estimation and stadiametric ranging with the reticle of the gunsight Mark 14 was investigated by Project N-105.³²

In the experiment, 185 enlisted men from the

Amphibious Training Base, Little Creek, Virginia, served as subjects. On the first day, the first 36 men were divided into two groups: 18 gunners and 18 range setters. These two groups were then trained, each in its own method, to estimate an opening range of 1,700 yards. Courses flown by the target plane included torpedo attack courses and level overhead runs at 2,000 feet altitude. A day later the two groups were tested and given further training. Six days later they were retested. The same procedure was followed in the training and testing of the 149 other men.

When the men reported for the experiment on their first day, they were given the following instructions.

The Navy has asked us to find out something about the ability to estimate opening range of a typical group of 20 mm gunners. As you know the 20 mm gunner will have no fire control equipment to aid in estimating opening range. This is something you have to do at the gun. The Navy wants to know just how good you men can get in estimating range. It also wants to know if there is any difference between the gunner, who looks at the plane through his sight reticle, and the range setter, who is using his seaman's eye.

Today we are going to divide you into two groups, with half of you as gunners and half of you as range setters, and we will give you training in estimating the opening range of the tracking plane. On some of the runs this morning we will call off the range of the plane as it flies in toward the line. This will give you an opportunity to see what the plane looks like when it is at opening range. On other runs we will test you to see how well you can estimate when it is at opening range.

This is the way we will make the tests: As the plane flies in, we will begin to call out letters of the alphabet over the range loud speaker, like this, "A," "B," "C," and so on. You are to follow the plane all the way in, either tracking it in your sight or just watching it if you are the range setter, and choose the letter being called when you think the plane is at opening range. We will use 1,700 yards as opening range. We will have radar on the plane so that we will know the exact range value for each letter. Remember you just watch the plane or track it in and choose the letter being called when you think the plane is at 1,700 yards. The same letter will not necessarily be correct on all trials, so don't try to pick one letter and stick to it. Make your estimates by what the plane looks like.

We will pass out cards on which to mark your answers. Do not mark your cards until the run is over. If you stop tracking or looking at the plane as soon as you have chosen your letter you might throw off the man next to you, so keep on the plane until it passes

RESTRICTED

over the firing line. You will not be marked on what you do, so you should work independently of each other. Your guess is probably as good as the next man's. All of you do as well as you can because this is an important question that the Navy wants the answer to.

You gunners are to set the range handle on the gunsight at 800 (or 1,200) yards and keep it set at that range for the entire time. Do not change it. We will pass out the cards and pencils to you in a moment. When you get the cards write your name, rate, and Little Creek crew number on the top line. Next to the word "Gun" on the card you will find a number, that tells you what mount you are to go to. If the back of the card is blank that means you are to be a range setter. On the back of the other cards you will see a diagram of two reticles with a plane centered in them. If you get a card with that on the back, you will be a gunner. The diagram shows you what the plane will look like when it is at opening range. The one on the left is for an SBD and the one on the right is for a TBF. The plane we will have is an SBD. You see it will occupy $\frac{1}{2}$ of the inner ring when it is at opening range.

Cards and red pencils were then passed out to the men. Two cards for each gun had previously been prepared and arranged in alternate order for gunner and range setter. Approximately 18 mounts were used at a time, with the number about equally divided between twin and single mounts.

Two officers stayed on the line with the men to maintain discipline and give any assistance that might be needed. They determined that the range setting on the gunsight had been made according to instructions (some at 800 and some at 1,200 yards), that all gunners were properly strapped into the guns, and that all men understood the procedure. During the testing they made sure that each man was watching the plane and tracking throughout the entire run and that the men did not discuss their estimates.

Range information was obtained from the Mark 26 radar on gun director Mark 52. As the plane flew in, one experimenter read the radar dial and called out successive letters of the alphabet each 200 yards of decreasing range.

The program consisted of both training and testing trials. A training trial consisted of calling off certain ranges of the plane as it flew in to the firing line. The ranges called were 4,000 yards, 2,500 yards, 1,700 yards, and 1,000

yards. The men were told to pay particular attention to the size and the appearance of the plane at these ranges.

On a typical testing trial, the experimenter announced the relative bearing of the plane as it flew out to sea from the firing line and directed the men to begin tracking. After the plane made its turn and was coming in, "Stand by" was announced about 800 yards before the plane reached the range at which calling was to begin for that trial. After the run, as the plane passed over the firing line, the experimenter told the men to stop tracking and to mark their cards. In order to prevent the same letter from being correct each time, the starting point of calling varied in a predetermined order from trial to trial. In addition to this, after the first day of the experiment, calling was not started with the letter A, but with various other letters. This served to disperse the correct letter throughout different parts of the alphabet.

The total training schedule included the following trials: day 1, 6 training trials, 4 test trials; day 2, 4 training trials, 8 test trials; day 3, 6 test trials. There were a total of 18 test trials for 8 of the groups of 36 men (4 groups at stadiametric ranging and 4 at free estimation). The other two groups had only 10 test trials because bad weather cut short the experiment. In all there were 82 test trials. Hence there were 82 distributions of test judgments for the five groups of men making stadiametric observations and 82 comparable distributions of judgments for those who made the free range estimates. The means and standard deviations for all these distributions were determined.

In general, free estimation was superior to stadiametric ranging, although both forms of range determination led on the average to underestimation, i.e., calling 1,700 range while the target was at a greater range. The grand mean estimate was made at 1,882 yards for stadiametric ranging and at 1,822 yards for free estimation. When the mean observations were compared, group by group as paired in the experiment, it was found that two-thirds of the time the mean range at which the free estima-

RESTRICTED

tion group would have opened fire was shorter than the mean range at which the stadiametric rangers would have opened fire. In the third method of comparison of these group tendencies, it was found that half the time the mean for the free estimating group was closer to 1,700 yards and half the time the mean for the stadiametric rangers was closer to 1,700 yards.

When the standard deviations of the observations were compared, it was found that more than two-thirds of the time the men making free estimates were more alike (had a lower group standard deviation) than the men ranging stadiametrically. The average standard deviation for the free estimating groups was 346 yards and for the stadiametric groups was 411 yards. This difference in standard deviations cannot be accounted for solely on the basis of the fact that the men making the free range estimates would have opened fire at shorter ranges (as indicated in the paragraph above). So it represents a real difference in consistency between the two ranging methods.

Because man-to-man variability was less by free estimation and because, furthermore, the men making the unaided estimates responded more to the training program, the investigators were led to the conclusion that, whenever the situation permits, the task of range determination should be assigned to the range setter rather than to the gunner in a 20 mm team.

Of the two ranging experiments just reviewed in this section, one indicates that the stadiametric ranging is better than other handheld instrument ranging, while the second indicates that free estimation surpasses stadiametric ranging in accuracy. These results reverse the ordinary opinions regarding the relative efficiency of the several methods. The test conditions, however, are important. What has been demonstrated is that stadiametric ranging with the reticle in the gunsight Mark 14 is not better than free range estimation. But the latter in turn may be inferior to range determination with the range indicator Mark 1. Such a comparative test should be run. As a matter of fact, the method of stadiametric ranging deserves more careful systematic study, particularly as it relates to the use of reticles in tele-

scopes which, unlike the gunsight Mark 14, have power.

18.6.6 Team Operating Procedures for Light Navy Gun Directors

In late 1943, the Navy began producing light director systems for 5-inch, 3-inch, and 40 mm weapons. Previous experience with the gunsight Mark 14 had indicated that the fleet did not use lead computing sights to best advantage unless satisfactory, printed operating instructions were delivered with the equipment. Accordingly, the Navy requested that the Applied Psychology Panel organize a project to study operating and tracking methods for the new lead computing director systems and to assist the Navy in the preparation of instructional pamphlets to be circulated for immediate fleet use. It was suggested that the project formed to do this work be set up in the Navy Yard, Washington, where preproduction models and early production models of all forthcoming directors would be available for study and operational testing. Project N-111 was soon organized at that location.

The developmental work of the project proceeded somewhat as follows. As soon as the pilot model of a new director was ready for examination in the laboratory where it had been built, one or more members of the project made trips to examine and learn about the equipment. This trip provided the group with a general understanding of what the new system was designed to do and how it proposed to do it. Ordnance literature on the director was routed to the project as soon as specifications and parts descriptions became available. When finally a preproduction model of the equipment arrived at the Navy Yard for testing, project members studied it thoroughly and learned how to operate it.

Operating methods were borrowed when possible from methods and techniques previously tested and developed by other research activities. Other methods were established by comparative experiments, in which the greatest emphasis was placed on comparing operating methods and techniques for efficiency in terms

RESTRICTED

of speed. Since the principal operating problems met with in the use of the new directors were problems of teamwork between members of the crew, the time criterion proved very satisfactory.

In developing the specific sequence of actions to be followed, the project worked in close cooperation with the Office of the Commander-in-Chief to develop a sequence which would be tactically sound and efficient. Emergency and casualty procedures, not always considered in detail by the equipment designers, usually had to be worked out by the project and cooperating Navy personnel. Special consideration was given to those tricks or special techniques of director and radar operation which would help the individual men of the crew at their jobs. These tips on operating techniques were advanced on several grounds: tactics, a job analysis of the operating tasks, or a general knowledge of the influence of particular operating conditions upon human perception and coordination. Recommended communications words and phrases were obtained from projects working on special communication problems. Where necessary in the interest of smoother operation, changes in equipment design details were proposed to the Bureau of Ordnance (Section 18.5). After the procedures had been evolved, they were given final trials at a firing point and aboard ship to make sure that particular firing or shipboard conditions did not preclude the use of any of the operating steps proposed.

During the period when the light-weight, lead computing director systems were being engineered, Project N-111 worked in turn with the gun director Mark 51, Model 3,⁴⁰ the gun director Mark 52,⁴² the gun fire control system Mark 57,⁴⁵ the gun fire control system Mark 63,⁴⁶ the gun fire control system Mark 60, and the gun fire control system Mark 56. Detailed outlines of tentative operating procedures were prepared for the last two mentioned systems. Complete operating pamphlets were written for the other four. Navy activities concerned with and cooperating in this work of pamphlet preparation included Cominch, BuOrd, BuPers, and the Ordnance and Gunnery Schools of the Navy Yard. The printed pamphlets were distributed by Cominch.

It is appropriate that pamphlets prepared in the manner just described undergo revision as fleet experience with the equipment develops and as further, more systematic experiments on operation methods are run. Each of the above pamphlets was first issued in a preliminary form. Some 8 months to a year after its preliminary distribution each pamphlet was to be revised and reissued. At the conclusion of the war, revisions had been issued for the pamphlets for the gun directors Mark 51 and 52. The manuals on the gun directors Mark 57 and Mark 63 were awaiting revision.

18.6.7

Comparative Study of CIC Operating Procedures

It was for the purpose of diversifying the anti-aircraft protection of each ship that the small gun directors discussed in the preceding section were developed. But it was soon recognized that the potential usefulness of these directors, installed six to ten per ship, is realized only if the ship develops a satisfactory way of distributing search information to these directors. Each director crew awaits instructions as to which of a number of attacking aircraft it is to engage. Each crew wants early search data on the location of its target so that it can acquire the target by systematic search or pickup procedures. The combat information center [CIC] with its search radar obviously becomes the critical distribution point for these data.

Since CIC was not designed originally for director control, many operating questions arose in connection with its newly required functions. How is contact between each director and CIC to be maintained? How many men in CIC can be given jobs of coaching the directors to locate their targets? From what devices should the coaches get their data? What telephone networks should be used?

In order to determine which CIC techniques would be the most satisfactory for the control of many directors, the Navy Department requested a program of special research on CIC operation. This research was undertaken by the Systems Research Laboratory, Harvard University, under a Division 17 contract, NDRC.

RESTRICTED

In part of the work, the Systems Research Group was assisted by Project N-111 of the Applied Psychology Panel. The work was undertaken late in the war, and only one significant experiment was reported (see Volume 3 of the Summary Technical Report of Division 17).

18.7 STUDIES OF MAINTENANCE, CALIBRATION, AND ADJUSTMENT METHODS

Some problems related to equipment maintenance, calibration, and adjustment fall in an in-between category—a category between operation in the literal combat sense and maintenance in the strict technical sense. Because it is generally true that the successful use of equipment depends on each operator's knowing when his unit is in proper adjustment, operators are often charged with a number of responsibilities which fall under the heading of operational maintenance. Ideally, every operator would be both operator and technician, user and maintenance man. In an emergency training program, however, all men must specialize and the best that operators can do is to learn that minimum amount of maintenance which will see them through. This is called operational maintenance. With knowledge of operational maintenance they become critical operators. Without it, their skill as operators means nothing when accuracy is lost through equipment maladjustments which they do not notice.

Assuming responsibility for the development of operational maintenance procedures as well as combat procedures, several projects under the Applied Psychology Panel studied maintenance and adjustment problems. The Height Finder Project investigated and described maintenance methods which stereoscopic heightfinder operators must use in the field. Rangefinder calibration on the basis of radar data was evaluated by Project N-114. Also dealing with operational maintenance problems were the following studies which were carried on by personnel of the Applied Psychology Panel and its contractors.

18.7.1 Comparison of Methods of Burst Spotting in Trial Shot Fire

In determining the range to a shell burst in trial shot fire, the Army has regularly used battery commander [BC] telescope methods, i.e., triangulation on the burst from two flank stations or from the gun position and single flank station. When it was observed that radars like the SCR-584 detected shell bursts, it was immediately apparent that the use of radar burst-ranging methods, if sufficiently accurate, would greatly simplify trial shot procedures.

In cooperation with the AAA Board and AAA School at Fort Bliss, Texas, Project SOS-6 of the Applied Psychology Panel undertook tests of the comparative accuracy of the radar and BC scope methods of ranging on shell bursts. Two experiments were run.^{22, 30} Burst ranges determined from phototheodolite records were used as the reference or criterion ranges against which both the BC telescope measurements and the radar measurements were evaluated. To assure the accuracy of the phototheodolite data, observations were made from three stations. This provided a double base line and two independent calculations of the criterion burst range. BC observations were likewise made from three stations, so that independent range calculations for two base lines could be made.

A complete summary of the experiments is presented in Table 3.

The overall accuracy of the burst measurements is indicated in the table column headed "Average error in yards." This column shows that when radar ranges to the burst are read by relatively experienced radar operators (Test 1), the ranges are more accurate than ranges obtained with a BC system. If the radar operators are inexperienced, as in the second test, the ranges so obtained may be less accurate than BC ranges. The very last line in the table shows the amount by which the potential accuracy of the radar method exceeds that of the BC method. When radar ranges are read from photographs taken of the range dial at the instant the burst occurs, the average error is only 25 yards. Good operators should be expected to approach this accuracy as they learn

RESTRICTED

to react quickly and spot on the scope the exact point where the burst occurs. The tendency of inexperienced operators is to call a range which is too long, as indicated by the "Bias or constant error" data in the last column of the table. Bias by the BC method averaged out in both tests but was consistently positive for all the radar measurements. Part of this bias might have been due to inaccurate radar cali-

veyed accurately. To eliminate bias in the radar method, operators must be trained to the point where they can calibrate their sets accurately and can read bursts without bias.

Needed at this point are satisfactory methods for training and scoring radar operators in burst spotting. Several methods have been proposed, but their efficiency remains to be investigated.

TABLE 3. Comparative accuracy of BC telescope and radar methods of ranging on shell bursts during trial shot fire.

	Number of bursts on which ranges were taken	Average error, dropping + and - signs (yd)	Standard deviation of observations, neglecting bias (yd)	Bias or constant error (yd)
First test: Range to trial shot point: 6,708 yards				
BC data				
0 ₁ 0 ₂ baseline (5,463 yd)	24	42.7	30.1	+39.0
0 ₁ 0 ₃ baseline (6,694 yd)	24	51.3	31.7	-49.9
Radar data				
4 radar operators	24	32.3	35.5	+18.0
1 radar specialist	21	27.2	31.6	+ 7.1
Second test: Range to trial shot point varied: 5,677 to 10,607 yards				
BC data				
0 ₁ 0 ₂ baseline (9,940 yd)	157	35.3	46	+ 4.8
0 ₁ 0 ₃ baseline (6,046 yd)	162	59.1	76	-39.9
Radar data				
9 inexperienced operators, SCR 584	170	66.9	55	+64.5
9 inexperienced operators, SCR 784	169	89.3	58	+87.3
Photographic record of radar dial, SCR 584	139	25.4	26	+16.5

bration, but because special precautions were taken to insure good calibration it is certain that most of the bias of the radar readings in the second test was operator bias.

Of importance are the data in the column headed "Standard deviation of observations." These numbers are measures of the observers' precision, that is, of their variability after bias or constant error was taken out. In the case of the first test, the standard deviation of the observations was about the same for the radar as for the BC method. The same is true in the second test. These comparisons of the standard deviations indicate that the BC and the radar methods of burst spotting for trial fire are equally precise. They should be equally accurate when the bias of both is zero. To eliminate bias in the BC method, the base line must be sur-

18.7.2 Alignment Procedures for Navy Director Systems

The gun and director crews in a battery face at least two problems in achieving satisfactory alignment. The first deals with the sequence to be followed in aligning—what to do. The second concerns the tolerance to impose on the alignment adjustments and methods of checking that the tolerance has not been exceeded—what to do to achieve the required alignment precision.

Alignment procedures become complex in cases where a single gun is tied in with more than one director and where the directors, in turn, are tied in with more than a single gun mount. Detailed outlines of what to do in alignment situations of this sort were included in

pamphlets on director operation prepared by Project N-111.^{45, 46}

As a follow-up to these general discussions of alignment, however, Project N-111 became interested in the particular problem of achieving precision of radar alignment with the gun fire control system Mark 63.²⁶ Aligning the radar antenna in this system requires that adjustments be made in the antenna servo drive. This adjustment is delicate and is to be avoided unless realignment is absolutely indicated. Accordingly, the project set out to determine how precisely an operator can judge when the radar is correctly aligned with the optical tracking system. The judgment requires observation of the general superposition of the radar tracking dot and the optically seen target both of which are visible in the same telescope.

The radar tracking dot jiggles continuously in the telescope field, but if radar and optics are properly aligned, the average position of the dot over any brief interval corresponds to that of the visible target. In tests with a group of three men, each man when serving as tracker was asked to turn the two spot correction knobs of the gunsight, thereby moving the director's optical line of sight, until the radar dot and target were judged to be in alignment. Over a large number of trials it was observed that the men arrived at alignment settings in elevation and in traverse which were different by as much as 10 mils. Further analysis of the data showed that an operator would have to make as many as 30 independent observations of alignment by the spot correction knob method (the observations alone would require 30 minutes to an hour), if radar and optics were to be aligned within a 2-mil tolerance, and if there was to be 95 per cent confidence that alignment was within this limit when the average spot correction knob setting indicated misalignment of 1 mil.

It is not known whether the principal variability observed in this test was due to some idiosyncrasy in the director system, although the system was completely checked by manufacturers' engineers before the test was run, or whether it was due to operator judgment variability. Whichever was the case, the results are of interest. They indicate that it may often

be profitable to study alignment operations and to determine their precision under specific observation conditions. If large variability shows up, one of two alternatives is suggested: either the system requires improvements to render it more stable or adequate alignment requires a long series of independent alignment observations, the mean of which is used in the adjustment.

Few fire control personnel recognize any real operator problem in alignment. It is conceived as a simple process of adjustment and readjustment, and it is assumed that by each readjustment the alignment is improved until it is finally right. Psychological data on errors of observation, however, suggest that there is just as great a likelihood of error in each readjustment as in the one before. If this is true, alignment should be based on a number of independent and distinct adjustments or observations rather than upon attempted successive readjustments. This applies to present-day radar alignment at least and may apply to optical alignment under some conditions. It means that alignment judgment is like any human psychological judgment and is subject to errors which can be eliminated by an averaging procedure.

18.8 DEVELOPMENT OF TRAINING FEATURES FOR ANTI-AIRCRAFT EQUIPMENT

Part of the problem of equipment design is the development of training features for field equipment. Applied Psychology Panel projects made a number of important contributions in this field.

18.8.1 Development of Checksights and Checksighting Methods

Inasmuch as the projects were concerned mostly with problems of tracking, it is not surprising that the training features in which they were most interested were devices for scoring tracking.

Their work in the development of check-

sights^{10, 21, 24, 34, 44} and checksighting methods^{11, 15, 16, 19, 20, 23} has been summarized earlier in Chapter 3.

18.8.2 Development of a Fire-Control Problem Solution Indicator

Another scoring and training device, however, deserves special discussion at this point. It is a device developed by Project N-114 for installation in the gun director Mark 37. It is called a solution indicator and is used to provide objective measures of the performance of the director and Mark 1 computer crews in obtaining solutions to the fire control problem.¹³ The solution recorded by the instrument is defined in terms of the agreement of generated bearing and elevation rates with the observed rates within predetermined limits. In the model constructed by Project N-114, a bell rang as soon as the generated and observed courses in bearing and elevation had not differed by more than 2 minutes of arc (plus a small tracking error) over a second interval of time.

When the pointer's and trainer's selector switches on the gun director Mark 37 are on Auto, bearing and elevation rates as generated by the computer control the director's line of sight. Any discrepancy between generated and observed courses must be corrected by hand-wheel rotation to keep the crosswires on the target. Consequently, if the crosswires are kept on the target, the rotation of the handwheels provides a direct measure of the adequacy of the solution in bearing and elevation. An indicator therefore can be constructed from a time relay, controlled so that it is reset to zero by motion of either the pointer's or the trainer's handwheel.

In the design of this solution indicator, motion of the handwheels turns rubber-tired wheels mounted to rotate against the outer edge of the left-hand handwheel of both pointer and trainer. Commutators on the shafts of the wheels provide 6 make-or-break contacts per revolution, or 50 contacts per revolution of the handwheel. This is equivalent to one contact for each 2 minutes of arc correction to the director's line of sight. Each make or break in the electrical circuit through the handwheel

commutators operates a relay which produces a momentary break in a second circuit through the time relay clutch magnet, allowing the time relay to reset. A checksight operator's switch or instructor's switch can also be used to break this circuit. This switch is held closed by the instructor only when the tracking error is less than some prescribed value, say 2 mils. The switch is opened when the director's line of sight is off target. Without the switch a solution would be indicated whenever the pointer and trainer both ceased tracking, regardless of whether the line of sight was on or off target. For checksighting, the instructor uses the control officer's scope in the director.

A stop watch is used to measure the time required to obtain solutions. Assuming that the target is on a straight course, the watch is started when the target is first picked up and stopped when the bell rings. The recorded time is a measure of the performance of the combined director and computer crew.

This fire control problem solution indicator was introduced by Project N-114 in classes for director operators at the Naval Training School, FC(O), Fort Lauderdale, Florida. It was particularly effective in stimulating competition between successive crews operating the director. Its effect was undoubtedly due to the fact that it provided a concrete measure of group performance which was missing in ordinary drill.

This particular device might well be used as a model or guide for the development of other training instruments. It demonstrates two important facts: first, that it is possible to build training devices into field equipment in such a way that they do not interfere with standard operation, yet where they will always be ready for use in training drills; and second, that it is possible, with a little ingenuity, to develop devices which score team performance and can be used to motivate team drills.

18.9

PERSPECTIVE

The work summarized in this chapter on the design and operation of antiaircraft equipment represents only a part of the work done in the

RESTRICTED

field. Interest on the part of the Applied Psychology Panel in design and operation problems was shared by many other laboratories and research organizations. The Foxboro Instrument Company Laboratory and the Franklin Institute Laboratory under Division 7, NDRC, worked on the investigation of tracking controls and tracking conditions. The Radiation Laboratories at Massachusetts Institute of Technology had groups interested in operational design, as evidenced by the well-organized radar console for the gun director Mark 56. The Antiaircraft Artillery Board, of the Army Ground Forces, and the Navy Antiaircraft Test Center regularly undertook tracking and operational field tests of new equipment. Theoretical papers on tracking controls, especially on rate and aiding mechanisms, were contributed by the Applied Mathematics Panel and by the Antiaircraft Artillery Board. Dealing with problems which parallel all those which have been mentioned, various British research groups, among them the Manual Tracking Panel, conducted a long series of operational and design experiments.

It is unfortunate in retrospect that none of

the research referred to in this chapter involved actual combat testing. By and large, too little is still known about the proficiency of operation of various pieces of equipment in an anti-aircraft battery during fire on enemy targets. It is suspected, and with good reason, that operator performance is poorer in action than during practice or drill. But how much worse is hard to estimate.

What is desired in military equipment is an operating arrangement and a set of controls and operating conditions which will provide the very best performance in combat. Whenever different operations might be adversely and differentially affected by combat conditions, laboratory tests cannot provide the final answer to the design problem. It seems safe to assume, however, that combat conditions will probably not have disproportional effects on different simple operational tasks, so the criterion of simplicity in equipment design is likely to remain valid. But the results of the British study should caution one against over-optimism regarding the absolute level of combat efficiency of a particular operating task until actual data are forthcoming.

Chapter 19

FIELD ARTILLERY EQUIPMENT

By William E. Kappauf, Jr.^a

SUMMARY

AN ANALYSIS of the errors in the operation of field artillery equipment led to the conclusion that two types of studies were desirable. The first study analyzed the scales used for panoramic telescopes and resulted in the development of an odometer type of scale which reduced greatly the number of errors made in reading the scale.

The second study resulted in the development of remote indicating equipment which recorded the entire action of a field artillery battery.

The project was terminated before either study was complete and before its work could affect actual firing practice. The methods and equipment are available. They should be employed in a continuing study by the field artillery in order to decrease the number of firing errors.

19.1 PROBLEMS IN THE OPERATION OF FIELD ARTILLERY EQUIPMENT

The occurrence of frequent and serious errors in the operation of field artillery equipment has been recognized for a good many years. In general, these errors can be traced to certain weaknesses in the field artillery fire control system and to certain inadequacies in the procedures for operating the equipment.

In regular peacetime training, there was time to give full consideration to these sources of error and to select gun crews by trial after partial training. Artillery officers placed their hope for the elimination of firing errors on careful instruction, repeated drills, prolonged training, and ultimate selection of good personnel. In this way, some types of errors were to a large extent eliminated.

Unfortunately the highly accelerated training program during the war did not permit the

same training and selection procedures. The frequency of artillery errors increased.

A glance at the field artillery fire control setup is sufficient to show that the potential sources of error are many. Four guns comprise a single battery. Typically they are controlled locally by the executive officer on the basis of telephone information received from a fire-direction center. The command post receives reports on the location of shell explosions from an observation post or airplane strategically located in relation to the battery position and the direction of fire. According to the type of fire, accuracy depends upon some or all of the following: the survey of the area or of particular points therein; the leveling of the guns; the setting of the various scales on the guns; the frequency and accuracy of reports from the observation post; the computation at the fire-direction center; and standard, unconfused commands to the guns.

A much-publicized, but by no means unique, gunnery error is the so-called 100-mil error. This error may arise from a variety of sources but most often from a misuse of the azimuth scale on the gunsight or on associated equipment. The azimuth position of the gun must be read from two scales on the gunsight, a coarse scale and a fine scale. Single spaces on the coarse scale represent 100 mils and correspond to a complete rotation of the fine scale. In order to read such broken scales properly, one must follow the rule of always reading the coarse scale to the nearest *lower* division (except in certain not too infrequent instances where the scale markings are slightly out of line). If the scale is read to the *nearest* division, it may be rounded up, and the result in such a case is a combined reading of the coarse and fine scales which is 100 mils too large. This source of error, among others, directed attention to the design of the scales used on the gunnery and surveying equipment.

At the request of the Army Ground Forces, April 1944, the Armored Medical Research Laboratory [AMRL] at Fort Knox, Kentucky,

^a This chapter is based upon the work of Project SOS-11 and that of the Armored Medical Research Laboratory.

and the Applied Psychology Panel both set up research projects to investigate ways of reducing field artillery errors. AMRL began its work in May 1944. NDRC Project SOS-11, set up under the Applied Psychology Panel, was organized at Fort Bragg in June 1944.

From the outset, the two laboratory groups made plans for cooperative work on their problems. In general, it was decided that the NDRC group would investigate the nature, distribution, magnitude, and correction of errors, while the AMRL group would study the procedures of fire control and fire direction. Although it is possible to conceive of system improvements accomplished, for example, by a complete change in the data transmission system to the guns—a substitution of selsyn transmission for telephone transmission—work toward such changes was left as a long-term job. It was set aside in favor of developmental work which might lead to the immediate improvement of field performance with equipment not fundamentally different from that in use. After a preliminary survey of the errors made throughout the entire battery, both research groups concentrated on special problems associated with the reading and setting of scales.

19.2 A SURVEY OF THE SOURCES OF ERROR IN FIELD ARTILLERY EQUIPMENT

In order to formulate a program of investigation and to determine where work might profitably be started on the reduction of errors, preliminary field observations were made at the Field Artillery Replacement Training Center and at the 100th Division, Fort Bragg, and at the Field Artillery School, Fort Sill.¹³ This study revealed the following sources of error.

1. *In survey*: errors in measuring angles, measuring distances, and in computing coordinates.

2. *At the battery*: errors in the use of the aiming circle, confusion in commands, and failure in communication while laying the battery; improper execution of commands; and errors in scale setting and reading.

3. *At the observation post*: errors in report-

ing direction of desired shift in fire, failure to send clear reports, misreading of instruments.

4. *In communication*: errors due to similarity of sounds, confusion of four-digit numbers, poor enunciation, etc.

5. *At the fire direction center*: errors in transmitting messages, making computations, and reading instruments.

The major sources of error were found in departure from standard operating procedures and failures to use the equipment correctly. The frequency of errors was significant and concentrated at the guns. Firing errors were distributed as shown in Table 1 (compiled and estimated from data reported in references 10, 11, 13). For the purpose of this analysis, errors less than 3 mils were not included.

TABLE 1. The frequency of field artillery errors.

<i>Observed Errors</i>	
Errors made by the executive:	
Frequency of errors in laying the battery ^{13a}	18 per 100 problems
Frequency of 100-mil errors in reading an aiming circle ¹¹	6 per 100 readings
Errors in firing:	
Frequency of errors in firing ^{13b}	50-100 per 100 problems
<i>Estimated Breakdown of Errors in Firing</i>	
Total frequency of errors in firing ^{13c}	60 per 1,000 rounds
Errors in deflection and elevation ^{13d}	40
Scale errors at the gun	25
100-mil error ¹⁰	1
Errors due to improper rounding, reading scale in wrong direction, transposing numbers, etc. ^{13e}	17
Errors with no obvious explanation ^{13e}	7
Errors due to confusion, communications, etc., nonscale errors	15
Errors in sight, range, fuze, etc. ^{13d}	20

Table 1 shows that nearly one-half of the firing errors could be attributed to scale-reading or scale-setting errors at the gun. This finding suggested that work on the gun scales would make a profitable beginning.

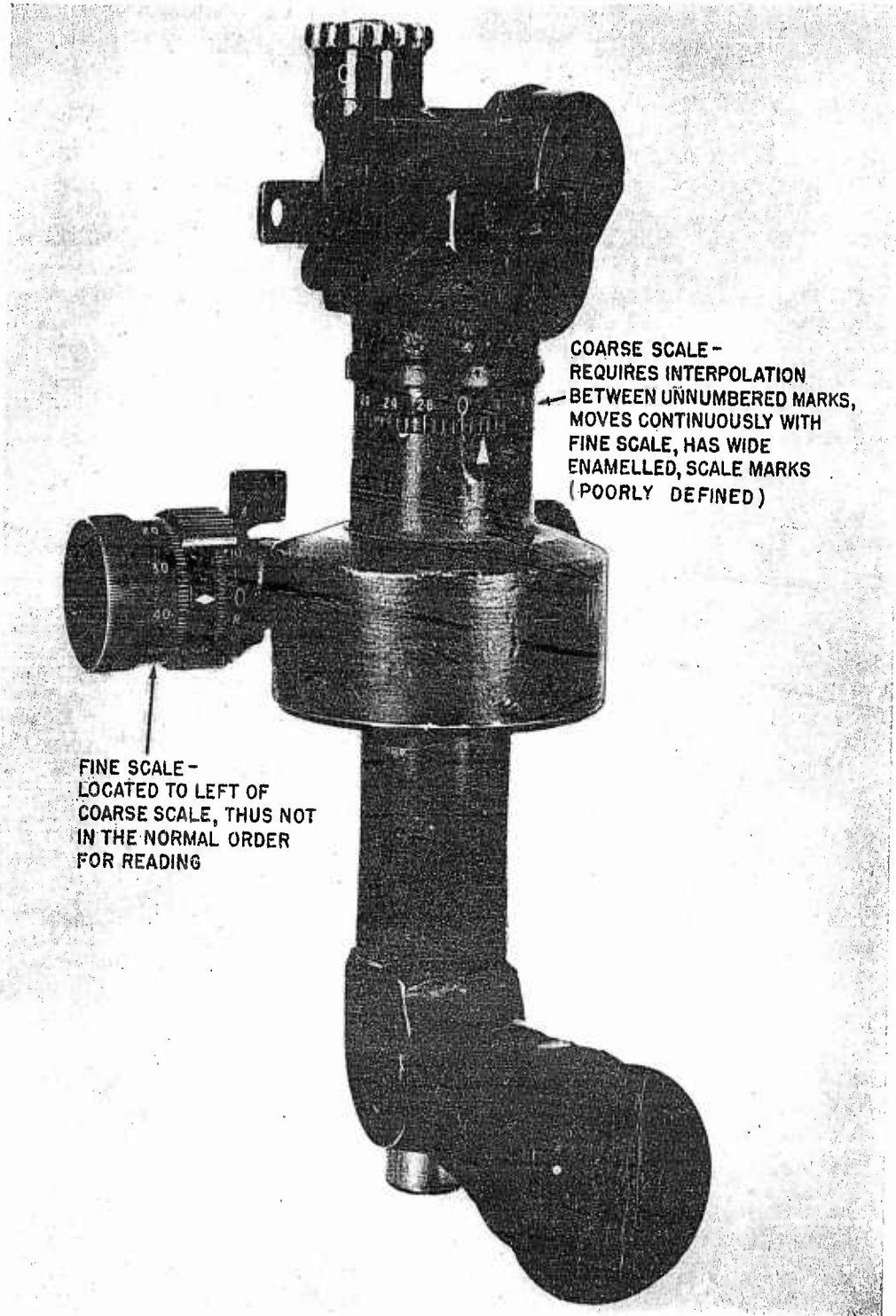

FIGURE 1. Panoramic telescope M-12.

RESTRICTED

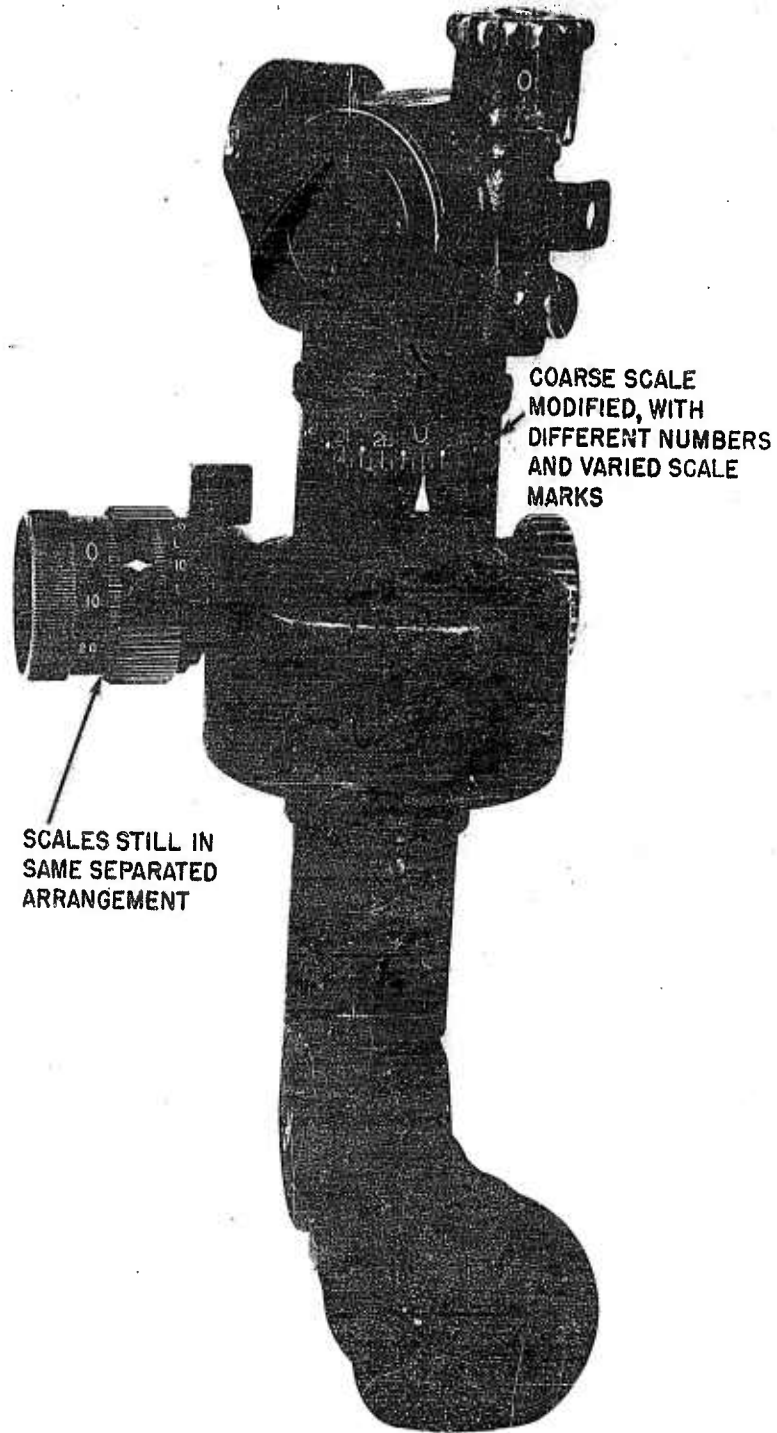

FIGURE 2. Panoramic telescope M-12 with modified coarse azimuth scale.

RESTRICTED

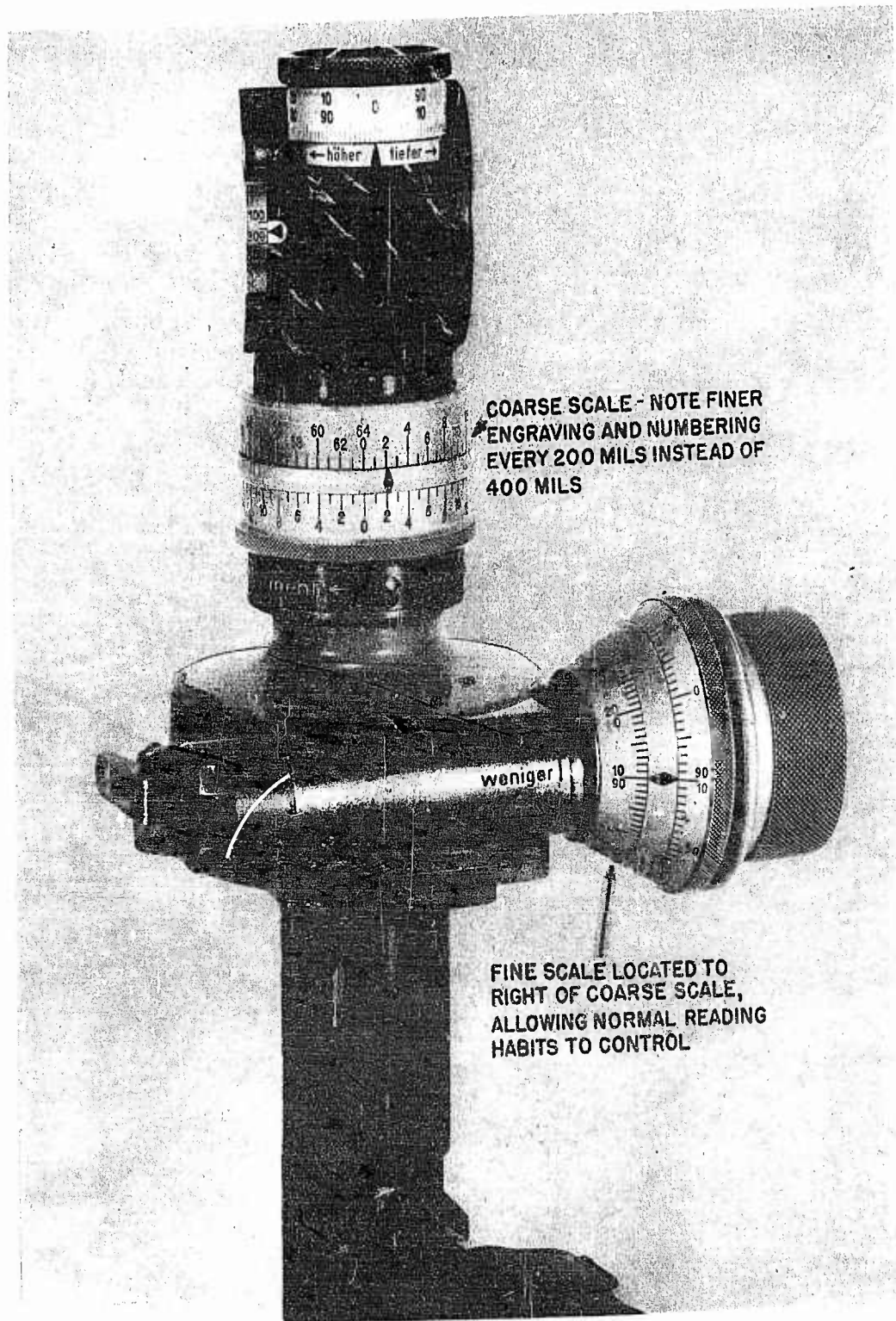

FIGURE 3. German panoramic telescope Rb1-F-32.

RESTRICTED

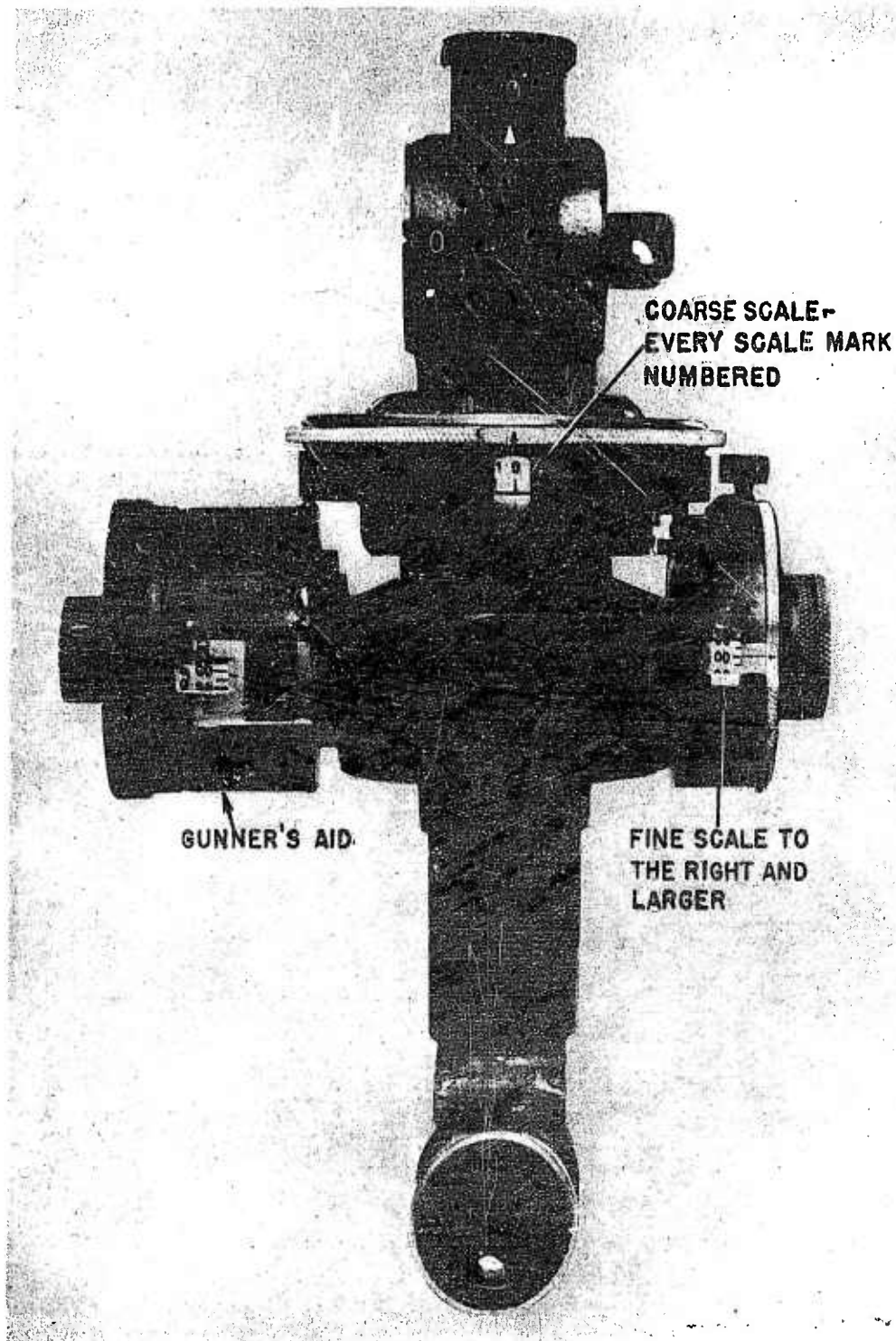

FIGURE 4. Panoramic telescope M-12 modified by Armored Medical Research Laboratory.

RESTRICTED

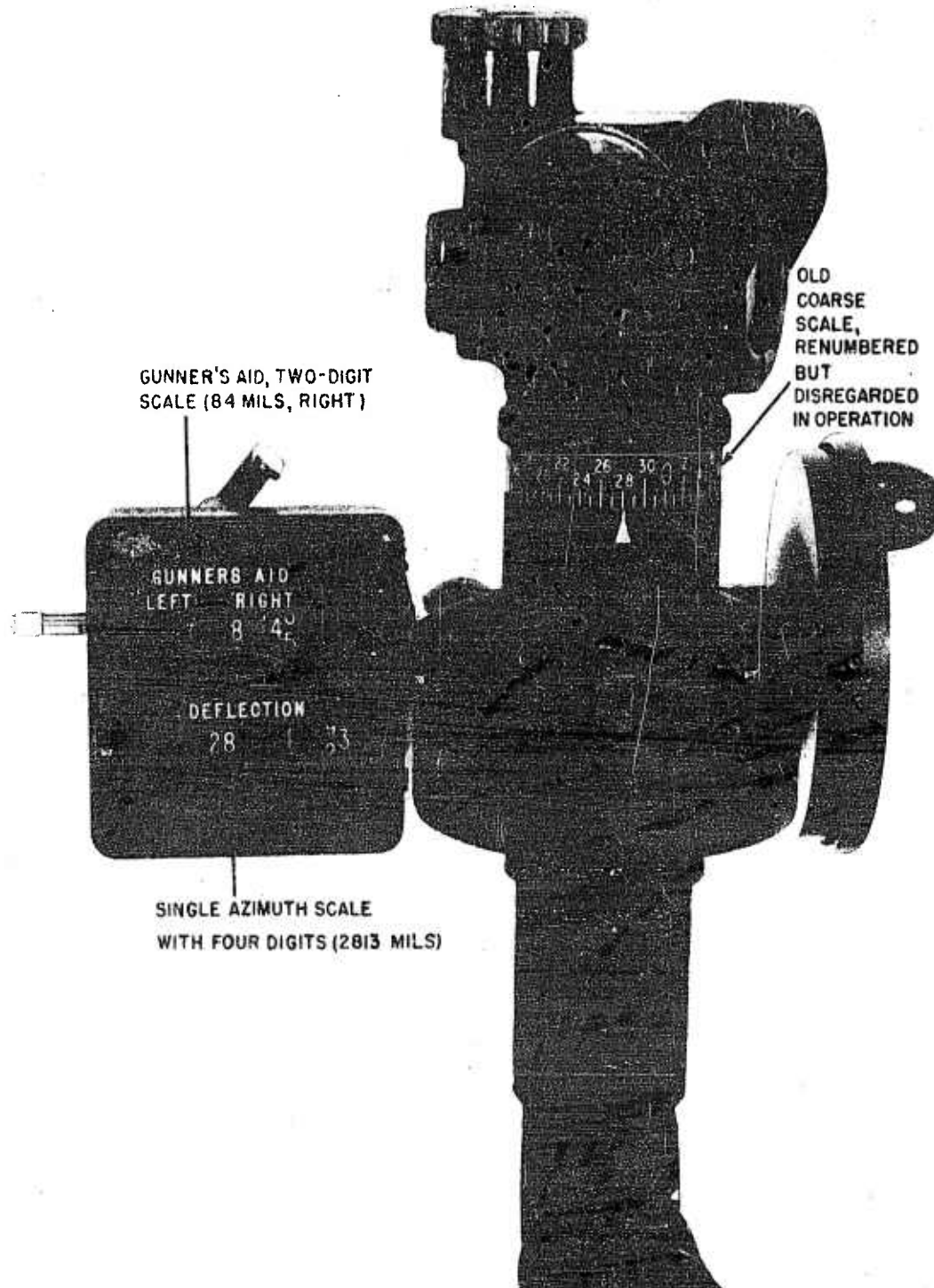

FIGURE 5. Panoramic telescope M-12 (T-138).

RESTRICTED

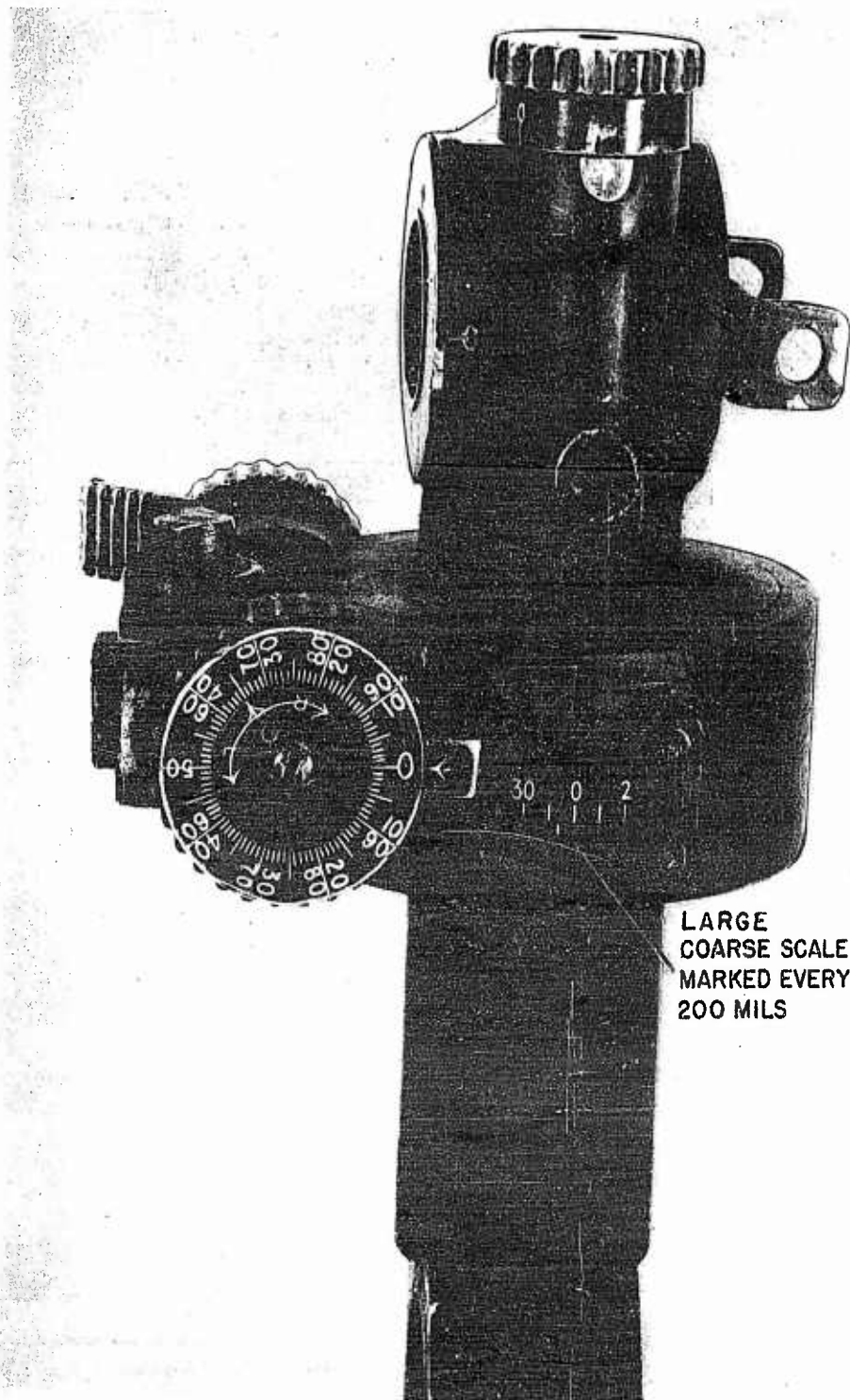

FIGURE 6. Panoramic telescope M-5.

RESTRICTED

19.3 THE RESEARCH PROGRAM—THE
ANALYSIS OF SCALES FOR
PANORAMIC TELESCOPES

Examination of the panoramic telescope M-12, the telescope now in standard use in field artillery, reveals many other shortcomings in addition to the fact that it has broken scales. These undesirable features, which unquestionably contribute to errors in the use of the instrument, are pointed out in Figure 1.

scope with very excellent scale engraving and with the fine scale in the natural reading position to the right of the coarse scale combined two significant design improvements. This instrument, shown in Figure 3, was available for comparative tests. AMRL designed¹⁴ and built a modification of the M-12 which carried the fine scale to the right and which increased the diameter of both the coarse and fine scales for easier engraving and reading. This modification is pictured in Figure 4. Finally, Project SOS-11

TABLE 2. Summary of errors made with different panoramic telescopes.

	M-12 (Fig. 1)	M-12 with modified (dotted) scale (Fig. 2)	German telescope (Fig. 3)	AMRL modified M-12 (Fig. 4)	Counter type T-138 (Fig. 5)	M-5 (Fig. 6)
Reading errors ^{5,12}						
Number of readings	2,400	2,400			2,400	2,400
Number of men	24	24			24	24
Errors, %	6.8	6.8			1.7	3.3
Setting errors ⁶						
Number of settings	1,800		1,800			1,800
Number of men	18		18			18
Errors, %	3.0		1.8			2.4
Errors in setting deflection shifts ^{5,12} (e.g., 120 mils to the right)						
Number of settings	2,400	2,400			2,400	2,400
Number of men	24	24			24	24
Errors, %	4.2	4.2			6.0	2.2
Gross reading errors, 100 mils or more ³ (made under conditions to exaggerate errors)						
Number of readings	1,248	1,248	1,264	1,248		
Number of men	79	79	79	79		
Average time for 20 readings	7'11"	7'14"	7'14"	6'35"		
Errors, %	10.8	10.3	1.8	0.7		

An early study explored the possibility that 100-mil errors with the M-12 might be reduced by attaching a red marker to the fine scale in the region between 85 and 100 where upward rounding errors in reading the coarse scale are most probable.¹ It was found that this mark did not decrease the likelihood of error in either reading or setting the scale.

Subsequent work turned, therefore, to an evaluation of more outstanding variation in telescope scale design. The coarse scales of several M-12's were modified to bear finer engraving and to have distinguishing dots on some of the unnumbered marks. This modification is shown in Figure 2. A German panoramic tele-

scope with very excellent scale engraving and which could be built onto the basic units of the M-12.^{2, 12} This new scale, shown in Figure 5, is one in which all groups associated with the research expressed particular interest because it combined the entire scale reading in one set of counter digits. The scale was no longer broken.

In a series of cooperative test programs,³⁻⁶ AMRL and Project SOS-11 compared the relative efficiency of these several instruments and the discarded panoramic telescope M-5 (Figure 6). The experimental technique used in each test was the same. Sufficient men were recruited as subjects to make the test results statistically dependable. These men were required to read

RESTRICTED

scales, make scale settings, or make deflection shifts on two or more of the telescopes. They worked on the several instruments in counter-balanced orders. Tabulated results were analyzed to determine the frequency and the type of errors made with each telescope. A summary appears in Table 2. For purposes of this summary, errors of less than 5 mils were disregarded.

An examination of the table shows that the panoramic telescope M-12 is inferior to all

by making minor scale changes (finer engraving plus dotted scale marks for every 200 mils) had no effect on the accuracy or speed with which the telescope could be used.

2. The German telescope, with fine scale engraving, and the discarded M-5 were both used with fewer reading and setting errors than the M-12.

3. The AMRL modification of the M-12 was excellent for reading. Actually most of the reading errors entered in Table 2 for this in-

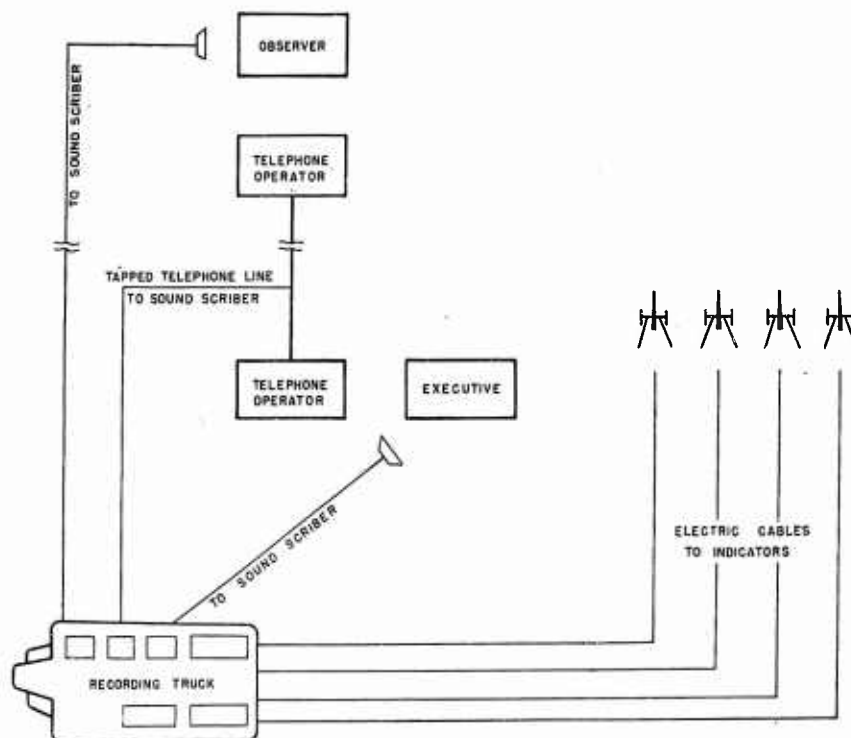

FIGURE 7. Schematic diagram of error recording system.

others for reading accuracy, inferior to the AMRL instrument in reading speed, inferior to the German instrument and the M-5 for making settings, and inferior to the M-5 for setting deflection shifts. In a further study,⁴ not referred to in the table, the M-12 was inferior to the AMRL, German, and M-5 instruments for reading and inferior to the M-5 for setting deflection shifts.

The following specific results may be cited.

1. Modifying the panoramic telescope M-12

instrument were caused by inaccurate cutting of the window over the coarse scale. Proper workmanship here would probably have reduced the frequency of reading errors on the AMRL instrument to practically zero. Many of the errors in using this instrument in making deflection settings, reported in another study,⁴ were likewise attributable to poor workmanship in the pilot model.

4. The counter type of scale (T-138, developed by SOS-11) was very satisfactory for read-

RESTRICTED

ing but was not used with accuracy in the test of making deflection shifts. The latter performance, however, was not considered representative of what could be done with the counter-type instrument. The model which was tested had a badly constructed units dial and scales for setting deflection shifts which ran to only 100 mils (Figure 5). Use of a less confusing units dial and of deflection scales (gunner's aid) which run to 1,000 mils should reduce the frequency of reading, setting, and shifting errors with this instrument.

As work on the T-138 progressed, further developmental work on the AMRL instrument was set aside. Unfortunately the T-138, when

neer may be the very features most important in the new device.

When the research program on improving scales for panoramic telescopes closed shortly before V-J Day, it left an indicated but not a proved solution to the scale design problem.

19.4 THE DEVELOPMENT OF RECORDING SYSTEMS FOR USE IN THE ANALYSIS OF FIELD ARTILLERY ERRORS

As indicated in 19.2 above, slightly more than one-half of observed field artillery errors are other than scale errors. They consist of report-

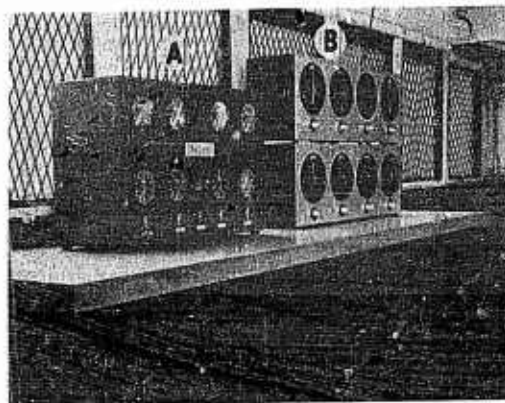

FIGURE 8. Interior of recording truck, left bench. A Range quadrant indicators; B tube position indicators.

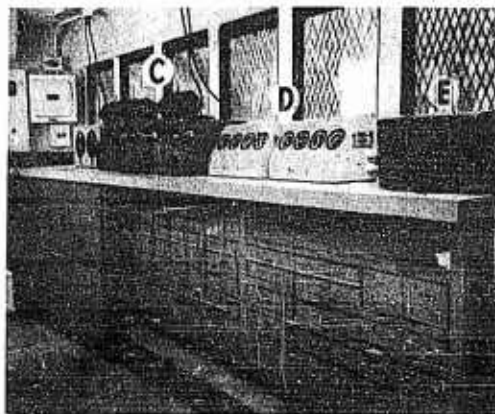

FIGURE 9. Interior of recording truck, right bench. C sound scribers; D panoramic telescope indicators; E electric cable junction box.

delivered for test by Project SOS-11, was not built according to original specifications. Corners had been cut in making the pilot model and some of the most important features of the instrument suffered changes not approved by the designer. Had the original specifications been followed, the field artillery might now have a satisfactory panoramic telescope for regular issue. As it turned out, tests of the poorly built pilot model (the one shown in Figure 5) could only be followed by recommendations for considerable modification and change.¹² If a lesson is to be learned from this experience in instrument design, it is that no construction changes in a pilot model should be made without the express approval of the designer. Features which are difficult to engi-

ing errors, computation errors, communication errors, confusion due to changes in commands, etc. The analysis of these errors and studies of their correction by better training or instrumentation require the development of satisfactory methods for observing, measuring, and recording the performance of a field artillery crew. Direct recording procedures, involving an observer who takes notes, checks settings, etc., are often slow and inefficient. Furthermore, they interfere with normal firing procedures in a way which tends to invalidate their use. For this reason the AMRL and NDRC research groups agreed early in their work that the development of remote indicating and recording systems would be a prerequisite to any refined and ultimate experimental program.

RESTRICTED

Remote recording of gun position presents no special problem. Within a few months after the projects began, a test model of a selsyn system for transmitting gun position had been completed.⁹ This system used two speeds of transmission in both azimuth and elevation: a fine dial at 100 mils per revolution and a coarse dial at 1,000 mils per revolution. The average error of the system was found to be 0.14 mil when readings were made to the nearest 0.1 mil. Maximum errors were 0.4 mil.

The development of other recording units which would make it possible to check the action of an entire field artillery battery took about a year.⁷ These units included instruments for indicating range settings at the guns, for indicating settings on the panoramic telescopes, and for recording (on wax disks) the conversations on the different telephone lines. AMRL designed and built the remote indicators for the panoramic telescopes. The other units were built or procured by Project SOS-11. All the receiving and recording units, together with the aforementioned gun position indicators, were installed in an ordnance maintenance truck M-16. Enough electric cable was provided so that the truck could be located about 100 yards from the battery. The general plan of the system is diagrammed in Figure 7. The various recording units are shown as installed in the truck in Figures 8 and 9. A complete description of the units and photographs of the transmitting devices on the guns and panoramic telescopes are given in reference 7.

The recording truck was ready for use a short time before the termination of the NDRC contract, at which time the equipment was turned over to the Field Artillery Board. The project had been able to carry out only preliminary tests of the accuracy of the recording under firing conditions, but these tests indicated that the equipment would be satisfactory. One result of the trials was important for future work. It was found that necessary gun stability (holding within 1 mil) was not possible with standard gun emplacement but it could be obtained by placing large logs behind the trail spades and holding the spades back against these logs under cable tension.

19.5 THE NEED FOR FUTURE RESEARCH AND DEVELOPMENT

The summary just presented is sufficient to show that the war research work succeeded in classifying field artillery errors, in establishing the areas where research was necessary, and in developing research tools. All results were preliminary or incomplete. No specific contribution resulted in the reduction of artillery errors on any of the battlefields. Such reduction will be achieved in the future only if there is a satisfactory application of facts learned during the war in a continuing program of active postwar research. Should the work be allowed to drop, the field artillery will remain the Service branch with the most outdated and inefficient fire-control system, the inadequacies of which are due, in part, to too great reliance on the ability of the average human operator.

A course for future research is already well determined:

1. The work on panoramic telescope scales should be continued. The odometer or counter type of scale should be perfected, starting with the completion and testing of a model which includes all the features of the instrument originally planned by Project SOS-11. When a satisfactory scale is developed, its use should be considered for a number of other instruments which now have broken scales.

2. The possibility of employing selsyn transmission of gun orders as the primary method of operating field artillery equipment (with the use of panoramic telescope scales reserved for secondary methods of operation) should be thoroughly explored.

3. The system of recording units now ready for research use should be applied in studies which include among their objectives the improvement and standardization of operating procedures as well as the improvement of equipment. Both the AMRL and the NDRC research groups have emphasized that the mounting number of errors in field artillery firing was due as much to the breakdown of operating procedures as to undesirable equipment design.

4. A thorough re-evaluation of the field artillery problem and its method of solution appears to be needed. Under conditions of modern war-

RESTRICTED

fare, what degree of firing precision is needed? Fine precision is not necessary when the artillery's task is to blanket an area, but against moving targets, against targets at great range, and against all pin-point targets, firing must be as precise as possible. Where can precision be improved in the present system? The observation that the gun trail spades have to be anchored to logs to ensure the gun stability

needed for recording and test purposes suggests that the same procedure might also be needed for precision firing in the field. Is this not a place where equipment redesign is necessary? True, at the moment, the firing errors which must be eliminated are errors of a magnitude far greater than those due to gun shifting, but thinking about problems related to precision within a few mils should not be postponed.

RESTRICTED

Chapter 20

THE DESIGN AND OPERATION OF B-29 GUNSIGHTS

By Charles W. Bray^a

SUMMARY

THE APPLIED PSYCHOLOGY PANEL was requested to develop military requirements for B-29 gunnery equipment which would simplify the task for the gunner and provide for better learning of the task by the average gunner. An experimental test apparatus was developed for the study of the gunner in relation to his equipment. This apparatus provided for ground and airborne scoring of performance against synthetic targets. A ground and an airborne synthetic trainer were developed from the experimental apparatus.

Experimental studies indicated that triggering the B-29 gunsight was a disturbing and nondiscriminating reaction which occurred semirhythmically and independently of the accuracy of fire. Continuous firing was recommended. A set of simplified hand controls for the B-29 gunsight was developed. They proved to be superior to the standard controls. A study of slewing methods indicated the need for attention to slewing in training and in the design of equipment. Viscous damping of the B-29 gunsight was shown to be superior to friction damping.

Psychological research on the B-29 gunner indicates that a limit to the complexity of the gunner's task may have been reached. The question is discussed and the need for further research on the relation between the gunner and his equipment is emphasized.

20.1

INTRODUCTION

20.1.1

The Task of the B-29 Gunner

In the early days of World War II the combat job of an aerial gunner operating the flexible^b

^a This chapter is based primarily upon the work of Project AC-94.

^b A flexible gun is one which can be fired in any direction relative to the path of the gunner's own ship. Flexible gunnery is thus contrasted with fixed gunnery since in the latter case the guns are brought to bear only by aiming the plane as a whole at the target.

machine guns of a bomber against enemy fighters was difficult. The gunner was generally squeezed into crowded spaces (there is little space in an airplane at best) without reference to the needs of the gunnery situation. For protection against cold and oxygen deprivation, he often wore a heavy, electrically heated suit and gloves as well as an oxygen mask. For long hours, sometimes isolated from his comrades, the gunner rode through enemy territory keeping constant watch for an attacker.

When an enemy plane was seen the gunner had to recognize its type. He had to note the zone from which it was approaching; this was not easy when there were no reference points in the surrounding visual space. He had to wait until the enemy came within range of his own guns and until he was sure he was being attacked. Then, in the space of a few seconds, he had to estimate how the enemy would move relative to himself during the time of flight of a bullet, aim his guns accordingly, and fire. At each pressure of the trigger the recoil of the gun moved it off the point of aim; firing had to be intermittent.

Despite its difficulty, the task of the gunner was "natural." It seemed essentially simple to the gunner himself. It was a task roughly comparable to that of firing a pistol from one rapidly moving car at another rapidly moving car. Disregarding the consequences of inaccuracy for the moment, the task seemed natural and the perceptual situation clear.

As the war progressed, new machine-gun sights were developed. These eliminated much of the guesswork, particularly in the matter of computation of lead. In so doing the gunner's freedom of movement was reduced. He could no longer "shoot from the hip" in free and easy style. Progressively he became tethered to his sight; freedom of head, arm, hand, and body motion became slight. Simultaneously, control over the gun became less direct. Motors replaced muscle. The gun pointed in a different direction from the sight. Finally, in the B-29, the gun was moved away from the gunner, so that in

some instances its fire could not even be heard. The result of these changes was that the gunner's task became unnatural to him even though accuracy of fire increased.

One of the B-29 gunsights is shown in Figure 1. Near the top of the sight is a forehead rest which was used to steady the sight. Just

its own axis changed the diameter of the reticle circle. Part of the gunner's task was to keep the target just framed in the circle of dots. Before the attack began the relation of circle size to range was adjusted for the size of the enemy ship; thus when framing was correct, the size of the reticle circle gave the range of the target.

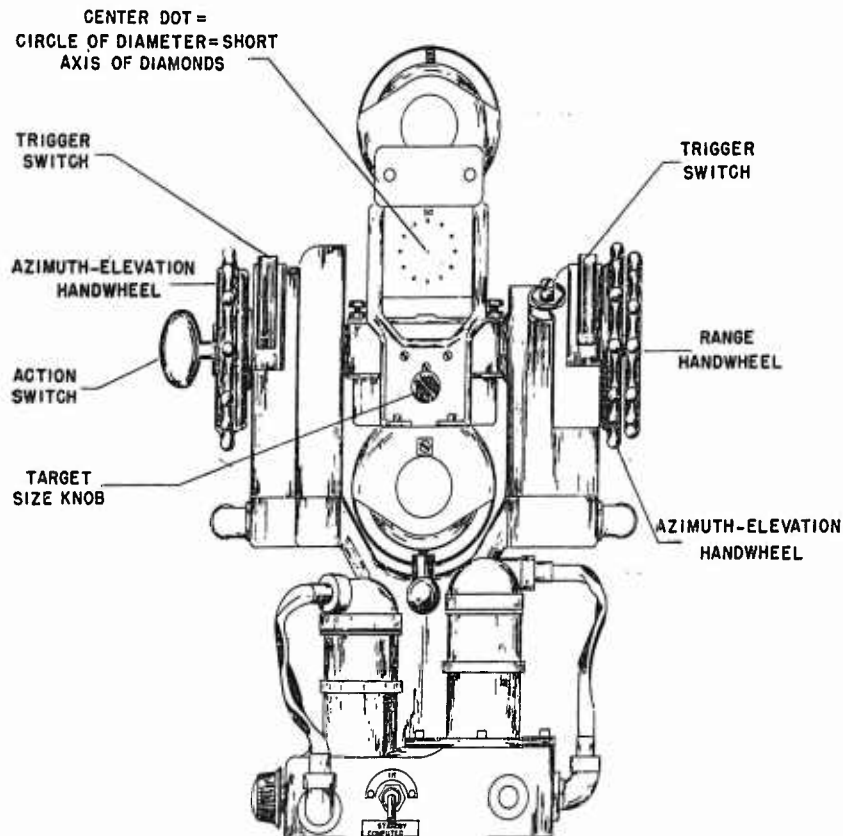

FIGURE 1. B-29 gunsight. See text for explanation.

beneath is the optical system through which the gunner sighted the target. The ring of dots and the central spot made an illuminated reticle. The fluted handwheel at the extreme left served as the azimuth-elevation tracking control with which the central reticle dot was held on the target. To track in azimuth, the gunner moved the sight as a whole around its vertical axis. He rotated the handwheel around its own axis to track in elevation.

The handwheel shown at the extreme right of the sight was used to determine the range of the target. Rotation of the range control about

Although the two hands had separate tasks it was necessary that they work together to provide stability to the sight. This was a particularly difficult problem for the right hand. The azimuth-elevation handwheel at the right of the sight was lightly held in the fingers. As the gunner changed range on the target his fingers had to slide over the inner ring, holding it just firmly enough to stabilize the sight yet not so firmly as to interfere with ranging or tracking.

The elevation and range controls were linked internally. In consequence, the movements of the range handwheel had to be made relative

RESTRICTED

to movements of the sight in elevation. Depending upon the direction and rate of elevation changes relative to range rate, the rate of hand movement in ranging might differ for the same target range rate.

Perhaps the most difficult learning problem for the gunner was to learn to tie together the asymmetrical movements of the two hands in response to the two quite separate aspects of the target stimulus, position and range change. The task was as difficult as patting the head with one hand and rubbing the stomach with the other, with the rhythm of each hand determined by separate, external stimuli.

To the complexities of tracking and ranging was added the duty of pressing the trigger. Two identical trigger thumb switches, for use of either thumb in triggering, were provided. They are shown in Figure 1 next to each handwheel. The triggers were mounted on a portion of the sight which moved in azimuth tracking but not in elevation tracking. Thus each trigger moved relative to the thumb during elevation tracking, and the right trigger also moved relative to the right thumb during range tracking.

The gunners were instructed to track accurately and smoothly, to range accurately, to fire when tracking and ranging were adequate, and to fire intermittently even when tracking and ranging continued to be adequate. These aspects of the gunner's performance were studied.

The problems of teamwork with other gunners, involving the use of a number of accessory switches and controls, were not subjected to experimentation by the Applied Psychology Panel, so they will not be described here.

20.1.2 The Request for Project AC-94

The task of the B-29 gunner was complex. Nevertheless the gunner was successful. Japanese attacks on the B-29 were fought off with relative ease. It was evident, however, that simplification of the gunner's task held possibilities for even greater success. The situation was clearly recognized by the Operations, Commitments, and Requirements Section of Army Air Forces Headquarters in a letter dated July 13, 1944:

(1) It is requested that the following project be submitted to the National Defense Research Committee: AC-94—Psychological Factors in the Operation of Flexible Gunnery Equipment. (2) The object of the project should be to conduct research and secure information necessary to establish military requirements that will insure the procurement of the types of equipment that may be most effectively operated by the average flexible gunner under combat conditions. (3) The increasing operational use of heavy bombardment aircraft has led to a corresponding increase in the defensive armament and fire power of these airplanes and has resulted in a rapid increase in the responsibility placed upon the flexible gunner and an increase in the difficulty and complexity of the gunner's task. Although rapid progress has been made in the development of turrets and firing equipment, only a limited amount of information is available concerning the ability of the gunner to use this equipment effectively against the enemy. If further improvements are to be made, and adequate protection is to be given to heavy bombers in missions over enemy territory, it is necessary that information be secured concerning the human limitations of the gunner, especially limitations in his ability to learn to use different types of equipment. It is especially important that requirements for equipment be established so that the average gunner can learn to use the equipment as rapidly and effectively as possible.

The Applied Psychology Panel accepted the request. Work began in September 1944 and continued until World War II ended. Because of the shortage of research personnel, studies were limited to the B-29 gunnery problem. A laboratory was established at the Research Division, Laredo Army Air Field, and all work was carried on in intimate cooperation with Army psychologists and other scientists of the Research Division. In many respects the NDRC staff served as a section of the Division.

Throughout the year of project work two objectives were kept in mind. First was a long-range program to develop the equipment and methods required in the psychological study of the gunner and his equipment. The Air Forces' request stressed the importance of generalized statements concerning the gunner's needs. For this purpose basic research was required. Second, many questions of immediate high priority had to be answered by experiment or consultation. These included questions of operating procedures, the design of the B-29 gunsight, and training methods. Consulting service on gunner problems for other sights was a by-product.

The basic and short-term phases of the proj-

ect received about equal attention from the staff. For a Panel project, this was a greater-than-usual emphasis on basic research.

20.2 METHODS AND PROBLEMS IN THE STUDY OF FLEXIBLE GUNNERS

The development of methods for the study of gunner performance constituted the first essential in the program of basic research. The problem was to find a way of measuring the gunner's contributions to the inaccuracy of the whole man-machine combination. It is commonly recognized that analysis and evaluation of the errors of the machine alone is difficult. Adding the gunner, thereby introducing the whole gamut of psychological variables, complicated the problem further.

Four methods of studying the gunner were considered. These were (1) measurement of the accuracy of air-to-air firing; (2) measurement of individual aspects of gunner performance in synthetic trainers; (3) simultaneous measurement of all important phases of the gunner's task in a relatively complete miniature of the aerial problem, i.e., in as complete a mock-up of the aerial situation as could be built; and (4) development of a synthetic target and recording system suitable for airborne use. In the last three cases the purpose was to reduce the effects of variables which could not be controlled in air-to-air firing.

20.2.1 Air-to-Air Firing

The first approach considered was to take men into the air and measure the accuracy of actual fire. For a number of reasons connected with the design of computing or director-type sights, the target could not be stationary (a ground or balloon-supported target) but had to be another plane or object on a realistic attack

^oThe reader is referred to the Summary Technical Reports of Division 7 and the Applied Mathematics Panel of NDRC for discussions of the problems of evaluation of fire-control matériel. The staff of Project AC-94 enjoyed the benefit of continuous cooperation with these groups in the development of methods for the measurement of the gunner.

course. Assuming that the target could be realistic when heavily armored or when uninhabited (radio-controlled or towed) and assuming that the error in firing could be measured with sufficient accuracy by use of, say, the frangible bullet or acoustic sleeve, there was still good reason to doubt that any but the crudest measures of the gunner could be obtained.

Measures of gunner performance were affected by the weather (wind, visibility), by the maintenance of the airplanes and gunnery equipment, by the skill of the pilots of own and target planes, and by the clarity of communications between them. And, like all human behavior, gunner behavior included a large inherent variability: motivation, training, and aptitude affected it. The only remedy for all these sources of variability would have been to take a great many observations. Even a few observations, however, required many hours of use of two or more aircraft with associated airfields, ground crews, and aircrews. It was concluded that air-to-air gunnery could provide only a rough observational or empirical check on conclusions established by sound experimentation of a more artificial but better controlled type.

20.2.2 The Modified E-14 Trainer

The second approach was quite artificial. It was to measure accurately a restricted aspect of the gunner's activity in a ground situation. The ground situation duplicated the aerial situation insofar as convenient and possible. The accuracy of tracking, framing, and triggering was measured, for instance with the Army E-14 trainer and a sight-recording system. The trainer presented a motion picture of a target plane making attacks upon the gunner's own "plane." Against this target the gunner operated a sight. In an experimental setup, actually used by the project, movements of the sight controls were recorded mechanically by pens on a moving-paper kymograph. Thus performance was recorded for later analysis. A measure of error was obtained by laying over the ink record a template drawn to scale from the measured position of the target as projected.

In order to be satisfactory for general experimental purposes, a synthetic target system must have an accuracy of the order of a mil for target position and of seconds of arc for target definition. Standard motion picture projectors did not provide either of these. Film alignment varied from frame to frame, speed of projection varied, and target wing tips were poorly defined. The scoring of performance was slow and required a large clerical section. Although the project used the method in several rush experiments,^{1, 2, 4} the method was rejected from the start as a general solution of the experimental problem.

20.2.3 The Ground Mock-Up

The third approach to the measurement of gunnery proficiency was to build a more accurate miniature system or mock-up of the aerial situation than that just described. This was done by producing an accurately controlled synthetic target and recording system. The remotely controlled test device¹³ to be discussed below was the result.

20.2.4 The Airborne Mock-Up

The fourth approach was to take the synthetic target and the recording system into the air. The major sources of unreliability in studies of air-to-air firing came from outside the gunner's own ship or from the difficulty of measuring the bullet's actual path. Therefore, reliable airborne measurement could be attained if the whole experimental situation was included within the gunner's plane. Only the guns and bullets had to be omitted in this system, and for psychological research the omission was unimportant.

The airborne test device would also provide an excellent trainer. Even though such a device would be expensive, its cost would have been well below that of an actual target plane. A pilot model, the airborne synthetic gunnery trainer and test device¹⁰ described below, was partially completed at the end of the war.

For the purposes of sound psychological ex-

perimentation the complete ground mock-up and the airborne mock-up had to have a number of common characteristics.¹³ The airborne system had to be smaller, lighter, more flexible, and vibration-proof, but these were essentially matters of detail. The important characteristics of both systems and the reasons for their importance are described in the following paragraphs.

Any test system must provide for convenient and realistic training of aerial gunners. In nearly all experiments the state and type of training of the gunner are variables of such importance that one cannot attempt to control, much less to measure, them by reliance on standard Army training. Chapter 5 presents evidence to show that gunners trained by different methods differ significantly in their proficiency. Hence training must be provided within the experimental setup.

Adequate training requires that the men practice on a variety of realistic attacks. It requires that they be motivated by valid, reliable scores of their performance on these attacks and by graphic records illustrating the effects of bad techniques in slewing, tracking, framing, and triggering. Scores and records should be available immediately after each attack, and provision should be made for instantaneous buzzer signals or other warnings of error during the attack. Any delay in informing the gunner of his performance is undesirable and every effort should be made to avoid delays of the order of several minutes. This type of rapid scoring is also required for convenient and practical experimentation. Solution of this experimental problem provided pilot models of scoring devices for general use in the Air Forces gunnery training program.

Any test system should provide accurate, separate measures of the principal contributions of the gunner to inaccuracy in fire: triggering, azimuth tracking error, elevation tracking error, errors in azimuth and elevation tracking rates, and framing error.

A record of the times of pressure and release of the trigger is a simple addition to any recording system. Analysis of triggering consists only in determining the times of depression and release of trigger for purposes of dif-

ferentiating performance during triggering from that at other times.

The solution of the measurement problem is also relatively simple, at least in theory, in the cases of azimuth and elevation tracking and framing. For these, true target position and size must be accurately known at all times, and it must be possible to compare the gunner's estimates of these quantities (handwheel positions) with the true values. For most purposes a direct record of the difference between true target position or size and sight position or reticle size is adequate. A graphic record of error is desirable, but for convenience in scoring the error should be integrated and stated in terms of one overall number for each component. For many purposes it is sufficient to score a man in terms of time-on-target (see Chapters 3 and 5) within certain tolerable limits. Nevertheless, provision should also be made for determination of error scores.

The problem of measuring error in tracking rate, whether for azimuth or for elevation tracking, is complex in theory as well as in mechanical detail. The gunsight and computer are constructed to predict the future position of a target from the data supplied by the gunner as to present position and rate of target motion (and from other data, such as time of flight of the bullet, own ship's speed, ballistic data, etc., which need not concern us here). In making its prediction, the computer must operate on some given set of assumptions about the target course. The computer must also average the fluctuating rates provided by the gunner over some period of time to provide a smoothed rate on which the prediction at any given moment can be based. In this latter process, frequency characteristics may be introduced so that certain types of oscillation of the sight are minimized. In the case of the B-29 sight an additional, nonlinear factor was introduced in the hope of eliminating or minimizing temporary periods of reversal of the direction of tracking, as when the gunner has just gone past the mark and slows his tracking to let the target catch up. These matters are commonly lumped under the term "smoothness of tracking." The term is very descriptive if interpreted as meaning the feeling of a certain kind of

movement of the human body, but it hides rather than reveals the complex mathematical analysis required to describe the mechanics involved in such movements.

The purpose of measuring gunner performance is, ultimately, to shoot down more airplanes. Therefore the most direct solution of the problem of measuring all gunner errors might be to measure the accuracy with which the computer predicts target position on the basis of the information supplied by the gunner. In an experimental situation true target position must be known at all times. Predicted position should correspond with true position at a moment one time of flight later than that at which predicted position is measured.

This last approach has been commonly used. It is realistic and for many purposes it is sound. It may be noted that, if it is used, analytic measures of the gunner's performance may as well be disregarded entirely. The gunner is no longer evaluated in terms of the absolute accuracy of his own performance but rather in terms of the accuracy of the man-machine combination as a whole. For many purposes this overall measurement is desirable. But it results in penalizing the man for the inadequacies of the machine, unless it is assumed that the man should correct for the inadequacies of the machine and be penalized if he does not do so. Thus, if the target course departs from that for which the computer is built, the gunner might compensate for the deficiency of the computer by tracking off the target or varying from actual target rate. In so doing he might produce more hits than by accurate tracking. In many studies it has been assumed, explicitly or implicitly, that the gunner should do this.

It is very doubtful that it is possible for the gunner to compensate for the deficiencies of the equipment. To do so (by design rather than by chance), he must make a series of very fine discriminations of the angle of approach, the aspect, and the relative speed of the target and integrate these in time.

It will be shown below that the B-29 gunner's task was already so complex that he responded to parts of it by semiautomatic reactions which were made independently of simpler discriminations than those described. It seems probable

that the gunner became hopelessly confused when he was instructed to depart from the simple task of tracking accurately and smoothly. Even the instruction to track smoothly was confusing to many gunners, perhaps because it was so poorly defined. Corrections for such inadequacies of the machine as now exist should be made by correction to the machine itself.

An alternative procedure in measurement of errors in the overall performance of the gunner was adopted by the project. The assumption was made that a valid measure of overall tracking, both as to rate and position errors, could be obtained by comparing the output of a computer fed by a gunner with the output of a computer fed mechanically by perfect tracking. This could be done most efficiently for training purposes, where rapid scoring was desired, by measuring the differential between the output of a computer fed by the gunner and that of a computer fed by the target drive system. When the computers were balanced,^{6, 10} dynamically as well as statically, the difference was the effect of the gunner's imperfections.

A convenient measure of the gunner which eliminates the necessity for the two computers and minimizes the effect of target course on the computer is the variability of computed lead. Variability in lead is undesirable (except as bullet dispersion is desired)—this can readily be obtained by other means than by asking the gunner to be variable). It can be measured with relative simplicity in the standard B-29 system. The B-29 computer drives the gun by adding a correction, equal to the lead angles in azimuth and in elevation, to present sight position. Tapping the computer to obtain the magnitude of the lead at each moment, and from this to determine the variability of lead, is an essentially simple mechanical detail.

Experimental measurement⁷ of the difference between mechanically determined and gunner-determined leads demonstrated that variability was generally two or three times greater when the gunner drove the computer. The amount of the difference varied with target rate. Although the preliminary data actually obtained did not warrant more refined analysis, there were indications that the gunners studied differed from one another in their effects on lead

variability. The point is of such importance for the study of the gunner that further research is strongly recommended.

By this method of study of overall error, conclusions must be limited to the particular gunnery system under study. For example, one cannot conclude that a control found to be superior for the B-29 sight is also superior for other computing systems. Thus it was desirable that the test setup be modifiable to accept other sights than that for which it was originally designed. The chief problem in this connection was to provide flexibility in recording. A remote recording system solved this problem.

20.3 TEST AND TRAINING EQUIPMENT

20.3.1 The Remotely Controlled Test Apparatus

The ground mock-up, named the remotely controlled test apparatus,¹³ is illustrated in Figure 2. The blister station (*A*) was a replica of this station on the B-29 airplane. It included the gunsight (*B*). The target consisted of a spot-of-light image on the screen (*D*) from the target projector (*C*). Azimuth and elevation position of the target image were controlled by moving the projector as a whole. In order to eliminate parallax between target projector and gunsight, the center of rotation of the target projector was placed at the center of the gunsight. Target size was varied by controlling a V-shaped slot in the beam of light. These changes were produced by a selsyn and servo system operating out of the cam drive (*F*) which contained separate cams for each target component.

The recording systems were also based on selsyn and servo. Data from the target drive and from the sight were fed into differential selsyns and repeaters at (*G*), (*H*), and (*I*). At (*G*) measurement of overall error of gunner and computer was accomplished. Provision was included to use either of the methods described above. At (*H*) a complete graphic record of positional errors in all components was made. At (*I*) various time-on-target scores were regis-

tered. The accuracy of all records was determined by the accuracy of the follow-up system employed, that of the B-29 gunnery system itself. There is reason to believe that the vast majority of gunners, although not all, contributed considerably more error than did this selsyn and servo system. Greater accuracy of recording than was attained may have been desirable.

20.3.2 The Remotely Controlled Ground Trainer

One by-product of the remotely controlled test device was the development of a synthetic trainer for ground use.⁸ It combined the graphic and time-on-target types of recording and scoring with a superior synthetic target. This target was developed at Buckingham Army Air Field by Privates R. L. Hobson and A. R. Strnad. It was a special model of an airplane

20.3.3 The Airborne Synthetic Trainer and Test Device

The Hobson-Strnad target permitted the development of the Airborne Synthetic Trainer and Test Device.¹¹ The target was mounted in a double gimbal system, as shown in Figure 3, to be fitted into the side blister of a B-29 airplane. Except in one significant detail the control of the target and the recording of data followed the procedure and served the functions outlined above for the ground mock-up. The exception was the development of an airborne graphic chart recorder which provided for (1) simultaneous, linear registration of as many as four separate motions; (2) use of the entire chart width (12 inches) for each of the four channels; (3) exact point-by-point simultaneity of the records in the four channels; (4) indefinite expansion of sensitivity of the record in any channel regardless of the size of any move-

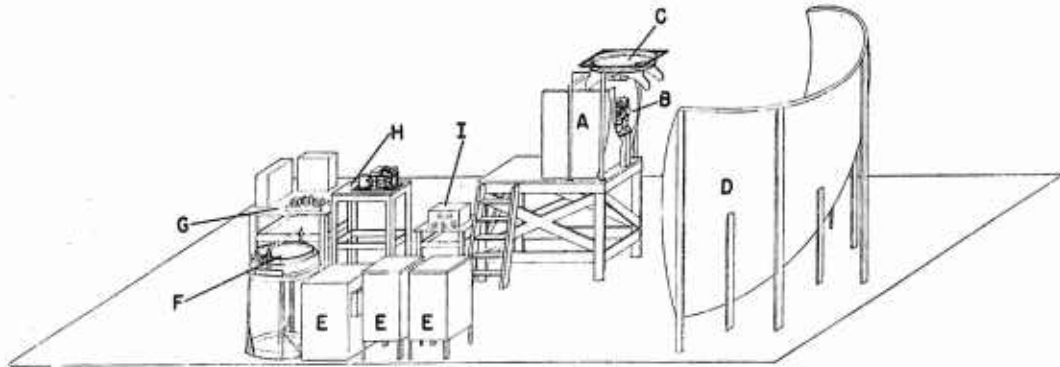

FIGURE 2. The remotely controlled test device.

- | | |
|-------------------------------------|--|
| A. Blister sighting station mock-up | E. Rectifiers, power-supply cabinet, and control box |
| B. Director-type sight | F. Cam table |
| C. Target projector unit | G. Tracking rate error recorder |
| D. Target screen | H. Sighting error recording unit |
| | I. Clock-recording unit |

which could be remotely controlled by the methods described above but which was much simpler and more realistic than the projector system since target aspect could be varied. A pilot model of the trainer was constructed and used in several of the experimental studies to be described below. Research on its efficiency as a trainer in the standard Army situation was postponed pending construction by the Army of a preproduction model. The preproduction model was not finished at the end of the project.

ment likely to be recorded; and (5) relative security of the record from the effects of vibration and shock. This ingenious recorder, which solves the vast majority of all graphic recording problems, for changes below about 5 cycles per second, is described in reference 12.

The airborne synthetic training and test device, like the ground mock-up and the ground trainer, was not fully tested at the end of the war but was turned over to Army Air Forces for final trial.

RESTRICTED

The experimental methodology developed by Project AC-94 represented the most ambitious effort of the Applied Psychology Panel to provide an adequate, systematic analysis of the man in relation to the machine. The termination of research prevented the project from demonstrating the value of systematic measurement of gunner performance. Nevertheless the ex-

perimentation, many more such conclusions can be reached, more rapidly and with greater assurance that they are sound. The methods involved are applicable not only to aerial gunnery but to aerial bombing, use of guided missiles, and any other problem in which human tracking performance is significant in determining computer accuracy.

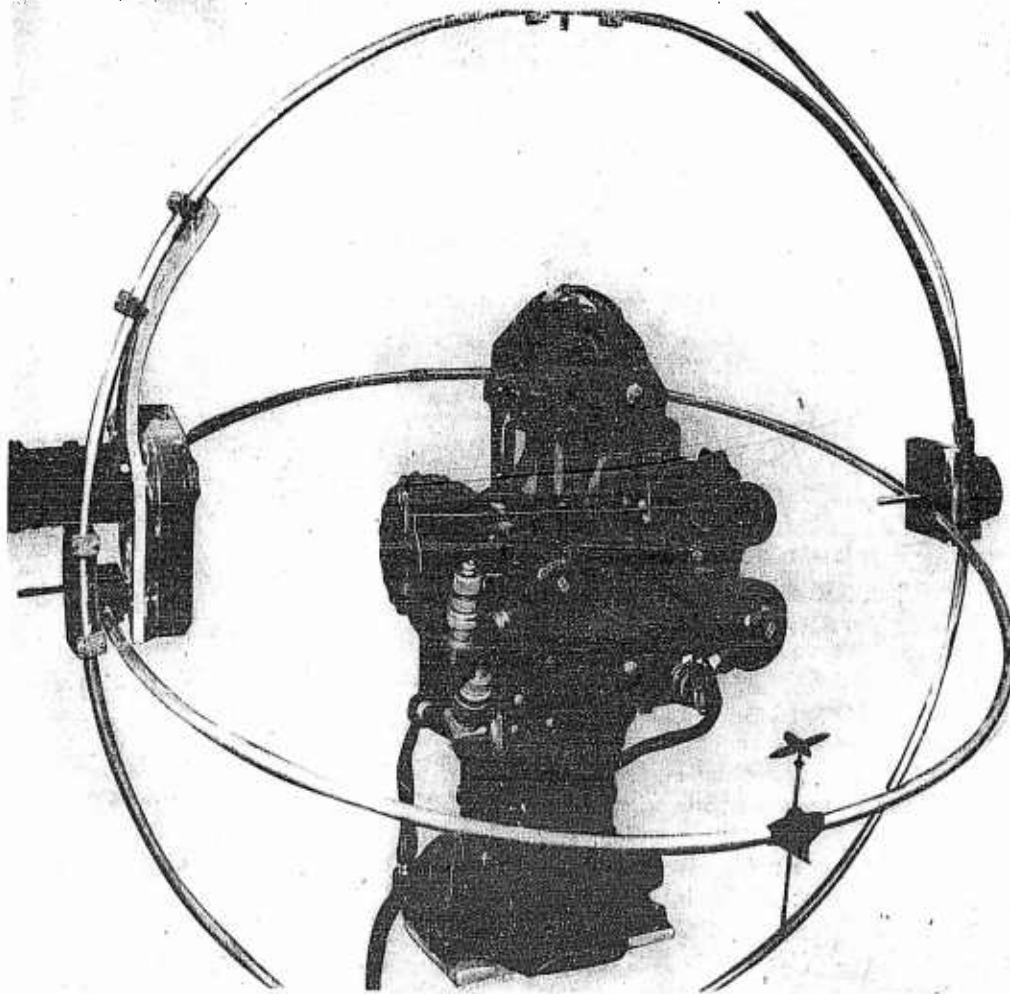

FIGURE 3. Airborne synthetic trainer and test system for insertion in B-29 blister gun station.

perimental studies to be reported in the next section of this chapter indicated the need for a continuation of basic research. Even the inferior experimental equipment used could not hide significant conclusions. With adequate ex-

20-1

EXPERIMENTAL STUDIES

The project completed four series of experimental studies on problems of operating procedures and equipment design. These included

RESTRICTED

studies of the effect of triggering on accuracy of performance, the efficiency of an alternative set of hand controls for the B-29 sight, the effects of slewing, and the effects of substitution of viscous for friction damping. Studies of the training of B-29 gunners were also carried out and are described in Chapter 5.

20.4.1 Triggering and the Accuracy of Performance

The first experimental work of the project was to study one relatively isolated component of the gunner's task: triggering.^{1,2} It is well known that triggering is a complicating feature even in rifle or shotgun fire. In a sight of such complexity as that of the B-29, triggering was expected to be a disturbing factor.

Thirty-four gunners of varying degrees of training were studied. They were given further training in the modified E-14 trainer described above; during 23 days each man "fired" a total of 160 attacks from the B-29 pedestal sight and 208 attacks from the ring sight. Tests of the effects of triggering followed the training: 80 attacks per man, fired during 5 days of tests, were available for analysis.

One analysis of the records was made by dividing each attack into successive periods of 0.133 second each. Each period was then classified as to whether or not it contained a sharp change in the elevation tracking record. A sharp change was defined as a point at which the direction of the curve changed 20 degrees or more. Separate counts were made for periods including a press or release of the trigger and for periods not including trigger action. For ten gunnery school graduates over a total of 27 attacks, 22 per cent of the intervals containing trigger action also contained a sharp change in the elevation tracking record, whereas only 7 per cent of the periods containing no trigger action showed such sharp changes ($p < .001$). A similar difference, sometimes more and sometimes less in amount but always statistically significant, was obtained on separate analysis of the records of groups of gunnery school candidates, ex-combat gunners, and ex-combat officers. Evidently triggering on this sight produced jerky tracking.

Other analyses were made including, for example, framing accuracy during periods of "firing" versus periods of "nonfiring." The average error in framing, measured in arbitrary units, was 46 for all subjects during firing and 47 during nonfiring periods. This difference was insignificant. The result opposes the reasonable expectation that the gunner will fire when he is tracking and framing accurately and that he will hold his fire when his sight is off the target or his reticle not framed properly. Even in practice the expected result was not obtained.

The facts are clarified when data on the characteristics of triggering are analyzed further. The duration of the triggering and nontriggering intervals was measured from records like those shown in Figure 4. In this

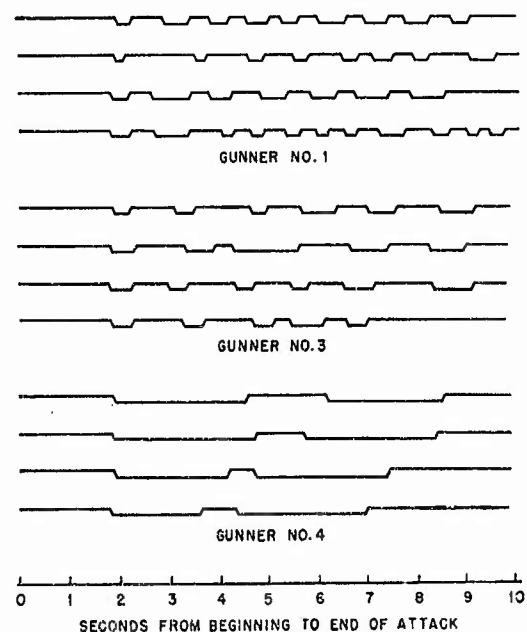

FIGURE 4. Sample triggering records of three gunners on pedestal station. Deflection downward of the trigger line indicates trigger depression, while upward deflection indicates trigger release. The length of this interval is that of a particular burst.

figure are the triggering records of three gunners, each of whom fired four attacks. The four attacks differed from one another, but the same four were fired by all three gunners. Even a casual examination of the figure shows that

each gunner had a relatively constant pattern of triggering and that the pattern differed from gunner to gunner. Thus some gunners triggered frequently and some infrequently, but each adopted a semirhythmic pattern of triggering. The rhythm was by no means precise, but analysis of the data showed that the ratio of time spent in firing to time *not* spent in firing was relatively constant. Since the firing was more or less rhythmical, it could hardly be related to accuracy of tracking or framing but must have been semiautomatic.

The conclusion of the project was that the task of the B-29 gunner was so complex that its minor components were carried out by the gunner independently of the perceptual situation. The attention of the gunner was so occupied by the tasks of tracking and framing that he could not make a clear and discriminating choice of the moments at which to fire. A human limit to complexity of task was being approached and may even have been reached.

The project's recommendation from this study was that the operational doctrine should be changed so that the gunner was told to press the trigger continuously once he had begun to fire. If it was necessary for reasons of matériel to fire in bursts, which was doubtful, a simple lightweight automatic burst-control device³ could be installed. In addition, the trigger should be redesigned.

20.4.2 Modified Hand Controls for the B-29 Sight

The experimental study of triggering, as well as a number of general psychological considerations, indicated the possibility that gunner performance, and particularly smoothness of tracking, might be improved by modification of the sight controls. The following types of change seemed to be indicated.

1. Freedom from interference between triggering and other movements.
 2. Freedom from interference between the movements involved in elevation tracking and ranging.
 3. Increased leverage in elevation tracking.
- These changes were incorporated in a new set

of controls together with certain other minor changes designed to make the new controls fit the hand more comfortably. The modified controls are shown in schematic diagram in Figure 5.⁹

Because the project's test equipment was not yet ready for experimental use, the modified controls were tested on the pilot model of the remotely controlled trainer described above (Section 20.3.2). The tests were by no means complete since the target courses were neither realistic nor a systematic sample of various rates and since only time-on-target scores were available for use in comparisons. Separate time scores were taken for accuracy in azimuth, elevation, and range tracking. The gunner was credited with being on target in azimuth when within ± 6 mils, on target in elevation when within ± 4 mils, and on target in range when within ± 6 per cent of "true" range. In addition he was scored for time-on-target when he met all three criteria simultaneously. All scores were recorded in terms of percentage of total time of each attack during which performance was satisfactory.

The gunners were instructed not to use the trigger during the experiment. This instruction was given because the trend in B-29 gunnery, supported by the triggering study just described, was for continuous fire once a gunner had begun to fire. It should be noted, however, that differences between the standard and modified sights would probably have been larger if intermittent fire under gunner control had been used.

Thirty enlisted men with no previous gunnery experience served as subjects. They practiced for 350 seconds per day for 23 days. During the first 11 days a buzzer signal was given to the men whenever they were on target. The men practiced on the two sets of controls on alternate days, half following an *ABBA* and half a *BAAB* order.

The results for all gunners are shown in Table 1. For the modified and standard sights respectively, Table 1 gives the mean per cent time on target for each component of the gunner's task and the mean per cent time on target for all components simultaneously. The differences between the sights and a summary of

statistical data required for evaluation of the differences are also shown. Throughout the experiment the modified sight showed a small, statistically significant superiority. The value of the new controls, expressed as an improvement over standard performance, ranged from 4 per cent to 22 per cent. Because the modified controls were primarily designed to increase

recalled that the gunners were completely inexperienced at the start. The significance of the result is unclear. The matter needs further investigation in relation to training and also in relation to the value of automatic ranging devices.

The project designed other sets of hand controls, including controls for the standard B-29

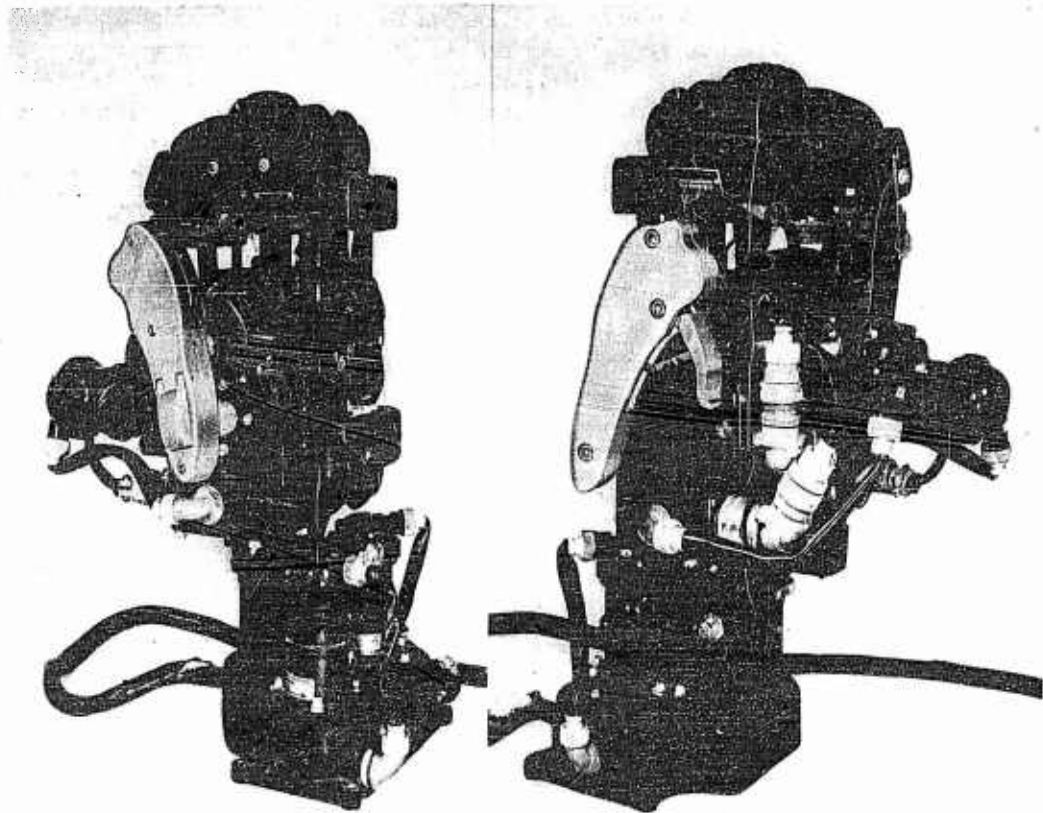

FIGURE 5. Modified B-29 gunsight controls. The left figure shows the left handgrip on which the trigger and action switch are mounted. The right figure shows the right handgrip on which a pressure-type ranging control is mounted. Both handgrips control azimuth and elevation tracking.

the smoothness of tracking, they might have an even greater advantage than that shown in the experiment if evaluated in relation to computed lead.

An interesting by-product of the experiment on sight controls can be observed in the data of Table 1. The gunners tended to become worse in their azimuth and elevation tracking and better in framing as the experiment progressed. This was true for both sights used. It may be

ring sight and for the General Electric gyro-stabilized sight. In addition the project prepared a tentative guide of general psychological principles for use of sight engineers in designing sights. The guide was based chiefly on a priori reasoning and general experience with gunnery so that it was by no means intended as the final word of the project. It was intended for practical war use as a compendium of the best available opinion. It also served to guide

RESTRICTED

the project in further research. Because of its general interest in all problems of equipment design, part of it has been included as an appendix to Chapter 24.

TABLE 1. Comparison of modified and standard controls for the B-29 gunsight. The data shown represent the mean per cent time-on-target in azimuth, elevation, and range, and in all components simultaneously. Results are given for the beginning, middle, and end of the training of the men. Also shown is the *t* statistic and the confidence level (*p* value) for each comparison.

	Azimuth	Elevation	Range	All components
Days 1-4				
Modified sight	83.6	50.9	44.2	21.7
Standard sight	68.7	47.4	42.4	17.6
Difference	14.9	3.5	1.8	4.1
<i>t</i>	9.25	2.10	1.09	3.87
<i>p</i>	.0001	.04	.28	.0001
Days 13-16				
Modified sight	63.2	48.2	56.1	18.7
Standard sight	55.2	43.5	53.5	15.0
Difference	8.1	4.7	2.7	3.7
<i>t</i>	5.19	4.52	2.00	4.58
<i>p</i>	.0001	.0001	.04	.0001
Days 17-20				
Modified sight	55.3	39.1	62.9	14.4
Standard sight	50.5	37.0	58.4	12.6
Difference	4.8	2.2	4.5	1.9
<i>t</i>	3.06	2.22	3.44	2.57
<i>p</i>	.002	.03	.0007	.009

20.4.3

Slewing

As a step in the development of methods for the evaluation of the gunner, the project undertook to test for itself the degree to which individual computers, or the same computer on successive trials, agreed in dynamic tests of the lead predicted from the same sight data. The method was to track a sight mechanically and to study the variability of lead prediction in successive trials either of the same computer or of different computers. The basic purpose of the project in this experiment was methodological. But the results should be emphasized also in relation to slewing. The conclusions will not surprise the matériel man since they simply reflect the specifications for the B-29 computer. But the training officer and

the psychological research investigator need to keep them continually in mind; there was little emphasis on methods of slewing in the training of gunners. The facts are that when methods of slewing are not rigidly controlled the computer prediction will show a probable deviation over the whole course of as much as 5 mils and differences between computers in predicted leads on the same mechanically tracked courses will run as high as 20 mils during the first 3 or 4 seconds of the course. On the contrary, when slewing is carefully controlled the differences become small.¹⁰ The implications for training are obvious.

It is at least doubtful that radical differences between gunners in slewing can be avoided by training. No experimental data on the point were obtained. Even if training reduced the differences between gunners in practice attacks it must be recalled that multiple attacks on a bomber were the rule and that gunners will almost certainly forget their training when the penalty for slowness in getting on a target is an enemy bullet. Many gunners, whatever their training, will swing their sights onto a second or third target in the most direct possible way. It is desirable that slewing problems be handled as automatically as possible and that experimental studies of the gunner's slewing habits be undertaken.

20.4.4

Sight Damping

The variability of computer correction for lead was also used as the criterion in a study of a B-29 pedestal sight modified by the substitution of viscous damping for friction damping in the azimuth system. The modification was introduced by the Armament Laboratory, Wright Field, and studied in relation to the gunner by Project AC-94.⁵ Ten graduate B-29 gunners were used. They received a small amount of additional training with friction damping and also with viscous damping before the experiment began.

A target, changing in azimuth only, was tracked by the gunners, first with friction damping and then with viscous damping. The target rates were 2 degrees and 6 degrees per

RESTRICTED

second. Each run lasted 10 seconds. The sight was unstowed in elevation even though the target varied only in azimuth position. Range input to the computer was eliminated, and no tracking in range was required. These relatively unrealistic conditions were necessitated by the shortage of time. Nevertheless the results are believed to be significant. They are shown in Table 2 in terms of mean probable deviation of computer lead correction. The correction was measured at ten equally spaced moments during the target course. The viscously damped sight showed a reduction of variability in computed lead of the order of 25 per cent, and the difference was significant at a confidence level of 1 per cent. The practical implication of the result is so clear that further experimentation with viscous damping under more realistic conditions and in terms of its effects on all components of the gunner's task

TABLE 2. Friction damping vs viscous damping of B-29 gunsights. The values given are mean probable deviations in mils of computer azimuth-lead corrections computed from values taken at ten equally spaced points in tracking a target course.

Gunner	Target rate 6°/second			Target rate 2°/second		
	Friction damping	Viscous damping	Diff.	Friction damping	Viscous damping	Diff.
1	3.58	2.47	1.11	2.25	1.72	0.53
2	3.99	2.01	1.98	2.02	1.38	0.64
3	3.07	2.22	0.85	2.39	1.49	0.90
4	3.58	2.47	1.11	2.62	1.48	1.14
5	3.25	2.77	0.48	1.71	1.82	0.11
6	2.93	2.32	0.61	1.94	1.77	0.17
7	2.75	2.86	-0.11	2.25	1.38	0.87
8	3.49	2.21	1.28	1.67	1.48	0.19
9	3.10	2.78	0.32	3.04	2.09	0.95
10	2.82	2.80	0.02	1.38	1.48	-0.10
Mean	3.26	2.49	0.77	2.13	1.59	0.54
σ_m			0.200			0.135
t			3.83			4.00
p			<.01			<.01
Reduction in probable deviation			23%			25%

is recommended. There is a radical difference in the "feel" of a viscously damped as compared with a friction damped sight, and viscous damping is believed to be preferable from the point of view of the gunner.

20.5

CONCLUSION

The task of the B-29 gunner in World War II was complex. The experimental work of Project AC-94 demonstrated that practical ways existed to simplify it by changes in matériel with consequent improvement in performance. The value of the improvement in terms of the cost of matériel change must be considered in terms of broad policy. When such a question arises it is clear that the measure of improvement in gunner performance which will be most useful is a measure of the efficiency of the whole man-machine combination. Much of the work of Project AC-94 was directed toward the securing of such measurements.

Despite the importance of the measurement of the whole man-machine combination it is also necessary to secure generalized information on the factors affecting the performance of the man independently of any given machine. Generalized information on the man is required in order to select or train him and it is required in order to plan future machines. To secure it, mass experimentation, with its demand for rapid, automatic, and accurate measuring devices, is required.

The most interesting psychological question raised by the work of Project AC-94 was whether the complexity of the tasks performed by human beings is approaching a limit (perhaps, whether the limit has already been reached) in the operation of military equipment. The B-29 gunner had to perform three relatively independent, difficult, continuous, perceptual-motor tasks simultaneously. These he did with an accuracy which was surprising in view of the awkward postures, the discomfort, and the relatively short training periods^d he received. Nevertheless, when the average gunner was also required to judge when his performance was good enough to warrant firing his gun, he responded by a semiautomatic and

^d Contrast the amount of training given to gunners with that which nearly every American boy gives himself in the simpler perceptual-motor coordination of throwing a ball. A gunner who actually used his sight for more than an hour in tracking real or simulated targets probably received far more actual experience than did the average B-29 gunner who met a Japanese plane.

RESTRICTED

nondiscriminating action. Triggering the B-29 sight was not marked by due consideration of the relation between reticle and target sizes or positions. This, it may be noted, was true even though the average gunner was considerably superior to the average American soldier in the capacities measured by the Army General Classification Test. Gunners were selected from the top 30 per cent of all men on that test.

The important psychological and military

question, then, is whether and how much the complexity of the task can be reduced by changes in matériel. In a few particular cases, successful and practical reductions of complexity of the B-29 sight were made. But the problem of complexity is general, extending to other gunnery systems and to many different military tasks. It is unlikely that it will be solved except by the type of systematic, mass experimentation contemplated by Project AC-94.

RESTRICTED

Chapter 21

THE OPERATION OF RADAR EQUIPMENT

By Donald B. Lindsley^a

SUMMARY

ON THE BASIS of limited experimentation the following conclusions and recommendations with regard to radar design and operation may be briefly summarized.^{16, 17} Caution and conservatism should be exercised in generalizing these results to include radar applications or procedures other than those on which the results were obtained.

Fixed hairline versus movable hairline. For range tracking with a J-scope (and probably also an A-scope) the use of a fixed hairline and a controlled or adjustable pip is more accurate than the use of a movable hairline and an adjustable pip.

Scope choice for tracking. A dot-on-cross-hairs' presentation is superior to a twin pip presentation or a meter presentation for bearing and elevation tracking.

Scope illumination. Ambient illumination of sufficient intensity (1 ffc or better) to read dials and manipulate controls is permissible, providing it is uniform and does not cast shadows or produce glare on the scope face. For best search efficiency, average or better trace brightness and moderate scope illumination are desirable. High illumination of a dim trace is to be avoided.

Effect of radar operation on operators. To avoid undue fatigue and loss of efficiency, search radar operating periods should be limited to 1/2 hour. Where possible, operating periods should be rotated among operators, thus providing adequate intervals of relief from scope observation. If longer periods of continuous operation are necessary (4 hours or more) they should be repeated only after 1 or more (preferably about every third day) days of rest.

Contrary to persistent rumors among radar operators, the continued viewing of a radar screen does not have a harmful effect on vision. Veterans with many hours of scope observation showed no permanent loss in visual capacities.

^a This chapter is based upon the work of Project SC-70, NS-146, and the work of Project N-114.

Radar code. The feasibility of presenting International Morse Code visually on radar screens was demonstrated. The specifications for speed, dot-to-dash ratio, letter grouping, letter difficulty, and recommended training methods were determined. Additional psychological problems dealing with the perceptibility of the code were suggested.

Calibrating and operating procedures. Calibration and operating errors in ranging may be reduced by paying careful attention to adequate warm-up of equipment, frequent checking of zero-sets, and precision of range scale marking and engraving. A modified range dial attachment was recommended for Mark 4 radars.

21.1

INTRODUCTION

The applications of radar are numerous and diverse. The complexity of the task confronting an operator varies from simple ranging on an A-scope, by keeping a pip adjusted to a gate or hairline, to multiple and simultaneous functions requiring detection, discrimination, and interpretation of target signals in addition to determining range, bearing, and altitude. The conditions under which these functions are performed range from the comparative security of a ground-based coastal search station to the dangerous and highly exciting circumstances of a bombing mission with its attendant hazards. In addition to radar equipment it may be necessary for an operator to use optical sighting systems, communications systems, computers, maps, and other supplementary devices. An operator may be solely responsible or may be part of a team.

The nature of the equipment to be used in a particular application depends first of all upon the amount, kind, and accuracy of information to be obtained from the radar scope. Engineering considerations and limitations are usually of first importance. It should be emphasized, however, that from the beginning of planning, the limitations and capacities of the human

operator should be kept constantly in mind. There are a number of psychological and physiological factors in terms of which the equipment design and the operating procedures must be evaluated, if optimal resolution, accuracy, and efficiency are to be obtained.

Some of these human factors which are related to equipment design problems and to the efficient use of radar equipment are as follows: sensory acuity and discrimination, perception of spatial relations and movement, speed of perception and reaction, coordination and smoothness of muscular adjustments, speed and intelligence in the making of judgments and decisions, motivation, resistance to fatigue, ability to maintain sustained attention, and emotional stability. Specific equipment factors which are related to the problem of human efficiency are as follows: the nature and characteristics of the visual display, the disposition and type of controls, and the position and lighting of the scope in relation to the optimal posture, comfort, and working space provided for the operator.

In this chapter only those human factors bearing directly on equipment design and operating procedures will be discussed. Although the importance of many of these factors has not been sufficiently studied, or has not been investigated in specific applications, such experimental evidence as is available will be cited. It should be emphasized that these studies were conducted during a war when time was at a premium and facilities were not always entirely adequate.

21.2 THE GENERAL TASK OF RADAR OPERATION

In all radar applications the primary focus of attention for the operator is on the visual presentation provided by the radar scope. From the visual display he obtains data, either directly or indirectly, which enable him to determine range, bearing, or elevation, or combinations of these. The scope presentation enables him to detect objects, discriminate between them, and in some instances to predict their type, number, or other characteristics. A

variety of information about the scanned area frequently can be derived from careful study of the visual phenomena presented on the radar scope. Thus the type of scope display is extremely important in determining the amount of information which may be obtained by radar. Of secondary importance is the nature and complexity of the controls by which the equipment is managed. The degree to which these may be manipulated smoothly, quickly, and accurately has much to do with the adequacy of the presentation on the scope and the amount of information which can be obtained from it, but especially with the accuracy of essential determinations and measurements.

21.2.1 Relation of Equipment Design to Operator Task

TYPE OF SCOPE PRESENTATION

Because of the variety of types of scope displays and the different operating tasks created by each, their representative designs and functions will be reviewed briefly.

A-Scope. This type of display in its simplest form consists of an oscilloscope with a horizontal sweep or time base upon which appear the main pulse and the target echo or pip. The distance along the base represents the range of the target, which may be read from a dial when the time base has been adjusted by means of a handwheel to make the pip coincide with a fixed hairline. The bearing or azimuth of the target may be determined by noting the position of the antenna when maximum pip amplitude is attained. Another form of this type of display is the double A-scan used in airborne search radar. In this case, when "homing" on a target, a double pip extends horizontally from either side of a vertical sweep. Range is indicated by distance along the vertical time base. Information on bearing to the target is given by the degree of equalization of the two pips. The operator's task is to keep the target dead ahead and therefore he must estimate and call heading corrections to the pilot, using the equalization of the pips on each side of the vertical time base as a guide. Still another form of the A-scope is that employed with rapid

RESTRICTED

switching of two antenna patterns producing overlapping beam lobes. Alternating returns from the two lobes produce two simultaneous vertical pips on a horizontal sweep; if the target is centered between the lobes the pips will be equal. The task of the operator (pointer or trainer) is to track the target by turning a handwheel in such a way that the target remains centered, thus indicating that the gun is on target in elevation and azimuth.

In all A-scope presentations there are complications such as the presence of noise or "grass," due to amplifier gain; bobbing of pips, especially in the case of aircraft targets; and interference lines or patterns, due to neighboring radar or from deliberate jamming by enemy radar. For maximum range, the signal-to-noise ratio is primarily an engineering problem, but the operator is an important factor since it is he who ultimately determines what can be read on the scope and what signal-to-noise ratio can be tolerated. Thus the effective range of a set is to a large extent determined by the human visibility factor, which in turn is a function of the type of scope presentation, the pulse width, shape and steadiness, the band width of the receiver, the recurrence frequency, the rate of rotation of the antenna, and the beam width. Each of these factors should be studied and considered not only from the point of view of engineering possibilities but also from the point of view of the operator who will use the equipment. The limitations should be established for the average operator rather than the laboratory research worker or technical expert.

Because of the rapid changes in the radar picture, the A-scope utilizes a low persistence screen. The question of the degree of persistence which is optimal for a particular application can be determined properly only under conditions of actual operation and in relation to the average operator.

J-Scope. This presentation, developed for range tracking, is similar to the A-scope except that the sweep is a curved line around the circumference of the tube face. This allows for greater expansion of the sweep range and therefore, presumably, greater accuracy of tracking. The target echo is represented by a pip, the front edge of which must be kept on

an adjustable hairline by means of handwheels. Both the pip and hairline rotate in some applications. This has raised the question of whether the tracking task can be learned more readily and performed more accurately with both the pip and hairline moving or with a fixed hairline and an adjustable moving pip. (The results of an experiment on this point will be reported in a later section.) Other questions which deserve study are the comparative accuracy of direct tracking as opposed to rate or aided tracking; also, the proper handwheel and aided tracking ratios. These problems may occur in connection with both A-scope and J-scope presentations. Parallax may be important when an overlying hairline is involved. Also, the following of a pip and the adjustment of it to a hairline when it moves on an arc, as in the J-scope, may be more fatiguing and less accurate than on a linear presentation. These factors may be disadvantages which outweigh the advantage of greater sweep length on the J-scope.

B-Scope. This type of display makes use of an intensity-modulated sweep and a persistence screen. A vertical sweep line moves back and forth across the screen horizontally. Range is provided by the vertical ordinate, and bearing by the horizontal one. The brightening of the sweep line at a given range and bearing leaves a persistent trace or blip on the scope face, representing a target echo. The *C-scope* is like this except that range and elevation data are provided by a horizontal sweep moving vertically. Problems of distortion frequently are presented by these square map presentations, which are not encountered in the following types of display.

PPI-Scope. The *plan position indicator* [PPI] utilizes an intensity-modulated, radial sweep which rotates through 360 degrees and thus presents a complete map of the area scanned. Bearing is read directly from the periphery in relation to the target echo and the center of the scope; range is read along the radius of the circle. Medium or long persistence screens are used depending upon the type of application. The signal-to-noise ratio is a problem here as in the other types of presentation. Other problems include the proper adjustment of focus and brilliance, adjustment of receiver and

video gains, amount of illumination on the scope face, persistence of the trace in relation to the speed with which information may be read and the speed of antenna rotation, the type of color filter suited to acuity, and dark adaptation requirements.

NATURE AND COMPLEXITY OF OPERATING CONTROLS

Tuning and Calibrating Adjustments. The type of controls for tuning and calibrating must be adapted to the delicacy and precision of the task. It is assumed that for most purposes a high degree of accuracy in radar operation is necessary and that this, in turn, is dependent upon the accuracy of tuning and calibrating procedures. There are frequently several steps involved in such procedures and sometimes different procedures may be followed to accomplish the same result. Obviously the simplest method consistent with the desired accuracy should be determined for the average operator, and this method should then be standardized. If tuning and calibrating are performed during the pitch and roll of a ship or during the flight of a plane, the resistance of controls to movement must be properly adjusted; suitable arm or hand rests must be provided for steadiness; and the type of movement of fingers, wrist, and arm should be considered in planning the type and position of the control. Other factors to be considered are the fineness and visibility of markings on control dials and the amount of illumination which can be tolerated without producing glare and reducing visibility of the scope presentation.

Operating Adjustments. The same factors are involved in the planning of operating controls as are described above. In addition, the position of operating controls which are used most frequently and those which are operated in response to changes in the scope picture must be so placed that they can be found readily without removing the gaze from the scope. Preferably, they should be placed near the scope. If it is necessary to place them at a distance they should be arranged laterally, as lateral movements are easier to gauge than vertical movements when automatic, blind reaching is involved.

Where the turning of a handwheel or other tracking control involves continuous change of adjustment such as changes in rate, stopping-starting, and acceleration-deceleration, the proper position and orientation of the control in relation to the body, its radius, mass, and resistance to movement must be carefully studied with regard to optimal accuracy in the specific performance. Frequently it is found that one type, rate, or direction of movement can be performed more accurately and smoothly and with less fatigue than another. This difference may depend upon the specific muscle groups used and upon the general body posture required.

PROBLEMS OF INTEGRATION AND TEAMWORK

Single versus Multiple Operation. One of the earliest radars used extensively in World War II was a long-range search set. This equipment required a team of four men who rotated positions at intervals of 30 minutes to an hour. One man served at the A-scope, locating targets, reading range, and calling echo maximization (signal to read azimuth). A second man read azimuth from a dial or from the base of a portable antenna. A third man kept a grid plot, and a fourth recorded range and azimuth readings and reported to a filter station by telephone. This system often led to bottlenecks when traffic was heavy. The question occurs as to whether equipment design and operating procedures might not have been modified to reduce the number of men required to one, or at most two, with increased efficiency of performance and with less confusion. If azimuth and range indicators could have been placed within the hood surrounding the scope, a single operator wearing a throat microphone and headphone might have reported directly to the filter station.

In another instance, a radar used for *ground control interception* [GCI] required two operators and one or more men for recording, plotting, and reporting. One operator searched with a PPI and determined range and azimuth; the other estimated pip ratios on an A-scope and by means of a table calculated altitude of the target. This system also led to bottlenecks and confusion when traffic was heavy. This confu-

sion might have been eliminated by a change of scope presentations or by arranging both scopes for one operator to read.

A fire-control radar used by the Navy required three operators, one each for range, bearing, and elevation scopes. Frequently the pointer and trainer confused targets or did not synchronize properly in their tracking. Reducing this situation to a one-man, or at most two-man, task by a modification in equipment design probably would have led to greater efficiency and accuracy.

Late in World War II an Army fire-control radar succeeded in utilizing automatic azimuth and elevation tracking, but required a range tracker using a J-scope. Two operators were necessary. A search operator using a PPI located the target in azimuth and elevation and established initial range, which was transmitted to the range tracker. At this point automatic azimuth and elevation tracking began, and range tracking was continued manually by the range operator. Loss of the target by the range tracker, by the automatic tracking mechanism, or as a result of interfering targets led to delay in establishing contact, which might have been reduced by a single operating position.

Radar made use of many teamwork situations on the ground, at sea, and in the air, and there were many instances of highly developed coordination and cooperation. Especially was this true in airborne operations where the radar operator, bombardier, and pilot coordinated. However, the trend toward the end of the war was to concentrate more and more activities in the hands of one man, the radar operator. This was made possible by the development of automatic controls and ingenious equipment design. Any function requiring precise timing and synchronization will profit in accuracy and efficiency if multiple reaction times are reduced in number. For example, it requires time to perceive a relationship on a scope, to formulate and transmit it verbally to another (bombardier or pilot), and for the second team member to comprehend the instruction and put it into action. On a high speed, high altitude bombing run, fractions of a second count, and a delay occasioned by the compounding of re-

action times may amount to a second or more and result in inaccuracy of the bomb release. A study¹⁵ of radar bombing errors during operational training has shown that the majority of range errors are long instead of short. This is especially true during the early stages of operational training and probably indicates that timing delays (summed reaction times) are responsible. Later in training the operator and bombardier learn to compensate for this error to some extent.

GENERAL OPERATING CONDITIONS

Length and Persistence of Operating Periods. The length and persistence of a radar watch vary widely for different applications. In some ground-based stations and on shipboard, frequent shifts in operators may be made; in general this rule of rotating positions has been followed at arbitrarily selected intervals depending upon demands and personnel available. On the other hand there are certain types of operations, such as antisubmarine patrol, long-range bombing missions, and the like, where continuous and persistent operation must be accomplished by one man, often for periods of 6 to 8 hours.

The length of time that an operator can continue to function efficiently depends upon a number of factors. Some are undoubtedly related to the general factors discussed in previous sections; others are related to some of the conditions described in this section. It is believed that each type of equipment has its own problems in this regard and that an answer given for one type of scope presentation and operating task will not necessarily suffice for another set of conditions. The factor of fatigue should be considered in the design of equipment and the planning of operating procedures for it.

Room and Scope Illumination. The amount of ambient illumination falling on a scope face may reduce the visibility of phenomena presented there. It may also produce glare and shadow effects which will adversely affect the operator, possibly producing eyestrain, headache, and fatigue. Another problem created by room illumination is that when operators rotate at the scope position they may require some

RESTRICTED

time for dark adaptation sufficient to function effectively at the scope after being in a brightly lighted room. This has been obviated in some instances by the wearing of red goggles during intermissions.

Adverse effects on the operator and his efficiency may also be produced by too bright phenomena on the tube face and by direct illumination of bearing circles, knobs, filters, and other devices close by or superimposed on the scope face. The matter of brilliance control is usually a matter for the operator to adjust suitably and is best covered by proper operating procedures. The illumination factors are intimately associated with the problem of design and should be carefully evaluated beforehand.

Filters are used as protective overlays as well as to provide range, bearing, and grid markings. These should be carefully studied from the point of view of operator comfort, visibility of scope phenomena, and dark adaptation level. The problems of parallax and accuracy of reading from filter markings should also be studied.

Room Temperature and Humidity. In a widespread war with many fronts, there are many different climatic conditions to contend with, and the radar operator, by virtue of the necessity of working in a somewhat enclosed and darkened room, is particularly susceptible. Improper temperatures and poor regulation of humidity are conducive to inefficiency and fatigue. Factors of this sort are usually independent of equipment design, as well as operating procedures, but may be secondarily related to the space provided for equipment, provision for eliminating heat generated by equipment, and suitable operating schedules adapted to the environment.

Postural Comfort and Working Space. In the interest of preventing fatigue as well as maintaining efficiency, the equipment should be so designed as to provide adequate working space and a reasonable degree of postural comfort. It is entirely possible for an operator to be provided with a comfortable chair and yet experience postural fatigue and cramps from stretching and craning the neck and body in order to see the scope and manipulate the controls. The seat should be adjustable and should be planned with vision, movement, and working

space in mind. In those cases where vigorous displacing movements occur, as on shipboard and in a plane, suitable provision for straps and supports should be made.

21.3 EXPERIMENTAL INVESTIGATIONS DEALING WITH DESIGN AND OPERATING PROBLEMS

The demand for new developments in radar and the urgency of maintaining production schedules were so great during World War II that engineers in developmental laboratories and in manufacturing centers had little time to experiment with the relative merits of specific designs and operating procedures. Indeed the demands for getting equipment into combat zones were so pressing that oftentimes equipment was not available for home training centers. Consequently, the first operational trials were often made in the field in the combat theater. The need was to put the equipment into actual use, and there was little time for careful experiments with regard to the design and operating procedures which would provide the greatest accuracy in the hands of the average operator.

An additional problem was that engineers, although exceedingly ingenious in the development of electronic circuits and the physical components of the equipment, could hardly be expected to have sufficient psychological and physiological information at hand to plan all details of the equipment for optimal use by the human operator. The adaptation of the equipment for human use was therefore often neglected or the solutions were arrived at by the best-guess method. When the equipment turned up in training centers it frequently became obvious that specific details involving the choice of scope presentation, the illumination factors, the operating controls, the seating and working space arrangements, the accuracy of calibrating and operating procedures in the hands of the average operator, and numerous other factors were not adapted for optimal efficiency. At this stage it was usually too late to do anything about revising the design since the equipment was already in production; un-

less the design was completely unusable, production continued with the original design.

In retrospect it appears that it would have been highly desirable to have brought consulting psychologists and physiologists into the developmental laboratories when initial planning of new equipment was begun. On the basis of general psychological and physiological principles, answers to some of the problems could have been given immediately; others would have required careful study which might have been coordinated with the efforts of the engineers during the actual development. A next step would have been to arrange for an experimental field training group who, coordinating their efforts with field training officers, would have taken the first pilot model of the radar set and used it to train an experimental group of average operators. This procedure would normally lead to quick reports on the adaptability of the equipment to human use, the accuracy to be expected under field conditions, and the relative merits of alternative designs. (The cooperative program suggested is similar to one requested by the Navy for the psychological evaluation of gun directors and fire-control systems. It is described in Chapters 24 and 25.)

The actual course of events developed rather differently. Midway in the war, groups of psychologists, at the request of the Army and Navy, were organized to work under OSRD on research problems dealing especially with selection and training. These projects were set up under the Applied Psychology Panel, NDRC, and were assigned to various field stations. In the case of radar, two projects in particular were assigned to selection and training problems. The two projects were these: Project SC-70, NS-146, located at Camp Murphy, Florida, and later at Boca Raton Field, Florida, which worked on all types of radar operator problems in both the Army and Navy training centers; and Project N-114, Selection and Training of Rangefinder and Radar Operators, which worked specifically on fire-control radar and was located at the Naval Fire Control School, Fort Lauderdale, Florida. In the course of their work both projects often found it necessary to investigate the accuracy of the equip-

ment in relation to the human operator before it was possible to carry out training studies.

The following is a résumé of the results of the experiments bearing on design and operating procedures. It should be emphasized that the projects were not set up initially with these problems as primary objectives and that the facilities and conditions for carrying on the experiments were often far from ideal. The main advantages were that the projects could work closely with training officers and with the type of men being trained as operators under the best available approximation of theater conditions. Desirable revisions of operating procedures on the basis of experimental findings could often be put into effect immediately in the training program, but suggested changes in design could only be referred to the proper channels.

21.3.1 Investigation of Radar Presentations for Specific Jobs

Three problems dealing with radar presentations were brought to the attention of the above-mentioned projects. Two of these led to completed experiments. The first dealt with the problem of ranging accuracy on a J-scope with a moving hairline and a fixed hairline. The second dealt with the comparative accuracy of radar tracking with paired pips, a dot on cross-lines, and a null meter instead of a scope. The third problem, on which considerable time was spent but which, due to technical difficulties, was not satisfactorily completed, dealt with a comparison of light and dark trace scopes.

TRACKING TO A FIXED HAIRLINE VERSUS TRACKING TO A ROTATING HAIRLINE

The purpose of this study⁷ was to answer a question raised by the Signal Corps concerning the basic design of the range tracking unit of the SCR-584. This radar set utilizes the J-scope for range tracking. Thus there is presented on a circular sweep an expanded portion of the range scale. When the radar set is on target in azimuth and elevation and the target is located in range, there appears on the circular sweep a pip. The task of the operator is to keep

an adjustable hairline (radial line) on the leading edge of the pip. He does this by turning a handwheel which governs a rate-motor or aided-tracking device, setting in the proper rate in order to keep the hairline on the pip which shifts with the range of the target.

The question raised was whether tracking by means of adjusting this rotating hairline to a rotating pip is as satisfactory as adjusting a moving pip to a fixed hairline. The fundamental question here was whether the human operator could adjust a hairline to the edge of a pip moving on an arc around a circle, where it is necessary to perceive the relative displacement and rate of movement of two moving objects, as well as he might adjust a pip to a fixed hairline in a vertical position, where it is necessary to perceive the relative displacement and rate of movement of a single object.

Two separate experiments were conducted. One consisted of a simple learning situation in which 18 enlisted men from Camp Murphy were taught tracking by the fixed hairline method. The performance (learning curve and terminal level) was then compared with that of a similar group of 25 enlisted men taught to track by the rotating hairline method. Both training sessions were conducted with the MIT basic trainer for SCR-584, a device which closely simulated the actual SCR-584 tracking task but had the advantage of having a Veeder scoring meter which provided an integrated error score, summing the amount and duration of off-target positions. The trainer task was varied by program cams which produced differential changes in the rate of range variations, thus providing a dynamic tracking problem.

In the second experiment 19 enlisted men were trained by both methods (fixed and rotating hairline). The men were given two trials by each method on each of 16 successive days. Learning curves and final performance for the two methods were compared.

Both experiments demonstrated the superiority of the fixed hairline method over the rotating hairline method. It was shown that the fixed hairline method of tracking can be learned in a shorter time and that its use results in more accurate tracking. These results were found to be statistically reliable. However, a

careful examination of the results showed that, with either method, terminal accuracy could be brought down to a level well below the margin of accuracy of the SCR-584. Consequently, the small differences in terminal performance, though statistically reliable, were hardly adequate to justify recommending a change in the design of SCR-584. It was recommended, however, that the fixed hairline method be given consideration, in preference to the rotating hairline, in the design of new tracking systems.

RELATIVE ACCURACY OF FIVE METHODS OF TRACKING

This study¹³ was conducted to investigate the relative accuracy of five methods of tracking aerial targets using the Navy Mark 12 radar. This radar is designed so that an associated gun director may be tracked in bearing and elevation by an oscilloscope presentation consisting of a spot against crosshairs, by an oscilloscope presentation (A-scope) consisting of paired pips to be kept matched in height or by a meter, the needle of which must be kept in the null position. These three methods and combinations of them in the pointer and trainer tracking positions were investigated to determine which would provide the most accurate tracking of air targets.

Two experiments were performed. The first dealt with a group of 15 student operators in their 2-week training period on the Mark 12 training mount. This group had had no previous training in director operation and only 4 hours of training in Mark 12 operation. The second experiment utilized 28 student operators during the last 2 weeks of their 16-week course. This group had considerable experience in the Mark 37 director and with Mark 12 radar.

In the first experiment, on the training mount, an air target flew a triangular course at about 5,000 feet elevation. The apex of the triangle was about 2,000 yards, and the base of each leg about 9,000 yards from the training mount. Each subject had three runs by each of five methods (meter alone, spot alone, pips alone, spot and meter, pips and meter) in both the pointer and trainer positions. Operators were scored by taking the mean of their errors in mils for each run, then the mean for the

RESTRICTED

three runs, either as pointer or trainer. Tracking performance was observed and measured with a specially designed Mark 79 telescope. During tracking runs on an aerial target, readings of the pointer's and trainer's deviations from the target in mils were made every 5 seconds by a trained observer. Each run consisted of 15 consecutive readings taken at 5-second intervals. Also during each run the target plane made an average of two turns.

In the second experiment the air target flew a course parallel to the platform on which the director was mounted at a distance from 4,000 to 7,000 yards and at an elevation of about 3,500 feet. The target plane made an average of two turns per run. Each operator served only as pointer or trainer, never as both. Each pair of operators remained in the pointer's or trainer's position for a series of three runs for each method of tracking. In addition to deviation from target scores, a record was kept of the number of times the target was lost.

The first experiment showed the spot presentation to be more accurate in train tracking; pips were the least accurate for pointers. In terms of targets lost, the spot method was the best and the pip method the worst. In the second experiment it was demonstrated that trainers perform with less accuracy by the pip method than any other but without significant differences among the other methods. There was no significantly best method for pointers in terms of accuracy. Again the rank order of preference in terms of targets lost was spot method, best; and pip method, worst.

The differences were not always significant, but, in general, tracking by means of the method of balancing pips was less accurate and more likely to result in the loss of a target than was tracking by means of other methods. In particular, the spot method, involving the keeping of a spot centered on crosshairs, appeared to be the most favorable method for accuracy and retention of targets.

COMPARISON OF LIGHT-TRACE AND DARK-TRACE PRESENTATIONS

This study was never completed because of technical difficulties which made it impossible to control properly the variables involved. The

purpose of the study was to compare the relative merits of light-trace versus dark-trace tubes. A large experimental tube was made available in which a reversal effect from light target blips on a dark background to the opposite situation with dark blips on a light background could be made.

Plans called for a study of accuracy of reading blip locations and accuracy of detecting minimal blips under conditions of varying degrees of trace and background brightness, varying rates of sweep rotation, and varying target densities. Since it was impossible to equate brightness intensities under the two conditions, the experiment had to be abandoned. However, it is of some interest to report that uncontrolled observations indicated that both presentations could be read equally well but that detection of blips of minimal size could probably be made more readily on the light-trace tube. The dark-trace tube was felt to be slightly easier on the eyes. These observations should not be accepted, however, without further study under properly controlled conditions.

21.3.2 Investigations of Scope and Trace Brightness

In the operation of radar scopes it is usually necessary to have some illumination in the operating room or cubicle in order to see the controls, read dials, or make calculations. Some scopes employ a visual hood, but even in these cases there may be a certain measure of illumination around the periphery of the scope or from edge-illuminated filters. Viewing hoods are frequently discarded by operators or are used with the head withdrawn from the hood. This often allows extraneous illumination to fall on the scope face.

Ambient illumination may reduce the contrast of the signals appearing on the scope face, thus making the detection of small or weak signals more difficult. The following investigation¹⁰ was conducted with an A-scope to determine the effect of ambient illumination on detection of signals and also the effect of scope or trace brightness on detection. Detection of signals was chosen as a criterion of visual dif-

faculty, since it provided a quantifiable aspect of the scope-reading performance and because it is an important part of the operator's task.

A radar trainer was used to generate synthetic signals and noise simulation. The resulting presentation appeared on a 5-inch oscilloscope, the actual indicator unit of a long-range search set. Strong and weak signals, graded in height, appeared at irregular intervals and varying ranges on the A-scope. Target signals, although varying in rate of presentation, averaged 15 per minute. The whole procedure of target presentation and simulation was planned to duplicate that typically found under operating conditions. An automatic recording system provided a quantitative record of signals and operator's responses, thus permitting an analysis of the type and number of signals detected and of those missed.

Three levels of *ambient illumination* were used. These were approximately 0, 1, and 22 afc. Three levels of *scope brightness* (trace intensity) were used. These were minimum intensity, or just strong enough to give a full presentation on the scope; intermediate intensity, or near the upper limit which would be chosen for operation of a nonilluminated scope; and maximum intensity, without introducing defocusing effects. These three levels of scope brightness were measured just above the baseline at 0.24, 1.37, and 6.0 afc, respectively.

Under a given set of conditions the subjects were given 20 presentations of each signal at each of three pip heights for a total of 60 presentations. An experimental session consisted of three such series of presentations in which the three conditions of the experimental variables (either ambient illumination or scope brightness) were presented.

Experiment I: Effect of Three Levels of Ambient Illumination on Signal Detection. Six subjects served in six experimental sessions during which the order of presentation of the three conditions of ambient illumination was varied in all possible ways. The intermediate scope-brightness, or trace-brightness, level was used throughout.

Results. At this brightness level it was found that there was no difference in the number of targets detected under the three different con-

ditions of ambient illumination. Even with the maximum ambient illumination, when background contrast in relation to signals was reduced approximately 50 per cent, detection of signals was unaffected.

Experiment II: Effect of Scope or Trace Brightness on Detection. With ambient illumination at the maximum intensity level the three levels of trace brightness were used. Four subjects completed three experimental sessions each. With minimum ambient illumination (no added illumination) the three levels of trace brightness were used. Three subjects completed three experimental sessions each.

Results. Under the first condition, with maximal ambient illumination, there were no differences in detection of signals under the different trace brightnesses, except possibly for the lowest trace brightness, where there was a slight reduction. However, it is unlikely that trace brightness would ever be this low operationally. Under the second condition, with minimum ambient illumination, there was no advantage or disadvantage for any of the three trace brightnesses.

Conclusions. Ambient illumination, except under unlikely conditions of maximal illumination and minimal trace brightness, does not adversely affect detection of signals on an A-scope. Therefore it is permissible to employ a reasonable amount (1 foot-candle or even more) of extraneous illumination for making controls visible and for providing a more wide-awake environment, without detriment to operating performance in the detection of signals.

Discussion. Two points are worthy of mention here. First, the above results should be generalized conservatively to other A-scope operating functions than detection. Reference should be made at this point to a study³ which dealt with pip-matching performance on an A-scope, with and without ambient illumination and showed a 10 per cent improvement with ambient illumination of 1 foot candle. This was attributed to light adaptation provided by the illuminated scope surround and to reduction of excessive contract and eyestrain. Contrary to this result, there was no indication of improvement in detection ability with increased ambient illumination in the above experiments.

RESTRICTED

It should be emphasized that the results reported in the above experiments apply only to the A-scope, and a caution should be added about generalizing, on the basis of the results, to include the PPI. The PPI depends upon an intensity-modulated signal which activates a persistence screen. The decay rate of persistence, in terms of brightness, is quite steep so that, although the initial persistence might be sufficiently bright to be affected relatively little by ambient illumination of moderate levels, the brightness at a subsequent point on the decay curve might be appreciably affected. Special studies taking persistence into account will have to be made before conditions of ambient illumination may be specified for the PPI.

21.3.3 Effects of Radar Operation on Operators

FATIGUE EFFECTS

There is no well-defined concept of fatigue. The term has been used in the subjective sense in which an operator states that he feels tired, worn out, and incapable of further efficient operation. Frequently it is referred to a specific area of deficiency such as eyestrain, sleepiness, jitteriness, or postural factors. Often it is related to boredom and the desire to be doing something else. From an objective point of view there is a limit, though perhaps a highly variable one for different individuals, as well as for the same individual at different times, beyond which physiological and psychological factors serve to reduce efficiency in a given performance. The possible causes underlying such factors may be extremely varied and may include such things as climate and its day-to-day variations, diet, amount of sleep and rest, anxiety, worry, personal relations with colleagues, postural discomfort, and emotional excitement.

In the experiment on fatigue, fatigue was considered principally in the objective sense. Fatigue was measured in terms of impairment of performance or loss of efficiency in a given task as performance was continued during any one session or through repeated sessions on successive days. It is unlikely that the same

factors, in their entirety, underlie impairment of performance resulting from continuous operation during a prolonged session and impairment resulting from repeated sessions on successive days. This is probably true since fatigue, in a strict physiological sense, is subject to recovery with adequate intervening rest, and the amount of rest intervening between daily sessions would seem to be sufficient to allow for recovery. Regardless of this fact, the study was based upon loss of efficiency as a function both of the length and the repetition of operating periods.

The purpose of this study² was first to determine whether long and repeated periods of operation of a radar A-scope result in loss of efficiency in performance. Secondly, it was desired to know when impairment of performance first begins and what relationship it bears to the length and frequency of operating periods. Two criteria of performance efficiency were accepted as measures. One was ability to detect signals, especially weak ones, on the radar scope. The other was accuracy of locating the targets represented by the signals, i.e., accuracy of azimuth determinations.

Under conditions closely simulating those of the actual radar screen in searching operations, the ability of eight men previously trained to a high level of proficiency was tested during 4-hour periods of continuous scope operation on successive days for 17 days. A Philco trainer generated a noise level in addition to synthetic signals which were weak, medium, or strong and which appeared at varying rates ranging from none during certain periods to rates of 12 per minute. Each man was presented 1,116 signals per 4-hour session each day, or a total of 18,972 during the 17 days.

Results. With daily repetition of a 4-hour operating period there was a progressive loss of efficiency in both detecting and locating targets. The loss of efficiency was related to both length and repetition of operating periods and revealed itself by an increase in the number of signal omissions, an increase in the rate of making omissions, a decrease in accuracy of azimuth determinations, and a general increase in variability of performance.

Analyzing each 4-hour period by 20-minute

intervals, it was apparent that a significant loss of efficiency first appeared after 40 minutes of operation on the third successive day. The impairment of efficiency tended to become progressively worse with repeated daily periods. These results suggest two things: first, that operating periods which are to be repeated daily (or at shorter intervals) should not exceed 40 minutes in duration; secondly, since no appreciable loss occurred during the first two 4-hour periods on successive days, that occasional operating periods of as much as 4 hours (and perhaps more) in duration may be tolerated providing one or more days of rest are interspersed.

Discussion. Although the above results do not deal with short operating periods repeated several times during the course of a day, with intervening periods of rest or an alternative activity of different type, it is suggested that such periods be confined to 30 minutes or less. Where personnel are available and the job permits, rotation of activities should be practiced. This not only relieves eyestrain, postural fatigue, etc., but serves to break up the day and relieve monotony and boredom. During the course of a battle, for example at sea, where it may be necessary for an operator to stay on the job several hours continuously, it seems unlikely, from the above results, that very serious loss of efficiency will occur. Under such circumstances all reserves are mobilized and motivation is at a high level. However, it would not be expected that prolonged periods of operation could be repeated without detriment to performance.

VISUAL EFFECTS

During the course of the war widespread rumors developed among radar operators that continued use of the radar scope impaired visual capacity and led to a variety of symptoms such as ocular fatigue, eyestrain, headaches, and other visual symptoms. In some quarters these complaints became a very real problem. Also reports¹⁸ came from the Panama Canal Zone indicating that there was a high incidence of refractive errors among operators of radar stations in that area. These reports suggested that numerous visual corrections

were necessary in order to reduce symptoms of visual fatigue. It appeared from a careful study of these reports that many minor refractive errors had been included and that the problem was not as serious as indicated.

In view of these reports, three investigations were made to determine whether radar operation actually has a deleterious effect on vision.

First Study. One study¹ was conducted in field operating stations of the Air Warning Division of the Army Air Forces School of Applied Tactics in Orlando, Florida. The vision of practically all radar operators in each of the nine field stations was tested by means of the Bausch and Lomb Ortho-Rater. The operators worked in 6- or 8-hour shifts and rotated assignments during each shift. They seldom remained at the scope for more than 1 hour at a time; the usual period of operation was 30 minutes. During an 8-hour shift each operator averaged 2 hours of actual time before the radar scope. The duration of experience ranged from 1 or 2 months to 18 months or more.

The aim of the study was to compare the visual capacities of a group of radar operators with those of a group of men of similar age who had never viewed an oscilloscope for any appreciable period of time. This latter group was composed of 112 ASTP students at Purdue University. The radar group was composed of 244 operators. Since there were operators of different periods of service it was also possible to compare the vision of long-term (18 months or more) operators with the vision of short-term (2 months or less) operators.

Results. A comparison of the visual capacities of the 244 radar operators with those of 112 ASTP students (nonoperators) revealed no significant differences on any of the Ortho-Rater tests, which included measures of visual acuity (near and far), muscle balance or phorias (lateral and vertical), depth perception, and color vision. Likewise, a comparison of the vision of 58 veterans, with 18 months' experience or more, with that of 52 short-term operators, with 2 months' experience or less, showed no significant differences. An analysis of visual histories and present ocular complaints of the operators tended to support test findings. Symptoms were reported no more frequently

RESTRICTED

by veteran operators than by inexperienced operators. It was agreed quite generally by operators that if they remained at a scope too long they sometimes suffered ocular fatigue, eyestrain, headaches, and other symptoms of visual distress, but the complaint was not specific to radar operation for it applied equally often when they read too long.

The results of this study indicate that radar operation (A-scope and PPI) does not impair visual efficiency, and it was recommended that the results be made known to operators generally. This was done by the Army^{19, 20} and Navy,²¹ using this study as a basis for the reports.

Second Study. Shortly after the previous study an opportunity was afforded to make another study⁴ of the effect of radar operation on vision. This seemed worth while since a group of air-surface-vessel [ASV] operators was available for study. In contrast to the men in the previous study, who served in air warning stations for short but frequent periods of operation, this group of airborne operators on antisubmarine patrol served during prolonged sea-search flights, often operating radar scopes for 4 to 8 hours at a time without relief. These operators used A-scopes, B-scopes, or PPI scopes. The men were part of the First Search Attack Group, stationed at Langley Field, Virginia.

Results. A group of 66 ASV operators showed no significant differences in visual acuity or muscle balance when compared to a group of 112 nonoperators (ASTP students). Also 19 operators of long experience, with more than 500 hours of operation, failed to show any deterioration of visual capacities.

These results support those of the first study in indicating that vision is not impaired by radar operation. It should be pointed out that this conclusion does not apply to visual fatigue during and immediately after long periods of radar operation. It is true that extended radar watches may result in some temporary impairment of visual efficiency. There is no basis for apprehension that any such immediate effects of operation will persist as permanent alterations of vision.

Third Study. A third study⁵ was conducted using 77 fire controlmen at the Naval Training School, Fort Lauderdale, Florida. These men operated optical instruments and radar scopes during a 16-week training course. The Ortho-Rater was used to measure visual acuity, phorias, stereopsis, and color vision. An additional test of stereopsis was obtained with the projection eikonometer (see the Summary Technical Report of the Applied Psychology Panel, Volume 1, Chapter 8). Tests were made at the beginning and end of the 16-week course.

Results. It was found that there was no deterioration in any of the visual functions tested. In fact, it was found that there was a slight improvement in visual acuity, stereopsis, and color vision, on tests at the end of the course.

OTHER EFFECTS

Another prevalent rumor among radar operators was to the effect that the amount of radiation (principally X rays) absorbed from operating a scope or being in the proximity of the transmitter would lead to sterility. The writer is not aware of any systematic study or report on this problem, although in several Army and Navy training centers informal investigations were made by having operators carry a piece of X-ray film under the belt. The complete results of these investigations is not known, but it is believed that they were largely negative. The general consensus, among officers concerned with the problem, was that there were many instances of men who had spent much time operating radar equipment becoming fathers and that therefore there seemed to be no reason to believe that sufficient X rays were absorbed to interfere with procreation. It is unlikely that sufficient X rays emanate from the cathode-ray tube face to have a harmful effect.^b In reply to an AAF Matériel Command letter requesting information concerning harmful effects of radar operation and fatigue, Project SC-70, NS-146 submitted a memorandum³ discussing this problem.

^bAs indicated by personal communication with W. B. Nottingham, of Massachusetts Institute of Technology.

RESTRICTED

21.3.4 Investigations of the Feasibility of Radar Code

Toward the end of the war the problem of presenting International Morse Code visually on a radar scope arose. Project SC-70, NS-146 was requested to collaborate with the Naval Research Laboratory in seeking the answer to some of the psychological problems involved in this method of presenting code. The subsequent investigations bear not only on the general feasibility of the method but also with a number of specific details concerning specifications of the method as well as training problems.

THE LEARNING OF RADAR CODE

The purpose of this study¹² was to determine some of the difficulties inherent in the proposed radar code method and to make recommendations concerning specifications of the method and training procedures.

Ninety radar operators in training at the Naval Training School, Fort Lauderdale, Florida, served as subjects in two experiments. The experiments extended over a 3-week period. Since a previous study at Bainbridge, Maryland, had shown that a satisfactory transfer occurs from blinker code training to the reading of visual code on the radar scope, blinkers were used for stimulus presentation. The experiments were designed to compare methods of code presentation by a letter-sending device and by fixed tapes and to compare learning under varying rates of stimulus presentation ranging from baud speeds of 0.122 second to 0.244 second. Also an analysis of code letter difficulty was made. The whole method of training was used rather than the part method; that is, the entire list of 15 letters was taught from the beginning of training. Repetition of letters was used, especially at the beginning, to facilitate the association of a clearly identified stimulus with the correct response to it.

Results. The whole method and repetition of letters, in contrast to the Bainbridge procedure using the part method and unrepeated letter presentations, was found to be more effective. Learning curves showed no advantage for the

letter-sending device over the use of tapes, although the former method made instruction easier and improved the morale of the students. Learning of the code was more rapid when the slower baud speed of 0.244 second was used, and the students who were started at this speed retained an advantage over those who were started at faster speeds even when the speeds were equated later in the training period. It was found that the letters used differed greatly in learning difficulty. Relative difficulty of a letter depended largely upon perceptibility (character composition) and upon resemblance to other letters in the list. The element of code composition which influenced learning difficulty most was the number of dots in a letter, difficulty varying directly with the number of dots. The order of difficulty for the 15 letters was established. The seven most difficult letters accounted for 60 per cent of the errors. The use of cards listing letters and their codes, during early training, was found to be without advantage.

Recommendations. It was recommended that the number of letters be reduced from 15 to 10, by eliminating the seven most difficult and by substituting two easy letters. The following training suggestions were recommended: (a) short training periods of 30 to 40 minutes duration; (b) two or three training sessions per day, with interspersed rest periods; (c) making results known to each student, session by session; (d) use of the whole method, with a speed of 0.25 second per baud at the beginning of training, and gradual increase in speed after thorough learning of the code at the starting speed.

Other Psychological Problems. It was recognized that one of the most serious difficulties in the perception of visual code is the discrimination of dots from dashes and that therefore the perceptibility of the code is largely dependent upon the dot-dash ratio. Discrimination of dots from dashes depends upon the difference in time of these components of the code. This was suggested as an experimental problem. Also it was felt that the absolute duration of the dot was a problem since a dot may be confused with two dots, with no dots,

and with a dash. The difficulty in perceiving the dot is believed to be related to phenomena of fusion and flicker. If a series of dots or flashes is speeded up, a point will be reached where fusion occurs and a continuous light is seen instead of discrete dots. Fusion frequency would be expected to occur with a flash duration of about 0.01 second for a bright stimulus flash and about 0.15 second for a very dim flash. Flicker would occur with a slightly longer flash duration. The duration of the dot in the present experiments was 0.122 second, and the brightness was relatively low, so that flicker and fusion frequencies may have been approximated for some men. When these occur, subjective impressions are apt to become confused and not necessarily agree with the physical nature of the stimulus. Since the duration of the dot is an important factor in code perceptibility, it is important to investigate the capacity of radar operators to receive visual code at different dot durations.

ACCURACY OF RECEPTION OF RADAR CODE

The purpose of this study¹⁴ was to investigate the factors which determine accuracy of reception of radar code presented visually. The study was requested by the Naval Research Laboratory in order to gain information which would assist in determining the characteristics of new equipment to be designed. The study was designed to provide answers to the following questions. (a) With what dot-to-dash ratio can visual code be most accurately read? (b) At what speed can the code be most accurately read? (c) How accurately can two-, three-, and four-letter code groups be read? (d) Does the presentation of repeated two-letter code cycles lead to inaccuracy in letter grouping? (e) Is there any difference in the accuracy with which width- and amplitude-modulated signals can be read? (f) How much retraining is required when operators skilled in auditory code reception are shifted to radar code?

The study was conducted at the Naval Training School, Fort Lauderdale, Florida. Special code tapes were prepared for different dot-to-dash ratios. Visual code was presented on an actual radar indicator by means of a special code simulator built by the Naval Research Labora-

tory. Each of four groups of 24 men was given thirty 25-minute periods of training and testing during the experiment which lasted 4 weeks. They were trained first on a five-letter auditory code and then shifted to visual radar code. At the conclusion of training final tests were run. These consisted of 50 two-letter groups, 50 three-letter groups, and 50 four-letter groups. Dot-to-dash ratios of 1 to 3, 1 to 4.3, 1 to 5, and 1 to 6.3 were used. Speeds of 4, 6, and 8 bauds per second were employed.

Results. Dot-to-dash ratios of 1 to 4.3, 1 to 5, and 1 to 6.3 were read with approximately equal accuracy, and all were superior to a ratio of 1 to 3. The ratio of 1 to 4 was recommended because it is more like conventional code than the other ratios. Code at a speed of 6 bauds per second was recommended because it could be read with greater accuracy than code of 8 bauds per second and with about equal accuracy to that of 4 bauds per second. Width- and amplitude-modulated signals were read with equal accuracy. Two-letter code was read with slightly more accuracy than three- or four-letter codes; the latter were read with about equal accuracy. The time plan for the two-letter code reduced the accuracy with which this code was read and caused occasional reversals in grouping. Therefore it was recommended that the time plan be changed to shorten the interval between the first and second letters of the group. Men who read auditory code with 95 per cent accuracy were reduced to 44 per cent accuracy on transfer to visual code; however, after 4 hours of training on visual code, accuracy increased to 85 per cent.

^{21.3.5} Accuracy of Calibrating and Operating Procedures

The accuracy with which range is obtained by radar is dependent upon several factors. Among these are the intrinsic stability and accuracy of the equipment; adequate warm-up of equipment before calibrating and operating, procedure of calibrating and operating, precision and fineness of scales used in calibrating, and, finally, the care exercised by the operator.

In order to determine how accurately cali-

brations and ranging are done by operators and what design factors might be modified to improve these determinations the following experiments were undertaken.

ADEQUACY OF ZERO-SET CALIBRATION PROCEDURES

This study⁶ was made to determine the adequacy of zero-set calibration procedures used in student training and on shipboard. Ninety-two student operators, representing four stages of training, were tested on standard Mark 4 radar training equipment in the making of zero-set calibrations. The experiment extended over a period of 6 days during which the equipment was kept in a constant state of warm-up. Two radar instructors made determinations of the correct zero by ranging on a target of known distance (16,875 yards) and checked the students' zero-sets. Each student made five zero-sets.

Results. The median error of zero-set for all students was not great enough to have statistical significance. Advanced students were no more accurate in their readings than beginning students, but there was less variability and greater speed on the part of the former. Fifty per cent of the individual differences in zero-sets were less than 7 yards, and the maximum difference was only 50 yards.

It was concluded that student operators make zero-sets with satisfactory accuracy and consistency and that no changes in the training methods or shipboard procedures for this adjustment are necessary.

ACCURACY OF RANGE READING

The range scale on the Mark 4 radar is marked in 100-yard divisions. It was estimated by training officers that it could be read to the nearest quarter division or 25 yards by the average operator. The purpose of this study⁸ was to determine the accuracy of range readings with the original range scale of the Mark 4 and with an auxiliary dial attachment which was enlarged and marked in 20-yard divisions. With the auxiliary scale, range in yards could be read in hundreds, tens, and units.

The student operators served as subjects. They had about two weeks' experience reading

the regular dial of the Mark 4 radar but none with the auxiliary dial. Each operator made ten readings of arbitrary range settings with each type of dial.

Results. The regular Mark 4 dial gave a mean standard deviation for ten subjects' readings of 11.07 yards; the mean standard deviation for the readings with the auxiliary dial was 1.73 yards. This difference is statistically significant. The results indicate that when operators are instructed to read to the nearest yard, 99 per cent of the range readings with the auxiliary dial fell within ± 5 yards of the true reading whereas 99 per cent of the reading with the regular dial fell within ± 33 yards of the true reading. Therefore it was recommended that the auxiliary dial attachment be considered for installation on all Mark 4 radar range units. It was concluded that the auxiliary dial would make possible more accurate and precise calibration and zero-settings than had hitherto been possible with the regular dial. This improvement would eliminate constant errors which might otherwise enter into range readings as a result of inaccurate calibrations.

DETERMINATION OF ZERO DRIFT AND RANGE DRIFT

Two types of drift error may enter into the range errors with fire-control radar. These are the drift of true zero over a period of time due to fluctuation of the position of the transmitter pulse and the drift in the value of measured ranges due to change in the measured range of a known range target. The purpose of this investigation¹¹ was to determine the magnitude of these two types of error after the equipment had been warmed up.

Three Mark 4 radars, two Mark 8 radars, and three Mark 12 radars were tested by an experienced operator at intervals of an hour for 8-hour periods on two successive days. All sets had been in warm-up condition for at least 12 hours before each day of experiment. All sets except the Mark 12's were calibrated at the beginning of each day on a known range target. An initial zero setting was made and not changed for the remainder of the day. A series of five readings was made every hour on each set for both the position of the transmitter pulse

(zero-set) and the known range calibration. The resulting data provided a measure of zero and range drift for each radar.

Results. Detectable zero and range drift were encountered in two Mark 4, two Mark 8, and three Mark 12 radars. One Mark 4 showed no zero or range drift over an 8-hour period. The zero and range drift did not coincide completely over 8-hour periods for two Mark 4's, two Mark 8's, and three Mark 12's. In general there was a tendency for drift to remain in either a posi-

tive or negative direction with relation to zero during the 8-hour periods. The maximum range of zero drift during an 8-hour period for Mark 4's was 200 yards; for Mark 8's, 25 yards; and for Mark 12's, 40 yards. The maximum range of range drift during an 8-hour period for Mark 4's was 250 yards; for Mark 8's, 20 yards; and for Mark 12's, 20 yards. The drift data are believed to be accurate so far as scale readings are concerned to the nearest 20 yards for Mark 4 and 5 yards for Marks 8 and 12.

RESTRICTED

Chapter 22

STEREOSCOPIC RANGEFINDERS AND HEIGHTFINDERS

By William E. Kappauf, Jr.^a

SUMMARY

RECORDS of stereoscopic rangefinder and heightfinder performance make it apparent that the actual ranging accuracy of the best observers does not approach the predicted, or theoretical, accuracy of the instrument. The Height Finder Project and Project N-114 developed a number of operating procedures and devices to improve performance on the existing equipment. These are:

1. An interpupillometer and template to ensure that the initial interpupillary setting of the instrument is adequately accurate.

2. Operation of the instrument at reduced aperture whenever possible.

3. An improved calibrating procedure. Long-continued practice in all methods of calibration is required to ensure that field calibration will be sufficiently accurate and dependable. An improved record form for use in calibration was developed.

4. Methods of making the height-of-image adjustment. Special training in height-of-image adjustment is required to secure adequate performance. Using each method, the student operator should be required to demonstrate his ability to make five successive adjustments with a spread of less than 1 mil.

Although the changes described above improve performance, radical improvement must await systematic redesign of the instruments. For this purpose further studies of the relation between operator and equipment are required. The results of such studies of the problem as were made during World War II are presented in relation to needed further experimentation.

22.1 PROBLEMS IN THE OPERATION OF STEREOSCOPIC RANGEFINDERS AND HEIGHTFINDERS

A stereoscopic rangefinder is a binocular instrument which provides the operator (ob-

^aThis chapter is based on the work of the Height Finder Project and Project N-114 and work directed by Division 7 of NDRC.

server) with two magnified views of the target to which the range is desired. When the observer fuses his right- and left-eye views of the target and simultaneously fuses the patterns of reticle marks seen by the right and left eyes, he perceives the target and the reticle in relative depth. The target may appear farther away than the reticle, nearer than the reticle, or at the same distance as the reticle. The operator's task is to turn a range knob until the target is at the same depth as the reticle. At that point, within the error of observation of the operator and depending on the accuracy of his methods of calibrating and using the instrument, the range dial on the rangefinder indicates the range to the target. The operator has triangulated on the target, using the base length of the rangefinder as the base of the ranging triangle. When the target is at the same depth as the reticle, the position of a set of prisms in the instrument represents the angle of convergence of the rangefinder's two lines of sight on the target. Since this angle is related directly to the range to the target, the measuring scale on the instrument can be and is marked off in range.

The operator's job in using a stereoscopic heightfinder is exactly the same as the job of operating a stereoscopic rangefinder. The heightfinder delivers a measure of target height by multiplying range by the sine of the target elevation.

In theory, increased precision of range (or height) measurements results both from increasing the base length of the rangefinder and from including magnification in its telescopes. Thus, on the basis of the established base length and magnification of a given instrument and on the basis of a measured level of stereoscopic acuity for the observer, it is possible to compute a *predicted* level of ranging accuracy when base length and magnification are changed. This accuracy varies with range. The observer's expected average error in range would be proportional to his stereoscopic acuity and to range squared and is inversely proportional to base length and magnification.

Records on rangefinder and heightfinder performance during the years before World War II, however, made it conspicuously apparent that the actual ranging accuracy of even the best stereoscopic observers did not approach the predicted accuracy of the instrument on theoretical grounds. It was this finding which prompted the war research program on rangefinders and heightfinders. Although a complete reconciliation of theory and fact has not yet been achieved, the war research did lead to improved accuracy of operation and laid the groundwork for future instrument design and research on operator performance. The research was handled by projects under Section D-2, later Division 7, of NDRC and by projects under the Applied Psychology Panel.

The earliest work was done at Fort Monroe, Virginia, by a Princeton University group, Section D-2 (see the Summary Technical Reports of the Applied Psychology Panel, Volume 1, Chapter 8, and of Division 7). These field investigations, covering the period from March 1941 through the summer of 1942, were supplemented by laboratory work carried out at other universities. It was shown that ranging errors resulted from instrument instability,^{1, 10, 10} inaccuracies of instrument adjustments made by the operator,^{5, 14, 31} inaccuracies in the operator's calibrating procedures, and variability of the operator's stereoscopic judgment.^{4, 6, 8} Basic facts on how to calibrate, adjust, and operate the heightfinder were established.

The interest of Division 7, NDRC, in rangefinder and heightfinder problems continued throughout the war. Under its direction, a general committee was formed to discuss preliminary plans and specifications for a super-rangefinder. A laboratory contract was let to Brown University to investigate the design of reticle patterns for use in stereoscopic instruments.^{39, 44, 45} A similar contract maintained basic research at Harvard University on the factors which influence stereoscopic acuity and depth perception.⁴⁷ A detailed summary of this and earlier rangefinder work is found in the Summary Technical Reports of Division 7.

In August 1942, field work on heightfinder operation was taken over by the Height Finder Project. This project was directed in turn by

the National Research Council, Committee on Service Personnel—Selection and Training, and by the Applied Psychology Panel. Inasmuch as the basic problems of operation had been isolated by the Princeton group, work of the new project was concerned specifically with the experimental study of operating techniques and with formalizing a set of standard operating instructions which would ensure the most efficient heightfinder performance in combat. The group was assisted by the staff of the Height Finder School at Camp Davis in preparing a complete manual on the operation and maintenance of the instrument.^{24, 25, 28}

At the request of the Navy, work on stereoscopic instruments was extended to Navy rangefinders in September 1943, when the Applied Psychology Panel Project N-114 was organized. The new project was set up at Fort Lauderdale, Florida, where it worked in cooperation with the Navy Fire Control School for the training of rangefinder and radar operators.

The present chapter deals with the summary (Sections 22.2 to 22.6) of the research on stereoscopic rangefinders and heightfinders which was carried out under the direction of the Committee on Service Personnel—Selection and Training, NRC, and under the direction of the Applied Psychology Panel, NDRC. In Section 22.7 below, some knowns and unknowns are discussed in relation to future research on rangefinder development.

22.2 THE DEVELOPMENT OF AIDS FOR MAKING ACCURATE INTERPUPILLARY DISTANCE SETTINGS

The Princeton project discovered that serious rangefinder errors could result from parallax between the target image and reticle.¹⁴ The telescope used in each half of a stereoscopic rangefinder is a fixed focus telescope. Its objective lens is at a fixed distance from the reticle. It is clear, therefore, that the image of the target can be exactly in the reticle plane when the target is at one and only one range. At all other ranges, less than or greater than the in-focus range, parallax exists between target and reticle. This is critical if the observer's pupil does not include the entire exit

RESTRICTED

pupil of the telescope, for then the seen position of the target in relation to the reticle, right to left and up and down, is determined by that part of the exit pupil which the observer is really using. If he moves his eye right to left across the exit pupil, the target moves sideways relative to the reticle. Thus if the observer uses only a part of one or both exit pupils, he is almost certain to see the target in a different stereoscopic position from the one implied by its range. This means that he reads the wrong range when he sets the target at the same stereoscopic distance as the reticle. The only way for him to avoid this error is to adjust the separation of the rangefinder exit pupils so that it is exactly equal to the separation between his own pupils and to position his head so that his eye pupils do not clip the exit pupils along their right or left edges.^{14, 31}

Before it had been pointed out that the interpupillary setting on a rangefinder or heightfinder was of critical importance, interpupillary distance measures were made by the observer himself using a simple hand-held instrument. The average error of measurement by this method was probably at least 1 mm. Measures with an average error of about 0.5 mm can be obtained with a Shuron pupillometer if an examiner obtains three measurements and takes the median. This is still not satisfactory, however, because it is necessary for each operator to know and set his interpupillary distance to a tolerance of 0.25 mm or less. Developments to achieve greater interpupillary adjustment accuracy progressed through three steps: (1) the design and testing of an interpupillometer which promised greater measurement accuracy; (2) an investigation of the accuracy of the interpupillary distance adjustment mechanisms and scales which are used on the standard stereoscopic instrument; and (3) the testing of templates for use in making more accurate interpupillary settings.

22.2.1 The NDRC Interpupillometer

Work on the design of a satisfactory interpupillometer began under the Height Finder Project and was concluded by Project N-114. The instrument in its earliest form²¹ consisted

of a Shuron pupillometer mounted in such a way that a man could measure his own interpupillary distance by looking into a mirror. On the Shuron pupillometer there are two sliding glass pieces with vertical hairlines. When these hairlines are centered, one over each pupil, the distance between them represents the measured interpupillary distance. Normal examining procedure calls for slide settings made by an examiner who instructs the observer to fixate the examiner's eyes alternately while the slide settings are being made and checked. The fixation procedure ensures reasonable parallelism of the line of regard of the left eye when the hairline is being centered over the left pupil with the line of regard of the right eye when the other hairline is being centered in the right pupil. Better control of parallelism of the lines of sight and better steadiness of head position can be achieved if the observer views his own eyes in a mirror while looking through the pupillometer slides and resting his head on a steady support. These features characterize the NDRC interpupillometer.

CONSTRUCTION²⁸

The interpupillometer is fastened to the lid of its carrying case in such a position that when the lid is turned back the instrument is ready for operation. The case provides a solid mount and places the instrument at a convenient height for use when the case is set on a table (Figure 1).

The instrument consists of a metal or lacquered Lucite box which contains an adjustable eyepiece assembly, a front-surface mirror, and lights for illuminating the observer's eyes and pupils.

The eyepiece assembly (Figure 2) is constructed of brass with all external surfaces oxidized to give a dull black finish. It contains two slides, the horizontal movement of which is controlled by thumbscrews at the right and left. A circular opening in the left slide and a diamond-shaped opening in the right slide carry vertical hairlines etched on glass. The horizontal separation of the two hairlines is indicated by a vernier millimeter scale attached to the upper edge of the slides in such a position that it can be read from the rear of the instru-

ment (rear view, Figure 2). To permit calibration, the glass carrying the hairlines is adjustable horizontally within the left-hand

Two 7-watt bulbs below the eyepiece assembly provide the required illumination on the observer's pupil.

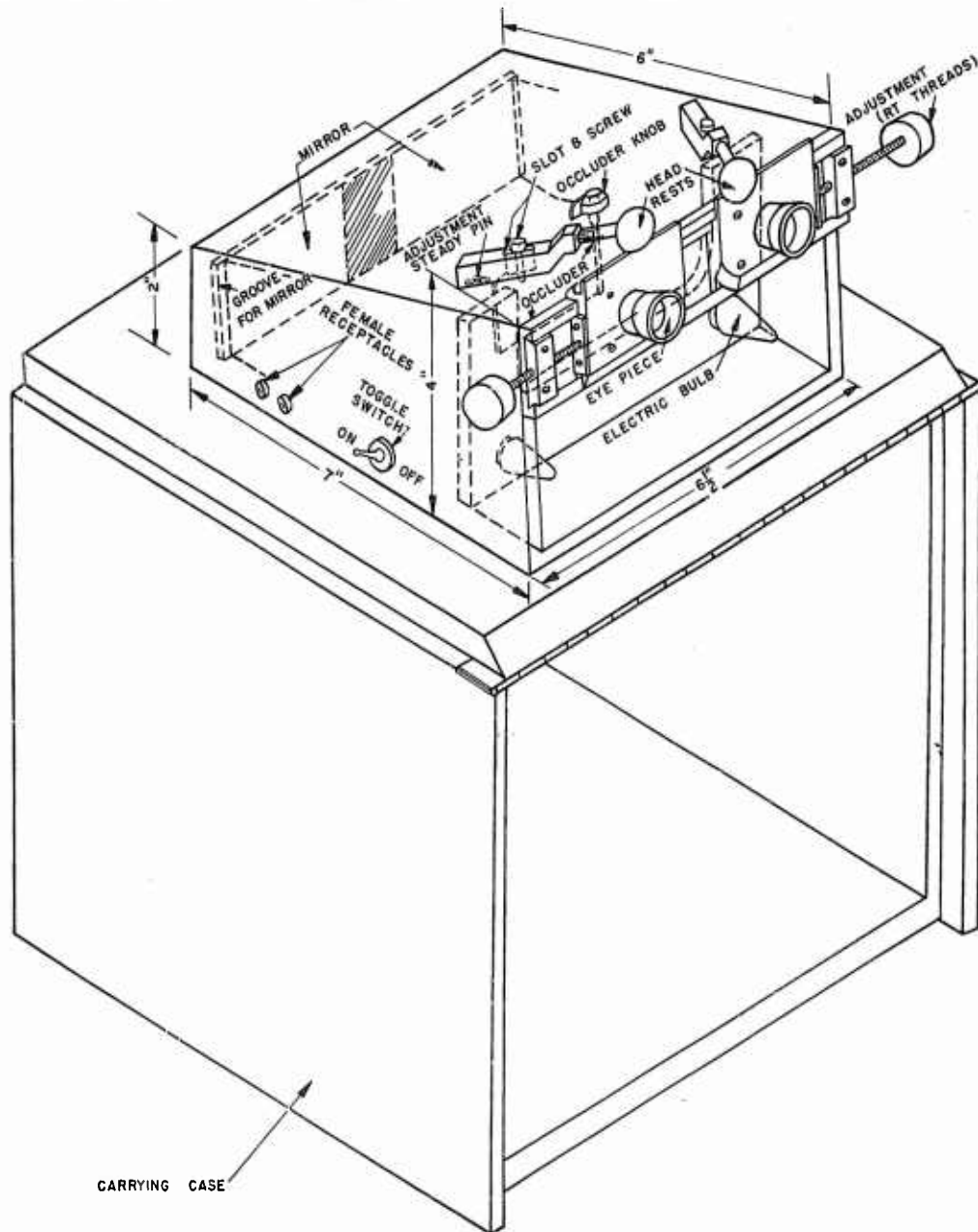

FIGURE 1. NDRC interpupillometer in position for operation.

slide by a threaded plunger (front view, Figure 2). An occluder is pivoted to the cover of the box (Figure 1) in such a way that the view of either eye can be obscured when necessary.

A front-surface mirror is mounted at the rear of the box, 6 inches from and parallel to the eyepiece assembly. When the observer looks through the eyepieces, he sees his eyes, the two

RESTRICTED

eyepiece openings, the two hairlines, and part of the lower half of his face in the mirror. He can look at his left-eye reflection with his left eye, and at his right-eye reflection with his right eye. Because a 1-inch strip in the middle section of the mirror is covered with black lacquer, neither eye can see the reflection of the other.

The fusion which might normally result when similar images are presented to the two eyes (each eye seeing its own reflected image) is

head firmly against the two head-rest buttons. He uses the one thumbscrew to adjust the controlled slide until the hairline bisects the one pupil and then adjusts the other slide with the other thumbscrew. He checks both settings to make certain he has done an accurate job and has not moved his head. The interpupillary measurement is then read from the vernier millimeter scale. Readings are made to the nearest 0.1 mm. The median of three readings is

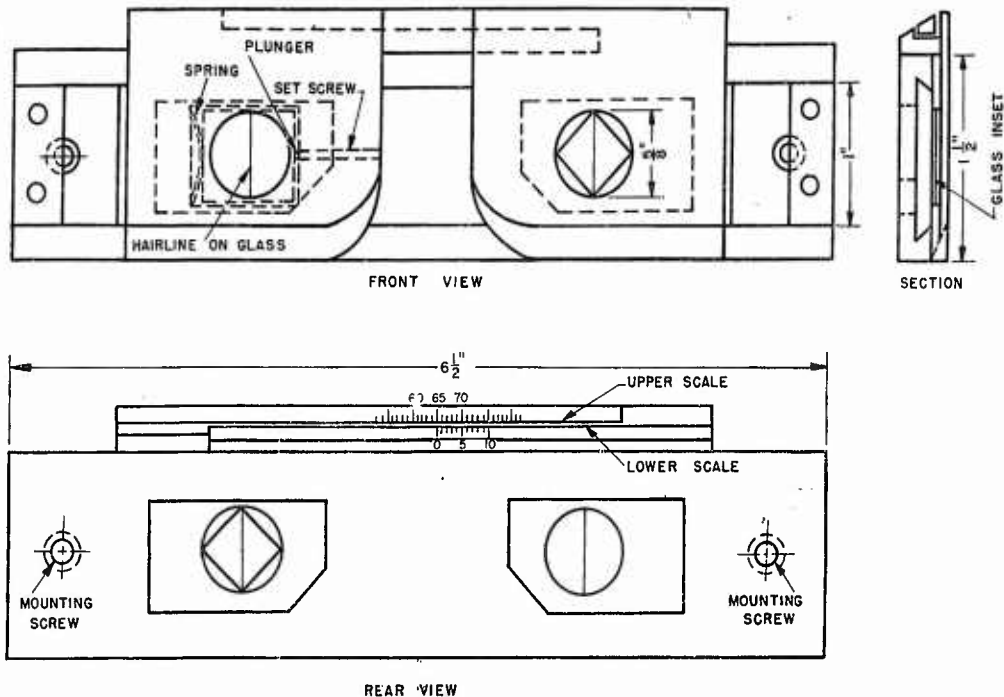

FIGURE 2. NDRC interpupillometer: eyepiece assembly details.

eliminated almost entirely by two characteristics of the instrument. (1) The openings in the right and left eyepieces are of different shape, a condition which reduces the tendency to fusion, and (2) the opening below the eyepiece assembly allows the operator to see the reflection of his nose and cheeks in the mirror.

In addition to the instrument, the carrying case (see Figure 3) contains an extension cord, a box of spare bulbs, a millimeter scale for calibration, and a screw driver for calibration.

MEASURING PROCEDURE

Measurement is accomplished by having the observer look through the eyepieces. He rests his

considered a single determination. If two determinations do not agree within 0.2 mm, a third is made, and the median of the three determinations is used.

RELIABILITY

In approximately 80 per cent of the cases, two determinations of the interpupillary distance of a given observer agree within 0.2 mm.^{21, 34} In almost all cases, they agree within 0.5 mm (Figure 4). A comparative test of this NDRC interpupillometer and the Bausch and Lomb "Duplex P-D Gauge" made on 59 men at NTS, Fort Lauderdale, demonstrated the NDRC instrument to be the more reliable.³⁴ It there-

RESTRICTED

fore represents the most satisfactory instrument now available for interpupillary distance measurement.

Several instruments were made and turned over to the Navy by the project. They were used for (1) selecting stereoscopic rangefinder

22.2.2 Accuracy of Interpupillary Scales on Heightfinders

As a second step in the achievement of more accurate interpupillary adjustment settings, a short investigation was made of the dependa-

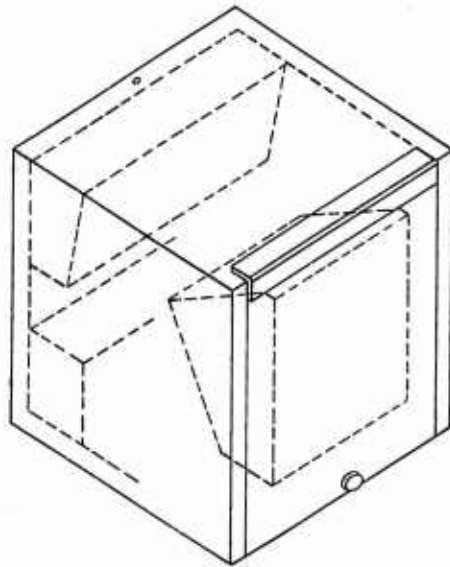

ISOMETRIC BOX CLOSED

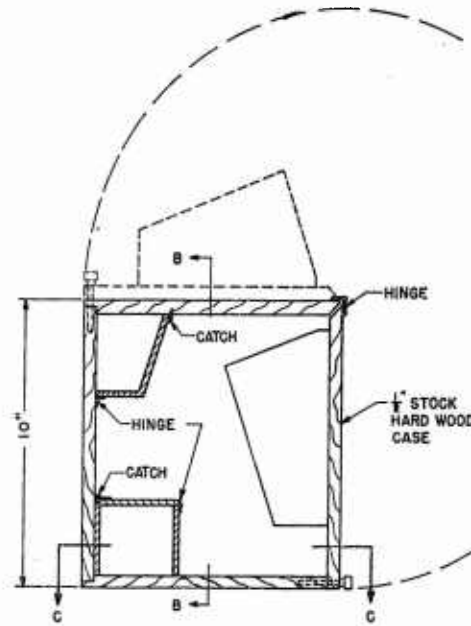

SECTION A-A

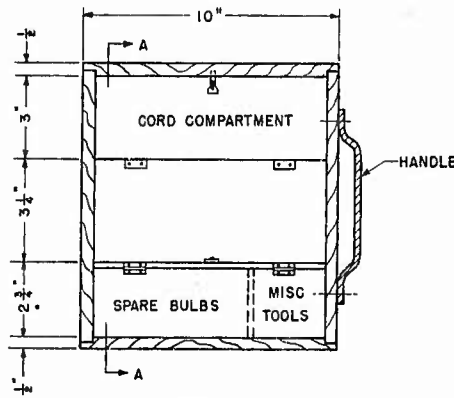

SECTION B-B

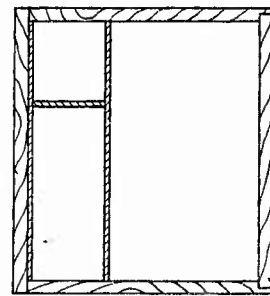

SECTION C-C

FIGURE 3. NDRC interpupillometer: carrying case details.

operators and recording their interpupillary distance for future use, (2) research on interpupillary distance in connection with other visual problems, and (3) as a model for use in connection with procurement of a number of the instruments by the Bureau of Ordnance.

bility of the interpupillary distance scales on rangefinders and heightfinders.²² These scales are intended to indicate what interpupillary setting has been made. Of nine heightfinders tested, five had scales which were within 0.25 mm of perfect readings at all points on the

scale. Among the other four, however, errors ranged as high as 1.25 mm, so that the average scale error for the instruments as a set was between 0.25 mm and 0.50 mm. Measurable backlash in the adjustment mechanism was also recorded for four of the nine instruments. These inaccuracies are greater than can be tolerated for precision ranging.

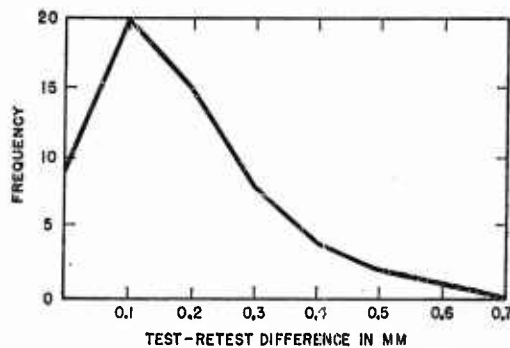

FIGURE 4. Distribution of differences between first and second interpupillary distance determination using the NDRC interpupillometer ($N = 59$).

As a wartime expedient, since instruments in use could not all be overhauled and improved, it was recommended that each rangefinder or heightfinder operator use a template to make the initial interpupillary setting on his instrument. Having made an accurate setting using the template, he was to read the instrument interpupillary scale in order to find what scale setting he should make thereafter when using the instrument. No other methods of determining this setting proved as dependable as the template method.²⁷

22.2.3 The Interpupillary Distance Template

The template which was tried out and initially recommended was one which could be made speedily in any tool or machine shop.²² It is made from a strip of hot-rolled $\frac{1}{16}$ -inch steel, 5 inches long and $\frac{3}{4}$ inch wide. Two holes are drilled in this strip as shown in Figure 5. One template is made for each observer. Center to center the holes measure the same as the observer's interpupillary distance.

The template is used by holding it above the heightfinder or rangefinder eyepieces at a distance where the exit pupils come into sharp focus on the diffusing paper which covers the template holes. The interpupillary adjustment on the instrument is changed by small steps by an assistant until the two exit pupils are exactly centered in the two template holes. The holes are drilled to a size which will be just larger than the exit pupils so that the centering judgment is easy to make. The adjustment operation is performed three times. Each time the interpupillary scale is read. The median of these three settings should provide an inter-exit pupil distance which is in error by less than 0.25 mm.

A more elaborate template was developed more recently by the Navy Bureau of Ordnance. Several templates of this design were procured by the Navy and tested by Project N-114. Details of the new instrument are shown in Figure 6. It will be seen that it is adjustable, so that one unit properly adjusted can be used by a number of men. Because a holder is provided, the user does not have the problem of holding the template delicately at just the proper height for maximum visibility of the exit pupils. The diffusing surfaces of this new template are frosted plastic with straight vertical hairlines. After the separation of the two hairlines has been adjusted to the observer's interpupillary distance, the template and holder are set over the rangefinder eyepieces, and the interpupillary adjustment is changed until the two exit pupils are bisected by the two hairlines. The precision of interpupillary distance setting with this template is slightly greater, but not by a statistically significant amount, than the precision of using the earlier template. Operators can use the new template faster and they themselves prefer it to the older one.²²

22.3 THE USE OF SLOT DIAPHRAGMS IN THE REDUCTION OF PARALLAX ERRORS

One way of reducing, if not avoiding, parallax errors in ranging is to reduce the size of the rangefinder exit pupils. Then when an operator

has made a correct interpupillary setting there will be less likelihood that he will fail to enclose the instrument exit pupils in his own because of poor head positioning. Operating the heightfinder (or rangefinder) at reduced aperture in order to obtain smaller exit pupils was recommended by Division 7, NDRC, in a series of reports.^{2, 14}

One objection which was raised to operating a heightfinder or rangefinder at reduced aperture was that the brightness of the visual field is cut in proportion to the reduction in aperture. If a 1-inch diameter diaphragm or aperture stop is used in the optical system, the light available to the observer is reduced by a factor of about 6. This shortens the effective use of the instrument at dusk by some 15 or 20 minutes.

solution to the dusk and night observing problem. Night operation at full aperture is satisfactory because parallax errors due to exit pupil clipping become less likely when the observer's pupils dilate with growing darkness.

22.4 THE STUDY AND DEVELOPMENT OF OPERATING PROCEDURES

As part of its directive, the Height Finder Project was instructed to prepare a manual on the theory, operation, and maintenance of the Army heightfinder. This manual was to be one which could be used as a school text and as a general reference book on the instrument (Chapter 3). Preparation of this text was much

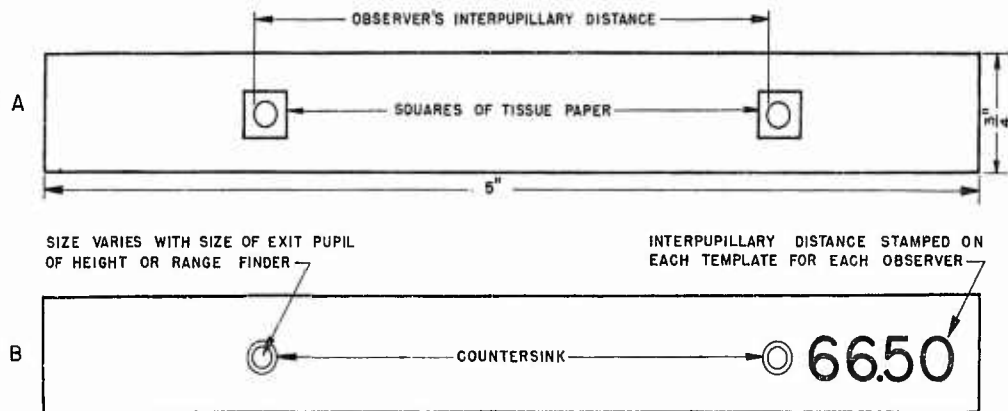

FIGURE 5. NDRC interpupillary distance template.

To increase the amount of light for the observer, yet retain all the benefits of reduced aperture, the Applied Psychology Panel project on heightfinder operation recommended the use of a slot-shaped diaphragm instead of a circular one.²⁸ The suggestion slot is 1 inch wide and is positioned vertically in the optical path, running the full height of the objective or the end window, at whichever the diaphragm is located. This slot diaphragm reduces the light available to the observer by a factor between 2 and 3 and shortens dusk-observing time only about half as much as does a 1-inch circular aperture.

Provision for removing diaphragms of either type, so that the instrument can be operated at full aperture whenever desired, is, of course, a

needed because the only existing Army manual on the subject was several years old and because no available publication included the results of the war research work on operation and maintenance. It was planned that the new manual would be thorough and detailed, describing as explicitly as possible each task in the adjustment and operation of the heightfinder. This called for an examination of existing procedures and an inquiry into the precision or tolerance involved in each adjustment or setting. Pertinent facts were assembled from the results of earlier Division 7 studies, from discussions with manufacturers and with the Princeton Branch of the Frankford Arsenal Design Section, and from a series of new experiments and studies.^{26, 33, 50} Some of the latter

RESTRICTED

were never described in separate reports, but their conclusions and results were incorporated in the procedures which were written into the new manual.^{24, 25, 28}

the arithmetic which the operator had to perform in getting a measure of the average departure of his observations from true range or true height and in combining his records to obtain a calibration value. The calibration correction applied by an observer on any one day is based on a progressive assessment of the records for the previous 3 days. In this way, the man is always making use of records which relate to the most recent condition of his instru-

22.4.1 Calibrating Procedures

The manual manuscript, parts of which later appeared in a number of Army publications,⁵²⁻⁵⁵

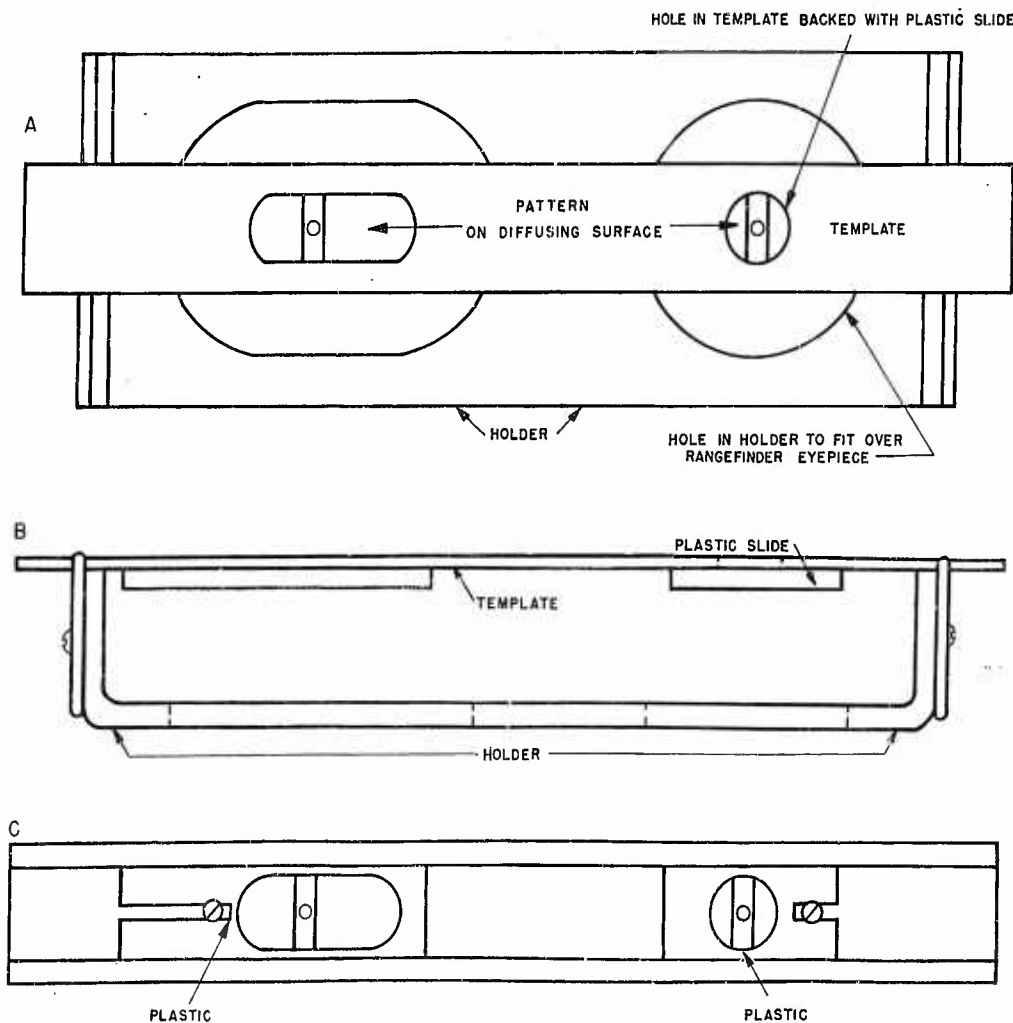

FIGURE 6. Bureau of Ordnance interpupillary distance template.

emphasized the importance of accurate calibration. A calibrating procedure, based on a quality control procedure, was developed around a series of new record forms.²⁵ These forms simplified

ment. At the same time, 3 days' records involve a sufficient number of readings to make the correction determined from them dependable.

On theoretical grounds, the process of cali-

brating a heightfinder should adjust it satisfactorily for reading either ranges or heights. Whether range or height measurements are desired, the operator should be able to read without bias. Similarly the method which the observer uses to obtain his calibration correction should be unimportant. As long as his instrument is in good adjustment, he should get the same correction whether it is based on range readings to known range ground targets, on internal adjuster correction scale readings on infinity targets (i.e., the sun, moon, or stars), on range readings on aerial targets to which the ranges are being determined simultaneously by a records section or by a radar, on height readings to an aerial target to which the height is being determined simultaneously by a records section, or on any other equally valid reference data. In practice, however, student observers do not get the same calibration correction value by these several methods. This is because they are not sufficiently skilled in keeping their instruments in adjustment or in making certain types of readings without error. A training school for heightfinder or rangefinder operators must therefore decide which method (or methods) of calibration it will teach. Logically, the choice should rest upon the kind of calibration opportunities which the operator is going to have in combat. For Army antiaircraft batteries in a forward area, the most likely methods of calibrating involve either ground ranges, infinity ranges, or radar ranges. For Navy rangefinders, the most likely methods of calibrating at sea use infinity ranges or radar ranges. Unfortunately, however, a field calibration procedure other than that using radar range may give the student such a bad calibration correction that his readings will be badly biased and he will lose faith in the method. Good observers are able to make very satisfactory height and range measurements to aerial targets using a single calibration correction based on previous aerial target readings.³³ But even for these good men, the disagreement between calibration corrections based on aerial target readings (with radar or records section reference data) and corrections based on ground target ranges^{33, 41} or on infinity target readings⁴⁰ seriously runs up their aerial target range

or height errors when nonaerial-target calibration corrections are used.

A study on Army personnel³³ showed that the average bias for short series of readings was increased by a factor of 2 or 3 when ground target calibration corrections were used for aerial target reading. When the heightfinders were not properly charged with helium, the average difference between ground target and aerial target calibration was over 7 units of error.

Records taken on the 12 best students in each of two classes of rangefinder operators at NTS, Fort Lauderdale, Florida, show similar results.^{41a} Each man determined a calibration correction based on 45 infinity target (star) readings, 45 known range-fixed target readings, and 45 aerial target readings (radar reference data). The average difference between the infinity target and known range calibration values was 6 units of error. The average difference between the infinity target and aerial target calibration values was about 4 units of error. The average difference between the known range and the aerial target calibration values was less than 3 units of error. When the men were compared with each other, they were most in agreement on their aerial target calibration values and least in agreement in terms of their infinity target readings. These data for student operators suggest that only long-continued practice at all methods of calibrating can bring operators to the point where they will be able to calibrate with equal accuracy and with dependable results by any technique that is at their disposal in the field.

It should be mentioned in passing that preliminary tests of the British technique of using the sun as an infinity target indicated the procedure to be successful. To reduce the brilliance of the sun, a partially coated rhodium window (Barr and Stroud infinity adjusting window) is inserted over the instrument end window. Observers will probably require extended practice at ranging on the sun before they do a satisfactory job, however. Man-to-man differences in the calibration corrections obtained on the sun are greater than similar differences for aerial target or known range calibration values.^{41b}

RESTRICTED

In special tests to determine how satisfactory radar ranges are for calibrating purposes, it was found that a radar Mark 10 supplies range readings on surface targets with a probable error of a little over 6 yards and that it has no systematic shift in bias with range. This radar is therefore a very satisfactory source of reference range data, when properly calibrated, and may be used for calibrating 13-foot range-finders provided the target ranges are over 6,000 yards.⁴⁴

22.4.2 Height-of-Image Adjustment Procedure

Important to good ranging is a satisfactory height-of-image adjustment. This adjustment brings the target images in the two fields of view to the same vertical position relative to the reticle pattern. An investigation of the precision of different methods of making this height-of-image adjustment indicated that the average error of adjustment, when the range-finder or heightfinder is used at 24 power, is about $\frac{1}{2}$ mil of apparent field.²⁶ There is no significant difference between the reliability of the monocular and double-image methods of adjustment. Those men who at first make poor and very variable height adjustments improve quickly when they are motivated by having records taken of the accuracy of their adjustments.

Height-of-image adjustment errors as large as 3 mils have no effect upon the precision of ground target range readings. Such adjustment errors, however, do decrease the precision of internal adjuster correction scale readings made on stars at night (Figure 7). Height-of-image errors may have accounted for many of the unsatisfactory calibration corrections obtained on star readings and discussed in Section 22.4.1 above. On this basis, it is recommended that all students be given special training in height-of-image adjustment until they can demonstrate the ability to make five successive height adjustments by each method with a spread of less than 1 mil. This testing requires the construction of a special scale to attach to the height-of-image adjustment knob.

22.4.3 Backlash Tests for Heightfinders

Checking for backlash in the measuring wedge and range scale system of the heightfinder was standard practice in heightfinder maintenance before the war. When work by research personnel with much-used school instruments revealed frequent and serious backlash in the height-conversion gearing system,⁵⁰

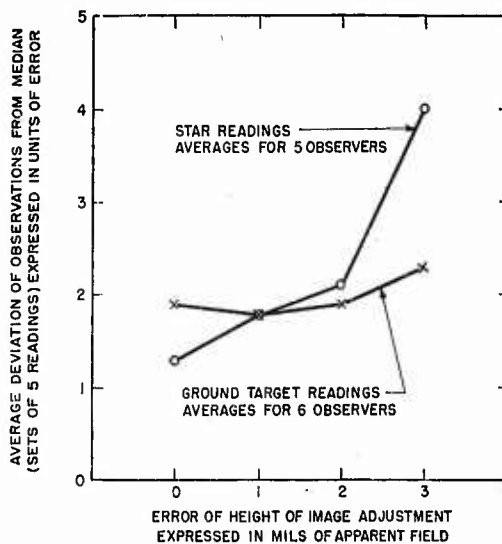

FIGURE 7. The effect of errors in height-of-image adjustment on the precision of heightfinder readings.

a special test for this condition was devised and included in the new set of heightfinder manuals.⁵²

22.4.4 Zero Mils Adjustment Checks for Heightfinders

Basic to the use of a heightfinder for measuring both ranges and heights there are at least two critical conditions: proper leveling of the instrument at the time of use; and proper alignment of the optical wedges in relation to the instrument's measuring scale and true level. The complete procedure for checking the alignment of the optical wedges had never been satisfactorily understood prior to the publication of reference 51. The procedure turns out to be very elaborate and much more complex than

previously used checking methods. In order to simplify the new testing procedure so that it could be carried out regularly in the field by enlisted personnel, a step-by-step checking chart was designed (Figure 8). Instructions on the chart make it self-explanatory. Since more tests than the traditional wedge check are included, the new record form is known as the zero mils adjustment form.⁵³

22.5 THE IMPORTANCE OF AIDING IN STEREOSCOPIC OPERATION

In the normal operation of Navy rangefinders in director turrets, range is regenerative; i.e., a

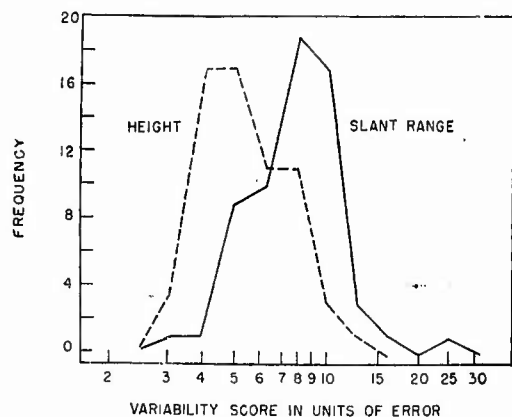

FIGURE 9. Frequency distribution of variability scores for height and slant range readings (plotted on a logarithmic scale).

range rate is established by a computer, and a generated range change is fed to the optical wedge assembly in the rangefinder. If the operator once sets the target in stereoscopic contact with the row of reticle marks, the target remains in contact as long as the generated range change applied to the wedges is exactly equal to the target's actual range change. This is aided ranging. Similarly, in the operation of Army heightfinders the reading of heights is essentially an aided task. The heightfinder really solves a range problem, but the process of tracking the target in elevation so changes the position of the optical wedges that the stereoscopic observer does not see the target move stereoscopically as long as it remains at the same height.

Not all rangefinder or heightfinder operation has the benefit of aiding, however. Many Navy rangefinders are set on stands and are operated without computers to generate range rates. Army heightfinder operators have an unaided task when measuring heights on a diving target or when measuring ranges to an aerial target.

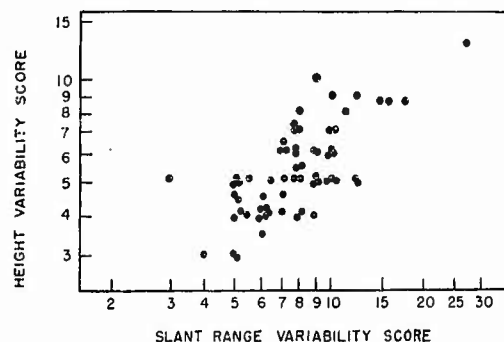

FIGURE 10. Scatter plot of variability scores in height and in slant range (plotted on logarithmic scales).

For tactical purposes as well as for purposes of interpreting student operator performance, it is of importance to know the relative precision of aided and unaided stereoscopic readings. One study of heightfinder records provides information on this point.³⁵

During a 2 weeks' period covered by their final examination period, 64 stereoscopic observers at the Height Finder School at Camp Davis took readings on an aerial target in both slant range and in height. Courses were run in pairs so that one course in which range readings were taken was followed immediately by a course of readings in height. Each observer took from 12 to 25 sets of readings under each of the two conditions. A variability score was computed for each set of readings, and for each man a median variability score for height reading and another for range reading were determined. Distributions of these scores for the group of 64 men are shown in Figure 9. Comparison of these distributions shows that the geometric mean of the variability scores for height readings is about 2.5 units of error less than the geometric mean of the variability scores for range readings. The unaided readings have a variability which is 33 per cent greater

than the aided readings. At the same time, the correlation between variability scores in height and range is good (Figure 10). The correlation coefficient for this scatter plot is $+0.71$ ($\sigma_r = .06$). Thus in general the men who make the more precise readings when aided are also those who make the more precise readings when unaided.

An important observation to add to these findings is this: when aiding is not present the stereoscopic operator should range in such a way that the last motion of his range knob in establishing contact moves the target in a direction which stereoscopically opposes its own motion. Thus if the target is approaching, the final knob motion should be one which moves the target back stereoscopically. Greater precision of ranging is achieved this way.⁴¹

22.6 VISUAL EFFECTS OF RANGEFINDER OR HEIGHTFINDER OPERATION

Because many operators of optical instruments and oscilloscopes in the Army and Navy feel that their work has an injurious effect upon their vision, a special investigation was made of the effects of a 16-weeks course for fire controlmen on various visual functions.⁴⁰ The training course given at NTS, Fort Lauderdale, required each student to spend a great many hours operating stereoscopic trainers, range-finders, and radar oscilloscopes, in addition to time spent in optical tracking and in reading and study. In the case of one class of 77 men, visual tests with the Ortho-Rater and with the projection eikonometer (see the Summary Technical Report of the Applied Psychology Panel, Volume 1, Chapter 8) were administered before and after the training course. The before and after change in test scores for these men was compared with the change in test scores found for control groups which were not subjected to visual training between tests. Most men improve in their test performance when retested, simply as a result of practice on the first test, so it is necessary to find whether a difference exists between the changes for trained and nontrained men in order to know what effects may be ascribed to the training experience.

The visual functions which were measured included visual acuity, lateral and vertical phorias, color vision, and stereoscopic acuity. In no case did the class average before and after training show that there had been any deterioration of visual function as a result of the work. There was a possible increase in visual acuity, an improvement in stereoscopic acuity as measured on both the projection eikonometer and the Ortho-Rater, a significant reduction of esophoria and hyperphoria for far vision, and an improvement in the Ortho-Rater color vision score.

On the basis of these results, it is recommended that all Service personnel who use their eyes in operations similar to those required in this experimental group be advised that it is much more probable that their visual functions are improving, rather than deteriorating, as a result of their training or practice.

22.7 FACTS FOR FUTURE RANGEFINDER AND HEIGHTFINDER DEVELOPMENT

In spite of the development and refinement of radar equipment and its extensive use for ranging during World War II, there will continue to be a variety of situations in which the optical rangefinder will have to be relied upon to supply range data—in situations where power for radar is not available, where the target does not provide a satisfactory radar echo, where the radar signals are confused, or where available radar instruments are casualties. To meet the needs of these situations, the development of an optical rangefinder superior to those now in use is much in order. The development of such an improved optical rangefinder requires increased knowledge of the mechanical, optical, and thermal limitations of present instruments and increased knowledge of those factors which make for better performance.

On the mechanical and optical side of this development, work during the war climaxed in the formation of the Division 7 committee which met to discuss the design of a super-rangefinder. This committee included representatives of Service groups, research laboratories, and manufacturing groups concerned with

RESTRICTED

rangefinder production and operation. It discussed probable limiting specifications for a new instrument and ways and means of minimizing errors found in instruments of conventional design. Optical bar problems may be eliminated by employing an optic arrangement as proposed by the Bureau of Standards.¹⁰ The reduction of parallax errors may be accomplished by the use of ortho-pseudoscopic instruments.¹¹ End reflector distortions may be eliminated by the use of fused quartz pentaprisms.¹⁰ Design developments like these are fundamental to the construction of an instrument which will not display the erratic errors found in standard Service equipment during the war.

On the operator and operational side, a great deal of useful information was gathered during the war. Some of this information is definitive and can be applied immediately. Other parts of the data are incomplete and suggestive in their present form, serving only to point the way to the kind of research which should be carried on in the early future. A brief summary of these operator and operational data follows. Important questions still to be answered are as follows. (1) What type of optical presentation is the most satisfactory for ranging? (2) What type of optical presentation is the most satisfactory for making the internal adjustment? (3) What reticle design should be used in a rangefinder of stereoscopic or other type? (4) What magnification should be used? (5) What physiological and psychological factors affect operator performance?

22.7.1 Choice of Optical Presentation for Ranging

The discussion of the relative merits of coincidence and stereoscopic ranging is an old one. Classical laboratory measurements of vernier acuity (coincidence) and stereoscopic acuity indicated that these two types of presentation would be about equal in their efficiency for use in rangefinders. Visual sensitivity measurements vary, however, with the conditions under which they are taken, and it is therefore desirable that any systematic comparison of rangefinder presentations make use of a stand-

ard testing instrument which permits the experimenter to vary the operator's visual task while keeping all other conditions constant. Two such special instruments were developed during the war, one at Eastman Kodak,⁹ and the other at the Carnegie Institute of Technology.¹⁸ Data presented in two reports^{11, 18} compare the following conditions: full field coincidence, full red field and green field coincidence, full field alternating (flicker) coincidence, split field coincidence, multistrip coincidence, reticle stereoscopic, full-field double-image ortho-pseudoscopic, and multistrip ortho-pseudoscopic. Of these the full-field double-image ortho-pseudoscopic presentation was the most precise. Reticle stereoscopic was the second most precise. The addition of flicker to the full-field coincidence presentation seemed to increase the precision of observation but not by amounts which made the flicker presentation comparable with the two stereoscopic forms.

The indicated follow-up study is a comparative test of these best presentations in standard, uniformly and well-built rangefinders. During the war, two comparison tests were run: reticle stereoscopic versus coincidence¹⁵ and reticle stereoscopic versus split-field ortho-pseudoscopic.¹¹ In each case, the results showed that the instruments compared were "about the same," but they are not revealing because instrumental errors were undoubtedly large enough to have masked operational differences. A good field test of optical presentations, then, must wait for the perfection, or at least improvement, of the mechanical and optical features of the rangefinder. The final decision on presentations must rest on field tests because of the fact that the clearness of images in laboratory test instruments, the lack of postural changes for the operator during a course of readings, and similar conditions special to laboratory observation may have distorted the relative efficiency measures summarized above for different presentations.

22.7.2 Choice of Optical Presentation for the Internal Adjuster System

Basic research on the choice of internal target presentation was performed under a Division 7

contract at Brown University. A comparison of a variety of monocular judgment situations with the standard stereoscopic judgment for internal adjustment indicated that monocular bisection of a narrow space between two lines or figures with a third line was more precise than stereoscopic judgment.²⁹ The monocular task had the added advantage that the mean settings made by different individuals showed greater agreement than their mean stereoscopic settings. A very brief repetition of this study on the rangefinder Mark 42 did not confirm these results, however.³⁰ In this study, stereoscopic precision was slightly greater. Clearness of field may be the critical factor here, so further study is indicated.

22.7.3 Choice of Reticle Design for a Stereoscopic Reticle

As part of the wartime effort to develop the most satisfactory conditions for operating existing stereoscopic reticle instruments, a considerable amount of laboratory work was done to determine the relative merits of different reticle patterns.^{30, 35, 46} The results provide a sound basis for future work in the field of stereoscopic rangefinder design. The facts uncovered were these: Plain, vertical-line reticle configurations provide the best insurance against poor ranging performance when, through an operator adjustment error, the height of the target above or below the reticle is unequal in the two fields of view. The suggested minimal length for these vertical marks is 4 to 5 minutes in true field. Opaque and illuminated reticles permit equally precise stereoscopic judgments. If reticle marks are opaque, they should not be so thick that they obscure large parts of stationary targets. A thickness of 0.20 minute of true field is suggested. If reticle marks are illuminated, the illumination should be set as low as possible since nonmoving targets with fine line detail may be dimmed out by a bright reticle, making stereoscopic vision inadequate. The addition of fore and aft marks in the reticle pattern does not improve stereoscopic judgments with either opaque or

illuminated reticles. The decision to use or not use fore and aft marks remains a Service decision to be made primarily on the basis of their usefulness in spotting. If fore and aft marks are used, experimental data indicate that there should not be more than a single pair of each and that 25 to 50 units of error is possibly the most satisfactory depth separation of these marks from the main row of marks. In order to reduce the likelihood of new student operators fusing noncorresponding reticle marks in the two fields of view, it is desirable that the marks in the main row of the reticle be irregularly spaced. Five unequally spaced vertical marks appear in the reticle design recommended by the Brown University group responsible for these studies.

22.7.4 Choice of Magnification for a Stereoscopic Instrument

According to the theory of the stereoscopic rangefinder, increase in the magnification of the two rangefinder telescopes should produce a proportionate increase in the efficiency of the range-finding operation. Magnification affects all visual angles and thus affects also the disparity between the two fields of view. If it is assumed that the observer continues to detect the same minimal disparity amount (i.e., in apparent field, at his eye), then doubling the magnification doubles the precision of his range readings in yards. Early records taken on the Army heightfinder M1 showed that this was not the case.⁴⁸ The ratio of the variability in yards of fixed target observations at 12 power and similar observations at 24 power was 1.1, not 2. In a similar test on aerial target observation,¹⁴ the ratio was about 1.3. In still a third tabulation,¹⁶ the records of 35 students indicated that the average ratio was about 1.5 for aerial targets but that for fixed targets the precision in yards was actually better at 12 power than 24. The advantages of 12 power, of course, vary with visibility conditions, and these are generally expected to be more important for ground target reading.

These results for the field operation of the

RESTRICTED

stereoscopic heightfinder are supported by data obtained in a series of laboratory and out-of-door studies in which observers judged when two objects in space were at the same distance.⁴⁷ For these judgments, the observers used cues based on binocular disparity, size changes, and accommodation changes. Although the results of the study describe precision in depth discrimination which so far exceeds that in previously reported data that one is inclined to question the adequacy of the experimental controls, the data on magnification show that there is no decrease in range observation errors when magnification is raised from 1 power to 40 power, in situations where ranges extend to 6,400 yards.

There is one feature which has been common to all magnification studies yet reported and which may account at least in part for the lack of improvement in stereoscopic observation with magnification. This is that many features of the judgment situation in addition to binocular disparity are affected by magnification. In the case of the heightfinder, for example, changing from 12 to 24 power doubles the size of the reticle marks and target, doubles the magnitude of any existing height-of-image error, doubles the spacing between reticle marks, and doubles the effect in angular disparity units of a given amount of turning of the range handwheel. Similarly in the laboratory studies, magnification increases the disparity rate of the target (since the target always moves in space at the same rate), increases the separation of target and reference object, and reduces the brightness of the field of view.

Thus, the critical study of magnification remains to be carried out. Data suggest that magnification has a very small effect. This may, of course, be the practical answer, i.e., that in practice it is not possible to design a range-finder which so presents the optical task that the observer does better by the expected amount with each increase in magnification. On the other hand, it is important to know wherein the limitation lies. It is difficult to believe that the limitation resides in the visual function of the operator. It almost certainly lies in the conditions of observation. To check the problem

thoroughly calls for a magnification study in which the angular separation of target and reference mark remains constant at all magnifications and in which disparity changes occur at the same rate at all magnifications.

22.7.5 Factors Which Influence Visual Judgments in Optical Rangefinders

Laboratory studies have investigated the possible influence of a good number of psychological and physiological variables on stereoscopic performance. Similar studies will play an important part in any future research program on instrument design.

TARGET-BACKGROUND CONTRAST

Haze operates to reduce the contrast between the target and its background.⁸ In a stereoscopic instrument which uses opaque reticles, the relative contrast of reticles to background and target to background changes with haze. Laboratory studies⁸ confirm field observations⁴ that when the target-to-background contrast goes down, men tend to obtain ranges which are too long: they are influenced in their range observations not only by the stereoscopic cue to depth but also by the contrast cue to depth. The Ohio State laboratory found evidence of this error as the contrast of target to background reached threshold values—although it seems likely that errors at greater contrast levels would have appeared had the visual task involved a different relation between target and reticle. The one used was a rectangular target in a circular reticle field. While field data⁴ for ground target ranging show that the contrast factor becomes more important when the target and the reticle mark become separated vertically, records for aerial target ranging show that errors do not change in a significant way with range^{9, 43} or with the contrast of the target with its sky background.⁴³ This makes it appear that low contrast of target and background is critical primarily in the case of ground target ranging at considerable range. Any attempt to calibrate out this error in combat is distinctly impractical, but operators of reticle stereoscopic instru-

RESTRICTED

ments will do well to avoid ever taking calibration readings on hazy ground targets. A good argument for using an ortho-pseudoscopic instrument, of course, is that it can never be subject to contrast errors.

RETICLE IMPERFECTIONS

Imperfections in reticles used in stereoscopic rangefinders are at times difficult to eliminate in manufacture. They are not serious, however, since they do not significantly reduce the precision of the stereoscopic observations made by an observer.³⁰

OCULAR CONDITIONS

A number of studies have been made to determine what ocular conditions favor or reduce the precision of stereoscopic observations. Precision seems to be best when convergence is zero⁶ and when accommodation is zero or nearly zero.^{6, 30} The convergence condition is met by most rangefinders, but in order to achieve the desired accommodation condition the observer must know how to focus his instrument properly.⁴⁰

Range errors on individual readings or biasing errors throughout a series of readings can result from a combination of cyclophoria and poor target location.^{4, 30} Unless there are strong fusion-holding areas in the observer's visual field, the observer's eyes may tend toward a cyclophoric position. The result of this eye rotation is to change the stereoscopic position of the target relative to the reticle if the vertical separation of the target and reticle is great. Presumably this error can be satisfactorily handled by adding cyclofusional cues in the reticle pattern and/or by obtaining accurate elevation tracking so that the target and reticle are always close together in the vertical direction.

Serious chromatic dispersion in the observer's eyes produces ranging errors when the target presents a different color contrast with the background from that presented by the reticle.^{7, 30} This error results from the lateral deviation of the reticle and target images relative to each other on the retina because of a prism effect of the eye lens. A field test of the importance of this source of error is needed. Lab-

oratory tests indicate that it could be important in the case of some observers. If the condition is important in instrument operation, men with serious chromatic dispersion could be weeded out by selection test or might use chromatic filters when rangefinding.

LOUD SOUNDS

In a Brown University study,¹² loud sounds were found to have no detrimental effect on stereoscopic observation on a laboratory instrument. These results mean that loud sounds per se have no effect, but there are no data to show whether battle sounds, with all their associative effects, may influence the stereoscopic operator's performance.

PHYSIOLOGICAL CONDITIONS

The Harvard University group under Division 7 demonstrated that metrazol, benzedrine, variations in blood sugar, and hyperventilation have small effect on stereoscopic acuity.¹³ Metrazol causes slight increases in precision and in speed of operation. Hyperventilation produces reduced precision for a short period, which suggests that crews should be stationed near enough to their heightfinder to avoid running when an alert comes.

LOSS OF SLEEP

Both Harvard and Dartmouth present evidence on the point that loss of sleep does not specifically decrease stereoscopic acuity.^{13, 23}

SEX DIFFERENCES

An inspection of data collected on men and women observers in different experiments revealed no differences in performance which presumably would not be overcome with practice.¹⁷

22.7.6

Some Conclusions

The war research program on rangefinders and heightfinders resulted in improvements to equipment and to operating procedures which raised the performance of existing equipment to about the best which can be expected of it. Men trained more adequately than those trained

RESTRICTED

during World War II will maintain and operate their instruments more satisfactorily, but any great step forward in the precision of range-finding will depend on systematic redesign. If there is Service interest in such a redesign program, the foregoing section proposes a number of research problems of practical and theoretical interest.

RESTRICTED

Chapter 23

STANDARD PROCEDURES IN VOICE COMMUNICATION

By Dael Wolfe^a

SUMMARY

23.1 COMMUNICATION IN AIRCRAFT

EXPERIMENTAL STUDIES were conducted to aid in the development of courses of instruction in voice communication procedures for AAF personnel. The following facts were established relative to the best methods of speaking and the best ways of using airplane interphone and radio telephone equipment in the presence of intense noise.

1. The most important factor in the use of the voice itself is loudness. In order to secure maximum intelligibility, the speaker should talk as loudly as he can without obvious strain. This is speech which produces a good loud side tone in the speaker's earphones.

2. The second most important factor is articulation. Even one hour of instruction, given in the presence of airplane-type noise, produces enough improvement in articulation to increase intelligibility significantly.

3. Message forms should be standardized. Message content should be standardized, and each type of message should be as unique as possible.

4. Words vary in intelligibility. Lists of words of known, and widely varying, intelligibility were prepared. Phonetic characteristics which influence intelligibility were analyzed.

5. In using the T-17 (hand-held) microphone in noise, maximum intelligibility can be secured by holding the microphone lightly touching the speaker's lips and parallel to the plane of the face.

6. The T-30 (throat) microphone should be worn on or slightly above the Adam's apple. It should never be worn below that point.

7. Intelligibility over the interphone is greater when the gain control is fixed at a high level than when listeners are free to adjust the volume to the level they prefer or consider most intelligible. Gain control should remain inoperative on the interphone.

Military airplanes are noisy, so noisy that ordinary conversation is impossible and even shouting may be ineffective. In order to make communication between crew members possible, an interphone system is commonly used. But the noise of the airplane affects the interphone, for the microphone into which a man talks picks up the airplane noise as well as speech. The listener finds that his headset does not exclude all the noise around him. Thus every message is heard against a high-level noise background, part coming over the interphone circuit and part coming directly to the ear.

Use of the radio telephone [R/T] between planes is beset by greater difficulties. Even when a ground station is being listened to there is still the noise of one's own plane to contend with and frequently there is static as well.

Noise makes communication difficult, but communication must go on and must be understood. Realizing these difficulties, the Army Air Forces asked the Applied Psychology Panel to develop methods for training aircrew personnel to speak in such a way that messages heard over interphone and R/T would be intelligible in spite of the noise.

The Voice Communication Laboratory was established by the Applied Psychology Panel in response to this request. Located at Waco Army Air Field, its personnel also worked in many other AAF installations. The project developed courses of instruction in voice communication which were adopted by the AAF and taught to all aircrew members (see Chapter 11). In the course of its work, Project SC-67 also developed or aided in the development of standardized procedures in voice communication.^b These procedures were of four types:

^b Section 17.3 of NDRC also did a great deal of work on airplane communication problems. In addition to the development of improved equipment, that section developed noise generators for simulating the conditions found in aircraft, methods of noise reduction and noise shielding, and measures of speech intelligibility. See the Summary Technical Reports of Division 17.

^a This chapter is based on the work of Project SC-67.

1. Improved procedures for use of the voice itself under conditions of intense noise.
2. Standardized message forms and message content.
3. Lists of words of known intelligibility.
4. The best methods of using some kinds of communication equipment.

23.2 STANDARDIZED PROCEDURES FOR USE OF VOICE

23.2.1 Loudness^{1, 4}

The question of how loudly one should speak is a basic problem in all voice communication carried on over interphone and radio in noise. Various recommendations were found in the training literature of the Air Forces. Talking with experienced fliers elicited still others. For example, one training manual recommended that the aviation cadet should "forget the surrounding noise and imagine that he is talking directly into the ears of the listener." A second common recommendation was for the speaker to use a "conversational" level of loudness. A third suggested a "normal" or "customary" loudness level. Almost universally the student was admonished not to shout into the microphone. On the other hand, as a physical principle it was known that within rather wide limits a direct relation exists between the signal-to-noise ratio in the listener's ear and the intelligibility of the transmitted speech. In order to determine the optimal loudness level for speech heard over the airplane interphone and radio more exactly than had been done before, the following experiment was conducted.¹

EXPERIMENTAL DESIGN AND TECHNIQUE

The general design of the experiment consisted of having a number of speakers read lists of words to panels of listeners who wrote down the words as they understood them. Each speaker read four word lists. Each of his word lists was spoken at a different loudness level. Comparisons could then be made of the percentage of words correctly recorded at each loudness level.

Speakers. Twenty-four cadet speakers were used for each experiment. Most of the speakers were student pilots. The remainder were on-the-line trainees who had been selected for the aviation cadet program on essentially the same criteria as the student pilots. Two speakers were chosen at random from each group of from 22 to 26 men sent to the Voice Communication Laboratory.

Listeners. The remaining 20 to 24 men in each group served as a listening panel. Like the speakers, these men had had some experience in speaking and listening in noise but not enough to consider them fully trained. The order in which different loudness levels were used was, therefore, systematically varied to counteract possible practice effects.

Test Material. The test material for each sub-experiment consisted in eight 24-word lists (see Chapter 11). Within each experiment the lists were all substantially equal in audibility or difficulty. The lists used with the different types of equipment were not always equated for difficulty, however, so the results should not be used as a means of comparing the different types of equipment.

Procedure. Both speakers and listeners were seated in an ambient noise of 108 to 110 db having a spectrum similar to that found in military aircraft.

Both throat and hand-held microphones were used in the recommended manner (see Section 23.5). The hand-held microphone (T-17) was held parallel to the face and close enough to touch the speaker's lips lightly. The throat microphone (T-30) was strapped on so that the two buttons rested against either side of the thyroid cartilage. It was adjusted to be snug but not uncomfortable. Both the T-17 and T-30 microphones were used simultaneously. Each microphone was connected to a BC-347-C interphone amplifier which fed a circuit of 12 pairs of earphones. With this arrangement, each word pronounced by a speaker produced a signal in both circuits, and data were obtained for both microphones simultaneously. A meter was connected across each microphone circuit so that maximum deflections produced by each word could be recorded separately for each microphone. Each speaker watched one of these

meters and used the meter deflection as a means of monitoring his own voice loudness.

Loudness Levels. Four loudness levels were determined by preliminary trial. For each headset a highest level was determined which was considered to be the maximum the subjects would be able to produce consistently. The three lower levels were placed at successive steps of approximately 3 db below the loudest one. These four loudness levels were expressed in terms of voltmeter readings, and the speakers were instructed to speak with sufficient loudness to produce the assigned voltmeter deflection on each word. With a little preliminary practice all subjects but one were able to maintain the as-

TABLE 1. Mean voltage and relative intensity of the four loudness levels used with interphone equipment.

Microphone and headset-earphone cushion combination	Loudness levels*			
	1	2	3	4 (loudest)
In MC-162†				
T-17	7.3	10.3	14.6	19.9
HS-23	-2.7	0.3	3.3	6.0
In MC-162-A†				
T-17	7.4	10.6	14.3	19.5
HS-23	-2.6	0.5	3.1	5.8
In MC-162-A†				
T-17	2.1	3.2	4.2	5.6
HS-33	-3.0	0.6	3.0	5.4
T-17-B
HS-33‡	-2.5	0.5	2.9	5.7
In MC-162†				
T-30-S	7.2	13.1	17.2	21.1
HS-23	-2.8	2.4	4.7	6.5
In MC-162-A†				
T-30-S	8.5	12.1	16.2	21.0
HS-23	-1.4	1.7	4.2	6.4
In MC-162-A†				
T-30-S	2.4	3.5	4.3	5.6
HS-33	-1.9	1.3	3.1	5.4
ANB-M-C1
HS-33	-3.0	0.1	3.1	5.5

*Where two figures are given, the upper is the mean voltage across the headphones. The lower is the relative intensity in decibels.

† Decibels relative to 10 volts.

‡ Decibels relative to 3 volts.

signed loudness satisfactorily.

More subjectively expressed, the four loudness levels may be described in the following terms.

1. Conversational level of speech.
2. Somewhat louder: about the level used for communication when there is considerable dis-

traction, or when speaking to an audience of 40 or 50 people.

3. Approximately the loudest level one can produce without extreme effort or noticeable strain.

4. The maximum loudness that the average speaker could maintain consistently. The subjects were shouting when using this level.

The mean voltage across the headphones and the relative intensity in decibels for each loudness level are given in Table 1 for the inter-

TABLE 2. Relative intensity of the four loudness levels used with aircraft radio sets.*

Radio sets	Loudness levels†			
	1	2	3	4 (loudest)
SCR-183	-1.4	1.1	3.7	6.0
SCR-274-N	-1.8	0.5	3.0	6.0
SCR-522	-2.5	0.6	3.1	5.8

*The T-17 (hand-held) microphone was used with all three radios. A headset across the receiver output provided a typical load on the receiver. A booster amplifier with a high impedance input that ensured negligible voltage drain on the output circuit supplied power for the listeners' headphones.

† The figures represent the mean signal levels expressed in decibels relative to zero db = 3.0 volts.

phone equipment. Table 2 gives mean signal levels for the four loudness levels with the radio telephone sets used.

EQUIPMENT

Since the effect of various loudness levels upon the listener is, in large part, a function of the headphone equipment used, separate sub-experiments were carried out for each of the several types of headset equipment in common use in the Army Air Forces in 1943. Since the characteristics of the microphone might also influence the effect upon the listeners of different loudness levels, three different types of microphones were used. Finally, separate experiments were conducted for intercommunication equipment and for three radio sets commonly used in AAF planes.^{1,4} The equipment combinations studied are given in Table 1 and Table 2.

RESULTS

Under all conditions, with all types of equipment studied, either the third or fourth loud-

ness level was the most intelligible. These results directly contradicted the common advice to speak in a "normal" or "conversational" manner that had often been given to aircrew more intelligible both over the interphone and radio equipment led directly to a revision of the instruction given to aircrew members and cadets (see Chapter 11).

TABLE 3. Intelligibility over Army Air Forces communication equipment of words spoken at four loudness levels.

Equipment	Loudness levels			
	1	2	3	4 (loudest)
T-17 (hand-held) microphone				
HS-23 headset, MC-162 cushions	36.9*	43.7	48.3	50.0
HS-23 headset, MC-162-A cushions	48.2	56.4	58.2	56.0
HS-33 headset, MC-162-A cushions	52.1	58.6	61.0	61.3
T-17-B (hand-held) microphone	25.8	68.4	71.4	67.2
ANB-M-C1 mask microphone	73.0	72.3	73.6	71.2
T-30-S (throat) microphone				
HS-23 headset, MC-162 cushions	18.2	31.4	33.0	30.0
HS-23 headset, MC-162-A cushions	35.1	37.7	37.9	31.8
HS-33 headset, MC-162-A cushions	45.3	47.6	49.5	40.6
SCR-183 radio	37.8	43.4	44.3	43.6
SCR-274-N radio	55.1	60.8	65.3	69.3
SCR-522 radio	59.5	65.7	68.9	66.3

*The figures in this table are per cent intelligibility scores. Each represents the percentage of all words heard correctly, under the stated conditions, by the average listener.

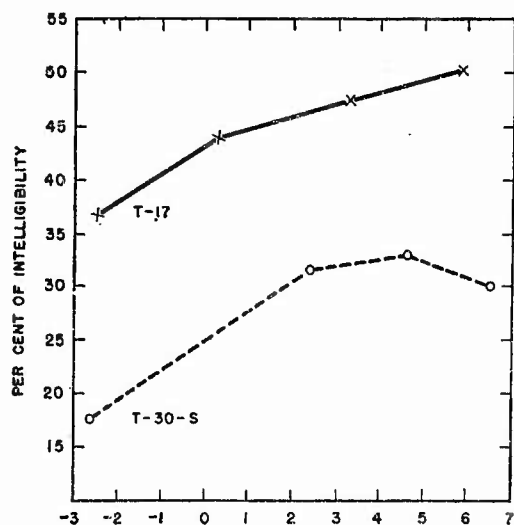

FIGURE 1. Intelligibility at four loudness levels (HS-23 headset in MC-162 earphone cushion).

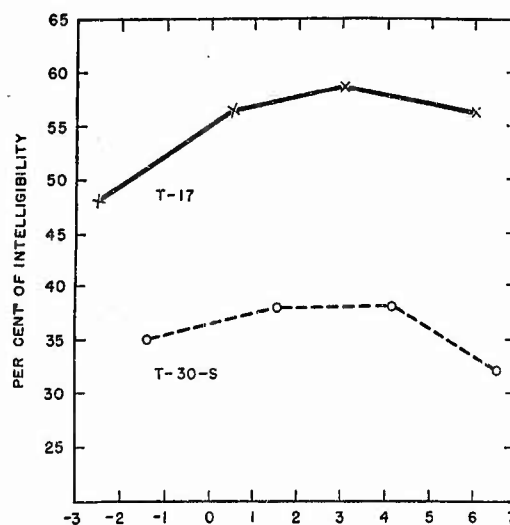

FIGURE 2. Intelligibility at four loudness levels (HS-23 headset in MC-162-A earphone cushion).

cadets prior to the establishment of these findings. The results, however, should not have been surprising to anyone who considered the direct relationship between the signal-to-noise ratio in the listener's ear and the intelligibility of the transmitted speech. The experimental demonstration of the fact that loud speech is

The detailed results are given in Table 3 and presented graphically in Figures 1 to 5.

Differences between successive loudness levels were not always large enough to be significant. The general trend, however, was consistent in all experiments except that on the ANB-M-C1 mask microphone. Analysis of variance tech-

niques showed the variance due to differences in loudness to be significant at or beyond the 5 per cent level of confidence in 10 of the 11 experiments and at or beyond the 1 per cent level of confidence in 7.

shielding to allow a good signal-to-noise ratio with even the lowest loudness level studied. This result, however, should not be used as a basis for recommending a low loudness level, for the following reasons.

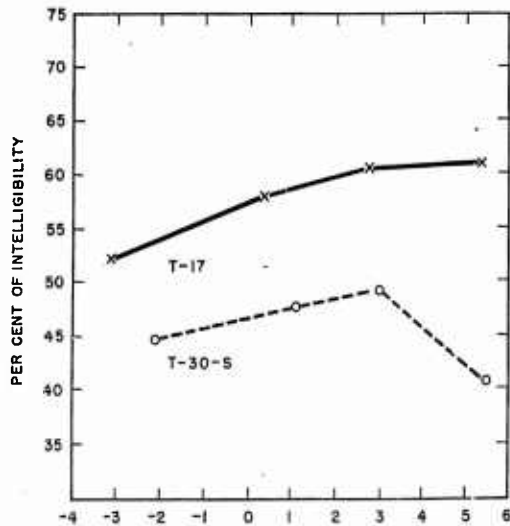

FIGURE 3. Intelligibility at four loudness levels (HS-33 headset in MC-162-A earphone cushion).

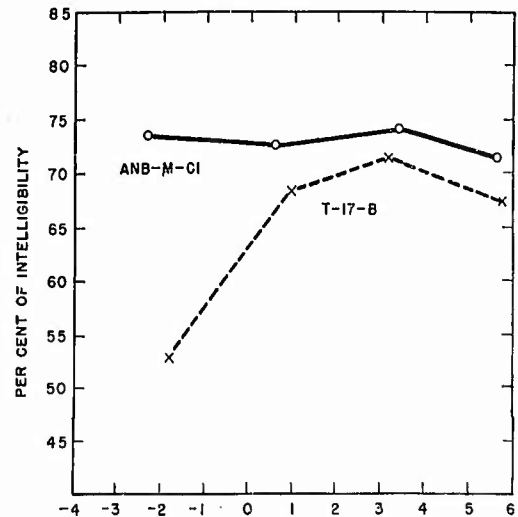

FIGURE 4. Intelligibility at four loudness levels (HS-33 headset).

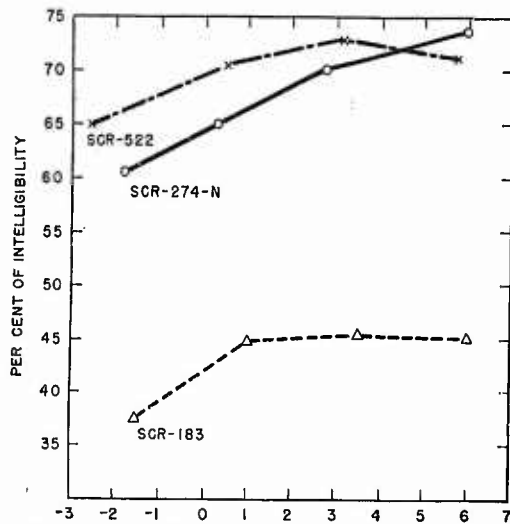

FIGURE 5. Intelligibility scores at four loudness levels for three standard AAF aircraft radio sets.

In the remaining case, that of the mask microphone, differences in loudness had no effect on the percentage of words correctly heard. Presumably, the A-10-R oxygen mask in which this microphone was used provided sufficient noise

shielding to allow a good signal-to-noise ratio with even the lowest loudness level studied. In the second place, the experiment was conducted at ground level and the mask is used at high altitude. Because signal strength becomes a critical factor with mask microphones as altitude increases, it was recommended that the same loudness level be used with the ANB-M-C1 mask microphone as was found best with the other equipment studied.

In some cases the fourth level of loudness was less intelligible than the third. This result was in accord with the fact that the fourth level was above the overload point of the amplifier.

It is obvious that for operating both aircraft radios and interphone, loudness of voice is an important factor. With all microphones used by the AAF and for either radio or interphone communication the speaker's voice should be loud, as loud as he can make it without the extreme effort of shouting. The best recommendation to give to the speaker is to tell him to talk with enough energy to produce a good loud side tone in his own earphones.

23.2.2

Pitch

The pitch⁷ of the voice has frequently been assumed to be a factor of importance in determining the intelligibility of speech over radio or interphone equipment. Some training films, for example, have included recommendations to pitch the voice higher than normal as one of the principal methods of increasing intelligibility.

The effect of differences in pitch, with loudness held constant at almost the optimal level (see Section 23.2.1) was studied. Speakers were trained to use four pitch levels, "natural," "higher," "very high," and "low," while maintaining constant loudness. Recordings of word lists read at these four pitches were then played to panels of listeners who wrote what they heard. A simulated airplane-type noise of 108 to 110 db was present during all speaking and listening. Standard AAF communication equipment (T-30, T-17, or ANB-M-C1 microphone; HS-33 headset; BC-347 amplifier) was used.

The average intelligibility of the 40 subjects at each of the four pitches is shown in Table 4. The "high" pitch average was poorer at the 2 per cent level of confidence and the "very high" poorer at the 1 per cent level of confidence than was the average intelligibility for normal pitch.

TABLE 4. Average intelligibility scores at four pitch levels.

Pitch level	Mean score	^a
Low	51.4	3.0
Normal	53.6	3.5
High	48.6	3.4
Very high	43.9	6.1

Supplementary studies of the intelligibility of speakers who had different "normal" pitches and analysis of the actual frequencies of the pitches used by the various subjects both gave corroborative evidence that intelligibility was not improved by having the speaker depart from his normal pitch. One supplementary investigation demonstrated that the pitch used in speaking at the high noise level employed (108 to 110 db) was, on the average, 16.2 cycles per

second (c) higher than that used by the same men speaking under quiet conditions. (Average pitch in quiet = 154.9 c, $\sigma = 19.3$; in noise = 171.1 c, $\sigma = 14.9$; $N = 12$).

23.2.3

Rate

Three studies were conducted of the influence of rate⁹ of speaking on intelligibility. In general the results gave some support to the belief that slow or normal rates (100 to 150 words per minute [wpm]) were more intelligible than fast rates (180 wpm and higher). The results also seemed to show that rate of speech was not a critical factor in determining intelligibility and that the importance of differences in rate had probably been overestimated.

23.2.4

Articulation

Four studies were made of the effect upon intelligibility of special training in articulation.⁸ Each investigated the possible improvement which might result from a different type of articulation training.

INSTRUCTION TO STRESS FINAL CONSONANTS

Each speaker read two lists of words, one in his normal manner and one with added stress on the final consonants. The order of reading was counterbalanced and the loudness level kept equal for the two lists.

Stressing final consonants produced a significant gain in intelligibility when the T-17 (hand-held) microphone was used. When the T-30 (throat) and ANB-M-C1 (mask) microphones were used the changes in intelligibility were within the amount expected by chance.

TRAINING TO STRESS SIBILANT SOUNDS

Twenty-nine subjects were each given two half-hour periods of training on stressing sibilants (s, z, sh, zh, ch, j). Tests given at the end of this training showed a slight loss in intelligibility when compared with similar tests taken before training. A control group showed a gain. It is possible that the strong sibilant articula-

tion distorted the word patterns, making the words less instead of more intelligible.

INSTRUCTION IN PRECISE ARTICULATION (IN QUIET)

Thirty men were given two half-hour periods of instruction, in a quiet classroom, in precise articulation. Instruction consisted of lecture and practice. It was directed toward general improvement in articulation rather than toward improvement in a specific type of sound or part of the word.

The trained men were significantly more intelligible than they had been before training. A control group showed no such gain.

INSTRUCTION IN PRECISE ARTICULATION (IN NOISE)

Thirty-seven AAF cadets were given one hour of training in precise articulation. The training included a short talk on the need for clear speech when talking in noise, examples of words low in intelligibility, drill with word lists and interphone messages, criticism of their own speech, and a demonstration recording on articulation. Both before and after this training the men were given a standard intelligibility test and a special test on difficult words.

Both testing and training were conducted in the presence of airplane-type noise and with standard AAF interphone equipment. Loudness was kept constant.

The men showed gains significant beyond the 1 per cent confidence level on both the standard test and the test on difficult words. A control group of 38 men showed a similar gain on the test of difficult words, which consisted of the same words both at the start and end of the experiment. The control group failed to gain on the standard test, which was similar to the standard test given at the beginning of the experiment but involving a different set of words. The data are shown in Table 5.

Recordings of the speech of twelve of the subjects were analyzed by a panel of nine persons, four of whom were specialists in speech. These judges were often able, with a range from 64 per cent for the poorest to 79 per cent for the best, to determine which utterance of

a particular word was made after training and which before.

The 12 speakers varied considerably in the effect that the hour of training had on their speech. In terms of the per cent of words better articulated after training than before, the range was from 94, for the man showing most improvement, down to a chance score of approximately 50 for five of the twelve subjects studied in this detail.

Instruction in noise seemed to be more effective than an equal amount of instruction in quiet. Too many conditions were different in the

TABLE 5. Effects of training on articulation.

	Initial		Final		Difference	
	Mean	σ	Mean	σ	$M_2 - M_1$	t^*
Standard multiple-choice test						
Trained group ($N=37$)	58.8	8.6	66.2	7.8	7.4	3.77
Control group ($N=38$)	63.4	8.7	64.1	7.4	0.7	0.80
Difficult words test						
Trained group ($N=37$)	38.2	11.3	46.3	10.2	8.1	4.39
Control group ($N=38$)	38.8	12.8	45.0	9.7	6.2	3.30
Correlations of initial vs final scores						
Trained group, multiple-choice test, $r = -.01$						
Control group, multiple-choice test, $r = .38$						
Trained group, difficult words test, $r = .49$						
Control group, difficult words test, $r = .60$						

* t 's from distribution of differences; t (1%) for 36 degrees of freedom = 2.75.

two experiments to be confident that the greater gain was due to the presence of noise. Other evidence of the value of noise in speech training of AAF personnel supports the assumption that noise used during the training was helpful.

The experimental evidence justifies devoting some time to instruction on articulation in a course on voice communication in airplanes. This instruction is probably more valuable if given in the presence of airplane-type noise. Noise lends face validity, at least, and is no hindrance.

RESTRICTED

23.2.5 Regional Differences in Speech

The region of origin (dialect) was considered as a variable which might influence intelligibility. The mean intelligibility scores for 1,913 student pilots were available for analysis.⁹ Each score was an average computed from the responses of panels of from 8 to 11 listeners who happened to be their classmates.

Because the only item of information regarding region of origin was the Service Command in which each man was inducted, this classification was used as a means of investigating dialects. A sample showed 74 per cent of the men had lived all their lives in the Service Command in which they were inducted.

The differences in mean intelligibility scores were in most cases too small to be relied upon. They were also inconsistent in trend. The differences did not justify any recommendation regarding either selection or training of men with different dialects.

23.2.6 Summary of Voice Factors

Five characteristics of speech were investigated: loudness, pitch, rate, articulation, and regional origin (dialect). The first four of these, it was thought, might be subject to improvement by training if the experimental results indicated that the characteristic was an important determiner of intelligibility. The last could be handled through selection.

The experimental evidence justified the following conclusions and action. These are arranged according to importance.

1. Personnel should not be excluded on the basis of geographical origin.

2. Differences in pitch are not related to differences in intelligibility over airplane communication systems. No justification was found for advising cadets to raise the pitch of their voices.

3. A slow to moderate rate of speech is slightly more intelligible than fast speech, but the difference is too small to justify paying attention to rate of speech in planning instruction.

4. Articulation affects intelligibility and can

be improved in most subjects by even 1 hour of special instruction and drill.

5. Loudness is the most important voice factor affecting intelligibility. As loud speech as can be consistently maintained without obvious strain is the most intelligible. This is speech which produces a good loud side tone in the speaker's earphones.

Courses of instruction in voice communications for AAF personnel should devote some attention to improving articulation but should place major emphasis on training the men to speak loudly.

23.3 STANDARDIZED MESSAGE FORM AND CONTENT

When communication must go on in the presence of intense noise, it is obviously desirable to give the listener as much help as possible in knowing what is said. One method of helping the listener in an airplane is to standardize and routinize names, commands, and message forms, while making them as distinct from each other as possible. Familiar sounds can be correctly perceived more readily than unfamiliar ones.

In order to make message content as familiar and easy to understand as possible, Project SC-67 worked on the standardization of both message form and message content.⁹

At the outset of the voice communication training program, the only procedures that were standardized were those specified by the Combined Communications Board. They included pro-words, numeral pronunciation, a phonetic alphabet, and the forms for call-up and sign-off. Several of these had been changed during the war, and older forms persisted in use in the AAF.

Recordings were made, unknown to the members of the crews, of all interphone communication on 40 bomber-training missions of different types. Analysis of the 2,377 calls made on these 40 missions showed great diversity. As one example, the type of request for repetition of a message not completely understood was in the approved form, "Say again," 16 per cent of the time. In 18 per cent of the messages, "Repeat" was used. In 50 per cent, "What" and

RESTRICTED

"Huh" were used. The remaining 16 per cent scattered over other forms of request, e.g., "I didn't understand." As a second example of unstandardized communication procedure, 35 per cent of the messages received no verbal response of any kind. This lack does not mean that all 35 per cent went unheard and unattended. But it must frequently have left the caller uncertain as to whether his message got across or not.

RELATIVE INTELLIGIBILITY OF PROCEDURES

Subsequent to this investigation, a request was received for recommendations to an AAF Interphone Conference, October 1944. As a basis for their recommendations, the project staff conducted an experimental study of the relative intelligibility of alternative names for the various crew positions. The most intelligible name for each position is given at the left in Table 6 and the discards at the right. The term *engineer* was reasonably intelligible, but it was frequently confused with other names, most commonly with *bombardier*. *Crew chief* was therefore substituted for *engineer* in the list of names recommended to the AAF.

Alternative forms of call-up were also investigated. These experiments indicated slightly greater intelligibility for the *A to B* and *A calling B* forms than for the *B from A* and *B, this is A* forms. Since the *B, this is A* form was already standard R/T procedure, it was adopted as standard for interphone use in spite of its slight disadvantage in intelligibility.

STANDARD INTERPHONE MESSAGES AND PROCEDURES

Analysis of recorded interphone messages and comparison with standard R/T procedures resulted in the recommendation of standard interphone message procedures to the AAF. These recommendations were embodied in a number of publications.¹⁰⁻¹³

RADIOTELEPHONE PROCEDURES AND MESSAGES

Standard procedures for the use of the radiotelephone existed in the AAF in 1943. But very frequently these procedures were not followed. Message content, as apart from procedures, was not standardized. Project SC-67 recommended standard phraseologies for position reports,

change-of-flight plans, taxi and take-off instructions, and landing clearance. These recommendations were incorporated by the AAF in the pilot's information file and were taught in voice communication training courses.

TABLE 6. Relative intelligibility of station names (T-30 microphone).

Most intelligible name	Less intelligible alternatives
Skipper	Pilot
Navigator	
Co-pilot	
Bombardier	Bomb
Radio	Radio operator
Top turret gunner	Top turret, upper, highball
Right waist	Right waist gunner, right, starboard
Left waist	Left waist gunner, port
Tail gunner	Charlie
Engineer	
Nose	
Tunnel	Tunnel gunner
Ball turret	Ball turret gunner, bellygun, ball gun

Similarly, the project made recommendations, which were in large part accepted, for standardized voice procedures in the use of the ground-controlled-approach equipment for enabling airplanes to land through fog and overcast.

Standardized R/T and interphone procedures produced greater intelligibility of communication and also made it possible to teach men, in voice communication courses, the actual message forms and procedures they should follow in combat.

23.4 INTELLIGIBILITY DIFFERENCES IN WORDS

In order to have some basis for choosing alternative words, the phonetic characteristics of words as related to their intelligibility^{5, 6} in noise were studied. Two types of analysis were made: the frequency with which each vowel and consonant sound was recorded correctly in a word in which some mistake occurred; and the phonetic characteristics which distinguished words of high from words of low intelligibility.

RESTRICTED

VOWELS

The vowels and diphthongs are listed in order of decreasing intelligibility. The sounds are those of the italicized vowels, as pronounced in the standard American dialect.

tape (most intelligible)	ton top
teem	tool
high	ten
tone	boy
cow	took
per	talk (least intelligible)
tip	
tap	

The diphthongs as a class were significantly (at or beyond the 1 per cent level) more intelligible than the vowels. Front vowels and diphthongs were significantly more intelligible than back vowels. Middle vowels were intermediate in intelligibility. Closed and open vowels and diphthongs did not differ appreciably.

CONSONANTS

Consonants appeared both before and after the vowel sound in the one-syllable test words employed in this study. Following, in decreasing order of intelligibility, are the consonants studied. Separate intelligibility lists for initial and final consonants are given.

Initial Consonant	Final Consonant
roar (most intelligible)	bell (most intelligible)
bet	slim
watt	push
year	roar
shot	on
how	lid
bat	top
kit	tick
sit	net
pat	ledge
jot	fizz
chat	leg
dot	loaf
get	which
ten	have
fox	gas

me	with (least intelligible)
which	
vat	
thin	
no (least intelligible)	

STRESS PATTERNS

Experimental tests of the intelligibility of 898 common one- and two-syllable words resulted in the following conclusions.

1. Two-syllable words are more intelligible than one-syllable words. This is true even when the number of speech sounds is the same. The superiority of two-syllable words was significant at the 1 per cent level of confidence.

2. Two-syllable words with accents on both syllables or with the accent on the second syllable are more intelligible than those with an accent on the first syllable. The difference was significant at the 1 per cent level of confidence.

ARTICULATION

Words whose articulation involved protrusion and recession of the lips were reliably superior to others in intelligibility.

LIST OF WORDS OF MEASURED INTELLIGIBILITY

The Voice Communication Laboratory prepared a list of 1,000 common one- and two-syllable words arranged in order of intelligibility. Similar lists were prepared at the Psycho-Acoustic Laboratory, Harvard University, under Section 17.3 of NDRC (see Division 17 Summary Technical Report).

SELECTING WORDS OF HIGH INTELLIGIBILITY

In some situations it is possible to select in advance words which will frequently be used in voice communication. This is true, for example, in naming the members of a bomber crew or the stations on a ship. It is sometimes also true of standard operating commands. Where choice of words is possible, it is worth while to select those alternatives which are highest in intelligibility.

The best basis for choice is empirical evidence on the relative intelligibility of two or more alternatives. This information can always be secured by following the experimental methods

RESTRICTED

described here. Sometimes it can be obtained from the word lists already prepared by NDRC Section 17.3 and Project SC-67.^o

Where word lists and experimental comparisons are not available, selection can be made on the basis of the principles described in the preceding paragraphs of this section. Two-syllable words are better understood than one-syllable words. If both syllables are accented, or if the second is the accented syllable, the word is more likely to be heard correctly than if the first syllable is accented. Some of the sounds listed in the sections above were much more intelligible than others. Observing these differences when selecting standard names and commands will make communication in intense noise more understandable and more likely to result in appropriate and immediate action.

23.5 BEST PROCEDURES FOR USE OF COMMUNICATION EQUIPMENT

The Voice Communication Laboratory investigated three problems involving the relative intelligibility of speech with different methods of using communication equipment. These studies were designed to determine:

1. The best position in which to hold the T-17 microphone.
2. The best position for wearing the T-30 microphone.
3. Whether or not use of the volume control by the listener would increase the intelligibility of speech heard over the interphone.

23.5.1 T-17 Microphone

Much of the interphone and radio communication carried on during the training of AAF pilots and aircrews employed the hand-held

^oThe work done by the Harvard Psycho-Acoustic Laboratory is described in Chapters 6 and 14 of Volume 3 of the Summary Technical Report of NDRC, Division 17. A list giving the intelligibility values of 1,000 common one- and two-syllable words was prepared by Applied Psychology Panel Project SC-67 but was not issued as an OSRD report since the war ended as the list was being completed. The manuscript copy of this list has been given to Headquarters, Army Air Forces, AC/AS-3, Training Research Group.

T-17 microphone.^{2,3} This microphone was also sometimes used in combat aircraft. Whenever a hand-held microphone is used under conditions of high noise level such as obtained in military aircraft, an important consideration directly affecting the intelligibility of communication is the position of the microphone relative to the speaker's mouth. However, a brief survey revealed little uniformity in actual practice. Even among experienced pilots and instructors, different special methods of holding the microphone were employed and recommended. The following experiment was designed to test the relative intelligibility of the most typical of these microphone positions.

Six different positions for holding the T-17 (hand-held) microphone were compared in terms of the intelligibility of transmitted speech. These positions were:

1. Plane of the face of the microphone parallel to the plane of the speaker's face, touching the speaker's lips lightly. Referred to as *zero-distance position*.
2. Plane of the face of the microphone parallel to the speaker's face, one-half inch from the speaker's lips. Referred to as *1/2-inch distance position*.
3. Plane of the face of the microphone parallel to the speaker's face, one inch from the speaker's lips. Referred to as *1-inch distance position*.
4. Plane of the face of the microphone rotated around its vertical axis 30 degrees from the plane of the speaker's face; closest edge of the microphone just touching the speaker's lips. Referred to as *30-degree angle position*.
5. Plane of the face of the microphone rotated around its vertical axis 45 degrees from the plane of the speaker's face; closest edge of the microphone just touching the speaker's lips. Referred to as *45-degree angle position*.
6. Speaker holding the microphone in his right hand with the thumb encircling the rim of the microphone face and with the microphone held as close to the mouth as possible, maintaining this hand position. Referred to as *thumb-encircling position*.

All these positions were used and recommended within the AAF. They were not, of course, necessarily all equally good. Compari-

RESTRICTED

sons among them were made by use of standard intelligibility tests. Each of 16 speakers read six word lists, using a different microphone position and listening panel for each list. The six microphone positions were used in different

the 1-inch and the 45-degree angle groups, may have resulted from chance factors.

The zero-distance and the thumb-encircling positions were found to be the two most intelligible of the six positions studied. The

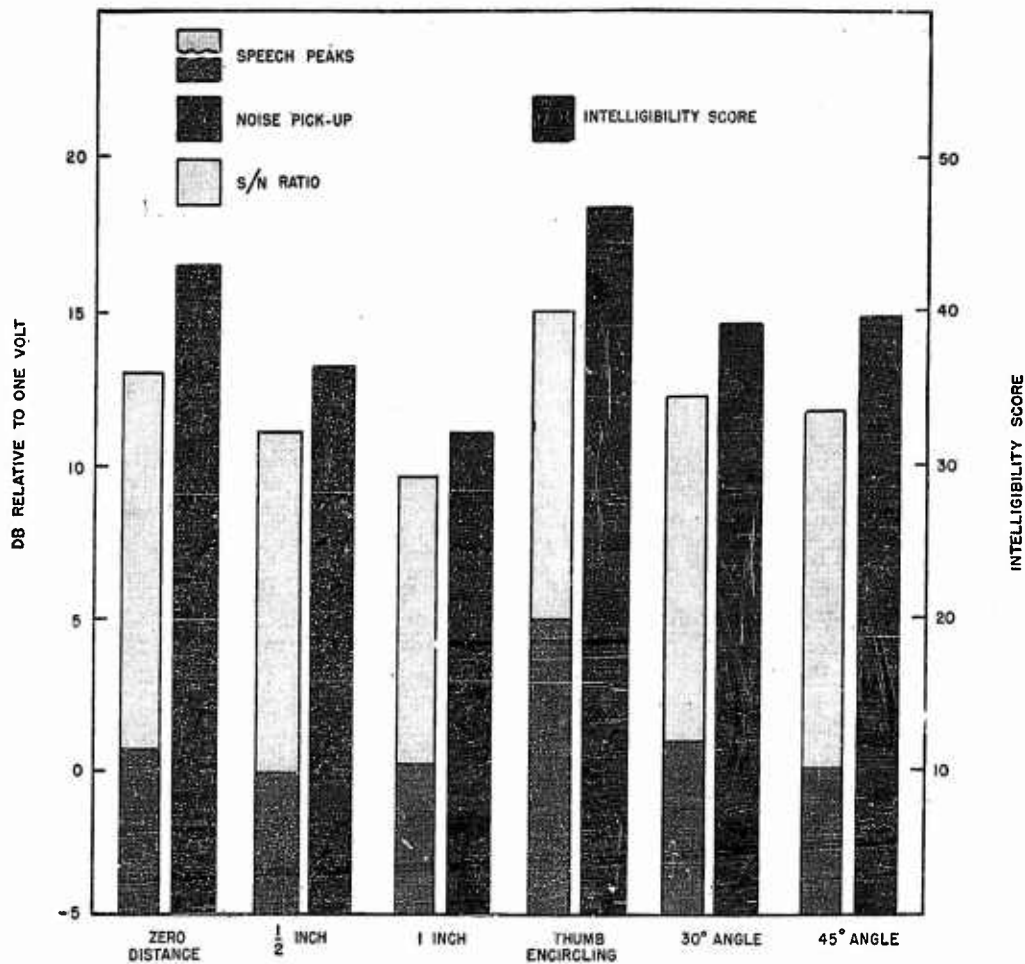

FIGURE 6. Relative intelligibility of six different positions of the T-17 hand-held microphone. The intelligibility data (solid bars) are per cent word intelligibility averages for 16 speakers. The speech and noise intensity data were read from a voltmeter connected across the earphone circuit. The total height of the light gray and dark gray bars represents geometric means of peak meter deflections read for each word, converted to decibels. The dark gray bars represent similarly averaged voltages read between words when the noise, but no speech, was being picked up by the microphone. The light gray portions represent the speech-to-noise ratios.

orders by each of the 16 speakers to avoid the influence of practice effects.

The results of this study are presented in Table 7 and Figure 6. Analysis of variance indicated that the overall differences in intelligibility were much too large to attribute to chance. Some of the individual differences, however, for example the difference between

thumb-encircling position, quite in contrast to the reason most commonly given for advising its use, was found to have a much higher noise pickup than any of the other positions. Accompanying this high noise pickup, or perhaps as a response to it, the subjects showed higher speech peaks on this position than on any other.

In a later study³ additional comparisons were

made between these two positions. With the mean signal level held constant by monitoring, the zero-distance position gave appreciably and reliably higher intelligibility scores than did the thumb-encircling position. Under these circumstances, it was also found that the noise pickup was about the same for the two positions. Observation during the experiment indicated that what seemed to happen was as follows: (1) If

training and combat crews. Three of the most usual positions were on, above, and below the Adam's apple. The effect of these three positions on the intelligibility of transmitted speech was tested by means similar to those outlined above for other intelligibility comparisons. Twenty-three subjects each read three intelligibility lists, one with the throat microphone in each of the three positions studied.

TABLE 7. Intelligibility scores and values for speech peaks, noise pickup of microphone, and signal-to-noise ratio for six microphone positions. Average for 16 speakers.

Microphone position	Intelligibility score	Speech peaks* in db	Noise pickup* of microphone	S/N ratio
Zero-distance	43.0	12.8	0.4	12.4
½-inch	36.1	10.9	-0.1	11.0
1-inch	31.4	9.6	0.0	9.6
Thumb-encircling	46.4	14.7	4.9	9.8
30-degree angle	38.7	12.2	0.8	11.4
45-degree angle	39.4	11.4	-0.1	11.5

*The values for speech peaks and noise pickup of the microphone are in decibels relative to 1 volt. The peak meter deflection for each word and the meter deflection between each two words were read from a vacuum tube voltmeter connected across the earphone circuit. The values given in the table are the geometric mean of these values converted to decibels.

the microphone was not held very tightly against the mouth with the thumb-encircling position, the noise pickup of the microphone was increased. (2) If the microphone was held very tightly against the mouth with the thumb-encircling position, the noise pickup of the microphone was decreased, but there was so much interference with articulatory movements of the mouth and lips that the speech became muffled and less distinct. Both results worked to the disadvantage of the thumb-encircling position. Moreover, regardless of the success the speaker had in reducing noise pickup, the data indicate that the intelligibility score suffered in comparison with that for zero-distance position.

The general conclusion was that the zero-distance position produced more intelligible speech than any of the other positions. Its use was therefore taught as standard procedure in voice communication courses.

23.5.2

T-30 Microphone

The T-30 microphone³ was commonly worn in a number of different manners among both

These three positions were located as follows.

1. A position in which the microphone was placed as nearly as possible at the level of the forward prominence of the Adam's apple, with the two buttons of the microphone resting on the side plates of the thyroid cartilage. This is referred to as *center position*.

2. A position which was definitely lower than this center position. The experimenter placed his finger across the front of the subject's larynx at a point corresponding to the center position and placed the microphone immediately below his finger. This is referred to as *low position*.

3. A position higher than the center position. The experimenter placed his finger across the larynx at a point corresponding to center position and placed the microphone just above the finger. This is referred to as *high position*.

The results are given in Table 8 and presented graphically in Figure 7. Both the high and center positions were superior, at the 1 per cent confidence level, to the low position. The difference between the high and center positions was not significant.

On the basis of these findings, voice communication courses taught students to wear the throat microphone at or slightly above the most

RESTRICTED

prominent part of the thyroid cartilage of the larynx. It should never be worn below that point.

TABLE 8. Intelligibility score data and signal levels for three positions of the T-30-S microphone.

	Position of microphone		
	Low	Center	High
Mean intelligibility score	17.3	33.4	35.5
Mean signal level in vu* T-30-S circuit	-6.2	-2.9	-2.2
Mean signal level in vu* Monitoring circuit	-0.6	-0.6	-0.4

* These measurements are in volume units [vu] relative to zero vu = 4.2 volts.

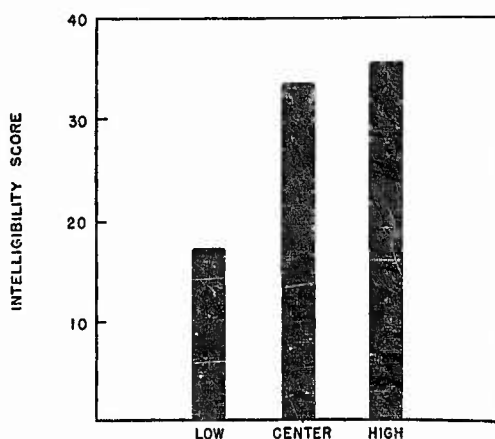

FIGURE 7. Relative intelligibility of three positions for the T-30-S throat microphone.

23.5.3

Use of Volume Control

The loudness or volume control⁹ in airplane communication equipment does not normally operate on the interphone system. A standard

intelligibility experiment of the type used in the studies described above was performed to determine whether or not the listeners could increase intelligibility by use of volume control. The results demonstrated (Table 9) that, at all four levels of speech loudness, intelligibility was significantly greater with a fixed gain than it was when the listeners were able to adjust the volume to the level they preferred or assumed to be most intelligible. Gain control should remain inoperative on the interphone.

TABLE 9. Mean intelligibility score as a function of loudness level and use of volume control.

N	Volts at listener's headset with fixed gain	Intelligibility score		Difference	t*
		Fixed gain	Controlled gain		
16	2.2	63.9	55.8	8.1	2.64
16	3.2	69.1	62.9	6.2	3.29
16	4.3	72.7	66.3	6.4	3.28
16	5.9	70.5	66.7	3.8	2.59

*t, 1% = 2.95; 2% = 2.60; 5% = 2.13.

23.6

CONCLUSION

The experimental studies reported in this chapter were conducted as part of a general program on the improvement of AAF voice communication. The results of these studies were incorporated in the training courses described in Chapter 11. These results have demonstrated that proper use of airplane communication equipment can greatly increase the intelligibility of communication. Obviously that increase means better coordination and team work during combat operations.

PRINCIPLES OF GOOD EQUIPMENT DESIGN

By William E. Kappauf, Jr.^a

SUMMARY

IF AN INSTRUMENT DESIGN is well suited to the human operator, it permits many men to qualify as operators, it permits qualified men to operate with efficiency, it permits easy training, and it is acceptable to operators.

The general procedure in evaluating the psychological efficiency of a design is described. A first attempt at providing a check list for use in evaluating new designs is included as an appendix.

Psychological research is a necessary part of a complete program of equipment design. There are always particular questions related to the different possible ways of building and arranging newly invented devices so that they may be used most effectively. In addition there are basic questions which can only be settled by fundamental research on human sensory and motor capacities.

24.1 PHASES IN THE DESIGN AND DEVELOPMENT OF NEW EQUIPMENT

The problem of fitting the instrument to the man can be defined in terms of a set of objectives: an instrument design which will allow more men to qualify as operators; a design which will make it possible for each qualifying operator to do a more efficient job; a design which makes the training task simpler; and a design which is acceptable to the operator. The general thesis of this chapter, and of those which have preceded it, is that money and effort spent in equipment development along engineering lines may be wasted unless these objectives of suiting the instrument to the operator are considered.

During World War II, engineering development proceeded rapidly along many lines. Manufacturers assembled equipment as quickly as possible, often constructing composites from

^a This chapter is based on the work of several Applied Psychology Panel projects.

units originally intended for varied uses. The resulting equipment was in many cases not well adapted to the characteristics of its operators or to a speeded-up training program. When equipment was subjected to operational and training tests and when suggestions for design improvements were made, it was always necessary to face the practical question as to whether the field forces could tolerate the delays in production which would be caused by design changes. Decisions were most often made in favor of continuing the production of the less ideally designed instrument rather than interfering with production schedules. The result was one of several: either extra effort had to be spent selecting operators, or operator training programs had to be extended, or less efficient operation had to be accepted. In peacetime, however, design can be more thoughtful and should, correspondingly, be more satisfactory. Whether it is completely satisfactory will depend on how generally it is understood that the problems of equipment control and operation are basically psychological and physiological in character.

The development of new equipment from a combined engineering and psychological point of view may be divided into four phases, as follows: (1) the choice and development of the basic mechanization, (2) the choice and development of specific details of the mechanization, (3) the development and addition of training features, and (4) the testing of pilot models. This chapter will open with an examination of these phases of developmental work.

24.1.1 Choice and Development of the Basic Mechanization

The first step in instrument design comes with the choice (often determined by a recent invention) of the type of system which is considered best or necessary for the job. If a communication system is needed, should it employ telephones, public address units, or radio? If

ranging equipment is to be included in a particular fire-control system, should it be a radar, a rangefinder, or a stadia ranging device? If data transmission is being considered, should it be by telephone, radio, selsyn, or automatic follow-up? If an aircraft gun turret is required, should it be under local gunsight control or under remote control?

The factors which determine these choices are not difficult to list. On the engineering side, they include availability of materials (at least in wartime), the caliber of workmanship required for manufacture, the intrinsic accuracy or fidelity of the system, and the likelihood of casualties or breakdowns in the system. On the side of Service use or application, they include considerations of cost, size, weight, power requirements, installation, maintenance, and replacement problems and, perhaps most important, the requirements of the tactical situations in which the system is to be used. On the operator or psychological side, important factors are the number of operators required, operating ease and efficiency, operator acceptability, and the training required for both operation and maintenance.

In general, if production is feasible, the choice of the basic design for a given piece of equipment is, and rightly so, a Service decision made primarily on the basis of the use to which the instrument is to be put. When an instrument is needed for use on a small ship, accuracy is often sacrificed in the interest of saving weight. When a highly accurate instrument is needed for a shore installation, a complicated engineering design may be accepted at the expense of maintenance difficulties and an elaborate maintenance training program. Changing combat requirements frequently call for a re-evaluation of existing equipment. As warfare changes in speed, range, or tactics, the relative importance of the criteria applied in choosing basic mechanizations may change very quickly. An example of an appropriate shift in mechanization during the war was the Navy's shift away from centralized antiaircraft fire control, involving only one or a few large directors aboard ship, to decentralized control, involving many small directors of light weight and relatively less complex design. Decentral-

ized control was demanded by the tactical development of low level, multiplane attacks on naval vessels.

24.1.2 Choice and Development of the Specific Details of the Mechanization

After the type of system has been decided upon, many supplementary decisions must be made about the form which the system should take. If a radar is to be used, should the operator view a scope, a dial, or a meter? At what illumination should he work? If a director is to be power driven, should rate tracking or aided tracking be provided? If a remote control turret is chosen as tactically best, should the operator's controls have low or high inertia, low or high friction? Such details of the mechanization concern the specific things which the operator has to observe or attend to, the specific controls with which he works, the conditions under which he works, and the way that the equipment is arranged. Other equally important design details include the size and weight of gears in mechanical systems, the types of tubes, resistors, transformers, and the like to use in electrical circuits. Such details are determined by engineering considerations. Service needs and use also dictate some details: provision for auxiliary dials, switches, pilot lamps, and the like.

This list of general factors is, not surprisingly, the same as that suggested in the preceding section: operator factors, engineering factors, and Service factors. So far as the design of most external details and of many functional details of equipment are concerned, however, engineering and Service factors do not preclude the possibility of settling on a design which is best from the point of view of the operator, that is, of giving the operator the displays and controls with which he can work best. Thus it is in this phase of design work that the psychologist takes particular interest.

During the war, a considerable amount of work was done by the Applied Psychology Panel and other research groups under NDRC in improving operator performance through minor instrument design changes or through changes

in the conditions of operation. By and large, recommendations on these matters were sought after the equipment was built and in use. For future development work, the importance of spotting opportunities for design improvements while equipment is still in the blueprint stage is obvious. Techniques for accomplishing early and satisfactory criticism of designs will be discussed below (see Sections 24.3 and 24.4).

24.1.3 The Development and Addition of Training Features

Relatively few instruments in the past have been designed with the problem of operator training in mind. This is not necessarily serious for a small military organization which can afford to be inefficient and devote a great deal of time to operator selection, to operator training, and to field trials which motivate men to drill and perform at their very best. In a large military organization, however, every technique of efficient training must be employed to the fullest if the training of its many men is to be accomplished with economy of time. Training ideas like the following become important. For a radar, is it possible to introduce an auxiliary circuit which serves to generate a synthetic signal? For a tracking instrument, is there opportunity to introduce a synthetic target system, or a checksight, or a mechanical scoring device of some sort? For a telephone system, can recorded noise be fed onto the line for training purposes?

Too much emphasis cannot be given to the need for including training features in original instrument plans. Experience has shown that it is all too difficult to build appropriate training aids onto or into equipment after designs have been frozen in production. One checksight for a Navy gunsight was designed within a few months after production of the gunsight started, but 20 months later the checksight was still not in production. Follow-up work was slow because other matters held priority over work on what was considered a mere training gadget. Actually the finished checksight can never be as satisfactory as one which might have been built as an integral part of the gunsight in the first place. It must be "patched on"

to the gunsight and requires careful collimation. Because it is extra equipment, it has a carrying case of its own, a fact which makes it too easy to leave the instrument below decks and out of service.

In planning training features, the need for prior or subsequent experimentation on the validity of methods of using them should not be overlooked. The validation of training devices is discussed in Chapter 16.

24.1.4 Testing the New Device

The testing of new equipment normally parallels its development step by step. Circuits, operating features, training features—each is tested in turn. But when the equipment is complete, further tests are needed to answer three specific questions. First, does the equipment do the job for which it was designed with the required precision or fidelity? This phase of the testing is chiefly a laboratory or physical testing job for equipment components and for devices on which adequate prior experience is available, such as amplifiers and radio transmitters. It requires not only laboratory tests but also careful field tests with expert operators (perhaps research men) in the case of elaborate new equipment, precision radars, fire control instruments, and the like. Second, can GI's learn to operate it with the required degree of skill? This phase of testing calls for tests with enlisted personnel. Finally, does the instrument meet with the requirements of operator acceptance and long-time training efficiency? Field trials on men with varied training backgrounds should answer this question.

24.2 HUMAN FACTORS IN INSTRUMENT DESIGN

Operator characteristics impose specific requirements on instrument design. In terms of these requirements, it is possible to set forth a series of psychological design principles. These principles cover important human factors which should be taken into account. They are divided into four subgroups: (1) The design must be one which permits many men to qualify as operators; (2) it must allow qualified men

RESTRICTED

to operate with efficiency; (3) it must permit easy training; and (4) it must be acceptable to operators.

24.2.1 Factors Related to Operator Qualifications

1. *Operation of the equipment must depend as little as possible on intellectual judgment, estimate, or decision (unless great inaccuracies can be tolerated). Whenever possible, quantitative data should be obtained by mechanized measurement. The operator should not have to learn elaborate principles or schemes of operation which vary from situation to situation. Aerial gunners, for example, should be freed whenever possible from the tasks of estimating deflection angles or target speed or from choosing a range calibration on the basis of target course. Studies at the Laredo Army Air Field have shown that when such judgments or estimates are required the inaccuracies are considerable.*

2. *Operation should require a level of sensory discrimination or sensorimotor coordination which is within the capacities of many men. This is the usual criterion of simplicity and must be met if many men are to qualify as potential operators.*

3. *The equipment must be adapted to men of different physical size and characteristics. It must be possible to adjust many equipment parts: seats, pedals, eyepieces, earphones, signal intensity, etc.*

24.2.2 Factors Related to Operator Efficiency

1. *The equipment must take advantage of a judgment or operation which a human operator can make very precisely, i.e., for which his threshold judgment, or error of observation, is very small. Thus, matching a needle to a pip is an observation which an operator can make more precisely than the matching of two pips side by side. Auditory pitch discrimination (measured in terms of frequency units) is more precise than intensity discrimination (measured in energy units). Thus the designer's question should always be: "With the energy*

or output differential which my instrument delivers, what kind of signal should I present to the operator so that his control of the instrument will be as precise as possible?"

2. *The equipment must provide the best possible conditions for making the required judgment or operation. Accompanying variables or conditions should be controlled for optimal discrimination. In the case of a visual judgment, for example, ocular convergence and accommodation, brightness, adaptation, magnification, and pattern in the visual field are all important variables. In the case of motor tasks, conditions should be arranged so that strength and steadiness are maximal. Fortunately it is usually true that there is a respectable range of conditions within which operation is efficient. But beyond these limits, performance can be expected to decline very sharply.*

3. *Operation should not require the operator to attend to or to do a number of things at the same time. A gunsight which requires the operator to track the target and to range on it by a stadiametric or framing device demands too much of most men. The result is that they do the two jobs alternately and irregularly, not simultaneously and smoothly. An operator's job should have the feeling of a single, unified series of movements.*

4. *The equipment must be designed so that its controls are easily identified. Spacing and the arrangement of controls should be such that the chance of accidental displacement of a control is avoided. Confusion of controls can often be avoided by giving them various colors or shapes.*

5. *The equipment must be designed to keep reaction times and movement times at a minimum. Switches and controls should be arranged so that it is easy for the operator to move from one to the other in carrying out his job.*

6. *It must be easy for the operator to recognize when the equipment is in proper operating condition and when it is properly adjusted for stand by. Adequate pilot lights, specific warning signals, and the systematic arrangement of switch positions simplify these problems.*

7. *Operation should depend on coordinated movements which are natural to the operator.*

Handlebar directors are easy to operate on a rolling deck because the operator's arm movements in tracking fall in with his normal postural readjustments to the roll and pitch. Handwheels which turn in the same direction as the dial or needle which they control are natural controls to use.

8. *The equipment should call for no more teamwork or group coordination than is absolutely necessary.* Such coordination usually increases the training time required. It may increase the likelihood of operational breakdown in a pinch.

9. *The equipment should provide automatic data transmission wherever possible.* Telephone talking is slow and messages are not always intelligible.

24.2.3 Factors Related to Operator Training

1. *The operating job should be easy to explain and understand.* This usually follows if the conditions in the previous two sections are met.

2. *Operation should be subject to ready observation and scoring by an instructor.* Training devices or performance-measuring instruments should be built into standard Service pieces wherever possible.

3. *Whenever possible, the equipment should make use of standardized units.* Standard dials, dial arrangements, control arrangements, and the like make it easy for a man with experience on a similar device to transfer his operating skill to new equipment.

24.2.4 Factors Related to Operators' Acceptance

1. *The equipment must be comfortable, that is, it must be adapted to the operator's body size, posture, and normal body motion.* Whenever necessary, seats, sights, floors, and the like should be adjustable so that every operator, no matter what his size, can use the equipment without stretching, straining, stooping, or doubling up. Undue enclosure or restrictions of body movement must be avoided.

2. *Operation must not be unduly fatiguing to*

the operator. When fatigue cannot be avoided, the limiting number of hours of nonfatiguing, efficient operation should be determined. Operating procedures or schedules should be established on the basis of such research (see Chapter 21).

3. *The equipment must be sanitary, and operation must be safe, that is, not such as to cause injury or ill health to the operator.* Adequate safety devices should be incorporated in the design. Possible physiological effects of operation should be investigated.

24.3 A PROGRAM TO ENSURE GOOD OPERATIONAL DESIGN

Only continuing interest in and attention to the problem of designing equipment to suit the operator will ensure the application of the foregoing design principles and a progressive improvement of the design of both new and existing equipment. Work along five lines appears to be indicated.

24.3.1 Continued Basic Research on Discrimination and Sensorimotor Skills

The past hundred years have seen the rise and development of laboratory physiology and psychology. During this time, there has developed an extensive literature on sensory function, the variation of sensory discrimination with the conditions of observation, the speed of human reactions, and the precision of various forms of sensorimotor coordination. Much of this information is of immediate value to the designer of military equipment. The usefulness of these and similar data will increase, however, as they are extended in two directions.

First, there is need for additional data on the performance of such sensorimotor tasks as are used or might be used in the operation of military equipment. One profitable investigation, for example, would be the study of new types of presentations for matching or nulling operations and of the precision which they permit. Further study is also indicated for oscilloscope presentations, for auditory operations, for handwheel and control characteristics, and for

the effect of various field conditions on discrimination and coordination.

Second, there is need for additional normative data on sensorimotor and discrimination functions, that is, data indicating what percentage of the population can exceed each performance level. Such data would make it possible to state, in advance of the development of an instrument, what numbers of men would probably qualify for operation within the required tolerances.

24.3.2 Assembling of Information About the Human Operator

Because work on the design of future equipment can proceed more efficiently if more people have in hand the available facts and information about the human operator and his characteristics, it is appropriate to prepare some sort of summary of this information. This factual summary—psychological, physiological, anatomical, and educational—would be of great practical assistance in the application of the design principles listed in Section 24.2. The summary should draw data from the general psychological and physiological literature, from anthropometric studies, from the war research files of this and other countries, and from such industrial laboratories as have investigated problems related to the design of both peacetime and wartime equipment. It should be as general and all-inclusive as possible.

The few summaries which are available at the present time are specialized and limited in character but they will be useful until better materials are forthcoming. Summaries are found in references 1, 6, 8, and 11, in addition to the present Summary Technical Report.

24.3.3 Operational Criticism of Blueprint Designs and Mock-ups

During the war, psychologists assisted in design and development work in two ways: by carrying out experiments on the relative advantages of two or more designs or by offering qualified and informed criticism of equipment without experimentation. Although the experimental approach was often the more

satisfactory because it was the more conclusive, the consulting approach was efficient in that it saved time and effort by achieving direct, if not always the very best, solutions to design problems. Peacetime design and development will advance in efficiency over wartime work as it seeks more and earlier qualified criticism of new equipment. Such criticism should be obtained when equipment is in the blueprint or mock-up stage of development. The most competent criticism along operating lines will be obtained from persons of psychological and physiological training, who have had some experience with design problems, perhaps for similar equipment. When the Services staff their research laboratories and ordnance departments, they would do well to seek men who meet these qualifications or who are interested in specialized training for design work.

24.3.4 Follow-up Tests of Pilot Models

Proving tests, already referred to in Section 24.1.4, are run for the purpose of determining whether equipment is efficient and acceptable. During such tests, data should be obtained on operator fatigue, operator acceptance of the device, and general teachability of the system. Questions of comfort and operating conditions may be reopened. Work with pilot models almost always suggests possible changes in design. In the consideration of such shortcomings as are discovered in a model, new reference to source materials and new experimentation on aspects of the design should continue as long as necessary.

24.3.5 Standardization of Units Wherever Possible

The value of standardization from the point of view of production, training, and the establishment of uniform operating procedures is well recognized. Interest in standardization does not mean that the development of better designs should be discouraged, but it does mean that *in the absence of experimental data* there is no reason for discarding one satisfactory and workable design for another. The standardization of cockpit design in planes of all types is

a much-needed step for the future. When it is effected, it will probably be on the basis of long and careful research as to the best possible arrangement of dials and controls. During the war, however, any form of standardized cockpit plan would have been an improvement over the confusing multiplicity of plans.

24.4 USE OF A CHECK LIST TECHNIQUE IN EQUIPMENT CRITICISM

When a blueprint or mock-up of a new piece of equipment is being examined, it is obviously desirable that no critical points be overlooked. One way to ensure a thorough study of the device is to prepare a check list of things to look for and features to examine with particular care. Such a list can be made from the principles set down in Section 24.2 above. It tends to be general in character if the person preparing it is relatively unfamiliar with the type of equipment under consideration. The list becomes increasingly specific as the person preparing it has more and more knowledge about the type of device and the operating problems which it presents. Thus, the value of both check list and criticism increases with the experience of the consultant with similar forms of equipment.

Project AC-94 recently prepared a check list of psychological factors important in the design of aerial gunsight equipment for daytime use.² The check list not only illustrates this method of approach to design questions but also shows the variety of contributions which skilled personnel can make to design development in an advisory or consulting way. The list applies experimental data in endorsing some design features. It applies general psychological knowledge in making other recommendations. It bases some of its comments on firsthand knowledge about aerial gunners and their adjustments in aircraft. Lastly, it indicates what design problems are particularly in need of experimental solution.

The list, as published, was only in tentative form. It must necessarily be considered as a first and hurried attempt at devising a systematic means of guiding equipment criticism. Some of its items need changing and revision,

but because it has already proved useful and is a singular example of this kind of work it is reproduced in a somewhat condensed form in Section 24.6 below.

24.5 THE PLACE OF RESEARCH IN EQUIPMENT DESIGN

Equipment design would be very simple if good design could always be achieved by calling in a qualified consultant or by looking up the necessary information in a book. Unfortunately not all design can proceed on the basis of facts assembled or experiments conducted in the past. Old facts do not always provide answers to design problems created by new inventions, or by the increasing complexity of equipment, or by the use of equipment under new conditions. Such circumstances make it necessary to perform developmental research to determine what operational design is really required.

Thus, anthropometric tables indicate the desirable height of equipment, size of equipment, range of adjustments on pedals, spacing between shoulder braces, etc., but they fail to provide information on how the body or its parts move.² Existing research records show that aided tracking is generally superior to position tracking and velocity tracking, but the degree of skill of operators in using an aided tracking device where the aiding constant changes with some situation variable, say range, cannot be assumed without further investigation.² Optimal handwheel designs have been developed for pointer matching jobs where handwheel loads are light, but parallel studies for high handwheel loads, as met on guns, are needed.² Engineers have been designing driving controls for many years, but it took direct experiments to demonstrate proper pedal positions and proper thrust distances.^{9,10} It required specific study to determine proper trigger load for tank guns.^{4,5,7}

Beyond the questions which can be settled by basic or general research on human sensory and motor capacity, there will always be questions related to the particular ways of building and arranging newly invented devices so that they may be used most effectively. Through field trials and proving tests on early models

of equipment, research serves as a regular check on design features based deductively on the results of previous investigations.

But it should also be remembered that design studies on many items of military equipment now in standard use can be of considerable value. Trial-and-error design development through the years, or long and accustomed usage, does not necessarily betoken efficient design. If such a simple item as rifle sights can be investigated with profit, as was recently done,³ then it is very likely that instruments of many other types may justifiably be taken back to the laboratory for operational testing.

Research, then, is an ever-necessary part of an equipment design program.

24.6 CHECK LIST OF PSYCHOLOGICAL FACTORS RELATED TO THE DESIGN OF COMPUTING SIGHT EQUIPMENT

1. General Factors in Design

a. Organization of the equipment in relation to airplane design

Has the equipment been planned with reference to required provisions for the gunner? Of special importance are adequate space for the gunner to move around, clear vision for the area of fire, adequate arrangement of oxygen supply, and proper seating provisions.

b. Appearance of the equipment

Are all cables hidden and protected, and are parts well organized? Can moving parts be hidden by easily opened covers? Can sharp metal edges or corners near the gunner's body be rounded or padded?

c. Entrance to and egress from gunner's position

Check ease of entrance into the turret or sighting station. Are there dangerous obstructions, complicated release mechanisms, or clumsy door arrangements?

d. Gun control

Check the possibility of remote control of the guns. Removal of the guns from the sighting station is indicated for high precision gunnery.

e. Independence of the gunner's operations

Check what measures have been taken to eliminate dependence of the operator upon other members of the crew. Can

such dependence be eliminated by automatic sources of information? Of particular importance is target location.

f. Safety provisions

Check the ease and simplicity of operation of emergency or stand-by equipment. Has the amount of emergency equipment been increased beyond a reasonable degree?

g. Serial order of operations as defined by location of components

The task of entering the sighting station, turning on the equipment, and operating the sight requires a series of acts in order. Has the organization of components been arranged so that these acts may be carried out in order without retracing of steps, reversal of movements, and repetition of acts?

2. Elimination of Operations Requiring Judgment

a. Design of the computing system

Check whether the gunner must learn the nature of the computing system in order to operate the sight. Consider carefully the need for selective use of the computer under different conditions before accepting a system which requires it.

b. Requirements for training

Check whether there are appropriate emergency precautions to make it unnecessary for the gunner to learn deflection shooting principles.

c. Solution of the slewing-on problem

Reduce as far as possible the need for the gunner to know deflection angles, to judge target direction, and to estimate target angles in order to reduce computer error in slewing on the target. Has the sight system a manually controlled gyro-caging device for eliminating slewing-on errors? A caging device is an important requirement for sights with relatively long solution times.

d. The target course problem

Check whether the sight has a computer calibration selector switch to be thrown by the gunner when the target is in a pursuit course or in linear flight. The average gunner will make many errors in using this type of control, and the judgment required will interfere with the successful performance of other duties. Alternative controls which require keen, rapid perception of

small differences of target courses are not recommended.

e. Harmonization

Have harmonization principles been worked out so that this process is simply an alignment problem as far as the gunner is concerned?

3. Postural Factors in the Arrangement of Equipment

a. Seating

Check the seating arrangement for the gunner. An upright sitting posture with a formed back rest is desirable. Other arrangements are acceptable when demanded by major engineering requirements or when actual trial under realistic conditions has proved their adequacy.

b. Leg space

Provide leg space which will permit the gunner to move around and avoid postural fatigue. The equipment design should permit some free leg movement.

c. Head position

Ascertain whether the sight requires sustained tension of the head and shoulders in order to view the reticle and to carry on search procedures. The position of the sight head should be such that it is in direct line with the eyes when the gunner is sitting upright in a relaxed fashion.

d. Position of manual controls

The manual controls should be located directly in front of the gunner at least 6 inches below shoulder level and not more than 18 inches in front of the torso when the gunner is in a sitting posture. Other designs are not considered satisfactory unless properly tested.

e. Change in arm and shoulder posture with maximum movement of sight controls

Check the maximum movement of the tracking controls in azimuth and elevation in order to determine whether twisted, unnatural postures must be assumed to make these movements. Power control (rate or position) with reduction in magnitude of control movement is the means of achieving a desired design on some director-type sights. Powered seating aids or sighting stations may solve these posture problems.

f. Change in head posture necessary for tracking

Do the movements of the sight lead to unnatural depression or twisting of the head and neck?

g. Change in posture during tracking

Does tracking the target require the gunner to change his overall posture? Designs requiring such adjustments should be avoided, inasmuch as it is difficult if not impossible to sustain precision movements with shifts in the basic posture of the body.

4. Motor Coordination Factors

a. General configuration of motor controls

Check whether or not switches or push buttons, requiring intermittent action during tracking, exclusive of a single trigger, are used on the handgrips. This is a very important point inasmuch as any intermittent reaction imposed on the manual controls can be expected to disturb the stability of tracking.

b. Contouring of the grips

Have the grips been made to fit the palm of the hand? If heated gloves are needed on the airplane, do the grips fit the contour of the gloved hand? In the latter case, check to see if there is any moving part of the grip on which the gloves can be caught.

c. Tracking movements required by the grips

The most natural arrangement of tracking controls is one in which the controls for azimuth and elevation move in the respective planes of the sight or turret movement. Any other combination requires learning of a novel set of visual-muscular coordinations. Twisting movements of the hand are unnatural at best, even for one dimension of control; they should not be amplified, for they are some of the most difficult movements to make smoothly and accurately.

d. Overall unity of form of the two manual controls

The two manual controls should be similar in form. Combinations of handgrips and twist grips or handwheels and twist grips are considered inferior design. The two hands tend to work together and the attempt to use radically different movements simultaneously is difficult.

e. Utilization of manual-pedal coordinations

If the sight involves stadiametric ranging, check on the question of the location of the control. Manual control of the finger-pressure type is probably better than all others.

f. Interaction of controls

Determine whether the control design is such that errors or irregularities of movement with one control cause errors in another control. The B-29 pedestal sight, for example, is so made that irregularities in elevation tracking may cause change in reticle size due to the interaction of the framing and elevation tracking controls on this sight. Similar control interaction occurs on other systems. The general principle to follow is that different but non-antagonistic movements should be used in effecting the primary adjustments of tracking and framing. A pressure-type framing control is preferred to several other types because of this principle.

g. Weight and inertia of sight controls

Specific studies of damping, friction, and inertia in tracking controls are needed. Experience to date suggests the present remote-control sights cannot be tracked effectively with sight controls which are heavily loaded. The controls should require very little effort to move slowly.

h. Separation of handgrips

On sight controls requiring a rotation of the control base to track in azimuth, the two handgrips should be separated by at least 10 inches and not more than 15 inches. Narrower widths between the grips do not permit a relaxed grasp nor will they allow the participation of shoulder movements in tracking in azimuth. The latter coordinations seem to be necessary for smooth control.

i. Trigger position

If a manual trigger is used it should be an index finger trigger, since movements of this finger can be made without inhibiting wrist and arm movements involved in tracking. The trigger should be on the far side of the controls and centered in relation to the elevation axis of the handles. Action of the trigger, which will thus have a position of minimum leverage, should not cause irregularities in the tracking. The trigger should be on the left hand

control if a framing lever is not used; on the right hand control if a manual framing lever is used. Foot triggers are recommended wherever possible.

j. Centering of the elevation component of the controls

Check to see that the handgrips are centered on the support so that elevation rotation will not be caused by pitch and roll of the plane.

k. Handedness of the controls

The configuration of controls should be such that the dominant hand, i.e., the right hand, primarily controls the tracking, while the subordinate hand, the left hand, performs the framing function if stadiametric ranging is employed.

l. Backlash in framing and tracking controls

Check for backlash in tracking and framing controls. Backlash should be reduced to a minimum inasmuch as it consists of an irregular and indeterminate linkage between the gunner's muscular system and the physical action of the sight.

m. Smoothing and linkage between the gunner's muscular system and the reticle system or guns

There are numerous methods of smoothing tracking operations and tracking data in order to eliminate the effect of tracking variability on firing. The different methods in use are (1) damping of sight controls; (2) utilization of rate control; (3) mechanical or electrical amplification or reduction of the ratios of movement between reticle, sight controls, and guns; (4) utilization of rate of lead control rather than rate control or direct tracking; (5) aided laying on the line of sight; (6) aided laying on the turret or sight base; and (7) aided laying on the sight controls. All these methods of smoothing represent some degree of breakdown of the normal relations existing between the gunner's visual orientation and visual pursuit reactions and the muscular adjustment which he makes to maintain pursuit. Experience and experimental data at present do not permit recommendations as to the best combination of smoothing functions to employ. Experiment should be carried out on several

problems in this field, especially those concerned with the optimum ratios of reticle movement with respect to gun and sight control movement and the utility of different aided laying factors available. Criteria of evaluation of these factors should include both the amount of training necessary to employ these smoothing aids and the absolute level of proficiency possible with them.

n. Design of the action switch

Check the following requirements: non-interference with movements of the hands in tracking; ease of action demanding no more than weight of hands on the control; location on the right hand control; features which might permit the glove to catch during action.

o. Thumb supports on manual controls

Manual controls should be designed to permit location of the thumbs on the upper surface of the grips so that the thumb and hand span the elevation axis of the controls. This provides a stable support for the grips and should reduce high frequency hand tremor.

p. Location of intercommunication and manual slewing-on switches

New sights may require, in addition to an intercommunication switch, a manual switch for caging gyros when slewing on target. Both of these switches should be incorporated into the handgrip configuration as thumb switches, one on each control.

5. Reaction Time Factors in the Organization of Sighting Equipment.

The organization of switches and control devices will determine in a large measure the speed with which operations of the equipment may be carried out. Poor location of switches may mean many seconds delay in activation of critical components of the equipment. Suggestions which appear significant are the following.

a. Power switches and component switches for the sight or for radar equipment

These switches should be located in a panel to the right of the sight in the periphery of the gunner's visual field.

b. Wingspan setting and automatic range selector switches

Both of these switches require rapid action just before the beginning of track-

ing. Preferably both switches should be located at positions on the sight or on the controls where they can be reached by the thumbs while the hands are held on the sight controls.

c. Avoidance of roundabout manipulations

Care should be taken to see that critical switches are so located that the gunner does not have to reach around interfering structures or cables in order to throw a switch or change posture to reach a critical switch.

d. Types of switches

Push-button types of switches can be activated more rapidly than throw switches. For critical controls, properly located push buttons will speed responses.

e. Marking of switches

To minimize response times, clear marking and differentiation of switch controls is essential. Check especially the possibility of using light indicators, color differences, or shape differences for critical switches.

6. Perceptual Factors in the Organization of Sighting Equipment

a. The field of search

Check the possibility of clearing the field of vision of all but the reticle housing. Camera or filter mounts in the field of vision, high location of the sight head, and limited turret or sighting station apertures should be avoided.

b. Resolution of retiflector reticles

Check for doubling and accommodation parallax in the reticle.

c. Type of reticle

There has been dissatisfaction among gunners with dot-type reticles. Studies in reticle design are needed.

d. Aided laying on the line of sight

Developments are in progress to devise perceptual aids to tracking and framing. These aids are now used in conjunction with the S-8 and the gyro-stabilized sight. The aid used may be based on target range or some other function of target action. The effect of generating an aided rate on the basis of a given control setting (e.g., range) upon accuracy of control in other aspects of sighting should be carefully evaluated by test. There is the possibility of perceptual confusion by such combina-

tions of sighting functions, which may prevent the gunner from knowing the source of his errors in adjustment. That is, the observed tracking picture no longer changes as a simple function of the movement of the tracking controls. It is further suggested that aided laying applied to both tracking and framing elements should be tested before adoption because of the degree to which this combined aid unlinks the action of the reticle from direct control.

7. Fatigue Factors in Sight Design

The degree to which some of the foregoing factors in design are considered will determine the extent to which operational fatigue of the gunner can be avoided. Especially important in prevention of fatigue are the factors of glare in the design of reticles, proper seating accommodations, space for some change in posture at the sighting station, and the degree to which sustained reactions are eliminated.

8. Emotional Factors in Sight Design

As in the case of fatigue factors mentioned above, confidence, fear, and anxiety in the use of gunnery equipment are mainly related to more basic psychological principles of design. Emotional reactions among gunners to the equipment have

been reduced materially by adoption of remote control sights and employment of armor for sighting positions. The local turret represents a serious adjustment problem to a gunner because of his isolation and because of the restricted enclosure demanded by present turret design.

9. Training Factors in Equipment Design

A complicated piece of equipment like a computing sight can never be used without systematic training. The effectiveness of this training will determine the eventual results achieved with the equipment. In original plans, it is therefore important to consider factors which will tend to promote effective mass training. Synthetic training devices are needed for every sight so far designed. In the building of such synthetic devices, it is always desirable that there be a means of securing mechanical or electrical data as to reticle position in azimuth, reticle position in elevation, and reticle diameter. Means of securing such information might be incorporated in the original design of the sight. A general psychological analysis should be made of the sight in planning stages in order to determine standard operating procedures and basic methods of training.

RESTRICTED

Chapter 25

THE DEVELOPMENT OF STANDARD OPERATING PROCEDURES

By *William E. Kappauf, Jr.*^a

SUMMARY

THE SATISFACTORY and efficient analysis of operating methods requires the understanding of the military problems involved in the use of the equipment under consideration in their mechanical, mathematical, psychological, and tactical aspects. The specific steps to be taken in achieving this understanding and developing the operating procedures are the following.

1. Study the equipment. Learn what it is supposed to do and how it works.
2. Determine all the tasks which have to be done in adjusting and operating the equipment.
3. Determine what the standards of accuracy of instrument operation should be and how limitations or approximations in the design of the equipment influence these standards.
4. Determine how each unit task should be done in order to achieve the greatest efficiency in time and accuracy.
5. Determine the proper sequence of actions.
6. Examine the sequence for short cuts.
7. Try out the procedure (or compare alternative procedures if more than one has been developed).
8. Evaluate operator acceptance of the procedure.
9. Standardize the procedure finally established.

These nine steps should culminate in the preparation of a manual of standard operating procedures to accompany a new piece of equipment as it is distributed for use.

25.1

INTRODUCTION

It should be clear from discussions presented in preceding chapters of this volume that the development of better equipment design and the development of more efficient operating procedures go hand in hand. All design improvements are motivated by considerations of

^aThis chapter is based on the work of several Applied Psychology Panel projects.

simplified and more efficient operation; and a usual by-product of a systematic study of operating procedures is a list of suggestions for equipment development or rearrangement. It is therefore not surprising that a reasonable amount of overlap should be found between the techniques and principles of design and those used in the analysis of operating procedures.

The problems which are involved in establishing the most effective way of operating a certain item or system of equipment naturally vary with the type of equipment. In the case of some military instruments, the job to be accomplished is relatively direct or simple, and the desired goal or level of operator performance is easy to establish. For such jobs, the task of developing satisfactory operating procedures may consist of little more than running a series of critical experiments to determine the operating conditions under which, or the methods by which, the desired performance level can be obtained. For equipment which is more complicated or which uses a number of men who must work in a team, operating procedures are necessarily more elaborate. In the development and study of such procedures, a great deal of time and research is often required in order to find those particular operating techniques which guarantee the greatest precision and the greatest speed.

So that the discussion which follows will be as general as possible, it will treat the problem of developing operating procedures for complex, precision equipment. The following sections elaborate on the steps to be taken and cite illustrations drawn from the various war research programs.

25.2

STUDY THE EQUIPMENT

It is axiomatic that the development of a sound operating procedure requires a complete working or functional knowledge of the equipment: how it is put together, what it does, and how it does it. Only with such knowledge in

hand is it possible to know about mechanism idiosyncrasies which may act as controlling features in the way the instrument should be used. Thus the nature of the smoothing circuits in a director determines whether the trackers should be instructed to correct an error slowly or as quickly as possible. The nature of these circuits also determines whether rangefinder data should be sent in reading by reading or smoothed by some intermediate operator.

Knowledge of equipment has further application at the final stage in the development of operating procedures when the time comes to prepare a manual or pamphlet on the subject. The person who describes operation with complete background information about the equipment itself can make more satisfactory explanations of operating technique. For those operating steps which are determined by system characteristics, he can state clearly why each operation must be carried out in the manner indicated.

25.3 DETERMINE WHAT JOBS HAVE TO BE DONE

Careful examination of the equipment indicates the nature of the unit tasks which are required in order to put it in operating order and to operate it. A supplementary investigation of the tactical organization of the group or groups in which the equipment is to be used reveals further what the operators' duties will be relative to men at other jobs. Designers provide such controls and gadgets as are needed for normal instrument operation. But they do not necessarily study how the operating tasks should be ordered in a sequence, how they should be divided among the members of the operating team (if there is more than one operator), how the operator should maintain communication with other parts of his organization, or how the operation of the instrument must be modified to meet certain tactical situations or casualties. There is need, then, for a cataloguing of all the unit tasks which have to be done in operating the equipment within a tactical organization, not only under normal but also under casualty conditions.

25.4 DETERMINE THE STANDARDS OF ACCURACY OF OPERATION

In order to assure the proper operation of any piece of equipment, standards of precision must be set for every job. Sometimes the equipment is very sensitive to an operating error. At other times, the operator controls an adjustment which registers on a very sensitive meter but which can be set within relatively wide tolerances so far as the function of the equipment is concerned. To do the right job with the required precision, the operator needs to know what the specific tolerances are for every job. Thus, an important early step in the development of operating procedures is a determination of the relative importance of errors in each of the component tasks in operation.

25.4.1 Conditions Which Allow Wide Operating Tolerances

The evaluation of operator errors or operating tolerances starts with a consideration of the magnitude of errors intrinsic in the equipment. In the case of computing devices, director systems, and the like, instrument errors are categorized as class A and class B errors. Class A errors are errors which result from the fact that particular instruments, when adjusted to meet manufacturing specifications and tolerances, do not match exactly the characteristics of the perfectly adjusted instrument which was originally designed. Class B errors are errors which result from a failure of the instrument plans to provide exactly the correct or needed solution. Class A errors are kept small by careful maintenance and by instrument design which reduces instrument-to-instrument variability. Class B errors may or may not be small. Fairly large errors of this type are sometimes accepted if they will buy simplicity of construction and maintenance.

Since instrument errors may exceed possible operator errors in importance, they sometimes set a limit to the precision required of the operator. In the operation of the stereoscopic heightfinder, for example, the variability of the instrument itself is so great that there is no

reason for the operator to make an internal adjustment or to determine a calibration correction more precisely than to the nearest unit of error (see Chapter 22). Operators are therefore permitted to round all of their scale readings in these operations to the nearest unit of error, instead of working to tenths or quarters of scale divisions as used to be the practice. This change in procedure speeds up their work and, at the same time, probably improves the accuracy of their arithmetic and scale reading. Similarly, class B errors in the gun fire control system Mark 52 are such that it is needless for the operator to set target speed to units closer than the nearest 50 knots.⁸

Wide latitude of performance of a piece of equipment often means that operator standards can be relaxed. At the time of issue of the gun fire control system Mark 52, the functional, angular width of its radar beam was not exactly known. Since the radar antenna, located on the director pedestal, had to be aimed by hand, there was considerable interest in knowing how far off target the beam could be aimed without losing the radar signal. An operations research group therefore ran tests of the sensitivity of the radar at different ranges, with targets of different size and with different amounts of radar beam error. The collected data indicated that the beam was sufficiently wide so that a set of simple rules for radar dish control could be established. These rules make it possible for the operator to set the dish on the basis of the kind of course which he observes the target to be flying. He does not have to aim the dish by eye or keep watching the aim at all points throughout the course.⁶

The tactical use of the equipment frequently sets the operating tolerances which may be applied. When anti-aircraft directors are used to fire a barrage without range data, not more than two zones can be fired conveniently (against targets which fly at present-day speeds) at ranges under 8,000 yards. So it is satisfactory to set up about four standard barrage zones, from which two may be selected for use during any given attack. Choice of barrage zone is made on the basis of an estimate of target range made to the nearest 1,000 or

2,000 yards.⁸ Similarly, the use of the computer Mark 6 in Navy surface fire control calls for ladder firing. Because a ladder is used, the computer operator does not have to read and use range rate values to accuracies greater than to the nearest 10 yards per second. This rounding simplifies his mental arithmetic (multiplying range rate by time of flight) and speeds the entire operation.⁸

25.4.2 Conditions Which Make Operating Tolerances Strict

In the operation of true precision equipment, the operator is required to be as accurate as possible on at least one aspect of the job. Here the tolerance is, in effect, zero. Such is the case for tracking with the gun director Mark 37, taking range measurements with any fire-control radar, setting scales on panoramic telescopes used in field artillery, or setting target wingspan on aerial gunsights. By way of caution, however, it should be added that reduction of operator errors to a minimum is not always desirable with existing equipment. It is conceivable, for example, that the class A and class B errors in some directors might be such that the probability of hitting the target is better if variable tracking errors are not too small. A variable error may increase bullet dispersion and thus increase the chance of scoring hits. The training problem, however, should not be complicated by teaching men to track less accurately than their best. When bullet dispersion is desirable, it should be introduced by the equipment, not by the operator.

In some situations, the peculiarities of instrument design demand a precision of operator performance which is far greater than one would expect. The interpupillary distance adjustment on stereoscopic rangefinders and heightfinders is such a case (Chapter 22). An operator can see through and operate the instrument even if the interpupillary setting on the instrument is in error by 2 mm or more. But his readings are accurate only if the interpupillary setting is made to a tolerance of about 0.25 mm. The reason for this, optical parallax,

RESTRICTED

is not obvious to the operator, who quite understandably thinks that any adjustment which allows him to see through the instrument with both eyes is satisfactory.

Accuracy standards, then, depend on the magnitude of instrument errors, the latitude of instrument performance, the peculiarities of instrument performance in relation to the operator, the tactical use of the equipment, and many other factors. Data on these standards of precision are prerequisites to the development of operating procedures.

25.5 DETERMINE HOW EACH UNIT TASK SHOULD BE DONE

After the tasks and their precision have been established, there remains the job of finding out how each task is best done. A number of criteria are involved when the best way is sought. These include rate or speed of operation, operator fatigue and effort involved, accuracy, safety, and teachability; they may also include the quality and skill of personnel available for training as operators.

There are a number of techniques whereby the best of several methods of operation can be established:

1. *Job analysis.* Techniques of job analysis have been described in Chapter 14. A complete procedure is also discussed in reference 1. The principal feature of the job analysis is that an observer watches what is done and records it in as great detail as possible. The merits of the approach lie in the fact that very often good operators do not know exactly what they are doing, or do not know how they are doing it, or cannot describe what they do in a way which emphasizes the most important phase of their actions. A detailed job analysis comparison of the technique of differently trained operators helps to isolate the best features of each operating method at least so far as speed, coordination, fatigue, and effort are concerned.

2. *Micromotion study.* When the details of operation are such that they cannot be caught by a job analysis, as when a number of persons work together in a team, there may be profit

in making a micromotion study. Here motion pictures are taken of the action and are analyzed frame by frame to determine just how the task is done by different groups. This type of study allows the precise timing of each action in a sequence and is particularly useful in analyzing operations where economy of time is sought. Application of the micromotion technique to the investigation of methods of operating the 3"/50 caliber gun³ showed that loading by the palm method of ramming was 1/2 second faster than loading by the fist method of ramming. The variability of the times for successive ramming was also less by the palm method. Data were also obtained, for example, as the length of time that the first loader has to wait for ammunition from the second loader and the most efficient way of grasping shells.

3. *Discussion with expert operators.* Good operators may have techniques or ways of doing things which are not apparent to the observer or to the motion picture camera. The stereoscopic rangefinder operator, for example, has an exclusive view of the rangefinder field. No one else can look at it while he is ranging. Where he positions the target relative to the reticles, when he prefers to change power or filter, whether he fixates the target or the reticle—these are facts which may provide important leads in developing better procedures. Such information obtained from operators supplements that obtained by direct observation. It should be used, of course, only in deciding on techniques which will be examined experimentally, not as a direct basis for establishing operating methods.

4. *Experimental tests.* It has already been pointed out that job analysis and micromotion studies permit the comparison of methods in terms of speed, coordination, and operator effort. Further comparison in terms of accuracy of operation, actual physical work load, speed, and teachability may be made by direct experimental tests of two or more operating methods. Such experiments are designed in the same way as experiments on the comparison of two or more designs for a piece of equipment. In determining the relative efficiency of two methods of moving powder charges in handling

rooms, a British research group made physiological measures of the energy consumed by men using the two methods.¹⁰ In determining the most satisfactory way of making calls on an interphone. Applied Psychology Panel Project SC-67 compared the number of calls answered by the right party when different call-ups were employed.⁴

All studies of methods of operation, by any of the four techniques just outlined, should be supplemented by a search for places where operation might be simplified or errors might be reduced by the use of computing aids or operating guides of one sort or another. Such work borders on the field of equipment design. It is exemplified in the development of the interpupillary distance template,² in the design of a shutter to be placed over a gunner's aid on a panoramic telescope to designate right and left deflections,⁷ in the design of range-finder slide rules,³ and in the recommended use of barrage zone tables on directors.⁸ Sometimes very simple additions to an operator's materials can appreciably improve his performance.

25.6 DETERMINE THE PROPER SEQUENCE OF ACTIONS

The methods used in the analysis of operating sequences are the same as those discussed in the previous section. Considerations of sequence in operation are particularly important when teamwork between men at one or several different stations is involved. Where communications are important, every effort should be made to keep them short and in words which are easily understood.

It is often necessary to consider the development of several methods of operation: a primary method and several secondary methods, that is, a normal method and one or more emergency methods. Emergency methods are commonly required either by the tactical situation or by equipment casualties. The sequence of operations which is worked out to meet emergencies is usually based on criteria other than accuracy, fatigue, stress, and the like, but it should be tested for its efficiency in meeting whatever criterion is applied.

25.7 EXAMINE THE SEQUENCE CAREFULLY FOR SHORT CUTS

Where can time be saved? What communications can be dropped out without interfering with the operating efficiency? What settings or adjustments can be made ahead of time, when the instrument is being set for stand-by condition?

Speed in the operation of military equipment is always important. This is particularly true in firing of all sorts. It is so important in action against suicide targets that drastic short cuts to get speedy firing are often advisable. With some Navy fire-control systems, for example, standard procedure near the end of the war was to open fire in secondary control and to shift to primary control only when the director had all the data needed for a satisfactory solution.⁹ Every possible short cut was made, even at the temporary sacrifice of accuracy.

25.8 CONDUCT FIELD TRIALS

When the procedures have been worked out and outlined and are ready for use, they should be given field trials. In these trials the complete combat situation, as it affects the operator, should prevail. Details which were previously overlooked in laboratory study may prove to be very important. Radars should be operated where masking echoes occur. Communication should be carried out under conditions of battle noise. Foul weather gear or flying gear should be worn if this will be standard when the equipment is in use. The need for such testing is sufficiently obvious to make further illustration unnecessary.

25.9 EVALUATE OPERATOR ACCEPTANCE OF THE PROCEDURES

It is important to know whether operators will accept and follow a recommended procedure of operation. They may not, either because of tradition, past training, fear for their safety, or just plain lack of knowing why the procedure is critical.

If operator rejection of a procedure is on the grounds of safety, further evaluation of the procedure may be necessary. Otherwise, one of several courses of action is indicated in order to put across the recommended procedure. Instruction plates or caution plates may be attached permanently to the equipment. Detailed explanations of the procedure and the reasons for it may be prepared in operating pamphlets or may be presented by officers, returned veterans, etc. Standardization of the procedure may be carried out very strictly.

25.10 STANDARDIZE THE PROCEDURES

Standardization of a completely developed and acceptable operating procedure concludes the work. Standardization of procedures has a number of advantages. It assures uniformity of instruction so that there is no conflicting doctrine regarding the use of a particular instrument and so that replacement of operating personnel is easy. Beyond this, it saves each training officer the time which he would ordinarily devote to the trial-and-error development of a procedure of his own and provides him with an experimentally and systematically proved procedure which in all probability is superior to any which he would set up. Finally, if some individual elaboration of procedure is desired by the Service concerned in order to encourage initiative and the development of local responsibility, these variations are imposed upon the background of a sound, effective procedure.

The most satisfactory way to prepare for the standardization of an operating procedure is to have a complete operating pamphlet available for distribution with the equipment. This means that research on operating procedures must be carried on early in the design and production program for a piece of new equipment. In wartime, this was difficult but was achieved for some equipment. In peacetime, production schedules will be slower, and it will be profitable, if necessary, to withhold the distribution of early units until research groups working on operating procedures have completed their

work and prepared a satisfactory operating manual.

A number of pamphlets may be cited to illustrate the type of operating instructions which were prepared with the assistance of Applied Psychology Panel projects, based on the kind of analysis outlined above. The following met with particular success in Service use.

Standard Submarine Phraseology. Commander Submarines Atlantic Fleet, Restricted.

R/T Procedures for Ground Controlled Approach, AAF letter, July 16, 1945, 100-57, Restricted.

Operating Instructions: Gun Director Mark 51, Mod. 3, Controlling Heavy AA Batteries, U. S. Fleet, Headquarters of the Commander-in-Chief, July 1944, Restricted.

Operating Instructions for the Gun Director Mark 52, U. S. Fleet, Headquarters of the Commander-in-Chief, January 1945, Restricted.

Operating Instructions for Use of the Gun Fire Control System Mark 57, U. S. Fleet, Headquarters of the Commander-in-Chief, January 1945, Confidential.

Operating Instructions: Gun Fire Control System Mark 63, U. S. Fleet, Headquarters of the Commander-in-Chief, March 1945, Confidential.

Stereoscopic Range and Height Finding, TM 44-250, War Department, June 15, 1944, Restricted.

Sample copy to illustrate this type of operating instruction is reproduced at the end of this chapter.

The degree of standardization achieved depends ultimately on several matters of Service policy. One concerns the centralization of training schools which would be necessary for strict standardization of method and doctrine. Another concerns the interpretation of procedures published in operating manuals. Are they to be thought of only as a guide from which training officers may depart at will? Or are they to be accepted as complete and final doctrine? Or are they to serve as basic procedures to which individual officers may make minor changes as variations in shipboard installations or as Service conditions require? On these matters, a "middle of the road" position will probably be

RESTRICTED

best, provided it is taken with the view that changes to published procedures be subjected to careful test. Reports of fleet experience and the suggestions of training officers can keep research alive by setting conditions and indicating the direction for future laboratory or operational testing of methods and procedures. As long as the attitude prevails that basic procedural changes should be made only after recourse to experiment, one can be assured that such changes as are made will be in the direction of improvement.

A final point to be borne in mind on the sub-

ject of standardization is that future Service policy will be important in determining the quality of future research on operating procedures. If the Services are willing to endorse procedures developed by their special research groups as doctrine, those research groups will understand their responsibility and will be motivated to do the best possible research job. If, on the other hand, the Services accept results as a mere guide to procedures which may take any pattern in the field, research groups will probably produce data and pamphlets of a quality proportional to the regard given them.

RESTRICTED

MANNING STATIONS

1. TURNING ON THE EQUIPMENT FOR TEST

TURN POWER SWITCH TO "ON"

THIS DRIVES THE GYROS
IN THE COMPUTER MARK 17

ABOUT 3 MINUTES ARE
REQUIRED TO BRING THE
GYROS UP TO FULL SPEED

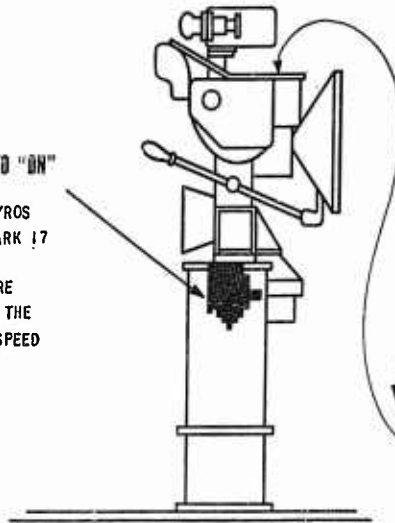

NOTE

POWER IS ALWAYS ON TO
HEATERS IN THE GYRO-
SCOPE DAMPING UNITS
RADAR MAIN POWER
SWITCH IS ALWAYS LEFT ON

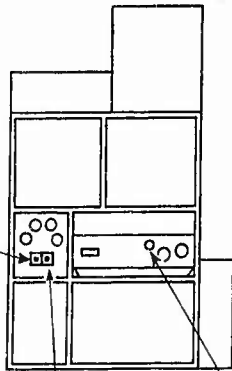

**TURN TRANSMITTER POWER
SWITCH TO "OPERATE"**

THIS PUTS THE RADAR IN
IMMEDIATE OPERATION
IT ALSO TURNS ON THE NU-
TATING MOTOR AND THE
FAN IN THE TRANSMITTER

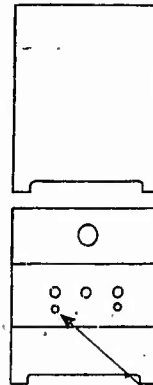

**TURN TIME MOTOR SWITCH
TO "0.2" OR "0.4"**

THIS TURNS ON THE TIME
MOTOR AND SETS THE
AIDED RANGING CONSTANT
AT 0.2 SECONDS OR 0.4
SECONDS WHICHEVER THE
RADAR OPERATOR PREFERS

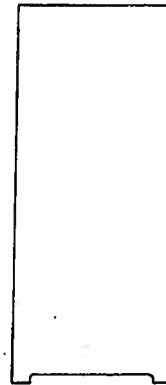

SHAP POWER SWITCH TO "ON"

THE ANGLE SOLVER
(THE COMPUTER MARK 16)
GOES INTO OPERATION
ABOUT 1 MINUTE LATER
WHEN THE POWER RELAYS
CLOSE

RESTRICTED

MANNING STATIONS

2. CHECKING EQUIPMENT

DIRECTOR POINTER AND
RADAR OPERATOR CHECK
ACTION OF T&E

DIRECTOR POINTER CHECKS
AIR HOSES; THEY MUST
NOT BE FOULED

DIRECTOR POINTER CHECKS
PUMP PRESSURE: 10-12
POUNDS

DIRECTOR TALKER MAKES
SURE THAT FAN IN TRANS-
MITTER BOX IS RUNNING

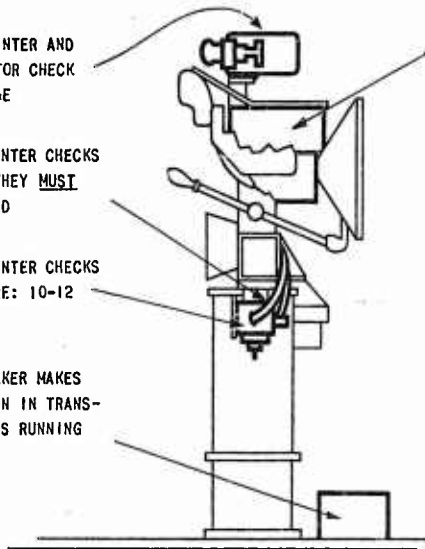

DIRECTOR TALKER CHECKS
RANGE TRANSMISSION TO
THE DIRECTOR

RANGE SETTING	SIGHT SENSITIVITY FOR 40 MM.
1000 YDS.1.24
2000 "2.90
3000 "4.95
5000 "	10.55

DIRECTOR POINTER AND WIND BOX
OPERATOR CHECK OPERATION OF
THE COMPUTER MK. 17 AND ANGLE
SOLVER BY CYCLING THE DIRECTOR
AND OBSERVING THE LEAD ANGLES
DEVELOPED

DIRECTOR POINTER CHECKS
THAT NUTATING MOTOR IS
RUNNING

GUN
ELEV. ELEV.
LEAD LEAD
TRAY.
LEAD

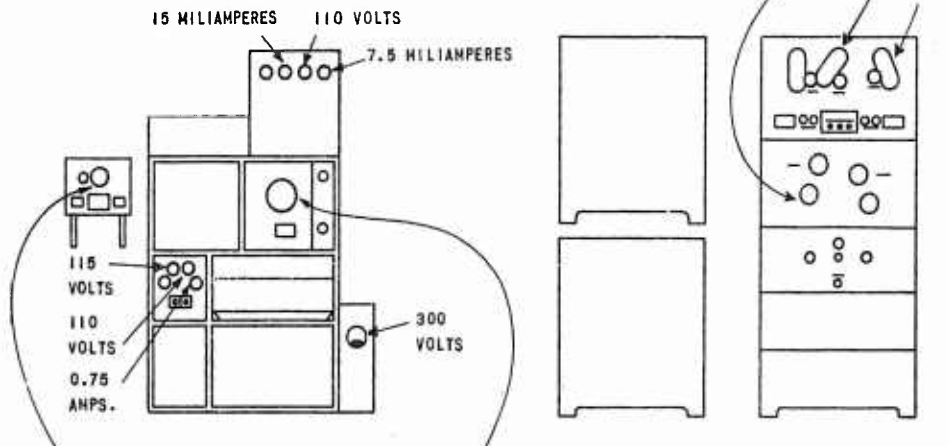

WIND BOX OPERATOR GETS
WIND DATA FROM THE
QUARTERMASTER AND
WRITES IT DOWN ON CHART
NEAR WIND BOX

RADAR OPERATOR CHECKS
RADAR ADJUSTMENTS:
FOCUS · INTENSITY ·
MANUAL RECEIVER TUNING
MANUAL GAIN CONTROL
ZERO SETTING

RADAR OPERATOR AND WIND
BOX OPERATOR CHECK ALL PILOT
LIGHTS. EVERY LIGHT MUST
BE ON (EXCEPT GREEN HEATER
PILOT ON THE RANGE UNIT WHICH
GOES ON AND OFF WITH THE
THERMOSTAT CONTROL)

ALL MEN CHECK COMMUNICATIONS

RESTRICTED

MANNING STATIONS

3. SETTING THE STANDBY CONDITION

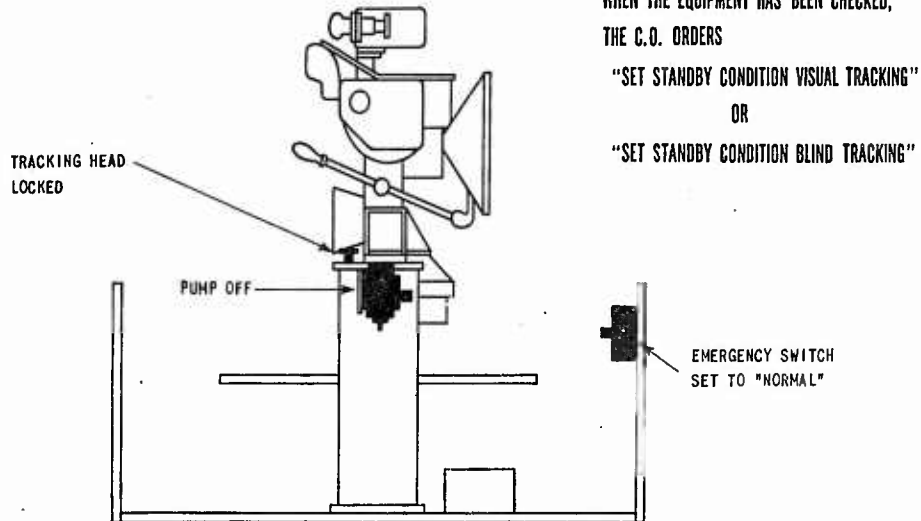

WHEN THE EQUIPMENT HAS BEEN CHECKED,
THE C.O. ORDERS
"SET STANDBY CONDITION VISUAL TRACKING"
OR
"SET STANDBY CONDITION BLIND TRACKING"

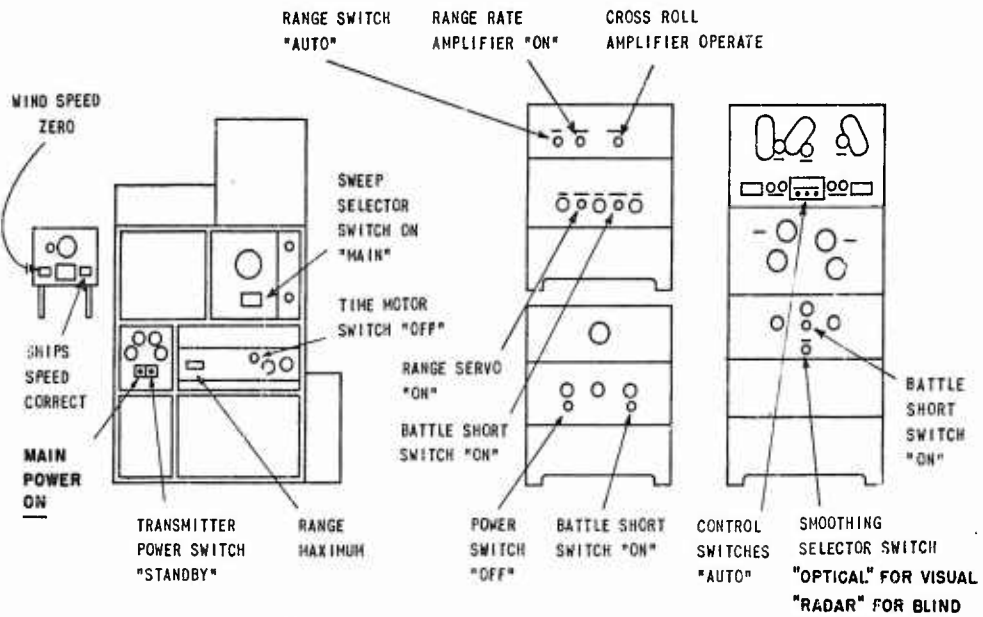

THESE PILOT LIGHTS SHOULD BE ON

- AMBER BATTLE SHORT PILOT ON RADAR POWER UNIT
- GREEN TRANSMITTER POWER PILOT ON RADAR POWER UNIT
- GREEN A.C. PILOT ON MODULATION AMPLIFIER
- RED SAFETY SWITCH PILOT ON MODULATION AMPLIFIER

RESTRICTED

PREPARING FOR ACTION:

4. BRINGING THE DIRECTOR TO THE READY CONDITION AT "GENERAL QUARTERS"

THE DIRECTOR POINTER UNLOCKS THE TRACKING HEAD

THE DIRECTOR POINTER TURNS THE PUMP POWER SWITCH TO "ON"

NOTE
ABOUT 3 MINUTES ARE REQUIRED BEFORE THE GYROSCOPES ARE UP TO FULL SPEED AND BEFORE THE LEAD ANGLES WILL BE MEASURED ACCURATELY

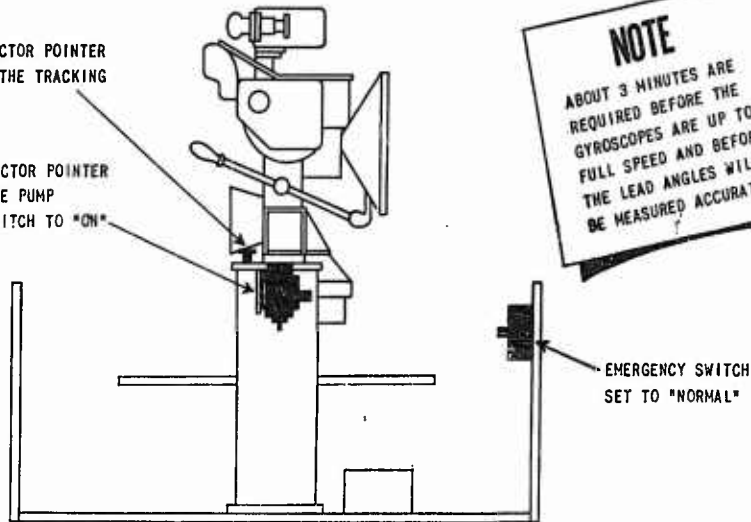

WIND BOX OPERATOR CHECKS SHIP'S COURSE, WIND SPEED AND WIND DIRECTION FROM BEST AVAILABLE DATA

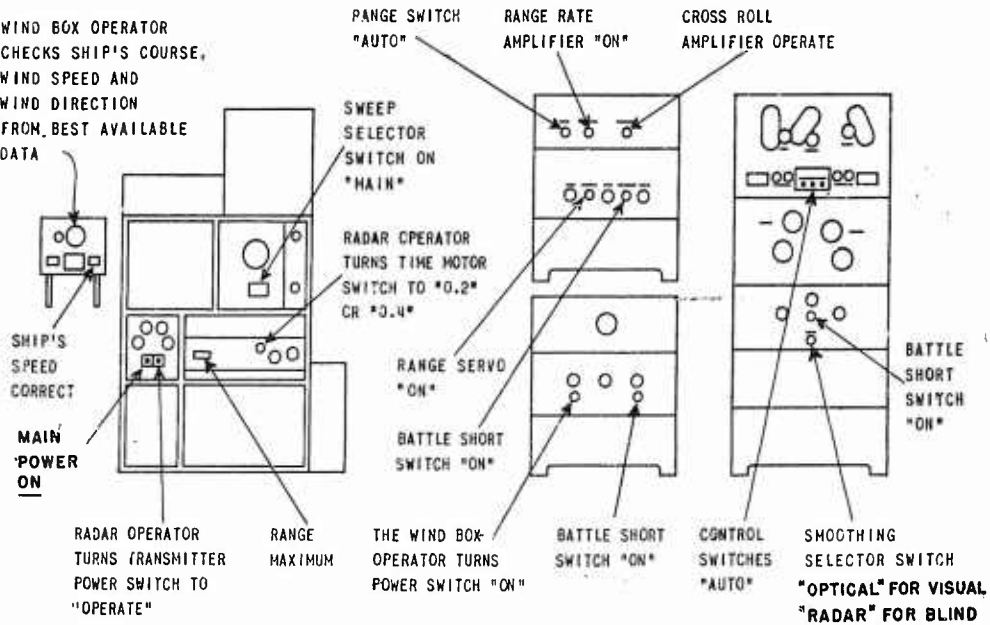

- ✓ RADAR OPERATOR AND WIND BOX OPERATOR CHECK THAT ALL PILOT LIGHTS ARE ON
- ✓ ALL STATIONS REPORT WHEN MANNED AND READY

RESTRICTED

**PROCEDURE
WHEN TARGET
IS SIGHTED
INSIDE THE
RANGE OF THE
DIRECTOR**

1 THE CONTROL OFFICER CALLS "ACTION" AND GIVES A BARRAGE RANGE FOR OPENING FIRE IN SECONDARY CONTROL

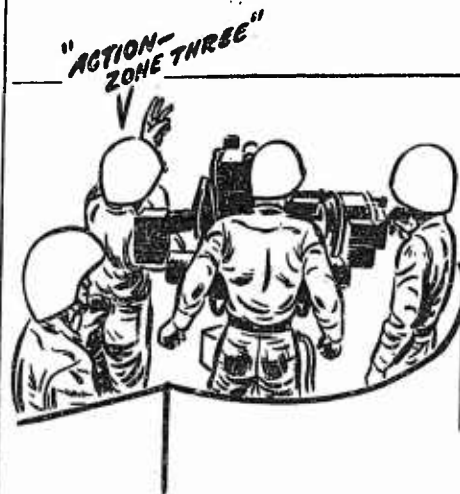

2 THE RANGE SETTER IMMEDIATELY SETS ZONE RANGE (3000 YARDS FOR ZONE THREE) AND REPORTS TO THE RADAR OPERATOR.

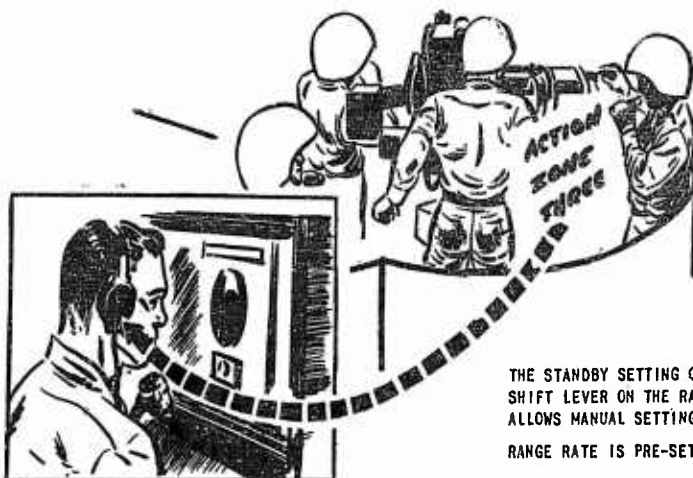

NOTE:

THE STANDBY SETTING OF THE DIRECTOR IS WITH THE GEAR SHIFT LEVER ON THE RANGE RECEIVER SET AT "RANGE". THIS ALLOWS MANUAL SETTING OF RANGE BY THE RANGE SETTER. RANGE RATE IS PRE-SET AT -200 KNOTS.

RESTRICTED

OPTICAL PICKUP—SHORT RANGE TARGETS

3 THE DIRECTOR PCINTER HOLDS THE CAGING SWITCH CLOSED AND SLEWS ON TARGET. HE CENTERS THE TARGET IN THE RETICLE AND CALLS "---

THEN HE RELEASES THE CAGING KEY AND LOCKS IT.

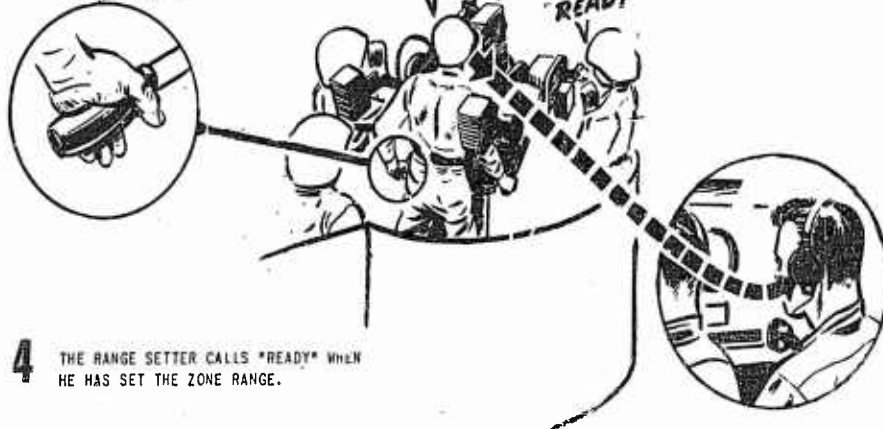

4 THE RANGE SETTER CALLS "READY" WHEN HE HAS SET THE ZONE RANGE.

5 OPENING FIRE IN SECONDARY

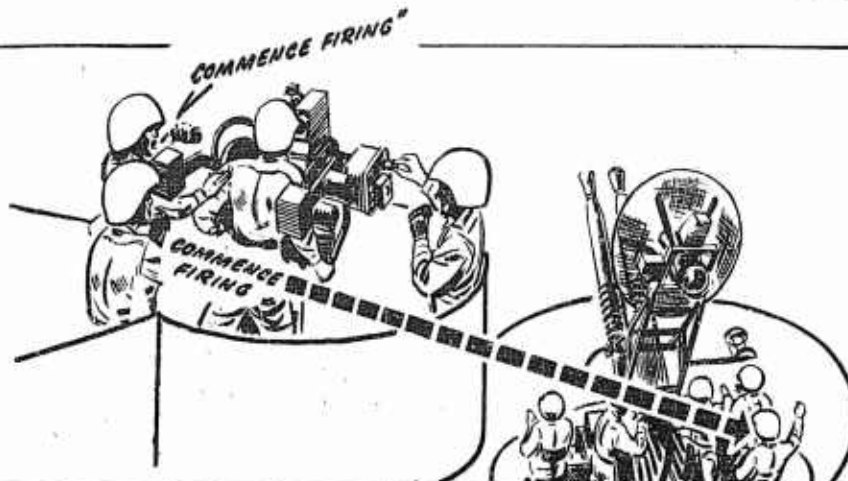

RESTRICTED

OPTICAL PICKUP—SHORT RANGE TARGETS

6 AS SOON AS THE RADAR PIP APPEARS, THE RADAR OPERATOR GATES IT USING THE SLEWING SWITCH.

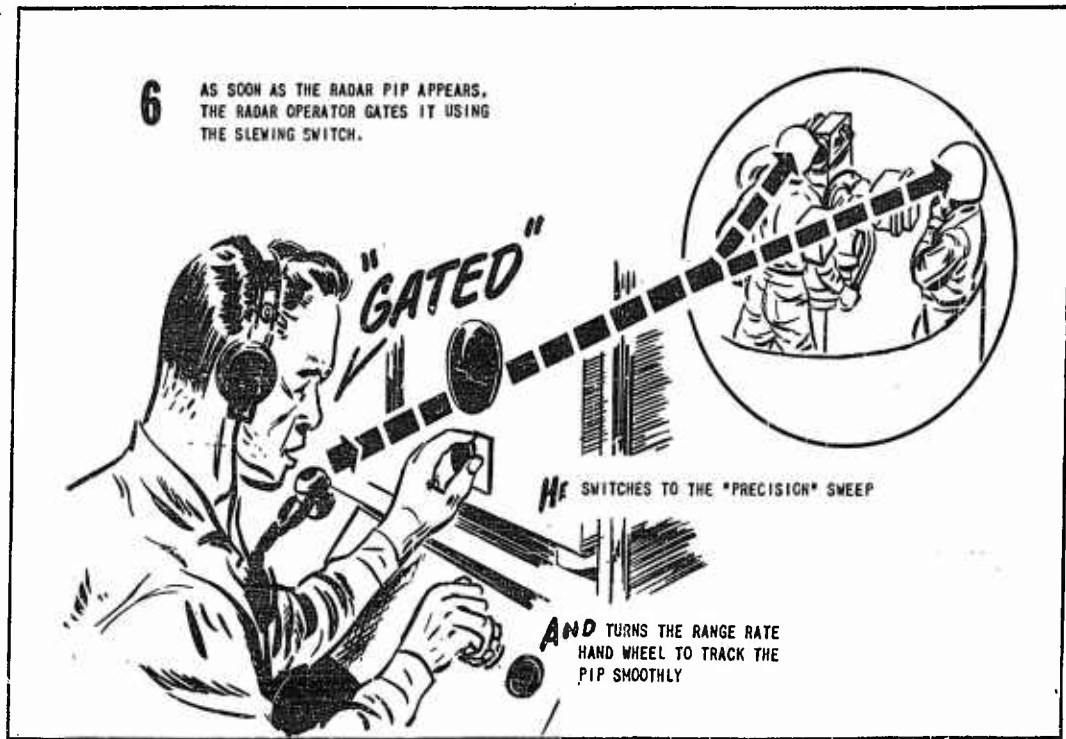

7 SHIFTING TO PRIMARY
AT "GATED", THE RANGE SETTER IMMEDIATELY TURNS THE GEAR SHIFT LEVER TO "RATE" AND MATCHES THE RANGE RATE METER

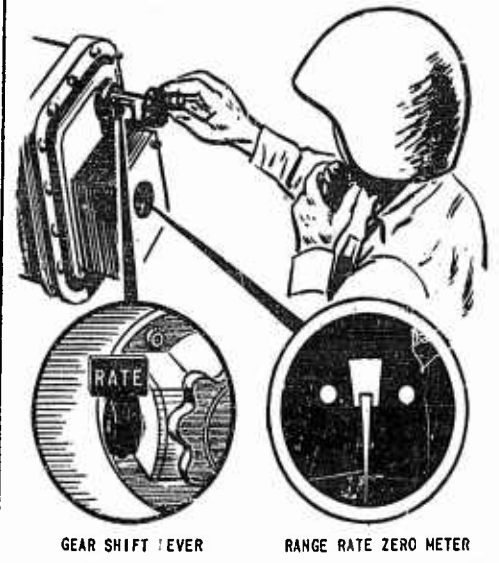

8 THE RANGE SETTER CALLS "SET"
RANGE IS NOW FED INTO THE GUN SIGHT AUTOMATICALLY. THE RANGE RATE INPUT IS CORRECT WHEN THE METER IS KEPT AT ZERO
THE SYSTEM IS IN PRIMARY OPERATION (DIRECT FIRE)

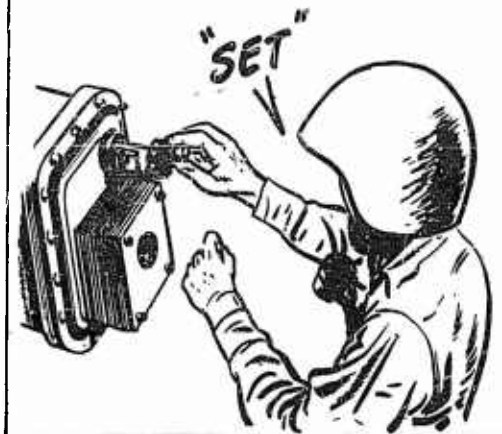

RESTRICTED

OPTICAL PICKUP—SHORT RANGE TARGETS

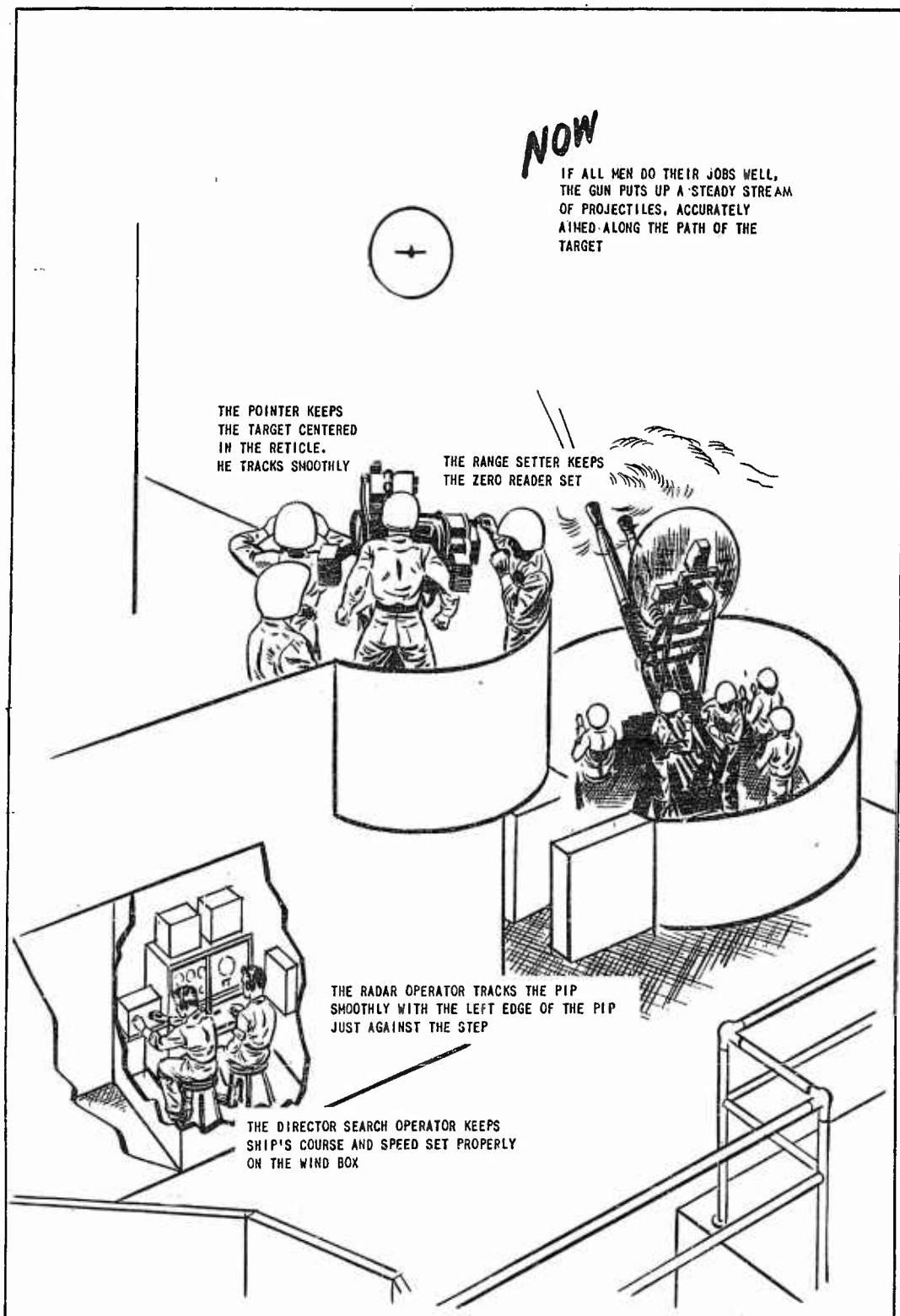

RESTRICTED

CHAPTER II

TRAINING

THE WELL-TRAINED CREW

A director crew can be considered well trained when every man knows his job and when --

- (1) the crew can get on a visible target, start radar ranging, set up the director problem, and be ready to fire in an average time which is under 7 seconds (measured from the "ACTION" command),
- (2) the crew can pick up an obscured target and be ready to fire in an average time which is under 15 seconds (measured from the "ACTION" command), and
- (3) the director pointer can track a visible aerial or surface target with an average tracking error of less than 1 or 1.5 mils.

CAREFUL SELECTION SAVES TRAINING TIME

Efficient training of a director crew depends on the careful selection of men for the different stations. Crew assignments should be made only after the qualifications and aptitudes of all men available have been examined. Final selection should be made on the basis of skill shown during periods of preliminary training on the equipment. When conditions allow, men should be rotated through the different operating jobs until the ones best suited for work at each station are found. These procedures take time, but this is a small price to pay for the greater amount of time saved later during training.

DRILLS SHOW THE NEED FOR TEAMWORK

Drills should begin as soon as every member of the crew has become thoroughly familiar with the parts and general function of the Gun Fire Control System Mark 63. At the outset, the emphasis during drills should be on the individual instruction. Each man must first become accurate at his job. He should learn WHAT to do, HOW to do it, and WHY he should do it one special way. Close supervision at this stage of learning may prevent bad habits of operation from developing.

After every man has learned his job, speed drills under battle conditions should be instituted. These drills should include every type of procedure that will subsequently be used, and should always begin with the routine operational checks of the equipment. Time records of team performance should be kept and made available to the crew members as an incentive to further improvement and as a permanent record of progress.

A type of drill which is particularly helpful in the early stages of training is a round-robin drill, where each member of the crew rotates through all jobs in the director system. By moving from one position to another, the men become aware of coordination problems and learn how their own actions influence the performance of others.

In particular, the control officer should take advantage of every opportunity to drill his men in TACU pickups. For these drills, the control officer should arrange to have C.I.C. furnish target bearing, range and elevation information so that searching can be carried out under the same conditions as might prevail during combat. He should also arrange to have a screen mounted around the gun sight to prevent the director pointer from seeing the target during the acquisition procedure. If C.I.C. cannot participate in the drill, range, bearing and elevation data may be phoned to the director search operator from any target designator.

RESTRICTED

ACCURACY CHECKS UNCOVER WEAKNESSES

TRACKING

The pointer's accuracy in tracking a visible target can be scored with the aid of the check sight which can be attached to the director and gun sight. The check sight equipment includes: (1) a special reflecting prism and mount which clamps over the gun sight eyepiece lens, (2) a bracket which attaches to the director, (3) a telescope (Mark 89) which mounts on the bracket, and a special reflecting prism which mounts over the objective lens of the telescope. The telescope is so placed in relation to the two prisms that anyone looking through the telescope can see exactly what the director pointer sees as he tracks.

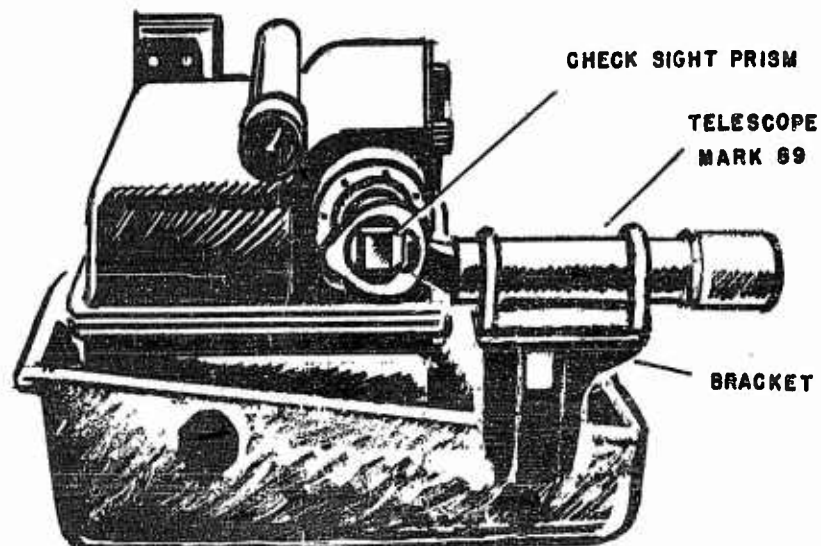

The reticle pattern in the check sight telescope is the same as the pattern in the fixed telescope on top of the gun sight. The pattern includes crosslines and a series of circles as shown in the sketch here. Notice the open area (in the very center) of the reticle. This area represents a circle which is 3.5 mils in diameter in terms of the gun sight field.

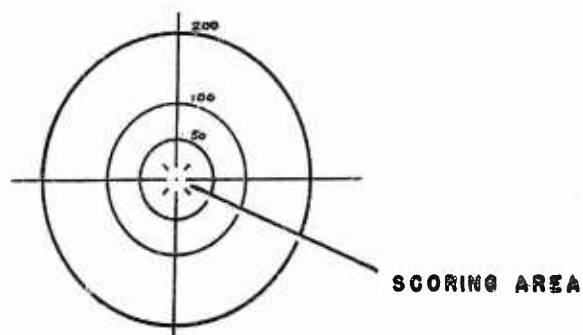

The director pointer's tracking ability can be measured by determining how much he keeps the center of the target (the intersection of the wing and fuselage) within the central 3.5 mils of the reticle circle. To use the check sight, the telescope must be adjusted so that its reticle is lined up with the gun sight reticle. The circle marked "50" should be just around the gun sight reticle. The instructor then scores the pointer by measuring how long he keeps the intersection of the wing and fuselage of the target within the central open area -- inside the eight converging lines.

RESTRICTED

DIRECT FIRE

- 1 All men search for the target in the direction indicated by search radar. The director pointer closes the slewing switch.
- 2 The man who spots the target points to it. The control officer gives the action command, (as "ACTION—STARBOARD—AIR—BEARING . . ."). He gives this command to the director crew and, by telephone, to the gun crew. The gun captain repeats the order to his crew.
- 3 The director pointer picks up the target. If he has to slew the director very far, he overshoots the target in train and elevation, snapping back to collapse the false lead angle developed while slewing toward the target. He uses the slewing telescope which is mounted on top of the gun sight. He looks through the telescope with his right eye while watching the target with his left.
- 4 The control officer estimates range of the target to the nearest 1000 yards. (If he has received search radar range from the Bridge, he uses that range value.) He calls his estimate to the director operator, (as "RANGE SEVEN"). The director operator repeats this range estimate, (as, "RANGE SEVEN"), to the radar operator in order to indicate the approximate range where the target pip may appear. The radar operator tracks the range needle to this range on the radar scope.
- 5 The control officer calls estimated target speed to the director operator, (as "SPEED ONE FIVE ZERO"). Estimates are made to the nearest 50 knots. The director operator sets target speed to this estimated value. The target speed selector switch moves in 50 knot steps.
- 6 The control officer estimates target angle, (as, "TARGET ANGLE THREE ZERO ZERO"). The director operator uses this estimate to offset the radar dish by the proper amount in train.
- 7 As soon as the director pointer sees the target in the slewing telescope on top of the gun sight, he leads it a bit with the slewing scope reticle and then shifts down to look through the gun sight telescope. When the pointer sees the target in the gun sight he calls, "MARK," and releases the slewing switch in the tracking handle. He centers the target in the gun sight reticle and begins to track smoothly.

NOTE: Releasing the slewing switch allows the gun sight to develop a lead angle. In early directors, releasing the slewing switch cuts out the slewing motor circuit and gives full control of range in the director and gun sight to the range servo motor. With the director in "Automatic", the servo motor automatically matches range in the gun sight with range set on the radar. In later directors where a "caging" device is used on the gyroscopes, the servo motor always has control of range in the gun sight as long as the "Hand-Auto" selector switch is at "Auto". Releasing the slewing switch simply cuts out the caging and lets the gyroscopes precess. In either case, releasing the slewing switch lets the gun sight develop the lead angle appropriate to the radar range.

The radar operator may or may not have found the target pip by this time. If he has not found the pip he keeps the range needle on the estimated range value. The pip never appears until the director pointer is nearly on target. Sometimes it does not appear until the gun sight has developed its lead angle.

- 8 When the radar operator sees the target pip he reports its range to the director operator to the nearest 100 yards, (as "RANGE SIX TWO"). He turns the range handwheel to put the range needle on the short range edge of the pip. As he keeps the pip matched by turning the range handwheel, an aided ranging mechanism in the computer begins to take over most of the job of tracking the pip. Soon the proper range rate is set up in the computer and the radar operator only needs to turn the ranging handwheel to keep the pip matched when the target's range rate changes.

RESTRICTED

PROCEDURE

- 9 The radar operator observes the zero reader meter on the computer to check that the range servo has driven the range setting in the director to match range in the computer. When the meter is at zero, he calls, "READY", to the director operator. At this point, the fire control problem is almost solved. The pointer is tracking well, and range is properly set in the gun sight.
- 10 To complete the solution of the fire control problem, the director operator must keep two sets of pointers matched: the range wind pointers (to send a wind correction to the radar) and the range rate pointers, (to send range rate to the gun sight). When these two sets of pointers have been matched and the radar operator has reported, "READY", the director operator calls, "READY", to the control officer.
- 11 The control officer orders, "COMMENCE FIRING". The director pointer closes the firing key in the right tracking handle and the gun captain passes the firing order to his crew.
- 12 During action, the director pointer tracks the target as smoothly as possible and reports any important changes in target angle. The director operator continues to match the range wind pointers and the range rate pointers. The radar operator tracks the target pip smoothly in order to guarantee a smooth range and range rate input to the director. The wind box operator continuously adjusts ship's course and ship's speed settings.
- 13 During action, the radar operator reports changes in pip size to indicate to the director operator when the pip is getting weak. He reports pip strength as "E1", "E2", "E3", "E4", or "E5", where a large number means a strong pip, and a small number a weak pip. The director operator adjusts the dish only when the radar operator reports "E1" or "E2".
- 14 As soon as the target is hit or passes out of range, or when a more threatening target appears, the control officer orders, "CEASE FIRING".
- 15 The director pointer opens the firing key after each gun has had time to fire its last projectile. He closes the slewing switch. The director operator sets target speed to 200 knots, and resets the radar dish to the zero position in train.
- 16 The entire crew prepares to engage a new target.

... and to change targets

- 1 The control officer slaps the pointer's back, calls "SHIFT TARGETS, NEW BEARING . . ." and points to the target.
- 2 The director pointer moves his head away from the gun sight in order to spot the new target. If the director is of the type which has the slewing switch in the right tracking handle, the pointer immediately releases the firing key and closes the slewing switch. If the director has a slewing switch in the left tracking handle, the slewing switch may be closed without checking fire if the preferred doctrine is not to check fire.
- 3 If the pointer does not spot the target immediately, the control officer assists him in getting on by slewing the director toward the target. He grasps the left hand gear box, swings the director in train and elevation, and sights on the target by looking along the upper, outer edge of the gear box. The pointer should then be able to pick up the target with little difficulty.
- 4 The pointer calls "MARK" when he is on target, and the operating procedure continues as outlined above.

RESTRICTED

Chapter 8

PROCEDURES FOR SURFACE FIRING

1. Four Procedures for Surface Firing

There are four ways of operating the Gun Director Mark 52 for surface firing.

- (1) *Using the Gun Sight Mark 15* and operating in exactly the same way as for antiaircraft firing. This procedure is used against fast PT boats at ranges under 7500 and 7000 yards.
- (2) *Using the Gun Sight Mark 15* in the same manner as for antiaircraft firing but with the range rate dial set according to target range.

This procedure can be used against low speed targets at ranges under 7500 or 7000 yards.

The Gun Sight Mark 15 was built to compute accurate lead angles for high speed targets. Characteristics built into the sight for handling high speed targets cause the sight to make certain errors in computing superelevation for low speed surface targets. Therefore, the range rate dial must be set as a function of range in order to obtain the right superelevation from the gun sight when firing at slow surface craft.

- (3) *Using the Gun Sight Mark 15* with the gyroscopes not spinning and with the range rate dial set according to target range.

This procedure can be used against low speed surface targets at ranges under 7500 or 7000 yards. It is used in preference to procedure (2) whenever the tactical situation permits stopping the gyroscopes. When the Gun Sight Mark 15 is used against surface targets with its gyroscopes spinning, the gyroscopes precess every time the director pointer makes a tracking error or tries to correct for an error. This disturbs gun aim and results in a greater dispersion of shots than would be obtained with a system specifically designed for surface fire control. One way to reduce this dispersion is to turn off the air pump and let the gun sight gyroscopes stop spinning. As long as the range rate dial is specially set, the gun sight computes the proper superelevation, drift and wind corrections.

- (4) *Using the Computer Mark 6* to determine sight angle and sight deflection while the train and elevation of the line of sight are obtained by tracking the target with a fixed line of sight. This procedure is used against all surface targets at ranges greater than the 7000 or 7500 yard limiting range of the Gun Sight Mark 15, and can be used against low speed targets at any range. Control of fire by the Computer Mark 6 results in less dispersion than either procedure (2) or (3) above and is used in preference to procedures (2) and (3) for short range firing whenever conditions allow.

2. Using the Gun Sight Mark 15 Against P. T. Boats

With radar and the gun sight in full operation, the procedure for engaging PT boats at short range is exactly the same as the procedure for engaging aerial targets. The power switch on the director is set to "Aircraft" and the "Hand-Auto" range selector switch is set to "Auto". Lead angle is computed by the gun sight on the basis of tracking rates, range input, range rate input and the corrections for superelevation, drift and wind. Target speed is set at 50 knots and train parallax corrections are transmitted to the guns.

In the event that a satisfactory radar signal is not received from the PT boat target (or if the radar is out of action for some other reason), the procedure changes to barrage firing with the "Hand-Auto" range selector switch set at "Hand". No formal barrage zone data

RESTRICTED

are required since fuzes are set on "Safe". The control officer calls an estimate of range rate to the nearest 50 knots (as "RANGE RATE MINUS FIVE ZERO"). He also calls for a range setting which is short of the target's present range. He calls for range to be set at some flat thousand yards (as "RANGE FOUR"). The director operator makes these settings, and calls the range value to the radar operator (as

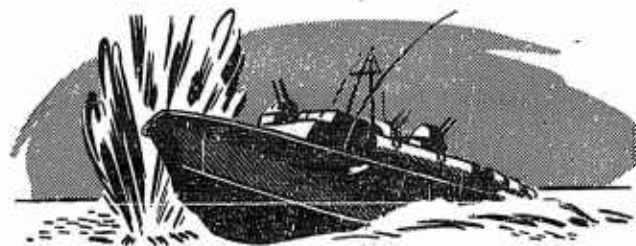

"RANGE FOUR"). The radar operator "tracks" this range value, gets a zero range rate in the Computer Mark 13, and thereby sends a satisfactory fuze time value to the train parallax corrector. The effect of the barrage is to lay down a pattern of projectiles which fall on the line of sight but which are originally short of the target. There is good probability of hitting the target as it closes in to the barrage range. When the control officer observes that projectiles are falling beyond the target, he orders a shift to a shorter zone. Zone is changed simply by changing to a new range setting (as "RANGE THREE"). It is convenient to use zones which are at 1000 yard intervals.

3. Surface Firing Using the Gun Sight Mark 15 with Gyroscopes Running but with Special Range Rate Dial Settings

a. Outline of procedure

In this procedure, the director power switch is set to "Aircraft". The director pointer gets on target and tracks as smoothly as he can. The wind box operator makes normal wind box settings. The radar operator tracks the target pip on the radar scope and range is transmitted by servo to the director and gun sight. The director operator matches the range wind pointer but *disregards the range rate data transmitted from the Computer Mark 13*. Instead of matching the range rate pointers, the director operator uses the inner red scale to set the range rate dial. This inner red scale on the range rate dial is graduated in thousands of yards range (see Dial Picture on pg. 30). The director operator turns the range rate control knob until the red scale reading agrees in range with the reading on the range scale on the director. When range wind is matched and when the range rate dial is properly set, the director operator calls, "READY". The control officer gives the firing order.

The range rate mechanism which corrects superelevation for future target position was built to give accurate corrections for high speed targets. Its corrections for low speed targets are only approximate. Thus, setting range rate to the value which represents the true range rate of a surface target (when it is zero or nearly zero) does not provide the right superelevation angle for surface firing. It is possible, however, to determine what arbitrary range rate scale setting should be used at each target range in order to obtain the proper superelevation for that range. These required settings for 3"/50 caliber and 5"/38 caliber installations are shown in the following table.

In order to simplify the control of superelevation for firing at low speed surface targets, the range rate dials on the Gun Sight Mark 15 and the Gun Director Mark 52 are engraved with additional inner scales marked in red. These inner scales are range scales (not range rate scales) and are based on the data in the table. When the red scale reading is matched with present range, superelevation is correct.

RESTRICTED

Standard Commands listed in "Standard Submarine Phraseology"

DIVING

Examples of messages to and from the CO or OOD are given first. The basic diving orders and reports have been starred (*). Other messages are often omitted, except during training dives or under other special circumstances. Examples of orders from the diving officer are divided according to the units receiving them.

<u>From</u>	<u>Over</u>	<u>Orders and reports</u>
Bridge	1MC	*Rig for dive. When all compartments have reported that they are rigged for dive, control room reports this fact to the bridge.
Bridge	7MC	Have Mr. R. check the gun access hatch.
CO		Clear the bridge.
CO or OOD	1MC	*Dive, dive, dive. At the same time, the diving alarm is sounded.
Diving officer		*Pressure in the boat, green board.
CO	7MC	*Six fi-yiv feet.
Diving officer	XJA	*Open bulkhead flappers and start the ventilation. All compartments report in turn that bulkhead flappers are open. The forward engine room also reports ventilation started.
Diving officer		One-third trim, niner ze-ro feet, two degree up bubble.
Diving officer		*Final trim, six fi-yiv feet.
Diving officer		Request speed.
CO	7MC	Take her down. (<i>for deep dives</i>)

RESTRICTED

Orders from Diving Officer to Control Room

To hydraulic manifold:

Open all main vents. Vent negative. Cycle the vents.
Flood safety. Flood negative. Shut the negative flood.

To trim manifold:

Pump from forward trim to after trim.
Air manifold reports: "Suction on forward trim, after trim venting."
Pump from auxiliary to sea. Flood auxiliary from sea.
Pump from auxiliary to after trim, fi-yiv hundred pounds.
Pump from forward trim to auxiliary, and report every fi-yiv hundred pounds.
Trim manifold reports: "Fi-yiv hundred out." "One thousand out." Etc.

To air manifold:

Bleed air.
Blow ali main ballast tanks. Blow negative.
Secure the air.

To planesmen:

Niner ze-ro feet. Six fi-yiv feet.
Two degrees up bubble. Thuh-ree degrees down bubble.
Ease the bubble. Ze-ro bubble.
Twenty degree rise on the bow planes. Ten degrees dive on the stern planes.
Take charge of your planes.

Orders from Diving Officer over XJA

Forward room, shift bow buoyancy vent to hand.
Forward room, open bow buoyancy vent by hand.
After room, shut number seven main ballast vent by hand.
Forward engine room, open number fi-yiv fuel ballast flood valves by hand.

RESTRICTED

GLOSSARY

LABORATORY NAME ABBREVIATIONS

AMRL. Armored Medical Research Laboratory, Ft. Knox, Ky.	PENN. STATE. Pennsylvania State College, State College, Pennsylvania
BROWN. Brown University, Providence, Rhode Island.	PRINCETON. Princeton University, Princeton, New Jersey.
C.E.E.B. College Entrance Examination Board, Princeton, New Jersey.	PSYCH. CORP. Psychological Corporation, 522 Fifth Avenue, New York 18, New York.
CUDWR. Columbia University Division of War Research, New York City.	ROCHESTER. University of Rochester, Rochester, New York.
HARVARD. Harvard University, Cambridge, Massachusetts.	STANFORD. Stanford University, California.
IOWA. State University of Iowa, Iowa City, Iowa.	TUFTS. Tufts College, Medford, Massachusetts.
M.I.T. Massachusetts Institute of Technology, Cambridge, Massachusetts.	U.S.C. University of Southern California, Los Angeles, California.
N.A.S. National Academy of Sciences, 2101 Constitution Avenue, Washington 25, D. C.	WIS. University of Wisconsin, Madison, Wisconsin.
N.Y.U. New York University, New York City.	YERKES LAB. Yerkes Laboratories of Primate Biology, Orange Park, Florida.
PENN. University of Pennsylvania, Philadelphia, Pennsylvania.	

OTHER ABBREVIATIONS

AA. Antiaircraft.	LCVP. Landing craft, vehicles and personnel.
AAA. Antiaircraft Artillery.	LSM. Landing ship, medium.
AAF. Army Air Forces or Army Air Field.	LST. Landing ship, tank.
AATTC. Antiaircraft Training and Test Center.	MAT. Mechanical Aptitude Test.
a.f.c. Affective foot candles.	MK-E. Mechanical Knowledge, Electrical (a test).
AKA. Assault cargo auxiliary.	MK-M. Mechanical Knowledge, Mechanical (a test).
APA. Assault personnel auxiliary.	N. Number of cases.
APP. Applied Psychology Panel.	NAVPER. Bureau of Naval Personnel publication number.
AR. Arithmetical Reasoning Test.	NDRC. National Defense Research Committee.
ASTP. Army Specialized Training Program.	NOB. Naval Operating Base.
ASV. Air surface vessel.	NRC. National Research Council.
ATB. Amphibious training base.	NTS. Naval Training Station.
BC. Battery Commander.	NTSCH. Naval Training School.
BUPEP. Bureau of Naval Personnel.	OQ. Radio-controlled aerial target.
c. Cycles per second.	OSRD. Office of Scientific Research and Development.
CIC. Combat information center.	OT. On target.
CMM. Chief Machinist Mate.	PA. Public address system.
COTCLANT. Commander, Operational Training Command, United States Atlantic Fleet.	PPI. Plan position indicator.
COTCPAC. Commander, Operational Training Command, United States Pacific Fleet.	PQ. Radio-controlled aerial target.
CWT. Chief Water Tender.	Q-CARD. Navy enlisted men's qualifications card.
db. Decibel.	r. Correlation coefficient.
DD. Destroyer.	RCT. Remote control test device.
DE. Destroyer escort.	ROA. Radio Operator Aptitude Test.
DRT. Dead reckoning tracer.	ROB. Radar observer (bombardment).
ESF. Equivalent square feet.	R/T. Radio telephone.
ETA. Estimated time of arrival.	SBD. Scout bomber.
FC. Fire controlman.	SD. Standard deviation.
FC(O). Fire controlman (operator).	σ . Standard deviation.
GCA. Ground controlled approach.	SK. Storekeeper.
GCI. Ground controlled interception.	S/N. Signal-to-noise ratio.
GCT. General Classification Test.	T AND E. Train and elevation.
gpm. Groups per minute.	TBF. Torpedo bomber.
IFF. Information friend or foe.	TM. Technical Manual.
IV. Initial velocity.	UOE. Unit of error.
JL. A shipboard telephone circuit.	WD. War Department.
LCI. Landing craft, infantry.	wpm. Words per minute.

BIBLIOGRAPHY

Numbers such as APP-213.3-M1 indicate that the document listed has been microfilmed and that its title appears in the microfilm index printed in a separate volume. OEMsr contract numbers and service project numbers are included in the references which have been microfilmed. For access to the index volume and to the microfilm, consult the Army or Navy agency listed on the reverse of the half-title page.

In the bibliography for each chapter OSRD publications are given first; they are followed by a listing of publications from other sources.

Chapter 2

1. *Radar Operator Training, Results of Study of SCR-270-71 Operators at Drew Field*, OSRD 1737, OEMsr-919, Service Projects SC-70 and NS-146, Research Report 1, Yerkes Laboratories of Primate Biology and U. S. Army Signal Corps, Southern Signal Corps School, Camp Murphy, Fla., Aug. 16, 1943. APP-213.3-M1
2. *Proficiency Measures for Classification and Assignment of Operators of ASV Radar Equipment*, Irving H. Anderson and Donald B. Lindsley, OSRD 2012, OEMsr-919, Service Projects SC-70 and NS-146, Memorandum 5, Yerkes Laboratories of Primate Biology and U. S. Army Signal Corps, Southern Signal Corps School, Camp Murphy, Fla., Sept. 29, 1943. APP-318.1-M1
3. *Development of Proficiency Measures for Classification and Assignment of Operators of ASV Radar Equipment*, Donald B. Lindsley and Irving H. Anderson, OSRD 2013, OEMsr-919, Service Projects SC-70 and NS-146, Report 2, Yerkes Laboratories of Primate Biology and U. S. Army Signal Corps, Southern Signal Corps School, Camp Murphy, Fla., Sept. 29, 1943. APP-318.1-M2
4. *Use of the Philco Trainer in the Training of A-Scan Oscilloscope Operators*, Irving H. Anderson and others, OSRD 2096, OEMsr-919, Service Projects SC-70 and NS-146, Research Report 3, Yerkes Laboratories of Primate Biology and U. S. Army Signal Corps, Southern Signal Corps School, Camp Murphy, Fla., Oct. 15, 1943. APP-621-M1
5. *A Study of the Foxboro Trainer as a Training Device for Learning to Track by Means of Pip-Matching*, Irving H. Anderson and others, OSRD 3102, OEMsr-919, Service Projects SC-70 and NS-146, Research Report 5, Yerkes Laboratories of Primate Biology and U. S. Army Signal Corps, Southern Signal Corps School, Camp Murphy, Fla., Dec. 16, 1943. APP-611.2-M2
6. *Analysis and Revision of Training Program for Shipborne Radar Operators at the Fleet Service School, Virginia Beach, Virginia*, Donald B. Lindsley, OEMsr-919, Service Projects SC-70 and NS-146, Informal Memorandum 9, Yerkes Laboratories of Primate Biology, Feb. 7, 1944. APP-213.2-M1
7. *A Study of the SCR-584 Basic Trainer as a Training Device for Learning Range Tracking*, Irving H. Anderson and others, OSRD 3344, OEMsr-919, Service Projects SC-70 and NS-146, Report 7, Yerkes Laboratories of Primate Biology and U. S. Army Signal Corps, Southern Signal Corps School, Camp Murphy, Fla., Feb. 10, 1944. APP-611.2-M5
8. *Analysis and Revision of Training Program for Shipborne Radar Operators at the U. S. Naval Training School, Point Loma, California*, Donald B. Lindsley, OEMsr-919, Service Projects SC-70 and NS-146, Informal Memorandum 13, Yerkes Laboratories of Primate Biology and U. S. Army Signal Corps, Southern Signal Corps School, Camp Murphy, Fla., Mar. 27, 1944. APP-213.2-M2
9. *Development of the Screen Interpretation Test for Airborne Radar Equipment*, Irving H. Anderson, Alfred L. Baldwin, and others, OSRD 3897, OEMsr-919, Service Projects SC-70 and NS-146, Research Report 12, Yerkes Laboratories of Primate Biology, July 15, 1944. APP-326-M1
10. *Low Altitude Bombing—A Workbook for Radar Operators and Navigators, Principles of Screen Interpretation for SCR-717-B, Developed for 111th Army Air Force Base Training Unit, Langley Field, Va., August 9, 1944*, Donald B. Lindsley, Service Projects SC-70 and NS-146, Informal Memorandum 17, Yerkes Laboratories of Primate Biology, Sept. 25, 1944.
11. *GCA Workbook, Problem Exercise and Quizzes for Unit and Team Training on GCA Equipment, Prepared for GCA Training Unit, Fort Dix Air Base, Fort Dix, New Jersey, October 1944*, Donald B. Lindsley, Service Projects SC-70 and NS-146, Informal Memorandum 19, Yerkes Laboratories of Primate Biology, Nov. 8, 1944.
12. *A Radar Trainer and Flash-Reading Method for Operators of the Plan Position Indicator*, Irving H. Anderson, Alfred L. Baldwin and others, OSRD 4489, OEMsr-919, Service Projects SC-70 and NS-146, Research Report 14, Yerkes Laboratories of Primate Biology, Dec. 23, 1944. APP-660-M2
13. *Low Altitude Radar Bombing, A Manual for the Bomber Prepared for the Naval Air Operational Training Command and used at Banana River, Florida, October 15, 1944*, Donald B. Linds-

- ley, OEMsr-919, Service Projects SC-70 and NS-146, Informal Memorandum 20, Yerkes Laboratories of Primate Biology, Dec. 27, 1944. APP-213.1-M2
14. *Development of Final Achievement Examinations for Navy Search-Radar Operators*, Irving H. Anderson, Alfred L. Baldwin and others, OSRD 4635, OEMsr-919, Service Projects SC-70 and NS-146, Research Report 15, Yerkes Laboratories of Primate Biology, Jan. 27, 1945. APP-213.2-M3
 15. *Instructor's Guide for Use of the H2X Film Trainer with Film Commentaries*, prepared for Army Air Forces, January 25, 1945, Donald B. Lindsley, OEMsr-919, Service Projects SC-70 and NS-146, Informal Memorandum 21, Yerkes Laboratories of Primate Biology, Feb. 6, 1945. APP-622-M1-2
 16. *Use of the PPI Flash-Reading Trainer in Training Navy Search-Radar Operators*, Irving H. Anderson, Alfred L. Baldwin, and others, OSRD 4831, OEMsr-919, Service Projects SC-70 and NS-146, Research Report 17, Yerkes Laboratories of Primate Biology, Mar. 20, 1945. APP-660-M3
 17. *A New Type Mechanical PPI Tracking Trainer*, Donald B. Lindsley, OEMsr-919, Service Projects SC-70 and NS-146, Informal Memorandum 26, Yerkes Laboratories of Primate Biology and U. S. Army Air Forces, Boca Raton Field, Fla., Sept. 4, 1945. APP-611.2-M21
 18. *Radar Scope Movies for Briefing and Reconnaissance Purposes*, Donald B. Lindsley, OEMsr-919, Service Projects SC-70 and NS-146, Informal Memorandum 30, Yerkes Laboratories of Primate Biology and U. S. Army Air Forces, Boca Raton Field, Fla., Sept. 24, 1945. APP-624-M3
 19. *Operator Achievement Examination for AN/APS-15*, developed for and used at Langley Field in summer of 1944 (no published report).
 20. *United States Navy Radar Operator Final Achievement Examinations, Groups I, II, and III (Forms A and B)*, NavPers 16880-85, Bureau of Naval Personnel, Standards and Curriculum Division, November 1944.
 21. *Final Report on Extended Training Experiment*, Headquarters AAF, Victorville, Calif., July 11, 1945, prepared by Service Projects SC-70 and NS-146 in collaboration with personnel of AAF, Victorville, Calif.

Chapter 3

1. *Developments in the Use and Construction of Training Aids for Four-Day Course in 20-mm Gunnery*, Morris S. Viteles, Kinsley R. Smith, and others, OSRD 1320, OEMsr-700, Service Project N-105, Project Memorandum 7, University of Pennsylvania, Mar. 5, 1943. APP-221-M1
2. *An Instrument for Tracking Training*, William E. Kappauf, F. A. Mote, OSRD 1497, OEMsr-815, Brown University, May 4, 1943. APP-611.2-M1
3. *Unit Lesson Plans for Four-Day Course in 40-mm Gunnery*, Morris S. Viteles, Kinsley R. Smith, Bernard J. Covner, R. A. H. Mueller, and Charles F. Johnson, OSRD 1781, OEMsr-700, Service Project N-105, Project Memorandum 8, University of Pennsylvania, Sept. 1, 1943. APP-221-M2
4. *A Study of the Foxboro Trainer as a Training Device for Learning to Track by Means of Pip-Matching*, Irving H. Anderson and others, OSRD 3102, OEMsr-919, Service Projects SC-70 and NS-146, Report 5, Yerkes Laboratories of Primate Biology and U. S. Army Signal Corps, Southern Signal Corps School, Camp Murphy, Fla., Dec. 16, 1943. APP-611.2-M2
5. *Recommendations for the Use of the Foxboro Trainer, (BC-968)*, Irving H. Anderson and others, OSRD 3103, OEMsr-919, Service Projects SC-70 and NS-146, Memorandum 6, Yerkes Laboratories of Primate Biology and U. S. Army Signal Corps, Southern Signal Corps School, Camp Murphy, Fla., Dec. 16, 1943. APP-611.2-M3
6. *Description of the Tufts Tracking Trainer*, Bradford B. Hudson and Lloyd V. Searle, OSRD 3286, OEMsr-581, Service Projects SOS-6, Report 11, Tufts College, Feb. 5, 1944. APP-611.2-M4
7. *A Study of Factors Determining Accuracy of Tracking by Means of Handwheel Control*, OSRD 3451, OEMsr-453, Division 7, NDRC Section D-2, Fire Control, Progress Report to the Services 71, Foxboro Company, Sept. 30, 1942. Div. 7-220.311-M1
8. *A Supplemental Study of Factors Determining Accuracy of Tracking by Means of Handwheel Control*, OSRD 3452, OEMsr-453, NDRC Section D-2, Fire Control, Progress Report to the Services 72, Foxboro Company, Dec. 7, 1942. Div. 7-220.311-M2
9. *A Study of the Tufts Tracking Trainer as a Selection and Training Device for Trackers on the Director M-7*, William C. Biel and Lloyd V. Searle, OSRD 3606, OEMsr-581, Service Project SOS-6, Report 12, Tufts College, Apr. 24, 1944. APP-611.2-M7
10. *Lesson Plans on Selection and Training for Range-finder Officers' Course, Fire Controlmen (O), Rangefinder Operators, Naval Training Schools, Fort Lauderdale, Florida*, D. C. Beier, D. G. Ellson, and Henry A. Imus, OSRD 3961, OEMsr-1171, Service Project N-114, Memorandum 7, University of Wisconsin, July 29, 1944. APP-216-M2
11. *A Check Sight for Observing Gun Pointing with the Computing Sight M-7; Its Reliability and Validity*, Guy E. Brown, William C. Biel and

RESTRICTED

- others, OSRD 4003, OEMsr-581, Service Project SOS-6, Memorandum 6, Tufts College, Aug. 11, 1944. APP-611.11-M1
12. *A Study of the Tracking Proficiency of Student Operators during Training on Aerial Tracking of the Mark 37 Gun Director with Mark 4 Radar*, S. D. S. Spragg, OSRD 4049, OEMsr-1171, Service Project N-114, Report 10, University of Wisconsin, Aug. 22, 1944. APP-611.2-M9
 13. *The Effectiveness of a Check Sight Technique for Training 40-mm Gun Pointers Who Are Using the Computing Sight M-7*, William C. Biel, G. E. Brown, Jr., R. M. Gottsdanker, and R. C. Hall, OSRD 4054, OEMsr-581, Service Project SOS-6, Memorandum 7, Tufts College, Aug. 22, 1944. APP-611.11-M2
 14. *Validation of the Modified Army BC-968-A Radar Trainer as a Training Device for Aerial Tracking of the Mark 37 Gun Director with Mark 4 Radar*, E. B. Knauff, S. D. S. Spragg, and H. A. Taylor, OSRD 4476, OEMsr-1171, Service Project N-114, Report 15, University of Wisconsin, Feb. 8, 1945. APP-624-M2
 15. *Generality of Tracking Training*, Guy E. Brown, Jr., OSRD 4508, OEMsr-581 Service Project SOS-6, Tufts College, Dec. 23, 1944. APP-221.1-M1
 16. *Check Sight Scoring Methods*, Henry P. Birmingham, A. S. Householder, William E. Kappauf, and Franklin V. Taylor, OSRD 4525, OEMsr-815, Service Project N-111, Report 1, Brown University, Jan. 3, 1945. APP-612-M3
 17. *Tracking with the Gun Sight Mark 15, Data on Tracking Accuracy and Learning*, Henry P. Birmingham, Thomas G. Hermans and others, OSRD 4547, OEMsr-815, Service Project N-111, Report 2, Brown University, Jan. 6, 1945. APP-611.2-M11
 18. *The Design, Construction, and Validation of a Mechanical Radar Pip-Matching Trainer for Learning to Track Aerial Targets with Mark 4 Radar in the Gun Director Mark 37*, E. B. Knauff, S. D. S. Spragg, and H. A. Taylor, OSRD 4636A, University of Wisconsin, Feb. 8, 1945.
 19. *A Comparison of Two Non-Timing Methods for Scoring On-Target Tracking on the 40-mm Gun Equipped with the Computing Sight M-7*, John H. Rappalie, OSRD 4647, OEMsr-581, Service Project SOS-6, Memorandum 11, Tufts College, Jan. 29, 1945. APP-611.2-M12
 20. *Design, Construction, and Validation of a Training Instrument for Optical Pointing and Training in the Gun Director Mark 37*, D. G. Ellson, OSRD 4474, OEMsr-1171, Service Project N-114, Report 14, University of Wisconsin, Dec. 18, 1944. APP-611.3-M4
 21. *Drill Manual for Synthetic Antiaircraft Gunnery Trainers*, A. G. Bayroff, John H. Gorsuch, and Morris S. Viteles, OSRD 4813, OEMsr-700, Service Project N-105, Memorandum 21, University of Pennsylvania, Mar. 15, 1945. APP-610-M1
 22. *The Relative Effectiveness of a Checksight Technique Compared with Two Other Methods Used in Training Gun Pointers on the 40-mm Gun Equipped with the Computing Sight M-7*, John H. Rappalie, OSRD 4975, OEMsr-581, Service Project SOS-6, Memorandum 12, Tufts College, Apr. 25, 1945. APP-611.11-M5
 23. *An Evaluation of a Frequently Used Technique for Appraising Tracking on the 40-mm Gun Equipped with the Computing Sight M-7*, John H. Rappalie, OSRD 4976, OEMsr-581, Service Project SOS-6, Memorandum 13, Tufts College, Apr. 23, 1945. APP-611.11-M3
 24. *Evaluation of a Plexiglas Checksight as a Testing and Training Aid with Gun Pointers on a 40-mm Gun Equipped with the Computing Sight M-7*, Guy E. Brown, Jr., OSRD 4977, OEMsr-581, Service Project SOS-6, Memorandum 14, Tufts College, Apr. 23, 1945. APP-611.11-M4
 25. *Retention of On-Target Tracking Skill on the 40-mm Gun Following a Training Experiment*, Guy E. Brown, Jr., OSRD 4978, OEMsr-581, Service Project SOS-6, Memorandum 15, Tufts College, Apr. 24, 1945. APP-611.2-M15
 26. *Supplementary Data on the Validity of a Non-Timing Method for Scoring On-Target Tracking on the 40-mm Gun Equipped with the Computing Sight M-7*, John H. Rappalie, OSRD 5219, OEMsr-581, Service Project SOS-6, Memorandum 17, Tufts College, June 18, 1945. APP-611.2-M18
 27. *A Photographic Determination of the Accuracy of Measures of Optical and Radar Tracking Error in the Gun Director Mark 37 by an Optical Check-Scope Method*, D. C. Beier, D. G. Ellson and H. A. Taylor, OSRD 5223, OEMsr-1171, Service Project N-114, Memorandum 11, University of Wisconsin, June 19, 1945. APP-611.2-M19
 28. *Studies in Aided Tracking*, Progress Report to the Services 102, NDRC Section D-2, Fire Control, Aug. 31, 1945.
 29. *A Camera for Recording Tracking Performance with the Gunsight Mark 14*, A. G. Bayroff, John H. Gorsuch, R. A. H. Mueller, W. E. Organist, and D. D. Wickens, OSRD 6230, OEMsr-700, Service Project N-105, Memorandum 34, University of Pennsylvania, Oct. 30, 1945. APP-611.2-M28
 30. *The Development of a Device to Indicate the Accuracy of On-Target Tracking of Aerial Targets (Final Report)*, J. D. Coakley, OSRD 5737, OEMsr-614, Service Project N-111, Report 6, University of Rochester, Sept. 17, 1945. APP-611.2-M25
 31. *Local Fire Control for Short Range Antiaircraft Weapons—Use of Forward Area Sight for Opening Burst*, Instructor's Manual for Drills, prepared with the cooperation of Service Project N-105, The Armed Guard School, Naval Section Base, Little Creek, Virginia, May 1, 1943.

32. *Lesson Plans for 4-Day Course in 40 mm Gunnery (Second Edition)*, prepared with the cooperation of Service Project N-105, Antiaircraft Gunnery School, USS *Wyoming*, Aug. 1, 1943.
33. *Need for a Checksight on the Mark 15 Gunsight and on All Sights of a Similar Nature*, William E. Kappauf, Service Project N-111, Memorandum 1, Brown University, Jan. 17, 1944. APP-611.1-M1
34. *Revision of OD-3447*, Henry Birmingham and William E. Kappauf, Service Project N-111, Informal Memorandum 3, Brown University, May 3, 1944. APP-611.1-M2
35. *Manual for Instruction on Machine Gun Trainer, Mark 1*, Morris S. Viteles and John H. Gorsuch, OEMsr-700, Service Project N-105, Memorandum 15, University of Pennsylvania, July 25, 1944. APP-613.1-M2
Manual for Instruction on Machine Gun Trainer, Mark 1, Preliminary Edition, (Manual prepared in cooperation with officers of the U. S. Navy), OEMsr-700, Service Project N-105, University of Pennsylvania and United States Fleet, Hdqrs. of the Commander-in-Chief, January 1944. APP-613.1-M1
36. *Preparation of the Manual on Operating Instructions for the Gun Director, Mark 52*, William E. Kappauf, OEMsr-815, Service Project N-111, Informal Memorandum 8, Brown University, May 18, 1945. APP-611.3-M6
Operating Instructions for the Gun Director, Mark 52, Cominch Report P-6, OEMsr-815, Service Project N-111, Ordnance and Gunnery Schools, Navy Yard, U. S. Fleet, Hdqrs., Commander-in-Chief, Washington, D. C. and Brown University, January 1945. APP-611.3-M5
37. *Achievement Examination Questions and Performance Tests for Use in Courses of Instruction in the Operation of the Gun Fire Control Systems Mark 52, Mark 57, and Mark 63*, William E. Kappauf and Clarence H. Graham, OEMsr-815, Service Project N-111, Informal Memorandum 10, Brown University, June 20, 1945. APP-611-M6
38. *A Second Summary of Project Comments on Director Operating Characteristics and Design*, William E. Kappauf, OEMsr-815, Service Project N-111, Informal Memorandum 12, Brown University, July 26, 1945. APP-611.3-M7
39. *Studies of the Reliability of the Scoring System of the Gunnery Trainer Mark 5*, William E. Kappauf, OEMsr-815, Service Project N-111, Informal Memorandum 12, Brown University, Aug. 29, 1945. APP-612-M6
40. *Preparation of the Manual on Operating Instructions for the Use of the Gun Fire Control System, Mark 57 (preliminary edition)*, William E. Kappauf, OEMsr-815, Service Project N-111, Informal Memorandum 13, Brown University, Sept. 4, 1945. APP-611-M7
Operating Instructions for Use of the Gun Fire Control System, Mark 57 (preliminary edition), manual prepared with the assistance of the Ordnance and Gunnery Schools, Navy Yard, Washington, D. C., United States Fleet, Hdqrs. of Commander-in-Chief and Brown University, January 1945. APP-611-M2
41. *Preparation of the Manual on Operating Instructions for the Gun Director Mark 51, Model 3, Controlling Heavy AA Batteries*, William E. Kappauf, Service Project N-111, Informal Memorandum 5, Brown University, Oct. 30, 1944. APP-611.3-M2
Operating Instructions for the Gun Director Mark 51, Model 3, Controlling Heavy AA Batteries, Service Project N-111, Ordnance and Gunnery Schools, Navy Yard, Washington, D. C., U. S. Fleet, Hdqrs. of the Commander-in-Chief, July 30, 1944. APP-611.3-M1
42. *Lesson Plans for a Course of Instruction in the Operation of the Gun Fire Control System, Mark 63 (preliminary edition)*, OEMsr-815, prepared by Service Project N-111 in cooperation with the Antiaircraft Training and Test Center, Dam Neck, Va.; and Ordnance and Gunnery Schools, Navy Yard, Washington, D. C.; and Brown University, Feb. 17, 1945. APP-611-M3
43. *Achievement Examination Questions and Performance Tests for Operators of Navy Fire Control Equipment*, W. J. Brogden, OEMsr-1171, Service Project N-114, Informal Memorandum 5, University of Wisconsin, Apr. 7, 1945. APP-313-M1
44. *Lesson Plans for a Course of Instruction in the Operation of the Gun Fire Control System 57 (preliminary edition)*, OEMsr-815, prepared by Service Project N-111 in cooperation with Antiaircraft Training and Test Center, Dam Neck, Va.; the Ordnance and Gunnery Schools, Navy Yard, Washington, D. C.; and Brown University, Apr. 30, 1945. APP-611-M5
45. *A Mechanical Trainer Simulating Tracking with the Mark 12 Radar Spot Presentation—Description and Learning Curve*, W. J. Brogden, OEMsr-1171, Service Project N-114, Informal Memorandum 4, University of Wisconsin, May 8, 1945. APP-611.2-M16
46. *Preparation of the Manual on Operating Instructions for the Gun Fire Control System, Mark 63 (preliminary edition)*, William E. Kappauf, OEMsr-815, Service Project N-111, Informal Memorandum 14, Brown University, Sept. 4, 1945. APP-611-M8
Operating Instructions for the Gun Fire Control System Mark 63 Cominch Report P-07 (preliminary edition), U. S. Navy Department, Ordnance and Gunnery Schools, Navy Yard, Washington, D. C., March 1945. APP-611-M4
47. *Obtaining Effective Tracking with Automatic*

RESTRICTED

- Weapons*, John H. Rappalie and William C. Biel, Service Project SOS-6, Informal Memorandum to Commandant AAA School, Tufts College, Sept. 6, 1945.
48. *Elementary Theory of Lead-Computing Gun Sights and Directors*, William E. Kappauf, OEMsr-815, Service Project N-111, Informal Memorandum 15, Brown University, Sept. 15, 1945. APP-611.1-M12
49. *The Construction and Operation of a Blind Tracking Demonstrator for the Gun Fire Control Systems Mark 57, Mark 60, and Mark 63*, Franklin V. Taylor, OEMsr-815, Service Project N-111, Informal Memorandum 17, Brown University, Sept. 14, 1945. APP-611.2-M24
50. *Plans and Instructions for Check Sights*, Training Bulletin 44, Hdqrs. Antiaircraft Command, Aug. 29, 1944.

Chapter 4

1. *The Eastman Trainer for Rangefinder Observers*, OSRD 989, OEMsr-56, NDCrc-186, Report to the Services 39, NDRC Division 7, Section D-2, Fire Control, Eastman Kodak Co. and Princeton University, Oct. 17, 1942. Div. 7-220.213-M5
2. *Learning Rate and Training Program for Stereoscopic Rangefinder Observers*, Merrill M. Flood, OSRD 1203, NDCrc-186, Report to the Services 48, NDRC Division 7, Fire Control, Princeton University, Feb. 15, 1943. Div. 7-220.14-M10
3. *Preliminary Suggestions for a Stereoscopic Spotting Trainer*, Lorrin A. Riggs, OSRD 1374, OEMsr-815, Research Project PDRC-759, Project Memorandum 3, Brown University, Apr. 3, 1943. APP-654-M1
4. *A New Motor Attachment for the M-2 or Mark II Stereoscopic Trainer*, William E. Kappauf, OSRD 1392, OEMsr-815, Research Project PDRC-759, Project Memorandum 4, Brown University, Apr. 26, 1943. APP-654-M2
5. *A Model of the Optics of the Stereoscopic Heightfinder*, William E. Kappauf, OSRD 1396, OEMsr-815, Research Project PDRC-759, Project Memorandum 5, Brown University, Apr. 26, 1943. APP-652-M2
6. *Training Manual for Stereoscopic Heightfinder Observers*, William E. Kappauf, B. McMillan and M. S. Swan, OSRD 1544, OEMsr-815, Project Memorandum 7, Brown University, June 15, 1943, Chaps. 1-5. APP-215-M1
7. *Training Manual for Stereoscopic Heightfinder Observers*, William E. Kappauf and M. S. Swan, OSRD 1730, OEMsr-815, Project Memorandum 10, Brown University, Aug. 12, 1943, Chaps. 6-19. APP-215-M1
8. *Height of Image Adjustment on the Stereoscopic Heightfinder*, J. K. Adams, William C. Biel, William E. Kappauf, E. B. Knauff, and M. S. Swan, OSRD 1967, OEMsr-815, Report 5, Brown University, Sept. 15, 1943. APP-652-M5
9. *Training Manual for Stereoscopic Heightfinder Observers*, William C. Biel, W. J. Brogden, C. H. Graham, Henry A. Imus, and William E. Kappauf, OSRD 2008, OEMsr-815, Project Memorandum 11, Brown University, Oct. 26, 1943, Chaps. 20-37. APP-215-M1
10. *The Calibration of Army Heightfinders*, William C. Biel, William E. Kappauf, and E. B. Knauff, OSRD 3375, OEMsr-815, Report 9, Brown University, Mar. 18, 1944. APP-652-M6
11. *Tank Fire Control, Visual Range Estimation, Rangefinders and Rangefinder Fields*, OSRD 3259, Report to the Services 77, NDRC Division 7, Fire Control, Bausch and Lomb Optical Co., February 1944. Div. 7-210.1-M2
12. *The Design, Accuracy, Construction, and Use of a Range Correction Computer*, J. K. Adams, D. G. Ellson, and William E. Kappauf, OSRD 3509, OEMsr-1171, Service Project N-114, Memorandum 2, University of Wisconsin, Mar. 22, 1944. APP-640-M1
13. *The Design, Accuracy, Construction, and Use of a Rangefinder Slide Rule*, J. K. Adams and T. R. Whitney, OSRD 3678, OEMsr-1171, Service Project N-114, Memorandum 3, University of Wisconsin, May 1, 1944. APP-651-M1
14. *Summary of Work on the Selection and Training of Stereoscopic Heightfinder Observers* (Final Report), William C. Biel, W. J. Brogden, C. H. Graham, Henry A. Imus, and William E. Kappauf, OSRD 3773, OEMsr-815, Report 11, Brown University, June 14, 1944. APP-120-M2
15. *The Construction and Calibration of the NDRC Interpupillometer*, D. G. Ellson and Henry A. Imus, OSRD 3797, OEMsr-1171, Service Project N-114, Memorandum 4, University of Wisconsin, June 19, 1944. APP-112.2-M2
16. *The Design, Construction, and Use of a Motor Drive Providing Range Movement and Tracking Errors for the Mark 2 or M-2 Stereoscopic Trainers*, D. G. Ellson and E. B. Knauff, OSRD 3907, OEMsr-1171, Service Project N-114, Memorandum 6, University of Wisconsin, July 17, 1944. APP-651-M2
17. *Lesson Plans on Selection and Training for Rangefinder Officers' Course, Fire Controlmen (O), Rangefinder Operators, Naval Training Schools, Fort Lauderdale, Florida*, D. C. Beier, D. G. Ellson and Henry A. Imus, OSRD 3961, OEMsr-1171, Service Project N-114, Memorandum 7, University of Wisconsin, July 29, 1944. APP-216-M2

RESTRICTED

18. *An Investigation of the Range Estimation Trainer, Device 5C-4, as a Method of Teaching Range Estimation*, Morris S. Viteles, John H. Gorsuch, and others, OSRD 4263, OEMsr-700, Service Project N-105, Memorandum 11, University of Pennsylvania, Oct. 18, 1944. APP-640-M2
19. *Learning Range Estimation on the Firing Line*, Morris S. Viteles, John H. Gorsuch, and others, OSRD 4405, OEMsr-700, Service Project N-105, Memorandum 17, University of Pennsylvania, Oct. 30, 1944. APP-640-M3
20. *Learning Curves for Operators of Stereoscopic Rangefinders*, D. C. Beier, OSRD, 4349, OEMsr-1171, Service Project N-114, Report 12, University of Wisconsin, Nov. 21, 1944. APP-216-M5
21. *Experimental Determination of Variable Errors in Ranging on a Surface Target by Radar Marks 4, 8, and 10*, J. K. Adams, Florence E. Gray, and E. B. Knauft, OSRD 4688, OEMsr-1171, Service Project N-114, Report 17, University of Wisconsin, Feb. 13, 1945. APP-623-M3
22. *Aerial Target Range Estimation*, M. W. Horowitz and William E. Kappauf, OSRD 5301, OEMsr-700, Service Project N-105, Report 4, Brown University, July 3, 1945. APP-640-M4
23. *Summary of Research on the Selection and Training of Rangefinder and Radar Operators* (Final Report), W. J. Brogden, OSRD 5358, OEMsr-1171, Service Project N-114, University of Wisconsin, July 23, 1945. APP-110-M1
24. *Evaluation of Methods of Training in Estimating a Fixed Opening Range*, M. H. Rogers, S. J. Spool, Morris S. Viteles, Harold A. Voss, and D. D. Wickens, OSRD 5765, OEMsr-700, Service Project N-105, Memorandum 23, University of Pennsylvania, Sept. 19, 1945. APP-640-M5
25. *Manual for Instruction on Mirror Range Estimation Trainer Device 5C-4, Equipped with Mark 14 Sight Reticle*, D. D. Wickens, John H. Gorsuch, and Morris S. Viteles, OSRD 5925, OEMsr-700, Service Project N-105, Memorandum 24, University of Pennsylvania, Sept. 19, 1945. APP-640-M6
26. *A Comparison of Free and Stadiametric Estimation of Opening Range*, Harold A. Voss and D. D. Wickens, OSRD 6114, OEMsr-700, Service Project N-105, Memorandum 29, University of Pennsylvania, Oct. 16, 1945. APP-640-M7
27. *Validation and Standardization of Tests Used in the Selection of Stereoscopic Rangefinder Operators*, NDRC Progress Report 15, Fire Control Research, Princeton University, July 13, 1942.
28. *Polaroid Spotting Trainer*, William E. Kappauf, OEMsr-815, Service Project N-111, Informal Memorandum 4, Brown University, June 5, 1944. APP-611.4-M1
29. *Achievement Examination Questions and Performance Tests for Operators of Navy Fire Control Equipment*, W. J. Brogden, OEMsr-1171, Service Project N-114, Informal Memorandum 5, University of Wisconsin, Apr. 7, 1945. APP-313-M1
30. *Analysis of Range Estimation Data*, Memorandum 20, Princeton Branch, Fire Control Design Division, Frankford Arsenal, September 1943.
31. *Errors in Visual Estimation of Range between 800 and 5000 Yards and the Learning Curve with Practice and Training*, AORG Report 140, Sept. 8, 1943.
32. *Antiaircraft Artillery Field Manual—Service of Heightfinders M-1 and M-2*, Field Manual 4-142, War Department, Oct. 20, 1943.
33. *Heightfinders, 13½ feet, M-1, and M-1-A1*, Technical Manual 9-623, War Department, Nov. 5, 1943.
34. *Heightfinders, 13½ feet, M-2 and M-2-A1*, Technical Manual 9-624, War Department, Nov. 27, 1943.
35. *Accuracy of Visual Estimation of Initial Range and Lead by Antitank Personnel*, AORG Report 225, September 1944.
36. *Visual Range Estimation, Direct and Differential*, Memorandum 34, Princeton Branch, Fire Control Design Division, Frankford Arsenal.
37. *Range Finding by Subtense Methods*, TAR Report 8, April 1944.
38. *Stereoscopic Range and Heightfinding*, Technical Manual 44-250, War Department, June 15, 1944.
39. *Instruction in Range Estimation on the Firing Line*, U. S. Atlantic Fleet, Fleet Operational Training Command, AA Training and Test Center, Dam Neck, Va., April 1945.

Chapter 5

1. *Comparison of On-Target Method and the Standard Hand-Scale Method of Scoring B-29 Sight-Camera Film*, Robert R. Sears, E. B. Knauft, Ruth Phillips, and Donald M. Purdy, OSRD 5222, OEMsr-1171, Service Project AC-94, Report 3, University of Wisconsin, June 19, 1945. APP-612-M4
2. *Psychological Factors in the Operation of Flexible Gunnery Equipment*, Service Project AC-94, Monthly Progress Report 12, University of Wisconsin, July 17, 1945 to August 15, 1945.
3. *Levels of Efficiency of B-29 Gunners as Measured by OT Scores*, W. J. Brogden, Service Project AC-94, Informal Memorandum 13, University of Wisconsin, Oct. 1, 1945.
4. *Knowledge of Results as It Affects Framing Accuracy in a Modified E-14 Trainer with the B-29*

RESTRICTED

Pedestal Sight, Charles S. Bridgman, J. E. P. Libby, and R. L. Solomon, OSRD 6050, OEMsr-

1171, Service Project AC-94, Report 8, University of Wisconsin, Oct. 5, 1945. APP-610-M5

Chapter 6

1. *General Recommendations Concerning Lookouts*, Carl H. Wedell, OEMsr-1136, Service Project N-115, Informal Memorandum 1, Princeton University, Sept. 15, 1944. APP-150-M2
2. *A Study of the Performance of Night Lookouts Aboard Ship*, William C. H. Prentice, OSRD 4087, OEMsr-1136, Service Project N-115, Report 2, Princeton University, Oct. 15, 1944. APP-150-M3
3. *A Night Lookout Trainer for Use Aboard Ship*, L. H. Lanier, OSRD 4323, OEMsr-1136, Service Project N-115, Report 3, Princeton University, Nov. 8, 1944. APP-150-M4
4. *The Best Way to Use Your Eyes at Night*, Science Service, Washington, D. C., August 1942.
5. *Recognition Journal*, No. 10, June 1944, pp. 26-27.
6. *Lookout: A Manual for Lookout Officers and Supervisors*, NavPers 16198, U. S. Navy, BuPers.
7. *Lookout Manual*, NavPers 170069, U. S. Navy, BuPers.

Chapter 7

1. *An Outline of a Four Day 20-mm Course of Instruction*, Morris S. Viteles, Kinsley R. Smith, John H. Gorsuch, F. K. Berrien, and W. J. Thompson, OSRD 1208, University of Pennsylvania, Jan. 15, 1943.
2. *Job Analysis Procedure*, Morris S. Viteles and Kinsley R. Smith, OSRD 1209, OEMsr-700, Service Project N-105, Project Memorandum 2, University of Pennsylvania, Jan. 15, 1943. APP-510-M1
3. *Developments in the Use and Construction of Training Aids for Four-Day Course in 20-mm Gunnery*, Morris S. Viteles, Kinsley R. Smith, John H. Gorsuch, F. K. Berrien, and W. J. Thompson, OSRD 1320, OEMsr-700, Service Project N-105, Project Memorandum 7, University of Pennsylvania, Mar. 5, 1943. APP-221-M1
4. *Unit Lesson Plans for Four-Day Course in 20-mm Gunnery* (accompanying manual), Morris S. Viteles, Kinsley R. Smith, John H. Gorsuch, F. K. Berrien, and W. J. Thompson, OSRD 1371, University of Pennsylvania, May 1, 1943.
5. *The 40-mm Gun: Training and Indoctrination of Crew* (accompanying manual), Morris S. Viteles, Kinsley R. Smith, Bernard J. Covner, R. A. H. Mueller, and Charles F. Johnson, OSRD 1591, OEMsr-700, Service Project N-105, Project Memorandum 9, University of Pennsylvania, July 1, 1943. APP-211-M1
6. *Unit Lesson Plans for Four-Day Course in 40-mm Gunnery* (accompanying manual), Morris S. Viteles, Kinsley R. Smith, Bernard J. Covner, R. A. H. Mueller, and Charles F. Johnson, OSRD 1781, OEMsr-700, Service Project N-105, Project Memorandum 8, University of Pennsylvania, Sept. 1, 1943. APP-221-M2
7. *Supplemental Lesson Plans for Course in 40-mm Gunnery* (accompanying manual), Morris S. Viteles, Kinsley R. Smith, Bernard J. Covner, R. A. H. Mueller, and Charles F. Johnson, OSRD 3088, University of Pennsylvania, Jan. 10, 1944.
8. *Detailed Fireroom Operating Procedures for Destroyer Escort Vessels, Turbo-Electric and Turbo-Geared Types* (accompanying manual), Bernard J. Covner, John H. Gorsuch and Morris S. Viteles, OSRD 3444, OEMsr-700, Service Project NR-106, Memorandum 1, University of Pennsylvania, Mar. 15, 1944. APP-217.2-M2
9. *Operation of Destroyer and Destroyer Escort Distilling Plants* (accompanying manual), Bernard J. Covner, W. E. Organist, A. G. Bayroff, John H. Gorsuch, and Morris S. Viteles, OSRD 3613, OEMsr-700, Service Project NR-106, Memorandum 2, University of Pennsylvania, May 15, 1944. APP-217.1-M2
10. Manuals entitled: (a) *The 20-mm Oerlikon Gun: Selection and Training of Crew—Instructor's Handbook* (revised edition), (b) *The 4"/50 Caliber Gun: Selection and Training of Crew—Instructor's Handbook* (first edition), (c) *The 5"/38 Caliber Dual Purpose Single Enclosed and Twin Mounts and Upper Handling Rooms: Selection and Training of Crew—Instructor's Handbook* (first edition), with accompanying manuals, Morris S. Viteles and John H. Gorsuch, Service Project N-105, Memorandum 12, University of Pennsylvania, June 1, 1944.
11. *How to Teach Gunnery, A Short Course in Effective Teaching Methods for Gunnery Instructors* (accompanying manuals), Kinsley R. Smith, S. M. Wesley, W. G. Willis, John H. Gorsuch, and Morris S. Viteles, OSRD 3876, OEMsr-700, Service Projects N-105 and NR-106, Memorandum 13, University of Pennsylvania, July 11, 1944. APP-221-M3
12. *Lesson Plans for 3"/50 Gunnery Instruction Destroyer Escort and Patrol Frigate Crews* (accompanying manual), Bernard J. Covner, S. M. Wesley, John H. Gorsuch, and Morris S. Viteles, OSRD 3908, University of Pennsylvania, July 18, 1944.
13. *Lesson Plans for Caliber .50 Machine Gun*, O. Backstrom, Jr., John H. Gorsuch, and Morris S. Viteles, OSRD 3909, OEMsr-700, Service Project

RESTRICTED

- N-105, Memorandum 14, University of Pennsylvania, July 19, 1944. APP-221-M4
14. *Manual for Instruction on Machine Gun Trainer Mark I* (accompanying manual), Morris S. Viteles and John H. Gorsuch, Service Project N-105, Memorandum 15, University of Pennsylvania, July 25, 1944. APP-613.1-M2
 15. *Pictorial Manual: Operation of the 40-mm Heavy Machine Gun* (accompanying manual), Morris S. Viteles and John H. Gorsuch, Service Project N-105, Memorandum 16, University of Pennsylvania, Aug. 1, 1944.
 16. *Activities of NDRC Project N-112 (Final Report)*, Morris S. Viteles and John H. Gorsuch, OEMsr-700, Memorandum 1, University of Pennsylvania, Sept. 21, 1944. APP-221.2-M1
 17. *How to Teach Engineering, A Short Course in Effective Teaching Methods for Engineering Instructors* (accompanying manuals), Morris S. Viteles and John H. Gorsuch, Service Project NR-106, Memorandum 4, University of Pennsylvania, Oct. 9, 1944.
 18. *An Investigation of the Range Estimation Trainer Device 5C-4 as a Method of Teaching Range Estimation*, Morris S. Viteles, John H. Gorsuch, and others, OSRD 4263, OEMsr-700, Service Project N-105, Memorandum 11, University of Pennsylvania, Oct. 18, 1944. APP-640-M2
 19. *The Use of Ship Models in Classroom Instruction*, Morris S. Viteles and John H. Gorsuch, Service Project NR-106, Memorandum 5, University of Pennsylvania, Nov. 1, 1944.
 20. *Lesson Plan Outlines for Progressive Engineering, Stage I* (accompanying manual), Morris S. Viteles and John H. Gorsuch, Service Project NR-106, Memorandum 6, University of Pennsylvania, Nov. 18, 1944.
 21. *Lesson Plans for Course in Practical Surface Gunnery* (accompanying manual), Morris S. Viteles and John H. Gorsuch, Service Project N-105, Memorandum 18, University of Pennsylvania, Nov. 18, 1944.
 22. *Lesson Plan Outlines for Stage II of the Progressive Engineering Course, Combatant Ships, "A," "B," "M" Divisions* (accompanying manuals), Morris S. Viteles and John H. Gorsuch, Service Project NR-106, Memorandum 7, University of Pennsylvania, Jan. 27, 1945.
 23. *Psychological Principles in the Design and Operation of Synthetic Trainers with Particular Reference to Antiaircraft Gunnery*, Morris S. Viteles and John H. Gorsuch, Service Project N-105, Memorandum 19, University of Pennsylvania, Feb. 1, 1945.
 24. *Curriculum for APA Gun Crew Training* (preliminary edition), with accompanying manual, Morris S. Viteles and John H. Gorsuch, Service Project N-105, Memorandum 20, University of Pennsylvania, Feb. 23, 1945.
 25. *Drill Manual for Synthetic Antiaircraft Gunnery Trainers* (accompanying manual), A. G. Bayroff, John H. Gorsuch, and Morris S. Viteles, OSRD 4813, OEMsr-700, Service Project N-105, Memorandum 21, University of Pennsylvania, Mar. 15, 1945. APP-610-M1
 26. *Report on Precommissioning Engineering Training Questionnaire*, Morris S. Viteles and John H. Gorsuch, Service Project NR-106, Memorandum 8, University of Pennsylvania, Mar. 20, 1945.
 27. *Memorandum on Training Manual for the Welin Gravity Davits*, first edition (accompanying manual), S. M. Wesley, John H. Gorsuch, and Morris S. Viteles, OSRD 4973, University of Pennsylvania, Apr. 23, 1945.
 28. *Suggestions for Routine General Quarters Drills on APA and AKA Type Ships*, Morris S. Viteles and John H. Gorsuch, Service Project NR-106, Memorandum 10, University of Pennsylvania, May 14, 1945.
 29. *Memorandum on Instructor's Manual for Stage II Auxiliary Ships ABM Divisions Combined* (accompanying manual), W. E. Organist, Jr., W. G. Willis, John H. Gorsuch, and Morris S. Viteles, OSRD 5121, University of Pennsylvania, May 26, 1945.
 30. *Memorandum on APA Engineering Course Curriculum—Units for Balance of Crew Training*, first edition (accompanying manual), Bernard J. Covner, John H. Gorsuch, and Morris S. Viteles, OSRD 5090, University of Pennsylvania, June 9, 1945.
 31. *Report on Questionnaire Survey of Precommissioning Engineering Training Program*, Morris S. Viteles and John H. Gorsuch, Service Project NR-106, Memorandum 15, June 30, 1945.
 32. *Memorandum on Operational Drill Charts for Soloshell Evaporator, Destroyer Escorts and APDs, DE Converted (Steam Driven) and Instructor's Manual*, P. H. Masoner, L. R. Watters, John H. Gorsuch, and Morris S. Viteles, OSRD 5324, University of Pennsylvania, July 10, 1945.
 33. *Suggestions for Three Series of Target Films for Gunnery Trainer, Mark 3*, Morris S. Viteles and John H. Gorsuch, OEMsr-700, Service Project N-105, Informal Memorandum 22, University of Pennsylvania, July 19, 1945. APP-610-M2
 34. *Multi-Answer Disc, Basic Damage Control Guide for CVE's, 105 Class*, Morris S. Viteles and John H. Gorsuch, Service Project NR-106, Memorandum 16, July 24, 1945.
 35. *Memorandum on Summary of Project NR-106 Activity at Precommissioning Engineering Training Center, Treasure Island, California*, Morris S. Viteles, John H. Gorsuch, and L. R. Watters, OSRD 5453, University of Pennsylvania, Aug. 20, 1945.
 36. *Progressive Engineering Instruction, Stage III*,

RESTRICTED

- Operational Training Building, Organization of Instruction, Instructor's Manual "A" Division, "B" Division, "M" Division, and "E" Division* (accompanying manuals), W. E. Organist and W. G. Willis, OSRD 5459, OEMsr-700, Service Project NR-106, Memorandum 18, University of Pennsylvania, Aug. 20, 1945. APP-214-M2
37. *Progressive Engineering Instruction, Stage III, Operational Training Building, General Quarters Drills* (accompanying manual), W. E. Organist, OSRD 5505, OEMsr-700, Service Project NR-106, Memorandum 21, University of Pennsylvania, Aug. 28, 1945. APP-214-M3
38. *Summary of Project NR-106 Activity at CVE Precommissioning School, Puget Sound Navy Yard, Bremerton, Washington* (Memorandum), Bernard J. Covner and Morris S. Viteles, OSRD 5508, University of Pennsylvania, Aug. 29, 1945.
39. *Special Engineering Training Programs, Instructor's Manual* (Memorandum), P. H. Masoner and L. R. Watters, OSRD 5535, University of Pennsylvania, Aug. 31, 1945.
40. *Evaluation of Methods of Training in Estimating a Fixed Opening Range*, M. H. Rogers, S. J. Sprol, Morris S. Viteles, Harold A. Voss, and D. D. Wickens, OSRD 5765, OEMsr-700, Service Project N-105, Memorandum 23, University of Pennsylvania, Sept. 19, 1945. APP-640-M5
41. *An Investigation of the Scoring Characteristics of the Machine Gun Trainer, Mark 1*, Morris S. Viteles and John H. Gorsuch, OEMsr-700, Service Project N-105, Memorandum 25, University of Pennsylvania, Sept. 20, 1945. APP-612-M7
42. *Manual for Instruction on Mirror Range Estimation Trainer Device 5C-4, Equipped with Mark 14, Sight Reticle*, D. D. Wickens, John H. Gorsuch, and Morris S. Viteles, OSRD 5925, OEMsr-700, Service Project N-105, Memorandum 24, University of Pennsylvania, Sept. 25, 1945. APP-640-M6
43. *Summary of Project N-105 Activity at Gunnery Section, Large Ship Precommissioning Training Center, Naval Training Station, Newport, Rhode Island* (Memorandum), A. G. Bayroff, John H. Gorsuch, R. A. H. Mueller, W. E. Organist, and Morris S. Viteles, OSRD 6049, University of Pennsylvania, Oct. 3, 1945.
44. *Lesson Plans for Bureau of Ordnance Gunnery Trainer Mark 7*, Morris S. Viteles and John H. Gorsuch, Service Project N-105, Memorandum 27, University of Pennsylvania, Oct. 15, 1945.
45. *Micromotion Analysis of the Service of the 3"/50 Gun*, David B. Porter and S. M. Wesley, OSRD 6176, OEMsr-700, Service Project NR-106, Memorandum 30, University of Pennsylvania, Oct. 19, 1945. APP-610-M7
46. *History and Final Report of Project NR-106 of the Applied Psychology Panel*, M. H. Rogers, Morris S. Viteles, and Harold A. Voss, OSRD 6177, OEMsr-700, Service Project NR-106, Memorandum 25, University of Pennsylvania, Oct. 22, 1945. APP-200-M1
47. *Drill Manuals for Bureau of Ordnance Gunnery Trainers, Mark 3, Model 2, Mark 3, Model 3* (accompanying manuals), A. G. Bayroff and R. A. H. Mueller, OSRD 6209, University of Pennsylvania, Oct. 24, 1945.
48. *The Operation of the 5"/38 Twin Mount*, Morris S. Viteles and John H. Gorsuch, OEMsr-700, Service Project N-105, Memorandum 32, University of Pennsylvania, Oct. 29, 1945. APP-610-M9
49. *The Operation and Use of the Bureau of Ordnance Gunnery Trainer Mark 3, Model 2*, A. G. Bayroff and others, OSRD 6229, University of Pennsylvania, Oct. 30, 1945.
50. *Drill Manual for Bureau of Ordnance Gunnery Trainer Mark 3, Mod. 5 and Mod. 6 (Incomplete)*, Morris S. Viteles and John H. Gorsuch, Service Project N-105, Memorandum 35, University of Pennsylvania, Oct. 30, 1945.
51. *History and Final Report of Project N-105 of the Applied Psychology Panel (Final Report)*, Morris S. Viteles, John H. Gorsuch, and D. D. Wickens, OSRD 6266, OEMsr-700, Service Project N-105, Memorandum 36, University of Pennsylvania, Oct. 31, 1945. APP-200-M2

Chapter 8

1. *Instruction in Operation of Electric Winch Trainer* (preliminary edition), OEMsr-1372, Service Project N-116b, University of Southern California, December 1944. APP-680-M1
2. *Validation of Miniature Electric Winch as a Training Device*, Floyd L. Ruch, OEMsr-1372, Service Project N-116b, Informal Memorandum 3, University of Southern California, Feb. 5, 1945. APP-680-M2
3. *Evaluation of a Subjective and an Objective Technique of Rating Winch Operating Ability*, Floyd L. Ruch, OEMsr-1372, Service Project N-116b, Informal Memorandum 4, University of Southern California, Feb. 28, 1945. APP-680-M3
4. *Summary of Work on the Selection and Training of Cargo Handling Teams for Combat Laden Vessels* (Final Report), Floyd L. Ruch, OSRD 5140, OEMsr-1372, Service Project N-116b, University of Southern California, May 29, 1945. APP-922-M1

RESTRICTED

Chapter 9

1. *Manual of Classification Procedure for Amphibious Training Bases* (accompanying manual), Kinsley R. Smith and Harold A. Voss, OEMsr-1298, Service Project N-117, Memorandum 1, Pennsylvania State College, Oct. 10, 1944. APP-512-M1
2. *The Achievement Testing Program in the U. S. Naval Amphibious Training Bases* (accompanying manual), Kinsley R. Smith and Harold A. Voss, OEMsr-1298, Service Project N-117, Memorandum 2, Pennsylvania State College, Oct. 19, 1944. APP-512-M2
3. *Training Manual of the United States Atlantic Fleet, Amphibious Training Command* (accompanying manual), Kinsley R. Smith and Harold A. Voss, OEMsr-1298, Service Project N-117, Memorandum 3, Pennsylvania State College, Jan. 2, 1945. APP-512-M3
4. *Analysis of Responses of Amphibious Force Personnel to the Questionnaire for Personnel Returning from Combat Zones*, Kinsley R. Smith and Harold A. Voss, OEMsr-1298, Service Project N-117, Memorandum 5, Pennsylvania State College, Mar. 15, 1945. APP-512-M4
5. *Lesson Plans for a Course in Gas Defense, Lesson Plans for a Course in Piloting for Attack Boat Crews* (accompanying manuals), Kinsley R. Smith and Harold A. Voss, Service Project N-117, Informal Memorandum 7, Pennsylvania State College, Apr. 15, 1945.
6. *Analysis of Amphibious Enlisted Billets, Series 1, Landing Ship, Tank; Series 2, Landing Ship, Medium; Series 3, Landing Craft, Infantry; Series 4, Attack Boats* (accompanying manuals), Kinsley R. Smith and Harold A. Voss, Service Project N-117, Informal Memorandum 8, Pennsylvania State College, Apr. 20, 1945.
7. *A Course in Personality Analysis for Specialists (C), Special Case Technicians* (accompanying manual), Kinsley R. Smith and Harold A. Voss, OEMsr-1298, Service Project N-117, Informal Memorandum 9, Pennsylvania State College, Apr. 21, 1945. APP-512-M6
8. *The Effectiveness of Classification Data in Predicting Billet Performance in Training in the Amphibious Force*, Kinsley R. Smith, Harold A. Voss and others, OSRD 5198, OEMsr-1298, Service Project N-117, Report 1, Pennsylvania State College, June 12, 1945. APP-512-M7
9. *Summary of Work in Job Analysis, Qualification, and Placement of Personnel in the Amphibious Force* (Final Report), Kinsley R. Smith, OSRD 5422, OEMsr-1298, Service Project N-117, Final Report 2, Pennsylvania State College, Aug. 8, 1945. APP-512-M8
10. *Development of Achievement Tests for the Landing Craft School, Coronado, California*, Norman Frederiksen, OSRD 5670, OEMsr-705, Service Project N-106, Report 21, College Entrance Examination Board, Princeton, N. J., Sept. 14, 1945. APP-314-M1

Chapter 10

1. *Seminar on Telephone Talking and Composition of a Manual for the Use of Sound-Powered Phones*, John C. Snidecor, OEMsr-830, Service Project N-109, Memorandum 1, The Psychological Corp., Sept. 28, 1943. APP-218.3-M1
2. *Methods of Training Telephone Talkers for Increased Intelligibility*, John C. Snidecor, Louis A. Mallory, and Edward L. Hearsey, OSRD 3178, OEMsr-830, Service Projects N-109(1) and SC-67, Report 4, The Psychological Corp., Jan. 28, 1944. APP-218.2-M1
3. *Information Regarding an Analysis of Recordings Made from the Telephone Circuits on Board a Battleship and a Destroyer*, OSRD 3312, OEMsr-830, Service Projects N-109(1) and SC-67, Memorandum 3, The Psychological Corp., February 1944. APP-218.3-M2
4. *Information Concerning Selection and Training of Telephone Talkers*, Louis A. Mallory, Service Project N-109, Informal Communication 2, The Psychological Corp., Apr. 26, 1944.
5. *Critique of Course for Telephone Talkers as Outlined in Supplement to Fleet Telephone Talkers' Manual, I* (Informal Communication), Louis A. Mallory, Service Project N-109, The Psychological Corp., May 8, 1944.
6. *Supplement to Fleet Telephone Talkers' Manual, I, A Guide for the Training of Instructors with Methods of Instruction for Telephone Talkers*, OSRD 3671, The Psychological Corp., June 1944.
7. *Experimental Investigation of a Course for Telephone Talkers*, George W. Hibbitt and Louis A. Mallory, OSRD 3863, OEMsr-830, Service Projects N-109(1) and SC-67, Report 9, The Psychological Corp., July 4, 1944. APP-218.3-M3
8. *The Status of Project N-109* (Informal Communication), George K. Bennett, Service Project N-109, The Psychological Corp., Sept. 16, 1944. APP-218.3-M4
9. *A Project for Standardizing Submarine Phraseology and Developing a Training Program in Submarine Voice Communications*, M. H. Abrams, William D. Neff, and others, OSRD 4795, OEMsr-653, OEMsr-830, and OEMsr-1128, Service Projects

RESTRICTED

- N-118 and N-109, Div. 6 Report P57/1421, Harvard PAL, CUDWR, and The Psychological Corp., Feb. 28, 1945. APP-218.4-M4
10. *Summary of Work on the Selection and Training of Telephone Talkers* (Final Report), Louis A. Mallory and William J. Temple, OSRD 5497, OEMsr-830, Service Project N-109(1), Report 19, The Psychological Corp., Aug. 27, 1945. APP-218.1-M2
 11. *Telephone Talkers' Manual*, NavPers 14005, U. S. Fleet, COMINCH, Nov. 19, 1943.
 12. *A Guide for Shipboard Telephone Talker Instruction*, NavPers 16148, Bureau of Naval Personnel, September 1944.
 13. *Submarine Telephone Talkers' Manual*, NavPers 16171, Bureau of Naval Personnel, December 1944.
 14. *Supplement to Fleet Telephone Talkers' Manual I: A Guide for the Training of Instructors with Courses of Instruction*, NavPers 16115, Bureau of Naval Personnel, March 1945.
 15. *Standard Submarine Phraseology*, Commander Submarines, Atlantic Fleet (undated).
 16. *Instructors Handbook for Basic Course in Submarine Voice Communications*, Commander Submarines, Atlantic Fleet (undated).

Chapter 11

1. *Modified Airplane Noise Generator*, OEMsr-830, Service Project SC-67, Informal Communication 1, The Psychological Corp., Jan. 24, 1944. APP-630-M1
 2. *Students' Manual for a Basic (Pilot) Course in Communication*, OSRD 3575, The Psychological Corp., March 1944.
 3. *Instructors' Syllabus for a Basic (Pilot) Course in Communication*, OSRD 3576, The Psychological Corp., March 1944.
 4. *Manuals for Instruction in Voice Communication for Aerial Gunnery*, OSRD 3655, The Psychological Corp., May 1944.
 5. *Intelligibility Measurement: Techniques and Procedures Used by the Voice Communication Laboratory*, C. Hess Haagen, OSRD 3748, OEMsr-830, Service Projects N-109(1) and SC-67, Report 7, The Psychological Corp., May 1944. APP-218.2-M4
 6. *Instructor's Syllabus for a Radio Operators-Mechanic Course in Voice Communication*, OSRD 3750, The Psychological Corp., May 1944.
 7. *Installation and Operation of Equipment Used in a Basic Voice Communication Course*, OSRD 3749, OEMsr-830, Service Projects N-109(1) and SC-67, Memorandum 8, The Psychological Corp., June 7, 1944. APP-218.4-M1
 8. *Relative Listening and Speaking Abilities among Student Pilots*, Service Project SC-67, Informal Communication 7, The Psychological Corp., June 7, 1944.
 9. *Training Studies in Voice Communication; Part I, Can Intelligibility of Voice Communication Be Increased by Training in Voice Technique?* James F. Curtis, I. P. Brackett, and others, OSRD 3862, OEMsr-830, Service Projects N-109(1) and SC-67, Report 8, The Psychological Corp., July 5, 1944. APP-218.2-M5
 10. *Training Studies in Voice Communication; Part II, The Use of Noise in a Training Program*, James F. Curtis, OSRD 4261, OEMsr-830, Service Project SC-67, Report 12, The Psychological Corp., Oct. 18, 1944. APP-218.2-M6
 11. *Instructor's Syllabi for Courses in Interphone Communication for Navigators and Bombardiers*, Henry M. Moser, I. P. Brackett, G. Paul Moore, and John W. Black, OSRD 4262, The Psychological Corp., Oct. 18, 1944.
 12. *Instructors' Handbook for Course in Voice Communication for Pilot Instructors (4 Hours)*, Service Project SC-67, The Psychological Corp., January 1945.
 13. *Indoctrination in Voice Communication for Instructors in Primary Flying Schools*, January 1945.
 14. *Instructors' Handbook for a Course in Voice Communication for Control Tower Operators (8 Hours)*, Service Project SC-67, The Psychological Corp., January 1945.
 15. *Indoctrination for Voice Communication at Altitude*, Harry M. Mason, OSRD 5307, The Psychological Corp., July 4, 1945.
 16. *Voice Communication Courses: Volume I. Handbook for Instructors*, Foster C. Shoup, I. P. Brackett, Henry M. Moser, Gayland L. Draeger, C. Hess Haagen, and Donald P. Veith, Memorandum 13; *Volume II. Course Outlines and Drills for Individual Training*, I. P. Brackett, Gayland L. Draeger, Henry M. Moser, Foster C. Shoup, and Wilmer S. Stevens, Memorandum 14; *Volume III. Course Outlines and Drills for Crew Training*, Gayland L. Draeger, Henry M. Moser, Foster C. Shoup, I. P. Brackett, and G. Paul Moore, Memorandum 15; OEMsr-830, Service Project SC-67, The Psychological Corp., July 1945. APP-218.1-M1
- Voice Communication Courses: Appendix I. Voice Communication for Night Fighter Operation*, Gayland L. Draeger and Foster C. Shoup, OEMsr-830, Service Project SC-67, Memorandum 16, The Psychological Corp., July 1945. APP-218.4-M5
- Voice Communication Courses: Appendix II.*

- Courses for Far East Air Forces*, Henry M. Moser and G. Paul Moore. OEMsr-830, Service Project SC-67, The Psychological Corp., July 1945. APP-218.4-M6
17. *Interphone Crew Trainer: Installation and Operation*, G. Paul Moore and E. J. O'Brien, OSRD 5363, OEMsr-830, Service Project SC-67, Memorandum 10, The Psychological Corp., Aug. 4, 1945. APP-670-M1
 18. *Intelligibility Measurement in Twelve-Word Tests*, C. Hess Haagen, OSRD 5414, OEMsr-830, Service Project SC-67, Report 17, The Psychological Corp., Aug. 4, 1945. APP-218.2-M10
 19. *Intelligibility Measurement of Twenty-Four Word Multiple-Choice Tests*, C. Hess Haagen, OSRD 5567, OEMsr-830, Service Project SC-67, Report 20, The Psychological Corp., Sept. 11, 1945. APP-218.2-M12
 20. *Summary of Work on Voice Communication* (Final Report), John W. Black, OSRD 5568, OEMsr-830, Service Project SC-67, Report 21, The Psychological Corp., Sept. 11, 1945. APP-218.1-M3
 21. *Facts about Voice Communication*, OEMsr-830, Service Project SC-67, The Psychological Corp. (undated). APP-218.1-M4
 22. *Students' Manual for a Basic Course in Interphone Communication in Flexible Gunnery Schools*, written by representatives of AAF Psychological Research Unit 11 (Gunnery) and Service Project SC-67, The Psychological Corp. (undated).
 23. *Student's Workbook, Radio Communications, Basic*, AAF Training Command (undated).
 24. *Instructor's Handbook: Basic Radio Communications* (third edition), AAF Training Command, Ground Training Technical Advisory Unit, AAF Central Instructor's School, Randolph Field, Texas, Sept. 1, 1944.
 25. *Commanders' Handbook for Interphone Training*, prepared by Service Project SC-67. (No facts of publication given.)

Chapter 12

1. *Radio Code School Practices*, Albert K. Kurtz, Harold G. Seashore, John M. Willits, and Stephen E. Stuntz, OSRD 1315, OEMsr-830, Service Project N-107, Memorandum 1, The Psychological Corp. Mar. 29, 1943. APP-212.42-M1
2. *The Code Receiving Tests* (accompanying manual), Albert K. Kurtz and Harold G. Seashore, OSRD 3157, OEMsr-830, Service Project N-107, Memorandum 2, The Psychological Corp., Feb. 2, 1944. APP-317-M4
3. *The Standardization of Code Speeds*, Albert K. Kurtz, Harold G. Seashore, Stephen E. Stuntz, and John M. Willits, OSRD 3490, OEMsr-830, Service Project N-107, Report 2, The Psychological Corp., May 1944. APP-212.41-M1
4. *The Effect of Early Introduction of Sending Code upon Learning to Receive*, Harold G. Seashore, Stephen E. Stuntz, and Howard R. White, OSRD 3445, OEMsr-830, Service Project N-107, Report 3, The Psychological Corp., June 7, 1944. APP-212.2-M1
5. *Training Radio Operators to Copy Code through Interference*, Harold G. Seashore and Stephen Stuntz, OSRD 3747, OEMsr-830, Service Project N-107, Report 4, The Psychological Corp., June 7, 1944. APP-212.42-M2
6. *A Comparative Study of Three Methods of Teaching Code in the Early Weeks of the Course*, Harold G. Seashore, Howard R. White, Albert K. Kurtz, Stephen E. Stuntz, and Cyril Rappaport, OSRD 3817, OEMsr-830, Service Project N-107, Report 6, The Psychological Corp., June 24, 1944. APP-212.4-M1
7. *Analysis of Errors in Copying Code*, Harold G. Seashore and Albert K. Kurtz, OSRD 4010, OEMsr-830, Service Project N-107, The Psychological Corp., Aug. 12, 1944. APP-212.21-M1
8. *Variation of Activities in Code Classes, An Experimental Study of the Problem of Monotony in Code Learning*, Harold G. Seashore, Albert K. Kurtz, Howard Kendler, Stephen E. Stuntz, and Cyril Rappaport, OSRD 4082, OEMsr-830, Service Project N-107, Report 3, The Psychological Corp., Aug. 31, 1944. APP-212.42-M3
9. *Variety in Code Learning, A Manual of Activities Designed to Increase Interest and Reduce Monotony in Code Schools*, Harold G. Seashore and Stephen E. Stuntz, OSRD 4083, OEMsr-830, Service Project N-107, Memorandum 3, The Psychological Corp., Aug. 31, 1944. APP-212.1-M2
10. *Graduation and Rating Test for Class A Radio Schools*, Albert K. Kurtz and Harold G. Seashore, Service Project N-107, Memorandum 5, The Psychological Corp., Aug. 21, 1944. APP-317-M5
11. *The Radio Code Research Project, Final Report of Project N-107*, Albert K. Kurtz and Harold G. Seashore, OSRD 4124, OEMsr-830, Memorandum 4, The Psychological Corp., Sept. 12, 1944. APP-212-M1
12. *A Comparison of Training Methods at Two Levels of Code Learning*, Fred S. Keller, Katherine W. Estes, and Paul G. Murphy, OSRD 4329, OEMsr-830, Service Project SC-88, Report 1, The Psychological Corp., Nov. 10, 1944. APP-212.1-M3
13. *Distribution of Practice in Code Learning*, Fred S. Keller and Katherine W. Estes, OSRD 4330, OEMsr-830, Service Project SC-88, Report 2, The Psychological Corp., Nov. 10, 1944. APP-212.1-M4
14. *The Relative Effectiveness of Four and Seven*

RESTRICTED

- Hours of Daily Code Practice*, Fred S. Keller and Katherine W. Estes, OSRD 4750, OEMsr-830, Service Project SC-88, Report 3, The Psychological Corp., Feb. 26, 1945. APP-212.42-M4
15. *The Code-Voice Method of Teaching International Morse Code*, Fred S. Keller, OSRD 4911, OEMsr-830, Service Project SC-88, Memorandum 1, The Psychological Corp., Apr. 9, 1945. APP-212.4-M2
 16. *The Use of Hand-Sent Clear Text as Practice Material in Learning to Receive Morse Code*, Marvin J. Herbert and Fred S. Keller, OSRD 5168, OEMsr-830, Service Project SC-88, Report 4, The Psychological Corp., June 4, 1945. APP-212.2-M2
 17. *Goodness of Signal Formation in Sending International Morse Code*, Fred S. Keller and Marvin J. Herbert, OSRD 5364, OEMsr-830, Service Project SC-88, Report 6, The Psychological Corp., July 23, 1945. APP-212.3-M1
 18. *A Test of Two "Remedial" Devices in High-Speed Code Reception*, Edward A. Jerome and Fred S. Keller, OSRD 5365, OEMsr-830, Service Project SC-88, Report 7, The Psychological Corp., July 23, 1945. APP-317-M6
 19. *Progress in Receiving International Morse Code*, Fred S. Keller and Edward A. Jerome, OSRD 5366, OEMsr-830, Service Project SC-88, Report 5, The Psychological Corp., July 23, 1945. APP-212.2-M3
 20. *The Radio Code Research Project, Final Report of Project SC-88*, Fred S. Keller, OSRD 5379, OEMsr-830, Report 8, The Psychological Corp., July 25, 1945. APP-212-M2
 21. *Development of Radio Code Receiving Examinations*, M. Duane Bown and Harold O. Gulliksen, OEMsr-705, Service Project N-106, Informal Memorandum 18, College Entrance Examination Board, Princeton, N. J., Sept. 27, 1945. APP-317-M7
 22. *Development of Morse-Code-Actuated Printer, Research on Project NS-366, Final Report of Contract OEMsr-830*, George K. Bennett, OSRD 6233, The Psychological Corp., Oct. 31, 1945. APP-212.3-M2
 23. *The Code-Voice Method: Instructors' Lesson Plans*, Training Division Basic and Specialist Command, ASFTC, Camp Crowder, Mo., and Service Project SC-88 (undated).
 24. *So This Is Radio*, Service Project SC-88 and Radio Training Section ASFTC, Camp Crowder, Mo. (undated).
 25. *International Morse Code (Instructions)*, Technical Manual 11-459, War Department, August 1945.

Chapter 14

1. *Job Analysis Procedure*, Morris S. Viteles and Kinsley R. Smith, OSRD 1209, OEMsr-700, Service Project N-105, Project Memorandum 2, University of Pennsylvania, Jan. 15, 1943. APP-510-M1
2. *The 40-mm Gun, Training and Indoctrination of Crew (Instructor's Handbook)*, Morris S. Viteles, Kinsley R. Smith, and others, OSRD 1591, OEMsr-700, Service Project N-105, Project Memorandum 9, University of Pennsylvania, May 10, 1943. APP-211-M1
3. *Detailed Fireroom Operating Procedures for Destroyer Escort Vessels, Turbo-Electric and Turbo-Geared Types* (accompanying manual), Bernard J. Covner, John H. Gorsuch, and Morris S. Viteles, OSRD 3444, OEMsr-700, Service Project NR-106, Memorandum 1, University of Pennsylvania, Mar. 15, 1944. APP-217.2-M2
4. *Operation of Destroyer and Destroyer Escort Distilling Plants* (accompanying manual), Bernard J. Covner, W. E. Organist, A. G. Bayroff, John H. Gorsuch, and Morris S. Viteles, OSRD 3613, OEMsr-700, Service Project NR-106, University of Pennsylvania, May 15, 1944. APP-217.1-M2

Chapter 15

1. *Unit Lesson Plans for Four-Day Course in 20-mm Gunnery* (accompanying manual), Morris S. Viteles, Kinsley R. Smith, John H. Gorsuch, F. K. Berrien, and W. J. Thompson, OSRD 1371, University of Pennsylvania, May 1, 1943. APP-221-M3
2. *How to Teach Gunnery, A Short Course in Effective Teaching Methods for Gunnery Instructors* (accompanying manuals), Kinsley R. Smith, S. M. Wesley, W. G. Willis, John H. Gorsuch, and Morris S. Viteles, OSRD 3876, OEMsr-700, Service Projects N-105 and NR-106, Memorandum 16, University of Pennsylvania, July 11, 1944. APP-221-M3
3. *Lesson Plans for Caliber .50 Machine Gun*, O. Backstrom, Jr., John H. Gorsuch, and Morris S. Viteles, OSRD 3909, OEMsr-700, Service Project N-105, Memorandum 14, University of Pennsylvania, July 19, 1944. APP-221-M4
4. *APA Engineering Course Curriculum-Units for Balance of Crew Training* (first edition), with accompanying manual, Bernard J. Covner, John H. Gorsuch, and Morris S. Viteles, OSRD 5090, University of Pennsylvania, June 9, 1945.

RESTRICTED

Chapter 16

1. *Developments in the Use and Construction of Training Aids for Four-Day Course in 20-mm Gunnery*, Morris S. Viteles, Kinsley R. Smith and others, OSRD 1320, OEMsr-700, Service Project N-105, Memorandum 7, University of Pennsylvania, Mar. 5, 1943. APP-221-M1
2. *Preliminary Suggestions for a Stereoscopic Spotting Trainer*, Lorrin A. Riggs, OSRD 1374, OEMsr-815, Research Project PDRC-759, Project Memorandum 3, Brown University, Apr. 3, 1943. APP-654-M1
3. *A New Motor Attachment for the M-2 or Mark 2 Stereoscopic Trainer*, William E. Kappauf, OSRD 1392, OEMsr-815, Research Project PDRC-759, Project Memorandum 4, Brown University, Apr. 26, 1943. APP-654-M2
4. *An Instrument for Tracking Training*, William E. Kappauf and F. A. Mote, OSRD 1497, OEMsr-815, Project Memorandum 6, Brown University, May 4, 1943. APP-611.2-M1
5. *Adjustment of the M-2 Trainer for Standard Testing*, Harold M. Fisher and Henry A. Imus, OSRD 1638, OEMsr-815, Project Memorandum 9, Brown University, June 17, 1943. APP-652-M3
6. *Trainers for Reporting and GCI Operators*, Donald B. Lindsley, OEMsr-919, Service Projects SC-70 and NS-146, Informal Memorandum 1, Yerkes Laboratories of Primate Biology and U. S. Army Signal Corps, Southern Signal Corps School, Camp Murphy, Fla., July 8, 1943. APP-624-M1
7. *Radar Operator Training, Results of Study of SCR-270-71 Operators-in-Training at Drew Field*, OSRD 1737, OEMsr-919, Service Projects SC-70 and NS-146, Research Report 1, Yerkes Laboratories of Primate Biology and U. S. Army Signal Corps, Southern Signal Corps School, Camp Murphy, Fla., Aug. 16, 1943. APP-213.3-M1
8. *Use of the Philco Trainer in the Training of A-Scan Oscilloscope Operators*, Irving H. Anderson and others, OSRD 2096, OEMsr-919, Service Projects SC-70 and NS-146, Research Report 3, Yerkes Laboratories of Primate Biology and U. S. Army Signal Corps, Southern Signal Corps School, Camp Murphy, Fla., Oct. 15, 1943. APP-621-M1
9. *A Study of the Foxboro Trainer as a Training Device for Learning to Track by Means of Pip-Matching*, Irving H. Anderson and others, OSRD 3102, OEMsr-919, Service Projects SC-70 and NS-146, Research Report 5, Yerkes Laboratories of Primate Biology and U. S. Army Signal Corps, Southern Signal Corps School, Camp Murphy, Fla., Dec. 16, 1943. APP-611.2-M2
10. *Recommendations for the Use of the Foxboro Trainer, BC-968-A*, Irving H. Anderson, Charles S. Bridgman, and others, OSRD 3103, OEMsr-919, Service Projects SC-70 and NS-146, Memorandum 6, Yerkes Laboratories of Primate Biology and U. S. Army Signal Corps, Southern Signal Corps School, Camp Murphy, Fla., Dec. 16, 1943. APP-611.2-M3
11. *Use of Foxboro Trainers in AAATC at Camp Stewart and Camp Davis*, Donald B. Lindsley, OEMsr-919, Service Projects SC-70 and NS-146, Informal Memorandum 5, Yerkes Laboratories of Primate Biology and U. S. Army Signal Corps, Southern Signal Corps School, Camp Murphy, Fla., Dec. 21, 1943. APP-613.2-M1
12. *PPI Trainer Equipment*, Donald B. Lindsley, OEMsr-919, Service Projects SC-70 and NS-146, Informal Memorandum 7, Yerkes Laboratories of Primate Biology and U. S. Army Signal Corps, Southern Signal Corps School, Camp Murphy, Fla., Jan. 8, 1944. APP-660-M1
13. *Modified Airplane Noise Generator*, OEMsr-830, Service Projects SC-67 and N-109(1), Informal Communication 1, The Psychological Corp., Jan. 24, 1944. APP-630-M1
14. *Description of the Tufts Tracking Trainer*, Bradford B. Hudson and Lloyd V. Searle, OSRD 3286, OEMsr-581, Service Project SOS-6, Report 11, Tufts College, Feb. 5, 1944. APP-611.2-M4
15. *A Study of the SCR-584 Basic Trainer, as a Training Device for Learning Range Tracking*, Irving H. Anderson and others, OSRD 3344, OEMsr-919, Service Projects SC-70 and NS-146, Yerkes Laboratories of Primate Biology and U. S. Army Signal Corps, Southern Signal Corps School, Camp Murphy, Fla., Feb. 10, 1944. APP-611.2-M5
16. *Proposed Recording System for Students' Performance on the Trainer BC-10.0-A*, Donald B. Lindsley, OEMsr-919, Service Projects SC-70 and NS-146, Informal Memorandum 11, Yerkes Laboratories of Primate Biology and U. S. Army Signal Corps, Southern Signal Corps School, Camp Murphy, Fla., Mar. 8, 1944. APP-690-M1
17. *Use of Foxboro Trainers in AAATC and AARTC Units, Report of Visits by Representatives of NDRC Projects SC-70 and NS-146*, Donald B. Lindsley, OEMsr-919, Informal Memorandum 12, Yerkes Laboratories of Primate Biology and U. S. Army Signal Corps, Southern Signal Corps School, Camp Murphy, Fla., Mar. 15, 1944. APP-613.2-M2
18. *A Study of the Tufts Tracking Trainer as a Selection and Training Device for Trackers on the Director, M-7*, William C. Biel and Lloyd V. Searle, OSRD 3606, OEMsr-581, Service Project SOS-6, Report 12, Tufts College, Apr. 24, 1944. APP-611.2-M7
19. *Polaroid Spotting Trainer*, William E. Kappauf, OEMsr-815, Service Project N-111, Project Memorandum 4, Brown University, June 5, 1944. APP-611.4-M1
20. *Installation and Operation of Equipment Used in*

RESTRICTED

- Basic Voice Communication Course*, OSRD 3749, OEMsr-830, Service Project N-109(1) and SC-67, The Psychological Corp., June 7, 1944.
APP-2184-M1
21. *The Design, Construction, and Use of a Motor Drive Providing Range Movement and Tracking Errors for the Mark 2 or M-2 Stereoscopic Trainers*, D. G. Ellson and E. B. Knauff, OSRD 3907, OEMsr-1171, Service Project N-114, Memorandum 6, University of Wisconsin, July 17, 1944.
APP-651-M2
 22. *Manual for Instruction on Machine Gun Trainer Mark 1*, Morris S. Viteles, OEMsr-700, Service Project N-105, Project Memorandum 15, University of Pennsylvania, July 25, 1944.
APP-613.1-M2
 23. *Recording Unit for Trainer BC-1070-A (Master), Application Instructions*, prepared in cooperation with officers of the U. S. AAF, OEMsr-919, Service Projects SC-70 and NS-146, Yerkes Laboratories of Primate Biology, Oct. 9, 1944.
APP-612-M1
 24. *An Investigation of the Range Estimation Trainer, Device 5C-4 as a Method of Teaching Range Estimation*, Morris S. Viteles, John H. Gorsuch, and others, OSRD 4263, OEMsr-700, Service Project N-105, Memorandum 11, University of Pennsylvania, Oct. 18, 1944.
APP-640-M2
 25. *A Night Lookout Trainer for Use Aboard Ship*, L. H. Lanier, OSRD, 4323, OEMsr-1136, Service Project N-115, Report 3, Princeton University, Nov. 8, 1944.
APP-150-M4
 26. *Design, Construction, and Validation of a Training Instrument for Optical Pointing and Training in the Gun Director Mark 37*, D. G. Ellson, OSRD 4474, OEMsr-1171, Service Project N-114, Report 14, University of Wisconsin, Dec. 18, 1944.
APP-611.3-M4
 27. *A Radar Trainer and Flash-Reading Method for Operators of the Plan Position Indicator*, Irving H. Anderson, Alfred L. Baldwin, and others, OSRD 4489, OEMsr-919, Service Project SC-70 and NS-146, Research Report 14, Yerkes Laboratories of Primate Biology, Dec. 23, 1944.
APP-660-M2
 28. *Notes on the Desired Characteristics of Trainers*, William E. Kappauf, Service Project N-111, Project Memorandum 7, U. S. Navy Department, Navy Yard, Advanced Fire Control and Brown University, Jan. 2, 1945.
APP-690-M2
 29. *Check Sight Scoring Methods*, Henry P. Birmingham, A. S. Householder, William E. Kappauf, and Franklin V. Taylor, OSRD 4525, OEMsr-815, Service Project N-111, Brown University, Jan. 3, 1945.
APP-612-M3
 30. *Validation of Miniature Electric Winch as a Training Device*, Floyd L. Ruch, OEMsr-1372, Service Project N-116b, Informal Memorandum 3, University of Southern California, Feb. 5, 1945.
APP-680-M2
 31. *Instructors Guide for H2X Film Trainer with Film Commentaries*, Donald B. Lindsley, OEMsr-919, Service Project SC-70 and NS-146, Informal Memorandum 21, Yerkes Laboratories of Primate Biology, Feb. 6, 1945.
APP-622-M2
 32. *Validation of the Modified Army BC-968-A Radar Trainer*, E. B. Knauff, S. D. S. Spragg, and H. A. Taylor, OSRD 4476, OEMsr-1171, Service Project N-114, Report 15, University of Wisconsin, Feb. 8, 1945.
APP-624-M2
 33. *The Design, Construction, and Validation of a Mechanical Radar Pip-Matching Trainer*, E. B. Knauff, S. D. S. Spragg, and H. A. Taylor, OSRD 4636A, University of Wisconsin, Feb. 8, 1945.
 34. *Drill Manual for Synthetic Antiaircraft Gunnery Trainers*, A. G. Bayroff, John H. Gorsuch, and Morris S. Viteles, OSRD 4813, OEMsr-700, Service Project N-105, Memorandum 21, University of Pennsylvania, Mar. 15, 1945.
APP-610-M1
 35. *Use of the PPI Flash-Reading Trainer in Training Navy Search-Radar Operators*, Irving H. Anderson, Alfred L. Baldwin, and others, OSRD 4831, OEMsr-919, Service Projects SC-70 and NS-146, Research Report 17, Yerkes Laboratories of Primate Biology, Mar. 20, 1945.
APP-660-M3
 36. *A Mechanical Trainer Simulating Tracking with the Mark 12 Radar Spot Presentation—Description and Learning Curve*, W. J. Brogden, OEMsr-1171, Service Project N-114, Informal Memorandum 4, University of Wisconsin, May 8, 1945.
APP-611.2-M16
 37. *Notes on the Design of Phototube Scoring Devices for Tracking Trainers*, William E. Kappauf, OEMsr-815, Service Project N-111, Informal Memorandum 9, Brown University, May 23, 1945.
APP-611.2-M17
 38. *Design and Development of a B-29 Ground Trainer and Test Device*, Karl U. Smith, OEMsr-1171, Service Project AC-94, Informal Memorandum 3, University of Wisconsin, May 30, 1945.
APP-611.1-M7
 39. *The Use and Design of Synthetic Trainers for Military Training*, Dael Wolfe, OSRD 5246, Applied Psychology Panel, NDRC, July 6, 1945.
APP-690-M3
 40. *Description of a Radar Air-Search Tracking Trainer*, Donald B. Lindsley, OEMsr-919, Service Projects SC-70 and NS-146, Informal Memorandum 24, Yerkes Laboratories of Primate Biology and U. S. Army Air Forces, Boca Raton Field, Fla., Aug. 22, 1945.
APP-611.2-M20
 41. *A New Type Mechanical PPI Tracking Trainer*, Donald B. Lindsley, OEMsr-919, Service Project SC-70 and NS-146, Informal Memorandum 26, Yerkes Laboratories of Primate Biology and U. S. Army Air Forces, Boca Raton Field, Fla., Sept. 4, 1945.
APP-611.2-M21
 42. *The Development of the Remote Control Aerial Gunnery Trainer*, Karl U. Smith, OEMsr-1171,

- Service Project AC-94, Informal Memorandum 12, University of Wisconsin, Sept. 10, 1945.
APP-610-M3
43. *The Construction and Operation of a Radar Tracking Demonstrator*, Franklin V. Taylor, Service Project N-111, Informal Memorandum 17, Brown University, Sept. 14, 1945.
 44. *Design and Construction of an Airborne Synthetic Gunnery Trainer and Test Device for Director-Type Computing Sights*, D. G. Ellson, OSRD 5938, OEMsr-1171, Service Project AC-94, Memorandum 4, University of Wisconsin, Sept. 26, 1945.
APP-610-M4
 45. *A Remotely Controlled Test (RCT) Device for the Analysis of Gunner Performance on Flexible Gunnery Equipment*, Carl H. Wedell, OSRD 6083, OEMsr-1171, Service Project AC-94, Memorandum 5, University of Wisconsin, Oct. 12, 1945.
APP-610-M6
 46. *Development of Morse Code Actuated Printer, Research on Project NS-366, Final Report of Contract OEMsr-830*, George K. Bennett, OSRD 6233, The Psychological Corp., Oct. 31, 1945.
APP-212.3-M2
 47. *Training Aids Manual*, AP 2655, Air Ministry, July 1944, Vol. 1, Sect. 1, Chap. II, AL No. 1, p. 392.
 48. *Instructors Handbook for Basic Course in Submarine Voice Communications*, published by Commander Submarines, U. S. Atlantic Fleet, 1945.

Chapter 17

1. *Service School Grades*, Harold Gulliksen, OSRD 3177, Memorandum 11, OEMsr-705, Service Project N-106, College Entrance Examination Board, Princeton, N. J., Jan. 6, 1944. APP-413-M1
2. *5"/38 Identification Test, Directions for Administering and Scoring*, NavPers 16620, College Entrance Examination Board, Princeton, N. J., January 1945.
3. *40 mm Identification Test, Directions for Administering and Scoring*, NavPers 16621, College Entrance Examination Board, Princeton, N. J., January 1945.
4. *20 mm Identification Test, Directions for Administering and Scoring*, NavPers 16622, College Entrance Examination Board, Princeton, N. J., January 1945.
5. *Caliber .50 Browning Machine Gun Identification Test, Directions for Administering and Scoring*, NavPers 16623, College Entrance Examination Board, Princeton, N. J., January 1945.
6. *Small Arms Identification Test, Directions for Administering and Scoring*, NavPers 16624, College Entrance Examination Board, Princeton, N. J., January 1945.
7. *5"/38 Performance Test, Directions for Administering and Scoring*, NavPers 16625, College Entrance Examination Board, Princeton, N. J., January 1945.
8. *40 mm Performance Test, Directions for Administering and Scoring*, NavPers 16626, College Entrance Examination Board, Princeton, N. J., January 1945.
9. *20 mm Performance Test, Directions for Administering and Scoring*, NavPers 16627, College Entrance Examination Board, Princeton, N. J., January 1945.
10. *Caliber .50 Browning Machine Gun Performance Test, Directions for Administering and Scoring*, NavPers 16628, College Entrance Examination Board, Princeton, N. J., January 1945.
11. *Small Arms Performance Test, Directions for Administering and Scoring*, NavPers 16629, College Entrance Examination Board, Princeton, N. J., January 1945.
12. *Achievement Examination Program for Class "A" Radio Schools* (a joint report of Project N-106 and the Achievement Test Unit [in] report of joint meeting of NDRC Project N-106 and Test and Research Section), Harold P. Bechtoldt and M. Duane Bown, College Entrance Examination Board, Princeton, N. J., Feb. 16, 1945, pp. 65-69.
13. *Test Development in Basic Engineering* (a joint report of Project N-106 and the Achievement Test Unit [in] report of joint meeting of NDRC Project N-106 and Test and Research Section), R. B. Porter and Nicholas A. Fattu, College Entrance Examination Board, Princeton, N. J., Feb. 16, 1945, pp. 70-75.
14. *Development of Achievement Examination for Class "A" Gunner's Mates Service Schools* (a joint report of Project N-106 and the Achievement Test Unit [in] report of joint meeting of NDRC Project N-106 and Test and Research Section), Norman Frederiksen and A. Eason Monroe, College Entrance Examination Board, Princeton, N. J., Feb. 16, 1945, pp. 76-83.
15. *Selection of LCVP Coxswains*, D. R. Miller, Service Project N-117b, Informal Memorandum 1, University of Southern California, May 19, 1945.
16. *The Development of Achievement Tests for Gunner's Mates Schools*, Norman Frederiksen and A. Eason Monroe, OSRD 5259, OEMsr-705, Service Project N-106, Report 17, College Entrance Examination Board, Princeton, N. J., June 25, 1945.
APP-311-M1
17. *Directions for Administering and Scoring Torpedo Identification Tests (Torpedoman)*, NavPers 16968, College Entrance Examination Board, Princeton, N. J., June 1945.
18. *Directions for Administering and Scoring Period*

RESTRICTED

- Performance Tests (Torpedoman)*, NavPers 16969, College Entrance Examination Board, Princeton, N. J., June 1945.
19. *Directions for Administering and Scoring Final Performance Tests (Torpedoman)*, NavPers 16970, College Entrance Examination Board, Princeton, N. J., June 1945.
 20. *Evaluation of Military Training by Means of Performance Tests*, address at Joint Army-Navy-OSRD Conference on Psychological Problems in Military Training, Norman Frederiksen, College Entrance Examination Board, Princeton, N. J., Aug. 16, 1945.
 21. *Achievement Examination for Signalman School*, M. Duane Bown, Thelburn L. Engle, and Harold P. Bechtoldt, OSRD 5460, OEMsr-705, Service Project N-106, Report 18, College Entrance Examination Board, Princeton, N. J., Aug. 20, 1945. APP-312-M1
 22. *Development of Achievement Tests for Class A Naval Training Schools for Torpedomen*, Charles M. Harsh and Joseph B. Cooper, OSRD 5520, OEMsr-705, Service Project N-106, Report 19, College Entrance Examination Board, Princeton, N. J., Aug. 31, 1945. APP-311-M2
 23. *Directions for Administering and Scoring Radio Code Receiving Examinations*, NavPers 16798, College Entrance Examination Board, Princeton, N. J., August 1945.
 24. *Performance Tests on DC Equipment, Directions for Administering and Scoring*, NavPers 16716, College Entrance Examination Board, Princeton, N. J., August 1945.
 25. *Performance Tests on Wiring: Directions for Administering and Scoring*, NavPers 16717, College Entrance Examination Board, Princeton, N. J., August 1945.
 26. *Performance Tests on AC Equipment and Interior Communications, Directions for Administering and Scoring*, NavPers 16718, College Entrance Examination Board, Princeton, N. J., August 1945.
 27. *The Development of Performance Tests for Use in Class A Electrical Schools*, Merrell E. Thompson and Norman Frederiksen, OSRD 5666, OEMsr-705, Service Project N-106, Memorandum 17, College Entrance Examination Board, Princeton, N. J., Sept. 13, 1945. APP-315-M1
 28. *Development of Achievement Tests for the Landing Craft School, Coronado, California*, Norman Frederiksen, OSRD 5670, OEMsr-705, Service Project N-106, Report 21, College Entrance Examination Board, Princeton, N. J., Sept. 14, 1945. APP-314-M1
 29. *Development of Radio Code Receiving Examinations*, M. Duane Bown and Harold O. Gulliksen, OEMsr-705, Service Project N-106, Informal Memorandum 18, College Entrance Examination Board, Princeton, N. J., Sept. 27, 1945. APP-317-M7
 30. *Summary Report on Research and Development of the Navy's Aptitude Testing Program*, Herbert S. Conrad, OSRD 6110, OEMsr-705, Service Project N-106, Final Report 24, College Entrance Examination Board, Princeton, N. J., Oct. 31, 1945. APP-322-M6

Chapter 18

1. *Job Analysis Procedure*, Morris S. Viteles and Kinsley R. Smith, OSRD 1209, OEMsr-700, Service Project N-105, Project Memorandum 2, University of Pennsylvania, Jan. 15, 1943. APP-510-M1
2. *M5A1E1 Modification of M5 or M5A1 Director for Intermediate Caliber AA Guns*, OSRD 1764, Report to the Services 60, NDRC Div. 7, Fire Control, Sept. 1, 1943.
3. *An Antiaircraft Computing Sight*, OSRD 1765, Report to the Services 61, NDRC Div. 7, Fire Control, Sept. 1, 1943.
4. *Tracking Errors in Systems Using Velocity-Tracking and Aided-Tracking Controls with Direct and Lead-Computing Sights*, OSRD 3332, Report to the Services 78, NDRC Div. 7, Fire Control, February 1944.
5. *A Study of Factors Determining Accuracy of Tracking by Means of Handwheel Control*, OSRD 3451, OEMsr-453, Report to the Services 71, NDRC Div. 7, Fire Control, Foxboro Co., Sept. 30, 1942. Div. 7-220.311-M1
6. *A Supplemental Study of Factors Determining Accuracy of Tracking by Means of Handwheel Control*, OSRD 3452, OEMsr-453, Report to the Services 72, NDRC Div. 7, Fire Control, Foxboro Co., Dec. 7, 1942. Div. 7-220.311-M2
7. *Handwheel Speed and Accuracy of Tracking*, OSRD 3453, OEMsr-453, NDRC Div. 7, Fire Control, Report to the Services 73, Foxboro Co., May 12, 1943. Div. 7-220.311-M3
8. *Inertia, Friction and Diameter in Handwheel Tracking*, OSRD 3454, OEMsr-453, NDRC Div. 7, Fire Control, Report to the Services 74, Foxboro Co., Sept. 15, 1943. Div. 7-220.31-M1
9. *Relative Accuracy of Handwheel Tracking with One and Both Hands*, OSRD 3455, OEMsr-453, NDRC Div. 7, Fire Control, Report to the Services 75, Foxboro Co., Nov. 20, 1943. Div. 7-220.311-M4
10. *A Check Sight for Observing Gun Pointing with the Computing Sight, M-7, Its Reliability and Validity*, William C. Biel, Guy E. Brown, Jr., R. M. Gottsdanker, and R. C. Hall, OSRD 4003, OEMsr-581, Service Project SOS-6, Memorandum 6, Tufts College, Aug. 11, 1944. APP-611.11-M1

RESTRICTED

11. *A Study of the Tracking Proficiency of Student Operators during Training on Aerial Tracking of the Mark 37 Gun Director with Mark 4 Radar*, S. D. S. Spragg, OSRD 4049, OEMsr-1171, Service Project N-114, Report 10, University of Wisconsin, Aug. 22, 1944. APP-611.2-M9
12. *The Effectiveness of a Check Sight Technique for Training 40-mm Gun Pointers Who Are Using the Computing Sight M-7*, William C. Biel, Guy E. Brown, Jr., R. M. Gottsdanker, and R. C. Hall, OSRD 4054, OEMsr-581, Service Project SOS-6, Memorandum 7, Tufts College, Aug. 22, 1944. APP-611.11-M2
13. *The Construction and Use of a Fire Control Problem Solution Indicator*, D. G. Ellson, OSRD 4381, University of Wisconsin, Nov. 27, 1944. APP-611-M1
14. *A Study of Errors of Prediction Resulting from Azimuth Tracking Errors on the Director M-7*, Alex L. Sweet, OSRD 4509, OEMsr-581, Service Project SOS-6, Memorandum 10, Tufts College, Dec. 28, 1944. APP-611.2-M10
15. *Check Sight Scoring Methods*, Henry P. Birmingham, A. S. Householder, William E. Kappauf, Jr., and Franklin V. Taylor, OSRD 4525, OEMsr-815, Service Project N-111, Report 1, Brown University, Jan. 3, 1945. APP-612-M3
16. *A Comparison of Two Non-Timing Methods for Scoring On-Target Tracking on the 40-mm Gun Equipped with the Computing Sight M-7*, John H. Rapparlie, OSRD 4647, OEMsr-581, Service Project SOS-6, Memorandum 11, Tufts College, Jan. 29, 1945. APP-611.2-M12
17. *Comparative Studies of Slewing and Central Tracking with a Variety of Types of Machine Gun Sights*, OSRD 4877, OEMsr-453, NDRC Div. 7, Fire Control, Report to the Services 88, Foxboro Co., January 1945. Div. 7-220.32-M1
18. *A Comparative Test of Reticle Patterns for the Gun Sight Mark 15*, Henry P. Birmingham, T. G. Hermans, A. S. Householder, William E. Kappauf, H. D. Meyer, and Franklin V. Taylor, OSRD 4878, OEMsr-815, Service Project N-111, Report 3, Brown University, Mar. 30, 1945. APP-611.1-M6
19. *The Relative Effectiveness of a Check Sight Technique Compared with Two Other Methods Used in Training Gun Pointers on the 40-mm Gun Equipped with the Computing Sight M-7*, John H. Rapparlie, OSRD 4975, OEMsr-581, Service Project SOS-6, Memorandum 12, Tufts College, Apr. 23, 1945. APP-611.11-M5
20. *An Evaluation of a Frequently Used Technique for Appraising Tracking on the 40-mm Gun Equipped with the Computing Sight M-7*, John H. Rapparlie, OSRD 4976, OEMsr-581, Service Project SOS-6, Memorandum 13, Tufts College, Apr. 23, 1945. APP-611.11-M3
21. *Evaluation of a Plexiglas Check Sight as a Testing and Training Aid with Gun Pointers on a 40-mm Gun Equipped with the Computing Sight M-7*, Guy E. Brown, Jr., OSRD 4977, OEMsr-581, Service Project SOS-6, Memorandum 14, Tufts College, Apr. 23, 1945. APP-611.11-M4
22. *Comparison of the Accuracy of Slant Range Measurement by Radar SCR-584 and BC Telescopes in 90-mm Gun Trial Fire*, Alex L. Sweet, Memorandum 16, OEMsr-581, Service Project SOS-6, OSRD 5210, Tufts College, June 15, 1945. APP-611.4-M3
23. *Supplementary Data on the Validity of a Non-Timing Method for Scoring On-Target Tracking on the 40-mm Gun Equipped with the Computing Sight M-7*, John H. Rapparlie, OSRD 5219, OEMsr-581, Service Project SOS-6, Memorandum 17, Tufts College, June 18, 1945. APP-611.2-M18
24. *A Photographic Determination of the Accuracy of Measures of Optical and Radar Tracking Error in the Gun Director Mark 37 by an Optical Check Scope Method*, D. C. Beier, D. G. Ellson, and H. A. Taylor, OSRD 5223, OEMsr-1171, Service Project N-114, Memorandum 11, University of Wisconsin, June 19, 1945. APP-611.2-M19
25. *Influence of Visual Magnification on Accuracy of Tracking*, OSRD 5304, OEMsr-453, Report to the Services 90, NDRC Div. 7, Fire Control, Foxboro Co., April 5, 1945. Div. 7-220.312-M2
26. *Summary of Research on Psychological Problems in the Operation of Antiaircraft Lead Computing Sights and Directors (Final Report of OEMsr-815)*, William E. Kappauf, OSRD 5425, Service Project N-111, Report 5, Brown University, Sept. 29, 1945. APP-611.1-M14
27. *Studies with the Variable Drive T-18 for 40-mm Gun Carriage, M-2-A1*, William C. Biel, Guy E. Brown, Jr., and William J. Griffiths, OSRD 5736, OEMsr-581, Service Project SOS-6, Report 13, Tufts College, Sept. 19, 1945. APP-611.2-M26
28. *A Comparison of Three Speed Ring Methods and the Computing Sight M-7 in Accuracy of Fire Control on the 40-mm Gun*, John H. Rapparlie and William C. Biel, OSRD 5762, OEMsr-581, Service Project SOS-6, Report 14, Tufts College, Sept. 21, 1945. APP-611.1-M13
29. *A Study of Tracking on Directors M-5-A2 and M-5-A2E1*, Robert M. Gottsdanker and William C. Biel, OSRD 5929, OEMsr-581, Service Project SOS-6, Report 15, Tufts College, Sept. 25, 1945. APP-611.2-M27
30. *A Further Study of Radar SCR-584 Burst Spotting on Trial Fire*, William C. Biel and Alex L. Sweet, OSRD 5930, OEMsr-581, Service Project SOS-6, Report 16, Tufts College, Sept. 25, 1945. APP-611.4-M4
31. *Study of Operator Performance on All Types of Antiaircraft Equipment, Research on Project SOS-6*, Richard N. Berry, William C. Biel, and others, OSRD 5931, OEMsr-581, Report 17, Tufts College, Sept. 25, 1945. APP-613.2-M3

RESTRICTED

32. *A Comparison of Free and Stadiametric Estimation of Opening Range*, Harold A. Voss and D. D. Wickens, OSRD 6114, OEMsr-700, Service Project N-105, Memorandum 24, University of Pennsylvania, Oct. 16, 1945. APP-640-M7
33. *Micromotion Analysis of the Service of the 3"/50 Gun*, David B. Porter and S. Medford Wesley, OSRD 6176, University of Pennsylvania and New York University, Oct. 19, 1945. APP-610-M7
34. *A Camera for Recording Tracking Performance with the Gun Sight Mark 14*, A. G. Bayroff, John H. Gorsuch, R. A. H. Mueller, W. E. Organist, and D. D. Wickens, OSRD 6230, OEMsr-700, Service Project N-105, Memorandum 34, University of Pennsylvania, Oct. 30, 1945. APP-611.2-M28
35. *Studies in Lead Tracking with Machine Gun Sights*, OSRD 5918, Report to the Services 92, NDRC Div. 7, Fire Control, Foxboro Co., June 1945. Div. 7-220.32-M2
36. *Studies in Aided Tracking*, Report to the Services 102, NDRC Div. 7, Fire Control, June 1945.
- 36a. *History and Final Report of Project N-105 of the Applied Psychology Panel*, Morris S. Viteles, John H. Gorsuch, and D. D. Wickens, OSRD 6266, OEMsr-700, University of Pennsylvania, Oct. 31, 1945. APP-200-M2
37. *Suggestions for the Design of Production Models of the Mark 15 Gun Sight and the Mark 52 Director*, William E. Kappauf, Service Project N-111, Informal Memorandum 1, Brown University, Jan. 24, 1944.
38. *A Variable Speed Assembly for the Azimuth Hand-wheel Drive of the 40-mm Gun*, J. G. Beebe-Center, OEMsr-581, Service Project SOS-6, Informal Memorandum 4, Tufts College, Mar. 1, 1944. APP-611.2-M6
39. *Observations While Training Gun Pointers in the Use of the T-10 Drive Control on a 40-mm Gun*, William C. Biel and Leonard C. Mead, OEMsr-581, Service Project SOS-6, Informal Memorandum 1, Tufts College, June 21, 1944. APP-611.1-M3
40. *Preparation of the Manual on Operating Instructions: Gun Director Mark 51 Model 3, Controlling Heavy AA Batteries*, William E. Kappauf, Service Project N-111, Informal Memorandum 5, Brown University, Oct. 30, 1944. APP-611.3-M2
41. *Review of the Project's Comments on the Operating Characteristics of the Gun Director Mark 51 and Mark 52, and Its Suggestions for the Improvement in the Design of These Directors*, William E. Kappauf, Service Project N-111, Informal Memorandum 6, Brown University, Nov. 10, 1944. APP-611.3-M3
42. *Preparation of the Manual on Operating Instructions for the Gun Director Mark 52*, William E. Kappauf, OEMsr-815, Service Project N-111, Informal Memorandum 8, Brown University, May 18, 1945. APP-611.3-M6
43. *AA Target Designation Studies, Baltimore Class Heavy Cruisers*, Systems Research Laboratory, Report 1, Harvard University, July 16, 1945.
44. *A Second Summary of Project Comments on Director Operating Characteristics and Design*, William E. Kappauf, OEMsr-815, Service Project N-111, Informal Memorandum 11, Brown University, July 26, 1945. APP-611.3-M7
45. *Preparation of the Manual on Operating Instructions for Use of the Gun Fire Control System Mark 57 (preliminary edition)*, William E. Kappauf, OEMsr-815, Service Project N-111, Informal Memorandum 13, Brown University, Sept. 4, 1945. APP-611-M7
46. *Preparation of the Manual on Operating Instructions: Gun Fire Control System Mark 63 (preliminary edition)*, William E. Kappauf, OEMsr-815, Service Project N-111, Informal Memorandum 14, Brown University, Sept. 4, 1945. APP-611-M8
47. *The Design of a Tracking Head for Use on Pedestal Type Directors*, William E. Kappauf, OEMsr-815, Service Project N-111, Informal Memorandum 18, Brown University, Sept. 15, 1945. APP-611.3-M8
48. *Test of Hand Held Rangefinders*, Antiaircraft Artillery Board, Camp Davis, N. C., May 5, 1943.

Chapter 19

1. *The Effectiveness of a Warning Mark on the Scale of the M-12 Panoramic Sight on 100-mil. Errors*, Richard N. Berry, Robert H. Brown, Leonard C. Mead, John P. Nafe, Lloyd V. Searle, and Kenneth S. Wagoner, OSRD 4265, Memorandum 1, OEMsr-581, Service Project SOS-11, Tufts College, Oct. 18, 1944. APP-611.12-M1
2. *The Development of a Counter or Odometer Type Scale to Replace the Micrometer Scale of the Panoramic Telescope M-12*, Lorrin A. Riggs, OSRD 4390, Memorandum 2, OEMsr-581, Service Project SOS-11, Tufts College, Nov. 28, 1944. APP-611.12-M2
3. *Gross Errors in Reading Scales of Panoramic Telescopes*, Richard N. Berry, Robert H. Brown, Leonard C. Mead, John P. Nafe, Lloyd V. Searle, and Kenneth S. Wagoner, OSRD 4934, OEMsr-581, Service Project SOS-11, Report 1, Tufts College, Apr. 13, 1945. APP-611.12-M4
4. *A Study of Gunnery Errors Made with Different Panoramic Telescopes on Bishop Trainers*, Richard N. Berry, Leonard C. Mead, John P. Nafe, Lloyd V. Searle, and Kenneth S. Wagoner, OSRD 4935, OEMsr-581, Service Project SOS-11, Report 2, Tufts College, Apr. 13, 1945. APP-611.12-M5
5. *Errors in Reading Scales and Changing Deflections*

RESTRICTED

- of Panoramic Telescopes, Richard N. Berry, Robert H. Brown, Leonard C. Mead, John P. Nafe, Lloyd V. Searle, and Kenneth S. Wagoner, OSRD 5070, OEMsr-581, Service Project SOS-11, Report 4, Tufts College, May 18, 1945. APP-611.12-M6
6. *Errors in Setting Deflections on Panoramic Telescopes*, Richard N. Berry, Robert H. Brown, Leonard C. Mead, John P. Nafe, Lloyd V. Searle, and Kenneth S. Wagoner, OSRD 5071, OEMsr-581, Service Project SOS-11, Report 3, Tufts College, May 18, 1945. APP-611.12-M7
 7. *A System of Automatic Devices for the Detection and Recording of Errors in a 105-mm Howitzer Battery*, Richard N. Berry, Robert H. Brown, Leonard C. Mead, John P. Nafe, Lloyd V. Searle, and Kenneth S. Wagoner, OSRD 5313, OEMsr-581, Service Project SOS-11, Report 5, Tufts College, July 6, 1945. APP-612-M5
 8. *Psychological Factors in Operation and Design of Field Artillery, Tank Destroyer, and Sighting Equipment*, Richard N. Berry, Robert H. Brown, Leonard C. Mead, John P. Nafe, Lloyd V. Searle, and Kenneth S. Wagoner, OSRD 5342, OEMsr-581, Service Project SOS-11, Final Report 6, Tufts College, July 16, 1945. APP-611.1-M9
 9. *Recording Device for Remote Indication of Gun Position*, John P. Nafe, OEMsr-581, Service Project SOS-11, Informal Memorandum 2, Tufts College, Nov. 3, 1944. APP-612-M2
 10. *The Number, Percentage, Disposition, and Places of Occurrence of 100-mil Errors, in 9,440 Rounds of Artillery Fire*, John P. Nafe, OEMsr-581, Service Project SOS-11, Informal Memorandum 3, Tufts College, Nov. 4, 1944. APP-612.1-M1
 11. *A Comparison of Performance on Reading American and German Aiming Circles*, John P. Nafe, Informal Memorandum 4, OEMsr-581, Service Project SOS-11, Tufts College, Jan. 10, 1945. APP-611.1-M4
 12. *Test Model of Panoramic Telescope M-12 (T-133)*, John P. Nafe, Informal Memorandum 5, OEMsr-581, Service Project SOS-11, Tufts College, Apr. 2, 1945. APP-611.12-M3
 13. *Studies of Errors in Field Artillery Practice (First Partial Report)*, Project AMRL 37, Armored Medical Research Laboratory, Sept. 18, 1944.
 - 13a. *Ibid.*, Table 2.
 - 13b. *Ibid.*, Tables 2 and 3.
 - 13c. *Ibid.*, Table 3.
 - 13d. *Ibid.*, estimated from proportions in Tables 1 and 2.
 - 13e. *Ibid.*, proportions from Table 6, weighting first three columns as one.
 14. *Studies of Errors in Field Artillery Practice (Second Partial Report)*, Project AMRL 37, Armored Medical Research Laboratory, Mar. 22, 1945.
 15. *Studies of Errors in Field Artillery Practice (Third Partial Report)*, Project AMRL 37, Armored Medical Research Laboratory, Apr. 6, 1945.
 16. *Studies of Errors in Field Artillery Practice (Fourth Partial Report)*, Project AMRL 37, Armored Medical Research Laboratory, Mar. 28, 1945.
 17. *Studies of Errors in Field Artillery Practice (Final Report)*, Project AMRL 37, Armored Medical Research Laboratory, June 13, 1945.

Chapter 20

1. *Analysis of Triggering on Remote Control Sights and Its Relation to Accuracy in Tracking and Framing*, J. K. Adams, OSRD 4863, OEMsr-1171, Service Project AC-94, Report 1, University of Wisconsin, Mar. 27, 1945. APP-611.2-M13
2. *Graphical Analysis of Triggering Reactions on B-29 Sights*, J. K. Adams, OSRD 4864, OEMsr-1171, Service Project AC-94, Report 2, University of Wisconsin, Mar. 27, 1945. APP-611.1-M5
3. *An Automatic Burst Control Device for Aerial Gunnery*, J. K. Adams, J. E. P. Libby, and R. L. Solomon, OSRD 5185, OEMsr-1171, Service Project AC-94, Memorandum 1, University of Wisconsin, June 8, 1945. APP-611.4-M2
4. *A Graphical Analysis of Sighting Performance on B-29 Sights*, Charles S. Bridgman, Florence E. Gray, and R. L. Solomon, OSRD 5221, OEMsr-1171, Service Project AC-94, Report 4, University of Wisconsin, June 19, 1945. APP-611.1-M8
5. *Comparison of Variability of Computer Azimuth Correction Obtained with a Standard G. E. Pedestal Sight and a Viscously Damped Sight*, W. J. Brogden, J. K. Adams, D. G. Ellson, and Florence E. Gray, OEMsr-1171, Service Project AC-94, Informal Memorandum No. 11, University of Wisconsin, Aug. 20, 1945. APP-611.1-M10
6. *Variability of B-29 Computer Output, Mechanical Tracking Using Constant Azimuth Rates*, J. K. Adams, D. G. Ellson, and Florence E. Gray, OSRD 5637, OEMsr-1171, Service Project AC-94, Report 5, University of Wisconsin, Sept. 10, 1945. APP-611.2-M22
7. *A Study of Rate Tracking by Gunners on the B-29 Pedestal Sight*, J. K. Adams, D. G. Ellson, and Florence E. Gray, OSRD 5638, OEMsr-1171, Service Project AC-94, Report 6, University of Wisconsin, Sept. 10, 1945. APP-611.2-M23
8. *The Development of the Remote Control Aerial Gunnery Trainer*, Karl U. Smith and William C. H. Prentice, OEMsr-1171, Service Project AC-94, Informal Memorandum 12, University of Wisconsin, Sept. 10, 1945. APP-610-M3

RESTRICTED

9. *An Experimental Study of the Efficiency of Sighting Performance with Modified Sight Controls as Compared to That with Standard Sight Controls on the B-29 Pedestal Sight*, D. C. Beier and William C. H. Prentice, OSRD 5558, OEMsr-1171, Service Project AC-94, Report 7, University of Wisconsin, Sept. 10, 1945. APP-611.1-M11
10. *A Sight Computer Test Apparatus for Study of Rate Tracking*, D. G. Ellson, OSRD 5735, OEMsr-1171, Service Project AC-94, Memorandum 2, University of Wisconsin, Sept. 19, 1945. APP-611.11-M6
11. *Design and Construction of an Airborne Synthetic Gunnery Trainer and Test Device for Director-Type Computing Sights*, D. G. Ellson, OSRD 5938, OEMsr-1171, Service Project AC-94, Memorandum 4, University of Wisconsin, Sept. 26, 1945. APP-610-M4
12. *A Graphical Recorder for Synchronous Linear Registration of Several Mechanical Movements*, Karl U. Smith, OSRD 5937, OEMsr-1171, Service Project AC-94, Memorandum 3, University of Wisconsin, Sept. 26, 1945. APP-611.5-M1
13. *A Remotely Controlled Test RCT, Device for the Analysis of Gunner Performance on Flexible Gunnery Equipment*, Carl H. Wedell, OSRD 6083, OEMsr-1171, Service Project AC-94, Memorandum 5, University of Wisconsin, Oct. 12, 1945. APP-610-M6

Chapter 21

1. *Effect of Oscilloscope Operation on Vision*, Donald B. Lindsley, Irving H. Anderson and others, OSRD 2051, OEMsr-919, Service Projects SC-70 and NS-146, Research Report 4, Yerkes Laboratories of Primate Biology and U. S. Army Signal Corps, Southern Signal Corps School, Camp Murphy, Fla., Nov. 15, 1943. APP-318-M4
2. *Radar Operator "Fatigue": The Effect of Length and Repetition of Operating Periods on Efficiency of Performance*, Donald B. Lindsley, Irving H. Anderson, and others, OSRD 3334, OEMsr-919, Service Projects SC-70 and NS-146, Research Report 6, Yerkes Laboratories of Primate Biology and U. S. Army Signal Corps, Southern Signal Corps School, Camp Murphy, Fla., Jan. 4, 1944. APP-230-M1
3. *Concerning Harmful Effects of Radar Operation and Fatigue*, Donald B. Lindsley, Service Projects SC-70 and NS-146, Informal Memorandum 10, Yerkes Laboratories of Primate Biology, Feb. 29, 1944. APP-230-M2
4. *Visual Status of ASV Radar Operators*, Irving H. Anderson, Charles S. Bridgman, and others, OSRD 3443B, OEMsr-919, Service Projects SC-70 and NS-146, Research Report 9, Yerkes Laboratories of Primate Biology and U. S. Army Signal Corps, Southern Signal Corps School, Camp Murphy, Fla., Mar. 20, 1944. APP-318.1-M3
5. *Tracking with Illuminated and Non-illuminated Oscilloscopes*. Report to the Services 79, NDRC Div. 7, April 1944.
6. *The Accuracy and Precision of Student Operators Zero-Sets on the Mark 4 Radar*, E. B. Knauff, OSRD 3723, OEMsr-1171, Service Project N-114, Report 4, University of Wisconsin, May 18, 1944. APP-623-M1
7. *Comparison of Range Tracking Methods: Tracking to a Fixed Hairline Versus Tracking to a Rotating Hairline*, Irving H. Anderson, Alfred L. Baldwin, and others, OSRD 3858, OEMsr-919, Service Projects SC-70 and NS-146, Research Report 11, Yerkes Laboratories of Primate Biology, July 4, 1944. APP-611.2-M8
8. *The Design, Attachment, and Precision of an Auxiliary Range Dial for the Mark 4 Radar*, E. B. Knauff, OSRD 3906, OEMsr-1171, Service Project N-114, Memorandum 5, University of Wisconsin, July 17, 1944. APP-623-M2
9. *The Influence of the Visual Tasks Required of Personnel in the Sixteen Weeks Fire Controlmen (O) Training Course upon Their Visual Proficiency*, J. K. Adams, D. C. Beier, and Henry A. Imus, OSRD 3970, OEMsr-1171, Service Project N-114, Report 7, University of Wisconsin, Aug. 1, 1944. APP-216-M3
10. *The Effect of Extraneous Illumination Upon Detection of Signals on an A-Scan Oscilloscope*, Irving H. Anderson, Alfred L. Baldwin, and others, OSRD 4264, OEMsr-919, Service Projects SC-70 and NS-146, Report 13, Yerkes Laboratories of Primate Biology, Oct. 18, 1944. APP-318-M7
11. *A Determination of Zero Drift and Range Drift after Warm-up of Radars Marks 4, 8, and 12*, E. B. Knauff, OSRD 4721, OEMsr-1171, Service Project N-114, Report 18, University of Wisconsin, Feb. 20, 1945. APP-623-M4
12. *Experiments in Training Radar Operators in Visual Code Reception*, Donald B. Lindsley, Irving H. Anderson, and others, OSRD 4811, OEMsr-919, Service Projects NS-146 and SC-70, Report 16, Yerkes Laboratories of Primate Biology, Mar. 20, 1945. APP-212.5-M1
13. *An Investigation of the Relative Accuracy of Five Methods of Tracking Aerial Targets Using Mark 12 Radar*, D. C. Beier and H. A. Taylor, OSRD 4927, OEMsr-1171, Service Project N-114, Report 20, University of Wisconsin, Apr. 16, 1945. APP-611.2-M14
14. *Factors Determining Accuracy of Reception of*

RESTRICTED

- Oscilloscope Code*, Irving H. Anderson, Alfred L. Baldwin, and others, OSRD 5280, OEMsr-919, Service Projects SC-70 and NS-146, Report 18, Yerkes Laboratories of Primate Biology, June 19, 1945. APP-212.5-M2
15. *Extended Training Experiment (Final Report)*, Hdqrs., U. S. AAF, Victorville, Calif., July 11, 1945, Donald B. Lindsley, Service Projects SC-70 and NS-146, Informal Memorandum 26, Yerkes Laboratories of Primate Biology, Aug. 10, 1945. APP-213.1-M3
 16. *Summary of Research on the Selection and Training of Rangefinder and Radar Operators (Final Report)*, W. J. Brogden, OSRD 5358, OEMsr-1171, Service Project N-114, University of Wisconsin, July 23, 1945. APP-110-M1
 17. *Summary of Work on the Selection and Training of Radar Operators (Final Report)*, Donald B. Lindsley, OSRD 5766, OEMsr-919, Service Projects SC-70 and NS-146, Report 19, Yerkes Laboratories of Primate Biology, Sept. 24, 1945. APP-213.3-M2
 18. *Ocular Fatigue Among Aircraft Warning Operators, and Report on Refraction of Oscilloscope Operators*, Communications from Hdqrs. 516th Signal Aircraft Warning Regiment, Mar. 3 and July 10, 1943.
 19. *Radar Operation Not Harmful to the Eyes*, Signal Corps Technical Information Letter 26, abstract of OSRD Report 2051, January 1944, pp. 40-41.
 20. *Radar Operation Does Not Impair Visual Efficiency*, General Staff Memorandum AG 413.68, abstract of OSRD Report 2051, Jan. 29, 1944.
 21. *Radar Operation Not Harmful to the Eyes*, Navy Department Bulletin, Section: Bureau of Medicine and Surgery, 44-435, abstract of OSRD Report 2051, Apr. 15, 1944.

Chapter 22

1. *Reduction of Range and Height Finder Errors Due to Temperature Stratification*, OSRD 49, Report to the Services 12, NDRC Section D-2, Fire Control, Aug. 29, 1941. Div. 7-210.11-M2
2. *Effect of Stopping Down End Windows of Rangefinders*, OSRD 378, Report to the Services 21, NDRC Section D-2, Fire Control, Feb. 11, 1942. Div. 7-210-M1
3. *The Precision, Consistency, and Accuracy of Visual Range Observations*, Ross A. McFarland, Alfred H. Holway, and others, OSRD 578, Report to the Services 25, NDRC Section D-2, Fire Control, May 14, 1942. Div. 7-220.12-M6
4. *Relative Position of Reticle and Target in the Stereoscopic Range Finder*, OSRD 622, Report to the Services 28, NDRC Section D-2, Fire Control, May 27, 1942. Div. 7-210.11-M4
5. *Relation of Accuracy and Variability of Stereoscopic Anti-Aircraft Range-Finding Operation to Correct Interocular Setting of the Instrument*, OSRD 626, Report to the Services 29, NDRC Section D-2, Fire Control, May 25, 1942. Div. 7-210.11-M3
6. *Analysis of Factors Effective in the Use of the Stereoscopic Range and Height Finder*, OSRD 869, Report to the Services 32, NDRC Section D-2, Fire Control, Sept. 9, 1942. Div. 7-220.213-M3
7. *The Chromatic Dispersion of the Human Eye and Its Possible Influence on Stereoscopic Range Finding*, OSRD 923, OEMsr-637, Research Project 10, Report to the Services 35, NDRC Section D-2, Fire Control, Ohio State University, Oct. 1, 1942. Div. 7-230.1-M1
8. *The Influence of Atmospheric Scattering in Range Finding*, G. A. Fry and Charles S. Bridgman, OSRD 930, OEMsr-637, Report to the Services 36, NDRC Section D-2, Fire Control, Ohio State University, Oct. 12, 1942. Div. 7-210.111-M2
9. *The Eastman Trainer for Range Finder Observers*, OSRD 989, OEMsr-56 and NDCrc-186, Report to the Services 39, NDRC Section D-2, Fire Control, Eastman Kodak Co. and Princeton University, Oct. 17, 1942. Div. 7-220.213-M5
10. *Temperature Effects in Stereoscopic Height Finders*, OSRD 994, NDCrc-186 and OEMsr-56, Report to the Services 38, NDRC Section D-2, Fire Control, Princeton University, Eastman Kodak Co. and National Bureau of Standards, Oct. 8, 1942. Div. 7-210.21-M3
11. *Ortho-Pseudoscopic Range Finder*, OSRD 995, OEMsr-55 and NDCrc-186, Report to the Services 43, NDRC Section D-2, Fire Control, Eastman Kodak Co. and Princeton University, Oct. 29, 1942. Div. 7-210.16-M1
12. *The Effects of Loud Sounds on the Accuracy of Azimuth Tracking and Stereoscopic Range Finding*, OSRD 1001, Report to the Services 37, NDRC Section D-2, Fire Control, Nov. 27, 1942. Div. 7-220.18-M4
13. *Stereo and Vernier Acuity as Affected by Metrazol, Loss of Sleep, Benzedrine, Variations in Blood Sugar, and Hyperventilation*, OSRD 1007, Report to the Services 44, NDRC Section D-2, Fire Control, Nov. 28, 1942. Div. 7-220.12-M18
14. *Perspective Effects in Stereoscopic Range Finders*, OSRD 1128, NDCrc-186, Report to the Services 40, NDRC Section D-2, Fire Control, Princeton University and National Bureau of Standards, Dec. 30, 1942. Div. 7-210.15-M2
15. *Comparative Test of Coincidence and Stereoscopic Height Finders*, Merrill M. Flood, OSRD 1129, NDCrc-186, Report to the Services 42, NDRC

RESTRICTED

- Section D-2, Fire Control, Princeton University, Oct. 28, 1942. Div. 7-210.14-M1
16. *Comparisons of Precision at 12 and 24 power of Observations Taken with the M-1 Height Finder for Fixed Ground Targets Aerial Targets*, Merrill M. Flood, OSRD 1130, NDCrc-186, Report to the Services 41, NDRC Section D-2, Fire Control, Princeton University, Jan. 20, 1943. Div. 7-210.15-M1
 17. *Sex Differences in Stereoscopic Ranging and in Visual Tracking*, OSRD 1250, Report to the Services 52, NDRC Division 7, Fire Control, Feb. 23, 1943. Div. 7-220.34-M2
 18. *Tests Made of Rangefinder Optical Systems at California Institute of Technology*, J. A. Anderson, Ira S. Bowen, and others, OSRD 1257, Report to the Services 51, NDRC Division 7, Fire Control, California Institute of Technology, Feb. 20, 1943. Div. 7-210.13-M4
 19. *Retention of Helium in Range and Height Finders*, OSRD 1258, NDCrc-186 and OEMsr-562, Report to the Services 50, NDRC Division 7, Fire Control, Princeton University and American Gas Association Testing Laboratories, Mar. 10, 1943. Div. 7-210-M2
 20. *Magnitude of Range Errors with M-1 Stereoscopic Height Finders*, OSRD 1362, Report to the Services 54, NDRC Division 7, Fire Control, Apr. 23, 1943.
 21. *An Instrument for the Measurement of Interpupillary Distance*, William E. Kappauf and W. J. Brogden, OSRD 1372, OEMsr-815, Research Project PDRC-759, Report 2, Brown University, Apr. 6, 1943. APP-653-M1
 22. *The Use of a Template in Making the Interocular Setting on the Heightfinder*, William E. Kappauf and W. J. Brogden, OSRD 1373, Project Memorandum 2, OEMsr-815, Research Project PDRC-759, Brown University, Apr. 7, 1943. APP-652-M1
 23. *The Effects of Motivation and of Fatigue on Stereoscopic Ranging and Direct Tracking*, OSRD 1478, Report to the Services 56, NDRC Division 7, Fire Control, Tufts College, May 31, 1943. Div. 7-220.16-M12
 24. *Training Manual for Stereoscopic Height Finder Observers*, William E. Kappauf, B. McMillan, and M. S. Swan, OSRD 1544, OEMsr-815, Project Memorandum 7, Brown University, June 15, 1943, Chaps. 1 to 5. APP-215-M1
 25. *Training Manual for Stereoscopic Height Finder Observers*, William E. Kappauf and M. S. Swan, OSRD 1730, OEMsr-815, Project Memorandum 10, Brown University, Aug. 12, 1943. Chaps. 6 to 19. APP-215-M1
 26. *Height of Image Adjustment on the Stereoscopic Height Finder*, J. K. Adams, William C. Biel, William E. Kappauf, M. S. Swan, and E. B. Knauff, OSRD 1967, OEMsr-815, Report 5, Brown University, Sept. 15, 1943. APP-652-M5
 27. *A Comparison of Methods for Setting the Oculars of the Height Finder at the Interpupillary Distance of the Observer*, J. K. Adams, William C. Biel, William E. Kappauf, and E. B. Knauff, OSRD 1968, OEMsr-815, Report 6, Brown University, Sept. 15, 1943. APP-653-M2
 28. *Training Manual for Stereoscopic Height Finder Observers*, William E. Kappauf and M. S. Swan, OSRD 2008, OEMsr-815, Project Memorandum 11, Brown University, Oct. 26, 1943, Chaps. 20 to 37. APP-215-M1
 29. *Comparative Study of Internal Adjuster Targets of Range and Height Finders*, OSRD 2061, OEMsr-570, Report to the Services 69, NDRC Division 7, Fire Control, Brown University, Nov. 29, 1943. Div. 7-210.112-M3
 30. *Factors Influencing the Use and Construction of Range and Height Finders*, OSRD 3162, Report to the Services 70, NDRC Division 7, Fire Control, Jan. 5, 1944. Div. 7-210-M4
 31. *Interocular Adjustment of Stereoscopic Rangefinders*, OSRD 3200, Report to the Services 76, NDRC Division 7, Fire Control, Jan. 13, 1944. Div. 7-210.112-M1
 32. *The Precision of Setting the Oculars of the Rangefinder with Interpupillary Distance Templates of Different Design*, J. K. Adams, OSRD 3273, OEMsr-1171, Service Project N-114, Report 1, University of Wisconsin, Feb. 2, 1944. APP-653-M3
 33. *The Calibration of Army Height Finders*, William C. Biel, William E. Kappauf, and E. B. Knauff, OSRD 3375, OEMsr-815, Report 9, Brown University, Mar. 18, 1944. APP-652-M6
 34. *The Reliability and Precision of the NDRC and Bausch and Lomb Interpupillometers*, J. K. Adams, D. C. Beier, and Henry A. Imus, OSRD 3475, OEMsr-1171, Service Project N-114, Report 2, University of Wisconsin, Mar. 29, 1944. APP-112.2-M1
 35. *The Relationship of Errors in Height and Slant Range Readings Made by Stereoscopic Observers*, J. K. Adams, William C. Biel, E. B. Knauff, and W. E. Kappauf, OSRD 3594, OEMsr-815, Report 10, Brown University, Apr. 29, 1944. APP-216-M1
 36. *The Precision of Internal Adjustment Settings of the Mark 42 Rangefinder*, E. B. Knauff, OSRD 3618, OEMsr-1171, Service Project N-114, Report 3, University of Wisconsin, Apr. 24, 1944. APP-651.1-M1
 37. *The Design, Accuracy, Construction and Use of a Rangefinder Slide Rule*, J. K. Adams, T. R. Whitney, OSRD 3678, OEMsr-1171, Service Project N-114, Memorandum 3, University of Wisconsin, May 1, 1944. APP-651-M1
 38. *The Construction and Calibration of the NDRC Interpupillometer*, D. G. Ellson and Henry A. Imus, OSRD 3797, OEMsr-1171, Service Project

- N-114, Memorandum 4, University of Wisconsin, June 19, 1944. APP-112.2-M2
39. *The Effect of Imperfections in the Reticle Field of Stereoscopic Rangefinders*, Robert M. Daley, Clarence H. Graham, and others, OSRD 3866, OEMsr-1059, Report to the Services 83, NDRC Division 7, Fire Control, Brown University, July 1944. Div. 7-210.32-M3
40. *The Influence of the Visual Tasks Required of Personnel in the Sixteen Weeks Fire Controlmen (O) Training Course upon Their Visual Proficiency*, J. K. Adams, D. C. Beier, and Henry A. Imus, OSRD 3970, OEMsr-1171, Service Project N-114, Report 7, University of Wisconsin, Aug. 1, 1944. APP-216-M3
41. *A Comparison of Five Methods of Calibrating the Mark 42 Rangefinder*, H. A. Taylor, OSRD 3977, OEMsr-1171, Service Project N-114, Report 8, University of Wisconsin, Aug. 4, 1944. APP-651.1-M2
- 41a. *Ibid.*, p. 8, data extracted from Table I.
- 41b. *Ibid.*, p. 11, data extracted from Table II.
42. *The Precision of Internal Adjustment Settings by Student Operators and Experienced Operators on Stereoscopic Rangefinders*, E. B. Knauff, OSRD 3997, OEMsr-1171, Service Project N-114, Report 9, University of Wisconsin, Aug. 10, 1944. APP-216-M4
43. *An Investigation of the Effect of Brightness Contrast upon Operators' Errors in Ranging on Aerial Targets with the Mark 42 Rangefinder*, D. G. Ellson and H. A. Taylor, OSRD 4380, OEMsr-1171, Service Project N-114, Report 11, University of Wisconsin, Nov. 27, 1944. APP-651.1-M3
44. *An Experimental Determination of Variable Errors in Ranging on a Surface Target by Radars Marks 4, 8, and 10*, J. K. Adams, Florence E. Gray, and E. B. Knauff, OSRD 4688, OEMsr-1171, Service Project N-114, Report 17, University of Wisconsin, Feb. 13, 1945. APP-623-M3
45. *Studies of the Design of Opaque Reticles for Stereoscopic Range and Heightfinders*, Clarence H. Graham, Lorrin A. Riggs, and others, OSRD 4925, OEMsr-1059, Report to the Services 89, NDRC Division 7, Fire Control, Brown University, March 1945. Div. 7-210.31-M9
46. *Studies of the Design of Illuminated Reticles for Stereoscopic Range- and Heightfinders*, OSRD 5386, Report to the Services 93, NDRC Division 7, Fire Control, July 1945.
47. *Factors Influencing the Magnitude of Range-Errors in Free Space and in Telescopic Vision*, Dorothea A. Jameson, Alfred H. Holway, and others, OSRD 6635, OEMsr-555, Report to the Services 100, NDRC Division 7, Fire Control, Harvard University, October 1945. Div. 7-210.11-M7
48. *Comparison of 12 and 24 Power in Ranging on Fixed Targets*, Princeton University, Fire Control Research, Progress Report 3 to NDRC, Aug. 18, 1941.
49. *A Different Method of Obtaining Eye Focus, XIV-1 of Height Finder Studies*, Princeton University, Fire Control Research, Apr. 19, 1942.
50. *A Study of Backlash between the Main Bearing Race and the Bevel Pinion in M-1 and M-2 Heightfinders*, William C. Biel, William E. Kappauf, and E. B. Knauff, OEMsr-815, Report 8, Brown University, Sept. 9, 1943. APP-652-M4
51. *Wedge-Check and Leveling Problems in the M1 Height Finder*, Branch Memorandum 18, Princeton Branch, Frankford Arsenal Fire Control Design Section, Aug. 10, 1943.
52. *Service of Height Finders M1 and M2*, Field Manual 4-142, Antiaircraft Artillery, War Department, Oct. 20, 1943.
53. *Stereoscopic Range and Height Finding*, Technical Manual 44-250, War Department, June 15, 1944.
54. *Height Finders, 13½ ft., M-1 and M-1A1*, Technical Manual 9-623, War Department, Nov. 5, 1943.
55. *Height Finders, 13½ ft., M-2 and M-2A1*, Technical Manual 9-624, War Department, Nov. 27, 1943.

Chapter 23

1. *Studies of Voice Factors Affecting the Intelligibility of Voice Communication in Noise: Relation between Loudness of Voice and the Intelligibility of Airplane Interphone Communication*, James F. Curtis, OSRD 3313, OEMsr-830, Service Projects N-109(1) and SC-67, Report 5, The Psychological Corp., February 1944. APP-218.2-M2
2. *The Relative Intelligibility of Typical Methods of Holding the T-17 Microphone for Communication in Noise*, OSRD 3505, OEMsr-830, Service Projects N-109(1) and SC-67, Report 6, Voice Communication Laboratory, The Psychological Corp., May 1944. APP-218.2-M3
3. *Microphone Position of the T-30-S and T-17*, C. Horton Talley, James F. Curtis, and C. Hess Haagen, OSRD 4260, OEMsr-830, Service Project SC-67, Report 11, The Psychological Corp., Oct. 18, 1944. APP-218.4-M2
4. *Voice Loudness over Aircraft Radios and Microphones*, C. Horton Talley, James F. Curtis, Elwin J. O'Brien, and C. Hess Haagen, OSRD 4290, OEMsr-830, Service Project SC-67, Report 10, The Psychological Corp., Oct. 27, 1944. APP-218.4-M3
5. *Phonetic Characteristics of Words as Related to Their Intelligibility in Aircraft-Type Noise*,

RESTRICTED

- Harry M. Mason, OSRD 4681, OEMsr-830, Service Project SC-67, Report 13, The Psychological Corp., Feb. 10, 1945. APP-218.2-M7
6. *Phonetic Characteristics Related to Intelligibility of Words in Noise; Sounds Correctly Understood in Misunderstood Words*, Harry M. Mason, OSRD 5174, OEMsr-830, Service Project SC-67, Report 15, The Psychological Corp., June 6, 1945. APP-218.2-M8
 7. *Studies of Voice Factors Affecting the Intelligibility of Voice Communications in Noise, Part II, Pitch*, I. P. Brackett, Harry M. Mason, and C. Horton Talley, OSRD 5413, OEMsr-830, Service Project SC-67, Report 16, The Psychological Corp., Aug. 4, 1945. APP-218.2-M9
 8. *Training Studies in Voice Communication, Part III, Effects of Training in Articulation*, Harry M. Mason, C. Hess Haagen, James F. Curtis, and John H. Wiley, OSRD 5461, OEMsr-830, Service Project SC-67, Report 18, The Psychological Corp., Aug. 20, 1945. APP-218.2-M11
 9. *Summary of Work on Voice Communication (Final Report)*, John W. Black, OSRD 5568, OEMsr-830, Service Project SC-67, Report 21, The Psychological Corp., Sept. 11, 1945. APP-218.1-M3
 10. *AAF Letter 50-93*, authorizing interphone training in the Continental Air Forces.
 11. *Use of the Interphone*, AAF Manual 100-126-1.
 12. *Radiotelephone and Interphone Communications*, a summary of AAF Manual 100-126-1 distributed to the Far East Air Forces.
 13. Summaries of interphone procedure related to aircrew specialists for specialist information files (pilots, navigators, bombardiers, radio operators, and gunners).

Chapter 24

1. *Proceedings of Part I of the Joint Army-Navy-OSRD Conference on Psychological Problems in Military Training, Conference held August 15 and 16, 1945*, John L. Kennedy, OSRD 6079, Washington, D. C., Oct. 11, 1945. APP-690-M4
2. *Psychotechnological Factors in the Design of Flexible Gunnery Equipment*, Karl U. Smith, OSRD 6222, OEMsr-1171, Service Project AC-94, Memorandum 6, University of Wisconsin, Oct. 26, 1945. APP-610-M8
3. *Design and Tests of Rifle Sights*, Supplement to Minutes and Proceedings of the Army-Navy OSRD Vision Committee, 14th Meeting, C. J. Warden, Sept. 11-12, 1945.
4. *Variation of Visual Reaction Time with Trigger Load*, K. J. W. Craik, H. C. L. Holden, and B. A. Langford, BPC 42/101, MPRC-MRC, Cambridge, Eng. (undated).
5. *Effects of Cold upon Hand Movements and Reaction Times*, K. J. W. Craik and S. F. Macpherson, BPC 43/196, MPRC-MRC, Cambridge, Eng., Mar. 13, 1943.
6. *Psychological and Physiological Aspects of Control Mechanisms with Special Reference to Tank Gunnery, Part I*, K. J. W. Craik and M. Vince, BPC 43/254, MPRC-MRC, Cambridge, Eng., Aug. 30, 1943.
7. *The Effect of Trigger Load on the Accuracy of Aim in Tank Gunnery*, Supt. AORG, AORG Report 141, Sept. 8, 1943.
8. *Instrument Controls and Display*, F. C. Bartlett, RNP 43/81, Cambridge, Eng., Dec. 10, 1943.
9. *Some Physiological Aspects of Tank Driving Controls, Part II: Characteristics of the Clutch Pedal*, BPC 44/379, P. Hugh Jones, MPRC-MRC, September 1944.
10. *The Pressure Which Can Be Exerted by the Foot of a Seated Operator with the Leg in Various Positions*, W. E. LeGros Clark and G. M. Weddell, RNP 44/153, GS 46, MRC-RNPRC, University of Oxford, November 1944.
11. *Visual Data*, K. J. W. Craik, Cambridge, Eng. (undated).

Chapter 25

1. *Job Analysis Procedure*, Morris S. Viteles and Kinsley R. Smith, OSRD 1209, OEMsr-700, Service Project N-105, Project Memorandum 2, University of Pennsylvania, Jan. 15, 1943. APP-510-M1
2. *The Use of a Template in Making the Interocular Setting on the Height Finder*, William E. Kappauf and W. J. Brogden, OSRD 1373, OEMsr-815, Research Project PDRC-759, Project Memorandum 2, Brown University, Apr. 7, 1943. APP-652-M1
3. *The Design, Accuracy, Construction and Use of a Rangefinder Slide Rule*, J. K. Adams and T. R. Whitney, OSRD 3678, OEMsr-1171, Service Project N-114, Memorandum 3, University of Wisconsin, May 1, 1944. APP-651-M1
4. *Summary of Work on Voice Communication (Final Report)*, John W. Black, OSRD 5568, OEMsr-830, Service Project SC-67, Report 21, The Psychological Corp., Sept. 11, 1945. APP-218.1-M3
5. *Micromotion Analysis of the Service of the 3"/50*

RESTRICTED

- Gun*, David B. Porter and S. Medford Wesley, OSRD 6176, OEMsr-700, Service Project NR-106, Memorandum 30, University of Pennsylvania, Oct. 19, 1945. APP-610-M7
6. *Review of the Project's Comments on the Operating Characteristics of the Gun Directors Mark 51 and Mark 52, and its Suggestions for the Improvement in the Design of These Directors* (Enclosure m), William E. Kappauf, Service Project N-111, Informal Memorandum 6, Brown University, Nov. 10, 1944. APP-611.3-M3
7. *Test Model of Panoramic Telescope M-12 (T-138)*, John P. Nafe, OEMsr-581, Service Project SOS-11, Informal Memorandum 5, Tufts College, Apr. 2, 1945. APP-611.12-M3
8. *Operating Instructions: Gun Director Mark 52*, U. S. Fleet, Office of the Commander-in-Chief, January 1945.
9. *Operating Instructions: Gun Fire Control System Mark 63*, U. S. Fleet, Office of the Commander-in-Chief, March 1945.
10. *The Energy Output of 16" MK III Magazine Crews*, J. A. B. Gray, W. D. M. Paton, Lt. Com. J. Streatfield, and G. Weddell, RNP 45/189, G. S. 58, Gunnery Sub-Committee, RNPRC-MRC (undated).

RESTRICTED

OSRD APPOINTEES

APPLIED PSYCHOLOGY PANEL

Chiefs

W. S. HUNTER

C. W. BRAY

Technical Aides

C. W. BRAY

J. L. KENNEDY

DAEL WOLFLE

Members

G. K. BENNETT

W. S. HUNTER

C. W. BRAY

J. M. STALNAKER

LEONARD CARMICHAEL

M. S. VITELES

C. H. GRAHAM

DAEL WOLFLE

CONTRACT NUMBERS, CONTRACTORS, AND SUBJECTS OF CONTRACTS

<i>Contract Number</i>	<i>Contractor</i>	<i>Subject</i>
OEMsr-581	The Trustees of Tufts College Medford, Massachusetts	Studies of operator performance and sources of error in the operation of field artillery, tank destroyer, and tank guns, and in all types of antiaircraft equipment.
OEMsr-614	National Academy of Sciences Washington, D. C.	To establish a Committee to carry on research on selection, training, and related problems of manpower use; to study the design of equipment in terms of human capacities; to advise NDRC as to additional research required in the above fields and to recommend to NDRC contractors for carrying on the work.
OEMsr-700	The Trustees of the University of Pennsylvania Philadelphia, Pennsylvania	Studies in the selection and training of naval gun crews and personnel for destroyers and destroyer escorts; evaluation of methods of training free (aerial) gunners.
OEMsr-705	College Entrance Examination Board Princeton, New Jersey	Studies and experimental investigations necessary to develop the Navy's aptitude and achievement testing program.
OEMsr-815	Brown University Providence, Rhode Island	Studies and experimental investigations in connection with the selection and training of heightfinder and rangefinder operators and fire controlmen; preparation of operating instructions for Navy gun directors; improvement in the design of fire control equipment.
OEMsr-830	The Psychological Corporation New York, New York	Studies in the selection of men for communication by voice and by radio code; development of methods of training voice and radio code communication personnel; development of a device for transferring Morse code signals to typescript.
OEMsr-834	Brown University Providence, Rhode Island	Studies of methods of identifying emotionally unstable men prior to their assignment to military duty; studies of the usefulness of Battle Noise Equipment in selecting and training military personnel and retraining psychiatric casualties.
OEMsr-919	Yerkes Laboratories of Primate Biology, Inc. Orange Park, Florida	Studies of the selection and training of radar operators and the operation of radar equipment.
OEMsr-1136	Princeton University Princeton, New Jersey	Studies of the selection and training of night lookouts and of night lookout performance.

CONTRACT NUMBERS, CONTRACTORS, AND SUBJECTS OF CONTRACTS—(Continued)

<i>Contract Number</i>	<i>Contractor</i>	<i>Subject</i>
OEMsr-1171	The Regents of the University of Wisconsin Madison, Wisconsin	Studies to develop military requirements for flexible gunnery equipment which should be determined by the characteristics of Army gunners; to assist in the development of valid training methods for flexible gunners; to develop adequate methods for the selection and training of personnel for duty in gun directors.
OEMsr-1213	The President and Fellows of Harvard College Cambridge, Massachusetts	Studies of methods of testing the relative strength of various interests by determining activity preferences.
OEMsr-1298	The Trustees of Pennsylvania State College State College, Pennsylvania	Studies of job analysis, qualification, and placement of personnel in the amphibious forces.
OEMsr-1340	The Board of Trustees of the Leland Stanford Junior University Stanford University, California	Studies of methods and devices to aid in the classification and placement of men in naval jobs.
OEMsr-1372	The Trustees of the University of Southern California Los Angeles, California	Studies in the selection and training of hatchmen and winchmen specialist teams on AKA and APA vessels.

SERVICE PROJECT NUMBERS

The projects listed below were transmitted to the Office of the Executive Secretary, OSRD, from the War or Navy Department through either the War Department Liaison Officer for NDRC or the Office of Research and Inventions (formerly the Coordinator of Research and Development), Navy Department.

<i>Service Project Number</i>	<i>Title</i>
<i>Army Projects</i>	
AC-92	Investigation of the Ability of Gunners to Learn the Use of Remote Fire Control Systems of Flexible Gunnery.
AC-94	Psychological Factors in the Operation of Flexible Gunnery Equipment.
SC-67	Training Program in Voice Communication.
SC-70	Selection and Training of Radar Operators.
SC-88	Methods of Training Radio Code Operators.
SOS-6	Study of Operator Performance on all Types of Antiaircraft Equipment.
SOS-7	Development of an Activity Preference and Interest Inventory.
SOS-11	Psychological Factors in Operation and Design of Field Artillery, Tank Destroyer and Tank Sighting Equipment.
.....	Selection and Training of Height Finder Operators.
<i>Navy Projects</i>	
N-100	Committee on Applied Psychology in the War and Committee on Service Personnel—Selection and Training.
N-104	Determination of Reliability, Objectivity, Validity and Independence of Medical Tests.
N-105	Selection and Training of Naval Gun Crews.
N-106	Research and Development of the Navy's Aptitude Testing Program.
N-107	Selection and Training of Radio Code Operators.
N-109	Selection and Training of Personnel Using Voice Communication Systems.
N-111	Psychological Problems in Operation of Antiaircraft Lead Computing Sights and Directors.
N-112	Study and Evaluation of Sighting Methods of Instruction Used in U. S. Naval Free Gunnery Training.
N-113	Research on a Personal Inventory and other Tests for Selection for Special Service Tasks.
N-114	Selection and Training of Rangefinder and Radar Operators.
N-115	Selection and Training of Night Lookouts.
N-116	Selection and Training of Personnel.
N-117	Job Analysis, Qualification and Placement of Personnel in the Amphibious Forces.
NR-106	Selection and Training of Personnel Assigned to Destroyers and Destroyer Escorts.
NS-146	Selection and Training of Radar Operators.
NS-366	Development of Morse Code Actuated Printer.

INDEX

The subject indexes of all STR volumes are combined in a master index printed in a separate volume. For access to the index volume consult the Army or Navy Agency listed on the reverse of the half-title page.

- A scope, radar, 235-246
 ambient illumination, 238-239, 242-243
 fatigue effects, 244
 visual effects on operators, 245-246
- Achievement tests, 155-178
 administration procedures, 166-169
 amphibious craft crews, 87
 characteristics of a good examination, 169
 criterion for validating selection tests, 173
 effect on learning, 171-173
 identification tests, 158
 improvement of service school grades, 176-178
 pencil-and-paper tests, 157
 performance ratings, 159-162
 performance tests, 162-166
 product ratings, 159
 quality control, 174
 reliability, 171
 search radar operators, 15
 teacher evaluation, 176
 types, 157
 uses, 155-157
 validity, 169
- Adaptation, dark, night lookout trainer, 74-75
- Aerial gunnery, performance measurement, 58-61, 222-232
 airborne mock-up, 223-225
 airborne synthetic trainer and test device, 226-227
 air-to-air firing, 222
 checksight, 60-61
 ground mock-up, 223
 hand controls for B-29 sight, modified, 229-231
 modified E-14 trainer, 222-223
 remote control test devices, 225-226
 scoring gun camera film, 58-60
 sight damping, 231-232
 slewing, 231
 triggering, 228-229
- Aerial gunnery trainers, 154, 222-227
- Aerial gunsight design, psychological factors, 291-295
 elimination of operations requiring judgment, 291-292
- emotional factors, 295
 fatigue, 295
 motor coordination factors, 292-294
 perceptual factors, 294-295
 physical comfort, 291
 postural factors, 292
 reaction time, 294
 training factors, 295
- Aerial target range estimation, 52-55, 196-199
 comparison of methods, 197-199
 experimental results, 54-55
 logarithmic analysis of data, 53-54
 methods of training experimental groups, 52-53
 testing procedure for estimation experiments, 53
- Aided ranging, 263
- Aided tracking, 20, 181
- Aids in teaching; *see* Teaching aids
- Air to surface vessel (ASV) radar, measures of training progress, 16
- Airborne mock-up, gunnery, 223
- Airborne radar operators; *see* Radar bombing training
- Airborne synthetic trainer and test device, 226
- Aircrew personnel training in voice communication; *see* Voice communication training, aircraft
- Air-search radar, 11-12
- AKA (assault cargo auxiliary) ships, winch operator training, 83
- Ambient illumination with radar display, 238-239, 243
- American Cystoscope Company reflector sight, 182
- Amphibious craft crews, training, 86-89
 achievement tests, 87
 gas defense and piloting, 88
 job analysis, 88-89
 personality analysis, 87-88
 questionnaire for returning combat personnel, 88-89
 summary and background, 3, 86
 training manual, 89
 training of amphibious base instructors, 86-87
- Amphibious training bases (ATB), 86-89
- Amphibious Training Command manual, 89
- Analysis of jobs; *see* Job analysis
- Antiaircraft fire control, 5, 179-205
 alignment procedures, 202-203
 anatomical requirements, 185-189
 burst spotting methods, 201-202
 checksights and checksighting methods, 203-204
 CIC operating procedures, 200
 computing sight M7 in 40 mm firing, 194
 design improvement, 189-190
 director design, 185-189
 director maintenance, 201-203
 operating procedures for Navy gun crews, 191, 199-200
 range determination methods, 196-199
 solution indicator for fire control problems, 204
 speed ring methods in 40 mm firing, 192-194
 summary and evaluation of research, 5, 179, 204-205
 telescope and sight studies, 182-185
 tracking control studies, 180-182
 tracking error correction methods, 195-196
- Antiaircraft fire control training; *see* Range determination, training; Tracking training
- APA (assault personnel auxiliary) ships, winch operator training, 83
- Arithmetical reasoning test (AR), 173
- Armament Laboratory, Wright Field, 231
- Armored Medical Research Laboratory, 206
- Army computing sight M7; 145, 194
- Articulation, effect on speech intelligibility, 275-276
- A-scan, double for airborne search radar, 235
- A-scope radar, 235-246
 ambient illumination, 238-239, 242-243

- fatigue effects, 244
visual effects on operator, 245-246
- Assault cargo auxiliary (AKA) ships, winch operator training, 83
- Assault personnel auxiliary (APA), ships, winch operator training, 83
- ASV (air to surface vessel) radar, measures of training progress, 16
- ATB (Amphibious training bases), 86, 89
- Attack boat personnel, training, 88
- Azimuth tracking, 180-182
- B-29 computer, 225
- B-29 gunnery training, 57-62, 219-227
coaching experiment, 61-62
equipment, 225-227
job analysis, 219-221
measurement of performance, 58-61, 222-225
modified hand controls for B-29 sight, 229-232
ranging and tracking abilities, 57
summary and conclusions of research, 2, 57, 62
triggering, effect on accuracy, 228-229
- B-29 gunsights; *see* Gunsight, B-29
- Backlash tests for heightfinders, 261
- Bausch and Lomb Ortho-rater, 245
- BC telescope method of burst ranging, 200-201
- Billet analyses, amphibious craft, 88-89
- Binoculars for night lookouts, 67, 75-76
- Bombing, radar; *see* Radar bombing training (ROB)
- B-scope radar, 236
- BuAer operational flight trainers, 143, 146
- BuOrd gunnery trainers, 141, 143
- Burst ranging methods in trial shot fire, 200-201
- Buzzer-training technique for tracking, 28
- Call-back method for acquiring code skill, 109
- Camera for scoring gunnery performance, 58-60
- Cameras, recording, for scoring trackers, 21-22
- Cargo handling trainer, 154
- Carnegie Institute of Technology, optical instruments for ranging, 265
- Checksight scoring, 19-30, 203-204
average error at selected bearing points, 26
average tracking error, 25-26
B-29 gunners, 60-61
elbow telescope M1A1; 22
per cent time on target, 25
Plexiglas, 22
use in selection of personnel, 30
- CIC (combat information center), operation of antiaircraft equipment, 200-201
- Code, radar, 247-248
- Code receiving tests, 117-118, 119
- Code training, Morse; *see* International Morse code, training
- Code-voice method, learning Morse code, 3, 107-109
- Coincidence rangefinder, 196
- Combat information center (CIC) operation of antiaircraft equipment, 200-201
- Communication, code; *see* International Morse code, training
- Communication, voice; *see* Voice communication training, aircraft
- Communication equipment, operating techniques, 90-97, 280-283
T-17 microphone, 280-282
T-30 microphone, 282-283
telephone, 90-97
volume control, 283
- Communication trainers, 154
- Computer Mark 13; 190
- Contrast, as a source of error in measuring performance of lookouts, 67
- COTCPac, survey of telephone talker training, 94-95
- Co-tracker guidance method, tracking training, 28
- Counter type scale for panoramic telescopes, 214-216
- Coxswain performance rating scale, 161
- C-scope radar, 236
- Destroyer escort (DE) program, training engineers, 80-81
- Direct fire procedure for air gun crews, 314
- Direct line-of-sight tracking, 20
- Directors, antiaircraft; *see* Antiaircraft fire control
- Disturbed line-of-sight tracking, 20
- Division 7, NDRC rangefinder and heightfinder research, 252
- Dot type of radar trainer, 39-40
- Drift errors, fire control radar, 249
- Drills, 91-93, 116-117
code learning, 135
Navy telephone talkers, 91-93
outlines, 36
training Navy operating engineers, 81
- E-14 Trainer, modified (gunnery), 222
- Eastman coincidence rangefinder, 196
- Eastman Kodak instrument for testing visual acuity, 265
- Eastman trainer for range determination, 42
- Eikonometer, stereoscopic acuity, 264
- Electric winch trainer, 83-84
- Electronic trainers, Navy Search Radar, 14
- Enemy planes, classification, 47
- Engineers (operating), Navy, training, 2, 79-82
- Equipment design principles, 6, 130, 284-295
check list technique in equipment criticism, 290-295
choice of type of system, 284-285
human factors, 286-288
mechanization details, 285-286
psychological factors, computing sight equipment, 291-295
recommendations for future research, 288-290
standardization of units, 289-290
testing new devices, 286, 289
training features, 286
- Equipment, military, operating procedures, 6, 296-311
- ESF (equivalent square feet) unit, 66
- Examinations; *see also* Achievement tests
amphibious craft crews, 87
radio code receiving, 119
search-radar operators, 15
"Eyes of the ship"; *see* Night lookouts

RESTRICTED

- Face validity, achievement tests, 169, 171
- Fatigue in radar operation, 244
- Field artillery equipment, errors in operation, 206-218
frequency of errors, 207
100 mil error, 206, 214
panoramic telescope scale errors, 208-216
recording systems for error analysis, 216-217
research recommendations, 217-218
sources of error, 206-207
- Film (gun camera) for recording gunner performance, 58-60
- Film trainer, H2X, 16
- Fire control (antiaircraft), training; *see* Range determination, training; Tracking training
- Fire control equipment; *see* Antiaircraft fire control
- Fire-control radar, drift errors, 249
- 5C-4, mirror range estimation trainer, 17-19, 49-50, 143
- Flexible gunners; *see* B-29 gunnery training; Gunsights, B-29
- 40 mm firing, speed ring method, 192-194
- Foxboro Instrument Company, tracking controls, 180, 185
- Foxboro radar trainer, 143, 145, 152
see also Pip matching radar trainers
- Gas defense, attack boat personnel, 88
- Gauges, product ratings, 159
- General classification test (GCT), 173
- German panoramic telescope, scale errors, 214-215
- Glare, effect on tracking accuracy, 184
- Glossary of Naval terms, 93
- Ground mock-up, B-29 gunnery, 223
- Gun camera film for scoring gunnery performance, 58-60
accuracy, 59-60
description, 58-59
measurement vs. estimation, 60
- Gun crew procedures, job analysis, 191-192
- Gun director and tracking trainers, 154
- Gun directors; *see* Antiaircraft fire control
- Gunner performance measurement; *see* Aerial gunnery, performance measurement
- Gunnery, B-29; *see* Aerial gunnery, performance measurement; B-29 gunnery training; Gunsight, B-29
- Gunnery (20 mm), outline of a 4-day course, 134
- Gunnery trainers, 35, 80, 154
- Gunnery training, Navy, 79-82, 316-317
- Guns, antiaircraft; *see* Antiaircraft fire control
- Gunsight, aerial, psychological factors affecting design; *see* Aerial gunsight design, psychological factors
- Gunsight, B-29; 5-6, 219-232
comparison of modified and standard controls, 231
friction damping vs. viscous damping, 232
modified hand controls, 229-231
sight damping, 231-232
- Gunsight Mark 14; 49-50
- Gunsight Mark 15; 190, 316
- H2X film trainer, 16
- Handwheel tracking design, pointer-matching operations, 120-181
- Haze effect on heightfinders, 267
- Haze effect on lookouts, 67
- Heightfinder operations, 2, 251-269
aided stereoscopic ranging, 263-264
backlash tests, 261
calibrating procedures, 259-261
general description, 251-252
height of image adjustments, 261
internal adjuster system, 265-266
interpupillary distance settings, 252-257
magnification, 266-267
manual, 258
optical presentation, 265
parallax errors, 252, 257-258
ranging accuracy, 251-252
research recommendations, 264-265, 267
reticle design, 266
slot diaphragms, 257-258
summary of training, 2
templates, interpupillary distance, 257
visual effects, 264
- visual judgment, 267-268
zero mils adjustment checks, 261-262
- Heightfinder operators, training; *see* Stereoscopic rangefinder operator, training
- Heightfinder performance, psychophysiological factors, 267-269
haze, 267
hyperventilation, 268
loud sounds, 268
metrazol and benzedrine, 268
ocular conditions, 268
reticle imperfections, 268
sex differences, 268
sleep, 268
target-background contrast, 267
- Height-of-image adjustment, heightfinders, 44, 261
- Identification friend or foe (IFF) procedures, 13-14
- Identification tests, achievement measurement, 158-159
- Illuminated sight Mark 7; 182
- Instructor training, 81-82, 86-87
amphibious craft crews, 86-87
gunnery and engineering, 81-82
- Instrument design; *see* Equipment design principles
- Intelligibility tests, speech training 99-100, 103-104
- Internal adjuster system, heightfinders, 265-266
- International Morse Code, training in receiving, 107-120
analysis of errors, 113-116
call-back method of learning code, 109
code-voice method of learning code, 107-109
hand-sent clear text as practice material, 112-113
interference effects on ability to copy code, 113
measurement of speed, 117-120
practice, 109-111
standardization of speeds, 120-121
training high speed operators, 116-117
training to copy through interference, 113
- International Morse Code, training in sending, 121-123
effect of early introduction of sending upon learning to receive, 121-122

RESTRICTED

- Morse-code-actuated printer, 122-123
 order of difficulty of characters, 122
- Interpupillary distance settings, heightfinders, 252-257
- Interpupillary scales, heightfinders, 256
- Interpupillometer, NDRC, 253-256
 design, 253-255
 measuring procedure, 255
 reliability, 255-256
- Job analysis, 127-131, 191-201, 219-221
 amphibious enlisted billets, 89
 B-29 gunner, 219-221
 CIC, 200-201
 comparison of speed ring methods in 40 mm firing, 192-194
 description of duties, 129-130
 gun crew procedures, Navy, 191-192
 light Navy gun director, 199-200
 presentation of findings, 127-128
 use in training program, 130-131
 J-scope, radar equipment, 236, 240
- Landing craft trainer, 154
- Lead tracking in 40 mm firing, 192-194
- Learning curves, 44-46, 119-120
 code receiving, 119-120
 search-radar training, Navy, 14
 stereoscopic ranging, 44-46
 tracking errors, 35
- Learning principles in military training; *see* Military training, learning principles
- Learning rate, 119-120
 Morse code, 119-120
 stereoscopic ranging, 44-46
 tracking, 29, 35
- Lesson plans, 132-139, 150
 classroom use, 138-139
 course objectives, 132-133
 organizing and writing lesson plans, 134-138
 outlining the course, 133-134
 summary of uses, 4, 126
- Line of sight tracking, 20
see also Tracking controls, Tracking training
- Link celestial navigation trainer, 146
- Link instrument trainer, 141, 148, 152
- Logarithmic error, range estimation, 54
- Lookouts, night; *see* Night lookouts
- Loudness level tests, voice communication, 271-274
 equipment, 272
 experimental technique, 271-272
 results, 272-274
- M2 stereoscopic trainers, 42
- M5 gun director, 181, 195
- M7 computing sight, 145, 194, 195
- M7 gun director, 195
- M12 modified panoramic telescope, 214-215
- M12 panoramic telescope, 208-217
- Machine gun trainer Mark 1; 146
- Magnification, antiaircraft director telescopes, 185
- Magnification, heightfinder, 266
- Manuals; Amphibious Training Command, 89
 code receiving tests (for instructor's use), 117
 heightfinder operations, 42-43
 lookout training, 76-77
 sample pages, 304-319
 stadiametric ranging, 47
 telephone talkers', 92, 96
 voice communication training, 102-103
- Mark 1 gunnery trainer, 141
- Mark 1 range indicator, 196-197
- Mark 2 stereoscopic trainer, 42
- Mark 3 BuOrd gunner trainer, 141, 143
- Mark 5 BuOrd gunner trainer, 141
- Mark 7 illuminated sight, 182
- Mark 12 radar, 241
- Mark 13 computer, 190
- Mark 14 gunsight, 49-50, 197-199
- Mark 15 gunsight, 190, 316
- Mark 37 director, 241
- Mark 42 rangefinder, 266
- Mark 51 gun director, 186-189, 200
- Mark 52 gun director, 183, 189-190, 200, 316
- Mark 56 gun fire control system, 200
- Mark 60 gun fire control system, 200
- Mark 63 gun director, 186-189, 190
- Mark 63 gun fire control system, 203
- Mechanical-optical trainer for target analysis, 14
- Microphones, operating techniques, 280-283
 T-17; 280-282
 T-30; 282-283
- Military equipment, design principles; *see* Equipment design principles
- Military training, learning principles, 124-126
 active participation, 125
 distribution of practice, 124-125
 knowledge of results, 14, 27-29, 126
 lesson plans, 126
 practice effects, 124-126
 records of progress, 125-126
 variation of material, 125
- Military training problems, 1-7
- Mirrorphone trainer, 147
- Mirror range estimation trainer, 17-19, 49-50, 143
- Mock-up, ground and airborne, 223
- Morse code, training; *see* International Morse code training
- Morse-code-actuated printer, 122
- Motivational principles, military training, 124-126
- Naval Training Station, Bainbridge, Maryland, training telephone talkers, 91
- Navy, search radar training; *see* Search radar, training
- Navy engineers (operating), training, 2, 79-82
 improvements in instruction, 82
 instructor training, 81-82
 summary, 2, 79-80, 82
 training procedures, 80-81
- Navy gunners, training, 79-82
- Navy telephone talkers, training, 90-97
 coordination of training ashore and afloat, 95-96
 evaluation of improvements, 97
 instructional methods, 91-95
 summary, 90-91
 training instructors, 95
 voice communications training for submarine service, 96-97
- NDRC interpupillometer, 253
- NDRC rangefinder and heightfinder research, 252
- New York University, Navy gun crew procedures, 191
- Night lookout, 63-78
 dark adaptation, 74
 data corrections, 64
 performance aboard ship, 63-71
 recommendations for training, 77-78
 summary of training, 2, 63
 training equipment, 71-77

RESTRICTED

- Night lookout trainers, 71-75
 Model A, 71-74
 Model B, 74-75
 Night vision trainer, 154
 100-mil error gunnery, 206, 214
 Operating engineers, Navy, training, 2, 79-82
 Operating procedures, standard, 6, 296-311
 Optical systems, rangefinders, 265
 Optical trainers, tracking, 33-36
 gunnery trainer Mark 5; 35
 Tufts' M7 trainer, 33-35
 Ortho-rater, visual acuity tests, 264
 Panoramic telescopes, 208-216
 research recommendations, 217
 scale reading errors, 208-217
 Parallax errors in ranging, 252, 257-258
 Performance ratings, 159
 Performance records, 58-61, 125-126
 Performance tests, 162-166
 Personality analysis, training amphibious craft crews, 87-88
 Personnel factors in equipment design, 286-288
 operator attitude, 288
 operator efficiency, 287-288
 operator qualifications, 287
 operator training, 288
 Personnel problems, amphibious craft crews, 87-88
 Personnel requirements, job analysis, 130
 Philco trainer, radar, 147, 244
 Phonograph recordings for training telephone talkers, 93
 Photography of gunnery performance, 58-60
 Phototube scoring device for tracking, 26-27
 Pip-matching radar trainers, 36-39
 Foxboro, 36-39
 optical-mechanical, 38-39
 Plan position indicator (PPI) scope, 236, 244
 Plan position indicator (PPI) trainers, 11, 144
 Polaroid ring sight for tracking, 182
 Position tracking, 20, 180-181
 PPI; *see* Plan position indicator scope
 Princeton University, stereoscopic trainer, 42, 252
 Product ratings, achievement measurements, 159
 Psychiatric cases, amphibious craft crews, 87-88
 Psychological principles, equipment design, 4-5, 286-295
 elimination of operations requiring judgment, 291-292
 emotional factors, 295
 fatigue, 295
 motor coordination factors, 292-294
 operator attitude, 288
 operator efficiency, 287-288
 operator qualifications, 287
 operator training, 288
 perceptual factors, 294-295
 postural factors, 292
 reaction time, 294
 training factors, 295
 Psychological principles in military training; *see* Military training, learning principles
 Quality control, achievement tests, 174-178
 improvement in school grades, 176-178
 Landing Craft School, 174-175
 radio schools, 175-176
 teacher evaluation, 176
 Radar, search; *see* Search radar, training
 Radar bombing training (ROB), 15-18
 criticisms and suggestions for training, 15-16
 description of training course, 15-18
 equipment, 6
 error analysis, 17-18
 H2X film trainer, 16
 measures of progress, 16
 radar scope movies, 16
 Radar code, 247-248
 Radar equipment, operation, 234-244, 248-250
 ambient illumination, 242-243
 calibrating and operating procedures, 248-250
 checking equipment, 304-307
 comparison of light-trace and dark-trace scopes, 242
 direct fire procedure, 314-315
 integration and teamwork among operators, 237-238
 scope and trace brightness, 242-244
 scope displays, 235-237
 summary and recommendations, 1, 234-235, 239-240
 tracking methods, accuracy, 240
 tuning and calibrating adjustment of controls, 237
 Radar operation, psycho-physiological factors, 244-246
 fatigue effects, 244-245
 harmful effects of radiation absorption, 246
 visual effects, 245-246
 Radar scopes; *see* Scope displays, radar
 Radar tracking, 20, 201-203
 Radar tracking demonstrator, 40
 Radar tracking trainers, 36-40, 154
 Foxboro, 143, 145, 152
 pip-matching, 36-39
 T and E type, 39-40
 Radio code, learning; *see* International Morse code, training in receiving
 Radio operators, training, 106-123
 receiving Morse code, 107-120
 sending Morse code, 121-123
 summary, 3, 106-107
 Radio telephone, aircrew communication; *see* Voice communication training, aircraft
 Radium plaque, night lookout trainer-Model A, 71, 72-73
 Range determination, training, 41-56, 196-199
see also Stereoscopic range finder operator, training
 estimation, 50-56, 196-199
 methods, 196-199
 procedures for short range targets, 308-311
 stadiametric ranging, 47-50
 stereoscopic rangefinder and heightfinder operators, 42-47
 summary, 2, 41
 Range estimation, 196-199
see also Aerial target range estimation
 Range indicator Mark 1; 196-197
 Rangefinders; *see* Heightfinder operations
 Rate control tracking, 20, 181
 Rating scale for performance tests, 160
 Recording cameras, scoring trackers, 21-22
 Recording systems for field artillery error analysis, 215-217
 Reflector sight, American Cystoscope Company, 182

RESTRICTED

- Remotely controlled ground trainer
for B-29 gunner, 226
- Research recommendations; equip-
ment design, 288-291
heightfinders, 264-267
panoramic telescope, 217
- Reticle design for heightfinders,
266
- Reticle Mark 14, for stadiametric
ranging, 49-50
- Reticle patterns, antiaircraft di-
rector telescopes, 182-185
- Ring sight, Polaroid, 182
- ROB; *see* Radar bombing training
- Scale errors, field artillery equip-
ment operation, 207-216
frequency, 207
panoramic telescope scales, 208-
216
- Scope displays, radar, 16, 235-237
ambient illumination, 242
A-scope, 235
brightness, 243
B-scope, 236
C-scope, 236
double A-scan, 235
J-scope, 236
PPI-scope, 236
- SCR-584 radar, range tracking
unit, 240
- Search radar, training, 8-15
achievement examinations, 15
air search, 11-12
calibration and tuning, 12
functions of radar operator, 10-
14
manipulation of controls, 12
schools, 8
suggestions for improvement, 9
summary, 1, 8-10
surface search, 10-12
synthetic targets, 11, 15-16
tactical uses of equipment, 10-12
target analysis, 13-14
trainers, 14
- Shuron pupillometer, 253
- Sight design, antiaircraft director
telescopes, 182-185
- Size judgments in ranging; *see*
Stadiametric ranging, train-
ing
- Slot diaphragm for heightfinders,
257-258
- Solution indicator, fire control
problems, 204
- Speech intelligibility factors, 3,
271-277
articulation, 275-276
- loudness, 271-274
pitch, 275
rate, 275
regional differences, 277
- Speech training courses, AAF, 98-
105
description, 100-102
effects of training, 103-105
instructional manuals, 102-103
- Speed of response code aptitude
test, 122
- Speed ring method of lead tracking,
192-194
- Stadiametric ranging, training, 47-
50
difficulty for antiaircraft firing,
47
manual, 47-49
training with Mark 14 reticle,
49-50
- Stereoscopic rangefinder operator,
training, 42-47
learning rates, 44-46
manuals, 42-43
overtraining, 44, 46
proficiency data, 46-47
training aids, 43-44
- Stereoscopic trainers, 42
- Submarine phraseology, 318
- Surface-search radar, 10-12
- Synthetic trainers; *see* Trainers
- T-17 microphone, 280-282
- T-30 microphone, 282-283
- T-138 panoramic telescope, 214-215
- T and E type radar trainers, 39-40
- Tangent-type rangefinder, 196
- Target analysis, Navy search-
radar, 13-14
- Target range estimation, aerial; *see*
Aerial target range estima-
tion
- Teacher training; *see* Instructor
training
- Teaching aids, 4, 80-82, 88-89, 132-
139
see also Manuals
gunnery training, 80
lesson plans, 132, 134-139
operating engineers, 81
outlines of courses, 132, 133-134
stereoscopic rangefinder opera-
tors, 42
telephone talkers, 93
- Telephone communication, experi-
ments of intelligibility, 3,
- Telephone communications, phrase-
ology standardization, 96-97,
318-319
- Telephone talkers' manual, 92
- Telephone talkers, training, Navy;
see Navy telephone talkers,
training
- Telescope studies, antiaircraft di-
rectors and guns, 182-189
magnification, 185
reticle patterns, 182-185
tracking hand design, 186-189
- Telescopes, panoramic, 208-216
- Testing achievement in military
training; *see* Achievement
tests
- Tracking controls, antiaircraft di-
rectors and guns; aided
tracking, 181
handwheel design for pointer-
matching operations, 180-
181
variable speed controls, 181-182
velocity tracking, 181
- Tracking error, average, 25-27
- Tracking training, 19-40, 312-313
checksights, 22-26
coaching method, 28-29
experiments, 27-29
instructional aids, 40
measurement of tracker's skill,
20-27
optical trainers, 33-36
phototube scoring device, 26-27
qualitative measurements, 20-21
radar tracking trainers, 36-40
recording cameras, 21-22
retention of tracking skills, 31
selection of personnel, 30
summary, 1, 19, 30-33
training goals, 30
transfer of skill from one device
to another, 31-33
types of tracking, 19-20
- Trainers, 4, 140-154
characteristics of good instruc-
tion, 148
characteristics of good trainers,
141-147
comparison with real equipment,
143, 151-153
definition, 141
evaluation, 140-141, 153-154
face validity, 143
knowledge of results, 144-146
lesson plans, 150-151
list of trainers built by APP,
NDRC, 154
physical characteristics, 146-147

90-97
CLASSIFICATION CHANGED TO
UNCLASSIFIED
AUTHORITY

RESTRICTED

UNCLASSIFIED

ATI- 14518

TITLE: Human Factors in Military Efficiency

REVISION (None)

AUTHOR(S) : Lindsley, Donald B.; Biel, William C.; Kappauf, William E. Jr., and *

ORIG. AGENCY NO. (None)

ORIG. AGENCY : Office of Scientific Research, NDRC, Applied Psychology Panel, **

PUBLISHING AGENCY NO. (None)

PUBLISHED BY : (Same)

DATE	DOC. CLASS.	COUNTRY	LANGUAGE	PAGES	ILLUSTRATIONS
1946	Restr.	U.S.	English	371	photos, tables, diagrs, graphs

ABSTRACT:

The document is a summary account of the war activities and accomplishments of the Applied Psychology Panel, NDRC. The document is divided into four parts: training of specialized military personnel, psychologic principles in military training, design and operation of special types of military equipment, and guiding principles for future development.

* others

** Washington, D. C.

~~EQ 10501 dd 5 NOV 1953~~

5/15/62

DISTRIBUTION: Copies of this report obtainable from CADO

 DIVISION: Military Operations (24)
 SECTION: Personnel and Training (3)

 SUBJECT HEADINGS: Training, Military - Applied psychology
 (95103.14)

AT SHEET NO.: R-24-3-18

 Central Air Documents Office
 Wright Patterson Air Force Base, Dayton, Ohio

AIR TECHNICAL INDEX

UNCLASSIFIED

RESTRICTED

RESTRICTED

UNCLASSIFIED

ATI- 14519

REVISION (None)

ORIG. AGENCY NO. (None)

PUBLISHING AGENCY NO. (None)

TITLE: Search-Radar and Bombing Radar Operators

AUTHOR(S) : Lindsley, Donald B.

ORIG. AGENCY : Office of Scientific Research, NDRC, Applied Psychology Panel,*

PUBLISHED BY : (Same)

DATE	DOC. CLASS.	COUNTRY	LANGUAGE	PAGES	ILLUSTRATIONS
1946	Restr.	U.S.	English	16	photos

5/15/62

ABSTRACT:

The training of search-radar and bombing radar operators is described and the similarity noted between the tasks of the two operators though they use widely differing equipment and procedures. He then discusses a number of instruments developed to aid in training radar operators, such as the mechanical-optical plan position indicators, the H2X film trainers, and radar scope movies, and calls attention to experimental work by which it was shown how substantial reductions in average bombing error can be attained.

* Washington, D. C.

~~EX-100-14519-1-1-55~~

DISTRIBUTION: Copies of this report obtainable from CADO

DIVISION: Military Operations (24)
SECTION: Personnel and Training (3)

SUBJECT HEADINGS: Training, Radar (95105)

UNCLASSIFIED

ATI SHEET NO.: R-24-3-18

Central Air Documents Office
Wright-Patterson Air Force Base, Dayton, Ohio

AIR TECHNICAL INDEX

RESTRICTED

RESTRICTED

~~UNCLASSIFIED~~

TITLE: Training Trackers for Antiaircraft Fire Control

ATI- 14520

REVISION

(None)

AUTHOR(S) : Biel, William C.; Kappauf, William E.

ORIG. AGENCY NO.

(None)

ORIG. AGENCY : Office of Scientific Research Development, NDRC, Applied Psychology*

PUBLISHING AGENCY NO.

(None)

PUBLISHED BY : (Same)

DATE	DOC. CLASS.	COUNTRY	LANGUAGE	PAGES	ILLUSTRATIONS
1946	Restr.	U.S.	English	22	photos, tables, diags, graphs

ABSTRACT:

Analyzes are made of the problems found in the training of trackers and the reliability of methods used for measuring the tracker's skill. Three devices which were developed for use in training are described.

5/15/62

* Panel, Washington, D. C.

~~20 10501 dd 5 NOV 1953~~

DISTRIBUTION: Copies of this report obtainable from CADDO

DIVISION: Military Operating (24)

SECTION: Personnel and Training (3)

SUBJECT HEADINGS: Training, Gunnery - AA (95101.15)

ATI SHEET NO.: R-24-3-18

Central Air Documents Office
Wright-Patterson Air Force Base, Dayton, Ohio

AIR TECHNICAL INDEX

RESTRICTED

~~UNCLASSIFIED~~

TITLE: Training Personnel in Range Determination

AUTHOR(S) : Kappaur, William E. Jr.
ORIG. AGENCY : Office of Scientific Research Development, NDRC, Applied Psychology*
PUBLISHED BY : (Same)

ATI- 14521

REVISION (None)

ORIG. AGENCY NO. (None)

PUBLISHING AGENCY NO. (None)

DATE	DOC. CLASS.	COUNTRY	LANGUAGE	PAGES	ILLUSTRATIONS
1946	Restr.	U.S.	English	16	tables, diagrs, graphs

ABSTRACT:

The range to a target may be determined stereoscopically, or by radar, or it may be estimated wither with or without the use of a stadiametric aid. The APP suggested a few improvements in stereoscopic trainers, but its major contribution was in the preparation of training manuals for instructing Army personnel in height-finder operation and Navy personnel in range-finder operation. A number of training aids and teaching aids were also developed.

5/15/62

~~NOV 5 1953~~

* Panel, Washington, D. C.

DISTRIBUTION: Copies of this report obtainable from CADO

DIVISION: Military Operations (24)
SECTION: Personnel and Training (3)

SUBJECT HEADINGS: Training, Radar (95105); Range finders (80600)

ATI SHEET NO.:

Central Air Documents Office
Wright-Patterson Air Force Base, Dayton, Ohio

AIR TECHNICAL INDEX

RESTRICTED

~~UNCLASSIFIED~~

RESTRICTED

ATI- 14522

REVISION (None)

ORIG. AGENCY NO. (None)

PUBLISHING AGENCY NO. (None)

TITLE: Training the B-29 Gunner

AUTHOR(S) : Bray, Charles W.

ORIG. AGENCY : Office of Scientific Research, NDRC, Applied Psychology Panel *

PUBLISHED BY : (Same)

DATE	DOC. CLASS.	COUNTRY	LANGUAGE	PAGES	ILLUSTRATIONS
1946	Restr.	U.S.	English	6	tables, graph

ABSTRACT:

Upon studying the training of B-29 gunners, the APP was able to demonstrate that time could be saved in the scoring of gunner performance for training purposes and that improvement in training methods was possible. In addition, the Panel suggested that systematic experimentation on training might yield some understanding of the limitations on gunner performance which the difficulty and complexity of the task impose.

* Washington, D. C.

~~20 10501 aa 5 NOV 1953~~

UNCLASSIFIED

DISTRIBUTION: Copies of this report obtainable from CADO

DIVISION: Military Operations (24)
SECTION: Personnel and Training (3)

SUBJECT HEADINGS: Training, Gunnery - Aerial (95101.2)

ATI SHEET NO.: R-24-3-18

Central Air Documents Office
Wright-Patterson Air Force Base, Dayton, Ohio

AIR TECHNICAL INDEX

RESTRICTED

RESTRICTED

TITLE: Night Lookouts

~~UNCLASSIFIED~~

ATI- 14523

AUTHOR(S) : Wolfle, Dael
ORIG. AGENCY : OSRD, NDRC, Applied Psychology Panel, Washington, D.C.
PUBLISHED BY : (Same)

REVISION

(None)

ORIG. AGENCY NO.

(None)

PUBLISHING AGENCY NO.

(None)

DATE	DOC. CLASS.	COUNTRY	LANGUAGE	PAGES	ILLUSTRATIONS
1946	Restr.	U.S.	English	16	photos, tables, graphs

ABSTRACT:

Shipboard observation of night lookouts on duty in an Atlantic convoy furnished information on the average ability and variation in ability of night lookouts to spot targets. Ability variations were not caused by difference in night vision. Two night-vision trainers and training exercise in the use of binoculars at night were constructed for the Navy. Assistance was given in the preparation of literature for the training of lookouts.

5/15/62

~~EO 12812 dd 5 NOV 1953~~

DISTRIBUTION: Copies of this report obtainable from CADO

DIVISION: Military Operations (24)
SECTION: Personnel and Training (3)

SUBJECT HEADINGS:

Training, Navy personnel (95104.4)
Vision, Night (97176)

~~UNCLASSIFIED~~

ATI SHEET NO.:

Central Air Documents Office
Wright-Patterson Air Force Base, Dayton, Ohio

AIR TECHNICAL INDEX

RESTRICTED

TITLE: Training Navy Gunners and Engine Room Crews

RESTRICTED

~~UNCLASSIFIED~~

ATI- 14524

REVISION
(None)

ORIG. AGENCY NO.
(None)

PUBLISHING AGENCY NO.
(Same)

AUTHOR(S) : Cooner, Bernard J.

ORIG. AGENCY : OSRD, NDRC, Applied Psychology Panel, Washington, D. C.

PUBLISHED BY : (Same)

DATE	DOC. CLASS.	COUNTRY	LANGUAGE	PAGES	ILLUSTRATIONS
1946	Restr.	U.S.	English	4	(None)

ABSTRACT:

Lesson plans, course outlines, and instruction manuals were written for the .50 caliber gun, the 20 mm, 40 mm, 3"/50, 4"/50, and 5"/38 guns, and for the main battery of large ships. Similar teaching aids were written for the instruction of operating engineers in training for duty aboard a number of types of Navy ships. Sources on how to teach gunnery and how to teach engineering were developed.

~~EO 12812-1~~ 5 NOV 1953

DISTRIBUTION: Copies of this report obtainable from CADO.

DIVISION: Military Operations (24)
SECTION: Personnel and Training (3)

SUBJECT HEADINGS:
Training, Gunnery - AA (95101.15)

ATI SHEET NO.:

Central Air Documents Office
Wright-Patterson Air Force Base, Dayton, Ohio

AIR TECHNICAL INDEX

RESTRICTED

~~UNCLASSIFIED~~

5/15/63

TITLE: Training Winch Operators

~~RESTRICTED~~

ATI- 14525

AUTHOR(S) : Wolfle, Dael
ORIG. AGENCY : OSRD, NDRC; Applied Psychology Panel, Washington, D. C.
PUBLISHED BY : (Same)

REVISION (None)

ORIG. AGENCY NO. (None)

PUBLISHING AGENCY NO. (Same)

~~UNCLASSIFIED~~

DATE
1946

DOC. CLASS.
Restr.

COUNTRY
U. S.

LANGUAGE
English

PAGES
8

ILLUSTRATIONS
photo, table, diagr

ABSTRACT:

5/15/62

A trainer consisting of a miniature electric winch was constructed to help train hatchmen and winchmen for duty on APA and AKA ships. The controls of the winch trainer were of same dimensions as the ones found on electric winches being installed at that time on AKA's and AKP's. They were used in conjunction with miniature booms and rigged yard and stay. In addition, a manual for instructors was developed.

~~EO 10501 dd 5 NOV 1953~~

DISTRIBUTION: Copies of this report obtained from CADO.

DIVISION: Military Operations (24)
SECTION: Personnel and Training (3)

SUBJECT HEADINGS:
Training equipment (95100)
Winches (99000)

ATI SHEET NO.:

Central Air Documents Office
Wright-Patterson Air Force Base, Dayton, Ohio

AIR TECHN INDEX

RESTRICTED

~~UNCLASSIFIED~~

RESTRICTED

TITLE: Training Amphibious Craft Crews

AUTHOR(S) : Wolfle, Dael

ORIG. AGENCY : OSRD, NDRC, Applied Psychology Panel, Washington, D. C.

PUBLISHED BY : (Same)

ATI- 14526

REVISION

(None)

ORIG. AGENCY NO.

(None)

PUBLISHING AGENCY NO.

(None)

DATE
1946DOC. CLASS.
Restr.COUNTRY
U. S.LANGUAGE
EnglishPAGES
4ILLUSTRATIONS
(None)

ABSTRACT:

Four training courses were developed. The purpose of one course was to instruct amphibious training base instructors in effective teaching methods. The purposes of the other three courses were (a) to train instructors in methods of measuring student achievement, (b) to instruct a group of classification specialists in the elements of personality analysis, and (c) to train attack boat personnel in gas defense and piloting.

~~EO 128121 dd 5 NOV 1953~~

DISTRIBUTION: Copies of this report obtainable from CADO.

DIVISION: Military Operations (24)
SECTION: Personnel and Training (3)

SUBJECT HEADINGS:
Training, Amphibious (95088.6)

ATI SHEET NO.:

Central Air Documents Office
Wright-Patterson Air Force Base, Dayton, Ohio

AIR TECH INDEX

RESTRICTED

UNCLASSIFIED

TITLE: Training Navy Telephone Talkers

RESTRICTED

UNCLASSIFIED

ATI- 14527

REVISION (None)

ORIG. AGENCY NO. (None)

PUBLISHING AGENCY NO. (None)

AUTHOR(S) : Wolfle, Dael
ORIG. AGENCY : OSRD, NDRC, Applied Psychology Panel, Washington, D. C.
PUBLISHED BY : (Same)

DATE	DOC. CLASS.	COUNTRY	LANGUAGE	PAGES	ILLUSTRATIONS
1946	Restr.	U.S.	English	9	(None)

5/15/62

ABSTRACT:

Special training courses were developed to increase the intelligibility of telephone communications. A telephone talker's manual, a manual for instructors, and phonograph records were prepared for use in a course for telephone talkers. The training ashore was integrated with subsequent training on board ship.

~~EO 12812-1 dd 5 NOV 1953~~

DISTRIBUTION: Copies of this report obtainable from CADO.

DIVISION: Military Operations (24)
SECTION: Personnel and Training (3)

SUBJECT HEADINGS:
Communication, Telephone - Voice training (23992.)

UNCLASSIFIED

ATI SHEET NO.:

Central Air Documents Office
Wright-Patterson Air Force Base, Dayton, Ohio

AIR TECHNICAL INDEX
RESTRICTED

TITLE: Voice Communication Training in the Army Air Forces

~~RESTRICTED~~

~~UNCLASSIFIED~~

AUTHOR(S) : Wolfle, Dael
ORIG. AGENCY : OSRD, NDRC, Applied Psychology Panel, Washington, D. C.
PUBLISHED BY : (Same)

ATI- 14528

REVISION (None)

ORIG. AGENCY NO. (None)

PUBLISHING AGENCY NO. (Same)

DATE	DOC. CLASS.	COUNTRY	LANGUAGE	PAGES	ILLUSTRATIONS
1946	Restr.	U.S.	English	8	photo, tables, diagr, graphs

ABSTRACT:

The intense noise levels of a military airplane make voice communication over radio or interphone very difficult. Training methods were devised and instructor's handbooks and students' manuals written for courses designed to teach aircrew personnel to speak so that their messages would be more intelligible.

~~EO 12958-1 dd 5 NOV 1953~~

DISTRIBUTION: Copies of this report obtainable from CADO.

DIVISION: Military Operations (24)
SECTION: Personnel and Training (3)

SUBJECT HEADINGS:

Communication, Voice - Air crew training (23995)
Communication, Voice - Intelligibility (23995.4)

ATI SHEET NO.:

Central Air Documents Office
Wright-Patterson Air Force Base, Dayton, Ohio

AIR TECHNICAL INDEX

RESTRICTED

~~UNCLASSIFIED~~

TITLE: Training Radio Operators

RESTRICTED

~~UNCLASSIFIED~~ ~~UNCLASSIFIED~~

AUTHOR(S) : Wolfle, Dael

ORIG. AGENCY : OSRD, NDRC, Applied Psychology Panel, Washington, D. C.

PUBLISHED BY : (Same)

ATI- 14529

REVISION

(None)

ORIG. AGENCY NO.

(None)

PUBLISHING AGENCY NO.

(None)

DATE
1946

DOC. CLASS.
Restr.

COUNTRY
U.S.

LANGUAGE
English

PAGES
19

ILLUSTRATIONS
photo, tables, graphs

ABSTRACT:

An account is given of improvements made in all phases of training radio code operators. The phases involved were initial learning of the code characters, acquiring receiving speed, learning to send, measuring both receiving and sending speeds and skill, and the standardization of code speeds.

~~EO 10501 dd 5 NOV 1953~~

DISTRIBUTION: Copies of this report obtainable from CADO

DIVISION: Education and training (38)

SECTION: Flight training (4)

23
4

SUBJECT HEADINGS:
Training, Radio (95107)

~~UNCLASSIFIED~~

ATI SHEET NO.:

Central Air Documents Office
Wright-Patterson Air Force Base, Dayton, Ohio

AIR TECHNICAL INDEX

RESTRICTED

TITLE: Psychological Principles in Military Training

AUTHOR(S) : Wolfle, Dael

ORIG. AGENCY : OSRD, NDRC, Applied Psychology Panel, Washington, D. C.

PUBLISHED BY : (Same)

~~RESTRICTED~~

ATI- 14530

REVISION

(None)

ORIG. AGENCY NO.

(None)

PUBLISHING AGENCY NO.

(None)

~~UNCLASSIFIED~~

DATE
1946

DOC. CLASS.
Restr.

COUNTRY
U.S.

LANGUAGE
English

PAGES
3

ILLUSTRATIONS
(None)

ABSTRACT:

~~UNCLASSIFIED~~

An account is given of the work done by psychologists for the purpose of improving military training. The work involved the study of the application of one or more well-established principles of learning: distribution of practice, active participation of the trainee, variation of practice, material, development of accurate performance records, giving the men an immediate knowledge of the results of their practice, and writing clear detailed plans for the instructor.

~~EO 12958-1 dd 5 NOV 1953~~

~~UNCLASSIFIED~~

DISTRIBUTION: Copies of this report obtainable from CADO

DIVISION: Military Operations (24)

SECTION: Personnel and Training (3)

SUBJECT HEADINGS:

Training, Military - Applied psychology (95103.14)

ATI SHEET NO.:

Central Air Documents Office
Wright-Patterson Air Force Base, Dayton, Ohio

AIR TRAINING INDEX

~~UNCLASSIFIED~~

RESTRICTED

~~RESTRICTED~~

~~UNCLASSIFIED~~

TITLE: Job Analysis of Duties to be Learned

ATI- 14531

AUTHOR(S) : Cooner, Bernard J.

REVISION (None)

ORIG. AGENCY : Office of Scientific Research Development, NDRC, Applied Psychology*

ORIG. AGENCY NO. (None)

PUBLISHED BY : (Same)

PUBLISHING AGENCY NO. (None)

DATE	DOC. CLASS.	COUNTRY	LANGUAGE	PAGES	ILLUSTRATIONS
1946	Restr.	U.S.	English	5	(None)

ABSTRACT:

An account is given of the work done in the field of job analysis. Detailed descriptions were prepared of the operations involved in a job. This suggested what skills are required. The information, so obtained, was used as a basis for establishing training programs, determining selection requirements, and identifying jobs which demand similar skills. The latter served as a source for securing replacement personnel.

* Panel, Washington, D. C.

~~EO 12801 dd 5 NOV 1953~~

~~UNCLASSIFIED~~

DISTRIBUTION: Copies of this report obtainable from CADO

DIVISION: ~~Education & Training (38)~~ 23
SECTION: ~~General (0)~~ 4

SUBJECT HEADINGS: Job analysis (54060)

ATI SHEET NO.:

Central Air Documents Office
Wright-Patterson Air Force Base, Dayton, Ohio

AIR TECHNICAL INDEX

RESTRICTED

TITLE: Course Outlines and Lesson Plans

RESTRICTED

AUTHOR(S) : Cooner, Bernard J.
ORIG. AGENCY : OSRD, NDRC, Applied Psychology Panel, Washington, D. C.
PUBLISHED BY : (Same)

ATI- 14532

REVISION
(None)

ORIG. AGENCY NO.
(None)

PUBLISHING AGENCY NO.
(None)

DATE	DOC. CLASS.	COUNTRY	LANGUAGE	PAGES	ILLUSTRATIONS
1946	Restr.	U.S.	English	8	(None)

ABSTRACT:

UNCLASSIFIED

Description is given of course outlines and lesson plans which were developed for the purpose of furnishing instructors with a detailed statement of the topics to be covered in a course and the time and method of teaching each topic. The principal features and advantages of the course outlines and lesson plans are pointed out and illustrated by examples.

~~EO 10501 dd 5 NOV 1953~~

DISTRIBUTION: Copies of this report obtainable from CADO.

DIVISION: Military Operations (24)
SECTION: Personnel and training (3)

SUBJECT HEADINGS:
Training, Instructor (95102)

UNCLASSIFIED

ATI SHEET NO.:

Central Air Documents Office
Wright-Patterson Air Force Base, Dayton, Ohio

AIR TECHNICAL INDEX

RESTRICTED

~~RESTRICTED~~

TITLE: The Use and Design of Synthetic Trainers for Military Training.

ATI- 14533

REVISION

(None)

ORIG. AGENCY NO.

(None)

PUBLISHING AGENCY NO.

(None)

AUTHOR(S) : Wolfle, Dael
ORIG. AGENCY : OSRD, NDRC, Applied Psychology Panel, Washington, D. C.
PUBLISHED BY : (Same)

DATE 1946	DOC. CLASS. Restr.	COUNTRY U.S.	LANGUAGE English	PAGES 15	ILLUSTRATIONS graphs
--------------	-----------------------	-----------------	---------------------	-------------	-------------------------

ABSTRACT:

~~UNCLASSIFIED~~

The steps are enumerated for development of a new trainer or in evaluation of an existing one, and trainers designed and built by projects of APP are listed. Items include 4 gun director and tracking trainers, 4 aerial gunnery trainers, 7 radar trainers, 3 communication trainers, 1 night vision trainer, 1 cargo handling, and 1 landing craft trainer.

~~EO 10501 dd 5 NOV 1953~~

~~UNCLASSIFIED~~

DISTRIBUTION: Copies of this report obtainable from CADO.

DIVISION: Military Operations (24)
SECTION: Personnel and Training (3)

23/
10,315

SUBJECT HEADINGS:
Trainers, Flight (95063)
Radar tracking aids (78015)

ATI SHEET NO.:

Central Air Documents Office
Wright-Patterson Air Force Base, Dayton, Ohio

AIR TECHNICAL INDEX

~~RESTRICTED~~

~~RESTRICTED~~

TITLE: Measuring the Effects of Training

AUTHOR(S) : Fredricksen, Norman
ORIG. AGENCY : OSRD, NDRC, Applied Psychology Panel, Washington, D. C.
PUBLISHED BY : (Same)

ATI- 14534

REVISION: (None)

ORIG. AGENCY NO.: (None)

PUBLISHING AGENCY NO.: (None)

DATE	DOC. CLASS.	COUNTRY	LANGUAGE	PAGES	ILLUSTRATIONS
1946	Restr.	U.S.	English	24	photos, tables, graphs

ABSTRACT:

UNCLASSIFIED

5/15/62

Five advantages to be derived from the use of good tests for determining the amount of skill acquired by men undergoing training are discussed. Several types of achievement tests are described together with information on the development of such tests.

~~EO 12812 OF 5 NOV 1953~~

UNCLASSIFIED

DISTRIBUTION: Copies of this report obtainable from CADO.

DIVISION: Military Operations (24)
SECTION: Personnel and training (3)

SUBJECT HEADINGS:
Training, Military - Applied psychology (95103.14)

ATI SHEET NO.:

Central Air Documents Office
Wright-Patterson Air Force Base, Dayton, Ohio

AIR TECHNICAL INDEX

~~RESTRICTED~~

~~RESTRICTED~~

~~UNCLASSIFIED~~

TITLE: Antiaircraft Directors and Guns

ATI- 14535

AUTHOR(S) : Kappauf, William
ORIG. AGENCY : OSRD, NDRC, Applied Psychology Panel, Washington, D. C.
PUBLISHED BY : (Same)

REVISION (None)

ORIG. AGENCY NO. (None)

PUBLISHING AGENCY NO. (None)

DATE 1946	DOC. CLASS. Restr.	COUNTRY U.S.	LANGUAGE English	PAGES 27	ILLUSTRATIONS photos, tables, diagrs, graphs
--------------	-----------------------	-----------------	---------------------	-------------	---

ABSTRACT:

Problems involved in the operation and design of new antiaircraft equipment and the improvement of methods of operating the older types are summarized. Findings and recommendations which led to improved accuracy of antiaircraft firing include a double handwheel for pointer matching, a handwheel rotation speed of about 100 rpm aided tracking, and means of elimination of obscurity in tracking.

~~EO 12812 dd 5 NOV 1953~~

DISTRIBUTION: Copies of this report obtainable from CADO

DIVISION: Military Operations (24)
SECTION: Personnel and Training (3)

SUBJECT HEADINGS:
Training, Gunnery - AA (95101.5)

ATI SHEET NO.:

Central Air Documents Office
Wright-Patterson Air Force Base, Dayton, Ohio

AIR TECHNICAL INDEX

~~UNCLASSIFIED~~

~~RESTRICTED~~

~~RESTRICTED~~

R-22-4-8

ATI-14536

Kappauf, William

DIVISION: Ordnance and Armament (22)

SECTION: Fire Control (4)

CROSS REFERENCES: Instruments, Optical (52250); Gun-sights, Computing (47420); Telescopes (92697)

ORIG. AGENCY NUMBER

AUTHOR(S)

REVISION

AMER. TITLE: Field artillery equipment

FORG'N. TITLE:

UNCLASSIFIED

ORIGINATING AGENCY: O.S.R.D., N.D.R.C., Applied Psychology Panel, Washington, D. C.

TRANSLATION:

COUNTRY	LANGUAGE	FORG'N.CLASS	U. S.CLASS.	DATE	PAGES	ILLUS.	FEATURES
U.S.	Eng.		Restr.	1946	14	11	photos, tables, diagr

ABSTRACT

Work was undertaken for the purpose of finding means of eliminating the errors occurring in the operation of field artillery equipment. An analysis of the scales used for panoramic telescopes resulted in developing an odometer type of scale which reduced the number of errors made in reading the scale. Remote indicating equipment was developed for recording the entire action of a field artillery battery.

UNCLASSIFIED

~~EO 12958-1, 2, 3, 4, 5, 6, 7, 8, 9, 10, 11, 12, 13, 14, 15, 16, 17, 18, 19, 20, 21, 22, 23, 24, 25, 26, 27, 28, 29, 30, 31, 32, 33, 34, 35, 36, 37, 38, 39, 40, 41, 42, 43, 44, 45, 46, 47, 48, 49, 50, 51, 52, 53, 54, 55, 56, 57, 58, 59, 60, 61, 62, 63, 64, 65, 66, 67, 68, 69, 70, 71, 72, 73, 74, 75, 76, 77, 78, 79, 80, 81, 82, 83, 84, 85, 86, 87, 88, 89, 90, 91, 92, 93, 94, 95, 96, 97, 98, 99, 100~~

~~RESTRICTED~~

ATI- 14537

TITLE: The Design and Operation of B-29 Gunsights

~~UNCLASSIFIED~~

REVISION (None)

AUTHOR(S) : Bray, Charles W.

ORIG. AGENCY : Office of Scientific Research and Development, NDRC, Applied

ORIG. AGENCY NO. (None)

PUBLISHED BY : (Same)

PUBLISHING AGENCY NO. (None)

DATE	DOC. CLASS.	COUNTRY	LANGUAGE	PAGES	ILLUSTRATIONS
1946	Restr.	U.S.	English	15	photos, tables, drwgs

ABSTRACT:

5/15/62

Studies were carried out to develop military requirements for B-29 gunnery equipment which would simplify the task for the gunner and provide for better learning of the task by the average gunner. An experimental apparatus was designed and constructed for studying the gunner in relation to his equipment. This was followed by the development of an air-borne synthetic trainer. Indications were also obtained that the complexity of the gunner's task has already reached its limit.

* Psychology Panel, Washington, D. C.

~~EO 12812-1 and 12958-1~~
~~NOV 5 1953~~

DISTRIBUTION: Copies of this report obtainable from CADO

DIVISION: Ordnance and Armament (22)
SECTION: Fire Control (4)

6-22
5-7

SUBJECT HEADINGS: Gun sights (47415.5); Training, Gunnery-Aerial (95101.2); B-29 (14880)

ATI SHEET NO.: R-22-4-73

Central Air Documents Office
Wright-Patterson Air Force Base, Dayton, Ohio

AIR TECHNICAL INDEX

RESTRICTED

~~UNCLASSIFIED~~

Lindsley, B

~~UNCLASSIFIED~~ ~~RESTRICTED~~DIVISION: ~~Electronics~~ (3)SECTION: ~~Radar~~ (2)

CROSS REFERENCES: Gun sights, Radar (47420.5)

ATI- 14538 015

ORIG. AGENCY NUMBER

REVISION

AUTHOR(S)

AMER. TITLE: The operation of radar equipment

FORG'N. TITLE:

~~EO 12812 dd 5 NOV 1953~~

ORIGINATING AGENCY: O.S.R.D., N.D.R.C., Applied Psychology Panel, Washington, D.C.

TRANSLATION:

COUNTRY	LANGUAGE	FORG'N.CLASS	U. S.CLASS.	DATE	PAGES	ILLUS.	FEATURES
U.S.	Eng.		Restr.	1946	17		

ABSTRACT

The work done on the operation of radar equipment is reviewed. Suggestions are made concerning the use of a fixed hairline instead of a movable one regarding the scope choice for tracking, the scope illumination, and the calibration and operating procedures. The effect of radar operation on operators is discussed. Attention is called to a modified range dial attachment and its use for Mark 4 radars is recommended.

~~UNCLASSIFIED~~

Kappauf, W. E.

~~RESTRICTED~~

19-22-4-18

ATI- 14539

DIVISION: Ordnance and Armament (22)

SECTION: Fire Control (4)

CROSS REFERENCES: Range finders (80600)

ORIG. AGENCY NUMBER

REVISION

AUTHOR(S)

AMER. TITLE: Stereoscopic rangefinder and heightfinders

FORG'N. TITLE:

ORIGINATING AGENCY: O.S.R.D., N.D.R.C., Applied Psychology Panel, Washington, D. C.

TRANSLATION:

COUNTRY	LANGUAGE	FORG'N.CLASS	U. S.CLASS.	DATE	PAGES	ILLUS.	FEATURES
U. S.	Eng.		Restr.	1946	19	10	diags, graphs

ABSTRACT

The actual ranging accuracy of the best observers does not approach the predicted, or theoretical, accuracy of the instruments at their disposal. Procedures and devices developed to improve performance of existing equipment were an interpupillometer and template, operation of instrument at reduced aperture, an improved calibrating procedure, and methods of making the height-of-image adjustment.

~~EO 12801 de 5 NOV 1953~~

~~UNCLASSIFIED~~

~~RESTRICTED~~

~~UNCLASSIFIED~~

TITLE: Standard Procedures in Voice Communication

ATI- 14540

AUTHOR(S) : Wolfe, Dael
ORIG. AGENCY : Office of Scientific Research Development, NDRC, Applied Psychology*
PUBLISHED BY : (Same)

REVISION (None)

ORIG. AGENCY NO. (None)

PUBLISHING AGENCY NO. (None)

DATE	DOC. CLASS.	COUNTRY	LANGUAGE	PAGES	ILLUSTRATIONS
1946	Restr.	U.S.	English	15	tables, graphs

ABSTRACT:

Experiments to improve AAF voice communication lead to the conclusions that maximum intelligibility is secured when speaker talks as loudly as he can, without obvious strain. Instruction in articulation improves intelligibility. Message form and content should be standardized. In using the T-17 microphone, the latter should lightly touch the speaker's lips and be held parallel to plane of trace. The T-30 microphone should be worn on or slightly above the Adam's apple. Gain control should be fixed at a high level and remain inoperative on the interphone.

* Panel, Washington, D. C.

~~EO 12958-1 dd 5 NOV 1959~~

DISTRIBUTION: Copies of this report obtainable from CADO

DIVISION: Military Operations (24)
SECTION: Personnel and Training (3)

SUBJECT HEADINGS: Communication, Voice - Air Crew training (23995); Microphones (62007)

ATI SHEET NO.:

Central Air Documents Office
Wright-Patterson Air Force Base, Dayton, Ohio

AIR TECHNICAL INDEX

~~UNCLASSIFIED~~

RESTRICTED

TITLE: Principles of Good Equipment Design

~~RESTRICTED~~

AUTHOR(S) : Kappauf, W. E.

ORIG. AGENCY : OSRD, NDRC, Applied Psychology Panel, Washington, D. C.

PUBLISHED BY : (Same)

ATI- 14541

REVISION
(None)

ORIG. AGENCY NO.
(None)

PUBLISHING AGENCY NO.
(None)

DATE
1946

DOC. CLASS.
Restr.

COUNTRY
U.S.

LANGUAGE
English

PAGES
12

ILLUSTRATIONS
(None)

~~RESTRICTED~~
UNCLASSIFIED

ABSTRACT:

5/13/62

APP studies require an instrument to be so designed that it will permit many men to qualify as operators, enable qualified men to operate with efficiency, make easy training possible, and be acceptable to operators. The general procedure in evaluating the psychological efficiency of a design is described, and a check list for use in evaluating a new design is offered.

~~TOP SECRET~~
~~NOV 5 1953~~

UNCLASSIFIED

DISTRIBUTION: Copies of this report obtainable from CADO.

DIVISION: Education and Training (38)

SECTION: General (0)

SUBJECT HEADINGS:

Training equipment - Psychological aspects (95100.4)

ATI SHEET NO.:

Central Air Documents Office
Wright-Patterson Air Force Base, Dayton, Ohio

AIR TECHNICAL INDEX

~~RESTRICTED~~

TITLE: The Development of Standard Operating Procedures

~~RESTRICTED~~

AUTHOR(S) : Kappauf, W. E.
ORIG. AGENCY : OSRD, NDRC, Applied Psychology Panel, Washington, D. D.
PUBLISHED BY : (Same)

ATI- 14542

REVISION (None)

ORIG. AGENCY NO. (None)

PUBLISHING AGENCY NO. (None)

DATE
1946

DOC. CLASS.
Restr.

COUNTRY
U.S.

LANGUAGE
English

PAGES
15

ILLUSTRATIONS
(None)

UNCLASSIFIED

ABSTRACT:

The standardization of operating methods requires the understanding of military problems involved in the use of a given type of equipment. The mechanical, mathematical, psychological, and tactical aspects of each problem must be carefully studied and analyzed. Nine steps must be taken in achieving this understanding and developing operating methods and procedures,

~~FO U 501 dd 9 NOV 1953~~

DISTRIBUTION: Copies of this report obtainable from CADO

DIVISION: Military Operations (24)
SECTION: Personnel and training (3)

SUBJECT HEADINGS:
Training equipment (95100)

UNCLASSIFIED

SHEET NO.:

Central Air Documents Office
Patterson Air Force Base, Dayton, Ohio

AIR TECHNICAL INDEX

RESTRICTED