



DEPARTMENT OF THE AIR FORCE
AIR FORCE RESEARCH LABORATORY
WRIGHT-PATTERSON AIR FORCE BASE OHIO 45433

MEMORANDUM FOR DTIC

02 November 2017

FROM: AFRL/RQON (STINFO)

SUBJECT: Change the Distribution Statement from the DTIC-Applied C for the Progress Reports Associated with the Following AD Numbers: AD0203743, AD0213968, and AD1038383

The following progress reports, which were auto-assigned a Distribution Statement C by DTIC due to their absent distribution markings when submitted to DTIC in the late 1950s, have been reviewed by AFRL/RQ lead scientists who have specific knowledge in the subject matter contained in the progress reports, security personnel, and the 88th Air Base Wing Public Affairs Office agent, Jeannie Masters (jeannie.masters@us.af.mil)—each of the reports has been cleared for public release:

Research In The Measurements And Theory Of Plasmoids And Their Applications To Missiles And Satellite Technology

Progress Report 1, AD0203743 - 11 Sep 1958; 88ABW-2017-5445, Cleared on November 1, 2017

Progress Report 2, AD0213968 - 13 Mar 1959; 88ABW-2017-5446, Cleared on November 1, 2017

Progress Report 3, AD1038383 - 11 Jun 1959; 88ABW-2017-5447, Cleared on November 1, 2017

Please accept the reports as annotated by the RQ STINFO Office to indicate “DISTRIBUTION STATEMENT A: Approved for public release. Distribution is unlimited.” Both move the reports to the public collection and provide to the initial requester.

Call with questions—(937) 938-4948.

ROUSH.RICHARD.V Digitally signed by
D.V.1262988186 ROUSH.RICHARD.V
Date: 2017.11.02 09:19:03
-04'00'

Rick Roush
STINFO Officer
Aerospace Systems Directorate
WPAFB OH 45433-7542

ARF

ARMOUR RESEARCH FOUNDATION OF ILLINOIS INSTITUTE OF TECHNOLOGY

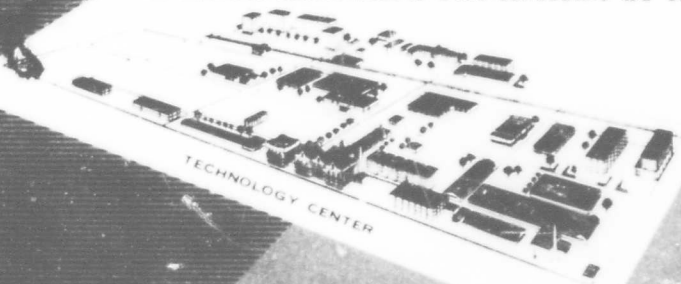

FC

ARF Project No. A 121

on

"RESEARCH IN
THE MEASUREMENTS AND THEORY OF
PLASMOIDS AND THEIR APPLICATIONS TO
MISSILES AND SATELLITE TECHNOLOGY"

Contract No. AF 33(616)-5791

(Task No. 70854)

Progress Report No. 1

FILE COPY

Return to

ASTIA

ARLINGTON HALL STATION

ARLINGTON 12, VIRGINIA

Attn: TISS

ASTIA
RECEIVED
OCT 6 1958
RECEIVED
TIPDR

Copy No. 25

RESEARCH FOR INDUSTRY

**DISTRIBUTION STATEMENT A: Approved for public release.
Distribution is unlimited.**

PA Case Number: 88ABW-2017-5445; Clearance Date: 01 November 2017.

ARMOUR RESEARCH FOUNDATION

of

Illinois Institute of Technology
Technology Center
Chicago 16, Illinois

ARF Project No. A 121

on

"RESEARCH IN
THE MEASUREMENTS AND THEORY OF
PLASMOIDS AND THEIR APPLICATIONS TO
MISSILES AND SATELLITE TECHNOLOGY"

Contract No. AF 33(616)-5791
(Task No. 70854)

for

Aeronautical Research Laboratory, WCLJH,
Wright Air Development Center,
Wright-Patterson Air Force Base, Ohio.

Progress Report No. 1

Covering the period of June 1, 1958 to August 31, 1958

September 11, 1958

ARMOUR RESEARCH FOUNDATION OF ILLINOIS INSTITUTE OF TECHNOLOGY

"RESEARCH IN
THE MEASUREMENTS AND THEORY OF
PLASMOIDS AND THEIR APPLICATIONS TO
MISSILES AND SATELLITE TECHNOLOGY"

I. INTRODUCTION

The existence of relatively stable configurations of ionized gas, or plasma, formed under certain conditions in a laboratory vacuum chamber, was first reported by Bostick,¹ who adopted the name "plasmoids" for these plasma entities. Using his original plasma gun in a rather poor vacuum in the absence of an externally applied magnetic field, he was able to obtain Kern-cell photographs (0.5 μ sec. exposure) of the formation of a plasmoid which appears to be toroidal in shape and which is projected across the vacuum space at speeds up to 2×10^7 cm/sec.

Applying a magnetic field perpendicular to the plane of the electrodes reduces the translational speed of the plasma (across the field lines) only by a factor of about 1/2, while the plasmoid elongates along the direction of the field into a cylindrical "broomstick-shaped" plasmoid.

Further investigations^{1,2} have shown a remarkable tendency of these plasmoids to maintain their integrity in a collision between two or more plasmoids, and very interesting multiple-source configurations have been observed. Many other investigations have been made, including a measurement³ of the velocity of the plasmoids as a function of the direction and magnitude of an applied magnetic field up to about 6 kilogauss, of the source voltage up to about 15 kv, and other circumstances. However, such

¹W. H. Bostick, Phys. Rev., 104, 292 (1956).

²W. H. Bostick, Phys. Rev., 106, 404 (1957).

³E. G. Harris, R. B. Theus, and W. H. Bostick, Phys. Rev., 105, 46 (1957).

of the behavior of plasmoids is not yet clearly understood, and there remains a fruitful area for further investigation of the properties of such plasma configurations.

The purpose of the present project is to perform additional experimental and theoretical investigations to obtain better information on the nature of plasmoids and their characteristics. In particular, it is intended to investigate theoretically the stability of cylindrical plasma configurations under ideal conditions, to determine experimentally the behavior of high energy plasmoids at various pressures, and to investigate what practical use might be made of plasmoids with respect to high-altitude vehicles. This report outlines the progress and planning of this project as of the end of the first quarter of the contract period on August 31, 1958.

II. THEORETICAL INVESTIGATIONS

Nearly all of the existing photographs of plasmoids have been obtained in a rather poor vacuum because the residual gas interacts with the plasmoid, slowing it down and causing more recombination in the plasma, thus making it easier to photograph the plasma by its own recombination light. Thus, although Bostick² has interpreted some of his photographs as showing a considerable bending and twisting of the flux tube which was originally a cylindrical plasmoid, probe measurements³ of the profile of the plasma front, presumably taken in a better vacuum, show the front to be quite straight over a length of at least 14 cm. These data tend to support the hypothesis⁴ that the plasmoids may be cylindrical plasma configurations which would be completely stable in the absence of loss mechanisms such as the presence of background gas.

⁴S. Chandrasekhar, private communication.

The simplest case one might postulate would be a static configuration in which the internal magnetic field of the cylinder is force-free, i.e., in which the Lorentz force ($\vec{J} \times \vec{H}$) vanishes. (Here \vec{H} represents the magnetic field vector and $\vec{J} = \frac{1}{4\pi} \text{curl } \vec{H}$ is the current density. Thus,

$$\text{curl } \vec{H} \times \vec{H} = 0,$$

or

$$\text{curl } \vec{H} = \alpha \vec{H}, \quad (1)$$

where α may in general be any scalar function of position, but had always been chosen constant merely for the sake of simplicity. Equation (1) has been solved for the case of an infinitely long cylinder, and the stability of the solutions has been examined by Trehan,⁵ who also noticed (private communication) that there exist no non-trivial solutions of Equation (1) with constant α which satisfy the boundary conditions corresponding to the case of a force-free cylinder of finite length embedded in a uniform external magnetic field. Therefore, it was originally proposed to investigate on this project the solutions in the latter case in which α is not constant, but some function of position which vanishes at the ends of the cylinder (thus joining smoothly with a constant external field, in which $\text{curl } \vec{H} = 0$, i.e., $\alpha = 0$).

Recent work by Woltjer,⁶ however, has shown that one condition for minimum energy in a force-free field is that α be constant. In the light of this development it seems unlikely that a stable configuration could be

⁵S. K. Trehan, *Astrophys. J.*, 127, 436 (1958).

⁶L. Woltjer, *Astrophys. J.*, in press.

found in which α is not constant, and Professor Chandrasekhar suggested that it might be more fruitful to consider a more complex situation in which there exist interactions of internal fluid motions with the internal magnetic fields. For the time being, however, we will retain (as in reference 5) the simplification of considering the plasma as an incompressible, inviscid fluid of infinite electrical conductivity.

This problem has been investigated by Chandrasekhar⁷ for more general axially symmetric fields, and he has set forth some general relations which must be satisfied by any solutions to such a problem. The equations of motion for this problem are:

$$\frac{\partial \vec{H}}{\partial t} = \text{curl} (\vec{v} \times \vec{H}),$$

$$\frac{\partial \vec{v}}{\partial t} = -(\vec{v} \cdot \text{grad}) \vec{v} + \frac{1}{4\pi\rho} \text{curl} \vec{H} \times \vec{H} - \text{grad} \left(\frac{p}{\rho} + v \right),$$

where \vec{v} is the velocity field, ρ the fluid density, p the pressure, and v the gravitational potential. Thus, in order for a stationary solution to exist,

$$\text{curl} (\vec{v} \times \vec{H}) = 0, \quad (2)$$

$$\text{curl} \vec{h} \times \vec{h} - \text{curl} \vec{v} \times \vec{v} - \text{grad} \varpi = 0, \quad (3)$$

where we have made the substitutions $\vec{h} = \vec{H}/\sqrt{4\pi\rho}$ and $\varpi = \left(\frac{p}{\rho} + \frac{1}{2} |\vec{v}|^2 + v \right)$, and used the vector identity $(\vec{v} \cdot \text{grad}) \vec{v} = \text{curl} \vec{v} \times \vec{v} + \text{grad} \left(\frac{1}{2} |\vec{v}|^2 \right)$.

The first special case to be considered was that of an infinitely long cylinder in which all processes are not only symmetric about the axis but

⁷S. Chandrasekhar, *Astrophys. J.*, 124, 232 (1956).

also independent of translation along the axis, thus depending on a single coordinate. This is the problem considered by Schlüter⁸ for the static force-free case. Introducing a cylindrical coordinate system s, ϕ, z , he assumed that all field components would depend only upon s , the perpendicular distance from the axis of symmetry, and was able to give an expression for the field components in terms of the energy density in the field, $q/8\pi$. By definition, $q = H_s^2 + H_\phi^2$. Then he found that

$$\begin{aligned} H_s &= 0 \\ H_\phi^2 &= -(s/2) dq/ds \\ H_s^2 &= q + (s/2) dq/ds = d(s^2 q)/ds^2 \end{aligned} \quad (4)$$

with certain restrictions found for the possible forms of q .

Now at this laboratory the problem was complicated slightly by adding a strictly rotational fluid motion (again depending only upon the s -coordinate). However, it was soon noticed that the restriction to s -dependence only was a very severe one, and that in fact Chandrasekhar's conditions (Equations 39 through 42 of reference 7) are satisfied trivially by any function of s only. Therefore, we went back to the equations of motion (2) and (3).

If $\vec{h} = (0, h_\phi, h_z)$ according to Equation (4), and $\vec{v} = (0, v_\phi, 0)$ because of the restriction to rotational motion, then $\vec{v} \times \vec{h} = (v_\phi h_z, 0, 0)$ and since both v_ϕ and h_z depend only on s , and since the ϕ and z components of $(\vec{v} \times \vec{h})$ vanish, Equation (2) is satisfied trivially and gives us no information about the form of \vec{v} or \vec{h} .

⁸A. Schlüter, Z. Naturforschg., 12a, 855 (1957).

Looking now at Equation (3),

$$\text{curl } \vec{h} = \frac{1}{s} \begin{vmatrix} \vec{i}_s & s\vec{i}_\phi & \vec{i}_z \\ \frac{d}{ds} & 0 & 0 \\ 0 & s h_\phi & h_z \end{vmatrix}$$

$$= \left[0, -\frac{d h_z}{ds}, \frac{1}{s} \frac{d}{ds} (s h_\phi) \right]$$

$$\text{curl } \vec{h} \times \vec{h} = \begin{vmatrix} \vec{i}_s & s\vec{i}_\phi & \vec{i}_z \\ 0 & -\frac{d h_z}{ds} & \frac{1}{s} \frac{d}{ds} (s h_\phi) \\ 0 & h_\phi & h_z \end{vmatrix}$$

$$= \vec{i}_s \left[-h_z \frac{d h_\phi}{ds} - \frac{h_\phi}{s} \frac{d}{ds} (s h_\phi) \right]$$

Similarly $\text{curl } \vec{v} \times \vec{v} = \vec{i}_s \left[-\frac{v_\phi}{s} \frac{d}{ds} (s v_\phi) \right]$

So,

$$\text{grad } \omega = \vec{i}_s \frac{d\omega}{ds} = \vec{i}_s \left[-h_z \frac{d h_\phi}{ds} - \frac{h_\phi}{s} \frac{d}{ds} (s h_\phi) + \frac{v_\phi}{s} \frac{d}{ds} (s v_\phi) \right]$$

$$\frac{d\omega}{ds} = -\frac{1}{2} \frac{d}{ds} (h_z^2 + h_\phi^2 - v_\phi^2) - \frac{1}{s} (h_\phi^2 - v_\phi^2)$$

and finally

$$\frac{d\omega}{ds} = \frac{1}{s} (v^2 - h_\phi^2) + \frac{1}{2} \frac{d}{ds} (v^2 - h^2). \quad (5)$$

Now if we consider the special case in which the force terms $\text{grad } \frac{p}{\rho}$ and $\text{grad } \gamma$ vanish, we find that $\text{grad } \omega = \text{grad } \left(\frac{1}{2} v^2 \right) = \vec{i}_s \cdot \frac{1}{2} \frac{d}{ds} (v^2)$.

Then Equation (5) reduces to

$$\frac{1}{2} \frac{d}{ds} (v^2) = \frac{1}{s} (v^2 - h_\phi^2) + \frac{1}{2s} \frac{d}{ds} (v^2 - h^2)$$

or

$$h_\phi^2 = v^2 - \frac{s}{2} \frac{d}{ds} (h^2) \quad (6)$$

Since the only remaining condition on the three functions h_ϕ , h_s , v_ϕ is that $h^2 = h_\phi^2 + h_s^2$, we see that we have introduced an additional infinity of solutions (because Equation (2) yielded no information) and are unable to realize our ambition of finding expressions for the three functions in terms of a single parameter, in analogy to Schlüter's success in the simpler case. It is also interesting to compare Equation (6) with Schlüter's equation for the superposition of two solutions $H^{(1)}$ and $H^{(2)}$ to his problem:

$$H_s^2 = a_1 (H_s^{(1)})^2 + a_2 (H_s^{(2)})^2,$$

$$H_\phi^2 = a_1 (H_\phi^{(1)})^2 + a_2 (H_\phi^{(2)})^2, \quad a_1, a_2 > 0.$$

Equation (6) then resembles the superposition of the ϕ -component of Equation (4) with the well-known special solution⁷ of Equations (2) and (3), $\vec{H} = \vec{v}$.

The solution of Equation (5) could have been considered at this point, but it was decided in consultation with Professor Chandrasekhar that this case was of no unusual importance, but was merely one of several special cases which should be considered eventually. Therefore, it was decided to look for more solutions of Equations (2) and (3), without the requirement of x -independence. This work has been started and will be reported next time.

ARMOUR RESEARCH FOUNDATION OF ILLINOIS INSTITUTE OF TECHNOLOGY

In the meantime, we have been examining a number of other German papers which appear to be pertinent to the question of plasmoids. None of them take into consideration the interaction of the magnetic fields with internal fluid motions, though some have considered fields due to currents on the surface of the plasma.^{9,10,11}

These three papers^{9,10,11} are concerned principally with toroidal configurations and probably should be examined in more detail at some later time for applications to the problem of the toroidal plasmoids; but we shall continue to concern ourselves with cylindrical configurations for the time being. Hain, Lüst, and Schlüter¹² have written an interesting article on the stability of a plasma, giving general considerations which hold for any hydromagnetic equilibrium, still assuming zero viscosity and infinite electrical conductivity, and have solved explicitly the case of a plasma cylinder with zero internal field.

Especially interesting, however, is the article by Lüst and Schlüter¹³ on "axially symmetric magnetohydrodynamic equilibrium configurations". Their basic equation corresponds to the present Equation (3) without the terms in \vec{v} , and they have used a method similar to that used by Chandrasekhar. The work planned for the next quarter on this project, therefore, corresponds to a generalization of their work.

⁹L. Biermann, K. Hain, K. Jörgens, and R. Lüst, Z. Naturforschg., 12a, 826 (1957).

¹⁰R. Kippenhahn, Z. Naturforschg., 13a, 260 (1958).

¹¹K. Jörgens, Z. Naturforschg., 13a, 493 (1958).

¹²K. Hain, R. Lüst, and A. Schlüter, Z. Naturforschg., 12a, 833 (1957).

¹³K. Lüst and A. Schlüter, Z. Naturforschg., 12a, 850 (1957).

III. DESIGN AND CONSTRUCTION OF EXPERIMENTAL APPARATUS

The over-all physical system has been planned and is shown schematically in Figure 1. Several parts are in various phases of design and fabrication and are treated in the following.

A. Magnetic Field

→ The magnetic field will be variable with 2,000 to 6,000 gauss needed for the initial range. A method employing a current pulse through a solenoid has been selected and the necessary calculations made. For a solenoid of 25 cm diameter and 50 cm length, the magnetic field at the center is given approximately by

$$B_c \approx \frac{\mu NI}{\sqrt{4r^2 + \ell^2}} \quad 2.25 \times 10^{-2} NI \text{ gauss,} \quad (7)$$

where r is the radius, ℓ the length, N the number of turns, I the current, and μ the permeability of the medium. Then, if we want $B_c \approx 6,000$ gauss, substituting the values in Equation (7), we get,

$$NI \approx 2.66 \times 10^5 \text{ ampere-turns.}$$

Assuming a large enough wire is used so that the resistance is negligible compared with the inductive reactance, the inductance of a single layer coil of round wire is given approximately by

$$L_0 = F N^2 d \text{ microhenrys, where } F \approx .01 \text{ for } \frac{d}{\ell} = \frac{1}{2}.$$

Then, for a coil of diameter $d = 10$ inches,

$$L_0 = .1 N^2.$$

The discharge circuit for $R \ll L$ can be approximated by an LC series circuit.

The solution for the current is easily obtained as

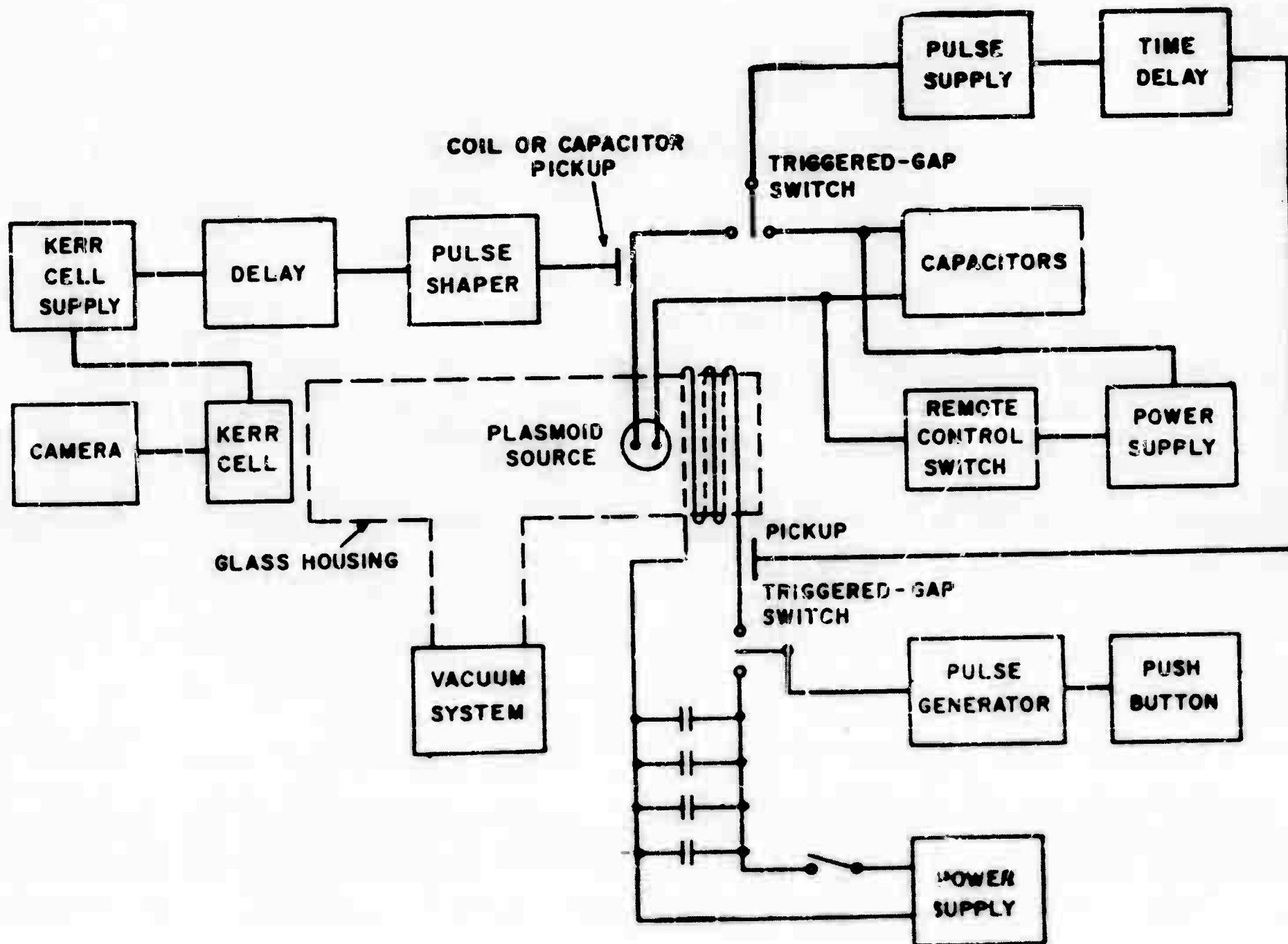

- 10 -

Figure 1. Block Diagram of Over-All Experimental System.

$$i = V \sqrt{\frac{C}{L}} \sin \sqrt{\frac{1}{LC}} t \text{ amps.}$$

The amplitude is given by $A = V \sqrt{\frac{C}{L}}$ amps, the period by $T = 2\pi \sqrt{LC}$, and the frequency by $f = \frac{1}{2\pi \sqrt{LC}}$. We are only concerned with using the first

half cycle for the field supply since the operation will be single-shot.

A requirement for reproducibility of the magnetic field is that the period of the magnetic field discharge be much larger than the time variation in the plasmoid crossing the solenoid; e.g., if the plasmoid is going to see an identical magnetic field for each shot in a series, the variation on the NI product curve must be small compared to the NI value at that position. For a sinusoidally varying NI function, as in this situation, the variation is reduced by increasing the inductance and operating near the peak of the curve where the slope is small. A calculation was made for $N = 20$ turns and a time delay in the plasmoid system of $0.1 \mu \text{ sec}$ at a slope of 1 and the results indicated a variation of about 0.1 per cent in the magnetic field value.

The capacitors to be used to supply the energy for the magnetic field are rated at $175 \mu \text{f}$ and 4,000 volts. There are 8 capacitors available and 4 will be placed in parallel for the original energy bank. Since $B \approx 2.25 \times 10^{-2}$ NI gauss and $NI_{\text{peak}} = NV \sqrt{\frac{C}{L}}$, four of these capacitors at full voltage could

$$B = 2.25 \times 10^{-2} \left(4 \times 10^3 \sqrt{\frac{N^2 C}{L}} \right) \approx 90 \sqrt{\frac{700}{0.1}} \approx 7500 \text{ gauss.}$$

The above figure is larger than needed, but the capacitors cannot stand voltage reversal at 4,000 volts so they will have to be operated at a reduced voltage rating.

To handle the large currents involved, a triggered-gap switch has been designed and fabricated. The triggering electronics is in the fabrication stage and should be completed shortly. Figure 2 shows the trigger circuit with the output to the triggering electrode. The operation employs a 15 KV pulse to the trigger to break down the air gap between two spherical electrodes. E. Cullington and associates¹⁴ developed the basic switch design and report excellent characteristics for the low voltage region. They report satisfactory operation as low as 1 kv for single shots with a time jitter of about .1 μ sec. This represents a considerable improvement over conventional switches where the time jitter is usually unacceptable at this voltage. Tests will be run on the trigger as soon as construction of the electronics is completed.

A 6 kv power supply is being constructed for charging the magnetic field capacitors. The output will be unfiltered and controlled by a variac input.

B. Plasmod Source

The plasmod source will initially consist of two deuterium loaded titanium wires in a button-type arrangement, as sketched in Figure 3.

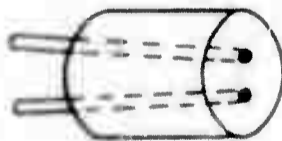
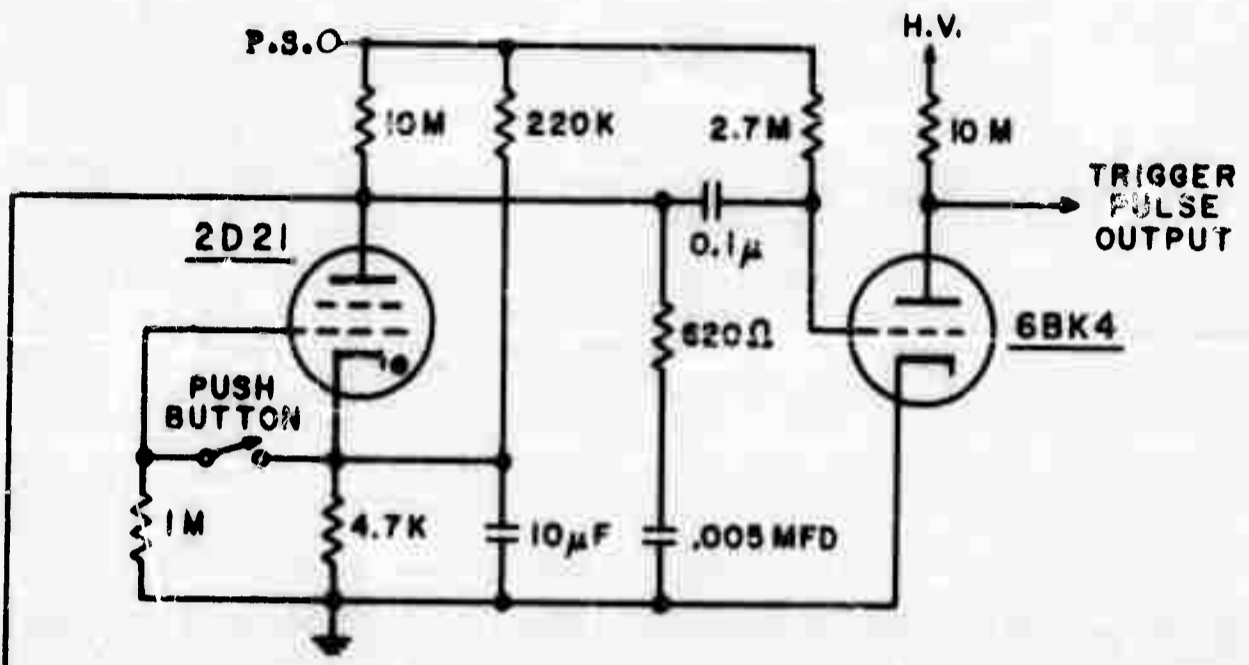

Figure 3. Button Plasma Source.

A method of preparing the wire is being sought by correspondence with the

¹⁴E. C. Cullington et al. Electronics (April 11, 1958), p. 86.



TRIGGER CIRCUIT

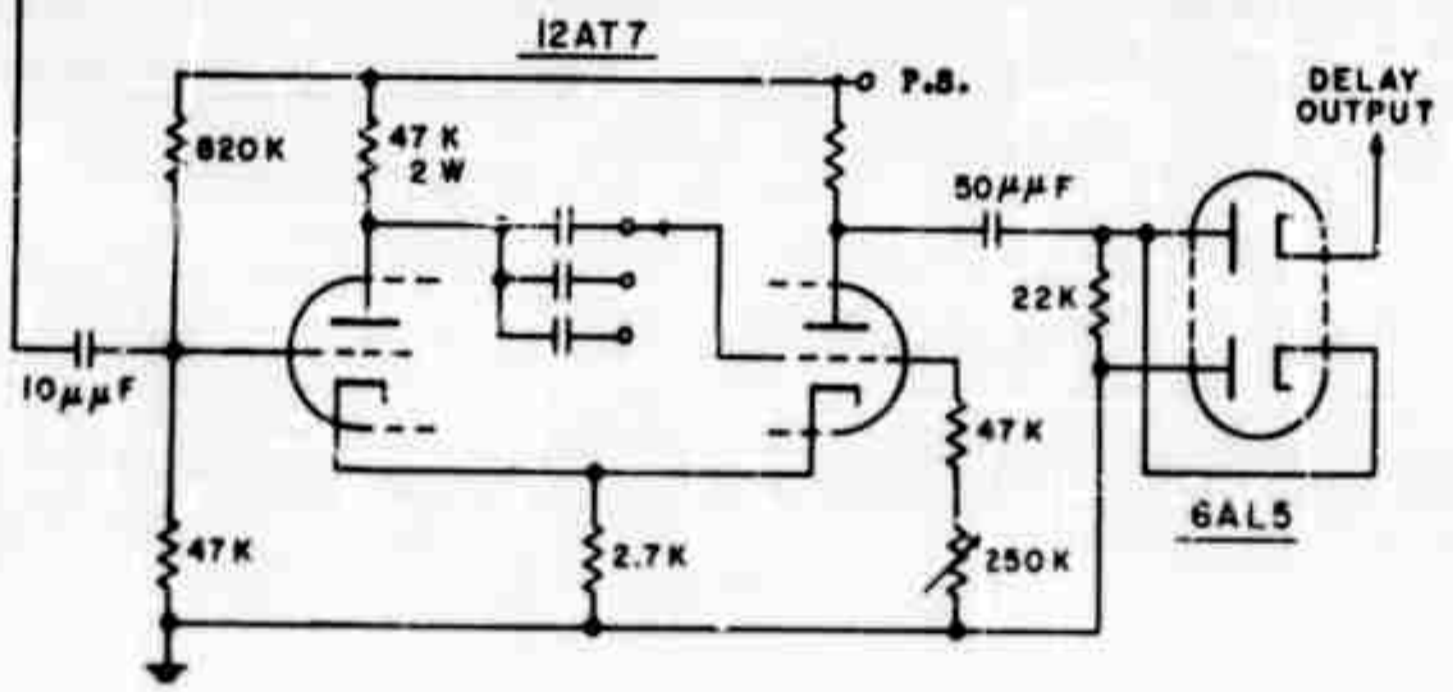

TIME DELAY

Figure 2. Trigger and Time Delay Circuits.

University of California Radiation Laboratory. New configurations and materials will be investigated at a later date.

As mentioned previously, the discharge to the source must be of 0.5 μ sec or less duration for the first half cycle to provide satisfactory conditions for the formation of the plasmoid. In addition to this, it is desired to transfer a maximum amount of energy into the source. The period of the discharge is proportional to \sqrt{LC} . Therefore, if the capacitance is increased in order to get higher energy, the discharge time is correspondingly increased. An alternate way of increasing the capacitance energy ($\frac{1}{2} CV^2$) is to increase the voltage. However, this is soon limited by practical voltage handling considerations. Also, the back emf of the plasmoid is considerably less than the capacitor voltage so that a highly underdamped condition exists. A high voltage, low capacitance combination is needed for a fast discharge, yet low voltage and large capacitance is desirable for impedance matching. The capacitance energy increases as the square of the voltage while the impedance is inversely proportional to the capacitance. From first order calculations it was indicated that a high voltage, low capacitance source seems to be desirable. Further calculations will be made to learn the dependence of the energy delivered to the source on the external circuit conditions after the voltage-current characteristics of the button plasmoid source have been determined.

The time delay circuit for the triggered-gap switch has been designed and is currently being fabricated. It is a multivibrator-type delay variable to 3 milliseconds and is shown in Figure 2. The triggered-gap switch for the plasmoid gun circuit is expected to be a variation of the one designed for the magnetic field supply with modifications made for

operation to 40 kv. Insulating and corona problems will be considerable in this region of operation. Since the capacitors have not been selected, the exact range is not known and these problems have not been considered in detail. At present, it is expected that operation will be between 10 and 40 kv with the lower voltage as the starting point. A 30 kv power supply is available and will be used until higher voltages are required.

C. High Speed Photographic Methods

The plasmoids that have been produced travel at velocities up to 2×10^7 centimeters per second and are about a centimeter in diameter. This means that if they are to be photographed in flight at a standstill, an exposure time of less than 0.1 microseconds must be used. At the present time, there are two possible methods for attaining photographic exposures as short as this. This is by the use of the Kerr cell or by an image converter. An electronic method of attaining the light intensity distribution across the plasmoid has also been described.¹⁵ Although it is highly sensitive, it does not have the resolution of the photographic methods.

The light output from plasmoids made in the past was not reported. It is known,¹⁶ however, that smear photographs were obtained of the plasmoids by means of a Kerr cell camera employing Polaroid high speed film which has an ASA rating of 400. Photographs were not obtained of the plasmoid in still flight because of the lack of light. It was, however, thought that with a higher speed photographic emulsion such photographs would be possible.

¹⁵D. Plakelstein, G. A. Sawyer, and T. F. Stratton, *Physics of Fluids*, 1, 188 (1958).

¹⁶V. H. Rostick, private communication.

Kerr cell cameras have been reported in the literature in many places.^{17,18,19} Effective exposure times of 0.007 microseconds have been reported.¹⁷ The Kerr cell is essentially a vessel filled with a liquid which exhibits uniaxial birefringence when stressed by an electric field. Two (usually plane) electrodes are immersed in the solution to which a high voltage is applied. When such a cell is oriented between two polarizers, crossed for minimum transmission, the arrangement constitutes an optical shutter. With no voltage applied, there is no transmission because of the crossed polarizers; however, with an applied voltage the state of the polarization of the light passing through the Kerr cell is altered and it is passed by the system.

The basic arrangement¹⁸ of the elements of a Kerr cell camera is shown in Figure 4. The two polarizers are arranged with their axes of polarization at 90° with respect to each other. The axis of polarization of the first polarizer is oriented at 45° with respect to the electric field lines in the Kerr cell. In practice a high voltage pulse of short duration is applied across the Kerr cell plates which applies a field of some 16,000 volts/cm within the liquid, thus opening the shutter for a given duration of time. The effective exposure time of the cell, however, is less than the duration of the pulse because the waveform of the pulse is not rectangular and the transmission of the Kerr cell is not a linear

¹⁷A. M. Zarem and F. R. Marshall, Rev. Sci. Instr., 21, 514 (1950).

¹⁸A. M. Zarem, F. R. Marshall and F. L. Poole, Electrical Engineering, (April, 1959), p. 282.

¹⁹W. Q. Nicholson and I. Ross, "Kerr Cell Shutter Has Submicrosecond Speed", Electronics, (June, 1955), p. 171.

function of the voltage across the cell. The transmission of the Kerr cell for a 45° orientation of the polarizers with respect to the E-field of the cell may be written

$$T = 50 \sin^2 \left[\frac{\pi}{2} \left(\frac{V}{V_0} \right)^2 \right] \text{ per cent,}$$

where V_0 is the applied potential needed for "full open" of the cell and V is the applied voltage to the cell. The "full open" potential in volts of the Kerr cell can be calculated from the expression

$$V_0 = 300 d (2\ell K)^{-1/2}$$

where d is the distance between the plates, ℓ is the length of the electrodes, and K is the Kerr constant, all in c.g.s. (electrostatic) units. For the case of Nitrobenzene, $K = 400 \times 10^{-7}$.

The optical transmission of the Kerr cell shutter system can be stated as the product of the transmissions of the individual elements or

$$T_0 = T_{L1} \cdot T_{L2} \cdot T_K \cdot T_P \cdot T_G$$

where T_{L1} is the transmission of the first collimating lens

T_{L2} is the transmission of the camera lens

T_K is the transmission of the Kerr cell liquid

T_P is the transmission of the polarizers

T_G is the transmission of the glass windows of the Kerr cell.

The transmission of each lens can be considered as 96 per cent. The nitrobenzene ($C_6H_5NO_2$) transmission characteristic is given in Figure 5 as a function of wavelength. The transmission characteristics of Polaroid J polarizing film is given in Figure 6. The transmission of the glass

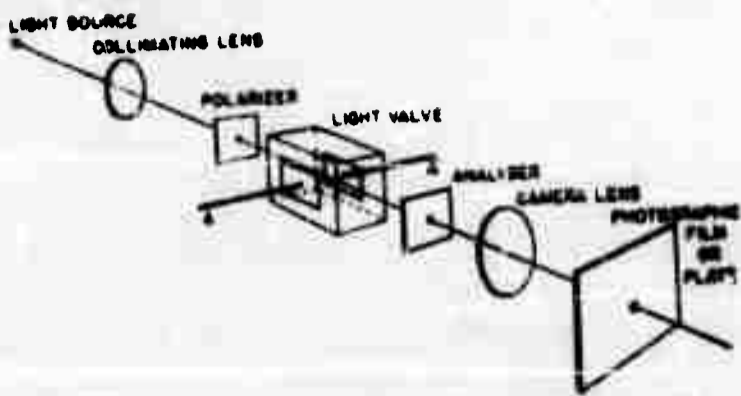

Figure 4. Components of a Kerr Cell Camera.¹⁸

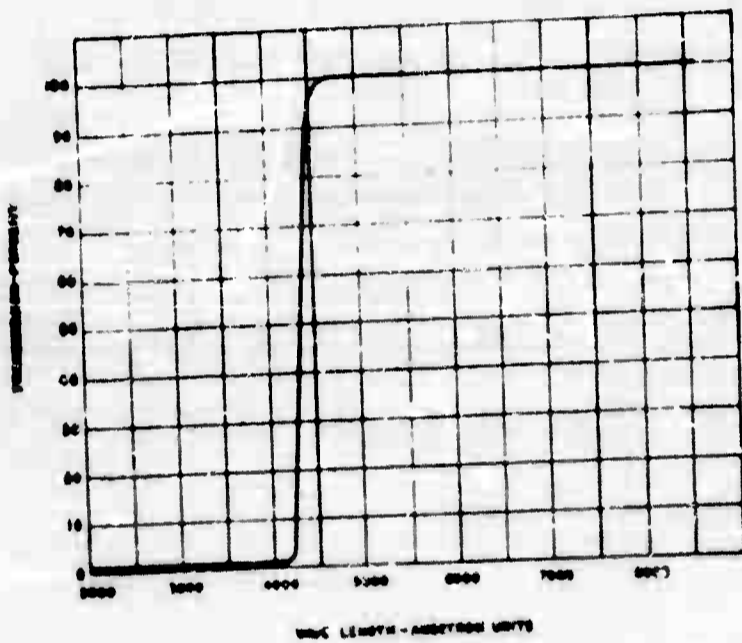

Figure 5. Spectral Transmission of Nitrobenzene Sample of One Centimeter Thickness.¹⁸

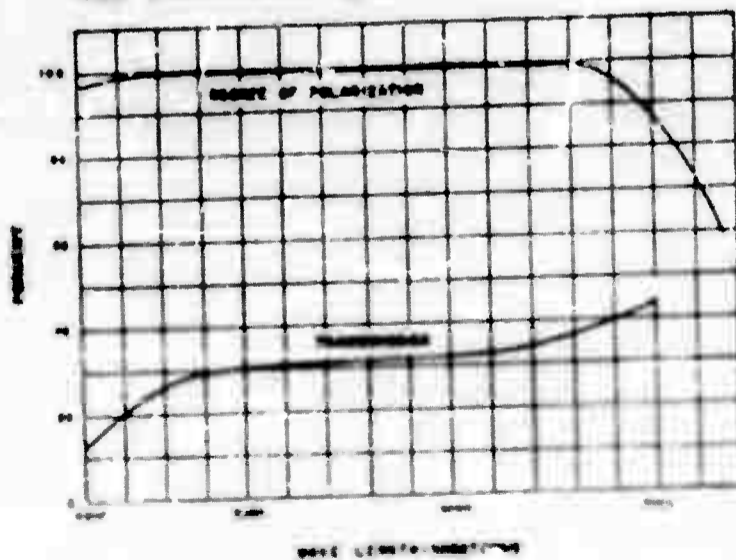

Figure 6. Characteristics of J Film Polaroid.¹⁸

windows is given as $1 - (n-n')^2/(n+n')^2$ for each surface, where n is the refractive index of the material through which the light passes first and n' is the refractive index of the second material. For glass of index of refraction of 1.4 and air, the transmission is .97; and for glass and nitrobenzene the losses may be neglected. The total transmission of all surfaces is approximately .86.

The total transmitted light is given as a function of wavelength in Figure 7.

The image converter is an electronic tube that has the property of converting an optical image falling on one face of the tube or cathode to a corresponding image on another face of the tube. It has found application in military situations where light in the infrared region of the spectrum is to be converted to a visible image. Its basic elements are a photocathode deposited on a front face, an electron lens system and a phosphor face. The photocathode produces an electron pattern which corresponds in intensity to the illuminated areas on the photocathode. This photocathode is constructed of photoemissive films evaporated onto the front face of the tube. Two typical photocathodes in use are the Cs-O-Ag, which has infrared response; and Sb-Cs, which responds to the visible spectrum. The electron pattern is accelerated by means of a combination electrostatic-magnetic lens to a phosphor coated anode where the optical image is reproduced.

Image converters may be used as fast photographic shutters by pulsing the accelerating voltage on for a short duration. Photographic shutter speeds of 3×10^{-8} seconds have been reported.²⁰ At the present time,

²⁰R. A. Chippendale, The Photographic Efficiency of Image Converters, Butterworths Scientific Publication, 88 Kingsway, London, W.C.2. (1956).

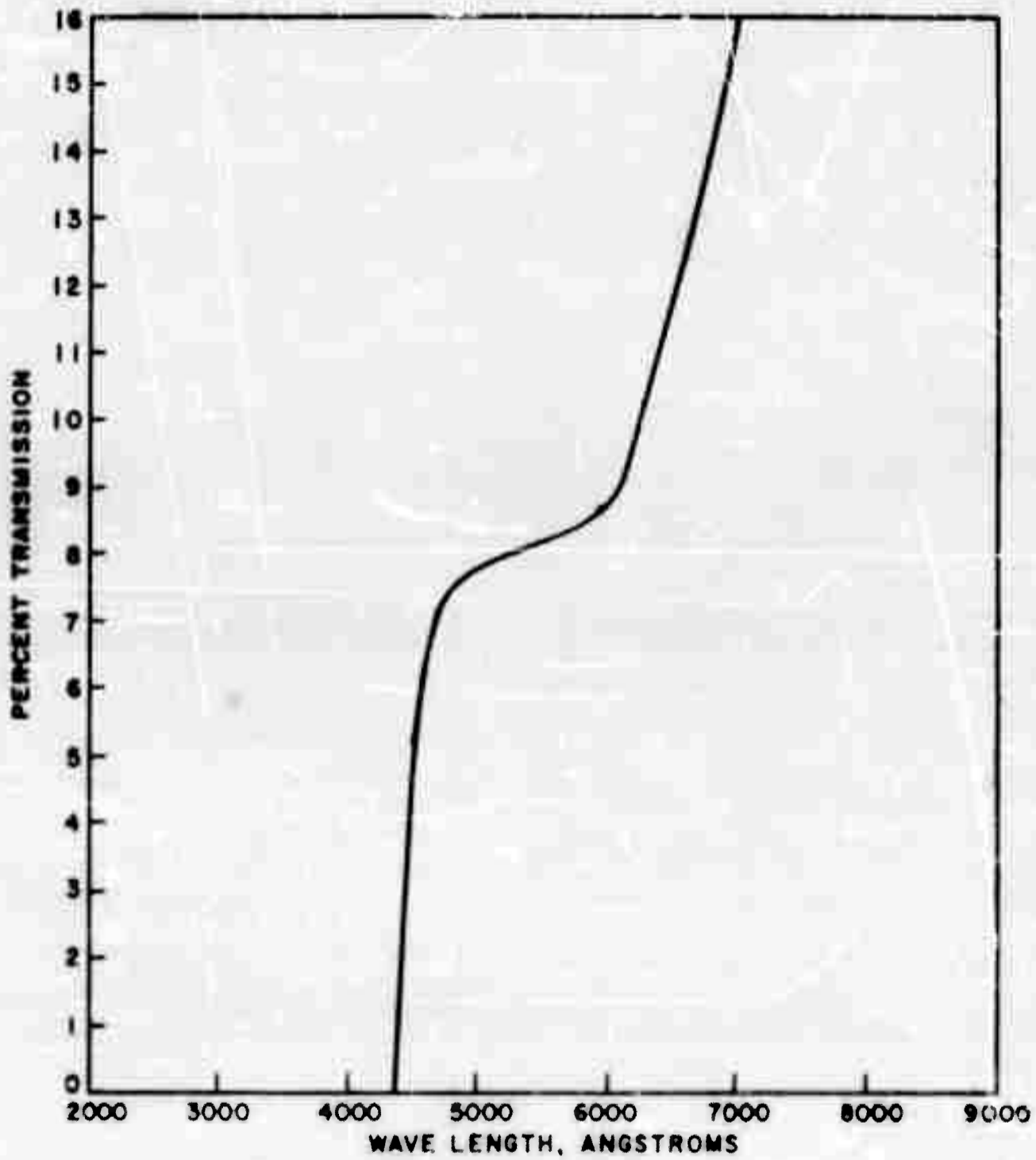

Figure 7. Total Transmission of Optical System Including Kerr Cell Liquid and Two Type J Polaroid Films (Axes Parallel).

only one image converter is manufactured that responds to visible light and is suitable for high speed photography. This is the ME-1201 manufactured by the Mullard Radio Valve Company, Ltd., in England. The tube employs a Sb-Cs cathode and can be ordered with either of two phosphor screens - a zinc sulfide screen or a willemitte (Zn_2SiO_4) screen. The willemitte screen has a longer decay time and thus is better for high speed photography. In theory the image converter should be capable of intensifying the image on the phosphor. This is not the case with the ME-1201 because of the rather large electron-optical magnification of 4. It has been shown by Chippendale²⁰ that with standard techniques sensitivities are in the same range as Kerr cells. New developments, however, on a tube with an electron-optical magnification of unity would greatly improve this. A tube of this nature is now in the development stage at Mullard and is not presently available.

The image converter, at present, does not present any advantages over the Kerr cell for high speed photography. It is, therefore, felt that the Kerr cell should be used because of its less stringent requirements on the pulse voltage waveform.

IV. LOGBOOK REFERENCES

The data of this project are recorded in ARF Logbook Nos. C-8026, C-8036, C-8319, and C-8326.

V. CONTRIBUTING PERSONNEL

The theoretical investigations are being carried out by Val W. Pratt.

R. L. Watkins and D. J. DeGeeter are responsible for design and construction of the apparatus and the planning of experimental investigations.

Respectfully submitted,

ARMOUR RESEARCH FOUNDATION
of Illinois Institute of Technology

Val W. Pratt

Val W. Pratt, Associate Physicist,
Electricity and Magnetism Section.

APPROVED BY:

James J. Brydson
James J. Brydson, Assistant Manager,
Physics Research Department.

ARMOUR RESEARCH FOUNDATION OF ILLINOIS INSTITUTE OF TECHNOLOGY