

UNCLASSIFIED

**A
D 216545**

Armed Services Technical Information Agency

**ARLINGTON HALL STATION
ARLINGTON 12 VIRGINIA**

**FOR
MICRO-CARD
CONTROL ONLY**

1 OF 1

NOTICE: WHEN GOVERNMENT OR OTHER DRAWINGS, SPECIFICATIONS OR OTHER DATA ARE USED FOR ANY PURPOSE OTHER THAN IN CONNECTION WITH A DEFINITELY RELATED GOVERNMENT PROCUREMENT OPERATION, THE U. S. GOVERNMENT THEREBY INCURS NO RESPONSIBILITY, NOR ANY OBLIGATION WHATSOEVER; AND THE FACT THAT THE GOVERNMENT MAY HAVE FORMULATED, FURNISHED, OR IN ANY WAY SUPPLIED THE SAID DRAWINGS, SPECIFICATIONS, OR OTHER DATA IS NOT TO BE REGARDED BY IMPLICATION OR OTHERWISE AS IN ANY MANNER LICENSING THE HOLDER OR ANY OTHER PERSON OR CORPORATION, OR CONVEYING ANY RIGHTS OR PERMISSION TO MANUFACTURE, USE OR SELL ANY PATENTED INVENTION THAT MAY IN ANY WAY BE RELATED THERETO.

UNCLASSIFIED

BEST

AVAILABLE

COPY

UNCLASSIFIED

AFSWP-1117

Copy No. 1

AD No. 216545

ASTIA FILE COPY

THERMAL RADIATION DAMAGE TO CELLULOSIC MATERIALS
PART IV. INFLUENCE OF THE MOISTURE CONTENT AND
THE RADIANT ABSORPTIVITY OF CELLULOSIC MATERIALS
ON THEIR IGNITION BEHAVIOR

Research and Development Technical Report USNRDL-TR-295

30 December 1958

by

S. Martin
K. A. Lincoln
R. W. Ramstad

**FC
BAC**



U S NAVAL RADIOLOGICAL DEFENSE LABORATORY

N FRANCISCO 24 CALIFORNIA

AD No. 216545

ASTIA FILE COPY

FILE COPY
Return to
ASTIA
ARLINGTON HALL STATION
ARLINGTON 12, VIRGINIA
Attn: TISS

ASTIA
RECEIVED
MAY 25 1959
TIPDR

UNCLASSIFIED

U N C L A S S I F I E D

AFSWP-1117

THERMAL RADIATION DAMAGE TO CELLULOSIC MATERIALS
PART IV. INFLUENCE OF THE MOISTURE CONTENT AND
THE RADIANT ABSORPTIVITY OF CELLULOSIC MATERIALS
ON THEIR IGNITION BEHAVIOR

Research and Development Technical Report USNRDL-TR-295
NS 081-001

30 December 1958

by

S. Martin
K. A. Lincoln
R. W. Ramstad

Physics and Mathematics
AFSWP - Thermal

Technical Objective
AW-7

Thermal Radiation Branch
W. B. Plum, Head

Nucleonics Division
A. Guthrie, Head

Requests by military activities or contractors for
additional copies of this report should be
submitted to ASTIA.

Scientific Director
P. C. Tompkins

Commanding Officer and Director
Captain J. H. McQuilkin, USN

U. S. NAVAL RADIOLOGICAL DEFENSE LABORATORY
San Francisco 24, California

U N C L A S S I F I E D

ABSTRACT

Measurements of the radiant exposure (as a function of irradiance) required for the ignition of alpha-cellulose at controlled levels of humidity and for various radiant absorptances show that the influence of the moisture content and the absorptivity of the material on its ignition behavior can be accounted for by the appropriate modification of the correlation moduli previously derived. The effects of moisture content and absorptivity were normalized by adding the heat capacity of the water to that of the dry cellulose and by multiplying both the radiant energy and irradiance values by the appropriate radiant absorptance.

Data were obtained for dark cellulosic sheet fuel in the relative humidity range 10 to 87 percent and for sheet cellulose having a broad range of absorptance values. The data for all but the white cellulose correlate well to a single ignition behavior pattern. It is suggested that this ignition pattern is sufficiently general to be used to predict the ignition behavior of a broad class of kindling fuels.

Limited experimentation with white cellulose indicates that for materials in the low range of absorptivity, the absorptance multiplier in the irradiance modulus should be raised to a power less than unity (approaching a value of roughly one-half for white, highly diathermanous materials).

SUMMARY

The Problem

It is well known that cellulose and cellulosic kindling fuels take up water from the surrounding air to an extent which depends on the relative humidity of the air. Previously it was not known, however, to what extent this water influences the ignition behavior of kindling fuels. The purpose of the experimental work reported here was to evaluate the influence of this sorbed water.

Similarly, it is known that the darker kindling fuels ignite more readily than lighter ones when exposed to thermal radiation. The magnitude of this effect, however, was not known to any quantitative degree. For this reason the investigation of the ignition of cellulose varying in color from black to white was included in this study.

The Findings

The moisture taken up by cellulose when exposed to air having relative humidities in the range 10 to 87 percent causes small, but measurable, increase in the radiant energy required to ignite the cellulose. This increase appears to be primarily due to the heat capacity of the added moisture with little or no significant contribution from heats of desorption or vaporization.

The data for all but the dead-white cellulose correlated well to a single ignition behavior pattern based on the heat conduction equation. It is believed that this pattern can be used to predict the ignition behavior of the bulk of the kindling fuels encountered.

ADMINISTRATIVE INFORMATION

Background of Work

During FY 1954, the U. S. Naval Radiological Defense Laboratory initiated a program, entitled "Thermal Radiation Damage to Cellulosic Materials," sponsored by the Armed Forces Special Weapons Project with the primary objective to study the influence of material properties and radiant energy exposure parameters on damage to thick (wood) and thin cellulosic materials and to study the mechanisms of ignition of cellulosic materials by intense radiant energy. In FY 1955 a sub-task, entitled "Ignition by Thermal Radiation," had as its objective the study of the macroscopic ignition behavior of selected systems of materials when exposed to intense radiant energy and to ascertain the mechanisms for the ignition-combustion processes.

Authorization and Funding

This work was authorized by the Armed Forces Special Weapons Project and was funded during FY 1954 through FY 1956 by Allotment 12001/53 and 92009/56, FY 1957 by Allotment 92009/56, FY 1958 by Allotment 99178/58, and during FY 1959 by Allotment 99178/59.

Description of Work

The ignition of cellulose and the products of pyrolysis were studied during FY 1957 using the carbon arc radiant source, the Mitchell thermal source, and the chromatographic equipment developed at this laboratory. Studies included: (a) The influence of material properties and radiant energy exposure parameters on ignition by thin cellulosic materials. Parameters of concern were the irradiance-time characteristics of the thermal pulse, the optical properties, and the thickness and density of the material; (b) The mechanisms of ignition of cellulosic materials of intense radiant energy.

During FY 1958 and FY 1959 the program, "Ignition by Thermal Radiation," was prosecuted by this laboratory, using the simulated nuclear weapon pulse of the Mitchell thermal source. The ignition behavior of alpha-cellulose materials was determined in the same manner as was done for constant irradiance exposures. Particular attention was given the alpha-cellulose since this material is representative of a broad class of ignitable materials. Variables included were density and thickness of material, simulated weapon yield and radiant power of the exposure. The data obtained were correlated in a manner similar to that used for the constant irradiance exposures.

This report was prepared at the specific request of the sponsor, the Armed Forces Special Weapons Project, and constitutes the conclusion of the studies outlined in part (a) above. The second phase, part (b); the mechanism of ignition of cellulosic materials of intense radiant energy, is currently under prosecution at this time.

It is hoped that information gained in these studies will lead to a better understanding of the ignition process and will also result in the establishment of the best possible techniques for the testing of materials of interest to the various agencies of the Department of Defense.

The authors wish to acknowledge the valuable assistance of Willard Pflueger, Captain, USA, who gave freely of his time aside from his normal duties as AFSWP liaison officer to procure the many parts and items of equipment used and to fabricate the controlled humidity exposure chamber in time to allow the completion of the experimental work on schedule.

Thanks are also due William Neall of the Radiological Safety Branch, USNRDL, for making available the glove box used in the experiment.

INTRODUCTION

The ignition behavior of cellulosic materials has been treated in some detail in previous reports in this series.^{1,2} By the use of a model cellulose fuel whose physical properties can be changed without changing its chemical composition and by the use of a data correlation technique based on the solution of the appropriate heat conduction equation, a generalized ignition behavior pattern was realized which revealed the interaction between such physical properties of the material as density, thickness, specific heat and conductivity and the parameters of exposure, irradiance and total radiant exposure.¹ This work was subsequently extended in an investigation of the effect on the ignition behavior of cellulose exposed to the input pulse which is typical of nuclear weapon air bursts.²

Two parameters of the cellulosic fuel, its moisture content and radiant (optical) absorptance, were purposely deferred to the last. Because of the anticipated importance of their influence and the difficulties expected in interpreting their interaction with the already complex system, it was deemed wise to attempt to understand, as well as possible, the ignition process while holding these two parameters fixed and then to evaluate them in turn.

This, the fourth and final part of the series, is a report of the experimental investigation of the influence of the moisture content and the radiant absorptance on the ignition behavior of cellulosic kindling fuels.

EXPERIMENTAL

The theoretical basis for the choice of material and the geometry of exposure as well as the techniques of exposure and radiant power measurement, etc., have received adequate treatment in previous reports, particularly in the second part of this series.¹

The main unique feature of this experimental study was the use of an exposure environment having controlled conditions of temperature and humidity. It was decided prior to doing the experiment that it would be necessary to hold the temperature constant to within a degree and to be able to obtain and hold several levels of humidity up to about 90 percent relative humidity (RH) during the entire period of sample exposure. This was accomplished by modifying a chemical glove box to make it an integral part of the source, i.e., the last lens of the optical system served as a window for the radiation in the exposure end of the box (see Fig. 1). Air of the proper temperature and humidity was fed into the opposite end of the box at a rate sufficient to exchange the air and effectively carry away the decomposition-combustion products but not so great as to cause drafts on the sample during exposure. To insure this, baffles were placed in appropriate positions in the box: one at the air inlet to divert and break up the air inflow, and a second above and behind the exposure plane to form a fume-hood chamber (having an exhaust port at its top) above the sample to carry off the smoke and decomposition products as they were released.

A portable air-conditioning unit was used as a source of dry air. By diverting the conditioned-air supply and causing it to recycle, the temperature of the air could be lowered to about minus 10°C. The air fed to the glove box was drawn from this cold air supply with a small centrifugal blower. This air when heated to 75°F (24°C) consistently provided a 10 percent relative humidity environment.

To get higher levels of humidity some of the recycling cold dry air was allowed to escape to the room while a controlled amount of room air was allowed to enter the stream to the glove box. For still higher humidities, steam from a steam generator was fed directly into the dry air stream. Although it was entirely possible to obtain controlled relative humidities up to 100 percent, humidities above 90 percent RH were avoided because of the tendency of cellulose to become wet, i.e., to take up moisture irreversibly to the extent that the fibers become saturated with liquid water. For this reason 87 percent RH was chosen as a convenient high humidity operating level. In practice the cellulose samples were kept (for at least 12 hours before use) in desiccators whose humidities were controlled by means of saturated salt solutions or sulfuric acid solutions. After environmental conditions in the glove box had been brought to the desired operating values, the samples were transferred into the glove box for final conditioning, usually 20 minutes before commencing radiant thermal exposures. If, at any time during the preconditioning or final conditioning, the humidity had inadvertently exceeded 90 percent, there was then a distinct possibility that the material would have an erroneously high moisture content which could very well persist through the experiment; consequently 87 percent RH was the upper limit for all of the experimental work.

Relative humidities were measured and continuously monitored throughout each experimental run by means of a specially constructed dew-point hygrometer.

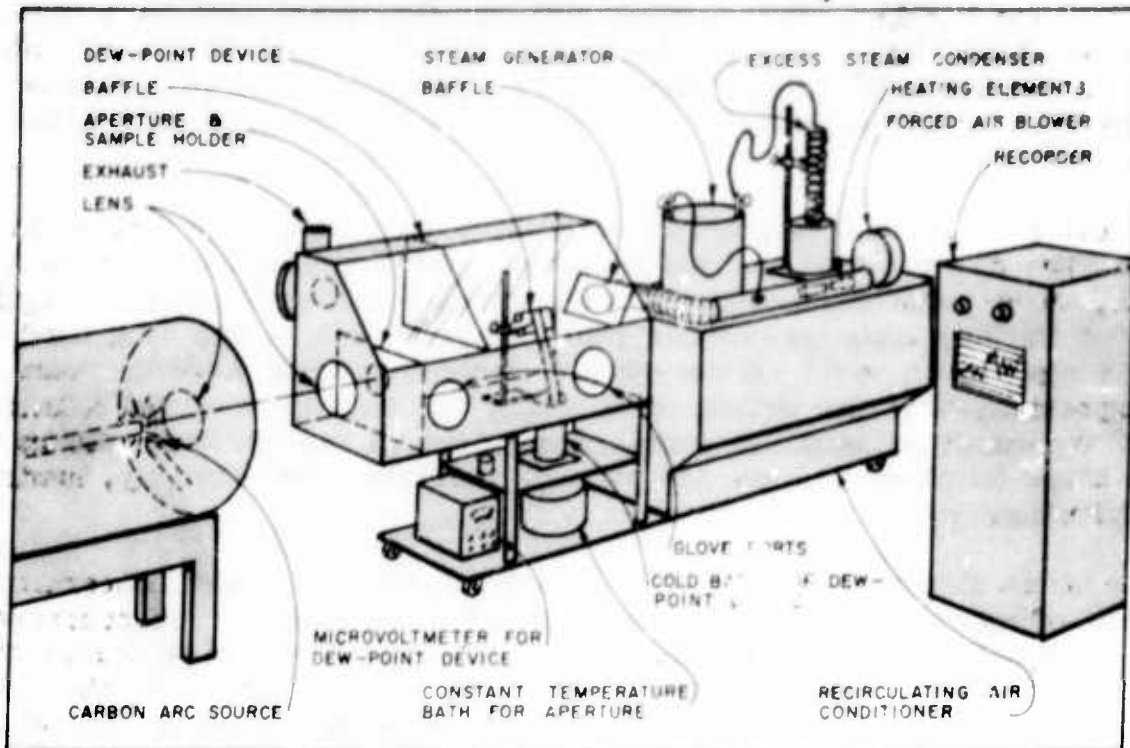
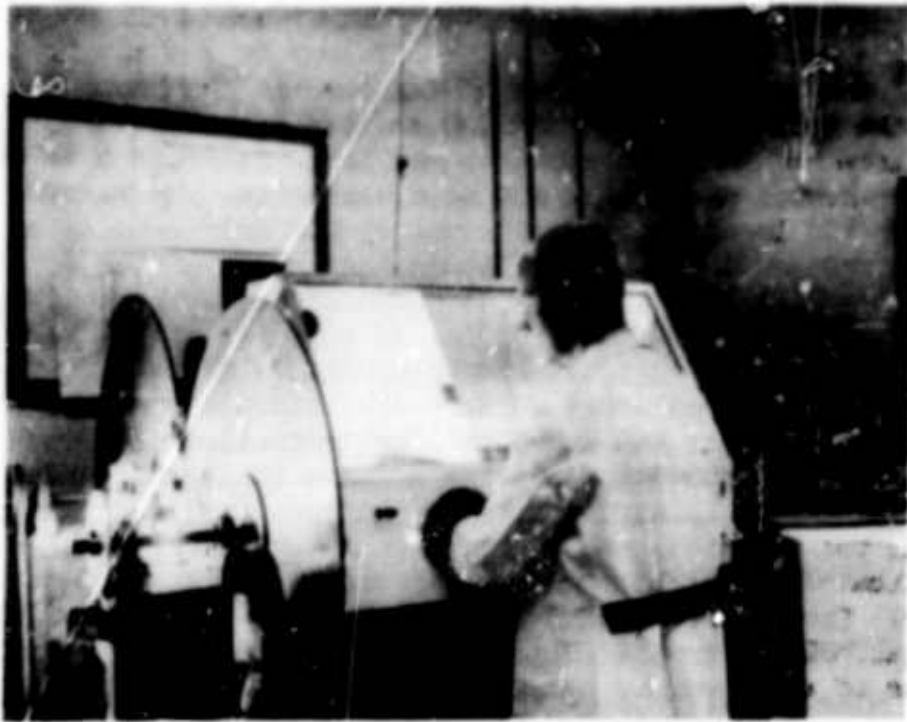

Fig. 1. Exposure system with apparatus for controlling humidity and temperature.

This device consists essentially of a $1/8 \times 1/2$ inch silver bar with a heat source at one end and a heat sink at the other to provide a thermal gradient along its length. Heat was provided by the radiant energy from a small light bulb enclosed in a metal box with a window adjacent to but not in contact with the upper end of the bar; this segment of the bar was blackened to adsorb the radiation from the bulb. The other end of the bar extended out through the bottom of the glove box where it could be partially immersed in a bath of cold water or dry ice-acetone mixture to act as a heat sink. By varying the voltage on the light bulb and by adjusting the level of the cold bath, a controlled temperature gradient could be produced along the length of the bar. The operating temperature was determined chiefly by the temperature of the bath, but the thermal gradient could be varied from about $1^{\circ}\text{C}/\text{in.}$ to somewhat higher values over approximately a three inch, highly polished length of the silver bar. In operation the temperature of the bar was adjusted so that the moisture condensed on the lower half of the polished surface and the "dew line" coincided with the location of a thermocouple junction imbedded under the surface of the bar. The reference thermocouple junction was located nearby in the open air, and the voltage difference between the two junctions was fed to a microvoltmeter. Thus, the voltmeter effectively indicated the difference between the temperature of the dew point and that of the air. The voltage read from the voltmeter was related to the relative humidity by a calibration graph. This procedure permitted a very direct and convenient means of continuously monitoring the humidity during the experiments.

To facilitate handling, the samples were cut into $1\ 1/2$ inch by $1\ 3/4$ inch rectangles and individually mounted in brass shim-stock holders. Each holder had an accurately-centered $3/4$ inch diameter hole punched through it. A water-cooled aperture with a slotted guide received the holders and automatically aligned them into the focal spot.

A preliminary series of exposures was run to compare this method of sample exposure to the slower, more tedious method of mounting circular samples in a peripheral, three-point suspension. No significant differences in the ignition behavior for the two exposure methods could be found and it was concluded that the one was equally as valid as the other. Besides cutting down the time lost between exposures, this new method of mounting the samples provided a large measure of pre-exposure handling convenience where it was necessary to go through the extra steps involved in, and the storage provisions required by, humidity pre-conditioning.

At one point about midway through the experiment some doubt concerning the measurement of exposure duration arose. From the earliest use of square-wave shutters on the Mitchell source, the time of exposure has been measured by means of two microswitches actuated by the opening and closing blades of the shutter. Previous measurements of the shape of the pulse made by recording the output of a photoelectric sensor with an oscillographic recorder revealed no particularly significant discrepancies between pulse duration and clock time (less than 0.02 sec). This time, however, there was found to be a difference of 0.05 to 0.07 sec.

For the remainder of the work a photoelectric timer designed to measure the pulse duration directly was used and all of the earlier exposure duration values were corrected accordingly.

Three levels of humidity were used for this study, 10, 30 and 87 percent RH. As in the past, for any given irradiance level the exposure time for an ignition effect was found by increasing the time if the previous exposure failed to ignite the sample, and decreasing the time if the previous exposure succeeded in producing an ignition, each successive step being smaller than the previous. When the exposure times for ignition were long enough, a statistical sequence was employed to evaluate the variance as well as the mean (see Appendix of reference 2).

RESULTS

The resulting ignition data for the three levels of humidity are shown in raw form in Figs. 2, 3, and 4 and are compared to the previously established ignition curves when moisture was not controlled. Figure 2 shows the data taken at 10 percent RH, Fig. 3 at 30 percent RH, and Fig. 4 at 87 percent RH. It is immediately apparent from these figures that the effect of moisture on ignition energy is small and there is seemingly as much variation of the new data from the old regression curves as there are consistent differences in values of ignition energy between levels of humidity. Moreover, even the data for the low humidity lie, in general, above the regression curves which represent nominal humidity environment (30 - 50 percent RH). These discrepancies will be discussed later (see Discussion of Results and Conclusions).

The moisture content of the materials used are listed in Table 1 for the three levels of humidity.

Table 2 lists the ignition energy values at three levels of irradiance for the alpha-cellulose materials having various optical absorptivities. These materials are identical to those previously used with the exception of their carbon-black content. The listed values of carbon-black additive are in terms of the percent by weight (dry) added to the pulp prior to forming into sheets and are somewhat higher than the actual content of the finished material. The radiant absorptances given are estimated values for the spectral distribution of the source (approximating a 5500°K black body) based on measured total hemispherical reflectances and transmittances in the visible region and the reported near infrared absorptance characteristics of similar cellulosic materials.^{4,5}

It has been pointed out⁶ that the heat capacity of cellulosic materials containing moisture is not equal to the sum of the heat capacities of the component

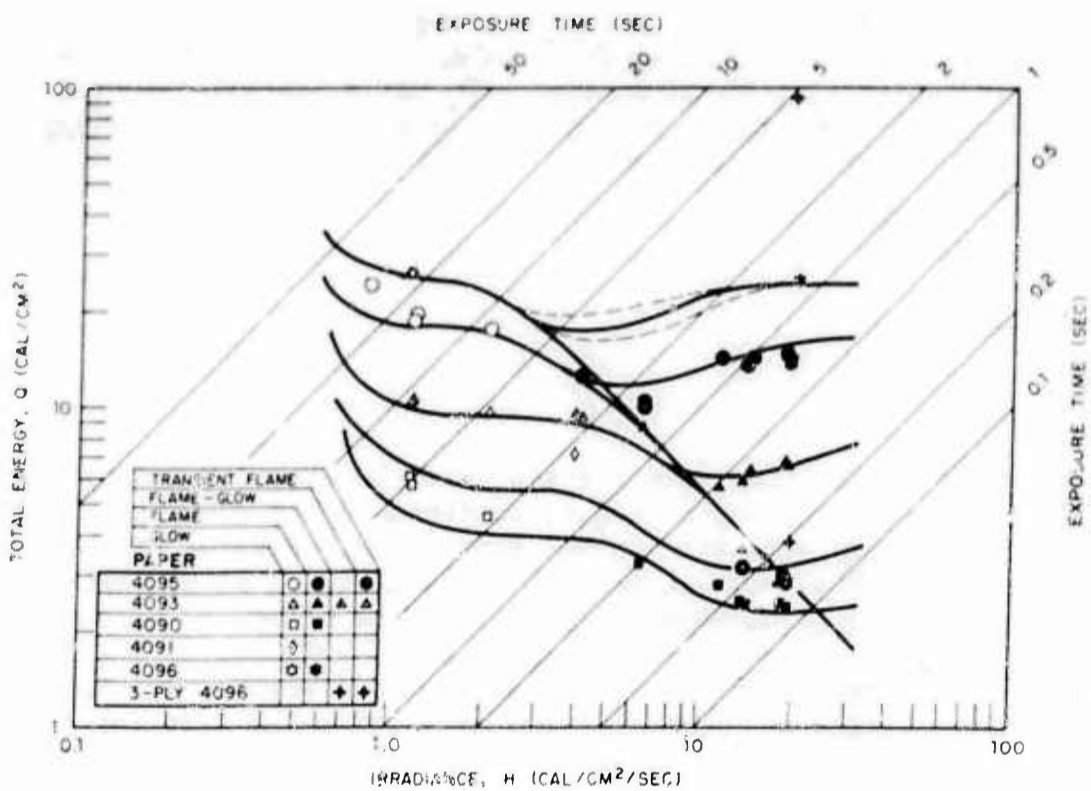

Fig. 2. Qht diagram of ignition data at 10% relative humidity. (Curves are from data of previous investigation - see text.) For description of materials see Table 1.

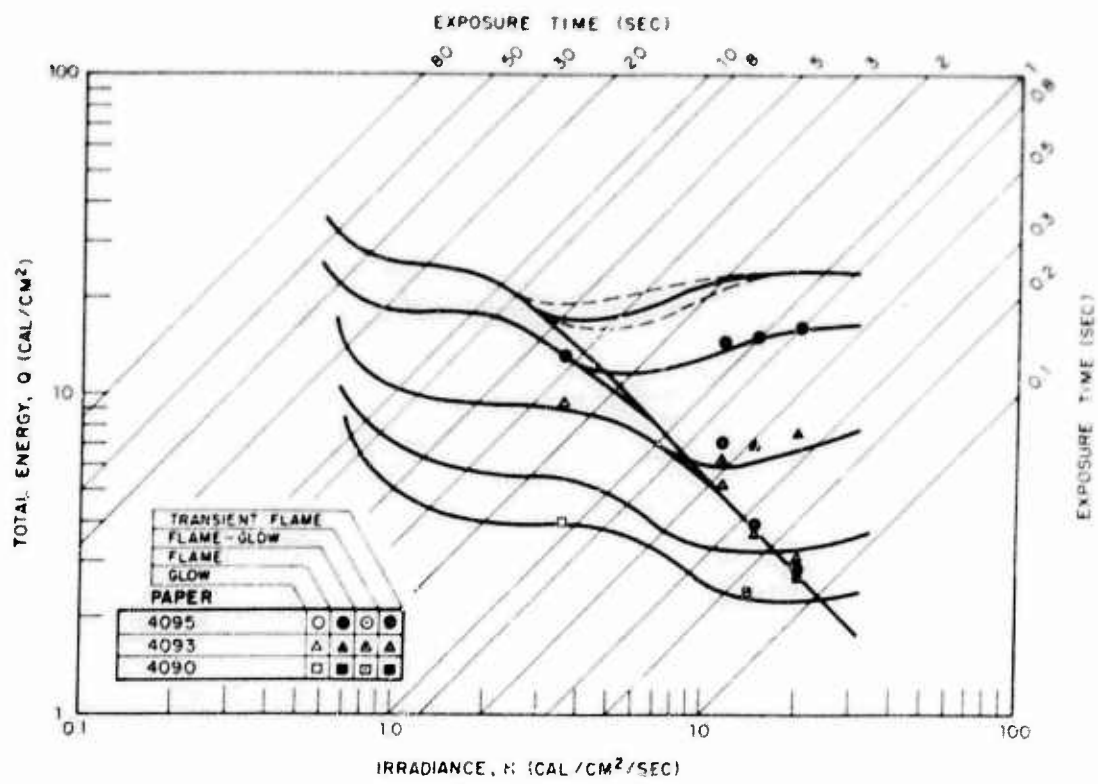

Fig. 3. QHt diagram of ignition data at 30% relative humidity. (Curves are from data of previous investigation - see text.) For description of materials see Table 1.

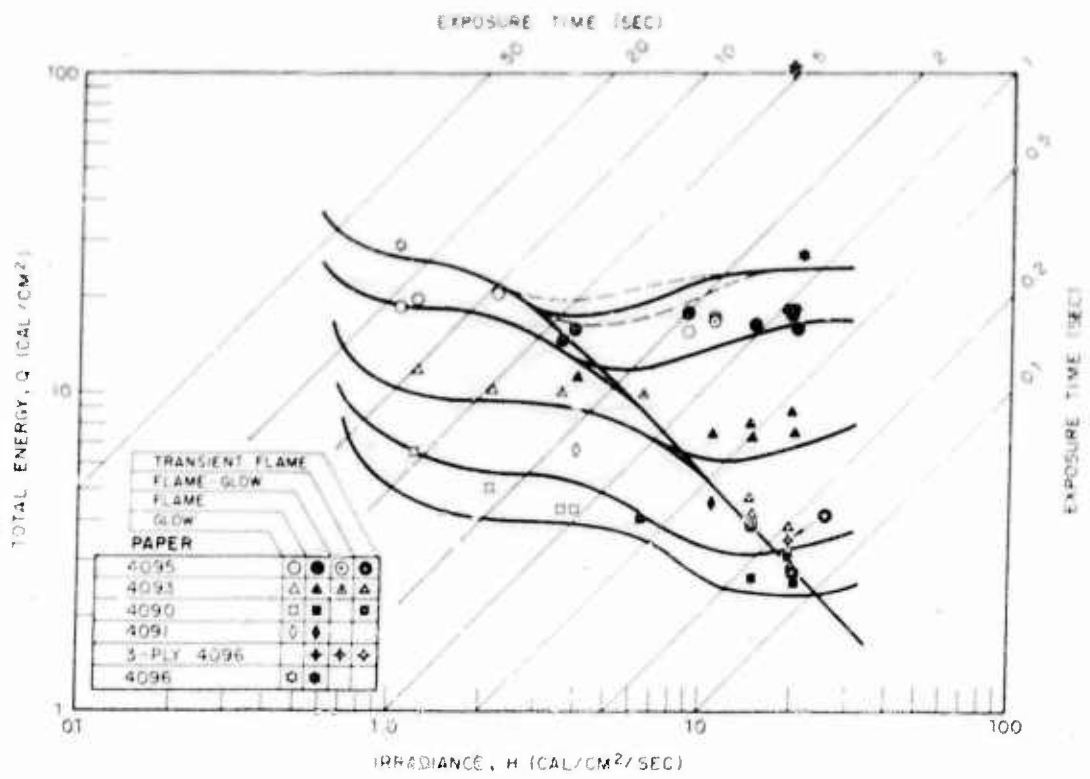

Fig. 4. QHT diagram of ignition data at 87% relative humidity. (Curves are from data of previous investigation - see text.) For description of materials see Table 1.

TABLE 1
DESCRIPTION OF DARK* CELLULOSE MATERIAL USED

Paper	Thickness***		Dens.***	Nominal Thermal Conductivity** ($\times 10^{-4}$)	Moisture content (% of dry weight)		
	cm	mls			10% RH	30% RH	87% RH
4090	0.012	5	0.62	1.9	2.3	3.8	11.9
4091	0.017	7	0.64	2.0	2.3	3.8	11.5
4093	0.027	11	0.67	2.1	2.3	3.8	11.2
4095	0.054	21	0.67	2.1	2.4	4.0	11.1
4096	0.078	31	0.68	2.2	2.6	4.4	11.1
3-4096	0.234	92	0.69	2.2	2.6	4.4	11.1

* 2 1/2% (dry weight basis) carbon black added to pulp prior to paper manufacture.

Estimated absorptance for distribution of Mitchell Source is 0.9.

** Specific heat capacity (dry) taken as 0.35 cal/deg/gm. Thermal conductivity is for material having nominal moisture content.

*** Thickness and density are dry basis values.

TABLE 2
IGNITION THRESHOLD OF CELLULOSE HAVING VARYING RADIANT ABSORPTIVITIES

Paper	Thickness (cm)	Density (g/cm ³)	% Carbon	Absorptance	Effect*	Irradiance Level	Radiant Energy
4070	0.029	0.54	2.5	0.9	F	19.36	5.32
					TF	19.36	2.42
					F	14.84	5.34
					TF	14.84	3.22
					F	9.58	4.58
					G	2.11	8.09
4069	0.029	0.54	1.0	0.8	F	19.36	5.71
					TF	19.36	2.0
					F	14.84	5.71
					TF	14.84	3.78
					F	9.58	4.92
					G	2.11	8.81
4075	0.030	0.54	0.25	0.7	F	19.36	6.83
					TF	19.36	4.55
					F	14.84	5.88
					TF	14.84	5.28
					F	9.58	6.65
					G	2.11	10.38
4068	0.030	0.52	0	0.1	F	19.36	44.62
					F	14.84	49.57
					F	9.58	53.91

* F - Sustained flaming threshold.
 G - Sustained glowing threshold.
 TF - (Transient flaming) - Spontaneous flaming threshold.

substances, but exceeds this by an amount which depends on the heats of absorption or desorption of water vapor. This "elevation of the specific heat" of cellulosic substances in terms of the moisture content and temperature has been derived⁶ from the work of Stamm and Loughborough⁷ on the thermodynamics of the swelling of wood by moisture, from the measurements of Stitt and Kennedy⁸ on the specific heat of dehydrated vegetables at various moisture contents, and thermal data of Katz⁹ for cotton and wood. Though there is shown to be a definite increase in heat capacity over the component sum for a material undergoing rapid heating from ambient to its ignition temperature, it appears quite unlikely that at any point this increase will exceed $0.07 \text{ cal deg}^{-1} \text{ gm}^{-1}$ (dry basis) for materials having moisture content of 12 percent or less. Compared to the sum of the specific heats of the dry material and the sorbed water, 0.34 to 0.37 $\text{cal deg}^{-1} \text{ gm}^{-1}$ for the alpha-cellulose used in this study, this elevation appears to be rather small. For the purpose of correlating the experimental data obtained in this investigation, any attempt to compensate for the elevation of the specific heat (because of its relatively small effect and because of the rather large uncertainty of its actual value) has been purposely avoided. It is important to keep this factor in mind, however, since its importance will be reflected in the lack of correlation, if any, of the data.

The correlation technique used in the earlier work¹ made use of a plot of an energy modulus $Q/\rho cL^*$ versus the Fourier Modulus $\alpha t_s/L^2$. Combination of these moduli results in a third modulus, the irradiance modulus HL/K . Though neither $Q/\rho cL$ or HL/K is dimensionless, their use is now generally preferred because of the ease of interpretation of their correlation plots.

In attempting to correlate data taken with materials having different moisture contents and radiant absorptivities, the most natural approach is to modify the correlating parameters in such a way as to compensate for the superficially apparent effects these factors have on the system and its interaction with the radiation.

For example, since by definition the absorptance

$$a = \frac{H_{\text{abs}}}{H} \quad \text{or} \quad H_{\text{abs}} = aH$$

and correspondingly

$$Q_{\text{abs}} = aQ$$

It is reasonable to multiply both moduli by the absorptance values of the materials under investigation. It has already been mentioned that, to a first approximation at least, the thermal capacity of the moist material will be greater

* See Glossary of Terms.

than that of the dry material by the heat capacity of the water contained. Accordingly the energy modulus may be expressed in terms of the thermal properties of the dry fuel and its moisture content, thus

$$M_Q = \frac{aQ}{\rho_0 c_0 L_0 (1 + \frac{m}{c_0})}, \text{ the modified energy modulus.} \quad (1)$$

Moisture would appear to have a twofold effect on the irradiance modulus. The first is a change in the thermal conductivity. The conductivity of cellulosic materials is known to be a function of the density of the material. Sauer¹⁰ has compiled conductivity data for various cellulosic materials in sheet form having moisture contents in the range 0 - 8 percent and shown that the values when plotted against density fall quite closely along a smooth curve. The portion of the curve lying between density values of 0.5 and 1.0 gm cm⁻³ is expressed adequately well by

$$K = (4.6\rho - 0.75) \times 10^{-4} \quad (2)$$

The second effect of moisture on the irradiance modulus is involved in the swelling of the material. For some time after manufacture the alpha-cellulose material exhibited a gradual change in thickness probably due to the relaxation of compressed fibers. Distinct from this is a reversible swelling exhibited by the material on the sorption of moisture. Dimensional changes can be represented by an empirical expression of the type

$$L = L_0 (1 + Bm\rho_0) \quad (3)$$

The swelling in the sheet form material is predominately in one direction, the thickness dimension. Thickness measurements were made of the materials used, both at controlled levels of humidity and when oven dry. These determinations indicated that the value of B in the swelling relationship is very close to one and has subsequently been ignored. Neglecting the other small dimensional changes, we may write

$$\rho = \rho_0 \left(\frac{1 + m}{1 + m\rho_0} \right) \quad (4)$$

$$K = \frac{\rho_0(4.6 + 3.85 m) - 0.75}{1 + m\rho_0} \times 10^{-4} \quad (5)$$

and for the modified irradiance modulus

$$M_H = \frac{a H L_0 (1 + m\rho_0)^2}{K_0 + (3.85 \times 10^{-4}) m\rho_0} \quad (6)$$

Some simplification of the irradiance modulus can be made after considering the magnitude of changes in conductivity due to moisture content. From equation (5) the calculated value of thermal conductivity for the dry material (assuming $\rho_0 = 0.7$) is 2.47×10^{-4} and for material containing 10 percent moisture is 2.58×10^{-4} cal cm deg⁻¹ cm⁻² sec⁻¹. Moreover, the swelling increases the thickness parameter and this compensates for the increase in conductivity. Over all, the irradiance modulus exhibits a 4 percent change for 0.7 gm cm⁻³ material taking up 12 percent moisture. Therefore, if nominal (40 percent RH) values of the thickness and thermal conductivity are used, an error of, at most, 2 percent is likely.

DISCUSSION OF RESULTS AND CONCLUSIONS

Correlation plots of the experimental data are presented in Figs. 5, 6, 7, and 8. The curve which accompanies these data is not the central tendency of these data but that of the much more extensive data taken previously when no attempt was made to control humidity or ambient temperature, i.e., equilibrium moisture content 5 ± 1 percent (30 - 50 percent RH) and ambient temperature $300 \pm 25^\circ\text{K}$. In addition to applying the corrections for moisture as indicated in the correlation moduli, the shutter timing error was also taken into account. Assuming all of the square-wave exposure time intervals measured in the previous experimental study were in error by the amount indicated during the present study (see Experimental), two corrections would have to be applied to the old data. The first and most obvious is a correction of all exposure times. Though in the main a 0.05 second correction is negligible, for the relatively few cases where ignition phenomena result in a fraction of a second (spontaneous ignition threshold for all materials and sustained ignition for the very thin materials), even such a small correction has a profound influence. It was gratifying to discover that the previously inexplicable lack of correlation for the 2, 4, and 6 mil material (see reference 1) is rectified by applying this correction.

The second correction stems from the fact that the determination of the irradiance level involves the measurement of the energy received by a calorimeter during a square-wave exposure interval generally 0.5, 1.0, or 2.0 seconds depending upon the magnitude of the irradiance level. Correspondingly, then, the timing error introduced a 10, 5, or 2-1/2 percent error into the measurement of irradiance and a similar error in the calculated radiant exposure value.

All of these corrections were applied and the resulting curve (shown in the figures) is the best estimate of the central tendency of all of the previous square-wave ignition data.

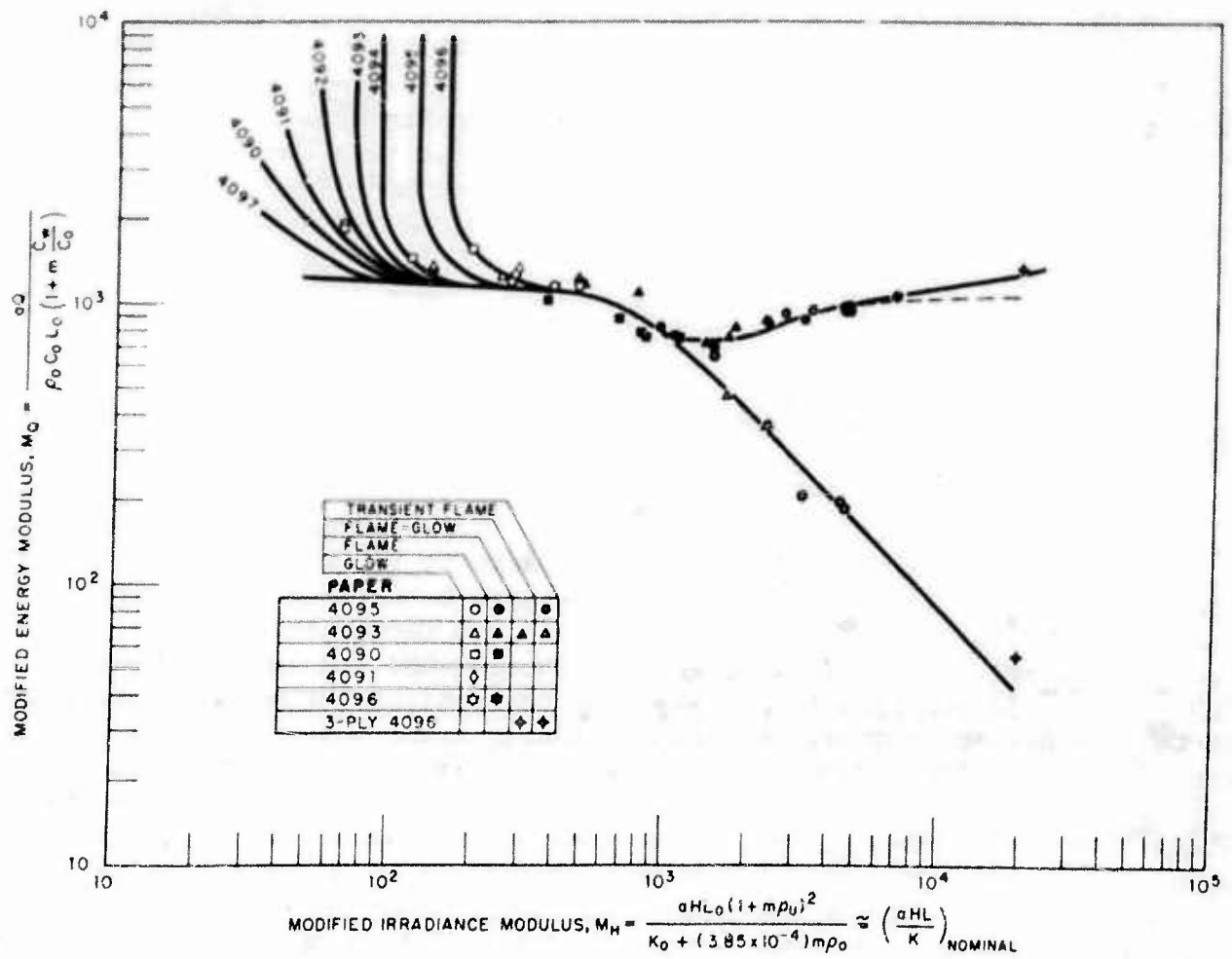

Fig. 5. Correlation pattern of ignition data taken at 10% relative humidity. (Curve is from data of previous investigation - see text.) For description of materials see Table 1.

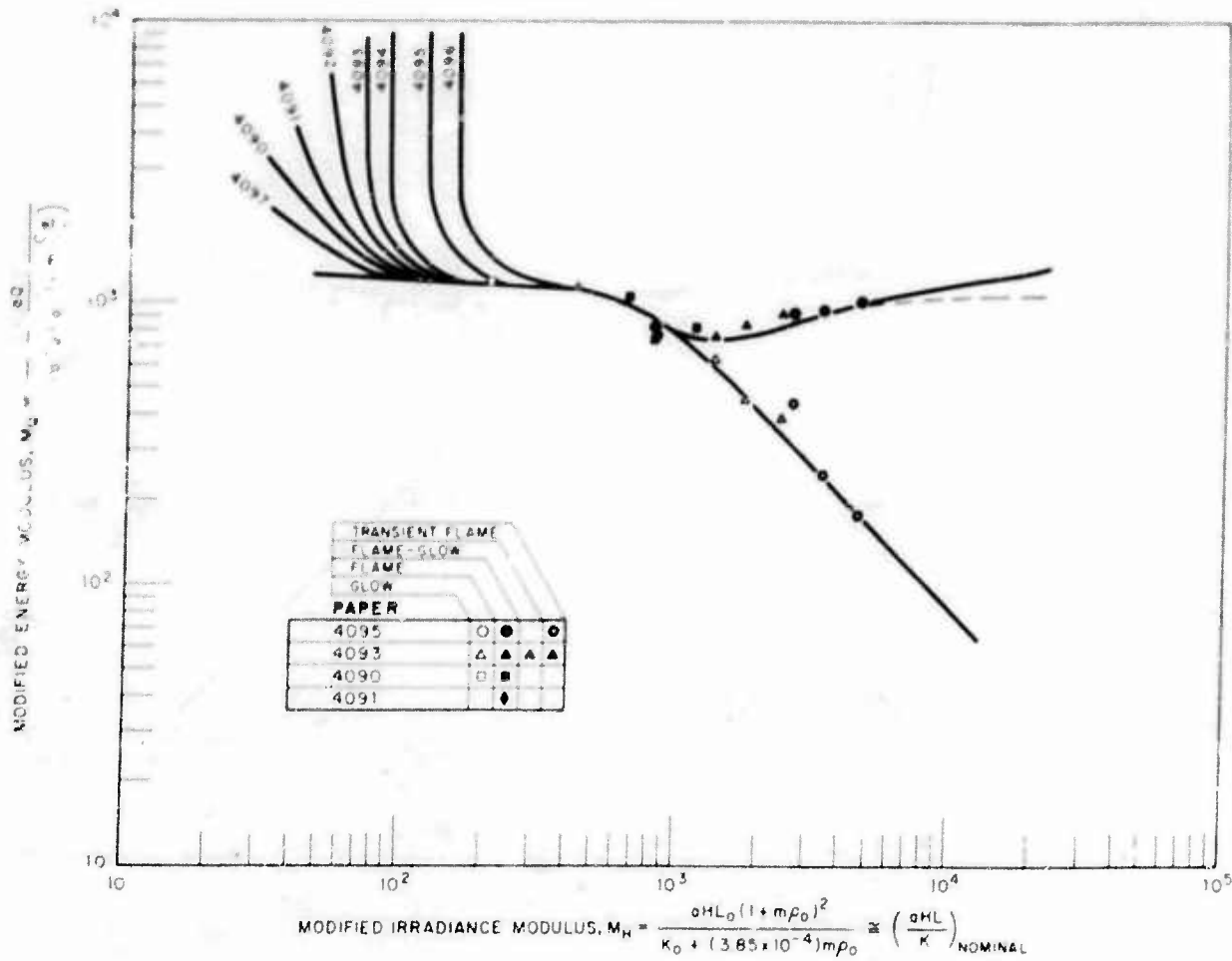

Fig. 6. Correlation pattern of ignition data taken at 30% relative humidity. (Curve is from data of previous investigation - see text.) For description of materials see Table 1.

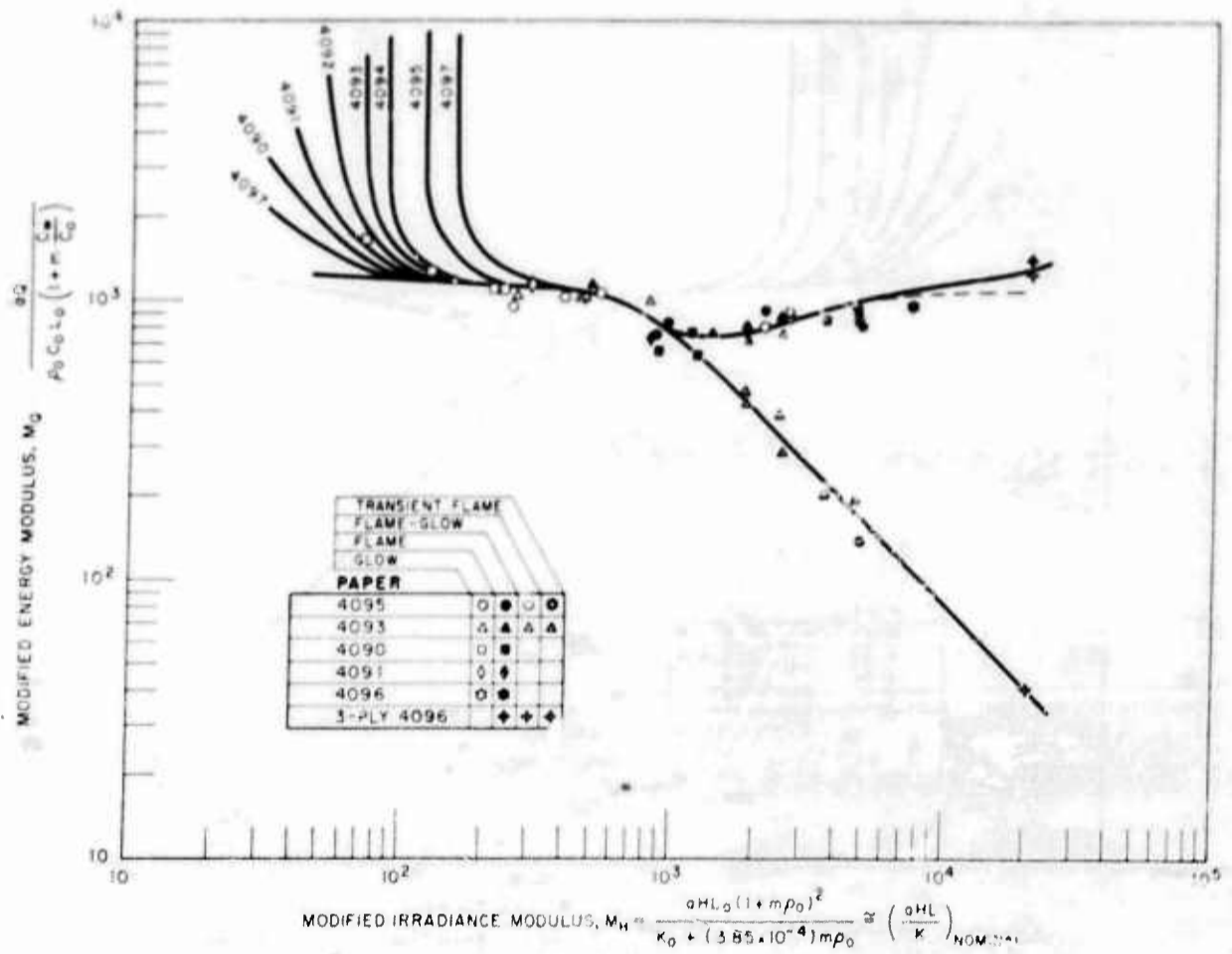

Fig. 7. Correlation pattern of ignition data taken at 87% relative humidity. (Curve is from data of previous investigation - see text.) For description of materials see Table 1.

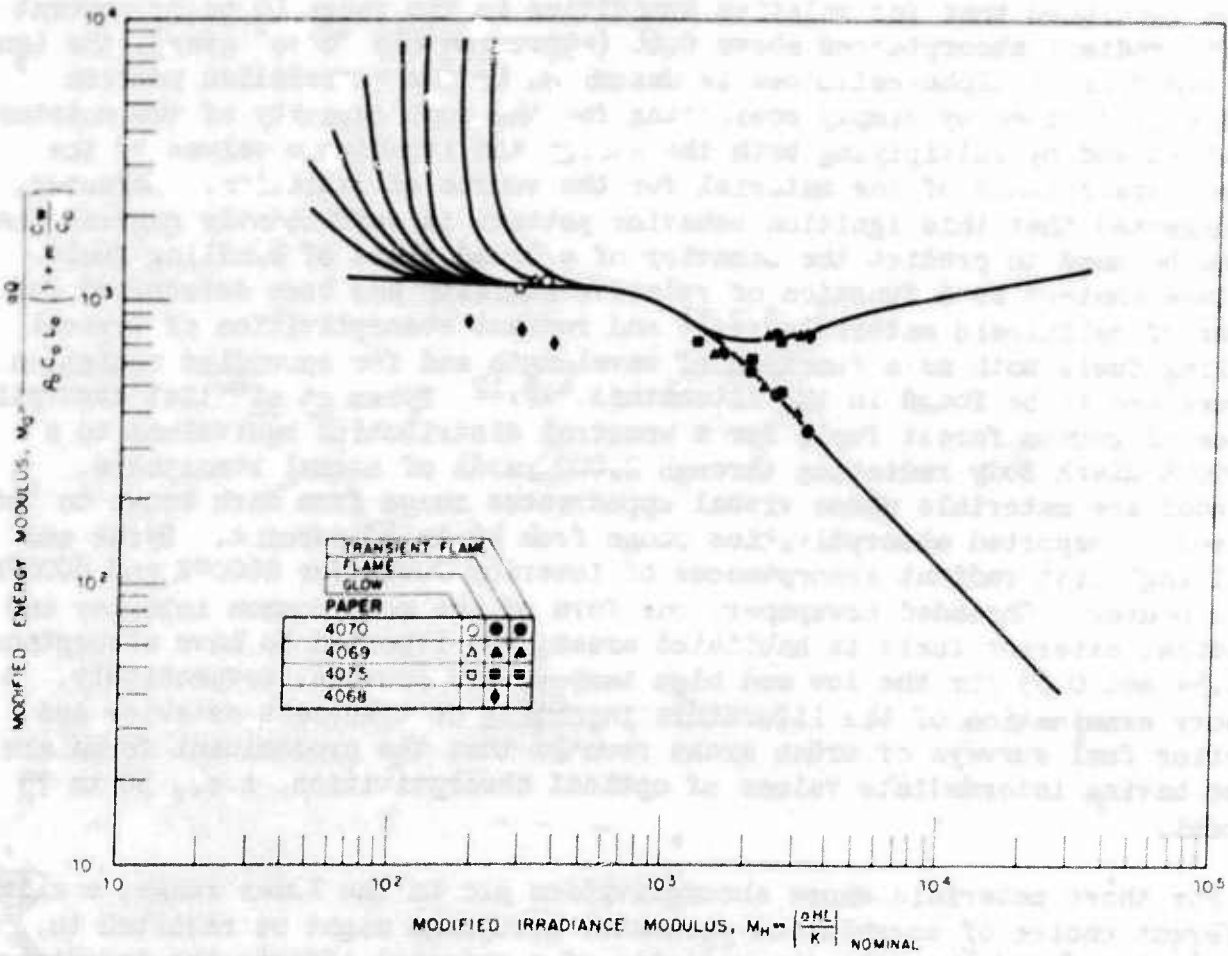

Fig. 8. Correlation pattern of ignition data for materials of different radiant absorptivities. For description of materials see Table 2.

With the exception of the data for the pure white cellulose, all of the experimentally determined points fall quite closely around the curve; and it can be concluded that for relative humidities in the range 10 to 87 percent and for radiant absorptances above 0.68 (approximately "dove" gray), the ignition behavior of alpha-cellulose is described by the correlation pattern previously derived by simply correcting for the heat capacity of the moisture contained and by multiplying both the energy and irradiance values by the radiant absorptance of the material for the source of radiation. Moreover, it is suggested that this ignition behavior pattern is sufficiently general that it can be used to predict the behavior of a broad class of kindling fuels. Moisture content as a function of relative humidity has been determined for a number of cellulosic materials^{3,7,11} and radiant absorptivities of typical kindling fuels both as a function of wavelength and for specified radiation sources are to be found in the literature.^{4,5,12} Byram *et al*⁶ list absorptivities of common forest fuels for a spectral distribution equivalent to a 10,000°K black body radiating through 2,000 yards of normal atmosphere. Included are materials whose visual appearances range from dark brown to "straw colored." Reported absorptivities range from 46 to 83 percent. Byrne and Schilling⁴ list radiant absorptances of interior fuels for 2600°K and 6000°K black bodies. Shredded newspaper, one form of the most common interior and transient exterior fuels in habitated areas, was reported to have absorptances of 0.54 and 0.55 for the low and high temperature sources, respectively. A cursory examination of the literature reporting on transient exterior and interior fuel surveys of urban areas reveals that the predominant forms are those having intermediate values of optical absorptivities, i.e., 50 to 75 percent.

For those materials whose absorptivities are in the lower range, a slightly different choice of correlation parameter groupings might be resorted to. Simms¹³ has noted that the absorptivity of a material affects the irradiance level for ignition less than the total radiant exposure. He points out that a material of low absorptivity absorbs little of the incident radiation until charring begins, when its absorptivity and therefore the energy absorbed increases rapidly. Assuming that charring and the emission of volatiles occur at about the same temperature and thus that little loss of volatiles occurs before charring, he suggests that there is little difference in behavior between blackened and unblackened material. Our experimental observations generally support this view. White alpha-cellulose consistently ignited with flames at irradiance levels too low to agree with flaming ignition data for materials of greater absorptivities. This indicates a need for an exponent with a value less than unity on the absorptivity term of the irradiance modulus.

To illustrate this point, the data for the materials having different optical absorptances are replotted in Fig. 9 using the square root of the absorptance in the irradiance modulus. The correlation of the white material is considerably improved though there is some lack of correlation introduced into the other data as a result. It appears that the value of the exponent applied to the absorptance

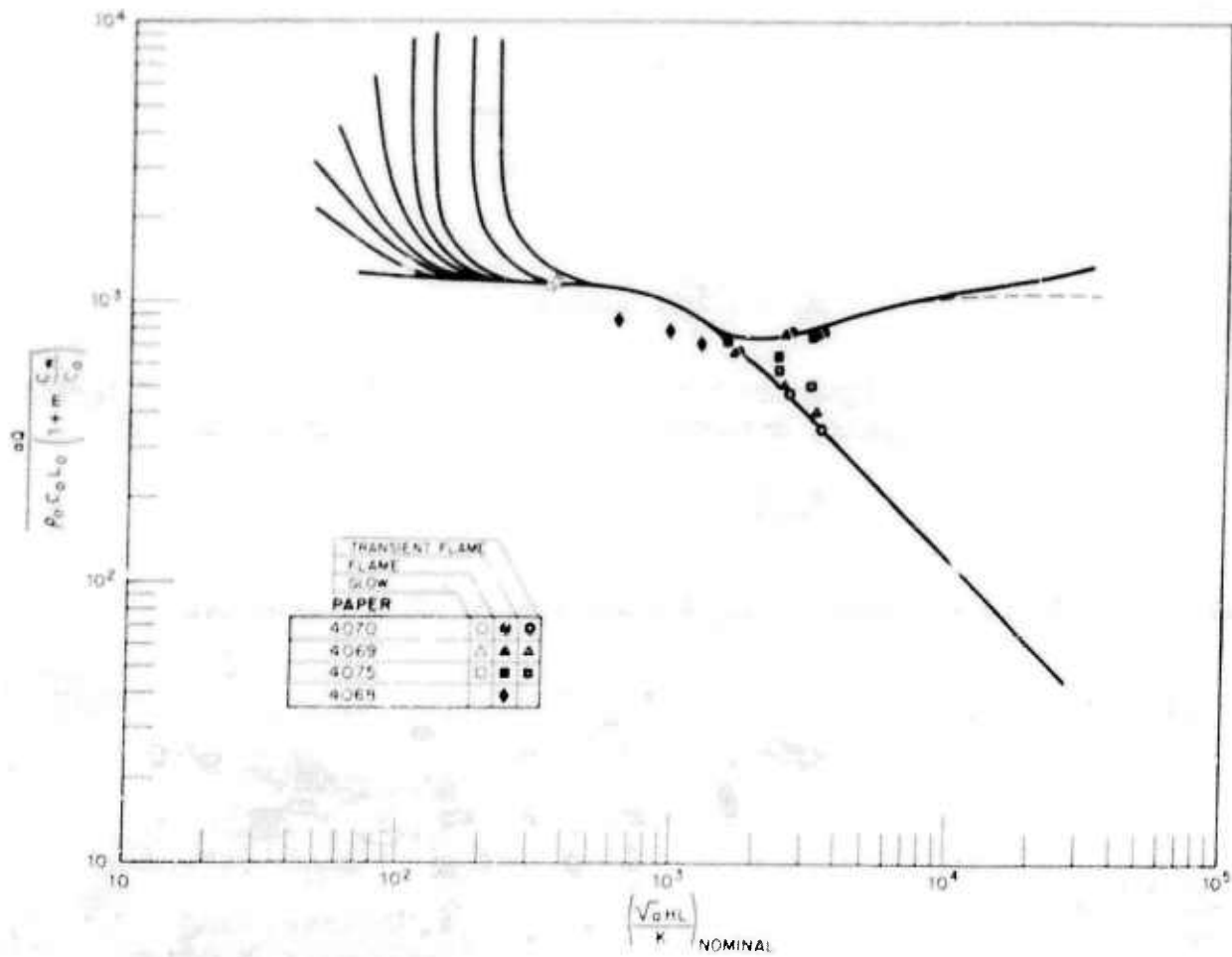

Fig. 9. Illustration of the effect of the use of \sqrt{a} in the irradiance modulus.

in the irradiance modulus is some function of the absorptance approaching unity with blacker, more opaque materials. For all practical purposes, however, since most materials have absorptivities of 50 percent or more, the correlation curves based on

$$M_Q = \frac{aQ}{\rho_0 c_0 L_0 (1 + m \frac{c_w}{c_0})}$$

and

$$M_H = \left(\frac{aHL}{K}\right) \text{ nominal}$$

adequately describe their ignition behavior. To estimate the type of ignition to be expected for the lighter materials, one can resort to the use of

$$\frac{a^n HL}{K}, \quad n \leq 1$$

the value of n to be estimated from the appearance of the material.

Approved by:

A. Guthrie

A. Guthrie, Head
Nucleonics Division

For the Scientific Director

REFERENCES

1. Butler, C. P., Martin, S., and Lai, W., "Thermal Radiation Damage to Cellulosic Materials. Part II - Ignition of Alpha-Cellulose by Square-Wave Exposure," USNRDL-TR-135 (AFSWT-906) November 1956. 130 650
2. Martin, S., and Lai, W., "Thermal Radiation Damage to Cellulosic Materials. Part III - Ignition of Alpha-Cellulose by Pulses Simulating Nuclear Weapon Air Bursts," USNRDL-TR-252 (AFSWP-1082) May 1958. 203 419
3. Lincoln, K. A., "A Semiautomatic Electromagnetic Balance and Its Application to the Determination of Moisture in Cellulose," USNRDL-TR-287 (AFSWP-1115) 2 December 1958. 213 902
4. Byrne, R. F., and Schilling, J. J., "Spectral Reflectance and Transmittance of Interior Fuel Materials," Mat. Lab. 5046-3, Part 49 (AFSWP-394) November 1953.
5. deLhery, G. P., Derksen, W., and Monahan, T. I., "The Spectral Reflectance and Transmittance of Standard Fabrics for Thermal Radiation Effects Studies," Mat. Lab. 5046-3, Part 91 (AFSWP-957) August 1956.
6. Byram, G. M., Sauer, F. M., Foss, W. L., and Arnold, R. K., "Thermal Properties of Forest Fuels," U. S. For. Serv., Div. of Fire Res. (AFSWP-404) October 1952.
7. Stamm, A. J., and Loughborough, W. K., "Thermodynamics of the Swelling of Wood," J. Phys. Chem 39, 121-132 (1935).
8. Stitt, F., and Kennedy, E. K., "Specific Heats of Dehydrated Vegetables and Egg Powder," Food Research 10, 426-436 (1945).
9. Katz, J. R., Koninklijke Akad. Wetenschappen Amsterdam, Section of Sciences 13, 958-981 (1910).
10. Sauer, F. M., "Ignition of Black Alpha-Cellulose Papers by Thermal Radiation," U. S. For. Serv., Div. of Fire Res. (AFSWP-869) page 25, September 1956.
11. McBain, J. W., "The Sorption of Gases and Vapours by Solids," George Routledge and Sons, Ltd., London, 1932, page 364.

12. Cooper, B. E., and Derksen, W. L., "Spectral Reflectance and Transmittance of Forest Fuel Materials," Mat. Lab. TR-NS-081-001, March 1952.

13. Simms, D. L., "The Minimum Intensity for the Spontaneous Ignition of Cellulosic Materials," F. R. Note No. 361/1958, Fire Research Station, Boreham Wood, Herts, U. K., June 1958.

GLOSSARY OF TERMS

Symbol		Units (c.g.s.)
a	radiant absorptance	dimensionless
B	empirical constant	$\text{cm}^3 \text{g}^{-2}$
c	specific heat capacity	$\text{cal deg}^{-1} \text{g}^{-1}$
H	radiant power, irradiance	$\text{cal cm}^{-2} \text{sec}^{-1}$
L	thickness dimension	cm
m	moisture content (% of dry weight)	dimensionless
o	(used as a subscript) refers to dry basis values	
Q	radiant energy, radiant exposure	cal cm^{-2}
s	(used as subscript) refers to constant irradiance (square-wave) exposure	
t	exposure duration	sec
w	(used as subscript) refers to liquid H_2O	
α	thermal diffusivity ($\alpha = K/\rho c$)	$\text{cm}^2 \text{sec}^{-1}$
K	thermal conductivity	$\text{cal cm cm}^{-2} \text{sec}^{-1} \text{deg}^{-1}$
ρ	density	g cm^{-3}

DISTRIBUTION

Copies

NAVY

1-9	Chief, Bureau of Ships (Code 423)
10	Chief, Bureau of Medicine and Surgery
11-12	Chief, Bureau of Aeronautics (Code AE40)
13	Chief, Bureau of Supplies and Accounts (Code SS)
14-15	Chief, Bureau of Yards and Docks (D-440)
16	Chief, Bureau of Ordnance
17-18	Chief of Naval Operations (Op-36)
19	Chief of Naval Operations (Op-03EG)
20	Commander, New York Naval Shipyard (Material Lab.)
21-23	Director, Naval Research Laboratory (Code 2021)
24	Director, Naval Research Laboratory (Code 2029)
25	Office of Naval Research (Code 422)
26	Chief of Naval Research (Code 811)
27-41	Office of Naval Research, FPO, New York
42	Office of Naval Research Branch Office, S.F.
43	CO, Naval Unit, Army Chemical Center
44	CO, U.S. Naval Civil Engineering (Res. and Eval. Lab.)
45	U.S. Naval School (CRC Officers)
46	Commander, Naval Air Material Center, Philadelphia
47	CO, Naval Air Development Center, Philadelphia
48	CO, Naval Air Development Center (Hardy)
49	Naval Medical Research Institute
50-51	CO, Naval Schools Command, Treasure Island
52	CO, Naval Damage Control Training Center, Philadelphia
53	U.S. Naval Postgraduate School, Monterey
54-55	CO, Nuclear Weapons Training Center, Atlantic
56-57	CO, Nuclear Weapons Training Center, Pacific
58	Commander, Naval Ordnance Laboratory, Silver Springs (Library)
59	Commander, Naval Ordnance Laboratory, Silver Springs (E)
60	Commander, Naval Ordnance Laboratory, Silver Springs (R)
61	Commander, Naval Ordnance Test Station
62	CO, Naval Electronics Laboratory
63	CO, Naval Supply, Research and Development Facility
64	Office of Patent Counsel, San Diego
65	Commander, Air Development Squadron 5
66	Commander, Naval Air Force, Atlantic Fleet (Code 16F)
67	President, Naval War College
68	CinC, Pacific Fleet
69	CinC, Atlantic Fleet

70-73 Commandant, U.S. Marine Corps
 74 Commandant, Marine Corps Schools, Quantico (Library)
 75 Commandant, Marine Corps Schools, Quantico (Dev. Center)
 76 CO, Naval Medical Field Research Laboratory, Camp Lejeune

ARMY

77-79 Chief of Research and Development (Atomic Div.)
 80-81 Deputy Chief of Staff for Military Operations
 82-83 Office of Assistant Chief of Staff, G-2
 84 Chief of Engineers (ENGEB, Rhein)
 85-87 Chief of Engineers (ENGNB)
 88-89 Chief of Transportation (TC Technical Committee)
 90-91 Chief of Transportation (Military Planning)
 92-93 Chief of Ordnance (ORDTN-RE)
 94-95 Ballistic Research Laboratories
 96-99 Chief Chemical Officer
 100-101 Quartermaster General
 102-104 CG, Chemical Corps Res. and Dev. Command
 105 Hq., Chemical Corps Materiel Command
 106 President, Chemical Corps Board
 107 CO, Chemical Corps Training Command (Library)
 108-109 CO, Chemical Warfare Laboratories
 110-112 CG, Aberdeen Proving Ground
 113 Office of Chief Signal Officer (SIGRD-8B)
 114 Office of Chief Signal Officer (SIGCO)
 115 CO, Army Medical Research Laboratory
 116 Director, Walter Reed Army Medical Center
 117 Brooks Army Medical Center
 118-121 CG, Continental Army Command, Fort Monroe (ATDEV-1)
 122 President, Army Air Defense Board, Fort Bliss
 123 President, Army Infantry Board, Fort Benning
 124 President, Army Artillery Board
 125-126 CG, Quartermaster Res. and Eng. Command
 127 Director, Operations Research Office (Librarian)
 128 CO, Dugway Proving Ground
 129-131 The Surgeon General (MEDNE)
 132 Office of Quartermaster General (R&D Div.)
 133 Office of Ordnance Research
 134 CO, USASRDL
 135 CO, Engineer Res. and Dev. Laboratory (Library)
 136 CO, Engineer Res. and Dev. Laboratory (Fire Suppression Br.)
 137 CO, Engineer Res. and Dev. Laboratory (Spec. Proj. Br.)
 138-140 CO, The Engineer Center
 141 CO, Transportation Res. and Dev. Command, Fort Eustis
 142 Commandant, Command and General Staff College
 143 NLO, CONARC, Fort Monroe
 144 Director, Office of Special Weapons Development, Fort Bliss
 145 Director, Waterways Experiment Station
 146 CG, Ordnance-Tank Automotive Command
 147 CO, Ordnance Materials Research Office
 148 CO, Watertown Arsenal

149 CO, Frankford Arsenal
150 CO, Picatinny Arsenal
151 Jet Propulsion Laboratory
152 Army Ballistic Missile Agency

AIR FORCE

153-154 Assistant Chief of Staff, Intelligence (AFCIN-3B)
155-156 Director of Research and Development (Guidance & Weapons Div.)
157 Deputy Chief of Staff (Plans and Progress)
158 Deputy Chief of Staff (Operations)
159-160 Commander, Air Materiel Command
161 Commander, Tactical Air Command
162 Commander, Air Defense Command
163-166 Commander, Wright Air Development Center (WCACT)
167 Commander, Air Res. and Dev. Command (RDTW)
168-170 Commander, Air Res. and Dev. Command (RDRWA)
171 Directorate of Installations (AFOIE-ES)
172 Director, USAF Project RAND
173-174 Commandant, School of Aviation Medicine, Randolph AFB
175 CG, Strategic Air Command (Operations Analysis Office)
176 CG, Strategic Air Command (OAWS)
177 Surgeon General
178-180 Commander, Special Weapons Center, Kirtland AFB
181-182 Director, Air University Library, Maxwell AFB
183-184 Commander, Technical Training Wing, 3415th TTG
185 CG, Cambridge Research Center (CRZT)
186-187 CG, Cambridge Research Center (CRQST-2)
188 Commander, Air Proving Ground
189 AFOAT - Headquarters

OTHER DOD ACTIVITIES

190-199 Chief, Armed Forces Special Weapons Project
200-201 Chief, AFSWP for WDI
202-207 Commander, FC/AFSWP, Sandia Base (FCTG Library)
208 Commander, FC/AFSWP, Sandia Base (FCDV)
209 OIC, Livermore Branch, FC/AFSWP
210 Assistant Secretary of Defense (Res. and Dev.)
211 Weapons Systems Evaluation Group
212 Hq., SHAPE
213-227 Armed Services Technical Information Agency
228 Commandant, Armed Forces Staff College

AEC ACTIVITIES AND OTHERS

229-230 Office of Civil and Defense Mobilization
231 AEC Scientific Representative, Japan
232 Aerojet-General Corporation
233 Aerojet-General, San Ramon
234 Alco Products, Inc.
235-236 ANP Project Office, Convair, Fort Worth
237 Argonne Cancer Research Hospital

238-247 Argonne National Laboratory
 248 Atomic Bomb Casualty Commission
 249-251 Atomic Energy Commission, Washington
 252-254 Atomics International
 255-258 Babcock and Wilcox Company
 259-260 Battelle Memorial Institute
 261-264 Bettis Plant
 265 Boeing Airplane Company, Seattle
 266-269 Brookhaven National Laboratory
 270 Brush Beryllium Company
 271 Carnegie Institute of Technology
 272 Chicago Patent Group
 273 Columbia University (Havens)
 274 Columbia University (SOO-187)
 275-276 Combustion Engineering, Inc.
 277 Convair-General Dynamics Corporation, San Diego
 278 Curtiss-Wright Corporation
 279 Defence Research Member
 280-282 duPont Company, Aiken
 283 duPont Company, Wilmington
 284 General Atomic Division
 285-286 General Electric Company (ANPD)
 287-292 General Electric Company, Richland
 293 General Electric Company, San Jose
 294 General Nuclear Engineering Corporation
 295 Gibbs and Cox, Inc.
 296-297 Goodyear Atomic Corporation
 298 Grand Junction Operations Office
 299-300 Iowa State College
 301-303 Knolls Atomic Power Laboratory
 304-305 Lockheed Aircraft Corporation, Marietta
 306-307 Los Alamos Scientific Laboratory (Library)
 308 Los Alamos Scientific Laboratory (Graves)
 309 Lovelace Foundation
 310 Maritime Administration
 311 Martin Company
 312 Massachusetts Institute of Technology (Hardy)
 313 Massachusetts Institute of Technology (Hottel)
 314 Massachusetts Institute of Technology (Williams)
 315 Medical College of Virginia (Ham)
 316-317 Midwestern Universities Research Association
 318 Mound Laboratory
 319 National Aeronautics and Space Administration
 320-321 National Bureau of Standards (Taylor)
 322 National Bureau of Standards (Library)
 323 National Lead Company of Ohio
 324 New Brunswick Area Office
 325-326 New York Operations Office
 327 New York University
 328-329 Nuclear Development Corporation of America
 330 Nuclear Metals, Inc.
 331 Oak Ridge Institute of Nuclear Studies
 332 Patent Branch, Washington

333 Pennsylvania State University (Blanchard)
 334-337 Phillips Petroleum Company
 338 Power Reactor Development Company
 339-341 Pratt and Whitney Aircraft Division
 342 Princeton University (White)
 343-344 Public Health Service, Washington
 345 Public Health Service, Savannah
 346 Rensselaer Polytechnic Institute
 347 Sandia Corporation
 348 Stevens Institute of Technology
 349 Sylvania Electric Products, Inc.
 350 Technical Research Group
 351 Tennessee Valley Authority
 352 Texas Nuclear Corporation
 353-354 Union Carbide Nuclear Company (ORGD)
 355-359 Union Carbide Nuclear Company (ORNL)
 360 Union Carbide Nuclear Company (Paducah Plant)
 361 U.S. Geological Survey, Denver
 362 U.S. Geological Survey, Menlo Park
 363 U.S. Geological Survey, Naval Gun Factory
 364 U.S. Geological Survey, Washington
 365 U.S. Patent Office
 366 UCLA Medical Research Laboratory
 367 University of California, San Francisco
 368-369 University of California Lawrence Radiation Lab., Berkeley
 370-373 University of California Lawrence Radiation Lab., Livermore
 374 University of Puerto Rico
 375 University of Rochester (Technical Report Unit)
 376-377 University of Rochester (Marshak)
 378 University of Rochester (Pearse)
 379-380 University of Washington (Geballe)
 381 University of Washington (Rohde)
 382 Vitro Engineering Division
 383-384 Westinghouse Electric Corporation (Schafer)
 385 Yale University (Breit)
 386 Yale University (Schultz)
 387 Yankee Atomic Electric Company
 388-412 Technical Information Service, Oak Ridge

USNRDL

413-440 USNRDL, Technical Information Division

DATE ISSUED: 30 March 1959

U. S. NAVAL RADIOLOGICAL DEFENSE LABORATORY
SAN FRANCISCO 24, CALIFORNIA

126
JHS:mep

MAY 21 1959

From: Commanding Officer and Director
To: Department of Defense Agencies on Distribution List for Report
Subj: U.S. Naval Radiological Defense Laboratory Report USNRDL-TR-295;
forwarding of
Encl: (1) U.S. Naval Radiological Defense Laboratory Report USNRDL-TR-295
(AFSWP-1117) entitled "Thermal Radiation Damage to Cellulosic
Materials. Part IV. Influence of the Moisture Content and the
Radiant Absorptivity of Cellulosic Materials on their Ignition
Behavior" by S. Martin, K.A. Lincoln and R.W. Ramsted.

1. Enclosure (1) is forwarded for your retention.
2. Subject report, USNRDL-TR-295, is Part IV of a four-part series and marks the completion of the first phase of the work: "The Influence of Material Properties and Radiant Energy Exposure Parameters on Ignition of Thin Cellulosic Materials." This work was prosecuted under the sponsorship of your headquarters and is currently listed in the USNRDL FY59 Technical Program Document as Program A2, Problem 13.
3. Although this publication marks the termination of scientific investigation into the influences of certain parameters on ignition of thin cellulosic materials, a further publication is contemplated to present the information published in all four parts. This summary report will present the information with emphasis on its application to common problems.
4. Currently the scientific investigation has turned to the second phase of the problem, "The Mechanism of Ignition of Cellulosic Materials by Intense Radiant Energy".

Paul C. Tompkins

PAUL C. TOMPKINS
By direction



UNCLASSIFIED

**A
D 216545**

Armed Services Technical Information Agency

**ARLINGTON HALL STATION
ARLINGTON 12 VIRGINIA**

**FOR
MICRO-CARD
CONTROL ONLY**

1 OF 1

NOTICE: WHEN GOVERNMENT OR OTHER DRAWINGS, SPECIFICATIONS OR OTHER DATA ARE USED FOR ANY PURPOSE OTHER THAN IN CONNECTION WITH A DEFINITELY RELATED GOVERNMENT PROCUREMENT OPERATION, THE U. S. GOVERNMENT THEREBY INCURS NO RESPONSIBILITY, NOR ANY OBLIGATION WHATSOEVER; AND THE FACT THAT THE GOVERNMENT MAY HAVE FORMULATED, FURNISHED, OR IN ANY WAY SUPPLIED THE SAID DRAWINGS, SPECIFICATIONS, OR OTHER DATA IS NOT TO BE REGARDED BY IMPLICATION OR OTHERWISE AS IN ANY MANNER LICENSING THE HOLDER OR ANY OTHER PERSON OR CORPORATION, OR CONVEYING ANY RIGHTS OR PERMISSION TO MANUFACTURE, USE OR SELL ANY PATENTED INVENTION THAT MAY IN ANY WAY BE RELATED THERETO.

UNCLASSIFIED