

UNCLASSIFIED

AD 221 608

*Reproduced
by the*

ARMED SERVICES TECHNICAL INFORMATION AGENCY
ARLINGTON HALL STATION
ARLINGTON 12, VIRGINIA



UNCLASSIFIED

NOTICE: When government or other drawings, specifications or other data are used for any purpose other than in connection with a definitely related government procurement operation, the U. S. Government thereby incurs no responsibility, nor any obligation whatsoever; and the fact that the Government may have formulated, furnished, or in any way supplied the said drawings, specifications, or other data is not to be regarded by implication or otherwise as in any manner licensing the holder or any other person or corporation, or conveying any rights or permission to manufacture, use or sell any patented invention that may in any way be related thereto.

**Best
Available
Copy**

S 564

SONAR COINTEGRATED

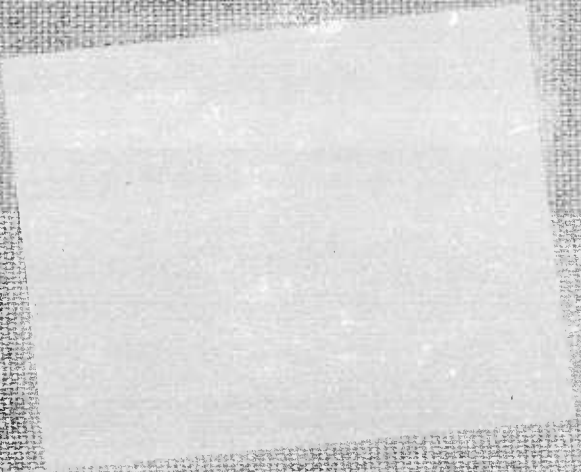

CLASSIFICATION CHANGED TO

~~CONFIDENTIAL~~

AUTHORITY: See Authority by 176

per J 204 313

DA HV 23 Apr 58

FC

NOTICE

This document has been withdrawn from the ASTIA bulk storage. It is the responsibility of the recipient to promptly mark it to indicate the reclassification action shown hereon.

CLASSIFICATION UNCLASSIFIED
AUTHORITY: office of Sec of Defense
BY: *W. M. Shannon* AUG 2 1960
DATE: 21 SEP 1960

4

SUMMARY TECHNICAL REPORT
OF THE
NATIONAL DEFENSE RESEARCH COMMITTEE

This document contains information affecting the national defense of the United States within the meaning of the Espionage Act, 50 U.S.C., 31 and 32, as amended. Its transmission or the revelation of its contents in any manner to an unauthorized person is prohibited by law.

This volume is classified SECRET in accordance with security regulations of the War and Navy Departments because certain chapters contain material which was SECRET at the date of printing. Other chapters may have had a lower classification or none. The reader is advised to consult the War and Navy agencies listed on the reverse of this page for the current classification of any material.

CLASSIFICATION CHANGED TO
~~UNCLASSIFIED~~ CONFIDENTIAL
AUTHORITY

Manuscript and illustrations for this volume were prepared for publication by the Summary Reports Group of the Columbia University Division of War Research under contract GEMsr-1131 with the Office of Scientific Research and Development. This volume was printed and bound by the Columbia University Press.

Distribution of the Summary Technical Report of NDRC has been made by the War and Navy Departments. Inquiries concerning the availability and distribution of the Summary Technical Report volumes and microfilmed and other reference material should be addressed to the War Department Library, Room 1A-522, The Pentagon, Washington 25, D. C., or to the Office of Naval Research, Navy Department, Attention: Reports and Documents Section, Washington 25, D. C.

Copy No.

276

This volume, like the seventy others of the Summary Technical Report of NDRC, has been written, edited, and printed under great pressure. Inevitably there are errors which have slipped past Division readers and proofreaders. There may be errors of fact not known at time of printing. The author has not been able to follow through his writing to the final page proof.

Please report errors to:

JOINT RESEARCH AND DEVELOPMENT BOARD
PROGRAMS DIVISION (STR ERRATA)
WASHINGTON 25, D. C.

A master errata sheet will be compiled from these reports and sent to recipients of the volume. Your help will make this book more useful to other readers and will be of great value in preparing any revisions.

CLASSIFICATION CHANGED TO
~~UNCONFIDENTIAL~~
AUTHORITY

SUMMARY TECHNICAL REPORT OF DIVISION 6, NDRC

VOLUME 19

Underwater Sound Equipment VI

COUNTERMEASURES

OFFICE OF SCIENTIFIC RESEARCH AND DEVELOPMENT
VANNEVAR BUSH, DIRECTOR

NATIONAL DEFENSE RESEARCH COMMITTEE
JAMES B. CONANT, CHAIRMAN

DIVISION 6
JOHN T. TATE, CHIEF

WASHINGTON, D. C., 1946

CLASSIFICATION CHANGED TO
~~CONFIDENTIAL~~
AUTHORITY

NATIONAL DEFENSE RESEARCH COMMITTEE

James B. Conant, *Chairman*

Richard C. Tolman, *Vice Chairman*

Roger Adams Army Representative¹

Frank B. Jewett Navy Representative²

Karl T. Compton Commissioner of Patents³

Irvin Stewart, *Executive Secretary*

¹Army representatives in order of service:

Maj. Gen. G. V. Strong Col. L. A. Denson
Maj. Gen. R. C. Moore Col. P. R. Faymonville
Maj. Gen. C. C. Williams Brig. Gen. E. A. Regnier
Brig. Gen. W. A. Wood, Jr. Col. M. M. Irvine
 Col. E. A. Routheau

²Navy representatives in order of service:

Rear Adm. H. G. Bowen Rear Adm. J. A. Furer
Capt. Lybrand P. Smith Rear Adm. A. H. Van Keuren
 Commodore H. A. Schade

³Commissioners of Patents in order of service:

Conway P. Coe Casper W. Ooms

NOTES ON THE ORGANIZATION OF NDRC

The duties of the National Defense Research Committee were (1) to recommend to the Director of OSRD suitable projects and research programs on the instrumentalities of warfare, together with contract facilities for carrying out these projects and programs, and (2) to administer the technical and scientific work of the contracts. More specifically, NDRC functioned by initiating research projects on requests from the Army or the Navy, or on requests from an allied government transmitted through the Liaison Office of OSRD, or on its own considered initiative as a result of the experience of its members. Proposals prepared by the Division, Panel, or Committee for research contracts for performance of the work involved in such projects were first reviewed by NDRC, and if approved, recommended to the Director of OSRD. Upon approval of a proposal by the Director, a contract permitting maximum flexibility of scientific effort was arranged. The business aspects of the contract, including such matters as materials, clearances, vouchers, patents, priorities, legal matters, and administration of patent matters were handled by the Executive Secretary of OSRD.

Originally NDRC administered its work through five divisions, each headed by one of the NDRC members. These were:

Division A—Armor and Ordnance
Division B—Bombs, Fuels, Gases, & Chemical Problems
Division C—Communication and Transportation
Division D—Detection, Controls, and Instruments
Division E—Patents and Inventions

In a reorganization in the fall of 1942, twenty-three administrative divisions, panels, or committees were created, each with a chief selected on the basis of his outstanding work in the particular field. The NDRC members then became a reviewing and advisory group to the Director of OSRD. The final organization was as follows:

Division 1—Ballistic Research
Division 2—Effects of Impact and Explosion
Division 3—Rocket Ordnance
Division 4—Ordnance Accessories
Division 5—New Missiles
Division 6—Sub-Surface Warfare
Division 7—Fire Control
Division 8—Explosives
Division 9—Chemistry
Division 10—Absorbents and Aerosols
Division 11—Chemical Engineering
Division 12—Transportation
Division 13—Electrical Communication
Division 14—Radar
Division 15—Radio Coordination
Division 16—Optics and Camouflage
Division 17—Physics
Division 18—War Metallurgy
Division 19—Miscellaneous
Applied Mathematics Panel
Applied Psychology Panel
Committee on Propagation
Tropical Deterioration Administrative Committee

NDRC FOREWORD

AS EVENTS of the years preceding 1940 revealed more and more clearly the seriousness of the world situation, many scientists in this country came to realize the need of organizing scientific research for service in a national emergency. Recommendations which they made to the White House were given careful and sympathetic attention, and as a result the National Defense Research Committee [NDRC] was formed by Executive Order of the President in the summer of 1940. The members of NDRC, appointed by the President, were instructed to supplement the work of the Army and the Navy in the development of the instrumentalities of war. A year later, upon the establishment of the Office of Scientific Research and Development [OSRD], NDRC became one of its units.

The Summary Technical Report of NDRC is a conscientious effort on the part of NDRC to summarize and evaluate its work and to present it in a useful and permanent form. It comprises some seventy volumes broken into groups corresponding to the NDRC Divisions, Panels, and Committees.

The Summary Technical Report of each Division, Panel, or Committee is an integral survey of the work of that group. The first volume of each group's report contains a summary of the report, stating the problems presented and the philosophy of attacking them and summarizing the results of the research, development, and training activities undertaken. Some volumes may be "state of the art" treatises covering subjects to which various research groups have contributed information. Others may contain descriptions of devices developed in the laboratories. A master index of all these divisional, panel, and committee reports which together constitute the Summary Technical Report of NDRC is contained in a separate volume, which also includes the index of a microfilm record of pertinent technical laboratory reports and reference material.

Some of the NDRC-sponsored researches which had been declassified by the end of 1945 were of sufficient popular interest that it was found desirable to report them in the form of monographs, such as the series on radar by Division 14 and the monograph on sampling inspection by the Applied Mathematics Panel. Since the material treated in them is not duplicated in the Summary Technical Report

of NDRC, the monographs are an important part of the story of these aspects of NDRC research.

In contrast to the information on radar, which is of widespread interest and much of which is released to the public, the research on subsurface warfare is largely classified and is of general interest to a more restricted group. As a consequence, the report of Division 6 is found almost entirely in its Summary Technical Report, which runs to over twenty volumes. The extent of the work of a Division cannot therefore be judged solely by the number of volumes devoted to it in the Summary Technical Report of NDRC: account must be taken of the monographs and available reports published elsewhere.

Any great cooperative endeavor must stand or fall with the will and integrity of the men engaged in it. This fact held true for NDRC from its inception, and for Division 6 under the leadership of Dr. John T. Tate. To Dr. Tate and the men who worked with him—some as members of Division 6, some as representatives of the Division's contractors—belongs the sincere gratitude of the Nation for a difficult and often dangerous job well done. Their efforts contributed significantly to the outcome of our naval operations during the war and richly deserved the warm response they received from the Navy. In addition, their contributions to the knowledge of the ocean and to the art of oceanographic research will assuredly speed peacetime investigations in this field and bring rich benefits to all mankind.

The Summary Technical Report of Division 6, prepared under the direction of the Division Chief and authorized by him for publication, not only presents the methods and results of widely varied research and development programs but is essentially a record of the unstinted loyal cooperation of able men linked in a common effort to contribute to the defense of their Nation. To them all we extend our deep appreciation.

VANNEVAR BUSH, Director
Office of Scientific Research and Development

J. B. CONANT, Chairman
National Defense Research Committee

SECRET

FOREWORD

THE STUDY and development of methods and devices quite commonly referred to as "Countermeasures" gradually came to involve substantial effort on the part of the Division. This was particularly true after the Division became interested in developments to assist our own submarines in their operations in the Pacific. Because of the late start made on these developments most of the devices did not become available before the war ended. However, the continuing importance of the subject warrants this report, and it is hoped that it will be of assistance to agencies continuing developments in this field. Developments and study should not only provide our own Navy with effective equipment and methods but can also enable our Navy to anticipate possible countermeasures which an alert enemy might employ.

This report was assembled and prepared under the direction of J. S. Coleman and the Division appreciates his willingness to undertake the task. The technical work reported upon was in large part performed by the Division's San Diego laboratory and by a laboratory group under one of the Division's contracts at the Massachusetts Institute of Technology.

The program was, of course, undertaken in close cooperation with the Navy and the Division particularly appreciates the efforts of that Service to provide every possible facility for the testing of experimental structures.

JOHN T. TATE
Chief, Division 6

UNCLASSIFIED
SECRET

PREFACE

ALTHOUGH it was our original intention to summarize in this volume only those countermeasure programs actually assigned to the several Division 6 agencies, it soon became apparent that to be of real value a much broader coverage was required. For this reason, an effort has been made to include related developments undertaken by Naval laboratories and experimental groups as well as the techniques employed for evaluation and calibration of the various devices.

Thus, in addition to the Division program of development which was carried on principally at CUDWR and MIT, a brief description is included of noisemakers devised and developed by the Naval Research Laboratory, the Naval Ordnance Laboratory, the David Taylor Model Basin, and other groups. The USRL was authorized to calibrate the acoustic performance of both NDRC and Navy devices and supplied the greater part of the response data for the devices described. Analyses and evaluations of the operational performance of the devices under various expected conditions were made by many groups, both in the Navy and the NDRC, including the SAG, the ORG, and ASDevLant, as well as operational units attached to the Pacific Fleet.

Some of the information pertinent to the countermeasures program has been covered in other volumes of this series. The measurements of submarine

target strength which underlie the development of the acoustic absorbing coating for submarines are discussed in Volume 8. Measurements of typical sound fields of surface ships and submarines are summarized in Volume 7. Masking studies for various types of noise directly related to noisemaker design are taken up in Volume 9. Many of these studies are an integral part of the countermeasures program, and appropriate references have been made throughout the volume.

The compilation, organization, and preparation of source material for this volume, much of which has never previously been published, is largely due to the efforts of Ellen Matteson of the SRG staff who received the generous cooperation of the groups and individuals that participated in this joint program. The assistance of David J. Evans of UCDWR, who was engaged in the development of many of the devices, is gratefully acknowledged. Particular thanks are also due to Frederick M. Varney, of Code 339 of the Bureau of Ships, and to Richard H. Bolt, of the MIT acoustics laboratory, for their helpful advice in the preparation of this manuscript.

J. S. COLEMAN
Editor

CONTENTS

CHAPTER	PAGE
1 The Noisemaker Program	1
2 Mechanical Noisemakers	10
3 Electronic Noisemakers	36
4 Explosive Noisemakers	46
5 Gas Ejection Noisemakers	67
6 Self-Propelled Submarine-Simulating Decoys	71
7 Depth Controls for Stationary Expendable Devices	111
8 Primary Batteries for Expendable Devices	128
9 Acoustical Treatment for Submarines	136
Glossary	147
Bibliography	149
Contract Numbers	154
Service Project Numbers	155
Index	157

UNCLASSIFIED
SECRET

Chapter 1

THE NOISEMAKER PROGRAM

1.1 INTRODUCTION

THE DEVELOPMENT of countermeasures to enemy sonar was undertaken with considerable urgency in the spring of 1943 by both Navy and National Defense Research Committee [NDRC] laboratories. Intense sources of underwater sound were needed to decoy acoustic torpedoes, fired by enemy submarines, away from Allied surface vessels and to confound enemy detection of Allied submarines. The early evasion devices were designed to mask submarine noise and to jam echoing detection methods. This program was soon extended to include the development of decoys which would both simulate the noises produced by evading submarines and return realistic echoes. The noisemaker programs conducted in the NDRC laboratories during the last two years of the war were carried out in close cooperation with the similar work proceeding in Navy laboratories.

This volume summarizes NDRC participation in the sonar countermeasures program. The report covers the development of certain devices as well as the preliminary investigation of many more. It also reports the experience of these laboratories with special techniques of noisemaker calibration and in the evaluation and analysis of numerous tests of noisemaker performance. Most of the Navy devices were measured by NDRC groups, and analyses of their performance have been included to give a more balanced picture of the field.

The Navy and NDRC devices, both experimental and production models, with which the NDRC groups had chief contact are listed in Table 1. A further tabular summary of the characteristics, physical dimensions, and performance of all the devices discussed in this volume is given at the end of the chapter in Table 2.

The NAC was the only NDRC device to be completed in time for extensive use by the fleet. This device was used in conjunction with FTS, FTC,⁸ and NAE in submarine evasion maneuvers during the spring and summer of 1945. The NAD-6 and the pepper signals were accepted but reached the fleet only in time for one unit of each to be used in combat. Although both NAD-6's and NAD-10's were

used for training, combat use of the NAD-10 was delayed for lack of its special batteries. At the close of hostilities the NAD-3 was nearing completion and the experimental XNAG gave considerable promise.

By the conclusion of the war the development programs begun in the NDRC laboratories at University of California Division of War Research [UCDWR] and at Massachusetts Institute of Technology Underwater Sound Laboratory [MIT-USL] had been transferred without interruption to Navy auspices for further work. The development of the NAD decoys was continued at the new Navy Electronics Laboratory at San Diego [USNEL], where the NAH was also under development as a successor to the NAC. The XNAG program was taken over by the David Taylor Model Basin [DTMB].

Completion of the pepper signal project was undertaken by the Naval Ordnance Laboratory [NOL]. Further information about these programs may be obtained from the Bureau of Ships.

The majority of the other devices studied in the NDRC laboratories were direct antecedents of these later devices. The electromagnetically driven diaphragm in the dual-head XNAG was derived from a series of experimental adaptations of the automobile horn which include the sonic sound beacon. The pepper signal was preceded by the experimental grenades; the principle of these explosive noisemakers was also applied by NOL to a number of different problems.⁸⁴⁻⁹¹ Mechanical noisemakers of many types were investigated during the program. Most of these were abandoned when it was established that the Navy's FXR was a satisfactory countermeasure to the German acoustic torpedo. Variations of a general rotary soundhead principle appear in the NAE, the XNAG, and the NAD-3, as well as in the experimental FXP and the rotary noisemakers. The use of electronic circuits to drive acoustic projectors was applied in the NAC, the NAD echo repeaters, and in the self-noise simulator in the NAD-10, as well as in the experimental stationary echo-repeater decoy [SERD]¹⁰⁸ and the towed projectors. The operation of these and of the rotary noisemakers depended upon the use of spe-

UNCLASSIFIED
SECRET

THE NOISEMAKER PROGRAM

TABLE 1. Major devices discussed in report of NDRC participation in noisemaker program.

Name of device*	Development laboratory	Status	Section reference
FXA ammonia jet noisemaker	NRL	Experimental	5.2
FXH-1 hammer bottle	MIT-USL	Experimental	2.5.3
FXP rotary noisemaker	NRL	Experimental	2.3.1
FXR towed parallel bars	MIT-USL, DTMB, ASDevLant	Used by fleet	2.2
Grenade Mk 2 (see pepper signal)	MIT-USL	Experimental	4.4.3
NAC sound beacon (see NAH)	UCDWR	Used by fleet	3.2
NAD-3 sound beacon	UCDWR	Experimental	6.4
NAD-6A sound beacon	UCDWR	Used by fleet	6.5
NAD-10A sound beacon	UCDWR	Accepted by fleet	6.6
NAE sound beacon	DTMB	Used by fleet	2.3.2
NAH sound beacon	UCDWR, USNEL	Experimental	3.2.4
Signal (pepper) Mk 14	MIT-USL	Used by fleet	4.4.1
Signal (pepper) Mk 20	MIT-USL	Accepted by fleet	4.4.2
Sonic sound beacon (see XNAG)	UCDWR, DTMB	Experimental	2.4.3
XNAG sound beacon	UCDWR, DTMB	Experimental	2.4.6
XPA crystal transducer	MIT-USL	Experimental	3.3.2

* Code designations for the noisemakers were supplied both by the Navy and by the laboratories. The name of the American torpedo decoy FXR is a contraction of the British Foxer, the term for a similar device. Thereafter, proposed torpedo decoys were coded in an FX series, the third letter indicating the noisemaker's operating principle, as the ammonia in the FXA, the hammer in the FXH, and the propeller in the FXP. The sound beacons constitute an NA series of expendable noisemakers within the Navy's N series of special devices. The third letter in these designations indicates the order in which each program was started. Thus the NAC development was followed by the development of the NADs, the NAE, the experimental (X) NAG, and the NAC modification designated NAH. The final design of the pepper signals, known as grenades during the early part of the development, received the official name signal (pepper) Mark 20, the term pepper indicating the sporadic nature of the explosions. Devices never accepted for Navy use received laboratory designations. Among these are the XTA or experimental projector Model A, and the XMX or experimental microphone Model X.

cially developed batteries. The use of compressed gas as a source of acoustic energy was explored in the FXH hammer bottle and in the FXA ammonia-jet noisemaker, while steam power was studied in the razzar. Depth controls of various types were also developed to support these devices during their operation and keep them from appearing at the surface where they might be seen by the enemy.

The history of the noisemaker program (Section 1.2), a summary of techniques used for calibrating noisemaker performance (Section 1.3), and a review of the status of the devices at the termination of hostilities (Section 1.4) are included in this chapter. In the subsequent chapters the discussion of individual noisemakers is divided somewhat arbitrarily according to common physical principles in their operation, with mechanical, electronic, and explosive noisemakers in Chapters 2, 3, and 4 respectively. Miscellaneous "gas ejection" noisemakers are grouped in Chapter 5. The self-propelled NAD decoys are covered in Chapter 6 together with a discussion of the problems of simulating submarine sound that underlay the NAD program. The depth controls and the primary batteries that were developed for use with these devices are assembled for discussion in Chapters 7 and 8. Chapter 9 deals with an altogether different type of countermeasure,

an acoustical treatment to reduce the echo-ranging reflectivity of submarines. For details of tests and data supplementary to the main discussion, reference is made throughout the volume to the NDRC publications and Navy sources listed in the bibliography. No attempt has been made to discuss the comparable research programs in Canadian and British laboratories^{45, 65} or the sonar countermeasures developed by the Germans or the Japanese.^{5, 129}

1.2 - HISTORY OF NOISEMAKER PROGRAM

The participation of the NDRC laboratories in the development of sonar countermeasures began in the spring of 1943. Previous to this time NDRC efforts had been concentrated on antisubmarine activities. With the shift of naval warfare from the Atlantic to the Pacific, prosubmarine problems began to receive greater emphasis. The American false target shells FTS and FTC, equivalent to the German *Pillenwerfer* bubble clouds,⁷ were completed by NRL and ready for test in the spring of 1943. At this time the submarine commanders requested more devices to assist evasion, suggesting false targets which would provide indication of doppler, loud noises for masking or obscuring sub-

SECRET

marine self-noise, supersonic signals to jam echo ranging, or possibly decoys which would simulate the self-noise and target characteristics of a submarine. Some of these proposed designs would obviously offer greater protection than others, but any device which would cause even temporary confusion to the enemy was worth developing.

Since the Japanese antisubmarine patrol system relied heavily upon its techniques of sonic listening, sonic masking devices were needed. Japanese destroyers were also equipped with some echo-ranging gear. For this reason and because of anticipated Japanese advances in sonar techniques, a device to jam echo ranging over a wide range of frequencies was seen as another necessity. For lack of information about Japanese methods it was agreed to set the best U. S. sonar technique as used against the Germans in the Atlantic as a standard for sonar countermeasures in the Pacific. Most of the evasion devices were to be designed for ejection from the 3-in. signal tube in modern submarines. Thus they had to include in a cylinder 37.5 in. long by 3 in. in diameter a source of power and a transducer as well as the auxiliary mechanisms needed for triggering, for an initial time delay, for propulsion or depth control, and for scuttling at the end of operation. The investigation of possible means of meeting these requirements was begun at once in the NDRC underwater sound laboratories of MIT and UCDWR, while similar programs were set up at Naval Research Laboratory [NRL], Naval Ordnance Laboratory, and David Taylor Model Basin.

The early work of the NDRC underwater sound laboratory of UCDWR at San Diego, since June 1941, had been in the development of antisubmarine devices and the training of antisubmarine personnel. The experience of this group with crystal transducers and with electronic circuits for underwater projectors had potential value for prosubmarine development. In setting up an evasion device program in June 1943, the laboratory was first requested to develop an expendable electronic noise-maker, the NAC, using a crystal projector capable of radiating a high-level supersonic signal to jam echo ranging. During the summer an additional request was made for an expendable mechanical noisemaker for sonic masking which led to the development of the sonic sound beacon. Development of the NAD self-propelled decoys incorporating

both noisemaking systems and echo repeaters was begun early in 1944.

Meanwhile a parallel noisemaker program was under way at MIT-USL. Part of the work of this laboratory since January 1941 had been in the development of mechanical noisemakers for sweeping acoustic mines. This group, reorganized on a NDRC contract in June 1943, was first requested to investigate the possible use of explosives in a submarine evasion device. The high ratio of stored energy to volume in explosive materials recommended them as a practical source of masking or jamming noise. A request was also made for the investigation of mechanical and other possible means of producing noise underwater. After the development of the FXII and preliminary work on the rotary noisemakers, no further work was done on mechanical noisemakers. Effort was concentrated on the explosive noisemaker development which led to completion of the pepper signals.

These development programs had just started when a more critical need for noisemakers arose. Reports from German prisoners of war indicated that a German acoustic torpedo,^a capable of homing on the noise from surface vessel screws was scheduled for use against Allied convoys by about August 1943. From the slight information available it could not be predicted whether towed or expendable noisemakers would be more effective as countermeasures to this weapon. Accordingly noisemakers of both types were hastily assembled on the basis of the knowledge and the devices then available in the several laboratories, and the noisemaker programs at NRL, NOL, DTMB, and MIT-USL were redirected towards this new problem. Since the frequency to which the torpedo would respond was unknown, the devices were selected for a wide-band output between 3 and 50 kc. Complementary programs were set up in other laboratories to analyze the probable circuit characteristics of such a torpedo so that working criteria for noisemaker performance could be established.^b

The noisemakers then available were chiefly those developed for minesweeping. An adaptation of the

^a For purposes of this discussion no distinction is made among the different designs of German acoustic torpedoes as subsequently recognized. The noisemaker program reported here was based on a listening rather than an echo-ranging torpedo.

^b This work is discussed further in Division 6, Volume 3, Chapter 15.

UNCLASSIFIED
SECRET

towed parallel bars became the FXR and the hammer box was adapted to give the FXH expendable hammer bottle. An early version of the explosive evasion device, the grenade, was proposed as a torpedo countermeasure. Both MIT-USL and UCDWR attempted to develop towed crystal projectors which would radiate an electronically generated signal to decoy the torpedo away from the towing vessel. The towed mechanical noisemaker FXP and the expendable ponomat¹ which produced bursts of sound from potassium-hydrogen explosions were developed by NRL. NRL also evolved the ammonia-jet noisemaker FXA. These and many other devices were proposed, tested by ASDevLant, and modified during the fall of 1943.³

The output of these noisemakers was measured in sea tests and compared with the noise output of a DE vessel at 15 or 20 knots. Expendable noisemakers had an obvious drawback in that their lives were necessarily short and that continuous protection would require the use of a noisemaker about every 90 sec.³ Towed noisemakers also appeared to have limitations for use against listening torpedoes.

Reports of the sinkings caused by the German torpedo were available by late September. From analysis of these it appeared that the FXR would offer better protection than the other devices. Sets of the parallel bars were supplied to the Allied convoys. Not until June 1944, when a German submarine was captured with two acoustic torpedoes aboard, were the noisemaker designers and the torpedo experts able to check their guesses. Field tests with the real torpedoes showed that the noise from the FXR not only kept the torpedo away from the ship, but also the high peaks of sound proved to have a paralyzing effect on the listening circuits so that the torpedo would weave erratically.

With the FXR established as a satisfactory torpedo countermeasure, the emphasis in the expendable noisemaker program was again placed on the development of submarine evasion devices. In the spring of 1944 MIT-USL and DTMB undertook a joint program to adapt the rotary principle of the FXP to the design of an expendable device, with the hope of achieving significantly higher output levels than had been realized so far by other means. After investigation of a number of rotary noisemaker designs this device was completed by DTMB as the NAE beacon.

By the summer of 1944 the NAC beacon was accepted by the Navy and production of 5,000 units

was started. The sonic sound beacon by the addition of a second soundhead became the XNAG. The explosive pepper signal, the NAE, and the two larger NAD's were taken to Pearl Harbor for Navy evaluation test late in 1944.^{13, 14} Field tests were made where submarines launched the devices in simulated combat conditions while surface vessels equipped with listening and echo-ranging gear attempted to hold contact. From these tests the need for certain modifications was seen. An adjustable time delay before the start of noisemaking was specified for all the devices. Launching methods for the NAD's were refined, and safety switches were added. The pepper signal was shown useful for masking only in shallow water so that a positive depth control would be required to keep the device off the bottom during operation. On the basis of these tests all the devices were accepted officially, contingent upon the inclusion of modifications as indicated above. Production was then initiated.

By the spring of 1945 the NAC was in use by the fleet along with the FTS and FTC, and the NAE saw service during the last months of the war. Production of the remaining devices, the NAD-6, NAD-10, and pepper signals, was well underway. The NAD-6 and the pepper signal were supplied to the fleet in time for one of each to be used in combat. These devices, with the still experimental XNAG, were taken to ASDevLant where carefully controlled acoustic measurements were made of all devices. The devices were also used by submarines against surface vessels in free evasive exercises in order to help establish doctrine for tactical use. Tests in simulated combat conditions were also made by ComSubsTrainPac to study the use of NAD decoys in combination with the jamming devices.¹⁴ At the close of the war the report of the ASDevLant tests²⁰ constituted the most comprehensive analysis available. Other analyses have been made of the operational usefulness of the NAC,⁷⁴ the pepper signal,⁸³ the NAE,^{52, 54} and the NAD.¹⁰⁵ Summaries of this material are included in later chapters as well as in Section 1.4.

1.3 TECHNIQUES USED FOR NOISEMAKER CALIBRATION

An essential part of the noisemaker program was the development of means of specifying noisemaker performance. Ideally, it would be possible to predict the effect of any type of noise upon any enemy

SECRET

detection gear for all possible oceanographic and tactical conditions if all contributing factors and conditions could be completely specified. This, however, is never the case, particularly for noisemakers. Controlled field tests with submarines and surface vessels, made in quantity and interpreted statistically, can provide some of this information. In the months of development before the noisemaker is ready for field tests, however, some means is required of describing its performance. Because of the many variables which will influence its ultimate effect upon the enemy operator, it has been impossible in the present state of the art to specify the critical performance requirements for a noisemaker. Nor has it been possible to set up measuring techniques to ascertain how well a given noisemaker will meet the actual requirements. The techniques which have been used in measuring the noisemakers reported here, although recognized as inadequate in a number of respects, provide enough information to permit significant intercomparison of proposed designs and to establish a useful basis for estimating probable performance.

In general the characteristics of a noise source which appear to be most relevant in countermeasure design are the total output of energy and the distribution of this energy in the frequency spectrum. A flexible means of describing the distribution of this energy with time is needed, since the noisemakers differ widely, some producing separated bursts of high-level sound, others maintaining a more continuous output level. The operating life and the directivity of any noisemaker also must be known in setting up tactical doctrine.

Rough field determinations of these characteristics are readily obtained, by using the same measuring techniques that are applied in studying ship sounds.²⁹ Such measurements cannot be precise or even repeatable, however, because of the variability of transmission and reverberation conditions and the difficulties in determining distances and other factors in the tests. A technique of short-range measurement, where distances and reverberation conditions are known and the conditions of each test carefully ascertained, offers certain advantages. Despite the difficulty of extrapolating such data for comparison with the ship sounds to be masked or simulated, the reproducibility of this test procedure makes it possible to obtain significant comparisons between noisemakers.

A short-range measuring system was available in

the USRL calibration station at Mountain Lakes, New Jersey.^c The rigging of the test pier permitted the distance between noisemaker and hydrophone to be set to a standard 6-ft separation. The amplifiers and recorders were able to respond to sound pressures in a frequency range from 0.05 to 150 kc. Fixed narrow-band filters were available for insertion in this system, and a heterodyne analyzer with sweeping filters of various widths was available for measuring frequency characteristics. This standard system, although set up primarily for the calibration of hydrophones and projectors, was adaptable to many of the purposes of noisemaker measurement. The XMX hydrophone was developed especially for noisemaker measurements; it is nondirectional in the plane of measurement and has a response that is essentially flat from 0.1 to 30 kc.³⁰ The USRL calibrations of noisemaker performance provide useful information about the devices. These data are included in succeeding chapters as a general illustration of the performance characteristics of the various noisemakers. Since similar techniques were employed by other laboratories in the course of the noisemaker program, this discussion applies to those results as well.

For purposes of this discussion the types of noise that were measured may be divided into three general classes: continuous, impactive, and frequency-modulated. The significance assigned to these terms, which have been adopted for convenience, is indicated in succeeding paragraphs. As further types of noisemaker are developed, this classification may be subject to revision.

Continuous noises, which have a fairly constant level throughout a fairly wide band of frequencies, can be measured with the conventional system of amplifiers, filters, and metering circuits, and can in many respects be treated like thermal noise. For cases in which the enemy can be assumed to be using wide-band sonic listening, corrections for differences between systems may be readily made. The output of the FXA, of the NAE, and of the rotary soundheads in the XNAG and the NAD-3 all fall into this general category of continuous noises.

The impactive noises, distinguished from the continuous noises only by the somewhat greater irregularity of their noise production as a function of time, raised new problems in instrumentation. The hammer bottle produces noise in sharp bursts of high-level sound at a rate of about 70 blows per

^c See Division 6, Volume 10, Chapter 6.

UNCLASSIFIED
SECRET

second. The pepper signal noisemakers produce their explosions at an approximate rate of 2 shots per second. The time constants of the meters in the standard system are such that they can neither respond to the high-frequency components of such noises nor integrate the energy from successive pulses sufficiently to record a constant level representing output pressure. For such noises waveform photographs obtained with a high-speed oscillograph recorder were made of the individual pulses as passed by the broad-band amplifier system. Fourier analysis of these pictures was used to determine frequency distribution from 0.1 to 30 kc. The frequency characteristics thus obtained, however, cannot be compared directly with the characteristics of the more continuous noises because this very difference in rate of noise production leads to a difference in the effect of the noise upon enemy detection circuits. What this effect might be would require extensive study and a fairly complete knowledge of the enemy circuits.

Waveform photographs made with a shorter time scale provide a useful means of studying these impactive sounds. These photographs, constituting a plot of sound pressure against time, indicate the degree of the departure of a given sound from continuous noise.

The third class of noises measured consists of those produced by the NAC and the XNAG electromagnetic soundhead where a tonal signal sweeps over a narrow range of frequencies 3 to 4 times a second. Here the problem lay chiefly in devising a means of presenting the results of measurement. Obviously the masking characteristics of such a noise source cannot be represented adequately by means of the same kind of graph which serves to define the properties of the continuous noises. Prediction of the effect of such an output upon the enemy listener is in the province of psychological acoustics^a and for such noises field tests were of especial importance.

Frequency characteristics were obtained for most of the noisemakers by the methods just described. Although any particular spectrum curve must be interpreted in terms of the special methods used in obtaining it, the pictures provide a useful indication of general energy distribution.

The output level of the noisemakers in a wide "overall" band was measured in many cases. Such

^a See Division 5, Volume 9

readings provide a useful index of performance in the comparison of similar noises where their spectrum distributions are also known. If such overall readings obtained in the laboratory are to be compared to submarine self-noise values measured at sea, the comparison is probably no better than ± 10 db. In such cases the validity of the comparison is checked in field tests where the noisemaker and ship are measured together in the same location and the same time.

Narrow-band measurements are given for the noisemakers in some cases. For noises of reasonably continuous output the conversion of narrow-band filter readings to spectrum level or sound pressure level in a 1-c band introduces no serious error.

A determination of "peak factor" was used as a means of expressing the distribution of the energy in time. The "peak factor" is the inverse ratio in decibels of the rms pressure contained in the noisemaker signal to the rms pressure of a sine wave signal of equal peak amplitude.²² The pepper signal output contains a great deal of energy, but this is produced in high-level bursts with nearly a half-second of silence between. For a firing rate of 2 shots per second the peak factor of the pepper signal noise is about 38 db. The FXA output, on the other hand, has a very low peak factor of the same order of magnitude as that of a sine wave.

The directivity of most of the noisemakers was uniform in the horizontal plane. This characteristic was usually measured for a wide-band output although the mechanism of noise production was occasionally studied by observing changes in the pattern with change of frequency.

The life of an expendable noisemaker was simply determined by plotting the change in overall output level as a function of time.

In accordance with Navy practice all sound pressure levels in this volume are expressed in decibels above 1 dyne per sq cm, which is 74 db above the reference level of 0.0002 dyne per sq cm. Conversions of level for distance are made on the basis of 6 db per distance doubled.

1.4 SUMMARY OF PERFORMANCE OF EVASION DEVICES

The performance of the devices developed in the noisemaker program is most readily summarized in terms of the tactics recommended for their use.

SECRET

While evaluations of the individual devices are given in the chapters that follow, their chief merits and limitations are reviewed together here to illustrate the status of the program at the close of NDRC participation. It was concluded, from the field trials at ASDevLant and ComSubsTrainPac, that FTS, FTC, NAC, NAE, NAD-6, NAD-10, and pepper signals all could be utilized to provide sufficient protection to make their use advisable in certain situations. Whereas none of the devices alone can provide complete protection the tactics developed for use of the devices in combination substantially increase the submarine's chances of successful evasion. Doctrine for use of the devices is proposed in the ASDevLant report.²⁰ This material was used in preparation of the "Submarine Evasion Devices Manual"¹⁶ for issue with the devices to the fleet.

The shortcomings of the individual evasion devices were demonstrated on many occasions. Tactics for combination use were designed to minimize these and to profit as much as possible from a confusion effect even when true masking or complete jamming was not realized.

The pepper signal, while capable of producing true masking of submarine self-noise at sonic frequencies in shallow water where reverberations maintain a masking level of noise, is not useful in deep water. In deep water, although the separate explosions produce some confusion, sonar operators are able to hold listening contact between the explosions.¹³ The individual NAE is good for masking at high sonic and supersonic frequencies, even producing some jamming in echo-ranging gear, but at lower sonic frequencies it is ineffective.¹³ The individual NAC although of demonstrated value was only partially effective against trained operators. The NAD-6 and NAD-10 had served to mislead sonar teams in the free evasive trials despite clearly obvious differences between their target characteristics and those of a true submarine. The FTS and FTC although lacking doppler or noise simulation are thoroughly reliable so that their use was recommended to contribute to the confusion needed for evasive action.

Tentative doctrine for use of evasion devices against echo ranging was proposed in the ASDevLant report. This recommended that NAC's and NAE's be injected in quantity to jam the receivers, to confuse the attack, and thus to break contact

when the submarine is certain that the enemy ship actually has sonar contact. These should be followed by FTS and FTC to add to the confusion. If, however, the attacking ship is not known to have contact, the NAC's and NAE's should not be fired since the sudden burst of noise serves to draw attention to the submarine. FTS and FTC can be used without this hazard when an attack is expected. The NAD beacons can be launched alone if the attacking vessel has no contact. In case of contact they should be launched only after the submarine has fired a screen of jamming devices. The decoy's course and the submarine's maneuvers should be selected so that the decoy emerges first from the masked area.

Against sonic listening it is recommended that the NAE and pepper signals be fired together in quantity and time delays be used to extend the period of masking. It is advisable to eject all of the devices in rapid succession so that their locations do not reveal the submarine's course. As with the echo-ranging jammers the noisemakers must not be fired until the submarine is certain that contact has been established. An NAD, preferably the NAD-10 because of its superior self-noise simulation, can be fired as a decoy under cover of masking by the other devices. Where the enemy is believed to be using both echo ranging and listening, it is recommended that all the devices be used in combination with tactics based upon the best possible idea of the movements and positions of all attacking ships.

While proposing this general doctrine for use of the available devices, lines for further development of evasion devices were also recommended in the ASDevLant report. The need was seen particularly for a jammer effective against sonic listening from 0.1 to 10 kc, with no restriction to shallow water use. The XXAG, still in experimental form at that time, promised to fill this need. An improved high-power jammer for echo ranging to replace the NAE and the NAC was also recommended with the NAE development underway to meet these requirements. Further modifications were also desired for the NAD's to permit greater flexibility in launching procedure as discussed in Section 6.7.

It can be seen from the preceding discussion, paraphrased from the ASDevLant report, that single units of the devices available by the end of World War II by no means provided complete protection. Work is continuing in the several Navy laboratories

UNCLASSIFIED
SECRET

to improve these devices and supply better ones. True acoustic masking of submarine noise has been shown to occur in parts of the submarine noise spectrum for certain range relationships with some of the devices. Large quantities of energy would be required to produce true masking at the low frequencies where the high-level gear whines occur. There is evidence that "confusing" noises can in certain cases be quite as effective as masking noises in upsetting the coordination of an enemy attack, and so perhaps can be shown to provide equal protection. This question requires further investigation* of the psychological factors involved in listening to submarine sounds and echoes.

* See Division 6, Volume 9.

A tabular summary of the devices discussed in this volume has been prepared and is given in Table 2. The weight in air and the method of use are given to aid in visualizing the devices. The purpose of the device and the evaluation of its performance are summarized in general terms subject to the detailed discussions in the chapters which follow. The output levels are indicated in several ways because of variations in the available calibration data. This material constitutes a synopsis of the information given in the italicized sections in succeeding chapters which describe each of the NDRC devices, as well as of such equivalent material as is available about the Navy devices.

TABLE 2. Summary of noisemakers and decoys.

Name	Weight (lb in air)	Useful life (min)	Purpose	Method of use	Output level* (rms pressure in db above 1 dyne per sq cm at 1 m)	Evaluation
<i>A. Devices in production</i>						
FXR	Decoy acoustic torpedo	Tow from ship	45-db spectrum level at 5 kc at 15 knots	Good performance as decoy
NAE Mks 1 & 2	13	6-7	Wide-band masking	Launch from signal tube	85 db in overall band; peak factor 15 db	Good high sonic masking and useful supersonic jamming
NAC	8	12	Jam echo ranging	Launch from signal tube	66-db spectrum level at 25 kc	Useful jamming
Pepper signal	19	5	Wide-band masking	Launch from signal tube	97 db in overall band (in shallow water); peak factor 38 db	Good sonic masking in shallow water only
NAD-6	80	35	Simulate submarine	Launch from torpedo tube	67 db in overall band	Good echoes and fair self-noise simulation
NAD-10	110	60	Simulate submarine	Launch from torpedo tube	67 db in overall band	Good echoes and good self-noise simulation
<i>B. Programs continuing in Navy laboratories</i>						
XNAG	10	7	Wide-band masking	Launch from signal tube	82 db in overall band; peak factor 28 db	Promising sonic masking
NAH	Jam echo ranging, tuned to enemy search frequency	Launch from signal tube	Experimental results good
NAD 3	8	25	Simulate submarine noise	Launch from signal tube	67 db in overall band	Self-noise simulation good. No echoes
NAE Mks 3 & 4	20	6-7	High-frequency masking and jamming	Launch from signal tube	Promising

SECRET

TABLE 2—(Continued)

Name	Weight (lb in air)	Useful life (min)	Purpose	Method of use	Output level* (rms pressure in db above 1 dyne per sq cm at 1 m)	Evaluation
<i>C. Programs discontinued</i>						
FXP	100	..	Decoy acoustic torpedo	Tow from ship	Complex and expen- sive
FXH	12	2-3	Decoy acoustic torpedo	Throw from deck	35-db spectrum level at 5 kc	Inadequate output and life
Rotary	Decoy acoustic torpedo	Throw from deck	44-db spectrum level at 5 kc	Led to NAE
Sonic sound beacon	8	12	Sonic masking	Launch from signal tube	67 db in overall band	Led to XNAG
Steam	Wide-band masking	Inadequate output
FXA	..	2-4	Wide-band masking	36-db spectrum level at 5 kc	Inadequate output
XPA	Decoy acoustic torpedo	Tow from ship	Inadequate output

* Useful standards for comparison may be summarized as follows:

Output level of submarine at 6 knots at periscope depth in an overall band is 67 db above 1 dyne per sq cm at 1 m (see Section 6.2);

Output level of a DE at 15 knots at 5 kc is 22 to 32 db spectrum level above 1 dyne per sq cm at 1 m.⁶⁰

Average deep sea nondirectional ambient noise without shrimp for sea state 2 at 5 kc is -52 db spectrum level relative to 1 dyne per sq cm.⁹

Average deep sea nondirectional ambient noise without shrimp for sea state 2 at 25 kc is -62 db spectrum level relative to 1 dyne per sq cm.⁹

UNCLASSIFIED
SECRET

Chapter 2

MECHANICAL NOISEMAKERS

2.1 INTRODUCTION

OF THE DEVICES developed in the noisemaker program for the two purposes of decoying the acoustic torpedo and of masking submarine sounds, the most successful were those of a mechanical type. The first noisemakers of this type to be developed relied for their effectiveness upon a high overall output level and wide frequency coverage. Of these the FXR towed parallel bars were used to protect convoys from the acoustic torpedo. The NAE, developed as the most efficient of the early rotary noisemaker designs, was accepted for fleet use as an evasion device for high sonic and low supersonic masking. The XNAG, which combines two different soundheads, represents a somewhat more sophisticated approach to the masking problem; here the aim was to produce masking noise at all frequencies used for listening detection of submarines. The most efficient noisemaker for such a purpose was logically one which simulated throughout the spectrum the distribution of submarine self-noise; in this respect the XNAG is allied to the NAD decoys discussed in Chapter 6. These mechanical noisemakers, towed and stationary, in the development or measurement of which the NDRC laboratories played a part, are discussed here together with the designs that preceded them or are of similar operating principle.

The FXR is discussed first (Section 2.2) for apart from its tactical usefulness its operation supplied information about noisemaker performance in general. The rotary noisemakers (Section 2.3) are unified by their operating principle of a rotating drive shaft which causes rollers to fly out against and roll inside a cylindrical diaphragm. This principle is found in the towed FXP and the expendable NAE as well as in the experimental 3-in. and 4-in. rotaries. A similar rotary principle is also found in one of the two soundheads in the XNAG as well as in the self-noise simulator in the NAD-3. These soundheads are in most cases driven by small electric motors powered by sea batteries. The feasibility of battery-powered devices depended heavily upon the development of special batteries as discussed in Chapter 8. Early in the program the use of compressed gas was investigated as an alternative

power source in the design of the hammer bottles discussed in Section 2.5 as well as in the FXA ammonia-jet noisemaker covered in Chapter 5.

A number of other mechanical devices were studied for possible application as underwater noisemakers. A long list is given in the COMINCH Sonar bulletin⁴ of a group of towed and expendable noisemakers which were proposed as countermeasures to the acoustic torpedo early in the program. None of these was considered sufficiently promising for further study.

The descriptions of the devices that follow in this chapter are based chiefly upon NDRC reports and measurements. Acoustic performance is described in terms of USRI calibrations where those exist, and from other NDRC sources. The description of techniques used in obtaining these measurements and the definition of the quantities measured are found in Section 1.3. Where further evaluation has been made of the devices by other NDRC groups or by the Navy this material is summarized. Additional information on noisemaker development continuing under Navy auspices after the termination of NDRC research in the spring of 1945 may be obtained from the Bureau of Ships.

2.2 FXR TOWED PARALLEL BARS

The FXR is a mechanical noisemaker which was towed by surface vessels to decoy the German acoustic torpedo away from the noise of the vessel's screws. Original designs were modifications of the towed pipes used in minesweeping by the United States, by the Canadians, and by the British. Two solid bars are clamped together in parallel position with rubber mountings and a spacer. This device is towed behind the ship on cable. When the flow of water around and between the pipes produces sufficient displacement the pipes strike together producing bursts of high-level sound in rapid succession. A number of different designs of the FXR were constructed in order to produce the desired output levels, increased stability, and convenience in handling. NDRC participated in making many of the early measurements of FXR performance. The

early models of the FXR were developed to combat the German torpedo at a time when its characteristics could be surmised only from prisoner-of-war reports. Certain assumptions were made about the circuits which could be expected in a torpedo, and the FXR was judged capable of decoying such devices. The capture of a German submarine in the spring of 1944 with two of these listening torpedos

to occur at a rate of approximately 500 times per second. A single blow is shown on an expanded time scale in Figure 2. The waveform can be recognized as characteristic of damped mechanical vibration. The effect of reverberation at the test location can be seen in the photograph. The variation in the base line prior to arrival of the blow is probably due to ship noise, whereas the first surface reflection, in

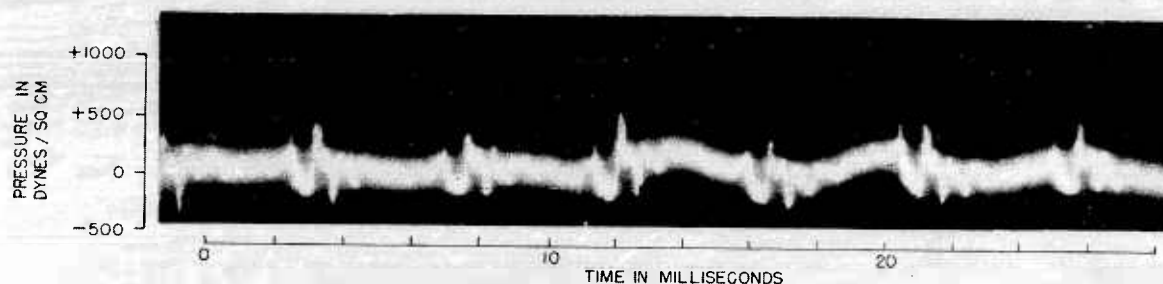

FIGURE 1. Waveform of FXR Mk 2 output for towing speed of 20 knots, measured at distance of 150 yd.

aboard permitted actual field tests of FXR performance against them. In these tests it was observed that the high peaks of the output had a paralyzing effect upon the torpedo circuits so that the torpedo would weave from side to side instead of heading directly for the noisemaker. This effect provided an unexpected advantage to the towing vessel since the weaving so reduced the torpedo's net forward speed that the ship could escape.

opposite phase from the direct wave, and the first bottom reflection can be recognized 0.25 msec and 0.75 msec after the blow itself.

The output of the FXR was measured in many field tests. Sound-pressure levels were usually recorded as the output of filter bands centered at 5, 10, and 20 kc. For a towing speed of 15 knots the FXR Mk 2 had an output at 5 kc of better than 45-db spectrum level above 1 dyne per sq cm ex-

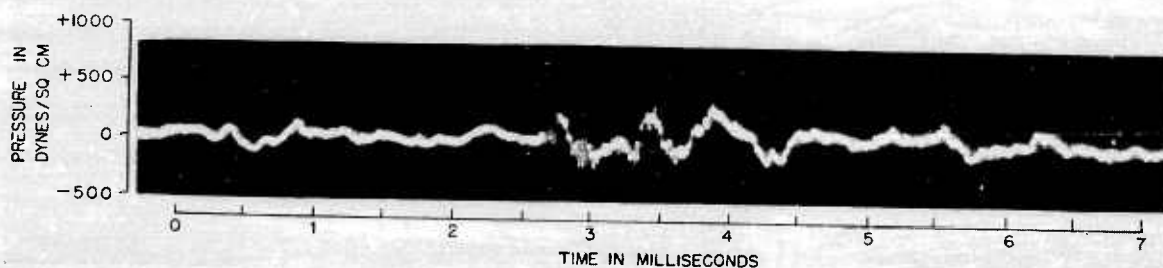

FIGURE 2. Waveform of FXR Mk 2 output on expanded scale, for towing speed of 20 knots, measured at distance of 300 yd.

The peaked type of noise produced by the FXR is illustrated in Figures 1 and 2.²⁴ The noise consists of a repeated pattern of high-level peaks, occurring at a rate depending upon the towing speed. These pictures were obtained with the FXR Mk 2, with a towing speed of 20 knots. The blows can be seen

pressed for 1 m distance.⁴ These levels were compared with DE output in the same bands. Early quantitative results may be found in reports of field tests made at ASDevLant.³²⁻⁴⁴ It was observed that typical DE output at a given speed falls off faster with increasing frequency than FXR output. This

SECRET

relation proved an additional advantage when it was found, in tests with the captured torpedoes, that the torpedo responds to a 27.5-ke signal instead of the 5 ke which had been surmised earlier in the program.

2.3 ROTARY NOISEMAKERS

The development of rotary noisemakers for masking submarine noises during evasion began somewhat late in the noisemaker program in May

noise simulator of the NAD-3 (Section 6.4.2).

2.3.1 FXP Noisemaker

The FXP, sometimes called the "noisemaking fish," is an experimental towed noisemaker developed by NRL. Sound is generated by ridged steel rollers striking the inside of a steel cylinder. The body of the FXP (shown in Figure 3) is streamlined with a tapered nose and stabilizing fins at the tail. A propeller (or impeller) is mounted at the tail so that it rotates as the FXP is towed through the

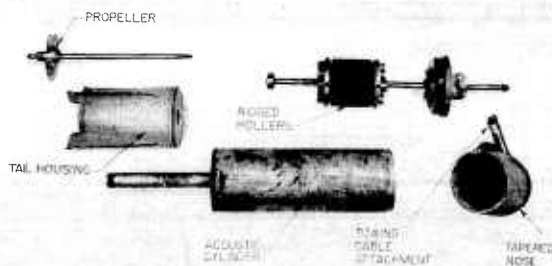

FIGURE 3. Components of FXP.

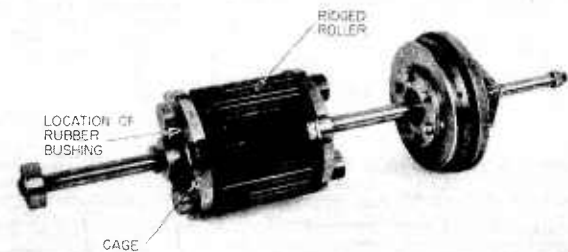

FIGURE 4. FXP soundhead.

1944. The towed FXP which supplied the fundamental operating principle for all subsequent rotary noisemakers had been built as a possible countermeasure to the acoustic torpedo in the summer of 1943 but was dropped in favor of the simpler and more convenient FXR. The FXP soundhead was modified to produce the NAE design. Similar noise-producing principles can be recognized in the rotary element of the XNAG (Section 2.4) and in the self-

water. This motion rotates the central drive shaft on which is mounted the cage which holds the rollers (shown in Figure 4). Rubber bushings constrain the rollers against the cylinder wall so that the rotary motion causes the ridged rollers to strike each ridge as they revolve thus producing a rapid succession of impacts. The FXP is 7 in. in diameter with a total length of 6 ft and a weight of approximately 100 lb.

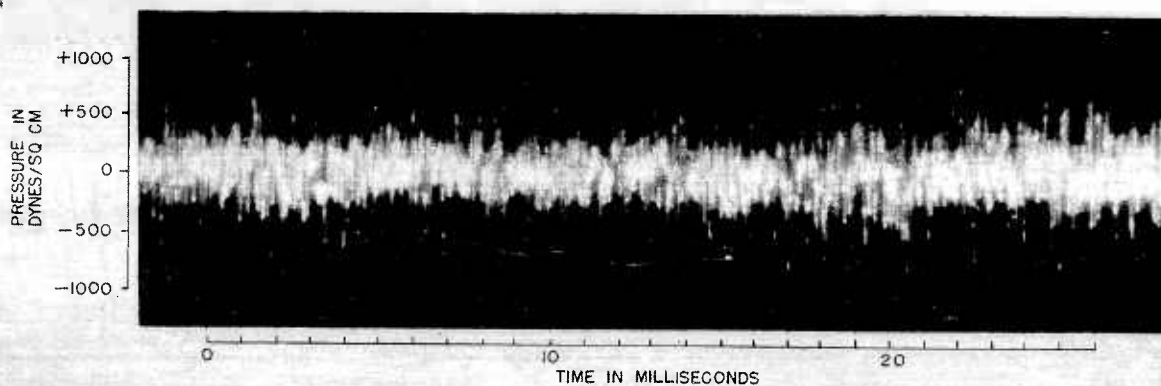

FIGURE 5. Waveform of FXP output, for towing speed of 17 knots, measured at distance of 320 yd.

SECRET

The output level of the FXP was judged in tests at ASDevLant to be adequate to protect a DE at towing speeds above 12 knots.⁴ Measurements of the output in narrow bands centered at 5, 10, and 20 ke were made.⁴⁶⁻⁴⁸

The waveform of the FXP output in Figure 5,²⁴

2.3.2

NAE Rotary Noisemakers

GENERAL

The NAE is an expendable mechanical noisemaker developed by DTMB and produced for use as a submarine evasion device. Its output at low

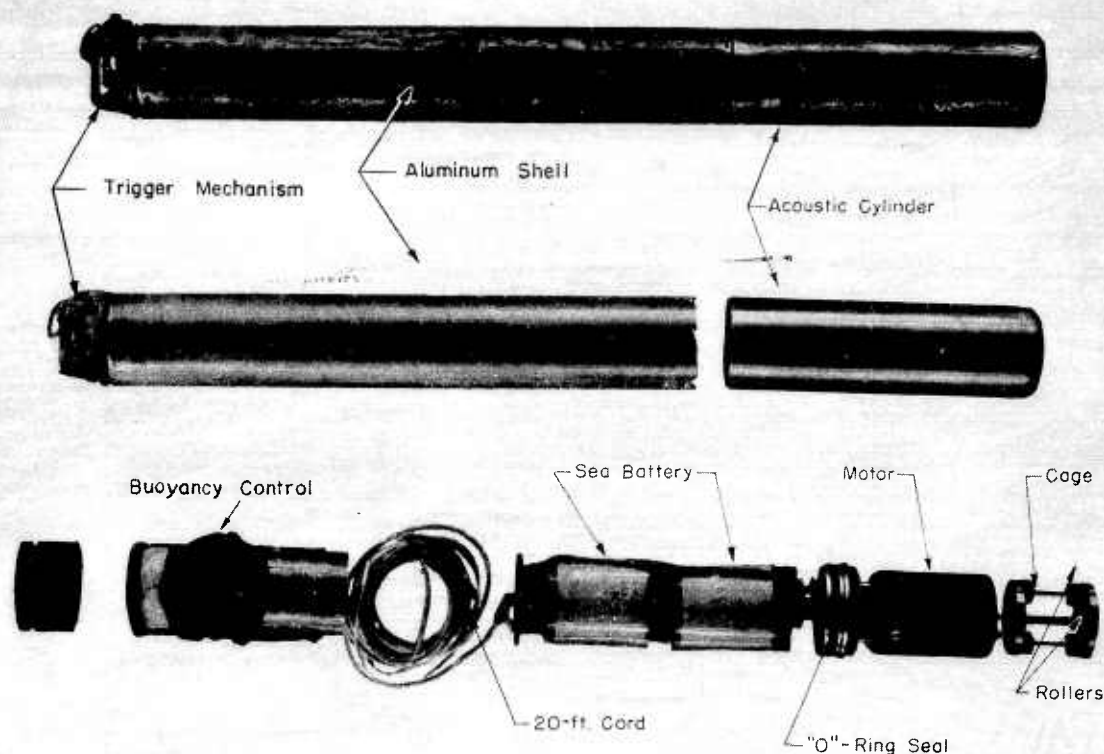

FIGURE 6. NAE sound beacon Mk 1.

shows that its output is more continuous than that of the FXR. The waveform of any one blow on the cylinder wall would have the appearance of a damped mechanical vibration similar to a single hammer-bottle blow as in Figure 42. In the FXP, however, the blows occur so often that the disturbances overlap and their components produce random noise which approximates typical ship noise in frequency distribution and level. A similar type of noise is produced by the other rotary noisemakers.

frequencies is not sufficient to mask submarine noise from listening detection, but above 6 ke the output is sufficient to make the NAE useful with proper tactical procedures to jam upper audio and low supersonic listening and echo ranging. At still higher frequencies the noise produces useful confusion. The life of the unit is 5 to 7 min. at full output. NDRC contact with this development aside from cooperation in early phases of the work was chiefly in making acoustic measurements. This device is covered here to permit comparison with others.

SECRET

The NAE Mk 1 and Mk 2 shown in Figures 6 and 7 are similar acoustically. Both conform to the requirements of size and weight for ejection from the

change made in the FXP design was the removal of the rubber bushings that forced the rollers against the cylinder wall. Instead the ridged rollers

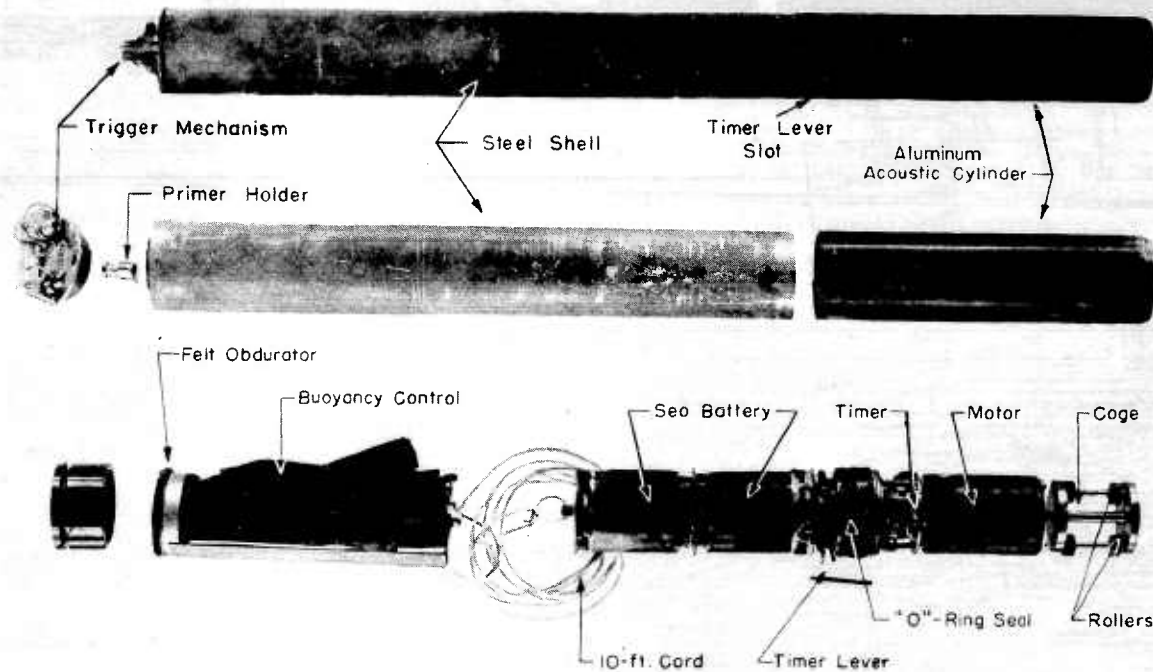

FIGURE 7. NAE sound beacon Mk 2.

3-in. ejector. The aluminum housing of the Mk 1 cannot withstand high static pressures and so the unit cannot be ejected at depths greater than 100 ft. After ejection it is supported from a balloon which floats on the surface. The Mk 2 was improved over the Mk 1 in several respects. A steel reinforcing shell was added to permit ejection at 400 ft. The depth control was equipped with a gas-release mechanism that keeps the supporting balloon hovering below the water surface so that the device is invisible from the surface or the air and cannot be recovered. A variable time delay is included to postpone the start of noisemaking as much as 10 min. after ejection. These devices are covered in the "Submarine Evasion Devices Manual."¹⁶

The development of the NAE began in the spring of 1944 with a joint program at DTMB and MIF-USL to adapt the noisemaking principle of the FXP to an expendable design. The most significant

were mounted in radial slots so that the centrifugal force of the rotating drive shaft would fling them out to strike the wall. This change provided a major reduction in the load on the driving shaft, and subsequent tests were made to ascertain the most efficient number of rollers, roller size, and design of roller shape. Once the design had been demonstrated as a feasible means of making noise the responsibility for completing the program was turned over to DTMB. Some additional joint effort was applied in developing the depth control, as discussed in Chapter 7. The Mk 1 was given field tests at Pearl Harbor in October 1944¹⁴ and thereafter, and units were supplied to the fleet in the spring of 1945. The Mk 2 modifications were introduced during the summer of 1945. The broad-band high-level output of the NAE recommends it for certain tactical uses, and it was apparent that several NAE's operating at the same time were considerably more effective

SECRET

than a single one. The addition of rocket propulsion to the NAE so that several could be fired in a pattern from the deck of a surface vessel was undertaken during the summer of 1945. This would permit the use of the NAE Mk 3 and Mk 4 in new tactics against acoustic torpedoes which are under investigation jointly by DTMB, NOL, and BuShips.

USRL CALIBRATION OF NAE Mk 1

Filter-band measurements. See Table 1.

TABLE 1. Analysis of NAE output.⁵⁵

Filter band	RMS pressure in band (db above 1 dyne per sq cm at 1 m)	RMS spectrum level for center frequency (db above 1 dyne per sq cm at 1 m in 1-c band)
Broad band 0.1-150 kc	88.5	...
Audio band 0.1-15 kc	84.9	...
0.5-kc band centered at 5 kc	70.0	43.0
1-kc band centered at 10 kc	74.4	44.4
2-kc band centered at 20 kc	75.1	42.1
3-kc band centered at 30 kc	74.7	39.8
4-kc band centered at 40 kc	73.1	37.1

Frequency characteristic. See Figure 8.

Peak factor. The peak factor of the NAE noise output is 15.5 db.

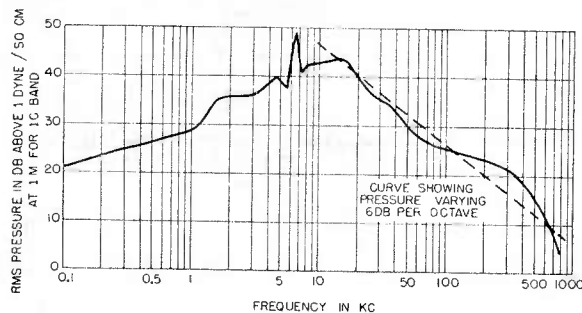
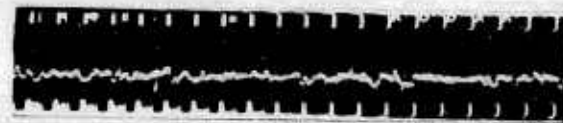

FIGURE 8. Frequency characteristic of NAE Mk 1.

Waveform. The output of the NAE is fairly continuous as can be seen in Figure 9. The blows that strike the cylinder wall occur in such rapid succession that the disturbances overlap and no systematic mechanical pattern can be recognized. For comparison see the waveform of the FXP (Figure 5).



←1 MILLISECOND→

FIGURE 9. Waveform of NAE output.

Life. The life of the NAE Mk 2 in production models is 5 to 7 min at full output with diminishing output for an additional 6 min. Figure 10 shows the life of a Mk 1 unit measured by USRL.

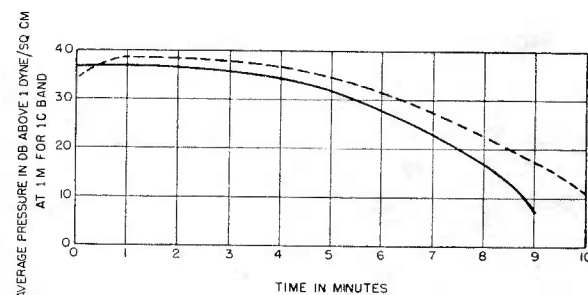

FIGURE 10. Life of NAE Mk 1 expendable unit, measured with two different sets of sea batteries.

2.3.3

MIT Rotary Noisemakers

GENERAL

The two designs of rotary noisemakers studied at MIT-USL were 3-in. and 4-in. devices. In this development a detailed study was made of such design parameters as the number and shape of the

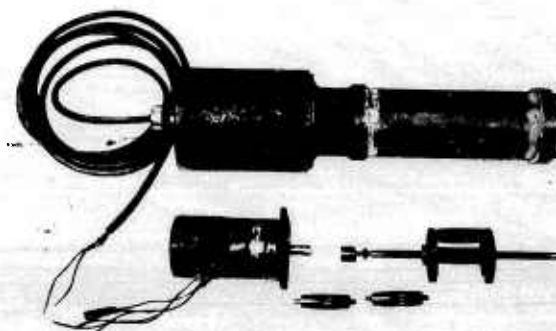

FIGURE 11. Four-in. rotary noisemaker test unit.

SECRET

rollers, wall thickness, and speed of rotation in its effect upon the noisemaker output. The 4-in. design undertaken to achieve an output substantially higher than was possible with the 3-in. design was calibrated by USRL. A comparison of these two designs with the early NAE unit (Table 3) indicated that the alternative designs offered no significant advantages. The 4-in. rotary test unit is shown in Figure 11. Details of construction and of test results are covered in reference 56d.

USRL CALIBRATION OF FOUR-INCH ROTARY⁴⁶

Filter-band measurements. See Table 2.

TABLE 2. Analysis of 4-in. rotary noisemaker output.⁵¹

Band	RMS pressure in band (db above 1 dyne per sq cm at 1 m)	RMS pressure level (for center frequency) (db above 1 dyne per sq cm at 1 m)
Broad band (0.7-150 kc)	86.0	...
Audio band (0.7-15 kc)	85.7	...
0.5-kc band centered at 5 kc	71.3	44.3
1-kc band centered at 10 kc	69.9	39.9
2-kc band centered at 20 kc	67.9	34.9
4-kc band centered at 40 kc	62.2	26.2

Frequency characteristic. See Figure 12.

Peak factor. The peak factor of the noise from the 4-in. rotary noisemaker is 20 db.

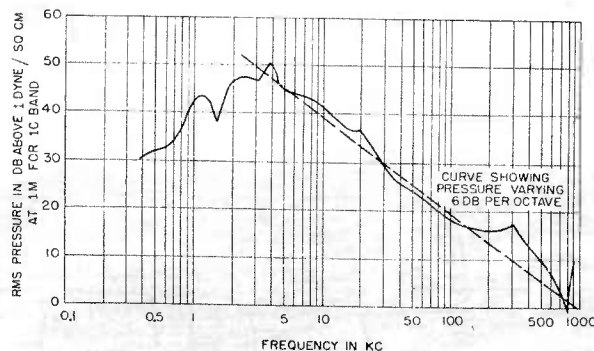

FIGURE 12. Frequency characteristic of 4-in. rotary noisemaker.

COMPARISON WITH NAE

Measurements of the experimental rotary noisemakers for various values of the power input are summarized in Table 3 for comparison with the performance of an early model of the NAE. The output at 5 kc of a standard DE at 15 knots expressed for an equivalent point source at 1 m distance is 22 to 32 db spectrum level above 1 dyne per sq cm.⁶⁶

TABLE 3. Output of three rotary noisemakers.^{56d}

Noisemaker	Power input (watts)	Spectrum level in db above 1 dyne per sq cm at 1 m			
		5 kc	10 kc	20 kc	
MIT 3-in. rotary	400	44	
	400	41	
	MIT 4-in. rotary	400	44	39	32
		600	47	43	35
		600	52	46	40
	800	49	46	37	
	800-900	49	46	37	
NAE (3-in.)	275	42	45	37	

2.4 DUAL SOUNDHEAD MECHANICAL NOISEMAKERS

2.4.1

General

The mechanical noisemakers discussed thus far attempt to produce a masking or decoying effect with a loud and wide-band noise centered at some useful frequency. The mechanical noisemakers developed by UCDWR to mask submarine sounds were tailored for a specific frequency distribution pattern. In the XXAG sound beacon and its predecessor, the sonic sound beacon, the output was adjusted to have a frequency distribution similar to that of a submarine at a level considerably higher than the submarine output.

The noisemaker development that culminated in the XXAG sound beacon can be divided into two phases. Preliminary work initiated in the summer of 1943 was devoted to developing a mechanical noisemaker to mask submarine sounds from listening detection in the sonic range. The original noisemaker was conceived as a sonic companion to the supersonic jammer, the NAC beacon (Section 3.2). Later it was decided to modify the beacon by adding a second soundhead to produce higher-frequency noise so that the resultant unit would mask

SECRET

at supersonic frequencies as well. Experiments were conducted with a variety of motor-driven impactors which produce a wide band of noise at frequencies extending well up into the supersonic range. In the XNAG design this type of noisemaker was considered the most promising of those available at the end of the war. The frequency distribution of its output is sufficiently similar to that from a submarine to produce confusing noise at any frequencies the enemy could be expected to use for listening detection. The output level, which is somewhat higher than that of a submerged submarine at 6 knots, provides considerable areas of safety for submarines operating at lower speeds.

2.4.2 Design Considerations

ACOUSTIC PERFORMANCE

The XNAG sound beacon was designed to satisfy the conditions of masking submarine sounds throughout the listening spectrum at both sonic and supersonic frequencies for the speeds normally used in evasion, for equal ranges from the enemy vessel, and for a reasonable region of bearing separation. A typical overall output for a submarine at 6 knots expressed as an equivalent point source at 1 m, was taken as 67 db above 1 dyne per sq cm as discussed in Section 6.2. The useful output level for a noisemaker must be at least equal to this value. The single-frequency whines characteristic of the operation of a reduction-gear-driven submarine rise higher than this level and must be taken into account. The range of frequencies swept by the electromagnetic soundhead in the XNAG effectively covers the region in which most of these whines occur. Although this does not provide true masking, the degree of confusion that is produced offers significant protection.

SUBMARINE SIMULATION

The ability of the ear to detect rhythmic sounds or special qualities of sounds even when many decibels below the background level recommends the use of masking noise particularly designed to resemble propeller cavitation and gear whine. For a 6-knot submarine the cavitation is a continuous noise extending at almost constant level from 1 to 10 kc and amplitude-modulated at the rate of propeller revolutions per minute. The gear whine for

reduction-gear-driven submarines is a constant-frequency tone, accompanied by its harmonics, which has a frequency approximately equal to 60 times the speed in knots so that gear whines are found chiefly in the 200- to 400-c range. The mechanical problems involved in producing noise to satisfy these special requirements received extensive study in this program as summarized in Section 2.4.4. Further related material may be found in Chapter 6 where the submarine-simulating decoys are discussed.

ELECTROMAGNETIC SOUNDHEAD

The vibrating diaphragm which constitutes the only soundhead in the early models and in the sonic sound beacon was initially driven at 300 c by a self-commutating vibrator in an adaptation of the common vibrator-type automobile horn. The stiff loading of the diaphragm produced an output rich in harmonics. This output spectrum proved to be too narrow for effective masking. For the sonic sound beacon a circuit was installed which swept the driving frequency from 250 to 330 c twice a second. The principle of frequency sweeping was found much more effective. After some experiments with a vibrator motor, a thermal-relay flasher-type Tung Sol tube was adopted to produce a sound output sweeping from 280 to 360 c three times a second. This device, used in the final XNAG prototype design, not only produces a more satisfactory spectrum, but further reduces the weight of the unit.

IMPACTOR-TYPE SOUNDHEADS

Several methods for producing noise over a wide continuous band of frequencies were investigated. One proposed the use of an electromagnetically driven hammer shuttling rapidly back and forth along a diameter of the tube to strike two opposite points of the wall. Another utilized an electric motor to drive a rotating shaft. In the early roller-impactor designs the shaft carried three rollers traveling against the inside wall of the tube, bearing on four curved sectors which controlled the vibrations of the wall. Considerable study was made of the sector designs and of other variations which would minimize the friction load upon the motor. A more efficient design using two rollers and six sectors produced an elliptical distortion of the cylinder that gave increased output. In the ball-impactor soundhead incorporated in the XNAG prototype model

SECRET

the two rollers are replaced by free-tying balls enclosed in a rotating tube which are flung against the sectors on the outside walls by centrifugal force as the driving shaft revolves.

DEPTH CONTROL

As for other noisemakers, the XNAG requirements stipulated a depth control that would support it at a depth of 50 ft during its noisemaking

life. The sonic sound beacon was of sufficiently light construction to permit use of the same depth control unit that was developed for the XAC beacon which can compensate for negative buoyancy of as much as 3 oz. The introduction of the second soundhead in the XNAG increased its weight to such an extent that additional displacement volume was provided by means of a telescoping shell at the top of the unit.^a



FIGURE 13. Sonic sound beacon.

2.4.3

THE SONIC SOUND BEACON

The sonic sound beacon shown in Figure 13 was an experimental expendable noisemaker designed to aid submarine evasion by masking self-noise from sonic listening. The beacon is 3 in. in diameter and 32.5 in. long. The upper section of the housing contains a buoyancy control and a sea battery. The lower part contains the electronic equipment and the electromagnetic soundhead. A diaphragm at the lower end of the beacon is driven by an electromagnet at a fundamental frequency that sweeps

from 250 to 330 c twice a second. The noise produced is rich in harmonic content. Tests of the beacon indicated that its output in an overall band from 0.02 to 100 kc is about 1 db higher than that of an average fleet submarine operating at periscope depth at a speed of 6 knots. The masking effectiveness of this beacon is considered marginal. After preliminary field tests the sonic sound beacon was superseded by the XNAG. This noisemaker development was carried out by UC DWR.⁶⁰

CONSTRUCTION

General. The sonic sound beacon shown in Figure 13 and in the drawing in Figure 14 is made up of two metal cylinders joined by a bracket attaching the thin-walled perforated container to the main housing. Water penetrates the upper container as soon as the unit is ejected and so activates the sea battery and buoyancy control. Inside the main container the considerable air space around the electronic unit provides flotation for the noisemaker.

PRESSURE COMPENSATION

Considerable difficulty was encountered in adapting the diaphragm in the electromagnetic soundhead to operation at any depth. The effect of increased static pressure on early designs was to hamper the diaphragm action and finally as the pressure increased to a critical value to halt it altogether. A siphon bellows was adapted to equal-

ize the pressure on the two sides of the diaphragm, eliminating this problem in the sonic sound beacon and subsequent designs. The cylinder wall was sufficiently stiff to resist static pressures down to 875 ft. By allowing an initial drop of 200 ft below the ejection point before the buoyancy control would take effect, the depths at which the XNAG could be safely ejected were restricted to 300 ft or less.

Electronic Unit. The electronic components of the sonic sound beacon are mounted on two sides of a plate inside the main container. The circuit is shown schematically in Figure 15. The time-delay lever set before ejection controls a clockwork mechanism. When the time delay has elapsed the voltage from the sea battery is supplied at once to the tube filaments and then after operation of the thermal time delay to the rest of the circuit.⁶⁰ The self-ex-

^a See Chapter 7 for description.

SECRET

cited thyatron inverter tubes V102 and V103 constitute the main oscillator. Tube V101 is a gas-relaxation oscillator and serves as the sweep control to vary the frequency range. The output of these tubes provides alternating current to the coils of

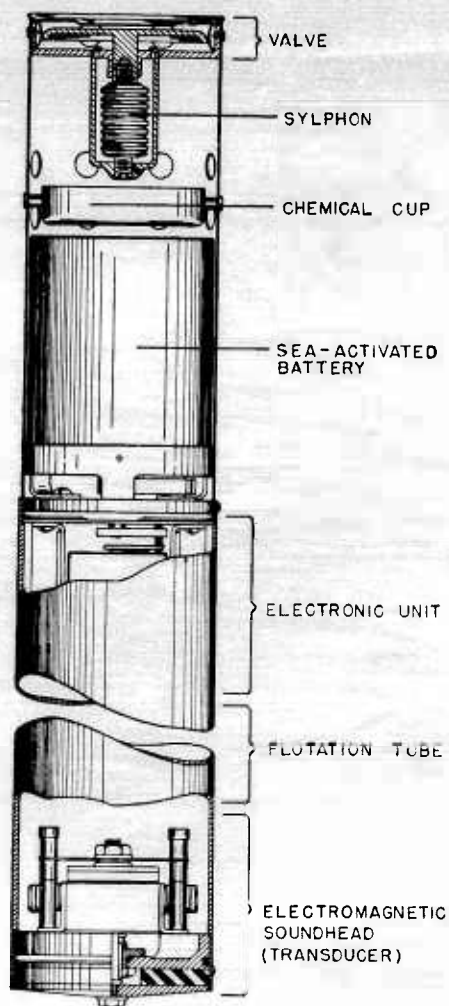

FIGURE 14. Drawing of sonic sound beacon.

the electromagnet at frequencies varying from 125 to 165 c twice a second. Since the magnet attracts the core twice in each cycle the fundamental driving frequency for the diaphragm varies from 250 to 330 c twice a second.

Electromagnetic Soundhead. The construction of the sonic sound beacon soundhead is shown in Figure 16. The mechanism comprises a field core and coil, and a spring-resonated moving armature to which is fastened a vibrating diaphragm. Upon passage of current through the coil the armature is

set in motion thus vibrating the diaphragm whose exterior face is in contact with the water. The field core, coil, and supporting framework for the resonating spring are mounted on a watertight bulkhead. The diaphragm is connected to the moving armature and resonating spring by a shaft which passes through the bulkhead and a hole in the field core. The shaft opening in the bulkhead is made watertight by a metallic bellows which also provides depth compensation for the water pressure on the diaphragm.

The soundhead is resonated by a flat, Phosphor-bronze spring. The size of this spring affects the level of the sound output but because of the low Q of the soundhead spring size is not critical. The resonant frequency of 300 c is near the top of the band of frequencies at which the unit is driven. The Q is low because the pole piece of the soundhead motor beats the core thus limiting any build-up in amplitude of motion of the moving parts. Beating of the core by the pole piece also gives the high harmonic content to the sound output of the beacon. If were this beating not present, the harmonic content would be greatly decreased without appreciably increasing the intensity of the fundamental frequency.

Output of the electronic unit is fed to the coil of the soundhead (V101 in Figure 15), through the power-factor-correcting condenser C107. Sound-pressure release is accomplished by a piece of Cell-tite rubber cemented to the back of the diaphragm. Assembly of the transducer in the housing provides a baffle around the diaphragm throughout its excursion to prevent sound leakage around its edges thus reducing cancellation by out-of-phase sound energy arising from the opposite face of the driving diaphragm and increasing net sound output.

Buoyancy Control. The buoyancy control unit in the sonic sound beacon is the same as that used in the NAC beacon. These mechanisms are described in detail in the discussion of depth controls in Chapter 7. The sonic sound beacon is set to operate at a depth of 50 ft and hovers there within ± 4 ft. The quantity of gas produced by the chemical is sufficient to support the unit for a life of 30 min before allowing it to sink.

NOISE PRODUCTION

The mechanism of sound production in the sonic sound beacon received some study. The low frequencies are radiated from the diaphragm itself and

SECRET

the directivity patterns show uniform response in all directions in the plane normal to the noisemaker axis. The pattern of the higher harmonics is more complex. At higher frequencies not only does the diaphragm vibrate but also the whole beacon housing. As the frequency increases, the radiation from the housing wall becomes more and more important, eventually, perhaps, exceeding that from the diaphragm.

In designing the noisemaker, the basic frequency was fixed at the lowest practical point. A lower basic

instant it is made up of a single fundamental frequency and its harmonics. Coverage of the frequency spectrum is effected by the high harmonic content of the noise and by sweeping the basic frequency. The resultant noise has a low-frequency cutoff at 250 c, and significant harmonics are present up to at least 10 kc. The problems that arise in presenting the results of any measurements of such an output illustrate the general problem in the noisemaker program of relating calibration measurements to probable operational effect. Compare,

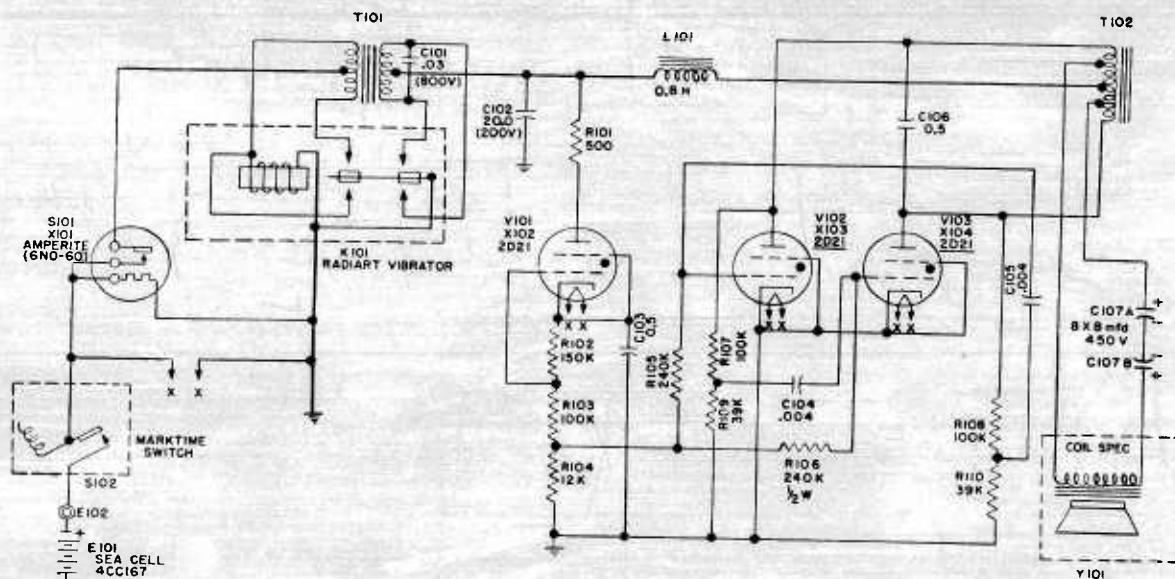

FIGURE 15. Schematic of sonic sound beacon circuit.

frequency would have produced a more useful spectrum, but dropping below the 250- to 330-c band would introduce severe mechanical problems because of the extreme amplitudes of diaphragm vibration required to maintain adequate sound pressure levels. The 3-in. diameter of the diaphragm renders conversion of mechanical energy into acoustical energy an extremely inefficient operation at frequencies below 250 c.⁵⁷

ACOUSTIC CALIBRATION

General. The output of the sonic sound beacon was measured by USRL at Mountain Lakes,⁵⁸ by UCDWR at the Sweetwater Calibration Station, and in tests at sea. The sound emitted by the beacon varies constantly in frequency, but at any given

for example, the frequency response curve obtained by UCDWR in Figure 21 with the USRL curve for this same noisemaker in Figure 17. These results are more significant as a measure of the differences between two heterodyne filter analyzer systems than as indications of the beacon's output.

Wide-Band Output. The overall output level for the sonic sound beacon for the overall band from 0.02 to 100 kc was measured in two sets of conditions. In the laboratory this output was measured as 60.5 db above 1 dyne per sq cm at 1 m. In sea tests,⁶⁰ where the submarine overall output at 6 knots was 67 db above 1 dyne per sq cm, the beacon displayed an output of 68 db, expressed for a 1-m distance. Much of this discrepancy can be ascribed to the difference in reverberation conditions.

SECRET

Frequency Characteristic. Some indication of the harmonic content of the sonic sound beacon can be obtained from the spectra shown in Figures 17 and 21. The multiple considerations of the effect of the swept output upon the level recorded by a given meter through filters of various bandwidths used in the analyzer systems, and of the various assump-

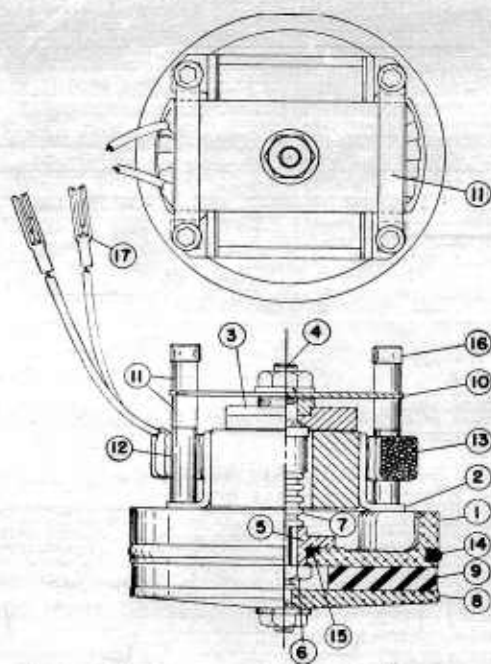

- | | |
|-------------------|------------------------|
| 1—Bulkhead | 9—Cushion |
| 2—Core | 10—Spring |
| 3—Armature | 11—Spring clamping bar |
| 4—Shaft | 12—Stand-off |
| 5—Bushing | 13—Coil |
| 6—Bushing nut | 14—O-ring |
| 7—Sylphon bellows | 15—O-ring |
| 8—Diaphragm | 16—Socket hand screw |
| | 17—Connectors |

FIGURE 16. Drawing of electromagnetic soundhead.

tions made and methods used in correcting for this sweep, make these curves of little further value.

SEA TESTS

Masking tests provide more useful information about the performance of the sonic sound beacon. In tests made in October 1944⁶⁰ the beacon was suspended from a stationary vessel while the USS *Spot* ran by at speeds from 2 to 6 knots. Listening with a nondirectional hydrophone with a response flat from 0.1 to 10 kc indicated that the beacon provides effective sonic masking of submarine noises

in this frequency range both at slow speeds and at the higher speeds where cavitation takes place. Overall measurements made at this time showed that the overall output of the beacon was about the same as that of the 6-knot submarine. It was evident from these tests that the masking effectiveness of the beacon would be considerably reduced in the presence of directional listening gear for any significant bearing separation between noisemaker and submarine with reference to the listening hydrophone. It was after these tests that the decision was made to develop a noisemaker to mask submarine sounds at higher frequencies as well.

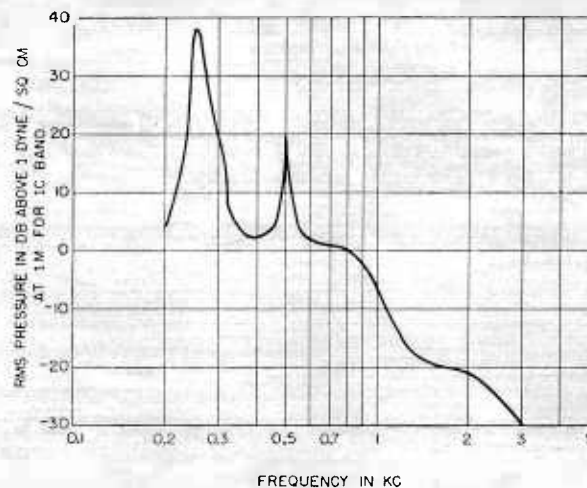

FIGURE 17. Frequency characteristic of sonic sound beacon, measured by USRL.

2.1.4 Development of Dual-Head Units

GENERAL

For a new noisemaker to provide masking at all frequencies from 0.1 to 50 kc the use of the electromagnetic soundhead for low frequencies and of a mechanical soundhead for high frequencies was proposed. A number of different soundheads of both types were studied and the most promising combined into several dual-head noisemakers.⁶⁰ A tabular comparison is given here to show the development of the designs that were finally incorporated in the XNAG preliminary and XNAG prototype models.

ELECTROMAGNETIC SOUNDHEADS

The design of the electromagnetic soundhead passed through several stages before the method

used in the final design was realized. The diaphragm in the sonic sound beacon in Figure 16 had been driven with a signal which swept from 250 to 330 c twice a second. In the vibrator-controlled electromagnetic soundhead included in the dual-head DS-1 test model the diaphragm was driven by a single frequency of 210 c. The swept-frequency vibrator-controlled head in the XNAG preliminary model used a short-circuiting resistor in series with a 180-c vibrator coil which swept the output from 320 to 360 c three times a second. In the final model used in the XNAG prototype a Tung Sol relay (in the circuit in Figure 32) produces a signal which sweeps from 280 to 360 c three times a second. The circuits and construction details of the experimental soundheads are covered in reference 60. The available measurements of the output from the soundheads tested alone are summarized for comparison in Tables 4 and 5.

TABLE 4. Overall output of electromagnetic soundheads.⁶⁰
(band level in overall band)

Soundhead	db above 1 dyne 6 per sq cm at 1 m	Figure
Sonic sound beacon measured at calibration station	60.5	16, 21
measured at sea	67	16
Vibrator-controlled electromagnetic soundhead	56.8	..
Swept-frequency vibrator-controlled electromagnetic soundhead
Tung Sol relay swept-frequency electromagnetic soundhead	75.5	31

MECHANICAL SOUNDHEADS

The mechanical soundheads were investigated at the same time as the electromagnetic heads. Except for the striker impactor in Figure 18, they all employ a motor-driven shaft to rotate the impactor elements which vibrate the cylinder wall. The output of the motor-driven cam soundhead, which used a developed cam to provide a controlled driving frequency, proved to have low harmonic content. The roller train in Figure 19 was considered. A series of rotary impactor designs like the model in Figure 20 was studied, culminating in the Model 4 used in the XNAG preliminary model. The investigation of the importance of various parameters of these systems in the design of rollers, striking sectors, and bearing construction, yielded information

that may be of use in the development of rotary noisemakers. A marked reduction in the friction load was achieved in the ball-impactor design developed for the XNAG prototype in Figure 33. The available measurements of the output from these mechanical soundheads tested alone are summarized for comparison in Table 5.

TABLE 5. Overall output of mechanical soundheads.⁶⁰
(band level in overall band)

Soundhead	db above 1 dyne per sq cm at 1 m	Figure
Motor-driven cam soundhead	55.5	31
Striker-impactor soundhead	62	18
Roller impactor Model 1	62.5	20, 23
Roller impactor Model 2	59	24
Roller impactor Model 3	72.5	..
Roller impactor Model 3 with thin sectors	67	..
Roller train	63	19
Roller impactor Model 4	72.8	..
Ball impactor	..	33

SUMMARY OF DUAL-HEAD UNITS

The electromagnetic and mechanical soundheads described above were combined into a number of

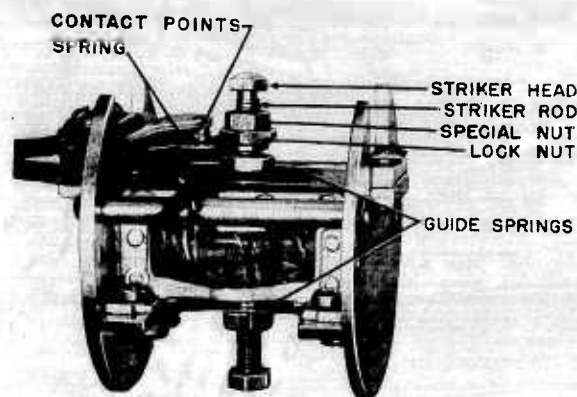

FIGURE 18. Striker-impactor soundhead.

test models before the completion of the final XNAG design. The performance of these is summarized below in Table 6 and the frequency characteristics are shown in Figures 21 to 28. The name of the test model is followed by the names of the two components to facilitate reference. Comparison of the frequency curves shows the influence of the low-frequency sweeps as well as the continuous

SECRET

noise-level output from the mechanical soundheads. A further comparison of XNAG output with the noise from submarine operation is shown in Figures 34 to 36.

RECOMMENDATIONS FOR FURTHER WORK

The XNAG employing two soundheads represents a considerable improvement over the sonic sound

put is realized with the aluminum alloy sectors over that developed with ramp sectors of steel. This effect may possibly arise from the fact that the

TABLE 6. Overall output of dual-head noisemakers.⁶⁰
(band level in overall band)

Soundhead	db above 1 dyne per sq cm at 1 m	Figure
DS-1 preliminary model (striker impactor and sonic sound beacon electromagnetic soundhead)	60.4	22
DS-1 test model (roller impactor Model 3 and vibrator-controlled electromagnetic soundhead)	72.5	26
XNAG preliminary model (roller impactor Model 4 and swept-frequency vibrator-controlled electromagnetic soundhead)	72.8	27
XNAG prototype model (ball impactor and Tung Sol relay-controlled swept-frequency electromagnetic soundhead)	75.5	28, 31

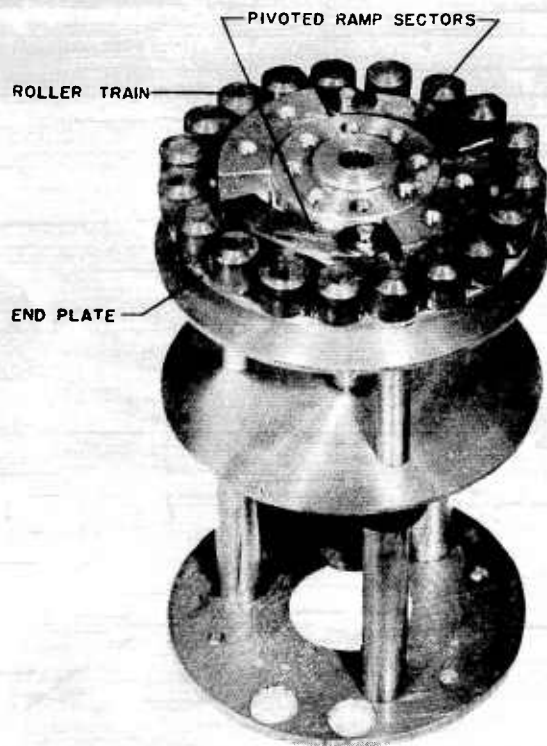

FIGURE 19. Roller-train impactor.

beacon which employed only one soundhead. The latest model shows an increase of about 15 db in overall level above that of the earlier sonic sound beacon. Most of this increase is concentrated in the low-frequency end of the spectrum. Because of limitations on the physical dimensions of the XNAG further increase of overall sound level can apparently come only from improvement of the efficiency of the unit. In this connection it should be observed that the first model of the impactor employed case-hardened steel ramp sectors and rollers. Subsequent models, both those with rollers and those with balls, utilize ramp sectors of aluminum alloy 24ST. Some slight improvement in sound out-

aluminum ramp sectors offer a smaller mass to be accelerated by the impact of the rollers or balls. The comparison cited above, however, was made

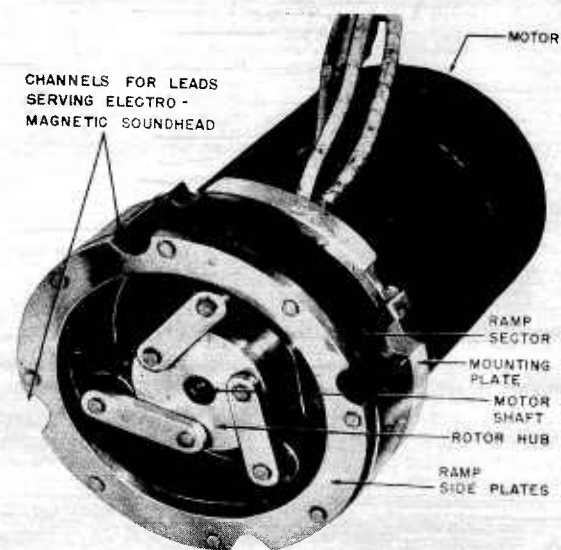

FIGURE 20. Roller impactor Model 1.

only for early models employing rollers, and it seems advisable that tests should be made of a model incorporating steel ramp sectors and the

SECRET

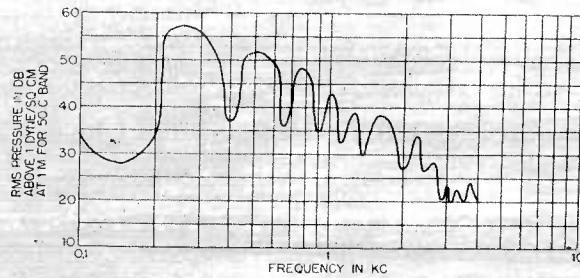

FIGURE 21. Frequency characteristic of sonic sound beacon, measured by UCDWR.

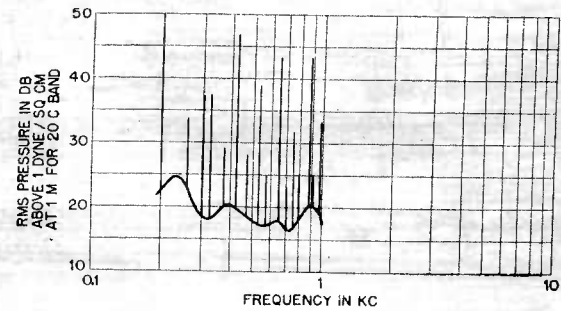

FIGURE 25. Frequency characteristic of single-frequency electromagnetic soundhead.

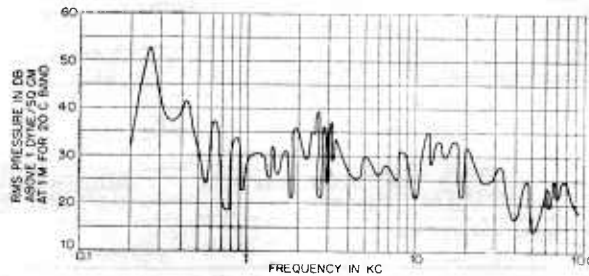

FIGURE 22. Frequency characteristic of DS-1 preliminary model.

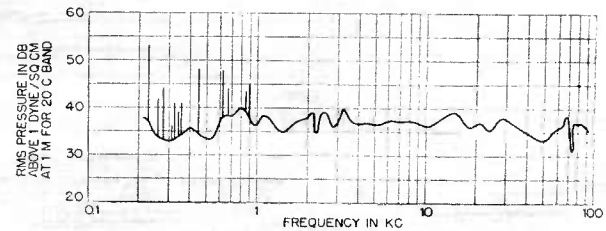

FIGURE 26. Frequency characteristic of DS-1 test model.

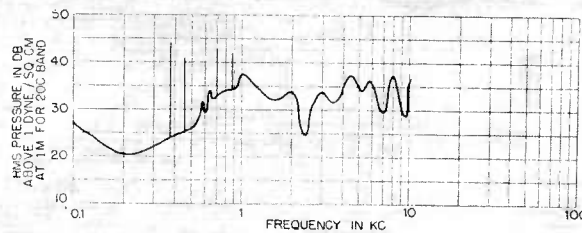

FIGURE 23. Frequency characteristic of roller impactor Model 1.

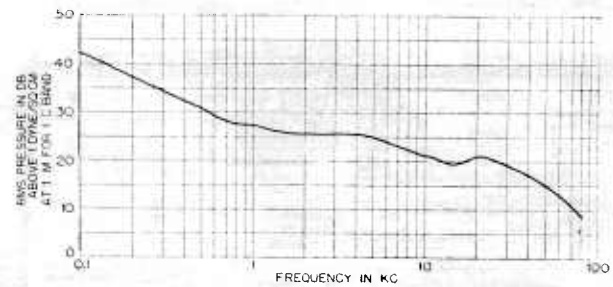

FIGURE 27. Frequency characteristic of XNAG preliminary model.

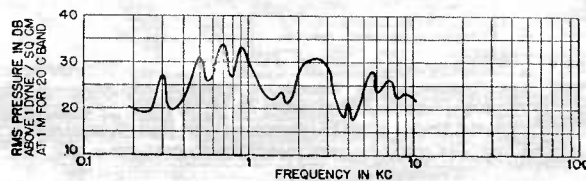

FIGURE 24. Frequency characteristic of roller impactor Model 2.

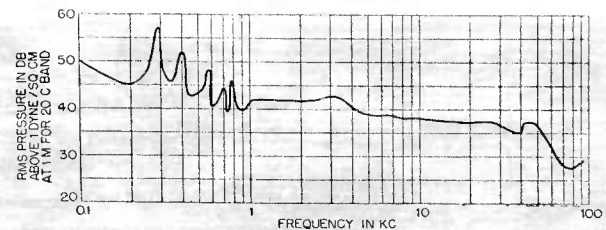

FIGURE 28. Frequency characteristic of XNAG prototype model.

SECRET

present design of impactor employing steel balls in a rotor tube. It has been noted that the indentations made by the balls in the aluminum alloy ramp sectors increase the frictional resistance to the rotation of the rotor. This phenomenon would conceivably not exist, or at least would be reduced in magnitude in a design in which steel ramp sectors were impacted by steel balls. The consequent reduction in friction might improve the efficiency of the device and consequently the sound output.

2.4.5 XNAG Preliminary Model

CONSTRUCTION

The XNAG preliminary model is similar in its outward appearance to the prototype model described in detail in Section 2.4.7. The buoyancy control with telescoping shell is the same as that used with the prototype model and is described in Chapter 7.

The roller-impactor soundhead consists of a 1/10-hp motor driving a two-roller six-ramp soundhead. The speed of the motor is approximately 4,300 rpm. The rollers run up a ramp incline and fall onto the next ramp producing about 430 impacts per second. The electromagnetic soundhead is excited by a vibrator. A short-circuiting resistor in series with the vibrator changes the frequency put out by the vibrator from 160 to 180 c three times a second. The frequency fundamental of vibration of the diaphragm accordingly varies from 320 to 360 c three times a second.

CALIBRATION

Filter-Band Measurements. Since the widths of the filter bands used to measure the XNAG output were considerably wider than the sweep of the electromagnetic soundhead fundamental, the values may be compared significantly with other noisemaker calibrations. Table 7 shows the rms levels⁵⁹ both in band level and spectrum level for four filter bands. These values indicate that most of the energy is below 2 kc with a very appreciable portion below 700 c. In the opinion of the XNAG designers, however, the large low-frequency content is misleading since it is improbable that a diaphragm 3 in. in diameter would have an output that continued to increase at such low frequencies. Possibly the harmonics of the modulation frequency were recorded

by the measuring system as part of the noise output.

Frequency Characteristic. See Figure 27. Because of the sweep of the signal the curve cannot be used for establishing absolute levels, but it does give

TABLE 7. Analysis of XNAG, preliminary model, output (in db above 1 dyne per sq cm at 1 m).⁵⁹

Frequency band in c	rms level with given frequency band	rms levels reduced to 1-c band
20-40,000	72.8	26.8
20-15,000	71.3	29.5
20- 2,000	71.1	38.1
20- 700	67.3	39.0

some indication of the relative frequency composition of the noise if the low-frequency portion of the curve is disregarded.

Peak Factor. The peak factor was determined for two of the units and the higher value observed was 27.8 db.

ASDEV LANT TESTS

Tests of eight XNAG units were made by ASDevLant, Fort Lauderdale, Florida, in June 1945.²⁰ The USS *Roncador* acted as target vessel running at speeds from 2.7 to 6 knots at periscope depth. Noisemakers were ejected at distances from 250 to 900 yd from the listening vessel. Both OAY nondirectional gear and JT directional gear were used for listening. Despite the unfavorable sea states from 2 to 3 prevailing on both days during the tests, some determination of the general effect of XNAG upon listening ranges could be made.

Under the test conditions listening ranges were reduced to approximately one-third their normal value in the presence of XNAG masking. By determining the 50 per cent ranges obtainable with and without the noisemaker the results shown in Table 8 were obtained. These results are averaged from the eight runs.

TABLE 8. Effect of XNAG upon listening ranges (averaged from eight runs).²⁰

Gear	Without XNAG	With XNAG
OAY	1,800 yd	600 yd
JT	1,300 yd	400 yd

With the submarine and the XNAG at the same range the effect of bearing separation could be studied. From the limited data obtained it was ap-

parent that the masking was effective for bearing separations of as much as 45 degrees, and that this angle increased further with increased ranges. This effect is discussed further in Section 2.4.6.

DESIGN CHANGES

Conclusions drawn from these sets of tests indicated the need for improvement in both the impactor and the electromagnetic soundheads. Attention was turned to a new type of impactor called the ball impactor and incorporated in the final

XNAG prototype. The tests had also shown the need for increasing the magnitude of the sweep in the fundamental frequency of the electromagnetic soundhead. The vibrator-controlled electromagnetic soundhead had extended the sweep from 320 to 360 c. By replacing the vibrator with a thermal-relay flasher-type Tung Sol tube, the sweep was extended from 280 to 360 c, sweeping that range three times a second. This unit not only produced a more satisfactory sound spectrum, but also reduced the weight of the device. These new components are described in Section 2.4.6.



FIGURE 29. XNAG sound beacon, prototype model, in contracted position before ejection.

2.4.6

XNAG SOUND BEACON PROTOTYPE

The XNAG sound beacon is an experimental expendable noisemaker designed to aid submarine evasion by masking self-noise from listening. The beacon is $3\frac{1}{16}$ in. in diameter and 34 in. long. The upper section of the housing contains sea batteries and a buoyancy control. The lower part contains a rotary soundhead to produce wide-band noise and an electromagnetic soundhead to produce noise at low frequencies. Field tests indicate the

effectiveness of this noisemaker in masking submarine sounds for a practical range of speeds. The overall output level of the XNAG, for a band from 0.02 to 100 kc, is 75.5 db above 1 dyne per sq-cm converted to 1 m. The operating life of the XNAG is approximately 11 min. The buoyancy control supports the noisemaker at 50 ft for approximately 30 minutes. UCDWR developed XNAG, and further research is continuing at DTMB.⁶⁰

CONSTRUCTION

General. The XNAG is shown in its contracted position before ejection in Figure 29. In Figure 30 the unit is shown after ejection with the buoyancy control chamber extended, and likewise with the housing shells removed. These components are also shown schematically in Figure 31.

Power Source. Sea batteries using sea water as their electrolyte supply 15 amp at 12 v to the XNAG for a life of about 11 min. These batteries are discussed in Chapter 8.

Time Delay. The clockwork time-delay mechanism is mounted on the upper bulkhead of the main housing. The time-delay control lever projects from the cylinder as shown in Figure 31. When the unit

is ready to fire the lever is moved from its zero position to the mark on the wall indicating the desired delay, and then moved back to zero. This starts the operation of the clock.

Electronic Circuit. The function of the electronic equipment associated with the electromagnetic soundhead is to convert the 12-v d-c battery power into a current interrupted at a frequency varying from 140 to 180 c three times a second. Figure 32 is a schematic wiring diagram for the XNAG showing the Tung Sol thermal relay and the 180-c vibrator. The vibrator is nominally rated at 180 c but its actual frequency is dependent to a certain extent upon the rate of current flow through its coil. This dependence is utilized to provide the desired

SECRET

frequency modulation of the sound output of the electromagnetic soundhead. The current conversion is accomplished by feeding the 12-v battery output to the vibrator through the two resistors. The 25-ohm resistor R103 is in the circuit at all times. The 15-ohm resistor R102 is put in parallel with R103

magnetic soundhead is energized by the current pulse occurring on each half-cycle of the vibrator.

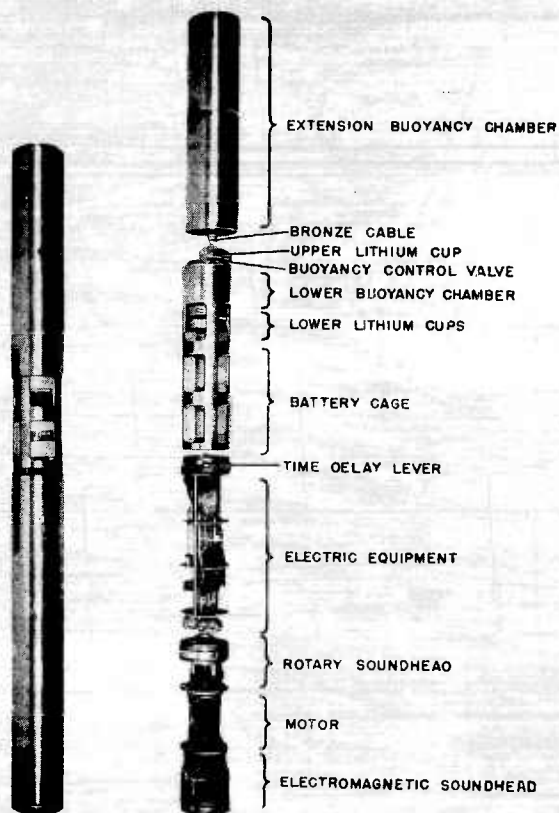

FIGURE 30. Construction of XNAG sound beacon.

and cut out again three times each second by the action of the Tung Sol thermal relay. R103 and R102 in parallel offer a resistance of only 9.4 ohms, as compared with 25 ohms when R103 is in the circuit alone. With the 25-ohm resistance in the circuit the vibrator operates at a frequency of 140 c; but the increased current flow through the vibrator coil occurring when the resistance is reduced to 9.4 ohms sweeps vibrator frequency up to 180 c; thus effecting in the operation of the electromagnetic soundhead an essentially sinusoidal frequency change between 280 and 360 c. The frequency change runs through three complete cycles each second. The soundhead frequency is twice the vibrator frequency because the coil of the electro-

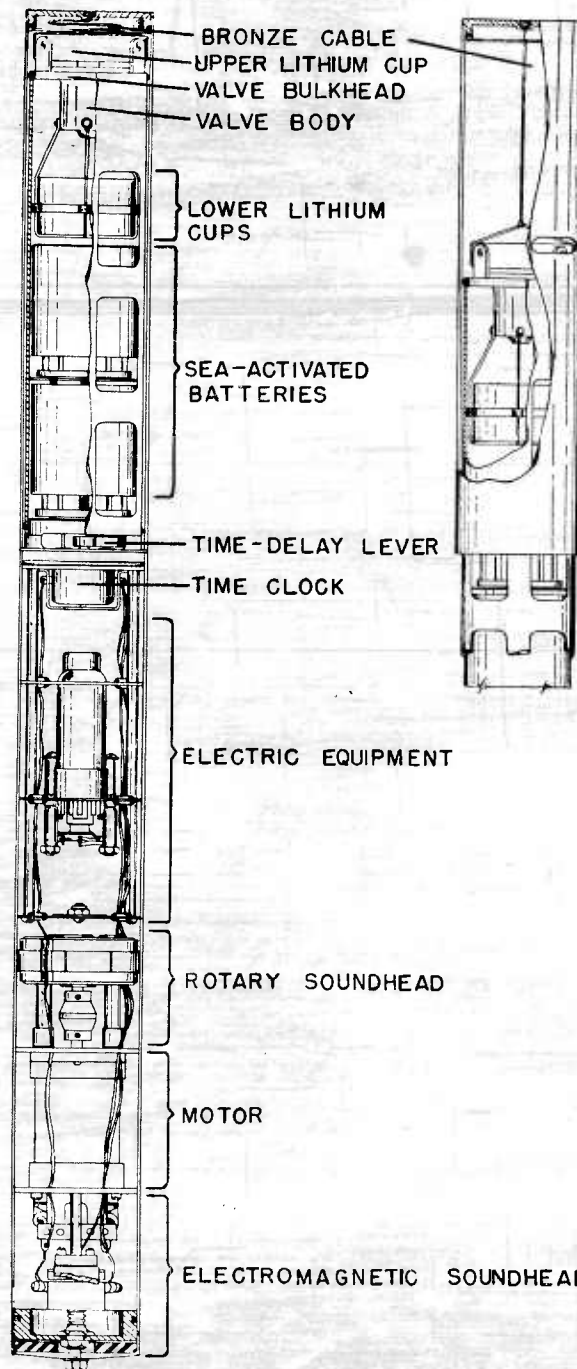

FIGURE 31. Drawing of XNAG sound beacon.

The vibrator is buffed by condenser C101. The vibrator frequency change is substantially linear

with time because of the inertia of the weighted vibrator reed. The thermal relay is a Tung Sol, sprung-vane type circuit intermitter designed for operation at 10 v. A 5-ohm resistor R101 in series with this relay renders it suitable for operation on 12 v.

Electromagnetic Soundhead. The electromagnetic soundhead has been altered from the similar

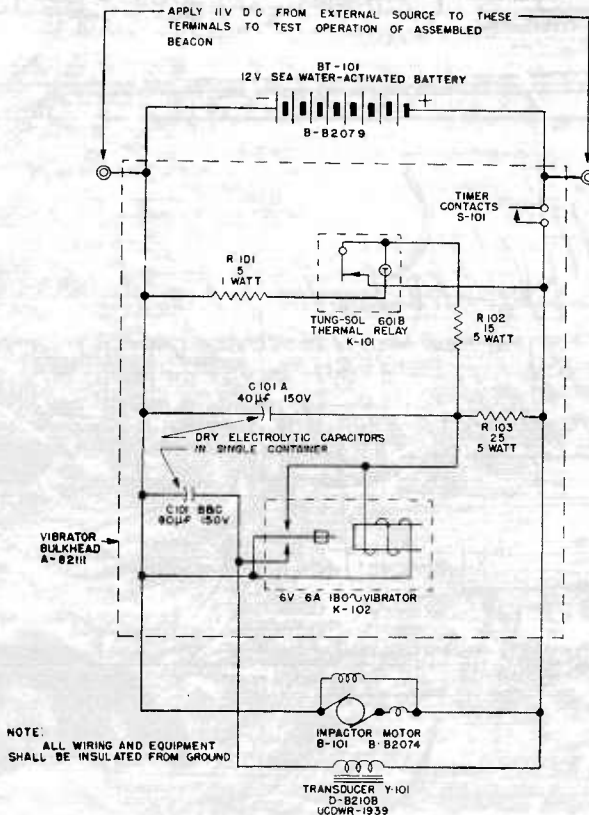

FIGURE 32. Schematic of XNAG circuit.

head in the sonic sound beacon in two particulars. The sweep of the exciting current is provided by the Tung Sol flasher-type tube control as the culmination of the various stages reported in Section 2.4.5. The baffle effect provided in the sonic sound beacon by the housing tube which surrounded the diaphragm throughout its excursion to cut down sound pressure loss around its edges is now achieved by a separate baffle ring.

Ball-Impactor Soundhead. The high-frequency soundhead consists of a serrated circular ramp composed of six curved wedge-shaped sectors, each pivoted through its approximate center to two side

plates. This structure can be seen in Figure 33. Within the confines of the ramp, and operating in its plane, is an open-ended rotor tube with an inside diameter of $\frac{3}{16}$ -in. and loosely containing two $\frac{1}{2}$ -in. chrome steel balls, one in each end. At the mid-point of its longitudinal axis the rotor tube is pierced by a fixed shaft directly connected to the motor shaft by a rubber coupling. Each sector of the serrated circular ramp is $\frac{1}{2}$ inch wide, increasing uniformly in thickness throughout its entire length in the direction of rotor rotation from 0.188 in. at

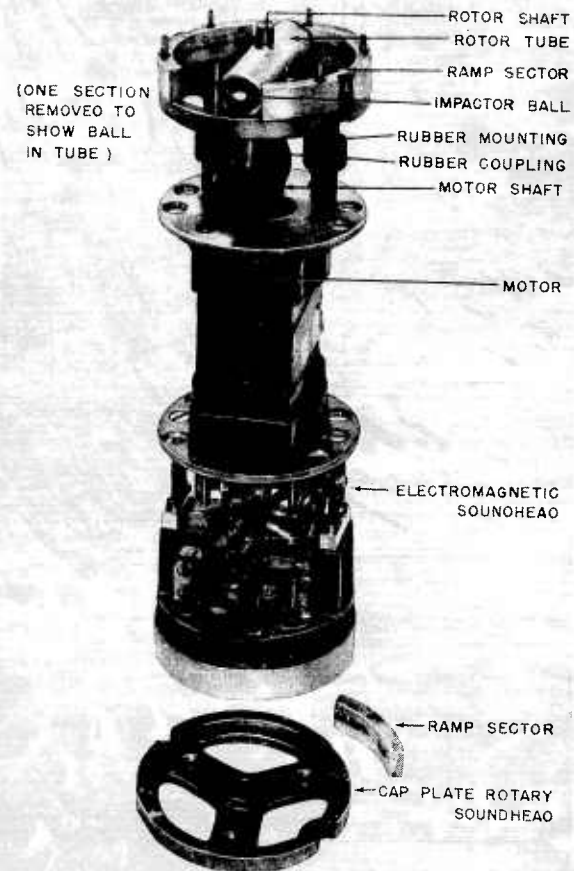

FIGURE 33. XNAG ball-impactor soundhead and motor.

the leading end to 0.234 in. at the trailing end, and curving to fit the inside diameter of the main housing tube. The rotary soundhead is mounted on the motor by means of rubber supports, and its rotor is driven through a flexible rubber coupling. This

vibration isolation was found necessary to insure proper operation of the motor. The rotary soundhead creates sound waves in the water by setting up vibrations in the beacon body tube through a continuous series of impacts on the tube wall. The mechanism of noise production by this impactor was studied in detail.⁶⁰

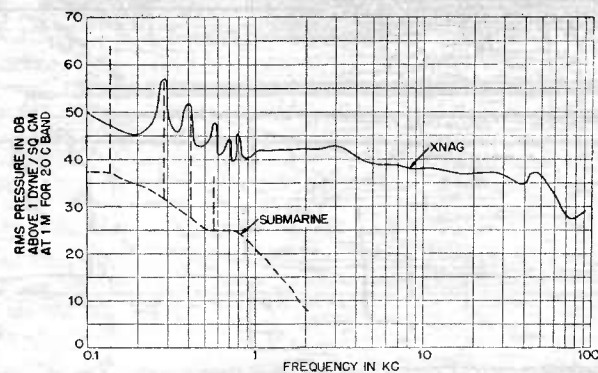

FIGURE 34. Output of XNAG compared with USS Spot at 2.5 knots.

Drive Motor. The motor is a 12-v, 75-w, shunt-wound unit shown in Figure 33. In this particular application it turns 4,700 rpm.

Heavy-Duty Buoyancy Control. The increased weight of the dual-head mechanism in the XNAG made it impossible to use the lightweight buoyancy control developed for the NAC beacon and used

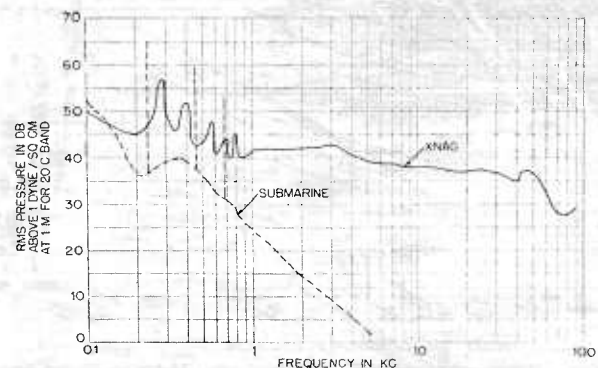

FIGURE 35. Output of XNAG compared with USS Spot at 4 knots.

also in the sonic sound beacon. Whereas in these lighter units it has been possible to provide sufficient flotation volume inside the body housing to bring the unit to within a few ounces of neutral buoyancy, the additional equipment inside the

XNAG necessitated increased displacement volume to float the unit. The heavy-duty buoyancy control comprises two separate buoyancy chambers, one telescoping down over the other when the unit is not in use, and both serving by a common control valve activated by a syphon bellows. The details of the buoyancy control design are described in Chapter 7.

OPERATION

Ejection of the XNAG is not recommended for depths greater than 300 ft because of limitations in the buoyancy control and in the strength of the body cylinder. Before ejection the unit is checked to see that no moisture has penetrated the battery and buoyancy control compartment. The time-delay lever is then set for the desired interval before the start of noisemaking and released to start its operation. The XNAG is placed in the ejector and should be ejected at once because of the elapse of the time delay and because of the hydrogen pro-

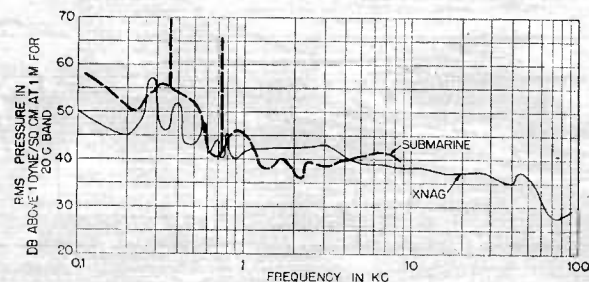

FIGURE 36. Output of XNAG compared with USS Spot at 6 knots.

duced when the sea batteries and buoyancy control are flooded with water.

Upon ejection the rapid generation of gas from the uppermost chemical cup in the buoyancy control displaces water from the upper buoyancy chamber so that the buoyancy of the entire unit is brought to within 1½ oz of neutral. The gas retained under the valve cover in the lower buoyancy chamber controls the rise of the unit to a depth of 50 ft and holds it there so that it hovers within 5 ft of its set depth until the gas supply is exhausted after about 30 min. Meanwhile the action of the sea water has produced voltage from the sea batteries. This is applied to the noisemaking units at the end of the clockwork-controlled time delay. The 12-v supply operates the motor which drives the rotary

soundhead at 1,700 rpm, producing wide-band continuous noise by impacts upon the body wall. The power is also converted to drive the diaphragm of the electromagnetic soundhead at a frequency that sweeps from 280 to 360 c three times a second. The life of the batteries, which is about 11 min, determines the noisemaking life of the unit.

ACOUSTIC PERFORMANCE

The output of the XNAG prototype model was measured by UCDWR. The overall sound level is 75.5 db above 1 dyne per sq cm at 1 m, for a band from 0.02 to 100 kc. As in the measurements of the XNAG preliminary model, the apparent increase in level with decreasing frequency is ascribed by the designers to resonance within the recording system.

The high peaks occurring between 100 c and 1 kc are produced by the electromagnetic soundhead. The peaks undoubtedly contain some high-intensity, single-frequency components; but, because the frequency of the electromagnetic soundhead is being constantly swept through a band from 280 c to 360 c the single-frequency components sweep through the 10-c band-pass filter of the analyzer so

rapidly that they cannot be identified by the recording apparatus. This accounts for the fact that the highest spectrum level is only 57 db above 1 dyne per sq cm compared to an overall level of 75.5 db above 1 dyne per sq cm.

COMPARISON WITH SUBMARINE SPECTRA

Comparison of the frequency characteristic shown in Figure 28 with the spectra obtained of submarine output are shown in Figures 34, 35, and 36. The submarine performance curves are obtained from measurements of the USS *Spot*.¹⁰¹ The vertical lines indicate the single-frequency components which were identified as gear whine. It will be observed in Figure 35 that for the submarine speed of 2.5 knots the peaks in the XNAG curve coincide fortuitously with most of these whine frequencies. At 4 knots and 6 knots in Figures 36 and 37 the single-frequency components of the submarine spectrum have shifted. The general level of the XNAG output is sufficiently higher than the submarine output, apart from the whines, to insure masking for the lower speeds, except at frequencies below 125 c. At 6 knots the general level of the submarine is con-



FIGURE 37. Experimental hammer bottle designs, numbered in order of construction.

SECRET

siderably higher than the XNAG output over most of the spectrum.

A further study of the probable effectiveness of the XNAG was prepared by UCDWR in an analysis of the areas of safety provided by the noisemaker for submarine operation.⁶⁰

EFFECT ON LISTENING

With the available measurements of XNAG performance it is not possible to make any final statements about its masking effectiveness. However, on the basis of listening tests and the ASDevLant measurements, and in the light of what is known about the phenomena of masking, a number of interesting observations may be made.

The overall output level measured for the XNAG is nearly 10 db higher than the overall output from typical submarine operation at 6 knots. In frequency distribution the XNAG output resembles submarine output in having continuous noise throughout the sonic and supersonic range, in the general rate at which this noise falls off at high frequencies, and in the possession of separated harmonic peaks at low frequencies.

To a listener the XNAG noise is recognizable as some sort of masking device rather than sounding like a submarine. The wide-band noise from the XNAG is its most prominent feature and its level is sufficiently high to make it extremely difficult for the listener to hear the submarine in the frequency range of cavitation noise. The attempt to detect the submarine through this masking by listening for gear whine is hampered by the second component of the XNAG output. The electromagnetic soundhead produces single-frequency sounds which sweep the range in which gear whine is normally produced. The listener, alert for some sort of whine, detects what appears to be a satisfactory noise below the level of the wide-band masking noise. Although the submarine whine is presumably constant while the XNAG whine keeps sweeping, the listener apparently has great difficulty in distinguishing them. The effect on the listener of the frequency modulation in the XNAG output seems to be to create the illusion of some sort of amplitude modulation. Since the rate of this modulation is close to the propeller-thrash amplitude modulation of cavitation it contributes to the impression of submarine noise. There

is room for considerable further study of the psychological effect of the XNAG output, and these remarks constitute only preliminary observations.

2.4.7

Future Work

The development of the XNAG carried on at UCDWR under NDRC auspices through March 1945 was continued at the laboratory for several months on a direct contract with the Navy. In August 1945 this work was terminated and the further development of the XNAG was transferred to DTMB. The present account covers the development through August 1945. Further information on subsequent work may be obtained from the Bureau of Ships.

2.5 HAMMER-BOTTLE NOISEMAKERS

2.5.1

General

The investigation of mechanical principles for making noise underwater led to a variety of promising designs during the summer of 1943. At that time the development of sea batteries for use in expendable noisemakers was scarcely begun, and the use of compressed gas as a source of power was studied as a possibility. The critical need in September 1943 for countermeasures to the acoustic torpedo accelerated the development of the hammer bottle which consists of a pneumatic riveting hammer mounted to strike the steel cylinder that houses its gas supply. Experimental quantities were produced within a month. Preliminary field tests indicated that the type of noise produced was at least promising for use in protecting a surface vessel from a listening torpedo. As the need for this type of countermeasure gave way to a need for noisemakers of substantially higher sound output, work on the hammer bottle proceeded at a reduced rate. Specifications for a compact preproduction model FXH-1 were accepted by the Navy and 100 such units were constructed for test. Some study was made of further modifications (including the inside-hammer design) to increase the sound output before the program was terminated.

TABLE 9. Analysis of FXH-1 output in decibels above 1 dyne per sq cm at 1 m.⁵¹

Filter band	RMS pressure in band		RMS spectrum level for center frequency	
	System Measurement	Pulse Analysis	System Measurement	Pulse Analysis
Broad band (0.7-50 kc)	77.8	76.4
Audio band (0.7-15 kc)	74.8	74.3
0.5 kc band centered at 5 kc	59.2	60.2	32.2	33.2
1-kc band centered at 10 kc	60.0	65.5	30.0	35.5
2-kc band centered at 20 kc	59.5	67.5	26.5	34.5
4-kc band centered at 40 kc	51.6	62.0	15.6	26.0

2.5.2

Experimental Work

EARLY MODELS

The minesweeping hammer box, which had been developed under Section 620 of the Bureau of Ships in 1942, was the basis for the expendable hammer-bottle noisemaker. It was hoped that the high acoustic output could be retained although the hammer was changed from operating in gas to operating in water, and although the radiating surface was changed from a large flat diaphragm to a small cylinder. A variety of combinations of hammer and gas cylinder were tried out as shown in Figure 37. The models are numbered chronologically in order of construction. Model 2 in the photograph is the XG5 which was rushed into production as described in the next paragraph. Model 5 is similar to the preproduction FXH-1 design in Figure 38. The other models were constructed to investigate possible modifications, such as the Model 1 design which was studied for adaptation to submarine ejection.

2.5.3

FXH-1 HAMMER BOTTLE

The FXH-1 hammer bottle is an expendable mechanical noisemaker developed as a possible countermeasure to the acoustic torpedo. A pneumatic riveting hammer produces noise by setting into vibration the steel walls of the cylinder housing its gas supply. The FXH-1 output is concentrated in the low sonic region. The spectrum level at 5 kc is 32 db above 1 dyne per sq cm. for a 1-c band measured at 1 m. The noise is impactive, produced by hammer blows occurring roughly 80 times a second, and the peak factor is 28 db. The FXH-1 was developed by MIT-USL. One hundred preproduction models were built for test. The device was never used operationally.⁶⁶

XG5 HAMMER BOTTLE

In the XG5 design shown as Model 2 in Figure 37 the hammer was mounted in a rigid frame so as to strike the gas cylinder perpendicularly at the center of the side wall. Tests showed this to be the most efficient region of excitation. The gas was supplied to the hammer through connecting pipes, a manually controlled valve, and a pressure regulator. The gas cylinder held sufficient gas to operate the hammer for 2 min. For use in initial tests a float was tied to the frame and the entire assembly was thrown overboard by hand. In response to the critical need for noisemakers which might be useful as decoys, 24 units of the XG5 model were built up within a month and supplied to ASDevLant for test.^{61, 63, 64} On the basis of XG5 performance in these and supplementary acoustic tests, the Navy recommended that further models be built. For ease of handling and storage it was requested that the design be modified to achieve greater compactness.

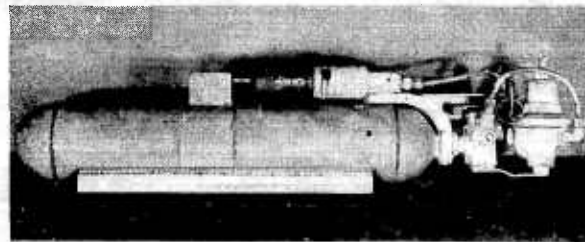

FIGURE 38. FXH-1 hammer bottle.

SECRET

CONSTRUCTION

This more compact hammer bottle, designated FXH-1, was constructed as a preproduction model, and 100 units were delivered to the Navy during the first months of 1944. In the FXH-1 design shown in Figure 38 and schematically in Figure 39 the hammer is mounted parallel to the gas cylinder and strikes an anvil soldered to the cylinder wall. The cylinder is charged with 4 lb of liquid CO_2 at a pressure of the order of 2,000 psi. A regulator reduces this to 100 psi to drive the hammer. The trigger-type valve is released by a fuse time delay which is ignited manually before the unit is thrown overboard. The complete loaded unit weighs about 21 lb in air. The container shown in Figure 40 serves as a float to support the hammer bottle in the water during its life and then insures its sinking after 5 min. The informal manufacturing specifications for the FXH-1 hammer bottle as accepted by the Navy can be found in reference 66.

USRL CALIBRATION

Filter-Band Measurements. See Table 9. These measurements except for the broad-band reading

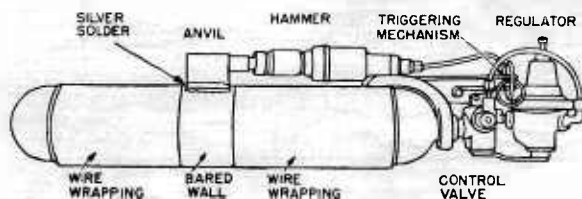

FIGURE 39. Drawing of FXH-1.

were obtained by integration from the frequency characteristic obtained by Fourier analysis of the hammer-bottle waveform.

Frequency Characteristic. See Figure 41. Two curves are shown, one for the frequency characteristic as determined with the USRL heterodyne analyzer, and one as determined by Fourier analysis of a waveform photograph of the hammer-bottle output. The agreement is within 3 db which is less than the observed variation among successive pulses.

Peak Factor. The peak factor for the hammer-bottle output determined graphically from the waveform photograph is 28 db, computed for pulses occurring regularly seventy times per second.

Waveform. See Figure 42.²⁴

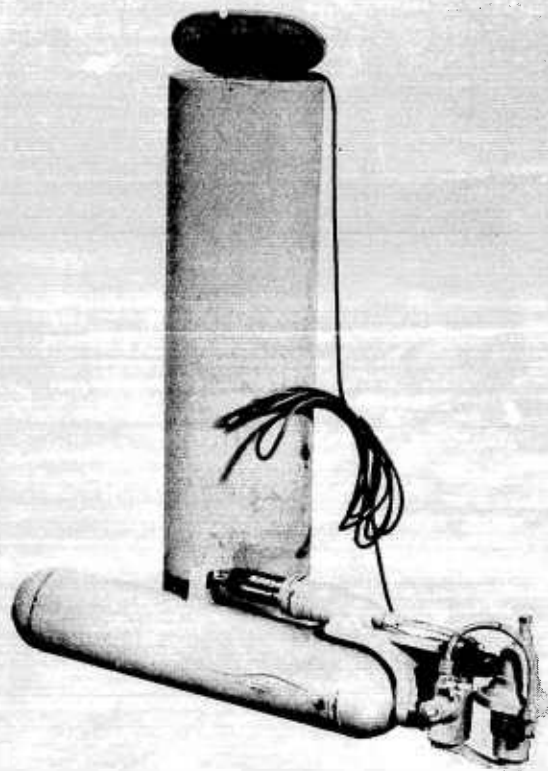

FIGURE 40. Hammer bottle and container.

FIELD TESTS

Comparison with DE Output. In comparative acoustic tests of noisemakers and DE's, the typical output for a DE traveling at 15 knots was measured at 5 kc as 22 to 32 db spectrum level above 1 dyne per sq cm, expressed for an equivalent point source

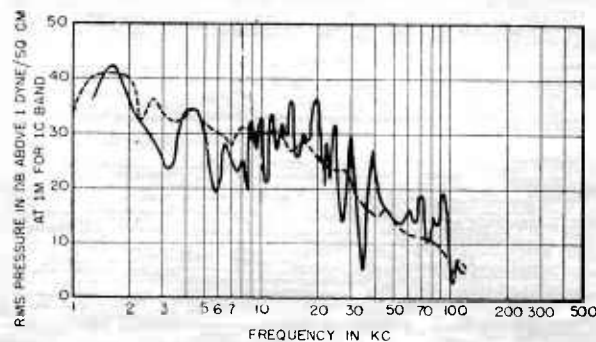

FIGURE 41. Frequency characteristic of FXH-1 output as obtained by Fourier analysis (solid line) and with heterodyne sweep analyzer (dashed line).

SECRET

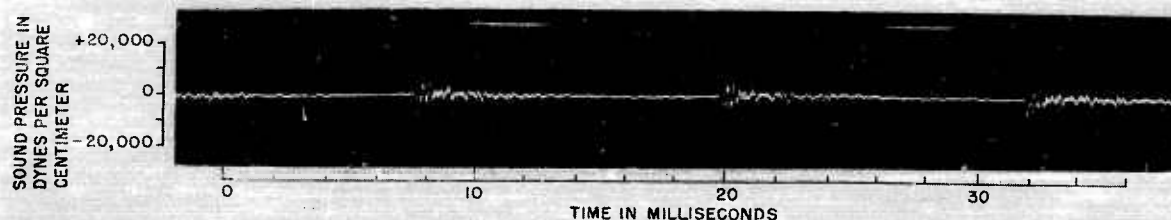

FIGURE 42. Waveform of FXH-1, measured at 6-ft distance.

at 1 m distance. A comparison of this value with the output expressed similarly of various hammer-bottle designs is given in Table 10. The designation FXH denotes early models with the hammer mounted parallel to the cylinder while FXH-1 denotes the specified preproduction design. The experimental XG5 had an output of 40 db while the lighter more compact FXH-1 showed a decrease in output to about 37 db. The models of the inside hammer showed an increase in output to about 44 db. None of these devices provided sufficient margin above the DE output to recommend them as torpedo countermeasures.

TABLE 10. Hammer-bottle output at 5 kc, given in decibel spectrum level above 1 dyne per sq cm at 1 m.

Unit	Spectrum level
XG-5	37, 38, 40
XG-5	40
XG-5	40
XG-5	44
FXH	34-36
FXH	37-39
FXH	34
FXH-1	37
FXH-1	37-38
FXH-1	32
Inside hammer	46
Inside hammer	43

Tests with Submarine. The hammer-bottle frequency characteristic falls off sharply below 1.5 kc, and thus provides little output in the region where most submarine sounds are produced in slow-speed operation. Field tests were made using submarines and surface vessels equipped with standard listening gear. These tests showed that the hammer bottle produced masking under some conditions, but the use of low-pass filters in the listening system

reduced the effectiveness of this to an unacceptable value. Application of the hammer bottle to submarine evasion was given no further consideration after these tests.⁶²

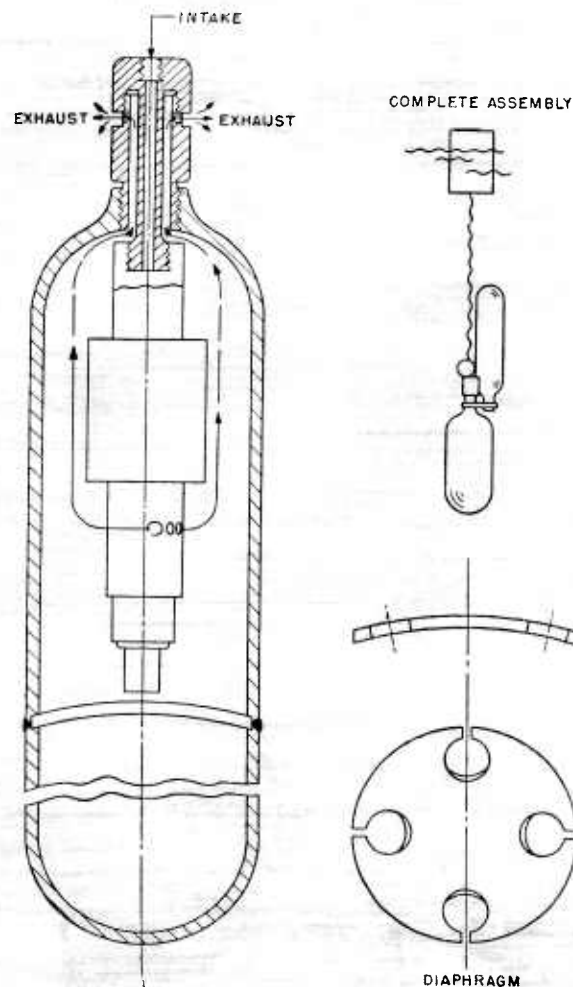

FIGURE 43. Drawing of inside hammer design.

SECRET

OTHER DESIGNS

Several other designs of hammer-driven noisemakers were built with no significant increase in the level at 5 kc. Models 8 and 11 in Figure 37 show the hammer mounted at the end of the bottle. In an attempt to use a resonant system the bottle was replaced by a solid metal rod. Both iron and brass rods were tried, the length of the rods being equal to half the wavelength at 5 kc for the material used. The 3-in. diameter rods proved to have a greater output than a 2-in. rod. Brass and steel had very similar output. Compared with the FXH-1, however, the level at 5 kc was only slightly improved and the levels at 10 and 20 kc were somewhat reduced.

The last hammer-bottle design tested, the inside-hammer design, did provide a significant increase in output. This design was investigated at MIT-~~USL~~ at the same time as the 4-in. rotary noisemakers when there was a need for an increase in

order of magnitude in the amount of noise produced by expendable noisemakers. These devices were considered for use by surfaced submarines to throw from the conning tower to decoy acoustic torpedoes while the submarine went into a quick dive. The inside-hammer design is shown schematically in Figure 43. A pneumatic riveting hammer is mounted inside a steel cylinder so that it strikes a steel disk welded to the inside walls and sets the walls into vibration. Gas to drive the hammer is supplied from a second gas bottle. Six of these units were built and tested. The spectrum level at 5 kc was 44 db or better as shown in Table 10 where it is compared with other hammer bottles. This increase over the outside-hammer design is presumably explained by the fact that the hammer is surrounded by gas instead of water and so experiences fewer losses. The development of this design was terminated in the fall of 1944 when production effort was concentrated on the more compact and powerful NAE.

SECRET

Chapter 3

ELECTRONIC NOISEMAKERS

3.1

INTRODUCTION

THE USE OF CRYSTAL projectors to produce masking and decoying sounds followed from earlier work on echo repeaters and underwater projectors. An advantage of crystal transducers over the mechanical devices discussed in Chapter 2 is the greater flexibility offered by electronic circuits in producing the frequency characteristics required for a specific problem. A disadvantage of crystal transducers for noisemakers encountered in the early work with X-cut Rochelle salt crystals is the high temperature dependence of their piezoelectric characteristics. Although this difficulty is not encountered with Y-cut crystals, all Rochelle salt crystals are subject to damage at temperatures above approximately 130 F. The later use of ADP crystals eliminated both of these difficulties.

Under the noisemaker program which was started in the spring of 1943, the first problem undertaken at UCDWR was the development of an expendable electronic device to jam echo ranging. It was initially believed that a jamming device presented fewer development problems than the attempt to simulate submarine sounds. The NAC beacon was completed in 1944 and 4,308 units were supplied to the submarine force.

A secondary program to improve upon the NAC

beacon was undertaken later in the war after the termination of the NDRC contract at UCDWR. Certain limitations in the efficiency and frequency range of the NAC's jamming effect were overcome in the design of the NAH beacon which is part of the development program continuing at the Navy Electronics Laboratory.

The crystal transducers used in the echo-repeater systems in the NAD beacons are discussed in Chapter 6.

Other attempts to use crystal transducers driven by electrical signals were less successful. Among the devices investigated as towed decoys for the acoustic torpedo were the XPA and the towed fish. Both of these were large arrays of Rochelle salt crystals in streamlined housings. The exciting signal carried in the towing cable was designed to drive the bank with complex frequencies to correspond to ship sounds. In tests of the towed fish it was found that the crystals melted at the power level necessary to provide a decoying level of sound. The only field tests made of the XPA were inconclusive. The engineering problems of towing a large body on electric cable with the additional requirement of keeping it out of the wake made further work on these programs appear impractical. The XPA did find subsequent application as a standard projector for calibration measurements.

3.2

THE NAC SOUND BEACON

The NAC sound beacon (Figure 1) is an expendable noisemaker that was used to aid submarine evasion by jamming echo-ranging detection. A crystal transducer is driven by a multivibrator circuit operating from a sea battery power supply. The NAC emits a frequency-modulated supersonic signal for about 12 min. This signal sweeps part of the supersonic range about four times a second in one of the three bands 15 to 19 kc, 17.5 to 22.5 kc, or

21.5 to 27.5 kc. Before ejection from the submarine the NAC's are set to jam in the band containing the frequency in use by the attacking vessels. The instantaneous sound output has a spectrum level at 2.5 kc of 62 db or more above 1 dyne per sq cm for a 1-c band measured at 1-m distance. A buoyancy control supports the NAC at 50 ft for approximately 30 min. An order of 4,308 NAC beacons was produced for the fleet. UCDWR developed NAC.

3.2.1

Construction

The NAC sound beacon shown in Figures 1 and 2 is constructed in three sections. The central section 3 in. in diameter and about 19 in. long, houses

the electronic parts of the signal-generating circuit. The projector is sealed in a can at the bottom of the beacon. A free-flooding can at the top houses the buoyancy control mechanism and the sea battery. A special moistureproof cover protects this section

from deterioration during storage. The methods of constructing the beacon and of achieving a satisfactory waterseal are adapted from methods of crimping which are standard in the canning industry.

ELECTRONIC CIRCUIT

The electrical system for producing modulated voltages at supersonic frequencies consists essentially of a multivibrator oscillator, a thyatron oscillator, a power amplifier, and vibrator power supply. It has five vacuum tubes in four envelopes, and all components are mounted on a single chassis. The multivibrator generates electrical oscillations at frequencies from 15 to 27 kc. The thyatron provides a sawtooth sweep voltage which varies the multivibrator frequency over one of the three selectable bands at a repetition rate of about four sweeps per second. The frequency increases approximately linearly with time and drops back in a negligible time after each sweep.

The frequency-modulated signal is amplified by a push-pull amplifier and coupled to the transducer through a series-tuned circuit designed to compensate for the transducer characteristics. The plate

V102, a thyatron oscillator V101 which is used to sweep the frequency over a fixed range, a power amplifier V103 and V104, and a vibrator power supply K101 and T101.

The multivibrator oscillator, a 6SN7GT, is capable of operation over the 15 to 27-ke range. The selector switch S101 changes condensers and resistors in the circuit to divide the voltages into three channels of operation with nominal frequencies of operation of 15 to 18 ke, 18 to 22 ke, and 22 to 27 ke. The actual frequency bands overlap these specified limits by about 0.5 ke to cover small variations in different units. When the switch S101 is set on the points 1 (marked in Figure 3), the grid potential of the 6SN7GT charges the condenser C104 through the fixed resistors R105, R110, and the variable resistor R104. When the condenser is fully charged, the cathode potential of the thyatron (an 884 gas tube) becomes sufficiently negative for this tube to fire, thereby discharging condenser C104. The values of the resistors (R105, R106, R107, R110, R111, R112) and the condensers (C102, C103) involved in the switching operations are chosen so that the periodicity of the C104 discharge is approximately 4 μ sec regardless of the setting of switch S101. The change



FIGURE 1. NAC sound beacon.

power requirements are furnished by a 180-c synchronous vibrator which is energized by the sea water battery. The filaments are supplied directly by the battery.

The schematic wiring diagram in Figure 3 shows all the components of the electronic circuit. The circuit is seen to comprise a multivibrator oscillator

in voltage across C104 as it discharges varies the bias on the grid of V102 so that the output frequency is varied. Thus when switch S101 is set on points 1 the multivibrator output covers the 15 to 18-ke range; when on points 2, the 18 to 22-ke range; and when on points 3, the 22 to 27-ke range. Variable resistor R104 is used to adjust the beacon

SECRET

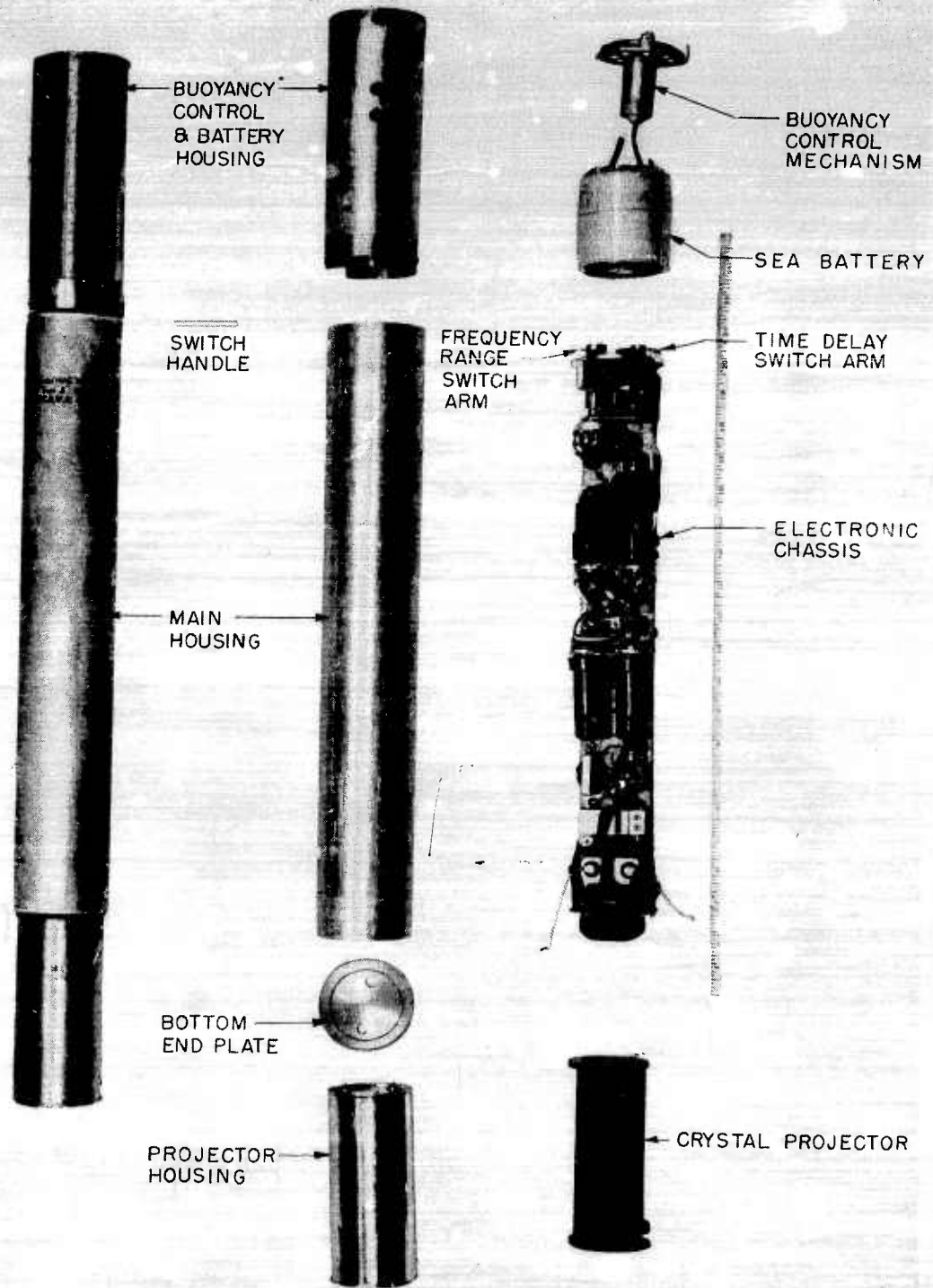

FIGURE 2. Construction of NAC.

SECRET

to the correct frequencies at the time of assembly. In each case the frequency varies in sawtooth fashion from the upper to the lower limits, 4 ± 1 times per second, as controlled by the firing of the thyratron. The switch arm extends through a watertight bushing in the upper end plate of the main container of the beacon assembly so that it can be set externally to any of the three markings on the outside shell.

Tube V102 is coupled to the push-pull power amplifier tubes V103 and V104 through condensers

end plate of the main container so that it can be adjusted externally before ejection. Filament current is supplied to the tubes as soon as the battery is wet so that the unit is ready to start producing signals as soon as the time delay applies power.

CRYSTAL PROJECTOR

The transducer that projects the signal into the water is a bank of Rochelle salt crystals hermetically sealed in castor oil inside a thin-walled can. Twenty Y-cut crystals, $1\frac{1}{2} \times 1 \times \frac{1}{4}$ in. each, are

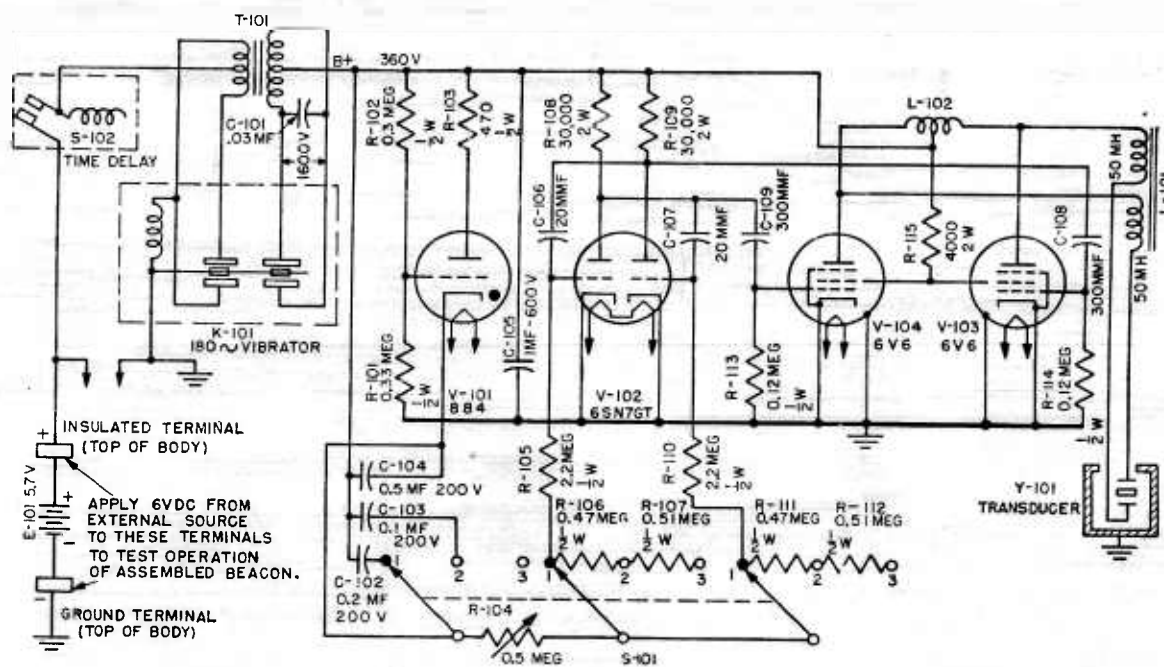

FIGURE 3. Schematic of NAC circuit.

C108 and C109. This output stage applies voltage to the transducer Y101 through resonating coils L101. It is capable of delivering 30 to 40 ma of current to the transducer.

Power is supplied to the circuit at 180 v and 360 v. The direct current at 5.7 v from the sea battery E101 is converted to 180 v by the synchronous vibrator unit K101, and stepped up to 360 v by the transformer T101. The variable time-delay switch S102 is a conventional delayed-action relay which interrupts the line from the battery to the transformer so that the application of plate voltage may be delayed from 0 to 11 min. Delay is controlled by a clockwork mechanism with a setting arm that extends through a watertight bushing in the upper

stacked as shown in Figure 4 and connected in parallel. Leads from the crystal bank are brought out through hermetically sealed terminals in the upper plates of the thin-walled container to make electrical connection with the signal-generating circuit in the main container. This projector is the CY4 type transducer.^a

The directional pattern of the CY4 is shown in Figure 6.

POWER SOURCE

A Burgess sea battery supplies approximately 15 amp at 5.7 v for a period of about 12 min. Since the sea battery develops no voltage until it is wet a

^a Discussed in Division 6, Volume 12, Chapter 6.

SECRET

means of testing the unit prior to use is provided by a pair of external terminals to which a 6-v external power supply may be connected. If it is operating properly, the unit emits characteristic audible sounds which can be heard to sweep a frequency range.

BUOYANCY CONTROL

The buoyancy control consists essentially of a source of gas and a pressure-operated valve. The mechanism is housed in the free-flooding section of the NAC container just above the sea battery. This buoyancy control is like that developed by UCDWR

negative buoyancy of the order of 55 g for which the buoyancy control compensates.

CONTROLS

The NAC has two external controls located at the top of the main container, which can be seen in Figure 1. These are the frequency band switch, which must be set definitely at one of the three marked positions, and the time-delay switch, which is moved out to the selected delay time and then back to its initial position labeled "operate." It is believed that failure to observe these rules in preparing NAC's for ejection has contributed to reported failures.

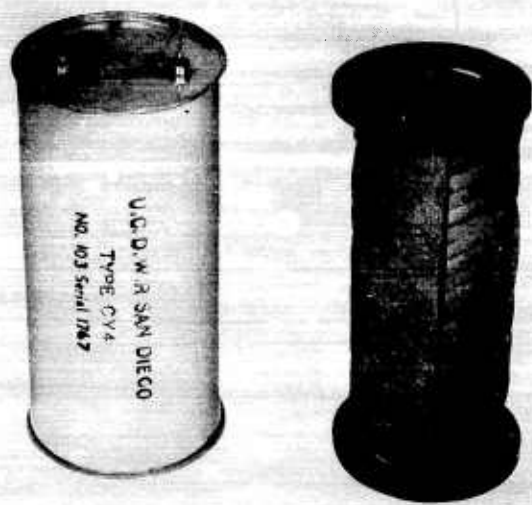

FIGURE 4. NAC crystal projector.

for use with the sonic sound beacon and other expendable devices and is discussed in Chapter 7 with the other depth control devices. The NAC buoyancy control causes the unit to seek a given depth and maintains it there for about 30 min, which allows for the full life of NAC operation plus the maximum value of time delay. Units are normally set for 50-ft operating depth, about which they may oscillate a few feet. Since the buoyancy control is designed to provide changes of only a few ounces in buoyancy, the unit itself must have a buoyancy close to zero. The light construction and considerable air space inside the central cylinder facilitate this. Lead ballast is used in assembling the unit to bring the weight to within 8 g of 3,220 g overall. The displacement of the unit is such that this results in a

3.2.2

Operation

Before ejection the NAC beacon is first taken from its container. The moistureproofing cap is removed and the moisture indicator is checked. The external switches are set for the desired frequency band for the output signal and for the desired time delay before operation.

Immediately upon ejection the sea water comes in contact with the gas-producing chemicals in the buoyancy control. This goes into operation at once, bringing the unit to its equilibrium depth. In practice the unit hunts slowly about this level with an amplitude of not more than ± 2 ft.

The sea water also comes in contact with the sea battery immediately upon ejection of the unit. Current is supplied to the tube filaments at once. At the end of the time delay, plate current is supplied to produce the signal.

The NAC signal is produced at its maximum output level sweeping the selected frequency range two to four times a second. As the sea battery nears exhaustion the level drops, with the normal life of the unit averaging 12 min. After 25 to 30 min the gas supply in the buoyancy control becomes exhausted and the unit sinks to the bottom.

USRL CALIBRATION⁷²

Frequency Characteristic. Figure 5 shows the frequency characteristic of the NAC output. Because of the sweep of the signal this curve conveys only a general picture of the output. The specifications for the NAC require that the output at 25 kc for a 10-ma input be not less than 66 db above 1 dyne per

SECRET

sq cm at 1 m. In practice the NAC's have an output somewhat greater than this.⁷⁰

Directivity. The directivity was measured for the three bands in a plane normal to the axis of the NAC housing as shown in Figure 6. The output is about 10 db higher opposite the free faces of the crystal bank than it is on either side.

3.2.3

Field Evaluation

Field tests of the NAC beacon were made in May 1944⁶⁷ and in June 1944,⁶⁹ and after many months of use in the Pacific war it was included in the test

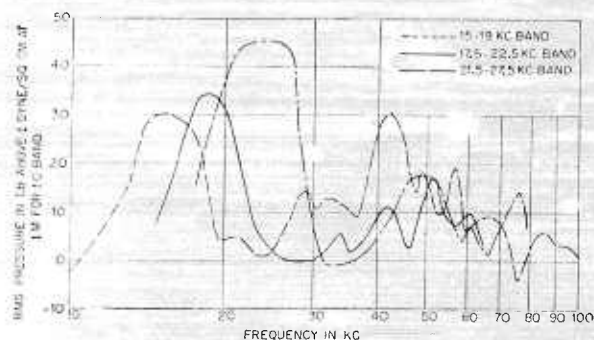

FIGURE 5. Frequency characteristic of NAC output.

of evasion devices run at ASDevLant in the summer of 1945.²⁰ It was on the basis of these last tests that COMINCH prepared the "Submarine Evasion Devices Manual"¹⁶ to be issued with the devices. The operational recommendations contained in these last two references are summarized below.

Tests of the NAC's used alone demonstrated their effectiveness against all echo-ranging frequencies within the bands covered, from 15 to 27 kc. Interference from beacons set at the middle range, 17.5 to 22.5 kc, was found troublesome to QC gear operating at 24.5 kc.

The extent of the jamming produced by a single NAC was largely determined by the bearing separation between the NAC and the submarine. About 15 to 20 degrees was permissible with NAC and submarine approximately 1,000 yd from the anti-submarine ship. However, it was found that the NAC becomes increasingly effective at short ranges so that when NAC was within 500 yd of the anti-submarine vessel, wide bearing separation was found to be permissible. This was due to the ex-

remely high noise peaks of the NAC which were readily picked up on the minor lobes of the sonar beam. However, a single NAC does not cause complete aural masking against supersonic listening. The relatively low pulse rate permits echoes to be heard between the pulses. When two NAC's are used together aural masking was found to be better but still not complete. However, the extremely high noise peaks are confusing and annoying to the sonar operator.

NAC caused considerable difficulty in reading the traces on a chemical range recorder. When a single NAC was used the NAC traces developed showed a regular geometric pattern through which the submarine echo was often discernible. When two or more NAC's were used together the irregular traces made submarine echoes more difficult to distinguish.

The NAC caused serious interference with BDI traces. The noisemaker pulses produced marked deflections and brightening. However, an extremely skillful operator could obtain reasonably good center bearings in the presence of NAC by using

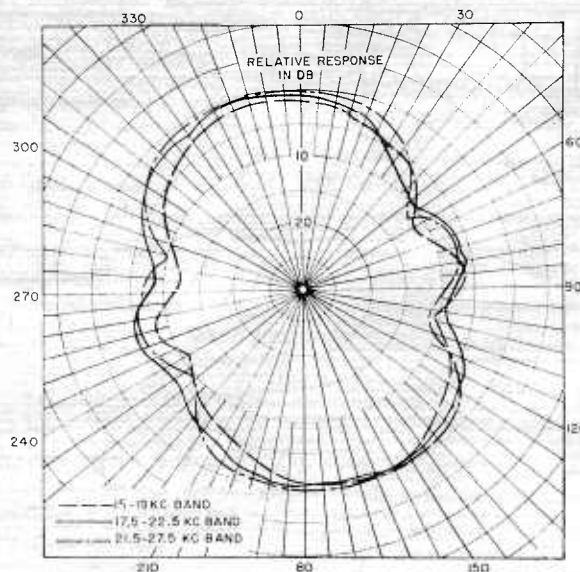

FIGURE 6. Horizontal directivity pattern of NAC.

aural indications in close conjunction with the visual trace.

The effectiveness of the NAC's was largely due to the high degree of confusion they produced. In this way they could be used to spoil accuracy and create difficulty in regaining contact.

Tactical recommendations for the use of NAC

stipulated that it be used in conjunction with other evasion devices. Both NAE and NAC were used together, three or four of each released in rapid succession. In most instances the use of echo-ranging jamming devices in this manner caused loss of contact by the surface ships. The speed with which the devices can be ejected becomes of great importance. Also in planning maneuvers it is important to keep the noisemakers between the submarine and the attacking vessel to minimize bearing separation.

A further evaluation of NAC performance is found in reference 74. This analysis was prepared in the spring of 1945 and was never issued. It embodies some useful material on the performance and limitations of the NAC beacon.

3.2.1

Future Work

The development of the NAE beacon as an improvement upon the NAC was undertaken at UCDWR in the spring of 1945 and is continuing there at the Navy Electronics Laboratory.

The NAC sound beacon possesses an inherent disadvantage in that its sound output covers a range of approximately 5 kc and a considerable amount of energy introduced into the water is not effective against enemy sound gear operating at any particular single frequency. Thus the enemy may shift his echo-ranging frequency and avoid the interference. This difficulty was appreciated and understood early in the NAC beacon development but because the units were considered adequate until an improved model could be developed they were put into production. UCDWR then undertook work on a unit similar to the NAC and designed to transmit only upon the frequency of the enemy's echo-ranging gear. This improved unit known as the NAE sound beacon is a controlled-frequency device designed for the same purposes for which the NAC beacon is used.

Actual development was begun in May 1945 and the device comprises a high-velocity magnetic recording tape or disk with a recording and playback unit which is arranged for periodic listening with its recording section in operation. When a ping is received the unit records the ping and then immediately transmits a continuous signal at exactly the frequency of the received ping. The transmis-

sion period is approximately 15 sec long after which the listening condition is resumed for a very short period. Since the unit is designed to cover the frequency range of 10 to 30 kc the next ping within this range which is received will cause the unit to begin the next transmission at the frequency of such next ping.²¹ Thus it becomes impossible for the enemy by changing his echo-ranging frequency to avoid the jamming effect of the beacon.

Further details about the construction and performance of the NAC may be found in the reports listed in the bibliography.⁶⁷⁻⁷⁵ Information on the progress of this work may be obtained from the Navy Electronics Laboratory.

3.3

TOWED PROJECTORS

3.3.1

General

The interference of either towed or expendable noisemakers used as torpedo countermeasures with any attempts by the surface vessel to detect the submarine of the approaching torpedo presented a serious problem. It was conceived that a towed crystal transducer might be used to supply listening in one frequency band while simultaneously projecting a decoying signal at another frequency. Two designs of towed noisemakers were constructed, but neither of them showed sufficient promise in preliminary field tests to merit further study for this application.

3.3.2 THE XPA CRYSTAL TRANSDUCER

The XPA crystal transducer is an experimental device designed to be towed from surface ships as an underwater noisemaker and listening device. It was used later as a projector for hydrophone calibration. The XPA consists of a bank of Rochelle salt crystals held in a rigid frame and covered with rubber. For towing purposes it was housed in a streamlined wooden body. The projector output is fairly uniform from 2 to 10 kc with useful output at higher frequencies up to 60 kc. Its relatively low impedance adapts it to various special purposes. The development of the XPA was carried on at MIT-USL.

SECRET

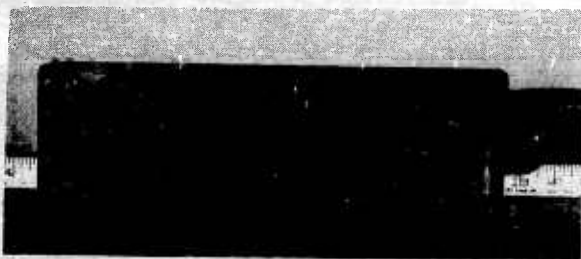

FIGURE 7. XPA crystal transducer.

CONSTRUCTION

The XPA crystal bank shown in Figure 8 consists of 144 Rochelle salt crystals. These are 45-degree X-cut connected in parallel and held in a bakelite frame that carries their electrical connections. A thin sheet of rubber is cemented to each pressure face of the crystal bank. An outer brass frame holds the bakelite frame and makes a water seal connection to the cable. The entire unit is watersealed by dipping it in rubber. The overall dimensions are about 2x4x14 in.

When used as a towed hydrophone and noise-maker, the XPA was mounted in a streamlined wooden body (Figure 9) about 36 in. long and 5 in. in diameter in the cylindrical portion. The cavity which appears in the photograph filled upon submersion so that the pressure faces were in contact with water. The streamlined shape was maintained by covering the cavity with a thin brass cylindrical diaphragm. The unit was towed by the electric cable connecting it with the listening and driving amplifiers.

Manufacturing instructions are included in the laboratory completion report.⁷⁵

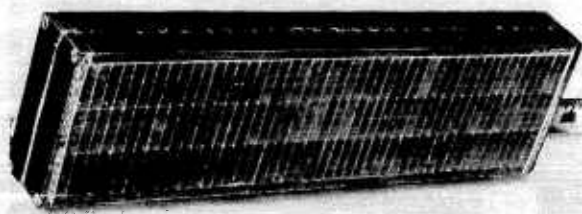

FIGURE 8. XPA crystal bank.

USRL CALIBRATION⁶⁸

The XPA was calibrated by USRL in June 1944. In all the measurements 25 ft of cable were used with the XPA. The large capacitance of the crystal bank makes the effect of this cable negligible.

Frequency Characteristic. The output spectrum of the XPA used as a projector is shown in Figure 10. This output was measured at several points along a line perpendicular to one of the pressure faces at its center, and expressed as a measurement at 10 ft. The pressure is given for this distance in decibels above 1 dyne per sq cm per volt input in series with 135 ohms impedance. It is also given in terms of ampere current input.

Directivity. The directivity of the XPA as a hydrophone was measured at frequencies from 2 to 100 kc. In a plane perpendicular to the long axis of the XPA the patterns are fairly smooth up to 10 kc. In the plane containing the axis and perpendicular to the two pressure faces, the patterns break up into lobes at somewhat lower frequencies. For applications in which the orientation can be controlled, such as hydrophone calibration, the lobes of maximum sensitivity perpendicular to the pressure faces of the crystal bank are useful even at the higher frequencies. Directivity patterns for the XPA are included in the Summary Technical Report of Division 6, Volume 11.

Impedance. The impedance of the XPA as a projector was measured at 82 F as a function of frequency (given in Table 1). The reactance corresponds approximately to a capacity of 0.13 μ f. from 0.5 to 20 kc.

Use in Calibration. The XPA has been used as a projector for making field calibrations by USRL

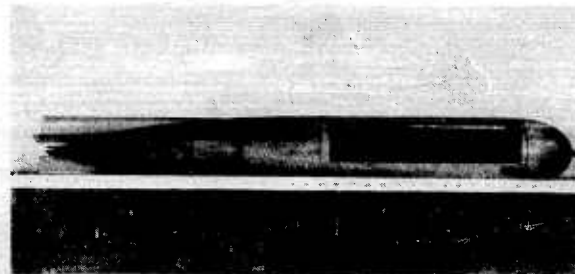

FIGURE 9. XPA in streamlined housing.

SECRET

and other laboratories chiefly because it combines fairly uniform response from 2 to 10 kc with useful output at higher frequencies. The relatively low impedance of the crystal bank permits coupling to the driver amplifier through as much as 500 ft of cable without the need for a matching transformer in the projector itself. As a hydrophone, it may be similarly connected to a receiving amplifier without serious loss in sensitivity. Connected through a

towing performance at high speeds of the XPA in its housing were also observed. Although not included in these tests, the proposed design called for the driving amplifier for the projector and the listening amplifier for the hydrophone to be synchronized so that the two functions would alternate rapidly. The results of the tests were generally unsuccessful, and although certain improvements were apparent, the development was dropped.

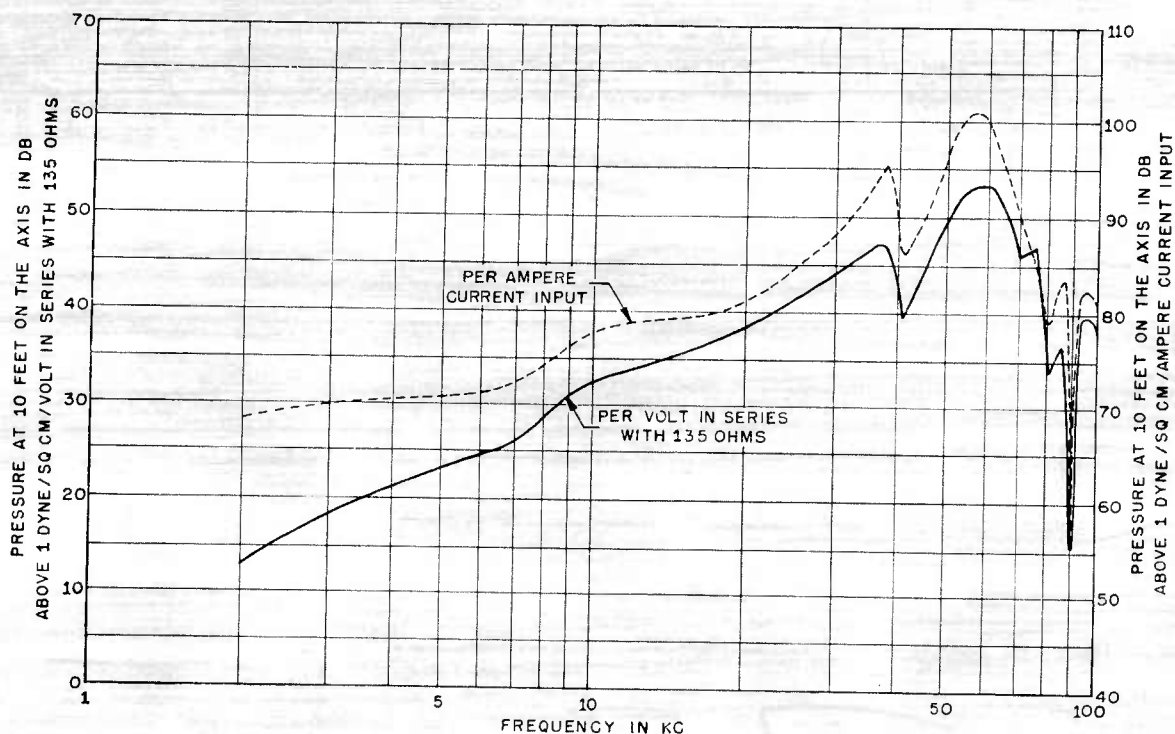

FIGURE 10. Frequency characteristic of XPA as a projector.

crystal-to-line transformer the XPA has been used as a hydrophone for the detection of subsonic sound.

FIELD TESTS

General. A set of tests of the XPA as a towed noisemaker and listening device was made in November 1943. The XPA in its streamlined housing was towed behind the Maritime Commission tanker SS *Colorado* at speeds up to 16 knots. The runs were intended to test the XPA performance from three points of view. As a decoy for acoustic torpedoes its output above 5 kc was compared with that of the *Colorado*. As a hydrophone it was intended to detect torpedoes long enough before arrival to permit altering the course of the vessel. The stability and

TABLE 1. Impedance of XPA as a function of frequency.⁷⁵

Frequency in kc	Resistance in ohms	Reactance in ohms
0.5	122.8	-j2345
1.0	69.4	-j1190
2.0	29.9	-j613
5.0	24.2	-j227
10.0	44.4	-j124.7
20.0	19.5	-j41.4
50.0	93.6	-j6.36
100.0	12.6	-j70.5

Decoy. When tested as a decoy the XPA was driven by a power amplifier which supplied 100 v average. The amplifier was excited by a sawtooth

SECRET

oscillator signal which passed through a 5-ke high-pass filter. Various base frequencies between 0.2 and 1 ke were tried in an attempt to produce sound closely approximating ship noise in quality. For comparison of the signal from the XPA with the ship noise a test vessel was anchored near the course of the *Colorado*. Disk recordings were made of the sound from the tanker and observers listened to the rims with sonic listening gear. Neither method was able to detect with certainty any sound from the XPA above the output of the tanker. The results of these tests were inconsistent with the calibration of the XPA although reasonable precautions were taken at the time to avoid uncertainties in the electronic driver or acoustic detection systems. The effect of the wake is sufficient to account for the results.

Hydrophone. When tested as a hydrophone the XPA was equipped with an amplifier, a sound level indicator, and earphones. For one type of test the XPA was towed behind the *Colorado* at 16 knots, and the sound level was measured at various distances astern. The XPA performed quite satisfactorily as a hydrophone although bubble noise inside the wake caused interference at times. During other tests, with the *Colorado* adrift and the XPA suspended 20 ft below the surface, it was found that electric torpedoes fired toward the *Colorado* could be detected 1 or 2 min before their arrival.

Towing Characteristics. The towing characteristics of the XPA were satisfactory at speeds up to 16 knots as indicated by listening tests in which the trim and streamlining of the housing evidently resulted in a stable course through the water without turbulence. An initial attempt to use a depressor

vane to make the XPA tow outside or below the wake was unsuccessful. After about 2 hours of towing at 16 knots, one of the conductors broke inside the cable near to the XPA.

Although these tests indicated the need for certain improvements in the design such as reinforced towing cable and a means of towing the XPA outside the wake, the doubtful acoustic performance suggested that the development might be long and perhaps unsuccessful. The program was accordingly discontinued.

3.3.3

The Towed Fish

The towed fish was developed by UCIDWR in the last months of 1943.

This device consisted of an array of $4\frac{1}{2} \times 1 \times \frac{1}{4}$ in. X-cut Rochelle salt crystals. Each $4\frac{1}{2}$ -in. crystal comprised three $1\frac{1}{2}$ -in. crystals fused together in order to obtain the crystal length needed to improve their low-frequency response. The transducer was to be excited by an amplifier in the towing vessel and provision was made for sweeping its output frequency rapidly between two limits in the neighborhood of 5 ke. An alternative plan was to overdrive the crystal unit to produce an output having a large number of harmonics over a wide frequency band.

In tests of this device it was found that in order to produce the necessary level of sound output the power supplied to the crystals caused them to melt at the temperatures produced. No further tests were made.^b

^b This development is reported in the Bimonthly Summary of Division 6, December 1, 1943.

SECRET

Chapter 4

EXPLOSIVE NOISEMAKERS

4.1

INTRODUCTION

THE INVESTIGATION OF EXPLOSIVES as a means of making noise under water led to the completion in the summer of 1945 of the pepper signal noisemakers. These evasion devices were used to mask submarine sounds from sonic detection in shallow water where bottom reverberation maintains high-level sound between the noisemakers' successive explosions. In the course of the explosive noisemaker development program the basic explosive stack design of the pepper signals (which can be seen in Figure 1) was studied as well for adaptation to other problems in acoustic warfare. The program also yielded information about the masking of continuous noise by intermittent sounds, the role of bottom reverberation in the effectiveness of the masking, and the instrumentation problems involved in measuring noises with the high peak factors characteristic of explosions. The adaptation of waveform recording and analysis to the study of acoustic transients was an important aspect of work in this program.

At the termination of NDRC participation in the spring of 1943 the investigation of explosives was begun at once as promising a rapid solution for masking in the sonic range. Because of the high ratio of stored energy to volume, explosive materials offered a likely source of high-level noise within the spatial restrictions of an expendable noisemaker. A significant advantage of explosives for a sonic masking device is in the concentration of energy in the lower audio-frequency range. Although it was recognized from the start that the spatial restrictions on such a noisemaker would necessitate a compromise between the rate of the explosions and the life of the unit, and that such a device would produce a confusing sound rather than any simulation of submarine sounds for decoy purposes, the development of an explosive noisemaker was requested first of all.

It proved, however, to involve an expensive and time-consuming program to satisfy to an acceptable degree all the requirements for a submarine evasion device. The compromise selected between the firing rate and the duration of firing in the final pepper

signal design limits the device to use in shallow water where its protection against sonic detection is considered satisfactory. The reverberation effect provides an advantage in permitting the submarine to adopt bearings relative to the enemy vessel as much as 45 degrees from the noisemaker. The pepper signal is of no tactical value in masking supersonic noises or in jamming echo ranging. At the termination of NDRC participation in the program it was anticipated that the pepper signals would be superseded by the mechanical noisemaker XNAG which provides masking with no limitation upon water depth.

At the termination of NDRC participation in the noisemaker program, the responsibility for further technical development of the explosive noisemakers was assumed by NOL. The scheduled tests were completed during the summer of 1945. Supervision of production and consultation on any further problems were provided by NOL. Further details about this development may be found in the reports listed as references 84-91.

4.2

DESIGN CONSIDERATIONS

The problems involved in adapting explosives to produce noise under water within the limitations specified for a submarine evasion device proved to be obstinate, dependent upon a variety of interrelated factors and, in most cases, of little general significance. For example, the variation in the burning rate and ignition temperatures of the fuse and explosive powders, although responsible for much of the delay in the development program, has been eliminated since the close of hostilities now that a company has been found which is capable of producing uniform powders. For many months of the development program, however, these variations obscured the significance of other factors in the design of an effective waterseal and of the ignition system. The development of the explosive noisemaker, with an account of the successive stages by which these problems were solved may be found in reference 86.

CRC Explosive and Fuse Powders. After a

preliminary survey of explosives commercially available, it was decided to design the explosive noisemakers from the materials developed by the Catalyst Research Corporation [CRC], which was

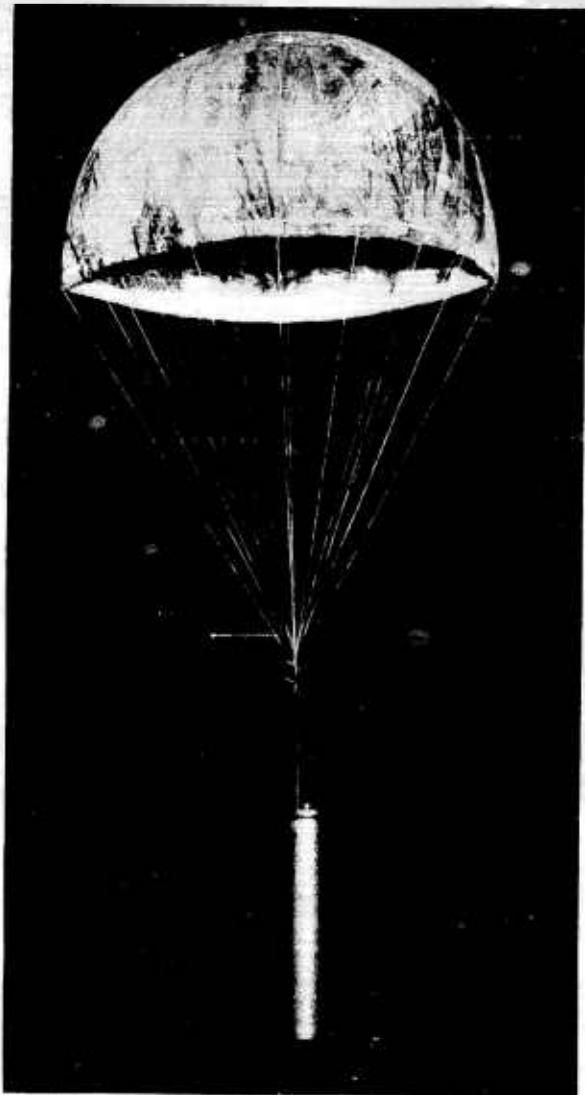

FIGURE 1. Pepper signal supported on its underwater parachute.

already providing special fuses for the Bureau of Ordnance. The CRC explosive material satisfied the acoustic requirements for output equivalent to that of a standard No. 6 blasting cap. The CRC fuse materials, which could be mixed to provide burning rates in the desired range, offered a convenient means for igniting the heat-fired explosive.

Since this fuse produces no gas its burning rate is independent of static pressure at different operating depths. Selection of the CRC materials promised a solution to the problems of countermining, ignition system, space requirements, and waterseal which had been encountered with commercial explosive materials.^{56a} It was felt that these considerations outweighed the obvious drawbacks of using chemical components in an experimental mechanical system which were themselves in an early experimental stage.

Acoustic Characteristics. A difficulty in using explosives lay in providing continuous masking protection by means of intermittent explosive sound since the recovery times of listening gear and the human ear are too short to provide any advantage. Attempts to maintain continuity by firing cartridge primers at intervals of a few milliseconds were unsuccessful, and the limited space prohibited the use of charges large enough to fill in between shots. It was found that intermediate charges such as No. 6 blasting caps excited reverberation in shallow water which masked ship noise for as much as 3 or 4 sec.⁹ With the assurance from Navy liaison officers that a masking device useful only in shallow water would be of operational value, the design of an explosive noisemaker firing one or two caps a second was undertaken. The CRC explosive caps provided adequate output, and on the basis of preliminary masking tests in December 1943⁷⁸ the firing rate of two shots per second was selected for the final design. Methods of calibrating the output of these explosions in terms comparable to measurements of other noisemakers and of submarine sounds received considerable study, as discussed in Section 4.3. Acceptance of the pepper signals for Navy use was based upon field performance with submarines and standard listening gear. The large low-frequency composition of explosive sounds and the latitude this noisemaker permits in the relative positions of submarine, noisemaker and search vessel, make it useful in shallow water for masking submarines from sonic listening detection even at speeds as high as 8 knots.

Size. For ejection from the submarine signal tube an evasion device was limited to a 3-in. cylinder, 37.5 in. long. The selection of explosive materials was accordingly limited to those which could be packed into this volume in sufficient number to be tactically useful. The large physical size of some

SECRET

commercial explosives and the sensitivity to countermining of others made it necessary to reject them for this application. The CR-3 caps used in the pepper signals are not sensitive to countermining and are sufficiently small so that 600 of them can be contained within the permitted volume which provides a life of 5 min for a firing rate of 2 shots per second.

Weight. In developing the pepper signals the experimental models were constructed of steel as the easiest material in which to work out the general design. After some investigation of plastics and magnesium alloys in an attempt to decrease unit weight, aluminum was found to provide a satisfactory material for the final design.

Time Delay. To satisfy tactical requirements, initial time delays of 30 sec, 2 min, and 6 min were provided, as requested, in the different models of the pepper signals. This requirement led to the search for a slow-burning fuse material in order to minimize the space taken up by the time-delay mechanism. It also influenced the decision to replace the parachute of the Mk 14 design with a positive depth control for the final model since in 6 min after ejection a parachute-supported device would fall to impractical depths before the firing even began.

Depth Control. The mechanical strength required by the use of explosive materials made it appear impossible from the start to produce an explosive noisemaker with a density close to that of water. The need for some mechanism to limit the rate of fall of a heavy device was accordingly recognized. A parachute which could be housed compactly at one end of the device and which would open after ejection to limit the rate of fall of the unit was developed for the experimental grenade models and for the Mk 14 pepper signal. Once it was established that the usefulness of this noisemaker was limited to shallow-water operation, and in recognition of the impaired performance occurring when the noisemaker is lying in a soft muddy bottom, it became clear that a noisemaker with even a small falling rate would be practically worthless for a submarine operating in shallow water over a mud bottom. The positive depth control described in Chapter 7 was developed for the Mk 20 pepper signal. This mechanism brings the signal from its ejection point to a depth of 50 ft, maintaining it there during its life and later allowing it to sink.

Although the possibility of adding rocket propulsion to the pepper signal was considered in order to separate it from the submarine before noisemaking began, the weight and instability of the cylinder made this scheme appear impracticable.

Waterseal. The development of a reliable water-seal system presented one of the most elusive of the design problems. The essential stack design of the explosive noisemaker is subject to leakage between the disks, around the individual shots, and into the already burned fuse through the holes left after the shots have fired. In operation the unit is also subject to the static water pressures at considerable depths and to the forces of the explosions. The final design incorporates gaskets, watersealing compounds, and mechanical compression of the entire stack to maintain a waterseal.

Reliability. Failures of the pepper signals to operate as designed can be broken up into a number of types. If the primary ignition system fails through water leakage, a defective primer, or faulty fuse, the unit is worthless. If the main fuse train burns all the way through the stack with a number of the individual caps proving to be duds, the device still provides a degree of masking protection. Failure of the main fuse part way through the stack has occurred in many experimental units, probably from defective fuse material or from water leakage. Failure of the secondary time delay to initiate the depth control mechanism can impair the tactical usefulness of the noisemaker from another standpoint, allowing it to plummet to the bottom. In accepting the pepper signals for fleet use the Navy recommended that they be fired in pairs since the useful operation of the units in production at that time was less than 80 per cent. The research continuing at NOL is directed in part towards these problems, and it is believed that the improved powders now available will largely eliminate these sources of trouble.

Production. The mechanical structure of the pepper signal includes nearly 800 individual parts, as well as the 10 different types of fuse and explosive powder. For reproducible performance most of the metal parts required machining to close tolerances, and elaborate inspection procedures were found necessary. A large share of the pepper signal development program was devoted to devising these procedures and to simplifying the production methods as far as possible.

SECRET

4.3 WAVEFORM ANALYSIS OF UNDERWATER EXPLOSIONS

4.3.1

General

The use of waveform photographs to study the acoustic performance of explosive noisemakers proved valuable from several standpoints. Where the frequency distribution and peak factors of explosive noisemaker output could not be determined by means of ordinary narrow-band filter measurements, Fourier analysis of waveform photographs yielded these characteristics in terms that could be compared with the measurements of other noisemakers. Calibrations were obtained of the CRC caps in the pepper signal, of the standard No. 6 blasting cap, and of other explosive noisemakers. With the high-speed photographic techniques the time scale in these waveform pictures could be extended to resolve all the frequencies passed by the rest of the measuring system. By using a shorter time scale a qualitative picture of the explosions could be obtained that provided significant general information about the noise. This permitted comparison of different noise sources, and clarified the mechanism of noise production by explosives. Waveform photographs also could be used to illustrate graphically the contribution of reverberation to effective masking noise.

The waveform analysis technique was applied by USRL to the calibration of explosive noisemakers, which have peak factors considerably higher than can be handled by the usual measuring system. Several explosions were photographed for each noisemaker. These waveforms were then analyzed for their frequency composition and the results averaged. Computation of output level was then made by assuming some regular firing rate. The calibration data for the explosives measured are summarized in Section 4.3.2.

The equipment used to obtain waveforms for the USRL calibrations is discussed in reference 26. The XMX hydrophone²⁸ feeding into the oscilloscope through the broad-band amplifier system passes frequencies that are satisfactory up to a square-wave signal of 100 kc and down to 100 c. The high-speed continuous film camera with a film speed up to 100 ft a second permits resolution of all the frequencies passed by the system. Calibration of the system to determine the pressure scale is

made by sending a calibrating signal from the hydrophone through the system and photographing the corresponding deflection on the oscilloscope screen.

For analysis by means of the Henrici-type analyzer the waveform photographs were enlarged by optical projection. The frequency distribution from 1 to 30 kc was then obtained, and output levels were adjusted for an assumed regular rate of firing. The error introduced by this assumption was shown to be small since the levels corresponding to assumed rates of 1 shot per second or 4 shots per second for the pepper signal were shown to be within 3 db of the level for the assumed 2-shot per second rate which was used. These analysis procedures are discussed in reference 26.

Once the frequency distribution was determined, it was used to plot the frequency characteristics of the noisemaker output. A value for the total rms pressure level for a wide band from 1 to 35 kc was also calculated. The peak values of the explosions were obtained as the average of values observed in the photographs. The peak-to-rms ratio was then determined graphically by squaring the area under the waveform curve. The results of this type of analysis are given in Table 1 and in Figures 2 to 5. Figure 2 includes the points obtained in the analysis of the pepper signal output which was made with a Henrici-type analyzer from curves similar to the one shown in Figure 9.

A less detailed analysis was made of the waveforms with shorter time scales. In an effort to study variations in the production of CRC caps, several thousand waveform photographs were obtained. The relative heights of the explosive peak and the first collapse peak were studied statistically. The time interval between these two peaks was also examined for dependence upon the static pressure at the depth where the explosion occurred. These studies were never completed although the preliminary information was of some assistance in the development program. The information in this section is based upon results reported in USRL calibrations^{82, 85, 89} and an MIT-USL report on waveform studies.²⁴

4.3.2

Noisemaker Calibration

For purposes of comparison the frequency characteristics and peak factors of the several explosive

noisemakers calibrated by USRL are discussed here. These include CRC caps in the pepper signal; the same caps in the grenade Mk 1 as constructed by NOL; standard No. 6 blasting caps; and the modified British MD-1 caps supplied by the Bureau of Ships for calibration.

The No. 6 blasting cap was used throughout the explosive noisemaker program as a standard for comparison. Preliminary tests indicated that a noisemaker which produced explosions equivalent to the No. 6 cap at a rate of 1 or 2 shots per second offered promise as a masking device in shallow

TABLE 1. Comparison of explosive noisemaker output with output of No. 6 caps at firing rates of 1, 2, and 11 shots per second, determined by waveform analysis.^{82, 83, 89}

Firing rate (per sec)	Noisemaker	Number of pictures averaged	RMS pressure (1 kc-35 kc) broad band level in db above 1 dyne per sq cm at 1 m	Peak factor db ratio of peak pressure to rms pressure	Explosion peak pressure in db above 1 dyne per sq cm at 1 m	1st collapse peak pressure in db above 1 dyne per sq cm at 1 m	2nd collapse peak pressure in db above 1 dyne per sq cm at 1 m
1	{ MD-1 cap	3	105.3	52.7*	158.0	144.0
	{ No. 6 cap	2	104.0	43.0*	147.0	137.5
2	{ Pepper signal	6	97.0	38.2†	124.0	135.2	Up to 129.6
	{ No. 6 cap	2	107.0	40.0†	147.0	137.5
11	{ Grenade Mk 1	3	100.9	30.5†	126.7	131.4
	{ No. 6 cap	2	114.4	32.6*	147.0	137.5

* Explosion peak. † First collapse peak.

The pepper signal produces noise by the explosion of CRC caps at a rate of approximately two shots per second. For purposes of calibration the frequency characteristic is computed for explosions occurring at a regular rate of two shots per second. The CRC cap explosion illustrated in Figure 10 is characterized by the steep rise of its second peak or first "collapse" peak which is consistently higher than the first or explosion peak. A second collapse peak is often observed as a third and much smaller peak in the waveform. The mechanism by which these peaks are produced is discussed further in Section 4.3.3.

water. For comparison with other noisemakers the frequency characteristic of the No. 6 cap has been computed by USRL for explosions occurring at a rate of 1, 2, and 11 shots per second. The No. 6 cap is a standard product of well-established uniformity produced by several explosives manufacturers. Its explosion, shown in Figure 6, displays a high sharp explosion peak followed by a collapse peak that is less steep and lower than the first peak. A second collapse peak has been observed also.

The noisemaker calibrated as grenade Mk 1 by USRL is an NOL modification of the explosive stack used in the pepper signals.⁷⁹ Its individual ex-

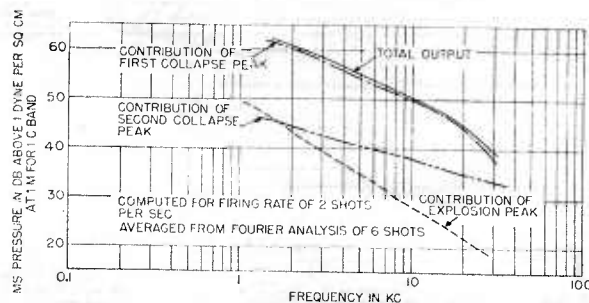

FIGURE 2. Frequency characteristics of pepper signal, firing 2 shots a second, determined from waveform photograph by means of Henrici analyzer.

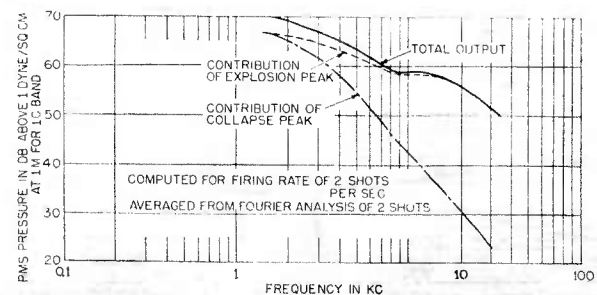

FIGURE 3. Frequency characteristics of No. 6 cap, firing 2 shots a second, determined from waveform photograph by means of Henrici analyzer.

SECRET

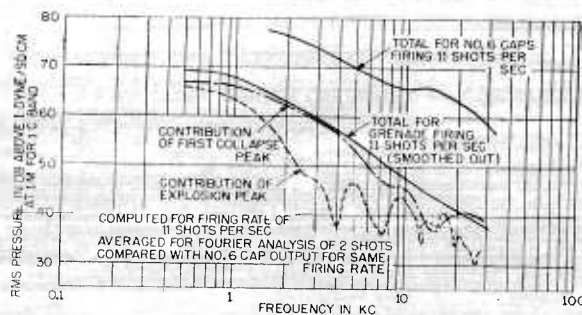

FIGURE 4. Frequency characteristic of NOL Grenade Mk 1, firing 11 shots a second, determined from waveform photograph by means of Henrici analyzer.

plosions are produced by CRC caps as in the pepper signal and grenade Mk 2. The assembly of the stack has been adjusted to produce explosions at a rate that reaches 11 shots per second in the middle of its operating life. To obtain its frequency characteristic the shots were assumed to occur at a uniform rate of 11 shots per second. Results were averaged from photographs of three explosions.

A number of modified British MD-1 caps were supplied to USRL by the Bureau of Ships for calibration. The frequency characteristic was computed for explosions occurring at a rate of one shot per second and compared with the output of a No. 6 cap at this rate. Like the No. 6 cap this explosive has an explosion peak that is higher and steeper than its collapse peak. Results were averaged from photographs of three explosions.

The results of the calibrations of these noisemakers are given in Table 1 and in Figures 2 to 5. The values for each noisemaker are paired with No. 6 cap values for the same firing rate. The total rms pressure level given in the table was computed from the Fourier analysis of the waveforms and corrected for a band from 1 to 30 kc.

The effect of firing rate upon the overall output level can be seen by comparing the wide-band levels for the No. 6 cap at the firing rates shown. For rates of 1 per second, 2 per second, and 11 per second, these are 104.0 db, 107.0 db, and 114.4 db respectively, as would be expected from the energy considerations. In Figures 3, 4, and 5, the shape of the No. 6 cap frequently characteristic is the same, with the changes in level corresponding to the different firing rates.

The peak factors for these shots are computed

from the highest peak. The entry in the peak factor column is labeled to indicate which peak this is in each case. The effect of increased firing rate of CRC caps appears in the reduction of the peak factor from 38.2 db for the pepper signal to 30.3 db for the grenade, corresponding to firing rates of 2 and 11 shots per second respectively. The peak factors for a No. 6 cap at 1, 2, and 11 shots per second are 43.0, 40.0 and 32.6 db respectively.

The peak pressure levels are given for the explosion and collapse peaks for each shot. The averages shown for CRC caps in the two noisemakers show some disagreement although this difference is within the variation observed for these caps.

The frequency characteristics obtained from these noisemakers have been plotted for the total output and also to show the contributions of the different peaks to the noise. Figures 2 and 3 are paired to show the frequency composition of the pepper signal and No. 6 cap both firing at a rate of two shots per second. In Figure 4 the total output of the Mk 1 and its components is shown compared with the total output of the No. 6 cap firing 11 shots per second. In Figure 5 the total output of the MD-1 noisemaker with its components is shown with the total output of a No. 6 cap at 1 shot per second.

In comparing these calibration curves with the calibrations of other noisemakers of more continuous output, it must be borne in mind that the intermittent nature of the noise is as important for a consideration of its effect upon sound-operated devices as the average level shown in these plots. For the pepper signals the frequency characteristic depicts the total output energy as it would be if averaged continuously over time. In practice the extent to which this averaging occurs depends upon the degree of reverberation at the location of firing

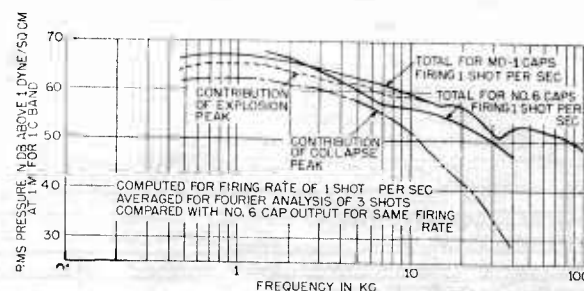

FIGURE 5. Frequency characteristic of MD-1 caps, firing 1 shot a second, determined from waveform photograph by means of Henrici analyzer.

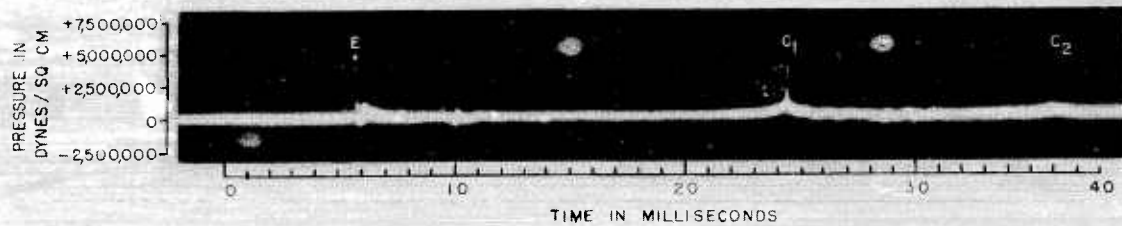

FIGURE 6. Waveform of No. 6 cap, measured at 5 ft, water depth 35 ft, source and hydrophone depth 12 ft.

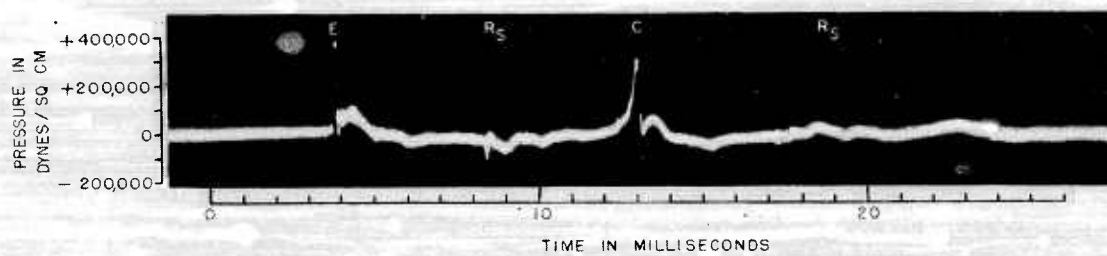

FIGURE 7. Waveform of S53 squib, measured at 5 ft, water depth 35 ft, source and hydrophone depth 12 ft.

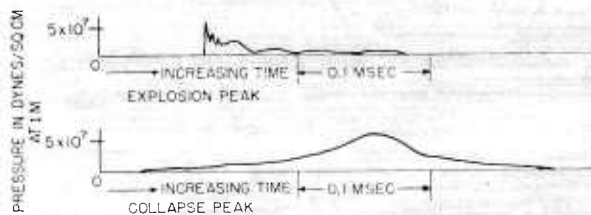

FIGURE 8. Waveform of MD-1 cap, measured with high-speed equipment, traced from photograph.

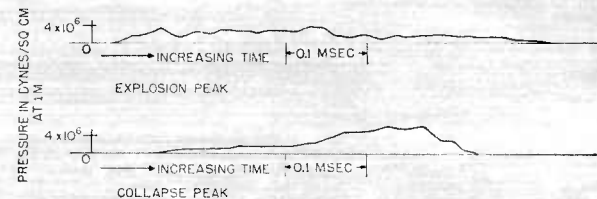

FIGURE 9. Waveform of CRC cap, measured with high-speed equipment, traced from photograph.

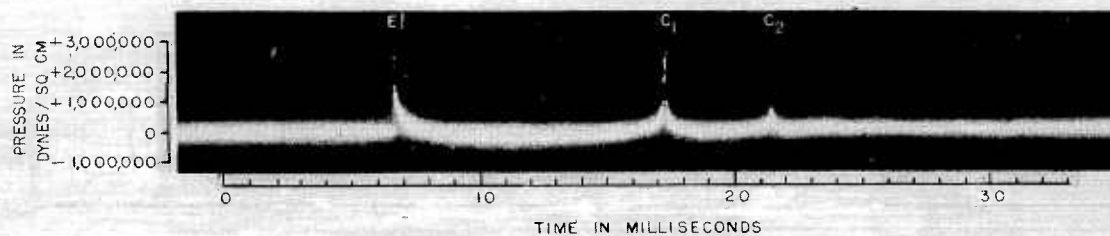

FIGURE 10. Waveform of CRC cap, measured at 6 ft, water depth 100 ft, source and hydrophone depth 50 ft.

SECRET

The multiple-source effect produced by reverberation must also be considered, as discussed in Section 4.5.

4.3.3 The Noisemaking Mechanism in Underwater Explosions

The contribution made by these waveform studies to a general understanding of underwater explosions was considerable. Parallel work was carried on as part of the Division 8 program at Woods Hole, and in the first months of work on explosives in the noisemaker program much assistance was obtained by consultation with this group. The information obtained about the action of noisemaking explosions is summarized here to clarify subsequent discussion in this chapter.

Early experience with measurement of the shock waves from explosives was chiefly in the field of geology. Measurements in air always showed a single peak to correspond to each explosion. Scattered observations of explosions in water had revealed the surprising occurrence of the second and third peaks now identified as the collapse peaks. In explosions in air the combustion produces one shock wave, and the explosion products then mix with the surrounding gases. In water, however, the incompressibility of the medium gives rise to a bubble action similar to cavitation. When the rate of collapse of the condensing gas volume is greater than the rate at which the water can replace it, the bubble walls strike each other sharply. It is further agreed that the oscillations of the collapsing bubble produce the second collapse peaks and a series of collapse peaks of decreasing amplitude.

Comparison of Figures 6 through 14 provides considerable information about the performance of explosives of different types. The photographs were made with a short time scale using the MIT-USL waveform equipment. The drawings taken from the USRL waveform photographs provide comparable information. To facilitate study of these waveforms the time scale is given in milliseconds on each picture. The pressure scale is given in dynes per square centimeter at 1 m. Upward deflections correspond to positive pressures, and downward deflections to negative pressures. The impulses coming directly from source to hydrophone can be distinguished from reflections by checking the time intervals be-

fore their arrival with the known geometry of the test location.

The photographs have been marked to indicate the location of the explosion peaks E , the first and second collapse peaks C_1 , C_2 ; the surface, bottom, and surface-bottom reflections R_s , R_b , R_{sb} .

The characteristic waveform of underwater explosions shows two or more separated peaks. The first peak is the explosion peak E corresponding to the sudden production of a quantity of hot gas. As this gas expands the sound pressure level drops to zero. Then the bubble collapses, producing the second sharp peak C_1 at the final instant of collapse. A third positive peak C_2 is often seen in the explosions of CRC caps and appears in the No. 6 cap explosion in Figure 6 as well.

The steepness of the explosion peak depends upon the type of explosive material. These materials are characterized as slow-burning, fast-burning, or detonating powders. With the time scales used in the photographs, the explosion peak of the slow-burning S-53 squib in Figure 7 displays a gradual rise while the fast-burning CRC cap and the No. 6 cap detonation produce pressure changes faster than the record can follow. In Figures 8 and 9 the better resolution provided by the USRL time scale spreads out the explosion peaks of the MD-1 and CRC caps to show more about their behavior. The MD-1 cap evidently produces an extremely rapid detonation since even at this resolution its initial rise is too fast for the system to follow.

The steepness and height of the collapse peak relative to the explosion peak depends upon the quantity of gas that remains at equilibrium temperature and pressure after the explosion. Both the No. 6 cap and the S-53 squib produce a gaseous residue which can be seen in bubbles rising to the surface after the explosion. This gas cushions the shock of the water walls in their collapse and so produces the type of collapse peaks shown in Figures 6 and 7 with gradual slopes and amplitudes less than that of the explosion peak. The MD-1 cap also has a waveform of this type. On the other hand, the products of the CRC cap explosion are solids at equilibrium temperature and pressure; the cushioning action is thus reduced and the resultant collapse peak is steep, reaching an amplitude consistently higher than that of the explosion peak. The second collapse peak is produced by subsequent oscillations of this bubble.

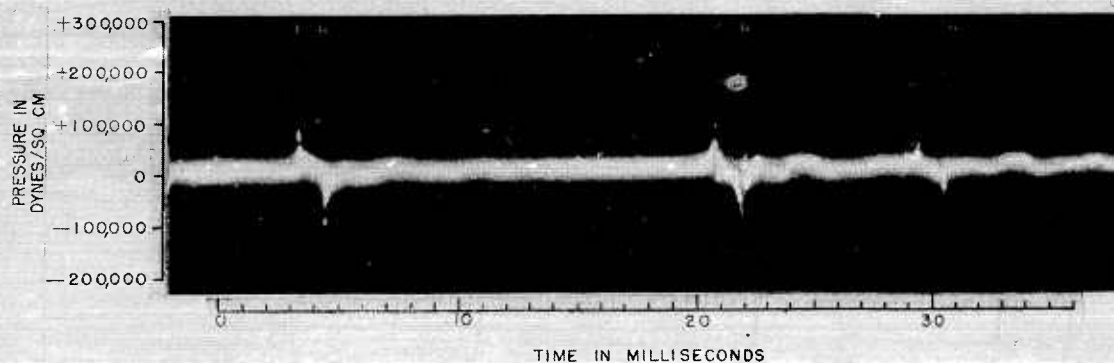

FIGURE 11. Waveform of CRC cap, measured at 35 yd, water depth 120 ft, source and hydrophone depth 25 ft.

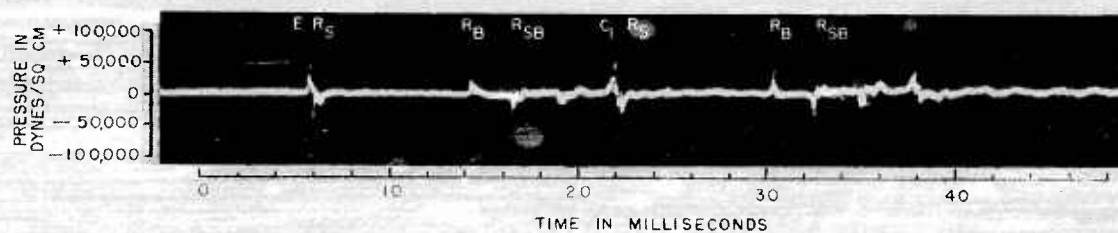

FIGURE 12. Waveform of CRC cap, measured at 200 yd, water depth 120 ft, source and hydrophone depth 25 ft.

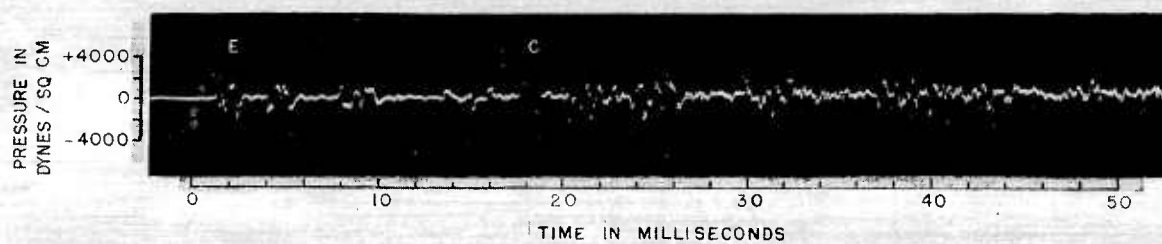

FIGURE 13. Waveform of CRC cap, measured at 2,000 yd, water depth 120 ft, source and hydrophone depth 25 ft.

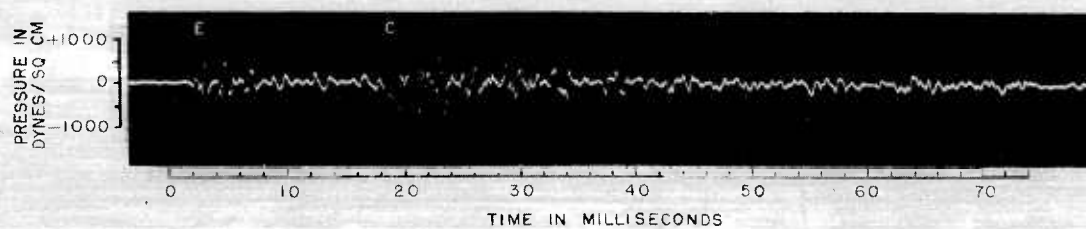

FIGURE 14. Waveform of CRC cap, measured at 5,000 yd, water depth 120 ft, source and hydrophone depth 25 ft.

SECRET

The interval between the peaks depends upon the static pressure at the firing depth as well as upon the quantity of gas produced. For the CRC caps this factor was studied in some detail. It was found that the time interval measured from waveforms of several thousand explosions at various depths was inversely proportional to the 0.7 power of the static pressure, in rough agreement with theoretical calculations.⁸⁶

Waveform photographs were used as a means of studying the variations in different lots of CRC caps in an attempt to establish production standards. Over 5,000 explosions of different experimental and production lots of these caps were photographed. Considerable variation was found in the heights and in the ratio of heights of the explosion and collapse peaks. The waveforms shown here can be taken as typical of more than 80 per cent of the CRC ex-

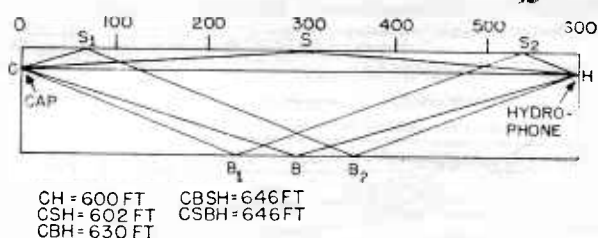

FIGURE 15. Geometry of test location for waveform in Figure 12.

plosions. In more than 99 per cent the collapse peak is still higher than the explosion peak. It can be assumed that improved methods of powder production introduced by NOL will reduce the variation in subsequent caps. In contrast with the variation observed in these experimental explosives, the uniformity of the No. 6 cap is interesting. No significant differences were detectable in the several dozen photographs made by MIT-USL. USRL found it sufficient for their calibration measurements to take the average from two No. 6 cap explosions as the comparison standard.

Similar to the action of the collapse peak in explosions is the noisemaking action of bubbles in the gas ejection noisemakers FXA and razzar which are covered in Chapter 5. The steam bubbles from the razzar condense so rapidly in cold water that the bubble walls collapse and strike with little cushioning action thus producing the sharp peaks observed in the razzar waveform, and contributing the high-frequency components of its measured out-

put. See Figure 7 in Chapter 5. In the FXA the ammonia-gas bubbles collapse similarly since the gas goes into solution immediately upon coming in contact with the water. The FXA bubbles are ejected at such a rate that the sharp peaks occur in random fashion. See Figure 4 in Chapter 5. It was observed that the razzar operated as well with ammonia as with steam.

4.3.4

Reverberation Pictures

Although the measurement conditions for most of the waveform photographs of explosives were selected to prevent the arrival of reflections until after the direct wave was recorded, in some cases the reflections provide useful information. The geometry of the test location can be used to identify the reflections appearing in the waveforms in Figures 6 and 7, and in 10 through 14.

In Figure 6 for example, in the No. 6 cap explosion, the cap was 5 ft from the hydrophone, and both source and hydrophone were 12 ft from the surface, in 35 ft of water. Each of the three positive peaks is followed by a small negative deflection. These can be identified as the first surface reflections of the wave occurring 4 msec after the direct impulses, or by a path 20 ft longer than the direct path, the speed of sound in water being approximately 5,000 fps. The reflected impulses are negative because of phase change at the water surface, and their reduced amplitude corresponds to the 20-ft difference in path length.

In Figure 7 the negative reflection R_s of the explosion peak of the S-53 squib is superimposed upon the direct impulses from subsequent low-amplitude oscillations of the cooling gas bubble. The path difference here is again 20 ft.

The series of CRC cap waveforms in Figures 11 to 14 shows the increase with increased distance of the relative contributions of reverberation to the effective masking noise. In Figure 10 the water and hydrophone depth were selected to eliminate all reflections from the waveform. In Figure 11 the first surface reflections are clear. In Figure 12 it is possible to identify the first surface reflection, the first bottom reflection, and the first surface-bottom reflection, for the explosion and for the collapse peak. The geometry for this test is shown in Figure 15. The difference in path length can be seen to agree

with the observed spacing of peaks in the waveform picture. In this case, since the bottom reflection of the first collapse peak coincides with the expected location of the second collapse peak, this feature becomes ambiguous. In Figures 13 and 14, as the direct and reflected paths become more nearly equal in length and as the reflections multiply, the details of the waveform are confused so that only the arrivals of the two main peaks can be identified by the change in quality of the trace.

4.1 CONSTRUCTION OF EXPLOSIVE NOISEMAKERS

4.1.1 SIGNAL (PEPPER) MK 14

The signal (pepper) Mk 14 is an expendable explosive noisemaker designed to aid submarine evasion by masking low-frequency sounds from listening detection in shallow water. The signal is 3 in. in diameter and 27 in. long. It consists of a base piece, a stack of 37 aluminum disks containing explosive charges and ignition fuse train, and a center rod to hold the assembly in compression. After an initial time delay, explosions are produced at a rate of approximately 2 shots per second and continue for 5 min. In water of 200 fathoms or less the reverberation serves to maintain a masking level between shots. Five sec after ejection of the signal from the submarine, a parachute opens to reduce the rate of fall of the unit to less than 1 ft a sec. The signal was developed by MIT-USL. The signal (pepper) Mk 14 was preceded by the experimental grenade Mk 2 design described in Section 4.4.3, and followed by the signal (pepper) Mk 20 discussed in Section 4.4.2. Further development is being carried out under the auspices of NOL.⁵⁶

CONSTRUCTION

General. The essential element of the various explosive noisemakers is the explosive stack. The construction of the stack with trigger mechanism and parachute suspension is shown schematically in Figure 17 with an accompanying code of parts. Parts are referred to by code letters at various points in the discussion. The components of the Mk 14 signal are described briefly below. Further details may be found in the production specifications.^{7,9} The major problems involved in developing the design have been discussed in Section 4.2. The explosive powders and fuse powders produced by the Catalyst Research Corporation [CRC] are loaded into aluminum disks which are the basic units of the design. The disks are stacked on a steel center rod or tube. The rod is screwed at one end into the base piece assembly which holds the trigger mechanism and time delay fuse. The initial firing mechanism is held in the base piece below the center rod. At the other end the rod is held by a nut and the top plate assembly. The waterseal system for the signal is provided by gaskets and cement. The parachute is housed at the end of the unit and is expelled from its can by operation of the knockoff mechanism which is housed inside the center rod.

CRC Explosive Powder. This powder is a gasless explosive, insensitive to shock, and composed of metallic titanium and nickel powders mixed with potassium perchlorate as an oxidizing agent. It is ignited by heat, and the products of the explosion are solid oxides. The explosive material is loaded into 22-caliber bronze shells with a "heel charge" of fuse powder (type 3) leading to the explosive charge (type 7) as shown in Figure 18.

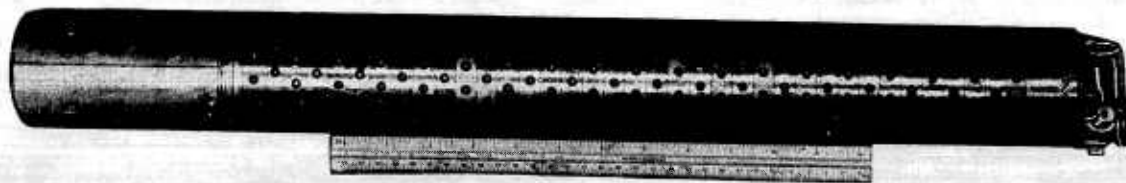
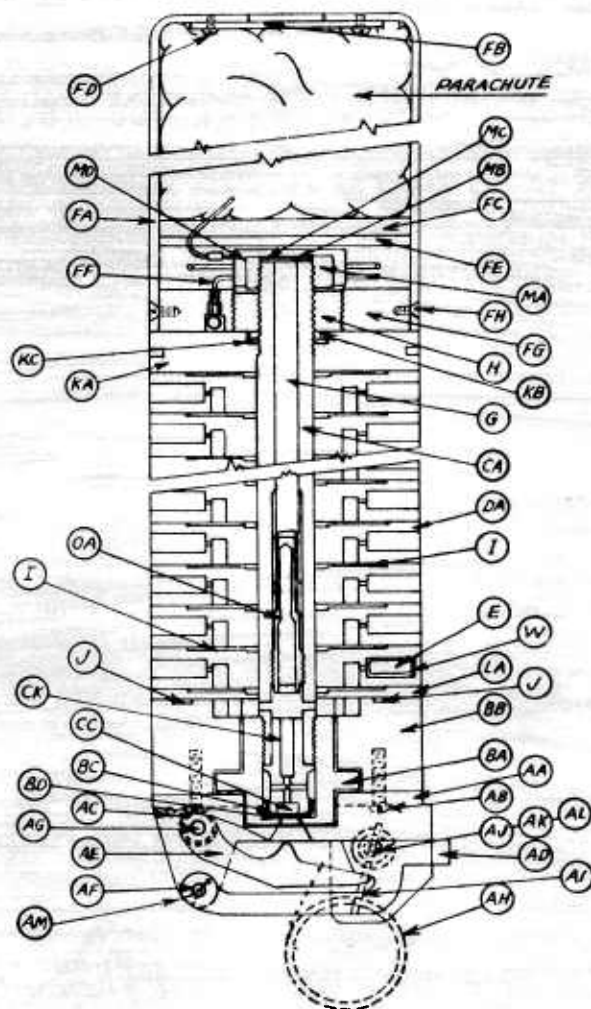

FIGURE 16. Signal (pepper) Mk 14 before ejection.

SECRET



- | | |
|---------------------------|----------------------------|
| AA —Aluminum die casting | FA —Split can container |
| AB —Machine screws | FB —Nose plate |
| AC —Trigger spring | FC —Felt washer |
| AD —Tripping lever | FD —Nose plate screws |
| AE —Hammer | FE —Steel disk |
| AF —Tripping lever pin | FF —Cable and connection |
| AG —Hammer pin | FG —Aluminum base |
| AH —Safety ring | FH —Can screws |
| AI —Safety cotter pin | FI —Lock screw (not shown) |
| AJ —Locking pin | G —Expulsion charge |
| AK —Locking pin spring | H —Steel nut |
| AL —Locking pin washer | I —Gasket |
| AM —Cotter pin | J —Base gasket |
| BA —Steel base insert | KA —Steel top plate |
| BB —Aluminum base | KB —Steel washer |
| BC —Sealing cup | KC —Grommet |
| BD —Sealing cup washer | LA —Aluminum plate |
| CA —Steel center rod | MA —Brass holder |
| CC —Initial primer | MB —Copper washer |
| CK —Initial primer holder | MC —Rubber washer |
| DA —Disk | MD —Steel covered cup |
| E —Explosive cap | OA —Heat transfer plug |
| | W —Bronze shell |

FIGURE 17. Drawing of Mk 14 pepper signal, with parts code.

SECRET

CRC Fuse Powders. The active ingredients of the fuse powders are finely divided metallic nickel powder and potassium perchlorate with various

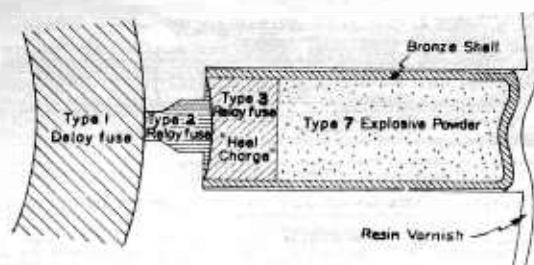

FIGURE 18. CRC explosive cap.

inert materials added as necessary. Burning rate and burning temperature are controlled by variations in the proportions of these ingredients. A number of different mixtures have been developed for use at different points inside the signal fuse train. These include the ring delay fuse (type 1) that controls the two shots per second firing in the disks, the hot relay fuse (type 2) to burn through small holes, the "heel charge" (type 3) that burns to a solid ash behind the explosive to keep it from blow-



FIGURE 19. Explosive disk.

ing back into the disk, the relay fuse (type 4) with low ignition temperature for critical points in the fuse train, the slow-burning fuse (type 5) for the initial time delay, the slow-burning fuse (type 6) for the parachute delay, the hot heat transfer charge (type 8), and the ignition charge (type 9) applied in paste form. The location of these fuse materials in the signal is shown in Figure 18.

Disks. Thirty-seven aluminum disks *DA*, $\frac{1}{2}$ in. thick, 3 in. OD, $\frac{3}{4}$ in. ID, make up the explosive stack. See Figure 19. In each disk 16 holes are drilled in the outside wall to hold the explosive rings, communicating through small holes to a machined groove into which the fuse material is packed. A

hole in the bottom of the groove permits the fuse train to burn to the next disk. The face of the disk contains a shallow depression to hold a gasket as part of the waterseal system.

Center Rod. A steel tube *CA*, $\frac{3}{4}$ in. OD, holds the stack of disks as shown in Figure 20. Since the tension in this tube must resist the explosive forces tending to separate the stacked disks, extra-strength steel is used. The tube is threaded at either end so it can be screwed into the base and top-plate assemblies.

Base Piece Assembly. The base piece consists of a 3 in. aluminum disk *BB* and a threaded steel insert *BA* into which the center rod is screwed, as shown in Figure 24. A thermal setting marine glue seals the insert to the disk. The first ring of the slow-burning fuse provides 30-sec initial time delay, and is packed in a machined groove in the top face of the aluminum disk. The trigger is screwed to the bottom of the base piece.

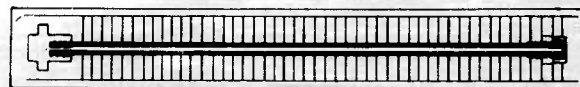

FIGURE 20. Center rod which holds disks.

Trigger. The triggering mechanism produced for the NOL emergency identification signal is adapted to fit the base piece of the pepper signal. In assembly the trigger mechanism is cocked and then locked in position with a cotter pin *AI* as shown in Figure 21. In firing, the signal is loaded into the submarine's signal tube, the projecting key of the tripping lever *AD* is placed in the keyway provided in the signal tube barrel, and the cotter pin is removed. See Figure 14 in Chapter 6. As the signal moves out the tube the key is raised at contact with the end of the keyway and the firing hammer *AE* is released to strike the initial primer. A copper cup *BC* lies between the hammer and the primer so that water cannot enter the initial firing system with the hammer blow.

Initial Firing Mechanism. The initial primer *CC*, which is held in a brass holder *CK*, ignites the fuse material packed in the lower end of the center rod. The course of the fuse train is shown in Figure 24 by tracing successive numbers. The fuse burns out

into the ring of the delay fuse in the base piece, providing a 30-sec time delay in signal (pepper) Mk 14 Model O. In Model 1 the additional length of slow-burning fuse to supply the 2-min delay is provided by a pair of special delay disks. In Model 2 two pairs of these disks as shown in Figure 24 are used to supply the 6-min delay. Insertion of these necessitates reduction of the explosive stack in

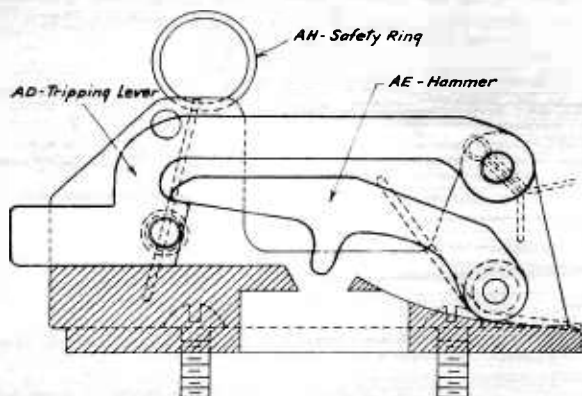

FIGURE 21. Trigger, modified from NOL emergency identification signal.

Model 1 and Model 2 to 36 and 35 disks respectively. After the fuse train burns through the slow delay fuse it passes through the hole in the transfer plate to ignite the face of the fuse ring in the first explosive disk.

Top Plate Assembly. The steel top plate KA, shown in Figure 22, assists in the compression of the explosive stack. In assembly, the top plate slides

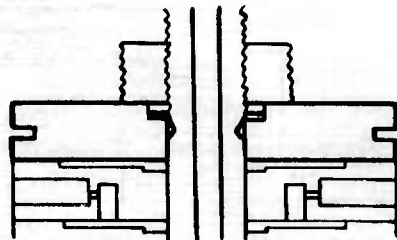

FIGURE 22. Top plate assembly.

onto the center rod on top of the thirty-seventh disk. When the rod is stretched to 20,000-lb tension by means of a hydraulic press, the steel nut H is screwed down hard into place. The nut and top plate accordingly apply this compression to the explosive stack. The lower face of the top plate is dished so this force is applied at the outer edge of

the disks. This top plate assembly also includes a compressed rubber grommet as a waterseal.

Waterseal System. The unit is protected from penetration of water under either the hydrostatic pressure or the explosive forces by four design features.

A rubber grommet KC is forced against the threads at the top of the center rod when the steel washer KB is forced down flush with the surface of the top plate by the steel nut. See Figure 22. This keeps water from penetrating along the center rod at the top.

Compressed gaskets of synthetic rubber (Fairprene) make a seal between disks and at the initial

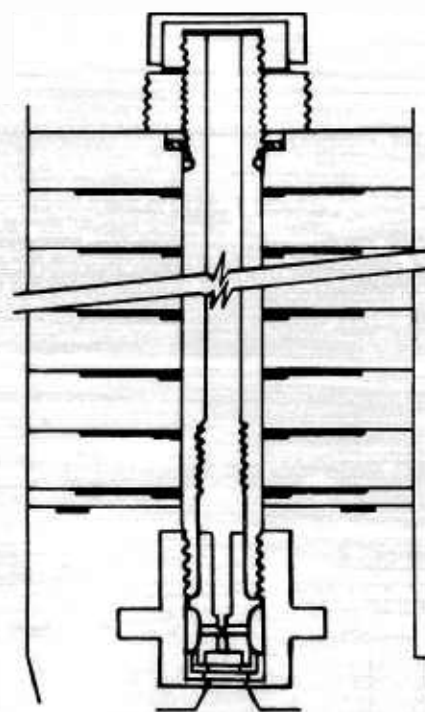

FIGURE 23. Locations of waterseals, gaskets shown in black, rubber grommet with hatched lines.

primer as shown in Figure 23. A hole in the gaskets between disks corresponds to the position of the disk through-hole and allows the fuse to burn through to ignite the next disk. Since water can penetrate into the fuse case of the disk after a shot has fired, an important function of these gaskets is to keep water from spreading between the faces of adjacent disks and possibly getting ahead of the burning fuse.

A thermal setting cement, marine glue, joins the steel and aluminum parts of the base piece. See Figure 24.

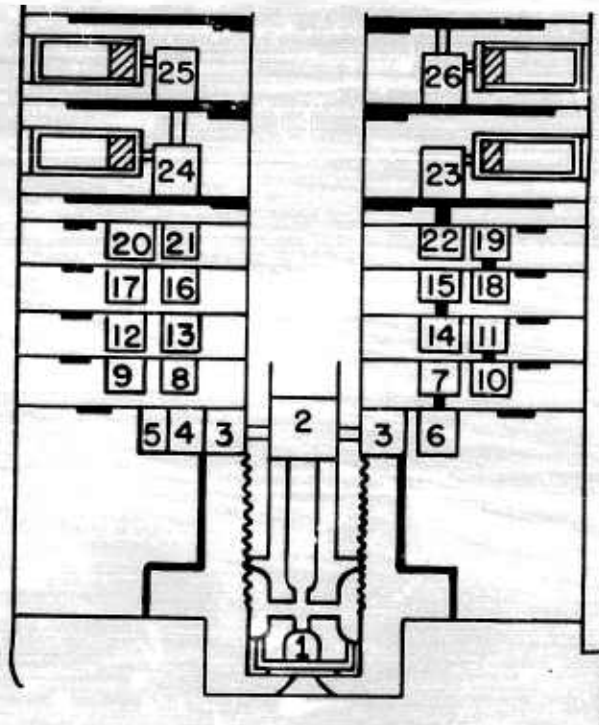

FIGURE 24. Basepiece and time delay in signal (pepper) Mk 14 Mod. 3. Successive numbers trace course of burning fuse.

An outside waterproof coating of resin varnish is applied by dipping the entire assembled unit. This provides a seal over the ends of the caps. See Figure 18. This material contains a solvent which evaporates leaving a tough resinous waterproof coating.

Parachute Assembly. The parachute assembly is made up as a separate unit and attached to the assembled signal by screwing its base *FG* onto the nut. The parachute is nylon, 4 ft in diameter, hemispherical in shape, and stained a mottled green color to reduce its visibility. Its shrouds are attached to a loop of steel cable made fast to the base. A steel plate *FE* and felt disk *FC* protect the parachute from burning by the expulsion charge *G*. This assembly and the knockoff mechanism are discussed further in Section 7. 7. 4.

Knockoff Mechanism. A flash from the coating on the heat transfer plug *OA* ignites an expulsion charge of black powder *G* which separates the parachute assembly from its base piece and causes the

split can *FA* to fall away. The exposed parachute then supports the signal as shown in Figure 1 and provides a falling rate of about 1 ft per second.

OPERATION

The signal (pepper) Mk 14 is ejected from the horizontal ejector tube at any depth down to 400 ft. The signal is selected for the desired time delay of 30 sec, 2 min or 6 min as indicated by model numbers 0, 1, or 2, respectively. The signal is placed in the ejector so that the projecting tip of the trigger lever lies in the firing groove. As the signal moves out the tube, the trigger is raised by contact with the end of the firing groove. The trigger operates the firing hammer so that it strikes the primer and initiates the two time-delay trains. After 5 sec the fuse activates the expulsion charge in the knockoff mechanism to open the parachute. See Figures 15 and 16 in Chapter 7. The parachute supports the signal as shown in Figure 1 and reduces its falling rate to less than 1 ft per second. Meanwhile, after the selected time delay has elapsed, the main fuse train ignites the fuse ring in the first explosive disk. The course of the fuse train inside the cylinder is indicated in Figure 24 by the successive numbers in the diagram. The fuse in each disk is ignited from the through-hole of the preceding disk, burns in both directions around the disk, ignites the shots as they come, and then burns through the through-hole to ignite the fuse in the following disk. Explosions occur at a rate of approximately two shots per second and continue for approximately 5 min of firing.

CALIBRATION

General. The acoustical performance of the signal (pepper) Mk 14 was calibrated by USRL in October, 1944.⁸² The frequency characteristic and peak

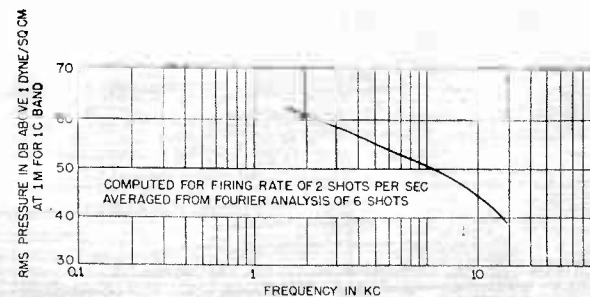

FIGURE 25. Frequency characteristic of pepper signal.

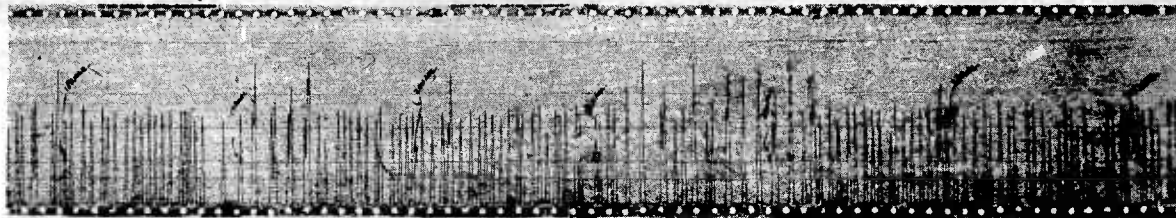

FIGURE 26. Record of shot spacing of pepper signal.

factor were determined by analysis of waveform photographs. For these calculations it was assumed that the explosions occurred at a uniform rate of two shots per second. The waveform analysis of explosions is discussed in Section 4.3.2. Other acoustical characteristics of the pepper signal were measured by MIT-USL during the development.⁸⁶

Frequency Characteristic. The output spectrum of the signal (pepper) Mk 14 is shown in Figure 25. It may be seen that the energy is very high in the lower audio-frequency range. Calculation of the energy in an idealized sawtooth wave similar to the actual waveform indicated that maximum energy should be obtained between 500 and 1,000 c, and that the variation with frequency is smooth. This should guide extrapolation of the curve in Figure 25. The rms pressure level for a broad band from 1 to 30 kc was computed from the waveform photographs to be 97.0 db above 1 dyne per sq cm at 1-m distance for a firing rate of two shots per second. The peak pressures at 1 m distance were found to be 1.6×10^6 dynes per sq cm for the explosion peak; 5.8×10^6 dynes per sq cm for the first collapse peak; and as high as 3.1×10^6 dynes per sq cm for the second collapse peak.

Peak Factor. The peak factor computed for CRC explosions occurring at a rate of two shots per second is 38.0 db.

Waveform. The USRL waveform trace shown in Figure 9 used an expanded time scale that resolved all the details of frequency passed by the measuring system. A more qualitative picture is given in Figure 10 as obtained with the MIT-USL oscillograph recorder. In every case there is an initial explosion peak followed by a larger collapse peak. As discussed in Section 4.3.3 there is essentially no residual gas from the explosive reaction so that the collapse is quite violent. In many cases, as in the one chosen for the figure, a third peak of appreciable size is noted. The waveform of the explosive noisemakers consists of sets of these peaks spaced relatively far apart.

Shot Spacing. The spacing of the explosions of a pepper signal has been studied by means of a high-speed graphic level recorder adjusted to indicate a single peak for each shot on a convenient time scale. A typical record is shown in Figure 26. The average shot interval for this typical distribution is about 0.5 sec with an average deviation of about 0.2 sec.⁸⁶

4.1.2

SIGNAL (PEPPER) MK 20

The signal (pepper) Mk 20 is an expendable explosive noisemaker designed to aid submarine evasion by masking low-frequency sounds from listening detection in shallow water. The signal is 3 in. in diameter and 31.5 in. long. It consists of a base piece, a stack of 37 aluminum disks containing explosive charges and ignition fuse train, and a center rod to hold the assembly in compression. Explosions are produced at a rate of approximately two shots

per second and continue for 5 min. In water of 200 fathoms or less the reverberation serves to maintain a masking level of noise between shots. Five sec after ejection of the signal from the submarine, a depth control mechanism is released. This device brings the unit to a depth of 50 ft during operation and maintains it there during operation, allowing it to sink to the bottom after 12 min. The signal was developed by MIT-USL.⁸⁶

SECRET

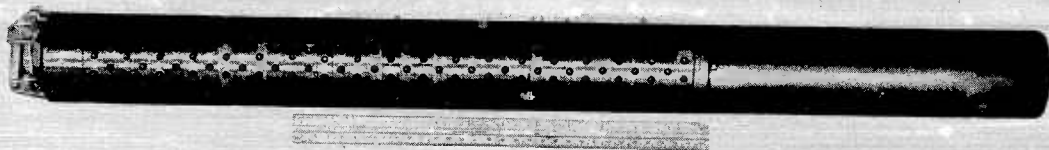

FIGURE 27. Signal (pepper) Mk 20 before ejection.

CONSTRUCTION

The Mk 20 signal differs from the Mk 14 only in the substitution of a depth control for the parachute. This change was introduced in order to increase the usefulness of the noisemaker by permitting operation in very shallow water.

Knockoff Mechanism. A flash from the coating on the heat-transfer plug *OA* ignites a black powder fuse which in turn ignites a smokeless powder charge. This charge removes the waterproof container and exposes the depth control assembly as discussed in Chapter 7.

Depth Control Assembly. Upon exposure to the water, granulated calcium hydride fills the supporting balloon with hydrogen, and the signal rises to a depth of about 50 ft. See Figure 28. The balance between a steady source of gas and a valving rate dependent upon depth causes the assembly to stay at the operating depth for about 12 min.

OPERATION

The operation of the Mk 20 pepper signal differs from that of the Mk 14 only in regard to its depth control. The performance of the Mk 20 depth control is illustrated in Figure 10 in Chapter 7.

ACOUSTIC CALIBRATION

Since the Mk 14 and Mk 20 pepper signals use CR-3 explosive caps and have explosive stacks of identical construction, their acoustical characteristics differ only because of scattering from the hydrogen bubble in the depth control of Mk 20. This scattering should have no effect at high frequencies and should lead to interference patterns at lower frequencies. Direct measurement of acoustic output is to be made by NOL.



FIGURE 28. Mk 20 pepper signal supported on depth control. Supporting wire is actually 10 ft long.

SECRET

4.4.3

GRENADE MK 2

The grenade Mk 2 is an experimental, expendable, explosive noisemaker developed to aid submarine evasion by masking low-frequency sounds from listening in shallow water. The grenade is 3 in. in diameter and 31.5 in. long. It consists of a base piece, a stack of 45 aluminum disks containing explosive charges and ignition fuse train, and a center rod to hold the assembly in compression. Acoustically the grenade is identical with the pepper signal noisemakers described in the preceding text. Explosions

are produced at a rate of approximately two shots per second and continue for about 6 min. In water of 200 fathoms or less the reverberation serves to maintain a masking level between shots. Five sec after ejection of the grenade from the submarine a parachute opens which reduces the rate of fall of the unit to less than 1 fps. The grenade was developed by MIT-USL, and constitutes the prototype for the production model signal (pepper) Mk 14.⁷⁸



FIGURE 29. Grenade Mk 2.

CONSTRUCTION

The Grenade Mk 2 is like the signal (pepper) Mk 14 except for a longer explosive stack, having 45 disks instead of 37 disks. It also uses a secondary primer system to operate the knockoff. This ignition system, clumsier to construct and less reliable than the heat transfer plug design in the Mk 14 and Mk 20 pepper signals, is described in the early production specifications for the grenades.⁷⁹ The grenade was the experimental predecessor of the two signals, and was not produced for Service use.

OPERATION

The operation of the grenade Mk 2 is essentially the same as that of the Mk 14 pepper signal which has a similar parachute. The grenade has a longer life than the pepper signal because of the greater number of disks in the explosive stack.

ACOUSTIC CALIBRATION

Acoustically the grenade Mk 2 is identical with the pepper signals. In fact the USRL calibration data given above for the signal (pepper) Mk 14 were obtained from an experimental model of the grenade Mk 2, and a majority of the evaluation tests were made of this noisemaker before its designation was changed.

4.5

MASKING EFFECTIVENESS OF
EXPLOSIVE NOISEMAKERS

GENERAL

The evaluation of the pepper signals as a masking device was shown to depend upon many aspects of its performance. Its reliability from a mechanical standpoint had to be considered as well as the acoustic output. This output was determined to correspond to a theoretical series of explosions occurring twice a second. This acoustic output was considered in turn in relation to the reverberation conditions to be found in the shallow-water areas where the pepper signals would be used in combat. The nature of enemy listening gear and the masking effect of the noise upon the human ear had also to be considered. Tactical use of the pepper signal was recommended for certain operational situations after elaborate field tests in the summer of 1945. It is reported that one signal (pepper) Mk 14 was used in combat in the course of a successful evasion maneuver.

MASKING TESTS

The field tests made in the course of pepper signal development provided essential information that the more quantitative laboratory calibrations could

SECRET

not supply. The results obtained in the field by using standard listening and detection gear, and with trained sonar operators to observe the masking effect of explosions upon the actual sounds from a submarine, provided the best indication of the tactical value of the noisemakers. These tests were made with various degrees of verisimilitude, first to establish general criteria, later to determine the limitations of the noisemaker, and finally to provide a basis for operational doctrine.

From preliminary tests with electrically fired blasting caps it was found that the reverberation for such explosions in shallow water masked ship noise for as much as 3 or 4 sec.⁹ Further development was undertaken on the assurance from liaison officers that a device with usefulness restricted to shallow-water operation would yet be desirable for operational use.

The first masking tests with a submarine were made at New London in December 1943.⁷⁸ Experimental grenades were supplied with shot spacings of 0.3, 0.5 and 1.5 sec. The tests were made in water about 40 fathoms deep. The grenades were suspended from a stationary surface vessel during operation. The submarine ran at periscope depth past a second surface vessel equipped with audio-listening gear. Since the characteristics of Japanese listening gear were not known at this time, an OAY nondirectional system and an overside JP directional installation were used. The 1.5-sec spacing permitted listening between shots even in these reverberation conditions. Both the 0.5 and 0.3-sec spacing effectively masked the submarine noise for a range of speeds and distances considered operationally useful. On the basis of these tests the 0.5 sec spacing was selected for the production design as a practical compromise between close shot spacing and long firing life.

Fleet tests of the grenade Mk 2 at Pearl Harbor in November and December 1944⁸⁹ and in February 1945¹³ showed that the grenade provided satisfactory masking in shallow water. The submarine executed various maneuvers at speeds from 3.5 to 7.5 knots and at depths from periscope to 250 ft. Here, too, nondirectional OAY gear and directional JP gear were used to detect the submarine. As an audio-masking device in deep water of 2,000 fathoms the grenade was judged from further tests to be essentially useless. The masking in shallow water from 100 to 300 fathoms was considered quite good. These tests were not intended to set quantita-

tive limits on masking, but primarily served to show that the grenade Mk 2 was useful enough to justify initiating production. At this time production of 5,000 units was ordered with the request that a depth control be substituted for the parachute because of the shallow water restriction.

Further tests were made in April 1945²⁰ under the auspices of ASDevLant in Florida. In order to obtain more detailed information on masking performance, a large number of runs was made in carefully controlled conditions. The water depth was 100 fathoms and the sea state was 1 or 2. Using R-class submarines as the listening target for preliminary tests, the spread in values obtained for listening ranges was first determined for these field conditions. The reduction in range produced by the pepper signal was then determined by repeating these runs while the noisemaker was fired from a surface vessel at certain preset ranges from the listening vessels. Various submarine speeds were employed and the listening gear included OAY, modified JP and JT gear as well as the wide band from 0.1 to 10 kc of the ASDevLant four channel measuring equipment.²⁹ The distance between submarine and listener was varied from 500 to 3,000 yd. To check the results five more runs were made with the fleet submarine *Roncador* as target.

Although little attention was given in these tests to the effect of explosive noisemakers upon echo ranging and supersonic listening some data were obtained. The explosive sound is completely ineffective for jamming echo ranging presumably because of the sharp directionality of the receivers and the relatively weak output of the explosive at high frequencies. The effectiveness against supersonic listening is less clearly determined. There have been cases in which masking has been good; others in which little disturbance was reported. No set of tests has been devoted to establishing the degree of supersonic masking to be expected although only a marginal effect is to be expected.

The final field tests of the pepper signal were in one day's runs in free evasive trials. Here the water depth was increased to 100 fathoms, but the results indicated good masking even with JT gear. In most cases two signals were used together to achieve a better fill-in between individual shots. This procedure was recommended for operational doctrine. On the basis of these tests the noisemakers were recommended to the fleet for immediate use. The tactics recommended for use of evasion devices were

SECRET

prepared from evaluation studies based on the tests.

The masking effectiveness of the pepper signals in combat cannot be determined from the one recorded instance of its use. It is reported that a single signal (pepper) Mk 14 was used by a U. S. submarine against a Japanese surface vessel in the course of a successful evasion maneuver.

EVALUATION AND TACTICAL USE

The results of the tests described above have been analyzed in a number of reports. The findings are summarized here in brief. Reference to overall evaluation of the noisemakers as they stood at the close of NDRC participation in the program is included in Chapter 1. The work continuing in the Navy constitutes a more up-to-date source for this type of theoretical evaluation.

A study of the probable masking effectiveness of submarine sounds by the pepper signal and the NAE was prepared by the Sonar Analysis Group [SAG] early in 1945.¹² This study combined the results of the noisemaker calibrations, the first sets of Pearl Harbor tests, experiments on the psychological factors involved in masking, and studies of the various listening ranges corresponding to sonic and supersonic frequencies. The conclusions presented indicated that the pepper signal at sonic frequencies and in shallow water can mask the sounds of a submarine at speeds as high as 6 knots even when the submarine is much closer to the enemy vessel than is the noisemaker itself. The effective source of the masking noise in shallow water is shown to be the image of the noisemaker reflected in the bottom so that where the water depth is significantly less than the range from enemy vessel to noisemaker, the noisemaker protects the submarine for a wide area of operation.

In a later study⁷⁷ an attempt was made to determine a critical ratio of the ranges to noisemaker and submarine which for given field conditions, firing rate of the noisemaker, and submarine speed, just assured masking. The variation in the data that could be used for this study was so great, however, and the data so few that this analysis could not be completed. Recommendations in this study led to the April tests at ASDevLant.

The ASDevLant tests provided sufficient data to permit some statistical study of the ranges of masking. Because of the large number of variables involved in listening, the data were subject to considerable fluctuation. The results were accordingly

expressed in terms of the 50 per cent listening range. Thus the listening range obtainable in the presence of the noisemaker could be expected in the given conditions to be less than this range half of the time and more than this range half the time. From these tests it was found that in OAY equipment, which corresponds fairly well to Japanese listening gear in its low-frequency response, the masking effect of the pepper signal is equivalent to a background noise level of 10 db above 1 dyne per sq cm or a sea state of 6.²⁰ This means of expressing performance follows from the observations that the maximum listening ranges against prevailing background were reduced by the same factor for all submarine speeds when the signal was operating, and that this reduction was the same for all distances between the signal and listener. Thus the masking effectiveness is independent of the range from listening ship to noisemaker for ranges from 500 to 3,000 yd.

Restatement of these conclusions was included in a study of the NAC beacon, NAE beacon and pepper signal made by SAG in the summer of 1945.^{17, 19} Here the difficulty of comparing noisemakers having such varied types of noise output complicated the presentation of comparative data.

On the basis of all these tests it was concluded that the pepper signal would be of use to the fleet in its present form although increased reliability of operation was requested for it as for all of the noisemakers. According to the doctrine recommended for use of evasion devices the pepper signal and the NAE were to be ejected together in quantity to mask the submarine from listening detection once it was certain that a contact had been made.

The recommendations urged however that a single noisemaker be provided which would provide masking at both sonic and supersonic frequencies from 0.1 to 10 kc with no restrictions on use due to water depth. The XNAG was then under development to fill these needs.

4.6

FUTURE WORK

The participation of NDRC in the explosive noisemaker program was terminated during the summer of 1945 when this work was transferred from MIT-USI to NOL auspices. At that time the signal (pepper) Mk 14 was in production. Final tests on the depth control attachment for the Mk 20

SECRET

were carried out under NOL auspices in August.¹¹⁹

The report on pepper signal performance in the "Submarine Evasion Devices Manual"¹⁶ and from the ASDevLant tests represents the final tactical evaluation of the device. The Mk 14 was recommended for immediate use in shallow water against sonic detection. The Mk 20 was recognized as more desirable since the depth control would keep the noise-making unit off a muddy bottom and thus prevent reduction of its output. The progress which was made in the XXAG development, however, indicated that this device has a fair chance of replacing the pepper signals as a noisemaker to protect against sonic detection with no restriction to shallow water use.

Before the close of hostilities a single Mk 14 was used in the course of a successful evasion maneuver. Whether the masking of the submarine from sonic

detection was decisive in the successful escape could not be determined.

The development program continuing at NOL is directed towards finishing the development of the design details that were still unsatisfactory at the end of the NDRC program. These were chiefly in the unreliability of the powders and in certain production procedures for the depth control.

The problem of powder variation was satisfactorily solved by NOL during the summer of 1945. It was found that the Metal Disintegrating Company in New Jersey had produced finely divided metallic powders for the Manhattan Project during the war. Their production techniques permit control of powder composition and particle size so that the variations encountered in CRC powder production are eliminated. This material can be mixed to reproduce the CRC fuse and explosive materials with assured uniform performance.

Chapter 5

GAS EJECTION NOISEMAKERS

5.1

INTRODUCTION

A GROUP OF RATHER miscellaneous devices designed to make noise by producing bubbles in sea water in various ways are, for convenience, treated together in this chapter. Of these the hydrogen-oxygen noisemaker produces noise by an exothermic reaction which might serve to class it with the explosives discussed in Chapter 4. The FXA and the steam noisemakers produce noise from a bubble



FIGURE 1. FXA ammonia-jet noisemaker.

collapse in a way analogous to the production of the second peak in the pepper signal explosions.

None of these devices produced sufficient noise or operated with the efficiency needed for a practical noisemaker. All were studied in the early months of the noisemaker program in an initial survey of possible noise sources, and their development was terminated in favor of work on more promising devices.⁴

5.2

AMMONIA JET NOISEMAKER

GENERAL

The rapidity with which ammonia vapor dissolves in water offered a possible source of noise from the collapse of the resultant "empty" bubbles in a manner similar to cavitation. Furthermore, for an expendable noisemaker the possibility of storing as a liquid the material that was to be used as a gas promised a desirable saving of space. The FXA ammonia jet noisemaker was built by NRL to utilize these principles. Ammonia bubbles of various sizes escape from the noisemaker into the water and collapse there, producing noise in a wide frequency range.

A number of units were constructed of the Model 1 and Model 2 FXA ammonia bottles. These were tested at ASDevLant^{2, 92} as possible torpedo decoys, and Model 2 was calibrated by USRL.⁹³ The similarity of the FXA output spectrum to ship noise was observed. The output level, however, was judged inadequate to provide protection against the torpedo.

CONSTRUCTION

The FXA unit consists of a bottle of liquid ammonia and a soundhead as shown in Figure 1. In

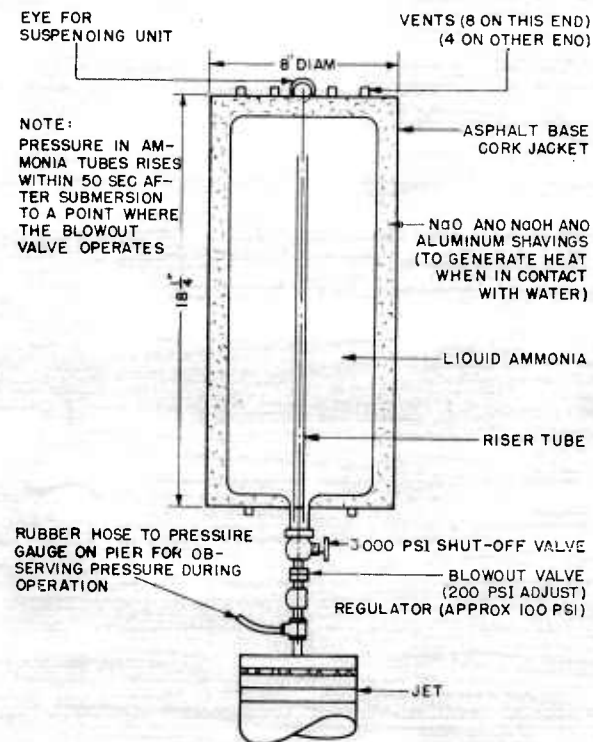

FIGURE 2. Drawing of FXA.

operation the unit assumes the position shown schematically in Figure 2 so that vapor is drawn off from the top of the gas chamber to escape through the soundhead into the water. The gas escape jets are provided by the radial grooves in the faces of stacked bakelite disks.

In operation the escape of the ammonia has a cooling effect, and so tends to lower the supply

pressure. To combat this the heat-producing jacket shown in Figure 2 was provided.

USRL CALIBRATION⁹³

Frequency characteristic. See Figure 3.

Peak factor. The peak factor of the FXA output

it can be assumed that the waveform of a single bubble collapse would resemble the razzler waveform in Figure 7 or the collapse peak of a CRC explosion shown in Figure 10 in Chapter 4. The variety of bubble sizes produced by the FXA serves to widen the output band.

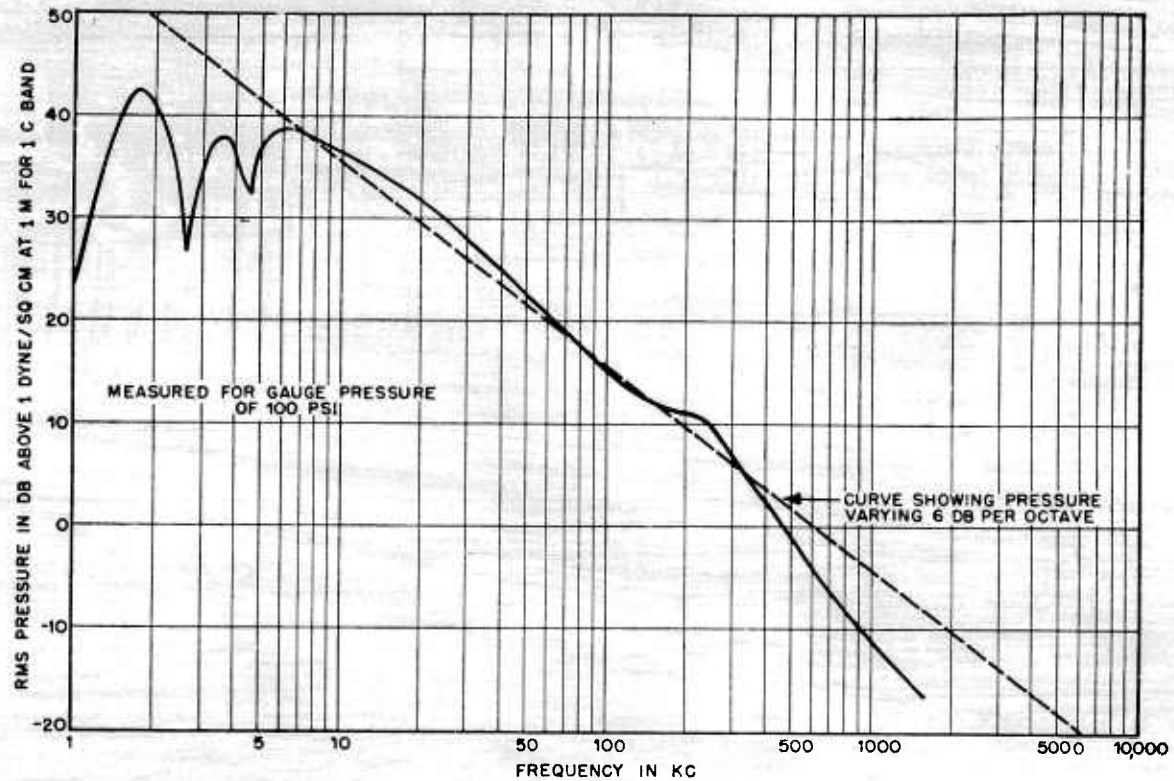

FIGURE 3. Frequency characteristic of FXA.



FIGURE 4. Waveform of FXA output.

is of the order of that of thermal noise which the FXA output closely resembles.

Waveform. The waveform photograph of the FXA output given in Figure 4 illustrates the wide-band output produced by random peaks. From an understanding of the FXA noisemaking mechanism

5.3

STEAM NOISEMAKERS

The energy released by the condensation of steam appeared to offer a useful source of energy for producing noise under water. Preliminary study of steam for noisemakers had been made in a number

SECRET

of Navy laboratories. At the start of NDRC participation in the noisemaker program, MIT-USL was asked to investigate this specific mechanism as part of the initial survey of noisemaking schemes. Steam noisemakers were considered both for expendable noisemakers and as devices that might be towed

the rubber sheets. Then the lip-valve opens, exhausting discrete steam bubbles into the water where they collapse. This oscillating flow of steam induces the vibration of the surface of the rubber which radiates low-frequency sound. Higher frequencies over a wide range are excited as the bubbles collapse, the sudden condensation of the steam leading to action similar to cavitation. The waveform photograph in Figure 7 bears out this analysis.

It has been found that substantially the same sound levels may be obtained from a razzzer if compressed ammonia is used in place of steam. The

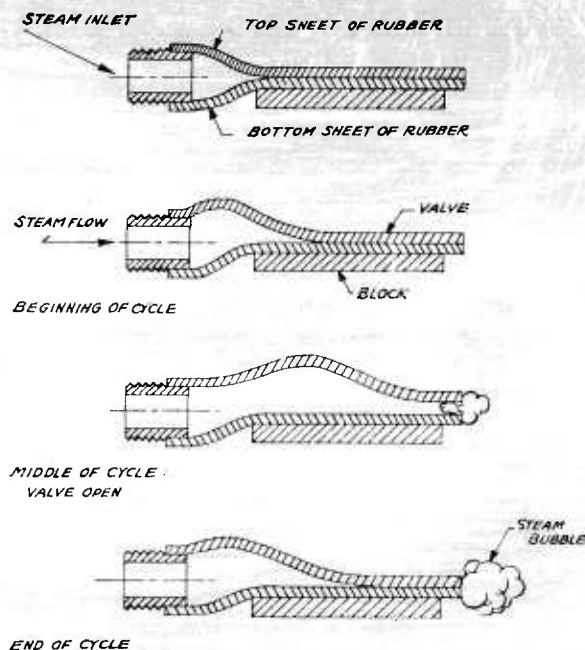
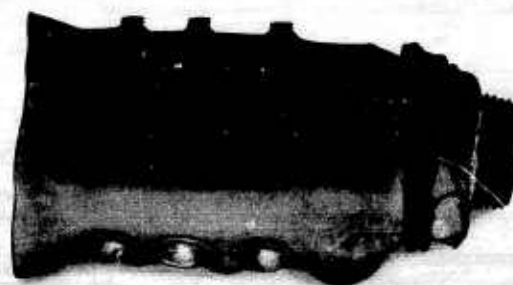

FIGURE 5. Diagram of razzzer operation.

from surface vessels. In the COMINCH summary of noisemakers developed for combatting the acoustic torpedo⁴ several steam noisemakers were listed; all of them, however, were judged impractical.

The razzzer development, which was carried along at low priority until January 1944, was dropped chiefly because the power requirements appeared excessive for an expendable noisemaker. In this device noise is produced by interrupting the flow of steam into water by means of a rubber valve similar in construction to a toy novelty noisemaker. The razzzer operation is indicated in Figure 5. The device consists of two sheets of rubber joined along a pair of opposite sides with a pipe fitting attached at the third edge for admission of steam and with the fourth edge, stretched tightly across a fiberboard block. A small razzzer is shown in Figure 6. As steam passes through the razzzer assembly, pressure is built up, stretching



A

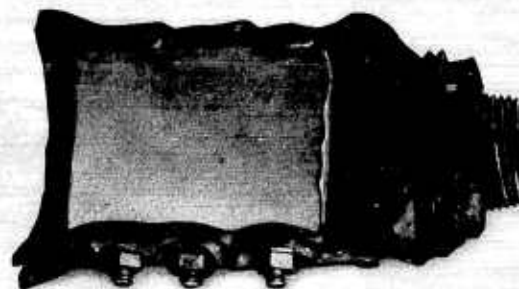

B

FIGURE 6. Top (A) and bottom (B) views of small razzzer.

high solubility of this gas in water leads to a sharp collapse of its bubbles, similar to the collapse of steam bubbles. Further details concerning their development may be found in the laboratory completion report.^{56c}

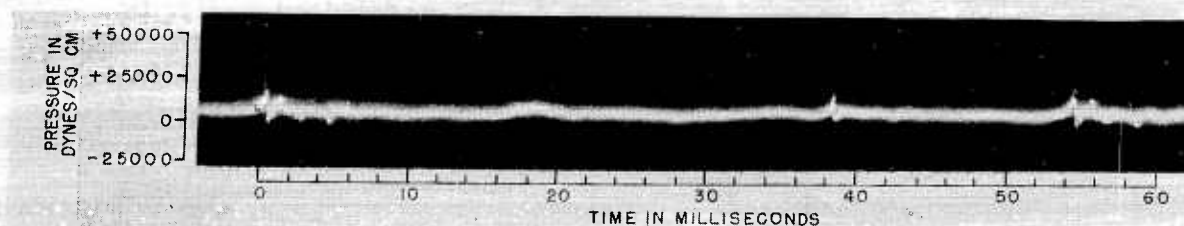

FIGURE 7. Waveform of steam razer.

5.4 HYDROGEN-OXYGEN NOISEMAKER

A method for producing a succession of underwater explosions by the combustion of hydrogen and oxygen was also studied. The experimental work

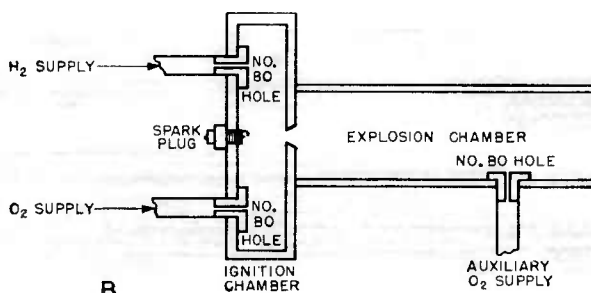

FIGURE 8. Photograph and drawing of hydrogen-oxygen noisemaker.

was confined to developing a firing head in which hydrogen and oxygen were mixed and ignited by an

electric spark. In all the models tested the gases were supplied from laboratory cylinders with pressure regulators. For an expendable noisemaker it was proposed that commercially available "lecture bottles" of the gases be housed in the prescribed space.

The most promising design developed for a firing head is shown in Figure 8. This unit is 5 in. long.

In operating this firing head the gas supply is first adjusted to give complete combustion in the ignition chamber; that is, with no bubbles of waste gas appearing. The supply of one of the gases to this chamber is then increased so that both a continuous flame and the excess gas emerge into the explosion chamber. The auxiliary jet of the other gas is directed into this flame. The resultant combustion produces somewhat irregular explosions at a rate of 8 to 10 per second. Final adjustment is made to minimize the waste gas.

The chief problem in the development was to obtain explosive oxy-hydrogen combustion rather than continuous burning which gives low sound output. Earlier designs using, for example, interrupted gas flow or a single firing chamber with periodic quenching of the spark by influx of water between explosions gave at best much slower firing rates. The design described here appeared to give the fastest firing rate combined with adequate stability for operation near the surface. No investigation was made of the effect of greater depths upon the operation. Further details about this development may be found in the laboratory completion report.^{56b}

SECRET

Chapter 6

SELF-PROPELLED SUBMARINE-SIMULATING DECOYS

6.1

INTRODUCTION

THE SUBMARINE-SIMULATING devices covered in this chapter constitute an approach to the problem of confusing sonar operators somewhat different from the efforts to mask underwater sounds. The NAD's are designed to simulate the self-noise and echo target of a submarine sufficiently to lure an enemy vessel into attacking the decoy while the submarine maneuvers to escape. Three distinct designs of the NAD sound beacon developed were the NAD-3, the NAD-6, and the NAD-10. These were designed as self-propelled, expendable evasion devices which would simulate the target characteristics of a submarine with various degrees of realism and by different means. The development of the three different designs proceeded in parallel since it could not be determined at the start which of the proposed schemes would prove most feasible.

The three decoys simulate in general the self-noise of an average fleet-type submarine making 120 rpm or approximately 6 knots. The sound output level is adjusted to be equivalent to that from an average submarine; somewhat noisier than the newest submarines but not so loud as to be unconvincing. The frequency distribution is adjusted to provide the noises most prominent in submarine self-noise. All the beacons were equipped to hold a straight course within ± 2 degrees so that the submarine could know the location of the beacon at all times. The direction of this course, relative to the line of ejection from the submarine, could be adjusted for angle shots from 90 degrees right to 90 degrees left. Thus the decoy could be ejected to adopt the course that might seem most probable for the evading submarine while the submarine itself would adopt some less probable divergent course, possibly behind a screen of masking noisemakers.^{14, 20}

The NAD-3 beacon as completed in production prototype in the summer of 1945 simulates the motion and the self-noise of a submarine. In order to make the unit small enough for ejection from the 3-in. signal tube no simulation of echo target was attempted. The NAD-6 was initially tested as a self-propelled echo repeater which would provide a

moving target to echo ranging with a target strength consistent with that of a full-sized submarine. For the final design a gear-driven noisemaker was added to simulate submarine self-noise at sonic and supersonic frequencies. The NAD-10 has characteristics similar to the NAD-6 in returning an echo as well as in simulating submarine self-noise to listening detection.

The NAD-6 and the NAD-10 were supplied to the fleet during the summer of 1945. Schools were established to train submarine personnel in the operation of these evasion devices, and one NAD-6 was fired in the course of a successful evasion maneuver 6 hours before the Japanese surrender. The further development of these and of the NAD-3 was continued under Navy auspices after the termination of hostilities.

The technical problems encountered in developing these decoys provided information that may be of use in subsequent work in this field. While analogous in many ways to torpedo design, the provision of the functions of course control and depth control in units of such small size at such low speeds involved a number of special problems. The design of the noisemaking heads provides further information on the production of underwater sounds of special characteristics. The soundheads in the NAD-3 and the NAD-6 are comparable to the rotary heads discussed in Chapter 2, differing in the greater flexibility in adapting their design parameters to special frequency requirements. For self-noise simulation in the NAD-10, the electronic circuit which drives the magnetostriction projector is similar to those developed to simulate ship sounds in sonar training devices. The echo repeaters in the NAD-6 and NAD-10 were developed from practice targets^a and are related to the program of crystal transducer design.^b

It will be observed that the development of the XNAG treated in Chapter 2 has many points in common with the decoy program. Both types of noisemakers were designed in accordance with the studies of submarine self-noise. In the XNAG, which is a masking device, the output spectrum is adjusted to match submarine output as the most ef-

^a See Division 6, Volume 4.

^b See Division 6, Volume 12.

ficient way of disguising telltale noises from listening detection at any frequency, whereas in the decoys the simulation is for the purpose of producing these telltale noises.

6.2 SIMULATION OF SUBMARINE SOUNDS

GENERAL

The simulation of submarine sounds by means of noisemakers of reasonable size has involved extensive compromises between ideal simulation and engineering necessity. A decoy which presented all the target characteristics of a submarine might have to be nearly the size of a second submarine. The problems are reduced somewhat by selecting a single condition of submarine operation and, for the decoys, the output from an average reduction-gear-driven fleet-type submarine at 120 rpm was adopted as standard. Measurements were made of average submarine output levels in these conditions and of the spectrum of submarine self-noise. Listening tests were made to discover what features of submarine sound are most prominent and thus most likely to be relied upon to indicate the submarine's presence to the various means of detection. While much of this material is treated in the reports of the extensive program of submarine noise measurements^e the particular studies which contributed to the design of these submarine-simulating decoys are summarized here.

The preliminary information about submarine noises was obtained from two recordings of a submarine operating at 2.5 and 6 knots. From listening to these recordings, the importance of cavitation noise from the propellers and of a whine from the reduction gears in characterizing submarine noise was established. While subsequent tests verified these conclusions from a more quantitative standpoint, the initial work in the decoy program undertook to simulate these two sounds with various types of mechanical and electronic noise generators. Tests of the masking noisemaker, the sonic sound beacon,⁹⁰ provided additional data about submarine sounds. Measurements in December 1944 of the fleet-type submarine USS *Spot*¹⁰¹ yielded detailed information about the overall levels and frequency distribution produced at speeds from 2 to 6 knots, and also indicated the importance of high-level

^e See Division 6, Volume 7.

single-frequency components of the output in betraying the presence of the submarine. Measurements of submarine target strength also contributed to the decoy program in establishing the amplification needed in the echo repeaters to produce an echo equivalent to that from a full-sized submarine.⁹¹ Measurements of the acoustic performance of the decoy noisemakers were compared with these standards of submarine performance.

The variation in the kinds of noises made by submarines of different nationalities or different classes, or by different ships in the same class, makes generalization difficult. Taking the reduction-gear-driven fleet-type submarine as a useful standard, and specifying operation near the surface with all auxiliaries secured as for a quiet evasion run, it was possible to reach enough general conclusions to undertake the design of decoys. The application of measurements^d of submarine self-noise to decoy design is presented at some length in the NAD-10 completion report.¹¹³ The chief conclusions from these studies are summarized here as a basis for the discussion of the NAD development.

CAVITATION NOISE

The cavitation noise produced by submarine operation is an amplitude-modulated continuous noise which varies in its character with the speed and depth of the submarine. This cavitation is produced chiefly by the propellers, and for periscope depth with fleet-type submarines begins at about 60 to 70 rpm or approximately 3 knots. Cavitation is unimportant or nonexistent at lower speeds. The cavitation noise is produced continuously throughout the spectrum at a fairly uniform level for low frequencies and falling off at higher frequencies at rates differing for different speeds. For 4-knots speed, the level above 1 kc falls off at about 6 db per octave. As the submarine speed increases the cavitation noise becomes increasingly prominent to the listener and the frequency distribution changes so that for 120 rpm, or 6 knots, the output spectrum has an almost constant level from 1 to 10 kc, falling off above that at 6 db per octave. The importance of cavitation noise continues well up into the super-sonic range since the background (is) falls off at about 6 db per octave at high frequencies.

Figures 1, 2, and 3 show the output spectra for

^d These measurements are also discussed in Division 6, Volume 7.

SECRET

the fleet submarine *USS Spot* at 2.5, 4, and 6 knots, respectively. While the peaks at low frequencies are chiefly due to gear whine and its harmonics, the shape of the curve at higher frequencies illustrates the behavior of cavitation noise.

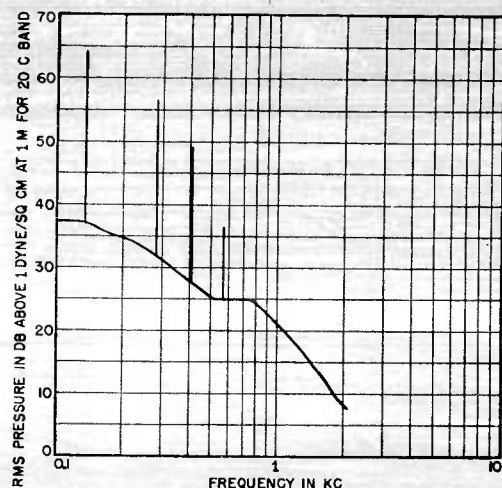

FIGURE 1. Submarine output spectrum at 2.5 knots.

In addition to its continuous character, cavitation noise is also distinguishable by the fact that it is amplitude-modulated at a rate corresponding to the propeller rotation. Since the human ear is able to

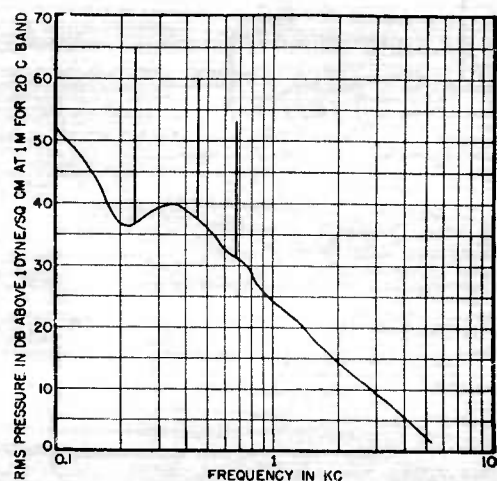

FIGURE 2. Submarine output spectrum at 4 knots.

detect sounds with special characteristics such as rhythm or tone at levels well below that of the prevailing background, the propeller beat is an impor-

tant feature in betraying submarines to listening. From listening tests it appears that the most prominent modulation corresponds in general to the shaft rpm rather than to the rate of successive blades. The decoys are accordingly equipped to produce a continuous noise that varies in amplitude at a rate of 2 c to correspond to 120 rpm. In the NAD-10 this rate can be adjusted to simulate shaft rates from 75 to 150 rpm so as to permit simulation of various conditions of operation.

GEAR WHINE

The other distinctive noises produced by submarine operation are the whines of nearly constant

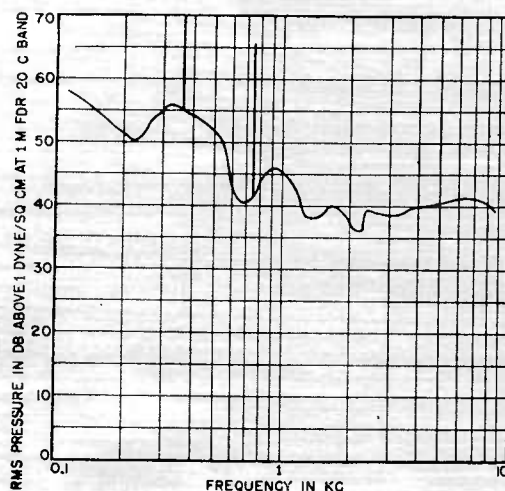

FIGURE 3. Submarine output spectrum at 6 knots.

frequency that have been identified as coming from the reduction gears. The fundamental frequency of this gear whine is approximately three times the shaft revolutions per minute. In fleet-type submarines the bull gear has 180 teeth so that for 100 rpm, or 5 knots, the resultant sound frequency is $(100 \times 180) / 60 = 300$ c. The first few harmonics of this fundamental are also important. Thus for 50 rpm, or 2.5 knots, the submarine output has prominent peaks at 150 and 300 c, while at 120 rpm these peaks are shifted to 360 and 720 c. For the XNAG masking noisemaker, the low-frequency output was designed to provide special protection between 240 and 360 c. In the decoys the gear whine simulators are adjusted to give a constant frequency whine at 200 to 300 c which represents a plausible value for the pretended submarine.

OUTPUT LEVEL

The actual sound pressure levels at which these noises are produced have been measured in various tests, Table 1 summarizes a number of results that

TABLE 1. Overall output levels of submarine self-noise at speeds from 2 to 6 knots for a band from 0.1 to 10 kc expressed in db above 1 dyne per sq cm at specified distance.

Speed	Fleet-type USS <i>Spot</i> ¹⁰¹		Earlier-type sub-
	At 1 m	At 200 yd	marines ¹⁰ At 200 yd
2 knots	46.5	0	18, 0, 4, 2
3 knots	50.5	4	3, 16, 10, 6
4 knots	53.5	7	16, 13
6 knots	58.5	12	20, 31, 23

Note. The values in this table may be taken as significant to within ± 5 db. Conversion of values to standard distances was made using 6 db per distance doubled transmission loss. The USS *Spot* measurements in reference 101 are considered representative for modern gear-driven fleet-type submarine performance. It will be noted that the values shown for comparison in the last column, compiled from measurements of earlier-type submarines as reported in reference 10, are significantly higher in level.

can be considered representative. Derived from various sources, and obtained by different techniques, the results are not comparable to better than about ± 5 db. It is, however, feasible to use the values for 6 knots as representative of submarine operation for judging decoy performance. Thus a fleet-type submarine at periscope depth making 120 rpm may be said to produce a sound output that, measured in an overall band from 0.1 to 10 kc, is probably not more than 66 db above 1 dyne per sq cm when expressed for a point source at 1-m distance, or 20 db for 200 yd. A convincing decoy should produce about this same output. A masking device should produce possibly 15 to 20 db more to provide protection over a useful region of bearing separation as well as to counteract the listener's ability to detect special sounds.

SPEED

Selection of a submarine at 120 knots for the decoy standard was based on a number of considerations. A noisy decoy was sure of detection at extensive ranges whereas a decoy that simulated lower-speed submarines would have the same short detection ranges. The simulated high speed of the decoy noise also allows the evading submarine some latitude in selecting her own speed. She might, for example, maneuver to escape at 60 or 80 rpm with some confidence that the noises corresponding to 120 rpm would carry more readily to the enemy

listeners and so lure them into attacking the decoy while she made her getaway undetected.

It will be noted in the decoy designs that the speed at which NAD's travel does not correspond to the speed of the simulated submarine. While 120 rpm is approximately 6 knots, the decoys in the noisemaking part of the run proceed at 3 to 4 knots. The power necessary to provide decoy speed of 6 knots would be obtained at the expense of operating life, and with the limited space available for batteries it was decided to use the lower speeds. It was believed probable that this inconsistency would be overlooked with conventional listening techniques. In proposing design features for a decoy to supersede these, however, it has been recommended that this inconsistency be eliminated.¹⁰⁵

DEPTH

A decoy with variable depth allows an additional adjustment in simulating some particular course. The NAD-6 was equipped to run at any depth between 50 and 100 feet, the NAD-10 at 10 to 100 ft while the NAD-3 was set for 50-ft operation.

This depth is a plausible one, putting the source of noise close to where it would be for a submarine at periscope depth. The selection of this depth for noisemaker design in general is based on the fact that a device at this depth is above any probable thermocline and still deep enough to avoid observation from the air. Since at the start of the program the Japanese were believed to have little if any depth-determination gear, the depth variation was not given special attention.

LISTENER

The nature of the listener enters into all of these considerations. The ultimate test of a decoy is whether or not it satisfies a sonar operator that he has a submarine contact. While research on the physiological and psychological factors in acoustic detection was proceeding at the same time as the noisemaker development, there was inevitably a lag in applying the findings of one field to the other. There is still room for a great deal of study of what types of noise provide successful masking and of what constitutes "good" simulation. However, the naïve approach to the problem was satisfactory for the most part since any new and unexplained noise in the water is likely to interfere with the coordination of a sonar team and since any additional way

SECRET

in which this noise displays the characteristics of a submarine requires the use of a higher quality of discrimination before the decoy can be rejected as a false contact.

ECHO SIMULATION

The simulation of the echo-reflecting characteristics of a submarine involved a different set of problems. By the time the decoy program was started much had already been achieved in the design of practice targets for training sonar operators.^e The echo repeaters developed for these devices and used in the decoys receive an incident ping, amplify it, and return it to the sender at a level approximately equivalent to an echo from a full-sized submarine for a corresponding aspect angle. These targets offer an advantage over FTS targets in that they are themselves in motion and so provide doppler in the echo. The calculations used to set up the gain requirements for the echo repeaters are covered in some detail in the NAD-10 completion report.¹¹³

The frequency range over which the NAD echo-repeaters would have to respond was determined by enemy practice. At the start of the program 16 to 26 ke seemed adequate coverage, but later changes made it advisable to provide for frequencies from 13 to 30 ke.

The type of echo returned by the decoys, although it had the right level and doppler, and some variation with aspect, was still under criticism at the close of NDRC participation in the program. A significant part of the echo received from a submarine at 120 rpm is from its wake and this is readily detectable by ear as well as visible on a chemical recorder. The present decoy echo lacks the blurry quality of true submarine echoes and shows no indication of a stationary wake target behind the moving target. It was proposed during the summer of 1945 to add FTS material to the decoys so that they would stream a wake of bubbles to soften the outline on the recorder trace and add a wake echo to the signal the operator hears.¹⁰⁷

Future development in decoy design will require both fundamental research and further engineering. Some of these lines of investigation are suggested in the above discussion, and in the following descriptions of the three NAD decoys developed by the end of 1945.

An analysis of NAD-6 and NAD-10 performance,

^e Refer to Division 6, Volume 4.

prepared at the end of the war in planning a new NAD-8 to supersede these decoys, summarizes the state of the art at that time and is given as Section 6.7.

6.3

DESIGN CONSIDERATIONS

GENERAL

Despite the many differences among the three NAD's, it is profitable to discuss their design requirements together. Their noise simulation problems were essentially the same, as discussed in the preceding section. The depth- and course-control problems were similar. The launching problems which were encountered in the NAD-6 and NAD-10 developments were avoided for the NAD-3 by use of the 3-in. ejector tube, but this in turn imposed stringent spatial limitations upon the smaller device. While many of the problems that delayed the development have no significance apart from engineering expediency, certain of them indicate desirable lines of inquiry for further work.

SELF-NOISE SIMULATION

The production of noise equivalent in level and similar in quality to submarine self-noise has been attempted in various ways. Mechanical noisemaking heads were used in the NAD-3 and NAD-6 because of space and weight limitations. These were developed after months of study of various ways of producing a single-frequency whine and an amplitude-modulated continuous noise with a motor-driven mechanical system. The greater space available in the NAD-10 permitted the use of a cylindrical magnetostriction projector driven by a complex electronically generated signal to simulate these noises. This system permits variation and control of the simulated signal by electronic means as well as the generation of low-frequency components resulting from the use of a large diameter (11 in.) magnetostriction transmitter.

ECHO-REPEATER DESIGN

The magnitude of the ability of a submarine to reflect incident sound energy is conveniently expressed in terms of its target strength. Ordinarily the target strength of an underwater target is defined in terms of a perfectly reflecting sphere of a diameter which will return an echo of strength equal to that of the target when ranged upon by like sources of equal intensity. For the purpose of echo-

SECRET

repeater design, however, a more convenient method of expressing the target strength is in terms of the apparent acoustic gain of a hypothetically perfect echo repeater which is small enough to be considered a point receiver and transmitter. The gain of this ideal system, expressed in decibels in terms of the ratio of the outgoing sound pressure from the echo repeater (at 1 yd) to the impinging sound pressure upon the echo repeater, is equal to the target strength of a submarine if the submarine may be replaced in a given sound field by the echo repeater without a change in the reflected intensity. In the design of echo repeaters for beacon application the physical size of the repeater is small enough to permit the above definition of target strength to be applied without correction.

The effect of feedback automatically sets a lower limit on the amount of isolation that must exist between the receiving and transmitting transducers to prevent sustained oscillation. If the loss over the feedback path is greater than the gain in the echo repeater such oscillation is prevented.

Extended investigations indicate that the target strength for the beam aspect of fleet-type submarines, corrected to ideal water conditions, is approximately 25 db, and that it changes quite rapidly with changes in aspect, being 10 to 15 db down on the bow and on the stern. These investigations also indicated that the target strength was independent of the frequency over the echo-ranging band from 10 to 30 kc.

On the basis of these results, two design requisites were established. The first of these was a linear frequency response over the frequency range including those frequencies thought to be employed by the enemy. The most reliable information that was then available indicated that the echo-ranging frequencies used by the Japanese fell within the 15- to 27-kc band. The second requirement was one of target strength and directivity. Since the aspect of the decoy could be readily determined by relative range rates, the decoy to be effective had to have not only a target strength comparable to that of a fleet-type submarine, but also an overall horizontal directivity pattern quite similar to that of the submarine represented.

The final consideration in the echo-repeater design concerned the maximum power output limitations of the repeater unit. For any given value of maximum power output there is a corresponding

value which represents the strongest sound field in which the echo repeater can operate without overloading. As the intensity of the sound field is increased beyond this value the apparent gain of the system (the target strength) decreases due to overloading. Under operating conditions the intensity of the sound field at the repeater is a function of both the output of the echo-ranging system and the distance between the system and the target. Assuming that the only loss suffered by the sound beam in its travel to the target is due to the inverse square law, it is possible to calculate the sound pressure at any distance from the echo-ranging system, provided the sound pressure at the transmitter is known. To establish preliminary power requirements, it was assumed that overloading at ranges of less than 200 yd could be tolerated without detrimental effects on simulation and that the sound pressure at 1 yd from the echo-ranging system would be approximately 110 db above 1 dyne per sq cm. Calculations indicated that to meet the above requirement the target must be capable of operating without overloading in a sound field of 64 db above 1 dyne per sq cm. Subsequent tests indicated that these requirements were too stringent. An echo-repeater amplifier based upon size, weight, and power limitations suitable for beacon operation would probably be incapable of delivering more than 15 w into a matched resistive load, and the variations in transducer impedance with frequency would limit the power transfer still more. Calculations showed that the maximum acoustic power that could be delivered by the transmitting transducer under these conditions would have an average value over the operating range of the order of 1 w. Past experience in transducer design indicated that the transmitting transducer would have a directivity index of approximately 12 db. If such a transducer were delivering 1 w of acoustic energy, the output level along the axis of the transducer at 1 yd would be approximately 83.6 db above 1 dyne per sq cm. Thus if the echo-repeater system had the required target strength of 25 db, overloading would occur only when the level of the sound field at the receiver exceeded 58.6 db above 1 dyne per sq cm. Using the same ranging system as before, overloading would occur only at ranges under 370 yd.

The wake effect and the effect of multiple reflections from a submarine's hull were second order effects for which no immediate methods of simula-

tion were considered. In view of possible future development work, a description of the investigations conducted later in these fields is given in reference 107.

BODY DESIGN

A major problem in the design of the decoys was to provide sufficient strength in the body construction to resist the 176-psi static water pressure at 400-ft depth. The O-ring waterseal system was applied in the final designs of these devices with great success.

For course stability at these speeds the body design required considerable study. The transducer housings in the NAD-6 were carefully streamlined and drag tests were made on all the units to determine their propulsion requirements. In the NAD-3 development many months were spent in the attempt to design a housing so stable that the unit would maintain an acceptable straight course before it was decided that it was necessary to provide gyro or compass control.

COURSE CONTROL

In the final models of all the decoys, course control is provided by a gyro or compass mechanism. Both types were prepared for the NAD-3 and for the NAD-6. The final designs of the NAD-6 and the NAD-10 use a small gyro specially developed by the L. N. Schwien Engineering Company. This unit is described in detail in reference 98. These control systems allow selection of any course from 90 degrees right to 90 degrees left relative to the line of ejection, and hold the units to within ± 2 degrees, with a maximum rate of precession of less than 6 degrees per 30 min of operation.

SEQUENCE TIMING

The operation of the decoys required that the various functions be initiated in sequence, subject to externally set controls and to various safety provisions. In the NAD-3 a spring-operated time clock determines the simultaneous drop in speed and start of noisemaking. In the early designs of the NAD-6 a set of thermal fixed time delay tubes provided the required time delay for the gyro to come up to speed before ejection and the length of the silent run before initiating noise simulation. Later the thermal delays were replaced by a timing cam motor to permit adjustment of the length of the

silent run, and provide the fixed gyro safety delay. Two similar timing cam motors control a more elaborate sequence of operations in the NAD-10 where provision is also made for actuation of a special retriever system for use in practice units.

SAFETY PROVISIONS

A possible hazard of the decoys is that after ejection they may become tangled in the superstructure, or possibly be jammed in a damaged torpedo tube. If simulation were to start under these conditions the submarine would betray her presence disastrously. Accordingly the NAD-10 is equipped with a simulation safety switch which does not supply power to the amplifiers until the unit has cleared the torpedo tube. The NAD-6 has a pressure-operated switch that stops all simulation at depths greater than 125 ft.

POWER SOURCE

The selection of batteries for the decoys required a favorable power-weight ratio as well as a good power-size ratio. Buoyancy and gas evolution were also taken into consideration. The primary batteries used in the evasion device development are discussed in Chapter 8. Of these a sea-water activated type was developed for the NAD-6 while the NAD-3 and NAD-10 use self-contained Edison primary batteries.

LIFE

For tactical reasons the minimum life for a useful decoy was initially set at 30 min. This life is provided in the NAD-3 and the NAD-6 while the NAD-10, operating from its Edison battery, runs for a full hour.

LAUNCHING

An NAD-3 can be launched from the signal ejector in as little as 30 sec, while at least 5 min is required to set, load, arm, and release either of the larger decoys from the torpedo tube. It was therefore necessary to design the larger decoys so that they could be loaded in advance of the probable time of release. Arming and releasing cables were designed accordingly so that the start of beacon operation could be controlled from the exterior of the tube door. The need for additional improvements in the launching methods is discussed in Section 6.7 in the recommendations for further work.

SECRET



FIGURE 4. NAD-3 sound beacon.

6.4 NAD-3 SOUND BEACON

The NAD-3 sound beacon is a self-propelled decoy developed to assist submarine evasion. It simulates in general the self-noise of a submarine making 120 rpm, so that to sonic and supersonic listening detection it closely approximates an actual submarine. No simulation for echo-ranging is provided. Upon ejection, the NAD-3 starts at 5 knots, adopting a preset course and a depth of 50 ft. After a preset variable time delay the speed drops to 3

knots and noisemaking begins. Gear whine at 200 c and propeller cavitation at 120 rpm are simulated by rotary mechanisms which vibrate the body wall. The noise output level for a band from 0.02 to 100 kc is 65 db above 1 dyne per sq cm for a distance of 1 m. Life of the unit is 30 min. The NAD-3 is 37.75 in. long and weighs 8 lb in air. The device was developed by UCDWR and at the termination of the NDRC contract on March 1, 1945, the program was transferred without interruption to Navy auspices for further study.¹⁰⁹

6.4.1 Experimental Development

The development of the NAD-3 sound beacon involved a number of interrelated problems. The construction of a noise generator to produce the desired output level and frequency distribution required considerable investigation. It was at first believed impossible to incorporate any servomechanism to provide automatic course control in such a small unit. Thus, the attempt was made to design a device with torques and operating trim so well determined that it would run a reasonably straight course. This was finally abandoned as unfeasible and the gyro and compass course control units were developed for the final design. Depth control was relatively straight forward. The incorporation of all these components into a single rigid body with a buoyancy close to neutral required considerable ingenuity.

The problem was first attacked in the search for a good mechanism for simulating submarine sounds. Spur gear trains were studied as a possible source of noise and their output appeared to simulate the wide-band noise from cavitation in a promising manner. A cam arrangement provided amplitude modulation of the output. A disadvantage of this

type of system was that the components of gear-whine frequency were modulated as well. The drive motor for the gears was combined with a propulsion mechanism using two counterrotating propellers to

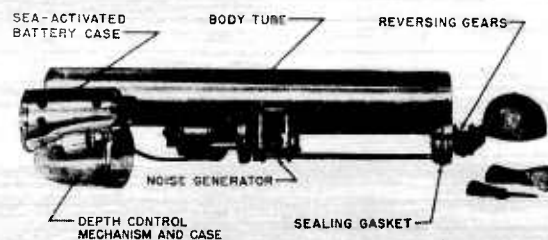

FIGURE 5. First experimental model NAD-3.



FIGURE 6. First evaluation model NAD-3.

reduce steering torques. The first experimental model, shown in Figure 5, which included these gears as a source of noise, a depth control mecha-

SECRET

nism, a sea battery for power, and two-propeller propulsion, displayed great instability in its course in the water.

In preparing the evaluation model shown in Figure 6, several changes were made. The depth control was pivoted on its fore-and-aft axis so that the intermittent deceleration of the motor from the modulation mechanism would not introduce a steering effect in the depth control elevators. A shift was made to single-propeller operation to save weight and increase efficiency when it was found that the steering torque could be overcome by the setting of an adjustable trim tab on the rudder. In an attempt to produce a unit which would keep a straight course without any type of servo control, various types of shroud rings were studied. Effort was also expended in devising wind tunnel tests to determine the trim-tab settings required. A "standard tail section" on which the correct rudder-tab setting had been determined by a series of actual trial runs was used for comparison with other untested tail sections in the wind tunnel. Tail sections thus adjusted gave satisfactory course operation in trial runs on the same body used for calibration of the "standard tail section." When assembled with untested production bodies, however, the results

take these gyro or compass course control units. Electrical correction signals from this control activated electromagnets in the tail compartment which operated a rudder with dimensions adapted for quick recovery of course. A number of other changes were also made for this design. The depth control was simplified once more. The Edison-type battery was substituted for the sea battery, providing longer life as well as eliminating the need for a free-flooding compartment. A timing clock was installed to permit adjustment of the length of a silent high-speed run. Noisemaking initiated by a switching arrangement at the end of the time delay was produced by two motors, the propulsion motor providing a constant frequency tone for gear whine and a second motor providing an amplitude-modulated wide-band output to simulate cavitation. Assembly technique was also improved in the use of a rigid internal skeleton and a single-piece housing shell.

The production model of the NAD-3 sound beacon, shown in Figures 4 and 7, incorporated all of these improvements. In preliminary tests it satisfied the specifications set up for its design. At the time this report was prepared the Navy evaluation tests of 50 units were not complete. Further information may be obtained from the Bureau of Ships.

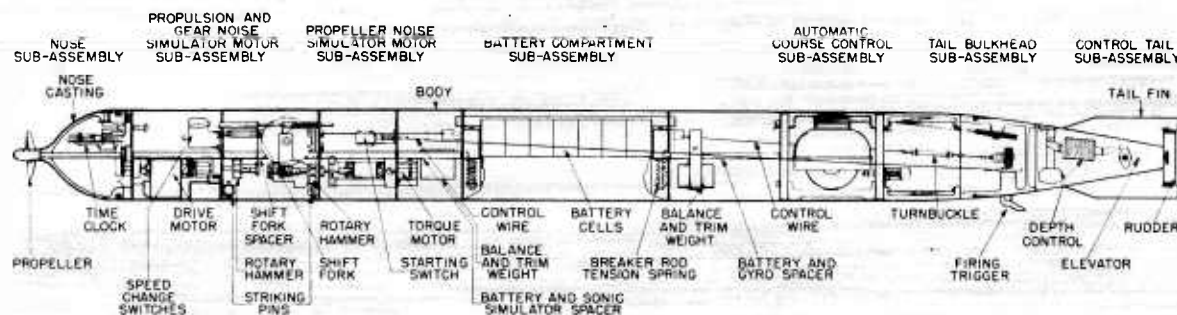

FIGURE 7. Assembly drawing of production model NAD-3.

were completely unsatisfactory due to minor variations in production body construction which overcame the steering effect of the rudder tab. It was accordingly decided to change to the use of a rudder controlled by a gyro or a compass unit which would provide continuous compensation for variations in the trim and the housing of production units. This type of servo control also permitted ± 90 -degree course selectability before ejection.

The production prototype model was developed to

6-4.2

NAD-3 Components

ASSEMBLY

The production model of the NAD-3 sound beacon is shown in Figure 4. The construction can be seen schematically in Figure 7 while gyro- and compass-controlled units are shown in Figure 8 before installation of their batteries and before insertion into the housing shell. The beacon components are assembled as a rigid internal skeleton over

SECRET

which the single-piece housing shell can be slipped into place. This eliminated the problem of securing the components to the inside of the tube and greatly simplifies production assembly.

COMPARTMENT CONSTRUCTION

The first compartment of the beacon contains the time-delay clock and the reduction gears to drive the propeller shaft. The propulsion motor is housed

adjusted as necessary for efficient motion through the water.

TRIM

In compensating for the two different moments of propeller torque corresponding to two-speed operation, the greater part of the unit's total ballast is placed to the left of the centerline. This is sufficient to counterbalance the torque that occurs at low

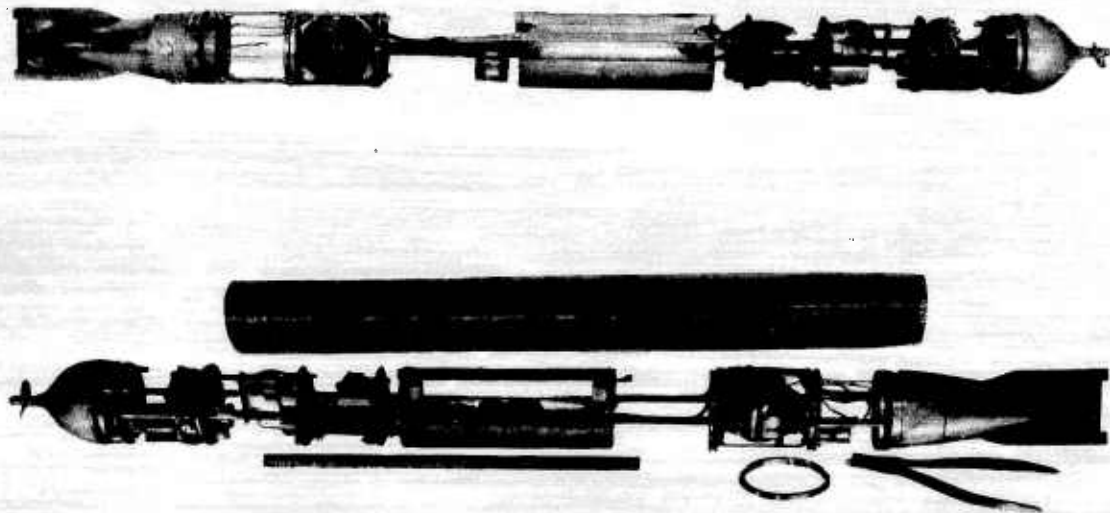

FIGURE 8. Production models NAD-3 before installation in single-piece housing. Compass control can be seen in top unit, gyro control in bottom unit. Batteries are absent.

in the next compartment, and this is followed by the noisemaking generators in the third compartment and the cavitation simulation motor in the fourth. The sixth compartment houses the battery with two small compartments on either side where the ballast and trim weights are adjusted. The eighth compartment accommodates either the gyro or compass course control mechanism. This is secured to the magnesium casting that forms the tail bulkhead. The final compartment is a free-flooding chamber housing the depth control and the course control electromagnets. The O-ring waterseal system makes the unit watertight from the propeller to the end of the tail bulkhead compartment, and the enclosed volume of air is sufficient to float the unit when ballasted for recovery. Ballast and trim are

speed. The torque that occurs at high speed rotates the body approximately 10 degrees past vertical, but due to the efficiency of the automatic course controls, this amount of torque is not sufficient to cause deviation from course.

PROPELLER

The propeller was designed to provide 5 knots speed at 6,000 rpm and 3 knots at 4,000 rpm. A 1.5-to-1 gear reduction is used between the propeller shaft and the two-speed propulsion motor.

TIME CLOCK

The high-speed silent starting run called for the development of a reliable time-delay clock. This unit is mounted inside the nose casting with its act-

SECRET

ting shaft extending to the top of the unit. The clock permits selection of time delay from 0 to 10 min within an accuracy of ± 10 sec. The clock is so designed that it starts to operate at the instant the setting key is removed from the setting shaft.

the overall motor resistance. Less current flows through the motor, resulting in the characteristic drop in speed of a series motor. The motor speed is reduced still further by the additional load placed on it by the shifting of the rotary hammer into

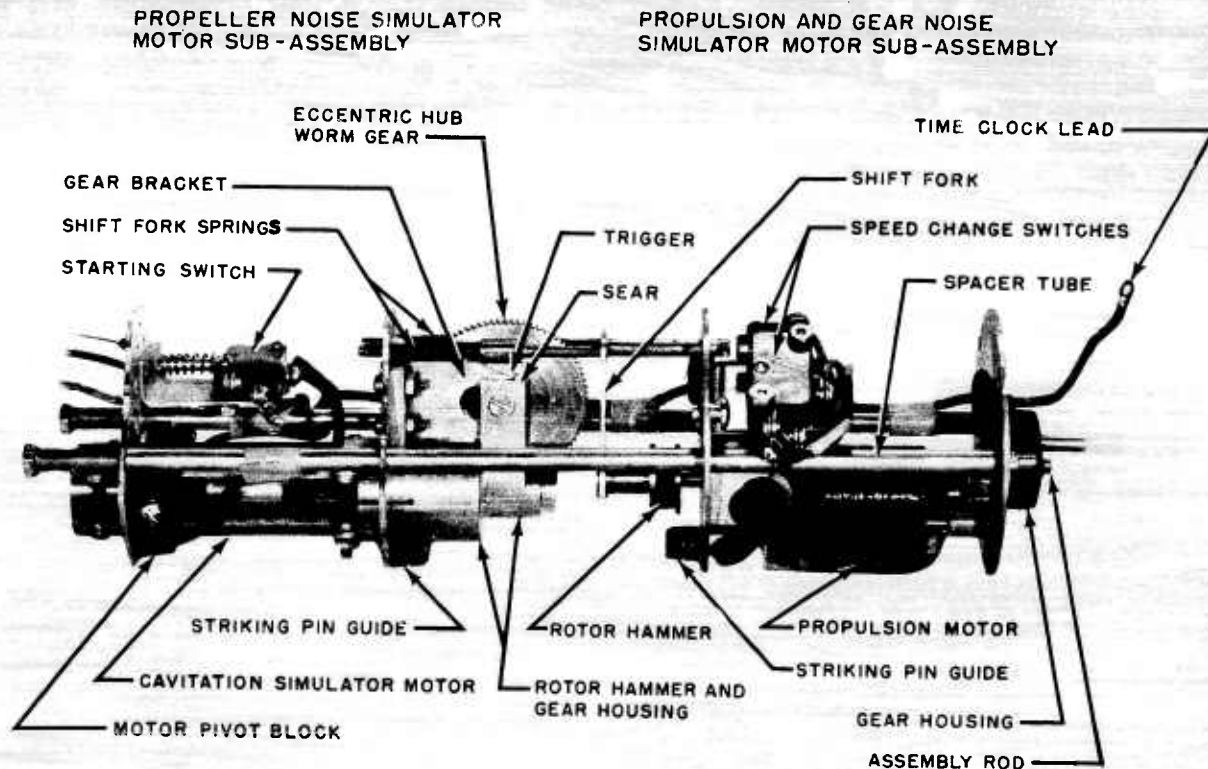

FIGURE 9. Propulsion and noise simulation mechanism in NAD-3.

This is not a significant handicap since an NAD-3 can be ejected in 15 sec. At the expiration of the selected time delay an electric contact is closed starting the cavitation motor which in turn actuates the speed change and noisemaker starter mechanism.

PROPULSION AND GEAR NOISE MOTOR

The propulsion motor shown in Figure 9 is built with its series field split into two identical windings. For high-speed operation, during the silent starting run, the two field sections are switched into parallel with each other but remain in series with the armature. This lowers the overall series resistance, permitting more current to flow through the motor. The system is adjusted for 9,000 rpm.

For slow-speed operation the two field sections are placed in series with each other thus increasing

operating position. The resultant speed is about 6,000 rpm. The front end of the propulsion motor shaft extends into the nose compartment to drive the propeller through a 1.5-to-1 reduction gear. The after end drives the rotary hammer which, when it has been shifted into noisemaking position, provides simulation of constant-frequency gear whine.

GEAR NOISE SIMULATION MECHANISM

The rotor hammer for the gear whine simulation mechanism can be seen in Figures 9 and 10. It is shifted into position over the single striking pin at the time of the speed change. The construction of the rotor hammer and pin mechanism can be understood from Figure 11. There are two hammers in this wheel. The single pin is seated in a pin boss on the propulsion motor's after support plate. A rubber

SECRET

ring holds it snugly against the outside tube wall so that no noise is created on the rebound. The frequency of 200 c for gear noise simulation is set by the motor speed of 6,000 rpm multiplied by the number of hammers on the hammer wheel.

CAVITATION SIMULATION MOTOR

A second motor was provided to simulate cavitation noise when it was found difficult to provide both

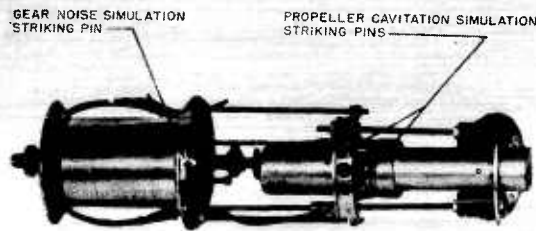

FIGURE 10. Bottom view of noise simulation mechanism in NAD-3.

modulated noise output and constant-frequency noise with a single motor. The assembly, consisting of a small permanent field motor, a rotor hammer

to simulate the amplitude modulation of a propeller shaft rate of 120 rpm. By placing a resistor in series with the motor, the speed is reduced to 9,600 rpm.

CAVITATION SIMULATION MECHANISM

The rotor hammer wheel, which can be seen in Figures 9 and 10, is driven by the shaft of the cavitation simulation motor. This wheel has two hammers. The three striking pins in the noise generator are of construction similar to those shown in Figure 11. They are spaced as closely together as possible and held in position by a guide shoe attached to a bulkhead. The pins are allowed to bounce between the tube wall and the guide shoe, an action which aids in producing the type of continuous wide-band noise that is desired. The hammers strike the pins during the downward half of each reciprocation so that the output is amplitude-modulated to correspond to the propeller thrash of a submarine making 120 rpm.

SPEED CHANGE MECHANISM

The start of the cavitation motor, which is determined by the current supplied when the contacts of the time-delay mechanism close, is also used to effect the speed change in the propulsion motor and

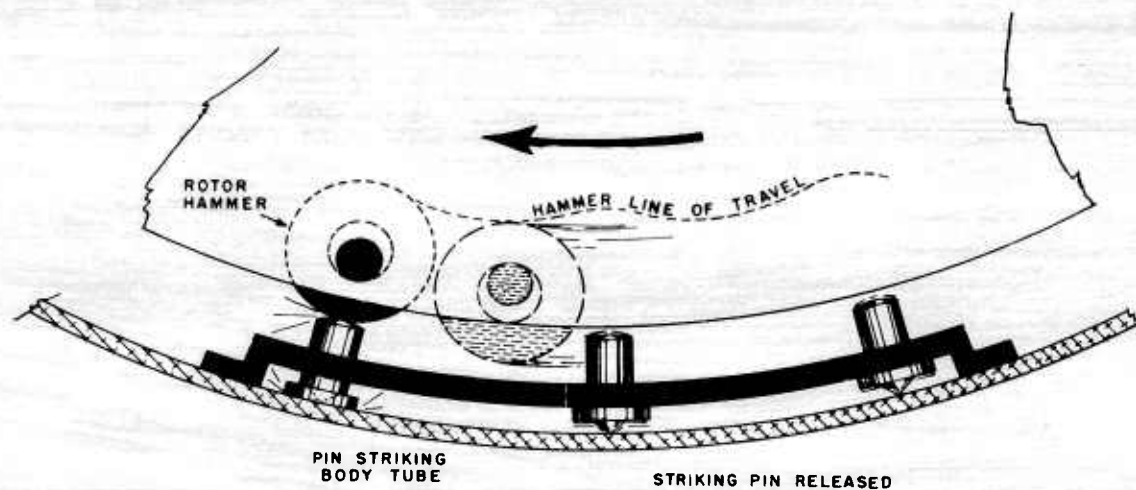

FIGURE 11. Diagram of hammer-and-pin simulation mechanism in NAD-3.

wheel, and a worm drive, is supported on a pivot block. A worm gear is supported on a bracket while the unsupported end of the motor assembly is driven up and down by following an eccentric hub on the worm gear. This reciprocating mechanism causes the rotor hammer to pump up and down at a rate of 2 c

to start the simulation of gear whine. A shift lever is mounted on a spring, as shown in Figure 9, so that the first downward motion of the gear casing on the worm gear releases it from the sear. The rod moves forward to depress two microswitches which change the fields of the propulsion motor from

SECRET

parallel to series. Simultaneously with this switching, the rod drives a fork which slides the rotor hammer of the gear-whine simulator into place over its striking pin.

BATTERY

The Edison K-type 7-cell battery used in the NAD-3 was specially built for this application. This battery, shown in Figure 6 of Chapter 8, carries its own electrolyte in sealed chambers above the plates. The previous use of sea batteries in experimental models of the NAD-3 had necessitated provision of a free-flooding chamber and had raised the problems of deterioration in storage and the trapping of gas during operation which might upset the trim. The totally sealed construction of this battery made it possible to use a single-piece watertight body tube for the unit, while no special precautions were needed against deterioration.

This battery produces an initial starting power of 12.5 v at 8 amp. After approximately 2 min it drops to 10.5 v at 8 amp and continues at that rate for 25 to 30 min. The construction and operation of the battery is discussed in Chapter 8.

In order to start operation of the battery, special plungers are forced downward by a spring-loaded breaker bar to break the thin cell walls between the electrolyte and plate compartments. A special battery case was constructed to hold the breaker bar and its tripping mechanism. A cable extends from the tripping mechanism to the external release shaft in the tail bulkhead wall. This is secured with a cotter pin until the unit is ready for ejection.

GYRO COURSE CONTROL

Both gyro- and compass-controlled units were developed for use in the NAD-3 and both proved satisfactory. Final selection was postponed until after the preparation of this report. Both satisfied the specifications by supplying ± 90 -degree course selectability, weighing no more than 225 g, and fitting into the allowed space. The construction and operation of both designs is covered in reference 109.

DEPTH CONTROL ASSEMBLY

The depth control elevator surfaces are mounted horizontally at the tail of the beacon as shown in Figure 13. The shaft joining them runs through the tail cone. Inside the cone, a bell crank on the elevator shaft is connected to the pendulum arm

through a link whose length is determined by water pressure on the syphon bellows forming this link. This can be seen from Figure 12. The pendulum is so connected as to correct the angle of rise or dive of the beacon when it moves forward under power.

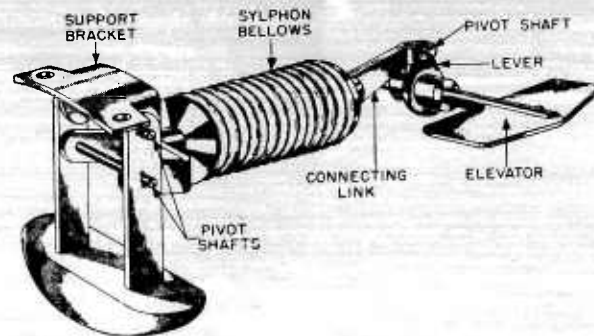

FIGURE 12. Depth control mechanism in NAD-3.

The elevator surfaces are preset at an angle which becomes parallel to the long axis of the body when the body axis is horizontal at a predetermined depth of 50 ft. At this depth the pressure shortens the syphon to the length necessary to bring the elevator attack angle to zero when the pendulum is vertical.

STEERING MECHANISM

The course control units supply electrical correction signals to produce right or left corrections of the course. These signal currents run through the coils of two electromagnets mounted inside the end

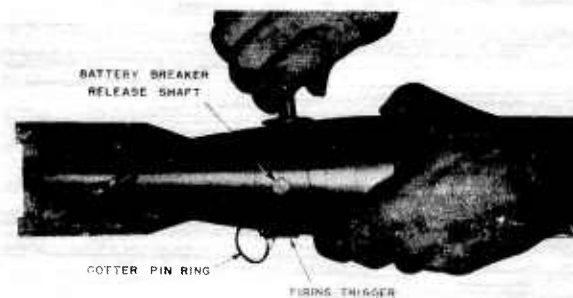

FIGURE 13. NAD-3 afterbody.

of the tail cone. The armature which responds to the magnetic attraction to guide the rudder can also be seen in Figure 13. Because the tail cone is free-flooding the magnet coils are impregnated with a watersealing material. Leads from the coils extend forward through glass bushings in the tail bulkhead.

SECRET

EXTERNAL CONTROLS

The external controls, shown in the view of the beacon afterbody in Figure 13, are constructed for easy initiation of beacon operation at the time of

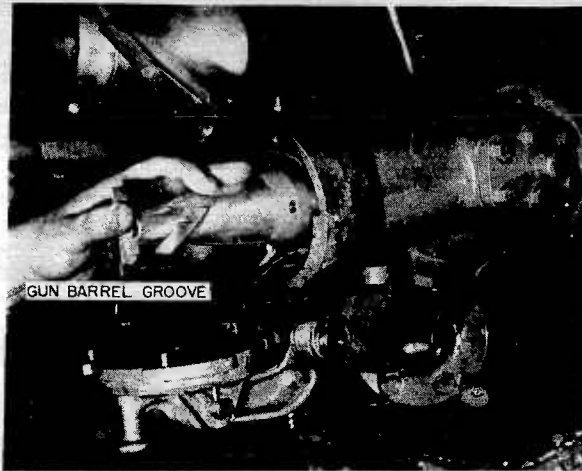

FIGURE 14. Guiding firing trigger into ejector groove.

firing. The battery breaker release shaft projects out from the body and is secured in its position by a cotter pin on a safety ring. The course-setting shaft opens on top of the afterbody as shown in Figure

the cotter pin is removed the trigger drops to the firing position shown in Figure 14.

6.4.3

Operation of NAD-3

No special precautions are necessary in the storage and handling of the NAD-3 since the self-contained batteries require no protection from moisture. Since the time-delay mechanism starts to operate at the instant the setting lever is removed, the selection of time delay should be postponed until just before ejection. To avoid premature operation of the propulsion mechanism, the trigger should not be moved into the ready position until the unit is already placed in the ejector tube. It is then guided into the firing groove as shown in Figure 14.

The sequence of events in the operation of the NAD-3 can be seen from the electrical circuit in Figure 15. The closing of the trigger by the ejector tube groove supplies voltage at once to the propulsion motor and to the fuse link that releases the course control caging mechanism. In the gyro unit, the gyro motor has had time to come up to speed. The depth control, responding to gravity and to static pressure, assumes control as soon as there is sufficient forward speed to affect the elevators. Thus

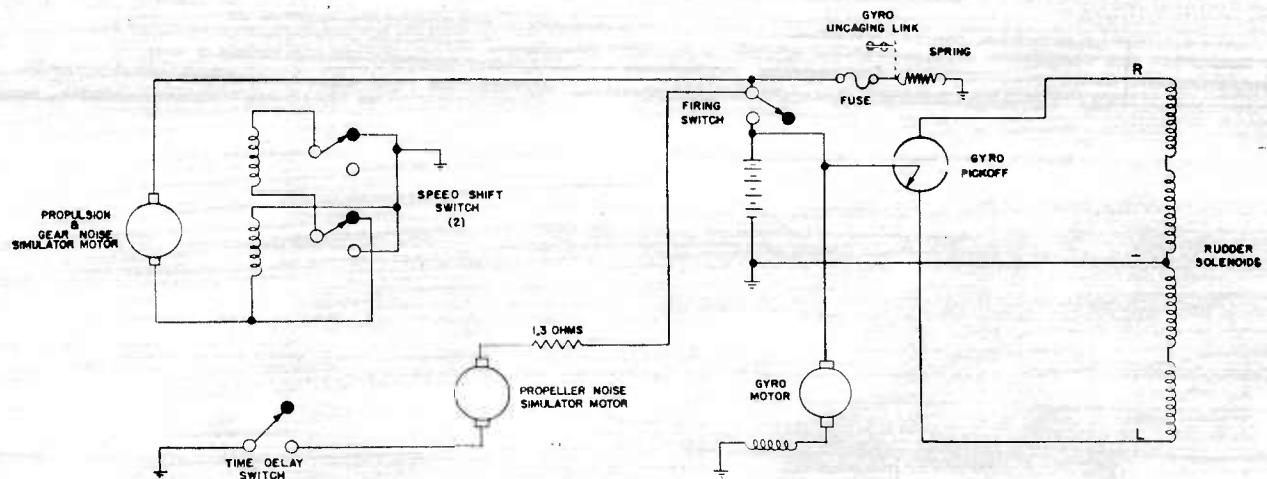

FIGURE 15. Schematic circuit for NAD-3 with gyro control.

13. The setter key supplied with the beacons has one end adapted to fit this hole. The time-delay setting shaft opens in the top of the nose casting. The setter key is also adapted to fit this hole. The firing trigger is shown in its safety position in Figure 13. When

the unit proceeds on the selected course at a speed of 5 knots and rises or sinks to a depth of 50 ft.

At the expiration of the time delay, the closing of the contacts in the clock supplies current to the cavitation simulator motor and the start of its oper-

SECRET

ation initiates the following changes: (1) the microswitches which control the windings of the propulsion motor are closed, shifting it to its low-speed winding, and (2) the gear-whine simulator mechanism is shifted into operation. Thus the unit proceeds on its noisemaking run at a speed of 3 knots on the same course and at the same depth as before. Gear whine is simulated by a 200-c tone and propeller cavitation for a submarine at 120 rpm by continuous noise, amplitude-modulated at 2 c.

Noisemaking continues for the life of the battery, which is 30 min or more. The propeller drives the unit at a speed of 3 knots. The gyro or compass course control keeps the unit within ± 2 degrees of its set course. The depth control maintains it within ± 4 ft of its set depth of 50 ft. The cavitation and gear whine of reduction gear driven fleet-type submarines at 120 rpm and periscope depth are simulated both in level and in quality of the noise.

When exhaustion of the battery stops the propulsion motor, the rudder and elevator lose control. Units ballasted as exercise shots float to the surface for recovery. For a war shot the ballast would be adjusted so that it would sink.

6.4.4

Evaluation

The NAD-3 sound beacon satisfies the specifications set up for its design. The noise generators manage to produce sound equivalent in level to average submarine output and characteristic of the constant tone of gear whine and the modulated continuous noise of propeller cavitation that are most prominent to listening detection in submarine self-noise. In the final design it has been possible to include all the diverse components of a self-propelled noisemaker within the prescribed space. Field tests of the units in quantity were not completed at the time this report was prepared, owing to delay in shipment of the special Edison K-type 7-cell batteries. The units under construction for these tests are ballasted as exercise shots so that they surface after exhaustion of their batteries. These tests serve also to evaluate the relative merits of gyro and compass course control.

The overall output of the NAD-3 for a band from 0.02 to 100 kc is 65 db above 1 dyne per sq cm corrected for 1 m distance. This is about the same as the output in this band for an average fleet-type submarine running at 120 rpm at periscope depth. The frequency distribution of the NAD-3 output shows continuous noise from the cavitation simulator which is nearly flat up to 10 kc and extends at gradually decreasing level up as high as 80 kc. The gear-whine simulator produces noise at its fundamental of 200 c and in harmonics that have significant level up to 2 or 3 kc. The resemblance of this noise to the noise of a submarine is decidedly convincing.

The development of the NAD-3 sound beacon covered here was completed in December 1945. Production of 50 units was underway at that time for use in Navy evaluation tests. The chief comment on NAD-3 usefulness must be arrived at by analogy with the other NAD's which have received more extensive study. The advantage offered by the NAD-3 is that ejection of decoys from the signal tube frees the torpedo tubes during a critical period. The beacon does present a moving source of noise that, to listening detection at both sonic and supersonic frequencies, gives plausible evidence of an actual submarine moving at 120 rpm.

A disadvantage of the NAD-3 is that it provides no echo-ranging target. Against Japanese patrol craft, which were often equipped with listening gear only, the NAD-3 might have been effective. To a destroyer equipped with echo ranging gear it would be less convincing.

In the program continuing at the Navy Electronics Laboratory at San Diego, further work on the NAD-3 is directed towards completion of the course control, and the possibility of incorporating a small echo-repeater unit into the decoy is also under investigation. The analysis given in Section 6.7 of the features that would be desirable in a proposed new NAD-8 makes no mention of the NAD-3. The small size of this decoy, however, offers an advantage that must also be considered in evaluating various possible designs. Details concerning the construction and performance of the NAD-3 may be found in the laboratory completion report.¹⁰⁹

SECRET

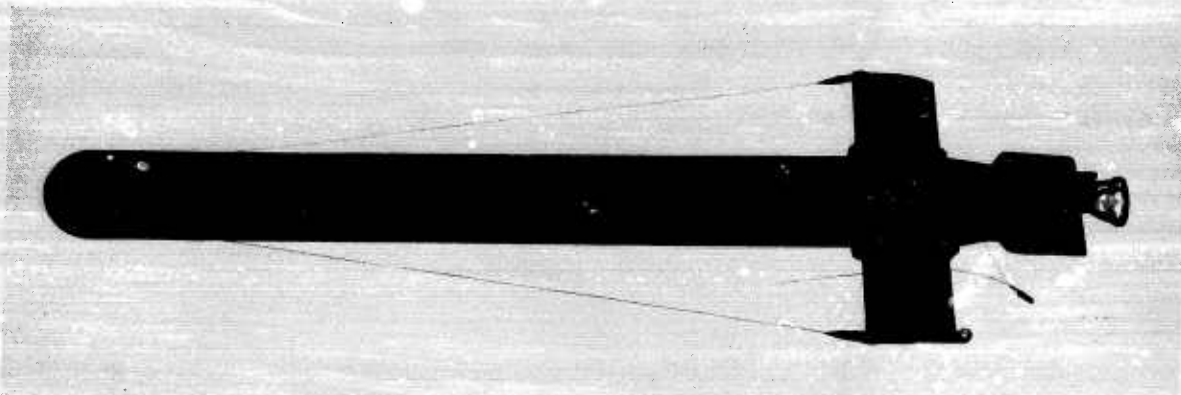

FIGURE 16. NAD-6A sound beacon.

6.5 NAD-6 SOUND BEACON

The NAD-6 sound beacon is a self-propelled decoy developed to assist submarine evasion. It simulates the self-noise of a submarine making 120 rpm and returns echoes with doppler which are equivalent to a submarine echo at any frequency from 14 to 28 kc. The NAD-6 runs out of a torpedo tube at 4 knots, adopting a preset course and depth. Noisemaking and echo repeating begin 35 sec after the start of propulsion. Gear whine at 300 c and

propeller cavitation at 120 rpm are simulated by electrically driven gears and rollers which vibrate the body wall. The overall noise output level for a wide band from 0.02 to 100 kc is 54.5 to 61.5 db above 1 dyne per sq cm for 1-m distance. Life of the unit is 30 to 35 min. The NAD-6 is 70 in. long and weighs 65 lb in air. The NAD-6 was developed by UCDWR, and at the termination of the NDRC contract the program was transferred without interruption to Navy auspices for further study.¹¹²

6.5.1 Experimental Development

At the start of the decoy program the installation of a 6-in. diameter ejector tube was proposed for all submarines, and the first work on NAD's was directed towards developing a device to suit this diameter. Later when the plans for such an ejector were dropped, the 6-in. diameter was preserved in the body tube of the NAD-6, although the greater space permitted by release from torpedo tubes allowed the NAD-6 transducers to be fixed in their operating position with tip-to-tip distance of 20¼ in.

The first experimental model of the NAD-6 was built without self-noise simulation. Tests of this beacon indicated that the propulsion mechanism and the course and depth controls could be made satisfactory while the echo-repeater mechanism appeared feasible. Although the possible value of a self-propelled decoy without self-noise simulation had been weighed, it was decided at this time that the NAD-6 could not be accepted for fleet use until a noise simulator was added to the design.

The NAD-6 evaluation model shown in Figure 17

was constructed accordingly, incorporating a motor-driven mechanical noisemaker as well as the echo repeaters. After successful tests in San Diego in October 1944, ten test units of this design were constructed for Navy evaluation. Some were sent to ASDevLant in Florida for tactical tests and some were tested for their engineering performance as well as tactical usage by ComSubsTrainPac at Pearl Harbor. These units were equipped to run either with lead-acid secondary batteries for short test runs or with sea-water activated primary batteries for longer runs and for war shots. On the basis of these tests, BuShips at the request of ComSubsPac initiated the procurement of 500 beacons of design similar to the evaluation model.

During the manufacture of these first NAD-6 beacons, the advance in general decoy design indicated that certain further modifications were desirable. In the NAD-6 evaluation model, the flooding of the torpedo tube determined the time of release of the beacon. Once the beacon was loaded into the tube, the breech door closed, and the tube flooded, the submarine was committed to releasing the beacon. The water in the tube initiated production

of voltage and the voltage activated a 45-sec thermal time delay which allowed the gyro course control motor to come up to speed. When this time elapsed, the propulsion motor started and the beacon ran out of the tube, starting its noisemaking after the elapse of a second time delay which was initiated simply by the end of the first. This method of sequence timing allowed no further control of the beacon's action once it had been loaded in the tube. Accordingly, the launching system was modified. A clamp was provided to secure the beacon in the tube. A releasing mechanism was provided which could be operated from the exterior of the breech door so

set up at Pearl Harbor and San Diego serving as the centers for supplying the decoys to the submarines. One of these beacons was used in the course of a successful evasion maneuver, six hours before the Japanese surrendered. The remaining beacons have been used in training programs for U. S. sonar teams.

A further modification of the NAD-6 was the NAD-6B shown in Figure 32 which provided adjustment of the duration of the silent run. An electric timing motor similar to that in the NAD-10 provides a fixed 45 sec period after the start of voltage production for the gyro motor to come up to

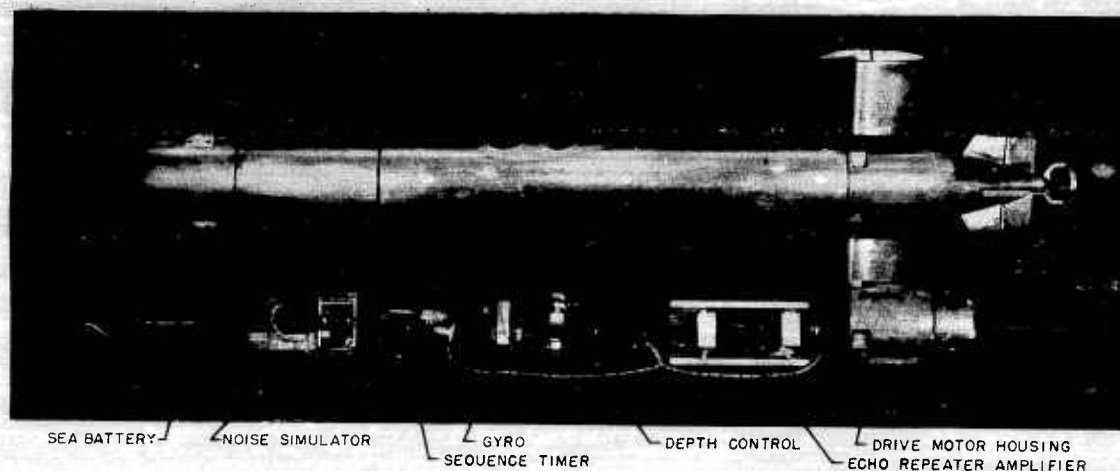

FIGURE 17. Exploded view of evaluation model NAD-6.

that the beacon could be released at any time after the gyro had come up to speed. A pressure-operated safety switch was also incorporated in the beacon so that operation of the noisemaker and echo repeater could not occur below 125-ft depth. This provided a means of shutting off decoy operation in case the beacon was for any reason lodged in the superstructure or trapped in a torpedo tube. The submarine could dive to safety below 125 ft and so shut off the noise that might betray her location.

These modifications were incorporated in the first 250 NAD-6 beacons by means of alteration kits supplied by the manufacturer. For the second lot of 250 beacons these modifications were included and the new design was designated NAD-6A.

The NAD-6A beacons and the modified NAD-6 beacons were supplied to the fleet in the spring of 1945. Training school and maintenance shop were

speed. Operation of the release switch at any time thereafter starts the propulsion motor and the start of the second time delay. This can be set for 0 to 10 min. This modification was accepted for the design of further production of the beacon, but because of the termination of hostilities only three experimental units of the NAD-6B were constructed.

Further decoy development is continuing on the basis of the experience gained from the decoys discussed here. Information on this program should be obtained from the Navy Electronics Laboratory at San Diego or from the Bureau of Ships.

6.5.2

NAD-6 Components

ASSEMBLY

The NAD-6A, as can be seen from the assembly drawing in Figure 18, is constructed in a series of

SECRET

sections. In place of the war-shot nose section shown here, an exercise head can be used which has lead-acid batteries for use in short practice runs. The simulator section houses the motor and gear-driven noisemaking mechanism which vibrate the external

In order to simulate the target strength pattern of an actual submarine with the echo-repeater response, the radiating surfaces of the crystal stack had to be those parallel to the axis of the beacon body. For the desired resonant frequency, if the

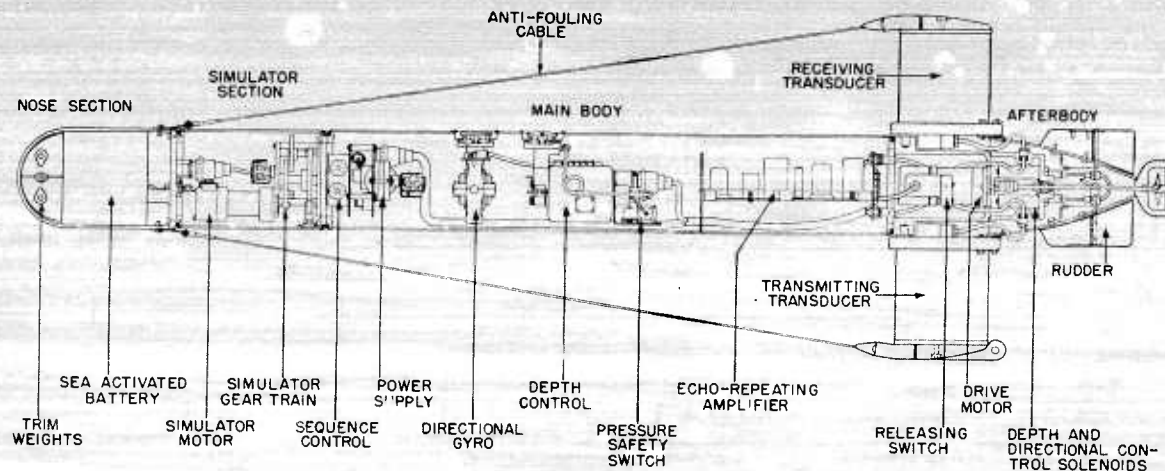

FIGURE 18. Assembly drawing of NAD-6A.

wall. The main body section houses the control systems and the electronic equipment. The afterbody houses the propulsion system and the solenoids which operate the elevators and rudders. The echo-repeater transducers project from the beacon body and antifouling cables are provided to protect them.

TRANSDUCER DESIGN

The echo-repeater design used in the NAD-6 was based upon the previous work at UCDWR on practice targets.^f The crystal stacks in the two beacon transducers are similar in operation to the OAS practice target transducers.

The receiving and transmitting transducers in the NAD-6 are identical vertical stacks of 21 45-degree Y-cut Rochelle salt crystals, operating free-free. One of these is shown schematically in Figure 19. This design is designated the KC-2 transducer. The use of the high impedance Y-cut crystals eliminates variation of sensitivity with change of temperature, thus keeping the system at constant gain and avoiding feedback. The crystals are each $2\frac{3}{16}$ in. long by $\frac{3}{4}$ in. wide by $\frac{1}{4}$ in. thick. This length puts the resonance of the stack in the center of the 14- to 28-kc band.

^f Discussed in Division 6, Volume 4.

usual practice of radiating from the narrow ends of the crystals were followed, the crystals were too long for convenient streamlining of the body. Accordingly, the problem was solved by the somewhat unconventional method of mounting the long sides of the crystals parallel to the beacon axis and having these act as the radiating surfaces. The horizontal directivity pattern of the NAD-6 is shown in Figure 20, and can be seen to be down 7 to 8 db at bow and stern. Submarine target strength is usually down 10 to 20 db at bow and stern.

The height of the stack, which is approximately $5\frac{1}{2}$ in. for each of the transducers, permits the beacon to clear the 21-in. diameter of the torpedo tube. This height was made as great as possible to increase vertical directivity and thus avoid feedback between the two transducers at high echo levels.

The $\frac{3}{4}$ -in. width of the crystals was selected as a minimum practical value for the stack while permitting use of the streamline type of housing shown in Figure 16. This housing is made of tin plate, and filled with castor oil. At the start of the program, when a 6-in. diameter ejector tube was planned, it was proposed to have the transducers swing into operating position after ejection. The later use of

21-in. diameter torpedo tubes for ejection permits them to be installed in the projecting positions before release.

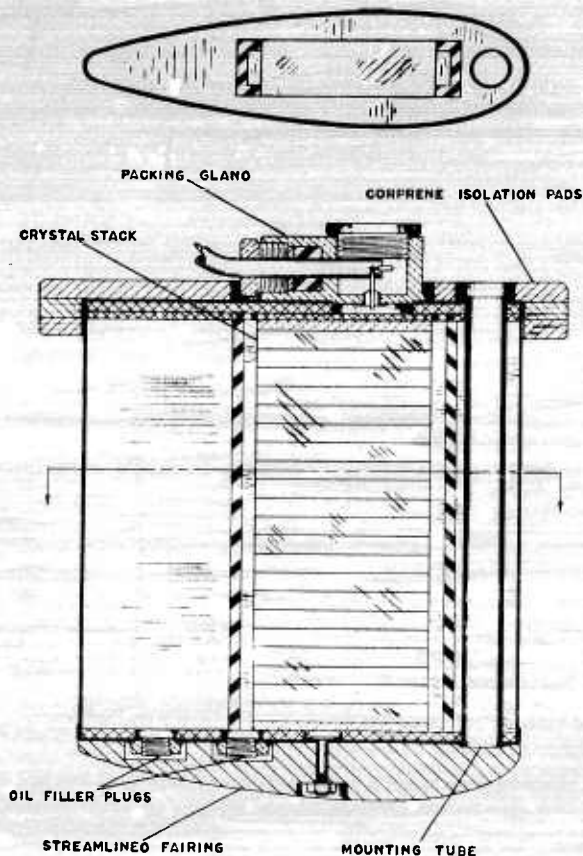

FIGURE 19. Sectional drawing of KC-2 transducer in NAD-6A.

ECHO-REPEATER AMPLIFIER

The amplifier for the beacon echo repeater was designed to provide the necessary gain for echo simulation and also to equalize the frequency characteristics of the transducers to provide a flat response for the system in the required region. The echo-repeater circuit for the beacon is shown in Figure 21. For the output stage, a pair of shunted 6V6 tubes operating in Class AB, with self-phase inversion satisfies the output requirements of the amplifier. The 6V6 tubes are coupled to the transducer through a series coil wound with two identical sections on a powdered iron core. Circuit elements are selected to provide resonance near the center of the 13- to 30-ke echo-ranging spectrum. The frequency response of the output stage and

transmitting transducer added to the frequency response of the receiving transducer were used to determine the amount of equalization needed in the amplifier to give a flat system.

This correction is provided in the band-pass circuit which uses high- Q coils overcoupled capacitatively to obtain a double peak response. The similar corrections made for the NAD-10 are shown in Figures 47 to 51. Figure 22 shows the resultant over-

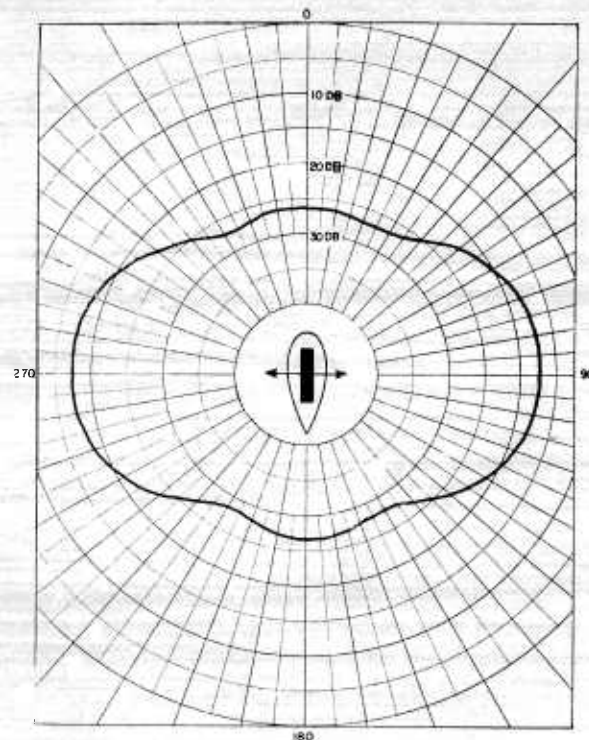

FIGURE 20. Directivity pattern of KC-2 in horizontal plane.

all response of the NAD-6 echo-repeater system which is flat to ± 2.2 db from 14 to 27 ke. The rapid attenuation outside this band protects the system from extraneous noises.

AMPLIFIER POWER SUPPLY

The B-power requirements for the amplifier were 400 v at 100 ma. The filaments are connected in series to the battery. A 24-v sea battery was constructed for the power source, and a 24-v synchronous 180-c vibrator power supply was designed, delivering 400 v at 100 ma and drawing 3 amp from the battery. The power supply appears schematically in Figure 29.

SECRET

BODY DESIGN

The 6-m. diameter body wall for the beacon was made of 24ST aluminum, $\frac{1}{8}$ in. thick. Calculations based upon reference 96 indicated that a shell of these dimensions would withstand 400-ft sea pres-

at high speed was needed to minimize the rolling torque applied to the body by the propulsion system. Calculations from the drag data based on reference 95, indicated that a low-pitch propeller should be 50 per cent effective for the beacon operation. In

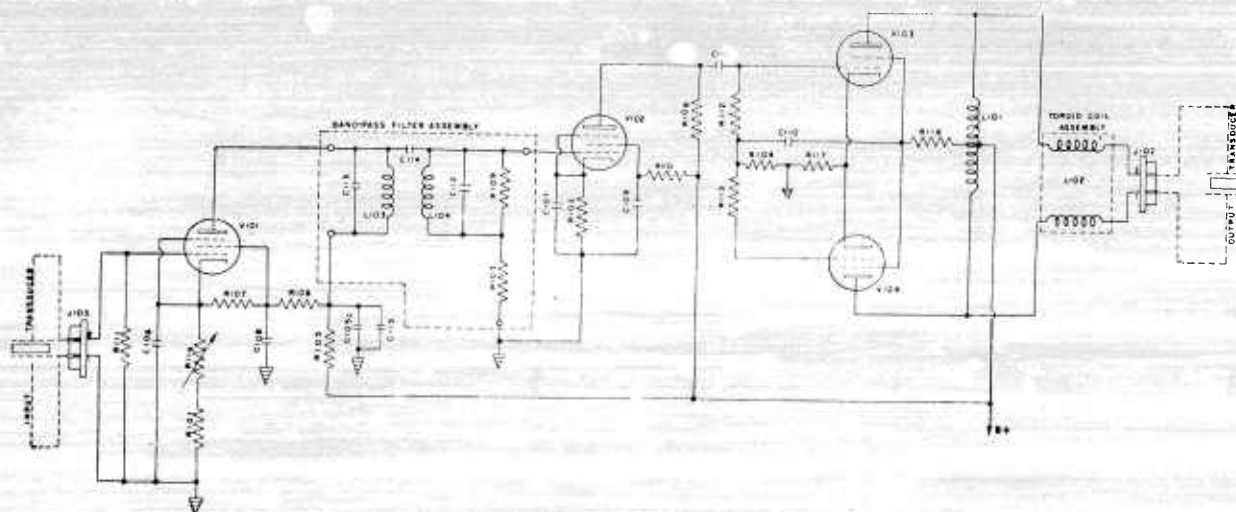

FIGURE 21. Echo-repeater amplifier circuit.

sure, or 176 psi. The streamlined housings for the transducers were then developed and a completed beacon body was towed to determine the body drag at speeds from 2 to 5 knots. Measurements indicated that $\frac{1}{20}$ hp, effective power, would drive a beacon of this design at 4-knot speed.

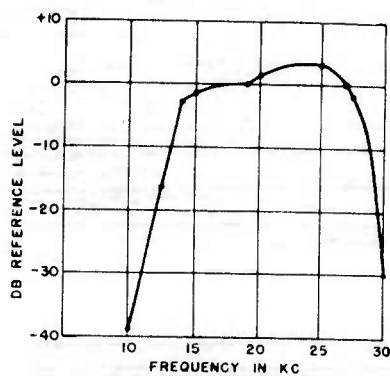

FIGURE 22. Frequency response of NAD-6 echo repeater system.

PROPULSION SYSTEM

A single-propeller drive was chosen for the beacon in order to avoid the complexities of counterrotating propeller systems. A low-pitch propeller operating

order to attain a speed of 4 knots with such a propeller, a high-speed series-wound motor was used which delivers approximately $\frac{1}{8}$ hp at 7,500 rpm under load. The propeller matches the motor speed for 4 knots, and is a four-bladed true-pitch propeller, 2 in. in diameter and 1.24 in. in pitch. The rolling torque moment on the body is compensated for by shifting the center of gravity of the power supply away from the centerline of the beacon.

COURSE CONTROL

Both magnetic and gyro course control units were developed for the beacon by the L. N. Schwien Engineering Company. The magnetic control was completed first. The gyro course control used in all of the NAD-6 beacons is similar to that in the NAD-10, the only difference being that the former is wound for 24 v while the larger unit operates on 12 v. This gyro control was used in all of the NAD-6 beacons and is covered in detail in the report prepared by the Schwien Engineering Company.⁹⁸

DEPTH CONTROL

The depth-control system used in the NAD-6, like that in the NAD-10 shown in Figure 39, utilizes a simple commercially available Pressuretrol. Es-

essentially, this system incorporates the sylphon-bellows depth control and the pendulum body-inclination control that are found in the more complex systems that govern high-speed torpedo operation. Mercury switches actuated by the sylphon control the solenoid-operated depth elevators. This unit is discussed further in connection with the NAD-10 in Section 6.6.2. A dial to control the depth selection is brought to the exterior of the NAD-6 so that the running depth can be set from 50 to 100 ft just before release.

SEQUENCE TIMING

Two consecutive time delays were needed for beacon operation. The gyro needs an initial period of 45 sec in which its motor can come up to speed before assuming control of the beacon course, this period starting from the application of voltage. With the sea-water activated battery, voltage production begins as soon as the beacon is placed in the torpedo tube and the tube is flooded. This same 45-sec interval is needed to allow time for complete flooding of the torpedo tube and for opening the outer door. The propulsion motor starting at the end of the 45-sec delay takes the beacon out of the 20 to 23-ft tube at 4 knots speed. To make sure that the beacon does not start its echo repeating until clear of the submarine, a second time delay of at least 35-sec duration after the start of propulsion is required.

Amperite thermal time-delay tubes were used in preference to a spring-driven clock mechanism since their operation would commence at the same time that voltage was supplied to the rest of the beacon. The first delay was provided by a tube which closed a relay 90 ± 45 sec after application of voltage to its heater, providing a 45-sec minimum. The second delay initiated by the closing of this relay, was 55 ± 20 sec, giving a 35-sec minimum.

The sequence timing unit for the beacon was developed with Amperite time-delay tubes shown in Figure 23. In the first beacons, the two tubes simply operated in sequence. In later models the operations were further controlled by the release switch and safety switch. These changes permit the beacon to be loaded into the torpedo tube and flooded without commitment to release it. Activation of the battery applies voltage to the gyro motor and at any time after 45 sec the first time delay permits the beacon to be released, but propulsion does not begin until

the release switch is operated from the exterior of the breech door. Echo repeating and noise simulation are initiated by the second time delay 35 sec after propulsion begins. Operation of these units is

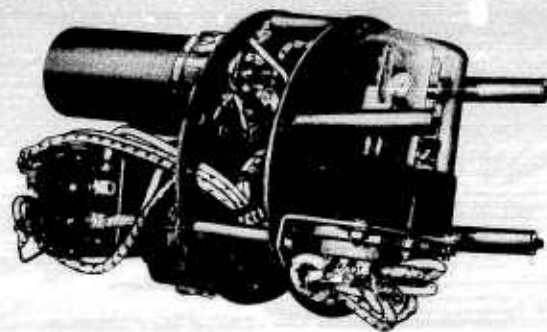

FIGURE 23. Control section in NAD-6A.

further controlled by the safety switch which opens their circuits at depths below 125 ft. The sequence of operations in the NAD-6A can be seen from the circuit drawing in Figure 29.

The electric timing mechanism substituted in the

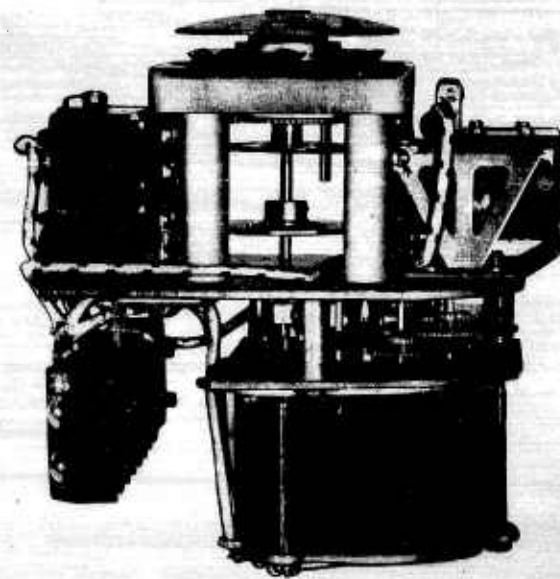

FIGURE 24. Timing motor in NAD-6B.

NAD-6B design provides a fixed initial delay of 45 sec, and an adjustable delay, from 0 to 10 min, which is started by the release switch. The timing unit consists of the motor shown in Figure 24 with

two timing cams, one fixed and one adjustable. Tests of three experimental NAD-6B beacons showed satisfactory performance and the new timing mechanism was accepted for any future units.

POWER SOURCE

The development of sea-water activated batteries to supply 24 v to drive the NAD-6 beacon was initiated early in the program. Before these became available, lead-acid batteries were used in test runs. Interchangeable nose sections were designed for the



FIGURE 25. Nose section with lead-acid batteries.



FIGURE 26. Nose section for sea battery operation.

beacon. The exercise heads contained four Willard NT-6 batteries as shown in Figure 25. The so-called war heads containing the BTL 17-3-E sea battery, discussed in Chapter 8, are illustrated in Figure 26.

SELF-NOISE GENERATOR

In developing the NAD-6 evaluation model the design was changed from the first experimental model to include simulation of submarine self-noise. After preliminary investigation of an adaptation of the FXP noisemaker and a cam-driven noisemaker, the gear-driven mechanism shown in Figure 27 was developed. This device simulates both gear whine and propeller cavitation noise.

In the NAD-6 noise generator, the noises are produced by three gear-driven pads which rest

against the wall of the beacon tube. Two of the pads are driven at 300 c to simulate gear whine, and the high-frequency components are damped out by means of a neoprene pad to produce a fairly pure tone. The third pad is driven at a higher rate and the harmonics are retained to produce a wide-band output. The gear driving this pad is made eccentric so that the output is amplitude-modulated twice a second to simulate a propeller thrash of 120 rpm.

The output spectrum of the NAD-6 resulting from these two noisemaking heads is shown in

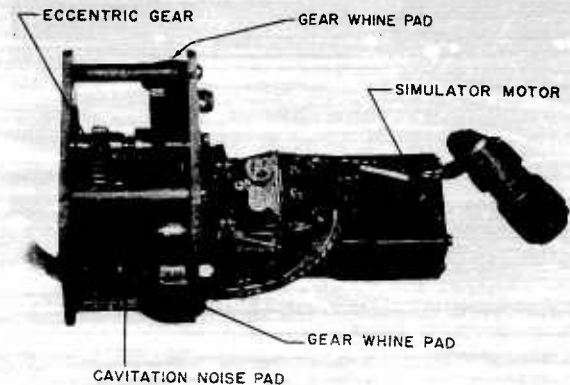

FIGURE 27. Self-noise simulator mechanism.

Figure 28. The overall output for a band from 0.02 to 100 kc is 64 to 71 db above 1 dyne per sq cm at 1 m, or 18 to 25 db at 200 yd, which is about the same as that of a reduction-gear-driven fleet-type submarine at 6 knots. The peak frequency of the beacon

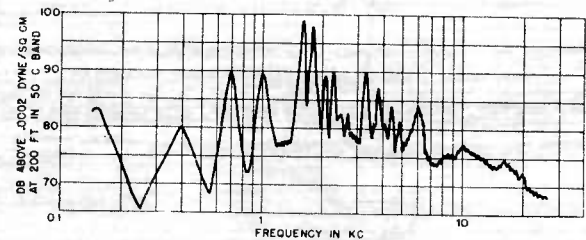

FIGURE 28. Frequency characteristic of NAD-6 noise output.

output is at 1.7 kc. Four peaks of lower level are seen to occur in the echo-repeater spectrum at 14.4, 15.9, 23.5, and 24 kc. At first it was thought that these components would start feedback in the echo repeater. Later tests showed that the echo repeater did enhance these frequencies, but no oscillations

were set up, and the effect served to improve the BDI image of the target.

RELEASE MECHANISM

The operation of the release mechanism can be seen from Figures 30 and 31. The fairing on the lower transducer is attached to the securing clamp and pinned with the free part of the release cable. The clamp is then locked and the cable is coupled to the line that runs through the breech door. When the door is closed, the tube is flooded and voltage production begins. The outer door is opened. At the will to fire the beacon is released by winding in the cable, which releases both the propulsion motor starting switch and the attachment of the fairing to the clamp.

6.5.3 Operation of the NAD-6A Sound Beacon

The operation of the NAD-6A can be summarized as follows. The depth-control dial is set to the required operating depth (from 50 to 150 ft). The course-control dial is set to the required operating course (from 90 degrees right to 90 degrees left for an angle relative to the direction of the torpedo tube). The beacon is then installed in the torpedo tube.

Flooding of the tube activates the battery and

leasing switch is pulled during this initial delay, it does not take effect until the 45 sec have elapsed. The beacon may be held in the tube after flooding, but since the battery is activated and the gyro running, any delay in releasing decreases the length of run of the beacon. The decrease is approximately 30 per cent for each hour's delay.

At the will to fire the release cable is wound in and the beacon runs out of the tube at a speed of 4 knots, adopting its preset course which it holds to within $\pm 1\frac{1}{2}$ degrees and its preset depth within ± 4 ft. When beacons are released from tubes in the forward torpedo room they must be released from a right or left tube to correspond to the angle of their course deflection, to avoid collision with the submarine. Figures 30 and 31 show the beacon installed in the torpedo tube.

The operation of the release switch started the operation of the second time delay so that 55 ± 20 sec after the start of the propulsion motor the noisemaker and echo repeater start operation. This is only on condition that the beacon has reached a depth of 125 ft or less. At greater depths the pressure-operated safety switch prevents these functions from starting. In case the beacon becomes fouled in the superstructure or caught in a damaged torpedo tube the submarine can dive to below 125 ft, shut off the simulators and thus prevent the beacon from betraying its position.

Except for a change in the sequence timing

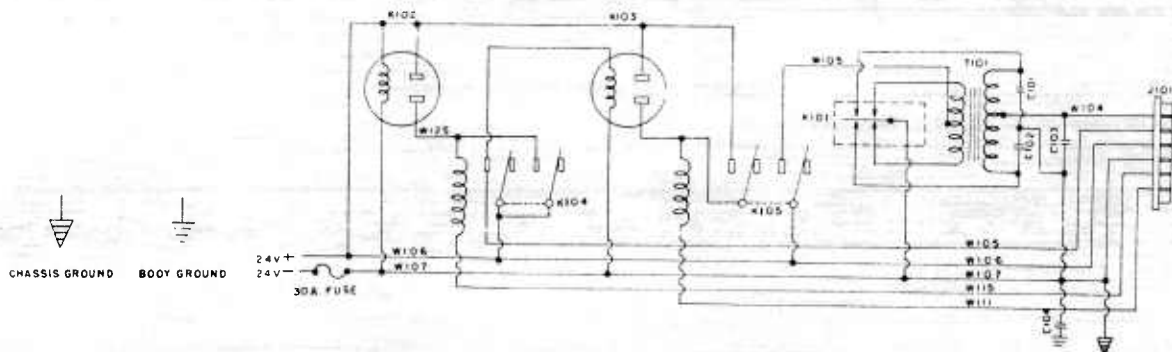

FIGURE 29. Timing circuit and power supply in NAD-6A.

supplies power to the gyro motor and to the first time delay. The sequence of events can be followed in the diagram of the control circuit shown in Figure 29. The torpedo tube outer door is opened. After 45 sec the gyro motor is up to speed and the beacon may be released at any time thereafter. If the re-

leasing switch is pulled during this initial delay, it does not take effect until the 45 sec. The second time delay initiated by the releasing switch can be set in advance for any interval from 0 to 10 min before the start of noisemaking by means of the control dial visible in Figure 32.

SECRET

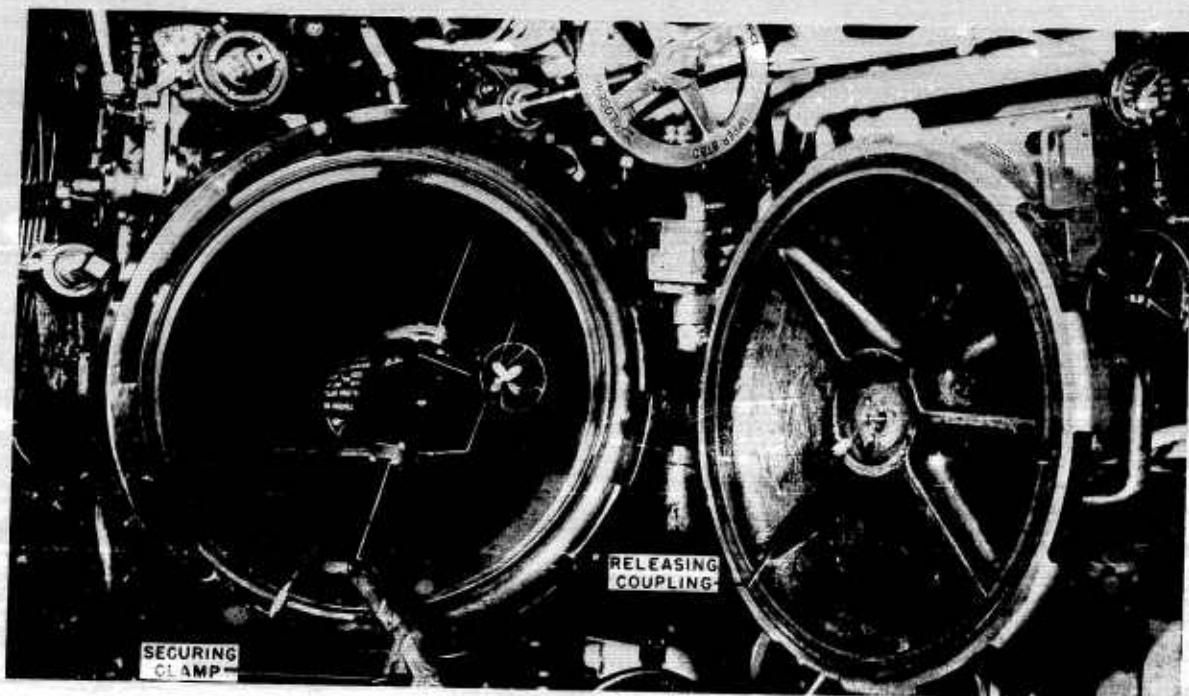

FIGURE 30. NAD-6A in torpedo tube with clamp attached but not locked.

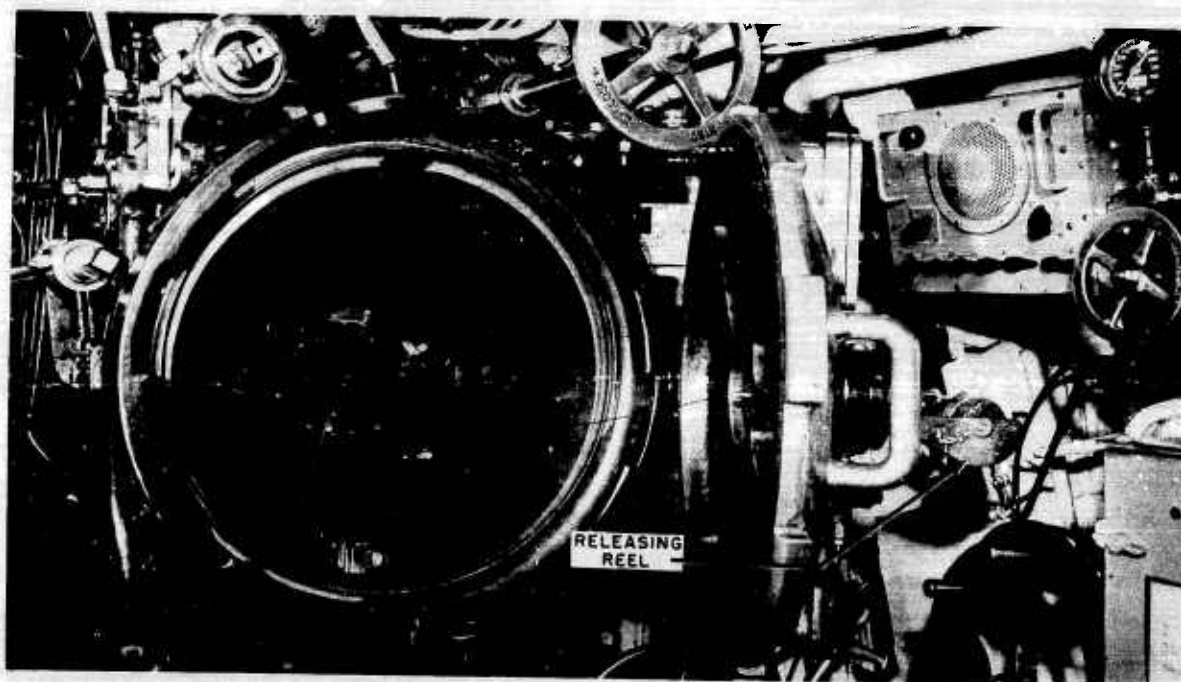

FIGURE 31. NAD-6 in torpedo tube with clamp locked and cables coupled.

SECRET

performed adequately in 13, and errors in assembly appeared to account for the failures.

In most of these tests the beacons were used in simulated combat conditions both against sonar operators who were familiar with the decoy and against crews who had never before encountered it.

The quality of the NAD-6 performance against echo ranging was evaluated for its audible echo, its trace on the chemical recorder, its BDI trace, and its noise in supersonic listening. The audible echoes were fairly realistic in quality, strength, and doppler. The escaping gas from the sea battery formed a light wake-like echo which added realism to the echo at oblique target angles.

The conclusions from these tests and from similar tests of the NAD-10 are summarized in Section 6.7. While the NAD-6 was recommended for immediate use by the fleet, the need for improvement in several features was indicated. The Navy report on these

tests can be found in reference 20. "The Submarine Evasion Devices Manual,"¹¹⁶ prepared to accompany the issue of the decoys and noisemakers, gives the directions for maintenance and operation of the beacons. More detailed information may be found in the instruction manuals.¹⁰⁴

Tests were also carried out at Pearl Harbor during the spring of 1945. These served to establish further tactical doctrine and led to a number of changes in the design which were incorporated into the NAD-6A model. These changes included the addition of the simulation safety switch, and the modification in the release mechanism which permits the beacon to remain in the tube without commitment to fire. The detailed results of the Pearl Harbor tests of the NAD-6 and NAD-10 beacons are covered in reference 111. Further details concerning the development of the NAD-6 may be found in the laboratory completion report.¹¹²



FIGURE 33. NAD-10A sound beacon.

6.6

NAD-10 SOUND BEACON

The NAD-10 sound beacon is a self-propelled decoy developed to assist submarine evasion. It simulates the self-noise of a submarine making from 75 to 150 rpm and returns echoes with doppler which are equivalent to a submarine echo at any frequency from 14 to 28 kc. The NAD-10 runs out of a torpedo tube at 7 knots, adopting a preset course and depth. After 1 min the speed drops to $3\frac{3}{4}$ knots, and after a predetermined time delay noise-making and echo repeating begin. Gear whine and

propeller cavitation corresponding to a selected rpm are simulated by an electronic circuit driving a magnetostriction projector. The overall noise output level for a band from 0.02 to 100 kc is 72.5 db above 1 dyne per sq cm for 1 m. Life of the unit is 1 hour when using a primary battery, or 45 min when using a secondary battery. The NAD-10A is 101 in. long and weighs 260 lb in air. The NAD-10 was developed by UCDWR and at the termination of the NDRC contract, the program was transferred without interruption to Navy auspices for further study.¹¹³

6.6.1

Experimental Development

The NAD-10 development was carried out in parallel with the work on the other decoys. Early

in the decoy program when it was found that tooling was complete and parts were available from the abandoned Mark 30 mine development, it was decided to adapt the body and propulsion system

SECRET

In case of a war shot the beacon continues on its course, making noise and returning echoes for the life of the sea battery, which is 35 min or more. When propulsion ceases, the elevators no longer control the beacon's depth and, ballasted as a war shot, it sinks to the bottom. A beacon equipped with a sea battery and ballasted for a practice run sur-

an important part of their detection methods. Accordingly the subsequent NAD-6 program was directed towards developing a beacon which would have both echo repeaters and a self-noise simulator while incorporating the indicated changes in the control system.

The NAD-6 evaluation model, incorporating the

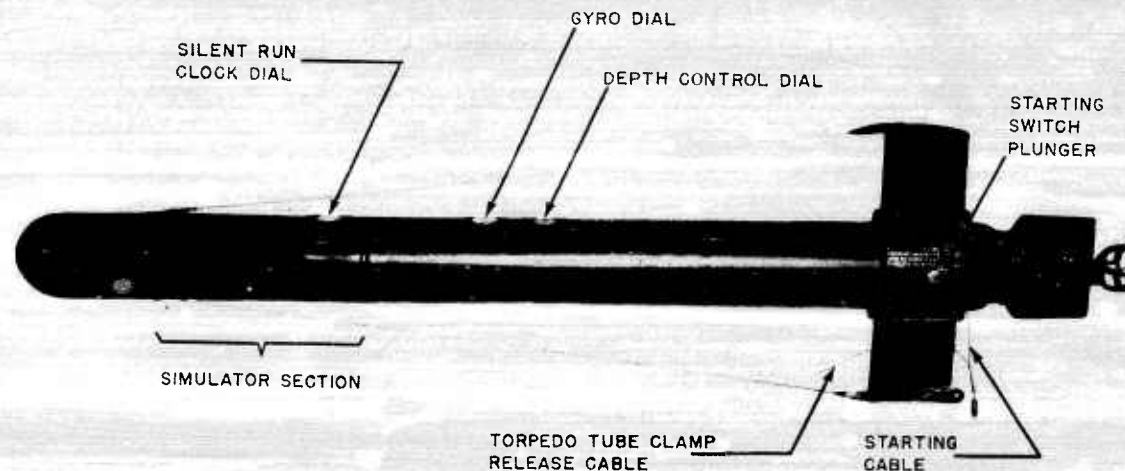

FIGURE 32. NAD-6B sound beacon.

faces when the power ceases. Units equipped with the lead-acid batteries in the exercise-head nose sections have a life of only 6 min and are ballasted to float at the end of the run.

6.5.1

Performance Tests

The first experimental model of the NAD-6 was ready for test in July 1944. This unit had the echo-repeater system, the propulsion system, the gyro course control, the depth control, the first sequence timing system described above, and was powered with lead-acid batteries. Running tests of the beacon indicated generally good performance of the course and depth control systems although a need for increased size of the control surfaces was seen. The feasibility of this echo-repeater system was established.

At this time it was agreed that submarine self-noise simulation must be included in any acceptable decoy. The enemy was known to be using both sonic and supersonic listening as well as echo ranging as

simulator and with control surfaces increased in area, was tested at San Diego in January 1945. This unit is shown disassembled in Figure 17. Except for the pressure-operated safety switch and the exterior starting switch this unit's characteristics were essentially the same as those of the NAD-6A.

This unit was released from the torpedo tubes of submarines in several tests, which served to establish techniques of launching. The echo-repeating and noisemaking performance of the beacon was considered satisfactory, as well as its mechanical operation, and an order for the production of 500 units was authorized by BuShips.

The NAD-6 beacon was also tested by ASDevLant in the course of the evasion devices evaluation program carried out in Florida during the spring and summer of 1945. These tests had no influence upon the further modification of the beacon design, but served to analyze its tactical value. Three of the evaluation model NAD-6 and four later production models of the NAD-6A were supplied. These beacons were ballasted for recovery and all were used several times over. Of 18 runs made, the beacons

SECRET

from this 10-in. diameter unit for a preliminary mockup of the self-propelled decoy which was at that time to have a 6-in. diameter in its final design. When the 6-in. diameter limitation was removed



FIGURE 34. Evaluation model NAD-10.

the development of the 10-in. decoy was carried to completion, providing a third type of NAD.

The NAD-10, completed in the NAD-10A production model, differs from the NAD-6 and NAD-3

from 75 to 150 rpm and so the noise can be made to agree with the actual speed of the decoy. Like the NAD-6, its running depth can be adjusted, in this case from 10 to 90 ft. Selection of course and length of silent run are provided as in the NAD-6B. Course and depth control in the NAD-10 are essentially the same as those in the other decoys. In the NAD-10 the length of the high-speed clearing run is adjustable during assembly and is usually set for a period of 1 min. Unlike the mechanical simulators in the other decoys, the self-noise generator in the NAD-10 is a magnetostriction loudspeaker driven by a complex electronic signal which provides good simulation of gear whine and cavitation noise from 100 c up to 30 kc.

The NAD-10 Model 1 was constructed after several months in which its various components had

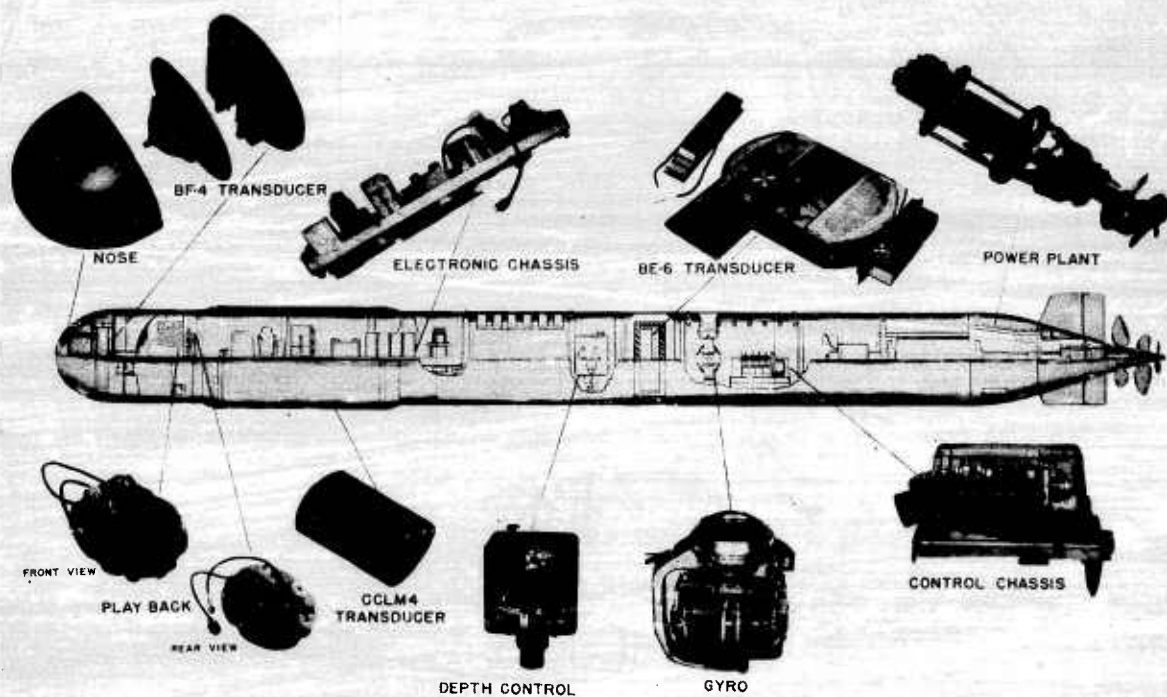

FIGURE 35. Exploded view of evaluation model NAD-10.

in its larger size, longer life, and the greater flexibility, in general, of its provisions for simulating a variety of conditions of submarine operation. For example, its self-noise simulation frequencies can be adjusted to correspond to submarine shaft rates

been developed separately. The two-propeller propulsion system and much of the body construction of the Mark 30 mine were used in this model. A third propeller on a concentric shaft provided the low-speed drive. This makeshift propulsion system

SECRET

necessitated extra length in this unit which was to be removed in later models when a two-speed single-propeller drive was complete. The final depth and course control systems were complete for the Model 1, however. The magnetostriction loudspeaker was in its final form although at this stage a magnetic wire recording was used to provide its signal. The echo-repeater system for the Model 1 used the BF4 as a receiving transducer and the BF6 as a transmitter. These designs were modified further for the final NAD-10A design.

After preliminary tests had indicated the satisfactory performance of NAD-10 Model 1, 11 more

run, and of a simulation safety switch were requested by the Navy.

The final production model NAD-10A included all of these modifications. The first 80 of the contracted 500 units were produced to be the same as the NAD-10 prototype. These were later modified by hand in the NAD shops at Pearl Harbor and San Diego as NAD-10 primes with the same operating characteristics as the final model. The only difference is that the NAD-10 primes still used lead-acid batteries. Production of the Edison primary batteries was not completed before the end of the war so that the NAD-10A, although used exten-

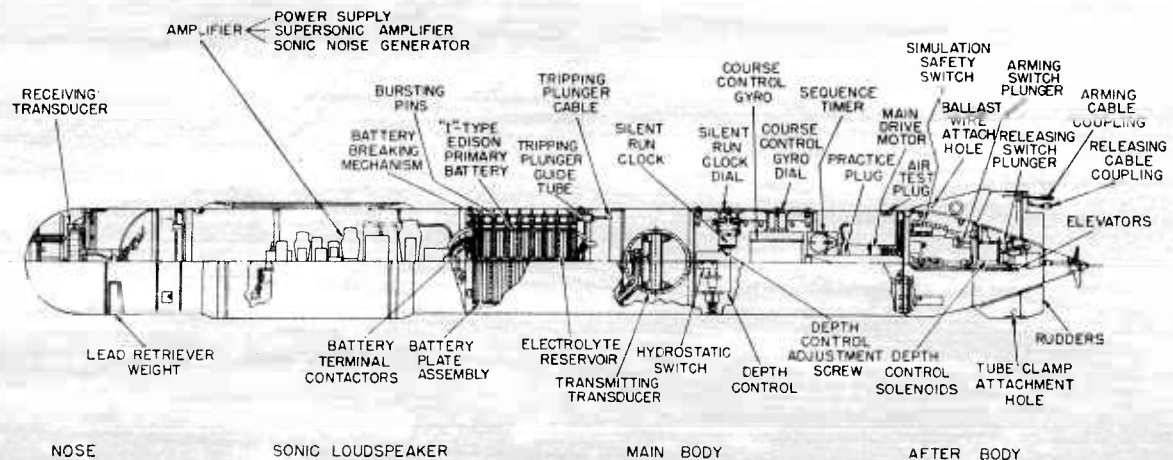

FIGURE 36. Assembly drawing of NAD-10A.

units of this design were constructed for Navy evaluation tests both at Pearl Harbor and at ASDeVlant. The evaluation model is shown in Figures 34 and 35.

A more advanced design, the NAD-10 prototype model, was also completed in time for these tests. For this unit the single-propeller two-speed drive was completed, and the self-noise simulation was provided from an artificial electronic signal as subsequently adapted for the final design.

Production of 500 models of this NAD-10 design was begun on a contract authorized by the Bureau of Ships at the request of ComSubsPac. Meanwhile the results of the evaluation tests indicated the need for further changes in the design. While lead-acid batteries could be used in test units, their use was not permitted aboard submarines on patrol. The further additions of arming and releasing switches which could be operated from the exterior of the tube door, of a selector for the length of the silent

run, and of a simulation safety switch were requested by the Navy.

sively for training purposes in evasion exercises, was not available for use against the enemy. The development of the NAD-10 series of decoy designs is covered fully in the completion report on the device.¹¹³ The instruction manuals for the NAD-10 prime and the NAD-10A¹¹⁰ give detailed information on the construction, maintenance, and operation of the production models. Information about the work continuing in decoy design should be obtained from the Navy Electronics Laboratory at San Diego or from Code 940 of the Bureau of Ships.

6.6.2

NAD-10 Components

BODY DESIGN

The construction of the NAD-10A, shown schematically in Figure 36, was based upon the body of the Mk 30 mine. The space left free by removal of

SECRET

the explosive charge and the special control systems was adequate to house the acoustic and electronic system for the decoy, and it was hoped that the propulsion and control systems used in the mine could be adapted directly to the decoy. This proved impossible, although much of the body tooling was retained, and the production techniques set up for the mine project were transferred to production of the decoys. In initial runs the elevator and control surfaces of the mine design were cut down to the 10-in. OD of the body cylinder, but this led to such erratic operation that the surfaces were again enlarged with the final construction as shown in Figure 33. With the course and depth controls adopted for the final unit, the beacon proved to be stable for both high- and low-speed operation.

RETRIEVER SYSTEM

For the experimental runs and for beacons which were to be used in training exercises, it was necessary to provide some sort of retriever system. After some investigation of the waterhead principle used in practice torpedoes, a drop-weight mechanism was developed. Buoyancy considerations make it desirable to have the beacon within 2 per cent of

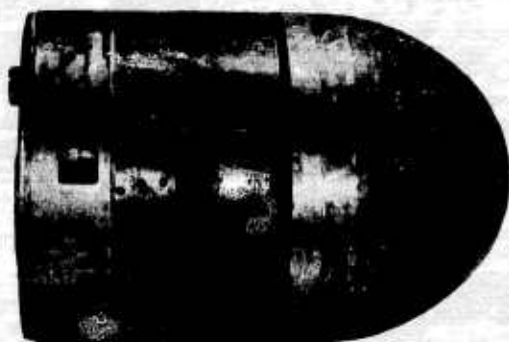

FIGURE 37. Ballast weight in retriever system.

neutral buoyancy when ballasted to sink, and for easy visibility at the surface the positive buoyancy when floating must be 2 per cent or more. As shown in Figure 37 a semicircular lead ballast weight, initially provided in the mine, was adapted to provide this change of buoyancy. A steel pin in the top of the weight is notched and snapped in place over a sear. This sear is actuated by a solenoid so that a signal from the control circuit described below with-

draws the sear, allowing the weight to fall free. This system proved completely reliable and required no further change.

PROPULSION SYSTEM

The propulsion system in the Mk 30 mine used two counterrotating propellers to provide a speed of 12 knots. It was clear that the two-speed propulsion required for the beacon's performance at approximately 7 and 3 knots could not be supplied efficiently from this same system. After some experimentation with changes in the supply voltage to produce the needed drop in speed, a makeshift construction was developed for use in the first evaluation models. The shaft of the two-propeller drive was rifle-bored to take the shaft for a third propeller which was driven from a second motor to supply the low-speed drive. The two in-line motors and three propellers appear in Figure 35. For the NAD-10 prototype and subsequent models a single propeller system was used. The drive motor is a compound wound, 12-v d-c motor, capable of delivering 5 $\frac{1}{2}$ hp at 2,800 rpm with reduced field excitation. A series-dropping resistor reduces the voltage across the shunt field in the initial high speed run. When this is shorted out at the end of a time delay, the increase in field excitation lowers the beacon speed. This operation is indicated in Figure 57.

COURSE CONTROL

Tests of the Mk 30 mine gyro showed that its rate of precession, although not detrimental to mine operation, was unacceptable for the beacon. The Schwien gyro which had been adapted for the NAD-6 beacon operating on a 24-v supply was accordingly rewound for 12 v and used in the NAD-10. The precession of this unit, shown in Figure 38, is less than 6 degrees for 30 min of operation. The details of this unit are covered in reference 98.

DEPTH CONTROL

The motorized depth control system needed for the Mk 30 mine was unnecessarily complicated for the purposes of the beacon. A simpler design of Pressuretrol obtained from the same manufacturer was adapted for use in both the NAD-10 and the NAD-6. Figure 39 shows its installation in the NAD-10. An internal adjustment permits the beacon to be set for operation at any depth from 10 to 90 ft. Although these pressure-control units had

SECRET

been designed to operate in a rigidly fixed vertical position as two-point systems of control, they exhibited a unique proportionate control property when electrically connected to the elevator system of a free body and mechanically attached to its hull. Under these circumstances the maximum angle of

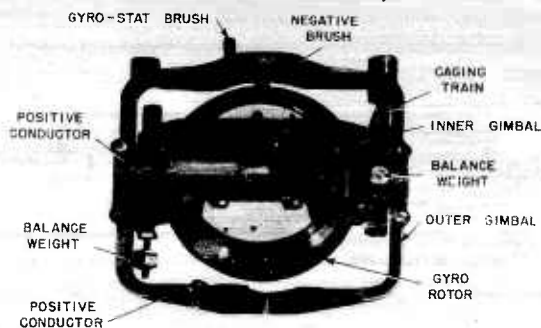

FIGURE 38. Schwien gyro in NAD-10.

dive or climb of the free body is limited by the number of feet that the body is above or below set depth.

The syphon bellows actuated by static sea pressure works against a freely pivoted rocker arm into an adjustable spring load. The motion of the rocker arm is transmitted through a lever system to a pivoted arm or bracket on which are mounted two mercury switches. An adjustment screw located at the top of the case provides a means of regulating the tension of the spring load, and a scale attached to the after side of the case provides an index for setting the spring tension to operate the body at a desired depth.

The mercury switches are so adjusted that they energize one or the other of the elevator solenoids whenever the switch bracket arm is one or more degrees from the horizontal position. That is to say that the mercury switches are 178 degrees apart and the bisector of the angle formed by them is normal to the switch arm. Thus the mercury switches, by controlling the elevators, will tend to regulate the angle of climb or dive of the body so as to hold the arm in a level position. Should the target be launched from (or otherwise attain) a depth which is not the same as the setting of the adjustment screw, the difference between the moment exerted by the pressure bellows and that exerted by the tension spring will rotate the arm so that it lies at an angle to the axis of the hull. As a consequence the

mercury switches produce control-elevator movement to return the arm to a level position and thereby put the body into a climb or dive. The rocker arm moves between mechanical stops which limit the maximum angle of dive or climb of the body to 14 degrees. When the body is 20 or more feet from its set depth, the arm is rotated until it comes to rest against the mechanical stop and the body assumes its maximum angle of climb or dive.

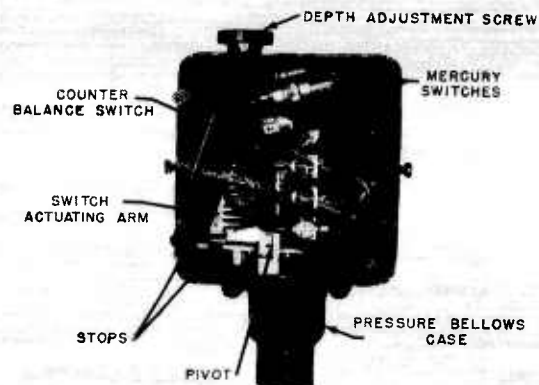

FIGURE 39. Pressuretrol in NAD-10 with dust cover removed.

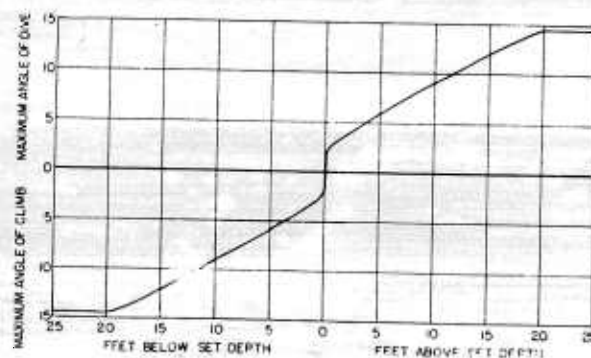

FIGURE 40. Performance characteristics of NAD-10 depth control.

Water pressure differentials equivalent to a depth error of less than 20 ft will produce a proportionate movement of the arm, and the angle of a climb or dive approaches zero as the target approaches set depth.

The mechanism is so arranged that when the beacon is running at set depth and on a level course, neither of the mercury switches is in a closed position and the body may pitch through an angle

± 2 degrees without producing a controlling signal.

Assume that the beacon is released at a depth greater than set depth. Under these circumstances the "up" mercury switch on the depth control unit is closed. The beacon begins climbing toward its set depth, and when its maximum angle of climb is reached, the mercury switch breaks the circuit and the control surface is returned to its neutral position by the centering spring. If the maximum angle of climb is exceeded, the "down" mercury switch closes, and the body is brought back to its maximum angle of climb. As the beacon approaches its set depth, the maximum angle of climb becomes smaller and smaller according to the curve given in Figure 40 until the set depth is reached. If the beacon is re-

leased above its set depth, the down elevator section of the control unit is actuated in a like fashion, and the beacon assumes its maximum angle of dive until set depth is reached.

The depth control unit is set by the manufacturer

TRANSMITTING TRANSDUCER

The design of transducers for use in the echo-repeater system in the NAD-10 necessitated a num-



FIGURE 41. Exploded view of BG-2 transmitting transducer.

ber of changes from previous echo-repeater practice. After some consideration of using transducers that would be mounted outside the body as in the NAD-

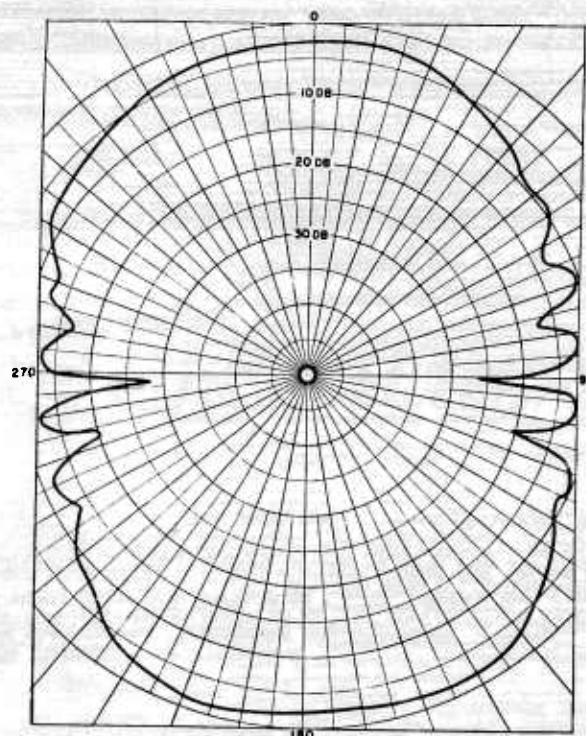

FIGURE 43. Horizontal directivity pattern of BG-2 transmitting transducer.

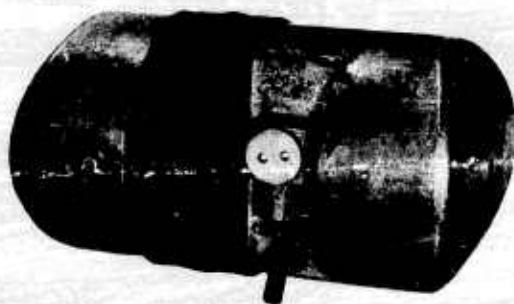

FIGURE 42. BG-2 transmitting transducer, assembled.

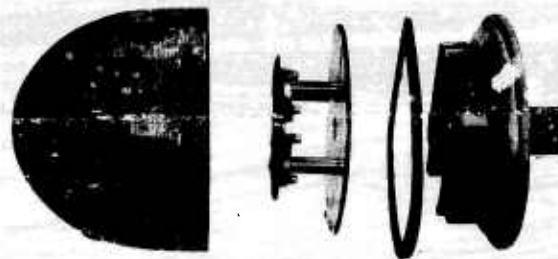

FIGURE 44. Exploded view of BF-6 receiving transducer.

for a running depth of 50 ft which is the recommended setting. This setting may be changed by rotating the knurled adjustment screw on top of the

depth control unit is set by the manufacturer

SECRET

plane, normal to the beacon axis, with a minimum at bow and stern.

RECEIVING TRANSDUCER

The receiving transducer was initially designed in the BF-2 model to have two crystal motors identical to those of the transmitter, but it was found that the response at the lower end of the frequency range was insufficient when the peak frequency was at the center of the range. The crystal length was changed accordingly, with the motors of the BF-4 and the final BF-6 consisting of 20 45-degree Y-cut Rochelle salt crystals, each $1\frac{3}{16} \times 1\frac{1}{4}$ in., with a frequency characteristic as shown in Figure 47. These two motors are connected 180 degrees out of

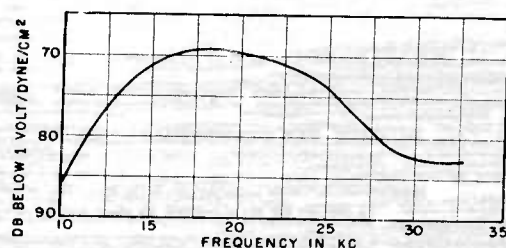

FIGURE 47. Frequency characteristic of BF-6 receiving transducer.

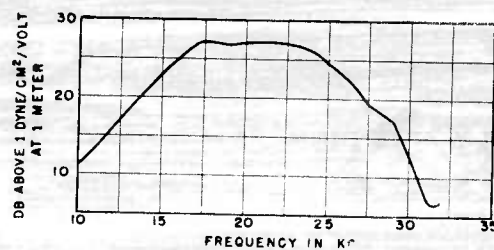

FIGURE 48. Frequency characteristic of BG-2 transmitting transducer.

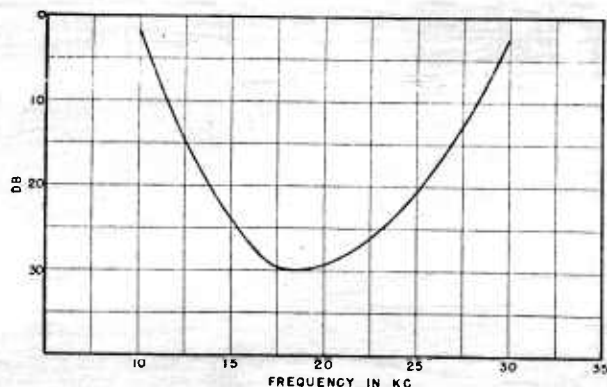

FIGURE 49. Combined response of BF-6, BG-2, output tubes, and peaking coil.

phase to increase further the isolation of the receiver from the transmitted signal. The BF-6, used in the final model and shown in Figure 44, differed from the BF-4 of the evaluation model only in mechanical changes made to increase its strength and ease construction and maintenance. The horizontal directivity pattern for the BF-6 is shown in Figure 45.

ECHO-REPEATER AMPLIFIER

The transducer characteristics of the BF-6 receiver and the BG-2 transmitter were combined as the basis for the echo-repeater amplifier design. The circuit used, shown in Figure 46, is of a type that had become standard for the practice target development. A pair of 6V6 tubes deliver the re-

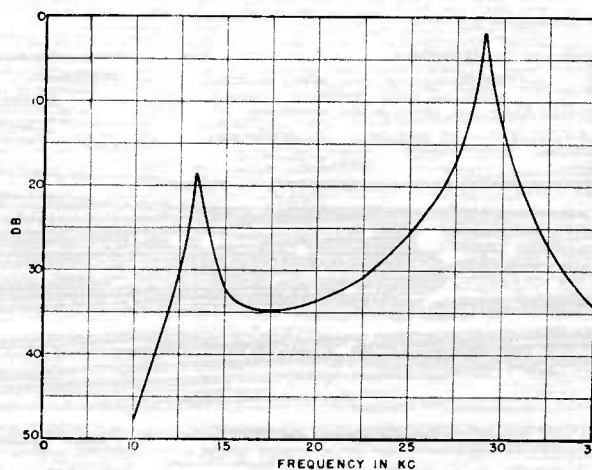

FIGURE 50. Band-pass characteristic of equalizer network.

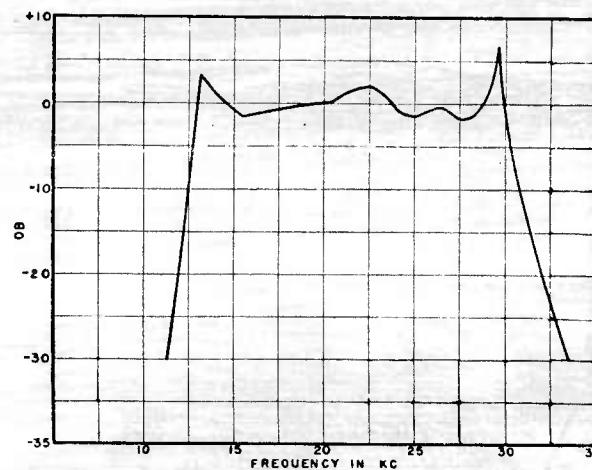

FIGURE 51. Frequency response of NAD-10A echo repeater.

SECRET

quired power to the transmitter through two series peaking coils. The frequency response of the output stage, the peaking coils and the transmitting transducer, added to the response of the receiver, indicated the amount of equalization required. These curves are shown in Figures 47-50. Two stages of preamplification were used, and the equalizing circuit inserted between them. The resultant characteristic is shown in Figure 51. Thus the acoustic response of the echo-repeater system measured along a beam aspect is flat within ± 1 db from 14 to 28 db and within ± 5 db from 13 to 29.5 kc. The rapid attenuation outside this band prevents the reception, amplification, and retransmission of unwanted noise. A discussion of this development is found in reference 106.

LOUDSPEAKER DESIGN

The magnetostriction loudspeaker for the NAD-10 self-noise simulation system was developed by A. L. Thuras at NLL at the request of UCDWR. Hitherto low-frequency noise production had relied upon mechanical generators in the 3-in. and 6-in. devices. The 10-in. diameter of the NAD-10 made it possible to develop a magnetostriction projector with satisfactory output at low frequencies. A number of experimental units were constructed in order to obtain the optimum efficiency and frequency re-

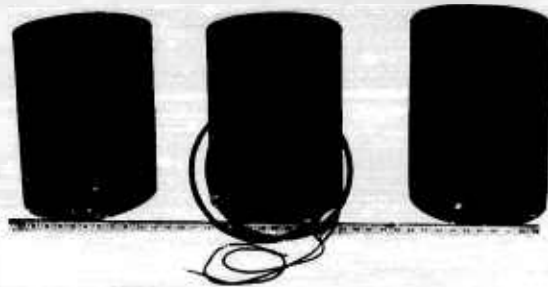

FIGURE 52. CCLM4 loudspeaker in primary stages of construction.

sponse. The CCLM4 unit which was adopted for the evaluation unit and all subsequent designs is shown in preliminary stages of construction in Figure 52. This is 11 in. in diameter, and consists of a 0.021-in. nickel cylinder wound with No. 16 insulated copper wire. The speaker is impregnated with the thermoplastic polythene, providing a satisfactory water-

proofing jacket without interfering with the acoustic performance. The mechanical resonance of this unit is at a frequency of 5 kc, but the impedance match in water makes its mechanical Q so low that the response is virtually flat in the desired range. The compliance of the main body tube serves as a pressure release for the inner surface of the speaker. The frequency response of the CCLM4 is shown in Figure 53.

SELF-NOISE SIMULATION

For the simulation of submarine sounds in the training program at UCDWR both magnetic wire recordings of submarine operation and artificially

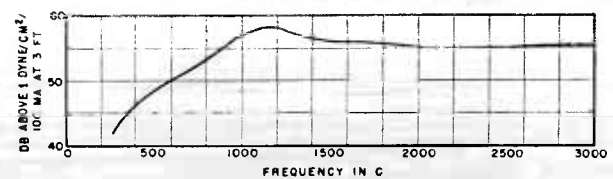

FIGURE 53. Frequency response of CCLM4 loudspeaker.

generated signals had been used. The wire recorder system used with the early beacon models, visible in Figure 35, displayed a low signal-to-noise ratio, considerable trouble with tube microphonics, and a narrow-band frequency response. For the production models the signal to drive the loudspeaker was provided by an electronic circuit which simulated both gear whine and propeller cavitation noise. This circuit is shown schematically in Figure 54. The type 2050 gas tube, held above its striking potential, generates noise over the entire sonic and supersonic range. The amplitude of this noise is modulated by an oscillator network which covers the 1.25- to 2.5-c range and so can be adjusted to simulate propeller speeds from 75 to 150 rpm. The gear whine generator, a simple phase shift oscillator, can likewise be adjusted to give a fundamental whine frequency from 250 to 350 c, corresponding to submarine speeds from 4 to 6 knots. The relative levels of the gear whine and cavitation noises are controlled by the adjustment of the gear whine coupling condenser. While the beacon is disassembled for check the self-noise simulation can be adjusted to simulate the required conditions of submarine operation.

POWER SUPPLY

The power supply for the electronic systems using

SECRET

6.6.3 Operation of NAD-10A

The NAD-10A can be rigged to operate with either Edison primary batteries or with lead acid batteries. In addition, by insertion or removal of the practice plug, it can be adapted either as a war shot so that it sinks, or as an exercise shot so that it rises

beacon can be set, loaded, armed, and released in as little as 5 min.

When the arming switch is pulled, power is supplied to the gyro rotor, to the amplifier filaments, and to the timing motor. The sequence of operation can be followed in Figure 57. After 45 sec the first timing switch arms the release circuit and opens the

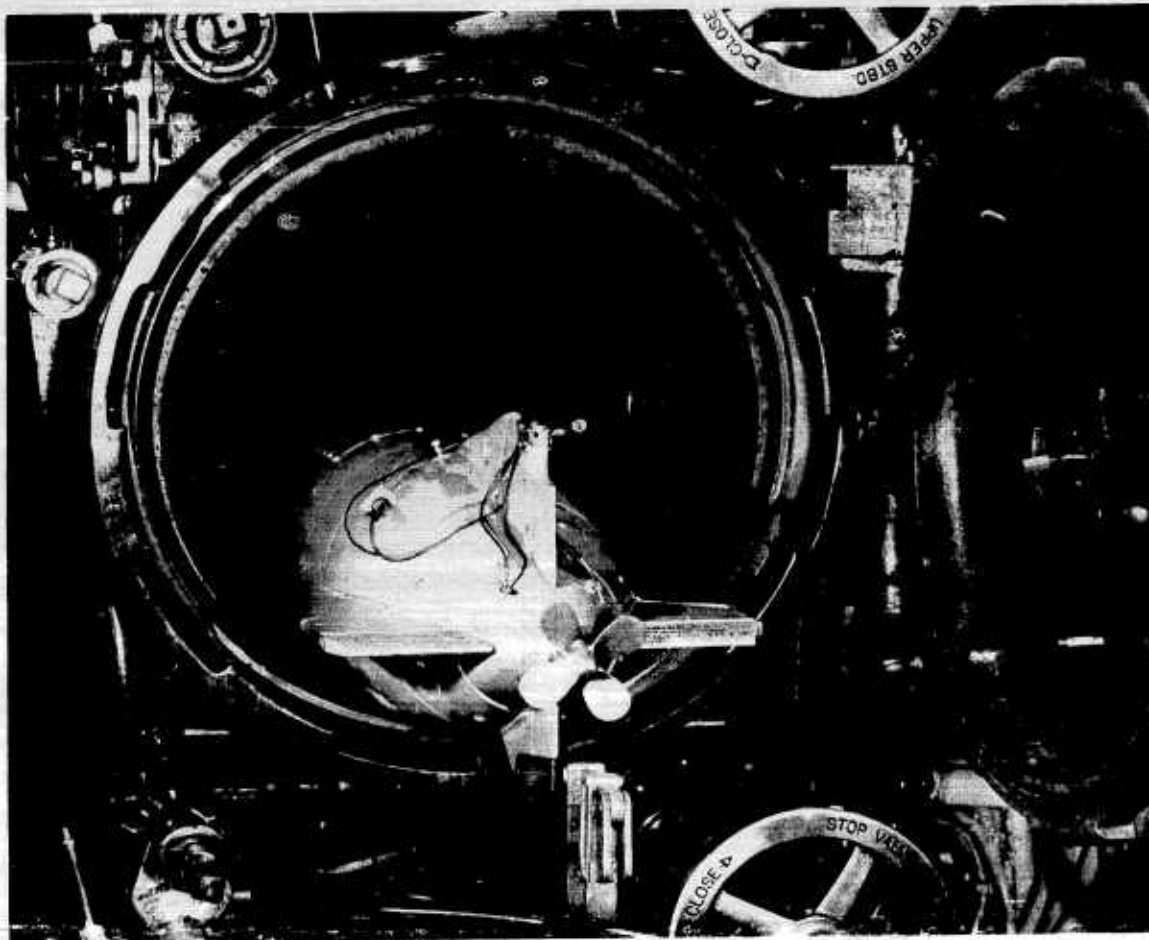

FIGURE 55. NAD-10A Beacon in torpedo tube with tube clamp attached.

to the surface for recovery. After the external controls are set for the selected course from 90 degrees right to 90 degrees left of the line of release, and for the length of silent run from 0 to 10 min, the beacon can be loaded into the torpedo tube and left there indefinitely. The loading is illustrated in Figures 55 and 56. The beacon must be armed at least 45 sec before it can start to move, but even after the arming switch has been pulled the release may be postponed for a further period. When necessary the

timing motor circuit. When the release switch is pulled, the beacon is released from its securing clamp and power is supplied to the gyro uncaging solenoid, to the drive motor in its 7-knot high-speed condition, and to the timing cam circuit. The timing motor starts again and the three remaining cams revolve together. The simulation safety switch is closed when the beacon has cleared the tube. Simultaneously, power is supplied to the rudder and elevator control circuits and to the silent run clock. This

SECRET

clock initiates echo-repeater and self-noise simulation at the end of the preset delay period.

One minute after release the 1-min switch closes, and shunts out a series resistor in the drive motor field through a relay, lowering the speed of the beacon to $3\frac{3}{4}$ knots.

Five minutes after release, which is 4 min after the change in speed, the third switch closes. If the beacon is rigged as a war shot with the practice plug removed from the control circuit, the operation of this switch stops the timing cam motor so that the

Twenty minutes after release, if the practice plug is in place, the final timing switch closes. This closes the circuit to actuate the retriever solenoid. The ballast is released and the beacon comes to the surface to end the practice run.

6.6.1 Performance Tests

The first modified Mk 30 mine body equipped with the beacon propulsion system, control, self-

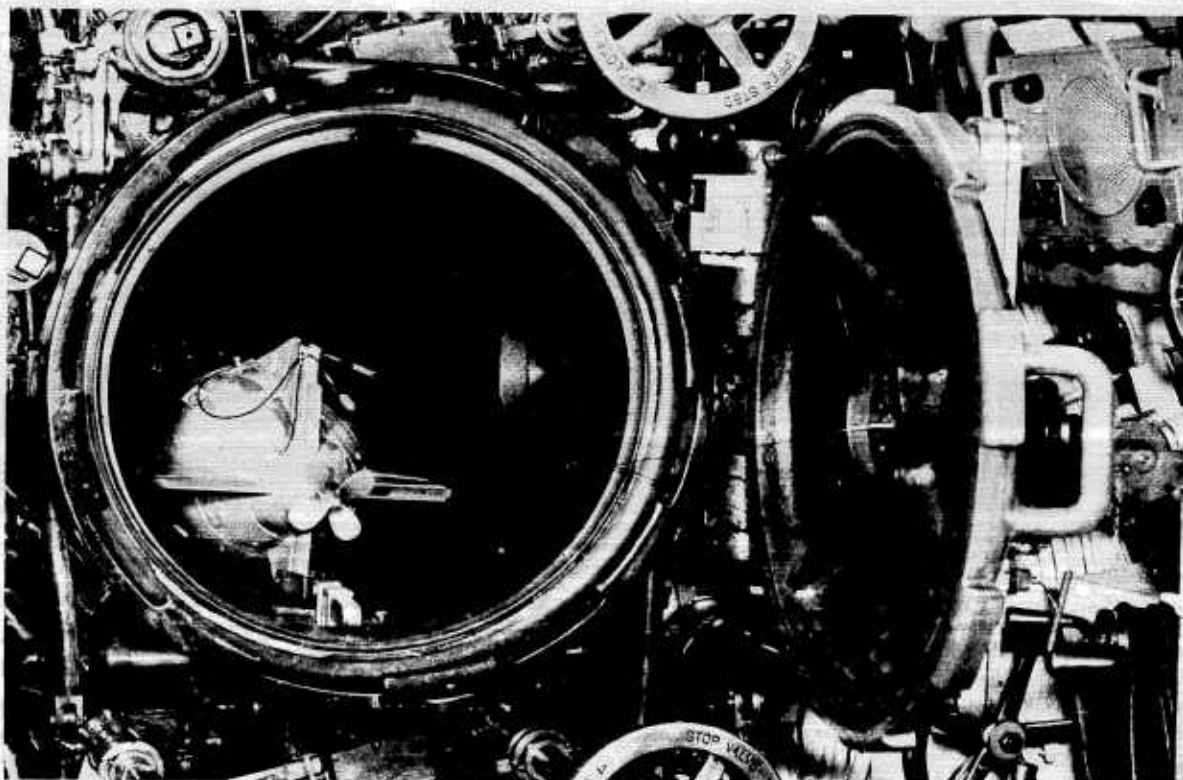

FIGURE 56. Arming and releasing cables attached to reel and lanyard on breech door.

timer has no further influence on the beacon's operation. The beacon continues its run and its simulation for the life of the batteries, sinking when the propeller ceases to operate. If the practice plug is in place, the 5-min switch arms the hydrostatic switch. Thus, if the practice beacon has not risen above or falls to a depth of 100 ft after the first 5 min of the run because of some failure in its control systems, this switch closes and actuates the retriever solenoid in the ballast release, bringing the unit to the surface.

noise simulation, and echo-repeating systems, proved to be too tail heavy for satisfactory depth control at low speeds. Accordingly an $8\frac{1}{2}$ in. section was added to the main body tube to compensate for the weight of the two in-line motors, and the unit was ready for test. On all runs this unit maintained depth within ± 1 ft and course within ± 2 degrees. With the echo-repeater amplifier operating at maximum gain there was no indication of parasitic oscillation or interference from the sonic simulator system. Good echoes were received at 1,800 yd. This

SECRET

unit was thought suitable for Navy test and 11 more units of this same design were constructed. These evaluation units were sent to ASDevLant at Fort Lauderdale and to ComSubsTrainPac while work continued on the prototype design.

Tests of the engineering performance as well as

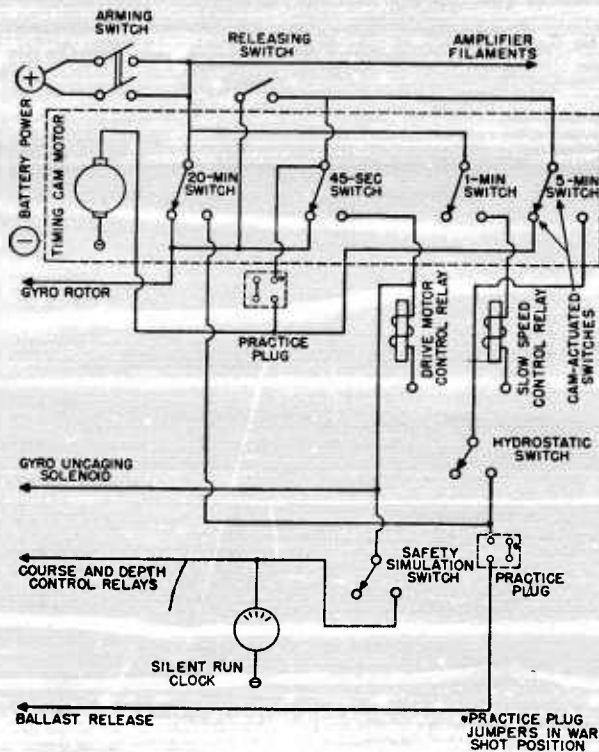

FIGURE 57. Control circuit for NAD-10A.

tactical usage of the NAD-10 evaluation model were carried out at Pearl Harbor.¹¹¹ From these runs modifications were requested for the final design. The external arming and releasing system, the adjustable silent run, the safety simulation switch, and the hydrostatic safety switch were all added to the NAD-10 prime and NAD-10A models. It was also agreed that a primary battery would be necessary for units which were to be carried for actual use aboard submarines on patrol.

A number of the evaluation models of the NAD-10 and some of the early production lot were supplied to ASDevLant for test in the tactical evaluation tests carried out during the spring and summer of 1945. Both the NAD-6 and the NAD-10 were tested against echo ranging and listening detection, and were used in various tactical combinations with

other evasion devices. Using the beacons several times over, 16 runs were made with NAD-10's. A few failed to operate because of faulty adjustment before release. As a result of these tests it was recommended that the NAD-10, as well as the NAD-6, be adopted for immediate Service use although improvements in the stability and the quality of the performance were requested.

Against sonic listening the NAD-10 was considered good. It conveyed the impression of gear whine and propeller cavitation convincingly, and was superior to the NAD-6 in this respect. In several of the free evasive trials the NAD-10 served to decoy the search vessel while the submarine managed to escape. Against echo ranging the NAD-10 was less satisfactory. The sharp echoes were considered too mechanical, being hard and clear at all angles. On a chemical recorder trace the clear echoes provided the best means of classifying the target as a decoy. The BDI traces from the NAD-10 were not even as good as those from the NAD-6, being characteristically square regular deflections regardless of beacon aspect. The supersonic noise indications were slight and were not detected in general by the sonar operators.

These conclusions, paraphrased from the ASDevLant report,²⁰ provided the basis for the recommendations in Section 6.7. Development of the decoys is continuing at the Naval Electronics Laboratory under the auspices of Section 940 of the Bureau of Ships.

Further details concerning the development and operation of the NAD-10 may be found in the laboratory completion report¹¹³ and in the instruction manuals.¹¹⁰

6.7 RECOMMENDATIONS FOR FUTURE DEVELOPMENT

After the close of hostilities it was apparent that further decoy development would be less concerned with improving the existing NAD's than with designing a different one. Certain improvements in the NAD-6 beacon design were suggested on the basis of the ASDevLant tests of its tactical use. It was felt that the NAD-6 self-noise simulation was inferior to that of the NAD-10, sounding more like a noise-maker such as the XNAG or the NAE than like a submarine. For flexibility in selecting the course and depth for the beacon until the final moment of re-

SECRET

lease, complete external control of the gyro and the depth selector was needed in a manner analogous to torpedo practice.

A drawback of NAD-6 and NAD-10 operation has been that, when released from the forward torpedo room, they require a right tube for a right deflection shot and a left tube for a left shot to avoid collision with the submarine. Thus two tubes must be left clear during evasive action. This limitation would be removed if the beacon included a timing mechanism which would let it leave the submarine on a 0-degree gyro and adopt its set course later on. The unit could be left loaded in one tube, its gyro controlled until the last minute, and could then leave the submarine within 30 sec of the will to fire.

Echo signals that vary in their characteristics with aspect and that are independent of the length of the ping are desirable. Wake echoes like those from a submarine, obtained by introducing slowly released bubble targets, might improve realism. This recommendation was investigated with promising results soon after the ASDevLant tests. The above conclusions, paraphrased from the ASDevLant report,²⁰ were based upon tests made in the spring of 1945.

A more general analysis of the limitations of the NAD beacons was made shortly after the close of hostilities.¹⁰⁵ In this analysis, design features were proposed for a new NAD-8 sound beacon which would incorporate the desirable features of the NAD-6 and the NAD-10 with modifications suggested by (1) advanced tactical practices, (2) experience gained in operation and testing of the existing beacons, and (3) anticipation of future developments in subsurface warfare.

The NAD-6 had certain vulnerable points which, if found by the enemy, would greatly reduce its effectiveness. One key to identifying a beacon quickly is to echo range on it at a frequency to which it will not respond. Thus, in a new beacon, the frequency band to which it is responsive should be as wide as possible. Various devices now in existence, which could at some time be used in the proximity of the beacon, operate from approximately 5 to 90 kc. If the new beacon is to simulate a submarine satisfactorily, it must have a frequency range of this order

A second method of identifying a beacon as such is by analyzing its return echo on a BDI or similar unit, which reveals the difference between the

smooth pulse returned by a beacon and the irregular pulse returned by a submarine. In order to introduce irregularities in the energy returned by a beacon, synthetic high-frequency propeller cavitation simulation could be put into the output transducer of the echo repeater. This would not only eliminate the need for a special speaker to put these sounds into the water, but would also superimpose high-frequency energy upon the pure echo-repeater pulse, thereby adding to the realism of the beacon. This is accomplished to a certain extent in the present NAD-6 beacon by the receiver hydrophone of the echo-repeater that picks up the high-frequency propeller beats from the mechanical simulator and sends them through the amplifier and output transducer. A similar effect has been studied in the NAD-10 by feeding the self-noise simulator signal into the echo-repeater amplifier so that its irregular high-frequency components produce irregularities in the BDI trace.

A third method of identifying a beacon is to compare the length of its echo trace when the beacon is approached from its bow or stern with the echo trace received from a submarine in a similar position. Submarines, when approached from bow or stern, return echoes which are longer in duration than the original pulse because the submarine as well as its wake forms a reflecting target. One way of increasing the apparent length of a beacon is to add a synthetic wake to it. The sea battery gas from the NAD-6 accomplishes this to some extent. If the new beacon is to use sea batteries the gas released might possibly be satisfactory for wake simulation. It should be noted, however, that the ASDevLant tests showed that the NAD-6 bubbles were not a convincing wake target on the chemical recorder trace.

Whereas in setting up the original NAD program it was felt that the depth was not too important, advanced techniques in determining the depth of a submarine are to be anticipated, and therefore the new beacon should be able to run at great depths like an evading submarine. Otherwise its true identity is more easily revealed. For example, a beacon whose true depth was 75 ft might not convincingly pass for a submarine because aircraft in the vicinity under favorable conditions could see a submarine at this depth. MAD-type detection could reject a beacon similarly. Advanced-type submarines will be able to operate at greater depths, and the NAD-8 beacon design should take this trend into account.

SECRET

A beacon's value is determined to some extent by the amount of time the enemy spends in investigating the false target. If the target is to resemble a submarine closely it should be able to operate submerged for long periods, and if the beacon's operating time is extended, it certainly should not maintain a fixed course during its entire run. A means of maneuvering should be incorporated which would allow the beacon to change course. It should not however be allowed to change its general direction since the releasing submarine should know its position at all times. A long operating life also suggests the need for a means of changing the beacon's speed from time to time. Also important is the need to interlock correctly the beacon's speed with simulation noises. Some attempt to do this was made in designing the NAD-10 with an adjustable modulation frequency in its propeller cavitation simulator. One might go so far as to design the new beacon to maneuver in three dimensions by allowing it to change operating depth during its run. If depth-determining methods were used by attacking vessels, as can be expected with advancing techniques, the beacon's vulnerability would be reduced by this means.

It has been proved that high-speed ejection of beacons is desirable, as this lessens the maneuvering restrictions of the releasing submarine. Also, to improve the releasing technique, the beacon should leave the tube with its gyro set for a zero angle as suggested in the preceding paragraph. After a time it should assume its course, turning with the turning radius of a submarine. It also would be desirable to have the beacon run at its releasing depth for a given time and then climb or dive as does a submarine.

Beacons are now released from the submarine's torpedo tube because this is the only opening large

enough for the purpose. In the future it is probable that submarines will have tubes especially designed for releasing evasion devices. The design of the new NAD should be such that it might be released from either the torpedo tube or from such a special tube.

The necessity in present beacons of selecting course, depth, and length of silent run before the beacon is even loaded into the tube imposes a significant restriction upon evasion tactics. If these controls were operable from the exterior of the launching tube, so that as with a torpedo they could be adjusted until the last moment before release, the usefulness of the beacons would be enhanced.

A new kind of safety mechanism should also be devised. The pressure-operated switch as now incorporated in the NAD-6 is of no value if the beacon is to run deep like a submarine. A simpler mechanism than the cable-reel system of arming as used in the NAD-10 would undoubtedly be devised. Possibly some electronic means could be developed whereby the beacon would remain silent if it were in close proximity to a large metal object.

The recommendations summarized here were drawn up in August 1945. From the work continuing on decoy development and from the advances in other fields it is to be expected that new uses for the NAD beacons and new tactics will suggest various changes in beacon design. It is, however, believed that the foregoing features are basic to a successful beacon and should be incorporated as far as possible.

The development of the decoys covered here was carried out by UCDWR at the San Diego laboratory under NDRC auspices until March 30, 1945, and for the next year under a direct Navy contract. Work is continuing at the newly established Navy Electronics Laboratory. Any further information on these devices should be obtained from that laboratory or from the Bureau of Ships.

SECRET

Chapter 7

DEPTH CONTROLS FOR STATIONARY EXPENDABLE DEVICES

7.1

INTRODUCTION

SOME TYPE of depth control mechanism is essential to the design of stationary expendable noisemakers. While floats that were visible at the surface and parachutes that merely reduced the sinking rate were used with early models of certain devices, the desirability of a mechanism to support the noisemaker below but near the water surface led to the development of a series of gas-operated depth control devices. These depth controls, with the common features of a gas-generating chemical, a variable displacement volume, and a siphon-operated gas-release valve, appear in the buoyancy control used by UCDWR in the NAC and other light-weight devices, in the heavy-duty buoyancy control of the XNAG, in the NAE Mk 2 developed by DTMB, and in the signal (pepper) Mk 20 developed by MIT-USL. While the major part of the technical material available on this development derives from the research at MIT-USL, it is applicable as well to general problems of depth control design. Work on gas-operated depth controls is continuing at DTMB in further development of the NAE, and at NOL in completion of the pepper signals.

The problems of designing a depth control increase with increase in weight of the noisemaker to be supported. General problems of depth control design are discussed in Section 7.2. At the end of this chapter, various types of stationary depth controls other than gas-operated designs are described in Section 7.6. The dynamic depth controls used in the self-propelled NAD's are discussed in Chapter 6.

The first use of the gas-operated depth control was made by UCDWR. The buoyancy control developed there for use with the NAC beacon and used later in such devices as the sonic sound beacon and the SERD can support loads of 15-g negative buoyancy at a preset depth of 20 to 50 ft for periods up to 50 min. This design was later modified for the heavy-duty buoyancy control used to support the heavier XNAG unit. In June 1944 the responsibility for further development of the gas-operated depth control was transferred within Division 6 of NDRC from the UCDWR laboratory to MIT-USL. Dur-

ing the summer a cooperative program at MIT-USL and DTMB led to the first designs of the NAE depth control. Here the problem is to support a unit weighing 2 kg to 4 kg in water by means of a device housed initially in a short cylinder 3 in. in diameter. As completed by DTMB for the NAE Mk 2, the depth control supports the noisemaker at a depth of 30 ft for 20 to 30 min.

In November 1944 the need was recognized for a depth control to replace the parachute in the pepper signal design. The effort at MIT-USL was accordingly directed towards adapting the gas-operated depth control principles to support this still heavier unit, which weighs about 5 kg in water. This depth control, as completed during the summer of 1945, performed reliably, bringing the unit from ejection depth to a preset depth of 50 ft, holding it within a few inches of this depth, and allowing it to sink after about 12 min. The changes in design parameters necessitated by the heavier load led to some results that are applicable to further work in depth control design. It is believed that this type of control could be adapted for loads as great as 20 kg. In the summer of 1945, the depth control program was transferred with the work on the pepper signal to NOL auspices for completion of the evaluation tests, supervision of production, and consultation on any further design changes.

7.2 DESIGN CONSIDERATIONS FOR A GAS-OPERATED DEPTH CONTROL

The performance desired in a gas-operated depth control is much the same for any of the stationary submarine evasion devices. It should bring the unit from the ejection depth to the operating depth without appearing at the surface. It should maintain the unit at this depth without significant oscillations. At the end of the unit's operation the depth control should allow it to sink to the bottom. One general design proposed for such a mechanism comprises a source of gas, a variable displacement volume, and a pressure-regulated gas-release valve. The gas is hydrogen, produced by the interaction of the sea water with metallic lithium, lithium hydride, or calcium hydride. The displacement volume is sim-

ply a free-flooding section of the body cylinder in the NAC beacon. In the XNAG a cylindrical shell extends to give added displacement. A balloon is inflated to provide buoyancy for the NAE and pepper signal noisemakers. A syphon bellows opens and closes the gas-release valve about some predetermined value of the static pressure. The problems involved in incorporating these features into a reliable mechanism required extensive study. Many of these considerations summarized here for the gas-operated depth controls apply as well to the design of other depth controls.

Security. In order that the expendable noisemaker may be invisible at the surface and irretrievable after use, the depth control must insure that the device at no time breaks the surface. Initially it was felt that no bubbles could be tolerated above the operating point, but this restriction was later removed.

Depth. The depths selected for the operation of expendable noisemakers were of the order of 50 ft. The NAC hovers at 50 ft. The NAE is suspended on a cord below its depth control so that the noisemaker is itself at 30 ft. The Mk 20 pepper signal hangs on a wire below its depth control so that the explosions occur at approximately 55 ft. The choice of depth is confined to this general range for a number of reasons. If the noisemaker is near the surface the submarine can take advantage of operating in a thermal layer below the noisemaker, and such gradients seldom occur at less than 50 ft. At 50 ft the devices are far enough below the surface to be invisible from the air in normal conditions. Another consideration is the fact that many of the failures encountered in underwater devices arise from leakage caused by excessive static pressure.

Life. The life of a depth control has to be sufficient to support the unit for the duration of its maximum time delay plus its operating life. Since the depth control life depends only upon the quantity of gas-generating chemical, this factor is readily adjusted.

Acoustic Influence. The presence of a large volume of gas near the noisemaker could be expected to reduce its acoustic output by providing a pressure release. In practice it was felt that this effect was reduced sufficiently by separating the NAE's and the pepper signals from their supporting balloons by a 10-ft cord. Measurements on the NAC, however, indicated little or no energy loss in its operating

band of 17 to 27 ke as a result of the small gas bubbles generated by its buoyancy control.

Size. In the already crowded cylinder permitted for an expendable noisemaker, the space available for a depth control before ejection was severely limited. In the pepper signal design, the substitution of the depth control in its 10.5-in. can for the 6-in. parachute container cylinder was made at the sacrifice of a full minute of firing time. In the light-weight NAC the displacement volume needed for a depth control was slight. In the heavier devices the necessary volume was obtained by causing a collapsed balloon in a compact housing to open to the needed size after ejection. For the NAE and the pepper signal this necessitated a knockoff mechanism to expose the depth control to action by the seawater, a quick fill to inflate the balloon at once, and a steady generation of gas to maintain the supply. This entire mechanism was designed to occupy minimum space at the top of the noisemaker.

Displacement Volume. The weight in water of the expendable noisemakers which use these gas-operated depth controls is about 3.6 kg less than their weight in air, since the displacement of the 3-in. cylinder itself is about 3.6 liters. By addition of ballast during the assembly of the NAC its weight is brought to within 15 g of this neutral buoyancy. In order to compensate for changes in weight up to 80 g, its depth control required an additional displacement volume provided inside the cylinder itself. For the NAE the additional displacement required is 2 to 4 liters, while the pepper signal requires 5 liters. To obtain these volumes a balloon was taken as the basis of the gas-operated depth control design.

Knockoff. In the depth controls where a balloon must be packed in a small volume to open after ejection, there is a need for a timed knockoff mechanism which will expose the gas-generating chemical to action by the sea water and allow the depth control mechanism to open into its operating position. The selection of smokeless powder for the knockoff charge in the Mk 20 pepper signal provides an advantage in that the force of its explosion increases with static pressure. Thus, at shallow depths where the housing comes off easily, the knockoff force is small while at greater depths the increased resistance is matched by an increased knockoff explosion.

Gas Generation. The reaction of metallic lithium, lithium hydride, or calcium hydride with sea water

to produce hydrogen is the basis of the operation of these chemical depth control devices. The different depth controls utilize these materials in various ways. In some designs, powdered material generates gas for quick initial fill while a stick or a cake provides a steady source of gas at a slower rate. In the NAC a layer of LiH provides the initial supply of gas while the slower generation from Li maintains the steady-state supply. One problem encountered in the use of LiH was that unless the water around the chemical's active surface is continually changed by the motion of the device, the concentration of hydroxide inhibits further generation of gas. It is observed that the rate of gas generation from lithium in fresh water is three times the rate of the reaction in sea water. These considerations are discussed in detail in reference 117.

Initial Fill. In order to provide the necessary buoyancy at once after ejection of the noisemaker a charge of the powdered chemical is sprinkled loose inside the balloon in the NAE and pepper signal design. By this means the fall of the unit while it is filling can be reduced nearly to zero. An excess of this initial fill material, however, can give the unit such a rapid rate of rise that it shoots to the surface momentarily before the valve can release the surplus gas. In the XXAG the initial fill is provided by special packing of the chemical cups.

Stability. A study of the gas laws governing the behavior of these gas-operated depth controls shows the essential instability of the operation. Any drop of the unit to a lower depth produces a corresponding compression of the gas balloon which decreases its displacement volume and thus causes it to fall lower still. Tests with the heavy pepper signal units showed that the response of the sylinder to this increased static pressure could not be relied upon to stop the escape of gas in time to recover the unit. Evidently the orders of magnitude were so different between the critical parameters of the NAC and pepper signal units that the operating principles could not be transferred by simple multiplication. An umbrella-like baffle, already included in the design to damp the vertical oscillations, was adapted to add derivative control to the release valve. Thus both depth and rate of change of depth control its valving rate. The resultant pepper signal operation is so stable that the unit remains within 3 in. of its preset depth. These considerations are discussed further in reference 117.

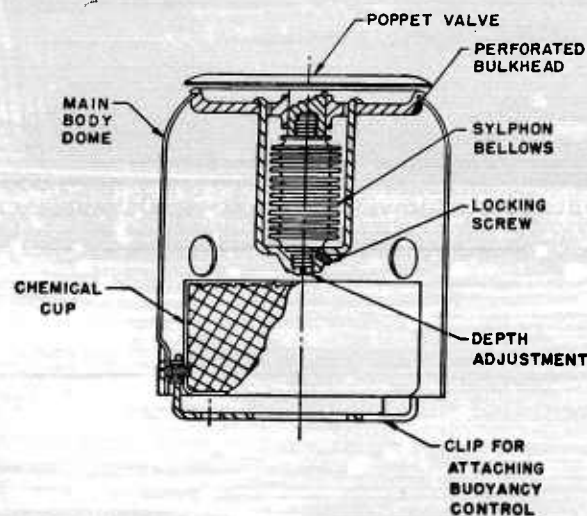

FIGURE 1. Model 2A buoyancy control.

7.3 UCDWR BUOYANCY CONTROL

The smaller buoyancy control developed by UCDWR is a mechanism for use with the expendable noisemaker which brings a device weighing less than 15 g in water to a predetermined depth below the surface, maintains it there during its operation, and then permits it to sink. Thus the device is invisible to surface craft and cannot be recovered. This buoyancy control is designed to compensate for changes in buoyancy of as much as 80 g such as may occur when the supported object is reduced in volume by the static pressures at great depths. This buoyancy control can bring a device from ejection depths as great as 400 ft up to a selected operating depth between 30 ft and 50 ft and support it there for as long as 50 min. The unit consists of a cup containing Li and LiH which react with the sea water to produce hydrogen, a sylinder with a preset spring rate, and a poppet valve with a large convex head. This assembly is housed in a free-flooding chamber with a perforated bulkhead at the top and perforations in the cylinder wall just above the chemical cup. Gas accumulates in the chamber formed under the closed poppet valve until the unit rises to the set depth. Then the valve opens to allow excess gas to escape until the unit falls below the set depth when the valve again closes. The control is made up as a separate unit, weighing 150 g, 3 in. in diameter, and 3½ in. long, or is installed in the free-flooding compartments at the top of such devices as the NAC beacon.

SECRET

CONSTRUCTION

The construction of the UCDWR buoyancy control can be seen in Figure 1 where the unit is made up as a separate unit called Model 2A. A cylindrical shell, 3 in. in diameter, houses the assembly. At the bottom is a cup containing the gas-producing chemical. Across the top is a heavy bulkhead at section A-A' in the figure. This bulkhead is perforated for the free passage of gas and water, and the poppet valve extends up through it. The head of the poppet valve when in its closed position makes contact with the rim of the bulkhead and so produces a chamber in which gas can accumulate. The row of holes in the cylinder wall, just above the chemical cup, determines the bottom of this gas chamber, and insures that there is always water in contact with the chemical surface. The poppet valve is attached to the pressure-operated sylinder suspended below the bulkhead. A depth-adjustment screw is used during assembly to set the spring rate of the sylinder to open and close the poppet valve about some predetermined depth.

The construction of the buoyancy controls in the NAC beacon⁷⁰ and the sonic sound beacon⁶⁰ differs only slightly from the Model 2A. In the NAC beacon, the unit is housed in the free-flooding compartment at the top of the unit above the sea batteries, which also require contact with sea water for their activation. The buoyancy control occupies the

space between the two top rows of holes. The upper holes permit the gas to escape from above the poppet valve cover. The lower holes are just above the chemical cup, permitting escape of excess gas from below the gas chamber. The structure of the poppet valve head as it is designed to close upon the perforated bulkhead is evident in the photograph in Figure 2. During assembly of the NAC beacons they are loaded with shot ballast to weigh within 15 g of neutral buoyancy. The 80 g compensation of the buoyancy control allows for compression at great depths.

The buoyancy control for the sonic sound beacon is essentially the same as the NAC unit, fitting into a similar compartment at the top of the noisemaker, as can be seen in Figure 14, Chapter 2. Like the NAC, the sonic sound beacon is loaded during assembly to within 15 g of neutral buoyancy.

The quantity and type of chemical placed in the cup is varied with the different applications. In the production units of NAC the charge consists of 25 g of metallic lithium. This is covered with about 0.75 g of LiH to insure an immediate supply of gas upon ejection. This quantity provides a life of 30 min for the depth control which is longer than the maximum time delay plus the operating life of the noisemaker as supplied by the voltage from the sea battery. In the Model 2A by filling the cup completely with metallic lithium an operating life of

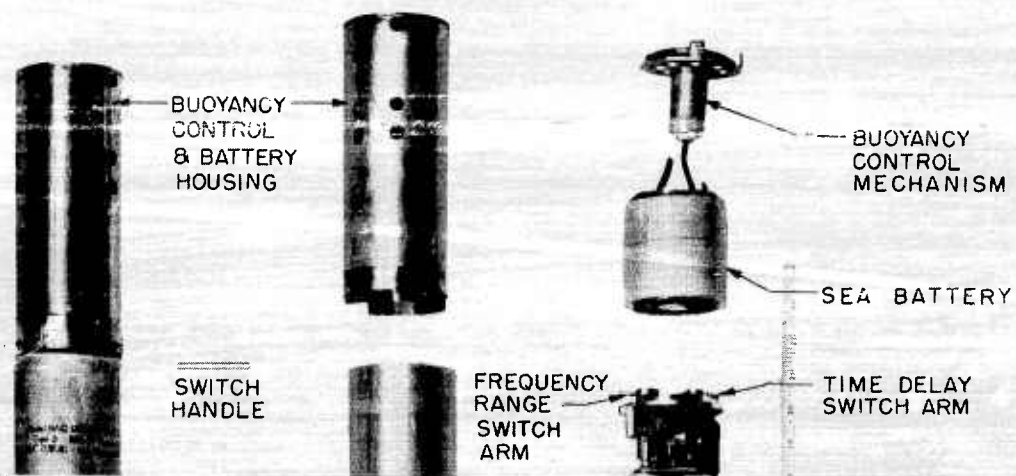

FIGURE 2. Upper portion of NAC sound beacon, showing buoyancy control.

SECRET

45 min can be achieved. If the operating life is to be increased further, a cup with greater capacity can be used.

The packaging of the buoyancy control unit is important in protecting it from moisture. The NAC production model is supplied with a light metal cylindrical cap which slips over the free-flooding section at the top of the unit and is sealed with a rubber sleeve at the lower end to prevent the entry of moist air between the cap and the main container. This protects the depth control and the sea batteries from premature activation. A small bag of color-indicating desiccant is inserted inside the cap to maintain the proper level of humidity and to provide a color indication in case any moisture may have penetrated.

OPERATION

Gas generation in the buoyancy control begins as soon as the sea water comes in contact with the gas-producing chemical. In the NAC the reaction of the surface layer of LiH is so rapid that it fills the gas chamber immediately, thus minimizing the initial drop of the unit after ejection from the submarine. When ejected below the standard operating depth the siphon is contracted and the poppet valve rests against the bulkhead so that gas accumulates in this chamber all the way down to the lower row of holes. This volume is sufficient to supply 80 g of buoyancy so that the unit rises swiftly towards its standard operating depth. When the initial charge of LiH is exhausted, generation continues at a lower rate from the lithium. At 70 ft the siphon extends to allow a small amount of gas to escape, although at a rate still less than the rate of generation. This reduces the rate of rise and thus reduces the tendency of the NAC to overshoot its set depth. As the static pres-

sure continues to decrease, the poppet cover rises so that at equilibrium the rate of gas generation and gas release are the same. In practice the unit oscillates about this equilibrium depth within ± 2 ft. When the supply of lithium is exhausted the unit falls slowly to the bottom.

The constants of this buoyancy control were designed for operation in sea water for loads within 15 g of neutral buoyancy. The gas chamber has a volume of about 80 cc to compensate for such increases of negative buoyancy as can occur at great depths by compression of the units under the static pressures. This compensation could be increased further by increasing the gas chamber volume. It should be noted, however, that with devices weighing as much as 5 kg in water the pressure control of the valving action does not supply sufficient stability, and the addition of velocity control was found necessary, as discussed in Section 7.6.

The quantity of the chemical charge is designed to provide for an operating life of 30 to 50 min. In early tests it was found that the oscillations of the unit about its preset depth were 12 to 13 ft in fresh water while in sea water they were only 3 ft. This corresponds to the tripled rate of gas generation. In checking the operation of these devices a recording depth gauge known as a silent stenographer was used, similar to the one used in obtaining Figure 16.¹¹⁴

The compactness of this buoyancy control assembly recommends it for use with expendable devices where the buoyancy can be brought close to zero. Since this development was essentially completed by the spring of 1944, some of the information gained in the subsequent depth control programs at DTMB and MIT-USI may be applicable in any further refinement of this gas-operated buoyancy control.

7.4 HEAVY-DUTY BUOYANCY CONTROL

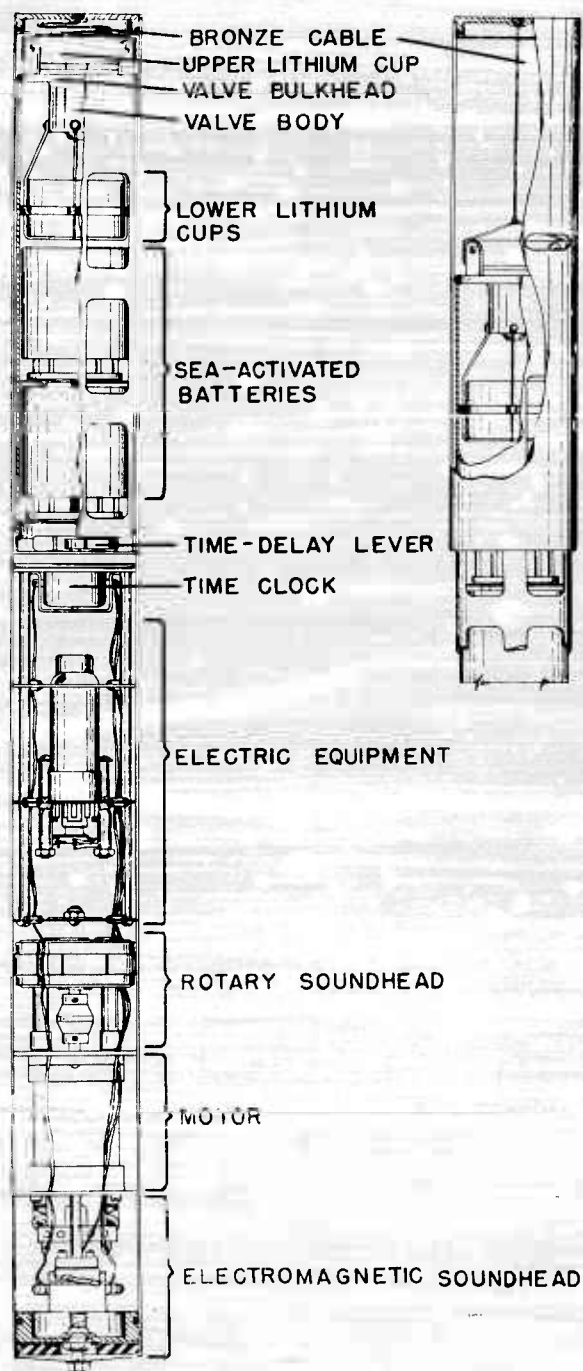

FIGURE 3. The heavy duty buoyancy control in the XNAG sound beacon.

The heavy-duty buoyancy control is a modification of the UCDWR device just described which was developed to support the XNAG sound beacon during its operation. This device is housed at the top of the beacon, and brings it to a depth of 50 ft, maintains it there for a life of 30 min, and then permits it to sink. Thus the unit is kept invisible to surface craft and cannot be recovered. This enlarged buoyancy control is designed first to bring the unit to within 15 g of neutral buoyancy and then to compensate for changes in buoyancy of as much as 80 g, such as occur when the supported object is reduced in volume by static pressure at great depths. The additional displacement volume that is needed to support the XNAG is supplied by the telescoping cylindrical shell at the top of the unit. This is filled rapidly with gas generated from the top cup in the buoyancy control unit and extends to support the device, supplying a fixed displacement capacity of 700 cc. As much as 200 cc more of displacement can be supplied by the operation of the control chamber which collects gas under the syphon-operated poppet valve and the perforated bulkhead shown in the figure. Gas accumulates in this chamber until the unit rises to its set depth of 50 ft. Then the poppet valve opens and allows gas to escape at the rate of generation. In operation the unit oscillates about the set depth within limits of ± 4 ft. This buoyancy control was developed for use in the XNAG sound beacon by UCDWR.⁶⁰

CONSTRUCTION

The XNAG buoyancy control assembly consists of two separate buoyancy chambers, one telescoping down over the other when the unit is not in use, and both served by a common control valve activated by a syphon, as in the smaller unit described in Section 7.3.

As illustrated in Figures 3 and 4, the syphon-activated valve is built into the upper bulkhead of the lower buoyancy chamber. The bulkhead is pierced by the stem of the valve and is also perforated to permit passage of gas from the lower buoyancy chamber into the upper chamber. The maximum extension of the telescoping upper chamber above the body of the beacon is fixed at 5 in. by a length of bronze cable.

SECRET

Two lithium cups are located in the lower buoyancy chamber as shown in Figure 4. In fresh water these two cups generate sufficient gas to suspend the XNAG at the desired 50-ft depth, but it is necessary to utilize a third lithium cup to achieve the same result in sea water. The third cup is supported above the buoyancy control valve and is encompassed by

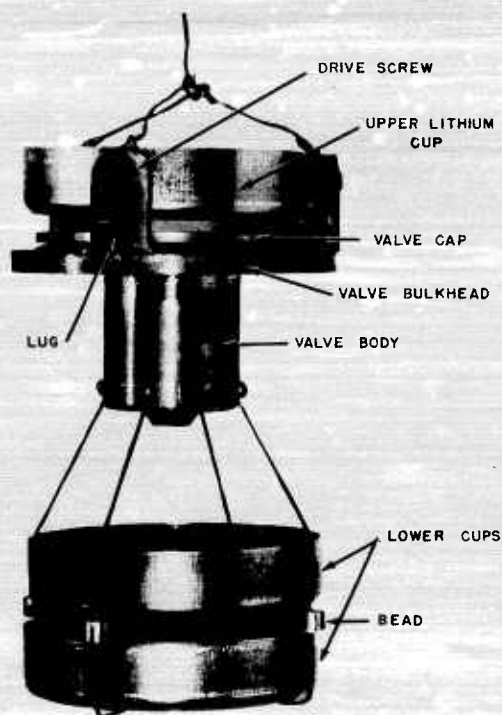

FIGURE 4. XNAG buoyancy control unit.

the telescoping extension buoyancy chamber. The extension chamber is perforated at a point $\frac{1}{8}$ in. above the surface of the third lithium cup to permit escape of surplus gas and insure contact of sea water with the active chemical. The maximum displacement capacity of the lower buoyancy chamber between the closed poppet valve and the lower row of holes is 200 g of sea water. Fixed displacement capacity of the extension chamber is 700 g.

Because of the relatively great negative buoyancy of the XNAG, a rapid action charge of the gas-producing metal was designed for the upper lithium cup to insure a high initial rate of hydrogen evolution when the lithium first comes in contact with the water so that the upper chamber is filled at

once. This rapid action charge was designed as illustrated in Figure 5. The charge consists of two layers of lithium metal with lithium hydride crystals pressed into the top surface of each layer. Their exposure to the action of the sea water is increased by means of deep indentations penetrating all layers.

OPERATION

As the unit comes in contact with the water a rapid charge of gas is generated from the top chemical cup which rises into the telescoping chamber to extend it and to displace any water that it may contain. The gas generated by all three lithium cups is sufficient to fill this chamber and provide a constant excess which slowly bubbles off through the escape ports. When the unit sinks to the 50-ft level the valve closes and the lower chamber fills with gas. When the lower chamber is filled any further excess gas escapes through openings in its walls and rises

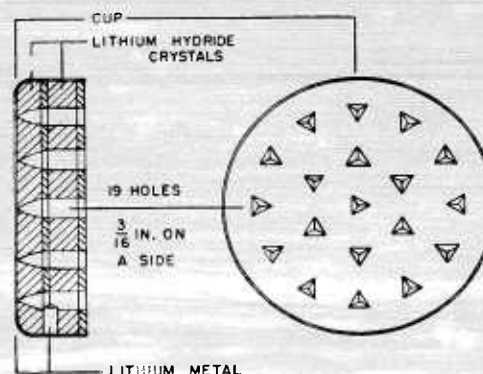

FIGURE 5. Loading of cup for rapid gas generation.

between the two chambers to displace any water which may have been forced by the increasing pressure into the upper chamber. The unit then seeks its operating level with minimum oscillation.

The XNAG equipped with this buoyancy control has a negative buoyancy of 40 g when the valve is open, while the lower chamber is able to compensate for changes in buoyancy of as much as 80 g. The syphon is set to hold the unit at a depth of 50 ft, and in operation the unit oscillates about this level within limits of ± 4 ft. After 30 min the supply of chemical is exhausted and the entire unit sinks to the bottom without ever having reached the surface.

SECRET

7.5 DEPTH CONTROL FOR NAE MK 2

The gas-operated depth control incorporated in the Mk 2 NAE beacon¹⁶ is similar in principle to both the UCDWR buoyancy controls and to the depth control in the Mk 20 pepper signal. At the time that the project for depth control development was transferred from UCDWR to MIT-USL the immediate problem was to adapt the principles of the gas-operated depth control to the NAE beacon. A joint program was carried on with MIT-USL and DTMB cooperating in early designs. The first development was a balloon for the Mk 1 NAE shown in Figure 14 which filled with gas after ejection from the submarine and floated on the surface to support the beacon on a line. This was put into production while the further development of a positive depth control continued. The general features of the balloon, umbrella, and valve were agreed upon before the joint program was terminated. DTMB continued the development of the depth control for the NAE while MIT-USL worked on a depth control for the still heavier pepper signal.

The more heavily constructed NAE Mk 2 weighs about 8 kg in air and 4 kg in water. Thus it requires about 4 liters of displacement volume to support it. The limited space available in the noisemaker led to the use of a balloon so that it could be housed in

tical oscillations. Figure 6 shows the depth control in its collapsed form with the umbrella foiled down over the balloon. The gas release valve is controlled by a sylphon which responds to the static pressure so that the rates of generation and release are equal at the equilibrium depth. When the balloon rises too high sufficient gas is exhausted to let it fall again; when it sinks gas is permitted to accumulate to raise it.

The initial inflation of the balloon is produced by the immediate reaction of the sea water with powdered LiH that is loose inside the balloon. A steady supply is provided from the packed LiH in the chemical cup.

A knockoff mechanism is used to expose the depth control unit to the sea water. Triggering of the NAE in the signal ejector starts a 4-sec fuse which in turn sets off a powder charge which blows off the steel shell on the trigger end of the NAE. A felt obturator protects the balloon from burning by the powder flash. Once the shell has blown off, the heavy end of the unit containing the acoustic cylinder falls away on the 10-ft cord while the balloon inflates and the umbrella extends.

In operation the inflated balloon brings the unit from its ejection depth, which may be as great as 400 ft, to its operating depth of 30 ft at a rising rate of about 5 ft per second. The noisemaker is thus at a depth of 40 ft. The device holds the noisemaker

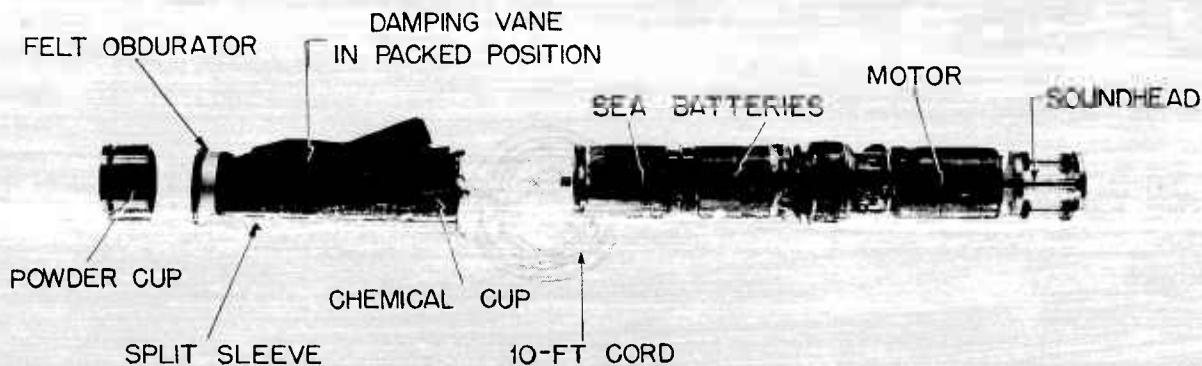

FIGURE 6. NAE Mk 2 with packed depth control.

its collapsed form before ejection and then open and inflate after ejection to provide the needed volume.

The depth control of the NAE Mk 2 consists of a cup of LiH, a balloon with a pressure-controlled valve in the side, and an umbrella to damp the ver-

there during its operating life of 12 min. When the gas-generating chemical is used up after 20 to 30 min, the balloon collapses and the assembly sinks.

Further information about the NAE may be obtained from DTMB or the Bureau of Ships.

SECRET

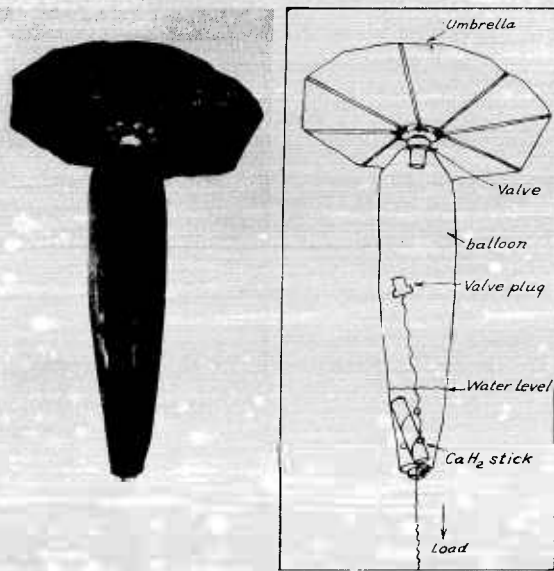

FIGURE 7. Depth control for signal (pepper) Mk 20 in steady state operation.

7.6 DEPTH CONTROL FOR SIGNAL (PEPPER) MK 20

This gas-operated depth control is a mechanism developed for use with expendable noisemakers which brings a device weighing 5 kg in water to a selected depth below the surface, maintains it at that depth during its operating life, and then permits it to sink. Thus the unit is invisible to surface craft and cannot be recovered. The depth control as used in the signal (pepper) Mk 20 explosive noisemaker brings the unit from depths as great as 400 ft up to an operating depth of 55 ft, and supports it there for 10 min to 12 min. The depth control unit occupies a cylinder 3 in. in diameter and 10.5 in. long at the upper end of the noisemaker. The depth control includes calcium hydride as its chemical source of gas, a supporting balloon, a dumping umbrella, and a gas-release valve. Five seconds after ejection the depth control is exposed to action by the sea water. The balloon is filled immediately by gas from a charge of powdered CaH_2 . Gas escapes through holes in the lower part of the balloon and through the valve at the top of the balloon. The valve opening is controlled by the static pressure as it effects the siphon and by the velocity of the vertical motion of the assembly, communicated to

the valve by the umbrella. These controls hold the unit within 3 in. of its set operating depth. This depth control was developed by MIT-USL and at the end of the NDRC contract the program was transferred to NOL for completion of evaluation tests and production specifications.

7.6.1

General

The requirements for a depth control for the pepper signal were similar to those for the NAE described above. The greater weight of the signal necessitated provision of a still greater displacement volume. The pepper signal depth control consists of a balloon containing a chemical source of hydrogen, calcium hydride in contact with water, and a pressure-velocity operated gas-release valve. The depth is held constant by the interaction of the gas generator, which tends to increase the buoyancy, and the gas release valve, which tends to decrease the buoyancy. The rate of gas generation is essentially constant, and the control valve is operated both by the depth of the device (that is, by static water pressure) and by its vertical component of velocity. The noisemaker is attached to the balloon by a 10-ft wire to avoid significant impairment of its acoustic output by the proximity of a pressure release gas volume.

The appearance of the depth control in operation is shown in Figure 7. Before ejection it is packed into a rigid container, 3 in. in diameter and 10.5 in. long, attached to the end of the explosive stack. The packing arrangement is shown in Figure 8. The sequence of operations by which the depth control is opened so that its gas generating chemical is exposed to action by the sea water is shown in Figure 9, with Figure 7 representing the final stage.

The outside container is first removed by the smokeless powder charge, ignited by a fuse from the heat transfer plug in the explosive stack. Next the half shells are forced apart by a flat spring and fall away, releasing the balloon assembly. Water entering the balloon reacts with finely ground calcium hydride, filling the balloon immediately with hydrogen and making the system positively buoyant. At the same time the weight of the explosive stack pulls downward on the bottom of the balloon, insuring that it turns topside up, and stretches the tightly coiled suspension spring out to a length of about 10 ft. Being positively buoyant, the depth control rises.

SECRET

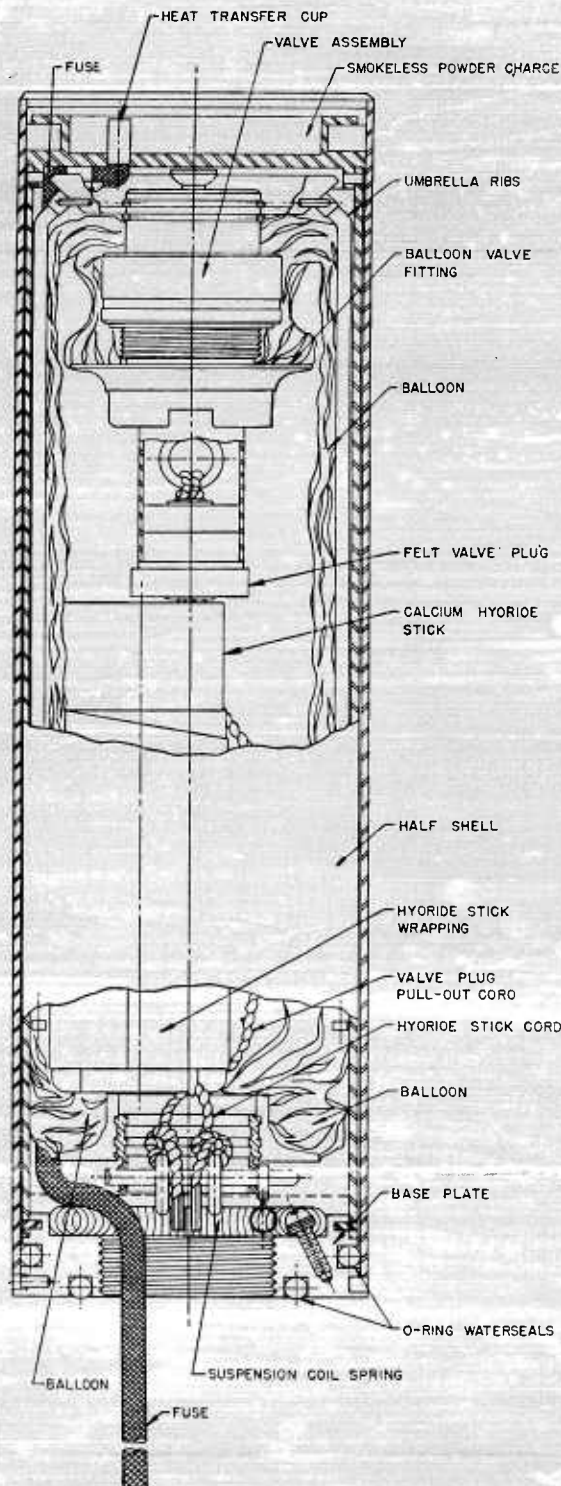

FIGURE 8. Packing arrangement of depth control.

As it approaches the preset operating depth of 45 ft, the valve releases hydrogen until the operating position and neutral buoyancy are reached. Hydrogen is generated continuously at a slow rate by a single stick of calcium hydride in the balloon and released just fast enough through the valve to maintain stability and depth. If the device gets above its preset operating depth, the excess gas is released and the device falls to its equilibrium position. After 10 to 12 min of constant-depth operation, the hydride stick is consumed and the device falls to the bottom. Figure 10 is a plot of depth against time for a typical unit, showing the slight initial fall after ejection and the slight overshoot as the unit rises to its set depth.

7.6.2

Principles of Operation

A brief and approximate mathematical analysis is sufficient to interpret the operation of the depth control. According to the familiar gas law, the volume of a given mass of gas is inversely proportional to pressure if the temperature is held constant. (For the range of ambient temperatures encountered in sea water, say -4 to $+30$ C, any error from assuming temperature constant would be less than ± 6 per cent.) For pressure expressed in terms of water depth this becomes

$$V = \frac{22.4M}{(1+d/33)} \quad (1)$$

where V is the volume of the gas in liters, M is the quantity of gas in gram-moles, and d is the depth of water in feet. The volume of gas in liters is closely equal to its buoyancy in kilograms for fresh water and $2\frac{1}{2}$ per cent less for sea water. Therefore (1) becomes

$$B = \frac{22M}{(1+d/33)} \quad (2)$$

where B is the buoyancy in kilograms.

From equation (2) it is clear that a device supported by a gas balloon is inherently unstable, for with zero buoyancy at any given time, if it starts to rise (d becomes smaller) the gas becomes more buoyant, and the device rises faster. Similarly, if it starts to fall, the gas becomes less buoyant and the balloon falls continuously faster.

SECRET

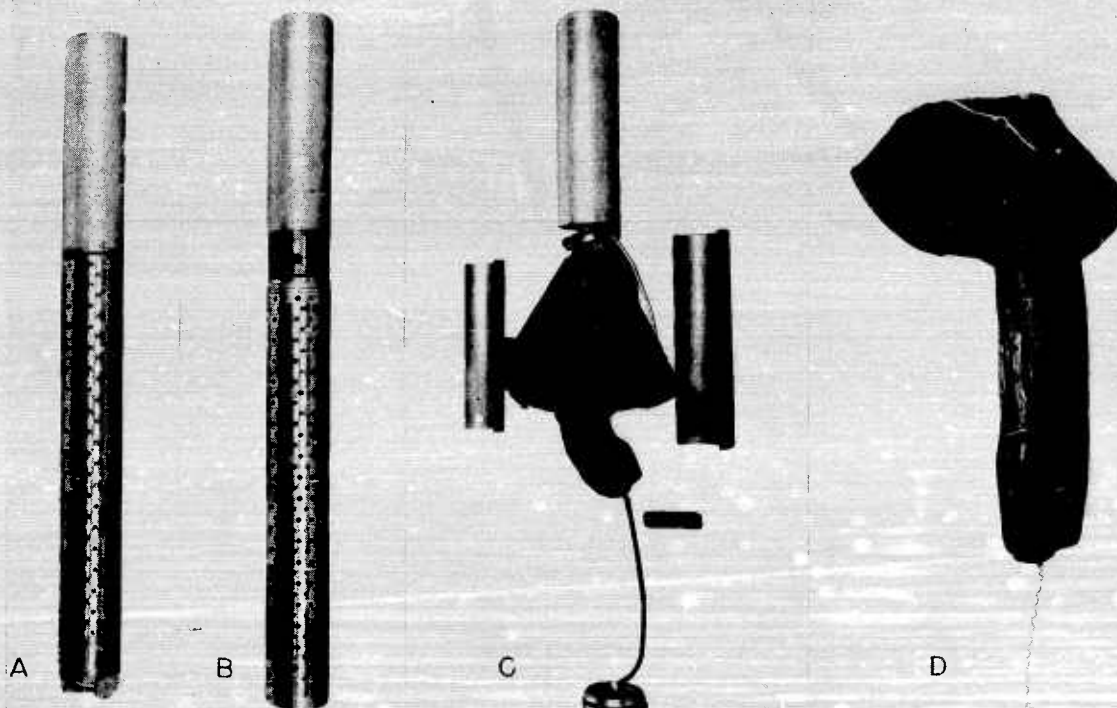

FIGURE 9. Pepper signal: (A) before ejection, (B) explosion removes container, (C) half shells fall away, (D) balloon inflates.

It is necessary to know the rate at which gas must be supplied or released to hold the buoyancy constant when the device is falling or rising. Rearranging equation (2) and differentiating, we find

$$M = \frac{B(1+d/33)}{22} \quad (3)$$

$$\frac{dM}{dt} = R = -0.00135v \quad (4)$$

where k is defined as the rate at which gas must be added in moles per second, and v is the velocity (upward taken as positive) in feet per second. From this equation, it is clear that the quantity of gas required to maintain constant volume or buoyancy for a given rate of fall is independent of depth when expressed in moles.

Because a buoyancy-operated system is inherently unstable, the control system must supply a series of corrections; it must reduce the net buoyancy to negative after it has become positive, then increase it to positive after it has become negative.

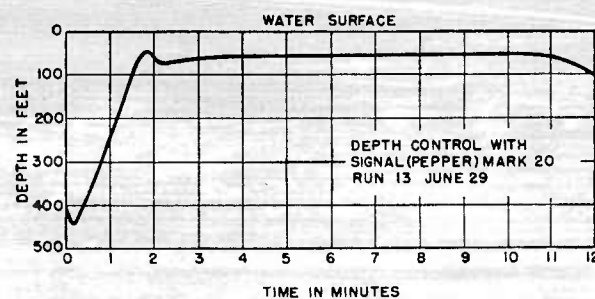

FIGURE 10. Depth-time plot of depth control performance.

The simplest mechanism for accomplishing this is to combine the gas container with a pressure- or depth-operated gas release valve and a continuous or controllable gas source. For such a system the force is equal to the net instantaneous buoyancy, and the resistance to motion is proportional to the velocity or some higher power of the velocity. The instantaneous buoyancy is difficult to express analytically because it depends both upon the depth and upon the difference between the total gas

generated and the total gas valved off. The latter are complicated time integrals. Within certain limits, which can be expressed qualitatively, such a system is stable although it is inherently oscillatory. Without setting up the rather complicated and non-linear equation, four phases of the cycle of operation can be discussed.

Phase 1. The unit is rising from its nominal equilibrium position to its maximum upward displacement. During this phase the valve is open, and gas must be released fast enough to offset both the expansion from rising and the new gas added from the generator.

Phase 2. During this phase the device is negatively buoyant and is falling to its equilibrium depth. The valve is still open, however, and gas is being lost undesirably.

Phase 3. During this phase the device is falling from its equilibrium position to its lowest displacement, and the valve is closed. The generator must supply gas fast enough (or the rate of fall must be slow enough) so that the net volume of gas increases and the device becomes positively buoyant.

Phase 4. During this phase the unit is rising to equilibrium, the valve is closed, and the restoring force is increasing as the gas expands and more gas is added.

It is because of the variation in gas volume with depth, and because of the phase lag in valving off gas after the device has become negatively buoyant (Phase 2), that this system always oscillates. From measurements of resistance of the device, valving rates, and gassing rates of various chemicals, design constants for this type of control were worked out. To make it stable, however, for a load of 5 kg or so, the required gassing rate was unreasonable, even when the resistance was increased by the use of a 19-in diameter damping vase or umbrells. Furthermore, it appeared desirable to eliminate oscillations, because of the danger of impairing the acoustic efficiency of possible noisemaker loads by enveloping them in small bubbles during the upward part of the cycle.

It is possible to minimize oscillations, and reduce markedly the required gassing rate by advancing the phase of the release of gas, so that most of the valving is accomplished during Phases 4 and 1 of the cycle rather than during Phases 1 and 2. This may be done by utilizing a valve whose opening depends upon the velocity of the device rather than

upon its position. This velocity or anticipating type of action has been utilized in many types of automatic controls.¹¹⁵ With a velocity type control, the valve opens when the device rises and the opening is proportional to the velocity. Thus, if the device is rising due to excess positive buoyancy, the valve is open. As the release of gas reduces the upward force, it slows down and the valve closes, being completely closed at the end of Phase 1 of the operating cycle described above. For the present depth control the accelerations are quite small, and there is practically no overshoot due to the inertia of the device at this or other parts of the cycle so that a velocity control can keep oscillations to a minimum or zero.

With only a velocity component of control, oscillations as described above cannot be large, but the device can drift very slowly up or down to any depth. To avoid this, the velocity-operated component of control is combined with a pressure-operated component. Depending upon their relative sensitivities, the pressure component can be considered as a correction term to keep the slow drift to zero, or the velocity component can be considered a correction term to keep the hunting to a minimum. Appropriate sensitivity ranges for these two components exist which reduce both drift and oscillations to negligible values.

7.6.3

Technical Development

The technical development of the gas-operated depth control for the pepper signal is covered in detail in reference 117. The major problems in the program were the selection of a suitable source of gas, the design of a reliable knockoff mechanism, the provision of a rapid supply of gas for initial fill of the balloon, and the control of steady-state operation so that oscillation and drift would be minimized.

The chief requirements for a gas source in this depth control were that it be compact (that is, its gassing rate be readily controlled) and that the gassing rate be independent of ambient conditions such as temperature, pressure, and salinity or other chemical impurities in the sea water. Investigation of lithium and lithium hydride for this application showed that these chemicals display great dependence of gassing rate upon the concentration of hy-

SECRET

dioxide at the gassing surface. Since the oscillations of this depth control assembly were not of sufficient amplitude to insure irrigation of this surface by fresh sea water, this limitation became important. Calcium hydride does not display this property and proved to be otherwise satisfactory. This material was also easily obtainable in various forms including the sticks and powder used in the final depth control design. The stick of calcium hydride that provides the steady supply of gas is taped to about 1 in. from the end so that the gassing surface is large at first and then is reduced to a constant area as the stick is so consumed.

The knockoff mechanism must insure reliable exposure of the depth control components to action by the sea water and yet avoid damage to these parts or to the noisemaker load. In the final design a knockoff charge of smokeless powder is ignited by the fuse train that also initiates operation of the pepper signal. This powder expels the packed depth control mechanism with a force that is proportional to the static pressure at the depth of ejection, and thus the force can be limited to the amount actually needed for the knockoff. The details of the ignition system for this device received considerable study to eliminate possible failures from water leakage or improper assembly.

The initial fill for the depth control is supplied by a charge of powdered calcium hydride shaken loose into the balloon. The quantity of this powder and its particle size had to be adjusted so that it would provide sufficient gas even at depths as great as 400 ft to make the buoyancy of the unit positive, and to provide this gas so fast that in an initial drop after ejection the device would fall no deeper than to 300 ft. It was, of course, desirable to have the unit brought to the operating depth as fast as possible, and yet the rate of rise should be such that the unit would not overshoot to appear at the surface. As can be seen from the plots of depth control performance in Figures 10 and 12, the initial drop and the tendency to overshoot were brought within satisfactory limits by the end of the program. It is felt that further work should be devoted to control of these features.

The steady-state operation of the balloon was successfully controlled so that it hovers at its set depth with oscillations of negligible amplitude, less than ± 3 in. The displacement of the gas balloon brings the net buoyancy of the device to zero. The

valving action of the sylphon in response to static pressure maintains the set depth. The additional valving action in response to velocity changes, as communicated from the damping umbrella, provides derivative control so that a tendency to drop or to rise is counteracted as soon as the upward or downward force is applied to the umbrella. The con-

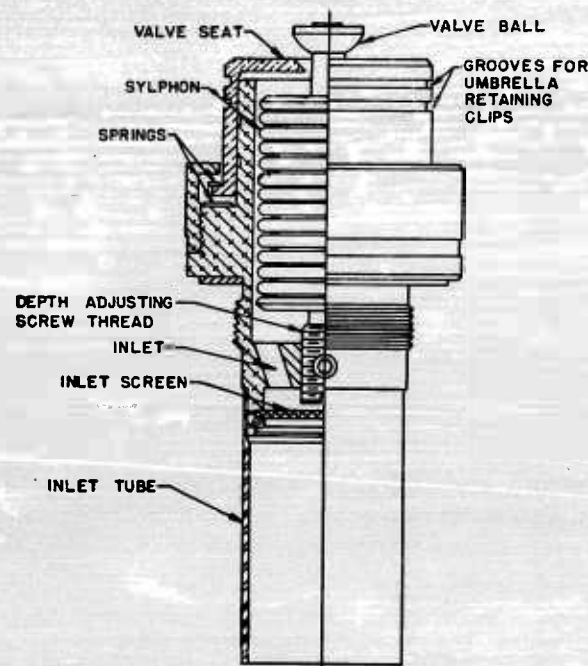

FIGURE 11. Assembly drawing of valve, showing sylphon, umbrella mounting, valves, and springs which provide derivative control.

struction by which these two types of control are applied to the valve can be seen from Figure 11.

At the close of NDRC participation in this development, the responsibility for further work on the depth control and the pepper signals was transferred to NOL. The test results covered below in Section 7.6.4 were carried out jointly by MIT-USL and the Navy laboratory. Information on the results of further tests and on details of subsequent development may be obtained from NOL.

7.6.4

Performance Tests

Tests of the performance of complete depth control units of the final design were carried out in

SECRET

Boston Harbor in 600 ft of water.¹¹⁸ A technique was worked out for performing tests from a boat or ship in such fashion that the units were recoverable and depth records during operation were obtained.

The records of depth as a function of time, of which those given in Figure 12 are typical, are obtained with a depth recorder similar to the silent stenographer developed by UCDWR.¹¹⁴ The co-

tion or replacement of the glass disk. For tests with dummy loads the depth recorder is lashed onto the load, and for tests with complete signals the recorder is attached to the explosive stack by a chain, which in turn is attached to the retrieving line. This arrangement keeps both the recorder and the light line 10 ft or so from the explosions.

The operation of the depth control appears to be satisfactory when used as a component of the signal (pepper) Mk 20. The design factors indicate that it could be readily adapted for other applications and for loads at least several times larger than the present 5-kg load. In subsequent tests carried out at ASDevLant in the summer of 1945 the performance records were similar.¹¹⁹

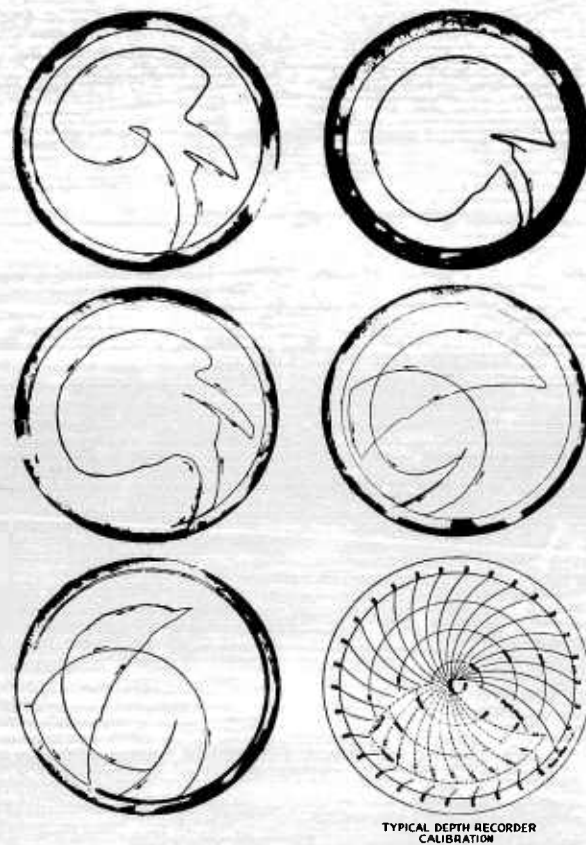

FIGURE 12. Records of depth control performance.

ordinate system relating depth and time for these graphs is also given in the figure. Figure 10 was obtained from one of these records. A conventional pressure gauge is mounted in a container together with a Mark Time clock which rotates a 2-in. smoked glass disk one turn in 15 min. A modified pointer on the gauge scratches on the glass a trace whose distance from the edge is a measure of the ambient pressure, or depth. The recorder can be easily assembled or taken apart for starting opera-

7.7 OTHER DEPTH CONTROL DEVICES

7.7.1

General

A number of mechanisms other than the gas-operated depth controls described thus far were employed in the course of the noisemaker program. These satisfied to a greater or less degree the requirements discussed in Section 7.2. Simple floats were used with certain of the expendable noisemakers which were to be thrown from the decks of surface vessels. A collapsed balloon that inflates after ejection to float on the surface is used with the NAE Mk 1. In the Mk 14 pepper signal a parachute opens after ejection and serves merely to reduce the rate of fall of the unit. Brief study was also made of the possible use of a motor-driven propeller to support expendable noisemakers. The construction of these devices is summarized in the sections that follow. In the NAD noisemakers a combination of pendulum and syphon control operates elevator surfaces to keep the units at the desired depth. These dynamic depth controls are discussed in Chapter 6.

7.7.2

Floats

Floats supplied the easiest means of supporting an expendable noisemaker at a fixed depth below the surface. For example, in tests of the early hammer bottles and grenades as torpedo decoys, life jackets were simply attached to the units on a cable. This method was of course unsuitable for operational use.

SECRET

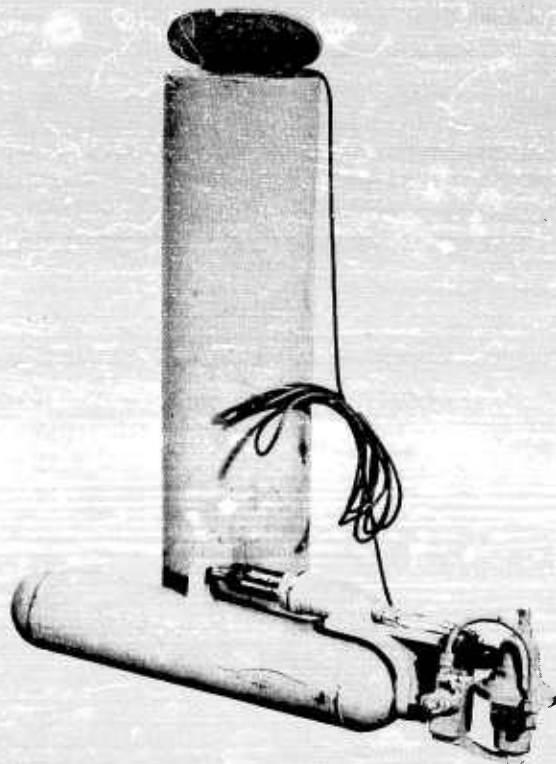

FIGURE 13. The FXH-1 with float container.

The production model of the FXH-1 hammer bottle was equipped with a container that also served as a float as shown in Figure 13. The hammer bottle is attached to the rim of its light metal housing so that when the assembly is thrown overboard the weight of the hammer bottle pulls the container into a vertical position with the open end down, thus trapping a quantity of air. The rope supports the noisemaker 20 ft below the surface. A

small hole located near the closed end of the container controls the rate at which the air escapes so that after about 5 min the entire assembly sinks. A drawback of this device is that it is visible at the surface, although the short life reduces the chances of its being recovered by the enemy. The construction of the float-container and the air vent are described in reference 66.

7.7.3

Balloon for NAE Mk 1

The Mk 1 NAE beacon¹⁴ uses a collapsible float. A balloon of sufficient displacement volume, about 3 liters, is housed compactly at the end of the noisemaker as can be seen in Figure 14. Gas from the reaction of sea water with a 7-g charge of finely powdered LiH inflates the balloon after ejection. It rises to the surface, supporting the noisemaker on a 20-ft cord. The gas-generating chemical is consumed 7 to 10 min after inflation. A small hole at the top of the balloon lets the gas escape gradually so that the whole assembly sinks.

The knockoff mechanism for this device is similar to that used in the Mk 2 NAE discussed in Section 7.5. The depth control and the sea-water battery are housed inside an aluminum shell to protect them from premature water penetration. As the device goes out of the ejector tube the trigger starts a 4-sec delay fuse. This fuse sets off 20 g of smokeless power. The resulting explosion blows off the shell, admitting water to the battery and balloon-inflating chemical. A split sleeve enclosing the balloon falls away, and the balloon inflates and rises to the surface.

Again the disadvantage of the depth control for the Mk 1 NAE is that it can be seen from the surface. The improvements embodied in the Mk 2 not

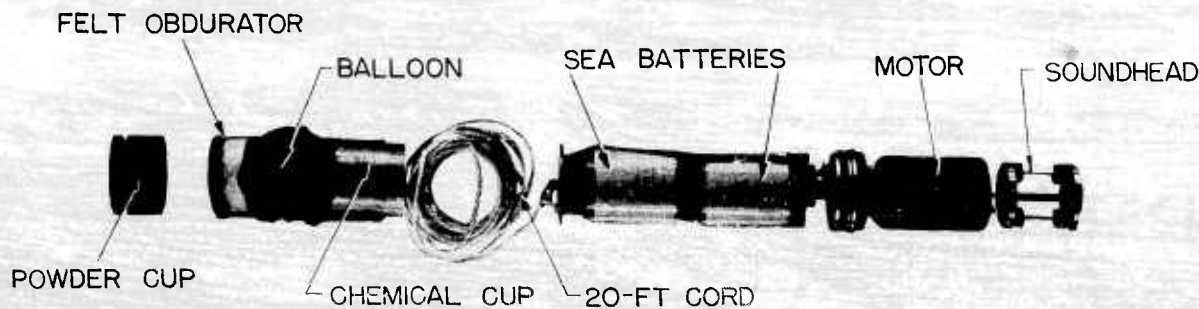

FIGURE 14. The NAE Mk 1 with balloon floats.

SECRET

only extend the range of depth at which the NAE can be ejected but provide a depth control that keep the unit invisible and irretrievable.¹⁶

7.7.4 Parachute for Signal (Pepper) Mk 14

The original depth control proposed for the explosive noisemakers was a parachute housed in a can at the top of the unit. This device was developed in parallel with the work on the explosive noisemakers and was supplied with the Mk 14 pepper signals for production prior to completion of the gas-operated depth controls. This parachute opens after ejection of the unit and reduces its falling rate to less than 1 ft a second. It is dyed a mottled green to reduce its visibility near the surface.

The design of the parachute and its knockoff mechanism, shown in Figures 15 and 16, were first developed from the analogous structure in the emergency identification signal developed by NOL. Even with a falling rate reduced to 1 fps, however,

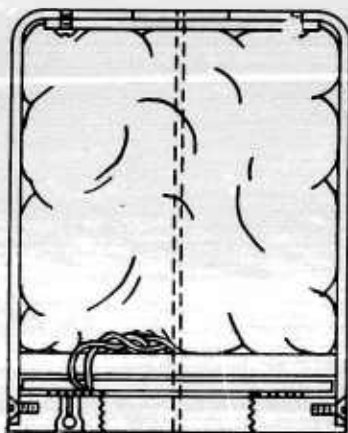

FIGURE 15. Parachute assembly for signal (pepper) Mk 14.

the parachute imposed a severe limitation upon the usefulness of the noisemakers. A unit with a 6-min time delay ejected, for example, at a depth of 400 ft, would have reached a depth of 760 ft before it started to fire and would be at 1,120 ft by the end of operation. Since the explosive noise is useful for masking only in shallow water, 1,200 ft deep or less, since the acoustic output is seriously impaired if the noisemaker lies in a muddy bottom, and since the noisemaker is most useful for evasion tactics when it is nearer the surface than the evading submarine,

it was apparent that a positive type of depth control must be provided for the pepper signal. In order not to delay production, however, the Mk 14 model was issued with parachutes, with a shift made to Mk 20 units with depth controls as soon as completion of the design permitted.

The knockoff mechanism for the pepper signal parachute is somewhat different from that for the depth control. The heat transfer ignition system, which is the same for both designs, in this case ignites a black powder charge as shown in Figure 16. This drives a steel cover a short distance up into

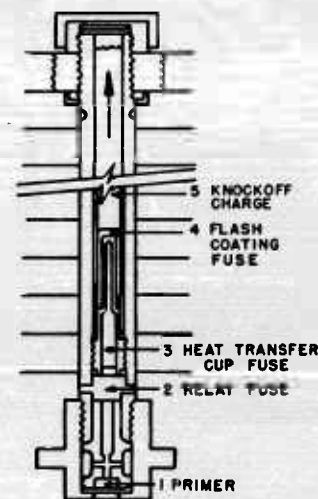

FIGURE 16. Knockoff mechanism of parachute for signal (pepper) Mk 14.

the parachute container, separating the parachute assembly from its base piece and causing the halves of the split can to fall away. The weight of the signal then pulls the parachute open and the assembly sinks slowly in the position shown in Figure 1 in Chapter 4.⁵⁶

7.7.5 Propeller-Operated Depth Control

The possibility of using a rotating propeller to support expendable noisemakers at a predetermined depth received some consideration before the gas-operated depth control design was proved to be acceptable acoustically and mechanically superior. After initial experiments where an experimental model with a 3-in. diameter propeller was shown to require 1-hp input to support a 10-lb load, a test

assembly was constructed to study the relations among propeller diameter, propeller pitch, rotation speed, and power input that were required to support a load of this approximate value. Although some preliminary data were obtained, the extensive test program that would be required to verify the

conclusions was not carried out. One set of results is given in reference 56e, which shows the variation of efficiency with propeller diameter for one set of conditions. The excessive power requirements indicated by these first results led to termination of work on this design.

SECRET

PRIMARY BATTERIES FOR EXPENDABLE DEVICES

8.1

INTRODUCTION

THE SUCCESSFUL DESIGN of evasion devices depended to a great extent upon the provision of suitable batteries. The limited size of expendable noisemakers necessitated an unusual power-size ratio, while the weight restrictions made necessary an exceptional power-weight ratio as well. While various types of secondary batteries were useful for test purposes, a number of considerations made it desirable to use primary batteries for the final expendable designs. The primary batteries that were utilized in this program were of two types. Seawater activated batteries^a were used in various models in the NAC beacon, the NAE beacon, the XNAG, and the NAD-6. The Burgess sea batteries developed under the auspices of the Bureau of Ships are documented in the files of Code 945. The Edison primary battery, which operates on an oxidation-reduction principle, was developed in the I-type and K-type designs for use in the NAD-10 and NAD-3, respectively. Since no discussion of the small size medium-power batteries so useful in this program is readily available elsewhere, the experience in using them is summarized here for the convenience of future workers.

Secondary batteries, that is, cells in which the chemical reaction is reversible, have certain disadvantages for use with expendable devices. The total weight includes not only the weight of the active chemicals but must provide some metal surface upon which these materials are deposited, as, for example, the lead grids in the usual lead-acid storage battery. Even when not in use, secondary batteries evolve hydrogen from local action within the cells, which is dangerous in any case and unacceptable for use aboard submarines on patrol. Secondary batteries lose their charge on standing so that they require special maintenance. The voltage produced in these batteries depends upon the concentration of the electrolyte so that the voltage characteristic falls gradually with time.

Even the high-grade Exide 101-13 12-v lead-acid

^a The sea batteries developed by BTL, chiefly for use in torpedoes, are discussed at some length in Division 6, Volume 18, Chapter 12.

batteries employed in the Mark 30 mine and later in early models of the NAD-10 beacon displayed these disadvantages. The standing loss was such that the capacity of the battery was reduced by 40 per cent in a 2-week storage period. As an example of the hazard from the hydrogen evolved by this local action, these batteries inside the NAD-10 can produce the 4 per cent concentration of hydrogen that constitutes the minimum explosive mixture in as little as 4 days. As a maintenance routine, the NAD-10 beacons stored with batteries in place had to be purged daily of the accumulated gas,¹¹⁹ and the batteries had to be removed from the beacon at least once every 2 weeks for the addition of distilled water to the electrolyte and for recharging. These special batteries in the NAD-10 provided a life of 45 min for the unit. The 6-v Willard-type NT-6 lead-acid batteries which were used for test purposes at other points in the program had far less capacity, providing a life of only 6 min for the NAD-6 practice units.

Primary batteries, that is, cells in which the chemical reaction goes in one direction only, avoid these disadvantages. Since the electrolyte is kept separate from the active plates until the action is to begin, there is no evolution of hydrogen or need for maintenance during storage. Since the chemical reaction goes to completion, these batteries can be designed to have one of the metals completely consumed so that the weight of excess metal is minimized. The concentration of the electrolyte is essentially constant so that the voltage characteristic is nearly flat, falling off sharply when the plates are exhausted.

The suitability of primary batteries for expendable devices is obvious since there is no need for recharging, and since size and weight are at such a premium. The sea batteries used in the stationary expendable noisemakers and in the NAD-6 start to produce current as soon as their plates become wet. This means that these devices must be kept dry in storage, in an atmosphere of 50 per cent humidity or less; they must have a free-flooding battery compartment; and hydrogen bubbles are evolved from the action of the battery. However, the storage weight of these devices is reduced by the elimination

of any electrolyte until use, and the free-flooding compartment and the hydrogen bubbles can be tolerated in most cases. In the development of the NAD-3 and the NAD-10 it was found preferable to use a different type, the Edison primary battery, in which the electrolyte is held in a sealed chamber above the active plates and is released to flood them when voltage production is desired. This type of battery requires no special moistureproofing and evolves no hydrogen in its operation. It was particularly useful in the NAD-3 in eliminating the need for a free-flooding compartment with the attendant reduction in buoyancy.

The primary batteries that have been used in the expendable devices discussed in this volume are of these two types. Since many of the arrangements were made verbally there is little documentation of this development. Sufficient mention is made of these batteries at points in the various development programs to justify the assembly of this material in a single chapter.

8.2 BTL SEA-WATER ACTIVATED BATTERIES

Sea batteries of two general types were used in the expendable program at UCDWR. The plate-type construction developed by BTL was studied for application to the NAC and to the NAD-10, while a 24-v unit was produced by a commercial company for the NAD-6 on a BTL design. The foil-type batteries developed by the C. F. Burgess Company are discussed below. Both of these batteries are activated by contact with the sea water and require special moistureproofing precaution before use. Their light weight is an advantage in reducing the storage weight of the units, but the free-flooding chamber required for their operation is a drawback in cases where flotation volume is at a premium. Hydrogen is evolved from these units in considerable quantities and some attention was given to the possibility of using this gas to supply the buoyancy controls for the devices.

Of the BTL battery designs^b the plate-type construction is the one that was adapted to the UCDWR needs. In initial conversations in the spring of 1943 it was agreed that a battery similar to the high-power units under development for

^b The BTL battery designs are discussed in Division 6, Volume 18, Chapter 12.

torpedo use could be adapted to the intermediate power requirements of the NAC beacon as then conceived and to other expendable devices.

The BTL batteries utilize the reaction of silver chloride and magnesium in a solution of sodium chloride. The cathode elements are made of fine silver screen, anodized, activated, and developed to give silver chloride. The cathodes are then pressed to a thickness of 0.022 in. The anode elements are made of 0.014-in. J1 magnesium alloy. Nylon spacers are used between the cathodes.

After further conversations in the fall of 1943, where the battery requirements of the NAC beacon were specified, this plate-type battery construction was used in the 1.4-v Kurie battery design. Owing to parallel investigation of a 5.8-v rolled-foil-type Burgess sea battery described in following text, this battery was never used although the laboratory used BTL batteries in later applications.

A number of the Kurie batteries, the type K sea-activated primary cell, were built by BTL. A BTL memorandum^c contains construction drawings of this unit and gives extensive data on its construction, characteristics, and the test performance of several batteries, selected at random from the lot constructed.

Interest in the BTL plate-type batteries was renewed when a 24-v primary battery was needed for use in the NAD-6 beacon. The Burgess foil-type battery, satisfactory for low-power design, was subject to leakage at high currents and high voltages. Specifications were set up at a conference on March 22, 1944, and the 17-3-E battery was designed and later produced in quantity for use in the NAD-6. These batteries met all the specifications and their performance was most satisfactory.

The 17-3-E battery shown in Figure 1 consists of 17 cells connected in series. Each cell contains three anodes and four cathodes. Each pair of plates delivers 7.38 amp-min per square inch of gross cathode area. The entire battery is contained in a phenol fiber case with openings in the top and bottom of the case for passage of sea water. Since the battery is housed in a free-flooding compartment in the nose of the beacon which is traveling at a speed of 4 knots the irrigation of the active surfaces by the sea-water electrolyte is assured.

^c Reference to this material in BTL files is the Memorandum for Record 1260-RTL-NO, dated January 25, 1944.

The discharge characteristic of the 17-3-E battery is shown in Figure 2. This provides a life to the unit of 36 min at an average voltage of 24.9 v and an average current of 13.0 amp. The average power



FIGURE 1. BTL sea battery 17-3-E.

is thus 324 w, and the energy delivered 194 whr. This flat characteristic is typical of primary batteries. Here the battery potential at the end of 36 min is still 96 per cent of its average value. The

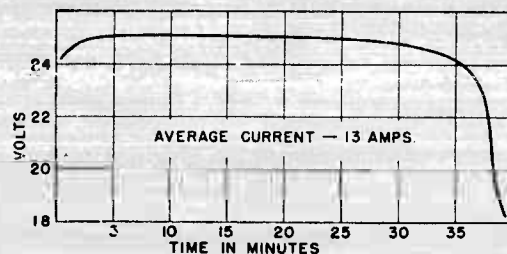

FIGURE 2. Discharge characteristic of BTL sea battery 17-3-E.

characteristics and construction of this battery are covered in a BTL memorandum for record.^d

The possibility of adapting this 17-3-E battery to

^d Filed under Case 23266-6, dated May 26, 1944.

the power requirements of the NAD-10 beacon was discussed in October 1944, just when the first production units were being completed. It was hoped that the tooling for the NAD-6 batteries could be retained for the NAD-10 units. The special requirements of the NAD-10 were for high current to supply the initial high-speed run, and a maximum life thereafter at reduced current drain. Calculations indicated that the plate and cell construction of the NAD-6 could be used, with the NAD-10 batteries differing only in the number of plates per cell and the total battery length. It was intended that two such batteries could be accommodated in a compartment no larger than that occupied by the lead-acid batteries in the NAD-10 test units. At this time considerable thought was given to the practicability of adopting a 24-v system for the NAD-10 in place of the 12-v system inherited from the Mark 30 mine design. In view of this and the fact that the higher voltage sea-battery would be more difficult to build, these experimental models, designated 17-5-E, were constructed for 24-v operation. Thus the general design could be tested under the most meaningful adverse conditions.

Three sets of the 17-5-E batteries were completed early in December 1944. The results of discharge tests were in agreement with predictions, releasing a total of 436 whr of work from the two parallel batteries before the voltage fell 20 per cent below its peak value under load. The dummy NAD-10 load called for 80 amp at 26.7 v for the first 4 min and 50 amp at an average of 25.6 v for the remaining life, which proved to last for 81 min more. Tests of these batteries are covered in a BTL memorandum for record.^e

Meanwhile the completion of a satisfactory propulsion system for the NAD-10 using 12-v supply made it necessary to change to a 12-v battery design. The plates of the 17-5-E were accordingly reassembled in a 12-v battery which had a capacity slightly greater than its predecessors. The same overall dimensions were used with 10 cathodes per cell and 8 cells in series. This battery was designated 8-10-E. Tests of this battery are covered in a BTL memorandum for record.^f

Further development of a sea battery for the

^e Memorandum for Record 1260-UBT,Jr-MH, Case 23266-6, dated Dec. 9, 1944.

^f Memorandum for Record 1260-UBT,Jr-MH, Case 23266-6, dated Mar. 6, 1945.

SECRET

NAD-10 was discontinued when it was apparent that the Edison I-type primary battery was more suitable for this application. In evaluating the two proposed batteries it was seen that the work capacities of the two batteries per unit volume were approximately equal. The BTL battery would necessitate major changes in body tooling and design, while the Edison battery of approximately equal capacity would be only slightly larger than the lead-acid battery and would require only minor modifications in the existing battery support rack. With the sea battery, a practice head of different design would be required to prerun the unit using secondary power, while with the Edison battery the primary and secondary batteries would be interchangeable so that no special practice head would be needed. Finally, a unit equipped with the Edison battery could be stored in readiness for firing in a flooded torpedo tube for prolonged periods, while the sea battery had either to be used when made ready or resealed to prevent deterioration from the moisture content of the air. On the basis of these comparisons it was decided to adopt the Edison battery for use in the NAD-10.

Detailed information concerning the BTL batteries investigated in the course of the UCDWR program can be obtained from the BTL files. Some additional information may be found in the UCDWR reports on the various expendable devices which used these batteries.^{112, 113}

8.3 BURGESS SEA-WATER ACTIVATED BATTERIES

The adaption of sea batteries of the foil-type as developed by C. F. Burgess Company was under close supervision by Code 945 of the Bureau of Ships. It was appreciated at the start of the program that a primary battery to fit the 3-in. diameter of the signal ejector would be of value at many points in the prosubmarine program. A number of Burgess 1.2-v and 6-v batteries were supplied to UCDWR, MIT, and NRL for test in the fall of 1943. In a conference with Jackson Burgess at UCDWR on February 10, 1944, the specifications were set up for a primary battery for use in the NAC beacon to supply 10 amp at 5 v for 12 min. This design was completed as the 4cc167 battery used in the NAC. Modifications of this essential de-

sign, to suit special requirements of voltage, life, or diameter, were used in the XNAG, the NAE, the experimental NAD-3, and other devices. The standard battery developed for BuShips was the 7.5-v 5cc153.

The foil-type construction of the Burgess cell developed by that company used electrodes of magnesium foil and of silver chloride deposited on silver



FIGURE 3. Burgess 4cc143 sea battery.

foil. This gives an electromotive force of 1.5 v per cell, and the life and watts output are determined by the area of treated silver. As first supplied, each cell was rolled separately, and the four or five rolls were connected in series and placed together in a metal container. In the final design, space is saved and the leakage is reduced by using the concentric construction shown in Figure 3. A special absorbent paper is placed between the electrodes to insure wetting of the active surfaces. The cells are insulated from each other by a waterproof paper that is also

made to extend beyond the rolls of cells at either end to reduce current leakage. The cells were connected with copper wires spot welded to the electrodes and lacquered to protect them from electrolytic action. The NAC uses the 4cc167 battery which provides 6 v from four 1.5-v cells at about 12 amp for about 12 min. Two of the 4cc133 batteries shown in Figure 3 are used in the XNAG⁶⁰ to provide 15 amp at 12 v for about 11 min. The performance characteristic of the 5cc133 used in experimental models of the NAD-3¹⁰⁹ is shown in Figure 4. These cells were tested by the Bureau of

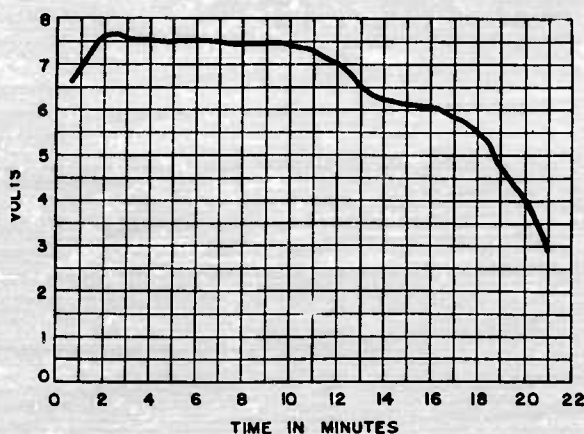

FIGURE 4. Discharge characteristic of Burgess 5cc133 sea battery.

Standards at the request of Code 945 of the Bureau of Ships. The results are reported in a BuShips letter, serial 945-1895, dated July 7, 1944.

The Burgess battery was also studied for possible application to the high-voltage needs of the NAD-6.¹¹² The No. 8 2cc450 shown in Figure 5 was built up with four concentric rolls of four cells each housed in the quadrants of a container built to fit the nose of the beacon. Tests of the performance of this unit compared with the BTL 17-3-E led to selection of the latter. The results of these tests are reported in a UCDWR memorandum dated February 28, 1945.

Later in the program at UCDWR some attention was given to the development of a 300-v sea battery of the Burgess design. The cells were rolled individually, and each was housed in a plastic compartment with a small orifice at the top to let in the sea water. This construction is reminiscent of the Edison batteries. It was proposed to eliminate the

leakage paths through the electrolyte by trapping a bubble of the evolved hydrogen in this orifice, thus insulating the cells from each other. Further

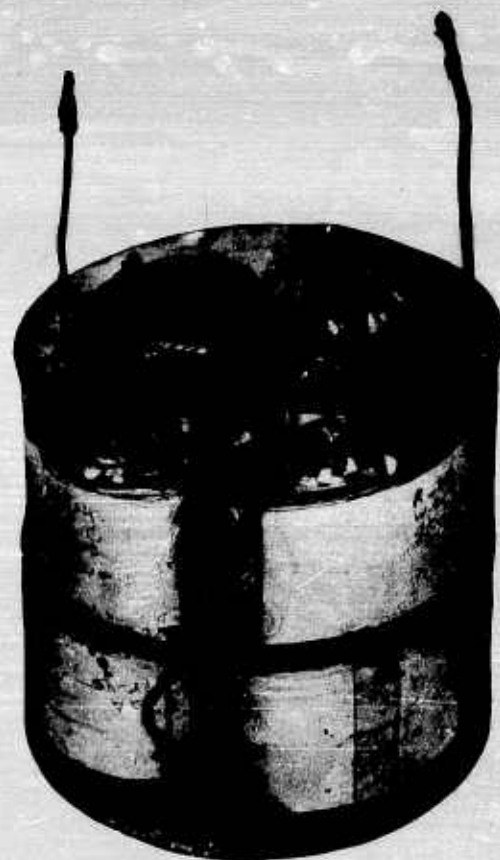

FIGURE 5. Burgess 24-volt sea battery.

information about this development may be obtained from the work continuing at the Navy Electronics Laboratory.

8.4 EDISON PRIMARY BATTERIES

A self-contained primary battery in which energy is released through an oxidation-reduction reaction so that no molecular hydrogen is produced, was adapted to the needs of the program at UCDWR. Similar batteries produced by the Thomas Edison Company had been used for some time in railway signaling. In its essential design the battery has its electrolyte sealed in an upper chamber separate

SECRET

from the plates so that there is no local action and no maintenance problem in storage. Battery action is initiated by perforating the partition between the electrolyte and the plate chambers so that the liquid floods down over the plates. This design was adapted as the I-type 8-cell battery for the NAD-10¹¹³ and as the K-type 7-cell battery for the NAD-3.¹⁰⁹ These batteries are shown in Figures 6 and 7.

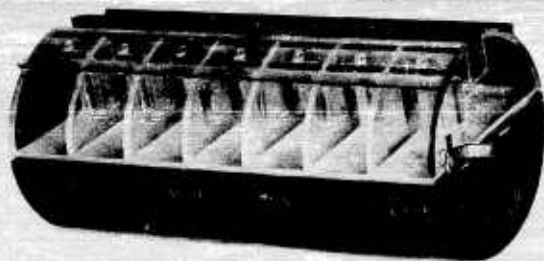

FIGURE 6. Edison K-type 7-cell battery.

The NAD-3 battery, like the earlier Edison batteries, uses copper oxide anodes while the NAD-10 battery uses silver oxide. Otherwise their operation is the same.

In each cell the plate structure is standard multi-

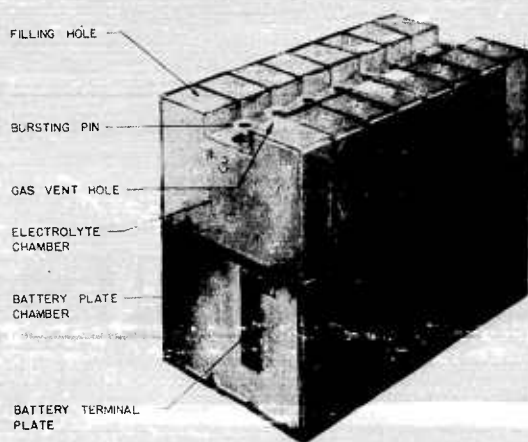
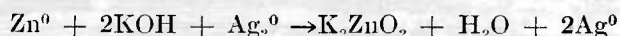

FIGURE 7. Edison I-type 8-cell battery.

ple flat-plate construction similar to that used in many of the present secondary cells. The positive electrode is composed of compressed silver oxide (or copper oxide) which has been embedded in nickel-plated copper screen, and the negative electrode consists of zinc plates which have been corru-

gated to increase their area and stiffness. Glass wool strips cemented to sheets of quick-wetting paper are used as mechanical spacers for fixed plate separation. The quick-wetting paper rests firmly against the positive grids and acts as a retainer for the active plate material. The paper also retards the growth of "silver-trees" which are formed by small particles of sealy silver and sediment that lodge on the positive plates. The electrolyte for the cell is a 40 per cent solution of potassium hydroxide to which a wetting agent has been added.

The electromotive force of the cell is set up by the oxidation-reduction action of the active plate material. The chemical equation for the reaction is as follows:



The silver oxide, as it is reduced to the metallic silver, serves as an efficient depolarizing agent. This feature along with the low internal resistance of the cell and the negligible local action tended to make the battery a high-current, constant-potential source. In addition to these features, the battery requires no maintenance and presented no inflammable gas generation problem.

Tentative specifications for a 12-v battery of this type for use in the NAD-10 were discussed with the Edison Company in October 1944, preliminary tests completed by the first of December, and four handmade I-type batteries were ready for test in the early part of March 1945. Discharge tests indicated that the batteries, operating into a dummy NAD-10 load, exhibited capacity of 568 whr and were capable of supporting beacon operation for a 50- to 55-min period. A second application of the Edison battery was used in developing the K-type design to supply 8 amp at 10.5 to 12.5 v for the NAD-3 beacon. This provided a life of 36 min or more. These batteries were specified for use in the final designs of both types of beacons although through delay in production they were not supplied in sufficient quantities for use during the war.

The production model of the I-type battery consisted of a vertically compartmented, rectangular plastic case which contained in each of its eight compartments a silver oxide-zinc primary cell and an electrolyte storage reservoir. Access to the reservoirs was gained through the filling holes along each side of the top of the battery. When the filling

process was completed, the holes were permanently sealed by small plastic disks which were cemented in place with collodion. These can be seen in Figure 8.

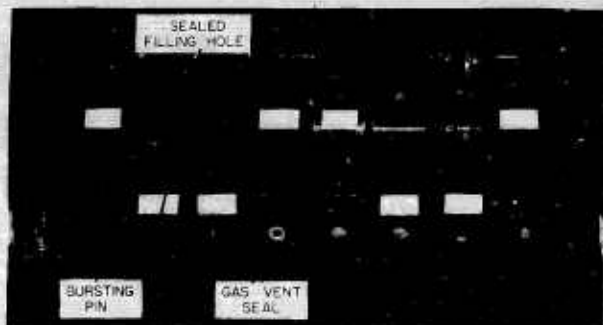

FIGURE 8. Top view of I-type battery with bursting pins installed.

Each electrolyte reservoir contained a vertical bursting-pin guide tube which extended through and was flush with the longitudinal recessed channel along the top center of the battery case. The other end of each of these tubes was terminated by a small rectangular plate which sealed the inside of the tubes from the inside of the battery case. The brittle plastic material, which constituted the separating bulkhead between each of the electrolyte reservoirs and its corresponding primary cell compartment, contained a low-strain bursting section which was located directly beneath and in line with the sealing plate on the guide tube. The bursting pins resembled long flat-headed rivets, and they fitted in the guide tubes and rested on the sealing plates which closed the ends of the tubes. The design was such that a vertical strain of 8 lb on any one pin would tear the sealing plate away from the end of the guide tube and thrust it through the bursting sheet on the separating bulkhead. The resulting hole in the bulkhead then allowed the electrolyte to pour from the reservoir into the primary cell below. To relieve the internal pressure that would otherwise be developed on the inside of the case during the chemical reaction, a vent sealed by a soft patch was contained in the top of each battery cell adjacent to the recessed channel.

The individual primary cells were connected in series through heavy internal copper bus bars, and the output terminals of the battery were brought out through the ends of the case and were termi-

nated by L-shaped copper terminal plates which were recessed in the ends of the plastic housing. When the battery was installed in the NAD-10 beacon body, the spring-loaded contactors in the battery compartment pressed firmly against the terminal plates, making a positive low-resistance connection. The terminal contactors and the terminal plates were both displaced from the centerline of the battery and battery compartment to avoid battery installations of reverse polarity.

The power necessary to shatter the bursting plates and to puncture the vent seals was supplied by a battery-breaking mechanism which fitted in the recess channel in the battery case. This is shown installed in its cocked position in Figure 9.

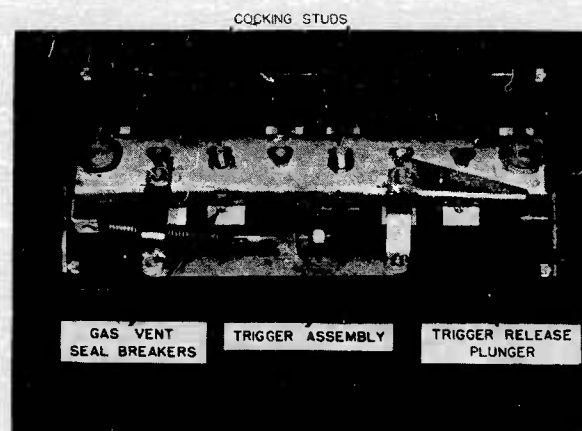

FIGURE 9. Battery in NAD-10 with breaking mechanism in cocked position.

A spring-operated hammer face housed in the breaking mechanism was held in a retracted position above the battery bursting pins by a trigger arrangement attached to the beacon's arming switch. Puncture pins, which extended through slots in the sides of the breaking mechanism housing, were securely attached to the sides of the channel-shaped hammer face. These pins, which were directly in line with the gas vents on the battery, were designed to puncture the vent seals during the downward travel of the hammer face. With the new arrangement it still was necessary only to withdraw the arming cable to arm the beacon. When the cable was withdrawn the arming switch plunger closed the arming circuit and retracted the tripping plunger on the battery-breaking mechanism. The heavy spring tension pushing

SECRET

against the hammer face thrust it downward with great force, driving the bursting pins through the bursting plates and the puncture pins through the

production batteries the average life was 60 min, and they delivered approximately 600 whr each.

The K-type 7-cell battery developed for the NAD-3 is similar. The plates are copper oxide and

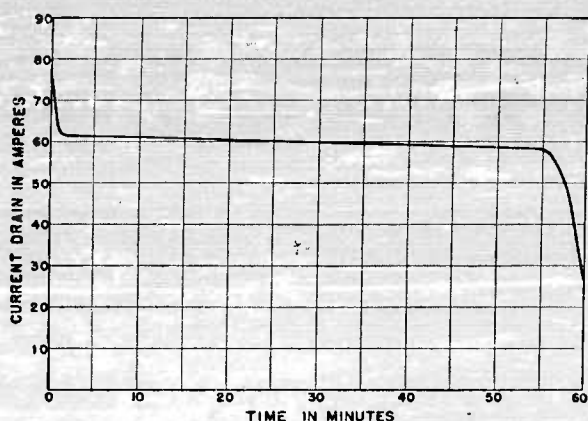

FIGURE 10. Discharge characteristic of Edison I-type battery.

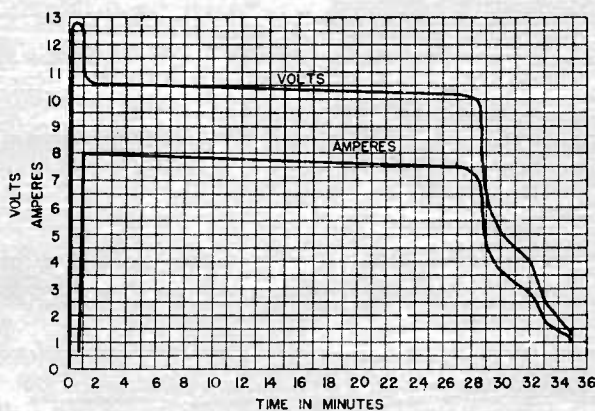

FIGURE 11. Discharge characteristics of Edison K-type battery.

vent seals. The electrolyte poured down into the cells and the battery began its discharge cycle.

The performance of the I-type battery working into the NAD-10 load is shown in the voltage and current characteristics in Figure 10. For the later

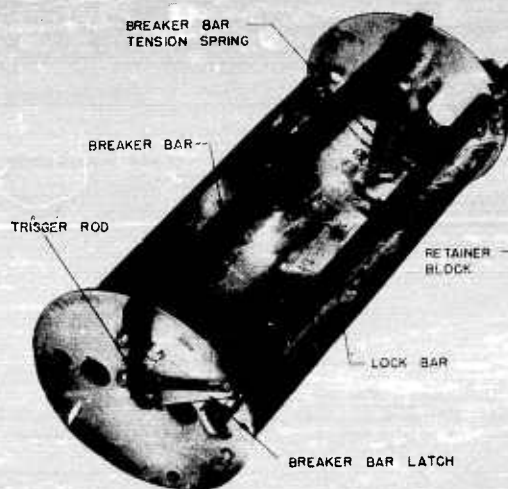

FIGURE 12. Battery compartment in NAD-3 with breaker bar in cocked position.

zinc, so that metallic copper is produced by the reaction. This battery furnishes an initial starting power of 12.5 v at 8 amp to drive the beacon in its high-speed run. After the speed change the voltage drops to 10.5 v at 8 amp and continues at that rate for 25 to 30 min. Figure 11 gives a plot of typical battery performance.

The construction of the K-type battery can be seen in Figure 6. The bursting pins are driven through the compartment wall by a battery-breaker mechanism specially designed to fit the NAD-3 case. This is shown cocked in Figure 12.

These batteries met the requirements of the beacon design in a most satisfactory fashion. Information about further work with these batteries can be obtained from the Navy Electronics Laboratory where work is continuing on the NAD beacons.

ACOUSTICAL TREATMENT FOR SUBMARINES

9.1

INTRODUCTION

THE DEVELOPMENT of an acoustical treatment for submarines to reduce their echo-ranging reflectivity was carried out both by German and by American laboratories. The reduction in detection ranges that correspond to a 10-db reduction in target strength would allow submarines to make significant changes in their tactics. Indeed, in certain water conditions, which commonly exist in various combat areas, such a reduction would render echo-ranging ineffective. The American program was undertaken in October 1943 and proceeded under NDRC auspices through October 1945. By this time a promising absorbing coating had been applied to the USS *Salmon* in preparation for field measurement of the range reduction produced. The methods used in applying this coating to the *Salmon* and the experimental work which led to this design are discussed here.

The subsequent work on this program, including the results and analysis of the *Salmon* tests, is covered in reports issued from the MIT Underwater Sound Laboratory (MIT-USL) after October 30, 1945. On this date the laboratory investigations were transferred without interruption to a direct contract between the Bureau of Ships and MIT.^a

It is of interest to note that the acoustic treatment developed by the Germans and applied to several of their submarines is similar in construction to the cemented coatings studied early in the NDRC program. The final German coatings,¹²⁹ called *Albericht*, comprised two layers of synthetic rubber cemented over the hull and superstructure. The underneath layer next to the steel plating was honeycombed with holes of two sizes. These were formed into air pockets by cementing on an outer layer of smooth rubber. This coating is reported to produce 50 per cent reduction (6 db) of sound at frequencies from 8 to 16 kc. A similar coating in which air pockets were constructed by using an under layer of perforated Vinylite was studied at

^a The development of the coating was continued as Task No. 1 on Contract NObs-25391 between BuShips and MIT, with Professor R. D. Fay as director of the laboratory which operates as DIC 6370. Classification Confidential.

the NDRC laboratory. It was in the course of this investigation that the absorption was traced to the air bubbles contained in the cement that bonded the layers. The subsequent program abandoned cemented coatings in favor of the sprayed coatings of aerated rubber cement.

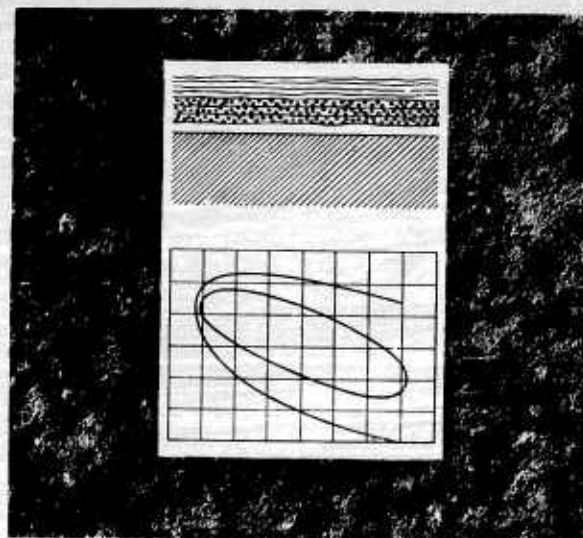

FIGURE 1. Absorbing coating showing bubbles (Figure 4), schematic drawing of coating construction (Figure 5), and absorption contours (Figure 6).

9.2

ABSORBING COATING

The acoustical treatment developed for submarines to reduce their echo-ranging reflectivity at echo-ranging frequencies comprises a coating of several layers of synthetic rubber applied as a paint. The acoustically active portion of the coating consists of layers of the plastic material in which a number of small gas bubbles are trapped. The aeration is accomplished by applying these layers with a standard spray gun. Outer layers serve as a tough protective coating. The final thickness of the coating is approximately 1/16 in. In tests of laboratory samples the coating reduces the reflection of sound by at least 10 db over a range of frequencies from 10 to 35 kc, and over a limited range of temperature and pressure. Experimental development and evaluation of this coating is continuing at MIT-USL.¹²⁸

DESIGN CONSIDERATIONS

The requirements for a practical acoustical treatment for submarines are not only that it furnish sufficient protection against echo-ranging detection to be of operational value, but also that it be either adequate as a marine paint or compatible with marine paints already in use.

The minimum acoustic requirements have not been formulated precisely. The original estimate that a reduction in reflection of 6 db would be of operational interest has been amended by reason of an operational analysis. In this analysis it was found that under certain prevalent water conditions a reduction in reflection of 10 db could reduce the detection range for deep-water operation sufficiently to make echo ranging ineffective.¹²⁴ This analysis is summarized in Section 9.7. The experimental coating described here produces at least 10-db reduction in reflection in its optimum range of temperature and pressure over the frequency range from 10 to 30 kc.

The determination of which surfaces of a submarine required treatment most was undertaken at the start of the research program. Optical studies were made of scale-model submarines, and plots were obtained of the variation of reflection with aspect angle. This work is covered in conjunction with other measurements of the reflection from scale models and from full-size submarines. Analysis of these results amended the original plan to reduce reflection by coating the conning tower alone, and led to a request for a coating which would reduce the reflection from the entire exterior.

It is necessary that this reduction in reflection exist over a sufficient range of frequency, temperature, and pressure. The required frequency range was taken as 10 to 30 kc. The sprayed coating under development shows little variation of absorption with frequency over this range. The required pressure range from 90 to 180 psi corresponds to depths from 200 to 400 ft. The temperatures of interest are those encountered at these depths in various combat areas. The coatings have been studied at temperatures from 35 to 85 F. The dependence upon both temperature and pressure is large with the present coating, and this is further complicated by hysteresis effects.

An additional problem of acoustic performance

¹²⁴ Refer to Division 6, Volume 1, Chapter 5 and 6.

lies in the relation between the performance of a coating on test plates in the laboratory and of this same coating on a full-size submarine. The variation in the rigidity of the steel backing plates at various points on the vessel can be expected to introduce some effect. The integration involved in ranging on a large surface at a great distance as compared with close measurements of a flat test plate would be subject to the further difference produced by the curved surfaces on a submarine. The study of variation in reflection with the incident angle of the sound is continuing under Navy auspices.

The isolation of a practical mechanism for absorption and its subsequent development make necessary a convenient laboratory method to measure the sound absorption of proposed coatings. Facilities were set up for measuring sample coatings applied to steel plates of convenient size. A pulsing technique was adapted to avoid the multiple reflections encountered in continuous wave sound in a small tank. This measuring system is described in Section 9.4.2.

The requirements for the coating as a marine paint were fairly well defined. The materials were to be procurable in suitable quantities and adaptable to large-scale painting techniques. The introduction of spray-gun application was fortunate in providing both a convenient means of aerating the material and a rapid method for coating large areas. It was found that the pigmentation necessary in a practical coating for camouflage purposes could be added to the sprayed coating without impairing its absorbing properties. No successful antifouling agent had been found, however, at the time the project was transferred to the Navy. Preliminary tests had shown that marine growths develop rapidly on the untreated rubber coating in warm water, and that neither of two standard antifouling chemicals constituted adequate deterrents. Otherwise, as a marine paint to resist abrasion and protect the underlying metal from rust and corrosion, the coating has been shown to be satisfactory in its present form.

The first phase of the development program was devoted to isolating a reliable absorbing mechanism. In the course of this search numerous designs were studied, including the Vinylite sandwich so similar to the German *Albericht* coating. With the discovery of the absorbing properties of bubbles in a

viscous medium, the program turned to the investigation of numbers of different plastic materials which could be aerated. Most of those studied were found to have some undesirable property such as cold flow, water solubility, lack of toughness, or difficulty in bonding which made them unsuitable for a submarine coating. Finally the commercial rubber cement which showed most promise on preliminary investigation was modified further, after consultation with the manufacturers, to suit the peculiar requirements of the acoustic treatment.

9.4 EXPERIMENTAL DEVELOPMENT

9.4.1

Theory

The theory of absorption of sound in a viscous bubbly medium has not yet been successfully elaborated, since the information available as to the relevant physical properties of the medium which contains the bubbles is insufficient. The assumed values for viscosity and propagation factors which have been used in setting up the analyses so far completed do not provide a satisfactory representation of the physical situation. Considerable theoretical analysis has been made of the transmission of sound in a liquid containing bubbles, as part of the study of wakes.⁶ Recent measurements seem to show that the basic assumptions made in this analysis do not satisfy the case of the absorbing coating. A study was also made¹²⁸ of the impedance to be expected from a viscous bubbly medium in terms of its thickness and certain other assumed physical properties. The rigidity of the backing wall was taken into consideration in this treatment. The assumption of a resonant bubble is not justified by any available measurements. Special attention has been directed to the theoretical aspects of the problem as part of the program continued at MIT.

9.4.2

Measuring System

In order to evaluate the acoustic performance of sample coatings it was necessary to design and set up a system by which measurements of sound absorption could be made in the laboratory. Since

⁶The study of wakes is discussed in Division 6, Volume 8.

it was obviously impossible to utilize continuous waves in a tank of reasonable size unless acoustic treatment was available at least as effective as the treatment to be developed, a pulsing technique was indicated. Two general schemes were considered: a setup in which the pulse reflected from an untreated plate could be compared in magnitude with the pulse reflected from a treated plate; and a setup in which the acoustic impedance of plates could be measured by virtue of the interference between the direct and the reflected pulse. The latter scheme was adopted, for it is almost essential in guiding the development to find the actual acoustic impedance of the samples.

The theory underlying the measurement of acoustic impedance in a sound field of standing plane waves is well known.¹²⁹ When the sound field is built up in pulses the same theory applies, provided a steady state is attained and provided the field consists of substantially plane waves. In particular, the steady state must exist for a time long enough to insure that an overlap exists between the direct and reflected waves at a reasonable distance from the surface to be measured. Furthermore, this overlap must be established before reflections from other surfaces cause interference. These conditions become increasingly difficult to fulfill as the frequency is lowered. In the system which has been set up the lower limit is about 10 kc.

Facilities were set up for measuring sound absorption of proposed coatings in samples applied to steel plates of convenient size. A pulsing technique was adopted using an electronic gate system which permitted the application of voltage to a projector during a time interval of adjustable length. This system also permitted the observation on an oscilloscope of the signal from a hydrophone during an adjustable time interval which was synchronized with the projector pulse. The acoustic signal consisting of the incident pulse and its first reflection from a coated plate could be observed in the region near the plate. The maxima and minima in this interference pattern, observed as the hydrophone was moved perpendicular to the plate, provided a measure of the absorption. A specially calibrated attenuator was added to the hydrophone receiving circuit so that reduction in reflection could be read directly in decibels.

The apparatus, shown schematically in Figure 2, comprises essentially a pressure tank with pressure

and temperature control, means for producing pulses of sound, a hydrophone, a lead screw for positioning the hydrophone, and an oscilloscope with appropriate controls. In addition, a specially calibrated

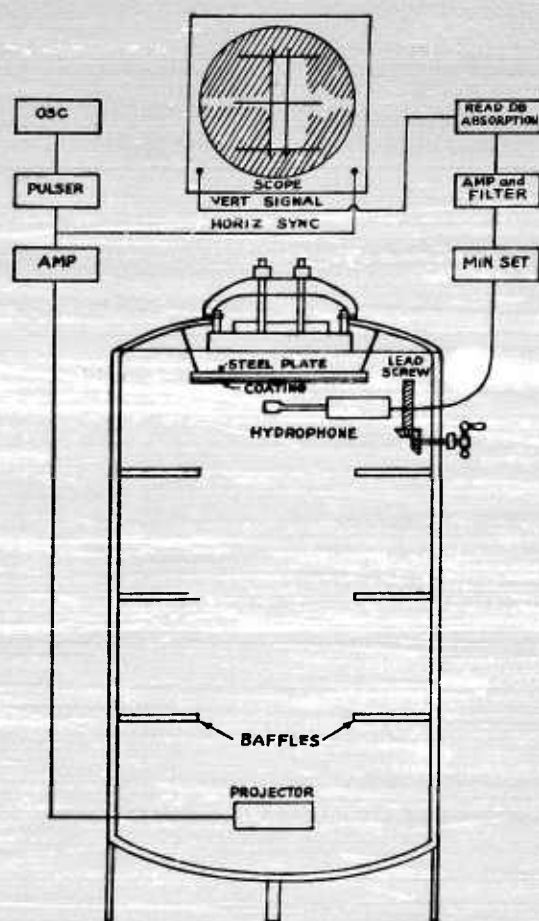

FIGURE 2. Diagram of absorption measuring system.

attenuator incorporated in the receiving circuit eliminates all calculation in finding the reduction in reflection. The same acoustic and electronic components had been used previously with an open tank for absorption measurements at atmospheric pressure. The steam coils and refrigeration plates are also used as temperature control for the pressure tank.

The pulser was built from circuits furnished by USRL. The projector is a Brush AX-70-1. The hydrophone is an XMN.³⁰

The horizontal sweep of the scope is triggered by the pulser to give one sweep for each pulse.

Ideally, the pattern seen on the scope screen would consist of a wave train having several abrupt changes in amplitude. These amplitudes represent the pressures in the incident wave, in the combined incident and reflected waves with a phase relation depending on the position of the hydrophone, and in the reflected wave alone. It is the second portion of the train that is used in these measurements. As the hydrophone is moved, there is a series of maxima and minima whose values represent the sums and the differences of the pressure in the incident and the reflected waves.

In practice the pattern on the scope closely approximates the ideal at high frequencies but shows considerable deviations in the range of chief interest. The procedure at these frequencies is to make measurements first on an untreated plate or a free surface where the reflection is known to be substantially complete. For this case the minimum is zero. Hence, the significant part of the pattern is in the region where zero amplitudes occur. If no zero is found, or if successive zeros are not found at half-wavelength intervals of hydrophone travel, reliable measurements are impossible. By adjusting the baffles it has been possible to find frequencies at which good zeros are obtained with the highly reflecting surfaces.

It is necessary to take precautions to insure that the surfaces under measurement do not contain superficial, transient air bubbles. An effective method for eliminating most of the dissolved air is to hold the water at a high temperature, say 100 F, for several hours before a measuring cycle is started, and to measure only with negative temperature increments. An additional precaution is to cause the water to flow across the test surface between measurements.

9.4.3

History

The development program was initially formulated in October 1943 as an investigation of the feasibility of an acoustic treatment for submarines capable of reducing the target strength 6 db at echo-ranging frequencies. At that time the most practical solution appeared to be to coat the ship with some form of acoustical diffraction grating whereby the echo would be directed at such angles that no energy would be reflected back toward the

SECRET

source. A treatment comprising alternate strips of acoustically soft and hard material was found to reduce normal reflection greatly, but the echo from surfaces slightly off normal incidence was large. The scheme was considered entirely ineffective. It was therefore decided that a satisfactory treatment would involve actual absorption of sound.

During November 1943 a preliminary analysis of the problem led to a line of attack which has been followed throughout the investigation. It is known that perfect absorption of sound is obtained if the acoustic impedance of the coated surface is the same as that of unbounded water. It was assumed that the untreated surface of a submarine has an impedance far greater than that of water, at least at echo-ranging frequencies. Hence any coating, to be of practical thickness, must be more compressible than water. To obtain the desired compressibility it appeared that a gaseous substance must be incorporated in the coating. It remained to find how to construct a coating containing gas such that the compression of the gas would involve the correct degree of damping. A number of other more obvious physical attributes are also essential in a practical coating. However, to obtain sound absorption, it was recognized that gas bubbles or pockets incorporated in a medium resembling water acoustically would, when backed by a massive plate, appear as a pure resistance in some frequency range, but it was not known how to control the magnitude of the resistance.

On December 1, 1943, Harvey Fletcher of the BTL was consulted in regard to this problem. He said that some preliminary work done on underwater sound absorption indicated that there was considerable energy loss associated with cyclic shear strain in many synthetic resins. In particular, a plastic washer with metal disks cemented to the ends would absorb underwater sound at the resonant frequency of the assembly.

The first absorbing coating that was made was constructed of three layers of rather highly plasticized Vinylite. The middle layer was perforated with holes about $\frac{3}{16}$ in. in diameter spaced so that 8 to 9 per cent of the total volume was removed. The three layers were cemented together to form a sandwich containing air pockets and the sandwich was cemented to a plate. This coating had high absorption. The measured reduction in reflection was at least 20 db indicating an absorption

of 99 per cent of the incident energy. However, the performance was far from stable. Other coatings of similar design always showed high absorption at first but lost their efficacy to a greater or less extent in a few days.

The samples of acoustic treatment used on certain German U boats are practically identical with some of these early samples made by the NDRC project. The only significant difference is that the German coating is made of synthetic rubber, rather than Vinylite, with a far superior bond between the layers. The perforated layer in the German coating has holes of two sizes. According to the German scientists interviewed on the subject after V-E Day¹²⁹ the size of these holes was carefully selected to provide resonance at the desired frequencies. It was further stated that the coating, although intended for absorption from 10 to 20 kc, actually had its selectivity in the band from 8 to 16 kc. The reduction in reflection provided by this coating is given as 50 per cent, or 6 db. The German studies were evidently directed towards an understanding of the proper air-rubber ratio and the relative numbers of small and large holes needed. The temperature variations encountered were ascribed to changes in the rubber viscosity. Pressure was also observed to produce a marked effect. It was stated that the coating was designed to protect stationary submarines from echo-ranging detection since the submarine in motion would be liable in any case to detection from hydrophone effect.

Tests of the MIT sandwich coating were carried out during February which were intended to indicate in what parts of the sandwich absorption occurred and how stability of performance could be achieved. In general, the results were the same as those obtained with the original sandwich. Finally a sample was made having three layers of Vinylite with no air pockets. This sample also absorbed fairly well. However, a sheet of Vinylite clamped to a test plate showed no absorption, and it therefore became obvious that the absorbing mechanism was in the cemented interfaces.

Early in May, investigation of various cements and cementing techniques established the fact that the best results were obtained when air was entrapped in the interfaces and the cement retained plasticity. A number of schemes were tried whereby the amount of entrapped air would be increased.

SECRET

The first important step in the transition to the present form of coating was made in July when it was decided to give up the sandwich construction and employ aerated cement applied as a paint.

At that time, two materials had been found which apparently could be adapted to form a practical, effective coating. One of these, B. B. Chemical Company No. 1019 cement, had been used extensively in constructing sandwich-type coatings. The other, made by the Standard Oil Company of New Jersey, called Vistanex No. 6, is a polyisobutylene used as an ingredient in synthetic rubber. Both of these materials could be saturated with air bubbles of suitable size by mechanical manipulation and both showed good absorption when painted on a plate. However, the No. 1019 cement was difficult to manipulate and exhibited rather large changes with aging. The Vistanex showed cold flow.

A mixture of the No. 1019 cement and Vistanex in solution showed great initial promise. The mixture could be worked fairly easily and did not cold-flow. It was, however, difficult to apply and the absorption decreased with age.

Vinylseal, a commercial cement intended for use with Vinylite, was found to be aerated more readily than any other material which was tried. The absorption was good but the bond to metal was unsatisfactory when exposed to water. No successful method was found to protect a Vinylseal coat from water.

Bakelite, various methacrylates, and polystyrene were found to be too stiff for good absorption.

An important step in the development was made in November when it was found that satisfactory bubbles were produced by spraying materials of appropriate consistency. Smooth, uniform coats of No. 1019 cement were readily obtained with standard spray equipment. There was still the drawback that the absorption decreased with time. The B. B. Chemical Company was consulted and produced a modified cement, Code J2024, which would cure in a few days to a stable rubber. This cement is now standard for the active portion of the coating.

During the late summer of 1944, tests were made to investigate the effect of pressure on the coating. These tests were inconclusive, since the effect of pressure was masked by the effect of temperature which at that time was not appreciated. As a result, temperature control was added to the laboratory task and a very considerable temperature

dependence was found. Figure 3 shows curves for two similar coatings, giving an idea of the extremes of variation among coatings. Absorption of 10 db or more over a range of 20 F was considered typical performance for coatings of this type, that is, one sprayed bubble layer of unmodified J2024.

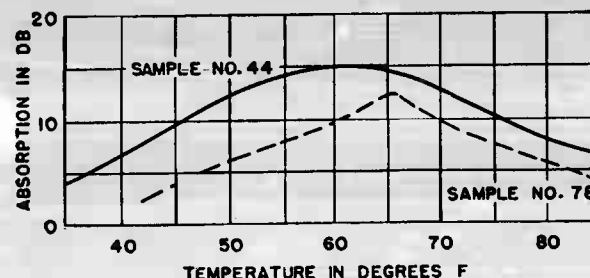

FIGURE 3. Variation of absorption with temperature for two coatings of similar construction.

It was not until March 1945 when the pressure tank at Mountain Lakes was in operation that the effects of pressure on absorption were measured reliably.

These measurements showed decided dependence on pressure but confirmed the fact that a coating with sufficient protective layers was not injured at pressures beyond the range of good absorption. It was now clear that a treatment of this type which was effective at the surface could not be effective over the range of submarine operating depths. There was still a possibility that the coating could be modified to give satisfactory absorption over a sufficient range of depths to be of operational interest. The figure 200 ft to 400 ft was suggested. It was also realized that the absorption at each pressure would be affected by temperature, and that it would be necessary to have means in the laboratory for controlling both.

Further pressure measurements at Mountain Lakes showed that coatings constructed with additional bubble layers or with larger bubbles showed a maximum absorption at pressures above atmospheric. In the time assigned to these measurements it was not possible to test at more than one temperature. The maximum absorption was rather low in these tests but was high enough to justify further work.

Measurements up to June 30, 1945, indicate that the thicker coatings of standard size bubbles give reasonably consistent performance. Coatings with

larger bubbles usually show higher maximum absorption but tend to be erratic.

The samples employing the J2024 cements usually improve with age. There is, however, a gradual shift in the conditions for best absorption toward higher temperature. This shift, which persists for two or three weeks, probably represents the loss of residual solvent.

The first field tests of the coating were made off Portsmouth, N. H., in November 1945. The *Salmon*, treated with four sprayed coats and five cover coats, and an untreated submarine of the same class lay to on the surface several miles apart. The measuring vessel equipped with echo-ranging gear approached them and circled each submarine, recording target strength as a function of aspect angle. For the results of these measurements and the subsequent analysis, reference should be made to the report issued by WHOI¹³¹ and to other reports from the MIT laboratory under the Navy contract effective after November 1, 1945.

9.5 DESCRIPTION AND CONSTRUCTION OF SPRAYED COATING

The acoustically active portion of the coating consists of a layer of plastic material in which a number of small gas bubbles are entrapped as can be seen in Figure 4. The most effective material

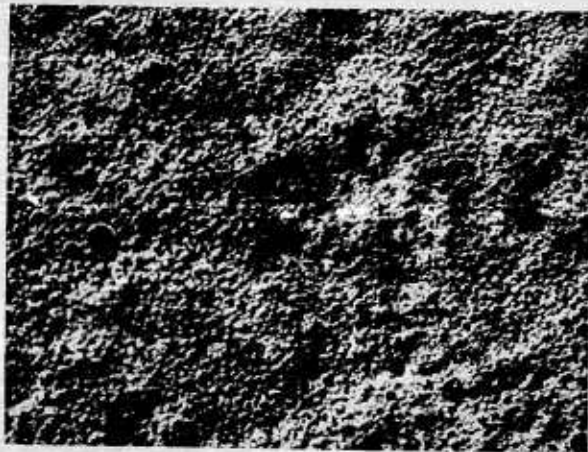

FIGURE 4. Active bubble layer enlarged 6 times.

which has been found for the purpose was developed by the B. B. Chemical Company at the request of MIT-USL. The exact ingredients in this material

have not been divulged, but it is based on Buna-N rubber in solution. The preferred solvent is methyl-ethyl ketone. The material, which has the code number J2024, is furnished with a sulfur curing agent in a separate container. Without the curing agent, the solution is stable for about two months. After the sulfur is added, the rubber solidifies in a few days.

Air bubbles can be entrapped by manipulation, but better results are obtained with much less effort if the material is applied with a spray gun. No modifications are required in standard spray guns designed for handling heavy materials. The average size of the bubbles which are entrapped in the process appear to depend entirely on the consistency of the material. The J2024 as furnished has a consistency which yields bubbles of the size and density desired.

The aerated material is somewhat porous and the acoustic properties are adversely affected by pressure unless a protective coat is added. The same material may be used for this coat if applied without entrapped gas. It is hoped that means may be found whereby the J2024 can be sprayed without incorporating air bubbles, but at present the only method known for obtaining a satisfactory cover coat is application with a paint brush. Additional solvent is added to the J2024 to facilitate brush application.

A priming coat is desirable both to protect the metal and to give a good bond. The B. B. Chemical No. 1018 cement, a standard product, has been used

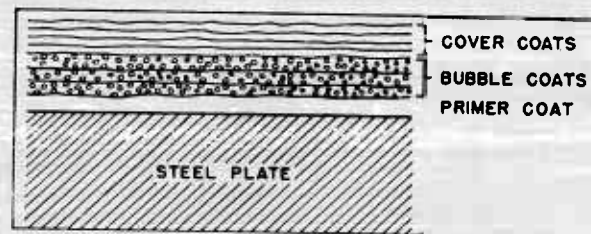

FIGURE 5. Drawing of absorbing coating.

for this purpose with excellent results. It is brushed rather than sprayed.

The whole process of constructing a coating involves the following steps, indicated in Figure 5.

1. Prepare the surface, usually by sandblasting and cleaning.
2. Brush on priming coat.
3. Spray on active coat or coats.

SECRET

4. Brush on protective coat.

A single priming coat has been found adequate. The primer dries out in about half an hour.

9.6 TESTS OF COATING PERFORMANCE

The performance of the coating depends on several factors, in particular on temperature and pressure. Moreover, the coating has been developed for treating surfaces which present an acoustic impedance which is large with respect to that of water. Both theory and test results show that a steel plate $\frac{5}{8}$ in. in thickness has sufficient impedance to sound in water at frequencies at least as low as 10 kc regardless of the backing of the plate. Information on the efficacy of the treatment on thinner plates with different types of mounting and backing is not available.

The effect of moderate changes in frequency has been found unimportant. The absorption is substantially constant at fixed temperature and pressure over the range 10 to 35 kc. The range for constant absorption is probably greater, but relatively few measurements have been made outside of these limits.

The more recent tests have been made at a fixed frequency of 10 kc at various pressures and temperatures. The results are plotted as contours of equal echo reduction on pressure-temperature coordinates. The measurements on which these contours are based are made at fixed temperatures with a complete cycle of pressure (usually with a maximum of 200 psi). In most cases the absorption curve is different with increasing and decreasing pressure. The tendency is for the peak absorption to occur at higher pressures when the pressure is increasing than when it is decreasing, but the peak value is usually about the same for the two cases. Measurements made with increasing pressure have been found to afford a reliable criterion of performance.

Contours are shown in Figure 6 for a typical coating. Contours of both 6- and 10-db reduction in reflection are shown. It has been found that the ratio of the absolute threshold pressures for 10-db reduction is about 2/1 for the best coatings at any one temperature. At a given pressure the 10-db contour covers about 20 F. These figures represent the best consistent performance of any coating.

These results apply to laboratory samples applied to $\frac{5}{8}$ -in. plates 14 in. by 14 in. It is expected that

the reduction to be obtained from the same treatment on an actual submarine will not be in agreement with the laboratory tests. The chief reasons that lead to this conclusion are as follows. The technique in spraying large surfaces is of necessity different from that involved in spraying a small plate, and there is better integration in ranging on a large surface at a great distance. The efficacy

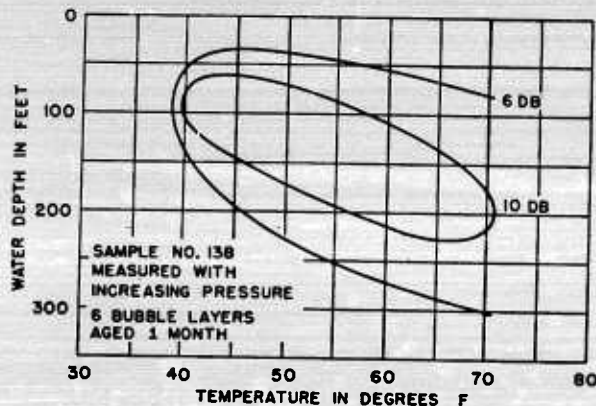

FIGURE 6. Absorption contours.

of the treatment on the thin metal of the superstructure backed by relatively rigid frames is unknown and cannot be evaluated in the laboratory. Finally, there should be a difference produced by the curved surfaces on a submarine as opposed to the flat plates in the laboratory.

The tests made on a can buoy during the winter 1944-45 showed a wide disagreement with the results predicted from laboratory measurements. At the time the buoy was treated, the magnitude of the effect of temperature was not appreciated; hence the treatment was based on laboratory samples measured at room temperature. A sample intended to represent the buoy treatment showed very little reduction in target strength at 35 F, yet two tests made on the buoy in Boston harbor in the presence of floating ice indicated that the treatment was remarkably effective. The treated buoy could not be detected by pinging, whereas an untreated identical buoy was easily found over a wide range of distance and azimuth.

Tests made by USRL at Orlando and at Mountain Lakes have in general checked the routine measurements made at MIT.¹²⁵ A phenomenon was observed on relatively large plates at Orlando and again on small plates at Mountain Lakes. The echo returned from a plate in the direction of the

source was measured as a function of the orientation of the plate. The main reflection occurred at normal incidence, but a sizable secondary reflection was also found at about 45-degree incidence. This secondary reflection was not found on the treated plate. It is conceivable that a curved surface might present enough surface at 45-degree incidence to make a large contribution to the received echo. This contribution, if it exists, would be eliminated completely by the treatment.

Tests of coatings applied over or under Navy paints have shown either a loss in acoustic performance or an unsatisfactory bond. The coating itself has been tested as a paint at various times and has been reported generally satisfactory.^{126, 127} A patch applied to a submarine operating out of New London stood up fairly well for two months although there were signs of porosity. Sample coatings were subjected to thorough Navy paint tests at the Norfolk Navy Yard. These tests indicated that pitting resulted from continued flow of water at a speed of 25 knots past the paint surface. Since these paint test samples were made, it has been found necessary to apply additional protective layers over the acoustically active layer in order to obtain a coating which stands up under pressure. It is believed that these additional protective layers have eliminated porosity and pitting.

Experiments were made to see whether this acoustical coating could be used effectively with a coating developed to reduce the radar signal from the conning tower. These tests, although not exhaustive, indicated that the two coatings could not be used simultaneously on the same surfaces.

Although at the end of NDRC work there were a number of important details to be investigated in regard to the behavior of the coating as a paint, the outstanding acoustical information which was required was to find the correlation between the performance in the laboratory and the performance in the field. Tests on the coating applied to the USS *Salmon* were designed to provide this correlation.

9.7 ANALYSIS OF EFFECT OF 10-DB ABSORPTION ON SUBMARINE DETECTION RANGES

A theoretical analysis of the effect that a 10-db reduction in submarine target strength would have upon its maximum detection ranges was made for

the Bureau of Ships a year before the actual coating was available.¹²⁴ It appeared that there were many sets of conditions in both deep and shallow water where a submarine so-treated might avoid echo-ranging detection altogether. For example, a submarine traveling deep at speeds under 3 knots or balancing on a density layer might take advantage of a reduction in range of almost 100 per cent.

Taking operating conditions on a year-round basis into account, the probable maximum echo range on a submarine operating in water over 600 ft deep in the Japanese Empire area would be reduced by about 30 to 50 per cent by an acoustic treatment supplying 10-db absorption. In water less than 600 ft deep over a *sand* or *mud* bottom, the fractional reduction in range is about the same as in deep water. Over a *sand-and-mud* or *rock* bottom, a 40 to 100 per cent reduction in range would occur.

This analysis is included in its entirety in the microfilm file. The results are based upon the values for probable maximum echo range which is defined as the range at which the echo from a submarine can be recognized 50 per cent of the time. Actual measurements made at San Diego of detection ranges on a fleet-type submarine in known conditions were taken as a basis for the analysis. The computations took account of the various types of ocean bottom encountered in Japanese Empire waters, of the transmission conditions prevailing at different months in the year, and of the differences in the beam patterns between Japanese and American echo-ranging gear due to the different operating frequencies. Both noise-limited and reverberation-limited conditions were considered.

Further analysis of the effectiveness of such a coating might be made on the basis of more recent information on submarine detection ranges and transmission conditions. The completion of tests on an actual treated submarine will permit comparison of the results with these theoretical conclusions.

9.8

FURTHER WORK

At the time that the development program was transferred from NDRC to direct Navy auspices, the *Salmon* had been coated and tests had been scheduled to determine the target strength. It had been planned to apply the coating in coordination

SECRET

with the docking schedule of the *Salmon* at the Navy Yard, Portsmouth, N. H. The treatment was to be applied from keel to superstructure while the ship was in drydock, and the job was to be finished after the ship was afloat. During the docking period, Japan surrendered and the *Salmon* was ordered to be scrapped. The acoustic treatment was completed as scheduled only up to the superstructure, and tests were arranged to evaluate this hull coating. When the scrapping order was received, the repair work to the *Salmon* was incomplete so that she could not submerge, and since the superstructure was not coated, the measurements were to be made with the submarine on the surface.

In order to determine whether or not laboratory measurements of coated plates give a correct indication of the efficacy of treatment on a submarine, it was arranged to make target strength measurements of the *Salmon* and of a similar but untreated submarine under like conditions. Then several test

plates were coated with a treatment as nearly as possible identical to that used on the *Salmon*. Evaluation of the efficacy of the treatment must depend upon the results from this and subsequent tests.

At this time it was generally established that the coating was practical to produce and to apply. A number of important details of the performance of the coating as a paint required further study. Tests of the inclusion of an antifouling agent were incomplete. The investigation of the variation of reflectivity with the angle of incidence of the sound was yet to be made. Fundamental studies were underway to determine the theoretical basis for the absorption of sound by bubbles in a viscous medium. The effect on this absorption of the variations in thickness of the steel backing wall was an additional problem for study. The results of further work in answering these questions are to be found in the reports from the MIT laboratory subsequent to November 1, 1945.

GLOSSARY

- ADP.** Ammonium dihydrogen phosphate, crystal having marked piezoelectric properties.
- AMBIENT NOISE.** Noise present in the medium apart from target and own ship's noise.
- ASDEVLANT.** Antisubmarine development, Atlantic.
- ASPECT ANGLE.** The orientation of the target as seen from the attacking ship.
- BDI.** Bearing deviation indicator.
- BEARING SEPARATION.** Angular difference between bearings of submarine and evasion device, as seen from attacking vessel.
- BTL.** Bell Telephone Laboratories.
- BUSHIPS.** Bureau of Ships.
- CAVITATION.** The formation of vapor or gas cavities in the water, caused by sharp reductions in local pressure.
- CHEMICAL RECORDER.** An indicator which records range on chemically-treated paper.
- COMINCH.** Office of the Commander-in-Chief, U. S. Navy.
- COMSUBSPAC.** Commander Submarine Force, Pacific.
- COMSUBSTRAINPAC.** Commander of Submarine Force Training, Pacific.
- CRC.** Catalyst Research Corporation.
- CUDWR.** Columbia University Division of War Research.
- DTMB.** David Taylor Model Basin.
- ECHO REPEATER.** Artificial target, used in sonar calibration and training, which returns a synthetic echo by receiving, amplifying, and retransmitting an incident ping.
- FIFTY PER CENT RANGE.** Median value detection range, derived from a set of determinations.
- FTC.** False target can, chemical bubble cloud.
- FTS.** False target shell, chemical bubble cloud.
- HAMMER BOX.** Mine-sweeping noisemaker, consisting of a pneumatic hammer which strikes a circular steel diaphragm.
- JP, JT.** Submarine sonic listening systems employing magnetostriction line hydrophones.
- MAD.** Magnetic airborne detector.
- MAGNETOSTRICTION EFFECT.** Phenomenon exhibited by certain metals, particularly nickel and its alloys, which change in length when magnetized, or (Villari effect) when magnetized and then mechanically distorted, undergo a corresponding change in magnetization.
- MIT-USL.** Massachusetts Institute of Technology Underwater Sound Laboratory.
- NDRC.** National Defense Research Committee.
- NOL.** Naval Ordnance Laboratory.
- NRL.** Naval Research Laboratory.
- OAY.** Nondirectional sound monitor system used in making submarine-noise measurements.
- PEAK FACTOR.** In this volume, 3 db more than the peak-to-rms ratio in decibels of an acoustic wave.
- PIEZOELECTRIC EFFECT.** Phenomenon exhibited by certain crystals in which mechanical compression produces a potential difference between opposite crystal faces, or an applied electric field produces corresponding changes in dimensions.
- PILLENWERFER.** German false target, chemical bubble cloud.
- PING.** Acoustic pulse signal projected by echo-ranging transducer.
- PRACTICE TARGET.** Buoy-mounted or towed echo repeater used in sonar training.
- PRIMARY BATTERY.** Battery which cannot be recharged.
- QC.** Standard Navy searchlight-type echo-ranging equipment, using magnetostriction transducers.
- RANGE RATE.** Rate of change of range between own ship and target.
- RECOGNITION DIFFERENTIAL.** The number of decibels by which a signal must exceed the background or other masking signal in order to be recognized 50 per cent of the time.
- REVERBERATION.** Sound scattered diffusely back toward the source, principally from the surface or bottom and from small scattering sources in the medium, such as bubbles of air and suspended solid matter.
- ROCHELLE SALT.** Potassium sodium tartrate ($\text{KNaC}_4\text{H}_4\text{O}_6 \cdot 4\text{H}_2\text{O}$), piezoelectric crystal used in sonar transducers.
- SAG.** Sonar Analysis Group.
- SEA BATTERY.** A primary battery which uses sea water as its electrolyte.
- SONAR.** Generic term applied to methods or apparatus that use Sound for Navigation and Ranging.
- SONIC FREQUENCIES.** Range of audible frequencies, sometimes taken as from 0.02 to 15 kc.
- SPECTRUM LEVEL.** Sound pressure level in a 1-cycle band.
- SUPERSONIC FREQUENCIES.** Range of frequencies higher than sonic; sometimes referred to as ultrasonic to avoid confusion with growing use of the term supersonic to denote higher-than-sound velocities.
- TARGET STRENGTH.** Measure of reflecting power of target. Ratio, in decibels, of the target echo to the echo from a 6-ft diameter perfectly-reflecting sphere at the same range and depth.
- THERMOCLINE.** A layer of water in which temperature decreases with depth; a negative temperature gradient.
- TRANSDUCER.** Any device for converting energy from one form to another (electrical, mechanical, or acoustic). In sonar, usually combines the functions of a hydrophone and a projector.
- UCDWR.** University of California Division of War Research.
- USRL.** Underwater Sound Reference Laboratories.
- WHOI.** Woods Hole Oceanographic Institution.
- X-CUT.** A cut in which the electrode faces of a piezoelectric crystal are perpendicular to an X- or electrical axis.
- Y-CUT.** A cut in which the electrode faces of a piezoelectric crystal are perpendicular to a Y- or mechanical axis.

BIBLIOGRAPHY

Numbers such as Div. 6-651.11-M1 indicate that the document listed has been microfilmed and that its title appears in the microfilm index printed in a separate volume. For access to the index volume and to the microfilm, consult the Army or Navy agency listed on the reverse of the half-title page.

Chapter I

TORPEDO COUNTERMEASURES PROGRAM

1. *Ship and Decoy Noisemaker Measurements*, NDRC 6.1-sr 1046-1040, Service Project NS-164 and MIT Research Project DIC-6187, MIT, Oct. 2, 1943.
Div. 6-651.11-M1
2. *Ship and Decoy Noisemaker Measurements (Supplementary Data)*, NDRC 6.1-sr 1046-1040, Service Project NS-164 and MIT Research Project DIC-6187, MIT, Nov. 12, 1943.
Div. 6-651.11-M2
3. *Countermeasures to the Acoustic Torpedo* (Memorandum 42), US Navy Department, Antisubmarine Warfare Operations Research Group, Nov. 20, 1943.
Div. 6-651.11-M3
4. *US Fleet Antisubmarine Bulletin*, COMINCH publication, May 1944.
5. *Countermeasures to the Acoustic Torpedo*, R. E. Navin, BuShips, Code 620, Sept. 10, 1945.
6. "The Silent, Invisible War Under the Sea," Ira Wolfert, *Reader's Digest*, November 1945, p. 116.

SUBMARINE EVASION DEVICES PROGRAM

7. *Pillenwerfer Design* (Internal Report 100), OSRD Liaison Office WA-328-16, HMA/SEE, Fairlie Laboratory, Great Britain, Sept. 15, 1942.
Div. 6-651-M1
8. *The Development of False Target Shell Mark I*, Report P-2086, Naval Research Laboratory, June 30, 1943.
9. *Evasion Devices for Submarines*, Service Project NS-164, DIC-6187, MIT, Aug. 10, 1943.
Div. 6-651.3-M1
10. *Survey of Underwater Sound, Sounds from Submarines*, Vern O. Knudsen, R. S. Alford, and J. W. Emling, Report 2, 6.1-NDRC-1306, Dec. 31, 1943.
Div. 6-580.1-M2
11. *Prediction of Sonic and Supersonic Listening Ranges*, NDRC 6.1-sr1131-1884, Service Project NS-140, CUDWR, Special Studies Group, December 1944.
Div. 6-570.1-M6
12. *Masking of Submarine Sounds by Mark II Grenade and NAE Beacon*, Lyman Spitzer, Jr., SAS-19, Memorandum for File 09-421, CUDWR, Sonar Analysis Section, Jan. 24, 1945.
Div. 6-651.12-M1
13. *Sea Trials of NAE Beacon and Mk II Grenades*, Donald P. Loye, Report P27/PHR82, CUDWR-NLL, Pearl Harbor Division, Feb. 22, 1945.
Div. 6-651.12-M2
14. *Secret Report of Comdr. Fahy on Pearl Harbor Tactical Tests of NAD-6 and NAD-10, from April 3 to 19, 1945*, File 09.45, Problem 1A, transmitted to BuShips by Kurie letter, May 7, 1945.
15. *Operational Data on Japanese Sonar and Anti-*

submarine Tactics Relevant to Sonar Countermeasures, COMINCH Memorandum, June 13, 1945.

16. *Submarine Evasion Devices Manual*, COMINCH P-0010, June 21, 1945.
17. *The Sound Output of NAC Beacons and Mark II Grenade (Signal Pepper)*, Edward Gerjuoy, SAG-41, Memorandum for File, CUDWR, Sonar Analysis Group, July 12, 1945. (See reference 19.)
Div. 6-651.12-M3
18. *Activities of the Massachusetts Institute of Technology Underwater Sound Laboratory under Contract OEMsr-1046*, OSRD 5513, NDRC 6.1-sr1046-2039, DIC-6187, MIT, Aug. 6, 1945.
Div. 6-114-M1
19. *NAD, NAC, and Submarine Spectrum Curves*, Edward Gerjuoy Memorandum to Miss Hunt (5815), File 09.40, CUDWR, Sonar Analysis Group, Aug. 9, 1945. (Accompanying correction of drawing for Reference 17.)
Div. 6-651.12-M4
20. *Tests of Submarine Evasive Devices*, ASDevLant, Aug. 9, 1945.
21. *Pro-Submarine Program at UCDWR. Part I, General Description of Operations; Part II, Technical Devices and Programs*, UCDWR, Sept. 28, 1945.
Div. 6-651.12-M5

MEASUREMENT TECHNIQUES

22. *American Standard Definitions of Electrical Terms*, Aug. 12, 1941.
23. *Transmission Loss of Underwater Sound off Block Island*, NDRC 6.1-sr1046-1058, NS-164 and DIC-6187, MIT, May 11, 1944.
Div. 6-651.2-M1
24. *Oscillographic Waveform Records of Underwater Sounds*, NDRC 6.1-sr1046-1670, NS-164 and MIT Research Project DIC-6187, MIT, Aug. 15, 1944.
Div. 6-651.2-M2
25. *The MIT Oscillograph Recorder. Design and Operation*, NDRC 6.1-sr1046-1671, NS-164 and MIT Research Project DIC-6187, MIT, Aug. 17, 1944.
Div. 6-651.2-M3
26. *The Use of the Henrici Harmonic Analyser to Obtain Frequency Spectra of Pulses*, Leslie L. Foldy, NDRC 6.1-sr1130-1831, Service Project NS-139, USRL, Sept. 18, 1944.
Div. 6-552-M13
27. *Calibration of Stanolind Oil and Gas Company Tourmaline Gauges*, Eginhard Dietze, NDRC 6.1-sr1130-1971, Service Project NS-139, USRL, Oct. 31, 1944.
Div. 6-554.3-M44
28. *Description of Equipment Used in Measurement of Underwater Acoustic Transients*, Earl C. Gregg, Jr., OSRD 4515, NDRC 6.1-sr1130-1978, Service Project NS-139, USRL, Dec. 18, 1944.
Div. 6-553-M9

UNCLASSIFIED

29. *Acoustic Measurements: Part I—Methods of Obtaining Acoustic Measurements, Part II—Methods of Analyzing Acoustic Measurements*, Memorandum from the MIT Measuring Group to Comdr. H. R. Hummer, ASDevLant, Fort Lauderdale, Florida, April 18, 1945.
30. *The XMX Hydrophone, Completion Report*, NDRC 6.1-sr1046-2036, Service Project NS-164, and MIT Research Project DIC-6187, MIT, May 31, 1945. Div. 6-553.1-M8
31. *Calibration Facilities and Techniques Used at University of California, Division of War Research*, David J. Evans, UCIDWR, August, 1946. Div. 6-651.2-M4

Chapter 2

PARALLEL-BAR NOISEMAKERS

See also references 3, 4, 24.

32. *Preliminary Investigations of the Parallel Pipe Noisemaker and of its Use as a Sweep for Acoustic Mines*, Report PHX-24, National Research Council of Canada; Division of Physics and Electrical Engineering, Oct. 8, 1941. Div. 6-651.311-M1
33. *Acoustic Trials of the American Parallel-Bar Noisemaker*, OSRD Liaison Office, WA-351-2C, Great Britain, Report SS 1138, June 4, 1942. Div. 6-651.311-M10
34. *Results of FXR Measurements Made October 7, 1943*, Service Project NS-164 and MIT Research Project DIC-6187, MIT, Oct. 16, 1943. Div. 6-651.311-M2
35. *Measurements of FXR Sound Output, Made November 2, 1943*, Service Project NS-164 and MIT Research Project DIC-6187, MIT, Nov. 12, 1943. Div. 6-651.311-M3
36. *Measurements Made on December 2, 1943 of the Sound Output of Three Sets of FXR-II Gear*, Service Project NS-164 and MIT Research Project DIC-6187, MIT, Dec. 23, 1943. Div. 6-651.311-M4
37. *Measurements Made on December 14, 1943 of the Sound Output of 22-inch FXR Towed Noisemaker and of the DE-150*, Service Project NS-164, and MIT Research Project DIC-6187, Jan. 5, 1944. Div. 6-651.311-M5
38. *Measurements Made on February 7, 1944 of the Sound Output of Canadian CAT Gear and of the DE-157*, Service Project NS-164 and MIT Research Project DIC-6187, MIT, Feb. 14, 1944. Div. 6-651.311-M6
39. *Measurements Made on February 16, 1944 of the Sound Output of Six FXR Units and the Towing Vessel LF 137*, Service Project NS-164 and MIT Research Project DIC-6187, MIT, Mar. 2, 1944. Div. 6-651.311-M7
40. *Measurements Made on March 14 and 15, 1944 of the Sound Output of 30" and 28" Parallel Bar Noisemakers and the Towing Vessel DD-144*, NDRC 6.1-sr1046-1472, Service Project NS-164 and MIT Research Project DIC-6187, MIT, Apr. 8, 1944. Div. 6-651.311-M8
41. *FXR Mark 4, Instructions for Use of*, BuShips, Code 620, May 30, 1944.
42. *Acoustic Measurements of Ammonia-Jet Noisemakers (FXA), Rotary Noisemakers (NAE), Parallel Bars (FXR-IV), and DD155*, NDRC 6.1-sr1046-1665, Service Project NS-164 and MIT Research Project DIC-6187, MIT, July 26, 1944. Div. 6-651.11-M4

ROTARY NOISEMAKERS

See also references 4, 12, 13, 14, 16, 20, 42.

43. *Measurements Made on September 12 and 13, 1944 of the Striking Frequency of FXR Mk IV and Other Experimental FXR Models*, MIT Research Project DIC-6187, MIT, Sept. 26, 1944. Div. 6-651.311-M9
44. *Starting and Stopping FXR Acoustic Output*, Report 151, ASDevLant, Jan. 15, 1945.
45. *CAT Trip Gear*, Report PHX-52, H.M.O. Naval Research Establishment, Halifax, N.S., Canada, June 20, 1945.
46. *Comparison of Sound Outputs of DE-150 and FXP-1 Noisemaker*, Service Project NS-164 and MIT Research Project DIC-6187, MIT, Dec. 18, 1943. Div. 6-651.312-M1
47. *Measurements of the Sound Output of the DE-180 and FXP-1 Noisemaker Made on December 27 and December 28, 1943*, Service Project NS-164 and MIT Research Project DIC-6187, MIT, Dec. 31, 1943. Div. 6-651.312-M2
48. *Measurements of the Sound Output of the DE-180 and Unbored FXP-1 Noisemaker Made on January 1, 1944*, Service Project NS-164 and MIT Research Project DIC-6187, MIT, Jan. 6, 1944. Div. 6-651.312-M3
49. *Development of 3" Rotary Noisemaker for Submerged Submarine Decoy*, A. H. Brooks, NS-164 Service Project and MIT Research Project DIC-6187, MIT, June 9, 1944. Div. 6-651.313-M1
50. *Status of Mark 1 Hammer Bottle and Rotary Noisemaker*, Service Project NS-164 and MIT Research Project DIC-6187, MIT, Aug. 15, 1944. Div. 6-651.315-M4
51. *Calibration of MIT 4" Rotary Noisemaker and Hammer-Bottle Noisemaker (Navy Model FXII-1)*, Leslie L. Foldy, NDRC 6.1-sr1130-1830, NS-139, USRL, Sept. 18, 1944. Div. 6-651.315-M5
52. *Effect of Rotary (NAE) on Sonic and Supersonic Sonar Gear in ASW Vessels*, ComASDevLant and ComTnthFlt S report ASDD S68, Serial 00111, Project 107, Sept. 21, 1944.
53. *Calibration of David Taylor Model Basin Rotary Noisemaker (NAE Beacon Mark 1)*, Eginhard Dietze, NDRC 6.1-sr1130-1835, Service Project NS-139, USRL, Sept. 29, 1944. Div. 6-651.313-M2

SECRET

54. *Field Test Report For ComSubsTrainPac*, T. R. Parkinson, Oct. 15, 1944.
55. *Calibration of David Taylor Model Basin Rotary Noisemakers No. 1-ML and No. 2-ML (NAE Beacon)*, L. P. Leighton, NDRC 6.1-sr1130-1970, Service Project NS-139, USRL, Oct. 27, 1944.
Div. 6-651.313-M3
56. *Some Exploratory Developments in Noisemaker Design*, NDRC 6.1-sr1046-2037, Service Project NS-164 and MIT Research Project DIC-6187, MIT, Apr. 30, 1945.
Div. 6-651.3-M3

DUAL-HEAD NOISEMAKERS

See also references 16, 20, 31.

57. *Displacements Associated with Noisemakers*, R. D. Fay and Herman Feshbach, Service Project NS-164 and MIT Research Project DIC-6187, MIT, Aug. 3, 1944.
Div. 6-651.3-M2
58. *Calibration of Pre-Production Sample, Model 2, Sonic Companion to the NAC Sound Beacon*, Genevieve D. Weldon, NDRC 6.1-sr1130-1983, Service Project NS-139, USRL, Jan. 4, 1945.
Div. 6-651.314-M1
59. *Calibration of XNAG Sound Beacon*, Eginhard Dietze, NDRC 6.1-sr1130-2300, Service Project NS-139, USRL, July 13, 1945.
Div. 6-651.314-M2
60. *Submarine Evasive Aid, Navy Model XNAG Beacon*, Service Project NS-164, NObs 2074. Problem 1E, BuShips and UCDWR, Jan. 10, 1946.
Div. 6-651.314-M3

HAMMER BOTTLE NOISEMAKERS

See also references 1-4, 6, 9, 24, 26, 28, 50, 51.

61. *Tests on Experimental Models, Pneumatic Noisemaker XG-5, Made on October 24, 1943*, Service Project NS-164 and MIT Research Project DIC-6187, MIT, Oct. 28, 1943.
Div. 6-651.315-M1
62. *Tests on Masking Effect of the XG-5 Noisemaker on Submarine Sounds*, Service Project NS-164 and MIT Research Project DIC-6187, MIT, Nov. 12, 1943.
Div. 6-651.315-M2
63. *Measurements Made on December 4, 1943 of the Sound Output of the Noisemakers XG-2 and XG-5*, Service Project NS-164 and MIT Research Project DIC-6187, MIT, Dec. 22, 1943.
Div. 6-651.33-M4
64. *Measurements Made February 8, 1944 on the Acoustic Output of FXH-1, the MIT Carbon Dioxide Bottle*, Service Project NS-164 and MIT Research Project DIC-6187, MIT, Feb. 25, 1944.
Div. 6-651.315-M3
65. *British Publican Noisemaker, Test of and Comparison with NAE Mark I*, Service Project 154, ASDevLant, BuShips, Nov. 21, 1944.
66. *The FXH-1 Hammer Bottle Expendable Noisemaker*, NDRC 6.1-sr1046-2032, Service Project NS-164 and MIT Research Project DIC-6187, MIT, Feb. 1, 1945.
Div. 6-651.315-M6

Chapter 3

See also references 14, 16, 17, 20, 21, 31.

67. *NAC Beacon Tests*, David J. Evans and Vaughn G. McKenney, NDRC-6.1-sr30-1685, Report 5M-215, UCDWR, May 19, 1944.
Div. 6-651.32-M1
68. *Calibration of MIT Crystal Projector XPA*, L. P. Leighton, NDRC 6.1-sr1130-1631, Service Project NS-139, USRL, June 29, 1944.
Div. 6-553.2-M8
69. *NAC Beacon Tests in 14th Naval District*, Vaughn G. McKenney and W. Bruce Beckley, Service Project NS-164, Report SM240, UCDWR, June 30, 1944.
Div. 6-651.32-M2
70. *The NAC Beacon*, Vaughn G. McKenney, Benjamin F. Howell, and others, NDRC 6.1-sr30-1746, NS-164, Report S-243, UCDWR, Aug. 15, 1944.
Div. 6-651.32-M3
71. *NAC Beacon*, BuShips Radio Division Specifications RE13 A963 B. NAVSHIPS (945-930 D). R. Edition, Aug. 28, 1944.
72. *Calibration of NAC Sound Beacon*, L. P. Leighton, NDRC 6.1-sr1130-1973, NS-139, USRL, Nov. 17, 1944.
Div. 6-651.32-M4
73. *Operating Manual for the Navy Model NAC Sound Beacon*, BuShips 307, Electronics Division, Dec. 27, 1944.
74. *Description of NAC Beacon*, Richard H. Bolt, May 1945.
Div. 6-651.32-M5
75. *The XPA Crystal Transducer*, NDRC 6.1-sr1046-2041, Service Project NS-164, and MIT Research Project DIC-6187, MIT, June 30, 1945.
Div. 6-553.2-M11

Chapter 4

See also references 1-4, 9, 12-14, 16-18, 20, 24-28, 56a, 63.

76. *Tests of Four Experimental Models, Grenade Mark I, Made on October 15, 1943*, Service Project NS-164 and MIT Research Project DIC-6187, MIT, Oct. 18, 1943.
Div. 6-651.33-M1
77. *Measurements of Sound Output of Thirteen Models, Grenade Mark I, Made on November 17, 1943*, Service Project NS-164 and MIT Research Project DIC-6187, MIT, Nov. 26, 1943.
Div. 6-651.33-M2
78. *Preliminary Tests on Masking Effect of Mark 2 Grenade on Submarine Sounds and Tests on Interference with Echo Ranging*, Service Project NS-164 and MIT Research Project DIC-6187, MIT, Dec. 4, 1943.
Div. 6-651.33-M3
79. *Proposed Ordnance Specifications for the Manufacture, Assembly, and Inspection of Navy Grenade Mark 2, Model 1, Model 2, and Model 3*, Confidential Memo to Chief BuOrd, Re2g, MIT-USL, Aug. 30, 1944.
80. *Tests of the USN Grenade Mark II*, J. E. White and William F. Arndt, Report P27 PHR52, CUDWR-NLL, and MIT, Dec. 11, 1944.
Div. 6-651.33-M5

UNCLASSIFIED

81. *Explosive Noise Source in Shallow Water*, MIT Research Project DIC-6187, MIT, Dec. 22, 1944. Div. 6-651.33-M6
82. *Calibrations of MIT Navy Grenade Noisemaker, Mark 2 and No. 6 Atlas Blasting Cap*, Leslie L. Foldy, NDRC 6.1-sr1130-1980, Service Project NS-139, USRL, Dec. 26, 1944. Div. 6-651.33-M7
83. *The Grenade Mark 2 Explosive Noisemaker*, Section 6.1 Memorandum for File, Service Project NS-164, MIT, Mar. 19, 1945. Div. 6-651.33-M8
84. *Development of the 3.5-inch Rocket Head (ENM) Mk. 12 Mod. 0*, R. B. Nottingham, Report 968, Naval Ordnance Laboratory, May 1, 1945.
85. *Calibration of Navy Bouillon-Fired Mark 1 Grenade Noisemaker*, Leslie L. Foldy, NDRC 6.1-sr1130-2304, Service Project NS-139, USRL, Aug. 2, 1945. Div. 6-651.33-M9
86. *The MIT Explosive Noisemakers*, NDRC 6.1-sr1046-2038, Service Project NS-164 and MIT Research Project DIC-6187, MIT, Aug. 15, 1945. Div. 6-651.33-M10
87. *Development of the Grenade Mk 1 and Mk 2*, NavOrd Report 31-45, Bureau of Ordnance, Sept. 25, 1945.
88. *Signal (Pepper) Mark 14 Mods. 0, 1, and 2, Description and Instructions for Use*, OP 1269 (preliminary), Sept. 28, 1945.
89. *Calibration of Noise Output of Modified British MD-1 Caps*, Leslie L. Foldy, NDRC 6.1-sr1130-2375, Service Project NS-139, USRL, Sept. 29, 1945. Div. 6-651.33-M11
90. *Development of the Demolition Firing Device Mk 11 and the Rocket Head (Pepper) Mk 12*, NavOrd Report 57-45, Bureau of Ordnance, Oct. 8, 1945.
91. *Development of the Signal (Pepper) Mark 14 and Mark 20*, G. Lee Ericson, Project Re2g 275, Report 32-45, Bureau of Ordnance, Nov. 8, 1945.
- Chapter 5**
- See also references 1-4, 22, 39, 51b, 51c.*
92. *Measurements of the Sound Output of the NRL Ammonia-Jet Noisemaker FXA, Made on March 16, 17, and 18*, NDRC 6.1-sr1046-1469, Service Project NS-164 and MIT Research Project DIC-6187, MIT, Apr. 3, 1944. Div. 6-651.34-M1
93. *Calibration of Multiple-Jet Noisemaker (Navy Model FXA)*, Eginhard Dietze, NDRC 6.1-sr1130-1825, Service Project NS-139, USRL, Aug. 24, 1944. Div. 6-651.34-M2
94. *An Airjet High Frequency Noise Source*, Wilbur T. Harris, Service Project NS-182, Report P34/R1276, NLL, Dec. 7, 1944. Div. 6-651.34-M3
- Chapter 6**
- See also references 14, 16, 20, 21, 31.*
95. *The Speed and Power of Ships*, David W. Taylor, Press of Ransdell, Inc., Revised: 1933.
96. *API-ASME Code for the Design, Construction, Inspection and Repair of Unfired Pressure Vessels for Petroleum Liquids and Gases*, Fourth Edition, 1943.
97. *Modifications and Tests Made on Taylor Model Basin Self-Propelled Practice Target*, David J. Evans, NDRC 6.1-sr30-1689, Service Project NS-144, Report M225, UCDWR, June 14, 1944. Div. 6-651.4-M1
98. *Directional Control Devices*, by L. N. Schwein Engineering Company, NDRC 6.1-sr30-1868, Service Project NS-293, Report U-266, UCDWR, Oct. 24, 1944. Div. 6-651.4-M2
99. *NAD-6 Beacon*, BuShips AD Interim Specification 16B 12 (RE), Jan. 15, 1945.
100. *NAD-10 Beacon*, BuShips AD Interim Specification 16B 5 (RE), Jan. 15, 1945.
101. *Underwater Sound Output of USS Spot (SS413)*, Project NObs-2074, Report M-296, UCDWR, Mar. 1, 1945. Div. 6-580.1-M10
102. *Report on NAD Tests, Pearl Harbor, February to April, 1945*, ComSubsTrainPac, Electronics Officer.
103. *Report on NAD Beacons*, ComSubsTrainPac memo., Electronics Officer to Chief Staff Officer, Aug. 20, 1945.
104. *Preliminary Instruction Manual for the NAD-6A Sound Beacon*, W. Orvis Johnston, Service Project NObs-2074, Report SM-332, UCDWR, July 20, 1945. Div. 6-651.42-M1
105. *Proposed Design Features for the New NAD-8 Beacon*, Raymond D. Atchley, Project NObs-2074, Report SM-355, UCDWR, Aug. 27, 1945. Div. 6-651.4-M3
106. *NAD-6 and NAD-10, Electronic Design for*, C. F. Bradley, File 09.455, UCDWR, Oct. 30, 1945. Div. 6-651.4-M4
107. *Wake Tubes for NAD-10*, NRL Secret Letter to Chief BuShips, ATT; Submarine Section, from Director NRL, S-S68 SS (452-GLR) S-5431-452-102/45, October 1945.
108. *The Stationary Echo Repeater Decoy for Submarine Use*, Project NObs-2074, Report SM-396, UCDWR, Feb. 28, 1946. Div. 6-651.4-M5
109. *Submarine Evasion Aid, Navy Model NAD-3, Sound Beacon*, Service Project NObs-2074, Report SU-364, UCDWR, Apr. 10, 1946. Div. 6-651.41-M1
110. *The NAD-10A Sound Beacon. Preliminary Instruction Manual*, Daniel E. Andrews, Report M-412, UCDWR. Div. 6-651.43-M2
111. *University of California, Division of War Research Activities on NAD Sound Beacon Project at Submarine Base, Pearl Harbor*, David J. Evans, Report SM-417, UCDWR. Div. 6-651.4-M6
112. *The NAD-6 Sound Beacon (Completion Report)*, R. B. Wagner, UCDWR. Div. 6-651.42-M2
113. *The NAD-10 Sound Beacon (Completion Report)*, Daniel E. Andrews, UCDWR. Div. 6-651.43-M1

Chapter 7

See also references 16, 20, 56e, 60, 66, 70, 86, 109, 112, 113.

114. *Buoyancy Control*, Raymond D. Atchley, NDRC 6.1-sr30-1302, Report M-135, UCDWR, Dec. 3, 1943. Div. 6-651.5-M1
115. *Automatic Control Engineering*, Ed Sinclair Smith, McGraw-Hill Book Company, New York, 1944.
116. *Buoyancy Control, General Instructions for Use*, Raymond D. Atchley, NDRC 6.1-sr30-1466, Report M-182, UCDWR, Feb. 22, 1944. Div. 6-651.5-M2
117. *A Gas-Operated Depth Control*, NDRC 6.1-sr1046-2040, Service Project NS-164 and MIT Research Project DIC-6187, MIT, Aug. 15, 1945. Div. 6-651.5-M3
118. *Test of Depth Control on Signal Pepper Mark 20 at Boston, Mass.*, W. S. Cramer, Memorandum 7769, 21C4320, NOL.
119. *Test of Depth Control on Signal (Pepper) Mark 20 at Port Everglades, Florida*, Memorandum 7768, 21C4320, NOL.

Chapter 8

See references 60, 70, 109, 112, 113.

Chapter 9

120. "Acoustic Transmission Line for Impedance Measurements," W. M. Hall, *The Journal of the Acoustical Society of America*, Vol. II, p. 140, July 1939, Service Project NS-222 and MIT Research Project DIC-6187.
121. *Steel Plates. Measurements of Specular Reflection from Scale Models of Submarines*, Progress Memorandum, Service Project NS-222 and MIT Research Project DIC-6187, MIT, Feb. 12, 1944. Div. 6-652-M1
122. *Acoustic Treatment of Conning Towers*, Service Project NS-222 and MIT Research Project DIC-6187, MIT, Apr. 11, 1944. Div. 6-652-M2
123. *Acoustic Treatment for Conning Towers*, Service Project NS-222 and MIT Research Project DIC-6187, MIT, Nov. 30, 1944. Div. 6-652-M4
124. *Percentage Reductions in Maximum Echo Ranges on American Submarines by Acoustic Treatment of Hull and Conning Tower*, Lyman Spitzer, Jr., N. Jeffrey Holter, Lt. Comdr. Roger Revelle, BuShips, Nov. 30, 1944. Div. 6-652-M3
125. *Absorption of Coated Steel Plates*, Eginhard Dietze, NDRC 6.1-sr1130-2146, Service Project NS-139, USRL, Apr. 5, 1945. Div. 6-552-M17
126. *Exposure Tests of Panels*, confidential letter, Commandant Norfolk Navy Yard JJ52(5-MSR), Apr. 18, 1945.
127. *Sonar Camouflage Paint—Test of*, confidential letter, ComSubsLant S19/(0616), Apr. 30, 1945.
128. *Acoustical Treatment for Submarines*, NDRC 6.1-sr1046-2042, Service Project NS-222 and MIT Research Project DIC-6187, MIT, Aug. 15, 1945. Div. 6-652-M5
129. NavTecMisEu Technical Report 352-45, Sept. 1945.
130. *Acoustical Treatment for Submarines*, NDRC 6.1-sr1046-2042a, Service Project NS-222 and MIT Research Project DIC-6187, MIT, Oct. 30, 1945. Div. 6-652-M6
131. *Sonar and Submarine Diving*, Report 17, Service Project NObs-2083, WHOI Dec. 10, 1945.

MISCELLANEOUS COUNTERMEASURES

132. *A Theoretical Study of Possible Countermeasures to Small Contact Depth Charges (Completion Report)*, NDRC 6.1-sr1046-2034, Service Project NS-211 and MIT Research Project DIC-6187, MIT, Feb. 15, 1945. Div. 6-653-M1

UNCLASSIFIED
SECRET

CONTRACT NUMBERS, CONTRACTORS, AND SUBJECT OF CONTRACTS

<i>Contract Number</i>	<i>Name and Address of Contractor</i>	<i>Subject</i>
OEMsr-30	The Regents of the University of California Berkeley, California	Maintain and operate certain laboratories and conduct studies and experimental investigations in connection with submarine and subsurface warfare.
OEMsr-1046	Massachusetts Institute of Technology Cambridge, Massachusetts	Studies and experimental investigations in connection with (1) underwater sound transmission and boundary impedance measurements; (2) ship sound surveys at high frequencies; (3) development of devices for the control of underwater sounds; and (4) development of intense underwater sound sources for special purposes.
OEMsr-1130	The Trustees of Columbia University in the City of New York New York, New York	Conduct studies and experimental investigations in connection with the testing and calibrating of acoustic devices.

UNCLASSIFIED
SECRET

SERVICE PROJECT NUMBERS

The projects listed below were transmitted to the Executive Secretary, NDRC, from the War or Navy Department through either the War Department Liaison Officer for NDRC or the Office of Research and Inventions (formerly the Coordinator of Research and Development), Navy Department.

<i>Service Project Number</i>	<i>Subject</i>
NS-144	Echo repeater target.
NS-164	Submarine evasion device.
NS-222	Acoustic treatment of the conning tower.
NS-293	NAD beacon.

SECRET

INDEX

The subject indexes of all STR volumes are combined in a master index printed in a separate volume. For access to the index volume consult the Army or Navy Agency listed on the reverse of the half-title page.

- Acoustic absorbing coating for submarines, 136-145
 aerated cement, 140-141
 coating performance tests, 141-144
 design considerations, 137-138
 detection range reduction, 144
 experimental development, 137-142
 German development, 136-137, 140
 NDRC development, final stage, 144-145
 pressure factors, 141, 143
 sandwich coating, 137, 140-141
 sound absorption measurement, 137-139
 sprayed coating, 142-143
 temperature factors, 141, 143
 Acoustic torpedo, German, 3
 Aerated cement for submarine coating, 140-141
 Albericht submarine coating, German, 136-137, 140
 Ammonia jet noisemaker, 67-68
 calibration, 68
 construction, 67
 B. B. Chemical Co.
 cement for submarine coating, 141-142
 sprayed coating for submarines, 142-143
 Batteries
 BTL, sea-water activated, 129-131
 Burgess, sea-water activated, 39, 131-132
 Edison primary, 105, 128-135
 secondary batteries, 128
 Blasting caps, standard No. 6; 47, 49-51, 53-55
 BTL sea-water activated batteries, 129-131
 construction, 129-130
 for NAD-6 sound beacon, 129
 for NAD-10 sound beacon, 130-131
 Buoyancy control, sound beacons, 114-117
 for XNAG sound beacons, 116-117
 heavy-duty buoyancy control, 116-117
 operating life, 114
 packaging of unit, 115
 poppet valve, 114
 UCDWR mechanism, 113-115
 Burgess sea-water activated batteries, 39, 131-132
 construction, 131-132
 development history, 131-132
 Calibration techniques for noisemakers, 4-6
 continuous noises, 5-6
 directivity, 6
 frequency modulated noises, 6
 impactive noises, 5-6
 life determination of expendable noisemaker, 6
 measurements by types, 5-6
 output level, 6
 peak factor, 6
 short-range measuring system, 5
 waveform photograph, 6
 XMX hydrophone, 5
 Catalyst Research Corporation, explosive and fuze powders, 46-49, 54-58
 Cavitation noise, submarine, 72-73
 Countermeasures, development, 1-9
 Countermeasures, table of major devices, 2
 CRC caps and explosive powders, 46-49, 54-58
 Crystal transducer
 see XPA crystal transducer
 Decoys
 see Submarine-simulating decoys
 Depth controls for noisemakers, 111-127
 buoyancy control, heavy-duty, 116-117
 floats, 124-125
 gas-operated types, 111-115
 miscellaneous devices, 124-127
 NAE Mk 1 rotary noisemaker, 125-126
 NAE Mk 2 rotary noisemaker, 118
 rotating propeller, 126
 signal (Pepper) Mk 14; 126
 signal (Pepper) Mk 20; 119-124
 Dual-head noisemakers, 21-25
 design development, 21
 future work, 23
 overall output, 22
 rotary impactor designs, 22
 test models, 22
 Edison primary batteries, 129-135
 bursting-pins, 134-135
 construction, 132
 electromotive force, 133
 I-type battery, 105, 135
 K-type battery, 135
 power, 134
 production model, 135
 specifications, 133
 Electromagnetic soundheads for beacons, output, 21-22
 Electronic noisemakers, 36-45
 background material, 36
 crystal transducers, 2, 36, 42-45
 jamming device, 36
 NAC sound beacon, 36-42
 NAH sound beacon, 42
 towed projectors, 42-45
 XPA crystal transducer, 2, 36, 42-45
 Explosive and fuze powders, CRC, 46-48, 58
 Explosive noisemakers, 46-66
 acoustic characteristics, 46-47, 63
 construction, 56-63
 depth control, 48
 design considerations, 46-48
 grenade Mk 2; 63
 history of program, 46
 latest work, 65-66
 masking effectiveness, 63-65
 masking tests, 63-65
 signal (Pepper) Mk 14; 56-61
 signal (Pepper) Mk 20; 61-62
 trouble sources, 48
 waveform analysis, 49-56
 False target shells, FTC and FTS, 1-3
 FXA ammonia jet noisemaker, 2, 67-68
 FXH-1 hammer bottle, 2, 33-34
 FXP rotary noisemaker, 2, 12-14
 FXR towed parallel bars, 1-2, 10-12
 Gas ejection noisemakers, 67-70
 ammonia jet noisemaker, 67-68
 hydrogen-oxygen noisemaker, 70
 steam noisemakers, 68-69

UNCLASSIFIED

- Gas-operated depth control for expendable noisemakers
see Depth controls for noisemakers
- Gear whine, submarine, 73
- German acoustic torpedo, 3
- German Albericht coating for submarines, 136, 137, 140
- German Pillenwerfer bubble clouds, 2
- Grenade Mk 2; 2, 63
- Hammer-bottle noisemakers, 2, 31-35
 as decoys, 32
 calibrator, 33-34
 comparison with DE output, 33
 development, 31-32
 early models, 32
 field tests, 33-35
 FXH-1; 2, 31, 33-34
 inside-hammer design, 35
 life per unit, 32-33
 MIT-USL developments, 35
 peak factor, 33
 XG5; 32
- Hydrogen-oxygen noisemaker, 70
- Hydrophone, 5, 45, 49
- Jamming device, 36
- Lithium cups in XNAG buoyancy control, 117
- Magnetostriction projector, 104
- Masking effectiveness, explosive noisemaker, 63-65
- Masking tests, explosive noisemakers, 63-65
 ASDevLant tests, 64
 fleet tests, 64
 preliminary tests, 63-64
- Mechanical noisemakers, 10-35
 background material, 10
 dual soundhead, 16-31
 FXR towed parallel bars, 10-12
 hammer-bottle, 2, 31-35
 rotary, 12-16
- Mechanical soundheads for sound beacons, 21-25
- Mercury switches, NAD-10; 100-101
- Mine Mk 30, adaptation for NAD-10 sound beacon, 98-100
- Mountain Lakes pressure tank, 141, 143-144
- NAC sound beacon, 1-2, 36-42, 114-115
 buoyancy control, 40, 114-115
 construction, 36-40
 electronic circuit, 37-39
 field evaluation, 41-42
 future work, 42
 multivibrator oscillator, 37-39
 operation, 40-41
 traces, 41-42
- NAD-3 sound beacon, 1-2, 78-85
 battery, 83
 compartment construction, 80
 components, 79-84
 course control, 78, 84-85
 depth control, 83-85
 electrical circuit, 84
 evaluation, 85
 experimental development, 78-79
 external controls, 84
 gyro course control, 79, 83
 noise generator, 78, 81-82
 operation, 84-85
 speed change mechanism, 82
 time clock, 80-81
 trim, 80
- NAD-6 sound beacon, 1-2, 86-96
 evaluation model, 86
 first model, 86
 launching system, 86-87
 operation, 86-87
 performance tests, 95-96
 silent run, duration adjustment, 87
- NAD-6 sound beacon, components, 87-93
 amplifier power supply, 89
 assembly, 87-88
 body design, 90
 circuit elements, 89
 course control, 90
 depth control, 90
 echo-repeater amplifier, 89
 output spectrum, 92
 power source, 92
 propulsion system, 90
 release mechanism, 93
 self-noise generator, 92
 sequence timing, 91-92
 transducer design, 88
 Y-cut crystals, 88
- NAD-10 sound beacon, 96-108
 components, 98-105
 depth control, 99-101
 experimental models, 96-98
 Mark 30 mine, adaptation, 96-100
 operation, 106-107
 performance tests, 107-108
- NAD-10 sound beacons, components, 98-105
 batteries, 105
 body design, 98
 control circuit, 105
 course control, 99
 depth control, 99-101
 echo-repeater amplifier, 103
 loudspeaker design, 104
 propulsion system, 99
 receiving transducer, 103
 retriever system, 99
 safety features, 105
 self-noise simulation, 104
 sequence timer, 105
 transmitting transducer, 101
- NAE Mk 1 rotary noisemaker
 balloon depth control, 125-126
 description, 13-15
- NAE Mk 2 rotary noisemaker
 depth control, 118
 description, 13-15
- NAH sound beacon, 2, 42
- Noisemakers, calibration techniques
see Calibration techniques for noisemakers
- Noisemakers, depth controls
see Depth controls for noisemakers
- Noisemakers, electronic, 36-45
 NAC, 1-2, 36-42
 NAH, 2, 42
 XPA crystal transducer, 36, 42-45
- Noisemakers, explosive, 46-66
 grenade Mk 2; 63
 signal (Pepper) Mk 14; 56-61, 126
 signal (Pepper) Mk 20; 61-62, 119-124
- Noisemakers, false target shells
 FTC, 1-3
 FTS, 1-3
- Noisemakers, gas ejection, 67-70
 ammonia jet noisemaker, FXA, 67-68
 hydrogen-oxygen noisemaker, 70
 steam noisemakers, 68-69
- Noisemakers, history, 2-4
 ASDevLant, 3-4, 6-7
 German acoustic torpedo, 3-4
 Japanese sonar techniques, 3
 production, 4
- Noisemakers, mechanical, 10-35
 dual soundhead, 16-31
 FXH-1; 2, 33-34
 FXP, 1-2, 12-14
 FXR, 1-2, 10-13
 hammer-bottle, 31-35

CLASSIFICATION CHANGED TO
 UNCLASSIFIED
 AUTHORITY: [REDACTED]

- NAE, 1-2, 13-15, 118, 125-126
 rotary, 12-16
 XNAG, 1-2, 16-31
- Noisemakers, performance, 6-9
- Noisemakers, primary batteries, 128-135
- Noisemakers, submarine-simulating decoys, 71-110
 NAD-3; 1-2, 78-85
 NAD-6; 1-2, 86-96
 NAD-10; 1-2, 96-108
- Noisemakers, table of major devices, 2
- Noisemakers and decoys, summary, 8-9
- OAY equipment, masking effect on, 65
- O-ring waterseal system, 77, 80
- Peak factor of a noisemaker, definition, 6
- Pepper signal, 56-62
 background material, 46-48
 Mk 14; 1-2, 56-61, 126
 Mk 20; 1-2, 61-62, 119-124
- Pressuretrol, 90, 99
- Primary batteries for expendable noisemakers, 128-135
 BTL sea-water activated batteries, 129-131
 Burgess sea-water activated batteries, 131-132
 design considerations, 128
 Edison primary batteries, 128-135
 secondary batteries, disadvantages, 128
 suitability, 128-129
- Razzer (steam noisemaker), 68-69
- Research recommendations
 acoustic absorbing coating for submarines, 144-145
 dual-head units for sound beacons, 23
 explosive noisemakers, 65-66
 general recommendations for evasion devices, 7-9
 NAH sound beacon, 42
 sound beacons, 108-110
- Reverberation pictures, waveform analysis, 55
- Rochelle salt crystals, 39, 42-43, 45, 88, 101-103
- Rotary noisemakers, 12-16
 FXP, 1-2, 12-14
 FXR, 10-13
 MIT-USL designs, 15
 NAE, 13-15, 118, 125-126
- Sandwich coating as acoustic treatment for submarines, 140-141
- Schwieb gyro, 90, 99
- Sea-water activated batteries
 BTL, 129-131
 Burgess, 39, 131-132
- Signal (Pepper) Mk 14; 1-2, 56-61
 calibration, 60-61
 center rod, 58
 construction, 56-60
 depth control, 126
 explosive stack, 56-58
 initial firing mechanism, 58
 knockoff mechanism, 60
 operation, 60-61
 trigger mechanism, 58
 waterseal system, 59-60
- Signal (Pepper) Mk 20; 61-62, 119-124
 acoustic calibration, 62
 construction, 62
 knockoff mechanism, 62
 operation, 62
- Signal (Pepper) Mk 20, depth control, 62, 119-124
 appearance, 119-120
 components, 119
 cycle of operation, 121-122
 gas source, 122
 initial fill, 123
 knockoff mechanism, 123
 mathematical analysis of operation, 120-121
 operation, 119-122
 oscillations, 122
 performance tests, 123-124
 pressure component, 122
 technical development, 122
- Silent stenographer depth recorder, 123-124
- Simulation of submarine sounds, 72-75
 cavitation noise, 72-73
 deception of listener, 74
 depth selection, 74
 echo simulation, 75
 gear whine, 73
 sound output level, 74
 speed selection, 74
 wake echo, 75
- Sonic sound beacon, 18-19, 114
see also XNAG sound beacon
 acoustic calibration, 20
 buoyancy control, 19, 114
 construction, 18-20
 electromagnetic soundhead, 19
 electronic unit, 18-19
 noise production, 19-20
- Sound beacons, buoyancy control, 114-117
 for XNAG sound beacons, 116-117
 heavy-duty buoyancy control, 116-117
 operating life, 114
 packaging of unit, 115
 poppet valve, 114
 UCDWR mechanism, 113-115
- Sound beacons, future development, 108-110
 depth requirements, 109
 identification of beacon, 109
 limitation analysis, 109-110
 value determination, 110
- Sound beacons, types, 1-2
 NAC sound beacon, 36-42, 114-115
 NAD-3 sound beacon, 78-85
 NAD-6 sound beacon, 86-96
 NAD-10 sound beacon, 96-108
 NAH sound beacon, 42
 XNAG sound beacon, 16-31
- Sprayed coating for submarines, 142-143
- Steam noisemakers, 68-69
- Submarine acoustical treatment
see Acoustic absorbing coating for submarines
- Submarine cavitation noise, 72-73
- Submarine coating performance tests, 143-144
- Submarine detection ranges, effect of 10-DB absorption, 144
- Submarine evasion devices, performance summary, 6-9
 recommendations for further development, 7-9
 recommendations for use, 7
 shortcomings of individual devices, 6-7
- Submarine gear whine, 73
- Submarine target strength, definition, 75-77
- Submarine-simulating decoys, self-propelled, 71-110
 design considerations, 75-77
 introductory material, 71-72
 NAD-3 sound beacon, 78-85
 NAD-6 sound beacon, 86-96
 NAD-10 sound beacon, 96-108
 recommendations for future development, 108-110
 simulation of submarine sounds, 72-75
- Target strength of submarine, definition, 75-77

CLASSIFICATION CHANGED
 UNCLASSIFIED
 CONFIDENTIAL
 AUTHORITY

- Thuras, A. J., magnetostriction projector, 104
- Towed parallel bars, FXR, 1-2, 10-12
- Towed projectors, 42-45
towed fish, 45
XPA crystal transducer, 36, 42-45
- UCDWR buoyancy control, 113
- Underwater explosions
see Waveform analysis of underwater explosions
- Underwater sound absorption, 140
- Waveform analysis of underwater explosions, 43-56
blasting caps, standard No. 6, 49-55
British MD-1 caps, 49-51, 52
collapse peaks, 53-55
CRC caps, 49-50, 53-55
explosion peak, 53-55
Fourier analysis, 49, 51
grenade Mk 1; 50-51
- Henrici-type analyzer, 49
noisemaker calibration, 49-53
peak values, 49, 51
reverberation curves, 53-56
S-50 quill, 53
waveform photographs, 6, 52
XMX hydrophone, 49
- XG5 hammer-bottle noisemakers, 22
- XMX hydrophone, 5, 49
- XNAG sound beacon, 1-2, 16-21
acoustic performance, 17
buoyancy control, 116-117
depth control, 18
design considerations, 17-18
dual-head units, 21-25
electromagnetic soundhead, 17
experimental sonic sound beacon, 18-25
future work, 21
impactor-type soundheads, 17
preliminary model, 23-26
pressure compensation, 19
submarine simulation, 17
- XNAG sound beacon projectors, 26-31
acoustic performance, 26
ball-impactor soundhead, 28
buoyancy control, heavy-duty, 27
construction, 26
drive-motor, 29
electromagnetic soundhead, 28
electronic circuit, 26-28
frequency compared with submarine signals, 26
masking effectiveness, 22
operation, 29
output, psychological effect, 28
- XPA crystal transducer, 1-2, 36, 42-45
calibration, 42
construction, 42-45
design, 44-45
field tests, 44-45
towed hydrophone use, 45-48
towing characteristics, 45
use in calibration, 45-48
- Y-cut crystals, 38, 86, 102-103

UNCLASSIFIED
CLASSIFICATION CHANGED TO
SECRET
CONFIDENTIAL
AUTHORITY

~~SECRET~~

TITLE: Countermeasures (Underwater Sound Equipment VI) Vol. 19

ATI- 30813

AUTHOR(S): (Not known)

REVISION
(None)

ORIGINATING AGENCY: Office of Scientific Research and Development, NDRC, Div. 6

ORIG. AGENCY NO.
(None)

PUBLISHED BY: (Same)

PUBLISHING AGENCY NO.
(Same)

DATE	DOC. CLASS.	COUNTRY	LANGUAGE	PAGES	ILLUSTRATIONS
1946	SECRET	U.S.	Eng.	162	photos, diagr, graphs

ABSTRACT:

The development of countermeasures to enemy sonar is summarized. Topics discussed in this volume include: mechanical noisemakers, electronic noisemakers, gas ejection noisemakers, self-propelled submarine-simulating decoys, depth controls for stationary expendable devices, primary batteries for expendable devices, and acoustical treatment for submarines. The experience of NDRC laboratories with special techniques of noise-maker calibration, and in the evaluation and analysis of numerous tests of noise-maker performance is reported. A tabular summary of the characteristics, physical dimensions, and performance of all the devices is furnished.

NOTE: Previously cataloged under No: NAD-18178 KK-23517

DISTRIBUTION: Copies of this report obtainable from Air Documents Division; Attn: MCIDXD

DIVISION: Electronics (3)
SECTION: Communications (1)

SUBJECT HEADINGS: Sonar (87431); Jamming (53608);
Research - Summary reports (81658.95)

ATI SHEET NO.: S-3-1-9

Air Documents Division, Intelligence Department
Air Materiel Command

AIR TECHNICAL INDEX

Wright-Patterson Air Force Base
Dayton, Ohio

~~SECRET~~