

UNCLASSIFIED

AD NUMBER
AD225780
NEW LIMITATION CHANGE
TO Approved for public release, distribution unlimited
FROM Distribution authorized to U.S. Gov't. agencies and their contractors; Administrative/Operational Use; Sep 1959. Other requests shall be referred to National Aeronautics and Space Administration, Washington, DC.
AUTHORITY
AFMC ltr, 19 Feb 2002

THIS PAGE IS UNCLASSIFIED

UNCLASSIFIED AD

225 780

FOR
MICRO-CARD
CONTROL ONLY

1 OF 1

Reproduced by

Armed Services Technical Information Agency

ARLINGTON HALL STATION; ARLINGTON 12 VIRGINIA

UNCLASSIFIED

"NOTICE: When Government or other drawings, specifications or other data are used for any purpose other than in connection with a definitely related Government procurement operation, the U.S. Government thereby incurs no responsibility, nor any obligation whatsoever; and the fact that the Government may have formulated, furnished, or in any way supplied the said drawings, specifications or other data is not to be regarded by implication or otherwise as in any manner licensing the holder or any other person or corporation, or conveying any rights or permission to manufacture, use or sell any patented invention that may in any way be related thereto."

NASA TN D-34

AD No. 225 780

ASTIA FILE COPY

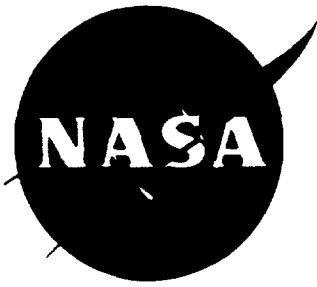

TECHNICAL NOTE

D-34

FC

AIRPLANE AND ENGINE RESPONSES TO ABRUPT THROTTLE STEPS
AS DETERMINED FROM FLIGHT TESTS OF EIGHT
JET-PROPELLED AIRPLANES

By Maurice D. White and Bernard A. Schlaff

Ames Research Center
Moffett Field, Calif.

FILE COPY

Return to

ASTIA

WASHINGTON HALL STATION
WASHINGTON, VIRGINIA

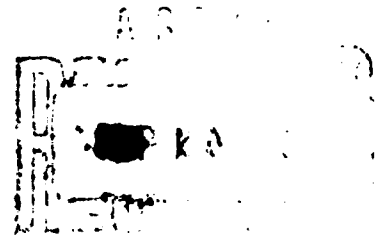

AD No. 225 780

ASTIA FILE COPY

NATIONAL AERONAUTICS AND SPACE ADMINISTRATION
WASHINGTON
September 1959

C

NATIONAL AERONAUTICS AND SPACE ADMINISTRATION

TECHNICAL NOTE D-34

AIRPLANE AND ENGINE RESPONSES TO ABRUPT THROTTLE STEPS

AS DETERMINED FROM FLIGHT TESTS OF EIGHT

JET-PROPELLED AIRPLANES

By Maurice D. White and Bernard A. Schlaff

SUMMARY

A-162

As a part of a generalized landing-approach investigation, determinations were made of the dynamic responses of a number of airplanes and engines to abrupt throttle steps. For the thrust levels above about 80 percent of design rpm to which the tests were mainly confined, the thrust responses to small-amplitude thrust changes (5-percent change in rpm) were representable by a first-order dynamic response ($1 - e^{-ct}$) in most of the cases; the exception used variable exit-nozzle area and temperature rather than engine rpm as a primary engine variable. For larger amplitude steps, the thrust variations departed significantly from that of a first-order response for some engines; while the differences from the first-order response would probably not be a serious factor in approximating engine response characteristics for landing-approach simulations, they might be significant for other applications. Engine dynamic response characteristics were not a limiting factor in carrier-type approaches where the characteristic small throttle movements would be associated with small time constants; this conclusion would not apply, however, in low-power tactical-type approaches. Similarly, in wave-offs from carrier-type approaches, the engine dynamic responses were rapid enough that this factor did not limit approach speeds. Responses of the various test airplanes to throttle steps were different in the degree to which normal accelerations developed as a result of trim changes due to thrust.

INTRODUCTION

The Ames Research Center of the National Aeronautics and Space Administration has been conducting a general study of the problems of the landing approach with several objectives. These include the identification of the factors that limit the approach speed (ref. 1), the development of means for decreasing the approach speed (ref. 2 and boundary-layer control studies), and the development of criteria for predicting the approach speed. As noted in reference 1, the throttle

may be used by the pilot as an important means for controlling altitude precisely in constant-speed types of approaches. Consequently, the dynamic responses of the engine and the airplane to throttle movement are significant during this type of approach. For this reason, these characteristics were documented in flight for a number of the airplanes tested in the aforementioned program, and the results are presented in this report.

NOTATION

A	exit area of jet nozzle, sq ft
A_x	longitudinal acceleration, units of gravity, g
A_z	normal acceleration, units of gravity, g
c	arbitrary constant
F_g	gross thrust, lb
F_g'	uncorrected gross thrust as determined from single probe in tail pipe
F_N	net thrust, lb
F_{ram}	ram drag, as defined in equation (1), lb
k	nozzle coefficient
p	static pressure, lb/sq ft
q	dynamic pressure, lb/sq ft
rpm	engine revolutions per minute
T	thrust, lb
T_e	absolute temperature, deg
T_{max}	maximum thrust at sea level, lb
t	time
V	velocity, knots
W	landing weight of airplane, lb

W_a	mass flow of air through engine, slugs/sec
α	angle of attack, deg
$\dot{\gamma}$	rate of change of flight-path angle
δ_e	elevator angle, deg
δ_{Tn}	throttle position
θ	ratio of absolute temperature at inlet to absolute temperature at sea level for standard conditions
ρ	atmospheric density, slugs/cu ft

Subscripts

o	standard condition
s	stall
T	tail-pipe location

AIRPLANES AND ENGINES

Dynamic response characteristics were determined for eight fighter-type jet-propelled airplanes; the FJ-3, F4D, F9F-6, F-86A, F-86F, F-94C, F-84F, and F7U-3. A two-view sketch of each of the airplanes is shown in figure 1.

The engine model and series designation for each of the airplanes is given in table I together with the type of fuel regulator. The engines were of axial-flow compressor type except for the J-48 engines used in the F9F-6 and F-94C airplanes which are centrifugal-flow compressor types. The J-57 engine installed in the F4D-1 airplanes is of the twin-spool type. Three of the engine types had afterburners, but the afterburners were not used in any of the tests reported here.

INSTRUMENTATION

Instruments and Static Calibrations

Standard NASA recording instrumentation was used to record airspeed, altitude, normal and longitudinal acceleration, angle of attack, throttle position, and tail-pipe pressure. Conventional techniques were used to calibrate the recording airspeed systems in the F7U-3, F-86A, F-86F, F4D, and FJ-3 airplanes. No airspeed calibrations were made for the F9F-6, F-94C, and F-84F airplanes; for these airplanes, nose-boom installations with static-pressure sources approximately 10 feet ahead of the airplane noses were assumed to provide static pressure with no appreciable error.

A single tail-pipe probe, which was used as an engine thrust indicator in accordance with reference 3, was calibrated statically by use of a ground thrust stand for each of the installations.

Engine rpm, tail-pipe temperature, and fuel weight were obtained from the airplane standard indicators by using a movie camera to photograph the instrument panel.

Dynamic Response Characteristics of Instruments

Since the present tests were conducted only incidentally to the landing-approach studies, no special instrumentation was installed to minimize the lag of the recorded values. A brief estimate of the dynamic response characteristics of the instruments used to define engine performance follows:

(a) Tail-pipe pressure: The natural frequency of the recorder was about 200 cycles per second, which would introduce negligible time lags for the effective frequencies of the pressure responses. For the lengths of tubing used in the pressure lines, the maximum lags were estimated to be about 0.01 second, based on the procedures of reference 4. The resultant lag of the recorded values of tail-pipe pressure, the primary indicator of thrust, is therefore considered negligible.

(b) Tail-pipe temperature: The time lags associated with the airplane indicating systems used for most of the test airplanes were relatively high, of the order of 2 to 4 seconds. However, sample calculations indicate that the computed thrust variations are not particularly sensitive to errors in recorded temperature, being of the order of 1 to 2 percent of the increment for the largest errors that were estimated to have occurred. This lag effect was considered small enough to justify its neglect in the data evaluation.

(c) Engine rpm: Laboratory tests of typical service indicators showed the indicator to lag step changes in voltage input from 80 to 100 percent of design rpm by 0.65 second, and step changes in voltage input from 100 to 80 percent of design rpm by 0.9 second. These figures represent moderate time lags, for which no attempts were made to provide corrections. It will be noted, however, that these measurements are not used in any of the calculations, but are presented only as time histories.

TESTS

A series of throttle steps was made with each of the airplanes, over a range of step amplitudes for increasing and decreasing thrusts. The airplanes were in the landing-approach configurations, and the tests were conducted with fixed controls at approximately the landing-approach speed for each airplane. The test altitudes ranged from 2000 to 8000 feet.

For most of the airplanes the tests were confined to the thrust range from 80 to 100 percent of design rpm, with thrust increments corresponding to rpm changes of 5, 10, 15, and 20 percent of design rpm. A broader range of engine thrusts was covered on one of the airplanes, the F-86A, the engine test rpm ranging from 40 to 100 percent. For the F9F-6 and F7U-3 airplanes the program of runs was not as systematic as it was for the other airplanes which were tested subsequently.

Some of the airplanes were evaluated in wave-off maneuvers. For these tests carrier-type landing approaches were made at a number of approach speeds. From these approaches, wave-offs were made with slow, intermediate, and normal throttle advances. These tests were conducted by several pilots at a field carrier-landing practice facility maintained by the Navy at Crows Landing, California.

Some of the test airplanes were equipped with afterburners but the afterburners were not used in any of the tests reported herein.

RESULTS

Static Thrust

The variations of thrust with corrected rpm for the test engines as determined from thrust-stand measurements at sea level are shown in figure 2. Data for the F7U-3 airplane are omitted from figure 2 because, as indicated later, the thrust variations for this airplane do not lend themselves to this type of presentation. The data are presented as the

ratio of thrust to maximum thrust in order to show the degree to which one approximate curve might serve for generalized studies. The data for the single-spool engines do show some consistency, but it is apparent that the legitimacy of such an approximation would depend on its intended use. The twin-spool engine (F4D) shows considerable disparity from the others.

Throttle Steps

Typical responses of the engines and the airplanes to abrupt step movements of the throttle are shown in time history form in figures 9 to 10. The throttle position, indicated engine rpm, net thrust, and longitudinal and normal accelerations are shown for each airplane for throttle steps from 80 to 85, 80 to 100, 100 to 80, and 85 to 80 percent of design rpm. For several of the airplanes, the F7U-3, F9F-6, and the F-86A, data were not obtained for the precise ranges designated, and the time histories are for ranges most nearly approximating them.

Values of the net thrust, F_N , were determined from the following equation:

$$F_N = F_g \cos \alpha - F_{ram} \quad (1)$$

where

$$F_g = k F_g' \quad (2)$$

and k is the nozzle coefficient determined from thrust stand tests. The values of F_g' and F_{ram} were obtained from the relationships given in reference 3.

$$\frac{F_g'}{A p_0} = f_1 \left(\frac{p_0}{P_T} \right); \quad \frac{W_1 \sqrt{T_e}}{A p_0} = f_2 \left(\frac{p_0}{P_T} \right); \quad F_{ram} = 1.69 W_1^2 \quad (3)$$

Unlike the other airplanes the throttle position for the F7U-3 airplane is plotted in terms of percent of maximum thrust available, the relationship of the throttle position to thrust being obtained from steady-state flight data at an altitude of about 5000 feet. The difference in throttle position presentation was required because of the fact that in the range of engine thrusts applicable to the carrier-approach condition, the engines of the F7U-3 were operated at constant rpm and the thrust was modulated by changing fuel flow and exit-nozzle area to alter temperature. Engine data for the F7U-3 airplane are presented for only one of the two engines installed in the airplane; the airplane responses correspond to thrust changes of both engines.

Data were recorded for the F-94C airplane at airspeeds of 140 and 160 knots. Since the response characteristics were found to be nearly identical at both speeds only the data for 140 knots are presented.

It will be noted in figures 3 to 10 that occasionally there was a difference between the indicated engine rpm and the rpm setting of the throttle at the beginning of the time history. Possible explanations for these differences would include play or backlash in the throttle system linkage, and differences in altitude between the test runs and the calibration curve for the throttle position.

DISCUSSION

Basic Engine Characteristics

The basic characteristics of conventional jet engines are such that the maximum allowable accelerations in rotation are limited as a function of the rotational speed (rpm). Stalling of the blades of the compressor is an important consideration in defining the limiting positive rotational accelerations, and flame blowout in defining the limiting negative accelerations. Fuel regulators usually schedule fuel so that engine operation will approach but not cross the boundaries established by these considerations.

Engine thrust responses at high thrust levels.- The actual thrust responses achieved in service installations as a result of these restrictions are indicated by the data shown in figures 3 to 10. The thrust data show the quantitative time constants that prevail as a result of the qualitative limitations indicated above. The results are confined to thrust levels which cover the ranges of values that are generally used in carrier-type approaches - above about 80 percent of design rpm for most of the airplanes. The restriction to this range of values was established on the basis that the pilots use the throttle as a basic altitude control mainly in this type of approach, so that the dynamic response characteristics were considered to be of significance only in this range (ref. 1). In the tactical type of approach described in reference 1, the engine is operated at low thrust levels where the dynamic responses are very slow, so that the pilots do not completely rely on obtaining a particularly fast engine response. Quantitative values of engine time constants would not be of as much interest for such operation.

The results in figures 3 to 10 indicate that there are variations in the responses of the different engine and fuel regulator combinations that preclude a simple general description. For practical purposes the responses of all the engines to steps of small amplitude (1- to 2-percent engine rpm) are describable as a first-order response ($1 - e^{-ct}$). This

indicates that, as would be expected, at small amplitudes the fuel regulation does not greatly modify the basic character of the response of the unregulated engine, which may be assumed as first order (ref. 5).

The responses to increasing steps of large amplitude vary considerably between engines. Plots of the variations of thrust with time show a decreasing slope with time that approximates a first-order response for the F-84F and F-86A airplanes. A relatively uniform slope is shown for the F-94C, F9F-6, F-86F, F4D, and FJ-3 airplanes. For the F7U-3 airplane the thrust appears to lag the throttle movement by a simple time lag.

A point of interest in connection with the foregoing comparison, which should also be borne in mind with regard to the following discussion, is the role of the fuel regulator in defining dynamic response characteristics. It will be noted in table I that several of the airplanes included in the investigation have the same basic engine designation but different fuel regulators; for example, the F9F-6 and the F-94C both have J-48 engines, the F-86A and the F-86F both have J-47 engines, and the FJ-3 and F-84F both have J-65 engines. Yet, a review of the response characteristics just described shows no consistency in response for the same engines. While some differences in response for comparable engines may be due to the engine differences associated with the dash designations (YJ65-W4 versus YJ65-W1A), it is more likely that the differences in fuel regulators are the cause. Accordingly, when dynamic response characteristics are, for convenience, described in terms of an engine (or airplane), it should be recognized that the fuel regulator is also an important variable among the different configurations.

Another characteristic which differed among the engines was the relative response for decreasing and increasing thrust changes. Generally, responses were more rapid for decreasing than for increasing thrust changes, which is probably a consequence of the fact that the considerations that limit the accelerations in the two directions are not the same. Exceptions in this regard were the F-84F, the F4D, and the F7U-3 for which the decreasing responses were about as rapid as the increasing. For the latter two airplanes the responses for increasing thrusts were so rapid as to leave little room for increase in rate for the decreasing thrust changes.

Several of the engines exhibited unusual variations from the general pattern of response that bear mentioning although they were in no case important enough to prompt pilots' comments. The initial abrupt thrust increases shown for the F9F-6 and F-86F, the overshoot in thrust for the F-86F and FJ-3, and the initial dip in thrust for the F-94C when stepping from the lower thrust levels would be included in this category.

Engine time constants at high thrust levels.- Figure 11 shows the variations of the effective time constant of the engines with the amplitude of the thrust changes for those engines for which significant data were available. The effective time constant is defined here as the time

interval from the initial throttle movement to the development of 63 percent of the final steady-state thrust, which is roughly equivalent to the time constant for a first-order response. It is possibly stretching a point to assign a first-order time constant to some of the responses, but it is done here as a matter of convenience.

The data of figure 11 show reasonably consistent variations in the form plotted and straight-line fairings would appear to be acceptable approximations to the data. It is of interest in this regard to note that attempts to plot the time constant against the mean rpm of the step, as was done in reference 6, led to much more scatter of the data. In contrast with the results of reference 7 which showed a decrease in time constant with increasing amplitude, the present results show no change or an increasing time constant with increasing amplitudes of thrust. Both of the above differences are probably attributable to the effects of the fuel regulators which were not included in the tests of references 6 and 7.

As already noted the time constants for decreasing thrusts were usually less than those for increasing thrusts.

In general it appears from these results that the assumption of a linear variation of first-order time constant with amplitude of thrust change would be a reasonable one to use for most simulator studies involving pilot operation of the airplane.

Engine thrust responses at low thrust levels. - For one of the test airplanes, the F-86A, engine responses were documented over a much wider range of thrust levels. Figure 12 shows the time required for the engine to develop maximum thrust as a function of initial rpm, the time for first crossing of the final steady-state value being used in cases of overshoot. (This time interval, it will be noted, differs from the effective time constant used in preceding figures; the thrust variations with time are so completely different from a first-order response for the lower rpm levels that a first-order response approximation would be unreasonable.)

The results show that for the lower values of initial rpm, the times required to attain maximum thrust are very long. Furthermore, the required times are much greater than could be predicted from an extrapolation of a linear variation of time constant with thrust amplitude. This indicates a limitation in the range of applicability of linear time-constant variations which should be considered in their use. Unpublished data for other engines of the same vintage confirm the trends shown in figure 12.

Further confirmation that linear variations of time constant with thrust amplitude may not be applicable at low thrust levels is given by the data of figure 13. These data, which show time histories of thrust response for a series of small amplitude throttle steps, indicate that even for thrust levels as high as 70-percent rpm there is a perceptible increase in time constant over the value for higher rpm.

Airplane Responses

A-162

The responses of the various test airplanes to abrupt throttle steps are indicated by the time histories of normal and longitudinal acceleration in figures 3 to 10, and these are summarized in figure 14. The data presented in these figures were obtained with the longitudinal control held fixed except for the large-amplitude runs shown for the FJ-3 airplane, and to a lesser degree the F9F-6 airplane. In the latter two cases the longitudinal control was eased forward as the maneuver progressed, so that the recorded normal accelerations are less than would have been obtained in a control-fixed maneuver. Also, for the F-86F airplane with blowing flap boundary-layer control, large trim changes result from changes in boundary-layer control air flow;¹ the longitudinal control was moved to minimize such trim changes so that the recorded accelerations are not the result of only throttle movements for this configuration. As will become apparent in subsequent discussion these discrepancies will not alter the qualitative conclusions to be drawn from the results. The responses in figure 14 are of interest as an indication of the ease with which the flight-path angle may be controlled when the throttle is used as the primary control. It should be obvious that the added energy resulting from a thrust increase may appear as an increase in velocity ($-A_x$) or as an increase in flight-path angles ($\dot{\gamma}$ or A_z/V). The distribution of energy between the two motions depends on the pitching-moment change due to throttle motion and the longitudinal stability of the airplane.

The data of figure 14 show some variations in the distribution of response (A_x versus A_z) among the different airplanes. The large rapid response in A_z and the average response in A_x observed for the F-86F airplane (with a blowing-flap boundary-layer control installation) were considered good for carrier-type approaches. The responses for the F-94C on the other hand showed the greatest delay in developing A_z of any of the airplanes. This characteristic may have some bearing on the reputation of the F-94C of being difficult to stabilize in speed in the approach. The other airplanes, which had characteristics somewhat intermediate between those of the two cited, were regarded as neither outstandingly favorable nor unfavorable.

Another characteristic of the responses which would influence the pilot opinion may be described as the stability of the response. The values of A_z for most of the airplanes tended to become constant after about 2 seconds. However, the A_z response of the F9F-6 increased continuously for about 4 seconds for the large amplitude steps shown. This was considered by the pilots to be an undesirable characteristic. This behavior may be due to the length of the period of the short-period longitudinal oscillation which was about 6 seconds. The effect of a

¹Even though the air for the boundary-layer control is extracted from the engine compressor, it would not be expected that this would influence the engine dynamic response characteristics significantly.

pitching-moment change due to throttle application would be expected to persist for a longer time on an airplane having a longer natural period. The degree to which the pilot reduced this effect by easing the stick forward, as noted previously, has not been determined; it may be inferred from the fact that the pilot applied a correction, however, that he regarded the response as excessive. Possibly the existence of a pitch-up tendency at higher angles of attack, may have influenced the pilot in his decision to check the motion.

A similar delay in reaching a steady-state value occurred with the FJ-3 airplane, but was preceded, in this case, by a short pause of 2 seconds. The period of this airplane is also approximately 6 seconds at low speeds and a pitch-up occurs at higher angles of attack. The lack of unfavorable comments by the pilots in this case may be due to the pronounced favorable longitudinal acceleration effects that occur simultaneously.

As observed in references 1 and 2 the pitching-moment changes with thrust are important for carrier-type approaches where the pilot uses the throttle actively in making flight-path corrections while maintaining constant speed, and particularly while flying on the "back side" of the drag-velocity curve. Figure 15 demonstrates the throttle action during a typical carrier-type approach made on the back side of the drag-velocity curve. From the frequency of the throttle changes it is apparent that the throttle is as important as the longitudinal control for flight-path control.

Throttle response characteristics are not so important to the pilot in tactical-type approaches in which the speed is varied continuously and close control of airspeed is not necessary. In this type of approach, low levels of engine thrust are generally used, and the large engine time constants associated with these low thrust levels would discourage the use of the throttle for rapid flight-path adjustment even if the pilot were so inclined. Illustrative of the time elements that influence this situation is the fact that the time required to change the thrust of the F-86A engine by 1100 pounds would be 6 seconds from a level of 50 percent of design rpm as against only 1 second from a level of 79 percent of design rpm.

Airplane-Engine Characteristics in Relation to the Landing Approach

Thrust margin.- The margin of thrust available for flight-path-angle control is a significant factor in evaluating approach speeds. On the basis of tests of the airplanes of this study as well as several other airplanes the following pilot ratings have been assigned to different ranges of thrust margin available at the approach speed.

<u>$\Delta T/W$</u>	<u>Pilot rating</u>
> 0.28	Excellent
0.12 to 0.26	Satisfactory
< 0.10	Limiting (in terms of further reduction in approach speed)

It is of interest to observe from the data in figure 14 that the initial rates of change of T/W for the F4D and FJ-3 airplanes that were rated excellent in thrust margin are actually slower than the rates for other airplanes considered less satisfactory. This would indicate that the absolute margins of $\Delta T/W$ available are more important than the small time differences in developing T/W .

A limited study of the effects of $\Delta T/W$ margin was made on a landing-approach simulator. This study indicated that pilots began to increase their approach speed as the value of $\Delta T/W$ was reduced below about 0.2. The difference between this value of 0.2 and the value of 0.12 indicated as a lower satisfactory limit in the preceding tabulation may be due to limitations of the simulator arrangement used. No provision was made on the simulator for the favorable trim change due to thrust such as existed for most of the airplanes included in these tests.

Wave-offs. - The results of wave-off tests conducted on four of the test airplanes from carrier-type approaches are summarized in figure 16 where a measure of rate of change of T/W , with corresponding pilot ratings, is plotted against the ratio of test speed to stalling speed. Allowing for certain discrepancies this method of presentation seems to define an approximate boundary between satisfactory and unsatisfactory rates of thrust development, which varies only slightly, but in the expected direction, with changing airspeed.

The results indicate that the minimum satisfactory thrust rates are below available levels for the test airplanes. To the extent that these available levels may be considered as representative, then, it appears that thrust rates currently provided are adequate for wave-off from carrier-type approaches. This conclusion should probably be further restricted to airplanes having reasonable thrust margins since all the four test airplanes had values of T/W margin greater than 0.11.

It will be noted that the level of acceptable thrust rates does not increase greatly as the speed is reduced below the minimum comfortable approach speeds which are at values of V/V_S of about 1.2. In fact,

the lower end of the test speed scale is only 7 percent above the stalling speed. From this it would seem reasonable to assume then that wave-off considerations have no significant effect in defining approach speeds in carrier-type approaches. Whether such a conclusion can be drawn with regard to lower power tactical-type approaches is open to question.

Simulator studies. - Limited simulator studies were made of the effect of engine time constant on carrier approach speeds. It was found that reaction of the engine time constant from actual values to a value of zero had no significant effect on the approach speed. This lack of effect was attributed to the small amplitudes of the throttle steps customarily used (fig. 15). For such small amplitudes, as has already been noted, the time constants of the engine at carrier approach rpm would be quite small.

These results cannot be regarded as definitive, particularly when, as was pointed out in an earlier section of this report, other pertinent parameters, such as pitching moment due to thrust, were not accurately included in the simulation. However, they do tend to confirm the view deduced from flight studies that engine time constants currently available in carrier-type approaches are not large enough to affect approach speeds adversely.

CONCLUSIONS

The dynamic responses of the airplane and the engine to abrupt changes in throttle position were investigated in flight for a number of jet-propelled fighter-type airplanes. The tests were not comprehensive enough to define a minimum acceptable response rate of the engine for the landing approach. However, for the operating range above about 80-percent engine design rpm to which most of the tests were confined, certain conclusions could be reached as follows:

1. For throttle steps of small amplitude the engine dynamic thrust responses were generally representable by first-order dynamic responses, the time constant of which increases linearly with magnitude of thrust change.

2. For larger size throttle steps the thrust variations for some engines departed significantly from that corresponding to a first-order response. This would probably not be a serious factor in approximating engine response characteristics for landing-approach simulations, but might be important for other applications.

3. In carrier-type landing approaches the throttle movements customarily used for control are in the form of small steps for which the first-order approximation would probably be valid and the effective engine time constants small.

4. For the large throttle steps used in wave-offs from carrier-approach thrust levels the dynamic responses of the engines tested were rapid enough that engine time constants in the wave-off did not limit approach speed.

5. Responses of the various test airplanes to throttle steps were different in the degree to which vertical accelerations developed as a result of trim changes due to thrust.

Ames Research Center
National Aeronautics and Space Administration
Moffett Field, Calif., Apr. 30, 1959

REFERENCES

1. Drinkwater, Fred J., III, Cooper, George E., and White, Maurice D.: An Evaluation of the Factors Which Influence the Selection of Landing Approach Speeds. Paper presented to Flight Test Panel of AGARD, Oct. 20-24, 1958.
2. Anderson, Seth B., Cooper, George E., and Faye, Alan E., Jr.: Flight Measurements of the Effect of a Controllable Thrust Reverser on the Flight Characteristics of a Single-Engine Jet Airplane. NASA MEMO 4-26-59A, 1959.
3. Rells, L. Stewart, Havill, C. Dewey, and Holden, George R.: Techniques for Determining Thrust in Flight for Airplanes Equipped With Afterburners. NACA RM A52K12, 1953.
4. Huston, Wilber B.: Accuracy of Airspeed Measurements and Flight Calibration Procedures. NACA Rep. 919, 1948. (Supersedes NACA MR L6E09 and NACA TN 1605)
5. Wenzel, L. M., Hart, C. E., and Craig, R. T.: Experimental Comparison of Speed-Fuel-Flow and Speed-Area Controls on a Turbojet Engine for Small Step Disturbances. NACA TN 3926, 1957.
6. Craig, R. T., Vasu, George, and Schmidt, R. D.: Dynamic Characteristics of a Single-Spool Turbojet Engine. NACA RM E93C17, 1953.
7. Delio, Gene J.: Evaluation of Three Methods for Determining Dynamic Characteristics of a Turbojet Engine. NACA TN 2634, 1952.

TABLE I.- PHYSICAL CHARACTERISTICS OF AIRPLANES AND ENGINES

Airplane	Airplane landing weight, lb	Wing area, sq ft	Engine model and series number	Engine compressor type	Landing-approach speeds, knots	Fuel regulator, service designation
FJ-3	13,990	288	YJ65-W4	Axial	111	TJ-L2
F4D	16,870	557	J57-P8A	Axial	121	JFC12-2
F9F-6	13,440	300	J48-P8	Centrifugal	114	A7011E
F-86A	12,335	288	J47-13	Axial	-	VS 26900 G6
F-94C	14,933	233	J48-P7	Centrifugal	131	A7508
F-86F	12,900	288	J47-27	Axial	111	VS2-14250-B2
F-84F	15,635	325	YJ65-W1A	Axial	132	TJ-J2
F7U-3	21,030	535	J46-WE-8B	Axial	108	58J846-2

A-162

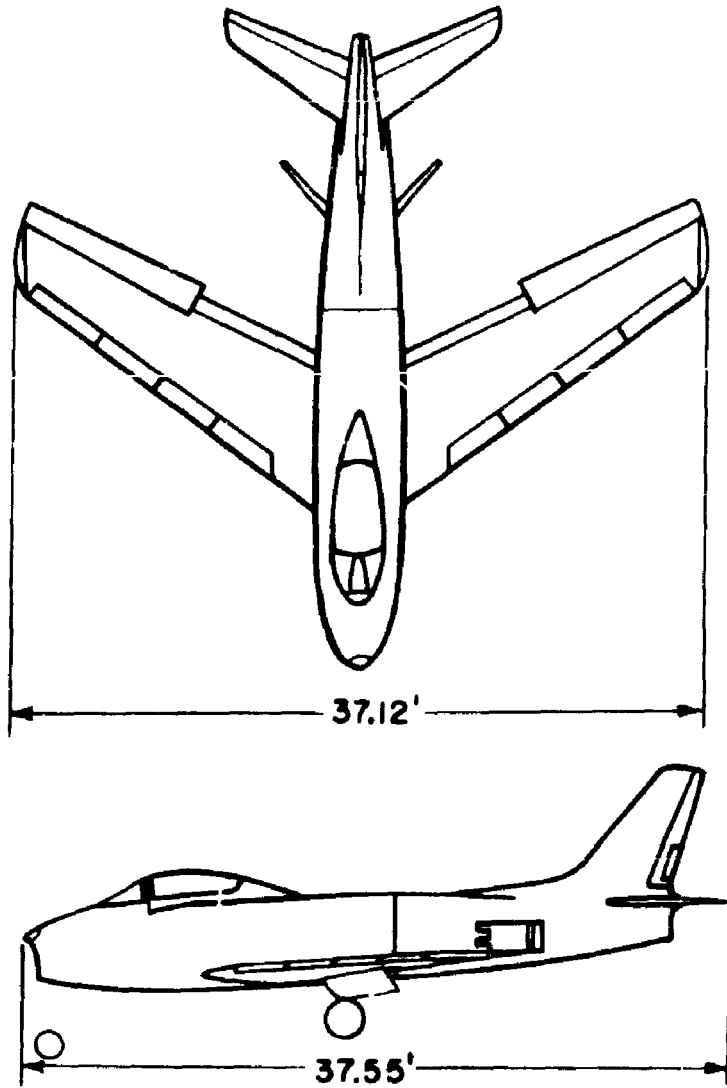

(a) FJ-3 airplane.

Figure 1.- Two-view drawing of the test airplanes.

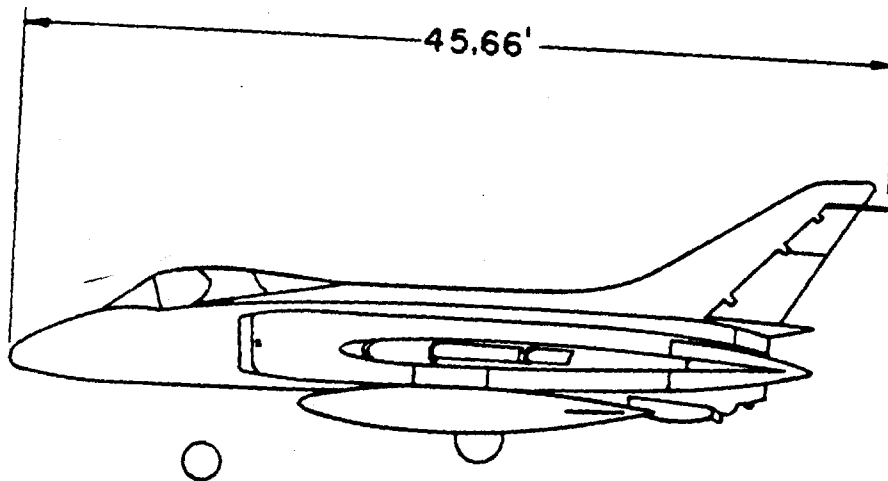
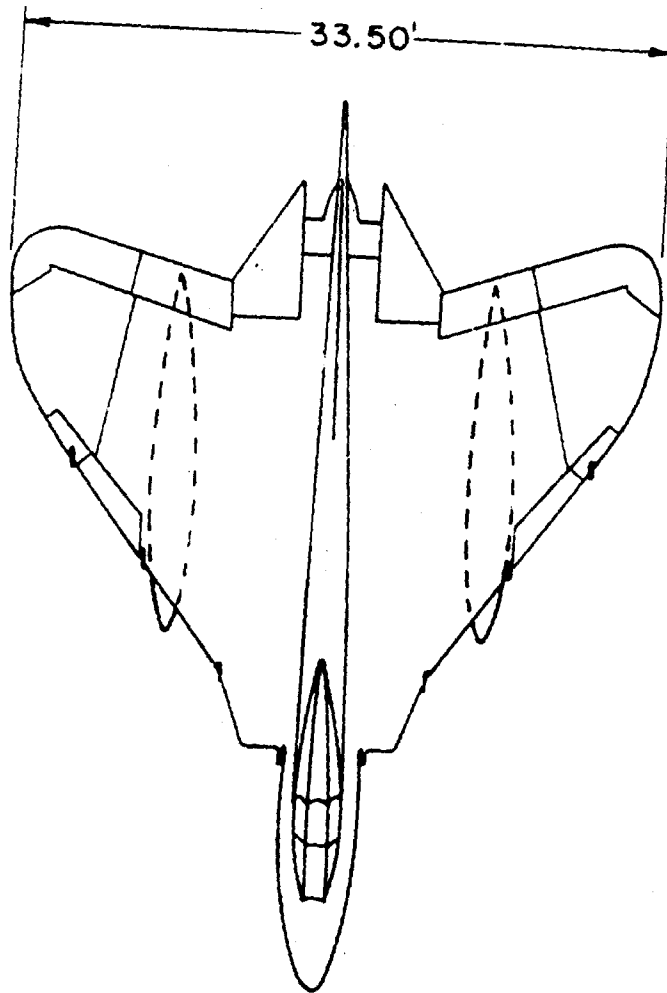

(b) F4D airplane.

Figure 1.- Continued.

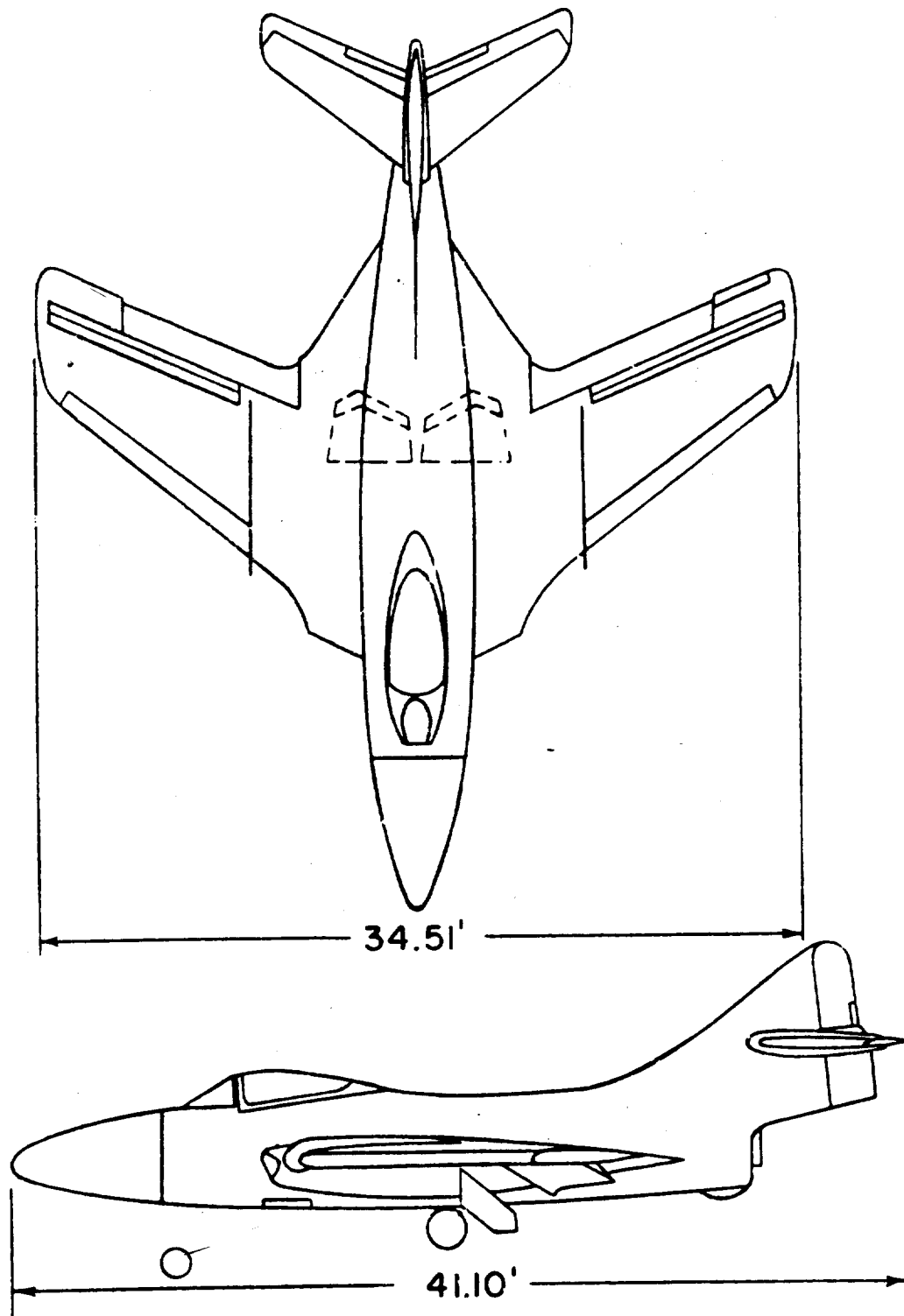

(c) F9F-6 airplane.

Figure 1.- Continued.

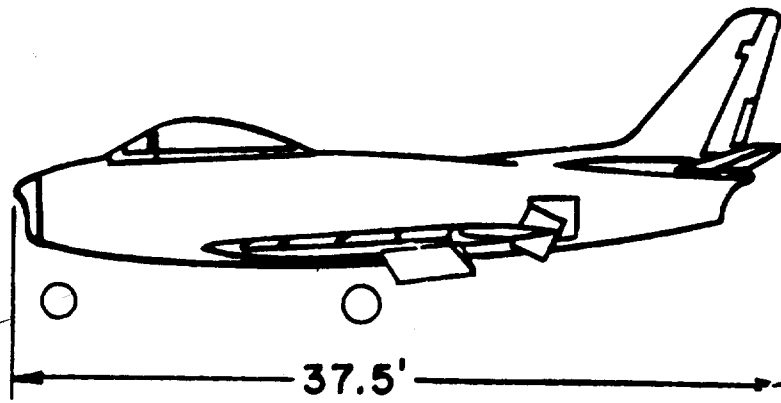
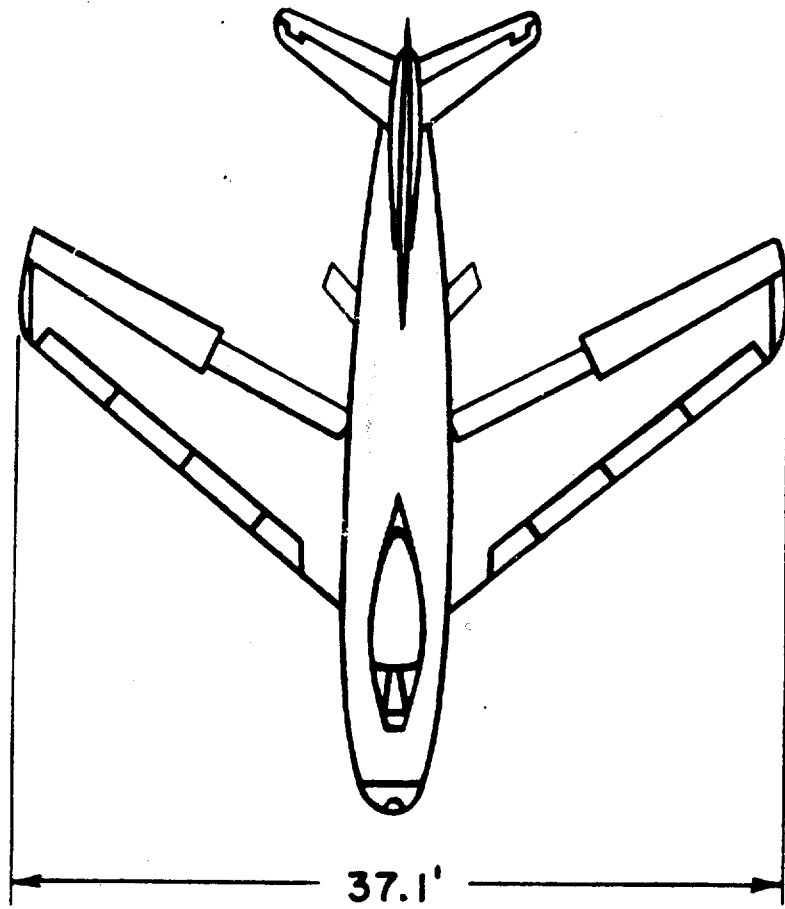

(d) F-86A and F-86F airplanes.

Figure 1.- Continued.

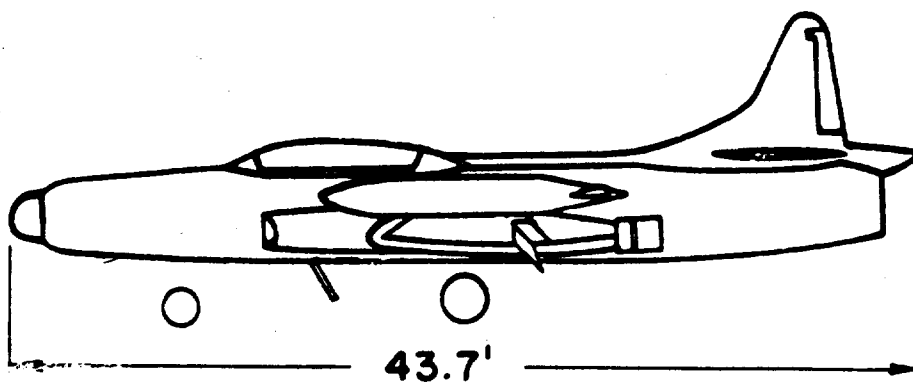
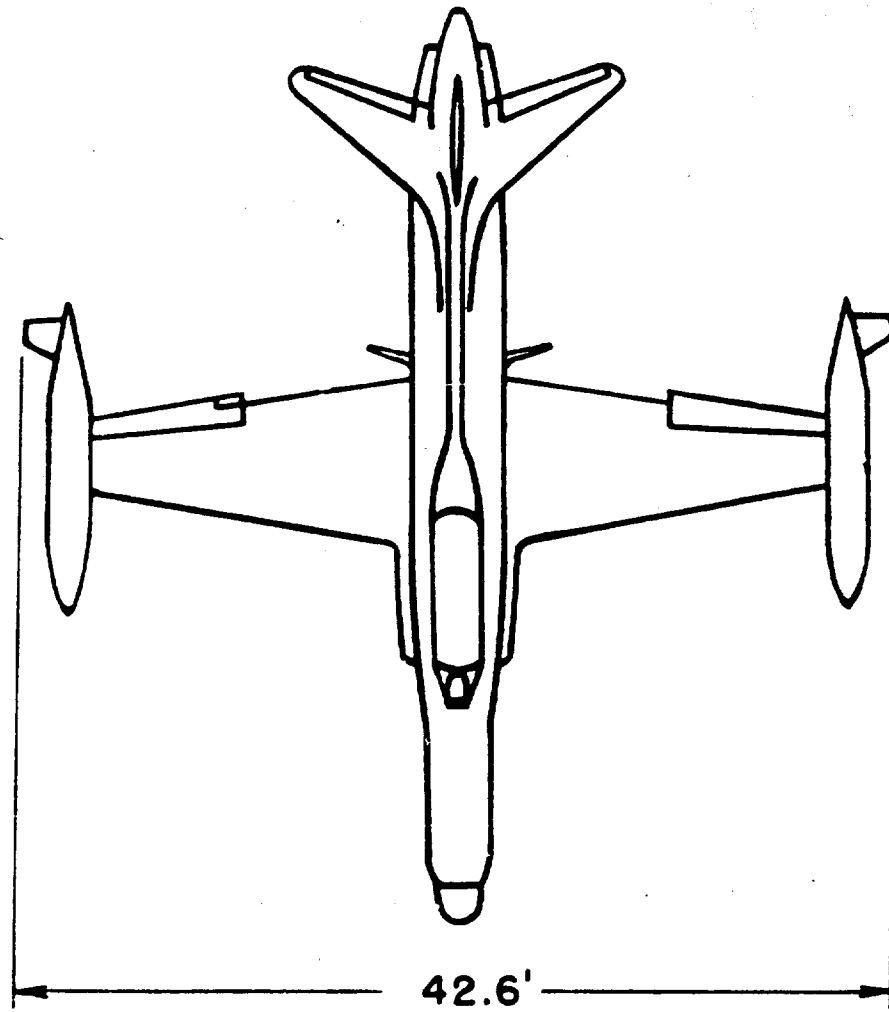

(e) F-94C airplane.

Figure 1.- Continued.

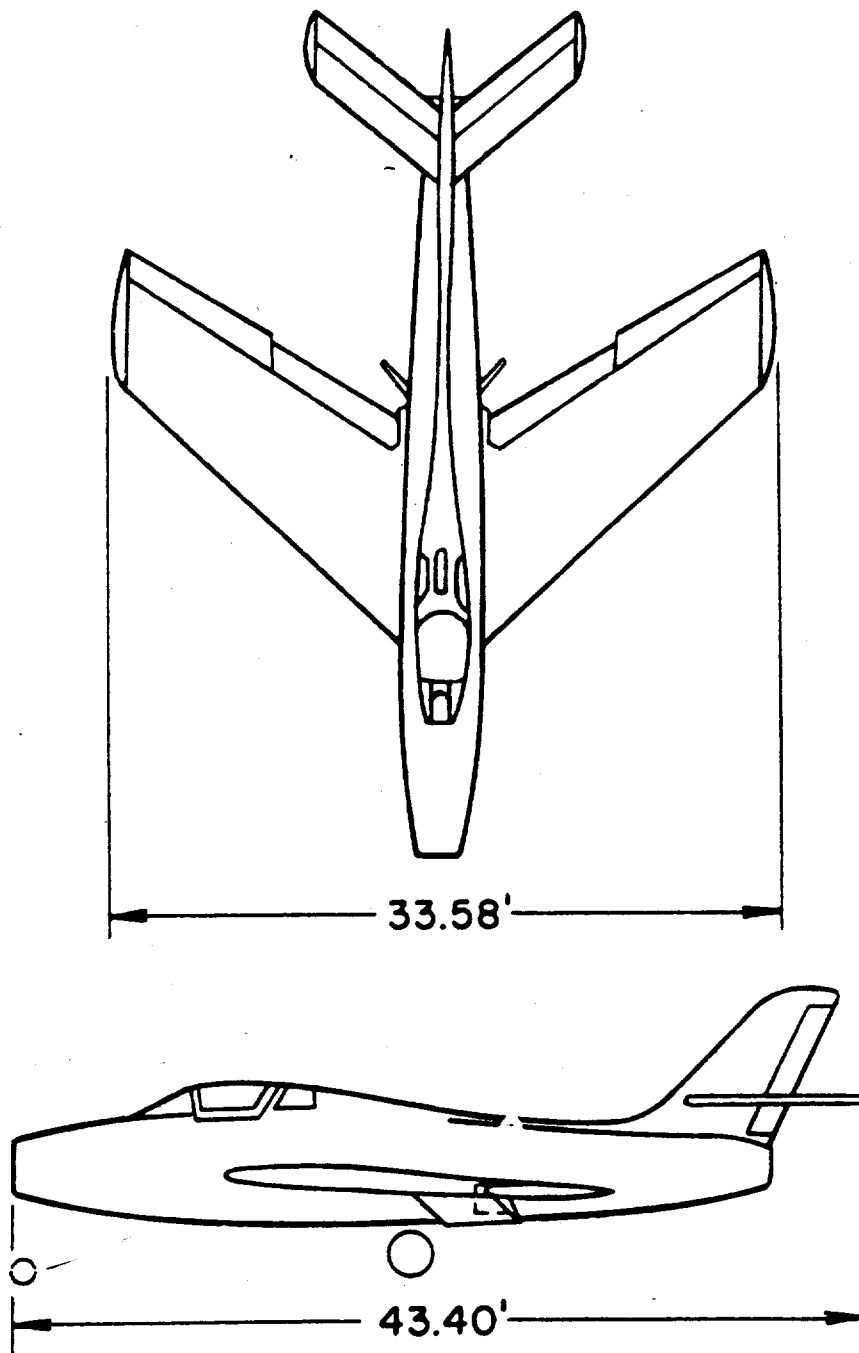

(f) F-84F airplane.

Figure 1.- Continued.

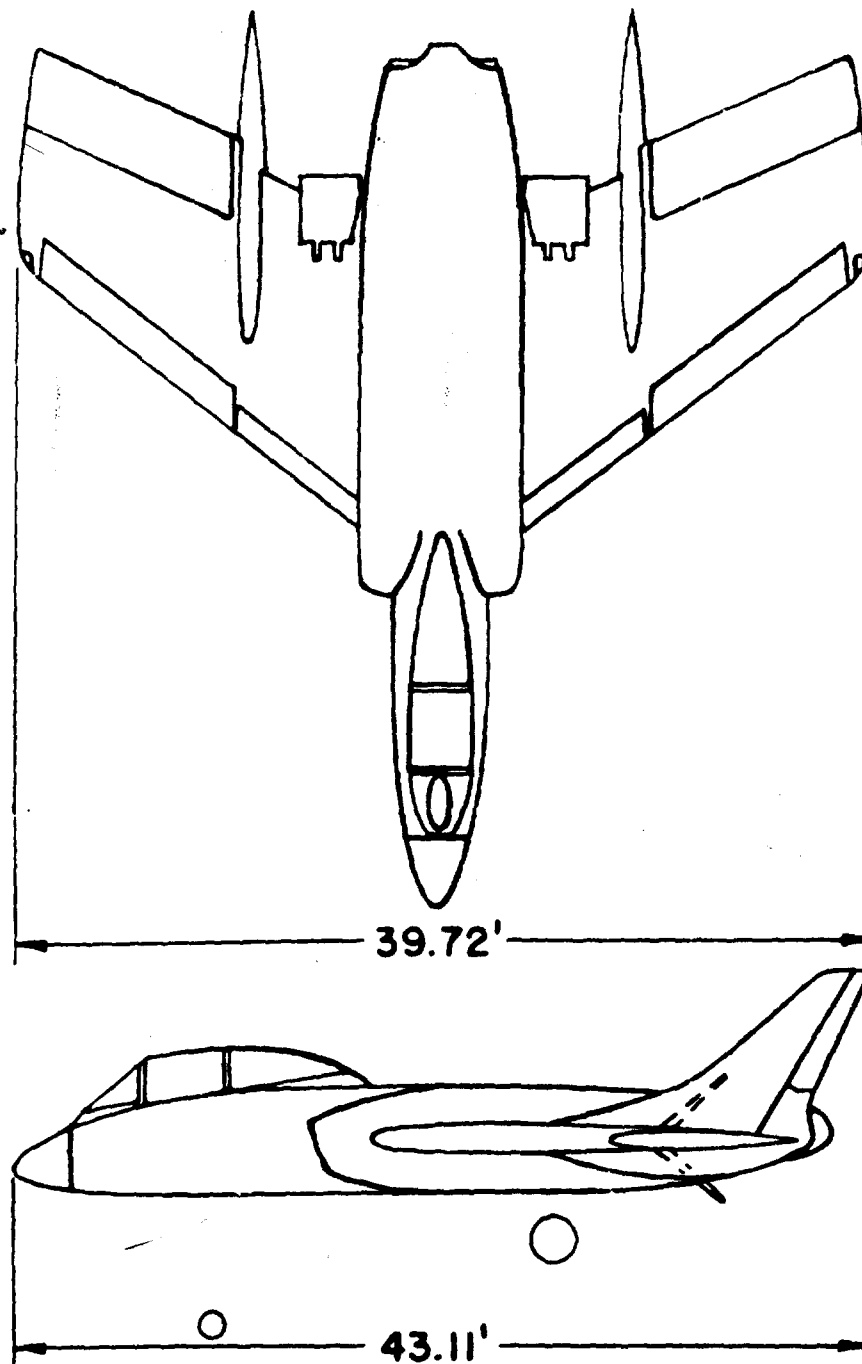

(g) F7U-3 airplane.

Figure 1.- Concluded.

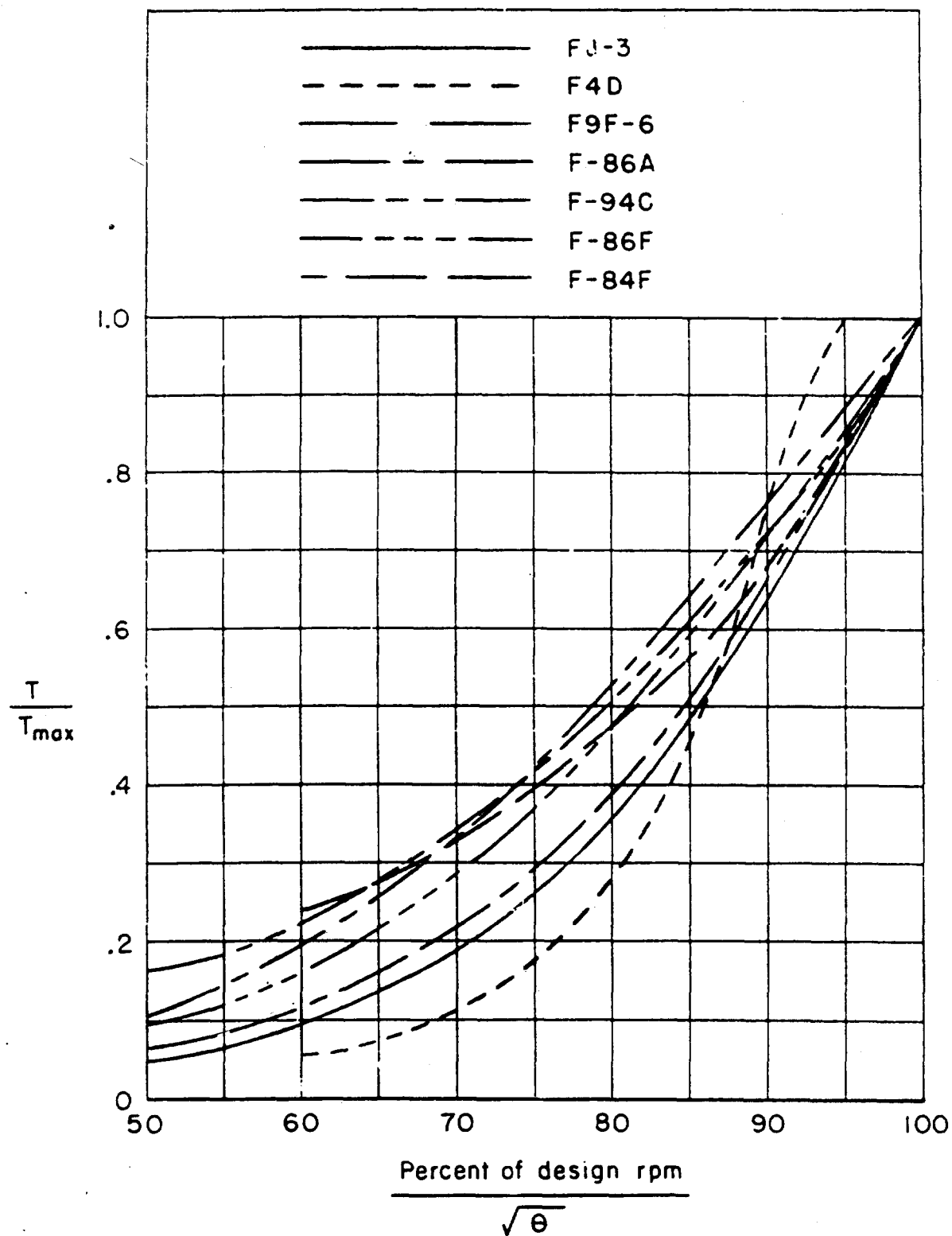

Figure 2.- Variation of installed-engine thrust with rpm for test airplanes as measured on thrust stand.

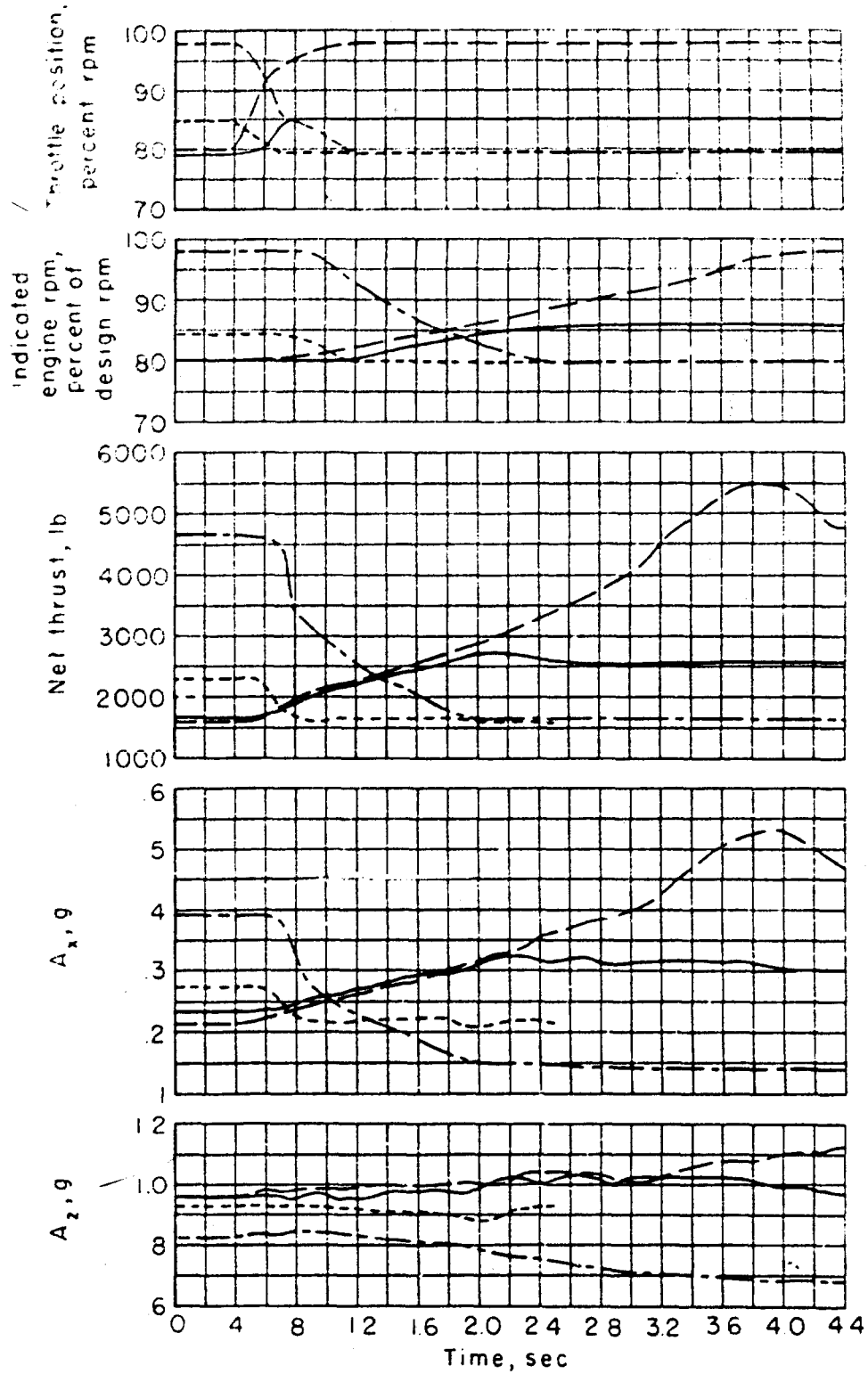

Figure 3.- Time histories of airplane and engine responses to step chrottle movements; FJ-3 airplane.

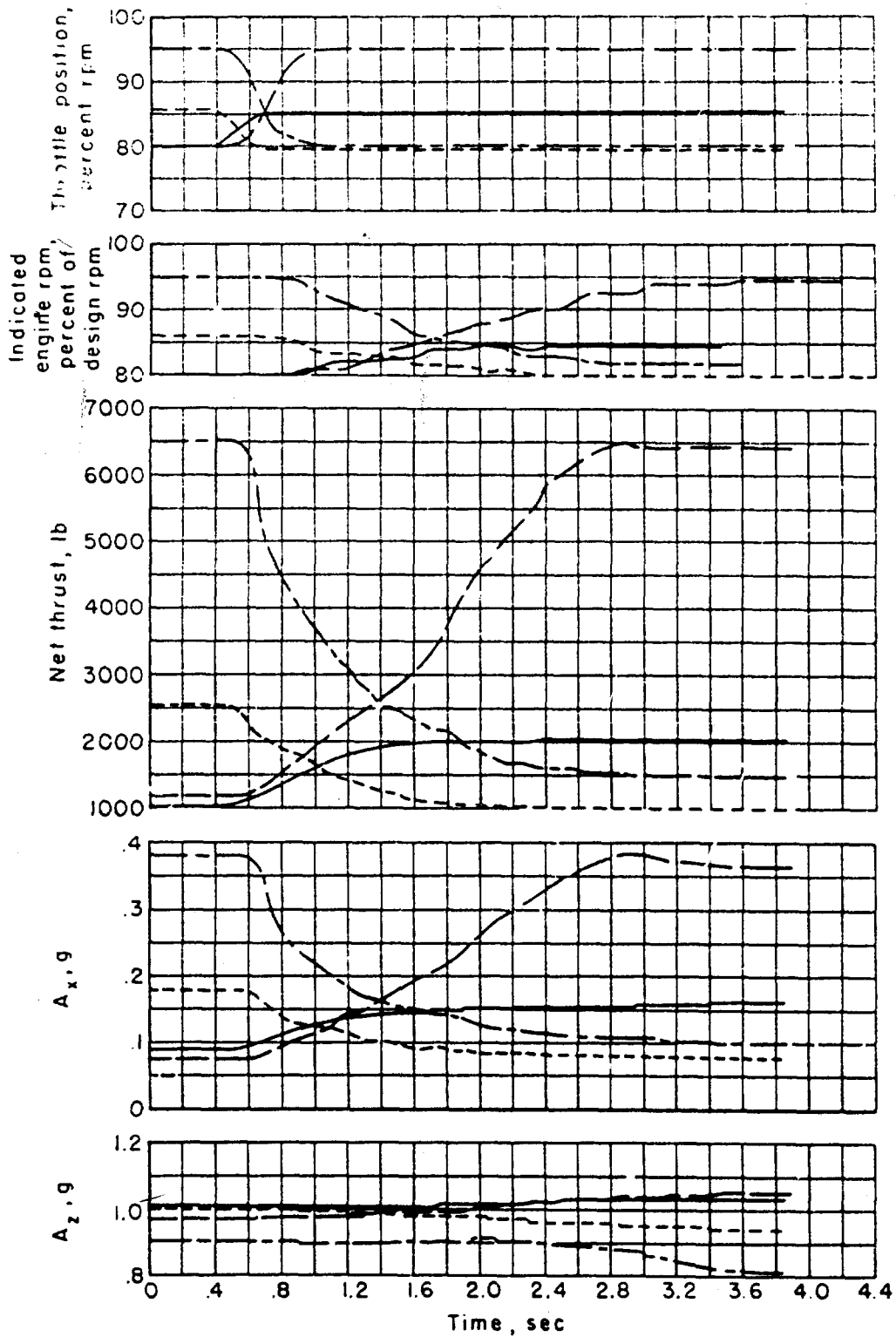

Figure 4.- Time histories of airplane and engine responses to step throttle movements; F4D airplane.

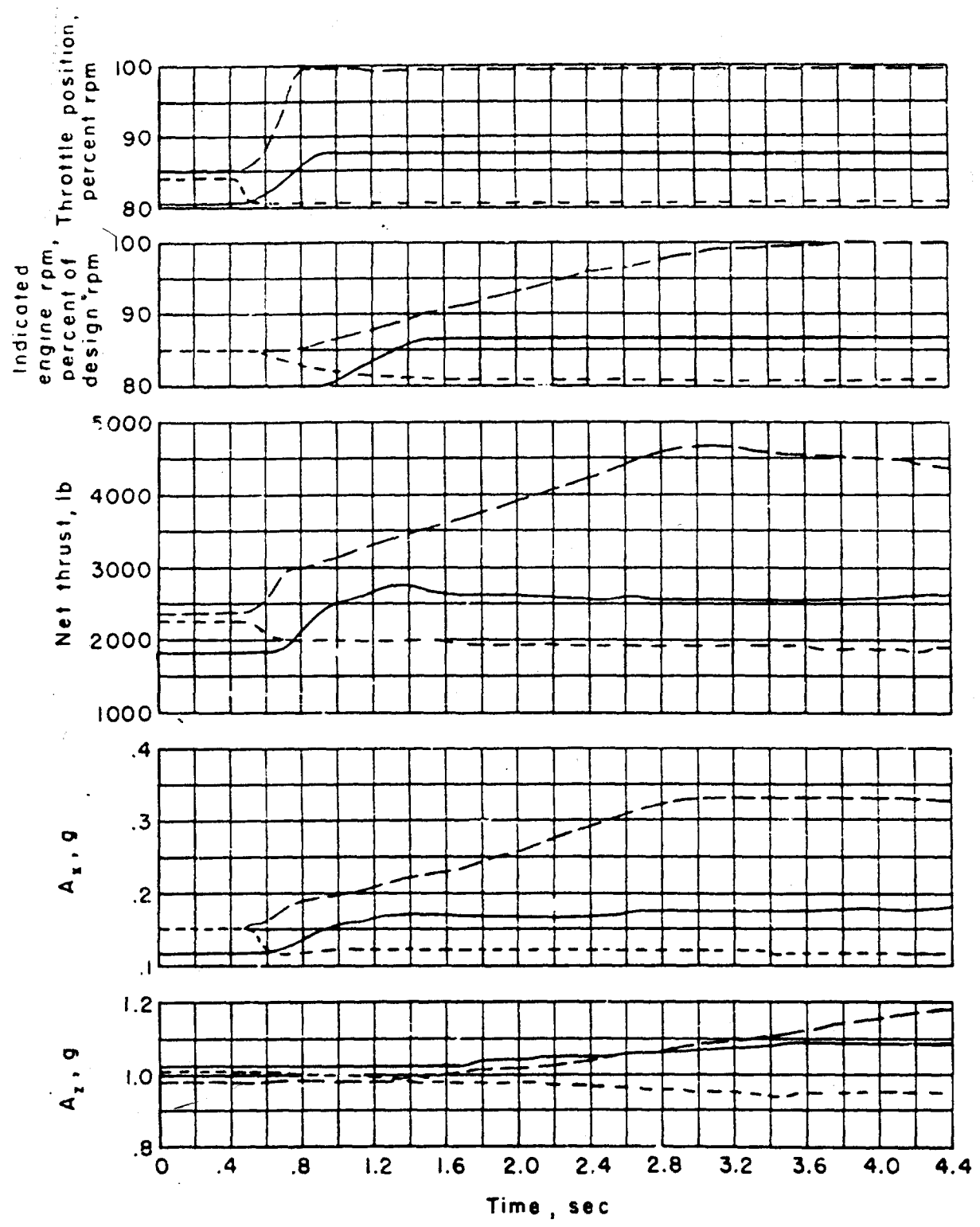

Figure 5.- Time histories of airplane and engine responses to step throttle movements; F9F-6 airplane.

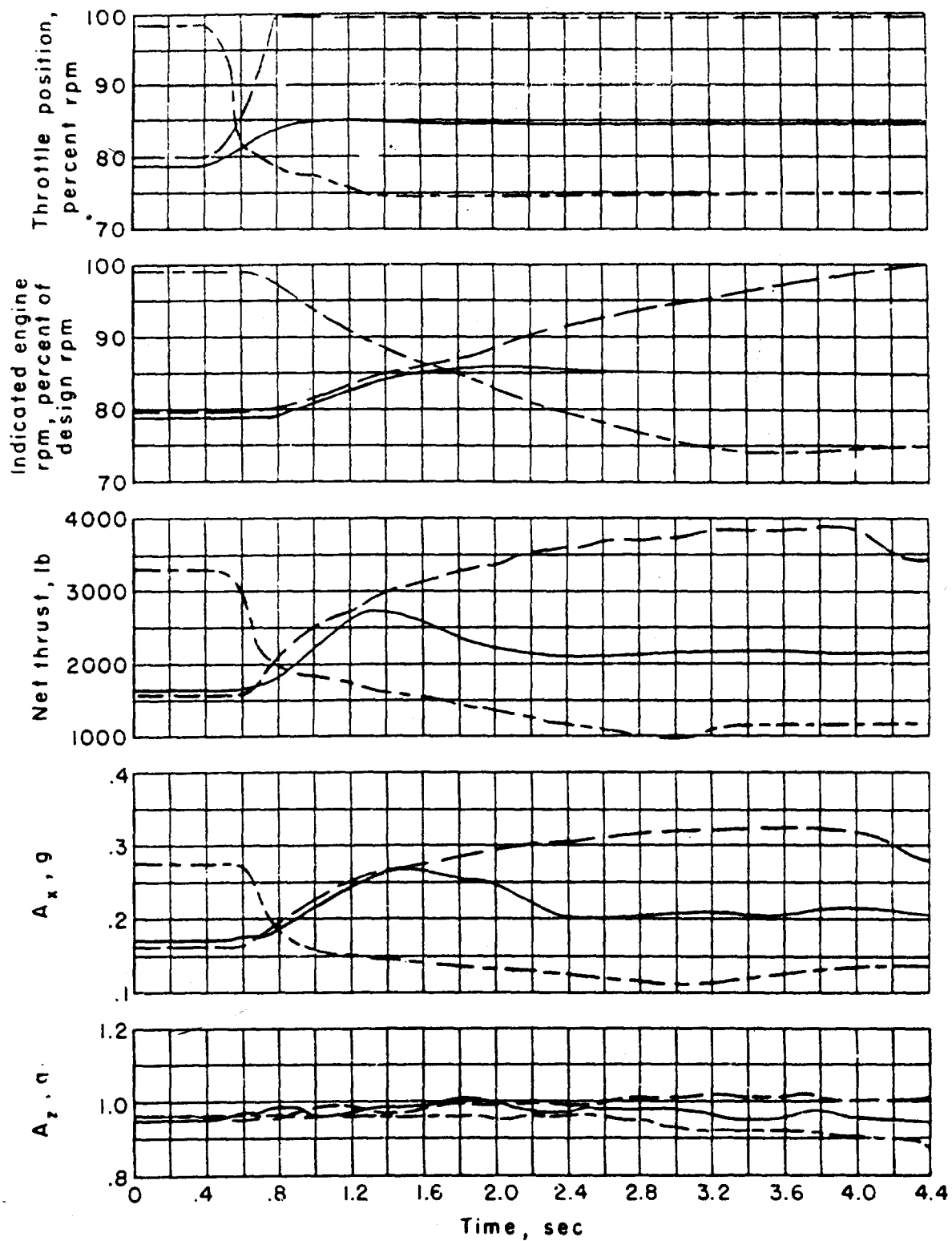

Figure 6.- Time histories of airplane and engine responses to step throttle movements; F-86A airplane.

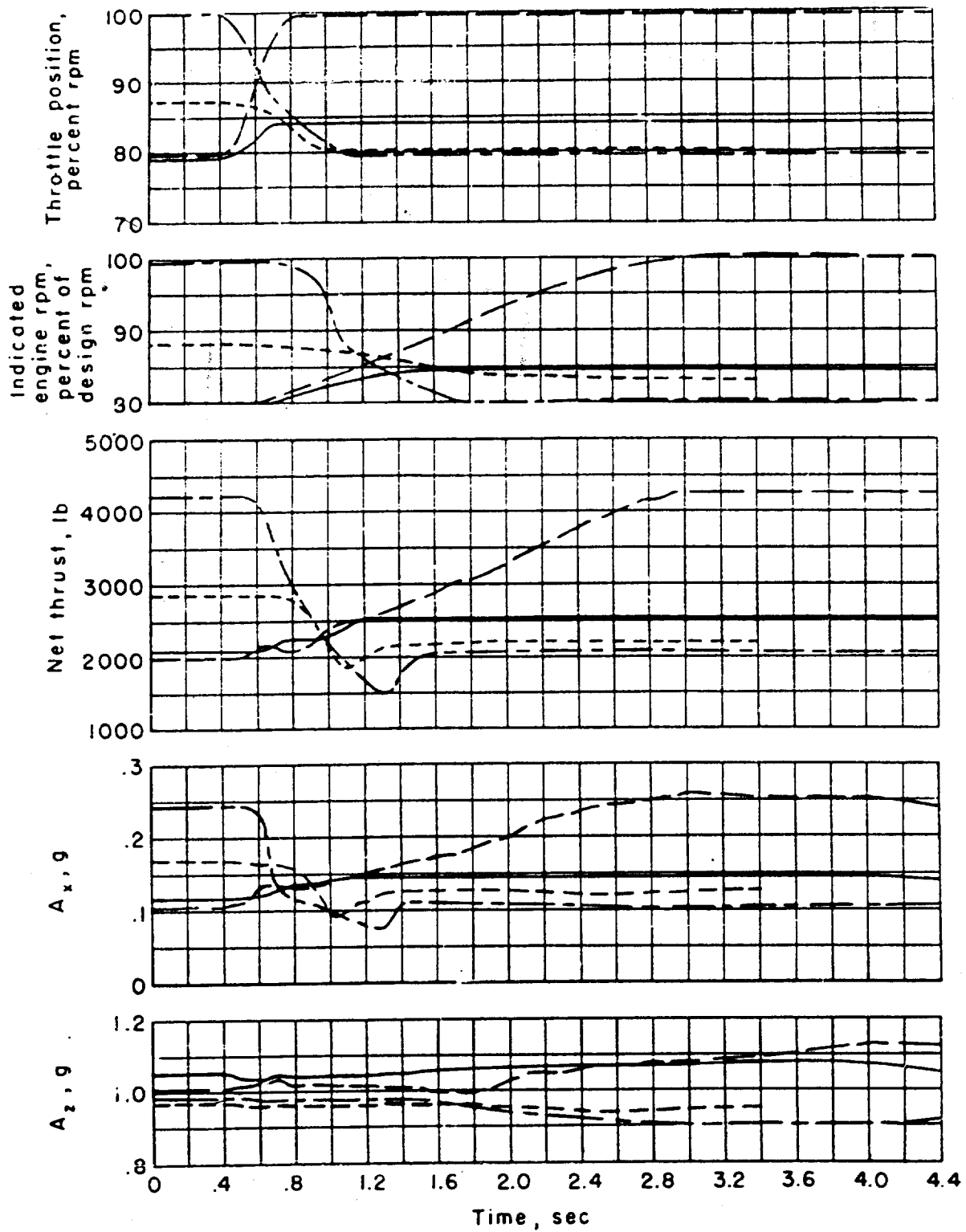

Figure 7.- Time histories of airplane and engine responses to step throttle movements; F-94C airplane.

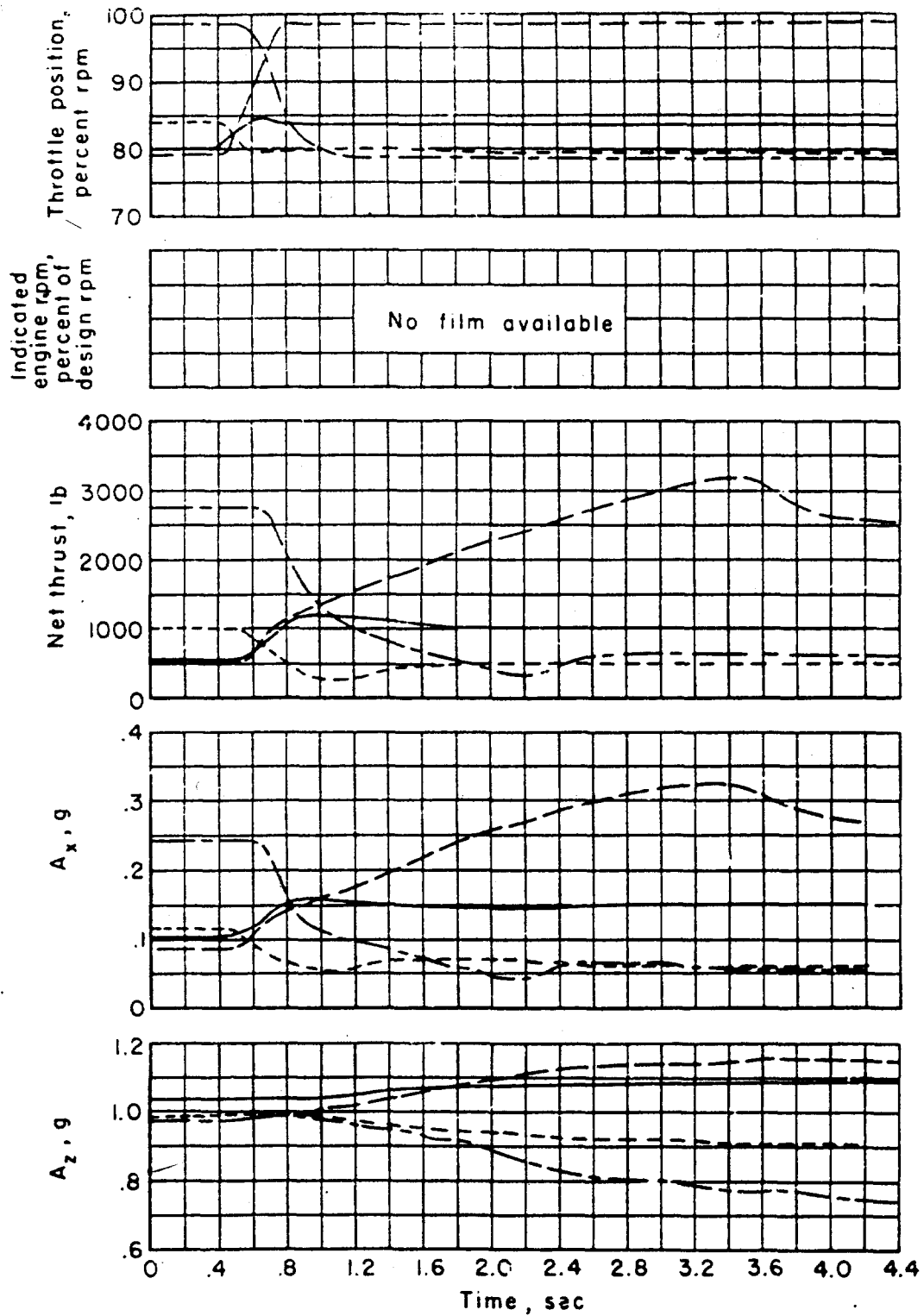

Figure 8.- Time histories of airplane and engine responses to step throttle movements; F-86F airplane with boundary-layer control; longitudinal control moved to compensate for trim changes due to boundary-layer control.

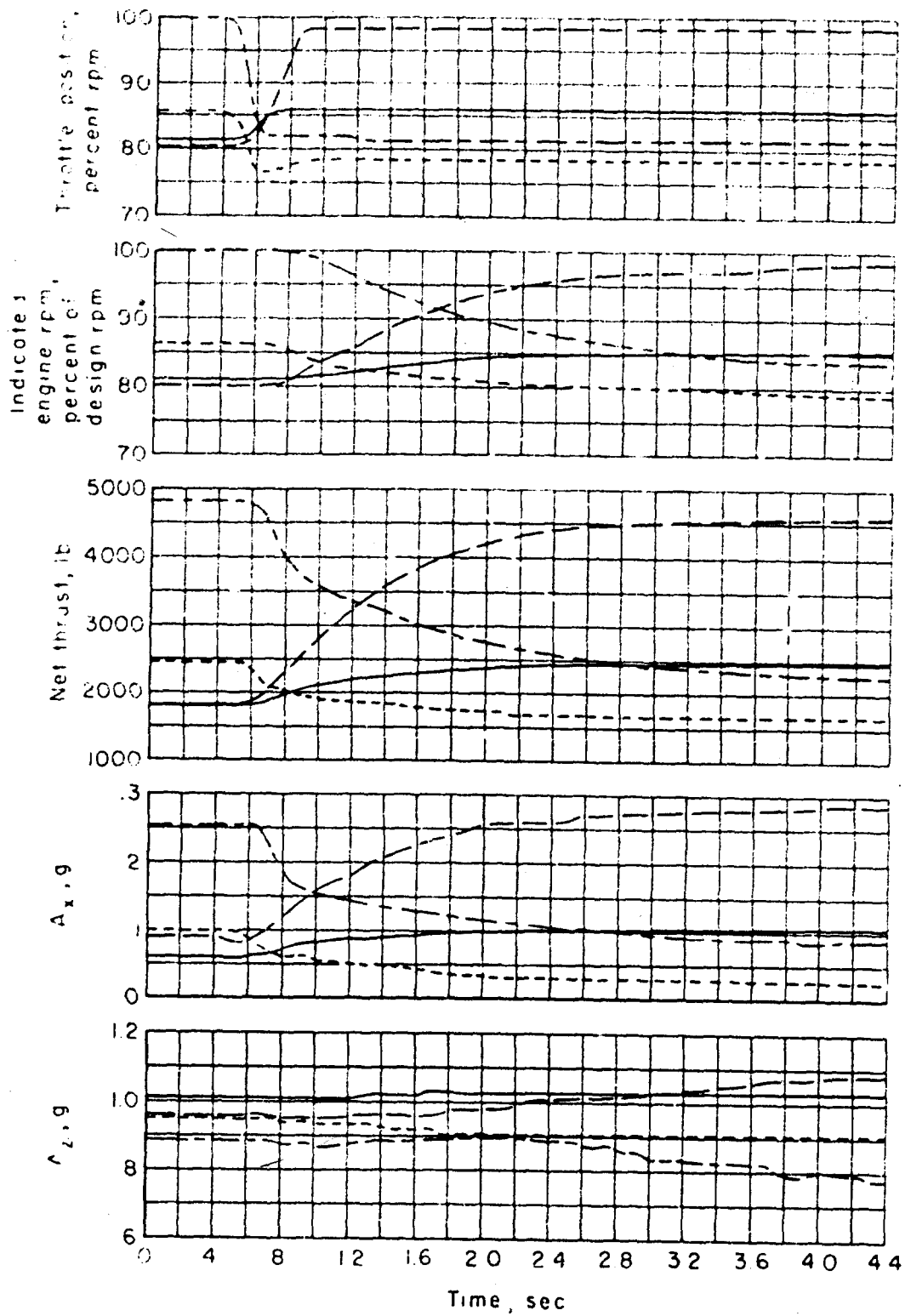

Figure 9.- Time histories of airplane and engine responses to step throttle movements; F-84F airplane.

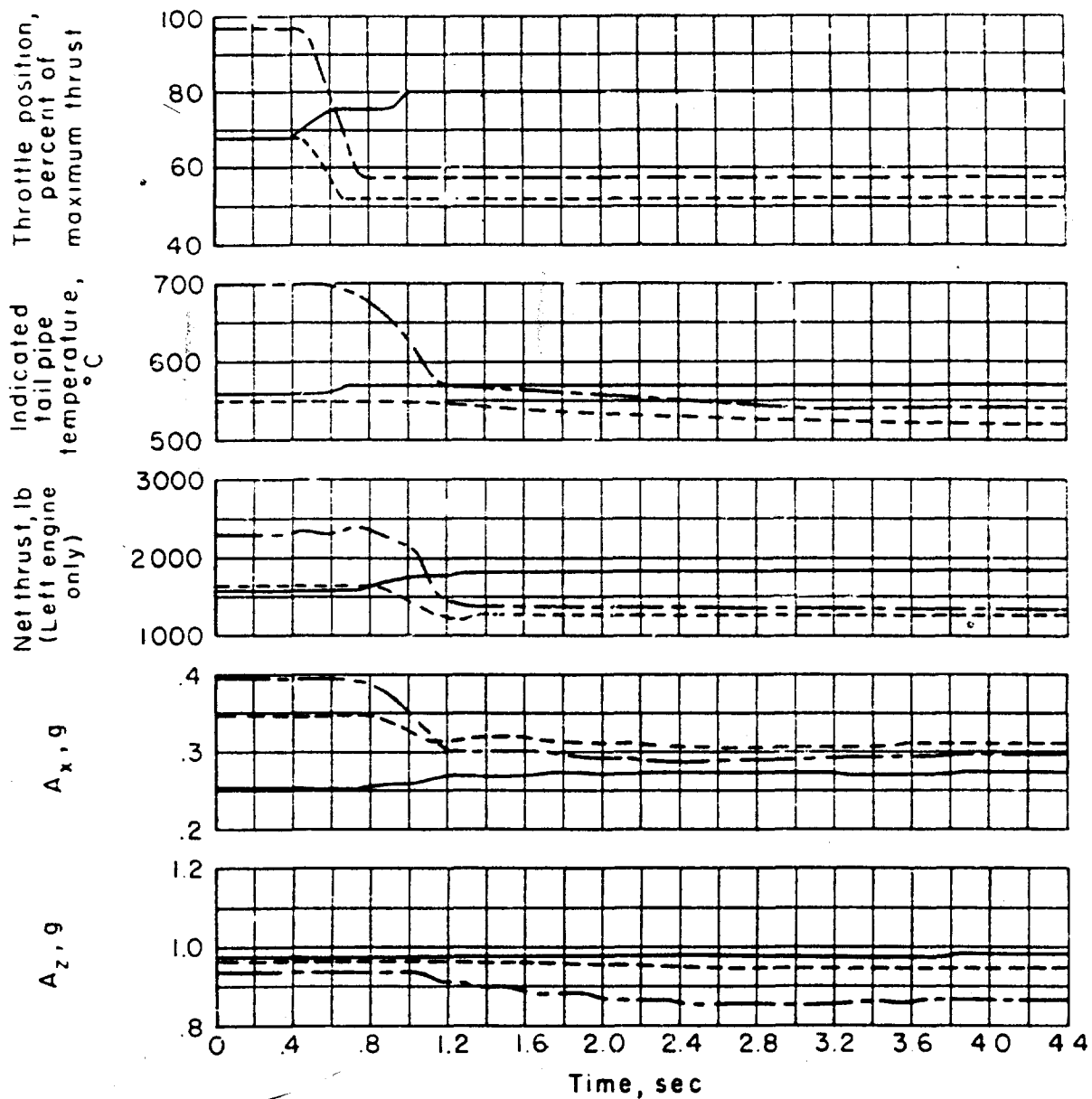

Figure 10.- Time histories of airplane and engine responses to step throttle movements; F7U-3 airplane.

A-162

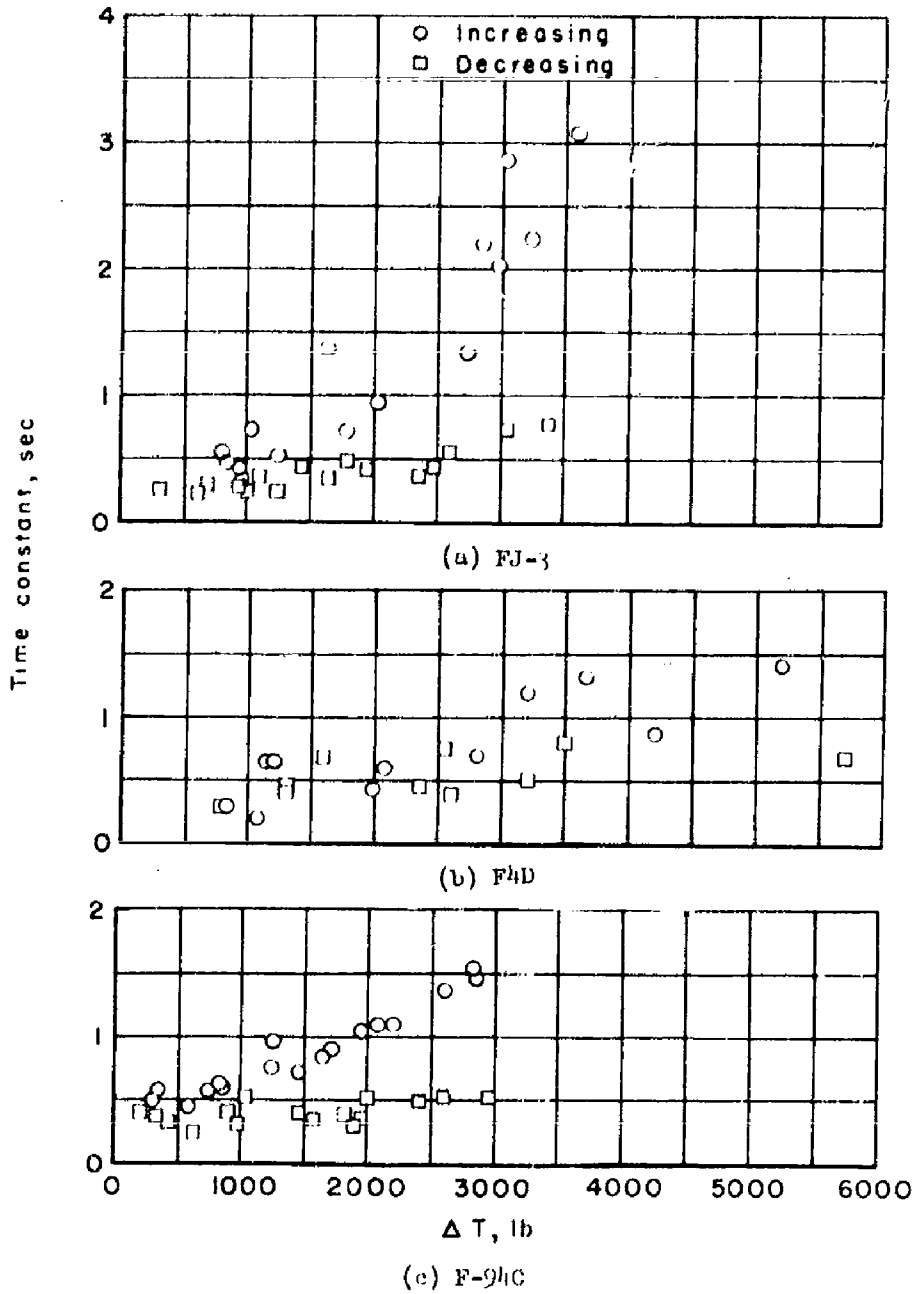
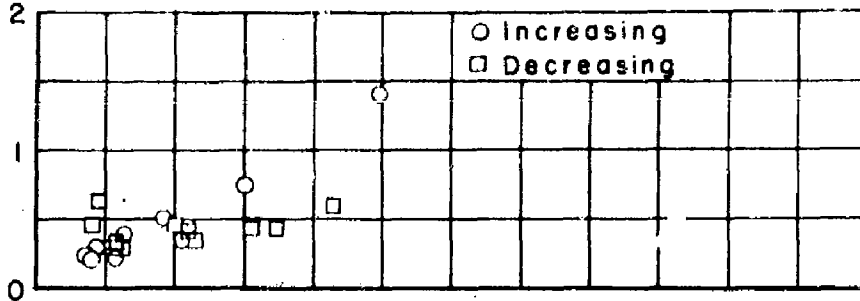
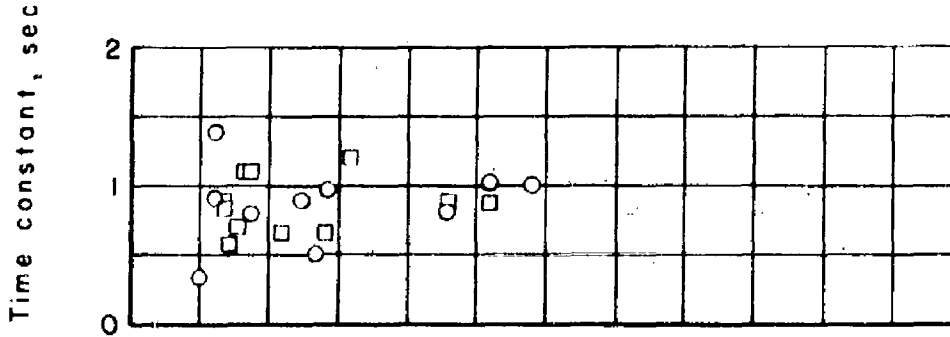

Figure 11.- Variation of time constant for thrust response with amplitude of thrust change for test configurations.



(d) F-86F



(e) F-84F

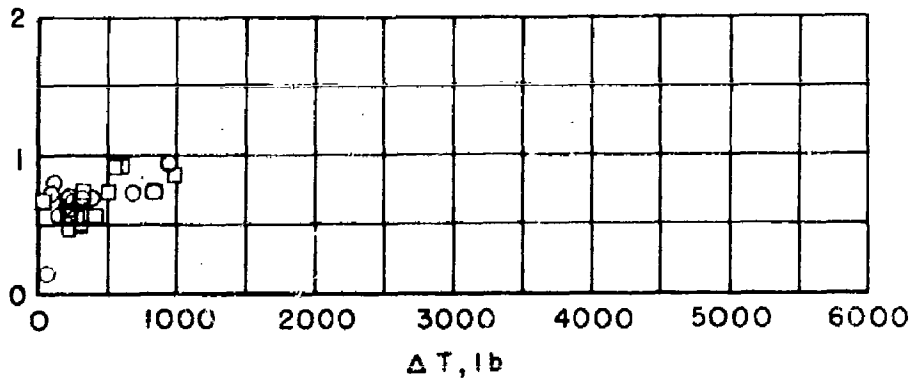

(f) F7U-3

Figure 11.- Concluded.

A-16

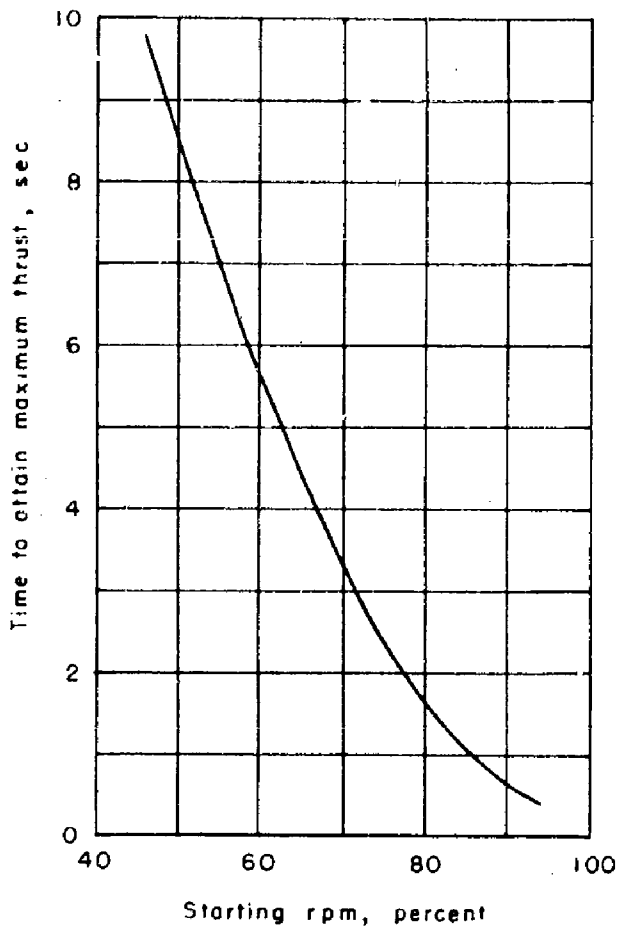

Figure 12.- Time required to attain maximum thrust after abrupt throttle steps from various levels; F-86A airplane.

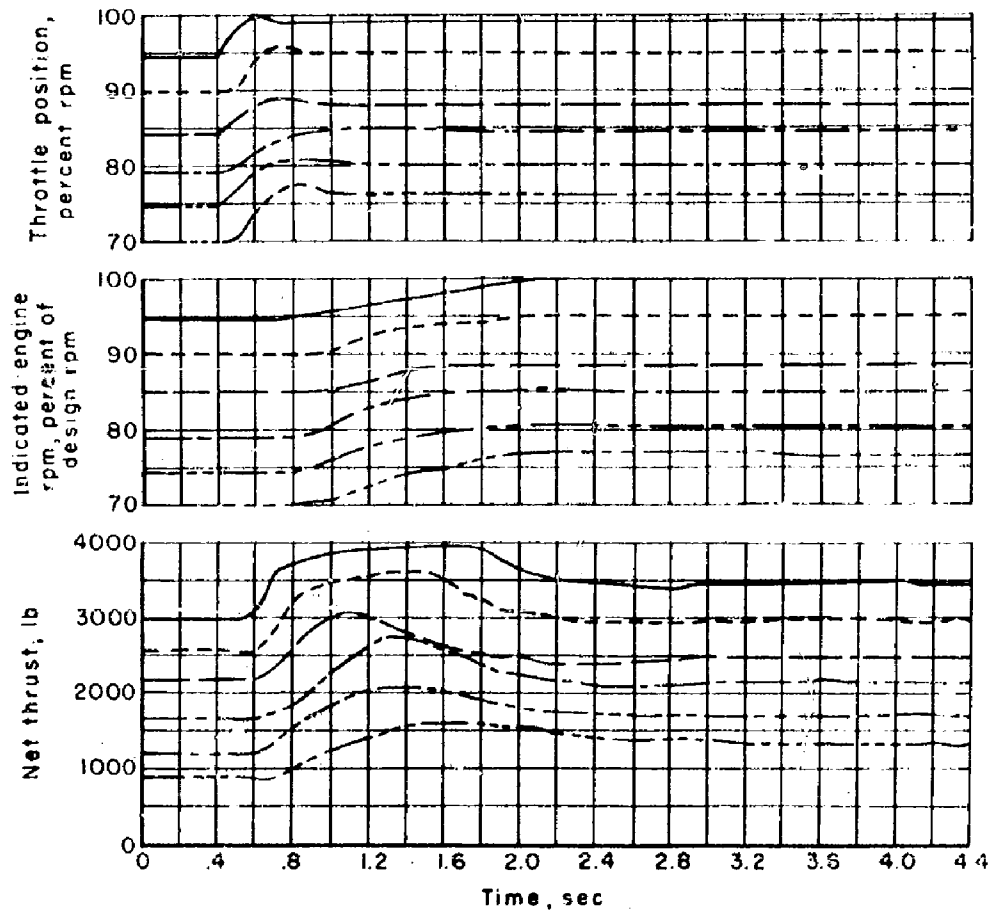

Figure 13.- Thrust responses to small-amplitude throttle steps for several ranges of rpm; F-86A airplane.

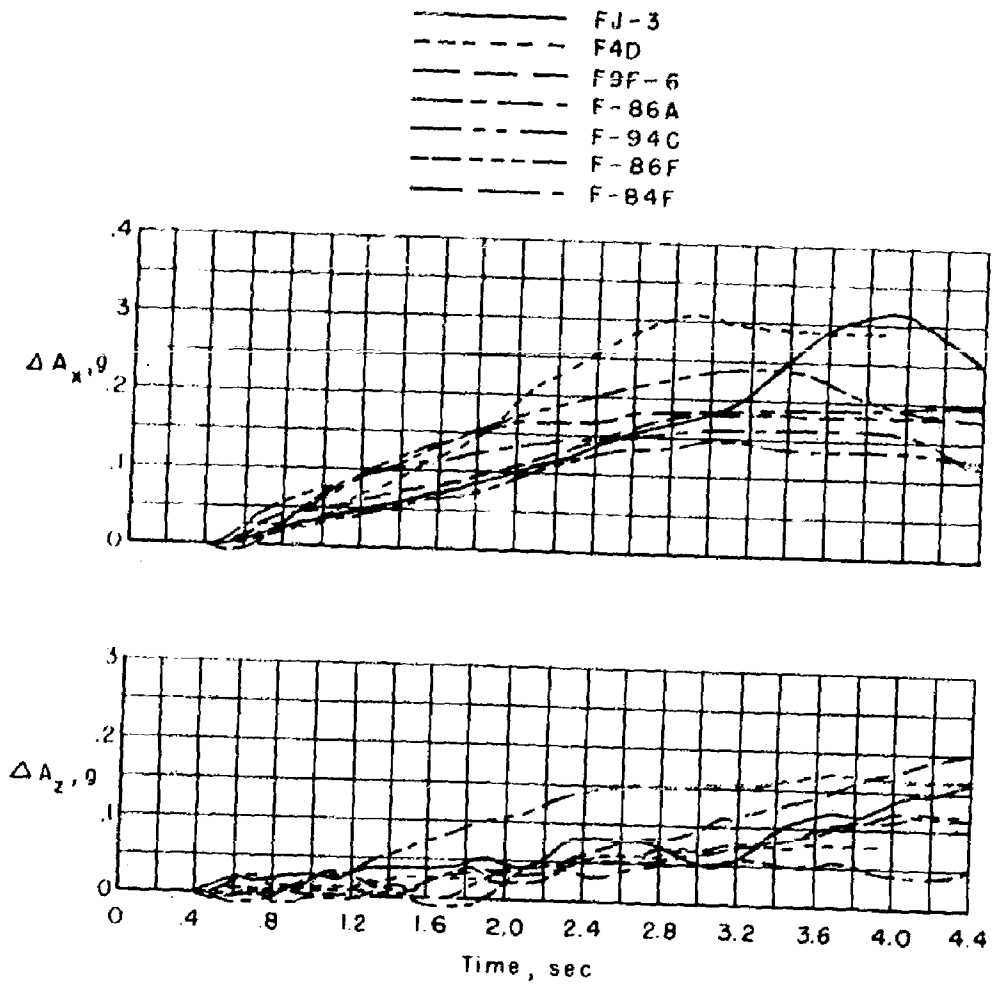

Figure 14.- Comparison of airplane responses to throttle steps for the test airplanes. Controls nominally fixed; small elevator movements apparent on F-86F, F9F-6, and FJ-3 airplanes.

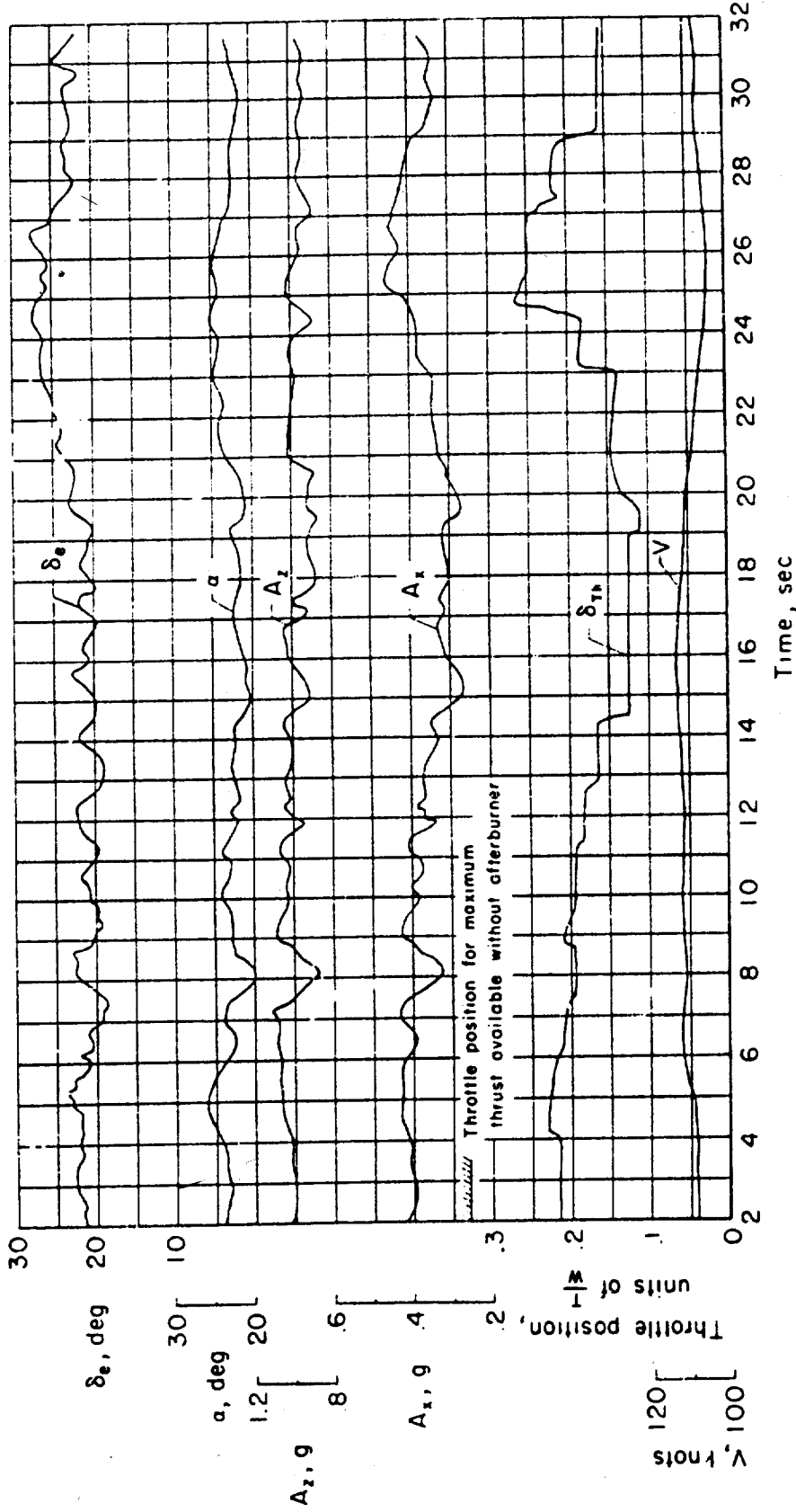

Figure 15.- Time history of typical landing approach; F7U-3 airplane.

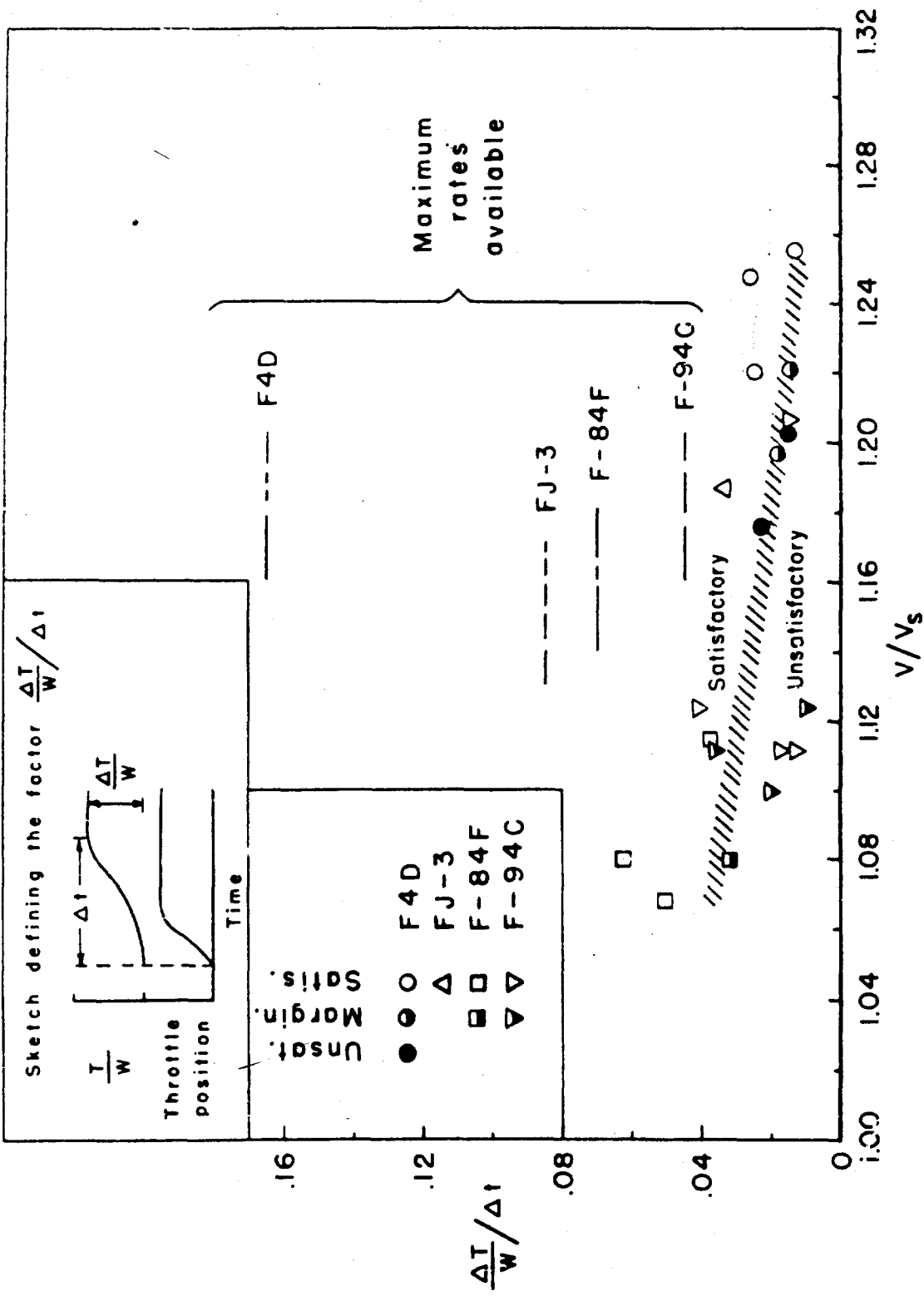

Figure 16.- Pilots' ratings of thrust rates in carrier approach wave-offs for a range of airspeeds.

UNCLASSIFIED
AD

2251780

FOR
MICRO-CARD
CONTROL ONLY

1 **OF** **1**
Reproduced by

Armed Services Technical Information Agency

ARLINGTON HALL STATION; ARLINGTON 12 VIRGINIA

UNCLASSIFIED



DEPARTMENT OF THE AIR FORCE
HEADQUARTERS AIR FORCE MATERIEL COMMAND
WRIGHT-PATTERSON AIR FORCE BASE OHIO

FEB 19 2002

MEMORANDUM FOR DTIC/OCQ (ZENA ROGERS)
8725 JOHN J. KINGMAN ROAD, SUITE 0944
FORT BELVOIR VA 22060-6218

FROM: AFMC CSO/SCOC
4225 Logistics Avenue, Room S132
Wright-Patterson AFB OH 45433-5714

SUBJECT: Technical Reports Cleared for Public Release

References: (a) HQ AFMC/PAX Memo, 26 Nov 01, Security and Policy Review,
AFMC 01-242 (Atch 1)

→ (b) HQ AFMC/PAX Memo, 19 Dec 01, Security and Policy Review,
AFMC 01-275 (Atch 2)

(c) HQ AFMC/PAX Memo, 17 Jan 02, Security and Policy Review,
AFMC 02-005 (Atch 3)

1. Technical reports submitted in the attached references listed above are cleared for public release in accordance with AFI 35-101, 26 Jul 01, *Public Affairs Policies and Procedures*, Chapter 15 (Cases AFMC 01-242, AFMC 01-275, & AFMC 02-005).

2. Please direct further questions to Lezora U. Nobles, AFMC CSO/SCOC, DSN 787-8583.

LEZORA U. NOBLES
AFMC STINFO Assistant
Directorate of Communications and Information

Attachments:

1. HQ AFMC/PAX Memo, 26 Nov 01
2. HQ AFMC/PAX Memo, 19 Dec 01
3. HQ AFMC/PAX Memo, 17 Jan 02

cc:
HQ AFMC/HO (Dr. William Elliott)



DEPARTMENT OF THE AIR FORCE

HEADQUARTERS AIR FORCE MATERIEL COMMAND
WRIGHT-PATTERSON AIR FORCE BASE OHIO

DEC 19 2001

MEMORANDUM FOR HQ AFMC/HO

FROM: HQ AFMC/PAX

SUBJECT: Security and Policy Review, AFMC 01-275

1. The reports listed in your attached letter were submitted for security and policy review IAW AFI 35-101, Chapter 15. They have been cleared for public release.
2. If you have any questions, please call me at 77828. Thanks.

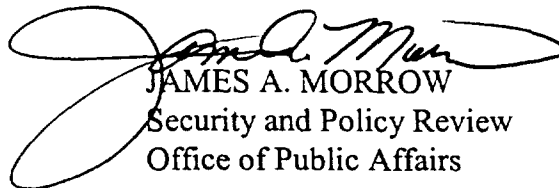
JAMES A. MORROW
Security and Policy Review
Office of Public Affairs

Attachment:
Your Ltr 18 November 2001

18 December 2001

MEMORANDUM FOR: HQ AFMC/PAX
Attn: Jim Morrow

FROM: HQ AFMC/HO

SUBJECT: Releasability Reviews

1. Please conduct public releasability reviews for the following attached Defense Technical Information Center (DTIC) reports:
 - a. *Emergency Fuel Selector Valve Test on the J47-GE-27 Engine as Installed on F-86F Aircraft*, January 1955; DTIC No. AD- 056 013.
 - b. *Phase II Performance and Serviceability Tests of the F-86F Airplane USAF No. 51-13506 with Pre-Turbine Modifications*, June 1954; DTIC No. AD- 037 710.
 - c. *J-47 Jet Engine Compressor Failures*, 7 April 1952; DTIC No. AD- 039 818.
 - d. *Evaluation of Aircraft Armament Installation (F-86F with 206 RK Guns) Project Gun-Val*, February 1955; DTIC No. AD- 056 763.
 - e. *A Study of Serviced-Imposed Maneuvers of Four Jet Fighter Airplanes in Relation to Their Handling Qualities and Calculated Dynamic Characteristics*, 15 August 1955; DTIC No. AD- 068 899.
 - f. *Fuel Booster Pump*, 6 February 1953; DTIC No. AD- 007 226.
 - g. *Flight Investigation of Stability Fix for F-86F Aircraft*, 8 September 1953; DTIC No. AD- 032 259.
 - h. *Investigation of Engine Operational Deficiencies in the F-86F Airplane*, June 1953; DTIC No. AD- 015 749.
 - i. *Operational Suitability Test of the T-160 20mm Gun Installation in F-86F-2 Aircraft*, 29 April 1954; DTIC No. AD- 031 528.
 - j. *Engineering Evaluation of Type T 160 Gun and Installation in F 86 Aircraft*, September 1953; DTIC No. AD- 019 809.

AFMC 01-273

- k. *Airplane and Engine Responses to Abrupt Throttle Steps as Determined from Flight Tests of Eight Jet-Propelled Airplanes*, September 1959; DTIC No. AD-225 780.
 - l. *Improved F-86F: Combat Developed*, 28 January 1953; DTIC No. AD- 003 153.
 - m. *Flight Test Progress Report No. 19 for Week Ending February 27, 1953 for Model F-86F Airplane NAA Model No. NA-191*, 5 March 1953; DTIC No. AD-006 806.
2. These attachments have been requested by Dr. Kenneth P. Werrell, a private researcher.
3. The AFMC/HO point of contact for these reviews is Dr. William Elliott, who may be reached at extension 77476.

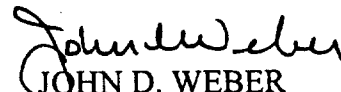
JOHN D. WEBER
Command Historian

13 Attachments:

- a. DTIC No. AD- 056 013
- b. DTIC No. AD- 037 710
- c. DTIC No. AD- 039 818
- d. DTIC No. AD- 056 763
- e. DTIC No. AD- 068 899
- f. DTIC No. AD- 007 226
- g. DTIC No. AD- 032 259
- h. DTIC No. AD- 015 749
- i. DTIC No. AD- 031 528
- j. DTIC No. AD- 019 809
- k. DTIC No. AD- 225 780
- l. DTIC No. AD- 003 153
- m. DTIC No. AD- 006 806