

REFERENCE COPY

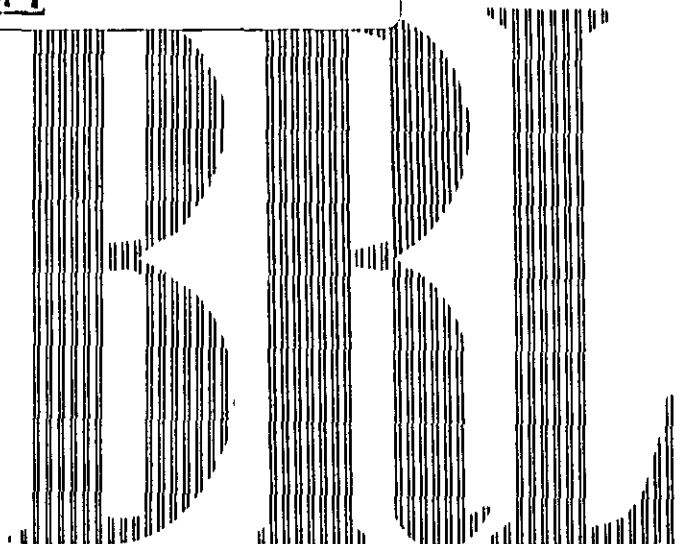

REPORT NO. 1080
SEPTEMBER 1959

STREAK INTERFEROMETRY

F. D. BENNETT
D. D. SHEAR
H. S. BURDEN

PROPERTY OF U.S. ARMY
STINFO BRANCH
BRL, APG, MD. 21005

DEPARTMENT OF THE ARMY PROJECT NO. 503-03-001
ORDNANCE RESEARCH AND DEVELOPMENT PROJECT NO. TB3-0108
BALLISTIC RESEARCH LABORATORIES



ABERDEEN PROVING GROUND, MARYLAND

BALLISTIC RESEARCH LABORATORIES

REPORT NO. 1080

SEPTEMBER 1959

STREAK INTERFEROMETRY

F. D. Bennett

D. D. Shear

H. S. Burden

PROPERTY OF U.S. ~~ARMY~~
STINFO BRANCH
BRL, APG, LD. 21005

Department of the Army Project No. 503-03-001
Ordnance Research and Development Project No. TB3-0108

ABERDEEN PROVING GROUND, MARYLAND

BALLISTIC RESEARCH LABORATORIES

REPORT NO. 1080

FDBennett/ DDShear/HSBurden/vmt
Aberdeen Proving Ground, Md.
September 1959

STREAK INTERFEROMETRY

ABSTRACT

A modification of the Mach-Zehnder interferometer is described which permits streak interferometry of transient axi-symmetric flows. Examples are shown of interferograms taken of flows produced by exploding fine metallic wires. Prominent features of the interferograms include 1) clearly defined shock waves, 2) a narrow, transparent, flow region behind the strong shock where fringes may be seen, 3) an opaque region presumed to be caused by the dispersed metal and 4) luminous regions associated with the second shock wave and electronic excitation of the material near the axis of symmetry.



1. INTRODUCTION

We report here a new interferometric technique which allows extension of the methods of gas flow interferometry to the study of unsteady, cylindrically symmetric, gas flow phenomena with varying amounts of self-luminosity.

Ladenburg and Bershader¹ give a comprehensive review of the optical techniques used in the double beam interferometry of plane and axi-symmetric supersonic gas flows which are independent of time. By these methods density may be obtained throughout the entire field of flow. Once density values have been found it is possible with the help of the fundamental equations of fluid flow and some additional assumptions to compute streamlines in the flow field and values of velocity components and pressure^{1,2}.

Until recently the application of interferometric techniques to transient, time-dependent flow phenomena such as occur in chemical explosions, electric sparks, exploded wires, etc. seemed to be limited to short time interval pictures of particular chosen phases of the phenomena. These are troubled by light intensity difficulties and poor resolution imposed by the necessity of "stopping" a high speed phenomenon with a brief flash of light.

By the technique we describe here it is possible to obtain in the x-t plane of the image of the transient disturbance, interferometric data comparable in quality to those obtained hitherto only for steady flow phenomena.

2: EXPERIMENTAL METHOD

2.1 Streak Backlighting

The possibility of streak interferometry was first appreciated at the time that a technique of streak backlighting was developed for the study of exploding wires³. Streak backlighting of axi-symmetric exploding wire phenomena is obtained by placing a plaque of closely-spaced, reflecting wires behind the disturbance and normal to the optical axis of the streak camera. When viewed through the slit one sees both a small portion of the transverse wire and the spaced spots of light reflected from the short sections of plaque wires visible through the slit. When this image, illuminated by the wire explosion, is swept by the rotating mirror, there appears on the film a series of parallel streaks each of which is interrupted by the refractive effects

caused by the shock wave through which the light must pass. Except in the immediate vicinity of the shock wave the streaks of light are both undeviated and of uniform size, indicating the well-known fact that refraction effects are negligible except at the shock wave. There, however, the details of the refraction indicate that as the rotating mirror sweeps the image, the light spots are capable of writing on the film with both high speed and high resolution.

In principle there is no difficulty in replacing the backlighting reflectors by a system of parallel fringes formed by an interferometer. In this case, as the mirror sweeps, the fringes will write combined refraction and retardation fringe shifts on the film, with speed and resolution limited by the light intensity, which places a maximum on the allowable mirror speed, and by the width of the viewing slit. To realize experimentally such a situation requires more complex instrumentation than that necessary for streak backlighting alone.

2.2 Modifications of the Mach-Zehnder Interferometer

We start with the basic elements of an interferometer for study of supersonic projectiles in free flight; viz., a light source, monochromator, Mach-Zehnder interferometer with 2" field, and rotating-mirror camera. This instrument has been described briefly in connection with an adaptation of a heated B-H6 mercury flash tube used as a light source⁴. We show in Fig. 1 a sketch of the optical arrangement including the interferometer and rotating-mirror camera.

For streak analysis, the interferometer is modified by the addition of two auxiliary slits, one in each beam as shown in Fig. 1. The slits are located at approximately equal optical distances from the camera objective lens and perpendicular to the parallel fringe system formed by the interferometer. For clearest fringes from a given circular source, the interferometer is adjusted to form fringes perpendicular to the plane of centers of its elements. Therefore the auxiliary slits are parallel to, or lie in, the plane of centers. The slits are adjusted so that their images coincide as seen by the rotating mirror camera. A still picture with this adjustment would show a single vertical slit crossed by evenly spaced light and dark bars representing the fringes. With this adjustment of the interferometer, the source of the

disturbance, in our examples a thin, cylindrical wire, is placed several centimeters behind one of the slits and perpendicular to both the optical axis of the camera and the slit itself.

2.3 Light Source

Since the interferometer is in effect backlighting the disturbance with a system of fringes, the need is for a bright flash of light of comparatively long duration. For the phenomena examined here the duration should be 15 μ sec or longer, or more than twice that of the heated flash tube described in Reference 4. To achieve the necessary lengthening of flash, inductance is added to the flash tube circuit in the form of a helix of heavy wire. In the circuit finally used, the tube receives a pulse from a condenser of $1/2 \mu$ fd charged to about 6-9 kv. At higher voltages the tube will frequently break under the internal pressure developed during the pulse. Triggering is accomplished by a spark gap with rounded cylindrical electrodes, and a coaxial, tickler electrode similar to those used in spark shadowgraph applications^{5,6}. The monochromator is usually set on the 4358A line of Hg and the slits opened until no more than 50 clear fringes are obtained in the interferometer during a flash exposure.

2.4 Synchronization of Light Source and Disturbance

The success of the method requires a technique whereby the disturbance and the interferometer backlighting can be made to occur in either order and separated by a small, reproducible time interval. Good results are obtained using two pulse transformers designed with 35 to 1 ratio to give a 15,000 v pulse with a rise time of 0.1 μ sec. With the primaries connected in parallel to the same thyatron triggering circuit, events initiated by the secondaries can be made to occur with a delay due to triggering of about 0.4 μ sec⁷.

In the present application a far longer delay of about 1.5 μ sec occurs in the B-H6 tube circuit due presumably to comparatively slow current rise and slow increase of light output. For this reason a more satisfactory method follows if we employ the pulse transformers as above but raise the voltage on the B-H6 tube, main triggering gap until breakdown occurs. The reflected pulse sets off the thyatron which then triggers the disturbance gap.

2.5 The Exploding Wire

For streak interferometry the disturbance needs only to be axisymmetric and reasonably transparent. The explosion of a fine cylindrical wire answers both these requirements and in addition exhibits both luminous and opaque regions in the same flow. The disturbances shown here as examples are produced by exploding fine cylindrical wires of copper about 1/2" long and 3-5 mils in diameter. An 0.5 μ f capacitor at 8-12 kv provides the current pulse for the wire explosion. A triggering gap similar to that used on the light source provides a means of initiating the phenomenon.

3. STREAK INTERFEROGRAMS

3.1 Examples

We show in Fig. 2 a streak picture of the exploding wire alone. The 3.8 mil copper wire (1.19 cm long) exploded at 8 kv with 16 joules stored energy shows a relatively small region of luminosity at the tip. On the other hand, the inward trajectory of the second wave is fairly clear and its wedge-shaped outward path after reflection is the most prominent luminosity of the photograph. This is in contrast to experimental results of an earlier paper⁸ where the front shock is extremely bright at the apex of the flash and the second shock is partially obscured by the subsequent decaying luminosity.

Fig. 3 shows a streak interferogram taken under conditions similar to those of Fig. 2. The front shock wave is visible for about 10 μ sec and fringes may be seen behind it down to the boundary of a fairly definite opaque region which appears to define the contact surface between the metal vapor and the ambient air. At later times the density of the metal vapor decreases enough so that fringes again can be seen. Near the axis, luminous phenomena appear which represent an unsymmetrical second shock pattern with some complicating features which are unexplained at present.

In Fig. 4 we see a 3.8 mil wire at slightly higher energy. Here the same general features are visible except that the initial flash is more luminous and the second shock is well formed. The semi-circular spot above the wedge-tip of the second shock is a reflection from some part of the apparatus and should be disregarded.

In Fig. 5 we show a streak interferogram of a 5-mil wire at 25 joules stored energy. The energy per unit volume of wire is slightly less than in Figs. 3 and 4. One notices that the flash is not very luminous and the opaque region is especially well defined. No luminous second shock appears. The semi-circular spot is spurious and again should be disregarded.

Finally in Fig. 6 we exhibit a single fringe interferogram of a 5-mil wire at higher energy density than any of the previous figures. The first and second shock waves are conspicuous. The fringes behind the front shock show the axisymmetric nature of the flow. The symmetry is less perfect than that obtained around projectiles in free flight; but nevertheless, sufficiently good so that data reduction for such a flow may be attempted with expectation of reasonably accurate values.

The shadow of the wire may be seen for nearly a microsecond before the flash (and also in Fig. 5). Its constancy in diameter during this interval suggests that a dark-pause expansion, as found by Müller⁹, is not present in this case.

3.2 Problems of Reduction

Methods of converting fringe shift values to densities are quite well worked out for axisymmetric flows of ideal gases^{1,10}. In the present cases several problems arise that will necessarily require a more elaborate reduction method than any given previously. We shall discuss these problems briefly and give an indication of probable conditions under which successful reductions will be possible.

One of the immediate problems facing the experimenter is to identify the fringes inside the shock wave, that is to number them correctly for comparison with the undisturbed fringes. For axisymmetric disturbances the fringes must be continuous in passing through the shock¹⁰; while, in contrast, the fringes show a discontinuity in passing through a plane shock. The theoretical expression for fringe shift is based on the assumption that the rays are undeviated by the density changes but merely retarded. For moderate shock waves ($M \geq 3$) in weakly refracting substances like gases, this assumption is reasonably well fulfilled; nevertheless even in these cases, calculations of the refraction effect^{11*} indicate that errors in the fringe shift of the order of one fringe can occur just inside the shock wave and that the sign of the error depends on the position of the plane of focus in the disturbance.

In the present cases the flow field is bounded by a strong shock in most of the visible region. That is to say that the shock Mach number is larger than 3 for $t \leq 6$ μsec and greater than 10 for $t \leq 0.5$ μsec . Thus the density jump at the shock is greater than 4 for most of the visible region, in contrast to the smaller values used in previous estimations¹¹.

If we assume that the density just behind a strong cylindrical shock remains constant, then fringe shifts of the order of 10 can arise in passing through the shock before 5% of the shock radius has been traversed. In Fig. 3 for example, the fringes near the shock are very densely compressed and one is able to count in the expansion region as many as 10 clear fringes that appear to laminate in the small band just behind the shock.

Attempts made to estimate fringe shift on the assumption of constant density behind the shock appropriate to its local Mach number, have given conflicting values for the same fringe encountered at different trace positions, that is at different values of t . It is suspected that this technique fails here, even though successful at low shock strengths¹⁰, because of refraction errors too large to ignore and in the present cases impossible to estimate.

Use of a "white light" fringe system to trace the most distinct, central fringe through the shock would offer hope of success if the center fringes pass through the shock at a late time when the shock is comparatively weak. Near the shock vertex, the fringe shift is larger than the number of "white light" fringes ordinarily available. Furthermore if the gas is appreciably ionized on passing through the shock, the center of contrast of the fringe system will be displaced an unknown amount unless independent information on ion and electron densities is available¹².

Since fringe shift is proportional to ambient density, a more promising approach is to reduce the ambient pressure at which the interferogram is taken. Reduction of pressure by a factor of 4 or 5 will reduce fringe shifts to values previously experienced with weaker shocks, and should allow direct tracing of fringes through portions of the shock. A vacuum apparatus is under construction at this laboratory to test this plan of approach.

Where the shock is sufficiently strong ($M \geq 10$) to excite internal degrees of freedom or to ionize the gas, the optical refractivity of the gas may be sensibly altered from its room temperature values^{12,13}; however, for

air through shocks where the temperature rise is not more than 5000° , ($M < 10$), ionization is negligible and optical refractivity is not seriously affected by the degree of dissociation. Thus, room temperature values may be used. Considerable portions of the flow fields in Fig. 2 are already seen to satisfy these requirements so reasonably accurate density values may be expected.

Conversion of density values, through flow theory, to values of other flow parameters such as velocity, temperature and pressure is considerably more difficult where excitation of internal degrees of freedom and dissociation exist. Some results for the flow of air, nitrogen and argon over the front surface of a sphere at $M=5$ have been obtained¹⁴. Comparison of these cases shows appreciable effects due to relaxation phenomena and account must be taken of the real gas properties of oxygen and nitrogen. It is hoped that the computational techniques used in the blunt body, steady flow problem can be adapted to calculation of flow variables in the unsteady flow fields of the present streak interferograms.

The semi-opaque region clearly seen in Figs. 3, 4, and 5 presents a problem not encountered before in flow field interferometry. The symmetrical, light-absorbing cloud is apparently caused by the expanding metal vapor of the wire. Fringes are seen within the edges of this region only at late times after the expansion has proceeded almost to its limit. The volume swept out by the dark cloud is of the order of 10^5 times the original volume of the wire. The state of aggregation of the metal during the expansion process is not known at present. Some experimenters^{15,16} have collected striated, metallic deposits on glass slides placed near the exploding wires. Our experiments have produced small quantities of a black powder which is presumably metal black, i.e., finely divided metal powder with particles of colloidal size, although the possibility of metal oxide powder has not been ruled out in the present case of copper wires.

In order to calculate quite accurately first and second shock wave trajectories for the exploding wire phenomena, it is only necessary to assume that the copper wire is converted into a perfect gas by the deposition of electrical energy¹⁷. The gamma of the copper has to be adjusted to secure a reasonable fit of the second shock wave. Thus only a vapor of copper needs to be assumed hydrodynamically although other evidence suggests the presence of colloidal particles and possibly globules or jets of molten metal.

The refractive properties of a metal vapor or of metal dispersions in air are not well known at present. The fringe patterns given in Fig. 2 suggest a distinct density change at the dark boundary. Further analysis may need to take into account the theory of light scattering and refractive index for solutions of colloidal particles¹⁸ suitably adapted to the case of metal dispersed in a gas.

3.3 The Shock Waves

Comparison of the shock trajectories in Fig. 2 with those obtained by the streak backlighting or the mirror methods^{3,8} shows streak interferometry to be superior in producing a continuous record over an extended period of time. Thus, even though the detailed reduction of the interferogram presents many new and difficult problems, the shock wave data obtained are more complete than those of either previous method.

Coordinates of points on the shocks shown in Figs. 3-5 have been measured and fitted to parabolas. According to a method of shock analysis⁸ based on similarity flow theory for blast waves, the trajectory of a strong cylindrical shock formed by instantaneous energy release along a line, at the origin of time, should be accurately parabolic. The apparent energy release, E_g in joules/cm, to form the shock wave can be determined from the latus rectum of the parabola as expressed by the theory. The experimental data for Figs. 3, 4, 5 and 6 give E_g to be 9.0, 9.8, 10.7 and 17.1 joules/cm respectively. When these values are multiplied by the length of the wire (1.19 cm) and divided by the energy stored in the capacitors, efficiencies of 67, 64, 51 and 62% are obtained for apparent transfer of electrical to mechanical energy. These values are about 10% higher than those encountered previously⁸.

The physical situation defined by the explosion of a fine cylindrical wire is only an approximation to the conditions of the similarity blast wave theory. As a consequence the energies and efficiencies calculated above can have only a limited validity¹⁹. Until further investigation is made of the problems involved, the degree of approximation cannot be stated with precision. The theoretical calculations of Rouse¹⁷ show that the only region where the flow even approaches similarity lies just behind the shock wave. From this point of view it is difficult to see why the shock should travel as nearly a similarity flow trajectory as it does, and why the energy values

indicated correlate well with other aspects of the electrical theory of the exploding wire circuit²⁰. Notwithstanding these uncertainties, the experimental evidence available indicates that both shock energies and efficiencies must be approximately correct and give a reasonably accurate indication of the transfer of energy from electrical to mechanical form.

F. D. Bennett
F. D. BENNETT

D. D. Shear
D. D. SHEAR

Henry S. Burden
H. S. BURDEN

REFERENCES

1. Ladenburg, R. and Bershader, D. "High Speed Aerodynamics and Jet Propulsion." Vol IX, Sec. A3, Princeton University Press.
 2. Sedney, R., Gerber, W. and Bartos, J. M., "Numerical Determination of Streamlines from Density Data." Ballistic Research Laboratories Report No. 1073 (April 1959).
 3. Bennett, F. D. and Shear, D. D., Phys. of Fluids 2, 338, (1959).
 4. Bergdolt, V. E. and Shear, D. D., Phot. Eng. 4, 240, (1953). For details of the interferometer design see Greenwald, A. J., and Bergdolt, V. E., BRLM Report No. 469, Aberdeen Proving Ground, Md., (1947).
 5. Kovasznay, L. S. G., Rev. Sci. Inst. 20, 696, (1949).
 6. Bergdolt, V. E., and Shear, D. D. "Shadowgraph Spark Sources for the 12 Inch Pressurized Range", BRLM Report No. 742, Aberdeen Proving Ground, Maryland, (1953).
 7. Shear, D. D. and Sleator, D. B., "A Device for Simultaneous Shadowgraphs with Two Spark Gaps", BRLM Report No. 1007, Aberdeen Proving Ground, Maryland, (1956).
 8. Bennett, F. D., Phys. of Fluids 1, 347, (1958).
 9. Muller, W., Physik Z., 149, 397, (1957).
 10. Bennett, F. D., Carter W. C., and Bergdolt, V. E., J. Appl. Phys., 23, 452, (1952). A recent study of the question of accumulation of random errors of measurement at points near the axis of flow is contained in "Reduction of Mach-Zehnder Interferograms by Least Squares Methods". Bennett, F. D., and Bartos, J. M., BRL Report No. 1027, Aberdeen Proving Ground, Maryland, (1957).
 11. Clippinger, R. F., "Comparison between the Jamin-Mach Interferometer and the Williams Interferometer etc . . .", BRL Report No. 576, Aberdeen Proving Ground, Maryland, (1945).
- *Unpublished results by Sedney, R. and Kahl, G. D., have extended Clippinger's calculations to cover planes of focus other than the median.
12. Alpher, R. A. and White, D. R., Phys. of Fluids, 2, 162, (1959).
 13. Alpher, R. A. and White, D. R., Phys of Fluids, 2, 153, (1959).
 14. Sedney, R. and Kahl, G. D., "Interferometric Study of the Hypersonic Blunt Body Problem", Fourth Symposium on Ballistic Missile and Space Technology, Los Angeles (August 1959). BRL Report to be published.
 15. Chace, W. G., Phys. of Fluids, 2, 230, (1959).
 16. Conn, W. M., Z. Angew. Phys., 7, 539, (1955) and Phys. Rev., 98, 1551 (1955) A.

17. Rouse, C. A., "Theoretical Analysis of the Hydrodynamic Flow in Exploding Wire Phenomena". UCRL 5519-T Lawrence Radiation Laboratory, Livermore, California (March 1959) or Proceedings of the Conference on the Exploding Wire Phenomenon, Boston Mass. (April 1959) to be published.
18. Zimm, B. H., and Dandliker, W. B., J. Phys. Chem., 58, 644, (1954).
19. Bennett, F. D., "Flow Fields produced by Exploding Wires", BRL Report No. 1075 (May 1959) or Proceedings of the Conference on the Exploding Wire Phenomenon, Boston Mass., (April 1959) to be published.
20. Bennett, F. D. Phys. of Fluids, 1, 515, (1958).

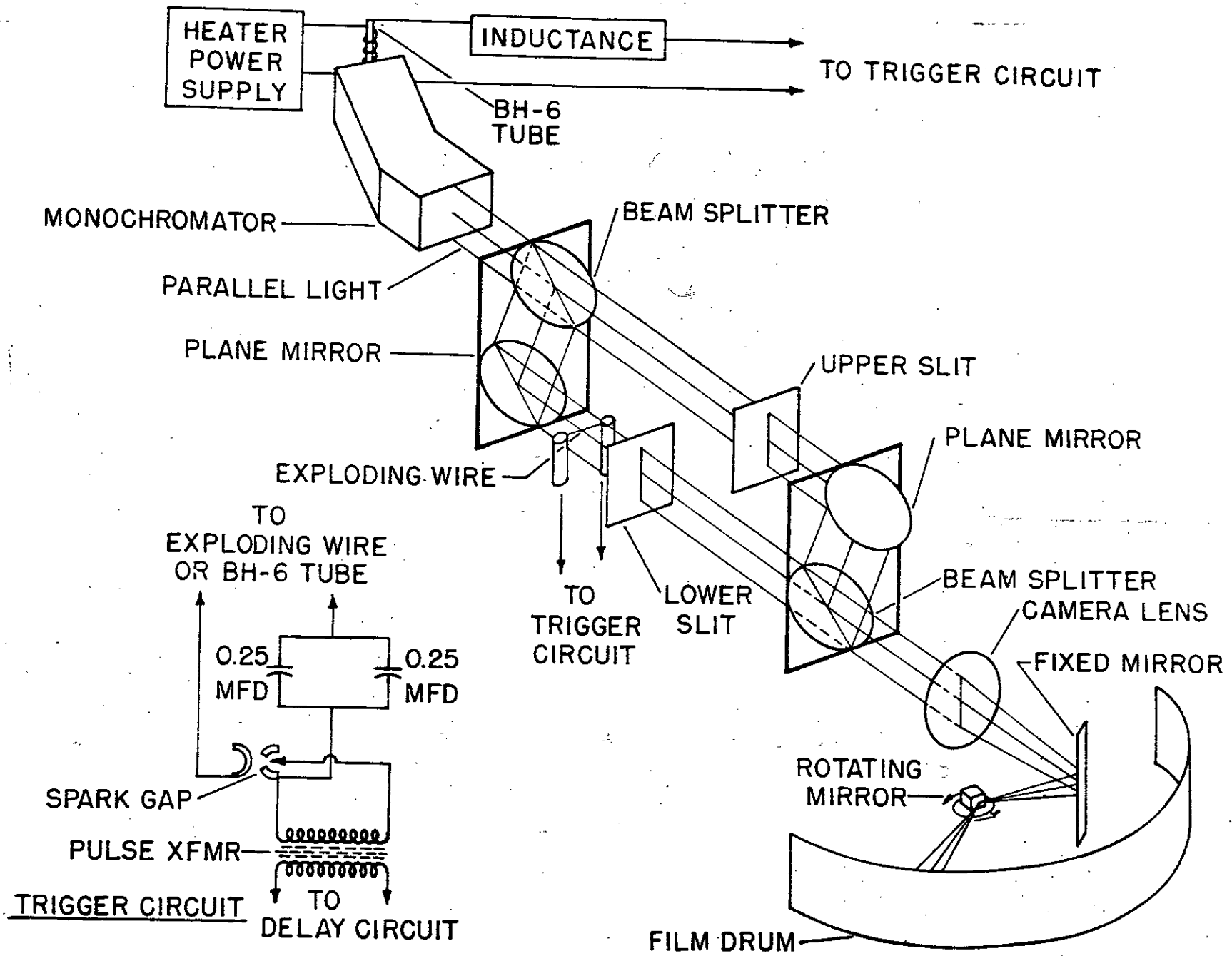

Fig. 1 Schematic of Streak Interferometer

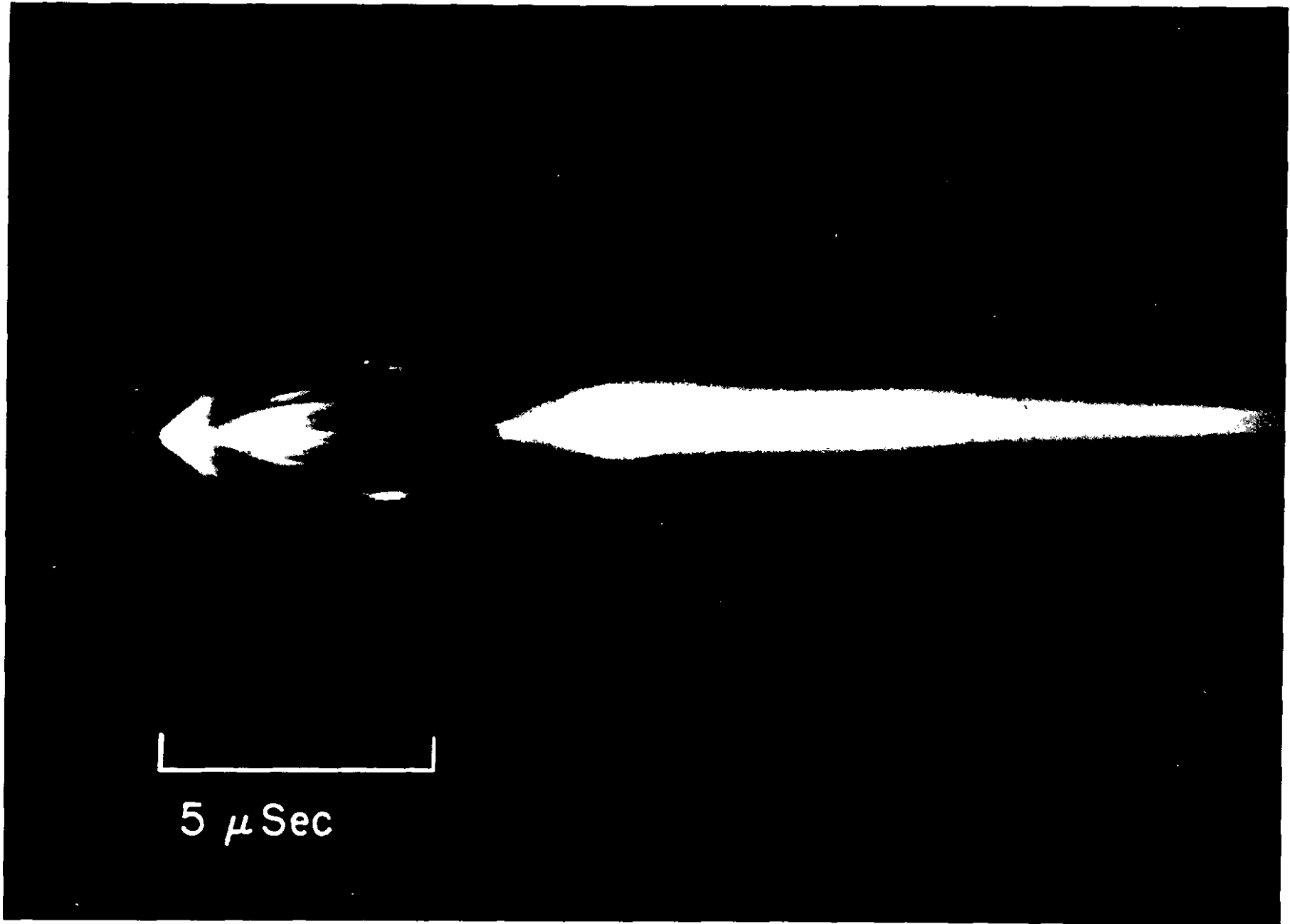

Fig. 2 Streak picture of 3.8 mil Cu wire at 8 kv.

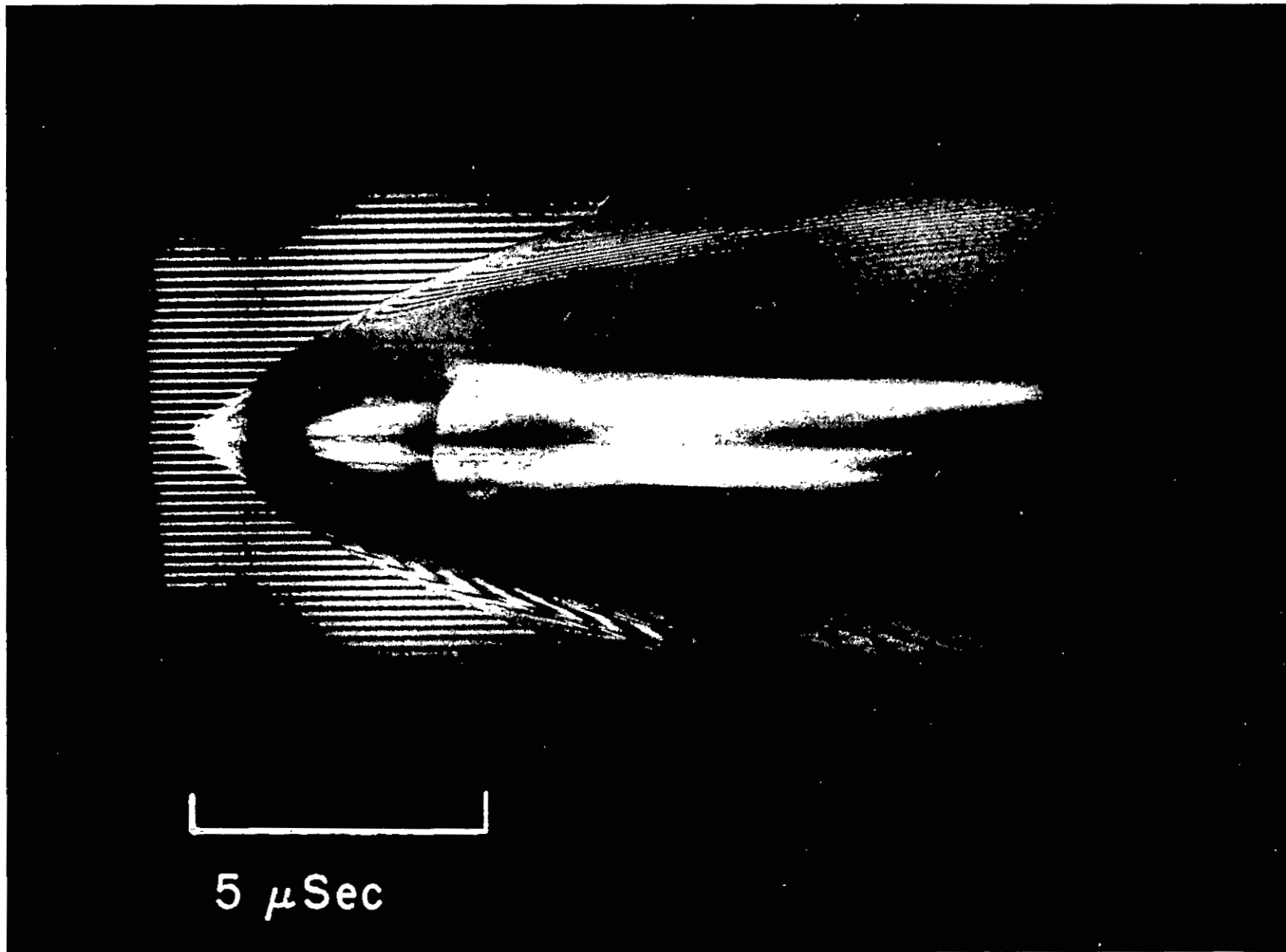

Fig. 3 Streak interferogram of 3.8 mil Cu wire at 8 kv.

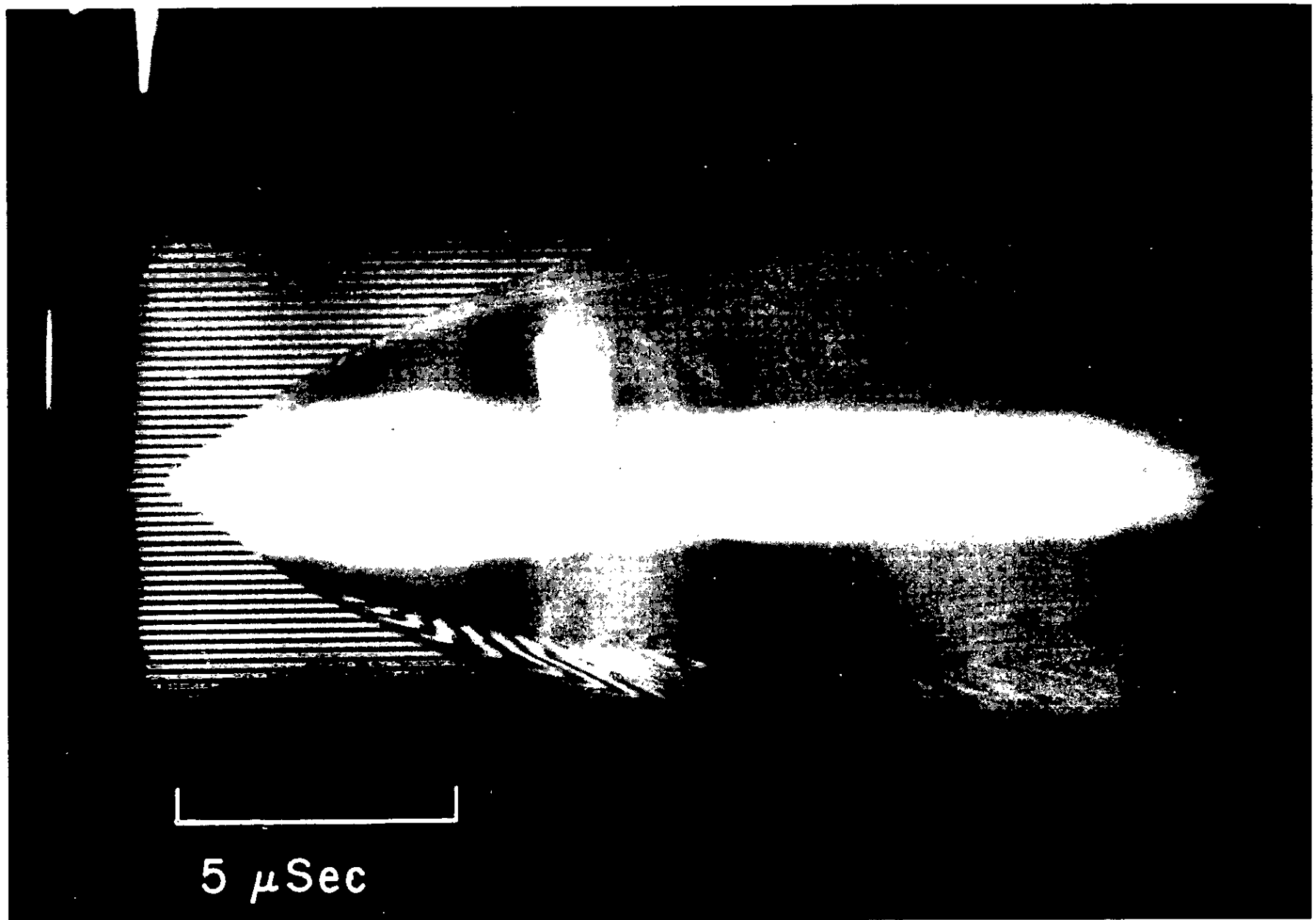

Fig. 4 Streak interferogram of 3.8 mil Cu wire at 8.5 kv.

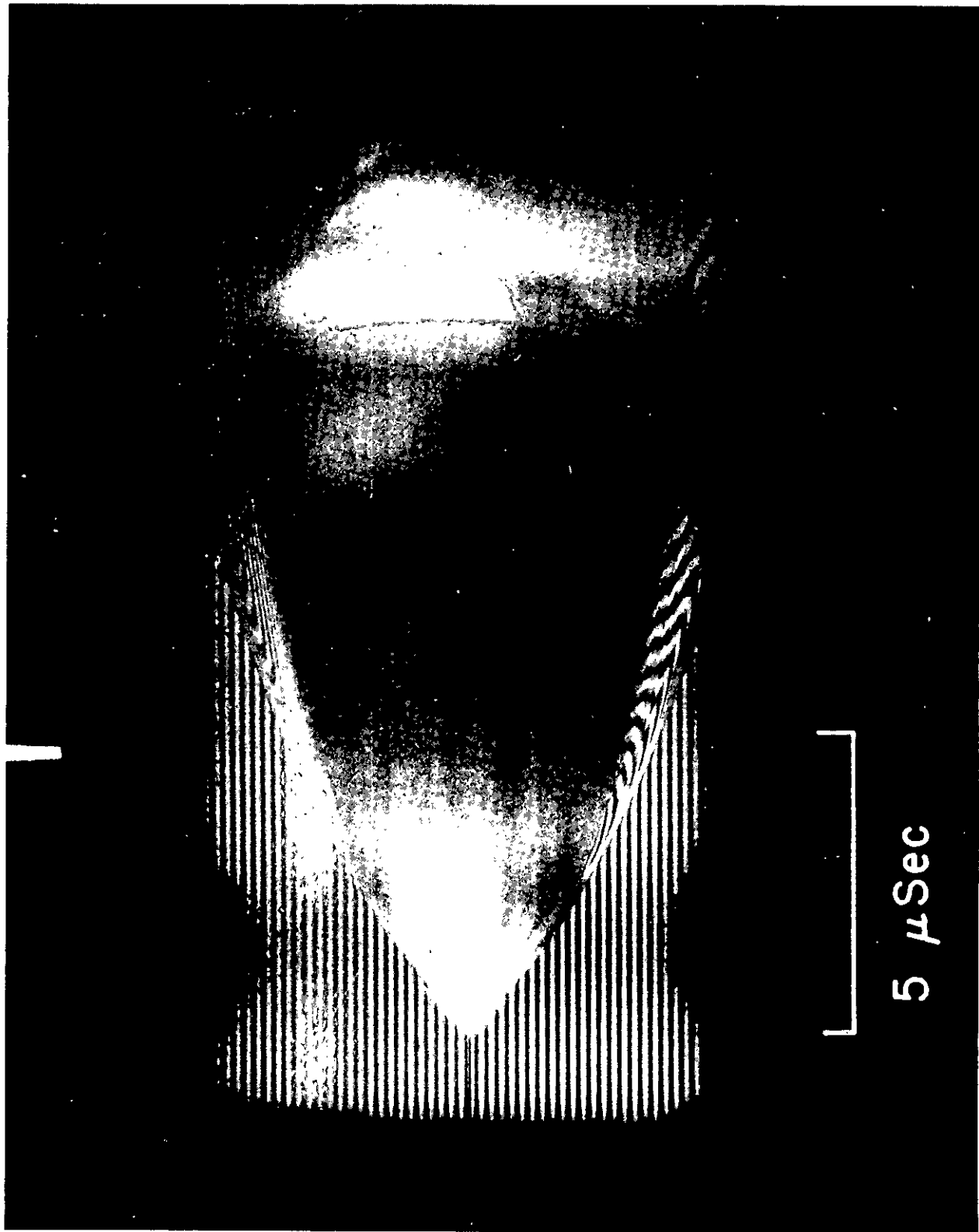

Fig. 5 Streak interferogram of 5 mil Cu wire at 10 kv.

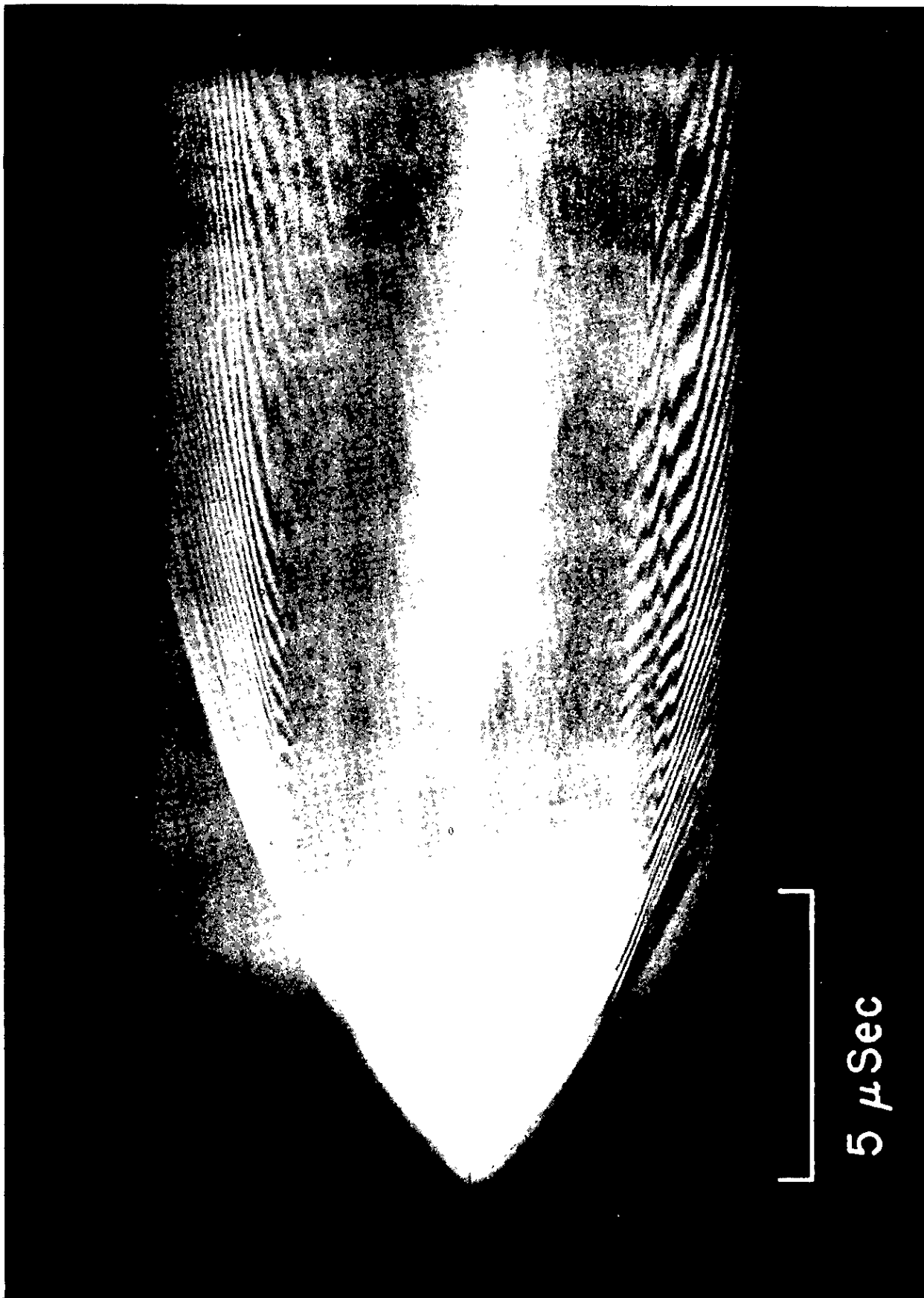
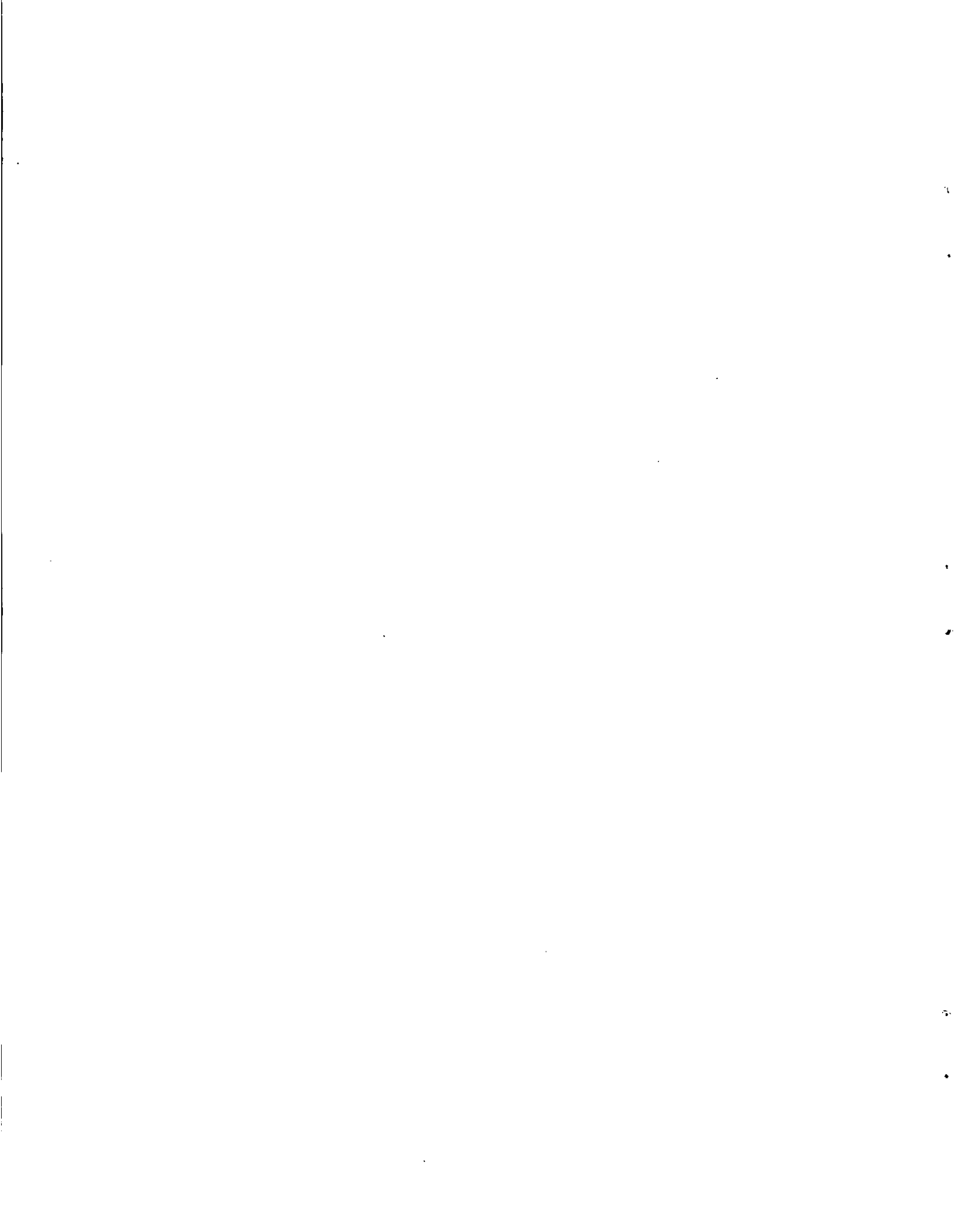

Fig. 6 Single fringe streak interferogram of 5 mil Cu wire at 11.5 kv.



DISTRIBUTION LIST

<u>No. of Copies</u>	<u>Organization</u>	<u>No. of Copies</u>	<u>Organization</u>
1	Chief of Ordnance Department of the Army Washington 25, D. C. Attn: ORDTB-Bal Sec.	2	Director U. S. Naval Research Laboratories Washington 25, D. C. Attn: Dr. A. C. Kolb Dr. V. E. Scherer
1	Commanding Officer Diamond Ordnance Fuze Lab. Washington 25, D. C. Attn: ORDTL-012	1	Superintendent U. S. Naval Postgraduate School Monterey, California
10	Director Armed Services Technical Information Agency Arlington Hall Station Arlington 12, Virginia Attn: TIPCR	1	Director Air University Maxwell Air Force Base, Alabama Attn: Air University Library
10	British Joint Services Mission 1800 K Street, N. W. Washington 6, D. C. Attn: Reports Officer	4	Commander Wright Air Development Center Wright-Patterson Air Force Base, Ohio Attn: WCIGR-4
4	Canadian Army Staff 2450 Massachusetts Avenue Washington 8, D. C.	3	Director Advanced Research Laboratory - GRD Air Force Cambridge Research Center L. G. Hanscom Field Bedford, Massachusetts Attn: W. G. Chane - CRZN M. A. Levine M. O'Day
3	Chief, Bureau of Ordnance Department of the Navy Washington 25, D. C. Attn: ReO	1	Commander Air Proving Ground Center Eglin Air Force Base, Florida Attn: PGEM
2	Commander U. S. Naval Weapons Laboratory Dahlgren, Virginia	3	Director National Aeronautics and Space Agency Lewis Flight Propulsion Laboratory Cleveland Airport Cleveland, Ohio
2	Commander Naval Ordnance Laboratory White Oak Silver Spring 19, Maryland Attn: Library		
1	Commander U. S. Naval Ordnance Test Station China Lake, California Attn: Technical Library		

DISTRIBUTION LIST

<u>No. of Copies</u>	<u>Organization</u>	<u>No. of Copies</u>	<u>Organization</u>
2	Director National Aeronautics and Space Agency Ames Laboratory Moffett Field, California Attn: Mr. V. J. Stevens Mr. Harvey Allen	3	Commanding Officer Picatinny Arsenal Dover, New Jersey Attn: Samuel Feltman Research & Development Labs. NASL Mr. S. S. Verner
2	Director National Aeronautics and Space Agency Langley Memorial Aeronautical Laboratory Langley Field, Virginia	1	Commander Army Rocket and Guided Missile Agency Supporting Research Branch Redstone Arsenal, Alabama Attn: Major D. H. Steininger
3	Director National Aeronautics and Space Agency 1520 H Street Washington 25, D. C.	1	Commanding General Army Ballistics Missile Agency Redstone Arsenal, Alabama Attn: Dr. T. A. Barr
1	Technical Reports Library U. S. Atomic Energy Commission Washington 25, D. C. Attn: Director of Military Applications	2	Applied Physics Laboratory 8621 Georgia Avenue Silver Spring, Maryland
3	U. S. Atomic Energy Commission Los Alamos Scientific Laboratory P. O. Box 1663 Los Alamos, New Mexico Attn: Dr. J. L. Tuck Dr. R. G. Schreffler Dr. R. E. Duff	1	California Institute of Tech- nology Aeronautics Department Pasadena, California Attn: Prof. H. W. Liepmann
1	Director, JPL Ord Corps Installation Department of the Army 4800 Oak Grove Drive Pasadena, California Attn: Mr. Irl E. Newlan Reports Group	1	Cornell Aeronautical Laboratory 4455 Genesee Street Buffalo 5, New York Attn: Elma Evans, Librarian
1	Commanding General Frankford Arsenal Philadelphia 37, Pennsylvania Attn: Mr. Charles Lukens, Bldg. 150	1	Cornell University Graduate School of Aeronautical Engineering Ithaca, New York Attn: Prof. E. L. Resler
		1	Datamatic Corporation 151 Needham Street Newton Highlands 61, Mass. Attn: Dr. R. F. Clippinger

DISTRIBUTION LIST

<u>No. of Copies</u>	<u>Organization</u>	<u>No. of Copies</u>	<u>Organization</u>
1	Case Institute of Technology Department of Mechanical Engineering University Circle Cleveland 6, Ohio Attn: Prof. G. Kuerti	1	Metcalf Laboratory Brown University Providence 12, Rhode Island Attn: Prof. D. F. Hornig
1	The Enrico Fermi Institute of Nuclear Studies University of Chicago Chicago 37, Illinois Attn: Prof. E. N. Parker	1	Director Moore School of Electrical Engineering University of Pennsylvania Attn: Prof. S. Gorn
2	General Electric Company Research Laboratory Schenectady, New York Attn: Dr. R. A. Alpher Dr. D. R. White	1	Pennsylvania State University Physics Department State College, Pennsylvania Attn: Prof. R. G. Stoner
1	Guggenheim Aeronautical Lab. California Institute of Technology Pasadena, California Attn: Prof. L. Lees	1	Princeton University Observatory Princeton, New Jersey Attn: Prof. Lyman Spitzer, Jr.
1	Harvard Observatory Harvard University Cambridge 38, Massachusetts Attn: Prof. F. L. Whipple	1	Stanford University Department of Mechanical Engineering Palo Alto, California Attn: Prof. D. Bershader
1	Hartford Graduate Center R.P.I. East Windsor Hill, Connecticut Attn: Prof. R. G. Campbell	1	Syracuse University Department of Physics Syracuse, New York Attn: Prof. C. H. Bachman
1	Johns Hopkins University Department of Aeronautics Baltimore 18, Maryland Attn: Prof. L. S. G. Kovaszny	2	University of Maryland Institute for Fluid Dynamics & Applied Mathematics College Park, Maryland Attn: Prof. S. I. Pai Prof. J. M. Burgers
1	James Forrestal Research Center Princeton University Princeton, New Jersey Of Interest To: Prof. S. Bogdonoff	1	University of Michigan Department of Physics Ann Arbor, Michigan Attn: Prof. Otto Laporte
1	Lehigh University Department of Physics Bethlehem, Pennsylvania Attn: Prof. R. J. Emrich	1	University of California Low Pressures Research Project Berkeley, California Attn: Prof. S. A. Schaaf

DISTRIBUTION LIST

<u>No. of Copies</u>	<u>Organization</u>
1	University of Oklahoma Department of Physics Norman, Oklahoma Attn: Prof. R. G. Fowler
1	University of Michigan Aeronautical Research Center Willow Run Airport Ypsilanti, Michigan
1	University of Illinois Aeronautical Institute Urbana, Illinois Attn: Prof. B. L. Hicks
1	Professor W. Bleakney Palmer Physical Laboratory Princeton University Princeton, New Jersey
1	Professor J. Lloyd Bohn Department of Physics Temple University Philadelphia, Pennsylvania
2	Professors H. W. Emmons G. F. Carrier Harvard University Cambridge 38, Massachusetts
1	Professor E. M. Pugh Carnegie Institute of Technology Department of Physics Pittsburgh, Pennsylvania
1	Dr. A. E. Puckett Hughes Aircraft Company Culver City, California
1	Dr. Carl A. Rouse Theoretical Division U. C. R. L. Livermore, California
1	Commander Air Force Special Weapons Center Kirtland Air Force Base, New Mexico Attn: SWRP

<p>AD <u> </u> Accession No. <u> </u> UNCLASSIFIED Ballistic Research Laboratories, APG STREAK INTERFEROMETRY F. D. Bennett, D. D. Shear, Interferometers-Applications H. S. Burden Aerodynamics - Testing Equipment BRL Report No. 1080 September 1959 Shock Waves - Measurement- Instrumentation DA Proj No. 503-03-001, ORD Proj No. TB3-0108 UNCLASSIFIED Report</p> <p>A modification of the Mach-Zehnder interferometer is described which permits streak interferometry of transient axi-symmetric flows. Examples are shown of interferograms taken of flows produced by exploding fine metallic wires. Prominent features of the interferograms include 1) clearly defined shock waves, 2) a narrow, transparent, flow region behind the strong shock where fringes may be seen, 3) an opaque region presumed to be caused by the dispersed metal and 4) luminous regions associated with the second shock wave and electronic excitation of the material near the axis of symmetry.</p>	<p>AD <u> </u> Accession No. <u> </u> UNCLASSIFIED Ballistic Research Laboratories, APG STREAK INTERFEROMETRY F. D. Bennett, D. D. Shear, Interferometers-Application H. S. Burden Aerodynamics - Testing Equipment BRL Report No. 1080 September 1959 Shock Waves - Measurement- Instrumentation DA Proj No. 503-03-001, ORD Proj No. TB3-0108 UNCLASSIFIED Report</p> <p>A modification of the Mach-Zehnder interferometer is described which permits streak interferometry of transient axi-symmetric flows. Examples are shown of interferograms taken of flows produced by exploding fine metallic wires. Prominent features of the interferograms include 1) clearly defined shock waves, 2) a narrow, transparent, flow region behind the strong shock where fringes may be seen, 3) an opaque region presumed to be caused by the dispersed metal and 4) luminous regions associated with the second shock wave and electronic excitation of the material near the axis of symmetry.</p>
<p>AD <u> </u> Accession No. <u> </u> UNCLASSIFIED Ballistic Research Laboratories, APG STREAK INTERFEROMETRY F. D. Bennett, D. D. Shear, Interferometers-Applications H. S. Burden Aerodynamics - Testing Equipment BRL Report No. 1080 September 1959 Shock Waves - Measurement- Instrumentation DA Proj No. 503-03-001, ORD Proj No. TB3-0108 UNCLASSIFIED Report</p> <p>A modification of the Mach-Zehnder interferometer is described which permits streak interferometry of transient axi-symmetric flows. Examples are shown of interferograms taken of flows produced by exploding fine metallic wires. Prominent features of the interferograms include 1) clearly defined shock waves, 2) a narrow, transparent, flow region behind the strong shock where fringes may be seen, 3) an opaque region presumed to be caused by the dispersed metal and 4) luminous regions associated with the second shock wave and electronic excitation of the material near the axis of symmetry.</p>	<p>AD <u> </u> Accession No. <u> </u> UNCLASSIFIED Ballistic Research Laboratories, APG STREAK INTERFEROMETRY F. D. Bennett, D. D. Shear, Interferometers-Application H. S. Burden Aerodynamics - Testing Equipment BRL Report No. 1080 September 1959 Shock Waves - Measurement- Instrumentation DA Proj No. 503-03-001, ORD Proj No. TB3-0108 UNCLASSIFIED Report</p> <p>A modification of the Mach-Zehnder interferometer is described which permits streak interferometry of transient axi-symmetric flows. Examples are shown of interferograms taken of flows produced by exploding fine metallic wires. Prominent features of the interferograms include 1) clearly defined shock waves, 2) a narrow, transparent, flow region behind the strong shock where fringes may be seen, 3) an opaque region presumed to be caused by the dispersed metal and 4) luminous regions associated with the second shock wave and electronic excitation of the material near the axis of symmetry.</p>