

UNCLASSIFIED

AD NUMBER: AD0230484

LIMITATION CHANGES

TO:

Approved for public release; distribution is unlimited.

FROM:

Distribution authorized to US Government Agencies only;
Administrative/Operational Use; 1 Apr 1959. Other requests shall be
referred to US Army Snow Ice and Permafrost Research Establishment,
Wilmette, IL 60091.

AUTHORITY

DDCTCA notice dtd 19 Apr 1972

UNCLASSIFIED

AD

230 484

FOR
MICRO-CARD
CONTROL ONLY

1

OF

6

Reproduced by

Armed Services Technical Information Agency

ARLINGTON HALL STATION; ARLINGTON 12 VIRGINIA

UNCLASSIFIED

"NOTICE: When Government or other drawings, specifications or other data are used for any purpose other than in connection with a definitely related Government procurement operation, the U.S. Government thereby incurs no responsibility, nor any obligation whatsoever; and the fact that the Government may have formulated, furnished, or in any way supplied the said drawings, specifications or other data is not to be regarded by implication or otherwise as in any manner licensing the holder or any other person or corporation, or conveying any rights or permission to manufacture, use or sell any patented invention that may in any way be related thereto.

FILE COPY

4

Return to

ASTIA

ARLINGTON HALL STATION
ARLINGTON 12, VIRGINIA

Attn: TISS



Translation 19

APRIL, 1959

Principles of Mechanics of Frozen Ground

Osnovaniia mekhaniki merzlykh gruntov

**by N. A. Tsytovich
and M. I. Sumgin**

Izdatel'stvo Akademii Nauk SSSR,
Moscow-Leningrad (1937)

Translated from the Russian by
E. A. Golomshtok, Stefansen Library

**U. S. ARMY SNOW ICE AND PERMAFROST
RESEARCH ESTABLISHMENT**

Corps of Engineers
Willetta, Illinois

PREFACE

iii

During the last 8 to 10 years, many problems relating to the mechanics of frozen ground have been investigated in the laboratories of the U. S. S. R., and a broad scientific-technological field investigation of permafrost has been made. Both types of investigations were closely connected with large-scale construction in the permafrost region and were conducted by two groups of research workers; one group was connected with the Komissiya po izucheniiu vechnoi mrazloty Akademii Nauk SSSR (Commission for the Study of Permafrost, Academy of Sciences, U. S. S. R.), and the other was connected with the laboratory of the Leningradskiy Institut sooruzhenii (Leningrad Institute of Construction) and the Leningradskiy Institut inzhenerov kommunal'nogo stroitel'stva (Leningrad Institute of Communal Construction Engineers). The second group worked as closely as possible with the Academy group.

As a result of this research, a considerable amount of data was accumulated which characterizes frozen ground and, particularly, permafrost from the construction point of view. This information is collected, correlated, and considerably developed in this book and is supplemented by material of other organizations, as well as by data from Soviet and, in part, foreign literature.

We have used comparatively little, and only the most important, data from foreign literature, as much foreign investigation, especially that dealing with permafrost, is only of a descriptive character.

It can be definitely stated that the U. S. S. R. is ahead of other countries in the study of the mechanics of frozen ground. This is especially true in the past few years, when the tremendous construction in permafrost areas has required science to solve a number of basic problems pertaining to characteristics of frozen ground.

Because of the comparative youth of the science of frozen ground, our Principles of mechanics of frozen ground can serve only as a foundation for the development of this science. Therefore, it is quite understandable that the reader will find answers only to basic questions in this book. Some questions are unanswered because they have not been investigated in these studies. Other questions, on which work has just been begun, are only partially answered.

Knowing the shortcomings of our work, we have nevertheless decided to publish it, since the theoretical and practical demands of construction in the permafrost regions are so great and insistent that, even with these shortcomings, we feel that this work will be of value to our country. We are convinced that engineers and technicians will profit by our data and use them, sometimes completely and sometimes as suggestions.

In addition, we believe that the investigators of frozen ground will find new problems stated which have been investigated little or not at all and require further work. In most cases a suggested approach has been indicated. We feel that the mere statement of such problems and suggestions for investigation will be of some value to future investigators.

As our work on frozen ground is the first and has no predecessors either in our own or in foreign literature, we were obliged to start from the very beginning - specifically, with systematization of the material and terminology, and end with conclusions and generalizations, many of which are given for the first time and constitute completely new material.

The frozen state of the ground, as indicated by the title, occupies a dominant position in our book. Although the processes of transition of the ground from the frozen to the thawed state and vice versa are discussed in detail, they have only an auxiliary importance.

Our work stands on the border of two periods in the study of frozen ground. During the first, the science of frozen ground, based on the work of former investigators - Middendorf, Lachevskii, and others, concentrated primarily on the study of permanently frozen ground. In the second, the phenomenon of seasonal freezing

iv

of the ground is included, as well as the properties of artificially frozen ground prepared in the laboratories; i. e., it embraces all problems connected with frozen ground.

We would feel completely satisfied if those engaged in practical operations under permafrost conditions and the theoreticians working with frozen ground find value even in some portions of this work.

Chapters I, IV, V, VI, and X, which deal primarily with the problems of mechanics, were written by N. A. Tsytovich, and Chapters II, III, VI, and VIII, which deal with the problems of geophysics, were prepared by M. I. Sumgin. Chapter IX, "Geotechnical investigations of permafrost," was prepared by both authors. In order to correlate the separate portions of the book, each chapter, as it was prepared was discussed by both authors.

The authors wish to thank in advance all the readers who would point out defects in the work and suggest changes and additions.

April 1936

N. A. Tsytovich and M. I. Sumgin

[Note on Translation: Because of the poor quality of the copy available, good reproduction of the photographs could not be obtained.]

Kindly address all remarks and suggestions to N. A. Tsytovich, Street No. 118 Apt. 55, Leningrad 5, U. S. S. R., or M. I. Sumgin, Piatnitskaia Street, No. 12, Apt. 7, Moscow 17, U. S. S. R.

CONTENTS

	Page
Preface	iii
Part I. Experimentation and theory	
Chapter I. Properties of components of frozen ground	
Definition of the concepts frozen and unfrozen	1
Frozen ground as a four-phase system	2
Mechanical properties of mineral particles and ice	6
Changes in properties of the ground during freezing	16
Chapter II. Physico-mechanical processes during freezing and thawing of the ground	
Crystallization temperatures of various types of water in the ground	20
Migration of moisture in freezing and frozen ground	29
Stresses in freezing ground and ground heaving	42
Universal deformation of the earth's surface	66
Chapter III. Physical properties of frozen ground	
Introduction	68
Unit weight	68
Specific gravity	69
Moisture	71
Porosity and coefficient of porosity of frozen ground	74
Water permeability	79
Capillarity of frozen ground	80
Evaporation	81
Condensation of water vapor	82
Changes of ground volume upon freezing	85
Thermal constants of frozen ground	87
Electrical properties of frozen ground	89
Chapter IV. Resistance of frozen ground to external forces	
Basic concept	91
Methods of studying mechanical properties of frozen ground	91
Effect of rate of load increase on mechanical properties of frozen ground	99
Compressive strength of frozen ground	99
Tensile strength of frozen ground	107
Shear strength of frozen ground	109
Adfreezing strength	114
Chapter V. Deformation of frozen ground under vertical load	
Types of deformation of frozen ground	129
Elastic deformation of frozen ground	133
Plastic deformation of frozen ground	145
Subsidence of frozen ground during thawing	151
Heat as an external force	161
Conclusions	172
Chapter VI. Behavior of frozen ground under load	
Introduction	173
Stress distribution in uniform layers of frozen ground	173
Specific cases of stress distribution in permafrost	177
Permissible stresses for frozen ground	184
Estimated forces of adfreezing	188
Part II. Practical applications	
Chapter VII. Permafrost and its construction properties	
Economics and construction in permafrost region in U. S. S. R.	190
Geographical distribution of permafrost	191
The active layer	191

CONTENTS (cont'd)

	Page
Part II. Practical applications (cont'd):	
Chapter VII. Permafrost and its construction properties (cont'd)	195
Thickness of permafrost.....	196
Thermal regime of permafrost.....	206
Degradation of permafrost.....	207
Hydrology of the permafrost area.....	217
Some data on soil in permafrost areas	
Moisture (ice content) of the ground in connection with building on permafrost.....	220
Chapter VIII. Interaction between permafrost and structures erected on it	226
Introduction.....	226
Earthwork.....	229
Heaving of posts and piles.....	231
Deformation of bridges.....	232
Thermal balance of foundations and the ground.....	241
Deformation of buildings and structures.....	
Chapter IX. Geotechnical investigation of permafrost for construction purposes	249
Introduction.....	250
Investigation of frozen ground.....	252
Study of the hydrological regime.....	253
Properties of permafrost from the point of view of construction.....	259
Mapping of frozen ground.....	
Chapter X. Planning and constructing foundations for structures on permafrost	262
Selection of type of foundation to be used under permafrost conditions ...	264
Data necessary for planning foundations.....	266
Calculating the stability of the frozen ground beneath the building	271
Planning the air space under the floor.....	
Planning foundations of structures built on the principle of eliminating permafrost.....	276
Heaving calculations.....	281
Examples of constructing foundations for buildings on permafrost.....	285

PART I. EXPERIMENTATION AND THEORY

CHAPTER I. PROPERTIES OF COMPONENTS OF FROZEN GROUND

Definition of the Concepts Frozen and Unfrozen.

It is well known that, with the advent of fall, the upper layers of the ground in the areas north and south of a certain latitude become cooled and freeze. This freezing is due to the fact that moisture contained in the pores of the ground is changed into a solid state — ice, at a temperature below 0C. Ground which is cemented by ice is referred to as frozen to distinguish it from unfrozen ground with a positive temperature. In the endless variety of conditions, however, there are cases where the ground has so little moisture that it remains uncemented even at a very low negative temperature. This occurs in ground which does not contain small soil particles, such as coarse sand, rock fragments, and other deposits with single-grain structure. In the Far East, M. I. Sumgin found deposits of gravel which was covered by frost during the winter, but the deposits were easily worked because the gravel was not cemented by the frost. For construction purposes, the transition from the unfrozen state to the frozen state (cemented by ice), and the reverse process, are of enormous significance. For a number of types of construction, however, the most important characteristic is not the cementing of the ground by ice at a negative temperature, but the very presence of this negative temperature. In a water supply system, the water is in equal danger of being frozen in the pipes whether the surrounding ground is cemented by ice or not, if the ground has a negative temperature. This also applies to drainage pipes, oil pipes, and many other types.

Thus, for a certain type of construction, it is necessary to know, first, whether the ground has a positive or negative temperature, and then, within the limits of this negative temperature, whether the ground is cemented by ice or not.

Consequently, ground can be divided into two classes: (1) ground with a positive temperature and (2) ground with a negative temperature.

Later on we will deal only with ground of the second class: ground of class 1 will be dealt with only on very rare occasions.

The ground of class 2 is divided according to water content: (1) ground containing water in the solid phase — ice, and (2) ground containing no ice, although it has a negative temperature.

These two categories of ground with negative temperatures may be subdivided into several types as follows:

Ground with a negative temperature

A. Ground with ice crystals — frozen ground

1. Ground is not cemented by ice, although it contains separate ice crystals.
2. Only parts of the ground are cemented by ice.
3. Ground is completely cemented by ice.

Note: The ground may simultaneously contain both water in the liquid state and ice.

B. Ground without ice crystals

1. Ground contains no water.
2. Ground contains only hygroscopic or film water in liquid state.
3. Ground contains water in supercooled state.
4. Ground contains salt solutions in supercooled state or at a temperature above the freezing point of the solution.

We shall use the term "frozen ground" for ground which contains ice. We will often consider ice as one of the components of the ground. In this sense even pure ice

1. The classification suggested here for ground with a negative temperature is satisfactory for our practical purposes: for theoretical purposes, it needs further delineation.

PRINCIPLES OF MECHANICS OF FROZEN GROUND

will, under certain conditions, be considered as ground.

With a rise in temperature frozen ground reaches a state when the ice contained in it begins to thaw, absorbing the so-called latent heat of thawing. During the thawing process, the ground contains both ice and water.

With a lowering of temperature, unfrozen ground reaches a state when the water begins to crystallize, emitting the latent heat of freezing. During the process of freezing, both water and ice coexist in the ground.

Consequently, ground containing ice crystals may be: (1) in a frozen state, (2) in the process of thawing, or (3) in the process of freezing. Ground containing ice crystals can be in a frozen state only when the emanation of the latent heat of freezing has terminated or when the absorption of the latent heat of thawing has not yet begun.

The processes of freezing and thawing of ground take place at a given negative temperature, usually somewhat below 0C but in some cases, as indicated later, considerably below 0C.

Consequently, the frozen ground has a lower temperature than the temperature of its thawing and freezing. For the sake of simplicity, we have not introduced in our classification special subdivisions for the states of freezing and thawing but have considered these as transition stages.

These are the simplest considerations which form the basis of our definition of the concepts: frozen, unfrozen, freezing, and thawing. Under natural conditions, the situation is much more complex than is presented here. In practice, water contained in the ground is always some sort of solution, although it may be an extremely weak one. Likewise, absolutely dry ground does not exist, and the processes of freezing and thawing may take place intermittently, with an alternation of supercooling and crystallization.

Frozen Ground as a Four-Phase System

Generally speaking, frozen ground can be considered as a system of contiguous substances. Every substance which may be separated from the system by purely mechanical means is called a phase. For example, water with floating ice is a two-phase system, and, if one considers the vapor over the water, a three-phase system. A freezing saturated salt solution forms a four-phase system consisting of salt, ice, water, and vapor.¹

Frozen ground is one of the most complex substances because, generally, it consists of solid mineral particles, ice particles, water, and air with a certain amount of water vapor. Therefore, frozen ground can be considered as a four-phase system: solid mineral particles, a binding substance (ice), water, and air. The mechanics of frozen ground then, is the mechanics of a four-phase system. The basic components of frozen ground will be the solid mineral particles and the ice which cements them.

Mineral particles

Later on we will consider the processes which take place during the freezing and thawing of porous ground, as well as the properties of the porous ground in the frozen state; bedrock will be considered only on specific occasions.

The mineral particles which form the skeleton of the frozen ground may have a variety of sizes and forms. They may be divided into groups and subgroups as shown in Table 1.

The basic properties of the sand and gravel particles are the hardness of the grain, the absence of cohesion, and a considerable resistance to friction. In a majority of cases, silt particles are round, which facilitates their mobility. The work of Professors Atterberg, Terzaghi, and others has established that clay particles have a clearly defined flaky, scale-like shape. They are elastic, plastic in the mass, highly compressible, and characterized by considerable cohesiveness.

¹ I. O. D. Khvol'son (1912) Kurs fiziki (Textbook of physics). Tom 3.

EXPERIMENTATION AND THEORY

3

Table 1. Classification of mineral particles forming skeleton of frozen ground

No.	Type of particles	Diam of particles (mm)
1	Gravel	>2
2	Sand: coarse medium fine	2-1 1-0.25 0.25-0.05
3	Silt: coarse fine (inorganic)	0.05-0.01 0.01-0.005
4	Clay: coarse fine	0.005-0.001 <0.001

The properties of the soil depend, to a considerable degree, upon the percentage of clay in the soil. Consequently, at the present time, the percentage of clay sizes in the soil forms the basis for classification of grounds which are heterogeneous in their grain size composition. Table 2 shows the classification according to grain size which is used in construction. The more detailed classification of V. V. Okhotin is used in road building.¹

Table 2. Classification of soil according to grain-size composition*

No.	Type	Weight of particles (%)		
		Clay <0.005 mm	Silt 0.005-0.05 mm	Sand 0.05-2 mm
1	Fat clay	>50	-	<3
2	Lean clay	60-30	-	More sand than silt
3	Clayey sand	30-10	-	
4	Silty sand	10-3	-	
5	Sand	<3	<20	>50
6	Silty clay	>30	More silt than either clay or sand separately.	-
7	Clayey silt	30-10	More silt than sand.	-
8	Sandy silt	10-3	-	-
9	Silty sand	<3	20-50	-
10	Silt	<3	>50	-

* [As the Russian classification does not correspond completely to any standard American classification, the soil terms cannot be translated precisely. Translations given in Table 2 are followed throughout the text.]

If the ground also contains gravel particles exceeding 10% of the total weight, the word "gravelly" is added to the specific classifying term of the ground.

The above classification, or one similar to it, is used to place frozen ground in a soil category. Actually, other properties, such as amount of ice and the temperature, are very often more significant for frozen ground than the grain size. A special classification of frozen ground taking physical-mechanical properties into consideration

I. V. V. Okhotin (1933) Granulometricheskaya klassifikatsiya gruntov na osnovе ikh fizicheskikh i mekhanicheskikh svoystv (Grain-size classification of soil on the basis of physical and mechanical properties). Leningrad: TsIAT.

PRINCIPLES OF MECHANICS OF FROZEN GROUND

would be more correct. Unfortunately, there is not sufficient data for such a classification at present.

The grain-size classification may serve only for a preliminary appraisal of frozen and thawed ground. Thus, sand and silty sand will have considerable water permeability after thawing, so that they settle under load very rapidly, for all practical purposes independent of the time factor. Saturated silt will easily become fluid when the hydrostatic balance of the water is disturbed.

The properties of clayey soil will depend almost entirely on the amount of ice in it. Frozen clay or clayey sand, owing to its extremely low water permeability, will lose its water content and consolidate very slowly after thawing (over a period of years or decades). Therefore, ice-saturated (especially supersaturated) clayey soil will often have an extremely low bearing capacity after thawing and will be extruded from under a foundation under load. Settlement of thawed clayey soil may continue for an extremely long time and, depending on the size of the load, will either decrease in the course of time (process of consolidation), or continue at the same rate and for an indefinitely long time (the process of plastic flow).

Sand and silty sand in the frozen state will be more rigid than clayey soil.

The influence of the grain size composition of frozen ground on resistance to an outside force and on deformation at a negative temperature, and also during the transition from the frozen to the unfrozen state, will be discussed in detail below.

Ice

The most important factor determining the mechanical properties of frozen ground is the ice content.

Ice may be found in frozen ground in various forms: (1) layers, (2) lenses, which under permafrost conditions may be several cubic meters (and even tens of thousands of cubic meters) in volume, (3) thin laminae between separate mineral grains, (4) rime, etc. In an overwhelming number of cases, the ice in frozen ground is more or less evenly distributed in layers of various thicknesses and, very rarely, in the form of grains; on some occasions, the ice is a thin film covering the soil grains.

Structure of ice. At the present time, it has been established that ice contains triple molecules of water (trihydrol). According to Barnes¹, water approaching the moment of freezing contains ice in the liquid state, or more correctly molecules of ice. According to this theory, water in the vapor state has single molecules (hydrol); in the liquid state, double molecules (dihydrol); and in the solid state, triple molecules (trihydrol). As water cools, the number of trihydrol molecules increase, forming 16% of the water at 100C, and 37% at 0C. At the present time presence of trihydrol molecules in ice is considered proved.

Prior to freezing, water contains ice (trihydrol) much in the same way as a solution contains salt, and the freezing point of water may be looked upon as that temperature at which the solution of ice becomes saturated.

During the transition from the liquid to the frozen state, water forms platelike hexagonal crystals, because ice crystallization is strong in the direction of the secondary axis and insignificant along the main axis.

Depending on the manner of ice formation, the following ice structures may occur: (a) inassive, (b) acicular, (c) layered, (d) neve, (e) small aggregates (irregular), and (f) porous-flaky.

(a) Massive crystalline ice originates during calm freezing of water in large basins, and most often corresponds to the average thickness of the ice cover of the water.

(b) Acicular structure usually forms in the lower part of the ice cover (where ice and water are in contact) as separate long crystals or pipes of various forms, containing air bubbles and sometimes forming several layers.

¹ H. Barnes (1934) Ledotekhnika, translation edited by V. E. Timonov, Gosenergiizdat, [Probably H. T. Barnes (1928) Ice engineering, Montreal, Canada: Renouf Publishing Company]

(c) Layered ice forms as a result of the settling of separate layers of wet snow or by separate layers of water freezing one at a time.

(d) Nèvé (or granular ice) forms when snow freezes into separate grains in the form of opaque ice spheres, several millimeters in diameter. On high mountains nèvé forms whole fields which often cover glaciers and move with them.

(e) Small aggregates of ice are due to the alternation of freezing and mixing; they have many varieties, often take irregular form, and are usually observed in the upper part of the ice of large water basins. They are formed during the initial freezing of the basin, when the wind breaks up the ice cover.

(f) Porous-flaky ice occurs in the freshly deposited snow cover and also when water freezes as it condenses from vapor. The ice crystals may assume very diverse forms.

It must be pointed out that, under great pressure, ice may change from one form of crystalline ice into another (ice I, II, and III).

Thus, according to Tammann's experiments, a lowering of ice temperature and an increase of pressure up to 2200 atm (or kg/cm²), will transform ordinary crystalline ice I into crystalline ice II, which not only differs from the ordinary type in structure but also is heavier than water. Ice I may also be transformed into ice III, which according to Tammann¹, is formed at a pressure of 2235 atm and at -34C and -64C.

Figure 1 shows the transition of ice I into ice II and ice III, and the changes of the thawing points with an increase in pressure.

The change of ice I into ice II and III is accompanied by sharp changes of volume and the consumption of enormous quantities of heat.

Water and air

Water and air occur in the frozen ground only under special conditions.

Water in the supercooled state, i. e. below 0C, may be found in frozen ground. The conditions of water freezing in thin capillaries and films are conducive to supercooling. According to Bouyoucos*, the freezing temperature of gravitational water in the ground often reaches -1.5C, while water in very thin capillaries, especially hygroscopic water, i. e., water which is held by molecular attraction, may not freeze at a temperature as low as -78C. Sumgin's experiments have shown that a film of water 1.4 microns thick placed between two sheets of glass did not freeze during 2 hours at a temperature of -17C. Apparently the presence of supercooled water in the frozen ground tends to decrease the general shearing strength of frozen ground.

Under permafrost conditions, after the long continuous influence of negative temperatures (for several millenniums) the presence of water in a supercooled state is much less probable than in the frozen ground of the active layer, i. e., the layer of annual freezing and thawing.

The temperature of water freezing depends not only on the forces of molecular interaction in the thin capillaries of the ground, but also to a great degree on the

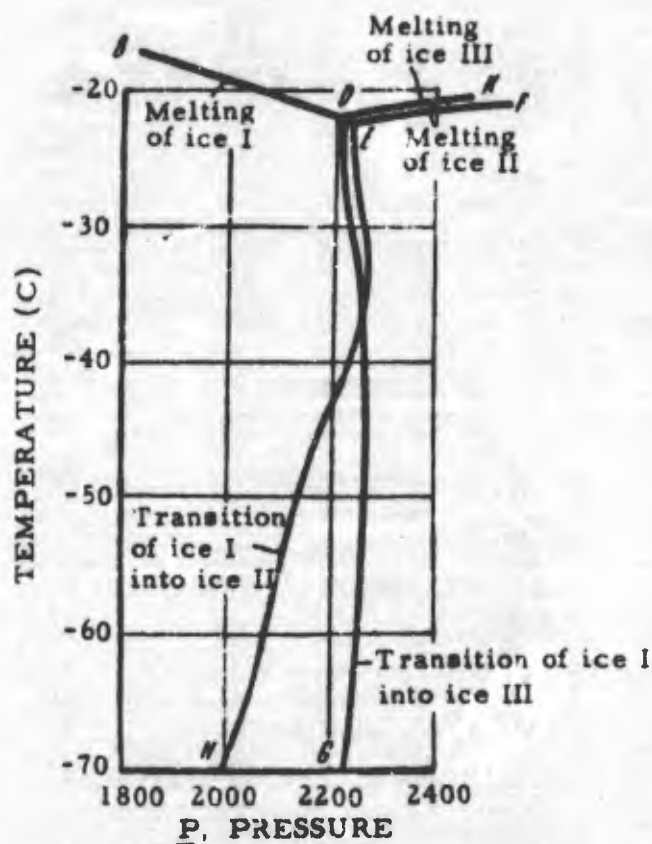

Figure 1. Transition of ice I into ice II and ice III, depending on pressure and temperature.

1. Cited from B. P. Veinberg (1908-1910) Obshchii kurs fiziki (General physics).

* [No reference given.]

PRINCIPLES OF MECHANICS OF FROZEN GROUND

quantity of substances dissolved in the water. To illustrate, data on the lowering of the freezing point of water as a function of the content of common salt, NaCl, are given in Table 3.

Table 3. Relation of freezing point of water to salt (NaCl) content.

Amount of anhydrous NaCl (g/100 cc of water)	0.0000	0.1208	1.479	10.77	22.90	30.40
Freezing point (C)	0.0000	-0.0736	-0.8615	-6.32	-14.77	-21.12

The transformation of water contained in frozen ground into ice, as well as the evaporation of water and ice, depends on temperature and pressure. This relationship may be represented by a "phase diagram" (Fig. 2).

Figure 2 shows the curves of equilibrium of various states of water.

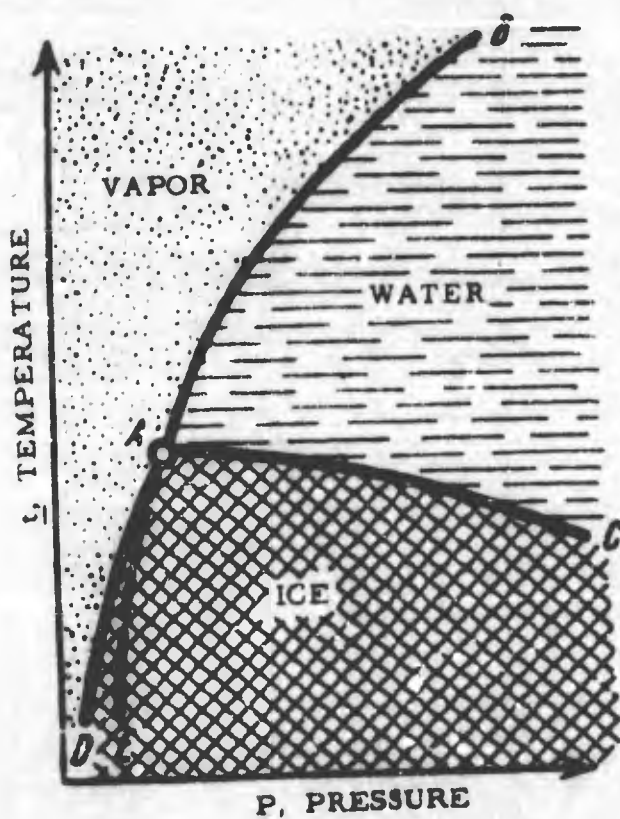

Figure 2. Phase diagram of water, vapor and ice.

At the pressure and temperature shown by the coordinates of point A, solid ice, the liquid phase of water, and vapor will be found in equilibrium and may remain in that state for an indefinitely long period without changing from one phase to another. Point A is the well-known triple point showing the conditions under which a substance can exist simultaneously in three phases: solid, liquid, vapor. For water, this point corresponds to 0.0074°C, and a pressure of 4.583 mm mercury.

The three curves of equilibrium are the border lines for the three fields of stable conditions: vapor, liquid, and ice crystals. On each curve the two conditions separated by the curve occur in equilibrium.

Air in frozen ground is: (1) free air, i. e., air connected with the atmosphere, or (2) enclosed air. Under natural conditions, the first type will occur primarily in ground which contains little ice, although it can occur in other types of ground where it can penetrate through the frost cracks. Its influence on the mechanical properties of frozen ground is so insignificant that it can be disregarded.

The second type, enclosed air, occurs in the pores of the ground, and, because it has an absolute elasticity, it may materi-

ally influence the elastic properties of frozen ground.

Mechanical Properties of Mineral Particles and Ice

Strength of mineral particles

The strength of the fragments of various rocks which form part of the composition of frozen ground is considerable. Their resistance to external forces is measured in tens and hundreds of kilograms per square centimeter.

I. V. K. Frederiks and A. P. Afanasev (1935) Kurs obshchei fiziki (Textbook on general physics). Leningrad.

EXPERIMENTATION AND THEORY

7

Table 4 shows the average ultimate^o compressive, tensile, bending, and shear strengths of natural stone materials, according to the experiments of Bach, Bauschinger, Feppel, and Ganish.¹

Table 4. Ultimate strength of rock.

Type of rock	Ultimate strength (kg/cm ²)				Average Young's modulus, (kg/cm ²)
	Compression	Tension	Bending	Shear	
Granite	450-2,000	40-80	100-230	70-100	3×10^5
Sandstone	200-2,000	40-80	100-175	13-36	7×10^4
Limestone	200-1,800	10-30	40-200	30-47	_____

It may be expected that the resistance of separate particles (granite, quartz, etc.) will be considerably larger than the values given in Table 4, which pertain to the cemented aggregates of these particles. Thus, for example, the ultimate tensile strength of a quartz crystal is 1100 kg/cm² when the force is directed parallel to the axis of the crystal, and 830 kg/cm² when the force is directed perpendicular to its axis.

The extremely large ultimate compressive strength of rock which, on the average, measures 1000 kg/cm², should also be noted.

Thus, under the usual stresses in natural conditions, disruption of the stability of frozen ground cannot be due to the mechanical properties of its mineral particles.

It is the properties of ice which are extremely important in the study of the mechanical properties of frozen ground. Ice fills the space between the separate mineral grains of the ground completely or partially and acts as a bond. The strength of the frozen ground, therefore, will depend on the strength of the ice bond.

Strength of ice

The strength of ice under stress depends on the structure of the ice, its temperature, and the conditions of the test. The mechanical properties of ice, which are so important for the solution of a number of engineering problems, have been studied for a long time.

As early as 1871, H. Moseley tested the elastic properties of ice by the bending method. Later, in 1902, H. Hess made a series of tests to determine its compressive strength, tensile strength, and modulus of elasticity. We must also note the thorough investigations of ice properties by B. P. Veinberg (1900-1913), the experiments of G. G. Bell (1914), the systematic tests of ice strength by V. N. Pinegin (1922), the experiments by H. Barnes (1914-1928), N. Finlayson (1927), and others.

According to these studies, the compressive strength depends on the direction of the outside force, i. e., whether the force is applied parallel or perpendicular to the axis of the ice crystals, and also on the negative temperature, the ice structure, and the duration of the load.

1. This table is compiled from data in: S. R. Brillings (1928) Kamennye konstruktsii, spravochnik dlia inzh. -stroit. (Stone construction, a handbook for civil engineers), tom I, Moscow.

* [Used throughout as ultimate strength for relatively brief loading (Russian term: "Vremennyi")].

Some values of the ultimate compressive strength of ice are given in Table 5. ¹ An analysis of the data leads us to the following conclusions.

1. The ultimate compressive strength of ice varies considerably with ice texture, even at the same temperature. According to the data, the compressive strength at temperatures between 0 and -2C varies from 17.5 to 127 kg/cm²; and, the strength values differ for the upper, middle, and lower portions of the river ice. The data show that the texture of the ice plays an important part in its strength.
2. Compressive strength of ice depends on the direction of pressure in relation to the axis of the crystal. It is greater when pressure is applied parallel to the axis of the crystals (which, for the ice cover of water basins, will be perpendicular to the water's surface) than when pressure is applied perpendicular to the axis of the crystals.
3. Ultimate compressive strength of ice depends on the negative temperature and increases with lower temperature.
4. Ultimate compressive strength of ice, as determined experimentally by crushing ice samples, depends on the rate of application of the compressing load (Brown's experiments). ^{*} Apparently, most investigators have paid little attention to this fact, which explains the differences in their results. As has been shown by recent investigations, the rate of stress increase is so important that it cannot be disregarded under any circumstances. Investigations conducted by the soil laboratories of the L. I. I. K. S. (Leningrad Institute of Communal Construction Engineers) show that the ultimate compressive strength of ice is 60 kg/cm² at a stress increase of 20 kg/cm² per minute, 37 kg/cm² at an increase of 36 kg/cm² - min, and 24 kg/cm² at 50 kg/cm² - min.

Therefore, the ultimate compressive strength of ice depends on a number of factors, the most important of which are its texture, temperature, and the rate of load increase.

The tensile and shear strengths of ice are also important factors. The results of experiments by various investigators are given in Table 6. ²

The data shown in Table 6 indicate that the ultimate tensile and shear strengths of ice depend on the same factors as the compressive strength (Table 5). However, the influence of these factors is different; the influence of temperature on shear strength is most evident at temperatures close to 0C.

In solving certain problems of the mechanics of frozen ground (for example, the problem of surface icing, etc.), the bending strength of ice is also important.

Average values of the ultimate bending strength of ice are given in Table 7 on the basis of data of various investigators.

1. Table 5 was compiled from the following sources:

H. Barnes, *op. cit.*

V. N. Pinegin (1924) Predvaritel'noe soobshchenie ob issledovanii prochnosti l'da v svyazi s temperaturnymi izmeneniyami (Preliminary communications on investigations of ice strength relative to temperature), Soobshcheniia o nauchno-tekhnicheskikh rabotakh v Respublike, vyp. 12.

A. N. Komarovskii (1932) Struktura i fizicheskie svoistva ledianogo pokrova presnykh vod (Structure and physical properties of ice cover of fresh waters), Gosenergizdat, Moscow.

B. N. Sergeev (1929) Ustroistvo zimnei perepravy vagonov po l'du i rabota ledianogo sloia pod deistviem nagruzki (Building a winter ice crossing for railway cars and behavior of an ice layer under load), 16th Compendium of the Department of Engineering Research, NKPS, Moscow.

2. Table 6 was compiled from the same sources as Table 5.

* [No reference given.]

EXPERIMENTATION AND THEORY

Table 5. Ultimate compressive strength of ice

No.	Investigator	Type of ice	Direction of pressure in relation to axis of ice crystals	Temp (C)	Ultimate compressive stress (kg/cm ²)	Remarks	
1	H. Hess (1902)	Glacial	-	-	25	-	
2	Bell (1914)	River	Parallel	0	41.5	Avg of 6 tests	
3	Barnes and Mackay (1914)	River, very clear	-	near 0	25.9	-	
4	" " "		Normal	near 0	24.9		
5	Brown (1926)	River	-	-2.2	21.0	At rate of 266 kg/sec	
6	" "		-	-10.0	48.5		
7	" "		-	-16.7	56.8		
8	Kreyger (1921)	Lake	Normal	-4.5 to -6	45 to 61	-	
9			Parallel	-4.5 to -6	65 to 109	-	
10	B. P. Vasenko (1897)	Artificial, from river water	-	-10	26.8	-	
11	" "		-	-12.5	28.6	-	
12	" "		-	-17.5	29.7	Avg of 3 tests	
13	" "		-	-18.8	40.5	Avg of 4 tests	
14	N. Finleyson (1927)	River, very uniform texture	Parallel	-1.6	127	-	
15	" "		Normal	-1.6	74	-	
16	V. N. Pinegin (1924)	River, upper part	Parallel	0 to -2	20.7	Avg of 3 tests	
17	" "		Parallel	-8 to -10	26.0		
18	" "		Parallel	20 to -23	38.4		
19	" "		Normal	0 to -2	18.4		
20	" "		Normal	-8 to -10	25.2		
21	" "		-	-20 to -23	28.2		
22	" "		Parallel	0 to -2	35.8		
23	" "		-	-8 to -10	32.8		
24	" "		River, middle part	-	-20 to -23		76.0
25	" "		Normal	0 to -2	28.2		Avg of 3 tests
26	" "	-	-8 to -10	33.5			
27	" "	-	-20 to -23	69.2			
28	" "	River, lower part	Parallel	0 to -2	17.5	Avg of 3 tests	
29	" "		-	-8 to -10	20.4		
30	" "		-	-20 to -23	37.6		
31	" "		Normal	0 to -2	12.0		
32	" "		-	-8 to -10	18.2		
33	" "		-	-20 to -23	32.1		
34	B. N. Sergeev (1929)		Volga River, upper part	-	near 0		22.4
35	" "	middle part		-	near 0	34.7	
36	" "	lower part		-	near 0	23.3	
37	A. N. Komarovskii (1932)	River, (recommended to be used as average)	-	0 to -2	30		

Table 6. Ultimate tensile and shear strength of ice.

No.	Investigator	Type of ice	Direction of pressure in relation to axis of ice crystal	Temp (C)	Ultimate tensile strength, (kg/cm ²)	Ultimate Shear strength, (kg/cm ²)	
1	H. Hess	Glacier	-	-	7.0-8	4.8 to 24.8	
2	B. P. Vasenko	Artificial	-	- 5	12.3 (avg)	-	
3	"		-	-15	17.6 (avg)	-	
4	V. N. Pinogin	River, upper part	Parallel	0 to -2	-	6.2	
5	"		Parallel	-8 to -10	15.2	6.8	
6	"		Parallel	-20 to -23	17.2	9.2	
7	"		Normal	0 to -2	6.8	6.1	
8	"		Normal	-8 to -10	7.6	7.1	
9	"		Normal	-20 to -23	10.8	12.8	
10	"		River, middle part	Parallel	0 to -2	11.4	6.5
11	"			Parallel	-8 to -10	15.5	8.7
12	"			Parallel	-20 to -23	18.1	12.5
13	"	Normal		0 to -2	10.3	6.5	
14	"	Normal		-8 to -10	12.6	10.4	
15	"	Normal		-20 to -23	14.6	13.2	
16	"	River, lower part		Parallel	0 to -2	10.5	6.0
17	"			Parallel	-8 to -10	11.4	-
18	"			Parallel	-20 to -23	12.7	9.1
19	"		Normal	0 to -2	5.4	6.9	
20	"		Normal	-8 to -10	7.1	8.8	
21	"		Normal	-20 to -23	8.2	9.5	
22	N. Finlayson	River	Parallel	-1.1	-	6.9	
23	"		Normal (usually)	-23.3	-	8.1	
24	M. L. Sheikov and N. A. Teytovich	Artificial	-	0.0	-	9.9	
25	"		-	-0.4	-	11.0	
26	"		-	-2.9	-	27.4	
27	"		-	-4.4	-	32.5	
28	"		-	-6.1	-	38.5	
29	"		-	-10.1	-	56.2	

It is interesting to note that the bending strength of ice, more than any other type of strength, depends to a great degree upon the ice texture. Under similar experimental conditions, B. P. Veinberg obtained values which varied from 4 to 29.6 kg/cm² for different parts of the same river ice.

The cementing action of ice in forming frozen ground masses is primarily a result of the so-called forces of adfreezing, i. e., the forces of adhesion of ice crystals and the mineral particles of the ground. The adfreezing strength of the ice is the adhesive strength of the frozen ground.

Several values of the adfreezing strength of ice with concrete and wood are given in Table 8. From the data we conclude that the adfreezing strength of ice with concrete and wood increases considerably with lower ice temperature.

Deformation of ice

Like any other physical body, ice is deformed by outside forces. Plastic deformation is especially important for ice. This deformation consists of the sliding of certain layers of ice in relation to others, and occurs when the shearing stresses under load reach a critical value.

Under the simplest stress condition, plastic deformation will be in direct proportion to the quantity and duration of load, and in inverse proportion to the coefficient of viscosity.

EXPERIMENTATION AND THEORY

Table 7. Ultimate bending strength of ice.

No.	Investigator	Type of ice	Temp of ice (C)	Bending strength, (kg/cm ²)	Remarks
1	Vasenko (1897)	River	-18.7	32.3	Avg of 5 tests
2	" "	Artificial	-18.7	34.4	
3	Kraygar (1921)	Lake	-0.2	16	Avg of 4 tests
4	" "	Lake	-4.0	34	
5	Pinogin (1922)	River	-3 to -5	18	Avg
6	" "	River	-9 to -11	33	"
7	Veinberg (1912)	River, upper layer	about 0	8.3	Avg
8	" "	River, middle layer		13.0	
9	" "	River, lower layer		12.7	
10	Veinberg (1923)	River, upper layer	-	12.1	Values differ considerably from the average. (Values for No. 10 ranged from 4-17 kg/cm ²)
11	" "	River, middle layer	-	11.2	
12	" "	River, lower layer	-	15.2	
13	Sergeev (1929)	River, upper layer	about 0	10.4	
14	" "	River, middle layer		3.9	
15	" "	River, lower layer		14.4	

Table 8. Adfreezing strength of pure ice with concrete and wood.

No.	Investigator	Material and type of adfreezing surface	Temp of ice (C)	Adfreezing strength of ice (kg/cm ²)	No. of tests for average
1	Bell (1911)*	Plastered concrete, not iron-plated	0	9.6	2
2	" "		-1.1	14.9	2
3	Tsyrovich (1930)**	Wood (pine) with a smooth surface, air-dried before it was placed in water.	-1	5.2	3
4	" "		-5	6.2	3
5	" "		-7	11.6	3
6	" "		-10	13.7	7
7	" "		-20	22.0	3
8	" "	Smooth concrete	-5 to -10	11.5	13
9	" "		-5 to -10	9.8	13

* H. Barnes, *op. cit.*

** N. A. Tsyrovich (1932) *Nekotorye opyty po opredeleniyu sily smerzaniya*, (Some experiments to determine adfreezing forces). *Bulleten' Leningradskogo Instituta sooruzhenii*, No. 25.

The coefficient of viscosity (or coefficient of internal friction) is defined as the total resistance at a fixed rate of motion per unit of surface area of the shearing layer per unit of angular rate of shear.¹

An extensive and carefully conducted investigation of the coefficient of viscosity of ice was carried out by B. P. Veinberg. According to his investigations, the coefficient of viscosity depends to a great degree upon the temperature of the ice and may be expressed by the following formula:

$$\eta = (1.244 - 0.502t + 0.0355t^2) \times 10^{13} \text{ g/cm-sec} \quad (1)$$

where t is the absolute value of the negative temperature, in C. The numerical values 1.244, 0.502, and 0.0355 were found by the experimental method.

1. B. P. Veinberg (1906) *O vnutrennem trenii l'da* (Viscosity of ice), *ZhRfKhO*, tom 38, vyp. 3 and 4.

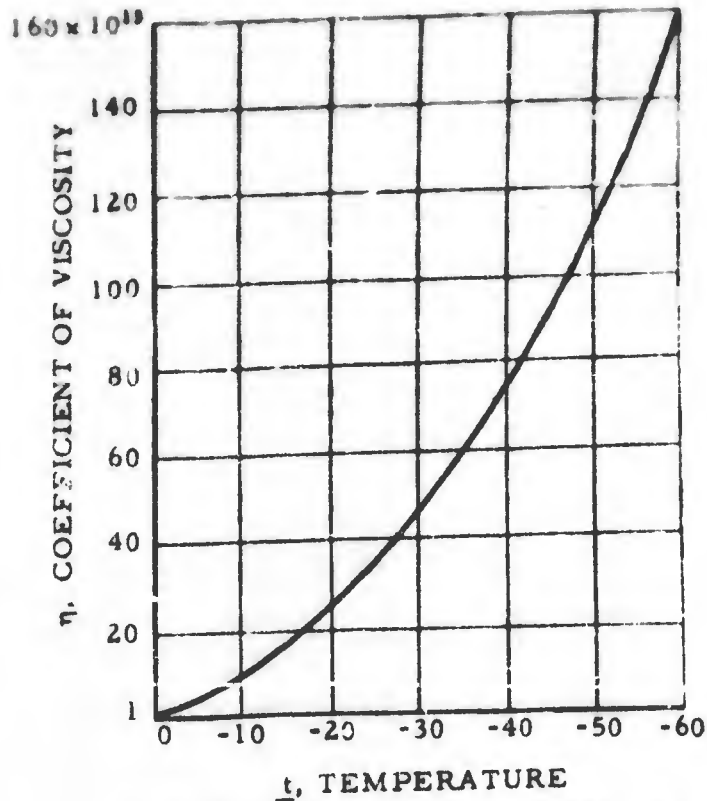

Figure 3. Relationship between coefficient of viscosity of ice and temperature.

Figure 3 shows the relationship between the coefficient of viscosity of ice and temperature.

The data shows that the internal friction of ice (viscosity), which determines its resistance to deformation, increases with a lowering of the temperature. However, at a temperature of 0C, the viscosity of ice is not equal to zero but is represented by a definite and significant value (1.244×10^{13} g/cm-sec). When ice melts, its viscosity decreases rapidly reaching an insignificant value of 0.0179 g/cm-sec. at 0C. But ice differs from water not only in the enormous value of its coefficient of internal friction, but also in the fact that this coefficient depends upon the rate of deformation, as was shown by the observations of B. P. Veinberg on the twisting of ice rods.

Ice deformation and the effects of temperature and amount of load has been studied by many investigators: Pfaff (1835), McConnell and Kidd (1888), B. P. Veinberg (1906), N. Royen (1921), V. N. Pinegin (1922), and others. According to experiments, the deformation of ice is almost directly proportional to the stress and is related to negative temperature, decreasing with lower temperatures.

Some experimental values of relative deformation of ice under compression and tension are given in Table 9.

The data show that relative deformation of ice under tension decreases with an increase in duration of load. Conversely, as shown in Table 9, deformation under compression increases with increase in duration of load.

Table 9. Relative deformation of ice under tension and compression.

No.	Investigator	Type of ice	Temp (C)	Type of stress	Stress (kg/cm ²)	Duration of tests. (hr)	Average unit strain per hr	
1	Pfaff (1875)	Granular (snow) Sea (water) Granular Sea	0	Tension	1	168	1.31×10^{-4}	
2	McConnell (1888)		0		2	0.17	1.86×10^{-2}	
3	"		0		2	72	1.3×10^{-5}	
4	"		0		2.75	6	3.4×10^{-4}	
5	"		0		2.75	16	1×10^{-4}	
6	"		0		2.8	48	7×10^{-6}	
7	"		0		3.2	120	3.3×10^{-4}	
8	"		0	3.2	72	1.1×10^{-5}		
9	Royen (1921)		Sea	-2	Compression	4.3	5	$4.8 \times 10^{-4*}$
10	"			-3		4.3	30	$5.8 \times 10^{-4*}$
11	"			-2		7.9	5	$1.4 \times 10^{-4*}$
12	"			2		7.9	30	$1.7 \times 10^{-4*}$

* According to the graph.

Figure 4 shows curves of relative ice deformation under compression in relation to ice temperature and duration of load. These curves characterize the plasticity of ice.

According to Royen, relative plastic deformation is directly proportional to the compressive load and depends on (a) duration of load, increasing with duration, and (b) the negative temperature of ice, decreasing with lower temperature.¹

The following data on the rate of plastic flow of ice from openings, are of interest.

Experiments by Tammann established that the plasticity of ice increases very rapidly at a temperature near the melting point. The results of Tammann's experiments are given in Table 10.² An analysis of Table 10 shows that ice can flow even at comparatively low temperatures under sufficiently high pressure.

Such great pressures can arise in frozen ground only under specific conditions at the points of contact between the mineral particles and the ice.

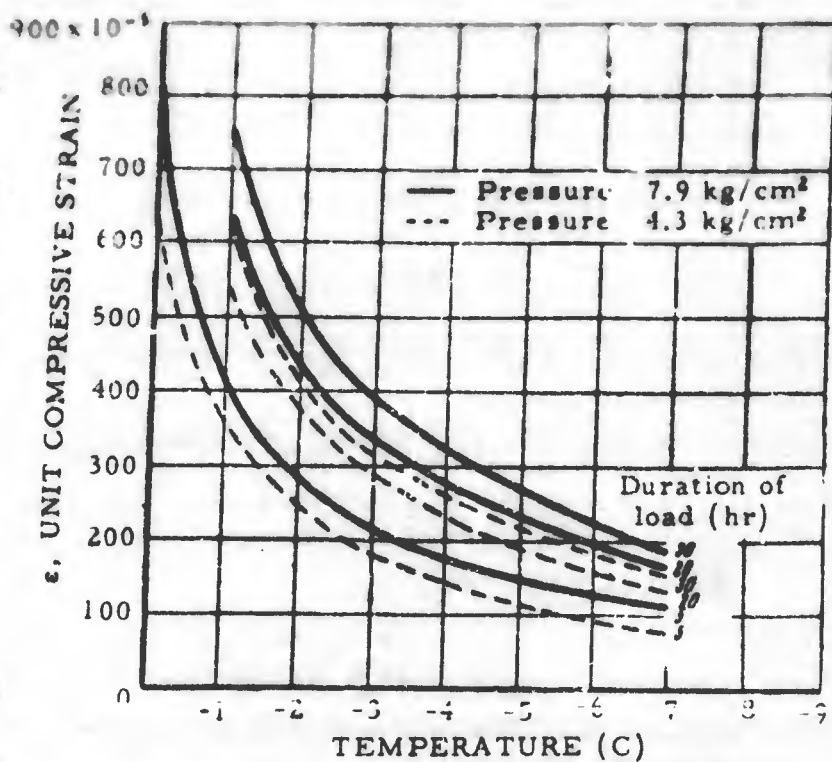

Figure 4. Relative deformation of ice under compression in relation to temperature and duration of load.

Table 10.

Temp (C)	Pressure at which more rapid flow takes place, (kg/cm ²)	Maximum pressure at which steady flow takes place, (kg/cm ²)	Pressure producing thawing, (kg/cm ²)
-5.7	665	642	678
-10.7	1,130	1,116	1,225
-15.7	1,729	1,611	1,681
-21.7	2,100	2,000	2,070
-27.6	2,240	2,220	-

Stresses at points of contact of mineral particles and ice. In frozen ground, the stresses at the points of contact may reach a considerable value even if the load acting on the top layer of the frozen ground is only a few kilograms per square centimeter.

We can apply Herz's formula from the theory of elasticity,* to determine the stresses at the contact point of mineral particles and ice.

1. A. N. Komarovskii, op. cit.
2. H. Barnes, op. cit.

* [S. P. Timoshenko (1934) Theory of elasticity. New York: McGraw-Hill Book Company, Inc. p. 343]

During the compression of two elastic spheres (Fig. 5), the radius of the surface of contact will be:

$$r = \sqrt[3]{\frac{3P(k_1+k_2)R_1R_2}{4(R_1+R_2)}} \quad (2)$$

and for a sphere pressing into a flat surface

$$r = \sqrt[3]{\frac{3P}{4}(k_1+k_2)R_2} \quad (2')$$

where P is the outside compressing force and R_1 and R_2 are the radii of the spheres:

$$k_1 = \frac{1-\mu_1^2}{\pi E_1} \quad \text{and} \quad k_2 = \frac{1-\mu_2^2}{\pi E_2}$$

where μ_1 and μ_2 are the values of Poisson's ratio for the materials in contact with each other, and E_1 and E_2 are the moduli of elasticity for the same materials.

The greatest pressure p_{\max} for both cases will be:

$$p_{\max} = \frac{3}{2} \frac{P}{\pi r^2} \quad (3)$$

For example, assuming that a layer of frozen ground has a load of $\sigma = 2 \text{ kg/cm}^2$, let us determine the maximum pressure at the contact points of the mineral grains with ice, assuming that the spherical grains have a radius of 1 mm and that the surface of the ice interlayer is flat.

The number of contact points of the mineral grains with ice per square centimeter of area under load will be approximately:

$$\frac{1}{4R^2} = \frac{1}{4 \cdot 0.1^2} = 25.$$

The pressure per grain will be:

$$P = \frac{2 \cdot 1}{25} = 0.08 \text{ kg}$$

using $E_1 = 3 \times 10^4 \text{ kg/cm}^2$ and $\mu_1 = 0.4$ for ice and $E_2 = 3 \times 10^5 \text{ kg/cm}^2$ and $\mu_2 = 0.2$ for the mineral grains, eq (2') will give $r = 0.0057 \text{ cm}$, and the maximum pressure at the point of contact, from eq (3), will be:

$$p_{\max} = \frac{3}{2} \left(\frac{0.08}{0.0057^2 \pi} \right) =$$

$$= 1170 \text{ kg/cm}^2.$$

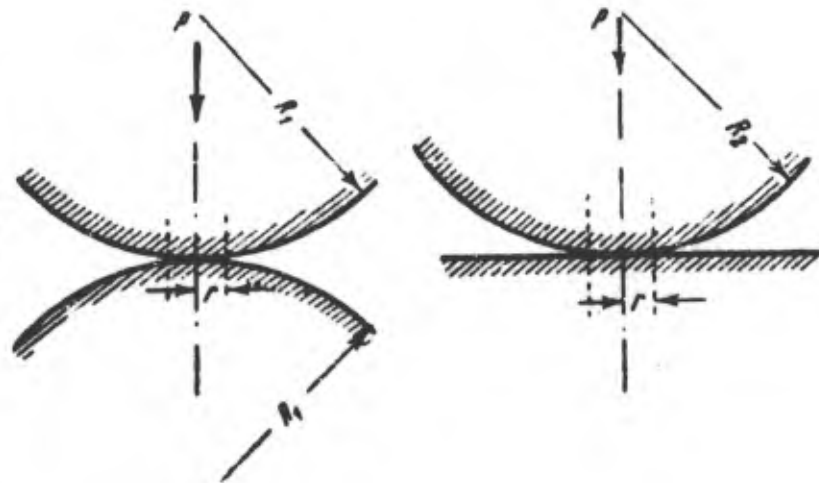

Figure 5. Schematic diagram of contact between the particles.

[Radius of top sphere to right should be labelled " R_1 " (see eq 2).]

It is clear that, under natural conditions, this pressure can last only a very short time, because plastic flow of ice will take place immediately, the area of contact will be rapidly increased, and the pressure will be diminished. Moreover, at such considerable pressures, ice at the point of contact may melt even at a negative temperature of the frozen ground. According to B. P. Veinberg,¹ the temperature of melting varies with the outside pressure as shown in Table 11.

Table 11. Melting point, specific volume, and latent heat of ice at various pressures

Pressure (atm)	Melting point (C)	Specific volume		Latent heat (cal)
		Ice	Wat.	
1	0.0	1.090	1.000	80.0
100	-0.7	(1.088)	(0.966)	(79.5)
250	-1.9	(1.085)	(0.988)	(78.6)
500	-4.0	(1.081)	(0.978)	(77.1)
1,000	-8.6	(1.072)	(0.956)	(73.6)

As the temperature rises to the melting point, the elastic limit of ice reaches zero irregularly; consequently, the above-cited relationships to determine the pressure should not be applied.

But despite the general treatment, the resultant pressure values demonstrate that considerable pressures are possible at the contact between mineral particles and ice. Even where the temperature of the frozen ground is low, these pressures are quite capable of causing plastic extrusion of the ice from the spaces between the mineral particles. This will undoubtedly have its effect upon the structure of the frozen ground.

Elastic deformation. In addition to plastic deformation, ice may also undergo elastic deformation. Because of the plasticity, elastic deformation of ice should be measured immediately after application of the load. Elastic deformation of ice depends on its texture, temperature, and origin.

The elasticity of any solid body is completely characterized by its modulus of elasticity (Young's modulus) and Poisson's ratio.

A considerable number of experiments have been made to determine the modulus of elasticity of ice, but, owing to the factors mentioned above, the values obtained show considerable deviation from the average.

For instance, according to data collected by A. N. Komarovskii, Young's modulus for ice varies from 92,700 to 4300 kg/cm², averaging about 30,000 kg/cm².

The temperature dependence of Young's modulus for ice, according to Krayger, may be expressed in the form of a linear function:²

$$E = (5 + 0.1t) \cdot 10^4 \text{ kg/cm}^2 \quad (4)$$

where E is the modulus of elasticity (kg/cm²) and t is the absolute value of the negative temperature (C).

On the basis of experimental data, V. N. Pinegin established that the modulus of elasticity of ice depends on the type of load (intermittently repeated or gradually increased), on the direction of application of the compressing forces in relation to the optic axis of the crystals, on the density, and on the negative temperature.³

1. Cf. B. P. Veinberg (1908-1910) Obshchii kurs fiziki (General physics).
2. Canadian Engineer, 1927. [No further reference given]
3. V. N. Pinegin (1927) Ob izmeneniakh modulia uprugosti i koeffitsienta Puassona u rechnogo l'da pri szhatii (Changes of the modulus of elasticity and Poisson's coefficient of river ice during compression), Nauka i tekhnika (Science and technology), Odessa NTOVSNK, nos. 3 and 4.

According to Pinegin, the other elastic constant for ice — Poisson's ratio — varies from 0.25 to 0.50, increasing with an increase in load.

Changes in Properties of the Ground During Freezing

In this section we will consider, in very general terms only, the changes of ground characteristics during freezing. The physical-mechanical processes during freezing, the properties of frozen ground, and the conditions of their stable existence, will be treated in more detail in subsequent chapters.

At this time we will only enumerate those changes in properties which distinguish frozen ground from ground with positive temperatures.

Zero curtain

During freezing of the ground, the presence of water has a considerable influence on the course of temperature changes with time.

The lowering of ground temperature from positive to negative takes place irregularly, primarily because of the emanation of the latent heat of thawing (80 cal/g of water).

The cooling curve changes its character radically at the freezing point. Though cooling of the ground continues, the emanation of the latent heat of thawing causes the temperature to remain constant during the whole period of freezing. The same process takes place at thawing, when changes in ground temperature are halted because the melting ice absorbs the heat coming from the outside. M. I. Sumgin suggested the term "zero curtain" for this phenomenon.

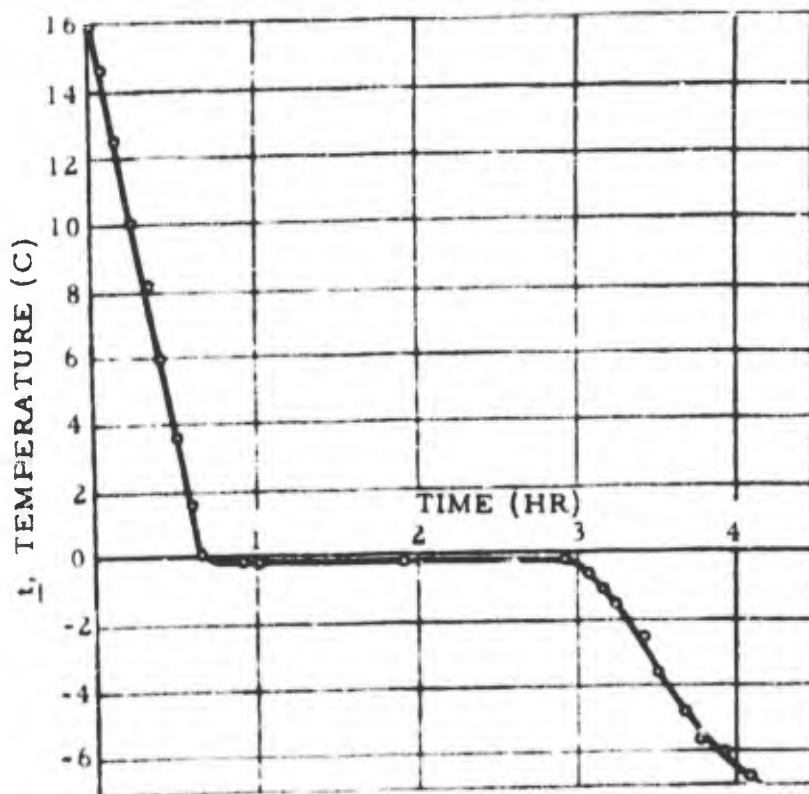

Figure 6. Ground temperature vs time.

The zero curtain retards the circulation of heat in the ground and, under natural conditions, moves gradually from the surface down to the maximum depths of freezing. The influence of the zero curtain on temperature changes increases with an increase in ground moisture.

Figure 6 shows the curve of ground temperature changes with time, based on laboratory experiments by Tsytovich; Figure 7 shows the temperature changes at 1.5, 2.0, and 2.8 m depths at the Bomnak station, based on Sumgin's data.¹

Figure 6 shows that the curves for positive temperatures differ from those for frozen ground. The rates of cooling of unfrozen and frozen ground differ owing to differences in thermal conductivity.

Thermal conductivity

The thermal conductivities of water and ice are very different. According to data of the Physikalisch - Technische Reichsanstalt (German Physical - Technical Institute),* the coefficient of thermal conductivity of water is:

1. M. I. Sumgin (1927) Vechnaia merzlota pochvy v predelakh SSSR (Permanently frozen ground within the U.S.S.R.). Vladivostok.

* [No reference given.]

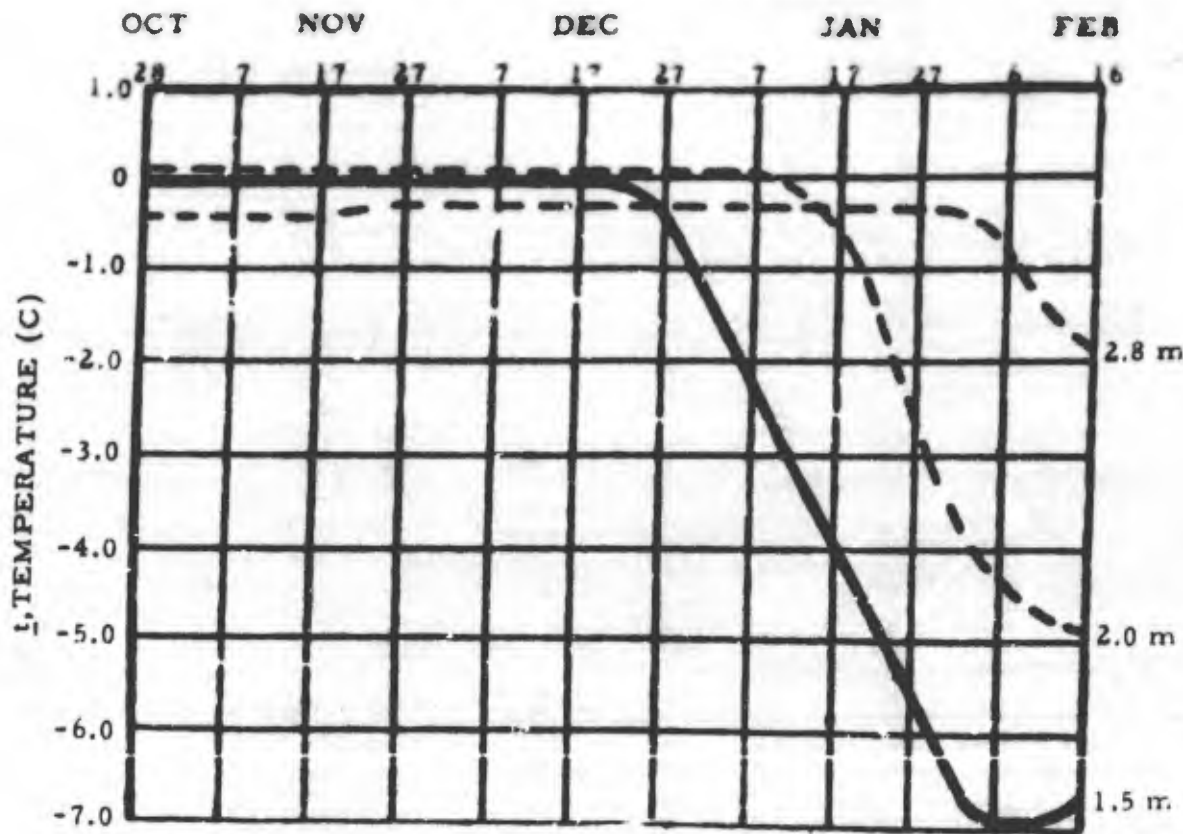

Figure 7. Temperature changes at the Bomnak station.

$$\lambda_w = 0.485 - 0.580 \text{ cal/hr/m}^2/\text{C},$$

while the coefficient of thermal conductivity of ice, according to Neumann's* experiments, is:

$$\lambda_i = 2.05 \text{ cal/hr/m}^2/\text{C},$$

i. e., the thermal conductivity of ice is several times greater than the thermal conductivity of water.

This circumstance materially influences the properties of frozen ground. In most cases, its thermal conductivity is greater than the thermal conductivity of the same ground in an unfrozen state.

Change in volume.

During freezing of the ground, its volume changes. Of the various causes, the most important are: (1) the increase of water volume when it changes from the liquid to the solid state (an increase of about 9% in volume), and (2) the growth of ice crystals which attract water from the underlying ground.

This change of ground volume is important for construction and will be treated in detail in the next chapter.

Evaporation of water.

Water evaporation takes place in various ways, depending upon whether the vapor is formed from ice or water. It has been observed that the vapor pressure formed by evaporation of water is greater than the vapor pressure formed by the evaporation of

* [No reference given.]

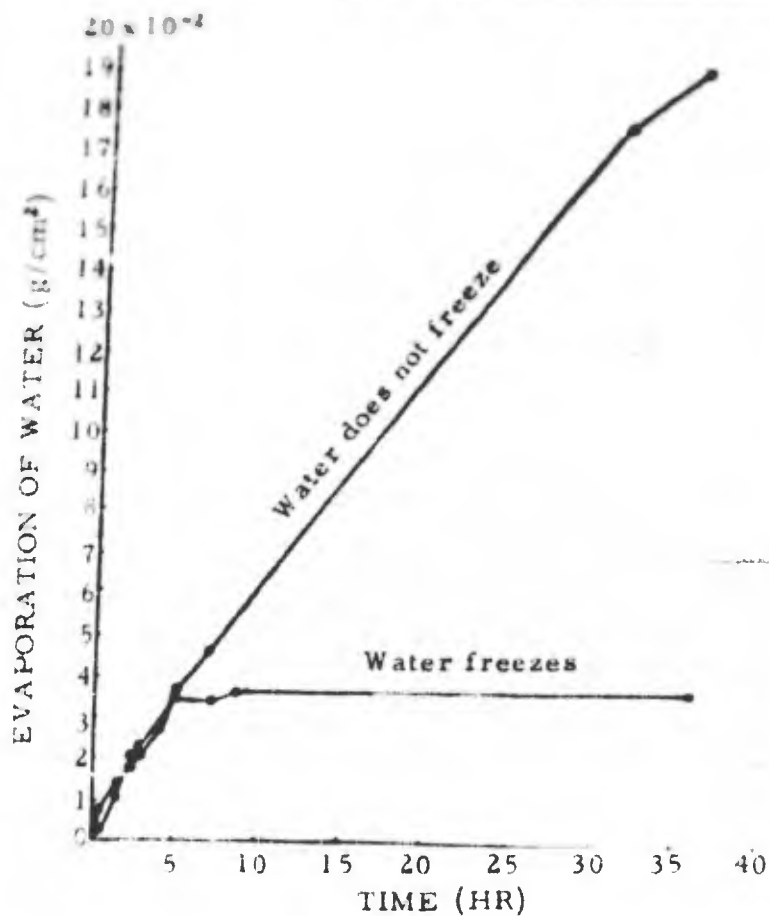

Figure 8. Curves of evaporation from a water surface.

When water freezes, its viscosity increases tremendously; as indicated previously the coefficient of viscosity increases from $\eta = 0.0179$ g/cm-sec (for water at 0C) to $\eta = 10^{13}$ g/cm-sec (for ice at 0C).

This explains the considerable binding capacity of ice, which cements the separate soil particles. Therefore, the resistance of frozen ground to outside forces increases so much that very often it has the same value as concrete and some rocks.

Influence of temperature.

Most building materials, for all practical purposes, do not change their mechanical properties at normal temperatures (from -50C to +50C), because these limits are very far from their melting point.

However, frozen ground is found under natural conditions at temperatures which are either very near or, at times, equal to its melting point.

By analogy to other solid bodies, one would expect that a temperature rise in frozen ground would increase its plasticity and decrease its Young's modulus and elastic limit, as well as its stability. Actual experiments, discussed later, confirm this.

During the lowering of ground temperature to the freezing point, a decreased rate of water evaporation is observed. In addition, there is a considerable decrease in permeability to water (for practical purposes, permeability reaches zero); a change in thermal conductivity, a sharp increase in volume; and a considerable increase in mechanical stability and cohesion. During the thawing of frozen ground, these properties

Ice.

It is interesting to note that evaporation from surfaces of unfrozen and frozen ground takes place at different rates. Figure 8 shows the evaporation (in g/cm²) from the ice surface and the water surface. Figure 9 shows the same data for surfaces of unfrozen and frozen ground (clay and silty sand). Both are based on experiments made in the frozen ground laboratory of the L. I. I. K. S.

Permeability.

The permeability of ground to water diminishes sharply when it changes from the unfrozen to the frozen state. The decrease is greater with increased water saturation. When the soil pores are completely filled with ice, its water permeability is zero; this situation is most frequently observed in permafrost areas.

For all practical purposes, permafrost may be considered as impermeable to water because of its ice saturation.

Stability.

The cementing action of ice causes an increase in the stability of the ground.

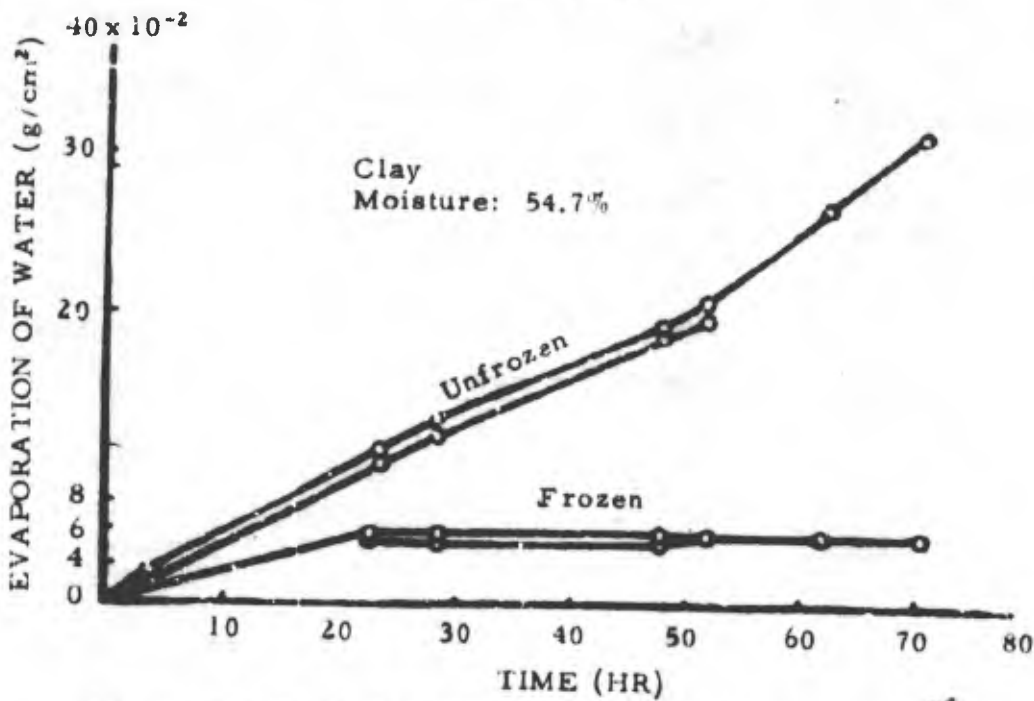
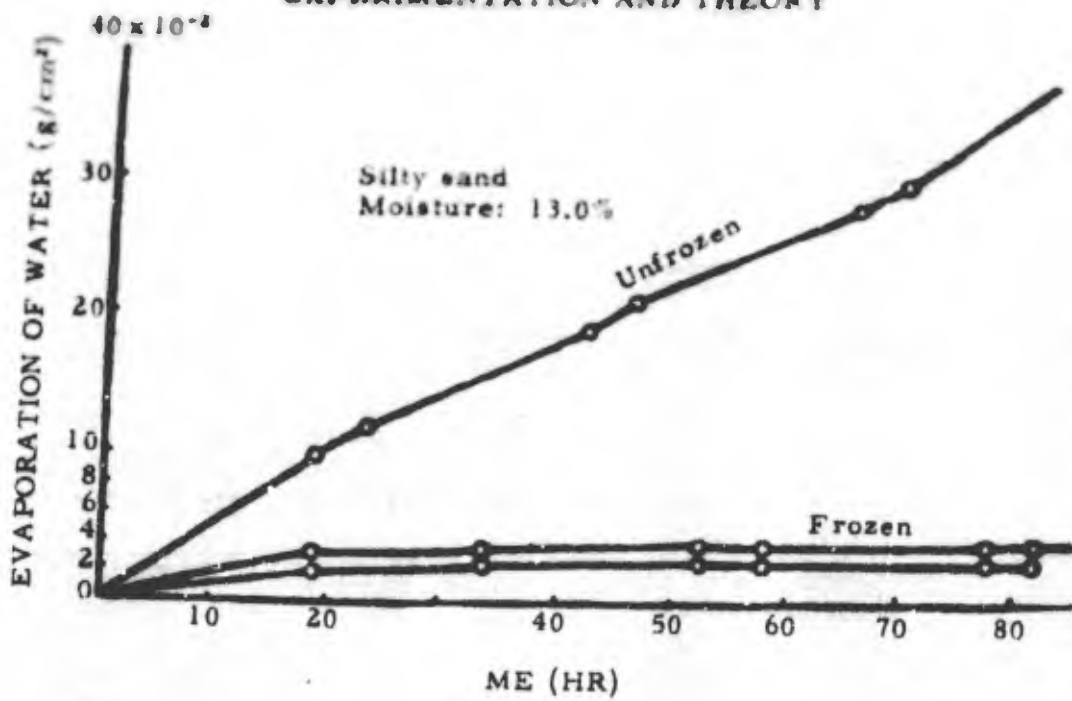

Figure 9. Curves of evaporation from a ground surface.

undergo the same changes in reverse. The stability and cohesion of ground decrease tremendously, the volume of the ground decreases, its water permeability increases, etc.

These changes are accompanied by a number of complex physical-mechanical processes which require special consideration.

CHAPTER II PHYSICOMECHANICAL PROCESSES DURING FREEZING AND THAWING OF THE GROUND

Crystallization Temperatures of Various Types of Water in the Ground

During the last 30 to 35 years, both foreign (Bouyoucos) and Soviet scientists (e. g. Lebedev) have established that water in the liquid state in the ground is of different kinds and can be divided into several categories. It has also been established that the different categories of water assume a solid state at different negative temperatures.

Lebedev,¹ distinguishes the types of water in the ground as: (1) water vapor, (2) hygroscopic water, (3) film water, (4) gravitational water, and (5) water in the solid phase — ice.

1. Water in the form of vapor fills all the free cavities of the ground, and, like gas, travels in the ground from places with greater vapor pressure to those with less vapor pressure. This property of water vapor plays a tremendous role in the processes of freezing and thawing of ground.

2. Hygroscopic water is water that is adsorbed by soil particles from the air. If dry soil is placed in moist air, its weight will increase because the soil particles will adsorb water molecules.

Two types of hygroscopic soil moisture are recognized: (a) incomplete, when the surface of the particles is not completely covered by water molecules; and (b) complete, or maximum, when the particle is completely covered by water molecules. Whether this film consists of a monomolecular or polymolecular layer has not yet been definitely established. Hygroscopic moisture in the ground does not travel in the liquid state but is first transformed into vapor and then adsorbed or condensed on the soil particles.

3. Film water is the entire water layer held in the form of a film on the soil particles by the force of molecular attraction. It is firmly retained in the ground, does not transmit hydrostatic pressure, and moves about in the ground in a liquid state from particles with thick films to particles with thinner ones.

But what is more essential is that film water, as has been shown by investigations in the last few years, possesses properties which liquids do not have. Deriagin's² investigations show that water in thin layers is elastic and is characterized by a shear modulus, and the thickness of the elastic layer reaches 1.5 μ and more, i. e., five or more monomolecular layers.

There are indications that the vapor pressure of film (or "bound") water is less than the vapor pressure of "free" water.

All these peculiarities in the physical properties of bound water are due to the fact that it is in a state of molecular interaction with the solid part of the ground.

The special characteristics of the transformation of thin water layers into the solid state, and its relationship to the temperature, will be discussed in detail below.

4. Gravitational water, like film water, occupies the pores of the ground, either completely or in part. It moves downward under the influence of gravity or is held in suspension by the surface tension of the liquid.

5. Water in the solid state — ice (in its various forms).

Water contained in the ground pores in the vapor state is transformed into ice in the form of frost or ice lenses when the temperature of the ground drops below 0C.

However, as yet, no investigations have been made to determine whether the vapor condenses into water and then crystallizes at a temperature of 0C and below, or is directly transformed from vapor into the solid phase — ice. Similarly, the precise

1. A. F. Lebedev (1930) Pochvennye i gruntovye vody (Soil and ground water). Moscow-Leningrad: Sel'khozizdat.

2. P. I. Andrianov (1933) K metodike izmerenii teploty smachivaniia poroshkov (Method of heat measurement in the wetting of powders), Zhurnal tekhn. fiziki (Journal of technical physics), tom 3, vyp 7.

temperature at which these changes occur has not as yet been investigated. Hygroscopic and film water are transformed into the solid phase at a temperature considerably below 0C.

It can be assumed that the statement by Bouyoucos that the "capillary adsorbed" "bound water" in the soil does not freeze at a temperature of -1.56°C ¹ refers to the above-mentioned categories of water. He also states that some of this water freezes only at a temperature of -4°C , and some does not freeze even at a temperature of -78°C . (He refers here to hygroscopic water.)

In Sumgin's experiments film water was obtained by pressing ordinary water (from the Leningrad water supply) between two well-polished pieces of glass and then exposing it to various low temperatures.² The data given in Table 12 were obtained.

Table 12

Experiment No.	Thickness of the water film (μ)	Temp (C)	Duration	Effect on the film
1	9.7	-11 to -16	1 hr	Froze
2	3.2	-4	1 hr	Did not freeze
3	<3	-16	1 hr 35 min	Froze
4	1.4	-17	2 hr	Did not freeze
5	1.4	-15 to -18	17 hr	Froze
6	1.3-1.4	-5	3 hr 40 min	Did not freeze

The following conclusions can be drawn from Table 12.

1. Experiments 2 and 3 show the importance of temperature in the transformation of water into the solid state. The duration and the thickness of the film of water did not differ greatly but there was a great difference in temperature. Water became crystallized at the lower temperature.

2. Experiments 4 and 5 show the influence of time. The thickness of the film was identical and the temperature was almost the same, but the duration of the experiment was quite different. In the longer experiment the water film was transformed into the solid state.

3. Experiments 3 and 4 show that the thinner the film, the more difficult it is to transform it into ice. The temperatures of the experiments were close and the duration was also almost identical (even slightly longer during the experiment with the thinner film); however, the thickness of the films were different. The thicker film was transformed into ice, while the thinner was not.

4. Experiments 4 and 6 show that a water film of about 1.4μ thick, with a short period of freezing, is not transformed into ice even at the temperature of -17°C .

Distilled water freezes at a temperature of 0°C . With correction for weak salt solutions, gravitational water in the ground should freeze at a temperature very near 0°C . However, water very often becomes supercooled, as is known from elementary physics. Results of the experiments of Borovik-Romanova, who worked with water in capillary

1. Evidently Bouyoucos considers the moment of freezing as the instant when water is transformed into the solid state.

2. M. I. Sumgin (1932) "Metod zamorazhivaniia vody v plenochnom sostoianii (Method of freezing water in the pellicular state)", in Sbornik: grunty, gruntovye i graviinye dorogi (Symposium on soils and dirt and gravel roads). TSIAT, Gostransizdat.

tubes,¹ are given as an illustration:

Freezing temperature of water in capillary tubes²

Diameter of U-shaped tubes (mm)	1.57	0.24	0.15	0.06
Freezing temperature of water (C)	-6.4	-13.6	-14.6	-18.5

These experiments corroborate the results of previous experiments on the supercooling of water, which showed that the freezing temperature of water fell sharply with a decrease in the diameter of the capillaries.

It is seen from the above that different types of water are transformed into ice at various temperatures. Consequently, it is difficult to generalize concerning the freezing of water in the ground. Any such statements (water freezing at 0C) can be considered only as approximations. It is clear that freezing processes in the ground are much more complex. This shows the need for laboratory experiments and field observations on soil freezing.

Such experiments and observations have been made by both foreign and Soviet scientists. Let us consider their results.

Bouyoucos³ subjected different types of soil to various conditions of freezing and various treatments. With clay from Wisconsin, a mixture of 4.5 g water and 20 g clay, the following results were obtained.

<u>Conditions of freezing</u>	<u>Freezing point of soil (C)</u>
First Freezing	-1.145
Second freezing	-0.955
Third freezing	-0.645
Fourth freezing	-0.620
Ground thawed, placed in a test tube, stirred lightly with a rod, and refrozen	-1.235
Ground cooled to -10C after stirring, then thawed and frozen again	-0.680
Light stirring with a rod in a test tube and subsequent freezing	-1.215

Similar results were obtained in experiments with other types of soil (clayey silt and others).

These experiments show that the freezing point of soil is below 0C and that it changes after various treatments. The rise of the freezing point during the second, third, and subsequent freezings, as well as after cooling the soil to -10C, is explained by Bouyoucos as follows: water in the large pores and capillaries freezes first; under the influence of

1. Borovik-Romanova, Pereokhlazhdenie vody v kapilliarnykh trubkakh (Supercooling of water in capillary tubes), ZhRFRKhO, Chast' fizich. (Journal of Russian Physico-chemical Society, Physical Section), tom 56, vyp 1. Table is taken from N. A. Kachinskii (1927) Zamerzanie, razmerzanie i vlazhnost' pochvy v zimnii sezon v lesu i na polevykh uchastkakh (Freezing, thawing, and soil moisture during the winter in forest and field). Moscow.

2. The concept of freezing is understood here as the instant the water is transformed from the liquid into the solid state.

3. G. J. Bouyoucos (1923) Movement of soil moisture from small capillaries to the large capillaries upon freezing, Journal of Agricultural Research, vol. 24, p. 427-431.

crystallization forces, the water from small capillaries and a portion of the film water is drawn to the crystals which have formed. When the soil thaws, most of the water remains in the large capillaries, so to speak, in a gravitational state; with new freezing it is transformed into ice at temperatures much closer to 0C.

Stirring the soil with a rod redistributes the water, which also affects the thin capillaries, so that the freezing point is lower during subsequent freezing, as is evident in the above tabulation.

Bouyoucos explains the formation of pedicels and lumps of ice in the soil by the presence of a crystallization force which "orients" (if one can use this expression) the water toward the already formed ice crystals and produces new crystals from this water.

Various small ice inclusions found in frozen ground have been described by many investigators. Consequently, they will only be mentioned here without describing them fully. However, the ice pedicels and the interesting ice inclusions cited in the work of Bykov¹ should be mentioned. In the frozen ground at Igarka, he found separate ice crystals which were either arranged in regular rows between the layers of ground or scattered as single phenocrysts in the ground. Two illustrations of such inclusions are given in Figures 10 and 11.

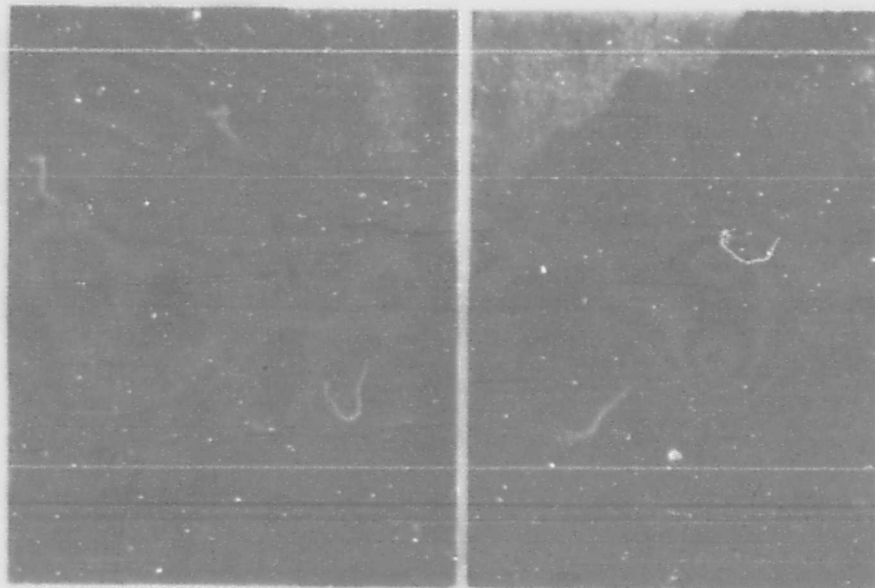

Figures 10 and 11. Ice crystals in frozen ground (Igarka).
Photo from drawing by N. I. Bykov.

Such ice inclusions are common in permafrost regions. From the construction viewpoint, they should be of interest to engineers, since melting of these particles causes supersaturation of the ground.

Wintermeyer² states that the percentage of frozen water in the soil depends on the

1. N. I. Bykov (1934) "Vechnaia merzlotia i stroitel'stvo Igarki (Permafrost and construction at Igarka)," in *Za industrializatsiyu sovetskogo Vostoka (Industrialization of the Soviet East)*. Moscow: Tsentral'noe Biuro Kraevedeniia.

2. A. M. Wintermeyer (1925) "Percentage of water freezable in soils, Public Roads, A Journal of Highway Research," U.S. Dept. Agriculture, Bureau of Public Roads, vol. 5, no. 12, p. 5-8

adsorbing properties of the soil, considering that the grain size composition of the soil does not always indicate the freezing conditions of water in the soil. However, he found that coarse-grained soils, generally speaking, freeze more easily than medium-grained soils. The cause of this is clear: coarse-grained soil contains a considerable percentage of gravitational water, and the amount of gravitational water decreases with an increased proportion of very fine-grained soil.

Wintermeyer's experiments demonstrated that the percentage of frozen water in the ground is in inverse proportion to the coefficient of adsorption, and, we must add, it is also in inverse proportion to the content of clay particles in the soil, a fact substantiated by Table 13, taken from the numerous data of Wintermeyer.

Table 13

Amount of frozen water (%)	Coefficient of adsorption (according to pigmentation tests)	Clay content (%)
82.5	6.9	15.8
72.9	20.3	25.1
65.1	31.8	35.1
55.8	60.4	42.5
45.6	74.7	51.4
31.8	145.0	58.7

Andrianov made a special study of soil freezing temperatures under laboratory conditions.¹ The following results were obtained.

Ground freezes² at a temperature below zero. In these experiments, 31 soil samples saturated up to 20% of moisture by weight were immersed in a cooling medium with temperatures varying between -4.5C and -7.5C. Freezing temperature was -1.56C for one sample, -1.23C for another; -0.50 to -1.00C for two samples; -0.20 to 0.50C for six samples; -0.11 to -0.20C for seven samples; and above -0.10C, i. e., near zero, for fourteen samples.

Andrianov agrees with Wintermeyer that the freezing process of moist soil depends greatly on its adsorption properties and that mechanical analysis does not determine these properties. There are types of soil which contain a small quantity of particles smaller than 0.001 mm, but include among these particles many colloidal particles which will materially influence the freezing temperature of ground.³

In most of Andrianov's experiments, the soil was first supercooled, and then the supercooled water was transformed into ice. The phenomenon was accompanied by a rise in temperature, as always, and the characteristic curves of ground freezing usually showed a sharp jump in temperature. The temperature jump was more distinct, the smaller the temperature difference between the freezing soil and the surrounding medium. Soil can freeze without a marked temperature jump when there is a sharp thermal imbalance.

Under the conditions of the experiments, when the cooling medium was at -4.5 to -7.5C, soil with a hygroscopic moisture of more than 5% either did not freeze at all or

1. P. I. Andrianov (1936) Temperaturny zamerzaniia gruntov (Freezing temperature of ground), Akademiia Nauk SSSR.

2. Andrianov defines freezing as follows: "The concept of freezing refers to the phenomenon of the transformation of the liquid portion of the ground into the solid state — ice, at the corresponding temperature."

3. It was seen above that in Wintermeyer's average values the adsorption qualities correspond to the mechanical analysis data although Wintermeyer himself does not make this conclusion.

froze without a temperature jump.

The influence of the adsorption properties of ground on freezing is seen from the following tabulation:

Moisture	t_s	t_f	j
0.14	-0.71	-0.05	0.66
2.67	-0.81	-0.45	0.36
5.10	?	?	0

where moisture is the hygroscopic moisture in percent (an average for 10 samples); t_s is the temperature of supercooling of the soil; t_f is the freezing temperature; and j is the temperature jump when the soil freezes.

According to Andrianov, the concentration of salts in the soil (for ordinary, not saline soil) has a secondary role in the phenomenon of freezing, in comparison with the water adsorption properties of soil (see Table 14.).

Table 14.

Soil No.	Hygroscopic moisture, (%)	Temperature of freezing, (C)	Percentage of salts in relation to dry weight
33	1.0	-0.13	0.025
41	2.43	-0.16	0.031
40	2.67	-0.22	0.070
38	3.52	-0.35	0.004
39	3.98	-0.57	0.006
34	5.34	No freezing recorded	0.024
36	5.82	No freezing recorded	0.021
43	10.06	No freezing recorded	0.031

Moisture of the samples is 20% of dry weight. Temperature of the cooled mixture is from -4.5C to -7.5C. Salt concentration is determined by the specific electroconductivity.

The freezing temperature of soil is proportionally lower with a decrease in soil moisture. Andrianov demonstrated this for several samples (see Table 15; t_s , t_f , and j have the same meanings as defined above).

In the process of ground freezing, Andrianov attributes special significance to the relative surface of the ground, which is directly connected with the heat of wetting.

Table 15.

Soil No.	Hygroscopic moisture (%)	t_s	t_f	j	t_s	t_f	j	t_s	t_f	j	t_s	t_f	j
		Moisture of soil samples (% of dry weight)											
35	0.29	20%			10%			7%			3.83%		
		0.94	0.12	0.82	0.77	0.21	0.56	0.81	0.27	0.54	0.85	0.70	0.15
41	2.43	20%			19.18%			15%			10%		
		0.94	0.16	0.78	0.76	0.21	0.55	0.80	0.32	0.48	0.87	0.77	0.10
34	5.34	40.68%			35.0%			30.0%			25.0%		
		0.98	0.22	0.76	0.76	0.17	0.59	0.97	0.20	0.77	0.91	0.51	0.40

PRINCIPLES OF MECHANICS OF FROZEN GROUND

Andrianov tested an entire series of soil samples taken from various localities of the U. S. S. R., some from permafrost regions. Ground from permafrost regions showed no special reaction to freezing as compared to other ground with the same hygroscopic moisture and heat of wetting.

Table 16 shows the mechanical analysis of the soil samples referred to above. [Tables 14 and 15.]

Table 16.

Sample	Percentage of grain-size fractions							Specific gravity	Hygroscopic moisture (%)	Heat of wetting (cal/g)
	Size of particles, (mm)									
	>0.5	0.5-0.25	0.25-0.05	0.05-0.01	0.01-0.005	0.005-0.001	<0.001			
33	23.23	25.51	48.96	0.87	0.29	0.52	0.61	2.651	1.00	0.73
34	1.06	1.06	88.27	2.32	1.46	1.89	3.94	2.683	5.34	4.41
35	50.67	17.61	29.69	0.98	0.37	0.38	0.30	2.600	0.29	-
36	0.53	0.37	89.30	2.44	1.54	2.74	3.08	2.606	5.92	4.06
38	0.52	0.37	90.01	3.57	1.91	2.52	1.00	2.563	3.42	1.81
39	8.07	7.58	77.06	2.20	1.27	1.80	2.02	2.492	3.93	2.92
40	34.16	15.93	46.90	1.05	0.28	0.54	1.14	2.674	2.67	2.30
41	36.23	16.40	43.72	1.21	0.54	0.94	0.96	2.662	2.43	1.39
43	-	-	-	Peat	-	-	-	1.606	10.06	-

During laboratory experiments with a starch and water mixture (containing 13.5 to 32.7% starch), the water did not freeze even at a temperature of -180°C . The result was so interesting and at the same time so unexpected that it requires further verification.¹

Kachinskii,² who observed soil freezing under field conditions, especially stressed the fact that the zero temperatures do not determine the boundary of the frozen ground. Some data from his work are cited below. It should be noted that he defines frozen ground as ground which is cemented by ice.

Kachinskii's observations were made at the meteorological station at Sobakino-Opytloe, in the former Zvenigorod district, Moscow region, near the site where soil thermometers were placed and under analogous conditions of deposition, vegetative cover, and snow cover. Table 17 is taken from Kachinskii's data.

Kachinskii correlates his field observations with the laboratory data of Bouyoucos and McCool, and those of Lobanov. The first two investigators froze various types of soil with different moisture content (in Beckman's apparatus, somewhat modified). The following results were obtained:

Freezing temperature of soil in relation to moisture content

Soil substratum	Quartz sand		Clayey sand		Kaolin	
	Moisture (%)	Freezing point depression ($^{\circ}\text{C}$)	Moisture (%)	Freezing point depression ($^{\circ}\text{C}$)	Moisture (%)	Freezing point depression ($^{\circ}\text{C}$)
Moisture (%)	1.50	15.0	16.39	35.84	13.50	78.60
Freezing point depression ($^{\circ}\text{C}$)	0.070	0.007	0.830	0.022	1.025	0.025

This tabulation shows that: (1) soil and ground freeze at temperatures below zero, and (2) the freezing point is lowered with a decline in moisture content.

1. A. V. Rakovskii, D. N. Tarasenkov, and A. V. Komandin (1935) Vliianie postoronnei tverdoi fazy na temperaturu zamerzaniia vody i slabykh vodnykh rastvorov (Influence of the solid phase of a foreign substance on the freezing temperature of water and weak solutions), Zhurnal obshchei khimii (Journal of General Chemistry), tom 5, vyp 10.

2. N. A. Kachinskii (1927) Zamerzanie, razmerzanie i vlazhnost' pochvy (Freezing, thawing, and soil moisture), Moscow.

EXPERIMENTATION AND THEORY

Similar results were obtained by Lobanov, as is seen from the following table:

Freezing temperature of light clayey-sandy podzolic soil in relation to moisture content

Soil substrata	Topsoil		Podzol layer		Red clay	
Moisture (%).....	15.74	8.49	13.96	3.75	14.14	9.06
Depression of freezing point of solution	0.277	0.747	0.067	1.220	0.131	1.990

From field and laboratory data, Kachinskii makes the following deductions: (1) the depth of the zero temperature in the ground, as shown by soil thermometers, does not indicate the depth of soil freezing at the moment of observation; and (2) frozen soil may have a positive temperature (see Table 17, data on field experiments on April 2, 1925).

Table 17. Freezing of soils and soil thermometer reading

Date of experiment	Depth of ground freezing* (cm)	Depth of snow cover at point of boring (cm)	Thermometer readings		Depth of layer with 0C thermometer reading (cm)	Depth of snow cover at thermometer (cm)
			Depth (cm)	Temp (C)		
December 23, 1922	7	23	10	-0.7	18	21
			25	+0.6		
March 16, 1923	17	54	10	-0.5	41	55
			25	-0.2		
			50	+0.1		
December 24, 1924	11	12	10	-2.3	28.3	10
			25	-0.3		
			50	+2.0		
April 2, 1925	From surface to 28	7	10	+0.5	0° at 18.3 and 66.7 cm; above 18.3 cm and below 66.7 cm temperature was above 0°	
			25	-0.4		
			50	-0.2		
			100	+0.4		

* Found by borehole method.

Unquestionably, Table 17, which shows the field observations of Kachinskii, is extremely interesting, and his first conclusion should be completely accepted and extended in the following sense. According to the data, Kachinskii observed supercooled soil at a certain depth. For example, on December 23, 1922, the following was observed.

Freezing of soil in the bore hole to a depth of..... 7 cm

Depth of the zero temperature, from thermometer data..... 18 cm

Consequently the thickness of the supercooled layer is..... 11 cm

In the same way, the thickness of the supercooled layer can be calculated from a number of other observations — for example on March 16, 1923, the thickness is 41 - 17 = 24 cm.

However, Kachinskii's second conclusion must be carefully rechecked before it is accepted. The problem is that the soil thermometers used at the Sobakino Station were

the [slow-recording] thermometers in ebonite tubes. According to Sumgin's investigations, this type of thermometer may give enormous deviations from the real temperatures at shallow depths of the ground. This is especially applicable to thermometers placed at a depth of 10 cm. Sumgin conducted special research to recheck the soil temperatures obtained with the [slow-recording] thermometers in ebonite tubes.¹

A special type of horizontal soil thermometer was constructed and installed. Next to it were set Savinov thermometers and thermometers in ebonite tubes, all at a depth of 11.5 cm. Observations were made from June 1 to July 10, 1914, in the city of Blagoveshchensk on a plot at the meteorological bureau station in the Amur region. The temperature of the ebonite thermometer was -0.3°C lower than the temperature of the horizontal thermometer during a 7-hr period. During a 13-hr period, the readings on the former were 4°C higher than those of the horizontal thermometer, and during a period of 21 hr they were -1.3°C lower. In one case, the ebonite thermometer showed a temperature 8°C higher than the horizontal thermometer (at 1 p.m. on June 13).

The two thermometers recorded different daily maximums and minimums and ranges of temperature. The investigations showed that the ebonite thermometer is absolutely unsuitable at a depth of 11.5 cm.

In the fall of 1911 and the spring of 1912, the readings of soil temperature at a depth of 10 cm were checked by a horizontal thermometer. In the fall, the thermometer in the ebonite tube registered negative temperatures at 10 cm when the soil at that depth had not yet frozen, and, in the spring it showed positive temperatures when the soil at that depth had not yet thawed.

For this reason, we question the positive temperature at 10-cm depth on June 2, 1925, as quoted by Kachinskii. Consequently, we doubt Kachinskii's conclusions made on the basis of this figure and others similar to it. In our opinion, more exact work is necessary for the study of the temperatures of frozen ground.

All of the above leads us to the following conclusions on the freezing of ground under natural conditions. First, there is no doubt that the temperature of water crystallization in the ground is below zero. For gravitational water, this depression is insignificant, usually less than one degree and only seldom somewhat more. Water crystallization takes place at a lower temperature in clayey soil than in the various sandy soils — all other things being equal. Second, on the basis of all experiments, one can expect that under natural conditions, as in laboratory experiments, not all of the water in the ground is crystallized; part of it, even at negative temperatures, remains in the liquid state. In addition, one may expect that the amount of water remaining unfrozen at negative temperatures will be proportional to the amount of colloidal particles in the ground.

We use the cautious expression "one may expect", because, in our opinion, laboratory results on the amount of crystallized and uncrystallized water in the ground cannot yet be applied completely to natural conditions. In a laboratory experiment, we can vary the temperatures to a great extent. The same applies to the pressure, as was done by Tammann and Bridgman. However, it is very difficult to deal with long periods of time, and in nature the time element in freezing ground varies to an unlimited degree: from less than an hour in the southern regions of temporary cooling of the soil up to tens of thousands of years in the permafrost regions.

The question is: if hygroscopic and film water remain in the liquid state during laboratory experiments (which usually last only a short time — hours or days), does this water remain liquid under natural conditions in the layers of seasonal freezing and especially in permafrost? Under natural conditions, it is necessary to consider the effect of time.

1. M. I. Sumgin (1915) Gorizontal'nyi pochvennyi termometr dlia nebol'shikh glubin: k kritike termometrov v ebonitovykh trubkakh (Use of horizontal soil thermometers at shallow depths: a critique on thermometers in ebonite tubes), *Izvestiia meteor. biuro Amursk. raiona (Proceedings of the Meteorological Bureau of the Amur Region)*, vyp. 3.

It is known that certain properties or processes may become apparent only after a considerable (sometimes very considerable) period of time. For example, both ice and cobbler's wax undoubtedly possess viscosity, but this property manifests itself only after a considerable period of time. Under normal temperature, a diffusion of metals does take place, but many years are necessary for an appreciable amount of diffusion.

Assuming the lengthy coexistence of liquid and solid phases in seasonal frozen ground and permafrost, we must assume that the vapor pressure of these phases is identical and that the presence of ice crystals does not cause the liquid to crystallize even though it has a negative temperature. This contradicts both theory and experiments. All these problems have yet to be solved for natural conditions. The observations now available are insufficient in our opinion.

In particular, the solution of this problem will reveal the effect of time on the transition of film water into the crystalline state at temperatures at which this type of water does not crystallize during short periods of time. This problem is of profound theoretical interest and of practical significance, for example, for the electrometric methods of surveying permafrost.

In addition, the solution of this problem has significance for analyzing weathering conditions of the bedrock. Does the crystallization of water found in the tiny cracks of the bedrock take part in this process? Or is the so-called frost weathering connected only with the uneven expansion caused by temperature changes of the component parts of the rock?

Migration of Moisture in Freezing and Frozen Ground

During recent years, Soviet scientists have been confronted with the question: What happens to ground moisture during the freezing process? Does it remain in place and become fixed there by freezing or does it move during the process of freezing? If so, how, where, and in what quantities? In other words, is the moisture at a given spot in the ground fixed there at the moment of freezing, or is the moisture present at a given spot a function of the freezing process? Many scientists accepted the theory of fixation. Kachinskii, as early as 1927, explaining the processes of ground freezing under natural conditions, and specifically the process of ice segregation during freezing, wrote that "the advent of freezing mechanically stops further downward movement of water and fixes the water distribution as it was during the last moment before freezing".

At the present time, the theory of moisture fixation in the ground by freezing temperatures has been rejected and the theory of migration, i. e., the theory of functional relation between ground moisture and the process of freezing, has been completely accepted.

The processes of the movement of various types of water in unfrozen ground have been exceedingly well worked out by Lebedev,¹ who believes that the vapor phase of water can move in the ground in the usual way.

The migration of water in freezing and frozen ground has a great deal in common with its migration in unfrozen ground, but it has its own qualitative and quantitative characteristics. Considerable work has been done on this problem, by both foreign and Soviet scientists, but the details are far from worked out.

Water in the form of vapor moves in freezing ground much as in unfrozen ground, from areas of greater to areas of lesser vapor pressure. As vapor pressure is directly proportional to its temperature, water vapor moves from the higher to the lower temperature. In unfrozen ground, transformation of the vapor does not go further than the liquid phase. In freezing and frozen ground, however, the vapor can and does become transformed into the solid phase — ice. The second significant difference is that, at negative ground temperatures, water vapor can move even at equal temperatures, depending on the state of the water (liquid - solid). This would take place when the ground contains both super-cooled water and ice at the same temperature, because the pressure of saturating vapor for ice and water is not the same at equal temperatures. This is clearly seen from the

1. A. F. Lebedev (1930) Pochvennye i gruntovye vody (Soil and ground water). Moscow and Leningrad: Sel'khozizdat.

data given in Table 18.¹

Temperature (C)	Pressure of saturating vapor (mm)		Difference in pressure (mm)
	For water	For ice	
+0.0074	4.582	4.583	0
0	4.581	4.580	0.001
-5	3.162	3.010	0.152
-10	2.145	1.946	0.199
-20	0.939	0.772	0.167

Consequently, supercooled water in proximity to ice of the same temperature may be transformed into ice in two ways: (1) from the liquid, by crystallization; and (2) from the vapor, by sublimation. According to the data given in Table 18, the difference in vapor pressure causes evaporation, and the presence of negative temperatures allows the vapor to be transformed directly into the solid phase — ice.

But water in the liquid state also moves in freezing ground, sometimes in enormous quantities as we shall see below. This movement is caused by (1) the forces of crystallization as the water freezes, and (2) stresses created in freezing ground as the water changes to ice and expands.

The first type of movement of water in the liquid state has been studied primarily by foreign scientists (Taber, Bouyoucos, Beskow) and the second type primarily by Soviet scientists (Sukachev, Sumgin).

We have given Bouyoucos's opinion concerning the transition of water from exceedingly small capillaries and films surrounding the soil particles to the ice crystals which are formed in the larger pores and capillaries. Taber,² developing this idea, wrote: "A growing ice crystal is in contact with a thin film of water similar to the adsorbed layer which forms on many other solids that are in contact with water. As a molecule in the film is oriented and attached to the crystal, it is replaced by another from the adjacent liquid, thus maintaining the integrity of the film."

In another study, Taber³ describes the growth of crystals in the upper layers of the ground at the expense of water from the lower unfrozen layers of the ground. "To build up a layer of ice, which consists of many prismatic crystals, the capillaries supplying the water must be closely spaced."

Laboratory experiments and numerous observations in the permafrost region, where enormous quantities of water sometimes collect in the icing mounds, prove that ground stresses can cause movement of water in freezing ground. Later, we will discuss in detail the causes and mechanisms of these stresses. Here we only mention that these stresses in the icing mounds often reach such a considerable strength that these mounds literally explode, throwing out enormous chunks of frozen soil and ice.

One of Sumgin's laboratory experiments⁴ demonstrates clearly the movement of liquid water during the freezing process. Sand from the Buzuluk forest was used:

1. B. P. Veinberg (1910) Obshchii kurs fiziki (General physics), tom 2.
2. S. Taber (1930a) Mechanics of frost heaving, Journal of Geology, vol. 38.
3. S. Taber (1929) Frost heaving, Journal of Geology, vol. 37. [p. 439.]
4. M. I. Sumgin (1929) Fiziko-mekhanicheskie protsessy vo vlazhnykh i merzlykh gruntakh v svyazi s obrazovaniem puchin na dorogakh (Physicomechanical processes in moist and frozen ground in connection with swelling formations on roads), Transpechat'.

Size of particles (mm).....	0.5-0.25	0.25-0.05	0.05-0.01	0.01-0.005	<0.005
Percent of total weight	52.62	37.40	0.73	0.03	0.22

Sand was placed in copper cylinders (70 mm high, base diam 60 mm) with perforated bottoms, and moistened by the capillary method up to a constant weight, almost to the limit of its moisture capacity. Then the cylinder was subjected to temperatures from -12C to -17C. The sand became completely frozen in about 4 to 5 hr. When the moist unfrozen sand was placed for freezing, its upper surface was moist but had no water layer, since, we repeat, the sand was moistened only up to its full moisture capacity.

During freezing; the surface of the sand became covered by water which froze in a layer of ice up to 2 and sometimes 3 mm thick. Usually this layer of ice did not completely cover the surface of the sand but only approximately a third or a half of it. The surface of the sand became slightly swollen, sometimes with protuberances through which water poured out in fine streams and spread across the sand surface (Fig. 12).

This movement of water in a liquid state during the process of ground freezing could literally be seen, and moreover, the water moved against the law of gravity.

The work of Petrov,¹ who described the explosion of an icing mound on the Onon River in the vicinity of the 124 km post of the Amur-Yakutsk Highway on March 28, 1928, shows the amount of water which can collect in one place under natural conditions during the process of ground freezing. During the explosion, enormous quantities of water burst forth.

"The moment of the explosion was accompanied by a loud noise similar to a cannon shot; the masses of ice were carried by a stream of water with a roar like that of a railway train. The water formed a wide stream, 75 m wide and 5 km long. This catastrophic situation on the Onon River did not last long. In two hours everything quieted down, the water subsided, the ice settled in the valley, and only chunks of ice, fragments of a bridge, bent bushes of the valley, and scratches on the bark of large trees bruised by passing ice floes testified to the icing catastrophe which had taken place."

It must be stated that the quantity of water collected in the mounds at the 124 km post of the Amur-Yakutsk Highway is unusual. Normal ground pressure forces much smaller amounts of water into the icing mounds.

In relation to migration of water, the following types of frozen ground may occur.

Case 1. The ground is so cemented by ice that it has no pores, thus presenting a system of mineral particles and ice. In this case, there can be no movement without outside forces because, without pores, there can be no water in the vapor state.

Case 2. The ground, cemented by ice, contains pores but absolutely no water in the liquid state. Water can move and does move in the form of vapor from points with greater pressure to points with less pressure, i. e., usually from points with a higher temperature to points with a lower temperature. In this case, ice will evaporate, and the vapor will condense on the ice within the ground or on the ground particles. The evaporation of ice is an intensive phenomenon. Data on evaporation given by Wild evaporimeters at a number of stations in the Far East are given in Table 19.

1. V. G. Petrov (1930) Naledi na Amursko-Iakutskoi magistrali (Icings on the Amur-Yakutsk Highway), NIAD, Leningrad.

2. P. I. Koloskov, Isparenie v Amurskoi obl. po evaporimetram Vilda (Evaporation in the Amur region according to Wild evaporimeters, Izvestia meteor. biuro Amursk. raiona (Proceedings of the Meteorological Bureau of the Amur Region), vyp 2.

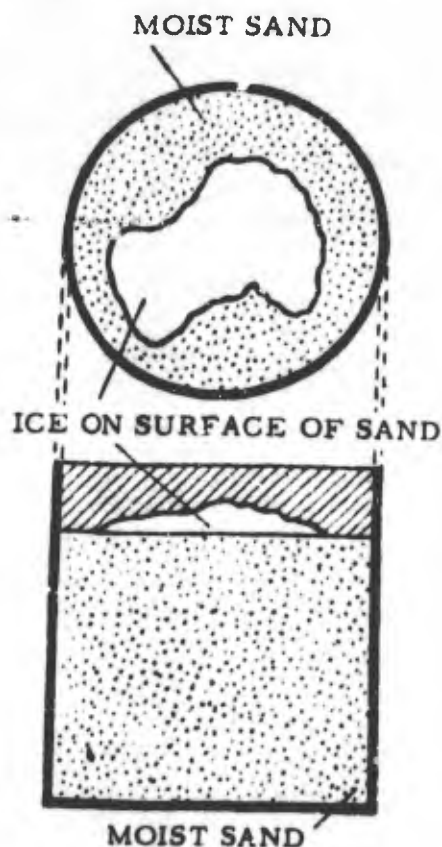

Figure 12. During the freezing of moist sand, water appeared on the surface.

PRINCIPLES OF MECHANICS OF FROZEN GROUND

Table 19. Evaporation of ice (mm)

Year	Month	Stations	
		Bornak	Mazanovo
1911	January	0.9	-
	February	12.6	-
	March	25.6	-
	December	1.6	-
1912	January	3.4	2.6
	February	7.8	6.3
	March	27.1	18.6
	December	1.5	0.4
1913	January	-	0.8
	February	-	6.7
	March	-	24.7
	December	-	2.5

The average air temperature at these stations was from -25C to -30C in December and January; from -18C to -22C in February; and from -11C to -14C in March.

We selected these months because, at the Bornak and Mazanovo stations, no thawing weather occurs during any of these four months. Consequently, evaporation from the cups of the evaporimeter undoubtedly took place at negative temperatures and in the shade, in accordance with the methods of observation with Wild evaporimeters.

Even in December and January, the figures of ice evaporation are noticeable; they increase in February, and are quite considerable in March.

Of course, these figures cannot be applied completely to ice evaporation in the ground, because we often find enclosed vapor-filled areas in the ground. But if there is an outlet for vapor to the earth's surface or to water-free areas in the ground, evaporation may be greatly increased. The evaporation figures obtained by Wild evaporimeters point out the possible extent of ice evaporation.

According to W. Thomson, water vapor in some cases will move even at equal temperatures.¹ Thomson established that saturated vapor has less pressure at a concave surface than at a flat surface, and less at a flat surface than at a convex one. Thomson derived the following equation:²

$$p' = p \pm A \frac{\sigma}{\delta} \cdot \frac{2}{r}$$

where p is the pressure of the saturated vapor at the flat surface; A is the capillary constant; σ is the density of the vapor; δ is the density of the liquid; r is the radius of the surface (and consequently $2/r$ is the curvature of the surface); and p' is the pressure of saturated vapor at the convex surface (using a plus sign before the second member of the right side of the equation), or at the concave surface (using a minus sign).

According to this equation, when convex and flat or concave surfaces are present, the water vapor will move from the convex to the flat or concave surface, just as, when only concave or only convex surfaces are present, the water vapor will move from one surface to another depending on the curvature.

On the basis of Thomson's law, it is evident that a snowflake cannot be preserved, because snowflakes have very sharp (extremely convex) edges. This was demonstrated by an experiment made by Veinberg,³ with the aid of V. D. Dudetskii. They placed snow-

1. The same phenomenon can take place in unfrozen ground also but it will not be discussed here.

2. V. A. Mikhelson (1930) *Fizika (Physics)*. GIZ, p. 265.

3. B. P. Veinberg (1929) *Nevozmozhnost' konservirovaniia snezhinok (The impossibility of preserving snowflakes)*, *ZhRFFKhO (Journal of the Russian Physico-chemical Society)*, vol. 58, p. 711-713.

flakes in a hermetically sealed, moist chamber, where the vapor was maintained in a saturated state, and observed the results under a microscope. Every snowflake "disclosed a gradual rounding of the sharp edges and a gradual change into an irregularly shaped small lump of ice."

On the basis of his experiments, Veinberg concludes that "the sharp edge of a snowflake cannot remain stable — especially since, according to Thomson's law, the vapor pressure at the edge of a crystal in general (and that of a snowflake in particular) must be extremely great, if not infinite."

When the frozen ground contains pores which are not filled by ice or supercooled water, these pores undoubtedly have surfaces of different curvatures. According to Thomson's equation, an exchange of vapor takes place between these surfaces even at equal temperatures, as temperature is not included in the equation, and sometimes a vapor exchange contrary to the temperature difference may take place.

In permanently frozen ground which exists for thousands of years, the effect of time may be felt with all its force in the process of vapor movement, according to Thomson's law.

Case 3. The frozen ground cemented by ice contains some supercooled water and some empty voids resulting from the freezing process. In such ground, in the first place, water may move in the form of vapor from points with higher temperature to points with lower temperature, as well as, at equal temperatures, from supercooled water toward ice, as we pointed out above. In the second place, movement of water in the liquid state is possible. When part of the supercooled water has been transformed into ice, thereby increasing its volume, the water which was not transformed into ice must move in some direction.

This third case may have a variant. In a ground-ice-supercooled water system with no pores, water in the vapor or solid state cannot move, and the liquid water cannot move without disrupting the ground. If some of the supercooled water crystallizes, movement of the liquid water remaining may disrupt the ground and form voids and cracks.

Our discussion of water migration in freezing ground is based on numerous laboratory experiments and observations in nature, so that the possibility of error is small. However, we must caution the reader that our conclusions concerning water migration in frozen ground are based only on the general laws of phase transition of "water in general", which are fully applicable only to water vapor and gravitational water among the types of water in the ground. Therefore, our reasoning in this respect can have only general value. As far as film and hygroscopic water are concerned, the results may be quite unexpected. We have set down our theoretical conclusions only as a working hypothesis upon which to base experimental study of the migration of various categories of water in frozen ground.

It was pointed out above that ice cannot move in frozen ground unless outside forces affect the given mass of ground. The possibility of such movement of ice within the frozen ground under a comparatively small outside load was pointed out in Chapter I.

It must be added that such loads may take place not only with man's participation (erection of buildings and structures), but also under natural conditions, undisturbed by man's activity, such as ground stresses during the formation of icing mounds. In such cases, plastic movement of ice may take place in the underlying layer of the permafrost, if it contains unfilled pores or empty cavities. It is obvious that ice may carry with it separate soil particles. The whole problem of plastic movement of ice in frozen ground under the influence of pressures is posed for the first time and requires further study.

Several examples of water migration in freezing ground will now be given. The first examples are from laboratory studies, foreign as well as Soviet.

Taber¹ packed dry powdered clay in waxed cardboard cylinders with perforated bottoms. The cylinders were 15 cm high and 9.5 cm in diameter. The clay in the cylinders was moistened by the capillary method, and the excess water was removed by slow evaporation

1. S. Taber (1929) Frost heaving, Journal of Geology, vol. 37.

with simultaneous light tamping of the soil in the cylinders. After this treatment, the degree of moisture in the lower portions of the cylinders was determined prior to freezing. Then the cylinders were placed so that the soil would freeze from the top down, and samples were taken from the bottom of each cylinder to determine moisture content. Comparative data on the moisture of the unfrozen and frozen soil in the bottom of the cylinders are given in Table 20.

As can be seen from this table, in every case the moisture of the lower part of the soil cylinder was considerably smaller after freezing. Water migrated toward the top where numerous ice layers up to 3 cm thick, were observed. Taber did not determine the amount of moisture in the upper part since he considered that water migration from the bottom to the top was shown by the ice layers in the latter (Fig. 13).

Johanssen took a sample of ground with an equally distributed moisture content of 31.6% and subjected it to gradual freezing from the top downward — as ground freezes in nature. After 24 hours, Johanssen determined the amount of moisture in his frozen sample, layer by layer, and obtained the following results:



Figure 13. Cylinder of frozen clay showing segregated ice layers formed during freezing. (From Taber).

Depth of sample, (cm)	Moisture (%)
0-3	46.0
3-6	28.3
10-13	28.9
20-23	29.6

It is clear that the moisture migrated to the very top layer of the sample of ground.

Samgin² used silt and sand in his experiments on moisture migration in the ground during freezing. The silt had the following mechanical composition:

Size (mm)	Percent of total weight
1.0 -0.5	0.39
0.5 -0.25	0.55
0.25-0.05	10.76
0.05-0.01	41.29
0.01-0.005	41.16
<0.005	5.85

The ground was either moistened by capillary action up to constant weight, or water was added to obtain predetermined moisture, or one close to it. The moisture content by layers was determined before and after freezing in the copper cylinders described previously (p. 31).

Table 20 *

Test No.	Water at bottom of clay cylinders (%)	
	Before freezing	After freezing
1	29.0	20.8
2	25.8	19.9
3	24.2	18.3
4	23.2	18.3

1. Cited from A. B. Dobrowolski (1923) *Historja Naturalna Lodu* (Natural history of ice). Warsaw.

2. See Samgin (1929) *op. cit.*

* [From Taber, 1929, p. 441.]

The results are given in Tables 21 and 22.

Table 21. Distribution of moisture by layers in unfrozen silty soil*

No. of cylinders	Average moisture (% of dry weight)	Moisture by layer (% of dry weight)				
		Samples taken from the central part of the cylinders along their axes				
		1	2	3	4	5
I. Moistened by capillary action up to constant weight						
4	31.52	31.57	31.22	31.07	30.97	31.09
II. Predetermined degree of moisture						
3	6.18	5.76	6.31	6.16	6.09	6.28
3	9.28	9.46	9.52	9.38	9.74	9.47
3	15.33	15.11	16.65	15.41	15.47	15.41

* Layers numbered from 1, upper layer, to 5, lower layer (at bottom of the cylinder).

Table 22. Distribution of moisture by layers in frozen silty soil

No. of cylinders	Average moisture (% of dry weight)	Moisture by layer (% of dry weight)				
		Samples taken from the central part of the cylinders along their axes				
		1	2	3	4	5
I. Moistened by capillary action up to constant weight						
6	31.30	31.34	27.40	26.75	28.08	29.61
II. Predetermined degree of moisture						
3	5.87	5.40	5.68	4.77	6.37	6.76
3	9.34	9.27	7.99	9.10	9.19	9.76
3	16.45	16.09	11.93	13.19	14.86	16.39

An analysis of the data shows that the moisture was distributed more or less equally in the layers before freezing, but in the frozen state a sharp decrease of moisture was obtained in the inner layers.¹ The uppermost layers did not always have the greatest amount of moisture because of the method of freezing the soil from all sides, so that often the excess moisture became concentrated in the sides during freezing.

The data (Figs. 14 and 15) present a clear picture of the decrease of moisture in the middle layers of the ground. The curves of moisture migration in sand are given also, though the tables for sand are not included.

1. The freezing in our experiments was done simultaneously from all sides, approaching the center of the cylinders concentrically. The freezing took place without access of water from the outside.

PRINCIPLES OF MECHANICS OF FROZEN GROUND

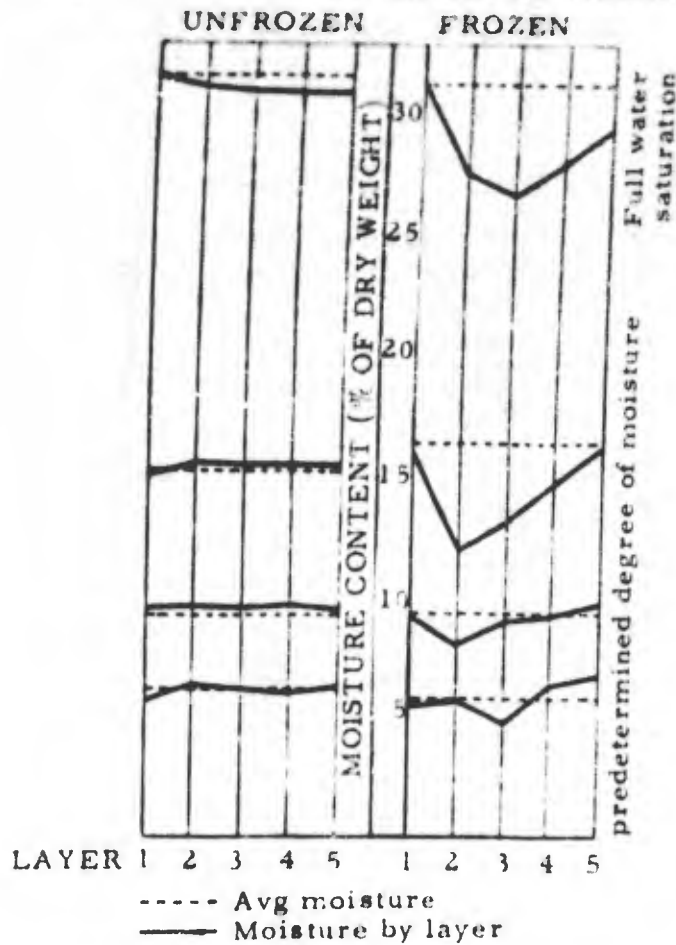

Figure 14. Distribution of moisture in unfrozen and frozen silt. [Layers are numbered from the top of the cylinder down.]

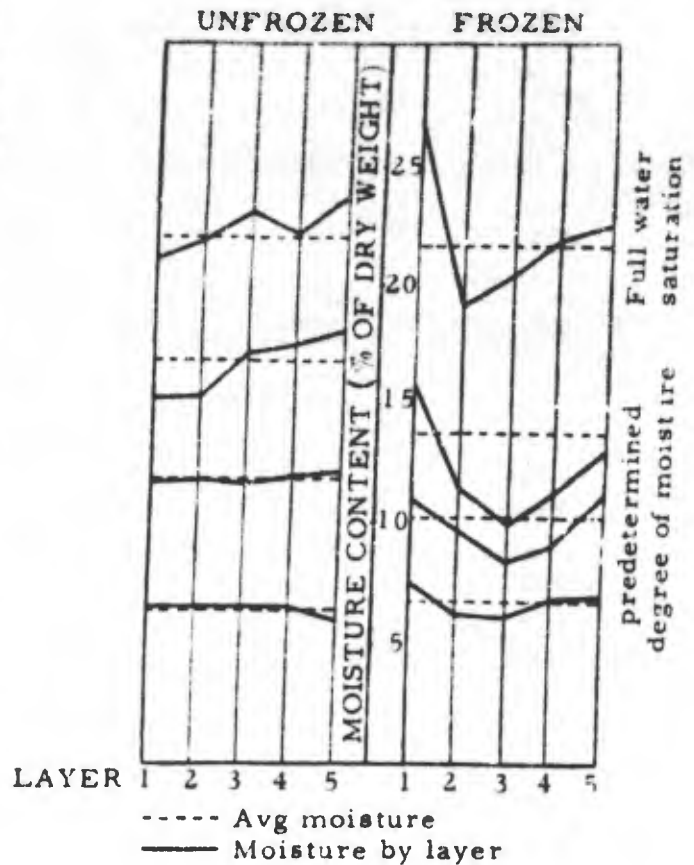

Figure 15. Distribution of moisture in unfrozen and frozen sand. [Layers are numbered from the top of the cylinder down.]

Laboratory experiments on formation of icing mounds, containing ice lenses, which represent analogous natural phenomena extremely well, are especially indicative of water migration during soil freezing, particularly water in the liquid state.

Sand of the following compositions was used:

Size (mm)	0.5-0.25	0.25-0.05	0.05-0.01	<0.01
Percent of total weight . . .	84.17	14.58	0.57	0.68

Sand placed in the above-described copper cylinders was moistened by the capillary method up to constant weight and subjected to freezing at a temperature of -16C to -19C. A copper disk, 5 mm thick, was placed on the sand surface, leaving a space of 0.5 mm between the cylinder walls and the edges of the disk.

A mound 4 mm high appeared on the surface of frozen ground, with a 3-mm thick ice lens 6-7 mm below it. In both experiments the whole mass of ice was, on the average, 0.57 g, or about 1% of the total water in the ground¹ (Figs. 16, 17).

1. M. I. Sumgin (1930) "Sovremennoe polozhenie issledovaniia vechnoi merzloty v SSSR i zhelatel'naia postanovka etikh issledovaniy v budushchem (Present condition of permafrost studies in the U.S.S.R. and a desirable program for the future)" in Vechnaia merzlota (Permafrost), Materialy KEPS (Commission of Productive Forces), sbornik 80, Leningrad: Izd. Akad. Nauk.

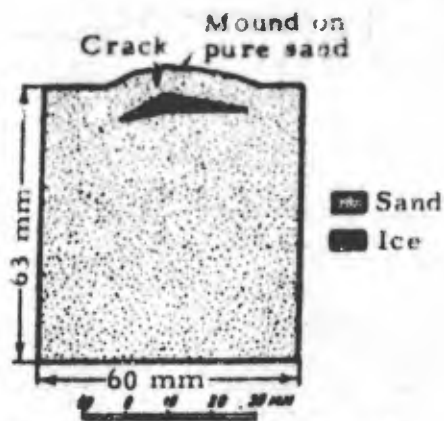

Figure 16. Formation of ice lens in sand.

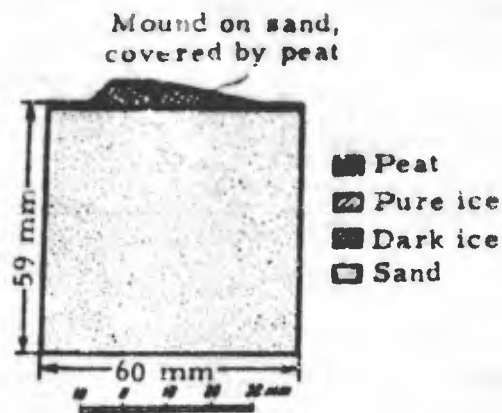

Figure 17. Sand was covered by a thin layer of peat and moistened. After freezing, an ice mound formed in the peat.

In other experiments with larger soil specimens, ice lenses up to about 10 g in weight were obtained.

This experiment and the one cited above prove the movement of water in freezing ground — specifically, water in the liquid state which subsequently froze in the form of a lens within the ground.

Fedosov¹ conducted freezing experiments on soil specimens in the form of beams 20 cm long and 2.5 by 2.5 cm in cross section, or slabs with a smooth surface devoid of any cracks prior to freezing.

The grain-size composition of one type of soil (Beskudnik clay) was as follows:

Size (mm)	Percent of weight
1.0 - 0.25	0.83
0.25 - 0.05	11.57
0.05 - 0.01	41.10
0.01 - 0.005	9.70
0.005 - 0.001	11.30
< 0.001	25.5

After freezing, cracks were observed in the clay. These cracks were always filled with ice, although the moisture in the sample was uniform before freezing. In one sample, which had a moisture content of 38.87% before freezing, the soil between the cracks had a moisture content of only 29.71% after freezing; i. e., it had decreased by more than 23%.

The duration of the zero temperature in the ground at a given depth is of great significance for the migration of moisture during freezing, and this has been repeatedly emphasized by both Soviet and foreign scientists. Moroshkin² conducted special laboratory

1. A. E. Fedosov (1935) Fiziko-mekhanicheskie protsessy v gruntakh pri zamerzanii i ottaivanii (Physicomechanical processes in the ground during freezing and thawing), Tranzheldorfstroi, Moscow.

2. V. I. Moroshkin (1933) "K voprosu ob obrazovanii ledianykh kristallov v merslykh gruntakh (The question of ice crystal formation in frozen ground)" in Borba s puchinami na zheleznodorozhnom polotne (Measures against frost heave on railroad beds), 28th sbornik, Instituta puti NKPS. Goszheldorizdat.

PRINCIPLES OF MECHANICS OF FROZEN GROUND

experiments on this problem. The grain size composition of the soil used was as follows:

Size (mm)	Percent of total weight
1.00 - 0.25	1.37
0.25 - 0.05	2.77
0.05 - 0.01	35.70
0.01 - 0.005	40.12
0.005 - 0.001	18.18
< 0.001	1.86

In these experiments, there was an inflow of water into the soil during the freezing. The cooling was conducted in such a manner that freezing could be stopped at a certain depth.

Distribution of soil moisture in depth was studied 209, 593, and 810 hr after the beginning of the experiment. The refrigeration chamber had a constant temperature of -16°C . After the first period, the zero isotherm was not deeper than 6 to 7 cm, and the soil was cemented down to 5 cm. The soil was cemented to 25 cm after the second interval and to 38.5 cm after the third and last interval. The distribution of ground moisture in depth is given in Figure 18.

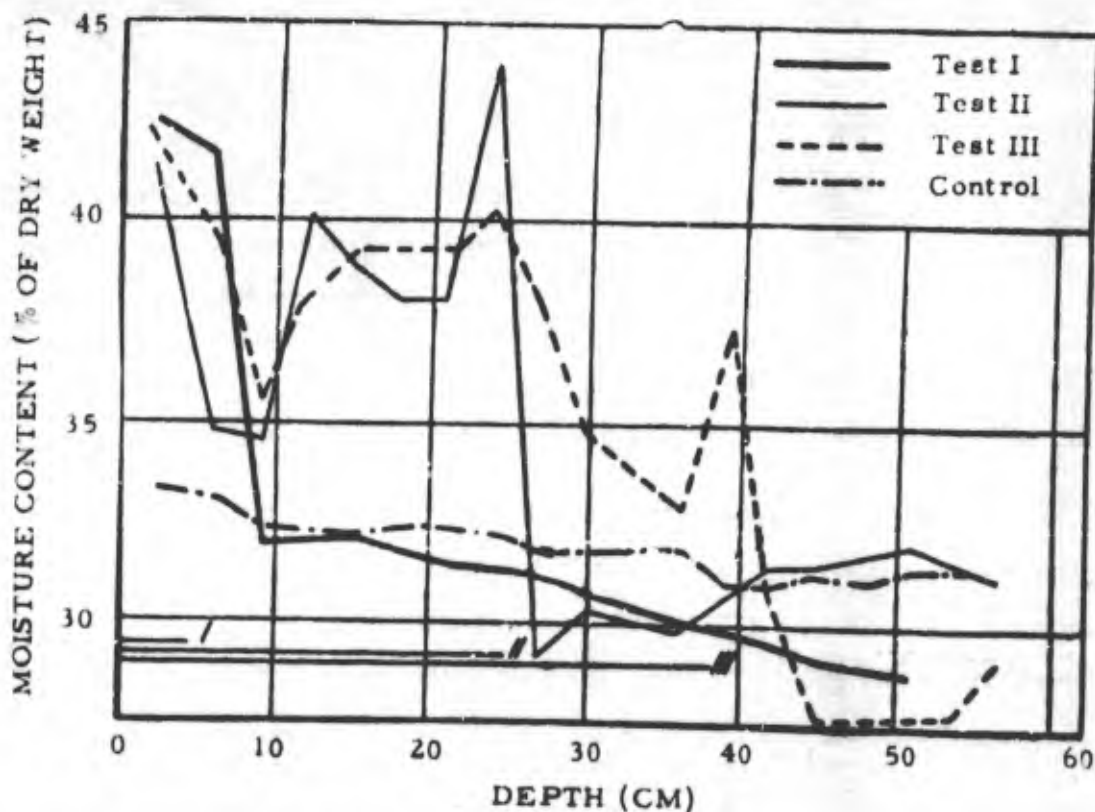

Figure 18. Below-horizontal lines: depth of cementing of soil by ice. (I - after 209 hr at -16°C ; II - after 593 hr; III - after 810 hr). Above: Moisture content.

Curve I (showing moisture distribution after the first interval) has one maximum close to the lower border of the frozen layer. Curve II has three maximums. Two correspond to approximately 5 and 25 cm, the two depths of soil freezing; the origin of the third maximum at approximately 12 cm is not clear.¹ Curve III has three definite

1. V. I. Moroshkin does not mention this in his work.

maximums which correspond to the three depths of soil freezing. All the boxes of soil were placed for freezing at the same time; the depth of freezing should have been manifested in moisture migration in all the boxes. Consequently, the condensation of the first box is repeated in the second box, and the condensation in the second box is added to it; the condensation of the first and second boxes is repeated in the third box, plus the condensation at the new depth of freezing after 810 hr.

After the soil was subjected to freezing for 20th hr, no ice layers were found in the soil. During the second test, 593 hr from the start of the experiment, thin ice layers (0.2 to 0.55 mm thick) were found at a depth of 25 cm. In the third box, 810 hr after the start of the experiment, very thin ice layers were found at a depth of 25 cm and lower.

Sumgin¹ gave an extremely simple mathematical expression for the thermal processes which take place during moisture condensation in ground at specific depths when freezing downward is slow or stops completely.

In such cases, a certain balance in the thermal-physical processes in the ground is established: the surface of the ground loses as much heat through radiation and other processes as the lower surface of the frozen ground receives from the deep layers of the ground and from the latent heat of transformation of water and water vapor into ice. Consequently, at this time the thermal balance at the lower border of the frozen layer is the sum of: (1) \underline{Q}_1 , the heat received by thermal conductivity from the deep layers of the ground; and (2) \underline{Q}_2 , latent heat from the transformation of water and water vapor into ice. Thus, the lower surface of the frozen ground receives a certain amount of heat energy, $\underline{Q} = \underline{Q}_1 + \underline{Q}_2$. This quantity of heat \underline{Q} is transmitted by thermal conductivity through the frozen ground to the earth's surface, and the same quantity of heat \underline{Q} is lost by the surface of the ground through radiation and other processes.

The longer this process goes on, the greater the thickness of ice layers that form, and vice versa. The snow cover may play an important role here. If its thickness increases, freezing of the ground may be retarded even with lower air temperatures, and ice layers continue to form at the lower border of the frozen layer.

Turning from laboratory data to observations under natural conditions, we have many observations on the migration of ground moisture during freezing. There is a great quantity of material on the accumulation of water in icing mounds in the permafrost region. An example of an exploding icing mound on the Amur-Yakutsk Highway was cited previously, from a series of such observations. There are works by Swedish and Finnish investigators as well. Of the Soviet investigators, we give an example from the previously cited work by Kachinskii (see Table 23).

It is seen from Table 23 that, during the winter of 1924-25, the ground was frozen only down to 40 cm and unfrozen below. The moisture content of the samples of frozen ground obtained at three depths — 5 to 8, 15, and 23 cm — was considerably higher than the moisture of unfrozen samples from the same depths before freezing. At a depth of 5 to 8 cm, the moisture content was 25.3% in the unfrozen state and 31.9% in the frozen state (Dec. 13). The moisture at 15 cm was 16.4% in the unfrozen state (Dec. 13) and 24.9% in the frozen state (Dec. 29). For 23-cm depth, the corresponding values were 13.9% and 18.0% moisture content.

Only at the depth of 40 cm was there no increase of ground moisture registered for the frozen samples.

In our opinion, these rapid increases of moisture are the result of the redistribution of moisture during the actual process of ground freezing. We cannot definitely say which factor had the most influence on the moisture redistribution — movement in the liquid state due to the forces of crystallization or the condensation and crystallization of vapor due to temperature differences — since Kachinskii's gives no data on which to base an opinion.

1. M. I. Sumgin (1930) Kratkii kurs dorozhnoi geofiziki (Short course in road geophysics). Moscow: Gostransizdat.

Table 23. Distribution of absolute moisture in unfrozen, frozen, and semi-frozen soil layers (% of dry weight).

Date of moistening the soil 1924-1925	Depth of samples (cm)				
	5-8	15	23	40	70
	A ₀	A ₀ /II	A ₂	B ₁	B ₂
October	15.7	13.4	12.3	14.7	18.3
November	25.3	19.5	11.2	9.6	13.1
December 13	31.9*	16.4	10.1	12.7	16.7
December 29	28.3*	24.9*	13.9	11.6	21.0
January	30.8*	20.8*	18.0*	14.2	17.2
February	29.8*	26.7*	14.3*	13.1*	15.6
March	36.6*	22.9*	15.9†	15.0	18.4
April 4	46.7*	22.4*	19.7*	15.2	12.4
April 6	46.5*	22.6*	18.7†	17.2	19.1
April 9	33.0	21.5*	19.8	11.3	19.2

* Moisture of frozen soil.

† Moisture of samples in a semi-frozen, slightly thawed state.

A case described by Lebedev and Talalaev¹ undoubtedly deals with moisture migration in the ground during freezing. During the spring of 1928, the crop of winter wheat in the northern Caucasus and in the Ukraine was completely ruined. Scientists studying the causes of this phenomenon investigated the soil conditions in the fields. We quote the above-mentioned investigators.

"The soil conditions on the experimental plot of winter wheat located at the Don Experimental Station were investigated first. For this purpose a pit 20 cm deep was dug on a protected strip of the plot on March 22. In the wall of the pit at a depth 7 cm from the surface, we found an ice layer, 0.5 to 1.0 cm thick.

"When a portion of this ice layer was extracted from the pit, it was found that it consisted of ice with particles of soil adhering to it on the upper and lower surfaces. The percentage of moisture in this layer was 242 to 343% of the weight of the dry soil" (Fig. 19).

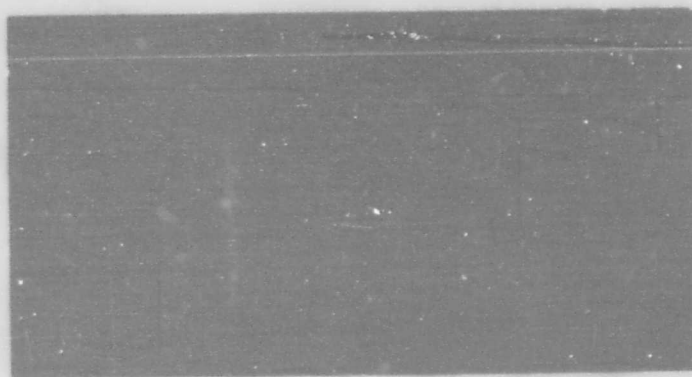

Figure 19. Cross section of frozen ground at the Don Agricultural Station at Rostov-on-Don. (- Ice layer).

1. A. F. Lebedev and E. V. Talalaev (1928) *Gidrologicheskie i klimaticheskie uslovia gibeli pshenitsy v 1927-28g.* (Hydrological and climatic reasons for loss of wheat crop in 1927-28), *Donskoe okruzhnoe zemel'noe upravlenie* (Don District Agriculture Department), Rostov-on-Don.

The authors explain the formation of this ice-filled layer by the condensation of vapor here during the process of soil freezing, although they state that in February the soil thawed approximately to the depth of this layer, and that water from melted snow reached this depth.

Thus, the fact of water migration in its various phases during the freezing of the ground and in frozen ground was demonstrated both by laboratory experiments by foreign and Soviet investigators and by observations under natural conditions. Let us repeat here that the theory of water migration in the ground during freezing is substantiated especially clearly by observations in permafrost regions during the study of icing phenomena (Fig. 20).

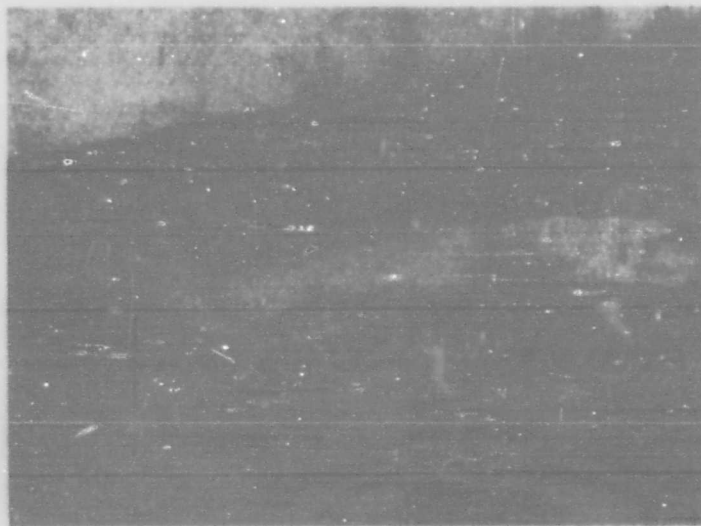

Figure 20. Ice mound at the 91st km post of the Amur-Yakutsk Highway which developed during the winter of 1928-29. (In the winter of 1927-28, this mound did not exist.) (Photographed May 17, 1929.)

The basic causes of water migration in freezing and frozen ground may be summarized as follows:

- | State of water | Basic causes of migration |
|------------------|--|
| I. Vapor | 1. Differences in vapor tension due to: <ul style="list-style-type: none"> a. Temperature b. Curvature of surface (Thomson's law) c. State of the substance (supercooled water and ice) |
| II. Liquid | 1. Gravity
2. Stresses in the ground during freezing
3. Capillary forces (movement through the voids)
4. Forces of crystallization |
| III. Solid (ice) | 1. Outside pressure |

Stresses in Freezing Ground and Ground HeavingCauses of stresses in freezing ground

The numerous cases of ground heaving during freezing and frost heaving cracks in frozen ground testify that some kind of forces are acting on the ground in these places. In some cases, the result is a rise of the ground — heave — and in other cases, the disruption of its continuity — the formation of cracks. These forces may be external or internal, i. e., connected with processes taking place in the ground.

At first glance we do not find outside forces which would cause the above-mentioned phenomena. We explain the ground heave either by the hydrostatic pressure of water, which is one of the components of the ground, or by the transformation of this water from the liquid to the solid state with an accompanying increase in volume. We explain the cracks either by the decreasing volume of the whole mass of frozen ground or by the same forces of water crystallization. Therefore, this deformation is connected with processes which take place in one of the ground components, particularly in water, although as we will see below, sometimes the other components of the ground act together with the water.

However, further investigation of the established internal causes of ground stresses and subsequent deformation shows that the basic cause is the heat which acts as an outside force on the ground. We can establish the following chain of events:

1. Heat as an outside force acting on the ground.
2. Change of thermal condition of the ground.
3. Processes in the ground components due to changes of thermal state of the ground (compression, expansion, change of physical state).
4. Stresses in the ground.
5. Ground deformation (swelling and frost cracks).

This chain of events is very clear to us, and it can be traced step by step even in very complex natural manifestations, though not in all cases. But as yet the interaction of the links of this chain is understood only in very general terms. A deeper analysis of these links of the chain is a task for the future.

Let us consider how the volume of the ground changes as it cools. We assume absolutely dry ground consisting of large particles. The pores contain air in more or less free contact with the outside air. In nature such ground is rarely encountered. Sand with no cohesion, gravel, and other types of coarse-grained soil are "dry" in the usual sense of this term, but actually contain some moisture, even though it is in the hygroscopic state and has little practical effect on our considerations. Here we will deal with unfrozen ground of a one-phase system. When the ground cools, the separate particles contract and the ground itself contracts also. As the coefficient of expansion of hard bodies is very small (for example, the linear coefficient of expansion of quartz¹ is 0.0000137, perpendicular to the axis, and 0.0000074, parallel to the axis), it can be disregarded for practical purposes.

If all the ground pores are completely filled with water, we have a two-phase system. During cooling, the solid phase will contract. The water also will contract until the temperature drops to +4C, and then it will expand.

At zero, or a certain negative temperature, water assumes the solid state and suddenly expands. After all the water has frozen, the whole system will decrease in volume with further lowering of temperature. The sudden increase in water volume when it changes into ice is more significant than all the stages of compression and decrease in volume of the ground.

For the sake of simplicity, we will assume that the ground freezes at 0C, and that all the water contained in it changes into ice.

1. F. Kol'raush (1924) Kratkoe rukovodstvo k prakticheskim zaniatiyam po fizike (Short manual for practical work in physics), 2nd ed. Odessa: Marezis.

Let us consider a unit volume of ground of a two-phase system, i. e., ground in which all the pores are completely filled with water at a temperature of 0C. With further cooling the water will begin to crystallize and the ground temperature will continue to be zero up to the end of crystallization. When all the water has been transformed into ice, the volume will increase to:

$$m + (1 - m) (1 + \beta_1) \quad (5)$$

where m = volume of the solid phase; $1 - m$ = volume of water; β_1 = coefficient of water expansion upon its transition into ice.

This increase in ground volume with freezing is the cause of stresses in freezing ground.

The volume of freezing ground increases at a greater rate than that shown in formula (5). During the transition of water into ice, the volume of ice in the ground pores becomes somewhat greater than the volume of the pores, so that mineral particles are pushed out by the ice, creating small cavities (pores of freezing) which may form a network of new capillaries in the already frozen ground.

Therefore, the unit volume of our ground after freezing is:

$$m + (1 - m) (1 + \beta_1) + n \quad (5')$$

where n is the volume of the "pores of freezing".

The presence of the pores due to freezing has been substantiated by experiments on the freezing of soil, especially sandy soil, which showed that the volume of the frozen ground is larger than theoretical calculations of the expansion of water contained in the ground would indicate.

The presence of pores and capillaries in the frozen ground has been substantiated also by experiments of foreign and Soviet scientists during the study of the density of air in the ground. In the winter, when the upper layer of the ground was frozen, a soil manometer at 1-m depth in the ground showed a free exchange between the air of the atmosphere and that of the ground.¹ This could occur only if voids were present in the frozen soil. The changes in atmospheric pressure penetrate the soil in the winter as if the soil were nonexistent.² This, of course, can take place only if the frozen ground contains voids. The fact that the ground does not freeze at 0C and that not all of the water in the ground is transformed into ice does not change the substance of the above-given considerations, but only introduces certain corrections into them.

With subsequent cooling of the already frozen ground, a decrease in its volume begins, but the coefficients of volume change of soil and ice are so small in comparison to the water expansion when it changes to ice that the ground does not return to its initial volume, i. e., its volume before freezing, even at the very low temperatures which occur under natural conditions.

We have been considering ground with pores completely filled with water. Now we will consider ground that is not completely saturated; i. e., part of the pores remain filled with air and water vapor (three-phase system). Theoretically speaking, such ground has inner resources for expansion. Up to a certain moisture content, the parts of the pores which are free of water will take up all the volume increase when the water is transformed into ice. Consequently, the ground will not increase in volume upon freezing; i. e., no heaving will take place.

The following designations are used: w_v is the moisture by volume (in percent of volume); w is the moisture by weight (in percent of dry weight); Δ is the specific gravity

1. A. Trofimov (1934) Kolebaniia barometricheskogo davleniia v pochve i pochvennyi gazoobmen (Fluctuation of barometric pressure and gas circulation in the soil), Zhurnal geofiziki, tom 4, no. 4(14).

2. These interesting results obtained in the European part of the U. S. S. R. (and abroad) should be verified under permafrost conditions.

of the ground; δ is the unit weight of the soil skeleton; n is the volume of voids or the porosity; β_1 is the coefficient of volume expansion of water at freezing.

The moisture by volume of unfrozen ground, w_v , can be expressed by the well-known equation

$$w_v = w\delta \quad (a)$$

and the volume of voids or porosity, in percent of the total volume, is

$$n = 100 \left(1 - \frac{\delta}{\Delta} \right). \quad (b)$$

If the temperature of water contained in the ground is near 0C, the volume of ice (in percent of the original volume of the ground) after freezing of the water will be

$$w_v (1 + \beta_1).$$

Assuming that the volume of ground voids remains constant, the volume of ice which fills all voids will be numerically equal to the porosity n (in percent of the total volume of the ground):

$$w_v (1 + \beta_1) = n.$$

It follows that the volume moisture of the ground which theoretically corresponds to complete filling of the voids by ice will be:

$$w_v = \frac{n}{1 + \beta_1}$$

and, according to equation (a)

$$w = \frac{w_v}{\delta},$$

the moisture in percent of dry weight will be

$$w = \frac{n}{(1 + \beta_1)\delta}$$

Substituting the value of n from equation (b) we have

$$w = \frac{100[1 - (\delta/\Delta)]}{(1 + \beta_1)\delta}$$

* [As defined subsequently:

Δ , specific gravity, is the weight per unit volume of the solid substance: $\Delta = W_s/V_s$;
 δ , unit weight of the soil skeleton, is the unit weight of the soil dried at 105C, assuming that the volume does not change.]

and, after algebraic transpositions, we have:

$$w = \frac{100(\Delta - \delta)}{\Delta \delta (1 + \beta_1)} \quad (c)$$

Substituting $\beta_1 = 0.0908$, according to Barnes, gives¹

$$w \approx 91.67 \frac{\Delta - \delta}{\Delta \delta} \quad (6)$$

Equation (6) gives the moisture content (by dry weight) at which all the pores will be filled with ice when the ground freezes, but no heaving will take place. This is what Tsytovich calls the critical moisture.

It is clear that, theoretically speaking, when the moisture is less than critical, the ground will not heave during freezing.

In determining the critical moisture, we have not taken into consideration the water which does not freeze, and which, as already pointed out, decreases with increase in grain size. For practical purposes, it can be considered that for sand, especially coarse sand, no ground heave would take place if the moisture were less than that given by eq (6).

These are the fundamentals of the theory of ground heave caused by the expansion of water upon transformation into ice. We have not yet touched upon the problem of water migration during ground freezing — which plays an exceptionally important role in the heaving.

There are opinions, however, which completely reject the above-stated theory of ground heave and advance the idea of the forces of crystallization. The proponents of such views state that the force of crystal growth, which is directed in a specific way in relation to the flow of heat, creates stresses in the ground. This idea has been advocated, among contemporary investigators, by Taber.² We will cite a number of his arguments on this subject.

"Pressure effects accompanying the freezing of soils are due to the growth of ice crystals and not change in volume. Pressure ... is determined chiefly by the direction of cooling. Heaving is often greater than can be explained by expansion." [Taber, 1929, p. 428].

In the same article [p. 447] he says: "It is commonly stated that frost heaving is upward because of less resistance to expansion in that direction, but this is not the true explanation. The pressure effects that accompany freezing are not due to change in volume, but to the growth of ice crystals. Crystals perform work in any particular direction by growing in that direction and overcoming the resistance to growth. The upward heaving that accompanies the freezing of soils is due to the growth of ice crystals in a vertical direction, and this is usually determined by the direction in which heat is conducted away most rapidly, and by the availability of the water necessary for growth."

In another work, Taber³ develops his thoughts in the same direction: "A crystal can develop pressure only in those directions in which it is growing."

1. N. A. Tsytovich (1930) "Vechnaia merzlota kak osnovanie dlia sooruzhenii (Permafrost as a structural foundation)" in *Vechnaia merzlota (Permafrost)*, Materialy KEPS, (Commission on Productive Forces), sbornik no. 80. Leningrad: Izd. Akad. Nauk.

2. S. Taber (1929) *Frost heaving*, Journal of Geology, vol. 37, no. 5.

3. S. Taber (1930b) *Freezing and thawing of soils as factors in the destruction of road pavements*, Public Roads, A Journal of Highway Research, U. S. Dept. Agri., Bureau of Public Roads., vol. 11 no. 6.

Taber distinguishes between the freezing of water in open and closed systems. In nature, in his opinion, the first takes place more often than the second. He considers that the theory of ground heave due to water expansion during its transformation into ice is correct only for the closed system. "Observations out of doors show that [most] soils when subjected to freezing under natural conditions [usually] behave as open systems rather than as closed systems."^{*} The results of pressure by crystals in open and closed systems are completely different. "In open systems, where the liquid can escape, the pressures resulting from freezing are not hydrostatic but are due directly to crystal growth, and are effective only in the direction of growth." According to Taber, a quite different situation takes place when the crystal grows in a closed system. "If the growing crystal exerts pressure against a liquid that is confined, hydrostatic pressure is the result; but in a closed system, the crystal is able to exert pressure only if crystallization is accompanied by an increase in volume" - which, we may add, is just what happens during the crystallization of water.

Taber states, however, that in nature ground with low water permeability freezes as closed systems.

Taber performed a number of experiments which proved the direction of the pressure of crystals. We quote the description of some of these experiments.

"Mixtures of white clay and water in different proportions were frozen in thin glass test tubes, half of them being buried in sand so that freezing was from the top down, while the others were exposed so that freezing took place from the sides inward. All of the latter were broken, longitudinal cracks extending the full length of the test tubes. But where - frozen from the top down none was broken, for the ice crystals grew only in a vertical direction. Alternating layers of clear ice and frozen clay were formed in the upper parts of the mixtures containing sufficient water, while shrinkage cracks developed below as water was withdrawn to build the ice layers above.

"When test tubes filled with clear water are exposed to low temperatures they do not usually break unless there is a constriction in the tube, for the density of water decreases on cooling from 4 to 0°C, causing the coldest water to rise and come in contact with the downward-growing ice crystals."¹

Taber describes another experiment: "Clay was packed around heavy copper bars standing in a carton with perforated bottom. The carton was placed on wet sand and then the entire apparatus was buried in the sand box for freezing as in previous experiments. When removed a layer of fibrous ice, about a centimeter thick, was found surrounding the copper, the crystals being normal to the copper bars. Ice veins, ranging up to 2 mm in thickness, branched off from the vertical ice layer and sloped steeply upward. Near the bottom of the carton a large mass of ice was formed which ruptured the carton and pushed part of the clay out into the inclosing sand.

"The rapid conduction of heat by the copper caused the growth of ice crystals radially outward from its surface, and the pressure of these growing crystals ruptured the carton. In other experiments the cartons were never ruptured by the direct pressure of growing ice crystals because heat conduction, and therefore crystal growth, were limited to a vertical direction."¹

As another argument for his theory that during crystallization the pressure is caused specifically by the crystal growth and not by the increase of crystal volume in comparison with the initial amount of liquid, Taber points out that nitrobenzene, which decreases in volume when it solidifies, creates pressure when frozen in an open system, but does not when frozen in a closed system.

Our own position is that, in the complex conditions encountered in nature, ground freezing occurs in both closed and open systems, but, in our opinion, more often in closed than in open systems, especially in the permafrost zone.

i. Both quotations are from Frost heaving. [Taber, 1929, p. 448, 450.]

* [Taber, 1930b. The words in brackets were omitted in the Russian quotation.]

Consequently, in freezing ground we have stresses which are due either to the increase of water volume when it changes into ice or to the pressure exerted by crystals during their growth. Stresses within the ground during its freezing may be expected to move water in the ground, or even masses of still unfrozen ground to a point where the resistance to pressure is less than in the surrounding ground, and less than the stresses in the ground. In this case, shifting of the ground in the direction of least resistance to pressure takes place.

In his experiments, Sumgin artificially created a less resistant mass within frozen soil. In the center of a cylinder of soil, he placed a rubber ball fixed to a glass tube which protruded from the cylinder. Both the rubber ball and the glass tube were filled with alcohol up to a certain point. He used fine-grained sand for his experiments, moistened by capillary action up to its full moisture capacity, and then froze the sand with the ball inclosed (see Figs. 21 and 22).

The soil, freezing from all sides, developed internal pressure and deformed the rubber ball, pushing it in from one side or from the bottom. The soil filled in the deformed parts of the ball and caused the alcohol to rise in the glass tube to a certain height (Fig. 22).

The pressure developed during the freezing of water (in a closed system) is illustrated by a simple experiment by Tsyto-
vich.¹ Water in small vessels was subjected to a temperature of approximately -12°C . After about 5 hr, the water froze along the entire periphery of the vessel, but a small quantity of water remained in the center enclosed on all sides by ice. The ice exerted pressure on the water, because, when a small crack appeared in the ice, the water rushed through it forming a small icicle or a sort of ice fountain. Everything seemed to indicate that this water was in a supercooled state (Fig. 23).

During repeated experiments, the upper layer of ice was pierced by a heated wire: in every case, the water inside the ice rushed out in the form of a fountain through this opening.

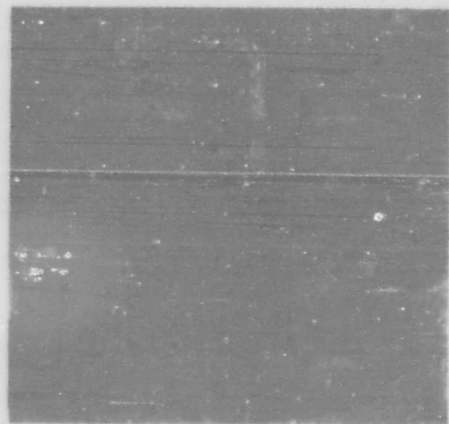
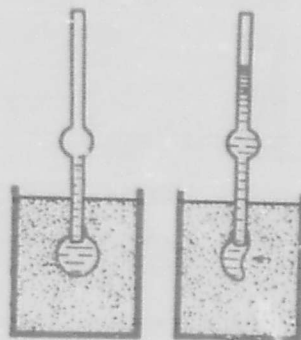

Figure 23. A small ice fountain formed by the emergence of supercooled water.



Figures 21 and 22.

We have already seen in Taber's experiments that, under certain conditions, soil was extruded from the cardboard cylinders during freezing, often breaking the cylinders (see Fig. 13). This and other experiments give visual proof of the existence of pressure in the ground and of the deformation caused by this pressure (Fig. 24).

The idea of ground stresses during freezing has received confirmation from a somewhat unexpected source during recent years. Seismologists began to notice that their apparatus registered the movements of the earth's crust in the fall during freezing of the soil. They attributed these movements to the action of frost on soil.²

These extremely interesting observations by seismologists support the observations of permafrost investigators that ground water often freezes in the following order: cooling \rightarrow supercooling \rightarrow formation of ice.

In our opinion, it is this last phenomenon which produces the jolts registered by the seismographs.

1. N. A. Tsyto-
vich, *Nekotorye opyty po opredeleniiu sil smerzaniia. Materialy po issledovaniu merzlykh gruntov* (Experiments to determine adfreezing strength. Material for the study of frozen ground), *Biulleten' Leningradskogo Instituta sooruzhenii* (Bull. of Leningrad Inst. of Construction), No. 25.

2. B. Gutenberg (1934) *Stroenie zemli* (Structure of the earth). Moscow and Leningrad: ONTI.



Figure 24. Left: Frozen cylinder, half sand and half clay. Much segregated ice in the clay but not in the sand. Right: Differential displacement of the cylinder due to ice segregation in the clay, but not in the sand. Cavity formed by dislodgment of dry sand. (From Taber, 1929.)

Taber's assertion that under natural conditions the freezing of ground takes place exclusively* in open systems cannot be accepted, because he speaks of seasonal freezing in those regions where permafrost does not exist. Seasonal freezing in the permafrost region takes place under the specific conditions of a closed system, as will be demonstrated in its proper place.

Theory of ground heaving

In discussing the mechanism and conditions of heaving, moisture migration and stresses in the ground during freezing will serve as the basic premises.

The term ground heaving is used in its general sense — a deformation of the ground surface which consists of elevation of the surface and subsequent lowering. Such phenomena may affect comparatively large areas measured in square kilometers or small areas measured in square meters. As most heaves are associated with ground freezing, they appear in the fall or winter and disappear during the spring, or, less often, in the summer, depending on the climatic conditions.

The term "heaving" in road building and construction practice is applied specifically to the local elevation, and subsequent lowering, of the ground — which Taber calls differential heaving.

A local elevation of ground surface which is usually accompanied by the formation of a mound is the first phase of the heaving phenomenon; the settling of the mound is the second phase, which is completed by the drying up of the ground.

It is necessary to distinguish between heaving without the inflow of water, and heaving with water flowing from the outside into the freezing ground.

The first type must be divided into two subgroups. In the first subgroup, water in the ground freezes without being redistributed in the freezing ground; i. e. the water freezes in the ground according to the theory of moisture fixation in the ground). As we pointed out above, such cases in their pure form do not exist in nature. But we can visualize such a case theoretically and, in practice, place in this category cases in which the water in a mass of frozen ground is extremely small in comparison with the water frozen in place without migration. Such cases occur under natural conditions when a comparatively thin layer of ground freezes during extremely cold weather.

In the second subgroup, redistribution of moisture takes place in the frozen layer of the ground. There are three types of migration: (a) migration of water only in the form of vapor; (b) migration of water only in the liquid state; (c) migration of water in both vapor

* [Sic. See footnote p. 46.]

and liquid states. But because the state in which moisture migrates during ground freezing has been little studied, we will not discuss it here, limiting ourselves only to a statement of the situation.

In the first subgroup, if the ground moisture is smaller than or equal to the critical moisture, theoretically there should be no heaving but actually a certain amount of heaving will take place. For complete absence of heaving, the water must be distributed in such a way that the volume increase caused by water freezing in each separate pore would be equal to or smaller than that part of the pore which was free from water before freezing. The probability of such a distribution is extremely small; consequently, a certain expansion of the ground will take place during freezing even though the average moisture content of the whole freezing ground is equal to or even smaller than the critical moisture.

If the ground moisture is greater than critical, up to and including complete saturation, heaving will occur according to the increase in water volume during its transition into ice.

In the second subgroup, when moisture is redistributed during freezing (such cases are normal under natural conditions), ice layers may form in the ground, usually of small thickness measured in millimeters or fractions of millimeters, although in some cases they may be larger.

The reader should note that all our discussions on heaving without an inflow of water from the outside into the mass of frozen ground are based on the theory that heaving is due to the increase in water volume during its transformation into ice, which, according to Taber, is correct only for closed systems.

But, even according to the theory that heaving is caused by the forces of water crystallization -- oriented only in the direction of crystal growth, heaving should still occur under the given conditions (without inflow of water into the freezing mass). With this theory, it is difficult to predict the increase in volume and consequently the growth of the heave, but larger water content in the ground will cause a greater heave, because, according to Taber, "the growth of an ice crystal in each separate direction is conditioned by the following three factors: (1) the presence or absence of water in contact with a crystal in this direction; (2) the temperature at the point of contact; and (3) the pressure at the point of contact (water with an ice crystal, considering that the water at this point will be in a supercooled state)."

However, for the permafrost region, for which the present work is primarily intended, the conditions of ground freezing are such that, at most, only the uppermost layers of the ground freeze in an open system. As soon as the top layers freeze, the conditions change, and we have a closed system even when the ground freezing is equally distributed over a large territory.

We now, also theoretically, consider the mechanical effects in the permafrost region during the freezing of the active layer without inflow of water from the outside¹ and without migration of moisture in this layer.

It is assumed that the freezing layer is horizontal, and has the same composition, structure, and moisture everywhere, the same type of vegetation and the same degree of snow cover, etc. It is evident that such a layer would freeze uniformly at all points.

We also assume that the upper surface of the permafrost is horizontal, that the freezing layer occupies an unlimited area, and that the ground freezes from the top downward.

In this ideal case, what forces will operate on an unfrozen layer of ground between the surface layer, which is freezing from above during the winter, and the underlying layer of permafrost?

A schematic cross section of ground is considered at a time when the ground has frozen to a certain depth but not to the permafrost layer, and is still freezing (Fig. 25). AB is the surface of the ground at the given moment u ; CD is the base of the frozen part of the layer of winter freezing [active layer]; EF is the upper surface of permafrost; h is the thickness of the frozen layer at the moment u .

1. See previously cited work of M. I. Sumgin in Vechnaia merzlota (Permafrost).

*[This is a translation from the Russian, not the author's original words. The quotation could not be identified in the references cited.]

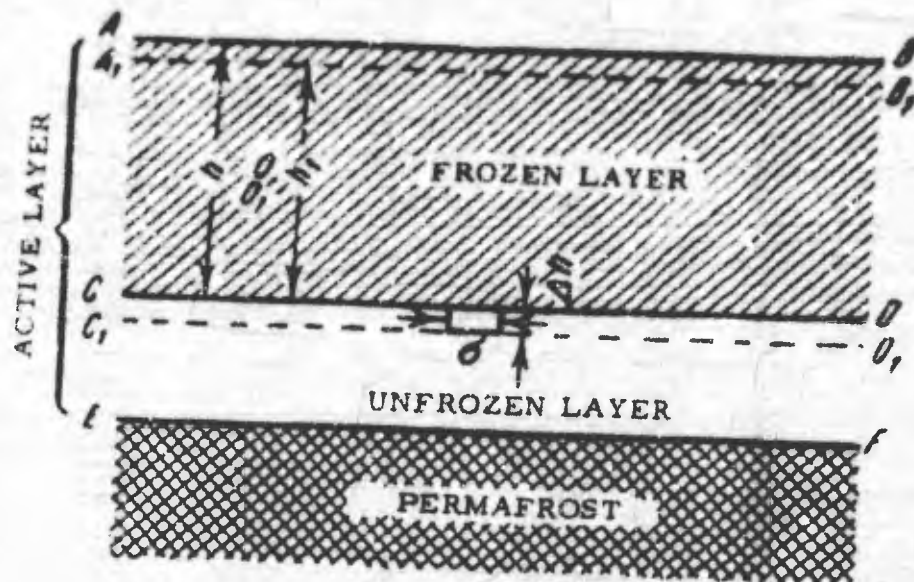

Figure 25.

We assume that the active layer has a certain amount of moisture and expands during freezing with a coefficient of expansion of β_1 . The time when freezing starts is designated as u_1 . The surface of the ground prior to freezing is A_1B_1 ; the thickness of the layer between A_1B_1 and CD , when it was unfrozen, is h_1 .

Therefore, the increase in the thickness of the layer caused by expansion during freezing is equal to $h - h_1$.

The question arises as to what forces operate on the surface CD at the moment when the ground has frozen to a depth of h , compared to the forces operating when the ground was unfrozen. We will consider a unit area dF on CD . At the moment u_1 , a column of ground with a volume of dFh and a weight of g , is exerting pressure on this area; (disregarding atmospheric pressure).

It is evident that, after freezing, the pressure on this area, for all practical purposes, will still be that of the same weight g (disregarding atmosphere), although the volume of frozen ground will be dFh_1 , since no changes took place in the ground except for the increase in volume.¹

Consequently, the pressure on the whole surface CD will be the same at moment u as it is at u_1 when the ground began to freeze. Disregarding atmospheric pressure, it may be numerically expressed as follows: Assuming $dF = 1 \text{ cm}^2$, the volume of the unfrozen soil column from the surface to depth $h_1 \text{ cm}$ will be $h_1 \text{ cm}^3$. If the average unit weight of dry soil is 1.5 g/cm^3 and of moist soil, 2.0 g/cm^3 , 1 cm^2 of surface CD will have a pressure of 200 g/m of soil thickness. The weight would remain the same in the frozen state.

These considerations apply to this phenomenon at its end moment. As a matter of fact, since this process is continuous and uninterrupted, the ground freezes to a very small depth during each small division of time, freezing gradually layer by layer. To analyze the mechanical process during the freezing of a ground layer, we consider the layer CDD_1C_1 (Fig. 25), with a thickness Δh . In this layer, a parallelepiped with a base of dF will have a volume of $dF\Delta h$, in the unfrozen state, and $dF\Delta h(1 + \beta_2)$ in the frozen state. Consequently,

1. The pressure of frozen ground will be somewhat less, as its center of gravity is higher than the center of gravity of unfrozen ground by the value $(h - h_1)/2$, and consequently, the gravitational pull is less, although only to a very small degree. There are also the dynamic conditions of freezing which we will not consider here.

the volume increase will be $dF\Delta h\beta_2$, where β_2 is the volume coefficient of expansion of freezing ground. The analysis of this case will be the same whether we accept the theory of expansion due to water expansion during freezing or the theory of pressure during crystal growth.

The parallelepiped tries to expand in all directions as it freezes. On both lateral sides, it meets freezing ground which is also trying to expand in all directions with the same coefficient of expansion and mechanical force, as we stipulated that the ground is the same throughout.

Consequently, on the sides equal and diametrically opposite forces will cancel out those in our parallelepiped. Therefore, there will be no lateral expansion, and only expansion upward and downward remains. For all practical purposes, there will also be no expansion downward. Expansion upward will encounter the pressure of a column of frozen ground with height h , which, as we have noted, will be 200 g/cm^2 for a height of 1 m (disregarding atmospheric pressure). After overcoming this pressure, the parallelepiped will expand upward, exerting a similar pressure downward.

Therefore, in our ideal case, expansion will take place only in the upward direction, overcoming the insignificant resistance. This resistance should not be confused with the enormous resistance, theoretically calculated at about 2100 kg/cm^2 at a temperature of about -21C , which frozen ground can overcome. In the case just discussed, this enormous force is unused, as the actual resistance encountered by this tremendous force is insignificant.

If we accept the theory of expansion due to the forces of crystallization, we consider our ideal case as a close system and all our deductions remain valid. Even if we consider this case as an open system, if the heat flows toward the ground surface, the ice crystals would grow in that direction and therefore exert pressure toward the ground surface. Consequently, all that has been said above is true even in this case.

Many investigators (foreign and our own, the latter as early as the 1800's) have noticed that the size of the heave is often much greater than the increased volume of water, calculated on the assumption that the frozen layer is saturated. These facts demand the assumption that some water enters the freezing layer from the outside and freezes in this layer, correspondingly increasing the volume of the ground and, therefore, the size of the heave.

Therefore, we must accept the fact that some heaving occurs with water flowing from the outside into the freezing layer and freezing in that layer - completely or in part.

Taber believes that the growing crystals take water for further crystallization (at the expense of heat energy) not only from the freezing layer but also from the underlying soil layers, with more rapid movement of water than by capillary action. During the growth of the ice layer in the ground, says Taber,¹ "water is not supplied by capillarity, for there is no free surface or meniscus. The force causing the upward flow of water to feed growing ice crystals is greater than that which results in the capillary rise of water in soil."

Taber arrived at this conclusion as a result of the following experiment. He took two cylinders of similar clay, one short and one tall, and moistened them by the capillary method. Naturally, water saturation took much longer for the tall cylinder. When these cylinders were frozen from above, however, the water moved to their upper parts in almost the same time.

A Russian engineer, Shtukenberg, as early as the last century, proposed a theory of heaving with the repeated influx of water from the outside into the freezing ground.

He noted that, under natural conditions outside the permafrost area, heaving often caused mounds tens of centimeters in height. This would require a considerable reserve of water, which, according to calculations, did not exist in the layer of frozen ground prior to its freezing. Shtukenberg considered that ground water was the source feeding these

1. Taber (1930b). [p. 122]

UNCLASSIFIED

AD

230 484

FOR
MICRO-CARD
CONTROL ONLY

2

OF

6

Reproduced by

Armed Services Technical Information Agency

ARLINGTON HALL STATION; ARLINGTON 12 VIRGINIA

UNCLASSIFIED

"NOTICE: When Government or other drawings, specifications or other data are used for any purpose other than in connection with a definitely related Government procurement operation, the U.S. Government thereby incurs no responsibility, nor any obligation whatsoever, and the fact that the Government may have formulate furnished, or in any way supplied the said drawings, specifications or other data is not to be regarded by implication or otherwise as in any manner licensing the holder or any other person or corporation, or conveying any rights or permission to manufacture, use or sell any patented invention that may in any way be related theret

mounds. This would require only that the freezing reach the capillary water which is always present above the ground water. When the "pores of freezing" form in the freezing ground and join to form voids (capillaries) in the frozen ground, the ground water, or the capillary water above the ground water, rises by capillary action into the frozen ground and freezes; new pores form and are filled with water, which freezes, etc. The result is a series of overlapping processes which would produce heaves of considerable size.

Shtukenberg expressed his theory in mathematical form. For a volume of moist ground v_1 , with the volume of its pores n_1 and water filling all pores, the volume of water will also be n_1 . For simplicity, assume that all the water freezes completely in this ground.

Transformed into ice, water will have a volume $(1 + \beta_1)n_1$. During this process, new pores, of volume n_2 , will form in the frozen ground. The water which fills this volume and is transformed into ice will have the volume $(1 + \beta_1)n_2$. Then we have new pores and a new volume — $(1 + \beta_1)n_3$, etc.

Mathematically this may be represented as follows:

Volume n_1 changes to $(1 + \beta_1)n_1$
 n_2 changes to $(1 + \beta_1)n_2$
 n_k changes to $(1 + \beta_1)n_k$
 n_s changes to $(1 + \beta_1)n_s$

$$\sum_{k=1}^{k=s} n_k \text{ is transformed into } \sum_{k=1}^{k=s} (1 + \beta_1)n_k = (1 + \beta_1) \sum_{k=1}^{k=s} n_k,$$

where β_1 is the volume coefficient of water expansion upon freezing.

Volume v_1 of our ground will assume the volume:

$$(v_1 - n_1) + (1 + \beta_1) \sum_{k=1}^{k=s} n_k \quad (7)$$

where the expressions in parentheses give us the volume of the mineral part of the ground; the expression under the sigma sign is the volume of ice formed in the ground; and s is the number of repeated freezings of water and ground.

If $n_1 < n_2 < n_3 \dots < n_s$ — i. e., the volume of the pores of freezing continues to increase, then the heaving will be intensive.

If, however, $n_1 > n_2 > n_3 \dots > n_s$ — i. e., the volume of voids decreases, the heaving will be slow.

As the reader can readily see, according to both Taber and Shtukenberg, the water reaches the freezing ground in one manner or another from the layers of the ground below the freezing layer. By such siphoning of water from below, Taber explained the large frost heaves in the United States which he called "surface uplift" and which sometimes reached 45 to 50% of the depth of freezing at a given locality; whereas, according to Taber's calculations, the heaving should not have been so great. "When water present in the voids of a soil freezes without the introduction of additional material, the amount of heaving is necessarily limited by the change in volume that accompanies freezing; and, since the water-content of the average soil is seldom as much as 50 per cent while the depth of freezing in the United States seldom exceeds 2 or 3 feet, the amount of heaving under these conditions should not be more than 1 or 2 inches, for the expansion in volume

of water on freezing is only about 10 per cent."¹

Similar reasoning was suggested by Shtukenberg, who, 25 years before Taber, applied his theory to railway heaves which reached heights of 20 to 40 cm in European Russia.

But the theories of Taber and Shtukenberg do not explain the phenomenon of heaving in the permafrost region, where swelling mounds 2, 4, or 6 m high were encountered, i. e., 2 to 3 times greater than the thickness of the whole active layer, where the base of mounds reaches 30 to 60 m diam; and where the mounds accumulate enormous quantities of water and sometimes air. Neither the expansion with freezing of the water in the freezing layer nor the pressure of ice crystals formed from this water can explain the formation of heaves 30-50 cm high.

The new theory needed to explain these phenomena was formulated by Soviet scientists from observations of heaving in the permafrost zone. This theory is based on the presence of stresses in the freezing ground, which cause migration of water and sometimes of liquefied soil into the mounds. The migration is mostly from the area surrounding the mound since, when the active layer is frozen down to permafrost, the area under the mound cannot supply water by this method.

This theory, in a very general form, was advanced at the beginning of this century by Sukachev, Nikiforov, and Dranitsyn. Recently, it has been completed and expressed mathematically by Sumgin.

The first three scientists emphasized the stresses in the ground during freezing and the presence above the permafrost of supersaturated ground which sometimes becomes liquefied; the action of the stresses on these liquefied masses and their movement, especially water, to the point of least resistance in the layer of winter freezing; and the formation of mounds at these points. Speaking of the peat mounds of the lower Yenisei River, Dranitsyn² pointed out that "the mounds are elevated by the slow increase of the force of the freezing water, which acts unnoticeably and powerfully like a vise, so that the smallest effect achieved is invariably fixed."

Today this theory is formulated as follows for the permafrost region.³

Consider an area of ground which began to freeze at a certain moment u . At the moment u_1 the margins of this area (for some reason, e. g. better thermal conductivity, absence of vegetation cover or snow cover) have frozen down to the layer of permafrost and firmly joined with it, while the middle part of the area still has an unfrozen layer filled with water.

The cross section of the area at moment u_1 is shown in Figure 26. At this moment, the depth of freezing is H where there is still an unfrozen layer, and the process of freezing is continuing. As the ground of the water-bearing horizon is saturated with water, it will continue to expand as it freezes. If 1 m^3 of this layer in the dry state has a weight g and volume moisture $w\%$, the amount of water in 1 m^3 of the ground will be wg . Assuming that all the water is transformed into ice, the increase in water volume is β_1 , and the increase of a unit volume of the ground is $\beta_1 wg$.

We assume that the freezing process ended when the ground froze to a depth of H' . Then, assuming that the unfrozen ground has the shape of a circle with the radius R , the volume of the frozen portion of the water-

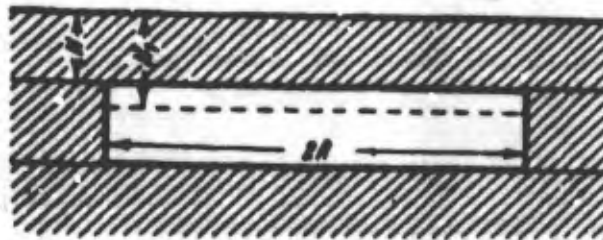

Figure 26.

1. S. Taber (1929) Frost heaving, Journal of Geology, vol. 37, no. 5. [p. 430].
2. D. A. Dranitsyn (1914) O nekotorykh zonal'nykh formakh rel'efa Krainego Severa (Zonal forms of relief of the Far North), Pochvovedenie (Soil Science), no. 4.
3. M. I. Sumgin (1931) Kratkii kurs dorozhnoi geofiziki (Short course in geophysics of roads), Moscow: Transizdat. See also previously cited article in Vechnaia merzlota (Permafrost).

PRINCIPLES OF MECHANICS OF FROZEN GROUND

bearing layer is $\pi R^2(H' - H)$. The dry weight of this layer is $\beta_1 \pi R^2(H' - H)$, the quantity of water in it is $w \beta_1 \pi R^2(H' - H)$, and the increase in volume due to the freezing of this water is:

$$V = \beta_1 w \pi R^2 (H' - H).$$

This increase in water volume will be the increase in volume of the frozen portion of the water-bearing ground, since there is no doubt, under the conditions, that this is a closed system.

The increase in volume causes very strong stresses in the ground, which create hydrostatic pressure in all directions. Naturally, this stress will be especially effective in the direction of least resistance, which is usually upward, but not always, as we will see below. If the resistance to bending of the mass of frozen ground overlying the water-bearing horizon is the same everywhere, then this frozen ground may be compared to a round disk fixed along the edges and subjected to a uniform pressure by a liquid. This stress will cause bending, with the greatest elevation in the center of the disk. This would be the generalized case of ground-heaving.

But if the layer of frozen ground has a point of least resistance, the stress will be more effective here and the frozen layer will bend in and around this point. With an increase in the depth of freezing, this bending will also increase and will be manifested by a mound, or what Taber calls differential heaving at this place. The hydrostatic pressure in the water-bearing layer will cause the water contained in it, and in some cases even liquefied soil, to move in under the mound.

Note that the radius of mound feeding, R , in our scheme may be quite large, exceeding tens of times the radius of the base of the formed mound. Therefore, the water concentrated under the mound may come from a considerable distance from the mound, and not from beneath the mound, as was pictured by Taber and Shtukenberg, who were not acquainted with the process of ground freezing under permafrost conditions.

Taber and Shtukenberg picture a mound as a type of intake pump which draws water from under the mound, where the water used can be replenished. In our scheme, the force which forms the mound may act from the outside of the mound and pump the water from a distance into the mound, as is shown in Figure 28.

It is clear that the mound will increase in size as the volume of the freezing water-bearing horizon increases. If the unfrozen ground freezes also, the mound will cease to grow.

If a mound has the form of a regular cone, and at a certain moment the radius of its base is equal to r and its height is h (Fig. 27), the volume of the cone will be

$$v = \frac{\pi r^2 h}{3}.$$

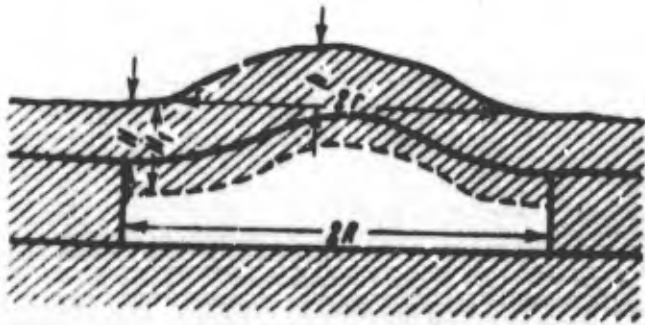

Figure 27.

On the basis that the increase in volume of the frozen portion of the water-bearing layer is equal to the volume of the resulting mound, we have the equation $V = v$, where V is the increase in volume of the frozen ground, and v is the volume of the mound which is formed.

Substituting the corresponding values for V and v we obtain

$$\beta_1 w \pi R^2 (H' - H) = \frac{\pi r^2 h}{3}.$$

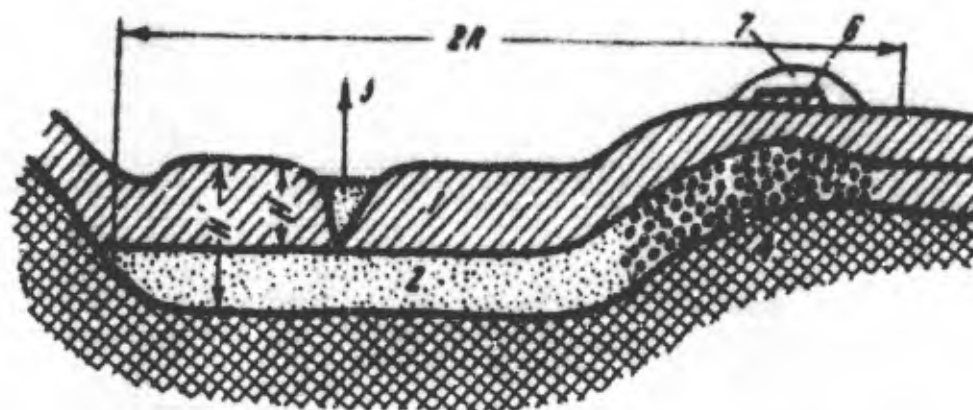

Figure 28. Formation of an icing mound adjacent to a stream of ground water (schematic). 1) non-water-bearing surface layers of ground subject to freezing in winter; 2) layers of ground with alluvial water; 3) dry layer of pebbles; 4) permafrost; 5) stream; 6) a road on the second terrace; 7) icing mound formed on the second terrace; water from the layer of alluvial flow passed through the pebbles into the mound.

Assuming that $\beta_1 = 0.09$, reducing, and simplifying, we have

$$0.27wgR^2 (H' - H) = r^2h. \quad (8)$$

This is the equation of the frost mound or the icing mound. The values of w and g in the left member of the equation are easily determined; R and $(H' - H)$ remain unknown. The values of r and h in the right member of the equation are determined by measuring the mound. Consequently, we have an equation with two unknowns. Transposing once again and placing all the known members on the right side, we have

$$R^2 (H' - H) = \frac{r^2h}{0.27wg}.$$

By using $\frac{r^2h}{0.27wg} = B$; the equation is

$$R^2 (H' - H) = B. \quad (8')$$

From this equation we can obtain the values of R in terms of $(H' - H)$:

$$R = \sqrt{\frac{B}{H' - H}} \quad (9)$$

or $(H' - H)$ in terms of R :

$$H' - H = \frac{B}{R^2}. \quad (10)$$

R is the radius of the area of mound feeding - i. e., the area whose water-bearing horizons or liquefied soil masses participate in the formation of the mound. Of course, under natural conditions, the area of mound feeding only rarely has the shape of a circle. This area may have the form of a trapezoid (e. g., in stream valleys when the valley widens along the course of the stream), the form of an ellipse, etc., but most frequently it will have an irregular shape. Likewise, the mound itself is most frequently encountered in nature in the form of a spheroid segment. But these circumstances, which change the value of R and r , present no difficulties for formulating and solving the mound equations.

$(H' - H)$ designates that thickness of the frozen ground which has a direct influence on the formation of the mound. In our case, it is much easier to determine $(H' - H)$ than R . By measuring H at the moment that the mound begins to form under natural conditions, and measuring H' at the moment of maximum development of the mound, we will know $(H' - H)$ and can determine the value of R from the above equations.

In the analysis of our equation, we consider only certain cases. If $H' - H = 0$, i. e., if H' is equal to H , the freezing process did not affect the water-bearing horizon (R will be equal to infinity, - see eq 9); i. e., there will be no mound. This can take place either during exceptionally warm winters with a normal snow cover, or at normal temperatures with an exceptional amount of snow.

With R constant and $(H' - H)$ increasing, the volume of the mound increases too, depending on the thickness of the water-bearing horizon. This means that the mounds will be larger during winters with deeper freezing.

If $H = 0$, eq (8') becomes $R^2 H' = B$. This means that the mound begins to form from the moment that the ground begins to freeze from its surface. Under natural conditions this would take place when the water-bearing horizon begins at the ground surface or when pure water freezes.

According to eq (8'), the volume of the mound is directly proportional to the thickness of the freezing layer and to the square of the radius of the area which participates in the formation of the mound. This means that the size of the mound will be more influenced by the radius of the mound-feeding area than by the depth of freezing.

Examples: If the icing mound has a radius of 7.5 at the base, a height of 2m, $(H' - H) = 1$ m, and 1 m³ of ground weighs 1.5 tons, with a moisture by weight of 25%, then (from eq 8) the radius of the area of mound feeding, R , is approximately 33 m.

If the mound has a radius at its base of 15 m, a height of 3 m, $(H' - H) = 1$, and the weight of 1 m³ of ground is 2 tons, with a moisture by weight of 20%, then R will be approximately 79 m.

If there are icing fields adjacent to the mounds, the volume of this ice must be added to the volume of the mound, of course.

Turning from theory to practice we must take into account the circumstance, described by Petrov,¹ that several adjacent icing mounds are often interconnected. On the Onon River, on the Amur-Yakutsk highway, where the mound explosion described previously took place, there were six mounds altogether. Only one of them exploded, but the explosion of a second one was imminent and was forestalled by the exploded mound. After this explosion, the second mound, which was ready to burst, ceased to make crackling noises and settled considerably.

It is clear that, in such cases, the sum of the volume of all mounds must be used in the equations.

Ground heaving under natural conditions

According to the theory of mound formation which we have just discussed, mounds may be formed in the permafrost region in places where there was absolutely no water in the fall when ground freezing began. Water may be hydrostatically pumped into such places from adjacent localities. Figure 28 represents such a case schematically.

1. V. G. Petrov (1930) Naledi na Amursko-Yakutskoi magistrali (Icings on the Amur-Yakutsk highway). Izd. Akad. Nauk.



Figure 29. Bulguniakh (icing) near the city of Yakutsk.

Under the impact of hydrostatic pressure during winter freezing, the ground water from the water-bearing horizon may cross over to the second terrace, pass through the pebbles to the road, and form a mound right on the road or near it.

Brief mention must also be made of the mounds which last for many years and reach a height of 40 m, known in the Yakutsk A. S. S. R. as "bulguniakh". Up to this time, we have discussed deformations of the ground, particularly mounds, which form in winter and settle almost completely in summer. But there is a type of mound formation, the "bulguniakh," which continues growing for a number of years, reaches a height of 40 m, according to the reports of investigators, and only then gradually disintegrates. Recently Khmyznikov¹ has pointed out that the "bulguniakh" at the mouth of the Yana River are remnants of the upper terrace (Fig. 29 and 30) and are not the results of the dynamic processes which take place in the ground.

However, a number of investigators still speak of bulguniakh as frost mounds. If that is the case, they are the most interesting formations in the permafrost region, for here one phenomenon is periodically superimposed on a similar phenomenon, producing a sum total of great effect, although each phenomenon taken separately is insignificant.

The formation of 40-m high mounds containing ice lenses has been questioned from the physical-mechanical point of view. Since the soil cover of the one-year mounds is often cracked, it was questioned that the soil cover of 40-m high mounds could remain uncracked and not burst completely, exposing the ice lens in it.*

Theoretically, this is explained by the

1. P. K. Khmyznikov (1934) *Gidrologiia basseina r. Iany* (Hydrology of the Yana River basin). Leningrad: Izd. Akad. Nauk and GUSMP (Northern Sea Route Administration).

* Reviewer's note: Most of these forms do have cracks. In those that do not, turf and soil may have slumped in to obscure the former crack.

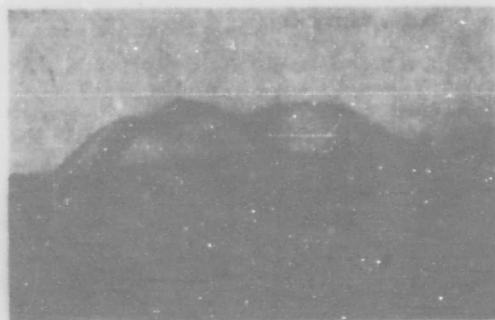

Figure 30. Bulguniakh in the process of disintegration.

high plasticity of the frozen ground and by the fact that the small and medium-sized cracks in the soil cover of the bulguniakh become filled with ice.

In our opinion, the whole question of "bulguniakh" requires further investigation, in addition to Khinysnikov's study. The Yakuts call every isolated elevation "bulguniakh", and it is possible that many investigators, following the example of the local inhabitants, sometimes ascribe the formation of such elevations to the dynamic process, without sufficient foundation.

We have made reservations above that stresses in a closed space do not always manifest themselves in an upward direction. Actually, the layer frozen in winter may be but weakly adfrozen with the permafrost layer. Consequently the force required to break off this layer may be less than the force required to bend the frozen ground. In such a case, the hydrostatic pressure in this closed space would tear the seasonally frozen layer from the upper surface of the permafrost, and the water would penetrate between them and freeze. In this way horizontal beds and layers of ice may form in the ground (Fig. 31).

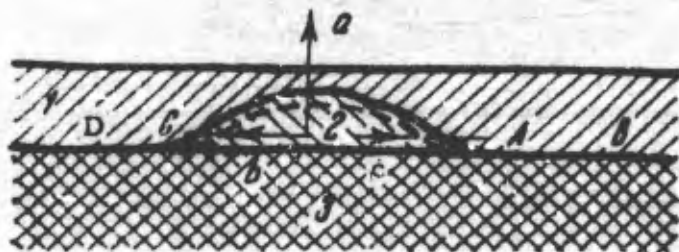

Figure 31. Formation of horizontal ice layers in the ground (schematic). 1) seasonally frozen ground; 2) unfrozen layer; 3) permafrost. With further freezing in the enclosed area (dotted line), either heaving will occur (arrow a), or the seasonally frozen ground will be separated from the permafrost along CD (arrow b) and AB (arrow c).

The theoretical considerations relating to the formation of mounds in permafrost conditions may be applied to areas beyond the permafrost region in cases where a layer of water-impermeable rock (or soil) acts in the same way as permafrost.

The formation of thin ice layers in clay and other soil should also be reconsidered from the point of view of the stresses created in the ground during freezing.

After all the theoretical considerations, let us consider several descriptions of ground swellings occurring within the borders of the U. S. S. R. — descriptions which confirm the wide distribution of this phenomenon throughout the whole territory of our country, both where permafrost exists and where it is absent.

According to data collected by Klunnyi,¹ ground heave was observed in the northern Caucasus during the winter of 1934-1935. At the Verblud Station of the North Caucasian Railway, the ground rose to a height of 30.75 mm in 5 days (March 2 to 6, inclusive). Heaving was also noted at Askaniia Nova in Azerbaydzhan (the young shoots of guayule plants were uprooted by frost), in Krasnodar, and in Sinel'nikovo.

Swelling has been observed near Moscow, and also on the Kola Peninsula (where, by the way, columns of ice are often formed).

It is evident that ground heaving is a widespread phenomenon in the European part of the Soviet Union. Heaves 2 to 3 cm high are of little importance for large buildings, but, as we have seen, they are dangerous for agriculture. On railways they can push the rails out of line, and on the highways they can destroy the asphalt surfacing.

However, larger heaves do occur in European U. S. S. R. and Siberia, in areas without permafrost. These are usually 10 to 15 cm high, but in rare cases are 30 to 50 cm.

Heaves of this size cause a great deal of trouble for rail and highway communication, and serious measures must be taken against these as well as smaller heaves.

The large heaves are important in planning the construction of buildings. Sites

1. G. M. Klunnyi, Vyryvanie s. kh. rastenii morozom (Uprooting of plants by frost), manuscript.

subject to heaving require special measures, discussed later. Preferably, these poor building sites should be avoided.

A post in the Maritime Zone Soy Bean Experimental Station, located 8 km from the city of Voroshilov in the Far East, is an example of heaving in an area without permafrost.

Near the nursery of this station, a post was sunk 40 to 50 cm into the ground. To a depth of 90 cm, the soil was clayey sand, covered by a layer of sand 2 cm thick to facilitate the work. The winter of 1932-33 was a severe one with an average air temperature of -23.5°C in January. At the beginning of the winter, the ground was supersaturated with water; a thick layer of snow covered the unfrozen ground so that freezing of the ground started late. It had frozen to a depth of 10 cm by November 28, and to 20 cm by December 12. The following spring (1933), the post near the nursery had been heaved 20 cm out of the ground (Fig. 32).

Similarly, according to Ianovskii,¹ a barrel of fuel almost completely buried in the ground in the fall of 1930 in Ust'-Tsyl'ma on the Pechora River, in the area of the Pechora Meteorological Station, had been pushed out from the ground by the spring of 1931 so that almost half of its height was above the surface.

Figure 33 shows the distribution of frost heave along the railways of European U. S. S. R., from data compiled by S. L. Bastamov. The following conclusions may be made from this map: frost heave is most frequent in the northwestern portion of the European part of the Soviet Union; in the southern half, it seldom occurs; and in the deep south, it disappears completely.

However, these conclusions are valid only at the present moment and may be changed later because there are no railways in the northeast where permafrost exists, and few railroads in the southeast, where there is considerable freezing though the ground is dry.

Table 24 shows the small size of heaves in the European part of the Soviet Union in comparison with the icing mounds in the permafrost regions.

The permafrost region is the classic region of ground heave, especially as far as the size of the mounds is concerned, but the frost mounds in the permafrost region will be discussed in detail in another chapter. Here, as an example, we will give briefly the results of Mironov's observations² on ground heave in a test plot near Petrovsk-Zabaikal'skiy. The test area, 200 by 200 m, was on the left bank of the Balyaga River and some 200 to 300 m from it, and was subdivided into smaller plots. On the surface of these plots, permanent points were established, and heaving was measured by leveling from a bench mark established on a rock. This leveling was done twice a month (on the 5th and on the 20th) from October 19, 1930, to April 22, 1932. The entire area was on a slight incline, sloping toward the



Figure 32. Post heaved 20 cm during winter of 1932-33 at the Maritime Zone Soy Bean Experimental Station (8 km from Voroshilov). Post had originally been driven in to the depth shown by the line of white paint.

1. V. K. Ianovskii (1933) Ekspeditsiia na r. Pechoru po opredeleniiu iuzhnoi granitsy vechnoi merzloty (Expedition to the Pechora River to determine the southern border of the permafrost zone), Trudy Komissii po izucheniu vechnoi merzloty Akademii Nauk (Proceedings of the Permafrost Commission of the Academy of Sciences), tom 2.

2. A. F. Mironov (1934) Polevye opyty i nabludeniia za pucheniem grunta i stoek na opytном uchastke Petrovskoi merzlotnoi stantsii (Field experiments and observations of heaving of ground and posts on the experimental plot of the Petrovsk Permafrost Station), Lng. Inst. sooruzh. (Leningrad construction institute), manuscript.

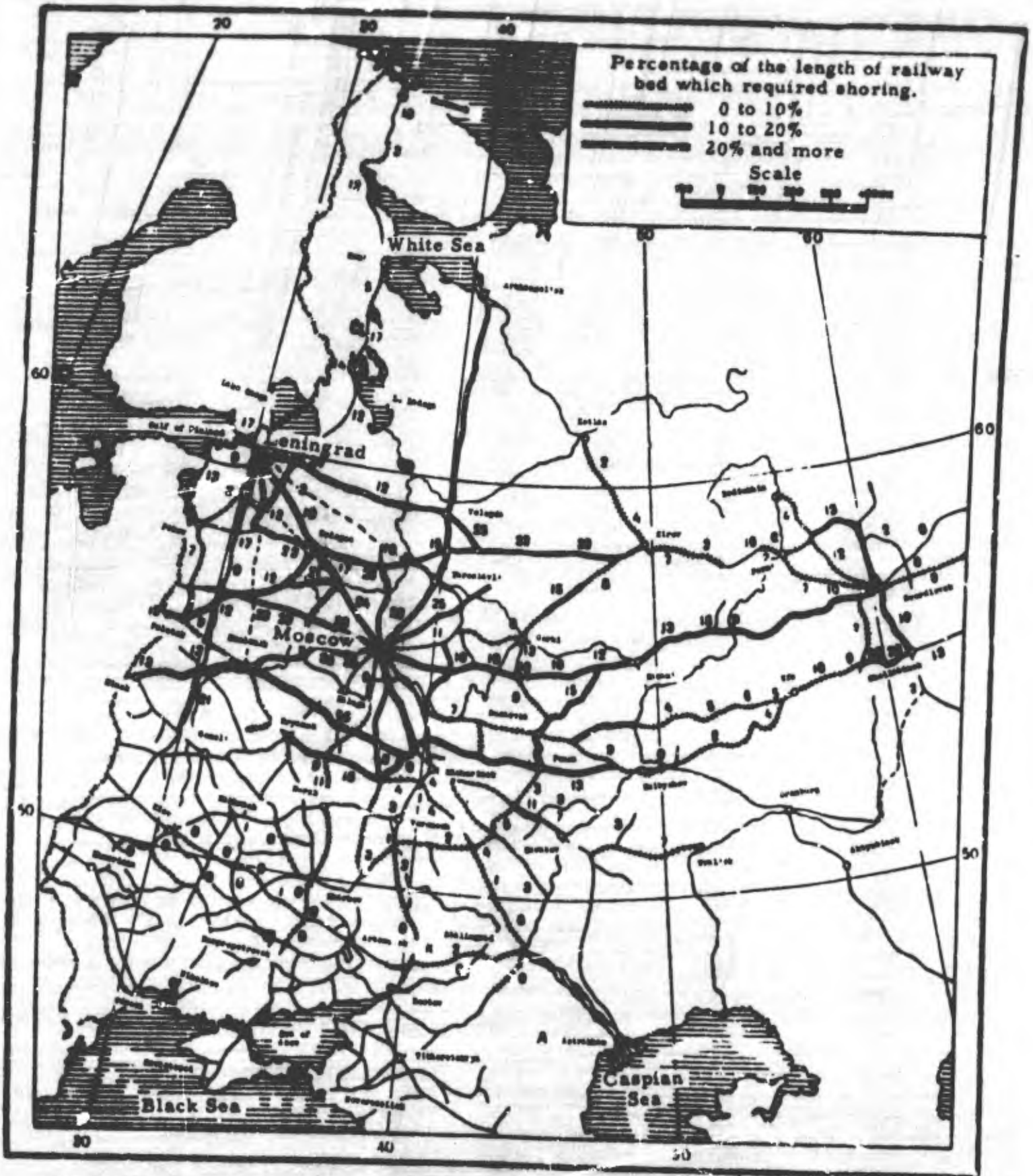

Figure 33. Map showing the distribution of frost heave along the railways of European USSR (compiled by S. L. Bastamov). The numbers on the map show the percentage of length of railway bed which had to be shored.

Table 24. Distribution of frost heave along railroads in European U. S. S. R., according to height.

Railroad	Distribution of frost heaves of various heights, in % of the total number			
	up to 2 cm	2 - 6 cm	6 - 10 cm	above 10 cm
Kirov	27	44	16	13
Northern	61	33	5	1
Moscow-Beloretsk-Baltic	46.5	41.1	8.2	1.2
Donets	45	47	8	-
Ryazan-Ural	48	45	7	-
Southeastern	45	45	9	1
Lenin	49	42	8	1
Perm	39	48	8	1

Balyaga River.

The results of these observations presented quite a diversified picture of ground heave on the various small sections. In the lowest plot, the conditions were as follows: the upper soil layers were clayey silt, with a saturation coefficient of 0.85 to 1.00 prior to freezing; the ground-water table was 1.0 - 1.8 m during May-October, and 2.0 - 2.5 m in April; the depth of winter freezing was 1.40 - 1.85 m. Below this depth, down to 4.7 m, the ground was unfrozen, and in deep places consisted of sandy gravel with ground water. In this plot, observations were conducted at four points. The amplitude of vertical fluctuation of the ground was 34.3 to 43.4 cm during the entire period.

In the second plot the soil was silty sand with lenses and interlayers of clayey silt; the saturation coefficient prior to freezing was 0.40 to 0.85; the depth of freezing was 1.65 to 2.50 m. Nine points were observed. These may be subdivided into two subgroups: In the first (five observation points) the active layer merged with the permafrost, and supra-permafrost water accumulated in the surface depressions of the permafrost. The amplitude of vertical fluctuation of the ground was 3.2 to 10.4 cm during the whole period of observations. In the second subgroup (four observation points), the active layer was underlain by an unfrozen water-bearing horizon with the ground-water table 1.5 to 3.0 m from the surface of the ground. Here the amplitude of vertical fluctuation of the ground was from 5.7 to 9.7 cm during the period.

In the third plot, located on a more elevated part of the area, there were 11 observation points, also divided into two subgroups. The first subgroup consisted of eight observation points: the soil was of light silty sand with lenses of fine sand, and coarse gravel in places; the coefficient of saturation prior to freezing was 0.2 to 0.4; the depth of freezing was 3.7 m; below this was unfrozen silty sand and, still deeper, sandy gravelly soil. The ground-water table did not rise above 4.2 m. The amplitude of vertical fluctuation of the ground varied from 1.0 to 3.3 cm during the entire period of observation. The second subgroup consisted of three points of observation. At one point the ground froze to the permafrost. At the second point permafrost was at a depth of 4.8 m, so that an unfrozen layer remained beneath the frozen layer. At the third point, the ground-water reached the base of winter freezing. The amplitude of vertical fluctuation of the ground during the entire period of observation was 3.3 cm at the first point; 2.7 cm at the second point; and 2.8 cm at the third.

In all the plots the vertical displacement of the ground surface was due to ground freezing: the summer rises were insignificant and did not occur everywhere. Where

summer rises did occur, they coincided with a rise of the ground-water table or with a considerable amount of precipitation.

The intensity of heaving, i. e., the rate of elevation of the ground surface, was calculated. The greatest rise per day was 3 mm in December; the greatest subsidence occurred in May. Where the winter frozen layer fused with the permafrost, heaving ceased after the moment of adfreezing. This usually occurred in January. But when there was an unfrozen layer with ground water beneath the layer of winter freezing, heaving ceased only at the end of April.

These figures show the enormous difference in ground heave even in a small area. It shows how carefully one should consider the selection of a plot for building and the specific location of buildings and structures on it.

Undoubtedly, buildings are in great danger of deformation if the ground surface is subject to elevations of 10 to 40 cm. However, if the ratio of height of ground surface rise to the depth of freezing is taken as a criterion of heave, as Taber suggested, the values are not so great. In the first plot, ground rise was between 20 to 31% of depth of freezing; in the second, from 1 to 5%; and in the third, even less than in the second. Therefore, the method of evaluating ground heave suggested by Taber is of little value in the regions of permafrost and deep winter freezing.

These are the theoretical fundamentals of the deformation of the ground surface, with examples illustrating it. This deformation, particularly when heaving occurs, has very serious effects on the construction and utilization of railways and highways.

Relation of heaving to type of soil

In our theoretical considerations we have been little concerned with the type of soil and the natural conditions in and among which deformation of ground surface occurs. The degree of deformation is affected by the orographic and hydrogeological conditions of the locale and by a number of other circumstances. However, detailed consideration of all these factors should be the subject of a special work; here we will treat only a part of this question and only in a very general way.

Ground expansion during freezing in relation to the mechanical composition of the soil has been treated in an interesting work by the Soils Laboratory of the LIKS,¹ from which we will cite some data. Soil was subjected to freezing in small ebonite cylinders without an inflow of water. In one series, the soil was frozen from the top under condition analogous to soil freezing in nature; in the second series, the soil was frozen from all sides at once.

Simultaneously with the calculation of the volume expansion, the moisture redistribution and the temperature within the sample were studied. (Temperature, measured by thermocouple, was recorded at definite intervals.)

Three types of soil were used: clay, silt, and sand; their grain size composition is given in Table 25.

Expansion in soil frozen from the top downward was studied in an apparatus specially constructed by Tsytovich, which recorded the expansion in the cylinders on a revolving drum similar to that used in meteorological apparatus (Fig. 34).

Thermocouples were placed at depths of 2, 4, 6, and 9 cm, so that the temperature regime of the freezing samples can be shown by thermoisopleths. The following results were obtained.

Sandy soil. The soil was frozen from the top only. The sample was 98 mm high, with 22% moisture by weight. Figure 35 shows the ground expansion in relation to time, the temperature distribution in the sample, and the redistribution of moisture. The total increase

1. I. S. Vologdina (under the direction of N. A. Tsytovich) (1935) Ob'ernoe rasshirenie gruntov pri zamerzani (Expansion of the volume of soil caused by freezing), manuscript, Labor. LIKS.

Table 25.

Properties	% of fractions		
	Clay	Silt	Sand
I. Grain-size composition (mm)			
1-0.25	0.1	0.8	60.2
0.25 - 0.05	0.4	2.9	39.8
0.05 - 0.01	3.2	47.5	-
0.01 - 0.005	34.3	34.3	-
<0.005	62.0	14.5	-
III. Capillary water capacity	48.2	27.99	20.0

in volume is insignificant — only 0.4%. After 9 hr, volume increase ceased under the conditions of the experiment. The curve of moisture distribution in the sandy soil is not characteristic.

Silty soil. Moisture content during the experiment was 28%; the height of the sample was 95 mm. Freezing was from the top only. The curve of expansion (Fig. 36) shows first a decrease in volume and then expansion, which proceeds rapidly and terminates after 6 to 7 hr. After 12 to 13 hr, the already frozen soil begins to contract. The moisture curve is the characteristic curve of moisture redistribution in soil during freezing. The total volume increase is 1.27% of the original.

Clay. The initial moisture content was 48%, and the height of the sample was 95 mm. As in the silty soil, a certain contraction takes place at first (less in the clay than in the silt), followed by a gradual and even increase in volume which continues for a long time (Fig. 37). The curve of moisture distribution is characteristic for the process of ground freezing. The total increase in volume was 2.38%.

The process of ground freezing from all sides at once was studied using Sumgin's apparatus (Fig. 38) which registered ground rise on the tape of a revolving cylinder.

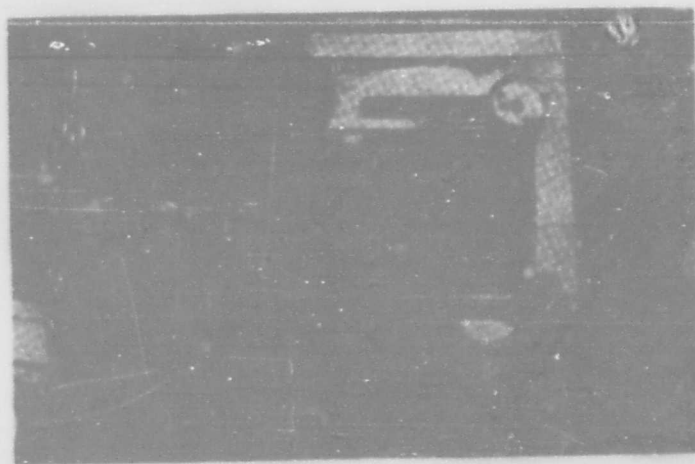

Figure 34. Tsytovich apparatus for the study of ground heaving.

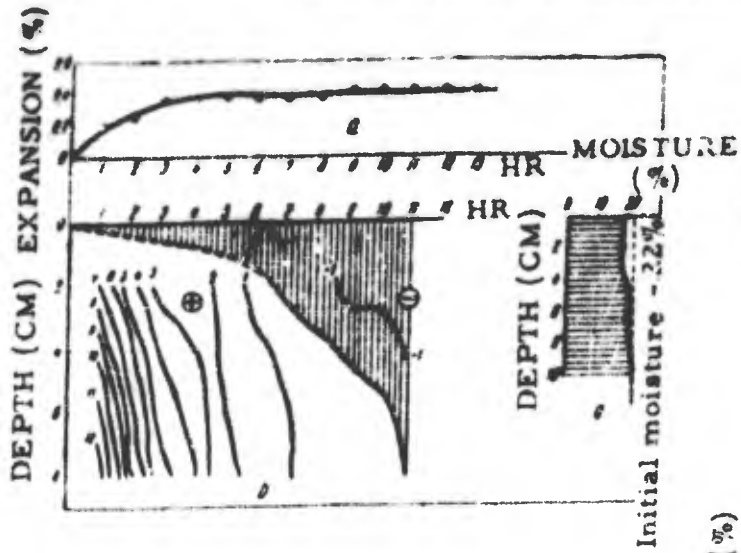

Figure 35. Expansion of sand. Freezing from the top.

Figure 36. Expansion of clayey silt. Freezing from the top.

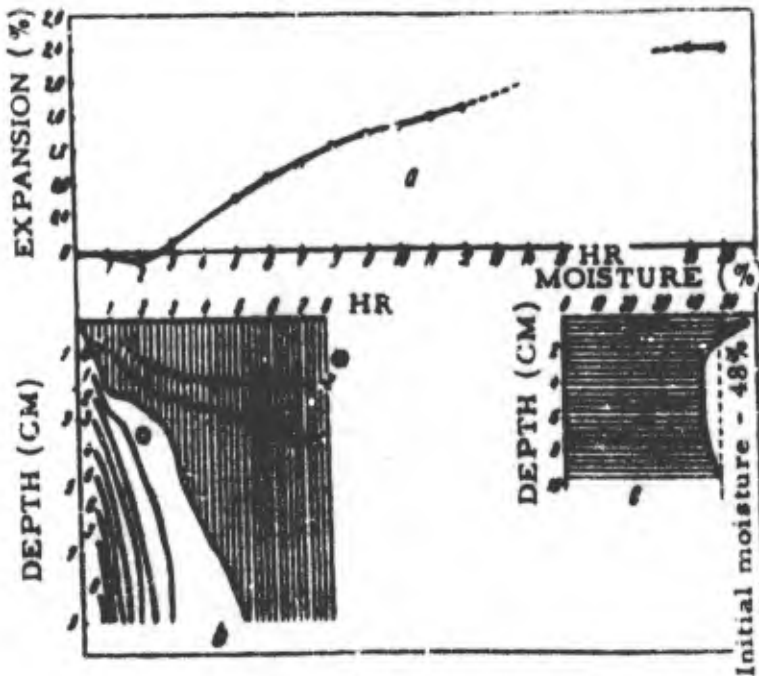
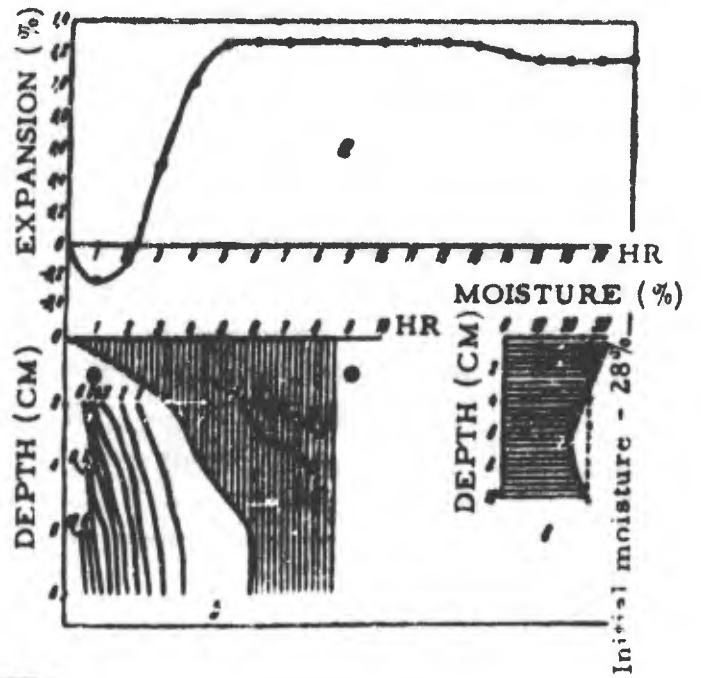

Figure 37. Expansion of Cambrian clay. Freezing from the top.

Figs. 35-37.

(a) curves of volume expansion of the soil; (b) thermoisotheles of a sample of freezing ground; (c) moisture distribution in-frozen soil.



Figure 38. Sumgin apparatus for the study of ground heaving.

Figure 39 shows curves of clay expansion — first with freezing from the top only, and second, with freezing from all sides. The second case shows a sudden rise of the ground; the nature of the curve during freezing from the top only was described above.

The difference between freezing soil from the top only and from all sides manifests itself also in the amount of expansion — it is greater in the latter case.

From these tests, we see that the process of swelling is different in sandy, silty, and clayey ground. At the present time, however, these differences are not fully explained. Differences in amount of bound water (water in molecular interaction with the ground particles) and volume of the pores of freezing in different types of ground are certainly factors. Perhaps the unequal amount and distribution of air in frozen ground is also influential.

All these questions require further study, especially because the results of different investigators do not always agree. In particular, Vologdina did not register the temperature jump during ground freezing which was so sharply manifested in the Andrianov experiment (see the beginning of this chapter). However, this jump was not present in all of Andrianov's experiments.

Different types of ground will have different heave characteristics under natural conditions also, but this question has been little studied as yet.

Ground heaving under outside pressure

Taber² conducted experiments with soil freezing under outside pressure. He constructed an apparatus in which soil samples could be frozen with practically no lateral support and under vertical pressure (Fig. 40).

In one of his experiments, a cylinder, 6 cm in diameter, was cut from hardened clay and placed on a support with a perforated bottom. A strip of adhesive tape, 2 cm wide, was wrapped around the bottom to prevent the cylinder from softening after it was saturated with water, and the cylinder was supported by moist clay packed around it.

The support and cylinder were placed in a large cardboard box, containing a layer of water-saturated sand. Then oil was poured into the cardboard box until level with the top of the cylinder. This oil did not freeze even at the cold temperature.

The clay cylinder was covered by a metal disk with a tight steel spring attached to the top in such a manner that it increased the pressure on the ground as the soil expands. Above the apparatus, the amount

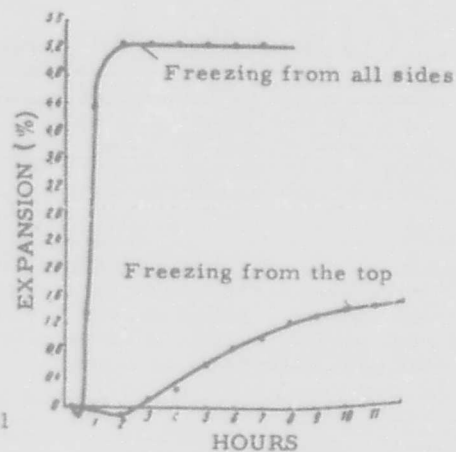

Figure 39. Volume expansion of Cambrian clay during different methods of freezing.

1. Such sudden heave was not observed in experiments with other clays frozen from all sides.

2. S. Taber (1929) Frost heaving, Journal of Geology, vol. 37, no. 5, [p. 448-450].



Figure 40. Apparatus for freezing clay cylinders under pressure.
(From Taber, 1929.)

of heaving and the spring pressure on the soil were recorded as the disk rises (Fig. 41).

This apparatus was buried in dry sand; the spring was adjusted to 101 lb pressure on the cylinder; and then the soil was frozen from the top. After 5 hr, the pressure decreased to 94 lb because of slow failure of the cylinder, but the freezing process continued. Fifteen hr later heaving had restored the original pressure of 101 lb, and the pressure continued to increase, reaching a maximum of 140 lb 76 hr after the experiment started. As soon as freezing penetrated to the bottom of the clay cylinder, the pressure became constant.

Subsequent study of the clay cylinder showed that heaving was caused primarily by the formation of horizontal veins of fibrous or columnar ice, up to 0.5 cm in thickness.

Taber made a series of experiments with this apparatus. In one case the pressure reached 155 psi (11 kg/cm²) before the side walls of the cardboard box broke (Figs. 42 and 43).

The clay as taken directly from the ground and containing 20% water had a crushing strength of 200 psi. The maximum pressure developed by the growing ice crystals must have reached more than 14 tons per square foot (14 kg/cm²). In some of the experiments, the lower portions of the clay cylinders without side supports were more or less shattered by the pressure and formed typical breccias.

This extremely interesting experiment by Taber furnishes an explanation for the winter rise of buildings and structures. If the ground under the foundation begins to freeze, then, according to Taber, the force of water crystallization may cause the elevation of buildings and structures even if the ground freezes in an open system. Actually, the pressure of the buildings and structures on the ground is usually 2 to 3 kg/cm², while the freezing ground may develop a force of more than 14 kg/cm² (the force which was measured directly was smaller than the actual force).

Universal Deformation of the Earth's Surface

All that has been said above indicates that, in regions where the ground freezes to a fairly considerable depth for a fairly long period and then thaws, the surface of the ground experiences vertical and sometimes also horizontal displacements. The basic cause of such displacements, as we have seen, is the transition of water from the liquid state into the solid state and vice versa.

A precise leveling in regions with seasonal freezing and thawing of ground e. g. from

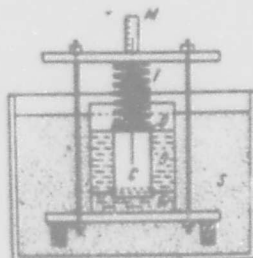

Figure 41. Apparatus for freezing clay cylinders under strong vertical pressure without lateral support (cross section). C - clay cylinder; O - viscous oil; W - sand saturated with water; D - steel disk; F - steel spring; M - graduated scale; S - dry sand. (From Taber, 1929.)

Vladivostok to Moscow, with one survey during the summer and another during the winter, would give different profiles for winter and summer. The winter profile would show a higher elevation at most points than the summer profile. Generally speaking, the difference would not be great; but it would be measured in centimeters in some places and in meters at others. A second summer survey would show very small differences from the first summer survey.

Such seasonal variations of the surface take place with the yearly change from winter to summer in these regions.

Considering this question more broadly, there are other factors which cause vertical and sometimes horizontal displacement of the earth's surface. Subsidence of the ground due to thermokarst and karst phenomena, moistening and drying of loose ground, earthquakes, expansion and contraction of ground when heated and cooled, and other conditions may be included in this category.

Most of these factors are important throughout the whole world. Therefore, we can speak of the universality of deformation of the earth's surface. This has been pointed out before by geologists and seismologists, mainly on the basis of seismic phenomena. I. V. Mushketov, in his Physical Geology, says that people are accustomed to consider the surface of the dry land "a symbol of durability and immobility," contrasting it with water and air which are in constant motion, although careful investigation shows that the land surface also fluctuates constantly.

In the chain of factors giving rise to this universal deformation, we include the freezing and thawing of the soil. Also, we consider this phenomenon from the standpoint of the stability of buildings and other structures, which is affected by the intensity, duration, and frequency of heaving on one hand, and the character of the structure, on the other hand.

For instance, a shepherd's hut remains intact even during a very strong earthquake (except for such catastrophes as the Lisbon earthquake), but the work of a seismic pendulum would be disrupted even in a building erected on rock on the shores of the ocean, because the force of the waves would shake the rock, the foundations of the building, and with them, consequently, the seismographic apparatus.

Consequently, when planning buildings and structures, it is always necessary to keep in mind the universality of the deformation of the ground surface and the fact that, for the region of permafrost distribution, the greatest significance lies in the deformation caused by the freezing and thawing of the ground connected with the transition of water from the liquid to the solid state, and vice versa.

This brings about deformation of buildings and other structures; a sufficient number of examples will be given later.

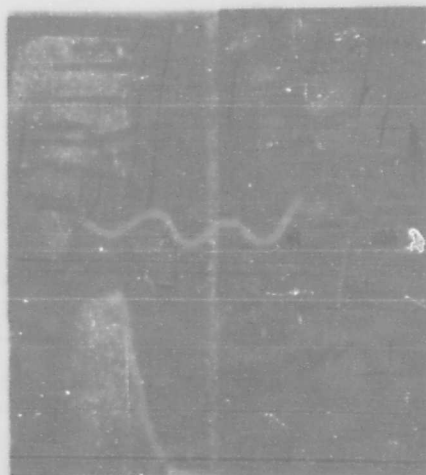

Figure 42. Left: Clay cylinder frozen under great pressure, showing ice veins and faults. Right: Clay cylinder frozen under great pressure, showing breccia. (From Taber, 1929.)



Figure 43. Clay cylinder frozen under strong vertical pressure with no lateral support. (From Taber, 1929.)

Introduction

This chapter, more than any other in this volume, justifies our statement in the introduction that in many cases we will have to raise questions that have not yet been answered and only indicate the proper path, in our opinion, to a solution of them.

In discussing frozen ground, we will sometimes touch upon the physical properties of unfrozen ground for comparison. This will be necessary, first, because questions will arise in building as to whether construction on frozen ground will be stable if the ground thaws; and second, because much of our terminology and concepts are taken from general soil mechanics.

However, it should be noted that ground with a positive temperature produced when a layer of permafrost thaws very often differs from similar ground which has not been frozen, even though the grain-size composition and moisture are identical. First, a freshly thawed layer has not yet assumed its proper structure and is, as it were, in *statu nascendi* in this respect, second, the freshly thawed layer is underlain — at a certain depth (depending on the thickness of the layer) — by a layer of permafrost which differs sharply from the thawed layer in its technical and physical properties.

Study of the physicommechanical properties of ground in the first moments in a thawed state has just been started. Laboratory investigations show that the ultimate compressive strength of ground which is frozen and thawed, and then frozen again, is considerably less than that of ground which is frozen only once.¹

Subsequently, ice in the ground will either be considered a component, similar to the mineral components of the ground (but with different physical properties), or be differentiated from the mineral particles of the ground and identified with water.

After this introduction, we move on to the separate physical properties of frozen ground.

Unit Weight

In soil mechanics, one distinguishes the following weights: (1) unit weight of soil containing natural moisture (weight per cubic centimeter or cubic meter of soil) in its natural state which we designate by γ ; (2) unit weight of the soil skeleton (i. e., dry weight, dried at 105°C, per unit volume, including voids, designated by δ).

Under natural conditions in mineral ground, as already stated more than once, the unit weight of frozen ground is less when the ground has less mineral particles. In such cases, the lower limit for the frozen ground is the unit weight of pure ice. With voids, the unit weight may be less than that of ice. The same holds true for peats — their unit weight can be less than the unit weight of ice.

Several examples of unit weight (γ) of frozen ground from samples taken in permafrost regions under natural conditions, are given below.

A sample of clayey silt from the Anadyr' River region had a unit weight of 1.34 g/cm³. Samples from the southern parts of the Far East:

	<u>Unit weight, γ</u>	<u>Moisture by dry weight (%)</u>
Clayey silt	1.99	21.8
Gravel	1.88	25.8
Lean clayey silt	1.60	28.7
Fresh peat	0.99	200.7
Loose peat with ice	0.85	844.4

1. M. I. Sumgin (1929) Fiziko-mekhanicheskie protsessy vo vlazhnykh i merslykh gruntakh v svyazi s obrazovaniem puchin na dorogakh (Physicommechanical processes in moist and frozen ground in connection with heaving on roads), *Transpechat'*; also V. G. Petrov (1933) Dinamika merslykh gruntov kak osnovy zheleznodorozhnogo stroitel'stva (Dynamics of frozen ground as a foundation for railway construction), *Problemy merslotnosti i promorashivaniya v stroitel'stve NKPS*. (Problems of Freezing and Susceptibility to Frost in Construction Under the People's Commissariat of Railroads), *Glavsheldorstroj, Sib. TsIS, Novosibirsk*.

As may be seen, we can and do find unit weights of frozen ground less than that of ice.

The unit weight of the soil skeleton (δ) of frozen ground with undisturbed structure is determined on the assumption that the volume of the ground does not change when the sample of frozen ground thaws and dries.

Consider, for example, a cube of frozen ground 1 cm^3 in volume, which consists of eight tiny grains of sand situated in the eight corners of the cube, and the remainder ice. If, after the ice melts and the water runs off, the sand grains occupy in space the same position which they had occupied in the frozen ground, then the unit weight of the soil skeleton would be equal to the weight of these sand grains.

In this case, the unit weight of the soil skeleton will be

$$\delta = \gamma - g_w \quad \text{or} \quad \delta = \frac{\gamma}{1+w} \text{ g/cm}^3$$

where g_w is the weight of ice and water per unit volume of frozen ground, and w is the moisture by weight of the frozen ground. For frozen ground, the unit weight of the soil skeleton (δ) would be zero if it were pure ice. The maximum unit weight of the soil skeleton of frozen ground is equivalent to the unit weight of the soil skeleton of unfrozen ground.

All the above may be expressed as

$$\delta_u \geq \delta_f \geq 0$$

where δ_u is the unit weight of the soil skeleton of unfrozen ground and δ_f is the unit weight of the soil skeleton of undisturbed frozen ground.

Specific Gravity

The specific gravity of the solid particles of the ground, Δ , is understood in soil mechanics as the weight of a unit volume of the solid particles without voids. The unit weight of the soil skeleton is sometimes called "apparent specific gravity."

If we base our determinations on frozen ground as found under natural conditions, then it should be considered as one unit composed of four components — the mineral part, ice, water, and air. Consequently, frozen ground should be considered as a unit of a four-phase system, for which the specific gravity should be determined which would correspond with what we have called unit weight above.

The components of frozen ground may be found in it in different proportions.

Thus, ice, according to our conditions, cannot be found in zero quantities but may occupy the entire 100% of volume.

The mineral part of the ground may be zero but cannot occupy all 100% of the volume, in accordance with the definition of unconsolidated ground and our definition of frozen ground.

Water in the liquid phase and air may be zero, but cannot either separately or in combination occupy 100% of the volume of the frozen ground.

The variable composition of frozen ground, and the complexity of the process by which it is formed make it difficult to obtain standard magnitudes of specific gravity such as we have, for example, for copper, iron, etc., or even for ice when in a pure state.

Under certain conditions, frozen ground can have a porosity of zero. We may visualize a whole range of such grounds, from pure ice (equating it with one of the mineral components of the ground), to ground with all its pores completely filled with ice — in other words, ground which froze with a water content corresponding to the theoretically critical moisture of freezing. It is much easier to determine the specific gravity of such frozen ground.

In this type of ground, ice and the mineral component of the ground constitute the variables. Starting from pure ice, the ice decreases and the mineral particles increase. The lower limit for ice will be when it fills all pores of ground with minimum porosity.

Let us determine the specific gravity of frozen ground composed of two components — solid particles and ice but no water nor air.

The specific gravity of such ground will vary, and will be less than one for pure ice. Here the difference between frozen and unfrozen ground is well manifested: The specific gravity of unfrozen ground with a mineral composition of inorganic solids is always more than one.

With the addition of mineral particles to pure ice, its specific gravity will increase and reach a maximum at the ice minimum — when ice fills all pores of ground with minimum porosity. If $m + n = 1$, where m is the maximum volume of the mineral part of a unit volume and n is the volume of ice, a volume series where the amount of ice will decrease from 1 to $n = 1 - m$ will result. The series of mineral components of the ground will increase from zero to m . The specific gravity of a series of such frozen ground will change from Δ_1 to $\Delta m + \Delta_1(1 - m)$, where Δ is the specific gravity of the mineral component of the ground and Δ_1 is the specific gravity of ice.

The specific gravity of ground with zero porosity will be equivalent to its unit weight.

For ground containing pores and voids not filled or not completely filled with water, the unit weight may differ considerably from the specific gravity for the type of frozen ground accepted by us. The unit weight in these cases will always be smaller than the specific gravity.

Thus, for example, let us take a certain volume of frozen ground V , and let us imagine that this volume is composed in the following manner:

m is the volume of the mineral component of the ground,

n is the volume of ice in the ground,

n' is the volume of voids,

Then $V = m + n + n'$. If the weight of the sample is g ; the unit weight is

$$\gamma = \frac{g}{V} = \frac{g}{m + n + n'}$$

and the specific gravity:

$$\Delta_2 = \frac{g}{V - n'} = \frac{g}{m + n}$$

It is clear that if $n' > 0$, then:

$$\frac{g}{m + n} > \frac{g}{m + n + n'}$$

Under natural conditions in the active layer, the ground often contains pores of different sizes; in these cases, the unit weight will always be less than the specific gravity. However, permanently frozen ground often has zero porosity, perhaps quite often. In such cases, the unit weight will also express the specific gravity of frozen ground.

Since the specific gravity of frozen ground is the weight of the unit volume of frozen ground minus voids, according to our definition, it can be expressed by means of the components of the ground — the mineral part and the ice.

If we designate the weight of a sample of frozen ground as g and the weight of ice in it as g_i , then the specific gravity of frozen ground will be expressed by

$$\Delta_2 = \frac{g}{\frac{g - g_i}{\Delta} + \frac{g_i}{\Delta_1}} \quad (11)$$

[Δ = specific gravity of mineral component; Δ_1 = specific gravity of ice.] If we assume that $g_i = 0$, then:

$$\Delta_2 = \frac{g}{(g/\Delta)} = \Delta.$$

If the mineral portion is zero, i.e., if $g - g_i = 0$, then $g = g_i$, and

$$\Delta_2 = \frac{g_i}{(g_i/\Delta_1)} = \Delta_1.$$

Thus, the specific gravity of frozen ground Δ_2 may vary between the specific gravities of ice and the mineral part of the ground.

$$\Delta_1 \leq \Delta_2 \leq \Delta.$$

Laboratory work can determine some standard specific gravities. In this respect, it is necessary to agree as to the specific state of the frozen ground to use. The initial state may vary. Thus, for unfrozen, plastic soils, the Atterberg plastic limit of rolling into threads may be taken - [the state at which a soil can still be rolled into threads $\frac{1}{8}$ in. diam without crumbling]. Under such a condition, the ground manifests a certain resistance to load. The state of least porosity may be taken as the initial state for non-plastic grounds. Some other initial conditions may be taken.

Unfrozen soils in the initial states are frozen and their specific gravity in a frozen state is determined. Determining by laboratory experiment the unit weights of frozen clay, silt, and sand with zero porosity will give standard values of specific gravity for various types of frozen ground.

As the specific gravities of the mineral components and ice differ greatly (in a ratio of 2.5 to 1 and more) and the specific gravities of the mineral components are close to each other, the quantity of ice in the ground has a great effect on its specific gravity. On the other hand, the changes of composition (not in quantity) of the mineral part will have little effect on the specific gravity of the frozen ground.

Consequently, any decrease in specific gravity, in comparison with the standard norms obtained in laboratory tests, would testify to deterioration in the construction properties of frozen ground. The degree of difference of the specific gravity in comparison with standard norms would show the degree of deterioration.

For construction purposes, it seems desirable in the future to obtain a certain number of specific gravities - a scale of specific gravities of various soils with an evaluation of each type.

During field work, it will be necessary to take the unit weight as the first rough approximation of the specific gravity of frozen ground. To lessen the margin of error somewhat, this crude method should be applied only when visual observation shows that the ground does not contain any considerable voids.

Moisture

The term "moisture", as other terms we use, is applied to frozen ground on the basis of its meaning relative to unfrozen ground. Perhaps, in the case of frozen ground, a more appropriate term such as "ice content" should be substituted. For "saturation coefficient" or, as others call it, "relative moisture" in application to frozen ground, the term "ice saturation," suggested by Tsytovich, can be used.

In this chapter, we are summarizing the physical properties of frozen ground for the first time, and, for the most part, giving new definitions. Consequently, thus far, we have only posed the problems of formulating a new term to be used instead of "moisture"

in frozen ground. For the present, we will primarily use the old term moisture, justifying it by the ease and everyday occurrence of the transformation of frozen ground into a thawed state. Sometimes we shall use the term ice content instead of moisture, considering it equivalent to moisture.

Analyzing the moisture or ice content of frozen ground, it seems to us irrational to treat the ice contained in the ground in the same category as the mineral part of the ground. The alternative is to treat ice specifically as a solid phase of water combined with a liquid phase of water, if it is present in frozen ground, and, in this combination, differentiated from the mineral part of the ground.

Consequently, we will not only use the term moisture (ice content), but we will differentiate, as in unfrozen ground, between the unit weight and the moisture by weight (ice content).

Moisture by weight of unfrozen ground is

$$w = \frac{g_1 - g_2}{g_2} \quad (12)$$

where w is the moisture content by dry weight; g_1 is the weight of the ground sample in the state of its natural moisture; g_2 is the weight of the ground sample dried to a constant weight at 105C.

As g_2 in frozen ground may vary from zero to g_1 and, consequently, $g_1 - g_2$ may vary from g_1 to zero,

$$\frac{g_1 - g_2}{g_2}$$

for frozen ground will vary from zero ($g_2 = g_1$) to infinity ($g_2 = 0$).

Thus in the field we find the moisture content of frozen ground varying from 300 to 500 to 700% and even up to many thousand percent in relation to the dry weight of the ground.

In this respect frozen ground differs sharply from unfrozen ground, where moisture content only rarely reaches 100% (with the exception of peat).

A sample of water from a river like the Syr-Dar'ya, which at times carries an enormous amount of mud, would give a very high weight ratio of the water to the mineral particles suspended in it. No one, however, would call the water of the Syr-Dar'ya "ground". But, at negative temperatures, pure ice, with $w = \infty$, will differ little, comparatively speaking, from ground which contains 300 to 500% ice by dry weight. Only when the temperature becomes positive will differences be apparent, and then frozen ground will no longer exist.

One can avoid enormous percentages of moisture content by comparing the weight of water in the ground not to the dry weight, but to the weight of the sample in its natural state of moisture, using

$$w = \frac{g_1 - g_2}{g_1} \quad (13)$$

which has the same designations as eq (12).

Under these conditions, as g_2 varies from zero to g_1 , the moisture will vary from 1 (or 100%) to zero.

The moisture by volume of unfrozen ground is determined by the well known equation:

$$w_v = w \delta$$

where w_v is the moisture per unit volume and w the moisture content per unit weight of the ground, and δ is the unit weight of the soil skeleton.

This equation can be applied to frozen ground but not to ice. If we apply this equation to a series of frozen ground samples in which the amount of ice constantly increases and the amount of mineral particles decreases, one multiplier, w , will increase up to infinity and the other, δ , decrease to zero. For ice, the limit is ∞ times 0, or an indefinite expression, although a definitely concrete substance - ice - is involved.

The moisture per unit volume of frozen ground may be expressed as the ratio between the volume of ice (and unfrozen water) in the sample and the total volume of the sample.

If the volume of frozen ground is $V \text{ cm}^3$, the weight of water in it (solid and liquid) is g ,* and g_w is the weight of bound water not transformed into ice, the volume of ice will be:

$$\frac{g - g_w}{\Delta_1}$$

and the volume of all water in solid and liquid phases will be:

$$\frac{g - g_w}{\Delta_1} + g_w$$

Then, the moisture by volume will be:

$$w_v = \left(\frac{g - g_w}{\Delta_1} + g_w \right) / V \quad (14)$$

Assuming $g_w = 0$, we obtain a simplified equation:

$$w_v = \left(\frac{g}{\Delta_1} \right) / V = \frac{g}{\Delta_1 V}$$

and if $V = 1$,

$$w_v = \frac{g}{\Delta_1}$$

This approach gives a rational value for pure ice also. To express moisture by volume in percent, multiply the values obtained above by 100.

From what has been said above, it follows that the maximum moisture content of frozen ground is limited by infinity for the usual moisture by [dry] weight, and by one (or 100%) for moisture by volume. According to the second method indicated, the maximum moisture by weight is also equal to one.

Consequently, ice saturation of frozen ground, if it is considered analogous to the saturation of unfrozen ground, cannot always be expressed by the usual moisture by [dry] weight, as the fraction may be infinitely large.

Ice saturation by volume can easily be expressed by a fraction, the numerator of which is the moisture by volume of the frozen ground at the given moment, while the denominator is the maximum moisture (or ice) content by volume which is equal to one. Consequently, the moisture by volume of frozen ground represents, at the same time, its ice saturation.

* [Editor's note: The authors are not always consistent in their use of designations, especially g , g_w , g_1 . The reader should note the specific definitions given.]

In order to obtain a rational value of ice saturation by weight, the weight of ice in a frozen sample (plus the weight of water which has not been transformed into ice) can be related to the moisture absorption capacity of unfrozen ground.

Though this violates the principle somewhat, these ratios will be of great value for evaluating the consequences of thawing.

Table 26 gives moisture contents by weight of frozen ground for several examples which occur in nature.

Table 26. Moisture content of frozen ground, by dry weight (%).

Type of soil	Min	Max	Avg of many tests	Max moisture capacity of unfrozen ground (%)
Sand	4.0	29.0	6.0-10.0	to 24.0
Sandy silt	5.0-7.0	70.0	15.0-25.0	28.0-36.0
Clayey sand	10.0	139.0	20.0-25.0	25.0-33.0
Clayey silt	10.0-11.0	154.0	25.0-35.0	32.0-35.0
Silty clay	17.0	165.0	30.0-40.0	33.0-68
Silty peat	20.0	1445.0	70.0-90.0	Not determined

In the Anadyr' region, a moisture by weight of 9,890% was registered. In an unfrozen state, this was not ground but a number of mineral particles suspended in water. But the ground, in a frozen state, had supported a fish cannery for 3 years. After this period of time, this cannery had reached such a state that it had to be moved to another place, but it survived that long.

Porosity and Coefficient of Porosity of Frozen Ground

We will consider ice as a formation equivalent in all respects to the mineral particles of the ground. The weight per unit volume of frozen ground is γ ; weight of all water contained in the ground, both solid and liquid, is g_1 ; and the weight of water which has not been transformed into a solid state is g_w . Consequently the weight of ice in the ground is $g_1 - g_w$.

The weight of the mineral part of the selected unit volume of ground is equal to $\gamma - g_1$. Designating the specific gravity of the mineral part of the ground as Δ , and the specific gravity of ice as Δ_1 , the volume of the mineral part of the ground will be

$$\frac{\gamma - g_1}{\Delta}$$

and the volume of ice:

$$\frac{g_1 - g_w}{\Delta_1}$$

Then the volume of voids will be

$$n = 1 - \left(\frac{\gamma - g_1}{\Delta} + \frac{g_1 - g_w}{\Delta_1} \right). \quad (15)$$

We shall obtain the simplest expression of porosity of frozen ground if we assume that all the water in the ground is frozen; i. e., $g_w = 0$. Then the volume of ice will be

equal to $\frac{g_1}{\Delta_1}$, and the volume of the voids will be

$$n = 1 - \left(\frac{\gamma - g_1}{\Delta} + \frac{g_1}{\Delta_1} \right). \quad (16)$$

If $\frac{\gamma - g_1}{\Delta} + \frac{g_1}{\Delta_1} = 1$, then the volume of voids or the porosity of frozen ground is zero.

If the ground contains water not transformed into ice, and if, as in the case of unfrozen ground, we consider the space occupied by water in the liquid state as voids, then the porosity of frozen ground will be equal to or larger than the volume of unfrozen water.

$$n \geq g_w.$$

When the ground contains "pores of freezing" or, in general, some voids not occupied by water, $n > g_w$. When the frozen ground contains neither "pores of freezing" nor voids unoccupied by water, $n = g_w$.

Seasonally freezing ground will have a porosity greater than g_w in some places and a porosity equal to g_w in others. The first case would occur when either "pores of freezing" or cavities produced by vegetable roots or other causes, or a combination of these factors, exist and are not filled with water. In permafrost, there must exist considerable areas of ground with a porosity equal to g_w . Possibly, there are some with a zero porosity if, under the influence of time (measured in millenia), even g_w has been transformed into ice.

If we consider the ice as a temporary cement of the mineral particles, and equate it with water, the space occupied by water in both liquid and solid states will be considered as voids.

Using the same symbols, the volume of the mineral portion of the ground is $\frac{\gamma - g_1}{\Delta}$; hence the porosity will be:

$$n_1 = 1 - \frac{\gamma - g_1}{\Delta}. \quad (17)$$

If $g_1 = 0$ (and therefore $g_w = 0$)

$$n_1 = 1 - \frac{\gamma}{\Delta} \quad (18)$$

which is the equation of porosity for unfrozen ground (as in this case, γ would correspond to δ , the unit weight of the soil skeleton). Consequently, the equation for porosity of unfrozen ground is a special case of the equation for porosity of frozen ground.

Considering ice as an unstable cement, it is important in respect to the construction characteristics of the ground to compare the porosity of a unit volume of frozen ground with its porosity after thawing. The formula for porosity of frozen ground, considering ice as a cement, has been given above as:

$$n_1 = 1 - \frac{\gamma - g_1}{\Delta}.$$

Assuming that the mineral particles in the ground retain the same position when the ice melts, the porosity of the thawed ground would be the same.

But the porosity of our ground after thawing will be expressed by the equation

$$1 - \frac{\delta}{\Delta}$$

where δ is the unit weight of the thawed ground, which may have a different volume from its volume when frozen.

Consequently, it is important to know the following ratio:

$$\left(1 - \frac{\gamma - g_1}{\Delta}\right) / \left(1 - \frac{\delta}{\Delta}\right).$$

If this ratio is larger than one, thawing would constitute an adverse factor for construction, if the ratio is equal to or less than one, it would constitute a favorable factor for construction, inasmuch as the settling of the ground after thawing depends on it.

If we assume that $\left(1 - \frac{\gamma - g_1}{\Delta}\right) / \left(1 - \frac{\delta}{\Delta}\right)$ is equal to A , then

$$A > 1, \text{ if } \frac{\delta}{\Delta} > \frac{\gamma - g_1}{\Delta} \text{ or } \delta > \gamma - g_1$$

$$A = 1, \text{ if } \frac{\delta}{\Delta} = \frac{\gamma - g_1}{\Delta} \text{ or } \delta = \gamma - g_1$$

$$A < 1, \text{ if } \frac{\delta}{\Delta} < \frac{\gamma - g_1}{\Delta} \text{ or } \delta < \gamma - g_1.$$

This means that the ratio of the porosities of frozen and thawed ground will be greater than one if the weight of a unit volume of the mineral part of thawed ground is greater than the weight of a unit volume of the mineral part of frozen ground, i. e., if the mineral particles of the frozen ground have been pushed apart by the ice. If, however, the unit weight of the mineral part of the frozen ground is equal to or even greater than the unit weight of the mineral portion of the resulting thawed ground, then the ratio of porosities will be equal to or even less than one.

Let us turn now to the coefficient of porosity [void ratio]. This coefficient can be determined for unfrozen ground very simply. For frozen ground, the question again arises, should the voids be measured in relation to the mineral part of the ground only or to the mineral part together with ice.

Later on, after a thorough analysis of this question, a definite decision will be reached. At this time, however, we shall give the coefficient of porosity in both ways, as we did for porosity.

Considering ice as a component of the ground on a par with the mineral particles, we will have the following equation for the coefficient of porosity:

$$e_f = \left[1 - \left(\frac{\gamma - g_1}{\Delta} + \frac{g_1 - g_w}{\Delta_1} \right) \right] / \left(\frac{\gamma - g_1}{\Delta} + \frac{g_1 - g_w}{\Delta_1} \right) \quad (19)$$

where, as above, γ is the weight of a unit volume of frozen ground; g_1 is the weight of water in solid and liquid states, g_w is the weight of water in the liquid state; Δ is the specific gravity of the ice, and e_f is the coefficient of porosity of the frozen ground, counting the voids in both the mineral portions and the ice.

EXPERIMENTATION AND THEORY

77

If we suppose that all water in the ground is frozen ($g_w = 0$), we obtain the simplest equation for the coefficient of porosity for the present treatment of this problem:

$$\epsilon_f = \left[1 - \left(\frac{\gamma - g_1}{\Delta} + \frac{g_1}{\Delta_1} \right) \right] / \left(\frac{\gamma - g_1}{\Delta} + \frac{g_1}{\Delta_1} \right). \quad (20)$$

If we calculate the coefficient of porosity for the mineral portion of the ground only, counting the space occupied by ice as voids also, we obtain

$$\epsilon_m = \left[1 - \left(\frac{\gamma - g_1}{\Delta} \right) \right] / \left(\frac{\gamma - g_1}{\Delta} \right) = \frac{\Delta - (\gamma - g_1)}{\gamma - g_1}. \quad (21)$$

This formula is identical with the formula for the coefficient of porosity:

$$\epsilon = \frac{\Delta - \delta}{\delta}$$

already known from the mechanics of unfrozen ground (δ is the unit weight of the soil skeleton of unfrozen ground).

If $\frac{\gamma - g_1}{\Delta} + \frac{g_1 - g_w}{\Delta_1} = 1$, then the coefficient of porosity, according to eq 19 is zero.

Consequently, in planning construction, it is necessary to keep in mind that the coefficient

of porosity in unfrozen ground may vary from zero to $\frac{\Delta - (\gamma - g_1)}{\gamma - g_1}$, whereas in frozen ground with a great amount of ice, $\gamma - g_1$ may be very small, and therefore $\frac{\Delta - (\gamma - g_1)}{\gamma - g_1}$ may be very large.

When $\gamma - g_1 = 0$ (pure ice), $\frac{\Delta - (\gamma - g_1)}{\gamma - g_1}$ is an indeterminate value, since Δ will also be zero. This will occur in the permafrost region, since permafrost layers often contain lenses of pure ice.

Applying the above considerations to determine the porosity of frozen ground under natural conditions, we must know the following:

- 1) weight of 1 cm³ of frozen ground with its natural structure, γ ;
- 2) weight of ice in 1 cm³ of ground, g_1 ;
- 3) specific gravity of the mineral portion of the ground, Δ ; and
- 4) specific gravity of ice, Δ_1 .

The values of γ and g_1 are easily determined in the field; the specific gravity Δ could also be determined in the field, at least in rough approximation; it can be determined more exactly in the laboratory. The specific gravity of ice is known.

Following are several sample calculations of the porosity of frozen ground in the permafrost region.

1. Test pit in the marsh on the upper part of a gentle slope. The sample, obtained at a depth of 1.0 consisted of clayey silt.

Unit weight of ground in natural state, $\gamma = 1.60$.

Weight of ice per cm³, $g_1 = 0.36$.

Specific gravity of the mineral part of the ground, $\Delta = 2.07$.

For specific gravity of ice, let us take $\Delta_1 = 0.917$.

1. The same value is used in the other examples.

Substituting the above in eq 16, we obtain:

$$n = 1 - \left(\frac{1.60 - 0.36}{2.07} + \frac{0.36}{0.917} \right) = 0.01.$$

According to eq 17, $n_1 = 0.40$.

2. Test pit in a "burial" mound on a water-shed. The sample was obtained at a depth of 2.0 m and consisted of clayey silt.

Unit weight of ground under natural conditions, $\gamma = 1.80$.

Weight of ice per cm^3 , $g_1 = 0.39$.

Specific gravity of the mineral portion of the ground, $\Delta = 2.71$.

Substituting in eq 16, $n = 0.06$.

Substituting in eq 17, $n_1 = 0.48$.

3. Test pit in a river floodplain overgrown by forest. The sample was obtained at the depth of 2.0 m and consisted of silty sand with ice and peat.

Unit weight of ground under natural conditions, $\gamma = 1.35$.

Weight of ice per cm^3 , $g_1 = 0.63$.

Specific gravity of the mineral portion of the ground, $\Delta = 2.62$.

From eq 16, $n = 0.04$, and from eq 17, $n_1 = 0.73$.

4. Sample from a depth of 2.0 m in the first test pit (pit in marsh), consisting of clayey silt.

Unit weight of ground in natural state, $\gamma = 1.61$.

Weight of ice per unit volume, $g_1 = 0.32$.

Specific gravity of the mineral part of the ground, $\Delta = 2.58$.

From eq 16, $n = 0.15$, and from eq 17, $n_1 = 0.50$.

These examples show that, even when we consider ice as a component of the ground on a par with the mineral part, the porosity of frozen ground may be either very insignificant (0.01) or considerable (0.15), as we had already established theoretically. Coefficients of porosity for the same samples are:

Sample 1, combining ice with the mineral part:

$$\epsilon_l = \frac{0.01}{0.99} = \frac{1}{99} = 0.011.$$

Combining ice and water:

$$\epsilon_m = \frac{0.40}{0.60} = \frac{4}{6} = \frac{2}{3} = 0.666.$$

Sample 2, correspondingly:

$$\epsilon_l = \frac{0.06}{0.94} = \frac{3}{47} = 0.064$$

$$\epsilon_m = \frac{0.48}{0.52} = \frac{12}{13} = 0.924.$$

Sample 3:

$$\epsilon_l = \frac{0.04}{0.96} = \frac{1}{24} = 0.042$$

$$\epsilon_m = \frac{0.73}{0.27} = 2.71.$$

Sample 4:

$$e_1 = \frac{0.15}{0.85} = \frac{3}{17} = 0.177$$

$$e_m = \frac{0.50}{0.50} = 1.00.$$

Water Permeability

Two types of water permeability of frozen ground may be distinguished: (1) water passes through frozen ground without changing negative ground temperatures to positive (this may take place when supercooled or mineral water with negative temperatures passes through frozen ground); (2) water passes through frozen ground by thawing out passages, or raises the temperature of the walls of already existing passages and thus disrupts the frozen state of the ground. Under natural conditions, the second type is more frequent, but the first type may also occur.

Kachinskii¹ has made detailed studies of the permeability of seasonally frozen ground to water, checking his conclusions by experiments. He found that soil in which all voids are completely filled with ice is absolutely impermeable to water. He selected for his experiments a 6 x 6 cm plot of ground without any apparent voids. A hollow was made and water poured into it. In 3 hr, the level of this water did not sink. From this, Kachinskii concluded that the frozen ground in this small area was impermeable to water. On April 4, 1952, in an area adjacent to the first one, where the ground was frozen to a depth of 33 cm from the surface and the plowed layer had a moisture content of 32.5%, a pit was dug 40 cm long, 30 cm wide, and 3 cm deep. Two and a half liters of water obtained from under the snow (with a temperature of 0C) was poured into the pit a little at a time, so that it covered the bottom of the pit continuously.

All the water was absorbed by the frozen soil in 1 hr and 15 m — at the rate of 17 mm/ hr. The water thawed the soil in the pit, on the average, to a depth of 3 mm. The rest of the soil remained frozen, but it was noticeably moistened and slightly smeary in places. Wormholes and other voids through which, in the main, the water passes had larger ice-free diameters, but even in them not all the ice thawed.

"The two following facts," says Kachinskii, "undoubtedly indicate the water permeability of frozen soil: during spring snow melt, water immediately appeared in pits dug in ground frozen from the surface even when the digging did not pass the frozen layer; during spring and winter thaws, lysimeters placed in and under the frozen layer sometimes register water, which could reach them only after penetrating the frozen layer."

This and other interesting observations and experiments by Kachinskii were made near Moscow where only seasonal freezing occurs. Engineer A. A. Shalobanov,² who also pointed out that frozen soil is permeable to water, made his experiments near Sverdlovsk. Consequently, both investigators worked with seasonally frozen ground.

Kachinskii's experiments also showed cases where the water thawed the walls of the channels through which it passed.

In the permafrost region Kachinskii's conclusions can be applied to the active layer, with corrections for the greater thickness, on the average, and lower temperatures of the active layer, which would decrease its water permeability and increase the number of completely impermeable areas, as was found in Kachinskii's experiments.

The layers of permafrost, in our opinion, should be considered impermeable to water, with the exception of rare cases that might occur along the southern border of permafrost.

No special experiments on the water permeability of permafrost have been made. Consequently, we must limit ourselves to theoretical considerations and results of observations.

1. Kachinskii (1927) op. cit.

2. A. A. Shalobanov (1903) Propuskaet li vodu merzlaia pochva? (Can water permeate frozen ground?), Pochvovedenie, no. 3.

First, we must remember the effect of the time element here. The layers of permafrost have been in a frozen state for a very long time. One can expect that all the voids of the upper portions of permafrost are completely filled with ice. Moreover, this process of filling has been repeated a great many times; i. e., if the frozen layer had voids and "pores of freezing," they would be filled with ice in the course of time. The water for this ice would be supplied either from the suprapermafrost or from within the permafrost layer itself.

These theoretical considerations are supported by many hundreds and thousands of bore holes in permafrost which always remained dry if they were well protected from water circulating in the thawed active layer.

The suprapermafrost water, which in smaller or greater quantity is very widely distributed in the permafrost region, can exist only if permafrost constitutes an underlying water-impermeable layer.

The water which pours out from icing mounds and remains on the surface instead of disappearing into the frozen layers also testifies that the permafrost layers beneath the mounds are impermeable to water.

Finally, very frequently excavations in the permafrost are located quite near the stream of intrapermafrost water, and a comparatively small thickness of the permafrost is sufficient to protect the excavation from this water.

Even if a talik* is encountered while digging a trench, an artificially formed layer of frozen ground serves as a water-impermeable layer, protecting the trench. The same thing is done in unfrozen ground by means of artificial refrigeration.

Water circulating within the permafrost mass as intrapermafrost water passes through thawed channels within the permafrost mass. Only mineralized water with a negative temperature sometimes penetrates the permafrost. Thus, according to N. I. Tolstikhin,¹ a temperature of -0.1°C was observed in the Shivia Spring in the Transbaikal region in October 1929, and a temperature of -0.3°C was recorded in June 1931 in the Kukin Spring.

What then takes place in taliks* that penetrate the permafrost mass and serve as passages for intrapermafrost waters?

When the temperature of the water circulating through these taliks rises, the taliks are enlarged, when the temperature of the water falls, the taliks contract. The limit of the first process is complete destruction of permafrost in the region of action of the intrapermafrost waters and the formation of a talik island [a mass of unfrozen ground]. The limit of the second process is a complete closing of the unfrozen channel and the transformation of it into frozen ground.

Thus, for the present, for all practical purposes, we must consider permafrost as impermeable to water. The movement of water in it, as a rule, takes place along the unfrozen passages, with the exception of extremely rare mineral springs with negative temperatures, probably required during their passage through permafrost.

Capillarity of Frozen Ground²

In presenting Shtukenberg's theory of swelling, we admitted the possibility of capillary phenomena in frozen ground. The capillary rise of water in the frozen active layer is restricted, first of all, by the thickness of this layer, since, even in small capillaries, water may ascend only to the surface of the ground. In addition, the rise is conditioned by the diameters of voids and passages in frozen ground. It is well known that the height of water rise in capillaries is in inverse proportion to the diameter of the capillary.

1. N. I. Tolstikhin (1934) Mineral'nye istochniki Zabaikal'ia (Mineral springs of the Transbaikal region), sb. 1, Vsesoiuznogo gidrogeologicheskogo s'ezda (Symposium of the 1st All-Union Hydrogeological Congress), Leningrad and Moscow.

2. This section could have been considered as a continuation of the preceding one, but it was decided to present it separately.

* [A layer of unfrozen ground between the seasonally frozen ground (active layer) and the permafrost. Also applies to unfrozen layers or bodies within the permafrost and to the unfrozen ground beneath the permafrost.]

After rising to a certain height and finding itself in a medium with a negative temperature, capillary water inevitably acquires a negative temperature and either remains in a supercooled state or is transformed into a solid state, i. e., ice.

Capillary phenomena in frozen ground is one of the least studied problems. As we have seen in our discussion of water permeability, frozen ground contains voids in the shape of passages of various diameter — mole holes, holes left by roots, etc., and also the "pores of freezing."

The first type of cavity usually has a considerable diameter and there is no capillary rise, for all practical purposes. The second group, the "pores of freezing," as shown by certain experiments, are usually of small diameter, and in these pores water may move by capillary rise through the frozen ground, particularly upward to the level of the active layer. Shtukenberg, giving his formula for swelling with access of water from the outside, based his theory precisely on the existence of these pores.

What we have said so far about capillary phenomena in frozen ground pertains to seasonal freezing. For permafrost, however, we must assume, with a great degree of probability, that capillary phenomena are absent as a general rule. Even if these phenomena should occur here or there, they are an exception. It would be extremely interesting to determine whether bodies of permafrost containing capillary water occur near the unfrozen passages in the permafrost mass, which would serve as canals for the passage of intrapermafrost water. In unfrozen ground which contains ground water, a layer with capillary water will occur above the water-bearing layer (Fig. 44).

Figure 44. Diagram of capillary rise of water above ground water. 1) layer into which the capillary water does not penetrate; 2) capillary-moistened layer; 3) water-bearing layer with stream of ground water; 4) water-impermeable layer.



It would be interesting to find out whether capillary water would be found around a narrow stream of intrapermafrost water in a permafrost layer (Fig. 45).

This problem has not as yet been clarified, and we state it simply because it is of enormous theoretical significance. If it were answered positively, it might answer the question as to how long water can exist in a supercooled state in the presence of ice crystals. For permafrost, the answer to this question may reveal that such coexistence may last for years, centuries, and millenia.

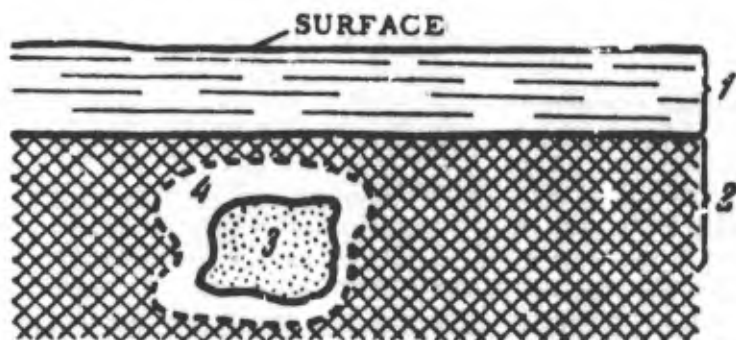

Figure 45. Diagram of a stream of intrapermafrost water in permanently frozen ground. 1) active layer; 2) permafrost; 3) lateral cross section of a talik through which a stream of water moves in a direction perpendicular to the plane of the drawing; 4) ring of permanently frozen ground which may contain capillary water.

Evaporation

Evaporation from frozen ground is, in general, evaporation of ice. This is a well-known fact and in accord with the general laws of water evaporation.

To demonstrate the intensity of ice evaporation at negative temperatures, we cited previously (Chapter II) figures on ice evaporation obtained with Wild evaporimeters. Our

data were obtained at three stations in the Far East during the winter months, when no thaws occur at these localities.

As we can see, even at the low temperatures during December and January at the stations selected, evaporation of ice was still perceptible; in February it became quite considerable, though the temperature was still very low.

At present, we have no quantitative values for evaporation from the frozen ground. We can judge the evaporation qualitatively by the dry layers, about 3-5 cm thick, which form during the winter on the ground surface if the soil is not covered by snow.

This evaporation may take place either from the surface of the ground or within the layers of frozen ground.

For the latter, voids and pores in the ground are necessary. If these voids are completely closed, then, when temperature is stable, the air in them should become saturated with vapor. If the temperature later starts to rise, evaporation begins again, until the saturation point at the new temperature is reached. If pores and voids are interconnected, the vapor in them must move from areas with greater pressure toward areas with lesser pressure, as in unfrozen ground. The difference between the vapor pressures is due either to differences of temperatures in the separate parts of the ground, or to differences in the curvature of the surface of ice crystals contained in the ground, as has been pointed out above. Finally, the differences may be due to the changes in the state (supercooled water versus ice).

The temperature conditions in the permafrost mass are more favorable for evaporation than at the three stations selected by us, because -6°C to -8°C temperatures of permafrost are quite low, and there are enormous masses of permafrost with a temperature of about -1°C . Consequently, if ice evaporation in February often exceeds 5 m, and sometimes even reaches 1 cm, one can expect a still greater degree of evaporation at the above-mentioned temperatures of permafrost. However, there are other circumstances which are not conducive to evaporation inside permafrost, such as the small volume of the voids, the zero value of the moisture deficit within them, etc.

However, this question has not as yet been investigated experimentally.

Condensation of Water Vapor

We have just discussed evaporation from frozen ground and have pointed out that evaporation should also occur in permafrost. We also indicated the basic motivating forces of evaporation.

The process of condensation is the reverse of evaporation. It takes place when vapors completely saturate a given space. In permafrost, condensation may take place only within the range of negative temperatures. If the ground contains only ice, temperature differences which produce differences in vapor pressure are necessary for condensation. When the ground contains supercooled water, condensation — sublimation may take place even at the same temperature; condensation also may take place at the same temperature according to Thomson's formula. But all these processes (and evaporation also) are not so simple as they appear at first glance. Supersaturated vapor can form, and vapor can condense directly to a solid state — ice. Kachinskii, according to his above-mentioned work, has observed, as have many others, the formation of frost in the cavities of the ground. "Quite frequently," he writes, "crystalline ice, with well-formed concretions of elongated, needle-like crystals, is encountered in worm holes and other cavities and on their walls, predominantly in the upper layer of the ground. This is a peculiar intra-soil frost whose only distinguishing characteristic is that the crystals here are of small size and are always of glasslike transparency. The presence in the ground of this evidently crystalline ice points to formation from water in the vapor state, which was condensed and frozen in the upper layer of the ground."

This process presents a much simpler picture when we consider the interrelationship of the frozen ground and the active layer during the summer. In the summer, the active layer thaws gradually and has a positive temperature; deeper down, we find the frozen ground. The result is a sort of distilling arrangement, in which the surface of the frozen ground serves as a condenser. The stream of vapor proceeds from the top downward to

the frozen layer, where it is transformed into water. But if, theoretically, there are no objections to this concept, no quantitative statements can yet be made. Frequently, we observe water or very moist ground above the surface of the frozen mass, but we cannot tell what part of the water or moisture is the result of condensation and what part is the result of thawing of the frozen ground.

This problem too requires an experimental approach. Furthermore, while there is no doubt that water vapor condenses on the lower surface of the seasonally frozen layer, we do not know how much of the ice that forms on this surface is derived from water and how much from vapor.

In short, we know the facts but we cannot as yet express them quantitatively.

Qualitatively, however, there are sufficient indications of the presence of supersaturated layers of ground above the permafrost layer and even above the seasonally frozen layer as it thaws downward. Examples are given throughout this book. At this time, however, we shall give two or three examples of the distribution of gravimetric moisture in the ground, which will show that a layer of supersaturated ground very often exists above the upper surface of frozen ground.

N. A. Tsytovich¹ gives such a distribution of gravimetric moisture for the active layer at the Ust'-Yeniseisk port (Fig. 46).

In Figure 46, the depth from the surface of the earth is plotted along the ordinate axis and the gravimetric moisture along the abscissa. The drawing shows that the moisture increases at the upper boundary of the permafrost and reaches its maximum at a depth of 1.11 m.

These observations were conducted in August 1930 when the upper level of the frozen ground was 0.61 m below the surface. During this year, the ground did not thaw to a depth of 1.11 m, and the supersaturated layer appeared, as Tsytovich says, "during one of the warmest summers". He adds, "the presence of the supersaturated layers at the upper permafrost boundary, it seems, allows us to determine the upper limit of permafrost at any time of the year on the basis of moisture distribution in the ground in the permafrost region."

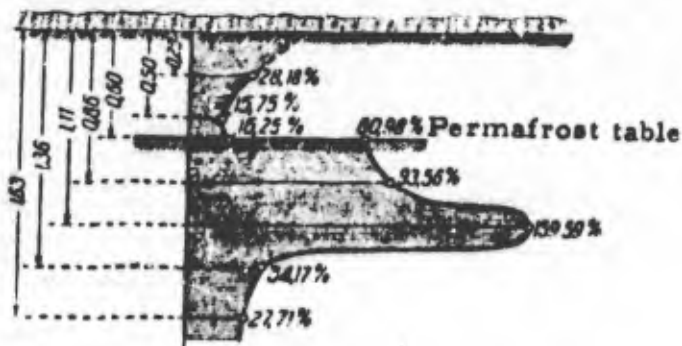

Figure 46. Ground moisture in the region of the Ust'-Yeniseisk port. Abscissa shows the gravimetric moisture (% of dry weight); ordinate shows depth (cm). (From Tsytovich).

We cite one more example of distribution of moisture by weight in accordance with depth, at a building site of the Commissariat of Communications in Yakutsk, where five bore holes were sunk to a depth of 10 m (see Table 27).

In bore holes 2, 3, and 4, there is a sharp increase in moisture between 2.25 and 2.75 m. Bore holes 1 and 5 do not show such an increase at this depth. In our opinion, this indicates that the upper permafrost surface is uneven. At bore holes 1 and 5, the permafrost must be somewhat higher, from which the excessive moisture has moved to the nearest depressions.

If the vertical distribution of moisture in the ground shows an excess of water above the frozen ground, as in the examples cited, this fact constitutes an adverse factor for construction.

All measure should be taken to get rid of this excessive suprapermfrost water on the site because it causes severe heaving of the ground.

1. N. A. Tsytovich (1932) Nekotorye issledovaniia vechnoi meraloty v nizov'iakh reki Eniseia letom 1930 g. (Permafrost studies along the lower reaches of the Yenisey in the summer of 1930), Trudy KIVM, Akad. Nauk SSSR, tom I.

Table 27. Gravimetric moisture in the ground (Yakutsk). *

Depth (m)	Bore hole				
	1	2	3	4	5
0.25	99.36	96.85	162.18	57.66	28.94
0.50	47.06	37.53	133.92	43.94	17.24
0.75	212.76	27.93	414.55	40.25	53.53
1.00	382.90	32.85	149.04	43.60	66.06
1.25	54.49	35.92	83.70	33.37	46.43
1.50	63.84	40.53	71.32	29.05	36.46
1.75	66.85	88.01	47.48	29.05	31.97
2.00	26.20	79.39	33.16	73.00	33.44
2.25	38.00	102.57	21.15	105.23	29.05
2.50	23.30	98.74	28.19	79.01	32.12
2.75	17.92	122.11	71.58	38.50	34.02
3.00	37.54	60.23	62.90	43.68	33.05
3.25	34.23	12.79	52.65	30.36	23.62
3.50	33.21	42.28	43.53	41.35	20.66
3.75	33.98	48.47	32.98	57.07	21.18
4.00	27.53	29.85	32.95	39.41	22.17
4.25	35.02	28.56	24.38	26.83	21.34
4.50	19.31	23.47	29.63	23.02	30.16
4.75	21.26	23.10	27.75	21.11	27.13
5.00	21.03	17.72	28.94	25.49	25.66
5.25	30.01	22.29	26.47	20.08	30.51
5.50	23.27	19.49	27.18	21.47	27.29
5.75	22.23	21.04	27.98	22.13	30.10
6.00	23.68	18.09	27.04	22.70	28.46
6.25	23.55	17.91	26.25	25.87	23.40
6.50	20.61	18.02	29.74	29.34	21.65
6.75	23.84	18.12	25.22	27.10	18.56
7.00	21.10	20.45	25.26	29.57	13.19
7.25	18.96	19.62	18.01	21.24	23.96
7.50	21.28	18.39	24.67	21.10	21.72
7.75	19.69	20.78	24.73	32.86	21.07
8.00	28.11	20.43	24.68	19.91	23.00
8.25	22.08	21.14	22.90	18.95	23.87
8.50	22.84	20.83	19.14	26.50	21.38
8.75	20.34	25.55	20.83	16.13	21.28
9.00	20.19	32.78	18.25	20.44	29.55
9.25	20.75	30.59	23.62	18.88	29.55
9.50	18.50	29.75	23.71	20.59	18.40
9.75	82.15	29.84	21.83	22.66	23.90
10.00	18.61	23.63	26.76	20.81	21.15

Note: Commissariat of Communications building site.

* [Moisture is apparently given in % of dry weight.]

But we must admit that the methods of drainage in the permafrost region have not been worked out. While drainage ditches are used in upland regions to eliminate surface water, the draining of ground water involves considerable difficulties, some of which are discussed later.

Changes of Ground Volume upon Freezing

Changes in volume of the mineral parts of the ground under the influence of temperature changes are gradual and very insignificant, as their coefficient of expansion is very small. Consequently, the effect of temperature changes on the volume of the mineral ground has no significance for construction, especially at the range of ground temperatures which occurs, for example, beneath the foundations of buildings and constructions. In the permafrost region and in the region of deep winter freezing, the following average amplitudes of soil temperature are observed:¹

<u>Stations</u>	<u>Depth (m)</u>	<u>Amplitude (C)</u>
Ulanga	3.0	0.2
Mazanovo	2.9	7.3
Gosh	3.0	4.2
Amur Experimental Station	3.2	6.0
Petrovsk-Zabaikal'skii	6.0	0.8
Skovorodino	5.0	0.4

Of course, with such amplitudes, the changes in volume of the mineral part of the ground would be very small.

As is well known from elementary physics, water — the second component of unfrozen grounds — has a number of peculiarities in its expansion due to temperature. In its liquid state, changes in volume occur gradually. But, as is well known, when water changes from a liquid to a solid state and vice versa, a sudden increase or decrease of volume takes place, and the gradual change becomes abrupt. The change is quite considerable and is expressed by

$$V_i = 1.0909 V_w,$$

where V_i is the volume of ice and V_w is the volume of water.

Maintaining the same designations² for the reverse phenomenon, we have the following equation:

$$V_w = 0.9167 V_i.$$

In the laboratory, these changes take place in distilled water at 0C. But the water in the ground is, first of all, a solution, though usually a very weak one, and second, it can be divided into gravitational, film, and other types of water. The above statements can be applied only to gravitational water, with certain corrections for the freezing point, which is somewhat below zero. We can, for the present, apply the same considerations and the same values of volume change to hygroscopic and film water, while admitting that a considerable deviation from the generally accepted values may exist. We already know that the temperature of transition from the liquid state to the solid is markedly different for these types of water. But the gravitational waters in the ground show the two most important characteristics of volume change: the discontinuity in the rate of volume change upon the transition from the liquid state into the solid, and the considerable degree of the change in volume, as has been pointed out in the above-cited formulas.

We will not deal with the changes of air volume under the influence of temperature changes.

Turning now from the components of unfrozen ground to the ground itself considered

1. M. Sumgin (1927) Vechnaia merzlota v predelakh SSSR (Permafrost in the U. S. S. R.). Vladivostok — and other sources.

2. O. D. Khvol'son (1925) Kurs fiziki (Textbook of physics), tom III.

as a three-phase system, we must point out that, in volume change caused by the temperature, gravitational water plays a very important role, particularly at freezing temperatures. In the process of change of ground volume due to temperature changes, we observe the following chain of events:

1. The temperature of unfrozen ground falls to zero and a change of volume takes place, which is the algebraic sum of volume changes of its three components. These overall changes of ground volume do not affect the buildings on it.
2. The temperature falls below the zero point, and supercooling of water takes place, but no transition of water into ice. Changes of the ground volume continue without affecting buildings, as was the case with the positive temperatures.
3. Finally, the negative temperature reaches such a degree that the gravitational water in the ground is transformed into ice. At this moment, the expansion of water as it freezes has a predominant influence. The overall expansion of the ground begins to affect structures on it. This influence is increased by the complexity of the process of water crystallization due to the migration of moisture at this time.
4. All of the gravitational water in a given volume of ground has been transformed into ice. The temperature continues to drop; all four components of the ground — the mineral part, ice, air, and water decrease in volume. As a rule, these volume changes do not affect structures (in view of the usually small variations of ground temperature). However, this is true only under normal conditions. During severe frosts, compressive stresses may be large enough to disrupt the frozen ground, and the cracks formed may cause structures to deform.

Point 3 requires elucidation. Changes of ground volume may affect structures only under certain conditions of water content in the ground. We have already discussed the critical moisture of the ground in relation to its expansion upon freezing. Theoretically, if the moisture is below the critical point and moisture migration is absent, the volume changes of water should not cause a volume change in the ground since the ground has inner resources to accommodate the increased water volume. From the theoretical point of view, ground moisture must be greater than the critical amount in order to have ground expansion when the water changes to ice. This problem is further complicated by the fact that part of the water in the freezing ground remains in a liquid state; that pores of freezing may be formed during the transformation of ground water into ice; that the increase of ground volume may take place in the open system due to crystal growth in one direction; and finally that the ground volume may increase due to moisture migrating into the freezing ground from unfrozen layers.

On the basis of all that has been said above, it is clear that it is very difficult to predict the increase in volume of the freezing ground. Consequently, we must obtain experimental values of volume increase and make deductions from these. We cite some data from the work of P. I. Andrianov¹ on ground expansion when the ground freezes without inflow of moisture from the outside. The expansion was measured by special dilatometer, not described here.

Table 28 shows that the calculated and the observed expansion of freezing water often differ sharply. Apparently, this discrepancy is due to the above discussed complexity of this phenomenon, which we are just now beginning to study.

A considerable expansion of ground at the moment of transformation of the water into ice and a decrease of ground volume when ice is transformed into water affect a structure in three ways: 1) when the ground freezes beneath the foundation, the building or structure rises; 2) when the ground thaws, the ground settles and the building settles with it; 3) the expanding of freezing ground adjacent to the building area may also affect a building by creating lateral pressure on its foundations with resulting deformation. This third point is still debatable.

1. P. I. Andrianov (1936) Koeffitsient rasshireniia gruntov pri zamersanii (Coefficient of expansion of ground upon freezing), SOPS and KIVM, Akad. Nauk. SSSR.

Table 28. Expansion of Ground upon Freezing

Sample no.	Volume of sample (cm ³)	Unit weight (g/cm ³)	Coefficient of saturation (% of total moisture capacity)	Temperature of freezing ground (C)	Water in sample (g)	Water not frozen at -3 C* (g)	Calculated expansion of water (mm ³)	Measured increase of volume (mm ³)	Coefficient of expansion (%)
1	2	3	4	5	6	7	8	9	10
33	6.19	1.6	100	-7.1	1.990	0.504	134	94	1.51
33	6.13	1.8	100	-7.7	1.970	0.500	133	99	1.61
33	5.79	1.7	60	-6.0	1.248	0.446	72	67	1.06
33	5.87	1.7	60	-6.7	1.266	0.452	73	63	1.07
34	5.845	1.5	100	-7.5	2.570	1.283	106	75	1.28
34	6.461	1.5	100	-7.5	2.850	1.417	120	81	1.24
34	4.870	1.2	60	-5.0	1.614	0.854	62	55	1.12
34	4.889	1.2	60	-4.2	1.626	0.858	63	53	1.08
35	6.16	1.7	60	-5.0	1.278	0.199	87	55	0.90
35	5.46	1.7	60	-4.8	1.134	0.176	78	46	0.83
36	5.751	1.3	100	-4.4	2.880	1.162	169	115	1.97
36	5.650	1.3	100	-4.7	2.830	1.140	156	123	2.16
36	5.058	1.1	60	-4.8	1.728	0.864	81	103	2.03
37	4.903	1.1	60	-5.4	1.700	0.837	80	91	1.86
38	5.733	1.3	100	-5.0	2.825	0.814	200	151	2.64
38	5.596	1.3	100	-4.6	2.759	0.795	197	185	2.40
38	4.518	1.4	60	-5.6	1.547	0.543	103	42	0.93
38	4.670	1.4	60	-5.0	1.602	1.602	107	52	1.12
39	5.94	1.4	100	-5.8	2.60	0.991	172	104	1.76
39	6.01	1.4	100	-4.8	2.63	1.002	147	112	1.87
39	4.497	1.1	60	-6.8	1.51	0.590	83	80	1.78
40	5.951	1.6	100	-5.5	2.34	0.586	171	90	1.54
40	5.935	1.6	100	-3.0	2.331	0.585	170	89	1.49
40	5.079	1.4	60	-7.0	1.452	0.438	101	86	1.29

* Calculated from $y = 5.61 q^{0.6}$, where q = heat of wetting, y = amount of water not frozen at -3C.

Thermal Constants of Frozen Ground

While the very definition of frozen ground is based on its thermal characteristics, the thermal constants of frozen ground so far have not been determined. The complexity of determining the thermal constants of frozen ground is a possible reason for this, but the main reason is undoubtedly the fact that the study of frozen ground is still very young. Scientific thought is almost completely concerned with morphological description of the outward manifestations of the processes of freezing and thawing, and especially with permafrost and phenomena connected with it, and has just begun work on precise numerical expression of these processes and the conditions under which they occur. Consequently, in this section we shall restrict ourselves to a rather general consideration of the problem.

As we can, and should, consider frozen ground as a complex body, we can apply the equation for heat capacity of complex bodies:

$$c = \sum g_i c_i \tag{22}$$

where g_i is the weight of each component part of the ground, and c_i is the heat capacity of each part (at a given temperature t).

Here we are confronted by the following difficulties. Having considered frozen ground as composed of four components — mineral particles, ice, supercooled water, and moist air — we must substitute in the formula corresponding values for each component. But, as we have pointed out several times, the precise determination of the quantity of each of the above components is a rather complex problem. First, we must determine the quantity of water which has not been transformed into a solid state by determining the coefficient of the ground expansion upon freezing. Next, using the previously mentioned method, we must determine the porosity of the ground, assuming that all the pores are occupied by air. Next, we must determine the amount of mineral particles and ice. Only then can we use eq 22.

The second difficulty in determining the heat capacity of frozen ground is that, during experiments, the heat capacity of bodies is measured per unit of weight and for a certain temperature interval, taking an average thermal capacity for this interval according to the formula:

$$c = \frac{Q}{t_2 - t_1}$$

where Q is the quantity of heat, and t_1 and t_2 are temperatures.

The change of temperature in frozen ground will be accompanied by either evaporation of ice or condensation of vapor in the voids and in the surrounding air. The heat energy spent for these processes must be excluded from the amount of heat energy which is used to raise the temperature of the frozen ground 1C (or emitted during the lowering of the temperature 1C).

Consequently, in order to calculate the amount of vapor that will be emitted into the voids, the porosity of frozen ground again must be known.

The third difficulty consists in the fact that both ice and film water, as components, will have variable values during the change in temperature.

It is clear that trying to determine the precise constant of the heat capacity of frozen ground is a big task, and at first we may have to calculate the coefficients of heat capacity of the ground in very general terms.

Here we shall try to give the theoretical heat capacity of "ideal" frozen ground, for which we earlier determined the specific gravity. As we pointed out above, this ground is composed of mineral grains and ice. The ground has no cavities and its porosity is zero.

Designating the specific heat of the mineral part as c_1 , its weight as g_1 , the specific heat of ice as c_2 , and its weight as g_2 , the heat capacity at a certain negative temperature t is:

$$c = c_1 g_1 + c_2 g_2. \quad (23)$$

This is a development of eq 22. Let us try to give a numerical value to eq 23, not in exact figures, but rather as a general characterization of the heat capacity of our "ideal" frozen ground.

Consider a unit volume of this ground with a porosity of 35% and all the pores filled with ice, $c_1 = 0.2$, $c_2 = 0.502$, and the specific gravity of the mineral part is 2.6.

Consequently, the volume of the mineral part of the ground is 0.65 cm^3 ; its weight = $2.6 \times 0.65 = 1.69 \text{ g}$, and the weight of the ice is 0.32 g .

Substituting the values into eq 23 we have:

$$c = 0.2 \times 1.69 + 0.502 \times 0.32 = 0.50.$$

Thus, we obtain a numerical value, which is close to the specific heat of ice.¹ This may be explained by the fact that the components of our frozen ground are ice and mineral particles. The specific gravity of the latter is close to 2.6, its specific heat is about 0.2; consequently, its volume specific heat is 0.52, or very close to the specific heat of ice, which is 0.502.

On the basis of the above, we can take, as the first approximation, the heat capacity of frozen ground as being equal to the thermal capacity of ice.

1. N. A. Tsytoovich (1933) Lektsii po raschetu fundamentov v usloviakh vechnoi merzloty (konspekt) (Lectures on foundation calculations under permafrost conditions (Compendium)), Leningrad Institute sooruzh.

Under natural conditions, of course, the situation would be more complex, the quantity of ice and unfrozen water would differ, and there would be pores and voids. But for frozen ground that is completely cemented by ice, or ground with an excess of ice, we can use the heat capacity of ice as a first approximation.

The problem of thermal conductivity is still more complex. Up to this time the so-called "temperature jump" which occurs during the transmission of heat from one body to another upon contact is still an unsolved problem of physics. Some investigators (Angstrom, Kolovrat - Chervinskii) assert that this jump does not exist and that heat passes at the contact points in an uninterrupted flow; others (Rogovskii, Poisson) assert that the jump does exist.¹ In frozen ground, there is an enormous number of heat transfers from one body to another. The path of the heat flow along a straight line in the frozen ground will be as follows: from mineral grain to supercooled water, to ice, to supercooled water, to mineral grain, to supercooled water, etc., with air inclusions in some places between water and ice or within the ice. This applies when not all the ground water has been transformed into a solid state. If, however, the ground does not contain any film water in a liquid state, the path will be simplified as follows: mineral grain to ice, to mineral grain, etc., with occasional inclusions of air.

At the same time, it must be kept in mind that, with a constant flow of heat, the quantity of film water may either increase or decrease, and this would be accompanied by the emanation or absorption of the latent heat.

Obviously, it would not be easy to determine in full detail the thermal conductivity of frozen ground. Meanwhile, it is necessary to make every effort to obtain a general thermal conductivity of frozen ground as a function of its moisture and temperature. At the present moment, this is necessary also for construction projects, and this is not a difficult task, comparatively speaking.

There is a similar lack of conclusive data for determining the latent heat of thawing and freezing of the grounds. For the time being, we must use the values for water. But these constants are applicable only for the gravitational water. For other types of water (film and hygroscopic), this problem still awaits investigation.

The same applies to the thermal constants of evaporation or condensation of vapor at temperatures below 0C. The question is whether the evaporation of film moisture is the same as the evaporation of moisture in general, or, in the same manner, whether condensation as film moisture is accompanied by the normal emanation of heat, or, whether, quantitatively, this emanation is different.

These and other problems now confront the students of frozen ground and, as far as unfrozen ground is concerned, the soil scientists.

At present we can only use the values determined by physicists for water in general. For instance, according to Leduc, the latent heat of fusion or freezing is 79.6 cal/g (15° calories).²

Electrical Properties of Frozen Ground

The study of the electrical properties of frozen ground is necessary for efficient field study of frozen ground by electrometric methods. In this respect, as in many others, only cautious steps are being taken thus far. Nevertheless, something is being done.

The work of A. N. Silberman, A. P. Liubimov, and A. B. Bazhenova³ has established that silty sand with 60% water saturation, when frozen at -19C had a resistance of 63,600 ohms. Prior to freezing, this unfrozen ground had a resistance of 2200 ohms; thus, there is a sharp difference in the resistance of unfrozen and frozen ground.

1. O. D. Khvol'son (1925) op. cit.

2. *ibid.*, p. 498 (gives figures of other investigators too).

3. "Nabludeniiia zamerzaniia i ottaivoniia pochvy metodom elektroprovodnosti" (Observations of Freezing and Thawing of Ground by Electroconductivity Methods), Zhurnal geofiziki, 1935.

PRINCIPLES OF MECHANICS OF FROZEN GROUND

Figure 47 shows the curve of resistance which was obtained during the freezing of this ground.

The authors used thin-plated steel electrodes (40 x 10 mm plates placed 20 mm apart). The resistance was measured by the Kohlrausch bridge with a telephone. As can be seen from the drawing, the resistance remained constant at the beginning (2200 ohms), then began to rise when freezing started, and reached 63,600 ohms when the ground froze completely.

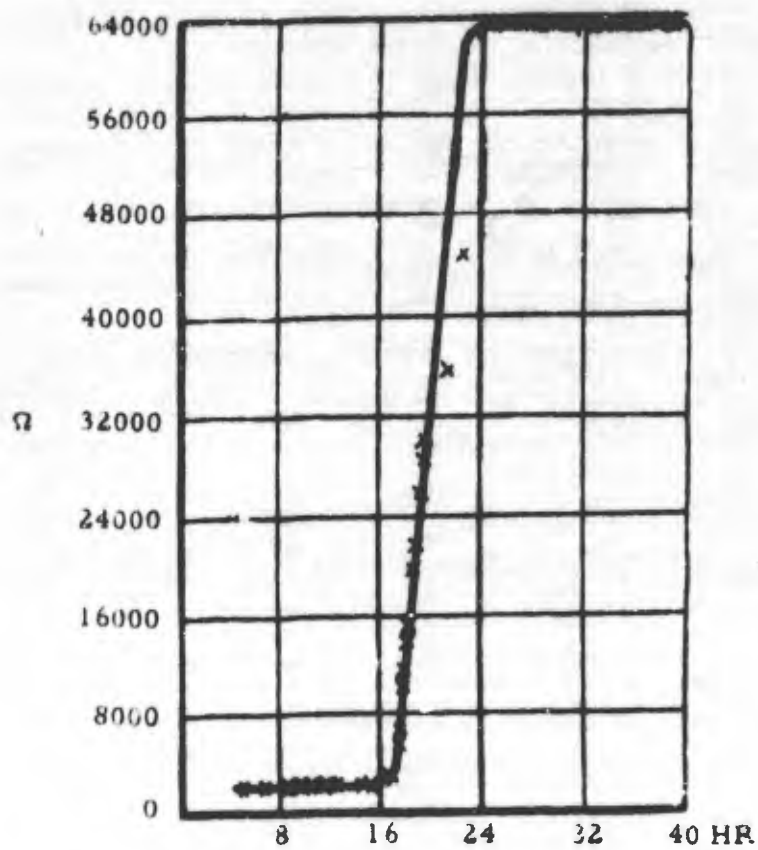

Figure 47. Electrical resistance of frozen ground.

CHAPTER IV. RESISTANCE OF FROZEN GROUND TO EXTERNAL FORCES 91

Basic Concept

One of the basic problems of interest to those who build on permafrost, excavate mine shafts using the freezing method, and do other earthwork and construction connected with frozen ground is the determination of the resistance of frozen ground to external forces.

If the load on a sample of frozen ground is gradually increased, a critical state of stress arises at a certain load. This state is characterized by considerable changes in the form of the material. In brittle materials, complete disruption of the structure occurs (when the forces of adhesion between separate particles are overcome), while, in plastic materials, an uninterrupted gradual change of form occurs without any change in volume, i. e., the phenomenon of flow.

The ultimate strength of brittle substances and the point of flow for plastic substances are, therefore, accepted as characteristic values of the mechanical strength of substances in the simplest states of stress, i. e., with forces acting in one direction only.

In general, however, a stress is directed at an angle to the area it affects. For a spatial problem, this angular stress may be divided into three components: one that is normal to the area and produces compression or tension, depending on its direction, and two components that are tangential to the area and produce displacement or shear.

In exactly the same fashion, in a plane problem, any stress acting at an angle to the given area may be resolved into perpendicular and tangential stresses.

Thus, the stress components in frozen ground will be perpendicular (compression and tension) and tangential (shear). Complex states of stress are composed of combinations of these simple states.

It should be noted that the study of the resistance of frozen ground to the simplest states of stress is also of considerable importance for determining the permissible stresses for frozen ground.

In determining permissible stress for a simple state of stress, the ultimate strength of the given material or the magnitude of stress to the flow point is reduced by a safety factor which depends on the uniformity and mechanical properties of the material, as well as on the precision with which both the external forces and the stresses in the frozen ground are determined. Thus, only after a thorough study of the resistance of frozen ground to the simplest stresses (and, based on these, to complex stresses also) will we be able to clarify the problem of permissible loads for frozen ground.

Besides the resistance of frozen ground to compression, tension, and shear, it is important, for practical purposes, to have data concerning the so-called adfreezing strength, which represents a special type of shear strength that exists only in frozen and freezing ground.

This chapter is devoted to the study of these problems.

Methods of Studying Mechanical Properties of Frozen Ground

Up to the present time, a considerable number of individual determinations of the mechanical properties of frozen ground have been made — primarily of their ultimate compressive strength.¹ However, the methods used often differed, and this sometimes makes a comparison of the results impossible.

Tests of the mechanical properties of individual samples of frozen ground are discussed below, but determining the mechanical properties of naturally occurring frozen ground is not discussed, in view of an almost complete absence of experiments in this direction.

The basic problems of testing the mechanical properties of samples of frozen ground

1. Ultimate compressive strength is the maximum compressive stress [for relatively brief loading] that the material can withstand.

will be considered. These are: the preparation of samples, their size and shape, conditions of freezing, test conditions, and the determination of the physical constants of the samples (temperature, moisture content, etc.).

Preparation of samples

Samples of frozen ground for testing may be taken directly from ground with natural undisrupted structure or prepared artificially.

Experiments on samples with natural undisrupted structure, particularly samples of permafrost, are of considerable value, and opportunities to test them should be exploited to the maximum. Unfortunately, these opportunities are often hampered by the remoteness of the permafrost regions from the appropriate laboratories.

When taking frozen-ground samples with undisrupted structure, one should be sure that the samples do not contain any cracks or defects. As a rule, samples are sawed out of a large block of frozen ground with a handsaw at an air temperature below 0C. The sawing is very difficult and must be performed as carefully as possible. The following values are determined for every sample: unit weight in its natural state, γ ; moisture by weight, w ; and specific density, Δ , of the solid part of the ground.

These characteristics of frozen ground are quite sufficient for evaluating its physical state. The sawed-out samples must be kept at negative temperatures and in hermetically sealed containers, with ice fragments included so that the natural moisture of the samples will not change.

It should be pointed out here that samples from the seasonally frozen layer may have entirely different properties than samples of permafrost.

Most experiments on the resistance of frozen ground to stresses were made on artificial samples of frozen ground, which only established the general range of values and indicated the basic relationships.

When preparing artificial samples of frozen ground of various mechanical composition, it is necessary to take into consideration quite a few conditions. Most important is that the required density and moisture must be obtained. The problems of freezing and testing the samples are also important.

It is very difficult to obtain samples with a particular density, since the density changes during freezing. In solving this problem, the ground must be divided into at least two types, sand and clay, for which methods of obtaining a certain density will be entirely different.

In sand (as is known from soil mechanics), the distribution of pressure is quite rapid; in clay, however, the full pressure will reach a spot some distance from the place of load application only after a considerable time. Therefore, mechanical compaction of samples by repeated application of load might be sufficiently effective for sand but completely inadequate for clay. To bring clay (and, in general, ground of low permeability) to a particular density and moisture content, a constant load must be applied for a considerable period of time.

Artificial samples prepared by the above methods approximate natural samples in density, since the process of compaction in nature is reproduced in the laboratory.

However, laboratory conditions cannot reproduce all the complex geological and geophysical processes which occur in nature and may considerably affect the resistance of frozen ground to loads. For this reason, samples of frozen ground prepared in the laboratory will not fully correspond to natural samples, but can only approximate them to a greater or lesser degree. For instance, experiments have established¹ that the compressive strength of natural and artificially prepared samples of sand are practically the same. No such comparative tests were made with clay and it cannot be assumed that the resistance to stress would be the same for natural and disturbed ground. So that

1. N. A. Tsytovich (1930) "Vechnaia merslota kak osnovanie dlia sooruzhenii (Permafrost as a base for buildings)", in Vechnaia merslota (Permafrost). Akademiia Nauk.

artificial samples will approximate natural samples. the proper compacting load for the required moisture content or for its porosity, according to the compression curve, should be selected on the basis of theoretical soil mechanics data.

This load must compact the moistened ground until settling has completely stopped, i. e., until the ground has achieved the required moisture content. With water-permeable soil, such a method may be successfully employed, since little time is required for settling (for a 7-cm cube, it would be a few minutes to half an hour). With soil of low permeability such as clay and sandy clay, it is quite a different matter, as the water is squeezed out of the pores of such soil extremely slowly (about 10 to 20 days for a 7-cm cube). This makes it practically impossible to prepare a large number of samples by this method.

In our soil mechanics laboratory, LIKS, the soil samples were prepared for freezing as follows:¹ the ground was brought to the required moisture content by mixing, and placed into molds, then subjected to the pressure which corresponded to the required moisture according to the compression curve. The compacting load was applied by degrees and only filled the molds completely; no squeezing out of water was observed during the process. Although we do not consider this method as fully meeting all the theoretical requirements, we regard it as acceptable. Compacting the samples by various types of pounding (e. g., strokes with a pile driver) would produce samples of varying degrees of density, and this would be reflected in the strength values.

Table 29

Type of Soil	Numbers of strokes with Baume' pile driver	Moisture by weight, (%)	Coefficient of porosity	Ultimate compressive strength, (kg/cm ²)
Medium-grained sand, passed through a sieve with 144 perforations/cm ² and retained on sieve with 225 perforations/cm ² . Samples in the shape of 7-cm cubes; initial moisture by volume 20% prior to packing. Temp = -12C.	20	14.7	0.615	67
	40	14.6	0.577	89
	60	14.0	0.572	95
	80	13.3	0.568	95
				(Average of 3 tests)

The data given in Table 29 were obtained in this manner. Figure 48 shows the relation between the ultimate compressive strength and the preliminary compaction of the soil (number of strokes with a pile driver). These data show that the density of the samples increases with an increase in the number of strokes, and this is reflected in their strength in the frozen state. A mechanical analysis of the soil samples after compaction with the pile driver shows a somewhat increased content of fine-grained particles, i. e., a breakdown of separate particles of the ground takes place. This, of course, cannot be permitted.

Thus, the only workable method is to compact the ground by a static load determined for the given moisture content in accordance with the compression curve.

When it is impossible to prepare ground samples by squeezing out water, the important purpose of preliminary compaction is to obtain homogeneous soil samples. This compacting pressure should not be greater than the pressure which corresponds to the compression curve for the required moisture content.

For more effective compaction (i. e., for a more homogeneous sample), full pressure must be applied to the sample in stages, with time intervals of no less than 10 min.

1. Laboratornye issledovaniya mekhanicheskikh svoystv merslykh gruntov (Laboratory studies on mechanical properties of frozen ground). SOPS and KIVM, Akademiya Nauk, sb. 1, 2 (1936).

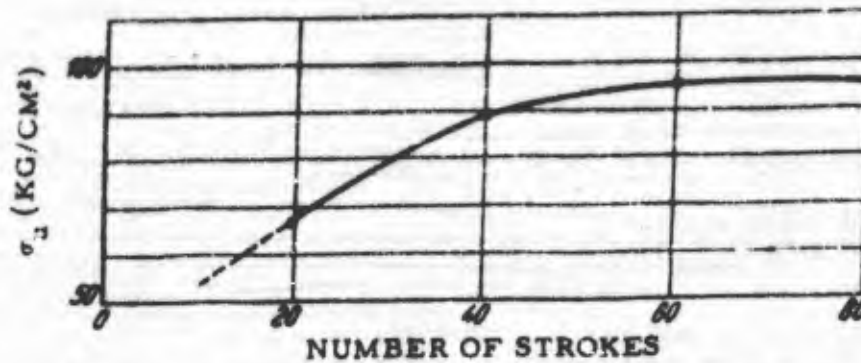

Figure 48. Relation between ultimate compressive strength of frozen sand and preliminary compaction.

Experiments have shown that this procedure results in a fairly uniform filling of the mold. It should also be pointed out that, taking the compacting load according to the compression curve, soil samples with a moisture content near the flow limit require no compacting and must be frozen in watertight molds.

Effect of size

In studying various mechanical properties of frozen ground in the laboratory, the size of the sample is often of considerable importance. Experiments show that, in most cases, the value of mechanical strength depends on the size of the sample tested; this dependence is especially marked with specimens which differ greatly in size. Table 30 shows the effect of the dimensions of the samples.¹ The ultimate compressive strength as determined by tests on 2-cm cubes is considerably lower than the values for 5 and 7 cm cubes. Between the last two, the difference in ultimate compressive strength is insignificant. The question arises as to whether the ultimate compressive strength remains independent of the size of the cubes with a further increase in size. Unfortunately, no systematic experiments have been performed in this direction.

Table 30.

No.	Type of soil and grain-size composition	Temperature (C)	Moisture by weight (%)	Ultimate compressive strength (kg/cm ²)		
				Cube dimension (cm)		
				2	5	7
1	Clean quartz sand (100% of particles 1 - 0.05 mm diam)	-4.3 to -5.0	11.9 to 14.3	9.9	41.6	40.0
2	Clayey soil (36% < 0.005 mm; 50% 0.01 - 0.005 mm)	-4.8 to -5.0	25.8 to 28.6	16.8	41.1	40.8
3	Same as 2	-5.2 to -5.7	32.4 to 32.9	-	39.2	39.1

1. O. M. Gumenskaia (1936) "Vlianie vlazhnosti i temperatury na soprotivlenie merzlykh gruntov sstatiiu (Effect of moisture and temperature on compressive strength of frozen ground)," in Laboratornye issledovaniia mekhanicheskikh svoistv merzlykh gruntov (Laboratory studies on mechanical properties of frozen ground, sb. 1, SOPS and KIVM, Akad. Nauk.

In studying the elastic deformation of frozen ground, we obtained the following data on ultimate compressive strength (σ_u) of 20-cm cubes.

1. For clay with a temperature of -3.0C and 47.1% moisture content, $\sigma_u = 33.9$ kg/cm².
2. For sand with a temperature of -3.9C and 16.5% moisture content, $\sigma_u = 58.8$ kg/cm².

If these data are compared with the values given in Table 30, and the effect of temperature and moisture are taken into consideration, it may be concluded that the ultimate compressive strength of frozen sand is considerably greater for 20-cm cubes than for 5- and 7-cm cubes. For clay, however, a further increase in the size of the sample does not affect the ultimate compressive strength.

Sample size also influences the resistance of frozen ground to other stresses. Table 31 gives data on the effect of the size of the posts and the depth of the ground on the adfreezing strengths of clay and sand to wood. The data are from laboratory experiments of the LIKS soil laboratory.¹

These data show that the effect of the experimental conditions (depth of the ground and diameter of the posts) on adfreezing strength is negligible for clay, and of considerable importance for silty sand.

Table 31. Effect of size of posts and thickness of layer of clay and silty sand on adfreezing strength.

Average moisture by weight = 22.8% for clay; 11.5% for silty sand.

Depth of soil layer (cm)	Diam of post (cm)	Adfreezing strength, τ_{ad} , (kg/cm ²)	
		Clay to wood at -1C.	Silty sand to wood at -5.3C.
8	4	7.5	—
6	4	—	8.4
4	4	7.6	7.8
4	2	6.3	—
6	2	—	4.7
8	2	7.1	5.1

Conditions of freezing

The mechanical properties of frozen ground may be substantially influenced by the conditions of its formation, such as the freezing conditions, etc. To transform all the water in the ground into ice, i.e., to freeze the ground, a certain intensity of cooling is required for a certain time interval. The time required for freezing will depend on the freezing temperature as well as on the thermal properties of the ground, but primarily on the amount of water contained in the ground. In addition, the size of the voids which contain capillary and film water has a substantial influence on the time required for freezing. The smaller the voids — and therefore, the stronger the capillary forces and the molecular attraction binding the water — the lower the temperature required and the longer the time interval required for freezing.

Experiments show that the length of freezing time of the soil samples affects the resistance to external stresses.

1. I. S. Vologdina (1936) "Sily smersaniia merslykh gruntov s derevom i betonom (Adfreezing Strength of Frozen Ground to Wood and Concrete)," sb. 1, Akad. Nauk.

Table 32 gives data obtained by us on the effect of the duration of freezing on the compressive strength of cubes of sand at -5°C . The cubes were frozen in a chamber of the refrigeration apparatus for 1 to 6 days, with the temperature regime kept approximately the same.

The data show that the mechanical strength of the samples of frozen sand is affected by the length of the freezing period. Allowing for the effect of the magnitude of the negative temperatures and the amount of ground water, the data in Table 32 indicate that 3 to 4 days must be considered as the minimum period of freezing of the samples at the given temperature. Freezing for a longer time does not yield any significant increase in strength of the frozen ground cubes.

Table 32.

Conditions of freezing				Ultimate compressive strength at -5°C (kg/cm^2)	Soil and test conditions
Moisture by weight, (%)	Range of temp (C)	Avg temp (C)	Time of freezing (days)		
14.3	-3 to -25	-14	1	48	Medium-grained sand, passed through sieve with 144 perforations/ cm^2 and retained on sieve with 225 perforations/ cm^2 . Samples in the shape of 7-cm cubes. Prior to test, all samples were kept for 3 hr at -5°C .
14.4	-3 to -25	-14	2	51	
15.9	-5 to -25	-15	3	59	
15.3	-7 to -27	-17	4	62	
16.4	-7 to -27	-17	5	64	
16.3	-7 to -27	-17	6	64	

Note: Ultimate compressive strength values are means of 3 tests. Temperature ranges and average temperatures refer to the entire period of freezing. Moisture contents are means of 9 tests.

Further experiments in this direction have shown that the freezing time at an average temperature of -12°C to -17°C should be at least 3 days for sand, and at least 4 days for clay which contains up to 40% of particles smaller than 0.005 mm in diameter. Shorter periods do not result in stabilization of the mechanical properties of frozen ground.

The mechanical properties of frozen ground are affected by the manner of freezing, which may vary. We will consider the following: (1) rapid freezing with subsequent aging of the sample at a given temperature; (2) slow freezing at a given temperature; (3) freezing the sample from all sides; (4) freezing in one direction only (for instance, freezing from the top only); (5) freezing with alternate rethawing; and (6) freezing under constant pressure.

As has been shown by investigations of the soil laboratory of the LIKS, the speed of freezing does not have a noticeable effect on the mechanical properties of frozen ground if, after freezing, the samples are kept for a sufficient time at negative temperatures. Tests of shear strength of frozen ground yielded the same results when freezing was rapid (within 3 to 3½ hr) and when freezing was 5 to 6 times slower if the samples were subsequently stored for 48 hr at -5°C to -25°C temperatures.

On the other hand, as shown above, soil samples frozen at the same speed under identical conditions but for different periods of time will show a substantial effect of the period of freezing on the mechanical strength of the frozen ground.

The direction of freezing (i. e., from all sides or only from the top), undoubtedly affects the structure of the frozen ground. The data in Table 33 show that the compactness of ground frozen by different methods varies, and this undoubtedly must be reflected in the

mechanical properties of the frozen ground.¹ Actually, while preparing cubes of frozen ground, we have observed the appearance of fine cracks, often filled with ice along the sides of the cubes. To avoid cracks during freezing, we wrapped the samples of frozen ground with moistened filter paper which proved highly effective.

Table 33.

Sample no.	Soil type	Coefficient of volume expansion (%)	
		Frozen from all sides	Frozen from top only
1	Sand	1.8	0.5
2	Silty clay	3.2	1.5-2
3	Clay	5.3	2.4

Thus, the method of freezing the samples undoubtedly affects the structure of the frozen ground. In practice, however, the effect is often quite negligible. Experiments on shear strength of frozen ground often yielded the same results for samples frozen from all sides and for those frozen from the top only.

Quite a different effect on the mechanical properties of frozen ground is obtained by alternate freezing and thawing. During freezing, the volume of water contained in the pores increases and, apparently, the pores themselves enlarge. If a sample of frozen ground is thawed and then frozen again, a decrease in strength is observed.

M. I. Sumgin found that the ultimate compressive strength of 2 x 2 x 2 cm cubes of frozen sand which have been thawed once and refrozen is 36-82% of that of frozen cubes which have not been thawed; thawed and refrozen cubes of frozen silt have 75-86% of their former compressive strength.²

Sheikov's³ experiments on the shear strength of frozen ground also showed a decrease in the strength of samples subjected to a single thawing. The strength decreased, on the average, to 80% for silty sand and 60% for clay, as compared to frozen ground samples which were not previously thawed. This decrease in the mechanical strength of frozen ground when alternately frozen and thawed is confirmed by other investigators (e. g., V. G. Petrov).

Constant external pressure applied to the sample may affect its freezing process as well as the mechanical properties of the frozen ground. Unfortunately, no experiments have been made in this direction with the exception of Taber's experiments on heaving.

After the ground is frozen, i. e., after all the water in the voids has been transformed into ice, it is necessary to bring the ground to the required temperature. This may be done by keeping the samples of frozen ground in a thermostatically controlled container at a given temperature. A special refrigeration chamber equipped with contact thermometers and an automatic thermoregulator or an insulated box cooled by a salt solution, alcohol, etc. may be used.

The most practical method of controlling the temperature of frozen ground samples is by placing thermocouples inside the samples during preparation.

1. N. A. Tsytovich (1934) Osnovy mekhaniki gruntov (Principles of soil mechanics). Leningrad, p. 255.

2. M. I. Sumgin (1929) Fiziko-mekhanicheskie protsessy vo vlazhnykh i merzlykh gruntakh (Physicomechanical processes in moist and frozen ground). Moscow: Transpechat'.

3. M. L. Sheikov (1936) "Soprotivlenie sdvigu merzlykh gruntov (Shear strength of frozen ground)," Akad. Nauk, sb. 1.

Conditions of testing

Experimental conditions are of considerable importance when characteristic values of the mechanical properties of frozen ground are being determined.

The first condition is the maintenance of the negative temperature both on the surface and within the samples. This requirement makes it necessary to conduct all experiments in refrigeration chambers or, at the very least, in special thermostatically controlled containers in which the required negative temperature can be maintained by circulating cooled alcohol or by using cooling mixtures.

As our investigations have demonstrated, the temperature conditions cannot be determined from temperature of the air surrounding the sample; it is necessary to measure the temperature of the sample itself. Mercury thermometers are difficult to use for this purpose, and often impossible (for instance, when determining compressive strength). The only accurate method for determining the temperature of a sample of frozen ground during an experiment is by thermocouples or electrical-resistance thermometers. The latter, because of their considerable size, are rather inconvenient to use, whereas the thermocouples, placed in the ground sample when it is prepared, are excellent for measuring temperature. The setup for thermocouples (constantan-copper) is shown in Figure 49.

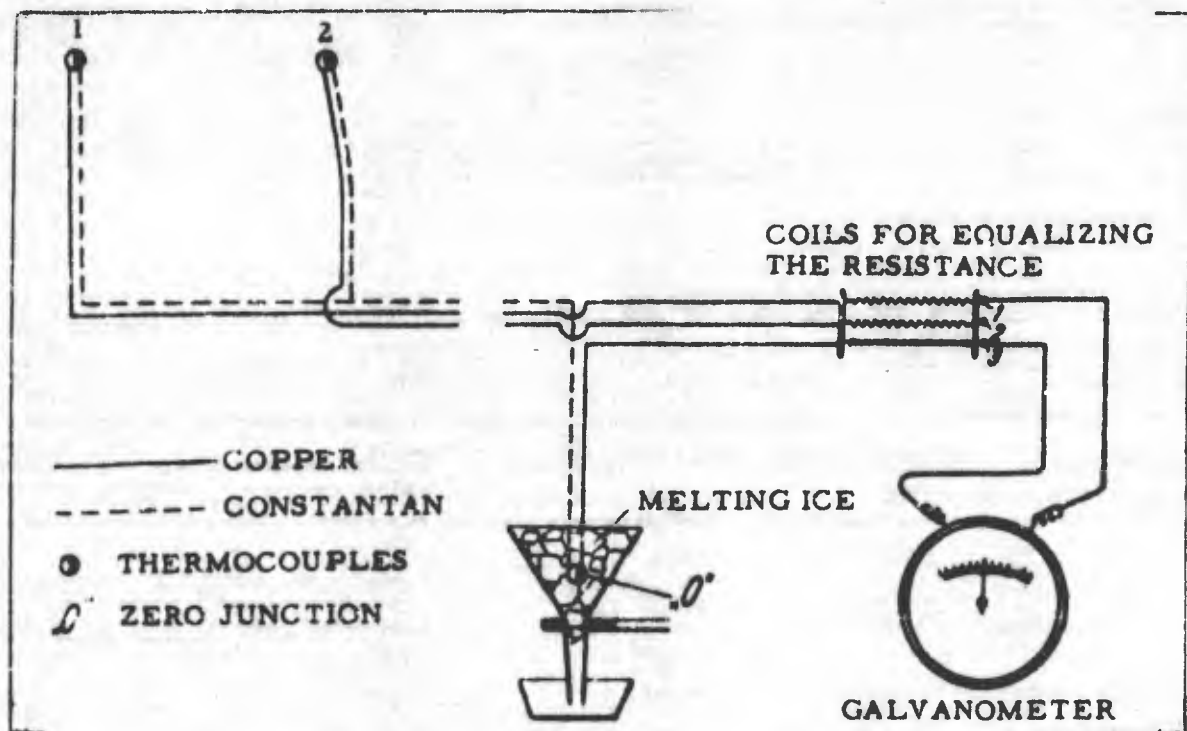

Figure 49. Setup for measuring temperature inside the frozen ground samples by thermocouples (schematic).

The size of the thermocouple junction usually does not exceed 1 mm diam, and the wires are between 0.25 and 0.5 mm thick. The constantan wire, like the copper wire, must be insulated by winding with silk and covered with a thin layer of shellac. Since only differences in temperature cause current in the thermocouple, it is always useful to place one junction (the external one) in melting ice. Then the electromotive force of the thermocouple is directly proportional to the temperature of the sample. This temperature is determined in accordance with the corresponding graduated curve. So that all the points of the thermocouple will have identical graduation, the resistance of their leads must be equalized by modifying the length of the copper wire, which is easily done by a resistance bridge.

The use of thermocouples produces practically no change in the mechanical strength of the ground (as has been established by experiments), and makes it possible to follow

the process of temperature changes in the ground sample while the test is in progress.

For accurate results, certain other details in the experimental procedure, in addition to the temperature conditions, must be taken into consideration.

The stresses must be applied centrally, the surfaces receiving the load must be level, etc. Leveling the surfaces is conveniently achieved by means of a non-heat-conducting cardboard lining or by smoothing down the surface by adding a thin layer of moist sand, which is subsequently frozen.

If, as some investigators do, we take the initial moisture content of the sample — the amount of water used for moistening the ground during the preparation of the sample — as the final moisture content, the results will be completely out of line. Actually, moisture is redistributed during the process of freezing. In addition, some evaporation of water from the surface of the sample may occur, and this can considerably modify the initial moisture content. Therefore, the moisture content (degree of ice saturation) of the frozen ground samples must be determined from small specimens taken from different parts of the sample after it has been tested.

As our experiments have demonstrated, the rate of load application also has a considerable effect on the mechanical strength of frozen ground. As has been established by recent investigations, this factor plays such an essential part in the study of the mechanical properties of ground that it requires separate consideration.

Effect of Rate of Load Increase on Mechanical Properties of Frozen Ground

During study of the mechanical properties of frozen ground conducted in the Soil Mechanics Laboratory of the LIKS, it was observed that the mechanical strength of frozen ground depends on the rate of load increase. This was first established during the study of shear strength of frozen ground; here the effect of rate of load increase is especially sharp.

Several subsequent experiments were conducted to study the effect of the rate of load increase on other types of mechanical strength of frozen ground.

Table 34 gives data obtained in 1935-36 (by M. L. Sheikov, I. S. Vologdina, and S. N. Sokolov) on the effect of the rate of load increase on shear and adfreezing strength, and also on ultimate compressive and tensile strength (G. A. Pchelkin) of frozen ground. For easier comparison, the value of a constantly increasing load is given for unit area and unit time.

An analysis of the data in Table 34 leads us to the following conclusions.

1. The ultimate resistance of frozen ground to external stresses (compression, tension, shear, adfreezing) depends, to a high degree, on the rate of load increase. The slower the rate of load increase, the smaller the ultimate strength value. With an accelerated rate of load increase, ultimate strength also increases. However, as shown by tensile strength experiments (when the load increase approaches the dynamic rate), the strength again decreases somewhat with very high rates of load increase.

2. The greatest decrease in strength with decreasing rate of load increase is observed in studying shear strength of frozen ground.

3. The above data demonstrate that the ultimate strength values of frozen ground are not comparable when obtained at different rates of load increase. This apparently explains the discrepancies in such data — given by various authors.

4. Mechanical tests on frozen ground require a fixed rate of load increase. It would be preferable to select some standard rate of testing, but this can be established only by a detailed analysis of the problem.

Compressive Strength of Frozen Ground

The compressive strength of frozen ground considerably exceeds that of unfrozen ground and has a value in the order of tens, and sometimes hundreds, of kilograms per square centimeter.

At the present time, ultimate compressive strength of frozen ground is evaluated

Table 34. Effect of Rate of Load Increase on Resistance of Frozen Ground to External Forces

Soil type	Moisture (%)	Temp (C)	Rate of load increase (kg/cm ² -min)	Ultimate shear strength (kg/cm ²)	Moisture (%)	Temp (C)	Rate of load increase (kg/cm ² -min)	Adfreezing strength (kg/cm ²)
Frozen silty sand (68% of particles >0.05 mm diam; 8% <0.005 mm)	19	-4	156.0	31.2	14	-0.2	22.2	9.3
			46.8	30.4			7.8	7.3
			23.2	21.8			1.8	5.7
			20.2	17.1			1.0	2.8
Frozen clay (36% of particles <0.005 mm diam)	-	-	-	-	31	-6.6	26.4	13.1
			-	-			0.1	4.1
Frozen sand (<1 mm diam)	15-18	-1	15	30	18	-4.5	31.9	Tensile strength (kg/cm ²)
			4	24			14.6	32
							8.7	29
							2.7	26
							23	

Note: Values of ultimate shear strength of silty sand and values of adfreezing strength of clay are means of 3 to 4 tests.

mostly on the basis of laboratory experiments on samples of frozen ground of disrupted and undisrupted structure. Almost no experiments have been conducted to determine the compressive strength of permafrost under natural conditions.

Laboratory experiments enable us to establish basic laws and the order of the magnitudes studied.

Laboratory investigation of the ultimate compressive strength of frozen ground was begun in 1929, with a series of experiments by Sumgin, in the laboratory of the Central Institute of Highway Transport (TsiAT),¹ and Tsytovich, in the laboratory of the Leningrad Institute of Civil Engineers (LIGI).²

Sumgin used 2 x 2 x 2 cm cubes at -4C. They were prepared by the methods customary in the TsiAT laboratories, and subjected to the same compaction regardless of their moisture content. These experiments showed that the ultimate compressive strength of both frozen sandy and silty soil increases with increased moisture content up to saturation. The ultimate compressive strength values obtained were: for sand, 19.0 to 40.4 kg/cm² (with moisture by weight ranging from 6.40 to 16.24%); for silty soil, 9.6 to 35.8 kg/cm² (with moisture by weight ranging from 5.01 to 15.00%). In view of the small size of the cubes tested, we regard these strength values as too small.

Tsytovich³ studied the ultimate compressive strength of frozen sand and clay at

1. M. I. Sumgin (1929) Fiziko-mekhanicheskie protsessy vo vlazhnykh i merzlykh gruntakh v svyazi s obrazovaniem puchin na dorogakh (Physico-mechanical processes in moist and frozen ground related to heaving of roads), NKPS.

2. N. A. Tsytovich (1930) "Vechnaia merzlota kak osnovanie dlia sooruzhenii (Permafrost as a base for foundations)," in Vechnaia merzlota (Permafrost). Leningrad: Materialy KEPS, Akademiia Nauk, sb. 80.

3. Ibid.

temperatures from -1C to -12C. The same degree of compaction was used to prepare soil samples with different moisture contents.

It must be noted that using the same compaction for all soil samples would not make them conform exactly to the natural density of ground; consequently, the results of such experiments are only of partial value.

In the experiments of 1929, the following relationships were established.

1. The compressive strength of frozen ground increases with a lowering of the negative temperature.
2. For sand (at constant negative temperatures), the ultimate compressive strength changes with the moisture content, reaching the maximum when the voids of the ground are completely filled with ice. In clay, under natural moisture conditions, ultimate compressive strength decreases as moisture content increases.

3. The values of ultimate compressive strength of frozen ground obtained in these tests varied as follows:

Ultimate compressive strength (kg/cm ²)	Temp (C)	Moisture content (%)	
Clay.....	24 - 50	-1 to -12	12.5 - 34.6
Sand.....	39 - 152	-1 to -20	6.3 - 19.4

The compressive strength of frozen ground has also been studied by: A. P. Veller-Bolotova,¹ R. M. Livshits,² Prof. P. M. Beliaev and V. N. Shchepochkin,³ and Prof. M. I. Evdokimov-Rokotovskii.⁴

Veller-Bolotova confirmed the general concept of redistribution of moisture in the soil samples during freezing. This has been discussed in detail earlier. Her experiments obtained results (see Table 35) for samples of sand frozen in the shape of cubes, in which 24.5% of the particles ranged from 3 to 1 mm and 0.8% of the particles was smaller than 0.01 mm.

Table 35 shows that the moisture content is redistributed in the soil samples during freezing, and this undoubtedly results in a lack of uniformity in their structure. This lack of uniformity may also change their resistance to external forces.

Experiments with clean sand (particles ranging from 1 to 0.25 mm in diam) have established that its compressive strength increases with an increase in moisture content, in the form of a definite curve. The compressive strength values of frozen sand obtained in the tests were 23.5 to 162.5 kg/cm² at -12C with 3.03 to 15.03% moisture content.

Livshits described laboratory experiments on the resistance of frozen ballast and ground to crushing. These experiments did not include measurements of the temperature of the samples. Tests were made at positive temperatures, and the moisture content of the ground after tests was not determined.

1. A. P. Veller-Bolotova (1932) "K voprosu o vliianii vlazhnosti na soprotivlenie merslogo grunta szhatiiu (Effect of moisture on compressive strength of frozen ground)," Sb. laboratornykh rabot 1930g. pod rukovodstvom inzh. N. A. Tsytovich (Symposium of 1930 laboratory studies under the direction of N. A. Tsytovich), Biulleten' Leningradskogo instituta sooruzhenii, no. 25.

2. R. M. Livshits (1931) Laboratornye opyty po izucheniiu svoistv zamerszhikh gruntov i soprotivleniiu ballasta razdrobreniiu (Laboratory experiments on properties of frozen ground and crushing strength of ballast), Trudy MIIT, vyp. 18.

3. P. M. Beliaev and V. N. Shchepochkin (1931) Opyty nad soprotivleniem zamerszhikh gruntov razdrobreniiu (Experiments on resistance of frozen ground to crushing), Sb. Inst. inzh. putei sozhshch., vyp. 103.

4. M. I. Evdokimov-Rokotovskii (1931) Postroika i eksploatatsiia inzhenernykh sooruzhenii v vechnoi merslote (Building and use of engineering structures on permafrost). Tomsk.

Table 35. Distribution of moisture in samples of frozen ground.

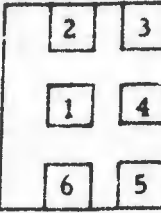
Sample	7-cm cubes (avg of 2 tests)		20-cm cubes (avg of 5 tests)		Location of samples
	Moisture by weight		Moisture by weight:		
	Absolute (%)	Relative	Absolute (%)	Relative	
Center 1	6.21	0.82	7.42	0.81	
Sides 2	6.70	0.89	8.16	0.89	
3	6.80	0.90	9.86	1.07	
4	7.71	1.02	9.03	0.98	
5	10.14	1.34	9.88	1.07	
6	7.83	1.03	10.91	1.18	
Avg. 1-6	7.57	1	9.21	1	

These circumstances make it impossible to compare these results with other data, and we will not analyze them.

Similar experiments to determine the crushing strength of frozen ballast were performed by Beliaev and Shchepochkin. Two series of experiments were conducted. The results of the two series differed considerably and sometimes were exactly opposite (for instance, the data on the effect of clay admixture).

The results of experiments conducted by Evdokimov-Rokotovskii (op. cit.) are known only in the form of graphs. His account of the experiments does not describe the preparation of the samples, so that analysis of the results is impossible.

We will only note that these experiments show that ultimate compressive strength increases with an increase in moisture content for all ground including clay. This is not always true. Most recent experiments have shown that, after naturally frozen clay (as well as artificially frozen clay) is fully saturated with ice, the ultimate compressive strength decreases with further increase of moisture content. According to Evdokimov-Rokotovskii, the ultimate compressive strength of frozen clay is greater than that of sand — a statement that is contrary to fact. Experiments with frozen ground show that its ultimate compressive strength is closely related to the negative temperature of the sample. Let us analyze this relationship in somewhat greater detail.

Effect of negative temperatures

A relationship between the ultimate compressive strength of ice and temperature was established in Chapter I on the basis of experimental data. Ice contained in frozen ground is a cementing substance, and the properties of the frozen ground depend on its properties. Therefore, the influence of negative temperatures on the ultimate compressive strength of frozen ground is expected. Table 37 gives data for frozen ground of different grain-size compositions with the moisture content kept fairly constant (within 1-2% of average moisture).

Experiments were performed on 7 x 7 x 7 cm cubes compacted by the pressure corresponding to the required moisture content, according to the compression curve.¹

1. O. M. Gumenskaia (1936) "Vliianie vlazhnosti i temperatury na soprotivlenie merslykh gruntov shtatuu (Effect of moisture and temperature on compressive strength of frozen ground)," in Laborat. issled. mekh. voistv merslykh gruntov (Laboratory studies on mechanical properties of frozen ground), sb. 1, Akademiia Nauk SSSR.

Samples prepared from clean sand were mechanically compacted with a hammer.¹

The data given in Table 37 indicate that the ultimate compressive strength of frozen ground increases with lower negative temperatures, increasing most sharply to -1C and less sharply at lower temperatures.

Figure 50 provides a graphic comparison of the data cited above. The ultimate compressive strength values of frozen ground are plotted along the vertical axis and the negative temperatures (C) along the horizontal axis.

The relationship between the ultimate compressive strength of frozen ground and temperature is in the form of a curve. This is shown both by Figure 50 and by comparing increases in ultimate compressive strength per degree change in temperature as shown in Table 36.

From the data given in Table 37, we can conclude that ultimate compressive strength of frozen ground is related to grain-size composition of the ground, on one hand, and the degree of ice saturation, on the other. Thus, the ultimate compressive strength of frozen sandy loam with a coefficient of saturation of about 0.5 is greater than that of the same ground at the same temperature but with complete ice saturation (coefficient of saturation of about 1).

Effect of moisture content (ice saturation)

The cohesiveness of frozen ground depends on the strength of adhesion between the solid mineral particles of the ground and the ice particles. The cohesiveness of the ground in general and, therefore, its ultimate compressive strength will be related to its ice content.

If the moisture content of the ground is zero (under natural conditions this is possible only for sand and, in general, for coarse-grained ground), then freezing

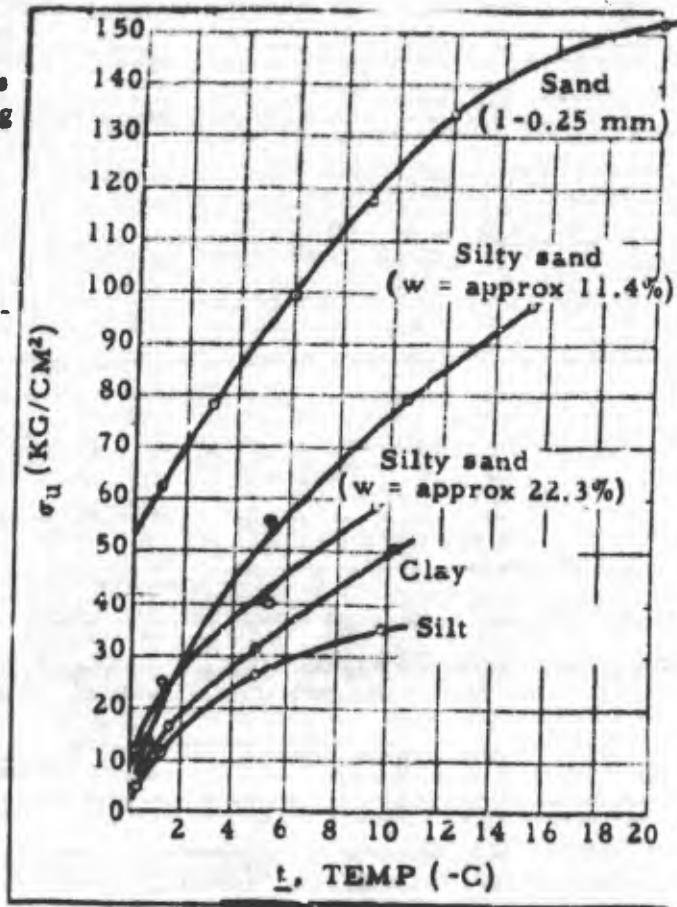

Figure 50. Ultimate compressive strength of frozen ground vs negative temperature.

Table 36. Increase of ultimate compressive strength (kg/cm²) with 1C temperature change.

Type of frozen ground	Temperature range (C)				Remarks
	-0.3 to -1	-1 to -5	-5 to -10	-10 to -20	
Silt	8.8	3.8	1.8	-	Coefficient of saturation is close to 1
Clay	9.6	4.5	3.8	-	
Silty sand	16.0	4.2	4.8	-	
Silty sand	-	9.3	4.1	3.8	Coefficient of saturation is 0.5 to 0.8.
Sand	-	7.4	6.0	2.3	

1. N. A. Tsytovich (1930) "Vechnaia merzlota kak osnovanie dlia soorushenii (Permafrost as a base for construction)," in Vechnaia merzlota (Permafrost), Materialy KEPS, Akademiia Nauk, sb. 80, Leningrad.

PRINCIPLES OF MECHANICS OF FROZEN GROUND

Table 37. Effect of negative temperatures on ultimate compressive strength of frozen ground.

No.	Type of soil and grain-size composition.	Temp (C)	Moisture by weight, (%)	Ultimate compressive strength (kg/cm ²)
1	Quartz sand (1 to 0.25 mm)	-1	17.2	62
		-3	15.7	78
		-6	16.3	99
		-9	16.4	118
		-12	17.0	134
		-20	15.7	152
2	Silty sand (68% of particles 1 to 0.05 mm diam; 8% <0.005 mm)	-0.3	21.2	12
		-1.1	21.3	25
		-5.2	20.8	40
		-9.5	25.8	58
3	Silty sand	-0.6	11.5	14
		-5.1	11.7	56
		-10.6	11.0	79
		-15.3	11.1	97
4	Clayey soil (50% of particles 0.01 to 0.005 mm diam; 36% < 0.005 mm)	-0.3	43.0	6
		-1.5	47.7	16
		-4.9	49.5	31
		-10.1	46.6	50
5	Silty soil (63% of particles 0.05 to 0.005 mm diam; 14% < 0.005 mm; 18% organic materials)	-0.3	58.7	5
		-1.1	52.1	12
		-4.9	58.2	26
		-9.8	61.3	35

Note: This table gives average data based on no less than 3 tests. Single determinations deviate from the average about 5 to 10%. For samples 2 to 5, temperature measurements were made at three points on the cube with thermocouples. Average temperature values of the cubes are given. The rate of load increase was about 15 kg/cm²/min.

will not change the cohesion between the particles, and, as demonstrated by experiments, the mechanical properties will in no way differ from the properties of ground at positive temperatures. The properties of such ground, called "dry permafrost," do not usually change even when its temperature rises from negative to positive. However, if the ground contains a certain amount of water, the situation is quite different. Water when it freezes increases in viscosity to a very high degree and cements the separate grains together. With increased moisture content, the number of contact points between the mineral particles and the water increases, and, upon freezing, the cohesiveness of the ground must increase.

Let us analyze the phenomena occurring in frozen ground when its voids are not fully saturated with ice. The separate mineral grains will occur in all possible arrangements and, in some places, will be in contact with each other. The water in the ground will become concentrated in the narrowest portions of the voids and, upon freezing, will cement separate particles into a single aggregate.

A load applied to the surface of frozen ground would produce tremendous stresses at the points of contact of separate particles.

These local stresses at the contact points will depend on the elastic properties of the particles, and on their shape and size. Stresses at the contact points of scale-shaped

particles such as clay will be less than at the contact points of particles with sharp corners.

Thus, depending on the shape and rigidity of the particles, stresses at the contact points will differ considerably.

The shear strength of the ground is a resultant of the values of adhesion (adfreezing of ice) and the degree of friction, which is directly proportional to the stress at the contact points. Therefore, the shear strength depends on the magnitude of the stresses at the contact points.

According to current theories of strength (the third theory of strength), destruction of material occurs when shearing stresses exceed a critical point.

Thus, compressive strength also depends on the resistance of the sample to shear stresses which, in turn, depends on the adhesion of ice and the friction of the particles at the points of contact.

Theory permits the conclusion that the compressive strength of frozen ground increases in proportion to the increase in adfreezing area of ground particles and ice, i. e., increase in ground moisture, and also in proportion to increase in the points of sharp contact.

As has been demonstrated by experiments, frozen sand, i. e., ground containing a great number of particles with sharp edges, has considerably greater ultimate compressive strength than clay, which has flat scales. This is in complete agreement with the above considerations.

With an increase in ice content in frozen ground, adhesion (adfreezing) increases, cohesion increases, and the ground will have a great compressive strength. However, with increased ice content, the number of sharp contact points between the mineral particles of the ground decrease; thus, the greatest ultimate compressive strength of frozen ground will be attained at a certain specific ice content. When the moisture content of the ground is close to complete saturation, the freezing water could even expand the particles, increasing the volume of the whole. This apparently will lower the ultimate compressive strength of the frozen ground.

It would seem that the ultimate compressive and shear strengths of frozen ground could be determined theoretically from the geometrical characteristics of the pores and the resistance of ice to shearing, adfreezing, tension, etc. However, in view of the extreme variety of shapes and sizes of the mineral particles that compose natural ground and the variety of geometrical characteristics of voids and of the position of the contact points, a theoretical determination would have to use a generalized classification of the particles, and that would hardly agree with the actual conditions. We are of the opinion that experimentally obtained data alone can answer these questions.

We now consider the results of experiments on the relationship between ultimate compressive strength of frozen ground and moisture content.

Table 38 gives data partly (nos. 1 to 5) based on experiments conducted by Tsytovich and the soil mechanics laboratory of LIKS, the rest (nos. 6 and 7) based on experiments by Sumgin. Figure 51 shows the relationship in graphical form.

From an analysis of the data, the following conclusions are reached.

1. When its voids are not completely filled with ice the compressive strength of frozen ground (sand, silty sand, silt) increases with increased moisture content.
2. At a certain moisture content, frozen ground reaches a maximum ultimate compressive strength. As shown by our experiments, this moisture content would be near to saturation, the complete filling of the voids of the ground with ice.
3. If all the voids of the ground are filled with ice (clay, silt, and also silty sand) further increase in moisture content will decrease the compressive strength, approaching a certain limit.
4. With considerable supersaturation, the effect of the mechanical composition on ultimate compressive strength (of silty sand, clay, and silt) becomes insignificant.

These data confirm the theory that local stresses at the contact points of frozen ground particles affect the ultimate compressive strength.

Table 38. Effect of moisture on compressive strength of frozen ground.

No.	Type of soil and grain-size composition	Temp (C)	Moisture by weight, (%)	Coefficient of saturation	Ultimate compressive strength, (kg/cm ²)	Remarks
1	Clay (51% of particles <0.005 mm, 31% 0.01 mm to 0.005 mm)	-12	4.3	0.3	20	2-cm cubes
		-12	12.5	0.8	48	7-cm cubes
		-12	16.5	G ≈ 1, (varying densities)	30	7-cm cubes
		-12	19.3		47	7-cm cubes
		-12	29.3		32	2-cm cubes
		-12	33.0		30	7-cm cubes
-12	34.6	28	7-cm cubes			
2	Medium-grained quartz sand (100% of particles 1 - 0.25 mm)	-12	6.3	0.30	66	7-cm cubes
		-12	10.0	0.48	99	7-cm cubes
		-12	16.3	0.78	133	7-cm cubes
		-12	17.9	0.85	135	7-cm cubes
3	Clay (50% of particles 0.01 - 0.005 mm; 36% <0.005 mm)	-5.0	21.2	G ≈ 1, (varying densities)	44.0	Nos. 3, 4, and 5 packed according to the compression curve
		-4.6	25.8		40.8	
		-4.8	30.6		36.5	
		-4.6	34.9		33.7	
		-4.9	49.5		31.0	
4	Silty soil (63% of particles 0.05 - 0.005 mm; 14% <0.005 mm; 18% organic material)	-4.7	30.1		30.2	7-cm cubes
		-5.0	36.5		27.4	
		-4.6	42.1		26.4	
		-4.9	58.2		26.1	
5	Silty sand (68% of particles 1 - 0.05 mm; 8% <0.005 mm)	-4.9	6.0		0.37	9.1
		-4.5	9.3	0.57	48.0	
		-4.1	11.0	0.67	55.8	
		-5.1	11.7	0.71	56.3	
		-5.2	20.8	1.27	39.5	
6	Sand (93% of particles 0.5 - 0.05 mm; 0.2% < 0.005 mm)	-4	6.4	0.29	19.0	2-cm cubes
		-4	12.2	0.56	23.4	2-cm cubes
		-4	16.2	0.74	40.4	2-cm cubes
7	Silt (11.7% of particles 1 - 0.05 mm; 82.5% 0.05 - 0.005 mm; 5.8% <0.005 mm)	-4	5.0	0.16	9.6	2-cm cubes
		-4	9.4	0.30	15.6	2-cm cubes
		-4	15.0	0.42	35.8	2-cm cubes

The fact that the ultimate compressive strength of frozen clay and silt decreases with increasing moisture content indicates that the greater the moisture content of these types of ground, the smaller should be the permissible unit load for structural foundations. This highly important factor is not taken into account by some investigators of frozen ground. Because of this oversight, they arrive at erroneous conclusions, and assume that the ultimate compressive strength of frozen clay increases with an increase in moisture content. This last conclusion is apparently made on the basis of experiments on ground with voids not completely filled with water (ice); it does not apply to natural clayey ground, in which all the voids are saturated with water (ice) in an overwhelming majority of cases:

Effect of grain-size composition

The data previously given (Tables 36 to 38) show that the ultimate compressive strength of frozen ground depends on the grain-size composition of the ground. According to Table 38, at a temperature of -12C, the compressive strength of frozen clay varies from 20 to 50 kg/cm², depending on the moisture content, whereas compressive strength of frozen sand varies from 66 to 135 kg/cm².

After analysis of the data, and a study of local stresses at the contact points of the ground particles, we conclude that degree of ice saturation being equal, the greater the percentage of hard grains in frozen ground, the greater will be the ultimate compressive strength of the ground.

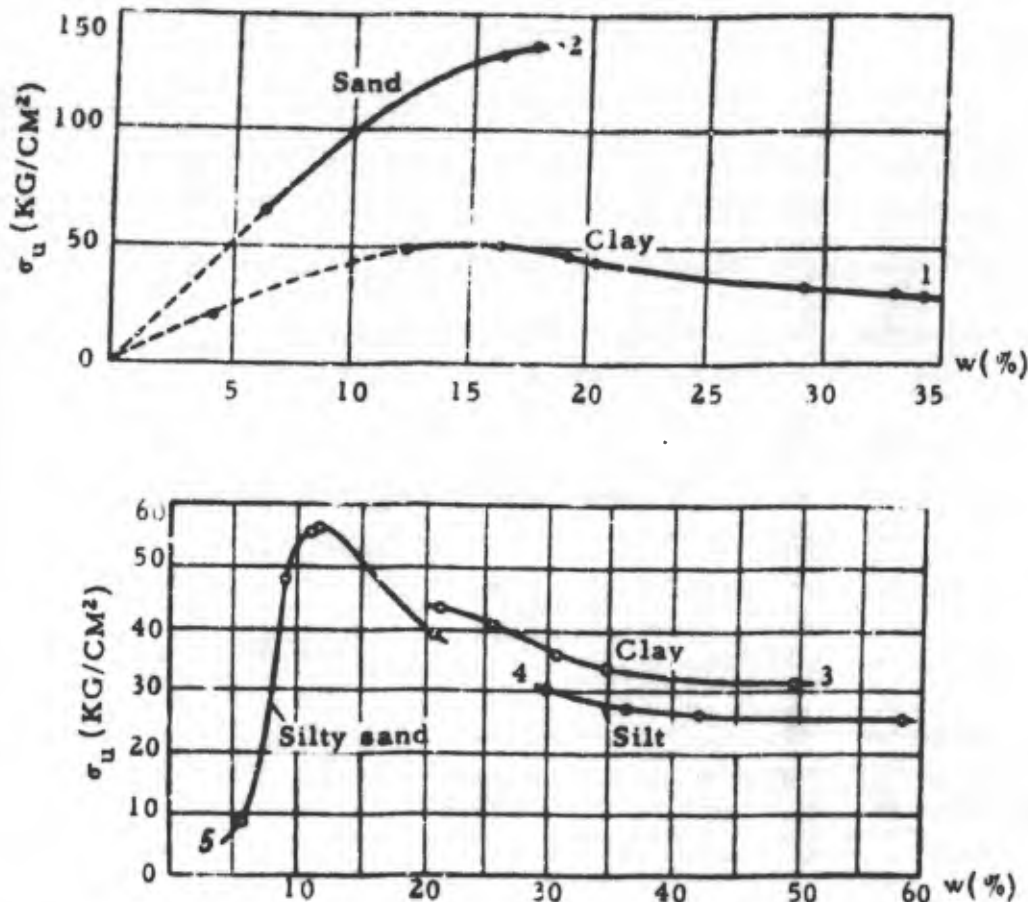

Figure 51. Ultimate compressive strength of frozen ground vs moisture content. (Nos. on curves correspond to those in Table 38.)

An increase in the content of scale-shaped particles (clay) in frozen ground lowers the ultimate compressive strength.

The above-mentioned data clarify the problem of compressive strength of frozen ground at relatively low temperatures (below -4C). However, the temperature of frozen ground in nature (such as permafrost at the bottom of a foundation) does not fall below -2C in a vast majority of cases. In addition, the ground in permafrost regions quite often has an excess of moisture. That is why data on compressive strength of frozen ground at small negative temperatures (between 0C and -2C) are highly important, particularly when the moisture content is close to saturation.

Results of experiments under such conditions, i. e., when temperatures are just below freezing and the voids are completely filled with ice, are shown in Table 39.

The data in Table 39 show that the ultimate compressive strength of naturally frozen ground, when the ground is completely saturated with ice and at a temperature not lower than -2C, is comparatively small — about 5 to 30 kg/cm².

Average values of ultimate compressive strength of naturally frozen ground (based on Table 39) are given in Table 40.

Tensile Strength of Frozen Ground

Few experiments have been made to determine tensile strength of frozen ground;

PRINCIPLES OF MECHANICS OF FROZEN GROUND

Table 39. Ultimate compressive strength of frozen ground of varying grain size at temperatures from -0.3°C to -2°C .

Sample no.	Soil type and grain-size composition	Temp (C)	Moisture content (%)	Ultimate compressive strength (kg/cm ²)
1	Sand with gravel (85% > 1 mm)	-1.4	15	27
2	Sand (80% > 1 mm)	-0.8	18	28
3	Granitic sand (61% > 1 mm)	-1.6	15	43
4	Granitic sand (44% > 1 mm)	-1.7	20	30
5	Silty sand (4% < 0.005 mm)	-0.4	33	22
6	Silty sand (10% < 0.005 mm)	-1.2	46	12
7	Silty sand (10% < 0.005 mm; 25% > 1 mm)	-0.4	17	10
8	Silty sand (10% < 0.005 mm; 5% > 1 mm)	-0.9	31	26
9	Sandy silt (7% < 0.005 mm; 0.5% > 1 mm)	-1.1	20	28
10	Silty sand (68% 1 - 0.05 mm; 8% < 0.005 mm)	-0.3	21	12
		-1.1	21	25
11	Silty sand (10% < 0.005 mm)	-0.7	36	15
12	Lean silty sand	-1.1	32	18
13	Silty sand (9% < 0.005 mm; 15% > 1 mm)	-1.5	48	23
14	Micaceous clayey sand (13% < 0.005 mm; 9% > 1 mm)	-0.6	32	19
15	Clayey sand (14% < 0.005 mm)	-0.8	32	24
16	Clayey sand with gravel (17% < 0.005 mm; 12% > 1 mm)	-1.8	23	22
17	Clayey sand (18% < 0.005 mm; 14% > 1 mm)	-1.9	27	26
18	Clayey sand (15% < 0.005 mm; 19% > 1 mm)	-1.3	21	20
19	Clayey sand (20% < 0.005 mm; 21% > 1 mm)	-0.6	37	22
20	Clayey sand (22% < 0.005 mm)	-1.4	43	22
21	Clayey sand (23% < 0.005 mm)	-1.9	41	27
22	Clayey sand (14% < 0.005 mm)	-0.8	28	17
23	Clayey sand (15% < 0.005 mm)	-1.0	34	15
24	Clayey silt (26% < 0.005 mm)	-2.0	52	29
25	Clayey sand (17% < 0.005 mm; 16% > 1 mm)	-0.8	26	23
26	Clayey sand (15% < 0.005 mm; 3% > 1 mm)	-0.8	37	18
27	Clayey sand (17% < 0.005 mm; 17% > 1 mm)	-1.6	29	24
28	Clayey sand (17.5% < 0.005 mm)	-1.3	24	17
29	Silty soil (63% 0.05 - 0.005 mm; 14% < 0.005; 18% organic substances)	-0.3	59	5
		-1.1	52	12
30	Silty soil (12% < 0.005 mm)	-0.7	40	12
31	Silty soil (14% < 0.005 mm)	-1.2	38	14
32	Silty soil (22% < 0.005 mm)	-1.6	52	24
33	Silty soil (13% < 0.005 mm)	-1.0	70	22
34	Clayey soil (36% < 0.005 mm)	-0.3	43	6
		-1.5	48	16
35	Clayey soil (30% < 0.005 mm)	-1.7	34	20
36	Clayey soil (26% < 0.005 mm)	-1.5	42	17
37	Clayey soil (45% < 0.005 mm)	-1.7	45	15

Note: Temp measured with thermocouples. Soils from permafrost regions (Trans-Baikal and Amur areas). Moisture content was close to complete ice saturation, and higher. Table gives averages of at least 3 results. Rate of load increase about: 15 kg/cm²-min.

Table 40.

Type of frozen ground	Ultimate compressive strength (kg/cm ²)		
	Temperature (C)		
	Not lower than -0.5	-0.5 to -1.5	-1.5 to -2.0
Sand	22	27	36
Silty sand	11	22	—
Clayey sand	—	20	26
Clay	6	17	—
Silty soil	5	15	23

only isolated experiments are described in the literature. Evdokimov-Rokotovskii¹ gives the results of his experiments on tensile strength in the form of a graph only. In the tests, samples in the shape of a figure eight were prepared, frozen, and ruptured on the cooled Michaelis apparatus.

Evdokimov-Rokotovskii's experiments gave the following results.

1. Tensile strength of frozen ground (clay and sand), like other types of strength, increases with lower temperature of the frozen ground.
2. Tensile strength of frozen clay and sand, with a moisture content from 10 to 20%, and at temperatures from -2C to -18C, ranges from 8 to 23 kg/cm² (according to the graph presented by Rokotovskii).
3. At equal temperatures and degrees of ice saturation, frozen clay has greater tensile strength than frozen sand.

The last conclusion, in our opinion, is doubtful, since tests for all other types of strength (compression, shear, adfreezing, etc.) showed a reverse relationship.

It is interesting to note that, according to Vasenko, tensile strength of ice ranged from 13.3 to 17.6 kg/cm², at temperatures from -4C to -12C, and, according to Pinegin, it ranged from 5.4 to 17.2 kg/cm² at 0C to -23C (see Ch. I).

From a comparison of the tensile strengths of ice and frozen clay and sand, it is possible to conclude that, under certain conditions, the ultimate tensile strength of frozen ground may be greater than the ultimate tensile strength of ice. This conclusion is confirmed by recent experiments in the laboratory of the LIKS, where, depending on the rate of increase of the load, the tensile strength of frozen sand varied from 33 to 23 kg/cm², at a temperature of -4.5C and a moisture content of 18%.

However, the conditions under which such a correlation would be observed, as well as other factors that influence ultimate tensile strength of frozen ground, must be investigated by systematic experiments to study the tensile strength of both ice and frozen ground.

Shear Strength of Frozen Ground

In problems concerning the mechanics of frozen ground — such as the bending of the layers of frozen ground by heaving, the conditions of fixing posts in frozen ground, and other problems of strength and stability, the shear strength of the ground is of fundamental importance.

Until recently, no data whatsoever was available on the shear strength of frozen ground.

In 1933-34, in the soil mechanics laboratory of the LIKS, some experiments were conducted on the shear strength of frozen ground. These experiments were conducted for two years by M. L. Sheikov.² The next part of this section is based on these experiments; we have analyzed the results, and summarized them here.

Experimental determination of the shear strength of frozen ground, as well as of other materials, is a highly complex problem, since pure shear is often either extremely difficult or almost impossible to obtain experimentally.

That is why, in shear tests, an effort is made to test the material under conditions similar to natural conditions.

Molds for samples of frozen ground were designed accordingly. They were called "molds with confined shear outline". Their design is shown in Figure 52.

1. M. I. Evdokimov-Rokotovskii (1931) Postroika i eksploatatsiia inzhenernykh sooruzhenii v echnoi merzloze (Building and use of structures on permafrost), Tomsk.

2. M. L. Sheikov (1936) "Soprotivlenie sdvigu merzlykh gruntov (Shear strength of frozen ground)", in Laboratornye issledovaniia mekhanicheskikh svoistv merzlykh gruntov (Laboratory studies on mechanical properties of frozen ground), sb 1 and 2, Akademiia Nauk SSSR.

UNCLASSIFIED

AD

230 484

FOR
MICRO-CARD
CONTROL ONLY

3

OF

Reproduced by

6

Armed Services Technical Information Agency

ARLINGTON HALL STATION; ARLINGTON 12 VIRGINIA

UNCLASSIFIED

"NOTICE: When Government or other drawings, specifications or other data are used for any purpose other than in connection with a definitely related Government procurement operation, the U.S. Government thereby incurs no responsibility, nor any obligation whatsoever, and the fact that the Government may have formulated, furnished, or in any way supplied the said drawings, specifications or other data is not to be regarded by implication or otherwise as in any manner licensing the holder or any other person or corporation, or conveying any rights or permission to manufacture, use or sell any patented invention that may in any way be related thereto.

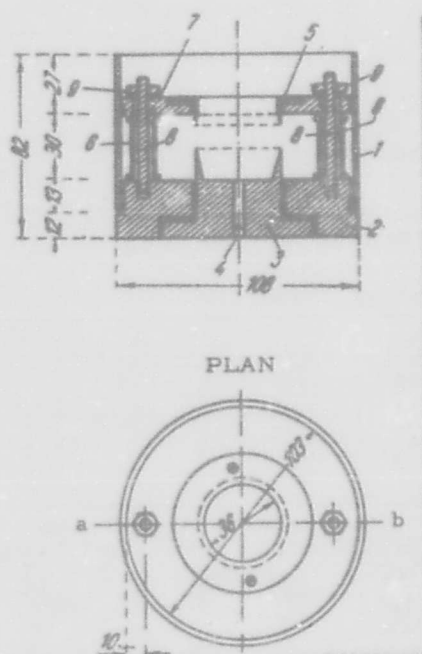

Figure 52. Mold for testing shear strength of frozen ground; 1) ring; 2) bottom plate; 3) lower insert; 4) slot for the thermocouple; 5) upper insert; 6) bushing; 7) cover; 8) bolt; 9) nut.

The sample is disk-shaped, with a centered, circular shear surface. A thermocouple was placed in the center of the sample to determine the temperature of the ground during the test. In addition, steps were taken to insure that shear occurred along the designated cylindrical surface (such as fixation of the rims of the sample, a protruding central section, etc.).¹

During the testing, the basic type of deformation was shear, as can be clearly seen in Figure 53. To facilitate observation, the sample was photographed upside down.

Effect of negative temperatures

Table 41 lists the results of shear strength tests of frozen clay and silty sand in relation to temperature. Results of experiments with pure artificial ice are also given. In preparing the samples, the moisture content was brought to a point close to the initial moisture content, according to the compression curve; it corresponded to a complete filling of the voids with water in the liquid state.

The frozen ground tested had considerable shear strength, varying from 3.7 to 48.5 kg/cm², depending on the temperature. These large values were obtained when the rate of the load increase was about 3.7 to 4.3 kg/sec; at lower rates of load increase, the shear strength of frozen ground is smaller.

It is concluded, after comparison with other data, that the ultimate shear strength given for pure, artificial ice is somewhat large. According to Pinegin's data (see Ch. I), shear strength of natural ice at temperatures from 0C to -23C

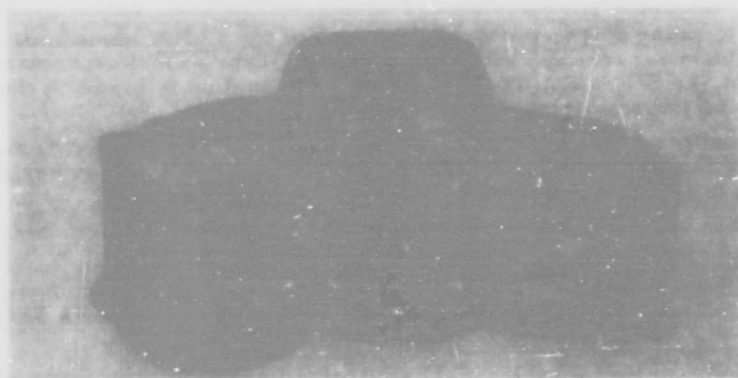

Figure 53. Shear deformation of a sample of frozen ground.

1. For details, see Sheikov, *op. cit.*

Table 41. Effect of negative temperatures on ultimate shear strength of frozen ground.

Sample	Type of soil and grain-size composition	Temp at time of test (C)	Moisture by weight (%)	Ultimate shear strength, (kg/cm ²)
1	Clay (50% of particles 0.01 - 0.005 mm diam; 36% < 0.005)	-0.4	45.5	3.7
2		-1.8	50.6	17.2
3		-3.0	49.8	20.9
4		-4.9	44.0	24.3
5		-6.3	42.0	28.5
6		-8.8	45.9	33.5
7	Silty sand (68% 1.0 - 0.05; 8% < 0.005 mm)	-0.4	18.4	4.9
8		-0.9	17.8	10.6
9		-3.1	19.1	21.8
10		-3.9	16.9	24.8
11		-6.7	19.0	44.2
12		-8.5	16.2	47.5
13	Pure artificial ice	-9.3	19.0	48.5
14		-0.0	-	9.9
15		-0.4	-	11.0
16		-2.9	-	27.4
17		-4.4	-	32.5
18		-6.1	-	38.5
19		-10.1	-	56.2

varied between 6.0 and 13.2 kg/cm². According to Finlayson, the shear strength of ice at temperatures from -1C to -17C varied from 4.8 kg/cm² to 24.8 kg/cm².

The relationship between temperature and ultimate shear strength of frozen silty sand, frozen clay, and ice is shown in Figure 54. According to these data, with lower temperatures of the ground (below zero) its shear strength increases in the form of a curve.

This dependence may be expressed by the following equation:¹

$$\tau_s = A + Bt - Ct^d \quad (24)$$

where τ_s is the shear strength; A , B , C , and d are coefficients that are constant for a given soil with given moisture content and rate of loading; and t is the absolute value of the negative temperature.

According to Sheikov, the ultimate shear strength of silty sand at 0C to -10C, and 17 to 20% moisture content, will be:

$$\tau = 1.4 + 8.8t - 0.23t^{2.28} \text{ kg/cm}^2.$$

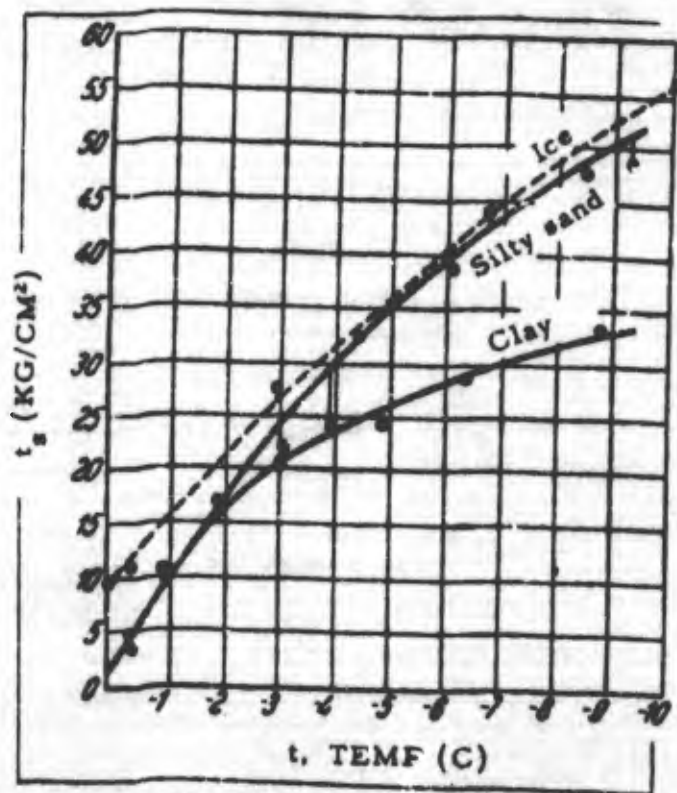

Figure 54. Ultimate shear strength of frozen ground and ice vs temperature.

1. Sheikov, *op. cit.*

PRINCIPLES OF MECHANICS OF FROZEN GROUND

For clay, with moisture content ranging from 40 to 52%.

$$\tau = 1.4 + 9.8t - 1.69t^{1.42} \text{ kg/cm}^2.$$

With the temperature of the frozen ground not lower than -2C , we may, with an accuracy adequate for practical purposes, assume a linear dependence between ultimate shear strength of frozen ground and temperature. Thus, under the experimental conditions described, i. e., at a rate of load increase averaging about 4 kg/sec and complete saturation of the ground with ice, it can be assumed that at temperatures not lower than -2C :

$$\tau_s = A + Bt \tag{25}$$

or, for the given experimental conditions:

$$\tau_s = 1.4 + 8.8t \text{ kg/cm}^2. \tag{25'}$$

where τ_s is the shear strength, in kg/cm^2 , and t is the absolute value of the negative temperature, in C (not lower than -2C).

Experiments have shown that this relationship also holds for other natural soil types with different grain-size composition, provided that the samples are ice-saturated and the rate of application of shear stress is about 4 kg/sec . With a slower rate of load increase the relationship loses its general validity and the coefficients change, especially the angle coefficient B .

Effect of moisture content

Table 42 gives the average results of experiments on the effect of moisture content on the shear strength of frozen ground. In Figure 55, the results of these experiments are shown graphically.

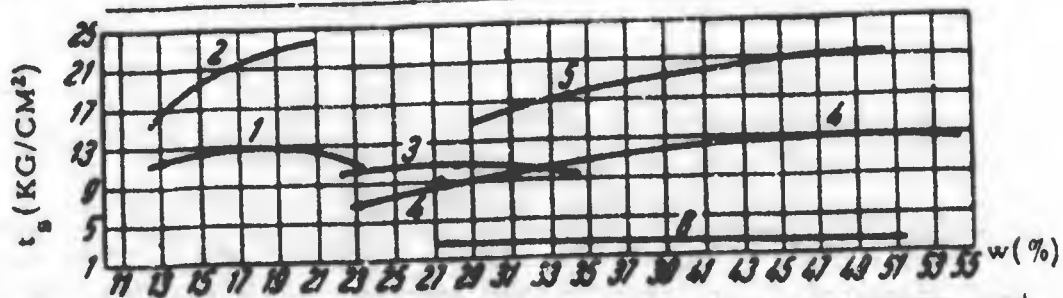

Figure 55. Ultimate shear strength of frozen ground vs moisture content.
 For silty sand: (1) $t = -1.8\text{C}$; (2) $t = -4.4\text{C}$. For silt: (3) $t = -1.8\text{C}$.
 For clayey soil: (4) $t = -1.8\text{C}$; (5) $t = -4.5\text{C}$; (6) $t = -0.3\text{C}$.

Analysis of these data brings us to the following conclusions:

1. Effect of moisture content on ultimate shear strength of frozen ground, although present, is not as sharp as the effect of temperature.
2. With increased moisture content, ultimate shear strength at first increases, reaches a maximum, then decreases with further increase of moisture content. As experiments have shown, the maximum shear strength is observed when the moisture content is close to the complete moisture capacity of the ground (as determined by the usual soil method).

Table 42. Effect of moisture content on ultimate shear strength of frozen ground (average of 115 tests).

Avg temp of samples, (C)	Clayey soil (36% of particles 0.005 mm)*		Silty sand (8% of particles 0.005 mm)*		Silty soil (14% of particles 0.005 mm; * 18% organic material)		Rate of shear load increase, (kg/sec)
	Moisture (%)	Shear strength (kg/cm ²)	Moisture (%)	Shear strength (kg/cm ²)	Moisture (%)	Shear strength (kg/cm ²)	
-4.5	30.5 36.8 42.8	16.8 18.3 22.7	13.2 15.6 19.9 23.5	16.7 19.7 21.9 22.4	- - -	- - -	About 4 (20 kg/cm ² -min)
-1.8	23.2 32.4 45.9 54.3 -	6.9 10.0 12.8 12.6 -	13.2 16.4 19.4 21.0 23.0	11.5 12.3 12.8 12.2 10.9	22.3 28.2 34.4 - -	9.9 10.4 9.3 - -	2 (~10kg/cm ² -min)
-0.3 -0.2	29.0 49.3	3.1 2.5					4 (20 kg/cm ² -min)

* [Apparently a printers error - Should be < 0.005 mm.]

3. At small negative temperatures (not lower than -1.5 or -2C), the ultimate shear strength of fine-grained soil which is saturated with ice may, for practical purposes, be assumed to be independent of the moisture content.

Effect of grain-size composition

If the voids of frozen ground are completely or nearly filled with ice, it would follow from the above data that the effect of grain-size composition on ultimate shear strength would become insignificant. A far greater effect is exerted by temperature and by the rate of increase of the shearing load.

Table 43 gives the results of experiments on ultimate shear strength of frozen ground from the permafrost region, with the ground completely saturated with ice, and at temperatures ranging from -0.6C to -2.1C. Numbers 1 through 20 give results of experiments performed at a slow rate of load increase, about 2 kg/sec (about 10 kg/cm²-min). Numbers 21 through 25 show the results of more rapid increase of shear stress application (approximately 4 kg/sec or 20 kg/cm²-min).

As can be seen from the data, grain-size composition does effect the ultimate shear strength within the limits of the tests, but the effect is quite negligible. Thus, at a slow rate of load increase (2 kg/sec) and at a temperature of about -1.9C, the ultimate shear strength of clay is about 8 kg/cm²; of silty sand, about 9 kg/cm²; and of sandy silt and gravelly silty sand, about 10 kg/cm².

It is interesting to note that, at a slow rate of shear load increase (10 kg/cm²-min), the angle coefficient B, in the linear equation which expresses the dependence of ultimate shear strength on temperature, will differ from the one given above. For the shear strength values given in Table 43 (nos. 1 to 20), B is about 3.5 to 5, averaging 4.3: i.e., it is about half the coefficient obtained at the rate of shear load increase of 4 kg/sec (20 kg/cm²-min).

Also note that experiments on the shear strength of frozen ground samples that had been subjected to a single thawing showed a decrease in ultimate shear strength to about half that of samples that had not been thawed.

Table 43. Shear strength of frozen ground from permafrost regions when voids are completely saturated with ice.

Sample	Type of soil and grain-size composition	Temp (C)	Moisture by weight, (%)	Ultimate shear strength (kg/cm ²)
1	Clay (45% < 0.005 mm)	-2.1	35	6.6
2	Clay (41% < 0.005 mm)	-1.8	33	8.0
3	Clayey soil (6% > 1 mm; 31% < 0.005 mm)	-1.9	29	9.0
4	Clayey sand (27% < 0.005 mm)	-1.9	28	8.9
5	Clayey silt (25% < 0.005 mm)	-2.0	36	8.0
6	Clayey sand (22% < 0.005 mm)	-1.9	34	9.0
7	Silty sand (17% < 0.005 mm; 13% > 1 mm)	-2.1	31	8.5
8	Silty sand (17% < 0.005 mm; 16% > 1 mm)	-1.8	27	8.0
9	Silty sand (15% < 0.005 mm)	-1.9	23	10.0
10	Silty sand (15% < 0.005 mm)	-1.6	29	7.0
11	Sandy silt (15% < 0.005 mm)	-1.3	23	6.0
12	Sandy silt (15% < 0.005 mm)	-2.8	23	14.0
13	Silty sand (14% < 0.005 mm)	-1.7	24	8.0
14	Sandy silt (14% < 0.005 mm)	-1.5	34	7.4
15	Diluted silty sand (14% < 0.005 mm; 12% > 1 mm)	-1.7	17	10.3
16	Gravelly silty sand (25% > 1 mm; 13% < 0.005 mm)	-1.6	19	10.8
17	Lean silty sand (11% < 0.005 mm)	-1.7	34	8.9
18	Silty sand (10% < 0.005 mm)	-2.0	39	9.5
19	Sandy silt (4% < 0.005 mm)	-1.6	26	10
20	Gravel (weathered granite) (44% > 1 mm)	-1.8	23	11
21	Silty soil (68% 0.01 to 0.005 mm; 14% < 0.005 mm)	-0.6	55	7.8
22	Silty sand (13.6% > 0.25 mm; 12% < 0.005 mm)	-0.9	37	8.9
23	Gravelly silty sand (33% > 0.25 mm; 9% < 0.005 mm)	-1.1	49	15.0
24	Sand (51% > 0.25 mm)	-0.7	18	10.9
25	Sand (34% > 0.25 mm; 3% < 0.005 mm)	-0.8	36	12.2

Note: Table gives average results for 2 to 3 tests. For nos. 1 to 20, the load increase was slow — about 10 kg/cm²-min. For nos. 21 to 25, rate of load increase was about 20 kg/cm²-min.

Adfreezing Strength

When making calculations for laying foundations under permafrost conditions, the so-called adfreezing strength between the ground and the foundation material is of considerable importance.

Materials used in foundations differ in porosity and coarseness. After being placed in moist ground, the material becomes saturated with water up to a definite limit for each material. Thus, water will be found in the separate pores of the material, moreover its degree of saturation will vary, depending on whether this material is of greater porosity (wood or rubble) or of lesser porosity (reinforced concrete). In addition, as the foundation is laid, the surface of the foundation may become either partially or completely wet.

When the moist ground adjacent to the foundation freezes, ice joins the ground and the foundation together at many points.

Seemingly, determination of what forces will break the adhesion between the foundation and the frozen ground must be based on the ultimate strength of ice. However, such a theoretical solution of the problem cannot furnish tangible quantitative results in view of the extremely large variety of phenomena noted. The adfreezing strength will depend on the moisture content, temperature, grain-size composition, and porosity of the ground; the contact surface of the ground and the foundation; the porosity, degree of saturation, and coarseness of the foundation, etc.

This incomplete enumeration of the factors affecting the adfreezing strength shows that a theoretical solution of this problem is hardly possible, and would be extremely complicated in any case.

We have approached the study of adfreezing of the ground to wood and concrete in a purely experimental way by determining what may be termed oblique adfreezing strengths.

The oblique adfreezing strength is the stress which must be applied to the foundation

to break its connection with the frozen ground, punching it through the layer of frozen ground. The full adfreezing strength, determined by this method, consists of the shear strength of the ice and the forces of friction between the foundation and the frozen ground.

In practice, for foundations that are subject to heave when the surrounding ground freezes, it is not the separate components of the resistance of the foundation to heave that are important, but their sum total. In view of this, in the future, this sum total will be determined in the experimental study of adfreezing strength.

Knowledge of adfreezing strengths is of particularly great importance for permafrost regions and for areas where the ground freezes to a considerable depth during the winter, because we use these data to determine the maximum values of the forces of heaving. Most important, this information enables us to work out measures to counteract these forces.

The first experiments to measure adfreezing strength were conducted by M. I. Chernyshev.¹ These experiments established that adfreezing strength of soil to wood depends on the temperature of the ground.

The first systematic experiments to determine the adfreezing strength of various types of soil to wood and concrete in relation to the temperature, moisture content, and mechanical composition of the soil were conducted by us in 1930.²

In 1933-34, upon an assignment by KIVM (Akademiia Nauk), experiments were conducted in the laboratory of the LIKS to study the adfreezing strength of typical soil in the permafrost region in relation to temperature and moisture content. These experiments were conducted by I. S. Vologdina.³ The results make it possible to define more accurately, and to develop further, the problems posed by us in 1930.

The analysis that follows in this section is based mainly on the results of these last two works.

We will describe briefly the methods of these studies and then turn to an analysis of the data.

Methods of investigation

Adfreezing strength was determined by forcing wooden and concrete posts through the soil layer to which the sides of the post had adfrozen. After determining the force which must be applied to the post in order to disrupt its connection with the adfrozen ground, the mean adfreezing strength was calculated by dividing the value of the required force by the area of the outside surface of the post.

The apparatus for measuring adfreezing strength consisted of a ring, a bottom plate, a post, a press, and a thermocouple (Fig. 56).

The apparatus was assembled as follows: The ring was placed on the plate and the post placed in the middle of the ring on a stand, which was removed after the soil was compacted. Then soil with the required moisture content was placed in the apparatus and compacted by pressure corresponding to the compression curve for the required moisture content. After this, the apparatus was placed in a refrigeration chamber for 2 or 3 days. Then, the adfreezing strength was determined by pushing the post through the frozen ground.

To maintain the temperature conditions, the entire apparatus was placed in an insulated chamber and the soil temperature was controlled during the tests by the thermocouples.

1. Zhurn. Zheleznodorozhnoe delo (Railroading), nos. 1 and 2, 1928.
2. N. A. Taytovich (1932) Nekotorye opyty po opredeleniiu sil smersaniia (Experiments on adfreezing strength), Biulleten' No. 25 Leningradskogo instituta sooruzhenii.
3. I. S. Vologdina (1936) "Izuchenie sil smersaniia merslykh gruntov s derevom i betonom (Study of adfreezing strength of frozen ground to wood and concrete)," in Laboratornye issledovaniia mekhanicheskikh svoistv merslykh gruntov (Laboratory studies on mechanical properties of frozen ground), sb. 1. Akademiia Nauk.

Systematic tests showed that the following factors have a considerable effect on adfreezing strength: state of adfreezing surface, degree of water saturation of the adfreezing materials, and rate of load increase. These factors must be taken into consideration when determining, experimentally, the adfreezing strength of the ground to building materials.

Thus, depending on the coarseness of the adfreezing materials, the force necessary to overcome the adfreezing of the ground to the post may vary to a considerable degree. To avoid introducing values for coarseness of the adfreezing material, which would be difficult to estimate, only smooth-surfaced building materials were tested.

The degree of saturation of the material has considerable effect on adfreezing strength. Air-dried posts in moist ground would give very different results from posts saturated with water.

The above statements are illustrated by the data listed in Table 44.

Table 44.

Adfreezing materials	Soil moisture (%)	Soil temp (C)	Adfreezing strength (kg/cm ²)	
			Wooden posts dry	Wooden posts saturated with water
Clayey soil (36% of particles < 0.005 mm) to a wooden post (depth of soil layer, 6 cm; diam of post 4 cm)	31	-1.2	4.1	10.0
Silty sand (8% < 0.005 mm) to a wooden post (same test conditions)	12-13	-5.4	8.4	20.8

These data show that saturating a wooden post with water prior to installation in the ground increases adfreezing strength to clayey soil or silty sand approximately 2.5 times.

Thus, the degree of water saturation of wood may modify its adfreezing strength within a considerable range. To eliminate this factor, experiments on adfreezing strength are usually conducted either with air-dried posts or with posts fully saturated with water, avoiding any intermediate states.

The considerable decrease in adfreezing strength of air-dried posts as compared with saturated ones is of considerable practical importance: it shows that, when setting the allowable adfreezing stress (for foundations in the permafrost regions), the coefficient of safety must allow for this decrease.

In addition to the factors indicated above, the rate of load increase on the post has a considerable effect on the adfreezing strength.

Table 34 gives the results of experiments on adfreezing strength of clay and silty sand with wooden posts at different loading rates; the data show that the adfreezing strength may vary up to 3.3 times, depending on the rate of load increase.

Effect of negative temperature

Since ultimate compressive and shear strengths of both ice and frozen ground depend on temperature, it is natural to expect a similar dependence for adfreezing strength. The basic component of adfreezing strength is the ice resistance; therefore, it was highly important to find out whether the adfreezing strength of ice depends on the temperature.

Several experiments were conducted to determine the relation between temperature and the adfreezing strength of ice to wood. The results (average of 19 separate tests) are given in Table 45 and Figure 56a.

Table 45. Effect of negative temperatures on adfreezing strength between soil and wood or concrete.

Sample	Adfreezing materials	Temp (C)	Moisture by weight, (%)	Adfreezing strength, τ (kg/cm ²)
1	Ice to smooth wood surface	-1	-	5.0
		-5	-	6.2
		-7	-	11.6
		-10	-	13.7
		-20	-	22.0
2	Ice to a smooth concrete surface	-5 to -10	-	9.8
3	Clayey soil (36% of particles < 0.005 mm), to water-saturated wood	-0.2	27.1	2.9
		-1.5	26.4	5.9
		-5.8	28.4	11.1
		-10.8	28.4	18.6
		-17.8	25.8	29.4
4	Silty sand (68% 1 to 0.005 mm; 8% < 0.005 mm) to water-saturated wood	-0.2	12.1	1.3
		-1.2	13.0	7.0
		-2.7	10.1	11.0
		-5.2	14.8	19.6
		-5.6	12.9	20.8
		-10.7	14.1	24.7
		-17.4	12.8	27.4
5	Silty soil (14% < 0.005 mm; 18% organic material) to water-saturated wood	-0.2	29.5	3.6
		-0.5	33.4	6.1
		-5.7	34.3	10.6
		-10.3	33.1	14.3
		-12.3	33.2	19.9
		-22.7	34.9	25.9

Note: Air-dried posts were immersed in water. Moisture content of ground is about half full moisture capacity. Table gives average data of 3 to 5 separate measurements. Rate of load increase for nos. 3, 4, and 5 was about 20 to 25 kg/cm²-min.

These data show that the relation of adfreezing strength of ice to temperature may be taken as approximately linear. The occasional deviations may be explained by varying ice structure (parallel or perpendicular to the crystal axis) and by the effect of rate of load application.

In experiments on the adfreezing strength of pure ice and wood, there is actually a crosscutting or shear of the ice particles along the plane of contact between the ice and the wood. Therefore, it is interesting to compare the adfreezing strength of ice with its ultimate shear strength, given in Chapter I. According to Finlayson, the ultimate shear strength of ice at temperatures from -1C to -12C ranged from 4.8 to 24.8 kg/cm², which is extremely close to the adfreezing strength of ice and wood obtained by us at -1C to -20C, 5 to 22 kg/cm² (Table 45).

Nevertheless, it should be noted that other investigators have obtained different values of ultimate shear strength for ice; for instance, Pinegin found values from 6.0 to 13.2 kg/cm² at temperatures down to -23C.

Thus, although actually there is little doubt that the adfreezing strength and shear strength of ice is the same, the question remains open until more reliable data are obtained.

With incomplete wetting and penetration of water into the pores of the wood, naturally, the shear and adfreezing strengths will be quantitatively different.

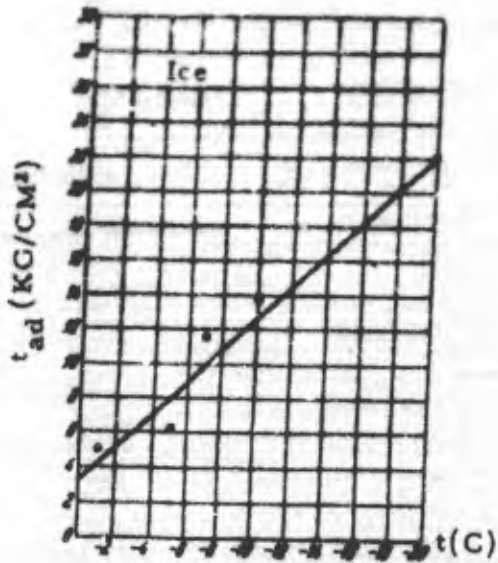

a. Ice and wood

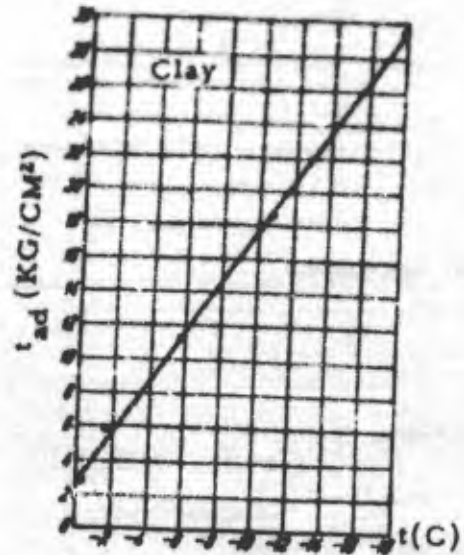

b. Clay and wood

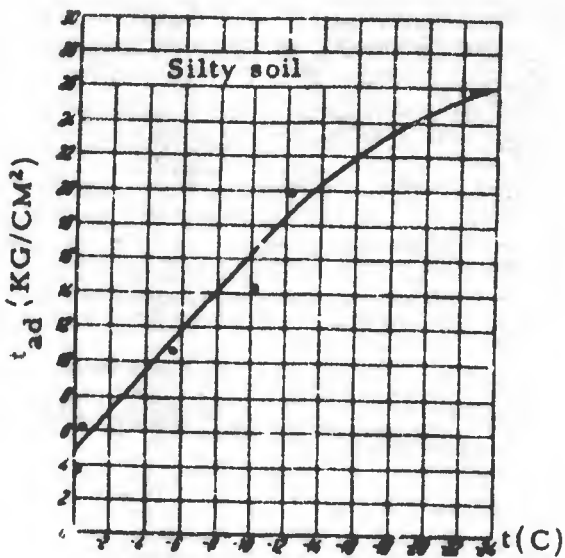

c. Silty soil and wood

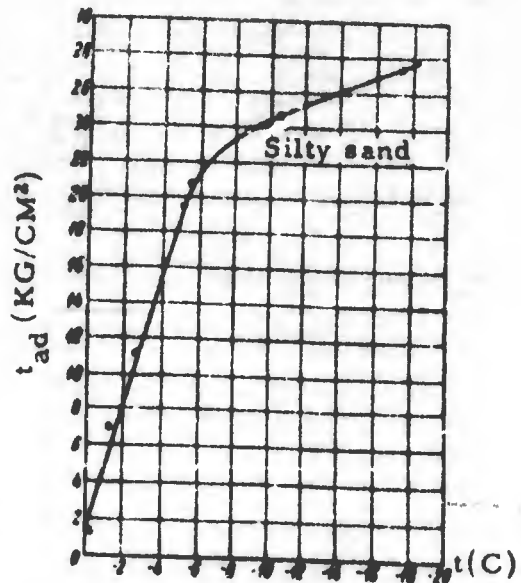

d. Silty sand and wood

Figures 56a-d. Adfreezing strength vs temperature.

From experiments on the adfreezing strength of typical permafrost soils and wood (Table 45, Fig. 56b-d), the following conclusions can be drawn:

1. The adfreezing strength of both soil and ice increases with lowering of the negative temperatures.
2. For the soils studied and under the conditions of the test, the relationship between temperature and the adfreezing strength of soil and wood, between 0C and -6C, may be assumed to be linear.

Within the specified limits, the relationship between temperature and the adfreezing strength of the soil may be expressed by

$$\tau_{ad} = a + bt$$

(26)

where τ_{ad} is the adfreezing strength; and a and b are coefficients, which depend on the grain-size composition and moisture content of the ground, as well as on the experimental conditions.

With moisture content close to half maximum moisture capacity and temperatures not lower than -6°C , the relation between adfreezing strength and temperature, according to tests made, may be expressed approximately as follows:

$$(1) \text{ For silty soil } - \tau_{ad} = 4.6 + 0.9t \text{ kg/cm}^2.$$

$$(2) \text{ For clay } - \tau_{ad} = 2.8 + 1.4t \text{ kg/cm}^2.$$

$$(3) \text{ For silty sand } - \tau_{ad} = 1.0 + 3.6t \text{ kg/cm}^2.$$

For these and other soils the coefficients of the linear equation expressing the dependence of adfreezing strength on temperature will be different for different moisture contents or rates of load increase.

Here it is interesting to note a certain functional dependence which apparently occurs in the variations of the parameters of this linear equation. With an increase in the solid part of the ground, the angle coefficient increases, while the initial coefficient, numerically equal to the adfreezing strength of soil and wood at 0°C , decreases. It should also be noted that at 0°C the adfreezing strength of soil and wood is not zero, but has a definite value. This fact has not been taken into account by some investigators.

Actually, the relation between the temperature and the adfreezing strength of soil and wood and soil and concrete is much more complex than would appear from the equation given above and may be considered linear only within certain definite limits. The values of the ratio coefficients (a and b) as pointed out above, depend on the grain-size composition of the ground as well as on many other factors. Therefore, the relation between adfreezing strength and temperature must be considered together with directly measured data.

Effect of moisture content on adfreezing strength of soil to wood and concrete

The ice content of frozen ground is the most important, fundamental factor determining the cohesiveness of the frozen ground and its adfreezing strength to wood and concrete.

It is possible, on the basis of geometric characteristics of the ground voids, ice content, and the tensile, shear, and adfreezing strengths of ice to arrive at a definition of the cohesive forces which determine the cohesiveness of frozen ground. Such an attempt was made by Prof. G. I. Pokrovskii.¹

Pokrovskii regards the adfreezing strength of soil and the cohesive forces that arise at the contact points of soil particles when the water freezes as identical. According to Pokrovskii, the adhesive strength of frozen ground per unit of surface, K , is determined by the following factors:

- (1) Ultimate tensile strength of ice, τ_0 ;
- (2) Ultimate tensile strength of the contact point of the soil particles and the ice, τ (adfreezing strength of soil particles and ice);
- (3) Ultimate shear strength at the contact point of ice and soil particle;
- (4) Average effective shape and size of soil particles;
- (5) Moisture content (ice content per unit of ground volume), w_0 ;
- (6) Water expansion during freezing and rate of freezing.

Assuming that freezing water concentrates in the narrowest places of the voids, and making a number of allowances for geometrical form of the soil particles, location of the

1. G. I. Pokrovskii (1935) Mekhanika merszlogo grunta (Mechanics of frozen ground), Zhurnal tekhnicheskiiia fizika, tom V, vyp. 6.

contact points between particles, number of contact points, and structure of the ground, Pokrovskii arrives, by mathematical analysis, at the following equation for adhesive (adfreezing) strength of frozen ground:

$$K = \left[\omega R \tau w_0^{0.6} + \tau_0 \left(\frac{w_0}{w_n} \right)^{0.6} \right] e^{-g w_0 R}$$

where K is adhesive (adfreezing) strength per unit of surface area; ω is a constant characterizing the ground structure; R is the average radius of the ground particle; τ is the tensile strength of the contact point between ice and particles; w_0 is the moisture content by volume of the ground, w_n is the complete moisture capacity (equal to complete filling of the pores of the ground with ice); g is a constant characteristic of the rate of freezing; and e is the Napierian number.

This equation relates most of the important factors that determine adhesion (adfreezing) and makes it possible to correlate them.

Thus, from the equation, it follows that frozen ground has greater cohesive strength than pure ice. This fact, as we have already seen, is confirmed by experiments.

Figure 57 shows, in a tridimensional system of coordinates, the relation between K , adhesion (adfreezing strength); R , the radius of the ground particles; and w_0 the moisture content by volume, according to the above equation.

It is interesting to note the existence of a maximum value for each moisture content, a fact which we have established experimentally¹ and will analyze in greater detail below.

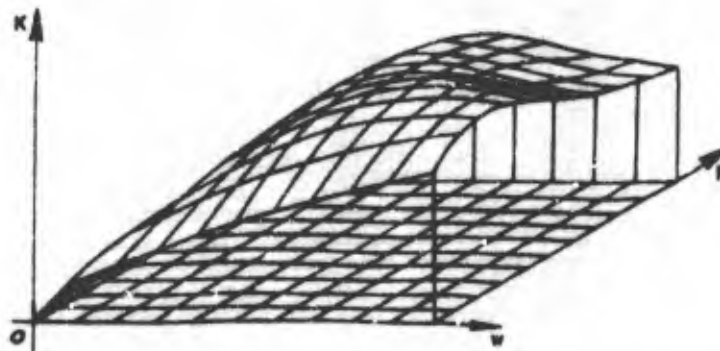

Figure 57. Relation between adfreezing strength K , the size of ground particles R , and the moisture by volume of the ground w_0 .

Pokrovskii's equation for the adhesive (adfreezing) strength of frozen ground is a successful mathematical interpretation of experimental data. However, even if we accept the allowances made in its formulation, this formula cannot (as Pokrovskii himself points out) be used for quantitative calculations. Therefore, determinations of the dependence of adfreezing strength on the moisture content and grain-size composition of the ground must be based on the results of direct experiments.

Table 46 gives average results of experiments measuring the adfreezing strength of silty soil, clayey soil, and silty sand to wood and concrete, at -10°C . Table 47 gives results for temperatures of -0.2°C and -1.2°C . Rate of load increase was 22 to 26 kg/cm²-min, so that the data given in the tables correspond to the maximum values of adfreezing strength.

The natural ground used in these experiments was artificially frozen and had a maximum degree of ice saturation (corresponding to a complete filling of the voids with ice in the loosest state of the ground) which was equal to 50% by weight for silty soil; 40% by weight for clayey soil; 23% by weight for silty sand.

Tables 46 and 47 give average results of experiments measuring adfreezing strength of various ground with moisture content varying from approximately 0.3 - 0.4 to 1.1 to 1.2 of the maximum ice saturation, a considerable range of variation. When making

1. N. A. Tsytovich (1932) *N kotorye opyty po opredeleniiu sil smerzaniia (Experiments on adfreezing strength)*, *Biulleten' Leningradskogo Instituta sooruzhenii*, no. 25.

Table 46. Effect of moisture content (w_0) on adfreezing strength, τ_{ad} , of soil to wood and concrete, at -10°C .

1. Silty soil (63% of particles 0.05 - 0.005 mm; 14% < 0.005 mm; 18% organic substances) to water-saturated wood.		2. Clayey soil (36% < 0.005 mm) to water-saturated wood.		3. Silty sand (58% 1 - 0.05 mm; 8% < 0.005 mm) to water-saturated wood.		4. Silty soil to water-saturated concrete.		5. Clayey soil to water-saturated concrete.		6. Silty sand to water-saturated concrete.	
w_0 (%)	τ_{ad} (kg/cm ²)	w_0 (%)	τ_{ad} (kg/cm ²)	w_0 (%)	τ_{ad} (kg/cm ²)	w_0 (%)	τ_{ad} (kg/cm ²)	w_0 (%)	τ_{ad} (kg/cm ²)	w_0 (%)	τ_{ad} (kg/cm ²)
18.8	6.9	18.4	12.8	5.7	7.9	17.4	7.8	18.9	20.6	7.5	10.0
33.9	14.1	21.6	15.7	10.1	12.6	32.5	21.8	25.1	21.9	11.9	22.8
41.5	28.7	28.4	18.6	13.9	21.4	46.4	20.2	34.6	25.3	18.1	24.2
51.0	34.8	41.4	32.2	19.9	32.3	51.8	28.1	46.1	20.1	23.8	21.0
62.2	34.7	55.6	31.9	33.5	33.5	58.3	27.7	-	-	-	-

Table 47. Adfreezing strength, τ_{ad} of ground to wood and concrete at different moisture contents and at temperatures of -0.2°C and -1.2°C .

Temp ($^\circ\text{C}$)	1. Silty soil (63% 0.05 - 0.005 mm) to water-saturated wood.		2. Clayey soil (36% < 0.005 mm) to water-saturated wood.		3. Silty sand (68% 1 - 0.05 mm) to water-saturated wood.		4. Silty soil to water-saturated concrete.		5. Clayey soil to water-saturated concrete.		6. Silty sand to water-saturated concrete.	
	w_0 (%)	τ_{ad} (kg/cm ²)	w_0 (%)	τ_{ad} (kg/cm ²)	w_0 (%)	τ_{ad} (kg/cm ²)	w_0 (%)	τ_{ad} (kg/cm ²)	w_0 (%)	τ_{ad} (kg/cm ²)	w_0 (%)	τ_{ad} (kg/cm ²)
-0.2	29.9	3.6	27.1	2.7	12.1	1.3	-	-	-	-	-	-
	22.4	7.0	22.4	3.2	6.7	2.8	16.4	4.4	17.8	7.8	5.8	2.8
-1.2	32.6	8.9	26.4	5.9	10.1	4.1	33.0	6.0	26.3	4.8	11.7	6.4
	43.8	7.1	37.3	13.0	13.3	7.2	46.0	9.2	36.2	6.4	12.1	7.0
	51.2	7.6	56.5	11.8	16.5	8.2	53.2	3.1	43.9	5.8	16.1	11.1

calculations for a foundation in frozen ground, which is often necessary in permafrost regions, data on adfreezing strength at small negative temperatures are of particular importance (see Table 47).

To illustrate the above data, the relationship between adfreezing strength of various soils and moisture content (ice saturation) is represented graphically in Figures 58 and 59.

A study of these data and the results of earlier experiments on the effects of moisture on adfreezing strength bring us to the following conclusions:

1. Adfreezing strength of ground to wood and concrete increases with an increase in moisture content (ice saturation of the ground). Adfreezing strength has a maximum value at a certain moisture content. As demonstrated by investigations, the maximum adfreezing strength at a given temperature corresponds closely to maximum ice saturation of the ground.

2. With increase in ice content beyond saturation, the adfreezing strength decreases, approaching the adfreezing strength of pure ice.

3. If we assume a linear dependence of adfreezing strength on temperature, and determine the parameters of the straight line at various degrees of ice saturation of the ground, we obtain the following results:

(a) The initial coefficient of the straight line, a (eq. 26), numerically equal to adfreezing strength at 0C when the ice content varies from 0.3 to 1.2, changes within the limits of 2 to 11 kg/cm², increasing with increased ice content of the ground. This shows that the adfreezing strength of the soil to wood and concrete depends to a high degree on the ice content.

(b) The angle coefficient of the straight line, b , which denotes the intensity of the variation of adfreezing strength with variations of the negative temperature of the ground, also increases with an increase in ice content, but within considerably narrower limits. Calculations have shown that, with ice saturation of clayey soil varying approximately from 0.3 to 1.2, the angle coefficient b varies approximately within the limits of 1 to 2. This shows that the rate of increase of adfreezing strength with declining temperature is much less dependent on the ice content than is the adfreezing strength itself, particularly at temperatures close to zero.

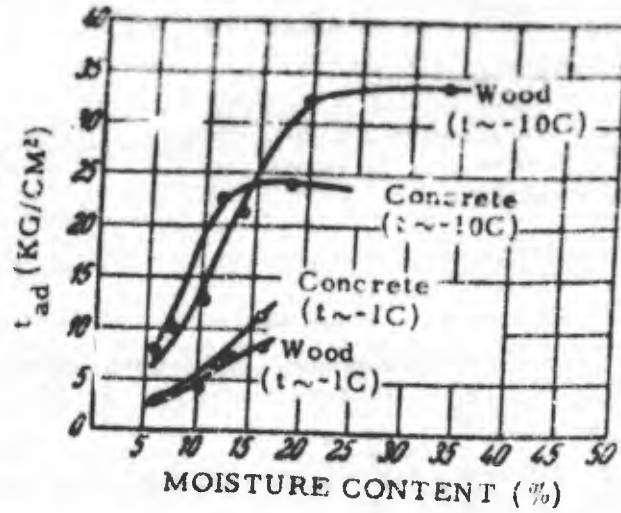

Figure 58. Relation between moisture content and the adfreezing strength of silty sand.

4. The adfreezing strength of the soil to water-saturated wood, when the moisture content of the soil exceeds ice saturation by 0.7%, is greater than the adfreezing strength of the same soil to concrete; when the moisture content is smaller, the reverse is observed. However, a number of deviations from the above principles do occur. These are observed especially often with silty soil containing up to 18% of organic material.

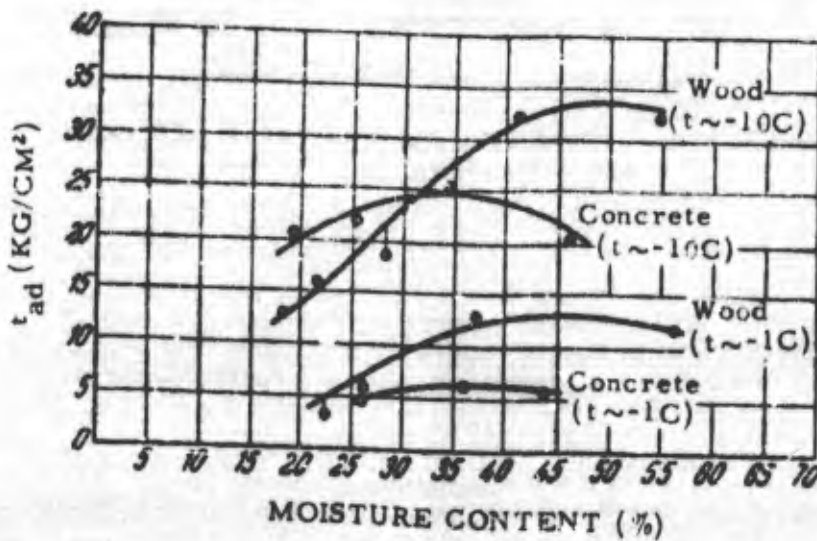

Figure 59. Relation between moisture content and the adfreezing strength of clayey soil.

Effect of grain-size composition on adfreezing strength

The data given on adfreezing strength of various soils to wood and concrete show that the value depends also on the grain-size composition of the soil. Thus, at equal temperature and ice content, the adfreezing strength of clayey soil is somewhat greater than that

of silty sand. However, the fine-grained soils studied above, which are the typical soils of the permafrost region, differ very little from each other in mechanical properties in their frozen state; this makes it difficult to determine a clear-cut relationship between adfreezing strength and size of soil particles.

Analysis of this problem requires a study of the adfreezing strength of homogeneous soil fully saturated with water. Table 48 and Figure 60 give results of experiments performed by Tsytovich on the adfreezing strength of soil to wood when the soil was saturated with water (coefficient of saturation was about 80%).

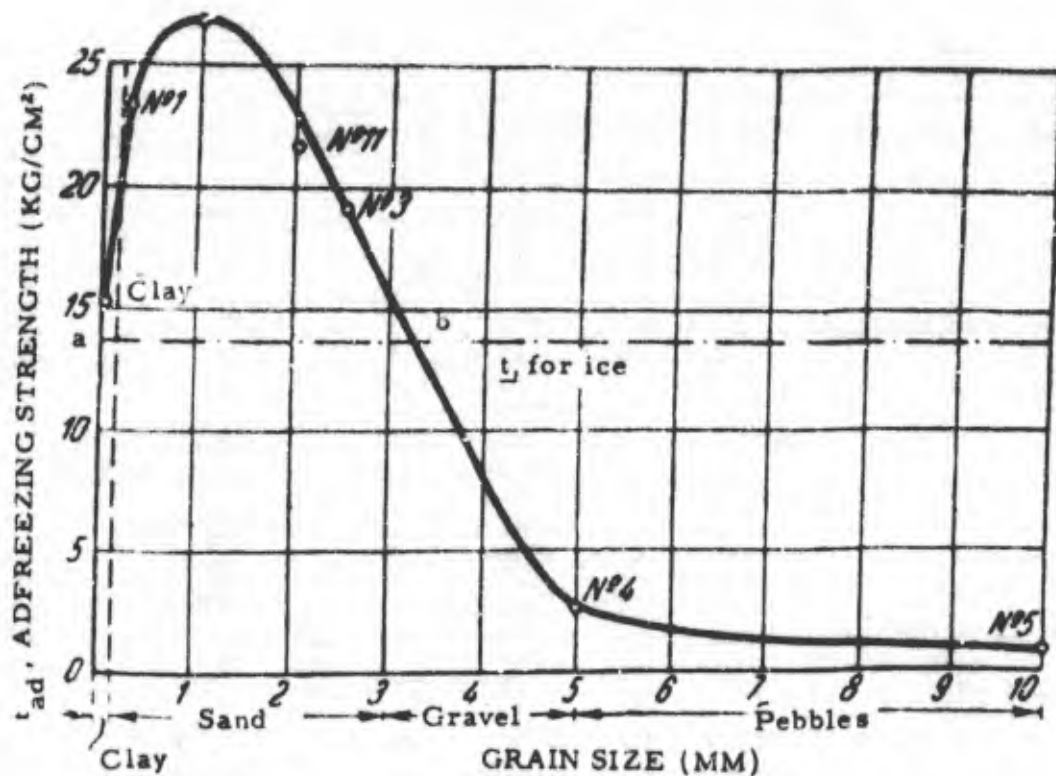

Figure 60. Relation between adfreezing strength and grain-size composition.

It is interesting to note that fine- and medium-grained sand had the greatest adfreezing strength, clean gravel and pebbles the least.

As pointed out previously, theoretical data (Pokrovskii's conclusions) also note the existence of a maximum adfreezing strength depending on the size of the soil particles. This fact was established by us as far back as 1930, by the experimental results given in Table 48.

Table 48. Adfreezing strength of various soils to wood.

Type of soil	Predominant grain-size (mm)	Temp (C)	Coefficient of saturation, (%)	Adfreezing strength, (kg/cm ²)
Clay	0.01	-10	77	15.3
Fine sand No. 1	0.25	-10	76	23.3
Medium sand No. 2	1.0	-10	78	26.8
Natural sand No. 11	3 - 0.25	-10	79	21.7
Coarse sand No. 3	3-2	-10	97	19.1
Gravel No. 4	5.0	-10	77	2.6
Pebbles No. 5	10.0	-10	79	0.9

It follows from these data that the smallest adfreezing strength is found in homogeneous, clean, pebbly ground, with the diameter of particles exceeding 10 mm; therefore, a pebbly fill of foundations may be recommended for the permafrost regions to diminish the adfreezing strength of the active layer to the material of the foundation.

However, the values for pebbly ground given in Table 48 will be valid only for clean pebbly ground having free water drainage.

To clarify the effect of silting of pebbly ground on the adfreezing strength to wood, several experiments were conducted. The results (Table 49) show that the silting of pebbly ground — and, even more so, the filling of its voids with ice or clay — considerably increase its adfreezing strength and make a clogged-up pebbly ground unsuitable for filling foundations.

Table 49.

Conditions of experiment	Moisture by weight (%)	Temp (C)	Adfreezing strength, (kg/cm ²)	Remarks
Clean pebbles washed with water to water-saturated wood	1.4	-9.9	0.9	Average results of tests are given
Pebbles washed with a silt admixture 3 times	2.8	-10.5	1.6	Silt content 1.8% by weight
Pebbles washed with a clay admixture 3 times	1.4	-11.1	2.1	Clay content 1.4% by weight
Pebbles, all voids filled with ice	27.9	-9.5	27.3	
Pebbles, all voids filled with clay	24.2	-10.2	30.6	Clay content 13.7% by weight

Thus, a pebbly fill will have a minimal adfreezing strength to the material of the foundation only if it is protected from silting and has free water drainage.

For calculating the resistance to heave of foundations in frozen ground, it is of considerable importance to know the adfreezing strengths of soils of different grain-size composition to the foundation material at comparatively small negative temperatures.

Some values of adfreezing strength of soil (with voids filled with ice) to water-saturated wood are given in Table 50.

Field experiments on adfreezing strength

In this section we will analyze the results of field experiments (1928-31) on adfreezing strength which were conducted at the Petrovskaja Permafrost Station of the Leningrad Institute of Construction.

Experiments were conducted in the following manner. Natural soil, moistened up to a specified moisture content, was firmly packed into boxes measuring 1.0 x 0.5 x 0.5 m. Prior to filling, a pole 12 to 14 cm in diam was inserted in each box through a hole in the bottom (Fig. 61).

The boxes containing soil were frozen in the open air for 15 to 30 days, after which, with the aid of a lever, the posts, adfrozen to the soil were pushed out.

Figure 61 is a diagram of a field installation used in experimental measuring of adfreezing strength of the soil to wood and concrete.

After the posts were pushed out, specimens were taken to determine the grain-size composition of the soil and its moisture content. To test the moisture content, eight specimens were taken: six near the post (top, bottom, middle) and two from a depth of 25 cm from the surface and 15 cm from the post; the moisture content of the entire soil layer was calculated as the arithmetical mean of the eight specimens.

Table 50. Adfreezing strength of various soils and water-saturated wood.

No.	Type of soil	Grain-size composition		Temp (C)	Moisture (%)	Adfreezing strength, (kg/cm ²)
		> 1 mm (%)	< 0.005 mm (%)			
1	Clay	None	45	-1.5	41	5
2	Clay	13	45	-1.0	39	6
3	Clay	-	41	-1.0	30	5
4	Clay	6	31	-2.2	29	7
5	Clay	2	30	-1.6	24	7.2
6	Clayey sand	None	27	-0.8	35	4
7	Clayey sand	"	25	-1.2	26	5
8	Clayey silt	"	24.82	-1.5	40	6
9	Clayey sand with ice lenses	"	23.5	-0.8	39	4
10	Clayey sand	"	22.04	-1.8	39	6
11	Clayey sand	"	22	-1.6	34	4
12	Clayey silt with ice lenses	"	22	-1.5	43	6
13	Clayey sand	"	20	-0.5	20	2
14	Clayey sand with sand lenses	"	18	-1.0	18	5
15	Clayey silt	14	18	-2.0	25	7
16	Clayey sand	13	17	-1.1	31	4
17	Clayey sand	17	17	-2.2	25	10
18	Clayey sand	None	16	-0.6	27	4
19	Clayey sand	"	15	-1.6	28	7
20	Clayey sand	"	15	-0.7	25	3
21	Clayey sand	3	15	-0.5	25	2
22	Clayey sand	3	15	-4.0	26	4.3
23	Clayey sand	-	14	-1.2	24	6
24	Clayey sand	None	14	-0.8	36	3
25	Clayey sand	"	14	-2.0	33	5
26	Micaceous clayey sand	1	14	-1.8	32	3
27	Micaceous clayey sand	9	13	-0.5	25	2
28	Clayey sand	25	13	-1.6	17	7
29	Clayey sand	-	11	-0.9	27	5
30	Clayey sand	23	10	-1.6	25	5
31	Micaceous clayey sand	None	10	-1.0	39	3.3
32	Clayey sand	5	10	-1.8	23	7.2
33	Sandy silt	-	9	-1.1	28	3.1
34	Sandy silt	0.5	7	-1.0	17	5.4
35	Silty sand	41	7	-1.5	16	1.3
36	Sandy silt with ice lenses	-	4	-1.6	27	3.3
37	Granitic gravel	61	Not determined	-1.7	14	2
38	Gravelly soil	80	3	-1.1	12	3.3

The experiments conducted in 1928-29 and 1929-30 were of a preliminary nature intended to clarify factors affecting the forces of adfreezing.

Unfortunately, the temperature of the soil tested was not measured in the 1928-29 experiments; only the air temperature on the day of the test was measured. In 1929-30, the temperature of the soil in the boxes was measured on the day of the test with a mercury thermometer; however, these measurements do not appear to be particularly reliable.

Field experiments in 1928-29 showed that the adfreezing strengths of gravelly sand and clayey silt to reinforced concrete are less than the adfreezing strength of the same soil to wood. The adfreezing strength of clayey silt to larch was less than that of the same soil to pine.

In the experiments of 1929-30, the boxes were filled with soil in December, after the ground had been thawed by burning the vegetable cover. This factor was reflected in a decrease in adfreezing strength of clayey silt. Thus, for instance, for gravelly sand, with a temperature of -15°C and a moisture content of 22%, the adfreezing strength was 1.9 kg/cm^2 (of the same order as in the experiments of 1928-29); while, for clayey silt at -9°C with a moisture content of 34%, the adfreezing strength was 2.2 kg/cm^2 , which is considerably lower than the values obtained for the same soil in 1928-29 (when moisture content was between 30 and 33%, temperature was -6°C to -17°C , and the adfreezing strength was 4.0 to 10.5 kg/cm^2).

In the winter of 1929-30, the adfreezing strength of ice to pine was also determined. An average of four tests gave 7.3 kg/cm^2 , with the temperature of the ice -9°C .

After studying the results of the work of 1928-30, the next winter's experiments were arranged with a greater number of repeat tests and with the greatest possible thoroughness (experiments were conducted by A. F. Mironov). The aim of these tests was to study the relation between the adfreezing strength of gravelly sand and clayey silt to wood and the moisture content of the ground.

The average results of the 1930-31 experiments are given in Table 51. An analysis of the results leads to the following conclusions:

(a) Adfreezing strength of both gravelly sand and silty soil increases with an increase in degree of ice saturation of the ground.

(b) For the soils studied, when coefficient of saturation and temperature conditions were the same, the values of adfreezing strength were very close; i. e., they do not depend on the grain-size composition of the soil.

The latter conclusion is not corroborated by the other experiments discussed. However, when the ground is close to ice saturation, it is true that the adfreezing strengths of various soils to wood are practically the same (see experiments with the three typical soils).

The above-cited data on the adfreezing strength of various soils to wood and concrete (at different temperatures and moisture contents) are of considerable importance for engineering purposes. Field tests have thoroughly demonstrated the importance of adfreezing strength of ground to foundations in causing structural deformations by heaving during freezing, and the necessity of allowing for adfreezing strength in determining the stability of structures erected where permafrost or deep seasonal freezing occurs.

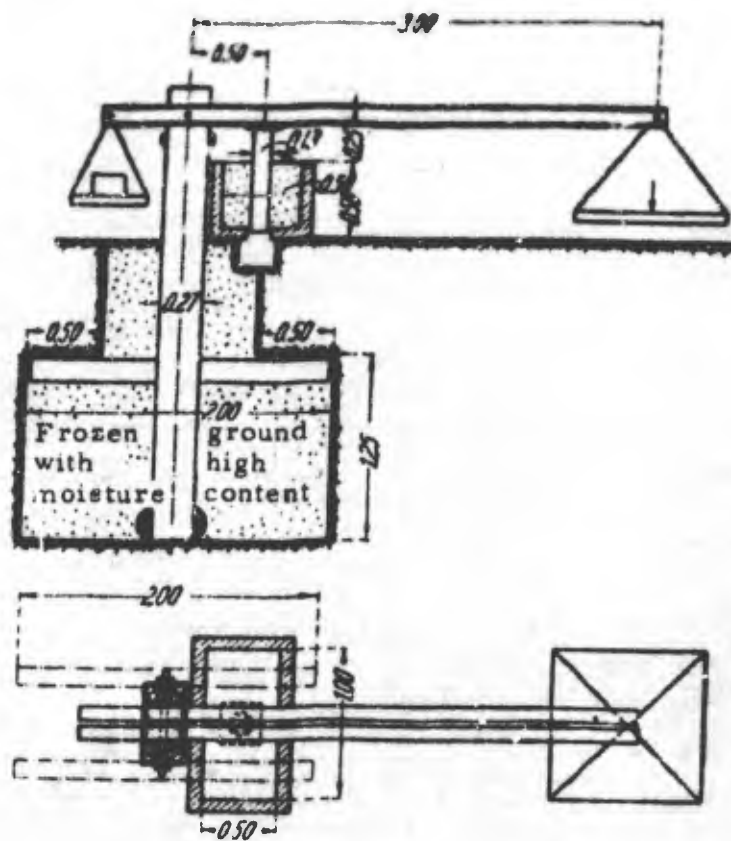

Figure 61. Field installation for measuring the adfreezing strength of ground to wood and other materials.

Table 51. Results of field experiments (1930-31) on adfreezing strength.

	Adfreezing materials		Grain-size composition (%)				Air temp (C)		Moisture		Avg adfreezing strength, (kg/cm ²)	No. of tests	Remarks
	Post	Soil	> 2 mm	2.0-0.05 mm	0.05-0.005 mm	< 0.005 mm	Avg for 10 days	At time of test	By weight, (%)	Coefficient of saturation			
1	Pine	Gravelly, pebbly sand	49	48	2	1	-32	-18	3.0	0.15	0.7	2	Grain-size composition is avg of 15 measurements
2	Pine	"	49	48	2	1	-33	-20	13.2	0.49	3.6	5	
3	Pine	"	49	48	2	1	-32	-20	15.9	0.60	8.9	4	Grain-size composition is avg of 2 measurements
4	Pine	"	49	48	2	1	-8	-10	21.6	0.80	13.7	4	
5	Pine	Clayey silt with gravel	13	38	37	12	-27	-28	14.7	0.49	3.5	2	Freezing entire layer
6	Pine	"	13	38	37	12	-8	-9	33	0.74	10.6	5	
7	Pine	"	13	38	37	12	-21	-12	39	0.72	11.6	2	Freezing layer by layer
8	Pine	Ice	-	-	-	-	-32	-16	-	-	9.7	5	
9	Pine	"	-	-	-	-	-8	-9	-	-	7.4	5	

CHAPTER V. DEFORMATION OF FROZEN GROUND UNDER VERTICAL LOAD

Types of Deformation of Frozen Ground

Basic concepts

For a correct solution of the problems of strength and stability of structures built upon frozen and permafrost ground, it is necessary to know not only the resistance of the frozen ground to external stresses, but also the deformation of the frozen ground produced by the external stresses. In many cases, the magnitude of the deformation, particularly of ground in the state of transition from frozen to thawed, will be the chief factor determining the strength and stability of structures erected upon the ground.

Experience has shown that any external force (load), no matter how small, when applied to a body causes a displacement of particles. This displacement of particles is called deformation.

Two basic types of deformation may be distinguished: elastic and residual or plastic. The capacity of bodies to return to their original form after the external stresses that cause the deformation are removed is called elasticity. If the deformation is such that the body is completely restored to its original form, it is called purely elastic deformation. If, after elimination of external forces, the body has a residual deformation and there is no restoration of the original form, the deformation is called plastic. If a load is applied to a sample of frozen ground, both plastic and elastic deformation will be observed. In this process, the particles are displaced until the external forces are balanced by the internal ones.

When the external forces reach a certain value, which depends on the particular physical properties and state of the body, purely plastic deformation will arise. Plastic deformation is characterized by the fact that, at the moment of maximum stress, called the critical value, increase of deformation in relation to time proceeds with greatest intensity, increasing almost in a direct ratio with time. Upon removal of the load, the deformation of a plastic body does not cease, but is considerably slowed down and stops after a certain time interval. However, the original form of the body will not be restored. The state of the material at the moment of the rapid increase of deformation with time, under a constant load, is called flow.

The essential distinction between frozen ground and elastic bodies is that the action of external forces on frozen ground always results in a residual deformation, concomitant with an elastic one. The sum of the residual and elastic deformations constitutes the total deformation.

In practice, all deformation of frozen ground is important — elastic, plastic, and total.

The total deformation of frozen ground under a vertical load is important for the distribution of stresses in the statically indeterminable systems of building structures (rigid frames, multispans girders, etc.) on such ground. In this case, both the amount of deformation (dependent on a number of factors) and the unequal deformation of different parts of the foundation are important. Unequal deformation is quite frequent under natural conditions because of the nonuniformity of sedimentation and variations in ground temperature, which depend on the temperature within the structure and its exposure to the sun.

Elastic deformation, which is a part of the total deformation, has a substantial effect on the distribution of stresses, primarily in the elements of the structure that are subject to dynamic loads (blows, vibrations, seismic oscillations, etc.). The stresses in foundations under vibrating machinery depend to a high degree on the rigidity of the bases. This is determined by the magnitude of elastic deformation.

In addition, the transmission of vibrations through the frozen ground (seismic and other waves) will also depend on the elasticity of the frozen ground.

Plastic deformations are not self-correcting with the passage of time and do not permit displaced frozen ground particles to return to their initial positions. They may therefore, have a major effect on the stability of a structure. The amount of plastic deformation,

as will be analysed later, depends to a high degree on the temperature of the frozen ground, and may be considerable when temperatures are close to 0C.

In our opinion, the study of plastic deformation of frozen ground, particularly at small negative temperatures, is one of the most important problems in the mechanics of frozen ground, and is capable of clarifying the behavior of frozen ground under load. This problem has not been studied previously and we present only our initial experiments in this direction. Further development and the posing of new questions concerning plastic deformation of frozen ground will probably be one of the most important tasks in the future study of the mechanics of frozen ground.

Let us analyze the nature of deformations of frozen ground and the relation between total, elastic, and residual deformations. Figure 62 shows the deformation of cubes of frozen silty sand and clayey soil (7 x 7 x 7 cm); these curves were obtained on the Amaler recording apparatus while testing the samples for compressive strength.

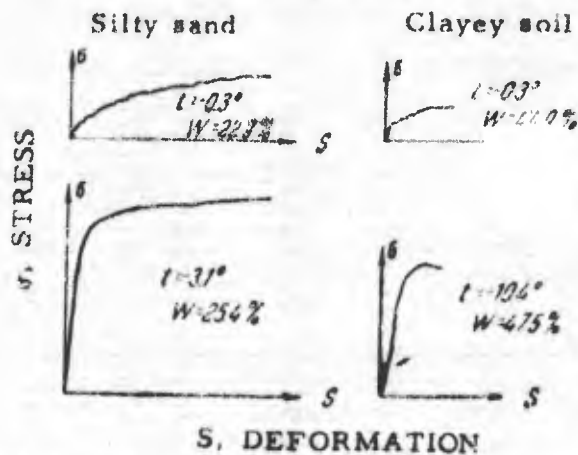

Figure 62. Deformation of frozen silty sand and clayey soil, (7 x 7 x 7 cm samples).

The upper curves in Figure 62 represent a soil sample at -0.3C, while the lower curves represent lower temperatures. At -0.3C, the relationship between deformation (S) and stress (σ) is curvilinear during the entire period of the stress increase, and there is no clearly expressed ultimate compressive strength. At lower temperatures, the relationship between stress and deformation is approximately linear within the same stress values as in the first case. With a further increase in load beyond a certain limit, the relationship between stress and deformation follows a curve similar to the deformation curve for metals. When the stress reaches a certain point, failure of the sample occurs. At low temperatures, this phenomenon occurs as in brittle bodies, often with a clearly expressed ultimate compressive strength.

The importance of temperature may be seen from the above examples of deformation of frozen ground.

Let us now analyze the correlation between the values of total, elastic, and residual deformations of frozen ground.

Table 53 lists data on the elastic and residual deformation of frozen ground under compression: we obtained these data by laboratory experiments on cubes with dimensions of 20 x 20 x 20 cm.

Table 52 gives the composition and basic physical properties of the soil used in these experiments, and in subsequently described experiments on elastic and plastic deformation of frozen ground.

Table 52.

Basic physical properties	Clay	Silty soil		Silty sand	Sand
		Undehydrated	Dehydrated		
Grain-size composition (%)					
Particles > 0.25 mm	1.5	0.8	0.5	39.9	71.2
0.25 to 0.05 mm	1.6	3.9	3.6	28.7	28.3
0.05 to 0.01 mm	10.8	15.8	14.2	12.7	0.5
0.01 to 0.005 mm	49.8	46.8	67.9	10.4	—
< 0.005 mm	36.3	32.7	13.8	8.3	—
Specific gravity in solid state	2.72	2.39	—	2.65	2.57
Full moisture capacity	28.9	29.0	—	25.7	20.1
Weight loss after dehydration by heat	—	—	17.8	—	—

Table 53. Elastic and residual deformation of frozen ground under compression.

No.	Type of frozen ground	Moisture content (%)	Temp of sample (C)	Load limits (kg/cm ²)	Time of load action (min)	Relative deformation		Ratio between elastic and total deformation (%)	
						Elastic	Residual (plastic)		
1	Clay	36.8	-2.8	0.5 - 1.5	6	6.6	7.4	49	
					7	6.1	12.9	32	
			10.5	12.7	71.9	15			
			11.5	14.2	56.2	20			
			12	22.0	135.0	14			
			13.5	20.0	125.0	14			
		32	-2.0	0.5 - 1.5	11.5	11.0	19.0	37	
					12.5	17.0	84.5	17	
			-1.5	0.5 - 3.5	13.5	22.0	205.0	10	
					14.5	20.0	356.0	5	
			-1.4	0.5 - 3.5	14.5	20.0	356.0	5	
					30	5.5	695.0	1	
2	Silty sand	17	-12.2	0.5 - 1.5	11	1.0	1.0	50	
					12	3.0	2.0	60	
			13	5.5	7.0	44			
			14	11.5	20.5	36			
			12.8	-1.7	0.5 - 2.5	17	4.2	7.6	33
						18	11.1	23.1	32
		16.9	-2.5	0.5 - 2.5	30	18.0	47.5	27	
					30	35.0	667.0	5	
		39.2	-4.9	0.5 - 1.5	11	3.5	0.1	97	
					12	9.0	4.5	67	
					17	19.0	14.0	58	
					34.5	43.0	73.0	37	
38.9	-1.0				0.5 - 3.5	18	33.5	26.0	56
						19.5	54.0	303.0	17

A study of the data (Table 53) leads us to the following conclusions:

1. Under compression, frozen ground shows both elastic and residual deformation. The initial elastic deformation, at the moment of load application, constitutes a significant part of the total deformation.

2. Under the given experimental conditions (under a load of 0.5 to 5 kg/cm² and at temperatures from -4.9°C to -0.8°C), the greatest elasticity is shown by silty soil. The ratio of elastic deformation to the total deformation ranges from 97 to 17%. Under the same conditions, silty sand shows less elasticity, and clay the least.

3. With a longer interval between loading, as well as with an increase in temperature, the elastic deformation of frozen ground decreases and the residual plastic deformation increases. The temperature of the frozen ground is one of the most important factors affecting plastic deformation.

4. With duration of load, the ratio between elastic and total deformation decreases; i.e., the elastic deformation constitutes a smaller part of the total deformation. Thus, for frozen clay with a moisture content of 32.2% and at a temperature of -1.3°C, elastic deformation constitutes barely 1% of the total deformation 30 min after loading. With longer duration of load, this ratio is still smaller.

Thus, the basic type of deformation of frozen ground under a constant load is residual deformation.

Nature of deformations

As noted before, frozen ground may be regarded generally as a four-phase system consisting of solid mineral particles, ice, supercooled water, and air. Under the action of external forces, each of the components will be deformed to a degree corresponding to its rigidity and its adhesion with other components.

The physical causes of elastic and residual deformation of frozen ground are different. They may be classified as follows:

Deformation

1. Elastic

Causes

- (a) Forces of molecular interaction among the separate components forming the frozen ground
 - (b) Elasticity of mineral particles and ice
 - (c) Elasticity of enclosed supercooled water and air
- (a) Modification of porosity under pressure
 - (b) Breakdown of solid particles
 - (c) Displacement of particles
 - (d) Plastic extrusion of ice at contact points between solid particles and between solid particles and ice

2. Residual

If all the voids of the frozen ground are filled with ice, which happens quite often under natural conditions, the deformation will depend primarily on the capacity of the ice to change its form under external forces; the intensity of deformation will depend on the negative temperature. With higher temperature, the deformation of ice increases, and its plasticity and fluidity become more and more evident. These factors exert a direct influence on the deformation of frozen ground.

Finally, with a rise to a positive temperature, the ice in the frozen ground begins to melt; deformation of the ground increases to an extreme degree, even without an increase in load on the ground; and the properties of the ground change radically. A temperature rise may exert a far greater effect on frozen ground under load than the load itself. It causes deformation of the ground to increase, slowly at first (at negative temperatures), but as the thaw point is approached, the deformation increases more and more, and, finally, at the thaw point, failure occurs. In studying the deformation of frozen ground, heat is considered as a kind of external force, and one of the sections of this chapter is devoted to its effect on the properties of frozen ground.

Methods of determination

Frozen ground deformation can be tested in the laboratory with frozen soil samples of a specific shape and volume. Also, the deformation of frozen ground and permafrost under natural conditions can be observed and measured.

In laboratory tests (in a cold room or in insulated containers), the samples of frozen soil may be artificial (prepared and frozen by one method or another) or natural, i. e., cut from a mass of frozen ground either in the active layer or in the permafrost layer. Experiments with soil samples of natural structure would be of considerable value, but no such experiments have been made as yet. Similarly, deformation of frozen ground under natural (field) conditions has been measured only in a few isolated cases. Because of the comparatively small deformation of frozen ground under customary loads on the ground, and because the instruments used for measuring were not sufficiently accurate, these tests give no positive results.

Yet, without doubt, measurement of the deformations of frozen ground under natural conditions would shed light on a number of problems regarding the mechanics of frozen ground.

The wire tensiometers of Davidenkov and the heat tensiometers of Polevoi, successfully tested in the laboratory (experiments of the LIKS), might prove quite useful for such tests.

The results of our experiments on deformation of artificially frozen ground from the permafrost region are given below.¹ Deductions from these experiments cannot claim

1. N. A. Tsytovich (1936) "O soprotivlenii merzlykh gruntov nagruzke (Resistance of frozen ground to load)" in Laboratornyye issledovaniia mekhanicheskikh svoistv merzlykh gruntov (Laboratory studies on mechanical properties of frozen ground), sb. I. Akademiia Nauk, SSSR.

N. A. Tsytovich and I. S. Vologdina (1936) "Opreделение uprugikh postoiannykh merzlykh gruntov i issledovanie ikh svoistv plastichnosti (Determination of elastic constants of frozen ground and investigation of its plastic properties)", ibid., sb. 2.

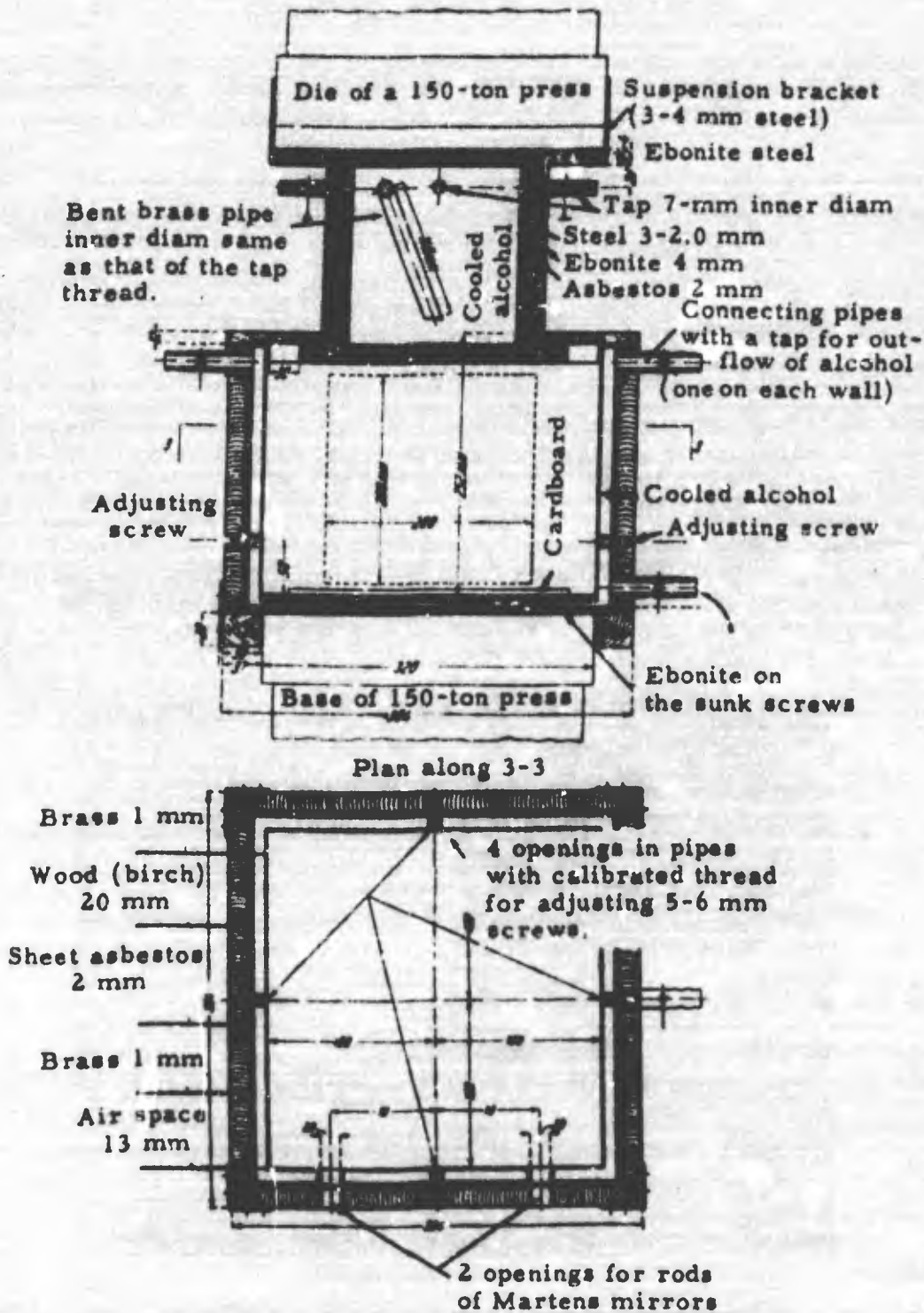

Figure 63. Cross-section of insulated box for testing mechanical properties of frozen grounds.

general validity. We think, nevertheless, that the order of the values obtained and the basic factors affecting deformations of frozen ground have been established.

Further experiments with natural samples of permafrost and experiments under field conditions will probably render the data more precise, and will introduce appropriate corrections.

Elastic Deformation of Frozen Ground

Laboratory experiments

Laboratory experiments were conducted on the dependence of elastic deformation on a number of factors (temperature, moisture, grain-size composition of the soil), using artificially frozen samples of four typical soils of the permafrost regions.¹

Laboratory experiments make it possible to expose the samples to conditions desired by the experimenter. In addition, they furnish material for the methodology of setting up field experiments and indicate the points to which attention should be given in field investigations.

The tests described below used frozen soil with a moisture content closely corresponding to complete ice saturation of the pores. Soil with the required moisture content was placed in removable metal molds (20 x 20 x 20 cm). Thermocouples were placed at four points inside the sample; then the sample was frozen and, to ensure the required negative temperature, was kept for 12 to 14 hr in an automatically regulated insulated chamber.

During the test, the cube of frozen ground was placed in an insulated box with hollow walls. The walls of the box, and the base and die of the press, were cooled by denatured alcohol at a negative temperature.

Figure 63 shows a cross section of the insulated box. Figure 64 shows a photograph of the entire set up used in the experiments (150-ton press, insulated box, galvanometer for reading the thermocouples, the melting ice for thermocouple reading at the zero point for control, etc.).

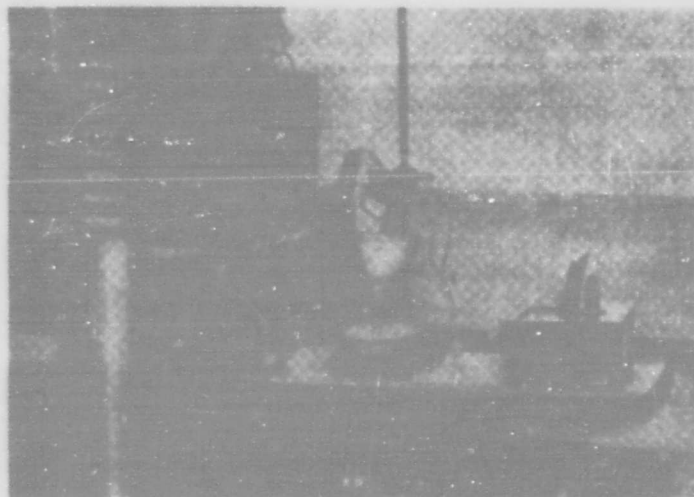

Figure 64. Setup of experiments measuring the elastic and plastic deformation of frozen grounds.

1. For physical properties of the soil used in this study, see Table 52.

Deformation of frozen ground caused by loading and unloading was measured with the Martens mirror apparatus, which gives a magnification of 500. To set up mirrors at the two sides of the frozen soil cube, metal plates (with a surface of about 0.5 - 1 cm²), soldered to screws (1.5 cm long), were placed 15 or 20 cm from each other. The screws with the plates were installed in apertures made in the cubes. The openings were plastered up with saturated soil so that, after freezing, the screws were firmly cemented in the frozen soil cubes. In some cases, the apertures for the screws were made with a red-hot metal rod, which speeded up the work.

Deformation was read with field glasses from graduated rods set up at a distance of 100 cm. Deformation of the frozen soil samples was measured either after loading and unloading (repeated several times when determining the modulus of elasticity), or under a constant load at definite time intervals, measured with a chronometer.

Young's modulus

As is well known, the elastic constants which fully define the properties of isotropic, homogeneous material are: the modulus of longitudinal (normal) elasticity (called Young's modulus) and Poisson's ratio.

Frozen ground is not an isotropic body. However, it may be regarded as a quasi-isotropic solid possessing a certain degree of elasticity. The relationship between deformation and stresses for elastic bodies follows Hooke's linear law. For frozen ground, the linear relationship between stresses and deformation may be assumed to be valid only within certain definite limits and under certain physical conditions. A certain stress at a given negative temperature would constitute such a limit. For practical purposes and without too great a margin of error, the linear relationship can be assumed to be valid for frozen ground at temperatures near zero, with the stresses that usually occur in laying foundations (of the order of 1 to 5 kg/cm²). At lower temperatures, the limit of application of this "linear" relationship increases.

Thus, in the future, when studying the elastic deformation of frozen ground, we shall accept the linear relationship between stress and deformation as valid within the established limits.

In laboratory experiments on elastic deformation, frozen ground was tested by two methods: (1) repeated, cyclic loading and unloading (within the limits of 2.5 to 5 kg/cm²); and (2) under a periodically acting load (always for the same time interval of 30 sec), within the limits of 0.5 to 5 kg/cm², with the load increasing 1 kg/cm² with every cycle.

In determining deformation, the entire length of the samples (20-cm cubes) was not measured, but only the middle part, which was 2.5 to 5 cm distant from the supporting and the compressing planes of the press. This method was followed in order to lessen the effect of the forces of friction arising along the planes of contact on the measured deformation.

As the longitudinal elastic deformation under compression is completely defined by Young's modulus, we give below the results of calculations of Young's modulus, based on measuring the elastic deformation of the frozen ground samples.

Young's modulus was calculated from

$$E = \frac{\sigma}{e} \quad (27)$$

where E is Young's modulus (usually measured in kg/cm²); σ is the stress (in kg/cm²) under which the deformation was measured; and e is the relative elastic deformation (the ratio of the elastic shortening to the original length).

During the experiments, the effects of temperature, moisture content, and grain-size composition, as well as the methods of load action, were studied.

The initial experiments conducted during the winter of 1933-34 showed that Young's modulus for frozen ground is high and depends on a number of factors. In these experiments, the frozen ground samples were subjected to loading and unloading within the limits of 2.5 to 5 kg/cm² until elastic deformation was approximately constant.

PRINCIPLES OF MECHANICS OF FROZEN GROUND

In the process, a certain packing of the frozen ground was observed. This was manifested by an increase in hardness, i. e., an increase in the modulus of elasticity. The measured section of the sample (20-cm cube) was 15 cm long. The results of six experiments conducted in 1933-34 are given in Table 54.

Table 54. Young's modulus for frozen ground under cyclical load of 2.5 to 5 kg/cm² (ice-saturated samples).

No.	Type of soil	Moisture by weight (%)	Temp of sample (C)	Young's modulus, (kg/cm ²)
1	Clay (36% of particles <0.005 mm)	47.1	-3.0	64,000
2	Silty soil (14% < 0.005 mm)	84.3	-2.0	31,000
3	Silty sand (8% < 0.005 mm)	21.9	-2.0	59,000
4	"	19.1	-2.5	62,000
5	"	19.2	-5.2	75,000
6	Sand (99% 1 - 0.05 mm)	16.5	-3.7	125,000

The data show that Young's modulus is higher for ice-saturated frozen ground than for pure ice (see Ch. I), and depends on the temperature as well as on the mechanical composition and moisture content of the ground.

Table 55 gives the results of our experiments (1934-35) on the dependence of the modulus of elasticity (Young's modulus) of frozen ground on temperature.¹ Experiments were made with 20-cm cube samples, and deformation was measured on the central part, which was 10 cm long. The moisture content (by weight) of the frozen ground samples, as indicated in the table, refers to this part of the sample. The moisture content is close to ice saturation of the ground cavities. Figure 65 shows the results graphically.

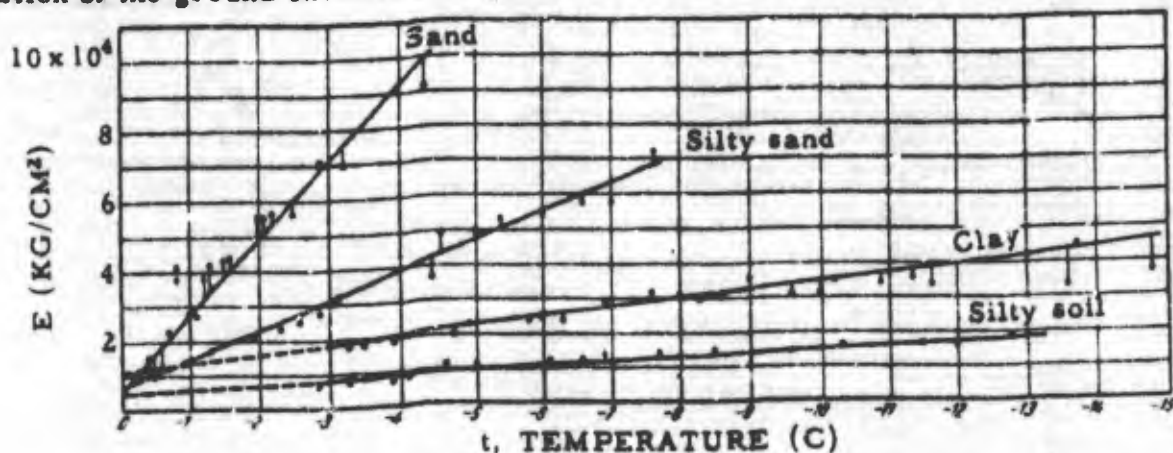

Figure 65. Young's modulus of frozen ground vs negative temperature.

These data show that the relationship between Young's modulus for frozen ground and temperature is linear, within the limits of these experiments, since the deviations of single measurements from the straight line do not exceed the experimental margin of error.

Therefore, we may write

$$E = a + \beta t \quad (28)$$

1. The table is given in an abbreviated form; for clay and silty soil, the results of odd-numbered measurements are given, i. e., nos. 1, 3, 5, 7. In the 1934-35 experiments, the values of Young's modulus were somewhat less than in the 1933-34 experiments, which may be explained by different test conditions (absence of repeated load, shorter length of the portion measured, different moisture content, etc.).

where E is Young's modulus, α and β are the parameters of the straight line, and t is the temperature in C.

Parameters of the straight line which expresses, under given experimental conditions, the dependence of Young's modulus for frozen ground on the negative temperature (Table 56) were determined from the experimental results (Table 55, Fig. 65). Table 56 also gives Krayger's equation for Young's modulus of pure ice.¹

Table 55. Dependence of modulus of elasticity of frozen ground on temperature loads from 2.5 to 5 kg/cm².

Clay (36% of particles < 0.005 mm; moisture 29%; volume weight 1.87 tons/m ³)		Silty soil (14% of particles < 0.005 mm; moisture 26%; volume weight 1.45 tons/m ³)		Silty sand (8% of particles < 0.005 mm; moisture 23%; volume weight 2.08 tons/m ³)		Sand (99% of particles to 0.05 mm; moisture 22%; volume weight 1.89 tons/m ³)	
Avg soil temp (C)	Young's modulus (kg/cm ²)	Avg soil temp (C)	Young's modulus (kg/cm ²)	Avg soil temp (C)	Young's modulus (kg/cm ²)	Avg soil temp (C)	Young's modulus (kg/cm ²)
-14.8	37,300	-12.8	19,200	-7.6	72,500	-4.3	91,100
-13.6	33,600	-12.0	16,600	-7.0	58,000	-3.2	69,500
-11.6	34,200	-11.5	16,500	-6.6	58,000	-2.9	71,400
-11.4	36,000	-10.3	16,400	-6.0	54,700	-2.5	56,800
-10.9	34,500	-9.6	14,700	-5.4	53,000	-2.2	56,800
-10.2	35,400	-8.5	15,700	-5.0	49,300	-2.1	55,500
-10.0	31,800	-7.7	14,900	-4.5	49,300	-2.0	55,500
-9.6	30,900	-6.9	14,000	-4.4	37,000	-1.6	43,800
-9.0	35,700	-6.5	12,500	-3.1	32,300	-1.5	43,500
-8.6	31,300	-6.1	12,300	-2.9	27,700	-1.3	42,900
-8.3	30,200	-5.3	12,000	-2.6	25,500	-1.2	38,400
-8.0	31,400	-5.0	10,700	-2.3	22,900	-1.1	27,300
-7.6	32,000	-4.6	12,000	-1.9	20,400	-1.0	27,700
-6.9	28,800	-4.3	11,200	-1.3	17,800	-0.8	38,400
-6.3	24,100	-4.1	8,800	—	—	-0.8	41,700
-6.0	25,000	-3.8	7,600	—	—	-0.7	22,700
-5.8	24,400	-3.3	7,500	—	—	-0.6	12,200
-5.4	22,700	-2.8	6,800	—	—	-0.5	10,200
-4.9	22,900	—	—	—	—	-0.4	14,700
-4.7	20,300	—	—	—	—	-0.4	12,100
-4.3	21,600	—	—	—	—	—	—
-3.9	18,600	—	—	—	—	—	—
-3.7	19,700	—	—	—	—	—	—
-3.5	18,200	—	—	—	—	—	—
-3.3	17,800	—	—	—	—	—	—

Table 56. Effect of temperature upon Young's modulus for frozen ground and ice.

No.	Soil	Moisture by weight (%)	Coefficient of porosity	Young's modulus, E (kg/cm ²)
1	Sand	22	0.658	$E = (0.5 + 2.18t) \times 10^4$
2	Silty sand	23	0.567	$E = (0.6 + 0.8t) \times 10^4$
3	Clay	29	0.876	$E = (1.1 + 0.24t) \times 10^4$
4	Silty soil	26	1.08	$E = (0.5 + 0.11t) \times 10^4$
5	Ice	—	—	$E = (5.0 + 0.10t) \times 10^4$

Upon analyzing Table 56, we conclude that the angle coefficient of the straight line (β), which expresses the dependence of Young's modulus on temperature, decreases with an increase in the soil skeleton, while the initial coefficient of the straight line for sand, silty sand, and silty soil remains almost constant (for the given experimental conditions). Thus, the effect of negative temperatures on Young's modulus is particularly significant for sand ($\beta = 2.18$) and becomes less significant for clay, silt, and ice.

1. A. N. Komarovskii (1932) *Deistvie ledianogo pokrova na sooruzheniia i bor'ba s nim* (Effect and control of ice cover on structures), Gosenergizdat, p. 21.

As shown by further experiments, the initial coefficient of the straight line a , which is numerically equal to Young's modulus for frozen ground at 0°C, depends on the degree of ice saturation of the ground.

It must be noted, however, that the experimental data concerning the value of Young's modulus give some rather divergent results. Therefore, the relationships indicated above must be regarded merely as determining the order of magnitudes of Young's modulus of frozen ground, as well as clarifying the effect of separate factors on its value.

In addition to the experiments described above, a series of tests was conducted with samples of frozen ground of varying moisture content and with the load increasing step-by-step at equal time intervals (30 sec). In these experiments, the load varied from 0.5 to 5 kg/cm², increasing 1 kg/cm² with each step. Each loading and unloading was repeated many times, while the temperature was increased gradually, so that it was possible to determine the relation of Young's modulus for frozen ground to the soil temperature for each step.

These experiments also were aimed at studying the effect of the ice saturation of frozen ground and the value of the cyclic load on the elastic deformation.

As an example, Figure 66 graphically presents the average results of eight experiments on the modulus of elasticity of frozen clay with a moisture content of 33.3% (five experiments); 27.4% (two experiments); and 18.9% (at three steps of loading: 0.5 to 1.5 kg/cm², 0.5 to 2.5 kg/cm² and 0.5 to 3.5 kg/cm²).

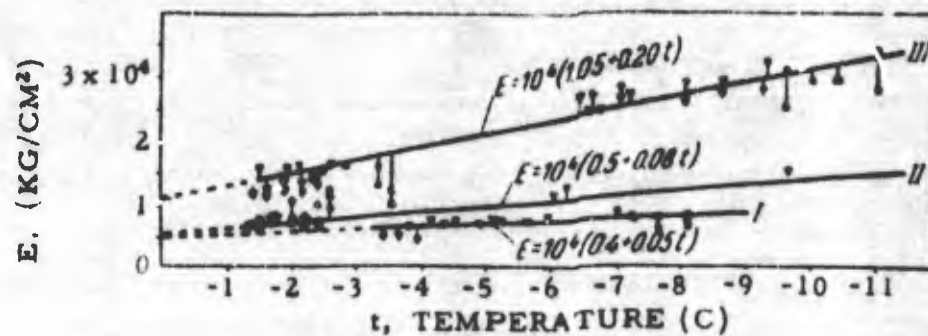

Symbol	Load in kg/cm ²	Line no.	Moisture in %	Coefficient of porosity
•	0.5-1.5	I	18.9	0.886
◦	0.5-2.5	II	27.4	0.857
◻	0.5-3.5	III	33.3	1.01

Figure 66. Effect of temperature and ice saturation on the Young modulus of frozen clay at various degrees of loading.

Results similar to those shown in Figure 66 were also obtained for frozen silty sand and silty soil.

The data obtained under the above-described experimental conditions indicate the dependence of the modulus of elasticity on the degree of ice saturation of the ground and on the negative temperature. We did not succeed in determining a load effect within 0.5 to 3.5 kg/cm²; within these limits, it may be assumed that Young's modulus for frozen ground does not depend on the value of the compressive load. However, with other methods of application and with a different load value, such a statement cannot be regarded as valid. On the contrary, other data, although they refer to ice, indicate the dependence of Young's modulus on the method of loading.

Table 57 gives the results of several experiments with river ice conducted by V. N. Pinegir. These experiments show that: " (1) the modulus of elasticity of ice falls very

rapidly under constantly increasing loads (stresses), and this decrease proceeds more intensively with smaller loads than with big ones; and (2) the modulus of elasticity of ice increases very sharply under repeated loading and unloading at increasing intervals."

Table 57. Modulus of elasticity of river ice under pressure in relation to magnitude and method of loading.

No.	Range of load, (kg/cm ²)	Temp (C)	Young's modulus (kg/cm ²)	Remarks
1	1.07- 3.75	-3	37,500	Samples from lower (looser) ice layer; load along the axis of crystals; tests conducted in open air; load applied by lever press and held for 3 to 5 min.
	3.75- 6.44	-3	13,700	
	6.44- 9.12	-3	9,400	
	9.12-11.80	-3	8,600	
	11.80-14.48	-3	6,000	
	14.48-17.16	-3	4,400	
	17.16-19.83	-3	3,400	
2	0.87- 1.74	-5	48,900	
	0.87- 2.61	-5	48,900	
	0.87- 3.48	-5	48,700	
	0.87- 5.22	-5	65,200	
	0.87- 6.09	-5	70,000	
	0.87- 6.96	-5	72,000	
	0.87- 7.83	-5	76,000	
	0.87- 8.70	-5	78,000	
	0.87- 9.57	-5	80,000	
	0.87-10.49	-5	81,000	
	0.87-11.31	-5	82,500	
	0.87-12.18	-5	84,000	
	0.87-13.05	-5	80,500	

Results of experiments on the effect of ice saturation of frozen ground on Young's modulus, at different negative temperatures, and with the load changing step-by-step from 0.5 to 3.5 kg/cm², may be summarized as in Table 58. From the data, we arrive at the following conclusions:

1. Within the limits studied, the modulus of elasticity of frozen ground under compression increases with increased ice content of the ground.
2. With increase in the negative temperature of frozen ground, its modulus of elasticity also increases; and the greater the ice content of the frozen ground, the greater the effect of the negative temperature on the modulus of elasticity (with an increase in moisture, the angle coefficient of the straight line increases).

The equations for the modulus of elasticity of frozen ground given in Table 58 and those obtained from many repeated loadings and unloadings from 2.5 to 5.0 kg/cm², are compared in Table 59.

Comparison of the equations expressing the dependence of the modulus of elasticity of frozen ground on temperature shows that the angle coefficient of the straight line changes only slightly for silty sand and clay (equations for these soils have been evolved on the basis of a large number of experiments).

Thus, the data establish the magnitude of the modulus of elasticity of frozen ground for four typical soils from the permafrost region, and its dependence on temperature, moisture

1. V. N. Pinegin (1927) Ob izmeneniakh modulia uprugosti i koeffitsienta Puassona u rechnogo l'da pri szhatii (Variations in modulus of elasticity and Poisson's ratio for river ice under compression), Zhurnal Nauka i tekhnika, Odessa NTO. VSNK., no. 3, 4.

(ice saturation), and grain-size composition of the frozen ground. To establish more precise relationships, and determine the effect of the type and size of the load require further experiments, especially with samples of permafrost of undisturbed structure.

Table 58. Effect of moisture (ice saturation) and negative temperature upon modulus of elasticity of frozen ground under compression (Load from 0.5 to 3.5 kg/cm²).

No.	Type of soil	Moisture by weight, (%)	Coefficient of porosity	Young's modulus, E (kg/cm ²)	No. of tests
1	Clay	18.9	0.826	$E = (0.4 + 0.05t) 10^4$	1
	Clay	27.4	0.857	$E = (0.5 + 0.08t) 10^4$	2
	Clay	33.3	1.01	$E = (1.1 + 0.20t) 10^4$	5
2	Silty soil	17.7	0.991	$E = (0.1 + 0.07t) 10^4$	1
	Silty soil	28.5	0.899	$E = (0.2 + 0.36t) 10^4$	2
3	Silty sand	11.2	0.483	$E = (0.1 + 0.26t) 10^4$	2
	Silty sand	15.7	0.519	$E = (0.1 + 0.75t) 10^4$	5

Table 59. Effect of temperature upon modulus of elasticity (kg/cm²) of frozen ground under varying conditions of load.

Type of soil	With repeated action of 1 load cycle		With 4-cycle load	
	Moisture by weight, (%)	Load 2.5 to 5 kg/cm ²	Moisture by weight, (%)	Load: 0.5 to 1.5 kg/cm ² 0.5 to 2.5 kg/cm ² 0.5 to 3.5 kg/cm ²
Silty sand	23	$E = (0.6 + 0.80t) 10^4$	15.7	$E = (0.1 + 0.75t) 10^4$
Clay	29	$E = (1.1 + 0.24t) 10^4$	33.3	$E = (1.1 + 0.20t) 10^4$
Silty soil	26	$E = (0.5 + 0.11t) 10^4$	28.5	$E = (0.2 + 0.36t) 10^4$

Poisson's ratio

The second constant characterizing the elasticity of isotropic bodies is Poisson's ratio, which is the ratio of the elastic, lateral relative contraction to the elastic, longitudinal relative elongation. In view of its extremely small numerical value (for homogeneous, isotropic materials, Poisson's ratio $\mu < 0.5$), determination of Poisson's ratio for frozen ground is, technically speaking, a highly complex problem.

We have made an attempt to determine Poisson's ratio for frozen ground by torsion.¹

Moistened ground was frozen in detachable metal molds and tested on an Amsler machine. The middle portion of the sample was cylindrical. Martens mirror apparatus for measuring deformation during torsion was set on two iron stems, which had been frozen into the sample. The shape of the sample after failure by torsion may be seen in Figure 67.

To insulate the sample from the surrounding air (when tests were performed at room temperature), the sample was wrapped in a layer of cooled cotton. If tests were conducted at negative temperatures, no insulation was applied.

The setup for the torsion experiments is shown in Figure 68.

The elastic angle of torsion was determined by measuring, during loading and unloading, the displacement of two sections of the cylindrical part of the sample, a certain dis-

1. N. A. Tsyrovich and I. S. Vologdina, op. cit.



Figure 67. Sample of ice after failure by torsion.

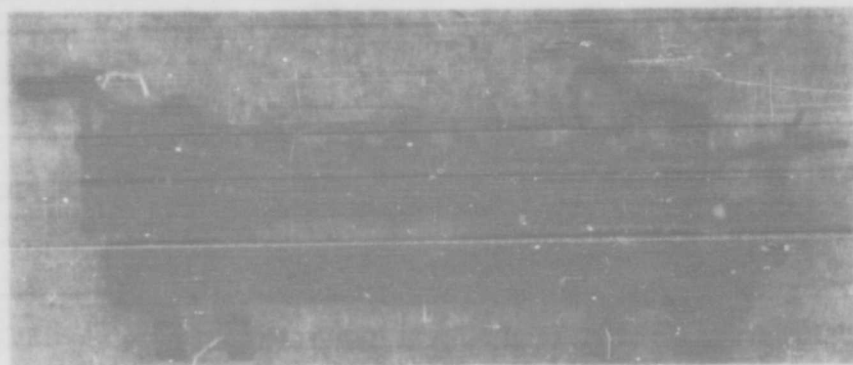

Figure 68. Setup for torsion experiments.

tance apart. Knowing the angle of torsion and, from the experiment, the moment of torsion, as well as the distance between the sections and the diameter of the sample, the modulus of elasticity in shear, G , of the frozen ground was calculated. From the shear modulus, Poisson's ratio was computed from the relationship well known from the theory of the resistance of materials:

$$G = \frac{E}{2(1 + \mu)}$$

where G is the shear modulus, μ is Poisson's ratio, and E is Young's modulus.

Practical application of the above equation proved to be extremely difficult since, to calculate Poisson's ratio, it is necessary to know Young's modulus, which is determined under precisely the same conditions as the shear modulus, and could not always be determined.

These experiments showed that torsion tests are poorly suited for determining Poisson's ratio for frozen ground. Consequently, the data obtained by torsion must be regarded as only approximate and merely indicative of the magnitude of Poisson's ratio for frozen ground.

Poisson's ratio for frozen ground, at temperatures from -0.3°C to -1.0°C , is:

For clay, moisture content about 33%	0.4 to 0.5
For silty soil, moisture content about 29%	0.3 to 0.4
For sand and silty sand, moisture content about 18%	0.2 to 0.4

V. N. Pinegin obtained values of Poisson's ratio for river ice under compression which ranged from 0.25 to 0.50.

In the case of stabilised plastic deformations, Poisson's ratio for frozen ground (as well as for other materials) will be equal to 0.5.

Table 60 gives the results of several experiments by Pinegin determining Poisson's ratio for river ice. From this table, we conclude that:

- (1) Poisson's ratio for river ice increases with an increase in stress and in number of load cycles;
- (2) Poisson's ratio for ice increases with the lowering of temperature, although this increase is quite negligible.

Table 60. Poisson's ratio for river ice under compression

Experiment no.	Stress intervals (kg/cm ²)	Temp (C)	Poisson's ratio	Remarks
1	1.07- 3.75	-3	0.266	Samples from lower part of ice; load along the axis of crystals
	3.75- 6.44	-3	0.280	
	6.44- 9.12	-3	0.250	
	9.12-11.80	-3	0.298	
	11.80-14.48	-3	0.289	
	14.48-17.16	-3	0.390	
	17.16-19.84	-3	0.404	
2	0.87- 3.04	-7	0.239	For nos. 2, 3, and 4, results of first cycle of loading are given; upper ice
3	0.58- 5.88	-9	0.318	
4	0.79- 1.58	-12	0.326	

Analytical determination of elastic deformation of frozen ground masses

To determine elastic deformation of frozen ground under the action of local load, the general deformation method (Boussinesq-Schleicher) and the local deformation method (Winkler-Schwedler) may be used. The first method takes into account elastic displacements, not only of the points lying beneath the loaded surface but also of the points lying beyond this surface. At present, the general deformation method is used to determine the elastic deformation of rigid foundations and to make calculations for elastic girders and slabs lying on a continuous elastic base. The local deformation method takes into consideration only the settling of the loaded surface, assuming that settling of the ground beyond the surface under load, as well as in the immediate vicinity of the loaded area, is equal to zero. This is contrary to direct observations.

The Boussinesq-Schleicher method. If a concentrated force is applied on a surface of ground which is limited by a horizontal plane and has considerable dimensions in all the other directions, then the vertical displacement (subsidence) of the points located on one-half the area of the limiting plane and situated at a distance R from the point of application of the concentrated force P will be defined, according to Boussinesq, by the

expression:¹

$$Y = \frac{P(1 - \mu^2)}{\pi ER}, \quad (29)$$

where Y is the vertical displacement or subsidence of any point of the limiting surface, and P is the concentrated force.

By designating:

$$C = \frac{E}{1 - \mu^2}, \quad (30)$$

we have:

$$Y = \frac{P}{\pi CR}. \quad (31)$$

If the surface of frozen ground is acted upon by a load p (pressure) uniformly distributed over an area F , the elastic subsidence of the loaded area will be determined by integrating the expression for Y from the action of the concentrated forces $p dF$.

If, in the preceding equation, we substitute

$$P = p(\xi, \eta) d\xi d\eta$$

and

$$R = \sqrt{(x - \xi)^2 + (y - \eta)^2}$$

where ξ and η are coordinates of the center of gravity of the designated elementary area dF , and x and y are the coordinates of the point whose subsidence is being determined, then

$$Y = \frac{1}{\pi C} \int_0^{a_1} \int_0^{b_1} \frac{p(\xi, \eta)}{\sqrt{(x - \xi)^2 + (y - \eta)^2}} d\xi d\eta. \quad (32)$$

Boussinesq gives the solution of this equation for a circle, and Schleicher gives it for a rectangle with any ratio of the sides $a = a/b$ (where a is the length of the rectangle, under load, and b is its width). In its final form, the formula for the subsidence of the points under the loaded area and for the average subsidence of the entire loaded area may be presented as

$$Y = \frac{\omega p \sqrt{F}}{C} \quad (33)$$

where ω is the coefficient dependent on the shape of the loaded area (in the case of a rectangle, on the ratio of its sides $a = a/b$) and on the rigidity of the load-transmitting body (foundation); p is the uniformly distributed relative load (pressure per unit area); F is the area; $C = E/(1 - \mu^2)$ is the coefficient of the elastic mass, where E is the modulus of elasticity and μ is Poisson's ratio.

Some values of coefficient ω for circles and rectangles with different side ratios, a , are given in Table 61. The coefficient ω_0 corresponds to maximum displacement at the

1. J. V. Boussinesq (1885) *Application des potentiels à l'étude de l'équilibre et du mouvement des solides élastiques*. Paris: Gauthier - Villars, p. 92; also in N. A. Tsytovich (1934) *Osnovy mekhaniki gruntov* (Principles of soil mechanics).

Table 61. Values of Coefficient ω , equation 33

Coefficient of shape	Circle	Square	Rectangle with ratio of sides $a = \frac{a}{b}$										
			1.5	2	3	4	5	6	7	8	9	10	100
ω_0	1.13	1.12	1.11	1.08	1.03	0.98	0.94	0.91	0.88	0.85	0.83	0.80	0.40
ω_m	0.96	0.95	0.94	0.92	0.88	0.85	0.82	0.80	0.77	0.75	0.73	0.71	0.37

center of a foundation with rigidity close to zero (membrane), while ω_m corresponds to the average displacement of the entire foundation. This subsidence differs very little from the sinking of an absolutely rigid die.¹ That is why the coefficient ω_m should be used to determine elastic deformation of rigid foundations, while coefficient ω_0 should be used to determine deformation of elastic slabs of slight rigidity. When we know the elastic constants (E and μ) for a given frozen ground, we can easily determine elastic deformation of frozen ground under the action of a local load, using the above relationships.

The second method of determination (or rather, calculation) of elastic deformation, the Winkler-Schwedler method, is based on Winkler's assumption, which may be expressed as:

$$p = ky \quad (34)$$

where p is the specific pressure on the ground; k is the coefficient of the "elastic bed" or the elastic foundation; and y is the elastic deformation of the ground at a given point.

Most methods of calculating for "girders and slabs lying on a continuous elastic base" as well as for foundations under dynamic loads (vibrations, strokes), accounting for the "elasticity" of the ground, are based on Winkler's assumption. However, according to the latest research, the coefficient of the elastic base does not represent a constant value, which would follow from Winkler's hypothesis, but depends on a whole series of factors, of which the most important are the size and shape of the loaded area, and the rigidity of the stamp (foundation) transmitting the load.

This dependence may be established by comparing the formula for elastic deformation, according to the Boussinesq-Schleicher theory, with the formula for local deformation.

According to eq (34)

$$y = \frac{p}{k}$$

We treat elastic deformation as identical:

$$\underline{Y} = y$$

Substituting the above relationships for deformation, we have:

$$\frac{\omega p \sqrt{F}}{C} = \frac{p}{k}$$

hence

$$k = \frac{C}{\omega \sqrt{F}} \quad (35)$$

1. S. P. Timoshenko (1934) Theory of elasticity. [McGraw-Hill Book Company, Inc.]. Translated from English by N. A. Shoshin, Leningrad, 1934, p. 372.

or, substituting

$$C = \frac{E}{1 - \mu^2}$$

we obtain

$$k = \frac{E}{(1 - \mu^2) \omega \sqrt{F}} \quad (35')$$

Equation 35' establishes the dependence of the coefficient of the elastic base on the elastic constants of the frozen ground, on the shape and size of the load-transmitting area, and on the rigidity of the foundation. The rigidity of the foundation is calculated by means of the coefficient ω , which is known for a flexible foundation with a rigidity close to zero (values of ω_0 in Table 61), and approximately known for highly rigid foundations (values of ω_m).

A more precise relationship between the coefficient of the elastic base and the rigidity of the foundation has now been obtained for an exceedingly long (to be more precise, an infinitely long) foundation beam; it is expressed as follows:¹

$$k = 0.352C^3 \sqrt{\frac{bC}{E_1 I_1}} \quad (36)$$

where $C = E/(1 - \mu^2)$ is the coefficient of the elastic semi-area (E is Young's modulus for frozen ground and μ is Poisson's ratio); b is the width of the beam; E_1 is Young's modulus for the beam material (foundation); and I_1 is the moment of inertia of the area of the transverse cross section of the beam.

We have dealt in some detail with the determination of the elastic-base coefficient of frozen ground because, at present, it is impossible to calculate for foundations undergoing vibrations (turbogenerators, steam hammers, sawmill frames, etc.) without knowing this coefficient. Moreover, this value is necessary for calculating for beams and slabs resting on an elastic base.

Therefore, the relationships obtained permit us to utilize, for practical purposes, the above-cited data on the modulus of normal elasticity (Young's modulus) and Poisson's ratio for frozen ground.

Plastic Deformation of Frozen Ground

Matter in a plastic state exhibits simultaneously the properties of solids and liquids. This condition is characterized by the fact that, at a certain (critical) value of stress, matter can flow like any viscous liquid. Deformation of a solid in a plastic state under constant load does not cease with the passage of time, but acquires a constant speed.

Plastic deformation of frozen ground and conditions under which it arises constitutes a very important factor which often determines the stability and strength of structures erected on permafrost. Frozen ground must not bear stresses which would cause this type of deformation.

The initial tests on plastic deformation of frozen ground were conducted by us simultaneously with the study of elastic deformation.² The results of these tests are described below.

1. N. M. Gersevanov and Ia. A. Macheret (1935) K voprosu o beskonechno dlinnoi balke na uprugoi pochve, nagrushennoi siloi P (Contribution to the problem of a beam of infinite length, under load P, resting on elastic soil), *Gidrotekhnich. stroit.*, no. 10; also B. P. Pavlov (1935) K raschetu balki, lizhashchei na uprugom osnovanii (Calculations for a beam on an elastic foundation), *Ibid.*, no. 11.

2. See Laboratornye issledovaniia mekhanicheskikh svoisty merslykh gruntov (Laboratory studies on mechanical properties of frozen ground), sb. 2, Akademiia Nauk, 1936.

In the future it will be necessary to organize a broad study of plastic deformation of frozen ground and enlarge and refine the preliminary conclusions thus far reached.

Experimental data

The experiments on plastic deformation of frozen ground under pressure were conducted with the same three soil types (clay, silt, and silty sand) for which the other mechanical properties were determined.

The deformation of a 10 cm-long portion of the central section of the sample (a 20-cm cube) was measured using Mariens mirror apparatus. The load remained constant during the entire time of observation. Measurements were made every 30 sec. Duration of load application was about 10 min (for 20 measurements). This proved to be sufficient time to determine the rate of deformation under a given load. The increase of deformation during this period became almost stable, as may be seen from the deformation curves of frozen ground with the passage of time (Figs. 69, 70, 71). Several control experiments with longer periods of load action (up to 30 min) produced similar results.

Figures 69, 70 and 71 show typical curves of relative deformation of frozen ground under the action of a constant load of varying intensity (from 1.5 to 5 kg/cm²).

Consideration of the above given data permits us to conclude that deformation of frozen clay, silty soil, and silty sand, under the test conditions indicated in the diagrams, does not disappear with the passage of time even under a load exceeding 1.5 kg/cm². Several minutes after the start of load action, the curve of relative deformation becomes a straight line. This indicates that the increase of deformation per unit time (the rate of deformation) assumes a constant value, i. e., plastic flow takes place.

The constant increments of relative deformation per unit time can be determined for the straight portion of the deformation curves. Such determination was made, based on 14 tests under 4 different loads. The data obtained, i. e., the constant increments of deformation per unit time (the constant rate of deformation) can be considered as a measure of the intensity of plastic flow of frozen ground under a constant load. The results of calculations are given in Table 62.

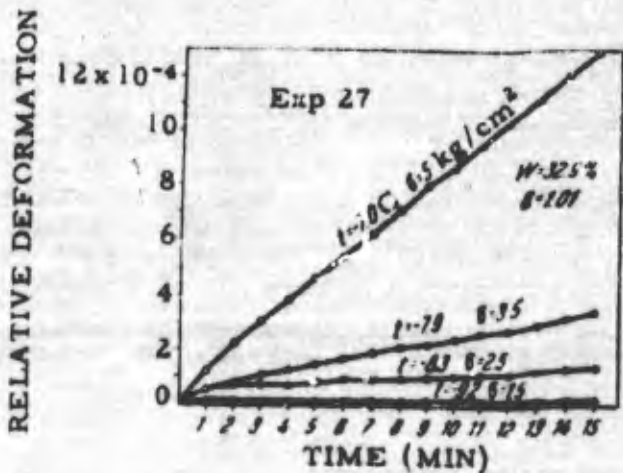

Figure 69. Relative deformation of frozen clay under constant load.

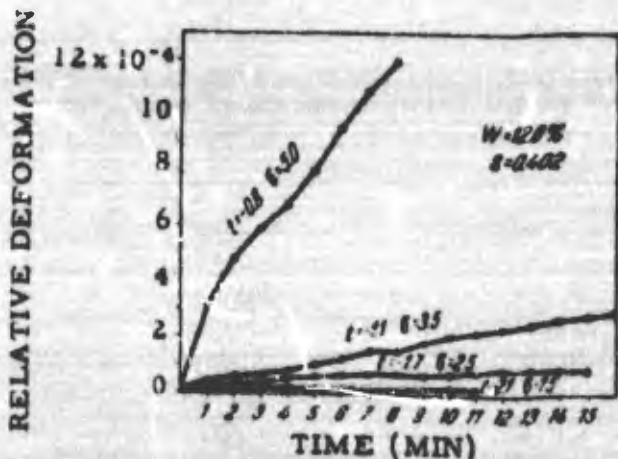

Figure 70. Relative deformation of frozen silty sand under constant load.

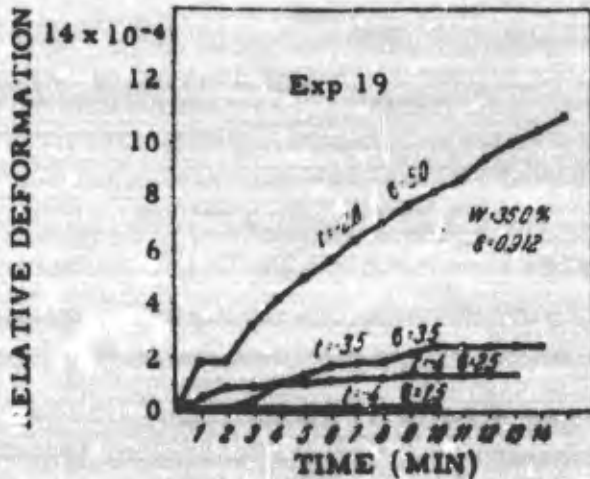

Figure 71. Relative deformation of frozen silty soil under constant load.

Table 62. Constant increments of relative deformation v per unit time for frozen ground under constant vertical pressure.

Test no.	Type of soil	Moisture (%)	Coefficient of porosity	$\sigma = 1.5 \text{ kg/cm}^2$		$\sigma = 2.5 \text{ kg/cm}^2$		$\sigma = 3.5 \text{ kg/cm}^2$		$\sigma = 5.0 \text{ kg/cm}^2$	
				Temp (C)	v (min ⁻¹)	Temp (C)	v (min ⁻¹)	Temp (C)	v (min ⁻¹)	Temp (C)	v (min ⁻¹)
5	Clay	35.6	1.03	-2.8	0.00001	-2.8	0.00007	-2.1	0.00011	—	—
6		34.5	1.02	-2.9	0.00002	-2.1	0.00005	-1.8	0.00022	—	—
7		32.0	0.93	-2.7	0.00002	-3.0	0.00009	-1.5	0.00028	—	—
27		28.7	0.86	—	—	-8.9	0.0	-7.9	0.00002	-6.0	0.00005
31		32.9	1.01	-9.2	0.0	-8.3	0.0	-7.9	0.00001	-7.0	0.00009
14	Silty soil	32.6	0.96	-2.4	0.00001	-1.0	0.00002	-0.8	0.00017	—	—
16		38.9	1.21	—	—	-1.4	0.0	-1.0	0.00002	-0.8	0.00018
19		36.0	0.91	-4.0	0.0	-4.0	0.00001	-3.5	0.00002	-2.8	0.00006
24		39.2	1.23	-2.9	0.0	-3.5	0.00001	-3.4	0.00001	—	—
29	Silty sand	12.8	0.40	-2.1	0.0	-1.7	0.00001	-1.0	0.00002	-0.8	0.00013
10		16.9	0.54	-4.6	0.0	-2.8	0.00002	—	—	—	—
18		13.5	0.50	-4.8	0.0	-2.6	0.00001	-1.0	0.00004	-1.0	0.00040
23		12.0	0.43	-9.3	0.0	-7.5	0.0	-6.0	0.00001	-4.0	0.00004
21		17.0	0.51	-12.2	0.0	-10.4	0.0	-8.7	0.0	-5.4	0.00004

To illustrate the data given in Table 62, curves were drawn showing the changes in the increments of deformation per unit time (v /min), in relation to a constant load, σ , on a sample of frozen ground (Figs. 72, 73, 74).

These curves show that, in all cases, changes in rate of deformation (increase of deformation per unit time) increased with an increase in compressive load. This was especially sharply manifested under a load larger than 3.5 kg/cm^2 . The slopes of the curves also increase with increase in negative temperatures. This shows that, the closer the temperature of frozen ground is to zero, the more intense will be the plastic deformations which do not diminish with time. Frozen ground under the influence of a constant load becomes analogous to an extremely viscous liquid, in that it undergoes constant deformation and assumes a fluid state.

A study of the above-cited data leads us to the following conclusions:

1. External load and negative temperature are basic factors conditioning the plastic deformation of frozen ground under compression.

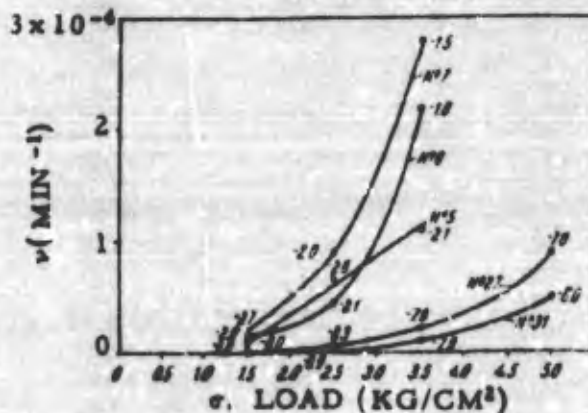

Figure 72. Rate of relative deformation of frozen clay under constant load.

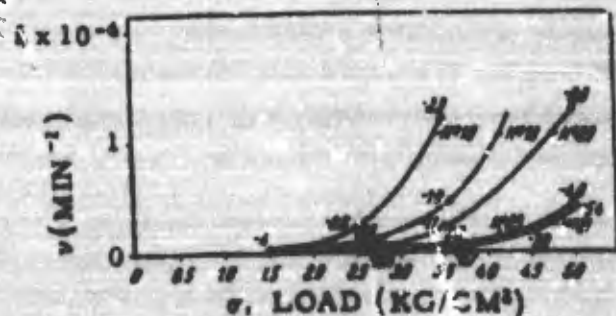

Figure 73. Rate of relative deformation of frozen silty sand under constant load.

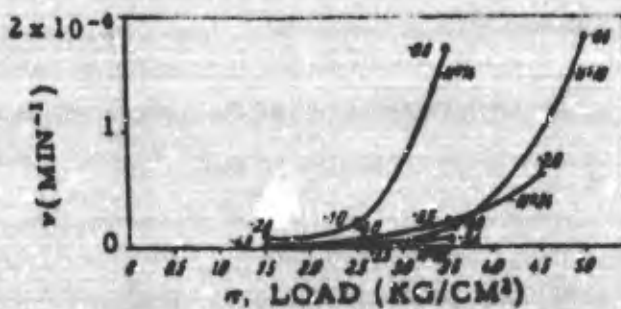

Figure 74. Rate of relative deformation of frozen silty soil under constant load.

2. The conditions for plastic deformation of frozen ground under constant compressive load are somewhat different for various types of soil. At temperatures from -4°C to -1°C , plastic deformation of frozen clay starts at any stress (within the limits of the tests conducted) from the first minute of the load action and does not cease with time. At lower temperatures (about -8°C), frozen clay shows rapidly diminishing deformation under a load of 1.5 kg/cm^2 , and a constant deformation flow under a stress of 2.5 kg/cm^2 . This constant deformation increases in intensity with an increase in stress.

Silty soil below -4°C is deformed to an extremely small degree under a load of 1.5 kg/cm^2 ; shows diminishing deformation under 2.5 and 3.5 kg/cm^2 ; and is in a state of constant flow under a load of 5.0 kg/cm^2 . Silty soil at a higher temperature (about -2°C) behaves similar to clay.

Silty sand at about -2°C is deformed like the first two soil types only under a load of 3.5 kg/cm^2 . At 2.5 kg/cm^2 , deformation dies out. A load of 1.5 kg/cm^2 , does not noticeably affect the ground, except for the initial deformation.

3. The above-cited data show that rise of negative temperatures (approaching zero) and greater compressive load cause greater plastic deformation in frozen ground.

4. Apparently plasticity of frozen ground must be attributed to: (a) the plastic properties of ice which either partly or completely fills the voids of frozen ground, or (b) the laminated structure of frozen ground, especially clay, clayey sand, and silty soils. The outside pressure, overcoming the inner resistance to friction, causes plastic deformations which are especially great in bodies of laminated structure.

Coefficient of viscosity of frozen ground

Frozen ground in a plastic state has the properties of a viscous fluid, i. e., the property of changing shape without changing volume (flow). Under certain conditions, this circumstance may cause extrusion (flowing out) of the frozen ground from under the foundation of a structure, and in some cases it may cause the shifting of considerable masses of frozen ground, a phenomenon analogous to the flow of glaciers.

When bodies change in shape, there arise both elastic stresses, dependent upon the magnitude of deformation, and frictional stresses, dependent on the rate of change of deformation in the course of time. The frictional stresses P are directly proportional to the area of the shearing layer F and to the rate of change of the angle of shear

$$\frac{da}{du},$$

where a is the angle of shear and u is the time. Consequently, this can be expressed by the formula:

$$P = \eta F \frac{da}{du} \quad (37)$$

where η is the coefficient of inner friction or the coefficient of viscosity.

We have conducted experiments to determine the viscosity of frozen ground by torsion. Among all existing methods, the torsion method is the most sensitive one for determining the coefficient of viscosity of solid bodies.¹

This method consists of the experimental determination of the rate of change ϕ' , in time, of the angle of torsion ϕ under the influence of a constant twisting moment.

The coefficient of viscosity when determined by the torsion method is calculated from

$$\eta = \frac{Pga^2}{J\phi'} \quad (38)$$

1. B. P. Veinberg (1906) O vnutrennem trenii l'da (Viscosity of ice).

where P is the stress in conventional units, g is acceleration of gravity, a is the distance between the active lines of force of the couple, l is the distance between two layers perpendicular to the length of the cylinder, $\dot{\phi}$ is the rate of change of the torsion angle, J_p is the polar moment of inertia of the cylindrical cross section.

A sample of moistened ground was frozen in the collapsible metal mold which is used for torsion experiments. One end of the sample was fixed and a constant couple was applied to the other end. The angle of torsion of two sections of the cylindrical part of the sample was measured after definite time intervals with Martens mirror apparatus. Table 63 gives the results of one of the experiments.

Table 63.

Test no.	Time (min)	Temp (C)	Increase of torsion angle, ϕ	Rate of change of torsion angle, $\dot{\phi}$ (min^{-1})	Conditions of Test
1	1	-0.8	0.0016	0.0016	Silty sand; moisture, 19.1%; load, 1503 g; $a = 16.55$ cm; Radius of cylindrical part of the sample, $r = 2.1$ cm; $l = 50$ cm.
2	3	-0.8	0.0007	0.00035	
3	7	-0.8	0.0005	0.00011	
4	10	-0.8	0.0004	0.00012	
5	15	-0.8	0.0008	0.00016	
6	20	-0.8	0.0007	0.00014	
7	30	-0.8	0.0011	0.00011	
8	60	-0.8	0.0037	0.00012	

Note: Average rate of change of torsion angle, based on nos. 3 to 8, is $0.000127 \text{ min}^{-1}$.

If we substitute the experimental data cited in Table 63 in eq 38, we obtain $\eta = 1.9 \times 10^{12}$ g/cm-sec for silty sand at a temperature of -0.8C and a moisture content of 19.1%.

In a similar way, the coefficient of viscosity was determined for clay (36% of particles less than 0.005 mm diam) at a temperature of -0.8C and a moisture content of 27.7% — $\eta = 0.9 \times 10^{12}$ g/cm-sec, and for clean quartz sand, moisture content 19.1% and temperature -0.4C — $\eta = 1.1 \times 10^{12}$ g/cm-sec.

We see that the coefficient of viscosity of frozen ground is less than the coefficient of viscosity of river ice, which, according to B. P. Veinberg, is 10^{13} g/cm-sec at 0C .

It is well known that viscosity increases with an increase in the amount of solid particles in a liquid. To explain the observed fact, it is necessary to suppose that the properties of ice in frozen ground differ considerably from the properties of solid ice (such as river ice). Moreover, a question arises as to whether the coefficient of viscosity of frozen ground might be smaller than the coefficient of viscosity of ice because not all the water in the frozen ground was transformed into the solid state but remained partly liquid. This problem may be solved only by specially conducted experiments.

The above-cited data also show that the Einstein formula for solutions cannot be used to calculate the viscosity of frozen ground on the basis of the volume of solid particles and ice viscosity.¹

The coefficient of viscosity of frozen ground can be determined by its rate of deformation under compression. This method is much less accurate than the torsion method because of the lack of uniformity in observed deformation of frozen ground under compression. In addition, when the coefficient of viscosity is calculated on the basis of the rate of deformation under compression, the coefficient of viscosity relative to changes in volume

1. The Einstein formula is: $\eta = \eta_0(1 + aV)$, where η is viscosity of solution, η_0 is viscosity of liquid, a is coefficient of shape (for spherical particles, according to Einstein, $a = 2.5$, and for the elongated particles, according to Prof. Mark, a is 4.7 to 11), and V is the volume of solid particles in a unit volume of a liquid.

is considered too small in comparison with the coefficient of viscosity relative to changes in shape.

In this case, the coefficient of viscosity is calculated from

$$\eta = \frac{Pg}{v} \quad (39)$$

where p is the pressure per unit area, g is acceleration of gravity and, v is the rate of relative deformation under compression or tension.

Eq 39 can be used with the data on rate of relative deformation of frozen ground (Table 62) to calculate the coefficient of viscosity. The results are given in Table 64.

Table 64. Effect of negative temperature t and stress σ on coefficient of viscosity η (g/cm-sec) of frozen ground under compression.

Type of soil	Moisture by weight, (%)	$\sigma = 1.5 \text{ kg/cm}^2$		$\sigma = 2.5 \text{ kg/cm}^2$		$\sigma = 3.5 \text{ kg/cm}^2$		$\sigma = 5 \text{ kg/cm}^2$		Tests on which given values are based
		$t(\text{C})$	$\eta \times 10^{12}$	$t(\text{C})$	$\eta \times 10^{12}$	$t(\text{C})$	$\eta \times 10^{12}$	$t(\text{C})$	$\eta \times 10^{12}$	
Clay	33.2	-2.8	4.4	-2.0	2.1	-1.7	0.8	-	-	Avg of 6 and 7 Avg of 27 and 31
	30.8	-	-	-	-	-7.9	10.3	-6.5	4.2	
Silt	32.6	-2.8	8.8	-1.0	7.3	-0.8	1.2	-	-	14
	37.6	-	-	-3.8	14.7	-3.5	13.7	-2.8	4.9	Avg of 19 and 24
Silty sand	13.1	-	-	-2.1	14.7	-1.0	6.8	-0.9	1.1	Avg of 29 and 18 23
	12.0	-	-	-	-	-6.0	20.6	-4.0	7.3	

An analysis of these data results in the following conclusions.

1. The coefficient of viscosity of frozen ground depends to a great degree on the negative temperature, greatly decreasing with rise in temperature.
2. The increase in quantity of solid particles in frozen ground results in an increase in the coefficient of viscosity. Thus, the coefficient of viscosity was smallest for frozen clay, larger for silty soil, and still larger for silty sand and sand.
3. Apparently, the coefficient of viscosity of frozen ground also depends on the compressive stress and the method of load application. However, because of the small number of experiments, this question should be left open.
4. Determination of the quantitative relationship of the coefficient of viscosity of frozen ground with the negative temperature and the grain-size composition of frozen ground also requires further experiments.
5. It must be pointed out that eq 39 can be used to express full plastic deformation of frozen ground under compression and under conditions of free expansion of frozen ground.

Thus

$$S_p = \frac{Pguh}{\eta} \quad (40)$$

where S_p is the full plastic deformation, p is the relative load, g is the acceleration of gravity, u is the time, h is the depth, and η is the coefficient of viscosity.

The equation shows that the degree of plastic deformation of frozen ground under compression and under conditions of free expansion will be directly proportional to the load and duration of load, and in inverse proportion to the coefficient of viscosity.

Subsidence of Frozen Ground During Thawing¹

In considering the influence of temperature on the deformation of frozen ground, we saw that the limits of temperature change are close to the thaw point (0C), but do not quite attain it.

In this section we will consider deformation (subsidence) of thawing frozen ground.

It is common knowledge that the destruction of structures built on permafrost is due primarily to settling due to the thawing of permafrost. This settling exceeds by tens of times the deformation of the same ground at negative temperatures. However, no one has yet made a systematic study of this question, so vitally important for practical purposes. The isolated field observations do not permit analysis of these extremely complex phenomena.

Determining the degree of settling of foundations on thawing ground is an extremely complex problem. The settling depends not only on the properties of the ground and the size of the foundations, but also on the process and intensity of thawing and the thermal properties of the ground. Consequently, the problem should be approached by first considering the simplest phenomena.

In the simplest case, a layer of frozen ground which is thawing in one direction only and cannot expand laterally settles under the action of an equally distributed load. Settling of frozen ground with limited lateral expansion and uniform thawing is a considerably more complex case.

A series of tests was made to study the settling of frozen ground during thawing. The experiments described below involved conditions of uniform thawing with a constant load on part of the ground surface. Two typical soils, sand and clay, were used. Their physical properties are given in Table 65.

Table 65. Physical properties of clay and sand.

Physical characteristics	Cambrian clay	River sand	Remarks
Grain-size composition (%)			
Particles 1-0.25 mm	0.5	11.3	Data are averages of 2 measurements
0.25-0.05 mm	0.7	87.6	
0.05-0.01 mm	14.7	0.6	
0.01-0.005 mm	43.3	0.5	
0.005-0.001 mm	13.5	-	
<0.001 mm	27.3	-	
Specific gravity, Δ	2.71	2.67	

According to the data in Table 65, the clay contained 40.8% of particles less than 0.005 mm in diam and 43.3% of silt. Fine-grained sand was used, with the basic component particles varying from 0.05 to 0.25 mm in diam (87.6%)

First series of experiments

The purpose of the first series of experiments was to study the settling of a rigid filter die on thawing sand and clay. Soil was placed in strong cylinders so that lateral expansion was impossible. Strong copper cylinders, 50 mm high with an inside diameter of 61.8 mm, were used.

Figure 75 shows a photograph of the apparatus, consisting of a strong cylinder with an adapter for placing the measuring instruments and the filter die.

1. This section is based on the work of N. A. Tsytovich (1934) Ekspierimental'noe issledovanie osadok mernykh gruntov pri ottaivanii (Experimental investigations of settling of frozen ground during thaw), Trudy Leningradskogo Instituta Soorushenii, manuscript.

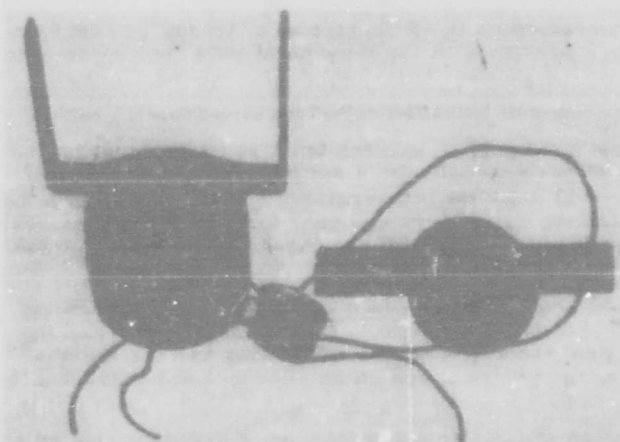

Figure 75. Apparatus for studying the settling of the frozen ground during uniform thawing under load without lateral expansion.

excess water removed with filter paper. The thermocouples were set while the sand was poured. Then, the sand in the apparatus was compacted under a load of 1 or 2 kg/cm² and placed in a refrigeration chamber to freeze for 2 days. After freezing, the apparatus was placed in a metal box (Fig. 76) and surrounded by the cooling mixture. Two measuring instruments were attached and a load of 3 kg/cm² was applied on the die. During the entire time of thawing, the settling was observed and the temperature of the soil measured by thermocouples.

Both before the tests and after the cessation of settling, the soil used was weighed, the initial and final height of the ground was measured, and the average moisture content by volume (5 to 6 determinations) of the soil sample was calculated.

The same type of apparatus was used for testing clay. The clay was moistened to the upper flow limit, and a certain quantity of it placed in the apparatus. Two layers of filter paper were placed on top of the clay and a compressing load was applied to the surface of the clay by a filter die. This load was maintained until settling ceased, thus preparing a sample of clay with a predetermined moisture content. The apparatus with the packed clay was placed in a refrigeration chamber for 2 days. After the soil froze, clay settling during thawing was studied by the same method used for sand.

Swelling of the soil was observed during the process of freezing and caused certain deviations from observed settling in the control tests.

The soil temperature during thawing was measured with thermocouples in the upper, lower, and middle parts of the soil. A Zeiss measuring instrument set on brackets screwed to the apparatus was used to measure the settling.

The copper cylinder was surrounded on the outside with a mixture of ice and salt which thawed gradually. Tests on the thermal regime within the soil sample, using thermocouples at nine points instead of three, show that, as a first approximation, we can consider the thawing of the ground to be uniform.

The die was subjected to a uniformly distributed load of 3 kg/cm² in the Lubny-Gertsyk press (Fig. 76).

The tests on sand were conducted as follows: The assembled apparatus was filled with water, a specific quantity of dry sand poured in, and the



Figure 76. Test of a sample of frozen ground on the Lubny-Gertsyk press.

Tests with sand. Tests were conducted with sand of different degrees of compaction and with sand completely saturated with water. Sand was compacted under two loads: 2 kg/cm² and 1 kg/cm². Table 66 shows the results for compact sand and sand of medium compaction (the grain-size composition is given in Table 65.). From the results, the coefficients of porosity were calculated as follows.

Table 66. Results of tests on settling of frozen sand thawed evenly under a load of 3 kg/cm² with no lateral expansion.

Time interval (min)	Average results of tests 1 and 2, with compact sand				Average results of tests 3 and 4, with sand of medium compaction			
	Settling (mm)	Temp of soil layer (C)			Settling (mm)	Temp of soil layer (C)		
		Top	Middle	Bottom		Top	Middle	Bottom
5	0.371	-1.2	-1.3	-1.3	0.386	-0.9	-1.1	-1.1
10	0.648	-0.4	-0.6	-0.5	0.721	-0.3	-0.5	-0.5
15	0.748	-0.1	-0.1	-0.2	0.444	-0.1	-0.2	-0.4
20	0.810	0.0	-0.1	0.0	1.071	-0.1	-0.2	-0.4
25	0.812	0.3	1.2	0.1	1.2.3	-0.1	-0.2	-0.4
30	0.867	1.0	0.6	0.6	1.345	0.0	-0.1	-0.3
35	0.876	4.0	2.6	3.8	1.420	0.0	0.0	-0.1
40	0.880	6.8	6.0	5.8	1.514	0.0	0.0	-0.1
45	0.885	8.9	7.7	7.8	1.567	0.3	0.2	-0.1
50	0.892	11.6	11.8	11.8	1.641	0.5	0.3	0.0
55	0.894	11.8	11.8	11.8	1.688	1.0	0.9	0.0
60	0.894	11.8	11.8	11.8	-	-	-	-
65	0.894	11.8	11.8	11.8	-	-	-	-
70	0.894	11.9	12.1	12.1	1.725	1.4	1.1	0.6
80	0.894	13.0	13.0	13.0	1.738	2.0	1.7	1.0
90	0.895	13.0	13.0	13.0	1.760	3.3	2.8	2.9
100	0.897	13.6	13.6	13.6	1.760	5.4	5.4	5.4
110	0.897	13.6	13.6	13.6	1.760	6.9	6.9	6.9
120	0.897	13.6	13.6	13.6	1.760	-	-	-
130	0.897	13.6	13.6	13.6	1.760	-	-	-

Note: For tests 1 and 2, average initial coefficient of porosity $e_1 = 0.735$; final coefficient of porosity $e_2 = 0.680$; average initial thickness of layer of sand $h = 27.6$ mm. For tests 3 and 4, average values are $e_1 = 0.75$, $e_2 = 0.64$, $h = 28.4$ mm.

The unit weight of the soil skeleton at the beginning of the experiment was determined on the basis of the initial thickness of the sample, h_1 , the known weight of dry soil, g , and the known area of the cylinder cross section, F , by the following equation:

$$\delta_1 = \frac{g}{h_1 F}$$

The initial coefficient of porosity was calculated from

$$e_1 = \frac{\Delta - \delta_1}{\delta_1}$$

where Δ is the specific gravity of the soil particles.

The coefficient of porosity, e_2 , of the ground after thawing and complete cessation of settling was calculated by the same equations, using the thickness of the sample at the end of the test, h_2 , instead of h_1 .

For analytical determination of the final settling of the sand layer, that is, settling which would occur under a load and after complete thawing and stabilisation, we can use the relationship well known in soil mechanics:¹

1. N. A. Tsytovich (1934) Osnovy mekhaniki gruntov (Principles of soil mechanics). Leningrad, p. 139.

$$s = h \frac{\epsilon_1 - \epsilon_2}{1 + \epsilon_1} \quad (41)$$

where s is the settling of the soil layer under compression without possibility of lateral expansion, h is the initial thickness of the layer, ϵ_1 is the initial coefficient of porosity (before thawing), and ϵ_2 is the final coefficient of porosity (after thawing).

Substituting numerical values, we obtain for the compact sand

$$s_{\text{theor}} = 27.6 \frac{0.735 - 0.68}{1 + 0.735} = 0.874 \text{ mm.}$$

The settling obtained experimentally (see Table 66), is

$$s_{\text{exp}} = 0.897 \text{ mm.}$$

For sand of average compaction, we have:

$$s_{\text{theor}} = 28.4 \frac{0.75 - 0.64}{1 + 0.75} = 1.78 \text{ mm.}$$

$$s_{\text{exp}} = 1.76 \text{ mm.}$$

Therefore, the equation for settling, as can be expected, is valid also for calculating the final stabilized settling of a layer of thawing sand.

The deviations between measured and calculated settling can be explained by inaccuracies in determining coefficients of porosity.

From the data given in Table 66, the settling of a solid filter stamp under a uniformly distributed load on thawing sand can be plotted as a function of time (Fig. 77). The curves of settling are similar for compact and loose sand, and differ only in magnitude depending on the initial and final porosity of the ground.

Tests with clay. The clay samples were compacted, by pressures of 1 and 2 kg/cm², to equal porosity. However, redistribution of moisture and expansion during freezing gave the frozen soil samples different initial porosities. The settling of the clay during thawing was determined by the above-described method. The same load of 3 kg/cm² was applied to all samples.

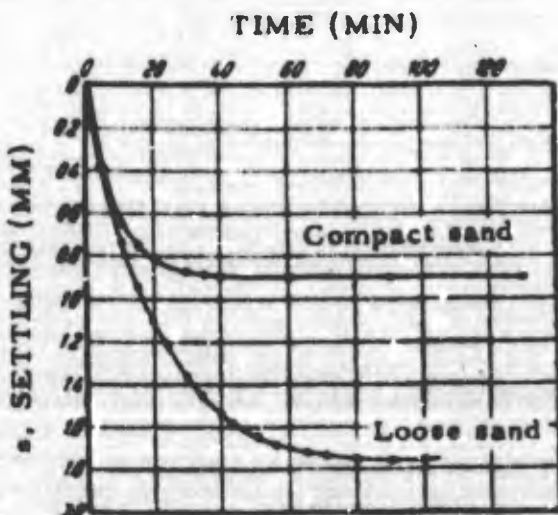

Under the test conditions (thermocouples in the soil) the coefficient of porosity could be calculated only from the unit weight of the soil, the moisture content, and the height of the soil layer at the beginning and the end of the test.

Eight tests on clay were made. Table 67 gives, as an example, the average results of three tests on the settling of a rigid filter die on thawing clay which had an initial coefficient of porosity of 1.03.

According to eq 41, the settling of a die on thawing frozen clay with no lateral expansion is

Figure 77. Settling of a rigid die on thawing sand with no lateral expansion.

Table 67. Settling of a layer of frozen clay during uniform thawing, with no lateral expansion, under a load of 3 kg/cm².

Time (min)	Average settling, (mm)	Average temperature (C)			Remarks
		Top	Middle	Bottom	
10	0.138	-0.4	-1.6	-2.0	Average values: $\delta_1 = 1.33 \text{ g/cm}^3$ $\delta_2 = 1.61 \text{ g/cm}^3$ $e_1 = 1.03$ $e_2 = 0.683$ $h = 31.4 \text{ mm}$
20	0.327	-0.3	-1.5	-1.7	
30	0.597	0.0	-1.1	-1.4	
40	0.940	0.5	-0.8	-1.2	
50	1.485	0.8	-0.4	-0.5	
60	2.113	1.5	-0.2	0.0	
70	2.722	—	—	—	
80	3.186	3.4	2.4	3.0	
90	3.541	3.8	4.2	4.6	
100	3.806	6.3	5.4	5.9	
110	4.020	7.3	7.2	7.2	
120	4.193	—	—	—	
130	4.364	—	—	—	
140	4.537	9.6	9.5	9.6	
150	4.667	10.1	10.1	10.0	
160	4.806	10.6	10.2	10.6	
170	4.905	—	—	—	
180	5.006	—	—	—	
190	5.093	—	—	—	
220	5.301	—	—	—	
250	5.437	—	—	—	
280	5.486	—	—	—	
310	5.544	—	—	—	

$$s_{\text{theor}} = h \frac{e_1 - e_2}{1 + e_1} = 31.4 \frac{1.03 - 0.683}{1 + 1.03} = 5.37 \text{ mm.}$$

The settling found by direct tests was $s_{\text{exp}} = 5.54 \text{ mm}$, i. e., the final settling of thawing clay can also be determined by eq 41.

Figure 78 shows the settling, based on the data given in Table 67.

The data show that the settling of a die under load on thawing clay, with no lateral expansion, is quite different in character from settling of thawing sand under the same conditions. This may be explained by the difference in water permeability and the relationship between the settling of thawed clay and time.

When clay begins to thaw, settling is very small, and the curve of settling shows an upward curvature. Later on, an intensive increase of settling takes place, apparently when ice is transformed into water throughout almost the entire thickness of the soil layer. Finally during the last stage, the settling of the thawed ground diminishes and the curve is the same as the typical consolidation (compression) curve for unfrozen clay.

Second series of experiments

The second series of experiments tested the settling of a rigid die on thawing sand and clay with limited lateral ground expansion. These tests were made in a large vessel, 25 cm in diam and 30 cm deep, not in a hard container as in the first series. The load was transmitted by a round die, 6.1 cm in diam (with an area of 30 cm²), and the ground thawed only on top. The ground was moistened to the necessary degree (for clay on the basis of the compression curve) by mixing with water. Then the container was put into a refrigeration chamber for 2 days.

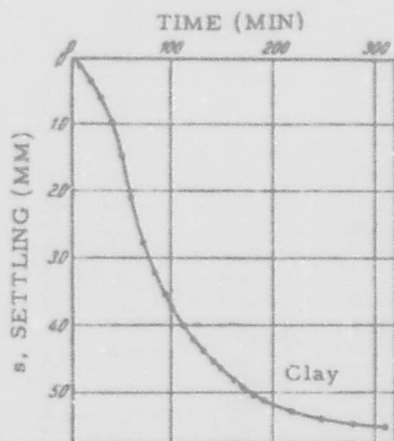

Figure 78. Settling of a rigid die on thawing clay, with no lateral expansion.

The tests were made with a lever press, and the ground was insulated on the sides and the bottom. Settling during the experiment was measured by two Zeiss apparatus and the mean of the readings was calculated.

Soil temperature was measured at ten points at the same time intervals as the settling. The thermocouples were placed along a vertical representing the center of gravity of the base area and also at a distance of 7 cm from that vertical.

Figure 79 shows the arrangement of the apparatus in the second series of experiments. Altogether four tests were made: tests I and IV with sand, and tests II and III with clay.

The results are summarized in Tables 68 and 69. Table 68 gives the results of the tests with compacted sand, with a pressure below critical on the die. Table 69 shows the results of experiments with sand and clay under a pressure which was above critical for the thawed condition of ground.

Table 68 gives the results of test I, with thawing frozen sand and a constant load of 3 kg/cm^2 . Complete cessation of settling was observed during this experiment. The initial state of the ground is also described.

The initial coefficient of porosity of the frozen sand was $\epsilon_1 = 0.75$. With an increase in pressure of 3 kg/cm^2 , the coefficient of porosity decreases, according to tests made previously, to $\epsilon_2 = 0.64$ (see tests 3 and 4 in Table 66).

If we calculate settling of the die from eq 41, the question arises as to what soil thickness we should use. For example, if we use the full thickness, $h = 25 \text{ cm}$, we obtain

$$s = 25 \frac{0.75 - 0.64}{1 + 0.75} = 15.7 \text{ mm.}$$

However, the test shows that $s = 3.814 \text{ mm}$ (Table 68).

Thus, we clearly see that under no circumstances should the total thickness of the soil layer be used in the equation.

Let us apply the previously worked-out method of an equivalent layer of ground. Computed thickness of the equivalent layer, i.e., of a layer whose settling, with no lateral expansion, will be equal to the settling of the die, may be expressed as follows:¹

$$h_s = A \omega_0 d$$

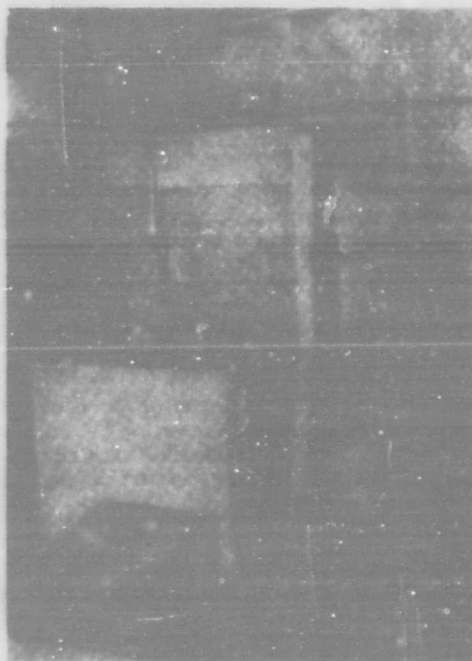

Figure 79. Apparatus for studying the settling of a rigid die on thawing ground with limited lateral expansion.

1. N. A. Tsytovich (1934) *Raschet osadok fundamentov, kak funktsii vremeni, svoistv grunta i rasmerov fundamentov* (Calculation of foundation settling as a function of time, ground properties, and dimensions of foundation), Leningrad. Inst. sooruzh.

Table 68. Sinking of a rigid die on evenly thawing compacted frozen sand (Test I in a large cylinder with limited lateral expansion of the soil).

Time (min)	Settling (mm)	Time (min)	Settling (mm)	Time (min)	Settling (mm)	Test description
-	-	92	2.280	222	2.876	Moisture by weight (avg of 3 measurements) $w = 14.3\%$ Unit weight, $\gamma = 1.75 \text{ g/cm}^3$ Unit weight of soil skeleton $\delta = \frac{\gamma}{1+w} = 1.53 \text{ g/cm}^3$ Coefficient porosity 75 Specific $\Delta = 2.67$ Load $p = 3 \text{ kg/cm}^2$ Total thickness of soil layer in cylinder $h = 25 \text{ cm}$
4	0.615	97	2.290	262	3.002	
7	0.852	102	2.354	297	3.002	
12	1.185	107	2.381	The next day		
17	1.390	112	2.406	1,437	3.701	
22	1.521	117	2.438	The next day		
27	1.650	122	2.456	2,792	3.797	
32	1.751	137	2.570	2,877	3.814	
37	1.835	142	2.608	3,117	3.814	
42	1.886	147	2.617	General settling		
47	1.940	152	2.627			
52	1.974	157	2.635			
57	2.036	162	2.697			
62	2.071	167	2.711			
67	2.100	172	2.731			
72	2.161	182	2.768			
77	2.178	192	2.787			
82	2.201	202	2.840			
87	2.265	212	2.864			

where $A\omega_0$, according to the table in the above-cited work, is 1.02 for a round die and d is the diam of the die.

Then,

$$h_s = 1.02 \times 61 = 62 \text{ mm}$$

and

$$s = h_s \frac{e_1 - e_2}{1 + e_1} = 62 \frac{0.75 - 0.64}{1 + 0.75} = 3.90 \text{ mm.}$$

The difference between this value and the value of settling found by experimental methods is:

$$m = \frac{3.90 - 3.814}{3.814} = 2.2\%.$$

This completely confirms the applicability of the method of equivalent layer. But, under a load less than the limit, which corresponds to the extrusion of soil from under the die, it can be assumed that the difference between the theoretical and experimental data will also be insignificant.

In test IV (Table 69), a looser sand was used and no cessation of the die settling was observed under a load of 1.5 kg/cm^2 . The same table gives the results of tests of die settling on thawing clay under a die load of 3 kg/cm^2 .

Results of tests I and IV and tests II and III are shown graphically in Figures 80 and 81.

The curves for sand are similar, in general, to those obtained in the tests with no lateral expansion, but some significant differences are observed. Under load which exceeds the critical load¹ (test IV with loose sand), the cessation of settling was not observed.

1. We use the expression "critical load" to designate a magnitude beyond which intense deformation proceeds without additional increase in load, and the ground is extruded from under the loaded die.

Table 69. Settling of loaded die on thawing soil with limited lateral expansion and load greater than critical (for thawed state).

Time (min)	Sand (w = 18.3%)	Clay (w = 35%)		Remarks
	Settling (mm)			
	Test IV	Test III	Test II	
10	0.237	0.120	0.028	In test IV (sand), temperature was 0C at 1 cm beneath the center of the die, after 50 min and 3.5 to 6 cm, after 155 min.
20	0.345	0.225	0.045	
30	0.411	0.327	0.066	
40	0.461	0.437	0.089	
50	0.505	0.576	0.110	
60	0.536	0.710	0.313	
70	0.570	0.847	0.157	
80	0.592	0.995	0.178	
90	0.618	—	0.218	
100	0.642	1.315	0.251	
110	0.666	1.440	0.328	
120	0.740	1.650	0.372	
130	—	1.790	0.415	
140	—	2.005	0.468	
150	0.781	2.180	0.508	
160	—	2.404	0.554	
170	0.865	2.690	0.625	
180	—	3.005	0.708	
190	0.952	3.264	0.806	
200	1.000	3.549	0.883	
210	1.050	3.912	0.968	
220	—	4.375	1.061	
230	0.125	4.750	1.158	
240	—	5.175	1.268	
250	—	5.565	1.370	
270	1.267	6.347	1.598	
300	1.352	—	1.964	
320	—	—	2.228	
350	—	—	2.693	
400	—	11.847	3.823	
450	1.727	13.197	—	
500	1.765	14.459	—	
550	1.843	16.550	—	
600	1.926	18.447	—	

*[Interval during freezing and thawing of the ground during which the temperature remains constant as cooling or warming is compensated by the latent heat of fusion during freezing or the absorption of heat when the ice melts.]

The curves of die settling on thawing clay correspond to only the first part of the compaction curve, which later enters a second stage of greater settling (see series of tests in the strong cylinder). No cessation of settling was observed with loads which exceeded the critical load.

It must be pointed out that, in tests III and II, thawing soil was extruded from under the die, and the thermocouple situated 1 cm beneath the die showed a negative temperature during the entire time. Thus, it appears that a thin layer of clay under the die was immediately squeezed out along the perimeter of the die when it thawed; i. e., the thawed layer did not pack and plastic flow of the soil took place. These observations, in our opinion, are of considerable interest. However, the small number of tests made prevent any definite conclusions about the plastic flow of frozen and thawing ground. Further experiments are necessary, both in the laboratory and on experimental structures under natural conditions.

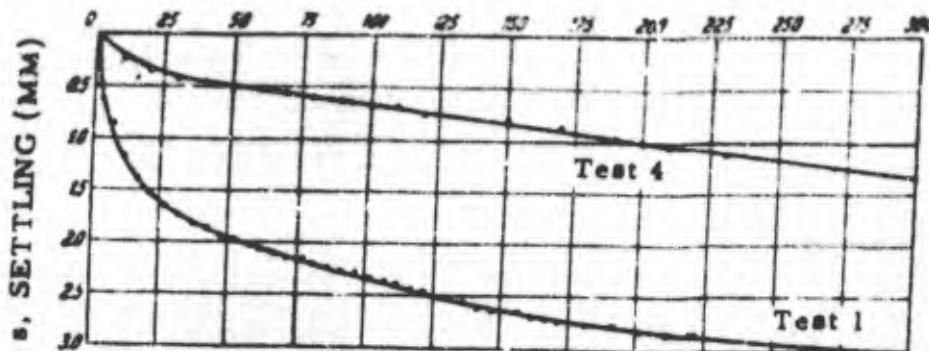

Figure 80. Settling of a rigid die on thawing sand, with limited lateral expansion.

One very important practical conclusion resulted from the experiments. When a die resting on the thawed ground is subjected to a load which exceeds the critical limit for extrusion of the thawed ground from under the die, the settling of the ground does not die out with time.

A layer of the frozen ground continues to settle during the entire period of thawing. This is especially observed with frozen clay, but also can take place in frozen sand.

When a structure is erected on frozen ground, emanation of heat by the structure will cause thawing of the frozen ground under the foundation, and considerable settling of the foundation is inevitable. If, in this case, the load on the ground is less than critical (the point at which extrusion begins), the settling will diminish with time and cease altogether. If, however, the load on the ground is greater than the critical limit, the settling of the foundation will not die out and may cause complete destruction of the structure. The latter is often observed when structures are erected on frozen clay without measures against thawing.

Some observations of foundation settling on thawing permafrost

The problem of foundation settling on thawing permafrost is of extreme practical significance. Data on the settling of the foundations of the Chita power station are cited below. These data were provided by the NTS Narkomkhoz (Council for Science and Technology of the People's Commissariat of Municipal Services) in connection with our findings regarding the deformation of the Chita Power Station.

Table 70 shows the observed data on settling of foundations, turbines, boilers, and pillars of the buildings of the Chita Power Station. Figure 82 shows the stratigraphic cross section of the ground. From these data we plotted the curves of settling (Fig. 82a).

From the curves of settling under the different foundations when frozen clay thaws, we conclude that the nature of foundation settling is completely analogous with the settling of dies on thawing clay with restricted lateral ground expansion, observed by us in the laboratory. This shows that the method of our tests corresponds to the phenomena observed under natural conditions.

In summarizing the results of the tests on settling of homogeneous frozen ground under conditions of uniform thawing, we conclude that

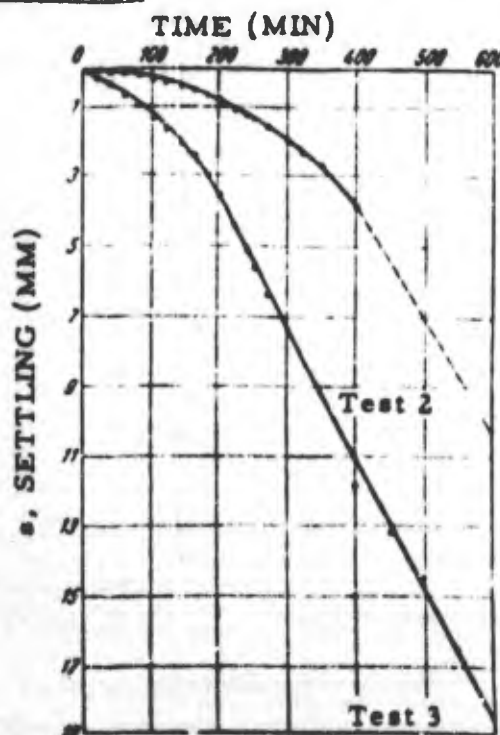

Figure 81. Settling of a rigid die on thawing clay, with a limited lateral expansion.

Table 70. Settling of foundations of the Chita Power Plant caused by thawing of permafrost beneath the foundations.

Type of foundation	Average settling (mm) from 1931 to 1934			
	Approx. 12 months	17 months	29 months	39 months
Under the Bergman steam turbine	20	47	91	97
Under the SMZ steam turbine	20	34	67	90
Under boiler no. 1	10	3	113	185
Under boiler no. 2	50	81	174	273
Under a pillar in steam-turbine room (average settling)	0	2.0	27	56
Under a pillar in boiler room (average settling)	0	6.5	30	77

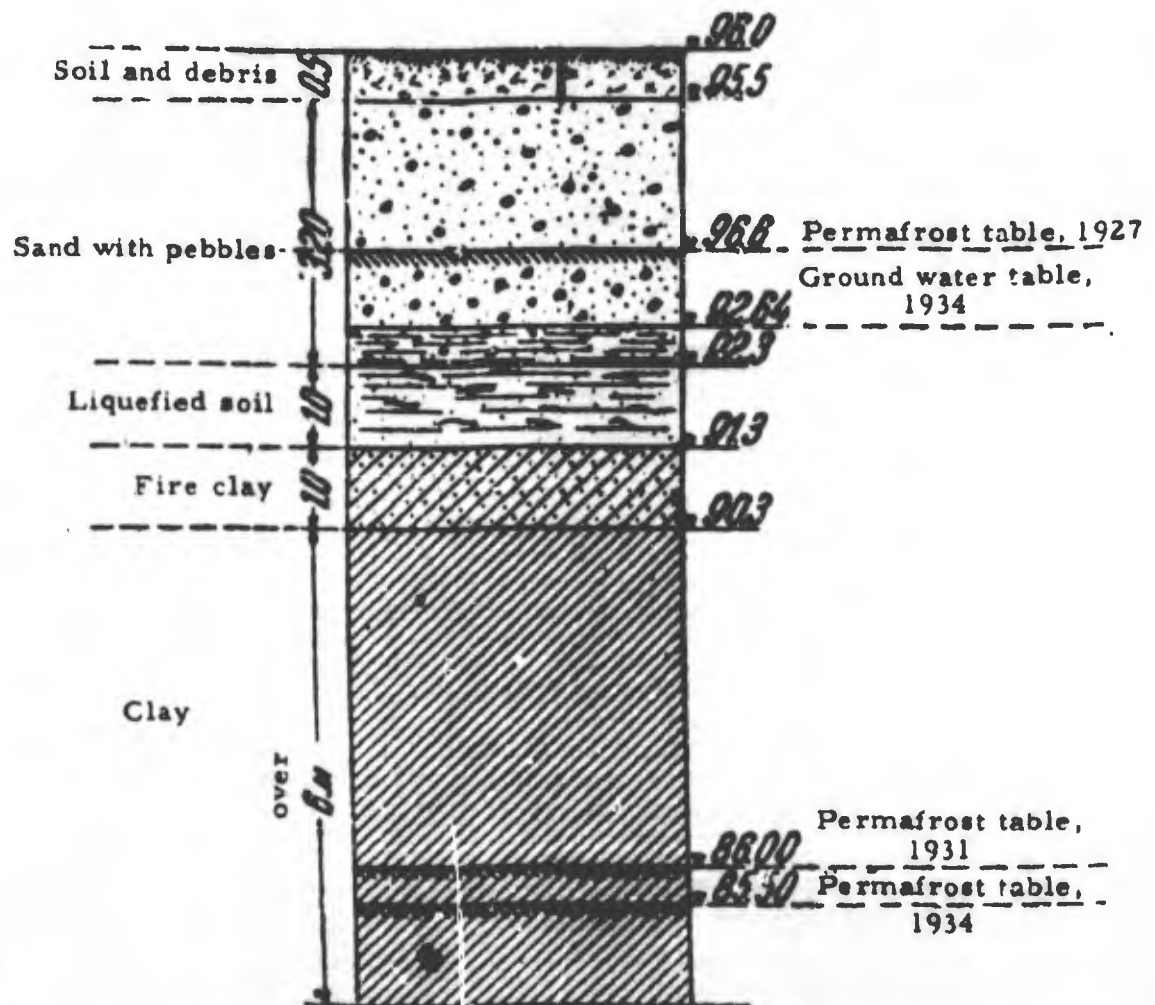

Figure 82. Stratigraphic cross section of the ground at Chita Power Station.

only the final die settling on thawing sand and clay, under less than critical load, can be determined by the method of equivalent ground layer with sufficient accuracy for practical purposes.

Determination of the settling of thawing ground as a function of time, which we have considered only on the basis of experimental data, requires further study and theoretical interpretation

Heat as an External Force

The data on the deformation of frozen ground at negative temperatures and during the transition from the frozen to the thawed state, which we considered above, demonstrated that the basic factor which influenced the degree and nature of the deformation is temperature. Two samples of the same frozen ground under identical loads and at different temperatures will show totally different deformation. Even a very small rise in the temperature of the frozen ground (as small as one-tenth of a degree) may have a considerable effect. For example, an increase in temperature of a cube of frozen sand from -3C to -1C (see Ch. IV) lowers the compressive breaking stress from 78 to 62 kg/cm².

If we calculate the amount of heat received by a 7-cm frozen cube when its temperature rises from -3C to -1C, and determine the decrease of breaking stress which corresponds to one large calorie, we obtain a value of about 20 to 30 kg/cm². For lower temperatures, smaller values are obtained. Similar relationships would be valid also for other soil types (clay, silty sand, etc.) under compression as well as other types of stress.

A rise of temperature to the melting point will have a still greater effect. The whole structure of frozen ground is disrupted, the cementing effect of ice ceases, and often the ground deformations cause complex failure.

Heat transmitted to frozen ground under load produces an additional amount of deformation, which is equivalent to an additional load. Therefore, when studying the deformation of frozen ground under an outside load, heat can be considered as an external force.

Buildings which are heated to positive temperatures are local sources of heat which is transmitted to the frozen ground through the foundations sunk in the ground and through the entire site area.

Theory

In solving the problem of temperature changes in frozen ground caused by the penetration of heat from buildings and structures, the Fourier equation of thermal conductivity

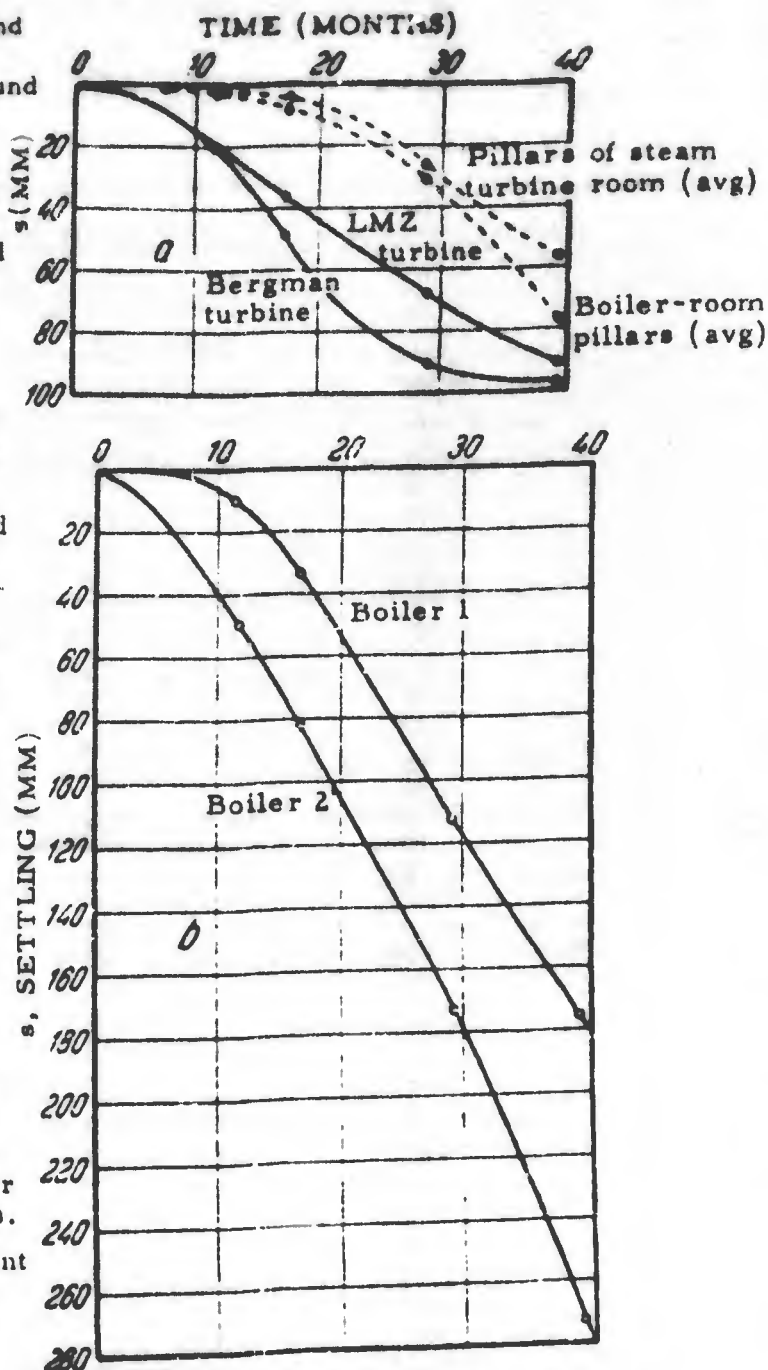

Figure 82a. Settling of the foundations of the Chita Power Station as a function of time.

can be applied. This equation has the following form:

$$dQ = -\lambda dF \frac{\partial \theta}{\partial n} du \quad (42)$$

where dQ is the quantity of heat which passes through the surface dF during the period of time du , $\frac{\partial \theta}{\partial n}$ is the thermal gradient (the rate of temperature decrease normal to the isothermic surface), and λ is the coefficient of thermal conductivity.

This equation shows that, with a temperature differential between the building and the frozen ground, a flow of heat will always take place, and the quantity of heat received by the frozen ground will be in direct proportion to the thermal gradient and time.

The following conditions must be satisfied for a stabilized flow of heat:

$$\nabla \theta = 0$$

where ∇ is Laplace's (or differential) operator, i. e.;

$$\nabla \theta = \frac{d^2 \theta}{dx^2} + \frac{d^2 \theta}{dy^2} + \frac{d^2 \theta}{dz^2} = 0$$

Here dx , dy , and dz are the sides of an infinitely small parallelepiped.

At the present time, as the literature indicates, Fourier's equation is solved for only three cases, namely, when the isothermic surfaces are either infinite parallel planes, infinite cylinders, or spheres.

It must be pointed out that Fourier's equation is valid only within the limits of temperature changes that would not cause a change of state in one of the adjacent bodies; i. e., it does not take into consideration the latent heat. The process of thawing (especially of frozen ground and ice) requires a larger quantity of heat than a rise of even several degrees in temperature. Consequently, Fourier's equation cannot be applied where the frozen ground thaws.

The process of thawing of frozen ground depends on the duration of heating and on the thermal properties of the ground. At the present time, the limit of thawing during local heating of frozen ground can be determined only for a linear problem. The solution to this problem was found by J. Stefan.¹

Mathematical analysis of the thawing process on a plane or in space was made by S. Kovner.² However, though his equations give an interesting analysis of the problem, they are not solved in final form.

Stefan analyzed the problem of determining the depth of water freezing or ice thawing in open basins. In a linear problem, a formula for the depth of thawing of frozen ground can be obtained in the same way.

The following designations are used: h is the depth of thawing, u is the time elapsed from the beginning of thawing, $\Delta \theta$ is the average difference between the outside air temperature and the temperature of the frozen ground, λ is the coefficient of thermal conductivity of thawed ground, ξ is the latent heat of melting of ice in the ground, w_0 is the volume of ice in the frozen ground, and ρ is the ice density.

1. J. Stefan (1890) Ueber die Theorie der Eisbildung, insbesondere uber die Eisbildung im Polarmeer (Theory of ice formation, particularly in the Polar Sea), Acad. Wiss. Math. IIa, 18, Wien.

2. S. S. Kovner (1933) Ob odnoi zadache teploprovodnosti (A problem of thermal conductivity), Zhurnal geofiziki, tom III, vyp. 1.

We calculate the thermal balance at the zero geoisotherm, taking this as the depth of thawing.

During the time du , the frozen ground below the depth of thawing, according to the equation of thermal conductivity, will receive the following amount of heat:

$$dQ_1 = \frac{\lambda}{h} \Delta\theta du.$$

This quantity of heat will thaw a layer of frozen ground with a thickness of dh , i. e., we will have:

$$dQ_2 = \xi w_0 \rho dh,$$

and, as

$$dQ_1 = dQ_2: \quad \xi w_0 \rho dh = \frac{\lambda}{h} \Delta\theta du.$$

Separating the variable, we have:

$$\xi w_0 \rho h dh = \lambda \Delta\theta du$$

Integrating within the limits from 0 to h and from 0 to u , we have:

$$\xi \rho w_0 \frac{h^2}{2} = \lambda \Delta\theta u.$$

Consequently, the depth of thawing of frozen ground will be:

$$h = \sqrt{\frac{2\lambda \Delta\theta u}{\xi \rho w_0}} \quad (43)$$

Introducing the designation:

$$a = \sqrt{\frac{2\lambda \Delta\theta}{\xi w_0 \rho}} \quad (44)$$

we will have:

$$h = a\sqrt{u} \quad (45)$$

i. e., the depth of thawing is directly proportional to the square root of time. This is Stefan's formula for the depth of thawing and freezing of a uniform medium. Applying this solution to the determination of the depth of thawing of a layer of frozen ground, we see that, during thawing, the upper surface of frozen ground moves parallel to itself.

For a symmetrical plane problem, assuming uniform temperature of the thawing medium, S. Kovner found that the line of thawing lowers along the arc of the circumference. The greatest depth of thawing along the axis of symmetry could be determined by Stefan's formula.

Figure 83 shows the lowering of the line of thawing in frozen ground calculated for equal intervals of time from the beginning of the thawing process. The maximum depth of thawing corresponds to Stefan's formula, and the outline of the bottom surface of thawing

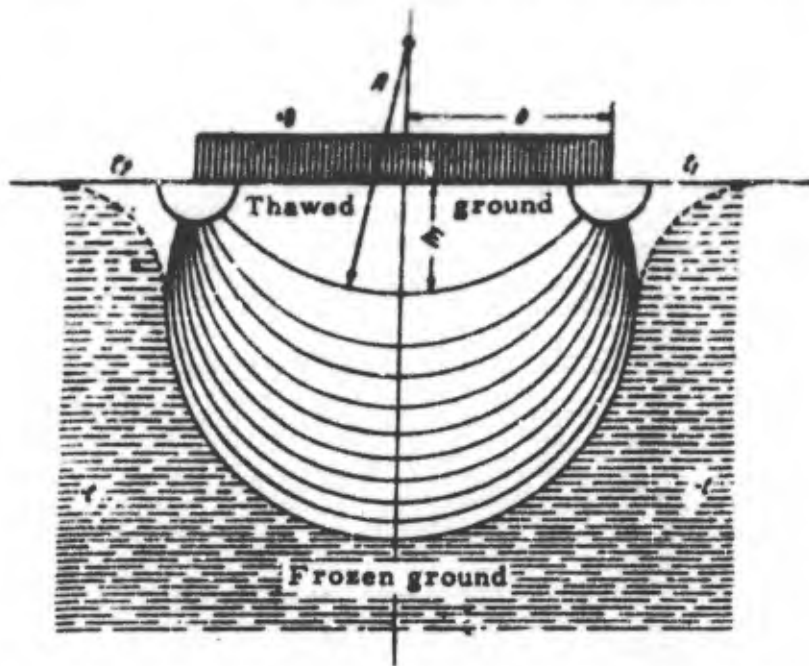

Figure 83. Lowering of lines of thawing in a homogeneous medium, for a plane problem.

for a symmetrical plane approximates the round cylindrical type, according to Kovner. The radius of the circumference of thawing, R , at the given maximum depth of thawing (along the axis of symmetry) is easily determined from purely geometrical relationships:

$$R = \frac{h^2 + b^2}{2h} \quad (46)$$

where h is the maximum depth of thawing and b is one-half the width of the heated area.

It should be pointed out that this picture of thaw lines is correct only when temperature is uniform in the area of heating and on the surface in adjacent areas. Moreover, the curves of thawing are disrupted where these areas meet (a certain area here should be excluded from consideration).

Therefore, only certain specific problems of heat distribution in a uniform medium have been solved. The problem of thawing, as we have seen, has been finally solved only in the case of a plane problem. Under natural conditions, when frozen ground is warmed by heat from heated buildings, or thawed under foundations, we are dealing with a problem in space, the exact solution of which is not available at this time.

A study of the heating and thawing of frozen ground must consider the results of direct experiments. Such data can be furnished by laboratory tests using models of foundations placed on the frozen ground and heated from above, as well as by observations under natural conditions (see Ch. VIII).

Experiments with models

Extensive experiments under natural conditions are not feasible because of the expense involved. In addition, it is difficult to find natural conditions which permit a systematic study of the question. The use of models allows the investigator to create the conditions he wants and study the influence of separate factors on the processes of freezing and thawing of frozen ground.

Typical results of our experiments with foundation models are given below.¹ The purpose of these experiments was to analyze the process of heat penetration into the ground through the foundation. Concrete models with thermocouples placed inside were used.

Vessels with triple walls were used for the tests (Fig. 84). Moistened ground was placed in the inner container to the required height (in some experiments the concrete model was installed, too), and the entire apparatus was put into a refrigeration chamber for 2 days until the ground was completely frozen. Then the apparatus was removed from the chamber and the concrete model was set on the surface or sunk to a certain depth in the frozen ground. It was covered to the required height by a layer of unfrozen ground at room temperature. Depending on the conditions of the experiment, the surface of the ground and the model were either heated or cooled, evenly or unevenly. Temperatures

1. N. A. Tsytoich (1934) O rasprostraneni tepla v modeliakh fundamentov, postavlyennykh v merslyi grunt (Heat distribution in foundation models set into frozen ground), Biull. Leningrad. inst. soorushenii, no. 25, 1932; also N. A. Tsytoich (1934) Laboratornye opyty po rasprostraneni tepla v modeliakh osnovanii i fundamentov (Laboratory experiments on heat distribution in models of bases and foundations), Leningrad. inst. soorushenii, ms.

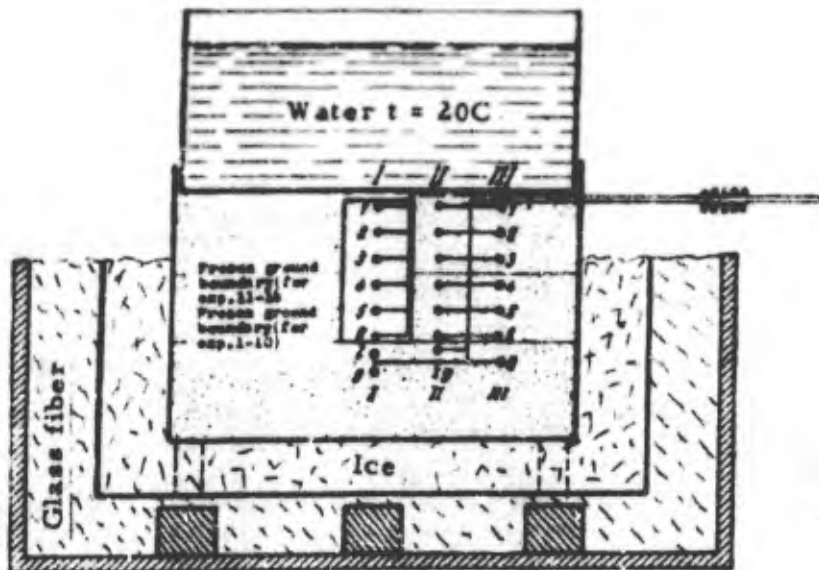

Figure 84. Sketch of the first series of experiments on heat distribution in base and foundation models.

inside the concrete model and at various depths in the unfrozen and frozen ground were determined at equal intervals (3 min) by the thermocouples (Fig. 84). A cooling mixture was placed between the walls of the vessel up to the level of the frozen ground and kept at a constant negative temperature. The following materials were used: clean medium-grained quartz sand and, for the model, concrete (mixture 1:3) and sawdust concrete.

The coefficient of thermal conductivity of sand ($\text{cal}/\text{m}^2\text{-C-hr}$), determined on the Christianson apparatus, was $\lambda = 0.26$ in the air-dried state, and, $\lambda = 1.1$ with 4% moisture by weight. For dry concrete (mixture 1:3) with unit weight $\gamma = 2.06 \text{ g}/\text{cm}^3$, $\lambda = 0.4 \text{ cal}/\text{m}^2\text{-C-hr}$.

First series of experiments

This series of tests used models with different thermal conductivities: a concrete model with a unit weight of $2.0 \text{ g}/\text{cm}^3$, and a sawdust-concrete model with a unit weight of $0.6 \text{ g}/\text{cm}^3$.

In some of the tests, models were set on the upper surface of frozen ground; for other tests, the models were sunk into the frozen ground to half their height. Temperature was measured during the course of 3 or 4 hr. As a rule, heat flow was stabilized during the first hour, as shown by the temperature changes.

For each point measured by the thermocouples, the average temperature for the period of stabilized heat flow was calculated (certain fluctuations in temperature were observed even during this period).

Temperature variations in the soil and the model were plotted for the period of stabilized heat flow, because it has the greatest practical significance. From these graphs, isotherms of the ground and foundations were drawn for each experiment.

Temperatures in the soil and in the foundation models during the period of stabilized heat flow are given in Table 71; tests with foundation models of different thermal conductivities are compared.

The soil used was natural medium-grained sand. In all tests, the initial moisture content of the sand was about 10%. After freezing, the sand was kept in a refrigeration chamber for two additional hours at a temperature of -5C before starting the tests.

In test 6 (concrete model), the soil moisture after the test was 7.2% on the surface of the unfrozen layer; 12.7% in the middle of the unfrozen layer; and, 12.3% in the middle of the frozen layer. During the period of stabilized heat flow, the water temperature in

Table 71. Temperature (C) of the soil and foundation models (single pillars) during period of stabilized heat flow.

Point	Foundation models resting on frozen ground						Foundation models set into frozen ground					
	Cross section						Cross section					
	I - I		II - II		III - III		I - I		II - II		III - III	
	Test 6	Test 9	Test 6	Test 9	Test 6	Test 9	Test 11	Test 16	Test 11	Test 16	Test 11	Test 16
1	11.8	15.5	12.2	14.1	10.3	12.1	10.7	12.7	10.3	11.1	10.3	11.6
2	10.7	13.0	9.6	11.3	8.5	10.1	8.8	8.7	7.5	8.1	7.2	7.7
3	8.6	10.2	7.5	8.0	6.8	7.5	6.2	5.6	4.8	5.2	4.3	4.7
4	6.4	7.5	5.6	4.9	5.0	5.0	3.8	3.1	1.7	2.2	1.5	2.3
5	4.4	4.7	3.3	2.4	2.9	2.5	1.8	0.5	-0.5	0.4	-0.9	-0.4
6	2.8	0.6	0.8	0.2	0.8	-0.1	0.5	-2.0	-1.6	-1.6	-2.0	-1.4
7	-0.3	-0.8	0.0	-0.5	-	-	-2.8	-2.5	-2.2	-2.1	-	-
8	-	-	-	-	-0.6	-1.2	-	-	-	-	-3.0	-2.6
9	-0.9	-1.2	-0.9	-1.3	-	-	-3.5	-2.9	-2.3	-2.9	-	-

Notes: 1. For tests 6 and 11, the models were concrete, with a unit weight of 2 g/cm³.
2. For tests 9 and 16, the models were sawdust-concrete, with a unit weight of 0.6 g/cm³.

the heater used in test 6 was 20.6C and was maintained by an electric heater consuming a current of 0.5 amp and 47 v. Altogether, 300 separate temperature measurements were made in test 6, but Table 71 gives only the average data for the period of stabilized heat flow.

In test 9 (with a sawdust-concrete model), the soil moisture after the test was 7.2% on the surface, 10.7% under the model, and 10.9% inside the frozen ground layer. The water temperature in the electric heater was 20.2C, with a current of 0.5 amp and 51 v. The temperature of the cooling mixture, as in test 6, varied from -3C to -4C. Figure 85 shows the isotherms of the ground and the foundation models in tests 6 and 9.

Figure 86 shows the isotherms of the ground and foundation models (for tests 11 and 16) which were sunk into the ground down to half their height. The soil moisture in test 11 was: 7.9% on the surface, 9.7% at the level of the base of the model, and 10.1% at the boundary of the frozen ground. The water temperature in the heater was 19.6C (with a current of 0.55 amp and 56 v). In test 16, moisture content was 7.2% at the surface of the thawed ground, and 9.2% at the boundary of frozen ground. The water temperature in the heating apparatus was 19.6C (no current measurement was made).

A study of the data given in Table 71, a comparison of the temperatures during equivalent time intervals from the beginning of the test, and a comparison of the isotherms of various models during the period of stabilized heat flow lead us to the following conclusions.

1. The isotherms curve downward in the foundation models and in the soil immediately adjacent.
2. The foundations with higher thermal conductivity show more rapid heating and thawing. In test 6, the boundary of frozen ground dropped below the base of the foundation, but in test 11 it coincided with the base of the axis of the model. In models of lower thermal conductivity, the boundary of thawing was much higher.
3. When the model was sunk to the surface of frozen ground, a convex mass of frozen ground is formed under the model, which makes it very unstable.
4. When the frozen ground touched concrete which had a positive temperature, a temperature rise along the axis of the model was observed. This can be clearly seen if a curve of temperature changes in depth is drawn (cross section I - I).

Second series of experiments

This series also studied temperature distribution in foundation models and in the ground during the period of stabilized heat flow, but the models were more complex. The test arrangement is shown in Figure 87 (test II) and in Figure 88 (tests IV and V).

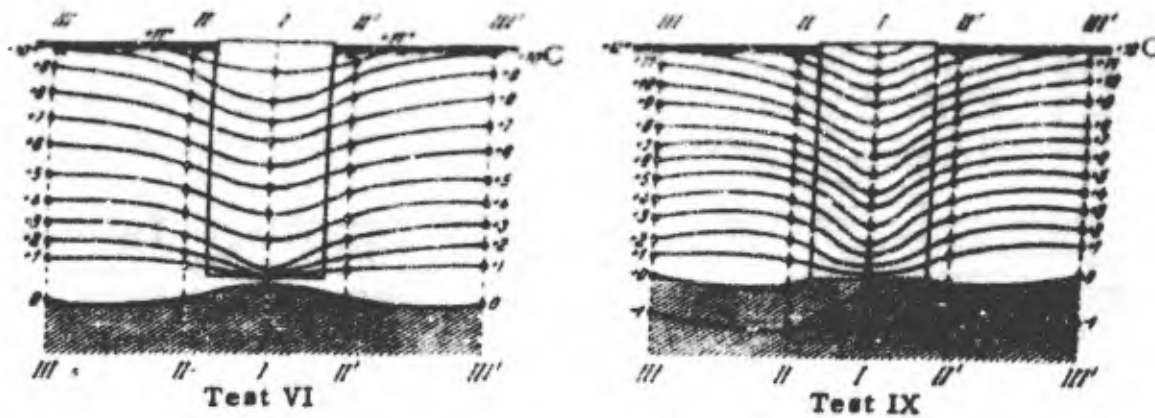

Figure 85. Isotherms in the ground and in foundation models installed on the surface of the frozen ground (tests 6 and 9).

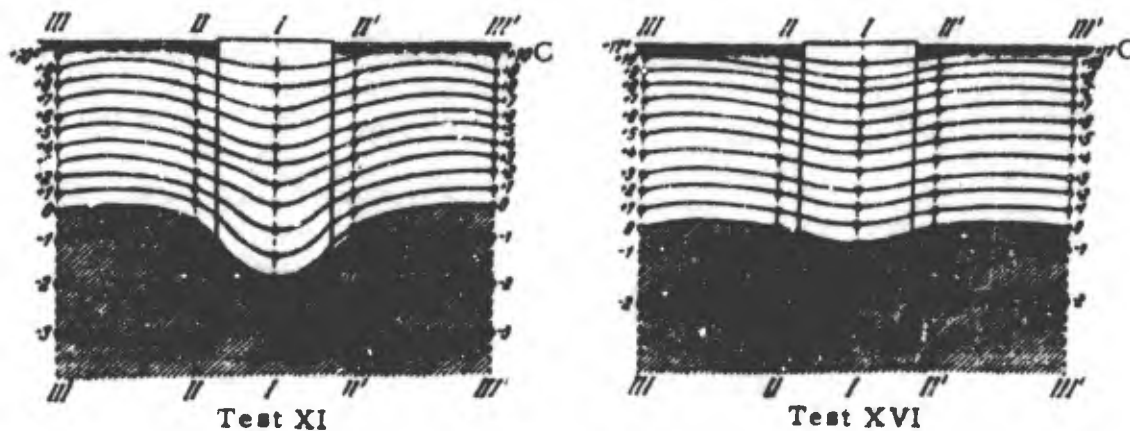

Figure 86. Isotherms in the ground and in foundation models sunk into frozen ground (tests 11 and 16).

In these tests, the source of heat (a container of water at a constant temperature of 25C) was placed directly on the model. The soil surface beyond the outside perimeter of the foundation had no heater and was under the influence of the air temperature of the room. Below, we consider the results of three typical tests (Nos. II, IV, and V) with concrete models (unit weight of concrete, 2.06 g/cm³).

In test II, a model of a solid foundation for the walls of a square building was placed on the frozen ground. The temperature inside the container (the heater for the model) was 25C, and the temperature of the outside air above the soil was 18C. Thus, the ratio of the temperatures was 25:18 or 1.4. The soil moisture after the test (an average of 3 measurements) was: 4.83% for the layer of unfrozen ground (instead of the calculated 5%), and 10.18% for the layer of frozen ground (instead of the calculated 10%).

In test IV (8 separate concrete pillars beneath a square container), the temperature of the heater, T , was 25C, and the air temperature, t , was 13.8C. Therefore, the ratio $T/t = 1.8$.

In test V (using the same type of model as in test IV) the ratio of the temperature in the water container above the model to the temperature of the air around the model was:

$$\frac{T}{t} = \frac{25}{13.4} = 1.865 \approx 1.9$$

UNCLASSIFIED

AD

230484

4 OF 6

FOR
MICRO-CARD
CONTROL ONLY

Reproduced by

Armed Services Technical Information Agency

ARLINGTON HALL STATION; ARLINGTON 12 VIRGINIA

UNCLASSIFIED

"NOTICE: When Government or other drawings, specifications or other data are used for any purpose other than in connection with a definitely related Government procurement operation, the U.S. Government thereby incurs no responsibility, nor any obligation whatsoever, and the fact that the Government may have formulated, furnished, or in any way supplied the said drawings, specifications or other data is not to be regarded by implication or otherwise as in any manner licensing the holder or any other person or corporation, or conveying any rights or permission to manufacture, use or sell any patented invention that may in any way be related thereto

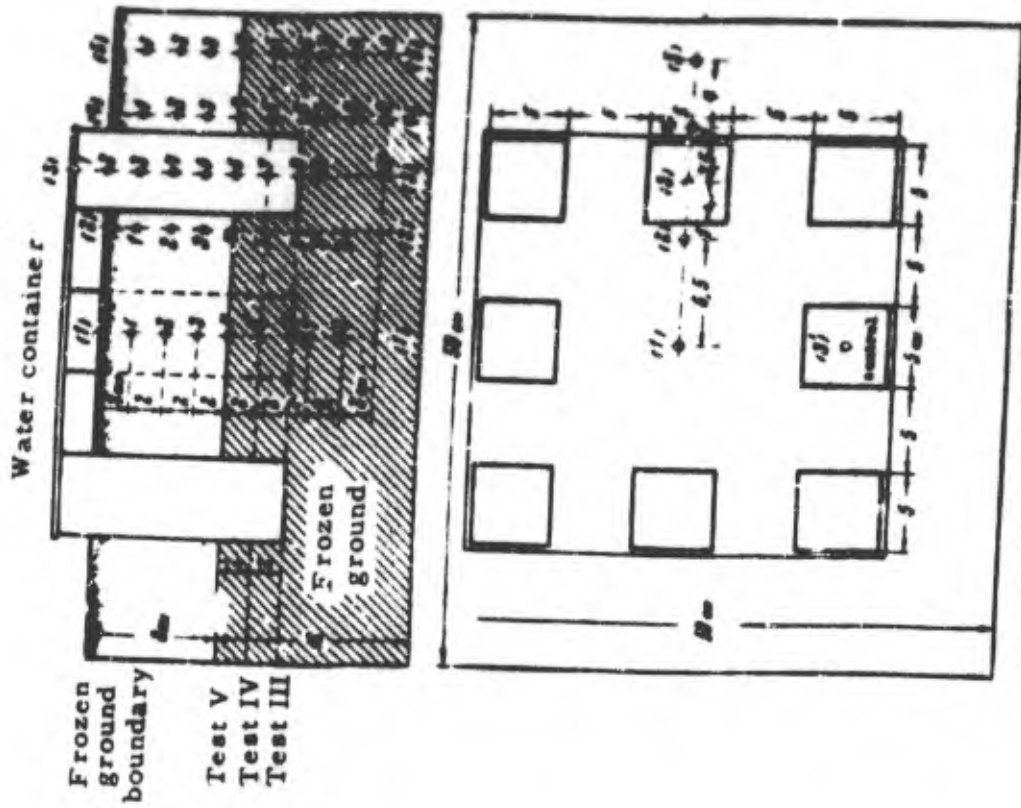

Figure 87. Sketch of test II.

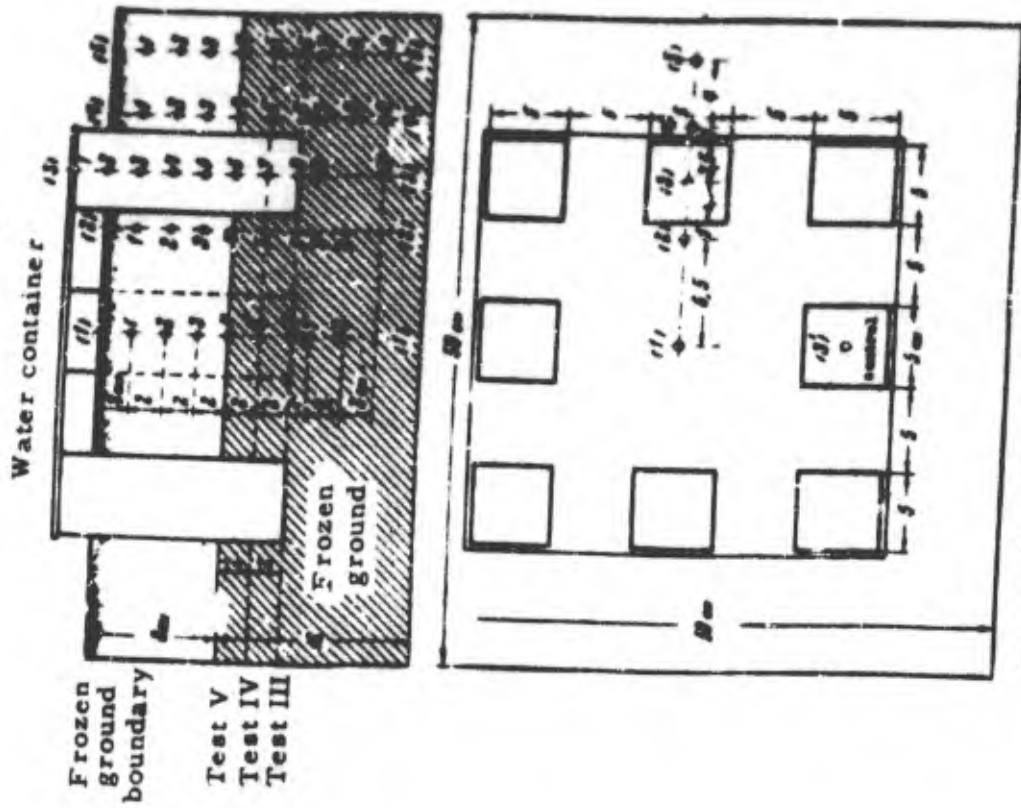

Figure 88. Sketch of tests IV and V.

EXPERIMENTATION AND THEORY

169

The unfrozen ground had a moisture content of 4.11% for test IV and 5.80% for test V; moisture content of the frozen ground was 9.80% for test IV and 10.45% for test V — all in percent of dry weight.

The size of the models, the location of the thermocouples, and the thickness of the unfrozen and frozen ground layers in tests IV and V are shown in Figure 88.

Table 72 gives temperature data for tests II, IV, and V (average of 6 measurements) for the period of stabilized heat flow.

Table 72. Temperature (C) of ground and of the complex foundation models (solid foundation under walls of a square building; system of separate foundation pillars) for period of stabilized heat flow.

Point	Test II					Test IV					Test V				
	Solid foundation					Foundation of separate pillars					Foundation of separate pillars				
	t = 18C		T = 25C			t = 13.8C		T = 25C			t = 13.4C		T = 25C		
(Gross sections (between thermocouples))															
	1-1	2-2	3-3	4-4	5-5	1-1	2-2	3-3	4-4	5-5	1-1	2-2	3-3	4-4	5-5
1	6.0	6.2	12.6	7.1	6.4	4.2	5.2	17.5	5.9	5.3	3.6	3.9	15.4	4.3	3.6
2	5.3	5.4	10.4	5.8	5.0	3.7	4.7	10.0	4.9	4.2	2.6	3.1	9.0	3.1	2.6
3	3.7	3.9	8.4	4.6	3.7	2.5	3.6	7.1	3.6	2.3	1.2	1.8	6.3	1.8	1.3
4	2.5	2.7	6.7	3.2	2.5	1.6	2.4	5.2	2.4	1.8	0.2	0.8	4.7	0.6	0.0
5	1.3	1.6	5.2	1.8	1.1	-0.5	1.3	3.8	1.1	0.5	-0.4	-0.2	3.3	-0.1	-0.6
6	0.1	0.1	2.9	0.6	0.3	-0.5	0.2	2.6	0.0	-0.5	-0.6	-0.5	2.4	-0.5	-1.0
7	-0.1	-0.6	3.9	0.1	-0.7	-0.9	-0.2	1.8	-0.2	-1.0	-0.9	-0.6	1.6	-0.6	-1.0
8	-0.3	-0.8	2.0	-0.2	-0.8	-0.9	-0.4	1.2	-0.4	-1.1	-0.9	-0.9	1.3	-0.8	-1.1
9	-	-	-0.1	-0.5	-0.7	-	-	-1.0	-1.4	-1.4	-	-	1.0	-1.2	-1.0
10	-	-	-0.5	-	-	-	-	-1.2	-	-	-	-	-1.1	-	-

From these data, curves of temperature distribution with depth were drawn for cross sections (1-1), (2-2), (3-3), (4-4), and (5-5), and, from these curves, the isotherms of the ground and the foundation models were drawn (Figs. 89, 90, and 91).

A study of the data in Table 72 and a comparison of the isotherms leads us to the following conclusions.

1. The shape of all isotherms, including the zero isotherm, is very complex and depends both on the general conditions of the experiment (area of heating, relationship between the dimensions of the models, the thermal properties of materials, etc.) and on the influence of the separate foundations on each other.

2. When the temperature inside the container is higher than the temperature of the outside air, the frozen ground under the foundations thaws unevenly, even when the coefficient of the thermal conductivity of the foundation material is less than the coefficient of thermal conductivity of the unfrozen ground (tests II and IV).

3. Maximum thawing takes place at a certain distance from the base of the foundation model, not under it. It occurs, as it were, under the influence of heat reflection from the side walls of the foundations.

4. Sinking foundations down to a certain depth in the frozen ground, depending on the size of the foundation and on the thermal properties of the ground (under the conditions of test V, down to $\frac{1}{2}$ the model's height), can preserve the frozen ground under the base of the foundations if air can circulate on the surface (a ventilated cellar).

Third series of experiments

In this series, the distribution of temperature in foundation models with uneven heat flow was studied. A number of experiments were made with foundation models sunk half-way into the frozen ground while the upper layer of unfrozen ground was freezing, so that the upper surface of the model was not cooled. Several experiments were made with uneven heating (by a large electric bulb) on the surface of one-half of the model (up to 40C), maintaining a constant temperature for the second half with a vessel of water at 8C. The rest of the test conditions (ground moisture, etc.) were similar to the conditions of the first series of experiments.

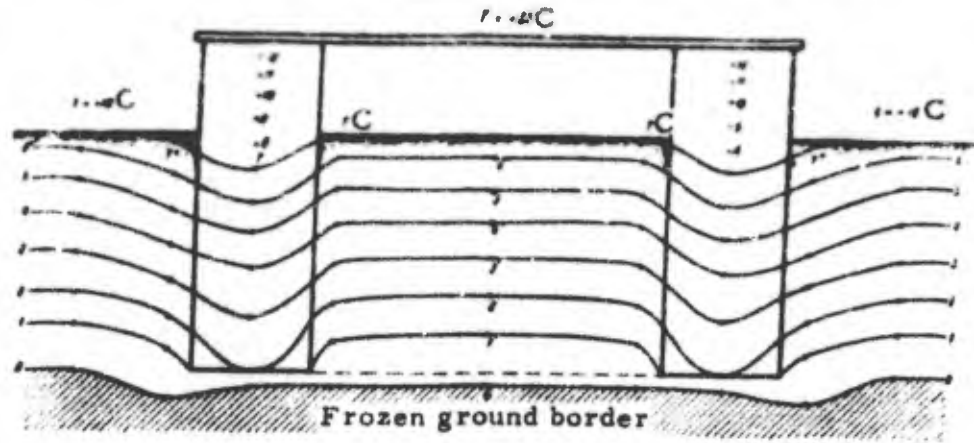

Figure 89. Isotherms in ground and foundations, test II.

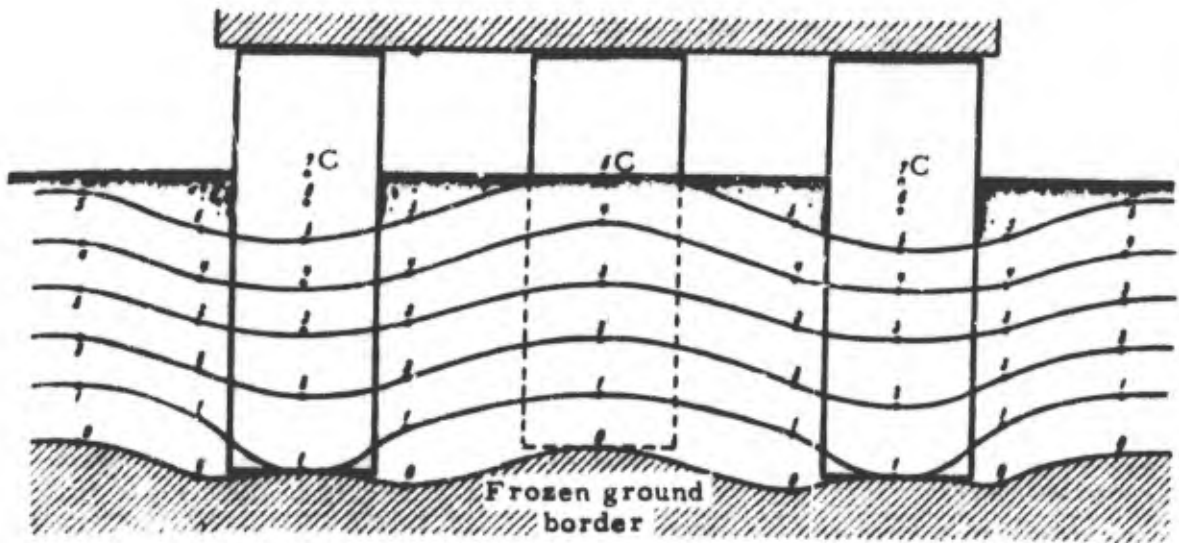

Figure 90. Isotherms in ground and foundations, test IV.

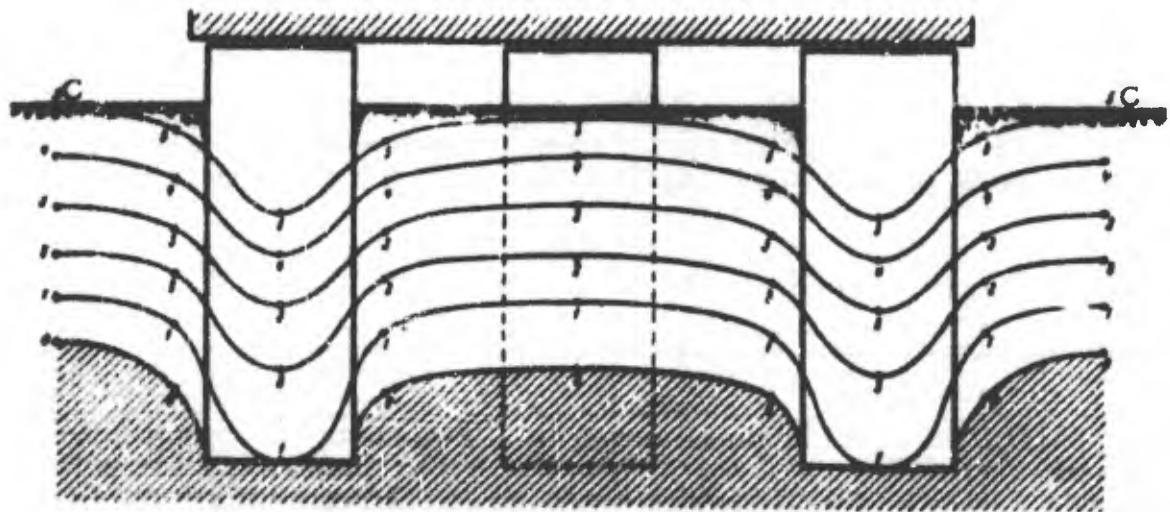

Figure 91. Isotherms in ground and foundations, test V.

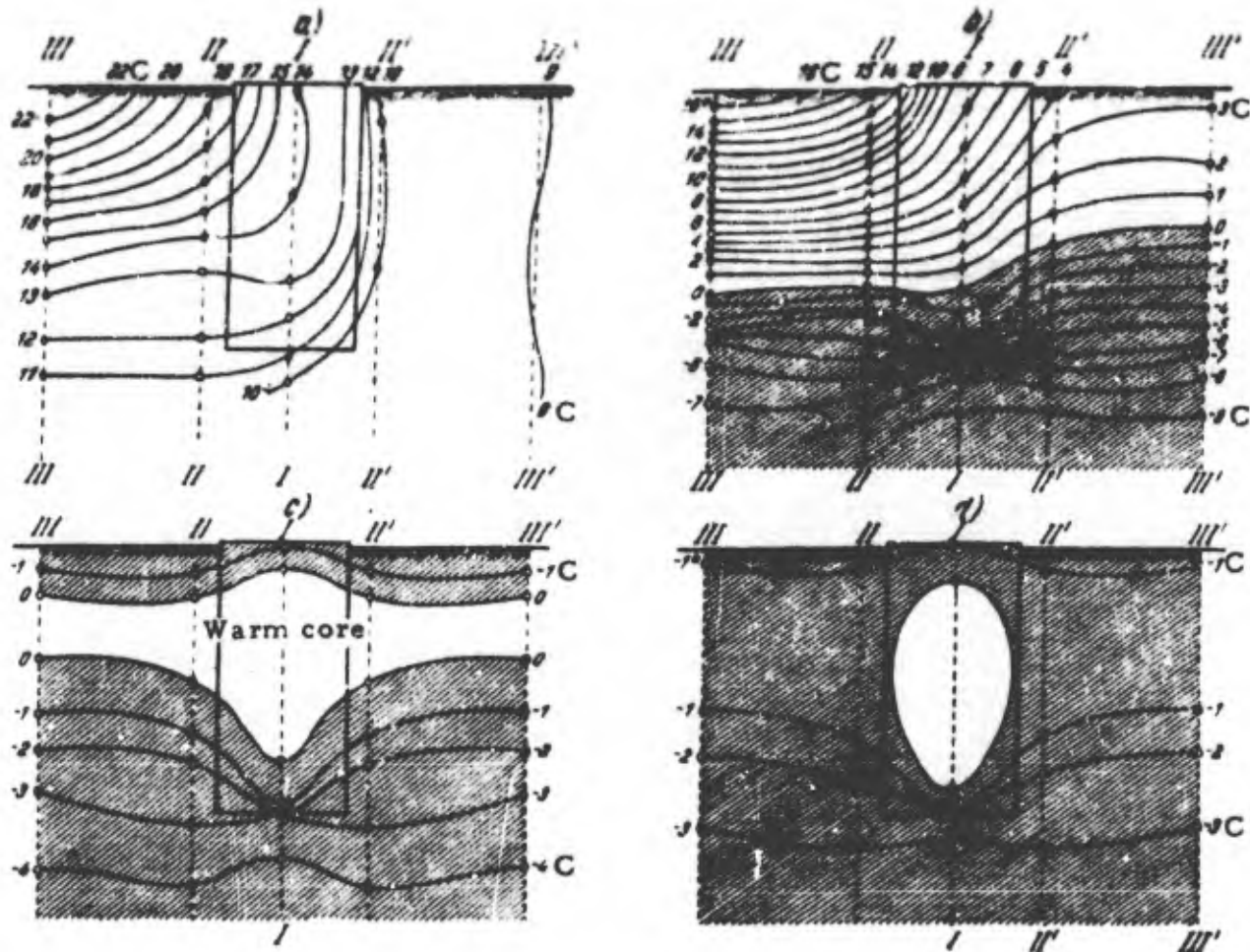

Figure 92. Isotherms in ground and foundations, third series of experiments
 a) foundation model in thawed ground; b) foundation model at the beginning of the experiment — half sunk into frozen ground; c) and d) foundation models sunk into frozen ground, with the upper layer of the ground frozen.

Figure 92a shows characteristic isotherms of the ground and of the foundation models for the third series of tests. It shows the isotherms of the ground and of a concrete foundation model set into the unfrozen ground under conditions of uneven heating (from one side) of the ground surface by the heat emanated from an electric bulb. In this case, the heat flows from the source of heat to the lateral surface of the model perpendicular to the isotherms.

The same picture is observed when the foundation model is sunk halfway into the frozen ground (Fig. 92b).

Figures 92c and 92d show the isotherms of the ground and of foundation models when the upper soil layer is frozen. In these tests the models were sunk halfway into the frozen ground at the beginning of the experiments. It should be pointed out that the flow of heat, which is characterized by the isotherms shown in Figures 92c and 92d, was nearly stabilized inasmuch as four thermocouple readings made every 30 min differ very little from each other.

In the cases considered here, the law of temperature change in the foundation models in the ground is exceedingly complex. In addition, for a certain period of time during the freezing of the upper soil layer, a warm core in the foundation and a warm layer in the ground are observed. The model tests show that, when temperature conditions near the

structure are not symmetrical (which occurs under natural conditions also), the isotherms of the ground and of the foundations will also be nonsymmetrical. This conclusion is supported not only by laboratory tests, but also by observations under natural conditions. These observations are described in detail in Chapter VIII.

Conclusions

A study of the above-cited theoretical and experimental data on the distribution of heat in frozen ground and in foundations and its influence on the mechanical properties of frozen ground leads us to the following conclusions.

1. The process of heat distribution in frozen ground and foundations depends on outside temperature conditions, on the geometrical dimensions of the foundations and the depth of their placement, and on the thermal properties of frozen ground and of foundations.
2. One of the most important factors influencing the rate of movement of the boundary of thawing of frozen ground is the degree of ice saturation of the ground. Everything else has only secondary significance in comparison.
3. Heat acting on frozen ground may be considered as an outside force, as the ability of frozen ground to resist deformation decreases with an increase in the amount of heat.

CHAPTER VI. BEHAVIOR OF FROZEN GROUND UNDER LOAD

Introduction

In previous chapters the simplest cases of stress and deformation have been considered: uniform compression, shear, and adfreezing. Under natural conditions, when structures are erected on frozen ground and permafrost, the ground experiences a considerably more complex state of stress. It is necessary to study both the distribution of stresses in frozen ground and the strength and stability of frozen ground under the action of a local load applied to its surface.

In construction, time and attention are given to that part of a building which is above the ground; very often even insignificant details are considered. On the other hand, the properties of the ground beneath the foundation of the structure are almost completely disregarded. Such neglect of the principle of equal stability never leads to good results. The building, carefully planned except for consideration of the properties of frozen ground, will inevitably become deformed, often making the entire structure completely useless.

In order to take into account the influence of the properties of frozen ground on structures and the influence of structures on the stability and strength of frozen ground, it is necessary to know the temperature conditions and the distribution of stresses in the ground to a depth considerably lower than the base of the foundation.

Without knowing the stress distribution, it is impossible to determine the strength of frozen ground under complex stress or the deformation of frozen ground when it thaws.

Stresses in frozen ground can be determined by two procedures: theoretical and experimental.

At the present time, the first procedure has not been worked out but the general conclusions of construction mechanics, primarily the theory of elasticity, may be quite useful. In studying the distribution of stresses, frozen ground under the small loads which occur in nature may be considered as a homogeneous and elastic body in many cases. This assumption is usually made when determining the stresses in ground with a positive temperature, with much less validity. Within certain stress limits, frozen ground, which is cemented by ice and therefore has considerable cohesiveness, corresponds very closely to linearly deformed elastic bodies.

The uniformity of frozen ground depends on the conditions of its natural formation. If the layer of frozen ground does not have many ice lenses, then, in many cases, it may be considered homogeneous.

Layered frozen ground or an unfrozen layer overlying frozen ground cannot be considered homogeneous for the purpose of determining stress distribution. The difference in hardness of the layers will be manifested more sharply in the distribution of stresses than in unfrozen ground. Young's modulus for frozen ground is measured in tens of thousands of kilograms per square centimeter; for unfrozen ground, it is 100 to 200 times smaller.

Because of the almost complete lack of experimental data, we can only point out the necessity for wide application of the experimental method in determining stress conditions of frozen ground, especially for layered frozen ground.

Stress Distribution in Uniform Layers of Frozen Ground

Concentrated stress

If a mass of frozen ground is sufficiently deep and wide, the formulas based on the theory of elasticity dealing with a semi-infinite body may be applied to it within specific limits. Thus, the formulas pertaining to a mass which is deformed linearly will be valid if the stresses do not exceed the limit of proportionality.

Stress distribution in an elastic body under the influence of a concentrated force on its surface has been given by Boussinesq.¹

1. J. V. Boussinesq (1885) Application des potentiels, etc., p. 92. Paris; see also N. A. Tsytoich (1934) Osnovy mekhaniki gruntov (Principles of soil mechanics).

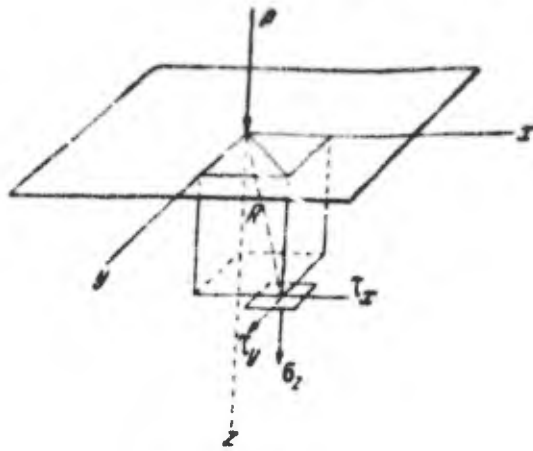

Figure 93.

An outside force P applied perpendicularly to a boundary plane of the mass (Fig. 93) causes a radial stress on any area parallel to the face equal to:

$$\sigma_r = \frac{3}{2} \frac{P z^2}{\pi R^3} \quad (47)$$

where z is the distance from the boundary plane to the area parallel to it for which the stress is being determined;

$$R = \sqrt{x^2 + y^2 + z^2}$$

is the distance from the center of gravity of the area under consideration to the point of application of the concentrated force.

Resolving the stress into three directions: one perpendicular to the area and the other two on the plane of the area, we get the following components of stress as calculated by Boussinesq:

$$\sigma_z = \frac{3}{2} \frac{P}{\pi} \frac{z^3}{R^3} \quad (48)$$

$$\tau_y = \frac{3}{2} \frac{P}{\pi} \frac{yz^2}{R^3} \quad (49)$$

$$\tau_x = \frac{3}{2} \frac{P}{\pi} \frac{xz^2}{R^3} \quad (50)$$

It should be noted that the values of stresses for the area parallel to the boundary plane do not depend on the elastic constants of the mass. As a result, the above formulas are widely used to calculate stresses not only in a uniform mass of ground but also in bedded sediments. In the latter case, however, this application produces an approximate result, as will be demonstrated later. According to Boussinesq, the stresses of the areas perpendicular to the boundary plane will be functions not only of the extent of the force and geometric elements, but also of the elastic constants of the mass (Young's modulus, Poisson's ratio).

Let us deal in somewhat greater detail with the perpendicular compressive stress, σ_z , because, at the present time, it is most frequently applied.

The question arises: under what conditions and for what materials would the Boussinesq equation be applicable for compressive stresses? This question can only be answered by experiment. Such experiments for determining the stresses in a mass under the influence of external forces were conducted for elastic bodies (by the optical method for a plane problem) and for loose ground. (Experiments were made by Kegler, Scheidig, Stroschneider, Kik, and Laletin, and others.)

The results of the experiments show the following:

1. The Boussinesq equations are completely applicable to elastic, isotropic bodies.
2. For loose ground (areas up to 1 m^2), the compressive stresses under the center of the area under load are larger than they should be according to the Boussinesq equation.
3. For areas located at a depth greater than twice the diameter of the area under load, the compressive stresses in sand can be determined with sufficient accuracy by the Boussinesq equation.

This last conclusion does not contradict Saint-Venant's well known principle on elasticity, which states that the distribution of stresses in areas located at a considerable distance from the point of force application depends only on the magnitude and the direction of the resultant force.

Concentration of stresses

Since the experimentally determined values of stresses for sand do not coincide with the values calculated according to the Boussinesq equation, O. K. Fröhlich¹ modified the equation for compressive stresses in the ground under a concentrated force by introducing a stress concentration factor ν . Thus, the equation for compressive stress becomes:

$$\sigma_z = \frac{\nu P}{2\pi R^2} \cdot \frac{z^\nu}{R^\nu} \quad (51)$$

where ν is the stress concentration factor, which may have different values depending on the physical characteristics of the ground.

If $\nu = 3$, eq 51 is the same as the Boussinesq equation 48.

A comparison by A. E. Cummings² of experimental data (on areas up to 1 in²) with the data obtained by eq 51 showed that, for loose sand, the value of ν should be 6. According to Fröhlich, the value of the stress concentration factor for cohesive soils is close to 3, i. e., the Boussinesq formula is applicable.

The distribution of compressive stresses along the sections parallel to the boundary plane depends on the stress concentration factor, as is clearly illustrated by Figure 94. It must be pointed out that, according to the latest data, the stress concentration factor depends not only on the type of soil but primarily on the magnitude of plastic deformation of the ground.

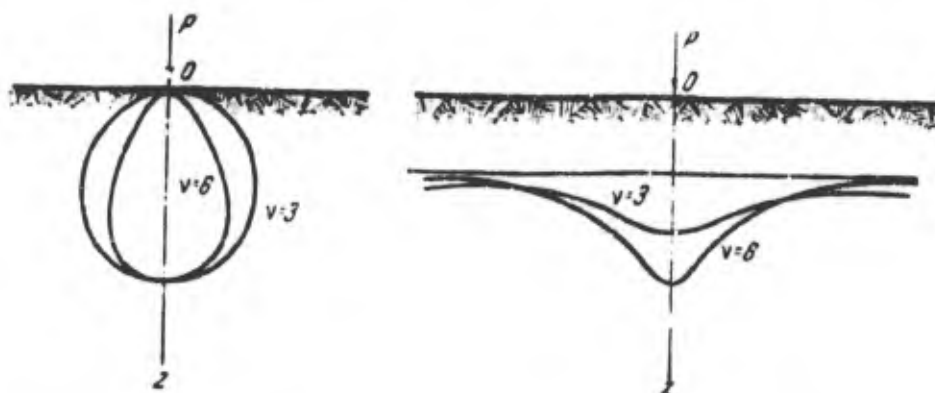

Figure 94. Distribution of pressure in a mass for different values of the stress concentration factor.

It is impossible to determine exactly which stress concentration factor ν would most closely correspond to the distribution of stresses in frozen ground cemented by ice since there is no experimental data on this subject.

Frozen ground has a considerable degree of cohesion (coherence) and under loads (up to 3 to 5 kg/cm²) which prevail during foundation construction may be looked upon as

1. O. K. Fröhlich (1934) Druckverteilung im Baugrunde (Pressure distribution in building foundations). Wien: Springer.
2. A. E. Cummings (1935) Distribution of stresses under a foundation, Proceedings of the American Society of Civil Engineers, vol. 61, no. 6.

a linearly deformed body. Therefore, we believe that the coefficient of stress concentration of frozen ground approaches 3 and, consequently, Boussinesq equation 48 can be used to determine compressive stresses in frozen ground under concentrated force.

If we substitute in eq 48, $R = \sqrt{z^2 + r^2}$ (where r is the distance between the center of gravity of the area and the vertical axis), then the formula for calculating compressive stresses may be expressed as

$$\sigma_z = K \frac{P}{z^2} \quad (52)$$

where:

$$K = \frac{3}{2\pi} \frac{1}{\left[1 + \left(\frac{r}{z}\right)^2\right]^{5/2}}$$

K is the coefficient depending on the ratio r/z . The values of this coefficient for the various values of r/z are given in Table 74,¹ which considerably facilitates the calculation of compressive stresses by eq 52.

Table 74.* Values of the Boussinesq coefficient K in equation 52.

Ratio $\frac{r}{z}$	Coefficient K	Ratio $\frac{r}{z}$	Coefficient K	Ratio $\frac{r}{z}$	Coefficient K
0.00	0.4775	1.00	0.0844	2.00	0.0085
0.05	0.4745	1.05	0.0744	2.05	0.0078
0.10	0.4657	1.10	0.0658	2.10	0.0070
0.15	0.4516	1.15	0.0581	2.15	0.0064
0.20	0.4329	1.20	0.0513	2.20	0.0058
0.25	0.4103	1.25	0.0454	2.25	0.0053
0.30	0.3849	1.30	0.0402	2.30	0.0048
0.35	0.3577	1.35	0.0357	2.35	0.0044
0.40	0.3294	1.40	0.0317	2.40	0.0040
0.45	0.3011	1.45	0.0282	2.45	0.0037
0.50	0.2733	1.50	0.0251	2.50	0.0034
0.55	0.2466	1.55	0.0224	2.55	0.0031
0.60	0.2214	1.60	0.0200	2.60	0.0029
0.65	0.1978	1.65	0.0179	2.65	0.0026
0.70	0.1762	1.70	0.0160	2.70	0.0024
0.75	0.1565	1.75	0.0144	2.80	0.0021
0.80	0.1386	1.80	0.0129	2.90	0.0017
0.85	0.1226	1.85	0.0116	3.00	0.0014
0.90	0.1083	1.90	0.0105	4.00	0.0004
0.95	0.0956	1.95	0.0095	5.00	0.0001

* [No table 73 in original.]

If several concentrated forces are acting on the surface of a ground mass, the compressive stress at any point of the horizontal area of this mass can be calculated as the sum of the stresses produced by the separate forces and depends on the distance between

1. For a more detailed table of values of K see: Proceedings of the American Society of Civil Engineers, vol. 59, 1933, p. 775-820, [Earths and Foundations: Progress report of Special Committee]; and the translation of the report Gruntzy i fundamente, edited by S. M. Melkumov, 1935.

the point and the forces, according to the equation

$$\sigma_z = K_1 \frac{P_1}{z^2} + K_2 \frac{P_2}{z^2} + \dots + K_n \frac{P_n}{z^2}$$

or

$$\sigma_z = \sum_1^n K_i \frac{P_i}{z^2} \quad (53)$$

where $K_1, K_2 \dots K_n$ are coefficients which are determined from Table 74, depending on the value of the ratio r_1/z .

Uniform load

The Boussinesq equation 52 was evolved for a concentrated force. It can also be used for approximate determination of the compressive stresses caused by a local load on the surface of the frozen ground.

If an unequally distributed load acts on a certain area, we divide the loaded area into separate elements and consider the load acting on each element as a concentrated force. Thus, we have a number of concentrated forces, producing a stress determinable for any point of the body by eq 53.

If we designate the length of the separate element as a_0 , the distance from the center of gravity of the element to the point on a horizontal area for which the stress is being determined as R_0 , and the probable error as i , then, according to Professor Gilboy, the error in calculations using eq 53 will be:

$$i = 6\% \text{ if } \frac{a_0}{R_0} = \frac{1}{2}$$

$$i = 3\% \text{ if } \frac{a_0}{R_0} = \frac{1}{3}$$

$$i = 2\% \text{ if } \frac{a_0}{R_0} = \frac{1}{4}$$

Specific Cases of Stress Distribution in Permafrost

Below we shall deal with the action of a local load on the frozen and unfrozen ground layers under permafrost conditions. Several possibilities exist, the most important of which are: (1) the load is transmitted to a layer of frozen ground which overlays either bedrock or unfrozen ground; (2) the frozen ground has one or more differently distributed unfrozen layers; (3) the load is transmitted to a layer of unfrozen ground underlain by frozen ground, but the thickness of the unfrozen layer is constantly increasing because of thawing; and (4) the layer of frozen ground has different elastic characteristics in the vertical and horizontal directions.

These possibilities of stress distribution in the ground in permafrost regions represent very complex problems, which can be solved only by accepting certain simplifying assumptions. The first assumption is a linear relationship between stress and deformation for loads up to 3 kg/cm^2 for both frozen and thawed ground, i. e., the assumption that the mathematical theory of elasticity is applicable here.

Influence of the area of load transmission

It is known from the theory of stress distribution in a solid medium that a large area under load transmits pressure to a greater depth. This fact, which is of considerable importance to general soil mechanics, is especially important in the mechanics of frozen ground.

At least two cases should be considered: (1) when a layer of frozen ground overlies bedrock, and (2) when a layer of frozen ground rests on a weak layer of unfrozen ground.

The distribution of compressive stresses, in general, will depend on the rigidity of the layer under compression. If the layer of ground under compression lies on a rigid foundation, the stress will be greater than on a uniform mass of ground. If the ground layer under compression is underlain by a less rigid layer, the stresses will be less in the compressed layer. This circumstance is manifested especially when there is a considerable difference between the elastic constants of the compressed layer and the underlying ground, and at certain relationships of the thickness of the layer to the dimensions of the loaded area.

The Boussinesq equations may be used to study the influence of the area of load transmission on the stresses arising in frozen ground. For a homogenous mass, these equations will describe the actual situation with sufficient accuracy, but they will give only an approximate general state of stress for layered ground.

The influence of the area under load can best be studied by a concrete example.

Assume that the surface of frozen ground supports two equally distributed loads: one on an area 1.5 x 1.5 m, and the other on an area 6 x 6 m. In both cases, the load intensity is 2 kg/cm². We will determine the vertical distribution of maximum compressive stresses for both cases.

For the first case, we find the compressive stresses for an area 1 m beneath the center of the loaded area. Then, we divide the loaded area into 25 separate sections, considering that the load for each section will be concentrated at its center of gravity (Fig. 95). Then the stress for the area located at the depth of z cm from the surface can be determined according to the equation

$$\sigma_z = \sum_{i=1}^n K_i \frac{P}{z^2}$$

For convenience, the calculations are given in Table 75.

The compressive stress is

$$\sigma_z = 6.1683 \frac{1800}{100 \times 100} = 1.11 \text{ kg/cm}^2.$$

As the ratio between the large dimension of the section and the distance from its center of gravity to the point under load is 0.3, the probable error of our calculation will be about 3%.

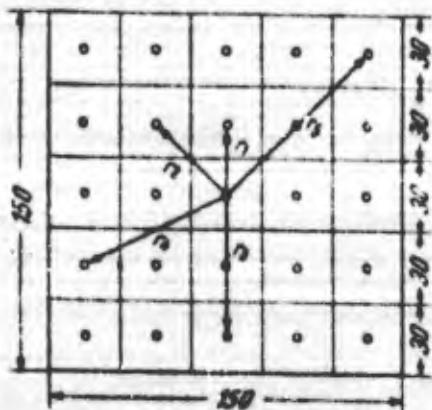

Figure 95.

The stresses for other points (on horizontal areas), can be obtained in the same way.

The results of calculations for both cases are shown in Figure 96.

Comparing our results for the two examples, we come to the following conclusions, which are valid both for frozen and unfrozen ground.

1. Compressive stresses at the same depth will be greater under the larger foundation than under the smaller one. The difference between these compressive stresses increases with an increase in depth. At a depth of 1 m, $\sigma_z = 1.11 \text{ kg/cm}^2$ for the area of 1.5 x 1.5 m; under the larger foundation, $\sigma_z = 1.95 \text{ kg/cm}^2$. At a depth of 3 m, $\sigma_z = 0.2 \text{ kg/cm}^2$ for the first case, and 1.4 kg/cm² for the second case. Beneath a foundation with a larger base area,

Table 75.

No.	Distance $\frac{r}{\text{cm}}^{\circ}$	$\frac{r}{a}$	Coefficient K	Number of sym- metrical elements $\frac{n}{2}$	Kn
0	$r_0 = 0$	0	0.4775	1	0.4774
1	$r_1 = 30$	0.3	0.3849	4	1.5396
2	$r_2 = 42.4$	0.424	0.3154	4	1.2616
3	$r_3 = 60$	0.600	0.2214	4	0.8856
4	$r_4 = 67.1$	0.671	0.1889	8	1.5112
5	$r_5 = 84.8$	0.848	0.1232	4	0.4928
			$\Sigma K_i = 5.1683$		

* For point positions see Figure 95.

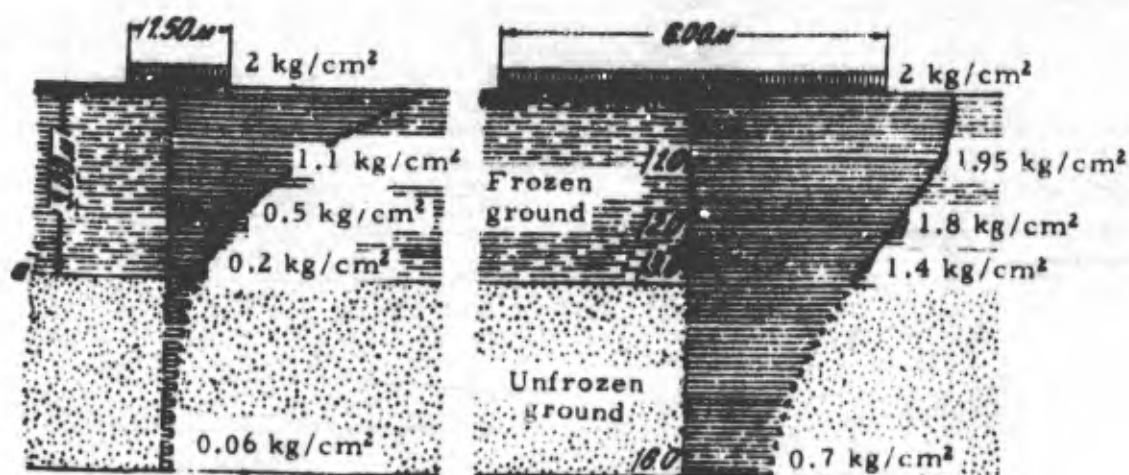

Figure 96. Distribution of compressive stresses under foundations with base areas of 1.5 x 1.5 m and 6 x 6 m.

the compressive stress along the z axis will be still greater.

For a foundation 12 x 12 m in area and under an external pressure of $p = 2 \text{ kg/cm}^2$, the compressive stress at the depth of $z = 3 \text{ m}$ will be $\sigma_z = 1.8 \text{ kg/cm}^2$. Therefore, foundations with larger base areas transmit pressure to a considerably greater depth than foundations with a smaller base area.

2. The above data show that we must know the properties of the ground at a depth at least twice the width of the area of the largest foundation base in order to have a clear concept of the durability and stability of structures erected on this ground. If the area is loaded in such a manner that the intervals between the sections under load are smaller than the sections under load, the effects on the separate loaded sections will be added to each other and it is necessary to investigate the properties of ground to a depth of about the width of the entire building in order to correctly estimate the ground properties under the foundation.

3. The above data make it possible to determine the importance of the layer under the frozen ground. If, in the example shown in Figure 96, bedrock occurs at a depth of 3 m from the surface under load, the stability and strength of the first and the second foundation would be approximately the same (assuming the same properties of frozen ground). An unfrozen layer of liquefied soil at the same depth will have practically no influence on foundation 1, which produces a compressive stress of about 0.2 kg/cm^2 at a depth of 3 m. However, the pressure beneath foundation 2 is 1.4 kg/cm^2 at 3 m, and the properties of

the unfrozen ground will be a decisive factor. Such pressure could squeeze out the soil from under the frozen layer, causing additional settling of foundation 2 and possible destruction.

4. Assume that permafrost occurs at depth and an unfrozen layer of considerable thickness lies between the base of the foundation and the permafrost. If the foundation has a small base area, a width 2-3 times less than the thickness of the unfrozen ground, the presence of frozen ground at the depth indicated in Figure 97 will have almost no practical significance. But if the foundation has a base approximately as wide as the thickness of the unfrozen layer, the presence of permafrost will constitute a factor determining the stability and strength of the foundation. If the ground thaws for some reason and the permafrost table is lowered, it would have no serious effect on the first foundation, but might cause excessive settling of the second foundation.

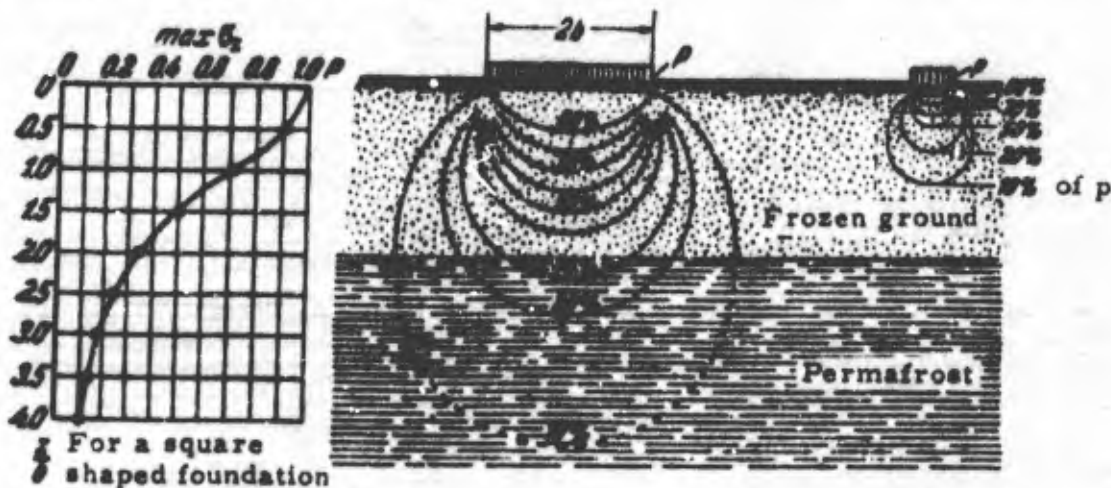

Figure 97. Relation between pressure and size of the loaded area.

Presence of unfrozen layers

If a loaded layer of frozen ground contains unfrozen interlayers, with compressive strengths several times lower than that of frozen ground, precise calculation of the stresses is a very complex problem. If, as is often done when investigating unfrozen ground, we apply the solutions for a homogeneous mass, the area of load transmission will still be of prime importance for the stresses in an unfrozen layer. However, the applicability of this solution may be questioned because, strictly speaking, the distribution of stresses in heterogeneous ground will be different than in homogeneous.

Figure 98 shows the distribution of compressive stress at various points along the vertical axis through the center of gravity of the foundation base. For the large foundation we have one continuous load, and, in the second, a number of equal separate loads. A layer of weak, unfrozen ground is located at a depth approximately equal to the width of the base of the first foundation. In the first case, this layer will receive a considerable load while in the second case (several small foundations) the load will be several times smaller.

Therefore, in this case, the construction qualities of the natural foundation will depend on the properties of the weak unfrozen layer as well as on the size of the building areas.

The presence of a thin unfrozen layer in the permafrost at depth h from the boundary plane decreases the maximum compressive stresses under load. This was shown by studies of such problems by M. A. Biot.¹

1. Travaux, (Organe de la Technique Francaise des Travaux Publics et du ciment Arme), 1936, no. 41.

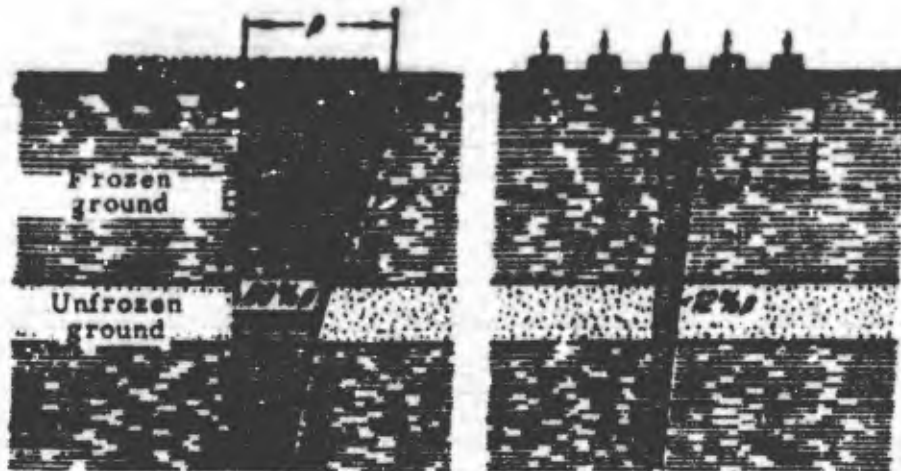

Figure 98. Distribution of pressure under a foundation and under a series of separate foundations.

Thus, according to Biot, the maximum compressive stress at depth h , with a number of concentrated forces and for a plane problem, is equal to

$$\sigma_z = 0.5942 \frac{P}{h} \quad (54)$$

where P is the concentrated force per unit of length and h is the depth of the layer from the bordering plane.

According to Flamant, the maximum compressive stress at the same depth for an isotropic mass under the same conditions will be¹

$$\sigma_z = \frac{2P}{\pi h} \quad \text{or} \quad \sigma_z = 0.6366 \frac{P}{h} \quad (55)$$

If a thin layer of unfrozen ground lies between the base of the foundation and the permafrost, we can determine the compressive stresses in this layer by using Melan's equation² for stresses in an elastic layer on a rigid foundation (Fig. 99).

For a plane problem on the boundary of the frozen ground, the greatest compressive stress arises along the axis of the load. According to Melan, the stress at the lower surface of the elastic layer (in our case of the unfrozen layer) will be

$$\sigma_z = 0.9195 \frac{P}{h} \quad (56)$$

If we compare the stresses (eq 55, 56), we see that a layer supported by a rigid foundation has a maximum compressive stress 28% greater than a homogeneous, isotropic medium. Thus, the unfrozen layer of ground between the foundation base and the permafrost layer will experience a considerably greater pressure than would a layer in a homogeneous mass. Also, the presence of the permafrost layer below the base of a foundation concentrates the compressive stresses along the axis of the load. In both cases, the sum of all compressive stresses is equal to the external load.

1. op. cit. Osnovy mekhaniki gruntov (Principles of soil mechanics), p. 90 - 91.

2. E. Melan (1919) Die druckverteilung durch eine elastische schicht (Pressure distribution in an elastic layer), Bet. u. Eisen, no. 7-8, 1919.

Distribution of pressure during thawing of permafrost

Melan's equation 56 which defines pressure in a layer of compressed ground supported by a rigid foundation, shows that the thinner the unfrozen ground layer, the greater will be the absolute value of its compressive stress (for sections perpendicular to the line of force and under the conditions of a plane problem). When the permafrost layer thaws, the concentration of the greatest compressive stresses will be especially sharply manifested at the beginning of the thawing process.

It is interesting to note that the distribution of compressive stresses along the base of a rigid die may be radically changed during thawing. If a rigid die is set on frozen ground cemented by ice, the distribution of pressure along the base of the die may be considered to be identical with the distribution in an elastic cohesive medium. When the frozen ground layer thaws, the distribution of pressures along the base of a rigid die may be quite different.

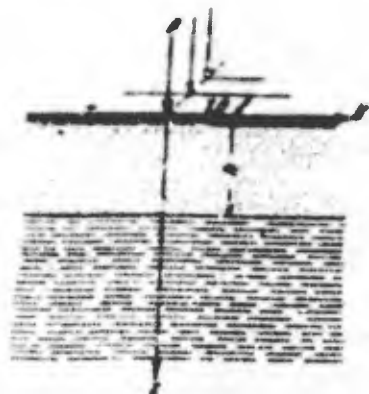

Figure 99.

ures along the base of a rigid die may be quite different.

Figure 100 shows the distribution of pressures under a rigid die 1 m in diam. The left figure represents the transmission of the load on frozen sand cemented by ice; the right figure shows the same sand in a thawed state (which, according to Professor F. Kogler, reacts like loose sand).

Comparing the pressures at the center of the loaded base we see that, in the first case — the die on frozen ground, $\sigma_0 = 0.5p$, and, in the second case, $\sigma_0 \cong 2p$, where σ_0 is the compressive stress in the center of the base, and p is the average pressure for the entire area.

This example demonstrates that considerable redistribution of compressive stresses along the base may take place when frozen ground thaws, which undoubtedly will also affect the structure of the unfrozen ground and the shifting of its particles.

When frozen ground thaws, a considerable concentration of stress may occur in sand, and a plastic squeezing out in clays.

However, redistribution of stresses will take place not only under the base of a foundation but also in a layer of ground at a considerable depth (equal to several diameters of the die) below the base. Thus, if the stress concentration factor, ν , in frozen sand

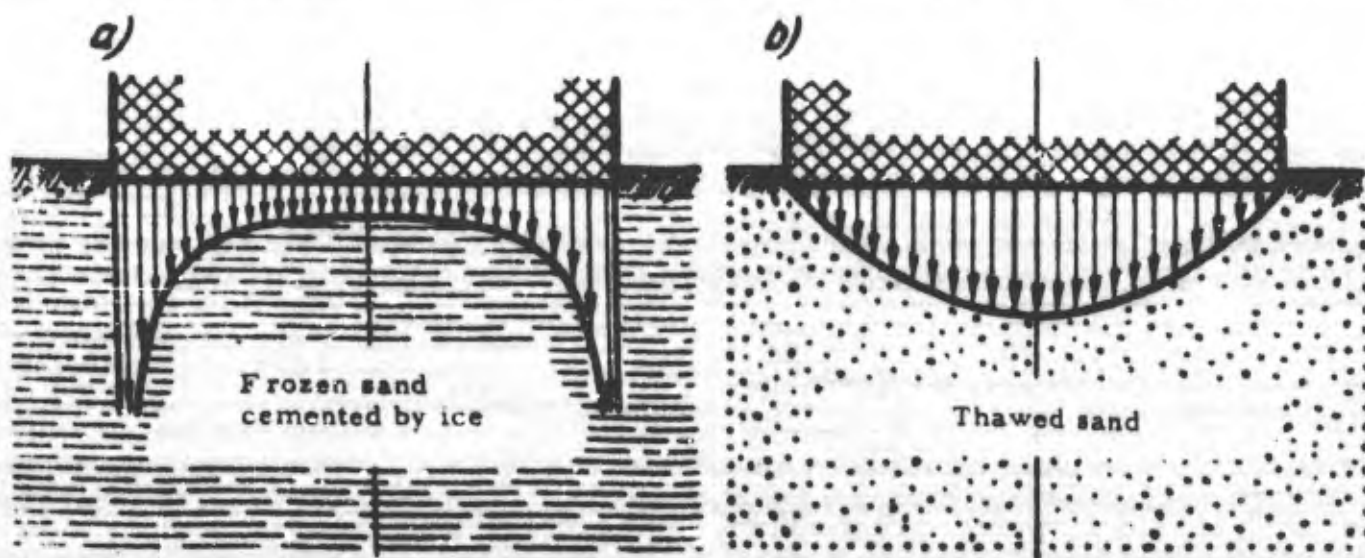

Figure 100. Distribution of pressure under a rigid die: a) Frozen sand cemented by ice (solid mass); b) Thawed sand (loose mass).

cemented by ice is considered as 3 for the Boussinesq equation, then it should be taken as close to 6 in thawed sand, with loaded small areas.

In the latter case, the equation for compressive stresses in the ground assumes the following form:

$$\sigma_z = 2K \frac{P}{z^2} \cos^3 \beta \tag{57}$$

where K , P , and z have the same values as before and β is the angle formed by the radius R (see Figure 93) with the axis z .

Influence of anisotropy

The Boussinesq equations which represent the basic relationships for determining stresses in frozen and unfrozen ground apply to isotropic bodies, i. e., bodies with equal elasticity in all directions. This does not correspond to the actual situation in such cases as (1) in layered frozen ground where elasticity along the vertical direction differs from elasticity along the horizontal, and (2) when load is transmitted to an ice surface, the elastic properties of which depend on the orientation of the optical axis of the crystals to the direction of the external forces. The presence of thick layers of ice in the frozen ground is a very frequent phenomenon under permafrost conditions.¹ Consequently, it is very important to consider the influence of the anisotropy of ice on the distribution of stresses in it.

K. Wolf² gives a solution for stress distribution in a mass when the modulus of elasticity is E_1 in one direction, say the horizontal, and E_2 in the other, the vertical. For a plane problem with a concentrated force, the equations will have the following form:

Stresses in masses

Anisotropic (according to Wolf)

Isotropic (according to Boussinesq-Flamant)

$$\left. \begin{aligned} \sigma'_z &= -\frac{2P}{\pi} \frac{kz^3}{r^2 r_1^2} \\ \sigma'_y &= -\frac{2P}{\pi} \frac{ky^2z}{r^2 r_1^2} \\ \tau' &= -\frac{2P}{\pi} \frac{kyz^2}{r^2 r_1^2} \end{aligned} \right\} \tag{58}$$

$$\left. \begin{aligned} \sigma_z &= -\frac{2P}{\pi} \frac{z^3}{r^4} \\ \sigma_y &= -\frac{2P}{\pi} \frac{y^2z}{r^4} \\ \tau &= -\frac{2P}{\pi} \frac{yz^2}{r^4} \end{aligned} \right\} \tag{59}$$

σ_z , σ_y , τ are corresponding stresses: σ_z and σ_y are parallel to the axes z and y , while τ is tangent to the horizontal or vertical plane for which the stress is being determined; z , y , are the coordinates of the center of gravity of the section; z is the vertical and y the horizontal; P is the concentrated force per unit of length; r is the distance from the center of gravity of the section to the point of application of concentrated force;

$$r_1 = kr$$

1. See Chapter VII.

2. K. Wolf (1935) Ausbreitung der Kraft in der Halbebene und Halbraum bei anisotropem material (Distribution of force in a semi-infinite disk and semi-infinite space for anisotropic materials), Zeitschrift für angewandte Mathematik und Mechanik, Band 15, Heft 5.

where

$$k = \sqrt{\frac{E_2}{E_1}}$$

E_1 is the modulus of elasticity of the material parallel to the y axis, and E_2 is the modulus of elasticity of the material parallel to the x axis.

According to Hess, the modulus of elasticity for ice at temperatures varying from 0 to -10°C is $E_2 = 18,200 \text{ kg/cm}^2$ along the length of the crystals, and $E_1 = 38,300 \text{ kg/cm}^2$ along the width of the crystals. Then:

$$k = \frac{E_2}{E_1} = \sqrt{\frac{18200}{38300}} = 0.688,$$

and

$$\sigma'_z = \frac{\sigma_z}{k} = 1.45 \sigma_z.$$

Similar relationships exist in the case under consideration and for other component stresses.

Thus, in ice and layered permafrost, the stresses may be concentrated along the axis of the load in some cases. This is caused by anisotropy and occurs at the expense of the stresses in the adjacent sections.

Summarizing the above data, we conclude that the stresses in the frozen ground under load depend on a number of circumstances: the size of the area under load, properties of the frozen ground, properties of the layers underlying this ground, etc.

Formulas given in this section, in many cases permit us to predict the phenomena which will occur in frozen or unfrozen ground under load. However, at this time, only certain basic relationships have been given. A more precise and fuller treatment will enable us to define in more detail the state of stress of frozen and unfrozen ground under foundations.

Permissible Stresses for Frozen Ground

The question of permissible stresses for frozen ground is complex and of great practical significance. The value of permissible stresses depends not only on the mechanical properties of frozen ground, but on the characteristics of the structures erected on frozen ground: the area covered, construction characteristics (rigidity), thermal regime inside the building, etc.

As a rule, determination of permissible stresses is based on an analysis of the simplest states of stress. For complex stress conditions, one of the theories of stability is applied, the most important of which are: the theory of maximum stress (Rankine), the theory of maximum strain (Saint-Venant), the theory of maximum tangential stresses or the so-called third theory of stability - the theory of Mohr, Hencky and Mises and others.¹

In considering the question of permissible stresses for the basic states of stress of frozen ground (uniform compression, shear, and others) selection of the proper safety factor is significant. The value of the safety factor depends on a number of conditions: the accuracy of the determination of external forces; the accuracy of the determination of stresses in the body under consideration; and the properties and homogeneity of the body itself. In addition, the value of the safety factor for frozen ground will depend on the type of construction and the method of building on permafrost; whether the building is erected according to the principle of preservation or destruction of permafrost under the base of the foundation.²

1. See, for example, A. I. Dymov (1932) Teorii prochnosti, koefitsient bezopasnosti i dopuskaemye napriazheniia (Theories of stability, the safety factor and permissible stresses): Gostekhisdat.

2. For further details on the methods of building on permafrost see Chapter X.

Permissible compressive stresses

Let us consider the problem of permissible compressive stresses for frozen ground with a negative temperature maintained and static forces. For simple compression, the permissible stress is determined from the equation:

$$\sigma_{pr} = \frac{\sigma_b}{n} \quad \text{or} \quad \sigma_{pr} = \frac{\sigma_s}{n_1}$$

where σ_{pr} is the permissible compressive stress, σ_b is the ultimate compressive strength, σ_s is the limit of mechanical flow and n and n_1 are the proper safety factors.

The first formula is applied for friable materials, the second for plastic materials. If we determine permissible compressive stress for frozen ground from experimentally determined values of ultimate compressive strength of cubes, then the relationship between the compressive strengths of a cube and of frozen ground under natural conditions must be analyzed, and the necessary value of the safety factor selected.

The compressive strength of frozen ground will be different for natural conditions and laboratory conditions. In fact, the destruction of a frozen cube by compressive forces occurs with free lateral expansion of the sample, while, under natural conditions, there is a definite limitation of lateral expansion. This limitation makes expansion almost impossible, and this undoubtedly increases the compressive strength. Thus, if we compare the vertical deformation of a cube with that of a sample under uniform compression but laterally confined (i. e., enclosed in a rigid container), then, within the limits of elasticity, we have for a cube:

$$e' = \frac{\sigma}{E} \quad (a)$$

and for a laterally confined sample, disregarding the friction against the walls of the container:

$$e'' = \frac{\sigma}{E} \left[1 - \frac{2\mu^2}{1-\mu} \right] \quad (b)$$

where e' and e'' are the relative vertical deformations, σ is the compressive stress, E is the modulus of elasticity (Young's modulus), and μ is Poisson's coefficient.

According to Saint-Venant's theory of stability, the permissible stresses for simple compression should be in the same ratio as the ratio between e' and e'' . Thus we have:

$$\frac{e'}{e''} = \frac{1-\mu}{1-\mu-2\mu^2} \quad (c)$$

If we take an average value of Poisson's coefficient for frozen ground cemented by ice, as for example $\mu = 0.4$, we will have:

$$\frac{e'}{e''} = \frac{1-0.4}{1-0.4-2(0.4)^2} = 2.1.$$

According to Saint-Venant, the allowable compressive stresses should have this relationship; i. e., when lateral expansion is impossible, compressive strength will be on the average 2.1 times greater. Under natural conditions, this relationship may be different, but, at any rate, compressive strength of frozen ground under natural conditions is much greater than compressive strength of a cube of frozen ground.

PRINCIPLES OF MECHANICS OF FROZEN GROUND

However, as demonstrated in Chapter IV, the compressive strength of a cube of frozen ground is not constant but, everything else being equal, depends on the rate of load increase, decreasing with a decrease in rate of load increase. Under an extremely slow load increase, the destructive compressive stress becomes several times smaller. This can be clearly seen by comparing the ultimate compressive strength of cubes of frozen ground with the value of a constant compressive stress which produces deformations which do not die out with time. Such a stress should be considered the flow limit of the frozen ground. It can be determined, experimentally, by studying the plastic deformation of frozen ground. Table 76, using average values, compares the flow limit of frozen ground with its ultimate compressive strength, on the basis of experiments we have performed.

Table 76.

Types of frozen ground according to grain-size composition	σ_s , Flow limit (kg/cm ²) with very slow load increase, at temp -1.5C to -2C	σ_b , Ultimate compressive strength (kg/cm ²) with rapid load increase at -1.5C.	Ratio $\frac{\sigma_b}{\sigma_s}$
Silty sand	3.5	22	6.3
Clay	2.5	17	6.8
Silt (with organic admixtures)	1.5 - 2.0	15	7.5 - 10

Note: Soil moisture corresponds to complete ice saturation.

The above-cited relationships indicate that the permissible stress for frozen ground would be more correctly derived from data on the flow limit. If the permissible load is determined on the basis of the ultimate compressive strength of samples of frozen ground, it is necessary to introduce a rather large coefficient of safety.

It should be noted that the flow limits of frozen ground under natural conditions shown in Table 76 are not the same as critical stress for plastic flow. Plastic flow caused by local load on a portion of the surface of the frozen ground will occur under different conditions than in the case of compression of a frozen cube.

To clarify the problem, it is necessary to turn to solutions of the mathematical theory of plasticity of solid bodies. For a plane problem, Prandtl obtained the following expression for critical stress for plastic deformation on the basis of Saint-Venant's theory of plasticity, according to which the maximum shearing stress is constant throughout the plastic stage:¹

$$\sigma_{cr} = \sigma_b \left(1 + \frac{\pi}{2}\right) \quad (60)$$

where σ_b is the usual ultimate compressive strength.

If, for plastic material such as frozen ground, at a very slow rate of load increase, we take the flow limit as the ultimate compressive strength, we will have:

$$\sigma_{cr} = \sigma_s \left(1 + \frac{\pi}{2}\right), \quad (60')$$

or

$$\sigma_{cr} = 2.57 \sigma_s.$$

1. A. Foppl and L. Foppl (1933) *Sila i deformatsiia (prikladnaia teoriia uprugosti) (Force and deformation: applied theory of elasticity)*, Gostekhizdat. [Translated from the German, *Drang und Zwang*.]

The above equation shows that the critical stress for homogeneous frozen ground under natural conditions is 2.57 times greater than the flow limit obtained when testing compression of frozen cubes. Therefore, the ratio between the critical stresses for plastic flow of the frozen ground layer and the cube will be greater than the ratio of their compressive strengths. This indicates that the ratios of ultimate compressive strength to the flow limit of frozen ground under natural conditions may be somewhat smaller than those given in Table 76.

On the basis of the above considerations we conclude that when determining the permissible stress on frozen ground from its ultimate compressive strength (according to the resistance of cubes), the safety factor should be between 5 and 6. Establishing the safety factor on the basis of ultimate compressive strength permits us to utilize for practical purposes the results of the tests on the mechanical properties of frozen ground.

For example, if we determine the permissible pressure on frozen ground from the values of ultimate compressive strength of frozen ground given in Chapter IV, using a safety factor of 6, we obtain the data given in Table 77.

Table 77. Permissible compressive stress (kg/cm²) for ice - saturated frozen ground with negative temperatures maintained.

Soil	Temperature (C)		
	-0.2 to -0.5	-0.5 to -1.5	-1.5 to -2.5
Sand	3.5	4.5	6
Silty sand	2.0	3.5	-
Clayey sand	-	3.0	4
Clay	1.5	2.5	-
Silty soil	1.0	2.0	3

Note: This data cannot be applied to frozen ground which has pure ice lenses.

It should be pointed out that the safety factor, 6 in this case, may change depending on the degree of uniformity of the frozen ground under the foundation and the rigidity of the structure. The value of the safety factor should be definitely established, and we feel that the considerations indicated above will be helpful in the preparation of standard specifications.

Permissible shear stresses

According to data on the ultimate shear strength of frozen ground (Ch. IV), permissible stresses can be determined if a certain safety factor is accepted. In selecting this factor, the effect of that portion of the frozen ground which will experience the shearing stresses should be considered, as well as the specific properties of the structure.

Taking into consideration that ultimate shear strength will decrease as much as twice with decreased rate of load application (see Ch. IV), and considering the considerable plasticity of frozen ground, we feel that the safety factor should be not less than 4. The permissible shearing stress for frozen ground may be determined from the results of direct experiments, as, for example, from the data cited in Chapter IV.

According to Sheikov, the permissible shearing stress for fine-grained frozen ground saturated with ice at a temperature not below -20 can be expressed for preliminary calculations with an accuracy sufficient for practical purposes by the following equation:¹

$$\text{permi. } \tau_s = 0.35 + 2.2t \text{ kg/cm}^2$$

1. Laboratornye issledovaniia mekhanicheskikh svoistv merslykh gruntov (Laboratory investigation of the mechanical properties of frozen ground), sb. 1, p. 130, Akademiia Nauk, 1936.

where τ_0 is the permissible shearing stress for frozen ground (for fine-grained ground containing from 8 - 36% of particles < 0.005 mm, the stress does not depend on the grain-size composition of the soil skeleton within the limits of the above investigations); 0.35 and 2.2 are numerical coefficients obtained by dividing the numerical values of the parameter of a straight-line, determined by experiments on ultimate shearing strength of frozen ground, by the safety factor 4 (the value of the safety factor, 4, was chosen considering a rate of loading of $20 \text{ kg/cm}^2\text{-min}$, which was used during the experiments); t is the absolute value of the negative temperature in $^{\circ}\text{C}$.

Estimated Forces of Adfreezing

In calculating the ability of foundations to withstand the heaving forces in the ground, it is necessary to calculate the adfreezing forces, whether building on the principle of preservation of the permafrost regime or on the principle of destruction of permafrost. Usually, in calculations, the maximum adfreezing strengths of the foundation material with the active layer and the permafrost layer are considered as the heaving forces.

Such an assumption provides a considerable safety factor, as can be established by comparing calculated data with observations on actual heaving of constructions, such as bridges. Laboratory experiments with posts in freezing ground also show that the heaving forces are at least twice as small as the maximum adfreezing forces.¹

The study of experimental data on adfreezing strength of ground with wood and concrete (Ch. IV), also shows that the adfreezing strength for the same type of ground at the same degree of temperature and moisture does not remain constant. These values depend on the degree of water-saturation of the adfreezing material and especially on the rate of load increase.

It has been established that adfreezing strength of air-dried materials may be as much as $2\frac{1}{2}$ times less than that of materials saturated with water. It was also established that the adfreezing strength may change as much as 3.3 times, depending on the rate of load increase. It decreases with decrease of the rate of load increase.

On the basis of the above, we feel that at least one-half of the maximum adfreezing strength determined by tests with a rate of shearing load $22 \text{ kg/cm}^2\text{-min}$ can be taken as an estimated value of the adfreezing strength of ground with the foundation material.

The estimated adfreezing strength is determined from the maximum adfreezing strengths found experimentally, such as those given in Chapter IV. For preliminary calculations the approximate values for fine-grained silty sand, clay, and silty soil can be taken from Table 78.

Table 78. Estimated adfreezing strength (kg/cm^2)

Adfreezing surface	Temp -1°C Ice saturation				Temp -10°C Ice saturation			
	0.25	0.50	0.75	1 to 1.4	0.25	0.50	0.75	1 to 1.4
Fine grained silty sand, clayey sand, clay, and silty soil (with 8-36% particles < 0.005 mm) with water-saturated wood	2	3	4	6	3	7	13	16
Same with water-saturated concrete	1	2	4	5	7	10	13	13

1. N. A. Tsytovich (1936) Issledovanie usilti v stoikakh, okrushenykh zamersaiushchim gruntom (Study of stresses on posts surrounded by freezing ground), sb. 2, Akademiia Nauk.

EXPERIMENTATION AND THEORY

189

Notes: (1) Estimated adfreezing strengths for other temperatures and degrees of ice saturation are determined by interpolation.

(2) Estimated adfreezing strength of pebbles protected from silting by a free outflow of water is taken as 0.4 kg/cm² for adfreezing with wood or concrete.

(3) Degree of ice saturation is determined as a ratio of natural moisture of frozen ground (ice content) w , to the moisture which corresponds to complete ice saturation of the ground w_i :

$$G_i = \frac{w}{w_i}$$

where

$$w_i = \frac{\Delta - \delta}{\Delta \delta (1 + \beta)}$$

β is the coefficient of the volume expansion of water at freezing;

$$\delta = \frac{\gamma}{1 + w}$$

where γ is the unit weight of frozen ground and w is its moisture content, Δ is the density of the mineral particles of the ground.

Substituting $\beta = 0.0908$ we have:

$$G_i = \frac{w}{0.92 (1/\delta - 1/\Delta)}$$

PART II. PRACTICAL APPLICATIONS

CHAPTER VII. PERMAFROST AND ITS CONSTRUCTION PROPERTIES

Economics and Construction in Permafrost Region in U. S. S. R.

As pointed out several times in this work, the principal application of the mechanics of frozen ground should be in areas where frozen ground plays a predominant role, i. e., in permafrost regions.

Within the borders of our country, this region has inexhaustible natural resources. As an example of water-power resources, the Angarastroi, upon completion, will be one of the world's largest sources of electrical energy. Then there are the Yenisey and Lena Rivers, which flow for thousands of kilometers, the Zeya, Bureya, and Kolyma rivers, and a number of others. All these rivers flow through mountainous countries where there are many suitable places for building dams with a water pressure of several tens of meters. At present, the potential water-power resources of the rivers of the Far East are calculated as 36 million horsepower.

The mineral resources include coal in the Usa region (Yorkuta), coal and graphite in the lower regions of the Yenisey River, as well as polymetallic ores in the same region (Noril'sk). Farther on there is salt in the Kempendyay region and gold in the regions of Tommot-Nezametnyi, Kolyma, and the Far East.

The Transbaikal, an enormous region of rare metals, has gold and polymetallic ores, and also iron.

Exceptionally large deposits of coal as well as iron ore have been found in the region where the Bureya Mining Combine is being built at the present time [1937]. N. Zakharov¹ stated that "the Bureya coal deposits are estimated to be 200 billion tons, and the Khingan Iron deposits - 2 billion tons."

With the exception of the comparatively few steppe areas and the tundras of the extreme north, the enormous territory of the permafrost region is completely overgrown with forest. However, if efficiently utilized, these steppe and tundra regions can become pasture land for millions of reindeer. The figure of millions is not an exaggeration. For example, during the period from 1842-1902, 1280 reindeer were brought from Siberia to Alaska. This small number grew into large herds of reindeer in northern and southern Alaska, where according to Stefansson² there are now 600,000 reindeer, besides the 250,000 head which were slaughtered for meat during this period. If we compare the territory of tundra and forest-tundra of Alaska with the tundra and forest-tundra of the Soviet Union, our estimate of many millions of reindeer in our north will not seem to be an exaggeration.

Thus, the permafrost region of the U. S. S. R. has enormous potentialities which we are already beginning to exploit. The utilization of this region proceeds simultaneously from the south and from the north.

The heroic voyages of our ships, which opened the road along the northern shores of the Arctic Ocean, are very well known. The so-called Kara Expedition and the mines of Amderma are also well known. In the south, we have the Amur-Yakutsk railway, already under construction, the above-mentioned Bureya Mining Combine, and a number of other enterprises.

We have pointed out certain natural resources and industrial enterprises in the permafrost region to show what vast construction must be done in the permafrost region, the kilometers of road, the number of river dams, socialist cities, state farms, and collective farms which will extend throughout this enormous territory. One should keep in mind that

1. N. Zakharov (1934) "Skazochnyi Krai" (The Fabulous Country), Pravda, 27 Nov., no. 326.

2. V. Stefansson (1933) Novaia strana na severe (New Northland). Dal'giz. [Apparently translated from the German: Neuland im Norden (Brockhaus, 1928), an elaboration of the author's Northward course of empire (Harcourt, Brace & Co., 1922)].

all these industrial enterprises, towns, cities, state and collective farms will be built according to the newest building techniques, with electric power stations, waterworks, sewage, airfields, etc. And this vast construction will have to cope with the specific problem connected with the building of railway beds, water supply systems, buildings, and structures on permafrost.

Geographical Distribution of Permafrost

Map [1] shows the territory occupied by permafrost in the Soviet Union, divided into regions according to the temperature of the permafrost at a depth of 10-15 m. Geographically, continuous permafrost coincides with the region of low temperature ground in the extreme north. To the south of this region there is a second region where islands of unfrozen ground begin to appear in the midst of the mass of permafrost. Still farther south, along the southern border of permafrost, there is a third region where islands of unfrozen ground are frequent, and, finally, beyond the southern border, isolated islands of permafrost occur sporadically.

Besides the enormous territory in the north and east of the U. S. S. R., permafrost is found in several places a considerable distance from the principal permafrost mass. Among such areas, primarily in mountainous country, Pamirs is particularly noteworthy. The general area of permafrost here is about 200,000 sq. km, according to the first preliminary data.

Within the borders of the territory indicated, permafrost occupies about 10 million square kilometers, or approximately 47% of the total territory of the Soviet Union.

Almost everywhere within these borders a layer at a certain depth beneath the surface of the ground has had a negative temperature continuously, in summer and winter, for many years, and for many thousands of years in some places.

This layer of ground, at a certain depth from the surface and with a negative temperature lasting continuously for an indeterminate period of time — from 2 years to thousands of years — is called the permanently frozen ground, or permafrost.

In permafrost regions, soil or rock with a positive temperature is called "thawed ground," or, in common parlance, "taliks."

Permafrost is also found in other countries. To the south of the Soviet Union, permafrost occurs in Mongolia and Manchuria. In North America, permafrost is found in Canada and Alaska.

Both in the Soviet Union and abroad these enormous territories have been investigated little or not at all, in spite of the fact that they contain great natural resources and other advantages, as was pointed out above.

The Active Layer

The permafrost layer is bounded above and below. The surface at that depth in the ground where the permafrost begins is called its upper boundary or its upper surface [permafrost table]. The surface where permafrost ends, and below which positive temperatures begin, is called the lower boundary of permafrost or its lower surface [base of permafrost].

The layer of soil or ground above the permafrost which thaws out in summer and freezes in winter is called the active layer.

It is essential to know how to determine the thickness of the active layer for determining the depth of foundation placement and understanding the processes which take place during the freezing of the ground, of which we have spoken many times before. It is particularly important in relation to the direction of movement of suprapermafrost ground water, and for all kinds of construction activities in the earth. The thickness of the active layer depends on many different factors: primarily on the geographical latitude of the locality, and also on the character of the ground, the type of vegetation, and its orientation.

Two basic principles influencing the thickness of the active layer may be established:

1. At higher latitudes the active layer is less thick, all other conditions being equal.

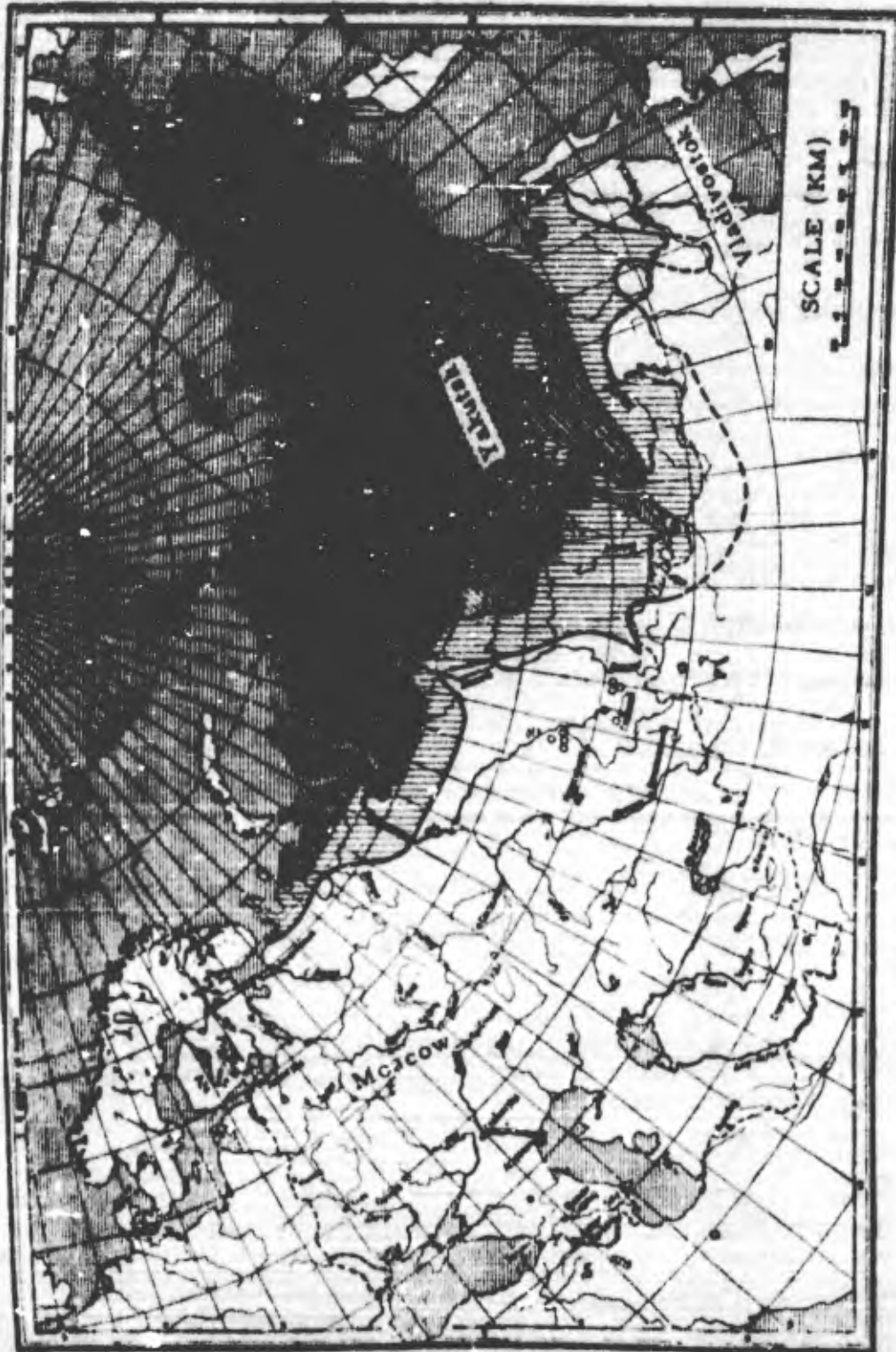

Map [1]. Distribution of permafrost in Eurasia.
 (Map from Atlas mira [World Atlas]).
 Prevailing soil temp at 10-15 m dept

- | | |
|---|---|
| <p>1. Below -5C;</p> <p>2. -5C to -1.5C;</p> <p>3. Above -1.5C;</p> <p>4. Permafrost islands (sporadic permafrost);</p> | <p>5. Permafrost only in peat mounds;</p> <p>6. Southern permafrost border in USSR;</p> <p>7. Probable southern permafrost border outside USSR;</p> <p>8. Border of considerable ice thickness in permafrost.</p> |
|---|---|

2. In a given territory, the greatest thickness occurs in dry sand and gravelly ground - the smallest in peat. The thickness of the active layer in clayey soils occupies an intermediate position between the first two, being nearer to the thickness of sandy soils.

Since by the "thickness of the active layer" we understand the greatest thickness of the thawing layer of ground over a long period of years, it is clearly not an easy task to determine this thickness for a given locale. The most favorable time for determination is late fall, when the ground begins to freeze from the surface.

By means of pits, boreholes, or by the electrometric method, we can find a first approximation of thickness of the active layer. The exact thickness can be determined only by observations over a period of years, either by annually repeating the boring and drilling in a selected area, or from data obtained for many years at meteorological stations. For this purpose, soil thermometers at the meteorological stations must be set to a depth somewhat greater than the expected thickness of the active layer.

Temperature observations over a number of years will provide all the necessary data: the average soil temperatures at various depths, the extreme limits of temperatures, and the greatest penetration into the ground of the zero temperature. Isoleths plotted from this data will serve as the basis for calculations. The distance between the ground surface and the deepest penetration of the zero temperature during the entire period of observation is taken as the thickness of the active layer. The ice-cemented ground will not reach that depth, but it is advisable to take the larger figure for purposes of construction.

When the thickness of the active layer is determined by boreholes or pits, it is advisable to compare the data obtained with long-term observations from a neighboring meteorological station and make the necessary correction.

This correction may be quite considerable. In Bomnak, the true thickness of the active layer determined on the basis of 10-years' observations differed by 80 cm from the thickness determined by one-year's observations. This was the largest correction for the Bomnak area.

Naturally the correction will differ for various localities. Until a precise value of this correction is worked out, it is permissible as a first approximation to add 50 cm to the results of single measurements of the thickness of the active layer in mineral ground in the territory south of the 55th parallel. So far, we have no data for this correction for the territory north of the 55th parallel.

At the present time, the average thicknesses of the active layer under natural conditions for the entire area of permafrost distribution may be expressed by the following figures:

For sandy soils	
Territory south of the 55th latitude	3-4 m
Territory on the latitude of the city of Yakutsk	2-2.5 m
Coast of the Arctic Ocean	1.2-1.6 m
For clay soils	
Territory south of the 55th latitude	1.8-2.5 m
Territory on the latitude of the city of Yakutsk	1.5-2.0 m
Coast of the Arctic Ocean	0.7-1.0 m
For peat-bog ground	
Territory south of the 55th latitude	0.7-1.0 m
Coast of the Arctic Ocean	0.2-0.4 m

The local conditions may sharply change these values. A moss cover of 30-40 cm on peat bog decreases the thickness of the active layer in mineral ground to 25 or 30 cm even south of the 55th parallel. If ground water circulates in sandy soil, the thickness of the unfrozen layer increases. The thickness of the active layer is usually smaller on the northern slopes than on southern slopes.

In planning foundations, it is essential to have the estimated thickness of the active layer, or the estimated depth of the permafrost table.

Up to this time we have given values of the thickness of the active layer under natural conditions. But the building of a structure or of a whole settlement will change these natural conditions and consequently will change the depth of the permafrost table. If it is decided to sink the base of the foundation 1 m into the permafrost, so that the negative temperature will remain constant under the base, the specific load of a building or structure will be determined on this basis. However, calculations based on the depth of the permafrost table under natural conditions will be upset if the permafrost recedes after construction, since positive temperatures may reach the base of the foundation and cause deformation of the structure, so common under permafrost conditions.

Estimation of the thickness of the active layer must take this into account to avoid the possibility of deformation of the building.

In the city of Irkutsk, many years of parallel observation of the temperature of ground covered with snow and of ground free from snow cover demonstrated that freezing penetrates 48 cm deeper in snow-free ground than in ground under a snow cover.

In planning the occupation of a locality, this figure (or in round number, 50 cm) should be added to the maximum thickness of the active layer determined for the place over a several-year period. For example, the thickness of the active layer in Bormnak over a period of 10 years was determined as 280 cm. Then, as the thickness used in construction, we take $280 + 50 = 330$ cm; in the same way, for Skovorodino we have $250 + 50 = 300$ cm

When determining the approximate thickness of the active layer on the basis of one-year's observations, we add three values:

- 1) the thickness of the active layer observed for one year, h_0 ;
- 2) correction, found by comparing the thickness observed in one year to the thickness according to many years of observations, h_1 ;
- 3) correction for the occupation of a locality, h_2 .

As a result we will have the rated thickness, h , from

$$h = h_0 + h_1 + h_2,$$

which should be used in estimating the depth of the foundation in ground containing permafrost.

As the first approximation for the territory south of the 55th parallel, as pointed out above, we can use $h_1 = 50$ cm and $h_2 = 50$ cm for practical purposes.

It is important to know the thickness of the active layer not only for foundations but also for earth work, which should be organized to utilize the maximum depth of thawing of the active layer. Where the frozen layer merges with permafrost during the winter, we have continuous frozen ground down to the base of the permafrost. Thawing begins in the spring, and gradually penetrates downward.

According to data of the Skovorodino Experimental Frozen Ground Station, the average thawing for a 5-year period was as follows:

<u>Date:</u>	<u>Penetration of thawing in cm:</u>
May 1	11
June 1	65
July 1	116
August 1	159
September 1	222
October 1	239

The ground was grass-covered clayey sand in open terrain. The table shows that the thawing per month was as follows:

PRACTICAL APPLICATIONS

<u>Month:</u>	<u>Thickness of thawed layer (cm)</u>
Prior to May 1	11
during May	54
during June	51
during July	43
during August	63
during September	17
total	239

At the extreme north in Novyy Port ($\phi = 67^{\circ}42'$; $\lambda = 72^{\circ}54'$) in 1927, thawing of the sandy ground proceeded as follows:

<u>Date:</u>	<u>Thickness of thawed layer (cm)</u>
May 8	2
June 8	27
July 1	95
August 15	108

To plan excavation work efficiently, such data must be obtained for the region. For example, according to the Skovorodino data, excavators will encounter thawed ground varying in thickness from 116 to 159 cm in July and from 222 to 239 in September, while in May, at the end of the month, it will be only 65 cm.

All that we have said about excavation work was based on manual or mechanical excavations without artificial thawing of the frozen ground. For large excavations, a method of thawing the frozen ground by fire, steam, heated or unheated water is used.¹ The energy of the sun is also used for thawing frozen ground. By this method, the work is planned so that only the ground which has thawed is removed, by hand or excavators. By the time the work is completed at one end of the section, the ground is thawed out at the other end; while the thawed ground at this end is being removed, the ground at the first end is thawing. Thus the work proceeds alternately as the ground thaws.

Thickness of Permafrost

Permafrost may be vertically continuous or layered. The first type may have two varieties. In the first variety, the permafrost table annually merges with the lower boundary of winter freezing. This is the most common type. In the second variety, the layer of permafrost is continuous, but its upper boundary is considerably deeper than the layer of ground which thaws in the summer and freezes in the winter. In this case, we have the following situation in the winter: a frozen layer extends from the earth's surface down to a certain depth. It is underlain by a layer with positive temperature, which overlies a mass of vertically continuous permafrost. Deep-lying permafrost may occur under pseudo-islands of the unfrozen ground (talik)* located in the midst of large areas of permafrost, or a lens of permafrost may be surrounded on all sides by ground with positive temperatures.

Finally, there may be, and are, cases when the layer of ground which thawed during the summer does not freeze completely during the winter, leaving a thawed layer (talik)* between the winter frozen ground and the permafrost. This layer may freeze the next year. This case occupies an intermediate position between the two varieties of vertically continuous permafrost.

The second major type of permafrost according to vertical distribution is the layered permafrost. Downward from the permafrost table, there is a certain thickness of permafrost, underlain by an unfrozen layer, which overlies another layer of permafrost, etc. Each layer of permafrost has its own upper and lower boundary.

Layered permafrost also has two varieties, depending on whether or not the active

1. S. P. Serebrovskii (1931) Zolotopromyshlennost' S. Sh. A. (Gold industry in the U. S. A.), Moscow-Leningrad.

* [The Russian term "talik" is used to designate the unfrozen layer between the frozen active layer and permafrost. It also is applied to layers or lenses of unfrozen ground within the permafrost and to the unfrozen ground beneath the permafrost.]

layer merges yearly with the upper layer of permafrost. The distance between the upper and the lower boundaries of permafrost is the thickness of permafrost. In the case of layered permafrost, we can take either the thickness of its separate layers or the total thickness of all layers. In the latter case, we can take either the sum of the thickness of the separate layers of permafrost or the thickness of all layers, frozen and unfrozen from the upper boundary of the upper layer to the lower boundary of the lower layer of permafrost.

Layered permafrost is most common in the southern parts of the permafrost region, but it also occurs in the north. Engineer N. I. Bykov¹ describes a shaft 62 m deep at Igarka. In this shaft, frozen layers alternated with five unfrozen layers within the frozen ground.

So far we know very little about quantitative thicknesses of permafrost. This is explained by the fact that it is a very difficult task to determine the thickness of permafrost. The fine geophysical methods (seismic and electric) which would aid us in determining the depth of the permafrost base without drilling are still in a state of development. Consequently, we must resort to shafts, pits, boreholes, etc. which are very complicated and expensive methods. This is why we have few such measurements. However, at a number of localities in the enormous territory of the permafrost region, the thickness of permafrost has been determined completely or partially (when the layer was not penetrated completely). Table 79 gives some of this data. These show that the thickness of permafrost varies from 1 to 274 m and more. The general principle is that the thickness of permafrost increases with an increase of latitude. The small thicknesses (1-2 m) have been found along the southern borders of permafrost distribution.

We have dealt in such considerable detail with the vertical distribution of permafrost and its thickness because this factor plays such an important part in building. For planning the type of foundation, it is necessary to know precisely what kind of ground we will encounter below the base of the foundation — unfrozen or frozen, and at what depth. Even when the permafrost table lies deep beneath the surface of the earth (10-20 m), it is important, for large constructions, to know whether permafrost occurs at depth, and especially whether it occurs in the form of lenses. These lenses are the last stage of permafrost degradation; they are thawing, and if they contain a considerable quantity of ice they will greatly decrease in volume, causing a settling of the surface of the ground and, as a result, settling of the foundation itself.

In some cases, along the southern permafrost border or in sporadic permafrost, it might be best to thaw frozen ground before building, if it is not very thick.

Thermal Regime of Permafrost

Negative temperature is the basic thermal characteristic of permafrost layers. The temperatures of the active layer, which are sometimes positive (summer) and sometimes negative (winter) also play a tremendously important role. Consequently, the changes in state of the water, which are so important for construction, take place primarily in the active layer.

Therefore, we will deal briefly with the temperatures of the active layer, on the basis of data from the three stations at Bormnak, Skovorodino, and Yakutsk.

Table 80 shows that at Bormnak the minimum average monthly temperature at a depth of 1.5 m occurs in March. As the minimum air temperature occurs in January, the minimum at a depth of 1.5 m lags 2 months behind the air temperature. The maximum ground temperature occurs in September and also lags 2 months.

At a depth of 2.0 m, the minimum lags 3 months and the maximum 2 months (as at 1.5 m).

At a depth of 1.5 m, average monthly temperatures change from negative to positive in August — and from positive to negative in January. In December, the average monthly temperature is 0C, and the ground at this depth is at the freezing stage.

1. N. I. Bykov (1934) "Vechnaia merslota i stroitel'stvo Igarki". (Permafrost and the construction of Igarka), in Sb. Za industrializatsiiu Sovetskogo Vostoka. (Industrialization of the Soviet East). Moscow: Tsentr. biuro kraevedenia.

Table 79. Thickness of Permafrost.

Regions and places of observation	Thickness of permafrost (m)	Penetration of permafrost	Source of data
I. North European U.S.S.R.			
1. Pustozersk.....	17.83	Cut through	A. Shrenk
2. Tal'boy Mine.....	23.25	"	B. N. Gorodkov
3. Vorkuta Mine.....	69.26	Not cut through	N. G. Datskii, from information given by foreman P. S. Lazarev
4. Town of Vorkuta-vom.....	22.5	Cut through	N. G. Datskii
II. Extreme North of Siberia			
1. Anderma.....	274	Not cut through	V. M. Ponomarev
2. Port of Ust'-Yenesey.....	100	"	N. A. Tsytovich. Interpolation from temperature data.
3. Mouth of Anadyr' River	100	"	S. P. Kachurin and P. Shvetsov. Interpolation from temperature data.
III. Basin of the Middle Lena			
1. Yakutsk.....	114	"	Middendorf
IV. Kolyma region			
1. Utinaya River, tributary of Kolyma River.....	113	"	R. F. Zeits
V. Vitim-Olekma mountain region			
1. Uspenskiy Mine.....	50-51	Cut through	V. A. Obruchev
VI. Region west of Baikal			
1. Verшинnyy settlement.....	32-31	"	V. B. Shostakovich
2. Mountainous southern region (Aliberovskiy Mine).....	100	Not cut through	I. I. Oreshkin. Interpolation from temperature data.
3. Tayshet-Padun line.....	1-2m/5m	Cut through in separate bore-holes	V. G. Petrov
VII. Transbaikal			
1. Bushuley Station.....	66-67	Cut through	V. B. Shostakovich
2. Petrovsk Zabaykal'skiy.....	49	"	"
VIII. Far East			
1. Skovo-odino.....	50	"	A. V. L'vov
2. Near Pikan Station (Middle Zeya).....	50	Not cut through	M. I. Sumgin
3. Taldan Station.....	77-71	Cut through	V. D. Shostakovich
4. Lake Kisi (Lower Amur).....	1-2	"	I. K. Stashevskii

1. In northern European U.S.S.R., we must expect to encounter a much greater thickness of permafrost; this is evident from the data for Vaigach Island and information on the thickness of permafrost in the Vorkuta Mine.

Table 80. Average soil temperature (C) over a period of many years, Bomnak.

Depth (m)	Period of observation.	Jan.	Feb.	Mar	Apr	May	Jun	July	Aug	Sept	Oct	Nov	Dec	Annual
1.5	1910-1919	-0.8	-2.6	-3.8	-2.9	-1.3	-0.7	-0.3	0.8	1.6	0.7	0.1	0.0	-0.8
2.0	1910-1919	-0.1	-1.2	-2.4	-2.5	-1.4	-0.9	-0.6	-0.2	0.3	0.2	0.05	0.0	-0.7

At a depth of 2.0 m, the change to positive average monthly temperatures occurs one month later — in September — and the change back to negative temperatures occurs in January, as at the depth of 1.5 m. In December, the ground at this depth has a temperature of 0C.

Thus, at Bomnak, December is the height of winter in the air and on the surface of the ground, but soil freezing and the related processes of moisture migration and volume increase are just taking place at a depth of 1.5-2.0 m. In other words, the dynamics of freezing are in full swing. The fact that the freezing layer is covered by a frozen layer of ground $1\frac{1}{2}$ m thick does not impede the dynamic process. This was pointed out above when describing Taber's experiments on the freezing of ground under an external load, and when discussing ground freezing in a closed system.

All this comes as a surprise to the observer in the permafrost region. In January he sees everything solidly frozen. The air temperature is -40C. Yet, processes taking place inside the ground are forcing water from the depths of the soil to the surface or forming mounds from the solidly frozen ground.

The reader can see from Table 81 that, in spite of numerical differences, the same pattern of maximum and minimum temperatures at various depths applies at Skovorodino, as well as the zero temperatures in December when the transition from positive to negative temperatures occurs.

Table 81. Average soil temperatures (C), Skovorodino

Depth (m)	Period of observation	Jan	Feb	Mar	Apr	May	Jun	July	Aug	Sept	Oct	Nov	Dec	Annual
0.4	1928-1930	-12.9	-13.0	-9.1	-3.3	0.3	6.2	10.7	11.8	7.4	1.5	-2.2	-8.6	-0.9
0.8	1928-1930	-8.3	-9.6	-7.6	-3.5	-0.9	1.6	6.4	8.5	6.4	1.6	0.0	-3.4	-0.8
1.6	1928-1930	-0.9	-3.5	-4.3	-2.9	-1.4	-0.9	-0.4	-1.3	2.4	1.0	0.1	0.0	-0.8
2.0	1928-1930	-0.4	-1.9	-3.2	-2.6	-1.5	-1.0	-0.7	0.0	1.0	0.6	0.1	0.0	-0.8

Similar causes produce similar consequences. Thus, at both Skovorodino and Bomnak, development of the icing phenomena reaches its height in December and January.

The zero curtain which we discussed before is manifested in the active layer. This problem was worked out in detail for the Bomnak station, and we can cite several examples from the data. At the depth of 1.5 m, during the transition from positive to negative temperatures, the zero temperature lasted without change for 49 days (an average for 10 years) or as long as 97 days in some years. At the depth of 2.0 m, it lasted 58 days (average for 7 years), remaining for 91 days, in some years, and for 115 days in 1911.

The zero curtain retards the movement of other temperatures. In 1913, the temperature of the ground at 1.5 m depth in Bomnak remained at 0.6C for 28 days, and, in 1917, the temperature of 0.1C was maintained for 74 days.

On the basis of this fact, it is theoretically advisable to surround water pipes by moist ground with low permeability. Then, when the ground freezes, its zero curtain will protect the water in the pipe from freezing.

With this in view, it is necessary to introduce a certain correction into a system of pipe placement suggested by M. Ia. Chernyshev and shown in Figure 101.¹ The pipes should be covered with ground to a distance equal to the radius of thawing. The radius should be calculated so that the ground around the pipe will remain unfrozen during operation of the water supply system. If operation of the water supply system is interrupted, the freezing of this layer will retard the cooling, and consequently the freezing of water in the pipes. Several variants of pipe placement are shown in Figures 102-104.

1. M. Ia. Chernyshev (1933) Vodosnabzhenie v vechnoi merslote (Water supply under permafrost conditions), Vses. n.-i. inst. Vodosnabzh. i sanit. tekhniki (All-Union Institute of Water Supply and Sewage Techniques), Moscow.

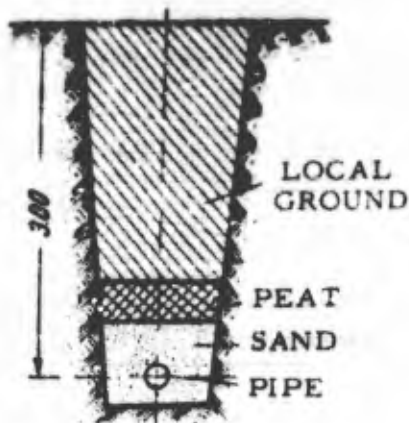

Figure 101. Schematic drawing of water pipe installation according to M. Ia. Chernishev.

Turning to an examination of temperature conditions in permafrost, we will deal first with the temperature of the ground at the boundary between the active layer and the permafrost layer. We have these temperatures for two cases — at the same stations of Bomnak and Skovorodino (Tables 82, 83).

The fluctuation of average monthly temperatures is 1.4C at Bomnak and 1.5C at Skovorodino. Since the ground at these depths is in a constantly frozen state, we use the value of thermal capacity which we obtained for frozen ground, 0.50, which gives an exceedingly small yearly cycle of heat for these depths: $1.4 \times 0.50 = 0.70$ to 0.75 cal/g-yr. Consequently, the complete inflow and outflow of thermal energy occurs in the active layer, and the latent heat of melting and freezing consumes the greater part of the heat energy.

For the permafrost layer itself, although the data are comparatively few for the enormous territory occupied by permafrost, sufficient progress has been made in determining the thermal regime to enable us to make some generalizations both for separate regions and for the whole area of permafrost.

We will begin with the northern part of European U. S. S. R.

For this part of the country, we have data for the middle portion of the basin of the Usa River (the right tributary of the Pechora River), for the vicinity of the Mezen' River and some figures for Vaygach Island.

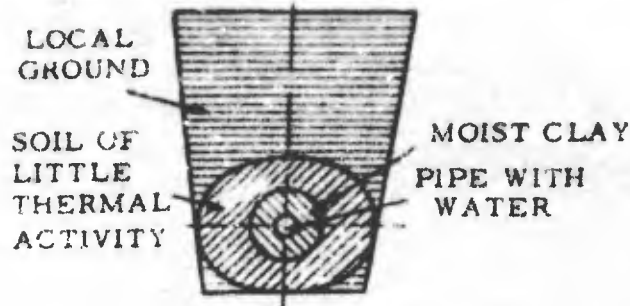

Figure 102. First variant of water pipe placement.

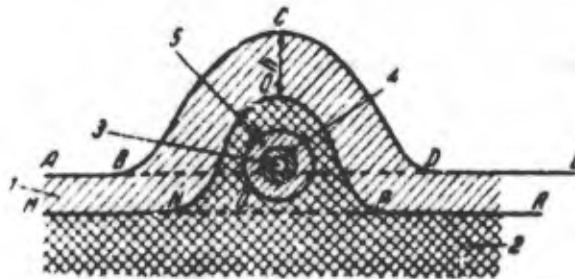

Figure 103. Second variant of water pipe placement. Pipe laid on the surface of the soil. 1) Active layer; 2) Permafrost; 3) Water pipe; 4) Moisture - bearing soil; 5) Insulating layer (peat).

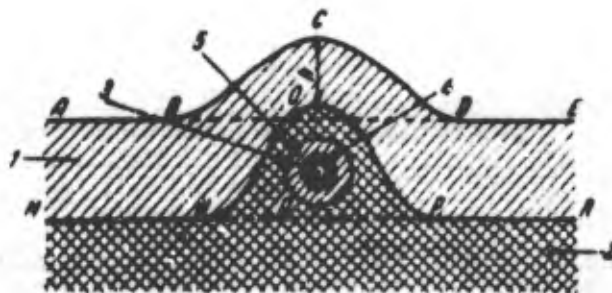

Figure 104. Third variant of water pipe placement. Pipe is laid at a certain depth in the active layer. 1) Active layer; 2) Permafrost; 3) Water pipe; 4) Moisture - bearing soil; 5) Insulating layer (peat).

PRINCIPLES OF MECHANICS OF FROZEN GROUND

Table 82. Average temperatures for 1911-1919, Bomnak, depth 2.8 m (C).

Jan	Feb	Mar	Apr	May	June	July	Aug	Sept	Oct	Nov	Dec	Annual
-0.2	-0.5	-1.2	-1.6	-1.4	-1.0	-0.7	-0.6	-0.4	-0.3	-0.2	-0.2	-0.7

Table 83. Average temperatures for 1928-1930, Skovorodino, depth 2.5 m (C).

Jan	Feb	Mar	Apr	May	June	July	Aug	Sept	Oct	Nov	Dec	Annual
-0.2	-0.2	-1.0	-1.7	-1.3	-1.0	-0.8	-0.7	-0.4	-0.2	-0.2	-0.2	-0.6

In the vicinity of the village of Ust'-Vorkuta, N. G. Datskii¹ found the following temperatures for August 16-20, 1932, in a borehole sunk into a peat mound:

Depth (m)	Temp (C)	Depth (m)	Temp (C)
0.6	-0.0	11	-1.3
1.6	-1.0	12	-1.1
3.2	-2.0	13	-0.8
5.0	-2.5	16	-0.6
6.0	-2.3	17	-0.5
7.0	-2.2	19	-0.4
8.0	-2.0	21	-0.1
9.0	-1.7	23	-0.0
10.0	-1.5	-	-

The mound was covered with a peat layer up to 1.5 m thick below which was mineral ground — clayey sand and silty sand. Near to the mound was unfrozen ground, with a temperature of +0.5C, +0.4C at a depth of 15-20 m.

The temperatures which Datskii observed in other places in the part of the Usa Basin which he investigated were of the same type or, in places, somewhat higher. In a borehole near the village of Semzha, north of the town of Mezen', Datskii² registered the following temperatures:

Depth (m)	Temp (C)
3.5	0.1
4.0	0.1
4.5	-0.1
5.0	-0.1
5.5	-0.1
6.0	-0.1
6.5	-0.1
7.0	-0.1

In this borehole, the base of the permafrost was encountered at the depth of 10 m.

Other boreholes in this region had temperatures varying from -0.1C to -0.2C. Some pits had temperatures of about -0.5C.

In the vicinity of the village of Mgly, in the midst of the hummocky tundra, the following temperatures were registered in a borehole made on 5 September 1933:

1. N. G. Datskii (1934) "Vechnaia merslota i uslovia stroitel'stva v Usinskom raione, (Permafrost and conditions of construction in the Usa Region)," SOPS and KIVM, Vechnaia merslota i uslovia stroitel'stva v Usinskoj lesotundre Severnogo kraia (Permafrost and construction conditions in the Usa forest-tundra of the North). Leningrad: Akad. Nauk.
2. N. G. Datskii Iuzhnyi predel rasprostraneniia vечноi mersloty v Mezenskom raione Severnogo kraia (Southern permafrost border in the Mezen' region of the North), manuscript.

PRACTICAL APPLICATIONS

Depth (m)	Temp (C)
0.5	0.0
1.0	-0.4
1.5	-0.6
2.0	-0.6
2.5	-0.7
3.0	-0.6
3.5	-0.7
4.0	-0.6

In general, the temperatures of the upper layers of the permafrost in these regions were not below -1.5C to -1.0C.

Such are the temperature conditions of the permafrost mass near the southern border in the European part of the U.S.S.R. Because of this and other data, it is considered that degradation of permafrost occurs in the region of Mezen' and the Usa. We have only brief indications concerning permafrost on the islands in the European portion of the Arctic Ocean! For instance, in the shafts on Vaygach Island, a temperature of -3C, -4C was registered at a depth of 25-30 m.

For the northern part of western Siberia we have the following soil temperature data from Obdorsk:

Depth (m)	July-September temperature fluctuation (C)
0.80	from 2.0 to 4.0
1.60	" -0.3 " -1.0
2.40	" -0.8 " -2.0
3.20	" -1.1 " -3.0
4.00	" -2.2 " -4.0
5.00	" -3.2 " -4.0

Temperatures observed by I. T. Guterman in a borehole at the Ust'-Yenisey port² are given in Table 84.

Table 84. [Temperatures in borehole 8, Ust'-Yenisey port.]

Date	Depth (m)	Temp (C)	Date	Depth (m)	Temp (C)
9/17	1	-1.2	9/17	12	-6.7
10/18	1	-1.8	9/18	12	-6.7
9/19	2	-2.8	9/19	16	-6.4
9/18	4	-5.5	9/19	18	-6.3
9/19	6	-7.4	10/8	18	-6.4
9/18	8	-7.6	10/13	18	-6.3
9/18	10	-7.2	—	—	—
10/9	10	-7.1	—	—	—

At a conference on permafrost investigation, Mining Engineer V. M. Ponomarev stated that he found temperatures of about -4C at a depth of 50 m and about -5C at 100-110 m in a borehole at Amderma.

Summarizing all data on the extreme north of western Siberia, it can be said that, when planning to build in this area, one must bear in mind that temperatures varying from -3 to -7C will be found in the upper 10 m of the ground. These temperatures permit the construction of buildings along the principle of preservation of permafrost, as has been confirmed by experience. There is reason to think that the large Taimyr Peninsula should also be included in this region, since it has somewhat lower temperatures.

1. B. N. Gorodkov (1932) Vechnaia merslota v Severnom krae (Permafrost in the Northern region). Leningrad: Akad. Nauk.

2. N. A. Tsytovich, Nekotorye issledovaniia vechnoi mersloty v nizov' iakh r. Eniseia letom 1930 g (Investigations of permafrost on the lower part of the Yenisey River during the summer of 1930), Trudy KIVM, Akademiia Nauk, tom I.

PRINCIPLES OF MECHANICS OF FROZEN GROUND

The situation at Igarka requires additional clarification. As pointed out above, we encounter layered permafrost in the territory of this town. The temperature in such permafrost should be about 0C, as was observed by Bykov at Igarka in a test pit 15 m deep and in a 62 m-deep borehole. Because of this, when we classify the permafrost region according to the temperature of the ground, we must exclude the town of Igarka from the area of permafrost with low temperatures. However, it seems to us that the temperature is low enough in the vicinity of Igarka where the permafrost is not layered.

Farther to the east, in the large territory stretching from the 112th meridian to the shores of the Pacific and from the Arctic Ocean to the 56th latitude, the temperature of the ground has been determined at several points. For the town of Yakutsk, we can give the latest soil temperature data along with some of the data supplied by Middendorf (Table 85).

Table 85.

Temperatures at the platform of the Yakut Hydrometeorological Institute			Temp in the Shergin shaft, from Middendorf	
Depth (m)	Avg yearly temp (C)		Depth (m)	Avg yearly temp (C)
0.8	-5.2	1 Nov. 1930 - 31 Oct. 1931 inclusive	2.13	-11.18
1.6	-5.3			
2.0	-5.3			
2.4	-5.2			
3.2	-5.0			
6.4	-3.6	(20 days in Nov. 1931)	6.10	-10.16

V. A. Fedortsev supplied us with data on the ground temperatures in the Verkhoyansk mountain range, obtained during explorations of the Bolbuk silver and lead sites:

The Bolbuk site. About 1450 m above sea level, on a north-facing slope. Thermometer placed in shaft no. 2 at a depth of 22 m. Average temperature from seven observations (28 July - 3 August 1930): -7.8C. The temperature was determined in boreholes made in the walls of the shaft.

There are also data on ground temperatures for the mouth of the Anadyr' River, obtained by S. P. Kachurin and P. F. Shvetsov in 1935 (Table 86). We cite the temperatures taken in one of the boreholes near the fish cannery on the shores of the Melkaya Bay of the Anadyr' Estuary. Observations were made during the second 10-day period of August 1935.

Table 86. Temperature of the ground in borehole 2 (Anadyr').

Depth (m)	Temp (C)	Depth (m)	Temp (C)	Depth (m)	Temp (C)
0.0	12.2	3.5	-3.6	7.0	-4.7
0.5	1.6	4.0	-4.0	7.5	-4.7
1.0	-0.7	4.5	-4.2	8.0	-
1.5	-1.5	5.0	-4.5	9.0	-4.9
2.0	-2.1	5.5	-4.6	10.0	-4.9
2.5	-2.6	6.0	-	11.0	-4.9
3.0	-3.1	6.5	-4.6	-	-

If we interpolate the Yakutsk and Anadyr' data boldly, we could conclude that all this territory east of the 112th meridian has comparatively the same low temperatures as the two localities previously described. However, there are data against such bold interpolation. At Serednikan, on the Kolyva River, K. N. Zhukov took regular soil temperature measurements at the meteorological station, and obtained the following data:

Serednikan on the Kolyma River, 1934

<u>Depth (m)</u>	<u>Average yearly temperature (C)</u>
0.4	-0.3
0.8	-0.7
1.6	-0.8
3.2	-0.4
6.0	-0.4

As the average monthly air temperatures for December and January are about -30C and -35C and the average yearly temperature is below -10C, these soil temperatures appear to be extremely high. However, the thickness of the snow cover, up to 87 cm in Serednikan, explains these high temperatures. Here the insulating role of the snow cover comes into the picture.

Therefore, we must refrain from generalizations and cautiously state that: In our vast northern territory, the Yakutsk and Bolbuk data on soil temperature should be used where there is little or no snow. Where there is a thick snow cover, the Serednikan data should be used for the first 10 m beneath the earth's surface.

The thickness of the snow cover, which sharply influences the temperature of the soil, must be figured at not less than 50 cm in December and January.

However, the data from Serednikan must still be considered an exception. For the same place, we have information from Comrade Volchanov that a number of boreholes have temperatures from -3 to -7C at a depth of 10-27 m.

Such is our reasoning concerning the ground temperature of the Yakutsk region of the U.S.S.R. and the adjoining regions of the Far East. But we also need to anticipate what will happen to ground temperatures in factory yards and mills and around buildings after the natural conditions are disturbed, just as we tried to find an estimated thickness of the active layer to use in planning construction. Unfortunately, in the Yakut Republic, with its exceptionally severe climate, we haven't the data for authoritative judgment on this question. We consider that the experiments in this connection in the Transbaikal and the Amur region are hardly applicable to Yakut conditions. In parts of the Yakut Republic which have deep snow, we can expect that ground temperatures will lower in the yards of future factories and mills, and on the streets of cities, since the snow will be disposed of or compacted. Experimental investigations in this direction are deemed absolutely necessary.

For the Transbaikal and Amur regions (the area occupied by permafrost), we have a whole series of observations on the thermal regime of the upper 10-15 m of permafrost.

In Petrovsk-Zabaykal'skiy, a pit 21 m deep was dug in 1928 and soil temperatures were measured in holes bored in the wall of the pit to a depth of 1.5 m. The results are shown in Table 87.

Thorough observations on soil temperatures have been made for the last few years at the Frozen Ground Experimental Station in Skovorodino. We have already used this material for describing temperature conditions of the active layer. Here we give the data on average annual temperatures in the permafrost layer:

<u>Depth (m)</u>	<u>Temperature (C)</u>
5	-0.7
10	-0.9
14	-1.0
15	-1.1
20	-1.3
25	-1.5
28	-1.6

Below a depth of 14 m the ground temperature is independent of the annual air temperature for all practical purposes. Table 88 shows the general character of soil temperatures in the Transbaikal and the Amur region.

Table 87. [Soil temperatures in Petrovsk-Zabaykal'skiy, 1928.]

Depth (m)	Dates of observation	Temperature (C)		Depth (m)	Dates of observation	Temperature (C)	
		Reading	Average			Reading	Average
6	9/4	-0.4	-0.40	11	9/23	-0.5	-0.43
	9/7	-0.4			9/24	-0.4	
	9/10	-0.4			9/26	-0.1	
7	9/9	-0.5	-0.50	12	9/26	-0.5	-0.53
	9/10	-0.4			9/28	-0.5	
	9/13	-0.6			9/29	-0.6	
8	9/12	-0.5	-0.50	13	10/18	-0.4	-0.40
	9/13	-0.6					
	9/20	-0.4					
9	9/15	-0.5	-0.57	14	10/18	-0.4	-0.40
	9/16	-0.6					
	9/20	-0.6					
10	9/18	-0.6	-0.60	15	10/18	-0.4	-0.40
	9/26	-0.6					

Table 88.

No.	Locality	Lat	Long	Elev (m above sea level)	Soil Temp	
					Depth (m)	Temp (C)
1	Petrovsk-Zabaykal'skiy	51°17'	108°51'	801	10	-0.6
					15	-0.4
2	Sokhondo Station	51°46'	112°45'	952	8.5	-1.2
					10.7	-1.0
					12.8	-1.0
					23.5	-1.0
3	Zilovo Station	53°01'	117°30'	696	12.5	-0.4
4	Skovorodino Station	50°58'	123°57'	396.5	10	-0.9
					14	-1.0
5	Bornak	54°43'	128°52'	352	5	-0.3

Taking other factors into account, we can say that in the enormous area from Baikal to the lower Amur River and from the 55th parallel to our national border, ground temperatures at the depth of approximately 15 m fluctuate from -0.4C to -1C. This fact must be taken into account by those who are planning construction.

The bottoms of ravines, which have considerable ice cement in the permafrost mass and have small streams frequently running through them, will be exceptions to this general situation. Here, although not always, the ground temperature may lower to -2 or -3C. We can state with certainty that, after human habitation, the temperature of these ravines will become the same as that of the surrounding territory, that is, about -1C, with a further temperature rise possible.

The region west of Baikal, bordered on the north by the latitude stretching through the northern end of Baikal, on the south by the national border, and on the west by the border of of permafrost, has sporadic permafrost in its lower areas. Temperature data concerning

these areas is given by V. G. Petrov.¹ In the many boreholes where the permafrost was penetrated completely, its thickness did not exceed 3.25 m. In those boreholes where permafrost was not penetrated completely, it was found to a maximum depth of 6.65 m, but but generally the depth was less.

In the region of Tayshet-Padun explored by the expedition, the temperature of the permafrost was found to be generally -0.1°C or 0°C ; only in one instance was it -0.2°C . Since these temperatures did not occur at very great depths, they may be lower in winter.

But in general this permafrost area has considerably higher temperatures than those east of Baikal, even though, as we have already seen, they are sufficiently high in the Baikal region.

For the southern, mountainous part of this region we have the paper of Mining Engineer I. I. Oreshkin² on permafrost on Botogol'sk Bald Mountain, formerly Aliberovski graphite mine. Oreshkin measured the temperature in a borehole at the altitude of 2200 m. Below is the data for the 8th to 10th of September 1930.

<u>Depth (m)</u>	<u>Temp (C)</u>	<u>Depth (m)</u>	<u>Temp (C)</u>
2	0	9	-3.9
3	-0.7	10	-4.8
4	-1.5	11	-4.9
5	-2.1	12	-5.1
6	-2.7	13	-5.2
7	-2.9	14	-5.2
8	-3.8	15	-5.3

These temperatures are closely related to the considerable altitude. At lower altitudes, we do not find any negative temperatures. Sumgin measured the temperature on one of the hills near Bratsk at a relative height of about 300 m in a pit almost 12 m deep and got a temperature of nearly 2.5°C . At the same time there was an island of permafrost at the very bottom, in the valley of the river which ran under the hill.

There remains a large territory south of the Taimyr Peninsula, through which run the right tributaries of the Yenisey River. For this territory, not counting the old Middendorf data, we have only one temperature reading, from a drill hole in the Noginsk mine on the northwest slope of Noga Mountain at an altitude of 250 m. At a depth of 27 m, the temperature in this bore hole was -0.1°C (1 July 1932).³

From our brief outline of temperatures in the permafrost mass, we see that, even though the data is scarce, so much material has been accumulated recently that we can confidently characterize certain regions on the basis of their temperature, and divide the permafrost area into regions on the basis of these characteristics. This outline is a first step in that direction.

I. First region — to the north of the city of Mezen' — ground temperature to a depth of 10 m is not lower than -0.5°C .

II. The basin of the lower course of the Usa River, a right tributary of the Pechora River, east to the mouth of the Vorkuta River which falls into the Usa. To a depth of 20 m, the ground temperatures are about -1°C with certain exceptions.

III. Region east of the northern part of the Ural Mountains to the Taz Bay; to the south — a little south of Obdorsk. Temperature of the first 10-15 m of the ground ranges from -3 to -5°C .

1. V. Petrov, Merzlotnaia ekspeditsiia po trasse Tayshet-Padun (Angara) v 1933g. (Permafrost expedition along the Tayshet-Padun route, Angara, in 1933). (Ms)

2. I. I. Oreshkin (1935) "Vechnaia merslota na Botogol'skom gol'tse v Vostochnykh Saianakh (Permafrost on the Botogol'sk Bald Mountain in Eastern Sayans)," in Zemlevedenie (Geography), tom XXXVII, vyp. 1.

3. S. L. Kushev (1934) Vechnaia merslota v ralone nizhnego techeniia r. Nizhnei Tunguski (Permafrost in the region of the lower reaches of the Lower Tunguska River), Trudy KIVM, Akad. Nauk, tom III.

IV. Region of the Tas Bay to the Anabar River; south to the line slightly north of Igarka. To depths of 20 m, ground temperatures range from -5 to -7C.

V. From the Anabar to the Kolyma River; south to the 64th parallel. To a depth of 20 m, ground temperature is from -6 to -8C.

VI. The shore regions of the Anadyr' estuary. Ground temperature to 10 m is about -5C.

VII. Region west of Baikal within the borders of the permafrost area. The northern border parallels the mouth of the Upper Angara River (where it flows into Lake Baikal) with the exception of mountain peaks. Where there is permafrost, its temperature is about -0.5C and higher.

VIII. Region east of Baikal to the Pacific Ocean; extends south to the national border and the southern border of permafrost; to the north, to approximately 55° latitude. Ground temperature at a depth of 10-15 m is, as a rule, not lower than -1 or -1.5C.

We have combined all these small regions into three vast regions according to temperature characteristics of the permafrost at a depth of 10-15 m. (See Map [1].)

The first region [No. 3 on map] stretches parallel to the southern border. Ground temperature at a depth of 10-15 m, as a rule, is not lower than -1.5C.

The third region [No. 1 on map] comprises the northern area from Yamal to the Anadyr' estuary, south to somewhat north of Yakutsk. Temperature at a depth of 10 m, as a rule, is not above -5C.

The second region is situated between the first and third regions; ground temperatures at the same depths are between -1.5 and -5C.

Degradation of Permafrost

The temperatures of the permafrost in Skovorodino fall with depth, as the careful reader will have noted. This circumstance allows us to draw several conclusions of the utmost significance. Figure 105 shows the course of temperature at Skovorodino and indicates the level of zero annual amplitude at a depth of 14 m. The decrease of amplitude with depth at Skovorodino is shown in Table 89. Below 14 m the amplitudes would be less than 0.1, so that 14 m may be considered (to an accuracy of 0.1C) as the level of zero annual amplitude; the temperature of the ground below that will depend solely on the temperatures of the depths of the earth and must be practically constant.

Table 89. [Decrease of temperature amplitude with depth at Skovorodino.]

Depth (m)	Absolute temp (C)		Absolute amplitude (C)
	Max	Min	
0.4	14.9	-15.9	30.8
0.8	10.7	-11.3	22.0
1.6	3.3	-5.6	8.9
2.0	1.7	-4.5	6.2
2.5	-0.1	-2.2	2.1
3.2	-0.3	-1.1	0.8
5.0	-0.6	-1.0	0.4
10.0	-0.8	-1.0	0.2
14.0	-1.0	-1.1	0.1

However, in Skovorodino we have the following situation.

The temperature of the ground, falling with depth, is -1.6C at a depth of 28 m. No further boring was done. We cannot say that the temperature of -1.6C is the lowest temperature in the permafrost mass; the decrease with depth may continue. We could have

established the lowest temperature by deepening the borehole and measuring the temperature. But we can be sure that, from the established minimum (be it -1.6°C or any other figure), the temperature will begin to rise with depth, first within the range of negative temperatures — until the curve intersects the ordinate axis [Fig. 105] — and then within the range of positive temperatures. The intersection of the curve with the ordinate axis coincides with the lower boundary of permafrost, possibly with a negligible deviation. According to data available for Skovorodino, the lower boundary is somewhere near 50 m, but, wherever it lies, it is of no importance for subsequent reasoning.

Our temperature curve has a curvature in the direction of negative temperatures. Physically, this signifies that, below the layer with constant annual temperature, the permafrost layer of a certain thickness has a lower temperature than the layers above and below it.

After considering the problem from all angles, we come to the inevitable conclusion that a normally cooled permafrost layer has stored-up cold, left as a heritage from times of colder climate.

A layer with a lower temperature must inevitably lose its low temperature under the influence of heat flow from above and below. The curve will reflect this by leveling off toward a form corresponding to a uniform rise of temperature from -1°C at 14 m to 0°C at 50 m.

Consequently, the temperature of the permafrost layer will rise, and this indicates the degradation of permafrost in Skovorodino, as was first pointed out by M. I. Sumgin in 1931.

An analysis of the temperature drop with depth in permafrost below the layer of constant yearly amplitude leads us to these conclusions:

From the point of view of natural history, the degradation of permafrost, as we have already stated, is of the utmost importance. From the practical point of view also, degradation is significant for building and construction, but the details of this side of the question have not been carefully studied as yet. We do not know the speed of degradation nor can we determine its extent. In order to judge the significance of degradation for construction problems, this data is essential. However, even with present knowledge, we can state that the heating of the ground under heated buildings will be more rapid in regions of permafrost degradation than in regions where there is no degradation. Therefore, when deciding the basic question for construction — whether to build on the principle of preservation or on the principle of destruction of permafrost — permafrost degradation must be taken into account. But we cannot act on the basis of degradation alone — it must be considered along with other factors. It makes a difference whether the temperatures of the degrading permafrost are -5 or -7°C , as happens in the North, or -0.2 or -0.5°C as occurs in the southern permafrost areas. In the first instance, we might decide, after weighing all the circumstances, to build on the principles of preservation of permafrost, even where there is degrading permafrost.

In concluding the section on temperatures of the permafrost mass, we cite the thermo-isopleths from the Bomnak and Skovorodino (Fig. 106 and 107).

These thermo-isopleths are used for calculating the penetration of freezing into the ground, discussed in Chapter V.

Hydrology of the Permafrost Area

In the first chapters of our work, we discussed the theories concerning processes taking

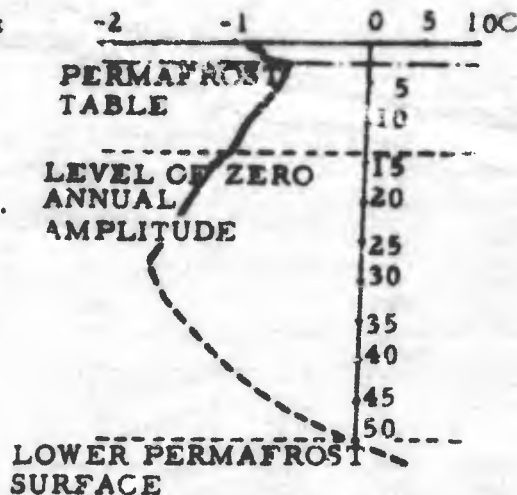

Figure 105. Distribution of temperatures with depth in the Skovorodino borehole.

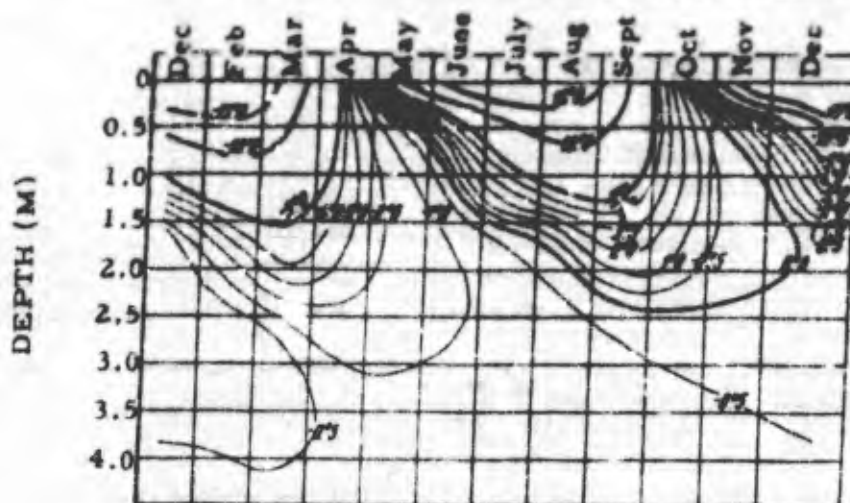

Figure 106. Thermoisopleths for Skovorodino Station, 1928-1930.

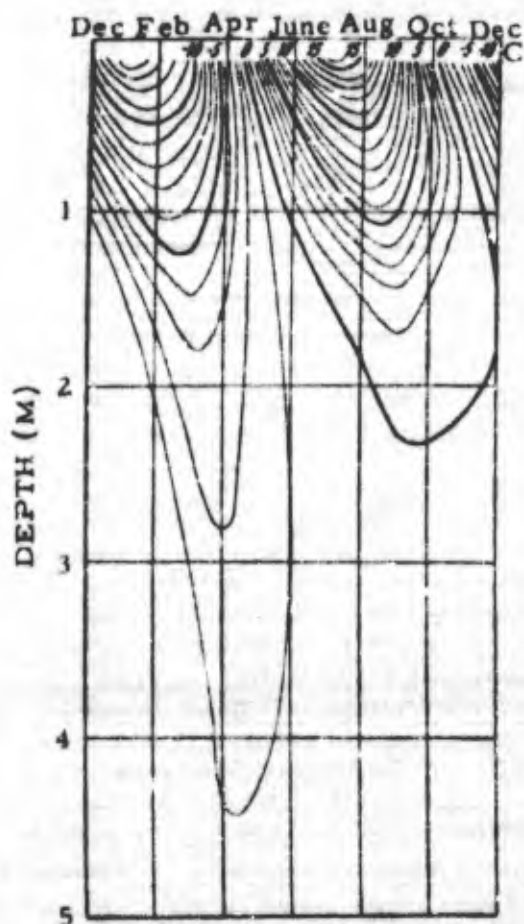

Figure 107. Thermoisopleths of soil at Bomnak.

place in freezing ground. In the present chapter we will describe how these processes manifest themselves in the natural environment of the permafrost area. But first of all let us point out the basic situation which is the background of all the hydrological phenomena of this area. Water in its liquid state has positive temperatures, except in those rare cases where it is supercooled, and permafrost always has negative temperatures. Therefore, liquid water and permafrost are highly antagonistic by nature. Heat from the water tends to bring the permafrost out of its frozen state; on the other hand, the permafrost absorbing heat from the water, tends to transform water from a liquid body into a solid — ice.

As a result, for each zone of the permafrost area, with its particular climatic conditions, a certain unstable equilibrium is established between the amount of liquid surface and ground water, on one hand, and the character of the permafrost — its temperature, the extent of its geographic continuity, and its thickness — on the other.

Against this general background, one must examine the amount of water in its liquid and solid phases in permafrost. There was a time when scientists doubted that liquid ground water could exist at all in the presence of permafrost. But numerous observations and theoretical discussions have shown that liquid ground water does exist in the permafrost area, but in smaller amounts than under the same conditions where permafrost is absent.

In evaluating the presence and quantity of ground water in the permafrost area, both its liquid and solid phases are considered. But, on the basis of the law of unstable chemical equilibrium, the amounts of liquid and solid water at given climatic conditions vary in one or the other direction, fluctuating around some center of equilibrium.

Classifying ground water by its position in relation to permafrost, we have three interrelated types; suprapermafrost, intrapermafrost, and subpermafrost ground water.

Suprapermafrost water occurs above the permafrost, which acts as a water resistant foundation. It is characterized by alternating solid and liquid phases of water according to the season of the year. Most of the processes connected with the transition of water liquid to solid take place here, in particular the horizontal and vertical migration of water into the layers not yet thoroughly frozen, as well as into the cracks and crevices of the frozen layers.

When the ground freezes, the suprapermafrost water is sometimes confined between frozen and unfrozen layers by pressures in the ground; sometimes it splits the frozen layers, as was discussed in the theoretical part of our work. This suprapermafrost water is the main cause of the soil heaving when the ground freezes, and sometimes flows out through cracks in the frozen ground, forming ice fields. The theory of these processes is also given above.

Builders must give very careful consideration to the suprapermafrost water, but must not depend on it for a water supply, because it does not usually meet sanitary requirements.

Wherever the permafrost table is below the lower limit of winter freezing, part or all of the suprapermafrost water remains liquid throughout the year.

The intrapermafrost water, in the permafrost mass, is characterized by the stability in time of its solid and liquid phases, within the range of their unstable equilibrium. The liquid intrapermafrost water flows along unfrozen veins or flows in a sheet in the permafrost mass. Its flow can sometimes be quite considerable. In solid form, intrapermafrost water occurs in extremely varied forms — layers, lenses, laccoliths of various shapes and sizes, and also very minute veins of ice and small crystals distinguishable only through a magnifier. The subject of ice in the ground is treated in greater detail later.

The subpermafrost water, below the permafrost, is characterized by the stability of the liquid phase and, with rare exceptions, by pressure. It occurs in alluvial deposits at the bottom of recent or ancient wide valleys. It is also widespread in bedrock.*

Suprapermafrost water may come: (a) directly, from atmospheric precipitation; or (b) from intrapermafrost water. In the second case, the intrapermafrost water may be derived from suprapermafrost water or from subpermafrost water which it brings to the surface. Talus on slopes of mountains and hillocks is frequently a collector of atmospheric precipitation (Fig. 108).

Figure 108. Feeding of suprapermafrost water by precipitation. 1) Talus; 2) Active layer; 3) Water-bearing layer with a stream of suprapermafrost water; 4) Permafrost; 5) Precipitations.

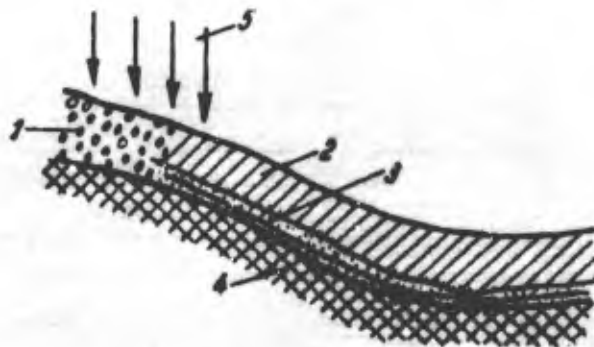

Intrapermafrost water has no independent significance and is fed either by water from atmospheric precipitation or by subpermafrost water. In the first instance, the water moving through the permafrost may emerge into the active layer, either forming a spring

* The basic data on ground water was taken from N. I. Tolstikhin (and developed by us): Podzemnye vody v chetvertichnykh otlozheniyakh raionov vечноi mersloty (Underground water in Quaternary deposits in the regions of permafrost), Trudy konferentsii AICHPE (International Assoc. for study of the Quaternary), vyp. II.

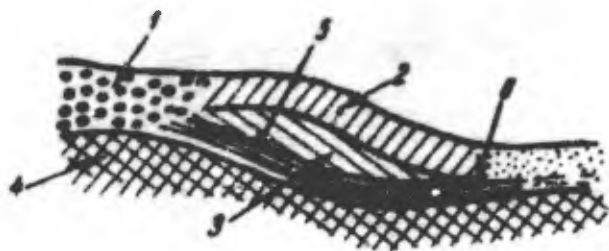

Figure 109. Feeding of suprapermafrost water by intrapermafrost water which originated from atmospheric precipitation. 1) Talus collecting atmospheric precipitation; 2) Clayey ground; 3) Permafrost above the intrapermafrost stream; 4) Permafrost under the intrapermafrost stream and (to the right) under the suprapermafrost stream; 5) Intrapermafrost water; 6) Intrapermafrost water flows into the active layer and becomes suprapermafrost water.

Figure 110. Feeding of suprapermafrost water by intrapermafrost water carrying subpermafrost water toward the surface. 1) Active layer; 2) Permafrost; 3) Suprapermafrost water; 4) Intrapermafrost water; 5) Subpermafrost water.

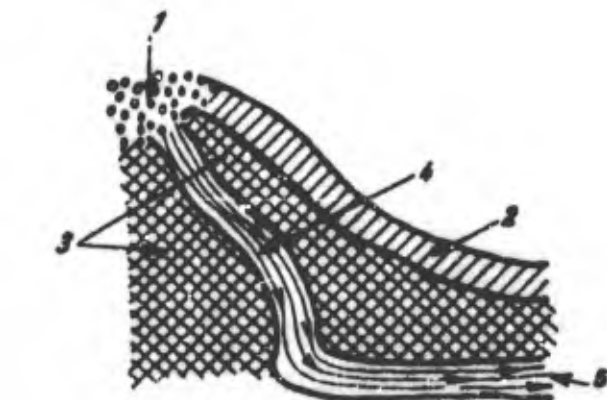
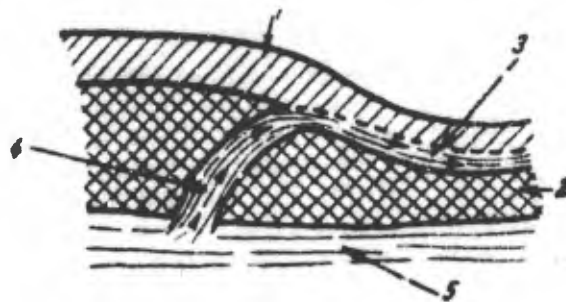

Figure 111. Feeding of subpermafrost water by atmospheric precipitation through intrapermafrost water. 1) Talus; 2) Active layer; 3) Permafrost; 4) Intrapermafrost water fed by atmospheric precipitation; 5) Subpermafrost water.

or flowing through the active layer as a stream of suprapermafrost water (Fig. 109). Or a descending stream of intrapermafrost water can carry atmospheric precipitation to below the layer of permafrost. In the second instance, the intrapermafrost water raises subpermafrost water toward the surface, forming a stream of suprapermafrost water or a spring at the point of emergence into the active layer (Fig. 110).

Subpermafrost water comes from atmospheric precipitation as described [Fig. 111] above or from precipitation without the participation of intrapermafrost water (Fig. 112), or by infiltration of water from rivers and lakes.

Theoretically, suprapermafrost water can be formed by condensation of water vapor in the air, but this problem has not been worked out at present. The origin of subpermafrost water by condensation — i. e., from juvenile water primarily — is still a debatable

Figure 112. Feeding of subpermafrost water by atmospheric precipitation without the participation of intrapermafrost water. 1) Soil; 2) Loose fine-grained soil; 3) Bedrock; 4) Rock detritus; 5) Permafrost; 6) Water from precipitation; 7) Suprapermafrost water; 8) Subpermafrost water.

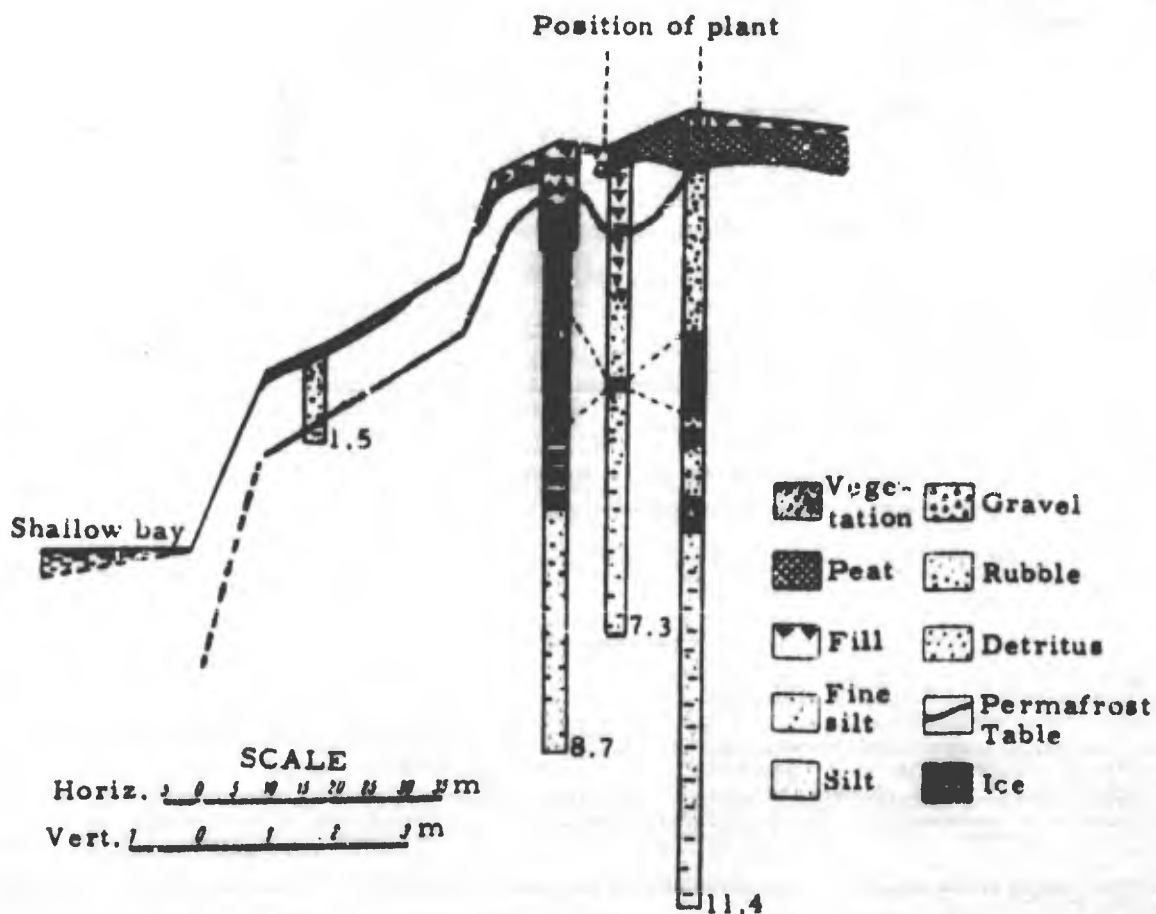
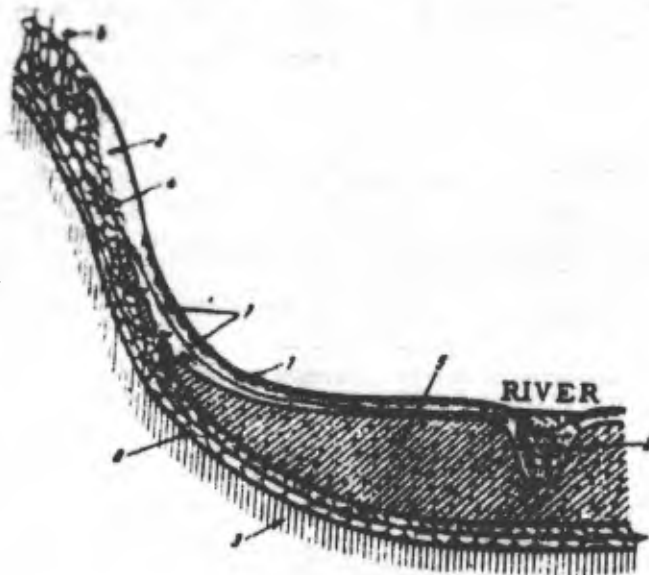

Figure 113. Ice layers under the Anadyr' fish cannery.

question.

In choosing water supply sources or a foundation site for a building, investigation of the ground water should be as detailed as possible. This is necessary for correct utilization of water or to protect buildings from its damaging effects.

Inclusions of ice in frozen ground affect the moisture content (ice saturation) of the frozen ground and its porosity, and therefore its construction properties. If there is a considerable amount of ice in the ground, thawing may cause catastrophic settling of the ground and the buildings. This is exactly what happened to the Anadyr' fish cannery.

which was built on ground containing many ice layers and lenses (Fig. 113).

The ice contained in permafrost is classified as follows:

I. Ice masses formed on the surface and then buried in the ground. The term "buried ice" is most applicable here. The following varieties belong to this category:

- 1) Glacial ice, preserved in the ground from glacial times to the present day. To this category belong the ice of Novosibirsk archipelago, the ice on the shore of Arctic Ocean east of the mouth of the Lena River, the ice of the Lena-Aldan water divide, and others. This buried ice occupies a tremendous area. When building, sites where the ground contains these ice masses must be avoided by all means.
- 2) Buried snow. Snow covered by soil is found mostly in the north; the areas where it occurs are not large. Ice formed in this way breaks up into round units.
- 3) Icings covered by the soil. This is a very common phenomenon in the whole area of permafrost, and must be reckoned with frequently when building railroads and roads. Areas occupied by such ice are small. It is better to avoid them in constructing roads and buildings, and it is usually easy once the ice has been located.
- 4) Frozen lakes buried in the ground. One such lake in the extreme north of Yakut A. S. S. R. is mentioned in the account of Wrangel's travels.
- 5) River ice thrown up on the shore and buried by soil.
- 6) Sea ice buried in the ground.

Buried ice of types 4, 5, and 6 is rare and presents no particular difficulties for building, since it can easily be avoided.

II. Ice masses formed by the freezing of water in the ground itself. To this category belong the following:

- 1) Ice of "underground icings" that is, ice formed in icing mounds. Areas occupied by this type of ice are insignificant.
- 2) Ice formed by freezing of suprapermafrost water. Such ice does not form thick layers, but can occupy large areas. This constitutes a negative characteristic of ground. First, the foundations must extend below this layer, and, second, if this layer thaws, refreezing can cause heaving of the ground.
- 3) Ice formed by freezing of intrapermafrost water.
- 4) Ice interlayers formed from the water in the ground, when an unfrozen layer is transformed into permafrost.
- 5) Ice from water vapor, formed in the following order: vapor-liquid-solid (ice).

III. Sublimated ice, theoretically possible according to the scheme: Ice — vapor — ice.

IV. Ice formed in two or several of the above-mentioned ways. For instance, a lake which is not frozen through to the bottom is covered by soil and the remaining water freezes within the ground. Thus, the ice which covered the lake entered the ground in a solid state: the water beneath the ice entered the ground in a liquid state and froze within the ground. The whole ice mass formed in this manner belongs to two types — I and II.

There are large areas in the permafrost territory where the embedded ice occupies the upper layers of the lithosphere. In addition, smaller masses of ice in the ground are fairly common in permafrost regions.

As we have already pointed out, ground which contains ice should be avoided in the building of large structures. Even ice lenses which are deep below the surface must be avoided. Though these lenses are protected by the ground from the direct action of heat, sun, and air, a migrating stream of ground water may melt an ice lens, causing the overlying ground to settle. For this reason, it is imperative to bore deep enough under the site for a large building, preferably to the base of the permafrost, to make sure that the ground does not contain thick ice lenses. Builders rarely take the trouble to consider these conditions, and the government often pays for their excessive self-confidence.

They often decide on the basis of superficial indications, forgetting that the permafrost was forming for thousands of years and that very often there are no surface signs of ice masses in the ground.

The conditions of the permafrost area are highly favorable for the formation of icings. The theory of this phenomenon has been developed in sufficient detail above.

River icing is a very widespread phenomenon in the permafrost area even on the large rivers. Pod'iakonov and other authors describe icings on such a tremendous river as the Lena. It can be stated with very great certainty that, in the permafrost area, a river, and especially a small river or stream, without icings is rare. Small rivers and streams are sometimes completely covered by icings. For building, it is important to distinguish whether the icings on rivers, streams, and rivulets were formed by the constriction of the river channel or according to Sumgin's theory (see Ch. II), since the swelling will be more energetic in the second case.

At the present time, on the basis of numerous observations, we are convinced that river icings are prevalent in shallow places, the shoals of the river. Although there is no conclusive proof, the data available indicate that it is advisable to bridge rivers at the deeper places, avoiding the shoals.

Some measures to combat icing have been developed. As early as 1927, Sumgin¹ wrote:

"If (during construction of a road) it is impossible to circumvent an icing, an attempt should be made to move icing by artificial means. For this purpose it is necessary to determine the direction of the spring which feeds it, if it is a ground-water icing, and intercept the water before it reaches the projected road. This is done by removing a strip of ground in the path of the stream, so that the water-bearing layer which feeds the icing will freeze very slightly. Then the icing will form in a new place, which must be selected so that it will not interfere with the road."

V. G. Petrov² brilliantly demonstrated that this could be done and, what is particularly important, put the theory into practice, together with the technical personnel of the Amur-Yakutsk railroad.

The Petrov permafrost belts have become widely known. The construction of these belts moved the icings from their natural places to wherever expediency warranted. But how long these permafrost belts would serve was not clear. Practice showed that a belt will work well for 3 to 4 years without any attention. But then the waters began to seep through under the ditch of the belt and again reach the road. Evidently, some maintenance of the belt is necessary to keep it in good working order, but the practical aspects have not been worked out. Theoretically, if the bottom of the ditch is covered for the summer with insulating material and the insulation is removed in the fall, a belt should serve without any trouble for many years.

Ground-water icings are widely distributed in the permafrost area, but of course, they are more common where ground water is more prevalent. They are less common in the extreme north, where there is little ground water because of the severe climate and the low temperatures in the permafrost.

Petrov² proved that construction in the permafrost area disturbs the hydrothermal regime of the ground established over the centuries and creates a condition which favors the formation of icings where they were nonexistent. This is caused especially frequently by the building of railroads and automobile roads with their banks, depressions, and drainage ditches.

The growth of icings formed from suprapermafrost water due to atmospheric precipitation is characteristically less than that of icings formed from intrapermafrost water,

1. M. Sumgin (1927) Vechnaia merzlota pochvy v predelakh SSSR (Permafrost within the limits of the U. S. S. R.). Vladivostok, p. 303.

2. V. G. Petrov (1930) Naledi na Amursko-Iakutskoi magistrali (Icings on the Amur-Yakutsk railroad). Akademiia Nauk and the Avtodorozhnogo inst. NKPS.

which are less developed than those formed from subpermafrost water. Therefore, the most developed icing is formed under the conditions shown in Figure 110 and the least developed is formed under the conditions shown in Figure 108. The morphology of a typical ground-water icing is characterized as follows: There are one or several mounds 3 to 4 m high with a 30-50 m diam at the base of each mound; the mounds are round or elongated in form. Cracks on the surface of the mound radiate from its summit. There are also longitudinal cracks, branching out. Water is emitted through these cracks. Ordinarily the mound is covered with an ice layer up to 2 m thick, generally less, which also spreads out around the mound — the so-called icing field. If we cut the mound, we will usually find the following layers from top to bottom: surface ice, which does not always cover the whole mound; then a layer of soil; one or two layers of ice — the ice core of the mound; water in liquid state; and unfrozen ground. Almost always there are channels from the mound into the ground through which the water is fed into the mound, as described in detail in the theoretical part of this work.

Under natural conditions, there are a number of deviations from this typical icing formation: mounds without ice fields, ice fields without mounds, etc.

Generally, an icing mound lasts for one year, but there are rare mounds which last many years — the bulgunniakhi. They have been noted in Yakutia, Transbaikal, and in the Far East.

The bulgunniakhi on the lakes of the Yakut ASSR are an interesting phenomenon. S. G. Parkhomenko¹ writes about such a bulgunniakh in the Vilyuysk district: "...about 2 versts before we reached the town of Verkhne-Vilyuysk, we came upon a domelike mound in the middle of Lake Bililyakh, making the lake ring-shaped." After a number of years, bulgunniakhi eventually deteriorate. Near the town of El'gias — says Parkhomenko — is a ring-shaped lake named Suoruialakh (the nest of a raven). About 10 years ago the bulgunniakh which was in the center of the lake collapsed, forming a deep lake, the water of which is used today by the population and cattle.

The formation of bulgunniakhi in the middle of lakes, in our opinion, completely fits our theory of the formation of icing mounds (Fig. 114). The radius of the lake corresponds to the feeding radius R . Observing the formation of such a bulgunniakh and making use of eq 8, we can establish the laws governing the formation of bulgunniakhi, heretofore unexplained.

Places where the icing mounds form are very dangerous for construction, like places where large and recurring deformation of the soil surface takes place. When such a place is discovered, it is best to leave it and choose another site. If building on such a site is unavoidable, which may happen, it is necessary to take steps to prevent mound formation at the site, and only then proceed with the construction.

Fundamental measures to combat formation of icing mounds are the draining² of the area and the diversion of springs which feed the mounds. The use of permafrost belts is a specific instance of diversion of mounds from the area of various engineering constructions.

Other manifestations of pressure in the ground during freezing are peat mounds and spot medallions. The first are mounds formed in peat bogs. They are generally scattered over the bogs in groups; 3-4 m, seldom more, in height; and 10-20 m and more in base diameter. Under the layer of peat inside the mound is the ice core or a core of frozen mineral ground. Peat mounds containing permafrost are found in U. S. S. R. on the Kol'skii Peninsula (in Karelia they do not have the frozen core), in the permafrost areas to the north in European U. S. S. R., in the northern part of western Siberia, and in several other northern areas of the permafrost region.

The spot medallions are bare, clayey spots which are approximately round in most cases, somewhat convex, and almost completely devoid of vegetation towards the center.

1. S. G. Parkhomenko (1928) Otchet o poezdke v Viliuiskii okrug (Account of the trip to the Vilyuysk district). Leningrad: Akademiia Nauk.

2. Unfortunately the problem of drainage in the permafrost area is not yet solved.

Narrow depressions covered with vegetation surround the spots. Other shapes occur also — some oval; some elongated, with the long axis downslope; and some hexagonal. Morphologically, the spot medallions are bare spots of various shapes, surrounded by a border of vegetation. Very often the mineral substratum of the spots consists of unsorted fragments of various sizes.

Spot medallions are most widespread in the Arctic, but they also occur in moderate latitudes and at various altitudes.

One of the authors of the present work observed spot medallions on the summit of the Stanovoy range; Reverdatto studied them in the mountainous Altai and in the Sayans; they have been seen on some summits in the Caucasian Mountains and in Mongolia. In the arctic tundra we see a remarkable prevalence of spot medallions, but they also occur in the forest tundra and in the forest sections of the Far East, on the latitudes of Moscow and south.

In the spotted tundra, they often occupy 80% to 85% of the whole area.

Many have noted that the mineral substratum of the spots is mobile, flowing to lower levels.¹

Both hummocky tundra and spotted tundra are difficult building sites. At present there are no tested methods for constructing roads or buildings in such areas. It is advisable to avoid such areas when possible, but we understand that it is not always possible. Clearly, this problem needs investigation.

Another very important phenomenon must be reckoned with in building — the thermokarsts. While ordinary karsts have long since attracted the attention of builders who had to deal with them (dams on the Volga, on the Samarskaia Luka, on the Angara in the region of Barkhatov), the thermokarst phenomenon is little known even to specialists. Prof. I. S. Shchukin does not say a word about it in his work "General Morphology of the Dry Land." In reality, thermokarsts are much more significant than ordinary karsts for building in the regions of permafrost.

The outward picture of the thermokarst phenomenon is this: part of the ground will gradually settle, forming a depression. This depression is sometimes quite considerable and fills with water, forming a "cave-in" or collapse lake.

If there was a forest on the sunken ground, the trees remain standing in water, where they die.

The essence of this phenomenon is this: there is embedded ice in the ground, or the ground itself is oversaturated with ice. For various reasons (cutting the forest, considerable blasting, construction, etc.), the established thermal regime of the upper part of the ground is disturbed in the direction of greater intake of heat. The ice in the ground begins to melt; consequently, the ground itself begins to settle.

It is hardly necessary to mention that places with thermokarst phenomena are extremely dangerous for building.

Thermokarst is widespread in the Yakut-Vilyuysk-Aldan region where there are many cave-in lakes. Such lakes also occur in the north in the Indigirka River drainage area near



Figure 114. Formation of a bulgunniakh in the middle of a lake. (From the work of Ogniev.)

1. V. V. Reverdatto (1931) *Morfologiya i rastitel'nost' platnistoi tundry Arkticheskoi i Al'piiskoi oblasti Sibiri (Morphology and vegetation of the spotted tundra in the Arctic and Alpine regions of Siberia)*, *Izvestia, Tomsk division, Gos. russk. botan. obshd.*, tom. III, no. 1-2.



Figure 115. Cave-in lake in the Far East.
(Photo by A. N. Tolstoy).

the Arctic Circle, in Transbaikal in the Tor-Tunkin valley, and in the southern regions of the Far East (Fig. 115).

There is a connection between buried ice and collapse phenomena. Where there is buried ice, expect collapse phenomena; where there are cave-in lakes, expect to find buried ice.

In our brief account we have described only the most important features of the permafrost area which are particularly pertinent to the problems of building and construction. In summary, we can say the following:

Water in its solid state contained in ground of the permafrost area is a permanent integral part of that ground.

In places (and frequently in large areas) the ice occurs in thick layers of 20-30-40 m or more.

The physical-mechanical processes in the upper part of the lithosphere are characterized by exceptional intensity; consequently, the deformation of the soil reaches tremendous proportions. In the permafrost area, we often encounter places where the surface of the earth rises in winter, forming mounds varying from almost unnoticeable centimeters to several meters in height, or shifting laterally.¹ The stresses in the soils manifest themselves in shifting of the ground water and "plyvun."* The presence of constant negative temperatures in the ground makes the hydrological regime of the permafrost area unique.

For the planning of buildings, special approaches are essential. Particularly, heat must be considered as an external force affecting the ground and thus the buildings. Very often the construction engineer is confronted with conditions that make it difficult and unprofitable to combat deformation by technical means. Then, the engineer must create conditions where the natural forces which will affect the construction will be counteracted by other natural forces.

1. See above — section on general deformation of the soil surface (Ch. II).

* [Thawed ground of mud consistency.]

Some Data on Soil in Permafrost Areas

The situation is complicated for the builder by the fact that the soil in the permafrost area has special characteristics of its own.

So far very few investigations of the soil of this tremendous area (10 million km²) have been made. However, a number of large regions have been investigated, and we can draw some preliminary conclusions. According to these conclusions, the soil in the permafrost area contains a large quantity of silt, which flows easily when wet.

Below we give a brief characterization of the soil, according to certain investigated regions in the permafrost area. Concerning the soil in the Mezen' vicinity and the territory to the north, N. G. Datskii¹ says: "In our region, silty soils are the most prevalent." Of the 19 soil samples taken from Mezen' and north to the mouth of the Mezen' River, only 3 contained as much as 1.5 to 5.38% of particles larger than 1 mm; 12 samples contained less than 10% of 1 to 0.5 mm particles; fractions of 0.25 to 0.01 mm constituted more than 50% of 16 samples. Clay fractions were comparatively small.

V. K. Ianovskii² and N. G. Datskii³ both note a high silt content in the ground in the Pechora basin. Both speak of the easy transition of most of the soil into flowing mud.

We give the grain-size analysis of several samples. Ianovskii gives data for the Malozemel'skaya tundra across from the village of Oksina on the lower course of the Pechora River (Table 90).

Table 90. [Grain-size composition, %, of soil samples from the Malozemel'skaya tundra.]

Depth of sample (m)	Particle size (mm)							
	>1.0	1.0-0.5	0.5-0.25	0.25-0.05	0.05-0.01	0.01-0.005	0.005-0.001	<0.001
0.10	1.15	0.50	3.73	33.57	16.91	22.37	6.84	14.93
0.80	3.69	—	0.72	15.93	41.29	22.84	6.70	8.83

As we see, the appreciable percentages begin with the particles of 0.25 mm and smaller. The ultimate compressive strength of this ground (in a dry state) is as follows (for 2 x 2 x 2 cm cubes): soil from a depth of 0.10 m — 24.2 kg/cm², from a depth of 0.80 m — 48.7 kg/cm².

Ianovskii notes that, judging by the ultimate compressive strength, such ground would be considered good for road construction, since soil with an ultimate compressive strength of 20-40 kg/cm² (in 2-cm cubes) is good according to existing standards. However, this soil became a mud-like mass which caused the walls of the test pits to collapse.

According to N. G. Datskii, sandy silt and silty sand are the most wide-spread soils in the Usa-Vorkuta mine region. Their grain size content is given in Table 91.

Sample 1 is from the mouth of the Vorkuta River, No. 2 from the Usa-Vorkuta railroad route, and No. 4 from the Usa railroad station. The first two are sandy silt, the

1. N. G. Datskii Iuzhnye predely vechnoi merzloty v raione g. Mezen' (Southern borders of permafrost in the Mezen' region), manuscript.

2. V. K. Ianovskii (1933) Ekspeditsiia na reku Pechoru po opredeleniiu iuzhnoi granitsy vechnoi merzloty (Expedition to the Pechora River for determining the southern border of permafrost), Trudy KIVM, Akademiia Nauk, tom I.

3. N. G. Datskii (1934) "Vechnaia merzlota i usloviia stroitel'stva v Usinskom raione" (Permafrost and conditions of construction in the Usa Region)" in Vechnaia merzlota i usloviia stroitel'stva v Usinskoj lesotundre Severnogo kraia (Permafrost and construction conditions in the Usa forest-tundra of the North). Akademiia Nauk.

Table 91. [Grain-size composition, %, of soil samples from the Usa-Vorkuta mine region.]

No.	Depth of sample (m)	Particle size (mm)						
		1.0-0.5	0.5-0.25	0.25-0.05	0.05-0.01	0.01-0.005	0.005-0.001	<0.001
1	0.2		3.75	25.14	45.07	11.16	7.13	7.75
2	0.4		1.25	1.65	57.34	21.7	2.24	55.81*
4	3.0	1.59	17.36	51.15	9.32	8.69	4.03	7.86

* [Sic].

last silty sand.

And here we see the same thing: the main ground mass is composed of silt, which sharply influences the flowing capacity of the ground; the 6-degree angle of repose in the water means complete spreading of the ground in the water, even though only under its own weight.

N. G. Datskii says that ground No. 1 and No. 2 "in the natural state, when samples were being taken, had the appearance of a peculiar doughlike kind of mud very prevalent under the local conditions."

To conclude the subject of soil types in the northern part of European U.S.S.R., let us cite an observation made by Y. A. Liverovski in the Malozemel'skaya tundra. A herd of reindeer walked over a small slope covered by ordinary tundra vegetation. Immediately after, the upper layer of soil began to move and flowed down the slope like water into the nearest small ravine. Apparently the jarring of the soil under the feet of the reindeer was sufficient for the soil to take on the properties of a liquid and flow.

The explorers of prerevolutionary times described the silty character of the soil of the Yakut Republic. This is confirmed by contemporary data. Table 92 gives the analysis (in percentage) of several types of soil taken on the Lena-Aldan water divide.

Table 92. [Grain-size composition, %, of soil samples from the Lena-Aldan water divide.]

No.	Particle size (mm)				
	1.00-0.25	0.25-0.05	0.05-0.01	0.01-0.005	<0.005
1	17.29	34.11	27.40	15.40	5.80
2	-	12.20	48.40	33.60	5.80
3	-	39.40	33.40	20.20	7.00
4	-	6.80	50.00	30.40	12.80
5	-	27.40	36.60	25.30	10.20

Frequently this silty soil is found in long stretches in the Far East, south of the Stanovoi mountain range. Here too we find soil which resembles No. 4 in the table for Lena-Aldan water divide. In such places, particles with diameters less than 0.05 mm constitute as much as 93% of the whole ground.

We do not wish to give the impression that only silty soil is widespread in the permafrost area. Naturally, we find other varieties. But builders should be warned that in all probability they will encounter ground with a large silt content in the permafrost area (see map 2). On the basis of numerous data, we conclude that the disintegration of the soil particles stops with silt, not continuing further into clay (particles less than 0.005 mm).

In the permafrost areas, physical processes of weathering predominate over chemical processes in the ground, because of the low ground temperatures, the severe climate, and the constant negative temperatures at small depths in the ground.

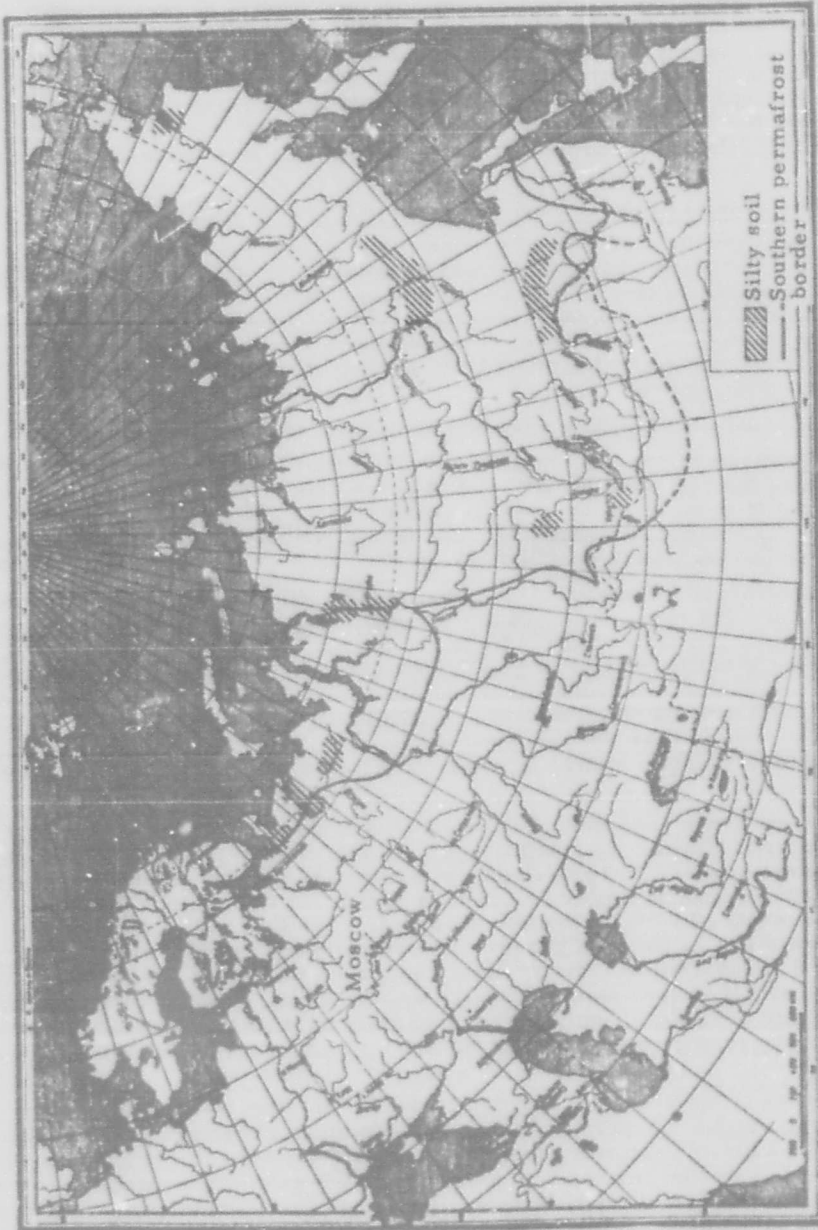

Map [2]. Showing distribution of silty soil in the permafrost zone in the USSR.

Thus, the wide distribution of silty soil in the permafrost area is explained by the very laws governing the weathering of rocks.

In the permafrost area, soil of organic origin — peat — is not very thick as a rule; 2-3 m is its maximum. Since the peat is usually covered with moss or a thick carpet of other bog vegetation (for example — wild rosemary), the thawing of peat during the summer is very insignificant, as was mentioned previously. At depth, the peat remains frozen. For this reason, laying of communication lines over bogs is conducted under entirely different conditions in the permafrost area than in other areas. Under a fill 2-3 m in height, permafrost rises and the peat becomes frozen. Consequently, there is none of the settling of the fill to the bottom which generally occurs in other marshy areas. If the peat does settle under the fills and is forced out from under them, this is limited to the active layer.

Moisture (Ice Content) of the Ground in Connection with Building on Permafrost

We will now examine the moisture of ground in the permafrost area as it is observed in nature. We have discussed suprapermafrost water and ice masses embedded in the ground, and have warned builders to avoid such places. Now, we give concrete evidence and specific examples. Six examples of vertical moisture distribution in the ground, in various permafrost areas, are examined, not as a characteristic of separate geographical provinces, but as concrete examples taken from nature which may be encountered in various parts of the permafrost area.

We will consider how the building engineer should act in each case.

Figure 116 shows cross section 1, to a depth of 19 m. Moisture content is high in the upper part; in places the saturation coefficient is more than one. From 3 to 3.5 m, there is an ice layer; deeper in the ground, separate seams of ice occur. From 7 to 8.5 m, ice seams increase in frequency, moisture rises with a tremendous jump. Only beneath the depth of 12 m is the saturation coefficient less than 1.¹

The temperature for the whole stratum is around -0.5°C . Conditions for laying foundations are very bad. The temperature of the ground is too high to be able to build on the principle of preservation of permafrost. If the ground thaws, large settling of the ground can be expected even if the foundation is laid deeper than the ice bed. For thawed ground, settling should be determined from the curve showing relation between pressure and moisture according to the observed moisture. But settling will begin even at negative temperatures near 0°C . It is best to abandon such a site. If it is absolutely necessary to build on such a site, a pile foundation should be used, considering the friction of the thawed liquefied ground.

Figure 117 shows cross section 2. In the upper 4.5 m, the moisture content of the soil is within acceptable limits. Except for the first half meter, the surface soils are sandy silt with coarse gravel overlying clayey silt with less gravel. Moisture conditions down to 4.5 m would be acceptable for foundations except for other circumstances: temperature is 0°C to a depth of 7 m; the moisture content from 4.5 to 5 m is about five times greater than the moisture capacity of the ground (saturation point = 5), and supersaturated layers of ground occur deeper. Under these conditions we cannot employ the principle of preserving permafrost under heated buildings without taking specific countermeasures. It is better to abandon the site. If building is absolutely necessary, piles should be used taking into account the friction of the thawed liquefied ground rather than the adfreezing forces.

Figure 118 shows cross section 3 to a depth of 14.0 m. The soil is the same throughout the cross section — clayey silt. Its full moisture capacity is around 32% to 34%. Down to 8 m inclusive, moisture is close to or slightly over the full moisture capacity, except at 1.5 m (the permafrost table) where the saturation coefficient is around 1.5. Below 8 m, moisture is acceptable — not more than two-thirds full moisture capacity. Temperature at depth is -0.8°C . The picture is clear. To build on the principle of the preservation of permafrost, figuring the thickness of the active layer as 2 m, the

1. Here and elsewhere, except for specified instances, we have in mind the mean moisture capacity of thawed ground; this also applies to observed moistures.

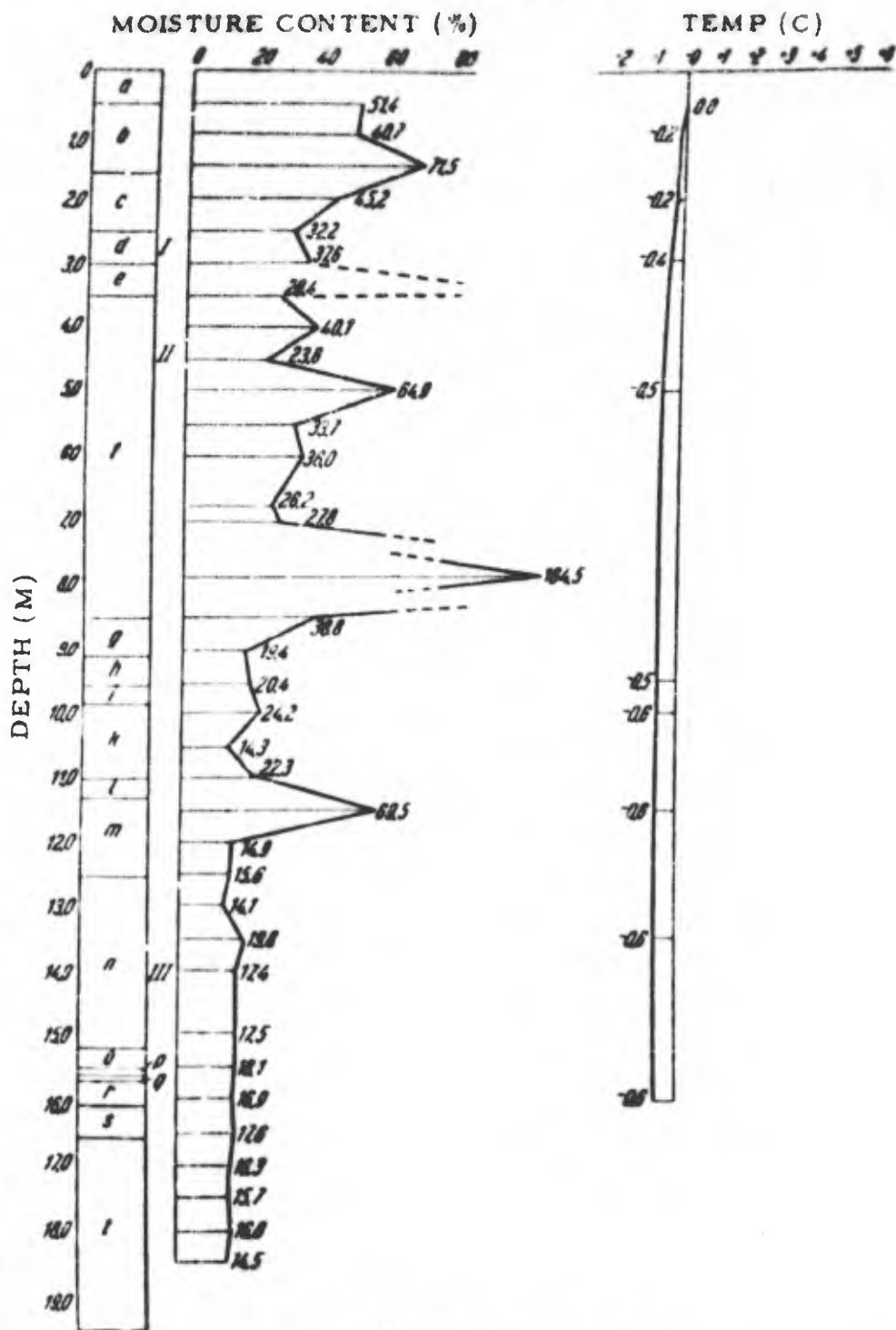

Figure 116. Cross section 1.

- | | |
|-------------------------------|------------------------------|
| a. peat | k. clayey silt |
| b. clay with ice veins | l. fine sand w/pebbles |
| c. clayey silt | m. clayey sandy silt w/ice |
| d. silty clay | n. lean clayey silt w/gravel |
| e. ice | o. sand |
| f. clayey silt w/ice | p. clayey sand |
| g. fat clayey silt | q. silty sand |
| h. lean clayey sand w/pebbles | r. lean clayey silt |
| i. fat clayey sand w/pebbles | s. silty sand |
| | t. lean clayey silt w/gravel |

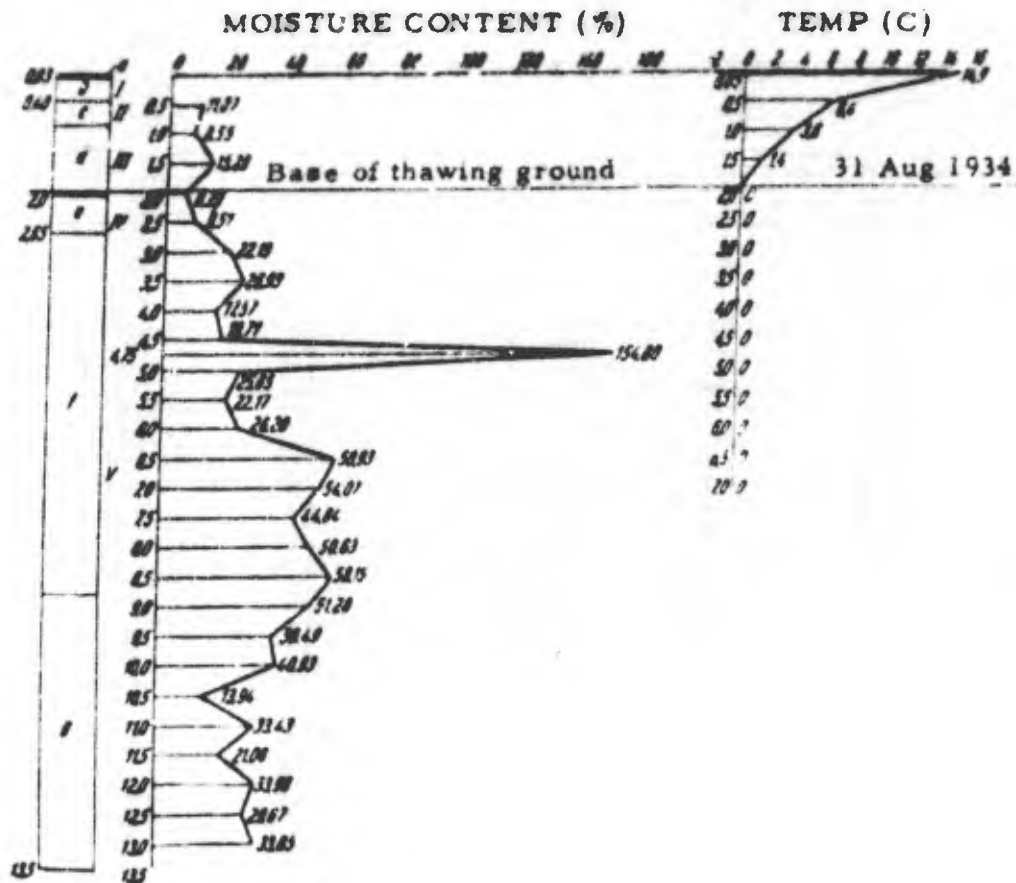

Figure 117. Cross section on 2.

- | | |
|--------------------------------|-------------------------------|
| a. vegetation | e. sandy silt w/ gravel |
| b. peat | f. lean clayey silt w/ gravel |
| c. lean clayey silt | g. fat clayey silt |
| d. clayey sandy silt w/ gravel | |

foundation should be laid deeper than 2 m. Building on the principle of destruction of permafrost would be highly complicated, since the ground to a depth of 8 m beneath the base of the foundation would change into mud with negligible bearing capacity if it thawed. Two alternatives remain — either a thick sand fill or piles, with allowance for the thawed ground. The moisture content of the ground is acceptable below 9.0 m, but it is impossible to lay a foundation at that depth.

Figure 119 gives cross section 4 to a depth of 5.09 m. From the top down, the ground is composed of clayey silt, sandy silt with pebbles, and clayey silt. In the upper part, moisture is about 3 to 4 times greater than full moisture capacity. From 3.5 m down, moisture of the ground is fully acceptable. The temperature drops to -1.5°C at the depth of 5 m. In regard to moisture, the laying of the foundation under permafrost conditions is fully acceptable below 3.5 m. But the upper layer of ground, as we see is highly super-saturated and must be dried out.

In cross section 5, (Fig. 120) the top layer is peat. Below there is a layer of lean clayey sand with pebbles, containing a layer of gravelly sand more than a half meter thick. Temperature is around -0.5°C . It is quite probable that, when the peat is destroyed by occupation of the locality, the ground temperature will rise above zero. Consequently, it is risky to build on the principle of preservation of permafrost without taking precautionary measures. Nevertheless, from the standpoint of moisture, it is possible to build at this site because moisture is below full moisture capacity everywhere except in the layer

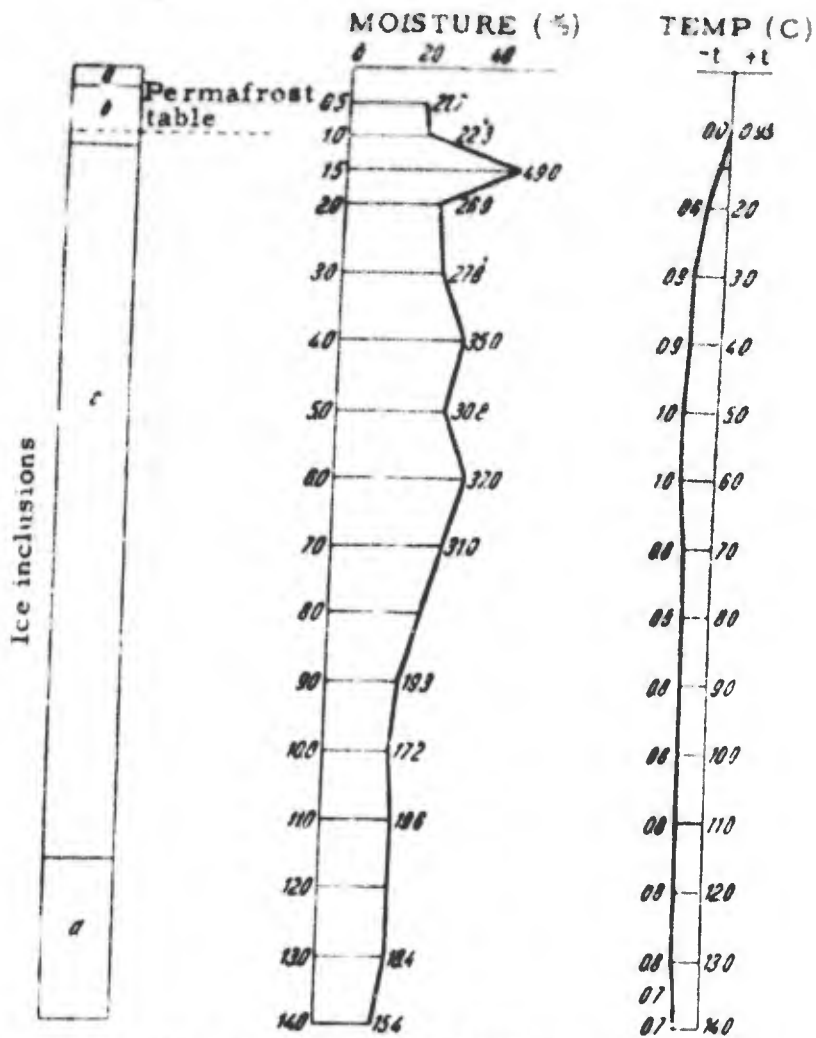

Figure 118. Cross section 3.

- a. vegetation
- b. clayey silt
- c. fat clayey silt w/ice
- d. fat clayey silt

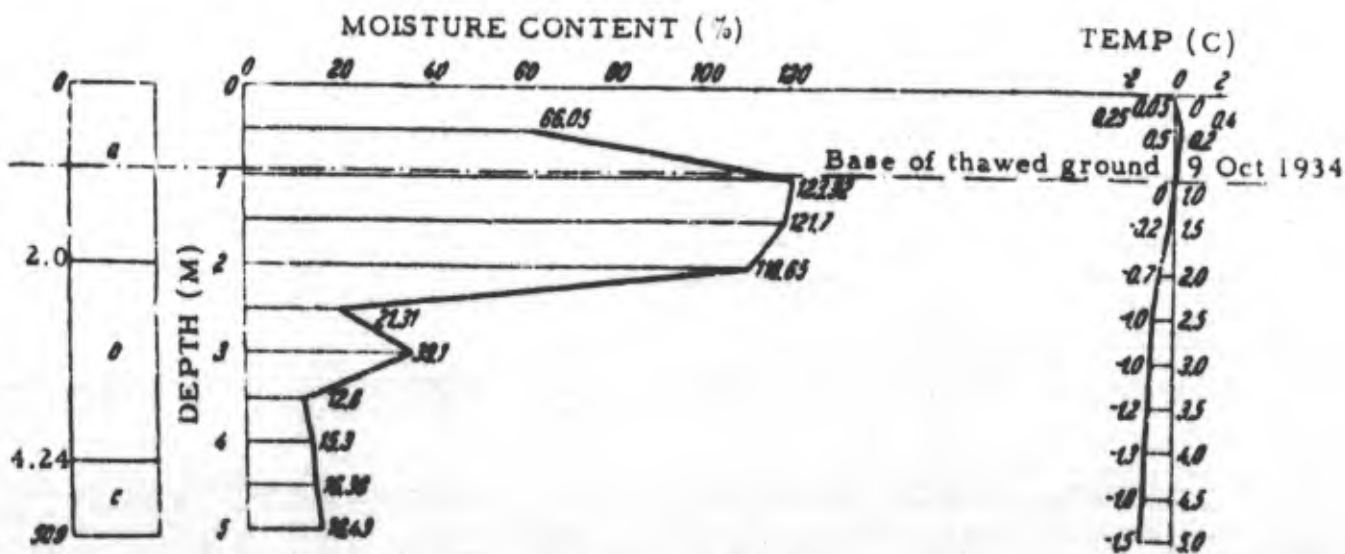

Figure 119. Cross section 4.

- a. fat clayey silt w/sand; b. clayey sandy silt w/pebbles
- c. fat clayey silt w/sand

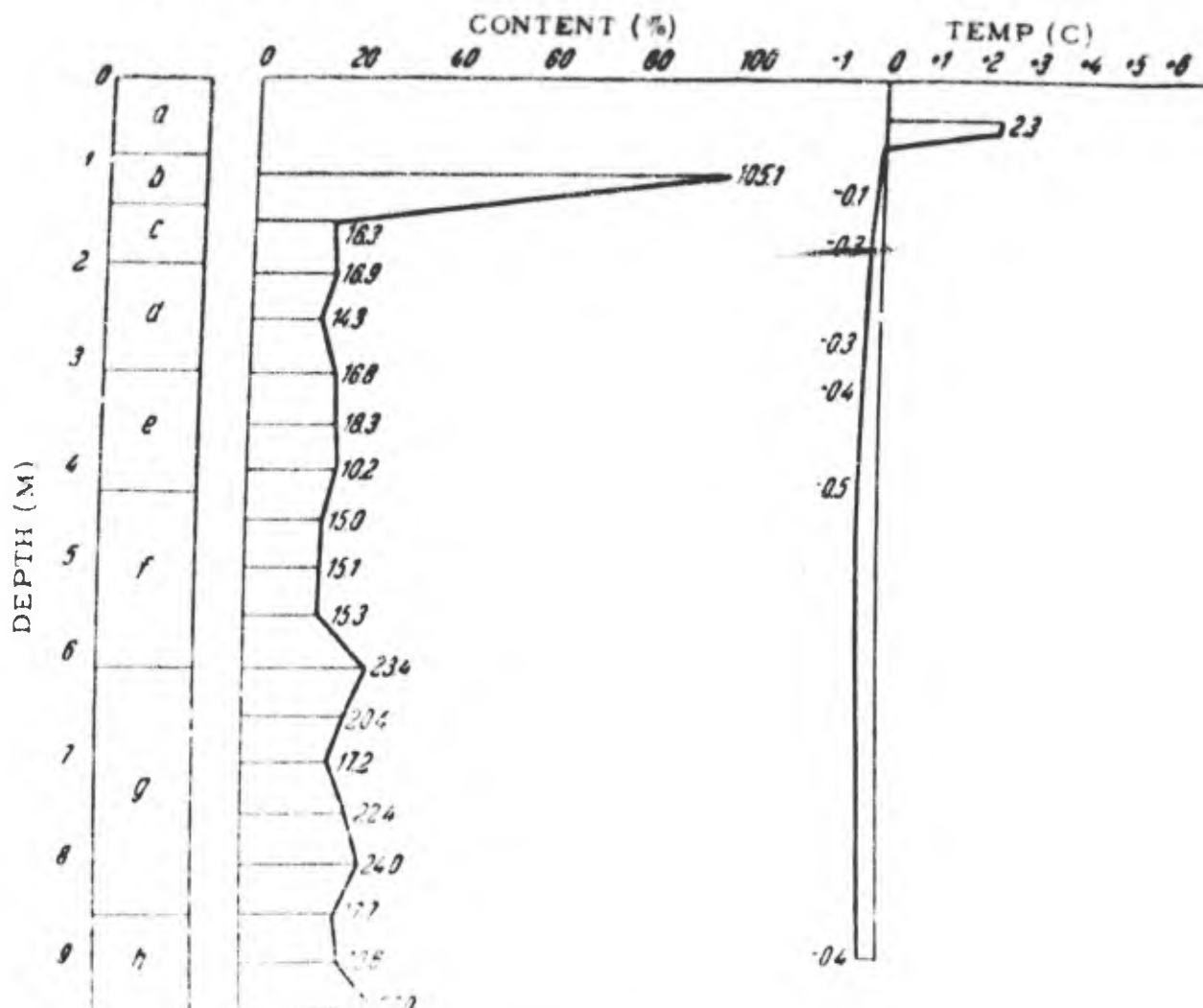

Figure 120. Cross section 5.

- | | |
|-------------------------------|-------------------------------|
| a. peat | d. clayey silty sand w/gravel |
| b. fat clayey silt | e. sand with gravel |
| c. clayey sandy silt w/gravel | f. silty sand w/gravel |

of the ground which is on the same level as the upper permafrost boundary. This layer must be dried out in order to decrease the swelling of the ground. The layer of gravelly sand will serve as a natural fill under the foundation.

Figure 121 gives cross section 6 to a depth of 8.8 m. Clayey sand covered with vegetation is underlain by gravel and pebbles to the base of the cross section. Temperatures are positive — this is a talik. To a depth of 2 m, the ground is supersaturated above the remnant of the winter frozen layer; below 2 m, the moisture is negligible. The soil and its moisture are quite favorable for laying foundations. But, since this cross section lies in the permafrost area, permafrost processes must be considered, too. Huge icings might occur at this very spot, which would nullify all the advantages of the ground and its moisture.

The reader will note that we have examined the following types of ground: those presenting construction difficulties due to ice lenses; those presenting construction difficulties due to high supersaturation, and ground acceptable for construction by reason of its moisture conditions.

We repeat once more that our examples were taken only for the purpose of examining

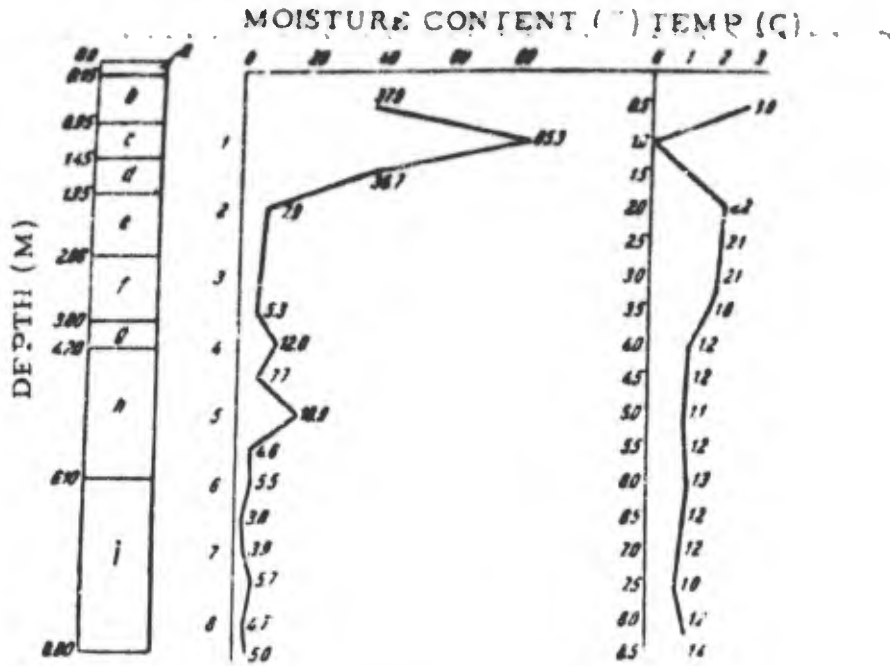

Figure 121. Cross section 6.

a. vegetation; b. fat clayey sand w/sand; c, d. fat clayey sand w/coarse sand; e, f, g. gravel; h, i. gravel w/rock fragments.

the ground moisture and were evaluated for building purposes solely from that point of view. We have touched on the properties of the ground and its temperature only slightly.

Proper evaluation of a building site must of necessity be complex (this matter is discussed elsewhere), allowing also for the filling in of the foundation by other ground.

In the examples analyzed above, one case frequently encountered in permafrost territory has not been discussed — the case of bedrock near the surface. Sometimes it is covered by loose ground whose thickness is less than that of the active layer. Such cases are ideal for foundations from the standpoint of permafrost. The only concern would be to see that heaving of the active layer does not have destructive effects on the foundations. To combat this, the following measures are important: drying of the active layer (see above remarks concerning drying); protecting the gravel fill against silting and filling up with water during use of the building; and securing the foundation in the bedrock.

UNCLASSIFIED

AD

230484

FOR
MICRO-CARD
CONTROL ONLY

5

OF

6

Reproduced by

Armed Services Technical Information Agency

ARLINGTON HALL STATION; ARLINGTON 12 VIRGINIA

UNCLASSIFIED

"NOTICE: When Government or other drawings, specifications or other data are used for any purpose other than in connection with a definitely related Government procurement operation, the U.S. Government thereby incurs no responsibility, nor any obligation whatsoever; and the fact that the Government may have formulated, furnished, or in any way supplied the said drawings, specifications or other data is not to be regarded by implication or otherwise in any manner licensing the holder or any other person or corporation, or conveying any rights or permission to manufacture, use or sell any patented invention that may in any way be related thereto.

CHAPTER VIII. INTERACTION BETWEEN PERMAFROST AND STRUCTURES

ERECTED ON IT

Introduction

Up to this point, we have analyzed the properties of frozen ground and the processes that take place in it; we have determined, whenever possible, the physical-mechanical constants of frozen ground; and finally, we have given brief information on permafrost regions, describing them from the point of view of construction.

Now we will try to describe briefly how structures in permafrost regions affect the active layer and the permafrost and the processes that take place within them. We will also describe how the active layer and permafrost affect structures on or in them.

Any construction — in the ground, on the ground, with or without foundation, or under the ground — introduces a new element into the complex of natural phenomena of the region and disrupts the established sequence and force of natural phenomena. These disruptions vary considerably in quantity; qualitatively, however, they can be caused by digging a small ditch or sinking a small pole into the ground, as well as by a big metallurgical plant with its hot shops and tall smokestacks.

Earthwork

Let us first consider earthwork; the construction of ditches, excavations, foundation pits, and fills. The difference between ditches, excavations, and pits is only quantitative. Therefore, we shall analyze them all together. All are cavities in the ground. Their sides and bottoms now receive the heat energy of the sun and the air, previously received by the earth's surface. Hence the thermal regime is disturbed. The depth of summer thawing beneath — and on the side walls of these excavations must be different from that of the surrounding area. On the basis of everything said above, the permafrost table in a given area changes shape, as shown in Figure 122. Line $CbcD$ is the former upper boundary of permafrost, separating the seasonally thawed layer from the permafrost layer. When the volume of ground bkc (in cross section) was removed from the permafrost layer, the permafrost in the cross section $abkldfe$ became part of the active layer. In other words, it became ground which freezes and thaws during the year.

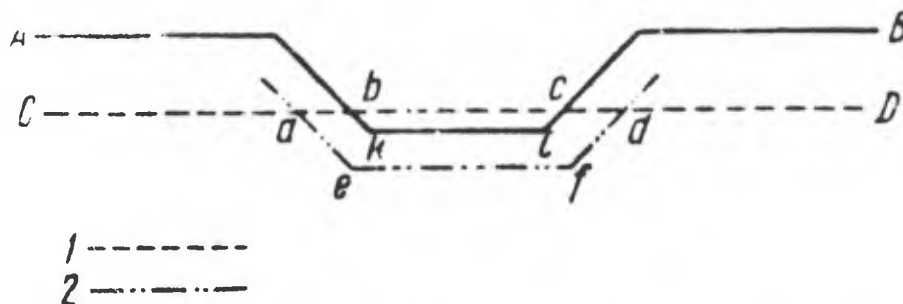

Figure 122. Diagram of the changes in position of the permafrost table with earthwork of the cavity type.

1. Permafrost table before excavation
2. Permafrost table after excavation

In regions where there is no permafrost, the reverse phenomenon occurs. If line $CbcD$ (Fig. 122) represents the lower boundary of seasonal freezing, the permanently unfrozen ground in cross section $abkldfe$ will become part of the active layer. As we see, the effect of our construction on the condition of the ground in the region of permafrost is opposite to the effect in other regions. In the permafrost region, positive temperatures penetrated deeper than before; in nonpermafrost regions, negative temperature appeared where it had not been before. This difference has other consequences. During the summer, a ditch on a slope, where point A is higher than point B, outside the permafrost region is a hill ditch collecting surface water. In the permafrost region under the same conditions,

the ditch also collects suprapermafrost water which flows on the permafrost surface from C to D.

In nonpermafrost regions, the ditch will collect ground water also if the soil is permeable above line CD and impermeable (clay) below. Such a situation seldom occurs. In the permafrost region, however, the flow of water over the frozen ground is a common phenomenon, except when the soil above line CD is impermeable to water.

These conditions in permafrost regions create new consequences. As the volume of the ground (cross section abklcdf) is usually permanently supersaturated, heaving occurs during the winter and deforms the bottom and side slopes of the ditch. This is one of the reasons for the exceptionally rapid deformation of ditches in permafrost regions.

A ditch in an area of especially silty soil, so common in permafrost regions, is even more deformed by slumping of its sides and erosion at the bottom due to the poor quality of the ground.

The disruption of the established natural conditions by railroad excavations is reflected in an increase in heaving; excavations are very subject to heaving. N. G. Datskii gives the following data on heaving in one permafrost region during 2 years, in relation to profile of the railroad.

1925-1926

- In excavations — 32% of the total excavations of the area
- In fills — 9% of the total fills of the area
- On level ground — 28% of the total level ground of the area

1926-1927

- In excavations — 46% of the total excavation of the area
- In fills — 13% of the total fill of the area
- On level ground — 31% of the total level ground of the area.

Wet ground expands when it freezes, and thus must add to the destruction of excavations and ditches. The coefficients of expansion of freezing ground, according to Andrianov, were given above. Until now, no special research has been done on the effect of this factor on the deformation of ditches and excavations. But, according to theoretical considerations and some practical data, it is quite probable that ditches and excavations (especially the former) will deform precisely when the active layer freezes, if conditions are suitable.

In the permafrost region there is another cause of deformation — the uneven settling of the bottom of the ditch. The ground beneath the ditch thaws and settles — usually irregularly. Consequently, the flow of the water is disturbed, which acts unfavorably on the bottom of the ditch.

Obviously, the effect on a fill is the opposite. The permafrost table rises beneath it and suprapermafrost water accumulates in front of it, if the fill crosses a slope. If the height of the fill is greater than the depth of thawing of the ground, permafrost penetrates the fill.

Because the frost mound which forms under the fill hinders the flow of water down-slope, icing mounds form during the winter in areas where there are streams of suprapermafrost water.

This also occurs where there are ditches, as the ground beneath and at their sides freezes down to the permafrost layer much faster than the surrounding area.

We see how earthwork complicates the processes in the ground, and what undesirable results are entailed.

1. N. G. Datskii (1935) Puchiny na zheleznykh dorogakh v usloviakh vechnoi merzloty (Heaving on railroads under permafrost conditions). Trudy KIVM., Akademiia Nauk, tom IV.

It seems strange to say that it is more difficult to dig stable, non-deforming ditches than to construct some types of building, but it is true since the processes caused by the digging of a ditch in a permafrost region have not been studied much.

Closed drainage also has not been studied very much. In nonpermafrost regions, a drainage system below the active layer can be expected to work all year. This is not so in permafrost regions where, in most places, the active layer joins the permafrost in the winter. At each depth in the active layer, we will have a positive temperature only part of the year, and positive temperatures occur at different depths during different months. Plans for closed drainage must take all these things into consideration.

For example, positive temperature, measured by soil thermometers, was distributed as follows at four stations (listed from north to south):

I. Sagastyr' (on one of the islands of the delta of the Lena River)

From September 1882 to August 1883, inclusive. $\phi = 73^{\circ}23'$; $\lambda = 126^{\circ}34'$.

<u>Depth (m)</u>	<u>Duration of positive temperatures</u>
0.4	3 months (July - Sept.)
0.8	1 month (Sept.)
1.6	Negative temperatures all year

II. Yakutsk

From November 1930 to October 1931, inclusive. $\phi = 62^{\circ}01'$; $\lambda = 129^{\circ}43'$. Observatory platform.

<u>Depth (m)</u>	<u>Duration of positive temperatures</u>
0.4	143 days (May 17 - Oct. 6)
0.8	134 " (June 1 - Oct. 12)
1.2	113 " (June 24 - Oct. 14)
1.6	79 " (July 26 - Oct. 12)
2.0	Negative temperatures all year

III. Bomnak

1914. $\phi = 54^{\circ}43'$; $\lambda = 128^{\circ}52'$

<u>Depth (m)</u>	<u>Duration of positive temperatures</u>
0.5	176 days (May 20 - Nov. 11)
1.5	118 " (July 21 - Nov. 16)
2.0	97 " (Sept. 9 - Dec. 16)
2.8	Negative temperatures all year

IV. Skovorodino

1928-1930. $\phi = 53^{\circ}58'$; $\lambda = 123^{\circ}57'$;

<u>Depth (m)</u>	<u>Duration of positive temperatures</u>
0.4	6 months (May - Oct.)
0.8	5 " (June - Oct.)
1.6	4 " (Aug. - Nov.)
2.0	4 " (Aug. - Nov.)
2.5	Average negative temperatures all year

The periods of positive temperature are shown in days for two stations, and in months for the other two. However, though one set of data is more detailed, it makes no essential difference.

What do the data show? First of all, they show how long and for what part of the year there is a positive temperature at a given depth. For instance, drains laid at a depth of 0.8 m in Sagastyr' would work during only one month, September. In Yakutsk, drains at a depth of 1.6 m would work only 79 days, beginning at the end of July. Up to that time, drains at this depth would be useless. In Bomnak, drains at a depth of 2.0 m would work from September 9 only until the middle of December; that is, only until the rainy season ends and the upper layer of the ground freezes.

Such data should serve as basic material for the engineer who uses closed drains in permafrost regions. We repeat that all our examples are for cases when the active layer merges with the permafrost in winter.

But we are describing thermal conditions in ground unused by man. When drainage is put into operation, those conditions will change, and these changes should be at least partly foreseen.

The problem is so complex that it is necessary to do experimental work in this direction — in particular, to clarify two-level drainage (at different depths); the best material for the drainage; the conditions for winter flow of water from the drain; and many other technical problems.

Draining the area is necessary for building aerodromes, factories, or living quarters. This problem is important and complicated, and its quick solution is necessary.

We shall say a few words about the actual earthwork in frozen ground. Frozen ground which for some reason or other is not cemented by ice, is worked, from the technical point of view, in the same manner as unfrozen ground; the only difference is in the working conditions — the necessity of protecting the workers from contracting rheumatism.

However, frozen ground cemented by ice can be worked by neither mechanical nor hand shovel. Either percussion tools must be used (e. g., crowbar, pickax); or the ground must be thawed by fire, steam, water, or explosives; or, as described above, alternately thawed by heat of the sun and excavated.¹

But even thawed permafrost ground is often very difficult to work. Silty soil with ice-saturation equal to or more than one, which is very common in frozen ground, turns into a flowing mass that is often very adhesive. It sticks to the shovel or the dipper of the excavator and makes excavation very difficult. This has been noted in old literature on frozen ground.² All these factors must be considered when investigating permafrost regions (by pits), when constructing buildings and other structures which require excavation for foundations or other reasons, and also when draining sites for factories, mills, etc.

Heaving of Posts and Piles

Moving on to construction, we shall begin with the simplest case — posts. Whoever has visited permafrost regions has very often seen fence and gate posts slanting in all directions, the so-called "drunken" fence and "drunken" gates. These are the result of ground heaving accompanied by the pushing out of the poles from the ground.

The mechanics of heaving of posts have been clarified in general, though not completely, by very recent works. There are still contradictions in details.

The process of heaving is described in the following sequence. By autumn, in the permafrost region, the post is in the ground which is completely or partly thawed. In the first case, when the ground freezes, it closely envelops the post and adfreezes to it. As we discussed in detail above, the volume of ground increases and its surface rises. Since the ground is adfrozen to the post, the force of heaving tends to lift it in proportion to the lifting of the surface of the ground. The heaving forces are counteracted by friction between the ground and the part of the post which is in unfrozen ground. While the latter force is stronger than the former, the rising ground slides along the post, like a stocking. However, as soon as the ground freezes to the point that the adfreezing strength between the ground and the post is greater than the friction of the post with the unfrozen ground,

1. There is evidence that ground with a temperature not lower than 1°C can be worked with powerful excavators.

2. D. Matseevich (1907; Sluchai vozvedeniia sooruzhenii na vechnoi merzlotie (Cases of building on permafrost), Izvestiia obshch. Grazhd. Inzh. (Bulletin of the Civil Engineering Society),

A. N. Passek (1911) Mestnye usloviia klimata i vechno merzlye grunty golovnogo uch. zapadn. chasti Amursk. zh. d (Local conditions of climate and permanently frozen ground in the head section of the western part of the Amur Railroad), Izvestiia sobr. inzh. putei soobshcheniia, no. 3.

the post is somewhat pulled out by the swelling frozen ground, leaving an empty space beneath it, which either stays empty (filled only by air) or is filled by water or ground and water.

After the ground freezes to its base, the post will rise with the ground as freezing penetrates deeper; that is, if the moisture of the ground under the post is greater than the critical heaving moisture. When the winter-frozen layer of the ground reaches the permafrost, or the freezing of the ground ceases, heaving of the post stops.

Post heaving was studied at the permafrost station of Petrovsk-Zabaykal'skiy. Posts made of separate vertical sections placed one on top of the other were sunk into the ground. As a result of heaving, the sections separated, as shown in Figures 123a and 123b.

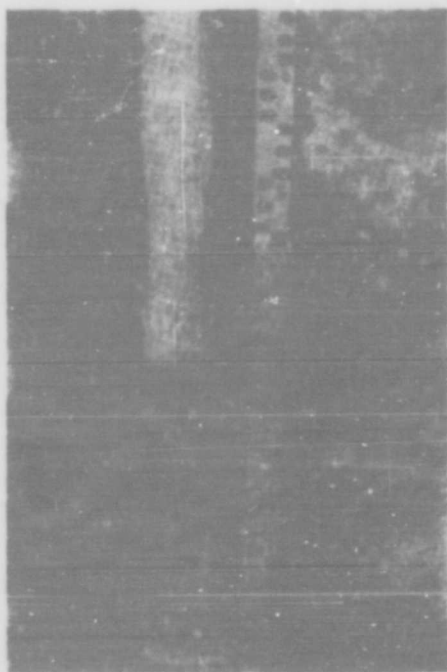

Figure 123a. A sectional post which was sunk into the ground and separated by heaving. Petrovsk-Zabaykal'skiy. Photo by A. F. Mironov.

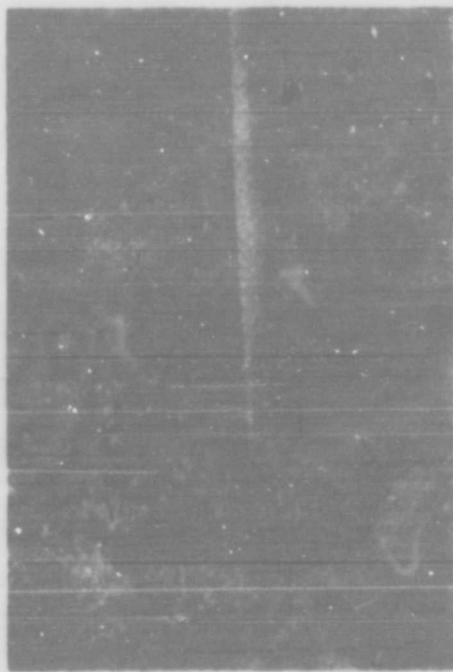

Figure 123b. A sectional post which was sunk into the ground and separated by heaving. Petrovsk-Zabaykal'skiy. Photo by A. F. Mironov.

The photographs and the following description were taken from the report by A. F. Mironov:¹ "In April, 1932, when some of the jointed posts were dug out, the following phenomena were observed:

- a. Separation of the joints varied from 13.5 up to 38.0 cm depending on the depth of the joint in the ground. Where joints were inside the frozen layer of the ground, the deeper the joint, the greater the separation;
- b. The joint of post no. 59 was at the boundary of the frozen ground. When it was dug out, the separation was equal to the vertical displacement of the upper part of the post (according to the leveling data, 38 cm). Therefore, the layers of the ground below the layer of seasonal freezing had no vertical displacement; that is, they did not heave."

1. A. F. Mironov, *op. cit.*

When thawing begins, ground which had previously heaved settles. A layer of thawed ground forms around the upper part of the post. The lower part of the post is in frozen ground. The friction of the settling ground tends to push the post down, but the adfreezing forces at the lower end of the post resist this. So, in the spring, it appears that the post is pushed out of the ground, when, in reality, the thawing ground settles around the post. After the ground thaws to the base of the post, the post settles with the ground, but it rarely settles back into the same space as before. If part of the space is filled by ground, the post cannot enter it. As a result of this winter-summer process, the post appears to be somewhat lifted above the surface of the ground. As the effects of this process accumulate from year to year, the post rises until it leans at first and finally falls to the ground. Hence "drunken" fences and "drunken" gates.

If the post is sunk deep enough into the permafrost and adfreezes with it, the heaving stress which acts through the adfreezing strength between the post and the active layer will be counteracted by the adfreezing strength of the post with the permafrost (Fig. 124).

If forces a are greater than forces b , (Fig. 124) the post will be somewhat pulled out of the thawed interlayer and the permafrost layer.

In 1930, N. A. Tsytovich¹ established, on the basis of theoretical data, that sinking a post in homogeneous ground to a depth twice the thickness of the active layer is sufficient to counteract heaving.

Experimental placement of posts at the Skovorodino Frozen Ground Station and observations on them, done completely independently, also established that posts set at twice the depth of the active layer (in Skovorodino, $2.5 \times 2 = 5$ m) are not pulled out of the ground; therefore, the freezing active layer slides along the post.

Crosses or other wood or metal pieces fastened to the base of the post will bring into action the shearing forces of the frozen ground as well. Then even if the post is set at a lesser depth, it will remain stable.

Our discussion of posts could be used in relation to piles. That is why piles must be put into the ground with the butt ends down and why they should not extend into the field of tensile stress. That is why posts and piles which are partly in the active layer must be smoothly filed or even lubricated with something that will diminish the adfreezing strength (for example, petroleum residue). In permafrost regions the part of the post or pile that extends into permafrost should be rough.

On the basis of laboratory experiments, which were discussed above, new conclusions are drawn. The forces of adfreezing can be diminished by salting or oiling the ground around posts; by covering the surrounding ground with insulating material in order to raise the temperature of the ground; and by several other measures. As yet, these measures have not been tried in practice, or have not been tested sufficiently.

Deformation of Bridges

It is logical to proceed from piles to bridges built on piles. The heaving of such bridges in permafrost regions² is well known. We shall give several examples. I. D. Belokrylov³ reports that, out of 49 wooden bridges on piles examined, 42 were deformed;

1. N. A. Tsytovich (1930) O vybore tipa fundamentov v usloviakh vechnoi merzloty (Choosing a foundation under permafrost conditions), *Stroit. promyshl.*, no. 6 - 7.
2. Bridges on piles heave in nonpermafrost regions also, but not as much.
3. I. D. Belokrylov (1931) "Vechnaia merzlota i zheleznodorozhnyi transport (Permafrost and railroads)," in Vechnaia merzlota i zheleznodorozhnoe stroitelstvo (Permafrost and railroad construction), Institut puti NKPS, sb. 8. Moscow: Gostransizdat.

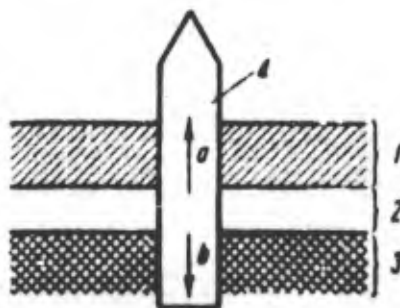

Figure 124. Sketch of the heaving of a post.

1. frozen ground
2. unfrozen ground
3. permafrost
4. post

in other words, 87%. And O. I. Fink¹ reports that "when the western part of the Amur railroad was transferred from construction to exploitation (that is, 2 years after it was built), 30% of the wooden bridges had to be repaired because of a relative displacement of more than 6.5 cm in height of important parts of the constructions." Further, "the deformation of wooden bridges is characterized by the individual supports, usually the center ones, being pushed out of the ground during the winter. This is accompanied by breaking of the joints and disruption of all the notches of the bridge."

In another part of this article, Fink points out that "of 83 bridges which heaved in the central and eastern parts of the N - railroad, 81 bridges were extruded as follows during the winter:

<u>Height of heaving*</u>	<u>Number of bridges</u>
0.04	10
0.05	8
0.06	13
0.09	19
0.11	11
0.12	5
0.13	3
0.15	2
0.17	2
0.21	2
0.26	2
0.32	3
0.43	1
Total	81 bridges

We will limit ourselves to these examples, which plainly show how strongly ground heaving in permafrost regions is reflected in deformation of construction (in this particular case, wooden bridges on piles.)

Thermal Balance of Foundations and the Ground

Buildings and structures can be heated or unheated; have foundations on or in the ground, or be completely sunk into the ground (mines and tunnels).

We will analyze the interrelation between permafrost and the simplest of buildings — a roofed unheated shed with a foundation not sunk into the ground. Such a building disrupts the thermal balance of the ground for the following reasons:

1. During the day, the shed completely prevents the penetration of solar energy into a certain area of the ground equal to the area of the shed.
2. During the same hours, the shed partially impedes the penetration of solar energy into other ground — the shaded areas on north, west, and east sides of the shed.
3. During the same hours, the shed increases the penetration into still other ground — namely, the area which receives not only direct solar energy, but also the rays reflected from the walls of the shed.
4. The shed, in certain periods, transmits part of the heat into the ground by thermal conductivity. In other periods, it receives heat from the ground and radiates it into the surrounding space.
5. The shed disrupts the heat radiation from the area it occupies.
6. The shed protects the area under it from precipitation of any kind — liquid or solid; it serves as an obstacle to wind, changing its direction. As a result, the snow around the shed is not distributed as it would be if the shed were not there. This, in turn, affects the thermal regime of the ground under the shed and around it.

1. O. I. Fink (1931) "Ustoychivost' sooruzhenii v usloviakh glubokogo promerzaniia pochvy (Stability of construction under conditions of deep freezing of the soil)." sb. 8, Institut puti NKPS.

* [No units given.]

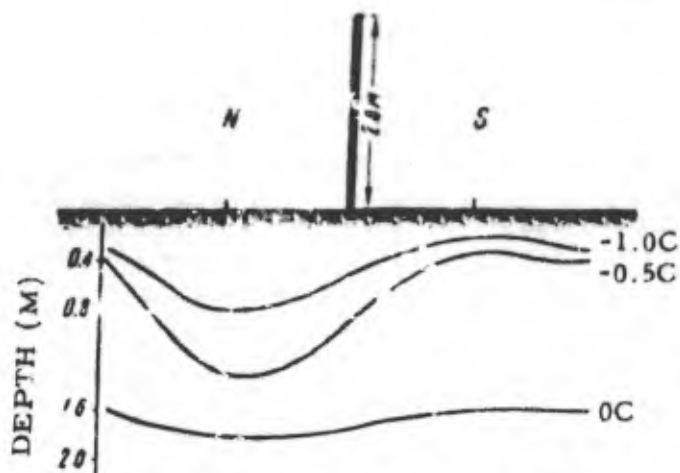

Figure 125. Yearly isotherms of the ground at the shield.

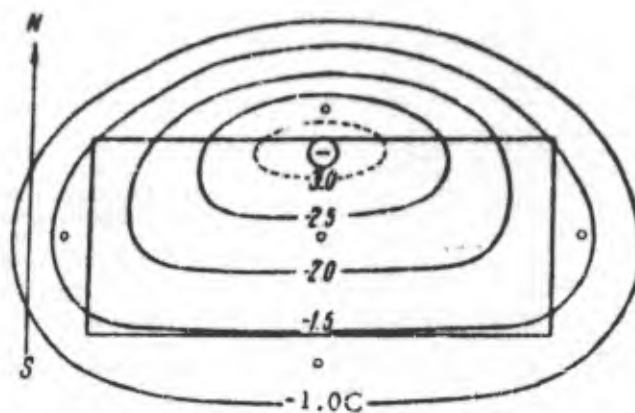

Figure 126. Yearly isotherms of the ground at a depth of 2.5 m beneath an unheated shed.

At present the heat losses or gains of the ground under and around the shed cannot be given in calories, especially as this problem is complicated further by the effect of the material of the roof and walls of the shed. However, there are some temperature data. In the article cited, Belokrylov writes that a 2-m high shield (fence) oriented lengthways from west to east was built at the Zilovo Station and ground temperature around the shield was observed from September 1929 to August 1930, at depths of 0.4, 0.8, and 1.6 m, on the northern and southern sides of the shield.

Figure 125 shows the yearly isotherms of the ground at the shield, taken on a line perpendicular to the length of the shield. The extreme points of the temperature profile were taken from observation points 10 m away from the shield. The temperature of the ground on the southern side of the shield is considerably higher than on the northern side.

Observations of ground temperature at a depth of 2.5 m under and around a shed at the Zilovo Station, over a period of a year, gave the results shown in Figure 126. Here we see considerable warming of the ground under and around the shed on its southern side in comparison with its northern side. At the Skovorodino Frozen Ground Experimental Station, boreholes showed that the permafrost table rises under an unheated shed (as shown in Figure 127). The effect of shading on freezing of the ground can be noticed even where there is no permafrost. Fink¹ notes that an investigation of the Khabarovsk water supply system discovered the following depths of freezing:

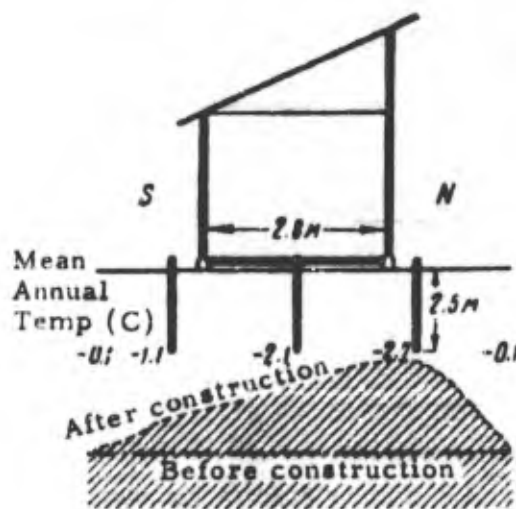

Figure 127. Rise of permafrost at the north wall of the shed.

Sunny slopes	}	Compact clay ground — 2.4 to 2.77 m
	}	Rocky ground — 2.56 to 3.09 m
Shady slopes	}	Clay — 2.51 to 3.05 m
	}	Rocky ground — 2.56 to 3.41 m.

1. O. I. Fink, op. cit.

If an unheated building has a foundation sunk into the ground, the above described influences on the thermal regime of the ground hold true. However, if the coefficient of thermal conductivity of the foundation is greater than that of the ground, the amount of heat that penetrates the walls of the foundation into the ground is also greater. Besides, foundations in the ground obstruct the flow of suprapermafrost water.

We can expect still greater changes in the thermal regime of the ground under heated buildings, since the effect of the heat will be added to all the effects of unheated structures. Under a heated structure, permafrost thaws to a certain depth, although often not under the whole construction. We have enough data to confirm this, some of which we give below.

In 1927, at the Skovorodino Frozen Ground Experimental Station,¹ a wooden dwelling was built on sleepers. As soon as the construction was finished (November 11), nine thermometers were placed at a depth of 2.5 m around and beneath the house. They showed the following temperatures.

<u>South wall</u>	<u>East wall</u>	<u>North wall</u>	<u>West wall</u>	<u>Center of building (under building)</u>
		Outside the building		
+0.8C	0.0C	-0.2C	-0.005C	
		Under the building		
+1.25C	0.0C	0.0C	+0.2C	+1.0C

The time of observation was from November 11 to November 30, 1927, inclusive.

As we see, the temperature of the ground around the building is affected by the east and west walls. At the Skovorodino Station, the temperature of the ground at a depth of 2.5 m under house No. 26 was observed for a whole year. The average yearly isotherm is given in Figure 128.

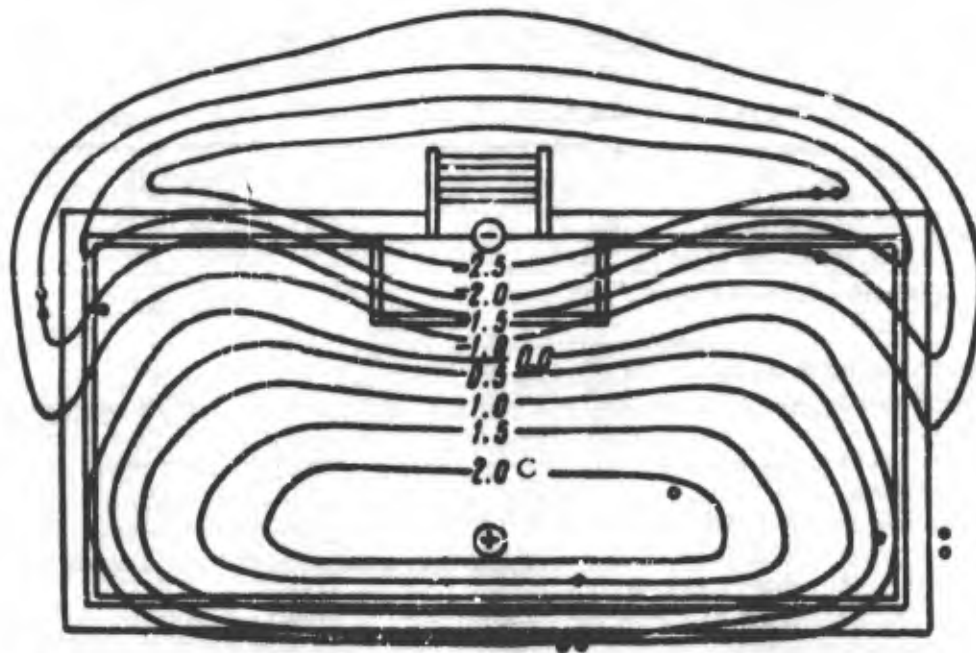

Figure 128. Average yearly isotherms at a depth of 2.5 m under a dwelling.

1. N. G. Datskii (1935) Puchiny na zheleznykh dorogakh v usloviakh vechnoi merzloty (Heaving on railroads under permafrost conditions). Trudy KIVM, Akademiya Nauk, tom IV.

The average yearly temperature 2.5 m beneath the house was +2.0C. As the permafrost table in Skovorodino is at a depth of 2.5 m, it is obvious that the permafrost table is lowered under the house.

A really complete investigation of the thermal regime of the ground and foundations requires experimental construction. This point has been raised repeatedly by both individuals and organizations, but little has been done, and, at present, we have only two or three experimental buildings. The Scientific and Technical Council of the Leningrad Institute of Construction decided to build two experimental houses on permafrost in Petrovsk-Zabaykal'skiy as early as 1928, and plans for the houses were completed. One house was to be built on a solid rubble foundation, and the other with a ventilated cellar on piles sunk into the permafrost to a depth equal to the thickness of the active layer of the ground. Thus, the full length of the piles would be double the thickness of the active layer.

The construction of the experimental houses and the measurement of the temperature of the ground and foundations by electrical and mercury thermometers was assigned to the Petrovsk-Zabaykal'skiy Frozen Ground Station of the Leningrad Institute of Construction. Owing to reasons for which the experimental station was not responsible, only one house was built in 1931, the one with a rubble foundation resting on the permafrost layer. The results of 3 years (1931-33) of temperature observations of the ground and foundation, as worked out by N. Tsytovich¹ (about 30,000 separate computations), are discussed briefly below.

Figure 129 gives the plan and cross section of the experimental house at the Petrovsk Station and shows where the 24 electrical resistance thermometers were placed. Daily readings of the temperature of the ground and foundation were taken.

We should note, however, that the placement of the thermometers could not be considered favorable, as the reading gives a detailed picture of temperature change only at a depth of 0.8 m below the surface.

The experimental house is 8 x 6 m in plan and 4.5 m from ground level to cornice. It is built on a solid rubble foundation, 0.70 m thick, laid 2.8 m deep in the ground, with its base in the upper permafrost zone (near the permafrost table). The base of the house is lifted 0.75 m above ground level and has four openings for ventilating the space under the floor during the summer. The walls of the house are made of two layers of brick with an air space 5 cm thick alternately after each 5th and 9th row. These spaces (as the walls are built), are covered on the outside of the wall with tar paper and filled with slag. Wooden beams, 27 cm thick, support a floor blackened with grease and spread with a layer of construction debris, 10 cm thick, on a layer of tar paper.

Besides electrical resistance thermometers, there were also mercury thermometers to measure the temperature of the air at the north, south and east walls of the house. After November 1933, there were several control mercury thermometers which could be extracted (in ebonite tubes) to measure the temperature of the ground and of the air beneath the house.

The experimental house was built in the valley of the Balyaga River, about 1 km from the Petrovsk factory. The whole valley has a very thick layer of permafrost. In some places, it extends as deep as 50 m from the earth surface. The thickness of the active layer under natural surface conditions is approximately 2.5 - 3 m. At the place where the experimental house was erected in 1931, the permafrost table was not deeper than 2.8 m.

1. N. A. Tsytovich (1934) Issledovanie temperaturnogo rezhima fundamentov i grunta v opytном dome Petrovsko-Zabaikal'skoi merzlotnoi stantsii Lngr. inst. soorzh (Research on the thermal regime of the ground and foundation of the experimental house at the Petrovsk-Zabaykal'skiy Frozen Ground Station of the Leningrad Institute of Construction), manuscript. Also N. A. Tsytovich (1936) Prinsipy konstruirovaniia i rascheta fundamentov sooruzhenii, vozvodimykh na vechnoi merzlotе (Principles of constructing and estimating foundations for constructions on permafrost), Trudy, Geologo-razvedochnoi konferentsii po Severu, GUSMP, tom III.

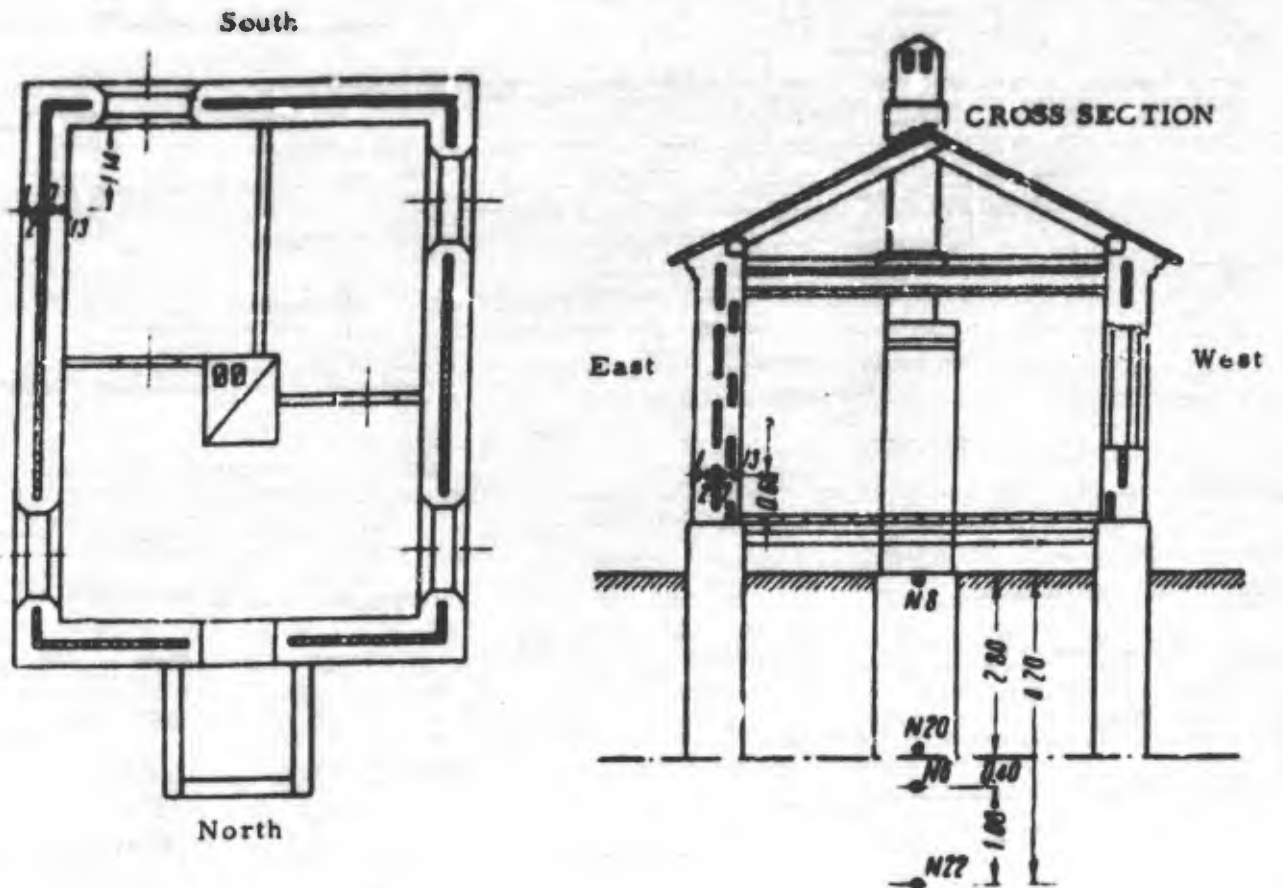

LONGITUDINAL SECTION

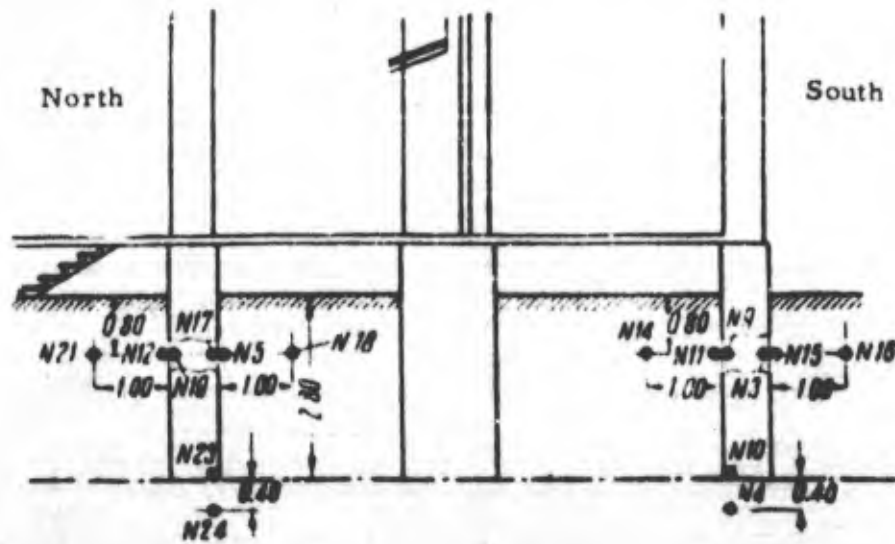

Figure 129. Plan and cross sections of the experimental house at the Petrovsk-Zabaykal'skiy permafrost station. [Position of electric thermometers shown by solid circles. Dimensions in meters.]

The soil at the site was mainly alluvial gravel and sand with layers of silty soil at a depth of about 1.5 m. The sand-gravel alluvium was quite thick — 15-20 m. Below these deposits was bedrock — laminated diorite — with a weathered surface.

The moisture content of the gravel-sand beneath the foundation was not higher than 9% of the weight of the dry ground.

From the temperature data for different parts of the ground and for the foundations of the experimental house, we compiled a table of the average 10-day and monthly temperatures. From the latter, we constructed a graph of temperature changes with depth and isotherms of the ground and foundations.

Since heat flow is perpendicular to the direction of the isotherms, the latter give a picture of the distribution of temperature and heat flow during the year.

To show the effect of buildings on the thermal regime of permafrost, Figure 130 gives the position of the zero isotherm (the permafrost table) for October and November of 1931 and 1932, drawn according to temperature observations.

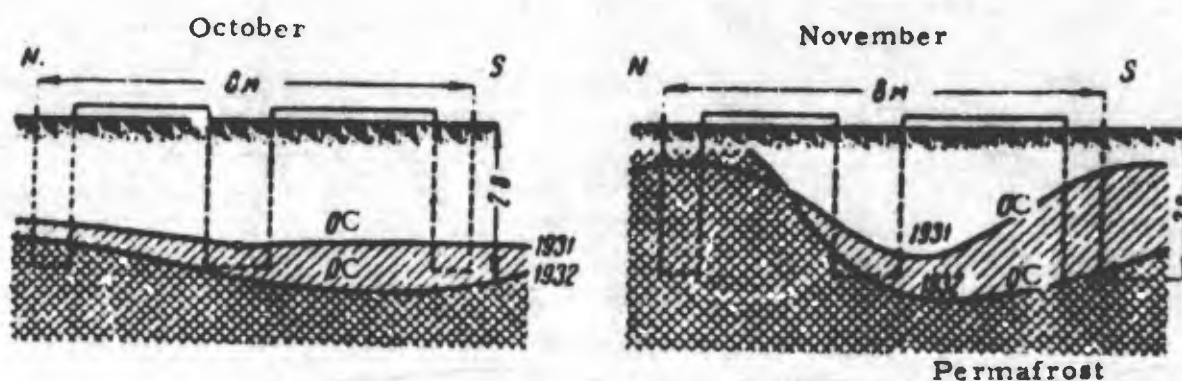

Figure 130. Position of the permafrost table under the experimental building.

From Figure 130, we conclude that a gradual warming of the permafrost and the active layer occurs under the experimental house. This warming is uneven. For instance, after one year, the permafrost table in November had lowered approximately 0.8 m beneath the southern part of the building, but had risen beneath the north side. As the experimental house does not occupy a large area, lateral freezing of the ground spread to almost the entire area.

Average monthly temperatures at different points of the foundations and the ground during 1933 are given in Table 92 [p. 238]. From the data, isotherms of the foundation and the ground are constructed for January, April, July, and October (typical months as far as heat is concerned). Average yearly isotherms are also given.

Comparison of the electrical and extraction mercury thermometer readings showed that the precision of the temperature determinations was approximately $\pm 0.5^{\circ}\text{C}$.

Figure 131 shows the isotherms for January, 1933. From the figure we conclude that the main direction of heat flow in January (perpendicular to the direction of the isotherm) is lateral from the perimeter to the inside of the house; the center of the warmer ground has moved toward the south wall.

The average isotherms for April, July, and October and the average yearly isotherm for 1933 are shown in Figures 132 - 135.

From the data, we conclude that a warm core existed under the experimental house in April. During the summer (in July), relatively even warming of the whole site took place, with some increase of thawing at the south wall. This is especially clearly shown by the isotherms for October.

The position of the permafrost table in October was verified by boreholes (Fig. 136), and found to be very close to the position shown in Figure 134. Thus, uneven warming of permafrost takes place under the experimental house. The base of the foundation at the

Table 92. * Average temperature of the ground and foundation of the experimental house at the Petrovsk Station - 1933.

Thermometer no.	Depth (m)	Temperature (C)												Yearly Avg
		Jan	Feb	Mar	Apr	May	June	July	Aug	S.pt	Oct	Nov	Dec	
Elec. 8	0	-0.5	-0.3	-0.2	+1.5	3.2	6.5	9.4	10.9	8.1	3.6	0	-1.8	3.4
16	0.8	-7.0	-8.6	-7.6	-1.2	-0.8	1.4	5.3	7.7	6.3	2.3	-0.6	-3.4	-0.4
15	0.8	-6.9	-6.9	-4.8	-1.3	1.2	5.0	7.7	9.5	7.1	2.9	-0.9	-4.1	0.8
3	0.8	-5.9	-5.9	-5.8	-1.3	+1.3	4.3	7.1	8.9	6.6	3.1	-0.6	-3.2	0.9
9	0.8	-4.8	-4.9	-3.9	-0.3	0.5	3.4	6.2	8.1	6.3	2.6	-0.8	-2.9	0.8
14	0.8	-0.9	-1.6	-2.0	-0.4	-0.6	0.2	4.1	7.2	6.6	3.2	-0.1	-0.5	1.4
5	0.8	-5.0	-6.0	-5.5	-1.4	-0.8	0.7	4.0	6.0	4.3	0.9	-0.8	-2.7	-0.5
17	0.8	-5.9	-6.8	-6.3	-2.1	-0.5	1.6	4.4	6.3	4.3	0.8	-1.0	-3.3	-0.7
19	0.8	-7.4	-7.9	-7.5	-2.8	-1.0	1.1	3.9	5.7	3.7	0.1	-1.3	-4.0	-2.1
12	0.8	-8.7	-9.6	-8.4	-2.9	-0.9	1.2	4.3	6.1	4.0	0.1	-1.3	-4.6	-1.7
21	0.8	-11.3	-11.7	-10.7	-3.6	-1.1	-0.4	2.4	5.1	3.2	-0.2	-1.2	-5.6	-2.9
10	2.8	-0.7	-0.3	-0.1	0.8	-0.1	0	0.3	-0.2	0.1	0	-0.3	-0.5	-0.2
20	2.8	-0.8	-0.4	-0.4	0.3	-0.2	-0.2	0.3	0.2	0.2	0.1	-0.4	-0.6	-0.3
23	2.8	-0.9	-0.5	-0.5	0.1	-0.7	-0.5	-0.7	0.5	-0.8	-0.8	-0.7	-0.7	-0.7
4	3.2	-0.7	-0.4	-0.3	0.5	-0.1	-0.1	-0.4	-0.4	-0.6	-0.7	-0.6	-0.6	-0.4
26	-	-0.9	-0.7	-0.5	0.1	-0.3	-0.3	-0.3	-0.5	-0.5	-0.7	-0.8	-0.8	-0.7
24	3.2	-0.9	-0.6	-0.5	0	-0.7	-0.5	-0.7	-0.5	-0.8	-0.8	-0.7	-0.7	-0.7
22	4.2	-0.9	-0.7	-0.6	0.1	-0.4	-0.3	-0.6	-0.6	-0.8	-0.8	-0.8	-0.8	-0.6
Extraction soil therm. (meteor. platform)	0.4	-10.3	-11.9	-9.4	-1.9	0.7	5.7	10.1	11.4	7.8	1.7	1.2	4.5	0.8
	0.8	-5.7	-9.3	-8.1	-2.3	-0.5	0.2	4.5	8.0	6.6	2.1	0.2	-0.4	-0.4
	1.6	-1.0	-2.7	-8.6	-1.3	-0.3	-0.2	0.2	2.0	2.8	1.4	0.3	0.0	-0.2
	2.4	0	0	-1.3	-1.0	-0.3	-0.2	0.1	0	0	0.5	0.3	0.2	-0.2
	3.2	0	0	0	0	0	0	0	0	0	0	0	0	
Air temp (meteor. platform)	-	-	-	-1.4	5.1	12.6	19.5	20.2	20.7	14.2	2.7	-11.2	-16.4	-

Remark: Position of electric thermometers is shown in Figure 129.

* [Two Table 92's in Russian original.]

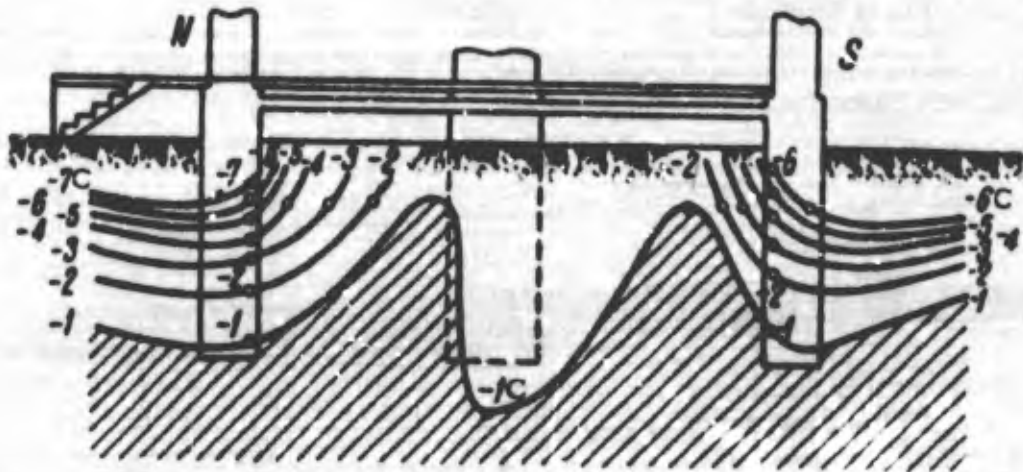

Figure 131. Isotherms of the ground and foundation under the experimental house, January 1933.

south wall is on thawed ground, and the base of the foundation at the north side is on permafrost. These conditions are favorable for settling of the south wall, which can create absolutely nonpermissible deformation.

An analysis of the temperature data permits the following conclusions:

1. A house built on a solid rubble foundation, under permafrost conditions, greatly disrupts the permafrost regime.
2. The disruption of the permafrost regime under the house and in its vicinity causes the permafrost table to lower at the south wall. This can cause considerable uneven subsidence of the foundation. At the north wall, rising of the permafrost table was observed.
3. Ground temperature rose under the whole site, as was very clearly shown by the average yearly isotherms of the ground and foundation (Fig. 135).
4. The orientation of the walls plays a very important part in the thermal regime of the foundation.
5. In the conditions analyzed, the warming effect of the rubble foundation on the permafrost under the house is negligible in comparison with the effect of the whole area of the house.

Thus, erecting heated buildings on solid foundations, without taking special measures will inevitably cause gradual, uneven heating of the permafrost beneath the foundation, which will make the ground a much poorer base for the building.

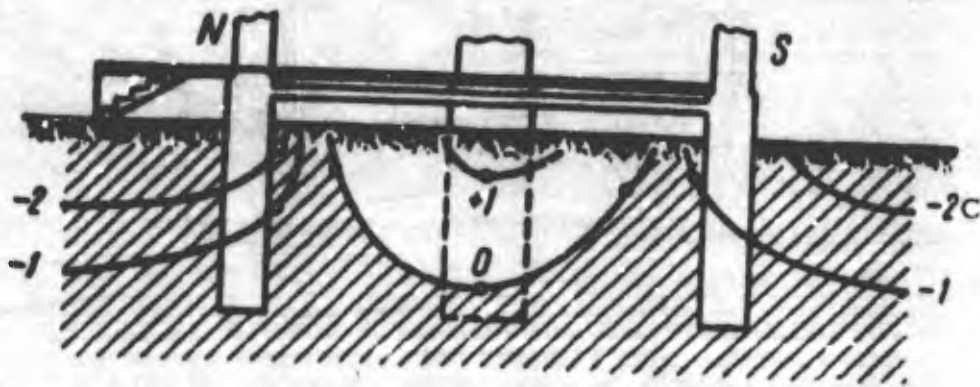

Figure 132. Isotherms of the ground and foundation under the experimental house, April 1933.

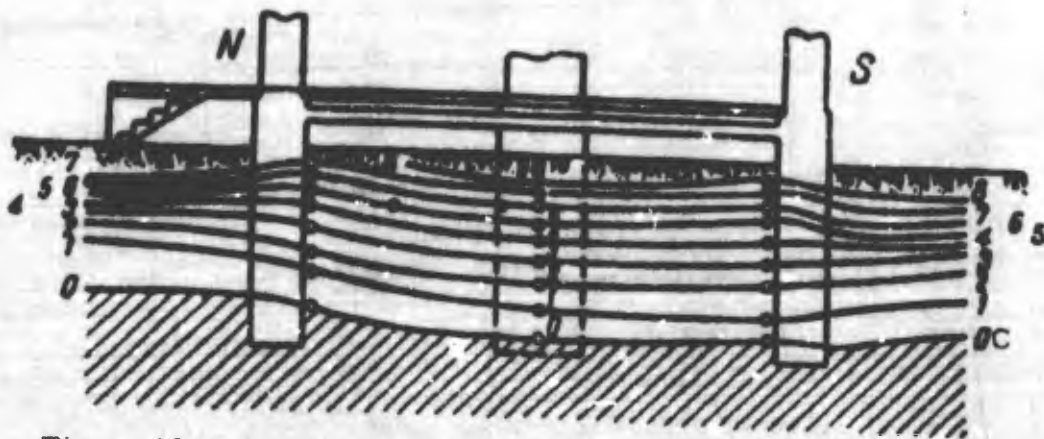

Figure 133. Isotherms of the ground and foundation under the experimental house, July 1933.

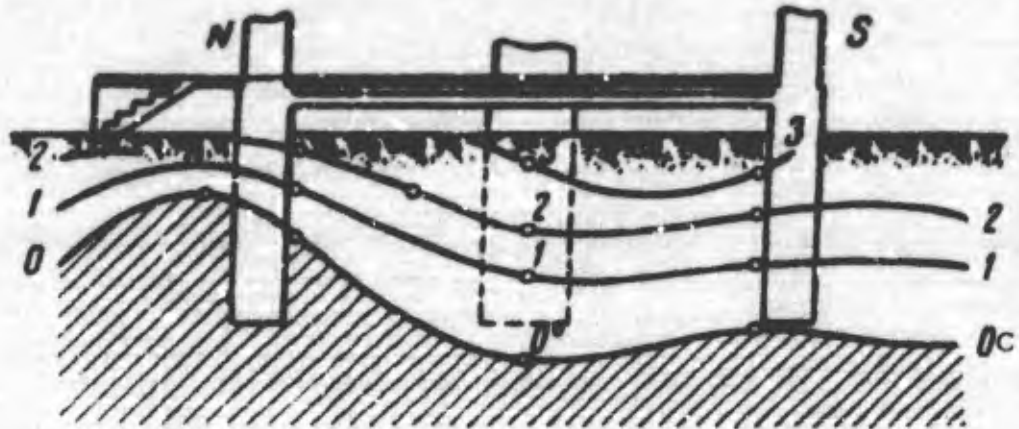

Figure 134. Isotherms of the ground and foundation under the experimental house, October 1933.

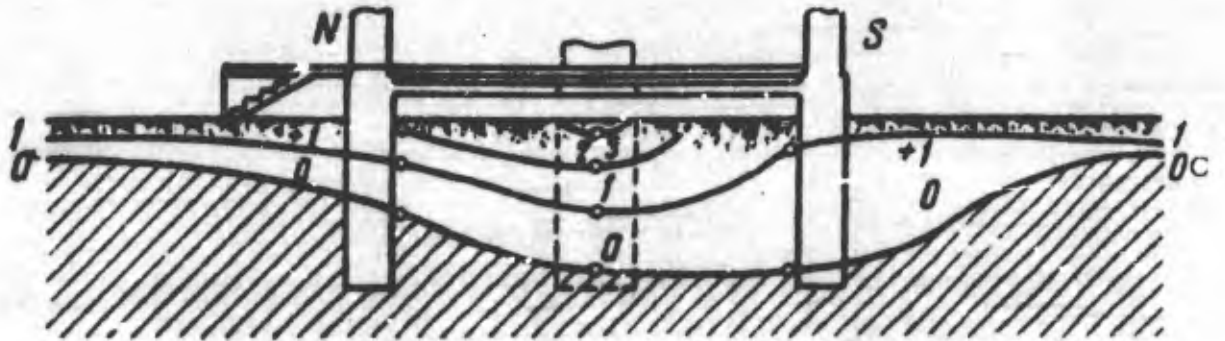

Figure 135. Average yearly isotherms of the ground and foundation under the experimental house, 1933.

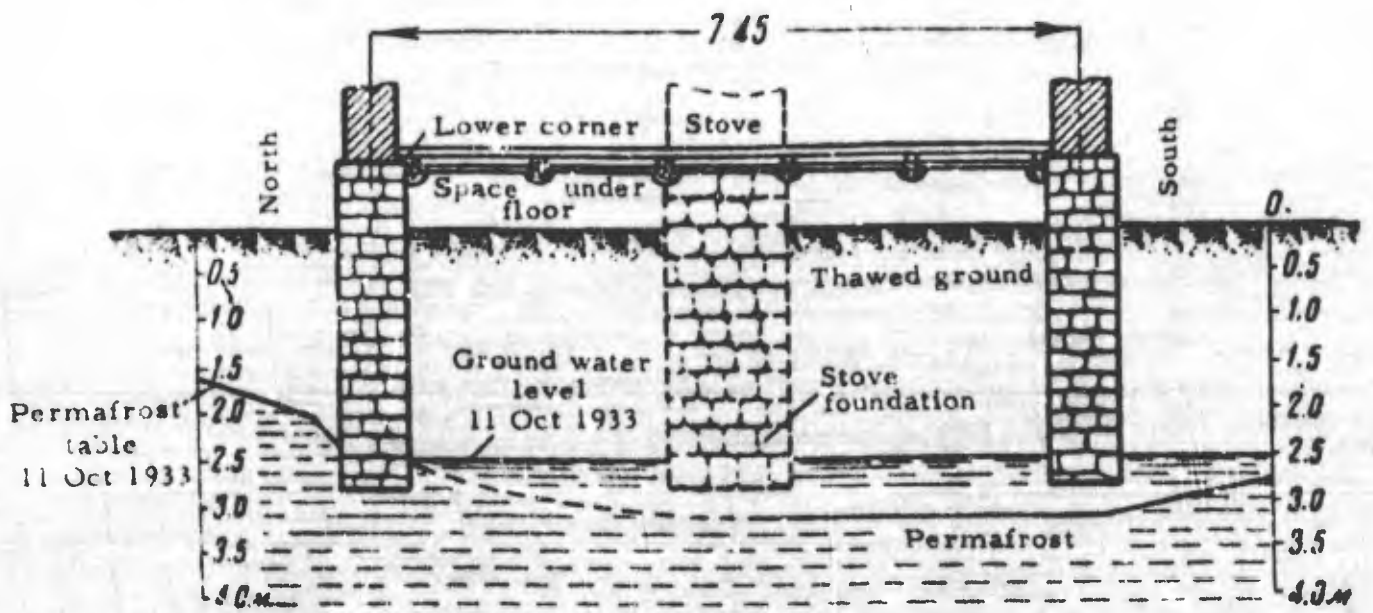

Figure 136. Permafrost table under the experimental house on October 11, 1933, according to measurements in boreholes.

The second experimental house was not built by the Institute of Construction. It was constructed by NKPS (People's Commissariat of Railroads) at the Skovorodino Station, using an altered plan but retaining the system of the foundation. The house was built on piles, with a space between the floor and the ground, which was ventilated in winter. The cross section of this experimental house is shown in Figure 137.¹

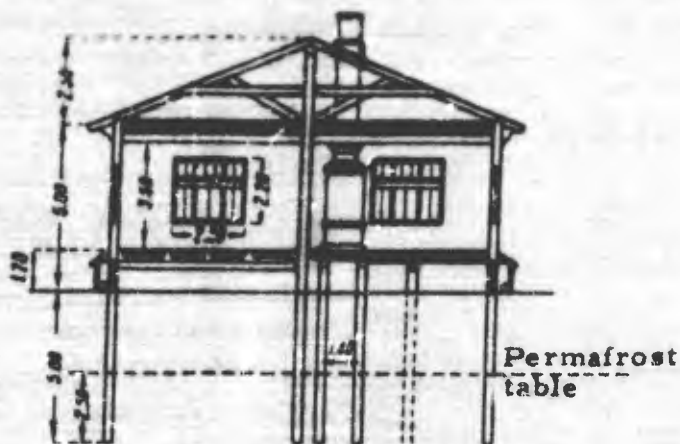

Figure 137. Cross section of the experimental house at the Skovorodino Frozen Ground Station.

The house occupied an area 12 x 24 m. In order to maintain the permafrost under the building, the space below the building (which is about 1 m high) had several vents which could be opened in the winter. The openings were about 0.5 x 1 m. The piles (which were 5 m long) were driven into holes of somewhat smaller diameter than the piles.

Table 93 gives the temperature measurements of the ground and foundation (piles) for 8 months of 1933, kindly provided by Mr. E. D. Belokrylov. These data show that the ground at a depth of 2.5 m (the permafrost table) beneath both the northern and southern parts of the building did not thaw during the whole period of observation (8 months) and had negative temperatures. Further measurements showed that the permafrost table actually rose, especially at the north wall of the building.

Table 93. Temperature measurements of ground and pile foundations in the experimental house with ventilated basement (Skovorodino).

Location of mercury thermometers	Depth (m)	Average monthly temp (C)							
		Mar	Apr	May	June	July	Aug	Sept	Oct
Middle of house under the floor	0.4	-9.5	-4.8	-1.7	-0.4	1.6	3.5	3.2	1.0
	0.8	-8.5	-4.8	-2.1	-0.9	-0.2	1.4	1.8	0.7
	1.6	-5.0	-4.0	-2.5	-1.5	-1.0	-0.7	-0.5	-0.4
	2.5	-1.2	-2.1	-1.9	-1.5	-1.3	-1.0	-0.8	-0.7
0.35 m from north wall	2.5	-	-2.9	-2.3	-1.6	-1.2	-0.9	-0.6	-0.4
	3.2	-	-0.9	-1.3	-1.3	-1.1	-1.1	-1.0	-0.9
0.35 m from south wall	2.5	-	-1.8	-1.6	-1.2	-1.0	-0.8	-0.7	-0.6
Pile N. 16 of the south wall	2.5	-	-2.4	-1.8	-1.4	-1.1	-1.0	-0.7	-0.6
	3.2	-0.4	-0.7	-1.0	-1.1	-1.0	-1.0	-0.9	-0.9
	5.0	-0.6	-0.6	-0.7	-0.8	-0.9	-0.6	-0.9	-0.9

Deformation of Buildings and Structures

The change of the thermal regime under buildings and structures leads to a change in the permafrost regime of the ground.

In general, cuplike hollows form in the permafrost under heated buildings. They are deeper on the south side, and sometimes the bottom of the cup is even raised on the north side (Fig. 138). Stoves also have a heating effect if they are not sufficiently insulated.

1. Vechnaia merslota i shelesnodor. str. (Permafrost and railroad construction), Inst. puti NKPS, sb. 8, 1931. p. 171.

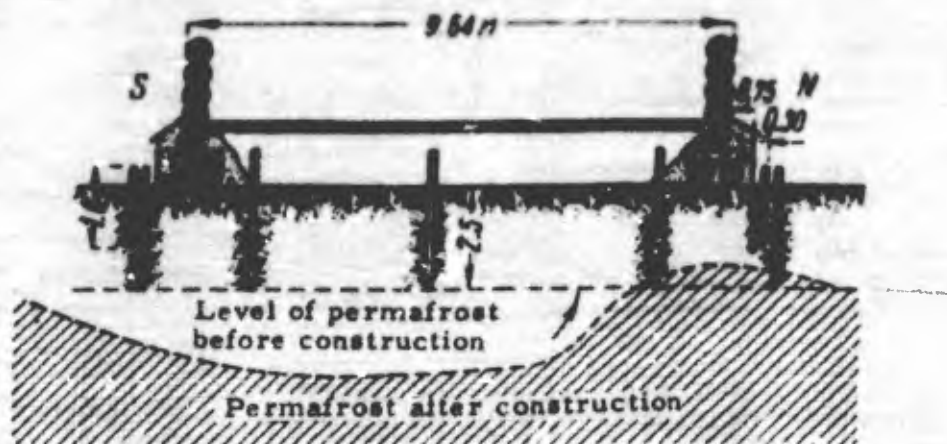

Figure 138. Cup of thawed ground under a dwelling.

N. E. Bykov¹ reports that, in Igarka, sawmill No. 2 has a water reservoir, 60 x 30 x 2 m, through which logs are moved to the plant to be sawed. The water is heated by exhaust steam and even in the winter has a temperature of about 20°C. After the reservoir had been used for a year, the permafrost regime was investigated by three boreholes made in the bottom of the basin. Permafrost was found at a depth of 6.5 m under the basin.

Not far from the reservoir, about 15 m to the east, there was a temporary power station where two mobile steam engines were placed, with furnaces sunk in the ground. This station functioned about 2 years. During the spring and summer of 1932, slanting of the foundations of these steam engines was observed. Boreholes between the furnaces revealed permafrost at a depth of 6.7 m. At the same time, at a small distance from the plant, permafrost began at a depth of only 1.2 m. Undoubtedly the 5.5-m lowering of the permafrost table was caused precisely by the action of the warm water of the reservoir for approximately a year, in the first case, and in the second, by the almost constant firing of the steam engines for 2 years. In estimating the extent of thawing of the ground in Igarka, one should take into consideration what has been stated above about the temperature of the ground in this city.

Similar thawing under dwellings was pointed out by Belokrylov, whom we quoted above. He gives a drawing which indicates lowering of the permafrost table under the south wall of the building and slight raising under the north wall.

Formation of the cup or trough under heated dwellings is a general phenomenon in the permafrost region south of the 55th parallel.

For the northern region, as far as this problem is concerned, we have very few observations. At Anadyr', a fish cannery was built, as mentioned before, on ground containing much ice and even ice lenses. Under parts of the building where there were furnaces, the ground thawed and the floor settled (Fig. 139). The cross section of the ground under the cannery (Fig. 113) shows the unfavorable ground conditions of the site.

The conditions created under heated buildings and structures are as follows: Part of the upper permafrost thaws. This thawed ground is surrounded by permafrost on the sides and bottom, so that it is located, as we said before, as if in a cup of permafrost. If the active layer and permafrost are supersaturated, ground water will collect in the cup, and the ground in it will become a semi-liquid mass if its grain-size composition is favorable for this.

If the ground thaws as deep as the base of the foundation, and this usually happens at

1. N. I. Bykov (1934) "Vechnaia merslota i stroitelstvo Igarki (Permafrost and construction at Igarka)" in Za industrializatsiiu Sovetskogo Vostoka (Industrialization of the Soviet East). Tsentr. biuro kraevedenia. Moscow: Izd.



Figure 139. Crack and settling in the concrete floor of the Anadyr' fish cannery. The rulers show the amount of settling of the floor of the building. Photo by S. P. Kachurin.

the south wall, the ground under this foundation will have a very low bearing capacity, very often smaller than estimated, and the building will settle toward the south. All investigators of buildings and structures in permafrost areas have noted this, often even when the buildings were apparently erected with some precautions. Nezhdanov¹ says that at the Mogzon Transbaikal Railroad Station

"almost all the structures are damaged because of heaving or settling of the foundations; the walls which face south and the main walls of buildings settle especially. Cement foundations 1 m deep in the ground were disrupted during the very first year of service. The middle settled and the structures took on the characteristic appearance of being broken in the middle.

"In building the railroad station at Mogzon, some measures were taken to protect the foundation against settling. A sandy pebble base was used under the foundation. The layer of sand was 2.56 m wide and 0.85 m thick. Above the layer of sand a concrete block, 0.64 m thick, was placed under all the walls and reinforced by rails. A rubble foundation of trapezoidal profile was built on this block to a height of 2.24 m. The general depth of the foundation pit was 3.73 m. The ground in the pit was composed of pebbles and sand, mixed with some silt highly saturated with water. Building was begun in 1908 and was finished in 1909. During the first 5 years of service, no defects in the condition of this building were noticed. But then, settling of the center wall on the south side under the heaviest part of the building was noticed. Two vertical cracks appeared

1. N. I. Nezhdanov (1931) "Is opyta ustroistva fundamentov zdaniy v usloviakh vechnoi mersloty (Experiences of constructing building foundations under permafrost conditions)," Inst. puti NKPS, sb. 8.



Figure 139. Crack and settling in the concrete floor of the Anadyr' fish cannery. The rulers show the amount of settling of the floor of the building. Photo by S. P. Kachurin.

the south wall, the ground under this foundation will have a very low bearing capacity, very often smaller than estimated, and the building will settle toward the south. All investigators of buildings and structures in permafrost areas have noted this, often even when the buildings were apparently erected with some precautions. Nezhdanov¹ says that at the Mogzon Transbaikal Railroad Station

"almost all the structures are damaged because of heaving or settling of the foundations; the walls which face south and the main walls of buildings settle especially. Cement foundations 1 m deep in the ground were disrupted during the very first year of service. The middle settled and the structures took on the characteristic appearance of being broken in the middle.

"In building the railroad station at Mogzon, some measures were taken to protect the foundation against settling. A sandy pebble base was used under the foundation. The layer of sand was 2.56 m wide and 0.85 m thick. Above the layer of sand a concrete block, 0.64 m thick, was placed under all the walls and reinforced by rails. A rubble foundation of trapezoidal profile was built on this block to a height of 2.24 m. The general depth of the foundation pit was 3.73 m. The ground in the pit was composed of pebbles and sand, mixed with some silt highly saturated with water. Building was begun in 1908 and was finished in 1909. During the first 5 years of service, no defects in the condition of this building were noticed. But then, settling of the center wall on the south side under the heaviest part of the building was noticed. Two vertical cracks appeared

1. N. I. Nezhdanov (1931) "Iz opyta ustroistva fundamentov zdaniy v usloviakh vechnoi merzloty (Experiences of constructing building foundations under permafrost conditions)," Inst. puti NKPS, sb. 8.

PRINCIPLES OF MECHANICS OF FROZEN GROUND

"In that wall. At the same time, the edges of the south wall, as well as the other walls of the building, remained unchanged. With time, the settling spread to the whole south side of the building and in 15 years the middle of the wall had settled 0.11 m."

We will not give more examples of settling, but only note that the main tendency of buildings and structures to settle toward the south is further proved by statistical data on one of the areas of the Transbaikal Railroad, where the following data were obtained [Table 94]:¹

Table 94.

Type of structure	Inspected	Deformed	% deformed	Deformed toward the south	
				No.	%
1. Stone building	2	2	100	2	100
2. Wooden building on horizontal beams	21	20	85	16	80
Wooden building on piles	61	61	100	43	70
Wooden building on stone foundation	6	6	100	5	83
3. Barns	—	24	—	17	71

Suprapermafrost waters tend to flow from the surrounding areas into the cup formed under the building. Rain from roofs, if not properly diverted, will also flow into the cup. All this increases the liquefaction of the ground and the settling of the buildings.

The ground water under the buildings partially freezes during the winter. Here we get an ideal example of frozen ground in a closed space and its inevitable heaving mainly on the south side, due to supersaturation. Thus, individual points mainly in the southern part of the building seem to be swinging along certain curves, the centers of which are located on the base line of the foundation on the north side.

We have already described the process of heaving. However, we shall note also that, if the ground under the base of the foundation begins to freeze, there can be two general situations which can be subdivided into more specific ones.

A. Freezing of the ground in a closed system.

I. The moisture of the ground is equal to or less than the critical moisture of heaving.

a) There is no migration of water when the ground freezes. In such cases, there is no heaving of ground nor deformation of the foundation.

b) Migration of water occurs when the ground freezes. In this case, ground heaving will occur if the water migrating in the freezing ground raises its moisture (even if only in individual layers) above critical moisture. Heaving can be considerable only if the ground under the base of the foundation freezes in a way that favors migration of moisture; that is, if the downward freezing stops, now and then, at certain depths. Therefore, deformation of foundations is possible, but should not be very great.

II. Moisture content of the ground is higher than critical for heaving. In this case, heaving will occur whether or not there is migration during freezing. Degree of heaving and, therefore, degree of deformation, will depend on the moisture content of the ground and the quantity of migrating moisture. The higher the moisture content of the ground and the greater the migration of moisture in the freezing ground, the greater will be the heaving and its deforming effect on the foundation.

1. I. D. Belokrylov (1931) in Inst. puti NKPS, sb. 8.

B. Freezing of the ground under the foundation in an open system. In this case, we will have freezing of ground under the pressure of the weight of the building or structure.

Taber's experiments showed that in such cases heaving stress could develop up to 14 kg/cm². Therefore, even if the ground under the foundation freezes in an open system, considerable swelling forces could develop and building foundations could be deformed.

From the above, it is clear that freezing of the ground under the foundation, in general, is a very dangerous phenomenon. This is the reason for the established practical rule that foundations should be laid below the level of winter freezing.¹

It is not uncommon in permafrost regions for a large amount of water to gather in the cup of thawed ground under the building or construction. This is not water from surrounding areas which supersaturates the ground under the building, but water from a ground stream. During the summer, this ground stream runs somewhere near the building. When the stream freezes in winter, it develops pressure, and the water, looking for an exit, is directed under a building or structure where there is thawed ground. If the ground stream is not very large, the water accumulates under the floor as if in a reservoir; if the building is not heated all winter, part of the water freezes under the building and part of the water flows out of the windows or different cracks and holes in the building and freezes. When there is a large amount of water in the stream, the water spouts out from under the building all winter. Thus, Nezhdanov,² describing deformation of the buildings in Mogson, says — "during the winter water rose in the cellars above ground level. There were examples where the water poured out from loosely plugged up vents 0.4 m above the ground, and froze in the form of an icing."



Figure 140. This was a railroad bath house which filled with ice. The bath house was dismantled and the ice can be seen on the left side of the illustration.

Descriptions of such cases are common in the literature on permafrost. During the summer, the frozen ground which had dammed the ground stream thaws, and the water flows from beneath the building back to its original bed. The picture repeats itself the following winter.

1. Lately, some have expressed the opinion that foundations should be laid at a depth less than the depth of winter freezing of the ground. It seems to us that the physical basis for this opinion is the concept that ground under the base of the foundation of heated buildings freezes at a shallower depth than in normal conditions. This problem has not been studied.

2. Op. cit.

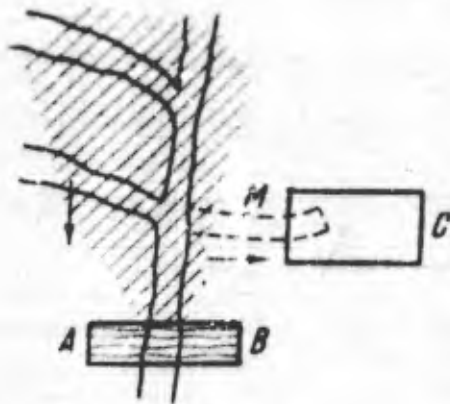

Figure 141. Diagram of the manner in which water under a building is diverted near a ground stream.

The shaded area is the feeding area of the ground stream; AB is the frozen dam which blocks the flow of the ground stream; M is the direction of stream flow after formation of the frozen dam; C is the building.

If the stream under the building cannot easily find an exit, it exerts hydrostatic pressure on the structure and can cause deformation. In such a case, we have a natural system of hydraulic press, as shown in Figure 141.

The shaded part of the drawing is suprapermafrost ground water which moves in the direction of the arrow and forms a stream at the bottom (as for instance in a water-collecting depression). At AB, the stream freezes and the water is directed into the ground, along channel M, where there is no water flow during the summer. The water enters the unfrozen ground under building C, where there is no exit for the water. The ground in the shaded part of the drawing continues to freeze and force water under C, which is thus deformed.

The causes of deformation, therefore, are as follows:

1. A ground stream near the structure.
2. The formation of a dam of frozen ground at AB.
3. Continued freezing of the ground in the shaded area of the drawing after formation of the dam.
4. The possibility of ground water flow along M during the winter.
5. Unfrozen ground under the structure C.
6. No outlet for the water under the structure.

To prevent deformation of the structure, it is necessary to break one link in this chain. Local conditions should show which link is best to break: whether to destroy the dam at AB, or create a dam at M (in which case an icing mound will form in front of the dam), or let the water out from under the building, etc.

Fink, in the work quoted above, mentioned a stone pier of a railroad bridge which was built on a rock base. During the first year, the pier was pushed out and tilted to the side. Because alarming cracks appeared in the pier, crates made of cross-ties were placed under the ends of the frame. In 1913, the pier was dismantled to the very base, the excavation was deepened by 0.40 m, and the broken layer of the original rock was removed. Springs discovered at the bottom of the excavation were cemented over. We are sure that detailed analysis of the situation would show that these springs were only results of the pressure of freezing ground at a distance from the bridge in the region which feeds the springs, acting according to the scheme described above. Thus, freezing of the ground in the shaded area of Figure 141 deformed the structure C (in this case, the bridge), at a distance from the freezing ground.

To conclude, we shall say a few words about the mechanism of heaving of buildings and structures. The general bases of this phenomenon were given when describing the heaving of posts. We shall now enlarge upon them.

First, we consider buildings which do not have a foundation in the ground. These would be, primarily, wooden barns and houses, built on wooden foundations of different types and on crib bridges. Such structures, says Fink, "are heaved exclusively by the forces applied to the base of the support. When the ground thaws completely, there is no residual heaving, and the structure settles completely with the ground under it."

To this, we must add that the ground, and the building, does not always return to the original position after heaving. Washing-in and washing-out of particles occurs in the ground and, in individual cases, affects the structure (particularly bridges with crib supports). In addition, heaving is not uniform throughout the whole structure, so that the structural balance is disturbed.

Structures with foundations in the ground are affected, in general, in the same way as posts. The stresses of ground freezing act upon the construction through the adfreezing strength. The point of application is on the side surface of the foundation; lifting and breaking of the foundation occurs, just as with jointed piles. Only when the ground freezes below the foundation are the forces applied at the base as well. Just as with posts, we have to consider the forces which counteract the heaving forces. These are the adfreezing forces of the foundation with the permafrost.

When the ground thaws, the structure settles, but usually only partially, as was discussed above. Fink calls this partial settling of the building "residual heave".

Thus, buildings constructed under permafrost conditions could settle because the thawed ground under the foundation loses its bearing capacity; or they could be heaved out of the ground upon freezing. In either case, the building or structure exhibits vertical displacement, which is so dangerous to its stability, especially when this phenomenon repeats itself.

We have given enough examples of deformation of structures due to the effects of settling and heaving. Such deformations are more or less explained.

Where there is permafrost and deep winter freezing of the ground, deformation can be caused by two other factors. The first is the lateral pressure of expanding freezing ground. This factor is a subject of argument: some recognize it as a deforming force on buildings and structures and some do not. We think that these lateral forces exist in permafrost regions and regions of deep winter freezing of the ground. However, decisive experiments and observations in this direction are needed.

The second cause is the sliding of the structure on the sloping surface of permafrost.



Figure 142. Forest growing on a slowly sliding slope.

PRINCIPLES OF MECHANICS OF FROZEN GROUND

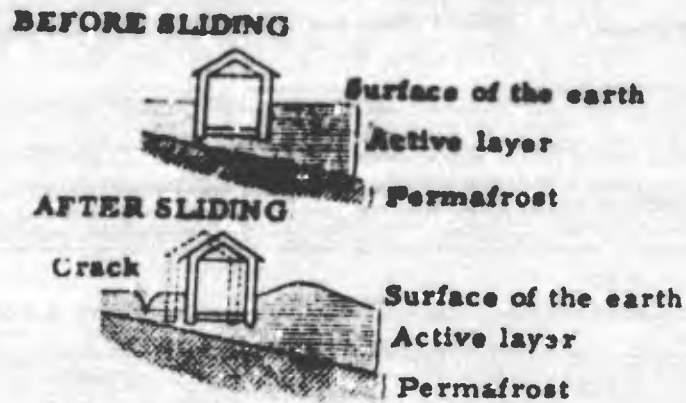

Figure 143. Sketch of the sliding of a structure above a slanting permafrost table.

A particular case of this phenomenon could be the sliding of ground masses where permafrost is present. The presence of sliding ground in permafrost areas cannot be doubted (Fig. 142). However, the part that the permafrost plays in this phenomenon is not yet clear. The sliding of the structure can be illustrated as shown in Figure 143. The structure itself is a load which disrupts the equilibrium of the system. When the structure and part of the ground slides, the ground buckles in the direction of sliding and cracks appear in the ground on the other side of the structure — very little is known about this phenomenon.

CHAPTER IX. GEOTECHNICAL INVESTIGATION OF PERMAFROST FOR CONSTRUCTION PURPOSES

Introduction

From all that has previously been said in this book, it is clear that for any considerable construction — a big plant, a city, a government farm — it is necessary to study the area where any construction work will be done.¹ This holds true for nonpermafrost regions, but it is absolutely essential for permafrost regions.

Two methods of investigation are favored by the authors. First, a reconnaissance survey should be made to select the site, within the limits determined by economic or other considerations. If the area under survey is of considerable size (for instance 20 or 30 square kilometers), the site with the best conditions for laying foundations should be chosen. It is desirable to have an area in which the main structures could be erected on rocky or sandy gravel ground at moderate depth. It is necessary to determine, even if only visually, the degree of the dynamics of the active layer at the site (icings, soil heavings, and landslides). It is obvious that preference should be given to an area where the dynamic processes of the active layer are either absent or very weak.

The reconnaissance survey is primarily visual, using shallow drill holes and test pits. Of course, conditions for water supply, sewage disposal, communication, planting around the factory or in the city, and other requirements should be taken into consideration.

Detailed investigations of the ground and of the permafrost are conducted at the selected site. They consist of the following:²

- I. Permafrost Investigation
 1. Depth of the permafrost table, which is also the thickness of the active layer.
 2. Character of the relief of the permafrost table.
 3. Type of vertical distribution of permafrost (continuous or layered).
 4. Thickness of permafrost (if possible).
 5. Thermal regime of the active layer and the permafrost.
- II. Study of the hydrological regime.
 1. Suprapermafrost water: quantity and direction of movement.
 2. Large ice inclusions in the ground (lenses or layers).
 3. Hydrogeological conditions of the area; source of the water in the area.
 4. Dynamic processes of the active layer (spot medallions, peat mounds, and icings).
- III. Building characteristics of the ground of the area (both the active layer and the upper part of the permafrost).
 1. Physico-mechanical characteristics of the ground (moisture content, unit weight, grain-size composition, etc.).
 2. Experimental loading.
- IV. Mapping of frozen ground.

1. Investigations of railroads and truck roads, for which special methods exist, are not covered here.

2. This brief discussion is concerned principally with the content of the most important investigations, and only partly with the methods. Detailed instructions on how to conduct ground and permafrost investigations are not given. The reader can find some instructive information in a book compiled by N. A. Tsyrovich and M. I. Sumgin (1931) Vremennaya instruktsiya po issledovaniyu vechnoi mersloty v tekhnicheskikh tseliakh (Temporary instructions for the investigation of permafrost for technical purposes). Blull. Leningrad. inst. soor. no. 7. In addition KOVM of the Academy of Sciences of the U. S. S. R. publishes detailed instructions for the study of permafrost.

Investigation of Frozen Ground

The first point of part I has already been discussed. (Only the most important points will be reviewed here. The depth of the permafrost table which in most cases coincides with the thickness of the active layer) must be considered in relation to the various kinds of ground, vegetation, and topography, and the estimated depth of the permafrost table, also previously discussed, must be kept in mind.

There are several ways of determining the depth of the permafrost table. One is the usual method of test pits and shallow drill holes. The others are geophysical methods — electrometric and seismographic. Although the latter methods have not had sufficient practical trial, it is already possible to measure the permafrost table very precisely by electrometric methods. The difficulty lies in the cost of this work. For the present, shallow boring costs much less.

Since there has been little development of permafrost areas, the construction site is usually in an area with undisturbed natural conditions, and, at best, only a year can be given to investigation. Therefore, the depth to the permafrost must be determined from observations made during only one autumn, and it is necessary to use data from all nearby meteorological stations which have taken measurements with soil thermometers. This problem was also discussed earlier. Thus, the depth of the permafrost table determined for a given year must be corrected by observations for a number of years and for the effect of occupation of the site.

The different depths of the permafrost table must be plotted to give the contours of the permafrost (point 2). The surface of the permafrost table does not always follow the contour of the earth's surface — this must be ascertained. The contours of the earth's surface should be surveyed first, as is always done for a big construction job. Then the depth of the permafrost table should be determined, not only at one or two points, but according to a certain system, in relation to the condition of the ground, its topography, and its vegetation. As is well known, this type of work should preferably be done during the late fall. The thickness of the thawed layer should be measured in the mineral part of the ground, not considering dead grass or moss cover. The frequency of drill holes and pits depends on the size of the construction; each different ground type and plant community should have its control drill hole. From the data obtained from the test pits and drill holes, the contours are drawn. It is convenient to coordinate this work with the survey of the site.

This work will clarify the horizontal permafrost distribution in the area — whether it is uninterrupted or broken up by islands of talik. This will be very clear from the compiled contour map of the permafrost.

Points three and four involve drilling, which builders are very reluctant to do. However, determination of the type of vertical distribution of permafrost is absolutely necessary for big construction. Determination of the thickness of permafrost is only desirable. In certain cases, therefore, it is sufficient to drill to 25 to 30 m deep, which will show the character of the vertical distribution of permafrost and whether permafrost in the given area goes deeper.

Geophysical methods, i. e., electrometric and seismographic, can also be used to determine the thickness of permafrost. The former — the direct current method — has given good results in permafrost with temperature of approximately -1C.

It is still necessary to drill even when geophysical methods are used, since drilling gives much that geophysical methods do not.

Drill holes to determine the vertical distribution of permafrost should be sunk so that one is in mineral ground and another in a peat bog. Two drill holes should be the minimum number. However, where the contour map of the permafrost indicates islands or pseudo-islands of permafrost, extra holes should be drilled to a depth no less than that of the main drill holes. For practical considerations it is useful to drill where the biggest buildings and structures will be placed. When the project is of considerable size, such as a large factory or small town, one or several drill holes should be sunk, in our opinion, to the base of the permafrost. This will supply much of the material necessary for solving many construction problems (degradation of permafrost according to the thermal gradient, the presence or absence of subpermafrost waters, the problem of the fundamental principles of construction under permafrost conditions in a given area, etc.). It is our opinion that

the expense of sinking drill holes 50, 75, or 100 m deep would more than pay for itself.

The actual process of drilling in permafrost ground usually meets no particular obstacles. It is of great value that the walls of the water-free drill hole are very stable when frozen, so that it is not difficult to sink pipes into drill holes under permafrost conditions.

However, when water appears in a drill hole, as for instance when an unfrozen layer is encountered, it freezes on the wall and the hole becomes narrower and narrower. Fitting a pipe in the hole then becomes difficult and often impossible.

In such cases, pipes are either warmed by heated iron bars or the ice is chopped away by a sledge-pump with the valve removed. All this work should be done quickly.

The sinking of the pipes should also be done very quickly, since the pipes will freeze to the walls of the drill hole otherwise.

The frozen ice on the walls of the drill hole are in the way of the drill tip when it is put in or removed.

If something goes wrong during the drilling and it is necessary to stop work, there is danger that the water will freeze the instrument into the hole. It would then be tremendously difficult, and sometimes impossible, to release the instrument. Therefore, at every halt in the work the drill must be immediately withdrawn.

When water is being pumped out of the drill hole, it does not freeze, but, if the pumping should stop, the water in the hole will very often freeze. If the hole is equipped with a bar-pump whose cylinder is at a depth where there is permafrost, the water in the cylinder will freeze and the piston and the valves will adfreeze to the cylinder. Then, it is again necessary to heat the instrument. This, however, is not always successful. To avoid, or at least minimize, these difficulties, it is useful to know beforehand the depth of the ground-water table, or the depth of the base of the permafrost if the water table is below permafrost. These depths can be approximated from temperature measurements in the drill hole. When the temperature approaches zero, the water table or the base of the permafrost is close. The geothermal gradient in this case should be considered to be not more than 12 to 15 m. Brine poured into the drill holes is used to prevent freezing on the walls and the instrument, but this is harmful to the instruments and is completely unsatisfactory if temperature observations are to be made in the holes.

The type of permafrost (vertically continuous or layered) and also its thickness (actually the base of the permafrost), is determined by one of the following methods when drilling:

a. By the degree of difficulty in drilling; this method is the most unreliable. Although frozen ground is characteristically difficult to drill, only experienced workers can distinguish whether the difficulty is due to frozen ground or to the natural resistance of unfrozen ground;

b. By direct observation, with the naked eye or a magnifying glass, of the ice crystals in the ground taken out of a drill hole. This method is reliable for relatively shallow depths when the instrument is still easy to remove. But this method cannot be used for deeper holes (30 m or more), since the ice crystals may melt when the drill is removed.

c. By temperature measurements discussed below.

Point five of the first part of our short program (temperature measurement) involves excavating and drilling. Therefore, this work must be combined with the determination of the permafrost depth and thickness. This will, however, be a single series of measurements which has considerable though incomplete significance. The best method is to dig pits in a certain portion of an area and insert several soil thermometers, taking regular measurements for a year or a year and a half. This will give us the temperature fluctuations at different depths, which is very important, for instance, in planning a water supply system, and the average yearly temperature, which is very important for general calculations. The thermometer should be placed not less than 6 m deep.

Measurements in deep drill holes will give the temperature of deeper layers of permafrost. Temperature observations should be conducted for an entire year in one or two of these deep holes and temperatures should be read at least once every 5 days. These measurements can be made by the same person who conducts the regular series of soil-thermometer observations.

The holes in which observations are to be made should not only be free of water, but the drilling itself should be done without the addition of water or brine.

Temperature measurements can be made during drilling which is desirable, or after the hole has been drilled to the desired depth.

The drilling process disrupts the thermal regime in the hole by raising its temperature. Therefore, it is necessary to stop the drilling at the depth where temperature is to be measured, and wait some time for the disrupted thermal regime to become stabilized. This time varies considerably from several hours to 2 or 3 days, sometimes even longer. Therefore, the waiting period must be determined experimentally for each case, and the thermometer must be lowered into the hole only after the temperature has returned to its original reading. The thermometer may be placed into the hole as soon as the drill is removed, but it will have to be kept there during the waiting period as well as during the measuring period.

Psychrometric thermometers are used to measure the temperature in the borehole. These thermometers are sealed in a metal pipe and are insulated; i. e., their mercury bowl is surrounded by heat resistant materials (cork, soot, etc.).

The insulated thermometer is lowered to the bottom of the borehole on a strong cord, then raised to about 1 cm above the bottom and left there until the time of reading. The drill hole opening is closed at this time, to prevent the penetration of precipitation and of cold air in the winter. When the necessary time has elapsed, the thermometer is removed and the reading taken.

An insulated thermometer should react slowly so that the temperature recorded in the drill hole will not change during the reading. The deeper the thermometer is to go, the slower its reaction should be.

If the temperature is measured after the borehole has been drilled to its full depth, the measurements are speeded up by tying several thermometers to a strong cord at certain intervals, (for instance, every 2 m). For instance, in a hole 30 m deep, five thermometers attached to a cord can measure the temperature in three operations. The temperature is not measured until the original temperature is restored in the hole. The thermometer is lowered to the bottom of the hole, left long enough to register the temperature, then read every 24 hours, until the results are identical. Then, the drill hole is ready for temperature measurements.

It is very convenient and fast to measure the temperature in the hole with an electrical resistance thermometer. Such thermometers cannot be bought ready made. They have to be ordered, specifying the length of the wires according to the planned depth of the holes.

Study of the Hydrological Regime

The hydrological regime of the area is studied simultaneously with the pitting and drilling. In some cases this investigation requires new pits both at the site and beyond it, as, for instance, when determining the source of suprapermafrost water.

In studying the winter regime of suprapermafrost water, the following information must be obtained: whether near-by water sources (rivers, brooks, lakes) freeze through to the bottom, when a solid ice cover forms, and whether there are nonfreezing areas and outlets of warm springs.

To investigate the summer regime of suprapermafrost waters, the ground-water level is measured in the pits several times during the summer. From these data, hydroisolines (lines of equal ground-water levels) are drawn, showing the direction of movement of suprapermafrost waters.

The occurrence and size of ice layers and lenses in frozen ground should be carefully studied when boring and especially when pitting. The ground-water table should be noted also.

Moisture distribution in the active layer and in the permafrost is studied from samples taken from the pits. These samples should be taken not less than every 0.5 m vertically from the surface to the bottom of the pit. The average depth of the pit should be no less than twice the thickness of the active layer. Additional samples for measuring moisture content are taken from some characteristic layers. To detect ice-supersaturated layers which would be beneath the building foundation, one very deep pit should be excavated.

From the theory of stress distribution (Ch. VI), it can be concluded that the ground layer which is significantly stressed and deformed by the local load will be approximately twice as thick as the width of the base of the square foundation. In determining the depth of the main pit, this value should be added to twice the thickness of the active layer. If the size of the foundation is not known, the depth of the main pit should be three times the thickness of the active layer.

In moisture determinations, sufficient reproducibility should be assured.

As stated in a previous chapter, data on the moisture content of the active and permafrost layers are very valuable in evaluating frozen ground for construction purposes. Also, these data are necessary for selecting from the tables (see Ch. IV) the adfreezing forces used to estimate foundation heaving.

The above investigation gives sufficient material for prognosticating the dynamic processes in the active layer when it freezes. But since prognosis is always based mainly on probability, it is extremely desirable to find out if there actually is vertical displacement of the ground in the area, exactly where it occurs, its amount, and its causes. Such observations are made during the winter by regular leveling from a stable bench mark (a rock or a special frozen-ground bench mark),¹ by small poles driven into the ground to a depth of 10 or 15 cm, which mark certain lines through the area. In studying icing formations, it is necessary:

- a. To locate the spots where icings appear every year;
- b. To determine their feeding sources;
- c. To note the natural obstacles to their spreading.

In certain areas, heaving of posts, strong deformation of structures, and tilting of trees will be observed, indicating the sliding of a mass of ground. The areas where these phenomena do not occur should also be noted.

Properties of Permafrost from the Point of View of Construction

When investigating the active layer and the permafrost layer at future construction sites, it is necessary to determine the physico-mechanical properties of the frozen ground as well as general hydrogeological conditions. Below a certain depth in the pits (0.5 or 1.0 m) the temperature of the ground is measured, and three kinds of samples are taken:

1. to determine the natural moisture
2. to determine grain-size composition and mechanical properties, from samples with disturbed structure
3. to determine unit weight and compressibility upon thawing, from samples with natural, undisturbed structure.

Moisture tests are made in aluminum or glass jars which can be tightly closed. If the moisture of the sample is to be determined after a lapse of some time, as for instance,

1. The frozen-ground bench mark suggested by us (see Bulletin of the Leningrad Institute of Construction) is a metal pipe with a hole in the lower half. This pipe is driven into a drill hole of corresponding diameter to a depth equal to three times the thickness of the active layer. This pipe is filled up to the level of the upper permafrost boundary with liquefied soil or water which subsequently freezes.

a day after the sample is taken, it is necessary to seal the jar with paraffin.

Disturbed samples of frozen ground, weighing 2-3 kg, are taken to determine grain-size composition, and, in some cases, for laboratory determination of the ultimate compressive and shear strength and adfreezing strength.

In addition to tests on moisture and grain-size composition, tests of the ultimate compressive strength and, especially, the compressibility after thawing of frozen ground samples of natural structure provide very valuable data for building. We strongly recommend that investigations of frozen ground for principal building sites include compressibility tests of frozen ground after thawing. These are tremendously important for evaluating permafrost as a base for construction.

Determination of the basic physical properties

The basic physical properties are: unit weight of frozen ground with natural structure γ , its moisture content w , and the specific gravity of the soil skeleton Δ . Moreover, a very valuable qualitative characteristic can be found by observing samples of frozen ground as they thaw.

The specific gravity of the solid phase of the ground Δ is determined in the laboratory in the usual way by a pycnometer. Generally speaking, the specific gravity of ground varies within quite narrow margins, from 2.5 to 2.8, averaging 2.65. For approximate estimations, $\Delta = 2.65$ can be considered as the average specific gravity of ground, especially for sand.

The basic characteristic of frozen ground and its natural consolidation is the unit weight of frozen ground with natural structure and moisture. This can be determined only in the field and should therefore be included in any geotechnical investigation of permafrost. Without knowing the unit weight, it is impossible to calculate the natural porosity of frozen ground, its coefficient of porosity or other constants, without which it is impossible to make any engineering estimates of natural bases, such as determination of permissible load and estimation of settling upon thawing.

The unit weight of frozen ground can be determined under natural conditions by the following simple method which yields very good results. In a pit, a small rectangular hole approximately 0.5 x 0.5 x 0.2 m, is cut out at the depth being investigated. The excavated frozen ground is carefully collected and weighed, and its volume is determined from the three dimensions of the hole. The unit weight of frozen ground with natural structure is determined by dividing the weight of the ground by the volume of the hole. The unit weight of frozen ground can also be determined by cutting rectilinear samples from the pit walls.

If the unit weight of frozen ground is determined at negative air temperatures (during the winter in the field or in a cold laboratory), the procedure is very easy with careful handling and preparation of the sample. With positive air temperature, the measurements are more difficult, but, after some training, they can be made with sufficient accuracy. To increase accuracy, the samples should be as large as possible and the determinations should be repeated at least three times.

The approximate error is as follows: If the dimensions of a cube, for instance, are accurate within 1 mm, the error will be of the order of 3% for a 10-cm cube, 6% for a 5-cm cube, and 9% for a 3-cm cube.

With training in this work, the error for 10-cm cube will not be greater than 1-1½%. Samples of frozen ground can be taken with containers of known volumes, usually sturdy metal cylinders with sharp edges which are forced into the frozen ground by pressure. But this method, which is standard for unfrozen ground, is difficult to use in frozen ground and is successful only after some experience.

In determining the properties of frozen ground which are important for construction, valuable information can be obtained by examining the thawing of frozen ground. A sample of frozen ground of undisturbed structure from the pit is placed in a glass container and heated. Observations are conducted while the sample thaws.

The results of this simple experiment sometimes make it possible to foresee in a general way the behavior of frozen ground under constructions. For example, in 1930,

in the port of Ust'-Yenisey, a fish cannery was being built without considering the properties of frozen ground after thawing. When we conducted the experiment described above, we found that, after thawing, one-third of the volume was solid particles and two-thirds water. While still under construction, the buildings of the plant already showed cracks and slants.

Studies of compressibility upon thawing

In many cases, qualitative investigation of thawing frozen ground is not enough especially when building on the assumption that the permafrost will be eliminated. Then, the coefficient of compressibility of frozen ground thawing evenly under load must be determined.

Undisturbed samples of frozen ground are tested in an apparatus suggested by N. A. Tsytovich. The basic part of the apparatus is a metal ring 2 cm high and 8 cm in diam which is used to obtain the sample of frozen ground and in the experiment (Fig. 144).

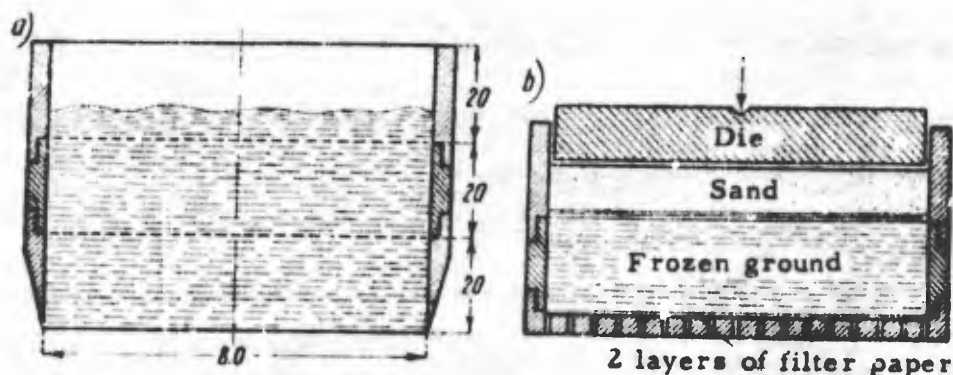

Figure 144. Apparatus for taking samples of frozen ground.
a) ring; b) assembled apparatus before the test.

A steel cutter is screwed onto the ring to cut out the sample of frozen ground. Another sample is taken for determining moisture content. After taking the sample, the cutter and the upper ring are unscrewed, and the frozen ground is carefully leveled with a sharp knife, until it is even with the middle ring. The height of the sample of frozen ground will then be exactly 2 cm. The sample is prepared at a negative temperature: in the open air in winter or autumn; inside the pit in the summer, sometimes using a double-walled vessel with a mixture of ice and salt between the walls. After leveling the surface, the ring and the frozen ground is quickly weighed on a balance. The sample for determining moisture content is also weighed. Then the top and bottom of the first sample is covered with carefully cut circular pieces of filter paper, and a bottom is screwed onto the base of the ring (Fig. 144b). A second ring is screwed on at the top and half filled with sand, which acts as a filter. A metal die is placed on the surface of the sand. The apparatus is placed in a wooden box and the required load applied to the die by a lever. The entire apparatus is taken into a warm room or, during the summer, placed in the sun, and settling is measured until it completely stops. All types of apparatus can be used to register the settling. The same type of apparatus as that used in determining deformation can be used (deflectometer, and others), as well as the very simple lever device illustrated in Figure 145, which we used successfully in the field. This lever device can increase the load up to twenty times.

The measurements will give us: h — the initial height of the sample of frozen ground (2 cm), F — the area of the cross section of the sample (with a diam of 8 cm, the area will be 50 cm^2).

- g — the weight of the frozen ground with undisturbed structure.
- s — the final settling of the frozen layer thawing under a load p .
- p — the specific load on frozen-ground sample.
- w — the initial moisture content by weight of the frozen ground, expressed in fractions (for instance, a moisture content of 24% is $w = 0.24$).

PRINCIPLES OF MECHANICS OF FROZEN GROUND

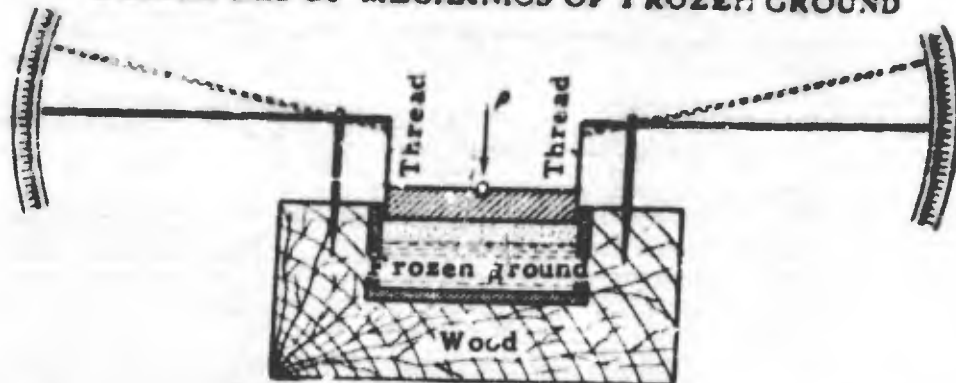

Figure 145. Apparatus for testing the compressibility of frozen ground.

It is also necessary to know the specific gravity of the solid phase of the ground Δ . This is determined by laboratory procedures.

With these values, it is simple to determine the coefficient of compressibility of frozen ground after thawing. The coefficient is the ratio of the difference between the void ratios before and after thawing to the applied pressure:

$$a_f = \frac{\epsilon_{f_1} - \epsilon_{f_2}}{p} \quad (61)$$

where ϵ_{f_1} is the initial void ratio of the frozen ground, i. e., the ratio of the volume of the voids in the frozen ground (including ice in the concept of voids) to the volume of the soil skeleton, ϵ_{f_2} is the void ratio of the ground after thawing under load until settling ceases completely.

As previously stated (see Ch. III), the void ratio is determined from eq 62

$$\epsilon = \frac{\Delta - \delta}{\delta} \quad (62)$$

where

$$\delta = \frac{\gamma}{1 + w}$$

and γ is the unit weight of the ground.

The unit weight of frozen ground of undisturbed structure is

$$\gamma_1 = \frac{g}{hF}$$

The unit weight of the soil skeleton is

$$\delta_1 = \frac{\gamma_1}{1 + w}$$

Therefore

$$\epsilon_{f_1} = \frac{\Delta - \delta_1}{\delta_1}$$

PRACTICAL APPLICATIONS

257

For determining ϵ_{f_2} , the weight of the soil skeleton is

$$G_0 = \frac{F}{1+w}$$

Then the unit weight of the soil skeleton after thawing is

$$\delta_2 = \frac{G_0}{F(h-s)}$$

and the void ratio of the ground after thawing is

$$\epsilon_{f_2} = \frac{\Delta - \delta_2}{\delta_2}$$

Therefore, having determined ϵ_{f_2} , the void ratio of the ground after thawing under a given pressure p , the coefficient of compressibility can be calculated from eq 61.

Usually the value of p is considered equal to the permissible pressure on frozen ground. If the value of p is not known, tests should be repeated under several different pressures, as for instance, $p = 1 \text{ kg/cm}^2$ or 1.5 kg/cm^2 , or 2 kg/cm^2 .

If the coefficient of compressibility of frozen ground upon thawing, a_f , and its initial void ratio ϵ_{f_1} are known, the final settling of the foundations in thawed ground can be calculated. This was pointed out in Chapter 5 and will be analyzed in more detail in Chapter X.

Experimental loading

Field investigations of frozen ground, along with other experiments, include experimental loading. This consists of loading a die placed on the ground with gradually increasing loads. Settling of the die with each load increase is observed until settling stops.

The considerable resistance and rigidity of frozen ground makes testing very difficult under natural conditions, since considerable loads must be applied (on the order of tens of kilograms per square centimeter). Therefore, measurement of the deformation should be very accurate. Because of this, experimental loading of frozen ground with a stable thermal regime is almost never done at present.

Simultaneous thawing and loading of frozen ground is quite another matter. This experiment can give very valuable practical information and requires much smaller loads. Usually such experiments use the permissible load estimated for the project. The die is usually $70.7 \times 70.7 \text{ cm}$, i. e., 5000 cm^2 in area. The experiments are conducted in pits at the level of the base of the future structure. The arrangement of the platform and the die is shown in Figure 146.

In experiments on thawing frozen ground, a heat-conducting pig-iron or iron die is usually used. The cooled die is placed on the frozen ground, the bottom of the pit is covered with a 20-30 cm layer of coarse-grained sand, and water is added. The required load is applied to the die by a loading platform. During the entire experiment, the water in the pit is constantly warmed by adding hot water or sending steam through coil pipes placed around the die. Sometimes, as for instance in the VIOS ground tests at the Petrovsk plant, a welded die warmed by steam from the inside is used.

Settling of the die is measured until it ceases completely. It is also very valuable to measure the vertical temperature profile of the ground during the test. The settling of thawing frozen ground may not always die out; then the load used should be considered as critical (ultimate). Often it would be very important to determine the minimum load at which settling would not die out with time. This requires repeated experiments in different pits with different specific loads.

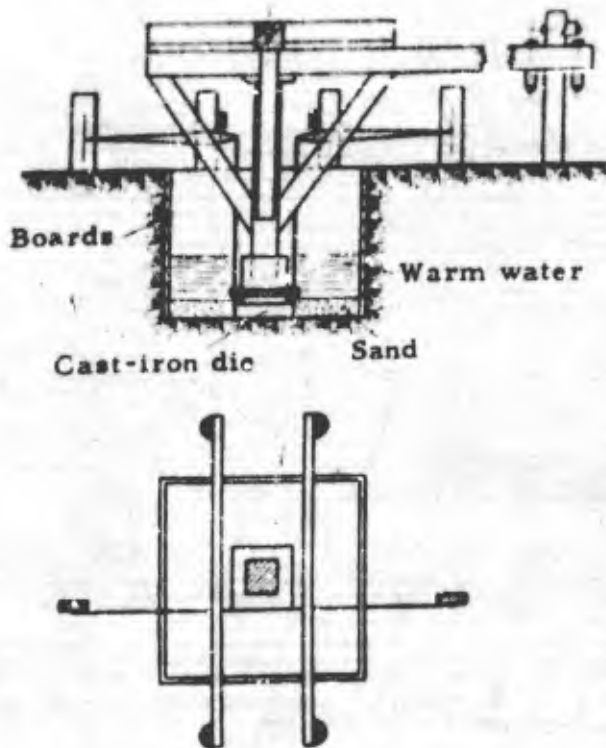

Figure 146. Setup for experimental loading of frozen ground during thawing.

The results of experimental loading of frozen ground during thawing, together with other data, make it possible to select the permissible compressive stress for thawing frozen ground. This value can be obtained by dividing the minimum critical (ultimate) load by the corresponding safety factor, which is taken as 1.25 to 2 depending on the rigidity of the structure.

If, under a given load, settling of the thawing ground ceases, the coefficient of compressibility of the ground can be determined by the method of the equivalent layer.

Ground settling (Ch. V) is determined by the equation:

$$s = h_s \frac{\epsilon_{f1} - \epsilon_{f2}}{1 + \epsilon_{f1}}$$

where ϵ_{f1} is the initial void ratio of frozen ground determined from the unit weight, moisture content, and specific gravity (see previous experiment) and ϵ_{f2} is the coefficient of porosity of the ground after thawing under load.

The value s is known from experimental loading; ϵ_{f1} is always determined when testing ground. The values ϵ_{f2} and h_s remain

unknown. According to Tsytovich, h_s , the thickness of an equivalent layer of ground is:

$$h_s = A_w b$$

where b is the width of the die. The factor A_w for soil of different grain-size composition (see Ch. X) can be taken from Table 95.

Table 95.

Soil type	Poisson's ratio (μ)	A_w
Sand	0.20	1.01
Silty sand	0.25	1.07
Clayey sand	0.30	1.17
Clay	0.35	1.32
Fat clay	0.40	1.71

Knowing the thickness of the equivalent layer of ground, h_s , the void ratio ϵ_{f2} can be obtained from

$$\epsilon_{f2} = \epsilon_{f1} - \frac{s}{h_s} (1 + \epsilon_{f1}). \quad (63)$$

All the values on the right side of eq 63 are known: then the coefficient of compressibility is determined from eq 61

1. N. A. Tsytovich (1936) Opređenje nekotorykh konstant gruntov po rezul'tatam probnykh nagruzok (Determination of certain ground constants from results of experimental loading). Trudy LIRK, sb. 4.

$$a_f = \frac{\epsilon_{f_1} - \epsilon_{f_2}}{p}$$

This method has been used several times and gives very accurate results.

Example. A 70.7 x 70.7 cm area of frozen sand, with initial void ratio $\epsilon_{f_1} = 0.76$, settled 2.4 cm when it thawed under a load $p = 2 \text{ kg/cm}^2$. To determine the coefficient of compressibility of the ground when it thaws:

$$h_s = A\omega b = 1.01 \times 70.7 = 71.4 \text{ cm,}$$

$$\epsilon_{f_2} = \epsilon_{f_1} - \frac{s}{h_s} (1 + \epsilon_{f_1}) = 0.76 - \frac{2.4}{71.4} (1 + 0.76) \approx 0.70,$$

and

$$a_f = \frac{\epsilon_{f_1} - \epsilon_{f_2}}{p} = \frac{0.76 - 0.7}{2} = 0.03 \text{ cm}^2/\text{kg}.$$

Mapping of Frozen Ground

The data obtained from hydrogeological observations of frozen ground in the field are organized and mapped. An example, compiled by V. K. Ivanovskii,¹ is shown in Figure 147. The map indicates spring outlets, places of icing formation, heaving mounds, cave-in lakes, funnel-shaped holes, areas of heave and subsidence, and migrating streams. When present, fossil ice is mapped. Various types of ground-water are marked by hatching.

It is often advisable, especially when surveying for road construction or for determining the direction of a water supply line, to provide a longitudinal geological and frozen-ground profile of the area. Figure 148 shows an example. The conventional symbols are used to indicate the different types of loose ground, bedrock, and permafrost, as well as the upper boundary of permafrost at the moment of observation. A plan of the ground is also given, and the vegetation, the division of the layout in sections, slopes, elevations, lengths of surveyed areas, and curvatures are indicated.

1. N. K. Ivanovskii (1936) K voprosu o metodakh issledovaniia vechnoi merzloty v tseliakh proektirovaniia inzhenernykh sooruzhenii (Methods of investigating permafrost for construction planning), Geologo-razvedochnoi konferentsii po Severu (Geological Research Conference on the North), Trudy I. Izd. GUSMP, tom III.

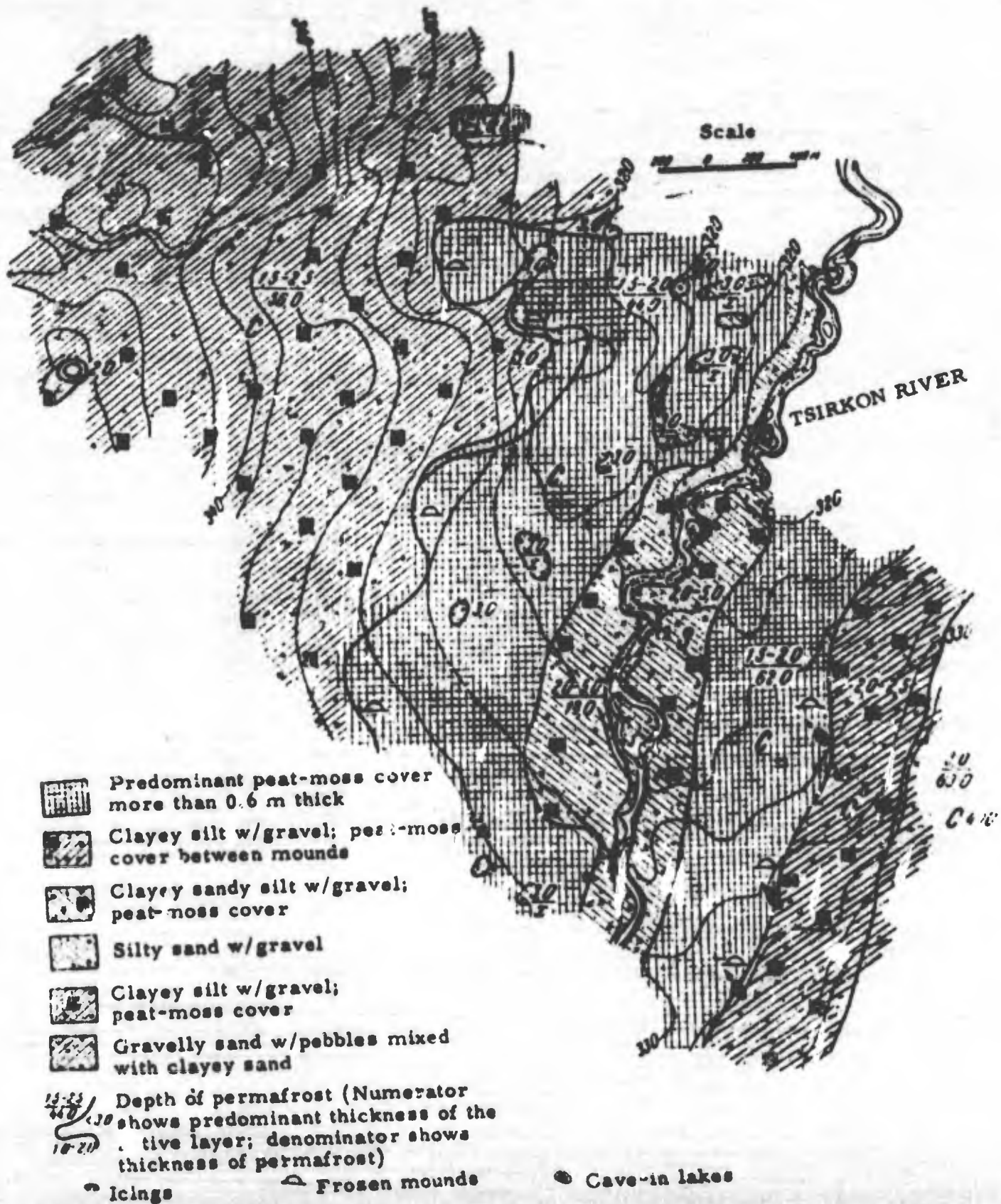

Figure 147. Map of the soil and frozen ground, at the site of a paper-cellulose factory.

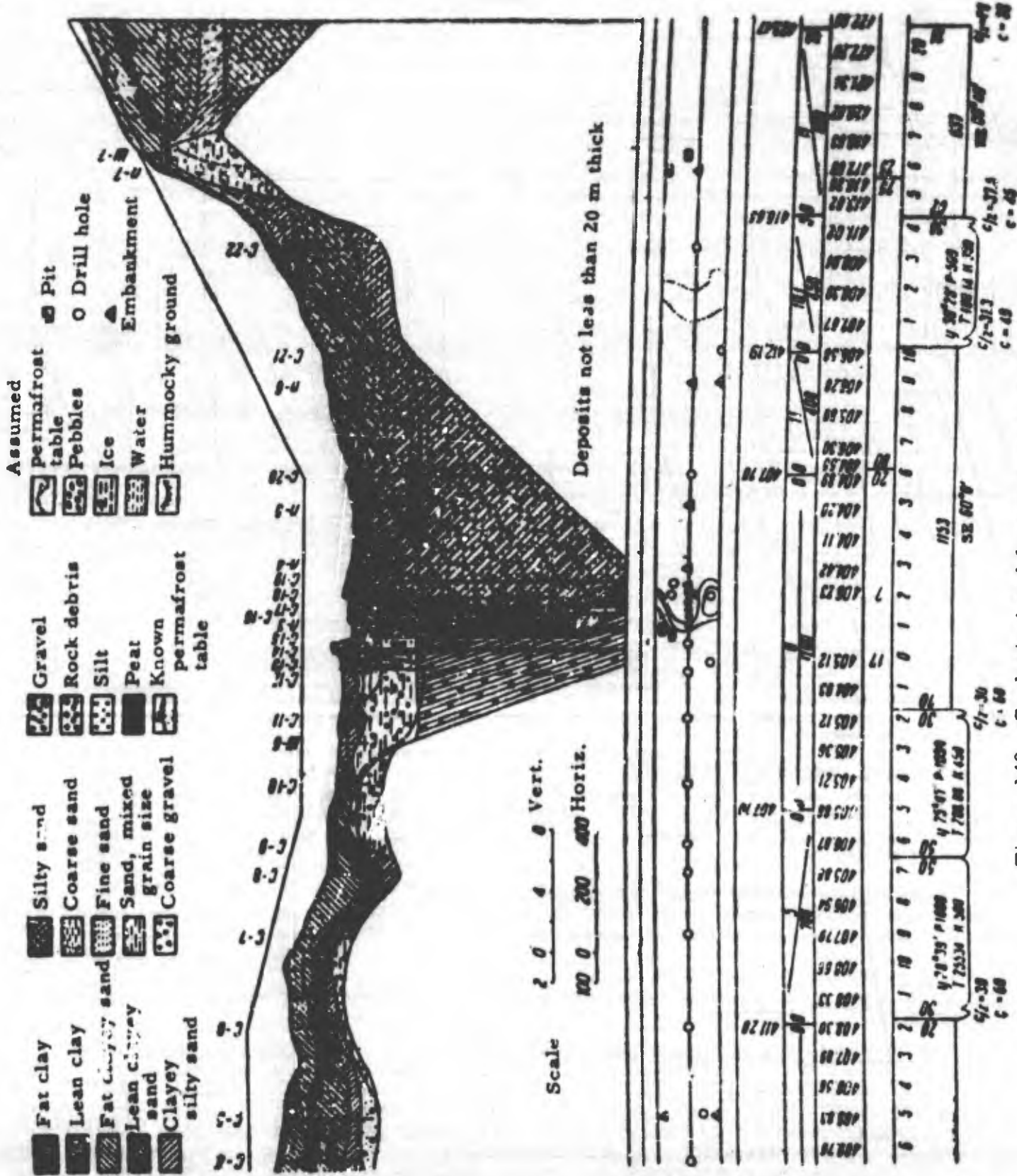

Figure 148. Geological and frozen ground profile.

CHAPTER X. PLANNING AND CONSTRUCTING FOUNDATIONS FOR STRUCTURES ON PERMAFROST

Selection of type of foundation to be used under permafrost conditions

General considerations

When building on permafrost, serious consideration must be given to the type of foundation. In many cases, the stability and strength of the entire structure will depend on the type of foundation selected.

At the present time, there are two fundamental principles for construction on permafrost: the principle of maintaining the permafrost regime under the construction and the principle of eliminating it.

The type of foundation for construction using either principle will often differ greatly. The selection of the type of foundation to be used and the method of its construction will depend both on the properties of permafrost and on the properties of the building itself.

The fundamental properties of permafrost which influence the selection of foundation are temperature, thickness, and vertical distribution of the permafrost, and also the ice saturation and hydrological regime of the construction site. In many cases, the grain-size composition is also an important factor.

The thermal regime within the buildings and the size of the building area, as well as certain structural characteristics, such as deep, heated cellars, the presence of water conduits, the discharge of waste hot water, will considerably influence selection of foundation and method of construction.

In constructing some metallurgical plants (such as an open-hearth, reverberatory furnace plant, and others) it would hardly be reasonable to choose the foundation according to the principle of maintaining the permafrost because of the considerable heat radiation by these structures.

Unheated structures or those which are heated only up to normal room temperature will disrupt the permafrost regime much less.

Where the thickness of the permafrost in a given region is considerable, its temperature is several degrees below 0C. Then the permafrost regime can be maintained, if the building does not radiate a great amount of heat, and construction should be done according to this principle.

Unheated wooden buildings and dwellings and community buildings which are heated to a normal temperature can be built on the basis of maintaining the permafrost regime. In these cases the depth to which the foundation should be laid and its construction (air space under the floor, etc.) are determined on the basis of a constant negative temperature at the base of the foundation.

When layered permafrost with a temperature of approximately -0.1C is present, or when the permafrost appears in island-like masses, negative temperatures are very difficult to maintain under heated structures and still more difficult under hot workshops. In this case, construction is based on the principle of gradually eliminating the permafrost under the structure. The procedure is the same as that used in weak unfrozen ground, but the heaving of the ground and possible settling of the foundation is taken into consideration.

Generalizing from the above and considering the data on regional distribution of permafrost according to temperature, which was analyzed in Chapter VII, the following conclusions may be drawn.

1. In regions where the temperature of the permafrost is about -5C, the basic method of building structures and foundations is the method of maintaining the permafrost regime. The only exceptions are those structures which emit a great amount of heat (workshops with high temperature). These are erected on solid rock or gravel (which contains no ice lenses).

2. In regions where the temperature of the permafrost varies from -5° to -1.5°C , both methods of construction can be used, and the choice of method will depend on local conditions, ice saturation of the ground, and the thermal regime of the structures.

3. In the southern region of permafrost where the temperature of the permafrost is above -1.5°C , especially in areas of sporadic or layered permafrost, the basic method of construction is based on the elimination of permafrost under the structure. However, as described below, the principle of eliminating permafrost can be applied only when the type of ground is suitable — pebble, gravel, or sandy ground — and layers of fossil ice are completely absent.

With ground of other grain-size composition, such as clay and silty soils, which become liquefied masses with very small bearing capacity when they thaw, it is impossible to build without taking special measures, which sometimes are very expensive. In these permafrost regions it would be reasonable to plan maintenance of the permafrost regime.

Selection of the construction site

In a permafrost region, special attention must be given to the selection of the construction site. Aside from general economic and other considerations, site selection should be based on studies of the properties of the ground of the given region. Frozen clay and silty soil are the least favorable. In many cases, because of their considerable ice saturation and poor drainage, they become liquefied when they thaw, and solidify very slowly under load. Moreover, these soils have a strong tendency to heave upon freezing.

More favorable types of ground for construction are sandy, gravelly, and pebbly ground. Moist ground of this category has little tendency to frost heaving. Moreover, these soil types still have bearing capacity when they thaw, although less than permanently unfrozen ground. Construction on these types of ground is considerably less difficult than on other types. However, the presence of suprapermfrost water causes heaving even in sandy and pebbly ground, as we have observed many times in permafrost regions.

When selecting the site for construction, special attention should be paid to the presence of lenses and ice interlayers in the permafrost. Undiscovered ice lenses will inevitably cause complete destruction of the building, especially if no measures were taken against permafrost thawing, as was noted previously regarding the fish cannery at Anadyr'.

If the structure is on rock (the most favorable situation), the erosion and decay of the rocks should be noted as well as their ice saturation. As a rule, bedrock at a considerable depth in permafrost is sheared, sometimes into fine sand or even dust.

Summarizing what has been said about construction sites under permafrost conditions, the following conclusions are drawn:

1. The most favorable base under permafrost conditions is bedrock.
2. Of the available types of ground, the best appears to be sandy, gravelly, and pebbly ground — especially when it has low moisture content.
3. The presence of large lenses of fossil ice makes an area unusable for construction.
4. Suprapermfrost water with a constant flow and swamp areas are negative characteristics of a region.

Selection of the foundation type

Choice of foundation type depends on the above-described properties of the active and permafrost layer, as well as on the thermal regime of the building, area of the site, and the type of structure.

At present, the main types of foundations are: 1) continuous foundations, 2) foundations in the form of separate pillars, 3) foundation slabs, 4) solid blocks laid at a great depth, 5) foundations on artificial bases, and 6) simplified foundations.

1. Continuous foundations, especially if made of rubblestone, are not satisfactory for permafrost conditions. Because of the considerable area of heat transmission, these foundations greatly disturb the thermal regime of the frozen ground and cause considerable

settling of the south wall in most cases. Moreover, the foundation does not withstand the tensile stresses which occur when the active layer freezes and swells, so that the foundations crack and become completely useless very quickly. The greater contact area of the ground with the uneven surface of the continuous rubblestone foundation increases the effect of heaving and makes this type of foundation unsuitable for either method of construction — maintaining or eliminating permafrost.

2. Foundations of the pillar type are the best under permafrost conditions, either for maintaining or eliminating the permafrost regime. The separate pillars should be of material which resists the tensile or bending stresses that may be caused by swelling of the ground of the active layer. Such materials are: ferroconcrete, sometimes reinforced concrete, and wood.

Calculations and observations of experimental structures indicate that almost the only method of maintaining the permafrost regime is a space between the floor and the ground which is ventilated during the winter. The following must be determined: conditions under which the permafrost regime will be most stable beneath the construction; how deep the foundation must be to reach permafrost which will be preserved; and the strength and stability of the foundations during swelling of the ground of the active layer.

When constructing according to the principle of eliminating permafrost, it is necessary to estimate the permissible pressure of the foundation on thawed permafrost, the resistance of foundations to heaving, and the expected settling of the constructions.

3. Solid foundation slabs are used with the method of permafrost elimination in ground which has low bearing capacity, due to thawing of the permafrost and great external loads on the bases. The foundation slabs must be laid deeper than the base of the active layer. Usually the external loads are transferred from the ground level to the foundation block by means of individual foundation supports. In many cases this type of foundation would be the most logical one to use.

4. If bedrock is not too deep (approximately 3-10 m) it will often be practical to use solid massive foundations in the form of thick individual pillars at a great depth. The size of the foundation should be determined according to the given external load and the foundation should be tested for heaving.

5. When building on frozen clay, silt, clayey sand and silty sand, using the principle of eliminating the permafrost, artificial strengthening of the natural base is necessary, because these soils have low bearing capacity when thawed. The use of thick sand and gravel fill, grillage foundations, and piles will improve their bearing capacity and distribute the load more equally.

6. Wooden houses in many cases require only foundations of sleeper supports or wooden cross bars.

Data Necessary for Planning Foundations

When foundations are to be constructed according to the principle of maintenance of the permafrost regime, the following data are necessary:

1. Temperature of the active layer (average for each month for not less than a year) and temperature of the permafrost mass.
2. Meteorological data, mainly air temperature.
3. Physical properties of the ground of the active layer and the permafrost layer (moisture content, unit weight, grain-size composition).
4. Mechanical properties of frozen ground.
5. Thermal properties of the active and permafrost layers and of the foundation and floor materials.

The temperature of the active layer and of the permafrost mass must be known in order to establish a heat balance when estimating the stability of permafrost under a building and determining the depth to which the foundation should be laid. In most cases, the required data are not available for the area under construction, and we must use the temperature observations from nearby permafrost or meteorological stations, compared with

temperature data from test pits. As previously stated, the temperature of permafrost can be determined by observations in drill holes.

Air temperature data are also taken from nearby meteorological stations. These data are necessary for obtaining a heat balance and for deciding the height of the ventilated basement. For this we usually take the average monthly air temperature over a period of many years. Unfortunately, meteorological stations give air temperature in the shade only. This makes it very difficult to evaluate the effect of insolation on the thermal regime of walls and foundations.

We compared data from the meteorological station with the air temperature observed at the north and south walls of the experimental house in the Transbaikal region.¹ The data of the meteorological station was close to the air temperature at the north wall; the air temperature at the south wall, however, was considerably higher. For convenience in comparing the temperature at the south wall with the temperatures in the meteorological shelter (measurements were taken in an English shelter), the coefficient of insolation χ is introduced:

$$t_s = t_{ms} (1 + \chi), \quad (64)$$

where t_s is the air temperature at the south walls, t_{ms} is the air temperature in the meteorological shelter (+ or -) and χ is the coefficient of insolation.

Table 96 shows our calculated values of the coefficient of insolation for the city of Petrovsk-Zabaykal'skiy.

Table 96. Coefficients of insolation χ for Petrovsk-Zabaykal'skiy.

Month	χ , coefficient of insolation				Avg air temp, 1886 - 1919, from meteorol. station (C)
	1932	1933	1934	3-yr avg 1932 - 1934	
Jan	-0.12	-0.23	-0.31	-0.22	-0.28
Feb	-0.29	-0.30	-0.37	-0.32	-22.7
Mar	-0.84	-0.95	-0.53	-0.74	-13.6
Apr	0.54	0.82	9.1	0.68	-1.5
May	0.29	0.30	0.18	0.26	6.9
June	0.19	0.44	0.12	0.25	14.3
July	0.17	0.19	0.14	0.17	17.2
Aug	0.17	0.22	0.18	0.19	13.9
Sept	0.19	0.29	0.49	0.32	6.3
Oct	0.43	1.70	-1.50	(0.21)	-3.3
Nov	-0.83	-0.49	-0.78	-0.70	-15.5
Dec	-0.30	-0.22	-0.63	-0.38	-23.9

Note: The value given in parentheses is doubtful.

For the north walls of the buildings, as observations showed, the coefficient of insolation is zero. It is essential to determine the coefficient of insolation for other permafrost regions. Without knowing its value, it is impossible to calculate the influence of the heating of the south walls on the permafrost regime, which is one of the primary reasons for the uneven settling of foundations.

1. N. A. Tsytovich (1934) Issledovanie temperaturnogo rezhima fundamentov i grunta v oytzorn dome Petrovsk-Zabaykal'skoi merslotnoi stantsii (Investigation of the thermal regime of foundations and ground in the experimental house at Petrovsk-Zabaykal'skiy Frozen Ground Station), Leningrad Inst. soorush., manuscript.

It is necessary to know the physical properties of the ground of the active and permafrost layers — moisture (ice saturation), unit weight, and grain-size composition, in order to select (from the proper table, see Ch. IV) the estimated value of the adfreezing forces and the permissible compressive and shearing stresses.

Data on the thermal properties of unfrozen and frozen ground: the coefficient of thermal conductivity and the heat capacity, which are necessary for thermal calculations for the foundations, are usually taken from the proper technical manuals.¹

When building on the principle of eliminating permafrost, the following data are necessary:

1. The physico-mechanical properties of the ground of the active layer and of the permafrost when it thaws, to a sufficient depth below the base of the foundation.
2. The temperature of the active layer at different depths, monthly averages during the period of negative air temperatures.
3. The coefficient of compressibility of the frozen ground when it thaws under load.

Of the properties mentioned in section one, the most important are: the angle of internal friction of the ground, the unit weight of the ground, and its natural porosity. These data are necessary for determining the permissible load on frozen ground after thawing. To check foundation heaving it is necessary to know the moisture distribution curves in the active layer and the upper layer of permafrost (to 1 or 2-m depths), the field characteristics of the ground based on grain-size composition, and the temperature of the active layer at different depths during the period of negative air temperatures.

To estimate settling, the coefficient of compressibility of thawing frozen ground under load must also be known. This can be determined by field tests or by the method of experimental loads, as was discussed previously.

Calculating the Stability of the Frozen Ground Beneath the Building

The experience of builders and an analysis of the chief types of deformation of structures built under permafrost conditions show that deformation is caused by uneven thawing of frozen ground under the base and heaving of the active layer, due to the annual freezing and thawing of the ground. Therefore, the main problems in planning foundations under permafrost conditions are: calculation of the stability of the permafrost regime under the building (if preservation of the permafrost regime is planned); and calculation of heaving.

As already stated, the problem of maintaining the permafrost regime under a structure, and the consequent problem of maintaining constantly negative temperatures at the base of foundations, is most simply solved by a space beneath the floor, ventilated in the winter and closed in the summer.

It should be noted once again that solid foundations with a closed basement are unsuitable for maintaining the permafrost regime under a building.

The use of nonconducting floors with considerable thermal resistance also does not solve this problem, since the permafrost will be heated anyway, although it will take somewhat longer. Actually, when the space under the floor is closed, there will be no heat loss by the surface of the ground under the building, because the temperature of the ground will always be lower than the temperature of the floor, even though the floor is non-heat-conducting; i. e., the permafrost will be heated by the heat emitted by the building. When the space below the floor is ventilated during the winter, however, the heat emitted by the building (because of the temperature difference between the interior of the building and the air space) will be carried away by the ventilating air.

The temperature of the air inside the building is designated as T , and the temperature of the outside air as t_0 . Obviously, the first of these values will be more or less constant approximately 15C to 20C, and the second will vary considerably depending on the season. At certain times of the year (for instance in summer), t_0 can be equal to or even greater

1. See for example, A. P. Kasantsev (1932) Spravochnaia kniga po otopeniiu i ventilatsii (Handbook on heating and ventilation). Moscow.

than T , and then the building will not serve as a source of heat. In other much longer seasons (fall, winter, and spring) the temperature of the outside air will be lower than the temperature inside the building, and then the building will emit heat with an intensity proportional to the temperature gradient.

If the permafrost regime is to be preserved under the building, it is necessary to determine whether the permafrost table will remain constant or will recede below the base of the foundation. We will discuss the foundation system composed of individual pillars, with the floor of the building elevated to a certain height above ground level and the space below the floor open on all sides. This is the best system, as far as heat is concerned, since it provides a maximum area of heat loss to the surrounding air and ground and a minimum area of heat transmission.

To solve the problem of a stable permafrost regime under buildings and foundations, it is necessary to examine two possibilities: first, the possibility of general warming of frozen ground under the entire building; and, second, the possibility of frozen ground being warmed by individual foundations, especially if the heat conductivity of the foundation material is greater than that of the surrounding ground. The method of approximation for determining the stability of the thermal regime of permafrost under an entire building will be discussed.

Depth of freezing and thawing of ground in the air space below the floor

The depth of freezing of the ground in an open area will be compared with the depth of freezing under a building with a space under the floor open on all sides but without any ventilation. The first approach will be to set forth the hypothesis that heat loss of the ground during winter is directly proportional to depth of freezing, in both cases. Such a hypothesis is quite logical. The more heat loss from the ground, the deeper the ground will freeze. The more heat received by the ground during the summer period, the deeper the thawing.

The following symbols are introduced:

h is the depth of freezing and thawing in an open area (thickness of the active layer).

h_1 is the depth of freezing of ground beneath the space under the floor.

h_2 is the depth of thawing of the ground beneath the space under the floor.

Q_1 is the amount of heat lost by the ground in an open area during the cooling period.

Q_2 is the amount of heat received by the ground in an open area during the warming period.

q_1 is the amount of heat radiated by the floor of the building during the winter.

q_2 is the amount of heat radiated by the floor during the summer.

Then, the depth of freezing can be expressed by¹

$$h_1 = h \left(1 - \frac{q_1}{Q_1} \right). \quad (65)$$

This equation would be correct if the amount of heat lost during the winter is equal to the amount of heat received during the summer, i. e., if the depth of penetration of the negative temperature in the ground, h' , is equal to the depth of thawing of the ground, h'' , i. e., if $h = h' = h''$.

In nature, however, this is not always correct. If $Q_1 > Q_2$, which is usually the case in permafrost areas, then the depth of penetration of the negative temperature in the ground will be greater than the depth of thawing.

To more closely approximate actual conditions in permafrost regions, a new factor, $\frac{Q_1}{Q_2}$, should be introduced into eq 65.

1. N. A. Tsytovich (1933) Lektsii po raschetu fundamentov v usloviakh vechnoi merzloty (Lectures on the calculations for foundations under permafrost conditions), Leningrad, inst. soor.

Then

$$h_1 = h \left(1 - \frac{q_1}{Q_2}\right) \text{ or } h_1 = h \left(\frac{Q_1 - q_1}{Q_2}\right). \quad (66)$$

Eq 66 can be used to determine the depth of freezing of the ground beneath the space under the floor.

Ground in an open area thaws to a depth equal to the thickness of the active layer. Thawing will not be as intense in the space under the floor as in the open area, which is heated by the sun's rays.

The influence of shade, which can be expressed by the shading coefficient, ψ , must be considered. The value of the coefficient ψ must be obtained by comparing measured depths of freezing and thawing in the shade and in the sun.

According to the experimental data of the Transbaikal Railroad (8th Symposium of NKPS, 1931, p. 79-80), the depth of thawing diminishes approximately 10-20% in the shade.

According to Vakulov (Symposium 13, on highways and dirt roads NKPS) the depth of thawing is approximately 18-20% less in the shade.

From this data, we can take the decrease as approximately 15%, which gives a shading coefficient $\psi = 0.85$.

Further experiments should define this value more accurately for different cases of shading and for different properties of the surface.

For the period of positive air temperatures, the relationship between the depth of thawing beneath the space under the floor h_2 and in an open area h will be

$$h_2 = h \left(\frac{\psi Q_2 + q_2}{Q_2}\right). \quad (67)$$

The simple equations 66 and 67 can give a first approximation for solving the problem of the stability of the permafrost regime under the entire structure.

Achieving a thermal balance

In order to apply these formulas, it is necessary to calculate q_1 , q_2 , Q_1 , Q_2 .

The amount of heat emitted by 1 m² of the floor of the building in 1 hr is determined by the generally known equation

$$q_{1,2} = \frac{(T - t_0)}{R}, \quad (68)$$

where R is the thermal resistance of the floor.

The thermal resistance R is the converse value of the general coefficient of thermal conductivity K which is used for thermal calculations in construction mechanics, and is equal to:

$$R = \frac{1}{K} = \frac{1}{a} + \frac{1}{a_0} + \sum_{i=1}^n \frac{l_i}{\lambda_i}. \quad (69)$$

The meaning of the values in eq 69 can be found in the handbooks on heating and ventilations, where a and a_0 are the total values of the coefficient of convection and radiation of the inner and outer surface of the floor of the building; λ_i is the coefficient of thermal conductivity of the floor material, and l_i is the thickness of the layer of the material of which the floor is built.

Eq 68 gives the amount of heat radiated by the floor during one hour. With the meteorological data giving average monthly air temperatures, the heat loss for each month can be calculated from

$$q_{1,2} = \frac{(T - t_a)}{R} \cdot 24 \cdot m \quad (70)$$

where m is the number of days with positive or negative air temperature.

As an example, we give our calculations of heat loss for the Yakutsk magnetic observatory, which was built with an under-floor space ventilated during the winter.

The following data were obtained:

Thermal resistance of the building floor: $R = 8.3$

Estimated inside temperature of the building: $T = +20C$.

Average Monthly Air Temperature (C)			
Jan	-43.5	July	+19.0
Feb	-35.5	Aug	+14.5
Mar	-22.2	Sept	+ 6.0
Apr	- 7.9	Oct	- 8.0
May	+ 5.6	Nov	-28.0
June	+15.5	Dec	-40.0

Then for the period of negative temperature, assuming that the temperature in the air space under the floor is equal to that of the outside air, which adds to the safety factor, we have:

$$\text{January } q_1 = \frac{20 + 43.5}{8.3} (31 \cdot 24) = 5680 \text{ (kcal).}$$

In the same manner, we obtain:

Month	q_1 (kcal)
Feb	4400
Mar	3780
Apr	2420
Oct	2510
Nov	4170
Dec	5440

Summarizing the values, we see that 1 m^2 of the floor lost 28400 kcal of heat during the negative temperature period. A similar calculation for the positive temperature period gives us:

Month	q_2 (kcal)
May	1287
June	390
July	90
Aug	493
Sept	1214

$$\sum q_2 = 3474$$

From these results, we can conclude that a building emits much less heat to the space under the floor during the summer than during the winter; i. e., the thermal regime under the building is determined by the winter period.

1. Usually, the thermal resistance of the floor structure is considerably smaller than that given in this example; on the average $R = 2 - 4$.

PRINCIPLES OF MECHANICS OF FROZEN GROUND

The thermal balance in the open air, i. e., the values Q_1 , Q_2 , can be obtained from actinometrical data (solar radiation, reflective and absorbing properties of the ground surface, etc.) or by direct calculation of the amount of heat received or lost by the ground, if the ground temperature during the year, its moisture, specific heat, and unit weight are known. The latter method will be used.

The following symbols are used:

- c_1 — specific heat of ice ($c_1 = 0.5$),
- c_2 — specific heat of dry ground.
- δ — unit weight of the soil skeleton (it should be noted that, for all types of ground, the product of $c_2\delta$ is very close to 0.50).
- w — moisture by dry weight of the ground (i. e., the ratio of the weight of the water in the ground to the weight of the dry ground), expressed in fractions, for instance: $w = 0.25$.
- t_1 — negative temperature at the beginning of the period.
- t_2 — positive temperature at the end of the period.
- h_1 — thickness of the soil layer (cm).

Then the amount of heat received by the ground over a certain period of time (for instance a month) during which the temperature changes from $-t_1$ to $+t_2$ can be expressed by

$$Q_2 = h_1 \left[\begin{array}{ll} c_1 w \delta t_1 & \text{heating of ice up to } 0\text{C.} \\ + c_2 \delta t_1 & \text{heating of the dry ground to } 0\text{C.} \\ + 80 w \delta & \text{latent heat of melting ice} \\ + w \delta t_2 & \text{heating of water from } 0\text{C to } t_2 \\ + c_2 \delta t_2 \end{array} \right]; \quad \text{heating of ground from } 0\text{C to } t_2$$

or

$$Q_2 = h_1 [c_1 w \delta t_1 + c_2 \delta t_1 + 80 w \delta + w \delta t_2 + c_2 \delta t_2]. \quad (71)$$

For calculation of the heat loss due to temperature change of the ground from $+t_2$ to $-t_1$, eq 71 will be:

$$Q_1 = -h_1 [c_1 w \delta t_1 + c_2 \delta t_1 + 80 w \delta + w \delta t_2 + c_2 \delta t_2]. \quad (72)$$

If the heating of the ground occurs only from $+t_2$ to $+t'_2$, then the amount of the heat received by the ground can be calculated from the formula:

$$Q_2 = h_1 [w \delta + c_2 \delta] (t'_2 - t_2). \quad (73)$$

Finally, if the ground cools only from $-t_1$ to $-t'_1$, eq 73 will be:

$$Q_1 = -h_1 (c_1 w \delta + c_2 \delta) (t'_1 - t_1). \quad (74)$$

As an example, we give the results for the construction area of the Yakutsk magnetic observatory, calculated according to the above method.

We have:

1. Ground temperature to a depth of 4 m, monthly averages for one year.
2. Moisture distribution in the ground taken every 10 cm to a depth of 4 m.
3. Data on the grain-size composition of the ground.

Calculations from these data show that heat loss from each square meter of area of the the ground is:

$$Q_1 = -92190 \text{ kcal.}$$

The inflow of heat for each square meter of the ground surface is:

$$Q_2 = +80160 \text{ kcal.}$$

It should be noted that (because of lack of data) we did not consider temperature changes at depths below 4 m, which could change the figures to some extent.

Substituting the data in eq 66 and 67, and taking 2 m as the thickness of the active layer, we have: Depth of freezing in the ground beneath the under-floor space is

$$h_1 = h \left(\frac{Q_1 - q_1}{Q_2} \right) = 200 \frac{92190 - 28400}{80160}.$$

$$h_1 = 159 \text{ cm.}$$

Depth of thawing beneath the under-floor space is

$$h_2 = h \left(\frac{\psi Q_2 + q_2}{Q_2} \right) = 200 \frac{0.85 \cdot 80160 + 3473}{80160}.$$

$$h_2 = 179 \text{ cm.}$$

Thus, the ground beneath the building will thaw 20 cm deeper each year than it will freeze. This is absolutely not permissible for maintaining the permafrost regime under a construction. The calculation shows that the amount of heat emitted by the floor is so great that the upper border of permafrost under the building will gradually lower. The heat emitted during the winter must be eliminated by ventilating the space under the floor or by increasing the thermal resistance R of the floor.

Planning the Air Space under the Floor

The amount of heat emitted by the floor of the building is expressed by eq 70:

$$q_0 = \frac{(T - t_0)}{R} 24 \text{ m.}$$

from which

$$R = \frac{(T - t_0) 24 \text{ m}}{q_0} \quad (75)$$

where T is the temperature inside the building; t_0 is the average temperature in the space under the floor for the period of negative air temperatures (if temperature data for the space are not available, the average temperature of the outside air can be used); m is the number of days with negative temperature during the year, and q_0 is the permissible amount of heat for maintaining the permafrost regime.

To maintain the permafrost regime beneath a building, the depth of ground freezing under the floor should not be less than the depth of thawing, i. e.,

$$h_1 \geq h_2$$

Substituting h_2 for h_1 and the permissible amount of heat q_0 for q_1 in eq 66 gives

$$q_0 = Q_1 - \frac{h_2}{h} Q_2 \quad (76)$$

Eq 76 can be used for determining the permissible amount of heat (for maintaining the permafrost regime) emitted by the floor of a building into a space under the floor which is open on all sides without ventilation.

The value of q_0 , from eq 76, is now substituted into eq 75, to determine the thermal resistance R of the floor. This is essential for maintaining the permafrost regime.

When R is known, the proper construction of the floor is chosen. To allow convection of the air, the height of the air space under the floor should not be less than 50 cm.

Another method of solving this problem is to determine what height the space must be so that the natural circulation of the air will remove the heat emitted by the floor of the building at the given thermal resistance of the floor, R .

The temperature of the floor t_n can be found from

$$t_n = t_0 + \frac{T - t_0}{a_0 R}, \quad (77)$$

where t_0 is the air temperature in the open space under the floor, which can be considered equal to the winter temperature of the outside air; T is the temperature inside the building; a_0 is the coefficient of the heat emission from the floor surface (ceiling of the air space) to the outside air (with little air movement under the floor, a_0 can be taken as 5 cal/m²-hr); R is the thermal resistance of the floor construction.

The amount of heat emitted by one square meter of the floor per hour can be determined by the formula:

$$Q = \frac{T - t_{av}}{R} \quad \text{cal/hr} \quad (78)$$

where, t_{av} is the average air temperature in the cellar which can be taken as approximately equal to:

$$t_{av} = \frac{t_0 + t_n}{2}$$

where t_0 is the average air temperature for the coldest month of the year, and t_n is the average air temperature of the floor surface in the space under the floor. This is the amount of heat which must be eliminated.

Calculating the amount of heat to be removed according to eq 78 gives us some engineering margin over that calculated from eq 76 and reduced to the same units.

The volume of air which must be eliminated can be determined from

$$L = \frac{Q(1 + \alpha t_{av})}{0.31(t_n - t_0)} F \quad \text{m}^3/\text{hr} \quad (79)$$

where α is the coefficient of volume expansion of the air, equal to $\frac{1}{273}$, and F is the area of heat emission for the entire space under the floor.

However, since not all the air which comes from below will actually acquire the temperature of the floor surface, the air volume as calculated in eq 79 must be increased. Usually, in planning ventilation, the increase in volume is considered to be from $\frac{2}{3}$ to 1.

If the volume of air subject to removal is increased by 1, eq 79 will read:

$$L = 2 \frac{Q(1 + \alpha t_{av})}{0.31(t_n - t_0)} F.$$

PRACTICAL APPLICATIONS

273

Knowing the volume of the air and the area of all the air vents beneath the floor, F_0 , the velocity of the air is determined from

$$v = \frac{L}{F_0} \quad (81)$$

If the volume of the air to be removed, L , is expressed in m^3/hr and the area of the air vents, F_0 , is expressed in m^2 , then the velocity of the air will be in dimensions of m/hr . This value must be divided by 3600 to convert it into m/sec .

To determine the pressure loss in the air vents, Torricelli's formula can be used:¹

$$H_1 = \frac{v^2 \gamma_{tc}}{2ga^2}, \quad (82)$$

where H_1 is the pressure loss, v is the air velocity in the area of the openings, γ_{tc} is the specific gravity of the moving air, g is the acceleration of gravity, and a is the coefficient of contraction (the coefficient of the narrowing of the air stream in the openings), which is usually considered to be 0.65. If v is expressed in m/sec , γ_{tc} in kg/m^3 , and g in m/sec^2 , the pressure H_1 will be in kg/m^2 or in mm of water column.

The pressure lost in the air vents must be less than the existing pressure, both expressed in millimeters of water column.

Considering the neutral zone to be at middle height of the air space, the existing pressure is calculated from

$$H = 0.5e (\gamma_{t_0} - \gamma_{t_{av}}) \quad (83)$$

Here, γ_{t_0} and $\gamma_{t_{av}}$ are the specific gravities of the air at the outside temperature and the average temperature of the air space. Specific gravity of the air is determined from:

$$\gamma_t = \frac{1.293}{1 + \frac{t}{273}}$$

Values of γ_t for different temperatures are given in the handbooks on ventilation.

For the necessary air circulation, there must be

$$H \geq H_1$$

or

$$H \geq \frac{v^2 \gamma_{tc}}{2ga^2} \quad (84)$$

Therefore, when working out the size of the space under the floor, the adequacy of the height is checked by eq 77 and 84.

1. The use of Torricelli's formula in this case was suggested by Engineer I. K. Khrenov in *K voprosu rascheta fundamentov v raionakh vechnoi merzloty* (Problems of planning foundations in permafrost regions). Manuscript. A more detailed discussion of the problems of natural ventilation is given in an article by Engineer G. Maximov (1930) *K voprosu ob estestvennom vozdukhobmene v zdaniakh pod vlianiem raznosti temperatur* (Problems of natural air circulation in buildings under the influence of temperature differences). *Biulleten' Gipromeza*, no. 7.

To improve ventilation of the air space and to acquire a greater pressure, a ventilating pipe should go through the center of the building into the space under the floor. Moreover, as indicated above, the height of the air space should not be less than 50 cm.

Stability of the permafrost regime under the base of foundations

We have analyzed the problem of a stable permafrost regime under an entire building, and established the conditions under which the permafrost table will not be lowered because of heat emitted through the floor. However, under certain conditions, warming and degradation of permafrost can occur under the bases of foundations, as the result of heat transmitted by the latter.

Theoretical and experimental data discussed previously (Ch. V), as well as observations in natural conditions (Ch. VIII) show that warming of permafrost can occur under foundations. There is an opinion that this happens only when the thermal conductivity of the foundation material is greater than that of the ground of the active layer. However, we will show that, even when the thermal conductivity of the foundation material is less than that of the ground, warming of the permafrost by foundations can occur under certain conditions.

Consider a building with a foundation made up of individual pillars, with a space below the floor which is ventilated during the winter (Fig. 149).

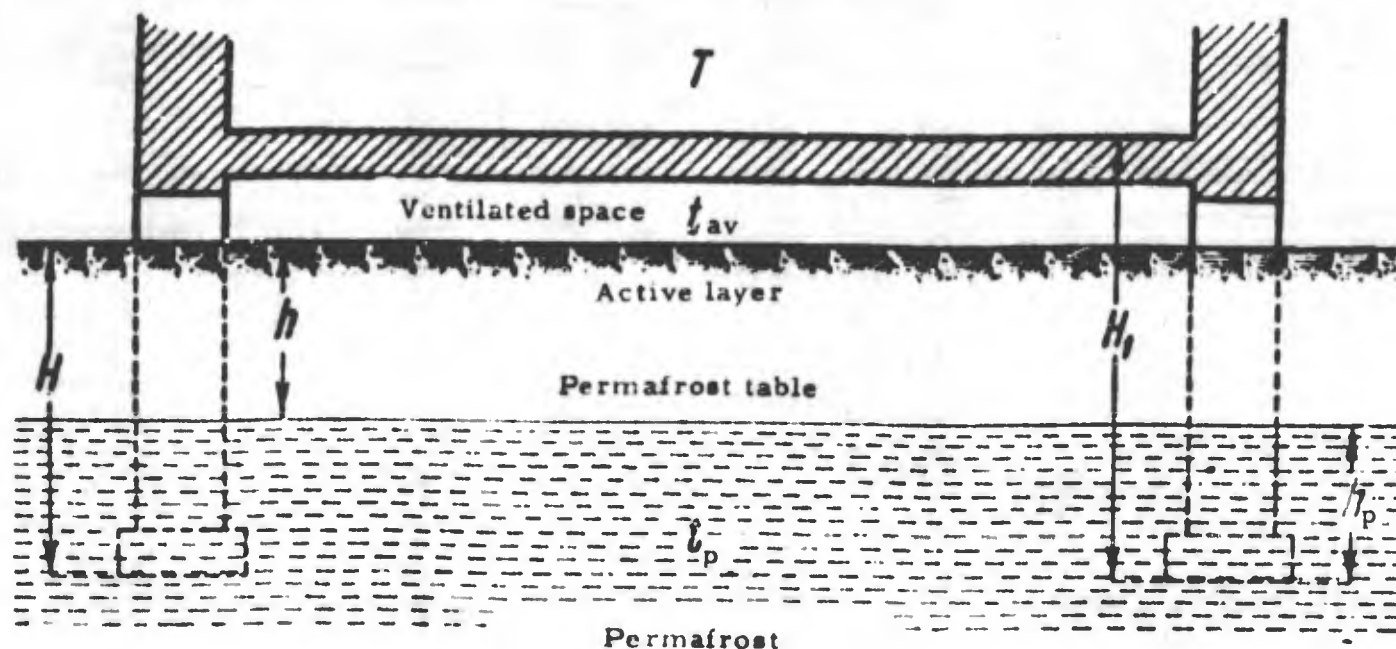

Figure 149. Plan of foundations planned according to the system of individual piles with a ventilated space under the floor.

The following symbols are used:

- H is the depth of the foundation beneath the surface of the ground.
- h is the thickness of the active layer.
- T is the temperature inside the building.
- t_{av} is the average temperature in the space under the floor during the period of observation.
- t_p is the temperature of permafrost at the level of the bottom of the foundation.

For stable heat flow on flat parallel surfaces, there is the following well-known equation.

$$Q = KF\Delta t$$

where Q is the amount of heat; K is the general coefficient of thermal conductivity — the inverse of the thermal resistance; F is the area of heat transmission; Δt is the temperature difference; and u is time.

Disregarding the lateral heat flow and considering only the downward direction of the main heat flow we can write the following two approximate equations for the summer period.

1. For the cross section of the foundation:

$$Q_1 = K_1 F \Delta t_1 u \quad (a)$$

where K_1 is the general coefficient of thermal conductivity of the foundation to the depth $H_1 - h_p$ (see Fig. 149) and $\Delta t_1 = T - t_p$.

2. For the cross section of the ground (halfway between foundations):

$$Q_2 = K_2 F \Delta t_2 u \quad (b)$$

where K_2 = coefficient of thermal conductivity of the layer of ground h , and $\Delta t_2 = t_{av} - t_p$.

The amount of heat transferred through the foundation should be less than or equal to the amount of heat transferred through the layer of ground with a thickness h and an equal area of heat transmission.

Therefore, the following approximate relationship can be written:

$$K_1 F \Delta t_1 u \leq K_2 F \Delta t_2 u \quad (c)$$

or

$$K_1 \Delta t_1 \leq K_2 \Delta t_2 \quad (85)$$

From this equation we can conclude that: the heating of permafrost by a foundation depends on the temperature differences Δt and on the general coefficient of K . Even if the thermal conductivity of the foundation material is less than the thermal conductivity of the ground, warming of permafrost under a foundation can occur under certain conditions if $\Delta t_1 > \Delta t_2$.

If eq 85 is fulfilled and the stability of the permafrost regime is assured by a ventilated space of the proper size under the floor, there is no particular reason to fear thawing of the permafrost under the foundations, since eq 85 leaves a certain margin although it does not consider the heat loss from the sides of a foundation.

The influence of a foundation on the general lowering of the permafrost table under structures can be estimated approximately and quite roughly by replacing the general coefficient of thermal conductivity of the floor k_1 (the inverse of the thermal resistance R) by k'_1 , determined from the equation:

$$k'_1 = \frac{f_1 k_1 + f_2 k_2}{f_1 + f_2}, \quad (86)$$

where f_1 is the free area of the floor (insulated from the bottom); f_2 is the total cross-sectional area of all foundations at the floor level; and k_2 is the general coefficient of heat conductivity of the foundations downward from the level of the floor to the surface of the ground.

At the present time, temperature distribution in the foundations can be discussed only in very general terms. It depends on a number of factors: the temperature within the building; the temperature of the active layer; the temperature of permafrost under the building and away from it; and the thermal properties of the foundation material and of the

ground. Moreover, the distribution of temperature in foundations will also be influenced by near-by foundations, the orientation of the building, and the shape of the foundations.

Because of the numerous factors influencing the temperature regime of foundations under permafrost conditions, an exact determination of temperature distribution in foundations presents considerable difficulties.

For these reasons, formulas based on equations of possible heat flow¹ should also be considered as only approximate.

It seems that the thermal regime of individual foundations and the influence of the thermal regime of a foundation on the stability of frozen ground under the structure can be determined more accurately by applying the method of heat balance to this case as well, taking into consideration the latent heat of thawing of ice.¹ The previously given thermal estimations of the stability of the permafrost regime under foundations are only a first approximation and are only generally confirmed by observations under natural conditions. Thus, observations of foundations of experimental buildings show that, if the space under the floor, ventilated during the winter, is the proper size, the stability of the permafrost regime is not disturbed, and also that foundations should be laid at least 1 or 2 m deeper than the maximum thickness of the active layer.

In conclusion, it should be noted that, when building according to the principle of maintaining the permafrost regime, besides the thermal calculations and the usual determination of the size of the foundation in relation to external forces (loads), it is necessary to estimate the possible heaving of foundations. In many cases this will be the factor determining the depth to which foundations should be laid.

Planning Foundations of Structures built on the Principle of Eliminating Permafrost

When constructing according to the principle of permafrost elimination, the basic considerations are:

1. Determination of the permissible load on the ground when the permafrost thaws, and determination of the size of the base of the foundation, according to the load.
2. Determination of the expected settling of foundations.
3. Estimation of heaving of foundations.

The first two problems will be analyzed in this section; foundation heaving is considered in a separate section, since it is of more general significance for all types of foundations on permafrost.

Determination of permissible load

When permafrost thaws, the bearing capacity of the ground decreases drastically. Determination of the permissible load on thawed ground must be based on the critical stress for plastic flow, i. e., the load at which extrusion of ground from under the foundation will begin.

For determining the critical load for plastic flow, Fröhlich's² equation from general soil mechanics can be recommended.

1. N. A. Tsytovich (1935) K voprosu rascheta fundamentov sooruzhenii vozvodimykh na vechnoi merzloty (Problems of planning foundations for structures on permafrost), Gipromez, Leningrad.
 (1930) O vybore tipa fundamentov v usloviakh vechnoi merzloty (Choosing the type of foundations for permafrost conditions), *Stroitel'stvo i promyshlennost*, nos. 6, 7.
 (1932) Lectioni po raschetu fundamentov v usloviakh vechnoi merzloty (Lectures on estimating foundations under permafrost conditions), Leningrad. inst. soor.
2. Ö. K. Fröhlich (1934) Druckverteilung im Baugrunde. Wien: Springer. See also N. A. Tsytovich (1934) Osnovy mekhaniki gruntov (Principles of soil mechanics), p. 235.

$$P_{crit} = \frac{\pi(p_{cap} + \gamma H)}{\cot \phi - \left(\frac{\pi}{2} - \phi\right)} \quad (87)$$

where: p_{cap} is the capillary pressure in the ground.

γ is the unit weight of the ground.

H is the depth to which the foundation is laid.

ϕ is the angle of internal friction of the ground.

For frozen ground which is thawing, the capillary pressure is zero. Then the equation becomes:

$$P_{crit} = \frac{\pi \gamma H}{\cot \phi - \left(\frac{\pi}{2} - \phi\right)} \quad (88)$$

The value ϕ expresses the angle of static internal friction of the ground, i. e., the angle of friction when the external load is transmitted totally to the soil skeleton. With thawing of permafrost, total transmission of the pressure to the soil skeleton can take place only under certain conditions. Calculations according to the theory of hydrodynamic pressures show that total transmission of pressure to the soil skeleton can be assumed only for water-permeable ground with a filtration coefficient greater than 10^{-6} cm/sec; and the compressed layer of ground under the footing of the solid foundation should not be thicker than approximately 3 m. For ground of low permeability, such as clay, total transmission of pressure to the soil skeleton will depend considerably on time and a diminishing resistance to friction will be observed. In this case, it is necessary to take into consideration the angle of internal hydrodynamic friction which varies with duration of consolidation from an insignificantly small value to the value of the static coefficient of internal friction.

The above analysis shows that, for frozen clay with a very small coefficient of water permeability, the permissible load at thawing will be so small that it appears impossible to build without taking special measures to strengthen the base.

The coefficient of internal friction for all other types of ground, (sand, silty sand, and clayey sand) should be determined in each case by the experimental method usually described in general soil mechanics. In preliminary calculations for sand and silty sand, the angle of natural slope in under-water conditions can be taken as the angle of internal friction, without large error.

For example, a foundation is laid to a depth of 3 m, on thawing frozen silty sand with a 22-deg angle of internal friction. The unit weight of the ground is $\gamma = 2$ t/m³, $\phi = 22^\circ$, $\cot \phi = 2.475$.

Then, according to eq 88:

$$P_{crit} = \frac{3.14 \times 2.3}{2.475 - \left(\frac{3.14}{2} - 0.384\right)} = 14.6 \text{ t/m}^2 = 1.46 \text{ kg/cm}^2.$$

To determine the permissible load, the computed value of critical pressure P_{crit} must be divided by the safety factor which can be taken as 1.2 to 1.5 depending on the design characteristics of the structure.

For instance, with a safety factor of 1.5, the permissible compressive stress is:

$$\frac{1.46}{1.5} \approx 1 \text{ kg/cm}^2.$$

If the calculated permissible pressure on thawing ground is very small (for example, 0.50 – 0.75 kg/cm² or less), it will be very difficult to construct foundations for heavy buildings (industrial or public buildings, and others). In such cases the weak ground under the foundations must be replaced with a sand-gravel fill. The depth to which the weak ground should be replaced can be determined by the theory of pressure distribution in the ground (Ch. VI). The maximum compressive stress along the vertical axis through the center of gravity to the base of the foundation is found; a diagram is constructed showing the vertical stress distribution in the thawed ground. Then, the required thickness of the sand-gravel fill is determined according to the permissible stress.

The permissible pressure for the sand-gravel fill can be found by the same equation, using the value of the angle of internal friction for sand, which, according to experiments by Professor Terzaghi, is 31-33°. After the permissible pressure on thawed ground and the size of the sand-gravel fill are determined, the size of the foundation is found in the usual way.

Estimation of foundation settling

Experimental data for determining the settling of frozen ground when it thaws were analyzed in Chapter VI. It was established that settling of thawing frozen ground under load depends primarily on the depth of thawing. The depth of thawing, as shown by laboratory and field experiments, is a very complex function of many factors. The most important factors are the temperature difference between the inside of the building and the frozen ground; the amount of ice in the frozen ground, the thermal properties of the ground, the foundation, and the floor of the structure and the insulation. Therefore, an exact determination of the settling of foundations on thawing frozen ground is hardly possible, and in any case an analytical determination would be very complex. At the same time, when building on the basis of permafrost elimination, it is necessary to predict the possible settling of the foundation, at least the approximate amount.

At least two cases should be analyzed: first, when the load of the construction is less than the critical load for the given type of thawing ground, and second, when the load is greater than the load which will cause extrusion of the ground from under the foundation, i. e., greater than critical.

In the first case, for uniform thawing, the final settling of the ground under load can be determined as described below.

In the second case, when the load is greater than critical, the settling will depend on the resistance of the adjacent ground to extrusion, and in many cases, especially for supersaturated frozen ground, the ground may settle nearly as much as the thickness of the thawed layer of ground.

This second case is absolutely unacceptable since the structure will be severely deformed and can be completely destroyed by the extrusion of liquefied soil from under the foundation. The critical load for thawing frozen ground, when the coefficient of its inner friction is known, is determined either by eq 88 or by experimental loading of thawing ground under a die.

In the first case, although the ground settles considerably as it thaws, it becomes consolidated with time, and the structure achieves a stable condition.

As our investigations in Chapter VI show, the final settling of uniformly thawing ground can be determined by the method of the equivalent layer. Uniform thawing can be assumed beneath foundations within the perimeter of a heated building. Under other foundations, thawing will be approximately uniform during the period of maximum heating (July and August). A foundation will settle finally and completely only when the ground under the foundation thaws to a considerable depth, which is sometimes several times greater than the width of its base.

The method of estimating the amount of settling of foundations according to the equivalent layer of ground takes into consideration the total zone of ground compressed under the foundation, the size and shape of the foundation, and the physical properties of the ground. This method makes it possible to predict the approximate final settling of the foundation when the permafrost layer thaws.

This method is only unapplicable to exceptionally heterogenous ground, as, for instance, ground with many ice lenses.

The final settling of the foundation on a layer of compressed ground is expressed by the equation:¹

$$s = h_s \left(\frac{a_f p}{1 + \epsilon_1} \right) \quad (89)$$

where h_s is the thickness of the equivalent layer of the ground, (i. e., the layer whose settling, with no lateral expansion of the ground, will be equal to the settling of a foundation of the given size and shape); a_f is the coefficient of compressibility of uniformly thawing frozen ground; p is the specific load (pressure) on the base of the foundation; ϵ_1 is the initial void ratio of undisturbed ground (the void ratio of frozen ground including voids and ice). The coefficient of compressibility of the ground, as pointed out before, is:

$$a_f = \frac{\epsilon_1 - \epsilon_2}{p}$$

where ϵ_2 is the void ratio of ground under load p after settling due to thawing ceases.

The coefficient of compressibility a_f , as stated before, is determined by testing a sample of frozen ground of natural structure or by experimental loading of thawing ground.

Substituting the equation for the coefficient of compressibility in eq 89, we get another equation for the final stabilization of the foundation settling:

$$s = h_s \left(\frac{\epsilon_1 - \epsilon_2}{1 + \epsilon_1} \right) \quad (90)$$

The thickness of the equivalent layer of the ground h_s according to Tsytovich is:

$$h_s = \frac{(1 - \mu^2)(1 - \mu)}{(1 - \mu - 2\mu^2)} \omega_0 b \quad (91)$$

where μ is the coefficient of lateral expansion of the unfrozen ground (analogous to Poisson's ratio for solid bodies); ω_0 is the shape factor which depends on the ratio of the length a of the rectangular base of the foundation to its width b , i. e., $a = \frac{a}{b}$, and on the rigidity of the foundation (this coefficient can be determined by using the theory of elasticity); b is the width of the base of the foundation.

If the effect of the coefficient of lateral expansion (Poisson's ratio) is expressed as A , then:

$$h_s = A \omega_0 b \quad (92)$$

To simplify calculation, Table 97 gives values of $A \omega_0$ for various coefficients of lateral expansion (from 0.15 to 0.45) and different shapes of foundation base (circle, square, and rectangles with ratios of sides from 1.5 to 100). The given data are for rigid foundations, (concrete and ferroconcrete). For very elastic blocks of little rigidity, the values of $A \omega_0$ will be larger.

1. N. A. Tsytovich (1934) Osnovy mekhaniki gruntov (Principles of soil mechanics), p. 201. Also Raschet osadok fundamentov kak funktsii vremeni, svoistv grunta i razmerov fundamentov (Estimation of foundation settling as a function of time, soil properties and size of the foundation).

Table 97. Values of A_{ω_0} for calculating the thickness of the equivalent layer of ground for the average settling of the entire loaded area.

Shape of the loaded area	a	Poisson's ratio (μ)							
		0.10	0.15	0.20	0.25	0.30	0.35	0.40	0.45
Circle	—	0.97	0.99	1.02	1.08	1.18	1.34	1.73	2.81
Square	1	0.96	0.97	1.01	1.07	1.17	1.32	1.71	2.78
Rectangle	1.5	1.16	1.18	1.23	1.30	1.40	1.60	2.07	3.37
"	2	1.31	1.34	1.39	1.47	1.60	1.81	2.34	3.81
"	3	1.55	1.58	1.63	1.73	1.89	2.13	2.75	4.48
"	4	1.72	1.75	1.81	1.92	2.09	2.36	3.06	4.98
"	5	1.85	1.88	1.95	2.07	2.25	2.54	3.29	5.36
"	6	1.98	2.02	2.09	2.21	2.41	2.72	3.53	5.64
"	7	2.06	2.10	2.18	2.31	2.51	2.84	3.67	5.98
"	8	2.14	2.18	2.25	2.40	2.61	2.95	3.82	6.21
"	9	2.21	2.26	2.34	2.47	2.69	3.04	3.92	6.42
"	10	2.27	2.32	2.40	2.54	2.77	3.13	4.05	6.59
"	20	2.67	2.75	2.82	2.98	3.25	3.67	4.75	7.73
"	30	2.91	2.97	3.08	3.25	3.54	4.00	5.18	8.44
"	40	3.10	3.16	3.28	3.47	3.77	4.27	5.53	8.99
"	50	3.25	3.32	3.44	3.64	3.96	4.47	5.80	9.43
"	100	3.73	3.80	3.94	4.16	4.54	5.12	6.64	10.81

Note: a = ratio of the sides of the rectangle $\frac{a}{b}$.

Very few experiments have been conducted to determine the coefficient of lateral expansion of the ground (Poisson's ratio). The data collected are given in Table 98.

Table 98. Coefficients of lateral expansion (Poisson's ratio) for ground at positive temperature.

Soil type	Poisson's ratio	Investigator	Recommended estimated value
Gravel-pebble	0.12 - 0.17	Tsytoovich and Kapylova (LIKS)	0.15
Sand	0.17 - 0.24	Wilson	0.20
Sand	0.20 - 0.29	Terzaghi	
Silty sand	0.21 - 0.29	Gumenski, Tsytoovich	0.25
Clayey sand	0.33 - 0.37	Pokrovski, Lash	0.30 - 0.35
Clayey ground	0.36 - 0.39	Terzaghi	0.37
Clay (fat)	0.40	Gumenski	0.40

With the data of Table 97 and 98, the void ratio of frozen ground, e_1 , and the coefficient of compressibility upon thawing, a_f , the final settling of a foundation on thawing ground can be determined.

Example. It is necessary to determine the final settling of a foundation on thawing frozen sand under a load of 1.5 kg/cm^2 . The foundation base is 6 m long and 1.5 m wide. The natural void ratio of frozen sand is $e_1 = 0.75$, and its coefficient of compressibility upon thawing under a load of 1.5 kg/cm^2 is $a_f = 0.05 \text{ kg/cm}^2$.

The ratio of the sides of the base is

$$a = \frac{a}{b} = \frac{6}{1.5} = 4.$$

From Table 97, for $n = 4$ and $\mu = 0.2$ for thawed sand, we find:

$$A\omega = 1.81;$$

then the thickness of the equivalent layer of the ground will be:

$$h_g = A\omega b = 1.81 \times 150 = 271 \text{ cm.}$$

From eq 89 the final settling is

$$s = h_g \left(\frac{a_f P}{1 + e_1} \right) = 271 \frac{0.05 \cdot 1.5}{1 + 0.75} = 11.6 \text{ cm.}$$

This settling will take a considerable period of time, long enough for the ground to thaw to a considerable depth under the foundation, several times deeper than the width of the base.

On thawing clay, the time required for settling to cease will depend not only on the depth and speed of thawing, but also on the water permeability of the ground, on the rate at which the clay is consolidated and the water squeezed out of its pores. Depth of thawing over a given period of time can be determined approximately by Stefan's equation (Ch. V), but the process of cessation of settling is much more complicated, and the rate of thawing will not coincide with the rate of increase of settling.

Heaving Calculations

When the active layer thaws, as discussed above (Chs. III and VIII), heaving forces appear which tend to lift the foundations. These forces are counteracted by the load on the foundation and by fixing part of the foundation in the ground below the depth of freezing. The estimation of heaving of a foundation is important whether the permafrost is to be preserved or eliminated.

When the permafrost regime is to be maintained, the problem is: to what depth should the foundation pillars be laid in permafrost in order to counteract the heaving forces.

Estimation will be made for a structure with a space under the floor ventilated during the winter.

Calculations have shown that the temperature difference between the outside and the ventilated space will be insignificant during the winter, approximately 1C to 2C. Therefore, it can be considered that the ground around the foundation will freeze symmetrically.

When the outside air temperature is negative, the ground around the foundation will begin to freeze, and heaving forces due to volume increase of the ground will appear. Their value can be considered equal to the adfreezing forces (Fig. 150).

If freezing penetrates far enough that the adfreezing strength between the ground and the foundation exceeds the load on the foundation and the friction between the foundation and the ground, heaving of the foundation will begin. Experience has shown that foundation heaving occurs at very small depths of freezing, in many cases not more than 10 cm. At present, there is insufficient data for determining the distribution of the adfreezing forces over the side of the foundation. It can only be noted that, if the temperature is lower on the surface of the ground than at a certain depth, the adfreezing forces will be greater at the surface and diminish with depth. Adfreezing forces do not depend solely on the negative temperature; they depend also on the moisture content and grain-size composition of the ground.

The following symbols are used:

τ is the estimated adfreezing strength, in kg/cm², of different sections of the active layer, depending on the temperature, moisture, and grain-size composition of the ground.

τ_f is the estimated adfreezing strength of the permafrost layer;

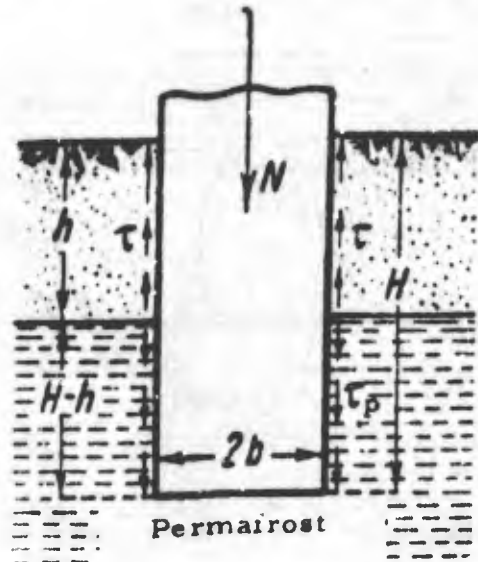

Figure 150. Diagram of stresses for foundation heaving calculations when permafrost is maintained.

must be laid so deep that the adfreezing strength of the part of the foundation in the ground will be sufficient to counteract heaving. Based on the above considerations and disregarding friction between the foundation and the ground, the following equation can be written for eight-sided foundations:

$$\tau_f S h_f \geq \tau S h - N \quad (a)$$

from which:

$$h_f \geq \frac{\tau S h - N}{\tau_f S} \quad (b)$$

This equation gives the depth of foundation pillars in permafrost which will counteract heaving.

In eq b, we assumed that the tangential adfreezing strength is uniform on the lateral surface of the foundation and vertically constant through the active layer. The variations of adfreezing strength with depth should be taken into account by replacing τ in eq b by the average adfreezing strength for the active layer as calculated by the equation:

$$\tau_{av} = \frac{\tau_1 l_1 + \tau_2 l_2 + \dots + \tau_n l_n}{l_1 + l_2 + \dots + l_n} \quad (c)$$

τ_1, τ_2, \dots are the adfreezing strengths of the different layers of ground depending on the temperature, moisture content, and composition of the ground; l_1, l_2, \dots are the thicknesses of the layers.

Substituting τ_{av} in eq b gives

$$h_f \geq \frac{\tau_{av} S h - N}{\tau_f S} \quad (93)$$

S is the perimeter of the cross-sectional area of the foundation;

h is the thickness of the active layer;

h_f is the depth to which the foundation is laid in permafrost; and

N is the load on the foundation, including its own weight.

The adfreezing strengths are taken from the tabulated results of direct tests (see Ch. VI). Calculation of the adfreezing strengths which occur in nature will give extremely large values. A foundation pillar with a 50 x 50 cm cross section and an adfreezing strength of $\tau = 5 \text{ kg/cm}^2$ of lateral surface will have a total adfreezing strength of $\Sigma \tau = 5(50 + 50) 2 \times 100 = 100,000 \text{ kg} = 100 \text{ metric tons}$ per meter vertically downward to the base of the foundation. The weight of the structure (the load on the foundation) will not always be sufficient to withstand such a considerable force. Therefore, the question arises of whether it is not possible to make these adfreezing forces work for us; i. e., to exploit the adfreezing strength between the permafrost and the foundation material. The foundation

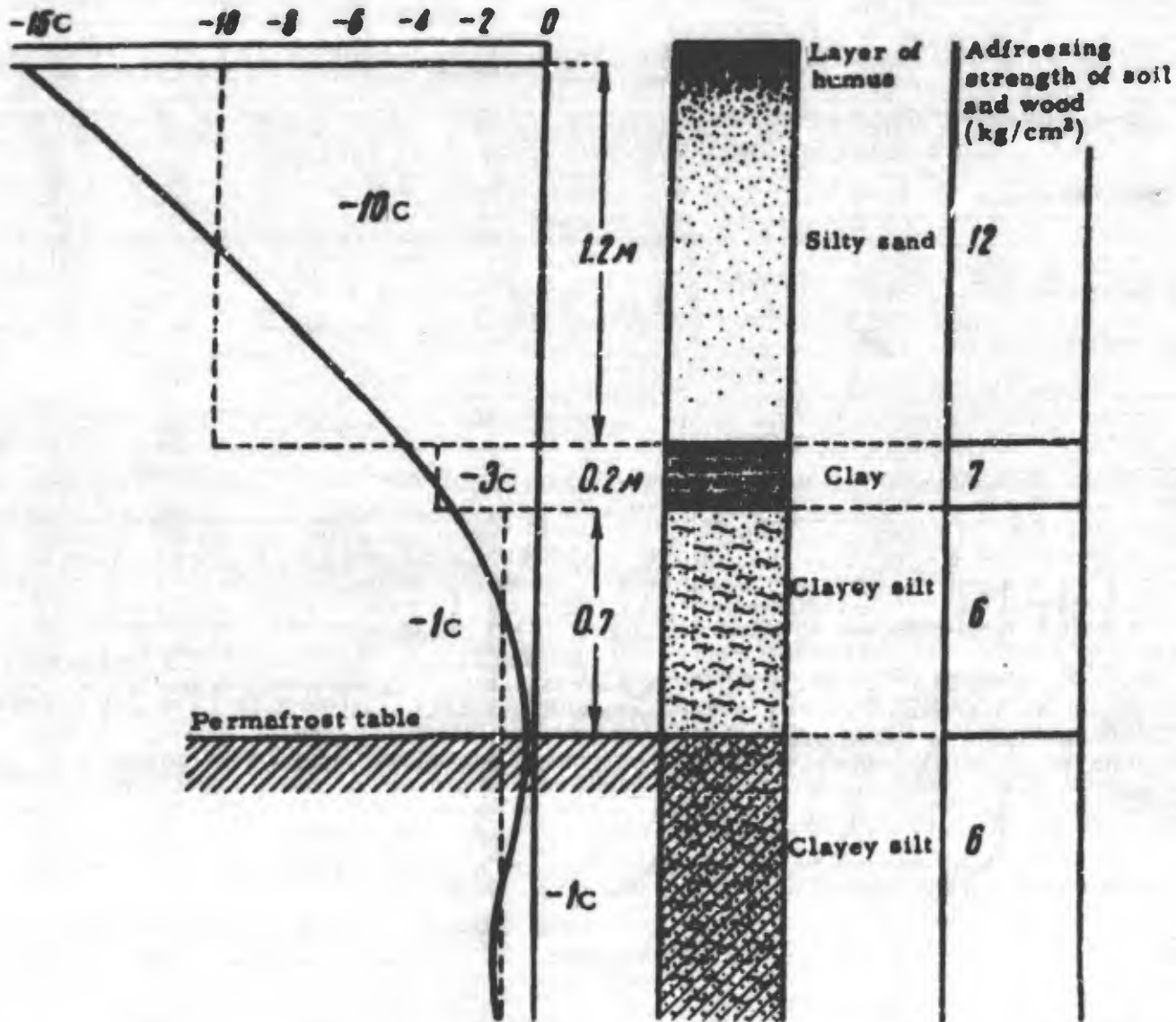

Figure 151. Data for foundation heaving calculations.

Example. The temperature of the ground, the moisture content and grain-size composition of individual layers (Fig. 151) are given:

$N = 60,000$ kg,

$h = 210$ cm,

$d = 30$ cm — the diameter of a wooden foundation pile,

τ kg/cm² depends on the average temperature, moisture content and grain-size composition of each layer.

The average estimated adfreezing strength for the whole active layer is

$$\tau_{av} = \frac{12 \times 1.2 + 7 \times 0.2 + 6 \times 0.7}{1.2 + 0.2 + 0.7} \approx 9.5 \text{ kg/cm}^2.$$

The perimeter of the foundation is $S = 94$ cm.

UNCLASSIFIED

AD

230484

**FOR
MICRO-CARD
CONTROL ONLY**

6 OF 6

Reproduced by

Armed Services Technical Information Agency

ARLINGTON HALL STATION; ARLINGTON 12 VIRGINIA

UNCLASSIFIED

"NOTICE: When Government or other drawings, specifications or other data are used for any purpose other than in connection with a definitely related Government procurement operation, the U.S. Government thereby incurs no responsibility, nor any obligation whatsoever, and the fact that the Government may have formulated, furnished, or in any way supplied the said drawings, specifications or other data is not to be regarded by implication or otherwise as in any manner licensing the holder or any other person or corporation, or conveying any rights or permission to manufacture, use or sell any patented invention that may in any way be related thereto.

Then according to eq 93

$$h_f = \frac{9.5 \times 94 \times 210 - 60,000}{6.94} \approx 226 \text{ cm.}$$

The total depth to which the foundation should be laid is

$$H = h + h_f = 210 + 226 = 426 \text{ cm} = 4.26 \text{ m.}$$

Allowing some margin, we take:

$$H = 4.5 \text{ m.}$$

If the depth calculated by this method is greater than the depth determined by the thermal method, the foundation can be laid at the lesser depth and fixed in the permafrost by some construction measure. A foundation pad in the form of a truncated pyramid placed with the lower base on permafrost and the upper base below the permafrost table will provide better sealing in of the foundation. Formulas for estimating the heaving of foundations which are broadened at the bottom or have strengthening devices in permafrost can be constructed for each case without any special difficulties.

It should also be noted that the cross sections of foundations under the influence of adfreezing forces undergo tensile stress during heaving. This should be taken into consideration in planning foundations. The actual existence of tensile stress in foundations under permafrost conditions is proved by study of the deformation of structures (cracks in foundations, the separation of portions of the piles and bridge supports, etc.). The stresses which develop under these conditions are very great. Therefore, material which has poor resistance to tensile stress (for example rubble stone and brick) cannot be used in permafrost conditions.

The greatest tensile stress in foundations occurs when the layer of winter freezing is nearly as thick as the active layer (Fig. 152).

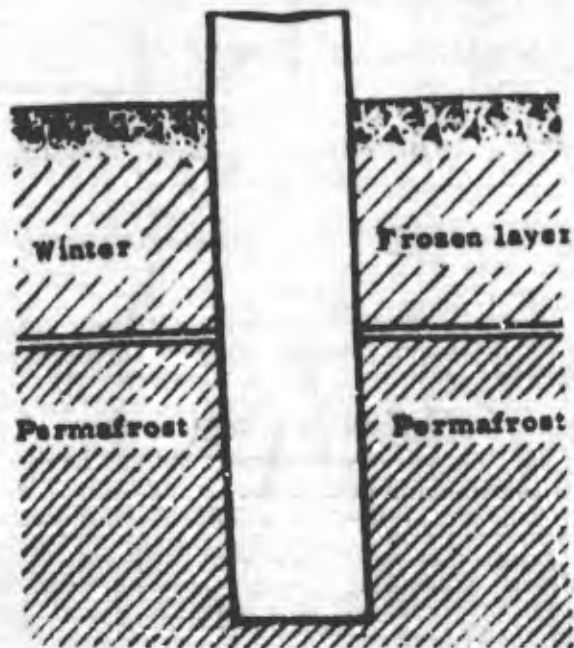

Figure 152. Diagram of the foundation for calculating tensile stress.

Since the adfreezing forces are ultimate stresses, the ultimate tensile strength of the foundation material must be used in calculations.

The cross-sectional area required for resistance to tension is:

$$F \geq \frac{\tau_{av} S h - N}{\sigma_{ult}} \quad (94)$$

where F is the cross-sectional area of the foundation at the level of the permafrost table and σ_{ult} is the ultimate tensile strength of the material of the foundation.

This simple formula is introduced here to emphasize the necessity of considering tensile stress when planning foundations in permafrost conditions.

For example:

Given: $h = 210 \text{ cm}$; $S = 94 \text{ cm}$; $N = 60,000 \text{ kg}$;
 $d = 30 \text{ cm}$; σ_{ult} for wood = 700 kg/cm^2 ; $\tau_{av} = 9.5 \text{ kg/cm}^2$.

Substituting in eq 94, we obtain:

$$F \geq \frac{9.5 \times 94 \times 210 - 60,000}{700} = 172 \text{ cm}^2.$$

When the diameter of the foundation pillar is 30 cm, the cross-sectional area meets the requirements with a safety factor of almost four.

When the gradual elimination of permafrost is planned, the forces which counteract foundation heaving are: the load on the foundation N , including the foundation's own weight; the weight of the ground of the bearing area (Fig. 153); and the frictional resistance in the ground mass equal to the perimeter of the bearing area of the foundation times the depth of the foundation (to the top of the bearing area).

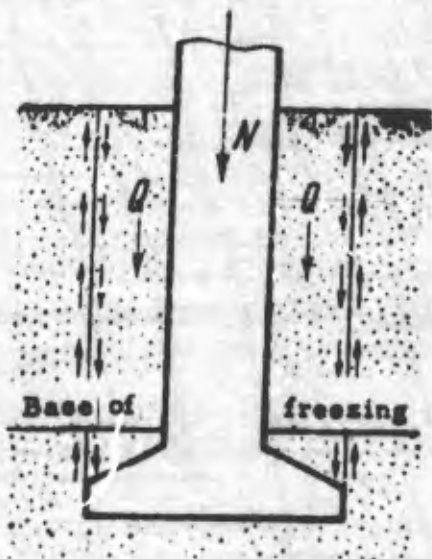

Figure 153. Diagram of stresses for foundation heaving calculations when permafrost is eliminated.

When the adfreezing strength of the ground and the foundation material is considerable, difficulties may arise in construction. This occurs when the sum of the load on the foundation and the resistance to heave of the part of the foundation which is below the base of freezing is considerably less than the heaving forces (estimated adfreezing forces).¹ In such a case, measures should be taken to diminish the adfreezing forces between the upper part of the foundation and the ground.

The chief method, which has been used many times, is to replace the ground around the foundation with a material having little adfreezing qualities, such as coarse homogeneous pebbles, protected from silting and from wetting by infiltrating waters. The use of pebble fillers will be discussed in the following section in connection with the general problem of foundation construction.

Examples of Constructing Foundations for Buildings on Permafrost

The problem of constructing foundations for buildings erected on permafrost will be solved in each specific case on the basis of the concepts mentioned above, the proper calculations, the local conditions, and the particular construction features of the buildings. A detailed study of this problem is beyond the scope of this book. Here we discuss only the different methods of foundation construction which are typical for permafrost regions: building according to the principle of maintaining the permafrost regime, and building according to the principle of eliminating the permafrost regime.

1. In the first case, the most practical foundation is separate pillars, ferroconcrete or wooden, with a space under the floor to be ventilated in the winter.

Figure 154 (a and b) shows two types of ferroconcrete foundation which supports, with the help of beams, the walls and floor of a stone building. To decrease the adfreezing forces, a fill of dry gravel is used to the bottom of the bottom of the active layer. This fill is protected from silting from the sides by wooden shields and from warming and wetting from the top by a non-heat-conducting, water-impermeable cover.

Figure 154c shows a wooden foundation pillar of the same design as the first.

Foundations for non-heated structures, such as bridge supports, are constructed without leaving a space to be ventilated during the winter. However, in these cases as well, it is necessary to use all means to decrease thawing of the frozen ground under the

¹. See Chapter VI.

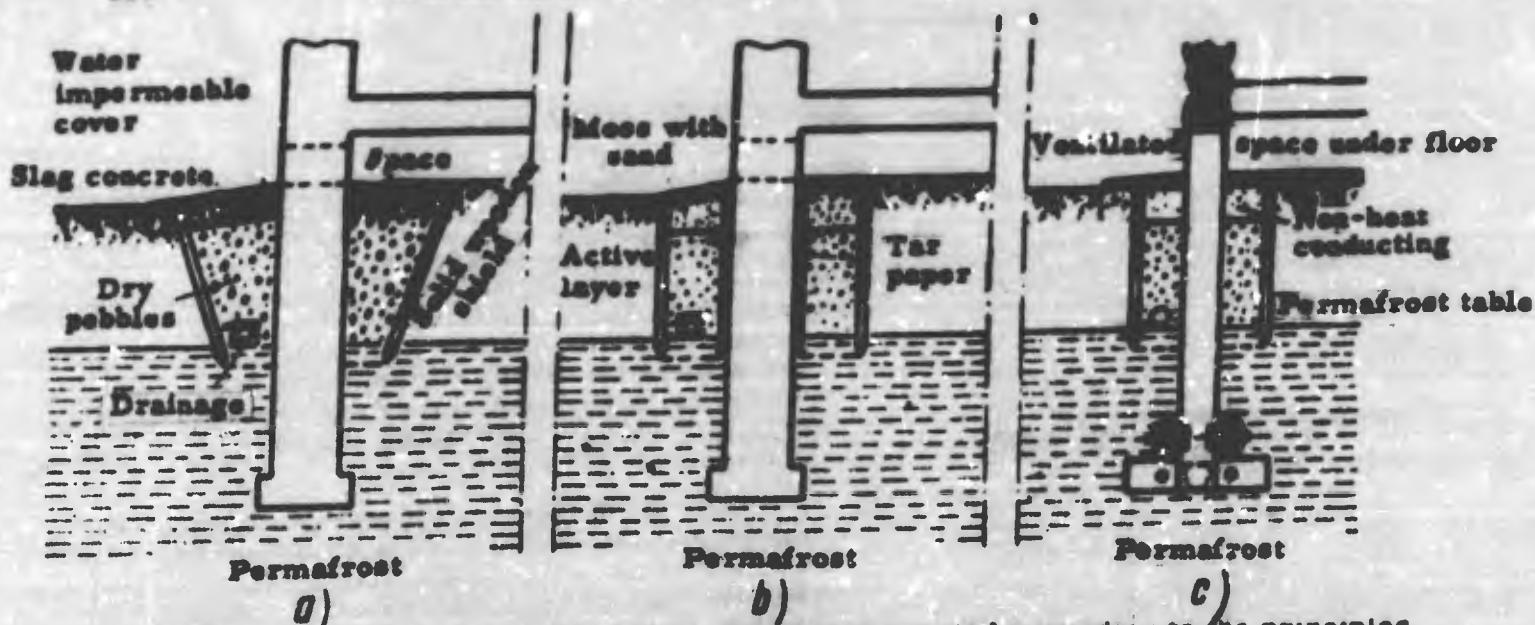

Figure 154. Types of foundations for structures erected according to the principles of maintaining the permafrost regime.

foundation. Such measures are: use of non-heat conducting pads (e. g., wooden or slag-concrete, and others), equalizing north and south exposures by use of bushy plants, diversion of surface water, and careful drainage of ground water.

Ground-water drainage requires special construction in permafrost conditions depending on local conditions. Because the active layer thaws gradually during the entire summer, there is no fixed depth at which the drainage should be laid. In many cases it would be sensible to use a continuous draining gravel layer from the surface of the ground to the upper boundary of permafrost.

The system of two-story drainage is also used. The upper drain works for half of the summer; the lower works the second half of the summer and during the fall.

When the permafrost regime is to be maintained, the method of artificial freezing of the ground proposed by Sumgin is useful in some cases. This method consists of laying pipes under the construction to cool the ground drastically in the winter.

2. If a gradual elimination of permafrost is planned, the following types of foundations are used: individual concrete or ferroconcrete pillars on solid blocks or wooden gratings, foundations resting on very thick sandy pebble fill, sometimes solid rubble-stone and ferroconcrete foundations, and simplified foundations for wooden buildings on sleepers.

Figure 155 shows a cross section of a foundation under the boilers of the Igarka electric power plant.¹ These foundations are slightly reinforced concrete columns laid to a depth of approximately 5 m.

The columns stand on a solid concrete slab, 35 cm thick, resting on a layer of tamped pebbles, which is underlain to a considerable depth by sand. An experimental load placed on the sand showed its good constructive qualities.² This building has been in use since 1930, and no deformations or cracks have been noted. This, according to Gipr Irev, [State Institute of the Lumber Industry] is about the only building in the port of Igarka which has not been deformed by frozen ground. Another power plant built 2 years later in

1. The drawing is taken from the book by Prof. Evdokimov-Rokotovskii (1931) *Postroika i eksploatatsiia inzhinernykh sooruzhenii na vechnoi merslote*. (Construction and exploitation of engineering structures on permafrost). Tomsk.

2. N. A. Tsytovich (1932) *Nekotorye issledovaniia vechnoi mersloty v nizoviiakh reki Eniseia letom 1930g* (Some studies of permafrost in the lower course of the Yenisey River during the summer of 1930). *Trudy KIVM, Akademiia Nauk, tom 1*.

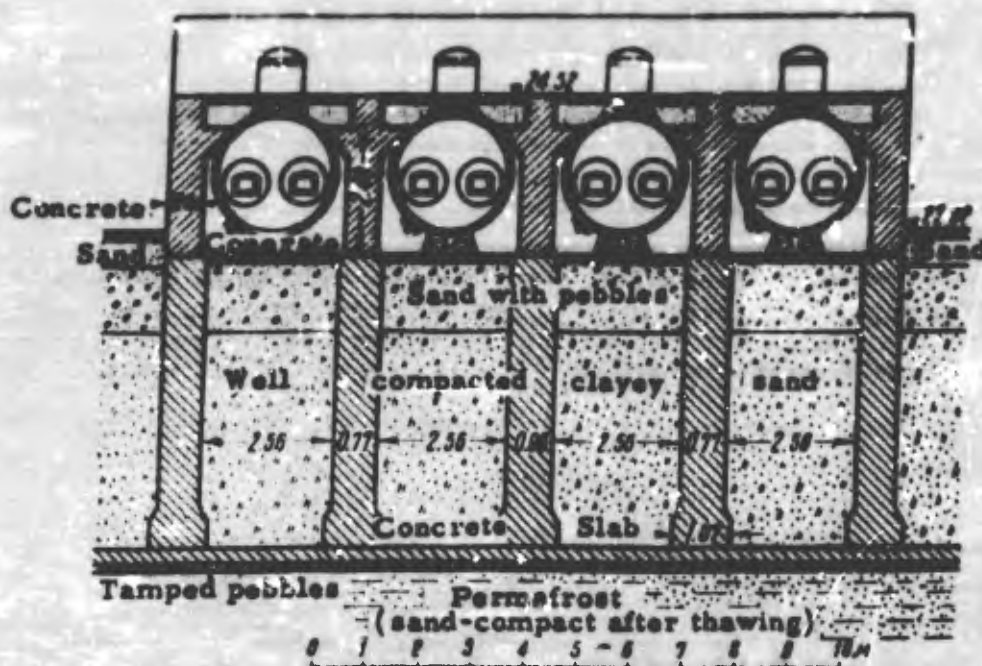

Figure 155. Foundations under the boilers of the Igarka Electric power plant (principle of eliminating the permafrost regime).

the very same part of Igarka, but without proper considerations of the properties of thawing frozen ground, has become quite intolerably deformed.

Figure 156a, b shows foundations under a heated plant. The foundations rest on a very thick sand fill and extend below the lower level of freezing of the ground in the given area.

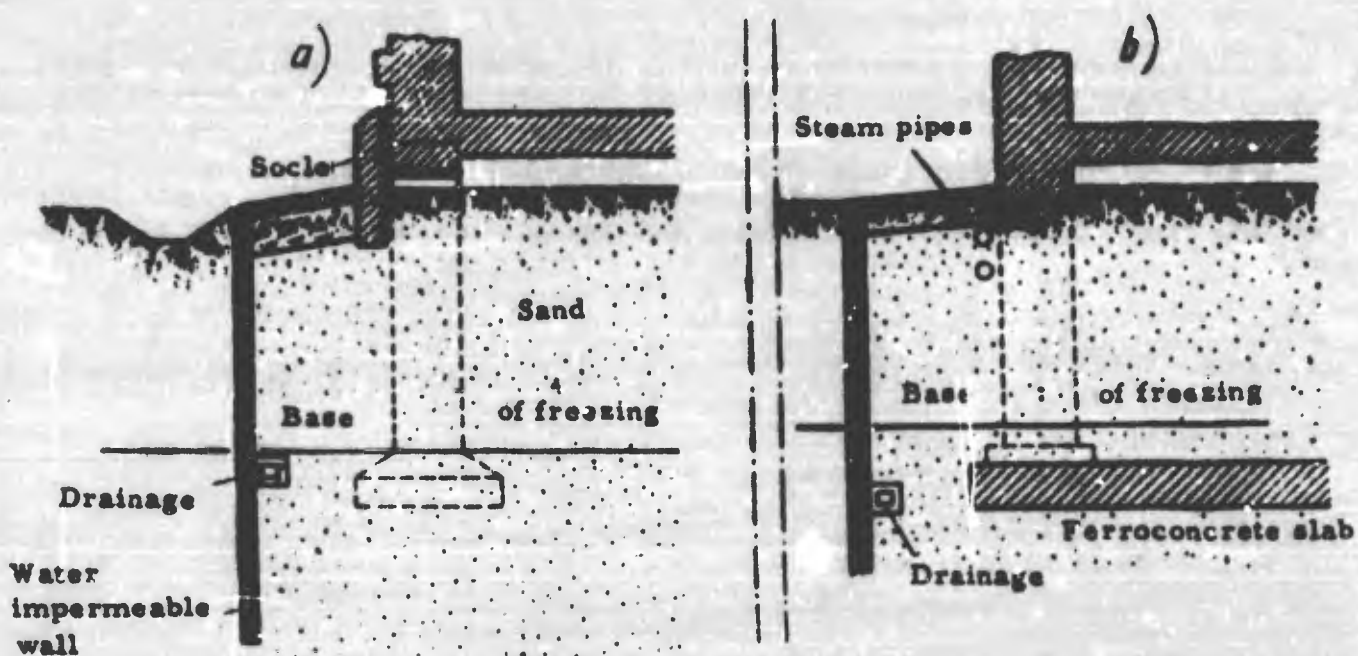

Figure 156. Types of foundations for structures constructed according to the principle of eliminating the permafrost regime.

UNCLASSIFIED

AD

230484

**FOR
MICRO-CARD
CONTROL ONLY**

6 OF 6

Reproduced by

Armed Services Technical Information Agency

ARLINGTON HALL STATION; ARLINGTON 12 VIRGINIA

UNCLASSIFIED