

UNCLASSIFIED

AD

233 528

Reproduced

Armed Services Technical Information Agency

ARLINGTON HALL STATION; ARLINGTON 12 VIRGINIA

NOTICE: WHEN GOVERNMENT OR OTHER DRAWINGS, SPECIFICATIONS OR OTHER DATA ARE USED FOR ANY PURPOSE OTHER THAN IN CONNECTION WITH A DEFINITELY RELATED GOVERNMENT PROCUREMENT OPERATION, THE U. S. GOVERNMENT THEREBY INCURS NO RESPONSIBILITY, NOR ANY OBLIGATION WHATSOEVER; AND THE FACT THAT THE GOVERNMENT MAY HAVE FORMULATED, FURNISHED, OR IN ANY WAY SUPPLIED THE SAID DRAWINGS, SPECIFICATIONS, OR OTHER DATA IS NOT TO BE REGARDED BY IMPLICATION OR OTHERWISE AS IN ANY MANNER LICENSING THE HOLDER OR ANY OTHER PERSON OR CORPORATION, OR CONVEYING ANY RIGHTS OR PERMISSION TO MANUFACTURE, USE OR SELL ANY PATENTED INVENTION THAT MAY IN ANY WAY BE RELATED THERETO.

UNCLASSIFIED

DISCLAIMER NOTICE

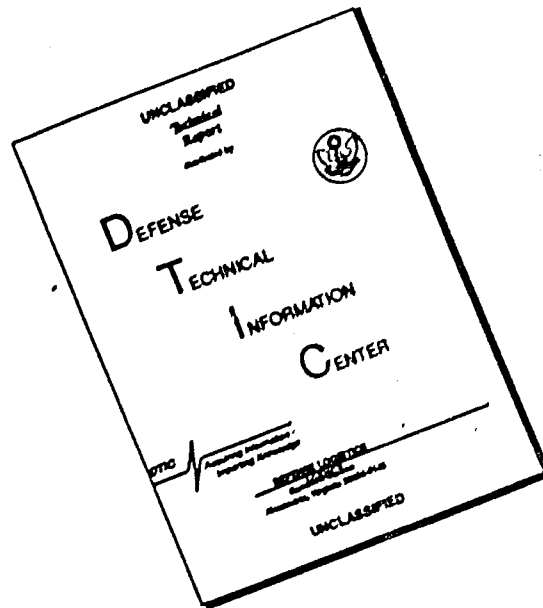

THIS DOCUMENT IS BEST QUALITY AVAILABLE. THE COPY FURNISHED TO DTIC CONTAINED A SIGNIFICANT NUMBER OF PAGES WHICH DO NOT REPRODUCE LEGIBLY.

AERONAUTIC AND STRUCTURES RESEARCH LABORATORY
MASSACHUSETTS INSTITUTE OF TECHNOLOGY

TECHNICAL REPORT 811

INVESTIGATION OF LARGE EXPANSION DIFFUSERS
FOR MINIMUM FLOOR AREA

BY

ROBERT L. COOPER

MEMBER OF TECHNICAL STAFF

FILE COPY

N-60-2-5

Return to

ASTIA

ARLINGTON HALL STATION
ARLINGTON 12, VIRGINIA

ATTN: TISS

MAILED

MA 1960

MASSACHUSETTS INSTITUTE OF TECHNOLOGY

77 MASSACHUSETTS AVENUE

CAMBRIDGE, MASSACHUSETTS 02139

TECHNICAL REPORT 811

MAILED

MA 1960

**AEROELASTIC AND STRUCTURES RESEARCH LABORATORY
MASSACHUSETTS INSTITUTE OF TECHNOLOGY
TECHNICAL REPORT 81-1**

**INVESTIGATION OF LARGE EXPANSION DIFFUSERS
FOR MINIMUM ROTOR AREA**

BY

**JEAN F. DUVIVIER
ROBERT B. McCALLUM**

FOR

**USA TRECOM
FT. EUSTIS, VIRGINIA**

PROJECT NUMBER 9R38-01-017-24

CONTRACT NUMBER DA-44-177-TC-486, J.O. No. 2

NOVEMBER 1959

**USA TRECOM
CRD 2359**



ABSTRACT

Means of reducing the size of a ducted fan for a given thrust and exit area were investigated. Short diffusers with expansion ratios from 4 to 8.71, were studied in two-dimensional and three-dimensional flow downstream of an operating fan with several wall shapes; center vanes, boundary layer control by localized suction and air injection, and shaped center bodies were used to control the flow in the diffusers. Various pressure distributions and velocity profiles were measured.

Results of this investigation show that short diffusers (length = 1.5 inlet diameter) with expansion ratios of 4 to 6 having limited boundary layer control can be designed to achieve efficiencies of the order of 75 to 80 percent in the two-dimensional cases and of the order of 80 to 85 percent in the three-dimensional cases. This would theoretically permit thrust/power increases of the order of 60 percent. With suitable flow control, the predominant parameter is the area ratio, not the expansion angle, or geometry of the diffuser. Localized boundary layer suction with mass flow ratios of the order of 2.5 percent is adequate, and suction over the whole wall area unnecessary.

Satisfactory diffuser operation was also achieved with air blowing along the inlet walls. Recommendations for further research work in this area are submitted.

FOREWORD

The study presented in this report was undertaken by the Aeroelastic and Structures Research Laboratory, Massachusetts Institute of Technology, Cambridge 39, Massachusetts and sponsored by the U. S. Army Transportation Research Command under Contract Number DA-44-177-TC-486, Job Order No. 2. The authors, Mr. Jean F. Duvivier and Mr. Robert B. McCallum are members of the Division of Sponsored Research Staff at M.I.T. This research program was carried out under the supervision of Professor Rene H. Miller of the Department of Aeronautics and Astronautics with Mr. Duvivier as project leader. This study began in September 1958 and was completed in November 1959. Mr. Richard Kennedy of the U. S. Army Transportation Research Command was the Research Contracting Officer Representative on this project.

The authors are indebted to Professor Miller for his constant guidance, to Professor Mollo-Christensen for his advice, Mr. Alex Baker for his assistance in the experimental program, the personnel of the Model Shop under Mr. Oscar Wallin, Mr. Don Tait for preparing the figures and to Miss Shirley A. Hogan for typing the report.

TABLE OF CONTENTS

	Page
ABSTRACT	i
FOREWORD	ii
TABLE OF CONTENTS	iii
LIST OF FIGURES	v
NOMENCLATURE	vii
CHAPTER I INTRODUCTION	1
1.1 Purpose of Investigation	1
1.2 Scope of Investigation	2
1.3 Plan of Report	4
CHAPTER II THEORETICAL CONSIDERATIONS	5
2.1 Thrust/Power Augmentation Factor	5
2.2 Diffuser Efficiency	8
2.3 Effect of Suction and Blowing on Efficiency	10
CHAPTER III EXPERIMENTAL APPARATUS	12
3.1 Two Dimensional Diffuser Test Stand	12
3.2 Two Dimensional Diffuser Assembly	13
3.3 Axisymmetrical Diffuser Test Stands	
3.31 Model 1, 18 in. Diameter Rotor	15
3.32 Model 2, 6 in. Diameter Rotor	16
3.4 Model 1 Diffuser	17
3.5 Model 2 Diffusers	17

TABLE OF CONTENTS (Continued)

	Page
3.6 Auxiliary Equipment	20
3.6.1 Suction equipment	20
3.6.2 Blowing equipment	20
3.6.3 Pressure measuring equipment	20
3.6.4 Flow visualization	22
3.6.5 Thrust measurement	23
CHAPTER IV TEST RESULTS AND DISCUSSION	24
4.1 General Remarks	24
4.2 Two Dimensional Diffuser Tests	25
4.3 Three Dimensional Diffuser Model 1	30
4.4 Three Dimensional Diffuser Model 2	32
CHAPTER V CONCLUSIONS AND RECOMMENDATIONS	37
REFERENCES	40
BIBLIOGRAPHY	45
TABLES	48
FIGURES	54

4

LIST OF FIGURES

<u>Figure</u>		<u>Page</u>
1	Variation of Thrust/Power with Disc Loading	54
2	Augmentation Factor Versus Area Ratio (at Constant Power)	55
3a	View of Two Dimensional Test Installation	56
3b	Two Dimensional Diffuser Test Installation	57
3c	Right Wall Detail	57
4	Two Dimensional Diffuser Rakes	58
5a	Two Dimensional Diffuser Wall Shape	59
5b	Two Dimensional Centerbodies and Vanes	60
6	Model 1 Schematic	62
7	Model 1 Installation	63
8	Model 1 Detail	64
9	Model 2 Test Stand	65
10a	Model 2 Ducted Fan Assembly	66
10b	Model 2 Rotor Blades	67
11a	Model 2 Diffuser Shapes	68
11b	Model 2 Centerbodies	69
11c	Model 2 Diffuser Rakes	70
12a	Two Dimensional Diffuser Inlet Velocities (Mid Height)	71
12b	Representative Boundary Layer Profiles $3/4^m$ Ahead of Inlet A-3 Diffuser	72
13	Effect of Inlet Reynolds Number	73

*

LIST OF FIGURES (Continued)

<u>Figure</u>		<u>Page</u>
14	Pressure Loss Factor of Two Dimensional Diffuser Configurations	74
15	Outlet Velocity Maps (a) A2 - No Suction	75
15	(Cont'd) (b) A2 + Vanes + Suction	76
15	(Cont'd) (c) A3 - No Suction	77
15	(Cont'd) (d) A3 + Vanes + Suction	78
16a	Flow Patterns in Diffuser A3	79
16b	Flow Patterns in Diffuser C3	80
17a	Diffuser A2 + W1 No Suction	81
17b	Diffuser A2 + W1 + Suction	81
18	Wall Pressure Distributions Two Dimensional Diffusers	82
19	Axisymmetric Flow Patterns Model 1 and 2	83
20	Model 1 Shroud Pressure Distribution	85
21	Model 1 Diffuser Inlet Velocity Profiles	86
22	Model 1 Outlet Velocity Profiles	87
23	Model 1 Boundary Layer Profile 2 in. Ahead of Diffuser Inlet Plane	88
24	Model 2 Diffuser Inlet Velocity Profiles	89
25	Model 2 Diffuser Outlet Velocity Profiles	90
26	Augmentation Factor for Best Axisymmetric Diffusers	91
27	Augmentation Factor Effectiveness	92

NOMENCLATURE

A	area (normal to axis) (in. ² or ft ²)
A _R	area ratio (non dimensional)
C _{PR}	pressure recovery coefficient (non dimensional)
D	diameter (in.)
H	total head (= p + q) (psi or in-alcohol)
K	head loss factor (non dimensional)
KE	kinetic energy (psi)
L	diffuser length (in.)
P	static pressure (psi or in. alcohol)
\bar{P}	mean static pressure (idem)
P _s	suction pressure differential (= p ₁ - p ₂) (idem)
P	power (HP)
Q	flow rate (ft ³ /sec.)
q	dynamic pressure (psi or in. alcohol)
R	outer radius = $\frac{D}{2}$ (in.)
Re	Reynolds Number based on width or diameter
r	radius (in.)
T	thrust (lb.)
v	airstream velocity (ft./sec.)
\bar{v}	mean airstream velocity (idem)
w	disk loading (lb./ft ²)
x	distance from diffuser inlet along axis (in.)
m	mass flow (slugs/sec.)

NOMENCLATURE (Continued)

y	distance from axis, normal to axis (in.)
α	augmentation factor = $\frac{(T/P)_2}{(T/P)_3}$ (non dimensional)
η_D	diffuser efficiency (non dimensional)
η_P	pressure efficiency (idem)
ρ	air density (slugs/ft ³)
θ	pitch angle of blade (degrees)
ϕ	half included diffuser angle (degrees)

Subscripts and Superscripts

a, a	atmospheric
B	blowing
1	inlet (two-dimensional diffusers); ducted fan inlet
2	outlet (two-dimensional diffusers); rotor plane
3	diffuser inlet plane (axisymmetrical models)
4	diffuser outlet plane (axisymmetrical models)
e, E	ducted fan exit
F	fan
i	ideal (no losses)
L	local
R	root
S	suction

NOMENCLATURE (Continued)

- I tip
- including losses
- mean value (weighted average)-

CHAPTER I

INTRODUCTION

1.1 Purpose of Investigation

Considerable interest exists at present in the use of ducted fans as a means of achieving vertical take-off and hovering for various types of aircraft. Several investigations have reported on the thrust obtainable and the horsepower required for such devices (Ref. 1,2,5,6,8,9).

It can be observed that ideally the T/P ratio increases with decreasing fan disc loading T/A (Fig. 1). If the air flow could be expanded without excessive losses from a small fan to a larger outlet, the same thrust/power ratio as that of an undiffused fan of the same outlet area would be obtained, with a lighter rotor and transmission, since the smaller fan would be able to operate at higher rotational speeds.

From momentum theory and assuming steady incompressible flow the thrust of a shrouded fan is

$$T = m v_e = \rho A_e v_e^2 \quad (1.1)$$

and the induced power

$$P_i = \frac{1}{2} m v_e^2 = \frac{1}{2} \rho A_e v_e^3 \quad (1.2)$$

Defining the disc loading for the diffusing fan as $w = \frac{T}{A_e}$ (which for a constant area duct reduces to $\frac{T}{A_r}$),

$$w = \frac{T}{A_e} = \rho v_e^2 \quad (1.3)$$

and the induced power loading:

$$\frac{T}{P} = \frac{2}{V_e} = 2\sqrt{\rho} \frac{A_e}{T} \quad (1.4)$$

Eq. (1.4) shows that the exit area is the only determining parameter. Therefore the size of the fan itself depends only upon the possibility of controlling the flow expansion from the fan to the exit.

In addition the effect of the diffuser would be to slow down the airflow at the exit and therefore reduce the magnitude of ground erosion which is known to create problems for VTOL vehicles.

1.2 Scope of Investigation

It is generally well known from the work done on diffusers in the past (Ref. 12 to 17) that for included angles 2ϕ exceeding 7 to 10° the friction and turbulence losses in the diffuser become quite large and the diffuser becomes very inefficient. But the flow has been controlled in some cases of two-dimensional and conical diffusers by means of boundary layer suction (Ref. 23,27,28,29,30,32), by vanes (Ref. 19,21,22), screens (Ref. 25), suitably shaped center bodies (Ref. 18), as well as by vortex generators and flow injection (Ref. 10).

All the cases studied in the previous references dealt with two-dimensional and axially symmetric (conical) diffusers of limited included angles, so that any appreciable area ratio could be obtained only with lengths several times the diameter which are unacceptable for the present application because of the space restrictions likely to exist in VTOL aircraft. The stringent limitations on diffuser length led to the present study of short diffusers having large expansion ratios and curved walls with suitable means of controlling the airflow in

the diffusers, with a length of the order of the exit diameter or less.

The first phase of this study dealt with two-dimensional diffusers of basic area ratios 4, 6 and 8, with limited boundary layer suction, vanes, and centerbodies. In the second phase, the information gained in this study led to the fabrication and testing of axially symmetric diffusers having area ratios of 4 and 8.71, with intermediate area ratios of 5.78, 6.52 and 6.55 with the introduction of shaped centerbodies. These diffusers were mounted onto two operating ducted fan models, of 6" and 18" diameter respectively, in order to study and measure the diffuser performance with the actual flow downstream of a rotor; boundary layer suction, blowing and vanes were used as seemed appropriate.

Total head and static pressure measurements were made ahead of and at the exit of the diffusers, and an axial pressure survey was made on each two-dimensional diffuser as well as the larger of the axisymmetrical models (Model 1). Boundary layer profiles ahead of the diffusers were obtained for several cases.

The tests reported herein are limited to an evaluation of diffuser efficiencies with large expansion angles. No attempt has yet been made to determine experimentally the feasibility of obtaining the theoretically predicted thrust augmentations at a given power since this would have required a precise determination of torques and a careful design of rotors with the correct pitch and chord distribution for each configuration tested. The rotor was considered primarily as a device for producing a three-dimensional flow which was then diffused through varying angles and with varying degrees of control. The results indicated that large area ratio short diffusers could be designed to operate at reasonable efficien-

cies with suitable flow control. The design of a rotor system capable of exploiting the advantages of such diffusion is a logical extension of the present work. Preliminary estimates have indicated that considerable care must be exercised in the design of such rotors if their full augmentation potentialities are to be realized.

1.3 Plan of Report

The predicted effect of diffuser area ratio upon the variation of T/P that can be expected with different diffuser efficiencies is presented in Chapter II, as well as a brief discussion of the meaning of diffuser efficiencies for the purpose of this study.

A description of the experimental apparatus that was designed and built for this investigation, the models used as well as the necessary auxiliary equipment follows in Chapter III.

The tests are discussed in Chapter IV, conclusions drawn from these test results will be found in Chapter V, as well as recommendations for further studies.

CHAPTER II

THEORETICAL CONSIDERATIONS

2.1 Thrust/Power Augmentation

It has already been pointed out in Chapter I that large expansion diffusers are known to have considerable pressure losses. It remains to be seen, how much diffuser losses affect the preceding analysis and what is the level of acceptable diffuser performance.

In the ideal case,

$$p_3 + q_3 = p_4 + q_4 \quad (2.1)$$

with a total head loss ΔH in the diffuser,

$$p_3 + q_3 - \Delta H = p_4^* + q_4^* \quad (2.2)$$

From which:

$$p_4 + q_4 = p_4^* + q_4^* + \Delta H$$

At the exit, $p_4 = p_4^* = p_0$ therefore:

$$q_4 - q_4^* = \Delta H ; \frac{q_4}{q_4^*} = \frac{\Delta H}{q_4^*} + 1 \quad (2.3)$$

The ideal induced power is

$$P_i = \frac{1}{2} m v_4^2 = A_4 v_4 q_4$$

and with losses:

$$\begin{aligned} P_i^* &= A_4 v_4^* q_4^* + A_4 v_4^* \Delta H \\ &= A_4 v_4^* q_4 \end{aligned}$$

Then

$$\frac{P}{P^*} = \frac{V_u}{V_u^*} = \sqrt{\frac{2V_u}{g_u}} = \sqrt{\frac{\Delta H}{g_u} + 1}$$

(2.4)

Similarly:

$$T = \rho A_u V_u^2$$

$$T^* = \rho A_u V_u^{*2}$$

and:

$$\frac{T}{T^*} = \left(\frac{V_u}{V_u^*}\right)^2 = \frac{\Delta H}{g_u} + 1$$

(2.5)

The thrust power ratio including diffuser losses is related to the ideal thrust/power ratio by

$$\frac{T^*/P^*}{T/P} = \frac{T^*}{T} \frac{P}{P^*} = \frac{1}{\sqrt{\kappa+1}}$$

where $\kappa = \frac{\Delta H}{g_u}$ (See Eq. 2.28)

Then:

$$\left(\frac{T}{P}\right)^* = \frac{T}{P} [\kappa+1]^{\frac{1}{2}}$$

(2.6)

For a ducted fan, from momentum theory,

$$\frac{T}{P} = 2\sqrt{\rho \frac{A_u}{T}}$$

Introducing $A_R = \frac{A_4}{A_3}$

$$\begin{aligned} \frac{T}{P} &= 2 \sqrt{\rho \frac{A_3}{T} \frac{A_4}{A_2}} & (2.7) \\ &= \left[\frac{T}{P} \right]_3 \sqrt{A_R} \end{aligned}$$

where

$$\left[\frac{T}{P} \right]_3 = 2 \sqrt{\rho \frac{A_3}{T}} = 53.5 \left[\frac{T}{A_3} \right]^{\frac{1}{2}} \quad (2.8)$$

(at sea level)

Substituting Eq. (2.7) into Eq. (2.8) yields:

$$\left(\frac{T}{P} \right)^* = \left[\frac{T}{P} \right]_3 \left[\frac{A_R}{K+1} \right]^{\frac{1}{2}}$$

The Augmentation Factor

$$\alpha = \frac{\left(\frac{T}{P} \right)^*}{\left[\frac{T}{P} \right]_3} \quad (2.9)$$

representing the thrust increase at constant power or the power reduction at constant thrust achieved by diffusing a ducted fan of a given size is:

$$\alpha = \left[\frac{A_R}{K+1} \right]^{\frac{1}{2}} \quad (2.10)$$

Figure 2 shows a plot of this parameter for various total head losses in function of diffuser area ratio. The highest curve $K = 0$ corresponds to the ideal case without losses.

The relationship of the total head loss factor K to the more usual diffuser efficiencies is established in the next section.

Eq. (2.10) and Fig. 2 show that to achieve any improvement ($\alpha' > 1$) the diffuser efficiency must be such that:

$$K < A_R - 1$$

2.2 Diffuser Efficiency

The efficiency of a diffuser has been defined variously in the literature, but two of the more common forms will be related to K for ease of comparison with previous diffuser work.

The first, generally referred to as "pressure efficiency" is a measure of the actual recovery of static pressure in the diffuser in comparison with the pressure increase that would be achieved under isentropic non-viscous flow conditions:

$$\eta_P = \frac{\bar{P}_4 - \bar{P}_3}{\bar{P}_3 \left(1 - \frac{1}{A_R^2}\right)} = \frac{C_{PR}}{C_{PRI}} \quad (2.11)$$

where $C_{PR} = \frac{\bar{P}_4 - \bar{P}_3}{\bar{P}_3}$ is the pressure recovery coefficient of the actual flow, and

$$C_{PRI} = 1 - \frac{1}{A_R^2} = \frac{P_4 - P_3}{P_3} \quad (2.12)$$

is the same coefficient in the ideal case without diffusion losses (Ref. 20).

This is the efficiency most commonly used in the early work on diffusers (Ref. 12,13,14,15,16,17). But it can only be used for comparison between diffusers having the same area ratio (Ref. 15,20), since that is an important parameter of the expression.

The second or "diffuser efficiency" is the ratio of

static pressure increase to the decrease in dynamic pressure (kinetic energy) accomplished by the diffuser:

$$\eta_D = \frac{\bar{p}_4^* - \bar{p}_3}{\bar{q}_3 - \bar{q}_4^*} \quad (2.13)$$

A more accurate form of this energy conversion effectiveness is also called diffuser efficiency:

$$\eta_e = \frac{\int_{A_4} \rho_4^* v_4 dA - \int_{A_3} \rho_3 v_3 dA}{\int_{A_3} \rho_3 v_3 dA - \int_{A_4} \rho_4^* v_4 dA} \quad (2.14)$$

The additional precision gained by using Eq. (2.14) instead of Eq. (2.13) was not considered to justify the additional labor and time involved when reducing the data on a sizable number of tests.

Finally, in order to relate diffuser efficiency to the Augmentation Factor α mentioned previously, an additional efficiency is used i.e. the ratio of total head loss to the exit dynamic pressure, since the thrust is directly dependent upon the exit velocity squared (Eq. 1.1).

$$K = \frac{\Delta H}{\bar{q}_4^*} = \frac{\bar{q}_3 - \bar{q}_4^*}{\bar{q}_4^*} (1 - \eta_D) \quad (2.15a)$$

$$K = \frac{\bar{q}_3 - \bar{q}_4^*}{\bar{q}_4^*} = \frac{\bar{q}_3}{\bar{q}_4^*} \eta_D \left(1 - \frac{1}{A_R^2}\right) \quad (2.15b)$$

The head loss factor K will be used primarily in this report as it is more meaningful in terms of ducted fan performance improvement, as developed in Section 2.1. However for the purpose of comparison with other diffusers and since other references on the subject make use of either one of the two

former efficiencies, these are also presented.

The average static and dynamic pressures at stations 3 and 4 were calculated from the measurements obtained at discrete points by weighting each reading by an increment of area over which the pressure reading was considered reasonably constant. Thus:

$$\bar{p}_{3,4} = \left[\frac{\sum_j p_j \Delta A_j}{\sum_j \Delta A_j} \right]_{3,4} \quad (2.16)$$

$$\bar{q}_{3,4} = \left[\frac{\sum_j q_j \Delta A_j}{\sum_j \Delta A_j} \right]_{3,4} \quad (2.17)$$

2.3 Effect of Suction and Blowing on Efficiency

If additional energy is required to control the flow by energizing the boundary layer, this should be accounted for in the diffuser efficiency. The efficiency of the work performed by the suction (or blowing) pump and manifold system will obviously vary with each installation. Therefore in this study of diffusers, only the net energy expended is included in the correction; the actual pumping power required when known would be added to the rotor power.

The additional net kinetic energy is considered added to the diffuser air stream between 3 and 4.

Per unit of main flow, the net suction work done is:

$$\frac{\Delta KE_s}{Q} = \frac{(P_s/\rho) M_s}{Q} = (p_a - p_{1s}) \frac{Q_s}{Q} \quad (2.18a)$$

where p_{1s} is the local static pressure at the suction location. Per unit of main flow the net blowing work done is:

$$\frac{\Delta KE_B}{Q} = (p_{2B} - p_a) \frac{Q_B}{Q} \quad (2.18b)$$

where p_{2B} is the local total pressure at the blowing slot exit. Then the corrected efficiencies become:

$$\eta_{D CORR} = \frac{\bar{p}_V - \bar{p}_3}{\bar{q}_3 - \bar{q}_V + (p_a - p_{1s}) \frac{Q_S}{Q}} \quad (2.19)$$

and:

$$K_{CORR} = \frac{[\bar{q}_3 - \bar{q}_V + (p_a - p_{1s}) \frac{Q_S}{Q}] - (\bar{p}_V - \bar{p}_3)}{\bar{q}_V} \quad (2.20)$$

for the suction case. For the blowing case $(p_a - p_{1s}) \frac{Q_S}{Q}$ is replaced by $(p_{2B} - p_a) \frac{Q_B}{Q}$ in both equations (2.19) and (2.20).

CHAPTER III

EXPERIMENTAL APPARATUS

3.1 Two Dimensional Diffuser Test Stand

This test stand was built around a 220V AC three-phased 2 speed axial fan rated at 4000 cfm (maximum) (Figs. 3a and 3b). The inlet to the fan was made of a size 20.00 x 10 truck tube tangent on its diameter to a short cylinder of .025 aluminum alloy sheet that fitted snugly inside the fan outer casing. The fan-inlet combination was mounted on four wheels that allowed 2 inches axial motion with respect to the remainder of the stand. This permitted bleeding off air downstream of the fan, thus permitting adjustment of the mass flow and airstream velocity into the diffusers, by means of a crank and threaded rod. Downstream of the fan was a constant area settling chamber followed by a nozzle that changed from a circular to a rectangular inner cross section with a contraction ratio of 2.74:1. After the preliminary testing of the installation showed considerable turbulence and rotation of the flow in the nozzle exit, a 2 x 2 in. square honeycomb and a single 16 mesh wire screen were installed between the settling chamber and the nozzle. The flow was improved satisfactorily. Three rakes, each consisting of five total head and one static pressure probes were installed permanently across the smallest dimension of the nozzle exit. These rakes will be referred to hereafter as the "diffuser inlet rakes". The static pressure and total head probes from the inlet rakes were connected to a multiple tube manometer.

A boundary layer probe traversed by a micrometer was

installed in the right wall of the nozzle and could be used to measure the boundary layer on the opposite (left) wall as well as the adjacent (right) wall. (Right and left walls refer to an observer facing upstream) (Fig. 3c). This probe could measure dynamic pressure as close as .003 inch from the wall surface. The local boundary layer dynamic pressures were read on a Prandtl manometer to an accuracy of ± 0.05 mm of alcohol (specific gravity 0.82).

A two inch wide 1/4 inch thick flange on all four walls of the nozzle exit was used to clamp the diffuser assembly in position.

3.2 Two Dimensional Diffuser Assembly

The permanent part of the assembly consisted of top and bottom parallel walls made of 3/8 in. thick plexiglas reinforced externally by 1/4 x 2 x 2 in. aluminum alloy angles. The bottom wall was positioned permanently and its downstream end supported on two steel angles extending from the stand table. The two interchangeable walls of the diffusers were made of .032 in. thick 24 ST aluminum alloy sheet bent along three 1/2 in. thick wooden templates cut to the desired contour, and fastened with flush headed screws to the templates. These were held together by wooden cross bars. The upstream end of each diffuser wall was perpendicular to a .125 in. thick aluminum alloy flange, which could be held in place against the corresponding nozzle flange with C-clamps.

Both expanding walls were then clamped symmetrically between the two plexiglas panels with wing nuts and threaded rods passing through aluminum tubing spacers of the correct length (Fig. 3c). Top and bottom walls were marked with a 1 inch square grid, which permitted locating tufts, disturbances etc... while observing the flow through the transparent material.

The joint between nozzle and diffuser walls was filled with Plasticene putty after assembly.

The following diffusers were made and tested: two with exponential wall curvature following Gibson's results (Ref. 12) with area ratios 4 and 6; two with reversed curvature of area ratios 6 and 8 and one with parallel walls for comparison purposes. The reversed curvature walls were intended to test extreme possibilities in controlling the flow against steep pressure gradients, while attempting to straighten out the flow axially at the diffuser outlet. They do not represent necessarily the best shape nor are they based upon any specific theoretical development (which would of necessity require arbitrary assumptions at this time). The diffuser geometries will be found in Fig. 5a.

One row of static pressure pickup in each diverging wall was located in the horizontal plane of symmetry. The pickups were made of 1/16" diameter brass tubing set flush in the walls and connected to a multiple tube manometer. Leakage of air between the divergent and the parallel walls was prevented by placing a single thickness of Scotch Drafting Tape between the flat surfaces of the wooden templates and the plexiglas surfaces, and tightening the wing nuts on the spacer rods. This method of assembly permitted making modifications readily, changing the walls, and introducing the center plate, center bodies and vanes with sufficient flexibility.

Suction areas were not added to the diverging walls until after the first series of tests had permitted observing the position of separation on those walls by various means (see Section 3.6.4). Then they were removed and 5 rows of .120 diameter holes with .190 pitch were drilled at the chosen location. A fiberglass suction manifold was made and fastened permanently to the outside of each wall, from which one or two

suction lines led to the measuring orifices and the suction pumps. One center plate and three wedge center bodies were made (see Fig. 5b). In addition a set of vanes was made for the $A_2 = 6$ and B diffusers with the optional addition of two shorter center bodies near the diffuser outlet. (CBI and CELL Fig. 5b.)

3.3 Axisymmetrical Diffuser Test Stands

3.3.1 Model 1, 18 in. Diameter Rotor

The Task motor, rotor assembly and ducted fan ring described in Ref. 1 were used as the basic flow producing device for the diffuser configurations described in Section 3.4.

The water cooled induction motor rated at 9.2 HP at 6500 rpm was supplied with three-phased AC current from a variable frequency generator through a 250 ft. insulated line of three No. 10 wires. The motor drove a two bladed 18 in. diameter rotor fully articulated in the vertical (flapping) and horizontal (lagging) planes. (Fig. 8). Three sets of blades made of balsa wood shaped around an aluminum alloy spar were available originally: one untapered untwisted set (called set A), one untapered set with 24° linear wash in (set B), and one untapered set with 24° linear wash out (set C). The airfoil section was NACA 0012 for all blades. A structural failure was experienced with set B in one of the early tests at high speed and tip pitch angle of 34° . Sets A and C were then reinforced by covering them entirely with strips of clear "scotch tape" laid on chordwise but set B was not replaced since Ref. 1 had shown that the difference in output from the different blade sets was small.

The model was mounted inverted (to avoid ground interference) in a large room, and supported at 3 points by strain

gage instrumented flexures, to rigid uprights bolted to the test bed. (Fig. No. 8).

3.3.2 Model 2, 6 in. Diameter Rotor (Fig. 9, 10)

A smaller model was made in order to permit more rapid changes in configurations, as the smaller diffuser models were quicker and cheaper to make and modifications much easier to install. Furthermore, it was possible that scale effects might be observed. For this reason, the shroud was made 1/3 the size of model 1 shroud with the exception of the inlet lip radius as will be explained in Section 3.5. The rotor (solidity .145) was made of two shaped aluminum alloy rigid blades 2 in. long, with constant chord of .9 in, the shanks of which were turned and threaded into the hub. Two pitch distributions were tried but little difference was found. Since the primary purpose of this program was to determine diffuser efficiencies and since the blades gave reasonably uniform inflow distributions, no other twist distributions were tested. (See Fig. 10b.) Pitch settings were held with a set screw.

The tip clearances of the rotor varied from .015 in. at 20° to .007 in. at 40° tip angles. The rotor hub shaft rotated in two precision bearings and was driven from the spinner side through a flexible shaft by a 115 V 60 cycles AC induction motor rated at 3/4 HP at 20,000 rpm. The model was mounted inverted to avoid ground effect interference on the flow. A Strobolux directed at the blades was observed from the control station by means of a plane mirror installed under the model, and served to measure the fan rotational speed. The rotor hub assembly was held in place securely by means of three .032 in. thick aluminum alloy struts fastened to the outside of the duct.

3.4 Model 1 Diffuser

The diffuser (Figs. 6 and 8) was made of two wooden rings, one at each end of a sheet metal cone with included angle $2\theta = 70^\circ$. The inner surface of the transition ring (upstream) was shaped according to Gibson's equation for circular diffusers (Ref. 12). It was undercut to make a circular suction chamber, and further downstream a blowing chamber into which were fastened the shaped suction and blowing manifolds respectively. The wall where suction was located was made of perforated metal strip (35 percent porosity) which could be covered partially with No. 33 plastic tape to modify the location and amount of suction area in the wall, over a small range. The blowing chamber was closed by a metal plate fastened flush with the wall at its upstream end and tapered to a sharp edge at its downstream end in line with the wall surface but leaving a gap of .010 in. When not in use, this gap was filled with plasticene, leaving a continuous wall surface. However, no blowing tests were carried out on this model, because difficulties were encountered in obtaining sufficient blowing capacity. Furthermore, the smaller model was by then completed and the required information obtained readily. A conical center body with curved transition could be mounted inside this diffuser to reduce the area ratio to 4 (Fig. 6). The diffuser was fastened to the main duct ring by wood screws. All the wiring and coolant lines were housed centrally in a 3 1/2 diameter tube fastened to the motor housing, and taken out radially through two streamlined tubes at the diffuser outlet. These tubes also served as struts between the center body and the diffuser.

3.5 Model 2 Diffusers

Initially two diffusers were made of wood. Diffuser

I was exactly $1/3$ scale of the Model I diffuser without the suction and blowing chambers (Fig. 11a). Suction openings were cut into the walls later, after tests without suction had determined the area of flow separation from the walls. Blowing was introduced by means of a ring manifold located between the main duct ring and the diffuser with the outlet tangent to the wall in the downstream direction. Diffuser II had a reversed curvature wall the upstream part of which had the Gibson exponential curvature already mentioned.

Both diffusers I and II had an area ratio of 8.71 without center bodies or with the tapered hub fairing (and of 8 with the untapered fairing) and a length equal to one and one half rotor diameter (0.55 outlet diameter). Different center bodies were used to vary the area ratio and the rate of change of area ratio.

Finally, diffuser III was made with area ratio of 4 and with the exponential curvature along its whole length. Table 3 gives the ordinates of the various components.

Suction areas were located in all cases after actual observation of the region of separation. The position of the separation boundary varied over a small range depending upon the operating speed of the rotor and consequently the air stream mean velocity (inlet Reynolds Number); it also varied with azimuth within about $3/4$ in. limits because of the strut wakes.

After delineating the limits of the separation boundary, the suction area was located so as to straddle the mean position. On diffuser II the first area (upstream) $5/8$ in. wide, consisted of 5 staggered rows of $3/32$ diameter holes drilled through the wood into a small plenum chamber in the outside wall; this was completed by a $1\ 1/4$ in. I.D. rubber tubing cut in half lengthwise and wrapped around the outside wall, and held in place by a layer of Fiberglass. Two manifolds

made of 1 1/4 in. brass tubing led tangentially from the plenum chamber at diametrically opposed points, and were connected to the suction hoses.

Subsequently a second suction area was located further downstream where additional partial separation occurred under certain conditions. It was found more convenient and less time consuming to cut interrupted slits 1/32 wide into the walls. Three such series of slits were staggered 3/16 in. apart. The plenum chamber and manifolds were made as before. This method proved quite satisfactory.

Diffuser I had only one suction area while Diffuser III had two in order to determine if there was any significant difference in the amount of suction required at the two positions to stabilize the flow.

Two fairings for the hub, one tapered and one untapered, were used as well as a set of circular vanes, shaped so as to divide the inlet cross section into smaller concentric diffusers of 7° included angle. Two center bodies, Nos. 1 and 2 (diffuser area ratio 6.55 and 5.78 respectively) were used with diffuser I and two center bodies Nos. 4 and 3 (diffuser area ratio 6.50 and 4.00 respectively) were used with diffuser II (Fig. 11b). It can be seen that compared with the two dimensional diffusers, the same area ratio can be achieved in an axisymmetrical diffuser over a smaller length since the cross sectional area of the latter varies with r^2 while the area ratio of the former varies directly with the width.

The original duct inlet had a lip radius of 16 percent of the diameter (twice the scaled radius of Model 1) in order to avoid separation that might be caused by small surface irregularities on a sharper lip. A second inlet with elliptic lip of the same overall thickness was also tested.

3.6 Auxiliary Equipment

3.6.1 Suction Equipment

Two commercial vacuum cleaner motor-fan combinations were used as pumps for all of the suction tests. Each had a 1 HP 115 V AC motor driving a fan with a rated suction capacity of 80 cfm. through 1 1/4 in. diameter hose at 15 in. H₂O. The pumps were controlled with Variac rheostats. The actual suction flow rate measured in each hose by a standard ASME orifice mounted in a 30" length of straight pipe near the pump (Ref. 36). The pressure taps were connected to a U-tube manometer. The orifices were calibrated by means of measuring nozzles of known characteristics.

3.6.2 Blowing Equipment

A single 1 1/2 HP constant speed centrifugal blower rated at 200 cfm at 3 in. H₂O pressure rise was used. A throttling valve served to vary the air flow. A pitot static tube in a 3 1/2 in. diameter straight length of pipe was used to measure the flow rate; the velocity profile in the pipe with various flow rates was measured by traversing the pitot static tube, from which the mean value of axial velocity at each rate was computed and the flow rate calculated. Afterwards a single reading of velocity under test conditions gave the flow rate from the calibrated data.

3.6.3 Pressure Measuring Equipment

As described in Section 3.1, three probe rakes (Fig. 4) were permanently installed in the nozzle of the two-dimensional test stand so that the probes measured static pressure and total head 3/4 in. upstream of the two-dimensional diffuser inlet plane. Since the probes are located in a region of constant cross section, the values obtained are con-

sidered to be the same as in the inlet plane. Each of the seven outlet rakes (Fig. 4) consisted of one static and five total head probes soldered on a vertical 1/4 in. diameter brass tube, that could be clamped to the top and bottom parallel walls in any position. All the probes were made of 1/16 in. diameter brass tubing. The total head probe openings were rounded internally so that the pressure measurements would be accurate within less than 1 percent up to 20° flow misalignment from either side (Ref. 35).

Inlet and outlet rake probes were connected to a multiple tube manometer by 1/16 in. diameter plastic tubes approximately 15 ft. long. This was not sufficient to provide complete damping of pressure fluctuations in the outlet readings. However the average calculated for a representative case, with the readings at a mean position and at both extreme positions showed agreement in the calculated diffuser efficiency within ± 1.5 percent; this was considered within the range of experimental error. The diffuser wall pressure pickups were connected to the same multiple manometer. The boundary layer probe (Section 3.1) was not installed until later in the test series.

Each of the axisymmetrical models had a throat rake (diffuser inlet) and an outlet rake, spanning a diameter of the model.

In model 1 the existing throat rakes were used (Ref. 1). They had 8 total head probes and 8 static pickups 2 inches downstream. Because of a variation of static pressure axially (Fig. 20) the static pressure in the wall at the level of the total head probes was used instead, to obtain the local dynamic pressures and velocities. A series of wall static pressures in the axial direction was installed in addition to the existing inlet static pickups. An extension of this line of pressure pickups along the diffuser wall per-

mitted measuring the axial pressure distribution from inlet to outlet of Model 1.

Four rakes removed from the outlet of the two dimensional diffuser and connected end to end spanned one diameter of the diffuser outlet. A boundary layer rake of five hypodermic tubing probes suitably flattened and ground was installed with the pressures measured 2 inches upstream from the diffuser inlet plane.

All of the pressure pickups were connected by 1/16 in. diameter plastic tubing to two multiple tube manometers (total 80 tubes); the tubing was approximately 25 feet long and provided adequate damping of pressure oscillations; thus the readings can be considered as the time averages of the individual pressures.

Similarly, Model 2 had a throat rake made in two parts consisting of 10 total head and two static pressures probes, and an outlet rake consisting of 16 total head and 4 static probes (Fig. 11c).

No wall pressures were measured on Model 2. In each run, the manometer boards were photographed with a Polaroid camera. Thus all readings were taken simultaneously.

3.6.4 Flow Visualization

Tufts were used extensively on the surfaces under observation, as well as a tufted wand held by hand used to explore the flow in the diffusers visually.

In addition some use was made of smoke in a few cases but the usefulness of this method is restricted to areas where the flow is not turbulent (such as Model 1 and 2 duct inlets) or where the velocities can be reduced (in some two-dimensional diffuser tests).

A better method which has worked quite well consists in mixing a small quantity of a fluorescent dye to a light weight oil and dissolving it as needed in various parts of varsel or querozene. This mixture is brushed on the surfaces to be observed under test. When exposed to ultraviolet light a pattern of bluish streaks shows the flow behavior in the boundary layer quite effectively (Ref. 34).

These various methods were used separately or together to obtain a better physical understanding of the flow in various configurations.

3.6.5 Thrust Measurements

Total thrust was measured on Model 1 and Model 2 by means of three rectangular beam flexures mounted 120° apart and instrumented with SR-4 strain gages on top and bottom of the beams. All three top strain gages were connected in series; the three bottom strain gages were similarly series connected. Each set made up one arm of a Wheatstone Bridge consisting of a Baldwin SR-4 box with meter. The flexures were caliorated by suspending known weights from the motor shafts.

The equipment described in this chapter with the exception of the motors and manometers was designed and built in the MIT Aeroelastic and Structures Research Laboratory.

CHAPTER IV

TEST RESULTS AND DISCUSSION

4.1 General Remarks

It was realized from the start of this investigation, that the data available on diffusers from the literature would be of limited usefulness since for large expansion ratios, the usual length of two-dimensional diffusers is of the order of 8 to 20 times the inlet width; almost all the data on three dimensional diffusers involved conical diffusers only, with maximum included angles of 20 to 30°, the exceptions being found in Ref. 12 (curved walls) and Ref. 27 (50° conical diffuser, but $A_R = 2$). Furthermore it is known that the pressure losses in diffusers are very much dependent upon the nature and thickness of the inlet boundary layer (Ref. 19,23,24,30). The geometrical parameters which affect the diffuser performance are area ratio, included angle, (or length/inlet width), and wall shape. Not all the parameters could be varied in all possible combinations because of the time that would have required. The length was chosen as $L/2y_1 = 4$ in the two dimensional case, and as 1.5 times the fan diameter in Models 1 and 2 (which corresponds to 0.53 D_4 for Diffusers I and II and to 0.80 D_4 for Diffuser III).

The amount of turbulence in the flow at the inlet affects the diffuser performance. It was therefore necessary to study the diffusers under inlet flow conditions quite different from those usually found in the literature i.e., smooth flow and thin laminar boundary layer. In this two dimensional investigation the inlet flow was kept turbulent though steady and the inlet boundary layer turbulent and approximately 0.050 in. thick.

The two-dimensional test series was intended to evaluate the feasibility of the extreme diffusers that were desirable from a practical point of view. The three-dimensional studies were then initiated and the diffusers designed on the basis of the information acquired in the earlier two-dimensional tests. The flow downstream of the fans in Models 1 and 2 could not be controlled except by the use of screens which would have introduced pressure drops considered excessive (Ref. 25); the effect of the rotor tip vortices on the boundary layer is unknown.

4.2 Two Dimensional Diffuser Tests

Recent work on plane two dimensional diffusers has shown that there exist four distinct flow regimes: (1) fully stable unseparated flow, (2) transitory stall with oscillating flow, (3) fully developed stall on one expanding wall: (4) fully developed stall on both expanding walls (jet flow) (Ref. 11, 21, 22). In the present investigation all four flow regimes were encountered at different times with the various diffuser configurations. Regimes 3 and 4 were most prevalent without flow control.

The inlet velocity profiles for all configurations tested were consistently similar; representative profiles are presented in Fig. 15. It will be noticed that the profiles have a shallow dip near the center and higher velocities nearer to the walls. The velocity distribution approximates more closely the effect of a fan hub than would a completely uniform velocity. Only the distribution in the horizontal plane of symmetry is shown since the velocity profiles at the two other locations are within + 2.5 percent of the ones shown. As could be expected, the mean velocity (and mass flow) increased for diffuser configurations having more flow control and smaller losses. Representative values of the loss factor and the effi-

ciencies are presented in Table 4.

The effect of inlet Reynolds Number on the diffuser loss factor was not the same with different configurations (Fig. 13). The general trend is towards lower K for higher Reynolds Number within the range of the tests. This does not mean that this trend would necessarily extend further. For instance in the case of the A2 diffuser with wedge W1 and suction there is a minimum K about $Re_1 = 275000$, and higher K's at lower and higher Reynolds Numbers.

Further tests at higher inlet Reynolds Numbers were not carried out with the available test installation; the inlet flow would decrease when attempting to reduce the inlet area to obtain higher velocities, due to stalling of the blower working against an excessive pressure rise.

Representative inlet boundary layer profiles are shown in Fig. 12b. The effect of suction $2 \frac{3}{4}$ in. downstream from the probe position is to steepen the boundary layer gradient near the wall. Otherwise the profiles are not particularly affected by configuration changes.

Diffusers A2 and A3

The patterns of flow were similar with both of these diffusers. The inlet mean velocity \bar{v}_1 varied from 77 to 170 ft./sec. (Re_1 from 1.65×10^5 to 3.6×10^5). For any configurations, \bar{v}_1 did not affect the flow pattern, but only the loss factor K.

With the bare diffuser, and smooth walls, the flow attached entirely to one wall (either one, in different runs) (Fig. 16), and occasionally would shift suddenly to the other wall (in the case of A2). Flow was highly turbulent. With increasing suction, the flow would attach permanently to both walls ($Q_s/Q = 0.04$ for A2 and 0.096 for A3) up to approximately

3 inches from the outlet where it would separate completely.

With the addition of a center plate, flow regime 4 was encountered: separation from both walls symmetrically to the center plate. With suction on both walls, the flow remained attached to about 3 inches from the outlet where it would again separate from the walls (Q_s/Q as before). The use of more suction than necessary for stable flow ($Q_s/Q = 0.05$ for A2 and $= 0.10$ for A3) caused separation along the center plate. The addition of two short straight vanes between the center plate and the walls would improve the performance and notably decrease the turbulence in the diffuser. With vanes and no suction, separation would occur approximately 4 inches further downstream than without vanes. Slightly less suction ($Q_s/Q = 0.037$ for A2) was required for attachment to the wall (downstream stall in the same location as before).

The effect of a wedge center body (W1 in diffuser A2, W1, W2 and W3 in diffuser A3) without and with suction was similar to that of the center plate with vanes (Figs. 17a, b). It was possible to detach the flow halfway down the center body by increasing suction beyond approximately $Q_s/Q = 0.055$ (A2) and $Q_s/Q = 0.12$ (A3) at $Re_1 = 1.6 \times 10^5$.

At higher Re_1 values, there was a decrease in suction flow ratio to achieve the same degree of attachment: for instance Diffuser A3 with W2 at $Re_1 = 2.5 \times 10^5$, $Q_s/Q = 0.093$ but at $Re_1 = 3.4 \times 10^5$, $Q_s/Q = 0.07$.

This follows substantially the trend in the data shown in Fig. 13, since less flow losses in the diffuser require less suction for correction. It is worth mentioning that in all of the tests with suction, after the flow attachment was achieved, the suction flow could be reduced to less than half its initial value before the primary stall would occur again. Over this range of suction the flow was stable. This effect was observed

consistently throughout the present program.

In the configuration using suction alone, center plate, vanes and suction, or wedge centerbody and suction, a backflow region occurred on either the top or the bottom plate as well as in the corners of the expanding walls. As the suction was increased beyond the values already mentioned, this backflow region would move upstream and increase in thickness (Fig. 16).

Representative velocity maps at the outlet of Diffusers A2 and A3 are shown in Figs. 15a, b, c and d, without and with flow control.

Diffuser C3 - C4

The bare diffusers with smooth walls had flow fully attached to either wall (regime 3); it was steady although turbulent. There were no oscillations between the walls. The diffuser loss factor was high (low efficiency). The use of suction areas straddling the stall boundary of each wall did not achieve attachment to both walls simultaneously. By increasing suction on one wall, the flow could be made to jump to the opposite wall. But increasing the suction on both walls did not change the flow regime. It was observed in this case (with smoke and tufts) that the back flow was sucked back slightly upstream and into the suction manifold of the stalled wall. As this seemed to indicate that the location of the suction was too far downstream, a second suction area was located $3/4$ in. further upstream on the walls of C3 and C4. But the flow would still not attach to both walls up to $Q_s/Q = 0.15$ which was the maximum available.

With the introduction of a center plate, the flow separated from both walls and remained in the center of the diffuser. (Regime 4). Attachment on the walls was obtained with $Q_s/Q = 0.058$ for C3, $Q_s/Q = 0.12$ for C4. At the same

time extensive back flow occurred on top or bottom plates which grew worse with increasing suction. A cluster of four curved vanes was added to the center plate (Fig. 5b). The flow attached to the walls completely in the case of C3 but only over a short distance for C4. At the same time a wide zone of back flow occurred on both sides of the center plate near the outlet. The addition of a short wedge (center body CBI) in the center improved this condition. A wider short center body CBII did not improve the flow further but slightly decreased the efficiency. The thick wedges of backflow on the top and/or bottom plates remained. The addition of suction did not affect appreciably the flow regime. This is understandable since the vanes nearest to the walls had the effect of preventing separation, even without suction.

With wedges W2 or W3 and with suction the flow could be attached to both walls and to the center body. ($Q_s/a = 0.075$ for C3, $=0.103$ for C4). However a thick back flow region occurred on the top plate, which occupied almost 1/3 of the outlet area. This condition became worse with increasing suction. Typical flow patterns for Diffuser C3 are shown in Fig. 16b.

From figure 15 and the previous discussion, it is obvious that the flow regimes in all the diffusers tested were always three-dimensional and turbulent. But with some form of flow control considerable improvement in performance was possible. The values of the head loss factor K were adversely affected by the backflow regions on the top and bottom plates and in the corners. Thus it was reasonable to expect that a three dimensional axisymmetric diffuser of similar configuration with flow control at all azimuths could avoid some of these losses and have comparatively lower K's. It can also be deduced that for the very large expansions, localized suction is

not sufficient to prevent separation. A combination of center body and suction seems to give the best overall results. The amount of suction should be adequate to establish and maintain attachment, but not more than necessary, as this tends to create zones of backflow at other locations which are detrimental. Suction applied to all four walls of a two-dimensional diffuser would possibly be able to eliminate or reduce the thick boundary layer growths occurring on the parallel walls.

4.3 Three Dimensional Diffuser Model I

Several runs were made with each configuration by varying the blade pitch settings and fan speed (5500 and 6500 rpm) ($AR = 432$ and 520 ft./sec.) Diffuser inlet Reynolds Numbers (based on the duct diameter) varied from 1.9×10^5 to 9.2×10^5 .

The diffuser was tested initially with the suction area sealed with smooth plastic tape. With the twisted blades (set C), at θ_f from -4° to 16° , the flow was in the form of a jet in the center of the diffuser, with no attachment whatsoever. (Pattern A Fig. 19.) Performance was poor and appreciable oscillations occurred: the thrust measurements varied over a range of the same order of magnitude as the average readings.

With untwisted blades (set A) however, at pitch settings $\theta_f = 10^\circ$ to 30° , the flow attached spontaneously to the walls leaving a central core with backflow (pattern B Fig. 19.)

This same flow pattern B was encountered with blade set C at $\theta_f = 16^\circ$, when the suction area was uncovered even as little as 1 inch, but not at lower pitch settings.

With suction applied over the whole suction area

($Q_s/Q = 0.04$) or over the last inch only (same Q_s/Q), the results were the same as described above for the different blades and pitch settings. The center body was then installed ($A_R = 6$) and faired smoothly into the motor housing, (Fig. 6). With blade set A (untwisted) at $\theta_r = 10$ to 40° and with or without suction (suction area uncovered) flow pattern D in Fig. 19 was encountered consistently, which would tend to indicate that this center body still allowed the flow to expand too rapidly. With blade set C $\theta_r = 6^\circ$ and 16° ($\theta_R = 30^\circ$ and 40°) with suction, flow pattern D was observed (Fig. 19). ($Q_s/Q = 0.065$).

All of the Model 1 tests displayed appreciable vibration of the diffuser and consequently of the whole installation.

In an effort to measure the thrust and oscillatory amplitudes accurately, the SR-4 Box in the flexure strain gage circuit was replaced by a Sanborn 2 channel Recorder and the output recorded graphically. The frequency of oscillation due to the flow turbulence was found to be very close to the natural frequency of the system on its supports, measured with the fan stopped. Thus, even though the flow was not violently turbulent the oscillations were of sufficient amplitude to make for poor accuracy in the thrust readings, (approximately ± 10 percent). Representative static pressure distributions along the wall are given in Fig. 21. They show that even with partially satisfactory diffuser operation, there exists an increase in flow velocity and reduced pressures over the duct inlet. Typical throat (diffuser inlet) and diffuser outlet velocity profiles are shown in Figs. 22 and 23, and typical boundary layer velocity profiles downstream of the rotor tips are shown in Fig. 24.

The slipstream rotation was not measured, however none was apparent by visual study of tufts at the diffuser outlet, which would tend to indicate that the flow rotation practi-

cally disappeared between the fan and the diffuser exit. Whether this is due to recovery of the kinetic energy associated with the radial component of the velocity vector of the flow behind the fan, or whether this was dissipated as friction drag has not been established.

4.4 Three Dimensional Diffusers Model 2

The size of the Model 2 installation made it much more convenient and flexible for the study of various changes suggested by the early results of Model 1 tests. Reynolds Numbers based on the duct diameter at the diffuser inlet were from 2.45×10^5 to 4.75×10^5 . Tests were made at blade tip pitch settings of 15° to 45° and at two rotational speeds, 7000 and 11000 RPM ($UR = 183$ and 288 ft./sec.). The first diffuser tried (Diffuser I, Fig. 11) had exactly the same geometry as the Model 1 Diffuser already discussed, but to the scale of $1/3$. In both cases the initial curvature was of the same type as that used in the two dimensional diffusers A2 and A3, followed by a straight cone to avoid the secondary stall near the outlet of the fully curved diffuser. The area ratio could be changed by the addition of two centerbodies.

Initially the gap ($1/32$ in.) between the diffuser and the main duct ring was not sealed along the inside wall, although there was a viscous fluid seal between the outside and inside of the duct, preventing the injection of outside air into the main stream. With the unsealed edges in the wall surface, the flow was attached to the diffuser wall to the outlet, with a central backflow core (Pattern B Fig. 19). When this gap was sealed smooth, the flow would still remain attached to the wall over a short range only, then separate. With the addition of either center body 1 or center body 2, the flow would be as in (C) Fig. 19 i.e. separated from the dif-

fuser wall and attached to the center body.

Diffuser II had a more pronounced convex curvature of the same type as before, followed by a gradual concave shape in order to straighten out the flow at the exit and recover as much as possible of the pressure difference axially.

With Diffuser II installed and no flow control, there would be no attachment to the walls (Pattern E Fig. 19). With diffuser II and center body 3 or 4 in place, the flow followed Pattern G (Fig. 19), the extent of the localized separation bubble varying somewhat with speed and blade setting; this would indicate that some revision of the wall shape could avoid this local separation and reattachment.

A blowing ring and slot were then introduced between the main duct ring and the diffuser. The slot was originally 0.050 in. wide, later increased to 0.100 in., and was located so as to blow the injected air tangentially to the duct wall in the downstream direction. Varying amounts of blowing quantity were used; in all cases, the effect of the blowing was to change the flow patterns in the diffusers with or without centerbodies from A to B, from C to D, from E to F and from G to H (Fig. 19), that is, complete attachment along the diffuser walls and a core of back flow air or some degree of separation on the centerbodies.

A cluster of six circular vanes of .025 aluminum alloy sheet designed to fit into Diffuser II distributed the flow over the whole diffuser, but was not tested further.

Diffuser III was designed to maintain the Gibson curvature to the exit with area ratio of 4. The length was kept equal to that of the other diffusers. Without flow control, at any fan speed, the flow separated. Pattern A (Fig. 19).

Diffusers II and III were then modified for suction. In both cases, suction was located at two points: the upstream

suction area straddling the stall boundaries visually observed; the downstream suction area for Diffuser II at the location where the separation bubble was observed (Pattern G, Fig. 19), and for Diffuser III halfway between the first position and the outlet (3 1/2 inches from the outlet plane).

Relatively little suction was required to attach the flow completely in Diffuser III. Either suction location was satisfactory, but the upstream location required less suction for the same results ($Q/Q_0 = 0.008$ for upstream suction; $s = 0.016$ for downstream suction). A zone of backflow existed in the center of the diffuser.

Diffuser II with center body 3 required relatively little suction for attachment, provided suction was applied at both points simultaneously. The flow was attached everywhere, walls and centerbody, and was very steady. This was the best axisymmetrical configuration tested.

The effect of changing from a circular inlet having a radius equal to sixteen percent of the duct diameter to an elliptical inlet having the same length and width was not significant. Of the two blade pitch distributions tested (D and E), (Fig. 10b) the former showed somewhat more uniform inflow distribution, and somewhat better results with the various diffusers.

Some representative diffuser inlet and outlet velocity profiles are presented in Figures 24 and 25; values of K for several axisymmetrical configurations are shown in Figure 26.

Table 5 demonstrates some typical values of K and efficiency measured in the axisymmetric diffusers.

Referring to Figures 14 and 26, it should be pointed out that the sloping solid line represents $\alpha = 1$ and that any point to the right of and below this line represents values of

higher than unity; therefore any configuration to the right of $\eta = 1$ is theoretically capable of improving the T/p ratio of a ducted fan; the further the point from that line the greater the improvement.

Figure 26 shows a plot of representative best axisymmetric diffuser configurations compared with a couple of the worst ones, superimposed on the data from Fig. 2. The plotted values of K are corrected according to equations (2.19) and (2.20). It can be seen that the best values occur in the vicinity of $A_R = 6$ with an Augmentation Factor of 1.6, i.e: 60 percent increase in T/p . The values obtained at $A_R = 4$ are very close to each other and the differences are not too significant since they undoubtedly include some experimental error. The values at $A_R = 8.71$ are not necessarily the best that can be achieved.

Figure 27 shows a plot of Augmentation Factor effectiveness, that is, the ratio of the expected to the ideal value (for $K = 0$). The trend is decreasing towards higher A_R 's; however it also tends to diverge from the curve $\eta = 1.0$ at those higher area ratios with adequate flow control; therefore it is possible that higher area ratio diffusers may yield even better values of η even though they are obtained at higher values of K .

Accuracy of the Results

The values of q_4^* obtained with turbulence are in general optimistic anywhere up to 10 percent because of measuring the squares of the velocity fluctuations. This applies mainly to the lower efficiencies.

This would tend to make the lower values of η_0 and the higher K 's optimistic. With the better flow configurations however, the turbulence is considerably reduced and the error

in q_h^* also reduced. All the pressures were read within ± 0.05 in. of alcohol, except for the boundary layer probe (± 0.05 millimeters of alcohol). Flow measurements (suction and blowing) are considered accurate within 5 percent of their mean value.

When taking into account the inclination of the outlet probes to the local flow direction, and using the data of Ref. 35, the calculated efficiencies are estimated to be within a range of 10 percent for the worse values and of 5 percent for the better values.

CHAPTER V

CONCLUSIONS AND RECOMMENDATIONS

Numerous tests were conducted on rapidly expanding two-dimensional and axisymmetrical diffusers with area ratios from 4.0 to 8.71. The axisymmetric diffusers had a ratio of diffuser length to inlet diameter of 1.5. The diffusers were tested with and without centerbodies, vanes boundary layer suction and blowing.

The results obtained to date in this investigation lead to the following conclusions, valid for all the diffusers tested, except as otherwise specified.

(1) Total head losses for the best axisymmetrical configurations tested were of the order of 15 percent of the diffuser inlet mean dynamic pressure. Such configurations would permit an augmentation factor of 1.6, i.e., a 60 percent increase in the T/p ratio. This corresponds to 67 percent of the ideal (no loss) augmentation factor for the same area ratios.

(2) Best results were obtained for the larger area ratios (axisymmetrical) with a blowing slot located at the diffuser inlet and with air flow ratios of 9 to 15 percent of the main flow.

(3) The most significant parameter in determining diffuser efficiencies with suitable flow control appears to be the area ratio and not the expansion angle. Tests with a large expansion angle diffuser and centerbody showed no significant difference from a diffuser with a smaller expansion angle and no centerbody, at the same area ratio, although there existed in the latter case a small core of turbulent backflow.

(4) A core of turbulent backflow existed in all diffusers tested without centerbody when flow attachment to the walls was achieved. This core occupied an increasingly larger part of the total diffuser volume as the area ratio increased.

(5) The shape of the diffuser walls does not appear to have any significant influence on the results, with controlled flow, for equal area ratios.

(6) Good axisymmetrical diffuser efficiencies were obtained with suction applied at two locations, one just downstream of the diffuser inlet and one at approximately half the diffuser length. Optimum suction flow ratios for stable attachment were of the order of 2.5 percent of the main air flow. Visual examination of the flow and the exit velocity distribution indicated complete attachment, and it is therefore concluded that suction over the whole wall area is not necessary.

(7) Limited tests with vanes showed generally lower efficiencies than those obtained with the best configurations tested.

(8) The use of two dimensional models as a guide to the design of axisymmetric configurations has been found satisfactory, and the efficiencies obtained for the axisymmetrical cases are of the order of magnitude indicated by the two dimensional diffuser tests, after correcting for corner and boundary layer effects.

Recommendations for further investigation:

(1) These tests should be continued in order to determine whether the theoretically predicted augmentation factors for the experimentally determined diffuser efficiencies could be realized in practice. This would require carefully designed low solidity highly twisted fans matched to the desired diffuser inlet conditions for some chosen diffuser configura-

tion. For such tests, the torque (hence the net applied power) should be measured directly at the rotor shaft. Separate thrust measurements on duct inlet, fan and diffuser would aid in interpreting the test results.

(2) Evaluate the effect of forced flow rotation on the diffuser efficiencies in order to provide attachment with a minimum of suction or blowing power.

(3) Because of the success obtained to date with large expansions, the diffuser tests should be continued with larger area ratios, with and without centerbodies. Such configurations would be of interest in providing out-of-ground-effect hovering capability for ground effect machines.

*

REFERENCES

1. Moser, H.H., and Livingston, C.L., Experimental and Analytic Study of the Ducted Fan and Fan-in-Wing in Hovering and Forward Flight, Report No. 79-1, 1959.
LAD - 213 3/6
2. GILL, W.J., Wind Tunnel Tests of Several Ducted Propellers in Non-axial Flow, Hiller Aircraft Corp., Report No. ARD-224, 1959.
3. Schwartz, I.R., Investigations of an Annular Diffuser-Fan Combination Handling Rotating Flow, NACA RM No. 19B28, April 1949.
4. Platt, Robert, Jr., Static Tests of a Shrouded and Unshrouded Propeller, NACA RML7H25, 1948.
5. Navy Dept., Bu. Aer., Research Div., A Study of Shrouded vs. Unshrouded Propellers, Report No. DR-1750, 1955.
6. Taylor, R.T., Experimental Investigation of the Effects of Some Shroud Design Variables on the Static Thrust Characteristics of a Small-Scale Shrouded Propeller Submerged in a Wing, NACA TN 4126, 1958.
7. Hubbard, H.H., Sound Measurements for Five Shrouded Propellers at Static Conditions, NACA TN 2024.
8. Minassian, B., Analytical Study of Shrouded Propellers, Longren Aircraft Co., Report LR-501, 1956.
9. Kruger, W., On Wind Tunnel Tests and Computations Concerning the Problem of Shrouded Propellers, NACA TM No. 1202, 1949.

10. Woollett, R.R., Preliminary Investigation of Short Two-Dimensional Subsonic Diffusers, NACA RM E56C02, 1956.
11. Kline, S.J., Moore, C.A., Cochran D.L., Stanford U., Wide Angle Diffusers of High Performance and Diffuser Flow Mechanism, Journal of the Aeronautical Sciences, Vol. 24, No. 6, June 1957, pp. 46-70.
12. Gibson, A.H., On the Resistance to Flow of Water Through Pipes or Passages Having Divergent Boundaries, Trans. Roy. Soc. (Edinburgh) Vol. 48, pt. 1, art. no. 5, 1913, pp. 97-116.
13. Polzin, J., Flow Investigation in a Two-Dimensional Diffuser, Ministry of Aircraft Production RTP Translation 1286, Ingenieur Archiv, Vol. XI No. 5 Oct. 1940, pp. 361-385.
14. Vedernikoff, A.N., An Experimental Investigation of the Flow of Air in a Flat Broadening Channel, 1926, TM 1059.
15. Peters, H., Conversion of Energy in Cross-Sectional Divergences Under Different Conditions of Inflow, TM 737, 1934, (also Ingenieur - Archiv, Vol. II, 1931 pp. 92-107).
16. Demontis, Jean, Recherches sur l'influence de l'Angle d'ouverture d'un ajutage divergent sur l'écoulement à deux dimensions de l'air à travers cet ajutage, Publications Scientifiques et Techniques du Ministère de l'Air, No. 87, Paris 1936.
17. Patterson, G.N., Modern Diffuser Design, Aircraft Engineering, Sept. 1938, p. 267.

18. Jamin, Raymond, Les Diffuseurs Courts à corps Central, Publications Scientifiques et Techniques du Secrétariat d'Etat à l'Aviation, No. 172, Paris 1941.
19. Kline, S.J., Abbott, D.E., Fox, R.W., Optimum Design of Straight-Walled Diffusers, Report PD-4, Stanford University, 1958.
20. Reid, E.G., Performance Characteristics of Plane-Wall Two-Dimensional Diffusers, NACA TN 2888, 1953.
21. Moore, C.A., Jr., and Kline S.J., Some Effects of Vanes and of Turbulence in Two-Dimensional Wide-Angle Subsonic Diffusers, NACA TN 4080, 1958.
22. Cochran, D.L., and Kline, S.J., Use of Short Flat Vanes for Producing Efficient Wide-Angle Two-Dimensional Subsonic Diffusers, NACA TN 4309, 1958.
23. Moon, I.Man., Distributed Suction Boundary Layer Control on Conical Diffusers, Aerophysics Dept., Mississippi State University, Research Report No. 17, 1958.
24. Little, B.H., Jr., and Wilbur, S.W., Performance and Boundary-Layer Data from 12° and 23° Conical Diffusers of Area Ratio 2.00 at Mach Numbers up to Choking and R.N. up to 7.5×10^6 , NACA Report 1201, 1954.
25. Schubauer, G.B., and Spangenberg, W.G., Effect of Screens in Wide Angle Diffusers, NACA TR 949, 1949.
26. Von Karman, Th., Theoretical Remarks on Thrust Augmentation, Reissner Anniversary Volume pp. 461-468, J.W. Edwards, Ann Arbor, Michigan, 1949.

27. Holzhauser, C.A., and Hall, L.P., Exploratory Investigation of the Use of Area Suction to Eliminate Air-Flow Separation in Diffusers Having Large Expansion, NACA TN 3795, Oct. 1956.
28. Biebel, W.J., Low Pressure Boundary Layer Control in Diffusers and Bends, 1945, NACA WR L-84 (ARR L5C24).
29. Manoni, L.R., Wide Angle Diffusers Employing Boundary-Layer Control, Report R-95460-12, Research Dept., United Aircraft Corp., 1952.
30. Gratzner, L.B., Smith, R.H., Boundary Layer Control for Wide Angle Diffusers, Aero. Lab. Rep. 300, University of Washington, 1948.
31. Jones, J.B., and Binder, R.C., Boundary Layer Flow in the Corner of a Diffuser, Purdue University, Eng. Bull. 115.
32. Wilbur, S.W., and Higginbotham, J.T., Investigation of a Short-Annular-Diffuser Configuration Utilizing Suction as a Means of Boundary-Layer Control, TN 3996, 1957.
33. Dannenberg, R.E., Gambucci, B.J., Weiberg, J.A., Perforated Sheets as a Porous Material for Distributed Suction and Injection, TN 3669, NACA 1956.
34. Loving, D.L., and Katzoff, S., The Fluorescent-Oil Film Method and Other Techniques for Boundary-Layer Flow Visualization, NASA Memo 3-17-59L, 1959.
35. Gracey, W., Letko, W., and Russell, W.R., Wind-Tunnel Investigation of a Number of Total Pressure Tubes at High Angles of Attack. Subsonic Speeds, NACA TN 2331, 1951.

30. American Society of Mechanical Engineers, Flow Measurements by Means of Standardized Nozzles and Orifice Plates, Power Test Codes, Supplement on Instruments and Apparatus pt. 5, ch. 4, 1949.

BIBLIOGRAPHY

Busemann, A., On the Gas Dynamics of a Rotating Impeller, (Zur Gasdynamik des drehenden Schaufelsterns), NACA TM 1385, March 1956, (trans. from Zeitschrift fur angewandte Mathematik und Mechanik, V. 18, No. 1, February 1958, p. 31-38).

Campbell, A.J., Investigation of a Wide Angle Diffuser with Air Augmentation for use as a Jet Muffler, Institute of Aerophysics, University of Toronto, UTIA Technical Note No. 15, 11 pp. 1957.

Dannenberg, R.E., Weiberg, J.A., and Gambucci, B.J., The Resistance to Air Flow of Porous Materials Suitable for Boundary Layer-Control Applications Using Area Suction, NACA TN 3094, January 1954.

Droblenkov, V.F., The Turbulent Boundary Layer on a Rough Curvilinear Surface, (Turbulentnyi Pogranichnyi sloi na sherpokhovatoi krivolineinoi poverkhnosti), NACA TM 1440, September 1958. (Translation from Akademiia Nauk SSSR, Izvestiia, Otdelenie Tekhnicheskikh Nauk, No. 8, 1955, p. 17-21).

Furuya, Yoshimasa, Experiments and Theory on Flow in the Diffuser, Memoirs of the Faculty of Engineering, Nagoya University Vol. 10, No. 1, pp. 1-39.

Gault, D.E., An Experimental Investigation of Regions of Separated Laminar Flow, NACA TN 3505, September 1955.

Gibson, A.H., On the Flow of Water Through Pipes and Passages Having Converging or Diverging Boundaries, Proc. Royal Soc. (London) Sec. A Vol. 83, No. 563, pp. 366-378, 1910.

*

Henry, John R., Design of Power Plant Installations - Pressure Loss Characteristics of Duct Components, NACA ARR L4826, WRL-208, 1944.

Henry, J.R., and Wilbur, S.W., Preliminary Investigation of the Flow in an Annular Diffuser - Tail Pipe Combination with an Abrupt Area Expansion and Suction Injection and Vortex Generator Flow Controls, NACA RML53K30, 1954.

Kline, S.J., Some New Conceptions of the Mechanism of Stall in Turbulent Boundary Layers, note in the Journal of the Aeronautical Sciences Reader's Forum, Vol. 24, No. 6, pp. 470-71, June 1957.

Laufer, J., The Structure of Turbulence in Fully Developed Pipe Flow, NACA Rept. 1174, formerly TN 2954, National Bureau of Standards, 1954.

Loeffler, A.L., and Perlmutter, M., Turbulent Flow Through Porous Resistances Slightly Inclined to the Flow Direction, NACA TN 4221, February 1958.

Ovchinnikov, O.N., The Influence of the Entry Velocity Profile on the Performance of a Diffuser, Trudy Leningrad Polytechnic Institute, Energomashinostroenie, 176, 1955, (translated by D.W. Black and P.W. McDavitt, Cambridge University).

Persh, J., and Bailey, B.M., A Method for Estimating the Effect of Turbulent Velocity Fluctuations in the Boundary Layer on Diffuser Total-Pressure-Loss Measurements, NACA TN 3124, January 1954.

Robertson, J.M., and Holl, J.W., Effect of Adverse Pressure Gradients on Turbulent Boundary Layers in Axisymmetric Conduits, Journal of Applied Mechanics, Vol. 24, pp. 191-196, 1957 (Discussion by Frazer and Uram in Journal of Applied Mechanics, March 1958, p. 159).

Ruetenik, J. Ray, Investigation of Equilibrium Flow in Slightly Divergent Channel, Report 1-19, The John Hopkins University, Baltimore, Maryland, 1954.

Stanitz, J.D., Design of Two-Dimensional Channels with Prescribed Velocity Distributions Along the Channel Walls, NACA Technical Report 1115, 1953.

Tulst, Harold, Flow Expansion and Pressure Recovery in Fluids, Proc. Am. Soc. Civ. Eng. Vol. 80, Separate No. 507, Dec. 1954.

Von Doenhoff, A.E., and Horton, E.A., A Low-Speed Experimental Investigation of the Effect of a Sandpaper Type of Roughness on Boundary-Layer Transition, NACA Rept. 1349, 1958.

Wood, C.C., and Higginbotham, J.T., Effects of Diffuser and Center Body Length on Performance of Annular Diffusers with Constant Diameter Outer Walls and with Vortex Generator Flow Controls, NACA RML54G21, 1954.

TABLE I

COORDINATES OF TWO-DIMENSIONAL DIFFUSERS
(in.)

x	y(x)	A2	A3	C3	C4
0		2.00	2.00	2.00	2.00
1		2.15	2.20	2.08	2.08
2		2.30	2.41	2.28	2.28
3		2.50	2.62	2.65	2.65
4		2.70	2.83	3.25	3.25
5		2.92	3.22	4.07	4.07
6		3.18	3.56	5.05	5.35
7		3.46	3.90	6.02	7.17
8		3.76	4.38	7.00	9.00
9		4.21	4.92	7.98	10.82
10		4.48	5.55	8.95	12.63
11		4.87	6.25	9.91	13.92
12		5.40	7.05	10.75	14.75
13		5.92	7.95	11.38	15.38
14		6.50	9.10	11.71	15.71
15		7.18	10.45	11.92	15.92
16		8.00	12.00	12.00	16.00

TABLE 2

COORDINATES OF MODEL 1
(INCHES)

x	$r(x)$	DIFFUSER	CENTER BODY
0		9.00	1.75
2		9.18	1.90
4		9.72	2.48
6		10.60	3.30
8		11.72	4.12
10		12.04	4.98
12		14.42	5.85
14		15.82	6.73
16		↓	↓
18		↓	↓
20		STRAIGHT	STRAIGHT
22		↓	↓
24		↓	↓
27		25.00	12.50

TABLE 3

COORDINATES OF MODEL 2 DIFFUSERS

DIFFUSER

x(in)	r(in)	I	II	III
	0		3.00	3.00
1		3.15	3.36	3.12
2		3.50	4.05	3.30
3		4.10	5.00	3.50
4		4.81	6.00	3.75
5		5.52	6.81	4.05
6		6.22	7.45	4.38
7		6.95	7.92	4.72
8		7.63	8.23	5.19
9		8.35	8.35	5.70

CENTER BODY

x(in)	r(in)	1	2	3	4
	0		1.00	1.00	1.00
1		1.19	1.05	1.30	1.30
2		1.40	1.28	2.00	2.00
3		1.72	1.82	2.86	2.90
4		2.10	2.42	3.87	3.45
5		2.50	2.48	4.71	3.80
6		2.92	3.46	5.29	4.00
7		3.38	3.93	5.73	4.12
8		3.78	4.40	6.02	4.20
9		4.18	4.82	6.15	4.20

TABLE 4

COMPARISON OF BEST TWO-DIMENSIONAL DIFFUSERS ($L/2y_1 = 4$)

Diffuser	A_R	K	K_{CORR}	η_p	η_o	η_{OCORR}
A2	4	2.88		.37	.41	
+ suction	4	1.55	1.48	.53	.62	.60
center plate	4	2.25		.47	.53	
" +suction	4	1.89	2.05	.65	.78	.76
wedge 1	3.5	2.55		.41	.46	
" +suction	3.5	1.14	1.28	.69	.76	.73
3 vanes	4	3.67		.46	.51	
" +suction	4	1.24	1.35	.64	.73	.71
A3	6	2.30		.36	.44	
+ suction	6	2.21	2.58	.53	.60	.56
center plate	6	3.70		.42	.47	
wedge 2	5.25	2.76		.324	.38	
+ suction	5.25	1.70	1.79	.588	.67	.62
wedge 3	5	2.91		.35	.41	
+ suction	5	1.53	1.62	.64	.77	.73
3 vanes	6	4.52		.39	.39	
+ suction	6	2.62	2.78	.52	.59	.55

TABLE 5

COMPARISON OF BEST AXISYMMETRIC DIFFUSERS CONFIGURATIONS

	A_2	K	$K_{CORR.}$	η_P	η_D	$\eta_{CORR.}$
Diffuser I (For Reference)	8.71	9.00		.54	.58	
" + Blowing	8.71	3.35	4.47	.71	.75	.69
" + CB ₁ + Blowing	6.55	1.28	1.79	.69	.78	.72
" + CB ₂	5.78	4.15		.74	.76	
" + CB ₂ + Blowing	5.78	.89	1.50	.72	.83	.74
Diffuser II + Blowing	8.71	2.77	3.54	.59	.65	.59
" + CB ₃	4.00	6.22		.60	.61	
" + CB ₃ + Blowing	4.00	.74	1.91	.91	.93	.84
" + CB ₃ + Suction	4.00	1.83	2.17	.84	.88	.86
" + CB ₄ + Blowing	6.55	.85	2.25	.92	.96	.77
Diffuser III	4.00	2.2		.70	.84	
" + Suction	4.00	1.14	1.24	.76	.82	.80

KEY TO NUMBERS ON FIGURES

1. Inlet
2. Fan Section
3. Settling Chamber
4. Nozzle
5. Diffuser Assembly
6. Diffuser Inlet Rake Location
7. Diffuser Outlet Rake Location
8. Boundary Layer Probe (or Rake) Location
9. Suction Hose
10. Pressure Probes or Pickups
11. Flexure

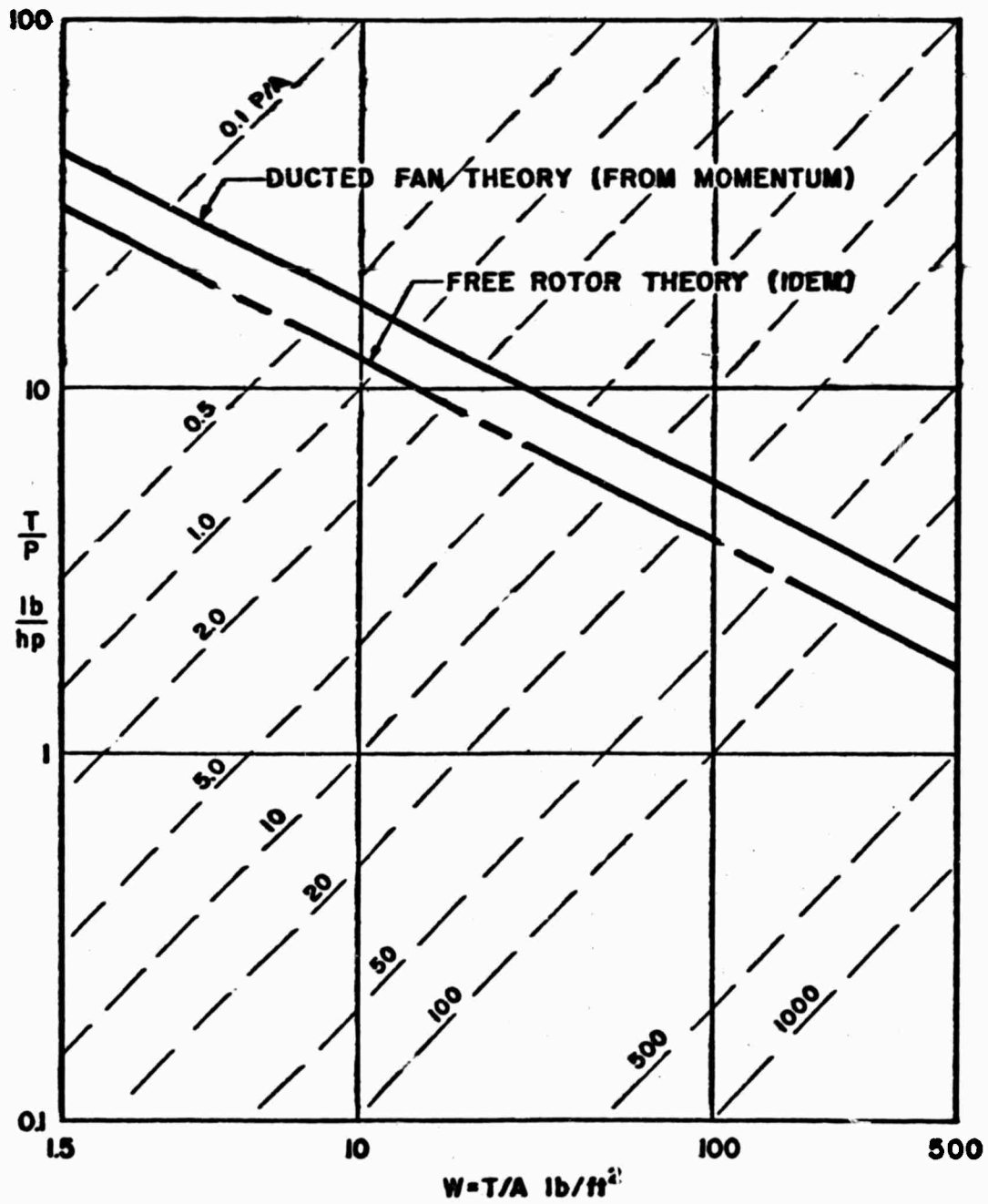

FIG. 1 VARIATION OF THRUST/POWER WITH DISC LOADING

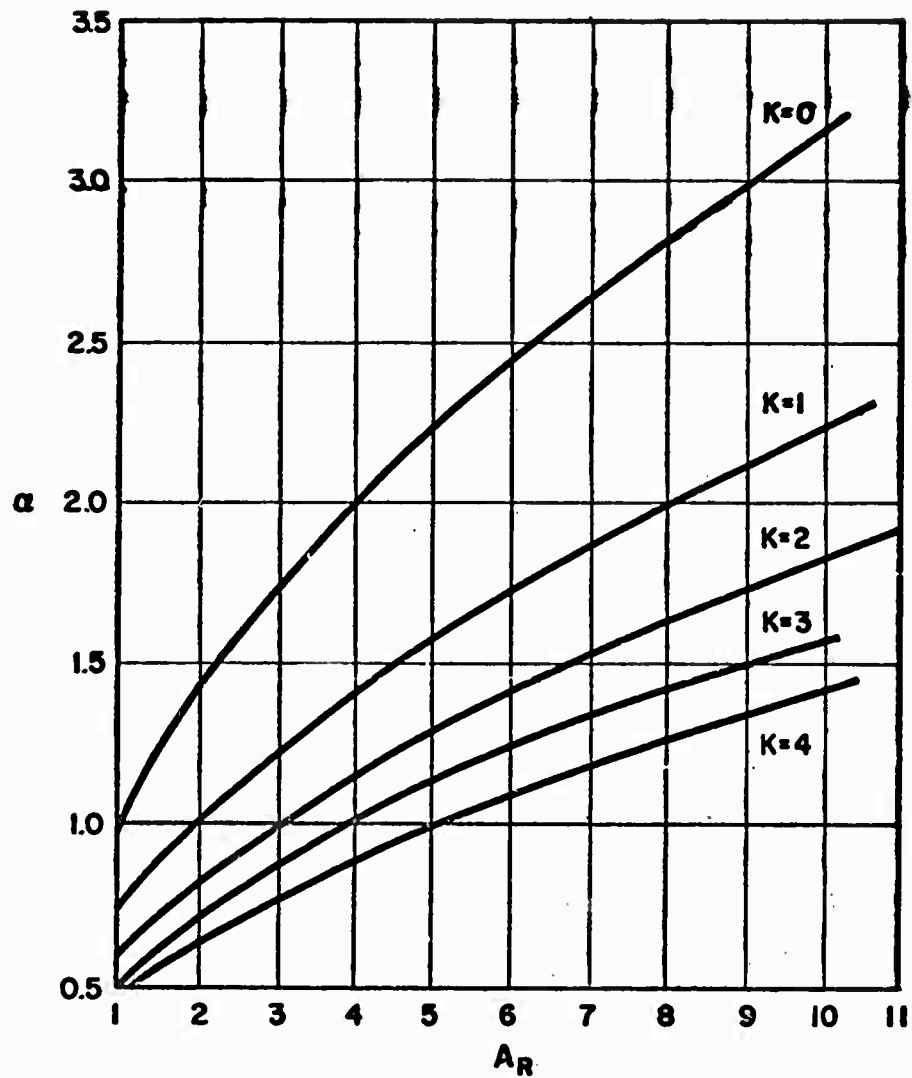

FIG.2 AUGMENTATION FACTOR VERSUS AREA RATIO (AT CONSTANT POWER)

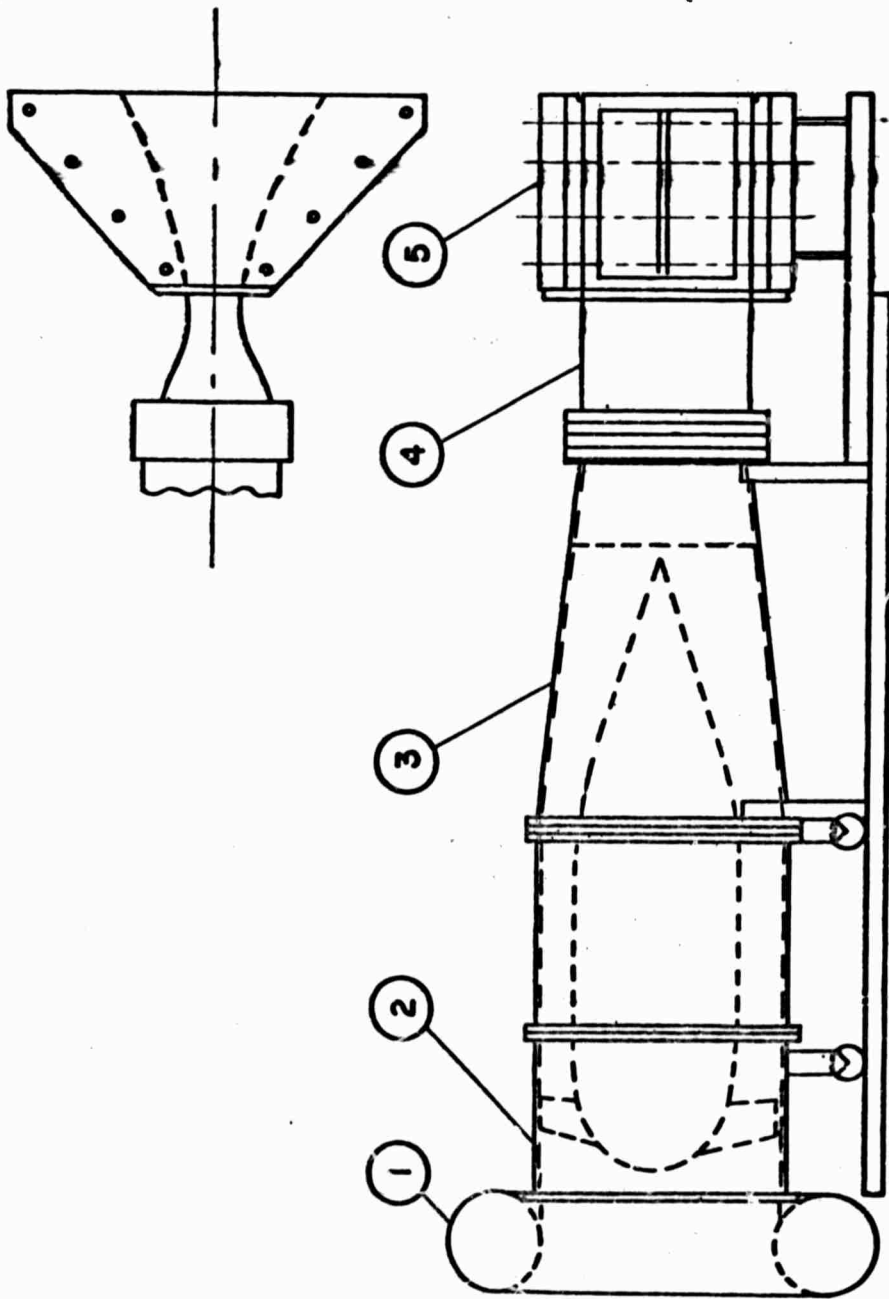

FIG.3 VIEW OF TWO DIMENSIONAL TEST INSTLLATION

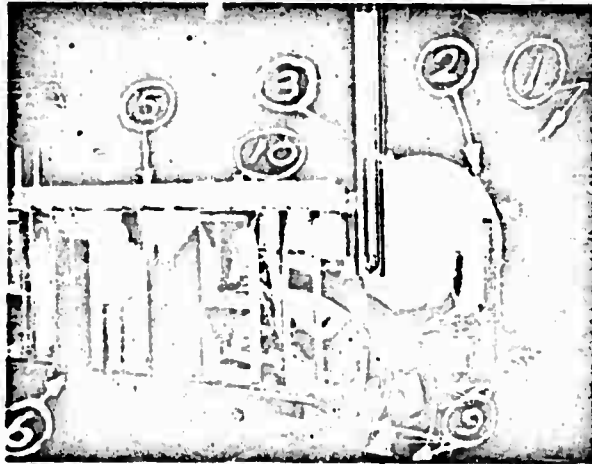

FIG. 3b 2-DIMENSIONAL DIFFUSER
TEST INSTALLATION

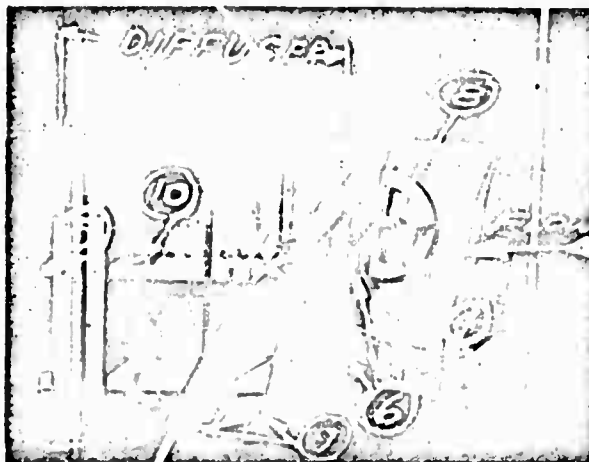
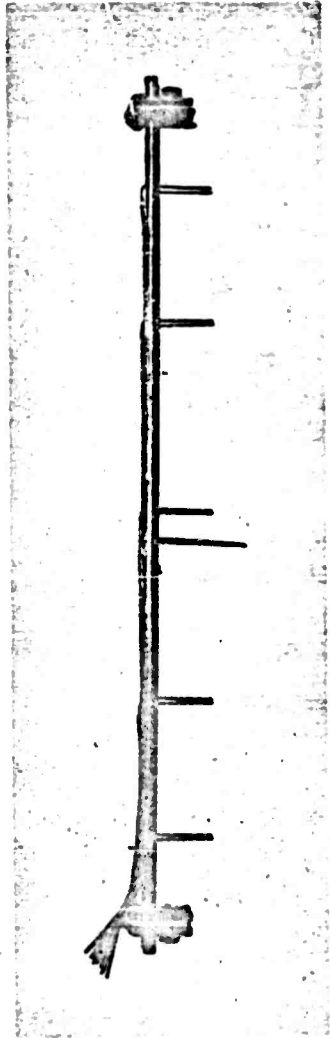
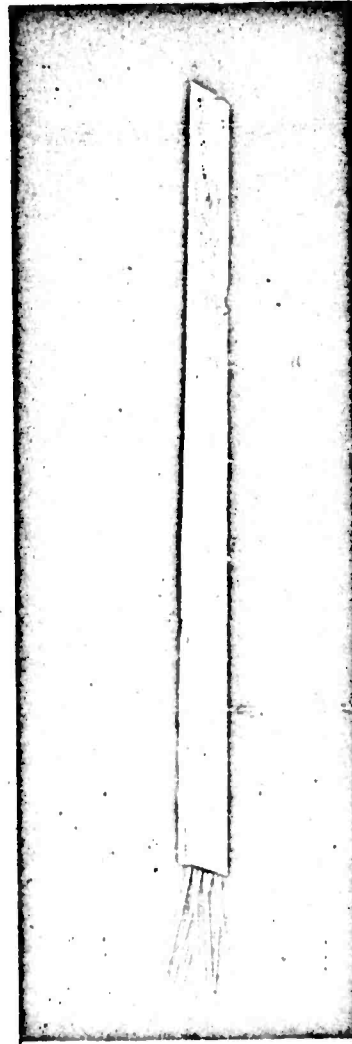

FIG. 3c RIGHT WALL DETAIL



OUTLET



INLET

FIG. 4 2 DIMENSIONAL DIFFUSER RAKES

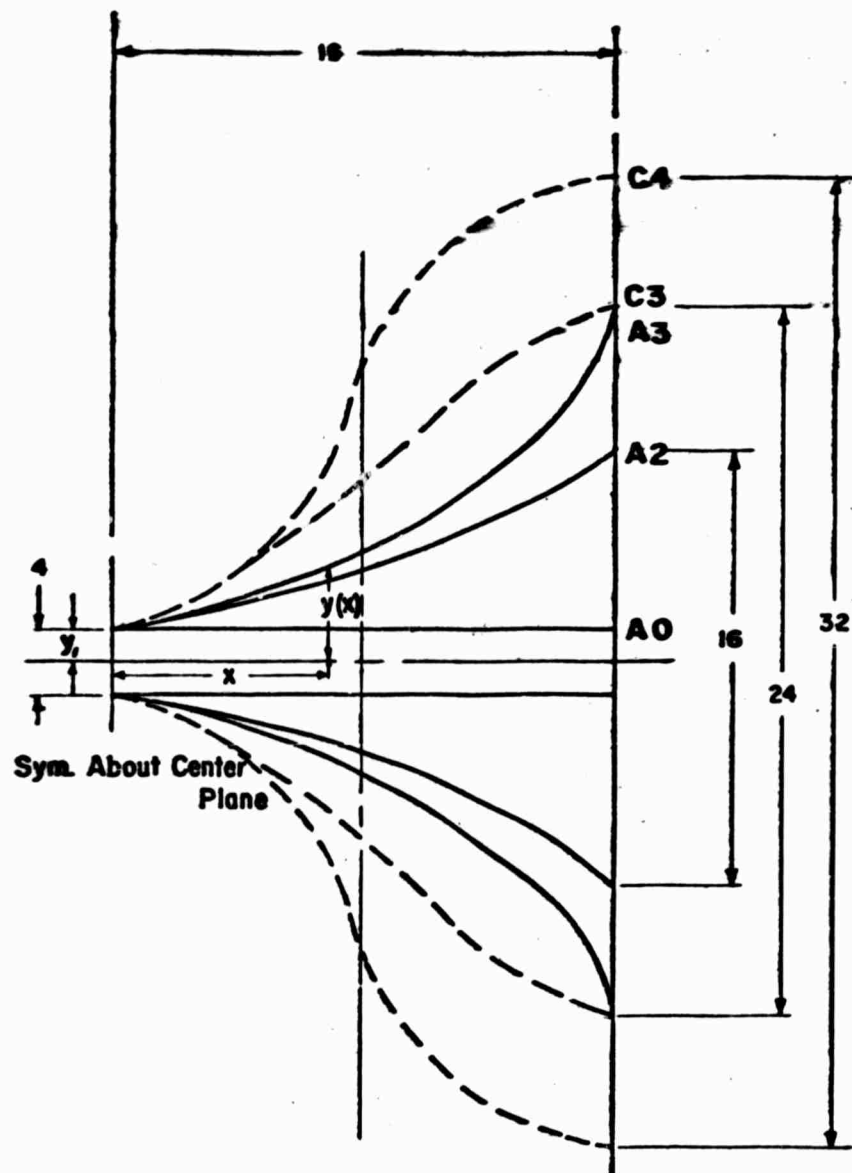
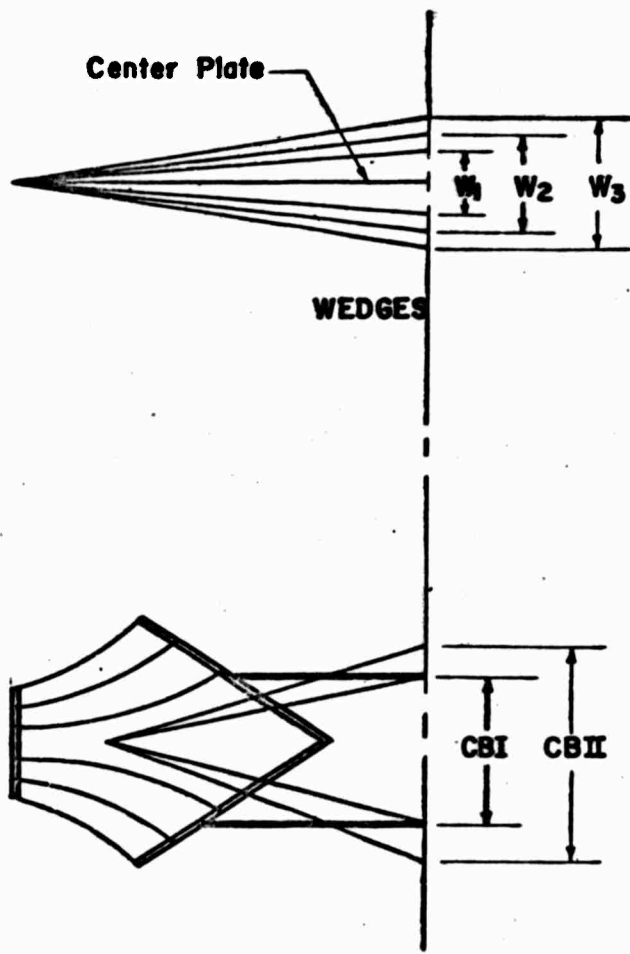
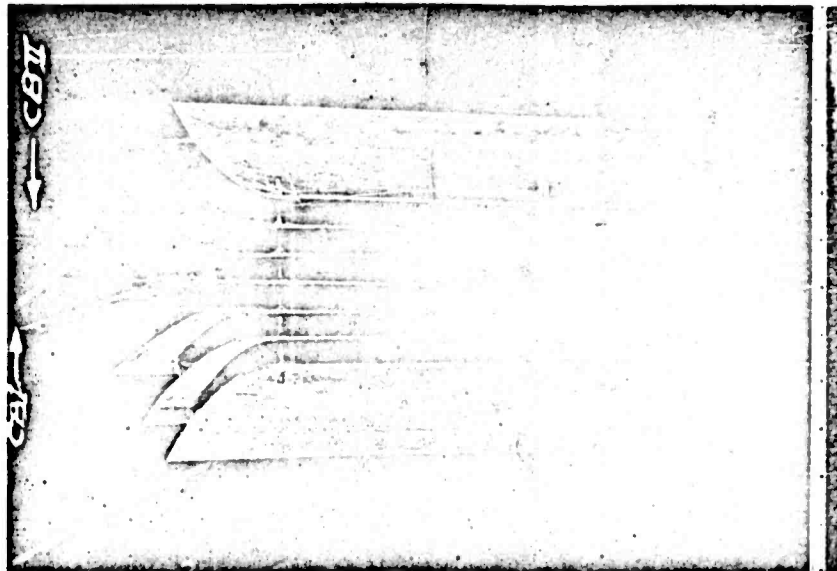

FIG.5a TWO DIMENSIONAL DIFFUSER WALL SHAPE



VANES & CENTERBODIES

FIG.5b TWO DIMENSIONAL CENTERBODIES & VANES



Vanes

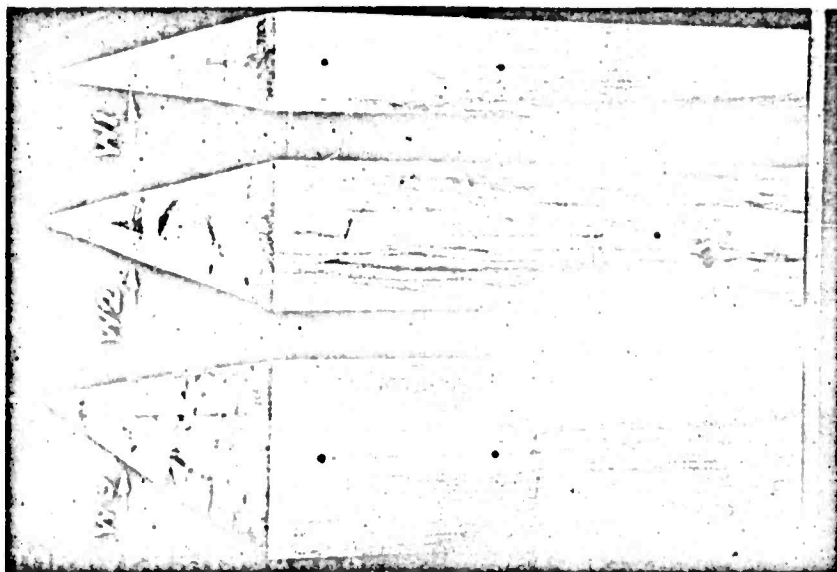

Centerbodies

Fig. 5b (Continued) Two Dimensional Centerbodies and Vanes

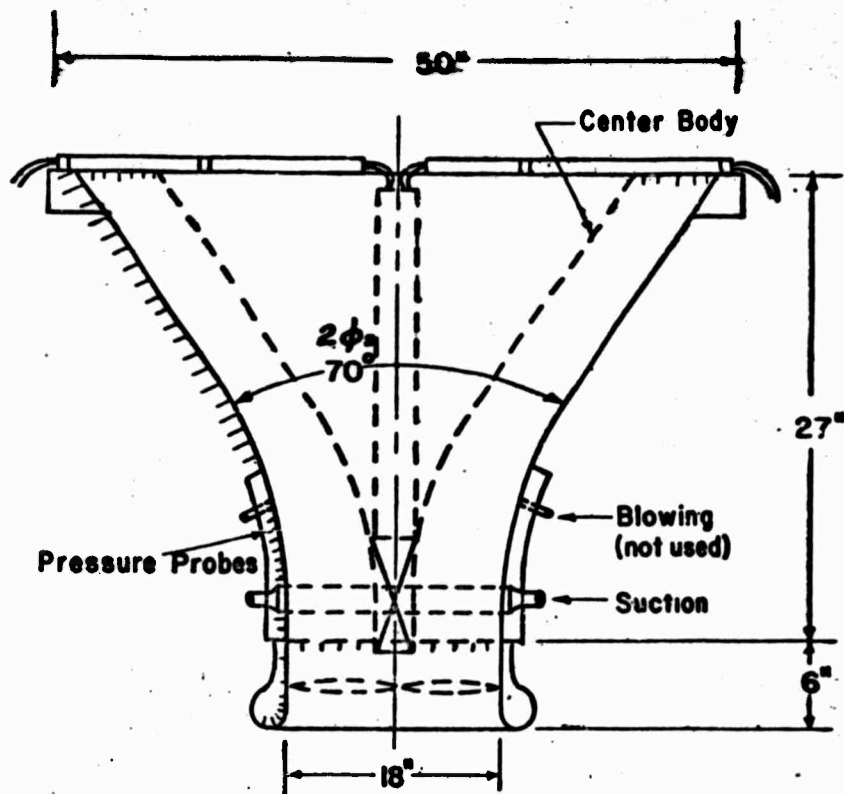

FIG.6 MODEL I SCHEMATIC

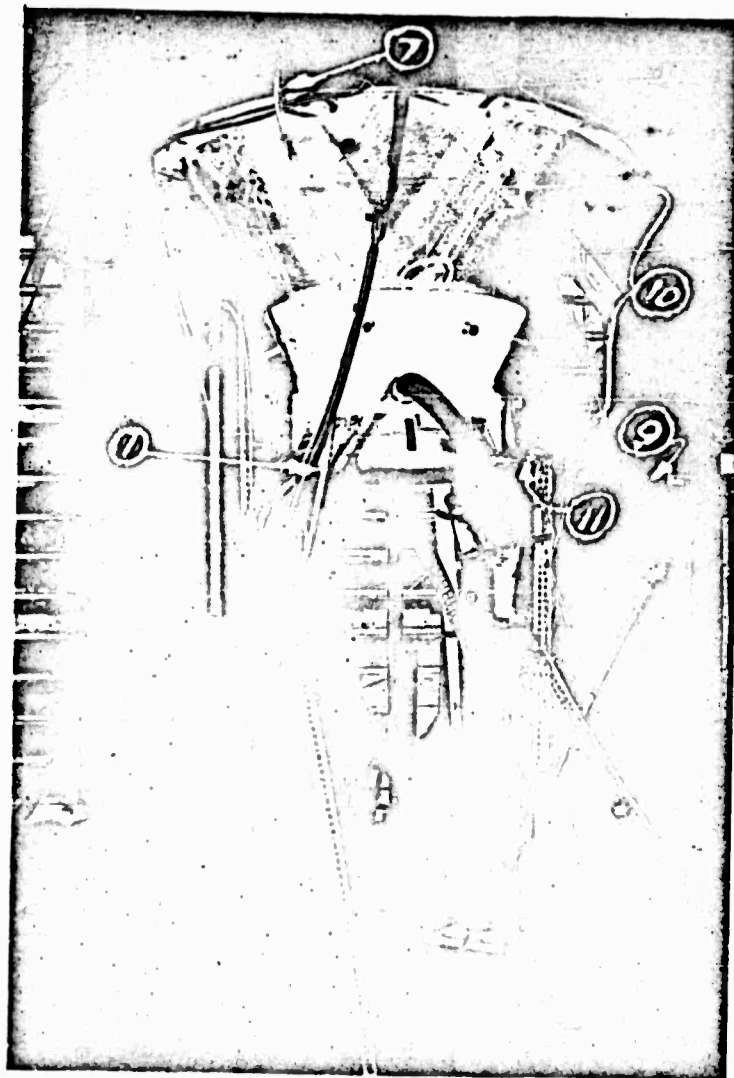

FIG. 7 MODEL 1 INSTALLATION

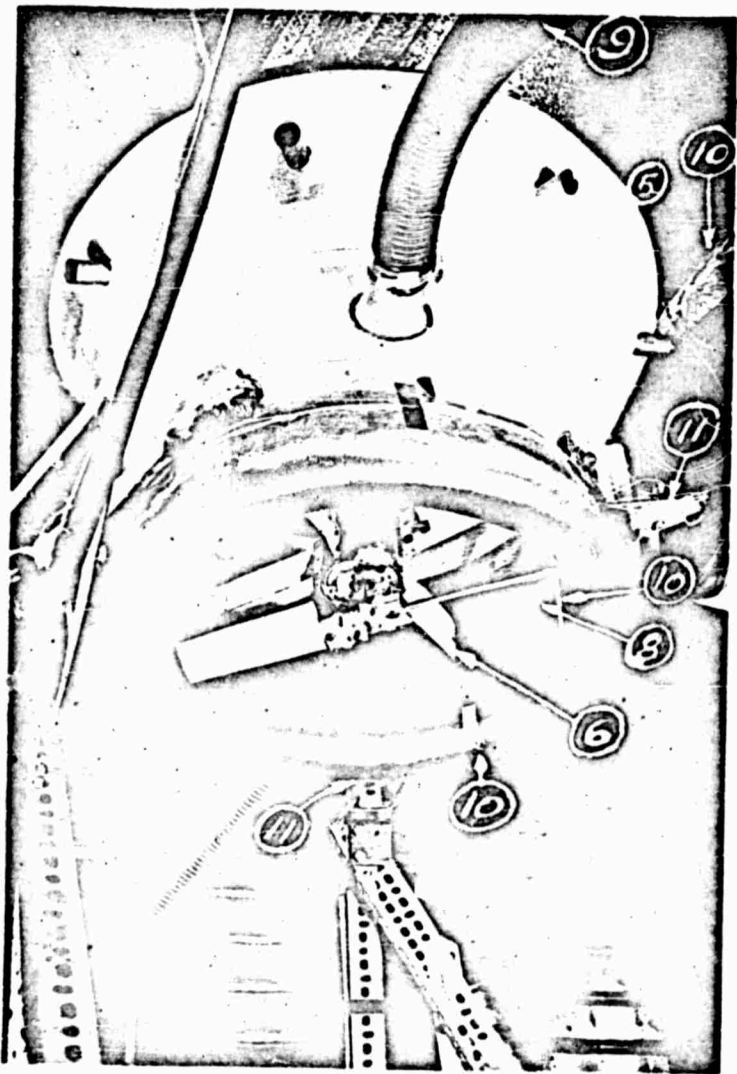

FIG. 8 MODEL 1 DETAIL

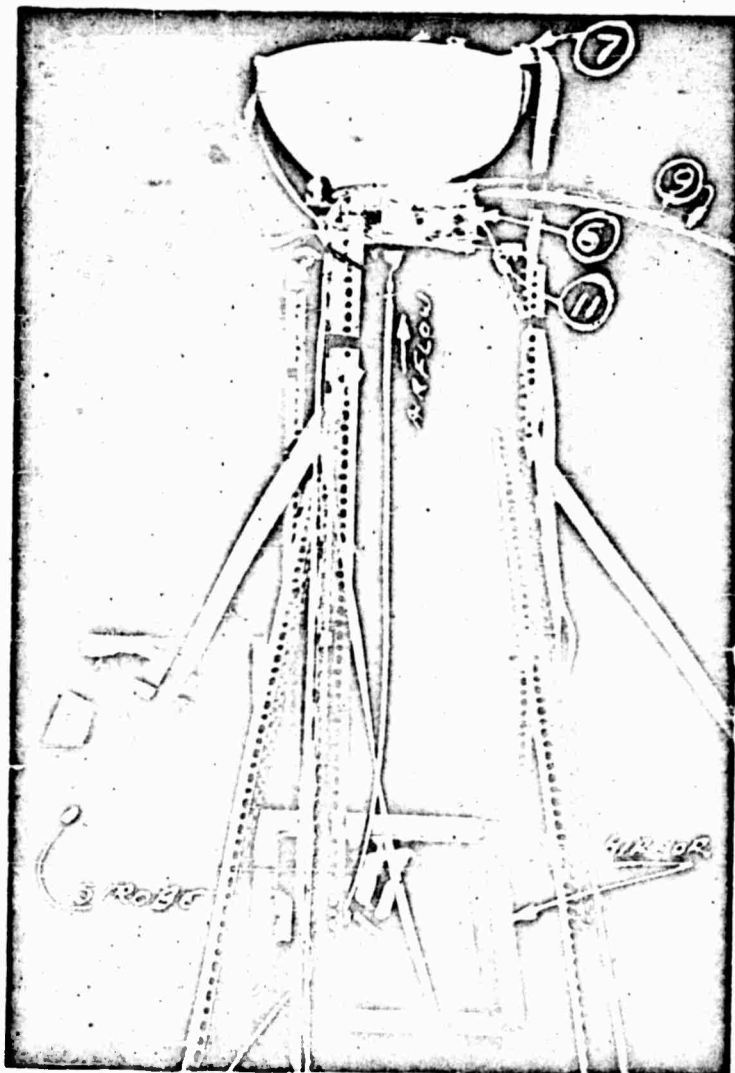

FIG. 9 MODEL 2 TEST STAND

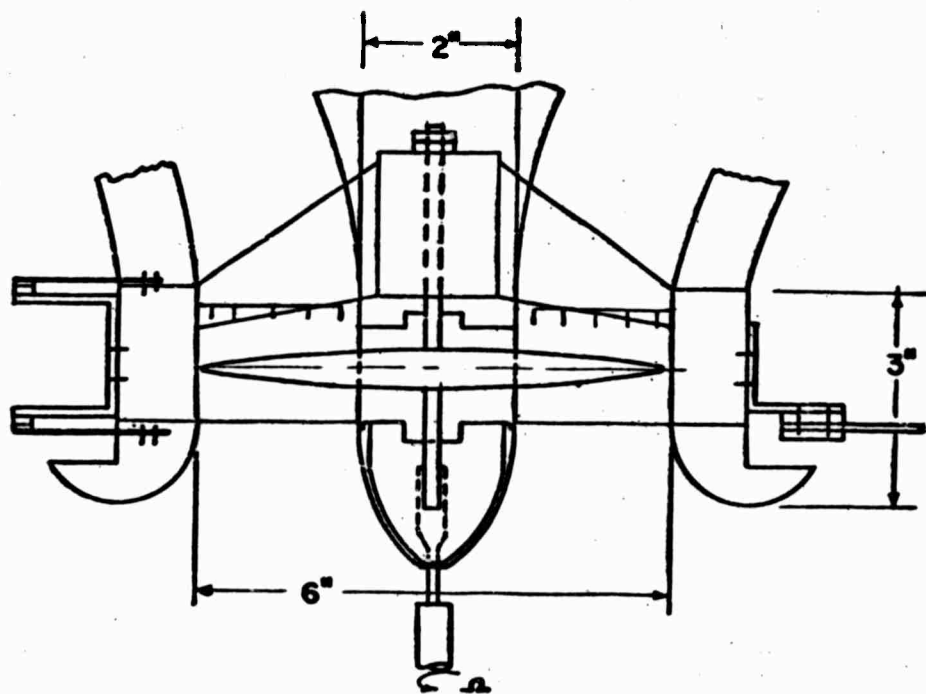

FIG. 10a MODEL 2 DUCTED FAN ASSEMBLY

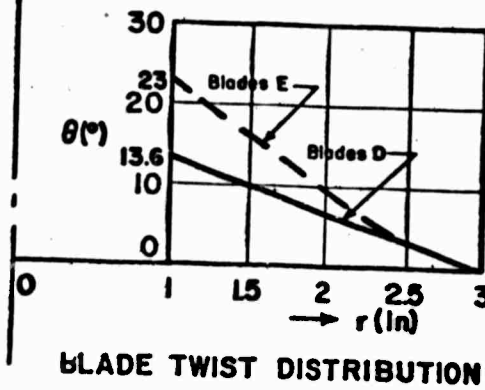
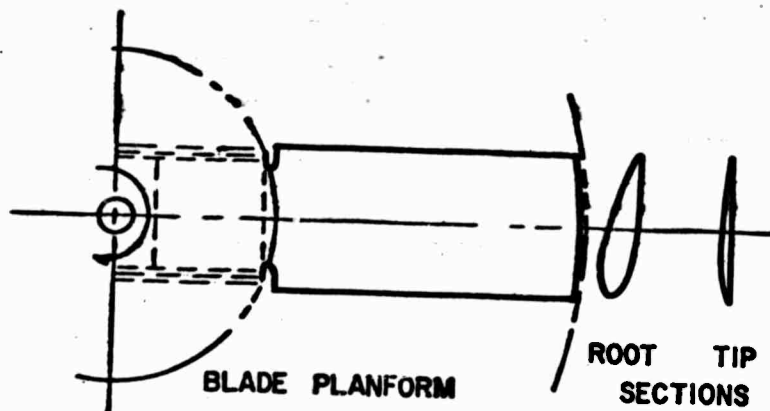

FIG. 10b MODEL 2 ROTOR BLADES

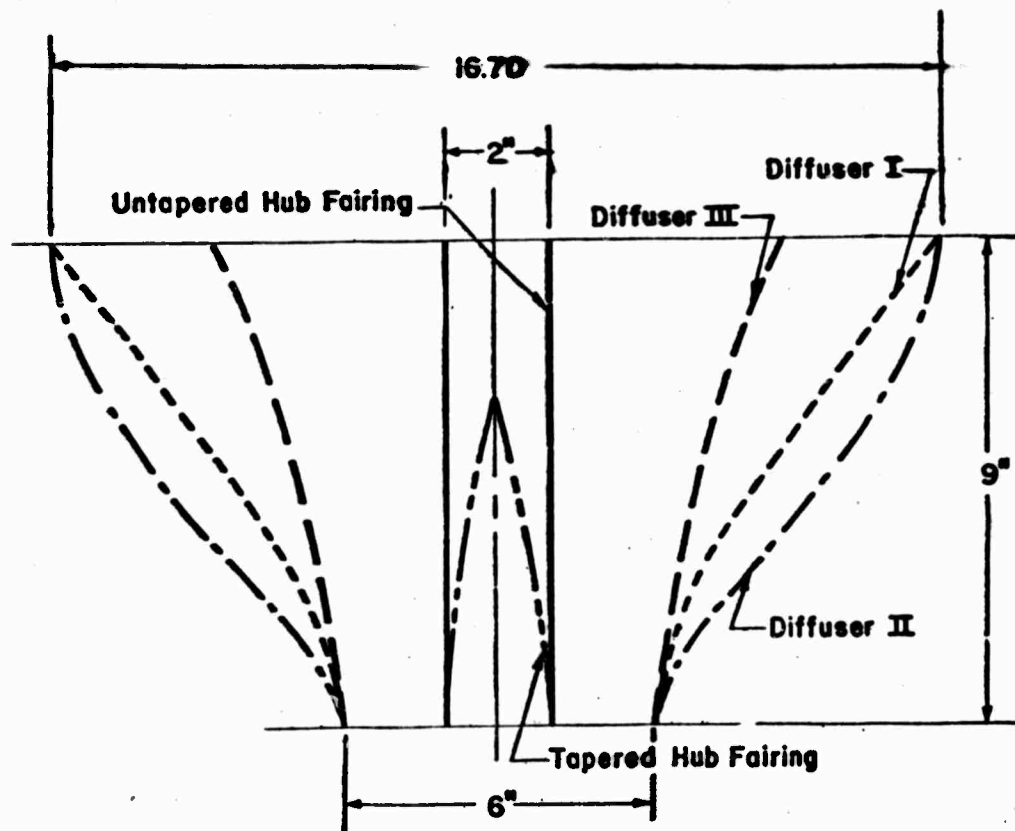

FIG.11a MODEL 2 DIFFUSER SHAPES

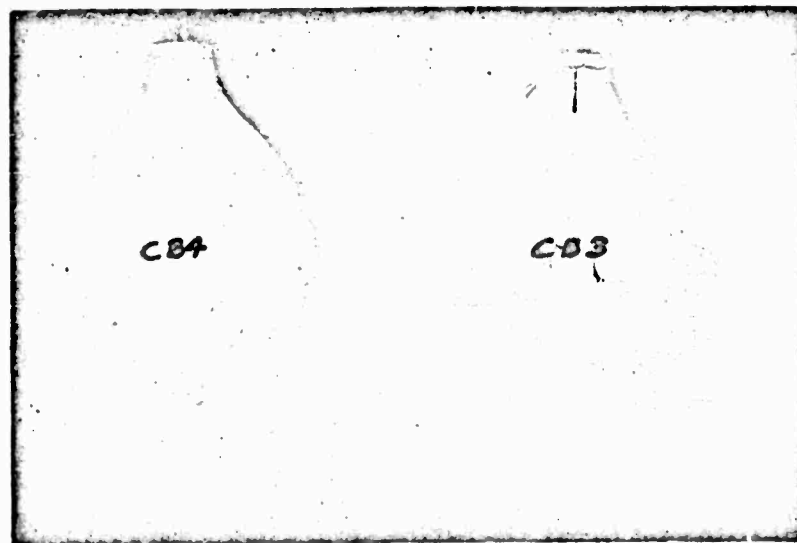
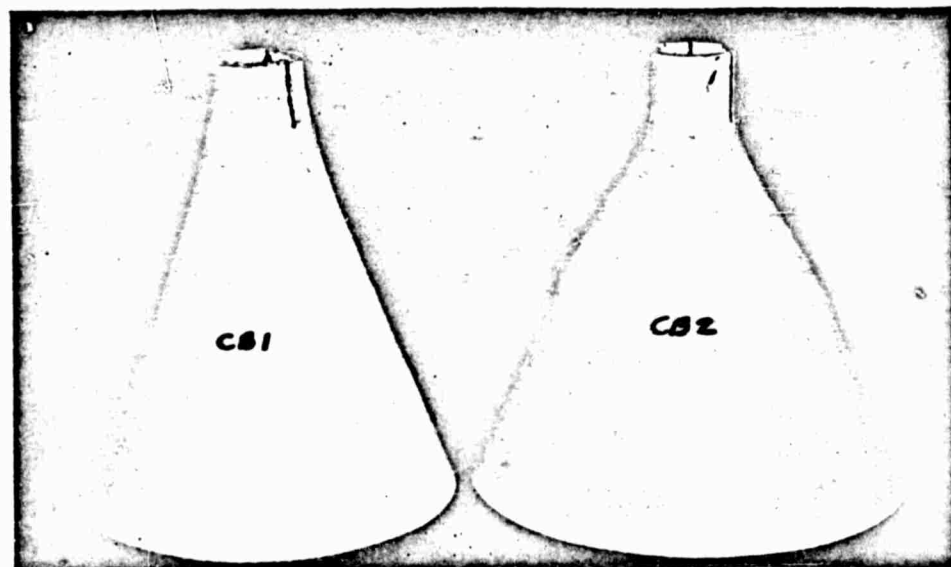

FIG. 11b MODEL 2 CENTERBODIES

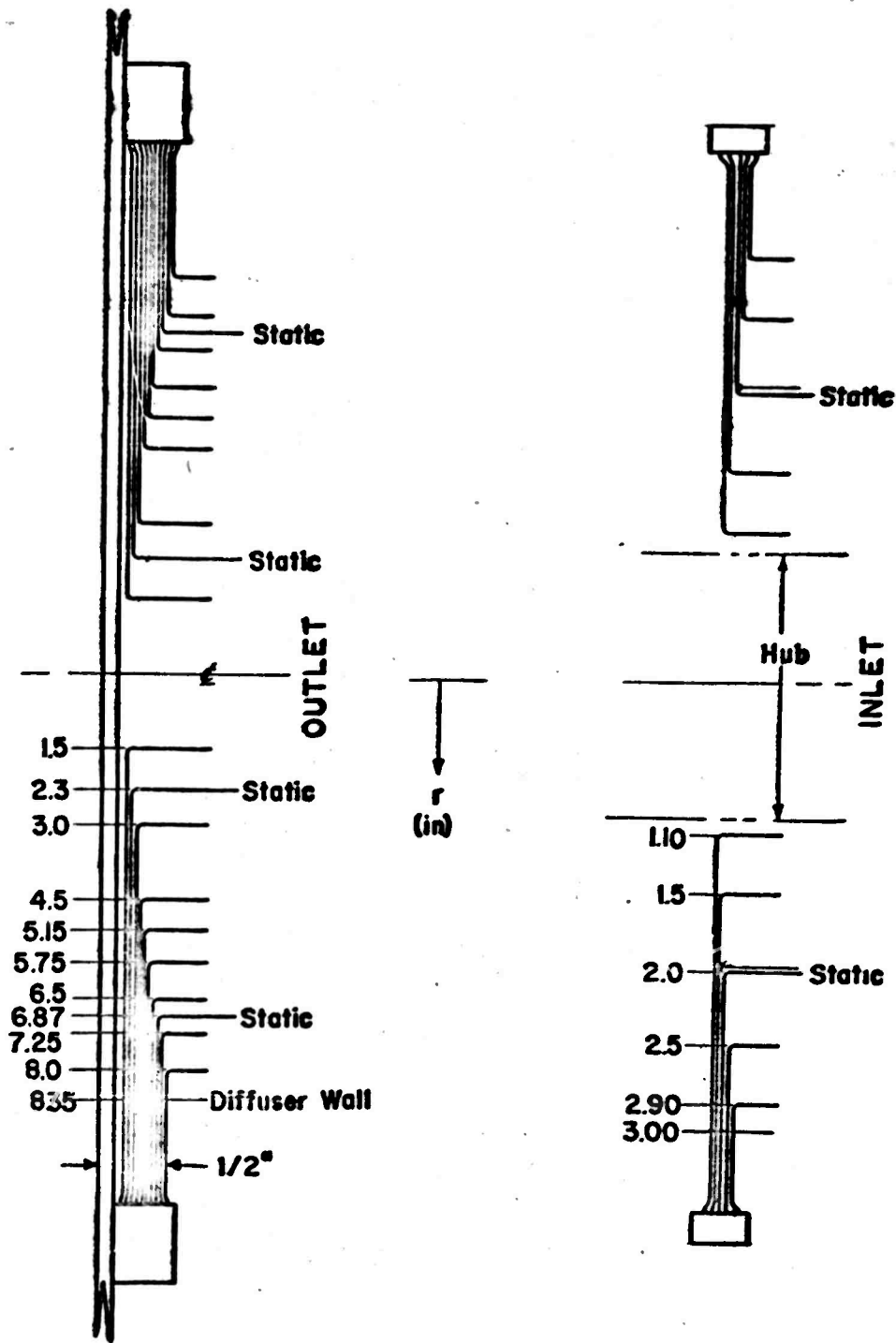
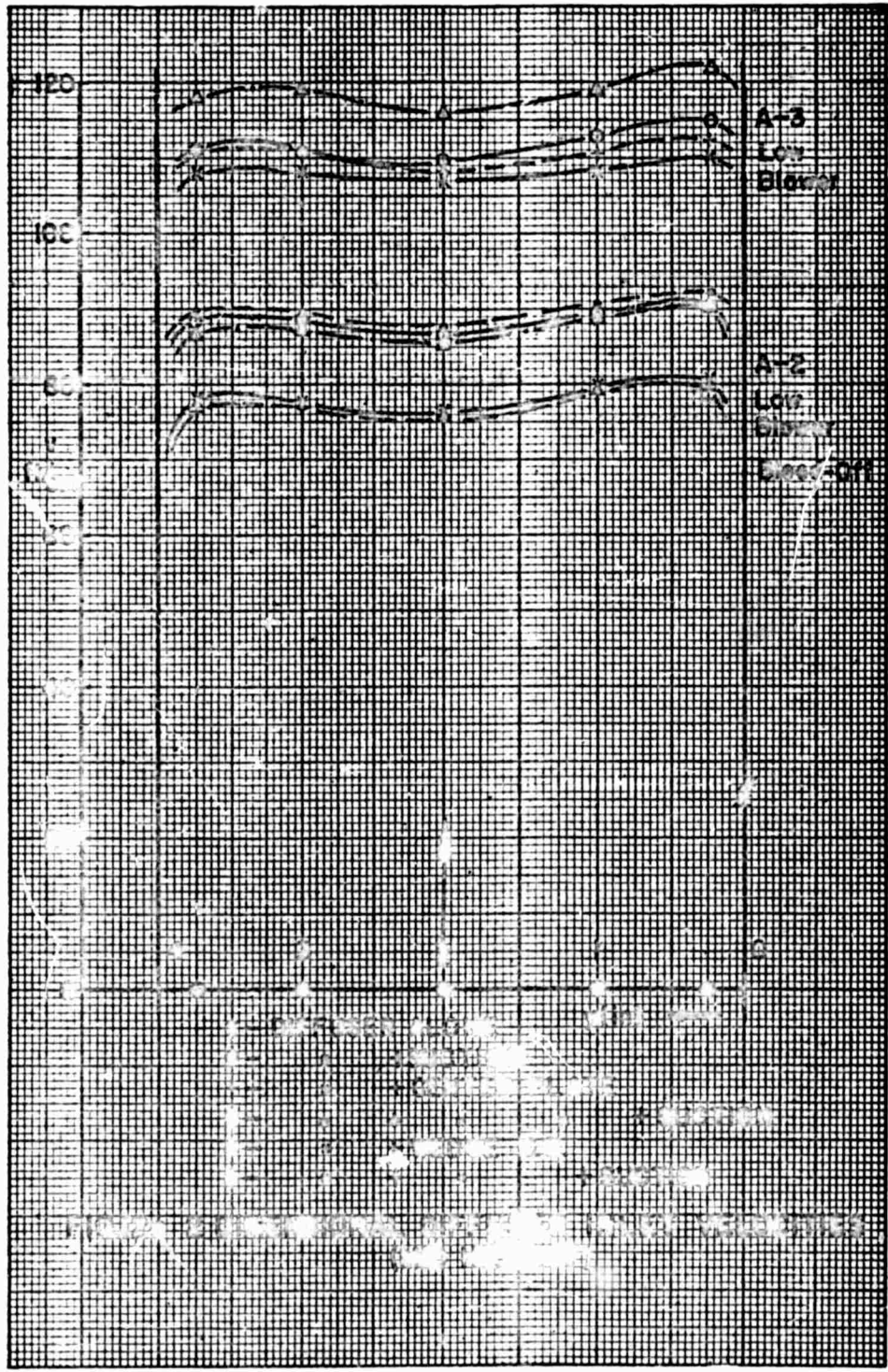

FIG.1c MODEL 2 DIFFUSER RAKES



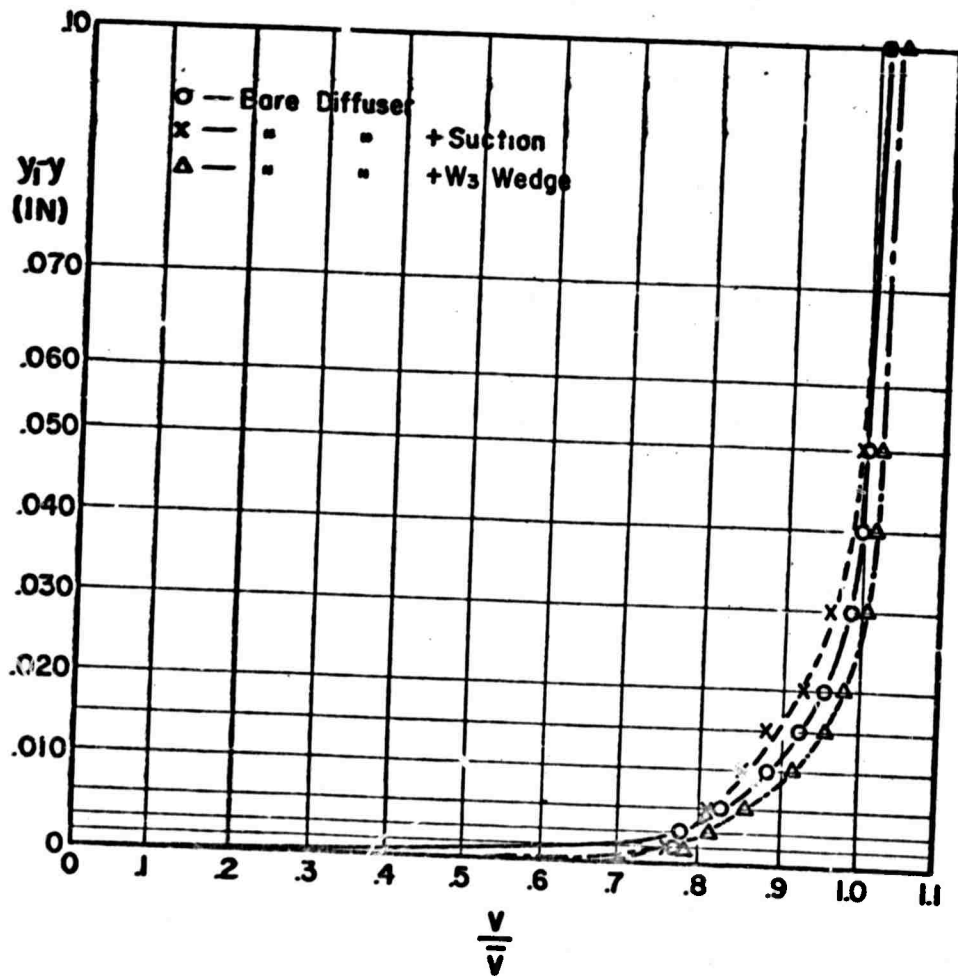
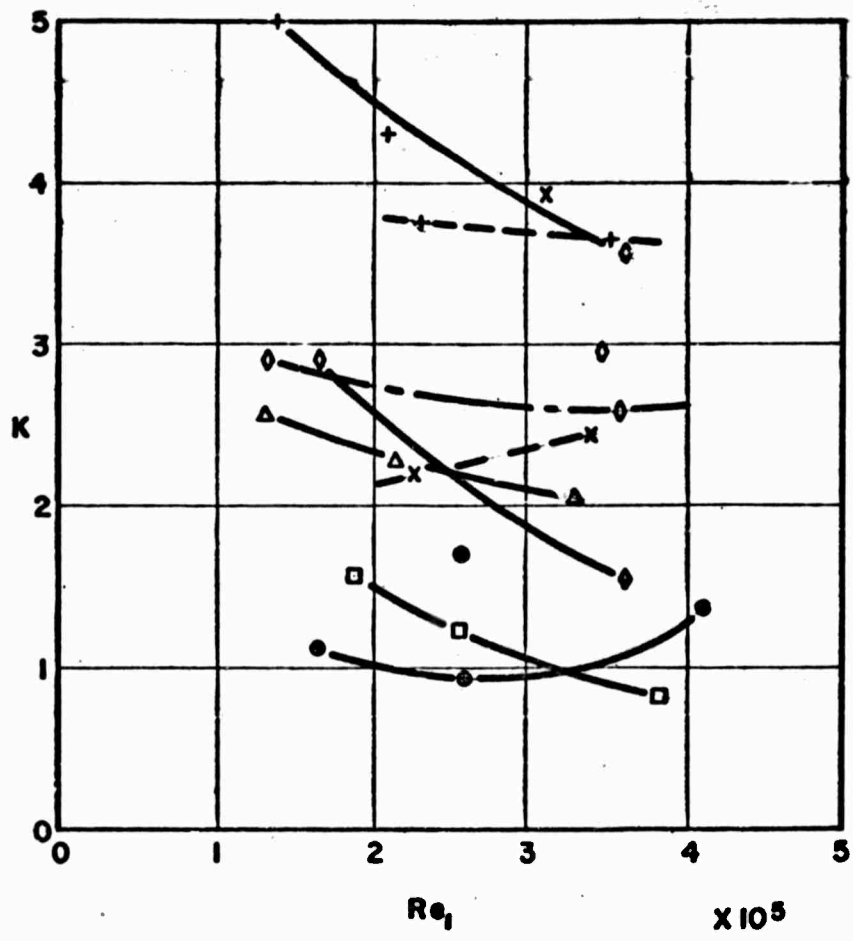

FIG.12b REPRESENTATIVE BOUNDARY LAYER PROFILES
3/4" AHEAD OF INLET A-3 DIFFUSER



(FOR LEGEND SEE FIG. 14)

FIG.13 EFFECT OF INLET REYNOLDS NUMBER
(TWO DIMENSIONAL DIFFUSER CONFIGURATION)

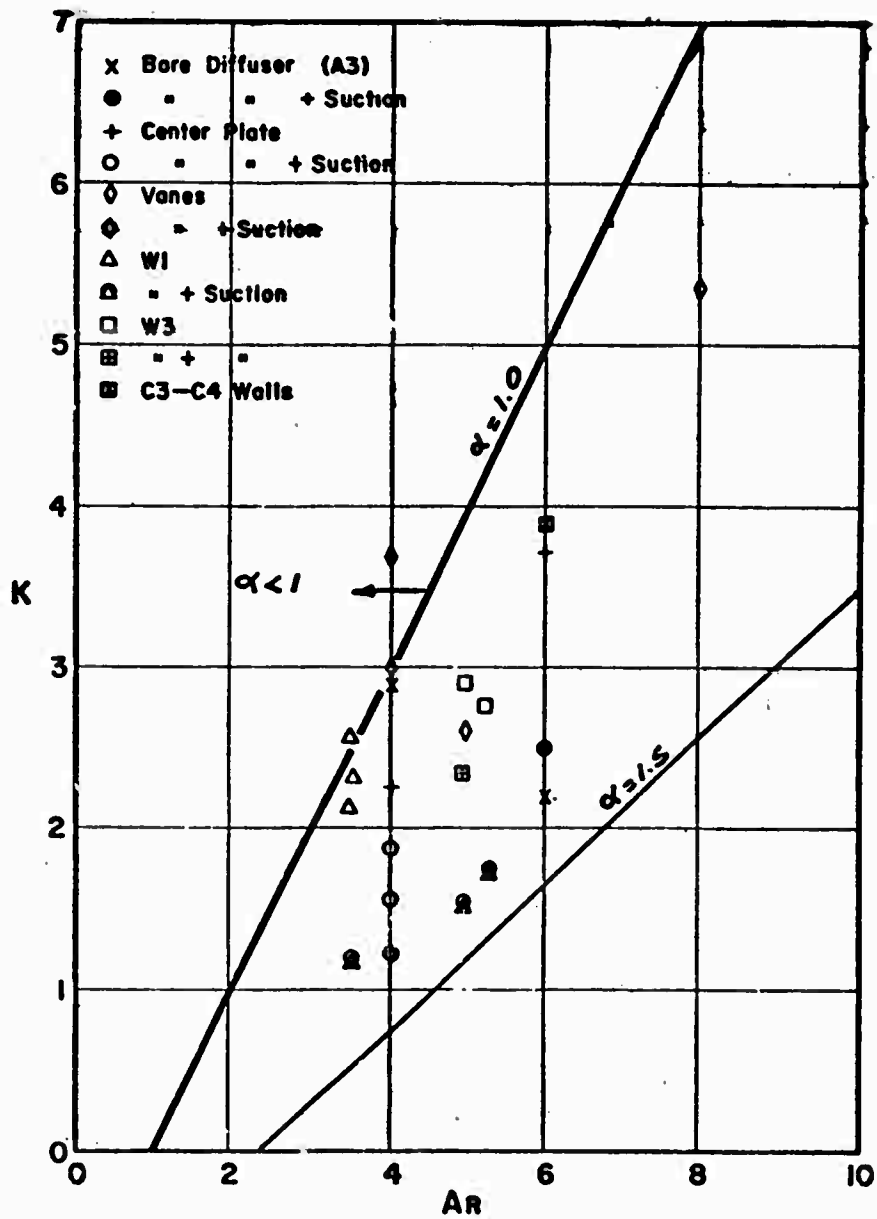

FIG.14 PRESSURE LOSS FACTOR OF 2-DIMENSIONAL DIFFUSER CONFIGURATIONS

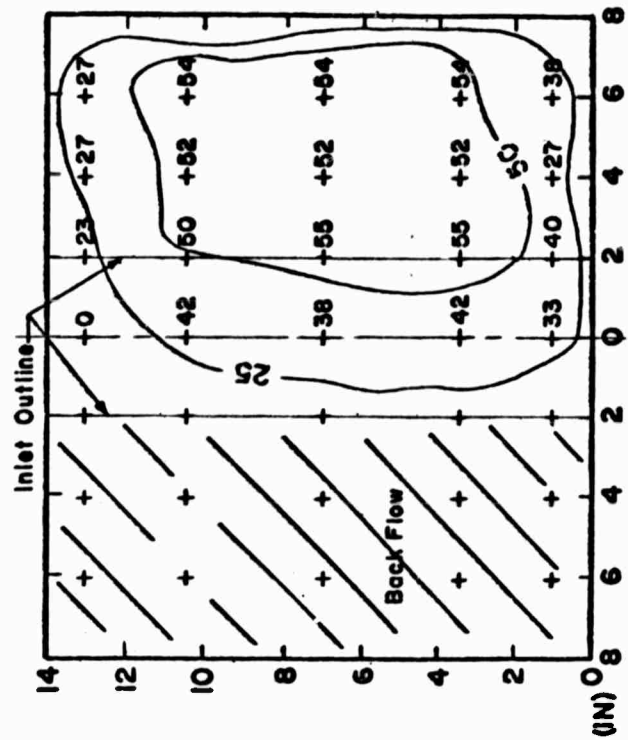

FIG.15 OUTLET VELOCITY MAPS
 a) A2 - NO SUCTION

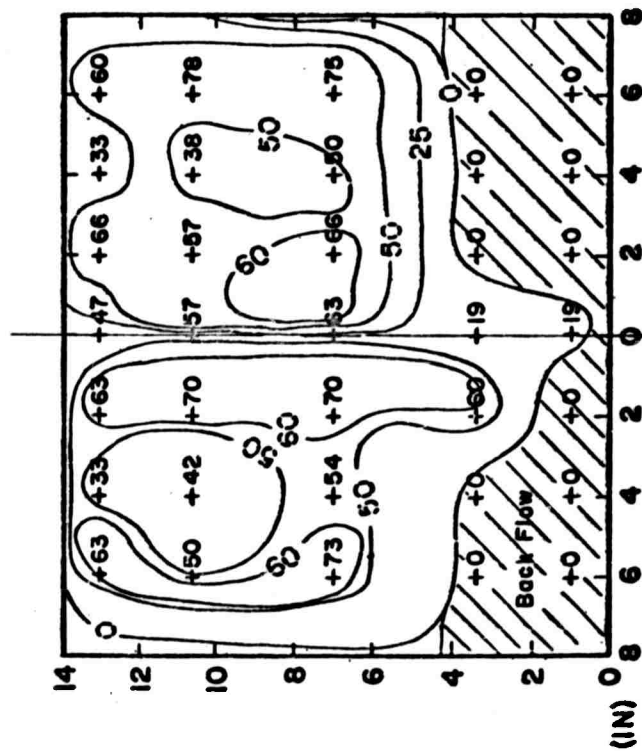

FIG.15 (Cont'd) (b) A2 + VANES + SUCTION

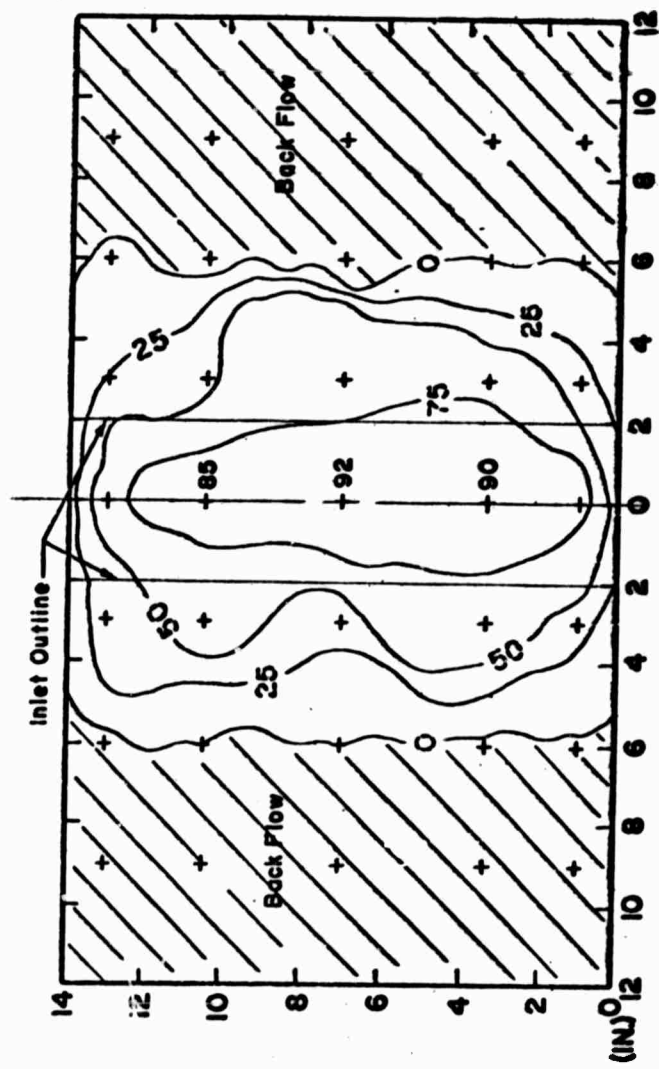

FIG.15 (Cont'd) (c) A3-NO SUCTION

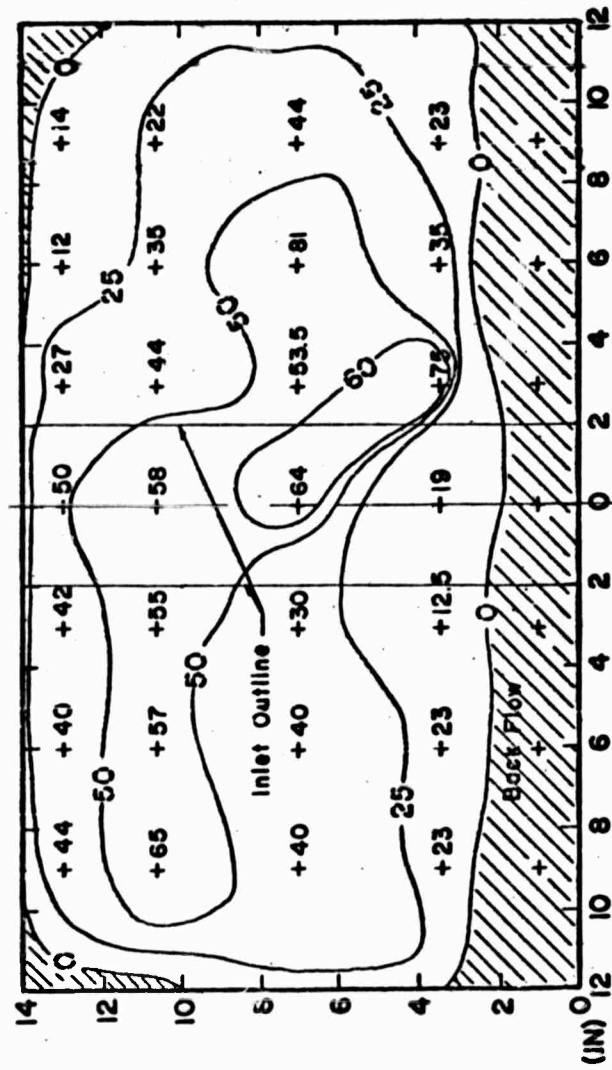

FIG.15 (Con'd) (d) A3 + VANES + SUCTION

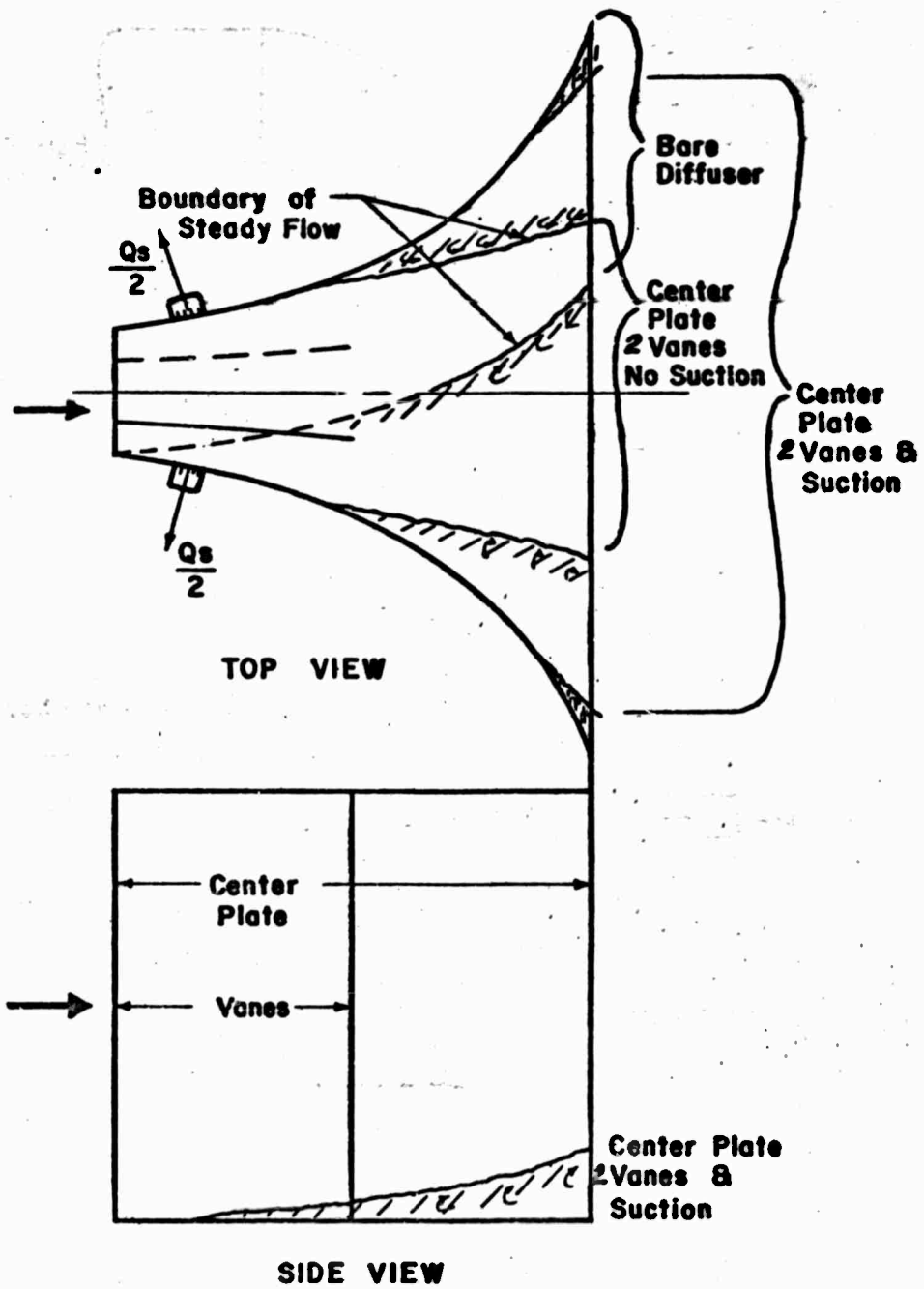

FIG.16a FLOW PATTERNS IN DIFFUSER A3

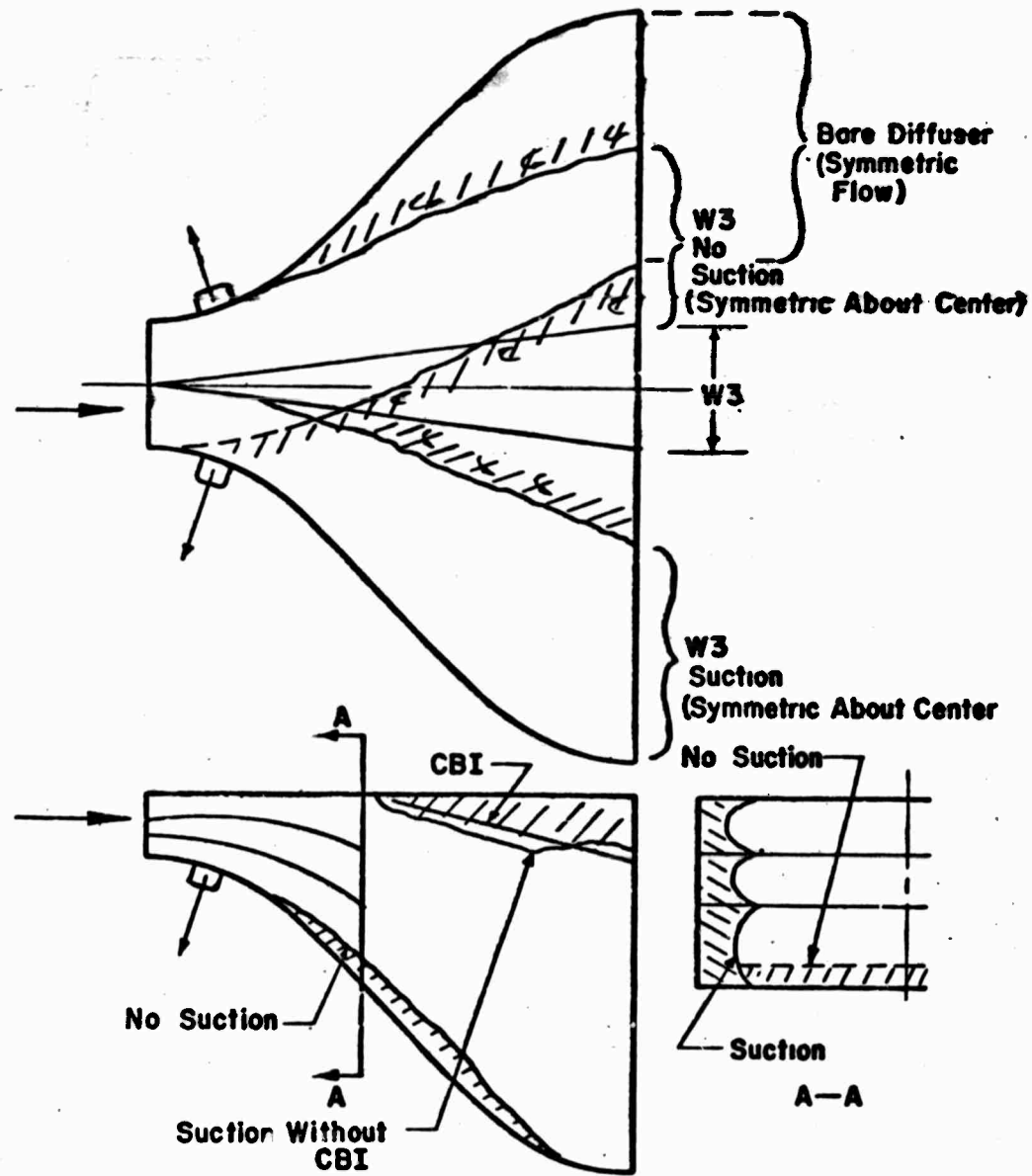

FIG. 16b FLOW PATTERNS IN DIFFUSER C3

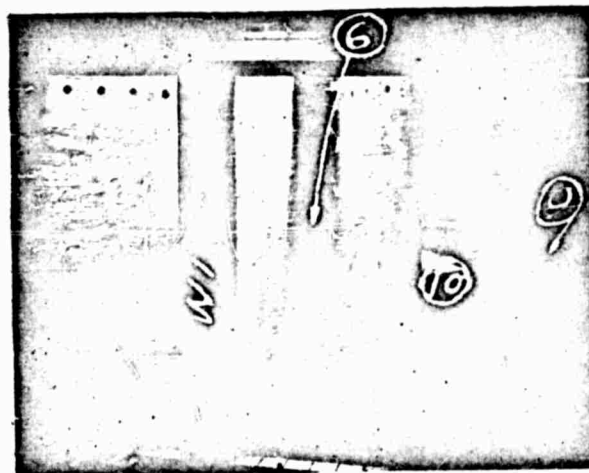
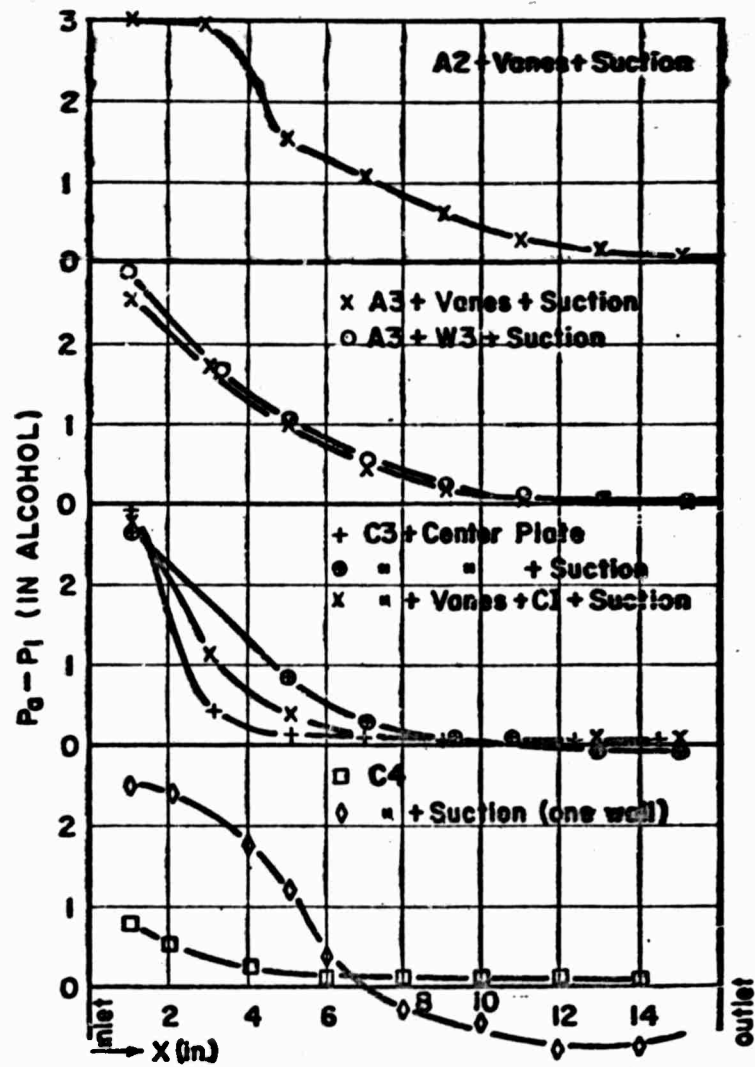

FIG. 17a DIFFUSER A2 + W1
NO SUCTION



FIG. 17b DIFFUSER A2 + W1 + SUCTION



**FIG. 18 WALL PRESSURE DISTRIBUTIONS
TWO DIMENSIONAL DIFFUSERS**

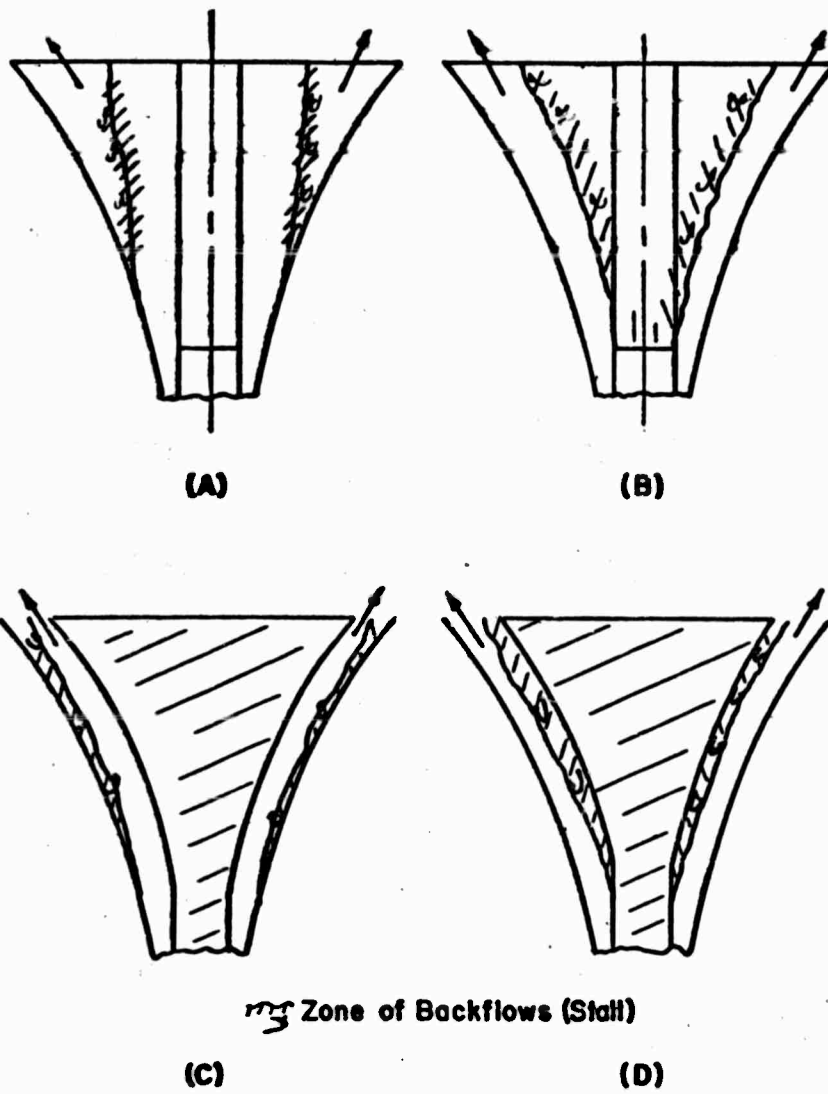

**FIG.19 AXISYMMETRIC FLOW PATTERNS
MODEL I & 2**

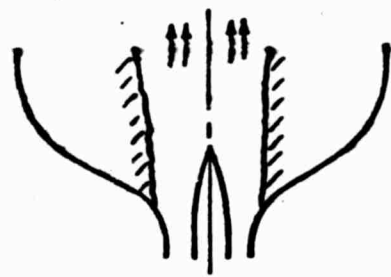

(E)

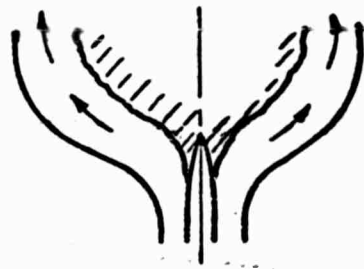

(F)

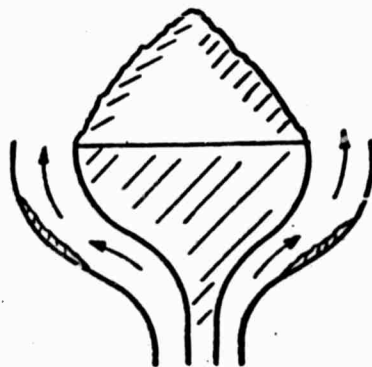

(G)



(H)

FIG. 19 (Cont'd)

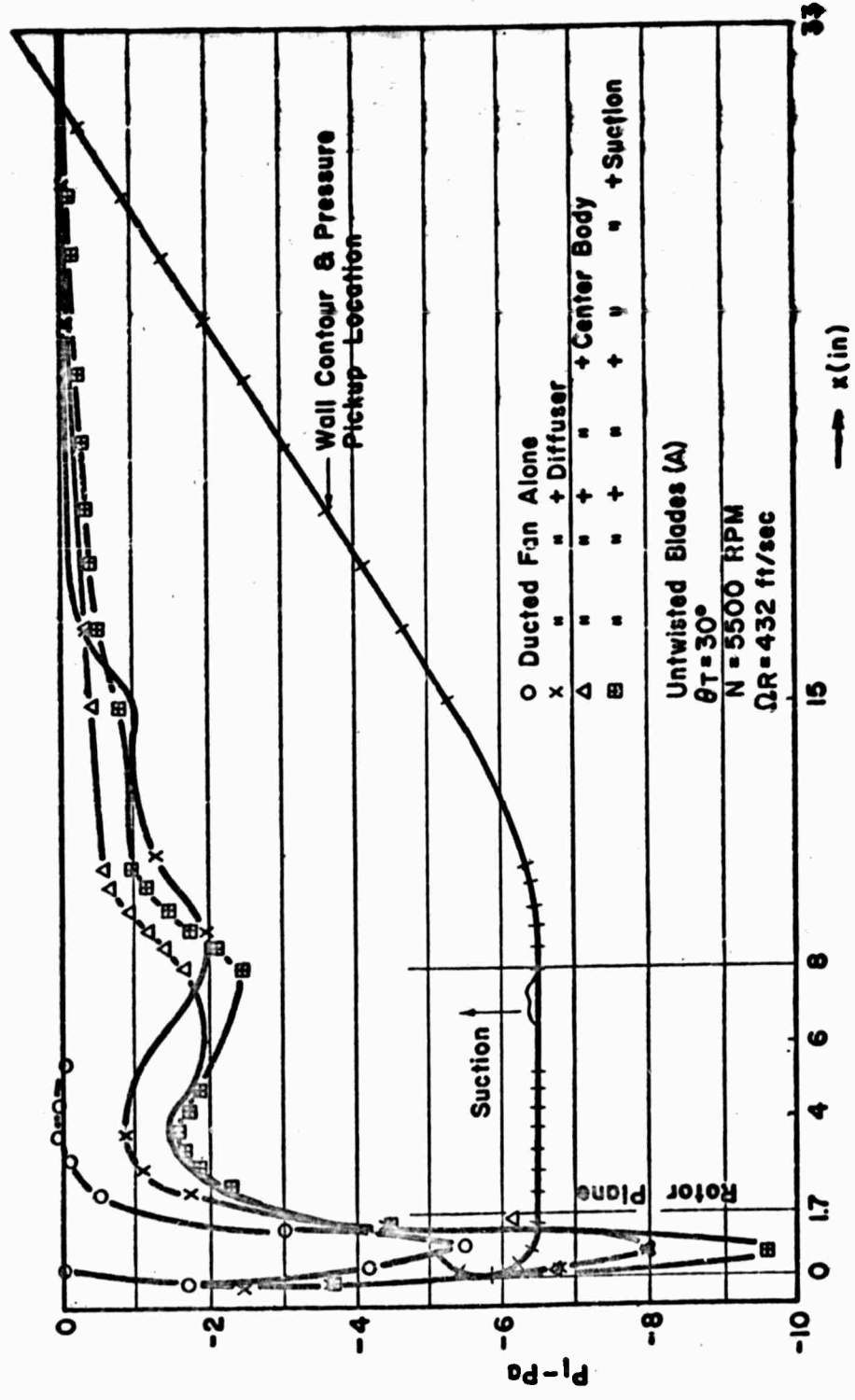

FIG. 20 MODEL I SHROUD PRESSURE DISTRIBUTION

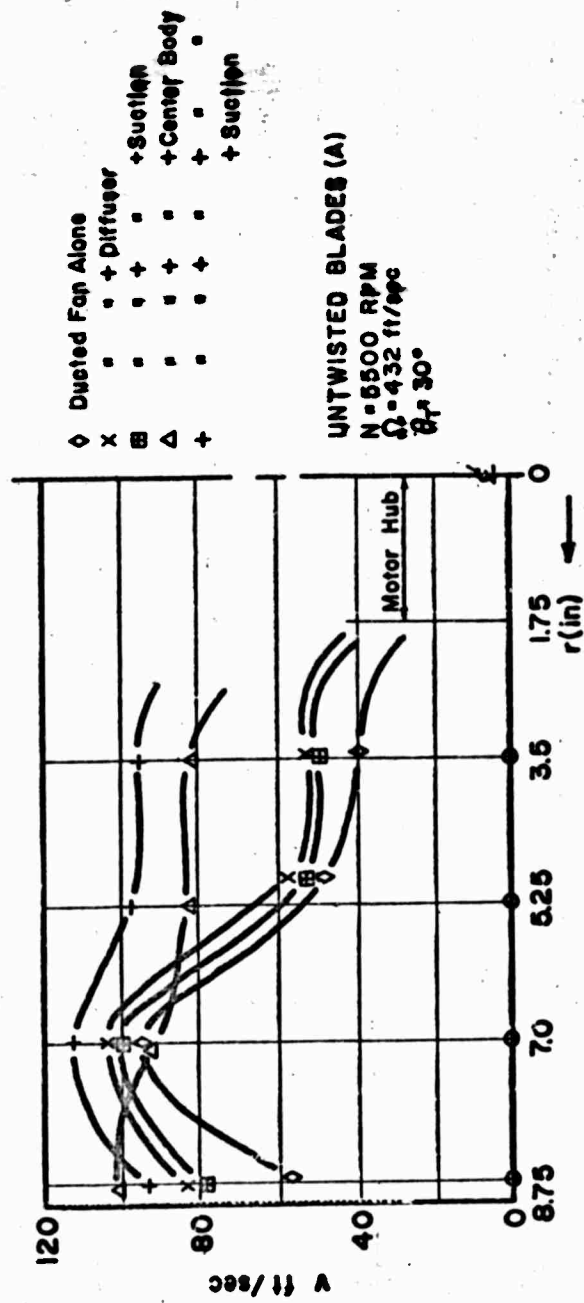

FIG. 21 MODEL I DIFFUSER INLET VELOCITY PROFILES

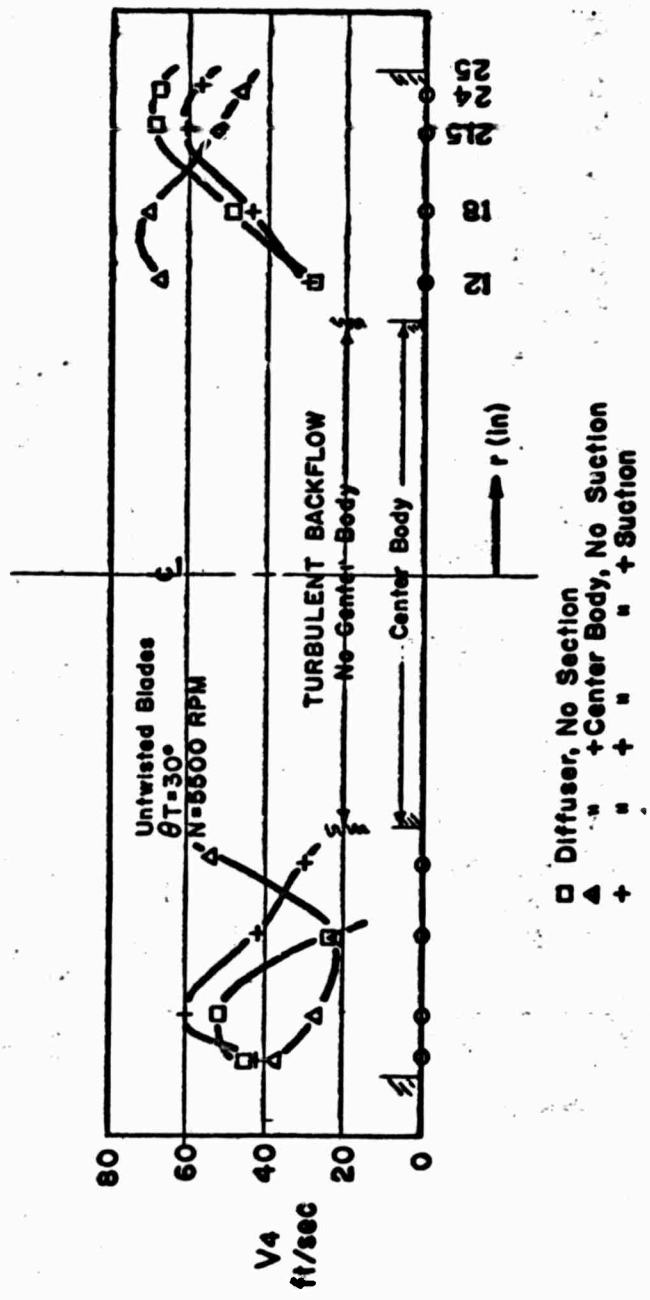

FIG. 22 MODEL I OUTLET VELOCITY PROFILES

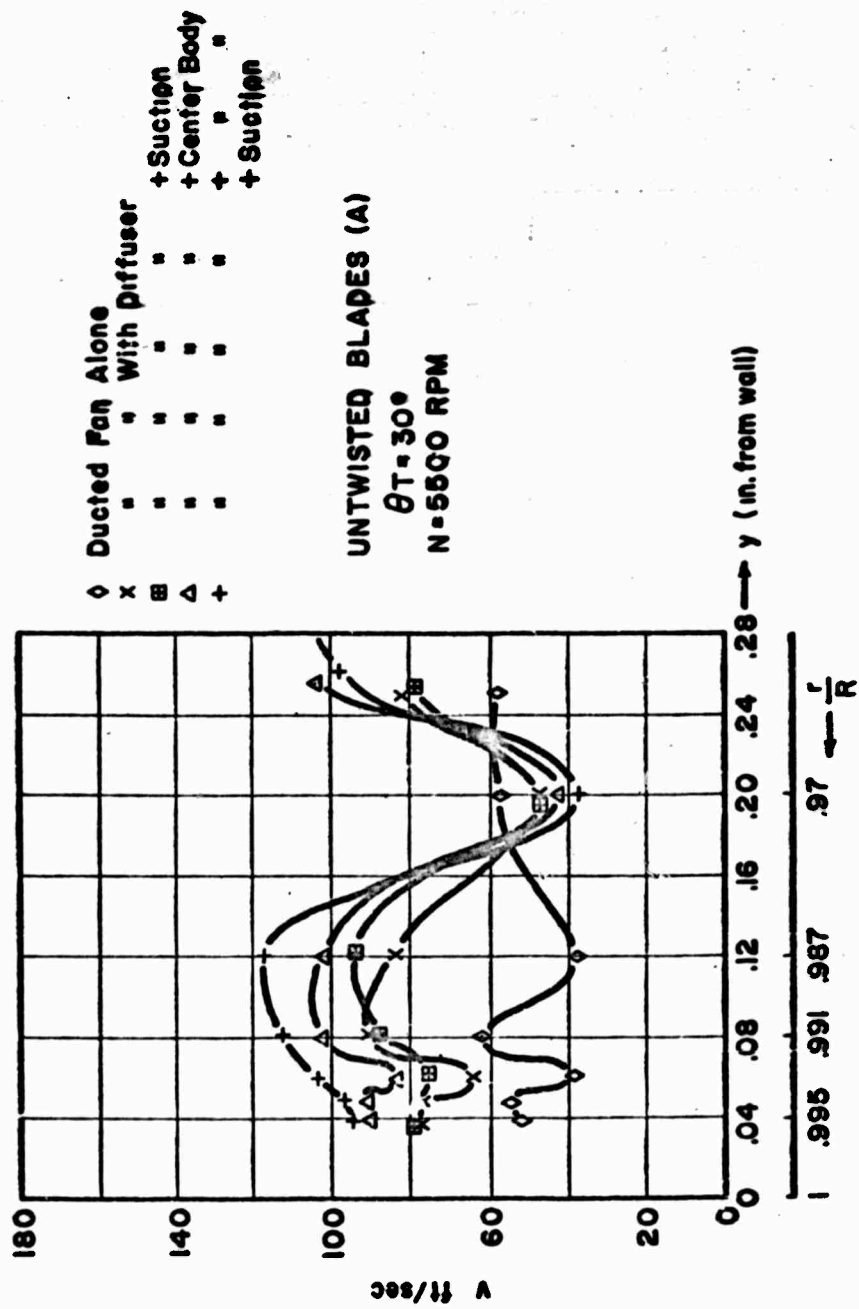

FIG. 23 MODEL I BOUNDARY LAYER PROFILES
2 IN. AHEAD OF DIFFUSER INLET PLANE

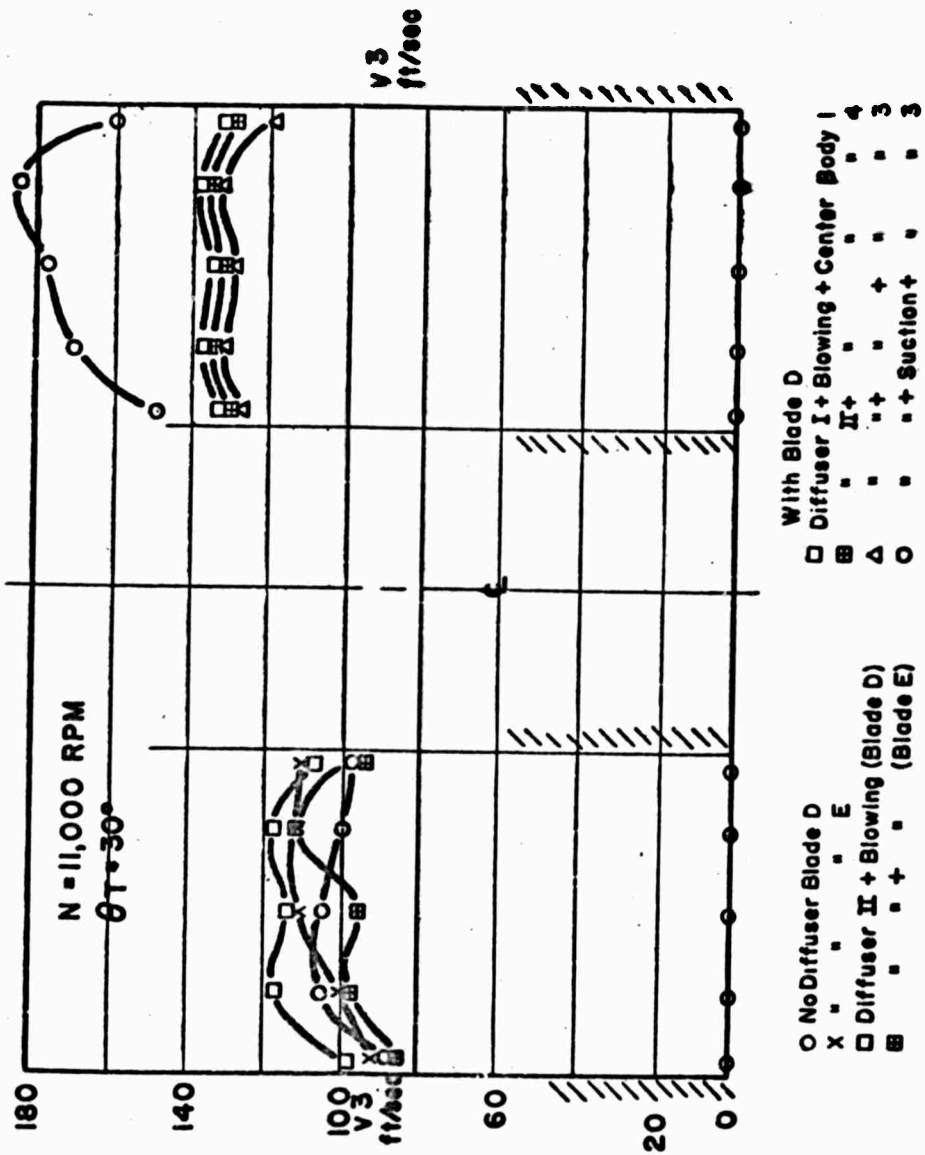

FIG. 24 MODEL 2 DIFFUSER INLET VELOCITY PROFILES

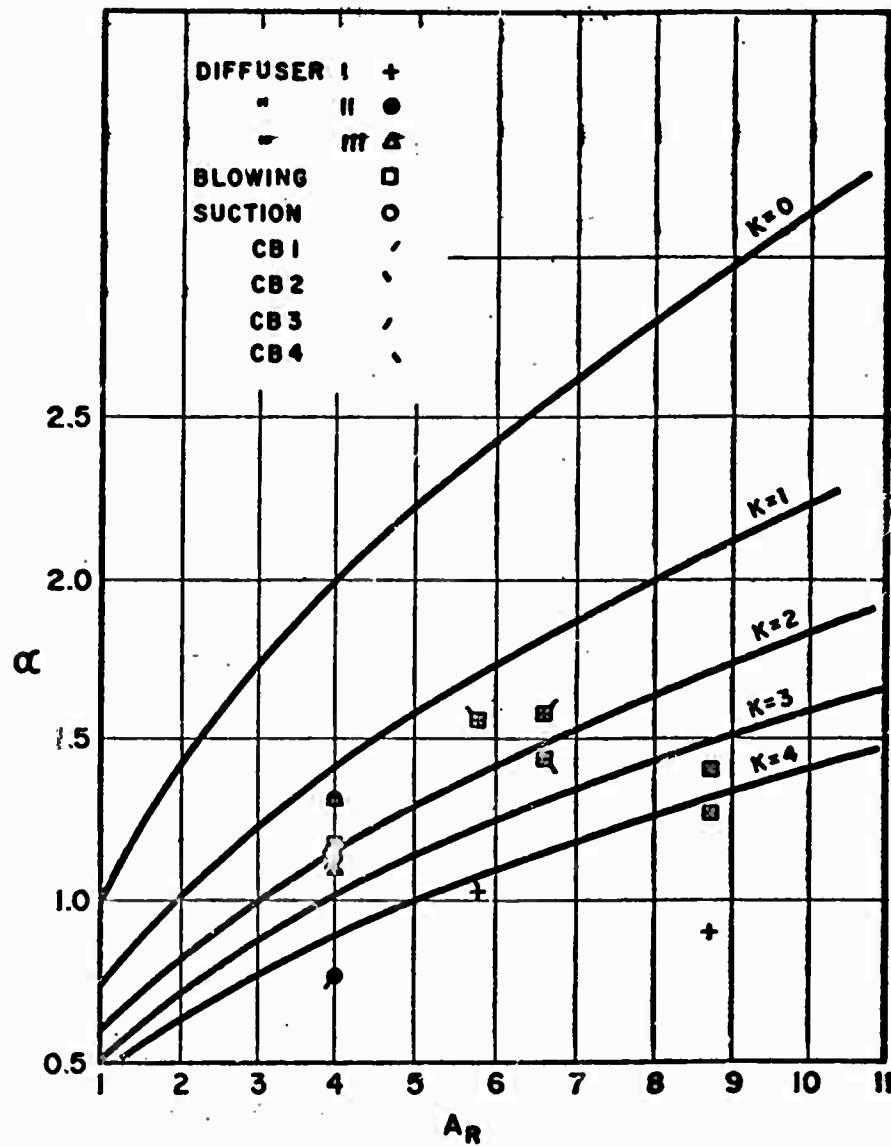

FIG. 26 AUGMENTATION FACTOR FOR BEST AXISYMMETRIC DIFFUSERS

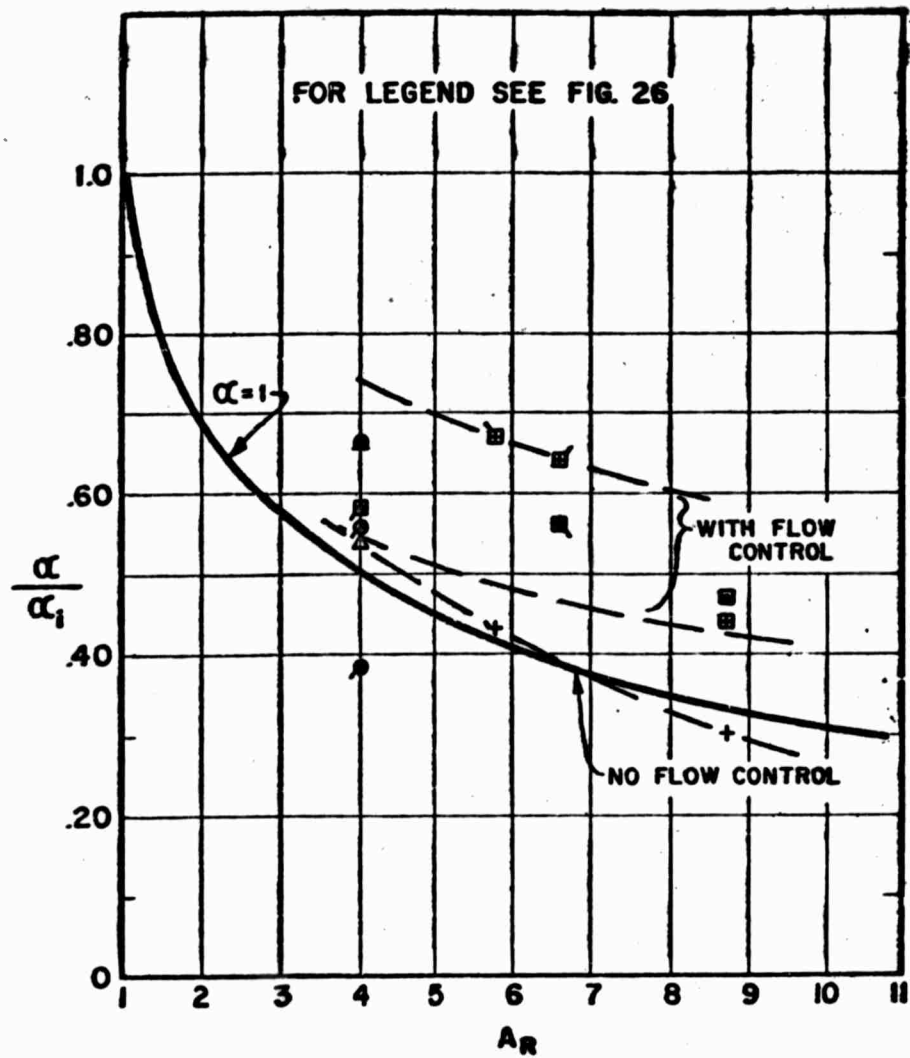

FIG. 27 AUGMENTATION FACTOR EFFECTIVENESS