

UNCLASSIFIED

AD NUMBER

AD236156

LIMITATION CHANGES

TO:

Approved for public release; distribution is unlimited.

FROM:

Distribution authorized to DoD and DoD contractors only; Administrative/Operational Use; MAR 1960. Other requests shall be referred to Army Transportation Research and Development Command, Fort Eustis, VA.

AUTHORITY

TRECOM ltr 18 May 1967

THIS PAGE IS UNCLASSIFIED

UNCLASSIFIED

AD

2	3	6		1	5	6
---	---	---	--	---	---	---

Reproduced

Armed Services Technical Information Agency

ARLINGTON HALL STATION; ARLINGTON 12 VIRGINIA

NOTICE: WHEN GOVERNMENT OR OTHER DRAWINGS, SPECIFICATIONS OR OTHER DATA ARE USED FOR ANY PURPOSE OTHER THAN IN CONNECTION WITH A DEFINITELY RELATED GOVERNMENT PROCUREMENT OPERATION, THE U. S. GOVERNMENT THEREBY INCURS NO RESPONSIBILITY, NOR ANY OBLIGATION WHATSOEVER; AND THE FACT THAT THE GOVERNMENT MAY HAVE FORMULATED, FURNISHED, OR IN ANY WAY SUPPLIED THE SAID DRAWINGS, SPECIFICATIONS, OR OTHER DATA IS NOT TO BE REGARDED BY IMPLICATION OR OTHERWISE AS IN ANY MANNER LICENSING THE HOLDER OR ANY OTHER PERSON OR CORPORATION, OR CONVEYING ANY RIGHTS OR PERMISSION TO MANUFACTURE, USE OR SELL ANY PATENTED INVENTION THAT MAY IN ANY WAY BE RELATED THERETO.

UNCLASSIFIED

AD No 236156

ASTIA

10

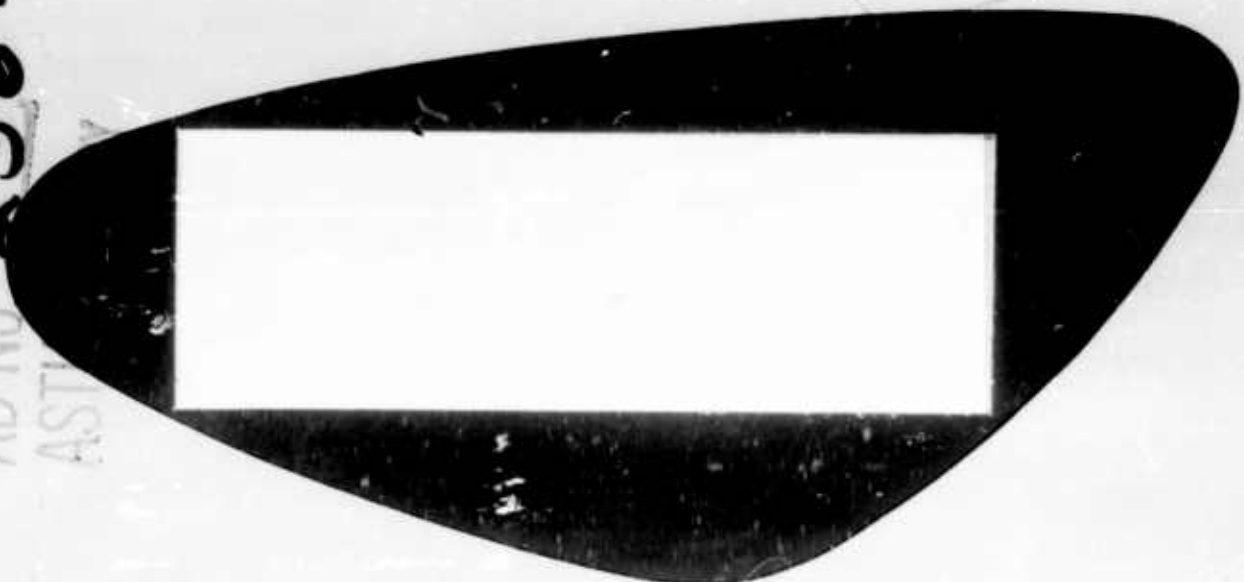

ASTIA
RECEIVED
MAY 3 1968
TYPE C

VERTOL

VISION

BOEING AIRPLANE COMPANY

FILE COPY

XEROX

M-60-3-3
Return to
ASTIA
ARLINGTON HALL STATION
ARLINGTON 12, VIRGINIA
Attn: TISS

CRD 2659



Department of Defense agencies
and their contractors
may obtain copies of this report
from the
Armed Services Technical Information Agency
Arlington Hall Station
Arlington 12, Virginia

Others may obtain copies from the
Office of Technical Services
Department of Commerce, Washington 25, D. C.

The findings and views contained in this report are those
of the contractor and do not necessarily reflect the views
of the Chief of Transportation.

The information contained herein will not be used for
advertising purposes.

8228 070

10

**DEVELOPMENT OF IMPROVED CARGO SLING
SYSTEM INCORPORATING LOAD STABILIZATION
FINAL REPORT ON PHASE I -
ENGINEERING ANALYSIS (U)**

R-186

**U.S. Army Transportation Research Command
Fort Eustis, Virginia**

**Project No. 9R38-01-017-52
Contract No. DA 44-177-TC-587
Code Identification No. 77272**

March 1960

ASTIA
RECEIVED
MAY 9 1960
RECEIVED
TIPDR

**VERTOL AIRCRAFT CORPORATION
Morton, Pennsylvania**

TABLE OF CONTENTS

	<u>Page</u>
I. INTRODUCTION	1
II. SUMMARY	2
III. DISCUSSION	3
1. Requirements	3
2. Criteria	4
3. Configurations	7
4. Hatch and Internal Pyramid...	16
IV. CONCLUSIONS AND RECOMMENDATIONS ...	19
V. APPENDICES	
I. Photo, Sketches, Computation	
II. Reference	
III. Distribution List	

I. INTRODUCTION

The U.S. Army CONARC determined that a need existed to provide a means of minimizing the effects of external loads on helicopter flight characteristics and to provide means of stabilizing sling loads in order to more fully exploit the benefits of transporting loads externally at high speeds. Accordingly, Contract DA 44-177-TC-587 was awarded to Vertol Aircraft Corporation for an improved external cargo sling system incorporating load stabilization.

The results of the Phase I study for the contract are presented in this report. The investigations covered the following areas for H-21C, YHC-1A, H-34A and H-37A cargo helicopters:

- a. External cargo systems which will allow the load line of action to pass near the c.g. of the helicopter;
- b. Means of stabilizing the attitude of the load with respect to the helicopter;
- c. Problems involved in providing internal pyramids in the four helicopters to provide a support near the aircraft c.g. for external loads.

A configuration of suspension system and load stabilizer is recommended for design and testing on an H-34 during Phases II and III of this program.

During the conduct of this study, discussions were held with the activities listed below in order to obtain comments from operating personnel and to maintain liaison with work being done in parallel areas:

Transportation Research Command, Ft. Eustis, Va.
Army Aviation Board, Ft. Rucker, Ala.
Airborne and Electronics Board, Ft. Bragg, N. C.
Nems-Clarke Co., Martinsburg, W. Va.

II. SUMMARY

A study was made of various means of improving the effective pivot point of helicopter external cargo suspension systems and of stabilizing the load in flight. Successful flights of a "cargo swing" system under another contract provided a criterion for evaluating the systems considered.

The results of the study were:

1. For concentrated, heavy loads pivot point improvement is required to permit operation up to V_{max} , but load stabilization may not be required for all loads.
2. Internal cabin space should not be taken up for the external load device.
3. For bulky, aerodynamically dirty loads stabilization will be required.
4. Rapid cargo pick-up is important, so the stabilizer must be out of the way for pick-up and quickly engaged thereafter.

The configuration which best meets the above requirements for the H-34 to be used in Phases II and III of this program is:

1. External hatch cover removed but floor above left in place;
2. Folding, double-axis cargo swing;
3. Fuselage-mounted stabilizer forward, with two degrees of freedom.

The work required to install an appropriate hatch for cargo slinging in the bottom of the H-21 was investigated. In essence, there would be required:

1. Removal of the keel and floor frame;
2. Installation of a hatch frame and doors;
3. Relocation of control cables and searchlight.

The H-34 has provisions for a hatch, which may be incorporated at SCAMP overhaul; the YHC-1A and H-37 have existing hatches. All the above hatches are somewhat smaller than those required to meet the criteria for both pivot point improvement and range of motion, so some compromise must be accepted in using them.

III. DISCUSSION

I. Requirements

The design requirements to be met by the equipment recommended in this study are to be the best compromise of the factors listed below. The contract specified certain requirements, and other recommendations were made during discussions at the Army Aviation Board, Ft. Rucker, Alabama.

A. Contractual Requirements:

- (1) Devise external load supporting equipment which will prevent the stability and controllability of the basic helicopter from being materially penalized by the sling and load.
- (2) The lifting device to allow the line of action of the sling load to pass through or near the c.g. of the helicopter.
- (3) The load stabilizer to operate in hover and forward flight to prevent excessive swinging, pitching and yawing of all configurations of external loads that are likely to be transported by Army cargo helicopters.
- (4) The weight of the systems to be kept to a minimum.
- (5) The support and stabilizing devices to be compatible with each other, with standard helicopter hooks, with the hook being developed under Contract DA 44-177-TC-560, with slings having the characteristics specified in AD 207201, and with the static electricity elimination program.
- (6) Maintenance requirements to be minimum.
- (7) Configuration to provide greatest general utility.
- (8) The study to include analysis of the weights and stresses in the recommended systems and an analysis of their aerodynamics.
- (9) The analysis to consider the feasibility of modifying existing fuselage structures to allow attachment of the sling near the c.g.

B. Operational Features:

In addition to the above, other desirable operating features of cargo slinging equipment were pointed out in meetings held at the Army Aviation Board and the Army Airborne and Electronics Board and are included here for completeness.

- (1) Equipment should be as inexpensive as possible.
- (2) Installation should require only ordinary tools used in the field.
- (3) Stowage should be accomplished readily in a position offering minimum drag.
- (4) Operation may be conducted by a crew chief because he will be aboard for cargo slinging operations.
- (5) Equipment should be immediately adaptable to all aircraft of a type and should not result in special mission aircraft.
- (6) All operations of equipment should be performed from within the aircraft.
- (7) Load pick-up and engagement of the stabilizer should be rapid.
- (8) Internal cabin space should not be taken up by external load devices.
- (9) Instantaneous release of the load should be provided.
- (10) Capability of night operation should be provided.
- (11) Equipment should provide single point load suspension.
- (12) Equipment should be air transportable in detached form.
- (13) Operation should present no hazard to ground crew.

2. Criteria

A. Pivot Point:

Under Contract DA 44-177-TC-578, tests were flown on the H-21 with a "cargo swing" device, which raises the effective pivot point of an external load from 124 in. below the c.g. of the aircraft to 30 in. below. This system is shown on Drawing 242, page 1-3, and the photo

on page 1-2. Pilot comments on this configuration are summarized in the statement that "qualitatively, the control and stability characteristics very closely resemble the flying qualities of the basic aircraft." The helicopter was maneuvered with alacrity and flown at speeds up to V_{max} during the test program. See Reference 1.

Since use of the cargo swing with external loads afforded fully satisfactory controllability and stability in all flight regimes, the pivot point geometry it affords is used in the present study as a criterion. The effective pivot point is 30 in. below the helicopter c.g.

The principle effect of the raised pivot point is to improve dynamic stability of the helicopter with load, especially in hover. The results of an analog study of lateral dynamic stability of the H-21 in hover are presented in Figure 1 for loads on the standard cargo sling, on the cargo swing and on the cabin floor. This plot confirms the pilot evaluation discussed above by showing that the accelerations toward normal attitude for the internal load and cargo swing start at the same time, about 1 second (deflection point). But for the standard sling this acceleration does not occur until 2 seconds. This is the effect felt by the pilot and is the one upon which his evaluation of stability is based. Note that the coupling of the helicopter-plus-load with the cargo swing creates positive dynamic stability which is not present in the basic aircraft.

In order to establish criteria for the YHC-1A, H-34 and H-37 equivalent to that flown successfully in the H-21, dimensionless constants for the factors affecting dynamic stability were selected.

$$\text{Geometric dimensionless constant} = \frac{r}{h}$$

$$\text{Weight dimensionless constant} = \frac{L}{W}$$

where r = vertical distance from c.g. to load
effective pivot point ~ in.

h = vertical distance from plane of rotors
to c.g. ~ in.

L = rated payload ~ lb.

W = flying weight of helicopter alone for
cargo mission ~ lb.

COMPARISON OF EXTERNAL LOAD

CARRYING DEVICES

Roll Angle vs Time
H-21

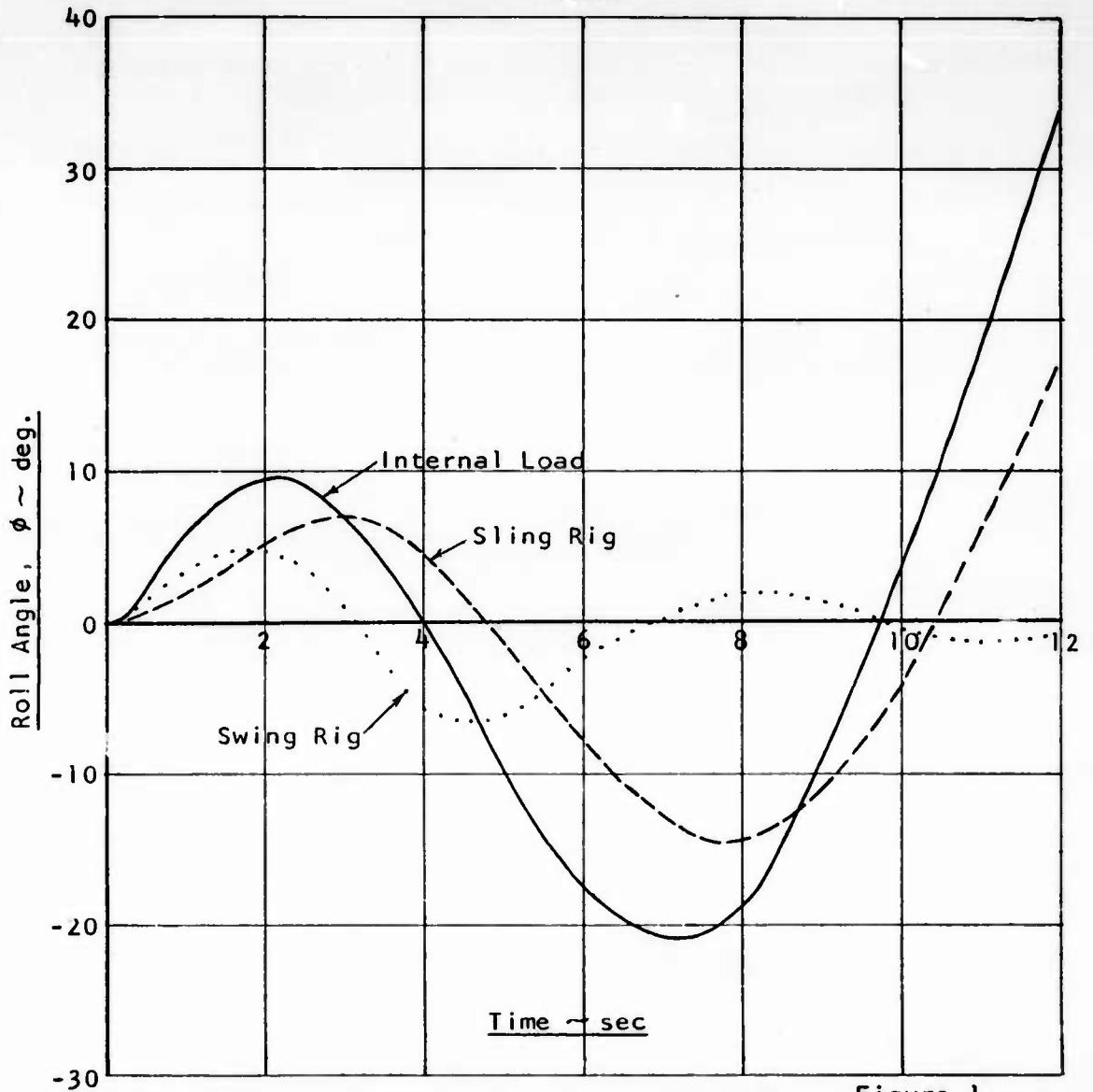

Figure 1

Thus, for equivalent effects on basic aircraft dynamic stability,

$$\frac{r_1}{h_1} \times \frac{L_1}{W_1} = \frac{r_2}{h_2} \times \frac{L_2}{W_2}$$

and solving for r_2 ,

$$r_2 = \frac{r_1 h_2}{h_1} \times \frac{L_1 W_2}{L_2 W_1}$$

Computations for equivalent r_2 's are tabulated below:

	$h \sim \text{in.}$	$L \sim \text{lb.}$	$W \sim \text{lb.}$	Cargo Swing $r_1 \sim \text{in.}$	Equivalent $r_2 \sim \text{in.}$
H-21C	81.2	2126	10300	30	--
YHC-1A	93.75	3786	10899	--	20.6
H-34A	82.	2083	8779	--	26.4
H-37A	81.	6045	23437	--	24.0

TABLE 1.

B. Angle of Motion:

In the H-21 cargo swing installation the lateral angle of motion of the load with respect to the helicopter was 30° , before contacting stops. This value was chosen to permit safe operations not only in extreme flight maneuvers but also during pick-up when the aircraft may not be perfectly centered over the load. Accordingly, the 30° criterion of motion from the vertical when hovering was retained for this study.

3. Configurations

A. Load Pivot Point Improvement:

- (1) All feasible configurations of devices which improve the actual or effective pivot point of external cargo were investigated in this study. Their characteristics are compared in Table 2 up to the points at which various ones are disqualified.

The systems are classified by their mechanics as kinematic or fixed devices, or by application to nonhatched or hatched helicopters.

- (2) The first two kinematic devices are one- and two-axis versions of the cargo swing successfully tested under Contract DA 44-177-TC-578. For tandem rotor helicopters pivot point improvement is only required for the roll axis because of the powerful pitch control available in the aircraft by use of differential collective pitch. The cargo swing, nevertheless, offers approximately 30% pitch plane improvement with respect to the standard cargo sling. For single-rotor helicopters, it is necessary to provide substantial improvement of pivot point about both pitch and roll axes, as with the double-axis swing. Both units provide effective pivot points 2-1/2 to 3 feet below the c.g., which has been found to be quite satisfactory. Drawing #242 and Sketches 9571 and 9504 show these concepts.

The cargo swing provides higher effective pivot points as the W-frame is made deeper. But, depth of the W-frame also poses ground clearance, retraction, weight, and drag problems so a practical compromise between these factors must be selected. One method of reducing weight and providing ready retraction is to design the legs and base of the W-frame of cable so that the unit can be folded easily for retraction into the helicopter or along its belly. This flexible construction is also desirable for preventing damage in case the swing should contact the load during operations in turbulent weather. The cable supporting the hook should be long enough to place the hook below the in-flight horizontal plane of the nose wheel on the H-21 or other aircraft having a nose wheel.

With the cargo swing system, adequate torsional rigidity can be provided to the cargo hook to orient and hold it in position for automatic hook-ups. The swing is also compatible with all of the means of load stabilization and it avoids interference with internal cargo space.

- (3) The second kinematic device is the radius rail, which is a trolley-on-beam, formed to an arc about a selected center near the helicopter c.g. The aircraft not having a hatch or those with too small a hatch to provide adequate trolley motion would have the rail mounted externally. For helicopters with large hatches the rails would be mounted in the area between the belly and the cabin floor,

thus providing ready accessibility, easy stowage and low aerodynamic drag. Since the effectiveness of this system depends on smooth operation of the trolley as the load swings, it is important that the rolling surfaces be kept free of fouling by blowing dirt or freezing precipitation. For the external application this hazard presents a major drawback, but for the unit in the hatch protection from the elements is feasible. See SK's 9424 and 9501.

- (4) Another possible configuration is a hanger extending through the sides of the aircraft and meeting at the hook beneath the fuselage. The hanger would be universally supported near the c.g. by a tripod mounted on the cabin floor. The kinematics of such a device could be very good, and structural rework of the fuselage would only be required in the sides, which are usually uncongested. However, many obvious difficulties appear to disqualify the design: Weight would be prohibitive; some rework of the aircraft would be required; handling and stowage of the device would be difficult; cabin space for internal loading would be compromised; and, aerodynamically, the installation would be dirty.
- (5) External kinematic motion could be provided by use of interconnected hydraulic cylinders hung below the helicopter. The hydraulic connections would keep the total length of the system from fuselage to cargo hook to fuselage constant, giving an effect equivalent to a pulley traveling along a cable slung beneath the aircraft, as discussed in the next paragraph.

Although both of these concepts raise the effective pivot to a point near the c.g. when the angle of motion is small, the effective pivot descends rapidly as the angle increases, thus giving negative stability. This is an unacceptable condition because the pilot must apply unproportionately large corrections as the magnitude of the disturbance increases.

- (6) The pulley-on-cable system has unsatisfactory kinematics as mentioned above. A further problem is presented by exposure to blowing dirt and ice which disturb or even prevent pulley motion.

- (7) In an attempt to overcome the kinematic deficiency of the pulley-on-cable, a design study was conducted of a system incorporating two coaxial cams which would provide true circular motion to the cargo hook about the helicopter c.g. However, requirements of the cam motion became mechanically impractical, so the concept was discarded.
- (8) Several versions of fixed devices for supporting the cargo were considered. The first was based on the concept of holding the load rigidly below the helicopter to prevent any relative motion. The aircraft plus cargo would then in effect be a single mass with the c.g. somewhat lower than when unloaded. Controllability would be satisfactory though somewhat reduced below that of the basic helicopter because of the higher moment of inertia with the external load. The principal difficulties with this system are encountered during hook-up to the load. If the load restrainer is fixed to the bottom (SK 9505) before lift-off, the aircraft must be lowered onto the load, which is considered too critical a maneuver for normal field operations, especially in gusty weather. If the restrainers are adjustable, excessively complicated controls are required to position them, and the time to position them will be too long. The requirement for hydraulic power is a further minor drawback. Local structural reinforcement of the airframe would be required at the points where the restrainers are attached. Also this system might not be satisfactory for certain delicate loads like radar antennae.
- (9) Two other fixed configurations having higher attachment points than the cargo sling have been built. The first was a ventral beam hung from the aft cargo sling attachment points of the H-21. The second is the YHC-1A installation of a fixed beam below the cabin floor, SK 9426.

Although these two approaches yield improvements proportional to the reduction of the distance from c.g. to hook, neither can be considered to direct the load line of action "through or near the c.g."

- (10) For hatched helicopters, the most obvious device for pivot point improvement is an internal pyramid having its apex at the desired height. The hook is suspended from a cable or bar which is universally mounted at the pyramid apex. The height of the pivot is selected as a compromise between distance from c.g. and angle of load motion permitted by the hatch. For the YHC-1A, H-34 and

H-37, use of the 30° load motion criterion results in the following pivot distances below the c.g., respectively: 27.3 in., 41. in. and 51.4 in. Comparing these with the equivalent r_p 's computed in Table 1, 20.6 in., 26.4 in. and 24 in., it is apparent that either the hatches are not large enough or the motion criterion must be narrowed in order to retain the effect produced by the cargo swing on the H-21. The internal pyramid nevertheless provides a simple, effective, easily stowed device for performing the required function in hatched helicopters without modification. Its principal drawback is that it requires internal cabin space. Modifications required to install a hatch in the H-21C are discussed in Section 4. Internal pyramid installations are shown in SK's 9469, 9502, 9503 and 9504.

- (11) A pivot point suspended by cables from the upper ladders, as shown in SK9505, produces the same effect as the internal pyramid and may be lighter. Structural support must be provided in the fuselage at the cable attachment points. The possibility of recoil of this cable system after release of a heavy load should be checked by means of a mock-up to determine whether a recoil prevention device is required.

B. Load Stabilization:

- (1) Most Army loads for external transport by helicopter may be slung satisfactorily in hover and forward flight. However, a few items such as rotor blade boxes and conex boxes have presented difficulties, either because of swinging under the aircraft or because they assume a maximum-drag attitude. So if flight at maximum speed is required when slinging these problem loads, stabilization would have to be provided.

The advisability of providing external load stabilization was quite thoroughly discussed with personnel of the Airborne and Electronics Board and the Army Aviation Board. These discussions point out that there is relatively little requirement for providing such equipment inasmuch as only a few of the loads present a problem. In these problem cases, the loads could be satisfactorily handled by reduction in speed rather than compromising the performance of the helicopter by installing special equipment for those special loads. As a result of the above, further action on load stabilization was discontinued, however, those stabilizing devices investigated during the initial phase of this contract are presented and discussed.

- (2) If stabilization should be required in some future program, the stabilizer should hold the desired yaw, pitch and roll attitudes of the load with respect to the helicopter during all normal maneuvers without in any way interfering with instantaneous release in case of emergency jettisoning. Safety in this situation is predicated on the use of a single cargo hook. The device should also be adaptable to a wide variety of cargo sizes by control from within the helicopter. The requirement for stabilizing equipment to be installed on the load at the time of its preparation is undesirable. Compatibility with the automatic hook-up system developed under Contract DA 44-177-TC-560 is required.

Characteristics of the various stabilizer configurations are compared in Table 3. Asterisks indicate the points at which configurations were eliminated.

- (3) The first stabilizer category investigated in this study is multiple-attachment. Three configurations include: Two separately supported cargo hooks in tandem; a cargo hook holding both the load and a stabilizing line from the forward end of the load, through a fixed ring; and a cargo hook plus a separately attached stabilizing line forward on the cargo. These concepts were discarded because of the multiple attachments, which compromised safety in emergency release, made automatic hookup difficult and required more specialized preparation of the load by ground crews. Further, a simple lifting force at the forward end of a load would not provide satisfactory yaw restraint. See SK's 9421, 9422 and 9426.
- (4) In the second category, helicopter-mounted stabilizers, four configurations were considered. The fixed ventral yoke could be made to operate with certain long loads, but was not very universal in application, especially when observing ground clearance requirements of the helicopter.

The adjustable stabilizer mounted on the bottom of the fuselage appeared to be the best compromise of the devices conceived. Adjustability gave the opportunity of retracting the unit for ground clearance and of giving the operator selection of the points at which to engage the load. For delicate cargos, such as radars, it is often desirable to avoid contact with the load and to contact the sling straps instead. This approach was also desirable in that it afforded a good point of engagement for yaw restraint and permitted contacting











the straps at a variety of distances below the aircraft. Accordingly, the contact area on the stabilizer was designed as a transverse bar having a series of slots capable of engaging the straps of the load sling. The hydraulic actuator of the extension unit is kept moderately pressurized when in use in order to maintain engagement with the load. The stabilizer is also spring loaded to the retracted position for safety in the event of hydraulic failure. A positive up-latch is provided. See SK's 9448, 9571 and 9574.

Undesirable features of this installation are its weight, drag, and requirements for hydraulic power and structural reinforcement.

Development testing would be required to provide a configuration that would not chafe the nylon straps or ropes supporting the load.

- (5) The ventral bumper concept is equivalent to the multiple-stabilizer system discussed in paragraph III3A(8), in that the load becomes part of a single mass with the helicopter as far as controllability is concerned. This system is the only one which satisfies the requirements both of pivot point improvement and of stabilization. However, the operational difficulties associated with pick-up and deposit of the cargo are considered excessive, so the concept was not recommended. See SK 9505.
- (6) An integral cargo swing and stabilizer was investigated using the concept shown in SK 9530 in order to provide stabilization with no compromise in the effect of the kinematic motion. This approach could be made feasible for the single-axis swing by making it sufficiently rigid torsionally to give a natural frequency higher than the six-per-rotor-revolution. However, with the flexible, folding double-axis cargo swing adequate torsional rigidity cannot be provided, and interference problems arise during retraction of the swing and stabilizer.
- (7) The last category of stabilizing equipment is that which is attached to the load at the time of preparing the cargo. Included are aerodynamic devices such as fins or drogues, a gyroscope, and special spacing of the load with respect to the fuselage to avoid rotor downwash. In general, these approaches are unsatisfactory because they either require that the loading crews have special equipment on the ground or they do not provide stabilization in hover, maneuvers and forward flight.

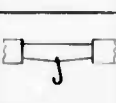
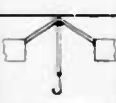
IMPROVED HELICOPTER SLING LOAD CAPABILITY
LOAD PIVOT POINT IMPROVEMENT

CONFIGURATION	SKETCH	REFERENCE	CLASSIFICATION	APPLICATION	PIVOT POINT DISTANCE BELOW C.G. (FOR 30° MOTION) in.	RELIABILITY	COMPATIBILITY WITH		WEIGHT ESTIMATE, LESS HOOK lb.	AERODYNAMIC DRAG sq. ft.	
							LOAD STABILIZATION	AUTOMATIC HOOKUP			
CARGO SWING 1-AXIS		242 SK 4752	KINEMATIC DEVICES	NONHATCHED AIRCRAFT	H-21: 30 TO 24 POTENTIALLY: 0	GOOD	FAIR	FAIR	46	6.0 POOR	
CARGO SWING 2-AXIS		SK 9468 SK 9504 SK 9506			H-34: 31 TO 33 H-37: 56 POTENTIALLY: 0	GOOD	FAIR	FAIR	110	12.0 POOR	
RADIUS RAIL		SK 9424 SK 9501			0	FAIR*	FAIR	FAIR	1-AXIS: 80 2-AXIS: 200	5.0 POOR	
HANGER THROUGH SIDES					0	GOOD	POOR	FAIR	* 185 PLUS HELICOPTER MODIFICATION	7.5 POOR	
MULTIPLE ACTUATOR					*	H-21: 8 TO 26	FAIR	FAIR	FAIR	60	2.2 FAIR
FIXED CABLE WITH PULLEY					*	H-21: 8 TO 26	FAIR	FAIR	FAIR	15	1.2 FAIR
MOVING CABLE WITH CAM ACTION					0	FAIR*	FAIR	FAIR	25	1.5 FAIR	
VENTRAL STABILIZER CONTROLLABLE		SK 9505	0	GOOD	EXCELLENT	FAIR*	100	12.0 POOR			
VENTRAL BEAM			*	H-21: 75	EXCELLENT	GOOD	GOOD	40	5.0 POOR		
FLOOR BEAM			*	YMC-1A: 52 H-37: 84	EXCELLENT	GOOD	GOOD	15	0.3 GOOD		
INTERNAL PYRAMID		SK 9423 SK 9502 SK 9503 SK 9504		H-37: 51	EXCELLENT	GOOD	GOOD	50	0.3 GOOD		
OVERHEAD CABLES TO C.G.				H-37: 51	EXCELLENT	POOR	GOOD	30	0.3 GOOD		

* POINT AT WHICH CONFIGURATION WAS ELIMINATED

1

IMPROVED HELICOPTER SLING LOAD CAPABILITIES
LOAD PIVOT POINT IMPROVEMENT

COMPATIBILITY WITH LOAD TABILIZATION		AUTOMATIC HOOKUP	WEIGHT ESTIMATE, LESS HOOK lb.	AERODYNAMIC DRAG sq. ft.	GROUND CLEARANCE	EASE OF RETRACTION	AIRCRAFT MODIFICATION REQUIRED	EASE OF INSTALLATION AND REMOVAL	ACAPTABILITY TO 1- AND 2-AXIS INSTALLATIONS	FEASIBILITY OF HOOKUP ON GROUND	ORIENTATION OF HOOK FOR HOOKUP	INTERFERENCE WITH INTERNAL LOADS
FAIR	FAIR	FAIR	46	6.0 POOR	POOR (PRESENT DESIGN)	POOR (PRESENT DESIGN)	ADD ELECTRICAL RELEASE	FAIR	1-AXIS ONLY	FAIR	GOOD	NONE
FAIR	FAIR	FAIR	110	12.0 POOR	POOR	POOR	ADD RETRACTION SYSTEM	FAIR	GOOD	FAIR IF RETRACTED	GOOD	NONE
FAIR	FAIR	FAIR	1-AXIS: 80 2-AXIS: 200	5.0 POOR	FAIR	FAIR	2-AXIS: STRUCTURAL REINFORCEMENT	FAIR	FAIR	GOOD	GOOD	NONE
POOR	FAIR	FAIR	* 185 PLUS HELICOPTER MODIFICATION	7.5 POOR	FAIR	FAIR	SIDE CUTOUTS AND REINFORCEMENT	POOR	GOOD	GOOD	FAIR	LARGE
FAIR	FAIR	FAIR	60	2.2 FAIR	POOR	1-AXIS: FAIR 2-AXIS: POOR	1-AXIS: FITTINGS 2-AXIS: FITTINGS AND SUPPORT STRUCTURE	GOOD	GOOD	1-AXIS: FAIR 2-AXIS: POOR	GOOD	NONE
FAIR	FAIR	FAIR	15	1.2 FAIR	POOR	GOOD	NONE	GOOD	POOR	GOOD	GOOD	NONE
FAIR	FAIR	FAIR	25	1.5 FAIR	POOR	GOOD	SUPPORT FOR CAM CYLINDERS	GOOD	FAIR	GOOD	GOOD	NONE
EXCELLENT	FAIR	FAIR	100	12.0 POOR	GOOD	GOOD	SUPPORT FOR STABILIZERS	FAIR	GOOD	GOOD	GOOD	NONE
GOOD	GOOD	GOOD	40	5.0 POOR	FAIR	FAIR	H-21: NONE	GOOD	GOOD	GOOD	GOOD	NONE
GOOD	GOOD	GOOD	15	0.3 GOOD	EXCELLENT	NOT REQUIRED	YHC: NONE H-21: N.A. H-34: STRUCTURAL REINFORCEMENT H-37: FITTINGS	GOOD	GOOD	GOOD	GOOD	NONE
GOOD	GOOD	GOOD	50	0.3 GOOD	EXCELLENT	GOOD	H-21 CUT MATCH * YHC H-34 H-37 NONE	GOOD	GOOD	GOOD	FAIR	MODERATE
POOR	GOOD	GOOD	30	0.3 GOOD	EXCELLENT	GOOD	H-21: N.A. YHC: STRUCTURAL REINFORCEMENT H-34 H-37 FITTINGS	GOOD	GOOD	GOOD	FAIR	* MODERATE

2

CONFIGURATION	SKETCH	REFERENCE	CLASSIFICATION	EFFECTIVENESS IN HOVER	EFFECTIVENESS IN FORWARD FLIGHT	STABILITY IN YAW ROLL PITCH	CREWMAN REQUIRED IN AIRCRAFT	NUMBER OF CONNECTIONS TO CARGO	AUXILIARY EQUIPMENT REQUIRED AT LOAD	APPLICABLE TO ALL TYPES OF LOAD
DOUBLE CARGO SWING TWO HOOKS		SK 9421	STABILIZATION BY MULTIPLE ATTACHMENT	GOOD	GOOD	GOOD	YES	2		
DOUBLE CARGO SWING HOOK AND RING		SK 9421		GOOD	GOOD	GOOD	YES	2		
STABILIZING LINE AND CARGO SWING		SK 9422 SK 9426		FAIR	FAIR	YAW ROLL PITCH FAIR GOOD	YES	2		
FIXED VENTRAL YOKE			STABILIZING EQUIPMENT ON HELICOPTER	GOOD	GOOD	LONG LOADS ONLY YAW ROLL PITCH FAIR GOOD	NO	1	NONE	POOR
CONTROLLABLE YOKE		SK 9440		GOOD	GOOD	YAW ROLL PITCH FAIR GOOD	YES	1	NONE	FAIR
VENTRAL BUMPER		SK 9505		GOOD	GOOD	GOOD	NO	1	NONE	GOOD
INTEGRAL CARGO HOOK AND STABILIZER		SK 9530 H-21 SK 9469 H-34		GOOD	GOOD	GOOD	YES	1	NONE	GOOD
FIN TAIL				POOR	FAIR	YAW ROLL PITCH FAIR POOR POOR	NO	1	* FIN AND ATTACHMENTS	GOOD
DROGUE CHUTE			STABILIZING EQUIPMENT ON LOAD	POOR	FAIR	YAW ROLL PITCH FAIR POOR POOR	NO	1	* DROGUE AND ATTACHMENTS	FAIR
GYROSCOPE ON LOAD				FAIR	FAIR	IN SPACE, ANY TWO AXES FAIR OTHER AXIS POOR	YES	1 - LOAD 1 - POWER	* GYRO, ATTACHMENTS AND POWER LINE	
CARGO REAR FUSELAGE				GOOD	POOR	POOR				
CARGO LONG DISTANCE BELOW HELICOPTER				FAIR	POOR	POOR				

* POINT AT WHICH CONFIGURATION WAS ELIMINATED

1

ED HELICOPTER SLING LOAD CAPABILITIES
CARGO STABILIZATION

APPLICABILITY TO ALL TYPES OF LOADS	LIFT MECHANISM	AUTOMATIC HOOKUP	WEIGHT ESTIMATE lb.	AERODYNAMIC DRAG ft. ²	RELIABILITY	SAFETY	GROUND CLEARANCE	EASE OF RETRACTION	AIRCRAFT MODIFICATION REQUIRED	EASE OF INSTALLATION AND REMOVAL	ADAPTABILITY TO MATCHED & NONMATCHED AIRCRAFT
POOR *	GOOD		25	1.0	GOOD	GOOD	FAIR	NOT REQUIRED	STRUCTURAL INSTALLATION FOR YOKE	GOOD	GOOD
FAIR	GOOD		55	2.0	FAIR	GOOD	GOOD	GOOD	STRUCTURAL INSTALLATION FOR DEVICE	FAIR	GOOD
GOOD	N.A.		35	3.0	GOOD	FAIR *	FAIR	NOT REQUIRED	PROVISION TO RAISE LIFTING CABLE THROUGH BELLY	GOOD	GOOD
GOOD	FAIR *		30 SINGLE UNIT ON CARGO SWING 40	6.0 H-21 WITH CARGO SWING & STABI- LIZER = 11.0	GOOD	FAIR	POOR	GOOD	LOAD ROD STRUCTURAL INSTALLATION	FAIR	HATCHED GOOD NONHATCHED FAIR
GOOD	GOOD	GOOD	5	0.3	FAIR	GOOD	N.A.	N.A.	NONE	GOOD	GOOD
FAIR	GOOD	GOOD	1	0.8 x AREA	GOOD	GOOD	N.A.	N.A.	NONE	GOOD	GOOD

2

Fins have been used in the field by Army crews with the ensuing comment that they are undesirable because ground crews would not normally have the material with the cargo, and each load needs a special size fin to be effective.

The gyroscope, even if it were heavy enough to stabilize a heavy load in forward flight would tend to maintain the cargo's attitude in space rather than with respect to the aircraft and so would be useless in maneuvers.

Special location of the load either very close to or far below the fuselage may prevent the cargo from feeling the influence of the rotor downwash in hover, but in maneuvers and forward flight, no stabilization is offered.

4. Hatch and Internal Pyramid

A. Modification for Hatch:

A contractual item of this study called for determination of the work required for installing a hatch in the floor under the c.g. of the aircraft. Of the four helicopters under study here, only the H-21 does not have an existing hatch. A summary of the structural modifications required to install such a hatch in the H-21 is presented below.

H-21C HATCH

SIZE: 28.0 x 34.5 (Fus. Sta. 319.5 to Sta. 354.0
Sym. about \bar{c} ship at B.L. 14.0)

STRUCTURE MODIFICATIONS

1. Remove Keel Sta. 319.5 to Sta. 354.0
2. Remove Floor Frame from R&L B.L. 14.0 at Sta. 339.5
3. Add Hatch Frame (28.0 x 34.5)
4. Add Hatch Doors
5. Add Removable Internal Pyramid. (Provide Stowage Space)
6. Modify Cabin Floor
 - a. At Hatch
 - b. At Sta. 311.81 - Control Cables

EQUIPMENT MODIFICATIONS

1. Relocate Search Light and Support Installation
2. Modify Troop Seat at Sta. 311.81 (Control Cables)
3. Add Control Cable Guard - Floor to Ceiling Sta. 311.81

CONTROLS MODIFICATIONS

1. Modify Flight Control Cables
 - a. Move Pulley Brackets & Pulleys at Sta. 354.0 fwd. to Sta. 311.81 - (Maintain same W.L. Dim.)
 - b. Add 6 Pulleys and Brackets at Sta. 311.81 at Side and Ceiling
 - c. Length of Cables will increase

B. Kinematics of Internal Pyramid:

An analysis of the kinematics available by use of a hatch and internal pyramid is presented here for the four subject helicopters because this simple system obviously places the load pivot point near the aircraft c. g., as in the HU-1A. However, for other reasons discussed earlier, this configuration is not recommended for Phases II and III of the present contract.

Using the geometry of existing hatches in the YHC-1A, H-34 and H-37, a study was made of the angle of motion permitted when using the criterion r's, or distance from c. g. to pivot point, from Table 1. Also, the r's available when using the $\pm 30^\circ$ motion criterion were determined.

The results of the above study are summarized in Table 4. For all the helicopters the hatches are somewhat smaller than would be required to meet the criteria for both pivot point improvement and range of motion, so some compromise must be accepted in using them.

**PIVOT HEIGHT AND MOTION LIMITS FOR PRESENT OR
RECOMMENDED HATCHES**

Helicopter	Criterion r	Motion Angle for Cri- terion r	Per Cent of Cri- terion Motion ($\pm 30^\circ$)	r Obtain- able with $\pm 30^\circ$ Mo- tion Cri- terion	Per Cent of Criterion r
H-21, pivot at belly; r = 70 in.	30 in.	$\pm 90^\circ$	300%		233%
H-21, hatched	30 in.	± 21	70%	42 in.	140%
YHC-1A, hatched	20.6 in.	± 25	83%	27.3 in.	133%
H-34, hatched	26.4 in.	± 17	57%	41 in.	155%
H-37, hatched	24.0 in.	± 19	63%	51.4 in.	214%

TABLE 4

IV. CONCLUSIONS AND RECOMMENDATIONS

The configurations of pivot point improvement and stabilizing systems recommended by this contractor for application to the H-34 in Phases II and III are: The folding double axis cargo swing and the hydraulic actuated stabilizer, which are shown in SK-9574. These two devices represent the best compromise of the features outlined in the "Requirements" section. They are applicable with minor modification to the four helicopters considered in the study and afford a system requiring no internal cabin space.

It is, therefore, recommended that the above conclusions be approved for detail design and flight test on the H-34 during Phases II and III of this contract.

APPENDIX I

<u>Photo</u>		H-21 In Flight with Cargo Swing Installation and Load
<u>Drawing</u>	#242	Cargo Swing Installation and Assembly - H-21
<u>Sketches</u>	SK-9421	Fore and Aft Cargo Swings - H-21 and H-34
	SK-9422	Cargo Swing and Stabilizing Line - H-21
	SK-9424	Radius Rail - H-21
	SK-9426	Beam in Floor and Stabilizing Line - YHC-1A
	SK-9448	Cargo Swing and Stabilization Yoke - H-21
	SK-9468	Double Axis Cargo Swing, Telescoping - H-34
	SK-9469	Integral Cargo Hook and Stabilizer - YHC-1A
	SK-9501	Double Axis Radius Rail - H-34
	SK-9502	Internal Pyramid - H-21
	SK-9503	Internal Pyramid - YHC-1A
	SK-9504	Double Axis Cargo Swing and Internal Pyramid - H-37
	SK-9505	Ventral Bumper Stabilizer - H-37
	SK-9506	Retracting Double Axis Cargo Swing - H-37
	SK-9530	Integral Cargo Swing and Stabilizer - H-21
	SK-9571	Cargo Swing and Hydraulically Operated Stabilizers - H-21
	SK-9574	Folding Double Axis Cargo Swing and Hydraulically Operated Controllable Stabilizer - H-34
<u>Computation</u>		Yaw Loads Imposed by Blade Boxes



H-25 in flight with Cargo Container and Load

APPENDIX II

Reference

1. Vertol Aircraft Corporation Report R-177, Flight Test Evaluation of an Improved External Cargo System for Helicopters

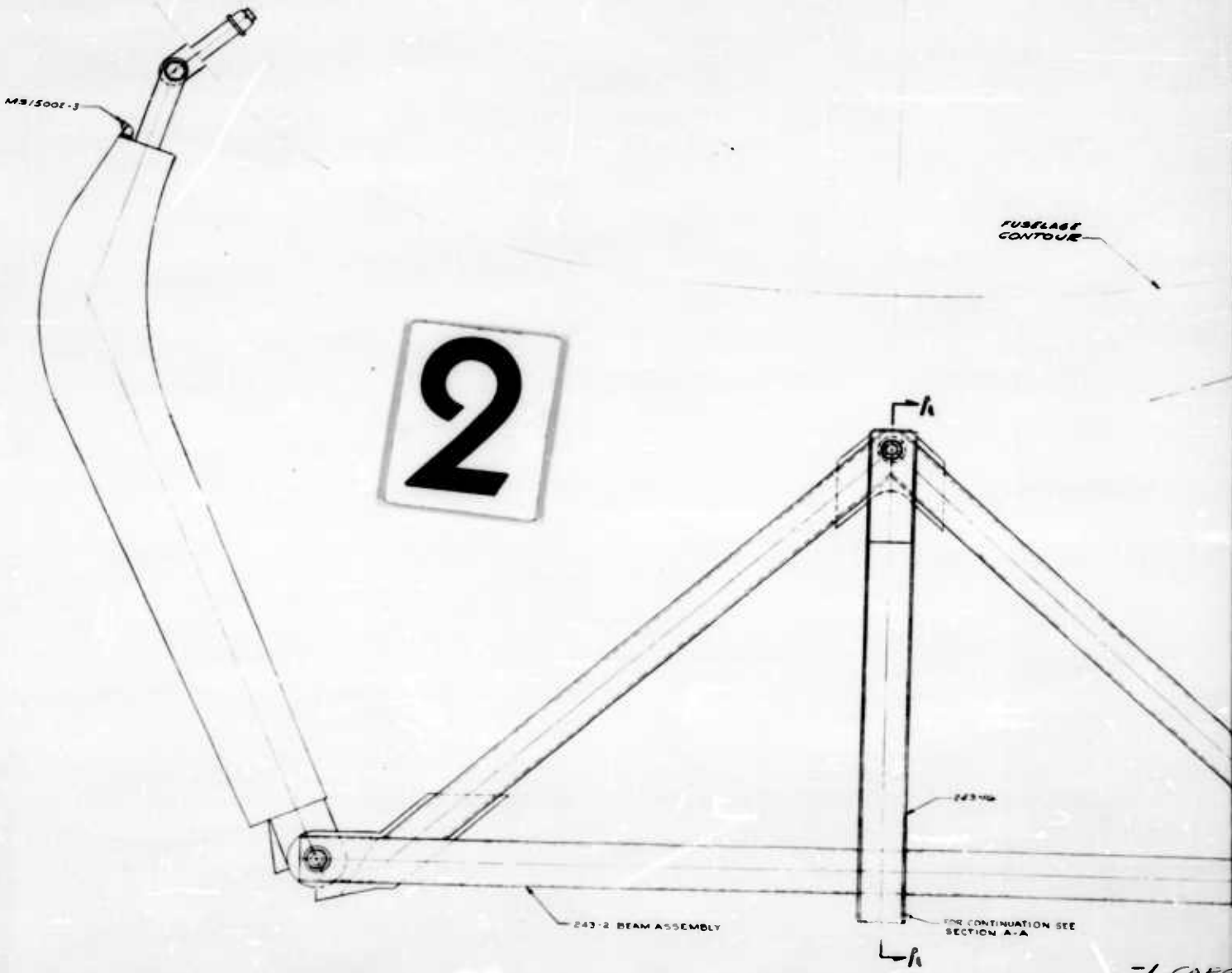

2

43/5001-3

FUSELAGE
CONTOUR

243-2 BEAM ASSEMBLY

243-106

FOR CONTINUATION SEE
SECTION A-A

-1 CAEG

3

AN310-3 NUT, CAST.
 NAS 251-4-16 PIN SPRING
 AN381-2-20 PIN, COTTER (INSERT COTTER PIN THRU
 AN360-8/6 WASHER I.D. OF SPRING PIN)

243-4

AN110-1A BOLT
 AN360-7/8 WASHER (LND HD)
 AN360-7/8 WASHER (LND NUT)
 AN360-7/8 NUT
 (2 PLACES)

244-1 ARM ASSEMBLY

AN10-14A BOLT
 AN360-1/2 WASHER (LND HD)
 AN360-1/2 WASHER (LND NUT)
 AN360-1/2 NUT
 (2 PLACES)

GRU NOTES

1. REMOVE CARGO SLING EYE BOLT AT STA 360 & REPLACE WITH 243-4.
2. PRIME & PAINT - 1 ASSY PRIMER & LACQUER ANA COLOR # 508 MIL-F-7173
3. LUBRICATE ALL JOINTS WITH GRAPHITE GREASE PER MIL-B-7187 AT ASSY.

-1 CARGO SW UG ASSY

REVISED SPEC			
REV	DATE	BY	CHK

THIS DRAWING IS A COPY OF THE ORIGINAL AND NOT A REPRODUCTION OF THE ORIGINAL. IT IS THE PROPERTY OF THE U.S. GOVERNMENT AND IS LOANED TO YOU BY THE U.S. GOVERNMENT. IT IS TO BE RETURNED TO THE U.S. GOVERNMENT AND NOT TO BE REPRODUCED OR TRANSMITTED IN ANY FORM OR BY ANY MEANS, ELECTRONIC OR MECHANICAL, INCLUDING PHOTOCOPYING, RECORDING, OR BY ANY INFORMATION STORAGE AND RETRIEVAL SYSTEM.

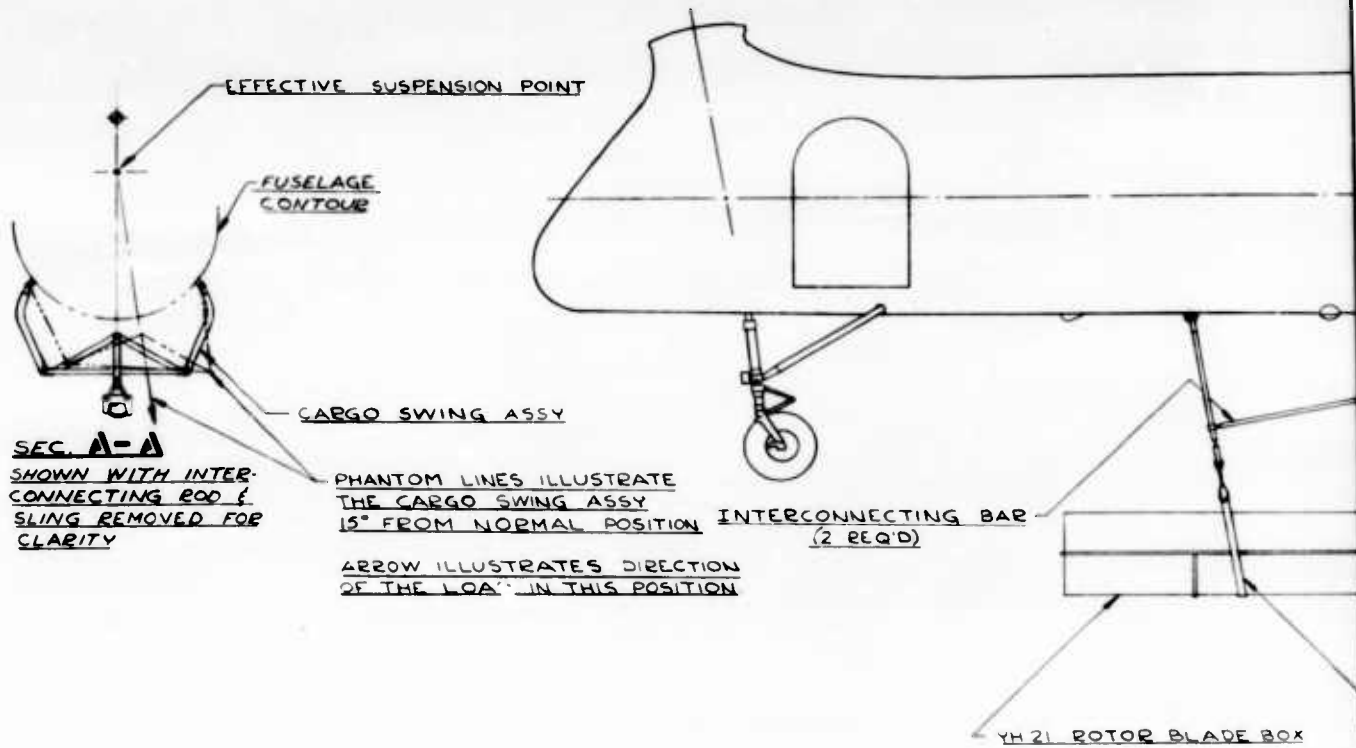

SEC. A-A
SHOWN WITH INTER-CONNECTING ROD & SLING REMOVED FOR CLARITY

PHANTOM LINES ILLUSTRATE THE CARGO SWING ASSY 15° FROM NORMAL POSITION
ARROW ILLUSTRATES DIRECTION OF THE LOA IN THIS POSITION

INTERCONNECTING BAR (2 REQ'D)

YH 21 ROTOR BLADE BOX

1

CONFIGURATION I
H-21 INSTALLATION

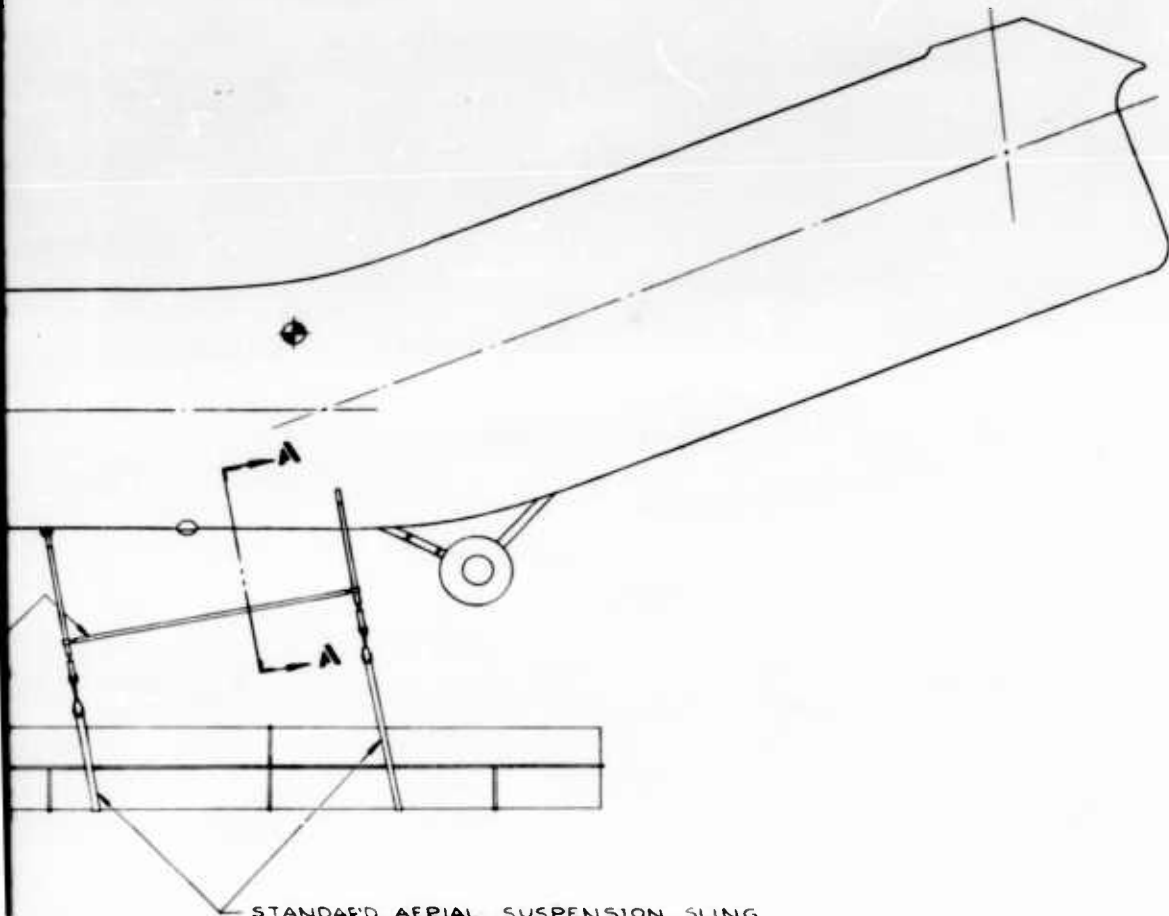

BLADE BOX

STANDARD AERIAL SUSPENSION SLING
(MULTIPLE THICKNESS)
(ASSUMED BAILED EQUIPMENT)

SECTION I
SECTION

2

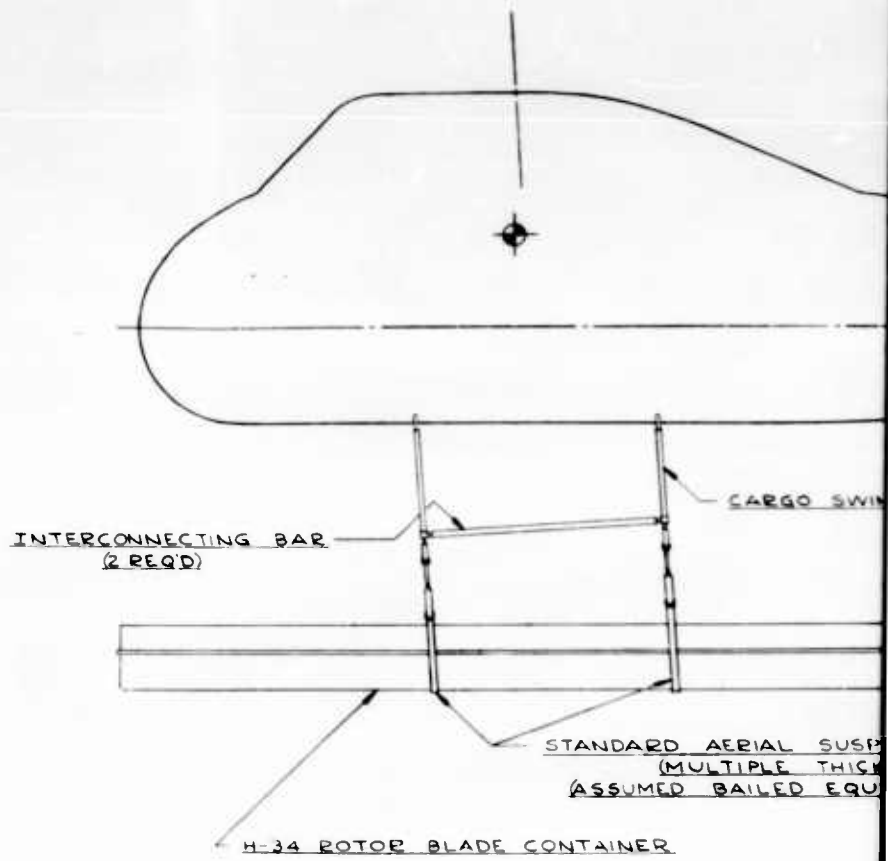

CONFIGURATION I
H-34 INSTALLATION

3

[REDACTED]

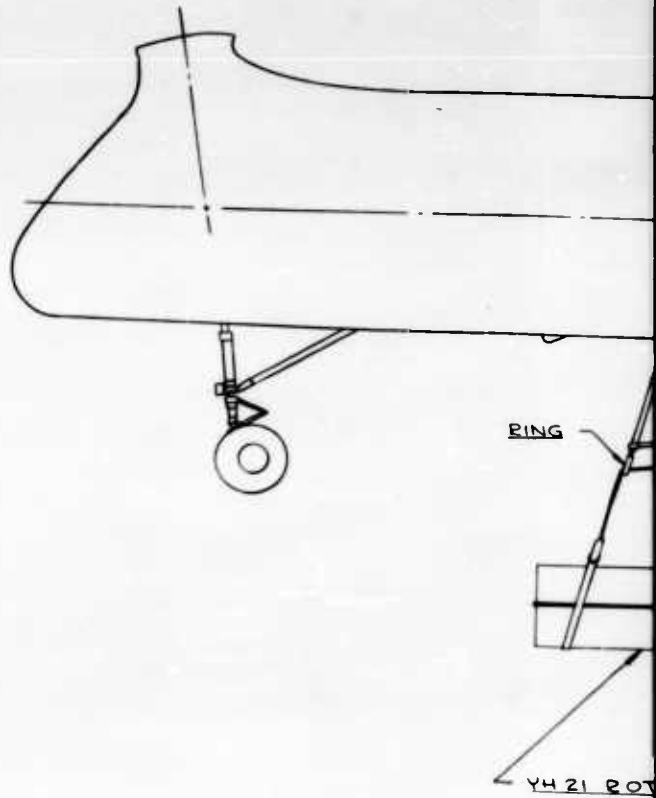

CONF

1

2

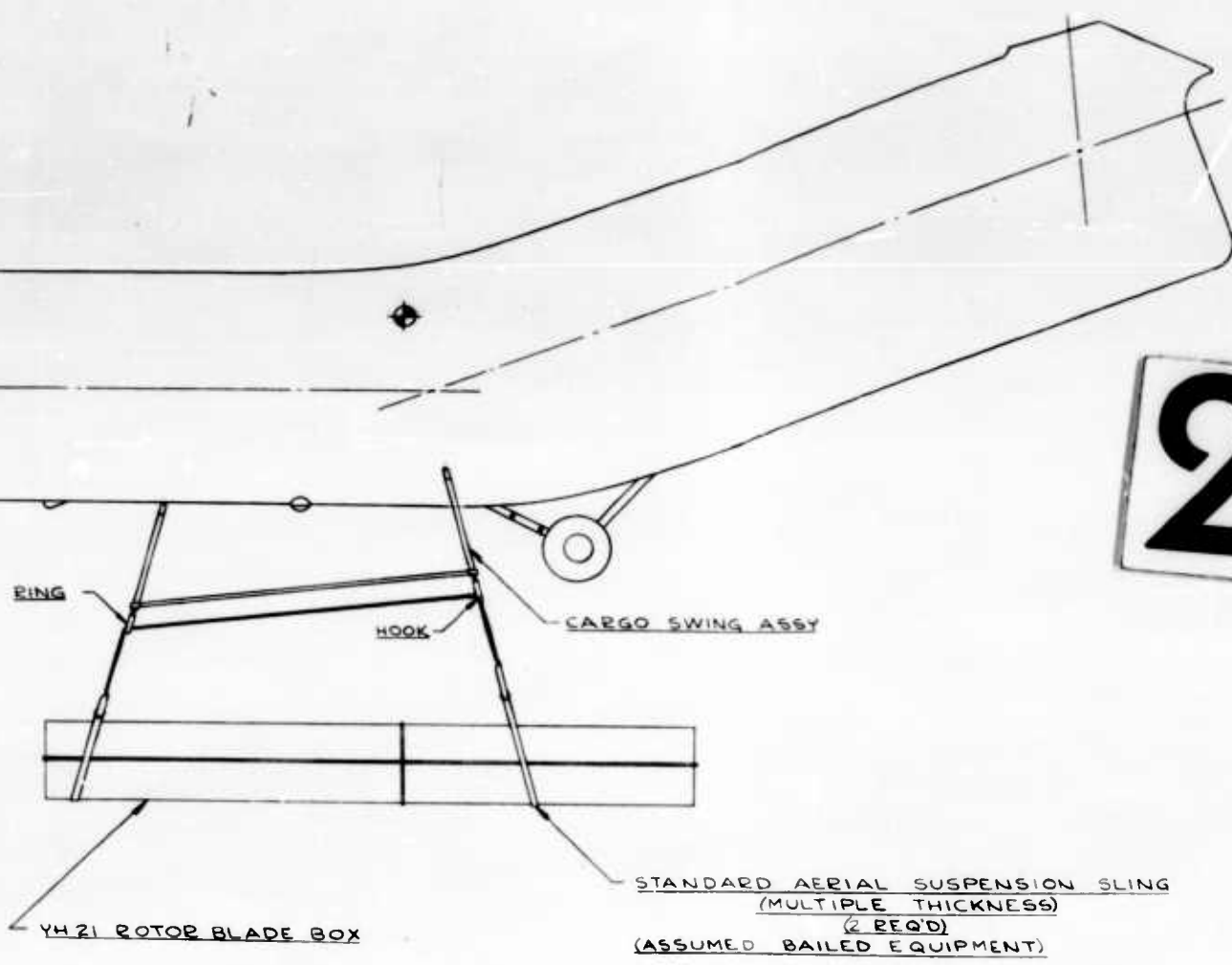

CONFIGURATION I-b

**PRINT REDUCED
ONE-THIRD
INDICATED SCALE**

FIGURE I
(SHEET 2)

PROPOSAL FOR IMPROVED CARGO HAND SYSTEM	SK 9421
CONFIG I-b	1 OF 2
SCALE 1:20	

SECRET

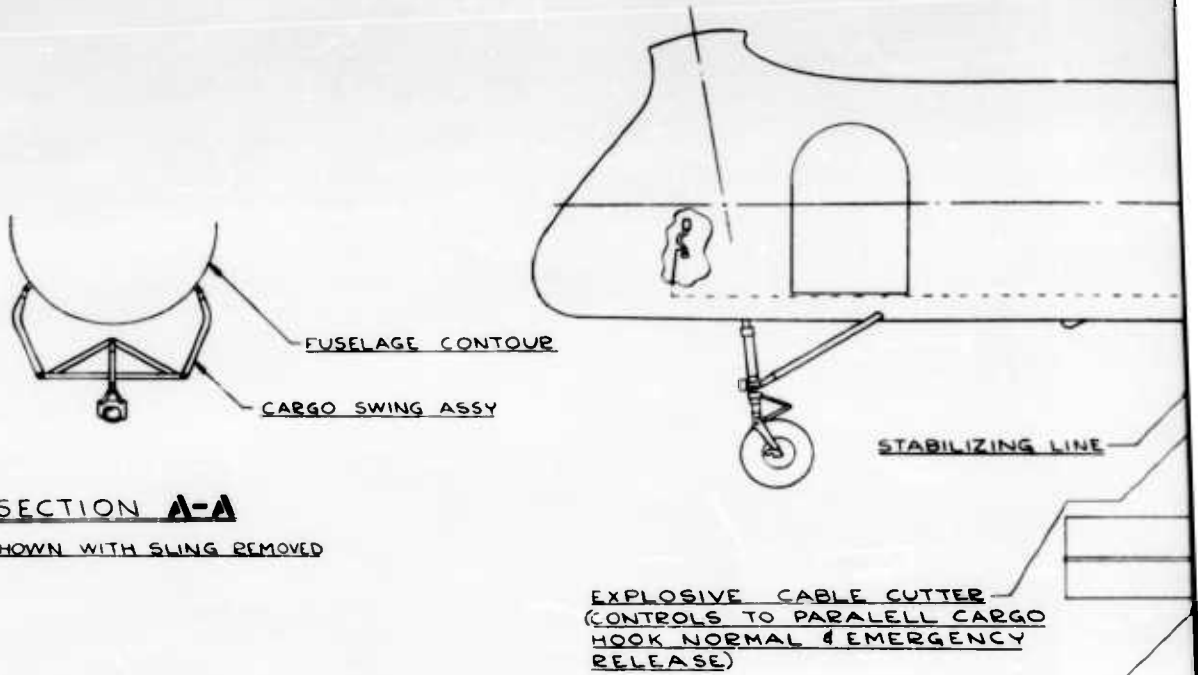

YH 21 POT

1

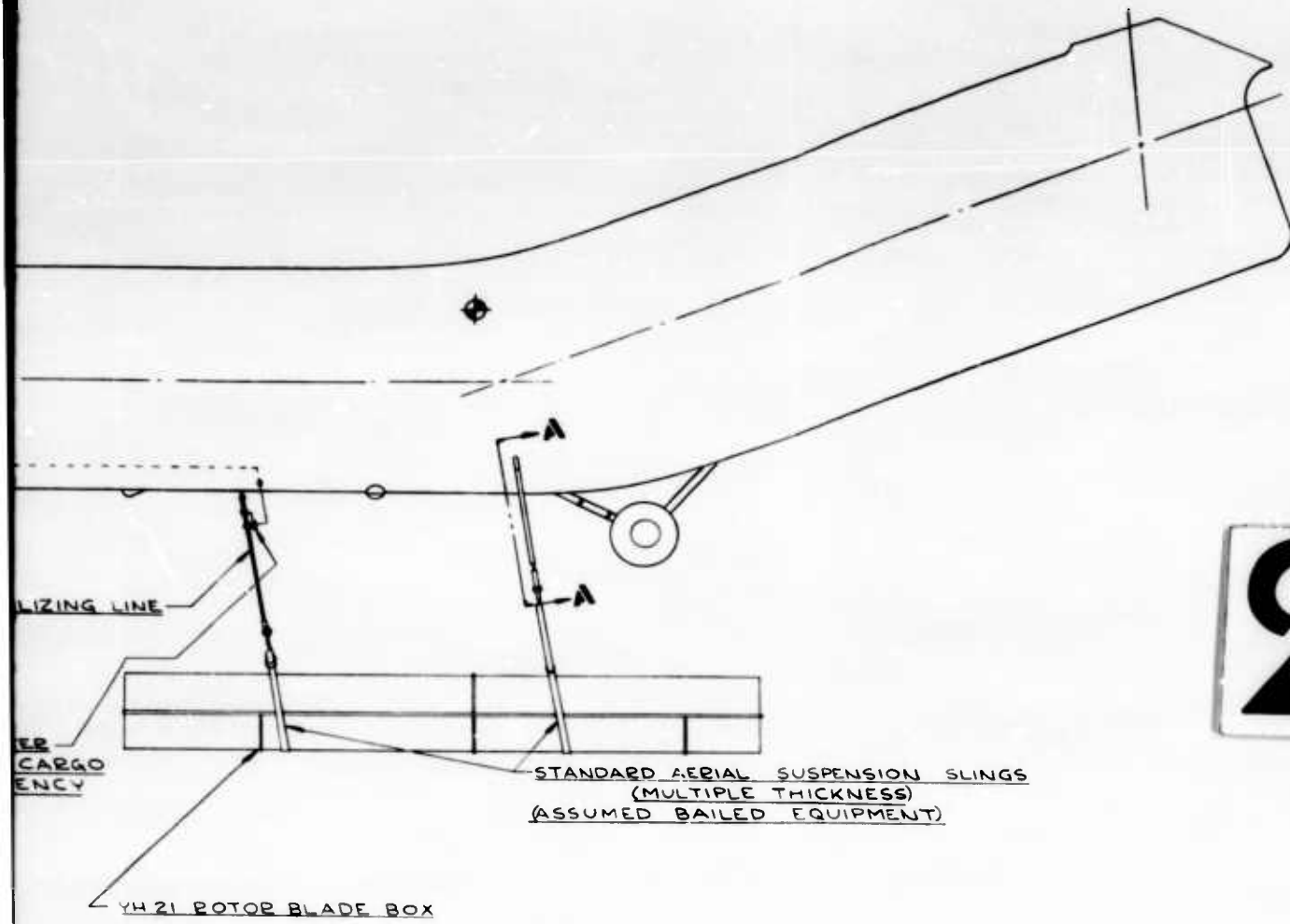

2

PRINT REDUCED
ONE - THIRD
INDICATED SCALE

FIGURE II

	PROPOSAL FOR	
	IMPROVED CARGO	
	HAND SYSTEM	
	CONFIG II	
	5K9422	

ALL DIMENSIONS ARE IN INCHES UNLESS OTHERWISE SPECIFIED. DIMENSIONS ARE TO CENTER UNLESS OTHERWISE SPECIFIED. DIMENSIONS ARE TO CENTER UNLESS OTHERWISE SPECIFIED.

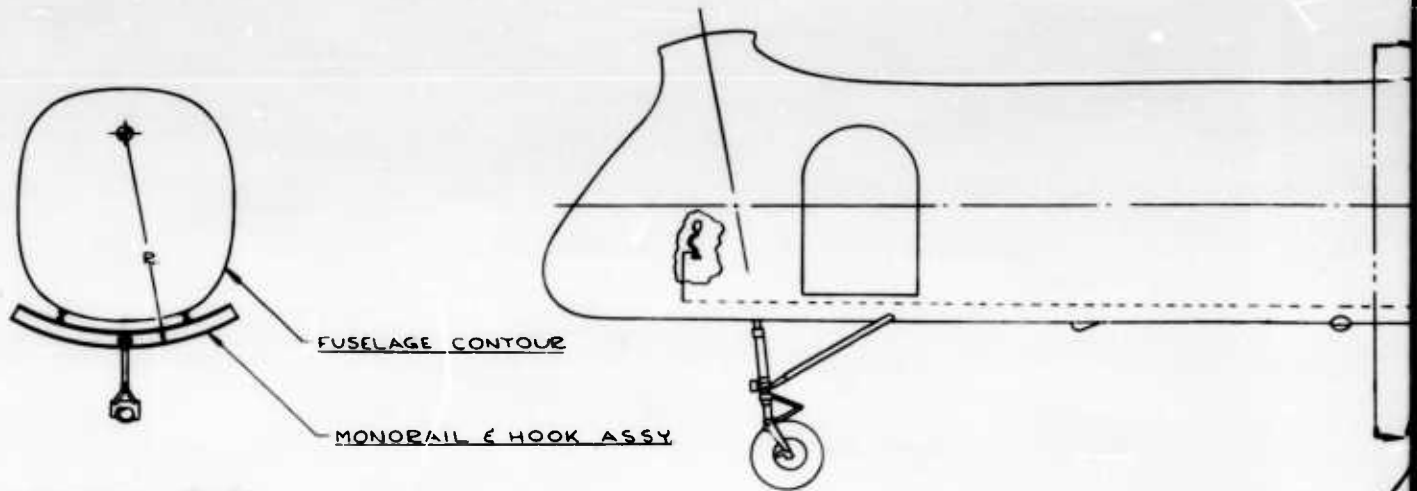

FUSELAGE CONTOUR

MONORAIL & HOOK ASSY

SECTION A-A

SHOWN WITH NET REMOVED

1

ALL DIMENSIONS UNLESS OTHERWISE SPECIFIED ARE IN INCHES. DIMENSIONS IN PARENTHESES ARE IN MILLIMETERS. DIMENSIONS IN PARENTHESES ARE TO BE USED ONLY IN CASE OF DISCREPANCY WITH THE DIMENSIONS LISTED IN THE DRAWING.

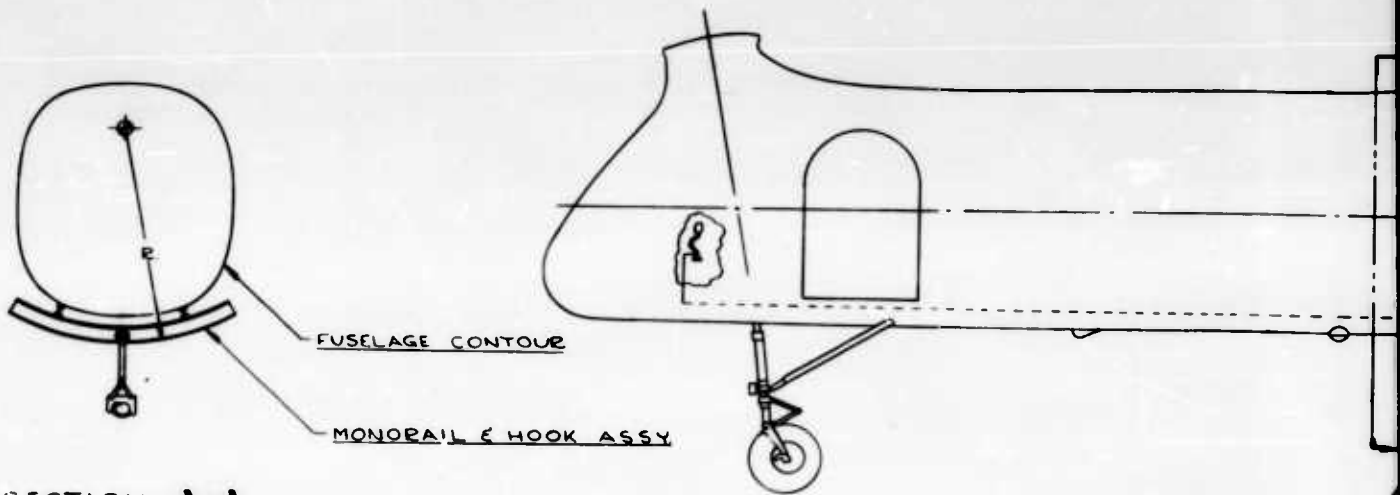

FUSELAGE CONTOUR

MONORAIL & HOOK ASSY

SECTION A-A

SHOWN WITH NET REMOVED

1

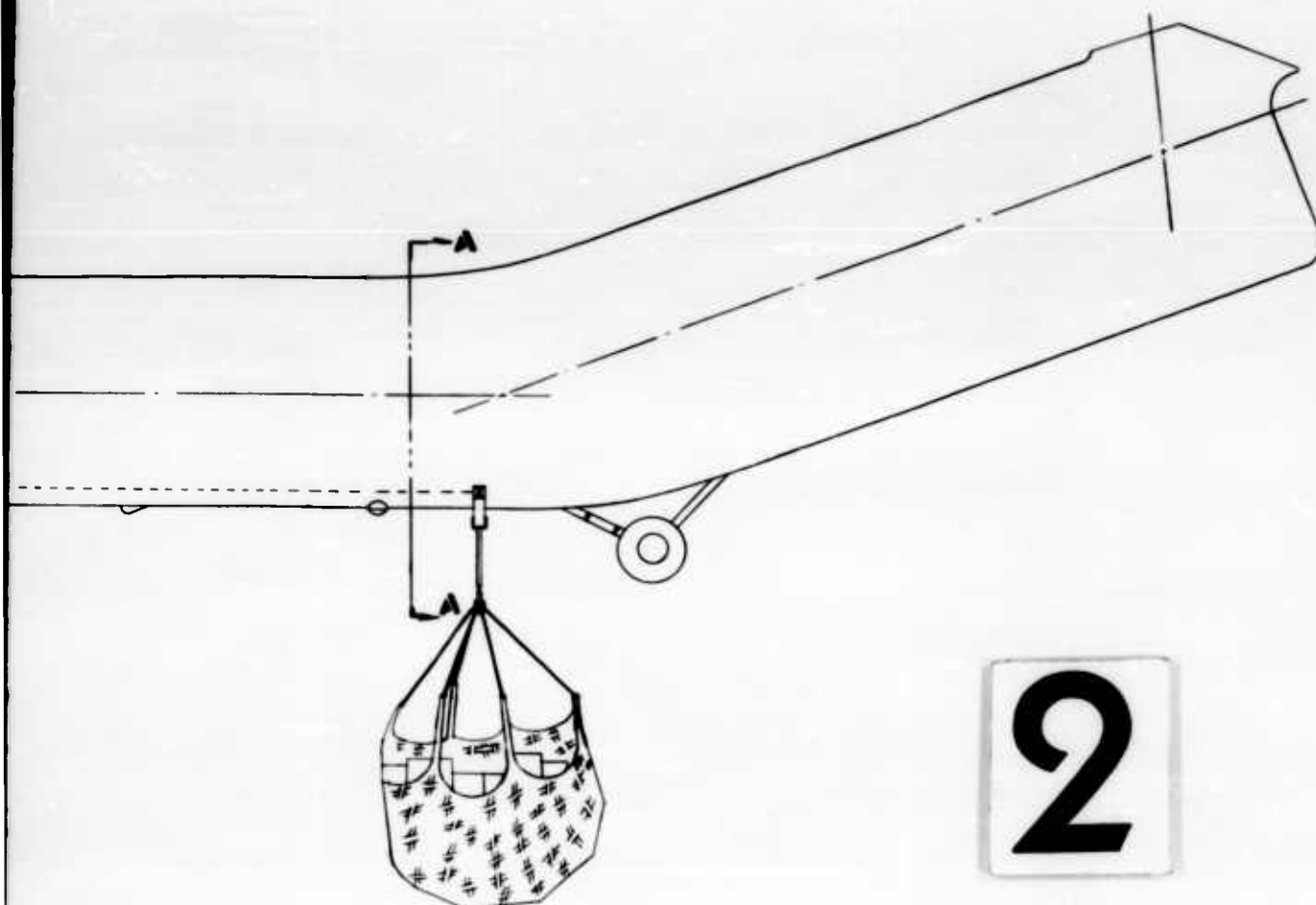

2

PRINT REDUCED
ONE-THIRD
INDICATED SCALE

FIGURE IV

	PROPOSAL FOR	Air Force Corporation
	IMPROVED CARGO	
	HAND SYSTEM	
CONFIG IV	SK9424	
SCALE 1:20	1 OF 1	

NOT DRAWN TO SCALE. DIMENSIONS ARE
FOR INFO. ONLY. DIMENSIONS OF THE
AND ONLY FOR REFERENCE PURPOSES. ALL
DIMENSIONS ARE IN INCHES. ALL DIMENSIONS
OF THE 1/2" UNLESS OTHERWISE SPECIFIED.
CONSTRUCTION OF DRAWING IS APPROVED.

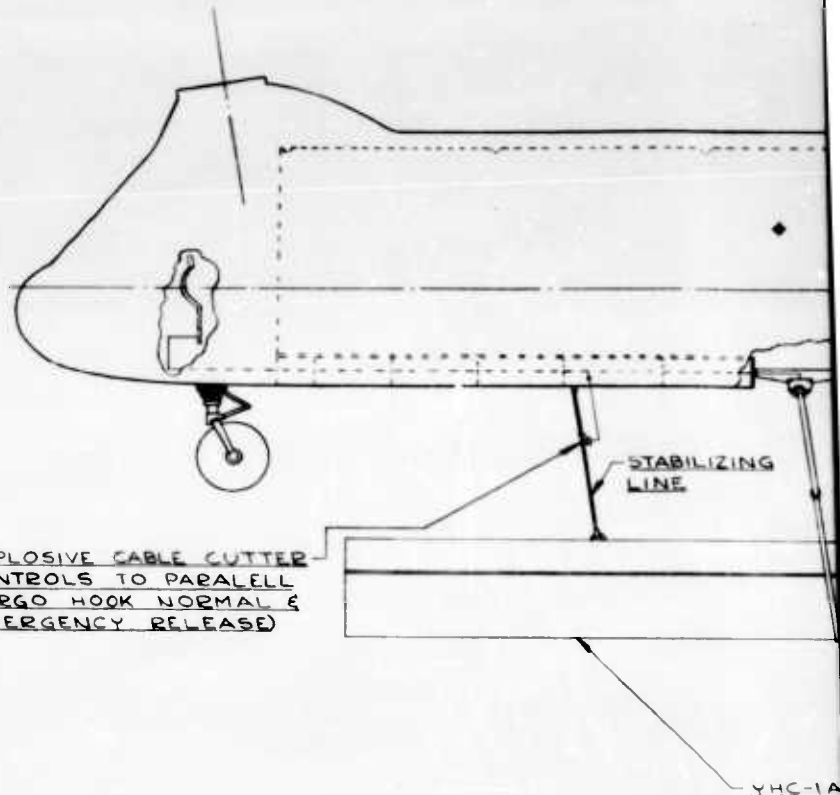

EXPLOSIVE CABLE CUTTER
(CONTROLS TO PARALELL
CARGO HOOK NORMAL &
EMERGENCY RELEASE)

STABILIZING
LINE

YHC-1A

1

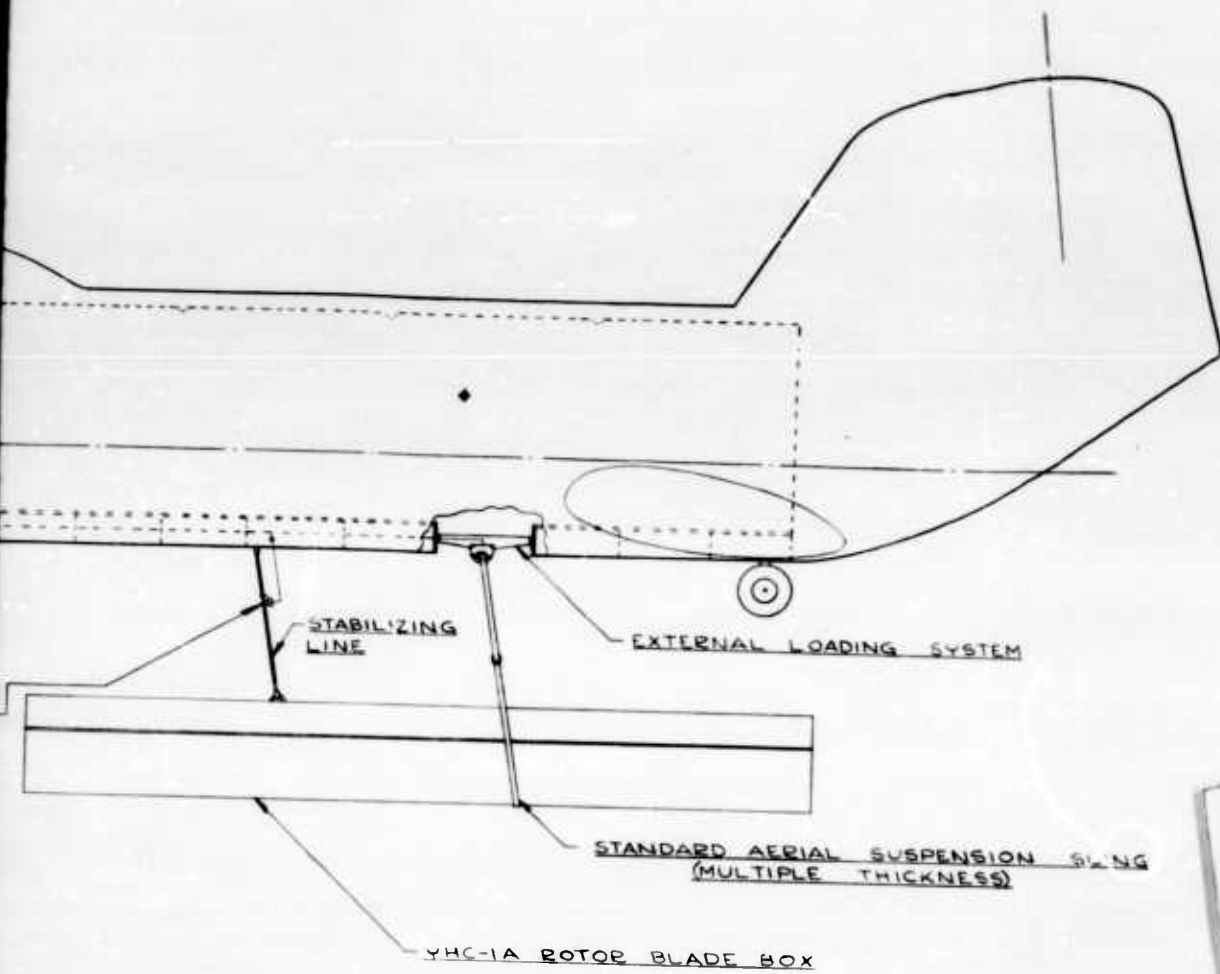

2

PRINT REDUCED
ONE-THIRD
INDICATED SCALE

FIGURE V

YHC-1A		
EXTERNAL LOAD CARRYING SYSTEM		
SCALE: 20' 1"		MODEL NUMBER SK9426

THIS DRAWING INCLUDES INFORMATION PROPRIETARY TO VERTIC AIRCRAFT CORPORATION AND SHALL NOT, WITHOUT PERMISSION OF VERTIC AIRCRAFT CORPORATION, BE USED OR REPLICATED BY ANYONE OTHER THAN AGENCIES OF THE U.S. GOVERNMENT ACTING PURSUANT TO CONTRACTUAL OR STATUTORY AUTHORIZATION

1

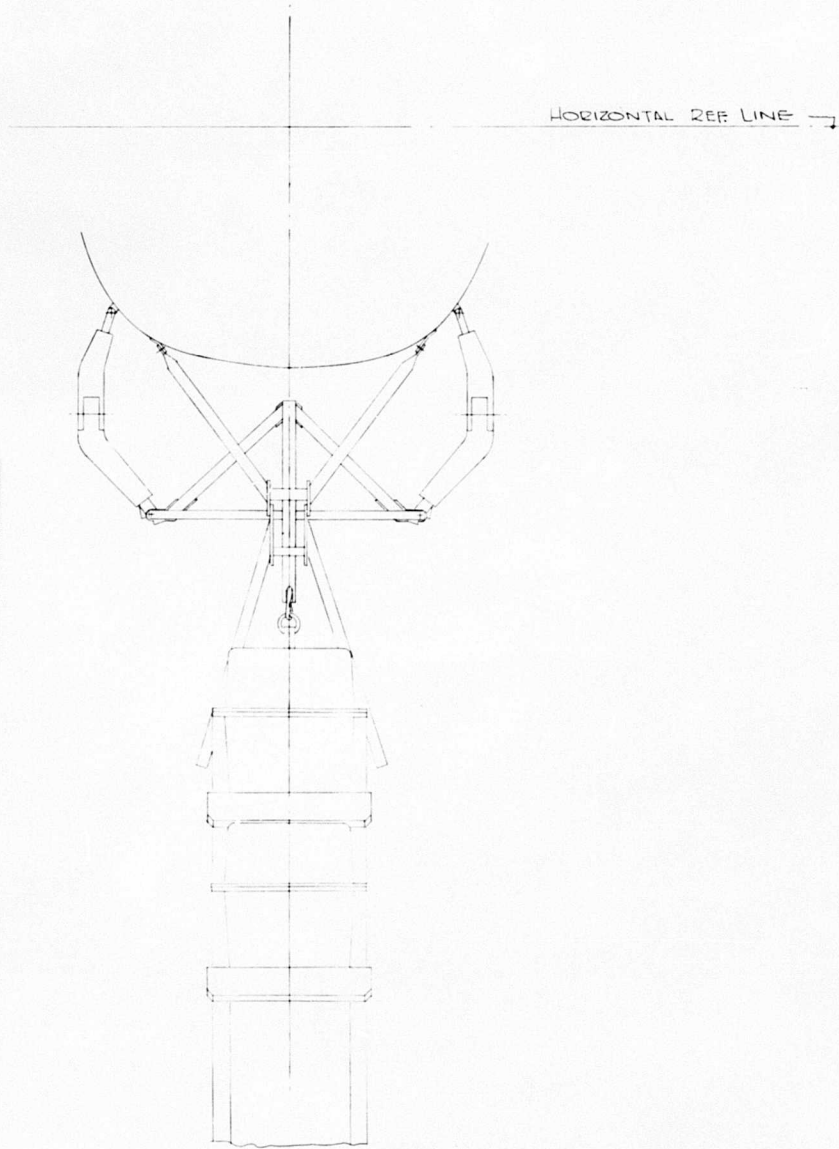

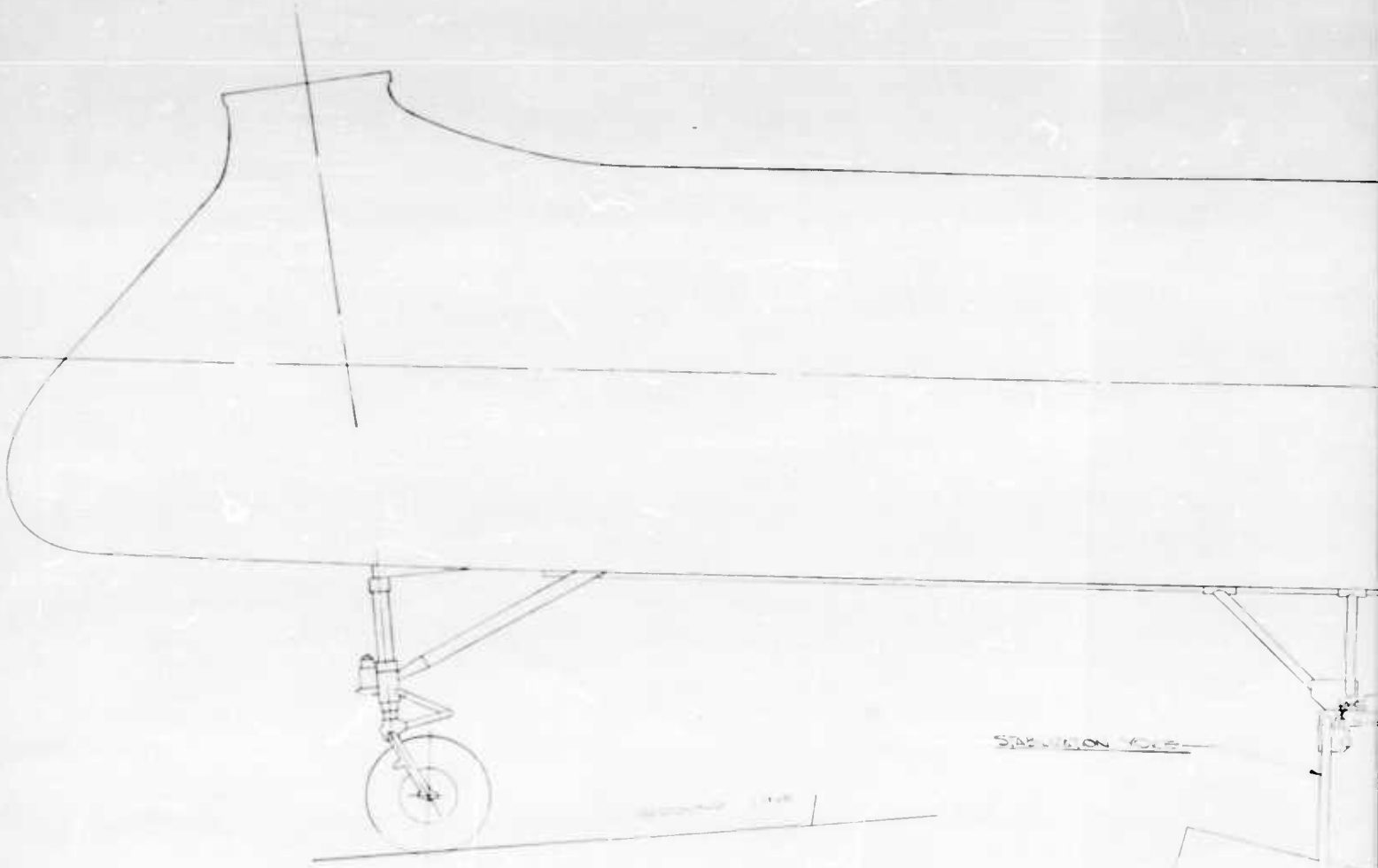

SECTION 10.3

2

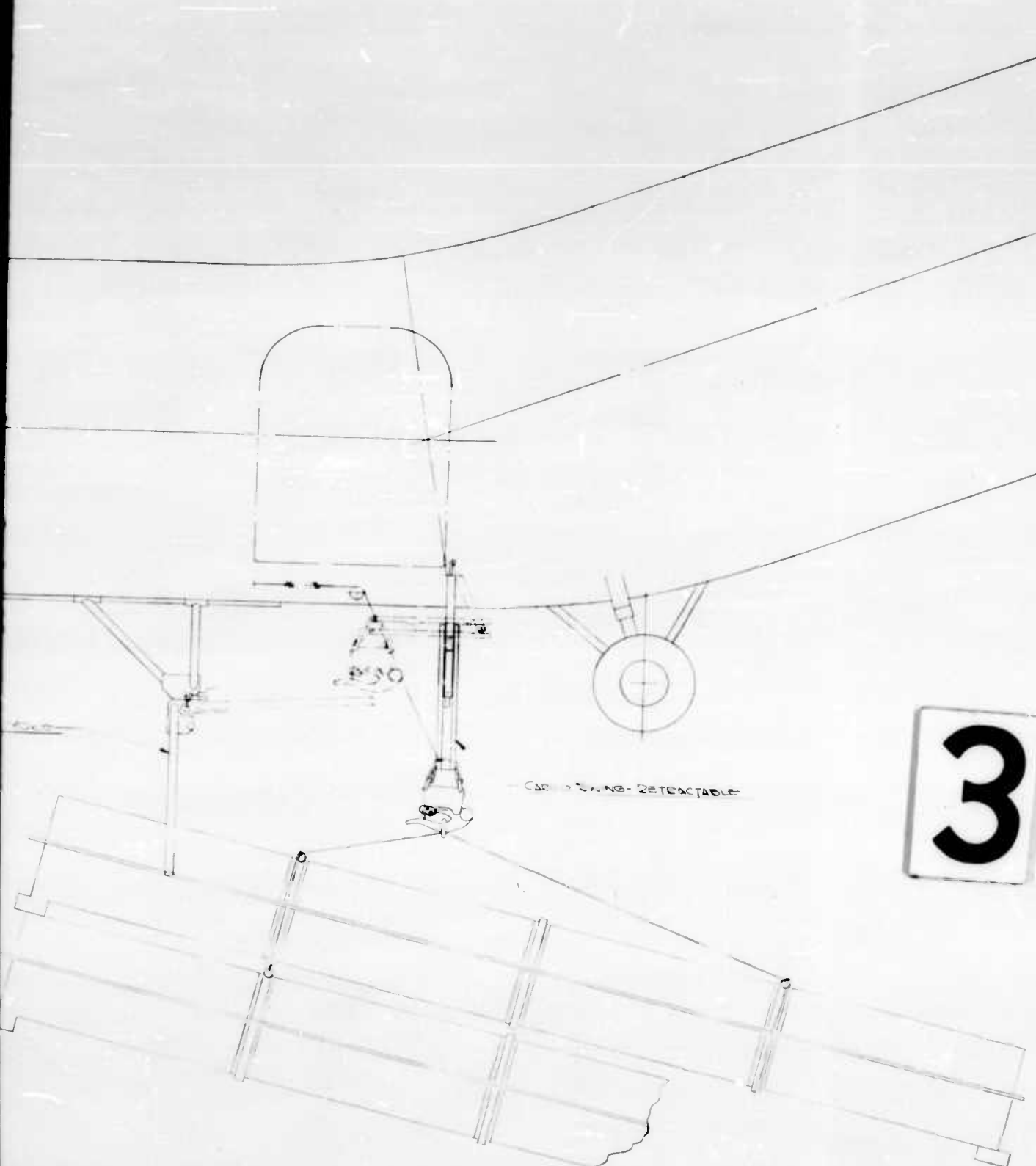

CARTRIDGE - RETRACTABLE

3

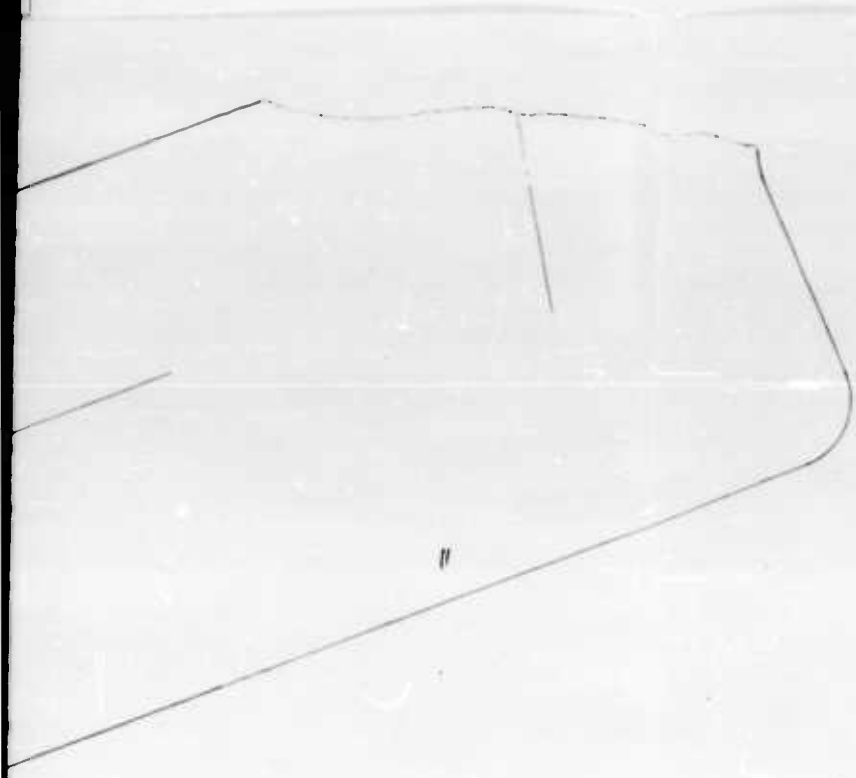

4

CARGO SWING AND STABILIZATION YOKE
FOR USE WITH U-21 HELICOPTER

**PRINT REDUCED
ONE - THIRD
INDICATED SCALE**

NO.	DATE	REVISED	BY	CHKD	CARGO SWING & STABILIZATION YOKE	<i>W. J. ...</i> <small>Aircraft Corporation</small>
REVISIONS ON	REVISIONS ON	REVISIONS ON	REVISIONS ON	REVISIONS ON		
1. ...	2. ...	3. ...	4. ...	5. ...	SCALE: 1/3	DRAWN: <i>W. J. ...</i>

THE DRAWING INCLUDES DIMENSIONS AND
NOTES TO WHICH DRAWING CONSTRUCTION
AND DIMENSIONS OF THE DRAWING
AND DIMENSIONS OF THE DRAWING
AND DIMENSIONS OF THE DRAWING
AND DIMENSIONS OF THE DRAWING

1

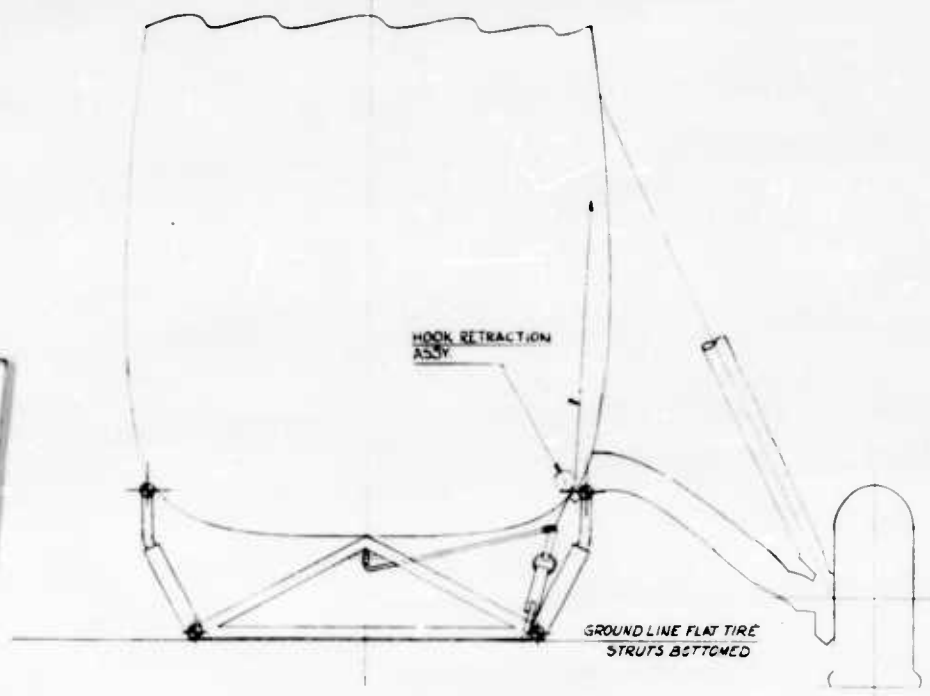

VIEW LOOKING AFT
CARGO SWING RETRACTED

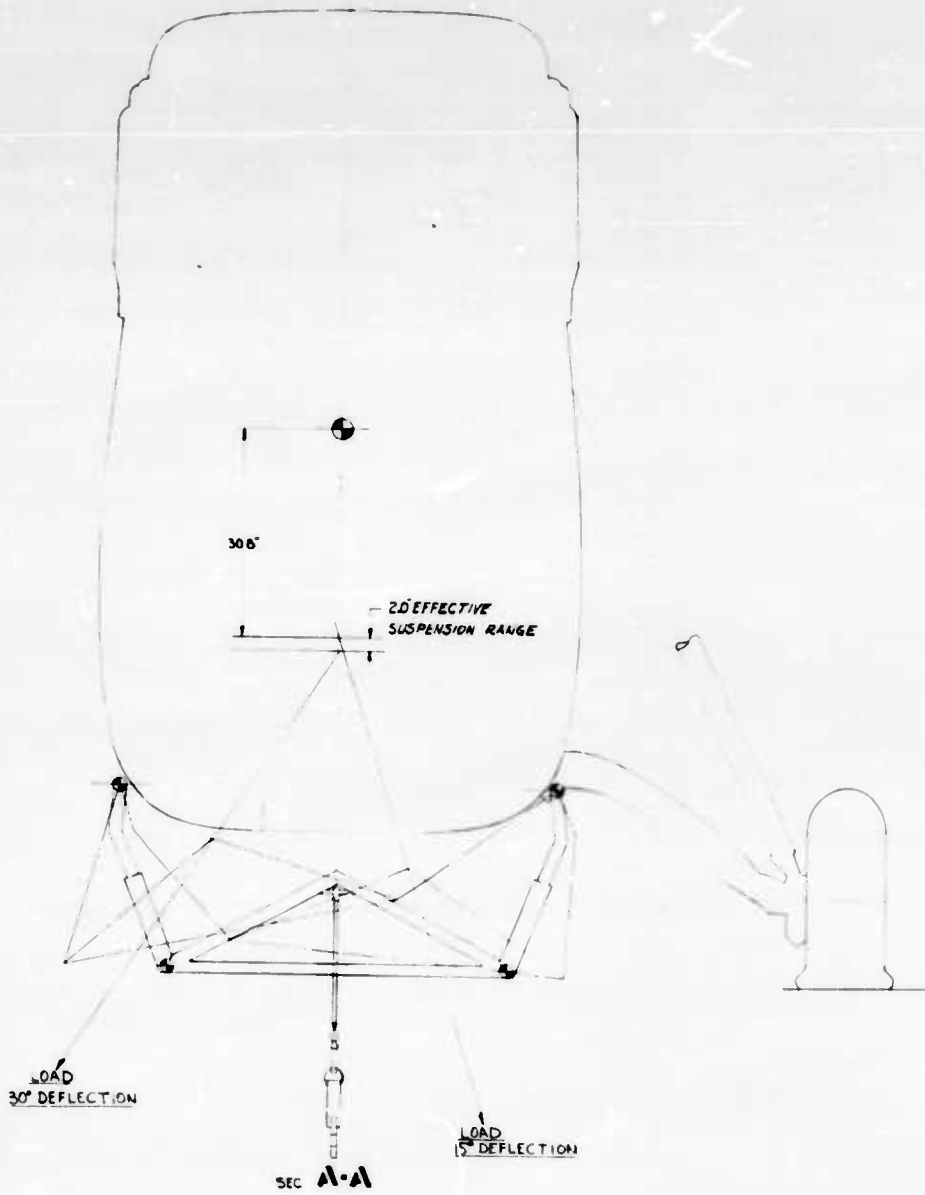

2

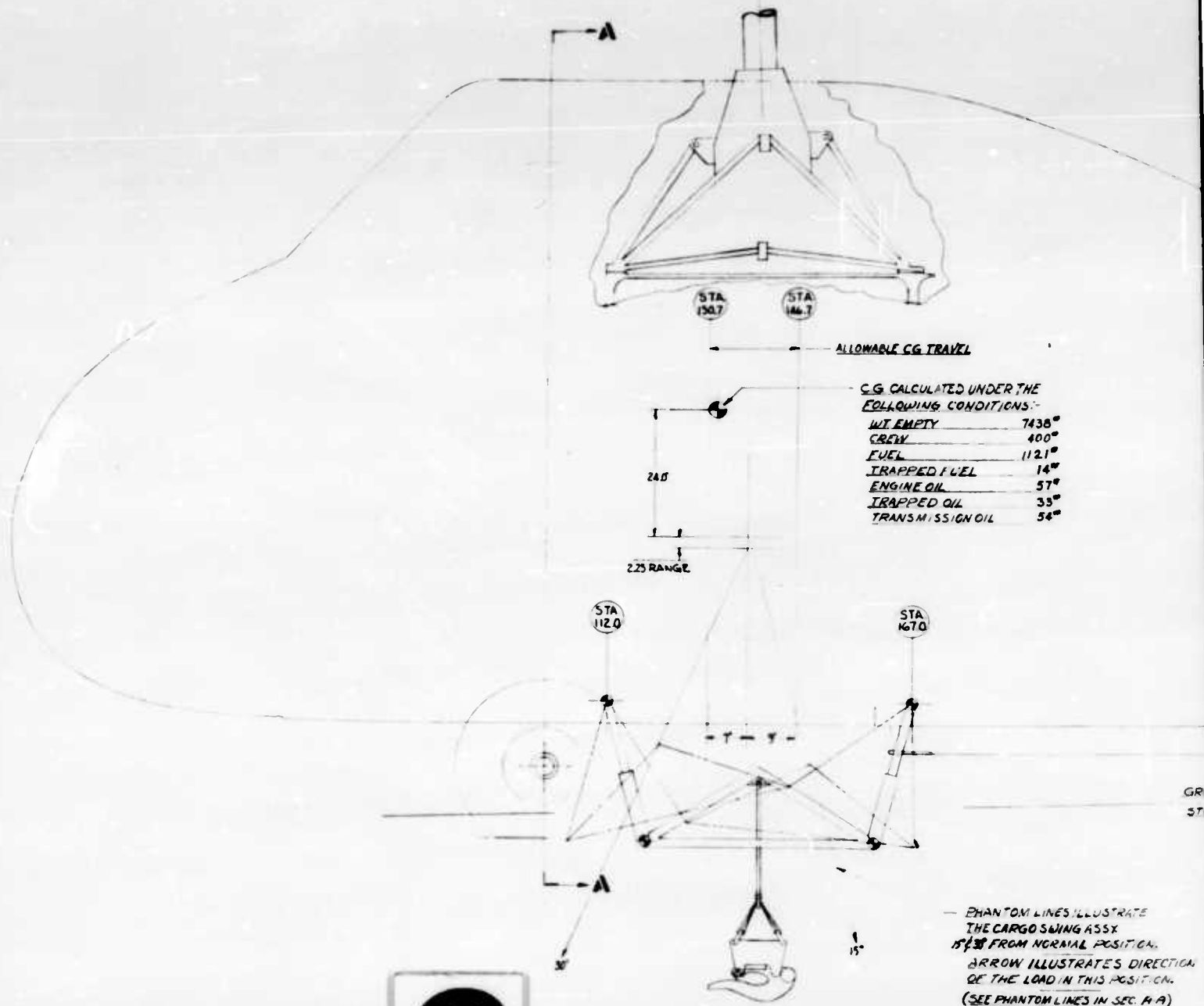

3

4

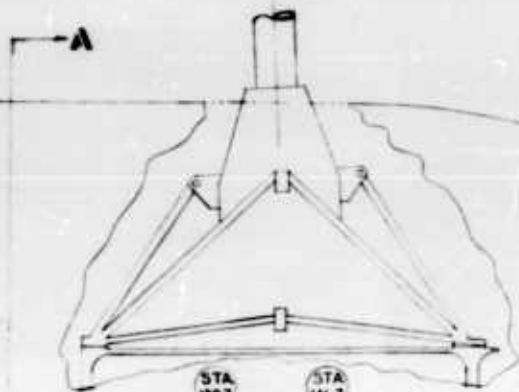

STA 1307

STA 1467

ALLOWABLE CG TRAVEL

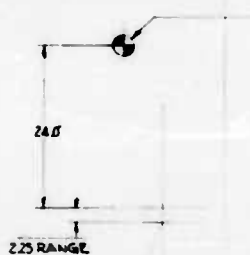

CG CALCULATED UNDER THE FOLLOWING CONDITIONS:

WT EMPTY	7438 ⁰⁰
CREW	400 ⁰⁰
FUEL	1121 ⁰⁰
TRAPPED FUEL	14 ⁰⁰
ENGINE OIL	57 ⁰⁰
TRAPPED OIL	33 ⁰⁰
TRANSMISSION OIL	54 ⁰⁰

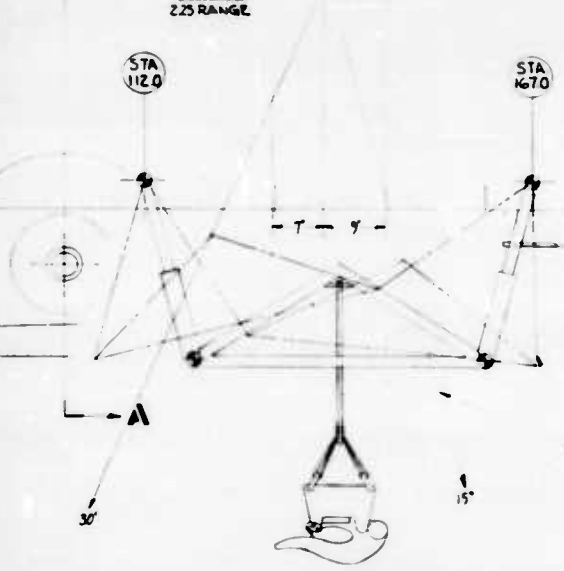

GROUND LINE - FLAT TIRE
STRUTS BOTTOMED

PHANTOM LINES ILLUSTRATE THE CARGO SWING ASX 15° FROM NORMAL POSITION. ARROW ILLUSTRATES DIRECTION OF THE LOAD IN THIS POSITION. (SEE PHANTOM LINES IN SEC. A A)

**PRINT REDUCED
ONE - THIRD
INDICATED SCALE**

<table border="1"> <tr><td> </td><td> </td><td> </td><td> </td></tr> <tr><td> </td><td> </td><td> </td><td> </td></tr> <tr><td> </td><td> </td><td> </td><td> </td></tr> <tr><td> </td><td> </td><td> </td><td> </td></tr> </table>																	STUDY OF IMPROVED HELICOPTER SLING LOAD CAPABILITIES - H-34 DOUBLE AXIS CARGO SWING	5K-9468 5K-9468

FOR OFFICIAL USE ONLY
THIS DOCUMENT IS UNCLASSIFIED
DATE 08-14-2011 BY 60324
AUTHORITY 48 CFR 1.101-11.6
UNCLASSIFIED//FOR OFFICIAL USE ONLY

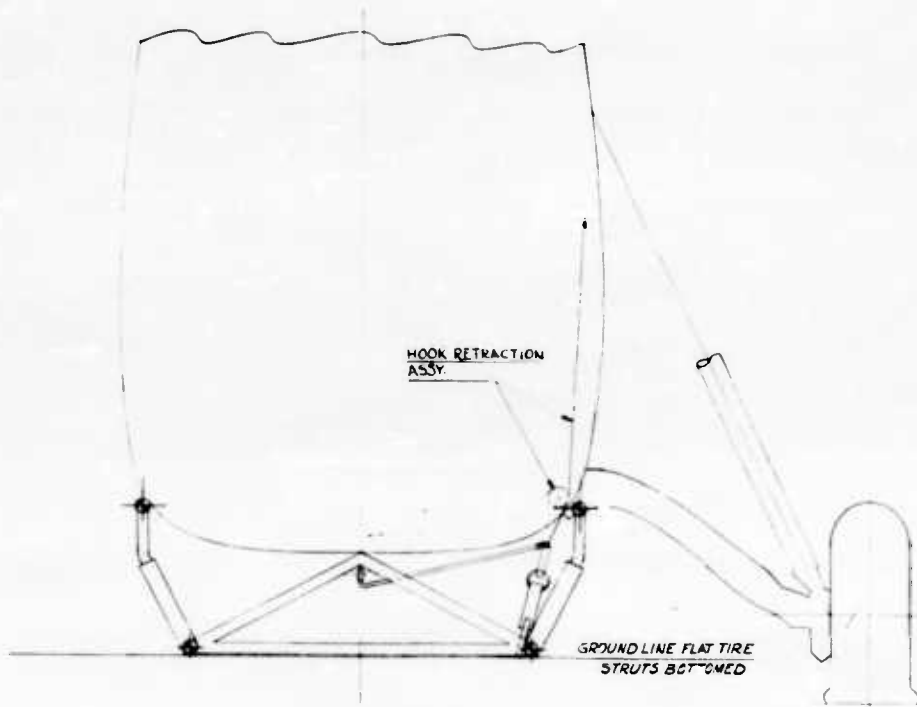

HOOK RETRACTION
ASSY.

GROUND LINE FLAT TIRE
STRUTS BOTTOMED

VIEW LOOKING AFT
CARGO SWING RETRACTED

1

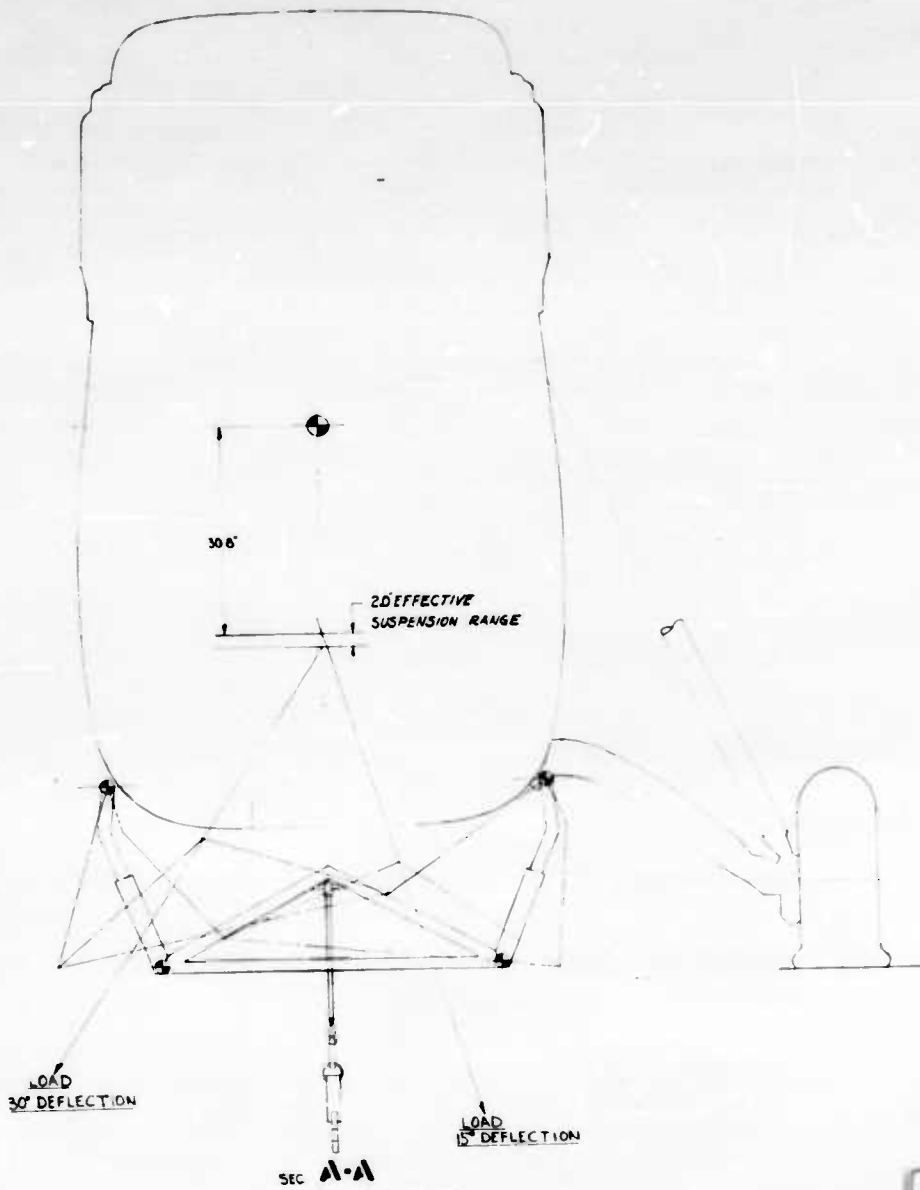

2

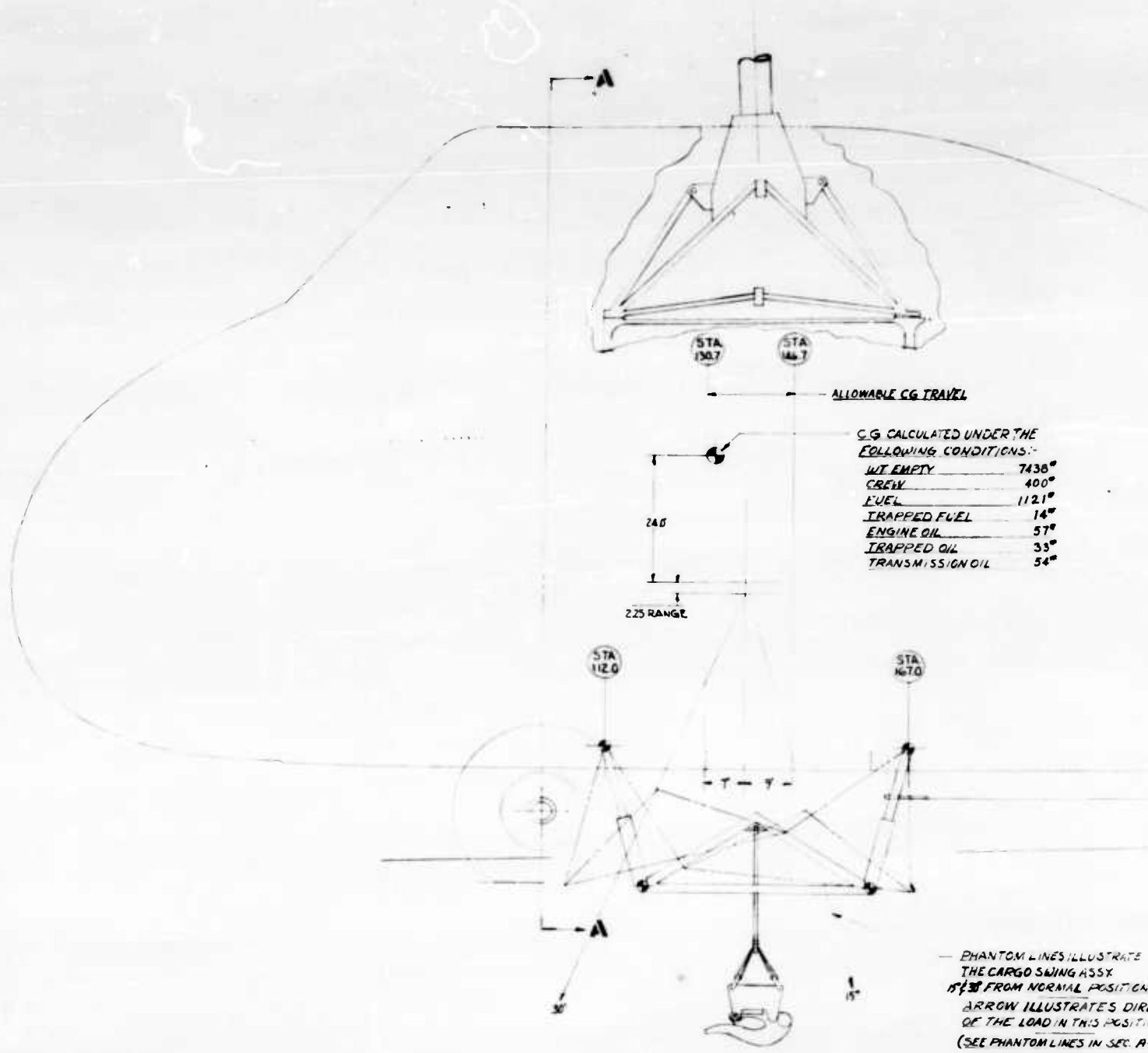

3

4

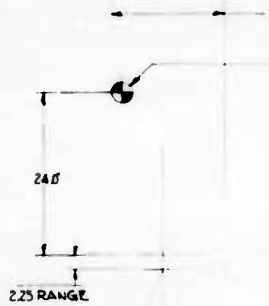
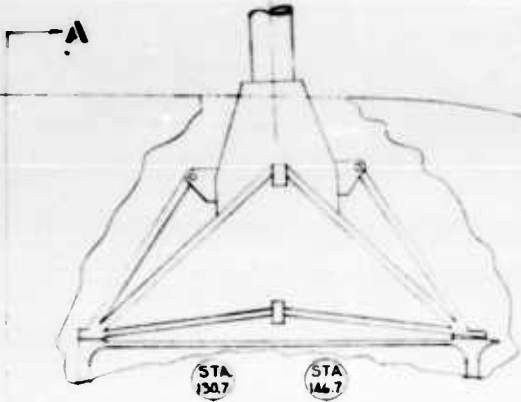

C.G. CALCULATED UNDER THE FOLLOWING CONDITIONS:

WT EMPTY	7436 ⁰⁰
CREW	400 ⁰⁰
FUEL	1121 ⁰⁰
TRAPPED FUEL	14 ⁰⁰
ENGINE OIL	57 ⁰⁰
TRAPPED OIL	33 ⁰⁰
TRANSMISSION OIL	54 ⁰⁰

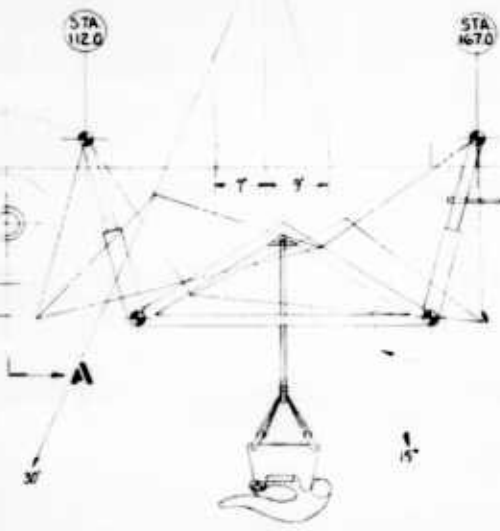

PHANTOM LINES ILLUSTRATE THE CARGO SWING ASSY 15° FROM NORMAL POSITION. ARROW ILLUSTRATES DIRECTION OF THE LOAD IN THIS POSITION. (SEE PHANTOM LINES IN SEC. A. A)

PRINT REDUCED
ONE - THIRD
INDICATED SCALE

STUDY OF IMPROVED HELICOPTER SLING LOAD CAPABILITIES - H-34 DOUBLE AXIS CARGO SWING	5K-9468
---	---------

THIS DRAWING IS UNCLASSIFIED AND IS NOT TO BE RELEASED TO THE PUBLIC WITHOUT THE WRITTEN AUTHORIZATION OF THE AIR FORCE OFFICE OF SPECIAL INVESTIGATION



SECTION A-A SHOWS CARGO SLING ON C

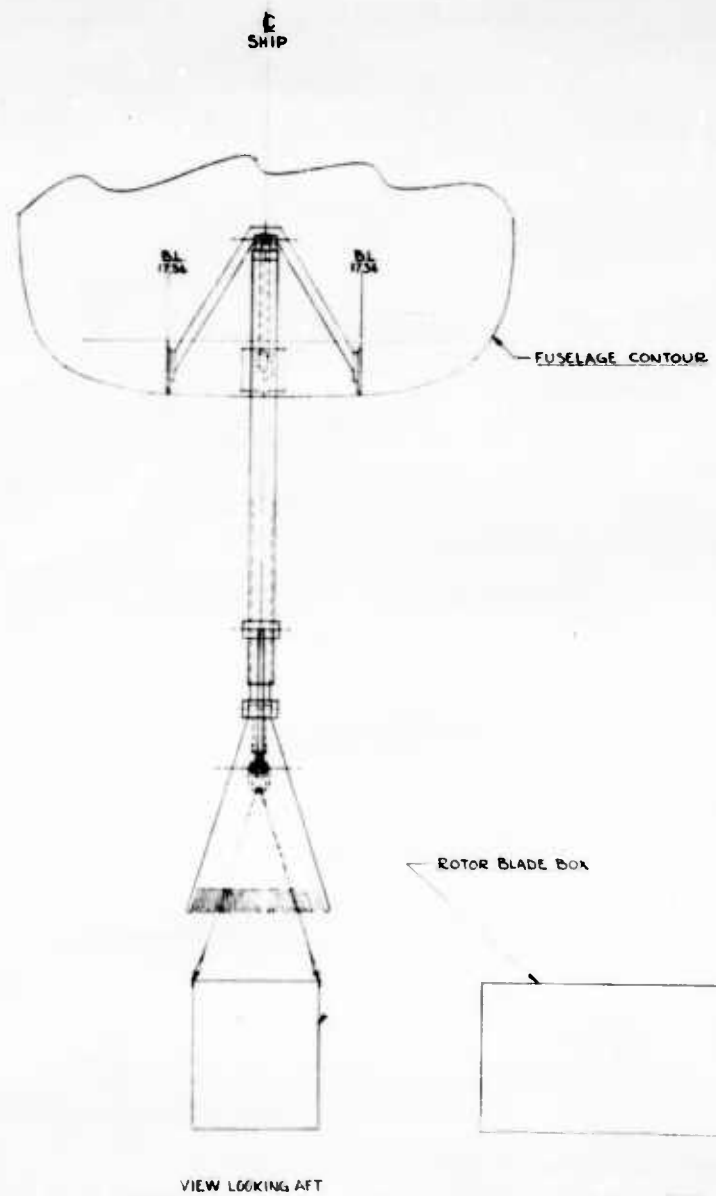

YORK

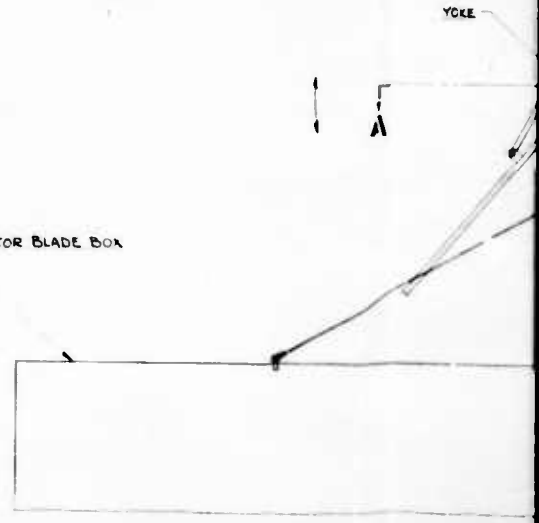

VIEW OF STABILIZING

1

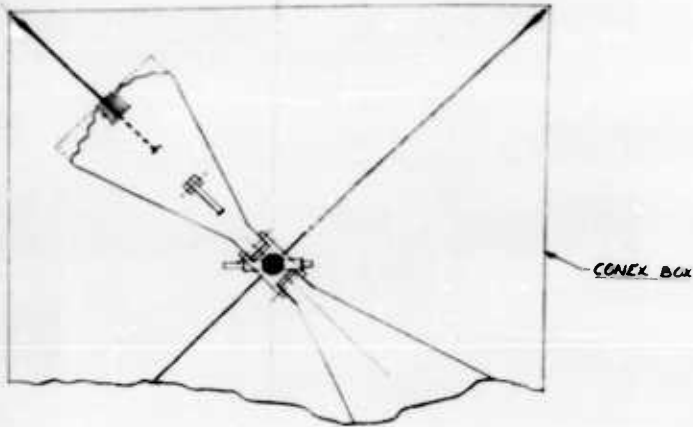

SECTION A-A SHOWING STABILIZER INDEXED 45° TO ACCOMMODATE CARGO SLING ON CONEX BOX

2

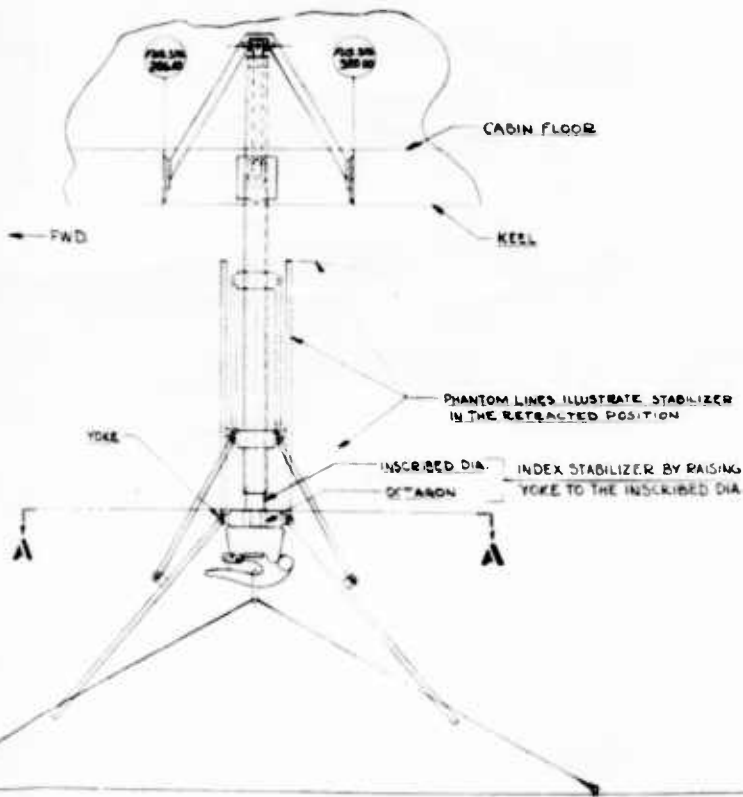

VIEW OF YHC-1A HATCH & CARGO STABILIZING DEVICE

PRINT REDUCED
ONE-THIRD
INDICATED SCALE

NO.	REV.	DATE	BY	CHKD.	DESCRIPTION	APPROVED
					STUDY OF IMPROVED HELICOPTER SLING LOAD CAPABILITIES - INTEGRAL CARGO	
					YHC-1A STABILIZER	
						5K-9469

THIS DRAWING AND USES OF INFORMATION HEREIN
ARE PRESENTED TO YOU BY THE AIR FORCE RESEARCH
AND DEVELOPMENT COMMAND (AFRDC) AND ARE NOT
TO BE REPRODUCED OR TRANSMITTED IN ANY FORM
OR BY ANY MEANS, ELECTRONIC OR MECHANICAL,
INCLUDING PHOTOCOPYING, RECORDING, OR BY
ANY INFORMATION STORAGE AND RETRIEVAL SYSTEM,
WITHOUT THE EXPRESS WRITTEN PERMISSION OF
THE AIR FORCE RESEARCH AND DEVELOPMENT COMMAND.

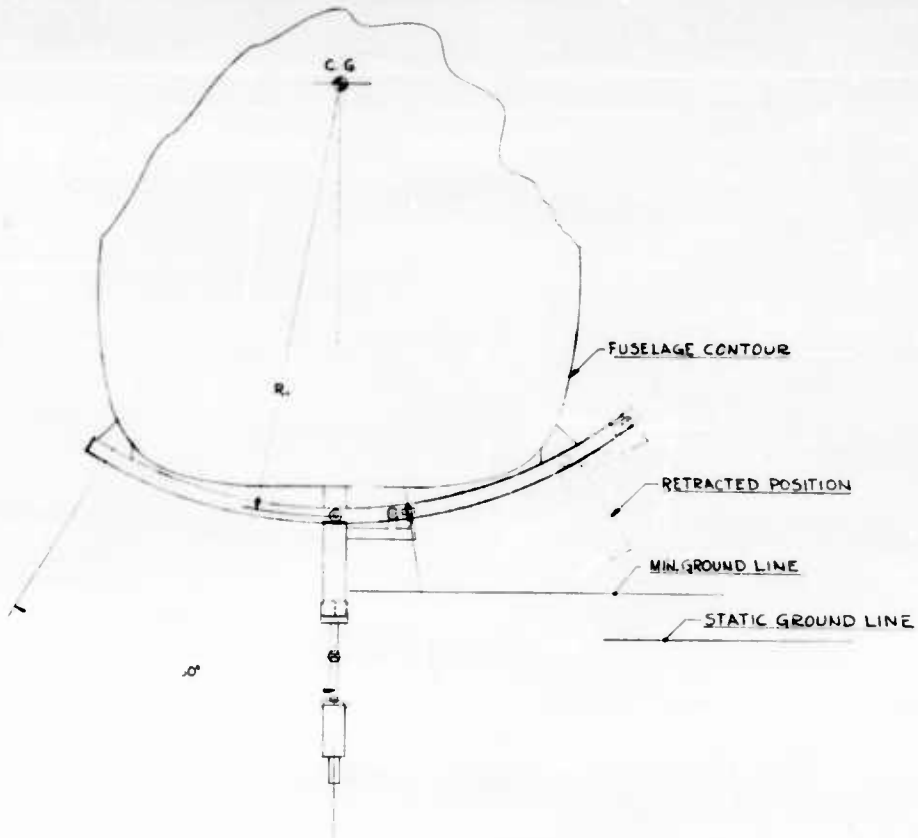

1

3

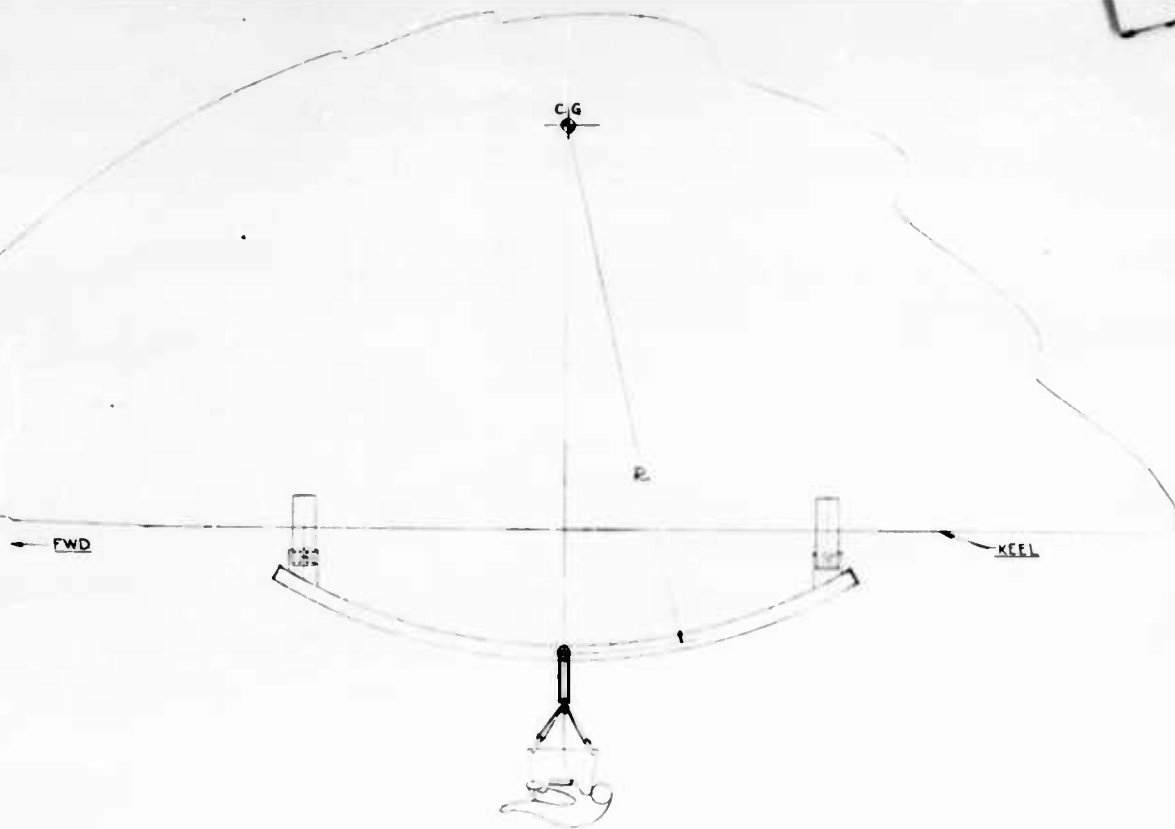

PRINT REDUCED
ONE-THIRD
INDICATED SCALE

NO.	DATE	STUDY OF IMPROVED HELICOPTER SLING LOAD CAPABILITIES - H-34 RADIUS RAIL	BY Aircraft Corporation
REV.	REV.		REVISION NUMBER
REV.	REV.		SK- 9501
REV.	REV.		REV.

THIS DRAWING INCLUDES INFORMATION FROM
THE AIR FORCE TO WHICH AIRCRAFT IS REFERRED
AND SHALL NOT BE REPRODUCED OR
REPRODUCED IN ANY MANNER WITHOUT THE
WRITTEN PERMISSION OF THE AIR FORCE
OR THE U.S. GOVERNMENT OR THE PROPRIETOR
OF THE PATENT OR TRADEMARK RIGHTS

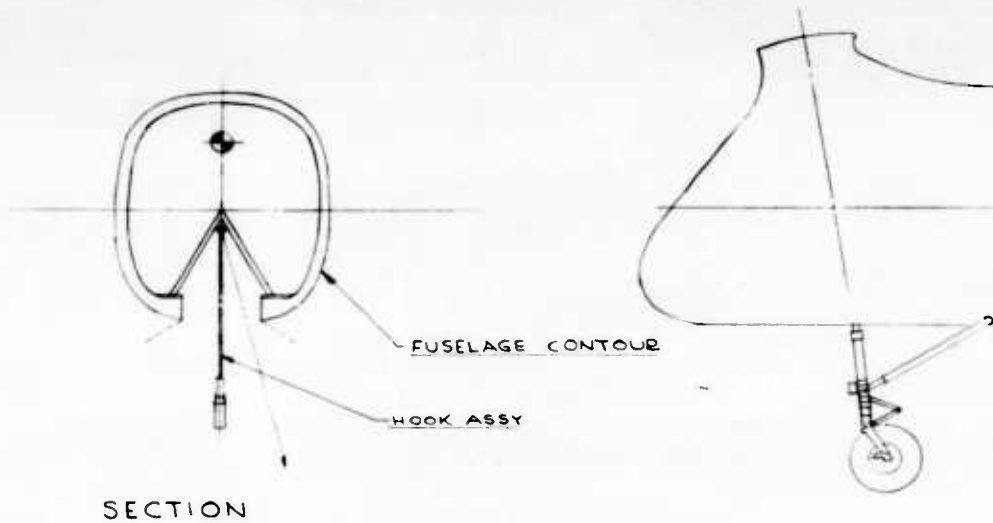

1

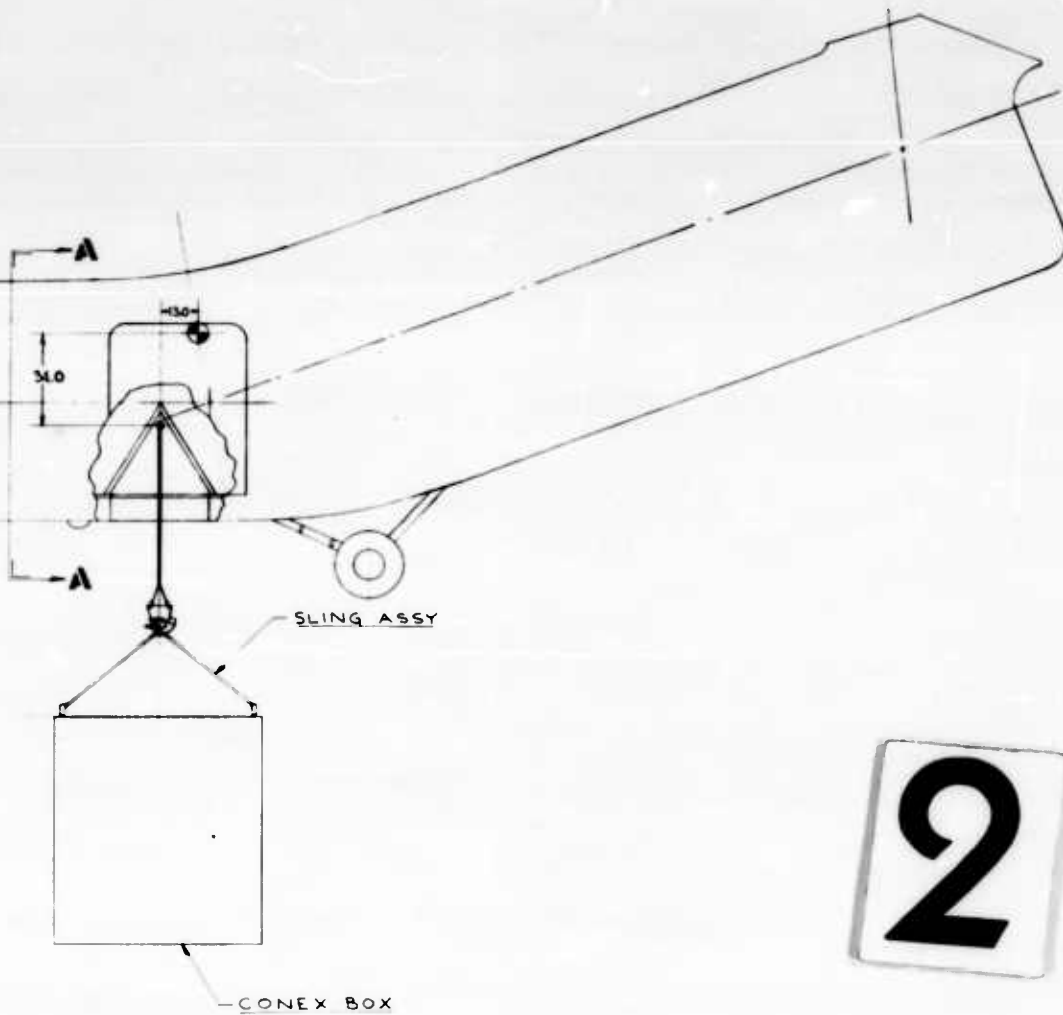

2

PRINT REDUCED
ONE - THIRD
INDICATED SCALE

STUDY OF IMPROVED	✓	Army
HELICOPTER SLING		Contract
LOAD CAPABILITIES		
H-21 WITH HATCH &		
INTERNAL DYNAMIC		OK-9502
1970		

ALL INFORMATION CONTAINED HEREIN IS UNCLASSIFIED EXCEPT WHERE SHOWN OTHERWISE BY A DATE AND AUTHORITY AS NOTED AT THE BOTTOM OF THIS PAGE.

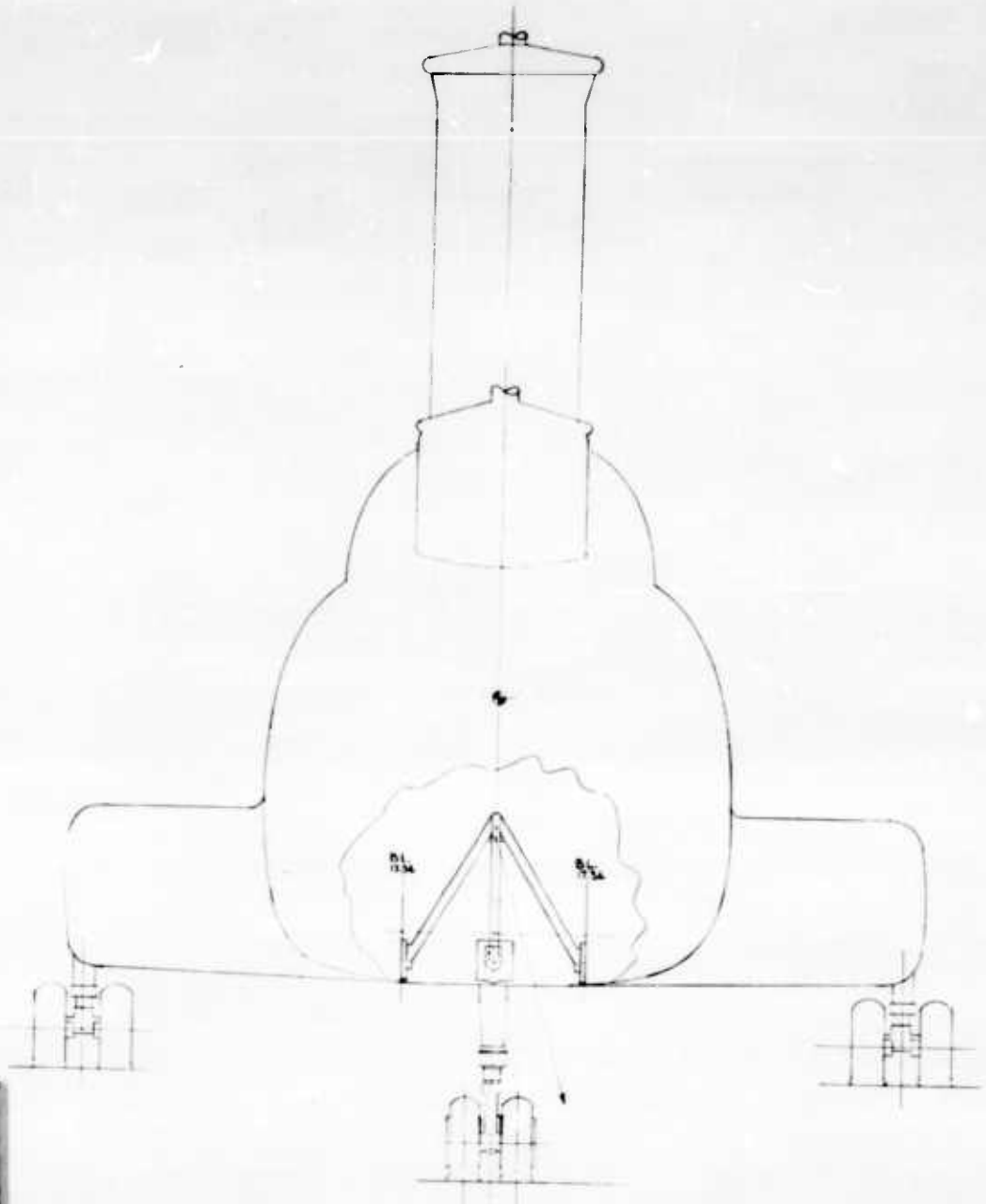

1

2

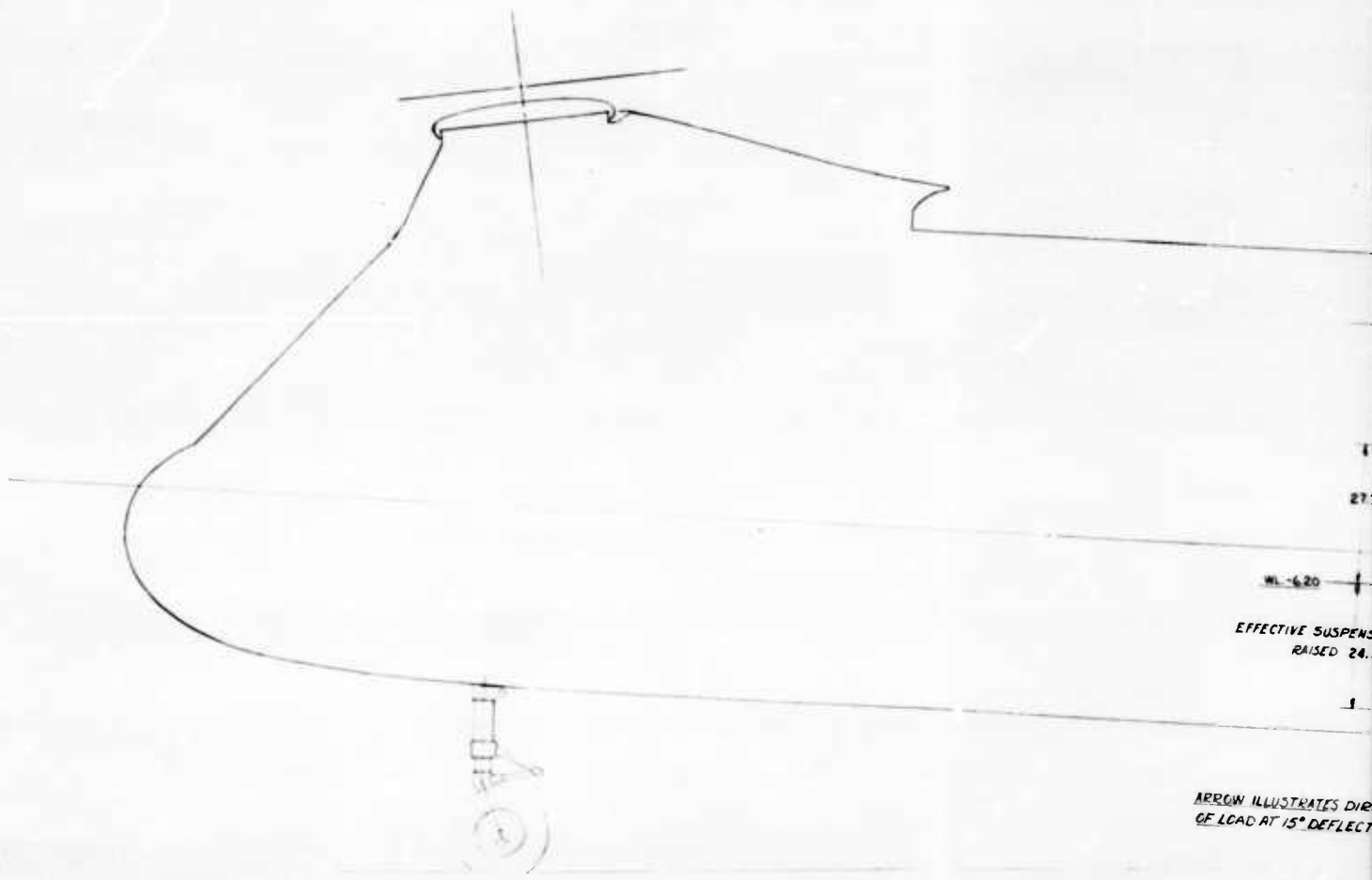

WL-620

EFFECTIVE SUSPENS
RAISED 24.5

ARROW ILLUSTRATES DIR
OF LOAD AT 15° DEFLECT

3

BETWEEN ROTORS

C.G. CALCULATED UNDER THE FOLLOWING CONDITIONS:

WEIGHT EMPTY	2080
CREW (3)	600
FUEL	1820
TRAPPED FUEL	17
TRAPPED OIL	10
TRANSMISSION OIL (INCLUDED IN WT EMPTY)	

273

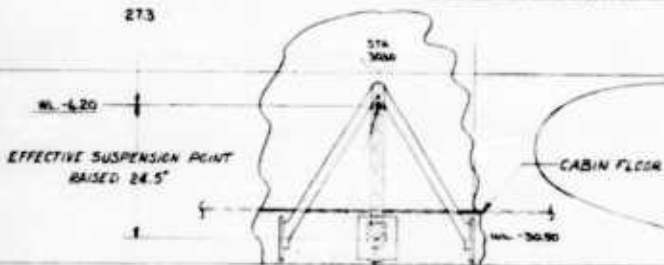

ARROW ILLUSTRATES DIRECTION OF LOAD AT 15° DEFLECTION

57A 300A

57A 300A

4

1045



CALCULATED UNDER THE
LOADING CONDITIONS:

NET EMPTY	2580
AV. CW	400
	1880
USED FUEL	17
USED OIL	10
MISSION C/L (INCLUDED IN NET EMPTY)	

PRINT REDUCED
ONE-THIRD
INDICATED SCALE

STUDY OF IMPROVED HELICOPTER SLING LOAD CAPABILITIES - YHC-1A INTERNAL	3K-9903
---	---------

THIS DRAWING IS THE PROPERTY OF THE AIR FORCE AND IS LOANED TO YOU BY THE AIR FORCE. IT IS TO BE USED ONLY FOR THE PURPOSES AUTHORIZED BY THE AIR FORCE. IT IS NOT TO BE REPRODUCED OR TRANSMITTED IN ANY FORM OR BY ANY MEANS, ELECTRONIC OR MECHANICAL, INCLUDING PHOTOCOPYING, RECORDING, OR BY ANY INFORMATION STORAGE AND RETRIEVAL SYSTEM.

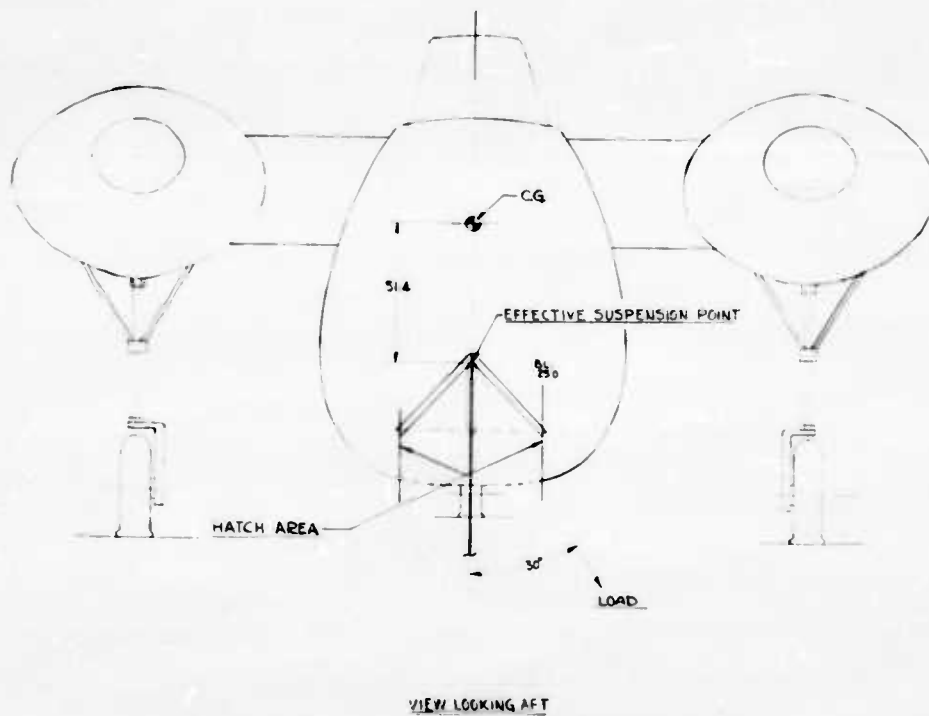
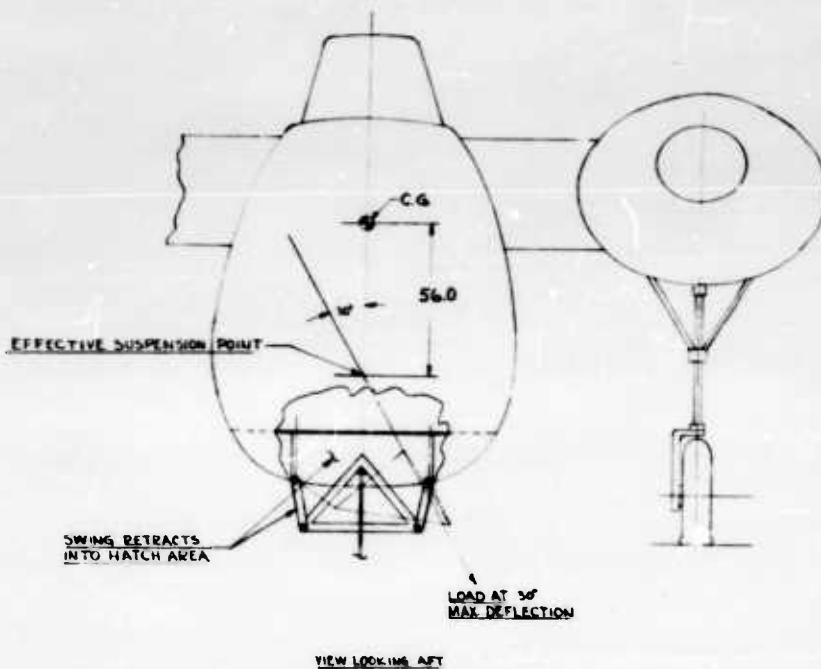

1

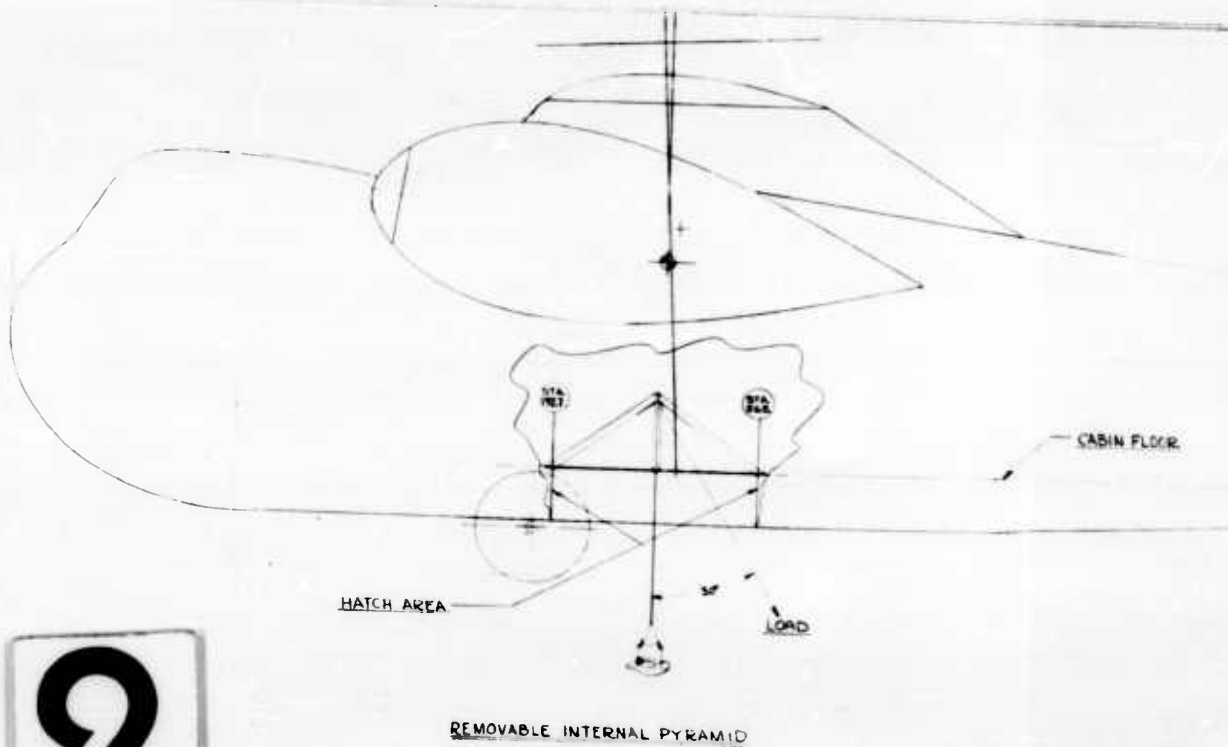
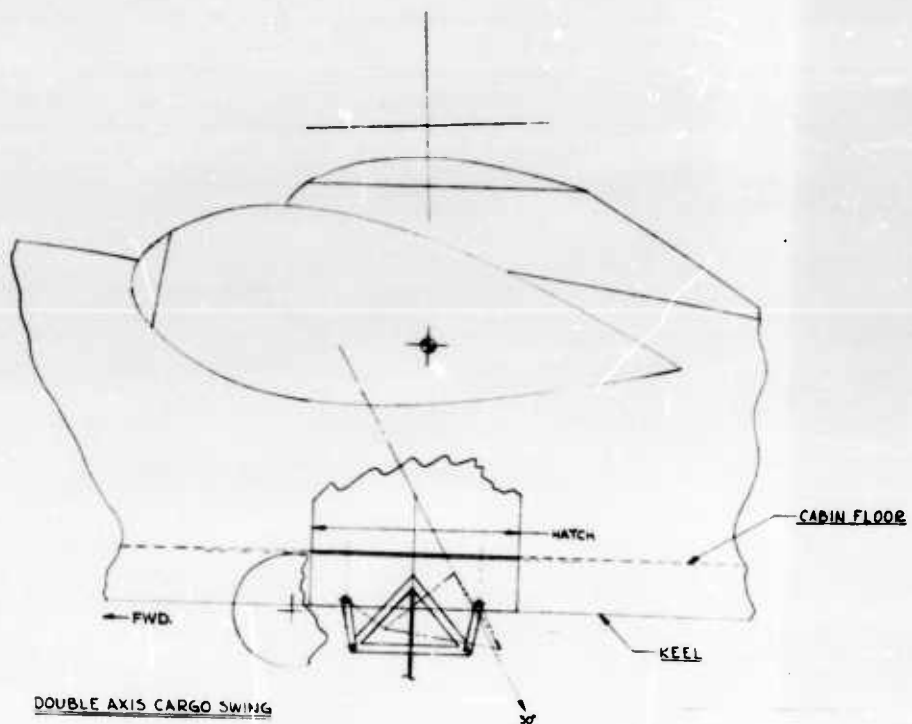

2

3

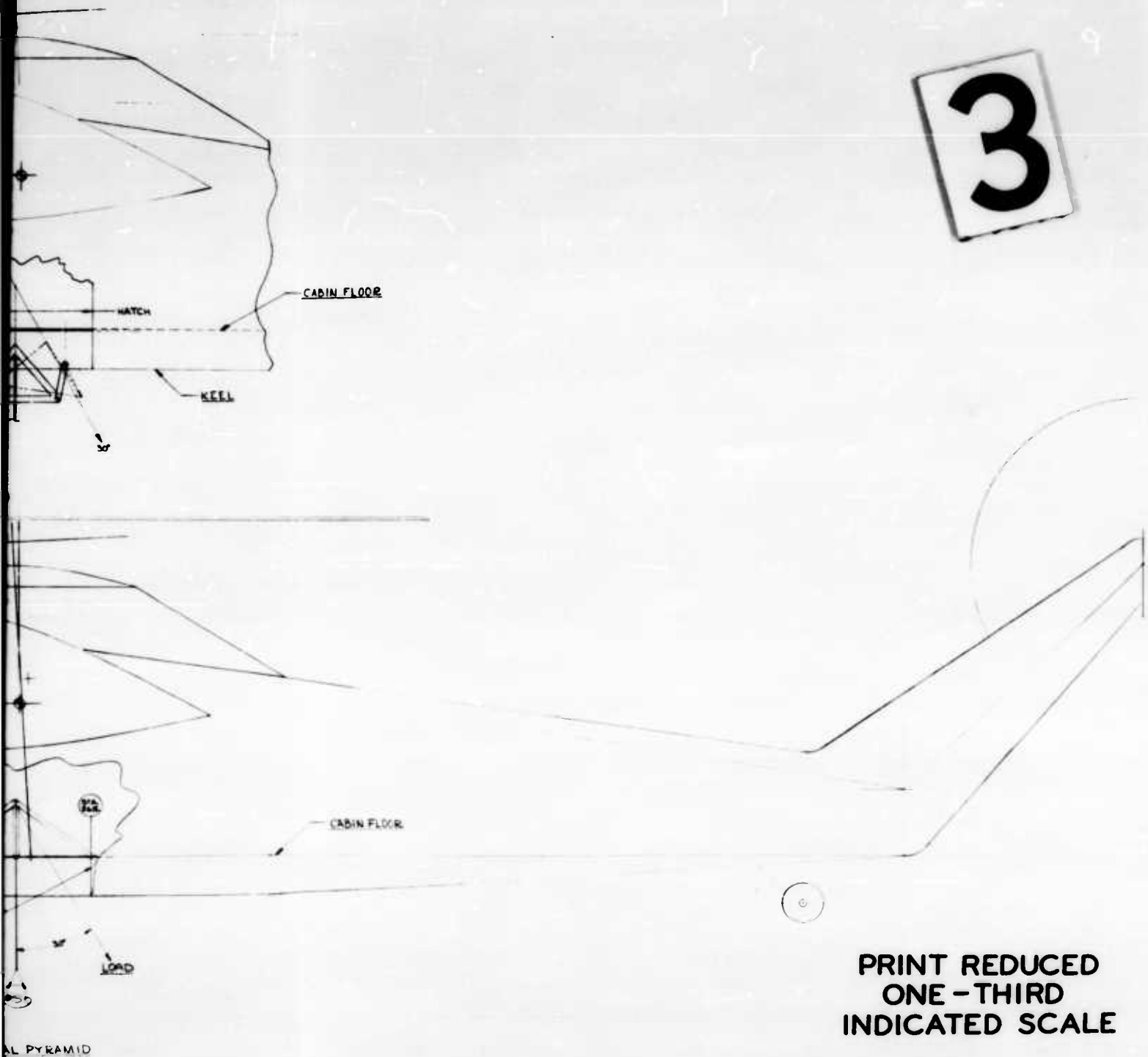

PRINT REDUCED
ONE - THIRD
INDICATED SCALE

STUDY OF IMPROVED HELICOPTER SLING LOAD CAPABILITIES - INTERNAL PYRAMID	ARMY RESEARCH OFFICE SK-9504
--	---------------------------------

THIS DRAWING, INCLUDING ALL DIMENSIONS AND NOTATIONS IS UNCLASSIFIED AND IS NOT TO BE RELEASED OR DISSEMINATED IN ANY MANNER WITHOUT THE WRITTEN AUTHORIZATION OF THE NATIONAL ARCHIVES AND RECORDS ADMINISTRATION.

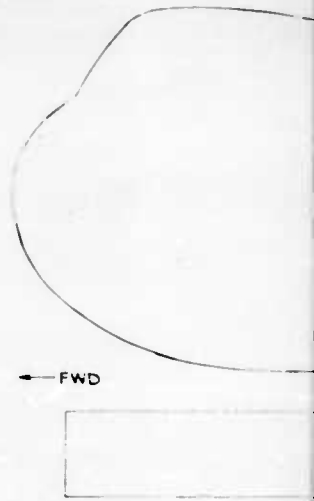
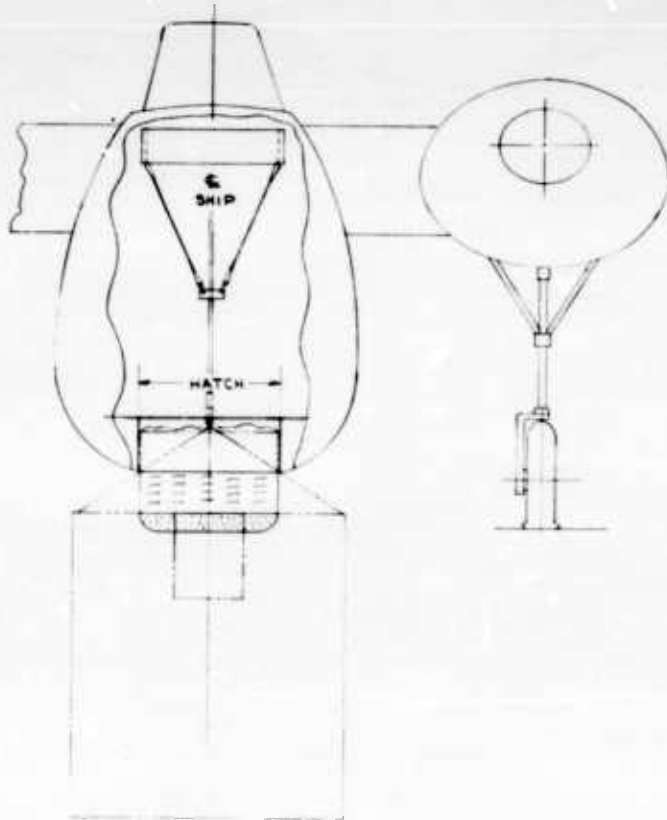

1

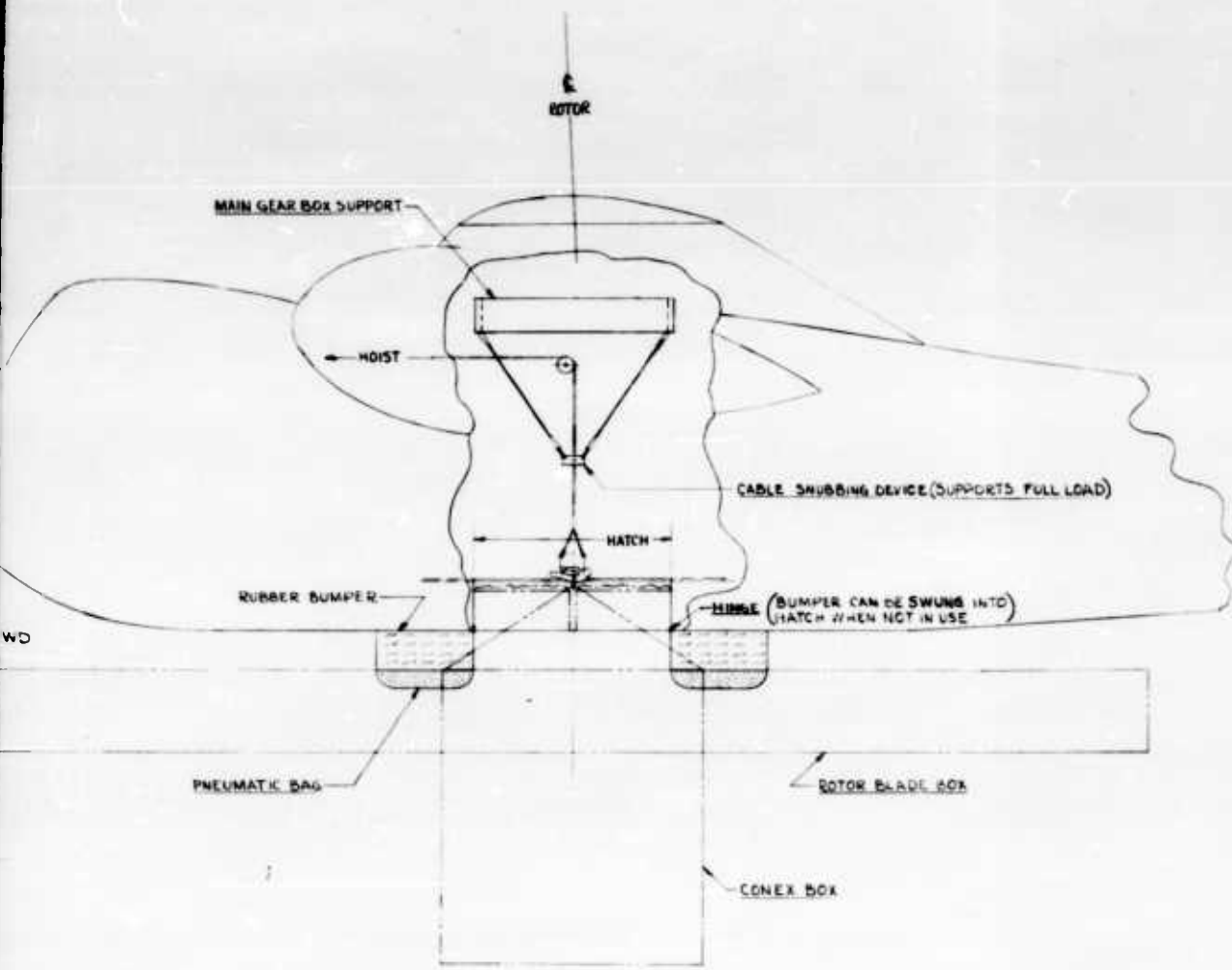

2

P
IN

↑
ROTOR

CABLE SNUBBING DEVICE (SUPPORTS FULL LOAD)

HATCH

-HINGE (BUMPER CAN BE SWUNG INTO HATCH WHEN NOT IN USE)

ROTOR BLADE BOX

-CONEX BOX

3

PRINT REDUCED
ONE - THIRD
INDICATED SCALE

NO.	DATE	STUDY OF IMPROVED HELICOPTER SLING LOAD CAPABILITIES - CENTRAL BUMPER STABILIZER	VEP/OL
REV.	REV.		Storage Component
DATE	REV.		5K-9505
REV.	REV.		

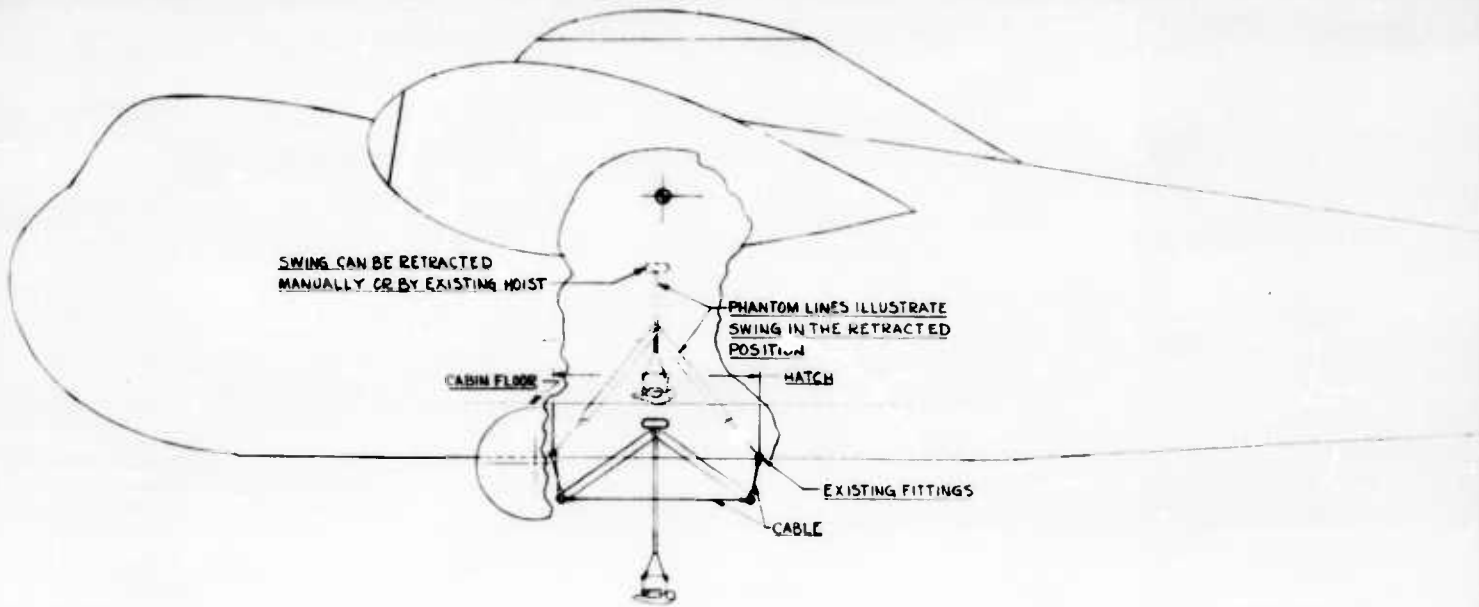

DOUBLE AXIS CARGO SWING - COLLAPSIBLE

2

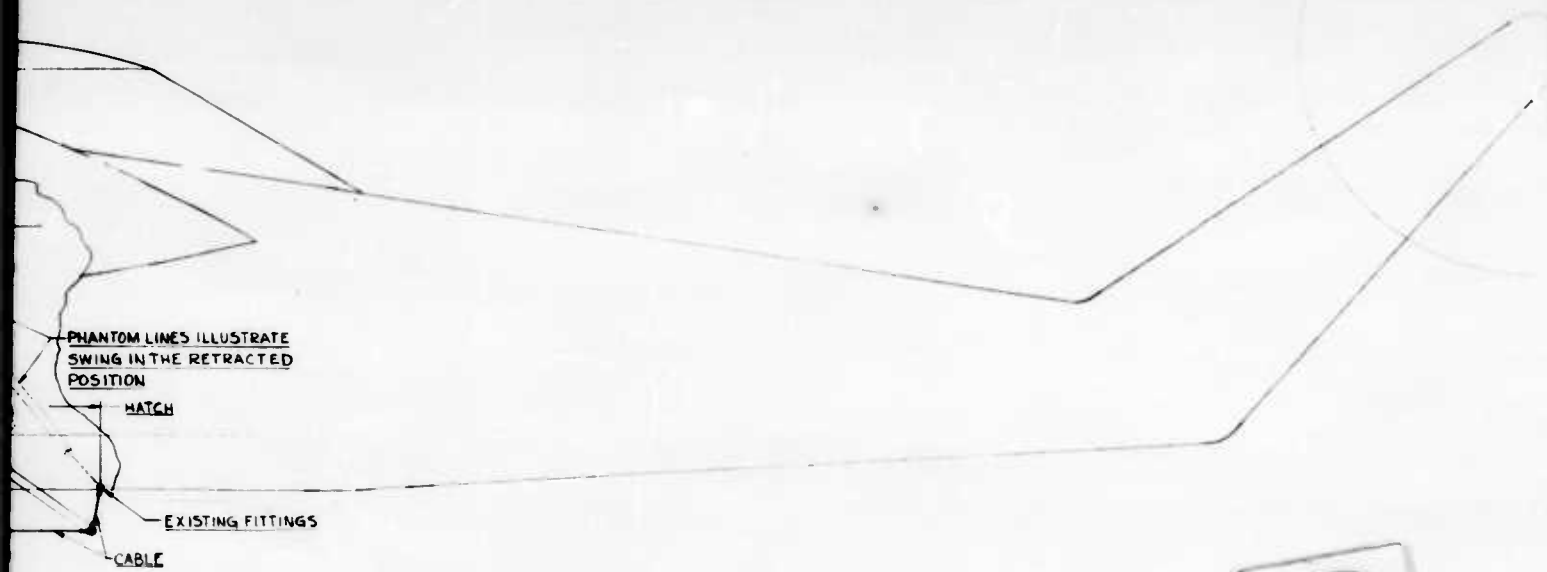

CARGO SWING - COLLAPSIBLE

3

PRINT REDUCED
ONE-THIRD
INDICATED SCALE

STUDY OF IMPROVED HELICOPTER SLING LEAD CAPABILITIES - H-37 DOUBLE AXIS CARGO SWING REVISED - 10	Army Experiment 5K-9506 1
---	---------------------------------

ALL DIMENSIONS ARE IN INCHES UNLESS OTHERWISE SPECIFIED.
DIMENSIONS ARE GIVEN IN PARENTHESES AFTER THE FIRST DIMENSION.
DIMENSIONS ARE GIVEN IN PARENTHESES AFTER THE FIRST DIMENSION.
DIMENSIONS ARE GIVEN IN PARENTHESES AFTER THE FIRST DIMENSION.

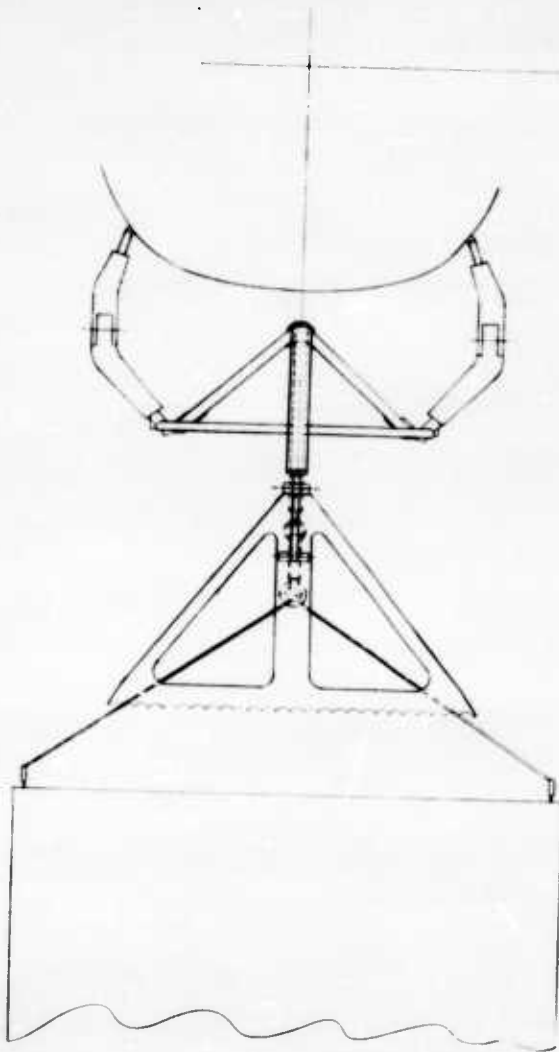

HORIZONTAL REF LINE →

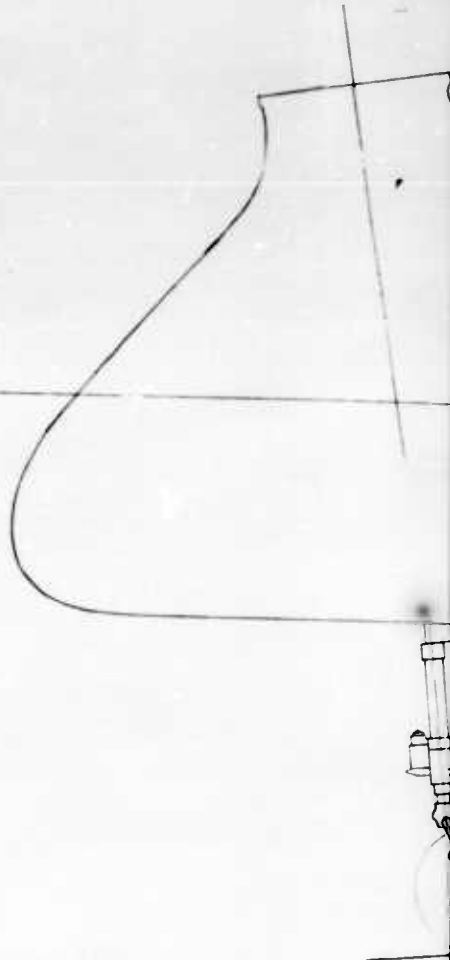

1

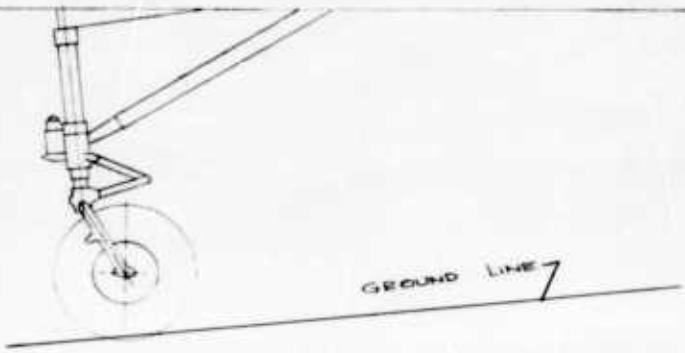

STABILIZER - HYDRAULIC OPERATED

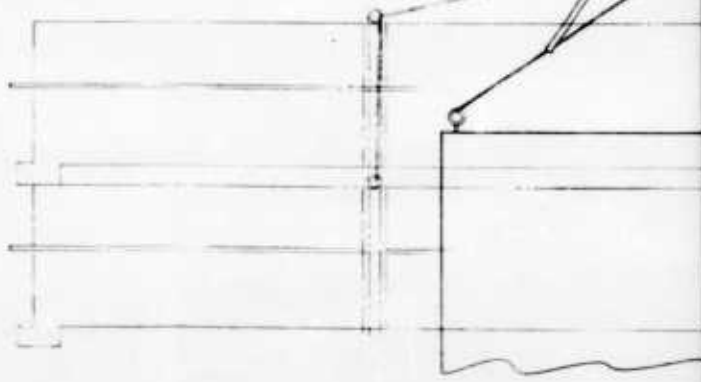

2

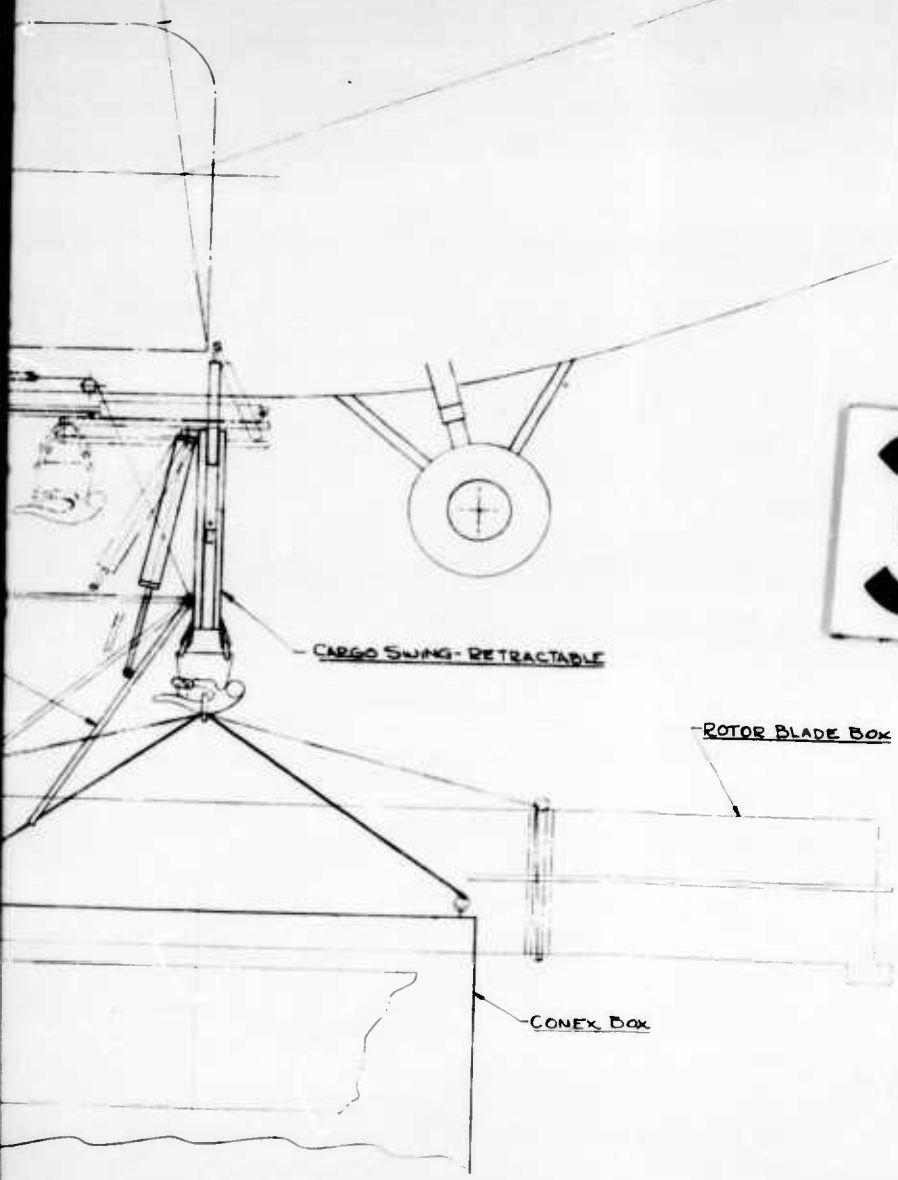

3

PRINT REDU
 ONE - THIR
 INDICATED S

DATE	GROUP	STATUS	FILE NO.	DATE	STUDY HELICOPTER LOAD CAP M-21 INT SWING & S HEAD V/D
1964	1000	1000	1000	1000	
DESIGNED BY		CHECKED BY		DATE	
DRAWN BY		APPROVED BY		DATE	
SCALE		SHEET NO.		TOTAL SHEETS	

4

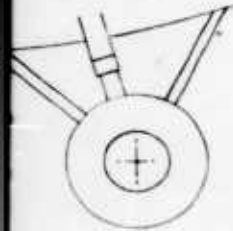

GO SWING - RETRACTABLE

ROTOR BLADE BOX

CONEX BOX

PRINT REDUCED
ONE - THIRD
INDICATED SCALE

PROJECT NO.	GROUP	STAGE	PHASE	DATE	SCALE	STUDY OF IMPROVED HELICOPTER SLING LOAD CAPABILITIES - H-21 INTEGRAL CARGO SWING & STABILIZER	SK-9530
100-100000	100-100000	100-100000	100-100000	100-100000	100-100000	100-100000	100-100000
100-100000						100-100000	100-100000

THIS DRAWING IS A TECHNICAL DRAWING AND IS NOT TO BE REPRODUCED OR TRANSMITTED IN ANY FORM OR BY ANY MEANS, ELECTRONIC OR MECHANICAL, INCLUDING PHOTOCOPYING, RECORDING, OR BY ANY INFORMATION STORAGE AND RETRIEVAL SYSTEM, WITHOUT PERMISSION IN WRITING FROM THE NATIONAL ARCHIVES.

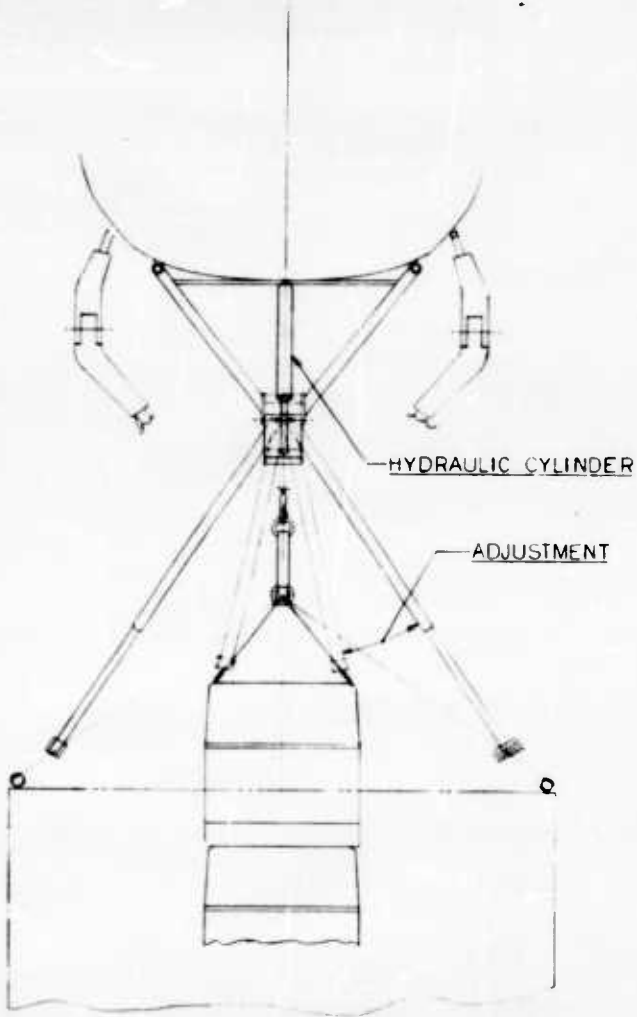

1

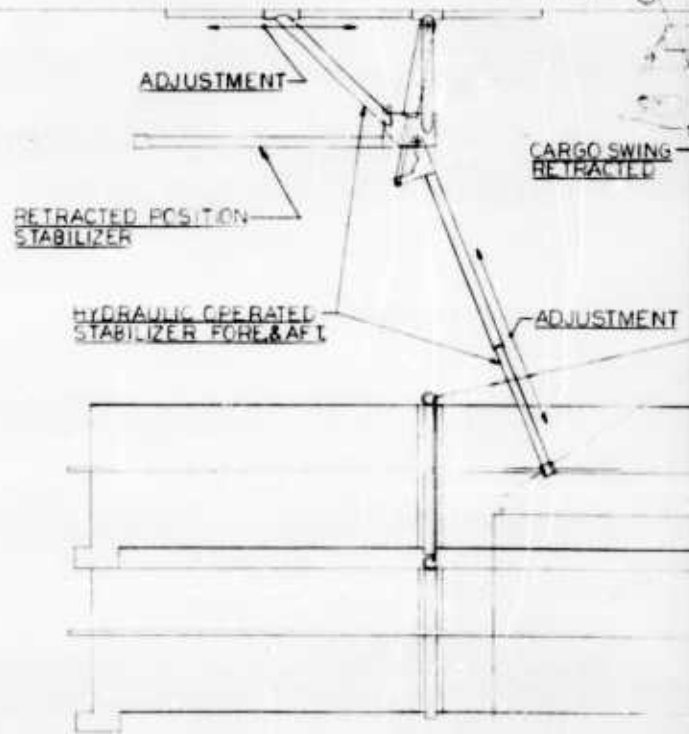

2

THE DRAWING IS A COPY OF A DRAWING FOR THE USE OF THE UNITED STATES GOVERNMENT AND IS NOT TO BE REPRODUCED OR TRANSMITTED IN ANY FORM OR BY ANY MEANS, ELECTRONIC OR MECHANICAL, INCLUDING PHOTOCOPYING, RECORDING, OR BY ANY INFORMATION STORAGE AND RETRIEVAL SYSTEM.

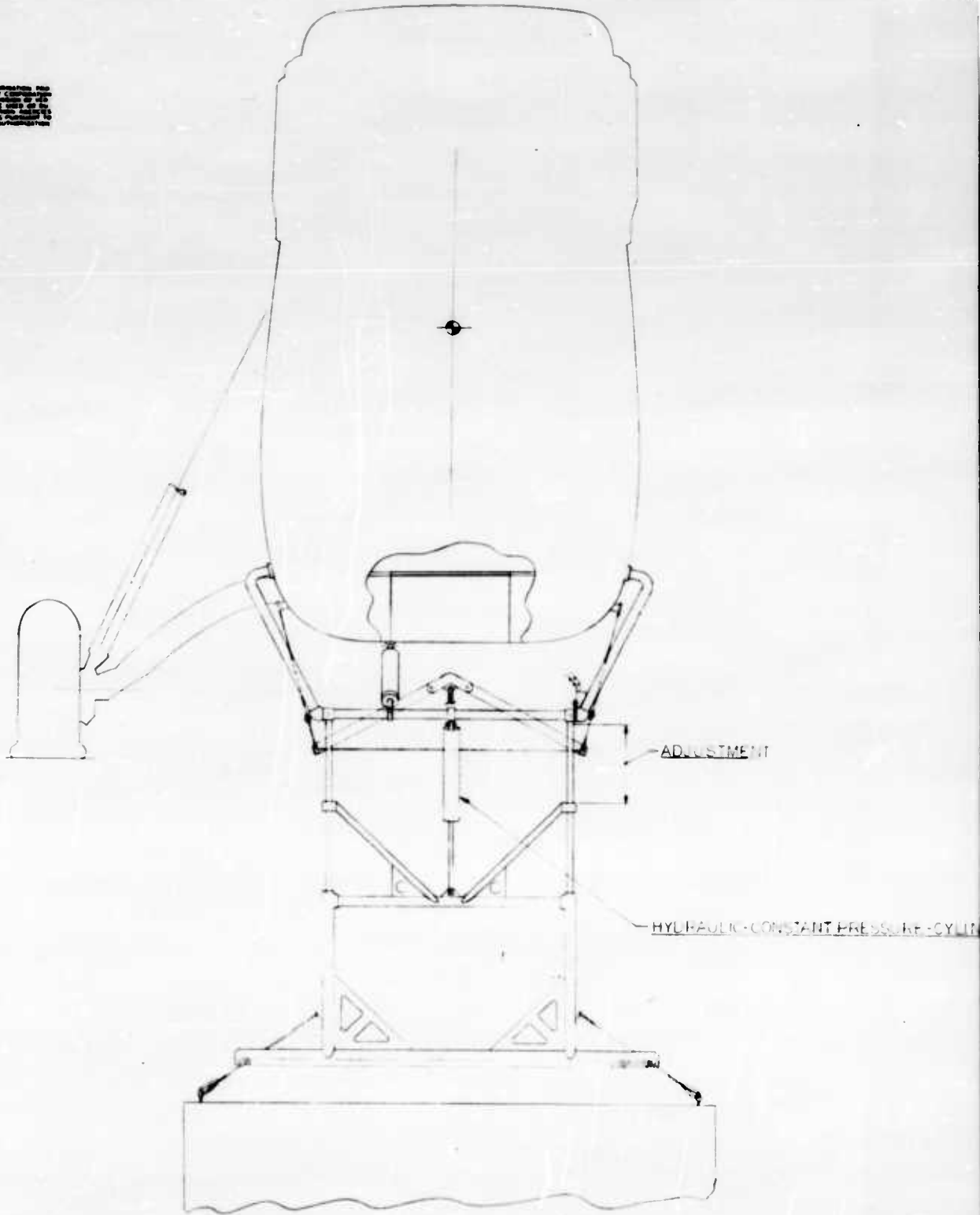

1

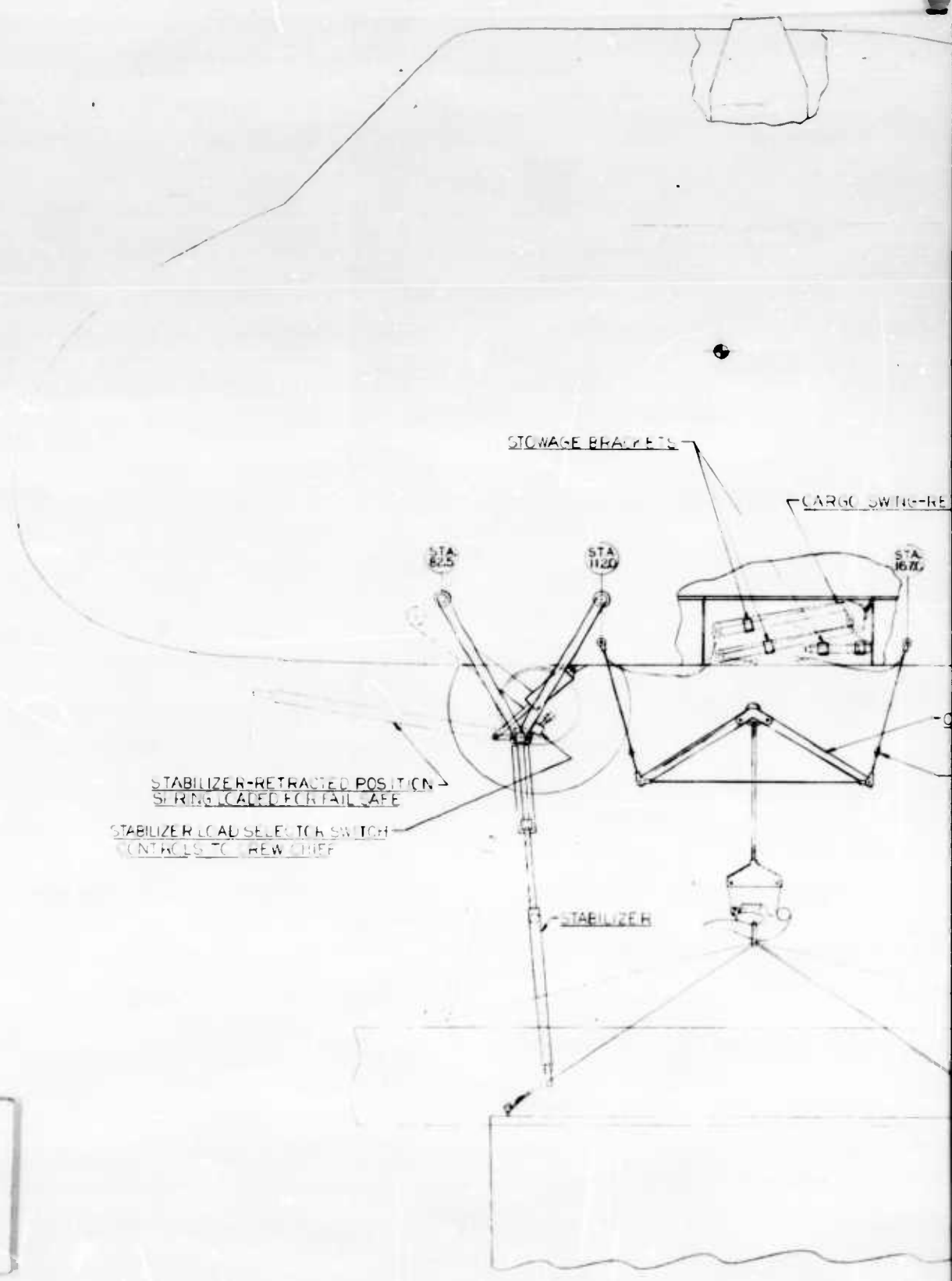

2

YAW LOADS IMPOSED BY BLADE BOXES

Cargo Swing with Yaw Restraint Strut

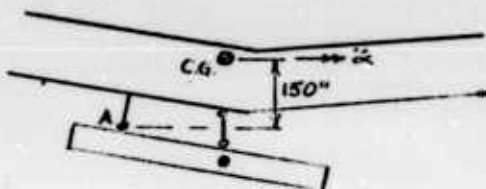

1. Available roll control about horizontal through c.g. for H-21

$$\ddot{\alpha} = 0.3 \text{ rad/sec}^2 \text{ per inch lateral stick travel}$$

$$\text{Total stick travel} = 4 \text{ inches}$$

$$\text{Roll inertia of the helicopter about c.g.} = 60,000 \text{ \# sec}^2\text{-in.}$$

$$\begin{aligned} \text{Available restoring moment in roll} &= I\ddot{\alpha} = 60,000 (0.3 \times 4) \\ &= 72,000 \text{ in.\#} \end{aligned}$$

Available lateral corrective force at A:

$$F_A = \frac{72,000}{150} = 480\#$$

2. % of lateral stick travel to counteract a rudder-excited yaw excitation of the cargo

$$\text{Yaw control } \ddot{\gamma} = 0.1 \text{ rad/sec}^2 \text{ per inch rudder}$$

$$\text{Total rudder travel} = 3.25 \text{ inches}$$

$$\ddot{\gamma} = 0.1 \times 3.25 = 0.325 \text{ rad/sec}^2$$

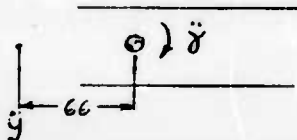

$$\ddot{y} = 66 (0.1 \times 3.25) = 21.5 \text{ inches/sec}^2$$

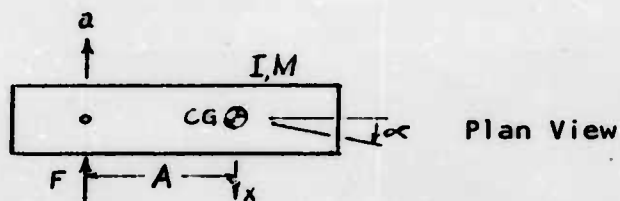

Find force, F , due to applied acceleration, a

$$\Sigma F_{cg} = F = M\ddot{x} \qquad \Sigma T_{cg} = I\ddot{\alpha}$$

$$\ddot{x} + A\ddot{\alpha} = a$$

Solving these three equations simultaneously,

$$\ddot{x} = a - A\ddot{\alpha}$$

$$F = m(a - A\ddot{\alpha})$$

$$FA = I\ddot{\alpha}$$

$$F = \frac{I}{A}\ddot{\alpha}$$

$$F = m(a - A\ddot{\alpha}) = \frac{I}{A}\ddot{\alpha}$$

$$ma - mA\ddot{\alpha} - \frac{I}{A}\ddot{\alpha} = 0$$

$$\ddot{\alpha} = \frac{ma}{mA + I/A}$$

$$\ddot{x} = a - A \frac{ma}{mA + I/A} = \left[1 - \frac{mA}{mA + I/A} \right] a$$

$$F = m\ddot{x} = ma \left[1 - \frac{mA}{mA + I/A} \right] = ma \left[\frac{I/A}{mA + I/A} \right]$$

Check

$$F = \frac{I}{A}\ddot{\alpha} = \frac{Ia}{A} \left[\frac{m}{mA + I/A} \right]$$

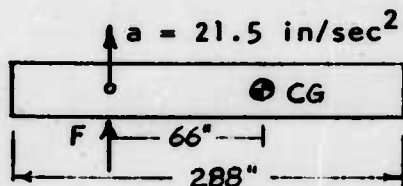

Weight = 3 boxes x 500# = 1500#
 on cargo sling
 (3 H-21 blade boxes)

$$\text{Inertia, } I_{CG} = \frac{1}{12} ml^2$$

$$m = \frac{1500}{386} = 3.88$$

$$= \frac{1}{12} \frac{1500}{386} (288 \text{ in.})^2$$

$$I_{CG} = 26,900 \text{ #-sec}^2\text{-in.}$$

$$F = \frac{Ia}{A} \left[\frac{m}{mA + I/A} \right] = \frac{26,900(21.5)}{66} \frac{3.88}{3.88(66.0) + \frac{26,900}{66}}$$

$$F = 51.2\#$$

$$\text{Req'd lateral stick travel} = \frac{51.2}{480} = 10.7\%$$

3. % of lateral stick travel to counteract a stick-excited lateral excitation of the cargo.

Assume 1" stick excitation in maneuvering helicopter

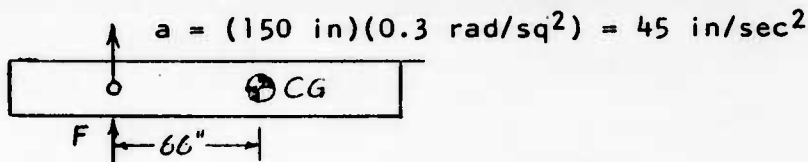

$$F = \frac{Ia}{A} \left[\frac{m}{mA + I/A} \right]$$

$$= \frac{26,900(45)}{66} \frac{3.88}{3.88(66) + 26,900/66}$$

$$F = 107.2\#$$

$$\% \text{ of lateral stick travel} = \frac{107.2}{480} = 22.3\%$$

CARGO SWING AND STABILIZATION YOKE
FOR USE WITH H-21 HELICOPTER

SK 9448

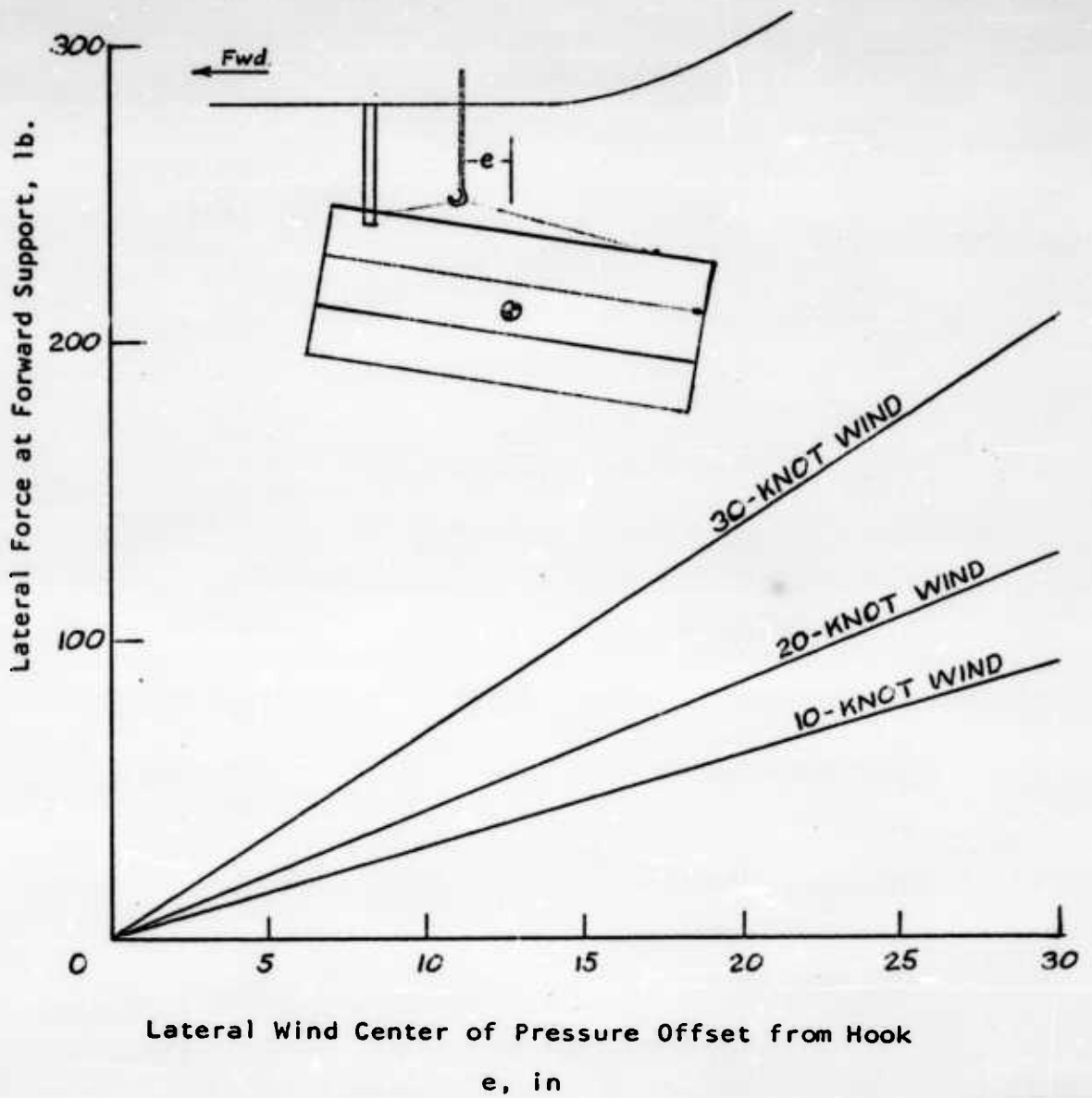

APPENDIX III

Distribution List

CONUS COMMAND

Commanding General
United States Continental Army Command
Fort Monroe, Virginia
ATTN: Materiel Developments (1)

Commanding General
United States Army Infantry Center
Fort Benning, Georgia
ATTN: Transportation Officer (1)

President
United States Army Aviation Board
Fort Rucker, Alabama
ATTN: ATBG-DG (1)

Commanding General
United States Army Aviation Center
Fort Rucker, Alabama
ATTN: Transportation Officer (1)

Commandant
Naval Air Test Center
Patuxent River, Maryland
ATTN: U. S. Army Liaison Officer (1)

Chief
Bureau of Naval Weapons
Department of the Navy
Washington 25, D. C.
ATTN: RA-4 (1)

TECHNICAL SERVICES

Commanding General
U. S. Army Ordnance Missile Command
Redstone Arsenal, Alabama
ATTN: ORDXM-T (1)

Commanding Officer
U. S. Army Transportation Combat Development Group
Fort Eustis, Virginia (1)

Chief of Transportation
Department of the Army
Washington 25, D. C.
ATTN: TCACR (2)

Chief of Engineers
Department of the Army
Washington 25, D. C.
ATTN: ENGNC (1)

Commanding General
U. S. Army Transportation Materiel Command
P. O. Box 209, Main Office
St. Louis 66, Missouri
ATTN: TCSMC-APU (1)

Commanding Officer
Transportation Aircraft Test and Support Activity
Fort Rucker, Alabama (1)

Commandant
U. S. Army Transportation School
Fort Eustis, Virginia
ATTN: Adjutant (1)

Commanding Officer
U. S. Army Transportation Research Command
Fort Eustis, Virginia
ATTN: Research Reference Center (4)
ATTN: Test Division (Mr. F. J. Limandri) (1)
ATTN: Originating Division (5)

Transportation Corps Liaison Officer
U. S. Army Engineer Research and Development Laboratory
Building 314, Room A-214
Fort Belvoir, Virginia (1)

UNITED STATES AIR FORCE

Commander
Wright Air Development Division
Wright-Patterson Air Force Base, Ohio
ATTN: WCLJA (1)

UNITED STATES MARINE CORPS

President
Marine Corps Equipment Board
Marine Corps Schools
Quantico, Virginia (1)

Director
MC Landing Force Development Center
Marine Corps Schools
Quantico, Virginia (1)

UNITED STATES COAST GUARD

Commandant
U. S. Coast Guard
1300 "E" Street, NW
Washington 25, D. C.
ATTN: Chief, Testing and Development Division (1)

MISCELLANEOUS

Director of Defense Research and Development
Room 3E - 1065, The Pentagon
Washington 25, D. C.
ATTN: Technical Library (1)

Deputy Chief of Staff for Military Operations
Department of the Army
Washington 25, D. C.
ATTN: Director of Organization and Training,
Doctrines and Combat Developments Division (1)

U. S. Army Standardization Group, U. K.
Box 65, U. S. Navy 100
FPO New York, New York (1)

National Aviation Facilities Experimental Center
ATTN: Library
Atlantic City, New Jersey (1)

Librarian
Langley Research Center
National Aeronautics & Space Administration
Langley Field, Virginia (1)

Ames Research Center
National Aeronautics and Space Agency
Mofett Field, California (1)
ATTN: Library

Armed Services Technical Information Agency
Arlington Hall Station
Arlington 12, Virginia (10)

Federal Aviation Agency
General Operations Branch
Washington 25, D. C.
ATTN: FS 440, Lt. Col. K. R. Eckert (1)

Senior Standardization Representative
U. S. Army Standardization Group, Canada
c/o Director of Weapons and Development
Army Headquarters
Ottawa, Canada (1)

Canadian Liaison Officer
U. S. Army Transportation School
Fort Eustis, Virginia (4)

British Joint Services Mission
(Army Staff)
DAQMG (Mov & Tn)
1800 "K" Street, NW
Washington 6, D. C.
ATTN: Lt. Col. R. J. Wade, RE (5)

Australian Military Mission (1)

President
United States Army Airborne and Electronics Board
Fort Bragg, North Carolina
ATTN: Major James E. Neel (1)

Office of Technical Services
Acquisition Section
Department of Commerce
Washington 25, D. C. (2)

UNCLASSIFIED

AD

236 1

Reproduced

Armed Services Technical Inform

ARLINGTON HALL STATION; ARLINGTON

NOTICE: WHEN GOVERNMENT OR OTHER DRAWINGS OR OTHER DATA ARE USED FOR ANY PURPOSE OTHER THAN THAT FOR WHICH THEY WERE ORIGINALLY DEVELOPED WITH A DEFINITELY RELATED GOVERNMENT PROJECT, THE U. S. GOVERNMENT THEREBY INCURS NO RESPONSIBILITY OR OBLIGATION WHATSOEVER; AND THE FACT THAT THEY HAVE FORMULATED, FURNISHED, OR IN ANY WAY SUBMITTED SUCH DRAWINGS, SPECIFICATIONS, OR OTHER DATA IS NO IMPLICATION OR OTHERWISE AS IN ANY MANNER LICENSED TO ANY OTHER PERSON OR CORPORATION, OR CONVEYED BY ANY PERMISSION TO MANUFACTURE, USE OR SELL ANY PRODUCT THAT MAY IN ANY WAY BE RELATED THERETO.

UNCLASSIFIED