

This information is furnished upon the condition that it will not be released to another nation without specific authority of the Department of Defense of the United States, that it will be used for governmental purposes only, that individual or corporate rights originating in the information, whether patented or not, will be respected, and that the information be provided substantially the same degree of protection afforded it by the Department of Defense of the United States.

# UNCLASSIFIED

# AD

2	3	7		6	4	5
---	---	---	--	---	---	---

Reproduced

## Armed Services Technical Information Agency

ARLINGTON HALL STATION; ARLINGTON 12 VIRGINIA

**NOTICE:** WHEN GOVERNMENT OR OTHER DRAWINGS, SPECIFICATIONS OR OTHER DATA ARE USED FOR ANY PURPOSE OTHER THAN IN CONNECTION WITH A DEFINITELY RELATED GOVERNMENT PROCUREMENT OPERATION, THE U. S. GOVERNMENT THEREBY INCURS NO RESPONSIBILITY, NOR ANY OBLIGATION WHATSOEVER; AND THE FACT THAT THE GOVERNMENT MAY HAVE FORMULATED, FURNISHED, OR IN ANY WAY SUPPLIED THE SAID DRAWINGS, SPECIFICATIONS, OR OTHER DATA IS NOT TO BE REGARDED BY IMPLICATION OR OTHERWISE AS IN ANY MANNER LICENSING THE HOLDER OR ANY OTHER PERSON OR CORPORATION, OR CONVEYING ANY RIGHTS OR PERMISSION TO MANUFACTURE, USE OR SELL ANY PATENTED INVENTION THAT MAY IN ANY WAY BE RELATED THERETO.

# UNCLASSIFIED

AD No. 237645

ASTIA FILE COPY

RESEARCH REPORT NO. 59-106

11

127648

# ULTRASONIC WELDING SURVEY REPORT AND ULTRASONIC WELDING EQUIPMENT MANUAL

W. C. Potthoff

H. L. McKaig

Released to ASTIA by the  
Bureau of **NAVAL WEAPONS**  
without restriction.

XEROX

AEROPROJECTS INCORPORATED  
WEST CHESTER, PENNSYLVANIA

**FILE COPY**

Return to  
**ASTIA** N-60-3-3  
**ARLINGTON HALL STATION**  
**ARLINGTON 12, VIRGINIA**

•  
Attn: TISSS

May, 1959

Prepared under  
Contract NOas 58-108-c

**ASTIA**  
**RECEIVED**  
**JUN 13 1960**  
**TIPDR** C

Submitted to  
**BUREAU OF NAVAL WEAPONS**  
**WASHINGTON 25, D.C.**

AEROPROJECTS INCORPORATED

ULTRASONIC WELDING SURVEY REPORT  
AND  
ULTRASONIC WELDING EQUIPMENT MANUAL

by

W. C. Potthoff  
H. L. McKaig

May 1959

Prepared under  
Contract No. NOas 58-108-c

Submitted to  
Bureau of Naval Weapons

Covering Period  
December 1, 1957 - December 1, 1958

AEROPROJECTS INCORPORATED  
West Chester, Pennsylvania

AEROPROJECTS INCORPORATED

PART I

ULTRASONIC WELDING SURVEY REPORT

TABLE OF CONTENTS

	<u>Page</u>
I INTRODUCTION . . . . .	1
II APPROACH TO SURVEY . . . . .	1
III SUMMARY OF VISITS AND DISCUSSION OF REQUIREMENTS . . . . .	2
IV CONCLUSIONS . . . . .	4
APPENDIX . . . . .	5

## I. INTRODUCTION

In accordance with Items 2 and 5, Section of Contract NOas 58-108-c, Aeroprojects surveyed the aircraft, missile, and electronics industries to determine the areas in which ultrasonic welding techniques could be most helpful and how ultrasonic welding equipment developments should be channeled to do the most good for the defense industry. The survey, undertaken in 1958, included eleven important suppliers of the Department of Defense who were carefully chosen as potential users from whom a representative cross section of present and future requirements of ultrasonic welding equipment needs could be obtained.

## II. APPROACH TO SURVEY

Because the former Bureau of Aeronautics had been closely associated, for the past several years, with the development of ultrasonic welding, Aeroprojects obtained the Bureau's help in the selection of contractors so that a wide variety of metal joining problems would be covered. The suggestions of the Bureau were combined with Aeroprojects' extensive background in ultrasonic welding in planning visits to defense installations to obtain the desired information.

A major objective of the survey was to be the delineation of present and future joining problems so that developments in ultrasonic welding techniques and equipment could be directed toward the accomplishment of maximum results in the over-all defense effort.

It was decided that in the aircraft and missile structure, jet engine, nuclear propulsion, rocket and missile engine, and electronic industries a wide range of important problems would be encountered, and that the investigations should include a detailed survey of materials, material combinations, material thicknesses, geometric and space considerations, and other special problems pertinent to each industry.

The following eleven defense industries were visited:

1. Sperry Rand; Long Island, New York, January 15, 1958.
2. Pratt & Whitney; CANLL Project, Middletown, Conn., January 27, 1958.

3. Pratt & Whitney Aircraft; East Hartford, Conn., January 27, 1958.
4. Sprague Electric, North Adams, Mass., January 28, 1958.
5. Boeing Aircraft Company; Seattle, Wash., February 7, 1958.
6. Lockheed Aircraft; Sunnyvale, Calif., February 10, 1958.
7. Lockheed Aircraft; Palo Alto, Calif., February 10, 1958.
8. Douglas Aircraft; Santa Monica, Calif., February 12, 1958.
9. Rocketdyne, North American Aviation; Canoga Park, Calif. February 13, 1958.
10. Chance-Vought; Dallas, Texas, February 19, 1958.
11. ANP Division of General Electric; Evendale, Ohio, March 3, 1958.

Thus the major defense industries were adequately covered. Divergent views and approaches to the fabrication of structures, engines, and electronic parts were obtained, and from the standpoint of welding problems a wide range of materials, material gages, geometries, and special considerations were covered. It is considered that the information obtained generally applies to a large section of industries engaged in Department of Defense work.

### III. SUMMARY OF VISITS AND DISCUSSION OF REQUIREMENTS

The correlation of detailed information obtained from the eleven visits (see Appendix) indicates that the problems tend to lie in either of two general areas.

The most important area seems to be in welding of high-temperature, high-strength alloy sheets in gages from 0.020 in. to 0.5 in. Although different materials were mentioned by different companies, difficulties in welding molybdenum to molybdenum, molybdenum to high-cobalt nickel alloys, beryllium to beryllium, titanium alloys to themselves and to stainless steel, and stainless steel to aluminum illustrate joining problems requiring immediate solution. Many companies indicated that their interest is in welding of materials up to 1/10- or 1/8-in. maximum

thickness; some companies specified thicknesses as high as 1/2 in. Almost all of the companies are interested in both spot-type and continuous ultrasonic seam welds in the materials and gages mentioned.

Since most of the structures in the aircraft and missile industry are rather large, machines having large throat depths are required. In some applications throat depths of 5 to 6 feet would be desirable. In other applications, where the work pieces can not be moved, portable welding heads of a wide variety of shapes and sizes are required. It appears that a full range of ultrasonic spot- and seam-welding equipment--large floor models, table models, and portable heads--are required. Equipment with power ratings of 3 to 12 times the present 4000-watt units probably will be required to solve the full range of problems uncovered.

On the other hand, the electronic components and the electronic assembly companies are interested in very light and thin materials, such as metalized paper or metalized plastic; in attaching 1 to 2-mil aluminum and gold wires to silicon or germanium; or in sealing of small-diameter holes in delicate parts. Although space limitation is a major problem in many of these applications, the joining of dissimilar metals, as in the missile and aircraft industry, is very important. However, the dissimilar metal combinations in the electronic industry are in many cases different from those of interest to the structures and engine manufacturers.

Extremely small ultrasonic welders are required for many electronic applications. These units must be low in power and small in size. Many of the units required will be table models where the work can be brought to the welder and in many cases this will be accomplished on automated production equipment. In other applications extremely small portable tweezer-type units are required.

One common point, raised by structures, engine, and electronic companies, is the need for military specifications for use with ultrasonic welding.

Many companies indicated that military specifications covering at least some materials or some combinations of materials would be of assistance in using this new metal joining technique in defense work since present resistance welding specifications are not applicable. These companies also indicated that without a military specification it would be quite difficult for them to undertake the use of this new welding technique because government inspectors would be reluctant to accept the use of the equipment without some official means of checking the process.

The question of the possible welding of ceramics, cermets, or metals to ceramics and cermets was raised in several places. This seems to be an important and very difficult problem and may be an area which should be explored.

#### IV. CONCLUSIONS

The many contacts made by Aeroprojects personnel, both in the field and with parties visiting Aeroprojects in West Chester to discuss their metal joining requirements, reinforce the findings of this survey. Contacts made outside of this survey cover many other industries engaged in the defense effort; and in most cases the general pattern of problems is similar. It may be concluded that:

1. The advantages to be gained by using ultrasonic welding are creating much interest, particularly in the joining of high-temperature and high-strength materials now of so much interest to the aircraft and missile structure industries.
2. The joining of dissimilar metals without the intermetallic compounds, normally associated with fusion welding, appeals not only to the structures groups but also to the electronics industries.
3. To meet the needs of aircraft and missile structures and engine applications, both spot-type and continuous ultrasonic seam welding equipment must be developed with power of 10 to 25 kva.
4. To meet the needs of the electronics applications several sizes and types of welders of 100-watts and less are required.
5. Military specifications covering at least a few basic types of materials should be developed to form a pattern for the broad range of similar and dissimilar metal combinations.
6. Because no arcing, sparking, or sputtering is produced to contaminate surrounding areas, the advantages of ultrasonic welding have raised widespread interest in the electronics field.
7. Exploratory investigations in the welding of ceramics, cermets, and metals to ceramics and cermets should be undertaken to determine the potential in this general area.
8. Ultrasonic welding equipment is presently available to meet many of the needs in the electronics field and in some of the structural applications. However, there is still work to be done in developing techniques, special tools, and special tips to meet the requirements imposed by geometry and space problems.

APPENDIXAIRCRAFT, MISSILE, AND ROCKET ORGANIZATIONSINTERESTED IN ULTRASONIC WELDING

<u>Organization</u>	<u>Area of Interest</u>
Aerojet-General Corp. Azusa, Calif.	Heat-treated steels up to 1/8 in. thick.
Boeing Airplane Co. Seattle, Wash.	Beryllium, molybdenum-titanium alloy, titanium alloys, and 17-7 PH stainless steel; dissimilar combinations of high-temperature metals; spot and seam welding in relatively heavy gages.
Chance-Vought Aircraft, Inc. Dallas, Texas	Molybdenum-titanium alloys and titanium alloys; welding of three or more layers at one time.
Convair Astronautics San Diego, Calif.	301-N and 17-7 PH stainless steel, K Monel, and 7075 aluminum alloy; welding of up to ten layers at one time.
Douglas Aircraft Co. Santa Monica, Calif.	Heavy gages of heat-treated steel such as 4340.
General Electric Co. Aircraft Nuclear Propulsion Evendale, Ohio	Molybdenum, cermets, and 17-7 PH stainless steel up to 1/8 in. thick; spot and seam welding of three or more layers at one time.
Grumman Aircraft Eng. Corp. Bethpage, New York	Dissimilar combinations of high-temperature metals such as titanium alloys.
Lockheed Aircraft Corp. Burbank, California	Titanium alloys to 17-7 PH stainless steel.
Lockheed Aircraft Corp. Palo Alto, Calif.	Beryllium, cermets, and dissimilar combinations of high-temperature metals.
Lockheed Aircraft Corp. Missiles Systems Division Sunnyvale, Calif.	Beryllium, cermets, cermets to metals, and stainless steel up to 1/2 in. thick, and dissimilar combinations of high-temperature metals; seam welding in relatively heavy gages.

Organization	Area of Interest
Pratt and Whitney Aircraft Jet Engine Division East Hartford, Conn.	High-temperature alloys such as AMS5504 and AMS5512 stainless steels, Inconel, and titanium alloys.
Pratt and Whitney Aircraft CANEL Operation Middletown, Conn.	Molybdenum, niobium, tungsten, stainless steel, and other metals and alloys up to 1/8 in. thick; metals to cermets; spot and seam welding.
Rocketdyne Division North American Aviation, Inc. Canoga Park, Calif.	Molybdenum and 4130 heat-treated steel; dissimilar combinations of high-temperature metals of heavy gage; seam welding.
Sperry Rand Long Island, New York	Welding of small aluminum, molybdenum, and stainless steel parts.
Sprague Electric North Adams, Mass.	Welding of a wide variety of dissimilar metals; connecting lead wires to metalized paper or plastic; and sealing of small diameter filler holes.

PART II

ULTRASONIC WELDING EQUIPMENT MANUAL

TABLE OF CONTENTS

	<u>Page</u>
I GENERAL DESCRIPTION OF ULTRASONIC EQUIPMENT . . . . .	9
A. Transducers . . . . .	9
B. Frequency . . . . .	9
C. Lateral Drive System . . . . .	11
D. Wedge-Reed System . . . . .	11
E. Electronic Power Sources . . . . .	13
II ULTRASONIC WELDING RELIABILITY RATIONALE . . . . .	15
III DESCRIPTIONS AND CAPABILITIES OF AVAILABLE EQUIPMENT . . . . .	18
A. Typical 100 Watt Welder . . . . .	18
B. Typical 300 Watt Welder . . . . .	19
C. Typical 500 Watt Welder . . . . .	20
D. Typical 2000 Watt Welder . . . . .	21
E. Typical 4000 Watt Welder . . . . .	22

LIST OF FIGURES

<u>Figure</u>		<u>Page</u>
1	Lateral Drive System . . . . .	12
2	Resonant Reed System . . . . .	12
3	Typical Electronic Power Source Block Diagram . . . . .	13
4	Randomly Obtained Pooled Data Representing Ultrasonic Weld Strength in 2XXX Series Aluminum Alloys . . . . .	16
5	Typical Variance in Ultrasonic Weld Strength in 0.040-in. 2024-T3 Bare Aluminum Alloy . . . . .	17
6	Comparison of Welder Capabilities . . . . .	23

## I. GENERAL DESCRIPTION OF ULTRASONIC EQUIPMENT

### A. TRANSDUCERS

With either the lateral drive, or wedge-reed, coupling systems described below, the transducer usually consists of a stack of thin Alfinol, nickel, Permendur, or nickel-cobalt alloy laminations embraced by a low voltage d-c polarizing coil and an a-c excitation coil. Metallurgically bonded to the coupling system as by brazing, these transducer materials are rugged, readily maintained within practical operating temperatures (below about 200°F) even at fairly high welding repetition rates of 18-24 welds per minute. Other transducer materials such as the ceramic types are cheaper and have advantages of better efficiency and absence of coil requirements, but they have not been used extensively to date, possibly because of attachment problems, fragility, high voltage requirements, and a low Curie temperature with poor thermal conductivity placing great emphasis on cooling, especially when high-power, high-repetition-rate welding is necessary, as in production. Ceramics with higher Curie temperatures are being developed.

### B. FREQUENCY

In vibratory welding, frequency *per se* seems to have no great practical significance in so far as "critical" frequencies permit or prevent welding.

Each welding machine does have a narrow frequency band within which it operates best just as does an ultrasonic drill, soldering device, cleaner, etc. With thicknesses or with materials demanding the maximum available power from a specific machine, it is sometimes possible to improve weld strength somewhat with fine adjustment of the frequency inside the narrow band at which the welding machine operates best. If for example, a 2000-watt machine operating at a nominal frequency of 15,500 cycles per second is used for thick or hard materials demanding its full power, it is sometimes possible to produce welds of higher quality or strength by precise adjustment of the frequency in a range of about 15,300 to 15,800 cycles per second. If the same work pieces were joined with a 4000-watt machine, very good welds would be produced without regard to precision adjustment. "Fine tuning" acts to bring the output of a machine to the razor edge of its maximum.

Within the narrow band at which a welding machine operates, the slight differences in best operating frequency sometimes observed with different material thicknesses result from minor force sensitivity of the transducer-coupling system, differing impedances presented by different materials or gages, temperature changes, or other factors none of which involve a significant frequency--material--gage interaction.

To emphasize further this point, which seems to be a source of misunderstanding, it can be stated flatly that a 2000- or a 4000-watt welding machine operating at its nominal 15,000 cycles per second, approximately, will join 0.002-in. aluminum foil, 0.002-in. copper, and other thin or delicate materials in a fraction of a second at reduced power. This can be likened to pushing one egg with a bulldozer and is not recommended. The 2000-watt machine will also join aluminum in thicknesses ranging up to about 0.045--0.060 in., and the 4000-watt machine will handle aluminum materials in thicknesses up to about 0.070--0.080 in., copper of about 0.060 in. thickness, and stainless steels up to about 0.032 in. On the other-hand, a 100-watt welding machine which operates at 50,000 or 60,000 cycles per second, will also join the same thin copper or aluminum or other delicate materials, but it will obviously not join heavy aluminum simply because it is very small and does not have enough power.

In general, very small (usually low-power) machines for fine work operate at relatively high frequencies, i.e., 50 kc or more, and large (high-power) machines operate at comparatively low frequency, i.e., 15 kc or less, but these welding machine operating frequencies are generally defined by the electromechanical and power handling characteristics of the transducers used and not by any frequency association with the object being joined. Welding machines within the 15--50-kc frequency band have been built and are in use as well, and they are usually of intermediate power.

It will be noted that the welding machines described in the following pages offer the operator convenient controls for welding power and weld time intervals only. These machines can be operated at full power and their effectiveness for different materials and material thicknesses that fall within their power capacity can be controlled by simply shortening or lengthening the weld time interval and adjusting the clamping force.

Two basic ultrasonic welding systems are used in a wide range of equipment which is capable of handling from 25 to 4000 watts of high-frequency electrical power, delivered at a suitable frequency to accommodate the welder being used on any application.

### C. LATERAL DRIVE SYSTEM

The lateral drive system, schematically illustrated in Figure 1, is used in the smaller welders accepting power of around 300 watts and less. The alternating current electrical energy is delivered to the coil of the magnetostrictive transducer where it is converted into vibratory energy by alternate lengthening and contracting of the transducer core under the influence of the alternating electrical field. The transducer usually consists of a stack of nickel, Permendur, Alfinol, or nickel-cobalt alloy, which is attached to an exponentially tapered coupler, the free end of which drives either a resonant or nonresonant welding tip (see Figure 1). The lateral motion of the tip delivers the vibratory energy to the material being welded. A clamping force, applied as a moment around the welder head mounting pivots, holds the weldment between the welder tip and the work support known as the anvil. An important consideration in lateral drive vibratory welders is the need for force-insensitive mounts between the coupler and the trunnions. Larger energy losses need to be precluded, and there should not be substantial interaction between clamping force and coupler response frequency.

### D. WEDGE-REED SYSTEM

Larger equipment, requiring more than about 600 watts, is usually designed to use a wedge-reed coupling system as schematically represented in Figure 2. The transducer and coupler function in the same manner as previously described for the lateral drive system with the exception that the coupler energy is transmitted through a reed (sonotrode) instead of directly to a welder tip. The sonotrode is fixed at the upper end, and flexes rather as indicated when excited by the transducer wedge. Losses in the sonotrode are reasonably low and the wedge-reed system offers quite acceptable force-insensitive characteristics in the clamping force range upwards of 2000 pounds. Attached to the free end of the sonotrode is the welding tip. The clamp force, delivered through the sonotrode by column loading, holds the tip in contact with the weldment supported by the welder anvil, while the vibrating tip delivers the welding energy.

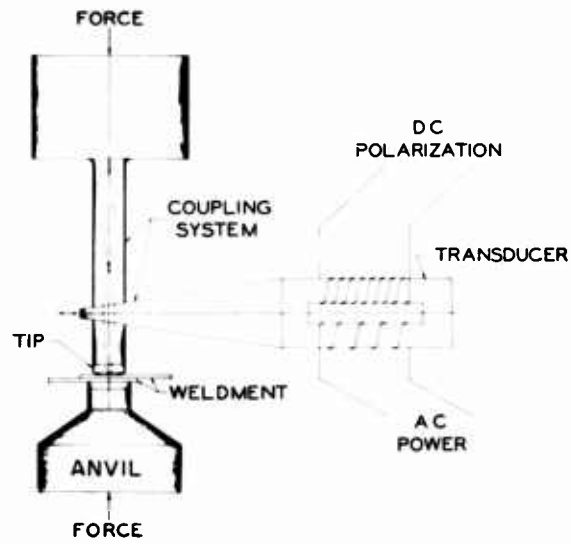

Figure 2. WEDGE REED SYSTEM

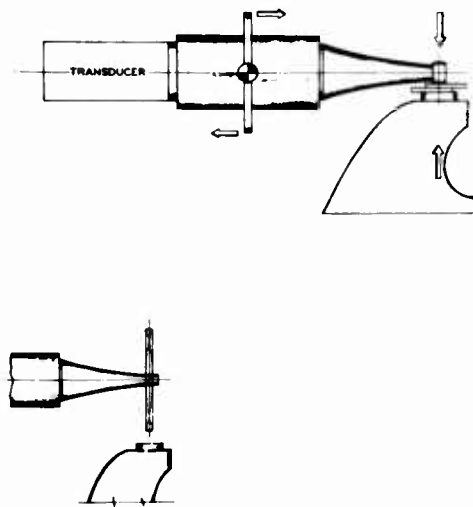

Figure 1. LATERAL DRIVE SYSTEM

E. ELECTRONIC POWER SOURCES

Of no relation whatever to the performance of an ultrasonic welding machine is the fact that the electronic gear which provides power for the welding machine may well offer a fairly broad range of operating frequencies. For example, some power packages sold with welding equipment, especially older experimental models, will operate over the entire frequency range between about 5000 and 100,000 cycles per second. Buyers of ultrasonic welding equipment sometimes like to consider the use of ultrasonic welding machine generators for purposes other than welding, even though the welding machine which goes with the generator does, in fact, operate only within a relatively narrow frequency band of a few hundred cycles. In some cases, generators have been equipped with frequency band switches so that, for example, they could be used for cleaning experiments, at say, 35 kc; the band switch would then permit the tuning dial to span only 34 to 36 kc, thus providing the cleaning experimenter with a fine frequency adjustment to match the frequency of his cleaning transducer system.

A typical block diagram for an electronic power source is illustrated in Figure 3. This equipment usually has five major components: an oscillator to generate the driving signal frequency, an amplifier to raise the

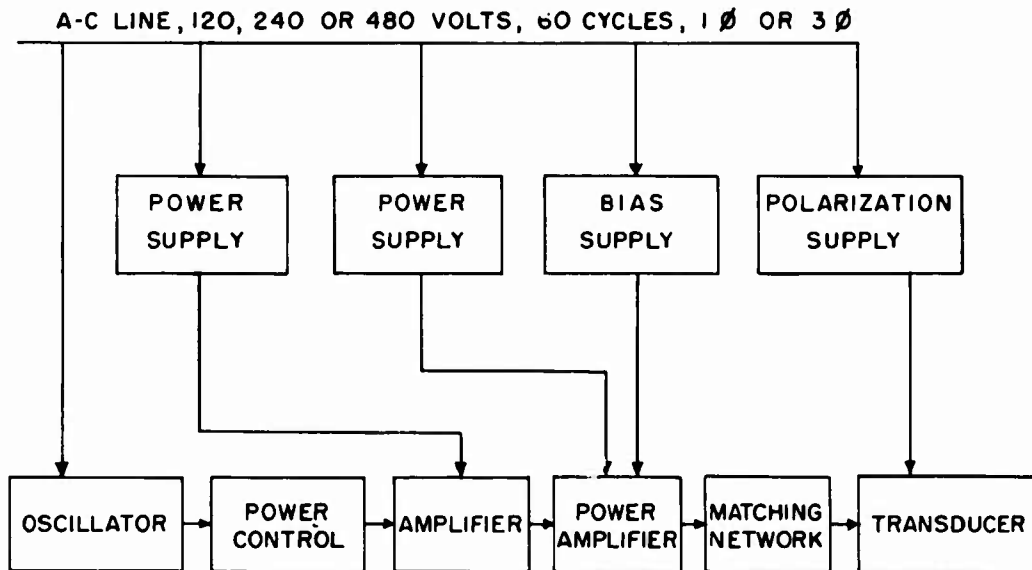

Figure 3. TYPICAL ELECTRONIC POWER SOURCE BLOCK DIAGRAM

signal to the desired power level, power supplies for both oscillator and amplifier, and a polarization supply for the transducer.

The oscillator converts 60-cycle electric current from the input power line to the desired high-frequency required for transducer operation.

The amplifier delivers the high-frequency electrical energy from the oscillator through a transformer and through an impedance-matching network into the transducer. Push-pull Class B operation, which is not uncommon, insures good efficiency. Power-supply units for the amplifiers conveniently incorporate mercury-vapor rectifiers with choke-input-filtering to provide regulation for Class B operation.

The polarization supply, which provides direct current for polarizing the magnetostrictive transducers, usually involves a conventional rectifier circuit. A reactor or filter choke will prevent loss of ultrasonic power into the polarization circuit.

Filters and blower units should be built into all higher power electronic sources to provide adequate cooling of the equipment with clean air.

## II. ULTRASONIC WELDING RELIABILITY RATIONALE

Ultrasonic spot-type welding has been extensively proven and is ready for application to many structural problems, as well as to electrical and electronic problems, of the aircraft, missile, and associated industries. Extensive testing in various structural aluminum alloys has demonstrated that ultrasonic welds are equivalent or superior to resistance spot welds in both ultimate and fatigue strengths. Figure 4 represents pooled data, randomly obtained, from ultimate tensile shear testing of both 2014-T6 and 2024-T3 aluminum alloy. The low-strength scatter, less than  $\pm 50$  pounds, is based on a 90% confidence interval. Due to the present lack of specifications for ultrasonic welds, the results are compared to the requirement for resistance spot welds per specification MIL-R-6858A. Test specimen sizes were also prepared to the same specification.

Figure 5 further exemplifies the reliability of the ultrasonic spot-type welding process for joining structural aluminum. Tensile shear strengths of daily control specimens were statistically analyzed to determine the variations encountered over a fixed period of time. The data presented are completely randomized; specimens were prepared by different persons using different equipment at different times of the day. It is thus straightforward to qualify a welder (Note Day 2 Set No. 1 of Figure 5). Analysis of this seven-day period shows an average spot strength of  $930 \pm 60$  pounds based on a 90% mean confidence interval.

Due to the relatively short history of ultrasonic welding, complete data such as the above, are not yet available for all metals and combinations of metals desired by industry, but the data being collected indicate that similar quality and reproducibility can be expected. Data relative to ultrasonic welding of ferrous, nickel, titanium and copper alloys are fairly comprehensive and show good results.

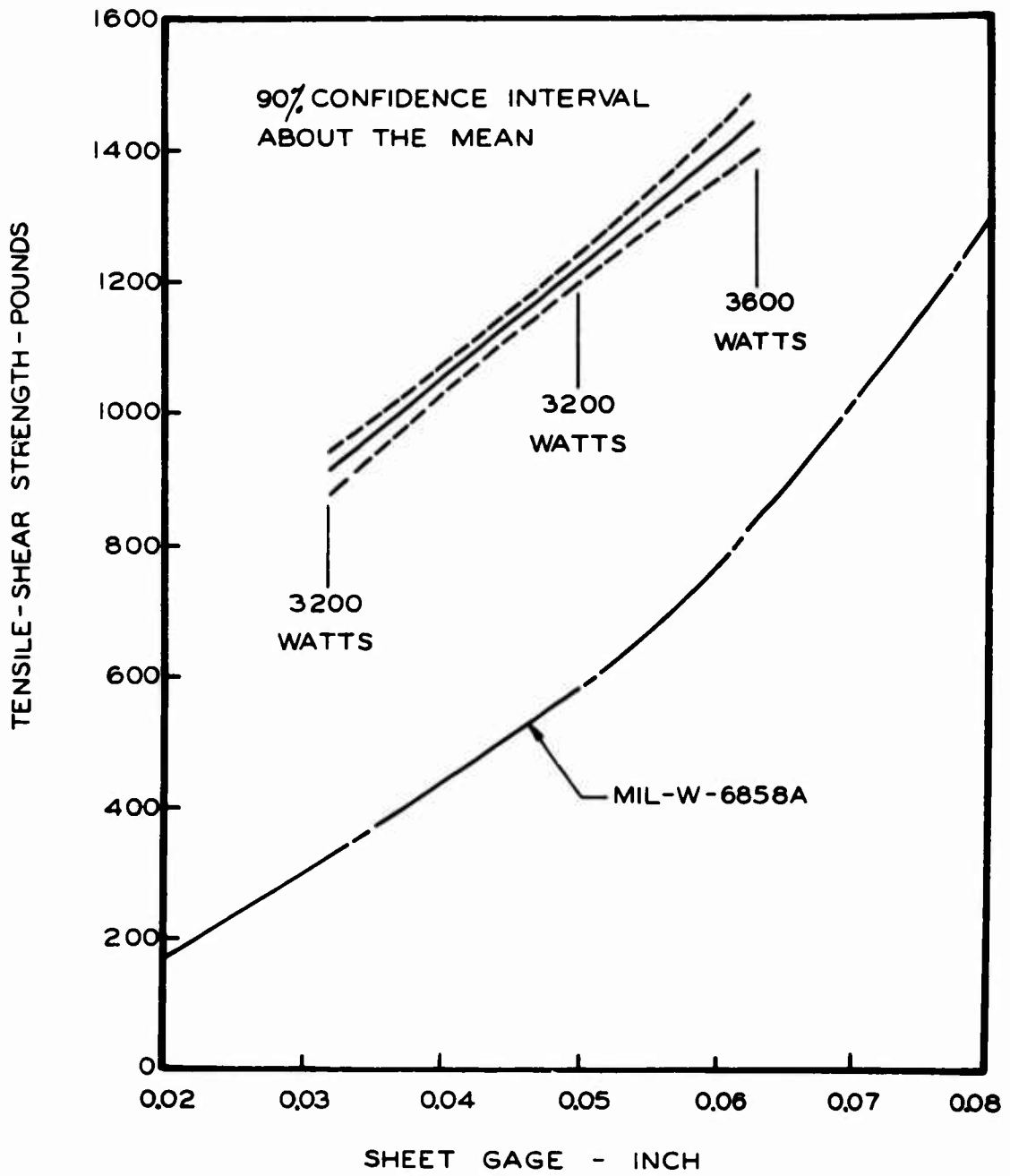

Figure 4. RANDOMLY OBTAINED POOLED DATA REPRESENTING ULTRASONIC-WELD STRENGTH IN 2XXX SERIES ALUMINUM ALLOYS

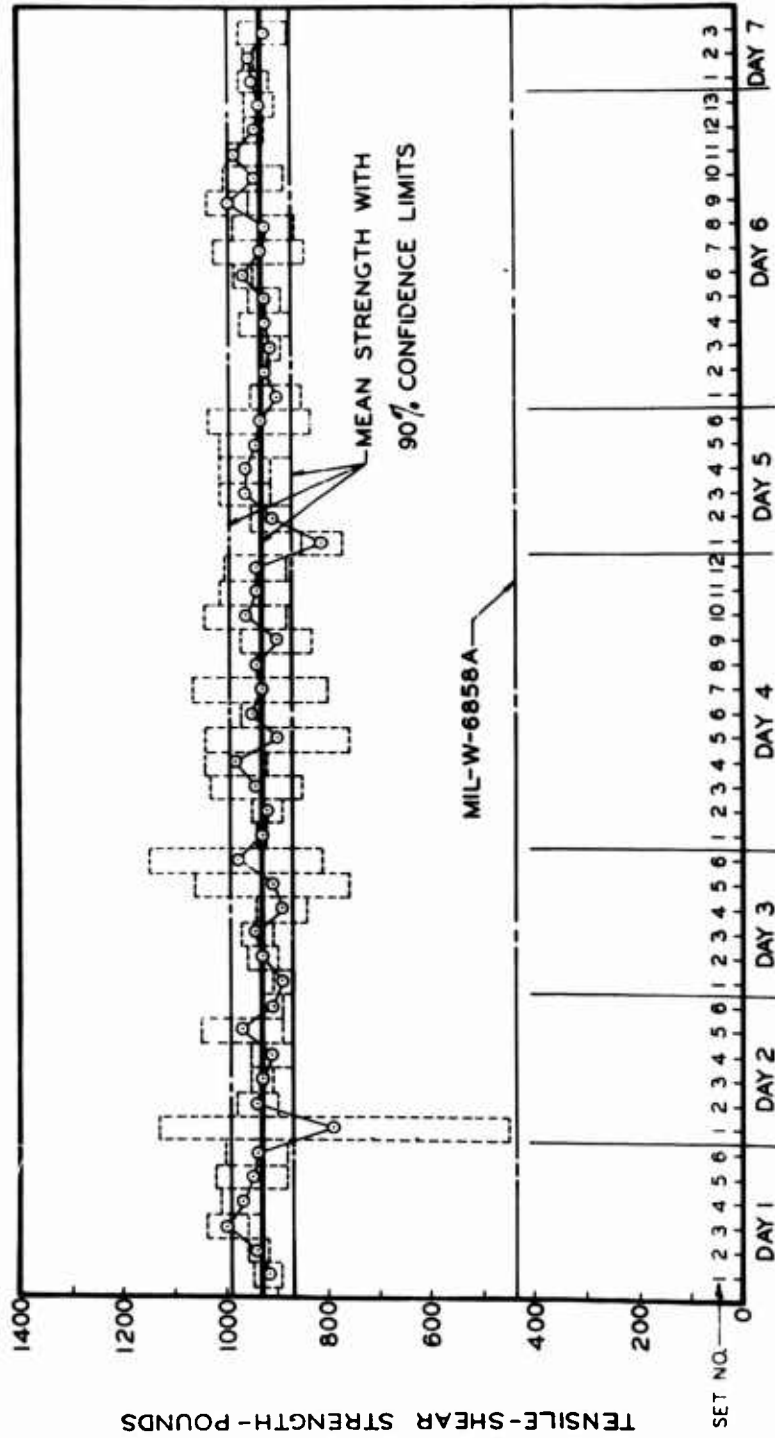

Figure 5. TYPICAL VARIANCE IN ULTRASONIC WELD STRENGTH IN 0.040-IN. 2024-T3 BARE ALUMINUM ALLOY. — (Dotted blocks represent 90% confidence intervals for individual test groups of three specimens each.)

### III. DESCRIPTIONS AND CAPABILITIES OF AVAILABLE EQUIPMENT

#### A. Typical 100-Watt Welder

Many joining requirements of the electronic component manufacturing companies can be fulfilled by a 100-watt ultrasonic welder.

A typical unit consists of a small precision welding head and a 100-watt output electronic power source which provides the necessary driving power at the proper frequency. Easily accessible controls are provided for controlling power, welding interval (time), and clamp force-- which though not especially critical can improve quality and save time. Once established for a given weldment, no further adjustments are necessary.

These welding units have been extensively employed in the fabrication of semiconductors where fine wire leads, 0.001 to 0.007 inches in diameter, are welded directly to semiconductors such as silicon and germanium. These junctions, which are sound bonds with extremely low resistance, are produced with no resulting heat damage to the leads or the semi-conductors.

As work supports (e.g. "anvil") micromanipulators for positioning work and microscope viewers have been incorporated into special welders to provide the handling and operating precision required for certain applications. Other welders have been designed for installation into automated production assembly equipment. Exceptional adaptability of this unit adds to its potential usage in the electronics field.

A list of metals and gages successfully welded with the 100-watt Welder includes:

#### Dissimilar metal welds

- 0.003-in. diameter gold wire to silicon or germanium.
- 0.007-in. diameter aluminum wire to silicon or germanium.

#### One-metal welds

- 0.003-in. thick 1100-H19 aluminum alloy.
- 0.001-in. thick gold
- 0.001-in. thick commercially pure copper.

### B. Typical 300-Watt Welder

Wires and foils, commonly used in the electronics industries, which exceed the capacity of the 100-watt machine, can be satisfactorily welded by a 300-watt ultrasonic welder.

A scaled-up version of a 100-watt machine, this unit operates at a much lower frequency because of its size and also incorporates the lateral drive transducer-coupling configuration. The Power Package provides the power and weld interval (time) controls and the welding machine includes the clamp force control and indicator. The operator has no frequency control. As with the smaller model, once the machine settings are established for a given weldment, no further adjustments are necessary. The welding cycle is activated by a foot switch.

The 300-watt machine has been used by electronic and electrical component manufacturers in the following applications:

Welding wire leads to foil capacitor and transformer cores.  
Joining foil in both similar and dissimilar metal junctions.  
Welding bridge wire assemblies for explosive detonators.

The following is a partial list of metals and gages ultrasonically spot-type welded with the 300-watt unit as one-metal welds:

0.012 in. thick 1100-H14 aluminum alloy  
0.005 in. thick 1/2 hard commercially pure copper.

### C. Typical 600-Watt Welder

A 600-watt ultrasonic welding machine meets the requirements of the electric and electronic industries for the welding of moderately heavy circuit wiring. This equipment also meets the requirements for spot-type welding of light gage structural materials.

This is one of the smallest wedge-reed types of ultrasonic welding machines and it provides good clearances for workpieces. The welding machine will handle up to 600 watts of high frequency power from the electronic power source at good repetitive rates. Power and time settings are adjusted on the face of the generator, while the clamp force control is located on the welder head.

The 600-watt ultrasonic welder has been used successfully for electrical and electronic applications such as bridgewire welding, thermocouple fabrication, component assembly, and joining lead to printed circuit boards. The ability to weld light gages of aluminum, copper, ferrous, and nickel alloys makes it possible to fabricate semi-structural assemblies with this unit.\*

This is a partial list of metals and gages ultrasonically welded with the 600-watt unit:

#### One-metal welds

- 0.025-in. thick 1100-H14 aluminum alloy.
- 0.015-in. thick commercially pure copper.
- 0.005-in. thick annealed 302 stainless steel.
- 0.025-in. diameter copper wire to copper.

#### Dissimilar metal weld

- 0.025-in. diameter copper wire to aluminum.

\* A unique application of this equipment is in closing and sealing a small exhaust tube after a partial vacuum has been created inside an assembly. The ultrasonic weld provides a helium leak-tight seal.

#### D. Typical 2000-Watt Welder

Light gage structural assemblies, typical of aircraft and missile work, can be ultrasonically spot-type welded using a 2000-watt ultrasonic welder.

The welding system employed in this equipment is of the wedge-reed configuration which provides improved clearance in the working area around the welder tip and anvil. The adjustable controls for power, clamp-force, and time are mounted on the face of the welder cabinet, within easy reach of the operator. The transducer-coupling system of this 2-kw machine operates at a design or nominal frequency of about 15,500 cycles/sec, the same as the 4-kw system described later.

Light gage structural materials--aluminum, titanium and steel--can be welded with this unit to produce spot-type welds in excess of strength requirements of specification MIL-R-6858A. Sufficient power is available for light gage bimetal welds between copper and aluminum, aluminum and stainless steel, and stainless steel and copper. This equipment can be used to produce overlapping spot-type seam welds which provide a helium leak-tight seal.

Representative materials and gages which can be welded with the 2000-watt welder are as follows:

##### One-metal welds

- 0.050 in. thick 1100-H14 aluminum.
- 0.040 in. thick 2014-T4 aluminum alloy.
- 0.030 in. thick commercially pure copper.
- 0.020 in. thick annealed 302 stainless steel.

### E. Typical 4000-Watt Welder

A significant number of the material alloys and gages of metals used for structures by the aircraft and rocket industries can be joined successfully by a 4000-watt ultrasonic spot-type welding machine.

The power increase in this equipment extends its range of usefulness into heavier gage materials and more difficult-to-join materials and alloys.

Ultrasonic welders of this type are being used for joining of materials which are either difficult or impossible to join by other welding techniques.

A sample listing of welds satisfactorily completed with the 4000-watt machine are as follows:

#### One metal welds

- 0.072 in. thick 2014-T6 aluminum alloy.
- 0.050 in. thick commercially pure copper.
- 0.035 in. thick annealed 302 stainless steel.
- 0.010 in. thick beryllium.
- 0.010 in. thick niobium.
- 0.032 in. thick 17-7 PH stainless steel.
- 0.040 in. thick 6-Al-4V titanium alloy.
- 6 plies of 0.008 in. thick AM-355-CRT stainless steel.

#### Dissimilar metal welds

- 0.050 in. thick Alclad to 0.101 in. magnesium.
- 0.032 in. thick annealed 302 stainless steel to 0.064 in. thick copper.
- 0.040 in. thick 2014-T6 aluminum alloy to 0.064 in. thick copper.

A comparison of the available welder capabilities is summarized in Figure 6.

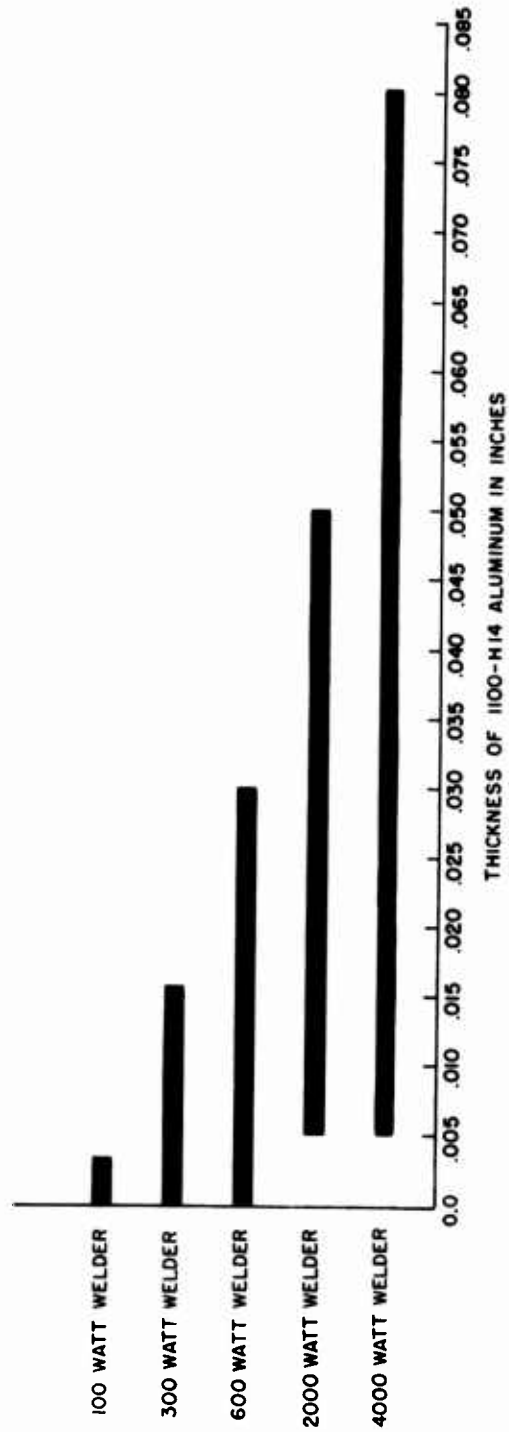

Figure 6. COMPARISON OF WELDER CAPABILITIES  
(WELD STRENGTHS IN ACCORD WITH MIL-R-6858A)

# UNCLASSIFIED

# AD

# 237 645

Reproduced

## Armed Services Technical Information Agency

ARLINGTON HALL STATION; ARLINGTON 12 VIRGINIA

**NOTICE: WHEN GOVERNMENT OR OTHER DRAWINGS, SPECIFICATIONS OR OTHER DATA ARE USED FOR ANY PURPOSE OTHER THAN IN CONNECTION WITH A DEFINITELY RELATED GOVERNMENT PROCUREMENT OPERATION, THE U. S. GOVERNMENT THEREBY INCURS NO RESPONSIBILITY, NOR ANY OBLIGATION WHATSOEVER; AND THE FACT THAT THE GOVERNMENT MAY HAVE FORMULATED, FURNISHED, OR IN ANY WAY SUPPLIED THE SAID DRAWINGS, SPECIFICATIONS, OR OTHER DATA IS NOT TO BE REGARDED BY IMPLICATION OR OTHERWISE AS IN ANY MANNER LICENSING THE HOLDER OR ANY OTHER PERSON OR CORPORATION, OR CONVEYING ANY RIGHTS OR PERMISSION TO MANUFACTURE, USE OR SELL ANY PATENTED INVENTION THAT MAY IN ANY WAY BE RELATED THERETO.**

# UNCLASSIFIED