

UNCLASSIFIED

AD 255 763

*Reproduced
by the*

ARMED SERVICES TECHNICAL INFORMATION AGENCY
ARLINGTON HALL STATION
ARLINGTON 12, VIRGINIA



UNCLASSIFIED

NOTICE: When government or other drawings, specifications or other data are used for any purpose other than in connection with a definitely related government procurement operation, the U. S. Government thereby incurs no responsibility, nor any obligation whatsoever; and the fact that the Government may have formulated, furnished, or in any way supplied the said drawings, specifications, or other data is not to be regarded by implication or otherwise as in any manner licensing the holder or any other person or corporation, or conveying any rights or permission to manufacture, use or sell any patented invention that may in any way be related thereto.

255763

CONTROLLED BY ASTIA
AS ARO, INC.



NOX

MEASUREMENT OF THE PRESSURE FLUCTUATIONS
IN THE TEST SECTION OF THE 16-FOOT TRANSONIC CIRCUIT
IN THE FREQUENCY RANGE FROM 5 TO 1000 CPS

By
H. L. Chevalier and H. E. Todd
PWT, ARO, Inc.

May 1961

83100

ARNOLD ENGINEERING
DEVELOPMENT CENTER

AIR RESEARCH AND DEVELOPMENT COMMAND



\$ 3.60



MEASUREMENT OF THE PRESSURE FLUCTUATIONS
IN THE TEST SECTION OF THE 16-FOOT TRANSONIC CIRCUIT
IN THE FREQUENCY RANGE FROM 5 TO 1000 CPS

By

H. L. Chevalier and H. E. Todd
PWT, ARO, Inc.

May 1961

ARO Project No. 220103

Contract No. AF 40(600)-800 S/A 11(60-110)

ABSTRACT

An investigation was conducted in the 16-Foot Transonic Circuit of the Propulsion Wind Tunnel Facility (PWT) to determine the inherent pressure fluctuations in the test section. Test results indicate that these pressure fluctuations are well within one percent of the free-stream dynamic pressure except at Mach numbers near 0.7. The relatively larger fluctuations near Mach number 0.7 result from a higher power spectral density in the 500 to 700 cps frequency range.

CONTENTS

	<u>Page</u>
ABSTRACT	2
NOMENCLATURE	5
INTRODUCTION	6
APPARATUS	
Test Facility	6
Test Articles	7
Instrumentation	7
TEST DESCRIPTION	
Test Conditions	9
Data Reduction	9
Precision of Measurements	10
RESULTS	10
CONCLUSIONS	12
REFERENCES	13

ILLUSTRATIONS

Figure

1. Location of the Wedge and Probe-Wing Models in the Test Section of the 16-Foot Transonic Circuit	14
2. Location of the Ogive Nose Model in the Test Section of the 16-Foot Transonic Circuit	15
3. Details of the 10-deg Wedge Model	16
4. Details of the Probe-Wing Model	17
5. Details of the Ogive Nose Model	18
6. Installation of the Models in the 16-Foot Transonic Circuit	
a. Wedge Model	19
b. Probe-Wing Model	20
c. Ogive Nose Model	21
7. Details of the Pressure Transducer Mountings for the Probe-Wing Model	
a. Forward Transducer	22
b. Aft Transducer	22
8. Details of the Pressure Transducer Mounting for the Ogive Nose Model	23

<u>Figure</u>	<u>Page</u>
9. Variation of Reynolds Number with Mach Number	
a. Wedge	24
b. Probe-Wing	24
c. Ogive Nose	24
10. Variation of the Pressure Fluctuations with Mach Number	
a. Wedge	25
b. Probe-Wing	25
c. Ogive Nose	25
11. Variation of the Pressure Fluctuations with Tunnel Total Pressures	
a. Probe-Wing	26
b. Ogive Nose	26
12. Variation of Power Spectral Density with Frequency for the Frequency Range from 100 cps to 1000 cps (50 cps Band-Pass Filter)	
a. $M_{\infty} = 0.60$	27
b. $M_{\infty} = 0.70$	27
c. $M_{\infty} = 0.80$	27
d. $M_{\infty} = 0.90$	27
e. $M_{\infty} = 1.0$	27
f. $M_{\infty} = 1.2$	27
g. $M_{\infty} = 1.6$	27
13. Variation of Power Spectral Density with Frequency for the Frequency Range from 400 cps to 800 cps (10 cps Band-Pass Filter)	
a. $M_{\infty} = 0.60$	28
b. $M_{\infty} = 0.70$	28
c. $M_{\infty} = 0.80$	28
d. $M_{\infty} = 1.00$	28

NOMENCLATURE

$F(\omega)$	Power spectral density, defined by Eq. (1), $\frac{\text{psf}^2}{\text{rad/sec}}$
f	Frequency, cps
M_∞	Free-stream Mach number
Δp	Root-mean-square amplitude of the deviation of a pressure fluctuation about a reference pressure, psf
p_t	Total tunnel pressure, psf
p_∞	Free-stream static pressure, psf
q_∞	Free-stream dynamic pressure, $0.7 p_\infty M_\infty^2$, psf
Re	Reynolds number per foot, V_∞ / ν_∞
V_∞	Free-stream velocity, ft/sec
ν_∞	Kinematic viscosity of the free stream, ft^2/sec
ω	Circular frequency, $2\pi f$, rad/sec

INTRODUCTION

The 16-Foot Transonic Circuit of the Propulsion Wind Tunnel Facility (PWT) has been frequently employed to investigate problems associated with dynamic stability, structural flutter, and surface pressure fluctuations. In this type of testing one would like to determine the response of a system to various dynamic conditions which might exist in actual flight. Any additional dynamic excitation introduced by the testing facilities, however, also acts as a system excitation which is not present in flight. Such extraneous disturbances may confuse or mask dynamic phenomena under study. It is, therefore, important to know the nature, that is, amplitude and frequency, of these foreign excitations so that the test results can be correctly interpreted.

Test section pressure fluctuations are a source of extraneous excitation which have been studied in the 16-Foot Transonic Circuit. Three tests were conducted in the Mach number range from 0.6 to 1.6 using different model shapes. Since it is difficult to design a model that is entirely free of model induced pressure fluctuations throughout this range, it was assumed that by comparing the measurements from the three different model designs, any significant model shape influence would be indicated.

The frequency range of this investigation was limited to 5 to 1000 cps. This is the range of primary interest for above mentioned tests and also the maximum range of the instrumentation employed for these tests.

APPARATUS

TEST FACILITY

The 16-Foot Transonic Circuit (PWT) is a variable density, closed-circuit wind tunnel capable of operation at Mach numbers from 0.50 through 1.60 and at stagnation pressures up to approximately two atmospheres. The test section is 16-ft square and is lined with perforated plates to allow continuous operation through the Mach number range with a minimum of wall interference. A sketch of the test section region and a detail of the test section wall liner are presented in Fig. 1. A more extensive description of the test facility is given in Ref. 1.

Manuscript released by authors April 1961.

TEST ARTICLES

Three different models were used — a wedge, a probe-wing type model, and an ogive nose with a cylindrical afterbody. The wedge was mounted on the test section wall, and the probe and ogive models were sting mounted. Figures 1 and 2 show model positions in the test section.

Details of the 10-deg wedge model are presented in Fig. 3. This model was designed to be mounted on the test section top wall, such that parasite data could be obtained during other investigations.

Figure 4 shows the details of the probe-wing type model. This probe design is similar to a model tested in several Royal Aircraft Establishment wind tunnels (Ref. 2). The probe was constructed of steel and mounted on an off-set sting. The off-set sting in conjunction with the sting-support system roll mechanism provided a means of obtaining measurements at any circumferential position on a 10-in. radius about the tunnel centerline. The model has the sharp leading edges designed primarily for Mach numbers above 1.0. It is also intended for use in the 16-Foot Supersonic Circuit of PWT.

Figure 5 shows the details of the ogive nose with the cylindrical afterbody. This model was designed and fabricated by the Martin Company in connection with fluctuating pressure tests for the Titan missile.

Installation photographs of the models in the test section are shown in Fig. 6.

INSTRUMENTATION

Various types of measuring equipment are available for determining unsteady pressures. Previous development tests at PWT have used both microphones and pressure transducers. Microphones are also quite sensitive to acceleration; consequently, it is difficult to determine whether the microphone output is caused by accelerations due to vibration of the microphone support structure or by pressure variations. For this reason, only strain-gage type pressure transducers, which are not affected by small accelerations, were used for this type investigation.

Only one pressure transducer with an amplitude range of ± 1 psi and a frequency range from 0 to 600 cps was used with the wedge model. The resonant frequency of the transducer was 4000 cps; however, the signal was filtered above 600 cps. Transducers with a resonant frequency above 4000 cps were not available at the time of this test, limiting the useful

range to 600 cps. The transducer was mounted at the base of the model with a short length of tubing connecting the pressure transducer to the orifice at the surface of the model. A reference orifice was located near the measuring orifice (Fig. 3) and connected to the reference side of the transducer with sufficient length of tubing to damp out all dynamics above approximately 5 cps.

The probe-wing model used two transducers located along the model centerline and spaced axially as shown in Fig. 4. The amplitude range of both transducers was ± 7.5 psi, and the frequency range was from 0 to 1000 cps. The resonant frequency of the transducer was 7000 cps; however, the signal was filtered above 1000 cps. The forward transducer was mounted internally with a small cavity around the surface of the transducer and connected to the surface as shown in Fig. 7a. The reference lead was also connected to the same cavity. The aft transducer was flush mounted and referenced to a small cavity around the side of the transducer as shown in Fig. 7b. The reference leads for both transducers were sufficiently long to damp out all dynamics above 5 cps.

The pressure transducer used for the ogive model was also internally mounted as shown in Fig. 8. To mount the transducer flush with the model surface would have resulted in a discontinuity of the curved model surface. For all internally mounted transducers, laboratory calibrations were made of the response of the transducers as compared to flush-mounted transducers. The results showed that the response was the same for both mountings throughout the usable frequency range of the transducers. The same type transducer with identical amplitude and frequency range was used with the ogive model as for the probe-wing model. The transducer reference lead was connected to a static orifice located on the model surface near the transducer.

The frequency response of the reference system for all three models was obtained with a pressure step input and was found to be very nearly a first order system response with a cut-off frequency of about 1 cps.

The electrical signals from all pressure transducers were recorded on magnetic tape and monitored on an oscilloscope. In addition, a true rms voltmeter was used with the probe-wing model to monitor the transducer signal during the test. A true rms voltmeter was also used to obtain pressure fluctuation data for the wedge and ogive nose models; however, this data was obtained from the magnetic tape after the tests were completed.

TEST DESCRIPTION

TEST CONDITIONS

As mentioned previously, the wedge data were taken as parasite data during another investigation. Data were obtained at various Mach numbers from 0.6 to 1.6. The Reynolds number range of the test is shown in Fig. 9a.

For the probe-wing model, measurements were made while either Mach number or tunnel total pressure was held constant and the other varied. By having a flat surface on the entire bottom side of the model, it could be pitched so that the static pressure on this surface was constant and as near to the free-stream static pressure as possible; therefore, the influence of the model was kept to a minimum. The Mach number range was from 0.6 to 1.6, and the tunnel total pressure was varied from 1175 to 2350 psf at a Mach number of 0.9.

The same test procedure was used for the ogive model, except that the angle of attack was held constant at zero. The Mach number range was from 0.7 to 1.6, and the tunnel total pressure was varied from 800 psf to 3750 psf at Mach numbers of 0.7, 0.8, 0.9, and 0.975.

Reynolds number ranges for the probe-wing and ogive models are shown in Figs. 9b and 9c. The primary variation of Reynolds number with Mach number for each model is shown as the upper solid line in Fig. 9, and the variation of Reynolds number at a constant Mach number is shown by the shaded area.

DATA REDUCTION

Selective data points were analyzed with a wave analyzer from which the power spectral density distribution of $2\pi F(\omega)$ versus frequency (f) was obtained. $F(\omega)$ is the power contribution of the pressure function $\Delta p(t)$ in an infinitesimal circular frequency increment, $d\omega$, so that the total power (or mean square pressure level) of the fluctuating pressure in the circular frequency range 0 to ω is:

$$(\Delta p)^2 = \int_0^{\omega} F(\omega) d\omega = \int_0^f 2\pi F(\omega) df \quad (1)$$

where:

$f = 600$ cps for the wedge

$f = 1000$ cps for the probe-wing model and ogive nose

To obtain power spectral densities for each data point would be both time consuming and expensive. To minimize the number of data points to be investigated using the wave analyzer, root-mean-square (rms) pressure levels (Δp) using a true rms voltmeter with the signal filtered out for frequencies above the useful range of the transducer were recorded at each test condition. These rms pressure values were plotted as a function of Mach number and total pressure to determine the test conditions of maximum pressure fluctuations. These maximum pressure fluctuations were then analyzed for frequency characteristics using the wave analyzer.

Voltages from the rms meter were recorded, and pressure fluctuations in psf (rms) were calculated and tabulated on-line during the probing test by a digital computer.

PRECISION OF MEASUREMENTS

The following table presents uncertainties which were determined by a statistical method based on a 95-percent confidence level and normal error distribution:

	$M_\infty = 0.70$	$M_\infty = 1.00$	$M_\infty = 1.60$
M_∞	± 0.005	± 0.005	± 0.003
q_∞	± 3.0 psf	± 2.0 psf	± 2.0 psf
p_t	± 5.0 psf	± 5.0 psf	± 5.0 psf

The following are estimates of the precision and were not calculated by a statistical method:

Δp	± 0.3 psf
$2\pi F(\omega)$	$\pm .002$ psf ² /cps

RESULTS

Figures 10 and 11 show variations in the ratio of the fluctuating pressure (Δp) to the free-stream dynamic pressure (q_∞) with Mach number and tunnel total pressure. Only variations with Mach number were obtained with the wedge model.

The results obtained from the wedge indicate the Δp to be approximately 0.5 percent of q_∞ , whereas the results of the probe and ogive show

values greater than 1.0 percent. However, this is to be expected since the frequency range of the transducer on the wedge model was 40 percent less than the range for the probe-wing and ogive models. Also, a check of the rms value of the instrumentation background noise was made by reading the value of the wind-off transducer signal, and it was found to be only slightly less than the minimum wind-on value obtained for each model. The equivalent pressure values of the wind-off signals were 1.0 psf for the wedge model, 3 psf for the probe model, and 3 psf for the ogive model. The wind-off instrumentation noise levels in equivalent $\Delta p/q_\infty$ are shown in Figs. 10 and 11.

When comparing the fluctuating pressure values with the wind-off values shown in Figs. 10 and 11, it can be concluded that the instrumentation background noise is usually at least one-half of the entire measured pressure fluctuation except for Mach numbers around 0.7 and for the higher total pressures. For some test conditions, for example, Mach numbers from 0.93 to 1.00 and $p_t = 800$ psf, the instrumentation background noise is equal to the measured pressure fluctuations. Also, the increase in pressure fluctuations with decreasing tunnel total pressure shown in Fig. 11 may be attributed to the increasing equivalent $\Delta p/q_\infty$ of the instrumentation noise. Since the $\Delta p/q_\infty$ values in Figs. 10 and 11 are the resultant of both test section pressure fluctuations and instrumentation noise, it can be safely concluded that the test section pressure fluctuations are well within 1 percent of q_∞ , except at a Mach number of 0.7, where 1 percent is exceeded slightly at the lower values of p_t .

Power spectral density values for selected data points are shown in Figs. 12 and 13. These figures also indicate that the largest fluctuation occurs at Mach number 0.7. The power spectral density in Fig. 12 was obtained using a 50-cps band-pass filter on the analyzer. To obtain more frequency resolution, a 10-cps band-pass filter was used for Mach numbers below 1.0 and frequencies between 400 and 800 cps as shown in Fig. 13. Both Figs. 12 and 13 show that the pressure fluctuations at Mach number 0.6 develop greater output at frequencies between 500 cps and 700 cps, and the magnitude of these fluctuations attains a maximum as the Mach number is increased above 0.7. The pressure fluctuations in this frequency range result from several bands of frequencies and no discrete frequency was observed. The source of these pressure fluctuations is not known. These fluctuations are probably being propagated upstream from the tunnel diffuser since they only exist subsonically. The power spectral densities at the other frequencies and test conditions are relatively constant.

A 10-cps band-pass filter was also used to investigate frequencies below 200 cps. The power spectral density was the same from 10 cps

to 200 cps throughout the Mach number range and agrees with the output level at 200 cps shown in Fig. 12, and no discrete frequency or band of frequencies could be observed.

For the frequency range from 5 cps to 10 cps the transducer signal was observed on an oscilloscope and oscillograph records. Although the power output could not be determined from this method, frequency characteristics could be observed. The 16-Foot Transonic Circuit compressor operates at 10 rps, and some tunnel structural vibrations have been observed near 10 cps in the region of the test section; however, no pressure disturbances were present in the airstream in the frequency range from 5 cps to 10 cps.

Figures 12 and 13 show that the differences between the frequency characteristics for the probe-wing and ogive nose models are quite small, which indicates that the influence of the models on the frequency characteristics was not appreciable.

The instrumentation background noise is included in Figs. 12 and 13; however, power spectral densities were obtained for the wind-off transducer signals for each transducer. The results showed that the power was relatively constant throughout the frequency range except for an occasional 60 cps and 400 cps input which did not affect the result of the test.

CONCLUSIONS

As a result of an investigation of the pressure fluctuations in the test section of the 16-Foot Transonic Circuit in the frequency range from 5 to 1000 cps, the following conclusions can be made:

1. The data indicate that the root-mean-square pressure fluctuations are well within one percent of the free-stream dynamic pressure except when near Mach number 0.7.
2. The pressure fluctuations that occur near Mach number 0.7 have an amplitude of approximately one percent of the free-stream dynamic pressure and prevail principally in the frequency range from 500 cps to 700 cps.
3. The pressure fluctuation spectra do not show any significant discrete frequency or band of frequencies in the Mach number range from 0.8 to 1.6.
4. Although tunnel structural vibrations have been observed near 10 cps and the tunnel compressor operates at 10 rps, no discrete pressure disturbances were present in the airstream at this frequency.

REFERENCES

1. Test Facilities Handbook, (3rd Edition). "Propulsion Wind Tunnel Facility, Vol. 3." Arnold Engineering Development Center, January 1961.
2. Owen, T. B. "An Interim Note on Measurements of Airflow Unsteadiness in Several R. A. E. Wind-Tunnels." Royal Aircraft Establishment, TMA-634, April 1959.

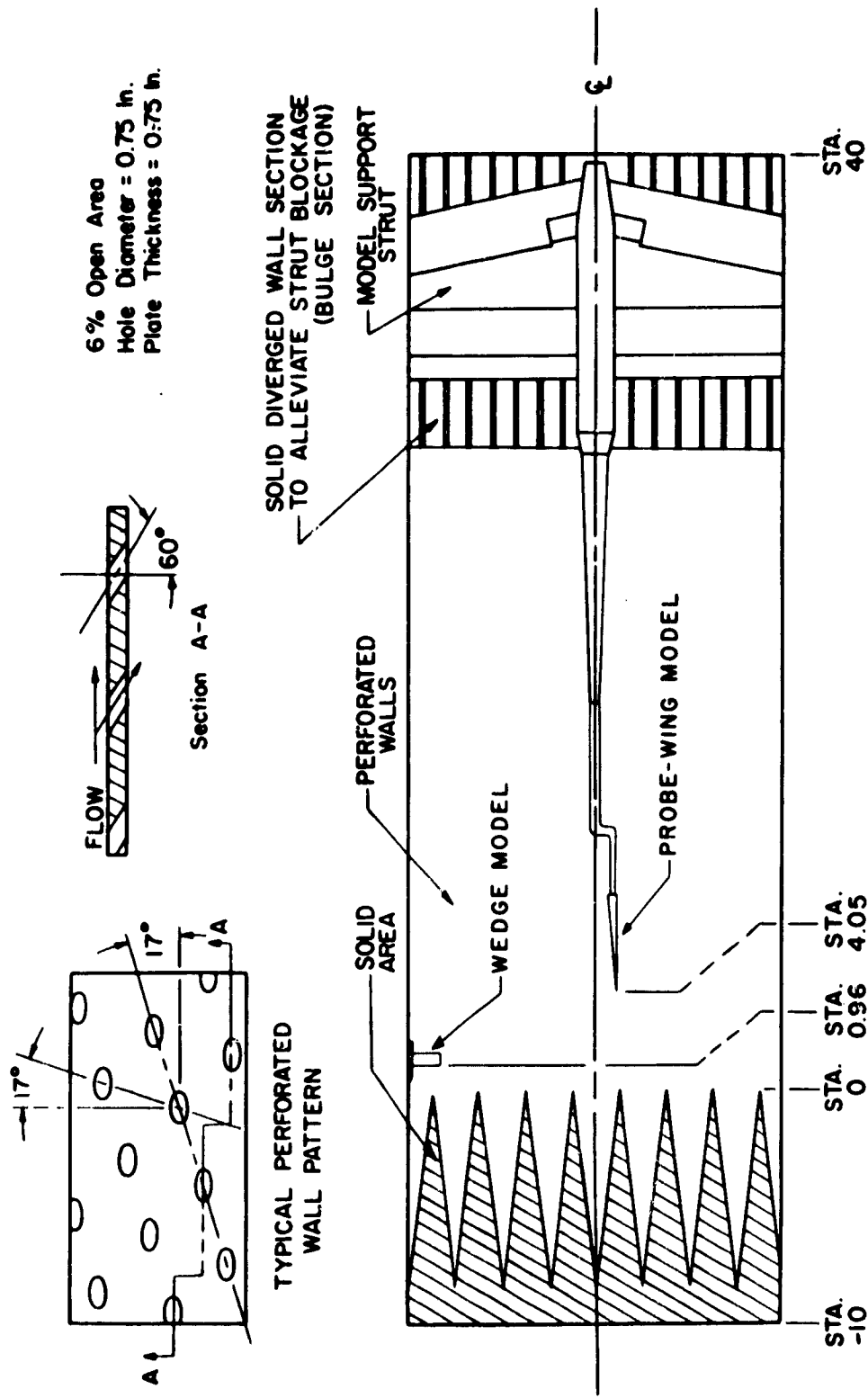

Fig. 1 Location of the Wedge and Probe-Wing Models in the Test Section of the 16-Foot Transonic Circuit

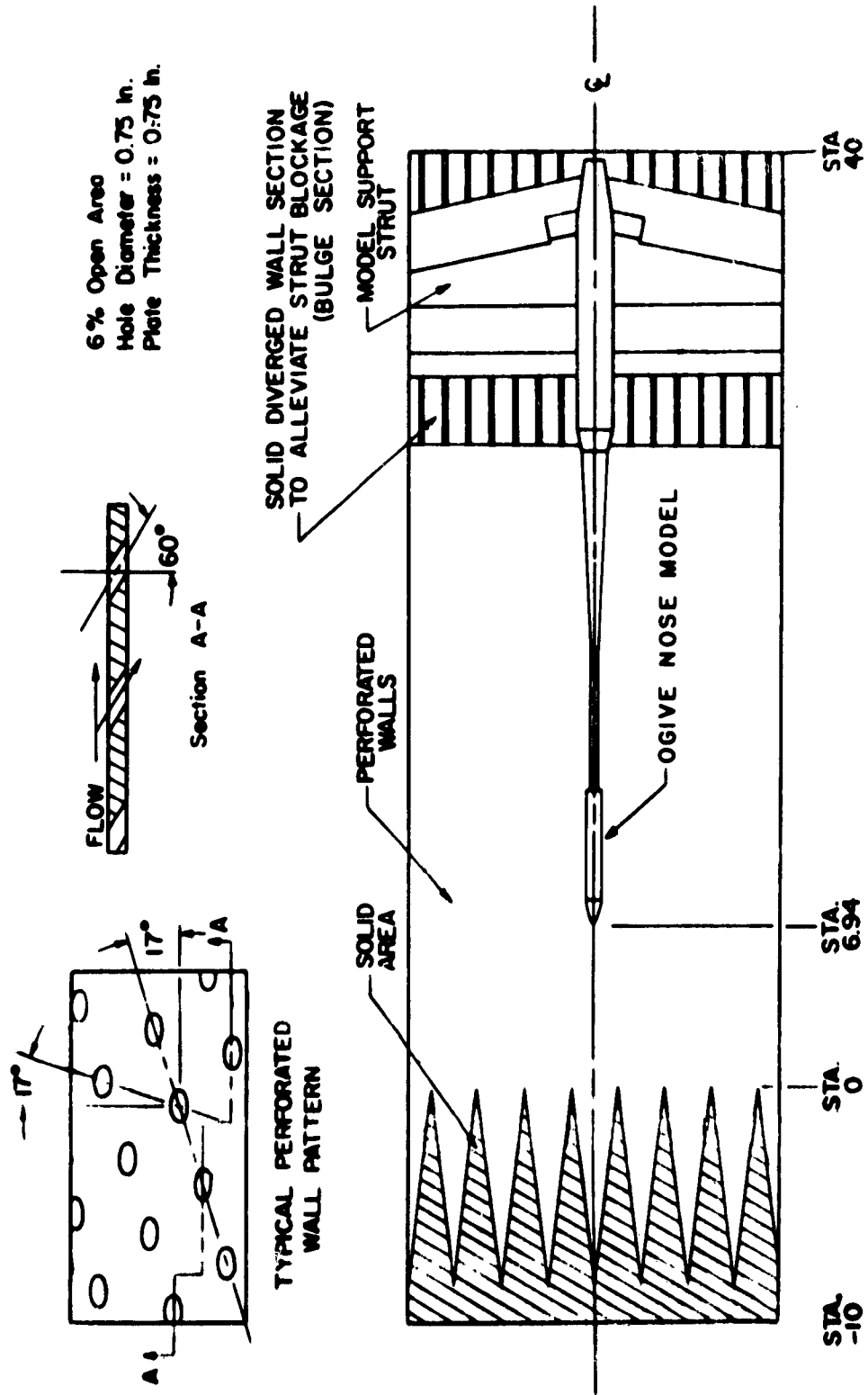
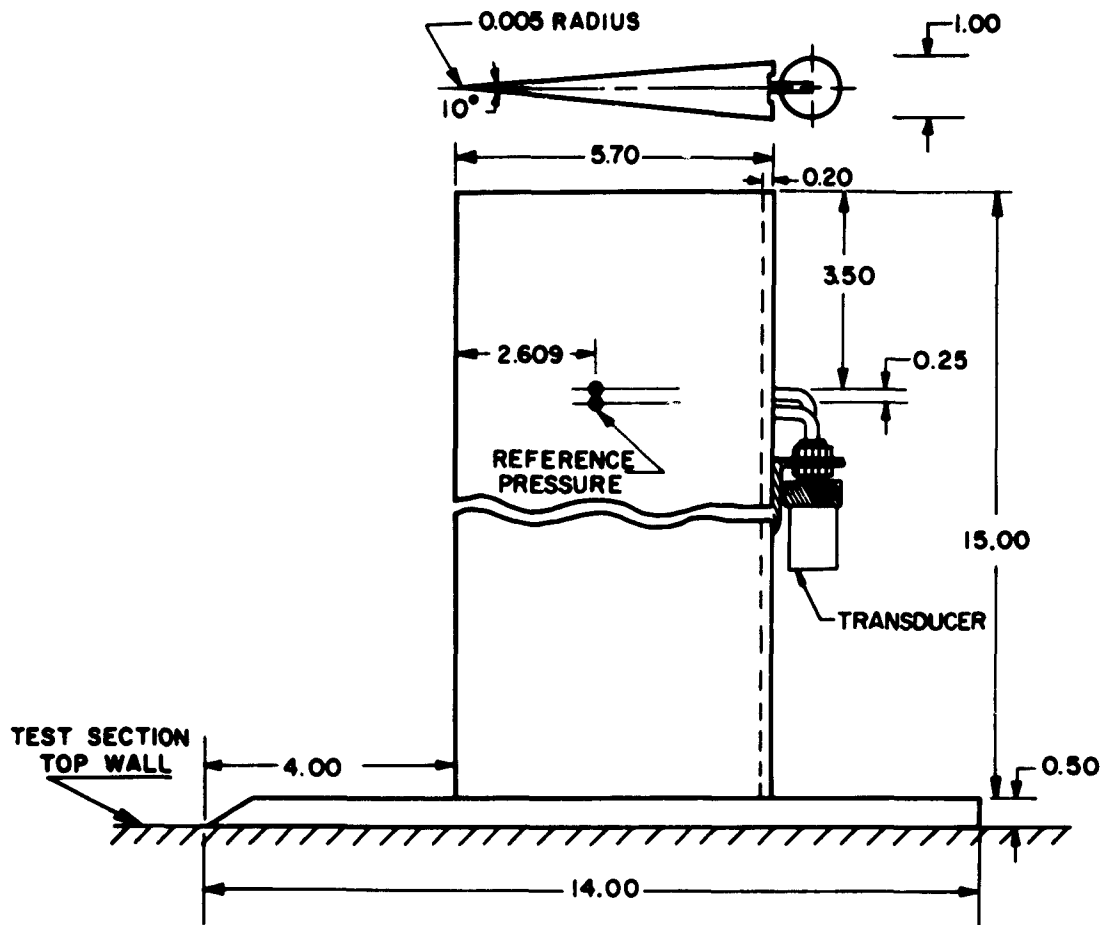
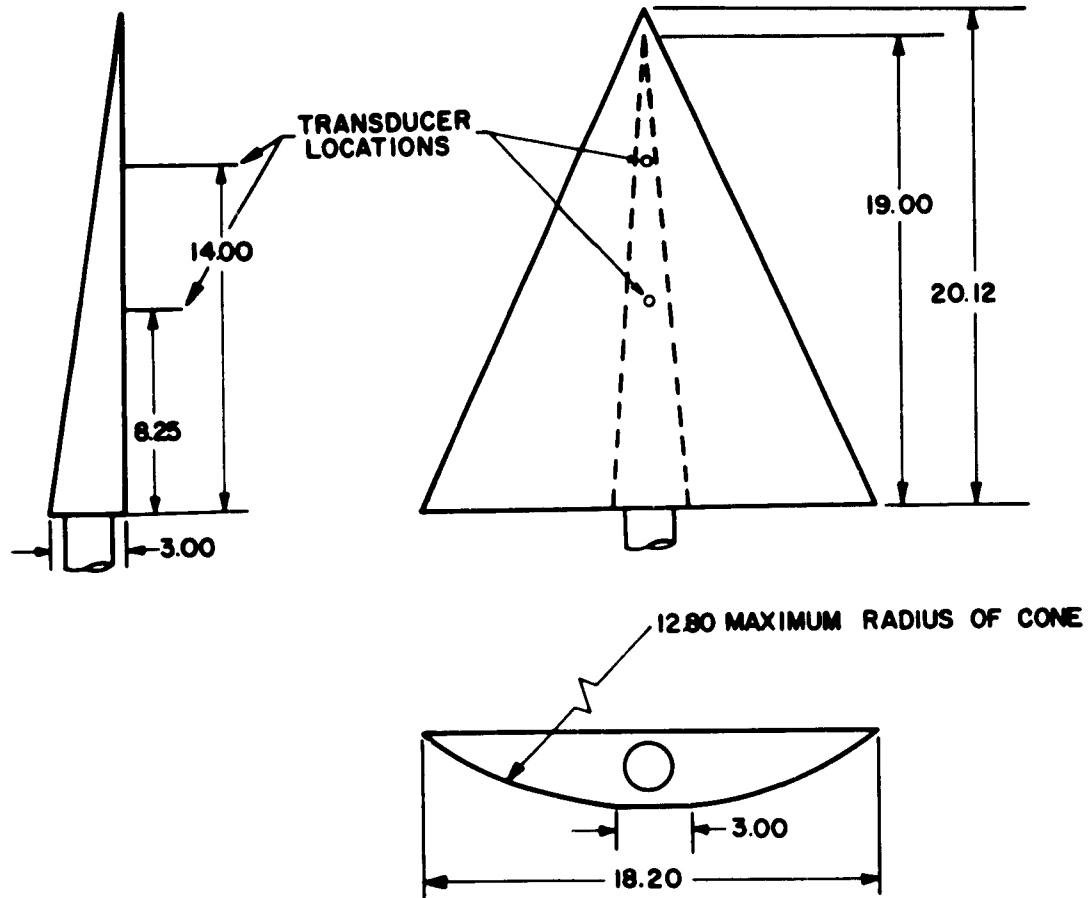

Fig. 2 Location of the Ogive Nose Model in the Test Section of the 16-Foot Transonic Circuit



ALL DIMENSIONS IN INCHES

Fig. 3 Details of the 10-deg Wedge Model



ALL DIMENSIONS IN INCHES

Fig. 4 Details of the Probe-Wing Model

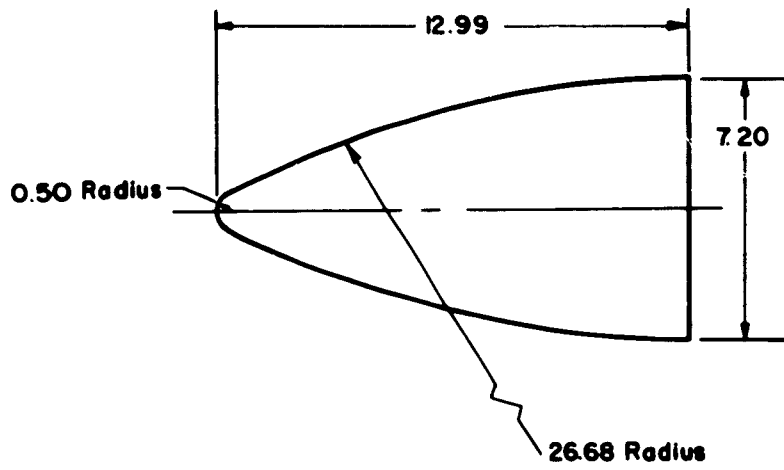
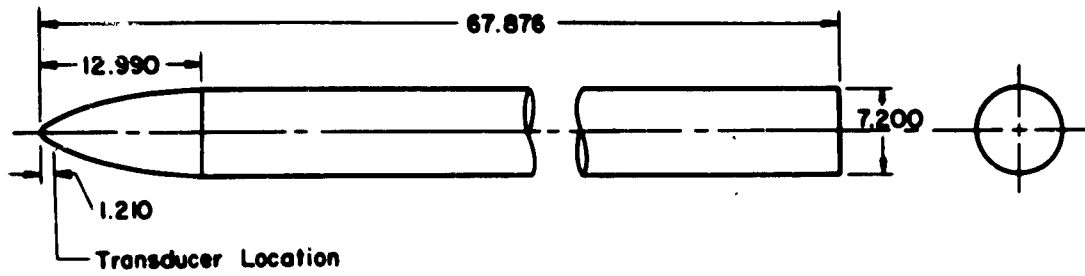

All Dimensions In Inches

Fig. 5 Details of the Ogive Nose Model



a. Wedge Model

Fig. 6 Installation of the Models in the 16-Foot Transonic Circuit



b. Probe-Wing Model
Fig. 6 Continued

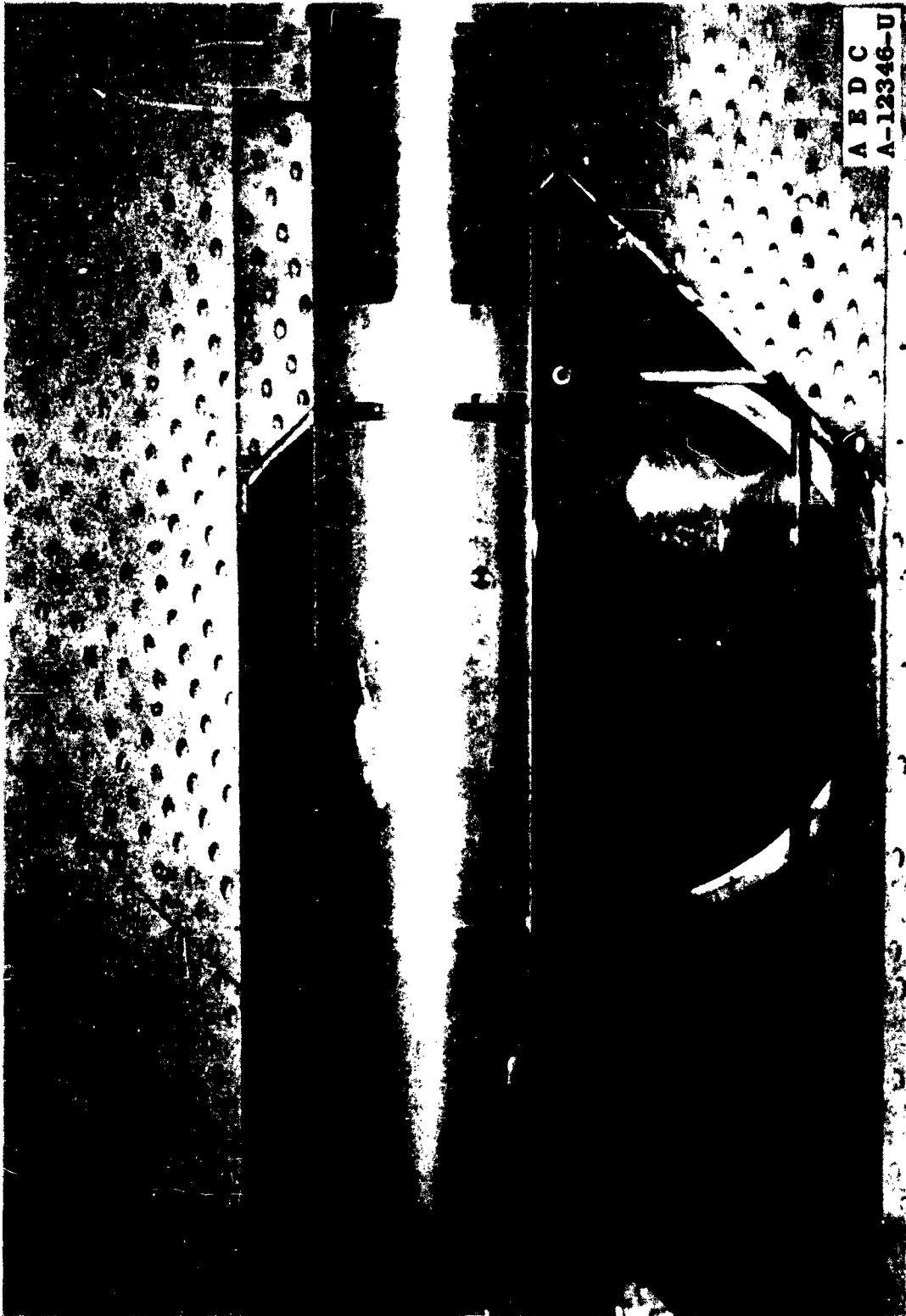

c. Ogive Nose Model

Fig. 6 Concluded

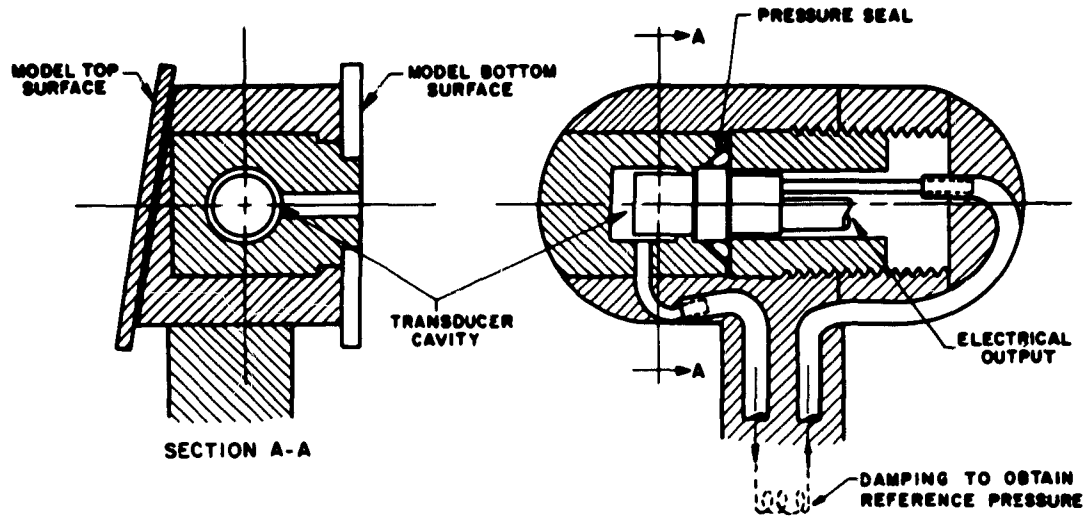

a. Forward Transducer

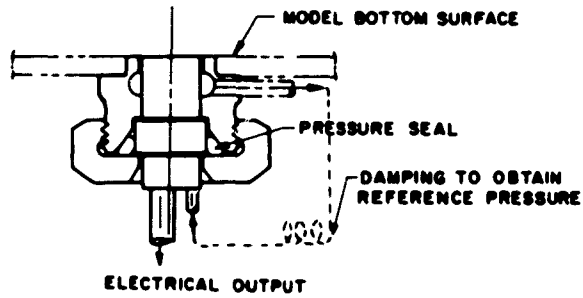

b. Aft Transducer

Fig. 7 Details of the Pressure Transducer Mountings for the Probe-Wing Model

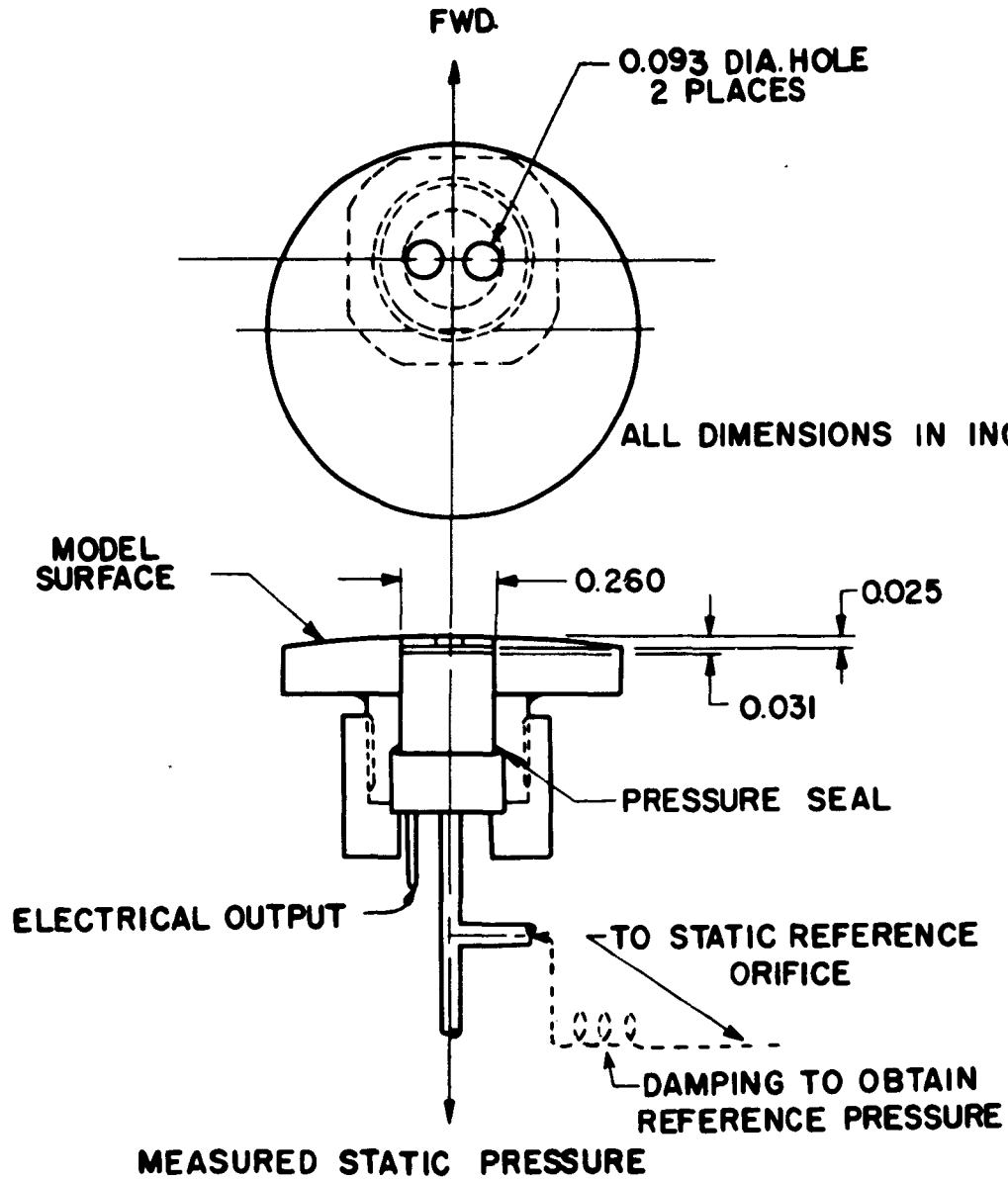

Fig. 8 Details of the Pressure Transducer Mounting for the Ogive Nose Model

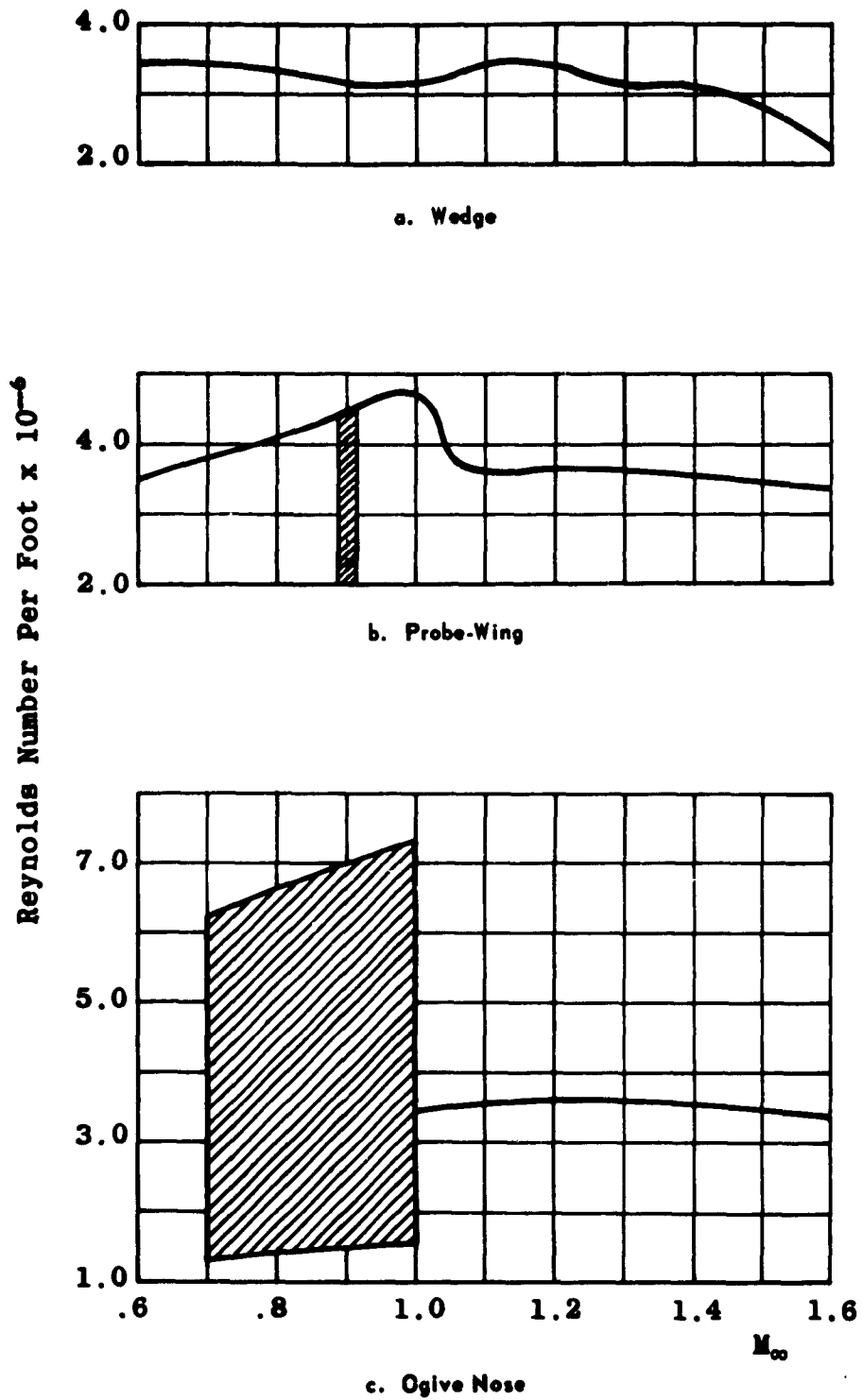

Fig. 9 Variation of Reynolds Number with Mach Number

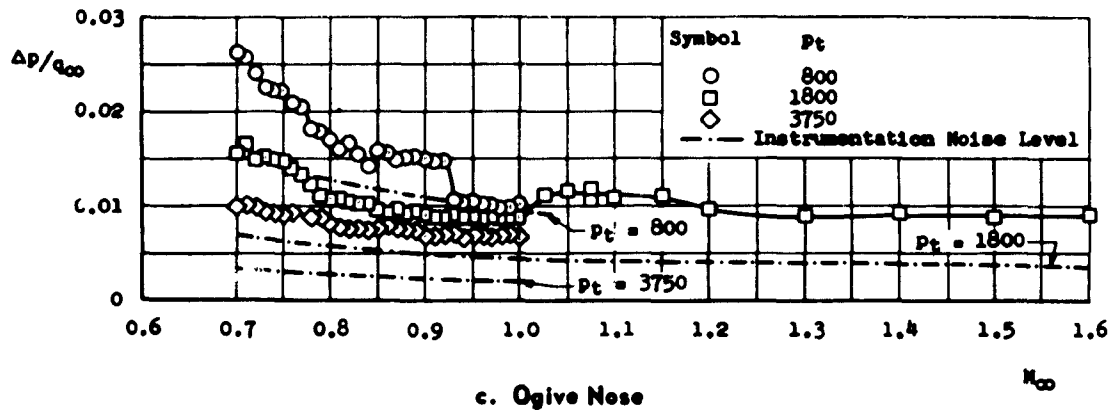
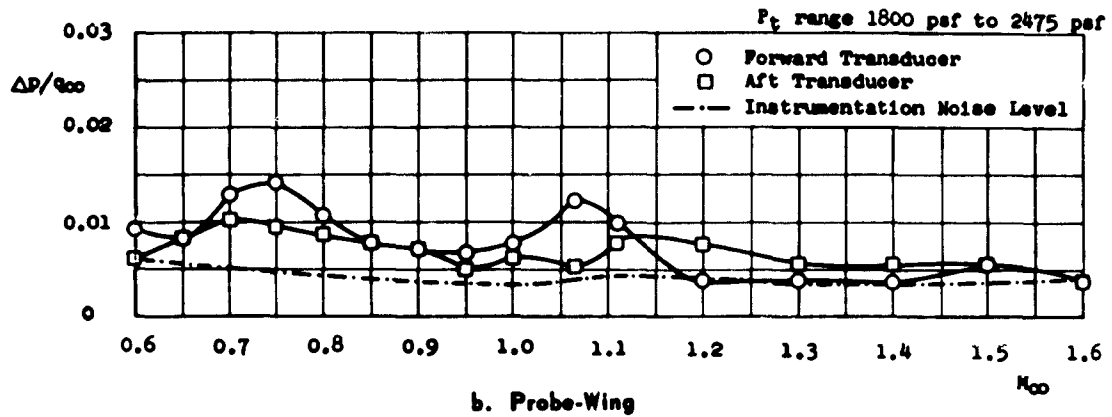
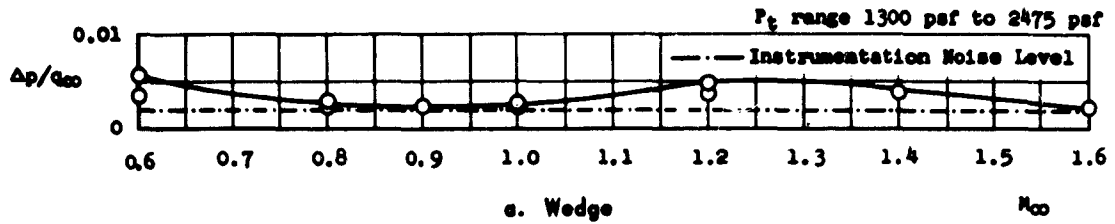

Fig. 10 Variation of the Pressure Fluctuations with Mach Number

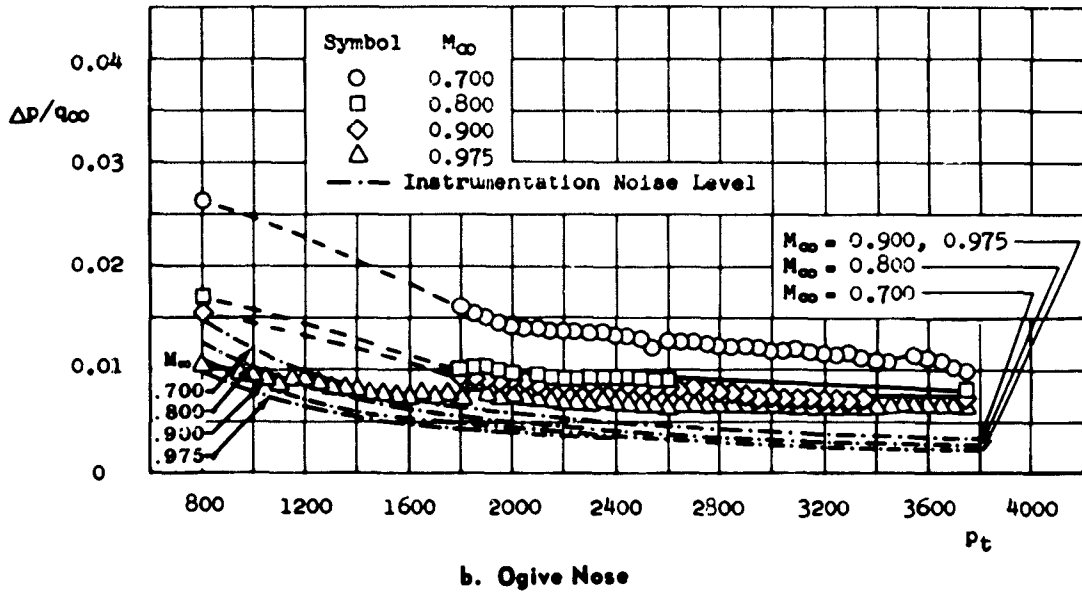
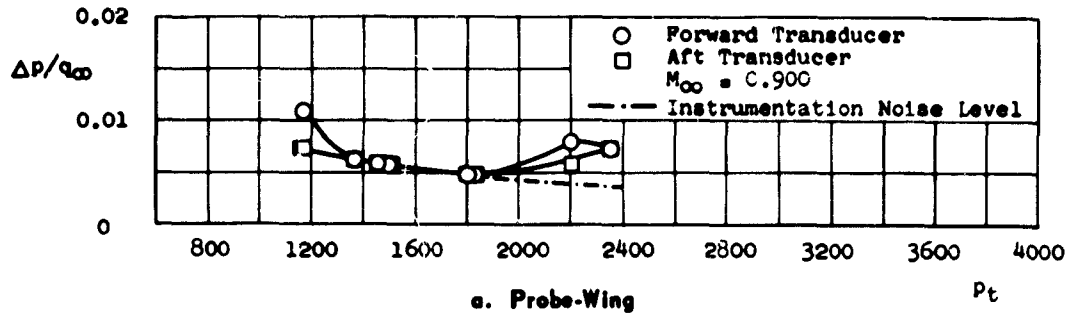

Fig. 11 Variation of the Pressure Fluctuations with Tunnel Total Pressures

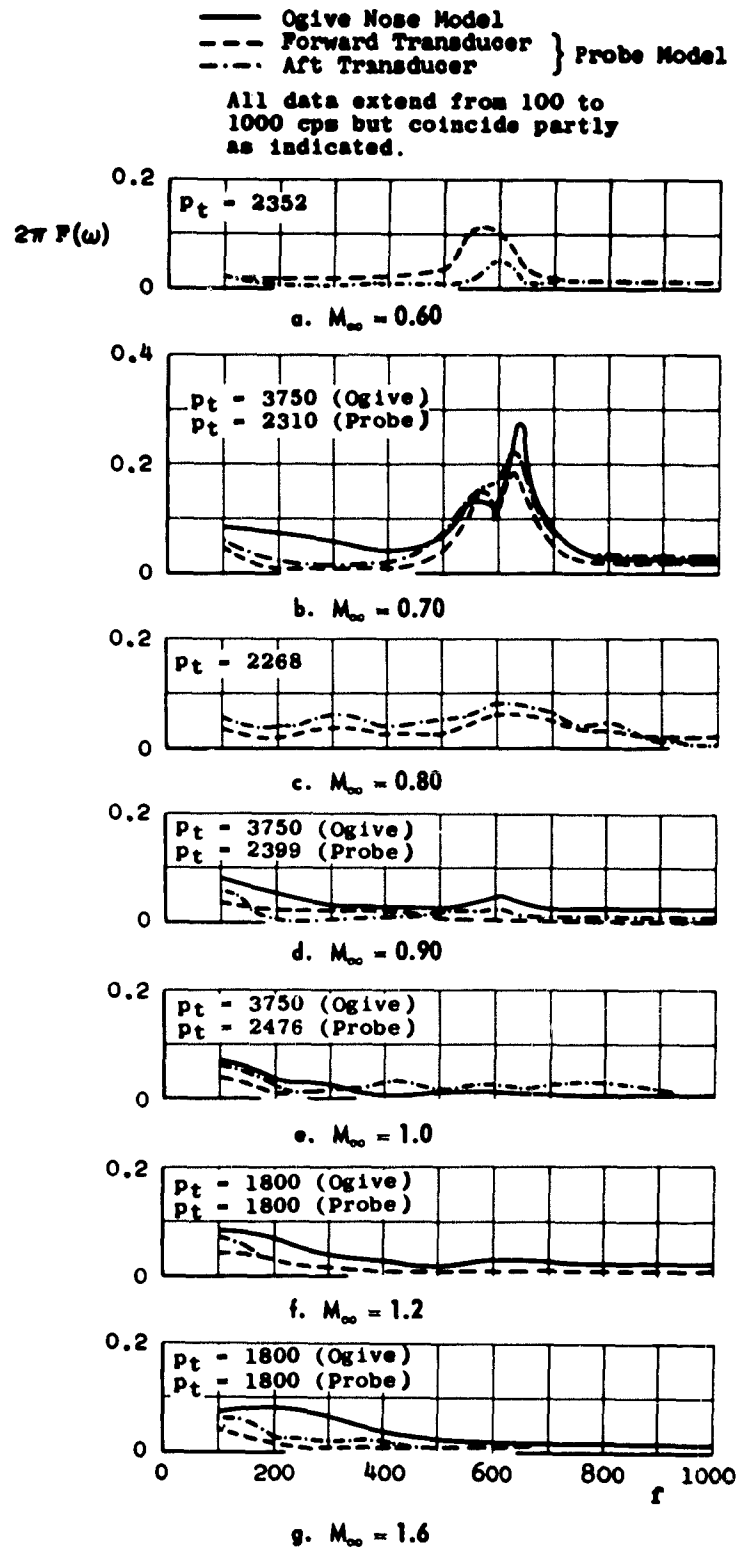

Fig. 12 Variation of Power Spectral Density with Frequency for the Frequency Range from 100 cps to 1000 cps (50 cps Band-Pass Filter)

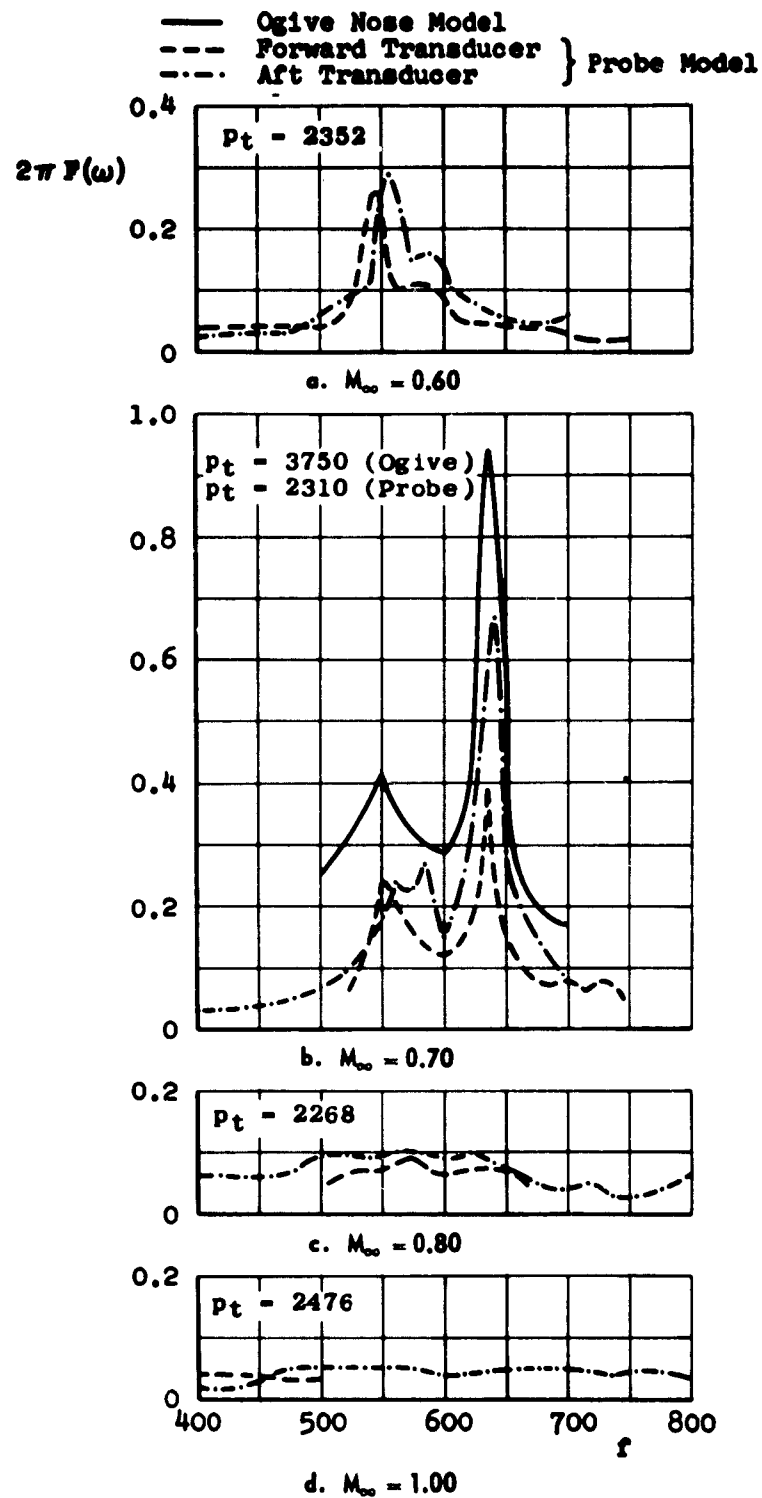

Fig. 13 Variation of Power Spectral Density with Frequency for the Frequency Range from 400 cps to 800 cps (10 cps Band-Pass Filter)

Cut on broken line

<p>AEDC-TN-61-51</p> <p>Arnold Engineering Development Center, ARO, Inc., Arnold Air Force Station, Tennessee</p> <p>MEASUREMENT OF THE PRESSURE FLUCTUATIONS IN THE TEST SECTION OF THE 16-FOOT TRANSONIC CIRCUIT IN THE FREQUENCY RANGE FROM 5 TO 1000 CPS by H. L. Chevalier and H. E. Todd, May 1961. 28 pp. (ARO Project No. 220103) (AEDC-TN-61-51) (Contract No. AF 40(600)-800 S/A 11(60-110)). Unclassified</p> <p>2 references</p> <p>An investigation was conducted in the 16-Foot Transonic Circuit of the Propulsion Wind Tunnel Facility (PWT) to determine the inherent pressure fluctuations in the test section. Test results indicate that these pressure fluctuations are well within one percent of the free-stream dynamic pressure except at Mach numbers near 0.7. The relatively larger fluctuations near Mach number 0.7 result from a higher power spectral density in the 500 to 700 cps frequency range.</p>	<p>UNCLASSIFIED</p> <p>1. Transonic wind tunnels-- Pressure fluctuations</p> <p>2. Transonic wind tunnels-- PWT</p> <p>I. Chevalier, H. L. II. Todd, H. E.</p> <p>AEDC-TN-61-51</p> <p>Arnold Engineering Development Center, ARO, Inc., Arnold Air Force Station, Tennessee</p> <p>MEASUREMENT OF THE PRESSURE FLUCTUATIONS IN THE TEST SECTION OF THE 16-FOOT TRANSONIC CIRCUIT IN THE FREQUENCY RANGE FROM 5 TO 1000 CPS by H. L. Chevalier and H. E. Todd, May 1961. 28 pp. (ARO Project No. 220103) (AEDC-TN-61-51) (Contract No. AF 40(600)-800 S/A 11(60-110)). Unclassified</p> <p>2 references</p> <p>An investigation was conducted in the 16-Foot Transonic Circuit of the Propulsion Wind Tunnel Facility (PWT) to determine the inherent pressure fluctuations in the test section. Test results indicate that these pressure fluctuations are well within one percent of the free-stream dynamic pressure except at Mach numbers near 0.7. The relatively larger fluctuations near Mach number 0.7 result from a higher power spectral density in the 500 to 700 cps frequency range.</p> <p>UNCLASSIFIED</p>
<p>AEDC-TN-61-51</p> <p>Arnold Engineering Development Center, ARO, Inc., Arnold Air Force Station, Tennessee</p> <p>MEASUREMENT OF THE PRESSURE FLUCTUATIONS IN THE TEST SECTION OF THE 16-FOOT TRANSONIC CIRCUIT IN THE FREQUENCY RANGE FROM 5 TO 1000 CPS by H. L. Chevalier and H. E. Todd, May 1961. 28 pp. (ARO Project No. 220103) (AEDC-TN-61-51) (Contract No. AF 40(600)-800 S/A 11(60-110)). Unclassified</p> <p>2 references</p> <p>An investigation was conducted in the 16-Foot Transonic Circuit of the Propulsion Wind Tunnel Facility (PWT) to determine the inherent pressure fluctuations in the test section. Test results indicate that these pressure fluctuations are well within one percent of the free-stream dynamic pressure except at Mach numbers near 0.7. The relatively larger fluctuations near Mach number 0.7 result from a higher power spectral density in the 500 to 700 cps frequency range.</p>	<p>UNCLASSIFIED</p> <p>1. Transonic wind tunnels-- Pressure fluctuations</p> <p>2. Transonic wind tunnels-- PWT</p> <p>I. Chevalier, H. L. II. Todd, H. E.</p> <p>AEDC-TN-61-51</p> <p>Arnold Engineering Development Center, ARO, Inc., Arnold Air Force Station, Tennessee</p> <p>MEASUREMENT OF THE PRESSURE FLUCTUATIONS IN THE TEST SECTION OF THE 16-FOOT TRANSONIC CIRCUIT IN THE FREQUENCY RANGE FROM 5 TO 1000 CPS by H. L. Chevalier and H. E. Todd, May 1961. 28 pp. (ARO Project No. 220103) (AEDC-TN-61-51) (Contract No. AF 40(600)-800 S/A 11(60-110)). Unclassified</p> <p>2 references</p> <p>An investigation was conducted in the 16-Foot Transonic Circuit of the Propulsion Wind Tunnel Facility (PWT) to determine the inherent pressure fluctuations in the test section. Test results indicate that these pressure fluctuations are well within one percent of the free-stream dynamic pressure except at Mach numbers near 0.7. The relatively larger fluctuations near Mach number 0.7 result from a higher power spectral density in the 500 to 700 cps frequency range.</p> <p>UNCLASSIFIED</p>