

UNCLASSIFIED

AD **257 039**

*Reproduced
by the*

ARMED SERVICES TECHNICAL INFORMATION AGENCY
ARLINGTON HALL STATION
ARLINGTON 12, VIRGINIA



UNCLASSIFIED

NOTICE: When government or other drawings, specifications or other data are used for any purpose other than in connection with a definitely related government procurement operation, the U. S. Government thereby incurs no responsibility, nor any obligation whatsoever; and the fact that the Government may have formulated, furnished, or in any way supplied the said drawings, specifications, or other data is not to be regarded by implication or otherwise as in any manner licensing the holder or any other person or corporation, or conveying any rights or permission to manufacture, use or sell any patented invention that may in any way be related thereto.

AN INVESTIGATION OF CERTAIN MEANS OF SOUND ATTENUATION
AT THE EAR

CATALOGED BY ASTIA
AS AD NO 257039

61-3-3
XEROX

Josef J. Zwislocki, Sc.D.



SYRACUSE UNIVERSITY RESEARCH INSTITUTE

AN INVESTIGATION OF CERTAIN MEANS OF SOUND ATTENUATION
AT THE EAR

Jozef J. Zwislowski, Sc.D.

June 23, 1958 --- December 31, 1960

This work was supported by a contract between the Office of Naval Research and Syracuse University. Contract: Nonr-669(11) Reproduction in whole or in part is permitted for any purpose of the United States Government.

1961

ACKNOWLEDGEMENTS

Some of the ideas which led to the investigation described on the following pages originated while I was still at the Psycho-Acoustic Laboratory, Harvard University. Quite possibly they would not have been pursued if not for the encouragement given me by Dr. S. S. Stevens, Director of the Laboratory, and Dr. E. B. Newman, Associate Director.

At Syracuse University, a first and decisive encouragement was given me by Dr. G. D. Hoople, Medical Director of the University's Hearing and Speech Center and a Trustee of the University. A further encouragement was given me by Dr. R. Trumbull, Head of the Physiological Psychology Branch of the Office of Naval Research. During the preparation of the project proposal, I enjoyed the helpful advice of the now deceased Dr. V. McLaughlin and during the project of Mr. Day, both of the Office of Naval Research.

The acceptance of the project proposal by the Office of Naval Research became a catalyst for the establishment of the Bioacoustics Laboratory which provided the needed independent organization and facilities. The decision to establish the Laboratory was taken at a conference between Mr. W. Wheadon, Director of the Research Institute of Syracuse University, Dr. W. Cruickshank, Director of the Division of Special Education, Dr. W. LePage, Chairman of the Department of Electrical Engineering and Dr. M. Trippe, Director of the Office of Research in Special Education and Rehabilitation. Prior to the establishment of the Bioacoustics Laboratory, Dr. L. M. DiCarlo, then Director of the Gordon D. Hoople Hearing and Speech Center, provided some space and equipment for the preliminary experi-

ments. During the whole project we enjoyed the valuable advice and effective help from Mr. W. Patchen, Business Manager of the Research Institute, and from Dr. M. Trippe, Director of the Office of Research in Special Education and Rehabilitation.

Some of the work required by the project had to be carried out in industrial plants. Mr. F. A. Verrillo and Mr. E. Sheldon provided the necessary contacts, and helpful technical advice. Gray-Syracuse Company produced a large number of samples for field testing, and Mr. J. Garret of this company helped greatly in obtaining them.

Dr. R. Verrillo of the Bioacoustics Laboratory assisted me with a great deal of skill and patience in developing the basic models of the investigated ear protectors. Mr. T. Lynch helped with the acoustic tests.

To all those mentioned above I wish to express my sincere gratitude for their help.

My appreciation goes also to Mr. Madonna, Head of the Research Institute's Machine Shop and to Mr. K. Chapman, one of its mechanics, for the many molds and ear protector parts manufactured on short notice.

Last but not least, I would like to mention all those who, for various periods of time, were on the staff of the project. Dr. A. S. Feldman and Mr. D. Shepard served as audiologists, Mr. E. Sheldon as chemist, Messrs. K. Korolenko, R. Ryan, S. Madonna and R. Gardinier as technicians, Mrs. S. Branscomb and Mrs. B. Nettle as secretaries.

My special thanks goes to Mrs. S. Zwislocki for her help in editing this report.

TABLE OF CONTENTS

	Page
ACKNOWLEDGEMENTS	ii
INTRODUCTION	vi
CHAPTER I	
THEORY OF SOUND ATTENUATION AT THE EAR	
1. Motion of an earmuff relative to the head	1
2. Sound attenuation provided by ear protectors	10
3. Optimum dimensions of ear protectors	20
CHAPTER II	
THEORY OF RESONATOR EARPLUGS	
1. Motion of earplugs relative to the ear canal	24
2. Sound attenuation by plain earplugs	25
3. Sound attenuation by resonator earplugs	28
CHAPTER III	
DEVELOPMENT OF RESONATOR EARPLUGS	
1. Preliminary experiments	33
2. Development of a standard resonator	37
3. Development of insert and semi-insert tips	39
4. Development of the headband	42
CHAPTER IV	
PSYCHOPHYSICAL EVALUATION OF RESONATOR EARPLUGS	
1. Effect of the resonator size	45
2. Effect of the resonator	46
3. Effect of the resonator volume	49
4. Effect of the mass of the resonator	50
5. Effect of the resonator damping	51
6. Effect of the insert tips	52
7. The resonator semi-inserts	53
CHAPTER V	
PHYSICAL EVALUATION OF RESONATOR EARPLUGS	
1. Evaluation of the resonator action	56
2. Resonator earplugs as earphone couplers	58

	Page
CHAPTER VI	
PSYCHOPHYSICAL TESTS OF THE RECEIVER-RESONATOR SYSTEM	
1. Threshold of audibility	62
2. Speech intelligibility	63
CHAPTER VII	
SUMMARY AND CONCLUSIONS	66
REFERENCES	71

INTRODUCTION

Noise control has become one of the most important aspects of acoustics. The publication of the Journal of Noise Control by the Acoustical Society of America and of a Handbook of Noise Control by McGraw-Hill Book Company bear witness to this development. The increasingly powerful engines, mass production coupled with automation, and the growing density of population in numerous centers have produced a steadily growing level of environmental noise in many places of human activity and rest. Under most circumstances, noise is identified with unwanted sound. It can interfere with various human activities and particularly with auditory communication. It can produce annoyance and disturb people at rest. For these reasons engineers and architects have undertaken numerous efforts to keep the noise at an acceptable level. Their success has been far from complete, and in a growing number of situations personal ear protectors must be used.

Numerous ear protectors, which should be called more accurately "acoustic ear protectors," are available on the market. They can be divided in two broad classes: earplugs and earmuffs. Earplugs are inserted into the external auditory canal and are usually made of a soft material in order to avoid discomfort. Earmuffs cover the whole external ear and are kept in place by a headband or a helmet. They consist of a hard shell fitted to the side of the head by means of a soft resilient cushion.

Simple ear protectors perform two main functions: they protect the sensitive parts of the ear against injury by excessive noise, and they reduce the annoyance or distraction effects of noise. In conjunction with earphones and microphones, they improve voice com-

munication. They are also needed in hearing testing whenever a sufficiently quiet room is not available.

A more extensive discussion of ear protectors can be found in Chapter 8 of C. M. Harris's Handbook of Noise Control (4). Nevertheless, a few more things about the earplugs and the earmuffs have to be mentioned here, because they show the reasons for the research described in this report.

First of all, it should be stated that ear protectors have a long history during which a large number of various models became known. The proliferation of suggested technical solutions reflects extreme technical difficulties in satisfying often conflicting requirements rather than a variety of possible applications. The configuration of the outer ear canal and of the side of the head as well as the sensitivity of the skin to pressure impose serious limitations on the construction and efficiency of ear protectors. The use of soft materials dictated by the considerations of comfort and the flexibility of the skin decrease substantially the attainable sound attenuation.

For a long while it appeared that earplugs promised a better chance of overcoming the existing difficulties. Several types were developed, which offered satisfactory sound attenuation and reasonable comfort. Earmuffs were considered almost exclusively as a means of coupling earphones to the ears. They provided little attenuation at low and medium frequencies.

The situation changed radically in the 1950's, due to the advent of the jet engine. The existing ear protectors became insufficient and a search for improved means began. During this phase it became evident that the development of earplugs reached a dead end, at least with respect to sound attenuation. At the same time a theoretical

and experimental reconsideration of earmuffs led to insights which permitted considerable acoustic improvements. Several models of earmuffs have exceeded the best available earplugs in their sound attenuation at medium and high frequencies, and are now chosen as ear protectors at the highest noise levels men have to endure.

In spite of this success, earmuffs have their limitations. A high sound attenuation requires large dimensions, and the bulk of the most effective earmuffs must be considered objectionable in many industrial and military applications. Furthermore, even the largest earmuffs provide little noise reduction at low frequencies which can produce an effective masking of speech sounds. Finally, the efficiency of an earphone placed under the earmuff is low, due to the large volume of air involved in sound transmission.

The present insufficiency of earplugs and the shortcomings of earmuffs have stimulated a search for still different means of sound attenuation at the ear. This search has been further encouraged by observations made in connection with experiments on acoustic sound transmission between the ears and on bone conduction. Békésy (1) connected perforated earplugs to pieces of plastic tubing and could vary the sound attenuation by changing the column of air coupled to the ear canal. The present investigator (18) succeeded in substantially increasing the sound attenuation in certain frequency bands by coupling perforated earplugs to small acoustic resonators.

The two experimental leads in conjunction with the theory of sound attenuation at the ear and the recent measurements of the acoustic impedance at the eardrum brought about the development of the ear protectors described in this report. They combine certain advantages of earplugs with those of earmuffs and make it possible to achieve a

high sound attenuation without objectionable bulk. They can serve as simple ear protectors or as earphone couplers.

The main portion of the project was devoted to an investigation of the basic properties of the new type of ear protectors. Although several production prototypes have been developed, the practical results achieved cannot be considered final. On the contrary, we hope that the way has been opened for further substantial improvements.

CHAPTER I

THEORY OF SOUND ATTENUATION AT THE EAR1. Motion of an earmuff relative to the head

The theory of sound attenuation by ear protectors was discussed in several papers and is summarized in Harris's Handbook of Noise Control (17). In addition to the references mentioned in the Handbook, pertinent information can be found in the 1955 Symposium on Physiological Psychology held in Pensacola (16) and in a more recently published article by Shaw and Thiessen (10). Because of certain aspects of the research described in this report, a restatement of the theory appears in order.

In previous theoretical evaluations only the motion of the ear protector in a sound field was considered; the head was assumed to be stationary. Furthermore, only a piston-like rectilinear motion was allowed. The theory presented below has been freed of these restrictions, and as a consequence, has led to new insights.

The complex shape of the head and of most earmuffs precludes an exact mathematical theory. Nevertheless, using rather far reaching simplifications, it is possible to gain an insight into some relationships. It is assumed, first of all, that the head can be approximated by a sphere with a radius $a_H = 9\text{cm}$, and a total mass $m_H = 3.5\text{ Kg}$ and, consequently, a mean density of 1.15 g/cm^3 . The ear protector is approximated by a shell with an external cross sectional area S_M , an internal cross sectional area S_i , and a depth D (Fig. 1). The mass of the ear protector is denoted by m_M and its mean density amounts to

$$\frac{m_M}{V_M} = \rho_M.$$

The ear protector can move relative to the head, since its hard

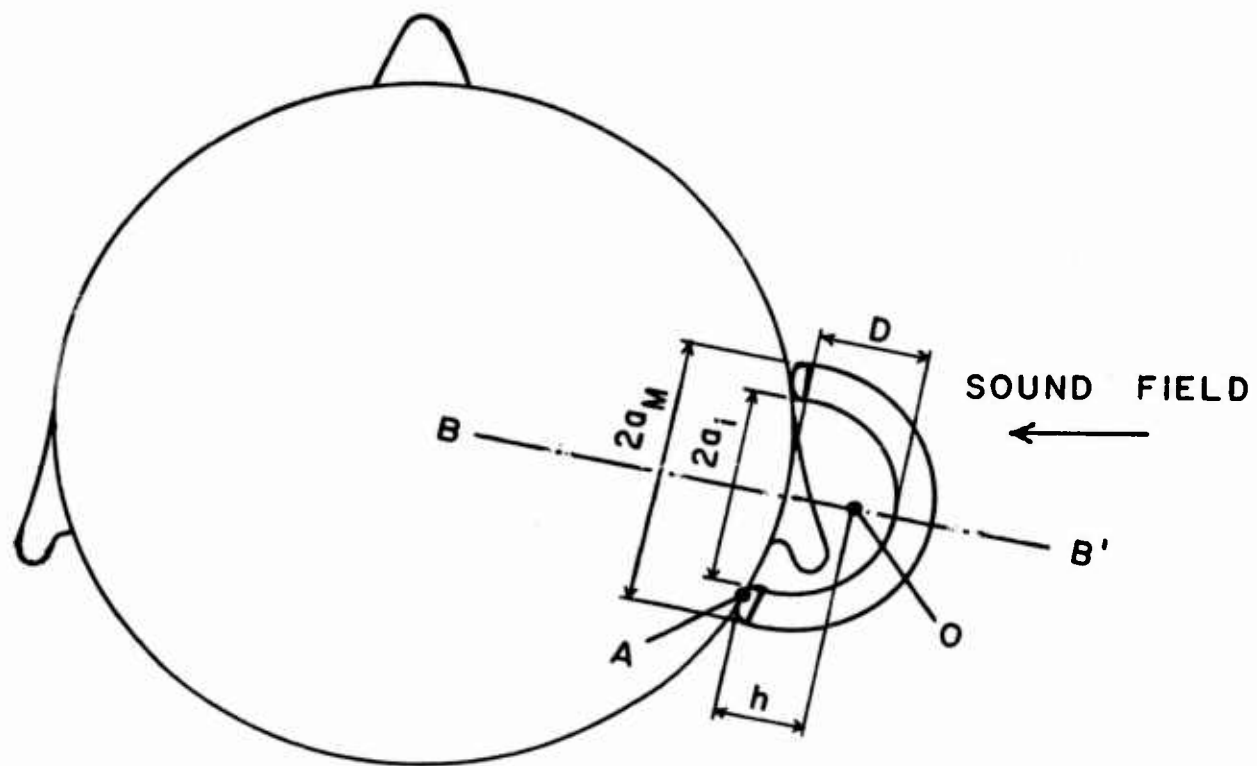

Fig. 1. Schematic drawing of an earmuff covering the ear.

shell rests on a flexible cushion and is separated from the skull by a layer of soft tissue. The cushion is necessary to achieve a tight seal and prevent discomfort. In general, the hard shell can rotate as well as move rectilinearly. In the following, only those motions will be considered which change the volume of air enclosed by the ear protector and, consequently, generate a sound pressure at the ear drum. Two situations are considered. In the first, the sound waves strike the head laterally, in the second, from the front.

The head with an earmuff on one ear and exposed to a lateral sound field is shown schematically in Fig. 1. It is assumed that the angle between the field and the axis B-B' which passes through the center of the earmuff and is perpendicular to the side of the head is small. It is assumed further that the earmuff moves piston-like parallel to the axis B-B' and also rotates around the axis A which is perpendicular to the plane of the drawing. The axis A lies in the interface between the sealing cushion and the mastoid process where the layer of soft tissue is thinner than at any other location around the ear and, consequently, the earmuff motion the most restrained

At low and medium frequencies, the sound field acting on the earmuff generates a force

$$F_M = p \times S_M, \quad (1)$$

where p denotes the sound pressure at the surface of the earmuff and S_M the cross sectional area of the earmuff at the junction with the head surface. It also generates a moment

$$M_M = F_M \times a_M, \quad (2)$$

If the head is held still, the force F_M and the moment M_M produce a composite motion of the earmuff with a velocity

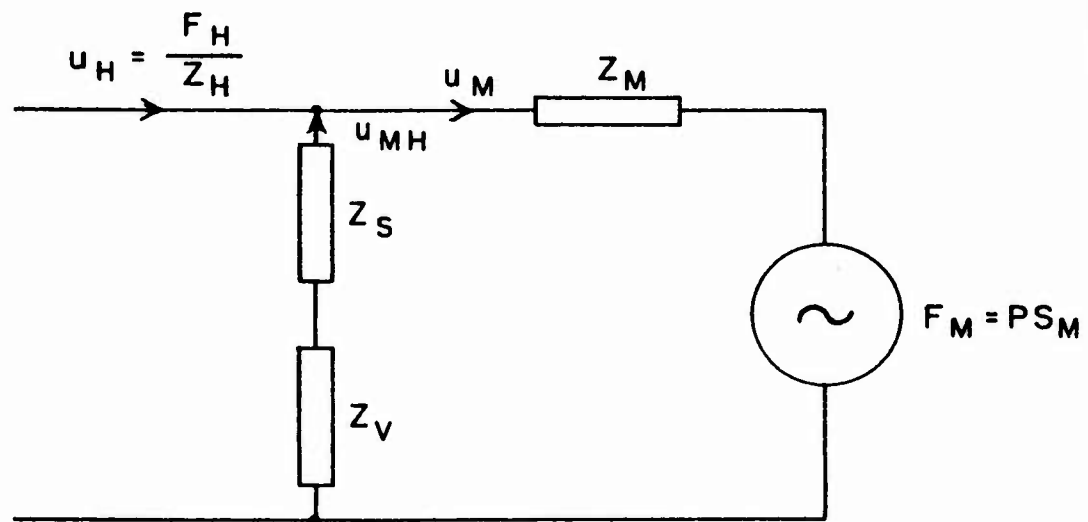

Fig. 2. An analog circuit of an earmuff secured on one side of the head.

$$u_M = \frac{F_M}{Z_M' + Z_S' + Z_V'} + \frac{M_M}{(Z_M'' + Z_S'' + Z_V'')a_M} \quad (3)$$

at the center of gravity O. In the last equation Z_M' and Z_S' , Z_V' and Z_M'' , Z_S'' and Z_V'' are impedance components due to the mass of the earmuff, to the mechanical properties of the sealing cushion and of the underlying tissue, and to the volume of air enclosed between the muff and the head surface, respectively. Since Eq. 3 can be written in the form

$$u_M = \frac{F_M}{Z_M' + Z_S' + Z_V'} + \frac{F_M a_M}{(Z_M'' + Z_S'' + Z_V'')a_M}, \quad (4)$$

or

$$u_M = F_M \left(\frac{1}{Z_M' + Z_S' + Z_V'} + \frac{1}{Z_M'' + Z_S'' + Z_V''} \right), \quad (5)$$

the impedances Z_M' , Z_S' , Z_V' and the impedances Z_M'' , Z_S'' , Z_V'' belong to two parallel channels and can be combined into a resultant impedance, so that

$$u_M = \frac{F_M}{Z_M + Z_S + Z_V}. \quad (6)$$

Now, the effect of the head motion can be introduced conveniently. The situation is illustrated by the circuit diagram of Fig. 2, where Z_M , Z_S , and Z_V have the same meaning as in Eq. 6, Z_H denotes the impedance of the head, and u_{MH} the velocity of the earmuff relative to the head. The velocity u_{MH} follows from the circuit diagram of Fig. 2 to

$$u_{MH} = \frac{F_M - \frac{Z_M}{Z_H} F_H}{Z_M + Z_S + Z_V} \quad (7)$$

Since Z_M is approximately equal to $j\omega m_M$ and Z_H to $j\omega m_H$, Eq. 7 can be rewritten in the form

$$u_{MH} = \frac{F_M - \frac{m_M}{m_H} F_H}{Z_M + Z_S + Z_V} \quad (8)$$

The last equation determines approximately the velocity of the center of gravity of the earmuff with respect to the head. The velocity u_{MH} is considered to be nearly perpendicular to the surface of the head.

When the sound source is in front of the head, three forces have to be considered in order to describe the motion of the earmuff. One force is generated directly by the pressure of the sound field and amounts approximately to $F_M = p \times S_M$. The second force stems from the pressure gradient across the earmuff; the third from the motion of the head, and indirectly, from the pressure gradient across the head.

The force exerted by a plane sound field on a sphere can be described by the equation (14)

$$F = 4\pi a^2 p (2/\pi ka)^{1/2} [H_{3/4}(ka) - ka H_{5/2}(ka)]^{-1}, \quad (9)$$

where a means the radius of the sphere, $k = \frac{2\pi f}{c}$ (f -sound frequency, c -speed of sound), and $H_{3/4}$ and $H_{5/2}$ are Hankel functions. Equation 9 describes approximately the acoustic force acting on the head, since the shape of the head can be approximated by a sphere with a radius $a_H = 9$ cm. For values of ka smaller than one the force F is nearly proportional to sound frequency and to the cube of the radius. For the head this is true up to about 600 cps. Consequently, it is possible to write for low frequencies

$$F_H = K a_H^3 f p. \quad (10)$$

Numerical calculations show that $K \approx 1.4 \times 10^{-3}$ sec cm⁻¹.

Under the action of the force F_H the head moves with a velocity

$$u_H = \frac{F_H}{j\omega m_H} \quad (11)$$

Looking at Fig. 1, it is not difficult to discover that a head motion perpendicular to the axis B-B' must produce a moment

$$M_{MH} = -j\omega u_H m_M h. \quad (12)$$

When u_H is expressed in terms of Eq. 11, the last equation becomes

$$M_{MH} = -F_H \frac{m_M}{m_H} h. \quad (13)$$

On the assumption that the shape of the earmuff can be approximated by a hemisphere, equation 10 can be applied to describe the force acting on the earmuff as a result of the pressure gradient.

$$F'_M = \frac{K}{2} a_M^3 f p. \quad (14)$$

This force is approximately perpendicular to the axis B-B' and located at a distance h' from the surface of the head. The exact location depends on the configuration of the earmuff, but it can be assumed that h' is of the same order of magnitude as h , the distance of the center of gravity. Consequently, we shall consider $h' = h$. Under these conditions, the force F'_M generates a moment

$$M'_M = F'_M h \quad (15)$$

and the resultant moment on the earmuff is

$$M_{ML} = (F'_M - F_H \frac{m_M}{m_H}) h \quad (16)$$

For purposes of further calculations, we divide the moment M_M by the distance between the axis of rotation and the axis B-B' which goes through the center of gravity of the earmuff. The result is a force perpendicular to the surface of the head and anchored at the center of gravity:

$$F_{MM} = \frac{h}{a_M} (F'_M - F_H \frac{m_M}{m_H}) \quad (17)$$

The total resultant force on the earmuff generated by a frontal field amounts to

$$F_F = F_M + \frac{h}{a_M} (F'_M - F_H \frac{m_M}{m_H}). \quad (18)$$

It produces a velocity perpendicular to the surface of the head,

$$u'_{MH} = \frac{F_M + \frac{h}{a_M} (F'_M - \frac{m_M}{m_H} F_H)}{Z_M + Z_S + Z_V} \quad (19)$$

Before the difference between the effects of the lateral and the frontal fields can be evaluated it is necessary to realize that the force F_M is approximately 90° out of phase with the force F_H . This is so because the first is generated by the sound pressure and the second by the gradient of sound pressure. The forces F'_M and F_H are approximately in phase, since both are generated by the gradient. As a consequence, the absolute magnitudes of the velocities u_{MH} and u'_{MH} are, respectively,

$$|u_{MH}| = \frac{(F_M^2 + \frac{m_M^2}{2} F_H^2)^{1/2}}{|Z_M + Z_S + Z_V|} \quad (20)$$

and

$$u'_{MH} = \frac{\left[F_M^2 + \frac{h^2}{a_M^2} \left(\frac{m_M}{m_H} F_H - F'_M \right)^2 \right]^{1/2}}{|Z_M + Z_S + Z_V|} \quad (21)$$

The velocity u'_{MH} produced by the frontal sound field differs from the velocity u_{MH} stemming from the lateral field by the terms $\frac{h}{a_M}$ and F'_M . From the configuration of the earmuff it follows that $\frac{h}{a_M}$ is of the order of 1/2. In order to evaluate the contribution of F'_M , we can compare it to $\frac{m_M}{m_H} F_H$. From Eqs. 10 and 14 we obtain

$$\frac{F'_M}{\frac{m_M}{m_H} F_H} = \frac{a_M^3}{2a_H^3} \times \frac{m_H}{m_M}, \quad (22)$$

and since $\frac{m_H}{m_M} = \frac{2a_H^3 \rho_H}{a_M^3 \rho_M}$, where ρ_H and ρ_M stand for mean specific densities,

$$\frac{F'_M}{\frac{m_M}{m_H} F_H} = \frac{\rho_H}{\rho_M} \quad (23)$$

With the help of the last expression, Eq. 21 can be transformed into

$$|u'_{MH}| = \frac{\left[F_M^2 + \frac{m_M^2}{4m_H^2} F_H^2 \left(1 - \frac{\rho_H}{\rho_M} \right)^2 \right]^{1/2}}{|Z_M + Z_S + Z_V|} \quad (24)$$

A comparison of Eqs. 20 and 24 shows that the vibration of the earmuff relative to the head surface tends to be smaller for a frontal sound field than for a lateral one, except for very light earmuffs.

When $\frac{\mathcal{S}_M}{\mathcal{S}_H} < \frac{1}{3}$, the reverse is true. Such light devices would be very ineffective, however, and are not worth considering. In commercial devices it is usual to find $\frac{\mathcal{S}_M}{\mathcal{S}_H} \approx \frac{1}{2}$. Under these circumstances, the difference in earmuff motion generated by the frontal and the lateral fields is but slight. In view of this finding, the following considerations will be limited to the frontal field which is standard in testing of ear protectors. It must be emphasized, however, that under some conditions, particularly when the ear protector is heavy, the effect of the lateral field may be considerably greater than that of the frontal field.

The next step is to evaluate the contribution of the head motion to the relative motion between the head and the earmuff. For this purpose, Eq. 19 can be rewritten in the form

$$u'_{MH} = u_1 + u_2, \quad (25)$$

with

$$|u_1| = \frac{\left(F_M^2 + \frac{h^2}{2} F_M'^2 \right)^{1/2}}{|Z_M + Z_S + Z_V|} \quad (26)$$

and

$$|u_2| = \frac{\frac{h m_M}{a_M m_H} |F_H|}{|Z_M + Z_S + Z_V|} \quad (27)$$

The velocity u_1 is produced by a direct action of the field on the earmuff, u_2 is due to the head motion. Their ratio amounts to

$$\frac{|u_2|}{|u_1|} = \frac{\frac{hm_M}{a_M m_H} |F_H|}{(F_M^2 + \frac{h^2}{2} \frac{F_M'^2}{a_M})^{1/2}} \quad (28)$$

or, when F_H , F_M and F_M' are replaced by their expressions from Eqs. 1, 10 and 14:

$$\frac{|u_2|}{|u_1|} = \frac{\frac{hm_M}{a_M m_H} K a_H^3 f}{(S_M^2 + \frac{h^2}{2} \frac{K^2}{4} a_M^6 f^2)^{1/2}} \quad (29)$$

The numerical values of several terms in the last equation have been established already. They are: $a_H = 9\text{cm}$; $K = 1.4 \times 10^{-3} \text{ sec cm}^{-1}$; $\frac{h}{a_M} = .5$. On the basis of commercially available devices it is reasonable to assume that $a_M = 5\text{cm}$ and $S_M = 80\text{cm}^2$. With these values we obtain

$$\frac{|u_2|}{|u_1|} = \frac{.5 \frac{m_M}{m_H} f}{80(1 + .3 \times 10^{-6} f^2)^{1/2}} \quad (30)$$

Since $.3 \times 10^{-6} f^2$ is considerably smaller than one even at a frequency of 1,000 cps, and we are only trying to establish the order of magnitude of the ratio $\frac{|u_2|}{|u_1|}$, we can simplify Eq. 30 to

$$\frac{|u_2|}{|u_1|} = 6.3 \times 10^{-3} \frac{m_M}{m_H} f \quad (31)$$

The mass of an earmuff with a radius $a_M = 5\text{cm}$ can be assumed to approximate 200g, so that with $m_H = 3.5\text{Kg}$

$$\frac{|u_2|}{|u_1|} = .36 \times 10^{-3} f. \quad (32)$$

The last expression shows that the contribution of the head motion grows with frequency. It is small at low frequencies and even at 1,000 cps $|u_2|/|u_1|$ does not exceed 1/3 substantially. Nevertheless, a heavier earmuff would change this situation radically. Increasing the mass from .2 Kg to 1.5 Kg would increase the ratio $|u_2|/|u_1|$ to 2.5 at 1,000 cps, and the effect of the head movement would become noticeable even at frequencies in the neighborhood of 200 cps. Of course, such a heavy earmuff is unlikely to be used in practice. The contribution of the head motion, as defined by Eq. 27, could be underestimated. This is so, because the ratio $\frac{h}{a_M}$ may be greater than the assumed value of .5 and the head does not vibrate entirely as a rigid body. Furthermore, part of the earmuff rests on the mandible of the lower jaw which can move relative to the skull. Such a movement would produce an additional motion of the earmuff relative to the skull. It should be clear, therefore, that the motion of the head may have a noticeable effect on the acoustics of ear protectors.

The inclusion of the head motion in the theory of sound attenuation provided by ear protectors permits us to answer several questions which have arisen in the course of previous investigations. They will be considered in the next section.

2. Sound attenuation provided by ear protectors

The vibration of an earmuff or of any other ear protector relative to the head produces a sound pressure in the ear canal. The ratio of this sound pressure to the sound pressure at the outside of the ear protector may be considered a measure of sound attenuation.

At reasonably low frequencies this measure should not depart considerably from a more conventional measure, where the sound pressure is measured at the same location, once with the ear protector in place, and once with the ear protector removed.

Combining Eqs. 25, 26 and 27, and ignoring the force F'_M , we can write for the frontal field

$$|u'_{MH}| = \frac{(F_M^2 + \frac{h^2}{a_M^2} \frac{m_M^2}{m_H^2} F_H^2)^{1/2}}{|Z_M + Z_S + Z_V|} \quad (33)$$

or, introducing the expressions for F_M and F_H from Eqs. 1 and 10,

$$|u'_{MH}| = \frac{(S_M^2 + \frac{h^2}{a_M^2} \frac{m_M^2}{m_H^2} K^2 a_H^6 f^2)^{1/2}}{|Z_M + Z_S + Z_V|} p \quad (34)$$

If the velocity u'_{MH} is regarded as the mean velocity of an earmuff at the surface of the head, then the sound pressure generated inside the earmuff amounts to

$$p_i = u'_{MH} Z_V / S_i, \quad (35)$$

where Z_V is the mechanical impedance of the air volume enclosed by the earmuff, and S_i the area of the head surface delimited by the sealing cushion. The sound attenuation A follows to

$$A = \frac{|p|}{|p_i|} = \frac{S_i}{|Z_V|} \frac{|Z_M + Z_S + Z_V|}{(S_M^2 + \frac{h^2}{a_M^2} \frac{m_M^2}{m_H^2} K^2 a_H^6 f^2)^{1/2}} \quad (36)$$

Preceding investigations have shown that, except at very low frequencies, $Z_S + Z_V \ll Z_M$, so that

$$A = S_i |Z_M| / \left[|Z_V| \left(S_M^2 + \frac{h^2}{a_M^2} \frac{m_M^2}{m_H^2} K^2 a_H^6 f^2 \right)^{1/2} \right]. \quad (37)$$

The mechanical impedance $Z_M = j2\pi f m_M$, and for simple earmuffs, the

$$Z_V = \frac{\rho_0 c^2 S_i^2}{j2\pi f V_i}, \text{ where } V_i \text{ means the volume of air enclosed by the ear-}$$

muff, ρ_0 —the specific density of air, and c —the speed of sound. Consequently, Eq. 37 can be written in the form

$$A = 4\pi^2 f^2 V_i m_M / \rho_0 c^2 S_i \left(S^2 + \frac{h^2}{a_M^2} \frac{m_M^2}{m_H^2} K^2 a_H^6 f^2 \right)^{1/2}. \quad (38)$$

The last equation provides an explanation for two phenomena noticed by Shaw and Thiessen (10). First of all, they observed that the attenuation provided by an experimental earmuff was less dependent on the mass of the earmuff than they would have expected. Their theoretical prediction was made on the assumption that the motion of the earmuff was mass controlled and the head stationary. Under such conditions, Eq. 38 can be simplified to

$$A = 4\pi^2 f^2 V_i m_M / \rho_0 c^2 S_i S_M, \quad (39)$$

and the attenuation A becomes proportional to the mass of the earmuff m_M . However, when Shaw and Thiessen increased the mass of their earmuff from 490g to 1490g the sound attenuation increased only 2db, instead of 9db. The earmuff had the following dimensions:

$S_M = S_i = 53 \text{ cm}^2$ and $V_i = 105 \text{ cm}^3$. When these dimensions are intro-

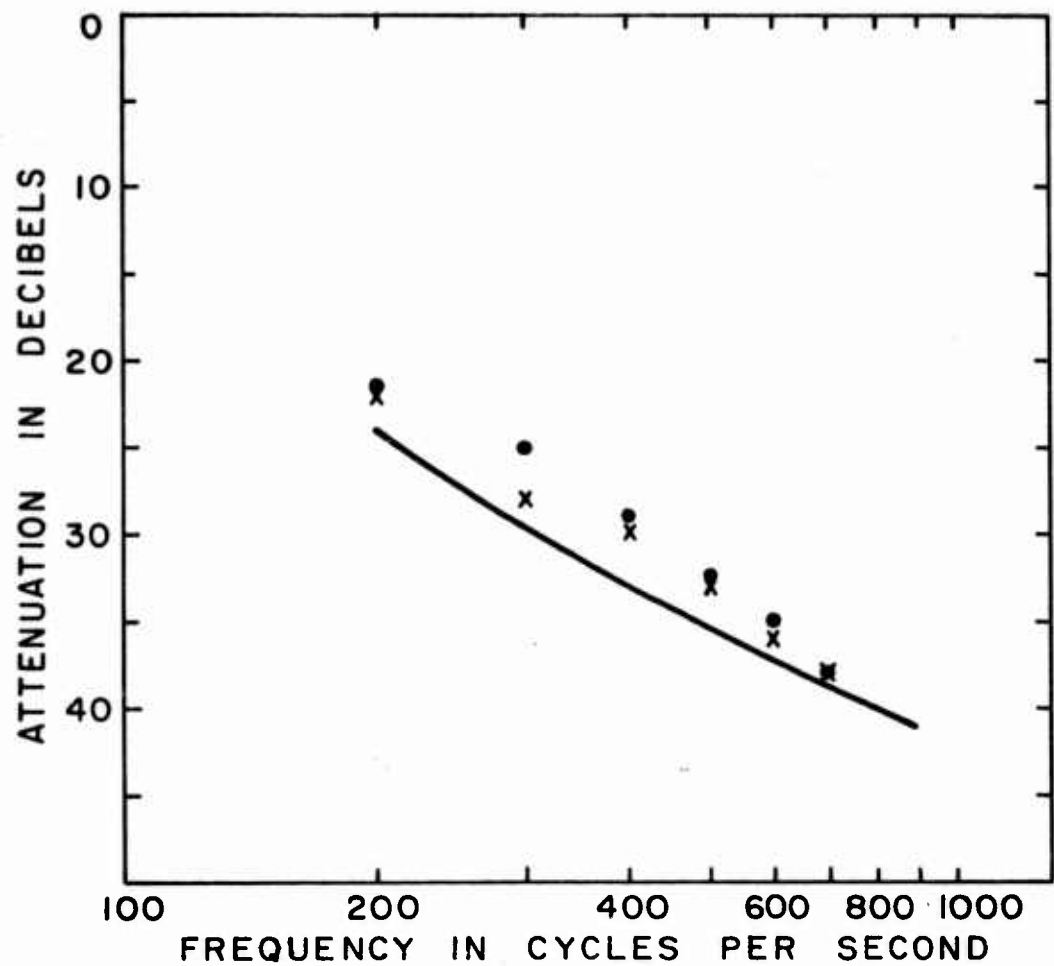

Fig. 3. Sound attenuation provided by an experimental earmuff. The points indicate experimental values, the curve is theoretical.

duced into Eq. 38 an attenuation of approximately 40db results for the smaller mass and of 45db for the larger at a frequency of 500 cps. Both the absolute attenuation and the difference in attenuation between the two earmuffs are too large when compared to the experimental values, although the attenuation difference is substantially smaller than 9db. The discrepancy may be attributed to the underestimation of the effect of head motion. In the experimental earmuff the quotient $\frac{h}{a_M}$ may have been larger than .5 and the experiments were performed in a spherical sound field rather than in a plane one. If, in view of these considerations, the effect of the head motion is increased three times, an attenuation of 35db is obtained for the lighter earmuff and of 36db for the heavier one at 500 cps. These figures are close to the experimental data and the remaining discrepancy of 2db in absolute attenuation may be attributed to the uncertainty in determining S_i and S_M .

The second observation of Shaw and Thiessen concerns the sound attenuation as a function of frequency. According to Eq. 39 the attenuation should increase with the square of sound frequency when the motion is mass controlled. However, the experiments have shown a lesser dependence. This is in agreement with Eq. 38 which includes the effect of head motion. The attenuation values calculated by means of this equation for the lighter earmuff are compared with the values computed from the data obtained by Shaw and Thiessen in Fig. 3. The theoretical curve is somewhat flatter than required by the experimental data, which indicates that the effect of the head motion has been slightly exaggerated. The difference between the absolute values may reflect the uncertainty in the determination of S_M and S_i , as has been mentioned above. In any case, the inclusion of the head

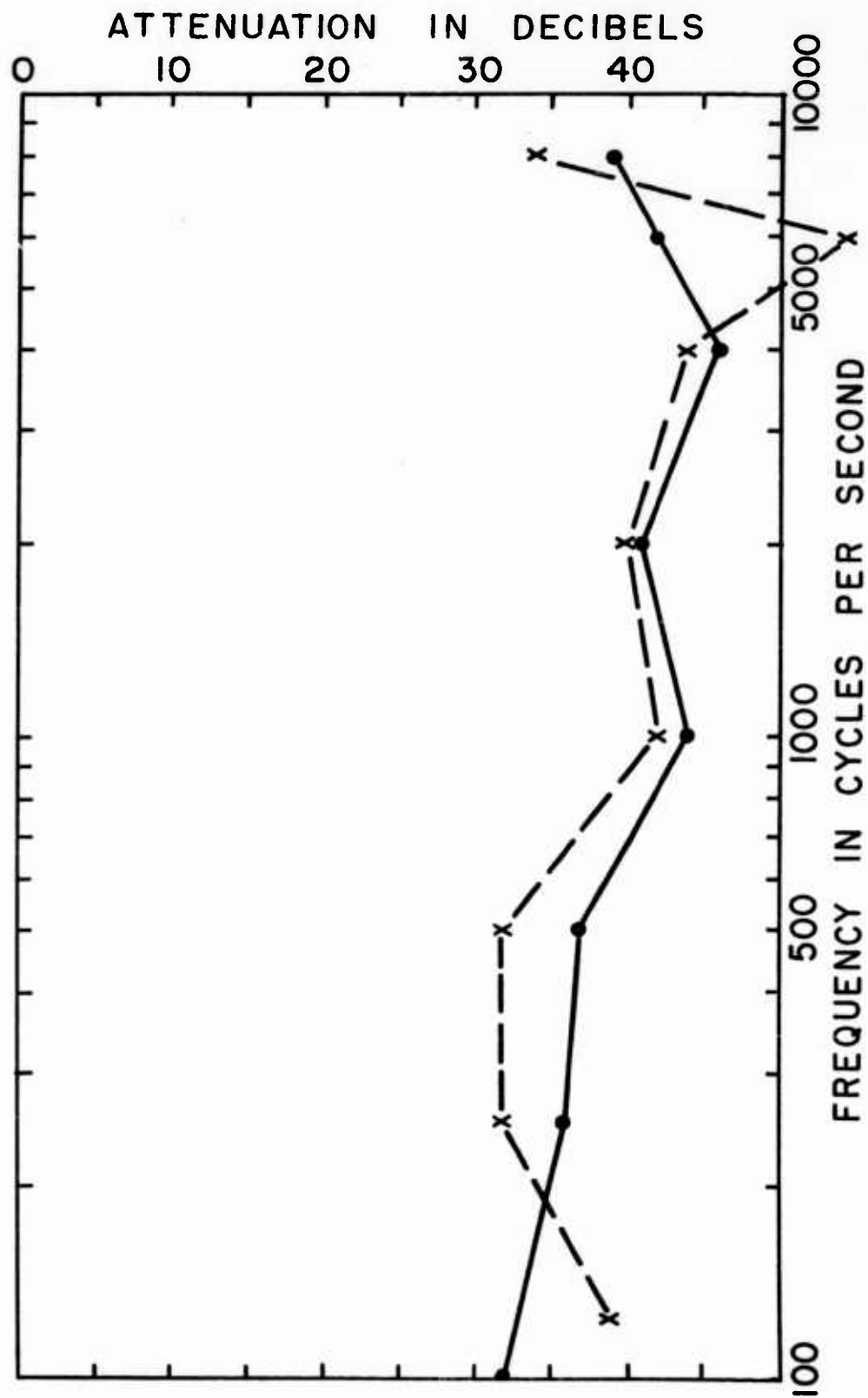

Fig. 4. Sound attenuation provided by earplugs and earmuffs worn together. The solid curve was obtained with light earplugs, the broken curve with heavy earplugs.

motion into the calculation can account fully for the fact that the sound attenuation is less than proportional to the square of the sound frequency, even though the sound transmission is controlled by the inertia of the ear protector.

Maybe the most important contribution of the theory introduced above is the explanation of the unexpectedly low sound attenuation that is achieved by means of earmuffs and earplugs in combination (17). It is a well known phenomenon that, when the ears are occluded with earplugs and covered with earmuffs, the resultant sound attenuation is smaller than the sum of attenuations provided by each device separately. The phenomenon remained hitherto unexplained. However, the recognition of the effect of the head motion leads to a plausible rationale.

It is not difficult to demonstrate theoretically that the sound attenuation provided by earplugs depends on the same parameters as that provided by earmuffs. Consequently, a somewhat generalized Eq. 36 should apply to the earplug situation

$$A_p = \frac{S_i}{|Z_V|} \frac{|Z_p + Z_S + Z_V|}{(S_o^2 + \gamma^2 \frac{m_p^2}{m_H^2} K_a^2 6 f^2)^{1/2}} \quad (40)$$

where A_p - sound attenuation by an earplug, S_i - the cross sectional area of the ear canal, S_o - the cross sectional area of the earplug at the entrance to the ear canal, m_p - the mass of the earplug, Z_p - the mass impedance of the earplug, and γ - a dimensionless constant which depends on the make of the earplug and the configuration of the ear canal; the other terms have the same meaning as in Eq. 36.

When the ear is covered by an earmuff, the direct effect of the sound field on the earplug is practically eliminated under favorable

conditions. This amounts to an omission of the terms S_0^2 in Eq. 40. The resultant sound attenuation becomes, therefore,

$$A'_P = \frac{S_1}{Z_V} \frac{|Z_P + Z_S + Z_V|}{\gamma \frac{m_P}{m_H} K a_H^3 f} \quad (41)$$

Its ratio with the attenuation obtained by means of earplugs, allow amounts to

$$\frac{A'_P}{A_P} = \frac{(S_0^2 + 2 \gamma \frac{m_P}{m_H} K^2 a_H^6 f^2)^{1/2}}{\gamma \frac{m_P}{m_H} K a_H^3 f} \quad (42)$$

and is practically independent of the acoustic properties of the earmuff. Rather, it is determined by the ratio between the direct effect of the sound field on the earplug and the effect of the head motion. For this reason, an addition of earmuffs should affect the attenuation provided by light earplugs somewhat more than that provided by heavy ones. This is substantiated by experiments (3,18). Figure 4 compares the results obtained with light earplugs consisting of a hollow shell of soft plastic with those obtained by means of a heavy earplug consisting of a plastic shell loaded with wax and steel. In both situations earmuffs were worn. It is evident from Fig. 4 that light earplugs are somewhat more effective under earmuffs than are heavy earplugs. Without earmuffs the reverse is usually true.

Now that certain enigmas of ear protectors have been explained, it is possible to analyze the situation from the point of view of optimum conditions for sound attenuation at the ear. Equation 40

may serve as a basis for the analysis, when the subscript p is interpreted to mean "ear protector" rather than "earplug." For the purpose of clarity, the right side of this equation can be rewritten as follows

$$A_P = \frac{|Z_P + Z_S + Z_V|}{|Z_V|} \frac{S_i}{\left(S_o^2 + \alpha^2 \frac{m_P^2}{m_H^2} K^2 a_H^6 f^2\right)^{1/2}} \quad (43)$$

When the ear protector provides any sound attenuation worth considering, the quotient $|Z_P + Z_S + Z_V| / |Z_V|$ must be considerably greater than one and consequently, $|Z_V| \ll |Z_P + Z_S|$. Furthermore, the expression Ka_H^3 / m_H is independent of the ear protector and will be abbreviated by H. As a result Eq. 43 can be simplified to

$$A_P = \frac{|Z_P + Z_S|}{|Z_V|} \frac{S_i}{\left(S_o^2 + \alpha^2 m_P^2 H^2 f^2\right)^{1/2}} \quad (44)$$

The mechanical impedance Z_V is equal to $Z_{Vac} \times S_i^2$, where Z_{Vac} means the acoustic impedance of the enclosed volume of air. At reasonably low frequencies $Z_{Vac} = \frac{\rho_o c^2}{2\pi f V_i}$, so that

$$A_P = \frac{|Z_P + Z_S|}{\rho_o c^2 S_i} \frac{2\pi f V_i}{\left(S_o^2 + \alpha^2 m_P^2 H^2 f^2\right)^{1/2}} \quad (45)$$

At sufficiently low frequencies the impedance Z_S of the sealing cushion and of the underlying flesh is considerably greater than the impedance Z_P which is due to the inertia of the ear protector. At these frequencies the effect of the head motion is negligible, as has been shown above. Consequently,

$$A_P = \frac{Z_S}{S_i} \frac{2\pi f V_i}{\rho_o c^2 S_o} \quad (46)$$

According to the last equation, the sound attenuation is proportional to the impedance of the sealing cushion and of the underlying tissue and to the volume of air enclosed by the ear protector, and is inversely proportional to the areas S_i and S_o . In order to determine the optimum dimensions of the ear protector it is necessary to realize that the impedance Z_S is likely to be proportional to the surface area of the sealing cushion, and that the volume V_i depends to a certain extent on the surface area S_i and on the depth of the ear protector. The effective surface area of the sealing cushion amounts to $S_o - S_i$ in an earmuff and is rather constant in earplugs. We can write, therefore, $Z_S = Z_{Ssp} \times S_o (1 - \frac{S_i}{S_o})$ for the earmuffs, and $Z_S = Z_{Ssp} \times \zeta$ for the earplugs. The volume V_i can be expressed as $V_i = \alpha S_i D$, where D means the depth of the ear protector and α a proportionality constant. With these expressions, Eq. 46 becomes

$$A_M = Z_{Ssp} \left(1 - \frac{S_i}{S_o}\right) \alpha D 2\pi f / \rho_o c^2 \quad (47a)$$

and

$$A_P = Z_{Ssp} \zeta \alpha D 2\pi f / \rho_o c^2 S_o \quad (47b)$$

for earmuffs and earplugs, respectively. From the equation for the earmuffs, it is immediately apparent that for a very narrow cushion ($S_i \rightarrow S_o$) the sound attenuation disappears. When $S_i < S_o/2$ the width of the cushion does not have much effect on sound attenuation. The attenuation provided by either earmuffs or earplugs is proportional to the specific impedance of the sealing cushion, to the depth of the ear protector and to the constant α which is equal to $\frac{V_i}{S_i D}$. The impedance Z_{sp} is maximum when the impedance of the sealing cushion is high compared to the impedance of the underlying

tissue. It has been shown in the past that it is possible to make such cushions. The constant α depends on the shape of the ear protector.

Summarizing, an ear protector can be expected to be the most effective at low frequencies when it has a sufficiently wide sealing cushion, a maximum possible depth and enclosed volume of air, and a small area S_i .

At medium frequencies the impedance Z_p produced by the inertia of the ear protector becomes more important than the impedance Z_s of the sealing cushion and of the underlying tissue. Also, the effect of the head motion becomes noticeable. Under these conditions, Eq. 45 can be approximated by

$$A_p = \frac{|Z_p|}{\rho_0 c^2 S_i} \frac{2\pi f V_i}{(S_0^2 + \rho_0^2 m_p^2 H^2 f^2)^{1/2}} \quad (48)$$

When the expressions for $Z_p = 2\pi f m_p$ and for $V_i = \alpha S_i D$ are inserted, Eq. 48 becomes

$$A_p = \frac{4\pi^2 f^2 m_p \alpha D}{\rho_0 c^2 (S_0^2 + \rho_0^2 m_p^2 H^2 f^2)^{1/2}} \quad (49)$$

When the ear protector is very light, Eq. 49 can be simplified to

$$A_p = \frac{4\pi^2 f^2 m_p \alpha D}{\rho_0 c^2 S_0} \quad (50a)$$

and when it is very heavy, to

$$A_p = \frac{4\pi^2 f \alpha D}{\rho_0 c^2 H} \quad (50b)$$

Consequently, in a light device the surface area S_o must be kept small for maximum attenuation. However, a very light device would be ineffective since the attenuation is proportional to its mass. In a heavy device the attenuation seems to be independent of both the area S_o and the mass m_p . The mass of an earmuff is limited by considerations of comfort, and the situation described by Eq. 50b is unlikely to arise, except for fairly high frequencies. In ear-plugs it can be reached more easily.

The attenuation at medium frequencies depends on the factor αD in the same way as does the attenuation at low frequencies. However, a new factor enters the picture and offsets to a certain extent the advantage of a large D . This factor is $\delta = \frac{h}{a_M}$. The distance h of the center of gravity from the surface of the head may be considered proportional to the depth D . Since the average radius a_M can be regarded as being proportional to the square root of the surface area S_o , we can replace δ by $\beta \frac{D}{S_o^{1/2}}$. Under these circumstances, Eq. 50b becomes

$$A_p = \frac{4\pi^2 f S_o^{1/2} \alpha}{\beta} \quad (51)$$

and the factors determined by the shape of the ear protector come to prominence. The constant α must be maximized, the constant β minimized. A further analysis shows that the two requirements are in conflict to a certain extent. A large α requires a spherical shape. This leads to $\frac{h}{a_m} = 1$ and a large β . The conflict between the factors α and β may be somewhat diminished by making the walls of the ear protector thick near the surface of the head and thin in its other parts.

Thus, in order to have an effective ear protector we must add

to the requirements determined for low frequencies the following:
 at medium frequencies it is important that the ear protector be sufficiently heavy and its center of gravity be located as near to the head surface as possible.

At high frequencies the situation becomes very complex because the head vibrates in sections and the effect of wave length cannot be ignored. Nevertheless, Eq. 51 can probably serve as a guidepost.

3. Optimum dimensions of ear protectors

The optimum dimensions of ear protectors are determined by the equations 47a, 47b, 50a, and 51. Furthermore, they depend on the anatomy of the ear and of the side of the head, and on the requirements of comfort. Conditions prevailing at low frequencies, where a high sound attenuation is the most difficult to obtain, must have priority.

We shall consider the muff type ear protector first. Experience has shown that the so-called supraaural cushions are both ineffective and uncomfortable. Therefore, a circumaural cushion which does not exert any pressure on the auricle, but is fully supported by the bones of the head surrounding the ear, is a primary requirement. This determines the minimum area S_i to about 20cc. According to Eq. 47a, S_o should amount to at least $2 \times S_i$, that means 40cc. A very deep earmuff becomes excessively cumbersome, so that D has to be limited to 7cm. With these dimensions and in an attempt to maximize the constant α we obtain the configuration of Fig. 5 which is symmetric with respect to the axis B - B'. This symmetry is a simplification and in practice the area S_i would have an oval shape to conform to the shape of the auricle. In Fig. 5, C indicates the sealing cushion, M a ring of heavy material and S-a shell of rigid but light material.

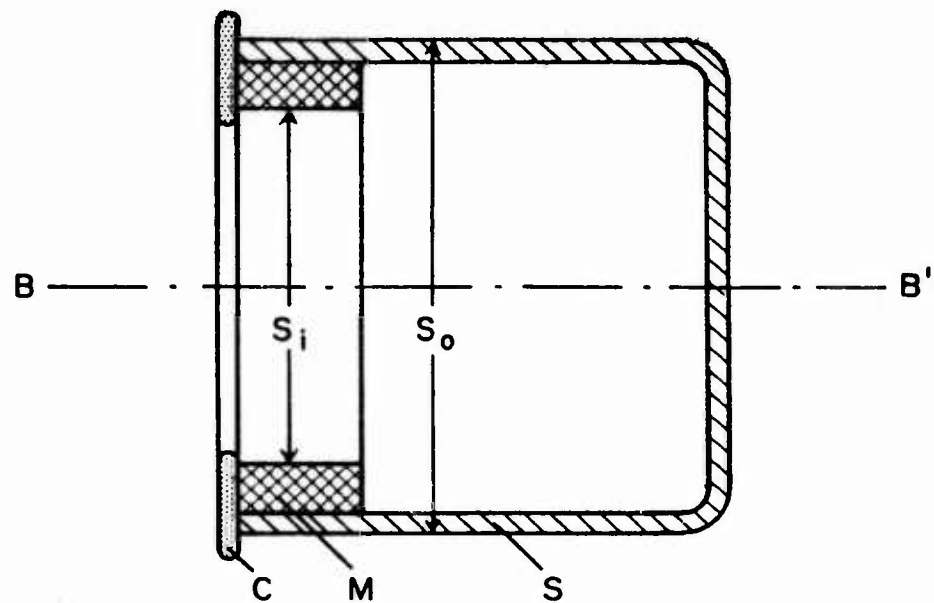

Fig. 5. Half schematic drawing of an earmuff.

When the constants established above are introduced into Eq. 47a and the value for Z_{Ssp} is calculated from the data of Shaw and Thiessen (10) a sound attenuation of 21db results at 125 cps. This is a high attenuation for an earmuff but, taken absolutely, is not impressive at all. The limiting factors are Z_{Ssp} , α and D .

At somewhat higher frequencies, Eq. 50a applies, and on the assumption of a mass of 200g an attenuation of 40db results. This attenuation may be considered fully satisfactory. In general, earmuffs provide a high attenuation at medium and high frequencies.

The earplugs provide a better chance of a high attenuation at low frequencies. Figure 6 shows a perforated earplug C with an attached hard shell S which increases the volume of the enclosed air. At very low frequencies, Eq. 47b applies and its parameters can be derived as follows. The mechanical impedance of the tissue lining the ear canal has been determined by v. Gierke (3) to

$$|X_S| = \frac{1}{2\pi f \times 2.06 \times 10^{-7}} \text{ dyne sec cm}^{-1} \text{ and } R_S = 4.4 \times 10^3 \text{ dyne sec cm}^{-1}.$$

The product αD is equal to $\frac{V_i}{S_i}$ according to definition.

The cross sectional area S_i has been estimated previously to $.5\text{cm}^2$, it is the cross sectional area of an average ear canal near the tip of the earplug. The cross sectional area S_o is approximately equal to the cross sectional area at the entrance to the ear canal and is here estimated to be 1cm^2 . With these values, Eq. 47b becomes

$$A_p = \left(\frac{6 \times 10^{11}}{f^2} + 1.94 \times 10^7 \right)^{1/2} 8.9 \times 10^{-6} V_i f \quad (52)$$

For a solid earplug, the volume V_i comprises the volume of air in the ear canal plus the equivalent volume measured at the ear drum. According to recent determinations V_i amounts on average to approx-

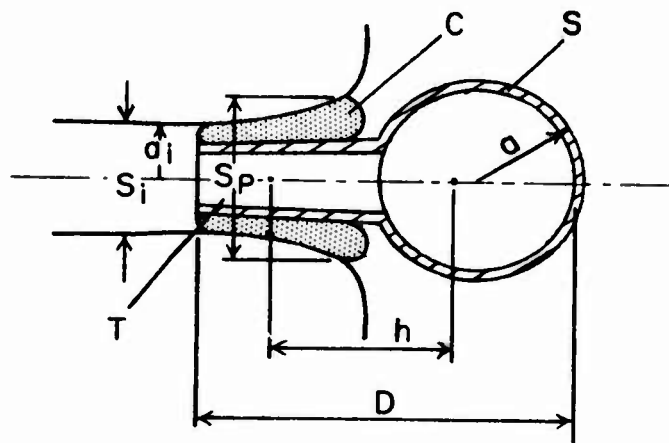

Fig. 6. Half schematic drawing of a perforated earplug with a small rigid tank. The device is called "resonator earplug".

mately 1.4cc. For such an earplug, Eq. 52 predicts a sound attenuation of 21 db at a frequency of 125 cps. This is the same attenuation as can be expected from an earmuff of about 300cc. When the earplug is perforated, and a small shell containing only 2cc of air is connected to the ear canal, as is shown in Fig. 6, the attenuation at 125 cps increases to 29db. An addition of a volume of 4cc may be expected to increase the attenuation to 33db. This is a promising result by comparison to the performance of earmuffs, and warrants a more thorough investigation.

At medium frequencies the sound attenuation can be described by Eq. 45. Here, the mass m_p of the ear protector as well as the constant \mathcal{K} become important in addition to the volume V_i . The mass of an earplug with a small attached shell is estimated to lie between 3 and 8g. The constant $\mathcal{K} = \frac{h}{a_i}$, where h is the distance of the axis of rotation from a plane containing the center of gravity and approximately parallel to the surface of the head, and a_i the distance of the axis of rotation from a plane containing the center of gravity and approximately perpendicular to the surface of the head. The axis of rotation is difficult to determine for an earplug. It does not seem too unreasonable, however, to assume that it is located at the wall of the ear canal near the middle portion of the sealing insert. Under such conditions, the distance h would be approximately half the length of the earplug with the shell, and a_i would be equal to the mean radius of the ear canal. For a volume of the shell of 2 to 4cc, the length has been estimated to about 2.5cm and, consequently, $h = 1.25$ cm. The mean radius of the ear canal follows from $a_i = \left(\frac{S_i}{\pi}\right)^{1/2}$ to .4cm. Thus, the constant $\mathcal{K} \approx 3$. This value is much larger than in an earmuff where it approaches 1/2.

When the values established above are introduced into Eq. 45, we obtain at 500 cps a sound attenuation of 31db for a mass of 3g and of 32db for a mass of 8g. This is true for a volume of the shell of 2cc. When this volume is decreased to zero, the attenuation drops to 24db; when it is increased to 4cc, the attenuation rises to 35db. Even this attenuation is smaller than the value that can be expected for a large earmuff. However, it will be shown in the following chapters that the sound attenuation produced by small shells connected to the ear canal can be improved considerably by means of acoustic resonance. Because of this effect, the devices will be called "resonator earplugs."

The advantage of the earplugs described above over the earmuffs is their compactness and a high ratio $\frac{V_1}{S_1}$ which leads to a high sound attenuation at low frequencies.

CHAPTER II

THEORY OF RESONATOR EARPLUGS1. Motion of ear plugs relative to the ear canal

The motion of an earplug relative to the ear canal can be described by Eq. 32, when the system is exposed to a frontal sound field. When the subscript "M" meaning "muff" is replaced by the subscript "P" meaning "plug", Eq. 32 takes the form

$$u'_{PH} = \frac{(S_P^2 + \frac{h^2}{a_i^2} \frac{m_P^2}{m_H^2} K^2 a_H^6 f^2)^{1/2}}{|Z_P + Z_S + Z_V|} \quad p \quad (53)$$

With the abbreviations introduced previously, and on the assumption that $|Z_V| \ll |Z_P + Z_S|$, the last equation can be simplified to

$$u'_{PH} = \frac{(S_P^2 + \gamma^2 \frac{m_P^2}{m_H^2} H^2 f^2)^{1/2}}{|Z_P + Z_S|} \quad p \quad (54)$$

According to the last section of the preceding chapter, the surface area S_P and the impedance Z_S are unlikely to vary substantially from one type of earplug to another and can be considered approximately constant. The constant H depends only on the properties of the head. The variables are therefore: γ which depends on the configuration of the earplug, m_P which is the mass of the earplug, Z_P which is directly proportional to the mass m_P , and sound frequency f .

A study of the velocity u'_{PH} as a function of these variables helps in the understanding of the acoustic properties of resonator earplugs. When the numerical values of the preceding chapter are

introduced into Eq. 55, we obtain

$$u'_{PH} = \frac{(1 + 8.2 \times 10^{-8} \gamma^2 m_p^2 f^2)^{1/2}}{[(6.28 \times m_p f - 7.7 \times 10^5 / f)^2 + 1.94 \times 10^7]^{1/2}} P \quad (55)$$

Figure 7 is a graphical representation of Eq. 55 for 2 values of γ and 4 values of m_p . It is apparent that u'_{PH} increases with γ . The effect of m_p . Above the resonance point there is a region where the velocity of motion decreases as the mass increases. At sufficiently high frequencies the motion becomes practically independent of m_p . The sensitivity of the system to changes in γ increases somewhat with m_p . Values of m_p in the neighborhood of 4g appear the most advantageous. For greater m_p the motion increases substantially at low frequencies and becomes sensitive to the constant γ which is difficult to control. For smaller m_p , the velocity u'_{PH} increases considerably at medium frequencies.

2. Sound attenuation by plain earplugs

The velocity of the volume displacement of air in the ear canal produced by the motion of the earplug is equal to the product of the mean velocity u'_{PH} and the surface area S_i . The sound pressure generated in the ear canal is equal to the product of the volume velocity and of the acoustic impedance at the tip of the earplug,

$$p_i = u'_{PH} S_i Z_{bp} \quad (56)$$

Since the velocity u'_{PH} is proportional to sound pressure, we can introduce $U'_{PH} = \frac{u'_{PH}}{p}$ and write

$$A_P = \frac{|p|}{|p_i|} = \frac{1}{U'_{PH} S_i Z_{bp}} \quad (57)$$

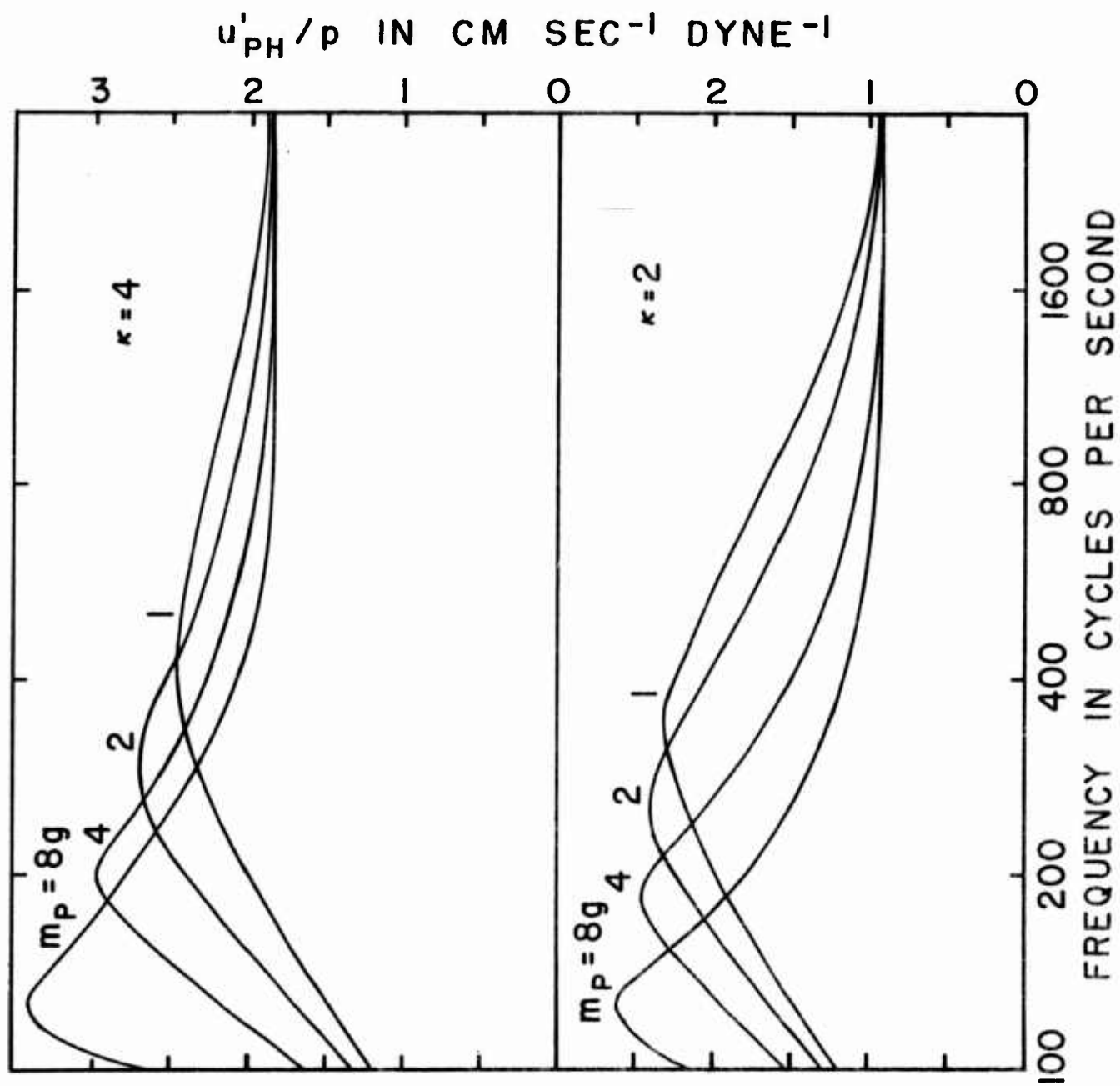

Fig. 7. Velocity of motion of an earplug in the ear canal, as a function of sound frequency, with the mass of the earplug and the constant κ as parameters.

The impedance "behind the earplug" Z_{bp} , which is identical with the impedance at the tip of the earplug, can be derived from measurements of the impedance at the ear drum. Figure 8 shows $|Z_{bp}|$ as a function of frequency. The numerical values have been obtained from two studies (7,19).

On the basis of Figs. 7 and 8, it is possible to calculate the sound attenuation A_p as a function of frequency for two values of χ and four values of m_p . Figures 9a and 9b show the results. It is apparent that for all parameter values the attenuation increases with frequency up to 3000 cps. The curves are flatter for $\chi = 4$ than for $\chi = 2$. The effect of the mass m_p is small and it decreases as the factor χ increases.

The curves of Figs. 9a and 9b have been calculated on the assumption that no sound can leak into the ear through the sealing cushion or tip. In reality, such a leakage cannot be excluded and probably limits the attenuation at medium and high frequencies. Furthermore, the assumption that the skull vibrates as a rigid body holds only at low frequencies. At medium and high frequencies complex modes develop which tend to effect χ . The leakage through the sealing tip and the complex mode of skull vibration may account for the fact that experimental attenuation curves obtained with plain earplugs tend to be flatter than the curves of Figs. 9a and 9b. Some measurements show also that, under favorable conditions, the skin impedance Z_s can be considerably higher than the value accepted for the above calculations.

In order to test the theory more directly, attenuation values have been calculated for one specific earplug which served to obtain the value of Z_s . In Fig. 10 the theoretical attenuation

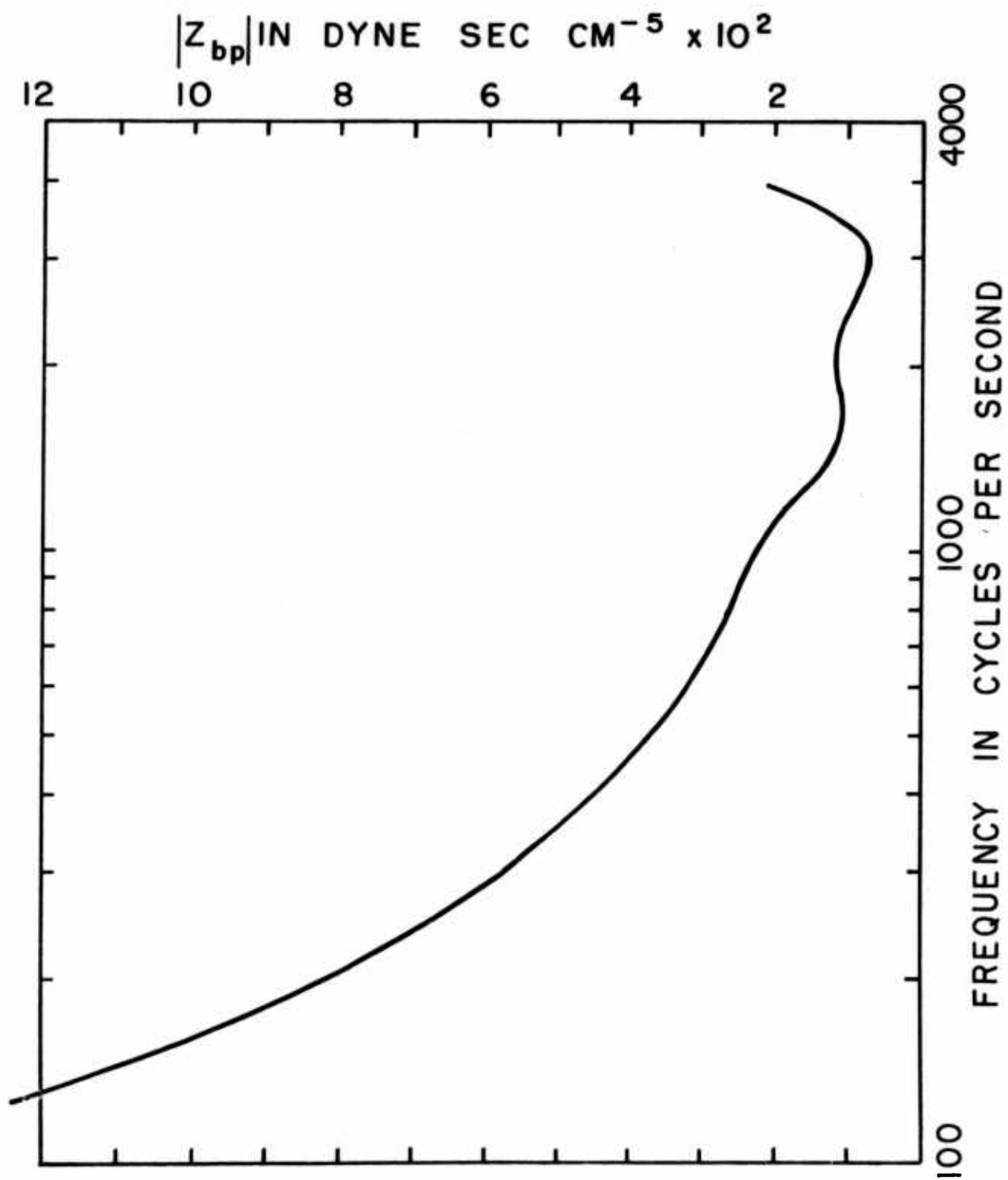

Fig. 8. Magnitude of the acoustic impedance near the entrance of the ear canal.

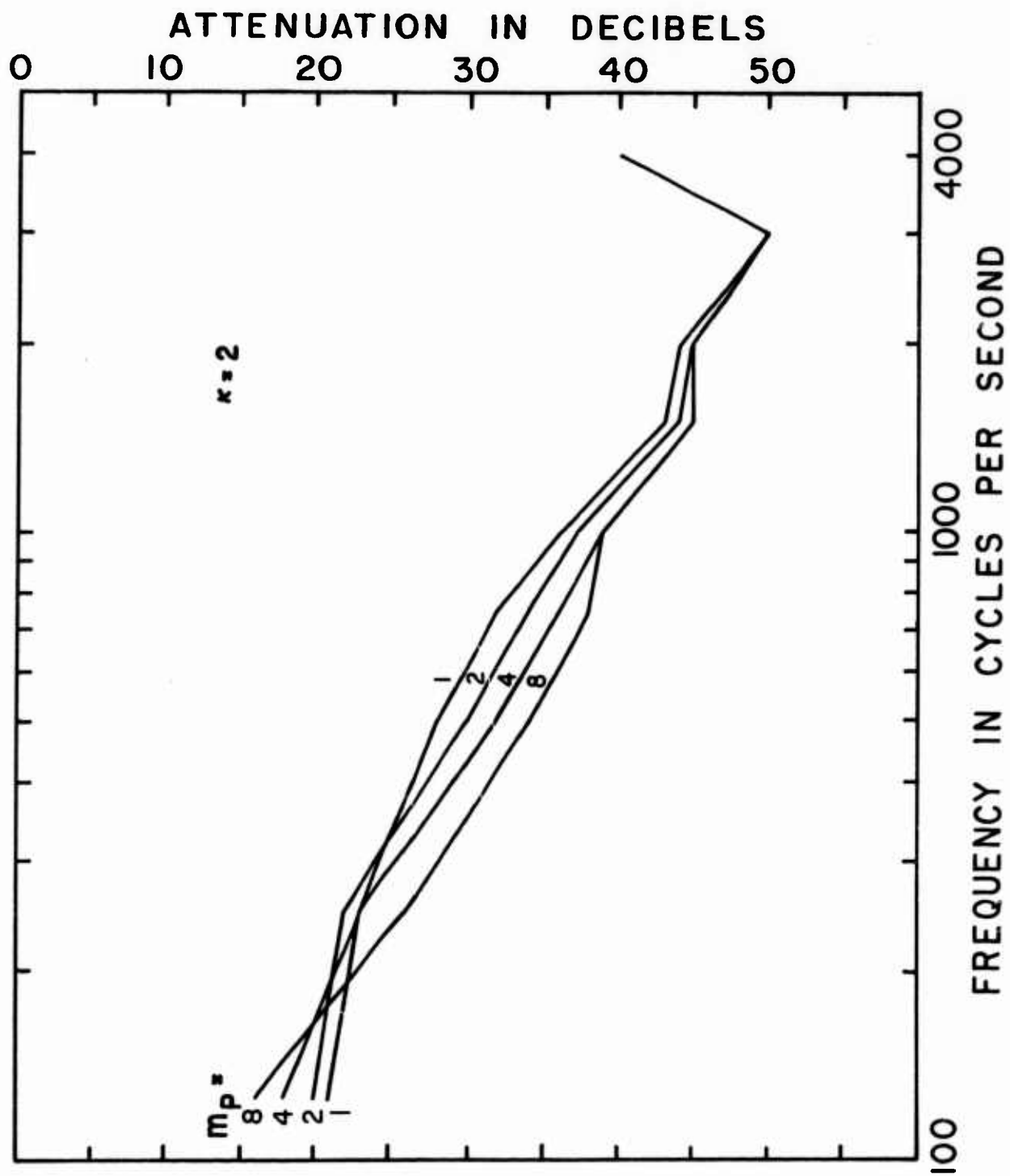

Fig. 9a. Theoretical sound attenuation provided by plain earplugs as a function of frequency, with the mass of the earplug as parameter.

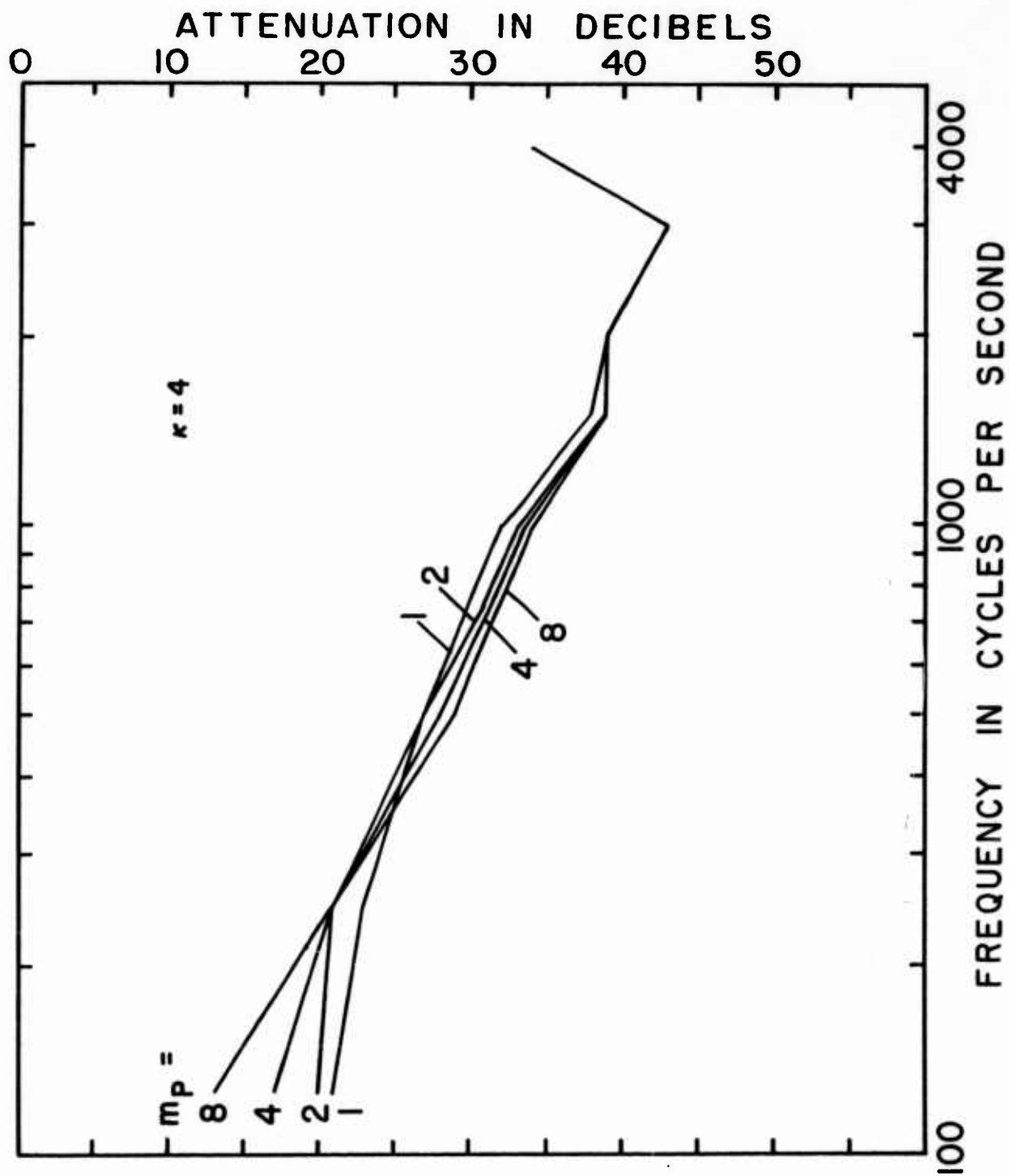

Fig. 9b. Theoretical sound attenuation provided by plain earplugs as a function of frequency, with the mass of the earplug as parameter.

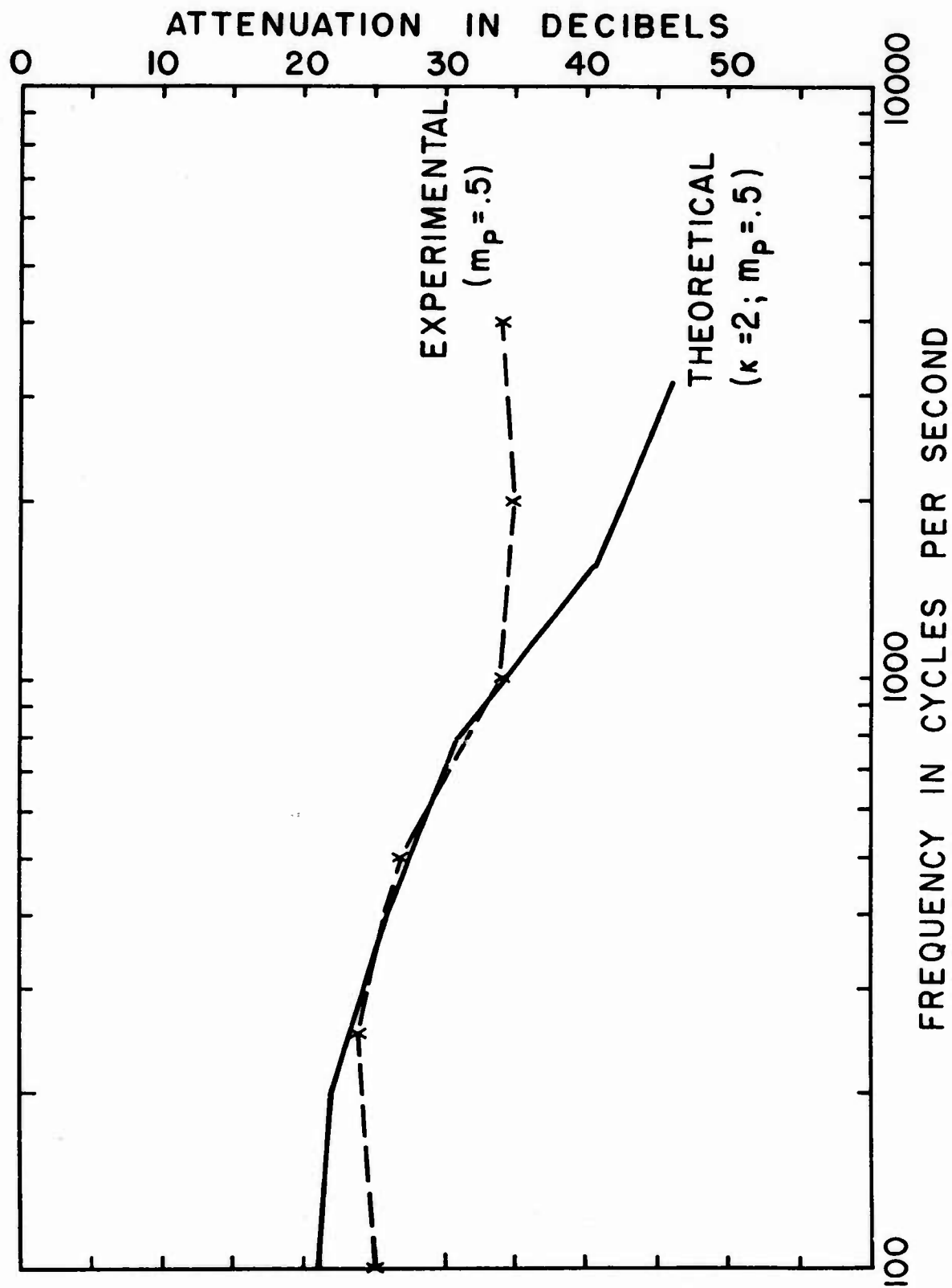

Fig. 10. Sound attenuation provided by the V51-R earplug. Solid line - theoretical; broken line - experimental.

curve is compared to an experimental one which was obtained in the same laboratory that determined Z_S . Between 250 and 1000 cps, the agreement between the two curves is excellent. Above 1000 cps, the experimental curve shows considerably less attenuation than the theoretical one. The discrepancy is probably due to a change in the mode of vibration of the earplug which is made entirely of soft material. At frequencies below 250 cps the measured attenuation is somewhat greater than the theoretical. The discrepancy could be eliminated by increasing the reactive component of Z_S by 60%, and such a correction would appear justified in view of the fact that Z_S was determined on only one subject. Nevertheless, it is also possible that the discrepancy in attenuation at low frequencies is due to an artifact in the psychophysical method of measurement. The experimental curve of Fig. 10 was obtained by means of threshold comparison. This method has been shown to yield somewhat larger attenuation values than other methods i.e. loudness balance techniques and physical measurements by means of probe microphones (5,9,13).

The following is a possible explanation of the exaggerated values of sound attenuation resulting from threshold measurements. When one remains for a while in a soundproof room, a faint noise, similar in subjective quality to a white noise, becomes audible. The noise increases somewhat in loudness when the ears are closed by earplugs. The amplification appears to affect particularly the low frequency component. This effect indicates that the noise is produced in the ear canal, possibly by blood circulation. If this is so, the noise level should be proportional to the impedance $|Z_{bp}|$, and consequently, decrease as the volume of air enclosed in the ear canal and the sound frequency increase.

The noise generated in the ear canal masks the test sounds and its effect is added to the attenuation effect produced by the earplug. Experiments described in Chapter IV lend a further support to the "noise hypothesis" which is in agreement with previous studies (2,11,12).

3. Sound attenuation by resonator earplugs

When the plain earplug is replaced by a perforated earplug connected to a hollow shell, as shown in Fig. 6, the impedance Z_{bp} is shunted by the acoustic impedance of the added structure. To the first order of approximation this impedance consists of the positive reactance of the connecting tube, $j2\pi f m_r$, and of the negative reactance of the shell, $-j/2\pi C_r$, where m_r means the acoustic mass of the tube, and C_r the acoustic compliance of the air volume of the shell. The acoustic mass can be calculated approximately from the equation

$$m_r = \frac{\rho_0 l'}{S_r} \quad (58)$$

with ρ_0 - specific density of air, l' - effective length of the tube and S_r - its cross sectional area. The effective length is equal to the geometric length l plus two end corrections Δl which are proportional to the radius of the tube a . The value of Δl depends somewhat on the configuration and varies from $.6a$ to $.85a$. The compliance C_r follows from the equation

$$C_r = \frac{V_r}{\rho_0 c^2} \quad (59)$$

with V_r - volume of the shell, ρ_0 - density of air and c - velocity of sound propagation. Bringing the two reactance components to-

gether results in the impedance equation

$$Z_r = -j \frac{1 - 4\pi^2 f^2 m_r C_r}{2\pi f C_r} \quad (60)$$

which characterizes the input conditions of an acoustic resonator.

The impedance Z_r disappears at the resonance frequency

$$f_r = \frac{1}{2\pi(m_r C_r)^{1/2}} \quad (61)$$

which is inversely proportional to the square root of the mass m_r and of the capacitance C_r . Consequently, the resonance frequency can be varied by varying the dimensions of the coupling tube and of the hollow shell.

A more exact equation of the input impedance of the resonator is

$$Z_r = \frac{\rho_0 c}{S_r} \frac{j \sin(\varphi - 4\pi \frac{l}{\lambda})}{1 - \cos(\varphi - 4\pi \frac{l}{\lambda})} \quad (62)$$

where

$$\varphi = \text{arc tg} \frac{-S_r c 4\pi f V_r}{S_r^2 c^2 - 4\pi^2 f^2 V_r^2} \quad (63)$$

In Eq. 62, the assumption that the tube is very short compared to the wave length is abandoned.

The input impedance of the resonator has been calculated for several volumes V_r and two coupling tubes of .8cm effective length, and with a cross sectional area of .24 and .1cm², respectively. Figures 11a and 11b show the results. At low frequencies, the impedance is negative and inversely proportional to the volume V_r . At high frequencies, it is practically independent of this volume.

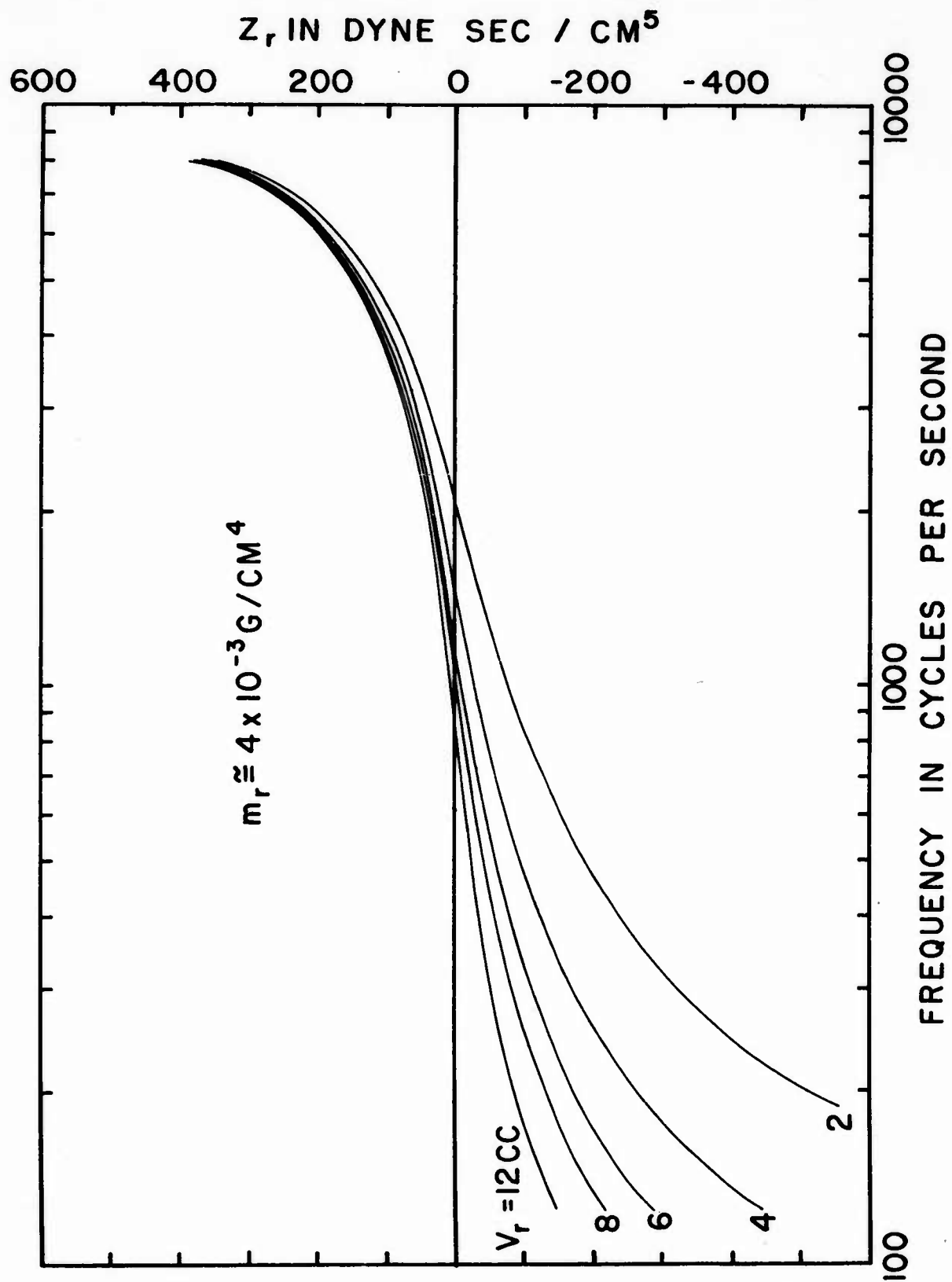

Fig. 11a. Input impedance of the resonator with a wide opening, with resonator volume as parameter.

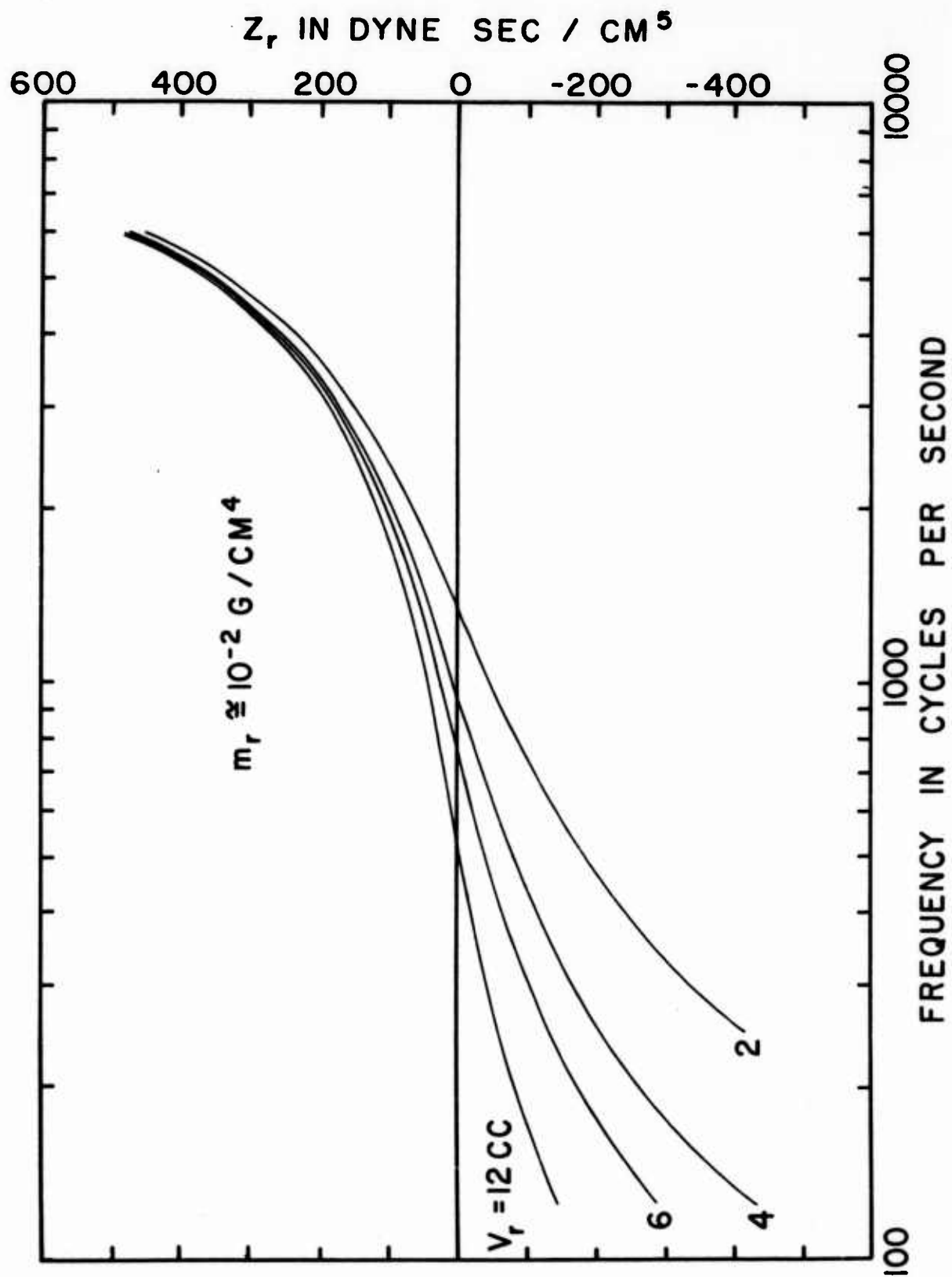

Fig.11b. Input impedance of the resonator with a narrow opening, with resonator volume as parameter.

It is positive and proportional to the acoustic mass m_r . The crossover from negative to positive values depends on both the volume V_r and the mass m_r . The greater V_r and m_r the lower the crossover frequency.

In order to find the sound attenuation produced by the resonator earplugs, the impedance $|Z_{bp}|$ in Eq. 57 must be replaced by the combined impedance of the ear and of the resonator. This impedance is equal to

$$Z = \frac{Z_{bp} Z_r}{Z_{bp} + Z_r} \quad (64)$$

so that Eq. 57 becomes

$$A_{pr} = \frac{|p|}{|p_{ir}|} = \frac{1}{U_{PHS_i}} \left| \frac{Z_{bp} + Z_r}{Z_{bp} Z_r} \right| \quad (65)$$

The effect of the resonator can best be described by the ratio of attenuations obtained with the resonator open and closed respectively. The first situation is described by Eq. 65, the second by Eq. 57. Consequently,

$$\frac{A_{pr}}{A_p} = \frac{|Z_{bp} + Z_r|}{|Z_r|} \quad (66)$$

If the impedances in Eq. 66 are assumed to be pure reactances ($Z_{bp} = X_{bp}$), the ratio A_{pr}/A_p is greater than one and the attenuation improved only when the impedance Z_r has the same sign as the reactance X_{bp} . When one is positive and the other negative, the attenuation is reduced, and disappears completely for $Z_r = -X_{bp}$. Figure 12 shows the relationship for a resonator volume of 2cc and two coupling tubes with an acoustic mass $m_r \cong 10^{-2}$ g/cm⁴ and 4×10^{-3} g/cm⁴, respectively. The values of X_{bp} have been derived

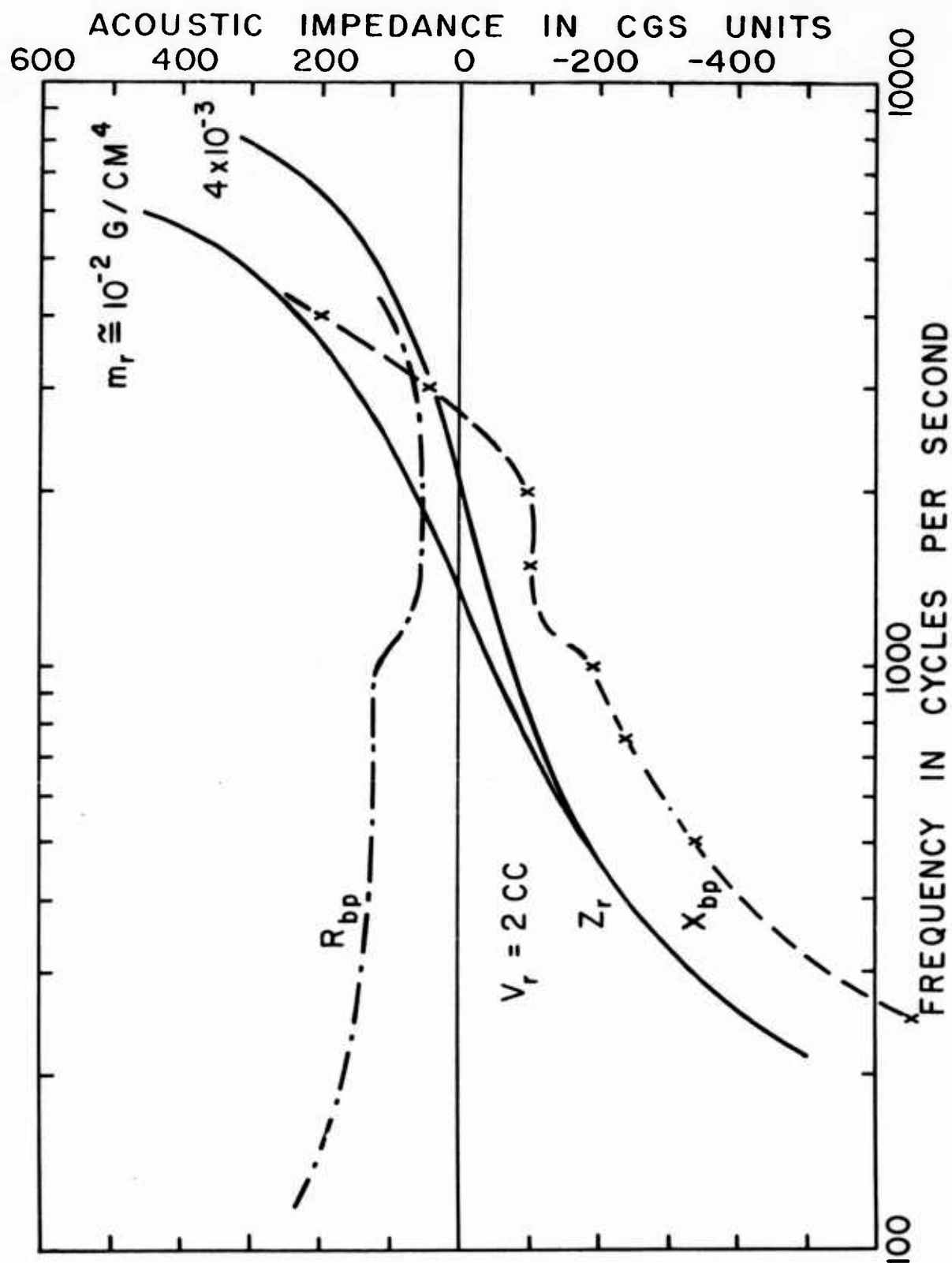

Fig. 12. Acoustic resistance and reactance near the entrance of the ear canal, and the reactance of a 2cc resonator for two different openings.

from two preceding studies (7,19). At low frequencies X_{bp} and Z_r are negative, at high frequencies they are positive. In both situations, an increased sound attenuation can be expected. However, there is an intermediate frequency region where X_{bp} is negative and Z_r positive. In this region, a reduced sound attenuation becomes possible. The conditions are worse for the larger mass m_r , i.e. for the narrower coupling tube.

In reality, the impedance Z_{bp} has a resistive component (R_{bp}) which renders the conditions less critical. In presence of this component a reduction of sound attenuation may be avoided, even though the reactive component of Z_{bp} has the opposite sign of Z_r , as $|Z_{bp} + Z_r| \geq |Z_r|$. Unfortunately, R_{bp} is very small in the critical region, so that m_r has to be minimized in order to avoid a reduction in attenuation.

Theoretical ratios A_{pr} / A_p have been calculated, assuming that $Z_{bp} = R_{bp} + jX_{bp}$ and $Z_r = jY_r$. Under these conditions, Eq. 66 can be rewritten in the form

$$\frac{A_{pr}}{A_p} = \left[\left(1 + \frac{X_{bp}}{Y_r} \right)^2 + \left(\frac{R_{bp}}{Y_r} \right)^2 \right]^{1/2} \quad (67)$$

Introducing the numerical values of Figs. 11a, 11b, and 12, curves of attenuation ratios have been obtained. They are plotted in Figs. 13a and 13b. It can be seen that for the wider opening of the resonator ($m_r = 4 \times 10^{-3} \text{ g/cm}^4$) there is an improvement in attenuation at all sound frequencies; for the narrower opening ($m_r = 10^{-2} \text{ g/cm}^4$) there is a small reduction of attenuation around 2000 cps, at all other frequencies the attenuation is improved. The finding that a resonator can improve the sound attenuation at the ear at all frequencies is of primary importance.

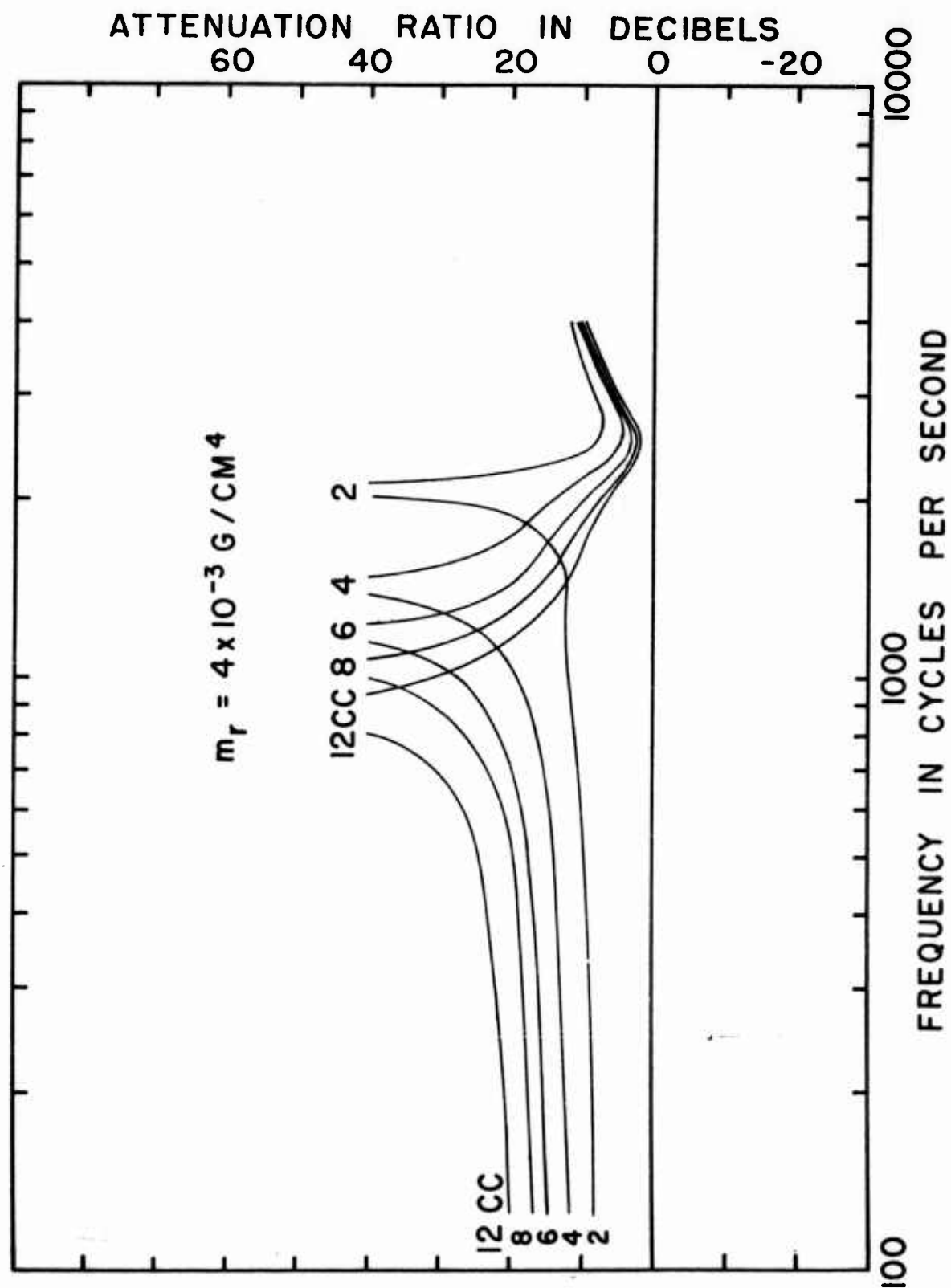

Fig. 13a. Theoretical increment of sound attenuation produced by the resonator with a wide opening for five different resonator volumes.

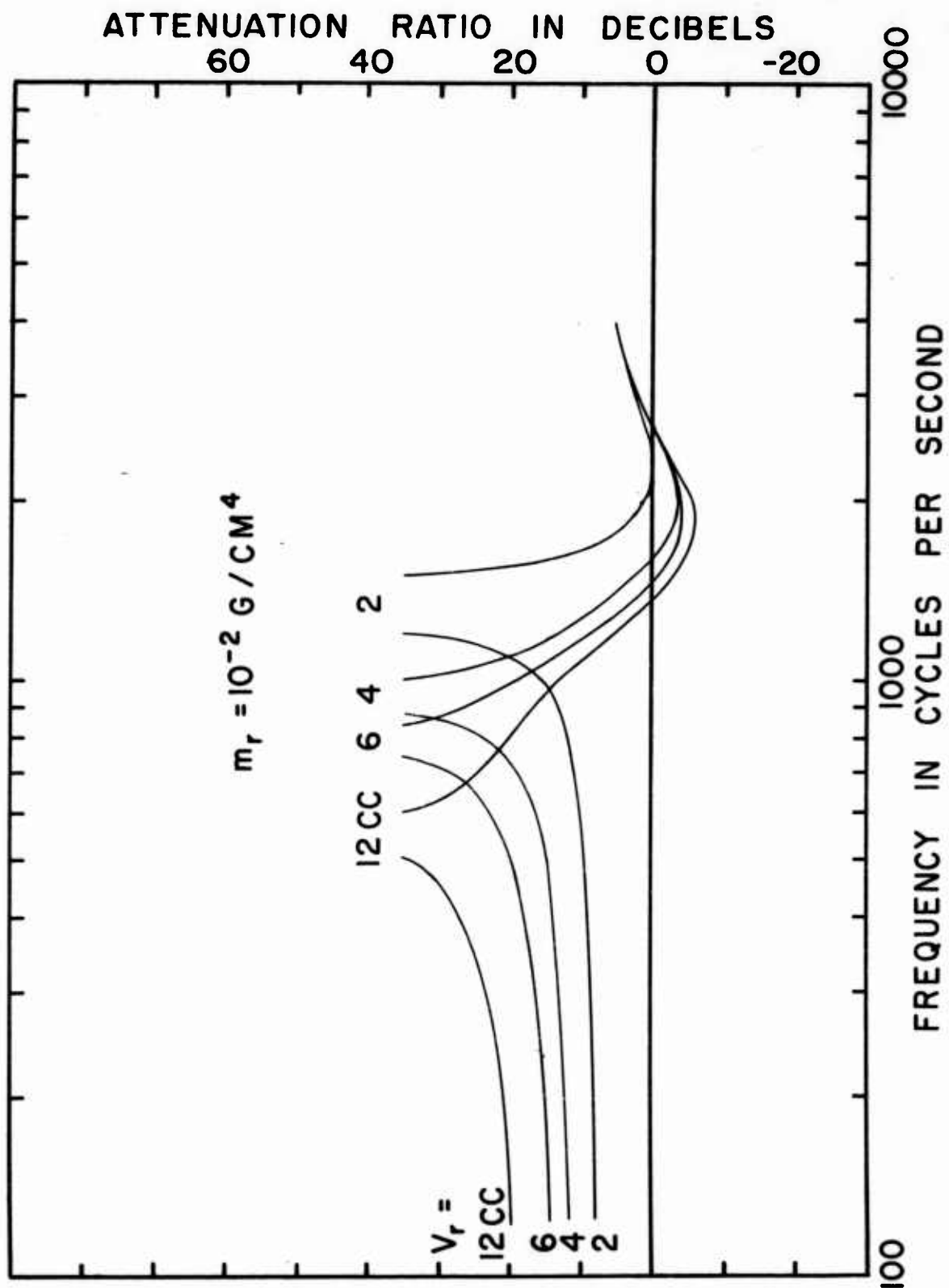

Fig. 13b. Theoretical increment of sound attenuation produced by the resonator with a narrow opening for four different resonator volumes.

Resonators used up to now decreased the sound attenuation in one frequency region while boosting it in another.

The condition for an increased attenuation at all frequencies is simple theoretically. It is sufficient to keep the acoustic mass of the resonator small. We now shall see if this is possible in practice. Before we do so, however, it may be of interest to pull all the theoretical factors together in an attempt to estimate the sound attenuation of a resonator earplug. The necessary information can be derived from Figs. 9b and 13b. The following numerical assumptions are made: $m_p = 4g$; $\gamma = 4$; $m_r = 10^{-2} g/cm^4$; $V_r = 4cc$. The resultant attenuation is plotted in Fig. 14. It is very high at medium high frequencies, due to the resonance effect. In practice this effect will be decreased, of course, because of energy losses. Nevertheless, a high level of attenuation should be attainable.

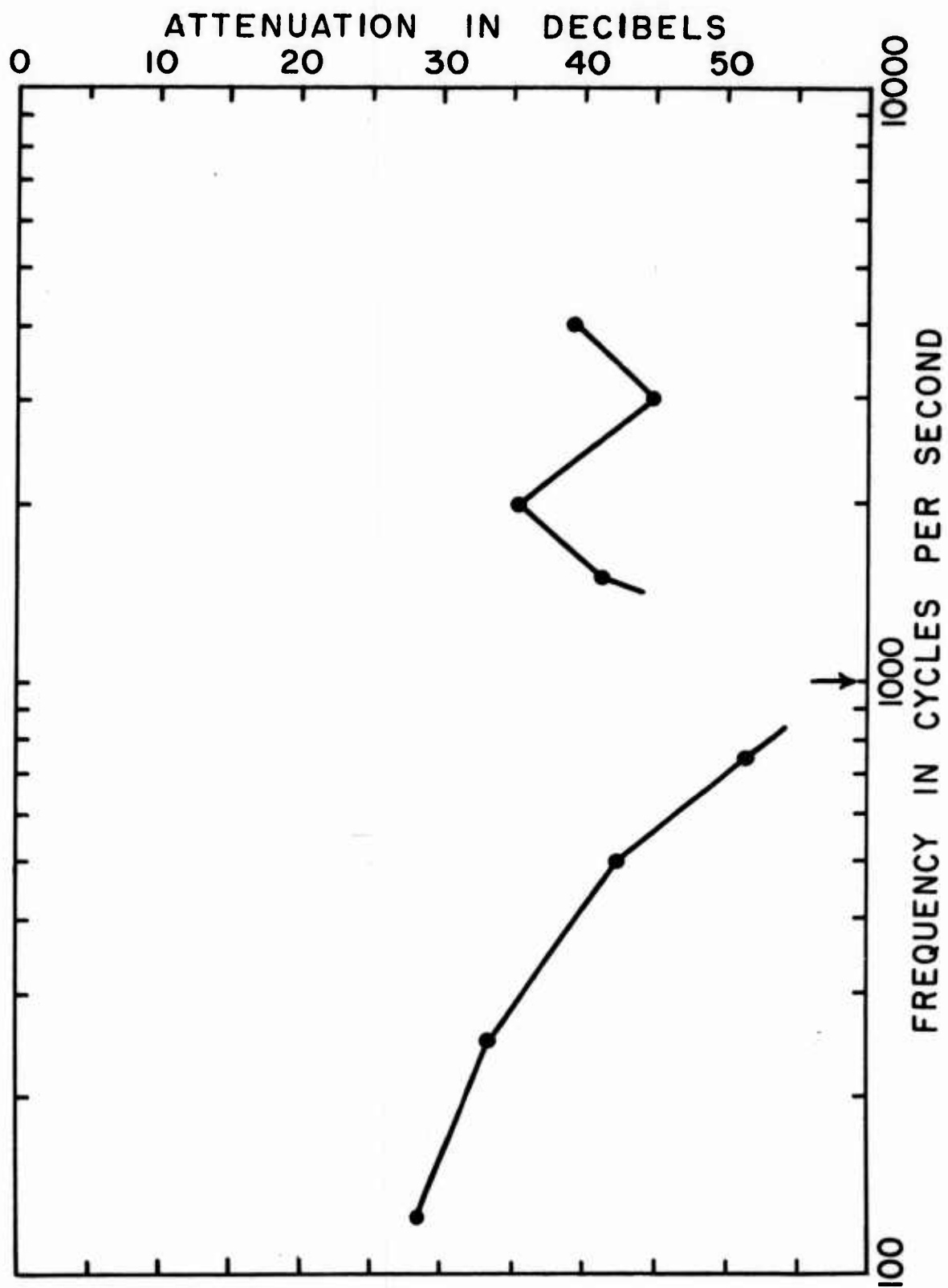

Fig. 14. Theoretical sound attenuation provided by a resonator earplug with a mass of 4, a constant $\gamma c = 4$, a coupling mass of 10^{-2} g/cm⁴ and a \mathcal{G} volume of 4cc.

DEVELOPMENT OF RESONATOR EARPLUGS1. Preliminary experiments

Possibly, the first resonator earplugs were used in my study of bone conduction in a free sound field (18). They consisted of a rather long tube connected to a resonance cavity. The tube was secured in the bony meatus by means of a semi-plastic earplug (15). The devices provided an attenuation of almost 70db in the neighborhood of 400 cps. However, for purposes of ear protection they were inadequate. First of all, the insertion of a plug into the bony meatus is extremely painful. Second, the long tube had a large acoustic mass, so that the high sound attenuation was limited to low frequencies. Above the resonance frequency, the attenuation was smaller than with plain earplugs.

For purposes of ear protection, a different design had to be taken into consideration. The coupling tube had to be shortened to a minimum in order to reduce the acoustic mass, and the earplug had to be made as comfortable as possible.

The first resonator earplugs for ear protection were made out of otologist's ear specula, by closing the wide opening with a rigid plate and fitting a soft sealing tip to the narrow end. Resonators of various shapes and sizes were tried, and the design of the sealing tips was varied. A few examples of the many combinations tested are described below.

Figure 15 shows a half schematic drawing of a speculum with an enclosed volume of air of approximately 5cc and an inner diameter of the small orifice of .4cm. A sealing tip of soft plastic is fitted on the narrow end. The same figure contains the median attenuation

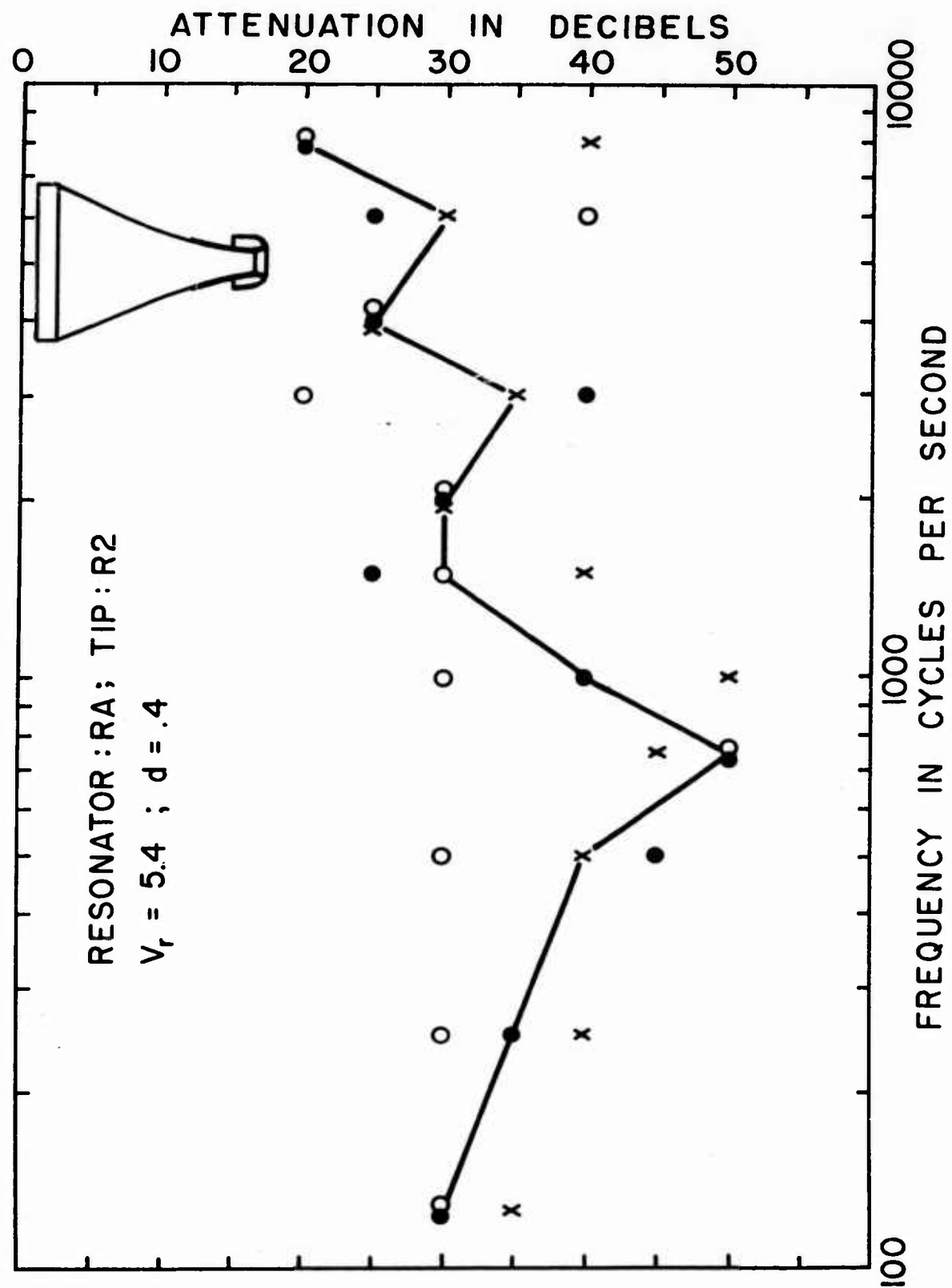

Fig. 15. A half schematic drawing of a resonator earplug made of an otological speculum, and the sound attenuation it produces. The points indicate individual values, the curve joins the medians.

curve obtained on three listeners. The listeners were seated in front of a loudspeaker at a distance of approximately three feet. The loudspeaker was placed in a corner of a soundproof room with sound absorbent walls. It was fed from a commercial audiometer via a power amplifier. Thresholds of audibility have been determined using the method of limits and the sound attenuation has been obtained by means of threshold comparisons. The individual data as well as the median curve are shown in Fig. 15. The curve is of the same type as the theoretical curve of Fig. 14. The resonance frequency produces a peak in the vicinity of 750 cps, which indicates a rather large acoustic mass. Accordingly, the sound attenuation above the resonance frequency is rather low.

In an attempt to improve the sound attenuation above the resonance frequency, a speculum of a somewhat different shape and with a slightly larger opening ($d = .57\text{cm.}$) was used. It enclosed a volume of 7.5cc. Figure 16 shows a schematic drawing of the speculum with its insert tip and the experimental data obtained in the same way as those of the preceding figure. The attenuation is increased at all frequencies with the exception of 1,500 cps. This improvement can be ascribed to the different sealing tip rather than to the different speculum, since the resonance frequency is of the order of 600 cps, and there is a distinct dip in attenuation near 1,500 cps, probably as a result of an anti-resonance.

The attenuation curves of Figs. 15 and 16 are in agreement with the theory regarding their course as well as the order of magnitude of attenuation. It has been concluded, therefore, that the theory is sound. At the same time they show that the shape of the otological specula is inadequate for the purpose of resonator earplugs. It produces an excessive acoustic mass which reduces the sound attenu-

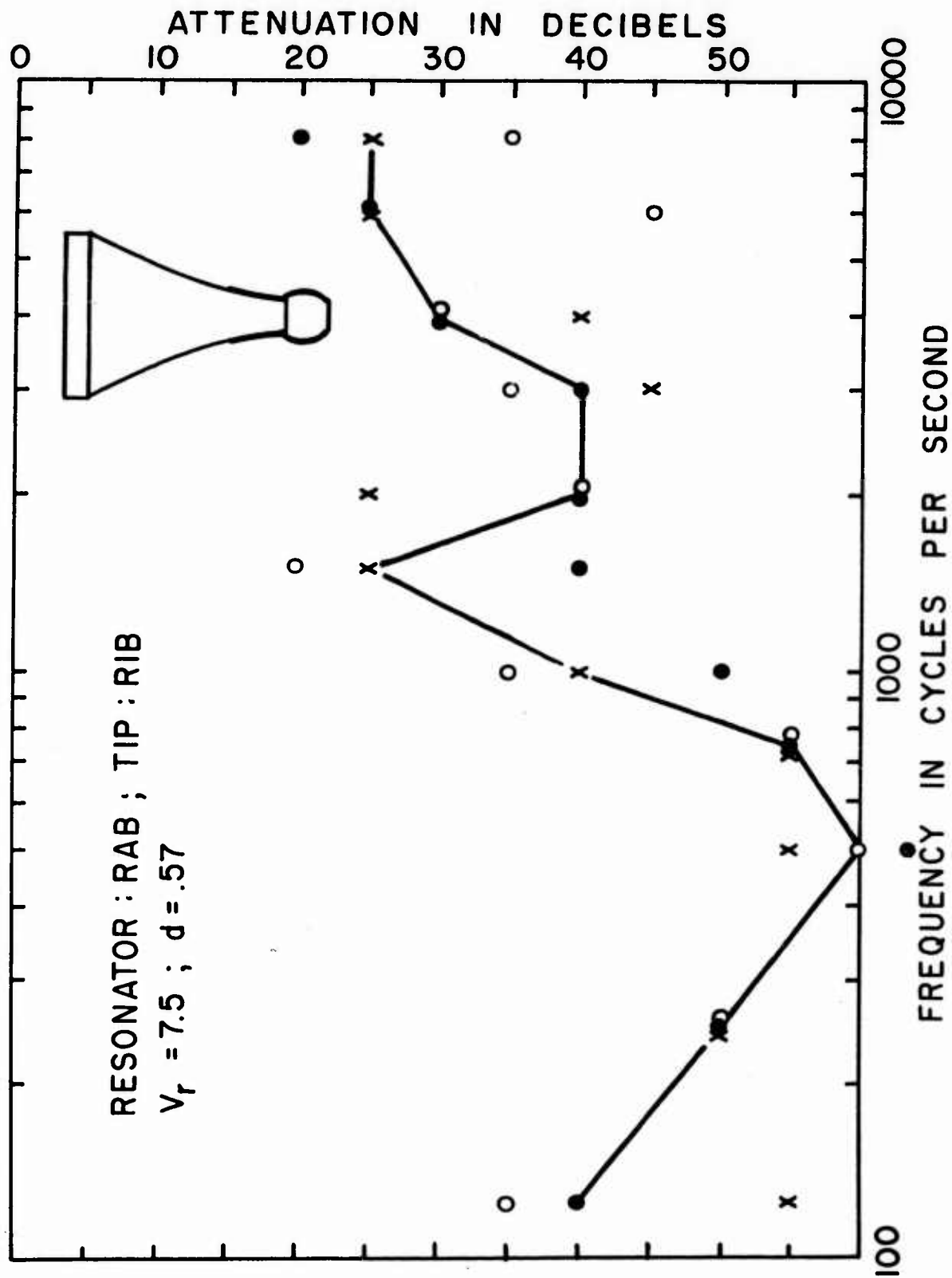
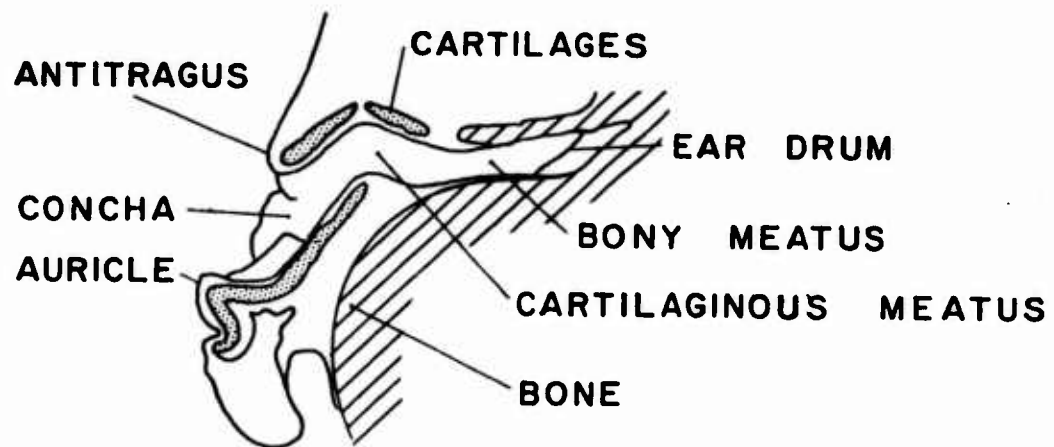

Fig. 16. A half schematic drawing of a resonator earplug made of an otological speculum, and the sound attenuation it produces. The points indicate individual values. The curve joins the medians.

ation above the resonance frequency. Consequently, substantial modifications in the design of the resonator has been undertaken.

The main purpose of the modifications has been to make the coupling tube as short and as wide as possible. This is more easily said than done. Due to the complex and asymmetrical configuration of the ear canal and of the auricle it is impossible to make a resonator earplug that would have a short coupling tube and a simple symmetrical shape at the same time. The difficulties become apparent in Fig. 17 which shows half schematically a horizontal section through the outer ear.

In a first attempt to fit the contours of the concha and the anti-tragus, the earplug shown in the figure has been made. It consists of two different portions of a speculum separated by a piece of copper tubing. All parts are soldered together. The resonators were fitted with slightly improved sealing tips, as can be seen in Fig. 17. The assembly produced the attenuation curve shown by the solid line of Fig. 18. A partial elimination of the attenuation minimum above the resonance frequency is apparent. The improvement amounts to 10db at 1,500 cps, 7db at 2,000 cps, 5db at 1,000 cps and 15 db at 4,000 cps relative to the resonator RA with a comparable internal volume of air. At and below the resonance frequency the attenuation remained approximately the same. The attenuation dip above 4,000 cps is of little practical consequence. It depends rather critically on the conditions of the sound field, and small head movements produce considerable differences in loudness of the test tones. No particular attention was paid to these frequencies in the following studies. In general, the experimental attenuation curve of Fig. 18 may be regarded as fully satisfactory. In the most important frequency range, between 250 and 4,000 cps, the average attenuation is slightly in excess of 40db.



RESONATOR : RC ; TIP : R4M

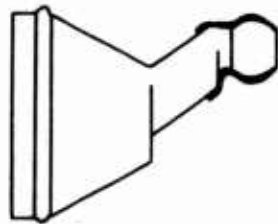

Fig. 17. A horizontal section through a typical ear canal and an experimental resonator earplug adapted approximately to the contours of the outer ear.

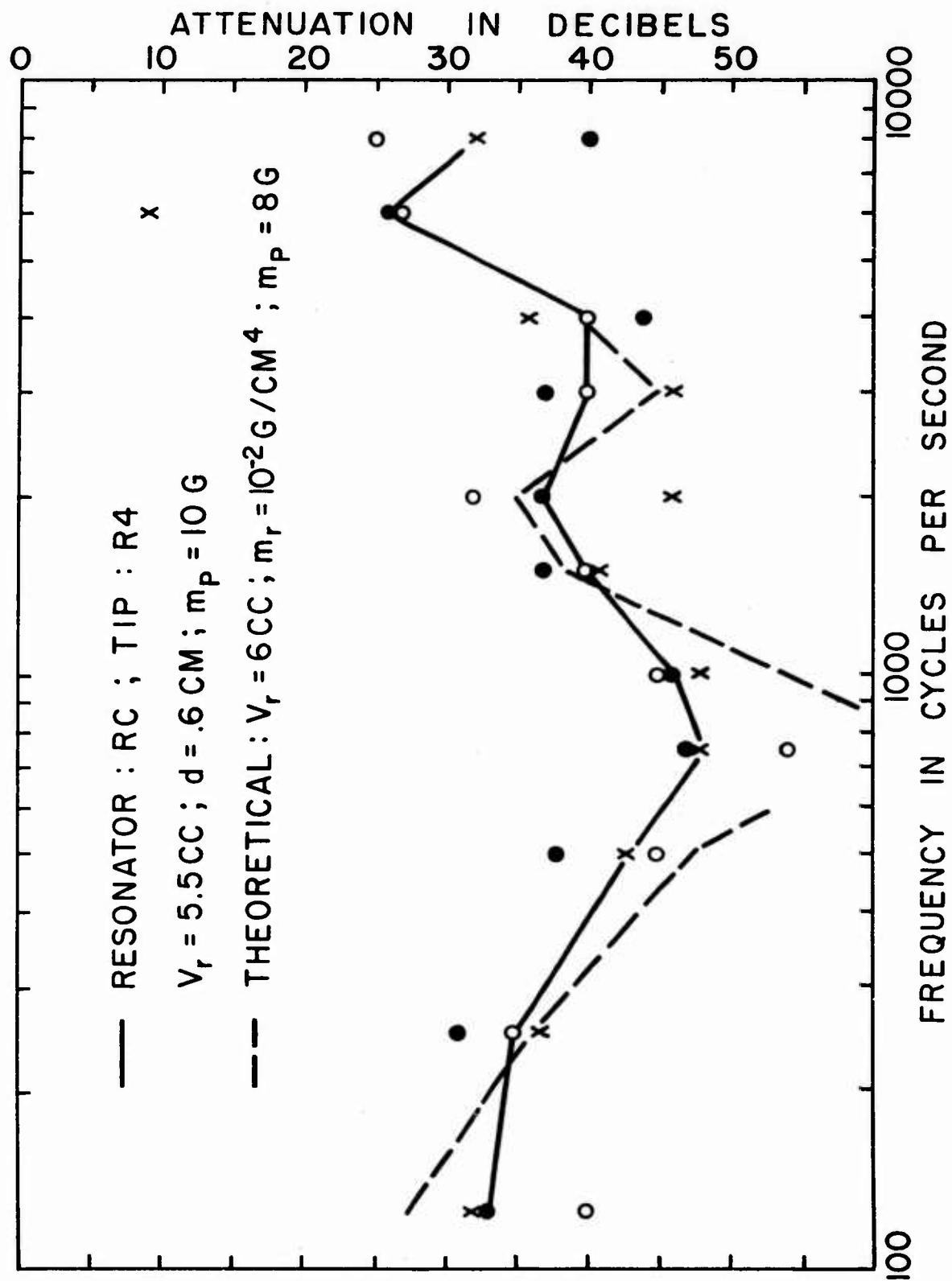

Fig. 18. Sound attenuation produced by the resonator earplug RC of Fig. 17. The points indicate the individual values, the solid curve joins the medians. The broken line has been calculated for a similar earplug.

NATURAL SIZE

SPECULUM

RESONATOR RD.



Fig. 19. The prototype of the final model of resonator earplugs developed in the study, and the speculum of which it has been made.

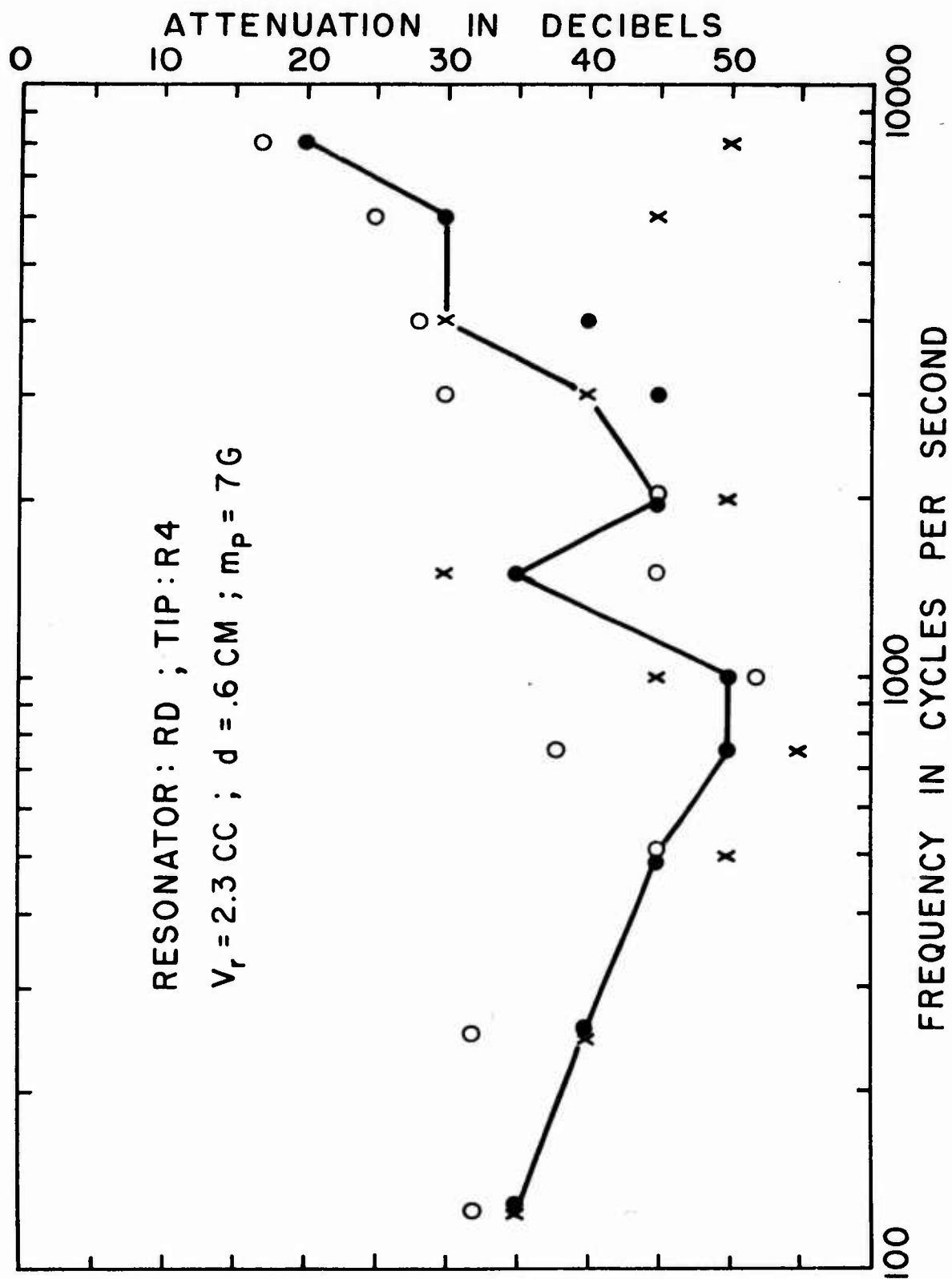

Fig. 20. The sound attenuation produced by the resonator earplug RD of Fig. 19. The points indicate individual values, the curve joins the medians.

For comparison purposes, a theoretical attenuation curve has been plotted in Fig. 18 (intermittent line). The calculation has been based on the following constants: $\alpha = 4$; $m_p = 8\text{g}$; $V_r = 6\text{cc}$; $m_r = 10^{-2}\text{g/cm}^4$. Except in the vicinity of the resonance frequency, the agreement between the theoretical and the experimental data is within 5db. The discrepancy near the resonance frequency is due to the fact that the resonator damping has been ignored in the theory. The agreement means that no substantial leakage of sound through the sealing tip was taking place in the experimental situation.

The results achieved with the resonator RC fully justify the theoretical expectations. The experimental attenuation values of Fig. 18 are superior to corresponding attenuation values achieved by the best commercial earmuffs at all frequencies up to 1,000 or 1,500 cps. Between 2,000 and 4,000 cps they are only slightly inferior. This result is obtained with devices which are about 50 times smaller than an average modern earmuff. Nevertheless, subsequent modifications have led to further improvements.

The resonator of Fig. 17 has an awkward shape. It fits the contours of the concha rather badly and has sharp corners which are likely to cause discomfort. A better adaptation to the outer ear would lead to a somewhat greater comfort as well as a shorter coupling tube, thereby decreasing the acoustic mass m_r . This was attempted in the next model which was fashioned out of an otological speculum by hammering. The speculum as well as the resonator are shown half schematically in Fig. 19. The resonator is very small and contains only 2cc of air. It was designed as an adapter for larger containers to be mounted on its top. However, attenuation measurements have convinced us that the small resonator is an excellent ear protector in its own right. Figure 20

shows that it produces as much sound attenuation as its predecessor with a 5.5 volume of air. The reason for this somewhat unexpected finding may lie in an improved mechanical balance, i.e. a smaller α . A smaller α is to be expected as a result of the smaller length of the resonator.

2. Development of a standard resonator

The resonator RD proved so satisfactory from every point of view that it was decided to use it as a standard. For purposes of further research the original handmade model had to be duplicated. This presented a problem, since the shape of the resonator precluded the use of machine tools, and molding appeared as the only reasonably economical process.

Making a mold for a complex shape of the kind shown in Fig. 19 requires direct duplication. The procedure is complicated if no parting lines are allowed, and for reasons of comfort, we attempted to avoid them. Due to this requirement, the whole mold had to be made out of one piece. A mold of hard material had to be excluded, because the extraction of the model, and later, of the finished replicas would have been impossible. As a consequence, we used the silicone resin, RTV-20, manufactured by General Electric Company. This resin has similar mechanical properties to rubber and remains highly flexible after curing. The curing can be done at room temperature. The resin has been developed specifically for molding purposes and gives a faithful reproduction of the original sample.

The outside shape of the available model could be reproduced without much difficulty by first, making a female RTV-20 mold, and then, by casting solid pieces of plaster of paris or of metals with a low melting temperature.

Since the resonator is hollow, a core had to be made that would fit the female mold leaving a free space of approximately .020" to .040" along the walls. This was accomplished, after several unsuccessful attempts, by making a solid metal reproduction of the original resonator and by reducing it by the required wall thickness on all sides. From this model an RTV-20 core could be obtained by a two-step procedure. The core was then secured in the female part of the mold. It then became possible to make a secondary model by filling the mold with a metal melting at a low temperature. This secondary model was used to produce a series of RTV-20 molds. Since the outside and the inside of the secondary model could be replicated directly, this step was reasonably straight forward. Nevertheless, the molds underwent a considerable evolution dictated by the requirements of mechanical rigidity and accurate assembly.

The next step was the selection of a suitable material for the resonators. The requirements were of three kinds: acoustic properties, mechanical properties, method of production. The acoustic considerations called for a rigid shell, the mechanical considerations called for a shatter-proof material, and the RTV-20 mold called for a material that could be poured at a low temperature. The metals with a low melting temperature were rejected as too soft, and out of the family of rigid plastics epoxy was selected as the most suitable material. By using combinations of various resins and catalysts, a satisfactorily short curing cycle (15 minutes) and a sufficiently low viscosity could be achieved.

The production of samples out of epoxy proved very tedious and time consuming, due to the limited equipment of our laboratory and the lack of experience with the material used. Two major pro-

blems emerged: the epoxy had a tendency to entrap gas bubbles which accounted for a large number of rejects; no satisfactory release agent could be found, so that the mold surface was rapidly damaged and a new mold had to be made. Nevertheless, a dozen pairs of resonators have been produced for use in this and other laboratories. Figure 21 shows the drawing of the finished product in a cross section and an elevation perpendicular to each other.

The wide opening of the resonators has been closed by a flat disc machined out of stainless steel, aluminum, or plastic. During some experiments, additional containers were fastened to the resonator.

The number of epoxy resonators produced in the laboratory was sufficient for laboratory purposes. For field studies a considerably larger number was needed. Because of the inefficiency of the laboratory production, it was decided to give the job to an industrial plant. After a careful analysis we came to the conclusion that the resonators should be made out of stainless steel and that they could be manufactured by means of the lost wax method. Gray Syracuse Co. kindly undertook the task. We supplied a carefully prepared model made of a soft metal, which served for the manufacture of primary molds. Nearly 300 resonators of stainless steel have been produced and distributed to various establishments for field test. Some have remained in the laboratory for further experimentation. The resonators produced by Gray Syracuse resemble closely those shown in Fig. 21.

3. Development of insert and semi-insert tips

The second essential part of the resonator earplugs is the soft tip that seals the ear canal. Many models made of several materials were tried out. Most of them were manufactured by dip-

RESONATOR RD

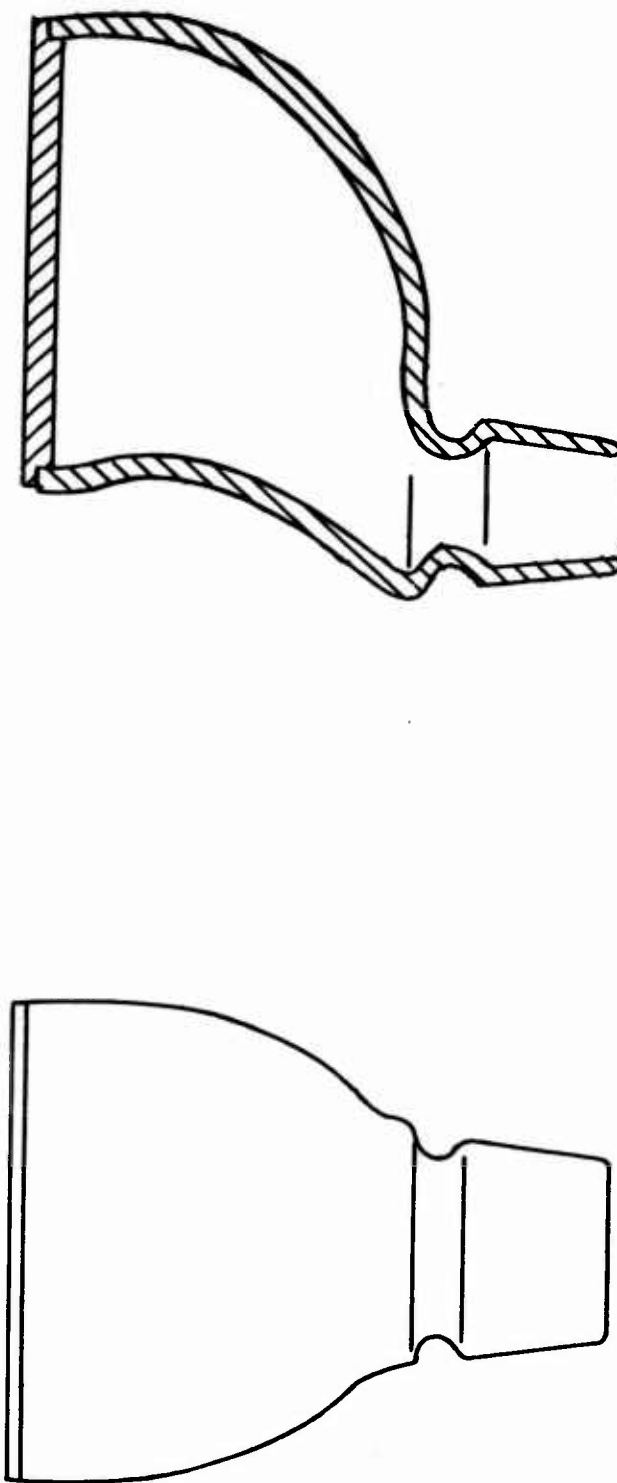

Fig. 21. The final model of the 2cc resonator (model RD).

ping. This method has proven easy to handle in the laboratory. Unfortunately, it limits somewhat the design possibilities, and we feel that there remains considerable room for further improvements. In industrial production, the injection molding would appear preferable to dipping. It should make more sophisticated designs possible.

Figure 22 shows a dipping mold which was used for the final design of the insert tips. It consists of two parts held together by a screw. The upper part (A) is of aluminum, the bottom part (B) of brass. It was used in the following way. First of all, the groove C was filled with plastisol. Then, the mold was turned over and placed on the bottom plate of a Carver press for about 30 seconds. The temperature of the plate was kept at 430° F. In the next step the mold was turned over again and dipped in a pool of plastisol for 10 to 15 seconds. In order to obtain the desired outside shape, it was necessary to withdraw the mold from the plate very slowly. After completion of the dipping process, the mold was put back on the hot plate for an additional 30 seconds of curing. Then it was cooled in water. Finally a hole of 6mm diameter was cut at the tip of the plastic piece, which permitted the piece to be removed from the mold. The removal necessitated a separation of the two parts of the mold. The 6mm hole is not only necessary for the removal of the molded piece; in the finished product it provides the connection between the resonator and the ear canal.

A finished tip of medium size is shown in Fig. 23. Three more sizes have been made, one smaller and two larger. The material used in the second phase of the project was a vinyl plastisol designated by the number 237-40 and manufactured by Auburn Plastics.

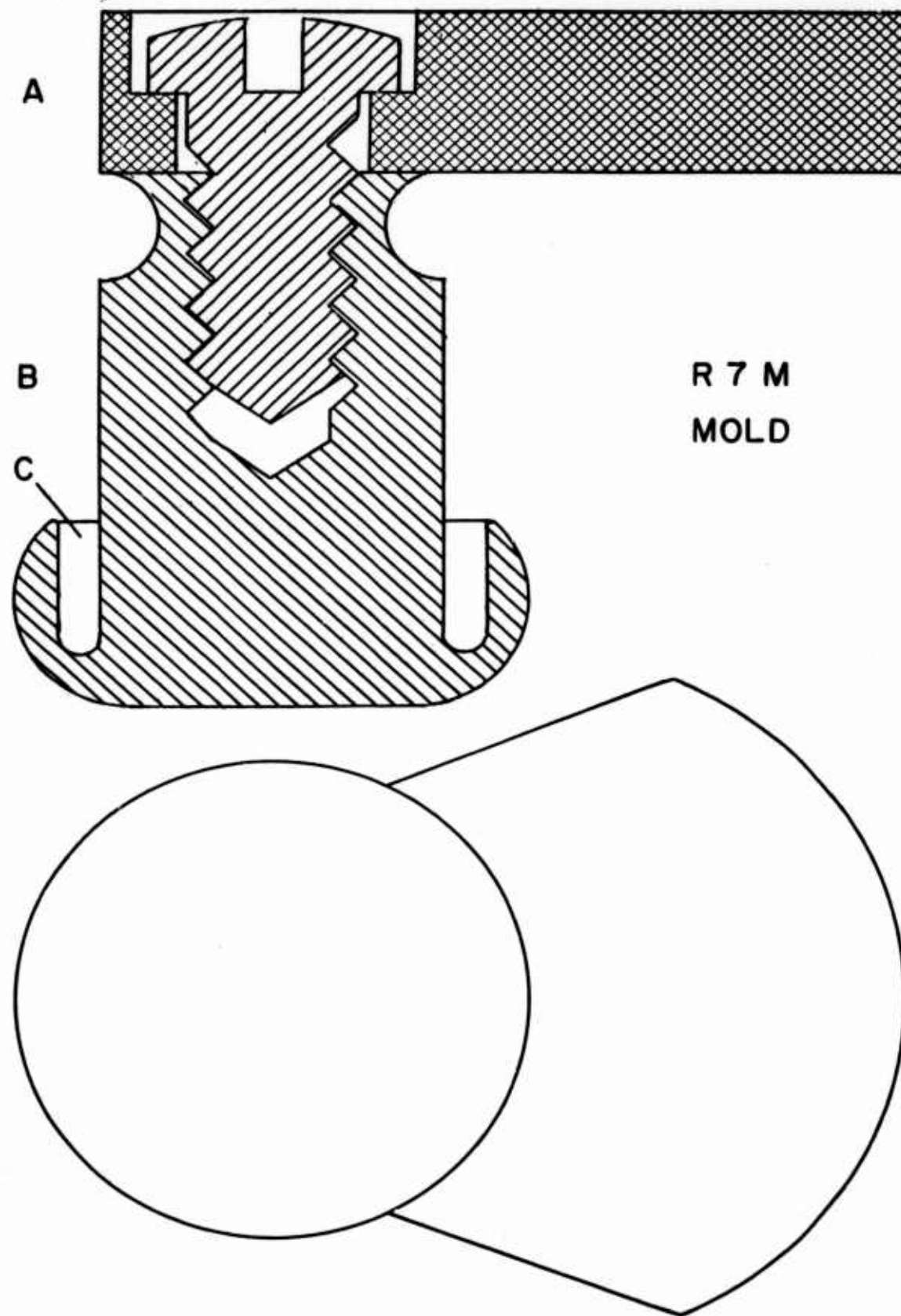

Fig. 22. A dipping mold for the insert tips.

The tips of the type shown in Fig. 23 have been designated as R7M. The letter M stands for the medium size. The other sizes carry the designations: R7S, R7L, and R7XL; the letters S, L and XL stand for: small, large, and extra large respectively.

The shape of the tips R7 has been developed in several steps based on the considerations of comfort, sound attenuation and method of production. It embodies the following features. The rim A fits into the groove of the resonator neck (Fig. 21) and holds the tip firmly in place. The flap B insulates the hard surface of the resonator from the surface of the concha. At the same time, it insures an easy removal of the tip from the ear canal, should the tip become separated from the resonator. The widened portion C with thin walls provides the actual seal of the ear canal. The thin walls assure an essentially even distribution of pressure on the walls of the ear canal. When the tip is forced into the ear canal, the thin walls are pressed toward the thicker flange D and come partially into contact with it. In this way, the sound transmission through the thin walls is decreased.

The tips R7 proved very satisfactory from the points of view of comfort and sound attenuation. They have two slight disadvantages. During the insertion into the ear canal, the wide portion C has the tendency to become even wider and make the insertion difficult. When the surface of the tip is wetted or greased slightly, this difficulty disappears almost completely. The second disadvantage is a slight tendency of the tips to pop out of certain ear canals. Neither disadvantage proved to be serious in practical use of the resonator earplugs. Nevertheless, attempts were made to overcome them. The tip of Fig. 24 is an example of a tip that is easy to insert and has a very good re-

R7M TIP

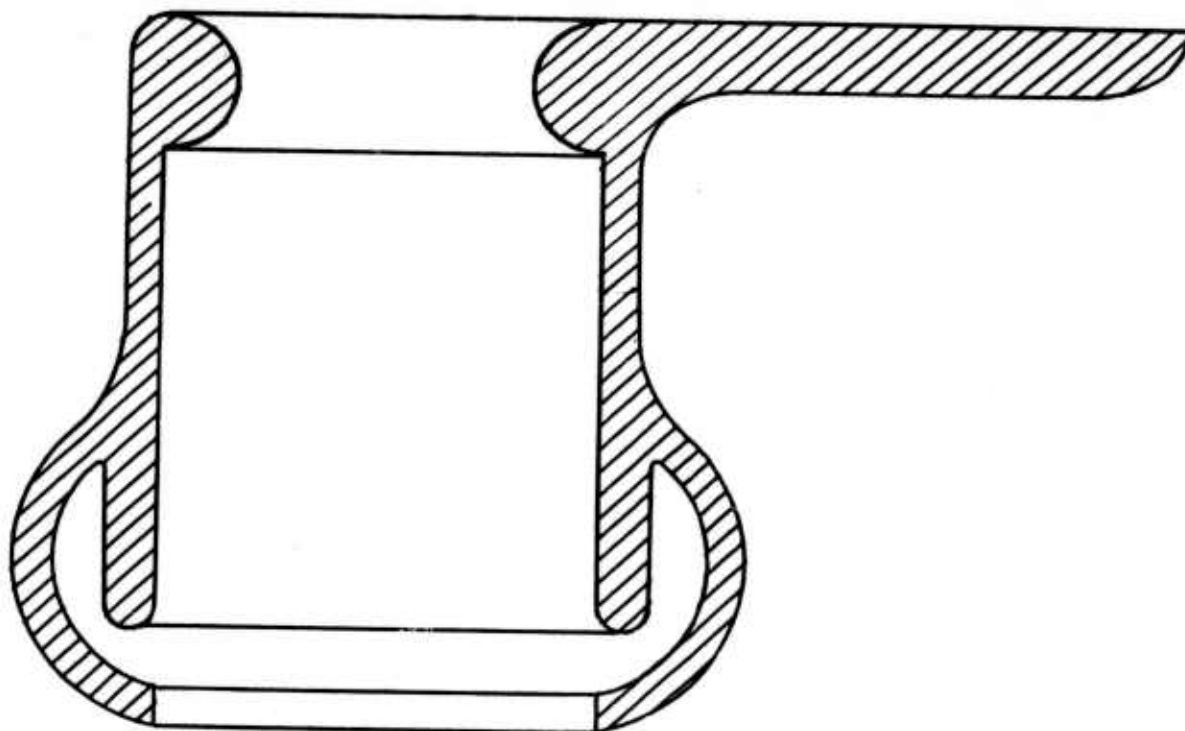

Fig. 23. The final model of the insert tips for the resonators RD (medium size).

tention in the ear. Unfortunately, it provides less sound attenuation and is less comfortable than the tips R7. This was also true for all other designs used. As a consequence, the tips R7 have been accepted as the best compromise.

The design of semi-inserts proved to be even more difficult than that of inserts. The semi-inserts have to seal the ear canal at its entrance. They are used in conjunction with a head band which holds the ear protectors in place. While the cross sectional shape of the ear canal is approximately elliptical and not difficult to fit, the surface at the entrance to the ear canal is geometrically complex and shows strong individual variations. Also, this portion of the ear is very sensitive to pressure, so that the semi-insert must be soft and the force exerted by the head band minimized. Under these conditions it is extremely difficult to obtain a good seal and avoid sound leakage through the soft material of the tip.

A large number of semi-inserts were designed and tested. They were dip molded, like the inserts, and the same material was used. Figures 25 and 26 show two designs which have been accepted as final. They provide approximately the same sound attenuation. Type RS8 of Fig. 25 is somewhat more comfortable; type RS9 is easier to place in the ear so that a tight seal is achieved.

4. Development of the headband

Since, to our knowledge, there are no semi-insert ear protectors on the market, no commercial headband was available for the resonator semi-inserts. The only headband of this kind in existence seems to have been developed at Harvard's Psycho-Acoustic Laboratory more than 15 years ago, but the device has not been produced commercially.

R2T TIP

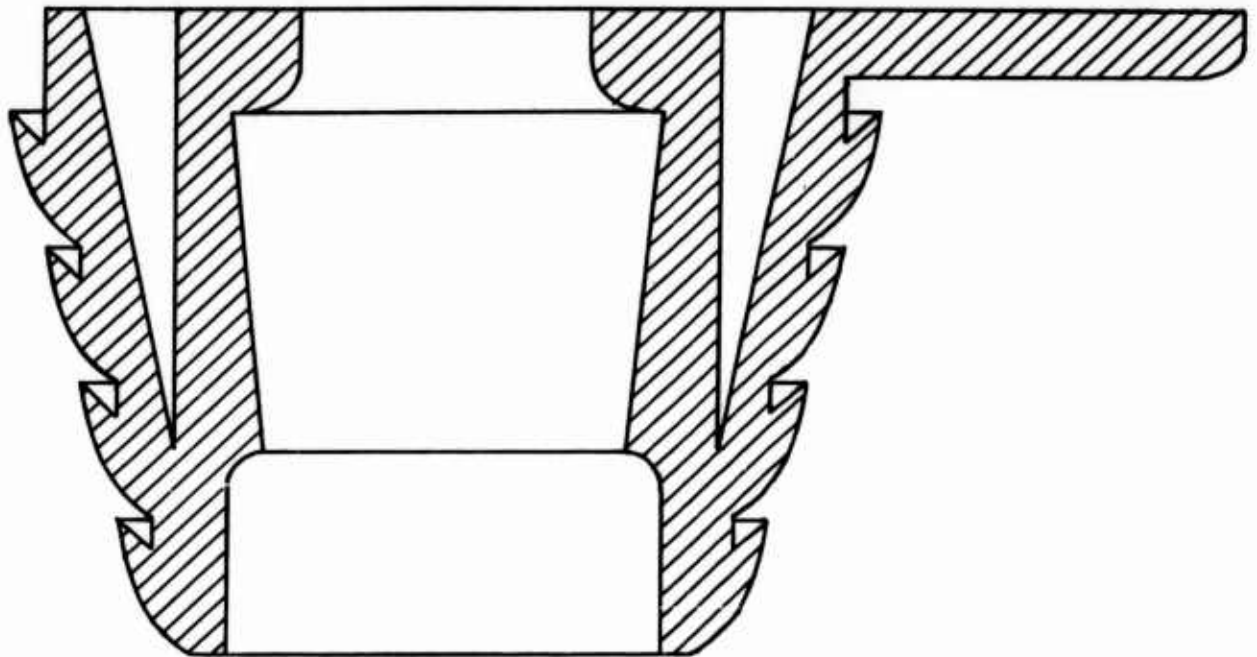

Fig. 24. An experimental insert tip for the resonators RD.

RS 8

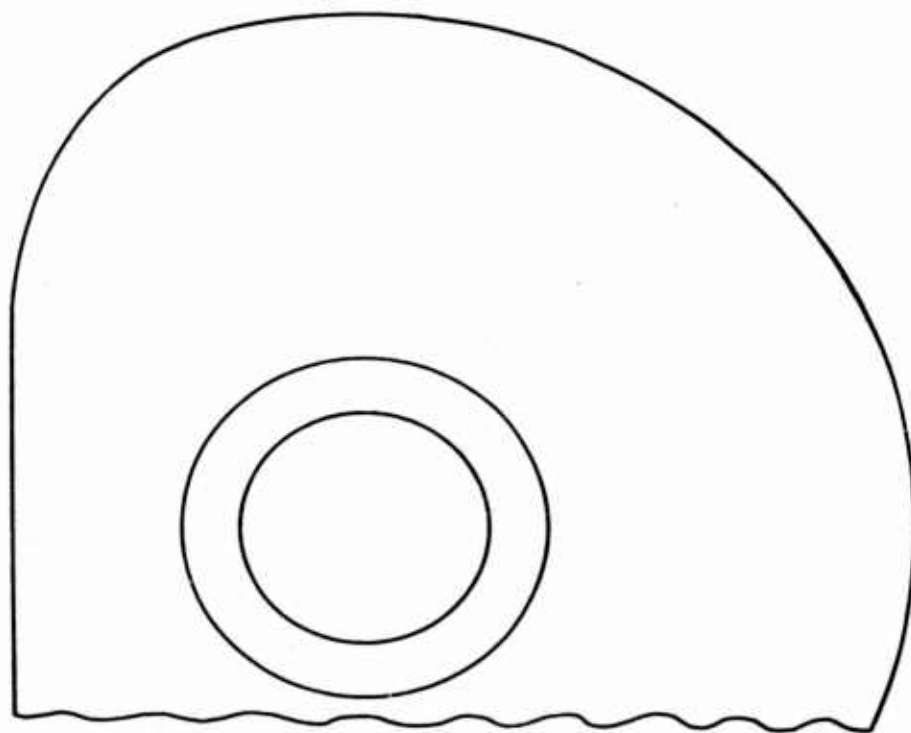
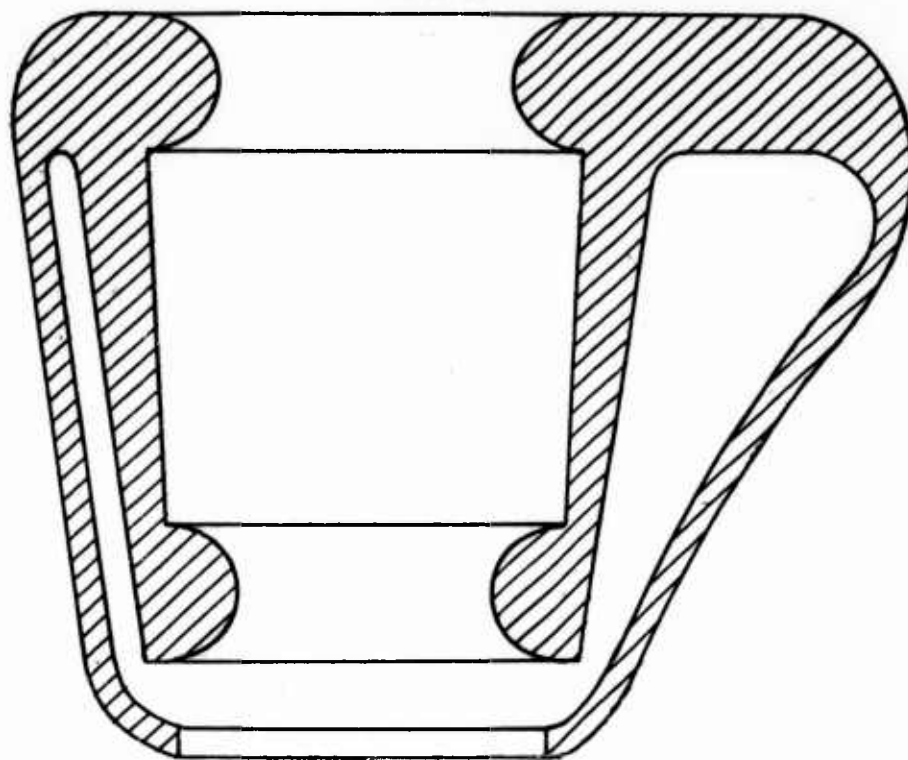

Fig. 25. The final model of the semi-insert tips for the resonators RD.

RS 9

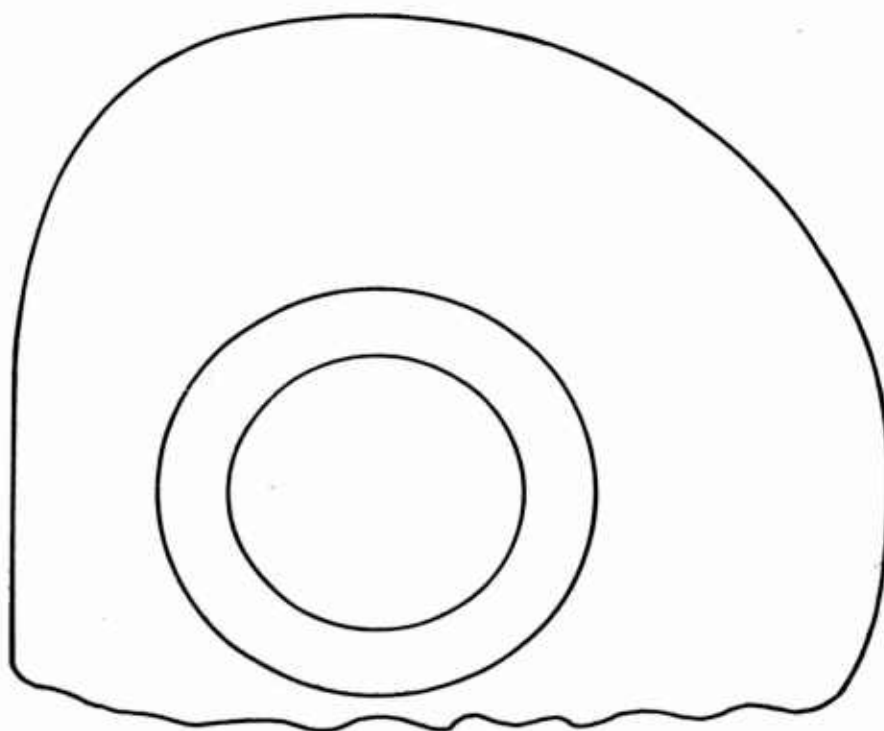
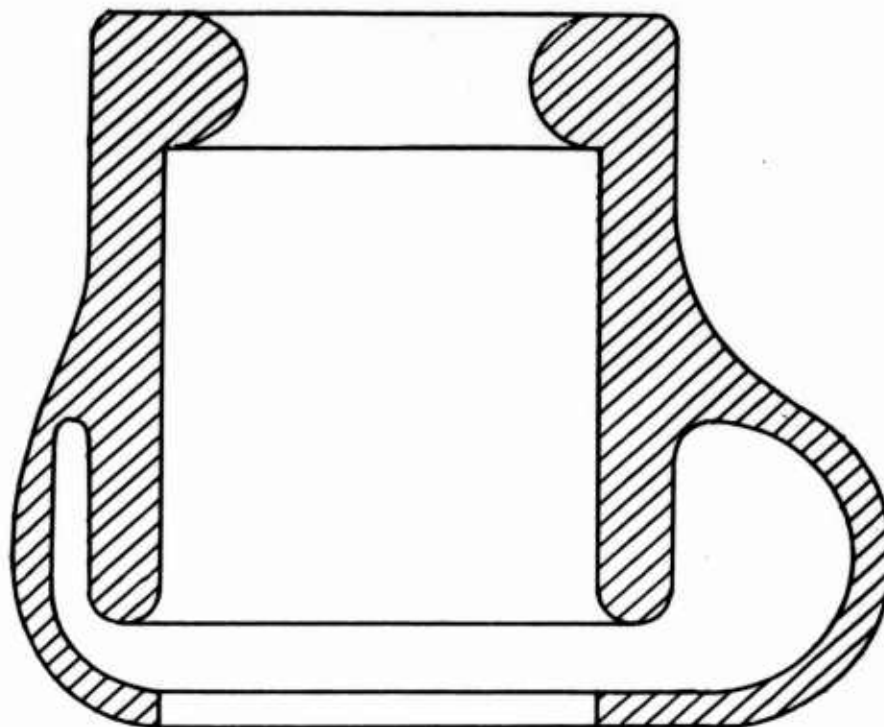

Fig. 26. The alternative final model of the semi-insert tips for the resonators RD.

A few samples of the Harvard headband could be obtained. They were carefully studied and an attempt was made to adapt them for our needs. Its success was less than complete for several reasons. The headband has been originally developed for a device substantially different from ours and is made of hard steel which, in our situation, does not provide a sufficient adaptability to the size of the head. Furthermore, the construction is rather sophisticated and makes the manufacture of the headband difficult by simple means.

Other commercially available headbands were tried. They ranged from standard headbands for earphones to headbands used in conjunction with hearing aids or with ear muffs for protection against cold, and even to headbands for holding the hair. All these attempts were only partially successful, and it was finally decided to develop a completely new headband.

After several misses, the headband shown in Fig. 27 was finally produced. It consists of three pieces of a steel band, of two plastic holders for the resonators, of two pieces of soft wire coiled around the steel bands, of a plastic tube covering the bands, and of two rivets.

The three pieces of steel band comprise a long center piece bent to fit the contours of the head and two end pieces which can slide along the center piece. Each end piece is held in place by a length of soft wire coiled around it and the center piece. In order to prevent the wire from sliding along the center piece, the last coil is jammed between the end piece and the end portion of the center piece, which is bent inward. The upper portion of the end pieces is bent outward in order to prevent them from slipping away from the wire coils. This simple con-

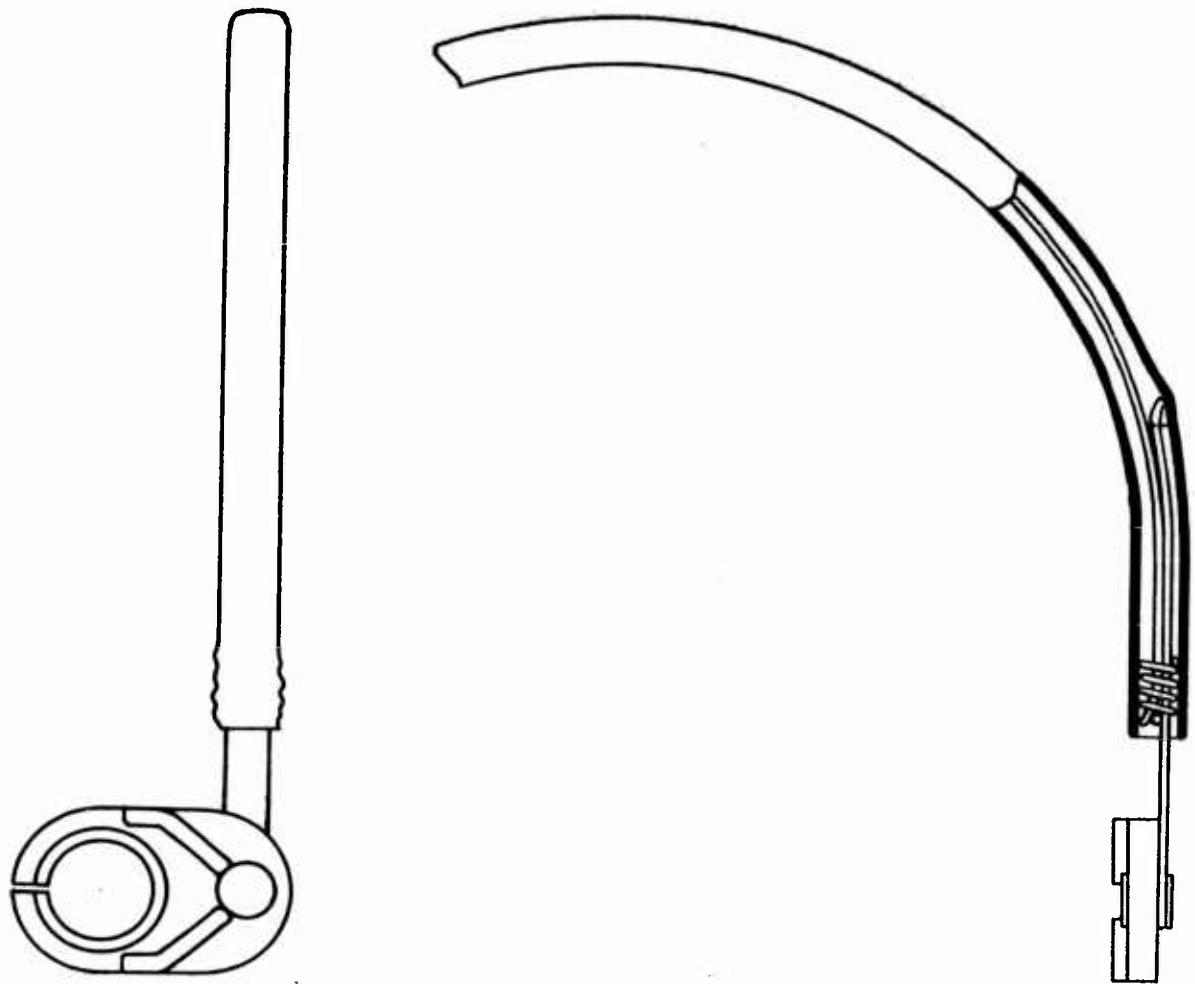

Fig. 27. The final model of the headband for the resonator semi-inserts.

struction insures a quick adjustment of the length of the headband for an accurate placement of the earplugs. Moreover, it is very inexpensive and requires only the simplest tools.

The headband must hold the resonator semi-inserts not only in an accurate position but also at a correct angle. In order to insure the latter, several types of holders for the resonators were investigated. All permitted a more or less restrained movement around three orthogonal axes. The holder shown in Fig. 27 proved the most satisfactory. It consists of a flat piece of a semi-hard plastic and carries two openings. The smaller opening is for the rivet which secures the holder to the end piece of the headband, the larger is for the resonator. The holder is reinforced between the two openings by two ribs and a flat piece of steel embedded in the plastic. A slit at one end of the holder facilitates the placement of the resonator which is secured by means of a groove in its outer cover.

The plastic tube covering the headband and partially cut away in Fig. 27 prevents hair from being trapped between the pieces of steel band and the coils of wire. It also serves an aesthetic purpose.

PSYCHOPHYSICAL EVALUATION OF RESONATOR EARPLUGS1. Effect of the resonator size

During the development of the resonator earplugs it has been observed that the air volume of the resonator has only a slight effect on the sound attenuation. This can be explained theoretically, assuming that the size of the resonator which grows in proportion to the enclosed volume of air has an adverse effect on the constant α and leads to increased inertia forces. Otherwise, the sound attenuation at low frequencies would increase almost at the same rate as the enclosed volume.

In order to test the relationship under extreme conditions, a resonator with a volume of 13.5cc was made and tested on two experienced listeners by means of the threshold method described in the preceding chapter. The sound attenuation so determined is plotted in Fig. 28 as a function of frequency. For comparison, the sound attenuation obtained on the same two listeners with the 2cc resonators, RD, using the same insert tips, R4, is also plotted. At low frequencies the difference in attenuation is on the average somewhat less than 10db in favor of the larger resonator. The theory would predict a difference of 13db on the basis of the ratio of volumes. The missing 4 to 5db may be attributed to the constant α which can be expected to grow with the resonator size. However, another factor, the masking effect of the physiological noise, may have intervened also.

From the practical point of view it is relevant that the larger resonator did produce a greater sound attenuation at frequencies below 1000 cps. This gain is offset to a certain extent by a slightly

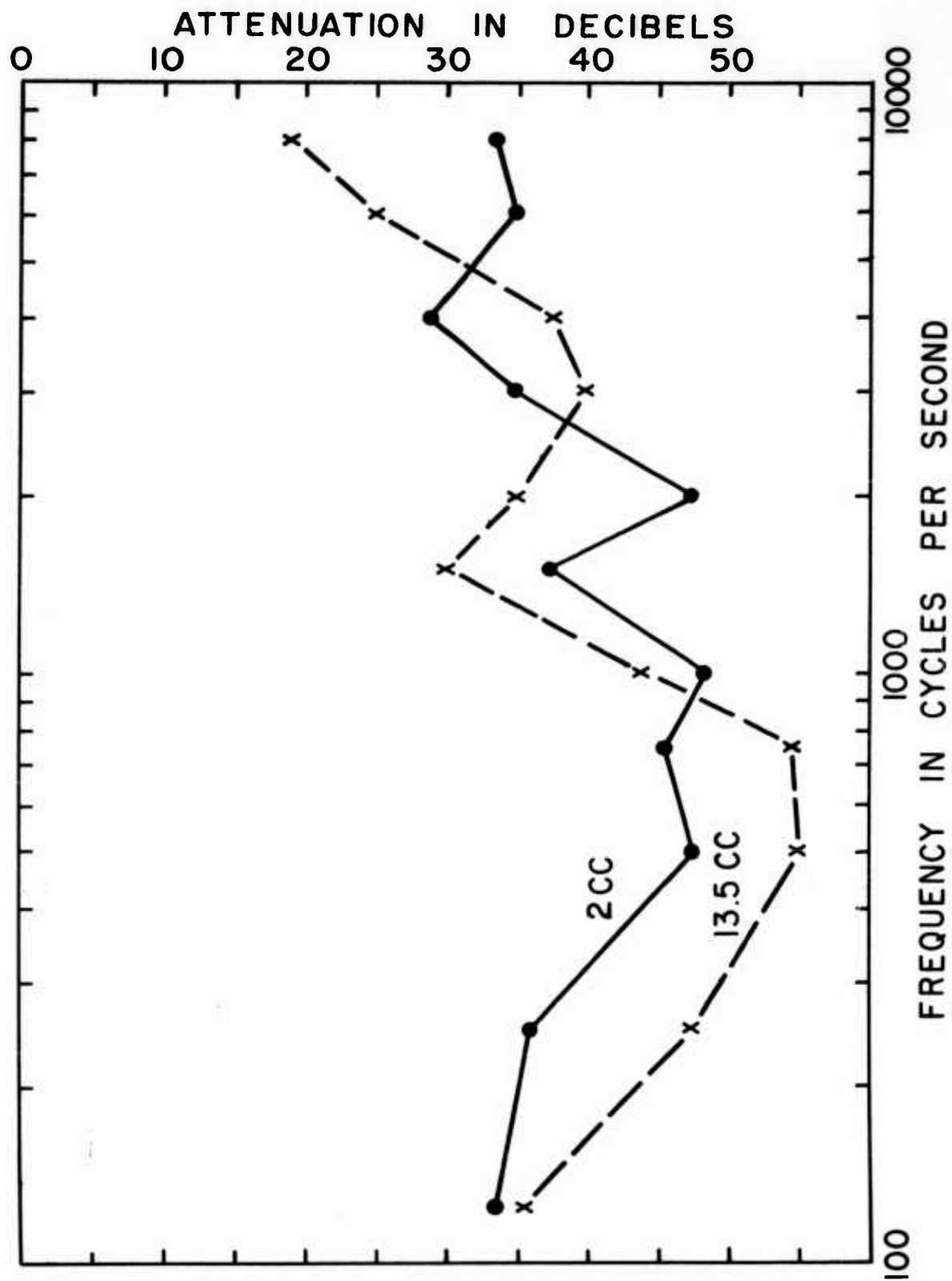

Fig. 28. Attenuation curves of resonator earplugs with a small and a large resonator, respectively (means of two subjects).

decreased attenuation above 1000 cps. Since sound frequencies around and slightly above 1000 cps appear to be the most harmful to the ear, the advantage of an emphasis in attenuation at low frequencies is questionable, unless the noise energy is concentrated in this region.

2. Effect of the resonator

The resonator earplugs provide a substantially higher sound attenuation at low and medium frequencies than do ordinary earplugs. The difference must be accounted for by two factors: the increased mass of the earplug and the increased volume of the enclosed air. In order to separate their effects, three experiments were performed. In one experiment, the opening to the resonator was closed by solder; in the second, the resonators were cut off and only their necks with closed opening left in the insert tips; in the third, the opening to the resonator was left open. The resonators RD and the insert tips R7 were used throughout, and the sound attenuations were obtained by the threshold method described in the preceding chapter. The differences in attenuation between the closed resonators and the closed necks of the resonators, obtained on four listeners, are plotted in Fig. 29. The solid line joins the median differences. At low and medium frequencies the earplugs with closed resonators produced a greater sound attenuation than the earplugs with the resonator necks. At high frequencies the reverse was true. The reduced attenuation at these frequencies may be due to a distortion of the sound field, to an increased constant α , or to both. At frequencies below 3000 cps the results are in agreement with the theory of Chapter II (Figs. 9a and 9b) in that the mass has only a slight effect on the sound attenuation. The maximum improvement at 250 cps

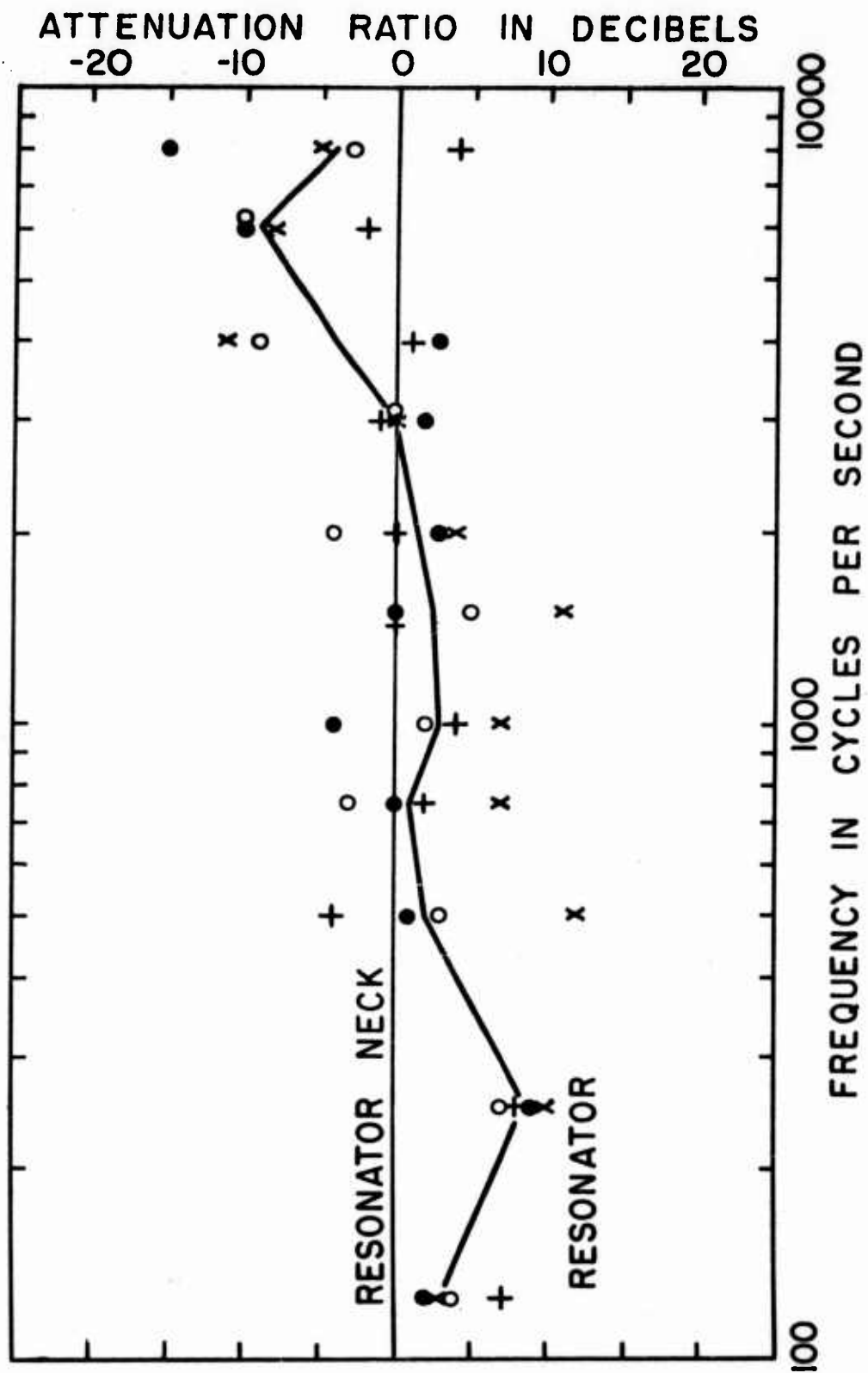

Fig. 29. Increment in attenuation due to the mass of the resonator. The curve joins the means obtained on four listeners.

may be ascribed to a shift in mechanical resonance that is produced by the elastic suspension and the mass of the earplug. The small attenuation difference at medium frequencies is consistent with a large δ (of the order of 4), also indicated by other experimental results obtained with resonator earplugs.

The difference in attenuation between open and closed resonators is shown in Fig. 30. Again, individual differences are plotted for four listeners and the broken line joins the medians. The solid line indicates the theoretical prediction of the preceding chapter for a resonator of 2cc volume and with an acoustic mass of $4 \times 10^{-3} \text{ g/cm}^4$. Except near the resonance frequency at approximately 2000 cps, the experimental and the theoretical curves are approximately parallel. However, the improvement in attenuation below the resonance frequency determined experimentally is about 4db smaller than theoretically predicted. This discrepancy finds no explanation in the theory developed in the preceding chapters and it appears to be of a similar nature to the "missing 6db" (8). The missing 6db refers to a not very well understood difference that results when the threshold of audibility determined by means of earphones is compared to the threshold of audibility determined in a free sound field. The free field threshold appears to be 6db better.

A possible explanation of the phenomenon is provided by the physiological noise already mentioned (211,12). When one sits quietly in a sound proof room a noise with a wide frequency spectrum and an irregularly variable intensity becomes audible. The noise source is localized at the ears and not in space outside the head or in the middle of the head. This introspective observation indicates that the noise is generated peripherally in each ear and that the two noise sources are independent from each other. When the ear canal

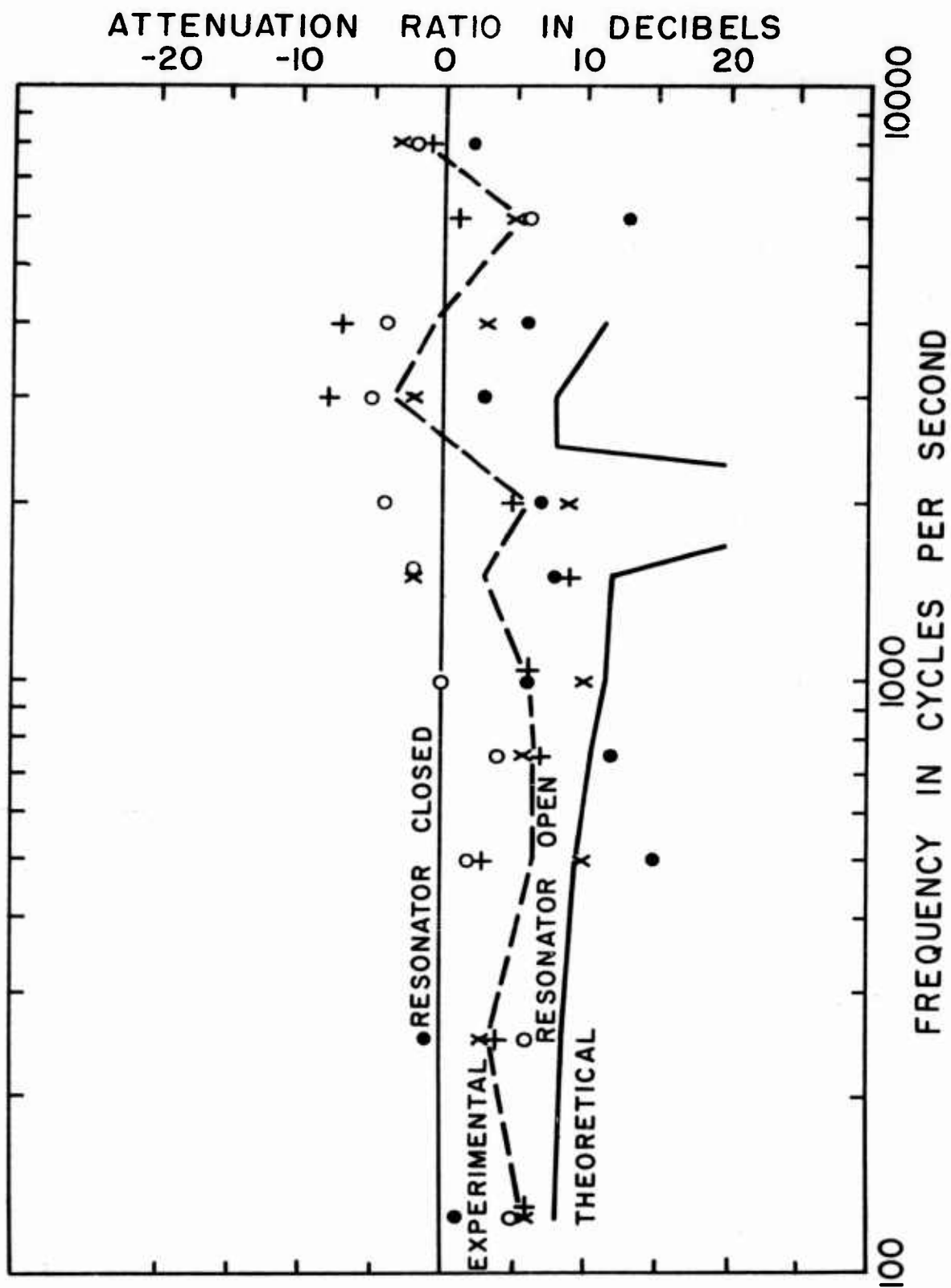

Fig. 30. Increment in attenuation due to the acoustic effect of the resonator. The broken line joins the means obtained on four listeners; the solid curve indicates the theoretical prediction.

is open most of the noise energy is radiated directly or via the ear drum into the ambient air. When the ear canal is closed, most of the noise energy is reflected back into the ear and the noise level rises. Under such conditions masking of faint sounds produced by external sources may take place. The level of noise generated in the transmitting system depends on the acoustic impedance of the device closing the ear canal. Since this is also true for external sounds, the ratio between the sound levels produced by the external and the internal sources, respectively, may remain approximately constant. As a consequence, the threshold of audibility would vary less than could be expected on the basis of impedance variations. If this reasoning is correct, the reduced effect of the resonator, which is apparent in Fig. 30, can be understood.

In order to have an additional confirmation of the "noise hypothesis", bone conduction tests were undertaken. It is well known that the bone conduction threshold at low and medium frequencies can be lowered to a considerable extent by occluding the outer portion of the ear canal. Occlusion of the bony part of the ear canal eliminates the effect completely. It has been concluded, therefore, that the bone conduction threshold at low and medium frequencies is controlled by sound pressure generated in the ear canal. This sound pressure may stem from compressions and dilations of the ear canal or from the relative movement between the skull and the occluding device. Since any sound pressure generated in the ear canal must depend in the same way on the acoustic impedance of the occlusion, the bone conduction threshold should be affected by the occlusion of the resonator in the resonator earplug to the same extent as the attenuation of sound produced by an ex-

ternal source. If the threshold change can be fully accounted for by the impedance change, the effect of physiological noise generated in the ear canal can be ignored. If the change is smaller than predicted, the hypothesis that a sufficient noise is generated to produce a noticeable masking effect is confirmed.

Bone conduction thresholds have been determined by the method of limits, with the vibrator placed on the forehead and the resonator earplugs in place. Three experienced listeners participated. The individual data (points) and their means (broken line) are plotted in Fig. 31. They show the bone conduction threshold obtained with the resonators open relative to the bone conduction threshold obtained with the resonators closed. At low and medium frequencies the threshold shift is of the order of 5db and it approximates closely the corresponding attenuation shift of Fig. 30. It is smaller by about 4db than the theoretical prediction based on the change in the acoustic impedance. Consequently, the hypothesis that the threshold of audibility determined with the ear canals closed is controlled by the physiological noise in the ear canal and, possibly, in the middle ear is confirmed. Due to this situation, the threshold measurements do not show the full improvement in sound attenuation produced by resonator earplugs over that produced by ordinary earplugs.

3. Effect of the resonator volume

The next step was the evaluation of the effect of the resonator volume on sound attenuation. For this purpose, plastic syringes of 5cc maximum volume and with removed bottom were mounted on the RD resonators. The total resonator volume was varied between 2 and 6cc, and the sound attenuation determined by means of the threshold method on three experienced listeners. The median sound attenuation

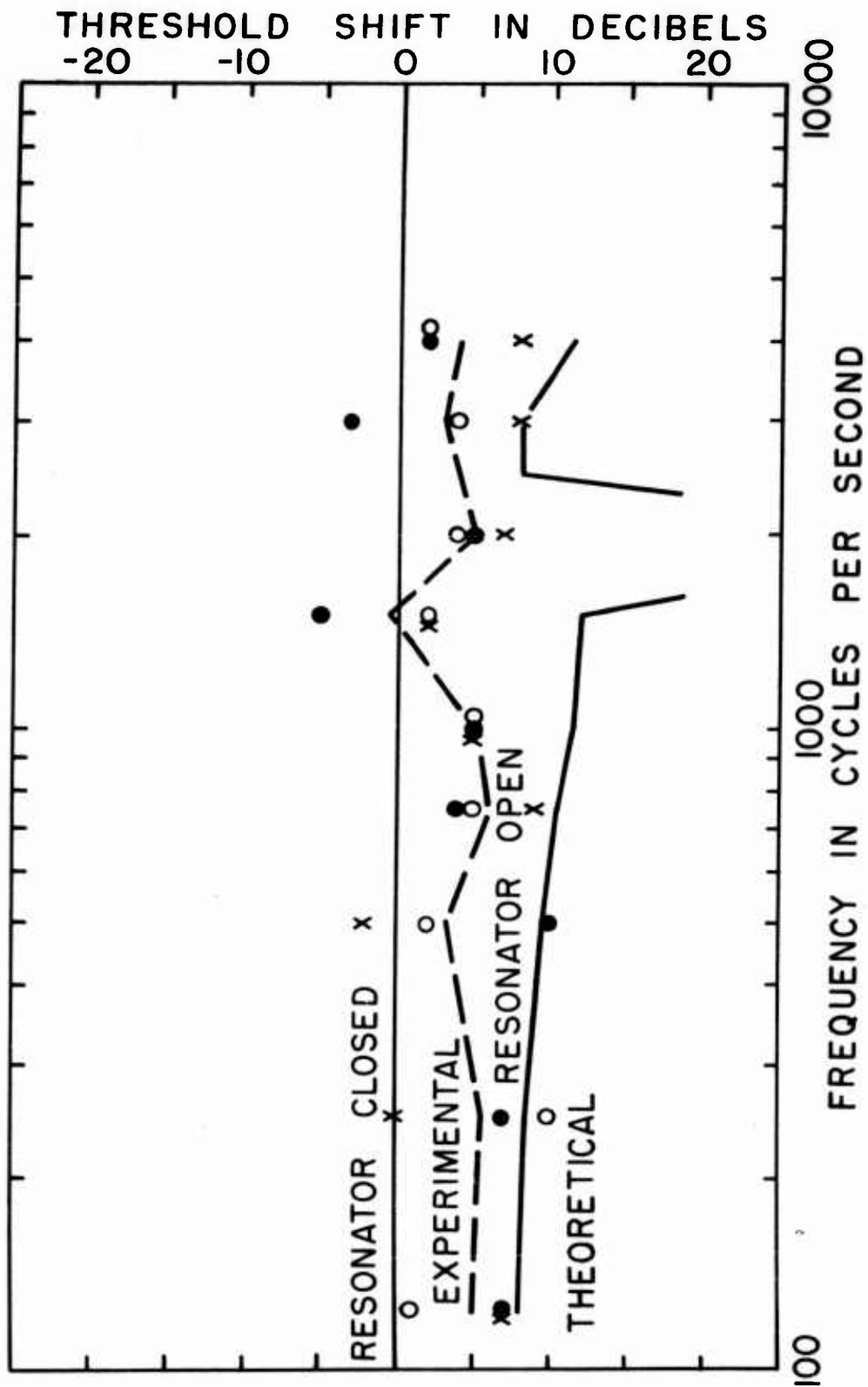

Fig. 31. Shift in the bone conduction threshold with occluded ears, due to the acoustic effect of the resonator. The broken line joins the means obtained on three listeners; the solid curve indicates the theoretical prediction.

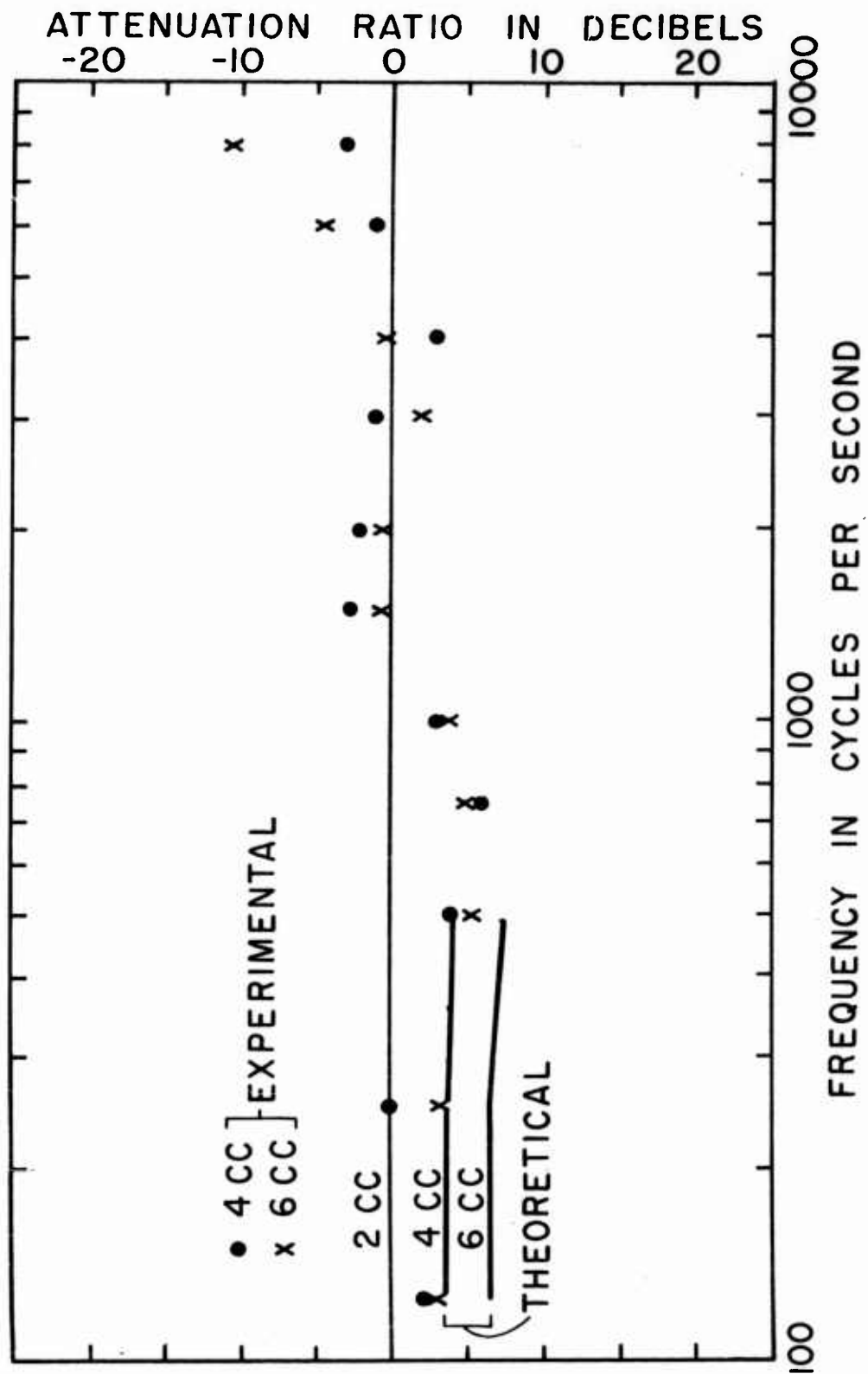

Fig. 32. Change in sound attenuation due to variation of the resonator volume. The 2cc volume serves as reference. The points indicate means obtained on three listeners, the solid curves are theoretical.

for 4 and 6cc's relative to the sound attenuation obtained with a 2cc resonator volume is plotted in Fig. 32. Theoretical curves derived from Fig. 13a are also shown for comparison. The measured effect is smaller again than the theoretically predicted, in agreement with the hypothesis of the masking effect by the physiological noise in the ear canal and the middle ear. The improvement in attenuation due to a larger resonator volume is limited to low and medium frequencies. From the practical point of view, such an improvement is of questionable value, particularly in consideration of a necessarily larger size of the earplug. For this reason, no resonators larger than 2cc have been made for field tests.

4. Effect of the mass of the resonator

According to the theory discussed in Chapter II and according to previous experiments the sound attenuation at medium frequencies depends on the mass of the earplug and on the distribution of the mass. In order to evaluate the effect, the sound attenuation of a very light resonator earplug was compared to that of a very heavy earplug. The first consisted of epoxy and weighed 2g, the second of steel and weighed 8g. The tests involved three experienced listeners. The results are shown in Fig. 33. The closed circles and the crosses indicate individual values for the 2g and the 8g earplugs, respectively; the lines join the means. It is clearly evident that the heavy earplugs provided a greater sound attenuation at low and medium frequencies. At high frequencies there is little difference. This result is consistent with the theory of Chapter II on the assumption of a constant factor \mathcal{K} .

It has been demonstrated theoretically in Chapters I and II that the distribution of the mass, reflected in the constant \mathcal{K} affects the sound attenuation. As the constant \mathcal{K} decreases, the

sound attenuation should increase. In order to test this hypothesis, the sound attenuation produced by the all steel resonator was compared to that of a resonator made of epoxy and closed at the outer end by a steel plate. The first earplug weighed 8g, the second 5g. In the first, the mass was distributed evenly; in the second it was concentrated in the steel plate. The attenuation measurements were performed on 10 listeners and Fig. 34 shows the median data. There is a clear difference in sound attenuation between the two resonator earplugs, but it is in the opposite direction to the theoretical prediction. The lighter earplug with an uneven mass distribution which should have led to a large α provided a greater sound attenuation at all frequencies. There does not seem to be any obvious explanation for the unexpected reversal, except the possibility that α changed in the opposite direction from what common sense dictates. Time did not allow us to investigate the situation further, and we are left with the conclusion that the acoustics of the resonator earplugs is not completely known, and consequently, there is room for further improvements.

5. Effect of the resonator damping

Individual attenuation curves produced by the resonator earplugs have an irregular shape and show pronounced peaks and dips. This is undesirable from the point of view of ear protection as well as from the point of view of voice communication. In an effort to obtain a smoother attenuation curve, the RD resonators were filled with foam rubber under varying degrees of pressure. The results for one experienced listener are shown in Fig. 35. The continuous curve indicates the sound attenuation produced without damping, the broken lines correspond to various degrees of damping. The values indicated by crosses have been obtained with a loosely packed

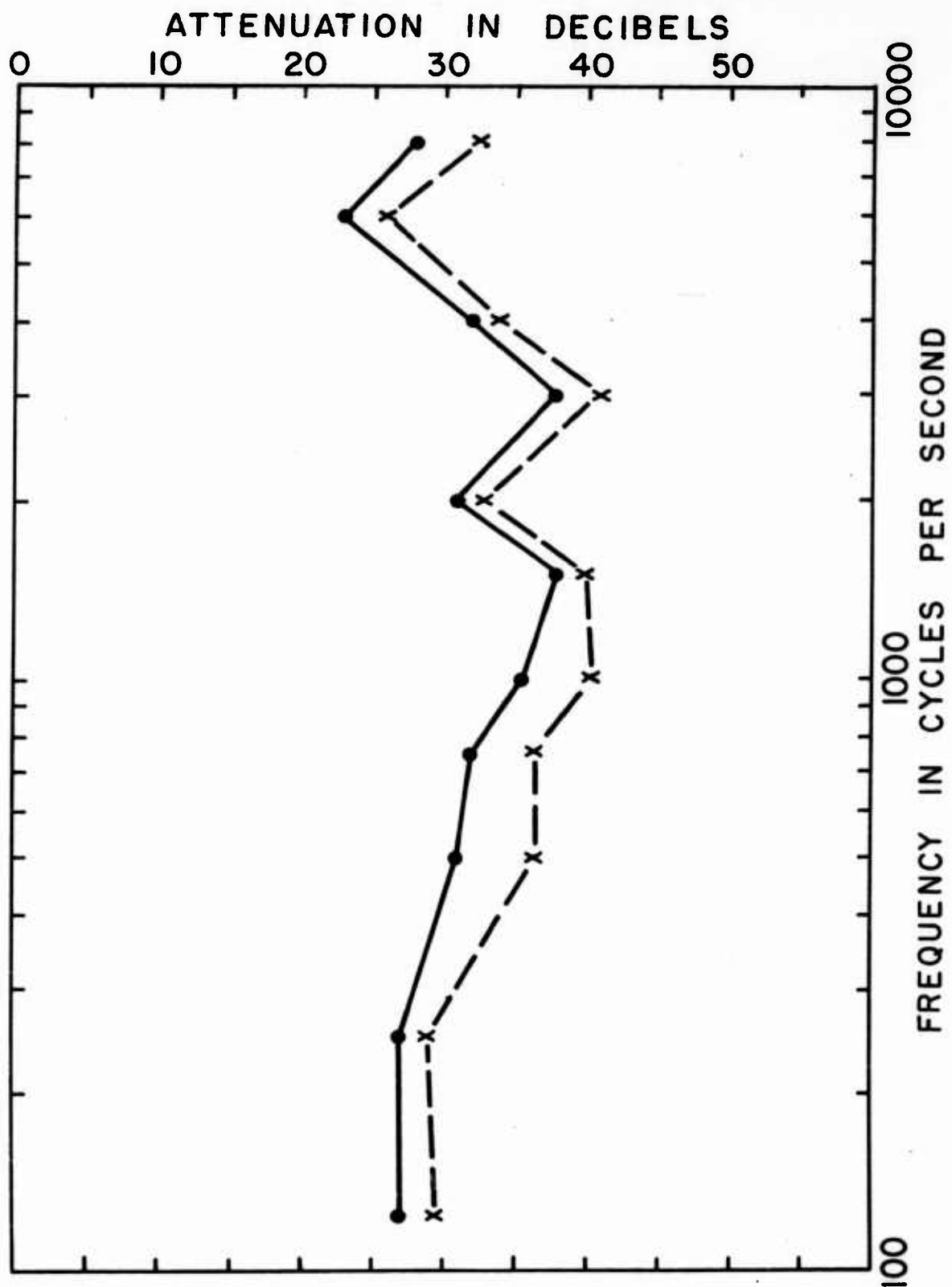

Fig. 34. Shift of sound attenuation of the RD-R7 resonator earplugs produced by a change in mass distribution. The solid curve was obtained with a more evenly distributed mass, the broken line resulted when the mass was concentrated in the top cover. (Medians of ten listeners).

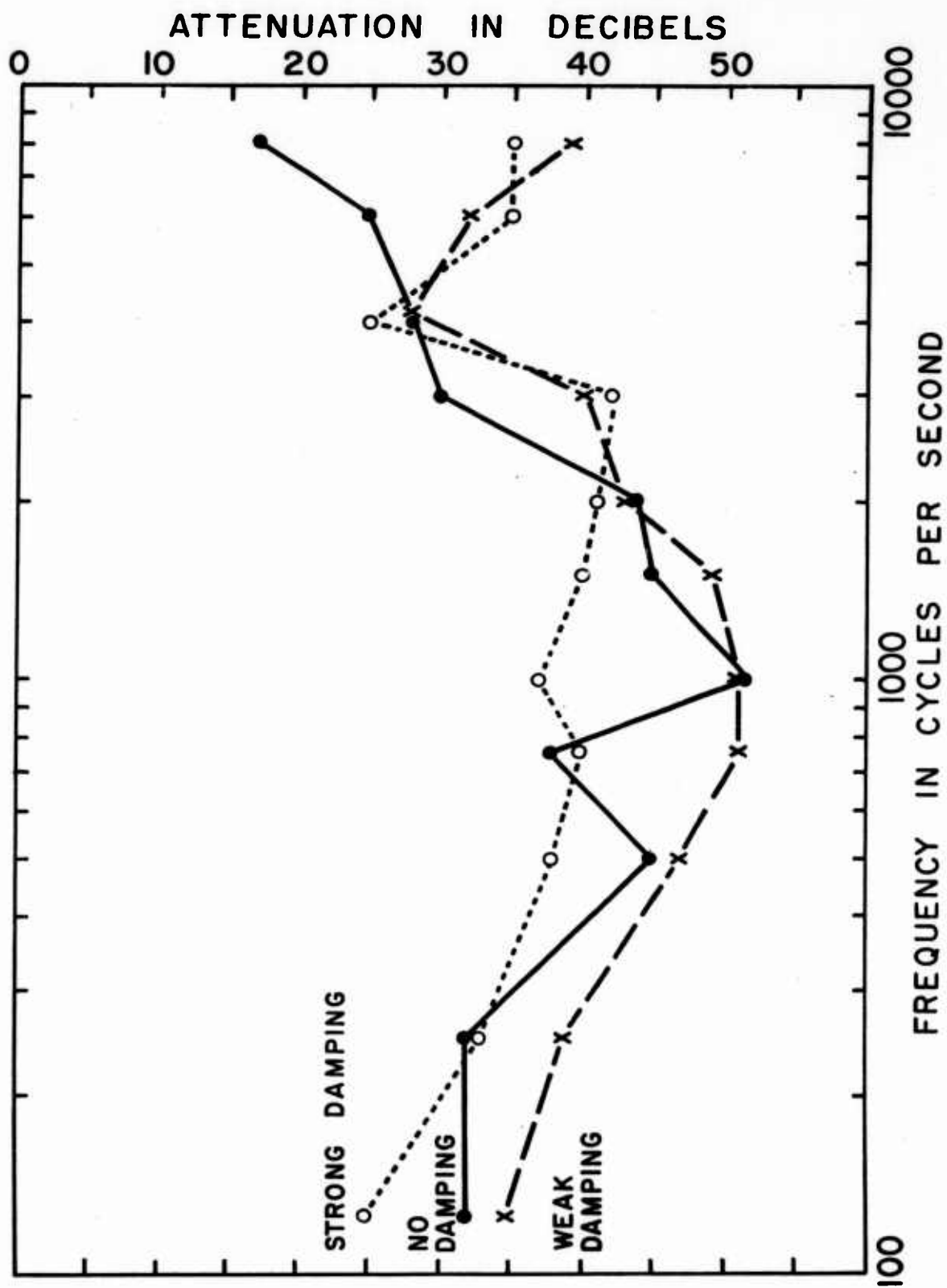

Fig. 35. Effect of foam rubber in the resonator. (individual curves).

foam rubber, those indicated by open circles after the rubber had been packed more tightly.

Resonators with both degrees of damping produced smoother curves than did undamped resonators. Particularly noteworthy is the result achieved with a light damping. In addition to a smoother curve, a substantially greater average sound attenuation has been obtained, particularly at low and high frequencies.

The problem of damping has not been pursued further in our study, and it is mentioned here mainly as a suggestion for further research.

6. Effect of the insert tips

As has been mentioned in the previous chapter, the insert tips that secure the resonators in the ear canal have a definite effect on sound attenuation. Since the rationale for the finally accepted design has already been given, it will not be repeated here. Instead, Fig. 36 shows the range of sound attenuation obtained on one experienced listener with a light resonator RD and four inserts. Three of the inserts were development stages of the final tip, R7, the fourth was an adaptation of the V51-R earplug. In the tips of R-type three main parameters were varied: the shape, the wall thickness and the size of the opening. The range of attenuation amounts on the average to approximately 10db and shows that good insert tips are essential in achieving a high sound attenuation.

Results of a more systematic investigation are plotted in Fig. 37 which shows the effect of the size of the opening in the R7 tips. The solid line connects the median attenuation values obtained with an opening of .6cm in diameter and the broken line those obtained with an opening of .4cm in diameter. Both series of data have been

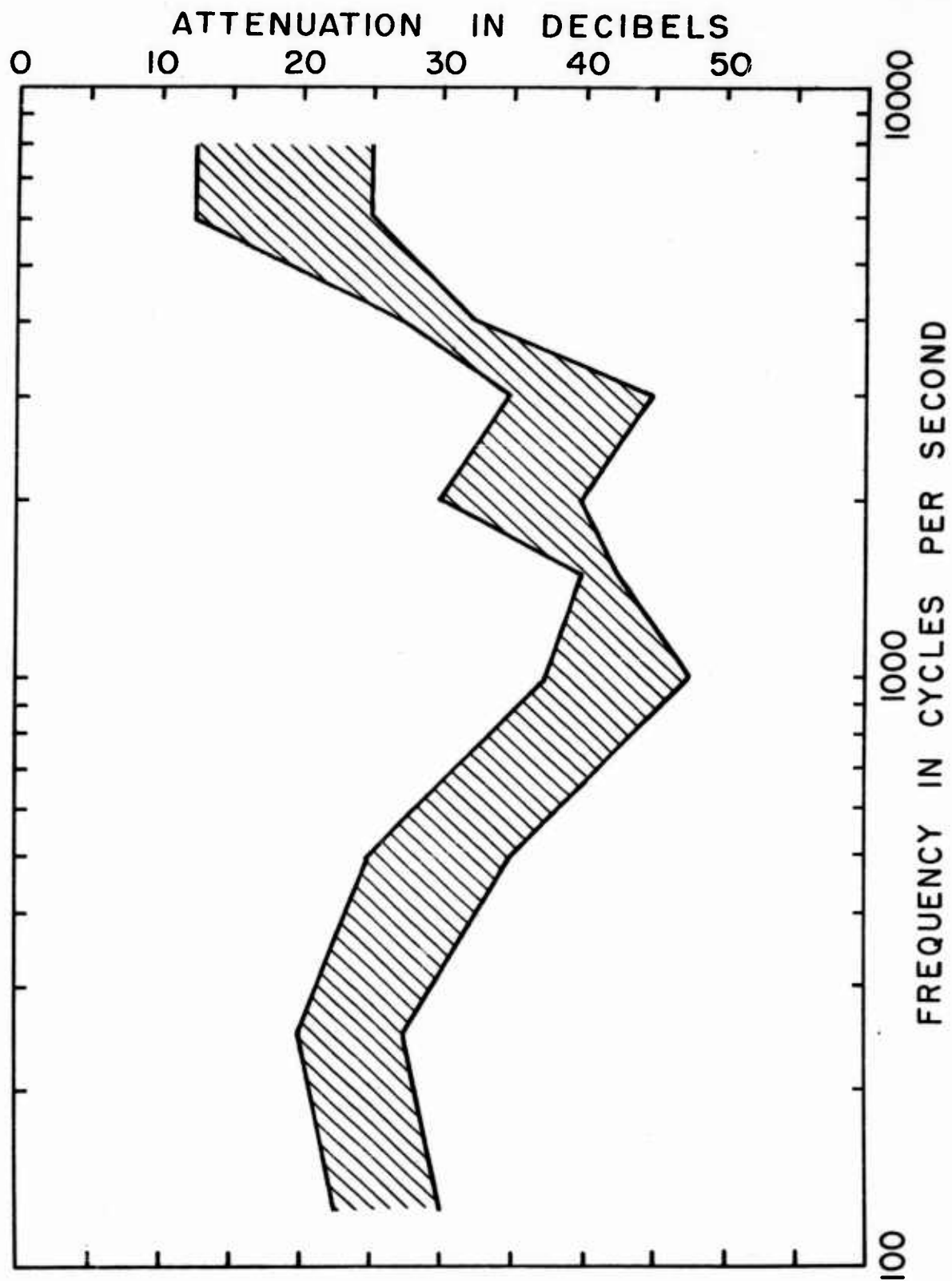

Fig. 36. Range of variation in sound attenuation due to differences in design of insert tips.

determined on a group of nine listeners, using steel RD resonators. The size of the opening affects the acoustic mass which couples the resonator to the ear canal. The wider opening should produce a smaller mass and, consequently, a higher resonance frequency. This is confirmed by the attenuation curves of Fig. 37. The wider opening produced an attenuation maximum around 2000 cps, the narrower one around 1000 cps. In general, the attenuation achieved with the wide opening is slightly superior to that achieved with the narrow one.

The steel resonators, RD, and the insert tips, R7, with an opening diameter of .6cm have been accepted as the final design of the resonator earplugs. As a consequence, the solid line of Fig. 37 is the representative attenuation curve. Had the plastic resonators with steel tops been accepted as the definitive design, the resultant attenuation would have been 2 to 5db greater.

7. The resonator semi-inserts

The basic research on the resonator earplugs was done using insert type tips rather than semi-inserts. The semi-insert type ear protectors introduce additional acoustic factors which are difficult to control. First of all, it is extremely difficult to achieve a tight closure of the ear canal without causing discomfort. Second, the coupling of the earplugs to a headband may change considerably their mode of motion under the direct force of the sound field and under the inertia force produced by the motion of the skull. As a consequence, the resonator design evolved as a ~~result~~ of experiments with insert tips. The designs that appeared suited for the purpose were then tested with semi-inserts. In general, it was found that the resonators that performed well with insert tips did so with semi-inserts. The RD resonators proved to be the most

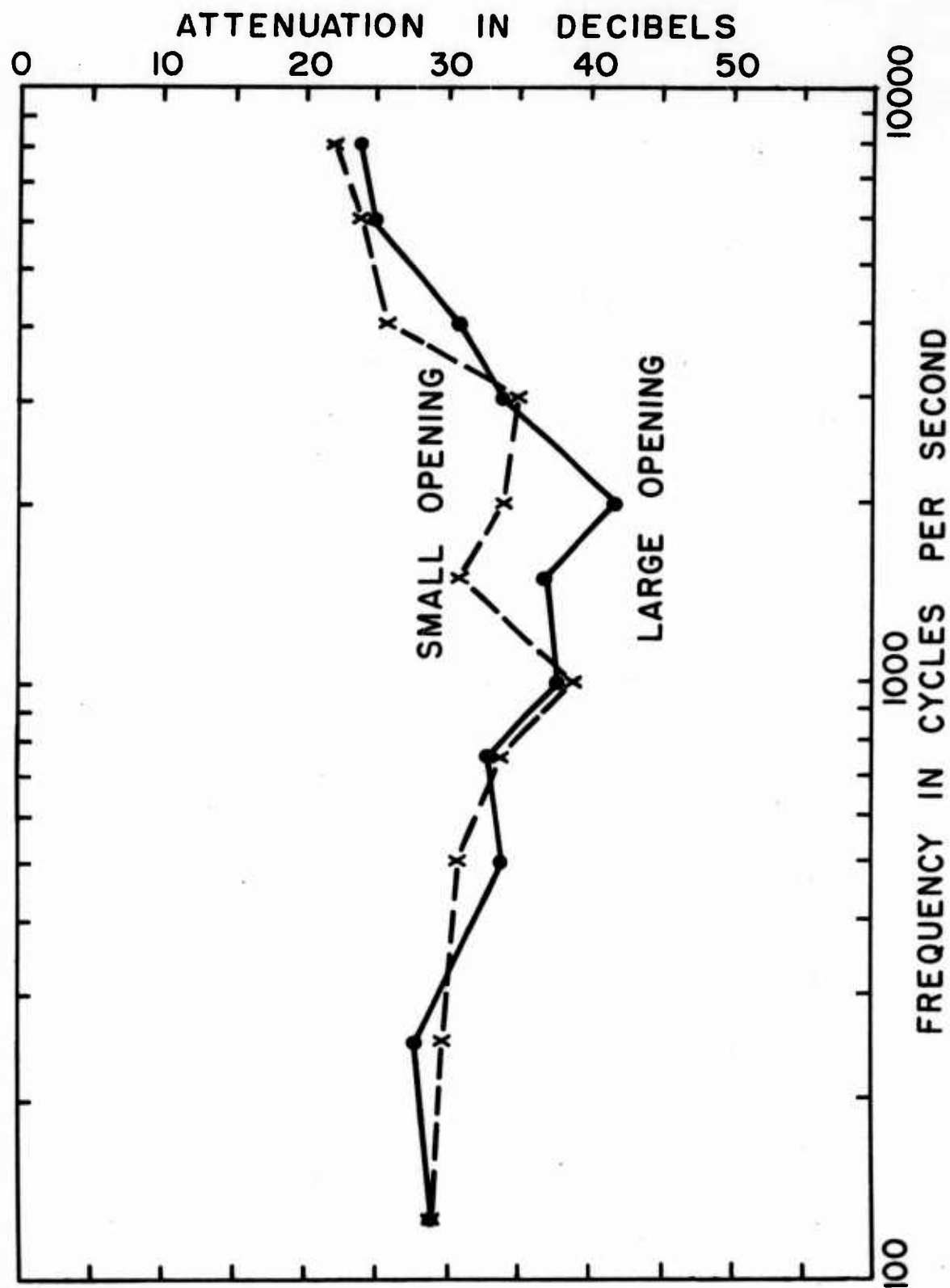

Fig. 37. Attenuation curves of RD-R7 earplugs obtained with two different openings in the insert tip. (Medians of nine listeners).

successful under both conditions.

The seal of the ear canal and the degree of comfort that can be achieved with semi-inserts depend critically on the headband. Several models of headbands were made during the duration of the project. Only the last model was tested systematically, however. It was not necessary to test the others extensively because their shortcomings became immediately apparent. The first models resembled closely headbands used for earphones and bone conduction vibrators. They did not provide either a sufficient stability or comfort. In later models, the coupling between the headband and the resonator was achieved through a ball joint. Although the degree of comfort was increased, no substantial improvement in stability was obtained. Finally, headbands of the type shown in Fig. 27 produced more satisfactory results. They were accepted by the observers as reasonably comfortable and kept the resonators firmly in position. They also showed a sufficient adaptability to the individual anatomy. The model of Fig. 27 was used for systematic acoustic tests.

Considerably more psychophysical testing was done on the semi-insert tips whose acoustic qualities were often not immediately apparent. A design similar to that used for the inserts proved to be the most successful. However, even the best tips that have been developed are not completely satisfactory. If not placed carefully, they do not provide a sufficient seal and the sound attenuation drops markedly. In addition to assuring a tight seal, the semi-inserts must keep the ear canal open; otherwise, the acoustic coupling between the ear canal and the resonator is decreased and the action of the resonator impaired. The semi-insert RS9 of Fig. 26 has this tendency because of its flat walls pressing on the concha

of the outer ear. The semi-insert RS8 of Fig. 25 has a more conical shape, and its narrow tip enters the ear canal sufficiently deep to keep it open. Unfortunately, it is sometimes difficult to achieve a tight seal with it. Figure 38 compares the sound attenuation achieved with RS8 (broken line) to that of a tip similar to RS9 but somewhat smaller (solid line). The points indicate medians of nine listeners. At low and high frequencies, the attenuation obtained with the RS8 tips is as high as that achieved with the insert tips R7; at medium frequencies it is lower. The semi-insert similar to RS9 provided even more sound attenuation at low and high frequencies. Unfortunately, it had to be discarded because of insufficient comfort and because it was too small for very wide ear canals.

The semi-insert RS8 has been accepted as the final design. As a consequence, the broken line of Fig. 38 is representative of the sound attenuation provided by the semi-insert assembly including the headband of Fig. 27, the resonators RD of Fig. 21 with a small modification in the top cover, and of the semi-inserts RS8 of Fig. 25.

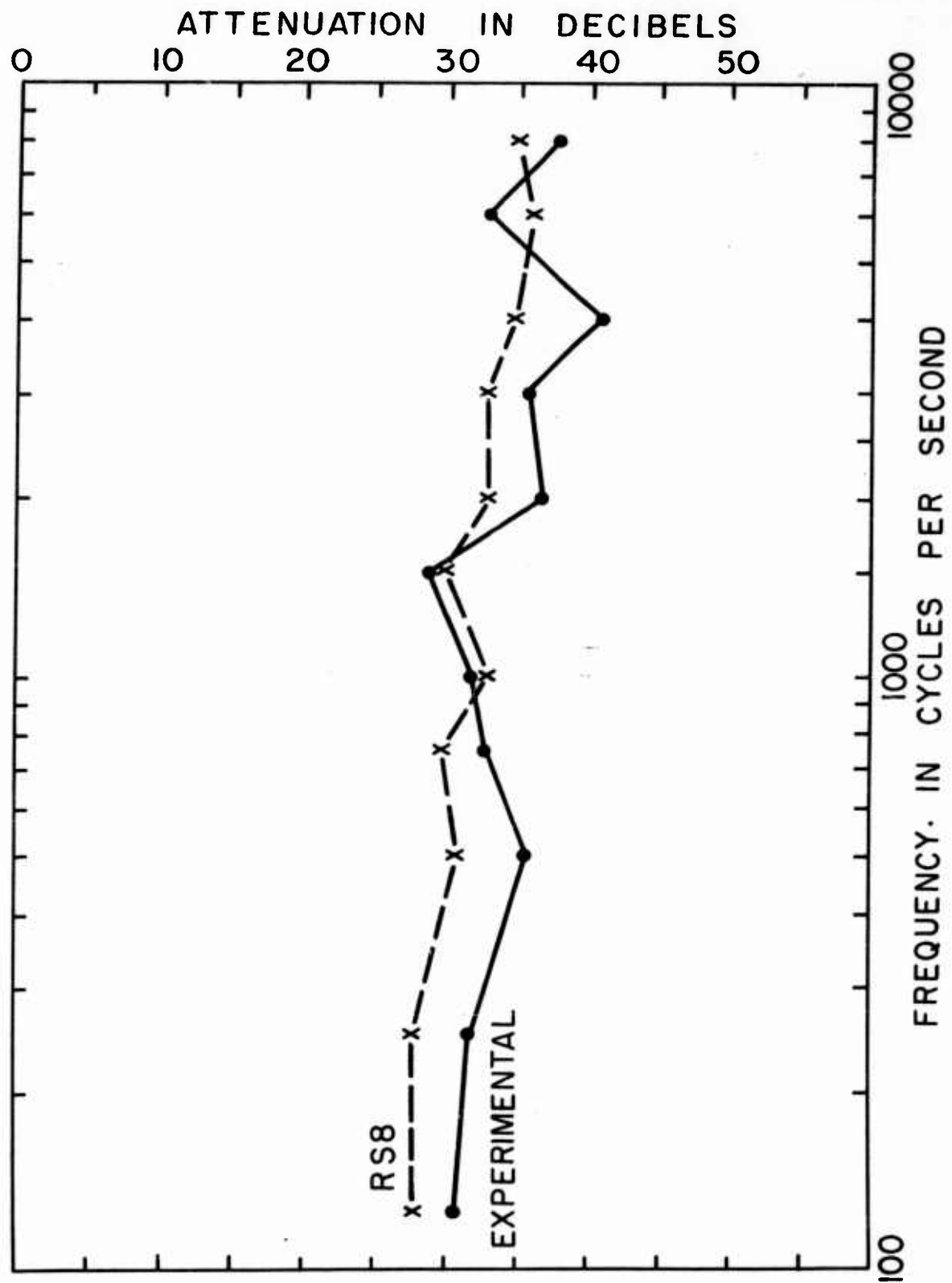

Fig. 38. Attenuation curves of resonator semi-inserts obtained with two different semi-insert tips. (Medians of nine listeners).

PHYSICAL EVALUATION OF RESONATOR EARPLUGS1. Evaluation of the resonator action

The physical testing of ear protectors has been suggested many times and attempts at such testing were undertaken in the past. Due to several unknowns and the difficulty in duplicating the conditions existing in the real ear, no standard procedure has been accepted.

The difficulties arising in the physical testing of earmuffs stem chiefly from the uncertainty concerning the mechanical impedance of the soft tissue underlying the sealing cushion. The acoustic conditions prevailing under the earmuff can be duplicated fairly well by a cavity with rigid walls. Because of the large volume of air enclosed under the earmuff, the acoustic impedance at the entrance to the ear canal has little effect on sound attenuation.

In testing of earplugs, the impedance at the ear drum in combination with the impedance of the small volume of air enclosed in the ear canal becomes important. This impedance is not purely reactive and cannot be duplicated by a cavity with rigid walls. The 2cc coupler used as a standard for calibration of hearing aid earphones does not approach, even remotely, the impedance properties of the ear. Impedance measurements performed in the recent years indicate that, at low frequencies, the average acoustic impedance at the ear drum is equivalent to a volume of air of .81 to .82cc (19). The volume enclosed in the ear canal between the earplug and the ear drum averages .55cc (3). Consequently, the resultant equivalent volume of air amounts to 1.37cc (19). This is considerably less than the standard 2cc. At medium and higher frequencies the resistive compo-

ment of the impedance at the ear drum becomes predominant. The magnitude of the ear impedance at the tip of the earplug is shown in Fig. 8 as a function of frequency. More detailed information can be found in the literature (6,7,19).

The purpose of the physical evaluation of the resonator ear-plugs was twofold. First, it appeared necessary to evaluate the action of the resonator, since the psychophysical tests were not completely conclusive as a consequence of the physiological noise. Second, the physical method has been estimated to be the more efficient way of evaluating the performance of earphones attached to the resonators.

The experiments on the resonator action were performed on a 1.52cc coupler mounted on a Western Electric condenser microphone. At low frequencies the 1.52cc duplicates the conditions in the ear to a sufficient degree for the resonator evaluation. The resonator was sealed to the coupler by means of wax. Sound was injected into the coupler through a hypodermic needle No. 26 which constituted a high impedance source. The sound pressure obtained with the resonator closed was compared to that obtained with the resonator open. The ratio of the two pressures is a measure of the resonator action. This ratio expressed in decibels is shown in Fig. 39 as a function of frequency. It is equivalent to an improvement in sound attenuation. At low frequencies, where a 1.52cc cavity is a reasonably good approximation of the acoustic impedance measured in the ear canal, the sound pressure ratio agrees closely with theoretical predictions. This finding reinforces us in the belief that the result of the psychophysical threshold determinations underestimates the resonator action. The resonance dip and, particularly, the anti-resonance peak in Fig. 39 are strongly exaggerated because of

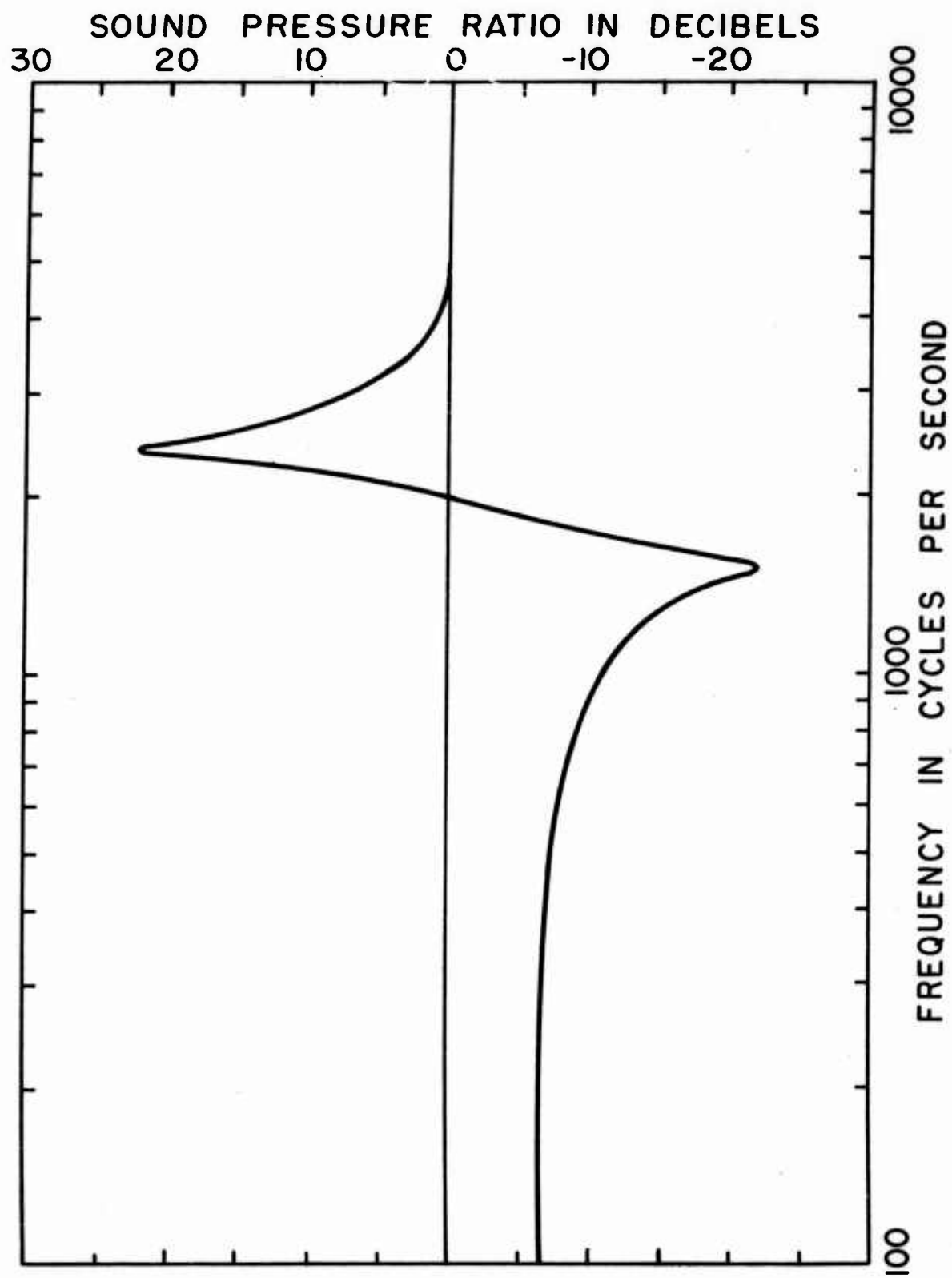

Fig. 39. Effect of the RD resonator on sound pressure in a 1.52cc cavity.

the small damping of the 1.52cc coupler and are not representative of the conditions in the ear.

2. Resonator earplugs as earphone couplers

In high levels of ambient noise, voice communication poses a serious problem. For this reason, several systems of short range radio communication have been developed. Earmuffs have been equipped with microphones, transmitters, receivers, and earphones. The earphones are usually mounted under the earmuffs. The earmuff systems are rather cumbersome because the earmuffs are large and the efficiency of earphones which have to generate sound in a large volume of air is low. Consequently, the received signal has to be amplified.

Since there is a chance that some of the shortcomings of the earmuff system could be eliminated using resonator earplugs in conjunction with miniature earphones, preliminary tests were undertaken. For practical reasons, it was decided to use standard type hearing aid receivers and to secure them on the top of the resonators in the same way as they are secured on the hearing aid ear molds.

The acoustic system consisting of the earphone, the resonator and the ear is shown schematically in Fig. 40. In the lower part of the figure an electrical analog is drawn. It has been assumed thereby that the earphone can be considered as a high impedance source, which appears quite reasonable for hearing aid receivers. On the basis of the analog circuit, the voltage analog of the sound pressure in the ear canal is determined by the equation

$$V_{\text{ear}} = \frac{i}{j\omega C_r} \times \frac{R_{\text{ear}} + jX_{\text{ear}}}{R_{\text{ear}} + j(X_{\text{ear}} + \omega L_r)} \cdot \quad (68)$$

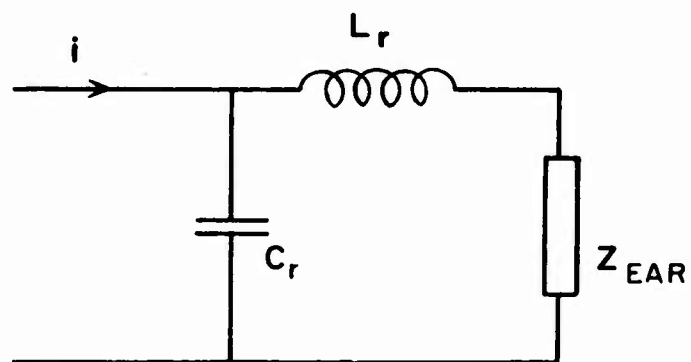
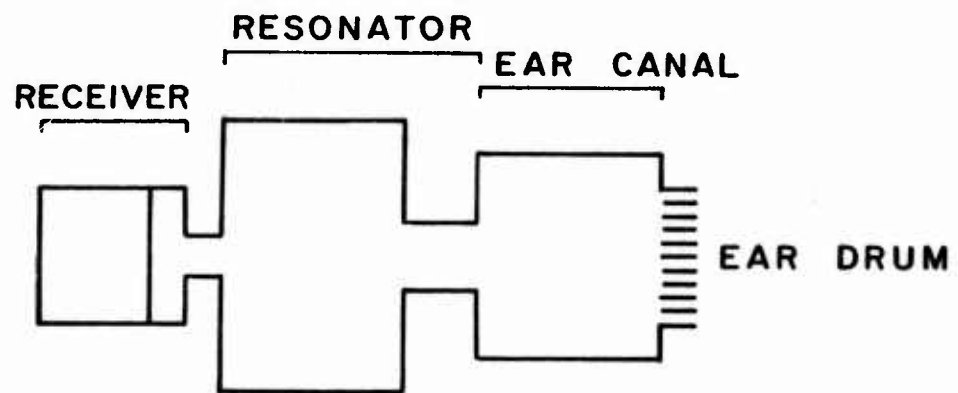

Fig. 40. The acoustic system consisting of a hearing aid receiver, the RD resonator and the ear, and its electrical analog.

For not too high frequencies, it can be assumed that the vibration amplitude of the earphone diaphragm remains frequency independent. Under these conditions, Eq. 68 can be simplified to

$$V_{\text{ear}} = \frac{K}{C_r} \frac{R_{\text{ear}} + jX_{\text{ear}}}{R_{\text{ear}} + j(X_{\text{ear}} + \omega L_r)} \quad (69)$$

The reactance X_{ear} is negative up to fairly high frequencies. This means that V_{ear} goes through a maximum near the resonance frequency, when $X_{\text{ear}} + \omega L_r = 0$, and then drops rapidly. From the dimensions of the resonator and from preceding experiments, the resonance can be expected between 1,000 and 2,000 cps. By means of a damping material in suitable amount it is possible to reduce or even eliminate the resonance peak. The drop of V_{ear} above the resonance frequency is more difficult to prevent. As a result, an earphone that emphasizes the high frequencies is needed.

In order to select an earphone with an appropriate frequency response, several models were tested on the 1.52cc cavity. The earphones were coupled directly to the cavity, without the intermediary of the resonator. Standard hearing aid earphones do not usually have a good high frequency response. They exhibit one or two resonance peaks in the frequency range between 1,000 and 4,000 cps. Above 4,000 cps their efficiency drops rapidly. For this reason, we set our hopes on a small moving coil earphone, DT-507, manufactured by Beyer Co. However, these hopes were frustrated. Instead, we found the 9C earphone of the Andivox Co. to be the most promising. Figure 41 shows the frequency response of the Beyer and of the Andivox earphones for a constant power input. It is apparent that the response of the Beyer earphone does not depart substantially from the response of an average hearing aid earphone,

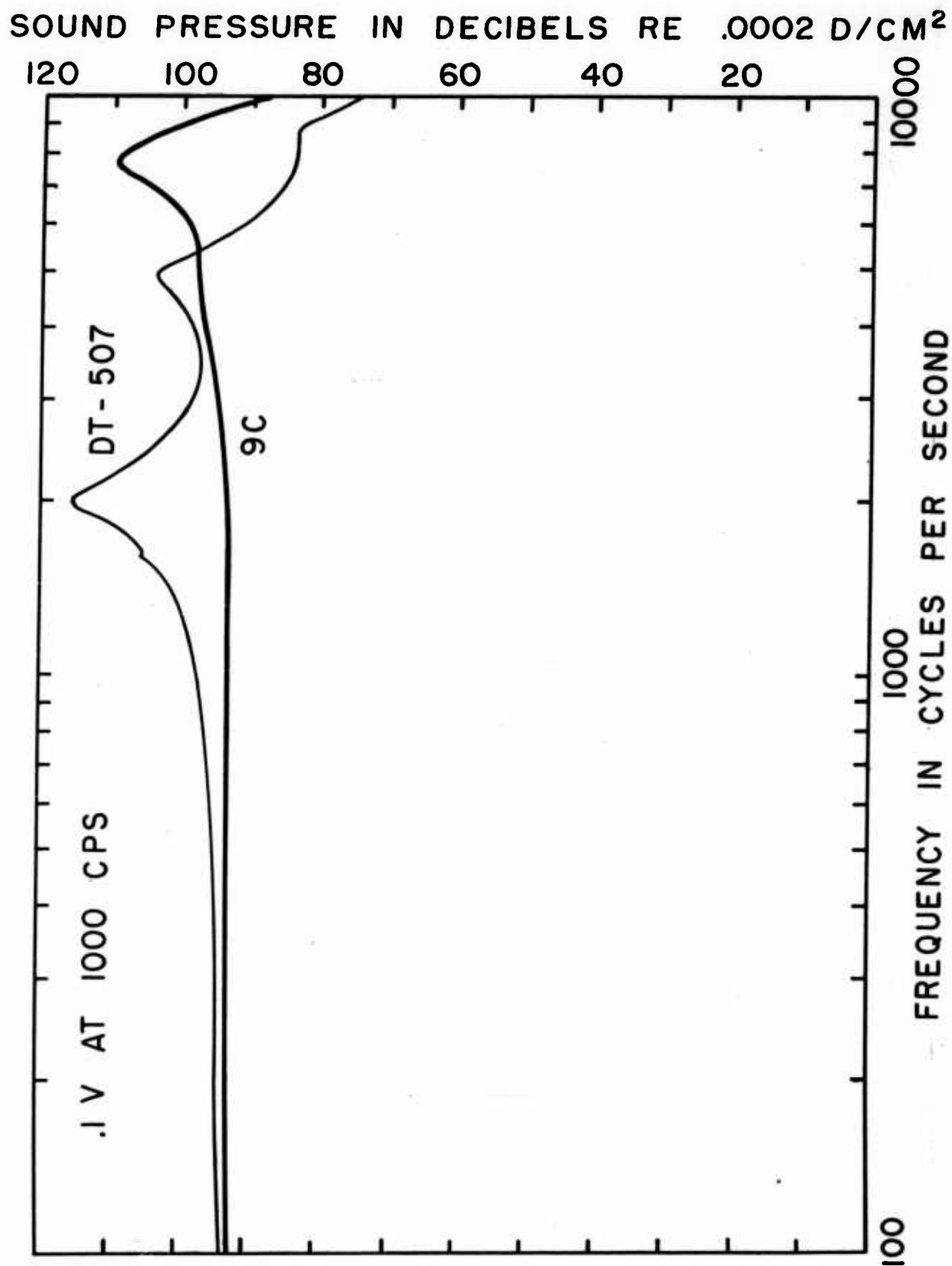

Fig. 41. Response curves of two hearing aid receivers obtained on a 1.52cc cavity.

while the 9C unit has an unusually high resonance and the cut-off occurs near 10,000 cps. The 9C unit has two additional advantages for our purposes. It can be sealed hermetically by means of a thin layer of lacquer, and it is very small. As a consequence, further experiments were limited almost completely to the 9C unit.

The next figure (42) shows the 9C unit mounted on a RD resonator. The response curve of this system, as obtained on the 1.52cc cavity, is plotted in Fig. 43. For comparison, the response characteristic obtained with the DT-507 earphone is also shown. Both characteristics show a peak in the vicinity of 2,000 cps caused by the resonator. Above this peak, the sound pressure produced by the DT-507 unit decays faster than that produced by the 9C unit.

It should be noted that the pronounced peaks in the response of both earphones are due in part to the small damping of the 1.52cc cavity. In order to approach the conditions prevailing in a typical ear more closely, this cavity was modified. Actually, it was divided into two cavities joined by a narrow opening. The first cavity, of approximately .55cc, was interposed between the diaphragm of the microphone and the resonator earplug. The second cavity, of approximately .8cc, was attached to the first by means of a short tube. The tube dimensions were adjusted empirically. For this purpose, a theoretical response curve for the 9C earphone, when coupled to the ear by means of the resonator, was calculated. This was possible with the help of Eq. 69 on the basis of the known impedance of the ear and the known impedance of the resonator. The result of the calculation is shown in Fig. 44 by means of the broken line. The solid lines indicate the result obtained with the acoustic analog of the ear. The values of the thin line have been obtained without acoustic damping, those of the heavy line with an

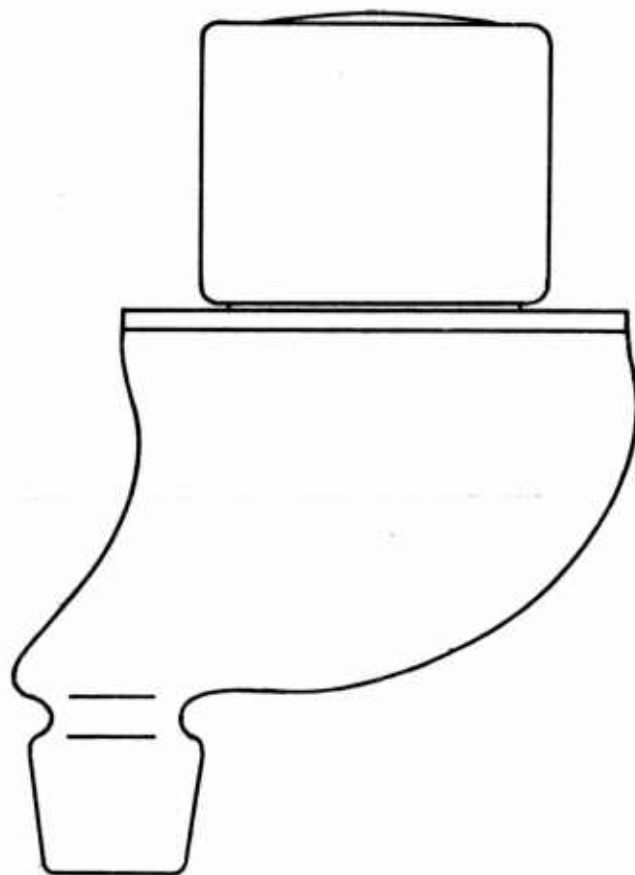

Fig. 42. The RD resonator with the Audivox 9C receiver.

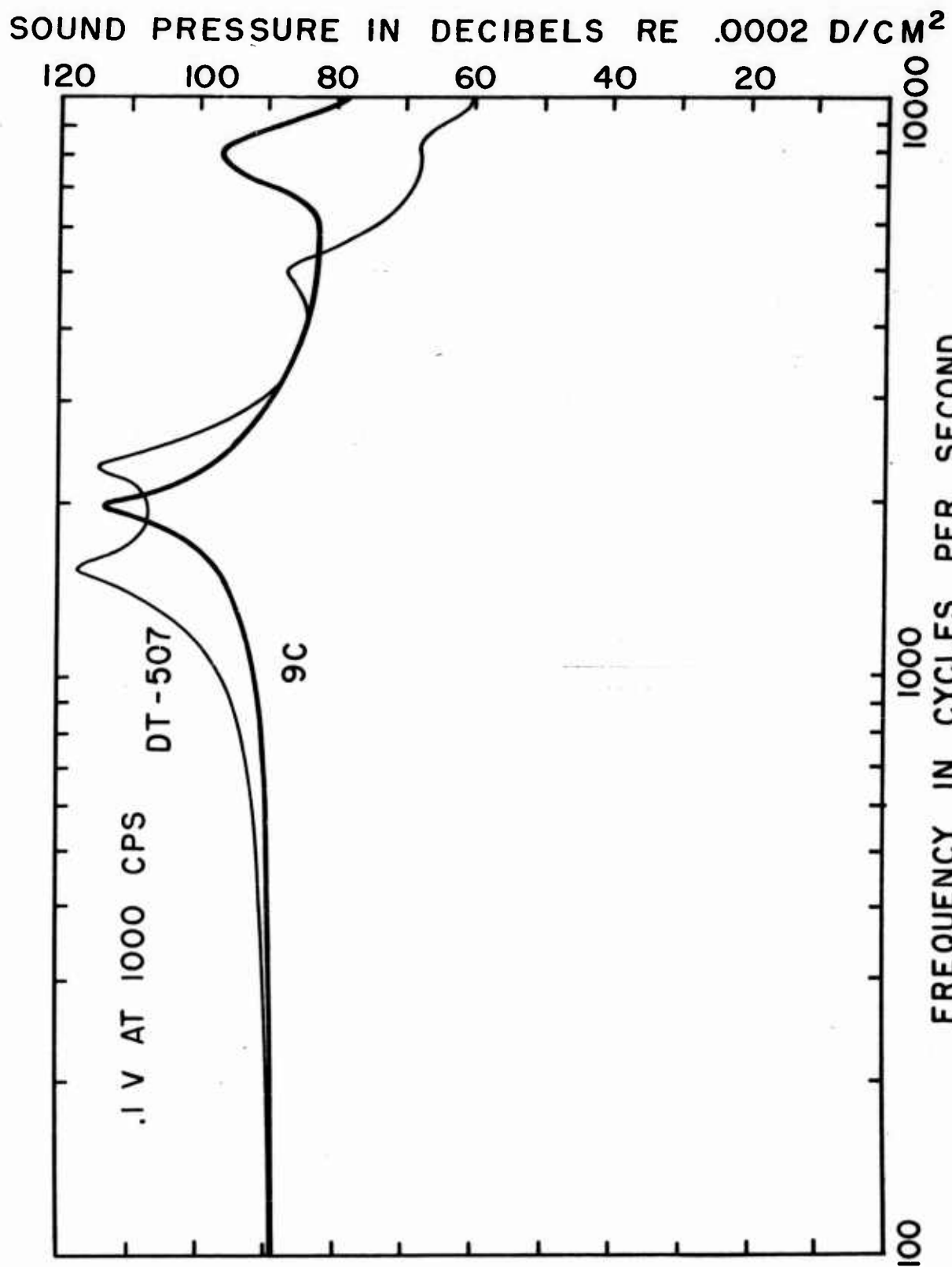

Fig. 43. Response curves of two hearing aid receivers coupled to a 1.52cc cavity by means of the RD resonator.

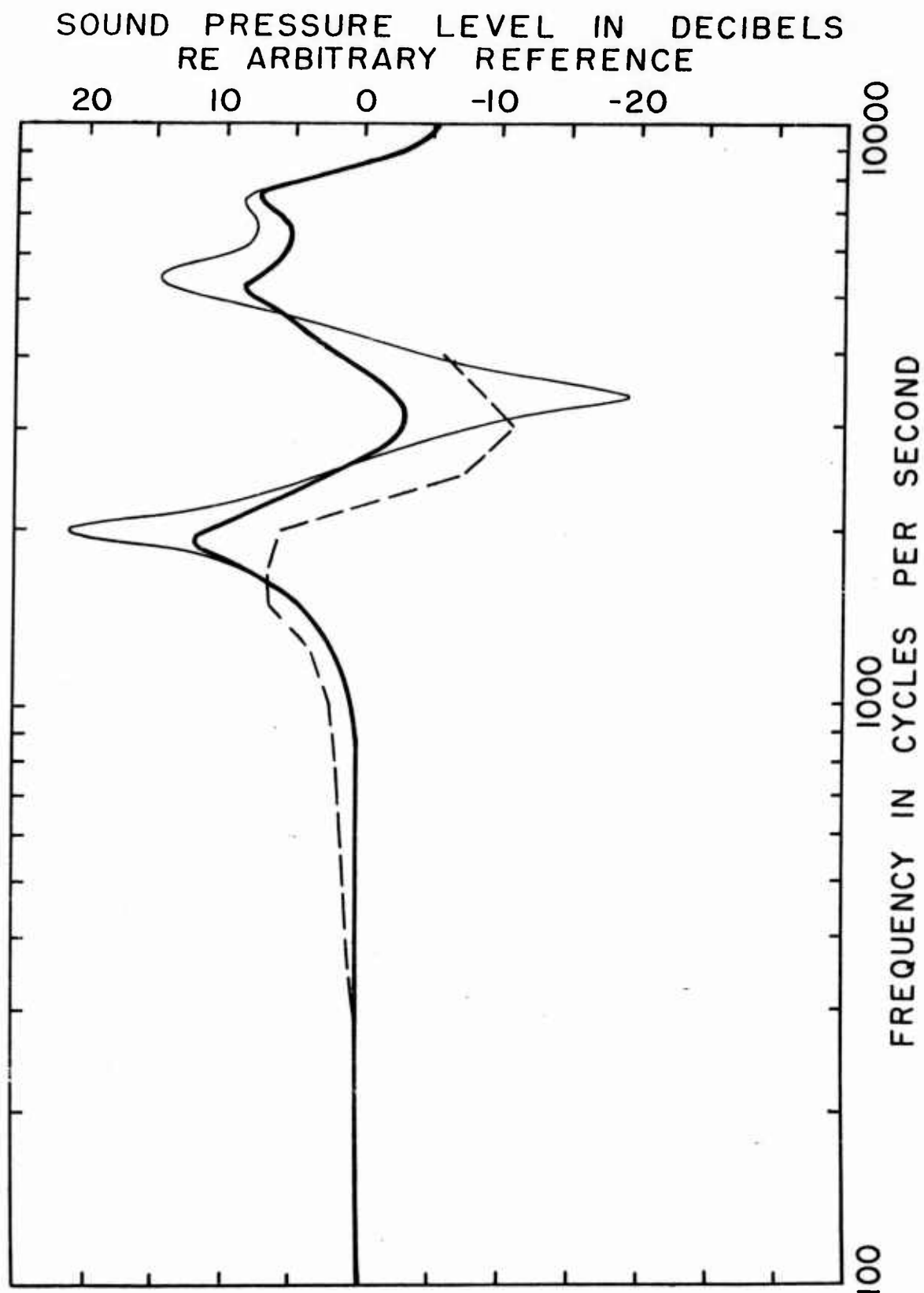

Fig. 44. Response curves of a 9C receiver mounted on a RD resonator, in decibels relative to an arbitrary sound pressure. Broken line - calculated for the real ear; thin line - on an acoustic ear analog without damping; heavy line - on an acoustic ear analog with damping.

appropriate amount of cotton wool in the .8cc cavity. As Fig. 44 shows, it was not possible by means of the simple analog to match exactly the theoretical response characteristic. However, the approximation was judged sufficient, particularly in view of the uncertainty that exists in impedance data determined at the ear above 1000 cps.

Using the ear analog, several modifications of the earphone-resonator system were investigated. The results indicated that no modifications of the earphone were necessary and that a small amount of foam plastic in the resonator neck was sufficient to make the response curve almost completely flat from 100 to 10,000 cps. The response curve is shown in Fig. 45. The flat maximum at 2,500 cps is probably absent in the real ear. This follows from the difference between the curves of Fig. 44, which indicates that in the neighborhood of 3,000 cps the sound pressure in the ear canal should be about 8db lower than in the analog device. Subsequent psychophysical tests have led to a similar conclusion.

It should be pointed out that the response of the 9C receivers varies somewhat from unit to unit, and further improvements in the response of the whole system would be meaningless at this moment. Also, the ear analog should be modified somewhat for the purpose. Such improvements would be hardly noticeable in communication and their usefulness would be limited to research work.

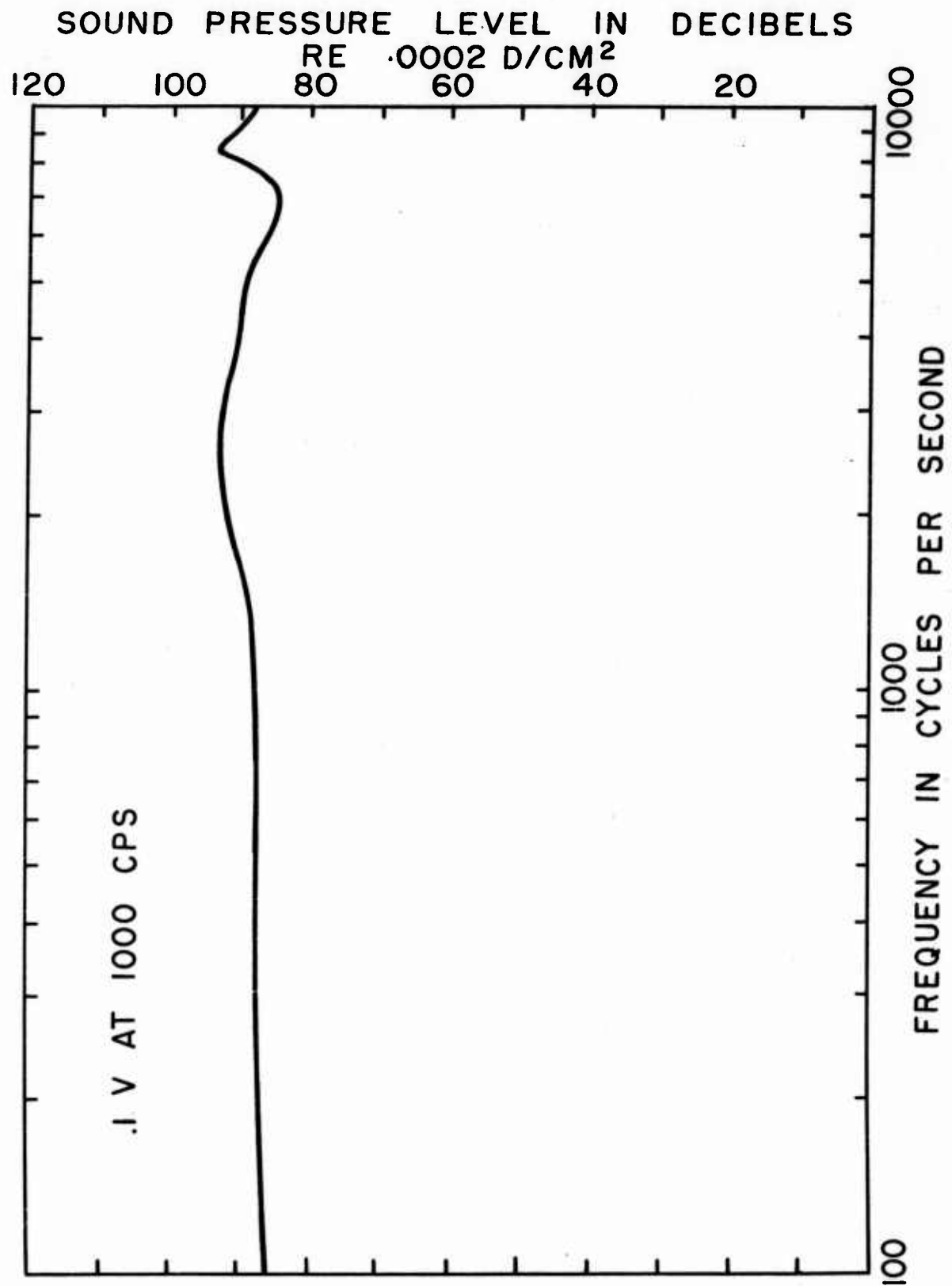

Fig. 45. Response curve of a 9C receiver obtained on the ear analog. The receiver was coupled by means of a RD resonator with foam rubber in the resonator neck.

SOUND PRESSURE LEVEL AND EMF LEVEL
IN DECIBELS RE ARBITRARY REFERENCE

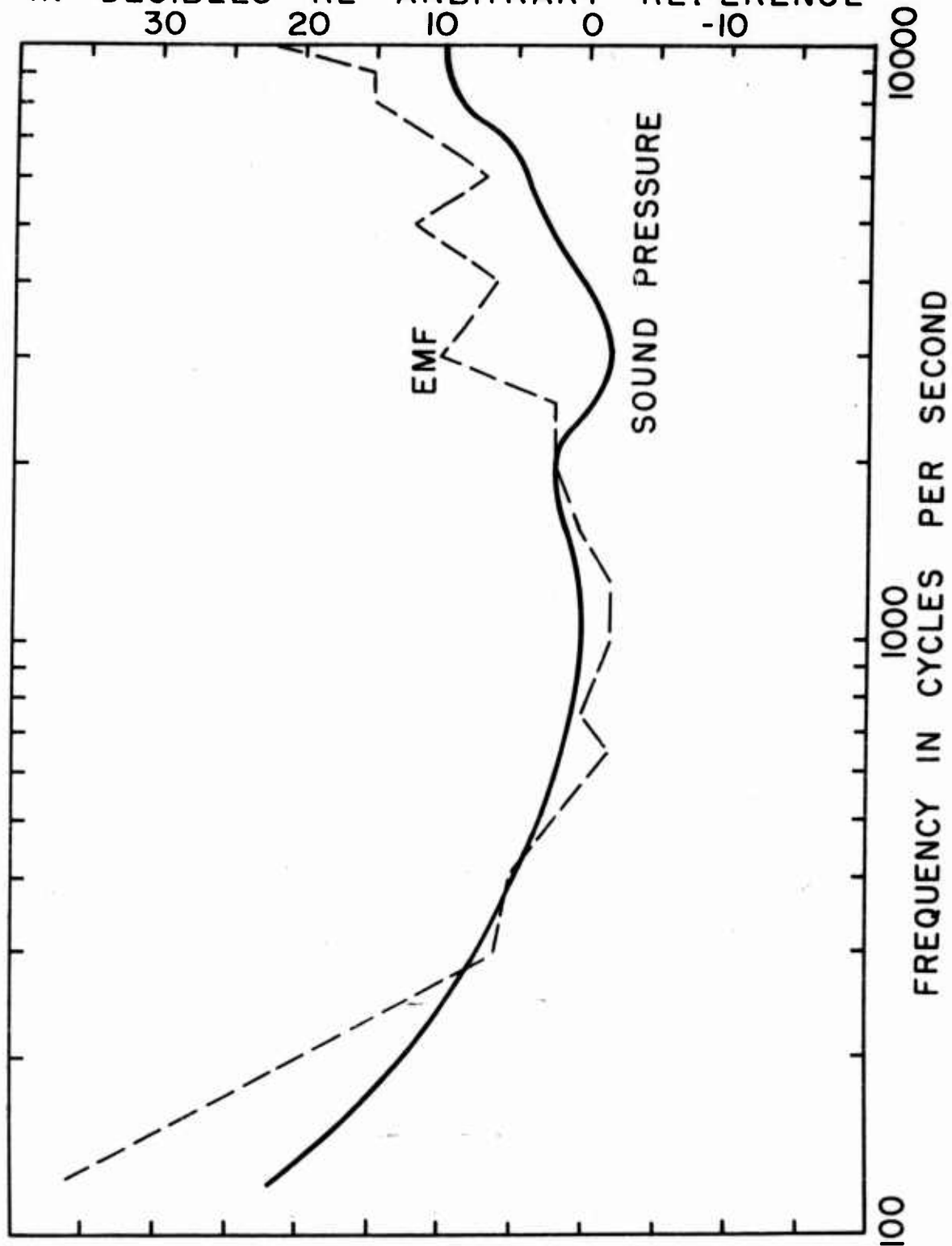

Fig. 46. The MAP measured by Robinson and Dadson (solid curve), and the EMF of a matched electric source driving a 9C receiver at the threshold of audibility.

PSYCHOPHYSICAL TESTS OF THE RECEIVER-RESONATOR SYSTEM1. Threshold of audibility

Pilot tests showed that the attenuation of extraneous sounds by the resonator earplugs with 9C receivers is about the same as without the receivers. Consequently, no systematic attenuation tests with the earphones were undertaken. Nevertheless, it can be pointed out that the 9C receivers have air leaks as a rule. They can be sealed with lacquer. It is also important to provide a hermetic seal between the receiver and the resonator. Usually, a thin plastic washer is sufficient for the purpose.

In order to check the frequency characteristic determined on the ear analog, threshold measurements with the resonator-earphone combination were undertaken. The thresholds were measured monaurally on five listeners, using the insert tips. The same receiver and the same resonator were used as in the final tests on the ear analog. Also, the receiver was fed from the same source. The median threshold curve obtained on five listeners has been plotted in Fig. 46 by means of the broken line. The solid line indicates the "minimum audible sound pressure" data determined by Robinson and Dadson for standard earphones. A reasonably good agreement between the two threshold curves confirms the measurements on the ear analog in that the response curve of the 9C earphone mounted on a damped RD resonator appears to be reasonably flat. This is the most important result of the experiment. However, there are small differences between the results of the physical and the psycho-physical measurements. The maximum sensitivity found around 2,500 cps in the physical experiment has been re-

placed by a relative minimum in sensitivity in the psychophysical experiment. The discrepancy can be ascribed in part to the difference between the acoustic conditions in the ear and in the analog, and in part to an effect of standing waves. Due to this effect, the sound pressure at the ear drum is enhanced relative to the sound pressure at the entrance to the ear canal for certain sound frequencies. The frequency of the maximum enhancement depends on the acoustic conditions near the entrance to the ear canal. When the ear canal is open, the maximum appears near 4,000 cps; when it is covered by an earphone with a standard earphone cushion, between 2,000 and 3,000 cps; when it is occluded by a resonator earplug, between 6,000 and 7,000 cps.

It should be pointed out that the difference between the two threshold curves in the neighborhood of 4,000 cps could be eliminated by means of minor modifications in the orifice that couples the earphone to the resonator. The feasibility of such an improvement has been demonstrated in a pilot investigation.

The discrepancy between the two curves of Fig. 46 at low frequencies seems to be characteristic for all earphones. It means that the earphone produces less sound pressure in the ear canal than at a calibrating microphone, or that the sound is masked by a physiological noise. It is also possible that both factors intervene simultaneously.

2. Speech intelligibility

Speech intelligibility may be regarded as the definitive test for a voice communication system. For this reason, several experiments with phonetically balanced (PB) lists were undertaken. The limitation of time did not permit us to conduct more refined tests, but the obtained results of the Speech Reception Thresholds (SRT)

appear quite significant.

First of all, free field tests were undertaken, using a loud-speaker with a reasonably flat response over the speech frequency range. In the first series, the listeners wore no earplugs. They repeated the PB words through an intercom system. In the second series, the same experiment was repeated, but with the steel RD resonators secured in the ears by means of the R7 tips. In the third and fourth series, a white masking noise was introduced. In the third series, the listeners did not wear the earplugs, in the fourth, they did. All four series were performed on a group of five listeners. From the data plotted in Fig. 47 it is evident that the earplugs shifted the speech reception threshold by about 32db when no masking noise was present, and by 2db when a white masking noise of moderate intensity was introduced. This result could have been predicted approximately from the pure tone investigations. Of interest is the finding that the psychometric functions with earplugs in place are steeper than without earplugs. Our data are not sufficient for an analysis of the phenomenon, but from the practical point of view it is advantageous. The steeper the psychometric function the less intensity is needed relative to the threshold of audibility in order to produce a sufficient speech intelligibility.

In a final experiment, the PB words were transmitted through the 9C earphones mounted on the RD resonator earplugs. In the first series, no masking noise was introduced. In the second the same masking noise was used as in the first experiment and it was produced by the same loud-speaker. The speech was presented either monaurally or binaurally. Again five listeners participated. The data plotted in Fig. 48 show that the monaural SRT is

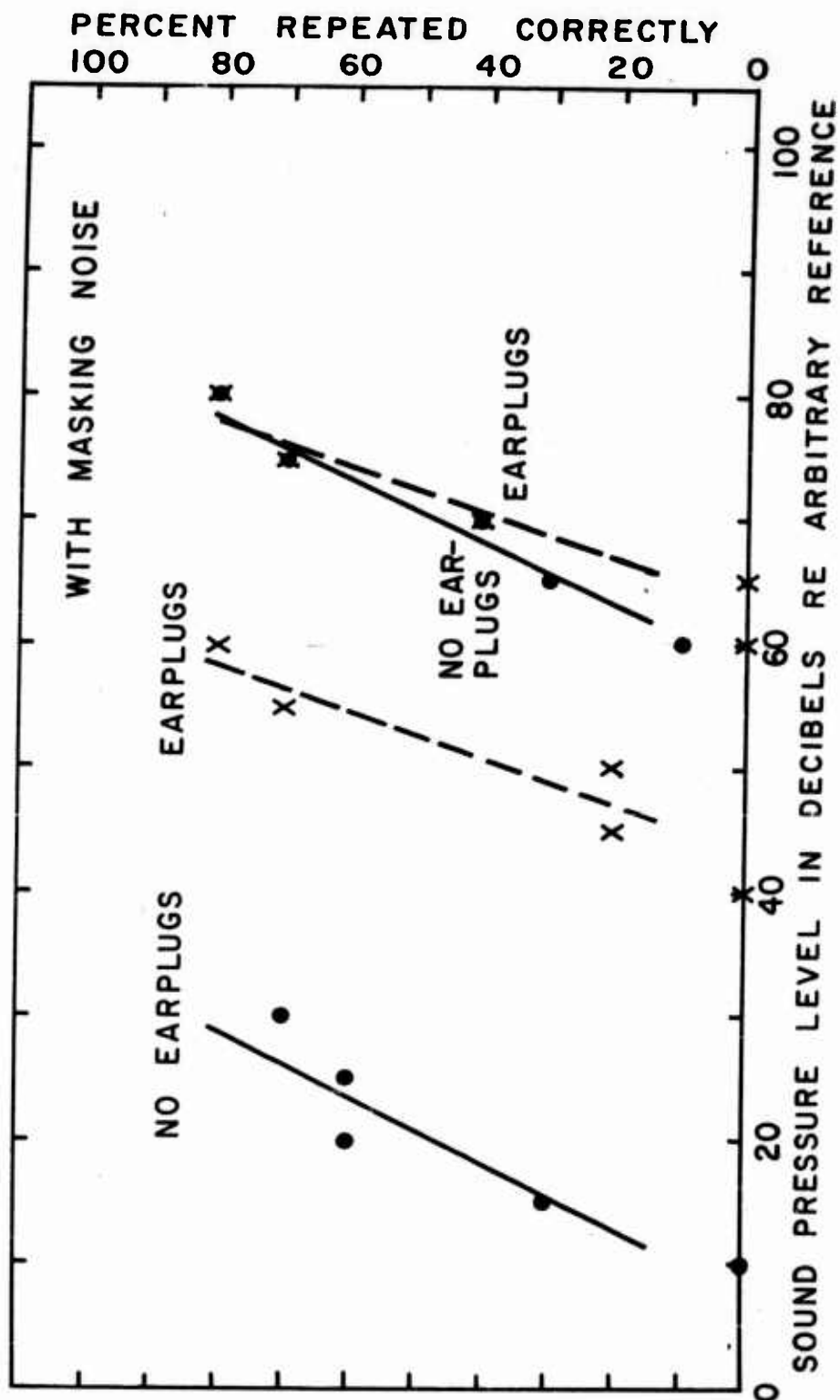

Fig. 47. Speech intelligibility scores obtained with phonetically balanced W-22 lists in a free sound field with unoccluded ears and with ears occluded by means of RD-R7 earplugs. The tests were performed in quiet and in presence of a white noise.

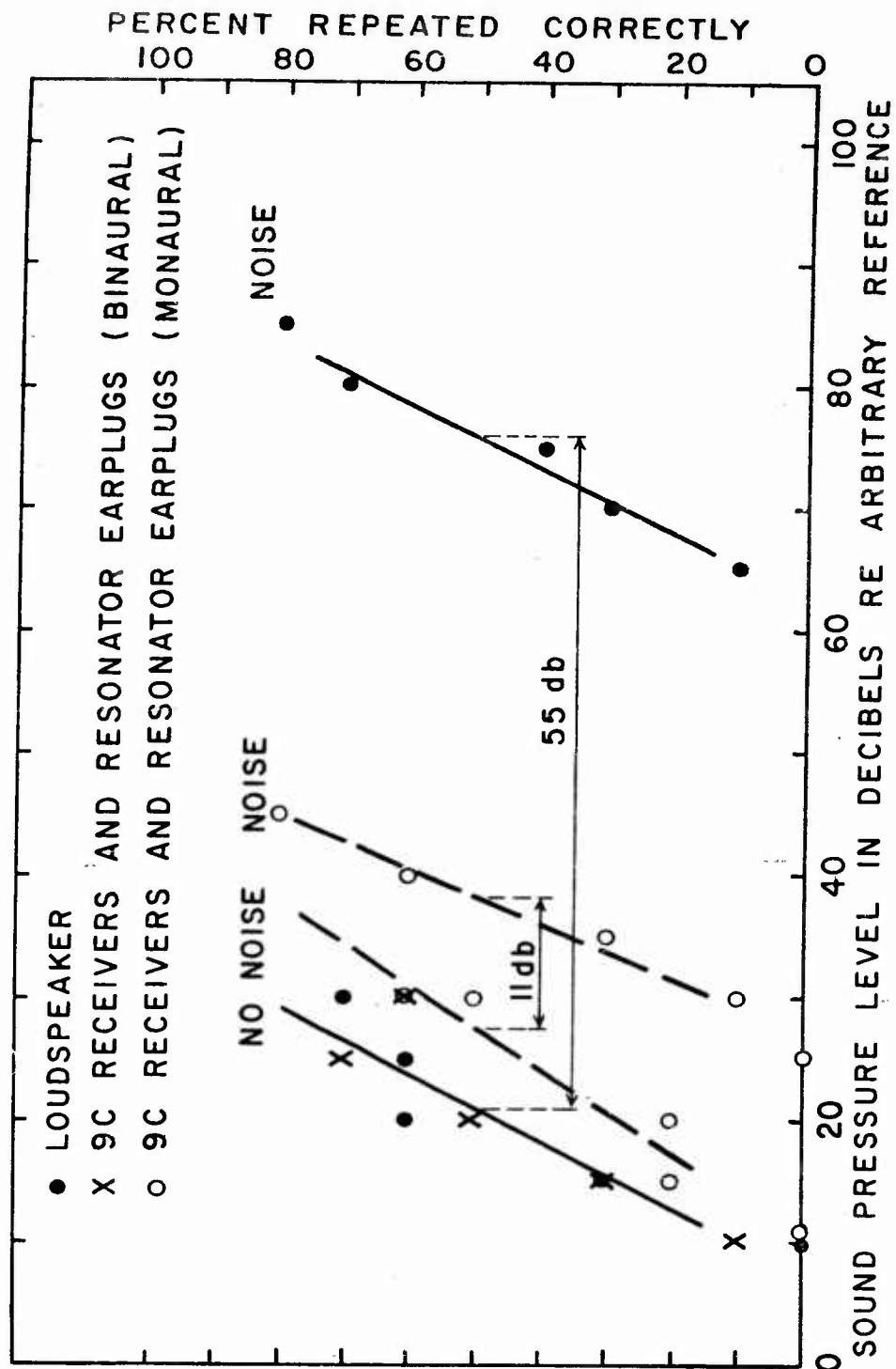

Fig. 48. Speech intelligibility scores obtained with phonetically balanced W-22 lists, using 9C receivers mounted on RD resonators. The tests were performed in quiet and in an ambient white noise. For comparison some data of Fig. 47 are also shown.

slightly higher than the binaural SRT, and that the masking noise shifted the SRT by about 11 decibels. This is 44db less than the corresponding shift without earplugs. The difference signifies a potential saving in sound intensity needed for speech communication. This saving is approximately the same as with Willson earmuffs, but the bulk necessary to achieve it is much smaller.

CHAPTER VII

SUMMARY AND CONCLUSIONS

The report consists of several chapters which deal with the theoretical, experimental, and practical aspects of acoustic ear protection and voice communication in noise. The theory and the experiments have led to a better understanding of the acoustics of ear protectors in general and to the development of a practical device called "resonator earplug".

The resonator earplug consists of a small container with rigid walls secured in the ear canal by means of a soft perforated tip. It combines some advantages of the earmuff with some advantages of the earplug and may be considered an intermediary device. It can be used as ear protector and also as an earphone coupler. The resonator earplug has been developed for the conditions in which the earmuffs are too bulky and the ordinary earplugs not effective.

The acoustic theory of ear protectors has been extended to include factors hitherto ignored. The customary assumption that the pertinent motion of the ear protectors is rectilinear and that the head is stationary have been abandoned. As a result, new insights concerning the acoustic characteristic and the optimum design have been gained. More specifically, it became possible to explain mathematically why the mass of an ear protector has less effect on sound attenuation than the classical theory predicts, and why the sound attenuation does not increase with frequency as rapidly as this theory indicates. Furthermore, it became possible to explain why the sound attenuation provided by earplugs and earmuffs in combination is, as a rule, considerably smaller than the sum of sound attenuations provided by each device separately. All three incon-

sistencies could be eliminated qualitatively as well as quantitatively by taking into account the inertia motion of ear protectors, which stems from the head motion in a sound field. The difference between the effects of a frontal and of a lateral field is discussed.

The theory emphasizes the configuration of the ear protector, which is expressed in the mathematical formulas by two constants called α and β . The constant α deals with the distribution of mass in the ear protector - it should be minimized. The constant β is a ratio between the volume of air enclosed by the ear protector and certain of its linear dimensions - it should be maximized.

The theory leads to an optimisation of the dimensions of earmuffs. For a high sound attenuation at low frequencies, the earmuff should have a wide sealing cushion, be deep, and cover a minimum possible area of the head. At medium and high frequencies, the mass distribution becomes important: the center of gravity should be as close to the surface of the head as possible. Taking all factors that appear relevant into consideration, it has been calculated that a maximum sound attenuation of 21db can be expected in the vicinity of 125cps, and of 40db in the vicinity of 500cps. These values are already approached by the best commercial earmuffs.

The dimensions of earplugs are determined almost completely by the anatomy of the outer ear. On the basis of this anatomy, the mechanical impedance of the tissue lining the ear canal, and the acoustic impedance measured in the ear canal, a sound attenuation of 21db at 125cps has been calculated for plain earplugs. For a frequency of 500cps, the theoretical sound attenuation rises to 24db

when the earplug weighs 8g. These figures are close to the experimental ones. The sound attenuation can be increased by perforating the earplug and coupling a small tank to the ear canal. For an additional volume of 2cc, the sound attenuation at 125cps increases theoretically to 29db and for an additional volume of 4cc to 33db. At 500cps the corresponding attenuations amount to 32db and 35db respectively. For a lighter earplug weighing 3g these attenuations would decrease by one or two decibels.

A more detailed calculation of the sound attenuation provided by the V51-R earplugs shows a good agreement of the theory with the experiment in the range of medium frequencies. At high frequencies, the measured attenuation is less than the theoretical; at low frequencies, the reverse is true. The first discrepancy is attributed to sound transmission through the flexible material of the earplug, the second to an underestimation of the tissue impedance, or to a masking effect of the physiological noise generated in the ear canal and in the middle ear. The latter factor is discussed in several sections of the report and is shown to interfere with psychophysical measurements of sound attenuation.

The discussion of sound attenuation provided by perforated earplugs with attached rigid containers leads to a theory of the resonator earplugs. This theory includes the motion of the earplugs relative to the ear canal, the input impedance of the resonator and the input impedance of the ear canal. In the first part, it is shown that the inertia forces resulting from the head motion are a predominant factor at medium and high frequencies. In the second part, the available data of the impedance at the ear drum and at the entrance to the ear canal are introduced. In the third, the acoustic impedance of the resonator is calculated.

The latter impedance is controlled by the compliance of the air volume enclosed in the resonator and by the mass of air moving in the tube that couples the resonator tank to the ear canal. It is shown theoretically that the resonator increases the sound attenuation at all frequencies up to the resonance frequency. Above the resonance frequency a decreased attenuation may be expected as a result of an anti-resonance. By making the coupling tube sufficiently short and wide the anti-resonance effect can be avoided. Under such conditions, an enhanced sound attenuation results at all speech frequencies. The theory predicts that the resonator earplugs should provide a greater sound attenuation at low and medium frequencies than the earmuffs.

In order to test the theory, a number of resonator earplugs have been made and investigated by psychophysical as well as by physical methods. In general, a good agreement between the theory and the experiments has resulted. Nevertheless, some psychophysical tests have shown a small numerical departure from the theory and the physical tests. The discrepancies point toward a masking effect of the physiological noise.

On the more practical side, it became possible to construct the resonator earplugs so that the anti-resonance effect is eliminated. The development led to a small device that consists of a 2cc container of hard plastic or metal secured in the ear canal by means of a soft tip. This resonator, designated by the letters RD, is shaped to fit the concha of the outer ear. When secured in the ear canal, it protrudes only a little beyond the auricle. The sound attenuation provided by the RD resonator earplug is equivalent to that of a 100 times larger earmuff. The earplug can be worn for hours without causing any objectionable discomfort.

The RD resonators can be secured in the ear canal by means of insert tips, or they can be held by a headband. In the latter case, they are coupled to the ear canal by means of a soft semi-insert. A simple, light headband has been designed for the RD resonators.

In conjunction with hearing aid receivers, the resonator earplugs can be used for communication purposes or for hearing testing. The Audivox 9C receivers have been selected as the most suitable, since they have a good high frequency response. The receivers are secured on the top of the resonators like on the ear molds. With the help of some foam damping in the resonator, they provide a practically uniform response from 100 to 10,000 cps, as could be demonstrated on an acoustic ear analog and by means of threshold measurements.

When the 9C receivers are sealed with a coating of lacquer, they do not reduce the sound attenuation provided by the resonator earplugs.

By means of speech audiometry, it has been demonstrated that the RD earplugs equipped with 9C earphones reduce the masking effect of an ambient white noise by nearly 45 db.

REFERENCES

1. Békésy, G.v., J. Acoust. Soc. Amer. 20,749,1948
2. Brogden, W.J., and G.A.Miller, J. Acoust. Soc. Amer. 19,620,1947
3. Gierke, H.E.v., and D.R.Warren, Benox Report, ONR Project NRL44-079, University of Chicago, 1953, p.47
4. Harris, C.M., Handbook of Noise Control, McGraw-Hill, New York, 1957
5. Hershkowitz, J., and L.M.Levine, J. Acoust. Soc. Amer. 29,889,1957
6. Møller, A.R., J. Acoust. Soc. 32,250,1960
7. Morton, J.Y., and R.A.Jones, Acustica 6,339,1956
8. Munson, W.A., and F.M.Wiener, J. Acoust. Soc. Amer. 24,499,1952
9. Shaw, W.A., and D.E.Yates, PNR 12, Psycho-Acoustic Laboratory, Harvard U., 1946
10. Shaw, E.H.G., and G.J.Thiessen, J. Acoust. Soc. Amer. 30,24,1958
11. Sivian, L.J., and S.D.White, J. Acoust. Soc. Amer. 4,288,1933
12. Webster, J.C., Noise Control 1,34,1955
13. Weinreb, L., and M.L.Touger, J. Acoust. Soc. Amer. 32,245,1960
14. Wiener, F.M., personal communication
15. Zwislocki, J., J. Acoust. Soc. Amer. 27,460,1955
16. Zwislocki, J., Physiological Psychology, ONR Symposium report ACR-1, Office of Naval Research, Dept. of the Navy, 1955, p. 182
17. Zwislocki, J., Handbook of Noise Control (C.M.Harris, Edit.), McGraw-Hill, New York, 1957, p.8-2
18. Zwislocki, J., J. Acoust. Soc. Amer. 29,795,1957
19. Zwislocki, J., J. Acoust. Soc. Amer. 29,1312,1957