

UNCLASSIFIED

259 882

*Reproduced
by the*

**ARMED SERVICES TECHNICAL INFORMATION AGENCY
ARLINGTON HALL STATION
ARLINGTON 12, VIRGINIA**



Best Available Copy

UNCLASSIFIED

NOTICE: When government or other drawings, specifications or other data are used for any purpose other than in connection with a definitely related government procurement operation, the U. S. Government thereby incurs no responsibility, nor any obligation whatsoever; and the fact that the Government may have formulated, furnished, or in any way supplied the said drawings, specifications, or other data is not to be regarded by implication or otherwise as in any manner licensing the holder or any other person or corporation, or conveying any rights or permission to manufacture, use or sell any patented invention that may in any way be related thereto.



DIVISION OF PHYSICAL SCIENCES

January, 1960

This document consists of 39 pages.

No. 2 of 3 copies, series A

AD 259882

Final Report

Classification changed to Secret
by authority of CDR H. J. S. C. I. Enk
on 17 March 61
(date)

(Signature) C. M. Kelley (Rank) Colonel
Office of Naval Research

A STUDY OF THE FUNDAMENTALS OF MASS TRANSFER BY LITHIUM:
DEVELOPMENT OF APPARATUS

245326
(2)

By M. F. Parkman

SRI Project 1745

RECEIVED

MAY 12 1960

LIBRARY
NAVAL RESEARCH LABORATORY

61-3-16
XEROX

Prepared for:

U.S. Navy Office of Naval Research
Washington, D.C.

Contract Nonr 2117(00)

Best Available Copy

Approved:

Clinton M. Kelley
C. M. Kelley, Chairman
Department of Chemical Physics

DOWNGRADED AT CERTAIN INTERVALS

DECLASSIFIED AFTER 10 YEARS

DOB DIR 5200.10

HC-C-77

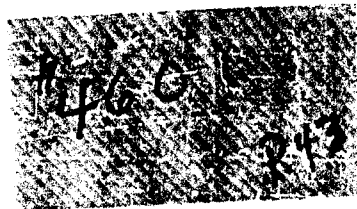

[Redacted] *[Handwritten initials]*



ABSTRACT

The results of a 37-month study of the fundamentals of mass transfer by liquid lithium are reported. The first 20 months were concerned with the use of the toroid circulating apparatus, and the results were previously reported: It was concluded that the method was not satisfactory for producing the desired data; most of the time was spent in solving tangent problems in handling, purification, and analysis of lithium.

The remainder of the effort has been devoted principally to the design and construction of a new apparatus to study the fundamentals on a more direct basis. This apparatus is described. Two runs were completed; and from these the usefulness of the method is estimated. A comparison of the data with the proposed theoretical model is made to point out the problem areas that remain before a concrete confirmation of the theory can be attempted. Not enough runs were completed to demonstrate the validity of the theory. However, it is concluded that data which can be obtained with this method are likely to be limited in accuracy by the available physical property information, rather than by experimental error.

CONTENTS

	<u>Page</u>
I INTRODUCTION	1
A. Historical	1
B. Objective	2
C. Background	4
D. Theory	7
II CONCLUSIONS AND RECOMMENDATIONS	10
III APPARATUS	11
IV EXPERIMENTAL	17
A. Procedure	17
B. Results and Discussion	20
REFERENCES	29
APPENDIX A Analysis of Lithium	31
APPENDIX B Estimation of the Diffusion Coefficient of Nickel in Lithium	37



LIST OF TABLES

	<u>Page</u>
Table I Summary of Analytical Data	21
Table II Summary of Data	23
Table B-1 Data for Estimating the Diffusion Coefficient of Ni in Li	39

LIST OF ILLUSTRATIONS

Figure 1 Various Rates Existing in a Cyclic Turbulently Flowing System	3
Figure 2 Vacuum and Inert Atmosphere Chamber for Handling Liquid Lithium. Lithium Purification Train	12
Figure 3 Furnace and Testing Assembly	14
Figure 4 Details of Tube Assembly	16
Figure 5 Physical Properties of Lithium	24
Figure 6 j Factor vs Reynolds Number for Conditions of Run 1	26
Figure 7 Inside Diameter of Nickel Tubes after Runs 1 and 2	27
Figure 8 Theoretical Concentration of Ni in Li at End of Tube of Length L/D for Conditions of Run 1, Tank 1	28
Figure A-1 Apparatus for Determination of N ₂ in Li	33



Final Report

A STUDY OF THE FUNDAMENTALS OF MASS TRANSFER BY LITHIUM:
DEVELOPMENT OF APPARATUS

I Introduction

A. Historical

In May, 1956 a program was begun at Stanford Research Institute for the study of the fundamentals of mass transport by liquid lithium under Contract Nonr-2117(00). The initial one-year program was extended by periods of 6 months, 2 months, 10 months, and 7 months; the last two periods followed shutdowns of 2 months and 6 months respectively because of contract negotiations.

During the first 18 months, work was concerned with the use of the toroid circulating apparatus containing a thermal gradient. (This apparatus had been used in a previous 3-year program on a similar study with liquid lead.¹) During the course of these experiments it was determined that the toroid apparatus could not provide data directly applicable to the problem, and the experience of other investigators showed that lithium data accumulated slowly and tended to be scattered.

The toroid apparatus was abandoned and a report on its use was issued.² A vastly increased understanding had been obtained of how the toroid works under temperature gradient mass transfer conditions, but a greatly extended program would be required to make data from such studies useful.

Other work had been undertaken during this early period in an attempt to learn some of the reasons why lithium corrosion data tended to be so erratic. Some small-scale experiments were conducted on lithium distillation and filtration and these were reported.³

~~SECRET~~

The principal conclusion from the effort of the first 18 months was that the problem was much more difficult experimentally than had been visualized, and that far more painstaking work in building equipment and conducting experiments would be required to produce any reliable data.

During the 2-month period, November-December, 1957, the problem was given reflection and was discussed with other workers and ONR personnel. It was decided to narrow the scope of the investigation sharply and to attack a small part of the problem with a new apparatus in which the maximum possible control over the variables could be obtained.

The rest of this report will be concerned entirely with the work conducted during the last two periods covering 17 months.

B. Objective

In practical systems where liquid lithium is used as a working fluid there commonly exist regions of higher temperature and regions of lower temperature. Because the solubility of container materials in lithium varies with temperature, a condition develops (near saturation) where the container material is continuously dissolved in the high temperature regions and precipitated in the low temperature regions. A plug thus forms in the system. Other complications also arise. The rate of transport by this mechanism may be influenced by many factors.

Manly⁴ has classified and described the many ramifications which have been previously observed. Even when the problem is reduced ideally to a two-component system -- pure solid isotropic container material and pure liquid lithium -- the complexity can be large; this can be realized by considering the turbulently flowing system shown in Figure 1. This schematic diagram shows how various rates in the system may be separated. The rates are specifically described in Figure 1 but they may be more generally classified as solution rates, precipitation rates, and circulation rates.

~~Handwritten scribble~~

Wall Bound-ary Liquid

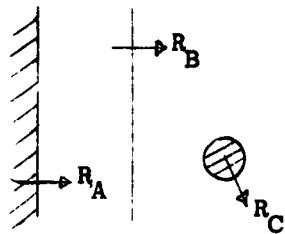

HOT
ZONE
 T_1, C_1

- R_A = Rate of solution of wall into boundary layer.
- R_B = Rate of diffusion of wall material through the boundary layer.
- R_C = Rate of solution of circulating load particles in hot zone (no mechanism postulated).
- R_D = Rate of fluid and circulating particle load flow from hot to cold zone.
- R_E = Rate of diffusion of dissolved wall material through the boundary layer.

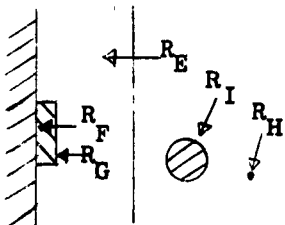
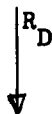

COLD
ZONE
 T_2, C_2

- R_F = Rate of formation of nucleation sites on wall.
- R_G = Rate of deposit on nucleation sites on wall
- R_H = Rate of nucleation in fluid.
- R_I = Rate of deposit on fluid nuclei.

FIG. 1

VARIOUS RATES EXISTING IN A CYCLIC TURBULENTLY FLOWING SYSTEM

The measured rate at which the wall at any point dissolves into the liquid is the corrosion rate, and may be controlled or influenced by any combination of one or more of the rates in any of the three general classifications. The corrosion rate is often used interchangeably with the solution rate; however, there are times when confusion arises, depending on how detailed is the mechanism under consideration. In this report, the corrosion rate will refer to the observed rate at which the walls are dissolved in a real closed-loop system and will always infer the presence of the several rates (depicted in Figure 1) which control it. The solution rate will refer specifically to the mechanism of transfer of a solid component into a solvent and will be used in its narrowest sense.

~~Handwritten scribble~~



The problem may be considered from two points of view. Engineering methods utilize a controlling rate so slow that one doesn't have to worry about any of the rates; concern is primarily with an application. Academic methods measure all the rates for a typical system and find out how they are affected by different variables; application is not of essential concern. In the first case, solving the problem requires a controlling rate so low that the effect of many variables on it cannot be reliably measured; the second case requires rates that can be measured.

In practice, nearly all work is guided by the first point of view, using such methods as alloy development, search for inhibitors, and search for elements of very low solubility. Considerable progress has been achieved as witnessed by existing large sodium-cooled reactors, pumped loops simulating liquid metal-fueled reactors, and the experimental pumped loop lithium systems developed by Pratt and Whitney for the indirect cycle nuclear aircraft engine.

Some work has been done with dynamic liquid metal systems from the second point of view. Most of this has been done under fluid flow conditions different from that in a pipe. As a result there has been little progress in developing a fundamental quantitative expression which will predict corrosion rates in a closed loop system. It is toward this goal that the present work is directed.

C. Background

Different kinds of equipment have been used in attempts to throw light on the mass transport problem. These include (1) the crucibles: "static" capsule, natural convection pot, and forced convection pot; (2) the closed loops: toroid, pumped loop, and thermal siphon; and (3) the open loops: see-saw arrangements and the once-through pipe.

Of the quantitative investigations, the methods of approach can be divided into three categories, each using one or more of the above kinds of equipment:

[REDACTED]

(1) Much of the general knowledge of mass transport has come from tests which were run for an engineering purpose. The data obtained were examined and conclusions as to the effect of many variables on mass transport were drawn. In many cases⁵⁻⁷ the data and conclusions were used to evaluate a "theory," with limited success. This approach is tantamount to operating the system shown in Figure 1 and attempting to deduce the values of all the rates by suitable changes of variables.

(2) A much smaller effort has been spent on attacking the problem by using systems in which only one or two of the rates occur. Most of this work has been done in the crucibles.⁸⁻¹⁶ In these cases fundamental expressions were written for the particular conditions and the experimental data were fitted to the form of the expression with good success. The information obtained from this approach, although valuable, has not provided much progress toward our goal of writing an expression which will predict the rates involved. The data obtained confirm the form of the equation written, but no equations were written from fundamental properties which predicted the magnitude of the data.

(3) The third category involves only a single program¹⁷ in which a quantitative expression was derived from fundamental properties, and then experiments were performed which confirmed the hypothesis both as to form and magnitude. The once-through pipe method was used and has provided us with the greatest advance toward our goal since the original analysis of Epstein and Weber.¹⁸

There is a good reason for the better success of the third category over the others. Mass transfer operations between phases inextricably involve fluid dynamics. This subject is largely empirical, and considerable success has been realized in correlation of the variables by use of dimensionless numbers and coefficients. In spite of the essentially empirical nature of this treatment, its adaptation to the mass transport problem is what is generally referred to as the fundamental or theoretical approach. It is fundamental in that the physical properties of the system are tied together in a cohesive unit as a result of both observation and basic theoretical considerations. It is valuable in that it enables

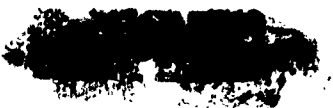

properties and measurements determined in one system to be utilized in another without redetermination. In only a very few liquid metal investigations have the data been determined in such a way that this can be done. It is significant that in these cases care was exercised in the description of the fluid dynamics. This is the crux of the present state of the art of measuring mass transfer in liquid metals.

One must always keep in mind the conditions under which the problem usually exists: that of mass transport in pipes at high Reynolds number (turbulent flow). The task is to determine whether the corrosion rate observed is controlled in the liquid phase, in the solid phase, or by an interphase reaction. To find out which condition applies requires an understanding of the relation between the variables where fluid dynamics is important. The development of this relation is nothing more than the development of the correct theory. In the one program of the third category, conditions were chosen in which the fluid dynamics were well known; then the equations which had previously been shown to apply in heat transfer work were adapted to the mass transfer condition. The systems chosen proved to have solution rates which were controlled in the liquid phase.

In the present investigation it was desired:

1. to be able to operate in both laminar and turbulent flow regions
2. to use a system in which the fluid flow was quantitatively defined to take advantage of the experience of Ferstenberg,¹⁷ and
3. to choose a solid metal whose solution rate by lithium could be rapidly measured and was controlled in the liquid phase.

In only two of the experimental methods previously mentioned are the fluid flow characteristics sufficiently well known to meet these requirements: the pumped loop and the once-through pipe. In both cases, an entry length can be established so that fully developed flow exists in the section to be studied. Before considering these methods further, it seems advisable to explain in more detail why the other methods are inadequate.

SECRET

The crucible method deserves serious consideration. Mass transfer coefficients developed in a natural convection pot can be scaled to a round pipe system.¹⁷ Probably data from a forced convection pot could be similarly scaled. Even the precipitation rates can be profitably studied.^{15, 16} But the circulation rates, especially in conjunction with the other rates, pose problems in scaling to the round pipe system which first require determination of the rates in the round pipe system. The toroid is inadequate because of its short length/tube-diameter ratio, undefined flow pattern, undefined temperature distribution in the slug (it is known that nearly all the temperature variation is in an annulus of unknown thickness at the outside of the slug), and unknown circulating load of particles formed in the cold zone.

The thermal siphon is inadequate because of its variable flow pattern,^{19, 20} limited velocity, inability to separate velocity from temperature, and unknown circulating particle load characteristics. The see-saws, as usually employed, are trivial, although one model which has been used²¹ could probably be developed into an adequate tool for use at low Reynolds number.

Of the two most adequate methods, the pumped loop is very expensive, experimentally difficult, and complicated by the possible circulating particle load. Although the once-through pipe is experimentally difficult and fairly expensive if designed for flexibility, it circumvents all the other objections to the other methods. It was therefore selected as the cheapest method of obtaining data which will avoid the criticisms considered.

D. Theory

The development of equations for mass transfer in liquid metals from the walls of round pipes is handled in most cases^{18, 5} by citing a heat transfer equation which has been shown to apply to the geometry and by changing the parameters of heat transfer to their analogous counterparts in mass transfer. Thus, the methods by which the equation was developed, the significance of the various terms, and the assumptions involved have

SECRET

not appeared in the liquid metal literature except for a summary in Ferstenberg's thesis.¹⁷ No analysis of the equations developed will be attempted here, because no data were obtained with which to test the assumptions. The system will be shown and the equation which is proposed to apply to it will be given with an explanation of how the parameters are measured.

The system is shown schematically as follows:

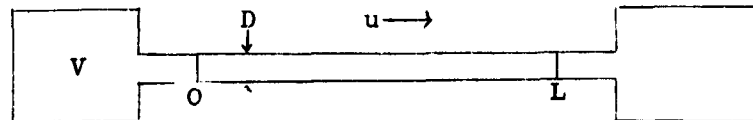

where

V is the volume of lithium to be passed through the nickel tube OL, the other surfaces being inert

D is the diameter of the nickel tube, and

u is the bulk velocity of the lithium through the tube.

The liquid is contained in the left hand volume and the system is brought to the desired temperature. Pressure is applied to the liquid and it is forced through the tube OL at velocity u into the right hand tank. The concentration of the tube material in the liquid is measured before and after the run. From these data the solution rate can be measured.

The equation which Ferstenberg proposed to apply to this system in the viscous flow region was a Leveque equation modified by Linton and Sherwood²² to

$$j_D = 1.61(\text{Re})_b^{-2/3} (L/D)^{-1/3} \quad (1)$$

where j_D is the mass transfer factor

$$j_D = \frac{k_D}{u} (\text{Sc})_f^{2/3} \quad (1a)$$

$(\text{Re})_b$ is the Reynolds number, evaluated from the bulk properties of the fluid.

$$(Re)_b = \frac{Du\rho}{\mu}$$

$(Sc)_f$ is the Schmidt number evaluated from the film properties of the fluid.

$$(Sc)_f = \frac{\mu}{\rho\delta}$$

L = length of tube, ft

D = inside diameter of tube, ft

k_D = mass transfer coefficient, ft/sec

u = bulk velocity of liquid, ft/sec

ρ = density of the liquid, lb/ft³ (assumed to be the same in bulk and film in our work)

μ = absolute viscosity of the liquid, lb/ft-sec (assumed to be the same in bulk and film in our work)

δ = diffusion coefficient of the wall material in the liquid boundary layer, ft²/sec.

This equation was derived assuming a linear velocity gradient near the wall and correlated well with Linton and Sherwood's data. It also agreed fairly well with the single run made by Ferstenberg in the viscous flow range.*

All of the parameters in this equation can be measured. The mass transfer coefficient k_D in the equation is an over-all coefficient which can be stated in terms of measurable quantities as follows:

Define: w = mass flow of nickel entering the lithium stream from the tube wall - lb/sec-ft²,

k_D = over-all mass transfer coefficient, related to w in such a way that

$$w = k_D(c_S - c_L) \quad (2)$$

*Ferstenberg's system was Zn-Hg. His apparently good correlation which depends on a liquid phase diffusion-controlled process must be reconciled with the conclusion of Bennett and Lewis¹³ that the reaction is partially chemical-rate controlled.

where c_S = concentration of nickel in lithium at the liquid-solid interface and is assumed to equal the solubility, and
 c_L = the average concentration of nickel in lithium in the stream at L.

The mass flow w is measured as

$$w = \frac{m(c_L - c_0)}{t\rho\pi DL} \quad (3)$$

where m = weight of lithium passed in time t
 ρ = density of lithium
 L = length of the nickel tube.

The velocity u is measured as:

$$u = \frac{4m}{\pi D^2 t \rho} \quad (4)$$

Inserting Equations 3 and 4 into Equation 2, the mass transfer coefficient is measured as:

$$k_D = \frac{u D(c_L - c_0)}{4 L(c_S - c_L)} \quad (5)$$

A different equation for flow in the turbulent region was also developed and confirmed by Ferstenberg but since no runs were made in that region on this project, the treatment will not be mentioned further.

The first goal of the present project was to find out whether the solution of nickel by lithium in a geometry similar to Ferstenberg's also could be described by Equation 1.

II Conclusions and Recommendations

It is concluded that the method is precise enough to insure that error in physical property data will be the limit in the method's ability to test the validity of Equation 1. The data obtained did not permit a conclusion whether Equation 1 was applicable to the lithium-nickel system studied, because of the large estimated error in physical property data and the lack of enough runs to test the different parameters.

SECRET

Further work should be undertaken to study mass transfer variables by this system, but the following things should be done prior to or concurrent with such work:

1. The solubility of nickel in lithium over the temperature range to be studied should be determined in the lithium which is actually used for the tests
2. The effect of nitrogen, nickel, and other impurities on the density and viscosity of lithium should be determined if high temperatures are used or if saturation of the element is reached.
3. The formation of nickel compounds on titanium surfaces or nitrided titanium surfaces should be checked whenever any relatively long exposure to high nickel concentrations is planned.
4. The diffusion coefficient of nickel in lithium as a function of temperature and concentration should be measured over the range of interest.
5. If other than pure lithium is used, the possibility of the formation of a compound containing nickel and lithium with a third element should be examined. Pure in this case is taken to mean small impurity content compared to the amount of nickel present.

The particular apparatus developed for this project appears to be satisfactory. For more precise work, some needed modifications include: (1) a recirculating gas purification system; (2) a better designed furnace plug to cut down heat losses, to stop metal vapors from entering the handling chamber, to improve the sampling time, and to improve the visibility of the lithium flow.

III Apparatus

The chamber used to conduct the experimental work is shown in Figure 2. The chamber consists of a furnace section A which contains the testing assembly, a handling section B in which the various manipulations involving the lithium are carried out, and a storage section C in which the nickel tubes are stored and which provides space into which the testing assembly may be lifted for changing nickel tubes. Adjacent to the handling section are a large air lock D for transferring materials in and out of the chamber, and a 4-inch high-vacuum pumping system E. Materials are handled by means

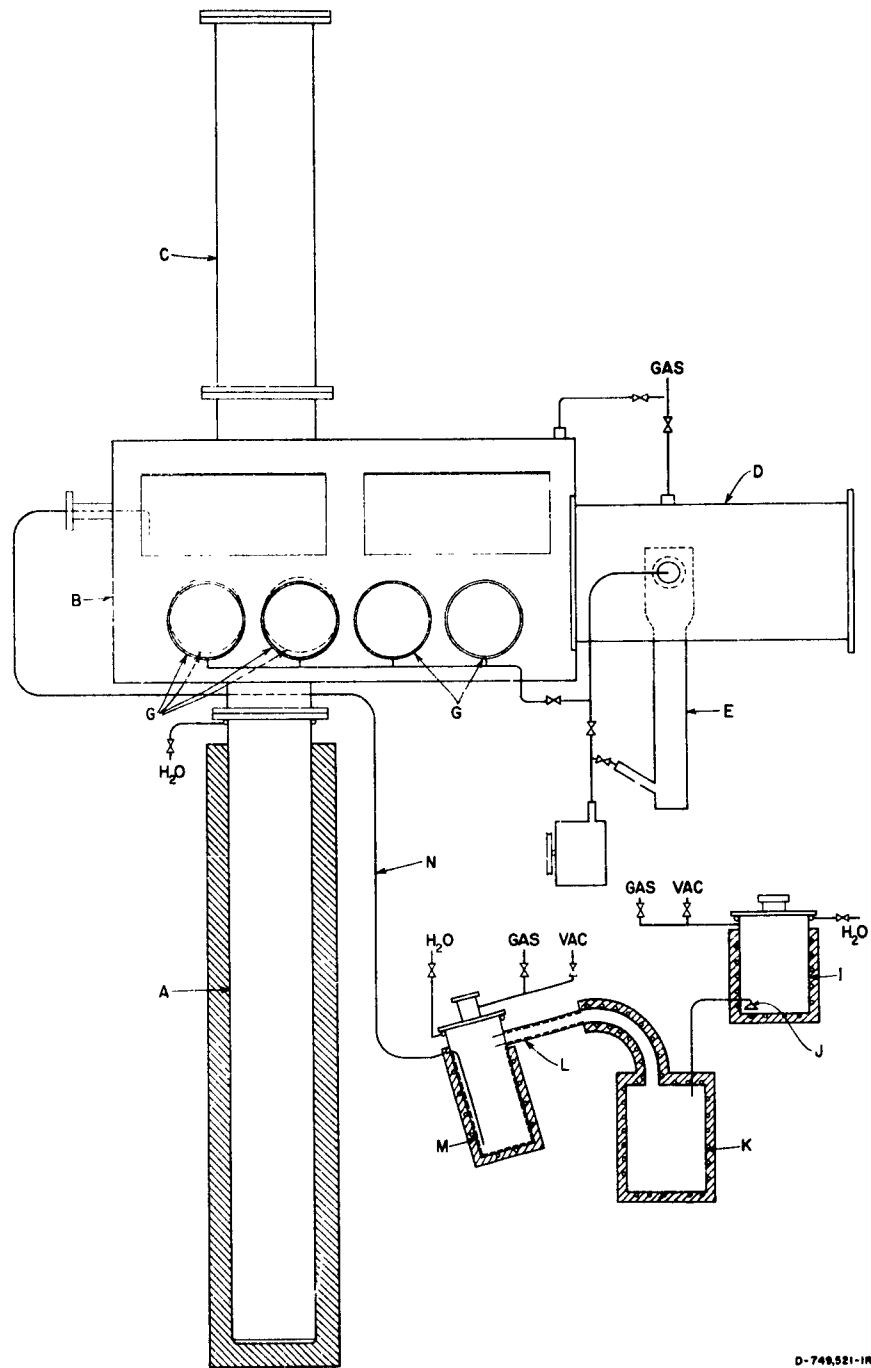

D-749,521-1R

FIG. 2
 VACUUM AND INERT ATMOSPHERE CHAMBER FOR HANDLING LITHIUM.
 LITHIUM PURIFICATION TRAIN

SECRET

of neoprene gloves G. The chamber may be operated under high-vacuum (to 1×10^{-5} mm Hg) or with a purified inert atmosphere. The air lock can be evacuated to 5×10^{-6} mm, and materials entering the chamber were routinely outgassed until 1×10^{-5} mm was reached.

Lithium is purified in the train indicated schematically in Figure 2. The filter pot I is loaded in air with lithium ingots or with lithium used for previous testing. The liquid is forced by argon pressure through the filter J into the still pot K. The metal is then distilled over into a titanium-lined condenser L which drains into the titanium-lined holding pot M. The lithium is forced by purified argon through the stainless steel tubing N into molds in the handling section. The cast ingots are stored until needed.

The testing assembly (Figure 3) consists essentially of a nickel tube with tanks at both ends contained in a furnace. A stainless steel furnace tube A is insulated on the outside with Fiberfrax and heated by Chromalox strip heaters B. A baffle, C, was originally planned to carry three helical, stainless steel-sheathed, MgO-insulated heaters between the baffle and the tube. The purpose of the internal heaters was to provide closer and much more rapid temperature control than was possible by outside heaters. The heaters shorted out during a test and were replaced, because of time limitations, by the strip heaters. A maximum temperature of about 1300°F could be reached with the six 750-watt heaters hooked up, two in parallel, across each phase of a 208 volt, 3 phase, Y-connected power supply. The temperature gradient along the furnace could be varied by changing the balance of the 3 phases. With the baffle, changing the gradient was a time-consuming job. The baffle was removed after the first run, and temperatures remained within $\pm 2^{\circ}\text{F}$ along the assembly within the tube except for the 6" from the removable furnace tube plug D. This plug insulated the furnace atmosphere from the rest of the chamber. However, because of the open sight hole in the plug, the atmosphere must be the same except for temperature.

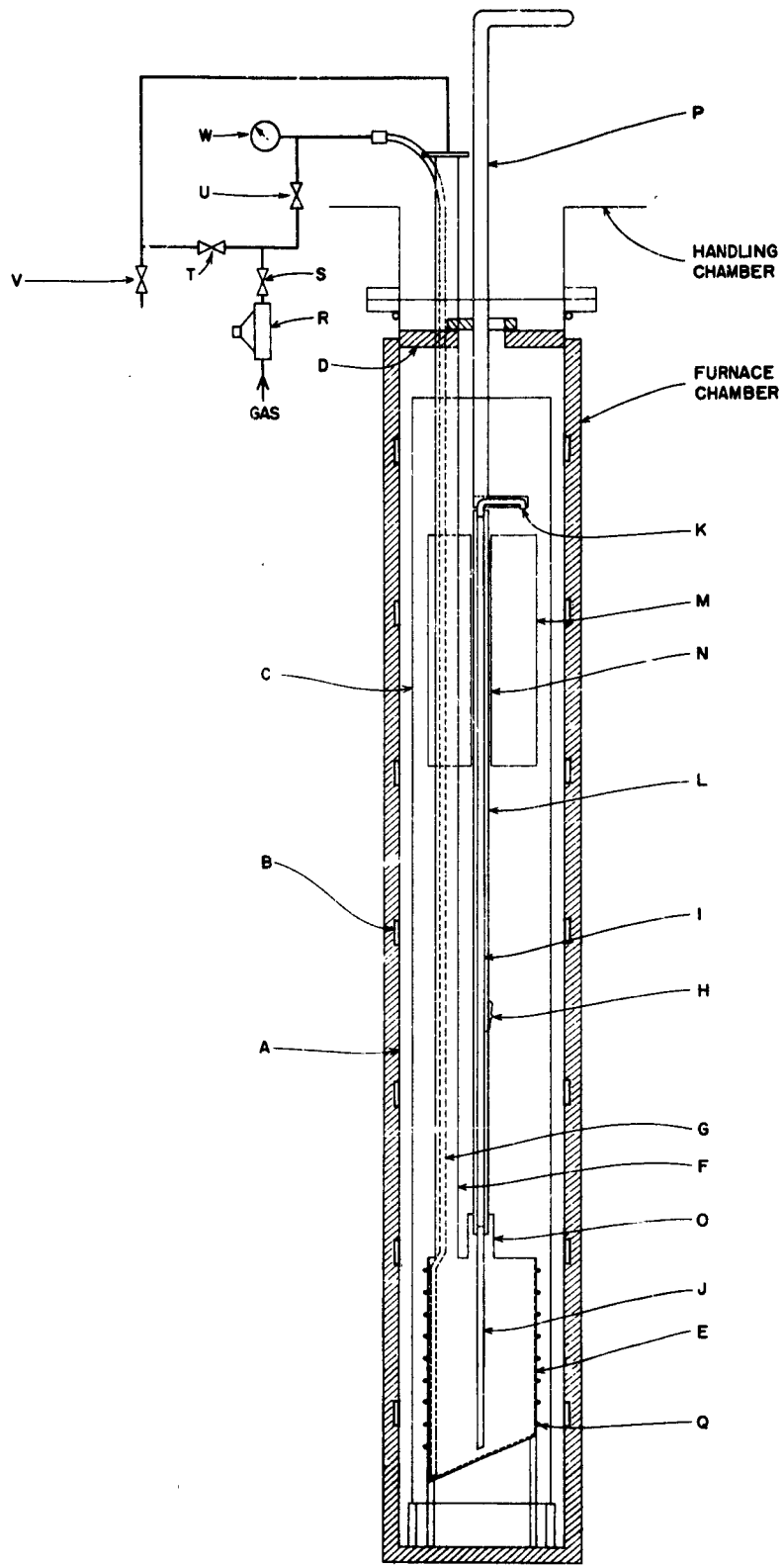

D-749,521-2R

FIG. 3
FURNACE AND TESTING ASSEMBLY

A titanium-lined bottom tank E is connected to the handling section by a stainless steel filling-and-sample tube F and a molybdenum drain line G. A tube assembly H is inserted through the top of the bottom tank at its vertical axis. This assembly consists of the nickel sample tube I, about four feet long; a titanium inlet tube J, about 18 inches long and of the same inside diameter as the nickel tube, a titanium discharge tube K of the same inside diameter as the nickel tube, and a stainless steel protection tube L into which the nickel and titanium tubes are inserted for strength. The inlet tube provided a calming length of about 86 diameters. Construction details are shown in Figure 4.

An upper tank M, Figure 3, will hold one to five titanium-lined sample tanks. The tube assembly is held in place by a top bearing N and a Crawford Swagelok O in the bottom tank. This Swagelok bears on the stainless steel protection tube and is tight enough to prevent excessive gas loss from the bottom tank while permitting the tube assembly to be rotated with the turning bar P. This permits the top tanks to be filled in succession to measure average flow rate and to provide samples during a run. Liquid samples may be taken through a hole in the furnace plug, or the furnace may be cooled, the sample tanks removed, and solid samples taken.

A Continental Sensing Company Inconel-sheathed* MgO-insulated thermocouple probe was adjustable to measure the temperature at any point in the furnace tube until it was destroyed by dipping it into the lithium early in the first run. Temporary Fiberglas-insulated thermocouples were installed for the second run but proved to be unsatisfactory because of attack by the small amount of lithium metal vapor in the furnace.

Argon was purified with calcium sponge at 650°C, followed by titanium sponge at 850°C. A 10-inch-diameter pot of molten lithium was kept in the box to getter impurities which diffused through the gloves. After the chamber was evacuated and refilled with argon, the initial charge would

*The thermocouple was thought to be stainless steel-sheathed. Investigation after its failure showed it to be Inconel.

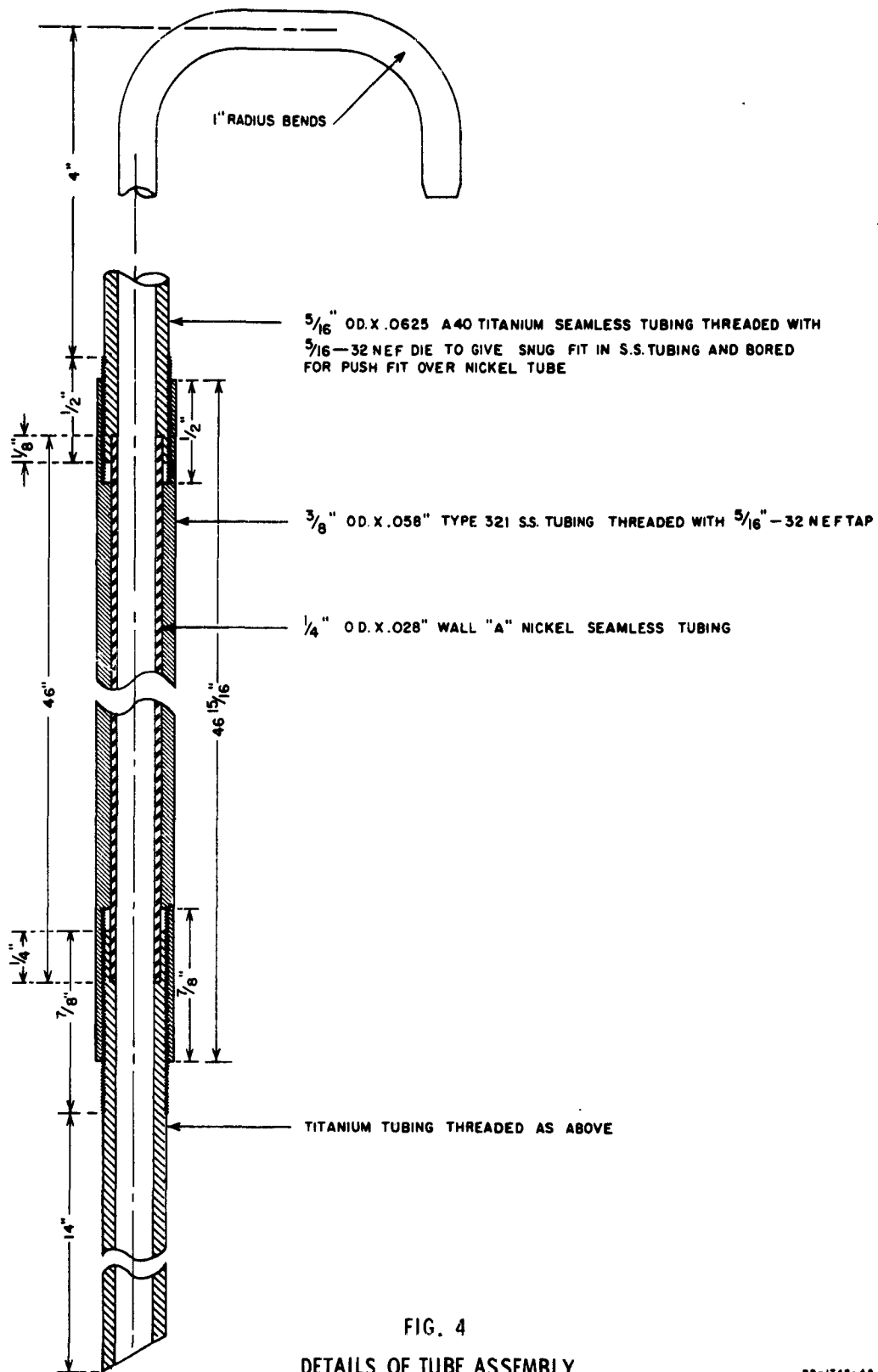



FIG. 4
 DETAILS OF TUBE ASSEMBLY

RB-1749-48



stay pure for about a day. The rate of diffusion of gas through the gloves was too great for the lithium pot to handle by natural convection, and after one day the pot would scum over rapidly. The system is considered inadequate for extended testing, or testing with low nitrogen- and oxygen-containing lithium, until a recirculating gas purification system is installed.

IV Experimental

A. Procedure

Lithium was prepared by distilling into the hold pot at 690°C. It was then forced by argon pressure into the handling section and cast by different methods for the two runs. In Run 1 titanium-lined molds were used to make ingots 1-1/4" diameter by 12" long. At the transfer temperature of 260°C the metal wetted the liners so that ingot removal was impossible without oiling the liners with mineral oil before filling. This procedure was unsatisfactory because of the oil fumes generated and the necessity of pumping the chamber for 2-3 days to evaporate the oil. Sticking could be avoided by casting just above the melting point and by nitriding the titanium surfaces. As the design of the transfer system prevented transfer at a temperature below 260°C, a different system was used for the second run.

A length of 1-3/8" OD stainless steel thin-wall tubing was placed under the metal delivery spout and rested on a titanium plate. The tubing was filled with lithium and as soon as the bottom froze, the titanium sheet was pried off and the mold attached to a wire was dropped down the fill tube. As the lithium melted out almost immediately, the tube could be pulled out and refilled without delay. The charge weight could be calculated from the number of molds filled. It was recognized that some nickel would be introduced in this way but the amount could be no more than the saturation value near the melting point of lithium.

While filling the molds, the lithium dripped from the 1/4" ID transfer tube in drops about 1/2"-5/8" diameter. Sampling was accomplished by catching two of these drops in a 4-cm³ capacity titanium crucible. Sample size thus ranged from 1.5 to 1.8 grams. Samples were analyzed for nitrogen and nickel content as described in Appendix A.

Before making a run, the titanium tanks were degreased, pickled in 40% HNO₃-2% HF, and washed with distilled water before the test assembly was placed in the furnace. The nickel tube was degreased, pickled with dilute HCl, and washed with distilled water and acetone before assembly. The planned procedure for making a run is as follows: The lithium for the run is cast, the test assembly is placed in the furnace tube, the furnace plug and turning bar are installed, and the system is evacuated. After the pressure reaches 10⁻⁴ mm the furnace chamber is heated to 950^oF and the temperature held for 2 days until the pressure falls to 1 x 10⁻⁵ mm and the excess oil evaporates. The chamber is then filled with argon and the furnace temperature turned up to about 1100^oF. Lithium ingots are dropped down the filling tube F and melted in the bottom tank E. When isothermal conditions are achieved in the furnace chamber two samples of the liquid are taken through the filling tube with crucibles attached to a wire. Gas lines are then attached to the filling tube and the drain line. These connect with the flow control system, shown schematically in Figure 3.

The proper pressure is preset at the regulator R and the two toggle valves T and U are opened. The needle valve S is cracked and the pressure allowed to rise rapidly to the desired level by observing gage W which can be read to 0.01 psi. The discharge end of the tube K is observed through the hole in the furnace plug by means of a mirror mounted on the filling-and-sampling tube. The lithium is forced up the tube and into the sample tanks. When lithium is observed coming from the tube, the pressure level is adjusted with the needle valve and the toggle valve T is closed. This forces the gas to enter through the 1/4" drain line and results in a constant head regardless of the liquid level in the bottom tank.

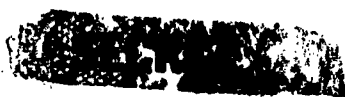

The flow is watched so that it may be switched from tank to tank by means of the turning bar P as each becomes full.

When the bottom tank empties, the pressure drops suddenly and the valves S and U are turned off.

The valve V is installed to release the pressure and drain the nickel tube if necessary during the run.

The turning bar P is moved to one side to expose the large hole in the furnace plug and duplicate samples are dipped from each tank. The furnace heat is turned off. When the assembly is cold, the plug and turning bar are removed, the assembly is lifted and the top tanks removed for weighing. The sample crucibles are inserted into weighing bottles and removed from the box for analysis of hickel and nitrogen.

The actual procedure for the two runs was slightly different. In Run 1, the gage W was installed on the wrong line so that fall of the lithium level corresponded to an increased gage pressure. The flow had to be judged visually and was therefore uneven, with periods of stoppage.

In Run 2, there was no time to replace the nickel tube, so the run was made with the same tube. The gage was installed on the correct line. This time, the pressure was maintained constant, but the flow gradually decreased until it stopped during the filling of the second tank. The difficulty, open valve T, was corrected and normal operation resumed after a 20-minute shutdown. Lithium continued to drain into tank 2 for a few minutes to clear the saturated solution before switching to tank 3.

Sampling after the second run was accomplished with a titanium tube rigged up as a pipette. The pipette was dipped into the tank near the bottom and allowed to fill to the tank level. The metal was then blown out with a squeeze bulb and gas allowed to bubble up through the liquid to aid in mixing. The sample was then taken and dripped into a crucible resting on the furnace plug. For sampling other tanks, excess metal was blown out of the pipette into the tank just sampled and the filling and emptying procedure was repeated three times to minimize contamination of

SECRET

the sample by metal from the previous tank. The procedure worked quite well. It was faster and more reliable than the crucible dipping method and prevented the outside of the crucible from becoming coated with lithium.

Times were recorded when lithium first discharged from the tube, when tanks were changed, and when the sudden pressure drop indicated that the bottom tank was empty.

The weight of lithium in each tank was determined by raising the assembly, removing the tanks from the chamber, and weighing to the nearest gram. The tanks were then inserted in the filter pot to melt out and recover the lithium.

B. Results and Discussion

Two runs were completed, of which one appears usable to test the hypothesis. The analytical data are shown in Table I. The nickel procedure used to analyze the samples from Run 1 proved to be unreliable. In some cases, it is believed that the metallic nickel failed to dissolve completely. Only with the first sample of the first tank was no difficulty with the analysis experienced. However, samples from the other tanks were estimable with much larger probable error.

The procedure was modified slightly for Run 2 to insure the complete solution of the nickel. Fair precision was achieved. However, the values came out unexpectedly high, even exceeding the supposed solubility. The solubility is not thought to be in such large error; however, it may vary widely with the nitrogen content. An attempt was made to use lithium having the same nitrogen content for the two runs, but air leaking into the chamber through a hole in a glove aborted the attempt. Some increases in nickel solubility with increased nitrogen content were expected because of the increased stainless steel corrosion found²³ in high nitrogen lithium. However, the increase in solubility from 255 ppm to an estimated 2000-3000 ppm seems excessive. If true, a stable soluble compound must form.

~~SECRET~~

Table I

SUMMARY OF ANALYTICAL DATA

Sample Location	Sample No.	Run Number				
		1		2		
		N ₂ -ppm	Ni-ppm	N ₂ -ppm	Ni-ppm	
Ingots	1	605	18	None taken	None taken	
	2	585	0 ¹			
	3	617	26			
	4	622	0 ¹			
Bottom tank before start	1	910 ²	26	1190 ³	404 ⁴	
	2	1045 ²	25			2390 ³
	3	None taken	None taken			
First tank	1	269	178	1100	951	
	2	230	4 ¹	845	396	
Second tank	1	Lost	132 ⁶	722	Lost	
			78 ⁶			
	2 ⁵	923	520 (136 est)	None taken	None taken	
Third tank	1	219	42 ⁶	720	915	
			128 ⁶			
	2	Lost	149±10%	1130	900	
Fourth tank	1 ⁷			565	830	
	2			910	935	
4 hrs later	3	Not used	Not used	446	478	
16 hrs later	4			281	159	

¹No color developed on these samples. Suspected that Ni not taken into solution.

²Samples taken 5 hours before run.

³Samples taken <1 hour before run.

⁴Nickel forceps dipped into molten sample. Also, run by noncalibrated method.

⁵Titrated sample size on which values calculated was much too low.

⁶Nickel analysis in doubt. Second value from aliquot from solution sample; first value from remainder of solution sample and considered more reliable.

⁷Total sample size in doubt.

~~SECRET~~

Another explanation for the high nickel content is possible. Examination of the nickel tube after the two runs showed the usual grain boundary penetration associated with high nitrogen lithium. Many complete grains had been removed. Consequently, particulate nickel may have been picked up in the samples.

The evidence tends to confirm the former explanation. During solution of the sample, nickel (as a black, flocculent substance typical of the selective solution of the major metal from an alloy) was observed to appear all during the dissolution, but the major amount was observed at the bottom of the crucible. As the samples took between 1/2 and 1-minute to freeze, settling of particulate or precipitated nickel had to take place in that time. Because the lithium in the bottom tank had stood for 3-4 hours before sampling, not much particulate nickel should have been present.

The analysis of the lithium from Run 2, Tank 4, is also interesting. The samples, taken 4 hours and 16 hours after the samples taken immediately after the run, show decreasing values of both nitrogen and nickel. The reduction of the nitrogen was to be expected as it was gettered by the titanium liner of the tank. The reduction of the nickel could have been caused by the reduced solubility as the nitrogen was gettered, partially by settling of particulate nickel, or by formation of a nickel-titanium alloy on the tank walls. The value after 16 hours is below the listed solubility, so the last mechanism may be important or a nickel-nitrogen compound may have formed which settled out. In any event, resolution of these problems should be made before resumption of testing.

Table II shows other data taken and the results of calculations. The physical properties of the lithium are shown in Figure 5, along with the source of the data. The diffusion coefficient of nickel in lithium was estimated by the method shown in Appendix B. This was the most uncertain factor at the start of the program and an estimate of the possible error involved will be shown later. The experimental error of the method had to be proved to be small (compared to the error in estimating the diffusion coefficient) before experimental work to measure the coefficient was justified.

Table II

SUMMARY OF DATA

Subject	Run No. 1			Run No. 2			
	1st tank	2nd tank	3rd tank	1st tank	2nd tank	3rd tank	4th tank
1. Weight of Li	1.445	1.659	1.57	1.342		.728	1.081
2. Time to fill	600	705	620	255	Not measured	205	405
3. Average flow rate	2.41	2.35	2.53	5.26		3.55	2.67
4. Average velocity (u)	.41	.39	.42	.84		.57	.42
5. Li temperature	1100	1100	1100	955	Uneven flow	955	955
6. Li density (ρ)	29.6	29.6	29.6	30.0		30.0	30.0
7. Li viscosity (μ)	2.15	2.15	2.15	2.35		2.35	2.35
8. Diffusion coefficient of Ni in Li (δ)	1.35	1.35	1.35	1.13		1.13	1.13
9. Length of Ni tube (L)	3.83	3.83	3.83	3.83		3.83	3.83
10. Inside diameter of Ni tube (D)	1.63	1.63	1.63	1.63		1.63	1.63
11. Initial Ni concentration (c_0)	.755	.755	.755	8.5		8.5	8.5
12. Final Ni concentration (c_L)	5.28	3.95	4.41	27.7		27.2	26.5
13. Solubility of Ni in Li (c_s)	17.8	17.8	17.8	7.65		7.65	7.65
14. Mass transfer coefficient (k_D)	1.58	.96	1.22	--		--	--
15. Reynolds number (Re)	920	875	940	1750		1180	885
16. Schmidt number (Sc)	53.8	53.8	53.8				
17. j factor for mass transfer (j_D)	5.5	3.35	4.25				

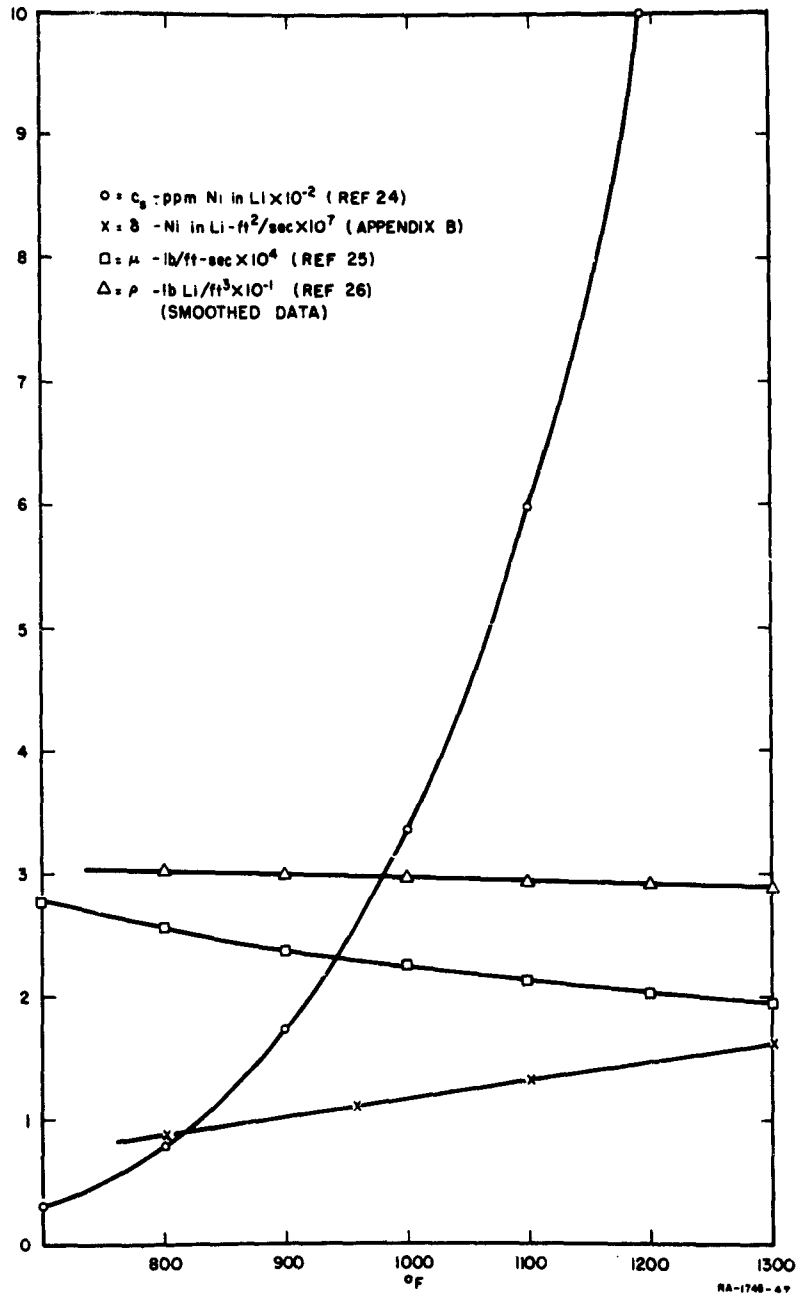



FIG. 5
PHYSICAL PROPERTIES OF LITHIUM



The bulk lithium velocity and mass transfer coefficient were calculated from Equations 4 and 5, respectively. The Reynolds and Schmidt numbers were calculated from the property values listed; then j_D was calculated using Equation 1a.

Only the j factors for Run 1 were calculated because of the difficulties mentioned above. These values are plotted in Figure 6 showing the theoretical value of j_D as a function of Reynold's number under conditions of the run (calculated from Equation 1). The bars indicate the known uncertainty in the analytical error alone and do not include sampling error, the error in temperature estimation, the error in the solubility, the effect of nitrogen and other impurities on the solubility, the error in the viscosity and density of lithium, and the error from estimating the diffusion coefficient of nickel in lithium. The last error alone could easily add the distance between the solid and dashed line to the length of a bar.

In view of the above possible errors, the agreement between the measured and theoretical values of j_D is regarded as fortuitous. The spread between the j_D values cannot be taken as a measure of the precision of the method because they are all from one run. However, they can be regarded as a measure of the spread obtainable within a run in spite of the analytical difficulties. When these difficulties are ironed out, excellent precision in data from tank to tank within a run should be obtainable.

In spite of the uneven success of the two runs, we conclude that the method will produce data whose accuracy will be limited by the available physical property data.

From Equation 1, it is apparent that the factor L/D is important for short tube lengths. It shows that the value of k_D becomes lower as the tube gets longer. As a result, the tube should dissolve more at the entrance than at the exit. The tube was cut up into 2" lengths and the I.D. measured at the entrance of each section with a ball gage and micrometer. The results are shown in Figure 7. Measuring error is estimated to have been $\pm 1/2$ mil. The maximum and minimum diameters

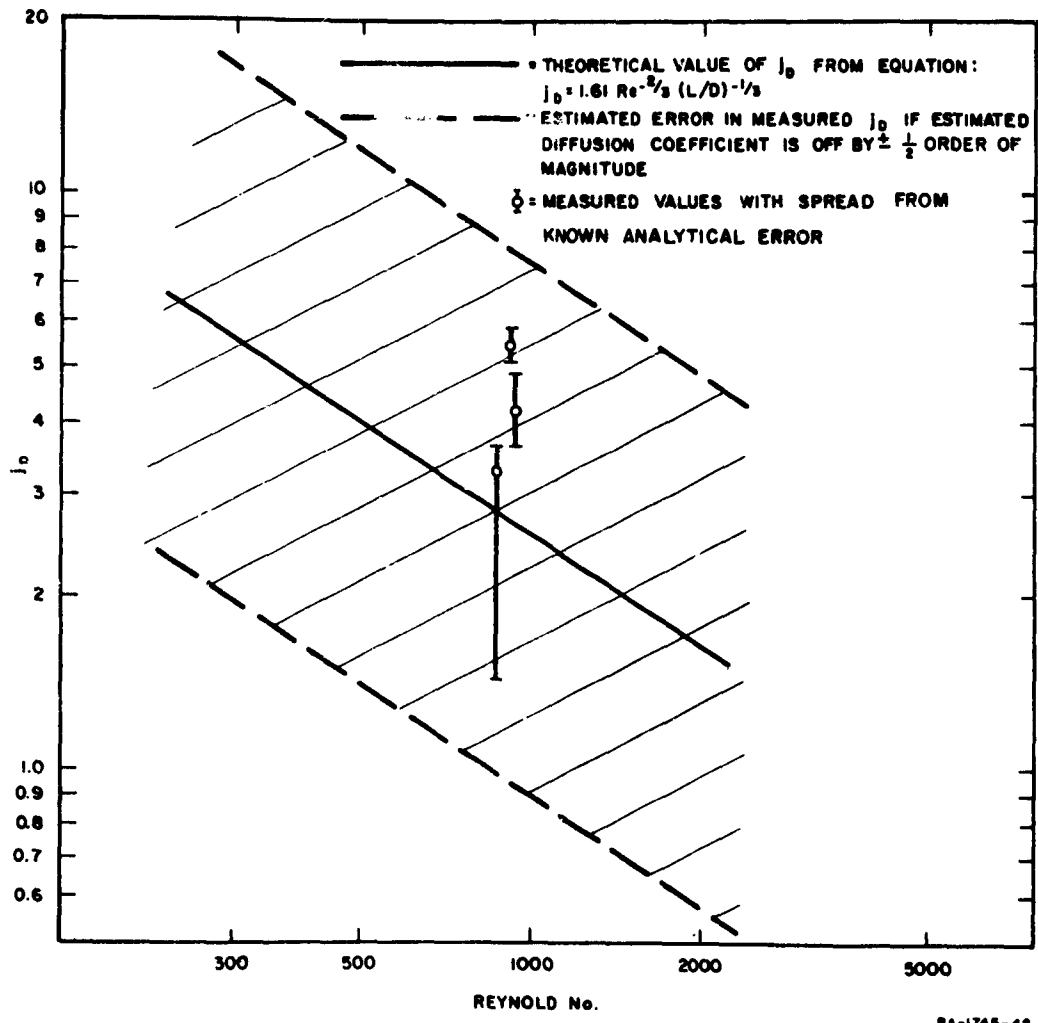
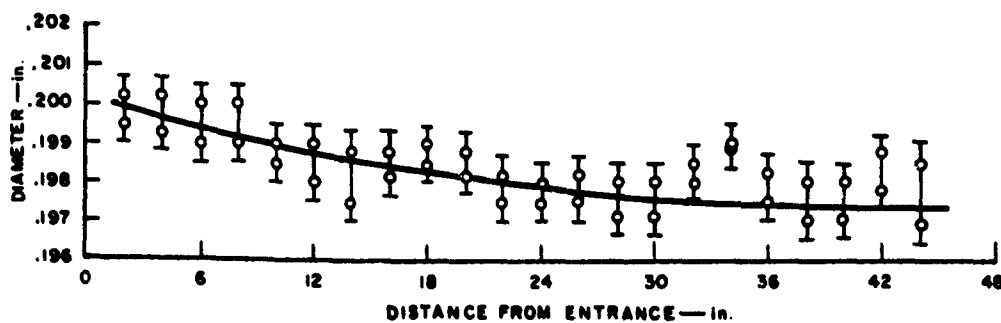

FIG. 6
 j FACTOR VS REYNOLDS NUMBER FOR CONDITIONS OF RUN 1



RA-1746-49

FIG. 7
INSIDE DIAMETER OF NICKEL TUBES AFTER RUNS 1 AND 2

found are shown as circles. The average diameter is shown to have a definite trend in becoming smaller toward the exit. As similar measurements were not made on unused tubing, no comparison is readily available as to the uniformity of bore of the piece of tubing used. Consequently, the three apparent "humps" in the curve may be due to original variations in the bore. A correlation between the observed trend with that theoretically derivable from Equation 1 is not attempted because of the uncertainty of the starting configuration.

It is instructive to combine Equations 5 and 1 and solve for the theoretical value of c_L as a function of tube length L/D , assuming $c_0 = 0$. Thus,

$$c_L = \frac{c_S}{K_1(L/D)^{-2/3} + 1} \quad (7)$$

where $K_1 = .155 (\text{Re})^{2/3} (\text{Sc})^{2/3}$

The equation is plotted in Figure 8 choosing conditions similar to our Run No. 1. The figure shows how the concentration of nickel coming from the end of the tube increases as the tube gets longer. Figure 8 also helps in choosing experimental conditions; with a given tube length, a quick estimate can be made of the required accuracy to obtain data of a given reliability.

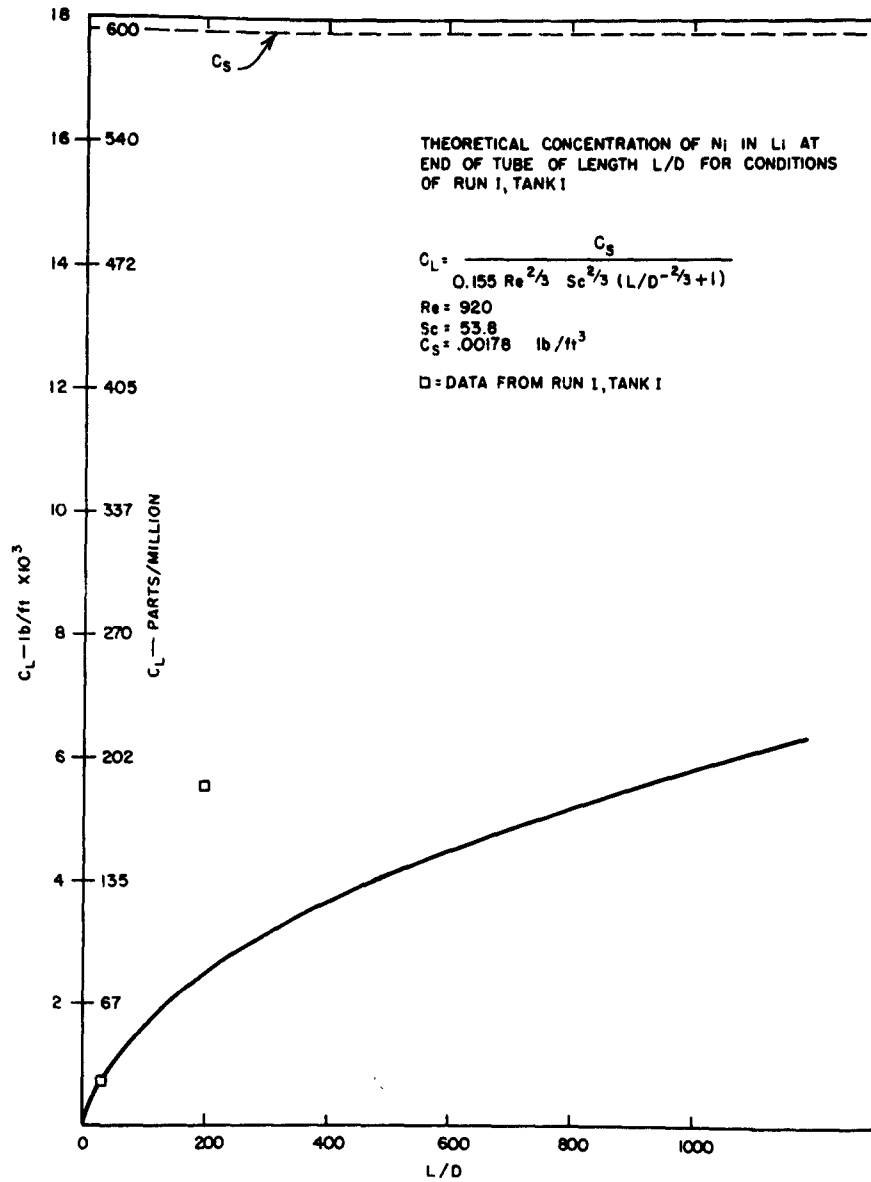

RA-1748-80

FIG. 8
 THEORETICAL CONCENTRATION OF NI IN LI AT END OF TUBE OF LENGTH L/D
 FOR CONDITIONS OF RUN 1, TANK 1

REFERENCES

1. Holman, W. R. and A. G. Wilder. Investigation of the Dynamic Corrosion of Metals and Alloys by Liquid Metals at Elevated Temperatures, WADC T.R. 54-104, Pt. 1 (1954)(UNCLASSIFIED, Pt. 2 (1955) SECRET, Pt. 3 (1956) SECRET.
2. Parkman, M. F. The Theory and Operation of the Toroid Circulating Apparatus, Technical Report No. 1, Office of Naval Research, Contract Nonr-2117(00). July, 1958 SECRET-RD.
3. Parkman, M. F. In Lithium Symposium, Analytical Procedures and High Temperature Corrosion, Oak Ridge National Laboratory, Oak Ridge, Tennessee, August 7-8, 1957, TID-7544 SECRET (not published).
4. Manly, W. D. Fundamentals of Liquid-Metal Corrosion, ORNL-2055(1956); Also in Corrosion 12: 3361 (1956).
5. Epstein, L. F. Static and Dynamic Corrosion and Mass Transfer in Liquid Metal Systems. Chem. Eng. Prog. Symposium Series No. 20, Vol. 53 (1957).
6. Keyes, J. J., Jr. Some Calculations of Diffusion Controlled Thermal Gradient Mass Transfer, ORNL CF-57-7-115, (7-22-57).
7. Horseley, G. W. Mass-transport and Corrosion of Iron-based alloys in liquid metals, J. Nucl. Energy, Part B: Reactor Tech. 1:84 (1959).
8. Eldred, V. W. Interactions Between Solid and Liquid Metals and Alloys, A.E.R.E. X/R 1806 (1955).
9. Ward, A. G. and J. W. Taylor. Solution rate studies with liquid metals. J. Inst. Metals 85:145 (1956); also as A.E.R.E. M/R 1866 (1956).
10. Kolodney, M. and B. Minushkin. A Method for Determining the Solution Rate of Container Metals in Lithium, NDA-41 (1957) SECRET-RD.
11. Ward, A. G. and J. W. Taylor, Dynamic solution-rate studies of solid metals in liquid metals. J. Inst. Metals 86:36 (1957); also as A.E.R.E. M/R 2113.
12. Taylor, J. W. and A. G. Ward, A.E.R.E. 2295 (1957).
13. Bennett, J. A. R. and J. B. Lewis. Dissolution rates of solids in mercury and aqueous liquids: The development of a new type of rotating dissolution cell. AIChE Journ. 4:418 (1958).
14. Taylor, J. W. Mass transfer caused by a thermal gradient in liquid metal systems. Rev. Met 54:960 (1957).

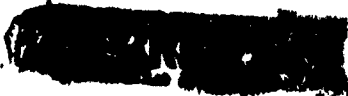
- 
15. Kerridge, D. H. A Study of the Rates of Crystallisation of Iron from Liquid Bismuth Solutions, A.E.R.E. M/R 2579(a) (1958).
 16. Weeks, J. R. and D. H. Gurinsky. Solid metal-liquid metal reactions in bismuth and sodium, in Liquid Metals and Solidification. ASM (1958).
 17. Ferstenberg, C. Mass Transfer to Mercury by Forced Convection, M.S. Thesis, Columbia University (1951). Reported in Dunn, W. E., C. F. Bonilla, C. Ferstenberg, and B. Gross. Mass transfer in liquid metals, AIChE Journ 2:184 (1956).
 18. Epstein, L. F. and C. E. Weber, Problems in the Use of Molten Sodium as a Heat Transfer Fluid, KAPL-362 published in J. Metallurgy and Ceramics, TID-70 (Rev), SECRET-RD, (1951).
 19. Hamilton, D. C., F. E. Lynch, and L. D. Palmer. The Nature of the Flow of Ordinary Fluids in a Thermal Convection Harp, ORNL-1624 (1954).
 20. Alstad, C.D., H. S. Isbin, N. R. Amundson, and J. P. Silvers. Transient behavior of single-phase natural-circulation loop systems, AIChE Journ. 1:417 (1955).
 21. Mausteller, J. W. and E. F. Batutis. Mine Safety Appliances Co., TR-36 (1955); also Liquid Metals Handbook, Na-NaK Suppl., p. 137 (1955).
 22. Linton, W. H., Jr., and T. K. Sherwood. Chem. Eng. Prog. 46:258 (1950).
 23. McKee, J. M. Effect of Nitrogen on Corrosion by Lithium, NDA-40(1957) SECRET-RD.
 24. Beardsley, G. E., Jr. Pratt and Whitney Aircraft, CANEL, Private Communication, 7/25/58.
 25. Novikov, et al. J. Nuclear Energy (USSR) 4:387 (1957).
 26. Liquid Metals Handbook - NAVEXDS P-733 (Rev) (1952).



APPENDIX A

ANALYSIS OF LITHIUM





APPENDIX A

ANALYSIS OF LITHIUM

Three measurements were made on each sample:

1. total lithium by titration with standard HCl
2. nitrogen content by a Kjeldahl method
3. nickel content by a colorimetric dimethylglyoxime method.

All samples were taken in titanium crucibles machined from 3/4" diameter bar stock. Bars 1" long were cut and a 5/8" hole drilled in one end to a depth of 7/8". Maximum capacity of the crucibles was 2 grams of lithium.

Crucibles were pickled in 40% HNO₃-2% HF solution until shiny, then washed in distilled water and acetone before being placed in the air lock for outgassing.

Samples were carried in glass weighing bottles sealed with a very thin ring of silicone stopcock grease. No trouble was experienced with leakage although samples containing less than 60 ppm N₂ were not handled.

The apparatus used for the nitrogen procedure, shown in Figure A-1 was the same as developed at Pratt and Whitney Aircraft and reported in the symposium of Reference 3.

The detailed procedure is as follows:

Preliminary

1. Weigh tared crucible containing sample to 0.01 gram on triple beam balance in the glove chamber.
2. Place in weighing bottle and remove from chamber.

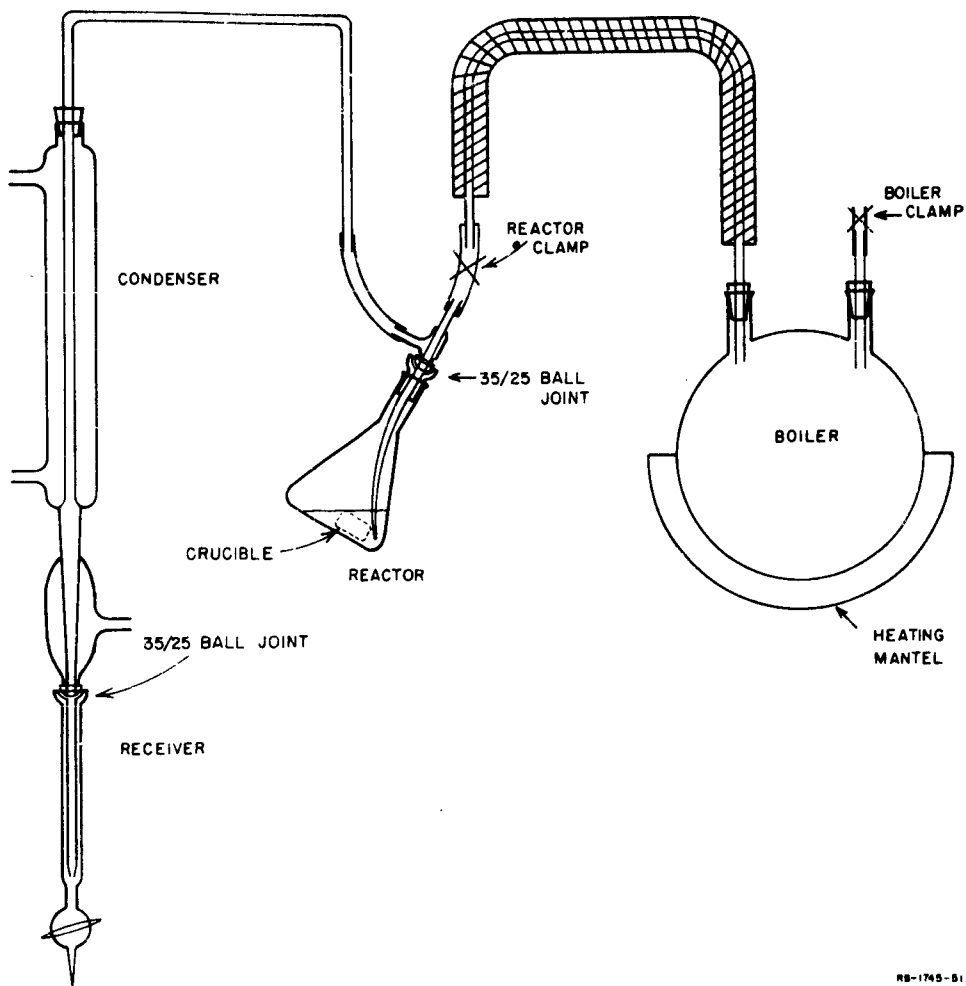

FIG. A-1
APPARATUS FOR DETERMINATION OF N₂ IN Li

Digestion

1. Heat up boiler and distill over a few mls of water to wash out apparatus.
2. Remove receiver and reactor and replace receiver containing 30 ml boric acid.
3. Add 50 ml water and 5 ml CP methanol to reactor. Methanol is used to slow the reaction rate.
4. Close the reactor clamp to prevent solution from backing into the boiler.
5. Remove the sample from weighing bottle, drop in reactor, and quickly replace the receiver, adjusting so that sample remains submerged.
6. When sample dissolves, admit steam to reactor. Heat may be applied to reactor in order to speed the digestion, but exceeding a certain temperature will result in a sudden rapid reaction rate which can't be stopped until the sample is dissolved. Ammonia will be lost when this happens because of the high hydrogen evolution rate.
7. Distill over about 35 ml of water, then shut off the steam.
8. Drain the receiver into a 100-ml volumetric flask, washing with water.
9. Remove the reactor and drain contents into a 250-ml volumetric flask. Wash crucible and reactor walls.

Total Lithium Determination

1. The solution in the 250-ml flask is made up to the mark and two 5-ml aliquots are pipetted into separate Erlenmeyer flasks. A wet pipette is used, which is washed by drawing exactly 5-ml portions.
2. The aliquots are titrated with 0.1 N HCl to a phenolphthalein end point.

Nitrogen Determination

1. The solution in the 100-ml flask is made up to volume.
2. A 20-ml aliquot (5-ml, if N_2 is high; two 20-ml aliquots, if very low) is pipetted into a 50-ml volumetric flask.

- 
3. Add water to about 46 ml and place in bath to bring to about 20°C.
 4. Add 2 ml of Nessler-Jackson reagent* and shake.
 5. After 10 minutes, read absorbancy at 420 mμ on the Model B Beckman Spectrophotometer.
 6. Read μ g of N₂ from calibration curve and calculate nitrogen content.

Nickel Determination

1. From the total lithium determination calculate the amount of concentrated HCl necessary to neutralize the remaining sample in the 250-ml flask.
2. Add that amount of HCl plus 10% more.
3. Reduce the volume on the hot plate until the solution is syrupy.
4. If working in the range over 20 ppm Ni, transfer the solution to a 100-ml volumetric flask and add water to the mark.
5. If working in the range of 20 to 200 ppm Ni, take an aliquot containing about 1 gram of lithium and pipette into another 100-ml flask. If working in the range over 200 ppm Ni, take an aliquot containing about 0.2 g lithium.
6. Make up the volume to about 75 ml.
7. Add bromine water dropwise until solution turns yellow, then add 2 ml extra.
8. Add 2.5 ml 20% tartaric acid if sample has contacted stainless steel and iron is present. Shake well and let stand a few minutes.
9. Add concentrated NH₄OH dropwise until color disappears, then add 5 ml more.
10. If necessary, cool to room temperature.

*Nessler-Jackson reagent: Dissolve 60 grams KI in about 35 ml of cold ammonia-free water. Slowly add a saturated solution of mercuric chloride until a slight red precipitate appears (about 415-425 ml). Add 400 ml of clear 36% NaOH solution. Dilute to 1 liter, let stand, and decant. The reagent is stable and can be used indefinitely.

APPENDIX B

ESTIMATION OF THE DIFFUSION COEFFICIENT OF NICKEL IN LITHIUM

No data could be found on the diffusion of elements in the alkali metals. A recent compilation⁵ of the available data on diffusion of elements in liquid metals in general shows that values of the diffusion coefficients lie in the range from 1×10^{-9} to 100×10^{-9} ft²/sec. Accurate values of the coefficient would be required to provide good experimental verification of the theory as shown in the main text. It was decided at the start to use estimated values until experience with the method showed that the possible error in using estimated values was a significant part of the total error of the method.

C. R. Wilke developed a method for estimating liquid diffusion coefficients on the basis of relations suggested by the Eyring theory of absolute reaction rates and the Stokes-Einstein equation. He showed that data correlated with the group $F = T/\delta\mu$, where F is function of the molal volume of the solute. F was found to be essentially independent of temperature for a given solute-solvent system. Although the F values of different solutes could not be correlated with solvent properties, it was possible to estimate F for a particular solute-solvent system if an experimental point existed for any solute in the solvent. Since no data exist for lithium as a solvent, data for aluminum were used because the atomic radii are approximately the same.

Table B-I shows K. Uenaura's data for the diffusion of nickel in aluminum, values for the viscosity of aluminum, and the calculated values of F . With the assumption of an F value of 2.2 for the Ni-Li system, the diffusion coefficients plotted in Figure 5 were estimated.

Table B-I

DATA FOR ESTIMATING THE DIFFUSION COEFFICIENT OF N1 IN Li

T °C	Diffusion Coefficient x 10 ⁵ cm ² /sec	Al viscosity centipoise (μ)	F
700	1.5	2.9	2.24
800	3.9	1.4	2.19