

UNCLASSIFIED

AD 259 970

*Reproduced
by the*

**ARMED SERVICES TECHNICAL INFORMATION AGENCY
ARLINGTON HALL STATION
ARLINGTON 12, VIRGINIA**



UNCLASSIFIED

NOTICE: When government or other drawings, specifications or other data are used for any purpose other than in connection with a definitely related government procurement operation, the U. S. Government thereby incurs no responsibility, nor any obligation whatsoever; and the fact that the Government may have formulated, furnished, or in any way supplied the said drawings, specifications, or other data is not to be regarded by implication or otherwise as in any manner licensing the holder or any other person or corporation, or conveying any rights or permission to manufacture, use or sell any patented invention that may in any way be related thereto.

259970

RADC TR-61-89

June 30, 1961

CATALOGED BY ASTIA
AS AD NO. _____

VIEWING SET TELEVISION AN/FXC (XW-1)
FINAL TECHNICAL REPORT

ITT Federal Laboratories
Fort Wayne, Indiana

Serial No. 3006

Contract Number AF 30(602)1951

Prepared for
Rome Air Development Center
Air Force Systems Command
United States Air Force
Griffiss Air Force Base
New York

521-3-5
NOX

ASTIA
RECEIVED
JUL 20 1961
JLPOB

201 Wayne Trace

Fort Wayne 1.

Indiana

ITT *Federal*
LABORATORIES



RADC TR-61-89

June 30, 1961

Copy No.

VIEWING SET TELEVISION AN/FXC (XW-1)

FINAL TECHNICAL REPORT

**ITT Federal Laboratories
Fort Wayne, Indiana**

Serial No. 3006

**Contract Number AF 30(602)1951
Project 1997
Task 55136**

**Prepared for
Rome Air Development Center
Air Force Systems Command
United States Air Force
Griffiss Air Force Base
New York**

**Prepared by
Nelson Hoag
Jerry Holsinger**

Approved by

**E. L. Byer
Executive Engineer**

**Dr. R. T. Watson
Laboratory Director**

PATENT NOTICE - When Government drawings, specifications, or other data are used for any purpose other than in connection with a definitely related Government procurement operation, the United States Government thereby incurs no responsibility nor any obligation whatsoever and the fact that the Government may have formulated, furnished, or in any way supplied the said drawings, specifications or other data is not to be regarded by implication or otherwise as in any manner licensing the holder or any other person or corporation, or conveying any rights or permission to manufacture, use, or sell any patented invention that in any way be related thereto.

ABSTRACT

Viewing Set, Television AN/FXC (XW-1) is capable of transmitting graphic information such as weather charts, briefing status boards, etc., over telephone lines having a bandwidth of approximately 300 to 3000 cps, phase equalized from 1000 to 2500 cps. Picture definition is a function of transmission time and as several different frame times are provided, pictures of varying qualities may be transmitted. A 400-line picture is the highest resolution information that can be transmitted. A two-way audio link and a real-time pointer system at the transmitter provides a system of maximum utility. Secure transmittal of information is assured when the system utilizes approved security devices. This report also presents the relative merits of two approaches: the scan conversion and direct slow scan modes performed on this development. In addition a summary of the AN/FXC (XW-1) performance is included in this report.

SUMMARY OF EQUIPMENT PERFORMANCE

The following is included to provide the reader with a brief summary of the operational performance of the AN/FXC (XW-1) equipment. A more thorough knowledge of the equipment and its functions can be gained by referring to Sections 1.0 and 2.0.

Before delivery about 300 hours of operating time was logged on the complete system in debugging, calibrating, and adjusting all parts of the system in order to insure a minimum amount of down time due to faulty components or circuitry after delivery. During this same period tests were performed to measure resolution, gray scale, sweep linearity, real time pointer calibration, bilateral audio link, etc. Maximum resolution of the system is 350 TV lines (120 seconds per picture) with four shades of gray: black, white, light gray, and dark gray). Gray scale is limited to the above four distinct levels due to the digital transmission system.

After delivery of the AN/FXC (XW-1) to RADC at Griffiss Air Force Base, Rome, New York several months of evaluation tests were performed. Briefly the tests were as follows:

- a. The AN/FXC (XW-1) was connected to and operated over a 500 mile telephone line for a period of 3 months. Results were very satisfactory in that 24-hour operation was possible with down time due to equipment failure or telephone line difficulties being negligible.
- b. By removing the SEBIT 25 data modems from the system and substituting the Collins GSC/4 transmitting-receiving equipment satisfactory image transmission was executed over a 500 mile phase equalized telephone line at a bit rate of 5000 bits per second. The GSC/4 has the advantage of requiring only one telephone line instead of two in order to transmit 5000 bits per second. Telephone line requirements as to phase and amplitude characteristics are however, more critical than those required by the SEBIT 25 data-modems.

- c. A four-hour period of secure image transmission was accomplished using TSEC/KX-3 encrypting equipment.
- d. Several demonstrations indicated:
 - 1. Minimum picture transmission time of 4 minutes with 2 minute viewing and 2 minute erase time.
 - 2. Contrast of the received image was somewhat less than that of a normal home TV picture. It was however 100 percent readable.
 - 3. Four men are required for a complete briefing sequence.
 - 4. Complexity of equipment requires that operator have several hours of operating experience.
 - 5. Future operational equipment of this type should be designed for automatic pushbutton type operation to reduce operator skill requirement.

Additional equipment developed towards the end of the project eliminated the need for scan conversion tubes. A special slow-scan vidicon capable of operating directly at the slow-scan parameters provides the narrow band video without the need for scan-conversion equipment. At the receiving end a direct-view storage tube provides the necessary storage for display and eliminates the need for scan conversion back to TV rates at the receiver. Digital transmitting equipment (SEBIT 25) remains the same. Experimental results using the vidicon-latron combination were quite gratifying. Some advantages of this system over the AN/FXC (XW-1) are:

- a. Physical size is reduced to the point where transmitter portion (excluding digital rack) is now completely portable for one man to carry.
- b. Only one unskilled operator is required.

- c. Cost of vidicon-Iatron chain and cost of operation is considerably reduced over that of the AN/FXC (XW-1).
- d. Vidicon-Iatron chain is far less complex in number of components.
- e. Viewing time for one stored picture can be extended to 8 minutes without loss of information and little loss in contrast.
- f. Storage and erase characteristics of the vidicon-Iatron chain are superior to the AN/FXC (XW-1).
- g. Resolution of both systems is about equal.
- h. Shading in the stored image is somewhat less.
- i. The real-time pointer can not be used with the vidicon-Iatron combination.

An analog transmitter-receiver using vestigial sideband transmission was designed and built. This unit complete with timer and power supply allows the vidicon-Iatron chain to operate completely divorced from the original AN/FXC (XW-1) system. By transmitting the narrow band video signal in analog form the original gray scale is preserved and the same resolution picture can be transmitted in 60 seconds instead of 120 seconds as required by the AN/FXC (XW-1).

Since the frequency components in the analog transmitter output are within the 800 to 3000 cycle band any good quality audio tape recorder can be used to record the transmitted signal for playback at some later date or other remote location. An experiment to test this possibility was performed at RADC. The modulated output from the analog transmitter was fed directly into an Ampex 960 series audio tape recorder and recorded on magnetic tape. The magnetic tape recording was then played back via the playback unit of the Ampex recorder directly into the demodulator portion of the receiver (normal telephone line input). The quality of the displayed image on the Iatron was

equal in every respect to that displayed when the vidicon-Iatron combination was connected back to back.

One final comment in regard to the vidicon-Iatron combination. For some applications it may be expeditious to use a vidicon at the transmitter and a scan conversion tube at the receiver. The advantage of such a combination lies in the fact that standard 17 inch or 21 inch TV monitors can then be used as the receiver display device.

CONTENTS

	Page
1.0 INTRODUCTION -----	1
2.0 DISCUSSION -----	2
2.1 Functional Description -----	2
2.1.1 Transmitter -----	2
2.1.2 Receiver -----	5
2.2 Specifications and Operating Parameters -----	9
2.2.1 System Specifications -----	9
2.2.2 Transmitter -----	10
2.2.3 Receiver -----	14
2.3 Equipment Supplied -----	16
2.4 Operational Tests -----	17
2.4.1 General -----	17
2.4.2 System Resolution -----	18
2.4.3 System Gray Scale Rendition -----	21
2.4.4 Photographic Rendition -----	24
2.4.5 Map Rendition -----	24
2.4.6 Letter and Chart Size Requirement -----	26
2.4.7 Telephone Line Requirements -----	29
2.4.8 500 Mile Telephone Link -----	37
2.4.9 Operation of AN/FXC (XW-1) at 5400 Bits Per Second -----	45
2.4.10 Operation of AN/FXC (XW-1) with Security Encoding Equipment -----	47
2.4.11 Demonstration Results -----	48
3.0 RELIABILITY -----	50
3.1 General -----	50
3.2 Safety Features -----	52
3.2.1 General -----	52
3.2.2 High-Voltage Interlocks -----	52
3.2.3 Fusing -----	53
3.2.4 Sweep Protection Circuits -----	53
3.2.5 Low-Voltage Interlocks -----	53
3.3 Operational Precautions -----	53
4.0 MAINTAINABILITY -----	55
4.1 General -----	55
4.2 Preventive and Corrective Maintenance Required -----	55

CONTENTS (Continued)

	Page
5.0	ADDITIONAL EQUIPMENT SUPPLIED FOR VIEWING
	SET TELEVISION AN/FXC (XW-1) ----- 57
5.1	General Information ----- 57
5.2	Functional Description ----- 57
5.3	Vidicon-Iatron System Specifications ----- 61
5.4	Equipment Supplied ----- 61
5.5	Power Requirements ----- 62
5.5.1	Camera and Camera Control ----- 62
5.5.2	Monitor ----- 62
5.6	Operational Tests on Vidicon-Iatron System ----- 62
5.6.1	General ----- 62
5.6.2	Back-to-Back Laboratory Tests ----- 63
6.0	CONCLUSIONS ----- 75
6.1	AN/FXC (XW-1) System ----- 75
6.2	Vidicon-Iatron Chain ----- 77
6.2.1	Physical Size ----- 77
6.2.2	Ease of Operator Control ----- 77
6.2.3	Viewing Time ----- 78
6.2.4	Picture Transmission Rate ----- 78
6.2.5	Resolution ----- 79
6.2.6	Shading ----- 79
6.2.7	Real Time Pointer ----- 79

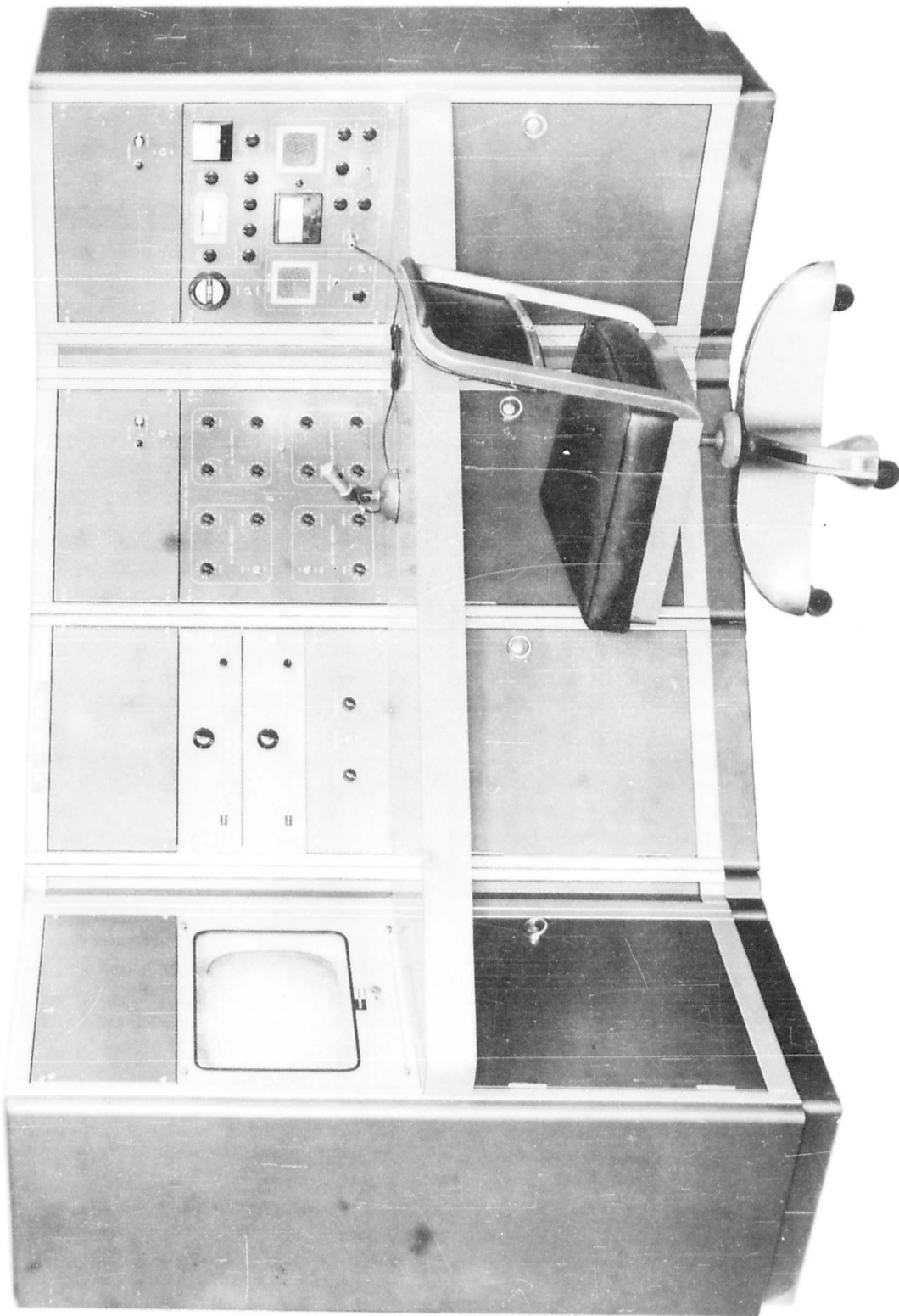

Figure 1 Transmitter--Operator's Console

A DIVISION OF INTERNATIONAL TELEPHONE AND TELEGRAPH CORPORATION

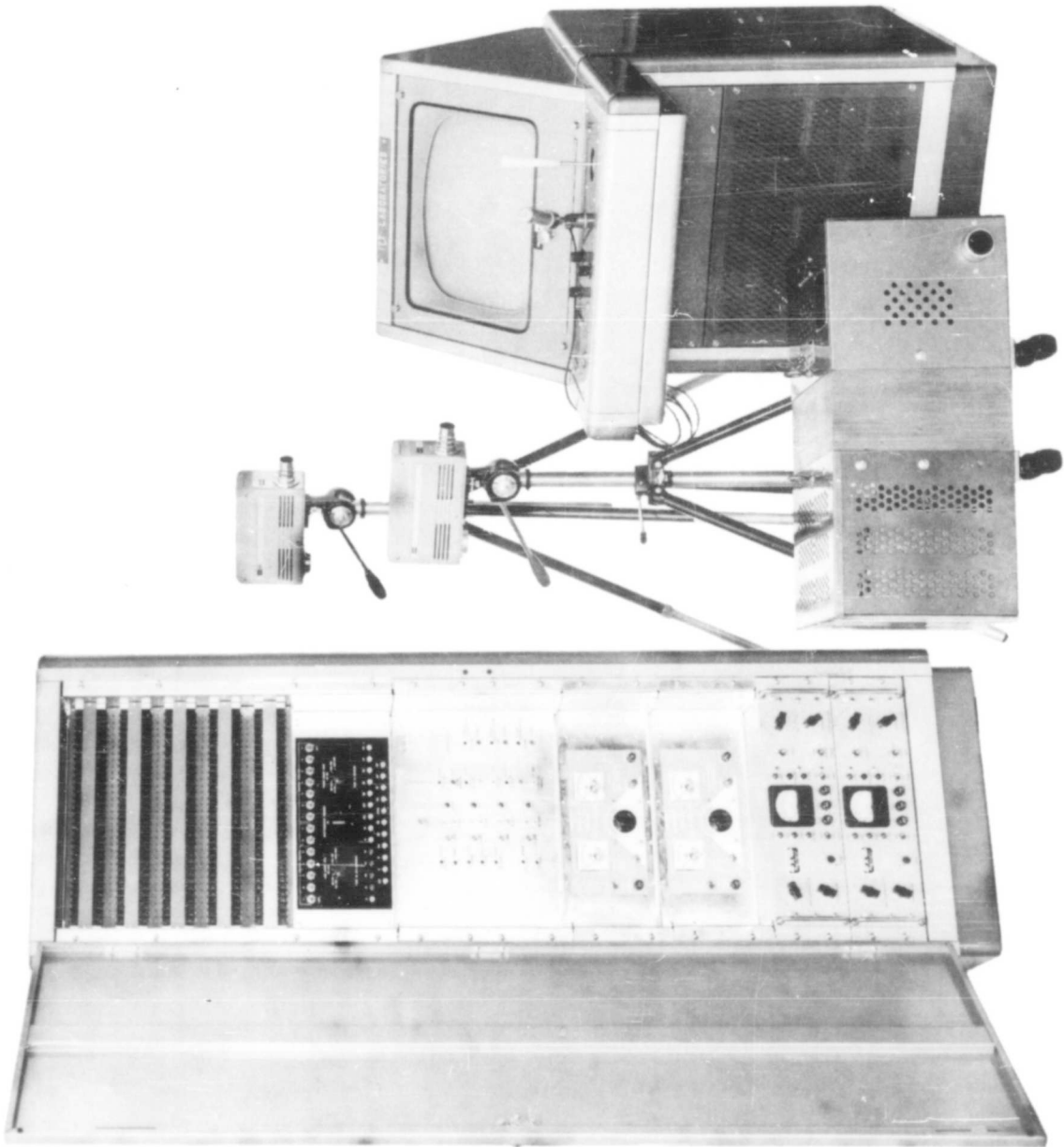

Figure 2 Transmitter Digital Rack, ITV Cameras, and Briefing Console

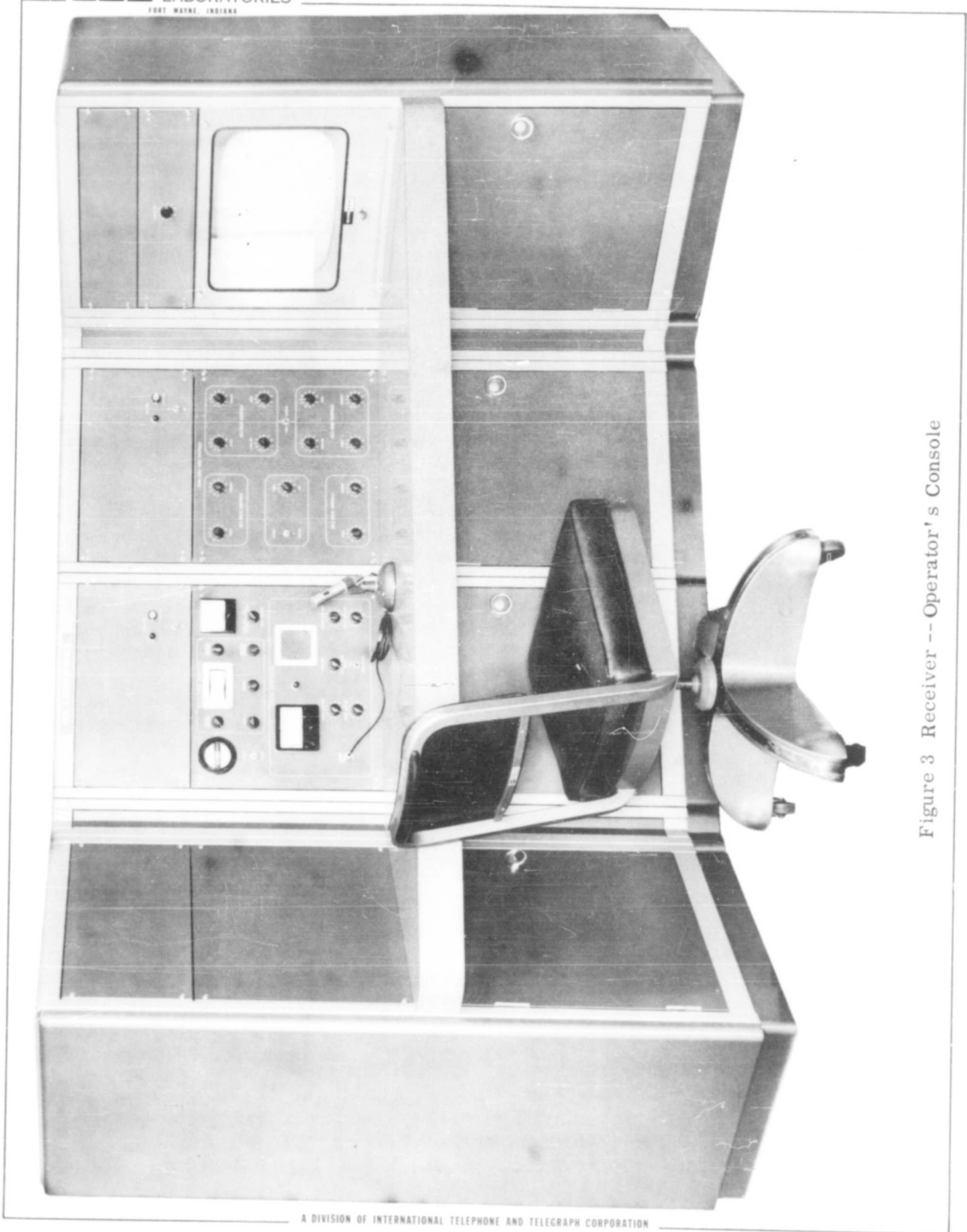

Figure 3 Receiver -- Operator's Console



Figure 4 Receiver Digital Rack and Audience Monitor

1.0 INTRODUCTION

Since this report is the final technical engineering report, individual circuit details will not be discussed; however, a short description of Viewing Set, Television AN/FXC (XW-1) is essential for a better understanding of the attempted goals.

Following the functional description (Section 2.1) the balance of the main body of the report is devoted to a discussion of the operational tests performed, reliability of the system, and maintainability of equipment. Viewing Set, Television AN/FXC (XW-1) is capable of transmitting graphic information such as weather charts, briefing status boards, etc., over telephone lines having a bandwidth of approximately 300 to 3000 cps, phase equalized from 1000 to 2500 cps. Picture definition is a function of transmission time and as several different frame times are provided, pictures of varying qualities may be transmitted. A 400-line picture is the highest resolution information that can be transmitted. A two-way audio link and a real-time pointer system at the transmitter provides a system of maximum utility.

The present equipment is a developmental model and, as such, does not have all the refinement features that a final model might have. Specifically, ease of operation is being referred to here. In other words, some of the controls now on the front panels would either be removed or made more automatic in order to allow equipment operation by less technically trained operating personnel.

More than 300 hours of operating time were logged by the equipment in the laboratory in debugging, testing, and improving the over-all reliability. Special emphasis was placed on achieving reliability and maintainability in the digital transmitting and receiving equipment.

In addition to the laboratory testing, after delivery the equipment was operated over a 500-mile telephone link for a period of about 3 months. During this period the digital equipment and transmit-receive equipment was operated on a 24-hour basis. Down time was considered negligible. The reader is referred to Section 2.4.8 for further discussion on the 500-mile operation.

Section 5.0 covers additional equipment supplied under this contract. Included in this was a vidicon camera, camera control unit, and a direct-view storage tube monitor which uses an ITT FW-221 Iatron designed specifically for slow-scan operation. The relative merits of this system for transmitting graphic information are discussed.

Section 6.0 (Conclusions) covers both the AN/FXC (XW-1) equipment and the vidicon-Iatron chain.

2.0 DISCUSSION

2.1 Functional Description

This narrow-band television relay equipment was developed for the Rome Air Development Center under contract No. AF30(602)-1951. The equipment is intended for use in transmitting stationary or printed information over commercial telephone lines.

Through the use of scan-conversion storage tubes the equipment converts the wide-band video signals from an industrial television camera into narrow-band video. The narrow-band video is digitized and may be coded before being transmitted. The receiver decodes the digital information and converts it to wide-band video at conventional TV rates by means of an additional scan-conversion storage tube. This information is then displayed on an ITV monitor.

Two additional operations occur simultaneously with the transmission of the video. These are the transmission of a pointer position code and the transmission of a bidirectional audio signal between the transmitter and receiver. Due to the necessity of real-time pointer code transmission, the pointer code information is digitized and mixed with the digital video signal before coding and transmission. The audio signal has optional scrambling and is transmitted over a separate telephone line.

Due to the time required to erase the information stored in the scan-conversion tubes at both the transmitter and receiver, two scan-conversion systems are used with each unit. In this manner one system may be used for the transmit-receive operation while the other system is erasing a previously transmitted scene. This allows the displayed scene to be changed rapidly without waiting for the scan-conversion tube to be erased.

The equipment consists of six major units. These are the transmitter console, transmitter digital rack, transmitter briefing monitor, receiver console, receiver digital rack, and receiver audience monitor.

2.1.1 Transmitter

The transmitter contains circuitry to convert the 525-line video to slow scan video, digitize the slow scan video, generate a digital video and pointer information, code the mixed signal, feed the mixed and coded signal to the telephone lines, generate an analog pointer signal, mix this with the 525-line video, and display this signal on an ITV monitor.

Figure 5 is a block diagram of the complete transmitter installation.

2.1.1.1 Write Section

The write portion of the transmitter contains wide-band video and 525-line sweep circuits that write the output of the ITV camera on the storage screen of the scan-conversion tube.

Referring to Figure 5 the write circuits are shown on the left side of the diagram. This illustrates the two ITV camera chains and scan-conversion systems.

The video amplifiers are conventional wide-band amplifiers used to increase the signal output from the ITV cameras to a level satisfactory to drive the scan-conversion tubes.

The write line and frame sweeps are synchronized with the sweeps in the ITV camera. The sweep chassis contains circuitry to derive the necessary deflection voltages as well as protection circuitry to prevent damage to the scan-conversion tube in case of sweep failure.

2.1.1.2 Read Section

The read system contains slow frame rate sweep and narrow-band video circuitry necessary to read the information from the storage screen of the scan-conversion tube.

Referring to Figure 5 the read circuits are shown on the upper right portion of the diagram.

The video signal is read from the scan-conversion tube at the target and collector by the narrow-band preamplifier. The preamplifier subtracts the target signal from the collector signal to reduce cross talk and amplifies the resultant signal. This is further amplified by the narrow-band video chassis and then clamped to provide a controlled d-c level. A video switch selects one of the two outputs from the scan-conversion systems and applies the amplified and clamped signal to the video monitor and the analog-to-digital converter in the digital rack.

Except for time constants, the line and frame sweep circuits are identical. Both circuits use d-c feedback amplifiers to obtain linear sweeps at the necessarily low sweep rates. Both sweeps are synchronized with the digital rack so that the narrow-band video may be digitized.

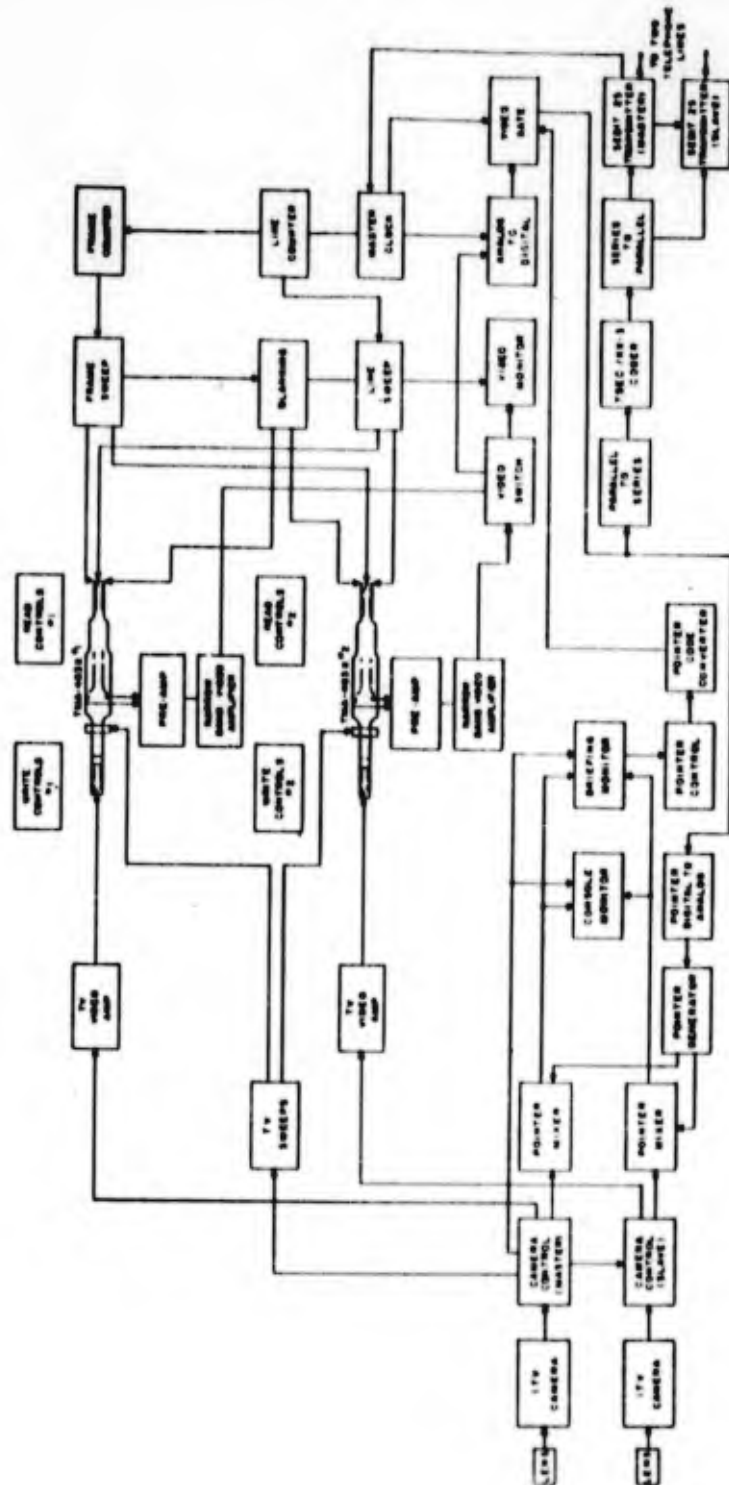

Figure 5 Transmitter Block Diagram

The blanking chassis accepts line and frame blanking signals from the digital rack and provides composite blanking at the scan-conversion tube grid.

2.1.1.3 Digital Rack

The digital portion of the transmitter has several functions. The master clock accepts sync from the SEBIT 25 transmitter and generates sync signals to control the slow-scan read sweeps. The line and frame counter in conjunction with the sync signal determines the number of bits per line and lines per frame for the different frame transmission times. Table I gives the frame times available for the two bit rates used in this equipment.

The pointer control or "joy stick" together with the pointer code converter provides a series two-channel binary code that represents the pointer position on the display.

The video gate is controlled by the line and frame counter outputs and selects the pointer code or video signal at the proper bit intervals.

The parallel-to-series and series-to-parallel converters provide proper signals for the TSEC/KX3 coder and SEBIT 25 transmitter.

2.1.2 Receiver

The receiver contains circuitry to restore the digital information received from the telephone lines, decode this information, generate sync signals from the decoded information, separate the video and pointer codes, convert both video and pointer codes to an analog equivalent, convert the slow-scan video to 525-line wide-band video, mix the wide-band video and analog pointer information, and display this mixed signal on an ITV monitor.

Figure 6 is a block diagram of the complete receiver installation.

2.1.2.1 Digital Rack

The digital portion of the receiver decodes the received signal and derives analog video and pointer information, as well as sync signals, from the decoded digital information.

Using the digital signal received from the telephone lines, the SEBIT 25 receivers generate a sync signal that is used to drive the slave clock in the digital rack. This insures that the slave clock has exactly the same bit rate as the master

Table I

Narrow-Band Sweep Parameters

FRAME TIME - SECONDS		LINES PER FRAME	LINE TIME - MS		BITS PER LINE
1667 BITS / SEC	2500 BITS / SEC		1667*	2500*	
15	10	210	72	48	120
30	20	312	96	64	160
60	40	428	140	93	232
120	80	608	197	131	328
180	120	748	240	160	400

* Bits per Second

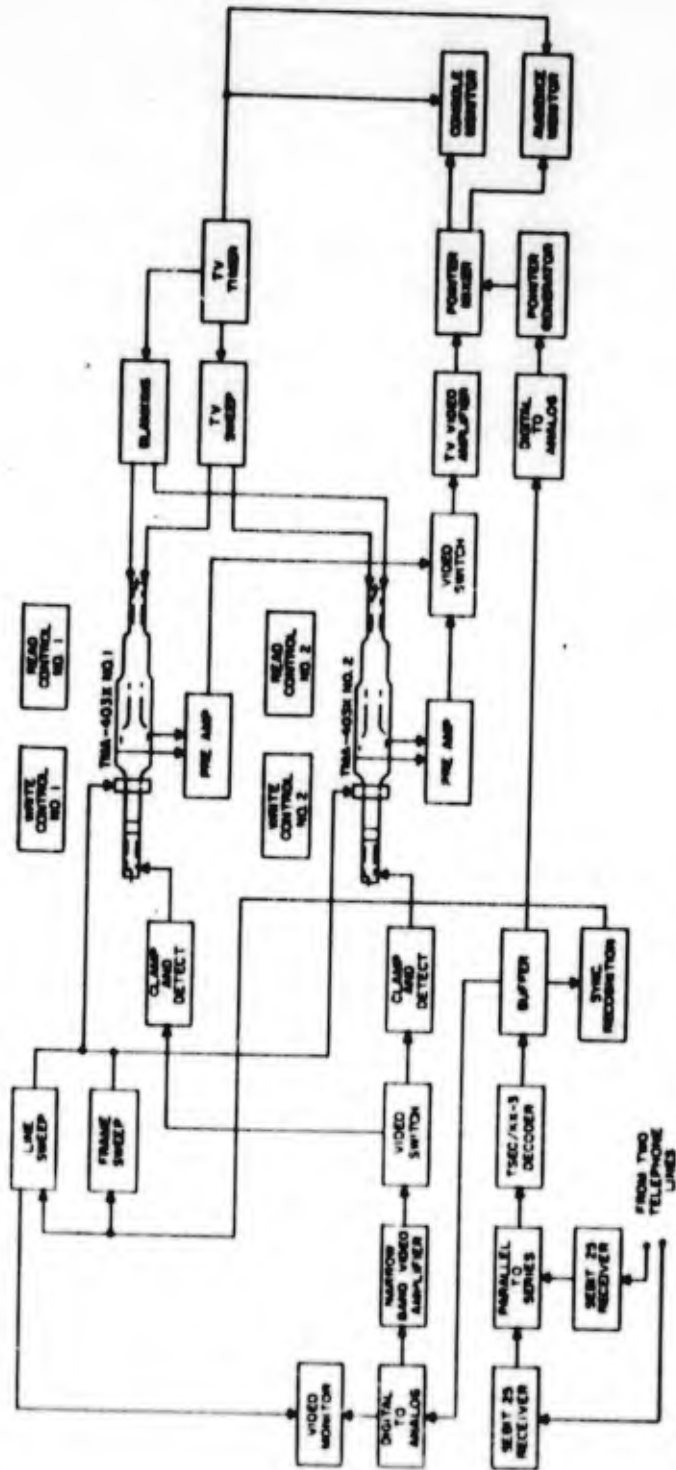

Figure 6 Receiver Block Diagram

clock in the transmitter. The slave clock, in conjunction with the sync recognition circuit, derives sync signals for the slow-scan line and frame sweeps.

The separation of video and pointer information is performed in the digital-to-analog converters by using the sweep sync signals. The output of each digital-to-analog converter then contains only video or pointer information in analog form.

The parallel-to-series and series-to-parallel converters are used in the receiver for the same reason that they are used in the transmitter; i. e., to provide proper signals for the TSEC/KX3 decoder and SEBIT 25 receiver.

2.1.2.2 Write Section

The write portion of the receiver contains narrow-band video and slow-scan sweep circuits that write the output of the digital-to-analog converter on the storage screen of the scan-conversion tube.

Referring to Figure 6 the write circuits are shown in the upper left portion of the diagram. This illustrates the two scan-conversion systems as used in the receiver.

The video, as received from the digital-to-analog converter, is coupled to the video monitor and to the narrow-band video chassis. This chassis modulates a high-frequency carrier with the slow-scan video and couples the resultant signal to a detector and clamp circuit that floats at -8 kv, which is the scan-conversion tube grid potential.

The write line and frame sweeps are synchronized from the digital sync outputs and are thus in sync with the transmitter read sweeps. The sweep chassis contains circuitry to derive the necessary deflection voltages as well as protection circuitry to prevent damage to the scan-conversion tube in case of sweep failure.

2.1.2.3 Read Section

The read system contains the 525-line sweeps and wide-band video circuitry necessary to read the information from the storage screen of the scan-conversion tube. Also included in the read section is the pointer generator chassis which generates the pointer signal and mixes this with the wideband video. The resultant output is displayed on the TV monitors.

Referring to Figure 6 the read circuitry is given in the upper right portion of the diagram.

The video signal is read from the scan-conversion tube at the target and collector by the preamplifier. This preamplifier subtracts the target signal from the collector signal to prevent cross talk and provides a portion of the total video gain. The preamplifier also incorporates a lead circuit which compensates for the lag at the tube element due to stray capacity. This results in an over-all flat frequency response.

The outputs of the two preamplifiers are coupled in the video switch which is used to select the desired scan-conversion system. The selected signal from the video switch is further amplified and then mixed with the pointer signal. The output of the pointer mixer then feeds the TV monitors.

The sweep chassis contains both line and frame sweep generators and amplifiers. These are electrostatic sweep circuits containing feedback amplifiers to assure linearity. Protection circuitry to prevent damage to the scan-conversion tube in case of sweep failure is also included on this chassis.

The sync for the read TV sweeps and the monitor sweeps is derived from a commercial TV timer.

2.2 Specifications and Operating Parameters

2.2.1 System Specifications

2.2.1.1 Service Conditions

Ambient temperature	0 to 39 degrees C
Line voltage	single phase, 105 to 130 volts
Line frequency	58 to 62 cps
Duty	continuous

2.2.1.2 Technical Parameters

Resolution	100 to 350 lines depending on operating mode
Gray levels	white, light gray, dark gray, black
Aspect ratio	4 to 3
Frame rate	Variable, 10, 20, 40, 80 and 120 seconds

Lines per frame	210 to 748 depending on operating mode
Bit transmission rate	2500 bits/sec/telephone line (two lines required)
Pointer transmission	real time
Pointer resolution	one part in 128 vertical and horizontal
Audio link	two-way link, automatic or manual
Scene brightness required	10 to 100 foot candles
Time required to change scene	3 to 4 minutes

NOTE: Two channels are provided to eliminate dead time between scene changes.

2.2.2 Transmitter

2.2.2.1 ITV Chain

2.2.2.1.1 Camera Unit (two required)

Power	from external source via camera control
Operation	continuous
Camera tube	6198A or equivalent
Lenses	Wollensak 1 inch f/1.5 Cine Raptar in type C mount
Scanning frequencies	standard EIA interlaced scan; 525 lines, 60 fields, 30 frames, synchronized with power line
Aspect ratio	4 to 3
Resolution	horizontal: 600 TV lines; vertical: 350 TV lines

Video bandwidth	± 1/2 db to 8 mc
Dimensions	9 in by 3 in by 5-1/2 in
Weight	7 lbs
Ambient temp. range	-25° to + 150° F
Cooling	convection
Automatic light compensation	1000 to 1
Operating distance	500 yards from camera control unit.

2.2.2.1.2 Camera Control Unit (two required, one with timer)

Power	117 volts ac ± 10%, 60 cps ± 10%
Operation	continuous
Aspect ratio	4 to 3
Resolution	horizontal: 600 TV lines; vertical: 350 TV lines
Video bandwidth	7 mc ± 3 db
Dimensions	16 in by 19 in by 5-1/4 in
Weight	38 lbs
Ambient temp. range	-25° to + 150° F
Cooling	convection
Timing generator	standard EIA interlaced scan: 525 lines, 60 fields, 30 frames/second, synchronized with power line H = 15,750 cps, V = 60 cps

2.2.2.1.3 17-Inch Monitor

Power Input 117 volts, 50/60 cps, 180 watts
Primary Fuse 3 amp, extractor post type
Video signal required 0.35 volt peak (min. for 50 volts at kinescope grid); sync neg.

Video Input Impedance

No. 1 High impedance for bridging approximately 470 k in parallel with 15 μf

No. 2 75 ohms terminating resistance with switch on rear apron.

Video Frequency Response

Flat to 8 mc; down 6 db at 10 mc

External Sync Signal 3 to 8 volts, sync neg.

Dimensions rack mounted, 19 in wide by 17-1/2 in high by 20-1/2 in deep.

2.2.2.2 Transmitter Write

The transmitter write circuits accept the video and drive signals from the ITV camera chain.

Video

Bandwidth 8 mc
Amplitude 1 volt peak-to-peak black negative
Impedance 1 megohm

Horizontal Drive

Pulse amplitude 4 volts negative going

Pulse width	5 microseconds
Pulse spacing	63.5 microseconds

Vertical Drive

Pulse amplitude	4 volts negative going
Pulse width	800 microseconds
Pulse spacing	16,667 microseconds

2.2.2.3 Transmitter Read

The transmitter read circuits set the characteristics of the narrow-band portion of the system.

Line time	48 to 240 milliseconds
Frame time	10 to 180 seconds
Video bandwidth	2.5 kc
Telephone line bit rate	1667 or 2500
Output impedance	600 ohms
Output level	-20 to 6 dbm
Video amplitude	0 to 20 volts with pedestal clamp at + 30 volts
Video output impedance	approximately 100 ohms

Table I illustrates the line and frame times available with this equipment.

2.2.2.4 Transmitter Analog to Digital

Sync input to clock	2500 cps sine or square wave
Sync input amplitude	10 volts peak to peak

Video amplitude required 0 to 20 volts (black is + 15 v)

Video input impedance approximately 50,000 ohms

Digital video output
amplitude 0 or 15 volts depending on whether it is
a zero or one.

2.2.2.5 Telephone Line Transmitter

See instruction manual for Data Modem Equipment, type SEBIT 25 built by Rixon Electronics, Inc., of Silver Spring, Maryland. Two units are required.

2.2.2.6 Line Regulator

Sola type 20-27-250

2.2.2.7 Telephone Line Requirements

No. required two video lines (4 wires)

one audio line (2 wires)

Video line bandwidth should be approximately 750 to 2500 cps and phase equalized to within 1.4 milliseconds relative delay referred to 1000 cps.

2.2.3 Receiver

2.2.3.1 Telephone Line Receiver

See instruction manual for Data Modem Equipment, type SEBIT 25 built by Rixon Electronics, Inc., of Silver Spring, Maryland. Two units required.

2.2.3.2 Receiver Digital to Analog Converter

Sync input to clock 2500 cps sine or square wave

Sync input amplitude 10 volts peak to peak

Digital video input amplitude -15 volts (one) to 0 volts (zero)

Analog video output amplitude 0 to -4 volts (black positive)

2.2.3.3 Receiver Write Circuits

The receiver write circuits accept the narrow-band information as generated by the transmitter. The specifications of the scanning parameters are therefore identical with those of the transmitter read circuits.

Input impedance	600 ohms
Input level	-40 to 10 dbm

2.2.3.4 Receiver Read Circuits

The receiver read section provides video and sync signals for the display monitors.

Video

Bandwidth	4 mc
Amplitude	1 volt peak-to-peak black negative
Impedance	75 ohms

Horizontal Drive

Pulse amplitude	4 volts negative going
Pulse width	5 microseconds
Pulse spacing	63.5 microseconds

Vertical Drive

Pulse amplitude	4 volts negative going
Pulse width	800 microseconds
Pulse spacing	16,667 microseconds

Composite Video and Sync

Bandwidth	4 mc
Amplitude	1 volt peak-to-peak black negative

Impedance 75 ohms

The composite signal conforms to EIA standards.

2.2.3.5 TV Sync Generator

Power required 115 volts, 60 cps, single phase, 350 watts

Outputs horizontal drive

vertical drive

mixed blanking

horizontal and serrated vertical sync

(all to EIA Specs).

Dimensions 19 in wide by 15-3/4 in high by 9 in deep

Net weight 51 pounds

2.2.3.6 17-Inch Monitor

See Section 2.2.2.1.3.

2.2.3.7 14-Inch Monitor

Specifications same as 17-inch monitor except for size of CRT.

2.2.3.8 27-Inch Monitor

Specifications same as 17-inch monitor except for size of CRT.

2.2.3.9 Receiver Line Regulator

Sola type 20-27-250

2.3 Equipment Supplied

Narrow-Band Television Communication Equipment subunits as follows:

Transmitter console and chair

Transmitter digital rack
Transmitter briefing monitor
Transmitter line voltage regulator
Receiver console and chair
Receiver digital rack
Receiver audience monitor
Receiver line voltage regulator.

2.4 Operational Tests

2.4.1 General

Viewing Set, Television AN/FXC (XW-1) as described previously is a means of transmitting pictures of graphic material long distances by means of telephone lines. Since, in the final analysis, the equipment must be subjectively judged on the quality of pictures transmitted it seemed fitting to operate the system in all its modes and looking at different types of pictures. During each test operation a picture was taken of the transmitter operator's console monitor and of the receiver operator's console monitor to provide a permanent record in pictorial form. Subsequent reproduction of the Polaroid pictures in report form will degrade the resolution slightly but should not materially harm their usefulness in determining the capabilities of the equipment. In addition to taking of the pictures such things as component failure, circuit failure, drift, pointer stability, etc., were checked out at the same time.

The equipment is designed to transmit digital information at either of two rates: (1) 1667 bits per second or (2) 2500 bits per second over the telephone link. Each bit rate has 5 modes of operation which provide different resolution capabilities. Table I is a tabulation of the different modes.

For operation at 2500 bits per second each bit is 400 microseconds in length, and for the 1667 bits per second transmission rate each bit is 600 microseconds in length. It is readily seen from Table I that regardless of the bit rate of transmission the sweep parameters are set to maintain one of five resolution modes as listed in the column titled Bits Per Line. The lines per frame was chosen to give equal resolution

in the other coordinate. For a full description of theory of operation the reader is referred to the Handbook, Operating Instructions Viewing Set, Television AN/FXC (XW-1).

2.4.2 System Resolution

2.4.2.1 Transmitted EIA Chart

The 17-inch monitor at the operator's console always shows the scene which the ITV camera is looking at. A toggle switch marked VIDEO SELECTOR selects the channel No. 1 or channel No. 2 ITV camera desired. In addition to the operator's console the briefing console also has the ITV scene with a selection switch for channel No. 1 or No. 2 as desired. A typical EIA test pattern is shown in Figure 7 as photographed from the operator's console by means of a Polaroid Land camera attached to a Speed Graphic. As shown, both ITV systems are capable of 600 TV lines horizontal resolution and slightly over 300 lines vertical resolution. Vertical resolution is limited by the number of active scan lines per frame. A slight amount of shading appears in both ITV systems on the left side of the picture. The degree of shading is insignificant as far as the ITV monitor is concerned; however, as the receiver monitors bear out in later pictures, a small amount of shading in the write-in side of the scan-conversion tube can cause considerable shading in the output. This is primarily due to the small dynamic range of video amplitude (2 to 3 volts) on the writing gun.

Also apparent in the ITV picture (Figure 7) is nonlinearity of sweep, especially the beginning of the horizontal line. Considerable time was spent in obtaining the best possible linearity adjustment. However, since the equipment was purchased equipment it was not in the best interests of the project to attempt anything other than circuit adjustment for best operation.

2.4.2.2 Received EIA Chart

Figures 8 through 12 are pictures taken from the 17-inch monitor on the operator's console of the receiver and are at the 1667-bit rate. The camera set up used was exactly the same as used at the transmitter.

Figure 8 indicates clearly the quality of picture at the faster frame rates (4 pictures per minute). The line time was 72 milliseconds and the frame period was 15 seconds. Theoretical maximum resolution of this mode is:

$$\text{Bits per line} = \frac{\text{line period}}{\text{bit width}} = \frac{72 \times 10^{-3}}{6 \times 10^{-6}} = 120 \text{ bits per line.}$$

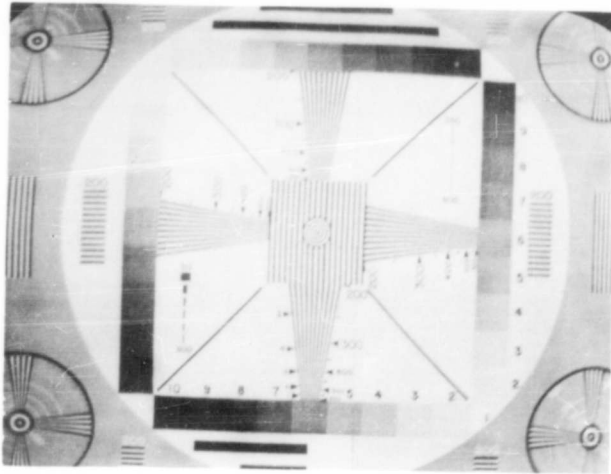

Figure 7 Transmitter Operator's Console

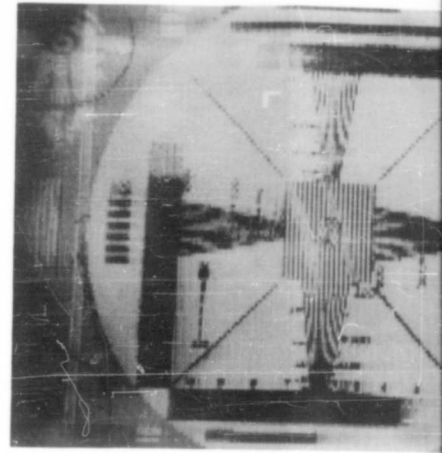

Figure 9 Receiver Operator's

Bit rate	1667 bits/sec
Line	93 milliseconds
Frame	30 seconds

1

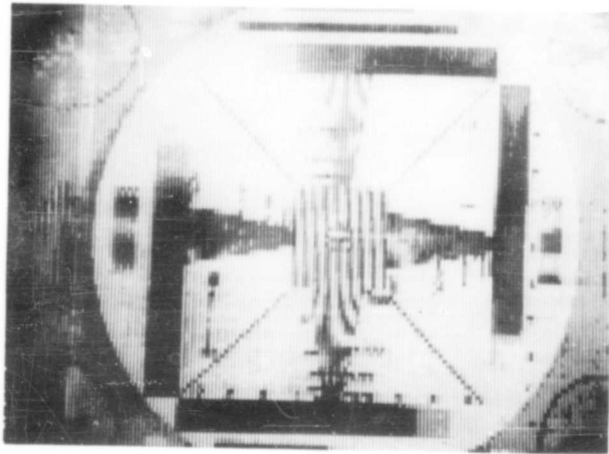

Figure 8 Receiver Operator's Console

Bit rate	1667 bits/second
Line	72 milliseconds
Frame	15 seconds

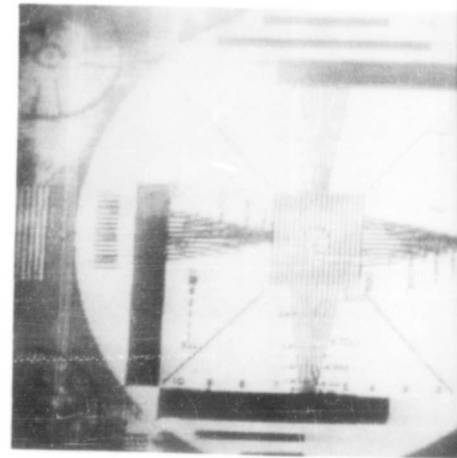

Figure 10 Receiver Operator's Console

Bit rate	1667 bits/second
Line	140 milliseconds
Frame	60 seconds

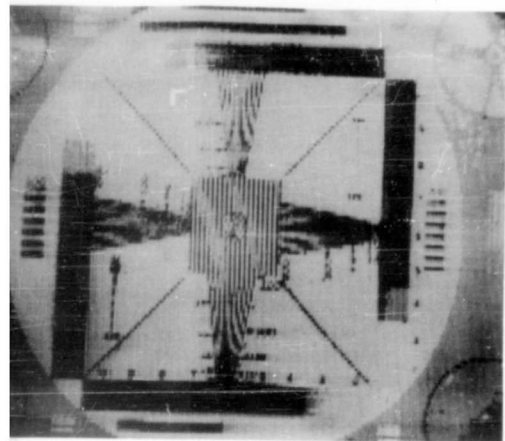

Figure 9 Receiver Operator's Console

Bit rate	1667 bits/second
Line	93 milliseconds
Frame	30 seconds

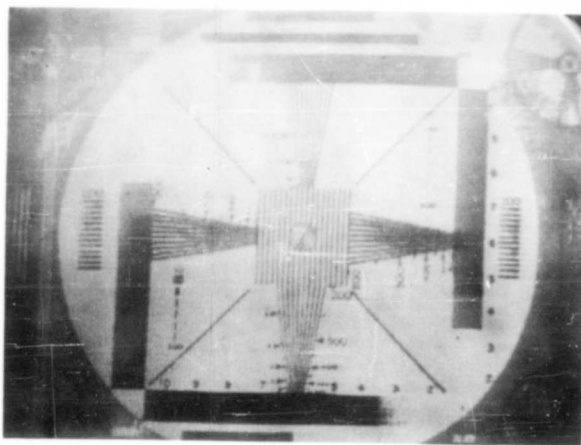

Figure 11 Receiver Operator's Console

Bit rate	1667 bits/second
Line	197 milliseconds
Frame	120 seconds

2

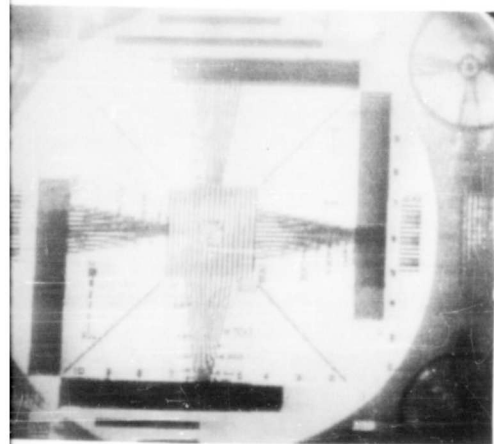

Figure 10 Receiver Operator's Console

Bit rate	1667 bits/second
Line	140 milliseconds
Frame	60 seconds

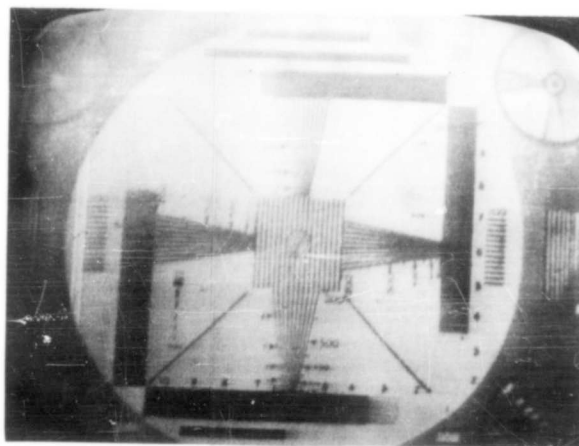

Figure 12 Receiver Operator's Console

Bit rate	1667 bits/second
Line	240 milliseconds
Frame	180 seconds

Twelve bits are utilized for line sync and pointer code, leaving 108 bits for video information. Frame resolution is maintained equal to line resolution in that:

$$\frac{\text{frame period}}{\text{line period}} \times 0.7 = \frac{15}{72 \times 10^{-3}} \times 0.7 = 147 \text{ active lines.}$$

Obviously, such a picture can not contain much detail other than for discernment of broad outlines. For example, Figure 8 is easily recognizable as the EIA chart even though the maximum picture resolution is less than the 200-line resolution portions of the chart.

Shading on the left side of the picture is quite noticeable at the receiver. This is due largely to the small dynamic range of the scan-conversion tubes. Since the bit length (600 microseconds) is significant compared to the line time, the diagonal lines and wedges are of jagged construction.

Figure 9 is the same as Figure 8 except that the line rate has been increased to 96 milliseconds and the frame time extended to 30 seconds. Even though the maximum theoretical resolution is:

$$\frac{96 \times 10^{-3}}{600 \times 10^{-3}} = 160 \text{ bits per line}$$

the system actually reproduces 200 TV lines in the horizontal direction. Beat notes which appear in the picture are due to the digitizing equipment having a bit size greater than the size element it is trying to reproduce.

Resolution beyond 250 TV lines appears in Figure 10 as a result of increasing the line time to 140 milliseconds and the frame time to 60 seconds. Table I shows a theoretical limit of 232 bits per line.

The final two modes Figures 11 and 12, show the maximum resolution capability of the system. Figure 12 has the longest frame time (3 minutes per picture) and has a theoretical resolution of 400 bits per line. Extinction resolution indicated in the photograph appears approximately at 350 lines (horizontal). Past experience in using the TMA-403X has indicated a maximum resolution of about 350 TV lines for long frame periods (approximately 3 minutes). Therefore, going to longer frame times would probably not improve the resolution characteristics of the system. A close scrutiny of Figures 11 and 12 fails to show any great difference in system resolution which tends to bear out the preceding statement.

One of the most severe of the operational problems encountered was the shading appearing in the pictures. As stated previously, the major reason for the shading occurs in the characteristics of the scan-conversion tubes. Reduction of scan in both directions (vertical and horizontal) to 0.8 its original value will cause the scanned area to be entirely within the target area. Such a reduction will substantially reduce the shading effects around the outer edges of the picture. Resolution, however, will be impaired slightly. As the system presently stands the target is over-scanned to give the greatest resolution capability, but if at some future date it is found that the maximum resolution is not required, then a reduction of scan to just cover the target area would be desirable. Actually, the 17-inch monitor as observed by the operator will have more usable information than the Polaroid pictures indicate since the operator will be observing the monitor at all times during scanning, and shading immediately after scanning is not as pronounced.

Figures 13 through 17 are the five modes of operation as listed in Table I under the 2500-bit rate. The only difference between the 2500-bit rate and the 1667-bit rate is that the rate of transmission or pictures per minute increases with the 2500-bit rate. The line and frame times have been set to maintain the same resolution for each mode as the 1667-bit rate. Since the digital equipment is capable of transmitting 2500 bits per second it is logical that the 2500-bit rate be used in actual operation since the rate of transmission is speeded up with no degradation in picture quality. For this reason the system was set up for the 2500-bit rate and left for the rest of the series of tests.

2.4.3 System Gray Scale Rendition

The system specification called for four shades of gray: black, dark gray, light gray, and white. A chart made up of 1-inch strips and of such a color to give equal steps in the wide band video chain was constructed for the system test. Figure 18 is a photograph of the transmitter operator's console monitor showing the four shades as seen by the ITV chain. Figures 19, 20, and 21 are three modes of the received picture as seen by the receiver operator's console monitor. Figure 19 has the jagged line construction due to the mode of operation being the one of least resolution. In other words, the bit size is large in comparison to the size element being digitized. Figures 20 and 21 show that the line structure becomes more detailed as the line and frame times are increased.

Four shades of gray are clearly defined in the pictures. It should be noted here that in order for the system to properly reproduce four shades of gray, care must be exercised by the operator in adjusting the scan-conversion tube controls

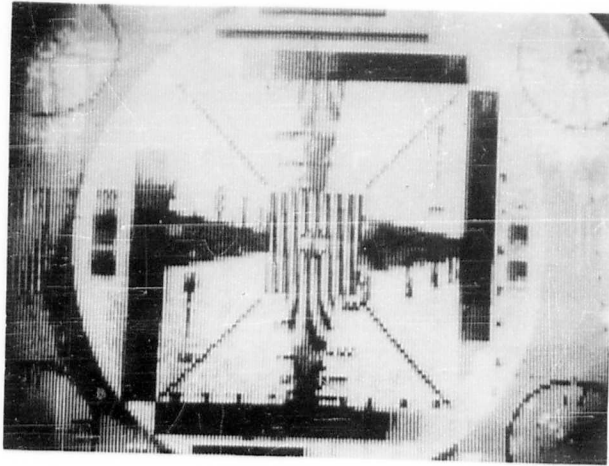

Figure 13 Receiver Operator's Console

Bit rate	2500 bits/second
Line	48 milliseconds
Frame	10 seconds

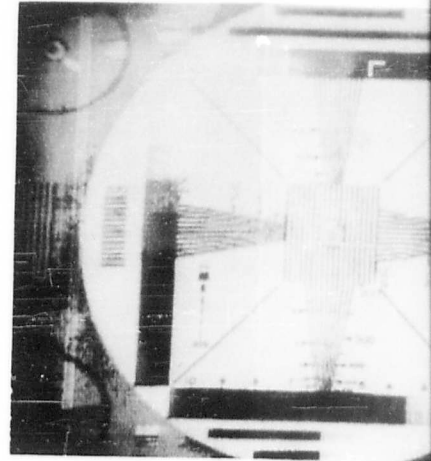

Figure 15 Receiver Operator's Console

Bit rate	2500 bits/second
Line	93 milliseconds
Frame	40 seconds

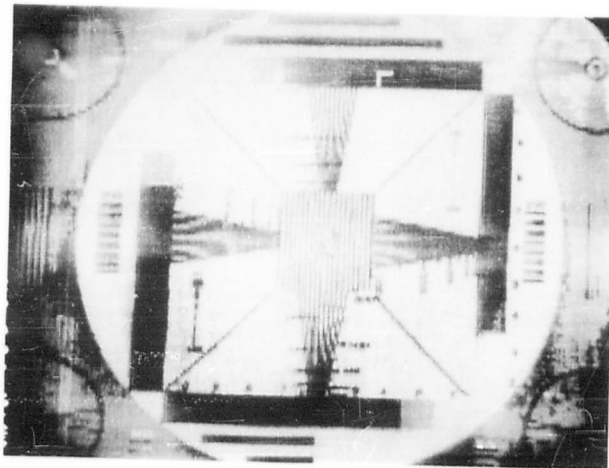

Figure 14 Receiver Operator's Console

Bit rate	2500 bits/second
Line	64 milliseconds
Frame	20 seconds

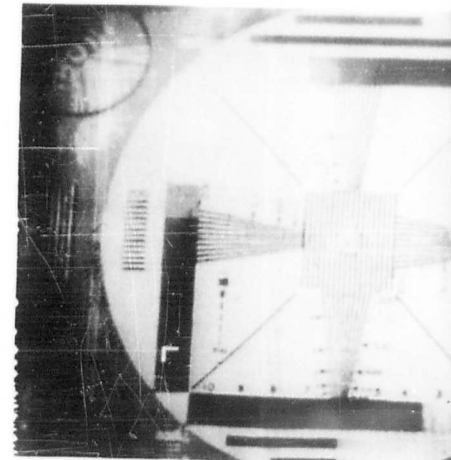

Figure 16 Receiver Operator's Console

Bit rate	2500 bits/second
Line	131 milliseconds
Frame	80 seconds

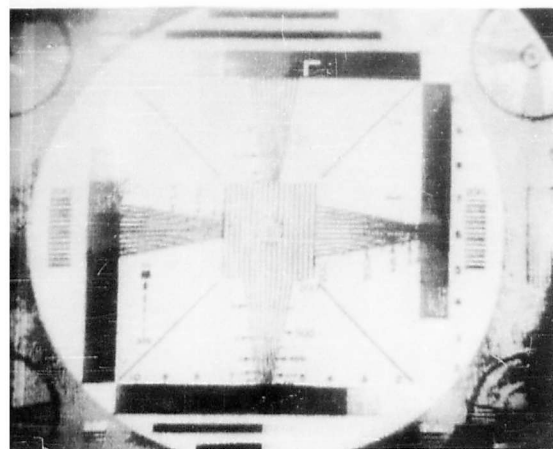

Figure 15 Receiver Operator's Console

Bit rate	2500 bits/second
Line	93 milliseconds
Frame	40 seconds

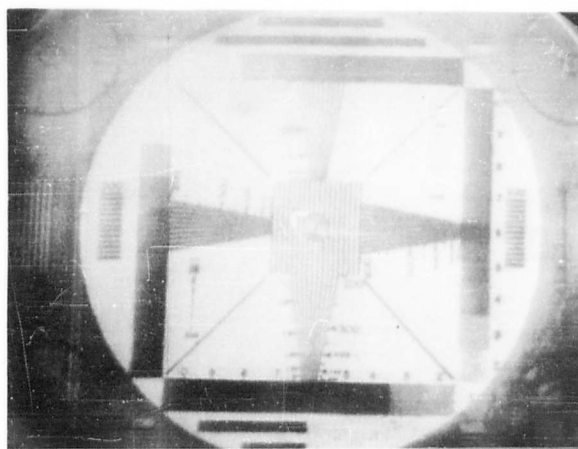

Figure 17 Receiver Operator's Console

Bit rate	2500 bits/second
Line	160 milliseconds
Frame	120 seconds

2

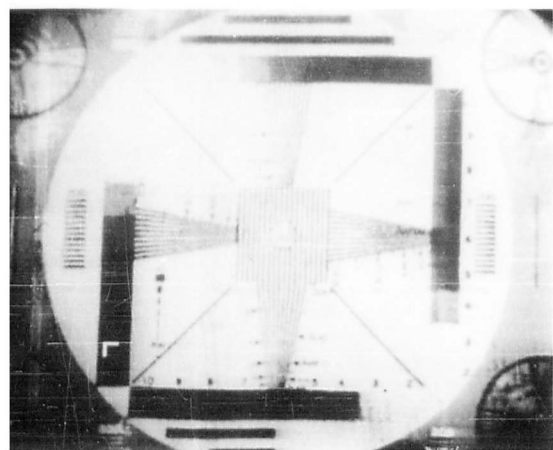
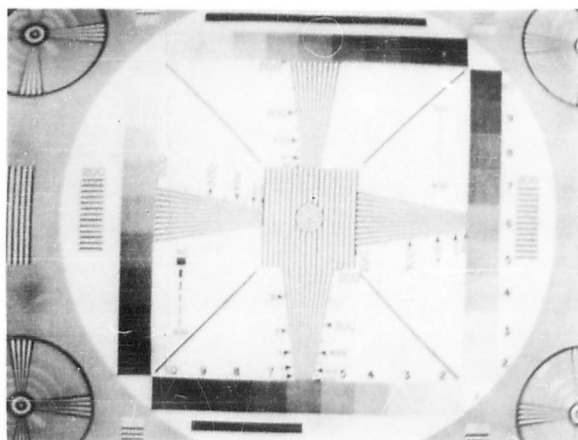

Figure 16 Receiver Operator's Console

Bit rate	2500 bits/second
Line	131 milliseconds
Frame	80 seconds



Transmitter Operator's Console

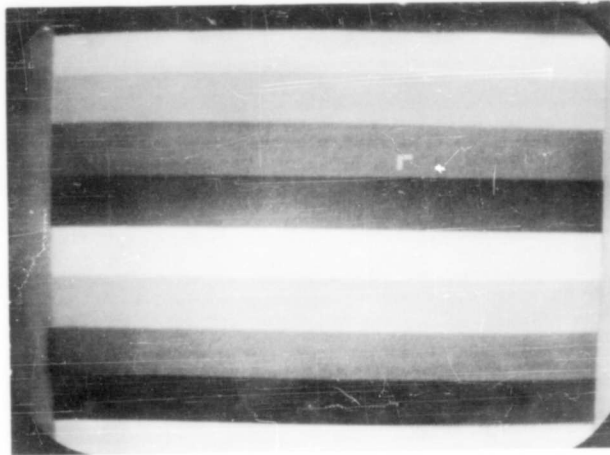

Figure 18 Transmitter Operator's Console

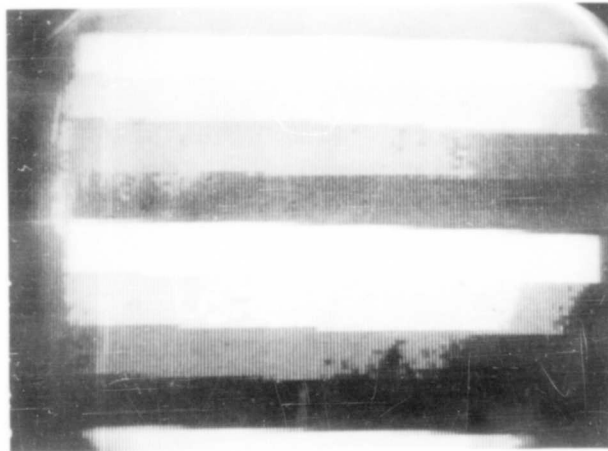
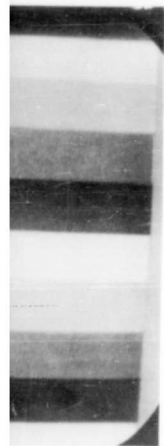

Figure 19 Receiver Operator's Console

Bit rate	2500 bits/second
Line	48 milliseconds
Frame	10 seconds



's Console

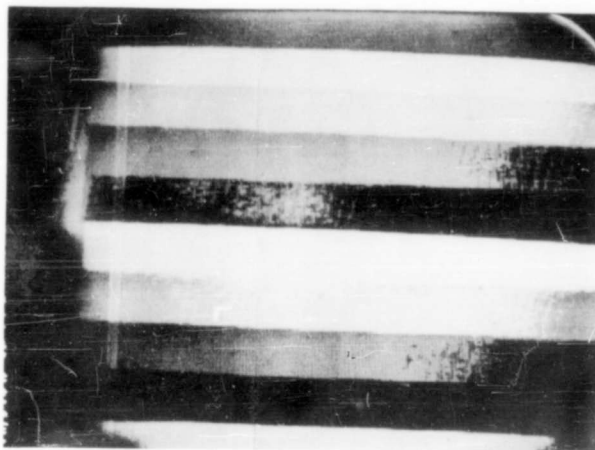
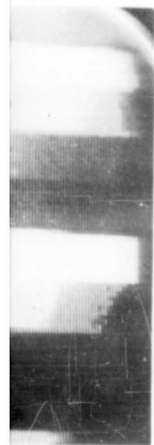

Figure 20 Receiver Operator's Console

Bit rate	2500 bits/second
Line	93 milliseconds
Frame	40 seconds



Console

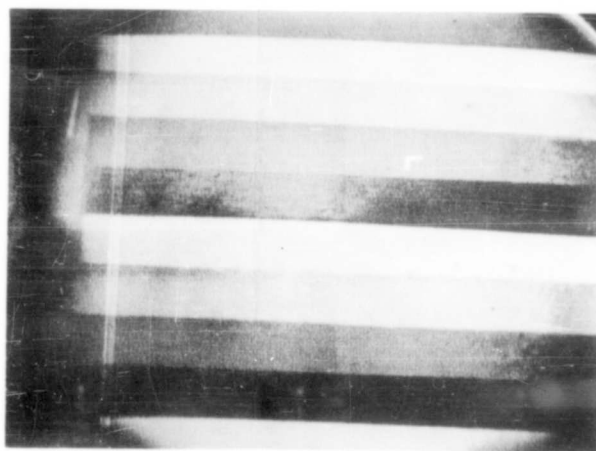

Figure 21 Receiver Operator's Console

Bit rate	2500 bits/second
Line	160 milliseconds
Frame	120 seconds

ond
ds

for the correct video amplitude. The video amplitude must vary from zero volts (ground) to 20 volts with a pedestal clamped to + 30 volts for the digital equipment to give four shades (black, dark gray, light gray, and white). For further description of the digital equipment the reader is referred to the Handbook, Operating Instructions Viewing Set Television AN/FXC (XW-1), Serial No. 2071, Section 6.3.4, Analog-to-Digital Converter, Video.

Figure 21 shows a light area just to the left of the pointer arrow. A careful comparison of Figure 21 with Figure 18 the transmitted picture will show that shading due to light reflections on the scene is present in the transmitted picture. Due to the digitizing to discrete levels the shading at the receiver is more pronounced. The point of the matter is that the illumination of the scene being televised by the ITV camera must be uniform. Bright spots or reflections will cause severe shading at the receiver and are hard to erase from the scan-conversion target once they are written in.

2.4.4 Photographic Rendition

The AN/FXC (XW-1) was not designed for the transmission of highly detailed photographic work such as pictures of people; however, it is interesting to observe the obtainable results. Figure 22 shows the transmitter monitor picture as televised by the ITV chain. Figure 23 is the received picture after being digitized, transmitted, received, converted back to analog information and finally televised on the receiver monitor. Four shades of gray are clearly distinguishable in the received picture. Positive identification of such a picture at the receiving ends depends upon the type of picture being transmitted. Four shades of gray appears to be sufficient for the transmission of peoples faces.

Here again, uniform lighting is necessary if the possible four shades are to be reproduced accurately in order to achieve the full capabilities of the system.

2.4.5 Map Rendition

2.4.5.1 White Background with Black Lines

A 14-inch by 22-inch simulated weather map having a white background was televised. Figure 24 shows the transmitter monitor as televised by the ITV camera and Figure 25 shows the received picture as shown on the operator's console monitor.

Except for the shading around the edges, the receiver monitor is entirely readable even to the dotted lines. The rate of transmission was 2500 bits per second with a line time of 160 milliseconds and a frame time of 120 seconds (2 minutes).



Figure 22 Transmitter Operator's Console



Figure 23 Receiver Operator's Console

Bit rate	2500 bits/second
Line	160 milliseconds
Frame	120 seconds

2.4.5.2 Black Background with White Lines

This test consisted of televising the same size weather map as above except that the background color was changed to black. Figure 26 is the televised map and Figure 27 is the received map. Comparison of Figure 27 (black background) with Figure 25 (white background) shows that the white background produces a more readable picture. The reasons for this are not obvious since first impressions would indicate that it would be easier to write white letters on a black background; however, this does not appear to be the case. For one reason, the charge dispersion on the scan-conversion tube target surface may be greater in the case of a black background. Another reason may be due to spattering of the electron beam when it strikes the outer target retaining ring. The light band around the edge of Figure 27 is an indication that electron spattering is occurring to some extent. Finally, better results might be obtained by making sure that the writing beam is cut off completely in the absence of video and then increase the video amplitude on write in.

2.4.6 Letter and Chart Size Requirement

Certain requirements must be imposed on the chart size and/or letter size to insure reliable transmission and 100 percent readability at the receiver. Table II indicates the minimum detectable letter width which the AN/FXC (XW-1) system can detect and transmit. The chart is based on using a 1-inch Wollensak f/1.5 Cine Raptar lens.

For the 120-second mode we desire to resolve 400 elements minus that lost in retrace or 388 elements in the horizontal direction on the face of the vidicon (0.5-inch useful length). The line width on the face of the vidicon will thus be:

$$\frac{0.5}{388} = 1.29 \times 10^{-3} \text{ inch}$$

To resolve a line width of 1.29×10^{-3} inch the subject line width must be:

$$\frac{1.29 \times 10^{-3}}{1 \text{ in}} = \frac{X = \text{subject line width in inches}}{D = \text{subject distance in inches}}$$

$$X = 1.29 \times 10^{-3} \times D$$

for 36-inch distance $X = 1.29 \times 10^{-3} \times 36 = 46.4 \times 10^{-3} \text{ inch}$

$$X \cong 0.05 \text{ inch}$$



Figure 24 Transmitter Operator's Console
White background with black letters

1



Figure 25 Receiver Operator's Console
White background with black letters

Bit rate	2500 bits/second
Line	160 milliseconds
Frame	120 seconds

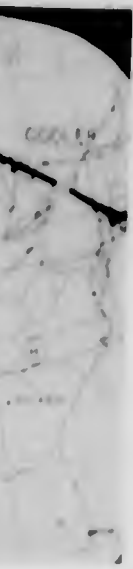

console
s



le

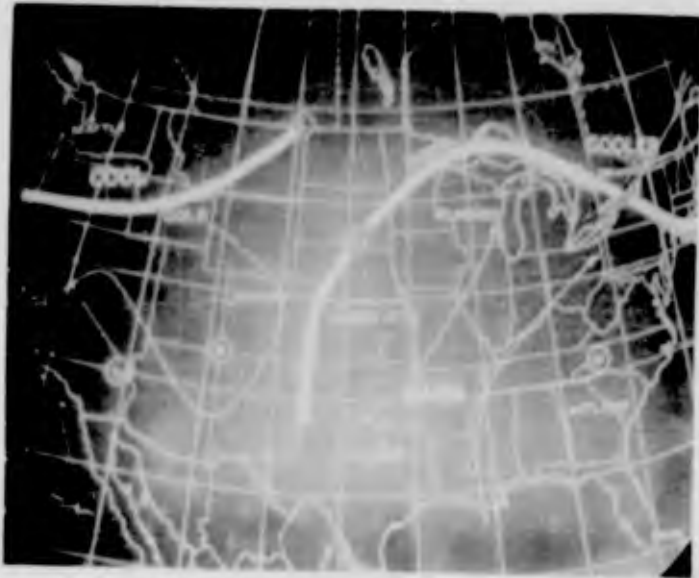

Figure 26 Transmitter Operator's Console
Black background with white letters

2



Figure 27 Receiver Operator's Console
Black background with white letters

Bit rate	2500 bits/second
Line	160 milliseconds
Frame	120 seconds

Table II

Distance (feet)	f/1.5 Wollensak Cine Raptar Lens Chart Size (inches)	Transmission Mode Letter width in inches			
		10 sec	20 sec	40 sec	80 sec
3	14 x 11.1	0.2	0.12	0.08	0.06
6	29 x 21	0.4	0.25	0.16	0.12
9	44 x 33	0.6	0.37	0.25	0.18
12	61 x 46	0.8	0.5	0.33	0.24

For a subject-to-lens distance of 72 inches the line width will have to be:

$$X = 1.29 \times 10^{-3} \times 72 \cong 0.1 \text{ inch}$$

The preceding calculation demonstrates the method of determining values for Table II.

The column showing chart size in Table II is based on the field of view for the 1-inch lens. Sizes shown have a 4 x 3 aspect ratio to correspond with the TV raster.

2.4.7 Telephone Line Requirements

2.4.7.1 Introduction

It is well known that the human ear can tolerate rather large amounts of distortion before spoken information becomes unintelligible. Since amplitude distortion is far more objectional to the ear than is phase or time delay distortion it has been common practice to control only the amplitude characteristics of telephone lines. Thus a typical voice communication circuit might have quite flat amplitude response but have a time delay characteristic that would vary widely over the voice frequency spectrum.

Studies have been made on selected long distance wire line circuits in an attempt to determine the amplitude and time delay characteristics of a typical line; however, there has been no general agreement on these characteristics. In spite of this it is possible to make certain general statements regarding the time delay characteristics of telephone lines. Time delay distortion is usually introduced by lumped constant networks such as filters or loading coils and is a function of the variation of attenuation versus frequency in the network. Thus it can be expected that the delay distortion will be most severe at the edges of the band where intentional attenuation is introduced.

Figure 28 gives the measured delay characteristics of a telephone line illustrating the concept of increased delay at the ends of the band and giving approximate magnitudes of delay to be expected.

The presence of delay distortion has been emphasized because the envelope of an AM signal is distorted when it is transmitted over a line having nonuniform delay versus frequency characteristics. Since, in this equipment, the envelope of the signal is detected and sampled to retrieve the digital intelligence, the distortion in the envelope can cause errors in the resultant digital signal.

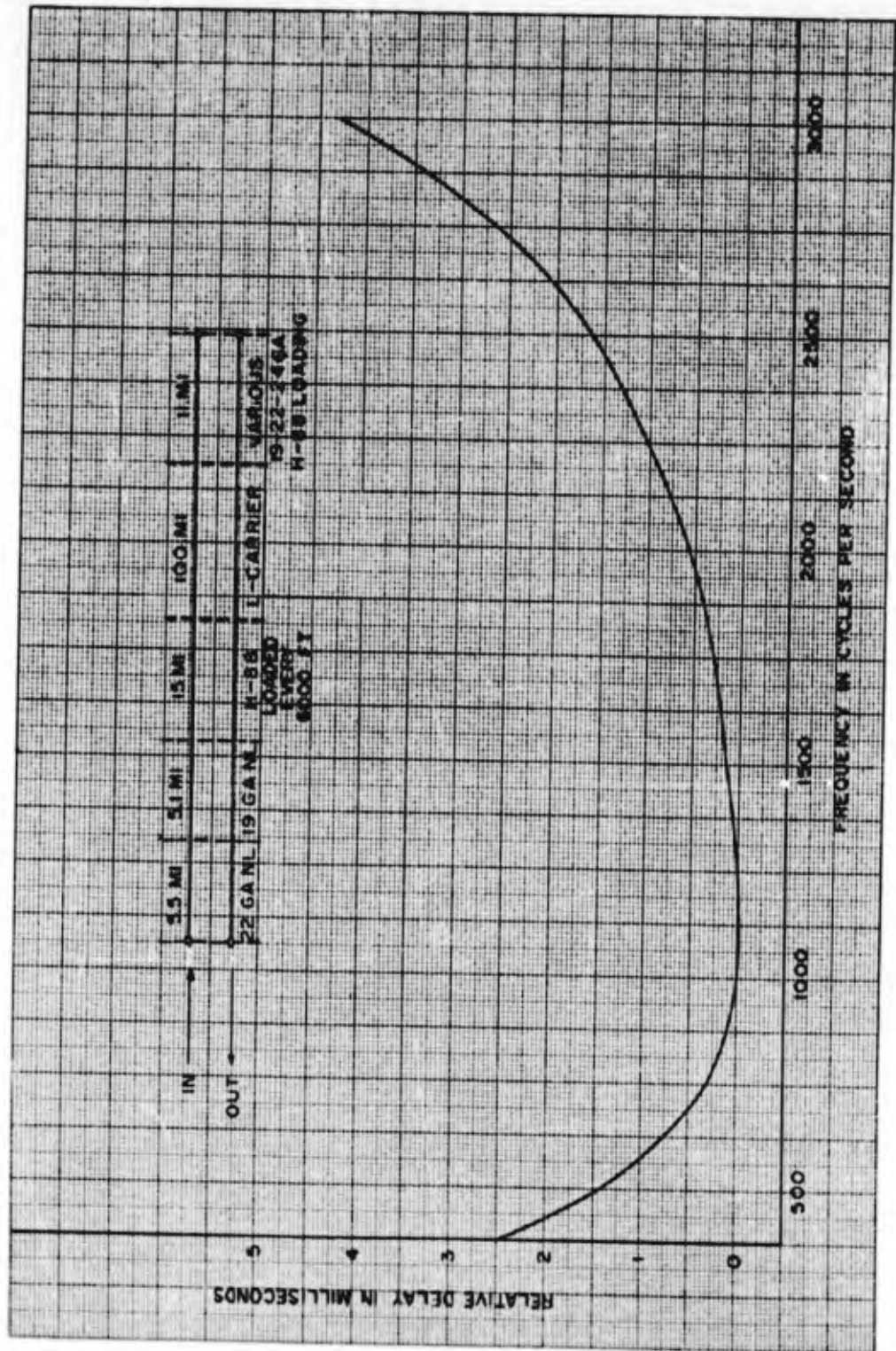

Figure 28 Makeup and Delay Characteristics of a 270-Mile Wire Line

It should be noted that the delay in Figure 28 is plotted in terms of relative delay with respect to 1000 cps. Since the AN/FXC (XW-1) transmits parallel in-phase signals over two telephone lines, the concept of absolute delay also becomes important. This is true since different telephone lines might have the same relative delay versus frequency characteristic and yet have different amounts of absolute delay.

From this it can be seen that compensation for relative delay must be made before detecting an AM signal and that compensation for absolute delay must be after detection so that the two parallel signals will again be in phase and have the proper time relationship.

The following two sections describe the two methods of delay compensation used in this equipment.

2.4.7.2 SEBIT 25 Digital Transmission Equipment

The AN/FXC (XW-1) uses four SEBIT 25's for transmitting digital information over conventional telephone lines. Two SEBIT's are used at the transmitter where they accept the two-channel digital information and modulate this onto a carrier for transmission over two telephone lines. The two SEBIT 25's used at the receiver accept the modulated signal from the line, compensate for amplitude and delay distortion and recover the digital information. As previously indicated, the resultant digital signal may not have the proper phase relationship due to possible differences in absolute delay in the two lines used. This requires delay equalization external to the SEBIT 25's and is discussed in the following section.

Since it is desirable to transmit the maximum amount of information, vestigial sideband transmission has been used in the SEBIT 25's. This places the 2500 cps carrier near the upper limit of the transmission band and limits the major portion of the spectrum of the sideband to frequencies between 1250 and 2500 cps. In this manner the delay in the transmission circuit at frequencies below 1 kc is not important and thus needs no compensation.

With the preceding as background it can be seen that the equalization adjustments provided in the SEBIT 25's which are shown graphically in Figure 29 will provide equalization for most telephone lines. There are two equalization controls in the SEBIT 25's. The FREQUENCY control determines the frequency between 1 and 2 kc at which there will be maximum delay introduced. There are five positions of this control corresponding to frequencies of approximately 1, 1.3, 1.6, 1.8, and 2 kc. The 10-position DELAY control determines the maximum delay that occurs at the frequency selected by the FREQUENCY control. The 10 positions

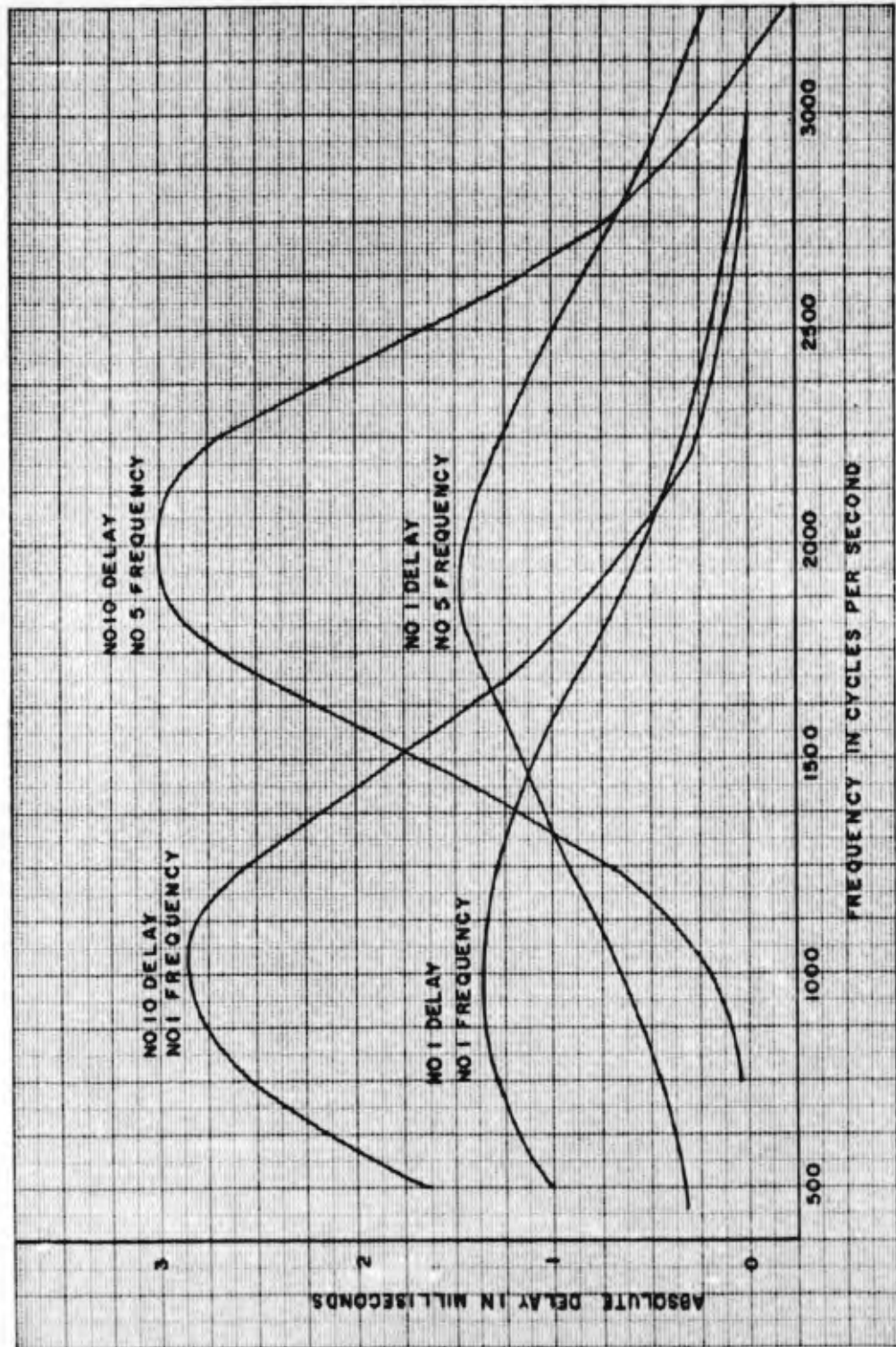

Figure 29 Delay Equalization Available in SEBIT 25

give delays ranging from 1.4 to 3 ms in approximately equal steps. Figure 29 shows four combinations of the possible 50 equalization settings and illustrates the range the controls will cover.

To allow system evaluation when operating over circuits with nonuniform delay characteristics, two line simulators were built which were also used to check the effectiveness of the SEBIT 25 equalization circuits. Figure 30 gives the delay characteristics, provided by the simulators.

Testing of the SEBIT 25's with the simulators indicated that delays greater than 2.4 ms gave an unacceptable error rate in the digital output signal when operating at 2500 bits per second. Although the error rate of approximately 1 in 10^4 is quite low, this is unsatisfactory not because of deterioration of the picture but because a digital sync code is transmitted during blanking intervals. If one bit is missed in either the line or frame sync code, the slow-scan sweeps will be interrupted causing the scan-conversion tubes to be turned off. For this reason the error rate in the SEBIT 25's must be extremely low.

Initial testing of the AN/FXC (XW-1) was done on a back-to-back basis with approximately 50 feet of twisted pair for each line. To allow system evaluation in the laboratory under conditions similar to those encountered when operating over telephone lines, the delays shown in Figure 31 were placed in series with the twisted pair lines used in the back-to-back tests.

It was found that the delay placed in line A did not require compensation in the SEBIT 25, thus giving an over-all delay characteristic for line A and the SEBIT 25 as shown in Figure 32 on the channel A plot. The channel B SEBIT 25 required compensation giving the over-all characteristic for channel B shown in Figure 32. With these characteristics both SEBIT 25's performed satisfactorily, giving the required low error rate.

Since only digital information is transmitted over the lines the quality of the telephone lines has no effect on the quality of the picture at the receiver until the line distortion becomes great enough to prevent reliable reproduction of the transmitted information. When this happens the sync code is lost and thus the entire picture is lost. Because of this there will be no deterioration in the received picture when operating over telephone lines with various delay characteristics. This is illustrated in Figures 17 and 33 which show the same picture transmitted first back-to-back and then over lines with the delay characteristics shown in Figure 31.

From the preceding it can be seen that the delay equalization provided in the SEBIT 25's will compensate for most lines encountered and that the SEBIT 25's give the required error rate when this compensation is used.

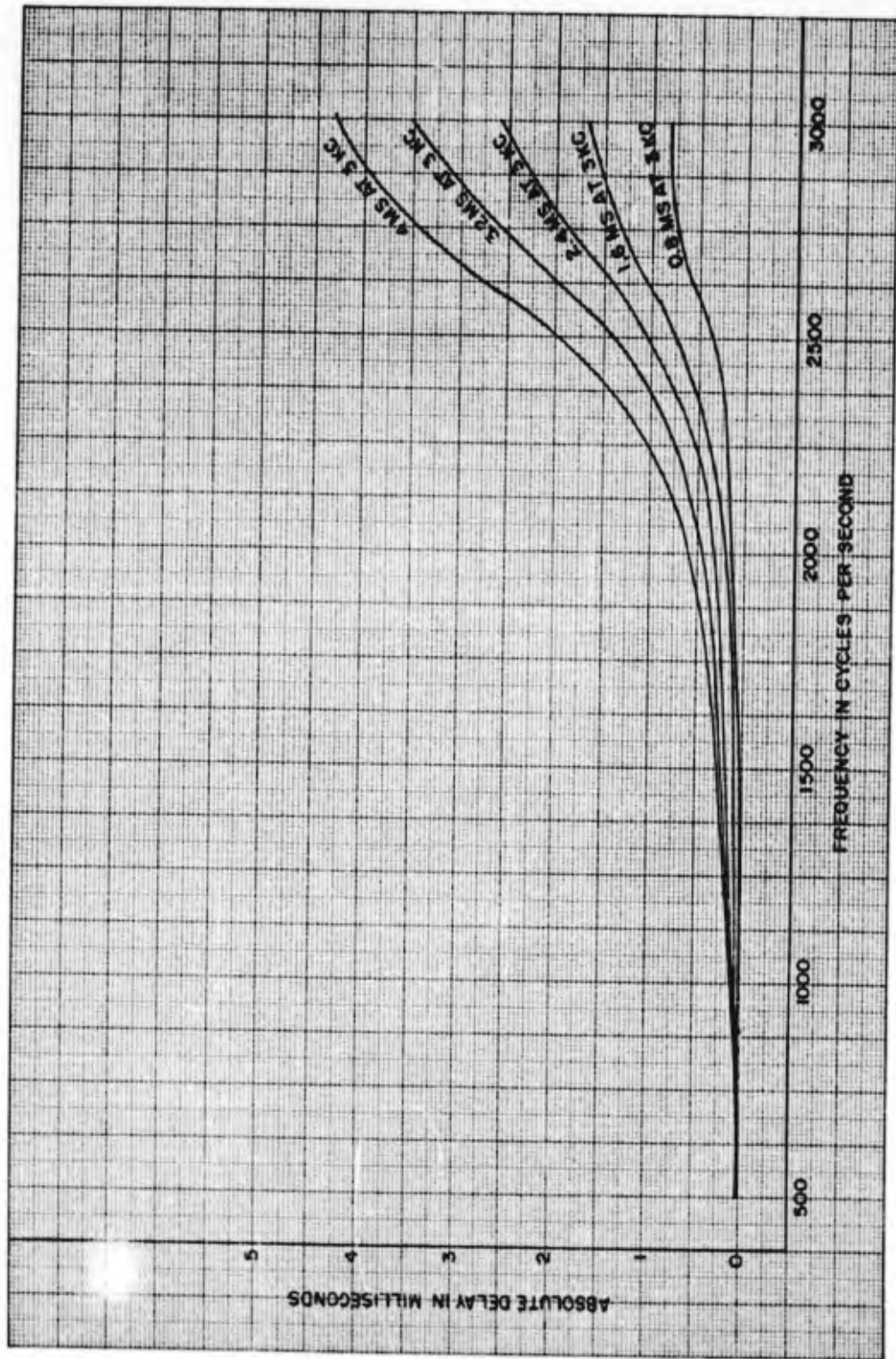

Figure 30 Delay Characteristics Available with Line Simulators

K-E 10 X 10 TO THE CM. 359-14
REUFFEL & FISHER CO. NEW YORK, N.Y.

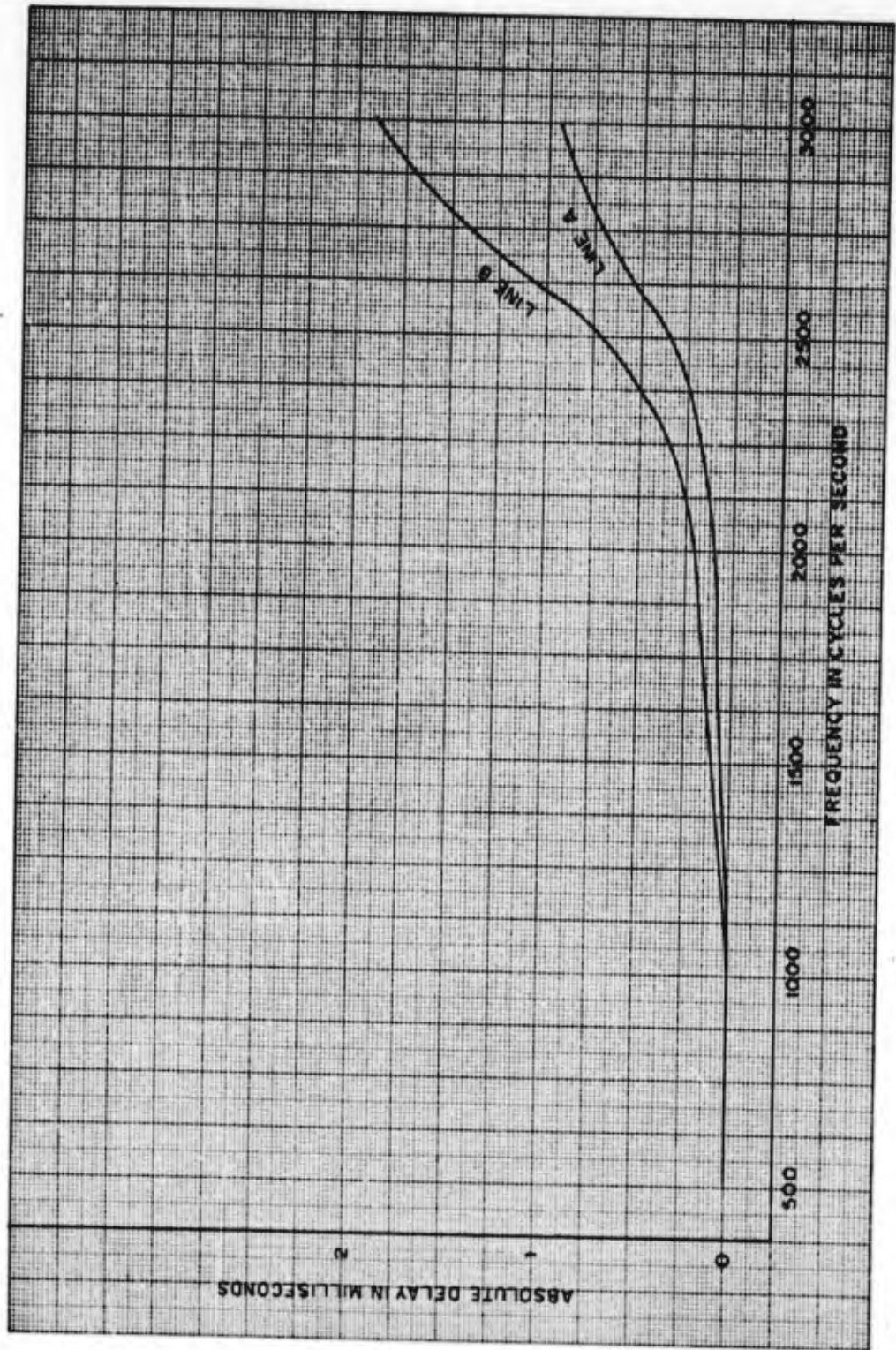

Figure 31 Delay Used in Channel A and Channel B Telephone Lines for Picture in Figure 33

K&E 10 X 10 TO THE CM 359.14
KUPPEL & FISHER CO. MADE IN U.S.A.

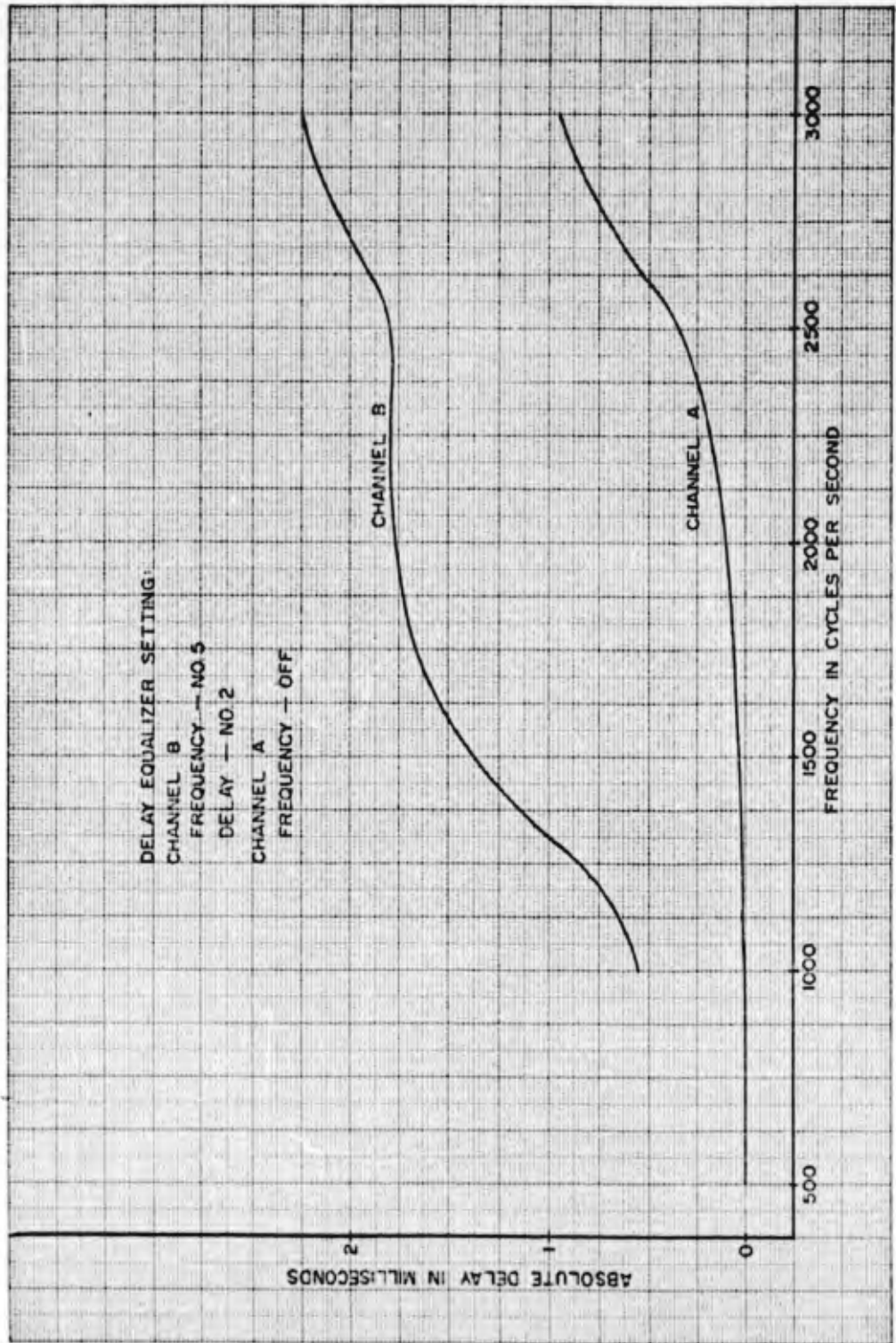

Figure 32 Over-all Delay Characteristics for Telephone Line and SEBIT 25 Delay Equalizer

The remaining equalization required is compensation for the time differential between the two digital signals from the SEBIT 25's due to possible difference in absolute time delay of the two telephone lines. This is the subject of the following section.

2.4.7.3 Absolute Time Delay Equalization

It was shown previously that it is possible for one of the received digital signals to be delayed with respect to the other signal due to a difference in absolute time delay in the two telephone lines. Since the two digital signals are sampled simultaneously in the digital rack it is necessary that these be in phase within less than one bit interval. If there is more delay than this between the two signals it is necessary that the signal arriving earliest be delayed so that it is in phase with the later signal. Because the signal to be delayed is digital the means for obtaining the variable delay is simple and consists of a 5-bit buffer with a selector switch allowing a choice of 0, 3/4, 1-1/2, 2-1/4, 2-3/4, 3-1/2, or 4-1/4 bits delay by selecting the output of the proper buffer. Normal operation of the equipment will be at 2500 bits per second making the length of one bit interval 400 microseconds and giving maximum absolute time delay equalization of 1.7 ms.

With the equipment set up using the delays given in Figure 31 to take the picture of Figure 33, the delay equalizer was set to delay channel A by 2-3/4 bits. With this compensation the system operated properly and the resultant picture was not deteriorated in any manner.

2.4.8 500 Mile Telephone Link

Operational tests were performed for a period of several months over a 500 mile telephone link. Figure 34 shows a pictorial diagram of the facilities provided by the New York telephone company. It will be noticed that a wire (twisted pair) link was provided between Griffiss Air Force Base, Rome New York and Utica, New York. From Utica to Syracuse, to Buffalo transmission was by microwave link. The return path from Buffalo to Syracuse, to Utica was via microwave and from Utica to the Air Base by wire. Two of these complete 500 mile links were provided since the AN/FXC (XW-1) requires two phone lines (4 wires) for operation (see Section 2.1).

Measured amplitude and phase characteristics of one of the 500 mile lines is shown in Figures 35 and 36. The amplitude response (Figure 35) indicates a normal telephone line response lying between 300 and 3000 cycles. Beyond these frequency points the attenuation increases very rapidly. Since the major frequency

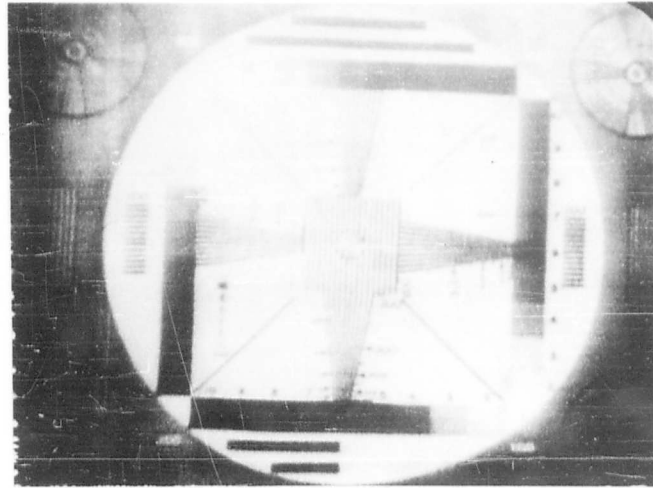

Figure 33 Receiver Operator's Console

Bit rate	2500 bits/second
Line	160 milliseconds
Frame	120 seconds
A line delay	0.8 milliseconds
B line delay	1.6 milliseconds

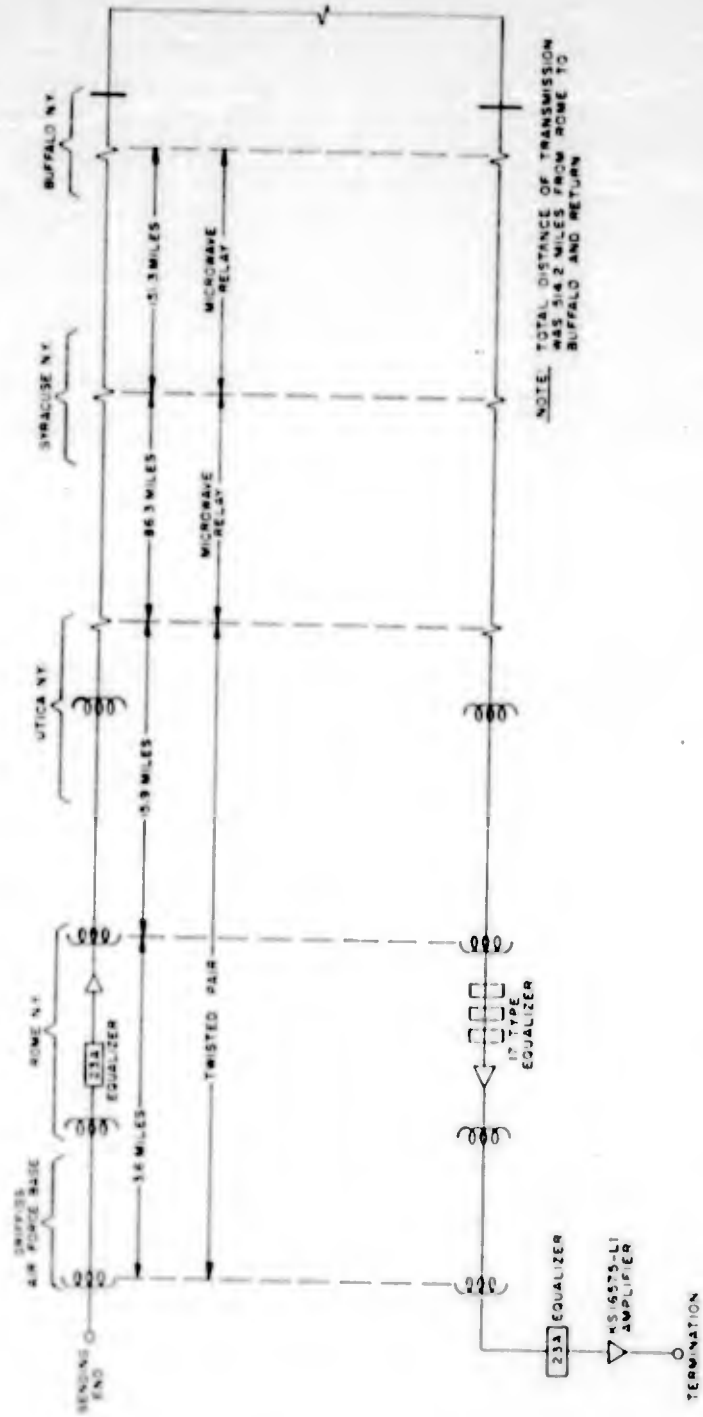

Figure 34 500-Mile Test Transmission Line

KT-5 SEMILOGARITHMIC 359-63
KUPPEL & BERRY CO. MADE IN U.S.A.
2 CYCLES OF 100 PERCENT DUTY

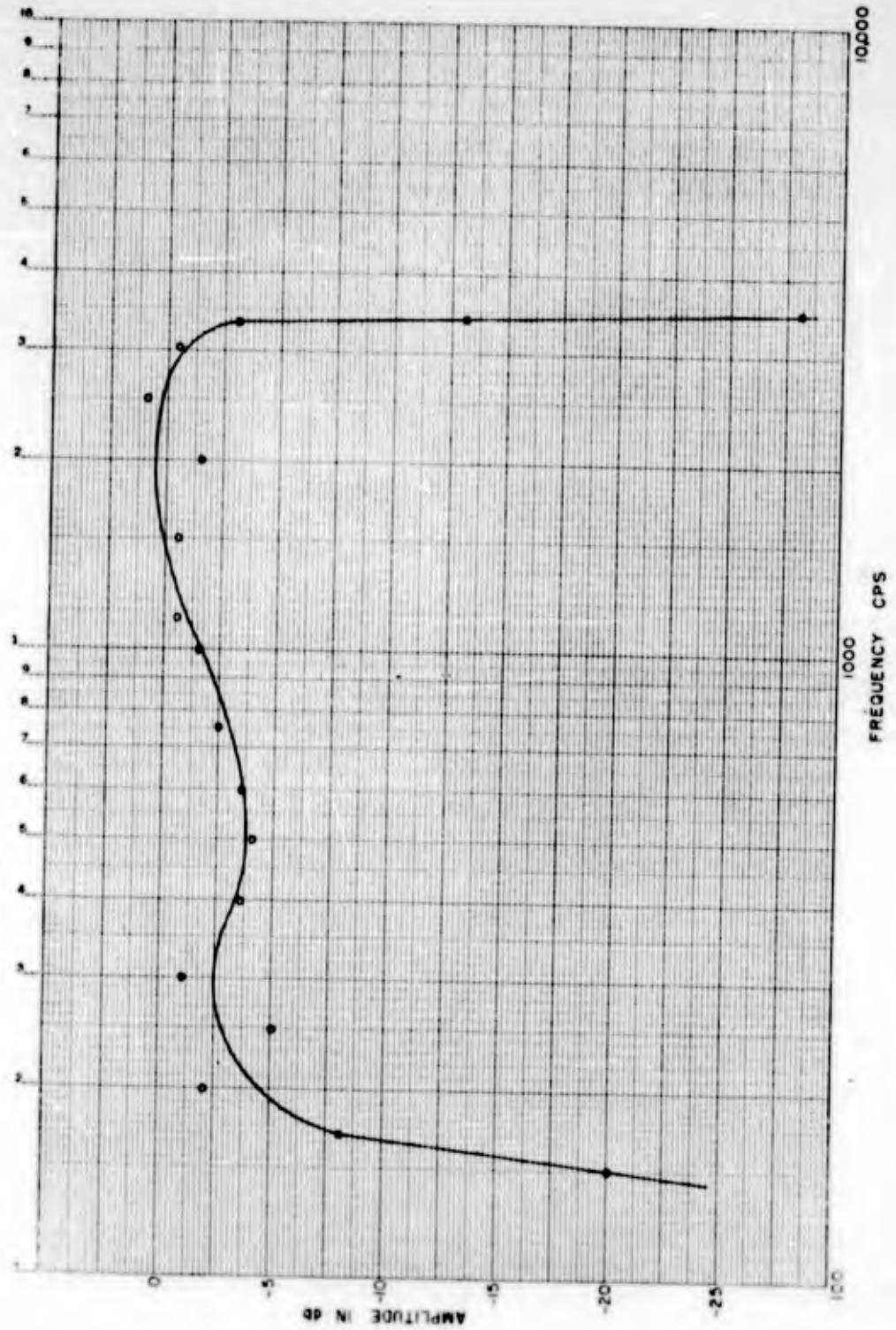

Figure 35 Amplitude Characteristic of 500-Mile Telephone Line

100 SIMULGAMATIC 359-63
LITTLE ROCK, ARKANSAS 72114
A Division of ITT

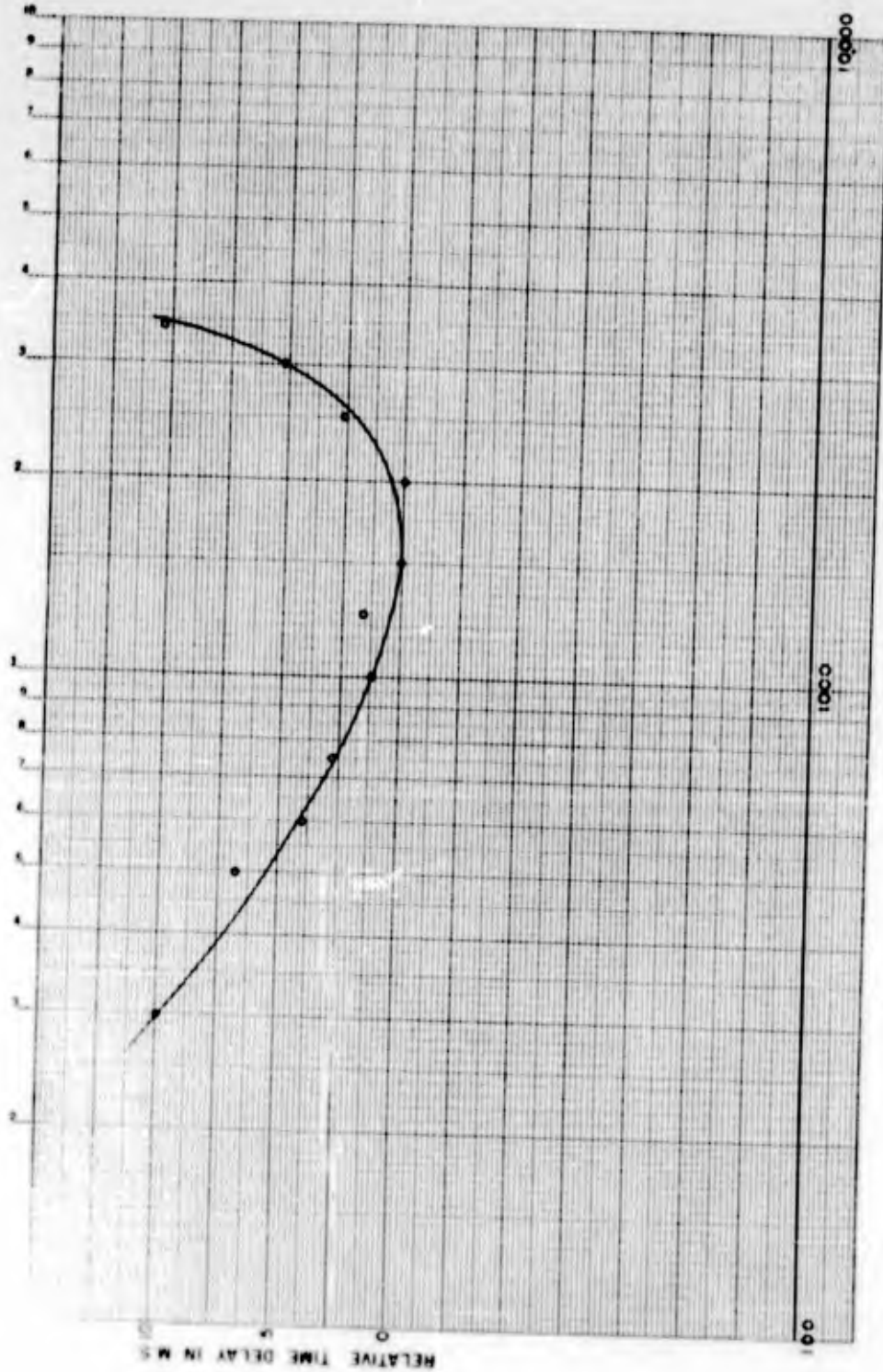

Figure 36 Relative Time Delay Characteristic of 500-Mile Telephone Line

components in the output signal from the SEBIT 25 transmitter lie between 1000 and 3000 cycles the amplitude response of the 500 mile telephone line is adequate.

Phase response of telephone lines is normally no problem where voice communications is concerned. Picture transmission however presents an entirely different problem. Phase shift which varies with frequency causes the different frequency components to be misplaced along the time axis thus producing distortion in the received picture. This type of distortion shows up as ghosts and if severe enough the whole picture content is lost. Figure 36 shows the relative time delay versus frequency as measured on the 500 mile link. Time delay by definition is:

$$TD = \frac{d\beta}{d\omega} \quad (1)$$

where

$$\beta = \text{radians}$$

$$\omega = \text{radians/sec}$$

For ease of measurement the time delay (TD) was converted to degrees (θ) and frequency (f) as shown below.

$$\begin{aligned} TD &= \frac{d\beta}{d\omega} = \frac{\text{radians}}{\text{radians/sec}} = \frac{\frac{\pi}{180} \theta}{2\pi f} \\ &= \frac{\theta}{180} \times \frac{1}{2f} = \frac{\theta}{360 f} \end{aligned} \quad (2)$$

therefore

$$TD = \frac{\Delta\theta}{360 \Delta f} = \text{seconds} \quad (3)$$

Equation 3 was used to measure and calculate the time delay in seconds for various frequencies throughout the passband. This was done by measuring with a phase meter the incremental phase shift for a very small band of frequencies centered about the frequency in question. Actually if the phase shift in degrees versus frequency is known the time delay can be determined by measuring the slope of the curve at various points along the frequency axis. This relationship holds since time delay is defined as $d\beta/d\omega$.

Time delay is not the important factor. The important factor is whether the time delay is constant for all frequencies in the pass band. In other words the relative time delay as referenced to the center frequency ideally should be a constant. This means that all frequency components are delayed by the same amount and thus arrive at the receiver in the same relationship as they were transmitted. Figure 36 is a plot of the relative time delay characteristic of the 500 mile link.

Fortunately the SEBIT 25 transmitter-receiver has means of correcting the phase characteristic of the transmission link over a certain range. Once phase corrections were made operation of the SEBIT 25 was reliable from day to day and month to month as far as phase is concerned. A comprehensive discussion of how phase equalization is accomplished in the SEBIT 25 can be found in Section 2.4.7 of this report.

One final word about phase. Since two telephone lines are required for operation of the AN/FXC (XW-1) the absolute delay between the two lines is important. This fact can be readily understood when it is realized that the digital code is transmitted in parallel form as a two bit code with each bit traveling over a separate phone line. To compensate for this type of delay special delay equalizers were installed at the receiver. The reader is referred to Section 2.4.7.3 for a complete discussion of the absolute time delay equalizer.

Results over the 500 mile link were most satisfactory in this respect since the most delay which had to be compensated for between telephone lines was one bit or 400 microseconds. During the 3 months of testing over the 500 mile link the absolute time delay between lines did not noticeably vary.

Noise on telephone lines has been a severe problem in most data transmission systems. The type of noise on telephone lines is predominately impulse type which may occur singularly, in short bursts, or in long bursts. The frequency of occurrence varies from day to day and even from hour to hour throughout the day. If the noise impulses occur during the video interval of a transmitted line the results normally do not destroy the intelligence being transmitted in the over-all picture. This can readily be visualized if one imagines a standard TV picture with one line of information removed or better yet take a photograph and draw a line across it. The loss of information in the viewed picture is normally insignificant. When the impulses of noise occur during the line sync period disrupting the line sync code the results still are not disastrous unless many lines are disrupted. Figure 37 is a received picture (test pattern) which has two vertical dark lines due to impulse noise occurring on the phone line. It should be noted that the effect of impulse noise disrupting several scan lines of information is lessened due to the memory

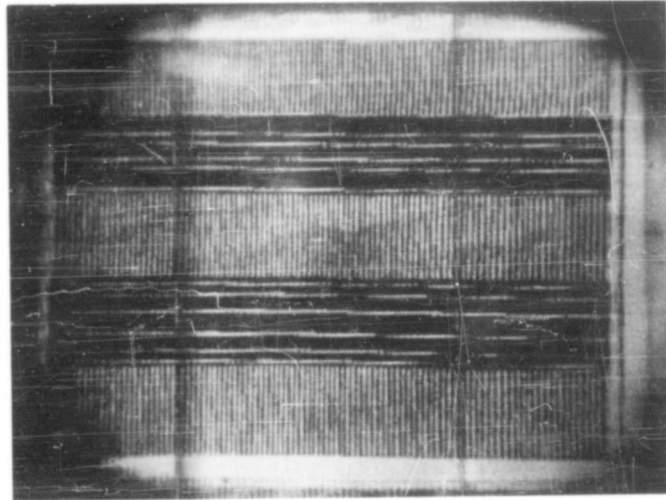

Figure 37 Effects of Impulse Noise on Telephone Line

of the scan-conversion tubes. The worst case occurs when noise on the line causes the frame sync recognition circuits to fire prematurely during a picture transmission. When this happens information in the entire picture is usually lost, the scan-conversion tube must be erased, and entirely new information transmitted again. Fortunately, the rate of occurrence for this type of error is exceedingly low. During 600 hours of transmission not more than 6 total frames were lost due to premature frame sync triggering. Assuming a picture transmission rate of one picture every 2 minutes makes a total of 18,000 pictures transmitted and received. In other words only about one out of every 3000 pictures was a total loss.

As stated before, the impulse noise on some days was more severe than others. On a few occasions the noise would suddenly get very severe causing streaking to occur all across the picture. Such occurrences were rare, however, for the most part reliable operation was possible.

It is important to state again that no degradation of picture content occurs in the transmission link: This is due to the fact that the picture signal is coded in binary form. Thus, if the receiver successfully decodes the digital information the received picture will be identical to the transmitted picture.

During the many transmission tests conducted at Griffiss Air Force Base, many Polaroid pictures were taken of the received information appearing on the receiver operator's console monitor. Figures 38 through 43 are typical of those taken at the receiver over the 500-mile telephone link.

In summarizing then we can say that operation of the AN/FXC (XW-1) over the 500-mile telephone link was very successful.

2.4.9 Operation of AN/FXC (XW-1) at 5400 Bits Per Second

During the period in which the AN/FXC (XW-1) was undergoing testing over the 500 mile link at RADC, Rome, New York another equipment designated the AN/GSC-4* was also being tested. The AN/GSC-4 is an equipment designed for transmitting synchronous binary data at rates up to 5400 bits per second over phase compensated telephone facilities having a bandwidth of 4 kc.

In order to transmit 5000 bits per second the present AN/FXC (XW-1) presently uses two SEBIT 25 transmitter receivers connected via two separate

* Digital Data Transmission at 5400 Bit/Sec Over Private Line, Telephone Facilities. Proceedings of the National Electronics Conference, 1960, Vol. 16, pp. 45-53.

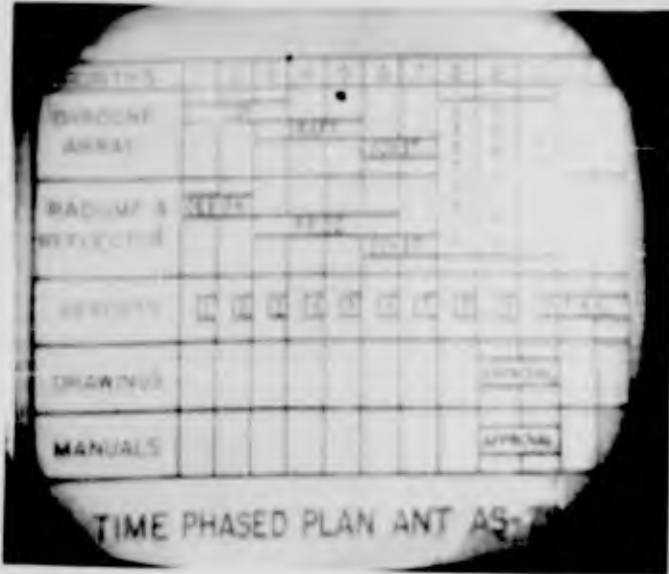

Figure 38

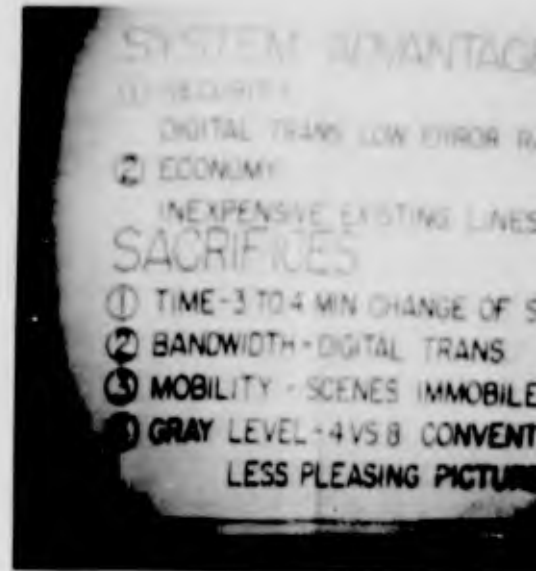

Figure 40

1

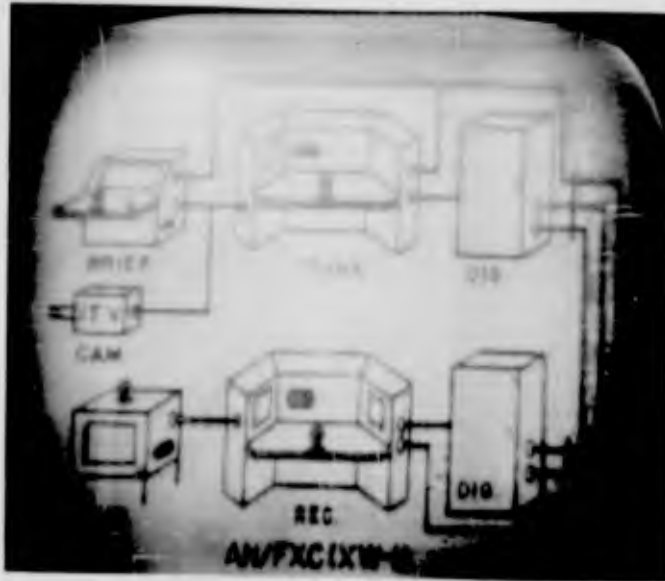

Figure 39

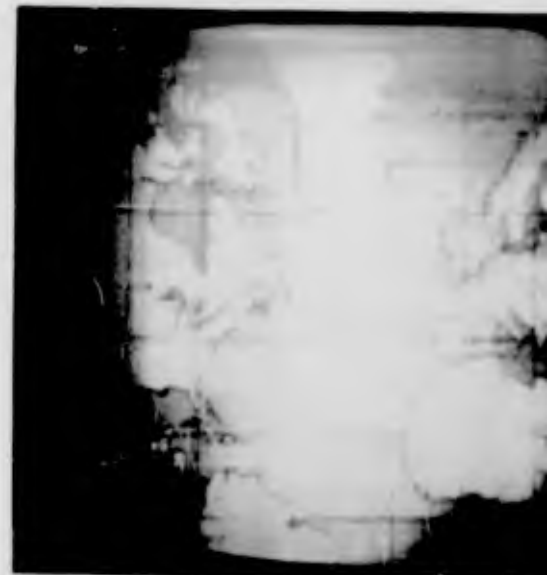

Figure 41

Typical Received Pictures Over 500-Mile

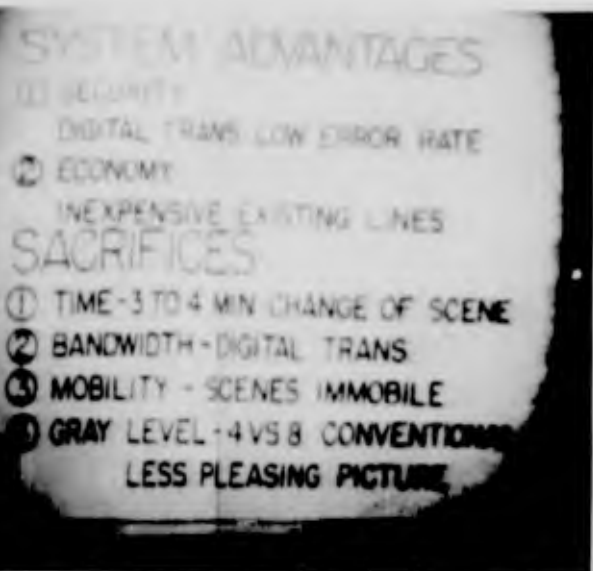

Figure 40



Figure 42



Figure 41

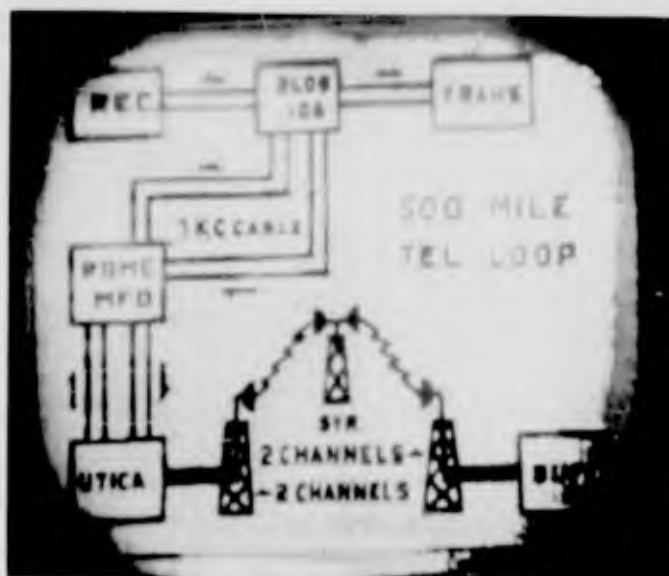

Figure 43

Received Pictures Over 500-Mile Telephone Line

phone lines. The binary information is simultaneously transmitted over the two lines in parallel form. Since the AN/GSC-4 equipment can transmit 5400 bits/second over one phone line it has one definite advantage that of eliminating one phone line.

Adapting the AN/FXC (XW-1) for operation in conjunction with the AN/GSC-4 was a simple matter since provision had already been provided in the logic circuitry of the AN/FXC (XW-1) for converting the 2500 bits/second parallel to 5000 bits/second serial.

After lashing the two equipments together, about 4 hours of transmission over the 500-mile phone line (this was a special line set up for the GSC-4) was logged. During this time errors occurred at about the same rate as had been occurring on the SEBIT 25 transmitter receivers. Insufficient time was available for detailed tests, however, as a result of the lash-up the compatibility between the two equipments was definitely shown. In fact only two items were required to make the system operable. These were:

- a. A divide-by-two circuit reduced the 5400 cycle sync from the GSC-4 to 2700 cycles for operating the clock circuitry in the AN/FXC (XW-1).
- b. The clock pulses in the AN/FXC (XW-1) were reduced slightly to accommodate the increased sync frequency. A screwdriver adjustment reduced each clock pulse from 50 microseconds to 45 microseconds.

2.4.10 Operation of AN/FXC (XW-1) with Security Encoding Equipment

One of the original requirements of the AN/FXC (XW-1) equipment required that it be able to operate with the TSEC/KX-3 cryptographic encoder. Since the KX-3 encoder accepts 5000 bits/second in serial form provisions were made in the AN/FXC (XW-1) for converting the 2500 bits/second parallel information to the 5000 bits per second serial. After encoding, the serial information was returned to the AN/FXC (XW-1) equipment for conversion back to the 2500 bits/second parallel form thus allowing normal transmission over the two SEBIT 25 transmitters. At the receiver the opposite sequence followed in that the parallel output from the receivers was converted to serial, decoded by the KX-3 decoder, converted back to parallel and finally converted from digital to analog for display.

Since the KX-3 encrypting equipment is classified equipment and requires a special operator it is difficult to obtain just for testing purposes. Fortunately we were able to perform a 4-hour operational test with actual equipment. The

results of this test were very satisfactory. With only minor difficulties, which were primarily due to lack of operating experience with the KX-3, the 4 hours of picture transmission was 100 percent readable. It must be remembered that even with the encrypting equipment in the system picture information is not degraded as long as the digital information is decoded properly.

2.4.11 Demonstration Results

During the course of testing, several demonstrations were given before military personnel. These demonstrations were carried out under actual operating conditions over the 500-mile telephone link. A briefer using five charts and the real time pointer gave a 20-minute briefing over the command audio channel. A total of four men were required: (1) one to give the oral briefing utilizing the audio channel and real time pointer; (2) one to change the charts being viewed by the two transmitter vidicon cameras; (3) one operator at the transmitter console and (4) one operator at the receiver console.

From these demonstrations various items worthy of note are discussed here.

First of all the time required to write in a picture at the transmitter, transmit it, write in at the receiver, view it for 2 minutes, and finally erase the picture in anticipation of the next scene requires 4 minutes. To eliminate dead time between scenes two channels of scan conversion at both the transmitter and receiver sites were provided. This allows one channel for transmission while the other channel is being erased and prepared for the next scene. Erasure of past information on the storage tube (TMA-403X) is accomplished by the read beam scanning the target surface many times at near zero bias conditions. Since the transmitter read frame sweep rates vary from 10 seconds to 120 seconds depending on the resolution required it can readily be seen that erasure at the transmitter becomes a rather slow process. This is the reason for stating that a minimum of 2 minutes is required for erase at the transmitter on the 40-second frame mode.

Contrast of the received image was difficult to maintain at the receiver. Since the write beam is scanning at the slow parameters (10 seconds variable to 120 seconds) and the read beam is scanning at standard TV rates, the information being written in occurs at a much slower rate than that being read out. This loss in contrast occurs primarily within 20 to 30 seconds after scan after which the image decay is much slower. The net result is a 100 percent readable picture having a contrast ratio somewhat less than the normal home TV picture.

Some TMA-403X storage tubes are better than others in this respect. In fact it was found that the original installation of storage tubes required checking individual tubes for storage capability and then placing it at the transmitter or receiver depending upon individual characteristics.

From the operator's standpoint it was found that a thorough knowledge of the equipment plus several hours of actual operating experience was required before suitable transmission of information could be accomplished. The reason for this is due to the fact that no attempt was made to automate the write and read controls of the scan conversion tubes. The equipment was development in nature and it was felt that reasonable access to controls should be made to allow proper evaluation. Future systems can and should be designed and built for automatic operation.

Additional equipment utilizing a special slow-scan vidicon at the transmitter and a direct-view storage tube (Iatron) at the receiver overcomes most of the difficulties experienced in the preceding paragraphs. For a description of this system the reader is referred to Section 5.0.

3.0 RELIABILITY

3.1 General

Since this model of Viewing Set, Television AN/FXC (XW-1) is a developmental model, reliability was not deemed as important a factor as was the system operation. However, throughout both the design and building phases every precaution was taken to ensure reliable operation of the system. For example, in critical applications, components were selected to give long-term stability. Polystyrene capacitors were used in all narrow-band sweep circuits because of their inherent low leakage and long-term stability. The use of 1 percent Nobeloy and wire-wound resistors replaced the standard carbon resistors in all critical circuits where freedom from drift was important. The voltage divider networks used to determine the amplitude of the narrow-band deflection sawtooth voltages were comprised of Nobeloy and Bourns wire-wound trimpots. A safety factor of 3 to 1 in power rating was observed in all resistor wattage values.

Where feasible, all circuitry utilized a high degree of feedback to maintain linearity of sweep, freedom from drift due to component change, etc. For example, feedback is incorporated in the pointer generator to prevent drift of the pointer with respect to the video display monitor. The amplifiers in the pointer generator are d-c coupled and have d-c feedback to prevent any d-c shift in position. One modification was performed on the Kin-Tel ITV system timer to improve reliability. The Kin-Tel ITV timer was transistorized completely; however, interaction occurred between the 2 to 1 count down and the master oscillator (31.5 kc) which in turn caused the 5 to 1 count down to misfire. As a result, interlace was lost with a resultant loss in vertical resolution. The transistor being used as buffer isolation between the 2 to 1 count down and the master oscillator was replaced by a sub-miniature tube. The resultant isolation prevented any interaction and improved the reliability of the ITV system in general.

Reliability in the digital portion of the system is paramount. Any loss of digital information will cause the transmitted picture to be lost; hence, the number of errors must be extremely small. In order to produce such reliability, a single NOR circuit printed board was used for all circuit functions except the clock pulse generator, digital-to-analog converter for the pointer, and the ± 25 volt series regulated power supplies. Each NOR circuit is composed of six resistors and one 2N526 GE transistor. The circuit design is such that the resistors may all be at their extreme ± 5 percent tolerance and the 2N526 transistor can be anywhere in its β range (53 to 90) and the circuit will still function properly. The power supply voltages for the NOR boards may vary from ± 20 volts to ± 30 volts; however, voltages must not increase beyond 30 volts due to transistor voltage rating. Each printed card has two NOR circuits for compactness.

Throughout the rest of the digital portion of the system, circuit design was such as to maintain circuit operation even though the individual components might vary through their maximum tolerance. Since digital techniques usually require a circuit to be on or off, it is quite easy to compensate for component parameter variation. To date, the only failures in the digital equipment have been due to careless insertion of cards causing blown transistors, high power supply voltage, or simply component failure. Down time of the equipment has been negligible over the 300-hour period of operation prior to delivery. Since delivery no down time has been recorded against the digital equipment even though it has been in operation 24 hours a day for a 3-month period.

The SEBIT 25 transmitter-receiver units purchased from Rixon Inc. had to be modified before reliable operation could be obtained. The SEBIT 25's as received, would not work. Ideally, the SEBIT 25 should be capable of operation on a random signal, an all-white signal, or an all-black signal. This was not the case, however, since an initial set up on an all-white signal would cause loss of sync at the receiver when the video shifted to an all-black signal and vice versa. For example, assuming an all-white signal, the slicing level in the SEBIT 25 could be adjusted to obtain proper operation which could produce the sync code plus an all-white video signal. Now if the video went all black for a period the slicing level in the receiver would be set wrong with the result that sync code would be lost with resultant loss of all information. This malfunction was due to circuit difficulties, one of which was loading of the bridge detection circuit in the agc loop. Loading was eliminated by the use of an emitter follower. For complete description of the changes required the reader is referred to the Instruction Manual Data Modem Equipment, type SEBIT 25. It is sufficient here to record that, with several circuit changes in the agc detection circuit, the problem of sync loss due to an all-white or all-black signal was eliminated.

The second problem encountered is referred to as lockout and means simply that the system fails to transmit either sync or video. With a random signal, lockout will not occur; however, if actual video is being transmitted and this video becomes such that maximum carrier exists, then receiver lockout can and does happen due to sharp transients or other phenomena which occur at a rate faster than the agc can follow. To eliminate the possibility of lockout due to lack of video changes, a special coding signal was developed in the digital equipment prior to the SEBIT 25's. This code was a 5 - 3 code which caused the video to be noninverted for 5 bits and then inverted for 3 bits in a continuous manner. Hence, even though the actual video might be all black or all white, the digital output to the SEBIT 25's varied in the prescribed manner (5 bits noninverted plus 3 bits inverted, etc.). Such a coding system provided enough changes in the modulated carrier to prevent receiver lockout and maintain reliable operation. Of course, at the receiver end, the inserted 5 - 3 code was removed, leaving the actual video signal as required.

A second type of lockout occurred due to temperature rise inside the SEBIT 25 case. A germanium transistor used as an emitter follower determined the bias on the agc oscillator in the receiver. As the temperature increased I_{CO} of the emitter follower increased causing the bias on the agc oscillator to shift. This of course caused the agc loop to malfunction until eventually, after sufficient warm up time, the increase in I_{CO} would cause complete lockout of the equipment. From a cold start it took from 2 to 3 hours before the temperature increased to the lockout point. Furthermore, if the unit was pulled out from its cover, temperature rise was not sufficient to cause any malfunction. The first attempt to solve the temperature problem was to replace the germanium transistor with a silicon transistor. Though silicon transistors have less I_{CO} , the temperature rise in the case was still sufficient to cause lockout. The problem was finally solved by adding a fan to force air into the case. Vent holes were also provided for escape of hot air.

The resultant reliability of the Rixon equipment has been most satisfactory. Since delivery of the equipment to RADC in Rome, New York, the Rixon equipment has operated 24 hours a day for a period of 3 weeks without any down time due to equipment malfunction. It is also worth noting here that the digital equipment is always turned on just as the SEBIT 25's are and, to date, no malfunctions have occurred even though operation has been continuous. The reason for not turning the digital and SEBIT 25's off is for frequency stability since, once the units are warmed up and operating, maximum frequency stability can be achieved only if they are never turned off.

3.2 Safety Features

3.2.1 General

Every precaution was taken to protect both operating personnel and the equipment from destructive malfunction. The following paragraphs give brief descriptions of precautions taken to ensure reliable operation of the television communication system.

3.2.2 High-Voltage Interlocks

All doors on the rear of the operating consoles which give access to areas where high voltage is present have interlocks. In the case of the -8.5-kv power supply, the interlock breaks the +300 volts and, in the case of the -1200-volt supply, the interlocks break the a-c primary power.

3.2.3 Fusing

All a-c and d-c power is fused according to the load being drawn. An additional d-c fuse was added in the d-c filament supply (Electro-Tek) since the only fuse was in the primary side and did not provide adequate protection to the power supply itself on d-c overload. For actual fuse layout the reader is referred to the Handbook of Operating Instructions for the AN/FXC (XW-1).

3.2.4 Sweep Protection Circuits

Every sweep circuit which drives the scan-conversion tubes also drives a sweep protection circuit which, in case of sweep failure, will immediately turn off the appropriate high voltage to prevent damage to the target area of the TMA-403X scan-conversion tubes. For a description of these circuits the reader is again referred to the Handbook of Operating Instructions for the AN/FXC (XW-1).

3.2.5 Low-Voltage Interlocks

In order to provide protection to the circuits in case of -300 or -150 volt power supply failure, relays are provided which will disconnect the + 300-volt power supplies from their circuits. Thus, tubes operating from fixed bias will not be damaged due to loss of bias.

3.3 Operational Precautions

Even though the system has been designed with many safety features, caution must be observed in setting the TMA-403X scan-conversion write controls. Damage to the target area can result if the write video gain or the write beam intensity or both are increased too far in the clockwise direction. Hence, when turning on the equipment or when changing a scene which the ITV is looking at, the write video and beam controls should be turned maximum counterclockwise direction. This will ensure writing beam cutoff condition and applies to both the transmitter and receiver. The audio link provided in the system should be used by the transmitter operator in order to forewarn the receiver operator of any changes being made. This can be done by a system of cues set up between the two operators. No harm can be done to the scan-conversion tubes by misadjustment of the other operating controls.

During the period when a new scene is being set up on the ITV camera there is the possibility of people walking or standing in front of the camera. Always turn the video gain counterclockwise (zero gain) in the channel being used to prevent

writing a lot of useless information on the target. Particular care must be taken to prevent such things as white shirts from getting in front of the camera since once an all-white pattern has been written into the target area of the TMA 403X several minutes will be lost in getting the surface erased down to black.

In conclusion it becomes evident that before satisfactory operation of the AN/FXC (XW-1) system can be achieved, operating personnel must study the manual and become thoroughly acquainted with the equipment and its capabilities.

4.0 MAINTAINABILITY

4.1 General

Ease of maintenance was an important factor in the layout and construction of the system. For example, all chassis construction (except commercially purchased items) is of the vertical configuration for easy access. All test points and adjustment potentiometers are readily available from the rear as are the electron tubes. Printed circuit cards are used almost exclusively throughout the digital rack. Furthermore since all the cards are of one type, that is a NOR board, only one type of card is required for spares. The simplicity of maintenance is obvious with such a configuration. A suspected defective NOR board can be easily checked by plugging it into the NOR board tester provided with the equipment. Two testers are provided, one for the transmitter and one for the receiver.

The SEBIT 25's built by Rixon Inc. also utilize printed boards. Spare boards have been included as spare parts.

4.2 Preventive and Corrective Maintenance Required

The degree of preventive maintenance required is expected to be negligible. The two fans in the ITV camera control units (transmitter only) and the two fans fastened to the Rixon case (receiver only) should be oiled occasionally. Probably the only other preventive item required is cleaning of the lenses, monitor screens, and transmitter scan-conversion tubes. Due to the large load impedances used at the collector and target of the transmitter scan-conversion tubes, cleanliness is necessary to prevent leakage currents which cause large disturbances in the narrow-band video signal. Provided the scan-conversion tubes are thoroughly cleaned when installed, they probably will need no attention for at least 500 hours in the normal indoor environment. The life of the present tubes is approximately 1000 hours; therefore, it should not have to be cleaned more than once unless an extreme amount of dust or moisture is present.

During the first 300 hours of operation before delivery, down time which required corrective maintenance amounted to approximately 10 hours. Thus 3 percent of the actual operating time was spent in repair of faulty components.

This equipment is, of course, a ground-based equipment to be operated indoors. Furthermore, it is the first developmental model and does not have the refinements that a full production model would have.

Sufficient fans, louvers, etc. have been employed to ensure climatic service conditions, both operating and nonoperating, over a temperature range of 0 degrees C to 39 degrees C.

The equipment was not required to meet MIL-E-4158 vibration and shock tests.

The weakest component in the system is probably the scan-conversion tube in respect to service life. It is anticipated that its useful life will be of the order of 1000 hours. More important however, is the fact that untrained personnel can damage the tube by writing too hard on the target surface (see Section 3.3). The result of overwriting the target is a permanent image which can not be erased.

Other precautions which must be observed are: (1) always turn the digital rack power OFF when changing a NOR board to prevent blowing the transistors, and (2) use caution in changing a printed board in the Rixon equipment to prevent binding or breaking the contacts. A card puller is supplied with each unit for this purpose.

5.0 ADDITIONAL EQUIPMENT SUPPLIED FOR VIEWING SET TELEVISION AN/FXC (XW-1)

5.1 General Information

Previous work done with slow-scan vidicon cameras using conventional vidicons resulted in low quality reproduction. This was due primarily to high dark current and excessive shading in the vidicon when operated at long frame rates. Recently, however, a new vidicon developed especially for slow-scan work was perfected by Westinghouse Corp. This vidicon designated as the WL-7290 exhibits extremely low dark current and a true long time constant allowing frame storage operation.

In addition improvements in storage and resolution characteristics of the direct view storage tube (ITT Iatron) have indicated suitability as a monitor for slow scan work.

In view of the above improvements the possibility of developing a simplified graphic communications system became evident. As a result, the equipment described in the following sections was designed and built for evaluation purposes. Figure 44 and Figure 45 show pictures of the vidicon-Iatron chain.

5.2 Functional Description

Figure 46 provides a block diagram of the vidicon-Iatron system. The dotted lines indicate those portions of the original AN/FXC (XW-1) equipment still used to provide d-c power and timing signals necessary for slave operation. Likewise the direct-view storage tube monitor using an ITT Iatron is slaved to the receiver digital rack for its power and sync information. It should also be noted here that the Iatron monitor was so designed that it would display the slow-scan video either at the transmitter or at the receiver. Figure 46 shows that the additional equipment consists of a narrow-band vidicon camera, a camera control unit and one direct-view storage tube monitor capable of operating either at the transmitter or receiver.

Briefly the system operates as follows: The narrow-band vidicon camera is scanned directly at the slow-scan parameters as determined by the AN/FXC (XW-1) equipment (see Table 1 page 6 of this report). The resulting video signal is thus generated in its narrow-band form directly and by means of switch S1 routed to the digital rack for normal processing and transmission as before. A convenient video outlet is provided at the camera control unit to allow the direct-view storage tube monitor to display the narrow-band video signal in its analog form at the transmitter.

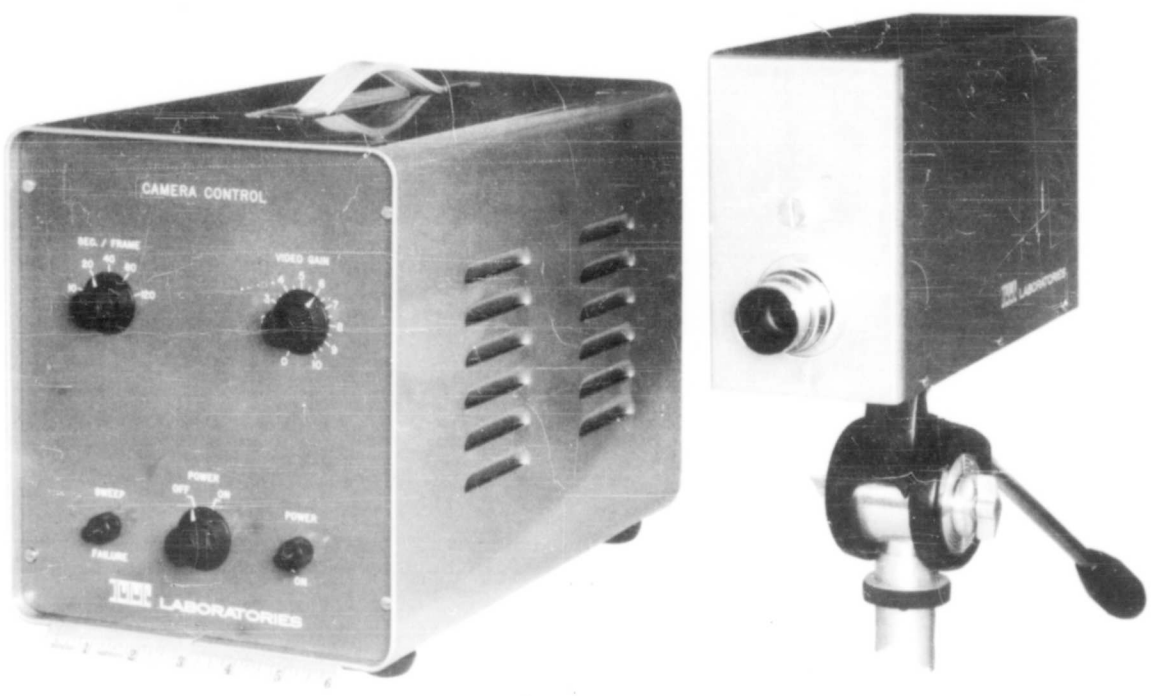
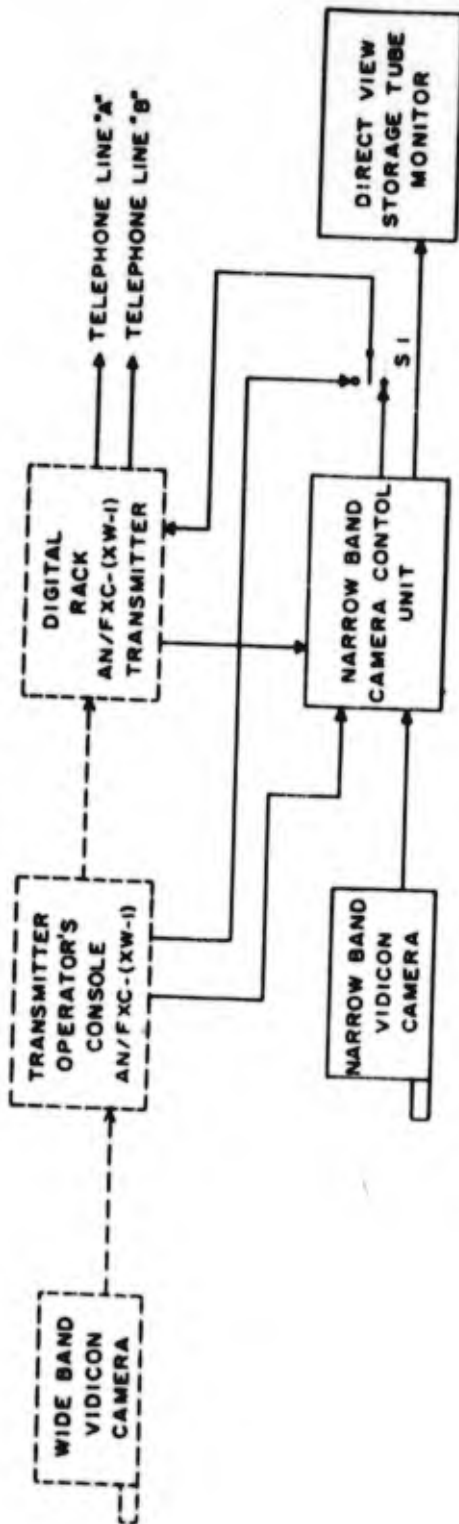

Figure 44 Slow-Scan Vidicon Camera and Camera Control Unit



Figure 45 Slow Scan Iatron Monitor

TRANSMITTER



RECEIVER



Figure 46 Vidicon-Iatron System

At the receiver the direct-view storage tube monitor displays the received video signal after conversion from digital back to analog form.

5.3 Vidicon-Iatron System Specifications

a. Operating rates: for operating rates see Table 1 page 6 of this report.

b. Picture aspect ratio: 4 to 3

c. Picture resolution:

Vidicon capability is approx. 400 TV lines

Iatron capability is approx. 400 TV lines/dia.

d. Scanning method: progressive (noninterlaced)

e. Scene illumination required: 1 foot candle or better (must be uniform)

f. Monitor image brightness: variable to 100 foot lamberts
(depends on desired persistence)

g. Camera pickup tube: WL-7290 Vidicon

h. Camera Lens: Wollensak 25 mm, f/1.5, C mount

i. Monitor display tube: ITT FW-221 Iatron (5 inch)

j. Monitor image persistence: 10 seconds to 8 minutes

5.4 Equipment Supplied

Items supplied are as follows:

a. Narrow-band camera with WL-7290 Vidicon

b. Camera control unit

c. Display monitor with FW-221 Iatron

d. One Wollensak f/1.5 camera lens

- e. One tripod for camera mounting
- f. 100 feet camera cable
- g. All necessary cables for interconnecting with the AN/FXC (XW-1) equipment.

5.5 Power Requirements

All power ac or dc as required by the units is taken from the available power in the AN/FXC (XW-1) equipment.

5.5.1 Camera and Camera Control

+ 300 volts	12 ma
-300 volts	1 ma
+ 30 volts	600 ma
-30 volts	105 ma
115 volts ac, 60 cps	

5.5.2 Monitor

+ 300 volts	60 ma
+ 30 volts	40 ma
-30 volts	55 ma
115 volts ac, 60 cps	

5.6 Operational Tests on Vidicon-Iatron System

5.6.1 General

Delivery of the AN/FXC (XW-1) to RADC occurred several months prior to the time that the vidicon slow-scan chain was completed. As a result, testing of the slow-scan vidicon chain had to be on a limited basis prior to delivery. By

deriving sync signals from low-frequency function generators, and connecting the Iatron monitor directly to the camera control unit testing of the system could proceed. All tests in the laboratory were conducted on an analog direct-wire basis between the vidicon camera and Iatron monitor. At first it would seem that such a connection really would not provide significant information. This is not the case however, because, we already know the effect of digitizing and transmitting over 500 miles of phone lines via the SEBIT 25 transmitters. As long as the narrow-band video signal from the vidicon camera control unit is identical in regards to d-c level, amplitude, and frequency response the results of digitizing and transmission will be the same as before.

Actually there are advantages in making a back-to-back test since in this manner one can determine the vidicon-Iatron characteristics pertaining to resolution and gray scale. The following sections describe various tests and their results which the vidicon camera chain was subjected to.

5.6.2 Back-to-Back Laboratory Tests

Several tests in the laboratory served to help provide both quantitatively and qualitatively some of the operating characteristics of the vidicon-Iatron chain for slow-scan operation. The more important of these are briefly discussed here.

5.6.2.1 Resolution

According to published specifications the WL-7290 is capable of 600 TV lines resolution when operating at standard 525-line 30-frame-per-second scan rates on a video chain having 8 mc. Resolution was determined by viewing a standard EIA resolution chart. As the frame time is increased by say 10 seconds resolution decreases due to lateral charge leakage along the photoconductor surface. For example a frame time of 60 seconds will decrease resolution capability of the vidicon to a value slightly in excess of 400 TV lines. Actual tests show this figure to be on the conservative side.

Resolution capability of the Iatron direct-view storage tube (FW-221) is measured as raster lines per inch at a specified percentage brightness. Figure 47 is a chart showing resolution versus brightness for the FW-221 Iatron operated under normal conditions, that is, no flood pulsing. From this chart it will be noted that at low brightness levels say 10 percent to 20 percent resolution in raster lines per inch is 100 lines or better. One hundred raster lines is 200 TV lines per inch. Using a 4 to 3 ratio a raster size of 3.2 inches by 2.4 inches is possible in a 4-inch diameter display. Resolution in the 3.2-inch direction will thus be approximately 600 TV lines and 480 TV lines in the 2.4-inch direction.

**Resolution Measured By The
Shrinking Raster Method
wEk = -450 volts**

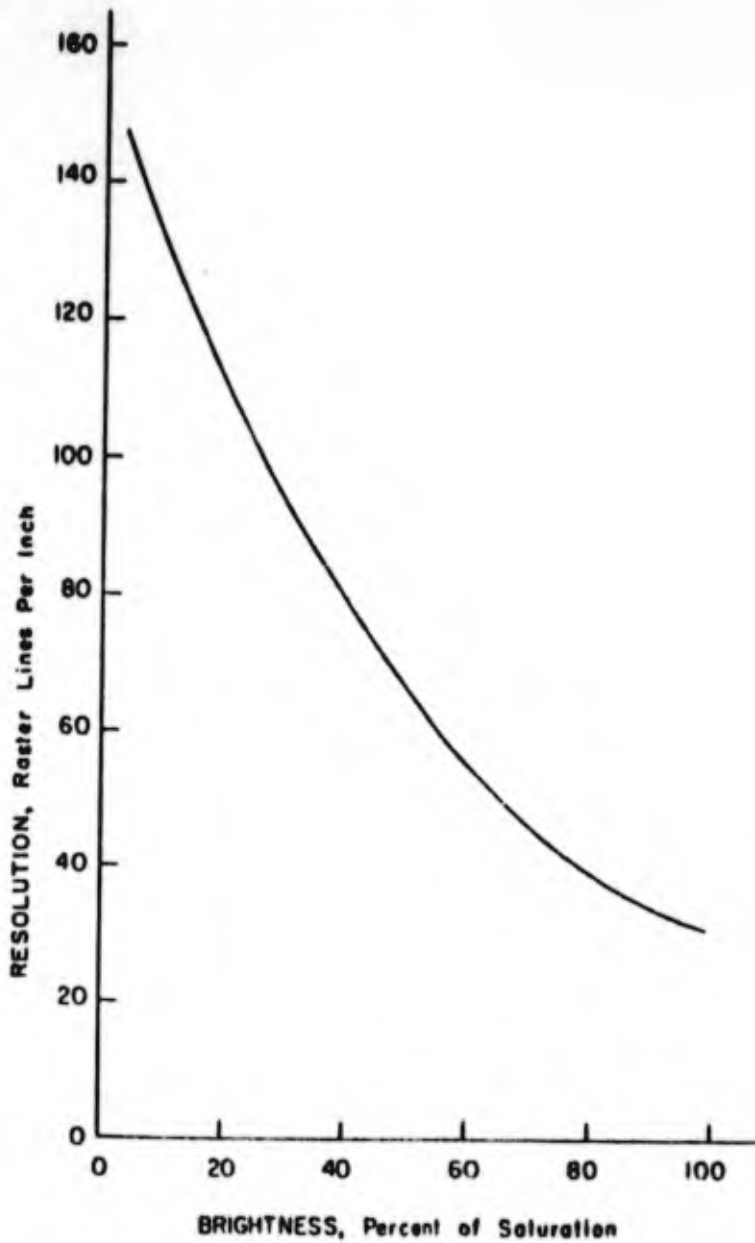

Figure 47 Resolution versus Brightness for FW-221

From the preceding discussion it then becomes evident that system resolution should be in the order of 400 TV lines. Figure 48 shows a Polaroid print taken of a stored Iatron display of the EIA resolution chart. Four hundred TV line resolution capability is evident in the display.

5.6.2.2 Gray Scale

System gray scale is limited by the direct-view storage tube. Normally storage tubes of this type can reproduce four to five shades of gray as seen on the EIA chart. The FW-221 can reproduce up to six shades of gray. This is possible due to the changes in the writing gun structure. For example the writing gun is a very low current gun (less than 1 microampere) and has a 16-volt dynamic range instead of the usual 3 to 4 volts. Various pictures throughout this section (5.6) show the gray scale capability of the system.

5.6.2.3 Shading

Shading of the final display in the original AN/FXC (XW-1) was quite severe and was largely due to the scan-conversion tubes. Due to digitizing the shading appeared more objectionable. Since the scan-conversion tubes are now eliminated and since the vidicon has extremely low dark current, shading at the transmitter is largely eliminated. Also the signal is analog in the pictures of this section (5.6) which allows full range of gray scale. Shading is present in most of the pictures as a bright area in the center. This is due to poor collimation of the flood beam in the Iatron. By adjusting the collimating voltages this type shading can be minimized. On a qualitative basis shading in the vidicon-Iatron chain is not as severe and is easier to control than shading in the original AN/FXC (XW-1).

5.6.2.4 Image Storage

The ability to write, store, and erase an image is one of the unique features of the vidicon-Iatron chain.

The WL-7290 vidicon is able to operate satisfactory at long frame times through the mechanism of time charge storage. It does not exhibit stickiness or lag. At long frame times the degree to which information is erased upon readout depends on the beam current used. At beam currents giving optimum resolution, the amplitude of the readout during the second frame is typically 20 percent of the first.

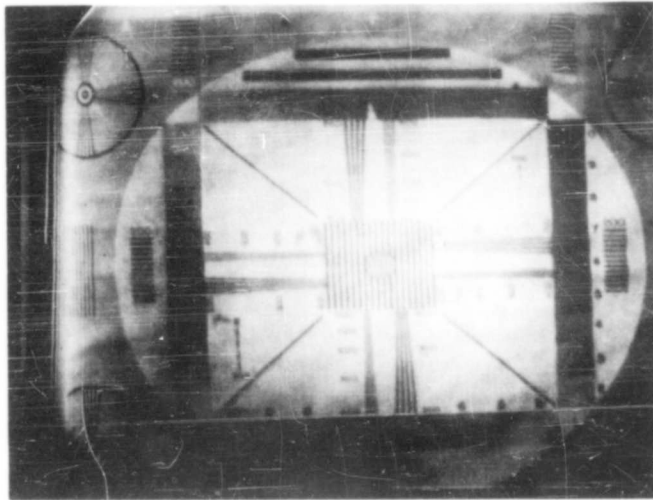

Figure 48 EIA Chart, Iatron Display

Actual measurements in the laboratory show the residual signal after one scan to be less than 10 percent of the first. This is probably due to using a slightly greater beam current than required.

At the transmitter end we thus have a pickup device which is capable of storage over long frame periods of several minutes and yet requires only one complete frame to erase old information and prepare it for new.

Turning now to the receiver we observe an equally satisfactory situation. This is because the FW-221 is capable of storing a picture from a few seconds to 8 or 10 minutes for observation. After viewing is completed, erase is almost an instantaneous operation and requires the operator to push and release an erase button.

Viewing time is extended in the Iatron by two means (1) a very thin insulator is used internally in the tube and (2) the flood cathode is pulsed on and off. A thin insulator increases viewing time since this physically increases the capacity between the insulator surface and backing screen. Thus it takes longer to ion write the insulator surface back to equilibrium. Secondly pulsing the flood cathode on and off slows the rate of positive ion generation in the tube due to collisions between flood electrons and gas molecules.

A combination of these two features provides an Iatron suitable for slow-scan operation by providing long viewing time and short erase. Actual storage time is much longer than the 8-minute viewing time so that degradation of the stored image during viewing is not severe. For 2- to 3-minute viewing times image degradation is negligible.

The ability to retain a suitable stored display and also the ability to erase the stored image at will gives the vidicon-Iatron chain a very great advantage over the original AN/FXC (XW-1) equipment. We could never store a single frame suitably for any length of time nor could we erase an image rapidly. See Section 2.4.11 for further discussion on this point.

5.6.2.5 Effects of Time Delay in Transmission Link

Deleterious effects of phase distortion have already been discussed in Section 2.4.7 and certainly apply here. It was interesting to determine the effects of phase distortion on an analog signal such as the narrow-band video from the vidicon. With the vidicon camera and Iatron monitor in a back-to-back connection via a twisted pair, line simulators were inserted to study the results of different degrees of phase shift at different frequencies.

Figures 49 through 56 show the results of inserting varying degrees of delay at 500 cycles and 3000 cycles. This delay is relative to that at 1000 cycles; 1.4 milliseconds relative delay at 500 cycles does not appreciably distort the display. In fact distortion is negligible. On the other hand 1.6 milliseconds relative delay at 3000 cycles is appreciable although still readable. Even 4 milliseconds delay is readable, however, the allowable relative delay depends somewhat upon the subject matter being transmitted.

In general when transmitting slow-scan pictures having scan parameters as shown in Table 1 page 6 a relative phase delay of 1.0 millisecond to 1.5 milliseconds can be tolerated at 3000 cycles and 500 cycles.

An article in the Bell System Technical Journal* provides information on telephone line characteristics. On a nationwide basis sampling of various facilities was performed. Reproduced here by permission of Bell telephone is Figure 57 showing average envelope delay characteristics for exchange, short haul (up to 400 miles), and long-haul facilities.

The relative envelope delay was measured by determining the derivative of phase with respect to frequency, $d\theta/d\omega$, which has the dimension of time. The curves are normalized to zero at the average frequency of minimum delay.

A study of these average curves shows that the phase delay of actual telephone facilities in most cases lies within the required phase characteristics of the slow scan vidicon system operated on an analog basis.

See Section 2.4.8 for discussion of time delay effects on the AN/FXC (XW-1).

5.6.2.6 Effects of Noise on Transmission Link

See Section 2.4.8 for discussion of noise affecting transmission of video information in digital form.

5.6.2.7 Effects of 60 Cycle Pickup

The basic bit rate of the AN/FXC (XW-1) equipment is 2500 cycles and is derived from a master oscillator operating at 100 kc. As a result the line and frame counters count down from the 2500 cycles to provide line and frame

* Bell System Technical Journal, May 1960, Capabilities of the Telephone Network for Data Transmission, pp. 431-476.

1



Figure 49
No delay
Transmitting rate: 20 sec/picture



Figure 50
Delay: 1.4 ms @ 500 cps
Transmitting rate: 20 sec/picture

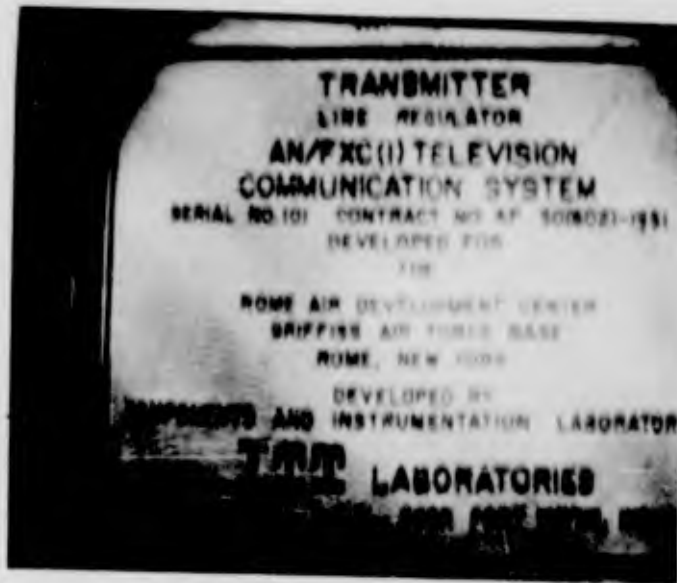

Figure 51
 Delay: 0.8 ms @ 3 kc
 Transmitting rate: 20 sec/picture

2



Figure 52
 Delay: 1.6 ms @ 3 kc
 Transmitting rate: 20 sec/picture



1

Figure 53
Delay: 2.4 ms @ 3 kc
Transmitting rate: 20 sec/picture



Figure 54
Delay: 3.2 ms @ 3 kc
Transmitting rate: 20 sec/picture



Figure 55
Delay: 4.0 ms @ 3 kc
Transmitting rate: 20 sec/picture

2



Figure 56
Delay: 4.0 ms @ 3 kc
1.4 ms @ 500 cps
Transmitting rate: 20 sec/picture

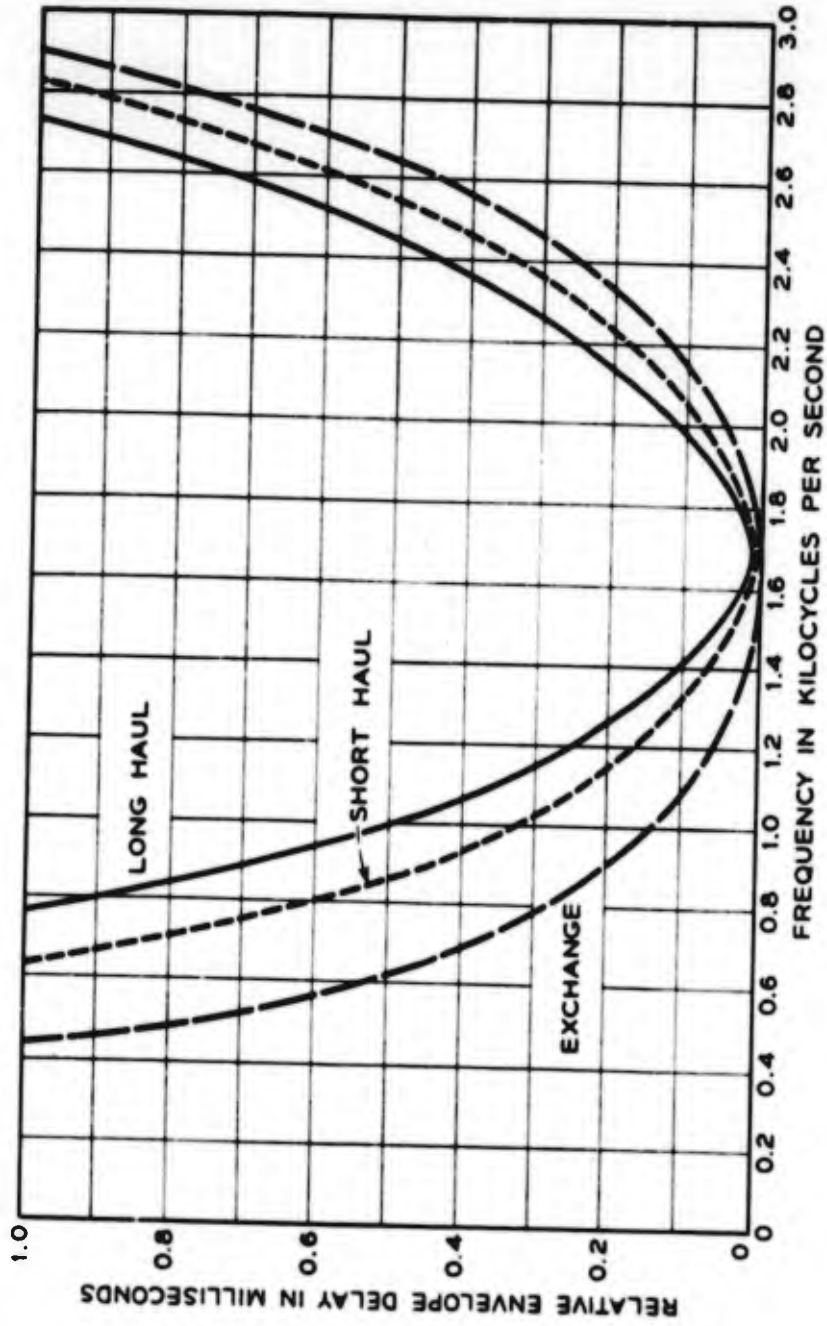

Figure 57 Average Envelope Delay Characteristics

times for particular resolution capabilities at a constant video bandwidth. See Table 1 of this report. No attempt was made to lock the line sweep frequency to the 60-cycle power line. Even though every precaution was taken to eliminate 60-cycle pickup from getting into the video some small amount still remained in the final display by virtue of magnetic coupling in the Iatron tube itself. Sixty-cycle hum shows up as a herringbone pattern in most of the pictures taken of vidicon-Iatron displays. To overcome this problem the Iatron was installed in a box by itself and shielded on all sides with ferretic-conetic shielding material. The results were very gratifying in that 60-cycle pickup was reduced to a negligible degree. Note: All pictures taken of vidicon Iatron displays were taken before additional shield was added.

The purpose of this section is to point out the importance of locking the line sweep frequency to the power line and also to provide adequate magnetic shielding around the direct-view storage tube.

5.6.2.8 Recorded Pictures

Polaroid pictures taken of various displays as received on the Iatron monitor are reproduced here for comparison purposes. All information pertinent to the stored display is recorded under each photograph.



Figure 58
One-half page type
40-sec mode

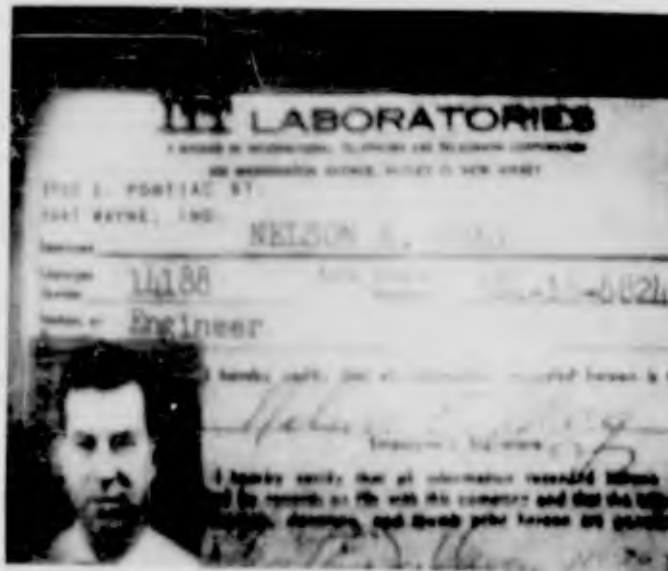

Figure 59
Identification photo
10-sec mode

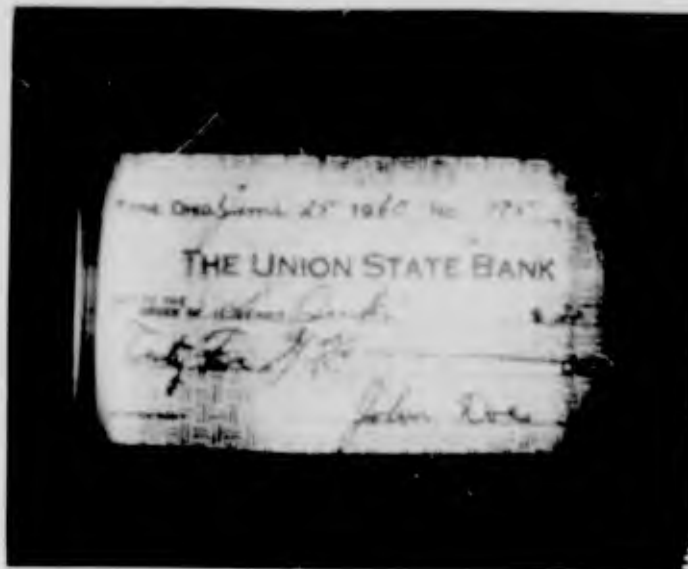

Figure 60
Check
20-sec mode

2



Figure 61
8-1/2 x 11 inch photograph
20-sec mode



Figure 62
8-1/2 x 11 inch chart.
Camera-to-subject distance 3 ft.
40-sec mode

1



Figure 63
8-1/2 x 11 inch chart.
Camera-to-subject distance 2 ft.
10-sec mode



Figure 64
8-1/2 x 11 inch chart.
Camera-to-subject distance 2 ft.
20-sec mode

2



Figure 65
8-1/2 x 11 inch chart.
Camera-to-subject distance 2 ft.
40-sec mode

6.0 CONCLUSIONS

6.1 AN/FXC (XW-1) System

The equipment as it now stands will operate according to specifications and will transmit, in digital form, a television picture over suitable telephone lines. Three telephone lines are required: two lines, phase equalized, are needed for the picture transmittal, and a third line is required for the bilateral audio link between transmitter and receiver.

To date the equipment has been operated over more than 500 miles of telephone line. The length of the telephone line does not make any difference in picture quality. If the SEBIT 25 receivers can successfully sync on the incoming signal, the received picture will not be degraded from the transmitted picture. This is due to the picture being in digital form.

Some improvement in operation might result if additional circuitry such as dynamic focus were added to maintain better focus over the scan-conversion tube target area. Additional protection circuits on any future models should be added on the write in portion of all scan-conversion tubes (write intensity) to eliminate the possibility of damaged target areas as described in the main body of this report (Section 3.3).

The weakest link of the whole system is probably the scan-conversion tubes themselves. This is due to shading, nonuniformity between tubes, poor storage characteristics, etc. In order to make sure that the digital equipment was not degrading the picture rendition, the following experiment was performed. In the back-to-back position, all digital equipment was removed and the narrow-band analog video signal was transmitted directly from the transmitter to the receiver. The only improvement distinguishable was a slightly better rendition of gray scale (five shades instead of four) since in the analog mode the system was not limited to four discrete shades of gray as it was with the digital equipment. Resolution was not improved. The results of this experiment definitely prove that the limitation of the system is primarily in the scan-conversion tube. Furthermore, it must be remembered that two scan-conversion tubes are required in the complete chain; one at the transmitter and one at the receiver.

The ability to erase old information from the scan-conversion tube was another problem encountered. Erasure of old information is accomplished during readout by the reading beam. At the transmitter the readout beam is operating at slow-scan rates and if the target has been written into the white region considerable time (several minutes) is required to erase and prepare the target for new information.

One possible way to reduce erase time is by suitably switching the target, collector, and shading electrodes and at the same time switch the readout beam to a fast-scan operating at zero bias. After a suitable interval, say 20 to 30 seconds, all potentials and scanning rates can be returned to normal in preparation of the next scene to be written in. Future equipment of this type should certainly consider erasing in this manner and it should be an automatic sequence initiated by a single push button.

Under continual readout conditions a single stored image does not retain a suitable degree of contrast for long periods. In other words the image must continually be written in to provide a stored image when it is desired to maintain a viewing time of more than 1 minute.

Shading around the edges of the display was quite objectionable in the AN/FXC (XW-1). This was due largely to overscanning of the writing beam. An experiment was performed whereby the scanned area was reduced to fit well within the actual target surface. Shading in the picture was reduced to a degree where it was no longer considered detrimental to picture quality. The original reason for overscanning was to maintain as high a resolution as possible through the scan-conversion tubes.

On future equipment the area scanned by the writing beam should be confined well within the target area to lessen the problem of shading. Loss in resolution due to the smaller scanned area is barely detectable on an EIA resolution chart and definitely a lot less objectionable than the shading.

Future work in this field might center around the use of improved scan-conversion tubes or possibly around other types of tubes, such as the barrier-grid storage tube, as they become available.

Another possible television communication system might involve the use of the ITT Federal Laboratories barrier-grid storage tube in place of the scan-conversion tube. The barrier-grid storage tube is capable of 1000 TV lines resolution at 70 percent modulation and at least five shades of gray. Such a system could, by properly timing the write and read sequence, eliminate the appearance of the slow-scan sweep moving across the face of the monitor. It also would eliminate the shading and resolution problems now existing. Such a system would be as complex as the present system; however, it would be superior to the present system since resolution would be improved and no slow-scan parameters would be visible in the display.

Other systems such as an all-digital system are possible. Such a system would remove all the problems due to scan-conversion tubes but would be expensive to develop.

In summarizing, it can be stated that the television communication system operates according to specifications and, at the present time, is limited by the performance of the scan-conversion tubes. Since delivery of the equipment to Griffiss Air Force Base, Rome, New York, operation of the equipment has been satisfactory. The AN/FXC (XW-1) is a developmental model and, as such, requires operators who have been trained in the equipment operation and set-up procedures. The reason for this is quite obvious when one considers the critical adjustments involved in operating scan-conversion tubes. With proper advance training, however, no difficulties should be experienced from the operational standpoint.

6.2 Vidicon-Iatron Chain

The vidicon-Iatron as described in Section 5.0 does not provide greater resolution or gray scale rendition than the AN/FXC (XW-1) equipment. It does, however, have several advantages which are noteworthy. First of all let us remember that the vidicon camera and Iatron monitor were slaved to the AN/FXC (XW-1) system. That is, all timing signals and power supplies of the AN/FXC (XW-1) were utilized. Also the same digital transmission link was utilized. We can thus compare results on a qualitative basis.

Upon working with the vidicon-Iatron combination several advantages have become quite apparent. These are discussed briefly in the following paragraphs.

6.2.1 Physical Size

A comparison of the photographs showing the AN/FXC (XW-1) equipment and those showing the vidicon camera, camera control, and Iatron monitor indicates a radical reduction in size and weight. The vidicon camera and camera control unit replace the major portion of the transmitter operators control console and all of the standard ITV equipment (note digital rack is still required).

6.2.2 Ease of Operator Control

One of the disadvantages of the AN/FXC (XW-1) was the necessity of requiring trained operators. At the transmitter of the AN/FXC (XW-1) three men are required: (1) man giving the briefing (2) man to change scenes (could be automated), (3) man to operate equipment. At the receiver an operator is required at the receiving operator's console. By automating the change of scene viewed by the ITV cameras the total number of men required is reduced to three.

The vidicon-latron chain requires only one man if change of scene is automated through the use of automatic slide changers. Thus the man giving the briefing can control the whole transmission by use of push buttons. For example assume that the system has previously been installed, set up, and adjusted for operation. The operator arrives, turns on the equipment, selects the chart or scene to be transmitted by means of an automatic changer and begins his oral transmission as soon as the scene has been transmitted one or two times. When he desires to change scenes he does not have to worry about erasure of old information since the vidicon does this in normal operation in one frame period. One frame will be garbled since both old and new information is present. However the next frame will contain all new information and will be suitable for transmission. At this point erasure of old information at the receiver can be instigated by means of vibrating relays at the receiver operated from the transmitter through multiplexing tones over the phone line. What all this is saying is that one operator through the use of automatic slide changers and multiplexing techniques can control both the transmitter and receiver and at the same time give any oral briefing required. No trained personnel are required for transmission.

Cost of equipment and cost of operation is considerably reduced in such a graphic transmission system as the vidicon-latron chain.

From a setup standpoint the vidicon chain is simpler than the AN/FXC (XW-1). The low light level required (1 foot candle or better) allows the camera lens to be stopped down to f/5.6 or more. At f/5.6 the depth of field at 4 feet is 3.2 feet to 5.4 feet allowing noncritical optical focusing.

The only critical adjustment involves the vidicon beam adjustment; however, once the beam current is adjusted for a particular setup it should need no further adjustment other than normal periodic maintenance.

6.2.3 Viewing Time

Viewing time for one picture (one complete frame) can be extended to 8 minutes without appreciable loss of information (see Section 5.6.2.4). This is a definite advantage over the AN/FXC (XW-1) which has a maximum viewing time of about 1 minute.

6.2.4 Picture Transmission Rate

Picture transmission rate in the vidicon-latron chain depends primarily upon the frame rate. Since one frame period is required to erase old information in the vidicon a single channel can transmit at the rate of one new picture every

two frames. Furthermore the Iatron can store a picture for many frames and then be erased in as little as 4 milliseconds if required. It thus becomes evident that picture transmission rate for the vidicon system is one new picture every two frames. By using two channels the transmission rate can be doubled or be one picture per frame. A frame rate of 60 seconds thus means a new picture can be transmitted every 60 seconds provided two vidicon-Iatron channels are used.

The storage and erase characteristics of the vidicon-Iatron chain are superior to the AN/FXC (XW-1).

6.2.5 Resolution

Resolution capability of the vidicon-Iatron system is approximately equal to that of the AN/FXC (XW-1).

6.2.6 Shading

As long as the scanned area is confined to that specified in the data sheets for the WL-7290 (1/2 in by 3/8 in) and as long as the beam current is properly adjusted, shading should be negligible in the vidicon camera.

At the receiver, shading of the display due to the Iatron will occur if the flood beam is not properly collimated.

On a system basis, shading is less and definitely is easier to cope with on the vidicon-Iatron display.

6.2.7 Real Time Pointer

The real time pointer operates only in conjunction with the standard TV rate portions of the AN/FXC (XW-1). It can not be used with the present vidicon-Iatron system.

UNCLASSIFIED

UNCLASSIFIED