

AD 261444
01

CATALOGED BY ASTIA
AS AD NO. 261444

AID Report 61-101

7 July 1961

61-101
NOX

ITEM OF INTEREST

Prepared by

Science and Technology Section
Air Information Division

SUBJECT: Some Details on the Soviet Spaceships

SOURCE : See List of References Below

1. Introduction

This item reflects certain data on the design of the pilot's cabin in Gagarin's spaceship, the "Vostok". The conclusions discussed below were reached as a result of a study of more than 50 official reports and articles published in connection with the first Soviet manned space flight. In the course of this study the following key statements were found:

- 1) the structure of the spaceship "Vostok" was similar to that of the previous Soviet spaceship-satellites;
- 2) all the Soviet ship-satellites, including the manned "Vostok", were launched and recovered by the same program;
- 3) the Soviet astronauts were trained in cabins similar to that of the "Vostok".

These statements were found in several sources, including references 1-6. Their interest lies in the fact that they make it possible to relate previously published information on the spaceship-satellites and the Soviet astronaut training cabin to the "Vostok." Several of these statements are cited below.

The official report on the Gagarin flight of April 12, 1961, states that the spaceship was built on the basis of experience obtained in launching the first ship-satellites. [1] According to A. Shternfiel'd, the structure of the "Vostok" was perfected during the previous launchings of Soviet ship-satellites. On the first, second, and third ship-satellites,

1001

2004100 4006

BEST AVAILABLE COPY

systems were perfected and checked which assured the establishment of the ship in its orbit and the flight safety and flight control required for manned travel and recovery. Space physics was also investigated during the flight of these ships. On the fourth and fifth ship-satellites, the "Vostok's" structure and its systems for safe flight and recovery were further perfected [2].

In his series of articles "Way to Space", Gagarin discusses the training period. He states that after the launching of the first ship-satellite carrying a dummy, it was clear that the spaceship had now been built and the perfection and checking of its systems were in progress. [3] The flight of the second ship-satellite (with the dogs Belka and Strelka) demonstrated the complete reliability of the ship which the astronauts had been studying and mastering. [4] The fourth and fifth spaceship-satellites launched in March, 1961, were considered final test shots for the "Vostok". In each of these vehicles, a dummy was located in the pilot's seat, and an experimental dog (Chernushka in the fourth ship and Zvezdochka in the fifth) was in the cabin. [1]

Discussing the so-called "mute chambers", in which the subject is isolated from the outside world, V. Grigor'yev states that a cabin similar to the spaceship cabin is set up in such a chamber. The astronaut spends a certain amount of time there and performs various tasks according to a program. [5] Academician A. N. Nesmeyanov asserted that tests were conducted "for days and weeks" in cabins which fully simulated the cabin of the space-ship. [6] This is also mentioned by Gagarin himself, who states that there were many training sessions in the model of the spaceship cabin. [3]

2. Was the "Vostok" a winged vehicle?

The official report [1], which gives a general description of the first Soviet manned flight, does not say that the "Vostok" was a winged vehicle, but there are some indications that it was. First, the majority of the numerous artists' conceptions of the ship published in the Soviet newspapers after the flight and in connection with the 1961 May Day celebration show a winged space vehicle with the word "Vostok" on its housing. A previous analysis of the Soviet literature [7] showed that the second Soviet ship-satellite which carried the dogs Belka and Strelka was also probably a winged vehicle.

The second indication that the "Vostok" had wings is given in an article by A. Shternfel'd [8] written in connection with the launching of the fourth ship-satellite. In this article, Shternfel'd calls the Soviet ship-satellites "raketoplany" (rocketplanes), a term which could not be used unless these vehicles are equipped with wings.

In addition, the official report [1] gives a description of the "Vostok" suggesting that it had wings which would enable it to fly in the earth's atmosphere probably for up to 10 days. According to this report, the structure of the "Vostok" makes recovery possible by using the natural resistance of the atmosphere should the decelerating system fail. The supplies of food, water, and regeneration material and the capacity of the power sources are calculated for a flight lasting up to 10 days. Precautionary measures are provided in the structure of the ship to prevent a cabin temperature increase beyond the rated limit during the prolonged surface heating caused by the gradual deceleration of the ship in the atmosphere. [1]

3. Shape and location of cabin

Fig. 1 shows the analyst's conception of the "Vostok's" cabin, which is based on several indications found in Soviet sources.

According to the official report [1], the "Vostok" consists of two main sections: the pilot's cabin and the instrument section. No indications that the spaceship has a spherical cabin are given in the text of this report. The published view of the interior of the astronaut's cabin (Fig. 2), however, leads to the conclusion that the "Vostok" had a spherical cabin consisting of two hemispheres, of which one hemisphere with joint is shown.

The second indication of the shape of the spaceship cabin is found in a report by a special correspondent of Komsomol'skaya pravda, O. Apenchenko, published on April 14, 15, and 16, 1961. [9] In the last part of this report, Apenchenko discusses the control of the spaceship by Gagarin during training. According to this report, the training cabin, called "Sphere One", and the command post, called "Earth", are located in neighboring rooms of the laboratory building and communicate with each other through the corridor. The article describes Gagarin's training in "Sphere One", from launching to orientation of the ship in space. Apenchenko states that when the spaceship was oriented and the training

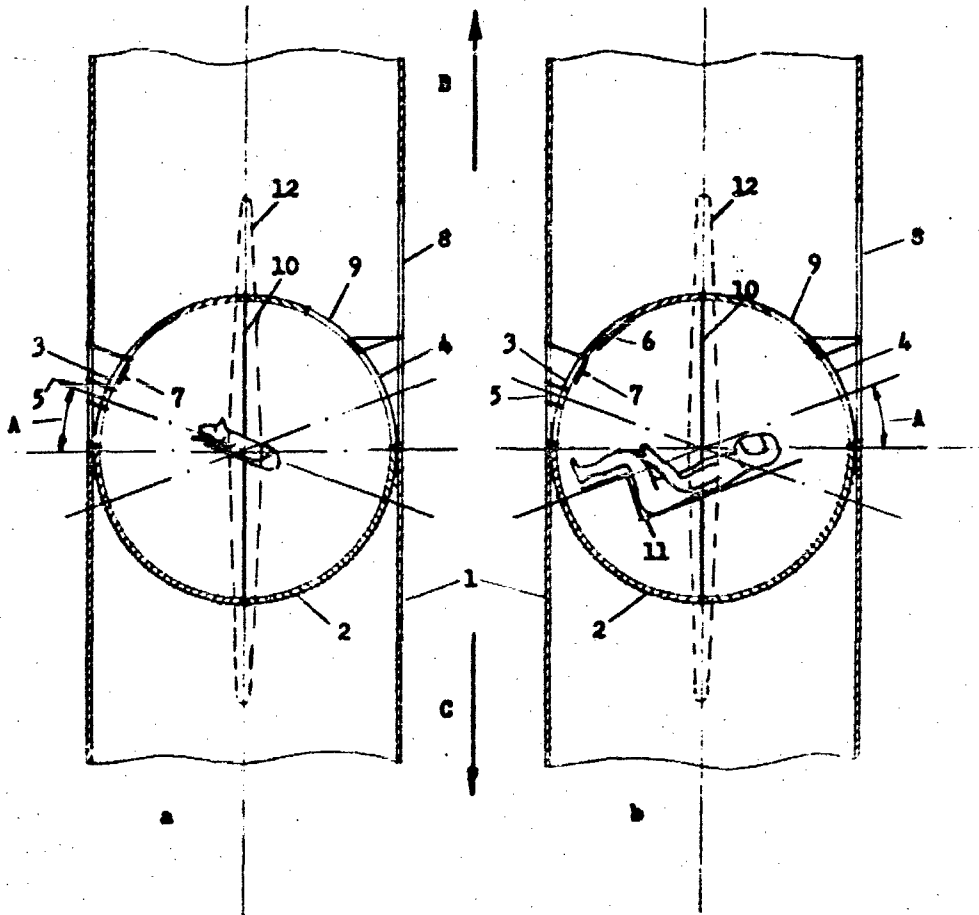

Fig. 1. Possible shape and location of the cabin in the Soviet space ships

a - cabin of second ship-satellite; b - cabin of the ship "Vostok"; 1 - external housing of ship; 2 - spherical cabin; 3 - fast-opening hatch with porthole; 4 - fast-opening hatch; 5 - porthole with optical orientator; 6 - instrument board with globe; 7 - television camera; 8 - door; 9 - hatch; 10 - parting line of cabin; 11 - pilot seat; 12 - ablating wing; A - angle between the lengthwise axis of the container (a) or the pilot seat (b) and the floor (cross-section) of the cabin; B - launching direction; C - reentry direction

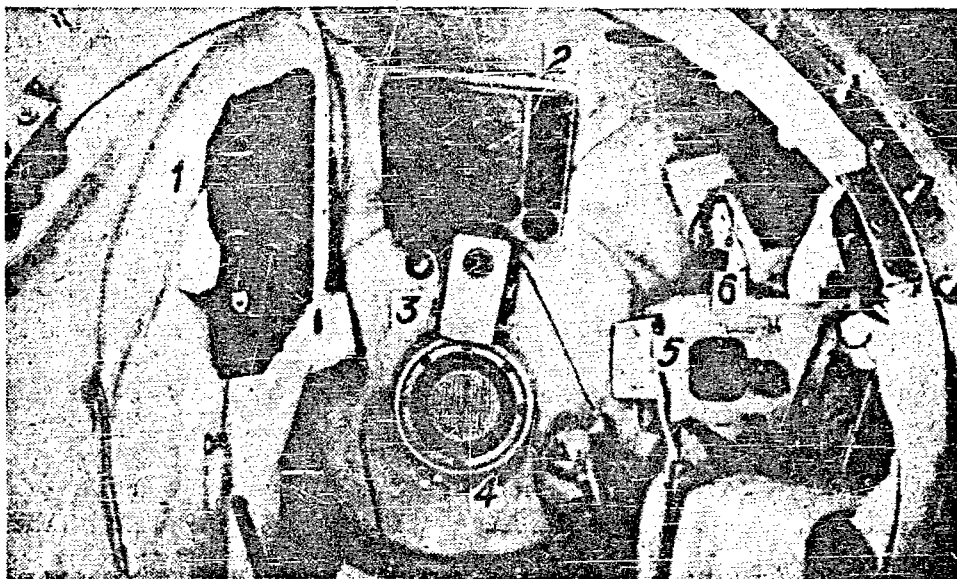

Fig. 2. View of the interior of the astronaut's cabin in the spaceship "Vostok" [1]

1 - pilot's panel; 2 - instrument board with globe;
3 - television camera; 4 - porthole with optical orientator;
5 - lever for controlling the ship's orientation; 6 - radio receiver; 7 - food container

in the cabin was over, "the astronaut lifts himself from the seat, firmly grips the handle and jumps out of the sphere". [9] The word sphere, which is used here without quotation marks, apparently refers not only to the name of the training cabin, "Sphere One", but also to the cabin's shape. These remarks indicate that the "Vostok" and the previous Soviet spaceships were equipped with spherical cabins, because, as noted above, the "Vostok" is described as similar to the previous Soviet spaceships, and the training cabin in the laboratory was similar to the cabin of the "Vostok".

In Fig. 1, the spherical cabin 2 is shown located in the ship's housing 1. This location is assumed on the basis of a statement made by Gagarin in discussing the meeting of the astronauts with the chief designer of the Soviet spaceships. The chief designer explained that the external surfaces of the ship and of the pilot's cabin are covered

AID Report 61-101

with heat protection. [10] This observation suggests that, since the pilot's cabin as well as the spaceship itself has its own external surface, the two are probably different units of the structure. In Fig. 1 the ship itself is shown as a cylindrical housing 1 and the pilot's cabin as sphere 2. The relative positions of the cylindrical housing 1 and the pilot's cabin 2 (Fig. 1) are shown on the basis of the following considerations.

The housing of the cabin has three portholes and two fast-opening hatches. The portholes, made of heat-resistant glass, are designed for visual observation during the entire flight. An optical orientator is mounted on one of the portholes. [1] The dogs Belka and Strelka in the second ship-satellite and Gagarin in the "Vostok" were photographed by the same television camera, according to Gagarin's account. When the chief designer demonstrated the spaceship for manned flight to the astronauts, Gagarin says, he showed them the same television camera which was later used on the second ship-satellite. [6] As has been previously shown, the second ship-satellite carried two small TV cameras. One, placed directly on the hatch of the container, transmitted a full-face picture of the dog Belka taken through the hatch window. The second was located in a position in the cabin from which it could transmit a side view of the other dog, Strelka, taken through the side window of the container. [7, p. 84] The TV camera mentioned by Gagarin is probably the one that transmitted the pictures of Belka, because the Soviet writers generally consider the full-face view camera to be the main camera and the side-view camera to be auxiliary. If so, the camera trained on Belka must have been located at the same place in the second ship-satellite where the camera is shown in Gagarin's cabin (Fig. 2). However, the "Vostok" was equipped with two TV cameras, as was the second ship-satellite. According to one article, the camera shown in Fig. 2 constantly observed the pilot and transmitted his picture, and a second camera was placed in the cabin, which is not visible in this photograph. Two images of the astronaut were simultaneously transmitted to the earth during the flight, full-face and sideview. [11]

The foregoing discussion makes it possible to conjecture that the dogs were located in the second ship-satellite as shown in Fig. 1. Reference 7 (pp. 91-93), angle A shown in Fig. 1 (a) was determined to be about 20° . The lengthwise axis of the container in the second ship-satellite was probably perpendicular to the center of the fast-opening hatch 3, because the dog container was catapulted through this

hatch. Thus, the position of hatch 3 in the spherical cabin 2 can be determined by angle A and from Fig. 2, where the relative positions of this hatch and parting line 10 are shown. The position of the fast-opening hatch 3 relative to porthole 5, the instrument board with globe 6, television camera 7, and pilot seat 11 is shown in Fig. 1 (b) according to Gagarin's description of the pilot's cabin. He states that in front of the astronaut are located the instrument panel with several needle indicators and "signal tableaux," an electric clock, and also a globe whose rotation is synchronized with the motion of the ship along its orbit. Below the instrument board was a TV camera for observing the astronaut from the earth and below the camera was the porthole with the optical orientator. [10]

This statement indicates that the pilot's seat was located in the spherical cabin 2 as shown in Fig. 1 (b). From this position, the astronaut was able to see the instrument board and observe the earth's surface through porthole 5 during the flight. According to Apenchenko [9], during re-entry the earth's surface should "run" from under the astronaut's foot up the porthole with the orientator; this accords with the relative positions shown for porthole 5, pilot seat 11, and wing 12. The sources give no data on angle A for the position of the pilot's seat. Gagarin states only that the seat is located in the cabin at such an angle that the acceleration forces act in the chest-back direction. [10] Since all the Soviet spaceships are said to be similar, the angle A for the pilot's seat was probably about 20°, as was the angle A for the container holding Belka and Strelka.

In manned flight, the pilot seat can be catapulted through the fast-opening hatch in 4 Fig. 1 (b). The pilot can leave the cabin through the fast-opening hatch 3 if a failure occurs in the catapulting system during landing. If the ship lands on water, the pilot will be able to leave the cabin through fast-opening hatch 3 or 4.

There are several indications that the cylindrical housing 1 has a door 8 and spherical cabin 2 is equipped with hatch 9. The door is mentioned by several authors. Discussing the start of Gagarin's flight, Golikov and Smirnov state that Gagarin fastened himself in the seat and waved his hand, and the "heavy metallic door of the cabin" was closed behind him. [12] N. P. Kamanin states, however, that the "heavy door of the spaceship" was shut behind Gagarin. [13] In an artist's conception of a Soviet manned spaceship, Professor Pokrovskiy shows a door in the cylindrical housing of the ship. [14] Gagarin himself discusses how he took his seat in the

cabin for the flight. He says he came into the cabin, smelled the air of the field, was placed in the seat, and the hatch was closed noiselessly. [15] He does not specify which hatch, but it was probably not the large fast-opening hatches 3 or 4, because hatch 3 is equipped with optical orientator 5 and TV camera 7, which are connected with the instrument panel, and hatch 4 is intended mainly for catapulting the pilot's seat. In addition, it would appear that the two fast-opening hatches are used only for special purposes, not as entrances to the cabin. They are probably not even equipped with hinges, in view of the fact that the fast-opening hatch of the second spaceship was separated from the ship before the container with Belka and Strelka was catapulted. [7, p. 85] Altogether, it seems logical to infer that Gagarin entered the spaceship through door 8 and the cabin through hatch 9.

Fig. 3 is a reproduction of a color sketch of a spaceship with a spherical cabin published in *Tudomány és technika* [16], a Hungarian popular science periodical. Although the sketch is not specifically identified as the "Vostok", it accompanies an account of Gagarin's flight. The weight given for the spaceship is 4725 kg, the same as the weight officially announced for the "Vostok".

Fig. 3. (See next page) 1 - the basic unit, a pressurized chamber; 2 - astronaut on tilting couch; 3 - equipment for changing the position of the pressurized chamber protecting the astronaut from the discomforts of acceleration and deceleration; 4 - cabin's oxygen tank and air-regenerating equipment; 5 - radar; 6 - control instruments; 7 - rocket deceleration control; 8 - supply of concentrated food; 9 - water-purifying equipment; 10 - communications system; 11 - various electrical devices; 12 - batteries and equipment for measuring external conditions; 13 - outer shell made of an alloy which can withstand high temperatures; 14 - automatic aerodynamic brakes; 15 - parachute compartment; 16 - small rockets for decelerating capsule. Small drawings in corners of figure show spaceship's orbit and capsule burning on reentry if various reentry steps are not undertaken.



Fig. 3. First Man in Space. A Simplified Drawing of a Space Capsule Weighing 4725 kg

AID Report 61-101

REFERENCES

1. Man's first flight into space. (Official) Izvestiya, 25 Apr 1961, 1, 3, and 4.
2. Shternfel'd, A. Yesterday, today, and tomorrow. Sovetskaya Rossiya, 30 Apr 1959, 3.
3. Gagarin, Yu. The way into space. Pravda, 2 Jun 1961, 3.
4. Gagarin, Yu. The way into space. Pravda, 7 Jun 1961, 4.
5. Grigor'yev, V. Training of an astronaut. Krasnaya zvezda, 18 Apr 1961, 2.
6. Press conference report. An unprecedented trip to the stars. Pravda, 16 Apr 1961, 1 and 2.
7. AID Report 61-72. Comprehensive analysis of the Soviet space program.
8. Shternfel'd, A. The strangeness of space navigation. Sovetskaya Rossiya, 12 Mar 1961, 4.
9. Apenchenko, Ol'ga. Captains of space. Komsomol'skaya pravda, 16 Apr 1961, 4.
10. Gagarin, Yu. The way into space. Pravda, 4 Jun 1961, 3.
11. In the astronaut's cabin. Znaniye-sila, no. 5, 1961, 6.
12. Golikov, A., and I. Smirnov. Start! Ogonek, no. 16, 1961, 6-7.
13. Kamanin, N. P. Everything is working normally. Ogonek, no. 20, 1961, 6-7.
14. Pokrovskiy, G. I. "Good luck". Artist's conception of the Soviet manned flight. Vestnik vozdushnogo flota, no. 4, 1961, insert between pp. 32 and 33.
15. Gagarin, Yu. The way into space. Pravda, 11 Jun 1961, 6.
16. The first man in space. Tudomány és technika, no. 9, 8 May 1961, back cover.