

UNCLASSIFIED

---

---

AD 262 538

*Reproduced  
by the*

ARMED SERVICES TECHNICAL INFORMATION AGENCY  
ARLINGTON HALL STATION  
ARLINGTON 12, VIRGINIA



---

---

UNCLASSIFIED

NOTICE: When government or other drawings, specifications or other data are used for any purpose other than in connection with a definitely related government procurement operation, the U. S. Government thereby incurs no responsibility, nor any obligation whatsoever; and the fact that the Government may have formulated, furnished, or in any way supplied the said drawings, specifications, or other data is not to be regarded by implication or otherwise as in any manner licensing the holder or any other person or corporation, or conveying any rights or permission to manufacture, use or sell any patented invention that may in any way be related thereto.

747  
200

MINI

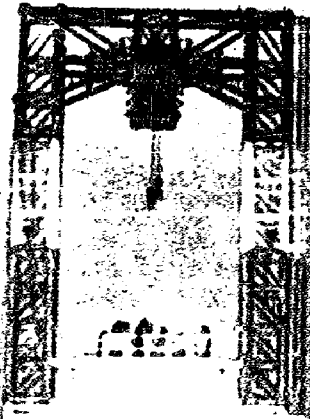

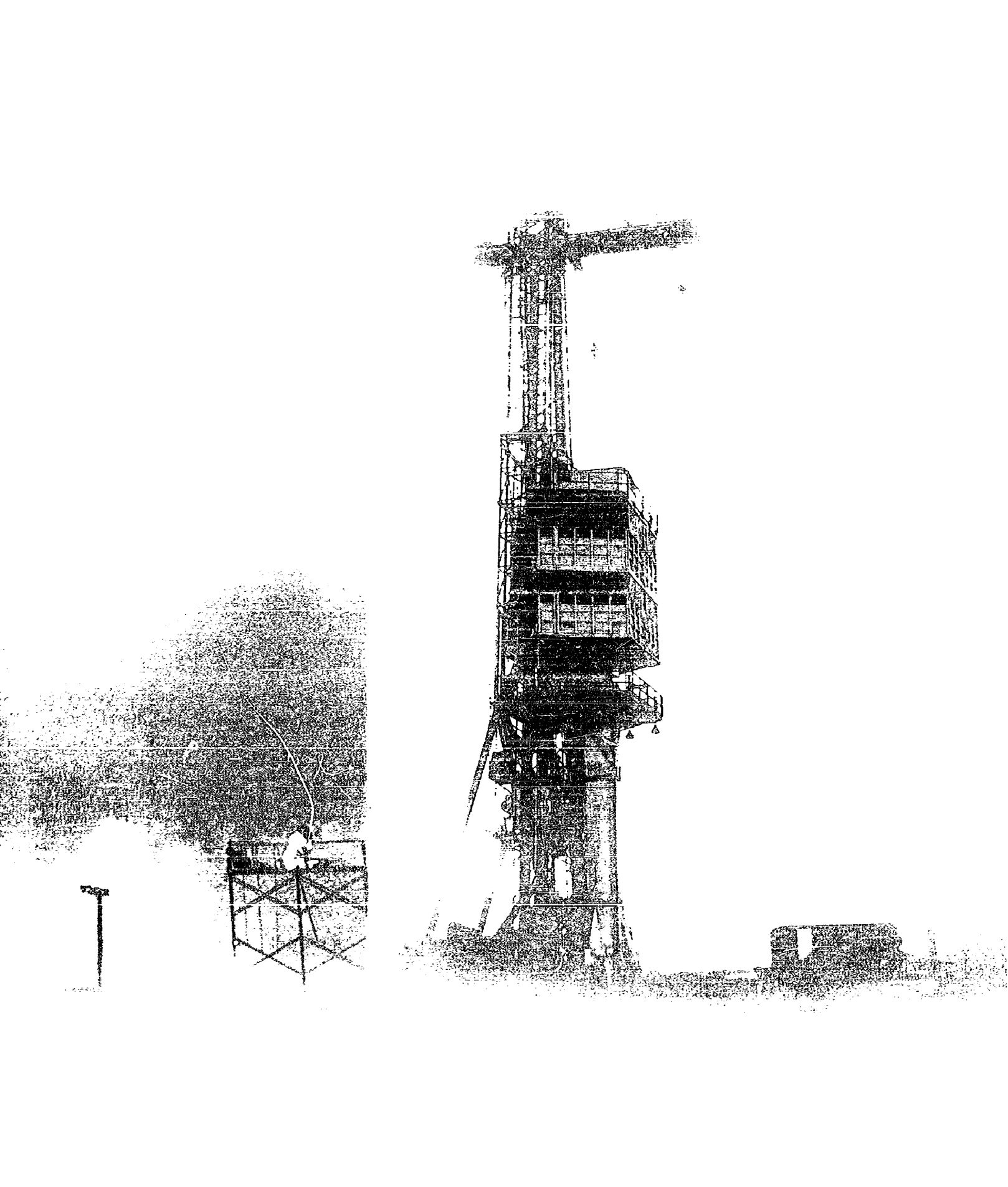



3

September 20, 1956, 1:47 am EST.

A modified *Redstone* missile, designated *Jupiter-C*, was launched through a heavy cloud cover to climb nearly 700 miles into space and plunge over 3000 miles down the Atlantic Missile Range. All stages of the re-entry test vehicle performed satisfactorily; communication was maintained. The mission was a success on the first firing. *Had the last rocket stage been loaded, the spinning payload could have been placed in orbit around the Earth.*

August 8, 1957, 1:59 am EST.

The *Jupiter-C* was again fired high and long down the Atlantic Missile Range. Passenger for this flight was a scale *Jupiter* IRBM nose cone, being tested for re-entry survival. The cone was recovered. The application of the ablation technique for protection against the effects of hypersonic re-entry velocities was proved.

January 31, 1958, 10:55 pm EST.

*Explorer I*, the free world's first Earth satellite, was placed in orbit on the first firing attempt, making the initial discovery of the intense upper-altitude radiation belts. The launch vehicle was the same basic *Jupiter-C* used for the re-entry tests in 1956 and 1957.

March 3, 1959, 12:10 am EST.

*Pioneer IV*, using a modified *Jupiter* IRBM, achieved Earth-escape velocity and was injected into space to establish a new tracking communication record and assume a heliocentric orbit with a possible life to equal that of the solar system.

# The JUNO

The code name *JUNO* was given to a series of scientific Earth-satellite and space-probe firings conducted cooperatively by the Army Ballistic Missile Agency (ABMA) and the Jet Propulsion Laboratory (JPL) as part of the United States' participation in the International Geophysical Year (IGY) program. The responsibility for non-military space-flight activities under the *JUNO* program was originally vested with the Department of Defense and their Advanced Research Projects Agency (ARPA), and later transferred to the National Aeronautics and Space Administration (NASA).

The *JUNO* program consisted of two parts, as defined by the two booster vehicles available. The *JUNO I* program utilized the modified *Redstone (Jupiter-C)* for Earth satellites in the 15- to 30-pound class. The *JUNO II* program utilized the higher energy capabilities of the modified *Jupiter* for space probes (Phase I) and Earth satellites in the 100-pound class (Phase II).

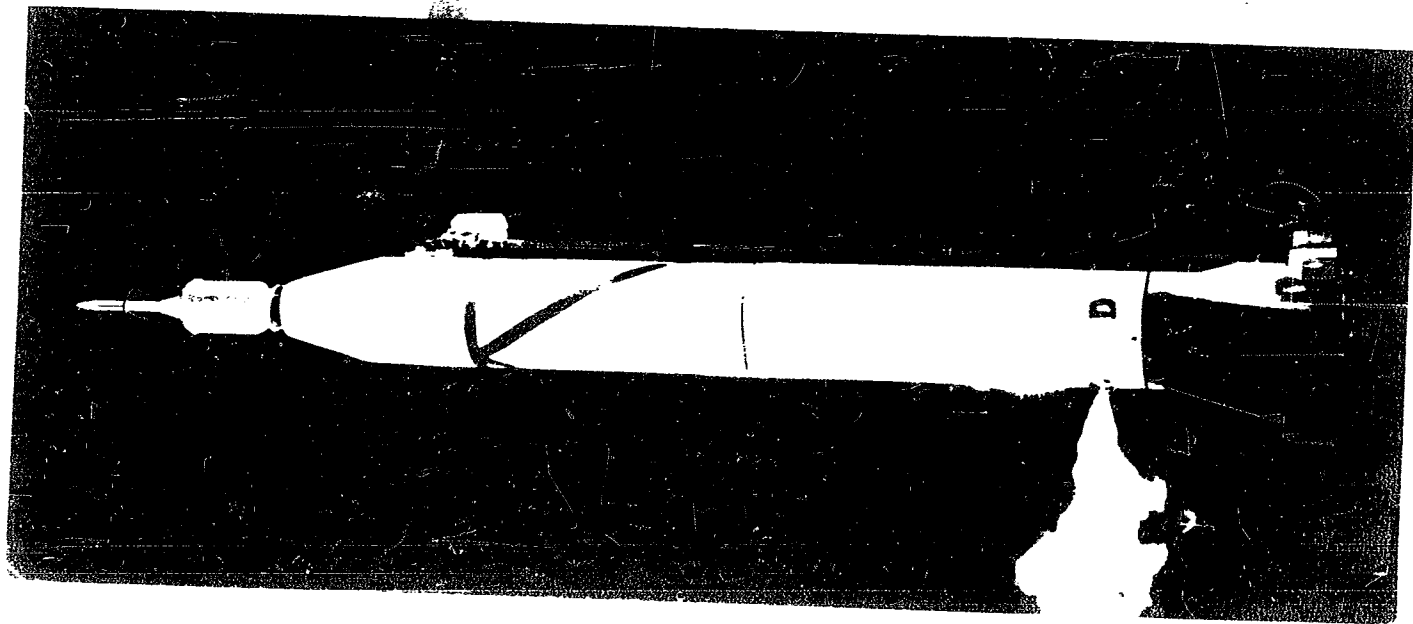

# Program

The one common denominator of the entire JON program was the spinning cluster of JPL high-speed stages that were mounted on top of both the *Redstone* and *Jupiter* vehicles. The high-speed stages were originally proposed in the Project *Orbiter* studies of 1954-55, and were developed initially for the RTV program of 1955-57.

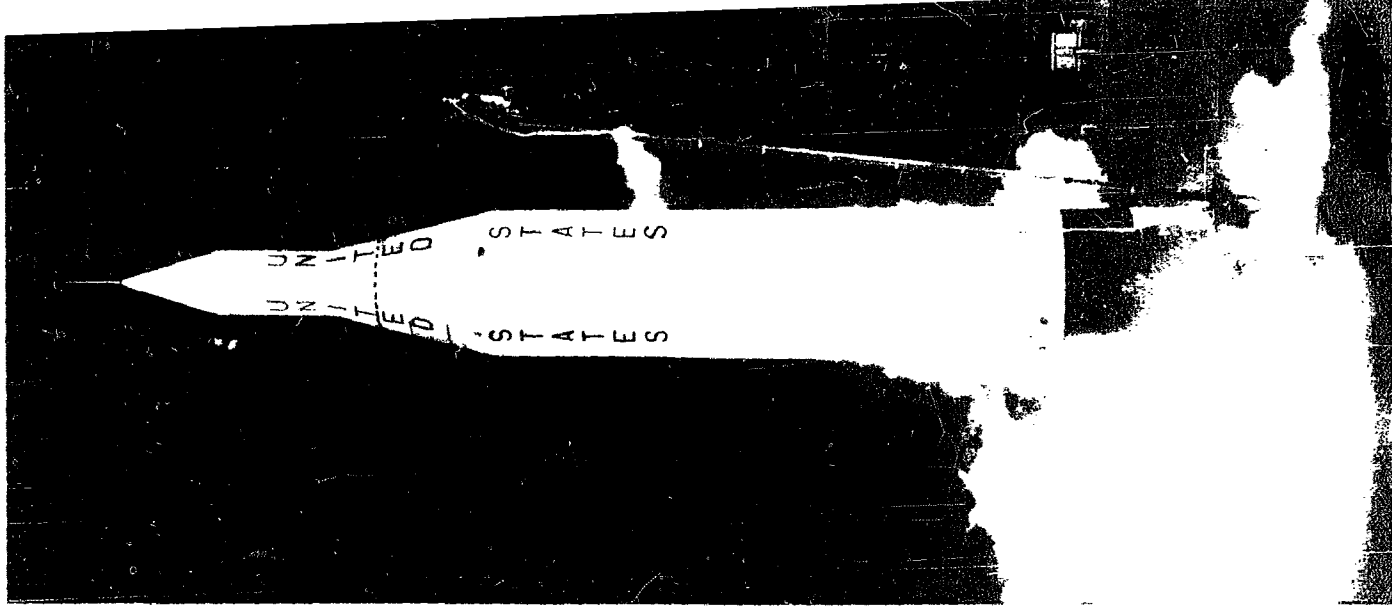

In the fall of 1954, the joint Army/Navy Project Orbiter was established with the ultimate objective of placing a minimum satellite in orbit around the Earth. The project was based on a proposal by the Army's Redstone Arsenal to use a four-stage vehicle that would utilize existing, proved, reliable rocket boosters. The proposed four-stage vehicle was to consist of a modified *Redstone* missile as the main booster and clusters of *Loki* solid-propellant rockets for the three-stage, spin stabilized, high-speed assembly. A single-rocket fourth stage was to carry the satellite payload. Design modifications to the *Redstone* were already under study as part of a concurrent re-entry test program.

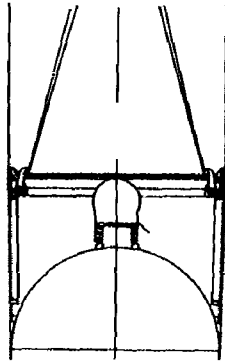

# PROJECT ORBITER

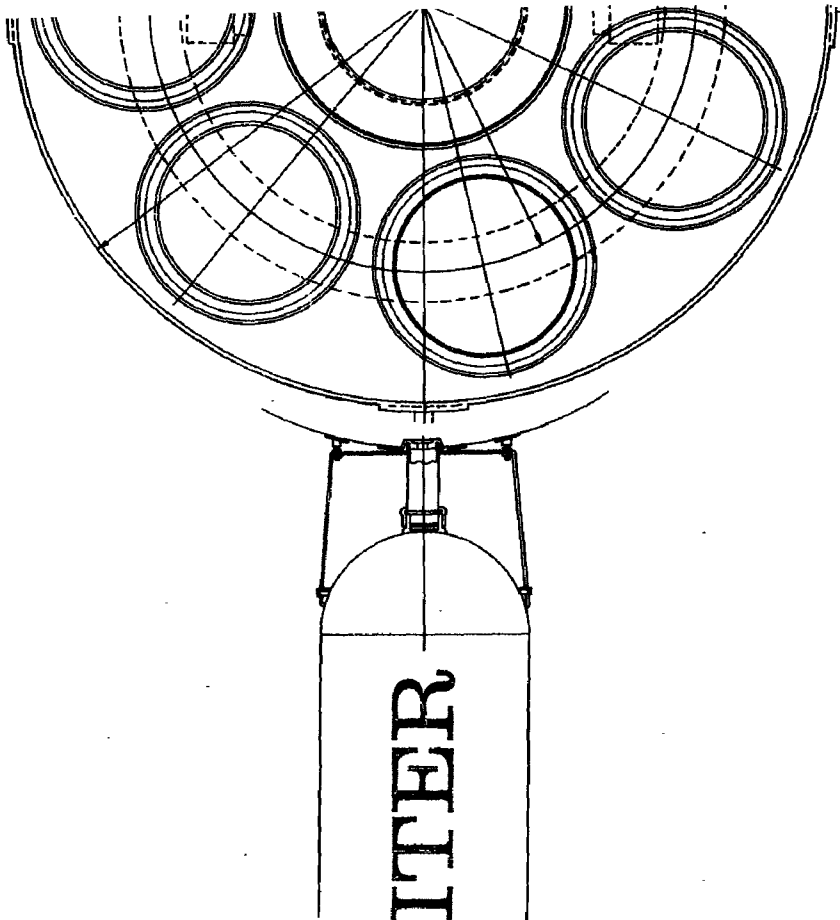

In support of the *Orbiter* program, JPL performed a feasibility study which eventually resulted in substituting scale *Sergeant* solid-propellant motors for the *Loki* rockets. The study indicated that the superior performance of the *Sergeant* motors would increase the payload capability of the vehicle and at the same time increase over-all reliability. A significant characteristic of the JPL feasibility proposal was that the high-speed assembly could be adapted for use with a re-entry test vehicle (RTV). As part of the feasibility study, the Laboratory also proposed a scheme for determining the trajectory of the satellite by radio techniques.

Project *Orbiter* was terminated in August, 1955, before the preliminary design phase was completed. Development effort on the high-speed stages, and the radio trajectory-determining system, was redirected toward the RTV objective.

## THE JUPITER-C

The *Jupiter-C* for the re-entry test program consisted of a high-performance version of the Army's liquid propellant *Redstone* ballistic missile, developed by ABMA, and two clustered stages of a scaled version of the Army's solid-propellant *Sergeant* motors, developed by JPL.

The *Redstone* booster was lightened, and lengthened to increase the fuel capacity. The standard warhead hull and nose cone were replaced by an instrument compartment on top of which was mounted a cylindrical launching tub containing the high-speed stages. The high-speed stages were rotated about the longitudinal axis (to reduce the effects of thrust dispersion) by two electric motors mounted in the instrument compartment. The instrument compartment was separated from the main booster after burnout and attitude positioned by gas jets prior to firing the high-speed stages.

The *Redstone* was designated as Stage 1, and the high-speed clusters as Stages 2 and 3. Stage 4 (as originally proposed) was replaced by an inert motor and beacon payload for Round 27, and by the scale *Jupiter* nose cone and a recovery package for Rounds 34 and 40.

The re-entry test vehicle was designated *Jupiter-C* and was to be used for design verification of a nose cone for the *Jupiter IRBM*. Official authorization to proceed with the RTV development was given in September, 1955. Final design of the high-speed stages had to be established by January, 1956, to meet the first firing date in September, 1956.

## RE-ENTRY TEST VEHICLE

The first proof-test version of the *Jupiter-C* was successfully fired on schedule, September 20, 1956. The RTV program was concluded in August, 1957, with the first successful recovery of a re-entry nose cone; this test proved the application of the ablation technique for protection against the effects of hypersonic re-entry velocities.

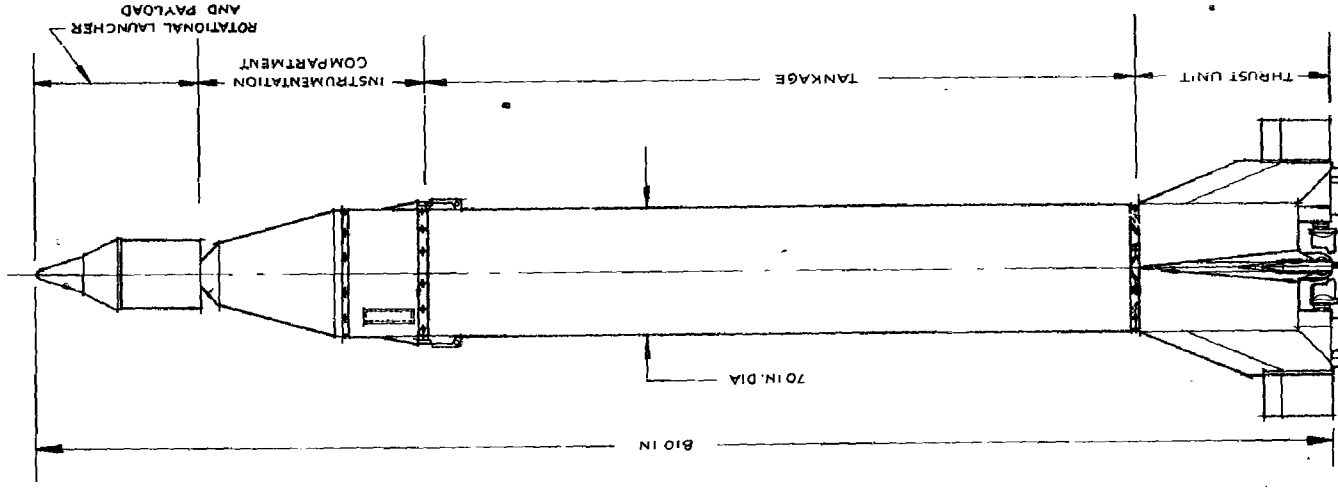

Development of the high-speed stages was influenced by several significant factors: the extremely short time schedule, reliability requirements, maintenance of the duplicate orbiting capability, and minimum budget.

A one-year development time coupled with the requirement for a high probability of success on the first firing demanded simplicity of design, and application of proved engineering, fabrication, and subsystem-testing techniques wherever possible. In addition, strict engineering drawing control was maintained to effectively conduct the concurrent design, development, and component proof-testing program.

## HIGH-SPEED STAGES

The high-speed stages consisted of clusters of scale *Sergeant* solid-propellant rocket motors. Choice of the *Sergeant* motors was based primarily on the consideration of reliability, since the performance and reliability of the individual scale *Sergeant* motor had been proved in some 200 static tests. The solid propellant was formulated at JPL and was of the case-bonded, radial-burning type with a star-shaped hole running nearly the full length of the 4-foot, 6-inch diameter motor.

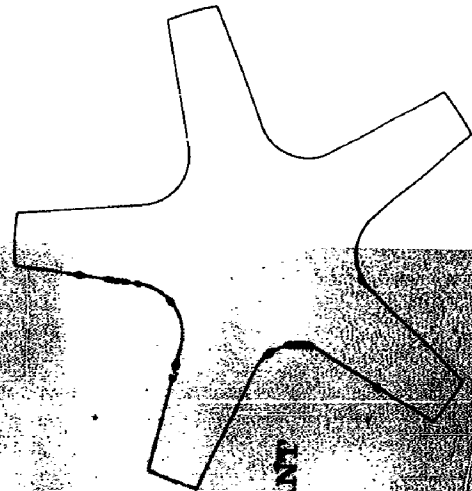
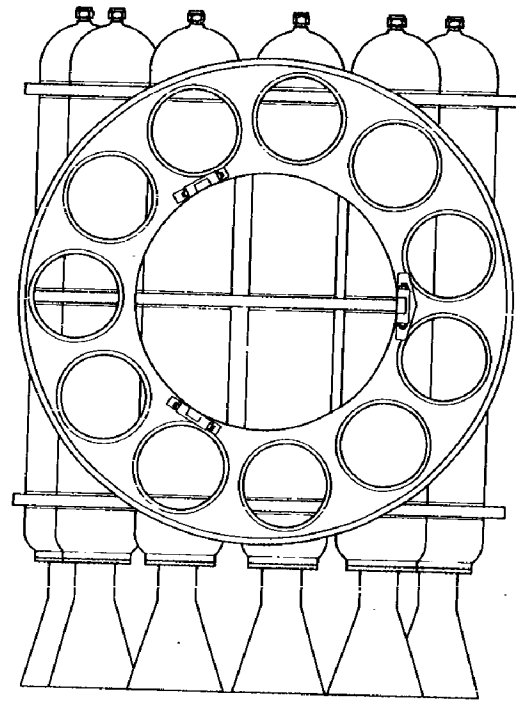

THE SERGEANT

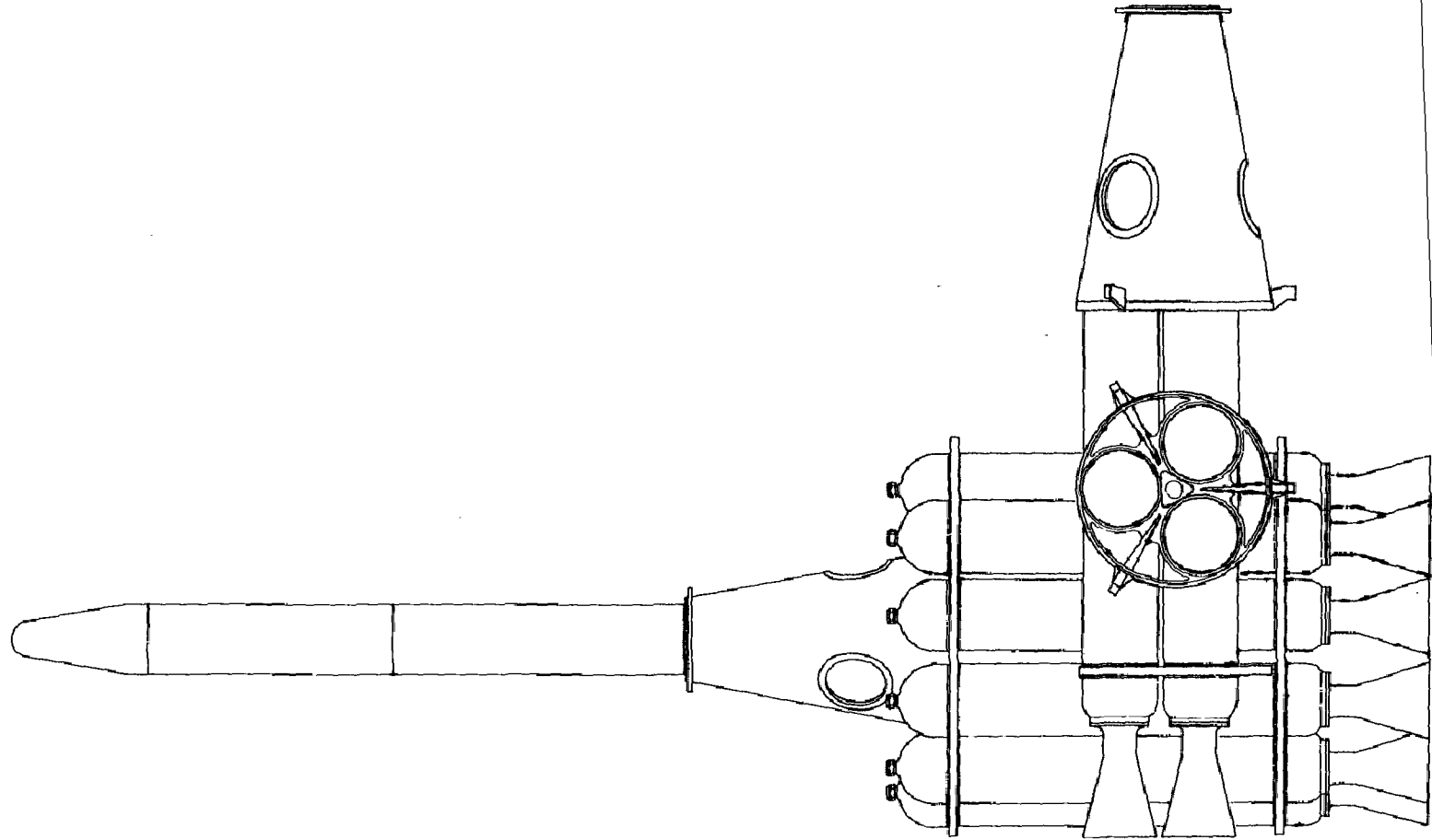

Two stages were required for the RTV mission and three for the potential orbiting capability. The first high-speed stage, designated Stage 2 of the *Jupiter-C* configuration, consisted of eleven motors assembled in a cylindrical ring formation by three transverse bulkheads, and attached to the rotational launching tub by an inner circumference tube. Within this tube was nested Stage 3 which consisted of three motors huddled together by transverse bulkheads. Stage 4 was designed to have a single orbiting motor and payload in series, to be mounted to a hollow truncated cone on the forward end of Stage 3. For the RTV mission, the recovery nose cone was attached to an adapter (that replaced the truncated cone) mounted on the forward end of Stage 3.

Spinup was initiated before launch and programmed during main booster burning. After separation from the main booster after burnout, the instrument compartment and high-speed assembly coasted in free flight. During the coast phase, attitude-control gas jets were programmed to aim the cluster properly for the firing of Stage 2 at a preselected point. Each stage was then fired sequentially after burnout of the previous stages, thereby attaining sufficient velocity for a re-entry trajectory, or satellite orbit when using Stage 4.

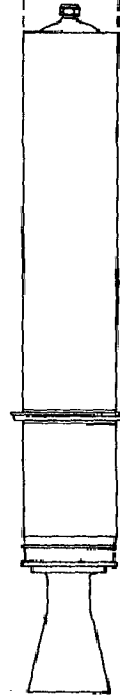

The RTV and potential orbiting missions required a minimum-weight, low-signal-level-detecting tracking and telemetering system. To meet this requirement the Jet Propulsion Laboratory developed a phase-locked-loop radio system, known as Microlock. The main feature of the system was its ability to lock to an extremely low-level signal. The lightweight missile-payload transmitter consisted of a crystal-controlled oscillator which was phase modulated by telemetering signals.

The primary unit of the ground station was a phase-locked receiver designed to detect the beacon signal and to track the doppler shift automatically. The Microlock antenna system used fixed helical

## MICROLOCK TRACKING AND COMMUNICATION SYSTEM

antennas either singly, in a multiple array, or in conjunction with a two-antenna interferometer system for determining angular position. Microlock stations were located at strategic points throughout the world along the payload trajectories to quickly and accurately determine their flight paths and record their telemetered data.

**Tracking of missile (or satellite) payloads by the Microlock station was accomplished by the use of an interferometer system.**

### JUPITER-C ROUND 27

Round 27 was successfully launched September 20, 1956. Principal objectives of the firing were to proof-test the staging techniques and structures of the three-stage, Jupiter-C configuration, and to investigate operation of a miniature dovap transponder and the Microlock insurramentation payload. The payload was attached to an inert fourth-stage motor and hollow truncated cone. The payload travelled more than 3000 miles down the Atlantic Missile Range with all systems working perfectly.

### JUPITER-C ROUND 34

Round 34 was launched May 15, 1957, and was the first missile to carry the scale Jupiter nose cone. The third stage of the Jupiter-C recovery configuration had a conical section that supported the nose cone and enclosed the recovery package. Although the cluster performed as expected, the missile did not follow the predicted trajectory due to guidance malfunction; consequently, recovery of the nose cone was not accomplished.

### JUPITER-C ROUND 40

Round 40 was launched August 8, 1957, and was the second test in which a scale nose cone was used. The nose cone was successfully recovered, fulfilling the mission of the RTV program. After Sputnik II was launched November 4, 1957, the nose cone was shown to a national TV audience by President D. D. Eisenhower.

ROUND 27 PAYLOAD

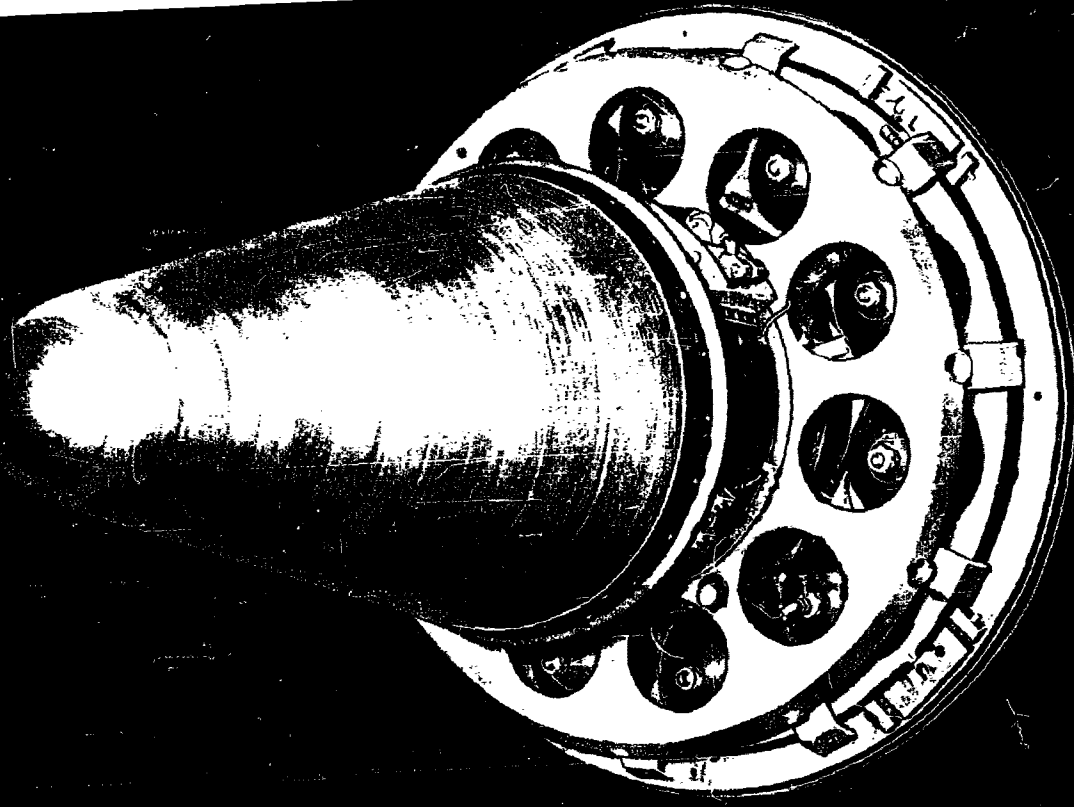

ROUND 40 NOSE CONE

# JUNO I

ON NOVEMBER 8, 1957, the Secretary of Defense announced that the Army was to participate in the IGY program. The code name *Juno I* was given to the satellite program and launch vehicles for the initial series of experiments—*Explorers I-V* and *Beacon*. The purposes of the experiments were to provide scientific information regarding satellite temperature, micrometeoroid impact and erosion, cosmic-ray count, geomagnetic field intensity, and atmospheric density.

The *Juno I* launch vehicles were the same basic *Jupiter-C*, as developed under the RTV program, with the addition of a Stage-4 motor and payload. The first three *Explorers* utilized existing boosters left over from the highly successful RTV program.

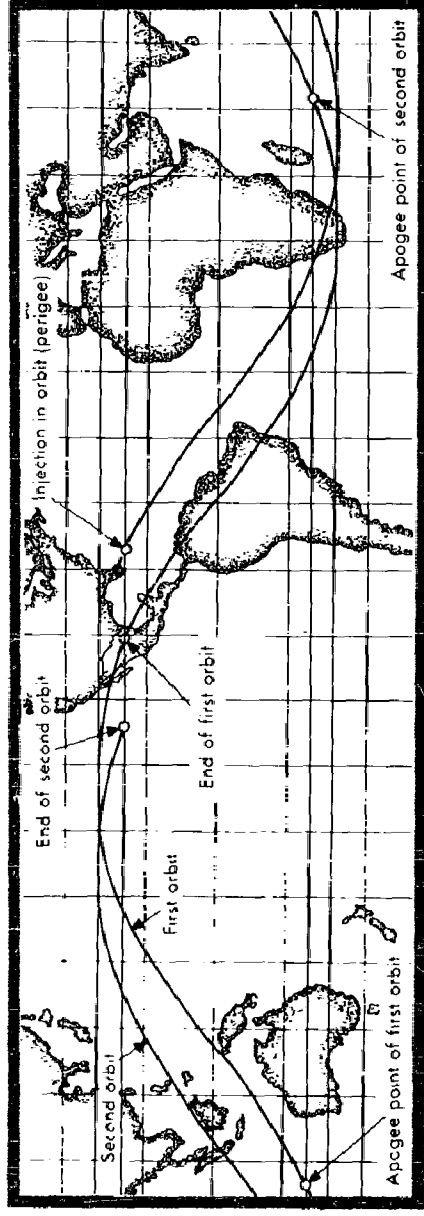

The *Juno I* mission was accomplished with the successful orbiting of *Explorers I, III, and IV*.

**I**N JUST 84 days from the announced authorization, at 5 seconds past 10:55 pm, EST, January 31, 1958, *Explorer I*, the free world's first Earth satellite, was placed in orbit through the cooperative efforts of the U. S. Army Ballistic Missile Agency and the Jet Propulsion Laboratory.

*Explorer I* was 6 inches in diameter and 80 inches long, and included the payload and the empty Stage-4 motor case. The payload was divided by a fiberglass ring into two compartments: a cylindrical instrumentation section and an aerodynamic nose cone. The stainless steel payload was sandblasted and striped with a white aluminum oxide coating to aid in thermal balance.

A midsection fiberglass ring served a multiple purpose as: support for the turnstile-antenna wires of the high-power transmitter, the dipole-antenna gap for the low-power transmitter, and thermal insulator against the Stage-4 motor.

All phases of the *Jupiter-C* vehicle, *Round 29*, performed satisfactorily, with the high-speed stages injecting the satellite into orbit at a velocity of 18,740 mph. Original estimates were that *Explorer I* would continue to circle the Earth for 6 years.

## EXPLORER I

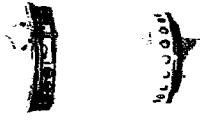
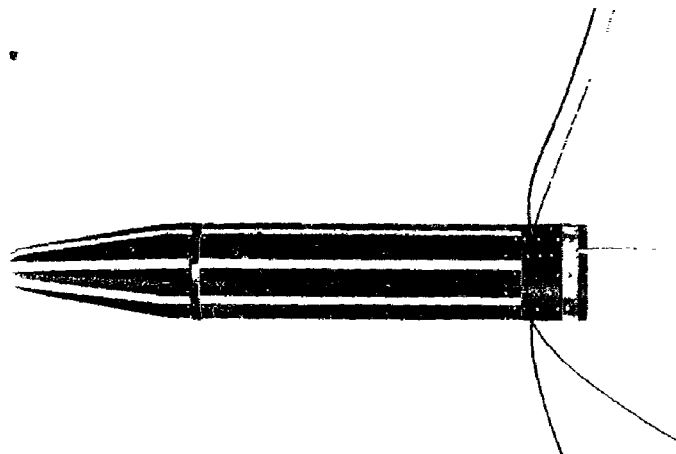

**E**XPLORER I used two completely redundant and transistorized transmitters, with a total of 8 telemetering channels to relay the environmental data to the ground tracking and communication stations; mercury batteries were used as the power source. The long-life, 10-milliwatt low-power transmitter was used in conjunction with the JPL developed, highly-sensitive Microlock system as the primary source of telemetered data. The 60-milliwatt high-power transmitter was used primarily in conjunction with Naval Research Laboratory's Mini-track system for orbit determination.

# EXPLORER I

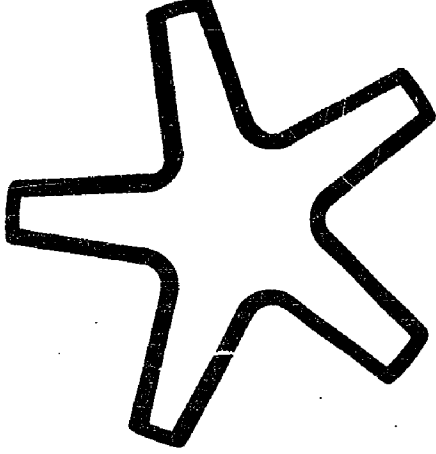
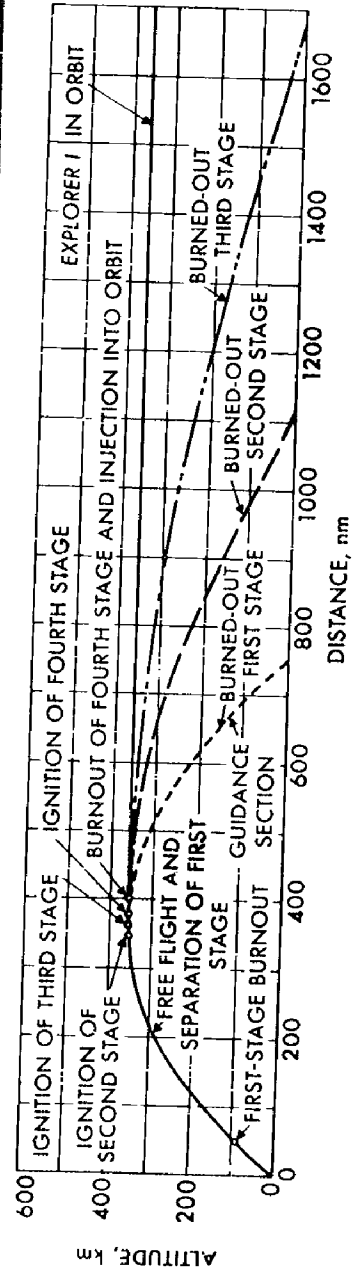

**T**HE SCIENTIFIC INSTRUMENTATION of the payload was divided into three categories: (1) cosmic ray, (2) micrometeoroid, and (3) temperature.

The cosmic-ray experiment consisted basically of a counting tube to measure, as a function of time and position, the cosmic-ray intensity outside the Earth's atmosphere.

The micrometeoroid experiment used an impact microphone and a set of twelve fracturable wire-grid erosion gauges to determine the statistical distribution of the space density and the relative momentum of micrometeoroids.

Temperature measurements were made at four locations to verify the application of surface coating for passive temperature control.

Ionospheric polarization effect, geomagnetic field intensity and atmospheric density information were determined by ground observation of the received radio signal and satellite orbital motions.

Initial Orbital Parameters	
Perigee	360 km
Apogee	2551 km
Eccentricity	0.1387
Inclination	33.3 deg
Period	114.7 min

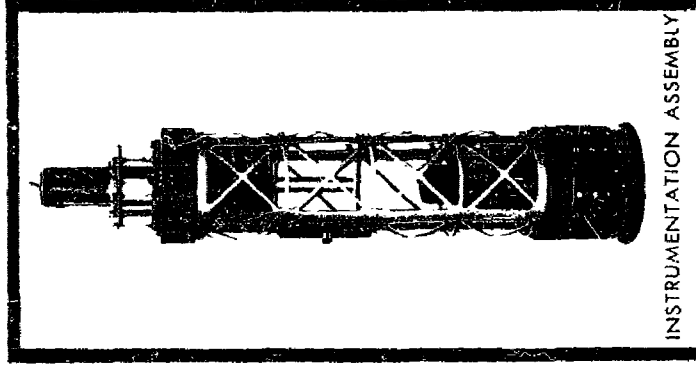

INSTRUMENTATION ASSEMBLY

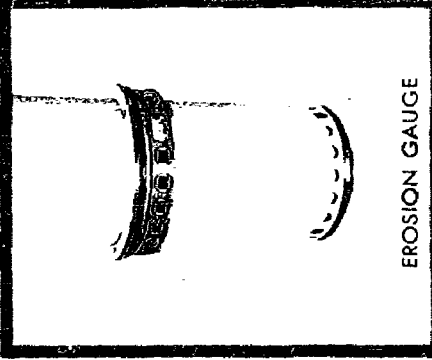

EROSION GAUGE

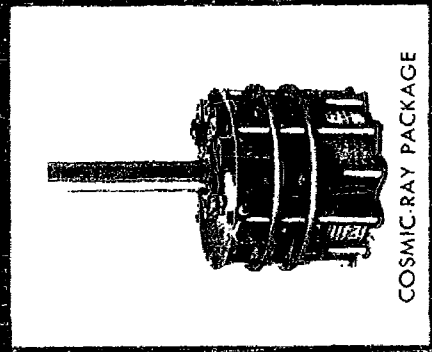

COSMIC-RAY PACKAGE

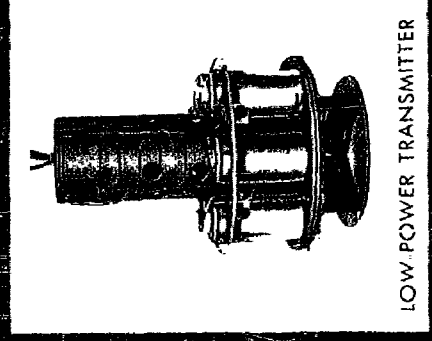

LOW-POWER TRANSMITTER

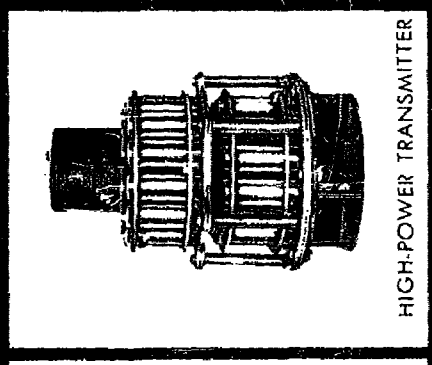

HIGH-POWER TRANSMITTER

**EXPLORER II** *Juno I Round 26* was launched on schedule at 59 seconds past 1:27 pm EST on March 5, 1958, and was intended to place *Explorer II* into orbit. Orbital velocity was not attained due to the lack of Stage-4 ignition. *Explorer II* satellite configuration was nearly identical with *Explorer I*, with the addition of a tape recorder for cosmic-ray data storage.

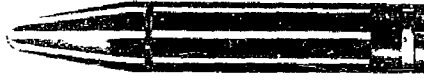

**EXPLORER III** was injected into orbit at 12:45 pm EST on March 26, 1958, by *Juno I Round 24*. The *Explorer III* payload instrumentation was very similar to *Explorer I*. The principal difference was the addition of a miniature tape recorder for storage and interrogation of cosmic-ray data, and elimination of the impact microphone and turnstile antenna. Valuable information was obtained regarding micro-meteoroid clouds and cosmic ray intensities. A large deviation in the local path angle at injection resulted in a high orbital eccentricity and limited the satellite lifetime to 93 days.

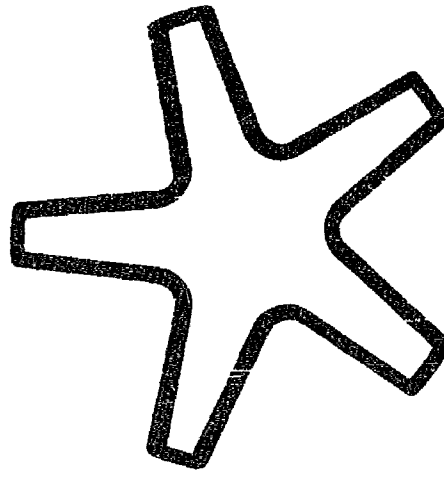

INITIAL ORBITAL PARAMETERS	
Perigee	188 km
Apogee	2801 km
Eccentricity	0.1660
Inclination	33.5 deg
Period	114.7 min

**EXPLORER IV** was injected into orbit at 10:06 am EST on July 26, 1958, by *Juno I Round 11*. The Stage-4 motor was loaded with a new high-performance propellant which allowed the payload to weigh nearly twice that of any previous *Explorer*. The payload was devoted entirely to radiation studies. The detectors included two Geiger-Mueller tubes and two scintillation counters, and were designed to measure artificial radiation, as well as natural, generated by small-yield nuclear detonations as part of the ARPA Project *ARGUS*. Lifetime of the satellite was 455 days.

**EXPLORER V** *Juno I Round 47* was launched on August 24, 1958, but was unsuccessful in placing *Explorer V* in orbit. The main booster launching was successful, but during the coast phase the separated *Redstone* thrust unit collided with the instrument compartment causing the cluster to be launched in the wrong direction. The firing was originally scheduled for August 9 but was delayed to allow time for payload modifications dictated by the results of the *Explorer IV* instrumentation. Both the instrumentation and Stage-4 motor were similar to *Explorer IV*.

**BEACON** *Juno I Round 49* was launched on October 22, 1958, but failed to place the *Beacon* (originally designated *Explorer VI*) payload into orbit, due to an inadvertent separation of the payload from the Stage-4 motor after liftoff. The principal payload consisted of an aluminum-foil covered inflatable plastic sphere for measuring high altitude atmospheric density by observation of its orbital characteristics. A nearly circular orbit was to be achieved by use of a perigee-increasing "kick motor."

INITIAL ORBITAL PARAMETERS

Perigee	262 km
Apogee	2210 km
Eccentricity	0.1279
Inclination	50.1 deg
Period	110.1 min

The *Juno II* - Phase I program was the result of a request in early 1958 for ABMA and JPL to utilize the increased capabilities of the Army's *Jupiter IRBM* booster to launch a space probe as part of the United States' participation in the IGY. JPL was to provide the high-speed stages, the space probe, and its associated ground tracking and telemetry equipment.

# JUNO II PHASE I

The basic objectives of the program were to measure cosmic radiation; and to establish the probe trajectory which was to verify the design of the tracking and communication system, and permit more accurate determination of the Moon's mass. These objectives were successfully accomplished with the launchings of *Pioneers III* and *IV*.



## THE JUPITER VEHICLE

The launching vehicle for the *Juno II*—Phase I mission consisted of a modified production *Jupiter* first stage, instrumentation compartment and rotational launcher, and the three-stage, high-speed assembly of scale *Sergeant* solid-propellant motors. The entire high-speed assembly was covered by a large aerodynamic shroud that fastened to the instrument compartment. The main body section of Stage I was elongated for greater fuel capacity to increase the burning time; the instrument compartment housed the guidance spatial control, the events programmer and cluster drive motors, and had the rotational launcher permanently attached.

The flight plan required separation of the instrument compartment and high-speed-assembly combination from the booster after burnout, shroud-cap ejection during the early coast period, proper attitude stabilization, ignition of the high-speed stages, and finally separation and despin of the payload after Stage-4 burnout.

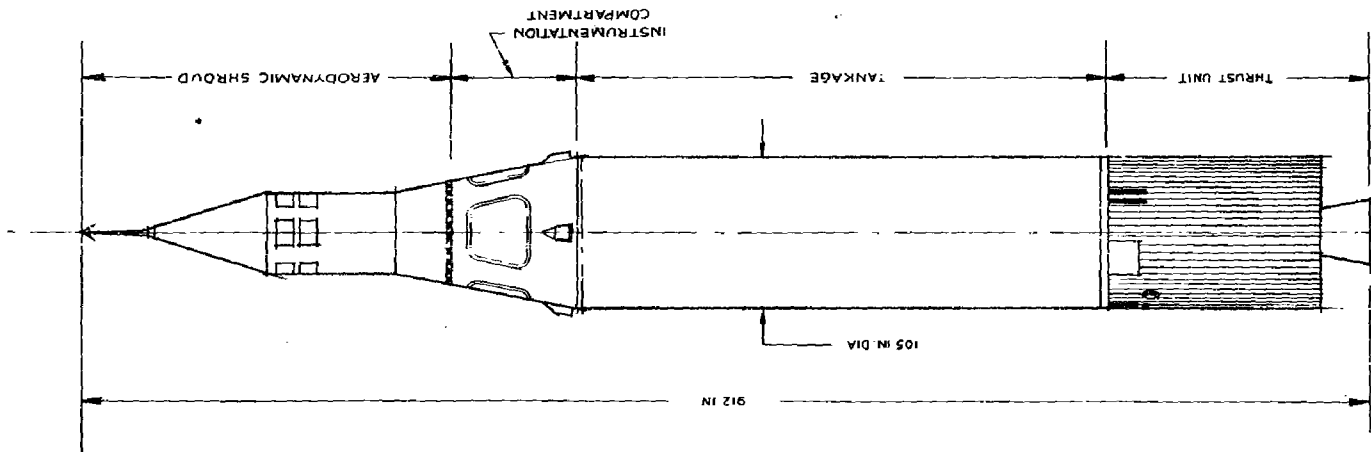

# DSIF

The tracking and communication system for the *Pioneer III* and *IV* space probes involved the early components of the presently established Deep Space Instrumentation Facility (DSIF), then referred to as the World Tracking Net.

In operation at that time was the equatorially mounted, 85-foot-diameter radio telescope at the Goldstone station, Camp Irwin, California. Stations were also established at the Cape Canaveral launch site and at Mayaguez, Puerto Rico, for tracking and communication during the early phases of the probe flight into space. The 250-foot radio telescope at Jodrell Bank, Manchester, England, participated independently in the *Pioneer* tracking operations.

The Goldstone and Puerto Rico tracking systems were basically the same except for their permanency and range capability, as differentiated by the size of their tracking antennas—85 feet as compared to 10 feet. Both systems utilized simultaneous lobing antenna beams, automatic tracking, and narrow-band, phase-locked receivers. The basic data supplied consisted of vehicle coordinates (angular position), one-way doppler (velocity), and telemetry (data).

Data from the three stations were channeled by telephone and teletype to the JPL computing center for trajectory determination and prediction.

## JUNO II PHASE I

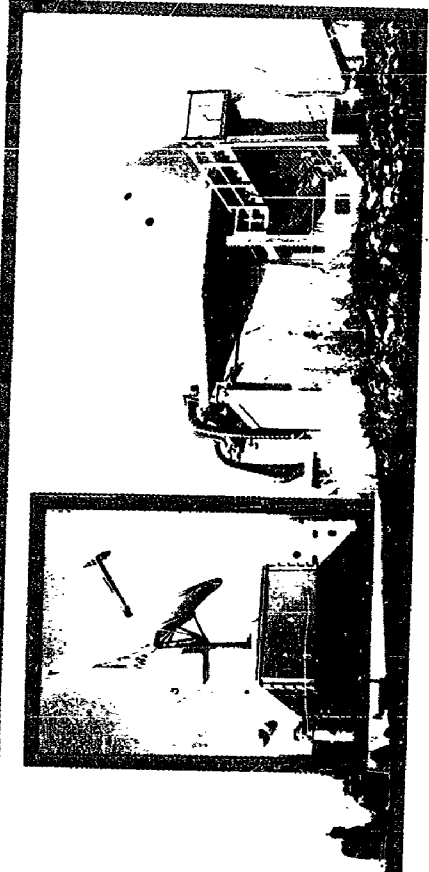

PUERTO RICO ANTENNA AND FACILITY

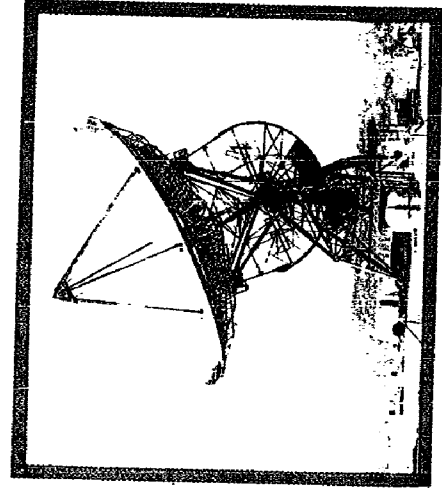

GOLDSTONE STATION

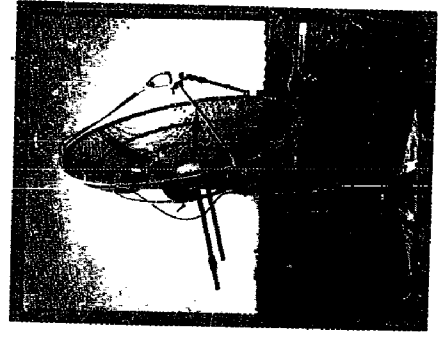

LAUNCH SITE ANTENNA

## THE PIONEERS

The *Pioneer* space probe was a 20-inch-long, gold-plated cone, that included a 9-inch-diameter instrumentation base and 3-inch-long, insulated antenna spike.

The thin fiberglass conical surface, and the instrumentation base, were striped with paint for thermal control. The gold plating made the conical surface electrically-conducting in order to serve as an unsymmetrical dipole antenna element in conjunction with the 3-inch spike.

Wrapped around the base was a two-wire mechanism for de-spinning the payload, which was necessary for operation of an optical trigger experiment.

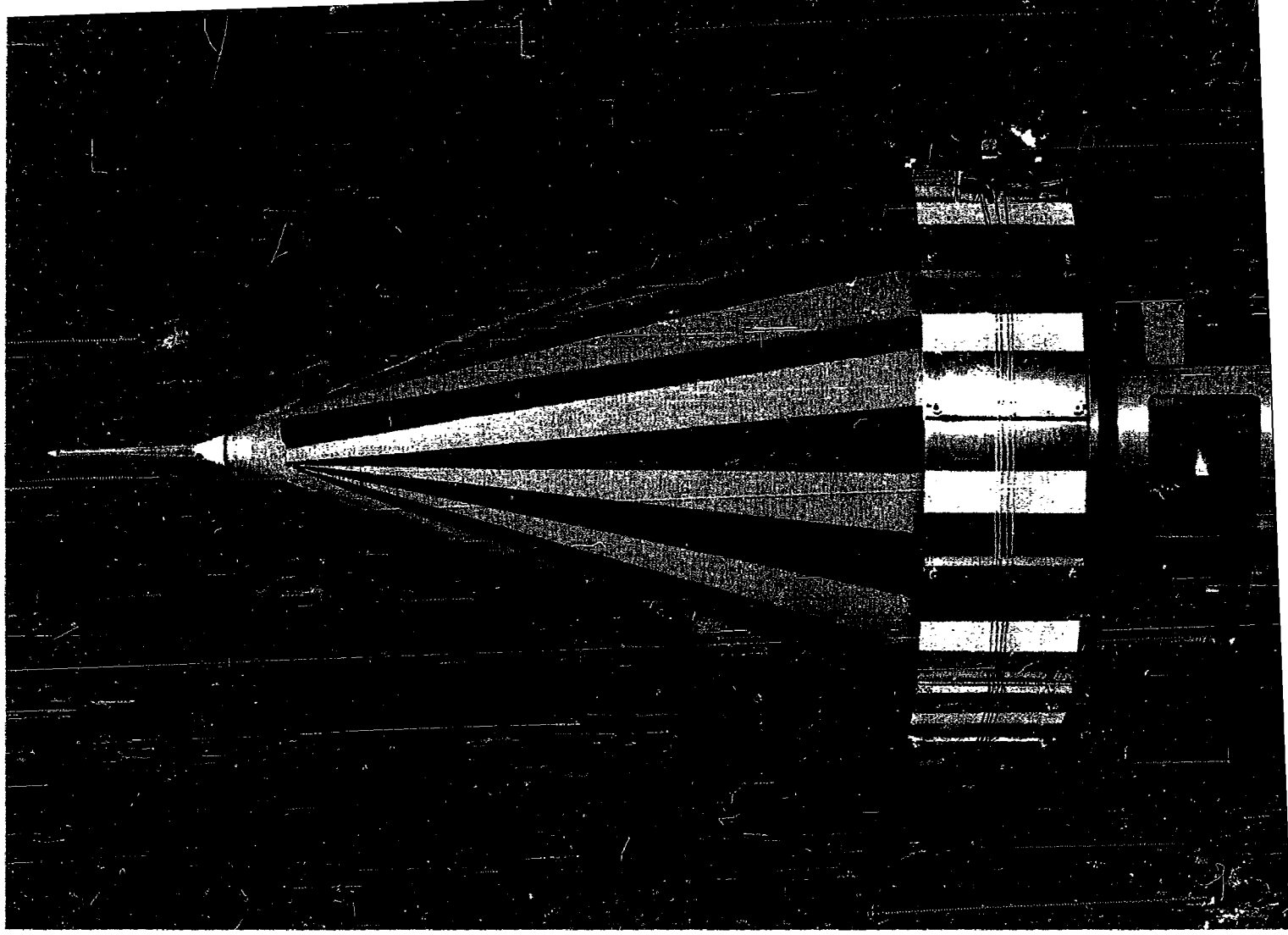

**T**WO GEIGER-MUELLER tubes were used, in conjunction with scalars, high-voltage power supply and associated circuitry, to further explore the upper altitude radiation regions that were discovered by the earlier *Explorer* satellite firings. The purpose of the experiment was to obtain a quantitative space profile



nominally between the Earth and Moon, and possibly beyond.

The telemetered data revealed that there were two distinct belts of radiation at approximately 3,000 and 10,000 miles altitude, and a series of narrow belts in a region between 30,000 and 60,000 miles.

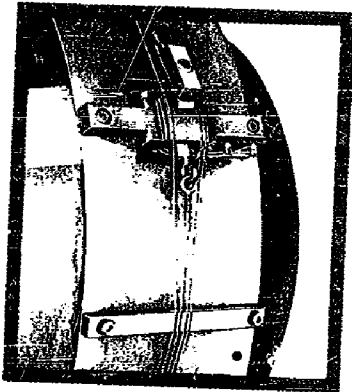

**T**HE DESPIN MECHANISM was a set of two 60-inch weighted wires, wrapped around the base of the payload in a direction opposite to that of the spin. When the weights were released, they flew outward due to centrifugal force, causing the cables to unwind, thus slowing down the payload spin. The wires were released upon full deployment. Although failing to operate on *Pioneer III*, the spin rate of *Pioneer IV* was reduced from 415 to 11 rpm.

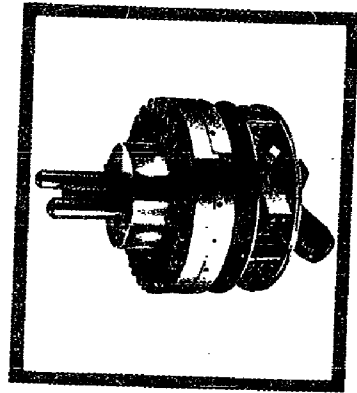
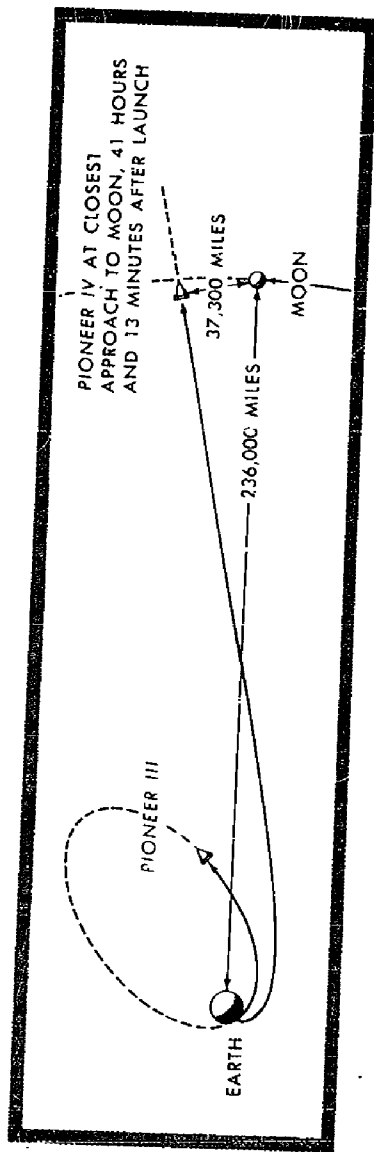

**T**HE PAYLOAD contained a tiny, transistorized, 1.1-pound transmitter with a total effective radiated power, including telemetry modulation, of 180 milliwatts. Three standard telemetry channels were used for relaying environmental and operational data.

Power to operate the telemetry oscillators and transmitter (as well as the radiation circuits) was furnished by a battery of 18 mercury cells mounted peripherally in the payload base.

**PIONEER III** (*Juno II Round AM-11*) was launched on December 6, 1958, at 00:44:52.3 EST, 4 seconds later than the optimum launch time. Initial acquisition by Goldstone of the probe, as it rose above the eastern horizon, was performed precisely from the spatial coordinate data supplied by the Puerto Rico station and converted by the JPL computing center.

Due to a premature cutoff of the booster and an angular dispersion in the high-speed stages, the probe failed to achieve escape velocity. A distance of 63,500 miles was achieved, however, leading to the discovery of the second Van Allen radiation belt.

**PIONEER IV** (*Juno II Round AM-14*) was launched on March 3, 1959, at 00:10:56.7 EST. Vehicle performance was such that at injection the velocity was below nominal, the pitch angle was low and the azimuth angle was slightly to the south. These errors resulted in the probe's closest approach to the Moon being 37,300 miles (7.2 deg E, 5.7 deg S).

Up to the time that the probe signal was lost due to battery exhaustion at 407,000 miles, the signal level at the Goldstone site was sufficiently high to indicate the capacity for tracking the payload to a distance of more than 700,000 miles. Since the probe did exceed Earth-escape velocity (24,611 mph), it continued out into the solar system and established a heliocentric orbit.

**Round AM-16.** Liftoff of *Juno II Round AM-16* occurred at 12:37:03 EST on July 16, 1959. The missile was destroyed by Range Safety after 5.5 seconds due to a malfunction in the booster electrical system. The 91.5 pound multi-experiment scientific payload was similar to the one successfully orbited by *Round AM-19A* later in October.

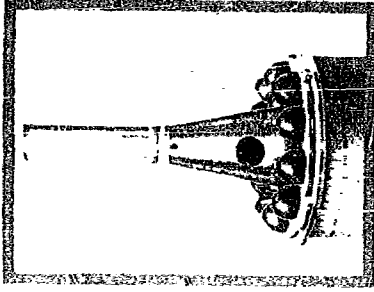

**Round AM-19B.** *Juno II Round AM-19B* was launched on August 14, 1959, but, due to guidance malfunctions, failed to orbit a 12-foot-diameter inflatable sphere and beacon instrumentation; the experiment was to determine the characteristics of the upper atmosphere in a region between 100,000 and 500,000 feet. The sphere was to be released from a blunt-ended, 7-inch-diameter cylindrical case mounted to Stage 3.

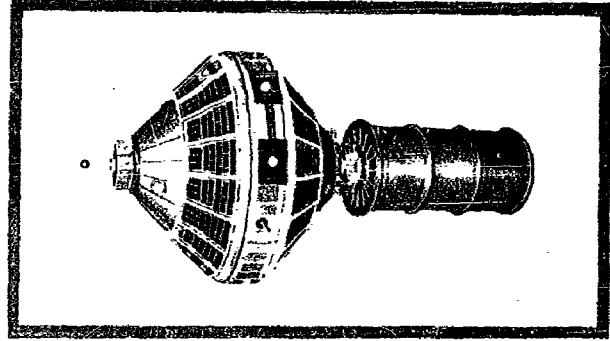

**Round AM-19A.** *Juno II Round AM-19A* was launched on October 13, 1959, and successfully placed the 91.5 pound multi-experiment *Explorer VII* into orbit. The scientific experiments included: a cosmic-ray, Lyman-Alpha, X-ray, and radiation and heat balance detectors; a micrometeoroid experiment; and heavy nuclei chamber.

INITIAL ORBITAL PARAMETERS	
Perigee	557 km
Apogee	1069 km
Eccentricity	0.0356
Inclination	50.3 deg
Period	101.2 min

THE *Juno II* Earth satellite program was the second phase of the *Juno II* program established originally by ARPA in early 1958, and later transferred to NASA on October 1, 1958. The *Juno II* —Phase II program was established to utilize the increased capabilities of the *Jupiter* booster for Earth satellite firings as part of the IGY. The vehicle for the satellite phase was the same *Juno II* modified *Jupiter* and four high-speed-stage configuration as used in the Phase I *Pioneer* series, with the addition of a support tube attached to Stage 3 to accommodate heavier payloads.

The staging responsibility was again an ABMA/JPL cooperative effort. Various agencies supplied the satellite payloads for a total of eight firings. The three successfully orbited payloads were designated *Explorers VII, VIII,* and *XI*.

**Round AM-19C.** *Junco II Round AM-19C* was launched on March 23, 1960, in an unsuccessful attempt, due to a cluster malfunction, to place a 22.5 pound Van Allen payload into a highly elliptical orbit. The purpose of the experiment was to make a detailed study of the two Van Allen radiation zones. The intensity distribution was to be monitored over an extended period of time to establish the origin, buildup and decay as related to solar activity. Also the experiment was designed to study the radiation composition, nature of the penetrating components and energy spectrum of the less penetrating components, and total energy flux in the trapped regions.

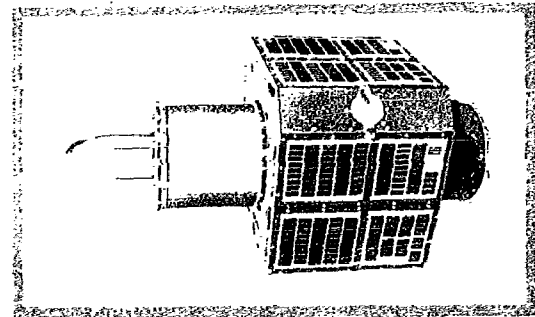

**Round AM-19D.** *Junco II Round AM-19D* was launched on November 3, 1960, and successfully placed into orbit *Explorer VIII*, instrumented to study and report the temporal and spatial distribution of the ionospheric parameters existing between 200 and 1200 km above the Earth. Correlative data comprised of measurements of the charge accumulations on the surface of the satellite and the relation of this data to electrical drag and density of the medium; also, measurements of the frequency, momentum and energy of micrometeoroid impacts were to be taken.

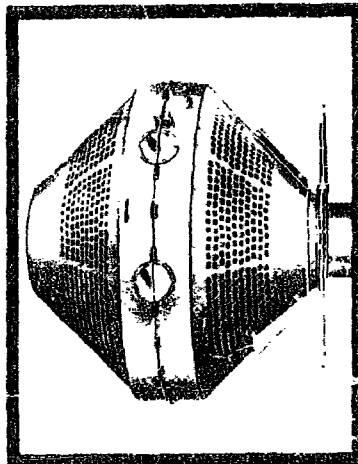

INITIAL ORBITAL PARAMETERS	
Perigee	459 km
Apogee	2289 km
Eccentricity	0.1211
Inclination	50.0 deg
Period	112.7 min

**Round AM-19F.** *Junco II Round AM-19F* was launched on February 24, 1961, in an unsuccessful attempt to place a 75-pound ionosphere beacon satellite into orbit. The payload was similar to that launched by *Round AM-19G*. Failure to orbit was apparently initiated by a mechanical malfunction of a shroud component.

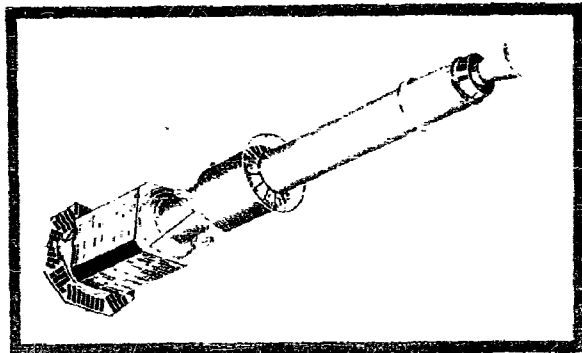

**Round AM-19E.** *Junco II Round AM-19E* on April 27, 1961, successfully placed into orbit the 85-pound gamma ray astronomy satellite — *Explorer XI*. The primary objective was to detect and map the high-energy gamma rays resulting from neutral pi-meson (pion) decay and to relate this data with the density of cosmic-ray flux and interstellar matter. The secondary objective was to measure the ratio of the high-energy gamma rays reflected by the Earth's atmosphere to the quantity of gamma rays falling upon the Earth.

INITIAL ORBITAL PARAMETERS	
Perigee	497 km
Apogee	1793 km
Eccentricity	—
Inclination	28.5 deg
Period	108.1 min

**Round AM-19G.** *Junco II Round AM-19G* was launched on May 24, 1961, in a second unsuccessful attempt to place a 75-pound ionosphere beacon satellite into orbit. The payload was designed to provide a means to study the ionosphere by propagating signals through the ionosphere. These signals would enable the acquisition of data relative to ionosphere absorption, anomalies, integrated electron density and Faraday rotation measurements, and possible transmission-time delays.

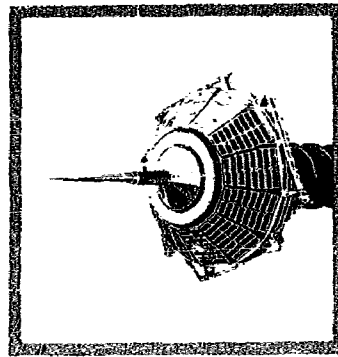

**T**wo system-development axioms were verified from the engineering policies successfully utilized in the development of the cluster system: (1) An advance in the state-of-the-art from a system stand point should not depend on advancement of the state-of-the-art in detail, (2) When timing and funding restraints are predominant, it is fundamental to base action, in a design and operating sense, on proved knowledge and simplicity.

In August, 1955, the initial planning indicated that to design and develop the cluster system for a high probability of working on its first flight atop the *Redstone* would require 2½ years and \$2,500,000. These figures were based on a normal development program assuming considerable advancement in the state-of-the-art and much environmental testing of the subsystems and the complete system. However, it was determined that, in order to be useful as a *Jupiter* nose cone re-entry test vehicle, the first flight of the *Redstone*/cluster system must occur in September, 1956. JPL was given only one year and \$500,000 to accomplish this first flight.

## SIGNIFICANCE OF THE CLUSTER SYSTEM DEVELOPMENT

These circumstances dictated the course of the design. It was clear that the development tests of the cluster system would have to be conducted on the first flight. No opportunity existed for stage, interstage, or complete cluster tests in simulated environments. These circumstances were probably fortuitous in that they forced a simple and conservative approach—simple, referring to the simplicity of the design, interfaces between booster and payload, and field operations; conservative, referring primarily to the use of *proved engineering*, fabrication, and testing techniques, insofar as possible, rather than high safety margins.

Having initially decided to use the scale *Sergeant* motors, of which some 200 static tests had already been performed, a no-change attitude was assumed with respect to the propellant grain composition and geometry, since the statistical information already generated had to be applied to the analysis of cluster performance and dispersion.

The clustering of many motors created a serious problem of thrust dispersion control. The accuracy with which such a system could follow a preset flight path was probably the only facet of the design to which the proved-techniques philosophy could not be applied *in toto*; accurate analysis and prediction was impossible by methods and facilities available at the time. The extreme difficulty of the dispersion analysis had its beneficial effect on the design in that extreme pains were taken to control, within narrow limits, the factors affecting dispersion.

What were the results? No failures occurred in the more than 600 static tests of the scale *Sergeant* motor. Flight tests were conducted on schedule, and the cluster performance was completely successful on the first four flights; these included the three 3-stage re-entry type configurations and the 4-stage *Explorer I* configuration.

**UNCLASSIFIED**

**UNCLASSIFIED**