

VARICOMP -
A METHOD FOR DETERMINING
DETONATION-TRANSFER PROBABILITIES

Prepared by:

J. N. Ayres
L. D. Hampton
I. Kabik
A. D. Solem

Approved by:

Chief, Explosion Dynamics Division

ABSTRACT: VARICOMP is a method for determining the detonation-transfer probabilities of an explosive train by substitution of explosive(s) of varied sensitivities or energies for the design explosive. These substituted--VARICOMP--explosives (whose response or output probability distribution functions have been calibrated relative to the design explosive) are used to measure the explosive drive inherent in the design system. Methods of calibrating explosives and carrying out VARICOMP performance tests are given along with statistical procedures for combining performance test and calibration data. These procedures are the basis for predictions, at high confidence levels, of very high reliability (or safety) of an explosive system based on a relatively small number of tests carried out on the explosive system. Computational aids and a number of illustrative examples are included.

PUBLISHED JULY 1961

Explosions Research Department
U. S. NAVAL ORDNANCE LABORATORY
WHITE OAK, MARYLAND

30 June 1961

The problem of prediction of high reliability or high safety for weapon systems has become of critical importance. These systems have been developed to such a high state of destructive capability and with such a high cost per weapon that it is imperative that malfunctioning be eliminated. At the same time they have become so complex that essentially perfect performance must be assured for the components of the system to assure that the system is safe and reliable.

This report summarizes an effort that has been carried out at the Naval Ordnance Laboratory that would lead to a satisfactory method for prediction of high reliabilities of (or safeties from) detonation transfer in explosive train systems.

The work leading up to this report has been going on for a number of years carried out under several Tasks. This included early testing of the concepts using standard military explosives on several weapons; efforts to develop a series of explosive mixtures of graded sensitivities whose manufacture, compositions, and sensitivities could be well controlled; and a standardized test procedure for calibrating the explosives as well as development of the concepts of the VARICOMP procedure itself. Most recently the work has been supported by WEPTASK RUME3E012/212 1/FO08/10004, Properties of Explosives and NOL-409, Guided Missile Fuze Explosive Train Research.

It is believed that this work should prove of interest in the fields of explosives sensitivity, reliability and safety estimation, and applied statistics. Established concepts and

NavWeps Report 7411

procedures in each of these fields may have been given violent adjustments to meet the exigencies of combining them into a single test procedure. This report is by no means considered a final word for this approach to safety and reliability estimation. It is to be hoped that it will stimulate improvements in this important area.

Numerous acknowledgements are in order. The most important, but by no means the only, criticisms, comments and discussions came from Mr. R. H. F. Stresau, Mr. W. Slie, Mr. M. Rowan, and Mr. A. M. Corbin of this Laboratory. Valuable discussions also came from personnel at the Naval Ordnance Laboratory, Corona, California and Bulova Research and Development, Inc., who have applied the method in assessing fuze train reliabilities.

W. D. COLEMAN
Captain, USN
Commander

C. J. ARONSON
By direction

NavWeps Report 7411

TABLE OF CONTENTS

	Page
1. INTRODUCTION	
1.1 Performance Requirements of Modern Weaponry.	1
1.2 Need for Verification of Performance Capabilities of Individual Components.	1
1.3 Explosive Components and Detonation Transfer Performance Capabilities.	1
1.4 Qualitative Description of VARICOMP	2
1.5 Previous Experience with VARICOMP	2
1.6 The Scope and Arrangement of this Report.	3
1.7 Report Numbering System	3
2. THE PROBLEM AND THE APPROACH	
2.1 Definitions of Weapon Safety and Reliability.	4
2.2 Series Action of Individual Components.	4
2.3 Reliability Demands Imposed on Individual Components	5
2.4 Sample Size Required to Demonstrate High Performance	7
2.5 Indirect Demonstration of High Performance.	9
2.6 The Idea of Penalty Testing	9
2.7 Illustration of Penalty Testing of a Mechanical System.	9
2.8 Effect of Variation of Environment and Performance Capabilities on Reliability	9
2.9 Comparison of Mechanical Penalty Testing and Explosive Penalty Testing	11
2.10 Complementary Nature of Safety and Reliability.	11
2.11 Implementation of Penalty Testing	11
2.12 Definition of Explosive Safety and Reliability.	13
3. PHILOSOPHY OF PENALTY TESTING	
3.1 The Logic of Penalty Testing.	15
3.2 Assumptions	15
3.3 Utilization of Previous Knowledge	16
3.4 Penalty Testing of Explosive Systems by Geometrical Modification.	16
3.4.1 Out of Line	16
3.4.2 Non Linear Behavior	16
3.4.3 Air Gap Anomalies	17
4. EXPLOSIVE PENALTY TESTING BY VARICOMP	
4.1 Comparison of Variably Loaded Donors and Acceptors.	19
4.2 Illustration of Variable-Acceptor VARICOMP.	19
5. THE STATISTICAL ASPECTS OF EXPLOSIVE SENSITIVITY	
5.1 The Detonation Process.	20
5.2 Initiation of Detonation.	20

NavWeps Report 7411

CONTENTS (CON'T)

	Page
5.3 Parameters of Sensitiveness	21
5.4 Mechanisms of Desensitization	22
5.5 Dosage vs. Stimulus	22
5.6 Sensitivity Testing	23
5.7 Rules of Sensitivity Testing.	23
5.8 Criterion of Fire	24
5.9 Sensitivity Tests	25
5.10 Sources of Variability.	25
5.11 Distribution of Response.	27
5.12 The Statistical Distribution Function	27
5.12.1 Gaussian	27
5.12.2 Logistic	28
5.12.3 Ash-Lacugna.	28
5.13 Population Parameters and Estimates Thereof.	29
5.14 Logarithmic Dosage-to-Stimulus Transform.	29
5.15 Statistical Model	29
5.16 Probability Spaces.	30
5.17 Methods of Presentation of Statistical Information.	31
5.18 Restriction to Gaussian Distributions	31
5.19 The Procedural Steps for a Statistical Operation.	31
6. THE VARICOMP METHOD	
6.1 Analysis of the Method.	35
6.1.1 Given	35
6.1.2 The Problem	35
6.1.3 The Approach.	35
6.1.4 The Answer	37
6.2 Plan of Action.	38
6.3 Calibration Tests	39
6.4 Performance Tests	39
6.5 Performance Test Criterion of Fire	40
6.6 Assumptions of Analogy.	40
6.7 Data Collection Methods	40
6.8 Inferential Methods	41
7. THE CHOICE OF THE VARICOMP EXPLOSIVES	
7.1 General Requirements.	42
7.2 Description of RDX/Calcium Stearate Mixtures.	42
7.3 Properties of RDX/Calcium Stearate Mixtures	42
7.4 Analysis of RDX/Calcium Stearate Mixtures	44
7.5 Effect of Density on Sensitivity.	44
7.6 A VARICOMP Series Made from Conventional Explosives	44
7.7 Advantages of a Binary VARICOMP Series.	46
7.8 Comparison of Inert Diluents with very Insensitive Explosives as the Secondary Component	46
7.9 Requirements for Explosives Suitable for a VARICOMP Series	46

CONTENTS (CON'T)

	Page
8. THE CALIBRATION TEST	
8.1 Calibration of Explosives	48
8.2 Calibration Tests, Sensitivity.	48
8.3 Calibration Tests, Output	49
8.4 Small Diameter Systems.	50
8.5 Large Scale Systems	51
8.6 Extent of Calibration	51
8.7 Presentation of Data.	53
8.8 Transformation to Probability Space	53
8.9 Ramifications	57
8.10 Centering of Calibration Tests.	57
8.11 Example	58
9. UP-AND-DOWN PERFORMANCE TESTS	
9.1 Choice of Plan.	62
9.2 Test Requirements and Objectives.	62
9.3 A Sophistication.	62
9.4 Bruceton Test Plan.	63
9.5 Biasing the Data.	66
9.6 Data Reduction, Estimate of the Mean.	66
9.7 Data Reduction, Computation of Confidence Limits.	67
9.8 Analytical Requirements	71
9.9 Example Bruceton Method	72
9.9.1 Data Collection	72
9.9.2 Data Reduction.	73
9.9.3 Reliability Estimate.	79
9.10 Errors Due to Unequal Spacing of VARICOMP Explosives	79
9.11 Errors Due to Variation in the Standard Deviation of VARICOMP Explosives.	81
9.12 Errors Due to Small Sample Size	82
10. RUN-DOWN PERFORMANCE TEST	
10.1 Data Collection.	84
10.2 Acceptable Test Modifications.	84
10.3 Single Explosive, Data Collection and Reduction.	84
10.4 Single Explosive, Reliability Estimate	87
10.5 Single Explosive, Confidence of Reliability.	89
10.6 Multiple Explosive, Data Reduction, Probit Analysis	91
10.7 Multiple Explosive, Data Reduction, Non-Iterative.	91
10.8 Errors Due to Calibration Uncertainty.	92
10.9 Example, Run-Down Method.	95
10.9.1 Single VARICOMP Explosive, Data Collection	95
10.9.2 Single VARICOMP Explosive, Algebraic Data Reduction.	95
10.9.3 Single VARICOMP Explosive, Graphical Data Reduction.	97
10.9.4 Two VARICOMP Explosives, Data Collection	99
10.9.5 Two VARICOMP Explosives, Data Reduction.	99

NavWeps Report 7411

CONTENTS (CON'T)

	Page
10.10 Small Sample Errors and Limitations, Single Explosive103
10.11 Small Sample Errors and Limitations, More than One Explosive103
11. COMPARISON OF VARIOUS DATA COLLECTION SCHEMES	
11.1 Choice Between Staircase and Run-Down Method.105
11.2 Other Staircase Testing Methods.105
12. DESIGN OF EXPERIMENT	
12.1 Recapitulation of VARICOMP Process107
12.2 Calibration Test107
12.3 Mock-up Calibration Test107
12.4 Lack of Analogy Between Calibration and Performance Tests.109
12.5 Combination of Reliability Data Derived from Various Sources.109
12.6 The Power of the VARICOMP Method110
13. APPLICATIONS AND EXAMPLES	
13.1 Lead-to-Booster Example.115
13.2 A Booster-to-Warhead Example115
13.3 Calibration Tests, Second Example.115
13.4 Performance Tests, Second Example.121
13.5 Reliability Estimates, Second Example.121
13.6 Comparison of Linear and Logarithmic Dosage-to-Stimulus Transforms, Second Example.124
APPENDIX A Procedure for Preparing a 100-Pound Batch of Desensitized RDX126
APPENDIX B Analytic Procedure for RDX/Calcium Stearate Mixes127
APPENDIX C Standard Detonation Sensitivity Tests.129
APPENDIX D Monte Carlo Experiment to Assess Errors Due to Unequal Spacing of Explosives.136
APPENDIX E Statistical Tables137
REFERENCES.140

ILLUSTRATIONS

		Page
Frontispiece	Questions Concerning an Explosive Train	xii
Figure 2.4	95-Percent-Confidence Single-Sided Estimate of the Lower Limit of Reliability for N Trials with zero, one, or two failures	8
Figure 2.7	Symbolic Representation of the Ability of Various Mechanical Designs to Withstand an Adverse Stress Environment	10
Figure 3.1	Explosive Penalty Testing by Variation of Barrier Thickness	14
Figure 3.4.1	Rotor-Alignment Arming System	17
Figure 4.2	Explosive Penalty Testing by Variation of Acceptor Sensitivity	18
Figure 5.11	Response to Dosage, Cumulative Distribution Function	26
Figure 5.16	Comparison of Gaussian and Logistic Distributions	33
Figure 5.17	Sensitivity of Various RDX/Calcium Stearate Compositions	34
Figure 6.1.1	The Explosive System	35
Figure 6.2	Flow Diagram for VARICOMP	36
Figure 8.7	Sensitivity Versus Composition for Various RDX/Calcium Stearate Mixtures	54
Figure 8.8	Observed and Adjusted Sensitivities of Various RDX/Calcium Stearate Mixtures	56
Figure 9.3A	The Bruceton Calibration Test--Variable Stimulus; Fixed-Sensitivity Explosive	64
Figure 9.3B	The Bruceton Performance Test--Fixed Stimulus; Explosives of Various Sensitivities	65
Figure 9.6	VARICOMP Estimate Based on Bruceton Performance Test Data	68

NavWeps Report 7411

ILLUSTRATIONS (CON'T)

	Page
Figure 9.7A (Graph III of AMP Report)	69
Figure 9.7B (Graph I of AMP Report)	70
Figure 9.9.1 Data From Typical Bruce-ton Test	73
Figure 9.9.2A Calibration of VARICOMP Explosives	74
Figure 9.9.2B Calibration of Design Explosive	75
Figure 9.9.3 Prediction of the Reliability of an Explosive System on the Basis of Bruce-ton Plan Performance Tests with VARICOMP Explosives	78
Figure 9.11 The Effect of VARICOMP Explosive Non-Parallelism Errors on Step Spacing in the Bruce-ton Performance Test	80
Figure 10.3 Treatment of Single VARICOMP Explosive Run-Down Performance Test Data	86
Figure 10.4 Estimate of Response of a System Loaded with the Design Explosive, Based on Single-VARICOMP-Explosive Run-Down Performance Test Data	88
Figure 10.9 Calibration of the Design and the Two VARICOMP Explosives	96
Figure 10.9.3 Analysis of Run-Down Performance Test with One VARICOMP Explosive	98
Figure 10.9.5 Analysis of Run-Down Performance Test with Two VARICOMP Explosives	101
Figure 10.10 Effect of Sample Size and Grid Spacing on Single-VARICOMP-Explosive Run-Down Reliability Estimates	102
Figure 12.3 Possible Lack of Analogy Between Conditions of Performance and Calibration Tests	108
Figure 12.6 The Effect of the Choice of VARICOMP Explosive on the Efficiency of Estimate of Reliability of Design	114

NavWeps Report 7411

ILLUSTRATIONS (CON'T)

		Page
Figure 13.2	Booster-to-Warhead Transfer Reliability Study by VARICOMP	116
Figure 13.3A	Calibration of Comp B	118
Figure 13.3B	Calibration of H-6	119
Figure 13.3C	Calibration of TNT	120
Figure 13.4A	Performance Test and Reliability Estimate	122
Figure 13.4B	Calibration Tests, Performance Tests, and Estimate of Reliability	123
Figure 13.6	Calibration Tests, Performance Tests, and Estimate of Reliability Based on Logarithmic Dosage-to-Stimulus Transform	125
Figure C.2.1A	Small Scale Gap Test	130
Figure C.2.1B	Small Scale Gap Test Setup	131
Figure C.3.1	NOL Booster Sensitivity Test	133
Figure C.4.1	NOL Propellant Sensitivity Test	135
Table 2.4	95-Percent Confidence Single-Sided Estimate of the Lower Limit of Reliability for N Trials with Zero, One, or Two Failures	6
Table 2.9	Penalty Testing as it is Used to Achieve Various Design Objectives	12
Table 5.16	Comparison of Gaussian and Logistic Distributions	32
Table 7.2	Properties of the RDX/Calcium Stearate Binary Explosive System in the Small Scale Gap Test When Loaded at 10 KPSI	43
Table 7.6	Typical Values of High-Explosive Sensitivities	45

NavWeps Report 7411

ILLUSTRATIONS (CON'T)

		Page
Table 8.4	The Calibration and Utilization of A VARICOMP Explosive Series (Conjecture)	50
Table 8.7	Fitted Values of the Sensitivities of Various RDX/Calcium Stearate Compositions	55
Table 8.11A	Calibration Data for Design Explosive	60
Table 8.11B	Computation of Design Explosive Response Expected Value and Lower 95-Percent Confidence Limit	60
Table 9.9.2	Calculations Used in Bruceton Data Reduction (Based on Fires Observed in Figure 9.9.1)	77
Table 9.12	Effect of Sample Size on the Estimate of the Minimum Reliability, at 95-Percent Confidence Predicted from Bruceton Data Giving Observed Reliabilities of 99 Percent	83
Table 10.3	The System of Notation	85
Table 10.5	Composite Confidence of Combined Estimates	90
Table 10.9.5	Computation of the Average Observed Stimulus Intensity	100
Table 12.6	Relative Sensitivities of a Series of Explosives	111
Table 13.3	Calibration Data And Results	117
Table E-1	Relationship Between Normit, Probability, Ordinate, and Weighting Factor	137
Table E-2	Cumulative "Student's" Distribution	138
Table E-3	95-Percent Confidence Single-Sided Estimate Lower Limit of the Reliability, L_R , for Sample Sizes of 20 or Less	139

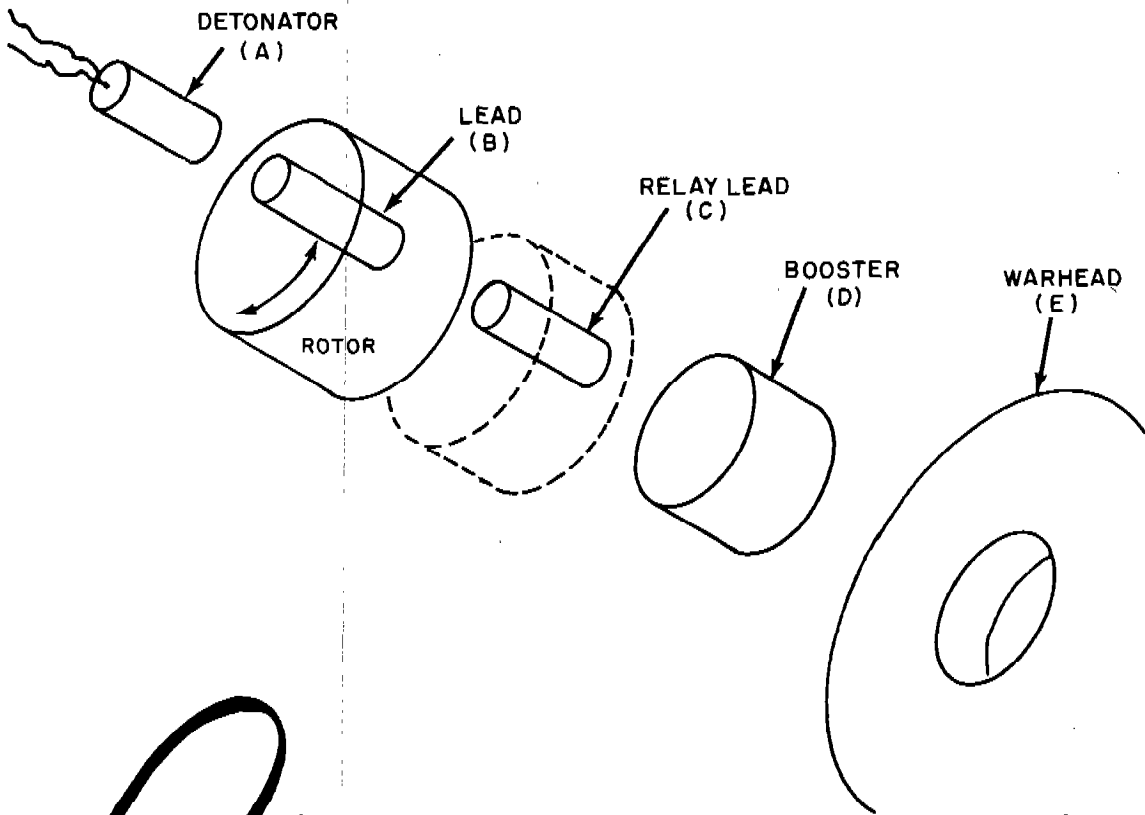

QUESTIONS CONCERNING AN EXPLOSIVE TRAIN:

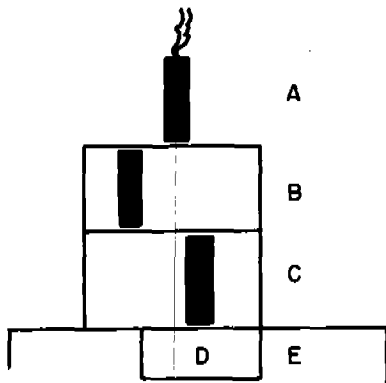

HOW SAFE?

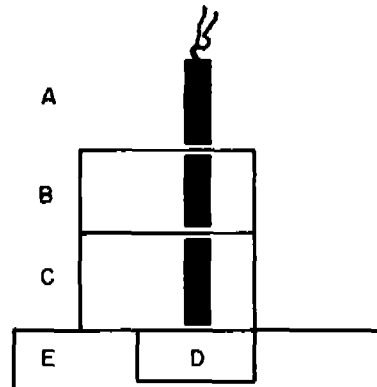

HOW RELIABLE?

VARICOMP

A METHOD FOR DETERMINING
DETONATION-TRANSFER PROBABILITIES

1. INTRODUCTION

1.1 Modern weaponry, because of the extreme complexity of weapon systems and the lethal potential they carry, imposes very high reliability requirements on the components of the system for firing and imposes very high safety requirements otherwise. The difficulty of attaining such high performance capabilities is obvious, and much effort has been expended toward achieving them.

1.2 It is imperative that verification of the performance capabilities of each system become part of its design (1,2,3). Such verification introduces additional problems for the weaponeer. Brute force testing of the whole weapon, or of its components, to establish the weapon system's reliability and safety is usually not feasible. The reliability and safety characteristics of the components that make up the system must therefore be determined by overtesting and combined in order to estimate the system's overall performance. Even such determinations pose serious difficulties, especially in the case of consumed one-shot items which cannot be repeatedly exercised to establish probability characteristics, e.g.,

warheads
explosive trains
explosive components
propulsion systems
chemical power packs.

Suitable combined experimental-statistical techniques must be used to provide the required demonstrations.

1.3 In perhaps all weapon systems, some form of explosive action is employed. In many cases (for instance, fuzes and safety-and-arming mechanisms) the explosive action involves the transfer of detonation from one explosive component to another such as:

Detonator → Lead → Relay → Booster → Warhead.

NavWeaps Report 7411

The important point in reliability and safety estimates for the system is verification of whether or not the detonation will progress along the chain. This report presents the VARICOMP procedure for evaluating the probability of transfer of detonation across explosive interfaces, thus yielding data necessary for predicting explosive component reliabilities. In the past, penalty testing (overtesting) by geometrical modification has been the experimental approach to evaluation of detonation transfer probabilities (4). The novelty of the VARICOMP procedure of evaluation lies in the ideas of penalty testing by alteration of explosive loading (VARIation of explosive COMPosition) rather than by geometrical modification.

1.4 The VARICOMP procedure is a combined experimental and analytical method for estimating very high detonation transfer reliability (or safety) at a high level of confidence on the basis of relatively scanty direct experimental evidence. It depends upon a systematic synthesis of previous experience and current experimentation to develop trends applicable to the system under study. The VARICOMP method is not a magic incantation, nor is it a cook-book procedure for ascertaining detonation transfer probabilities. It is not even an across-the-board best way of finding the answer. It is to be expected that each time VARICOMP is applied, novel and unique differences from previous applications will be found. The cleverness and ingenuity of the experimenter can be greatly supplemented but not supplanted by VARICOMP. Its limitations and potentialities have not yet been fully explored because of its recent development. So far, it can be said that each time VARICOMP has been utilized, it appears to have answered more questions than it has raised.

1.5 The first use of this approach at the Naval Ordnance Laboratory occurred in late 1952 and early 1953 (5) in a program which compared the abilities of a number of different detonators to initiate charges of booster-like configurations, the charges being made of different sensitivity explosives. The concept of tailor-making explosives for use in such studies was explored rather fully (6) at about the same time. This technique of assessing the detonation transfer probabilities of a weapon system has been applied a number of times.* The term VARICOMP was first applied to the process in 1959.

*This technique has been used, for instance, at NOL in establishing detonation transfer reliabilities in the TALOS safety-and-arming mechanism and warhead, the experimental EX-38 warhead, and the SHADOW explosive train. It has been further used by the Navy and Army to establish detonation transfer in explosive trains for a number of guided missiles.

NavWeps Report 7411

1.6 The assumptions, concepts, and application of the VARICOMP method will be given here along with such tools as sensitivity data and specialized statistical procedures needed to apply the method to practical cases. (It is assumed that the user will have available the necessary statistical experience to find and utilize the more conventional techniques as found in any standard statistical reference (7)). Attempts will be made to guide potential users of this process by the inclusion of suitable references, examples, and admonitions. The discussion here will cover in Sections 2, 3, and 4 the problem, the approach, and the philosophy of explosive penalty testing; in Section 5 the statistical aspects of explosive sensitivity; in Sections 6 and 7 the VARICOMP explosives and experimentation; in Sections 8, 9, 10, and 11 various VARICOMP calibration and performance tests; in Section 12 problems associated with design of the VARICOMP experiment; and in Section 13 application and examples. Specific information found important to utilization of the VARICOMP process but not necessary to the understanding thereof is given in a series of Appendices.

1.7 In order to facilitate referral, Figures and Tables have been given the same number as the paragraph in which they are first mentioned. In addition, they are bound in a physical location as close as possible to the paragraph of this same number.

2. THE PROBLEM AND THE APPROACH

2.1 A weapon system will accomplish its intended purpose only if it functions as intended at the place and instant intended. Prediction of the weapon system performance can be carried out in part by evaluating the following probabilities:

Weapon Reliability -- The probability that the weapon will function where and when intended.

Weapon Safety -- The probability that the weapon will not function except where and when intended. (The safety is customarily reported as the complementary function -- the Probability of Unsafe Action).

Note that the above probabilities are independent of any predictions, except dud rate, involving how well the weapon performs, such as limited yields, kill probabilities, or functioning on unsuitable targets.

2.2 Most weapon systems are complex, requiring the concatenation of many factors for proper functioning. The Weapon Reliability probability figure can be computed by the multiplicative combination* of the individual probabilities of the series elements. For instance, the explosive train pictured in the frontispiece is composed of a number of components. Each of these components will exhibit a certain performance with probability of individual action:

- p_1 Detonator bridgewire will be intact.
- p_2 Detonator flash charge will be in contact with bridgewire.
- p_3 Flash charge will initiate base charge.
- p_4 Detonator base charge will give at least specification minimum output.
- p_5 Rotor will be lined up within tolerance.
- p_6 Lead will respond to detonator output of specification quality.

*This implies that each of the series elements functions independently of the others upon receipt of the proper firing impulse.

- p_1 Lead will give specification output.
- p_2 Relay lead will respond to lead output of specification quality.
- p_9 Relay output will give specification output.
- p_{10} Booster will respond to relay lead output of specification quality.
- p_{11} Booster will give specification output.
- p_{12} Warhead will respond to booster output of specification quality.

The probability that the warhead will be initiated as a result of delivery of the proper firing signal into the explosive train is:

$$P_f = \prod_{i=1}^{i=12} p_i = p_1 \cdot p_2 \cdots p_{12}$$

2.3 Because of this multiplicative combination of the individual reliabilities, the reliability of the entire system will be less than the reliability of the least reliable of any of the components. Even where all of the components are of similar reliability, the system reliability will be found to decrease seriously as the number of components increases. In order to estimate this increased individual reliability imposed by the required reliability of the complete chain, the following reasoning can be used:

Take

$$P = \prod_{i=1}^{i=n} p_i$$

where

P is the system reliability

p_i is the reliability of the i^{th} component

n is the number of individual components.

Assume

$$p_1 = p_2 = p_3 = p_4 = p = 1 - q.$$

Table 2.4

95-PERCENT CONFIDENCE SINGLE-SIDED ESTIMATE
OF THE LOWER LIMIT OF RELIABILITY FOR
N TRIALS WITH ZERO, ONE, OR TWO FAILURES

N Number of Trials	L _R , Estimated Lower Limit of Reliability, for		
	No Failures	One Failure	Two Failures
5	54.94	34.25	18.94
6	60.67	41.81	27.14
7	65.18	47.92	34.11
8	68.79	52.95	40.00
9	71.71	57.06	45.02
10	74.13	60.56	49.32
12	77.92	66.11	56.18
14	80.74	70.35	61.44
16	82.94	73.60	65.57
18	84.67	76.23	68.97
20	86.10	78.38	71.77
50	94.18	90.88	87.96
100	97.05	95.34	93.85
200	98.51	97.65	96.88
500	99.40	99.06	98.74
1000	99.70	99.53	99.37
2000	99.85	99.76	99.69
5000	99.94	99.91	99.87
10,000	99.97	99.95	99.94
>10,000	$\frac{N}{N+3}$	$\frac{N-1}{N+3.74}$	$\frac{N-2}{N+4.30}$

If

$$nq \leq 0.1$$

then

$$P = p^n = (1-q)^n \approx 1-nq \quad *$$

$$nq = 1-P = Q$$

$$q = Q/n,$$

This can be interpreted: "In order to achieve a system failure rate no greater than Q for a series of n equally reliable components, each component failure rate must not exceed Q/n ." Experience has shown (2) that a certain small portion of the components cannot achieve the necessary high reliability. These components "use up" so much of the available margin that a more realistic value of q might be given by:

$$\frac{Q}{1000n} < q < \frac{Q}{10n}$$

2.4 The indirect demonstration of very high reliabilities for an element, by testing to failure or by penalty testing, is difficult. The demonstration of high reliability by direct, brute-force testing is usually prohibitive. This is true because a very large number of successful tests must be carried out to give sufficient authority to a statement of high reliability. Table 2.4 and Figure 2.4 illustrate just how large a sample size would be needed to permit the following typical statistical statement:

"On the basis of no failures out of N trials, the population from which the sample is drawn can be said, at 95-percent confidence, to be at least R reliable".

Note that the statement is made in the approved style with the usual statistical qualification "at 95-percent confidence". In other words, for this sample (size N) the minimum reliability is considered provisionally to be P . Only after many, many samples had been tested, or else after the whole population had been expended, would it be possible to tell whether or not the reliability of the population was truly equal to or greater than P . Lacking such omniscience, the experimenter knows that he runs a 1/20 risk of overestimating the true population probability when using the above procedure.

*The error of this estimate is less than $(nq)^2/2$

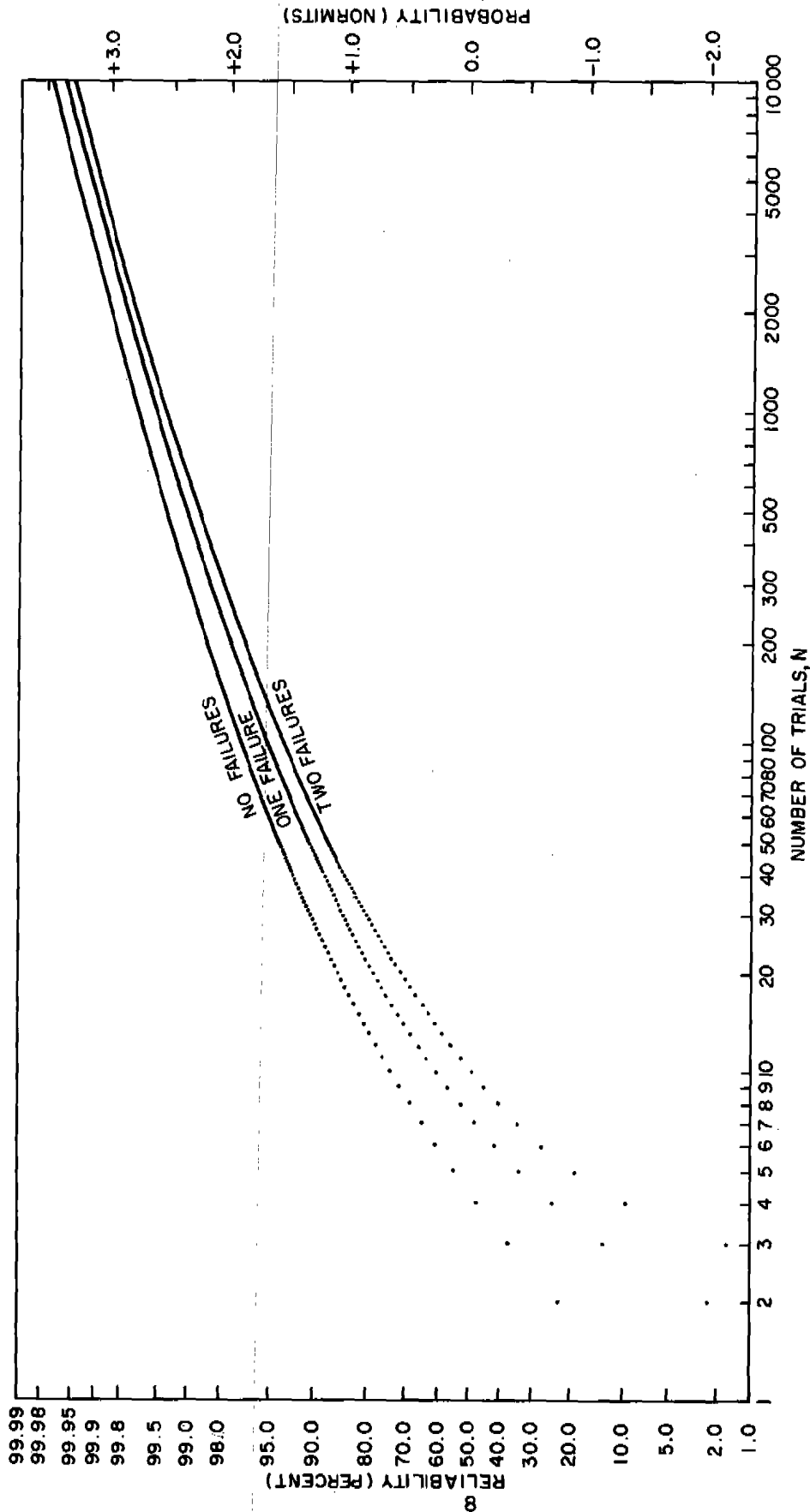

FIGURE 2.4 95-PERCENT-CONFIDENCE SINGLE-SIDED ESTIMATE OF THE LOWER LIMIT OF RELIABILITY FOR N TRIALS WITH ZERO, ONE, OR TWO FAILURES

2.5 If reliability prediction by direct demonstration is not feasible, then the answer must be obtained by some other approach. One such approach is by the synthesis of relevant data such as past experience, penalty testing results, or colinear studies to give a quantitative basis for statistical inference. Such a process, though usually not formalized, is what is meant by the phrase "engineering judgement". The relevant data, then, are taken from similar devices or situations to augment the limited information that can be obtained by direct experimentation. Such similarity data must be handled skillfully in order to prevent invalidation of inferences because of the dissimilarities that do exist.

2.6 Penalty testing (overtesting, testing-to-destruction) is an exact source of relevant data only when the conditions of the penalty test differ in intensity but not in kind from the natural environment. This is an ideal which, for detonation transfer systems, may be very difficult to attain. It is possible to use data which are gathered from systems whose conditions are not exactly the same but are analogous. Provided the analogies do apply, penalty testing offers a method for obtaining data which will permit higher probability estimates for a given sample size than would be possible by direct testing.

2.7 Figure 2.7 is a symbolic presentation of the concept of penalty testing as it might apply to a mechanical system subjected to adverse environmental stresses. It shows to some extent the statistical nature of the problem. Four designs, A, B, C, and D, are shown as having different capabilities for resisting the adverse environment. Because of the unavoidable and inherent differences between individual items of a sample taken from the parent population, the "strengths" (abilities of the design to resist an adverse environment) are shown as being distributed about a characteristic central value. In this example, design A has a failure response to relatively low intensities of the adverse environments. Design B is somewhat more resistive. Designs C and D are still more resistive. They show about the same central values of failure response to adverse environments. However, the response of design C is much more scattered than that of design D and is, in fact, marginal whereas design D is clearly reliable.

2.8 The environment intensity with which the design must cope is also random in nature and is therefore shown as being distributed about a central (average) value. Whether or not a particular design is sufficiently reliable depends upon how much more durable the design actually is than the environment.

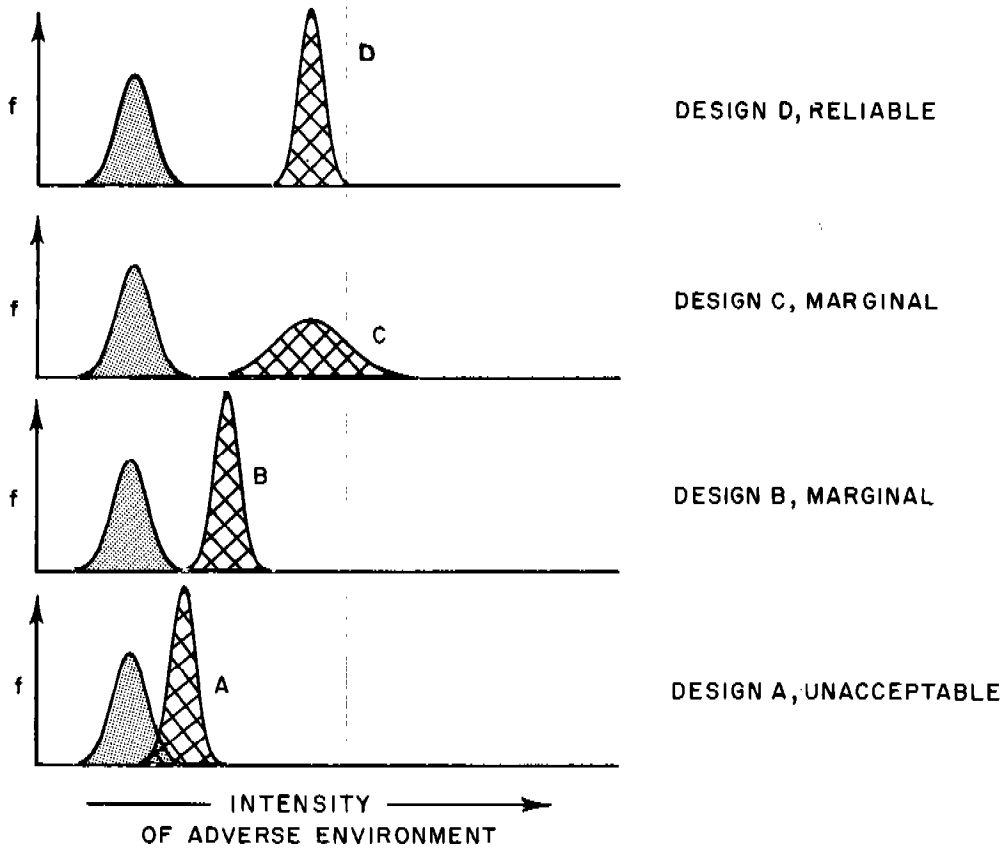

f = RELATIVE FREQUENCY

 = PROBABILITY DENSITY FUNCTION DESCRIBING THE ADVERSE STRESS ENVIRONMENT THAT THE DESIGNS WILL ENCOUNTER IN USE.

 = PROBABILITY DENSITY FUNCTION DESCRIBING THE FAILURE RESPONSE OF VARIOUS MECHANICAL DESIGNS TO THE ADVERSE STRESS ENVIRONMENT.

FIGURE 2.7 SYMBOLIC REPRESENTATION OF THE ABILITY OF VARIOUS MECHANICAL DESIGNS TO WITHSTAND AN ADVERSE STRESS ENVIRONMENT

it will meet. In the case of designs A, B, and D, the position of the mean (50-percent response) intensities has a major effect on the reliability. It is evident that design A will not be able to cope with the expected environment. About 10 percent of these items would be expected to fail. Design B would be considered marginal because a slight increase in stress and/or decrease in design capability would lead to failures. Design D could be considered to be adequately reliable. Design C, on the other hand, is marginal even though its average capability is equal to that of design D. Some of the worst items of design C are no better than the worst of design B.

2.9 Penalty testing, as it would be applied to explosive systems and in particular to detonation-transfer studies, appears to be different in nature from the mechanical concepts indicated above. Yet this difference can be resolved by proper definition of terms and goals as in Table 2.9.

2.10 From Table 2.9 it can be seen that detonation-transfer safety and detonation-transfer reliability are complementary in concept and in testing approach. However, the safety tests and the reliability tests often differ in matters of interpretation of evidence, particularly in the case of marginality. After a marginal explosive safety test, there will often be enough witnessing of the explosive vigor and action from the appearance of the inert parts that marginality can be deduced. In fact, it is often possible to deduce the cause of marginality. On the other hand, the uproar and damage produced by imperfect functioning of a marginally reliable system may not be distinguishable from the performance of a fully reliable system.

2.11 The general method of penalty testing, mechanical or explosive, response or non-response, is:

Find the severity of conditions that will induce system failure.

Find the severity of conditions which will ordinarily be encountered by the system.

Take the separation between the severity of conditions which the system can resist and the severity that actually exists to be the measure of the conservatism inherent in the system design.

Table 2.9
 PENALTY TESTING AS IT IS USED TO ACHIEVE
 VARIOUS DESIGN OBJECTIVES

Factors	Mechanical Design	Detonation-Transfer Safety	Detonation-Transfer Reliability
Environment	Vibration, tension, compression, etc.	Detonation shock wave	Detonation shock wave
Design Objective	Be able to withstand expected environment.	In "Safe Position" explosive train should resist (not respond to) the shock-wave. Detonation should <u>not</u> be transferred.	Detonation <u>should</u> be transferred.
System Failure	Fatigue failure, fracture, shear, etc.	Shock wave passes through or around safed mechanism.	Shock wave fades out to low order or complete non-reaction.
System Success	No damage or incipient failure.	Quenching of detonation.	Detonation propagation.
Method of Testing	Test to failure. Find the environment intensity that will cause system failure.	Weaken obstructions to detonation transfer. How much weakening can occur without supporting detonation? Load target* with over sensitive explosive. How sensitive can the explosive be without supporting detonation?	Strengthen obstructions to transfer. How much extra can the shock overcome? Load target* with insensitive explosive. How insensitive can the explosive be without quenching detonation?

*Target is here used to designate that component whose probability of being initiated is being studied.

It can be seen that penalty testing is but a new name for a time-honored approach to engineering problems. The structural engineer uses penalty testing to find failure levels for the materials he will specify. He finds out how much more durable the material is than is necessary for the intended application. That is, he designs so that the structure will be able to withstand much greater static and dynamic loads than it will ever experience. The capability of the structure is a measure of how conservatively designed (over-designed) the structure is. It is in some fashion a measure of how reliable the design is.

2.12 Specifically, penalty testing can be applied to explosive systems to evaluate quantitatively their safeties and reliabilities:

Safety.* A true probability of response (usually very low) which is less than some specified value for a given stimulus.

Reliability.* A true probability of response (usually very high) which is greater than some specified value for a given stimulus.

In order to facilitate treatment of the material in this report, reliability concepts will be considered primarily, with the understanding that complementary safety concepts will ordinarily apply in similar fashion.

*A confidence limit must also be specified (usually quite high) to allow the estimates to incorporate the correction necessary to compensate for component manufacturing variations and possible errors in the penalty testing determinations.

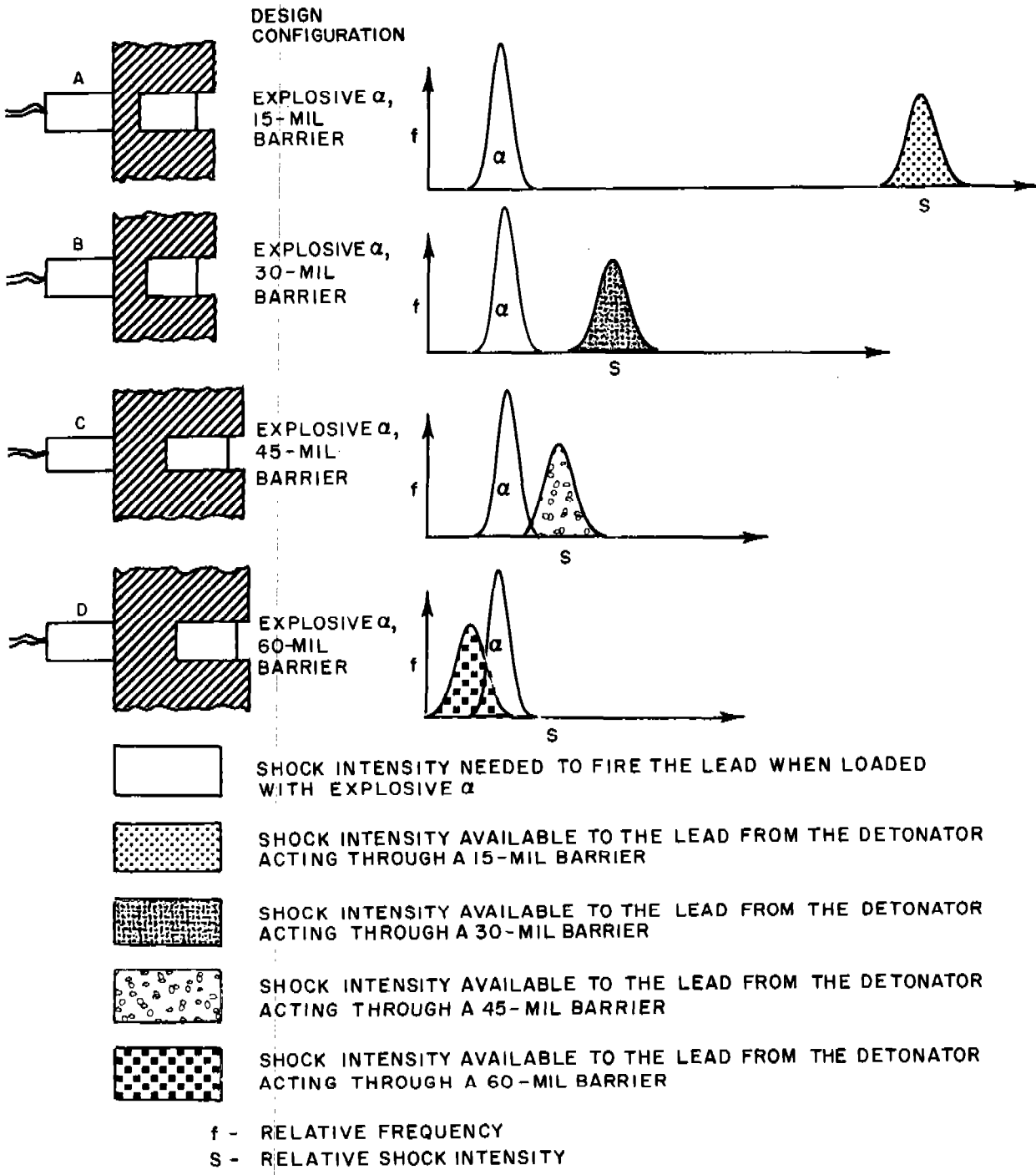

FIGURE 3.1 EXPLOSIVE PENALTY TESTING BY VARIATION OF BARRIER THICKNESS

3. PHILOSOPHY OF EXPLOSIVE PENALTY TESTING

3.1 The basic idea of penalty testing is in some ways analogous to handicapping as it is used in sporting events, although for a different reason. A handicap is imposed in an attempt to make an equal match between otherwise unequal contestants. The magnitude of the handicap is a measure of how much better one contestant is expected to be than another on the basis of past experience. If an explosive transfer is penalized by some alteration in the system, the amount of penalization should give a measure of how much the original system would outperform the penalized system. For instance, in Figure 3.1 a typical detonator-to-lead arrangement is shown in which the lead is separated from the detonator by a metal barrier (design A). Penalization of the detonator-to-lead transfer can be accomplished geometrically by thickening the barrier as in designs B, C, and D. If in designs B, C, and D detonation transfer occurs as shown and it can be assumed that the increase of the barrier thickness in no way enhances the transfer but in fact degrades it, then it can be seen that the detonator has considerable reserve in the design configuration. It will be shown later how to measure the magnitude of this apparent reserve and convert it into a reliability estimate.

3.2 The generalized assumptions underlying the methods of penalty testing are:

- ASSUMPTION 1 A response is caused by an environment.
- ASSUMPTION 2 The environment exists in various intensities or dosages.
- ASSUMPTION 3 The experimenter can control, or at least measure, the dosages.
- ASSUMPTION 4 The test environment can be related meaningfully to the actual weapon system environment.
- ASSUMPTION 5 The probability of response is a monotonically increasing function of the dosage.

These statements may appear a bit obvious or trivial. Yet the validity of the penalty testing approach depends upon the verity of each of them.

3.3 It now becomes obvious that penalty testing is not a way of getting something for nothing. The above listed assumptions are tenable only if the technology, knowledge, and previous experience bear them out. The last sentence of Paragraph 2.6

" . . . penalty testing offers a method for obtaining data which will permit higher probability estimates for a given sample size than would be possible by direct testing . . . "

is implicitly augmented by the phrase

" . . . because of the previous existence of a large body of relevant information."

3.4 Considerable experience with the penalty testing of explosive systems by geometrical modification has been amassed by using such techniques as misalignment of train and interposition of barriers. In many cases this has been an effective approach. However, in some instances, erroneous results have been obtained because the modification of the geometry of the explosive system has violated one or more of the basic assumptions, as indicated by the following examples.

3.4.1 A traditional method for demonstrating the reliability of a rotor-arming fuze train (Figure 3.4.1) is to determine how much angular misalignment, θ , can be introduced before detonation transfer failures occur. Certainly, the value of $\bar{\theta}$ (the angle at which the detonator will initiate the lead in 50 percent of the trials) will be a measure of how reliable the system will be in terms of the mechanical alignment errors to be expected in the arming process. However, the angle $\bar{\theta}$ is so strongly dependent upon the physical alignment of the charges that there may be little difference between $\bar{\theta}$ for a rotor lead which has fully reliable sensitivity and the $\bar{\theta}$ for a rotor lead which is marginally sensitive. The work done by Stresau and Starr (8) on transfer between misaligned explosive columns loaded into heavy-walled containers is an illustration of this effect.

3.4.2 A different type of irrelevant effect has been recorded where a partially aligned train was reliable but a fully aligned train failed because the explosive components could be dislodged rather than initiated by the explosive action.

3.4.3 Variable air gaps introduced between the donor and acceptor charges to measure reliability can lead to erroneous conclusions because maximum reliability can occur at intermediate values of air spacing. For both lesser and greater air spacings the reliability may fall off sharply. This has usually been observed with cased donor charges. This stand-off effect is therefore attributed to the fact that the donor case forms fragments (9,10,11). During the transit across the air gap, the fragments are accelerated by the detonation process. An optimum gap can be found wherein the fragments have enhanced the initiation process. Beyond this optimum gap the initiating pulse has been attenuated to such an extent that initiation becomes more difficult. In such cases, the assumption of monotonic increase of the shock attenuation (and therefore of the penalty) with increasing gap is invalidated. Before this nonmonotonic tendency of air gaps was recognized, variable air gap penalty testing was frequently used to evaluate explosive systems. In one instance, a design which had been accepted on the basis of such data, exhibited a 40-percent dud rate in the pilot lot.

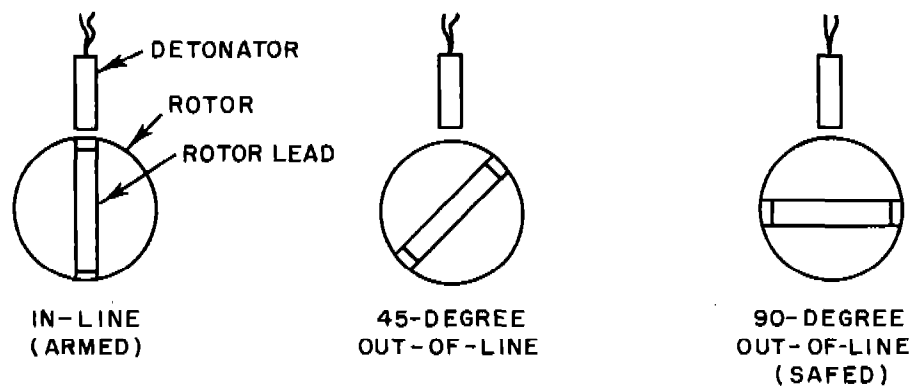
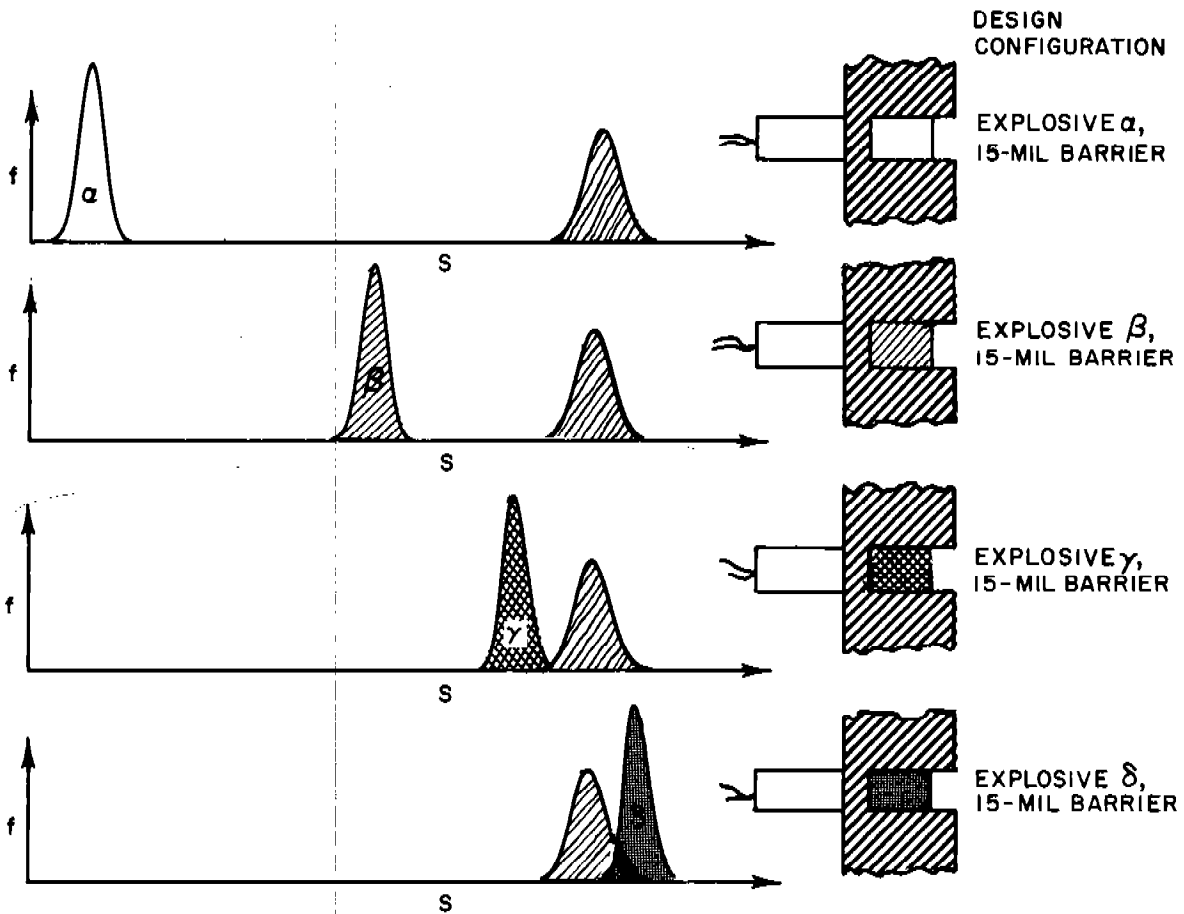





FIGURE 3.4.1 ROTOR-ALIGNMENT ARMING SYSTEM



 SHOCK INTENSITY AVAILABLE TO THE LEAD WHEN ACTING THROUGH A 15-MIL BARRIER

 SHOCK INTENSITY NEEDED TO FIRE THE LEAD WHEN LOADED WITH EXPLOSIVE α

 SHOCK INTENSITY NEEDED TO FIRE THE LEAD WHEN LOADED WITH EXPLOSIVE β

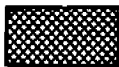
 SHOCK INTENSITY NEEDED TO FIRE THE LEAD WHEN LOADED WITH EXPLOSIVE γ

 SHOCK INTENSITY NEEDED TO FIRE THE LEAD WHEN LOADED WITH EXPLOSIVE δ

f = RELATIVE FREQUENCY

S = RELATIVE SHOCK INTENSITY

FIGURE 4.2 EXPLOSIVE PENALTY TESTING BY VARIATION OF ACCEPTOR SENSITIVITY

4. EXPLOSIVE PENALTY TESTING BY VARICOMP

4.1 The discussion so far has been limited to penalization of detonation transfer by geometrical modifications. The effect of such changes is to reduce the shock strength which has arrived at the acceptor. The reduction has been accomplished by out-of-line, barrier, or gap modifications. Another method of penalization of a detonation transfer (another way to reduce the probability of transfer) would be to modify the explosive in a way that would make it more difficult for detonation transfer to take place. Two methods of VARIation of explosives COMPosition can be used to penalize a detonation transfer:

The donor charges can be made from explosives of different output. Output variation can be accomplished by changing charge density, quantity, or formulation.

The acceptor charges can be made from explosives of different initiabilities (sensitivities). The sensitivities can be varied by varying charge density or formulation.

4.2 Figure 4.2 illustrates the VARICOMP method for evaluation of a detonator-to-lead transfer. The example has been chosen intentionally so that the design configuration is identical with the design configuration of Figure 3.1. A careful comparison of these two examples will delineate some of the similarities and some of the differences between the two methods of detonation-transfer penalty testing:

Geometrical Modification

VARICOMP.

In the example shown in Figure 4.2 the design configuration is loaded with Explosive α . Penalization in the test is accomplished by the use of successively less sensitive explosives--Explosive β , Explosive γ , and Explosive δ -- as a method of imposing increasing penalty. Note that in this case the magnitude of the shock arriving at the lead is the same in all configurations, whereas in Figure 3.1 the magnitude of the shock was varied while the explosive target (lead) sensitivity was held constant (Explosive α). One version of VARICOMP, namely, variation of donor explosive, is very similar to Figure 3.1 in that the shock strength is varied while the acceptor sensitivity is held constant.

5. THE STATISTICAL ASPECTS OF EXPLOSIVE SENSITIVITY

5.1 Since this report deals with the transfer of detonation from one explosive charge to another it is appropriate to describe the detonation process and how it is established. Detonation in solid explosives is a steady, high-speed reaction sweeping through the material as a wave. As this wave passes each point in the charge there occurs:

First, the passage of an intense compressional shock.

Next, after an adequate induction time* the reaction of the compressed explosive. This reaction is accomplished in a fraction of a microsecond with the formation of gaseous detonation products which are at very high temperatures and pressures.

Finally, the expansion and further recombination of the detonation products. (The work from the detonation is obtained during this stage of the process.)

The detonation wave progresses at 7000 to 8000 meters per second; the detonation pressures obtained are on the order of 200,000 to 300,000 atmospheres; the maximum temperatures of the gases are on the order of 3500 to 4000° Centigrade.

5.2 A detonation wave in an explosive is normally self-sustaining. A detonation wave entering an explosive must be reestablished in the new charge even though it had been stable at all points up to the interface. (Any transition across an interface is considered entering a new charge.) The reestablishment of detonation is accomplished by starting a chemical reaction in the explosive with an external stimulus. If conditions are right, detonation will result. A stimulus which would start the reaction would normally be a heat pulse, a shock, or both.

Heat Stimulus. Initiation by a heat pulse would occur from exposure to a wire bridge or a heat bath at a high enough temperature. Explosives are classified as primary or secondary on the basis of their response to such a stimulus. Reaction of a primary explosive initiated by heat grows rapidly to a detonation.

*The induction time may vary from a fraction of a microsecond for a material like RDX to several microseconds for other less sensitive explosives.

Reaction of a secondary explosive initiated by heat would be burning without detonation. Detonation would occur only if pressures could build up to develop the shock that must precede the detonation. (By practical tests the primary explosives are also much more sensitive than the secondary explosives to shocks.) Since this initiation mechanism will not generally yield detonation in secondary explosives (high explosives) it will not be considered further.

Shock Stimulus. Shock or impact on the charge surface will send a shock wave into the explosive. If the shock is intense enough the explosive behind the shock will start reacting rapidly, the energy released will feed the shock, and the reaction will grow to detonation. If the shock is weak, little or no reaction will occur behind it and the shock wave will die out without producing detonation. All intermediate degrees of reaction might occur for intermediate intensities of shock.

Numerous references to this subject are available. The most pertinent are: A discussion on the initiation and growth of explosion in solids under the leadership of F. P. Bowden, F.R.S. (12), the Gilbert B. L. Smith Memorial Conference on Explosive Sensitivity (13), and the Third Detonation Symposium (14).

5.3 The intensity of the shock stimulus needed to initiate detonation in an explosive charge is a function of many factors. These include, among others:

Type of explosive

Impurities present and their distribution within the charge

Diluents present in the charge

State of the explosive (cast, pressed, particle size)

Density of the charge

Ambient conditions

Confinement

Method of application of the stimulus.

Each of these factors in its place might be important in affecting the response of the explosive to a stimulus. If precise control of these various factors could be maintained, then presumably, a quantitative relationship of explosive response to initiating stimulus could be described. This control is not possible. Further, in detonation transfer considerations the quantitative response of the explosive is not needed but only knowledge of whether or not the charge detonated. The problem of characterizing the response of the charge is thus simplified to the determination, by a statistical experiment, of the percentage of detonations that will occur for stimuli of various intensities.

5.4 The sensitivity or, more precisely, the order of sensitivity, of explosives can be characterized by a sensitivity test. (A number of such tests will be indicated later.) Explosive compounds can be found that fall almost anywhere on the sensitivity scale from spontaneous explosion to practically non-explodable. With the proper precautions and procedures common explosives are insensitive enough to be handled (compounded, loaded, stored, deployed, and launched) with little risk. Yet they are sensitive enough to be initiatable with nominal magnitudes of stimuli. Sensitive explosive compositions can be desensitized by adding homogeneously distributed diluents. These diluents are soft inert materials such as waxes. The desensitizing process is:

Coating of the explosive grains

Providing heat sinks to absorb energy that would otherwise initiate the explosive

Filling interstitial voids, thus distributing the heat of compression more uniformly so that the hot-spots are less hot.

In the reverse direction, insensitive explosive compositions can be sensitized by the addition of small amounts of some sensitive explosive.

5.5 In previous paragraphs of this section, the explosion process has been described as being caused by some form of external stimulus. Because the initiation process takes place at the molecular level inaccessible to direct sensing by instruments and observation, the nature, amount, and character of the stimulus can only be inferred. It cannot be measured. What can be measured (and usually also controlled) is the dosage. The dosage is defined as the intensity of an environment which

can initiate explosive action. Note that dosage is measurable while stimulus is not. Yet, as will be brought out later, the statistical techniques of VARICOMP are based on the predictions of performance as related to stimulus rather than dosage.

5.6 The sensitivity of an explosive is therefore determined in terms of the physical variable--the dosage--which is the measurable parameter in the experimental method. It is customary to report the sensitivity as the intensity* of the parameter at which 50-percent response is observed. As a consequence, in cases such as drop sensitivity, electrical pulse sensitivity, bullet sensitivity, etc., the larger the 50-percent response intensity, the less sensitive the explosive. (It might be said that these are "explosive insensitivity figures".) In other tests, wherein a standard input signal is moderated by a variable attenuator and the size of the attenuator is the physical variable, the numerical value will vary in the same sense with sensitivity unless a transformation function such as reciprocal gap or logarithm of the reciprocal gap (15) is used. Many different sensitivity tests (6,15,16,17,18,19,20,21) have been developed, some oriented more toward ordering explosive sensitivities with respect to loading conditions, and others with respect to performance in explosive end items. Part of the technique of VARICOMP lies in the appropriate choice of sensitivity test.

5.7 The technique of making explosive sensitivity determinations on a sample of explosive charges or items must accommodate rather unusual restrictions which arise from the inherent nature of explosives. These restrictions become evident from the following tabulation of possible results and inferences of a sensitivity test.

An explosive item when subjected to a sensitivity test will either be initiated (in the desired fashion), or be not initiated.

When the item is initiated, it is not possible to determine how much less the dosage could have been and still have caused initiation.

*In some cases a mathematical transformation of the intensity figure is used, the transformation being an attempt to state the sensitivity as a function of stimulus.

NavWeps Report 7411

When the item is not initiated, it should not be retested--the item (if not destroyed) may have been altered as a consequence of the test. It can no longer be considered to be from a true sample of the parent population. It is therefore not permissible (or even possible) to determine from a failed item the dosage* that would have caused initiation.

Thus it can be seen that each item can be tested only once, and that for each test it can be said only that the item fired or did not fire. This type of testing is called Go/No-Go testing. The statistical methods of treating data from such tests are classed as the "Analysis of Attributes" (7,22,23).

5.8 It would seem that the alternative nature of the possible results of a sensitivity test--fire or not fire--would at least simplify the problem of identifying the outcome of each test. Unfortunately, in some cases, there exists a gray area that requires sophistication in the determination of whether or not the item responded in the design mode as differentiated from another mode of explosive action. The choice of criterion of fire can affect the interpretation of the observed behavior and can also affect the final values of sensitivity deduced from the data (15,24). As a philosophical digression, consider the possibility of errors in the assessment of the data resulting from changes in the observer's knowledge:

The assessment depends upon the acuteness of the observer and upon his evaluation of what he observes. His evaluation and judgement is based on his knowledge and experience. But his knowledge and experience are being amplified even as he is carrying out the test. Is it possible that his knowledge can be so altered during the test and by the test results that his basis of judgement changes materially during the test?

*If it can be assumed that the subjection of an item to a sensitivity test cannot convert that item from a "dud" to a "fireable unit", then the failed item can be retested at a high intensity level with the following possible results and inferences therefrom:

Did Fire -- Therefore was not a dud.

Did Not Fire -- No conclusive answer (The item may have been duded by the first test).

While the above interaction probably is in most cases a second-order effect, the possibility of its occurrence should not be forgotten.

5.9 The factors which control the response of a particular explosive to a particular firing input are manifold as mentioned in Paragraph 5.3. As a consequence, the statement of the sensitivity of an explosive becomes meaningful only when the kind of sensitivity under the specific test conditions is also specified. For instance, "gap test sensitivity" is not a sufficient designation since there are, among others,

The small scale gap test (15)

The propellant sensitivity test (20)

The wax gap boosting sensitivity test (18)

A number of different sensitivity tests are useful in the VARICOMP procedure. Depending upon the relative importance of the factors which would differentiate the way the explosive would respond under the different test conditions, it is logical to seek a correlation between results of different sensitivity tests. In fact, the VARICOMP approach becomes particularly effective when good correlations between appropriate sensitivity tests exist. As a word of caution-- impact or drop sensitivity data should not be expected always to be relevant in this general area of detonation transfer. In general, however, the correlation between impact sensitivity and gap sensitivity of many explosives is often good enough to permit the use of the impact sensitivity test in a search for likely candidates to consider in a VARICOMP program.

5.10 The sensitivity of an explosive is measured experimentally by subjecting a number of explosive charges or items to various dosages. In such a program there are unavoidable differences in the items, each from the other; the ambient environment varies throughout the course of the test; there are unavoidable differences between the intended and the achieved dosages of each successive trial. As a consequence of these and other variabilities there exists a certain band or zone of dosages within which the items will be found sometimes to respond and sometimes not to respond. The less the variability, the narrower will be this zone of chance response. In the limit (absolute control of charge, environment, and dosage) it might be expected that there exists a single value of dosage below which none would respond and above which all would respond. This model is an over simplification in that the initiation process is in itself random in nature.

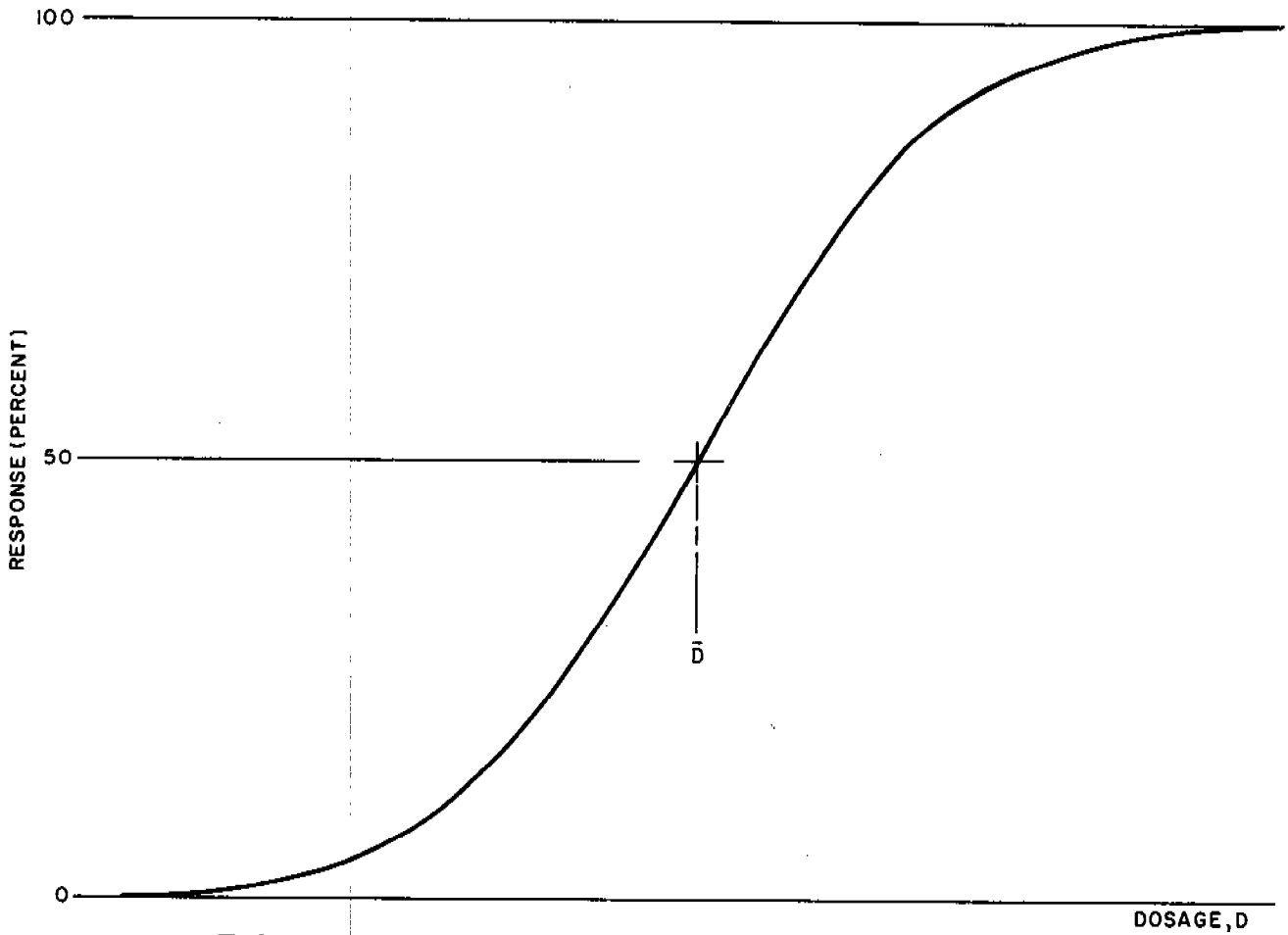

FIGURE 5.11 RESPONSE TO DOSAGE, CUMULATIVE DISTRIBUTION FUNCTION

5.11 Finer detail can be resolved within the zone of chance response. As shown qualitatively in Figure 5.11, there is a level of dosage* at which one half of the population would be expected to respond. This particular dosage is termed the 50-percent point.

For progressively less than the 50-percent point the response asymptotically approaches zero. Similarly above the 50-percent point as the dosages are increased the response asymptotically approaches a probability of 100 percent.

Because of this asymptotic behavior, concepts of a "no-fire level" or an "all-fire level" are of dubious value. They lead to ambiguities, particularly when attempting to predict population parameters from the sample parameters. In particular, the term "all-fire level" implies that the devices are so perfectly made that all will function--that there are no duds. Actually, it is not possible to tell whether or not the response-dosage relationship is truly asymptotic in the extreme. For instance, it is beyond human capabilities to differentiate by any experiment between the dosage which will give 99.9990-percent functioning and the one that will give 99.9995-percent functioning.

5.12 The Statistical Distribution Function. There are many equations which might be considered to express relationship such as is shown in Figure 5.11.

5.12.1 The most generally encountered distribution is the normal, or Gaussian, whose probability density function is:

$$p(x) = \frac{1}{\sigma\sqrt{2\pi}} \exp\left\{-\frac{1}{2}\left(\frac{x-\mu}{\sigma}\right)^2\right\}.$$

The Gaussian cumulative distribution function is:

$$P(x) = \int_{-\infty}^x p(x) dx = \frac{1}{\sigma\sqrt{2\pi}} \int_{-\infty}^x \exp\left\{-\frac{1}{2}\left(\frac{x-\mu}{\sigma}\right)^2\right\} dx.$$

*Usually indicated mathematically by drawing a bar over the symbol for the dosage.

5.12.2 More recently the logistic distribution has been studied and found of use in a number of explosive systems (25). It is defined in cumulative form as

$$P(x) = \frac{1}{1 + \exp\{-(\alpha + \beta x)\}}$$

or in a form particularly useful for computation

$$\text{logit } P = \ln \left[\frac{P(x)}{1-P(x)} \right] = \alpha + \beta x.$$

Expressed in the symbolism used in this report it can be written as

$$\ln \left[\frac{P(x)}{1-P(x)} \right] = \frac{x - \mu}{\delta}$$

where μ represents the mean, $-\alpha/\beta$, and $\delta = 1/\beta$.

5.12.3 In certain cases both Gaussian and logistic distributions have been found not fully satisfactory as a description of explosive systems. In general, the observed sample responses at high dosages are less than would be predicted by observations near the mean firing levels. Similarly, responses at low dosages are greater than would be predicted. Work by Ash and Lacugna (13) suggests that the following distribution might be of particular value for those distributions which appear to have much longer tails than the Gaussian. The probability density function is:

$$p(x) = \frac{A}{\xi} \exp \left\{ -B \sqrt{\frac{|x - \mu|}{\xi}} \right\}$$

*Fisher and Yates (26) discuss this type of distribution function with

$$P(x) = \frac{\exp\{2z\}}{1 + \exp\{2z\}}, \quad p(x) = \frac{1}{2} \text{sech}^2 z$$

where A and B are arbitrary constants. The cumulative distribution function is:

$$P(x) = \int_{-\infty}^x p(y) dy.$$

5.13 In the above equations the symbols μ , σ , γ , and ξ represent population parameters:

μ is the value of the stimulus, x , at which 50 percent of the population will respond.

σ , γ , and ξ are inversely proportional to the slope of the cumulative distribution function when the value of x is equal to μ .

The parameters, σ , γ , and ξ are measures of the variability of the population. The bigger their values, the more variable is the population. Greek symbols μ , σ , γ , and ξ are reserved for the population parameters. The corresponding sample properties are represented by \bar{x} (the value of stimulus at which 50-percent response was noted), and s and g (the measures of the observed sample variability). In the case of the Gaussian distribution, s is the "standard deviation" (the square root of the sample variance).

5.14 All of the above distribution functions relate functioning probability to stimulus. As was mentioned in Paragraphs 5.5 and 5.6, the stimulus is not necessarily the same as the dosage. Experience has generally shown that these two things are not the same. Some transformation function has to be found to relate the physical variable to the stimulus (27). In a number of instances the logarithmic transform has been chosen as the most suitable.

5.15 Statistical Model. The term "statistical model" is used to refer to the mathematical relationships which describe the response of an explosive system to the environment being studied. The statistical model therefore is made up of

The probability distribution function,

The dosage-to-stimulus transform.

The term "probability distribution function" as used herein does not distinguish between the probability density function (the bell-shaped curve such as Figure 3.1) and the cumulative function (the sigmoidal curve such as in Figure 5.11). The term is used to differentiate between distributions such as Gaussian, logistic, etc.

5.16 Probability Spaces. By using specialized coordinate systems it is possible to devise methods for plotting statistical information in a manner which will facilitate computations and demonstrate relationships. The sigmoidal plot suppresses the detail above 98 percent and below 2 percent--the zones of particular interest. It is also not amenable to eye-fitting of observed data--it is much simpler to fit data with a straight line than with a compound curve. Probability graph paper has been designed to display details of extreme probabilities and to facilitate fitting of data. The vertical coordinates are symmetrically arranged about a midpoint on the vertical axis representing a probability of 50 percent. The probability increases upward approaching, but not reaching, 100 percent; and similarly it approaches 0 percent as it decreases downward from the midpoint. In graphical displays of this form, the vertical coordinates are often presented in units of probits, normits, or logits in addition to, or instead of, the probability values.

The normit is based on a Gaussian distribution whose mean, μ , is zero, and whose standard deviation, σ , is unity. Its probability density function therefore is:

$$p(x) = \frac{1}{\sqrt{2\pi}} \exp\left\{-\frac{1}{2}x^2\right\}.$$

The normit and the probit are cumulative response units, and are of identical size. However, the number of probits corresponding to a given percent response is 5.0 greater than the number of normits.

The logit is related to the logistic distribution as the normit is to be the Gaussian; the probability density function being:

$$p(x) = \frac{1}{4} \operatorname{sech}^2 \frac{x}{2}.$$

Note that in the case of the logistic function, γ is a measure of the variability but is not the standard deviation.

The Gaussian and logistic distributions are compared in Table 5.16 and presented in a probability space (to illustrate the forgoing concepts) in Figure 5.16.

5.17 Two methods will ordinarily be used to present statistical information graphically in this report. Figure 5.17 shows the sensitivity of the same three typical explosives to illustrate the two methods of presentation.

5.18 For the purposes of this report, the Gaussian distributions will be used throughout--it being left to the reader to adapt the techniques as necessary, should some other distribution function be indicated.

5.19 In order to systematize the methods of presenting knowledge and judgement three basic steps must be taken:

Assumption of a statistical model for the response of the explosive as a function of stimulus.

By experiment, determination of the sample properties.

In terms of the statistical model, estimation of the limits for the population parameters, using the sample properties as data.

Table 5.16

COMPARISON OF GAUSSIAN
AND LOGISTIC DISTRIBUTIONS

<u>u</u>	<u>Gaussian</u>	<u>Logistic (1)</u>	<u>Logistic (2)</u>
4.0	99.997	99.87	99.83
3.5	99.977	99.71	99.63
3.0	99.865	99.33	99.17
2.5	99.38	98.32	98.18
2.0	97.73	96.56	96.05
1.6	94.52	93.51	92.77
1.2	88.49	88.10	87.15
0.8	78.81	79.14	78.18
0.4	65.54	66.08	65.42
0.0	50.00	50.00	50.00
-0.4	34.46	33.92	34.58
-0.8	21.19	20.86	21.82
-1.2	11.51	11.90	12.85
-1.6	5.48	6.49	7.23
-2.0	2.27	3.44	3.95
-2.5	0.62	1.68	1.82
-3.0	0.135	0.67	0.83
-3.5	0.023	0.29	0.37
-4.0	0.003	0.13	0.17

Notes:

u is the normalized variable

The Gaussian distribution is computed for the case of $\bar{u} = 0$ and $\sigma = 1.0$

Logistic (1) is computed for $\bar{u} = 0$ and $\sigma = 0.6$ (so that the Gaussian and logistic distributions coincide at 15.87-percent, 50-percent, and 84.13-percent responses)

Logistic (2) is computed for $\bar{u} = 0$ and $\sigma = 0.623$ (so that the Gaussian and logistic distributions are tangent at 50-percent response).

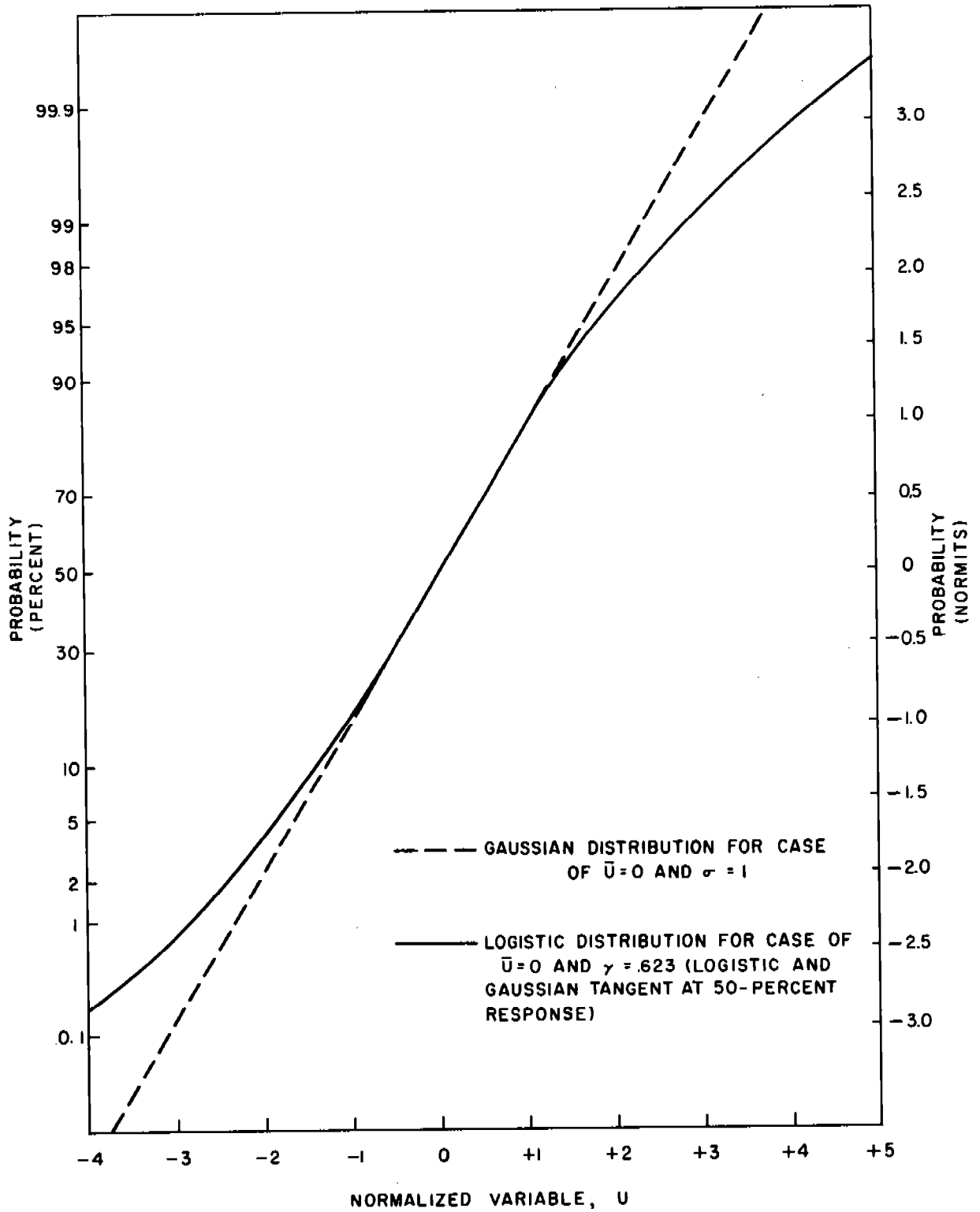

FIGURE 5.16 COMPARISON OF GAUSSIAN AND LOGISTIC DISTRIBUTIONS

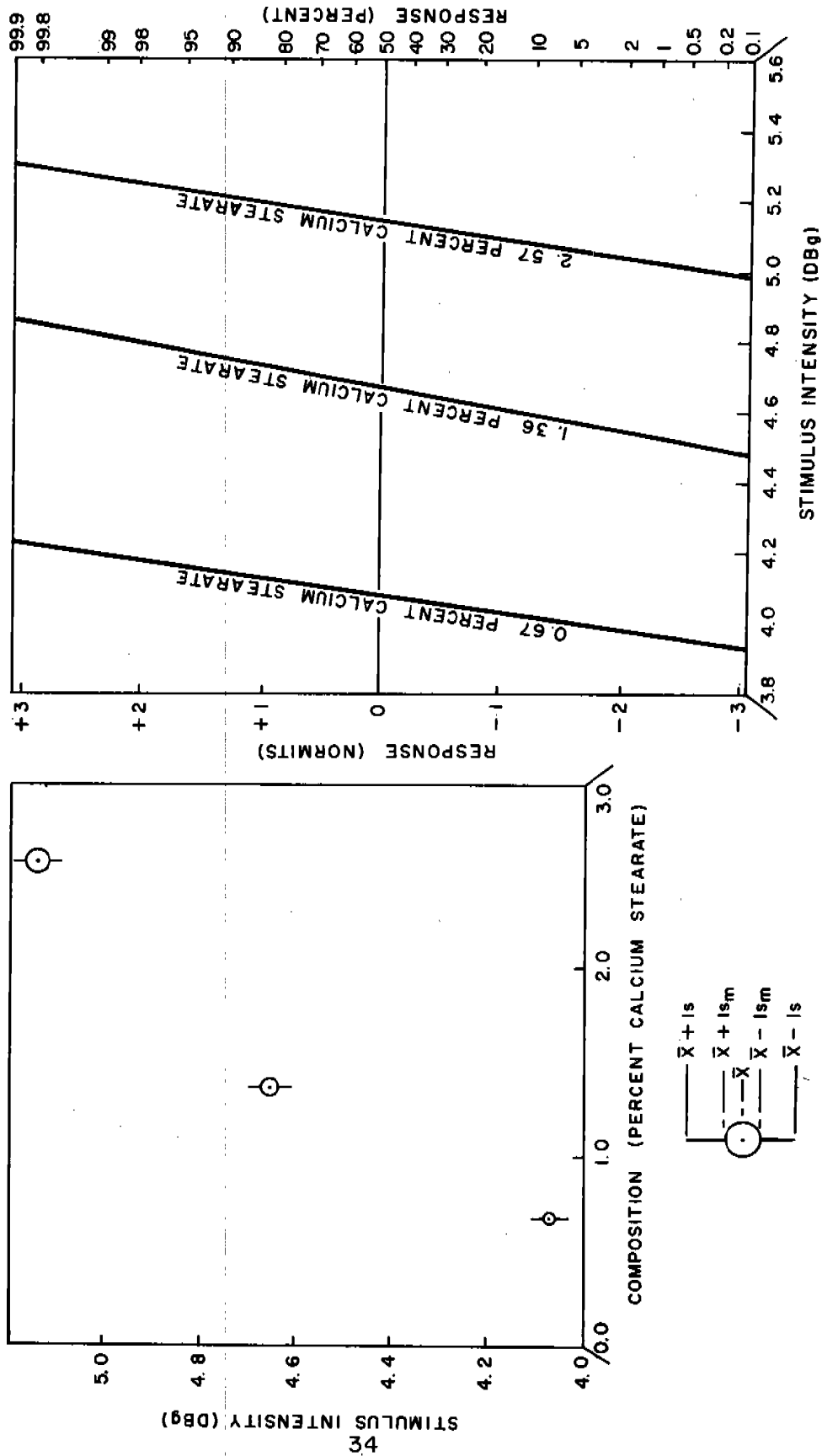

FIGURE 5.17 SENSITIVITY OF VARIOUS RDX/CALCIUM STEARATE COMPOSITIONS

6. THE VARICOMP METHOD

6.1 The basic approach and application of the VARICOMP method is:

6.1.1 Given: Two explosive charges in a weapon system separated by some demarcation such as a metallic or plastic membrane, an air gap, or perhaps just a surface of physical contact between the two charges. The

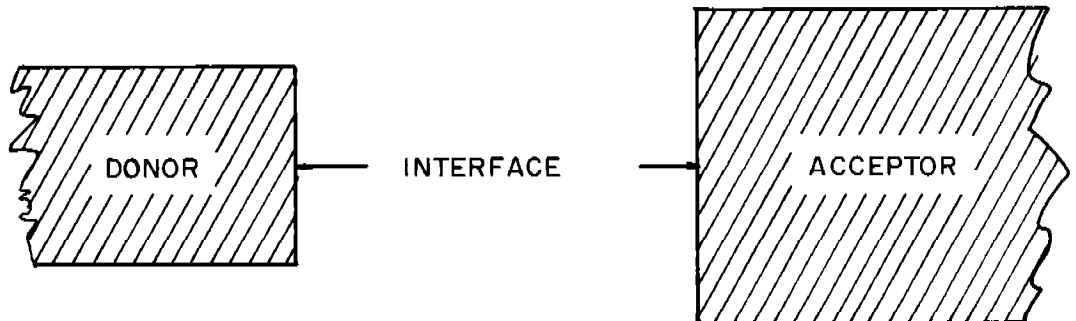

FIGURE 6.1.1

THE EXPLOSIVE SYSTEM

demarcation is termed the interface. The donor is the charge which is initiated externally and is the source of detonation which is to be transferred across the interface into the acceptor (Figure 6.1.1).

6.1.2 The Problem: What is the probability that detonation will be transferred from the donor, across the interface, into the acceptor? What is the confidence that can be associated with the estimated transfer probability?

6.1.3 The Approach: The explosive system is tested with the acceptor made from one or more explosive compositions which are known to be less sensitive than the design explosive. (Alternatively, the system can be tested with the donor made from one or more explosive compositions which are known to have less output than the design explosive.) These trials, termed Performance Tests, are to be carried out with a minimum deviation from the configuration of the weapon both as to the interface and the surrounds for donor and acceptor. Here again the skill of the

NAWEPs REPORT 7411

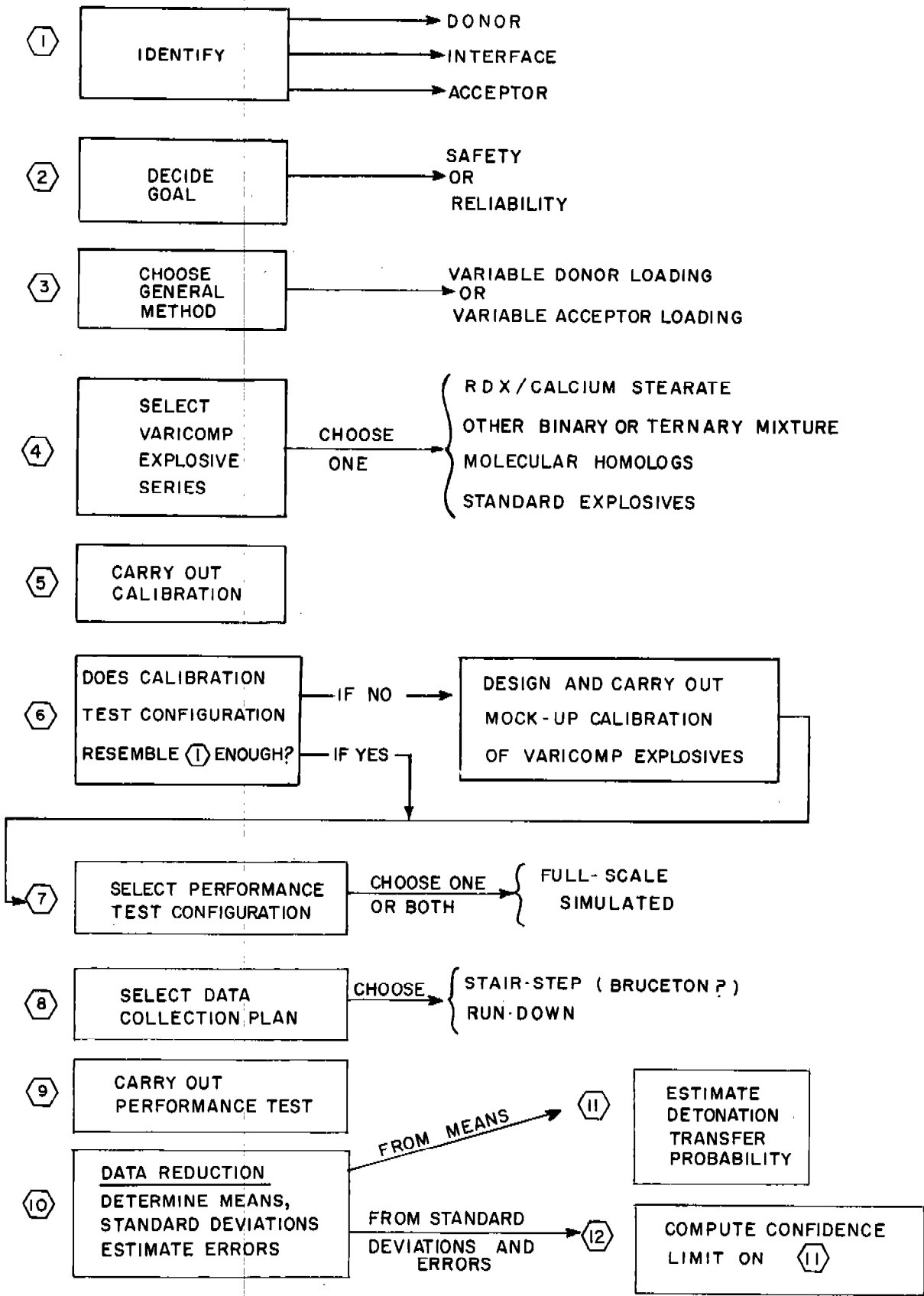

FIGURE 6.2 FLOW DIAGRAM FOR VARICOMP

experimenter is drawn upon. In the interests of economy of material and time, as little hardware as possible would ordinarily be used other than that which affects the detonation transfer. The performance tests are used to determine how reliable the weapon will be, even when loaded with the less sensitive (or less vigorous) explosives.

6.1.4 The Answer: By knowing how reliable the weapon is under the adverse conditions of the performance tests, it should be possible to estimate how much more reliable it would be under the standard conditions.

6.2 Plan of Action. Figure 6.2 shows the various segments of the VARICOMP process, although not necessarily in the order of accomplishment in a specific application. Some of these steps have already been discussed and explained in detail. Others will be amplified in ensuing sections. Enough background has now been given and terms defined to permit classification of the various portions of the process before describing them. Capsule explanations of each step are given in order to prepare the reader for the detailed discussions that will follow.

1. Identify: Establish exactly the essential geometry and materials of the components or explosive charges acting as donor and acceptor. Determine the confinement of the explosive components and of the interface. Determine the geometry and materials of the interface. Determine tolerances, allowances, and sources of variability that might affect the detonation transfer.
2. Decide Goal. Is the problem to establish the certainty with which the detonation will transfer, or is it to establish the certainty that it will not? How reliable (or safe)? With what confidence?
3. Choose General Method. Will the explosive loading be varied in the donor or in the acceptor? Here a balance will have to be made for each of the following factors:

How much variability is attainable compared to what is needed?

Difficulty of loading and of testing.

NavWeps Report 7411

Availability of calibrated VARICOMP explosives.

Criterion technique--simplicity of response assessment.

4. Select VARICOMP Explosive Series. This goes hand-in-hand with Step 3 and the general strategy of tackling the whole problem.
5. Carry Out Calibration. Ordinarily this will have been done previously. Explosives to be used in a specific problem will already have been procured and tested for sensitivity (or output). The data from these tests would usually be

Observed composition: Analysis and density expressed in terms of their means and standard deviations.

Observed sensitivity (or output): The mean stimulus and the standard deviation of the stimulus.

Adjusted sensitivity (or output): Corrections made by curve fitting.

6. Does Calibration Test Configuration Resemble Step 1 Enough? How much of a guess? How much risk? How much faith?
- 6A. Mock-Up Calibration. This will be the consequence of a no to question, Step 6. This type of testing is likely to yield less information for effort expended to obtain it than the case where the answer to question, Step 6, is yes.
7. Select Performance Test Configuration. In all likelihood, this will be controlled by the size of the pocketbook and allowable lead time. The closer this resembles the true weapon, the less chance of invalidation of assumptions.
8. Select Data Collection Plan. A properly designed experimental plan should take into account the possible outcomes and should map out interpretations and further work to be done for each of the outcomes. Changing of test plans and ground rules in the middle of an experiment usually falls in the category of "statistical hanky-panky" or "cooking-the-data". Uncontrollable bias injected into the program can introduce serious distortions.

9. Carry out Performance Test.
10. Data Reduction.
11. Estimate Transfer Probability.
12. Compute Confidence Limit.

6.3 Calibration Tests. The quantitative comparison of the properties of the design explosive with the VARICOMP explosives is done by calibration tests. Such data collected in previous and current programs represent at least part of the organized experience upon which engineering judgement can be based. The various tests represent yardsticks for comparing various explosives. It is too much to hope that a single yardstick will serve for all applications. The ideal situation is to have as many explosives as possible measured on as many of the necessary yardsticks as possible and with as much experimental determination of their inherent accuracy as possible.

6.4 Performance Tests. As has been previously stated, the performance tests should be carried out with a minimum deviation from the configuration of the weapon. In some cases, the complete weapon might be tested, the only changes from the standard weapon being different loading of the acceptor (or donor). It is more probable that some portion of the weapon (a portion which, of course, will include completely the transfer elements) will be selected. It will be necessary in the final analysis to decide whether or not enough of the weapon hardware had been included in the setup so that there is really no difference as far as the transfer of detonation is concerned. In many cases, the exact hardware and complete charge cannot be used for the performance tests (too expensive, too much explosive). If this is the case, some form of simulated performance test will have to be devised. The experience and skill of the experimenter will have to be drawn upon heavily. Each point of difference will have to be assessed. The best approach to the problem will be to adjust the differences so that if any significant effect on the transfer can be expected, it will be in the direction of further penalty on the system. The quantitative measure of such penalties cannot be hoped for and therefore cannot be cranked into the reliability estimates. They probably can be converted into extra peace-of-mind for the experimenter.

6.5 Performance Test, Criterion of Fire. Acceptors loaded with different compositions may differ in output as well as in sensitivity. This could lead to confusion when judging whether or not initiation took place. A reduced output of a desensitized explosive may result from either of two conflicting reasons:

The diluent has reduced the total energy available. For instance, the reduced output of a fully initiated explosive may be judged as a partial detonation.

The acceptor is being initiated marginally by the donor.

6.6 There are a number of assumptions of similarity (analogy) upon which the validity of the VARICOMP process depends. These assumptions are in turn dependent upon the five listed in Paragraph 3.2 and will therefore be numbered in continued sequence. The assumptions are that:

ASSUMPTION 6 The mechanism of initiation of the VARICOMP and design explosives in the calibration test is the same throughout the range from the least to the most sensitive, and that the calibration test statistical model is applicable.

ASSUMPTION 7 The mechanism of initiation of the VARICOMP and design explosives in the performance test is the same throughout the range from the least to the most sensitive, and that the performance test statistical model is applicable.

ASSUMPTION 8 There is a linear transform between the two statistical models.

6.7 There are a number of methods which might be used for collecting data in the performance test. These methods refer to the scheme for selecting and sequencing the explosives to be used in the test. Two of these methods will be discussed* in detail:

The Bruceton up-and-down or stair-step data collection plan (7,22,29), (Section 9).

The run-down data collection plan (Section 10).

*These discussions, for simplicity and brevity, will be restricted to performance testing using variable acceptor explosives.

Other schemes such as modified stair-step (30) and the Bartlett plan (31) could be handled with appropriate modifications. Because of the differences in the procedures and assumptions, Section 11 is included to aid the experimenter in designing the experimental program and in deciding just what data collection plan should be used. The final estimate of the weapon system probability figures should be based on all pertinent data. The VARICOMP test data will ordinarily not be the sole source of information.

6.8 Inferential Methods. Graphical methods will be given for relating performance and calibration test data and for making estimates of detonation transfer probabilities. The graphical method is not the only way to the answer, but it does offer a valuable assistance in visualizing the reasoning process and understanding the relationships. For the remainder of this report it will be assumed that the calibration data are in graphical form. The discussion will be concerned with the methods of plotting the performance data and of obtaining final answers by appropriate graphical and computational operations.

7. THE CHOICE OF THE VARICOMP EXPLOSIVES

7.1 RDX, diluted to varying degrees with wax or with calcium stearate, has been used to study detonator-to-lead and lead-to-booster transfer reliabilities (5,32). Considerable effort has been expended to develop procedures for making such RDX mixtures. It is most important that any particular batch of such mixtures (sometimes referred to as degraded RDX) be homogeneous from the standpoint of sensitivity. It is also highly desirable, though not quite as important, that these mixtures be reproducible, batch-to-batch. As will be indicated, the lack of batch-to-batch reproducibility will lead to an increased within-batch calibration testing in order to realize an equivalent precision from the VARICOMP process. For explosive train applications the ordinary loading procedures involve pressing into inert containers, or perhaps the formation of pressed pellets. Therefore, in addition to the above requirements, the explosive mixes must be loadable.

7.2 The RDX/Calcium Stearate mixtures have been found to be more useful than RDX/wax mixtures. They appear to be more uniform within-batch and to be more reproducible batch-to-batch. This may be because greater quantities, by weight, of the calcium stearate have to be used to give the same desensitization. As a consequence, the sensitivity of a mix could be expected to be less subject to errors in composition. Various stearate salts and various methods of compounding have been tried. A chemical precipitation of calcium stearate onto RDX suspended in water slurry has been found the most satisfactory. The process (Appendix A) is adapted from the manufacturing specifications for explosive CH-6. Batch sizes to date have been 5 to 20 pounds. Pilot batches of considerably greater quantity are being manufactured. These will be studied for uniformity, loadability, etc. Table 7.2 shows a typical series of such RDX/Calcium Stearate mixtures with indications of how their sensitivities to initiation by shock vary with composition.

7.3 There are certain generalized relationships characteristic of the steared-RDX's:

The sensitivities of the mixes are a function both of the composition and the density of the mixes.

At a given consolidation pressure, the greater the proportion of calcium stearate, the more nearly does the density approach the TMD (Theoretical Maximum Density).

Table 7.2

PROPERTIES OF THE RDX/CALCIUM STEARATE
BINARY EXPLOSIVE SYSTEM IN THE SMALL SCALE GAP TEST
WHEN LOADED AT 10 KPSI

Composition (% Ca St)	Density (%TMD)*	Sensitivity			Output** (Mils)
		Mean (Mils)	S_m (DBg)	S_m (DBg)	
0.00	86.5	470	3.28	0.01	64
0.67	88.1	392	4.07	0.01	63
1.36	89.8	342	4.66	0.02	64
1.35	90.1	332	4.79	0.01	66
1.63	90.3	340	4.68	0.02	64
1.87	90.9	313	5.04	0.02	65
2.57	91.9	306	5.14	0.01	61
2.66	91.6	299	5.25	0.01	65
3.69	92.8	297	5.28	0.02	64
3.76	92.4	283	5.48	0.03	63
4.97	93.4	278	5.56	0.01	62
5.28	93.3	276	5.59	0.02	63
7.47	94.4	261	5.84	0.01	61
6.94	94.2	262	5.82	0.02	61
11.06	96.0	245	6.11	0.02	57
10.81	95.9	250	6.03	0.02	59
13.96	96.2	239	6.22	0.01	55
13.99	96.5	237	6.25	0.02	54
14.32	95.7	230	6.38	0.05	53

*TMD means theoretical maximum density.

**Output measured by depth of dent in a steel block as described in reference 28.

Note: The Decibang (DBg) is defined in Appendix C.

NavWeeps Report 7411

The greater the proportion of calcium stearate, the more variable is the sensitivity and the more difficult is the analysis.

7.4 Considerable difficulty has been encountered in the analysis of what appears, on the surface, to be a simple two-component system. Gross discrepancies have been discovered between results obtained on supposedly the same mix from different analyses (different analysts). The exercise of the utmost care and good technique is necessary in order to obtain reliable results. If it is necessary to analyze RDX/Calcium Stearate mixtures, the analytical procedure in Appendix B is recommended.

7.5 In some circumstances it has been found that changes in the density of an explosive charge will make a great change in the charge sensitivity (15) even to the extent of masking differences which can be attributed to composition (34). The general trend is towards decreasing sensitivity with increasing charge density. To a lesser degree, the output of an explosive charge will also be affected by density. The output will increase with density providing the ability of the charge to be detonated and to support detonation will not be adversely affected at the very low or very high densities. Within the limits of practical charge fabrication there may be instances where, by changing the charge density, the VARICOMP procedure could be applied. Variation of charge density could be used to control acceptor sensitivity or to control donor output.

7.6 It will not be feasible to employ the RDX/Calcium Stearate series in all applications. Certainly it should be possible to establish an alternative series using different conventional explosives. Table 7.6 indicates a group of explosives, with their different sensitivities, that might be suitable for a castable series. Some thought has been given to the possibility of producing a series of pure chemical compounds which are molecular homologs (14, 35, 36). Such a series might in addition be quite valuable in furthering knowledge of the relationship between molecular structure and sensitivity. Unfortunately, such a series may be expensive to establish, since in many cases the pilot production synthesis process must also be developed.

Table 7.6

Typical Values of High-Explosive Sensitivities

Explosive	Impact (cm)	NOL Propellant Sensitivity Test (inches)	NOL Booster Sensitivity Test (inches)
HEX-3	87	1.41	----
TNT	150 to 215	1.38	0.82
TRITONAL	87 to 104	1.26	0.58
BARATOL	----	1.18	0.32
PENTOLITE	38	2.66	2.06
COMP B	82	2.01	1.39

Note: The above values were obtained from references 18, 38, 39, 40, and 41.

7.7 A VARICOMP series of explosives made by varying the proportions in a mixture offers an advantage over one made from a collection of different standard explosives. (This statement is made on the assumption that the mixture properties will vary in a systematic fashion with the proportions of the components of the mixture.) The advantage lies in the fact that the total sample size needed for measurement of the sensitivities should be less for the variable proportion mixes than for a series of different standard explosives. Data obtained on the individual mixes of a binary mix system can be plotted against the composition. Then a smooth curve fitted to the 50-percent firing points would be expected to compensate partially for the experimental error in determination of individual 50-percent firing points. Similarly the individual observed standard deviations might well be combined to give a better estimate of a standard deviation characteristic of all the mixes.

7.8 One drawback of mixtures such as RDX/Calcium Stearate, which depend on desensitization of a sensitive high explosive by the addition of an inert diluent, is that the more desensitized mixes are less explosive in character: their outputs fall off; their abilities to sustain detonation diminish. It may therefore be logical to use an insensitive explosive as the diluent. With this arrangement it would be expected that the members of the series would respond with more nearly the same dynamic performance. Nitroguanidine is suggested as a possible insensitive component. Nitroguanidine/RDX or Nitroguanidine/PETN binary mixtures might have good pressing or pelleting properties. A ternary mixture of Nitroguanidine/RDX/TNT (suggested name: Cycloguanitol) might either be castable, or when granulated, suitable for press-loading. A similar ternary mixture might be Nitroguanidine/PETN/TNT.

7.9 Explosives suitable for use in a VARICOMP series must have the following properties:

Maximum within-batch homogeneity (composition, particle size, sensitivity)

Good batch-to-batch reproducibility

Good mechanical durability (must not segregate as a result of shipping vibration; screening; handling)

Non-hygroscopic

Stable up to 70° Centigrade

NavWeps Report 7411

For press loading the explosive should be fine enough to pass through a No. 35 screen. However, if the explosive is extremely fine, problems may arise in handling: excessive dusting, caking on loading tools, having too low a bulk density, etc.

Certain other requirements usually specified for high-performance explosives, such as dimensional stability at high temperatures, high energy content, and high detonation velocity, may be abrogated in favor of the above requirements.

8. THE CALIBRATION TEST

8.1 Calibration of Explosives. The VARICOMP method is an extrapolation

From the observable behavior of the VARICOMP explosive(s)

To a prediction of the behavior of the design explosive

In the performance test system

Based on data which compare the VARICOMP explosive(s) with the design explosive.

These comparative data are obtained from the calibration of the explosives under consideration. The precision and accuracy of the extrapolation is obviously enhanced as the extent and accuracy of the calibration are increased. The ultimate goals of the calibration are:

Identification of the distribution functions of each of the explosives

Measurement of the statistical parameters of the VARICOMP explosives. (It is assumed that this is done for each batch or lot.)

Measurement of the statistical parameters of enough different lots or batches of the design explosive to yield data representative of the expected production process variability.

8.2 Calibration Tests, Sensitivity. There are a number of sensitivity tests (see Appendix C) such as the small scale gap test (15), the propellant sensitivity test (20), and the boosting sensitivity test (18), which might be used to calibrate the sensitivity of the acceptor explosives. Although it is desirable to use standard sensitivity tests for the calibration of the acceptor explosives, there will be in some instances so much difference between the weapon configuration and the ordinary test configuration that the sensitivity data may not be relevant. In such cases, mock-up calibration tests might be indicated. These would be compromise variants having as much as possible the arrangement of some standard sensitivity test

but modified to represent the salient aspects of the weapon system interfaces and donor-and-acceptor-surrounds. The mock-up-calibration tests would be used to search for correlations of the sensitivities of the VARICOMP explosive in the calibration and performance configurations. When the correlation is considered to be sufficiently good, the doubt as to relevance of sensitivity data to the weapon system can be discarded.

8.3 Calibration Tests, Output. When the VARICOMP method is applied with only the design explosive in the acceptor but with modification of the donor explosive, the donor explosives might be calibrated by measuring the dent produced in a witness plate (28), or perhaps by high-speed camera measurements of detonation parameters. Such calibrations will yield continuous data rather than the Go/No-Go data characteristic of sensitivity testing. Because continuous-data tests are considerably more efficient than Go/No-Go tests (they yield more information per shot) it would seem sensible to carry out the VARICOMP procedure using the degraded approach. Unfortunately, the main point of uncertainty has not been reduced. It merely has been moved to a different location:

Variable Acceptor Sensitivity: Is the mechanism of initiation in the calibration test the same as in the weapon? Is the proper calibration dosage-to-weapon acceptor stimulus transform being used?

Variable Donor Strength: Is the dent producing ability of the donor a measure of its ability to initiate the acceptor? Is the proper output-to-stimulus transform being used?

8.4 Small Diameter Systems. The calibration of explosives (and, in fact, the whole VARICOMP process) is most easily and quickly carried out with the smaller diameter explosive systems. Because their charge diameters rarely exceed 0.25 inch, detonator-to-lead transfer systems will require relatively small quantities of explosives to carry out VARICOMP studies. The practical explosive batch size (25 to 100 pounds of an RDX/Calcium Stearate mix, for instance) appears to be large enough so that rather extended calibrations can be carried out with an expenditure of only a minor portion of the batch. The cost of the calibration can be amortized over a goodly number of different systems. Calibration by the revised small scale gap test would probably give relevant sensitivity data for detonator-to-lead studies provided its characteristics (heavy confinement, initiation by shock through condensed medium, bare charges) are near enough to the system under study.

Table 8.4

THE CALIBRATION AND UTILIZATION OF
A VARICOMP EXPLOSIVE SERIES (CONJECTURE)

1. 10 mixes at 50 pounds per mix	Total: 500 pounds
2. Calibration 200 small scale gap test shots per batch	Total: 10 pounds
3. Detonator-to-lead system. (200 trials or less loaded from the various batches)	From 0.1 to 0.5 pound per system
4. Lead-to-booster system (probably both mock-up- calibration and performance tests)	From 5 to 20 pounds per system

Lead-to-booster studies represent a greater departure from the conditions of the small scale gap test. In general, this is because there is a donor-to-acceptor diameter transition ratio of 0.25 or less and because the acceptor is essentially unconfined (semi-infinite solid). Mock-up-calibration is therefore more likely to be required for lead-to-booster studies. Yet, even with mock-up-calibration tests as well as performance tests, the total explosive requirements for lead-to-booster studies should ordinarily use limited quantities of the explosives. Strictly subjective guesses of the quantities of explosives that might be used in small diameter VARICOMP experiments are given in Table 8.4.

8.5 Large Scale Systems. One of the difficulties with large scale system (booster-to-warhead) studies by the VARICOMP method is the difficulty of maintaining charge uniformity. For instance, at the Naval Ordnance Laboratory the limit for a single melt of castable explosive is about 100 pounds. A calibration by the Naval Ordnance Laboratory booster sensitivity test requires about 0.5 pound of the explosive per trial. Frequently, the performance test will use from 1 to 3 pounds of the VARICOMP explosive per trial. Thus, it can be seen that a relatively few experiments will expend the explosive from a single melt. Bitter experience has shown that there is sometimes much greater variability between successive melts of an explosive than there is within a melt. The calibration effort must recognize the following limitations:

Too Few Trials -- Low precision.

Large Number of Trials -- Not enough explosive left to do performance tests.

Batch-to-Batch Nonuniformity.

8.6 Extent of Calibration. The choice of the magnitude of the calibration effort (the number of shots per explosive) is governed by the gain in precision versus the increase in cost as the number of trials is increased. The gain in precision (decrease in variability as evidenced by the decrease in the standard deviation of the mean, A_m , and of the standard deviation of the standard deviation, A_s , is proportional to the square root of the number of trials. Thus a determination of the sensitivity based on a two hundred-shot Bruceton run would be expected to be twice as precise as a fifty-shot determination. Another way of looking at this relationship is to see that a two-fold improvement in accuracy will cost four times as much. At this point the advantage of the binary-mix system of VARICOMP explosives becomes very attractive. If the following assumptions are valid--

ASSUMPTION 9 The sensitivity is a continuous smoothly-varying function of the composition

ASSUMPTION 10 The standard deviations of each of the mixes is not a function of the composition, and is the same for all mixes

--then each of the determinations of the standard deviation (one for each mix) can be considered as an individual estimate (replicate determinations) of the standard deviation characteristic of the system. The system standard deviation can be computed by combining the individual variances of the sensitivities:

$$S = \sqrt{\frac{\sum_{i=1,j} (n_i) A_i^2}{\sum_{i=1,j} (n_i - 1)}} = \sqrt{\frac{\sum_{i=1,j} (n_i) A_i^2}{N - j}}$$

where m_i is the effective sample size* of the i^{th} mix,

A_i is the standard deviation of the i^{th} mix,

N is the total effective sample size,

j is the number of mixes.

This having been done the system standard deviation of the mean, S_m , and the system standard deviation of the standard deviation, S_A , can be computed by

$$S_m = \frac{S}{\sqrt{N}}$$

and

$$S_A = \frac{S}{\sqrt{2N}}$$

From this it can be seen that if ten mixes were tested with an equal number of trials for each, the precision of the system parameters, S_m , and S_A , is better than three-fold improved over the precisions of the determinations for individual mixes. Standard statistical procedures can be used to test the validity of the above assumptions for specific collections of data.

*The term "effective sample size" is used to denote the fact that for Bruceton data, n_i is not the number of trials, but is rather the number of fires or the number of fails, whichever is least.

8.7 Presentation of Data. Ordinarily the measured and reported sensitivity data for individual mixes are

\bar{x} , the 50-percent point

A , the standard deviation

n , the effective sample size.

For fitted data the corrected 50-percent points, the system standard deviation, S , and the total sample size, N , would be given. Figure 8.7 shows the observed sensitivities for a typical RDX/Calcium Stearate series (Table 7.2). The corrected (fitted) data are also indicated (Table 8.7). Sometimes it will not be possible to adjust, or fit, the data for a number of explosives. For instance, a series of standard explosives would yield individual means and standard deviations that are essentially independent--e.g., the standard deviation of TNT is not necessarily characteristic of various cyclotols. In such cases, only observed data would be given. Whether smoothed or observed data are reported, the composition and density, plus any other charge preparation or special configuration information, should also be given for each sensitivity figure.

8.8 Transformation to Probability Space. In order to apply the VARICOMP process the data must be converted to straight-line relationships of response versus stimulus. This can be done by plotting them on appropriate probability graph paper. For instance, the fitted data of Figure 8.7 are plotted in this manner in Figure 8.8. Mathematically the equivalent (and alternative) method is to generate the equations of the line in the general form

$$R = Ax + B$$

where

$$A = 1/A$$

and

$$B = -\bar{x}/A$$

Here R is the probability expressed in normits, and \bar{x} and A (previously defined) are expressed in the units characteristic of the stimulus.

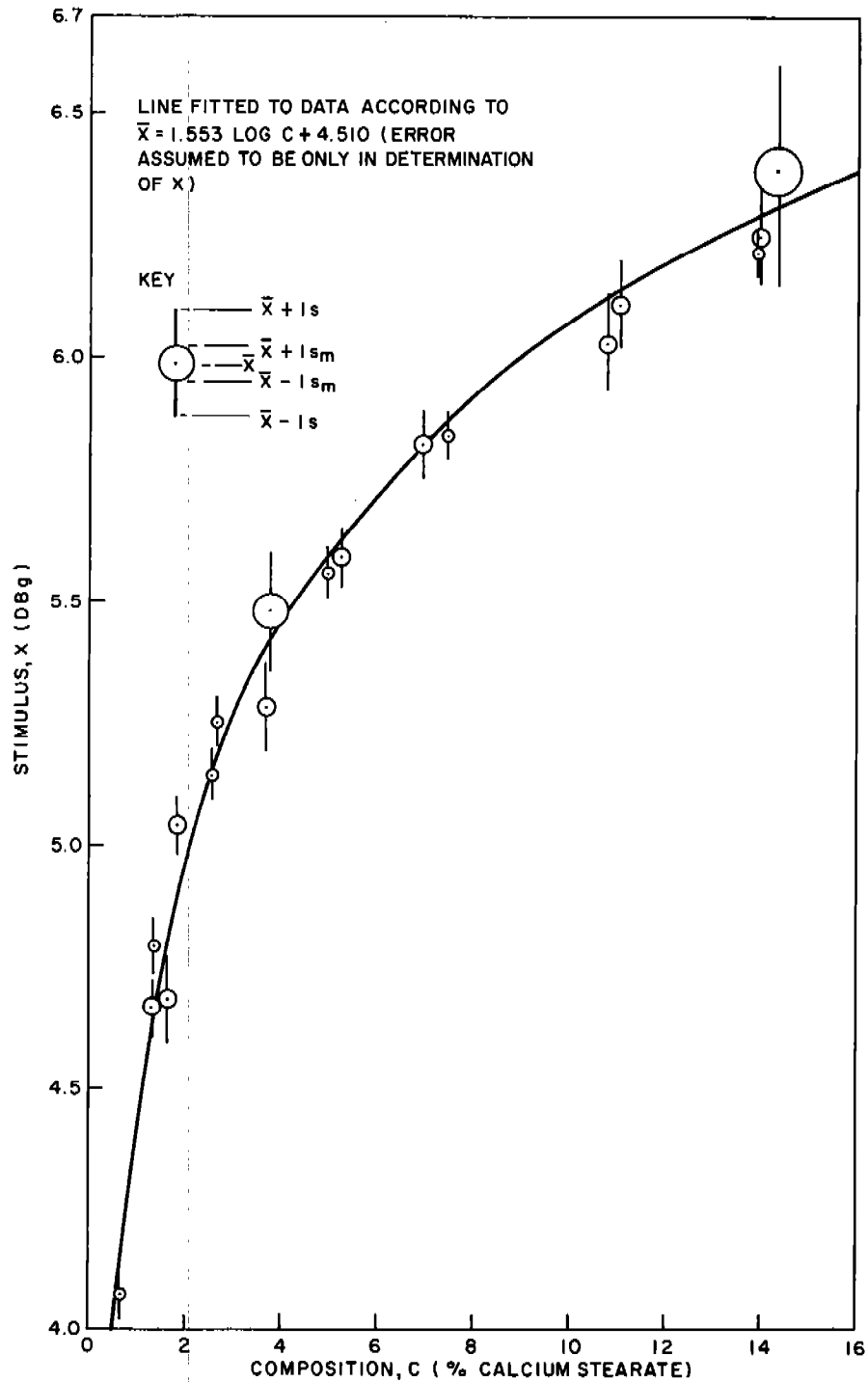

FIGURE 8.7 SENSITIVITY VERSUS COMPOSITION FOR VARIOUS RDX / CALCIUM STEARATE MIXTURES

Table 8.7

FITTED VALUES OF THE SENSITIVITIES
OF VARIOUS RDX/CALCIUM STEARATE COMPOSITIONS

C, Composition (% Ca Stearate)	\bar{X} , 50 Percent Point (DBg)	
	Observed	Fitted
0.67	4.07	4.24
1.35	4.79	4.71
1.36	4.66	4.72
1.63	4.68	4.84
1.87	5.04	4.93
2.57	5.14	5.15
2.66	5.25	5.17
3.69	5.28	5.39
3.76	5.48	5.40
4.96	5.56	5.59
5.28	5.59	5.63
6.94	5.82	5.82
7.47	5.84	5.87
10.81	6.03	6.12
11.06	6.11	6.13
13.96	6.22	6.29
13.99	6.25	6.29
14.32	6.38	6.31

Values fitted according to

$$\bar{X} = 1.553 \log C + 4.150.$$

Composite standard deviation of the sample, S , is 0.087 DBg.

Composite standard deviation of the mean, S_m , is 0.02 DBg.

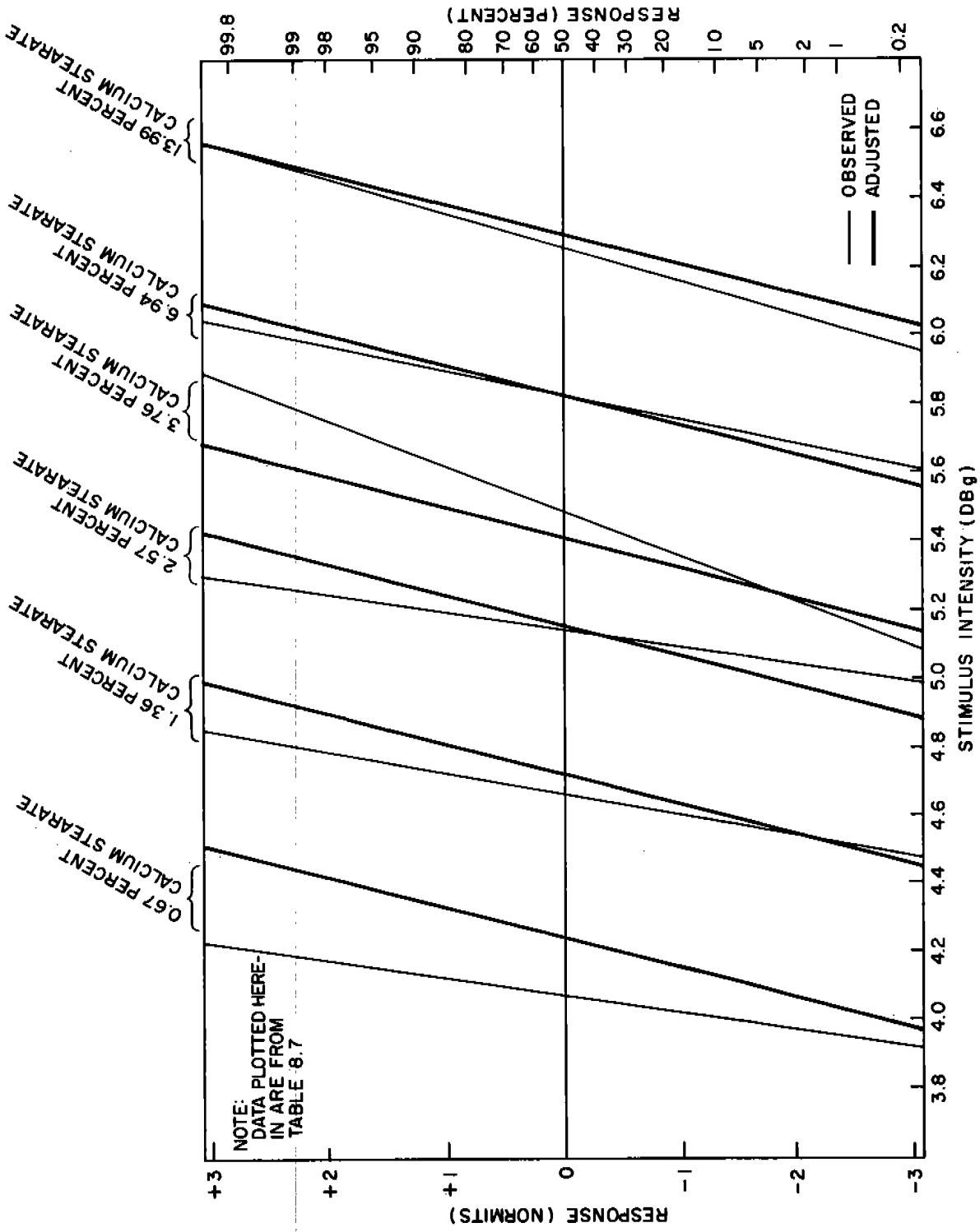

FIGURE 8.8 OBSERVED AND ADJUSTED SENSITIVITIES OF VARIOUS RDX/CALCIUM STEARATE MIXTURES

8.9 When the sensitivity picture cannot be presented as simply as above, because of batch-to-batch variation, limited sample size, or suspected or detected inaccuracies of the test method, it will be necessary to present additional information--confidence intervals about the various parameters, statements of experimental and inherent error in the determinations, qualifications, etc.

8.10 Centering of Calibration Tests. Ideally, the calibration of the design explosive should be carried out by some test plan which will have the greatest precision at the level of performance which the design is expected to exhibit. Thus, if a reliability figure is to be estimated at some level (such as 99 percent) it would be desirable to establish, with most precision, the stimulus which will cause this response. It is very difficult, if not prohibitive, to calibrate in this fashion at the higher reliabilities. The practical alternative is to find a compromise centering level which approaches, but may not reach these reliabilities. Therefore, it would be best to try for the least variability at a 70-, 80-, or even 90-percent functioning level (30, 20, or even 10 percent for safety testing). An example of off-center calibration is given in Paragraph 8.11. The extrapolation from VARICOMP performance test data to the response to be expected from the design explosive will be much less tenuous when the design explosive sensitivity is extended not from 50-percent response data but from 90-percent response data. Certain specialized stair-step plans can be used for estimating other than 50-percent response data. However, the more generally effective approach appears to be a carefully planned run-down series. If both reliability and safety estimates are to be made using the same calibration test data for the design explosive, it may well be that the familiar Bruceton test plan will turn out to be the most efficient approach. The centering of the calibration of the VARICOMP explosives is optimum at the 50-percent level. This is because the total sample size of each VARICOMP explosive will be relatively small. The observed responses will ordinarily fall in the range of 5 percent to 95 percent and will, in general, be centered about 50 percent. It is therefore sensible to calibrate the VARICOMP explosives with greatest precision at the expected level of performance.

8.11 Example. As an example of handling the data a hypothetical calibration of an explosive will be analyzed using Probit techniques. This example will be used in the analysis of stair-step performance test data in the next two sections so that the details will be followed through step by step. (This type of calculation is discussed in reference 23.)

The first step in the calibration of an explosive is to decide the levels at which tests are to be made, the total number of trials, and the way in which these trials are to be allotted to the different test levels. As has been pointed out in paragraphs 8.6 and 8.10 the total number of trials should be large and the test levels should be centered at or above the expected 70-percent level. Since the weighting factor (given in Table E-1) decreases for higher values of probability (response) it is desirable to assign the higher levels a greater number of trials than the lower levels in order to compensate for this decrease. The test is then carried out and the percent of fires observed at each level is recorded. These values are then converted into probits or normits using a table such as Table I, page 264, of reference 23. (Table E-1 of this report could be used if no other is available.)

For the present example it has been decided to make five-hundred trials. The levels used for testing have stimuli with intensities ranging from 4 to 8, these levels being chosen since previous experience indicates that the 50-percent response will occur at a stimulus of about 4 or 5. (Corresponding dosage levels might be 398, 316, 251, 200, and 158 mils gap in a small scale gap test.) The number of trials assigned to each of these levels ranges from 85 to 135 to compensate for the expected decrease in the weighting factor. These data together with the observed number of fires and the response in percent, probits and normits are given in Table 8.11A.

For the calculations based on these data it is convenient to form a table such as Table 8.11B. It is also convenient to change the independent variable from the stimulus x to $x - x_0$ where x_0 is one of the central values of x . In the case of this example x_0 was taken as 6. In Table 8.11B are entered the values at each testing level of the stimulus, x , the adjusted stimulus, $x - x_0$, the response, R_D , in normits, the number of trials, N , the weighting factor, w , obtained from a table such as Table E-1, and the value of the products Nw , $Nw(x - x_0)$, $Nw(x - x_0)^2$, NwR_D , and $NwR_D(x - x_0)$.

NavWeps Report 7411

The next step is to find the sum of each column of these products. (If a desk computer is available not all of these columns need to be written down. The products are obtained and summed in one operation.) The computation proceeds as follows:

Compute the mean value of $x - x_0$, $[\sum N_w(x - x_0)] / \sum N_w$

$$\bar{x}, \quad x_m = \left\{ [\sum N_w(x - x_0)] / \sum N_w \right\} + x_0$$

$$R_0, \quad (\sum N_w R_0) / \sum N_w.$$

Compute $\Delta = [\sum N_w(x - x_0)^2](\sum N_w) - [\sum N_w(x - x_0)]^2$

$$\Delta_m = [\sum N_w R_0(x - x_0)](\sum N_w) - [\sum N_w(x - x_0)](\sum N_w R_0)$$

$$\Delta_k = (\sum N_w R_0)[\sum N_w(x - x_0)^2] - [\sum N_w(x - x_0)][\sum N_w R_0(x - x_0)]$$

$$C = \sum N_w / \Delta$$

$$D = 1 / \sum N_w$$

$$m = \Delta_m / \Delta$$

$$k = \Delta_k / \Delta.$$

The best straight line fit for the expected response is then

$$R_0 = m(x - x_0) + k.$$

The computation of this equation can be checked by substituting the mean values of the variables. These should satisfy the equation. If they do not, some error has been made in the computation. The equation for the lower limit of the response at a specified confidence level is

$$R_0 = m(x - x_0) + k - t \left[C(x - x_m)^2 + D \right]^{1/2}$$

where t is the Student's t (given in Table E-2). In this table F is the desired confidence level and n is the number of degrees of freedom which is two less than the number of trials.

NavWeps Report 7411

The straight line for the expected response can be obtained graphically. However this is not recommended for two reasons: first, it is difficult to give the proper weights to the points in fitting by eye; second, it would be impossible to obtain the estimate of the lower limit by this method.

The weights used in this example are based on the observed responses rather than the expected responses as described in reference 23. In using the method described there the computation should be repeated using weights based upon responses as predicted from the equation obtained above. This iteration would continue until there was no longer an appreciable difference in the result obtained.

Table 8.11A
Calibration Data for Design Explosive

Dosage	Stimulus (x)	No. of Trials (N)	No. of Fires	Response		
				Percent	Probits	Normits (R ₀)
398	4	85	36	42.4	4.81	-0.19
316	5	85	47	55.3	5.13	0.13
251	6	95	65	68.4	5.48	0.48
200	7	100	80	80.0	5.84	0.84
158	8	135	119	88.1	6.18	1.18

Table 8.11B
Computation of Design Explosive Response
Expected Value and Lower 95-Percent Confidence Limit

x	x-x ₀	R ₀	N	w	Nw	Nw(x-x ₀)	Nw(x-x ₀) ²	NwR ₀	NwR ₀ (x-x ₀)
4	-2	-0.19	85	0.536	45.56	-91.12	182.24	-8.656	17.312
5	-1	0.13	85	0.600	51.00	-51.00	51.00	6.630	-6.630
6	0	0.48	95	0.530	50.35	0.00	0.00	24.168	0.000
7	1	0.84	100	0.477	47.70	47.70	47.70	40.068	40.068
8	2	1.18	135	0.368	49.68	99.36	198.72	58.622	117.244
					244.29	4.94	479.66	120.832	167.994

NavWeps Report 7411

The mean value of $x - x_0$ is $\frac{4.94}{244.29} = 0.02$

Therefore, the mean value of x is 6.02

The mean value of R_0 is $\frac{120.832}{244.29} = 0.495$

$$\Delta = (479.66)(244.29) - (4.94)^2 = 117151.7378$$

$$\Delta_m = (167.994)(244.29) - (4.94)(120.832) = 40442.3442$$

$$\Delta_k = (120.832)(479.66) - (4.94)(167.994) = 57128.3868$$

$$C = 244.29/117151.7378 = 0.0021$$

$$D = 1/244.29 = 0.0041$$

The equation for the expected response is

$$R_0 = 0.345 (x - x_0) + 0.488 = 0.345x - 1.582 .$$

To check this equation substitute the mean values of x and R_0 given above

$$0.495 = (0.345)(6.02) - 1.582 = 0.4949 .$$

The check is satisfactory.

The equation of the lower limit for the response at 95-percent confidence is

$$R_0 = 0.345x - 1.582 - 1.65 \left[0.0021(x-6.02)^2 + 0.0041 \right]^{1/2} .$$

The value of 1.65 is used for t since we wish to have a statement at a 95-percent confidence level and we have 500 trials.

9. UP-AND-DOWN PERFORMANCE TEST

9.1 Choice of Plan. The Bruceton test plan (4,7,22,29,30) is the most generally used up-and-down data collection plan for explosives testing. Other plans have been developed for specific and specialized applications (Section 11). The Bruceton test plan and analytic procedure will be the only up-and-down method treated in detail.

9.2 Test Requirements and Objectives. The test method requires that there be an array of equally spaced test levels in the normalized probability space, from which can be chosen any level at any time in the test sequence. It is the expectation that:

At low levels few if any test subjects will respond.

At high levels nearly all will respond.

At some very high level all will respond (no duds).

The purpose of the experiment is to deduce the test level at which 50 percent of the population would respond. This deduced level is not required to be any of the test levels and, in fact, is usually anything but. In addition to the estimate of the level at which 50-percent response is to be expected, it is also the purpose of the experiment to obtain an estimate of the variability of the test subjects--the precision of the experiment.

9.3 A Sophistication. There is a very fundamental difference between the performance test as used in the VARICOMP method and the usual explosive sensitivity test.

In the usual sensitivity test, which would include the calibration test of the VARICOMP method, the explosive is kept the same and the stimulus intensity is varied. The object of the test is to estimate the response of the explosive to any stimulus intensity. The results of a test might show, for example, that if the stimulus intensity were 3 units the response would be 40 percent; if the stimulus were raised to 4 units the response would be 55 percent; if the stimulus were increased to 5 units the response might be 63 percent.

The results of the test would give the response as a function of the stimulus.

In the VARICOMP performance test, explosives of different sensitivities are subjected to the same stimulus and their responses given as a function of their sensitivities. These sensitivities might be expressed as the stimuli required for 50-percent response or possibly by purely arbitrary units.

Figure 9.3 shows the difference between the tests graphically. The responses of the explosives are represented by diagonal lines. A fixed stimulus is represented by a vertical line (EH, Figure 9.3B). There are many different explosives and many different stimulus intensities. These would be represented by families of diagonal and vertical lines.

In the usual sensitivity test the varying intensity could be considered as a moving vertical line which intersects a fixed diagonal line (Figure 9.3A). The observed data give estimates of the positions of these intersections. The fixed diagonal line is obtained from observations with a variable vertical line representing the variable intensity.

In the VARICOMP performance test the explosive is varied: the diagonal line is the moving line (Figure 9.3B). The observed data give the intersections of the moving diagonal line with the fixed vertical line representing the fixed intensity. In this case the vertical line is obtained using observations with a variable diagonal line (variable explosive).

9.4 Bruceton Test Plan. Make up an array of test levels ranging in order from the lowest to the highest probability of response. Select, for the test on the initial item, a test level at which approximately 50-percent response is anticipated. Test the remaining items, one by one, at test levels which are chosen on the basis of the observed response of the immediately preceding item according to the following rules:

If the item responds, set the next test level one step lower than the preceding level. Customarily, in a reliability test, a response (a fire) is indicated by x .

If the item does not respond, set the next test level one step higher than the preceding level. A non-response in a reliability test (a fail) is indicated by o .

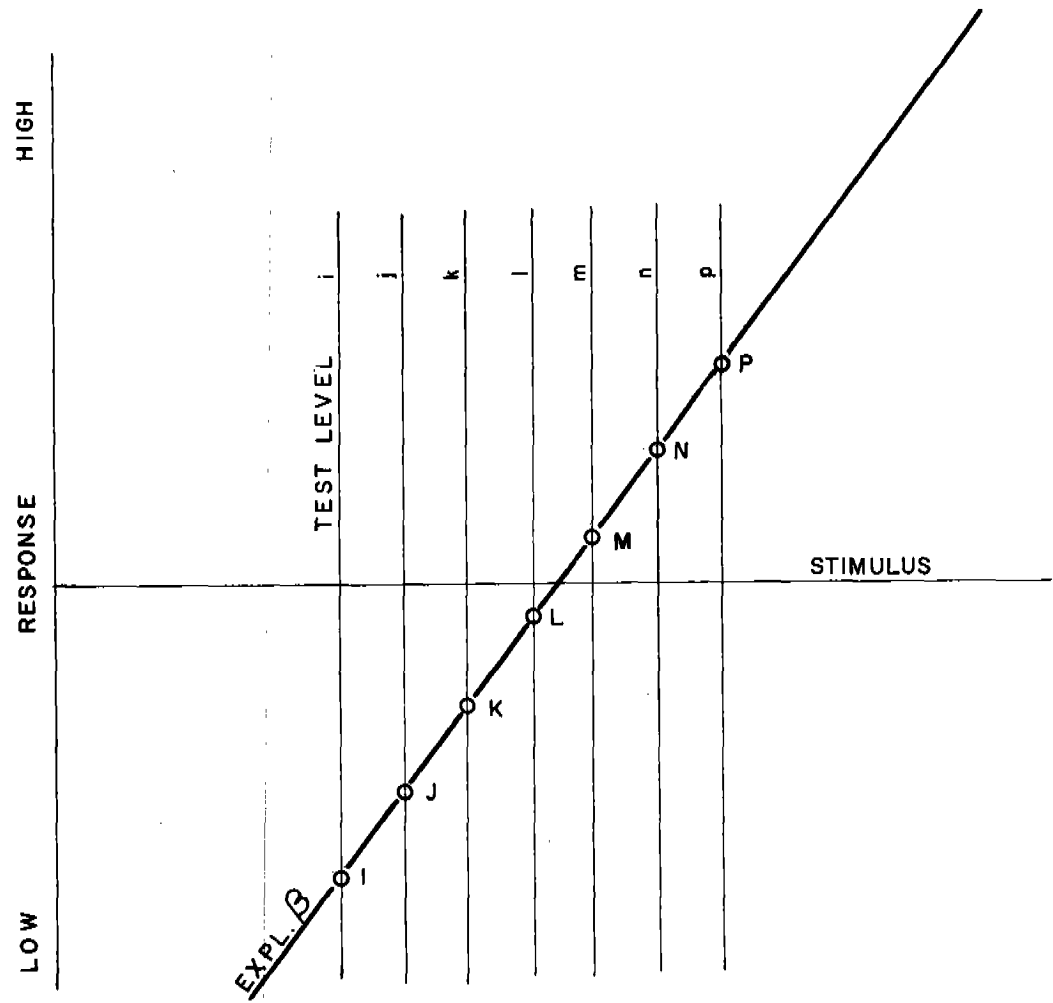

NOTE:
THE EXPECTED RESPONSE OF EXPLOSIVE β TO TEST LEVELS
i,j,k,l,m,n,p IS GIVEN BY THE ORDINATES OF POINTS I,J,K,L,M,N,P.

FIGURE 9.3 A THE BRUCETON CALIBRATION
TEST --- VARIABLE STIMULUS;
FIXED-SENSITIVITY EXPLOSIVE

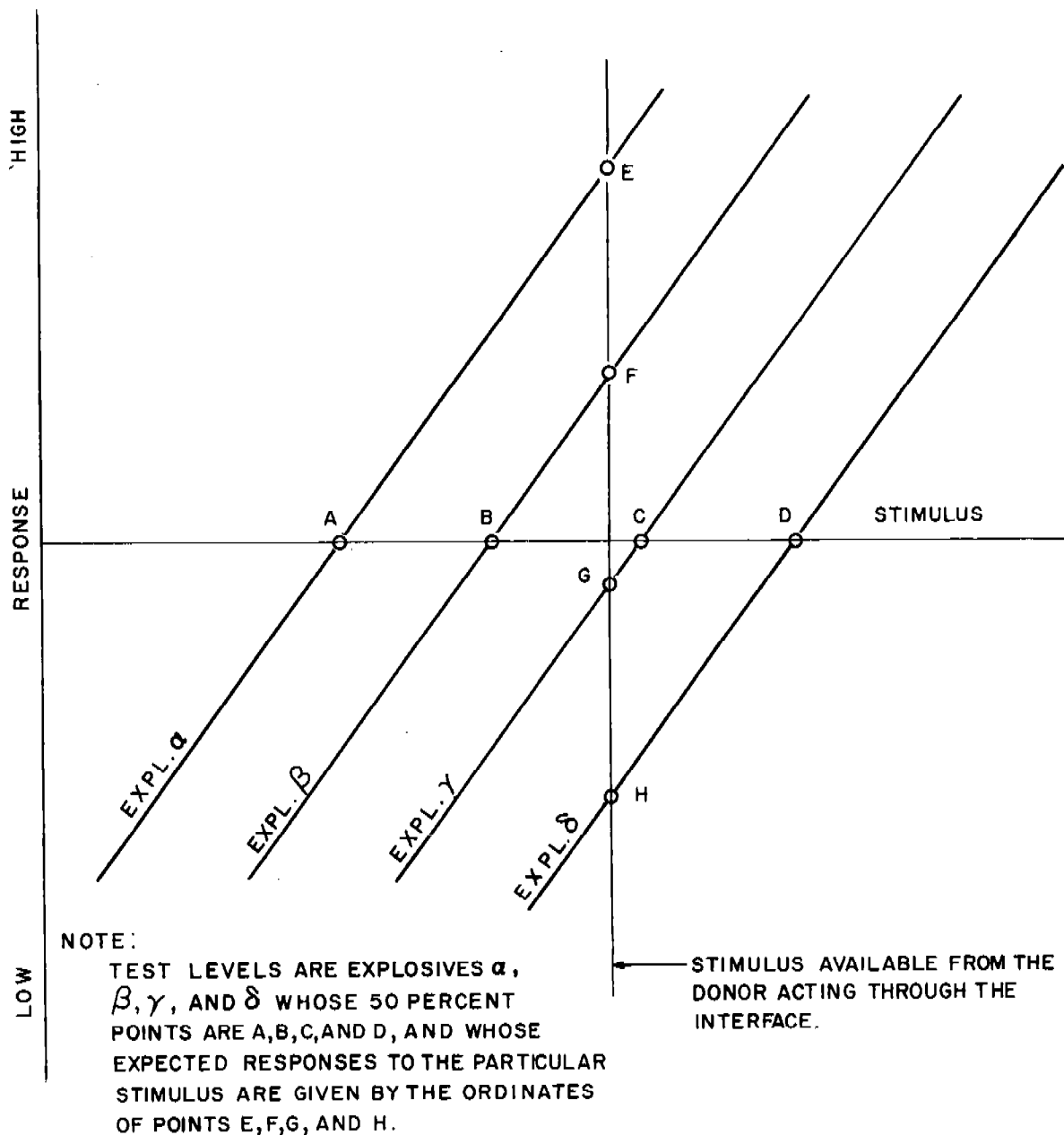

FIGURE 9.3 B THE BRUCETON PERFORMANCE TEST---FIXED STIMULUS; EXPLOSIVES OF VARIOUS SENSITIVITIES

As it is applied to the variable-sensitivity VARICOMP process, the test level is the performance test configuration loaded with some particular VARICOMP explosive. The higher probability test levels are those performance test devices loaded with the more sensitive explosives; the lower levels are those loaded with the less sensitive explosives.

9.5 Biasing the Data. A predetermined number of items should be tested in the Bruceton plan. The total number of trials should not be changed on the basis of results being obtained. For instance, an experimenter might be tempted by the following reasoning:

"Normally in a twenty-five-shot Bruceton run, the number of test levels does not exceed four. If six or more levels are required there must be some difference from normal circumstances. Probably the material is more variable. In order to compensate for the loss of efficiency because the step size is too small for this variability, increase the Bruceton run to fifty shots."

The experimenter is trapped. He is injecting a personal bias by accepting data when he thinks the variability is low enough and by insisting on additional testing when he thinks the variability is too large. This particular practice will probably not bias the 50-percent point estimates but can be expected to underestimate the standard deviations by rejecting those cases when the standard deviations are properly large. There are many ways to distort the results at any point in the data collection and reduction process. One of the best general methods of avoiding such trouble is to decide beforehand

How the test program shall be carried out, including result-dependent sequencing of alternatives.

The interpretation of the various possible outcomes.

The confidence levels that will be used for consistency checks and final estimates.

9.6 Data Reduction, Estimate of Mean. The analysis of Bruceton data can be carried out by the following stepwise procedures which can also be found in the literature (4,22,29,30):

Assign consecutive integral numbers to the array of regularly increasing test levels. The consecutive integers can be arranged in either increasing or decreasing order.

Eliminate from further consideration any trials which were made before the first reversal in the sequence of observed data. A reversal is defined as being either a response followed by a non-response or a non-response followed by a response.

Beginning with the two trials which constitute the first reversal, count the number of X's and O's at each test level (i.e., for each VARICOMP explosive).

Determine whichever of the total number of X's or of O's is the least. Let n_0, n_1, \dots, n_k denote the frequencies of this lesser event at each of the levels for which the event occurred where n_0 denotes the frequencies at the lowest level and n_k at the highest.

Compute the mean according to

$$\bar{x} = y_0 + (y_1 - y_0) \left[\frac{\sum_{i=0,k} i n_i}{\sum n_i} + \Delta \right]$$

where y_0 is the lowest level at which a test is recorded. (Associated with $i=0$)

y_1 is the next higher level. (Associated with $i=1$)

Δ is + 1/2 if the lesser event is a non-response

and Δ is - 1/2 if the lesser event is a response.

This process has developed a value, \bar{x} , which is a measure of the stimulus, x , delivered to the acceptor in the performance test system. If this value of stimulus is substituted in the design explosives calibration equation, the value for the expected system reliability, R_p , will be found (designated as point Q in Figure 9.6).

9.7 Data Reduction, Computation of Confidence Limits.

In order to place upper and lower limits on the estimate it is necessary to compute the standard deviation of the mean, Δ_m , which in turn is derived from Δ . Because of the particular method of obtaining the data, the calculation of Δ_m requires the use of correction term G , given in Figure 9.7A so that

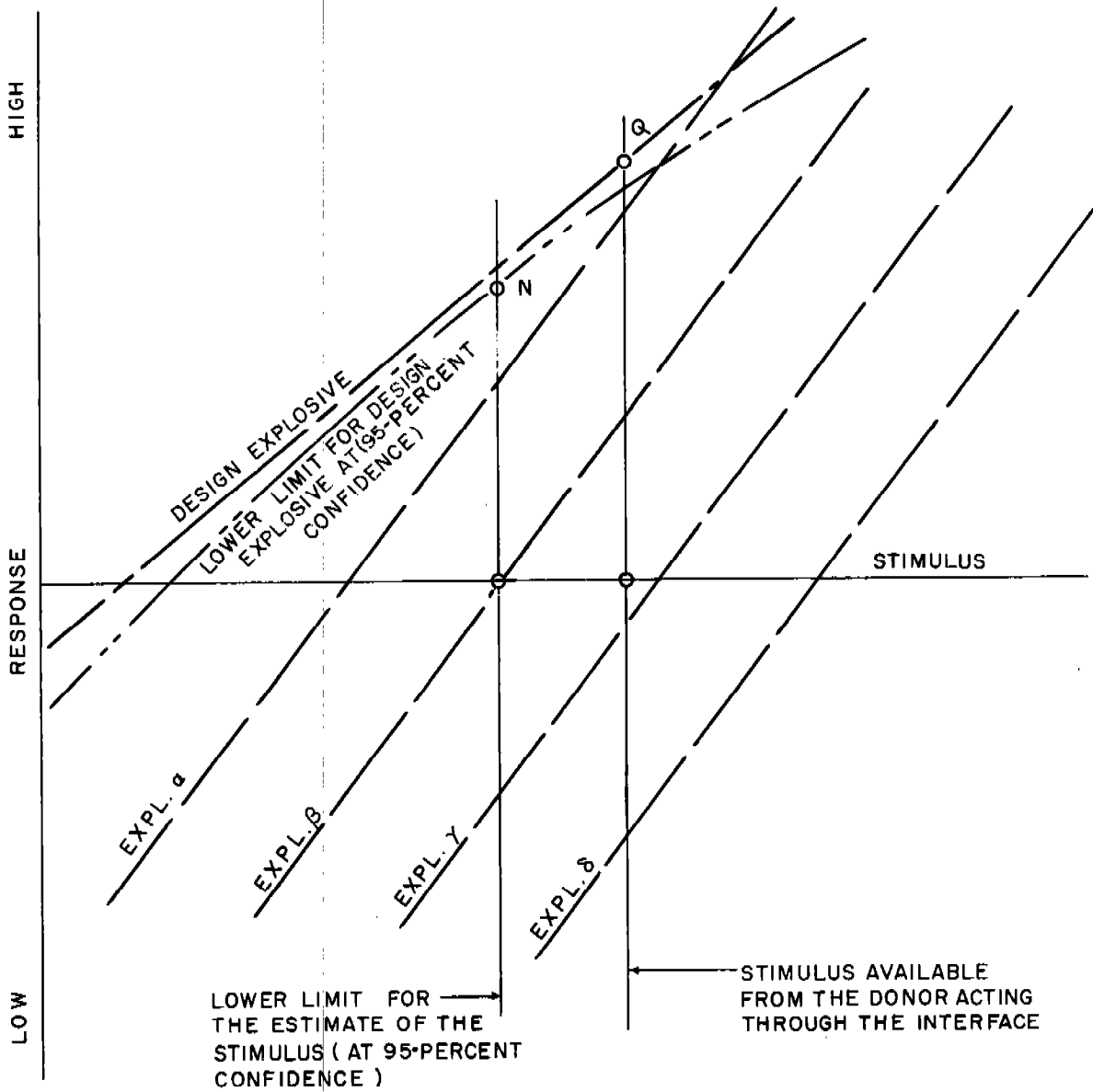

FIGURE 9.6 VARICOMP ESTIMATE BASED ON BRUCETON PERFORMANCE TEST DATA

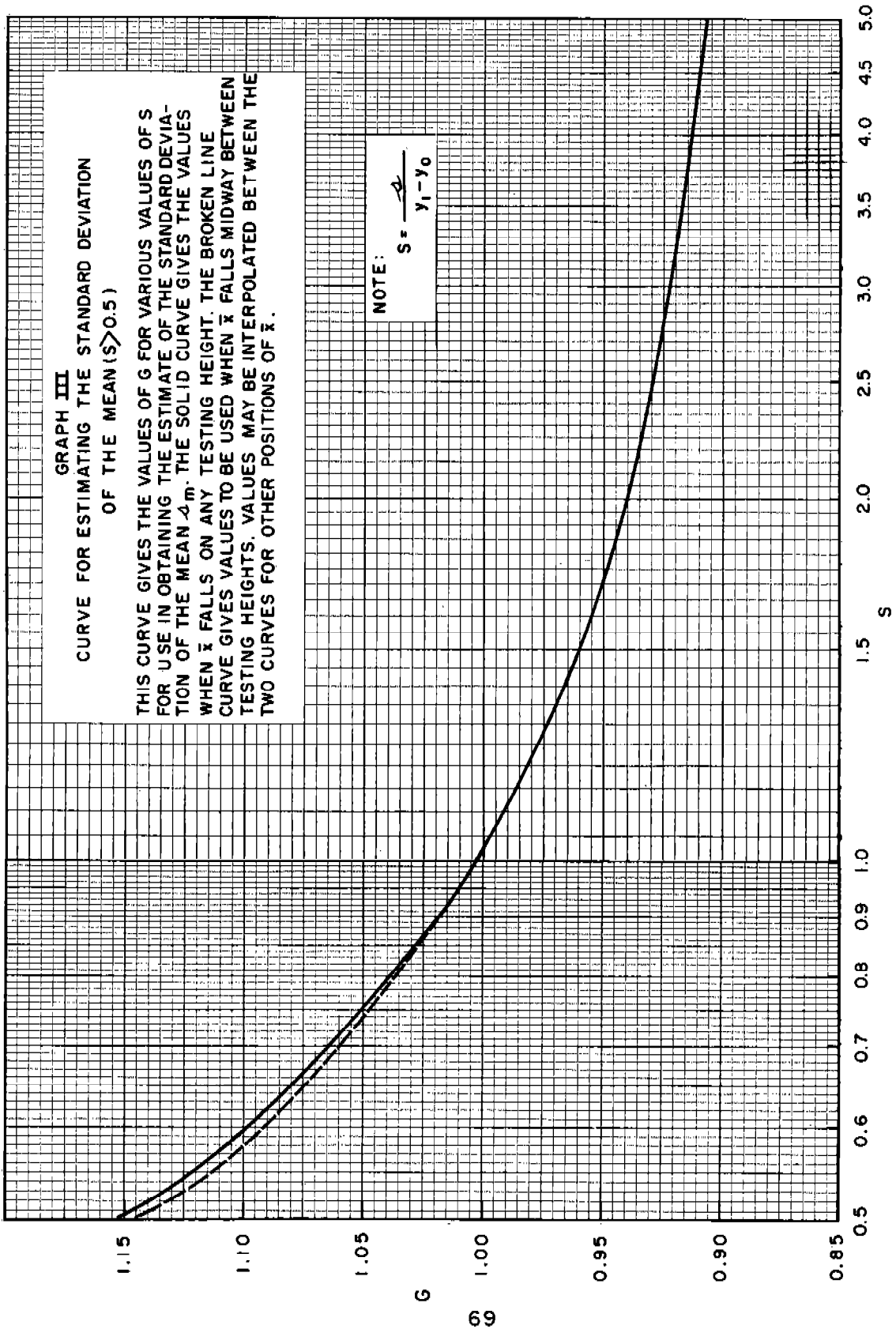

FIGURE 9.7A GRAPH III OF AMP REPORT

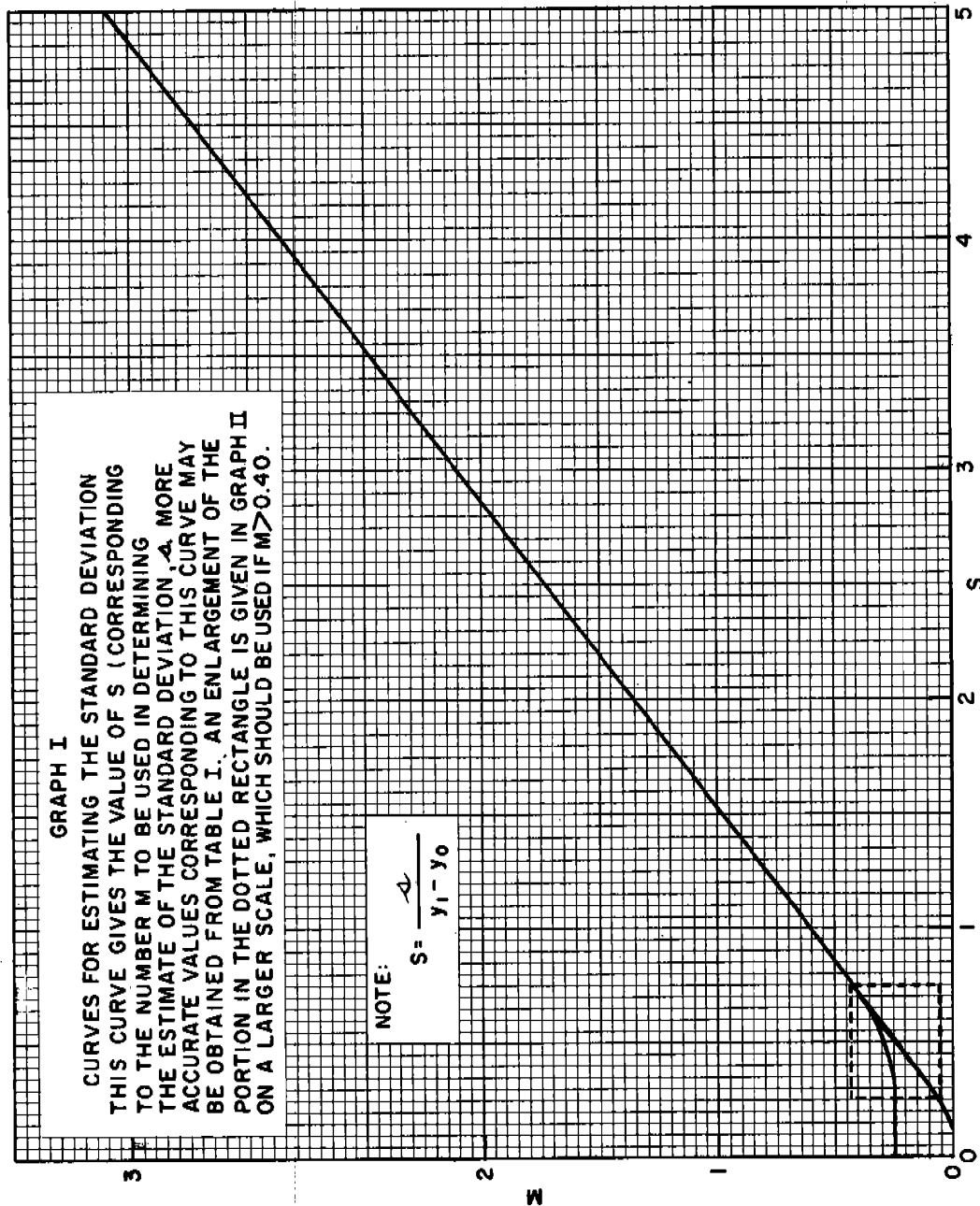

FIGURE 9.7B GRAPH I OF AMP REPORT

$$A_m = \frac{\Delta G}{\sqrt{N}}$$

where

$$N = \sum_{i=0}^{i=k} n_i$$

To obtain A , compute first

$$M = \frac{\sum_{i=0,k} i^2 n_i - \frac{(\sum i n_i)^2}{N}}{N}$$

If $M > 0.5$ A can be obtained from Figure 9.7B or from the expression

$$A = (y_i - y_0)(1.601 M + 0.064).$$

Special methods for computation of A when M is less than 0.5 can be found in the literature (4,22). The confidence interval for the estimate of the population is then obtainable by computing the limits according to $\bar{x} \pm t A_m$ where t is the Student's t . When the limit $\bar{x} - t A_m$ is converted into the proper stimulus units (indicated by the x-coordinate of point L of Figure 9.6) the corresponding pessimistic estimate of the system reliability R_0 (indicated as the R-coordinate of point N of Figure 9.6) can be found graphically or by substitution in the design explosive calibration equation. The method of combining the confidences of this pessimistic estimate as discussed in Paragraph 10.5 also applies in the present case.

9.8 This analysis depends upon the following conditions:

The levels are equally spaced.

The number of X's and O's in the usable part of the test is at least 50.

The standard deviation, σ , is at least one half the difference between two consecutive levels.

Even if these conditions do not hold, the Bruceton analysis can sometimes still be used with these variations:

The effect of unequal spacing is discussed in Paragraph 9.10. If the spacings must be considered as unequal the data must be analyzed by the Probit method (23).

If the total sample size condition cannot be met, less accurate, but still reasonable, estimates of \bar{x} and σ are obtained. Alternate schemes for analysis for smaller sample size estimates are given in the AMP report (22).

When the step size is greater than 2 standard deviations the AMP report should be consulted (22).

9.9 Example, Bruceton Method. This example is given, independent of any physical system, to illustrate the approach to testing, data collecting, and data reduction. In this illustration a fire is considered as a response and a fail as a non-response since this is a reliability test.

9.9.1 For this example it is assumed that a series of five VARICOMP explosives has been calibrated. This calibration has shown that their sensitivities can be regarded as equally spaced* and that it is reasonable to expect that when used in the ordnance design they will cover the range of sensitivities from high to low reliabilities. It has been decided that the test will be made having twenty trials, the count to begin with the first reversal. The first trial is made with VARICOMP Explosive Four and results in a non-fire. This is recorded by entering an O in Line Four of the record, Figure 9.9.1. Moving in the direction of the more sensitive explosives, the next trial is made with Explosive Three. This also gives a non-fire so an O is entered in Line Three of the record. The next trial is with Explosive Two and a fire is observed. This is recorded as an X in Line Two of the record. This gives the first reversal. The previous trial

*Note that sensitivities are equally spaced in the stimulus scale. The distribution between stimulus and dosage (5.14 and 5.15) should be kept in mind.

NavWeps Report 7411

(the one with Explosive Three) is the first trial of the twenty to be made in the test. The next trial is with Explosive Three. This is a fire: an x is entered in Line Three. The next trial is made with Explosive Four. Testing is continued in this way until the twenty trials have been made. This completes the data collection of the performance test.

EXPL	FIRST USED DATUM POINT															X	O			
1																				
2			X			X				X	X								4	0
3		0		X		0	X			0	0	X	X						4	4
4	0				0		X		0				0	X			0		2	4
5								0									0		0	2
6																				

X = FIRE
O = NON-FIRE

FIGURE 9.9.1

DATA FROM TYPICAL BRUCETON TEST

9.9.2 Data Reduction. For the calculations based on the data collected in this example it is assumed that the calibration has given the following information:

The 50-percent points of VARICOMP Explosives One to Five are 6, 8, 10, 12, and 14 in the intensity units chosen in the stimulus scale (Figure 9.9.2A).

A five hundred-trial calibration of the design explosive with stimuli having intensities from 4 to 8 gives the best straight line for the prediction of its response to be as given in Paragraph 8.11

$$R_D = 0.345\gamma - 1.582$$

where R_D is the response in the normits* and γ is the stimulus intensity in the units chosen (Figure 9.9.2B).

The 95-percent lower confidence limit for the response of the design explosive is

$$R_D = 0.345\gamma - 1.582 - 1.65 [0.0021(\gamma - 6.02)^2 + 0.0041]^{1/2}$$

*For the relationship between the normit and the cumulative normal distribution function see reference 37, Table E-1 and Figure 5.16.

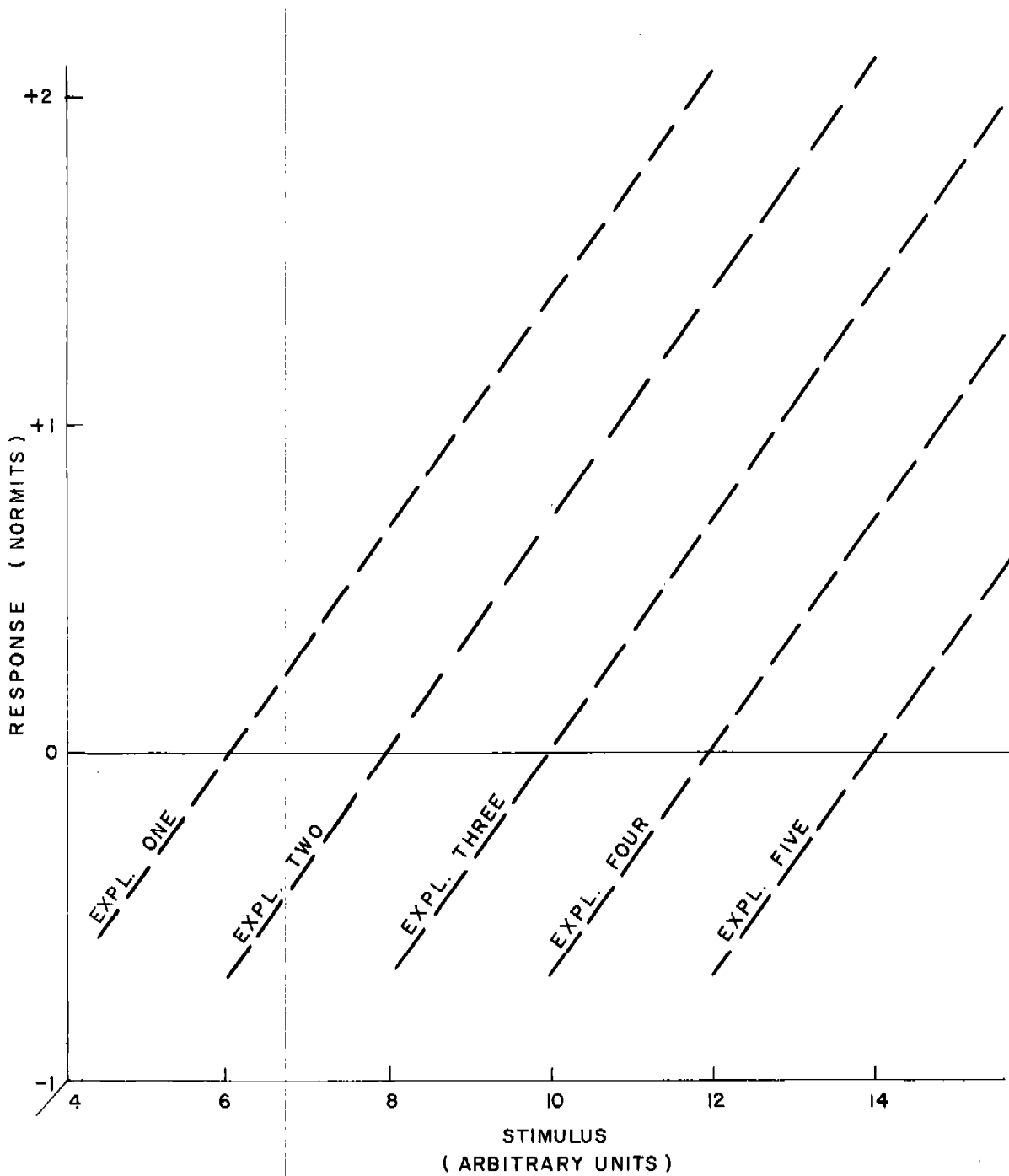

FIGURE 9.9.2 A CALIBRATION OF VARICOMP
EXPLOSIVES

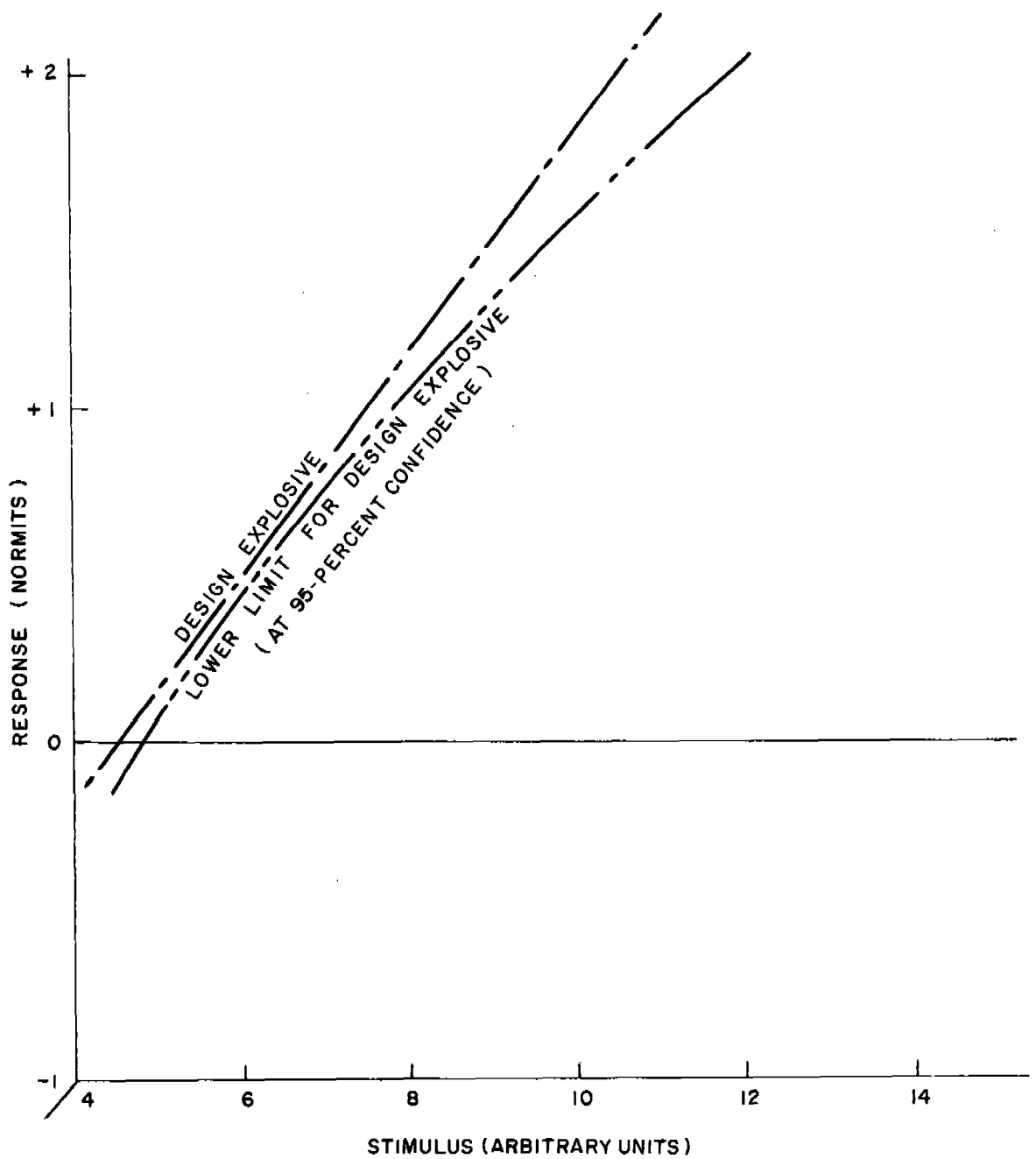

FIGURE 9.9.2 B CALIBRATION OF DESIGN EXPLOSIVE

Note that since the testing was concentrated at stimulus levels which give 55- to 85-percent response, the greatest precision (and the closest approach of the lower limit hyperbola to the straight line) is at 70 percent rather than 50 percent. Paragraph 8.10 discusses the reasons for this off-center testing.

Before beginning the computation it is decided that the expected reliability and the lower 95-percent confidence limit of this reliability shall be computed. The first step in the data reduction is to count the number of fires and non-fires recorded in the test for each of the VARICOMP explosives. In this example the results are: for Explosive Two, four fires and zero non-fires; for Explosive Three, four fires and four non-fires; for Explosive Four, two fires and four non-fires; for Explosive Five, no fires and two non-fires. Since the results of the twenty trials are equally divided between fires and non-fires, either may be used in the calculations. For this example, the fires will be chosen. Table 9.9.2 shows a convenient way of forming the required sums and products. In this table, n_i is the number of fires (or non-fires) and N is the total of all the values of n_i . The mean step number 1.2 corresponds to a hypothetical Explosive Two-Point-Eight whose number is 2.8, the mean explosive number for the fires. A correction of 0.5 must be added to the explosive number giving 3.3 as the mean explosive number. Had the non-fires been used their mean explosive number would have been 3.8 and the correction of 0.5 would be subtracted giving the same final result. If the equation in Paragraph 9.6 were used to compute the mean explosive number, the arithmetic would be

$$\begin{aligned}\bar{x} &= 4 + (3-4) \left[\frac{12}{10} + (-\frac{1}{2}) \right] \\ &= 4 + (-1) [0.7] = 3.3\end{aligned}$$

in agreement with that obtained above.

To convert the mean square deviation, M (given above and in Paragraph 9.7), to a standard deviation use Figure 9.7B. The result in this case is 0.95. The standard deviation of the mean, A_m , would be

Table 9.9.2

Calculations Used In Bruceton Data Reduction
(Based on Fires Observed in Figure 9.9.1)

Title	Explosive		i^*	n_i	$i n_i$	$i^2 n_i$
		Number				
Two		2	2	4	8	16
Three		3	1	4	4	4
Four		4	0	2	0	0
Sums				10	12	20

Find the correction term = $\frac{(\sum i n_i)^2}{\sum n_i} = \frac{12^2}{10} = 14.4$

Find the mean step number = $\frac{\sum i n_i}{\sum n_i} = \frac{12}{10} = 1.2$

Find the mean square deviation, $M = \frac{\sum i^2 n_i - \text{correction term}}{\sum n_i}$
 $= \frac{20 - 14.4}{10} = 0.56$

*In this table i designates an arbitrary naming of the explosives used in the test where $i = 0$ is assigned to the lowest explosive at which a response occurred.

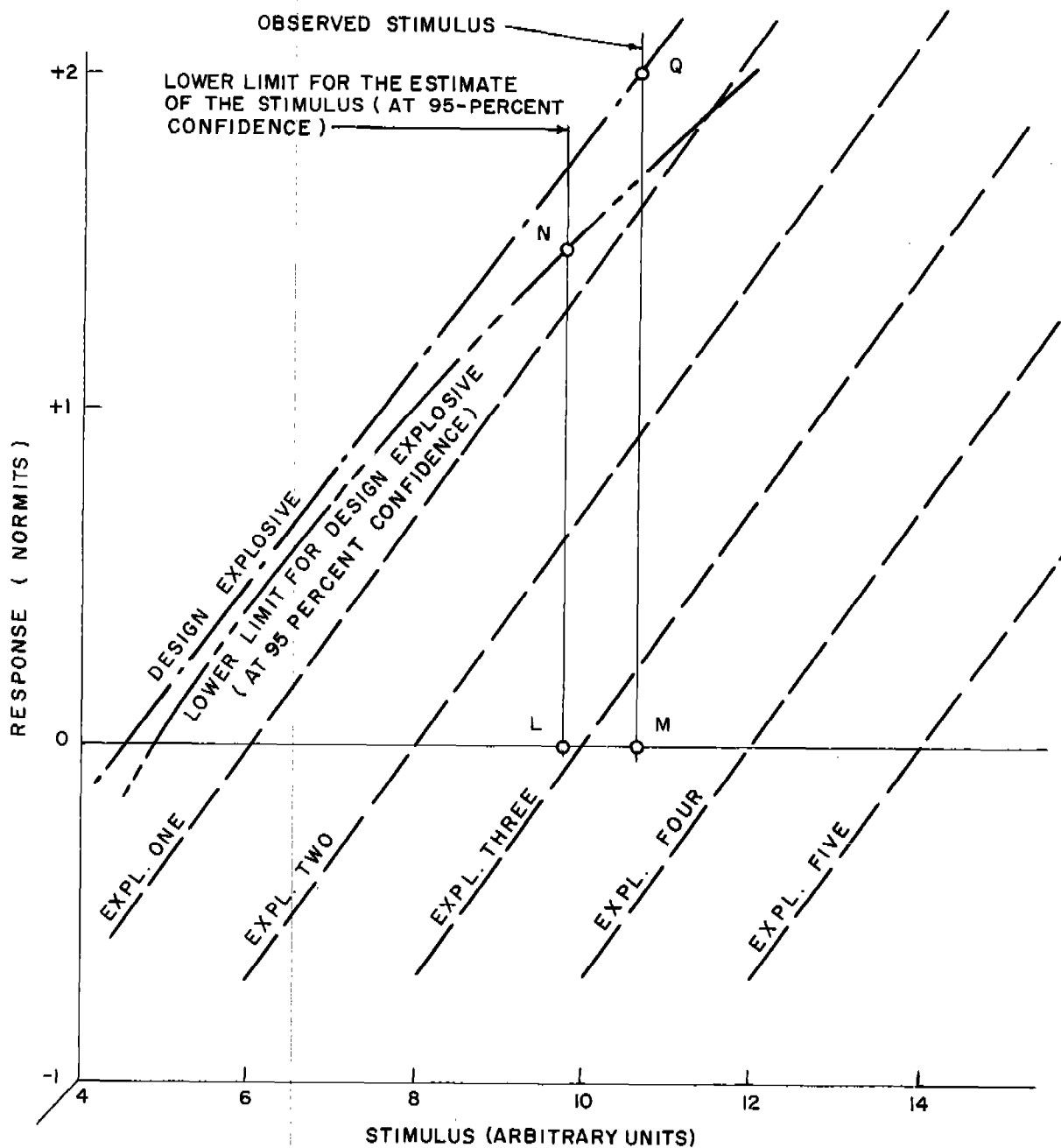

FIGURE 9.93 PREDICTION OF THE RELIABILITY OF AN EXPLOSIVE SYSTEM ON THE BASIS OF BRUCETON PLAN PERFORMANCE TESTS WITH VARICOMP EXPOSIVES

$$\Delta_m = \frac{\Delta G}{\sqrt{N}} = \frac{(0.95)(1.01)}{\sqrt{10}} = 0.30.$$

G is found by use of Figure 9.7A. The values of the mean and its standard deviation above are in terms of explosive numbers as units and must be changed to the stimulus intensity units. Making this change they become 10.6 for the mean and 0.60 for the standard deviation of the mean. The lower confidence limit for the value of \bar{x} can be found using Student's t distribution

$$\bar{x}_L = \bar{x} - t \Delta_m$$

where the value of t depends upon N and the degree of confidence desired. For a one-sided 95-percent confidence and N equal to 10, t is 1.8*. Thus the lower 95-percent confidence limit for \bar{x} is 9.52 in this example. This is the \bar{x} coordinate of the point L in Figure 9.9.3 and the mean, 10.6, is the \bar{x} coordinate of the point M.

9.9.3 Reliability Estimate. The estimates of design reliability and its lower limit may be obtained graphically (Figure 9.9.3) or by substituting these values of \bar{x} in the equations for the expected reliability and its lower limit. This gives an expected reliability of 2.08 normits with a lower limit of 1.42 normits. The estimated reliability is therefore 98.1 percent with a lower 95-percent confidence limit of 92.2 percent.

9.10 Errors Due to Unequal Spacing of the VARICOMP Explosives.

A fundamental assumption in the analysis of data by the Bruceton technique is that the stimulus steps are equally spaced**. This condition will be satisfied if the VARICOMP explosives have equally spaced 50-percent sensitivity values and if the slopes of their sensitivity lines are the same. That is, the lines representing the VARICOMP explosives in Figures 9.3 and 9.9.2A must be equally spaced and parallel. The 50-percent points of the VARICOMP explosives will probably not be equally spaced because of uncontrollable variations in their preparation. A statistical desk-top experiment has been carried out by the Monte Carlo technique (Appendix D) to investigate the effect of unequal spacing. This experiment showed that, if the differences in the locations of the 50-percent

*See, for instance, Mood "Introduction to the Theory of Statistics" Table IV, Mc Graw-Hill Book Co., 1950. Also Table E-2 of this report.

**Note that as previously stated, the stimulus is the transformed dosage which normalizes the response of the system.

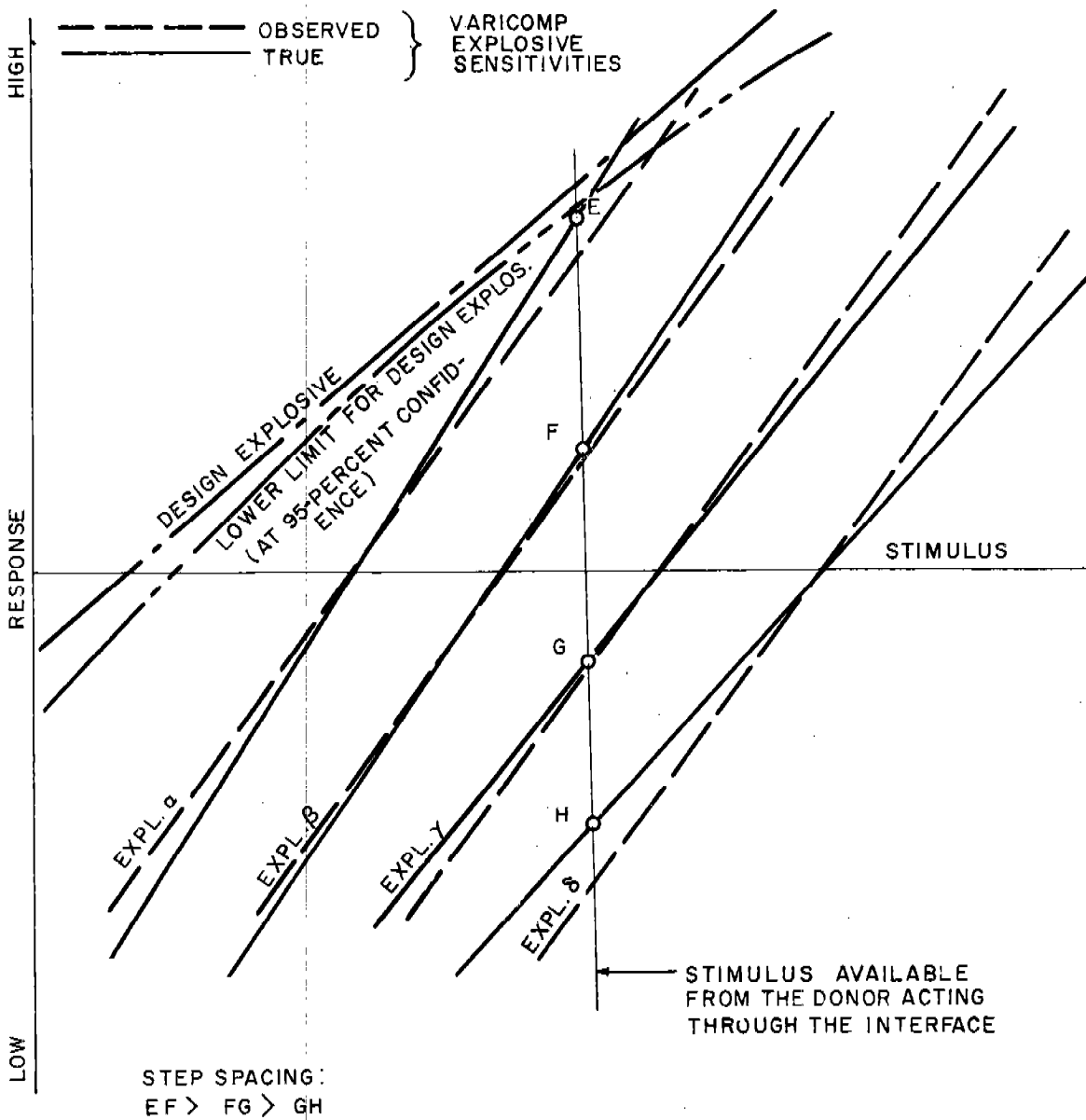

NOTE: COMPARE WITH FIGURE 9.6

**FIGURE 9.11 THE EFFECT OF VARICOMP EXPLOSIVE
 NON PARALLELISM ERRORS ON STEP SPACING
 IN THE BRUCETON PERFORMANCE TEST**

points of a series of unequally spaced explosives with respect to the locations of the 50-percent points of a series of equally spaced explosives is taken as normally distributed (mean equal to zero, standard deviation equal to some fraction of the spacing between explosives), the effect of unequal spacing would be small for standard deviations less than one-tenth the explosive spacing. The effect would be appreciable if the standard deviation were larger than one-fifth the step size.

9.11 Errors Due to Variation In the Standard Deviations of the VARICOMP Explosives. The variation within any one of the VARICOMP explosives is measured by the standard deviation of its sensitivity. This variation is inversely related to the slope of the sensitivity line of the appropriate explosive. It has been assumed that these lines are parallel, i.e., the standard deviations of the VARICOMP explosives are equal. This seems to be a reasonable assumption for a series of similar explosives such as RDX/Calcium Stearate in different proportions. However, it might be that the standard deviation changes in some systematic way with the composition. It might, for instance, increase with increasing diluent. If the VARICOMP series were made up of unrelated explosives, a possibility which has already been pointed out, the standard deviations might be unrelated. Experience in sensitivity testing gives some indication that the standard deviation is a characteristic of the test system rather than of the explosive. In Figure 9.9.3 the vertical line through M represents the constant stimulus to which the acceptor is subjected. The testing procedure measures the response of the VARICOMP explosives to this constant stimulus. In other words, it deals with the intersection of the vertical line through M with the line of the VARICOMP explosive tested. If, as shown in Figure 9.11, the VARICOMP lines are not parallel, the actual test levels will not be equally spaced for the constant stimulus even though the 50-percent points are equally spaced. The effect of parallelism errors will be similar to the errors in the 50-percent points. The effect will be smaller for explosives whose 50-percent points are closest to the constant stimulus characteristic of the particular test--for instance, Explosives Three and Four of Figure 9.11. If the slopes of the lines decrease steadily (the standard deviations increase) from the more to the less sensitive explosives the effect is to make the steps closer together with the less sensitive, and farther apart with the more sensitive explosives. The result of this would be to predict a somewhat higher performance of the ordnance item than the correct value (overestimate its reliability). The error does not seem to be great, although not enough work has been done to give an exact statement concerning its magnitude.

9.12 Errors Due to Small Sample Size. The point M in Figure 9.9.3 is determined by the mean obtained from the Bruceton test results. The standard deviation of the mean, which is the measure of the precision, varies inversely with the square root of the number of trials in the test. Two situations were studied and are presented in Table 9.12 to give an indication of the magnitude of uncertainty which can be expected as the sample size is changed.

Table 9.12

Effect of Sample Size on the Estimate of
the Minimum Reliability, at 95-Percent Confidence
Predicted from Bruceton Data
Giving Observed Reliabilities of 99 Percent

	Test I	Test II
Normit Space Between Levels (Vertical Spacing)	0.25	1.00
Number of Levels	8	4
Maximum Level (Normits)	+1.10	+1.40
Minimum Level	-0.65	-1.60

Number of Items Tested	Single-Sided Lower Limit 95-Percent Confidence Estimate, at 95-Percent Confidence, of Reliability (in percent)	
	Test I	Test II
25	97.6	97.2
50	98.2	98.0
100	98.5	98.3

10. RUN-DOWN PERFORMANCE TEST

10.1 Data Collection. Run-down performance tests can be made with one or with more than one VARICOMP explosive. The number of explosives and the number of trials with each explosive should be decided upon before the run-down phase of the experimentation begins. It is often good strategy to run a preliminary up-and-down type of test in order to select the run-down test levels. Note that the stipulation of a predetermined number of trials at each level is in contradiction to the Bruceton plan where only the total number of usable trials is predetermined. The number of test levels and trials at each level is not at the option of the experimenter. For the run-down method the choice of explosive(s) from the series should be made with the objective of observing mixed responses (fires and non-fires). The optimal choice will ordinarily be the explosive(s) giving the closest to 50-percent response in the performance test system.

10.2 Acceptable Test Modifications. The stipulation of a predetermined number of trials at predetermined test level(s) can be set aside for certain legitimate reasons. For instance, assume that a level is being studied wherein the performance test results must exhibit a high percentage of functioning in order for the design system to be reliable. If in the first few trials some or all fail, indicating an unreliable system, there is no point in expending any more time or material. At this point a redesign, and/or a reevaluation of the goals is in order. This approach has been used profitably in the past wherein unreliable systems were quickly detected, often with less than ten, or even less than five, trials.

10.3 Single Explosive, Data Collection and Reduction. This is the simplest possible application of the VARICOMP method. The notation used here is explained in Table 10.3.

Let the performance test be carried out for N trials with one VARICOMP explosive, with the observation of n_x successes and n_o failures, where N is the sum of n_x and n_o .

Compute the observed probability of response, ${}_oR_i$, as n_x/N . This locates point M on the calibration line of the VARICOMP explosive shown in Figure 10.3.

RESPONSE COORDINATE		STIMULUS COORDINATE	CATEGORY
DESIGN EXPLOSIVE	VARICOMP EXPLOSIVE		
R_D	R_i	X	POPULATION
${}_oR_D$	${}_oR_i$	${}_oX$	OBSERVED (EXPECTED OR MOST LIKELY)
${}_oR_D$	${}_oR_i$	${}_LX$	SINGLE-SIDED LOWER-LIMIT ESTIMATE
${}_LR_D$	${}_LR_i$		
${}_LR_D$	${}_LR_i$		COMPOSITE SINGLE-SIDED LOWER-LIMIT ESTIMATE

NOTE : CONFIDENCE OF ESTIMATES MADE ON THE BASIS OF PERFORMANCE TEST DATA (SIGNIFIED BY LEADING SUBSCRIPT L--eg. ${}_LR_D$) IS C_p

NOTE : CONFIDENCE OF ESTIMATES MADE TO ALLOW FOR LIMITED CALIBRATION SIZE AND /OR MULTIPLE BATCHES (SIGNIFIED BY AN UPPER CASE-SCRIPT R) IS C_c

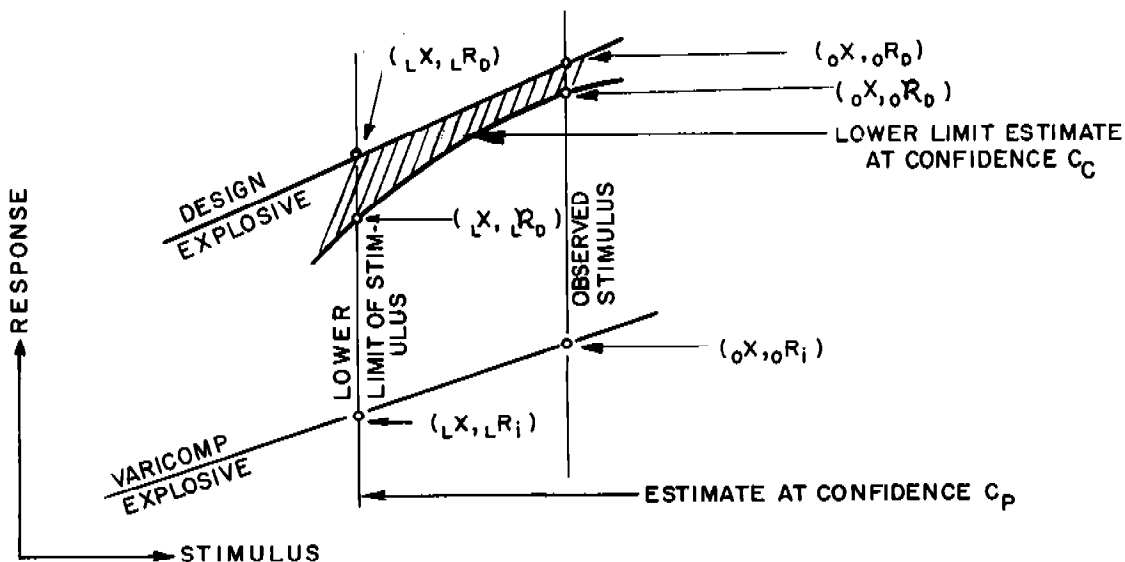

TABLE 10.3
THE SYSTEM OF NOTATION

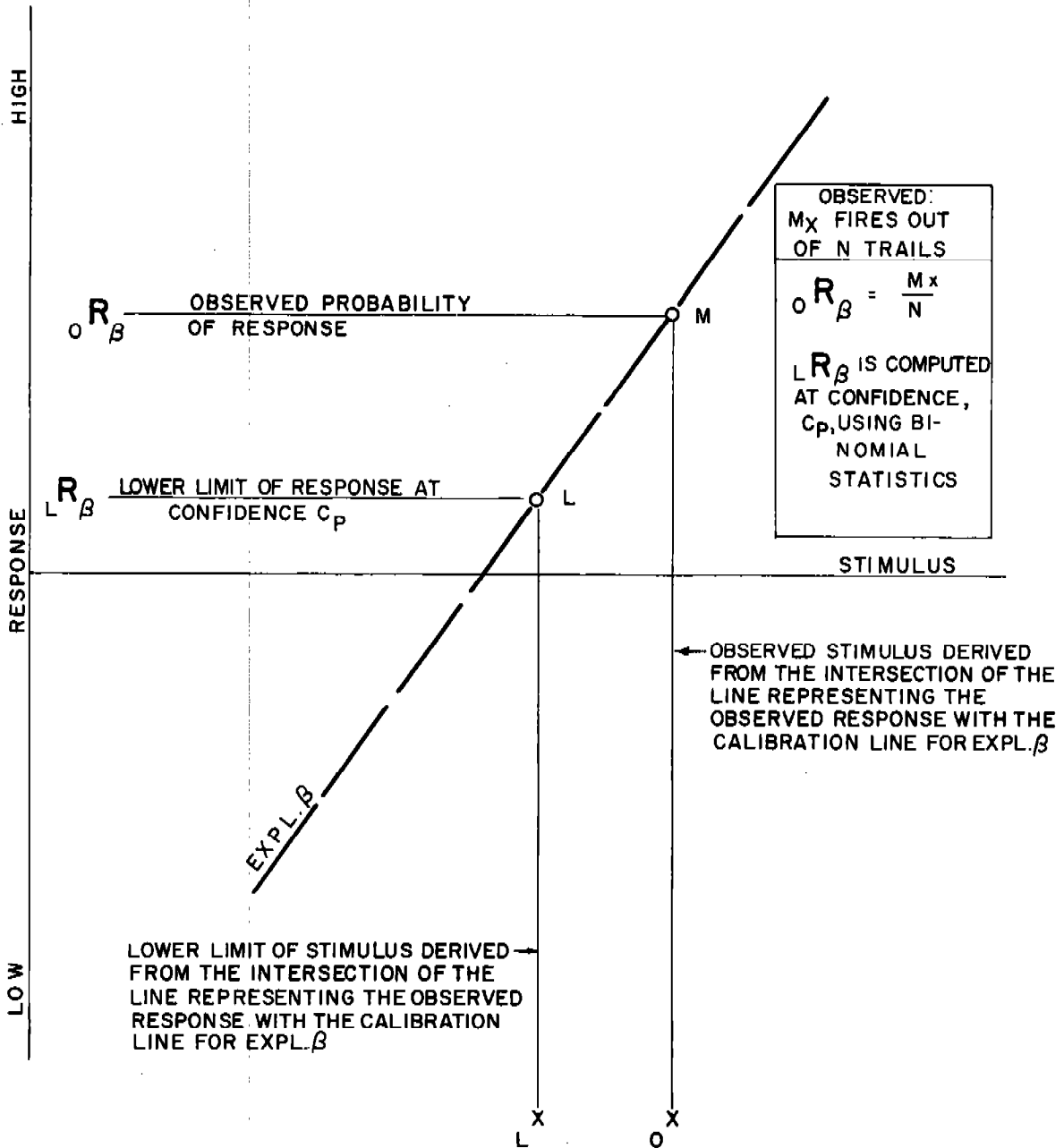

FIGURE 10.3 TREATMENT OF SINGLE-VARICOMP EXPLOSIVE RUN-DOWN PERFORMANCE TEST DATA

Select a confidence level, C_p , which will be associated with ${}_L R_i$, the estimate of the lower limit of the response of the performance test system when loaded with the VARICOMP explosive.

Select a confidence level, C_c , which will be associated with estimates based on the calibration equation for the design explosive.

Compute the lower confidence limit, ${}_L R_i$, for the estimated probability of response, R_i , in the performance test system using binominal statistics. Tabulated values as in Table 2.4, can be found in standard books on statistics. (Care must be exercised to identify whether "one-tailed" or "two tailed" limits are tabulated, and to decide which of these limits is appropriate to the task in hand.) This lower confidence limit, ${}_L R_i$, is plotted at point L on the calibration line in Figure 10.3. Corresponding to the limit, ${}_L R_i$, determine the value of the stimulus, ${}_L X$, which is the estimate of the stimulus, X , derived from the donor, the estimate being made at a confidence C_p . The value of ${}_L X$ can be read from Figure 10.3, or else by converting ${}_L R_i$ into normits followed by substitution into the VARICOMP explosive calibration equation. In those cases where a saturated response is observed (all-fires or all-fails) ${}_O R_i$ becomes either $+\infty$ or $-\infty$ when transformed to normits. The lower limit, ${}_L R_i$, for the all-fire case (the upper limit ${}_U R_i$, for the all-fail case) is tabulated the same as for mixed responses. The stimuli associated with such limits can be computed as described above.

10.4 Single Explosive, Reliability Estimate. The performance test above has yielded a value of stimulus, ${}_O X$, which is taken to be the least intense stimulus which can be expected from the donor at a confidence C_p . The expectation of response of the design system when exposed to the stimulus can be found from the design explosive calibration equation. Again, this estimate can be made either graphically, as in Figure 10.4, or algebraically. When the observed stimulus, ${}_O X$, is substituted in the equation for the observed calibration of the design explosive, an estimate of the most likely reliability, ${}_O R_o$, will be obtained (point Q in Figure 10.4). When the lower limit of the stimulus, ${}_L X$, is substituted in the equation for the lower limit of the design explosive the most pessimistic estimate, ${}_L R_o$, is obtained (point N in Figure 10.4).

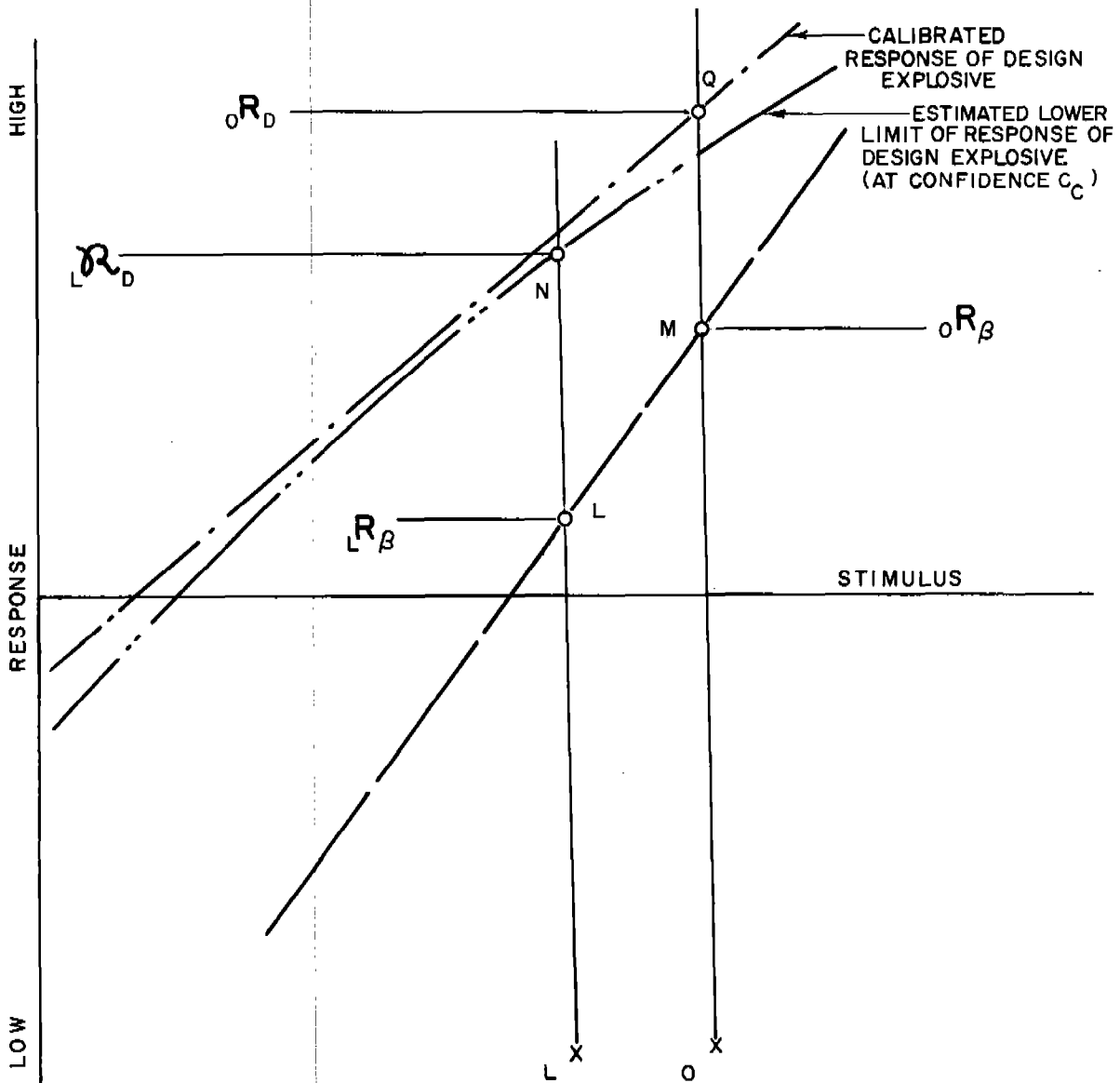

FIGURE 10.4 ESTIMATE OF RESPONSE OF A SYSTEM LOADED WITH THE DESIGN EXPLOSIVE, BASED ON SINGLE-VARICOMP-EXPLOSIVE RUN-DOWN PERFORMANCE TEST DATA

10.5 Single Explosive, Confidence of Reliability. The estimate ${}_1R_D$ is a two-step conservative estimate. That is, it is a minimum limit for the value of TR_D , given the value of ${}_1X$. But ${}_1X$ is in itself a lower limit for the estimate of \mathcal{R} . The computation of the confidence of the composite estimate is not simple. The true confidence value can be bracketed partially:

The total estimate of TR_D is made up of two independent sub-estimates, one R_D and the other ${}_1X$.

There are four possible situations for these estimates. Either of the two estimates can be right or either of them can be wrong, each independent of the other. The probability of each estimate being right is given by its confidence level. The individual and joint probabilities are listed in Table 10.5. From this table it can be seen that

The probability that the final joint estimate is wrong will be at least as great as P_D (both estimates wrong).

The probability that the final joint estimate is right will be at least as great as P_A (both estimates right).

In those situations wherein one estimate is right and the other is wrong, it is not possible to tell whether or not the joint estimate is right or wrong. The probability of this ambiguous situation is $P_B + P_C$.

The derivation of the distribution of

$$P(TR \geq {}_1R_D | C_P \& C_C)^*$$

may require the use of Monte Carlo techniques. There is some basis for a suspicion that the above distribution function may be influenced by the conditions of the test. For instance, it may be altered by the relationship between the slopes of the two calibration curves. In any case, it is proper to say that the confidence of the combined estimate falls between the two limits $C_C \cdot C_P$ and $(1 - C_C)(1 - C_P)$.

*This symbolism expressed in words is

The probability that the true reliability, TR , is equal to or greater than the joint conservative estimate of the reliability, ${}_1R_D$, given the confidences, C_C and C_P , of the sub-estimate.

NAVWEPS REPORT 7411

SITUATION	CONSERVATIVE ESTIMATE OF RESPONSE OF DESIGN EXPLOSIVE, GIVEN THE STIMULUS		CONSERVATIVE ESTIMATE OF STIMULUS	
	CONDITION	PROBABILITY	CONDITION	PROBABILITY
A	WITHIN LIMIT $\{x R_D \geq R_D\}$	C_P	WITHIN LIMIT $\{X \geq_L X\}$	C_C
B	OUTSIDE LIMIT $\{x R_D < R_D\}$	$1 - C_P$	WITHIN LIMIT $\{X \geq_L X\}$	C_C
C	WITHIN LIMIT $\{x R_D \geq R_D\}$	C_P	OUTSIDE LIMIT $\{X <_L X\}$	$1 - C_C$
D	OUTSIDE LIMIT $\{x R_D < R_D\}$	$1 - C_P$	OUTSIDE LIMIT $\{X <_L X\}$	$1 - C_C$

$$P \left[R \geq_L R_D \right] = P_A = C_P \cdot C_C$$

$$P \left[R ?_L R_D \right] = P_B = (1 - C_P) C_C$$

$$P \left[R ?_L R_D \right] = P_C = C_P (1 - C_C)$$

$$P \left[R <_L R_D \right] = P_D = (1 - C_P)(1 - C_C)$$

NOTE: THE SYMBOL $x R_D$ DENOTES THE TRUE RESPONSE OF THE DESIGN EXPLOSIVE FOR A SPECIFIC STIMULUS, x

TABLE 10.5 COMPOSITE CONFIDENCE OF COMBINED ESTIMATES

10.6 Multiple Explosive, Data Reduction, Probit Analysis.

If more than one VARICOMP explosive is used the results for all of the explosives must be included. The determination of the probability of the response for each explosive will have a certain precision. This precision will depend upon the expected probability of response for each particular explosive. Note that this is the expected probability and not the observed probability. The separate observations or determinations should be combined as a weighted average wherein the weighting takes into account the individual precisions, and therefore the individual expected probabilities. The expected probabilities cannot be determined until the stimulus which will cause them has been found. But the computation of the stimulus depends upon weighting of the data according to this expectation. The technique of probit analysis as developed by Finney (23) converges on the correct answer by using the observed data as a first guess of the expected values. A provisional stimulus is found from which new expected probabilities will generate new weights for the observed data. This process is continued in an iterative fashion until an answer is obtained.

10.7 Multiple Explosive, Data Reduction, Non-Iterative.

If the probability of the system is distributed according to the logistic function, the one-shot, non-iterative logit analysis (25) gives efficient estimates with very little computational effort. An equivalent method in the Gaussian probability space, called the normit analysis (37), is somewhat more complex. A simplified one-shot weighted average can be used which borrows from the probit analysis by using the weighting factor:

$$w = \left(\frac{z^2}{pq} \right)$$

where:

p is the observed probability of fire*

*For a saturated level (where the trials are either all x's or all O's), the practice is to convert one of the trials to a 1/2 x and a 1/2 O. For instance, if six out of six fired, then n_x would be 5.5 and n_o would be 0.5.

f is the observed probability of non-fire

z is the ordinate of the probability density function associated with p . (See Table V reference 23 and Table E-1 of this report.)

This weighting factor, when rewritten in the notation of Paragraph 10.3, becomes

$$w = \frac{z^2}{R(1-R)} = \frac{N^2 z^2}{n_x n_o}$$

The analysis which will use this weighting factor could be carried out in the following sequence:

For each VARICOMP explosive compute the observed probability, ${}_oR_i$, and find the corresponding normit values.

From the calibration equations compute the observed stimuli, ${}_oX_i$, corresponding to the normits just computed.

The weighted average of all of the stimuli is computed according to

$${}_o\bar{X} = \frac{\sum N_i w_i X_i}{\sum N_i w_i} \quad i=1, j$$

where j is the number of VARICOMP explosives used in the performance test. This average is the estimate of the stimulus derivable from the donor through the interface into the acceptor.

The substitution of the estimated stimulus value in the calibration equation for the design explosive will yield an estimate of the reliability of the performance test system when loaded with the design explosive.

10.8 Errors Due to Calibration Uncertainty. As was mentioned previously the calibrations of the design and VARICOMP explosives will be subject to errors--errors in determination of the standard deviation (slope of the line) and of the 50-percent point (X -axis intercept). The computation of the combined effect of these errors on the precision of the reliability estimate will be given for the case

of a single VARICOMP explosive used in a run-down performance test. The following derivation of the procedure for computing this effect is based on a generalized system. (All reliabilities are expressed in normits.)

Let the true calibration equation for the design explosive be:

$$R_D = m(x - D). \quad (10.8.1)$$

Let the calibration equation, based on experiment, have errors in slope, Δm , and in the 50-percent point, ΔD .

$${}_oR_D = (m + \Delta m)[x - (D + \Delta D)]. \quad (10.8.2)$$

Let the true calibration equation for the VARICOMP Explosive A be:

$$R_A = m(x - A). \quad (10.8.3)$$

Let the experimentally determined equation for the VARICOMP Explosive A be:

$${}_oR_A = (m + \Delta m)[x - (A + \Delta A)]. \quad (10.8.4)$$

Note that the true slopes of the sensitivity lines of the two explosives are taken equal, and that the error in determination of the slopes is the same for both.

The true value of stimulus, x , can be taken as zero without loss of generality. Therefore,

$$R_D = -mD \quad (10.8.1a)$$

and

$$R_A = -mA. \quad (10.8.3a)$$

Since only the effect of calibration error is being studied, it can be assumed for the present that ${}_oR_A$ and R_A are equal. The description of the observed stimulus for the VARICOMP Explosive A can therefore be obtained by combining Equations (10.8.3) and (10.8.4):

$${}_o x = \frac{\Delta A \Delta m + m \Delta A + A \Delta m}{m + \Delta m}. \quad (10.8.5)$$

That is, any departure of the value of the observed stimulus, X_o , from the true value, X , must be due to the VARICOMP explosive calibration errors Δm and ΔA . When the above observed value of stimulus is substituted in the calibration equation for the design explosive, the value for the estimated observed design reliability becomes

$$R_o = \Delta A \Delta m + m \Delta A + A \Delta m - D m - D \Delta m - m \Delta D - \Delta D \Delta m. \quad (10.8.6)$$

The reliability estimation error, \mathcal{E} , is given by $R_o - R_D$. Therefore,

$$\mathcal{E} = \Delta A \Delta m + m \Delta A + A \Delta m - D \Delta m - m \Delta D - \Delta D \Delta m. \quad (10.8.7)$$

This equation expresses a relationship which will hold for each experiment in this system. To generalize for all experiments this equation is more properly written

$$\mathcal{E}_i = m(\Delta A_i - \Delta D_i) + \Delta m_i(A - D) + \Delta m_i(\Delta A_i - \Delta D_i). \quad (10.8.7a)$$

The last term can be neglected since it is of the second order and therefore small compared to the other terms. By squaring and summing the remaining terms for all possible errors (for cases $i=1$ to $i=n$) and by dividing the sum by n , the variance of R_D (neglecting performance test reliability) is found to be

$$V_{R_D} = \frac{\sum \mathcal{E}_i^2}{n} = m^2(V_A + V_D) + (A - D)^2 V_m. \quad (10.8.8)$$

In Equation 10.8.8 the sums of the cross products of the errors ΔA , ΔD , and Δm have been omitted on the assumption that the individual errors are uncorrelated. For this reason these sums are equal to zero. Equation 10.8.8 gives the variance of the reliability estimate due to calibration errors. If now the variance, V_p , of the determination of the VARICOMP explosive response in the performance test is also included (that is if R_A is taken equal to the sum of R_A and ΔR_A) the complete equation is

$$V_{R_D} = V_p + m(V_A + V_D) + (A - D)^2 V_m \quad (10.8.9)$$

These variances must be expressed in (logits)², (normits)², or similar units and not in percentages.

10.9 Example, Run-Down Method. Assume that there exists a system for the study of which the design explosive and two VARICOMP explosives, Explosive A and Explosive B, have been calibrated (Figure 10.9). The calibration equation of the design explosive is:*

$$R_D = 0.345x - 1.582$$

with its lower limit, at 95-percent confidence, given by

$$R_D = 0.345x - 1.582 - 1.65 \left[0.0021(x - 6.02)^2 + 0.0041 \right]^{1/2}$$

The calibration of Explosive A is

$$R_A = 0.35x - 2.5$$

and of Explosive B is

$$R_B = 0.25x - 3.0.$$

In the above equations the response is expressed in normits.

10.9.1 Single VARICOMP Explosive, Data Collection. Five fires are observed in seven trials with VARICOMP Explosive A in the performance test. The observed response is therefore 71 percent. The lower one-sided 95-percent confidence limit for the estimate of the true response in this case is 34 percent (from Table 2.4 or reference 42).

10.9.2 Single VARICOMP Explosive, Algebraic Data Reduction. The calibration equations given above may be used to obtain the reliability predictions. Since the values of R_D , R_B , and R_A in these equations are in normits, the observed response and its lower limit must be changed to these units. Thus 71 percent becomes 0.55 normits and 34 percent becomes -0.41 normits. The values of x which correspond to the observed response and to the lower limit of the estimate of the response with the VARICOMP Explosive A are found to be 8.72 and 5.97 by substitution in the equation of the line for this explosive. Substitution of the first of these values of x in the equation for the expected response

*This is the same design explosive as was used in the Bruceton example, Paragraph 9.9.2 and Figure 9.9.2A.

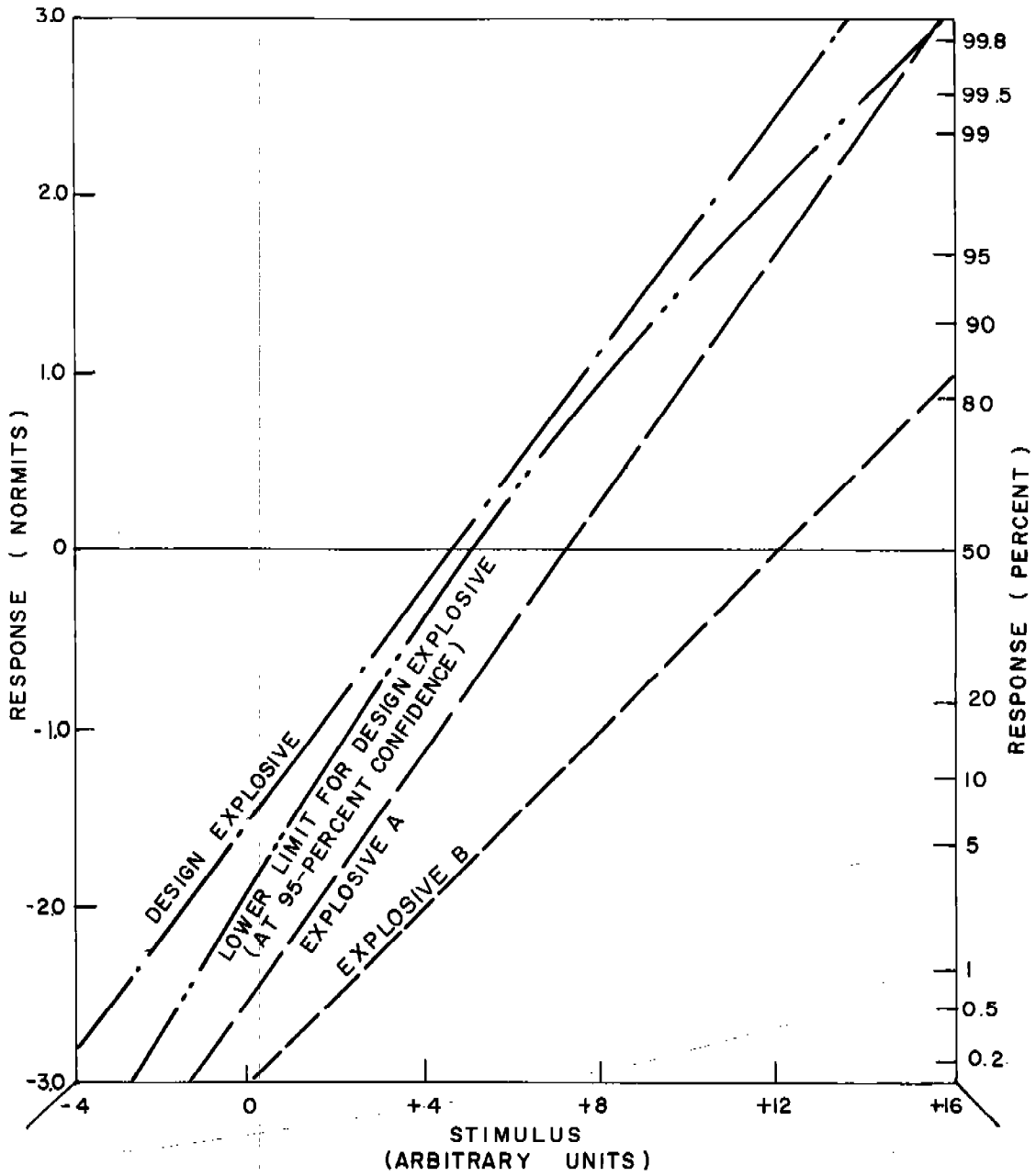

FIGURE 10.9 CALIBRATION OF THE DESIGN AND THE TWO VARICOMP EXPLOSIVES

of the design explosive gives 1.43 normits which is equivalent to 92.4 percent as the expected reliability of the ordnance design. Substitution of the lower limit for the value of x in the equation for the lower limit for the response of the design explosive gives a value of 0.37 normits or 64.4 percent for this lower limit. The estimate of at least 64.4-percent reliability is made at a confidence between 90.25 percent and 99.75 percent.*

A short cut can be taken if the responses of the design explosive and the VARICOMP explosive can be represented by parallel lines spaced a known distance, say 1 normit, apart. In such a case the final estimates could be obtained by adding this amount to the values of the responses for the VARICOMP explosive. If this technique were used in the above example, for instance, the expected reliability would be 1.55 normits or 94 percent with a lower limit of 0.59 normits or 72 percent. These results, which are based on the assumption that the sampling error of the design explosive can be neglected, are in error. Since the two explosives are not represented by parallel lines the short method should not be used here. In this case, the result would be too optimistic because of the upward convergence of the two calibration lines.

10.9.3 Single VARICOMP Explosive, Graphical Data Reduction. The intersection of the 71-percent response line R_A , with the calibration line (point M of Figure 10.9.3) yields an observed stimulus, x , of 8.7. The lower one-sided 95-percent confidence limit for the estimate of the true response of VARICOMP Explosive A, R_A , is 34 percent. The intersection of the 34-percent response line with the calibration line (point L of Figure 10.9.3) yields a stimulus, x , of 5.9. Drawing vertical lines from these points to intersect the band for the design explosive, the predictions of 92.4 percent (point Q of Figure 10.9.3) and 64.4 percent (point N of Figure 10.9.3) are obtained for the expected reliability and its lower limit at greater than 90-percent confidence.

*These confidence levels are obtained from

$$C_p \cdot C_c = 0.95 \cdot 0.95 = 0.9025$$

$$1 - (1 - C_p)(1 - C_c) = 1 - (0.05)(0.05) = 0.9975$$

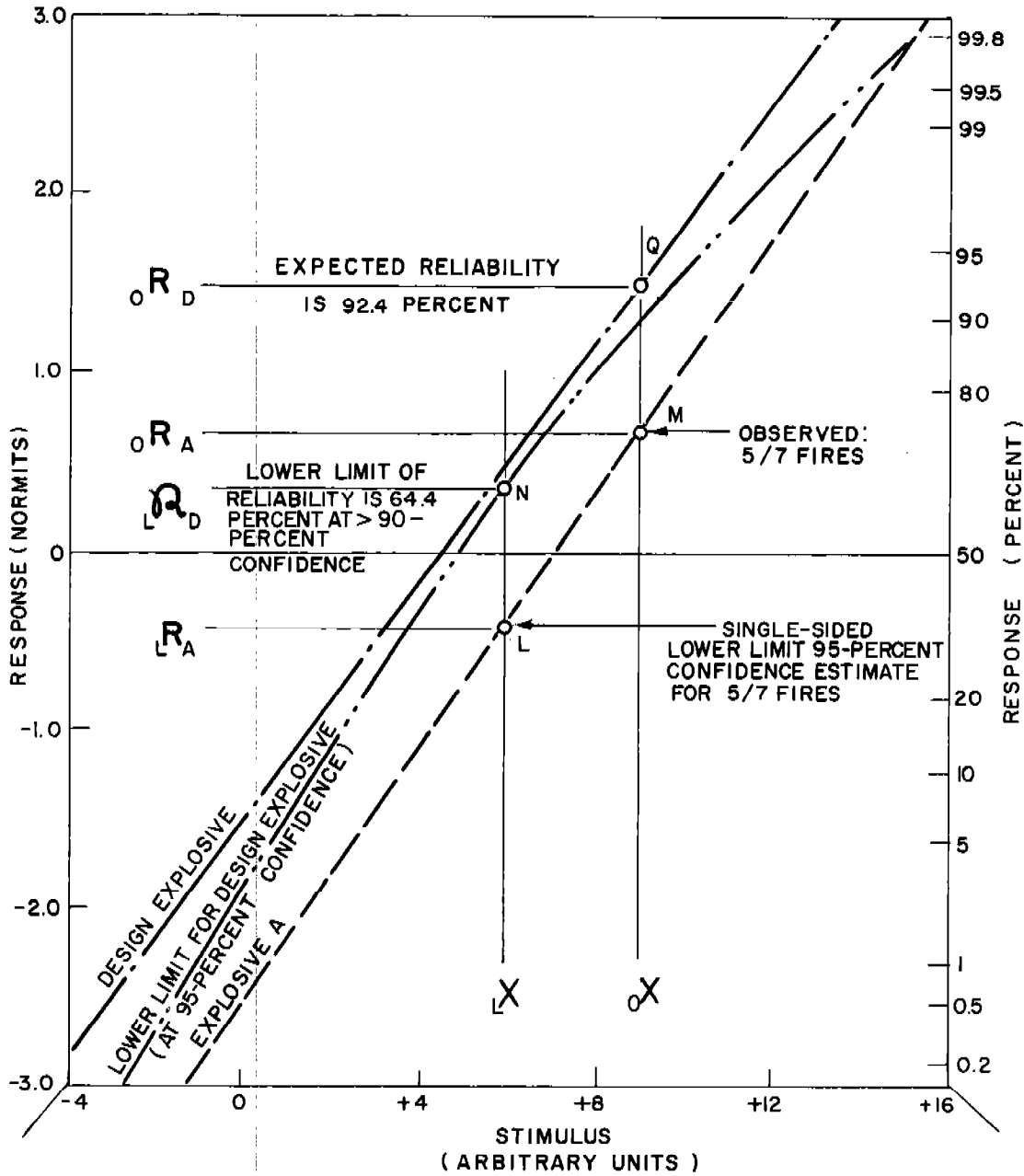

FIGURE 10.9.3 ANALYSIS OF RUN-DOWN PERFORMANCE TEST WITH ONE VARICOMP EXPLOSIVE

10.9.4 Two VARICOMP Explosives, Data Collection.

For an example of collection and analysis of data when using two VARICOMP explosives with the run-down scheme it is assumed that the design tested in the previous example has been modified geometrically in an effort to improve its reliability. The improved design is to be tested by making ten trials with the VARICOMP Explosive A and five trials with VARICOMP Explosive B. (The equations of the responses of the explosives are given in Paragraph 10.9.) The results of the performance test, made according to the above plan, show all ten trials with VARICOMP Explosive A as fires and two of the five trials with VARICOMP Explosive B as fires.

10.9.5 Two VARICOMP Explosives, Data Reduction.

Since the observed 100-percent response with VARICOMP Explosive A cannot be expressed in normits, the data are treated as suggested in Paragraph 10.7. Calculations are made using 9.5 fires in ten trials with this explosive. The computation follows the steps in Paragraph 10.7 and is outlined in Table 10.9.5. Substitution of the average value of \bar{x} in the equation for the expected response of the design explosive gives 2.24 normits which is equivalent to 98.7 percent. Figure 10.9.5 shows the plot of the observed data and the expected response of the system with the design explosive.

Table 10.9.5

Computation of the Average
Observed Stimulus Intensity

Explosive	n Number of Trials	Observed Response percent	normits	Stimulus \bar{x} from Calibration Curves
A	10	95	1.64	11.8
B	5	40	-0.25	11.0

Explosive	\bar{x}	w	nw	nwx
A	11.8	0.22	2.20	25.96
B	11.0	0.62	3.10	34.10

$$\begin{aligned} \sum nwx &= 60.06 \\ \sum nw &= 5.30 \\ \frac{\sum nwx}{\sum nw} &= \bar{x}_{AB} = 11.33 \end{aligned}$$

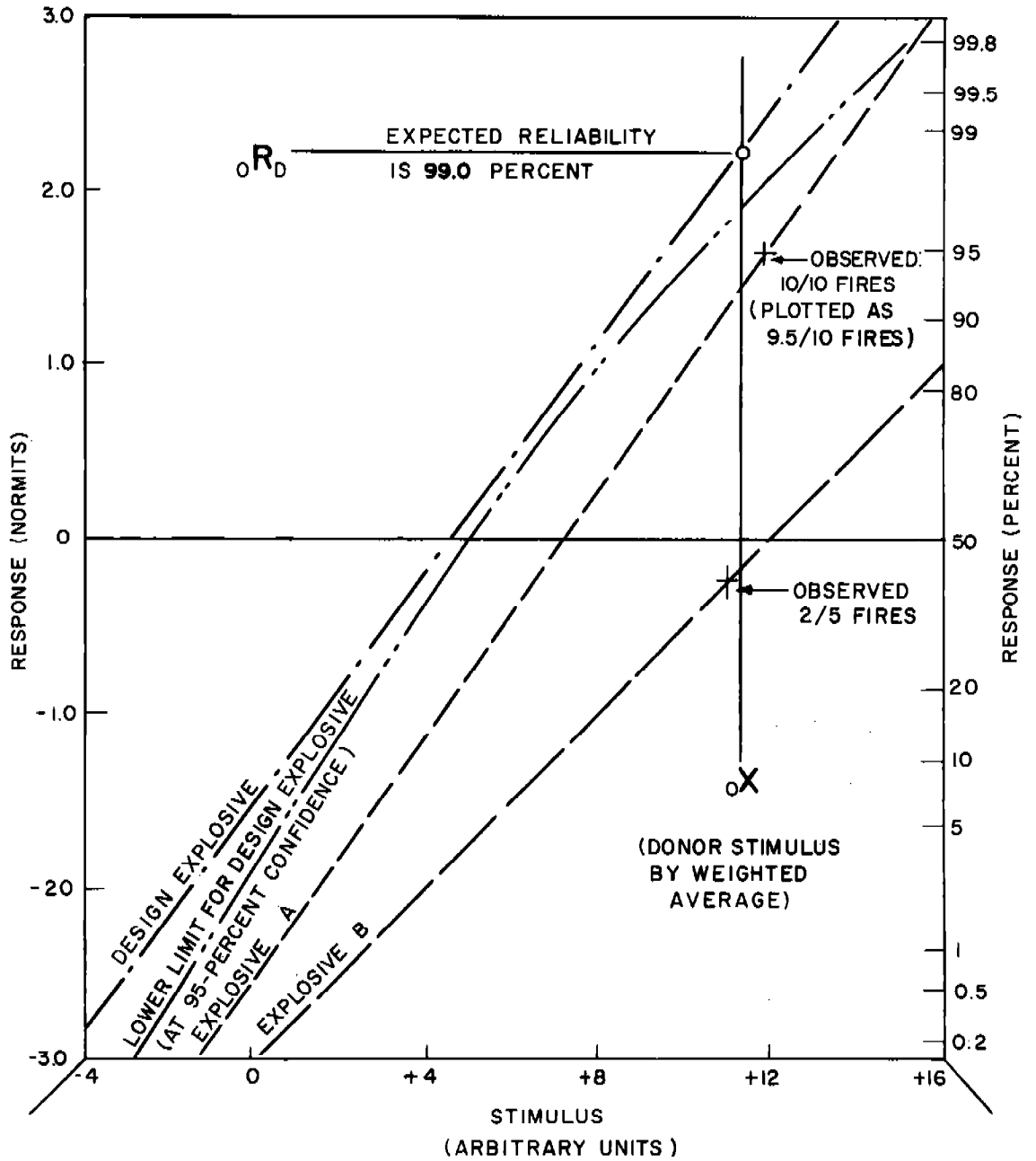

FIGURE 10.9.5 ANALYSIS OF RUN-DOWN PERFORMANCE TEST WITH TWO VARICOMP EXPLOSIVES

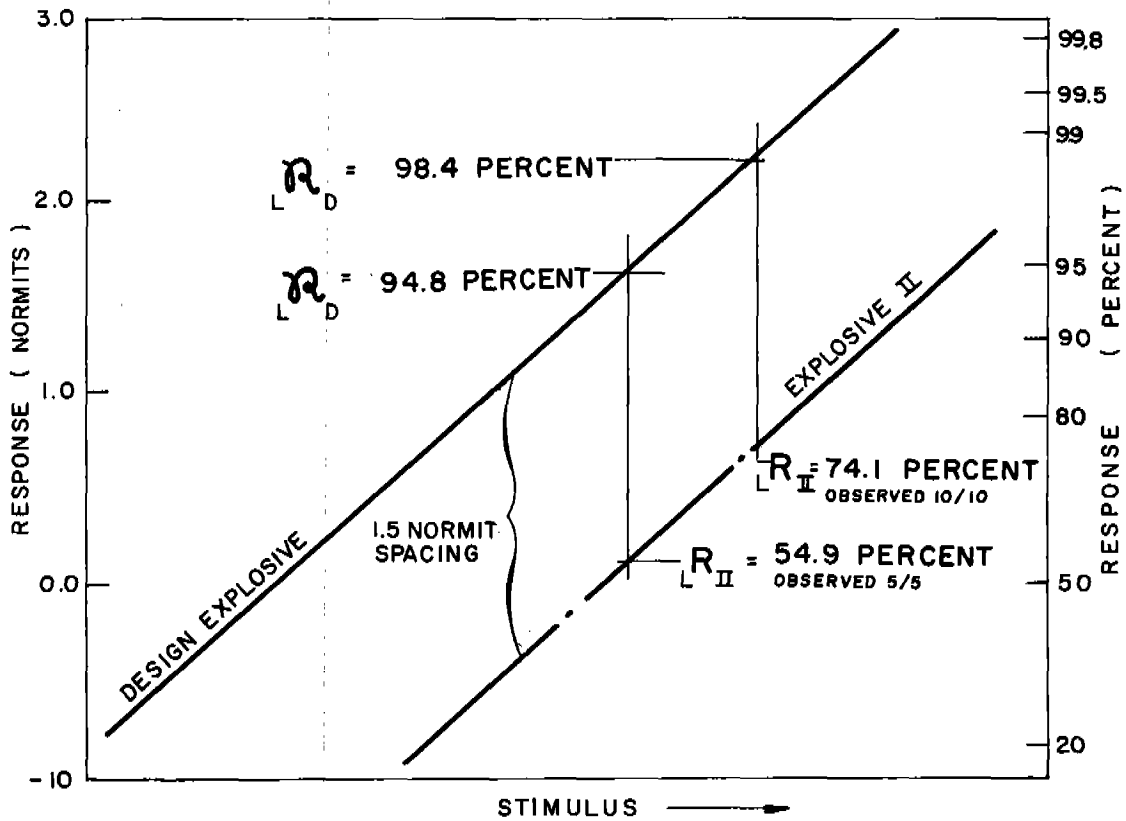
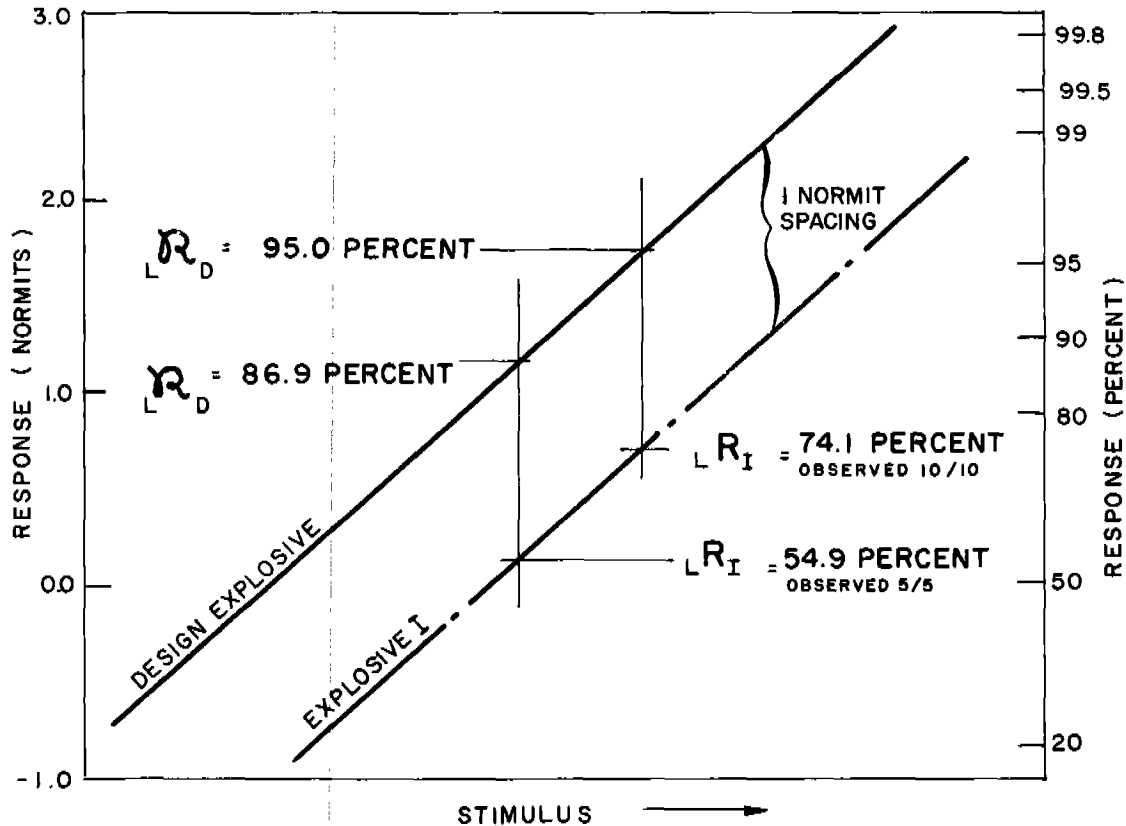

FIGURE 10.10 EFFECT OF SAMPLE SIZE AND GRID SPACING ON SINGLE VARICOMP-EXPLOSIVE RUN-DOWN RELIABILITY ESTIMATES

10.10 Small Sample Errors and Limitations, Single Explosive.

The observed response obtained from a small number of trials will not be the true value for the probability of fire. First, the sample will not be perfectly representative of the general population (sampling error). Second, a sample of five, for instance, can only show a percent response of 0, 20, 40, 60, 80, or 100 while the true value might be anything between 0 and 100 percent. The amount of this uncertainty when one VARICOMP explosive is used and no more than two non-fires occur is shown in Table 2.4. This is the effect on the performance of the ordnance item with the VARICOMP explosive in place of the design explosive. The effect on the final estimate will depend on the difference in sensitivity between the two explosives. For instance, with a VARICOMP explosive whose sensitivity line is parallel to the design line and spaced 1 normit less sensitive (measured on any vertical line), an observation of no non-fires in five shots with the VARICOMP explosive would indicate a weapon reliability of at least 86.9 percent (Figure 10.10). An observation of no non-fires in ten trials would indicate a reliability of at least 95.0 percent. If the VARICOMP explosive is spaced 1.5 normits less sensitive than the design explosive, minimum reliabilities for the above observations would be 94.8 percent and 98.4 percent, respectively (Figure 10.10). These are the highest reliabilities that can be demonstrated for these sample sizes and spacings regardless of how reliable the system might be.

10.11 Small Sample Errors and Limitations, More than One Explosive. When more than one VARICOMP explosive is used in the performance test the effect of the small sample size will be a combination of the separate errors of this sort for each explosive. The Monte Carlo approach has been used to estimate the magnitude of this effect in desk-top tests. Four VARICOMP explosives were simulated. Their sensitivities to a stimulus for which the design explosive was set at a response of 97.5 percent were 93, 79.9, 55.6, and 28.8 percent.

Eight replicates were performed in which ten trials were made with each VARICOMP explosive. For those cases in which all fires occurred the data were corrected as described in Paragraph 10.7.

The computed standard deviation of the weapon reliabilities in terms of normits was 0.185. Three standard deviations below the central value gives a predicted reliability of 92.0 percent (to be compared with the assumed 97.5 percent response).

NavWeps Report 7411

A set of sixteen replicates was carried out in which five trials were made with each VARICOMP explosive. The standard deviation of the predicted reliabilities was 0.277 normits. Three standard deviations below the central value gives a reliability prediction of 89.5 percent (to be compared with the assumed 97.5 percent response).

The magnitude of this effect will undoubtedly depend upon the number of VARICOMP explosives used, on the spacing of their sensitivities, and probably on other factors. The results quoted above can therefore be taken only as an indication of the effect of this uncertainty.

11. COMPARISON OF VARIOUS DATA COLLECTION METHODS

11.1 Choice Between Stairstep and Run-down Methods. The choice between the use of a stairstep or up-and-down procedure and the use of a run-down procedure will depend upon one or more of several factors. Each type of test has certain features which may make its choice desirable. The analysis of any up-and-down test, such as the Bruceton test, ordinarily assumes that the test levels are equally spaced. This requires that the 50-percent points of the VARICOMP explosives be equally spaced and that the slopes of their sensitivity lines be equal. The slopes of the lines need not be known. With the run-down method the 50-percent points do not need to be equally spaced nor do the lines need to be parallel. However, both the 50-percent points and the slopes of the VARICOMP lines must be known. The up-and-down method requires the use of several VARICOMP explosives arranged in a regular graded series of sensitivities. The run-down method may use several explosives if this appears desirable, but it may be used with only one VARICOMP explosive. In an up-and-down test the result of one trial must be known before the set-up for the next trial can be made. In a run-down test the trials are made independently of each other. The set-ups could all be made in advance and randomized. Such randomization would not be possible with an up-and-down test. The up-and-down test would therefore be subject to errors due to trends which might occur in the loading of test items. The design of an up-and-down test will concentrate the trials at a certain point. For instance, the Bruceton test concentrates the trials near the 50-percent point. In the run-down test the levels used are chosen entirely according to the judgement of the experimenter. On the other hand, the run-down test can be designed to center about some other point. As has been pointed out in Paragraph 8.10, it is often desirable to calibrate the design explosive with most of the trials (and therefore the greatest precision) in the vicinity of the 70-, 80-, or 90-percent point. The up-and-down methods require a series of several explosives equally spaced in sensitivity represented by parallel lines in the calibration. If it is not possible or desirable to use such a series of explosives the run-down method should be used.

11.2 Other Staircase Testing Methods. For most testing, either in the calibration or performance tests, the best method will be either a run-down or a Bruceton test. However, there may be situations in which some one of the other staircase

methods of sensitivity testing may be advantageous. This would be the case, for instance, if a trial which resulted in a fire was very much more expensive than one which resulted in a non-fire. In this situation, the single explosion method as described in reference 30 might be used to estimate the VARICOMP explosive number which would have a response of 10 percent in much the same way as the Bruceton method estimates the explosive having a 50-percent response. The result of a test carried out by this method would be plotted in the same way as the point M in Figure 9.9.3 except that it would be located on the 10-percent line rather than the 50-percent line. Other methods described in this reference might be desirable in some cases.

12. DESIGN OF EXPERIMENT

12.1 In the use of the VARICOMP procedure the reliability of an ordnance item is evaluated using one or more of the VARICOMP explosives. Then, in terms of the calibration tests, an estimate is made of the increase in reliability which can be expected when the design explosive is used in place of the VARICOMP explosives.

12.2 The calibration test should be an extensive test which would determine very accurately the comparative sensitivities of the VARICOMP explosives and the design explosives, such as Tetryl, CH-6, and TNT. This calibration, like any other calibration, would ordinarily have been done before the performance test program is formulated and by a different person. The type of test used in the calibration should be one which would give results applicable to as wide a variety of practical systems as possible. The small scale gap test is worthy of consideration. However, since the interface between donor and acceptor is a solid barrier in this test, it may not be exactly applicable to a system in which the transfer mechanism depends largely upon fragments striking the acceptor. There might also be other conditions which affect its applicability. The person using the VARICOMP method of evaluating a practical system should be sufficiently well acquainted with the calibration test to be able to decide whether or not the calibration is applicable to his system.

12.3 If the experimenter decides that the existing calibration cannot be used with his system, a new calibration must be made using a mock-up of his system. If several VARICOMP explosives are used in the performance test, and if the best straight line through the points representing their responses departs significantly from the vertical (Figure 12.3), this may be an indication that the conditions of the calibration test differ significantly from those of the performance test. It should be remembered that if it is necessary to discard the extensive calibration much of the advantage of the VARICOMP procedure will be lost. The error in the final reliability estimate will be a combination of the error of the performance test and the error of the calibration. If the precision inherent in an extensive calibration must be abandoned this loss can only be made up by a considerable increase in the number of trials in the performance test. To this must be added the

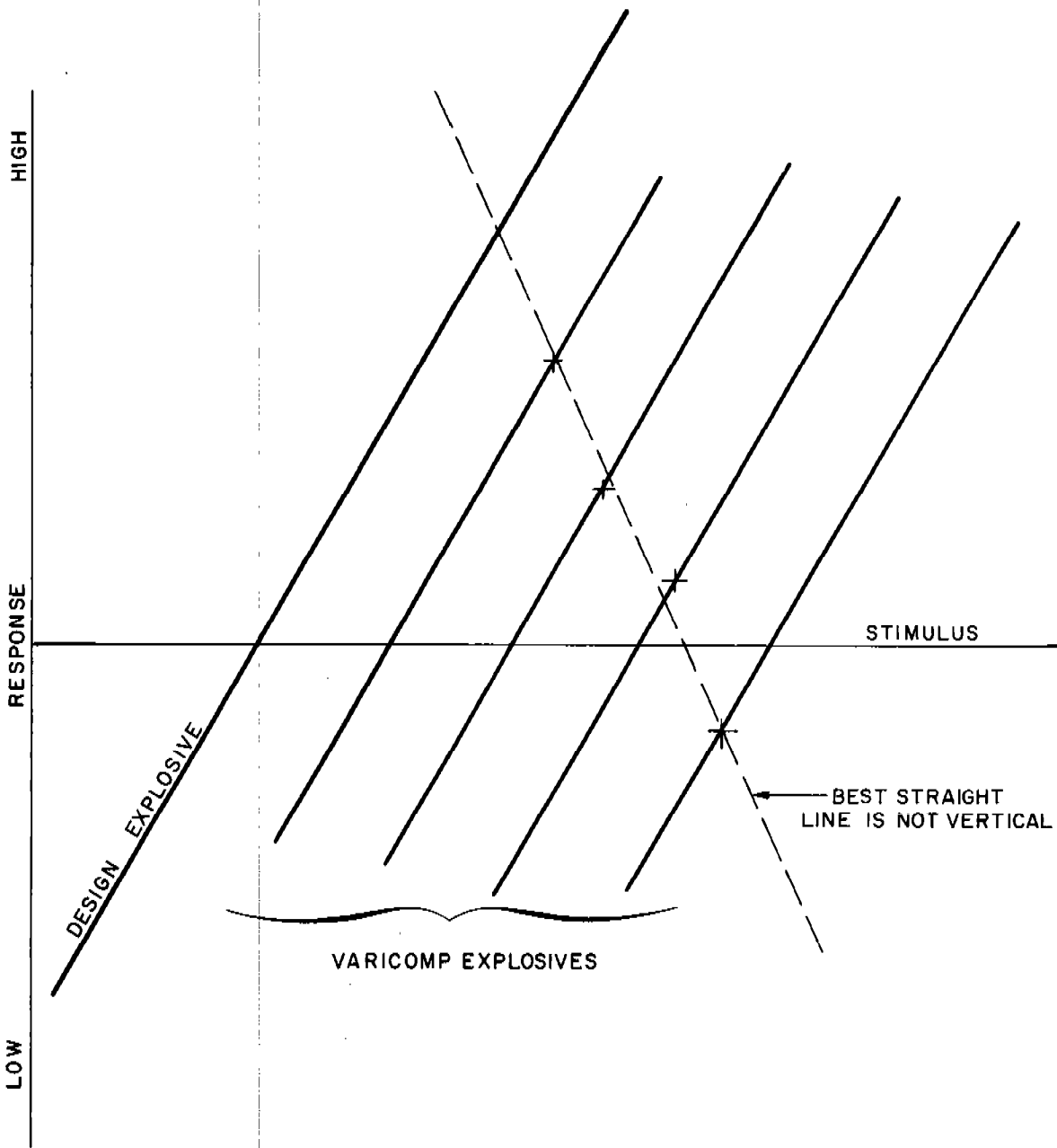

FIGURE 12.3 POSSIBLE LACK OF ANALOGY BETWEEN CONDITIONS OF PERFORMANCE AND CALIBRATION TESTS.

increased effort of recalibration with the mock-up tests. It should also be remembered that the objections listed against changing the geometry of the ordnance item will probably apply to the mock-up calibration tests. In some cases, in spite of the above limitations, it is possible to use the VARICOMP process to demonstrate clearly that a system is adequately reliable or that it is not reliable and therefore needs improvement.

12.4 The mechanism by which transfer of detonation takes place may not be the same in the ordnance design as in the calibration test. If the relative sensitivities of the explosives considered are not affected by this difference, the results of the calibration test are still applicable. It might be that the effect of this difference between the two tests would be proportional to the sensitivities of the explosives. In this case the best straight line through the points representing the responses of the VARICOMP explosives will depart from the vertical. If the calibration and performance tests are different there are several choices open to the experimenter.

He can assume that the sensitivity of the design explosive is affected by the difference between the two tests in the same way as the VARICOMP explosives. In this case he can extend the oblique line which best represents the responses of the VARICOMP explosives until it intersects the response line of the design explosive.

If the departure of the line from the vertical is not great he can ignore it and proceed as described before by using a vertical line.

If he is in doubt between these two choices he can make both estimates and accept the more pessimistic of the two.

If none of these alternatives is acceptable a new calibration must be made using a test which more nearly simulates the essential features of the ordnance design.

12.5 It is possible for the experimenter to use several methods of measuring the desired reliabilities, and then to combine the results of these investigations, thus obtaining the final estimate. It should be fairly obvious that the rules for obtaining these combined results should be firmly established before the experimentation begins. If he waits until after

the results are in, he could very easily find a way of combining them so as to get almost any answer he wishes. The rules for combining these results should take into consideration such things as the expected precision of the methods used. It is obviously impossible to make more than general statements of this kind concerning the problem of combining the results of several methods. The experimenter must make his own decisions in the light of his own knowledge and judgement.

12.6 The strategy of the VARICOMP method can be considered as a methodical search for an explosive which can be used to estimate the magnitude of the explosive drive, χ , available across the interface. The sought-for explosive, being less sensitive than the design explosive, will exhibit a lower probability of fire. In fact, the explosive should be chosen so that it will exhibit a mixed response--both fires and fails--in the performance test. The greatest precision in the determination of the response of the VARICOMP explosive to the stimulus and the greatest efficiency in the extrapolation to the expected reliability of the design explosive will be achieved when the VARICOMP explosive response to χ is near 50 percent. An illustrative example follows, in which the experimenter will fire only six shots in the performance test. The most probable observation, and the inference therefrom, will be explored as a function of the explosive that might be chosen.

The design explosive, and ten VARICOMP explosives are available to the experimenter. The true responses of these explosives to the stimulus, χ , are not known to the experimenter. The experimenter knows the relative sensitivities. These relative sensitivities are expressed in terms of the normit spacing below the design explosive. Let the true responses and relative spacings be as given in Table 12.6. For computational ease, the responses are given in probits rather than normits.

The explosive chosen as the VARICOMP material will exhibit one of seven possible responses-- 6/6, 5/6 ... 0/6. The probability of each of these responses can be computed from the binomial distribution according to

$$p(x) = \frac{n!}{x!(n-x)!} p^x q^{n-x}$$

NavWeps Report 7411

Table 12.6

Relative Sensitivities of
a Series of Explosives

Explosive	True Response To		Relative Spacing Below Design Explosive (probits or normits)
	\bar{x} percent	probits	
Δ	99.9	8.0902	—
A	98	7.0537	1.0365
B	88	6.1750	1.9152
C	80	5.8416	2.2486
D	70	5.5244	2.5658
E	63	5.3319	2.7583
F	50	5.0000	3.0902
G	37	4.6681	3.4221
H	30	4.4756	3.6146
I	20	4.1584	3.9318
J	12	3.8250	4.2652

NavWeps Report 7411

where n is the number of trials

x is the number of successes

p is the probability of response

and $q = 1 - p$.

Thus for explosive E (the probability of firing from stimulus x being 63 percent) and for a great number of six-shot trials,

6/6 would be observed 6.25 percent of the time,

5/6 would be observed 22.03 percent of the time,

4/6 would be observed 32.35 percent of the time,

3/6 would be observed 25.33 percent of the time,

2/6 would be observed 11.16 percent of the time,

1/6 would be observed 2.62 percent of the time,

0/6 would be observed 0.26 percent of the time.

Whenever 6/6 responses are observed a lower limit estimate of 60.67 percent (at 95-percent confidence) would be made for the response of the VARICOMP explosive. Similarly, 22.03 percent of the time (for the 5/6 case) the corresponding estimate would be 41.81. For all possible cases, and for a great number of six-shot runs, the average minimum response would be computed as

$$(6.25)(60.67) + (22.03)(41.81) + (32.35)(27.14) + (25.33)(15.13) \\ + (11.16)(6.29) + (2.62)(0.85) + (0.26)(0.0)$$

$$6.25 + 22.03 + 32.35 + 25.33 + 11.16 + 2.62 + 0.26$$

which is 26.39 percent (4.3686 probits or -0.6314 normits).

NavWeps Report 7411

When the explosive spacing (in this case 2.7583 normits) is added to the average minimum response of the VARICOMP, the average minimum predicted reliability of the design explosive is obtained--in this case 7.1269 probits or 98.33 percent.

Suppose this general procedure has been carried out for explosive A through J for two weapon reliabilities-- 99.9 percent when loaded with Explosive A and 98 percent with Explosive A (Figure 12.6). It is apparent that the greatest efficiency of extrapolation will be achieved when the VARICOMP explosive has been chosen so that its true response to x is between 30 and 70 percent. Note that for six trials a reliability of about 98.5 percent can be demonstrated in the case shown as curve 1. About 225 shots would be required with the system loaded with the 99.9-percent reliable explosive in order to exhibit a 98.5-percent response. Thus, the "power" of the VARICOMP technique in this particular case is $\frac{225}{6}$, or about 37.

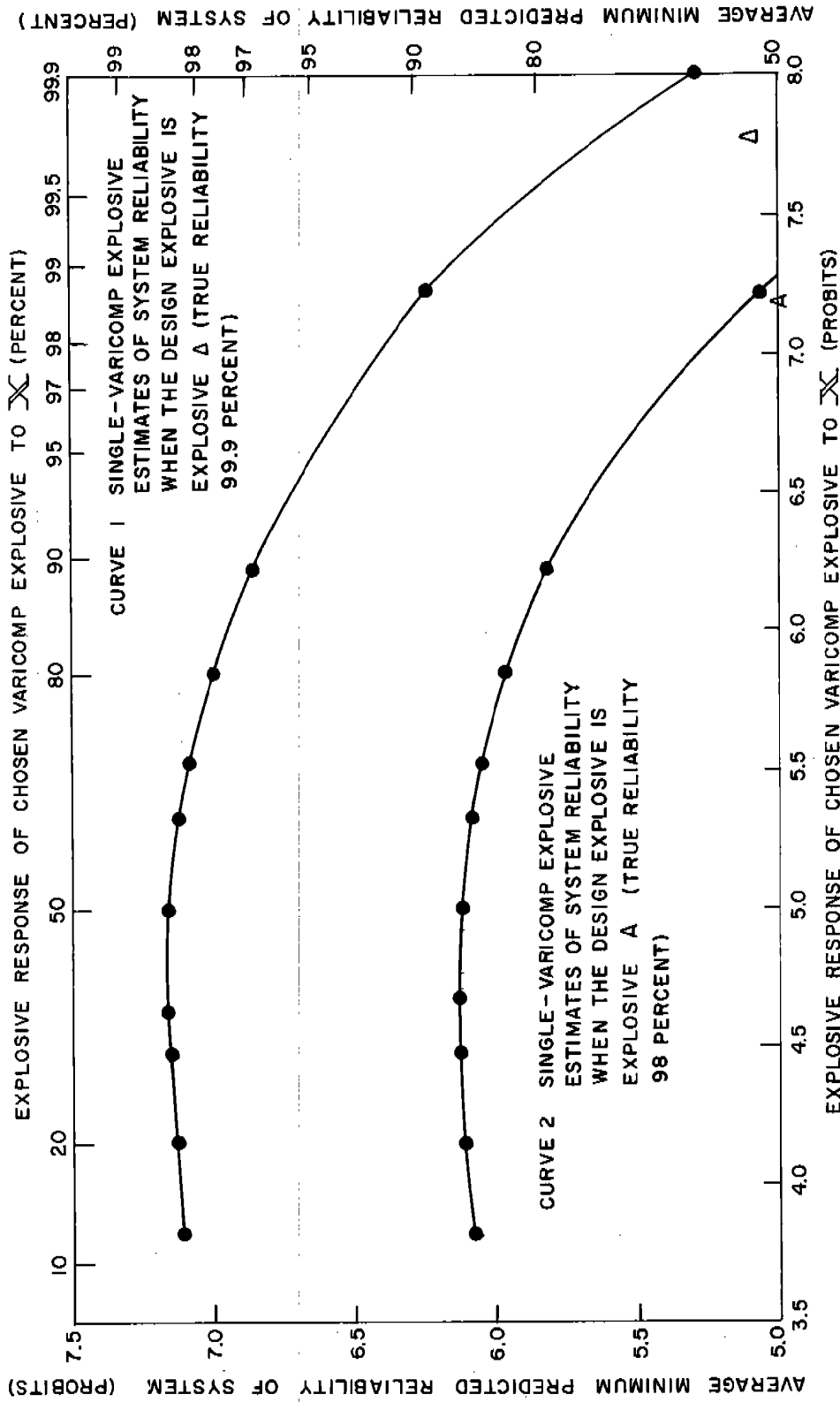

FIGURE 12.6 THE EFFECT OF THE CHOICE OF VARICOMP EXPLOSIVE ON THE EFFICIENCY OF ESTIMATE OF RELIABILITY OF DESIGN

13. APPLICATIONS AND EXAMPLES

13.1 The first use of the VARICOMP procedure was in 1953 (5). In this case, a detonator was expected to initiate a tetryl booster in a certain fuze system. A series of several explosives less sensitive than tetryl was used in performance tests. Using an acceptor of RDX/wax (96/4) one experimental initiator was successful in detonating the acceptor in seventeen out of twenty-five trials while another initiator was successful in five out of nine trials. Each initiator was successful in initiating Comp A in one out of six trials. On the basis of these results and a knowledge of the comparative sensitivities of RDX/wax (96/4), Comp A, and tetryl, it was predicted that these initiators would be successful in initiating a tetryl booster at least 95 percent of the time. Reference 6 describes briefly the idea of the VARICOMP procedure and then describes several variations of a test which was used to calibrate a series of RDX/wax mixtures along with tetryl. The results of this calibration were used in a VARICOMP performance test of a certain fuze (33). The performance test indicated a reliability of well above 99 percent.

13.2 Another example of the use of the VARICOMP method is the evaluation of the reliability of detonation transfer between a booster and a main charge separated by a steel tube containing several holes (Figure 13.2). This complication of design made it quite difficult to assess the reliability by geometric modification without tampering with the mechanism of transfer. It was therefore decided to use a VARICOMP approach to the problem. At this stage of the design development, the final choice of the explosive to be used in the main charge had not been made. Both Comp B and H-6 were being considered. The plan used in the test was to estimate the reliability of the design with each of these explosives using TNT as the VARICOMP explosive.

13.3 Since it was not considered desirable to make an extensive calibration test, it was decided to attempt to use a less precise test. The lack of precision was compensated for by taking the most pessimistic interpretation of the experimental results which would be consistent with the data. The calibration was made using a variable barrier test with the response of the explosive being expressed as a function of the barrier through which it was initiated by a standard donor.

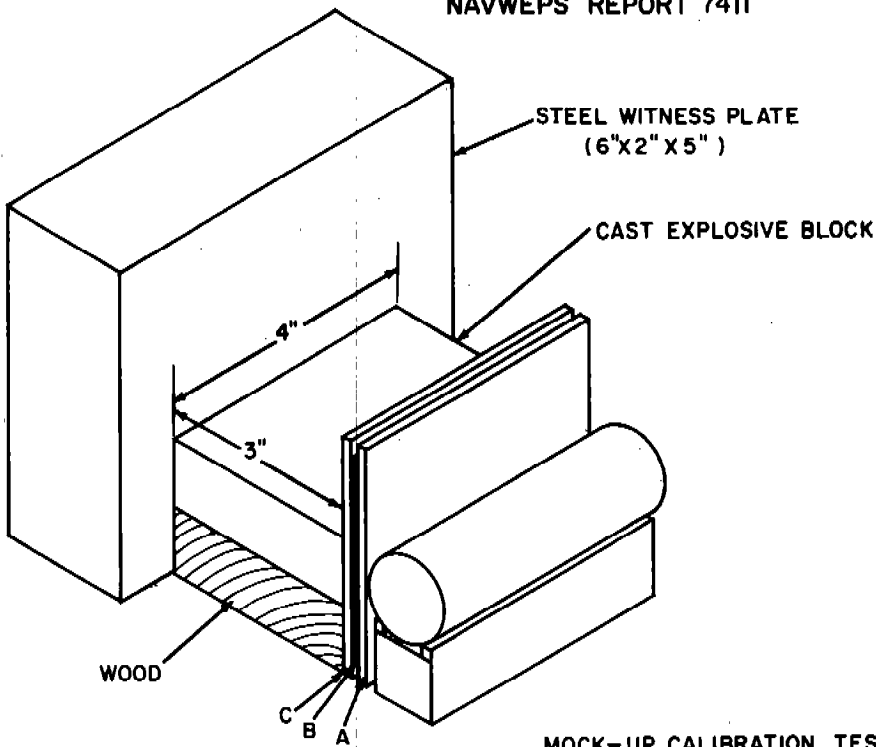

MOCK-UP CALIBRATION TEST ARRANGEMENT

- A - 1/8" STEEL PLATE
 - B - AIR GAP
 - C - VARIABLE THICKNESS
- STEEL BARRIER

PERFORMANCE TEST ARRANGEMENT

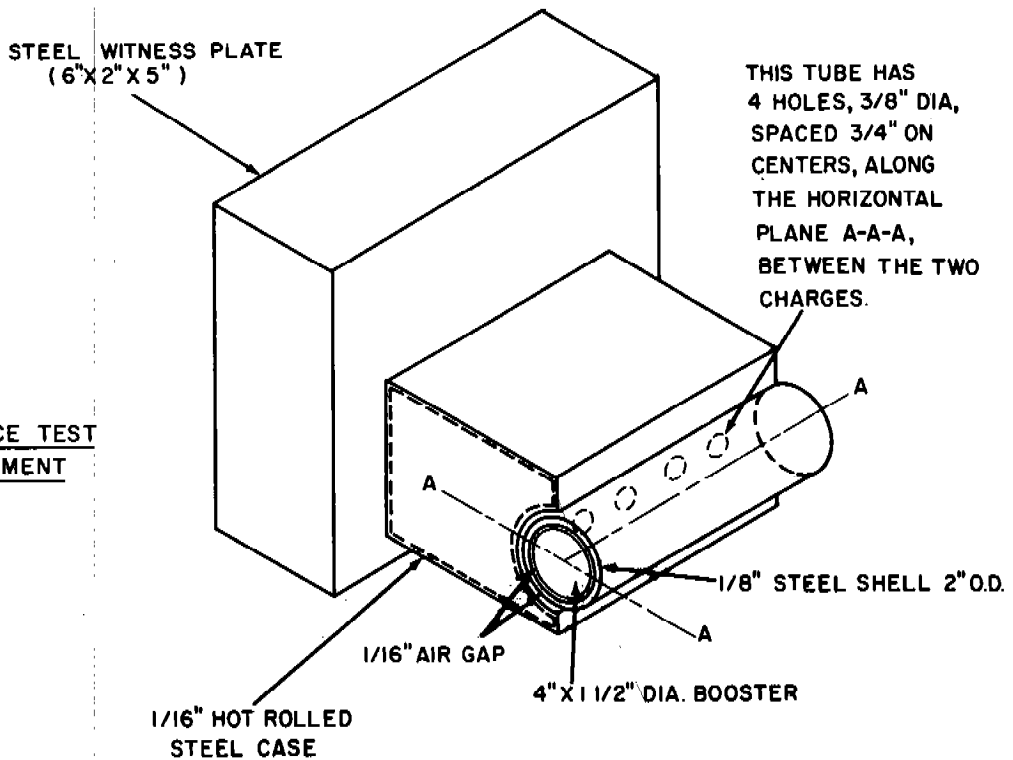

FIGURE 13.2 BOOSTER-TO-WARHEAD TRANSFER RELIABILITY STUDY BY VARICOMP

NavWeps Report 7411

Each explosive was tested at two levels of intensity represented by barrier thickness. Twenty-five trials were made in each test with Comp B, ten trials in each test with H-6, and six trials in each test with TNT. Using an available table which gave two-sided 95-percent confidence limits for the probability in a binominal distribution, a range was obtained from each observed response within which the true value could be expected to lie. The observed data, together with this expected range for each observed response, are given in Table 13.3.

Table 13.3
Calibration Data and Results

Explosive	Barrier (mils)	No. Trials	No. Fires	Observed	Response (%)	
					95%-Conf Lower	Interval Upper
Comp B	306	25	4	16	4.6	35.2
	234	25	22	88	68.8	97.5
H-6	205	10	0	0	0.0	30.8
	165	10	10	100	69.2	100.0
TNT	38	6	0	0	0.0	45.9
	18	6	5	83	35.9	99.6

The confidence intervals for the expected responses of Comp B are plotted in Figure 13.3A as the vertical lines AB and CD. The graph of the expected response could be any straight line which cuts both AB and CD. The most pessimistic estimate of the reliability of this explosive for different stimulus intensities would consist of the broken line made up of

The part of the line DA which extends beyond A ,

The line segment AC ,

That part of BC which extends beyond c .

Figure 13.3B shows the calibration results for the other design explosive H-6, in a similar way except that only the line FG can be drawn since the other confidence limits cannot be plotted. The results for the calibration of the VARICOMP explosive, TNT, are treated differently in one respect. The most pessimistic prediction of the reliability of the design explosive in the

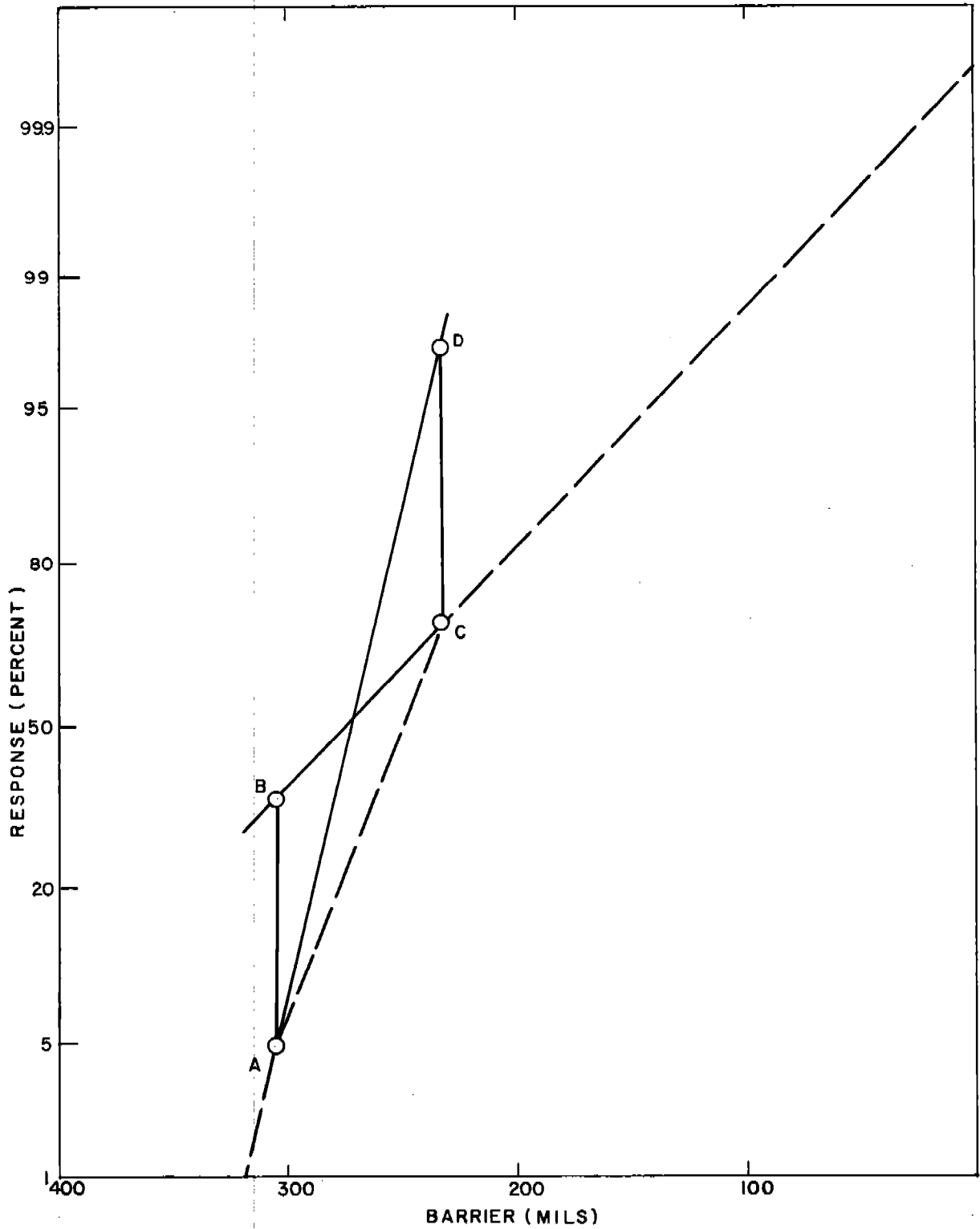

FIGURE 13.3A CALIBRATION OF COMP B

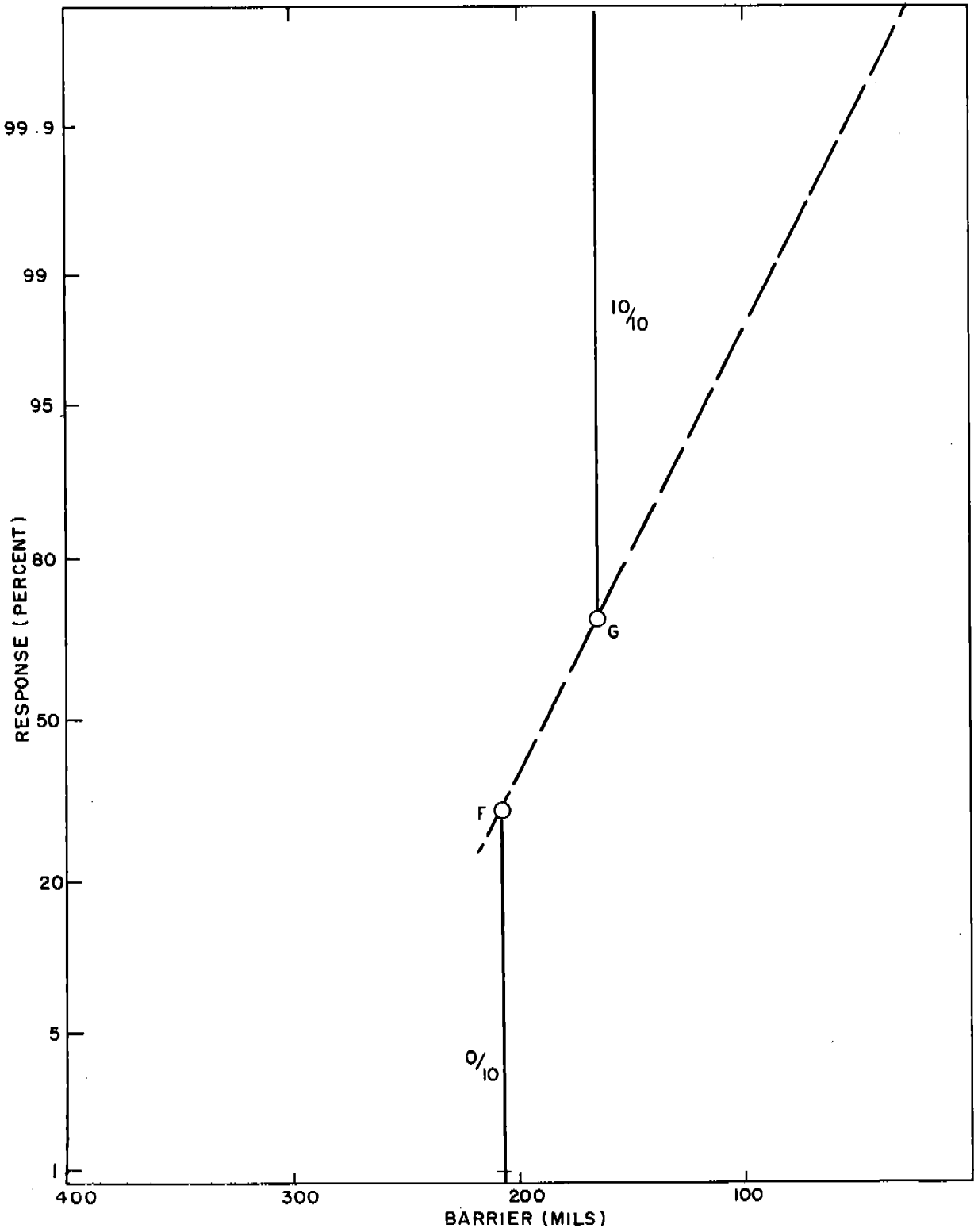

FIGURE 13.3 B CALIBRATION OF H-6

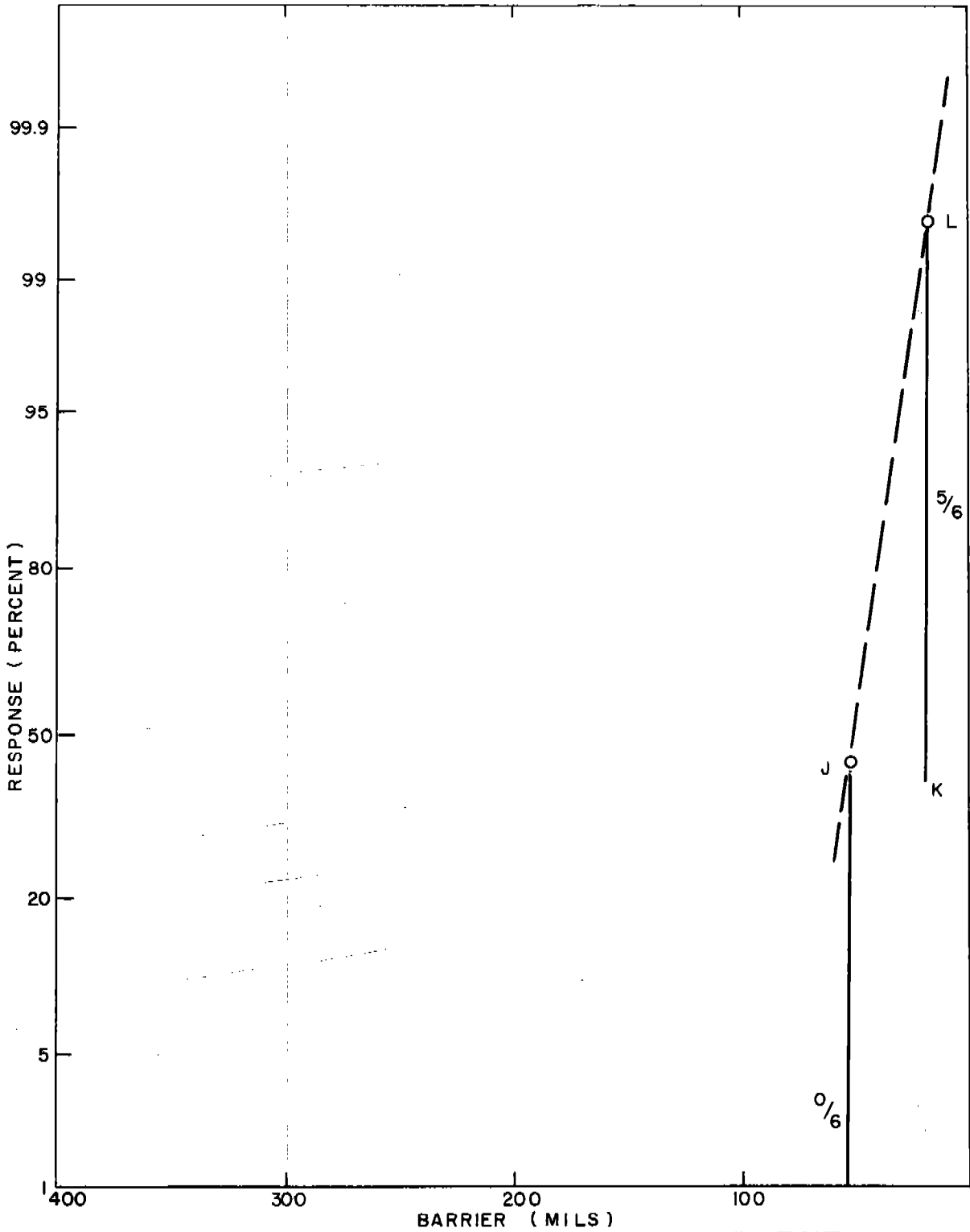

FIGURE 13.3C CALIBRATION OF TNT

ordnance item will be made by taking the highest acceptable estimate of the response for TNT in the calibration since this makes the difference between the TNT and the design explosive the least. The line to be used is therefore the one passing through JL. This is the upper rather than the lower, boundary of the zone representing the possible predictions. Figure 13.3C shows the calibration of TNT with this boundary. Again, as was the case for H-6, only part of this boundary can be drawn since the lower end of one of the ranges cannot be plotted.

13.4 For the performance test, ten trials were made in which the performance of the ordnance design was observed with TNT substituted for the design explosive. All ten of these trials resulted in fires. The two-sided 95-percent confidence limits associated with this result are 69.2 percent and 100 percent. Using the calibration graph for TNT the stimulus intensity which corresponds to 69.2 percent response for TNT is found to be that obtained with a barrier thickness of 43 mils as shown on the TNT line in Figure 13.4A (point τ). The vertical line through this point intersects the lower limit of the response expected with H-6 at 99.95 percent (point ν). The corresponding prediction with Comp B is 99.83 percent (point u). The confidence associated with these predictions is high. The lower limit which was used in the prediction for Comp B, for instance, was obtained by combining the upper limit of the response range for a 306-mil barrier with the lower limit for the range with 234-mil barrier. Since the results of these tests would not be expected to be correlated in this way, it seems reasonable to expect the lower limit obtained in this fashion would be associated with a higher degree of confidence than the 95-percent confidence of the ranges. A one-sided limit would be more appropriate for the results of the performance test since the final prediction is to be in the form: "The reliability of the ordnance design is at least as great as . . .". Table 2.4 gives this one-sided 95-percent confidence limit as 74.13 percent when all ten trials are fires. Using this value the final prediction becomes: "The reliability of the item is at least 99.85 percent with Comp B and 99.96 percent with H-6. The complete VARICOMP process, going from calibration and performance test data to the final reliability estimate is shown as a composite graph in Figure 13.4B.

13.5 The estimate of the lower limit of the weapon reliability is made on the basis of a chain of independent conservative estimates:

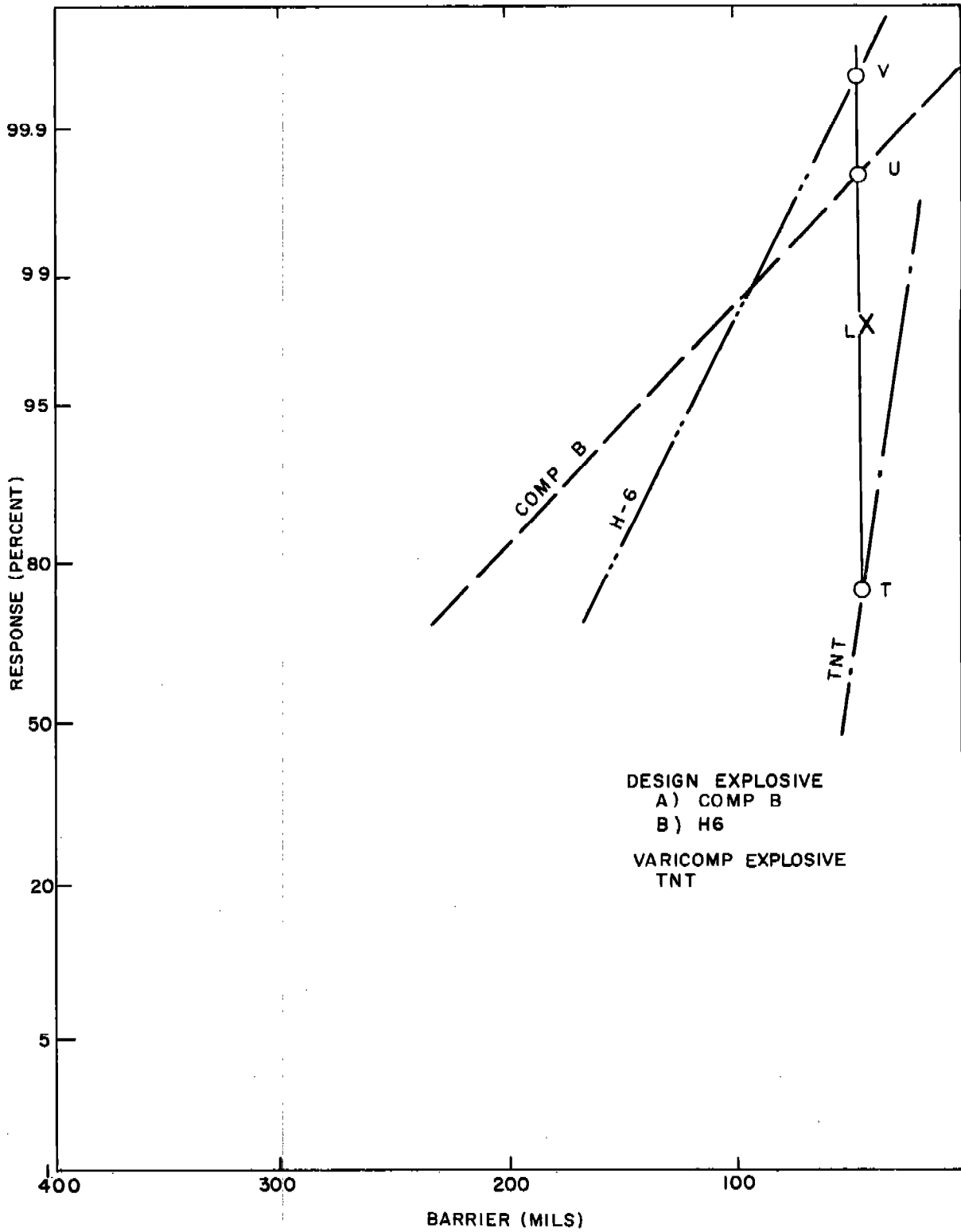

FIGURE 13.4 A PERFORMANCE TEST AND RELIABILITY ESTIMATE

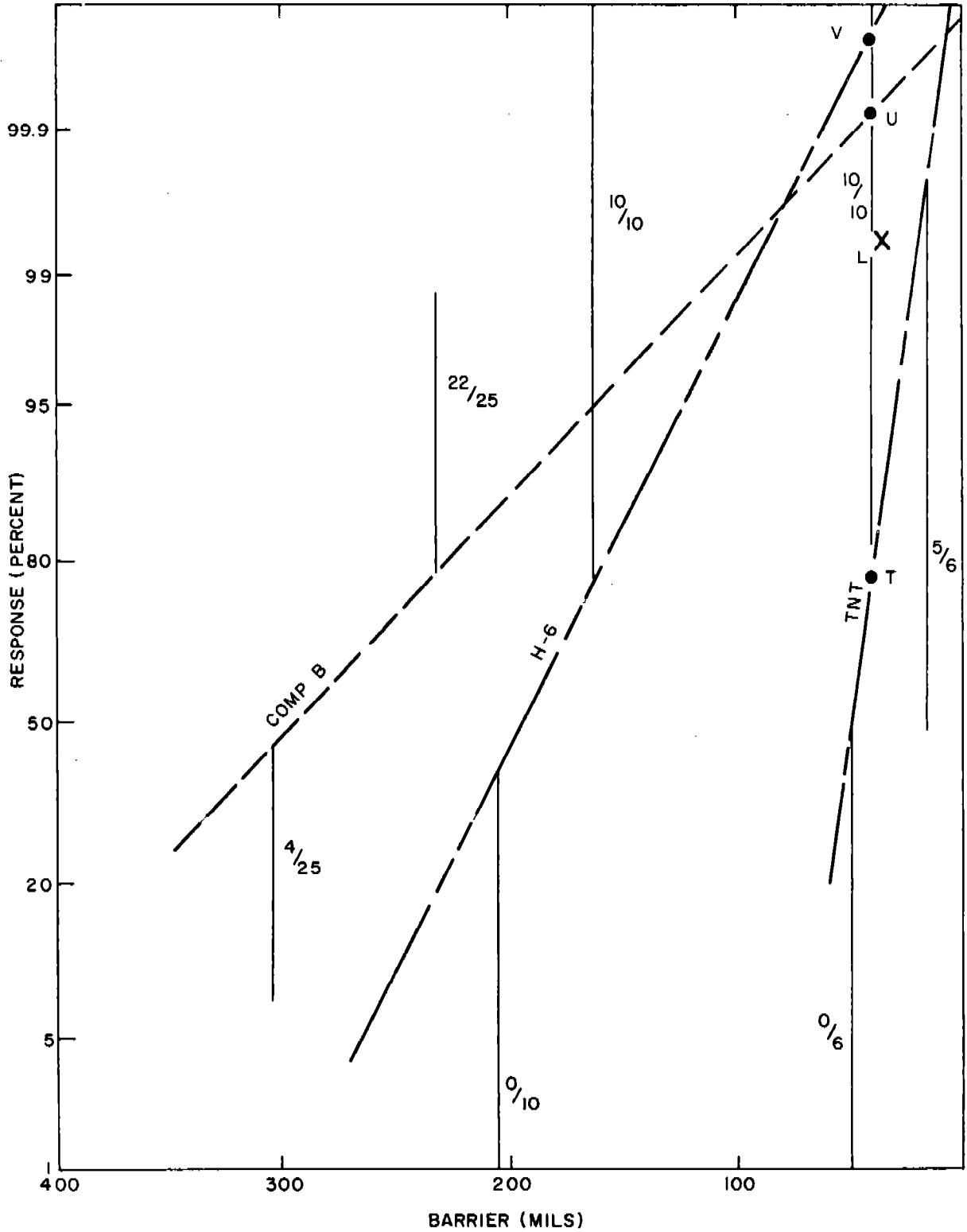

FIGURE 13.4 B CALIBRATION TESTS, PERFORMANCE TESTS, AND ESTIMATE OF RELIABILITY

NavWeaps Report 7411

Warhead explosive calibration--two separate 95-percent confidence estimates. TNT (VARICOMP explosive)--two separate 95-percent confidence estimates.

Performance test--one separate 95-percent confidence estimate.

Performance test configuration (judged to be more difficult to initiate than the warhead system)--one separate ? -percent confidence estimate.

The computation of the combined confidences is much less accessible in the present instance than as indicated in Paragraph 10.5. However, it is difficult to believe that the above circumstances can lead to anything but a highly conservative estimate--probably much higher than 95-percent confidence.

13.6 A higher reliability is indicated for H-6 than for Comp B even though comparison of the 50-percent points shows Comp B to be the more sensitive. The result is brought about by the apparent difference in the variability of the two explosives. An element of conservatism not pointed out in the previous discussion is the use of a linear scale for the barrier thickness as the measure of stimulus intensity. As has been mentioned in Paragraph 5.14, there is considerable evidence that the logarithm of the barrier thickness would fit the facts better than the linear scale. The effect of making the change from a linear to a logarithmic scale would be to accentuate the difference between the TNT and the design explosives. Thus, the final predictions would be much higher. They would, in fact, be greater than 99.99999 percent for either H-6 or Comp B as shown in Figure 13.6 which can be compared directly with Figure 13.4A. It is also worth noting that the design reliability would be high even if two of the ten trials in the performance test had been non-fires. In this case, the lower 95-percent confidence limit, given in Table 2.4, is 49.32 percent for TNT. The corresponding lower limits of design reliability are 99.8 percent for Comp B and 99.92 percent for H-6. The linear scale was used for the stimulus in this case.

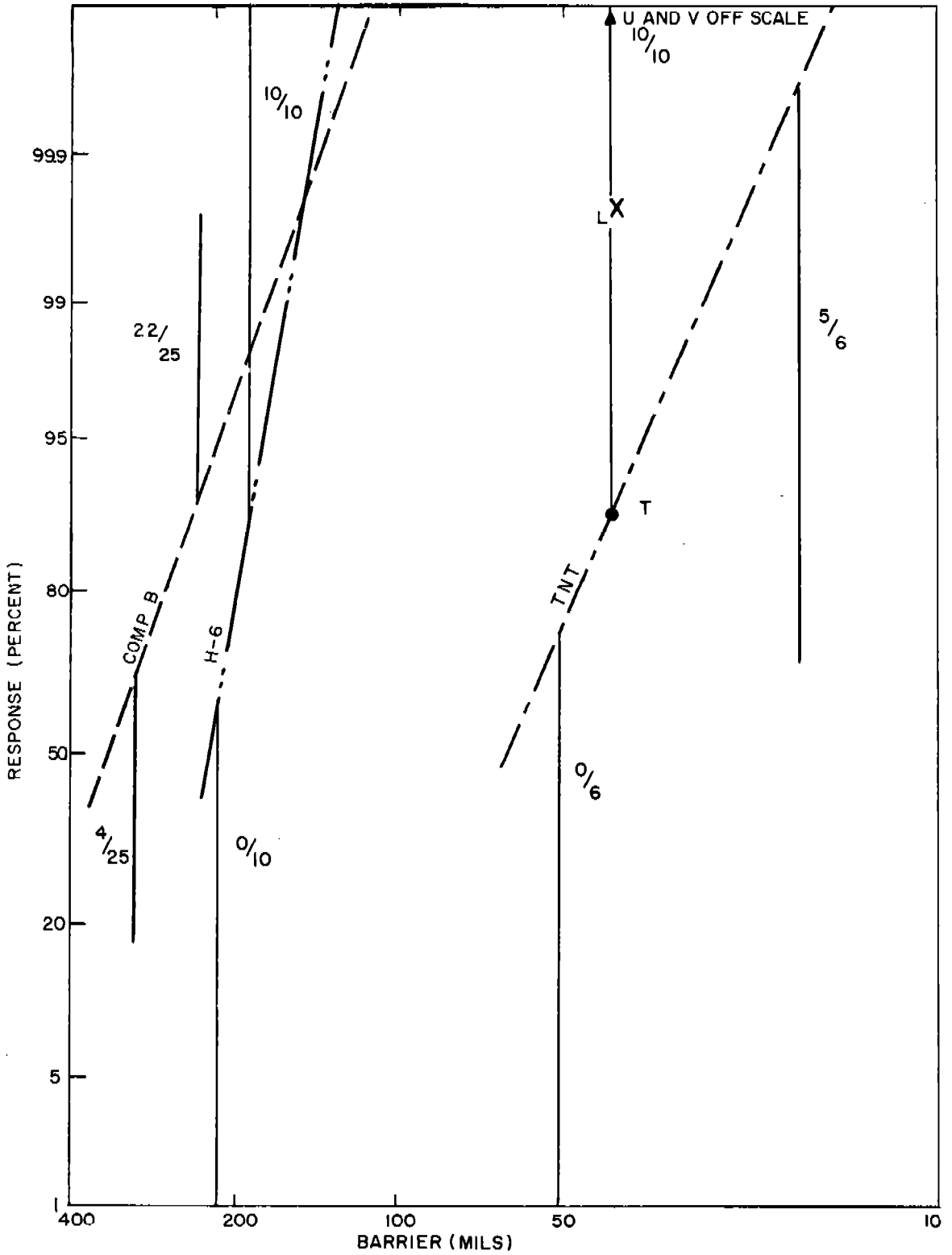

FIGURE 13.6 CALIBRATION TESTS, PERFORMANCE TESTS, AND ESTIMATE OF RELIABILITY BASED ON LOGARITHMIC DOSAGE-TO-STIMULUS TRANSFORM.

APPENDIX A

PROCEDURE FOR PREPARING A 100-POUND
BATCH OF DESENSITIZED RDX

A.1 Let X be the numerical value of the desired percentage of RDX in the final product.

A.2 Prepare an RDX-water slurry by adding X pounds of RDX (JAN-R-398 Type B, Class A) to $10X$ pounds of distilled water at 70 to 80° Centigrade.

A.3 Prepare a sodium stearate solution by dissolving $(100-X)$ pounds of sodium stearate (Technical Grade) in $(1300-13X)$ pounds of distilled water at 70 to 80° Centigrade.

A.4 Prepare a calcium chloride solution by dissolving $(75-0.75X)$ pounds of calcium chloride (O-C-104, Class 1) in $(1500-15X)$ pounds of distilled water at 70 to 80° Centigrade.

A.5 Add the sodium stearate solution to the RDX slurry with rapid stirring.

A.6 With rapid stirring, add the calcium chloride to the RDX-sodium stearate mixture (addition should take from 15 to 30 minutes).

A.7 Filter and wash with distilled water until the effluent wash water is free of chloride ion. This can be detected by testing the wash water with a silver nitrate solution.

A.8 Dry the filtered and washed product at 70° Centigrade on trays over steam coils.

NavWeps Report 7411

APPENDIX B

ANALYTIC PROCEDURE FOR RDX/CALCIUM STEARATE MIXES

B.1 Procedure

B.1.1 Sample size should be set to yield approximately 0.3 gram of calcium stearate after the extraction of the RDX. From the standpoint of safety an upper limit of 3- to 5-gram sample size is recommended.

B.1.2 Standard dry powder sampling and sample blending procedures should be employed.

B.1.3 Medium porosity sintered glass should be thoroughly washed, soaked in boiling acetone, dried and tared.

B.1.4 Sample should be weighed in the tared sintered glass crucible.

B.1.5 The weight loss by volatiles should be determined by weighing the sample and crucible after vacuum drying for one hour at 70° Centigrade and 50-millimeters Hg absolute pressure.

B.1.6 The RDX should be extracted by 8 washings of 20 milliliters each of boiling acetone. During each washing the sample should be triturated continuously with a tared glass stirring rod, in order to break all lumps.

B.1.7 The calcium stearate residue, crucible, and stirring rod should be vacuum dried for one hour at 70° Centigrade and 50-millimeters Hg absolute pressure.

B.1.8 The residue and glassware should be weighed after being allowed to cool for 30 minutes in a desiccator. The weight loss from the acetone extraction is taken as the amount of RDX and the weight of the residue as calcium stearate.

B.2 Precautionary Notes

B.2.1 Particularly above about 8 percent of calcium stearate the analysis becomes rather difficult and subject to gross error due to poor analytic technique. The error seems to be due to incomplete RDX extraction which apparently is due to the tendency of the calcium stearate to form a protective coating on the surface of the RDX particles. The obvious approach of increasing the amount of washing with hot acetone is not considered advisable because of the increased chance of loss of calcium stearate.

B.2.2 Particularly when there seems to be an unacceptably high volatile content, (above 0.2 percent should be viewed with suspicion) there may have not been adequate washing of the mix during its manufacture. In such cases the presence of calcium chloride should be suspected since such a material would lead to hygroscopicity of the mix.

B.2.3 At the present time a specific procedure has not been developed for the quantitative determination of the chloride ion. A number of approaches seem promising. Perhaps the best one is to perform a replicate analysis as above except for the inclusion of an extra step between steps B.1.5 and B.1.6 which would include a water wash followed by a vacuum drying and reweighing of the residue and a quantitative precipitation of chloride ion from the filtrate.

APPENDIX C

STANDARD DETONATION SENSITIVITY TESTS

C.1 As a matter of convenience to the reader, three of the standard sensitivity tests will be described to facilitate an understanding and comparison of test conditions.

C.2 The Small Scale Gap Test.

C.2.1 This test (15) is an arbitrary configuration to study the transfer of detonation between small-diameter charges loaded into heavy-walled containers. The initiating shock (derived from a standardized RDX-loaded donor) is varied by changing the thickness of lucite interposed between the donor and acceptor. The acceptor charges are 1.5 inches long and 0.2 inch in diameter, loaded into 1.0-inch diameter brass cylinders. Usually the explosive is in powder form and pressed into the acceptor at a pressure which will give a desired charge density. The firing is normally done at room temperature, but has been carried out at temperatures ranging from -60° Centigrade to +120° Centigrade.* The general arrangement and individual component configuration for the small scale gap test are shown in Figures C.2.1A and C.2.1B. The data are reported in units of DBg (Gap Decibang) which is taken as the proper dosage-to-stimulus transform. The DBg is computed by:

$$\text{DBg} = 10 \log \left\{ \frac{\text{reference gap in mils}}{\text{observed gap in mils}} \right\}$$

and with a reference gap of 1.00 inch,

$$\text{DBg} = 30 - 10 \log \left\{ \text{observed gap in mils} \right\}.$$

*The elevated temperatures were achieved by individual heating of each acceptor by means of a disposable nichrome wire heating jacket fashioned onto the acceptor body.

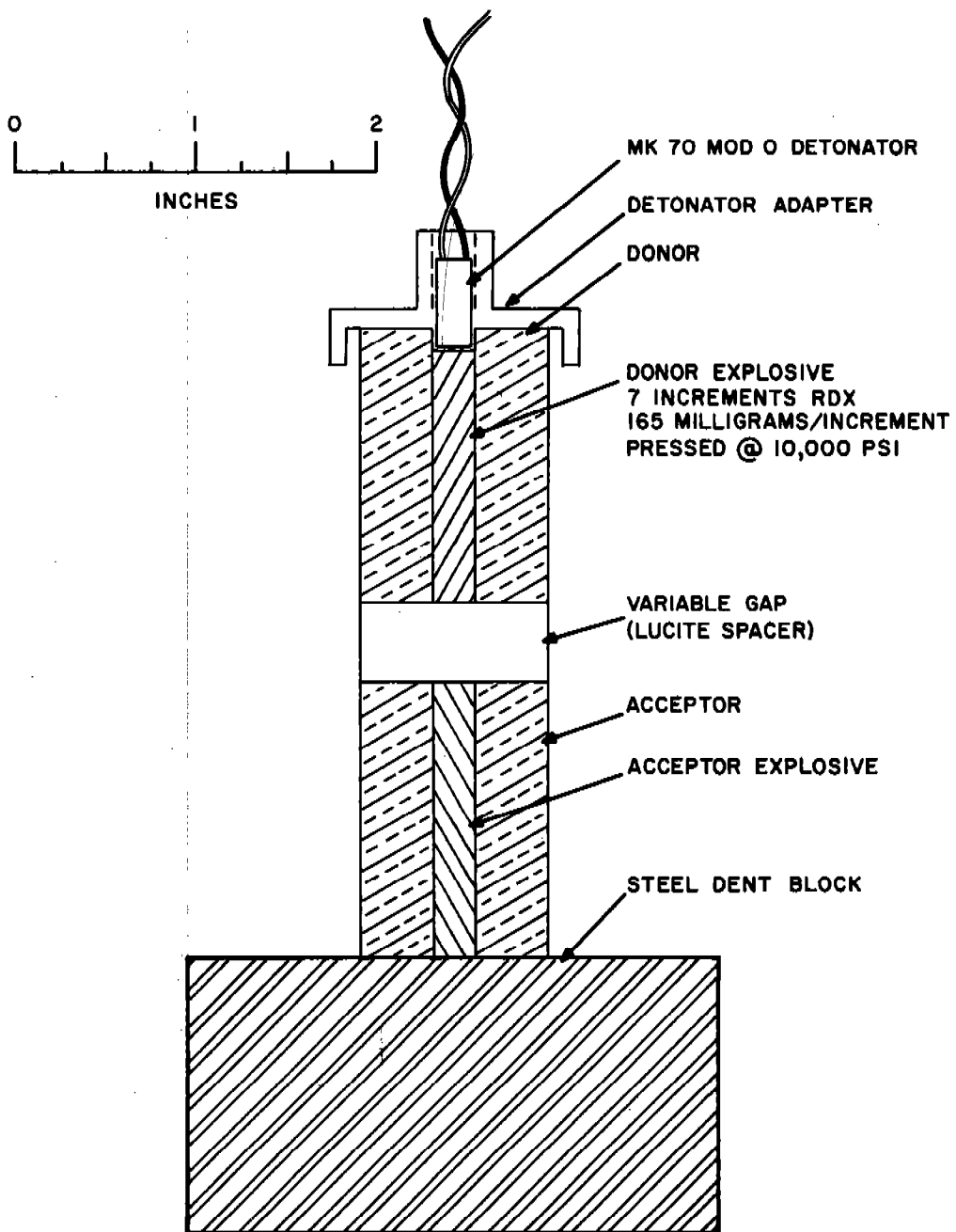

FIGURE C.2.1 A SMALL SCALE GAP TEST

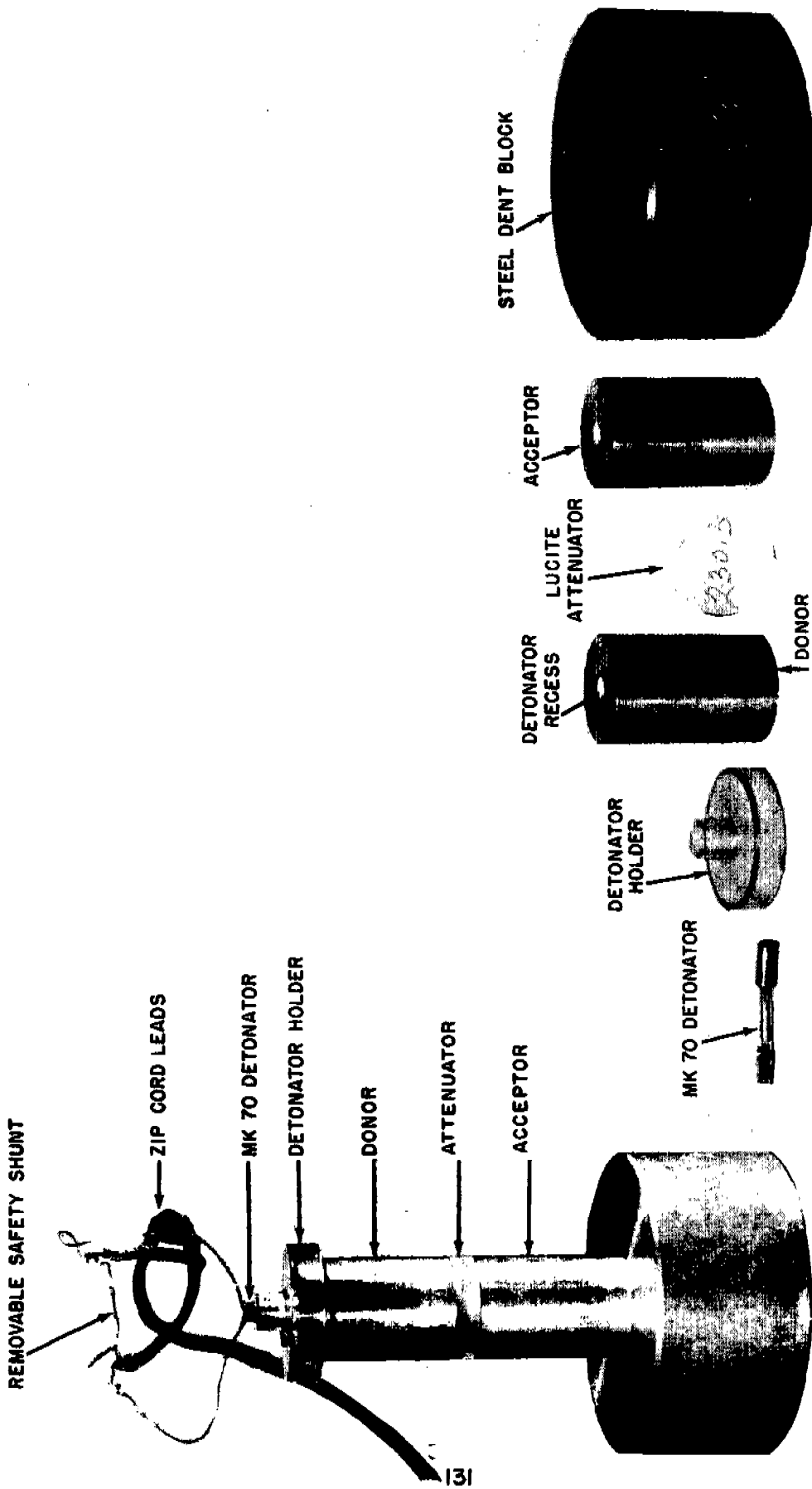

FIGURE C.2.1B SMALL SCALE GAP TEST SETUP

ASSEMBLED VIEW

C.2.2 The small scale gap test is most closely related to detonator-to-lead situations. Because the charges are bare-ended, and because the attenuation is achieved by a condensed medium rather than by an air gap, the input signal applied to the acceptor is almost pure detonation shock. In explosive trains the inert materials enclosing, or immediately surrounding, the donor charge often enter into the initiation process by being a source of high speed fragments. This difference may be very important particularly in safety considerations when fragments might occasionally cause initiation over unexpectedly large air gaps.

C.2.3 The small scale gap test is not well suited to explosive loading by casting or by molding at elevated temperatures. Although TNT and TNT bearing compositions have been cast into the acceptor bodies, there is strong reason to suspect that the crystal growth and arrangement would be grossly different from larger diameter cast charges. Cylinders of pre-cast or pre-molded material slipped into the acceptor are dubious representations of a realistic system since some air gap is to be expected between the cylindrical surfaces of the explosive pellet and the acceptor body wall. Such gaps, even if only a mil or so, would be expected to have significant effects on the way the explosive would accept and sustain detonation and might, therefore, give data representative of uncontrolled experimental conditions. As a stop-gap measure it might be possible to fill the airspace by coating the pellets with a grease which would be much closer to explosive hydrodynamically than an air filled void.

C.3 NOL Booster Sensitivity Test.

C.3.1 This test (Figure C.3.1) has been in use for about 15 years. The acceptor charge size was selected to be large enough to suppress effects due to failure diameter and to build up to detonation. The wax spacer was cast in the 1 5/8-inch diameter and machined to length. The spacer lengths were normally made in 0.05-inch steps, and where possible in one piece for each test rather than stacked up to the desired length.

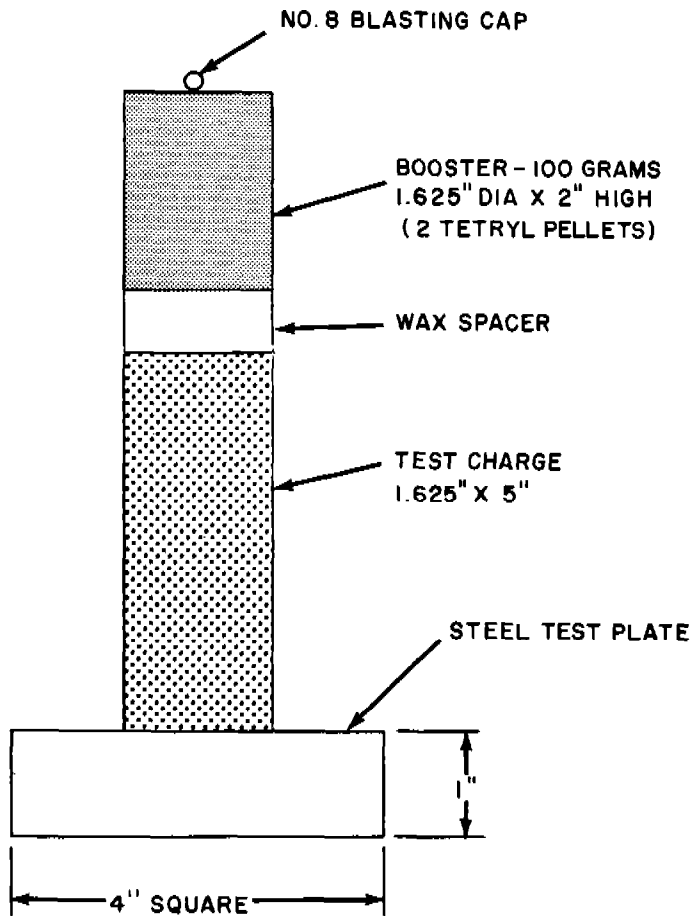

FIGURE C.3.1 NOL BOOSTER SENSITIVITY TEST

C.3.2 This test is suitable for those explosives which when cast, pressed or molded will form a charge which will have sufficient mechanical strength to support itself and the initiator-booster-attenuator assembly above it. The test has been run in a modified form to test liquid assemblies. The test arrangement is inverted with the test explosive being poured into a wax-coated and wax-sealed cardboard tube which rests on the wax gap attenuators and which in turn supports the steel witness plate. Presumably powders or fragile pressed pellets might be tested in similar fashion.

C.4 Propellant Sensitivity Test. The propellant sensitivity test is described in reference 20. The experimental set-up is shown in Figure C.4.1. It is quite similar to the NOL booster sensitivity test described in reference 18 and in Appendix C.3. The wax spacer is replaced by a suitable number of cellulose acetate cards 0.010 inch thick. The acceptor propellant or explosive is confined in a steel tube rather than being unconfined as in the booster sensitivity test. The donor consists of two tetryl pellets 1.0 inch thick with a diameter of 2.0 inches pressed to a density of 1.63 gm/cc. The weight of each pellet would be about 84 grams. Although used principally to determine the sensitivities of propellants it has also been used to some extent to measure the sensitivities of high explosives.

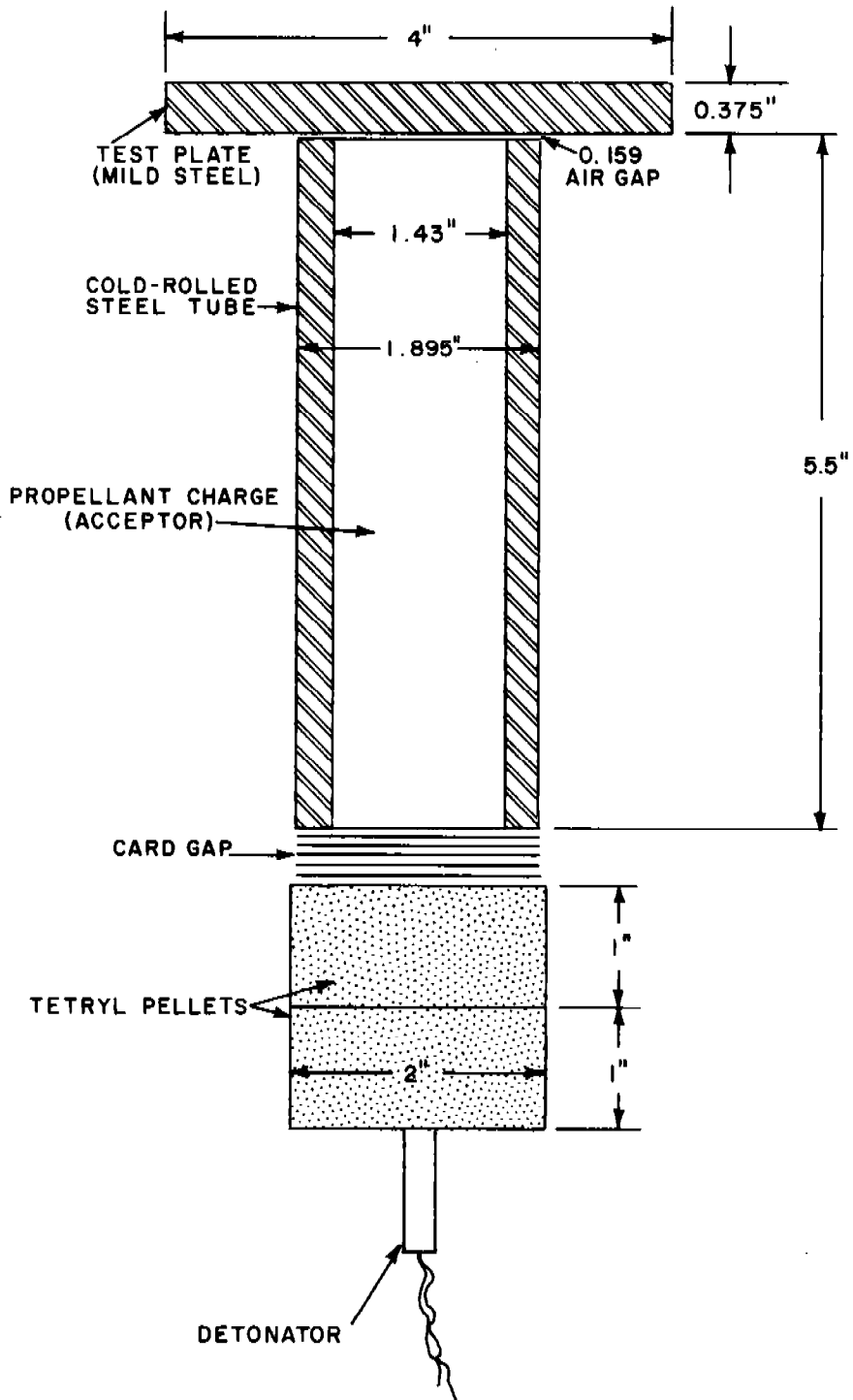

FIGURE C.4.1 NOL PROPELLANT SENSITIVITY TEST

APPENDIX D

MONTE CARLO EXPERIMENT TO ASSESS ERRORS
DUE TO UNEQUAL SPACING OF EXPLOSIVES

D.1 It was assumed that there was a series of explosives whose 50-percent points differed from equal spacing by amounts which were randomly distributed according to the normal law.

A table of random numbers was used to determine a group of such difference--amounts chosen from a population having a mean of zero and a known standard deviation. These errors were then added to the intended 50-percent values for a set of VARICOMP explosives to give a set of true 50-percent values. The results which could be expected, if these explosives were used for the steps of a Bruceton test, were then computed. The difference between the mean thus obtained and that which would be expected, had the steps been equally spaced, was noted. This was done ten times for each of four different combinations of step size and standard deviation of the random difference-amounts. The standard deviation of these difference-amounts was assigned values from one-twentieth to one-fifth of the distance between steps. For each of the four groups the standard deviation of the shift in the mean of the test caused by the irregular spacing was computed. The smallest of these was one-fifteenth and the largest slightly more than one-tenth of a step. Although not enough work was done to be able to make a very definite statement it would seem that the effect of this type of error would be small if the standard deviation of the difference-amounts of the 50-percent points of the VARICOMP explosives was less than one-tenth of the difference between two consecutive explosives. However, it would be appreciable if this standard deviation became as large as one-fifth of the step size. A more extended investigation would make it possible to make a more definite statement of the magnitude of this effect.

APPENDIX E

Table E-1

Relationship between Normit, Probability,
Ordinate, and Weighting Factor

<u>Normits*</u>	<u>P</u> <u>(Probability)</u>	<u>z</u> <u>(ordinate)</u>	<u>z²</u>	<u>W</u> <u>(weighting factor</u> <u>= $\frac{z^2}{p \cdot q}$)</u>
0	0.5000	0.399	0.1592	0.6366
0.1	0.5398	0.397	0.1576	0.6343
0.2	0.5793	0.391	0.1529	0.6274
0.3	0.6179	0.381	0.1455	0.6161
0.4	0.6554	0.368	0.1356	0.6005
0.5	0.6915	0.352	0.1240	0.5810
0.6	0.7258	0.333	0.1110	0.5579
0.7	0.7580	0.312	0.0975	0.5316
0.8	0.7881	0.290	0.0839	0.5026
0.9	0.8159	0.266	0.0708	0.4714
1.0	0.8413	0.242	0.0586	0.4386
1.1	0.8643	0.218	0.0475	0.4047
1.2	0.8849	0.194	0.0377	0.3703
1.3	0.9032	0.171	0.0294	0.3359
1.4	0.9192	0.150	0.0224	0.3020
1.5	0.9332	0.130	0.0168	0.2691
1.6	0.9452	0.111	0.0123	0.2375
1.7	0.9554	0.0940	0.00885	0.2077
1.8	0.9641	0.0790	0.00623	0.1799
1.9	0.9713	0.0656	0.00431	0.1544
2.0	0.9773	0.0540	0.00292	0.1311
2.1	0.9821	0.0440	0.00193	0.1103
2.2	0.9861	0.0355	0.00126	0.0918
2.3	0.9893	0.0283	0.00080	0.0756
2.4	0.9918	0.0224	0.00050	0.0617
2.5	0.9938	0.0175	0.00031	0.0498
2.6	0.9953	0.0136	0.00018	0.0398
2.7	0.9965	0.0104	0.00011	0.0314
2.8	0.9974	0.0079	0.00006	0.0246
2.9	0.9981	0.0060	0.00004	0.0190
3.0	0.9987	0.0044	0.00002	0.0146

*Relationship between normit and probit is:

$$\text{Probit} = \text{normit} + 5 .$$

Table E-2
 Cumulative "Student's" Distribution

n ^F	0.75	0.90	0.95	0.99
1	1.000	3.078	6.314	31.821
2	0.816	1.886	2.920	6.965
3	0.765	1.638	2.353	4.541
4	0.741	1.533	2.132	3.747
5	0.727	1.476	2.015	3.365
6	0.718	1.440	1.943	3.143
7	0.711	1.415	1.895	2.998
8	0.706	1.397	1.860	2.896
9	0.703	1.383	1.833	2.821
10	0.700	1.372	1.812	2.764
11	0.697	1.363	1.796	2.718
12	0.695	1.356	1.782	2.681
13	0.694	1.350	1.771	2.650
14	0.692	1.345	1.761	2.624
15	0.691	1.341	1.753	2.602
16	0.690	1.337	1.746	2.583
17	0.689	1.333	1.740	2.567
18	0.688	1.330	1.734	2.552
19	0.688	1.328	1.729	2.539
20	0.687	1.325	1.725	2.528
21	0.686	1.323	1.721	2.518
22	0.686	1.321	1.717	2.508
23	0.685	1.319	1.714	2.500
24	0.685	1.318	1.711	2.492
25	0.684	1.316	1.708	2.485
26	0.684	1.315	1.706	2.479
27	0.684	1.314	1.703	2.473
28	0.683	1.313	1.701	2.467
29	0.683	1.311	1.699	2.462
30	0.683	1.310	1.697	2.457
40	0.681	1.303	1.684	2.423
60	0.679	1.296	1.671	2.390
120	0.677	1.289	1.658	2.358
∞	0.674	1.282	1.645	2.326

Table E-3
 95-Percent Confidence Single-Sided Estimate
 Lower Limit of the Reliability, R , for
 Sample Sizes of 20 or Less

SUCCESSES TRIALS	1	2	3	4	5	6	7	8	9	10	11	12	13	14	15	16	17	18	19	20
1	5.00																			
2	2.54	22.37	36.86																	
3	1.70	13.53	24.88	47.28																
4	1.27	9.77	18.94	34.25	54.94															
5	1.02	7.65	15.31	27.14	41.81	60.67														
6	0.85	6.29	12.88	22.52	34.11	47.92	65.18													
7	0.73	5.34	11.11	19.28	28.94	40.00	52.95	68.79												
8	0.64	4.64	9.77	16.89	25.13	34.48	45.02	57.06	71.71											
9	0.57	4.11	8.73	14.99	22.26	30.38	39.33	49.32	60.56	74.13										
10	0.51	3.68	7.87	13.51	19.98	27.10	35.00	43.52	53.00	63.53	76.18									
11	0.46	3.33	7.19	12.28	18.09	24.51	31.56	39.12	47.27	56.18	66.11	77.92								
12	0.43	3.04	6.60	11.27	16.56	22.39	28.74	35.52	42.76	50.51	58.98	68.34	79.41							
13	0.39	2.81	6.11	10.41	15.29	20.60	26.40	32.53	39.06	45.98	53.40	61.44	70.35	80.74						
14	0.36	2.60	5.68	9.65	14.16	19.11	24.40	30.03	35.96	42.23	48.89	55.97	63.69	72.09	81.88					
15	0.34	2.42	5.31	9.03	13.20	17.79	22.65	27.87	33.33	39.15	45.12	51.61	58.35	65.57	73.60	82.94				
16	0.32	2.27	5.03	8.46	12.39	16.61	21.17	25.97	31.06	36.44	42.00	47.85	53.94	60.45	67.39	74.98	83.83			
17	0.30	2.13	4.70	7.97	11.64	15.64	19.89	24.43	30.00	34.07	39.23	44.59	50.19	56.11	62.29	68.97	76.23	84.67		
18	0.28	2.01	4.45	7.53	10.99	14.73	18.77	22.94	27.38	32.05	36.79	41.78	47.05	52.40	58.14	64.10	70.42	77.39	85.43	
19	0.27	1.90	4.21	7.14	10.41	13.94	17.73	21.70	25.86	30.21	34.70	39.41	44.22	49.26	54.47	59.93	65.59	71.77	78.38	86.10
20	0.26	1.81	4.02	6.81	10.00	13.00	16.50	20.00	24.00	28.00	32.00	36.00	40.00	44.00	48.00	52.00	56.00	60.00	64.00	68.00

Reliability Entries in the Body of the Table are Expressed in Percent.

NavWeps Report 7411

REFERENCES

1. H. E. Lacey, D. W. Sencenbaugh, "A Natural Approach to the Calculation of Systems Reliability", NavOrd Report 5660, 31 October 1957
2. "A Study of Methods for Achieving Reliability of Guided Missiles", NAMTC Technical Report No. 75, 10 July 1950, Restricted
3. D. E. Allmand, J. H. Armstrong, R. H. Blair, E. W. Blevins, A. H. Corbin, and M. B. Rowan, "Relative Accident Reliability Analysis", NavOrd Report 4135, 1 November 1955, Confidential
4. H. P. Culling, "Statistical Methods for Evaluation of Fuze Explosive Train Safety and Reliability", NavOrd Report 2101, 13 October 1953 (U. S. Department of Commerce, OTS, PB 122070)
5. L. D. Hampton, W. M. Slie, and R. H. Stresau, "Direct Initiation of Boosters by Electric Initiators", NavOrd Report 2815, 13 March 1953, Confidential
6. L. D. Hampton, "Comparative Sensitivity of Tetryl and of RDX/Wax Mixtures as Booster Explosives", NavOrd Report 3551, 14 October 1953, Confidential
7. W. J. Dixon, F. J. Massey, Jr., "Introduction to Statistical Analysis", McGraw-Hill Book Company, Inc., New York, N. Y.
8. R. H. Stresau, Jr., L. E. Starr, Jr., "Some Studies of the Propagation of Detonation Between Small Confined Explosive Charges", NOLM 10577, 15 July 1950, Confidential
9. R. H. Stresau, L. D. Hampton, and L. E. Starr, "Boostering Requirements of Mines", NavOrd Report 4277, 7 August 1956 Confidential
10. R. L. Graumann, A. E. Robertson, "The Effect of Air Gaps on the Initiation of a Lead by a Detonator", NOLM 9707 25 June 1956, Confidential
11. L. D. Hampton, "Sensitivity and Pelleting Characteristics of Certain Desensitized RDX Mixtures", NavOrd Report 4320, 25 June 1956, Confidential
12. F. P. Bowden, et.al.,
Proceeding of the Royal Society, A 246, 146-247, 1958

NavWeps Report 7411

REFERENCES

13. "Proceeding of the Gilbert B. L. Smith Memorial Conference on Explosive Sensitivity", Edited by R. McGill and P. L. Holt, NavOrd Report 5746, 2 June 1958, Confidential
14. Third Detonation Symposium on Detonation, James Forrestal Research Center, Princeton University, 26-28 September 1960, Office of Naval Research Symposium Report ARC-52, Volumes 1 and 2, Unclassified, and Volume 3, Confidential
15. J. N. Ayres, "Standardization of the Small Scale Gap Test", NavWeps Report 7342, 16 January 1961
16. E. H. Eyster, R. F. Davis, "Sensitivity Studies with the Drop-Weight Impact Machine", OSRD 5744, 19 November 1945, Confidential, "Booster Sensitivity Test", OSRD 5746, Confidential
17. E. H. Eyster, L. C. Smith, "Studies of the ERL Type 12 Drop Weight Impact Machine at NOL", NOLM 10,003, 25 January 1949, Confidential
18. E. H. Eyster, L. C. Smith, and S. R. Walton, "The Sensitivity of High Explosives to Pure Shocks", NOLM 10,336, 14 July 1949, Confidential
19. J. H. Majowicz, S. J. Jacobs, "Initiation to Detonation of High Explosives by Pure Shocks", NavOrd Report 5710, 1 March 1958, Confidential
20. A. B. Amster, R. L. Beauregarde, G. J. Bryan, and E. K. Lawrence, "Detonability of Solid Propellants; I. Test Methods and Instrumentation", NavOrd Report 5788, 3 February 1958
21. H. Dean Mallory, "The Development of Impact Sensitivity Tests at the Explosives Research Laboratory, Bruceton Pennsylvania, During the Years 1941-1945", NavOrd Report 4236, 16 March 1956, Confidential
22. Statistical Research Group, Princeton University, "Statistical Analysis for a New Procedure in Sensitivity Experiments", AMP Report 101.1R, SRG-P No. 40, (OSRD Report 4040) July 1944
23. D. J. Finney, "Probit Analysis, A Statistical Treatment of the Sigmoid Response Curve", Cambridge at the University Press, 1952.

NavWeps Report 7411

REFERENCES

24. J. Savitt, "Some Observations on the Growth of Detonations", NavOrd Report 3753, 25 August 1954, Confidential
25. J. Berkson, "A Statistically Precise and Relatively Simple Method of Estimating the Bio-Assay with Quantal Response, Based on the Logistic Distribution Function", Journal of the American Statistical Association, 48, 565-599, September 1953
26. R. A. Fisher, F. Yates, "Statistical Tables for Biological, Agricultural, and Medical Research", Introduction, Oliver and Boyd, Edinburgh, 1938
27. M. S. Bartlett, "The Use of Transformations", Biometrics, Volume 3, No. 1, 22 - 38, March 1947
28. W. M. Slie, R. H. F. Stresau, "Small Scale Dent Tests for Confined Charges", NavOrd Report 2422, 23 April 1952, Confidential
29. W. J. Dixon, A. M. Mood, "A Method for Obtaining and Analyzing Sensitivity Data", Journal of the American Statistical Association, 43, 109 - 126, March 1948
30. T. W. Anderson, P. J. McCarthy, and J. W. Tukey, "'Staircase' Method of Sensitivity Testing", NavOrd Report 65-46, 21 March 1946
31. M. S. Bartlett, "A Modified Probit Technique for Small Probabilities", Supplement, Journal Royal Statistical Society, Volume VIII, No. 1, p 113, 1946
32. J. Savitt, "The Propagation of Detonation in Some Special Explosive Systems", NavOrd Report 2844, 13 April 1953, Confidential
33. L. D. Hampton, "The Effects of Gate Size on the Reliability of a Leadless Fuze", NavOrd Report 3628, 29 January 1954, Confidential
34. J. N. Ayres, "The Effect of Composition and Density on the Sensitivity and the Output of DATB and DATB/Zytel 95/5 (U)", NavWeps Report 7348, 15 January 1961, Confidential
35. M. J. Kamlet, "Variation of Heat of Detonation with Oxidant Balance for Structurally Related Compounds", NavOrd Report 6117, 21 September 1958, Confidential

REFERENCES

36. M. J. Kamlet, "A Correlation of Impact Sensitivities of Explosives with Oxidant Balances", NavOrd Report 6126, 26 September 1958, Confidential
37. J. Berkson, "Estimate of the Integrated Normal Curve by Minimum Normit Chi-Square with Particular Reference to Bio-Assay", Journal of the American Statistical Association, 50, 529-549, 1955
38. "Explosion Effects Data Sheets", NavOrd Report 2986, 14 June 1955, Confidential
39. George Svedeba, "Sensitivity of Explosives to Impact, Period 1 May 1952 through 1 July 1953", NavOrd Report 2940, 1 July 1953, Confidential
40. George Svedeba and Sarah Duck, "Sensitivity of Explosives to Impact, Period 1 July 1953 through 1 November 1954", NavOrd Report 3955, 27 November 1955, Confidential
41. R. A. Clairmont, Jr., I. Jaffe, D. Price, and G. Roberson, "Large Scale Gap Test: Interpretation of Results for Propellants", NavWeps Report 7401, 15 March 1961, Confidential
42. R. M. McClung, "First Aid for Pet Projects Injured in the Laboratory or on the Range, or What to Do Until the Statistician Comes", NOTS Technical Memo 1113, 29 January 1952

NavWeps Report 7411

DISTRIBUTION LIST

	Copies
Chief, Bureau of Naval Weapons Department of Navy Washington 25, D. C.	
DIS-32	2
RRRE-8	1
RUME-3	1
RUME-32	1
RMMO-2	1
RMMO-5	1
RREN-312	1
 Director Special Projects Office Department of Navy Washington 25, D. C.	
SP-27	1
Code 20	1
 Chief Bureau of Ships Department of Navy Washington 25, D. C.	
	2
 Chief Bureau of Yards and Docks Department of Navy Washington 25, D. C.	
	1
 Chief of Naval Research Department of Navy Washington 25, D. C. Chemistry Branch	
	2
 Commander Operational Development Force U. S. Atlantic Fleet U. S. Naval Base Norfolk 11, Virginia	
	2
 Commander U. S. Naval Ordnance Test Station China Lake, California	
Code 556	1
Code 4572	1
Technical Library	2
B. A. Breslow	1
J. Sherman	1

NavWeps Report 7411

	Copies
Director Naval Research Laboratory Washington 25, D. C. Technical Information Section	2
Commander Naval Air Development Center Johnsville, Pennsylvania Aviation Armament Laboratory	1
Commander U. S. Naval Weapons Laboratory Dahlgren, Virginia Technical Library J. Payne L. Pruett P. Altman J. Gray Weapons Department Terminal Ballistics Department	2 1 1 1 1 1 1
Commander U. S. Navy Electronics Laboratory San Diego, California	1
Commandant U. S. Marine Corps Washington 25, D. C.	1
Commanding Officer U. S. Naval Weapons Station Yorktown, Virginia R & D Division	2
Commanding Officer U. S. Naval Ordnance Laboratory Corona, California	5
Commanding Officer U. S. Naval Propellant Plant Indian Head, Maryland Technical Library EODTC	1 1
Commander Naval Radiological Defense Laboratory San Francisco, California R. Schnider	1

NavWeps Report 7411

	Copies
Commander Pacific Missile Range Point Mugu, California	1
Superintendent Naval Post Graduate School Monterey, California	1
Commanding Officer Naval Ammunition Depot Crane, Indiana	1
Commanding Officer U. S. Naval Ordnance Plant Macon, Georgia	1
Commanding Officer U. S. Naval Ammunition Depot McAlester, Oklahoma R. E. Halpern	1
Commanding Officer U. S. Naval Ammunition Depot Waipale Branch Oahu, Hawaii Special Projects Officer Quality Evaluation Laboratory	1
Commanding Officer U. S. Naval Ammunition Depot Navy Number Six Six (66) c/o Fleet Post Office San Francisco, California	1
Commanding Officer U. S. Naval Ammunition Depot Bangor, Maine Quality Evaluation Laboratory	1
Commanding Officer U. S. Naval Ammunition Depot Concord, California Quality Evaluation Laboratory	1
Commanding Officer U. S. Naval Underwater Ordnance Station Newport, Rhode Island	1

NavWeps Report 7411

	Copies
Commanding Officer Naval Torpedo Station Keyport, Washington	1
Commanding Officer U. S. Naval Weapons Evaluation Facility Kirtland Air Force Base Albuquerque, New Mexico	1
Office of Chief of Ordnance Department of Army Washington 25, D. C.	
ORDGU	1
ORDTB	1
ORDTN	1
Office of Chief of Engineers Department of Army Washington 25, D. C.	
ENGNE	1
ENGEB	1
Commanding General Picatinny Arsenal Dover, New Jersey	
ORDBB-TH8, Technical Information	1
ORDBB-TJ1, H.E. Section	1
ORDBB-TK3, Prop. and Expl. Unit	1
ORDBB-TM1, Chem. Res. Section	1
ORDBB-TP1, Proj. Fuze Section	1
ORDBB-TP2, GM, Rocket and Bomb Fuze	1
ORDBB-TP3, Init. and Spec Dev.	2
ORDBB-TR2, Phys. Res. Section	1
ORDBB-TS1, Pyrotech. Lab.	1
Commanding Officer Diamond Ordnance Fuze Laboratory Connecticut Avenue & Van Ness St., N. W. Washington 25, D. C.	
Ordnance Development Laboratory M. Lipnick (Code 005)	1 1
Commanding Officer Office of Ordnance Research Box CM Duke Station Durham, North Carolina	1

NavWeps Report 7411

	Copies
Commanding Officer Rock Island Arsenal Rock Island, Illinois	1
Commanding Officer Chemical Corps Chemical & Radiological Laboratory Army Chemical Center Maryland	1
Commanding Officer Engineer Research & Development Laboratory U. S. Army Ft. Belvoir, Virginia Technical Intelligence Branch	1
Commanding Officer Fort Dietrick Maryland	1
Commanding General U. S. Army Ordnance Ammunition Center Joliet, Illinois	1
Commanding General U. S. Army Proving Ground Aberdeen, Maryland BRL	1 1
Commanding General Frankford Arsenal Philadelphia 37, Pennsylvania S. Picoli	1
Commanding Officer Holston Ordnance Works Kingsport, Tennessee	1
Commanding General Redstone Arsenal Huntsville, Alabama Technical Library	1
Commander Army Rocket & Guided Missile Agency Redstone Arsenal, Alabama ORDXR-RH	1

NavWeps Report 7411

	Copies
Commander Ordnance Corps Lake City Arsenal Independence, Missouri Industrial Engineering Division	1
Commanding General White Sands Proving Ground White Sands, New Mexico	1
Chief of Staff U. S. Air Force Washington 25, D. C. AFORD-AR	1
Wright Air Development Division Wright-Patterson Air Force Base Ohio WWAD	2
Headquarters Air Proving Ground Center U. S. Air Force, ARDC Eglin Air Force Base, Florida Attn: PGTRI, Technical Library	1
Commander Air Research & Development Command Andrews Air Force Base Washington 25, D. C.	1
Commander Rome Air Development Center Griffis Air Force Base Rome, New York	1
Commander Holloman Air Development Center Alamagordo, New Mexico	1
Commanding Officer Air Force Missile Test Center Patrick Air Force Base Florida	1

NavWeps Report 7411

	Copies
Commander Air Force Cambridge Research Center L. G. Hanscom Field Bedford, Massachusetts	1
Commander Hill Air Force Base Utah OOAMA	1
Hanscom Air Force Base Massachusetts AFCCDD	1
CCSEI-1	1
Capt. Long	1
Armed Services Technical Information Agency Arlington Hall Station Arlington, Virginia TIPDR	10
Office of Technical Services Department of Commerce Washington 25, D. C.	100
Atomic Energy Commission Washington 25, D. C. DMA	1
Chief Defense Atomic Support Agency Washington 25, D. C.	1
Director U. S. Bureau of Mines Division of Explosive Technology 4800 Forbes Street Pittsburgh 13, Pennsylvania	1
Director USAF Project RAND (Via USAF Liaison Office) The Rand Corporation 1700 Main Street Santa Monica, California	1

NavWeps Report 7411

	Copies
Lawrence Radiation Laboratory University of California P. O. Box 808 Livermore, California Technical Information Division	1
Director Los Alamos Scientific Laboratory P. O. Box 1663 Los Alamos, New Mexico	1
National Aeronautics and Space Administration Headquarters 1520 H Street, N. W. Washington 25, D. C.	1
National Aeronautics and Space Administration Goddard Space Flight Center Greenbelt, Maryland	1
Lewis Research Center, N.A.S.A. 21,000 Brookpark Road Cleveland 35, Ohio Library	1
Director Applied Physics Laboratory Johns Hopkins University 8621 Georgia Avenue Silver Spring, Maryland Solid Propellants Agency	2 1
Sandia Corporation P. O. Box 5400 Albuquerque, New Mexico	1
Sandia Corporation P. O. Box 969 Livermore, California	1
Director Waterways Experiment Station Vicksburg, Tennessee	1
American Potash and Chemical Corporation National Northern Division P. O. Box 175 West Hanover, Massachusetts Mr. J. A. Smith, Security Officer	1

NavWeps Report 7411

	Copies
Armour Research Foundation Technology Center Illinois Institute of Technology 10 West 35th Street Chicago 16, Illinois	1
Alleghany Ballistics Laboratory Cumberland, Maryland	1
Arthur D. Little, Inc. 30 Memorial Drive Cambridge 42, Massachusetts Dr. G. R. Handrick Reports Library, V. Vabri	1 1
Aerojet-General Corporation Ordnance Division Downey, California Dr. Louis Zernow	1
Bermite Powder Company Saugus, California	1
Denver Research Institute University of Denver Denver 10, Colorado	1
E. I. duPont deNemours Eastern Laboratories Explosives Department Gibbstown, New Jersey Dr. L. Coursen	1
The Franklin Institute 20th Street & Benjamin Franklin Parkway Philadelphia 3, Pennsylvania Project TA1-2707 AA (Mr. Gunther Cohn)	1
Hercules Powder Company Experiment Station Wilmington, Delaware J. Roth Dr. Lawrence	1 1

NavWeps Report 7411

	Copies
Hercules Powder Company Port Ewen, New York C. Wood G. Scherer	1 1
Librascope-Sunnyvale 670 Arques Avenue Sunnyvale, California	1
Lockheed Aircraft Corporation P. O. Box 504 Sunnyvale, California	1
Stanford Research Institute Poulter Laboratories Menlo Park, California	1
University of Utah Salt Lake City, Utah Dr. Melvin Cook, Explosive Research Group	1
Universal Match Corporation Marion, Illinois	1
Western Cartridge Company Division of Olin Industries East Alton, Illinois	1
Bulova Research and Development Inc. 52-10 Woodside Avenue Woodside 77, New York	1
General Electric Company Missile and Ordnance Systems Department 2198 Chestnut Street Philadelphia, Pennsylvania T. W. Kennedy	1
Elgin National Watch Company Micronics Division 21001 Nordhoff Chatsworth, California	1
Hamilton Watch Company Allied Products Division Lancaster, Pennsylvania	1

NavWeps Report 7411

	Copies
The Martin Company 815 Elwell Street Orlando, Florida	1
McDonnell Aircraft Corporation P. O. Box 516 St. Louis, Missouri	1
U. S. Flare Division Atlantic Research Corporation 19701 W. Goodvale Road Saugus, California	1
Daystrom Electric Corporation 229-A Manchester Road Poughkeepsie, New York	1

Naval Ordnance Laboratory, White Oak, Md.
 (NAVWEPs report 7411)
 VARICOMP, A METHOD FOR DETERMINING DETONATION-TRANSFER PROBABILITIES (U), by J.N. Ayres and others. 30 June 1961. 143p.
 Project RUM#3E012/212 1/FOOS/10004.

1. Explosives - Sensitivity
2. Explosives - Detonation
3. Explosive trains
4. Detonation - Probabilities
5. VARICOMP
- I. Title
- II. Ayres, J.N.
- III. Project

VARICOMP is a method for determining the detonation-transfer probabilities of an explosive train by substitution of explosive(s) of varied sensitivities or energies for the design explosive. These substituted-VARICOMP-explosives (whose response or output probability distribution functions have been calibrated relative to the design explosive) are used to measure the explosive drive inherent in the design system. Methods of calibrating explosives and carrying out VARICOMP performance tests are given along with statistical procedures for combining performance test and calibration data.

Naval Ordnance Laboratory, White Oak, Md.
 (NAVWEPs report 7411)
 VARICOMP, A METHOD FOR DETERMINING DETONATION-TRANSFER PROBABILITIES (U), by J.N. Ayres and others. 30 June 1961. 143p.
 Project RUM#3E012/212 1/FOOS/10004.

1. Explosives - Sensitivity
2. Explosives - Detonation
3. Explosive trains
4. Detonation - Probabilities
5. VARICOMP
- I. Title
- II. Ayres, J.N.
- III. Project

VARICOMP is a method for determining the detonation-transfer probabilities of an explosive train by substitution of explosive(s) of varied sensitivities or energies for the design explosive. These substituted-VARICOMP-explosives (whose response or output probability distribution functions have been calibrated relative to the design explosive) are used to measure the explosive drive inherent in the design system. Methods of calibrating explosives and carrying out VARICOMP performance tests are given along with statistical procedures for combining performance test and calibration data.

Naval Ordnance Laboratory, White Oak, Md.
 (NAVWEPs report 7411)
 VARICOMP, A METHOD FOR DETERMINING DETONATION-TRANSFER PROBABILITIES (U), by J.N. Ayres and others. 30 June 1961. 143p.
 Project RUM#3E012/212 1/FOOS/10004.

1. Explosives - Sensitivity
2. Explosives - Detonation
3. Explosive trains
4. Detonation - Probabilities
5. VARICOMP
- I. Title
- II. Ayres, J.N.
- III. Project

VARICOMP is a method for determining the detonation-transfer probabilities of an explosive train by substitution of explosive(s) of varied sensitivities or energies for the design explosive. These substituted-VARICOMP-explosives (whose response or output probability distribution functions have been calibrated relative to the design explosive) are used to measure the explosive drive inherent in the design system. Methods of calibrating explosives and carrying out VARICOMP performance tests are given along with statistical procedures for combining performance test and calibration data.

Naval Ordnance Laboratory, White Oak, Md.
 (NAVWEPs report 7411)
 VARICOMP, A METHOD FOR DETERMINING DETONATION-TRANSFER PROBABILITIES (U), by J.N. Ayres and others. 30 June 1961. 143p.
 Project RUM#3E012/212 1/FOOS/10004.

1. Explosives - Sensitivity
2. Explosives - Detonation
3. Explosive trains
4. Detonation - Probabilities
5. VARICOMP
- I. Title
- II. Ayres, J.N.
- III. Project

VARICOMP is a method for determining the detonation-transfer probabilities of an explosive train by substitution of explosive(s) of varied sensitivities or energies for the design explosive. These substituted-VARICOMP-explosives (whose response or output probability distribution functions have been calibrated relative to the design explosive) are used to measure the explosive drive inherent in the design system. Methods of calibrating explosives and carrying out VARICOMP performance tests are given along with statistical procedures for combining performance test and calibration data.