

UNCLASSIFIED

---

---

AD **263 408**

---

*Reproduced  
by the*

ARMED SERVICES TECHNICAL INFORMATION AGENCY  
ARLINGTON HALL STATION  
ARLINGTON 12, VIRGINIA



---

---

UNCLASSIFIED

NOTICE: When government or other drawings, specifications or other data are used for any purpose other than in connection with a definitely related government procurement operation, the U. S. Government thereby incurs no responsibility, nor any obligation whatsoever; and the fact that the Government may have formulated, furnished, or in any way supplied the said drawings, specifications, or other data is not to be regarded by implication or otherwise as in any manner licensing the holder or any other person or corporation, or conveying any rights or permission to manufacture, use or sell any patented invention that may in any way be related thereto.

# DISCLAIMER NOTICE

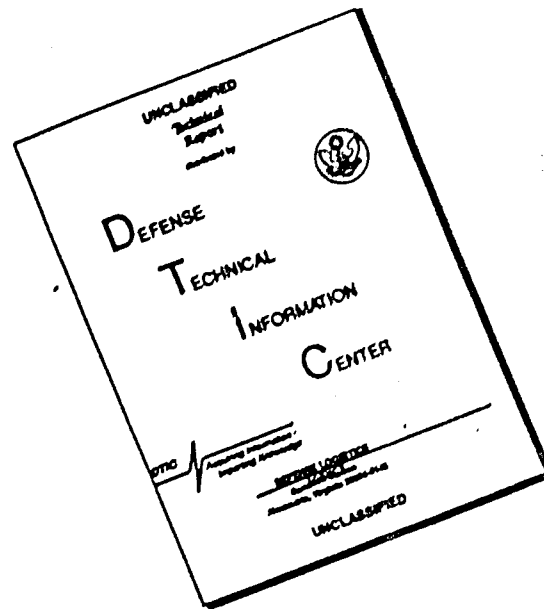

THIS DOCUMENT IS BEST QUALITY AVAILABLE. THE COPY FURNISHED TO DTIC CONTAINED A SIGNIFICANT NUMBER OF PAGES WHICH DO NOT REPRODUCE LEGIBLY.

263700

Addendum 1  
AFFTC-TR-60-21  
May 1961

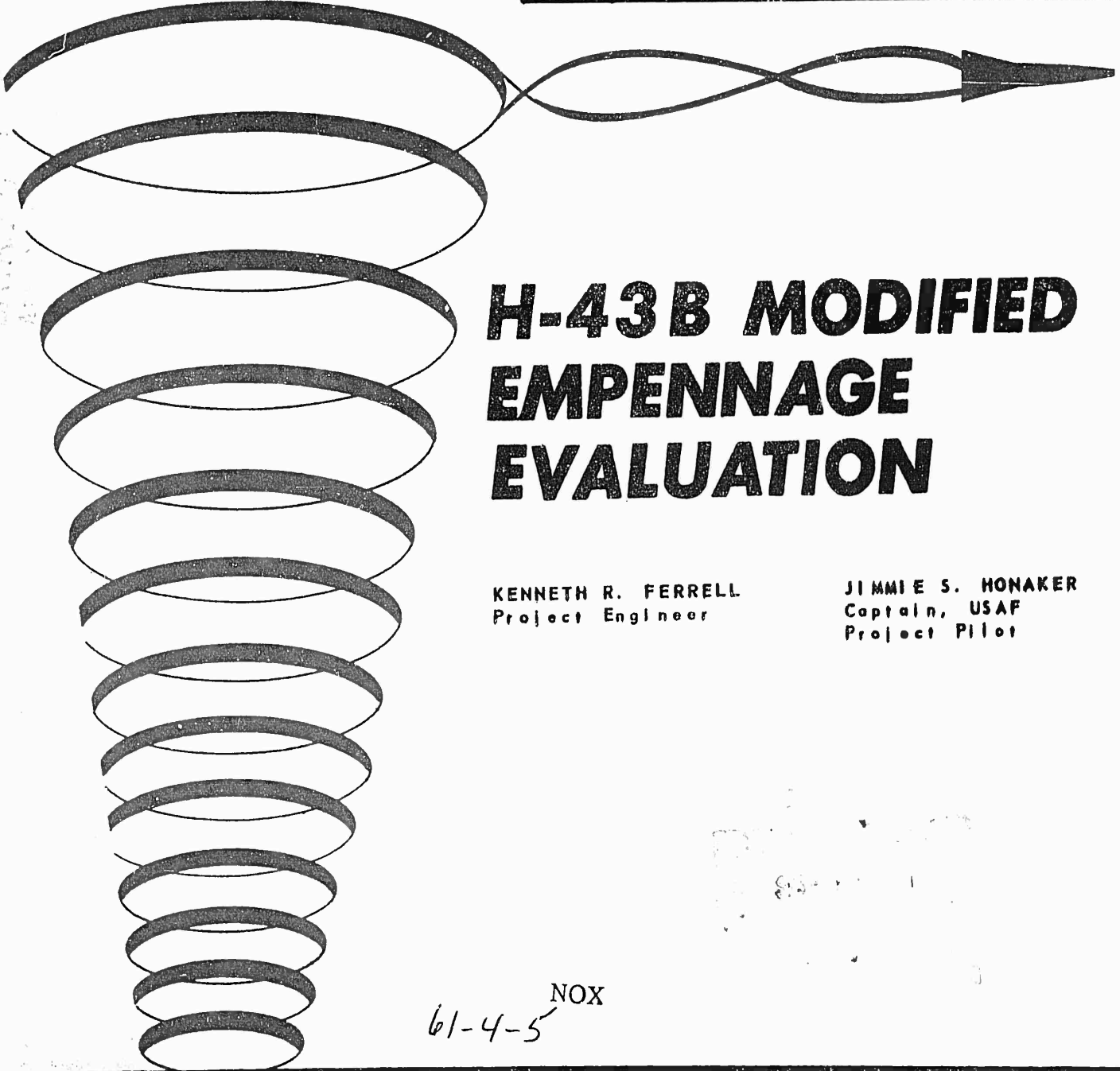
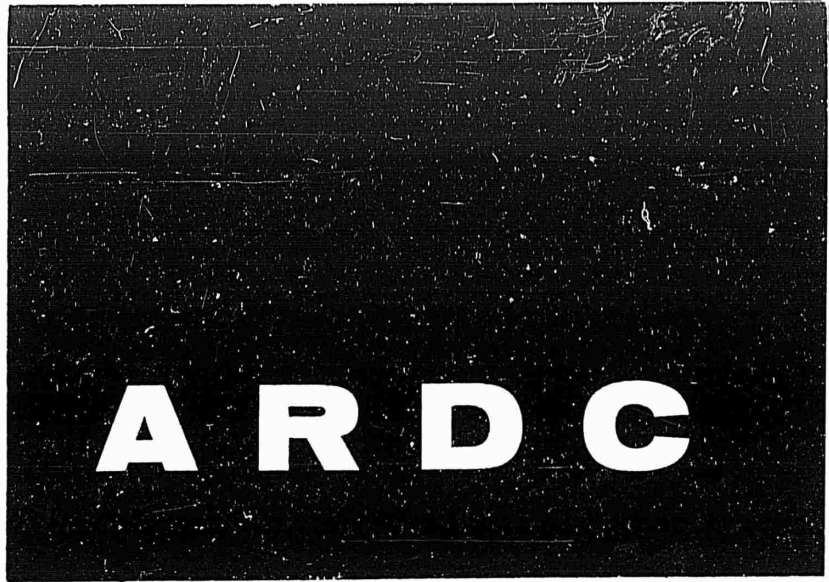

# H-43B MODIFIED EMPENNAGE EVALUATION

KENNETH R. FERRELL  
Project Engineer

JIMMIE S. HONAKER  
Captain, USAF  
Project Pilot

61-4-5<sup>NOX</sup>

AIR FORCE FLIGHT TEST CENTER  
EDWARDS AIR FORCE BASE, CALIFORNIA  
AIR RESEARCH AND DEVELOPMENT COMMAND  
UNITED STATES AIR FORCE

Addendum 1  
AFFTC-TR-60-21  
May 1961

# **H-43B**

## **MODIFIED EMPENNAGE**

### **EVALUATION**

KENNETH R. FERRELL  
Project Engineer

JIMMIE S. HONAKER  
Captain, USAF  
Project Pilot

# ABSTRACT

This addendum report presents the results of a limited comparative evaluation of rotor blade-to-tail clearance and stability and control of the original production H-43B and one of modified empennage with the vertical stabilizers lowered 14 inches and equipped with 10 inch frangible fiberglass tips. The tests were conducted at the Air Force Flight Test Center and at the Kaman Aircraft Corporation facility in Bloomfield, Connecticut, during the period June through August 1960. Additional verification of blade to tail clearance was obtained during follow-on testing at the AFFTC in October 1960.

The modified empennage was developed to correct rotor blade-to-tail interference which resulted in an aircraft grounding and suspension of testing on 4 May 1960. After in-service aircraft with unmodified tails were equipped with frangible vertical tail tips, flight was permitted within a very limited flight envelope.

The results of the limited comparative tests are being published at this time to familiarize using organizations of the handling qualities of the modified empennage configuration at the earliest possible date. Complete Category II stability and control tests will be resumed after completion of the Category II performance tests presently being conducted. The anticipated date for completion of the performance testing is June 1961.

The modified empennage configuration on the H-43B provides increased blade to vertical tail clearance and makes the possibility of interference very remote. Flying qualities of this helicopter with the modified empennage are acceptable for service use with the directional stability augmentation system (DSAS) operative at the optimum setting utilized during this test program. Without the DSAS functioning properly, the H-43B with the modified empennage should not be flown except for flight test or pilot familiarization with an instructor pilot aboard.

Vibration levels during high speed flight and longitudinal stability (static and dynamic) are improved with the modified empennage configuration, however, several undesirable stability and control characteristics still exist. For example, during autorotation, the static directional stability is poor with the DSAS operative and unsatisfactory with it inoperative. Autorotation is also accompanied by low lateral and directional control sensitivity and response as well as a large nose down pitching tendency following a throttle chop or a sudden reduction in collective pitch. This reaction could be dangerous during operations near the ground. Despite these deficient areas the autorotational capabilities are considered good due to the high rotor inertia and low rate of descent. Additional deficient stability and control areas result from forward speed being restricted by longitudinal cyclic available in level flight and poor lateral-directional dynamic stability with the DSAS operating and unsatisfactory stability with it inoperative for all flight conditions. Low lateral and directional control sensitivity and response are also apparent in level flight.

During these tests it was found that static directional stability would vary considerably with small differences in control system riggings. It is very important that the contractor and/or user closely monitor control system riggings. A further investigation to determine the optimum DSAS settings will be made during the Category II stability and control tests at the AFFTC.

Despite the stability and control deficiencies contained in this report, the performance capabilities of the H-43B represent a significant improvement in USAF helicopter rescue capabilities at high altitudes.

This report has been reviewed and approved

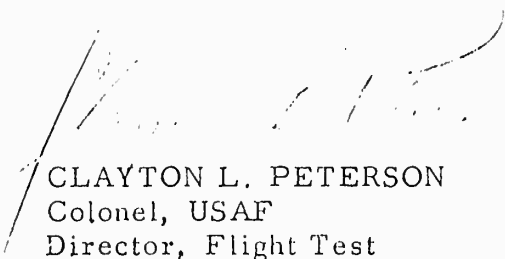

CLAYTON L. PETERSON  
Colonel, USAF  
Director, Flight Test

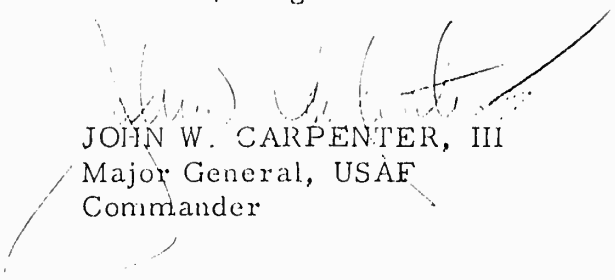

JOHN W. CARPENTER, III  
Major General, USAF  
Commander

INTRODUCTION	1
TEST RESULTS	3
Climb	3
Level Flight	4
Autorotation	14
Blade to Tail Clearance	16
CONCLUSIONS	17
RECOMMENDATIONS	18
APPENDIX I	20
Stability and Control Plots	21
APPENDIX II	142
General Aircraft Information	142

**ORIGINAL EMPENNAGE  
CONFIGURATION**

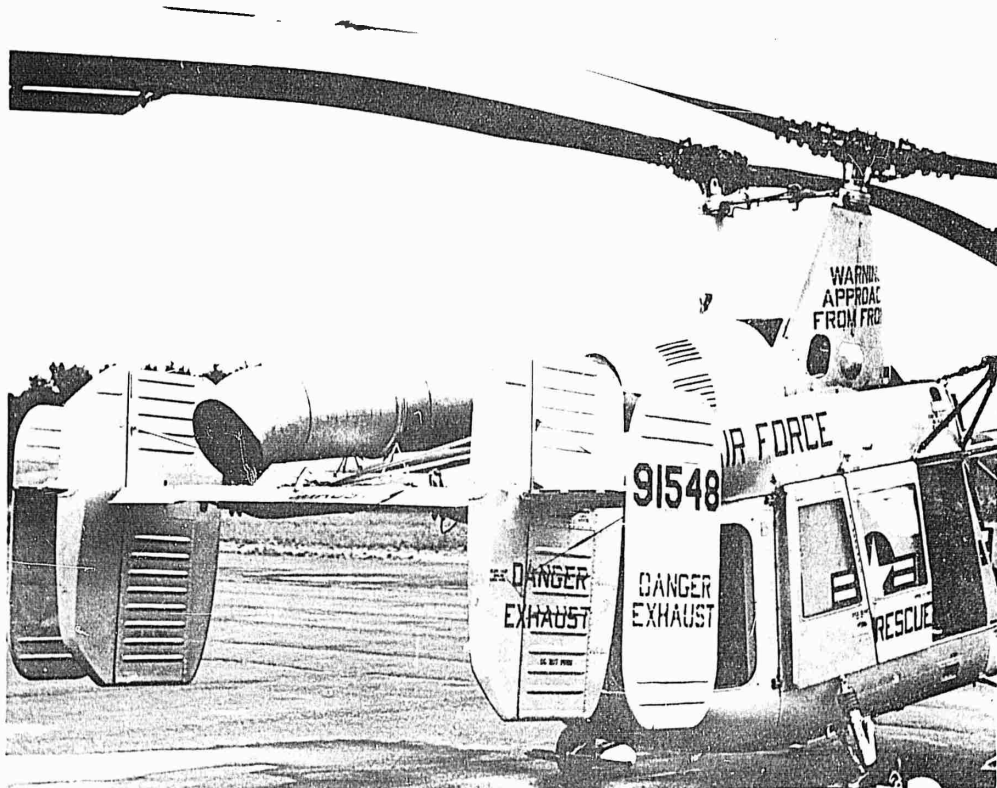
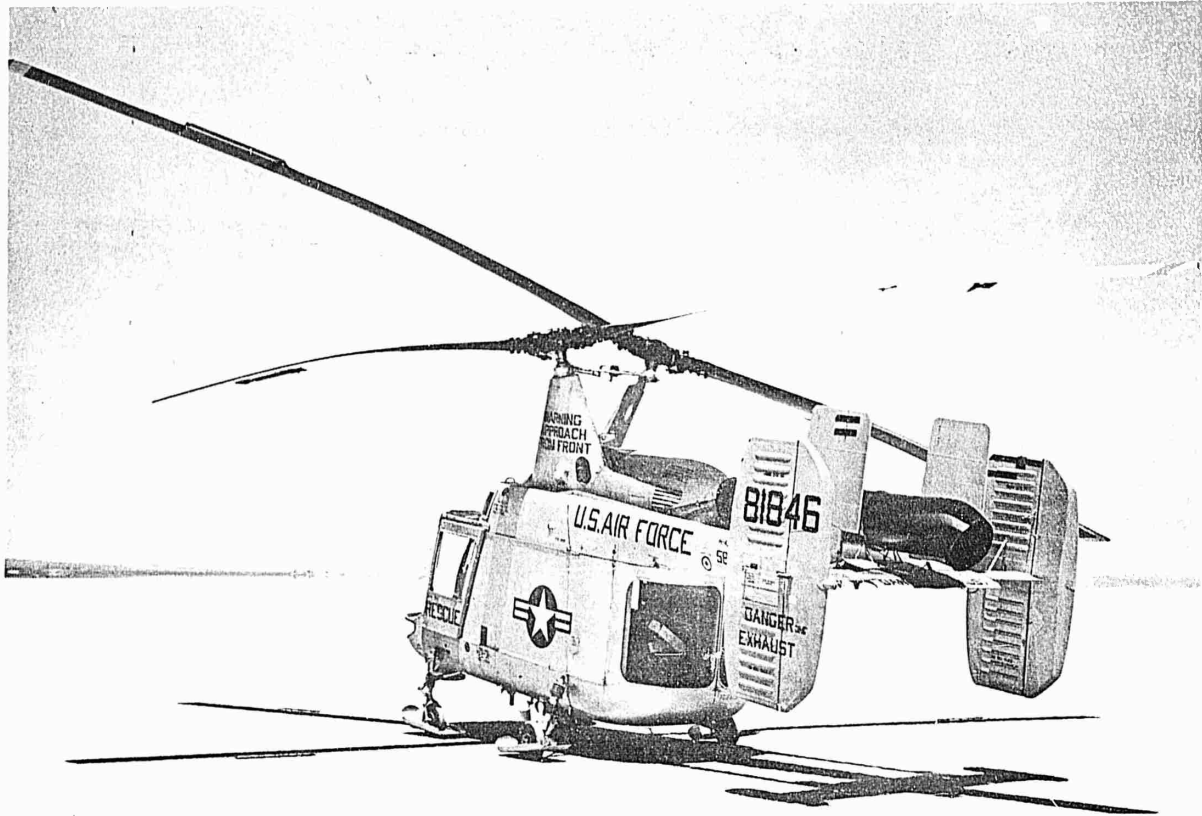

**MODIFIED EMPENNAGE  
CONFIGURATION**

# INTRODUCTION

This report presents the results of a limited stability and control evaluation conducted during June and August 1960, on two H-43B helicopters equipped with different empennage configurations.

- H-43B Serial Number 58-1849 was equipped with the original empennage configuration utilizing high vertical tail surfaces and H-43B Serial Number 59-1548 was equipped with a modified empennage configuration utilizing low vertical tail surfaces.

To evaluate the stability change caused by small differences in control rigging, an original empennage was re-installed on aircraft 59-1548 and limited data was taken. This data was then compared to that obtained from helicopter 58-1849.

The change in the empennage design of the H-43B resulted from blade-to-tail interference on vehicles operating with the original configuration which resulted in aircraft grounding on 4 May 1960. At that time, seven reported incidents had occurred where the rotor blades had contacted one or more of the vertical tail surfaces. Of this number, four had occurred while the aircraft were on the ground and three occurred during flight. After in service aircraft had been equipped with frangible vertical tail tips the grounding was terminated but the aircraft was restricted to a very limited flight envelope.

At this time, a limited stability and control evaluation on aircraft Serial Number 58-1849 was conducted at the AFFTC to obtain baseline data on the handling qualities of helicopters equipped with the original empennage configuration. Twenty-one flights for a total of 15 flight test hours were flown. At the completion of contractor flight tests of the modified empennage configuration, 11 flights for a total of 12.5 flight test hours were flown on helicopter Serial Number 59-1548 at the Kaman Aircraft Corporation in Bloomfield, Connecticut.

The results of these limited tests are being published at this time to familiarize using organizations of the handling qualities of the modified empennage configuration as well as to facilitate improvements in the configuration at the earliest possible date. Complete Category II stability and control tests will not be initiated until completion of the Category II performance tests presently being conducted. The anticipated date for completion of the performance testing is June 1961.

The H-43B is a twin intermeshing rotor type helicopter (synchropter) and is powered by a single Lycoming T53-L-1B free turbine engine. This engine is derated to a maximum continuous power of 685 engine shaft horsepower at 260 rotor rpm and an output shaft speed of 6300 rpm. The maximum take-off gross weight is 8250 pounds with internal loading and 9150 pounds with internal loading plus a sling load. The maximum allowable load on the cargo hook is 1500 pounds. The primary mission of this helicopter is local crash rescue. A cabin is provided to carry litters and the necessary personnel for the crash rescue mission. When required, a secondary mission of fire suppression and crash entry is feasible with the employment of trained crewmen and a fire suppression kit.

The flight control system of the H-43B consists of conventional pilot controls which operate servo-flaps located on the rotor blades. Longitudinal and lateral control is obtained by fore and aft and lateral tilting of the rotor discs through movements produced by the servo-flap. Directional control is obtained through differential collective and cyclic pitch on the rotors by deflecting pedals. Movement of the collective stick, in addition to collectively changing the pitch on both rotors moves a tab on the horizontal tail which controls the position of the floating empennage in forward flight. A directional stability augmentation system (DSAS) is provided and controls the movable rudders. The system consists of a pedal transducer, pressure switches and a stability control unit. The stability control unit is essentially an accelerometer/rate gyro combination which senses lateral accelerations and yaw rates. The function of the DSAS is to improve both static and dynamic directional stability.

Definitions of the stability and control terms used in this report are presented in Appendix I. A complete description of the empennage configurations evaluated and the flight control system is presented in Appendix II of this report.

# TEST RESULTS

## CLIMB

Both empennage configurations exhibit satisfactory stability and control characteristics during climb. Static directional stability is acceptable and dynamic behavior following small pulse inputs is essentially deadbeat about all axes. Stability and control characteristics during climb were determined for an airspeed of 60 knots CAS, 260 rotor rpm, and a mid center of gravity location (station 119). The tests were conducted through an average density altitude of 5000 feet and an average gross weight of 5900 pounds.

### Static Stability in Climb:

The H-43B exhibited positive apparent static longitudinal stability under all test conditions for both the original and modified empennage configurations. Aircraft attitude and airspeed are easily controlled during climb. No directional anti-torque correction is necessary with this type helicopter configuration and the pedal position was essentially the same for all throttle and collective positions.

Static directional stability during climb is satisfactory (positive stability) for both empennage configurations with the DSAS on and off. The static directional stability tests were conducted at a climb airspeed of 60 knots CAS, a rotor speed of 260 rpm, and military power. Results of these tests are presented in Figs. 7 through 9, Appendix I.

### Dynamic Stability in Climb:

Dynamic longitudinal stability during climb is satisfactory for both the original and modified empennage configurations. This positive dynamic stability greatly aids the control of airspeed and aircraft attitude when flying in turbulence. The aircraft motion following a forward pulse control displacement is deadbeat and there is essentially no change in airspeed. Small aft pulses result in a slight de-

crease in airspeed and a stable nose high attitude. Large aft pulses (1 inch or more) result in a pitch-up to approximately 15 degrees. At this time the helicopter pitches down, and it is necessary to initiate recovery because of the high nose down pitching velocity. The motion appears to be oscillatorily divergent, however, the period of the oscillation could not be determined because recovery was necessary. This divergence is acceptable since the long period of the oscillation allows adequate control. The helicopter has no undesirable rolling or yawing tendencies during longitudinal disturbances. Longitudinal dynamic stability improves as rotor speeds decrease.

Lateral-directional stability during climb is acceptable for both empennage configurations with the DSAS on and off. The motion in roll following a lateral pulse is essentially deadbeat. With the DSAS on, the result of a directional pulse is an oscillation in roll and yaw. The period of the yawing oscillation decreases as airspeed increases, and at all airspeeds, the oscillation is essentially damped within one-half cycle. The aircraft immediately yaws in the direction of pedal input with a small initial opposite roll. The lateral-directional stability characteristics deteriorate slightly with the DSAS off.

### Controllability in Climb:

The longitudinal pitching rate per inch of control displacement during climb is satisfactory for both empennage configurations. However, quantitative controllability tests during climb were conducted only for the original configuration. For this configuration the rate of pitch per inch of control displacement was 16 degrees per second for both forward and aft displacements at an airspeed of 60 knots CAS at 260 rpm. The maximum pitching rate was reached

2.0 seconds following the control displacement. The rolling and yawing rates resulting from longitudinal step control displacements were negligible.

The maximum roll rate resulting from various size lateral step type control displacements was determined for the same condition as the longitudinal axes and was found to be 20 degrees per second per inch for both left and right lateral inputs. The maximum rolling velocity was reached approximately 2.0 seconds following the control displacement. The roll response following the step control displacement consisted of an immediate roll in the direction of control displacement. After a small control input, the rolling velocity reached a maximum, remained constant for several seconds (2 to 4), and then decreased to zero. The resulting bank angle reached a maximum approximately 7.5 seconds following the control displacement and remained constant. This rolling characteristic is very noticeable and is objectionable. A given lateral displacement of the cyclic control should result in a constant roll rate. If the roll rate begins to decrease, the reaction is to apply more cyclic control. As a result, several lateral cyclic inputs are required to obtain the desired bank angle. For large control inputs, the rate of roll did not decrease during the time required for the helicopter to reach bank angles up to 30 degrees. (B 2)<sup>1</sup>

Yawing response, as a result of lateral displacements, was not apparent for 4.5 seconds following the control displacement, then slowly increased to a maximum and remained essentially constant. The angle of sideslip increased to approximately 15 degrees before the aircraft would start to turn, and then during the turn the sideslip angle decreased to approximately one-half the maximum

value and remained constant. The directional maneuverability of a helicopter is determined by the ability to make pedal-fixed turns and the amount of rudder input required to co-ordinate the turn. The large angle of sideslip and the large angle of bank reached before the H-43B starts to turn, plus the large pedal deflection required to coordinate a turn, readily demonstrate the undesirable lateral-directional maneuvering characteristics.

The maximum rate of yaw per inch of control displacement input was 4 degrees per second for both left and right pedal displacements at a climb airspeed of 60 knots CAS. The time of 1.9 seconds required to reach the maximum is excessive. The helicopter motion following a pedal step is the same for both empennage configurations and consists primarily of an immediate yaw in the direction of control input, followed by an opposite rolling response. Damping in yaw and roll increases as airspeed increases. At 40 knots, the yaw response is a slightly damped oscillation with a period of approximately 2 seconds. The roll response is a small neutrally damped oscillation with approximately the same period as the yawing oscillation. At 60 knots, the yawing oscillation essentially damps out within one-half cycle and no roll response is apparent. Representative time histories of the helicopter motion following step type control displacements and helicopter response as a function of control inputs are presented in Figs. 50 through 52, and Fig. 32, Appendix I.

#### LEVEL FLIGHT

The stability and control characteristics of the modified empennage configuration are acceptable for service use when the DSAS is operating at the calculated optimum setting. With the DSAS off, the static directional stability is neutral or negative for both empennage configurations at airspeeds below 40 knots CAS. In general, the static directional stability was better with the original empennage than with the modified empennage configuration. Longitudinal dynamic stability is slightly

<sup>1</sup>Numbers indicated as (B 2), etc, represent the corresponding recommendation numbers as tabulated in the Recommendations section of this report.

improved with the modified configuration. Vibration levels during high speed forward flight are improved with the modified empennage configuration.

Stability and control characteristics during level flight were determined for airspeeds of 40, 60 and 80 knots CAS with a center of gravity location at station 119 (mid). The tests were conducted at an average gross weight of 6000 pounds, an average density altitude of 6000 feet, and rotor speeds of 238 and 260 rpm. These tests were performed with the DSAS both on and off at airspeeds below 80 knots, and off at airspeeds of 80 knots and above. The tail configurations evaluated were as follows:

1. Original H-43B.
2. Modified empennage with original DSAS setting.
3. Modified tail with "Calculated optimum DSAS setting."

#### Static Stability in Level Flight:

The apparent longitudinal static stability of the H-43B is positive for all conditions tested. At all test conditions, maximum airspeed was limited by longitudinal control travel, not by power available. Allowing for a 10 percent control margin, maximum airspeed at the test conditions was 88 knots CAS at 238 rpm and 98 knots at 260 rotor rpm. This maximum airspeed control limitation is a violation of military specification MIL-H-8501, Para. 3.2.1., which states that maximum forward airspeed may not be limited by control travel. Longitudinal control position is 20 percent more forward at 238 rpm than at 260 rotor rpm. The additional horizontal tail surfaces on the modified empennage configuration have little effect on the longitudinal control positions. For the modified empennage, maximum airspeed is severely limited by longitudinal

control at aft cg locations. Maximum airspeed at full forward cyclic was 60 knots at a density altitude of 9750 feet, a center of gravity location of 123 (aft) and 250 rotor rpm. A comparison of the longitudinal control positions for the original and modified empennage configurations is shown in the following figure.

At high cruise airspeeds (80 to 90 knots CAS), the longitudinal control position is too far forward for pilot comfort. The contractor recommended cruise airspeed (at a gross weight of 6000 pounds, a pressure altitude of 6000 feet, and 236 rotor rpm) is 89 knots. At these conditions, the longitudinal control position is at or very near the forward stop, depending on center of gravity location. There is insufficient control available to control the effects of longitudinal disturbances. The effects of altitude on control positions and control effectiveness was not determined during this limited program. (A 2)

Lateral and directional control positions were satisfactory for all conditions tested. However, an excessive variation in the trim control position was found when comparing two standard H-43B helicopters. This variation was attributed to the different rigging of the two aircraft.

Static directional stability was investigated for both the original and modified empennage configurations. The tests conducted on the modified empennage included an evaluation of the effectiveness of a change in DSAS setting. Results of the static directional stability tests are presented in Figs. 10 through 25, Appendix I.

Static directional stability for the original empennage was determined utilizing two aircraft (Serial Number 58-1849 and 59-1548). A comparison of the results indicates an excessive variation of the static directional stability characteristics. The following figure

COMPARISON OF THE LONGITUDINAL  
CONTROL POSITION FOR ORIGINAL  
AND MODIFIED TAIL CONFIGURATION

LEVEL FLIGHT

AIRCRAFT	DENSITY ALT	GROSS WT.	CSAS	TAIL CONF.	RPM
S/N 58-1548	6150 FT	6080 LB	ON	ORIGINAL	260
S/N 59-1849	5830 FT	5080 LB	ON	MODIFIED	260

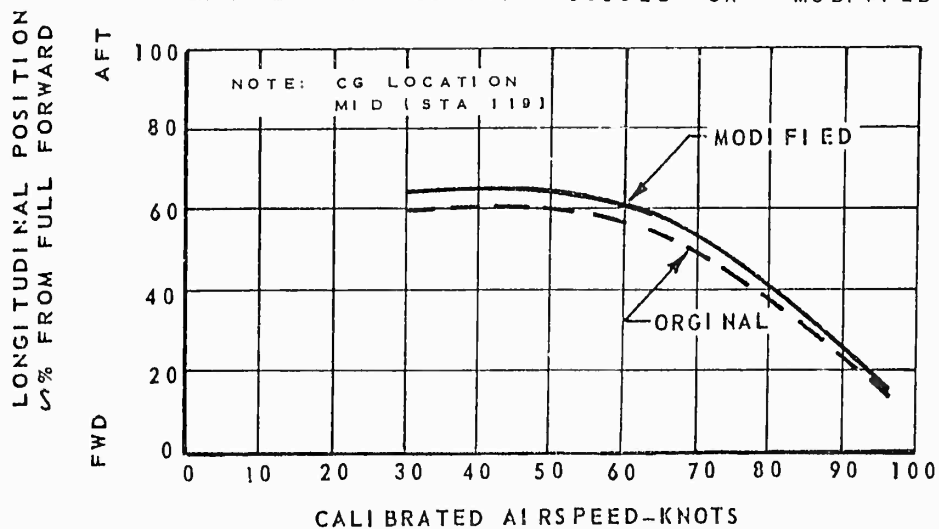

VARIATION IN STATIC DIRECTIONAL  
STABILITY FOR TWO STANDARD  
H-43B HELICOPTERS

LEVEL FLIGHT

AIRCRAFT	AIR SPEED-KTS CAS	CSAS	TAIL CONF.	RPM
S/N 58-1548	40	OFF	ORIGINAL	288
S/N 59-1849	40	OFF	ORIGINAL	238

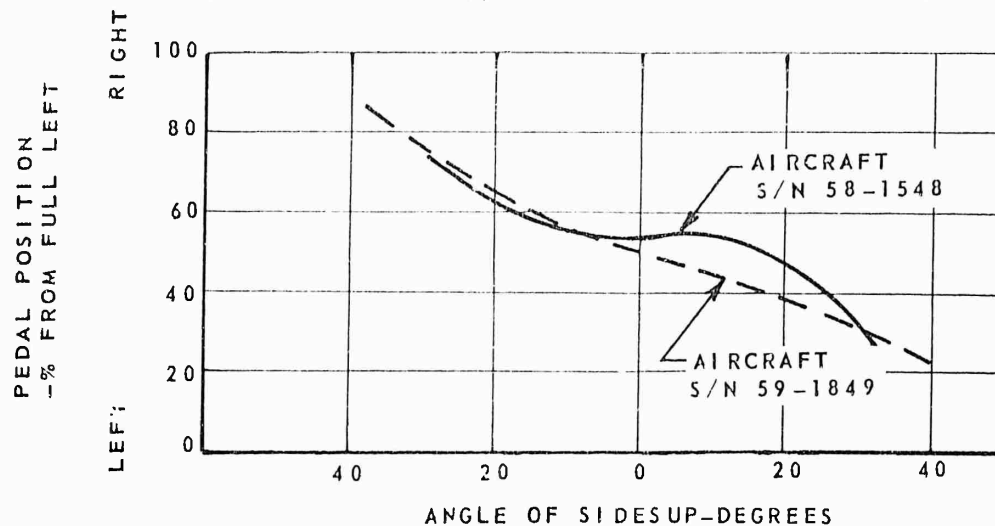

illustrates this variation. (B 3)

The static directional stability characteristics of the modified empennage configuration with the standard DSAS setting are unsatisfactory for the following reasons:

1. Negative static directional stability during low speed (40 knots CAS) level flight at 238 rotor rpm with the DSAS off.
2. Neutral or negative directional stability  $\pm 3$  degrees from trim at all flight conditions with the DSAS both on and off.

To improve the stability characteristics of the modified empennage configuration, the DSAS setting was changed to a calculated optimum and tests were conducted to determine any change in the directional stability characteristics. The stability characteristics were improved in all areas with the modified DSAS on. The improvement in the stability characteristics with the modified DSAS are shown in the following figure. (A 1)

Future AFFTC Category II stability and control tests will be conducted to determine the optimum DSAS setting rather than just using a calculated optimum; however, this was beyond the scope of this limited evaluation.

In general, the static directional stability characteristics improve as airspeed or rotor speed increases. The accompanying figures illustrate the stability characteristics as a function of airspeed and rotor rpm.

The primary cause of the variation, according to the contractor, was the difference in the main rotor azimuth setting on the two aircraft. An investigation revealed that the setting of the two azimuths varied by  $3/4$  to 1 degree. Both aircraft had been set in accordance with the existing rigging instructions. The DSAS greatly improves the static directional stability characteristics. This improvement is illustrated in the accompanying figure. (A 3, A 4)

Static directional stability for all conditions tested is presented in Figs. 10 through 25, Appendix I.

#### VARIATION IN STATIC DIRECTIONAL STABILITY CHARACTERISTICS WITH A CHANGE IN DSAS SETTING

##### LEVEL FLIGHT

AIRCRAFT	AIRSPD-KTS	CAS	DSAS	TAIL CONF.	RPM
S/N 58-1548	60		ON	MODIFIED	238
S/N 58-1548	60		ON	MODIFIED	238

(CHANGED)

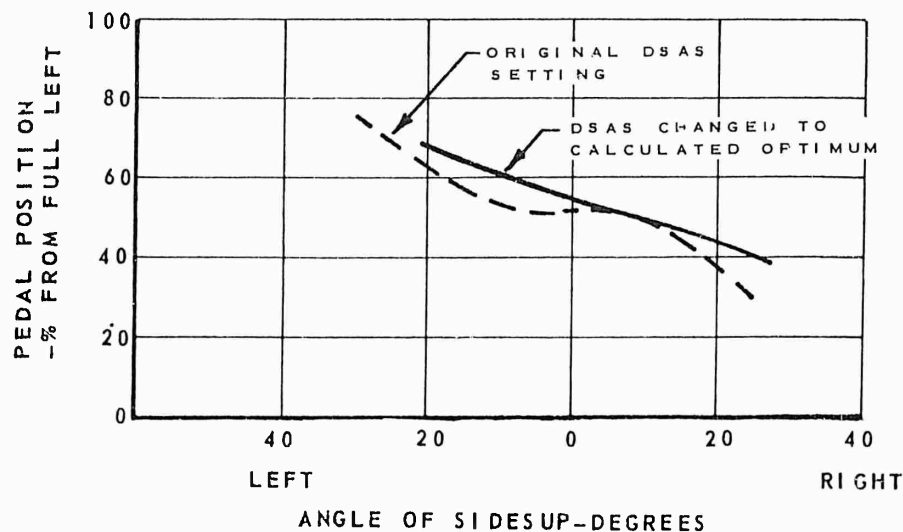

STATIC DIRECTIONAL STABILITY  
AS A FUNCTION OF AIRSPEED

LEVEL FLIGHT

AIRCRAFT	AIRSPEED-KTS CAS	DSAS	TAIL CONF	RPM
S/N 58-1548	80	OFF	MODIFIED	260
S/N 58-1548	40	OFF	MODIFIED	260

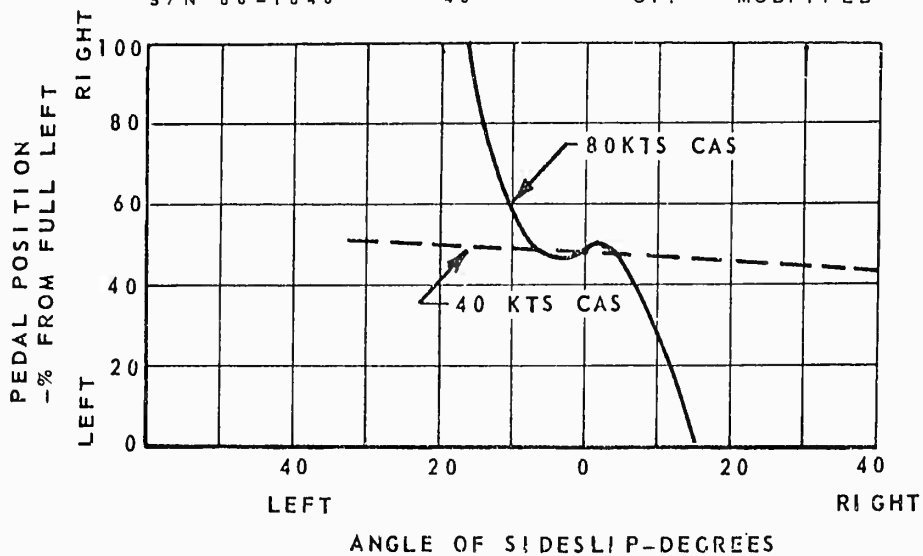

STATIC DIRECTIONAL STABILITY  
AS A FUNCTION OF ROTOR SPEED

LEVEL FLIGHT

AIRCRAFT	AIRSPEED-KTS CAS	DSAS	TAIL CONF	RPM
S/N 58-1548	40	OFF	MODIFIED	260
S/N 58-1548	40	OFF	MODIFIED	238

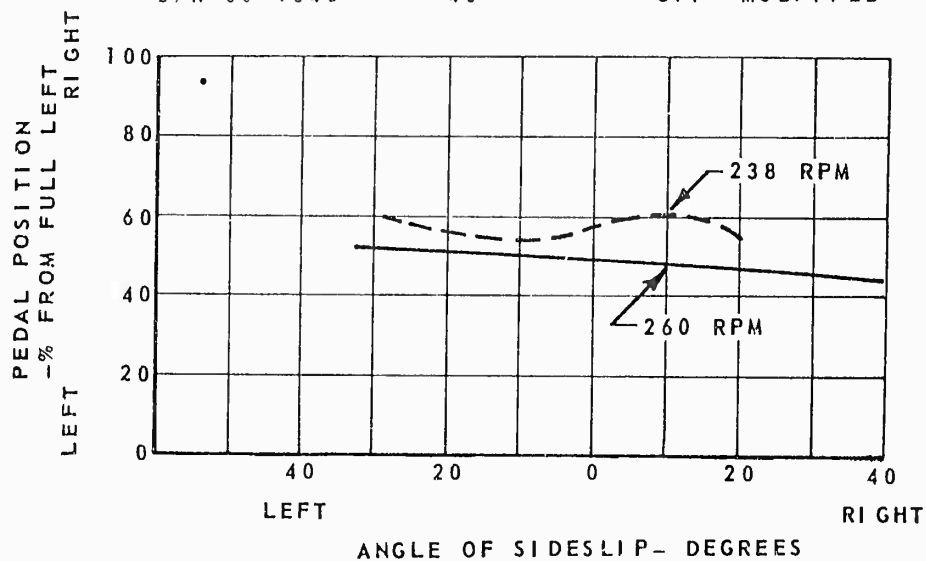

VARIATION IN STATIC DIRECTIONAL STABILITY WITH DSAS ON AND OFF

LEVEL FLIGHT

AIRCRAFT	AIR SPEED-KTS	CAS	DSAS	TAIL CONF	RPM
S/N 58-1848	60		OFF	MODIFIED	260
S/N 58-1848	60		ON	MODIFIED	260

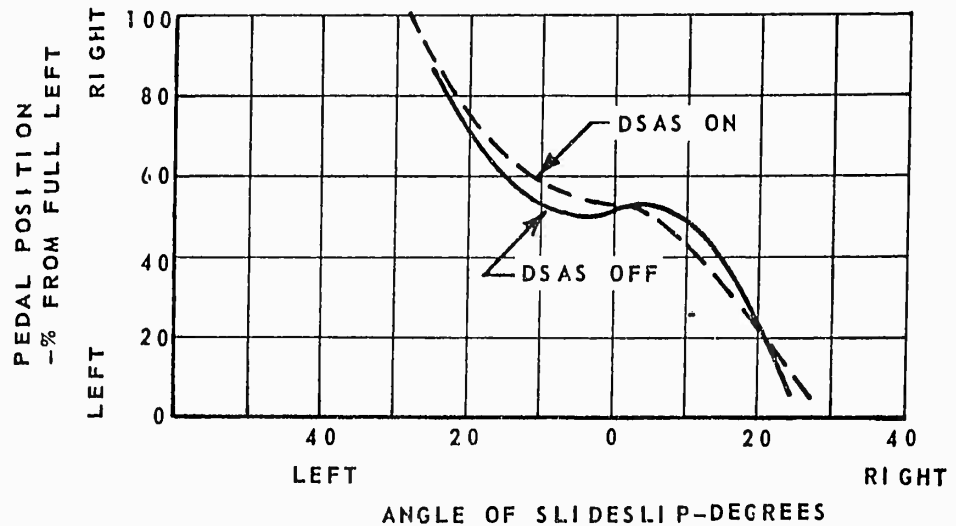

Dynamic Stability in Level Flight:

The dynamic stability characteristics were determined by studying the aircraft behavior following artificial disturbances. Artificial disturbances were accomplished by rapidly displacing the control from the trim position, holding the new control position for approximately 1 second, then rapidly returning the control to the trim position.

Longitudinal dynamic stability in level flight was improved with the modified empennage configuration. The stability characteristics were much the same for 40 and 80 knots CAS and for forward and aft pulses. Small ( $\frac{1}{2}$  inch) forward pulse inputs resulted in a pitching oscillation that damped in approximately one cycle. Larger pulses resulted in a slightly damped, large amplitude oscillation of undetermined period.

With the original empennage configura-

tion, the helicopter was longitudinally divergent for all pulses larger than  $\frac{1}{2}$  inch. For a forward pulse, the aircraft would pitch down and then up until recovery was necessary. For an aft pulse, the aircraft would tend to pitch up until recovery was initiated. Response to small pulses was deadbeat with no apparent residual oscillation; however, a change in attitude was present several seconds following the control input. This motion rather than the divergent response to large pulses was the contributing factor to the poor rough air handling qualities of the original configuration. Longitudinal dynamic stability deteriorated as airspeed increased. There were no significant rolling or yawing tendencies for longitudinal disturbances for either the original or modified tail configurations. Representative time histories of the helicopter motion following longitudinal disturbances with both empennage configurations are presented in Figs. 53 through 57, Appendix I.

With the modified empennage, the helicopter motion following a lateral pulse is an immediate roll in the direction of initial control displacement and an opposite yaw approximately 1.5 seconds later. The rolling and yawing oscillations are well damped at the higher airspeeds (80 knots CAS). The random motions in pitch and yaw which were observed for the original empennage were not noted during the evaluation of the modified configuration. Lateral dynamic stability of the original empennage configuration was essentially the same for all airspeeds investigated (40 through 80 knots CAS). The motion following a small lateral control displacement consisted of a roll in the direction of initial control input accompanied by random motions in pitch and yaw. The roll response was damped out within one-half cycle. The random motions in pitch and yaw were still present 10 seconds after the control displacement. The random motion in pitch and yaw, and the resulting attitude changes increased as airspeed increased. These random motions and the resulting attitude changes made flying in turbulent air difficult. After the lateral disturbance, the angle of bank reached a maximum, and then decreased to some arbitrary value above zero. Some bank angle was usually present 10 seconds after the control input. Representative time histories of the helicopter motion following lateral pulse type control displacements are presented in Figs. 58 through 61 Appendix I.

The dynamic lateral-directional stability during level flight is unsatisfactory for both the original and modified empennages. For the original empennage the motion following a pedal pulse was an oscillation in roll and yaw, with the roll in the opposite direction of pedal displacement in all cases. The amplitude of the directional response to a given control input decreased as airspeed increased. The rolling and yawing oscillations were heavily damped; however, a random motion about all three axes was present several seconds following the control displacement. There was no significant difference in the lateral-directional stability characteristics for DSAS on or off.

Dynamic lateral-directional stability deteriorated with the addition of the modified empennage configuration. The motion following a pedal pulse is similar; however, the resulting attitude changes are larger. Dynamic lateral-directional stability with the modified empennage is better at 40 knots CAS than at 80 knots. The change in rough air handling qualities as a result of the different stability characteristics of the modified empennage was not determined during this evaluation. (B 2)

#### Controllability in Level Flight:

The longitudinal controllability is adequate and the lateral and directional controllability are poor for both empennage configurations. There is no significant difference in these characteristics for the two empennage configurations.

The longitudinal control sensitivity (maximum pitching acceleration per inch control displacement) is satisfactory and was found to be 4 degrees/second<sup>2</sup>/inch for forward control displacements and 15 degrees/second<sup>2</sup>/inch for aft control displacements at an airspeed of 80 knots CAS. The aircraft responded with an immediate pitching acceleration which reached a maximum approximately 0.8 seconds following the control displacement. The following figure shows the longitudinal control sensitivity as a function of airspeed and rotor rpm for the original tail configuration.

The maximum longitudinal pitching velocity per inch of control displacement (response) for the original empennage at cruise airspeed was 26 degrees/second/inch for forward control displacements and 11 degrees/second/inch for aft control displacements. The unequal response was not objectionable. The average time required to reach the maximum pitching rates was slightly higher for the modified empennage than for the original empennage. For both empennage configurations, the pitching rate per inch of control displacement increased as airspeed and rotor rpm increased. The longitudinal response of the original empennage configuration as a function of airspeed is presented in the following figure.

LONGITUDINAL CONTROL SENSITIVITY  
 AS A FUNCTION OF AIRSPEED AND RPM  
 H-43B USAF S/N 58-1849  
 ORIGINAL EMPENNAGE

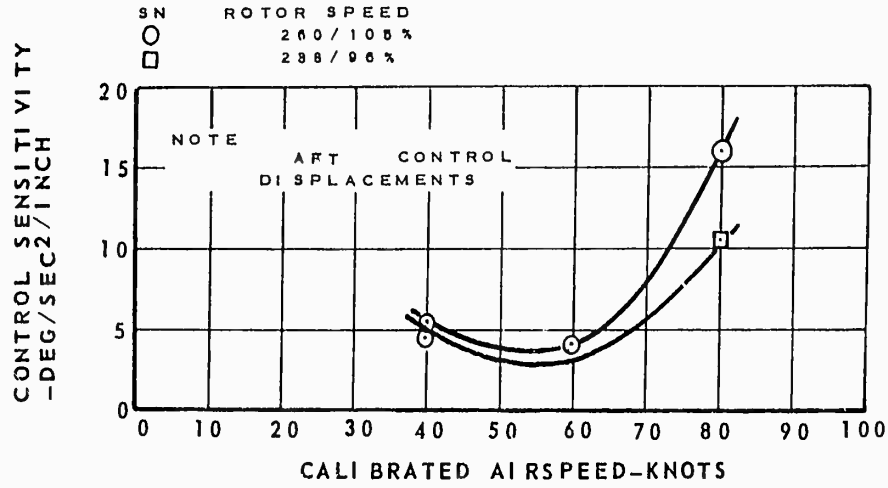

LONGITUDINAL RESPONSE AS A  
 FUNCTION OF AIRSPEED  
 H-43B USAF S/N 59-1849  
 ORIGINAL EMPENNAGE CONFIGURATION

NOTE: FORWARD CONTROL DISPLACEMENT

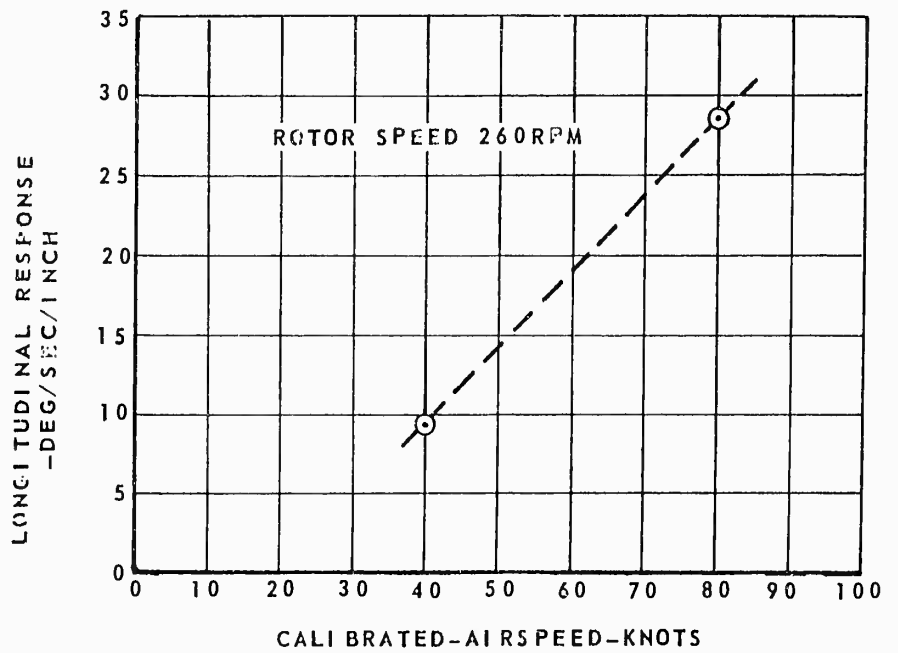

LATERAL CONTROL SENSITIVITY AS A  
FUNCTION OF AIRSPEED  
H-43B USAF S/N 58-1849  
and S/N 59-1548

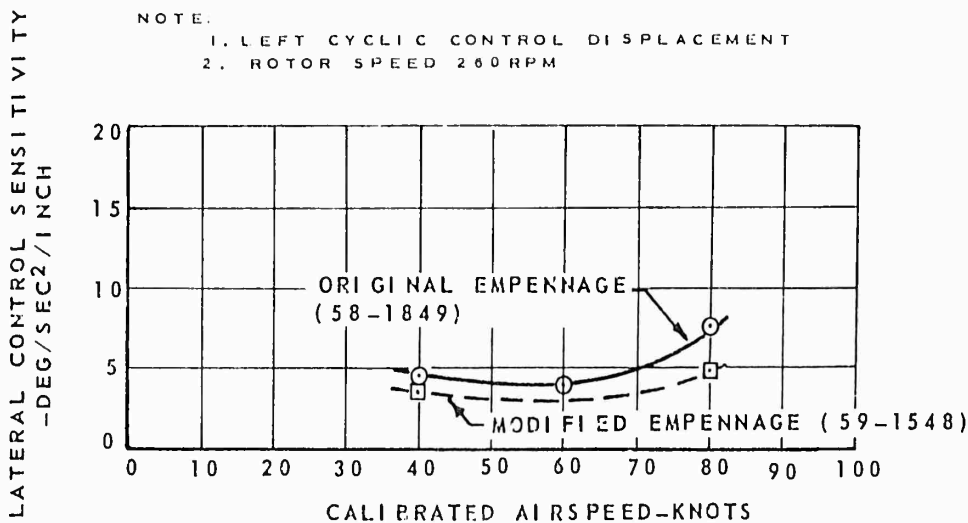

For the original empennage, a 1 inch lateral control displacement resulted in a maximum acceleration of 7.5 degrees per second<sup>2</sup> for both right and left control inputs at an airspeed of 80 knots CAS. For the same conditions, the control sensitivity is 5.0 degrees/second<sup>2</sup>/inch and 4.5 degrees/second<sup>2</sup>/inch for right and left control displacements with the modified empennage. The unequal control sensitivity resulting from left and right control inputs is not objectionable; however, the overall sensitivity is too low. The time required to reach the maximum acceleration is approximately 0.5 seconds. For both empennage configurations, the lateral control sensitivity increased with airspeed and is summarized in the following figure. (B 1

The roll response of the H-43B is inadequate.

The roll rate per inch of control displacement was found to be 10.5 degrees per second and 6.0 degrees per second for right and left control displacements for the original empennage at an airspeed of 80 knots CAS. For both empennages, the roll rate is higher at 80 knots than at 60 knots and increases as rotor speed increases. Following control dis-

placement, the roll rate reaches a maximum within approximately 4.0 seconds. After reaching the maximum, the rate slowly decreases to some value slightly above zero, and then remains constant. A slight opposite yawing response immediately follows the lateral control displacement. Approximately 8 seconds after the control displacement, the helicopter turns in the direction of the control input, and continues to turn until recovery is initiated. The excessive delay in turn initiation and the large bank angle reached before the aircraft starts to turn results in poor handling qualities when flying in turbulence. As a result pedal fixed turns are unsatisfactory, and to co-ordinate the helicopter in a turn the pilot must initiate rudder pedal input prior to, or simultaneously with, the lateral control input. Approximately 50 percent of the total pedal travel available is required to co-ordinate a bank angle of 30 degrees at an airspeed of 60 knots.

Directional control sensitivity during level flight is inadequate. Control sensitivity is so low that full pedal displacements can be made with little effect on the aircraft heading. Control sensitivity with

VARIATION IN STATIC DIRECTIONAL STABILITY WITH DSAS ON AND OFF AUTOROTATION

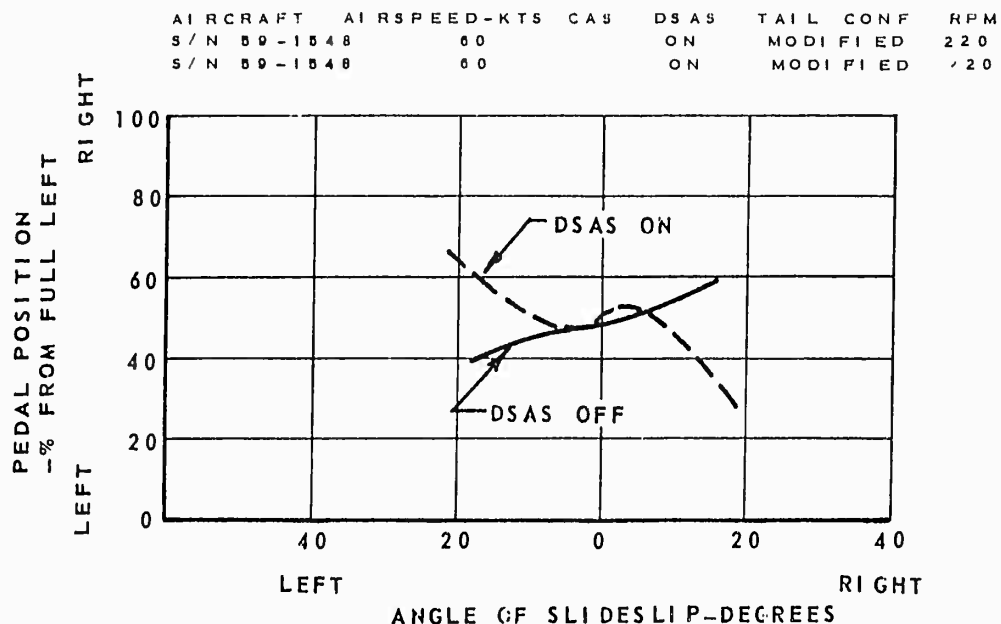

the modified empennage was slightly lower than with the original empennage configuration. The maximum immediate angular yawing acceleration per inch of pedal displacement was 8.0 degrees per second<sup>2</sup> for left pedal and 5.0 degrees per second<sup>2</sup> for right pedal displacements at an airspeed of 80 knots CAS with the original empennage. There was no significant difference in control sensitivity with the DSAS off. The maximum acceleration occurred 0.9 seconds following the control displacement. The control sensitivity decreased as airspeed was increased.

With the modified empennage, the maximum yaw rate for a 1 inch displacement was 2 degrees per second left or right and was reached 2.8 seconds following the control displacement at an airspeed of 80 knots CAS.

Directional response in cruise flight does not have the same significance as in the lateral or longitudinal case since directional maneuverability also depends on the directional response to lateral control inputs. Therefore, directional response from pedal inputs cannot be used as a direct measure of directional maneuverability during level flight. Response with the DSAS off at 40 and 60 knots CAS consisted of a yaw in the direction of control displacement with a simultaneous opposite roll. This response resulted in the helicopter turning right while having a left bank angle which is uncomfortable and disconcerting. Response with the DSAS on was improved and consisted of a simultaneous turn and bank in the direction of pedal displacement.

Complete curves of the variation in control sensitivity and response as a function of control inputs, as well as typical time histories of step inputs about all axes, are presented in Figs. 43 through 49, Appendix I.

VARIATION IN STATIC DIRECTIONAL STABILITY CHARACTERISTICS WITH A CHANGE IN DSAS SETTING  
H-43B USAF S/N59-1548  
AUTOROTATION

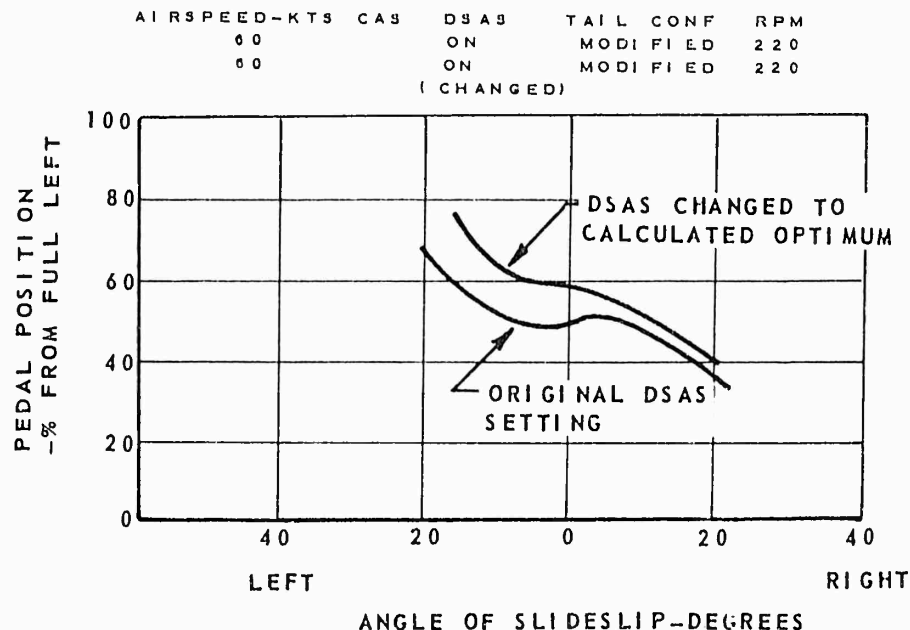

AUTOROTATION

Stability and control characteristics during autorotation are unsatisfactory. Static directional stability is unsatisfactory for both the original and modified empennage configurations. Dynamic stability and controllability are better with the original empennage than with the modified empennage.

All stability and control tests during autorotation were conducted with a center of gravity location at station 119 (mid), an average gross weight of 6000 pounds, an average density altitude of 5800 feet, and using 220 (88.7 percent) rotor rpm.

Static Stability in Autorotation:

Control positions were recorded for airspeeds of 35 to 90 knots CAS. No control limitations were found and the control position curves indicate positive static longitudinal stability. Longitudinal control position was found to vary 13 percent (1.7 inches) for the airspeed range tested.

Static directional stability was determined by recording the pedal position required to maintain various magnitudes of sideslip angle. Static directional stability during low speed autorotation with the DSAS off is unacceptable for both the original and modified empennage configurations. The original H-43B empennage configuration had better static directional stability characteristics than the modified configuration, and the stability was improved with the DSAS on for all test conditions. Static directional stability was also improved by increasing the rotor rpm and airspeed. Results of the static directional stability tests are presented in Figs. 26 through 28, Appendix I. The following figure compares the static directional stability for the modified empennage with the DSAS on and off.

With the original H-43B the static directional stability was positive at 60 knots CAS with the DSAS on. Stability became negative at low airspeeds (41

knots) with the DSAS turned off. This negative stability makes control of heading very difficult during autorotation and could result in a dangerous condition during light to moderate turbulence. Stability with the modified configuration (using the original DSAS setting) was slightly negative for  $\pm 5$  degrees of sideslip at 60 knots, 220 rotor rpm, and the DSAS on. At the same conditions with the DSAS turned off, the stability was more negative for angles up to 17 degrees left sideslip and 15 degrees right sideslip. The angle of bank during steady state sideslip was very uncomfortable.

The static directional stability characteristics are improved with the modified DSAS setting. The figure on page 14 illustrates the improvement in stability characteristics with the modified DSAS setting.

#### Dynamic Stability in Autorotation:

Longitudinal dynamic stability for the original empennage was satisfactory during autorotation. The response to small ( $1/2$  inch) forward or aft pulses was a heavily damped long period oscillation. No significant attitude or airspeed changes were noted as a result of the pulses. Longitudinal dynamic stability with either empennage configuration was essentially the same.

The H-43B has a large, and rapid nose down pitch that occurs when the throttle is chopped, or the collective is lowered. Quantitative tests to determine the magnitude of this trim change were not conducted; however, qualitative tests indicated that these pitching characteristics are improved with the modified empennage configuration for airspeeds below 60 knots CAS. There was no difference in the pitching characteristics for the two configurations at airspeeds above 60 knots. At these airspeeds an engine failure could be hazardous since under some conditions full aft cyclic is required to recover from the nose down attitude.

Dynamic lateral-directional stability characteristics during autorotation are satisfactory for both empennage configurations with the DSAS on. The oscillations resulting from artificial disturbances are well damped. Following a pedal pulse, the helicopter yaws in the direction of pedal input and then returns to trim position. A pedal input results in a slight roll response that is not objectionable. The dynamic lateral-directional stability is unsatisfactory for both empennage configurations with the DSAS off. The motion following small pedal pulses is divergent for both empennage configurations. Large opposite pedal inputs are required to stop the yawing response. With the modified configuration this divergence in yaw is accompanied by an unsatisfactory nose down pitching tendency at sideslip angles of 15 to 20 degrees. This nose down pitching tendency is considered a safety of flight hazard and the aircraft should be restricted from sideslip angles above 15 degrees during autorotation. As the nose pitches down and the bank and sideslip angles increase, the helicopter appears to be entering a snap roll type maneuver. Since the aircraft is already in an unusual attitude and the control positions are not normal for the condition, there is likely to be some confusion as to what control movements should be made to control the aircraft. (A 5)

Recovery should be made by immediate control application to return to straight co-ordinated flight and addition of power if available. Since the bank angle is opposite to the direction of turn a cross control input must be used, i.e., with a left sideslip the aircraft will be turning to the right and banked to the left; therefore, left pedal must be used to stop the right yaw and right lateral control to roll level, accompanied by aft cyclic to return the nose to a desired attitude.

### Controllability in Autorotation:

The pitching rate per inch of control displacement of the H-43B is satisfactory with both empennage configurations. For the original empennage, the longitudinal response was 10 degrees/second/inch and the maximum was reached approximately 2.0 seconds following the control displacement. This high longitudinal response is desirable for maneuvering the helicopter and controlling airspeed and attitude during the descent and landing. The pitch rate per inch of control displacement was essentially the same for airspeeds of 40 and 60 knots CAS. The pitching response following a small forward step was divergent with the nose pitching down continuously until recovery. Small aft steps resulted in a long period neutrally damped oscillation. The pitching response was divergent for all large longitudinal steps during autorotation. No rolling or yawing tendencies were noted during the longitudinal steps.

The lateral roll rate per inch of control displacement resulting from lateral step type control displacements was inadequate. For the original empennage, a 1 inch displacement resulted in a maximum rate of 8 degrees per second for both left and right control displacements at an airspeed of 60 knots CAS. The maximum rolling velocity was reached 2.0 seconds following the control displacement. The roll rate per inch of lateral control displacement of the H-43B during autorotation is relatively low. This low roll rate, coupled with the poor turning characteristics during lateral control inputs, greatly reduces the maneuverability of the helicopter during autorotational descent.

With the original empennage, the dynamic characteristics following a lateral step are very similar to those recorded during level flight. The yawing response was found to lag the rolling response by approximately 3.5 seconds. The roll and yaw motions were both in the direction of control displacement. The rolling response reached a maximum and remained constant while the yawing response increased until recovery was initiated.

The yaw rate per inch of control displacement is very similar for both empennage configurations and is considered deficient. The yaw rate of this helicopter is approximately one half that recorded for other current helicopters and the time required to reach the maximum is approximately 1 second longer. With the original empennage, the maximum yaw rate per inch of control displacement was 4.0 degrees per second and occurred approximately 1.9 seconds following control displacement. For both empennage configurations the aircraft motion following a small pedal step consisted of an immediate yaw in the direction of pedal input. Approximately 2.5 seconds following the control displacement an opposite roll response was noted. The shape of the roll and yaw rate curves are similar and both returned to essentially zero within 4.0 seconds after the pedal input. The angle of turn slowly increased to approximately 12 degrees at the end of 7.0 seconds and the bank angle was about 27 degrees. Both the angle of turn and the angle of bank were increasing when recovery was initiated. (B 1,

Typical time histories of the helicopter response to step control displacements are presented in Figs. 82 through 84, Appendix I.

### BLADE TO TAIL CLEARANCE

Blade to tail clearance is greatly improved with the modified empennage configuration and the possibility of striking a tail surface is considered very remote.

Tests were conducted on the ground in calm wind conditions. With the collective pitch full down, each control was incrementally moved from neutral until full travel was reached. For these tests each control was moved slowly and individually while the other two controls were held fixed in the neutral position. The rotor speed was varied from 220 rpm to 260 rpm.

After full control was investigated for each axis the pedal was slowly displaced to full deflection, and then the

longitudinal control was slowly moved full aft. The lateral stick was held in the neutral position. This simultaneous control test was conducted with the collective pitch control full down at 240 rotor rpm, and with the collective pitch control approximately 20 percent from full down at 220 rotor rpm. Attached frangible sticks rising 10 inches above the four vertical tail surfaces were not contacted during these tests.

Transient blade flapping from turbulence and abrupt control movements, and blade to tail clearance during side-ward and rearward flight were not determined. These tests will be conducted during the performance evaluation.

Under some of the above conditions the vertical tails could be struck with the original empennage configuration.

## CONCLUSIONS

The installation of the modified empennage configuration in the H-43B greatly increased the blade to vertical tail clearance and makes the possibility of interference very remote. Flying qualities of this helicopter with the modified empennage are acceptable for service use with the DSAS operative at the optimum calculated setting utilized during this test program. Without the DSAS functioning properly, the H-43B with the modified empennage should not be flown except for flight test or pilot familiarization with an instructor pilot aboard.

Vibration levels during high speed flight and longitudinal stability (static and dynamic) are improved with the modified empennage configuration. However, several undesirable stability and control characteristics still exist. For example, during autorotation, the static directional stability is poor with the DSAS operative and unsatisfactory with it inoperative. Autorotation is also accompanied by low lateral and directional control sensitivity and response as well as a large nose down pitching tendency following a throttle chop or a sudden reduction in collective pitch. This could

be dangerous during operations near the ground. Despite these deficient areas the autorotational capabilities are considered good due to the high rotor inertia and low rate of descent. Additional deficient stability and control areas result from forward speed being restricted by longitudinal cyclic available in level flight, and poor lateral-directional dynamic stability with the DSAS operating and unsatisfactory stability with it inoperative for all flight conditions. Low lateral and directional control sensitivity and response are also apparent in level flight.

During these tests it was found that static directional stability would vary with different control system riggings and that it is important for the contractor and/or user to closely monitor the control system rigging. A further investigation to determine the optimum DSAS setting will be made during the Category II stability and control tests at the AFFTC.

Despite the stability and control deficiencies contained in this report, the performance capabilities of the H-43B represent a significant improvement in USAF helicopter rescue capabilities at high altitudes.

# RECOMMENDATIONS

A. It is recommended that the modified empennage be placed in service use as soon as possible<sup>2</sup>, and in order to obtain the best flying qualities with this empennage configuration the following should be accomplished:

1. Flight in the H-43B be restricted to operation only with the DSAS operative (except during flight test and limited pilot familiarization with an instructor pilot) (page 7). (This has been incorporated into the Flight Manual.)

2. Increase longitudinal control so that the full high speed capability of the helicopter may be utilized and also move control position aft to decrease pilot fatigue (page 5). (The ECP is being prepared.)

3. The quality control of production rigging be closely monitored to insure the best possible static directional stability in all flight conditions with DSAS on (page 7). (This has been accomplished.)

4. The contractor conduct sufficient production flight testing to insure positive static directional stability with the DSAS on, prior to acceptance flights by the military representative (page 7). (This has been accomplished.)

<sup>2</sup>This has been accomplished on all service aircraft.

---

5. During autorotation and partial power descents the aircraft should be restricted from sideslip angles in excess of 15 degrees (page 15 ). (This is under study.)

B. In order to improve the flying qualities of the H-43B, studies should be initiated to accomplish the following:

1. Increase the lateral and directional control sensitivity and response (page 12 ). (Studies are being made.)

2. Improve the lateral-directional dynamic stability (page 4 ). (Studies and tests are being accomplished.)

3. Investigate aircraft rigging and determine the feasibility of rigging all production aircraft to give stability characteristics similar to those found in aircraft Serial Number 58-1849 (page 7 ). (This has been accomplished.)

# APPENDIX I

## data analysis methods

In this report the following flight techniques and data analysis methods were used:

1. The apparent longitudinal stability was determined by recording longitudinal control positions as a function of air-speed. The tests were conducted at a constant density altitude and the collective pitch position was changed as air-speed and longitudinal control position varied. Increased forward longitudinal control position with an increase in air-speed indicates positive longitudinal static stability. This apparent static stability is neither angle of attack nor speed stability, however, is considered important since to the pilot it is the composite longitudinal stability of the helicopter.

2. Static directional stability was evaluated by noting the pedal position required to maintain various magnitudes of sideslip angle. The helicopter was stabilized at each sideslip angle and the control positions recorded before proceeding to the next condition. The collective pitch position, aircraft heading, and rotor speed were held constant and tests were conducted on an inclined flight path. Positive static directional stability (left pedal for right sideslip and right pedal for left sideslip) is necessary for the pilot to hold a constant heading and prevent directional wandering particularly during turbulence. Under these conditions lack of positive static directional stability results in poor directional handling qualities and excessive pilot fatigue.

3. The dynamic stability was evaluated by noting the short period response of the helicopter following an artificial disturbance. The disturbance was accomplished by making a rapid control displacement approximately 1 inch from trim position, holding for approximately 1 second, then quickly returning to the trim position and holding the control fixed until recovery is necessary. Jigs were used on the controls to prevent any undesired control inputs during the maneuver. For the helicopter to have good flying qualities during turbulence it is necessary for the damping and period of the oscillations to at least conform with the requirements of MIL-H-8501, Para 3.2.11.

4. Controllability was evaluated in various flight conditions by recording the motion of the helicopter in terms of control sensitivity and control response following various size step type

control displacements. A step control input consisted of rapidly displacing the control position from the trim position and then holding the control fixed until recovery was necessary. Control sensitivity (maximum immediate angular acceleration per inch of control displacement) and control response (maximum immediate angular velocity per inch of control displacement from trim) are determined from the maximum immediate (less than 1 second) values recorded during the time history of the step displacement. The maximum values along with the time required to reach the maximum and the general shape of the curve are all utilized to determine the overall comment on the controllability of the helicopter.

Throughout the figures presented in Appendix I, the standard tail and modified tail refers to the original and modified empennage configurations described in Appendix II.

#### STABILITY AND CONTROL PLOTS

Figure No.		Page
1	Control Positions in Forward Flight	22
7	Static Directional Stability	28
29	Longitudinal Control Sensitivity	50
32	Longitudinal Response	53
36	Lateral Control Sensitivity	57
39	Lateral Response	60
43	Directional Control Sensitivity	64
46	Directional Response	67
50	Time Histories	72

FIGURE No 1  
 CONTROL POSITIONS IN FORWARD FLIGHT  
 H-45B 5N 59-1548  
 MODIFIED EMPENNAGE

SYM	FLIGHT COND	DENSITY ALT.	GROSS WT	RPM	C.G.
○	CLIMB	7200 FT	6000 LB	260	119 (MID)
△	AUTOPOSITION	7100 FT	6000 LB	220	119 (MID)

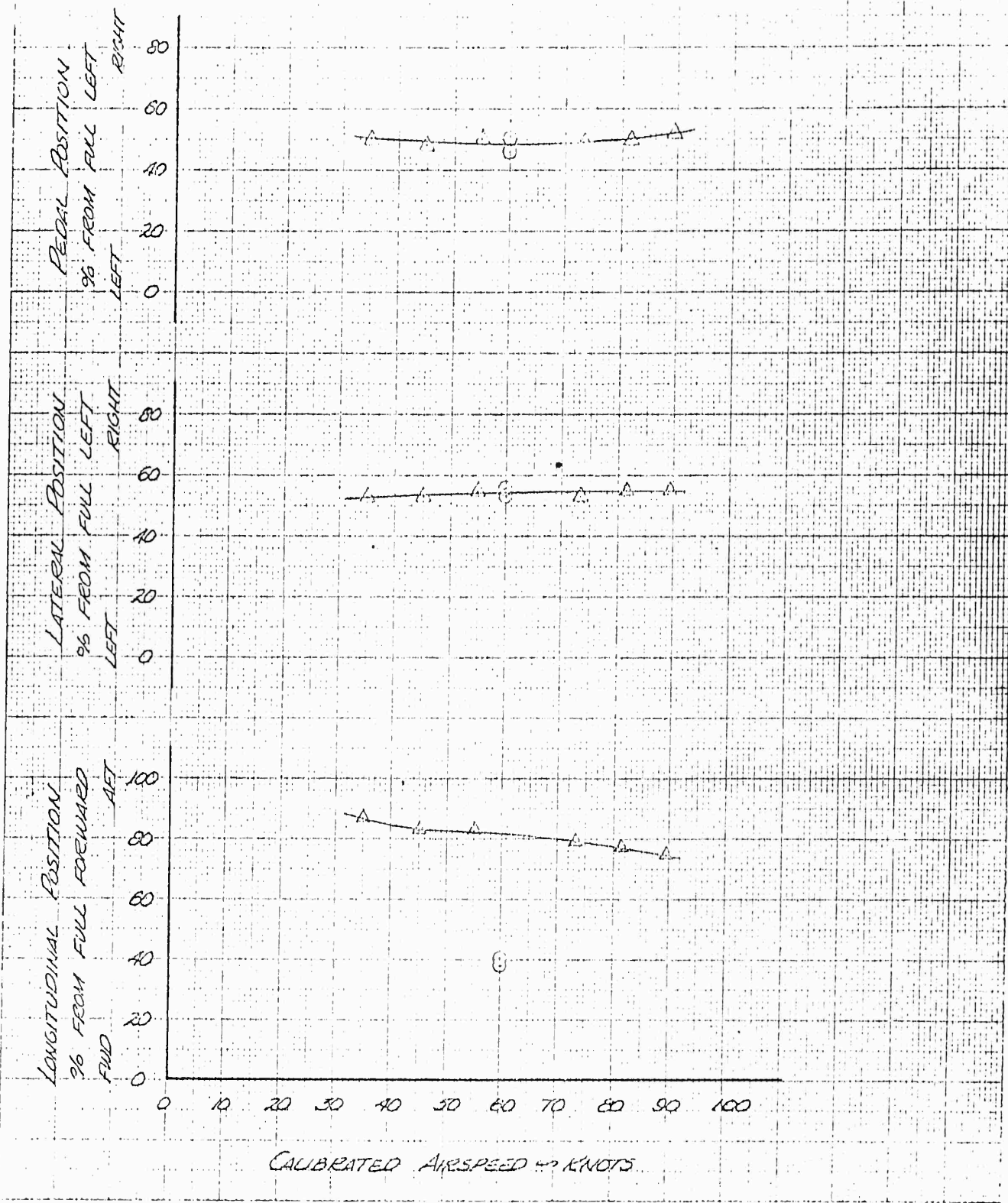

FIGURE No 2  
CONTROL POSITIONS IN FORWARD FLIGHT  
H-43B S/N 58-1849  
MODIFIED EMPENNAGE

SYM	FLIGHT COND.	DENSITY ALT.	Avg Gross Wt.	RPM	C.G.
○	LEVEL FLT	3970 FT	8150 LB	245	123(AFT)
□	LEVEL FLT	9150 FT	8190 LB	250	123(AFT)

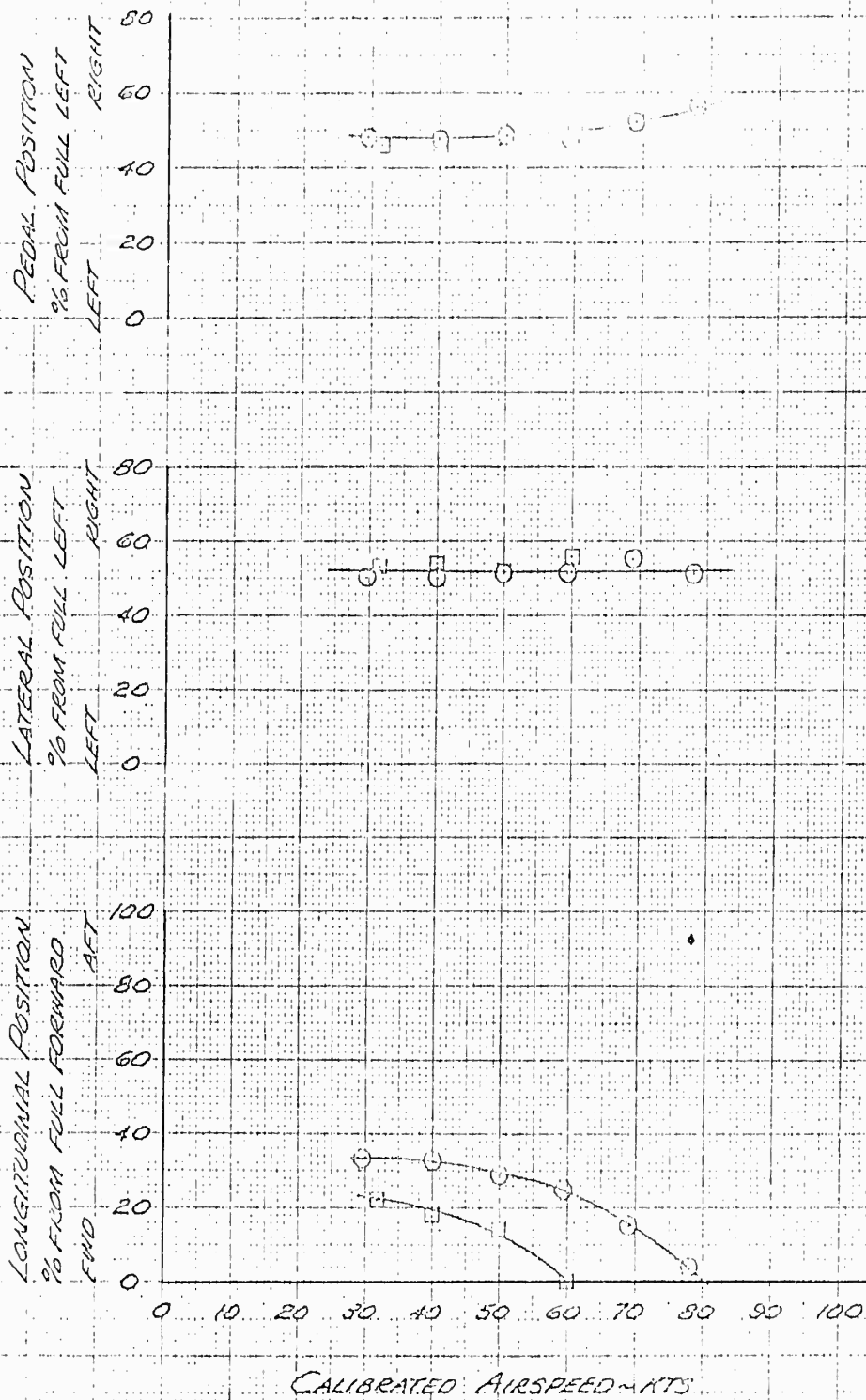

FIGURE No 3  
 CONTROL POSITIONS IN FORWARD FLIGHT  
 H-43B SN 58-1849  
 MODIFIED EMPENNAGE

SYM.	FLIGHT COND.	DENSITY ALT.	AVE. GROSS WT.	RPM	C.G.
○	LEVEL FLT.	3880 FT.	8170 LB.	260	123 (AFT)
□	LEVEL FLT.	9840 FT.	7000 LB.	260	123 (AFT)

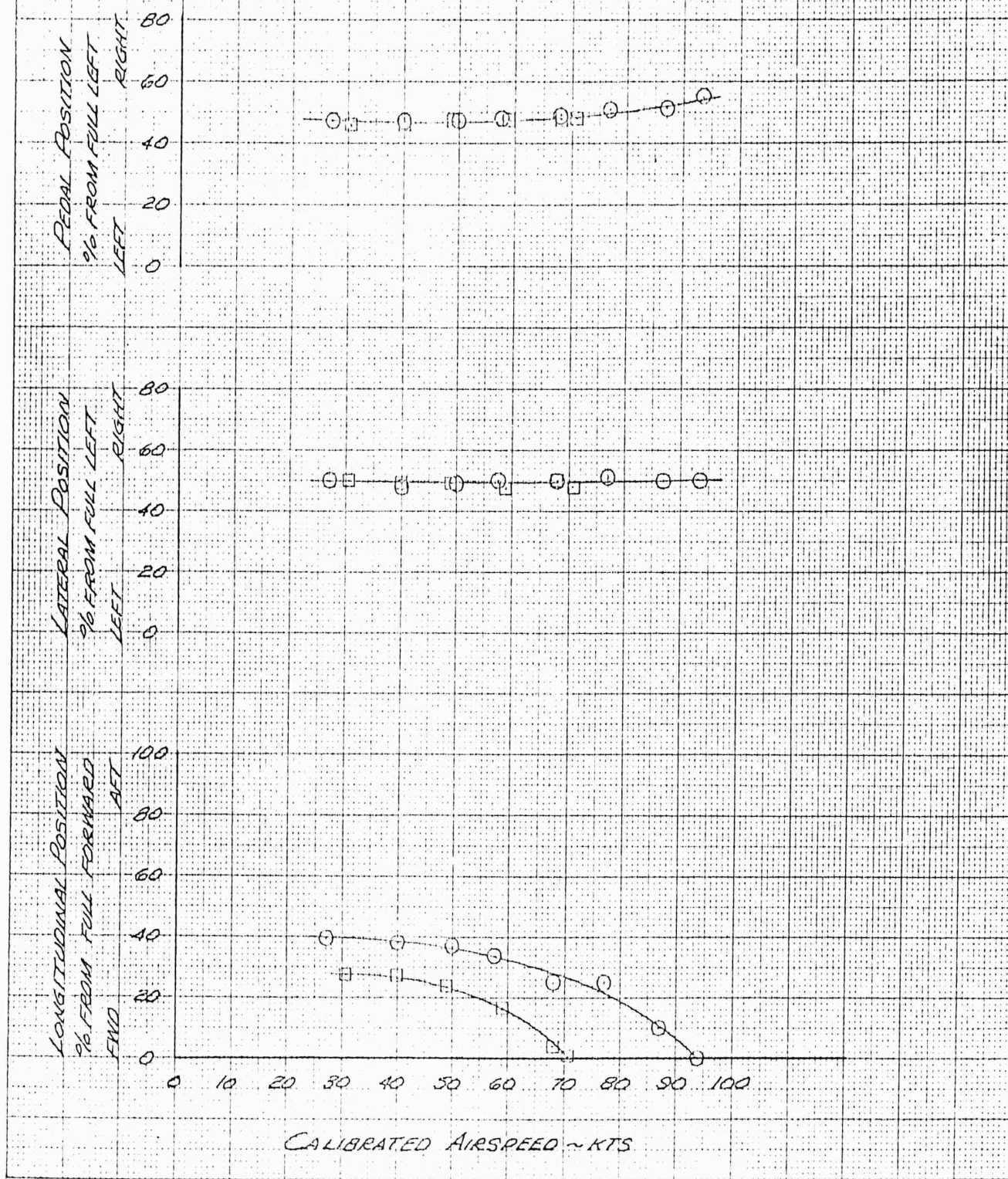

FIGURE No 4  
 CONTROL POSITIONS IN FORWARD FLIGHT  
 H-43B SN 59-154B  
 MODIFIED EMPENNAGE

SM FLIGHT COND DENSITY ALT AVE GROSS WT RPM CG  
 O LEVEL FLT 6320 FT 6000 LB 260 119 (MID)

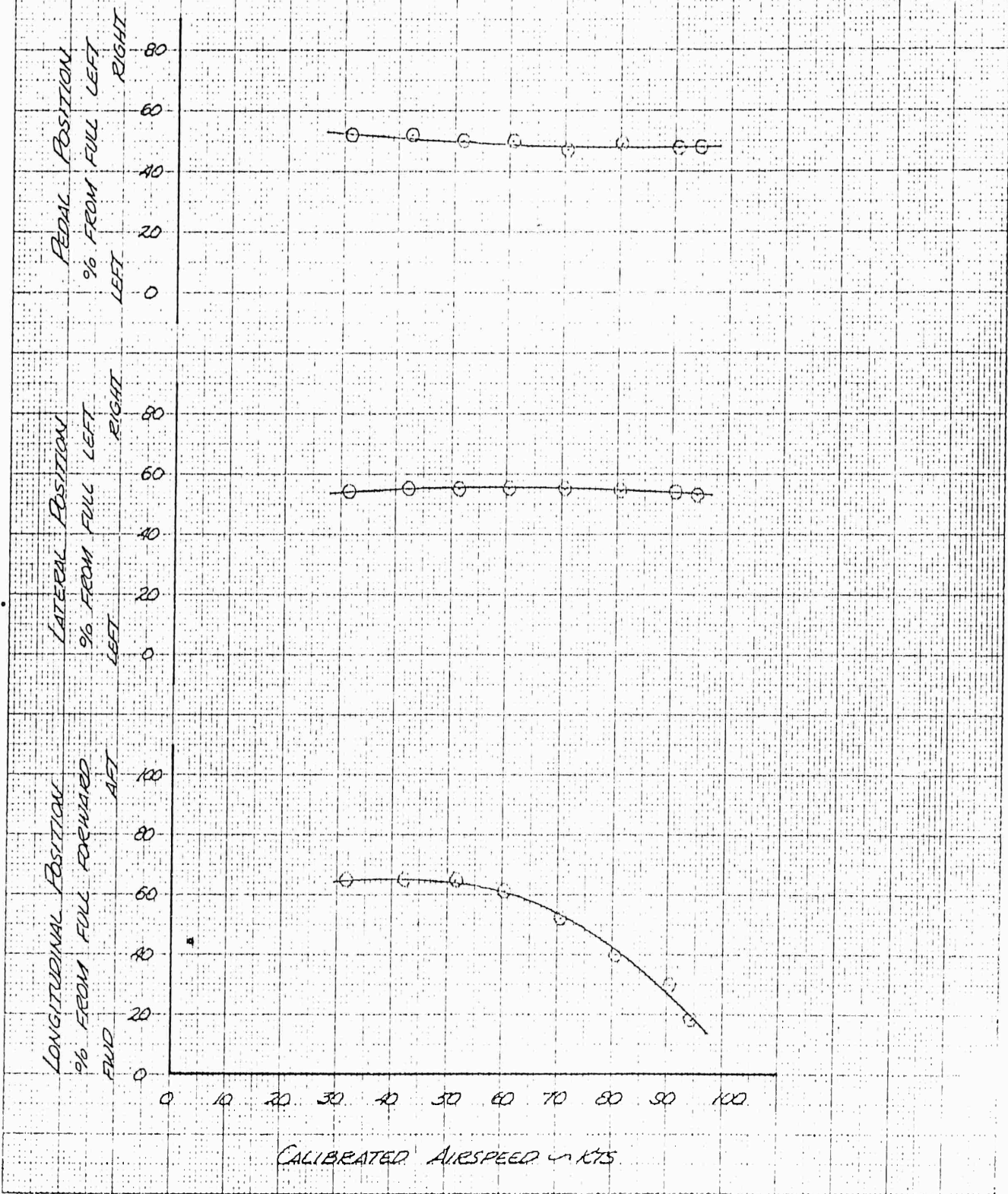

FIGURE No 5  
 CONTROL POSITIONS IN FORWARD FLIGHT  
 H-43B 5/4 53-1649  
 ORIGINAL EMPENNAGE

SYM. FLIGHT CONDITION DENSITY ALT AVE. GROSS WT RPM CG  
 O LEVEL FLIGHT 5830 FT 6080 LB 260 119 (MID)

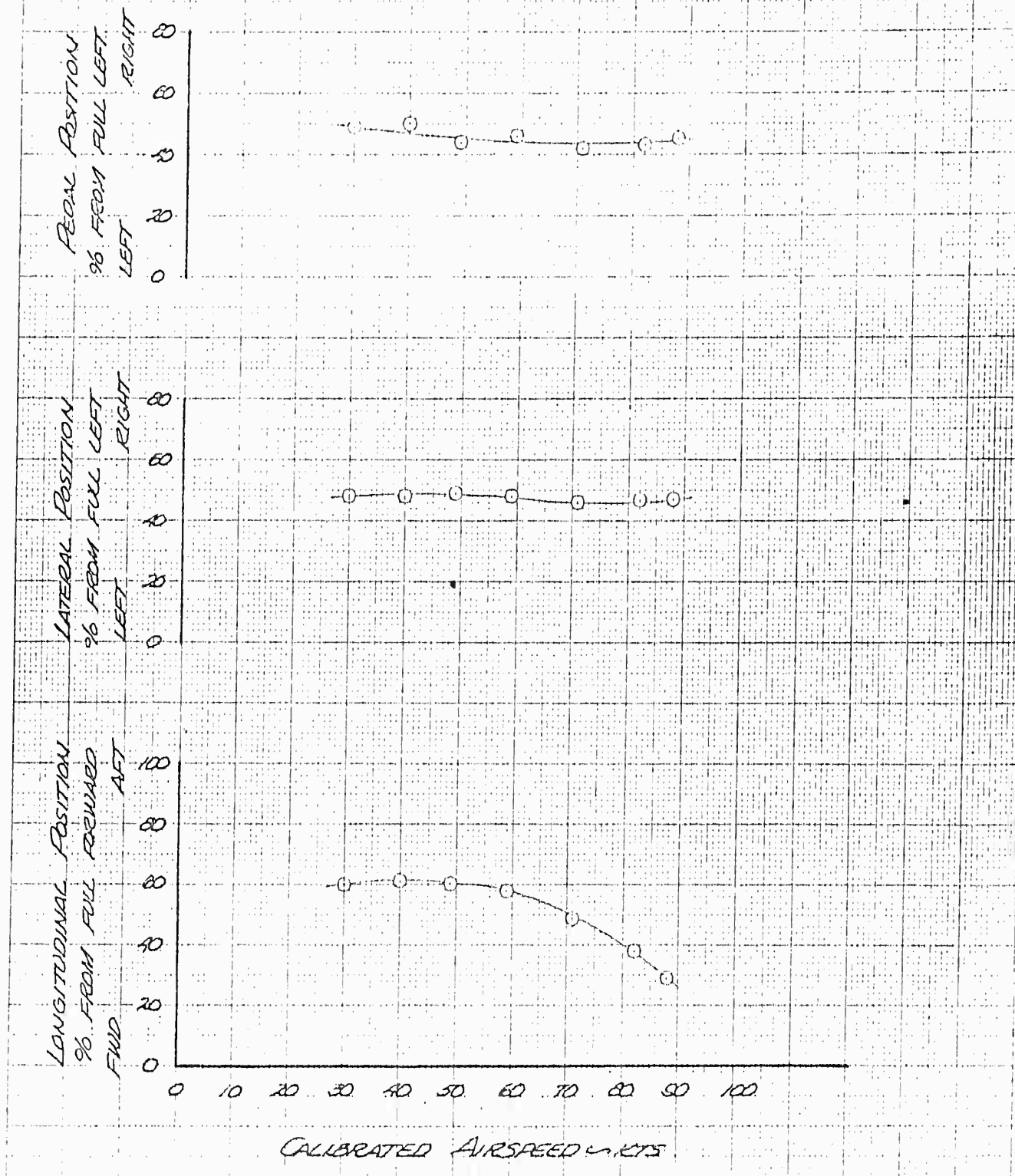

FIGURE 16 6  
 CONTROL POSITIONS IN FORWARD FLIGHT  
 H-43B 3/4 JB-1849  
 ORIGINAL EMPENNAGE

SYM FLIGHT CONDITION DENSITY ALT AVE GROSS WT RPM CG  
 O LEVEL FLIGHT 6100 FT 5970 LB 238 119(MID)

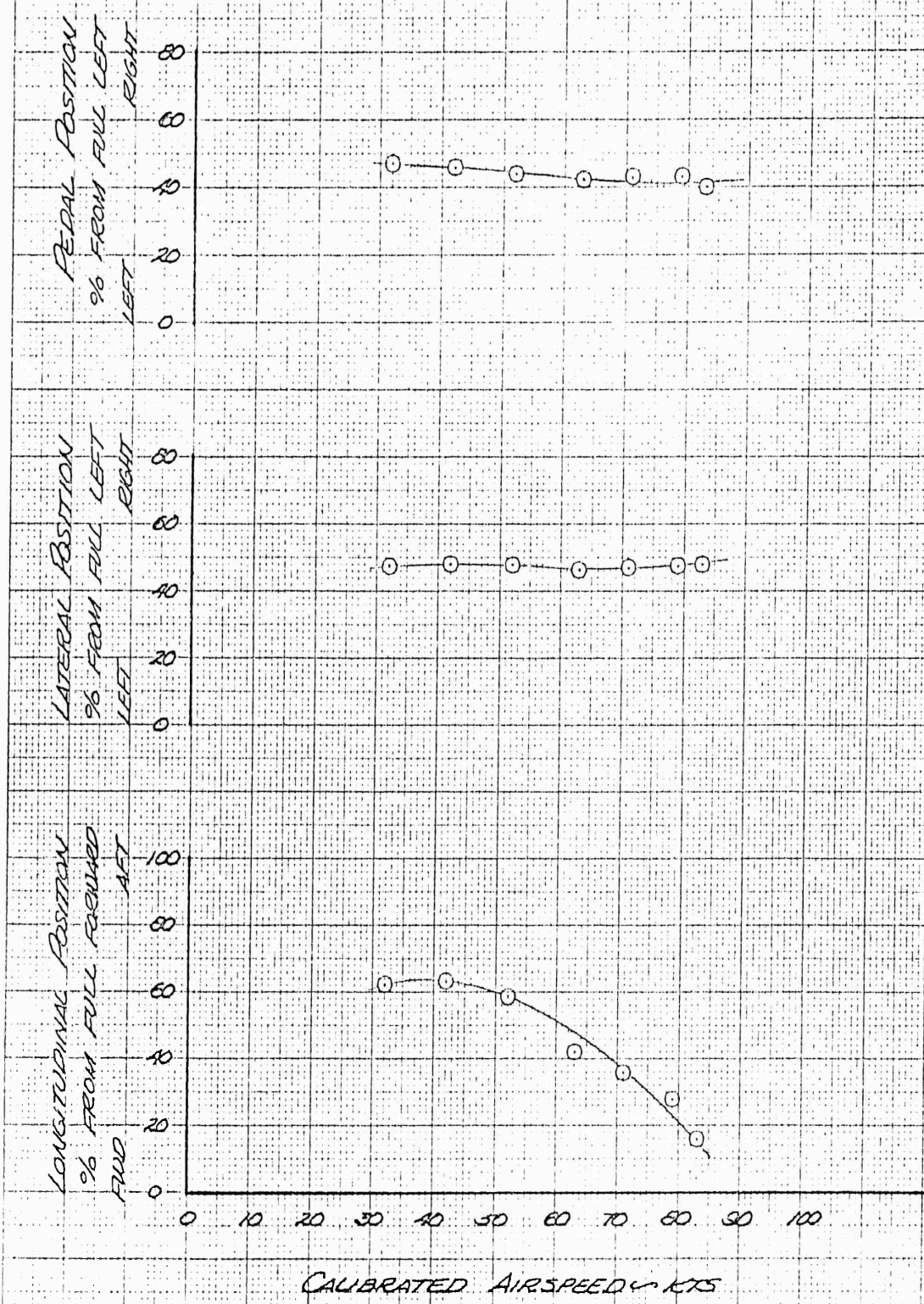

FIGURE No. 7  
 STATIC DIRECTIONAL STABILITY  
 H43B S/N 59-1548

CLIMB

SYM	CAS KTS	RPM	DECS	AVE DENSITY ALT FT	AVE GROSS WT LB	TAIL CONFIGURATION
□	60	260	ON	5200	6040	MODIFIED
□	60	260	ON	6700	5870	MODIFIED
△	60	260	ON	5300	5820	STANDARD

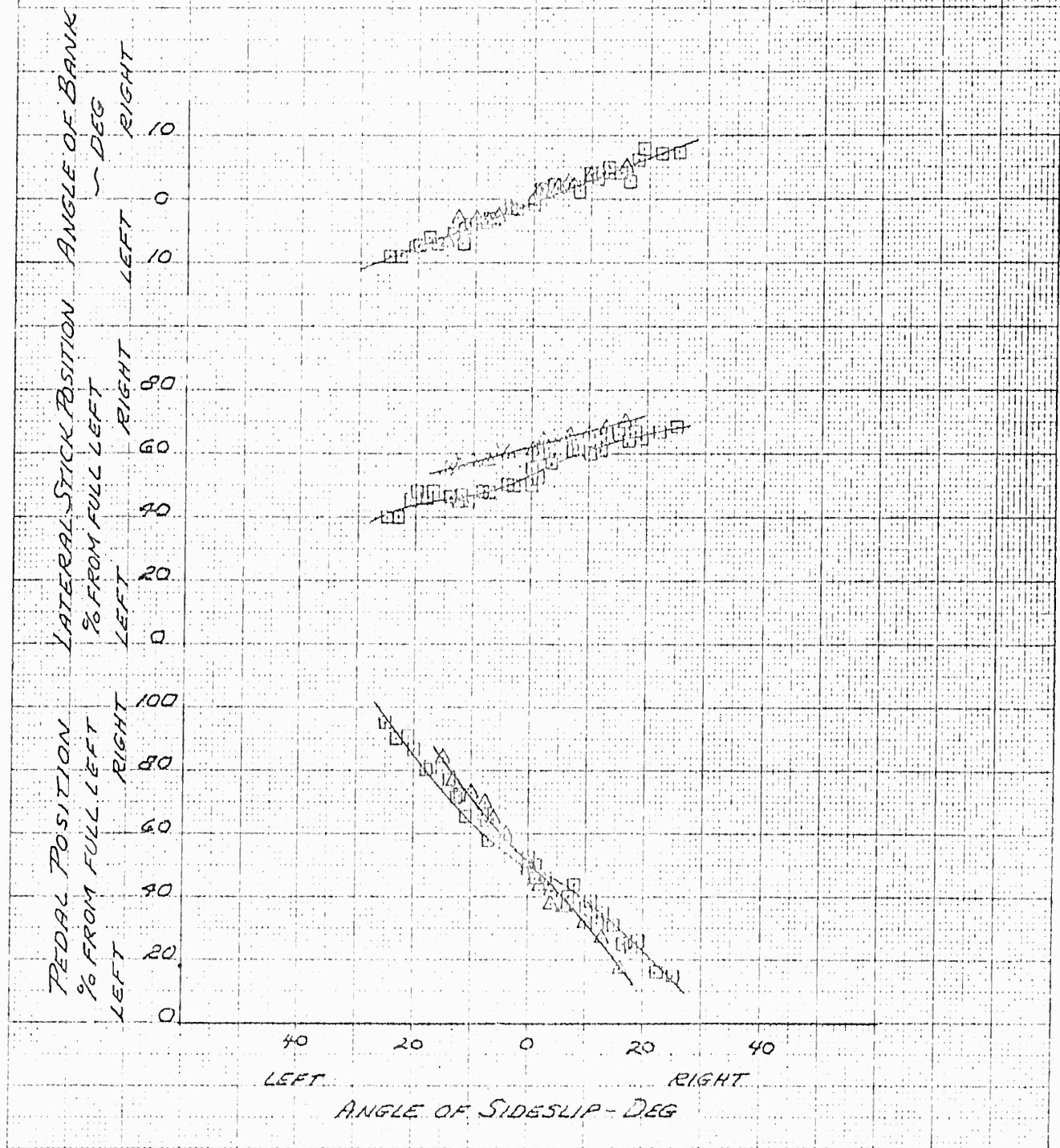

FIGURE No 8  
 STATIC DIRECTIONAL STABILITY  
 H-43B S/N 58-1849  
 AND S/N 59-1548

CLIMB

A/C S/N	SYM.	CAS KTS	RPM	DSAS	AVE DENSITY ALT FT	AVE GROSS WT LB	TAIL CONFIGURATION
1849	○	60	260	ON	6200	5830	STANDARD
1548	□	60	260	ON	5200	6040	MODIFIED
1548	□	60	260	ON	6700	5870	MODIFIED

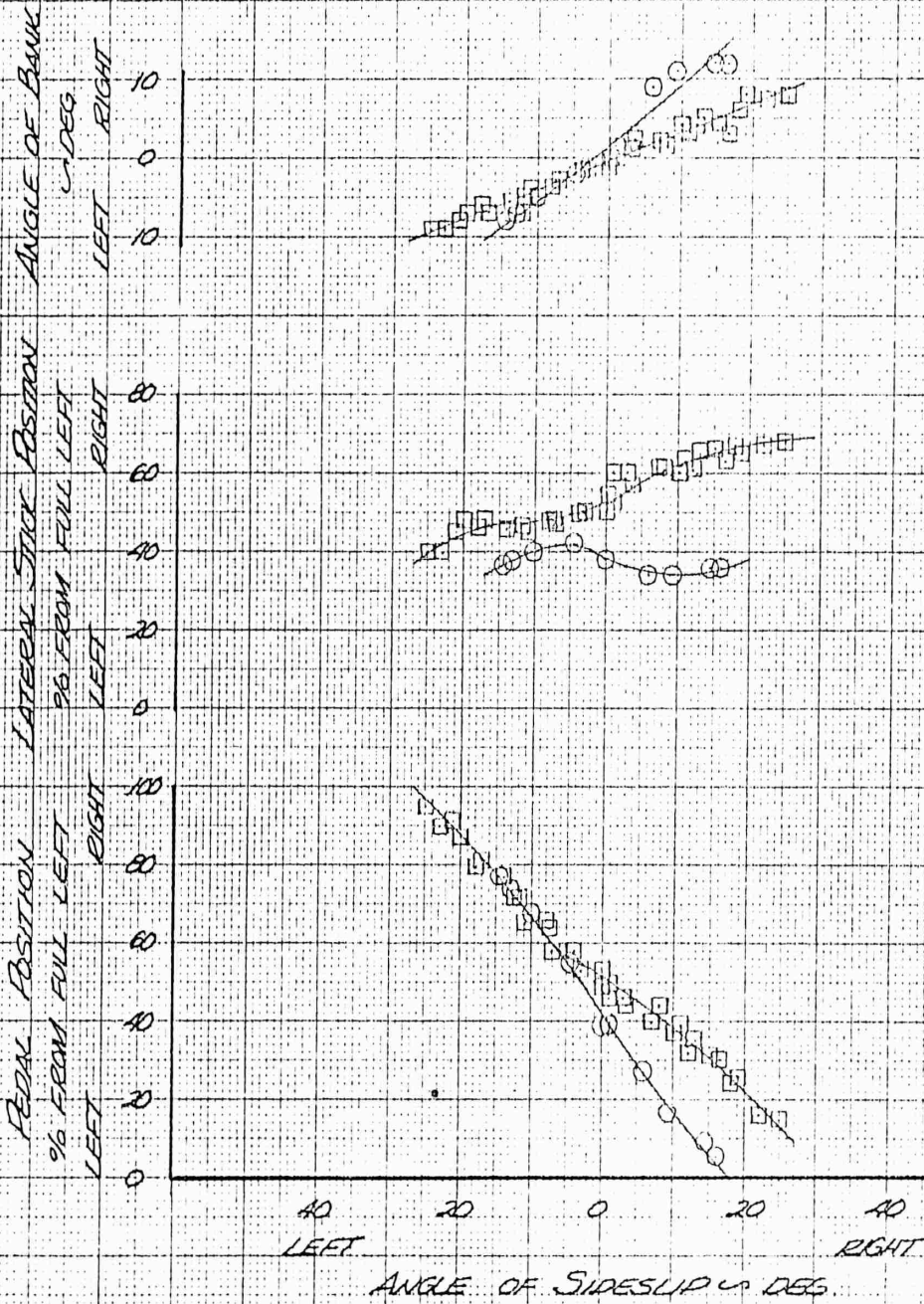

FIGURE No 9  
 STATIC DIRECTIONAL STABILITY  
 H43B SIN 59-1548

CLIMB

SYM	CAS KTS	RPM	DSAS	AVE DENSITY ALT FT	AVE GROSS WT LB	TAIL CONFIGURATION
□	60	260	OFF	5800	6000	MODIFIED
△	60	260	OFF	5300	5820	STANDARD

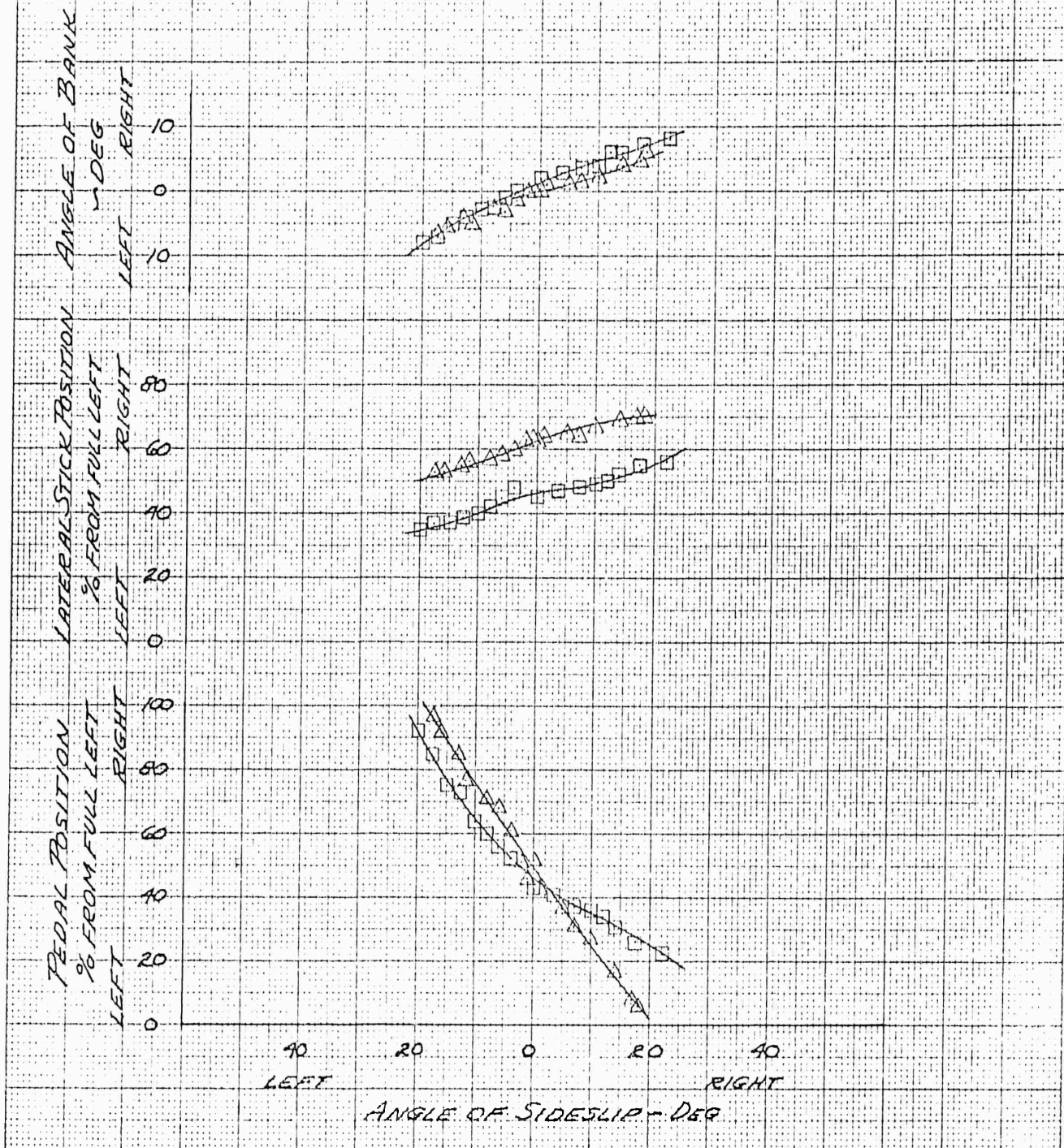

FIGURE No 10  
 STATIC DIRECTIONAL STABILITY  
 H-43B S/N 58-1849  
 AND S/N 59-1548

LEVEL FLIGHT

AK S/N	SYM	CAS KTS	RPM	DSAS	AVE DENSITY ALT <sup>ft</sup>	AVE GROSS WT <sup>lb</sup>	TAIL CONFIGURATION
1849	○	40	260	ON	5670	6020	STANDARD
1548	□	40	260	ON	6000	6100	MODIFIED

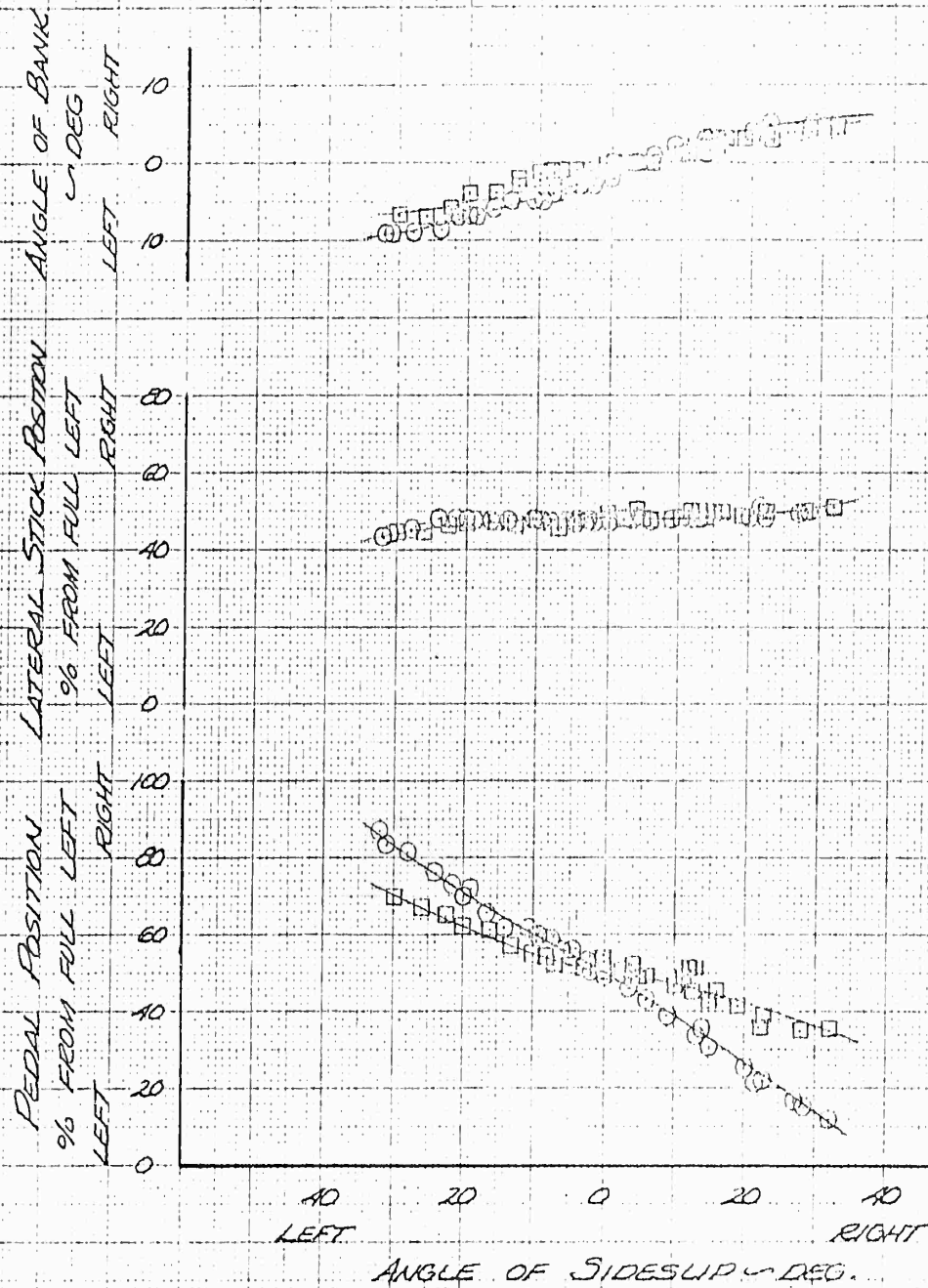

FIGURE No 11  
 STATIC DIRECTIONAL STABILITY  
 H-43B S/N 58-1849  
 AND S/N 59-1548

LEVEL FLIGHT

AC S/N	SVM	CAS KTS	RPM	DSMS	AVE DENSITY ALT FT	AVE GROSS WT LB	TAIL CONFIGURATION
1548	□	40	250	OFF	6450	6060	MODIFIED
1649	○	40	250	OFF	5840	5950	STANDARD

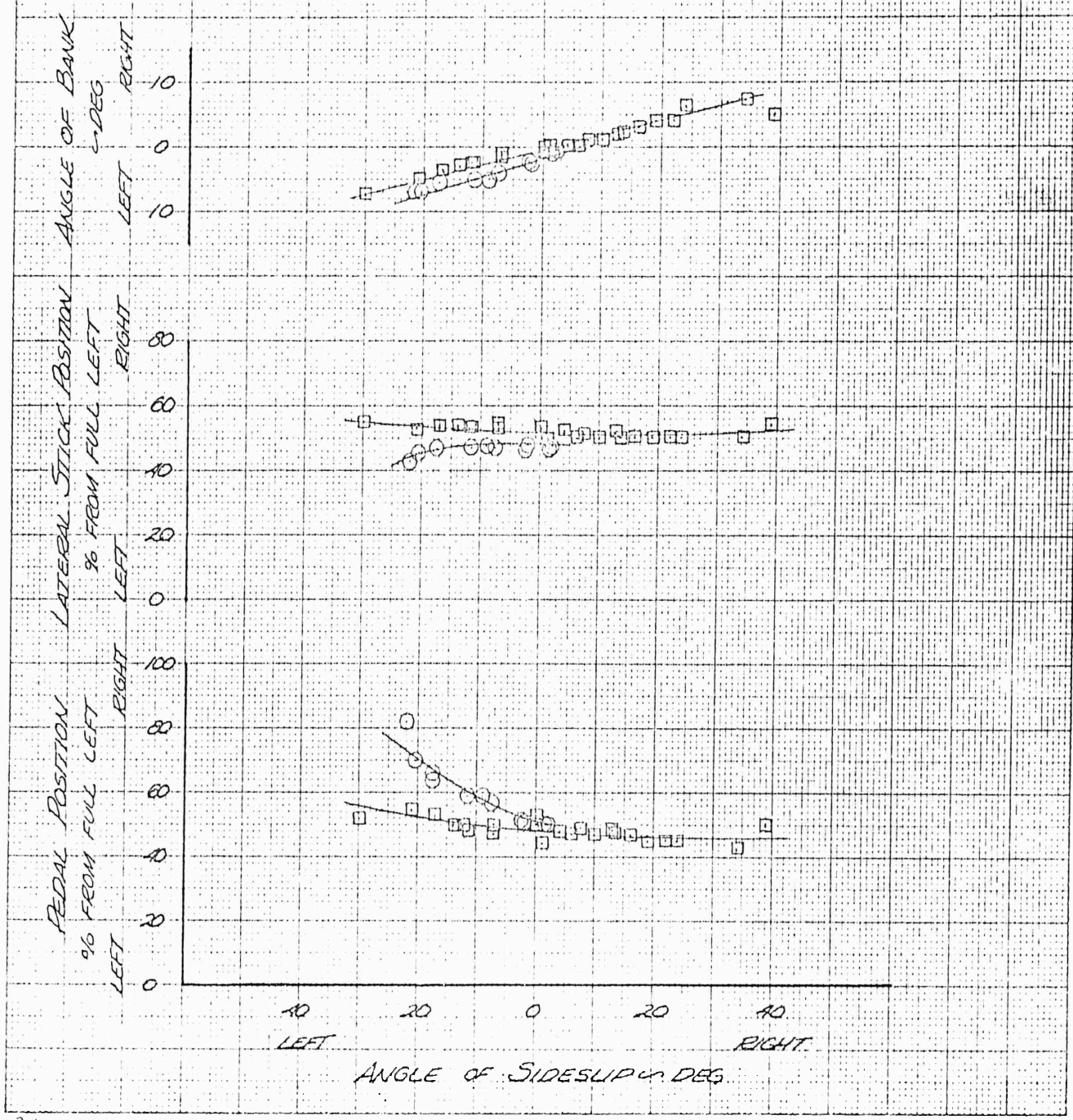

FIGURE NO 12  
 STATIC DIRECTIONAL STABILITY  
 H-43B SN 58-1349  
 AND SN 59-1548

LEVEL FLIGHT

AC SN	SYM	CAS KTS	RPM	DSAS	AVE DENSITY ALTFT	AVE GROSS INTWLB	TAIL CONFIGURATION
1849	○	40	250	ON	5360	6060	STANDARD
1548	□	40	238	ON	7000	5750	MODIFIED

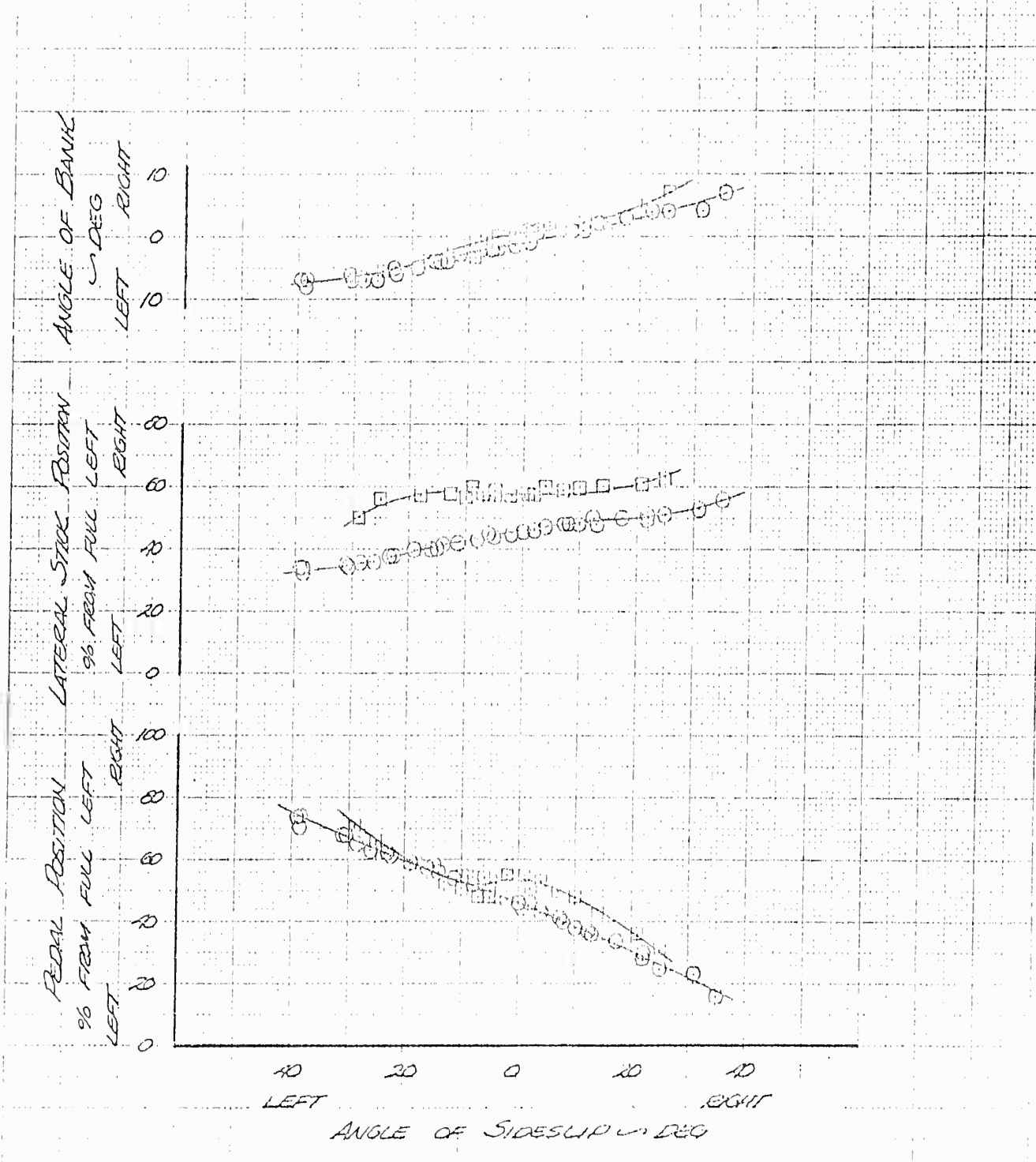

FIGURE No. 13  
 STATIC DIRECTIONAL STABILITY  
 HASE S/N 59-1548

LEVEL FLIGHT

SYM	CAS KTS	RPM	DSAS	AVE. DENSITY ALT <sup>ft</sup>	AVE. GROSS WT <sup>LB</sup>	TAIL CONFIGURATION
□	40	250	ON	7000	5750	MODIFIED
▽	40	250	QU/CHANN	5700	6000	MODIFIED
△	40	250	ON	6400	6100	STANDARD

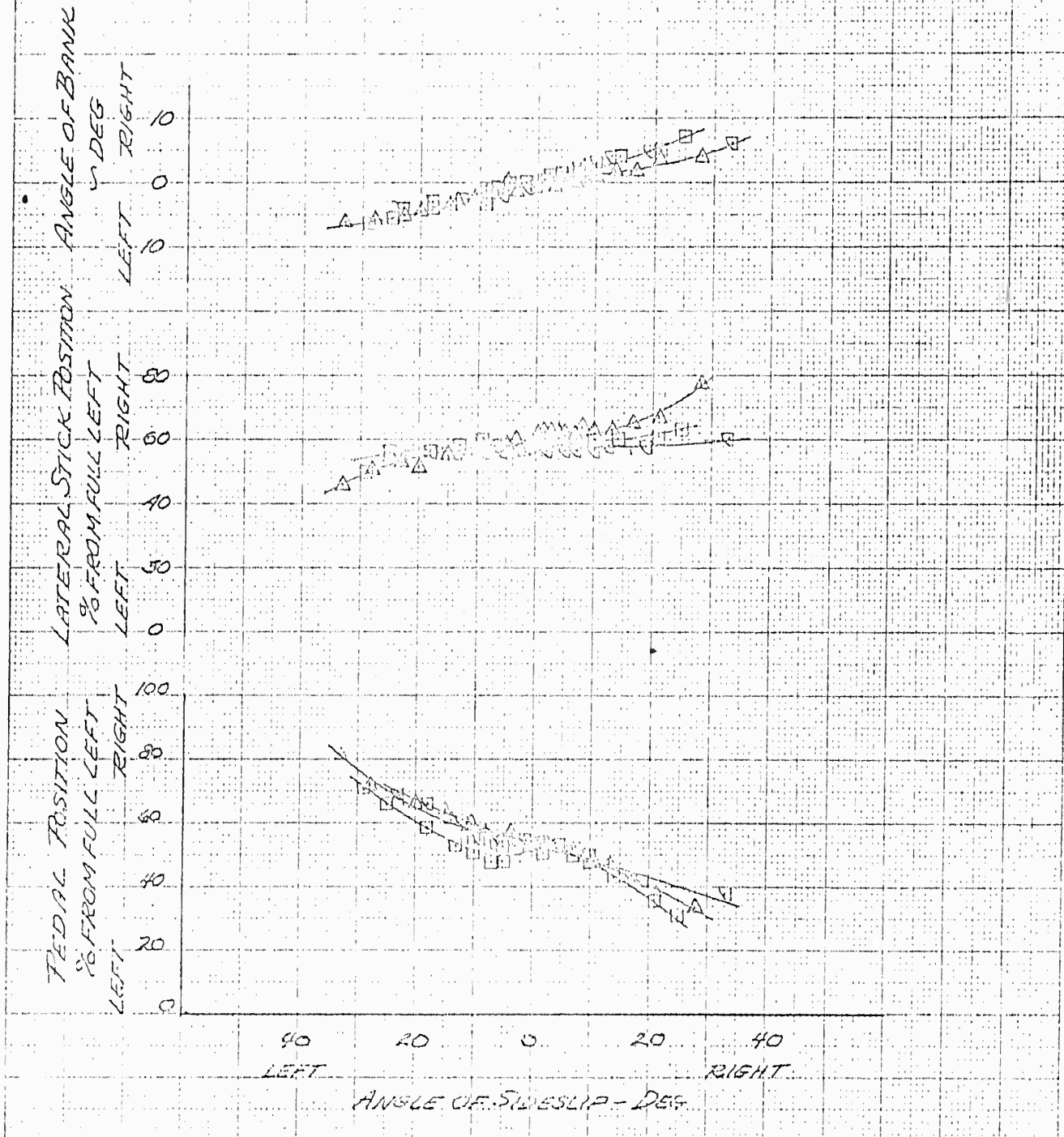

FIGURE No. 14  
 STATIC DIRECTIONAL STABILITY  
 H-43B SN 58-1849  
 AND SN 59-1548

LEVEL FLIGHT

A/C SN	SYM	CAS KTS	RPM	DSAS	AVE DENSITY ALT FT	AVE GROSS WT ALB	TAIL CONFIGURATION
1548	□	40	238	OFF	6700	5890	MODIFIED
1849	○	40	238	OFF	5000	5790	STANDARD

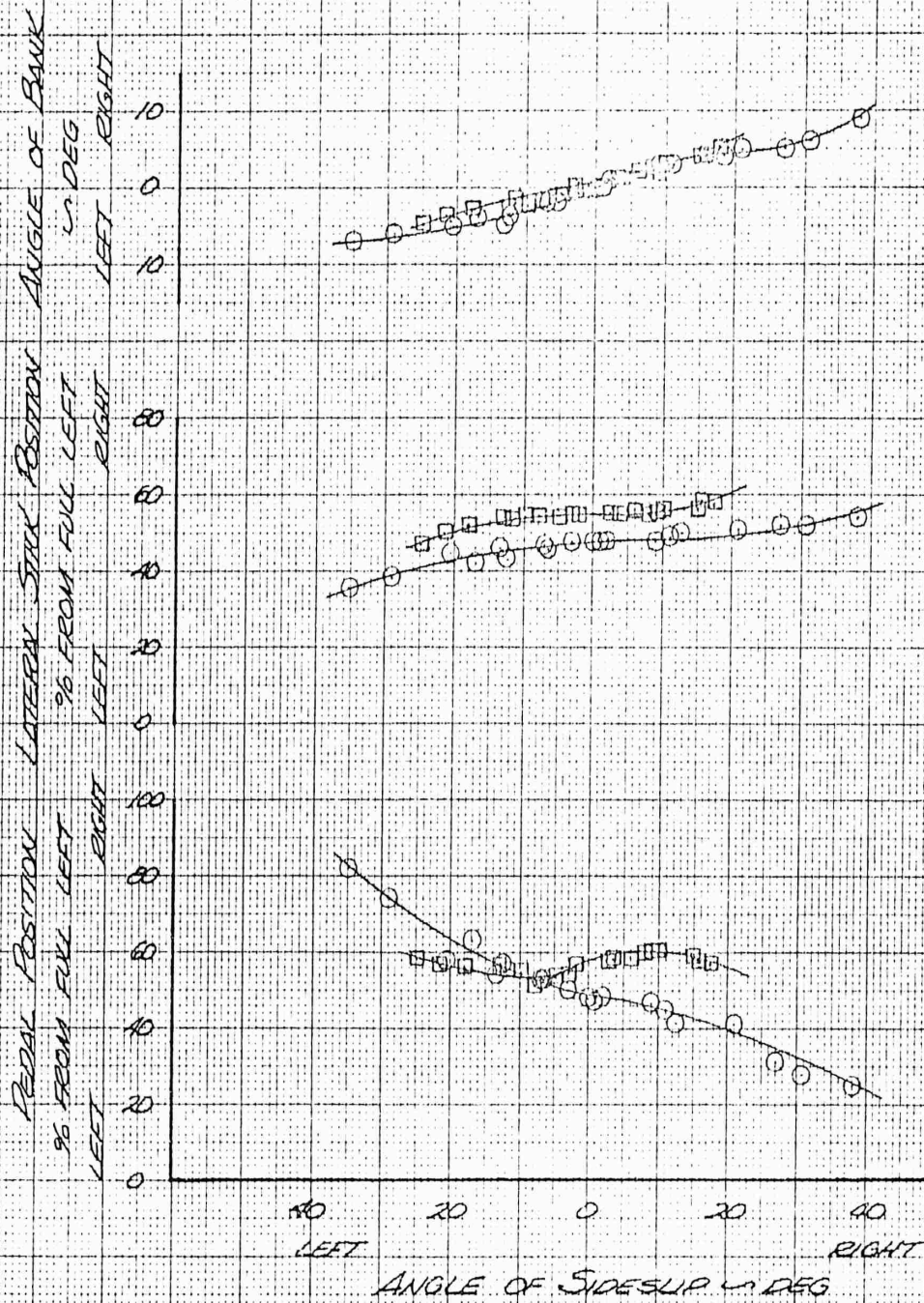

FIGURE No 15  
 STATIC DIRECTIONAL STABILITY  
 H43B S/N 59-1548

LEVEL FLIGHT

SYM	GAS MKTS	RPM	DSAS	AVE DENSITY ALT <sub>4FT</sub>	AVE GROSS INTALB	TAIL CONFIGURATION
□	40	238	OFF	6700	5890	MODIFIED
△	40	238	OFF	6100	5990	STANDARD

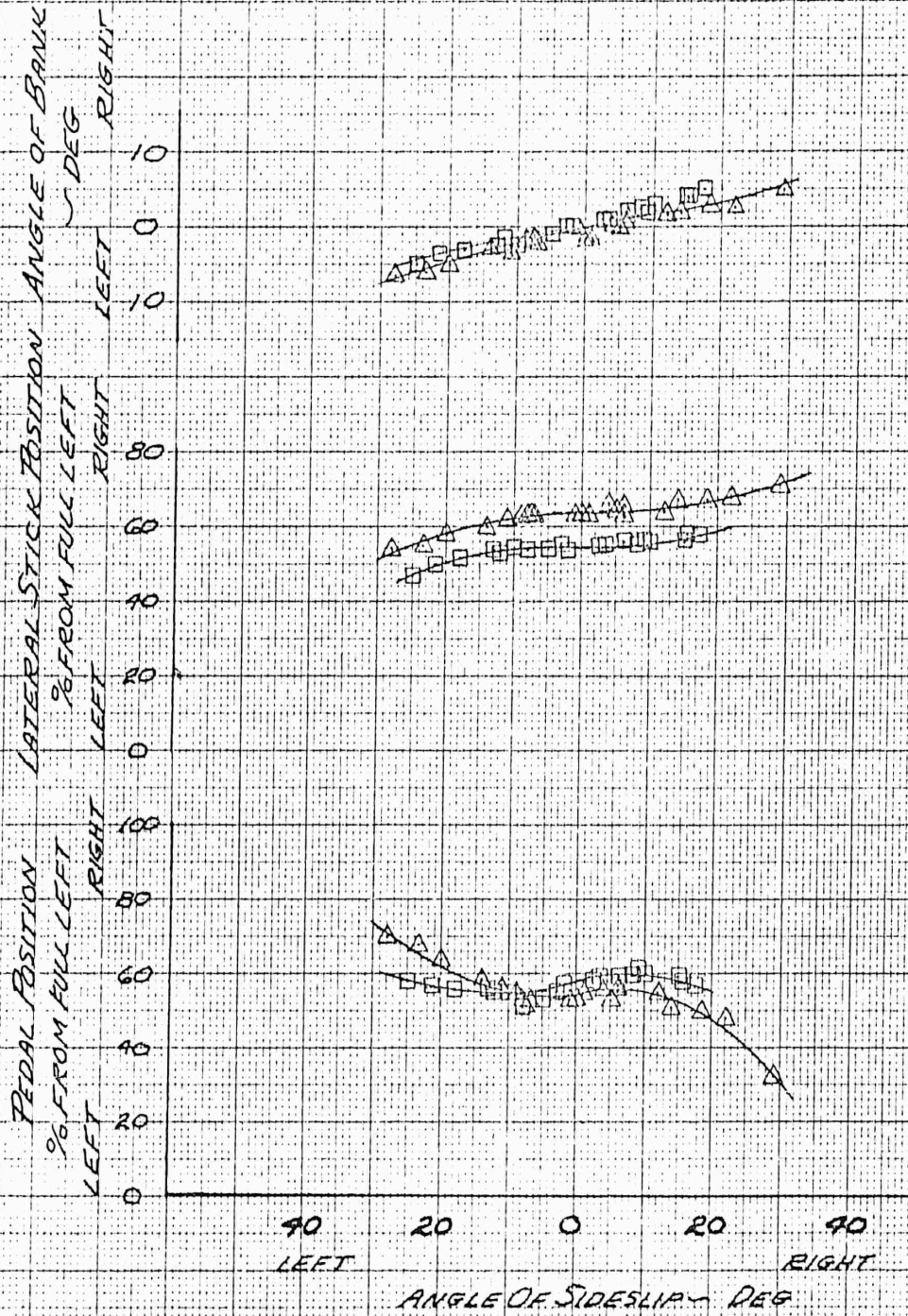

FIGURE No 16  
 STATIC DIRECTIONAL STABILITY  
 H-43B 5/1 58-1849  
 AUD 5/1 59-1548

LEVEL FLIGHT

A/C S/N	SVM CAS W/KTS	RPM	DS45	AVE DENSITY ALT WFT	AVE GROSS WT WLB	TAIL CONFIGURATION
1548	□ 60	233	ON	5350	6080	MODIFIED
1849	○ 60	233	ON	5420	5980	STANDARD

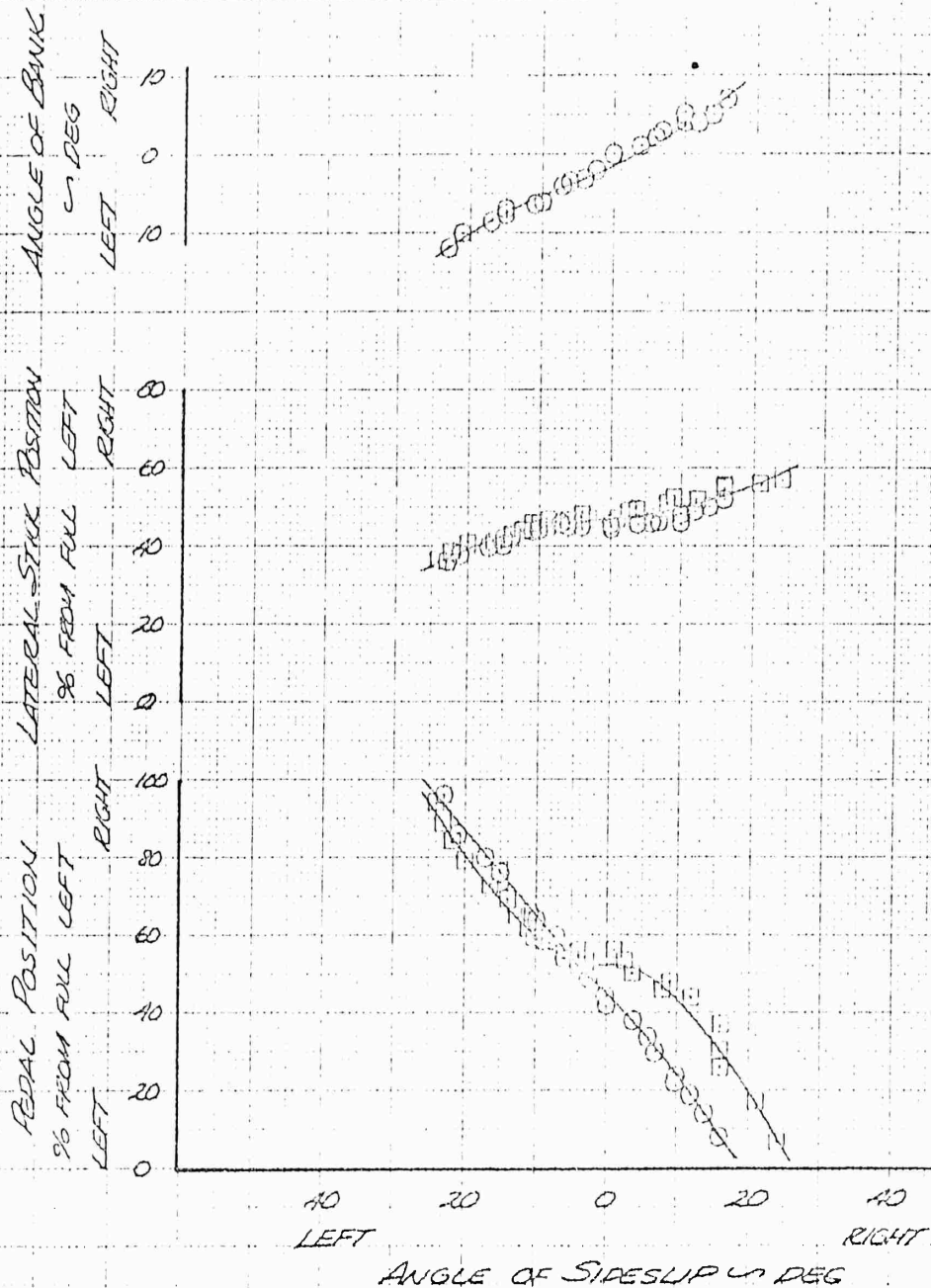

FIGURE No. 17  
 STATIC DIRECTIONAL STABILITY  
 H-43B 5/11 53-1849  
 AND 5/11 53-1548

LEVEL FLIGHT

AC 5/11	SYM.	CAS KNOTS	RPM	DRAG	AVE DENSITY ALT FT	AVE GEOS WT/LB	TAIL CONFIGURATION
1578	□	60	280	QU	6300	5350	MODIFIED
1849	○	60	280	QU	5710	6100	STANDARD

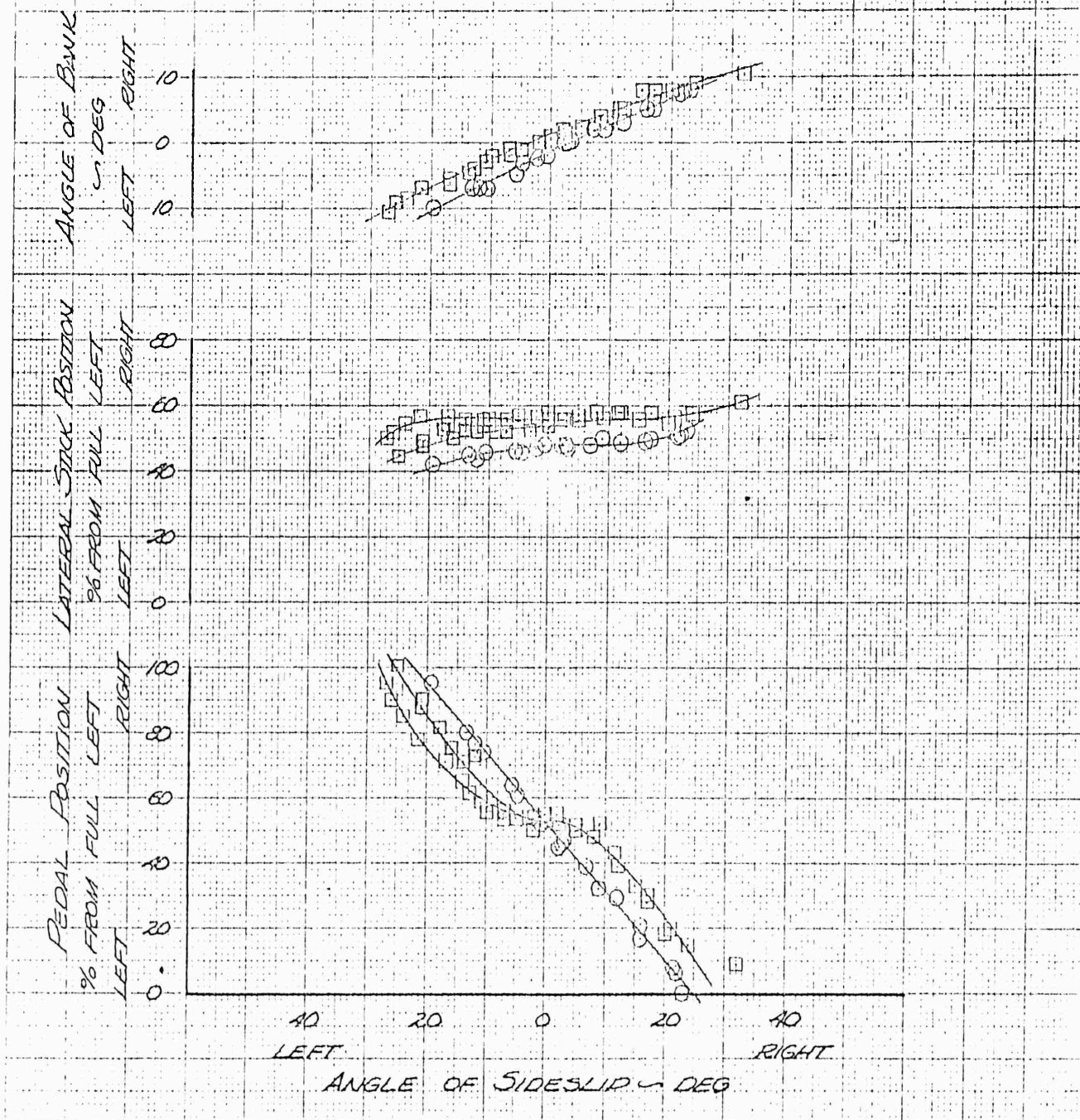

FIGURE No. 18  
 STATIC DIRECTIONAL STABILITY  
 H-43B S/N 58-1849  
 AND S/N 59-1548

LEVEL FLIGHT

A/C S/N	SVM CAS KTS	RFM	DSAS	AVE DENSITY ALT WFT	AVE GEOS. WT WLB	TAIL CONFIGURATION
1849	60	260	OFF	5600	6730	STANDARD
1548	60	260	OFF	6220	5970	MODIFIED

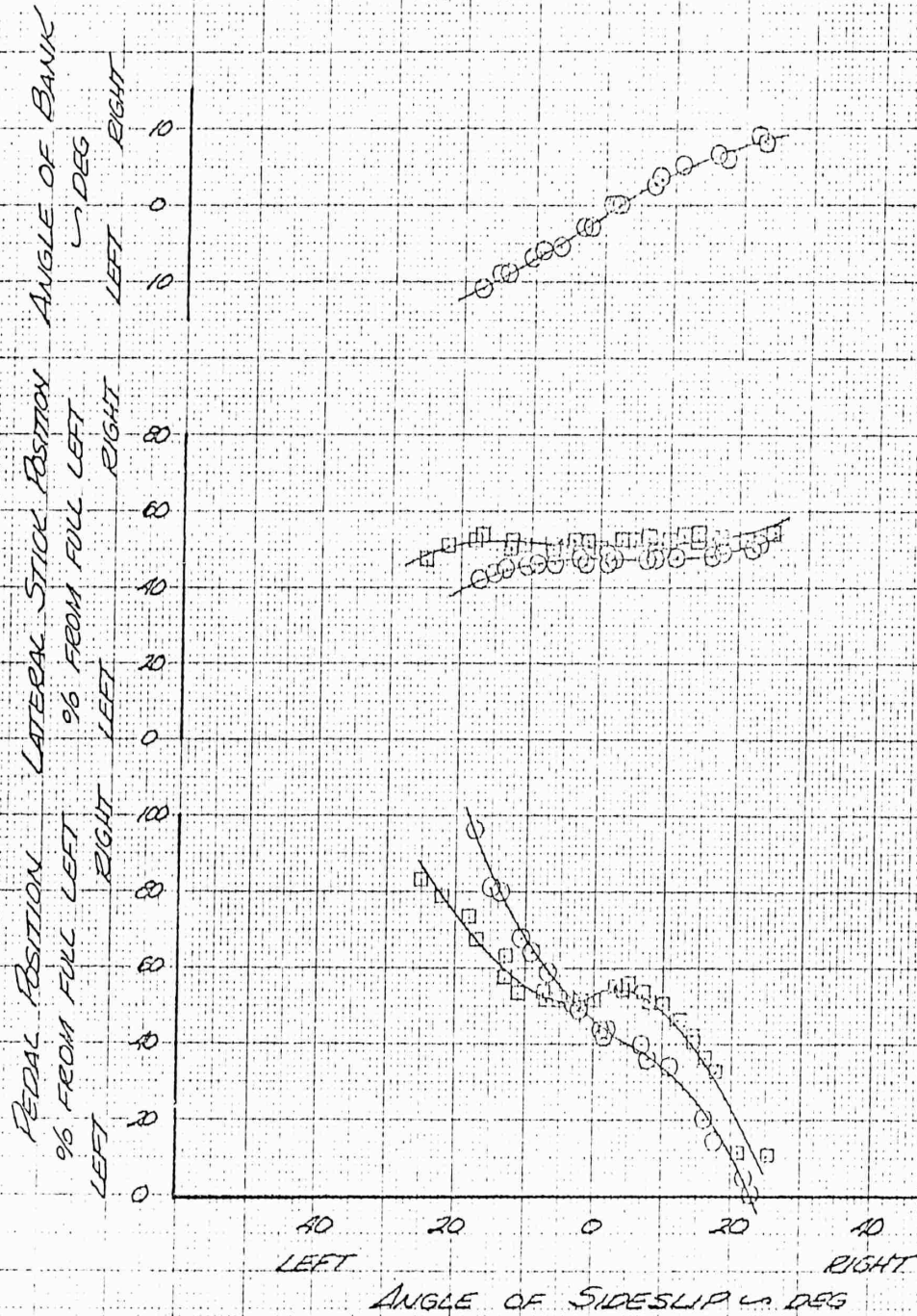

FIGURE No. 19  
 STATIC DIRECTIONAL STABILITY  
 H43B S/N 59-1548

LEVEL FLIGHT

SYM	CAS KTS	RPM	DSAS	AVE DENSITY ALT-FT	AVE GROSS WT-LB	TAIL CONFIGURATION
△	60	260	OFF	5600	6030	STANDARD
□	60	260	OFF	6220	MODIFIED	

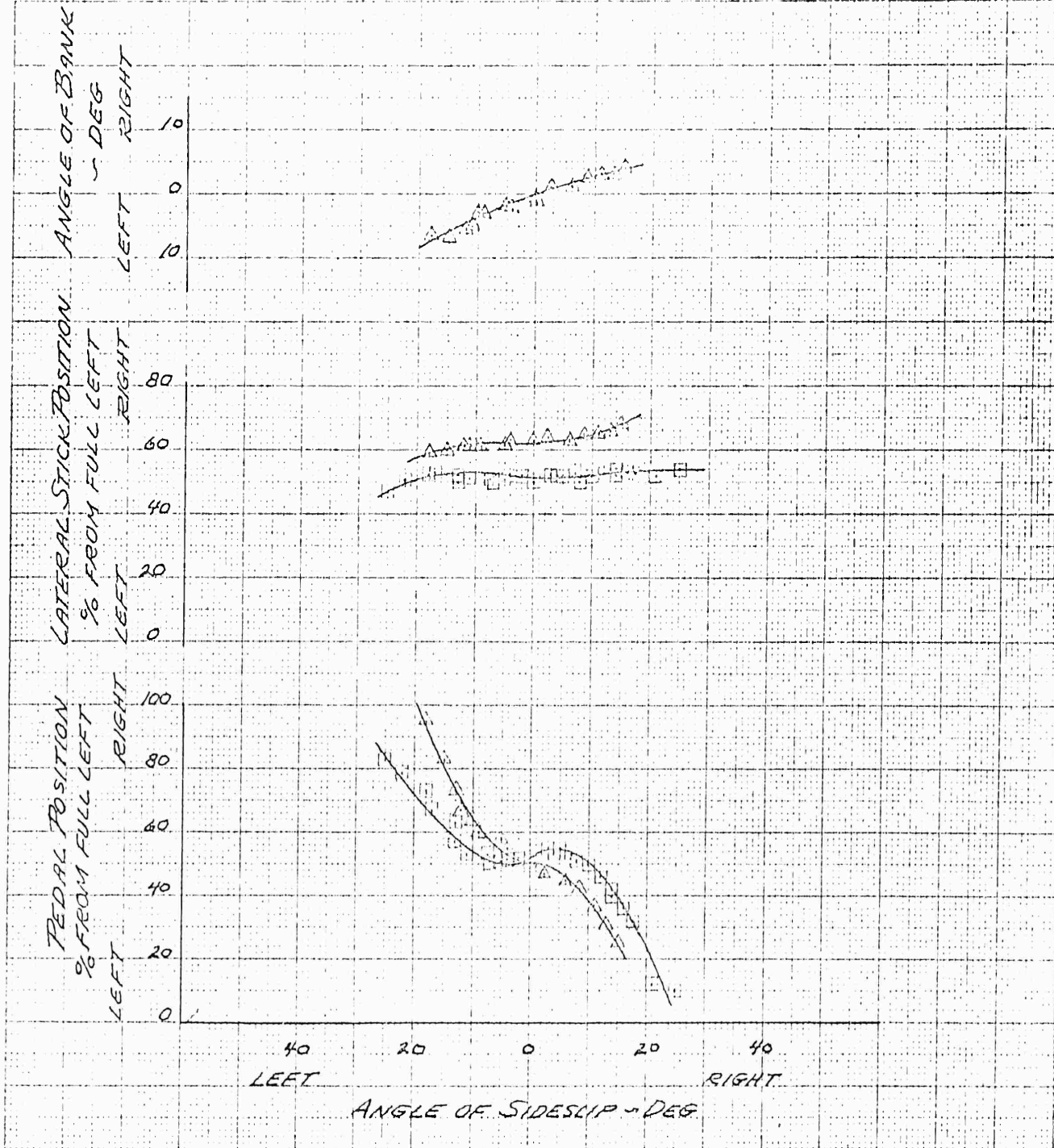

FIGURE No. 20  
 STATIC DIRECTIONAL STABILITY  
 H-43B SN 59-1548

LEVEL FLIGHT

SYM	CAS KTS	RPM	DSAS	AVE DENSITY ALT FT	AVE GROSS WT LB	TAIL CONFIGURATION
□	60	238	ON	5650	6080	MODIFIED
▽	60	238	ON (CHANGED)	5900	6100	MODIFIED
△	60	238	ON	6600	6090	STANDARD

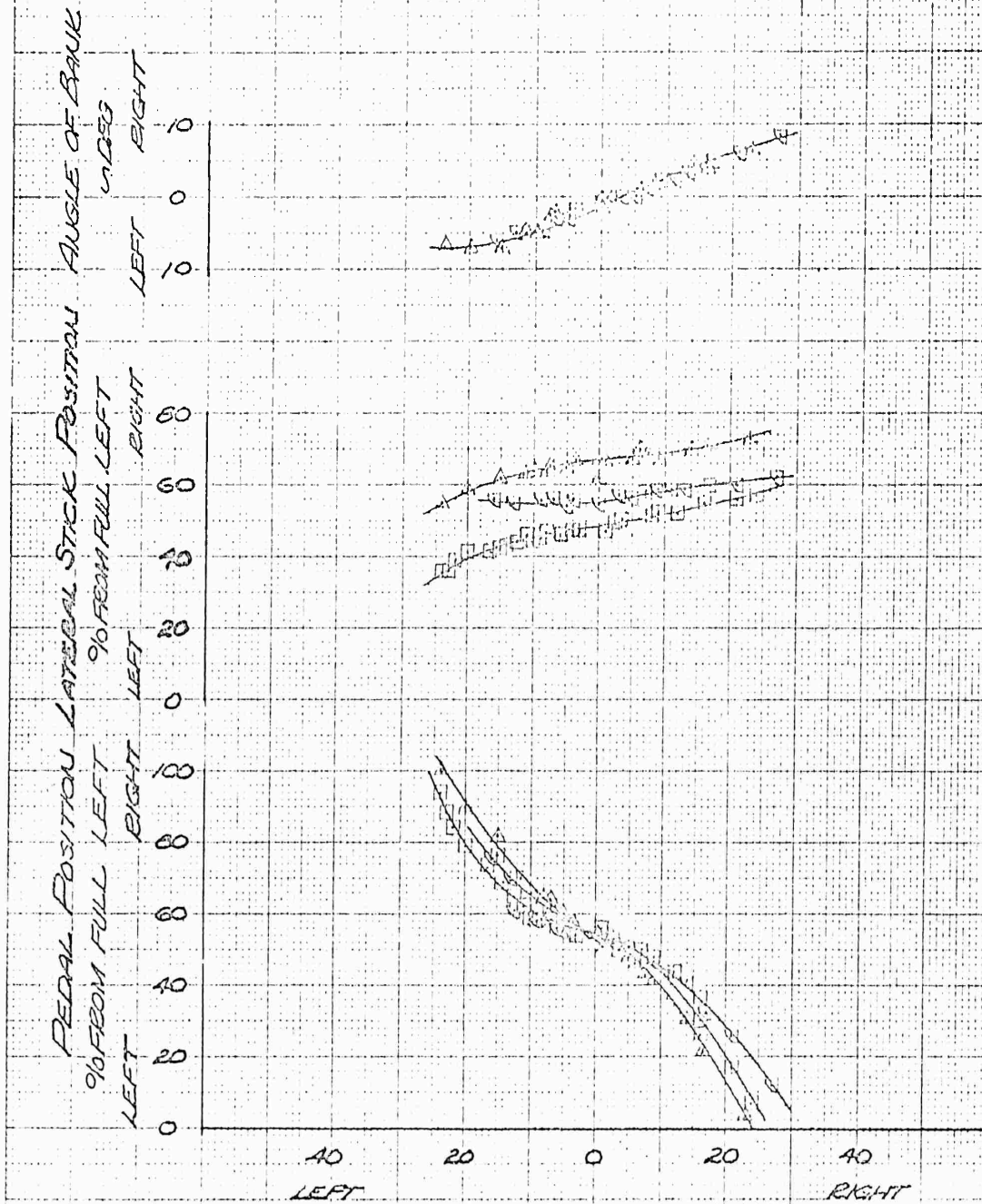

FIGURE No. 21  
 STATIC DIRECTIONAL STABILITY  
 H-43B S/N 58-1849  
 AUC S/N 59-1548

LEVEL FLIGHT

AUC S/N	SVM	CAS KTS	RPM	DSAS	AVE DENSITY ALT WFT	AVE GROSS WT LBS	TAIL CONFIGURATION
1548	□	60	238	OFF	5900	5950	MODIFIED
1849	○	60	238	OFF	4800	5350	STANDARD

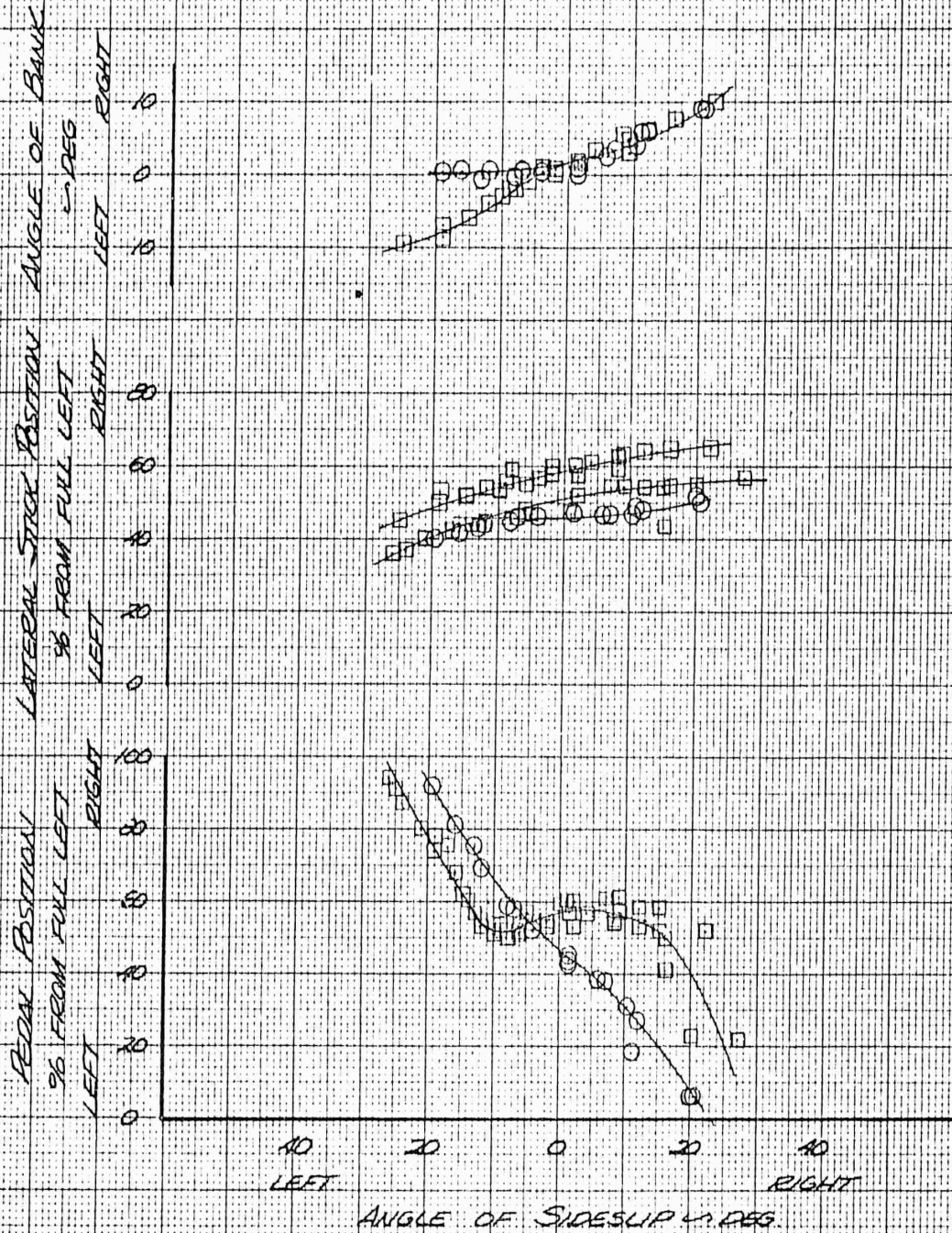

FIGURE NO 22  
 STATIC DIRECTIONAL STABILITY  
 H43B SIN 59-1548

LEVEL FLIGHT

SYM	CAS KTS	RPM	DSAS	AVE DENSITY ALT WFT	AVE GROSS WT WLB	TAIL CONFIGURATION
□	60	238	OFF	5900	5950	MODIFIED
△	60	238	OFF	6400	6030	STANDARD

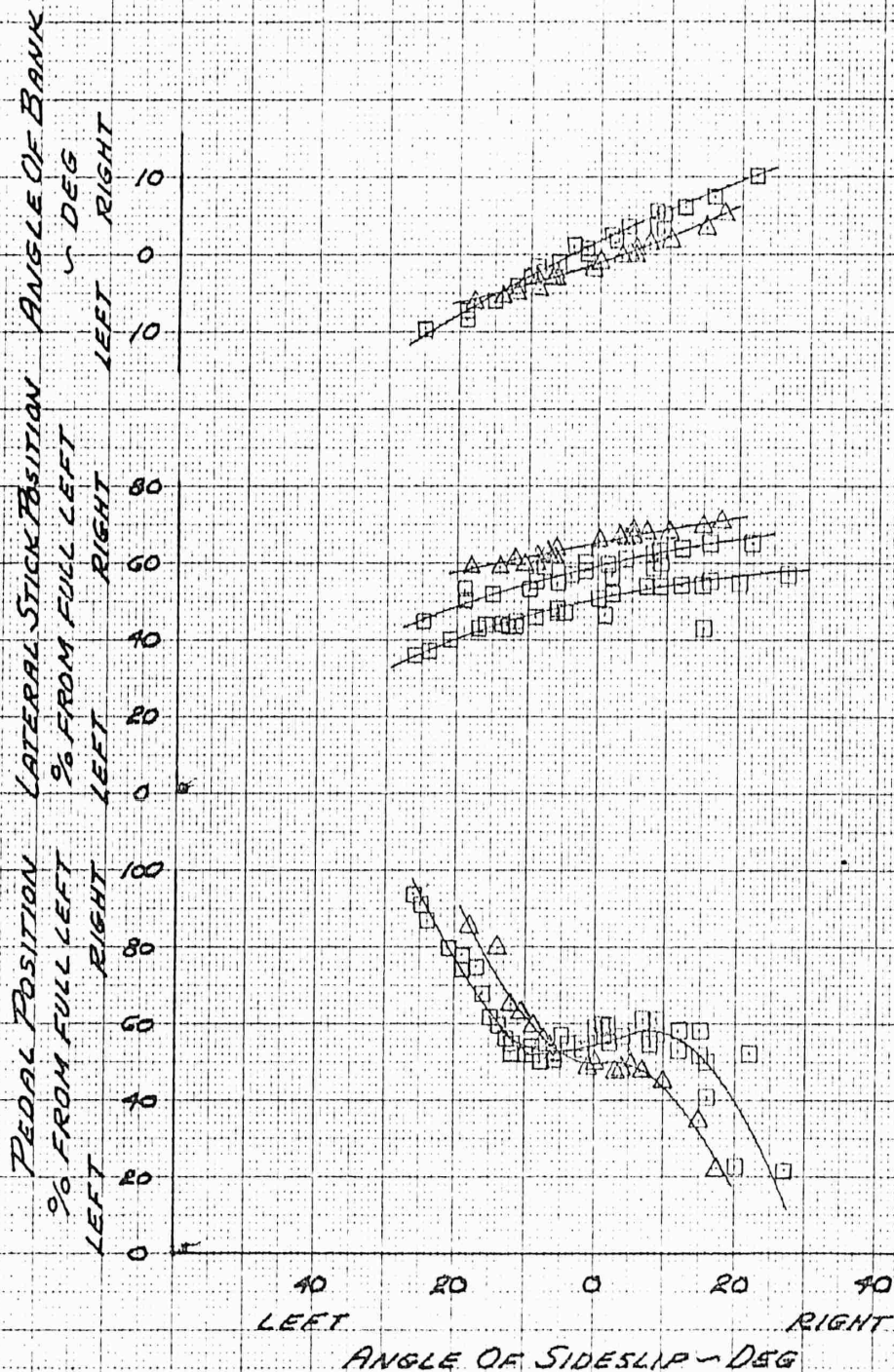

FIGURE No 23  
 STATIC DIRECTIONAL STABILITY  
 H-43B S/N 58-1849  
 AND S/N 59-1548

LEVEL FLIGHT

ALC S/N	SYM	CAS KTS	RPM	DSAS	AVE DENSITY ALT FT	AVE GROSS WT LBS	TAIL CONFIGURATION
1548	□	80	260	OFF	5850	6090	MODIFIED
1849	○	80	260	OFF	5900	6030	STANDARD

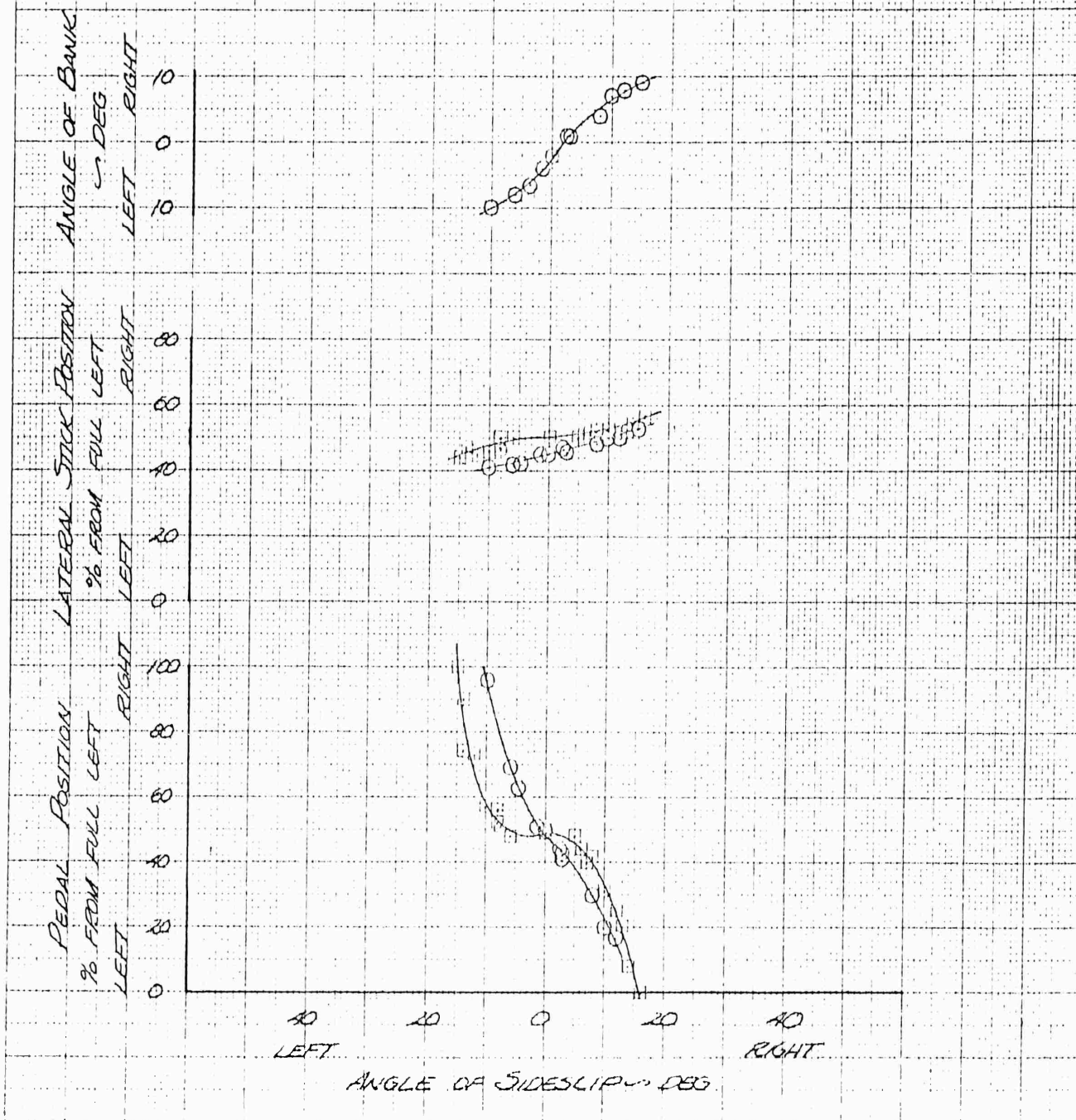

FIGURE NO 24  
 STATIC DIRECTIONAL STABILITY  
 H43B S/N 59-1548

LEVEL FLIGHT

SYM	CAS KTS	RPM	DSAS	AVE DENSITY ALT <sup>4</sup> FT	AVE GROSS WT <sup>4</sup> LB	TAIL CONFIGURATION
□	80	260	OFF	5850	6090	MODIFIED
△	80	260	OFF	6300	5850	STANDARD

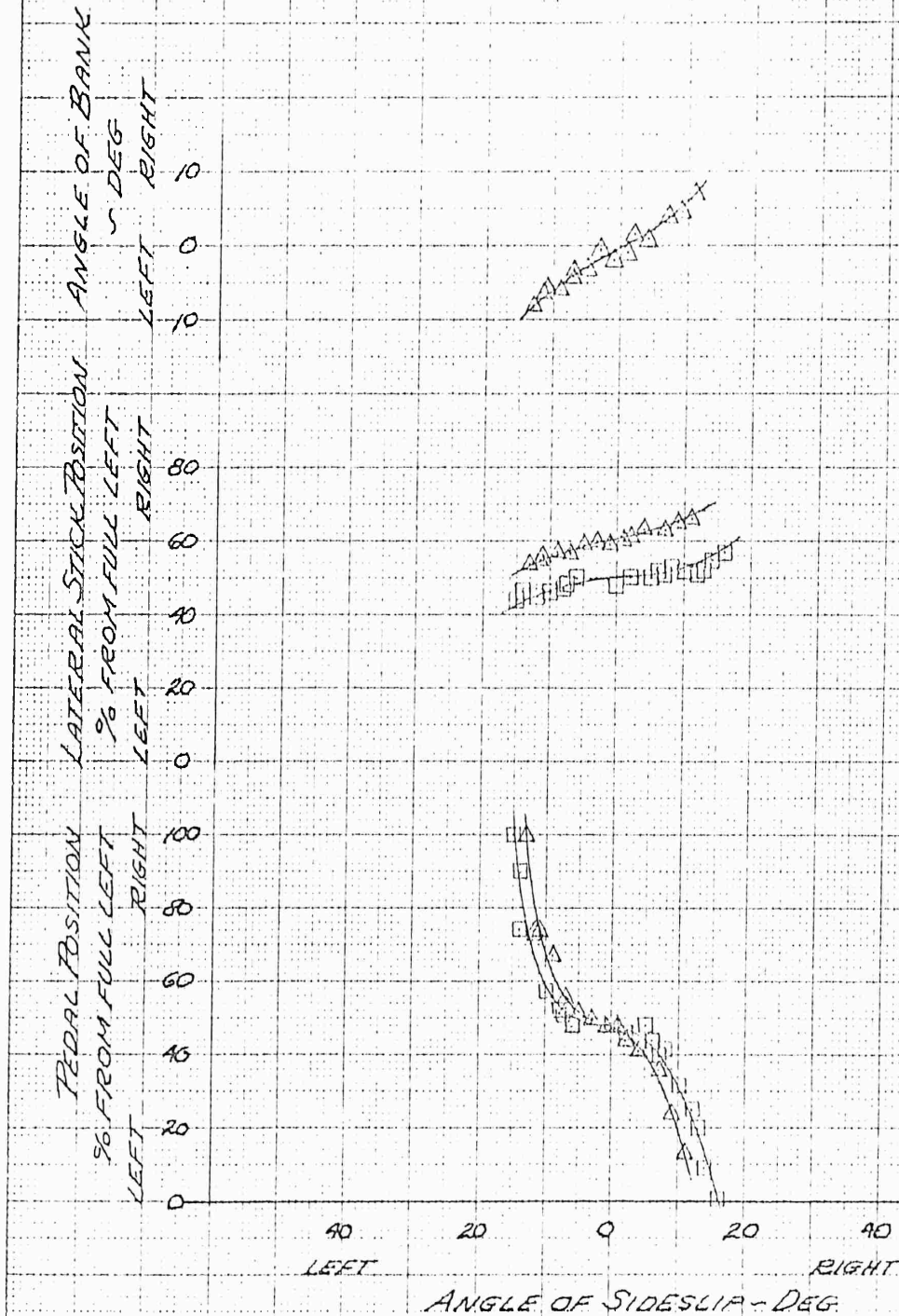

FIGURE No 25  
 STATIC DIRECTIONAL STABILITY  
 H-43B SN 58-1849

LEVEL FLIGHT

SYM	CAS KTS	RFM	DSAS	AVE DENSITY ALT <sup>ft</sup>	AVE GROSS WT <sup>LB</sup>	TAIL CONFIGURATION
0	80	238	95F	5080	6130	STANDARD

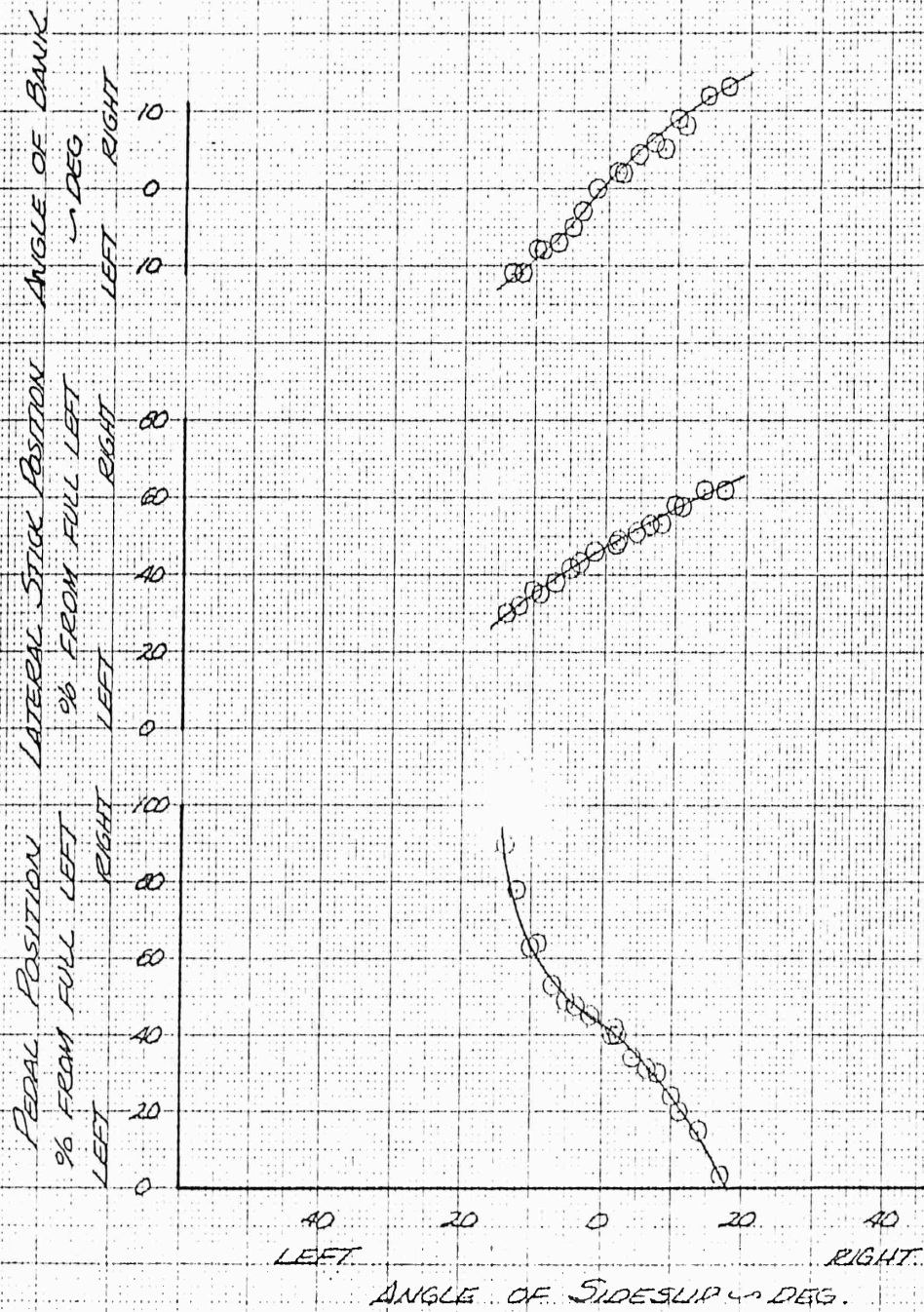

FIGURE No. 26  
 STATIC DIRECTIONAL STABILITY  
 H-43B SN 58-1849  
 AND SN 59-1548

AUTOROTATION

A/C SN	SYM	CAS KTS	RFM	DSAS	AVE DENSITY ALT FT	AVE GROSS WT LB	TAIL CONFIGURATION
1849	○	60	220	ON	6500	5630	STANDARD
1548	□	60	220	ON	5460	6010	MODIFIED

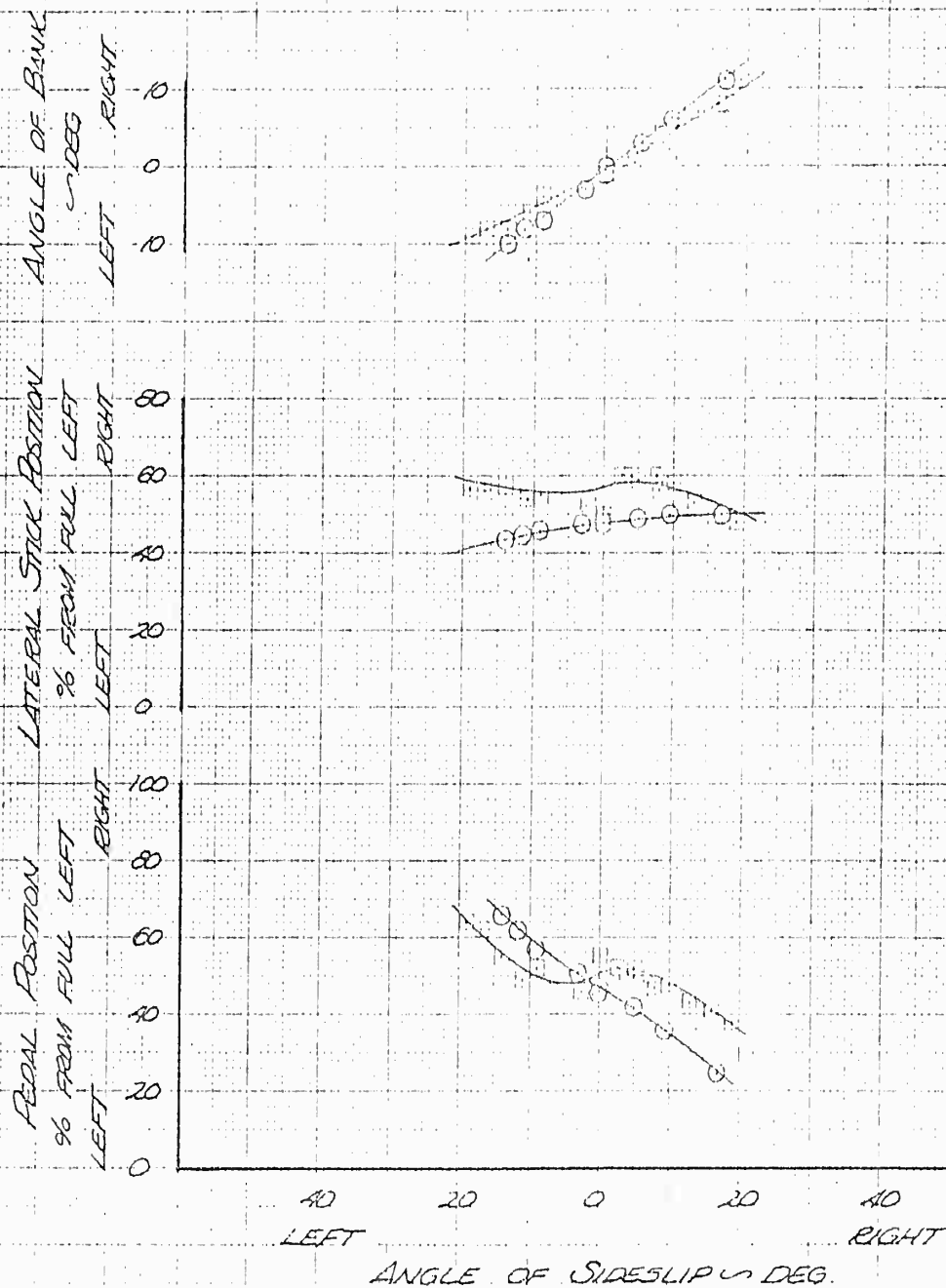

FIGURE NO. 27  
 STATIC DIRECTIONAL STABILITY  
 H43B S/N 59-1548

AUTOROTATION

SYM	CAS KTS	RPM	DSAS	AVE. DENSITY ALT (FT)	AVE. GROSS WT (LB)	TAIL CONFIGURATION
□	60	220	OFF	5800	6070	MODIFIED
△	60	220	OFF	5000	5800	STANDARD

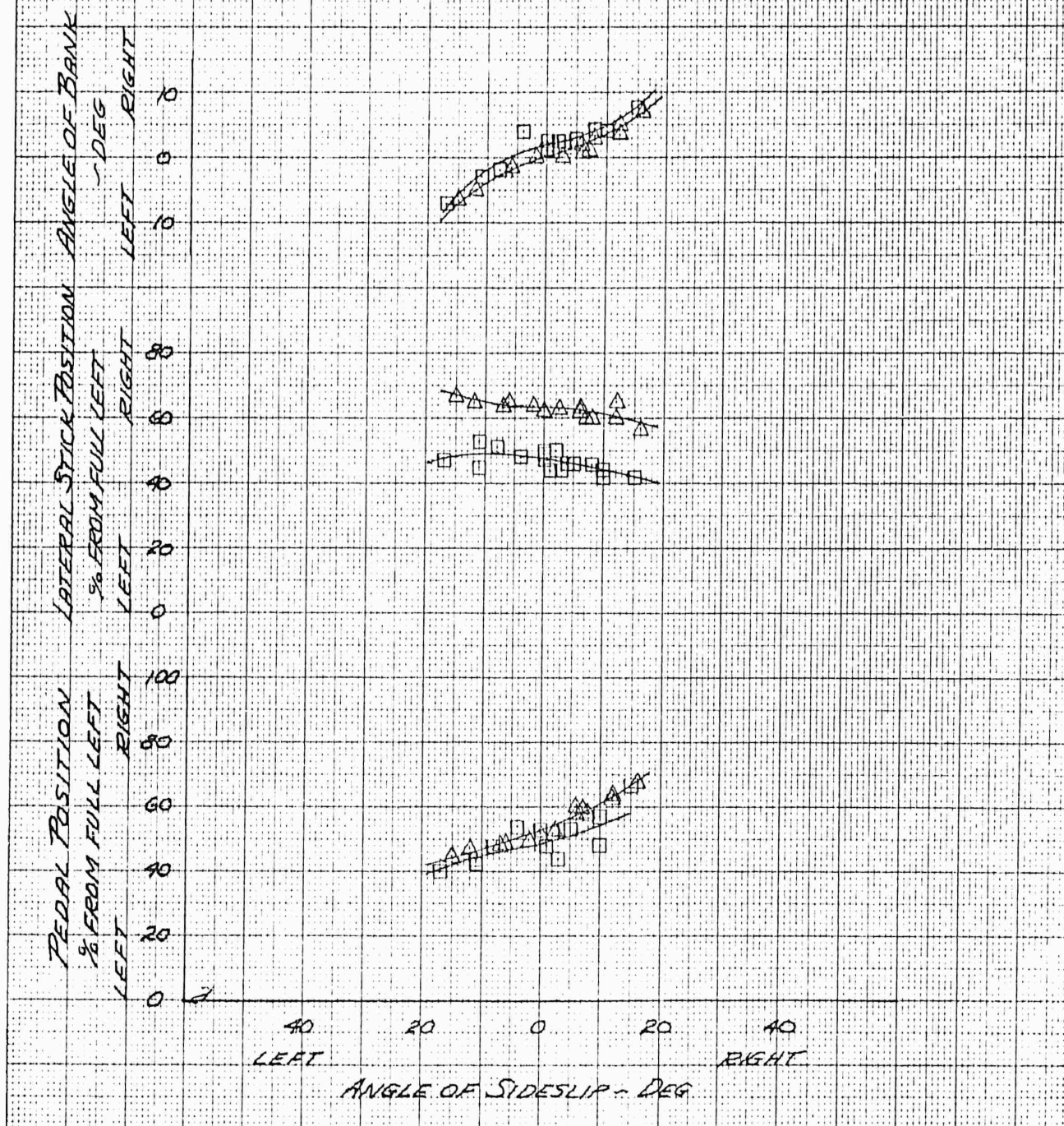

FIGURE No. 28  
 STATIC DIRECTIONAL STABILITY  
 H43B SN 59-1548

AUTOROTATION

SYM	CAS KTS	RPM	DSAS	AVE DENSITY ALT-FT	AVE GROSS WT-LB	TAIL CONFIGURATION
□	60	220	ON	5460	5560	MODIFIED
◇	60	220	ON/CHANK	5000	6000	MODIFIED
△	60	220	ON	5000	5850	STANDARD

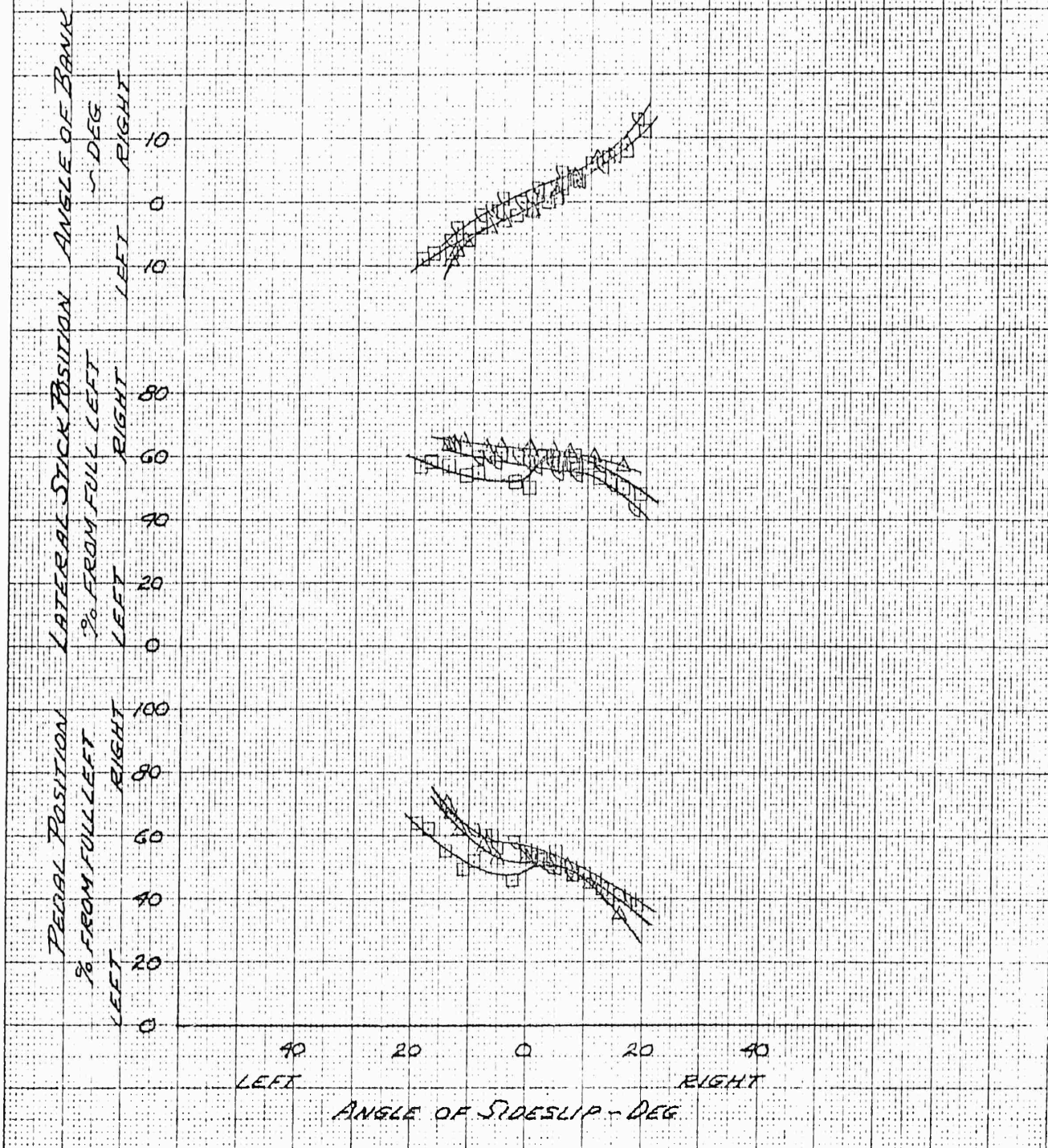

FIGURE No. 29  
 LONGITUDINAL CONTROL SENSITIVITY  
 H-43B USAF S/N 59-1849  
 RPM = 260/105%  
 LEVEL FLIGHT  
 ORIGINAL EMPENNAGE

NOTES:

1. FULL LONGITUDINAL CONTROL TRAVEL = 13 INCHES
2. COLORED SYMBOLS DENOTE DSAS "OFF"
3. MAXIMUM ACCELERATION REACHED APPROXIMATELY 0.8 SECONDS FOLLOWING CONTROL DISPLACEMENT

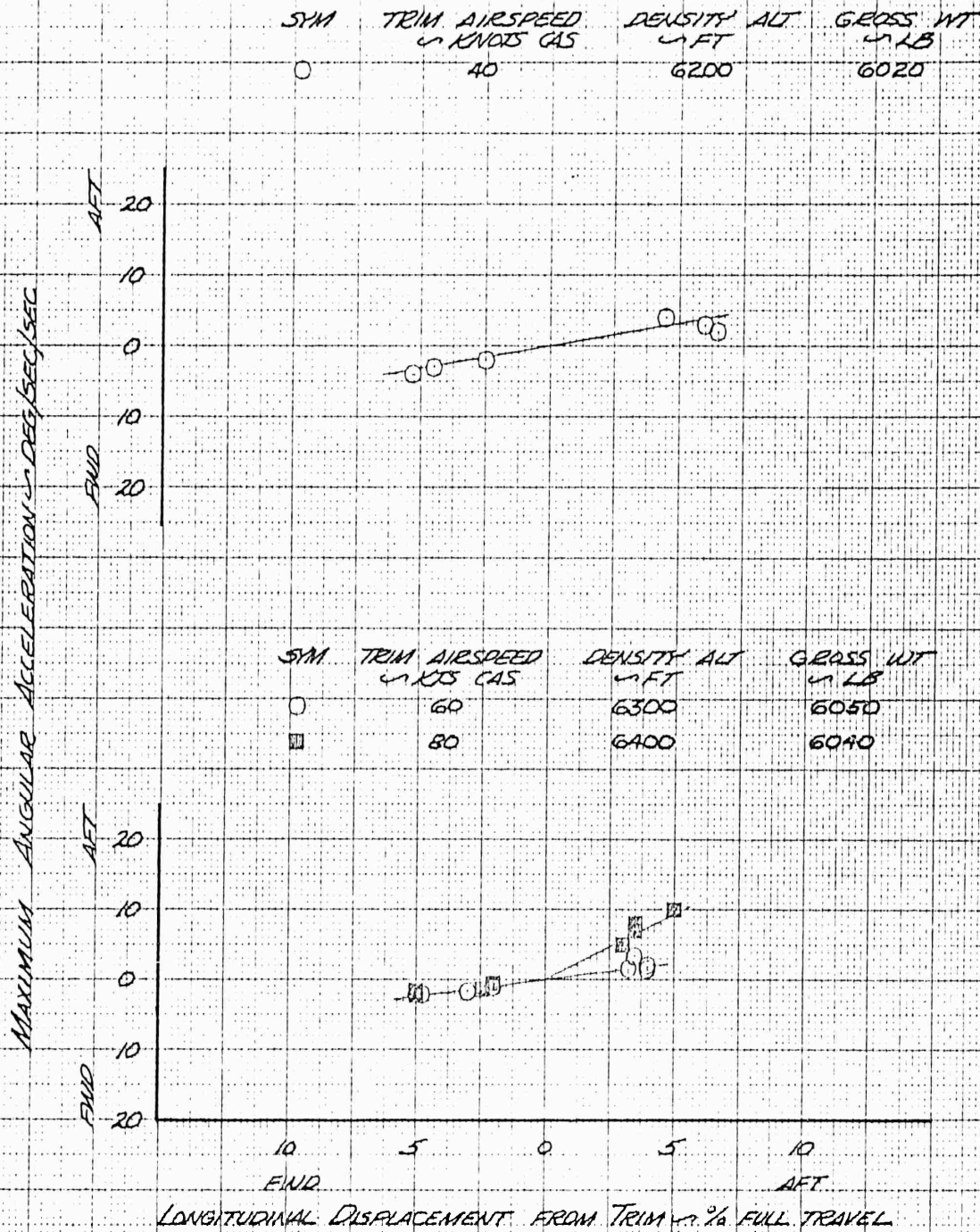

FIGURE No 30  
 LONGITUDINAL CONTROL SENSITIVITY  
 H-13B USAF 44 58-1840  
 RPM = 238/96%  
 LEVEL FLIGHT

- NOTES: ORIGINAL EMPENNAGE
1. FULL LONGITUDINAL CONTROL TRAVEL = 13 INCHES
  2. COLORED SYMBOLS DENOTE DSAS "OFF"
  3. MAXIMUM ACCELERATION REACHED APPROXIMATELY 0.8 SECONDS FOLLOWING CONTROL DISPLACEMENT

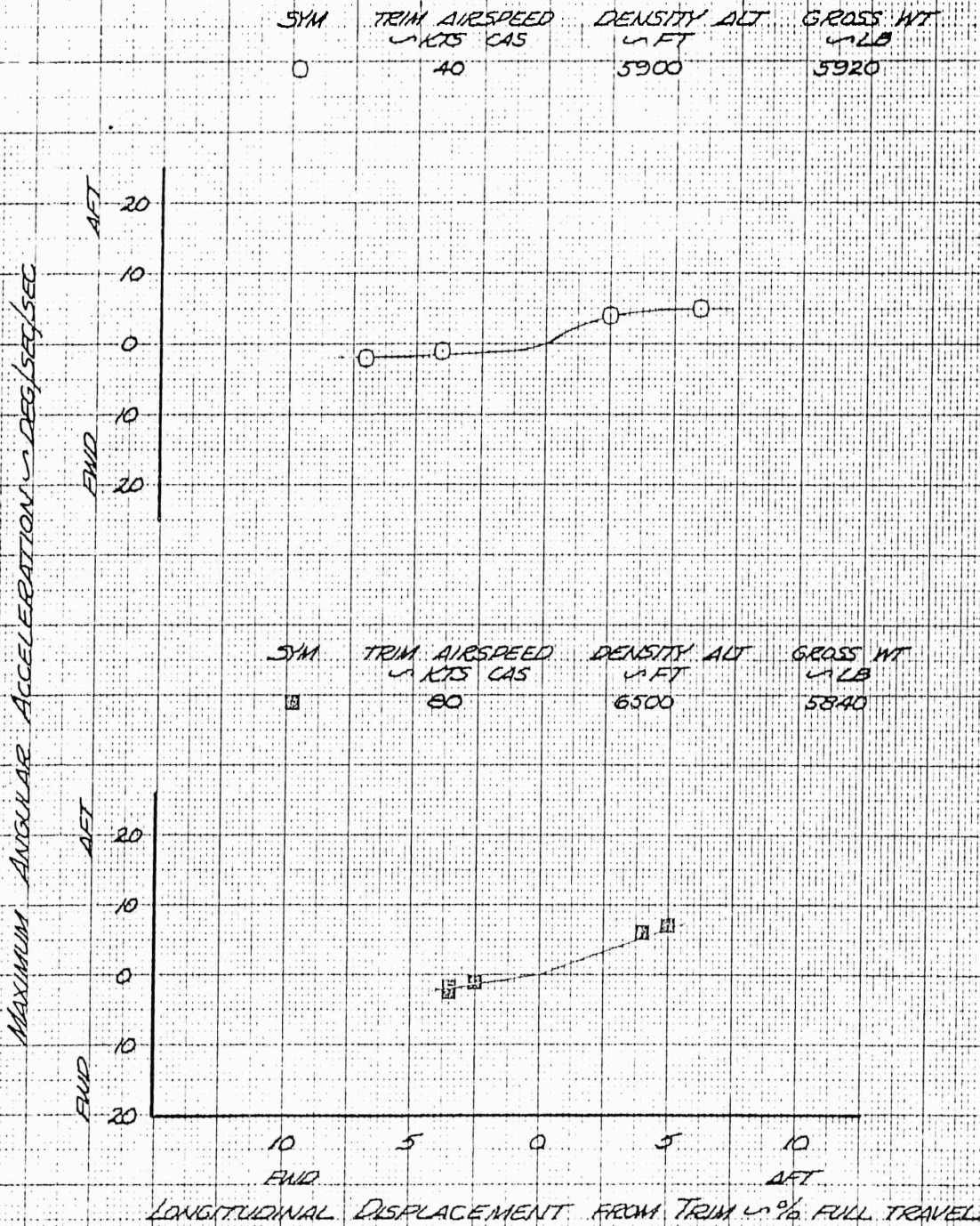
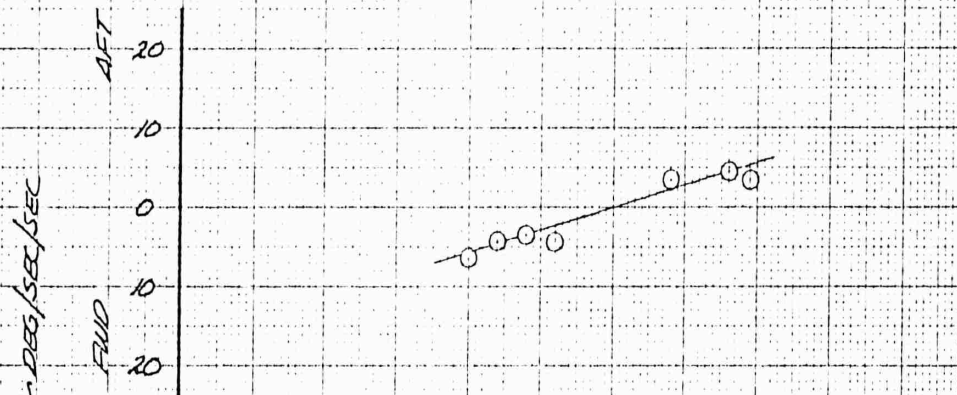

FIGURE NO 31  
 LONGITUDINAL CONTROL SENSITIVITY  
 H-43B USAF 5N 59-1548  
 RPM = 260/105%  
 LEVEL FLIGHT

- NOTES: MODIFIED EMPENNAGE
1. FULL LONGITUDINAL CONTROL TRAVEL = 13 INCHES
  2. COLDRED SYMBOLS DENOTE DSAS "OFF"
  3. MAXIMUM ACCELERATION REACHED APPROXIMATELY 0.8 SECONDS FOLLOWING CONTROL DISPLACEMENT

SYM TRIM AIRSPEED DENSITY ALT GROSS WT  
 ↳ KTS CAS ↳ FT ↳ LB  
 ○ 40 2160 6030



SYM TRIM AIRSPEED DENSITY ALT GROSS WT  
 ↳ KTS CAS ↳ FT ↳ LB  
 ■ 80 2600 5770

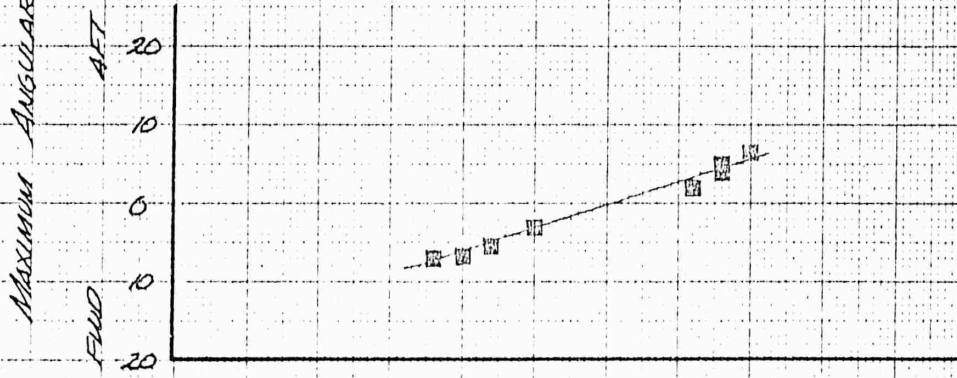

LONGITUDINAL DISPLACEMENT FROM TRIM ↳ % FULL TRAVEL

FIGURE No 32  
 LONGITUDINAL RESPONSE  
 H-13B USAF SN 59-1849  
 ORIGINAL EMPENNAGE

NOTES:

1. FULL LONGITUDINAL TRAVEL = 13 INCHES
2. COLORED SYMBOLS DENOTE DSAS "OFF"
3. MAXIMUM RATE REACHED APPROXIMATELY 2.0 SECONDS FOLLOWING CONTROL DISPLACEMENT

SYM	FLIGHT CONDITION	TRIM	AIR SPEED KTS CAS	DENSITY ALT FT	GROSS WT LB	RPM
○	CLIMB		60	4950	6000	260/105%
□	AUTOROTATION		60	4950	6000	220/88.7%



FIGURE No 33  
 LONGITUDINAL RESPONSE  
 H-43B USAF SN 59-1849  
 RPM = 260/105 %  
 LEVEL FLIGHT

NOTES: ORIGINAL EMPENNAGE

1. FULL LONGITUDINAL CONTROL TRAVEL = 13 INCHES
2. COLORED SYMBOLS DENOTE DSAS "OFF"
3. MAXIMUM RATE REACHED APPROXIMATELY 2.0 SECONDS FOLLOWING CONTROL DISPLACEMENT

SYM	TRIM	AIR SPEED	DENSITY	GROSS WT
	↳ KTS	CAS	ALT ↳ FT	↳ LB
○	40		6150	6020
○	40		6100	6020

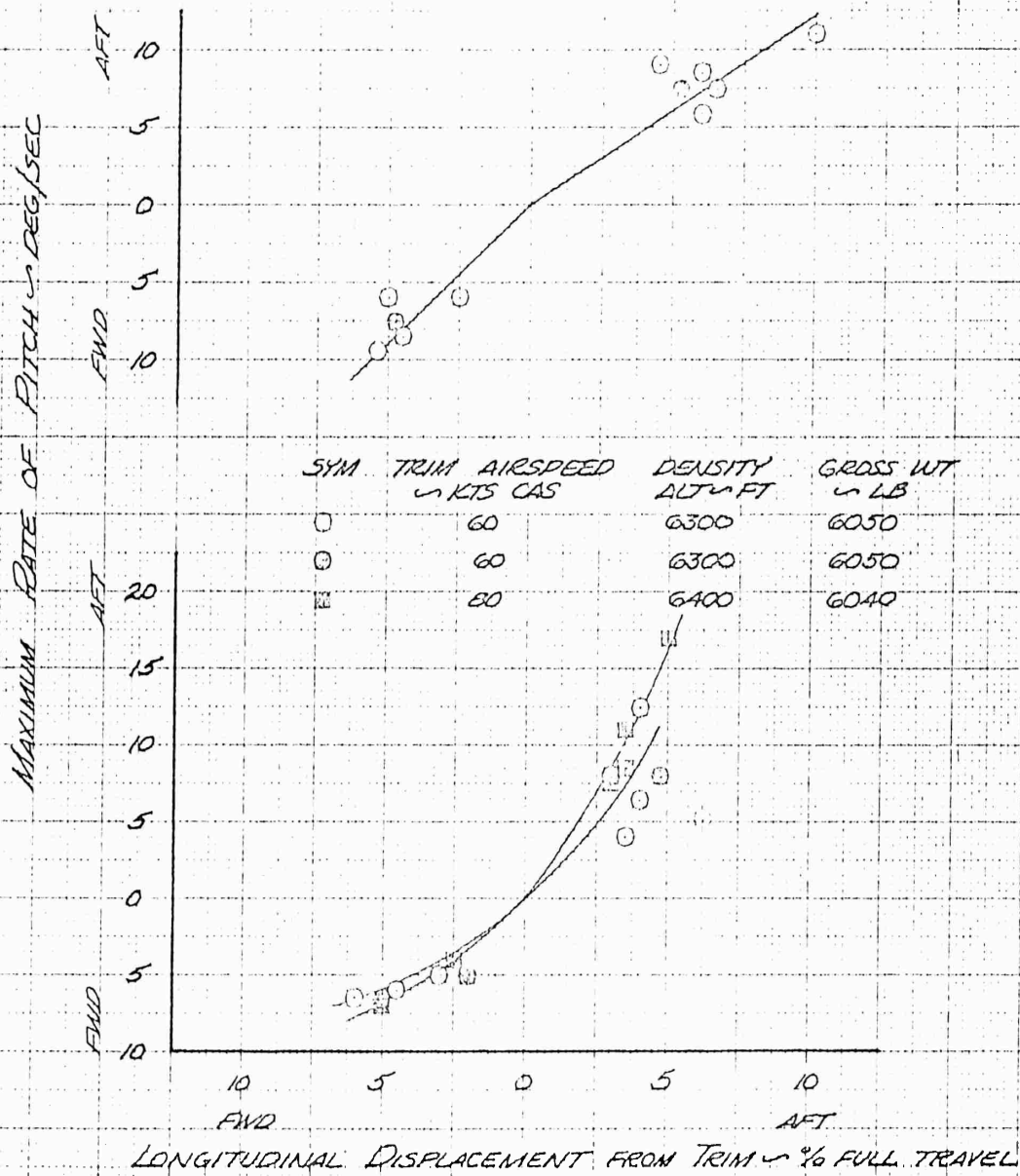
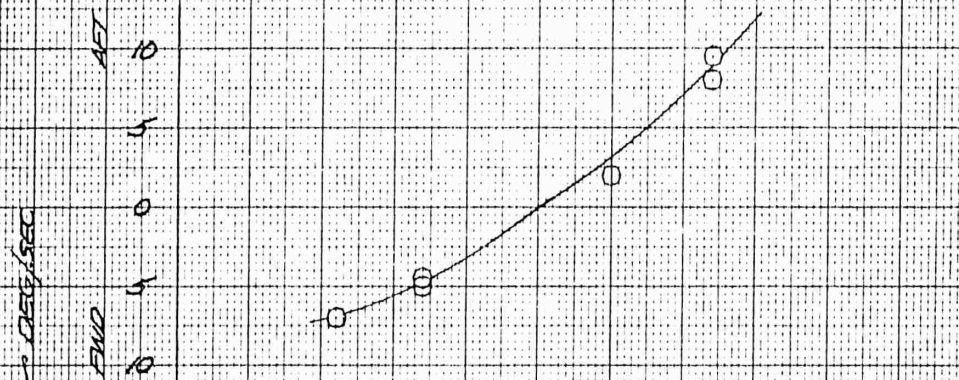

FIGURE No 34  
 LONGITUDINAL RESPONSE  
 H-43B USAF 5A 59-1849  
 RPM = 238/96 %  
 LEVEL FLIGHT

- NOTES: ORIGINAL EMPENNAGE
1. FULL LONGITUDINAL CONTROL TRAVEL = 13 INCHES
  2. COLORED SYMBOLS DENOTE OSAS "OFF"
  3. MAXIMUM RATE REACHED APPROXIMATELY 2.0 SECONDS FOLLOWING CONTROL DISPLACEMENT

SYM	TRIM	AIR SPEED	DENSITY ALT	GROSS WT
	↳ KTS	CAS	↳ FT	↳ LB
○		40	5900	5920



SYM	TRIM	AIR SPEED	DENSITY ALT	GROSS WT
	↳ KTS	CAS	↳ FT	↳ LB
□		80	6500	5840

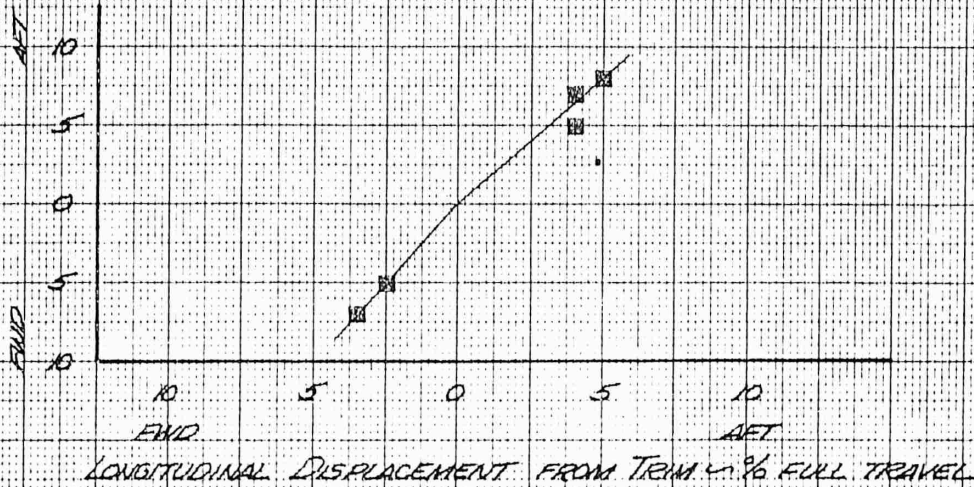

FIGURE NO 35  
 LONGITUDINAL RESPONSE  
 H-43B USAF 3/15/59-1548  
 RPM = 260/105%  
 LEVEL FLIGHT

- NOTES: MODIFIED EMPENNAGE
1. FULL LONGITUDINAL CONTROL TRAVEL = 13 INCHES
  2. COLORED SYMBOLS DENOTE DSAS "OFF"
  3. MAXIMUM RATE REACHED APPROXIMATELY 2.5 SECONDS FOLLOWING CONTROL DISPLACEMENT

SYM	TRIM	AIRSPEED	DENSITY ALT	GROSS WT
	INCHES	CAS	FT	LB
○		40	2160	6030

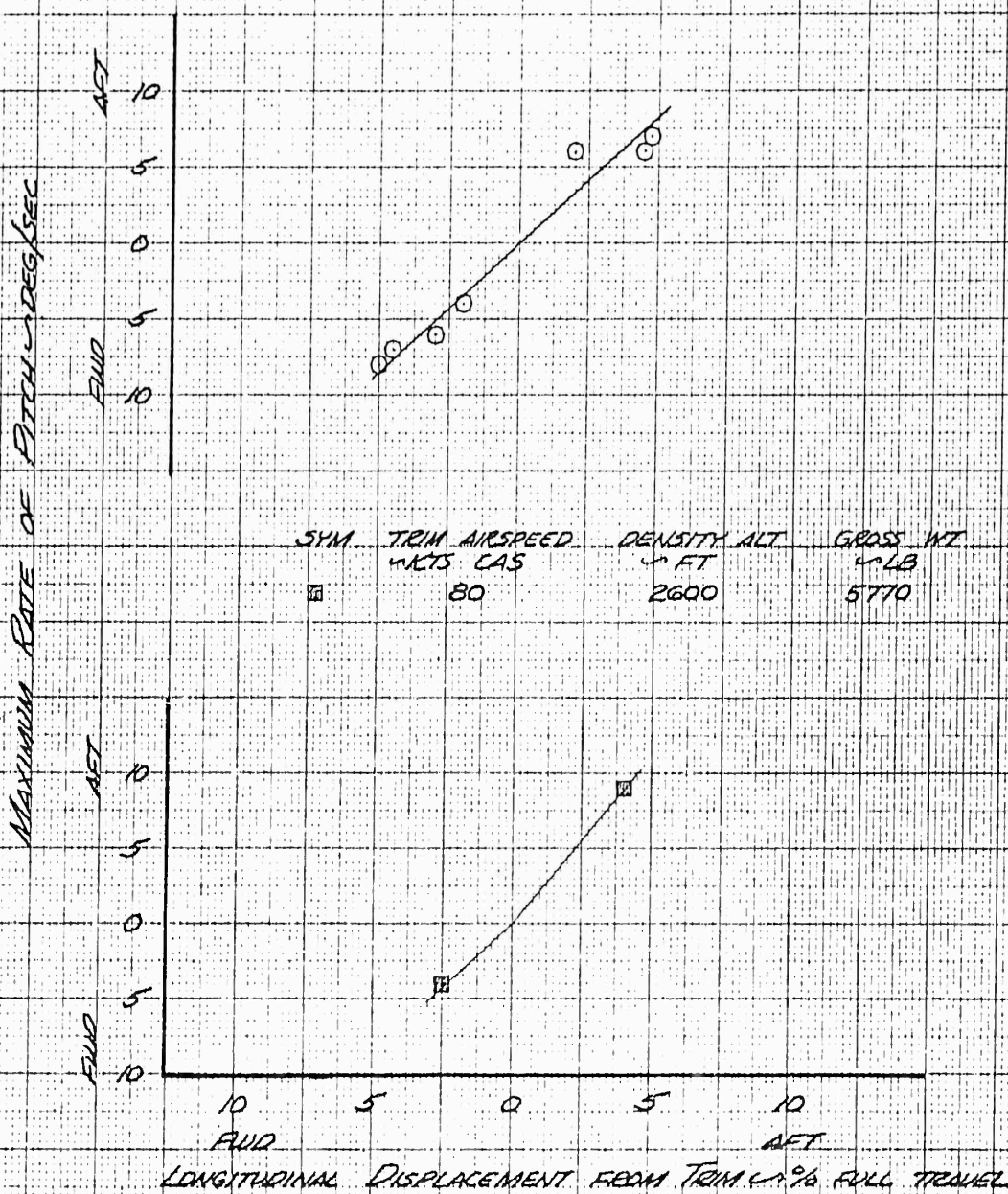

FIGURE No 36  
 LATERAL CONTROL SENSITIVITY  
 H-43B USAF 9659-1049  
 RPM = 260/105%  
 LEVEL FLIGHT

- NOTES: ORIGINAL EMPENNAGE
1. FULL LATERAL CONTROL TRAVEL = 14.4 INCHES
  2. COLORED SYMBOLS DENOTE DSAS "OFF"
  3. MAXIMUM ACCELERATION REACHED APPROXIMATELY 0.5 SECONDS FOLLOWING CONTROL DISPLACEMENT

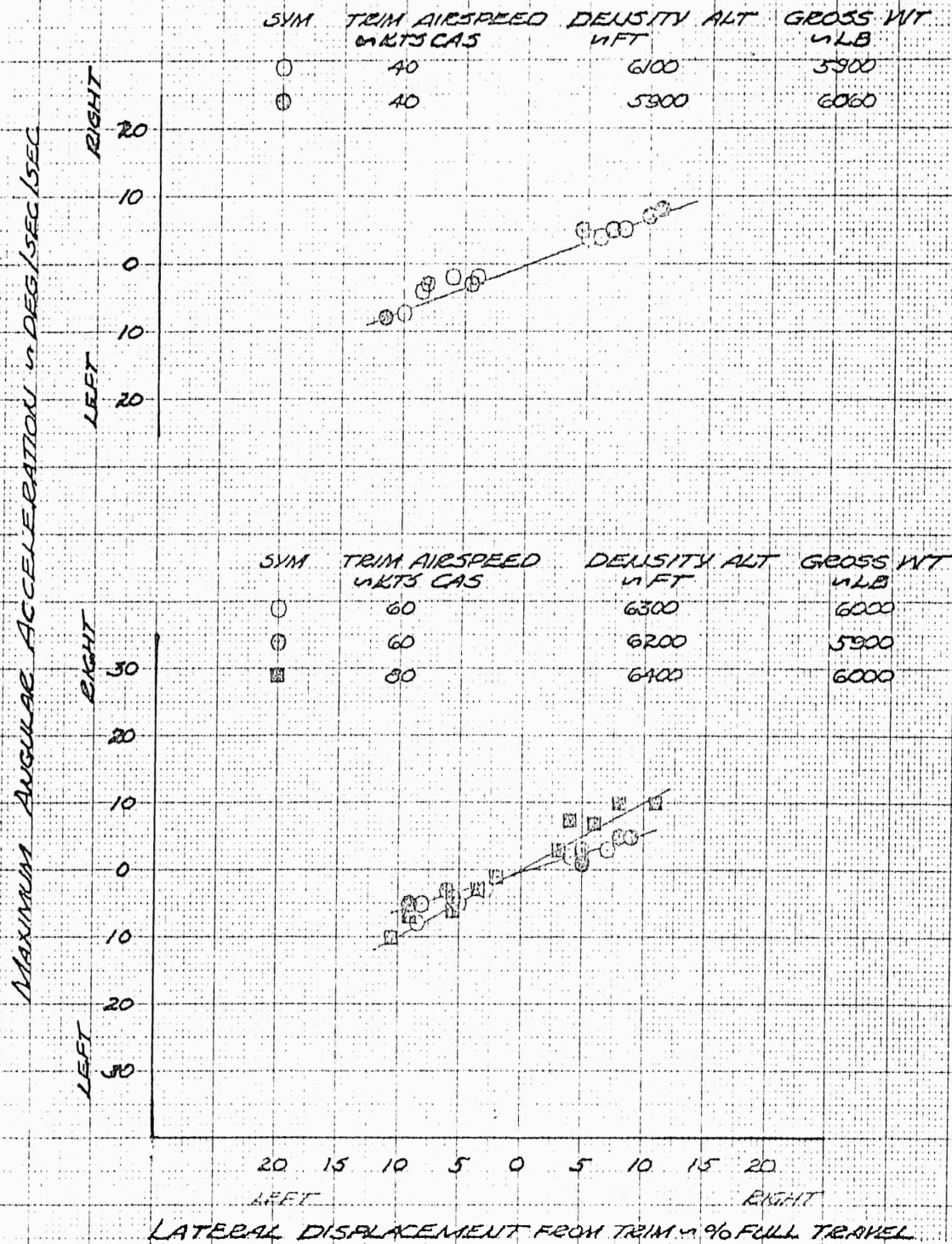

FIGURE No 37  
 LATERAL CONTROL SENSITIVITY  
 H-43B USAF 5/159-1849  
 RPM = 258/96%  
 LEVEL FLIGHT

- NOTES: ORIGINAL EMPENNAGE
1. FULL LATERAL CONTROL TRAVEL = 14.4 INCHES
  2. COLORED SYMBOLS DENOTE DSAS "OFF"
  3. MAXIMUM ACCELERATION REACHED APPROXIMATELY 0.5 SECONDS FOLLOWING CONTROL DISPLACEMENT

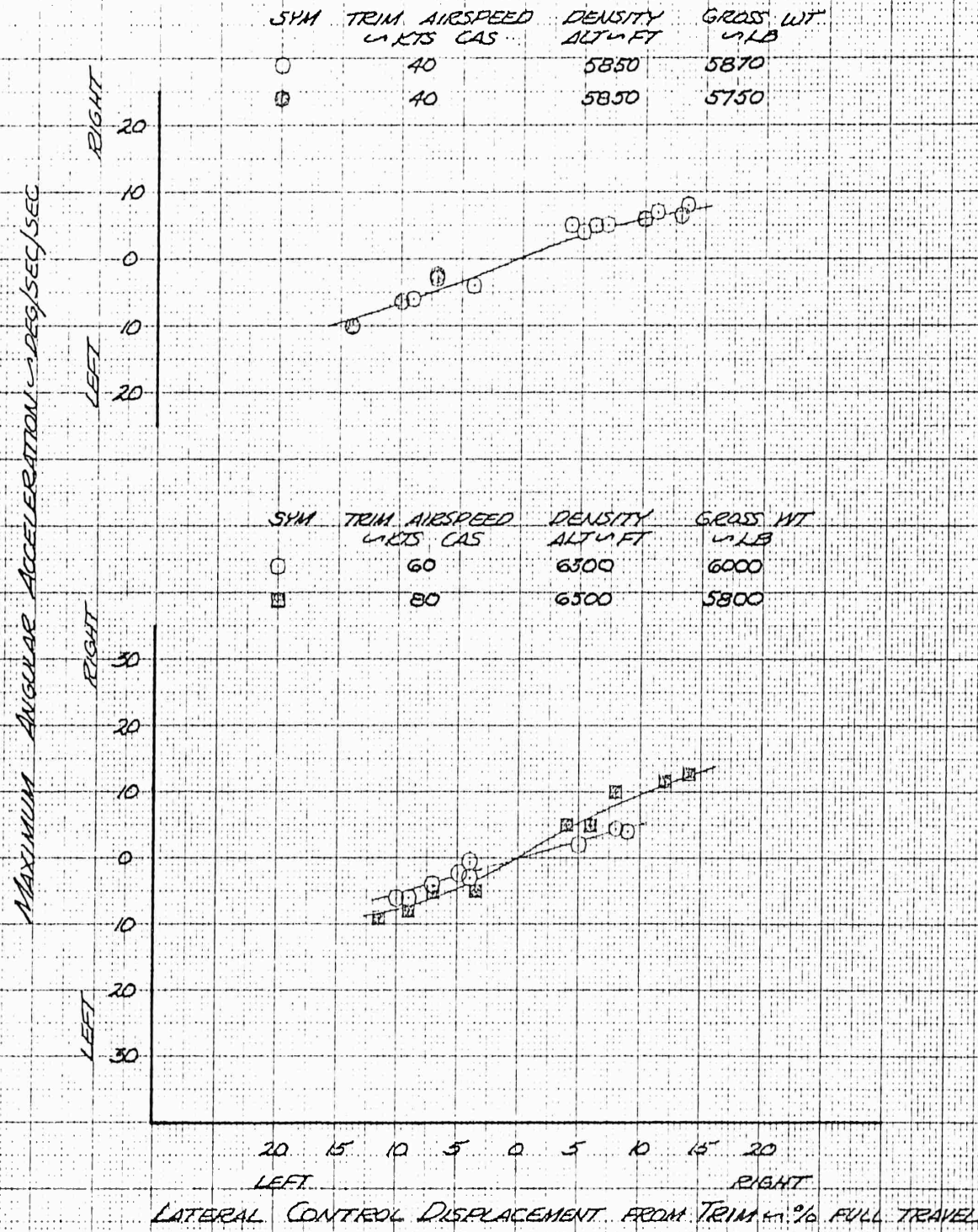

FIGURE No 38  
 LATERAL CONTROL SENSITIVITY  
 H-43B USAF 9A 30-1548  
 RPM = 260/105%  
 LEVEL FLIGHT

- NOTES: MODIFIED EMPENNAGE
1. FULL LATERAL CONTROL TRAVEL = 14.4 INCHES
  2. COLORED SYMBOLS DENOTE DSAS "OFF"
  3. MAXIMUM ACCELERATION REACHED APPROXIMATELY 1.0 SECONDS FOLLOWING CONTROL DISPLACEMENT

SYM	TRIM	AIR SPEED	DENSITY	GROSS WT
	✓ KTS	CAS	ALT ✓ FT	✓ LB
○		40	2250	6100

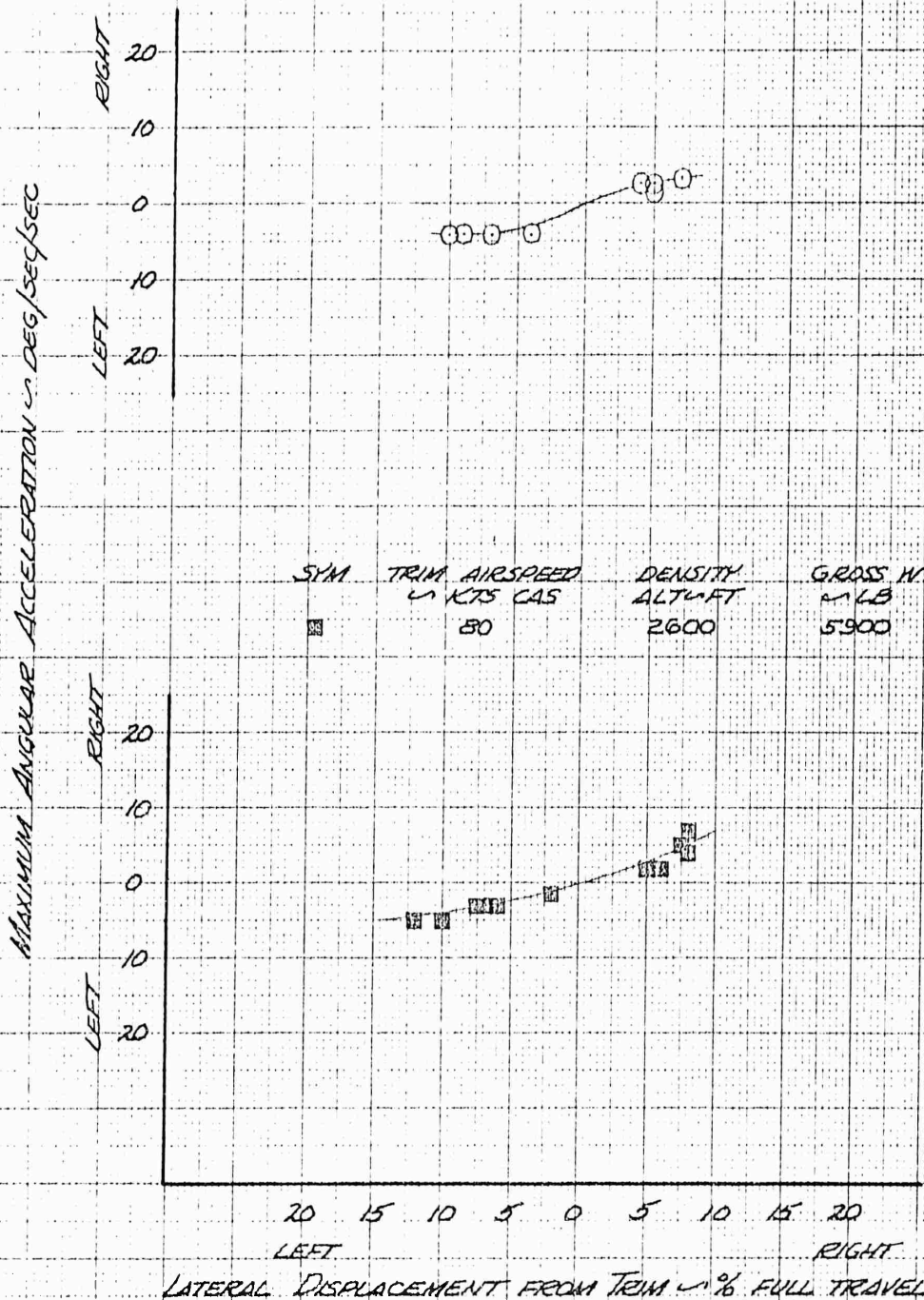

FIGURE No. 39  
 LATERAL RESPONSE  
 H-43B USAF 3/1 59-1849  
 ORIGINAL EMPENNAGE

NOTES:

1. FULL LATERAL TRAVEL = 14.4 INCHES
2. COLORED SYMBOLS DENOTE DSAS "OFF"
3. MAXIMUM RATE REACHED APPROXIMATELY 2.0 SECONDS FOLLOWING CONTROL DISPLACEMENT

SYM	FLIGHT CONDITION	TRIM	AIR SPEED KTS CAS	DENSITY FT	ALT FT	GROSS WT. LB	RPM
○	CLIMB		60		4940	5820	260/105%
□	AUTOROTATION		60		4940	5820	220/88.7%

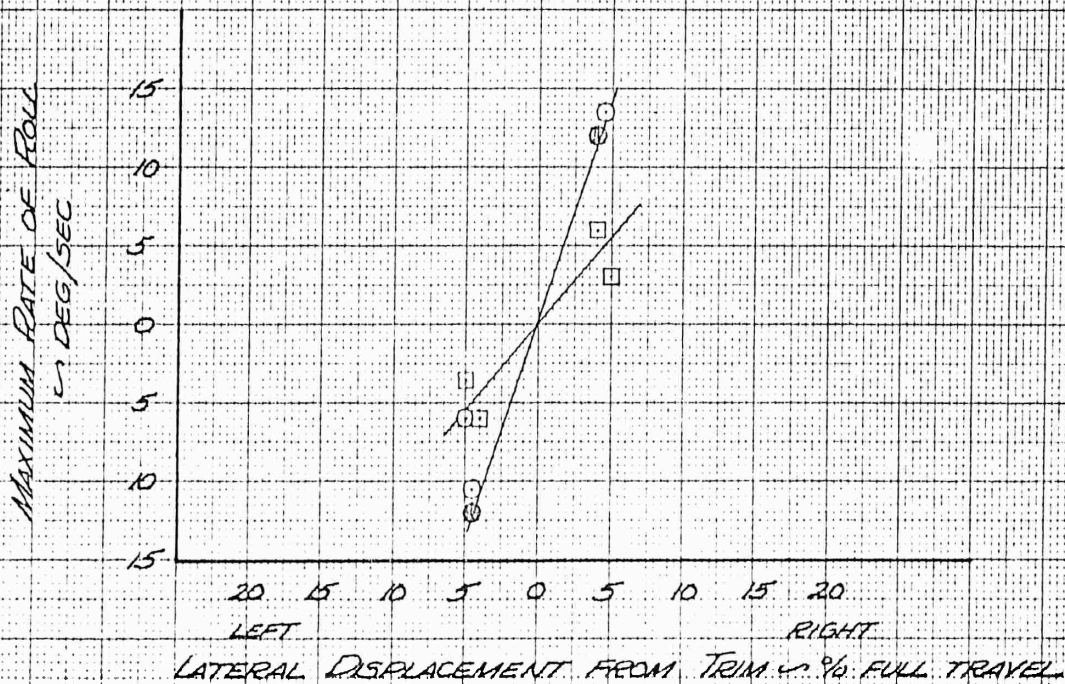

FIGURE No. 40  
 LATERAL RESPONSE  
 H-43B USAF SN 59-1540  
 RPM = 260/105%  
 LEVEL FLIGHT

NOTES: ORIGINAL EMPENNAGE

1. FULL LATERAL CONTROL TRAVEL = 18.4 INCHES
2. COLORED SYMBOLS DENOTE DSAS "OFF"
3. MAXIMUM RATE REACHED APPROXIMATELY 2.0 SECONDS FOLLOWING CONTROL DISPLACEMENT

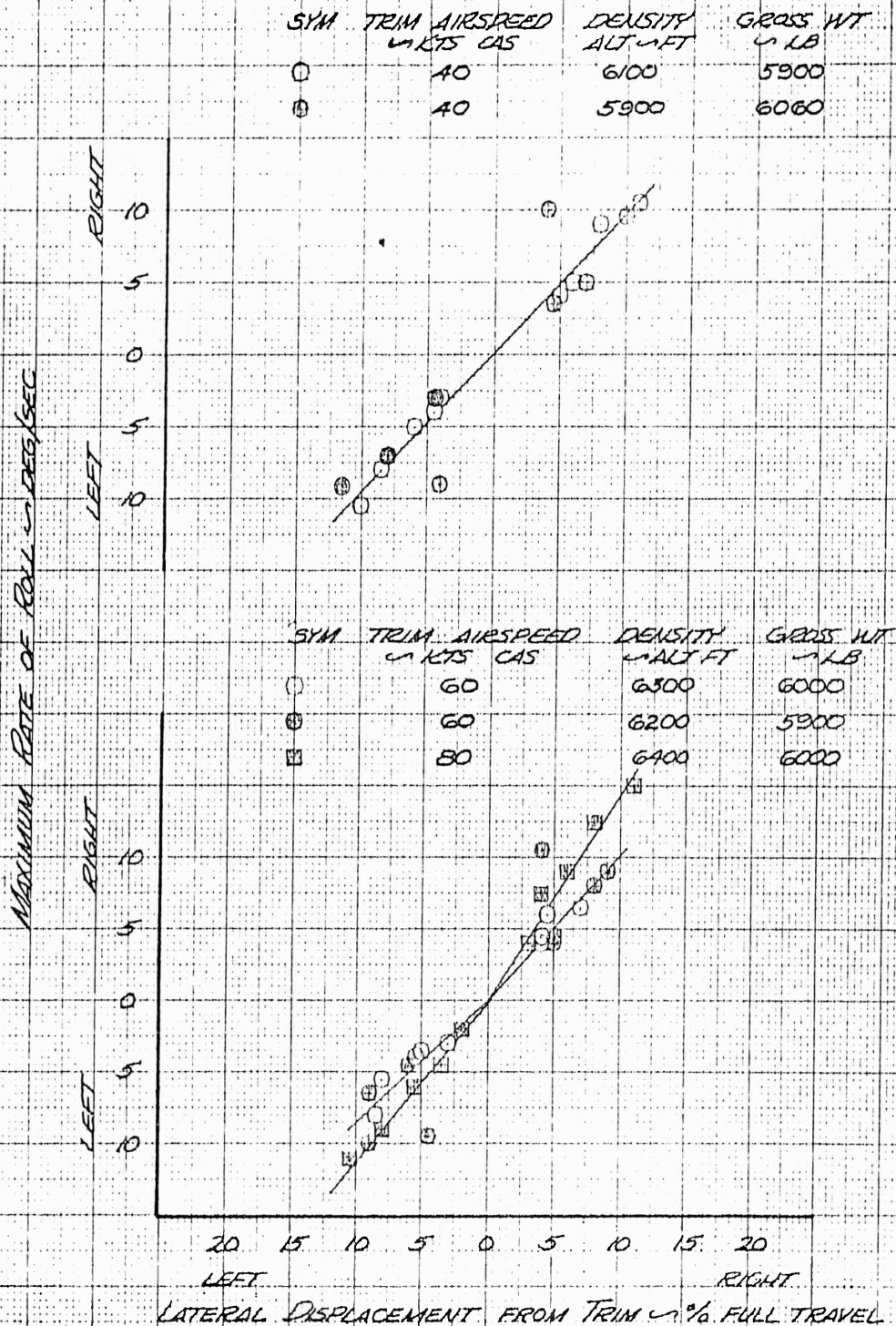

FIGURE No 41  
 LATERAL RESPONSE  
 H-43B USAF 5/4 59-1849  
 RPM - 238/06%  
 LEVEL FLIGHT

- NOTES: ORIGINAL EMPENNAGE
1. FULL LATERAL CONTROL TRAVEL = 14.4 INCHES
  2. COLORED SYMBOLS DENOTE RAS "OFF"
  3. MAXIMUM RATE REACHED APPROXIMATELY 2.0 SECONDS FOLLOWING CONTROL DISPLACEMENT

SYM	TRIM	AIR SPEED	DENSITY	GROSS WT
	INCHES	CAS	ALT FT	IN LB
○	40	40	5840	5870
⊗	40	40	5860	5750

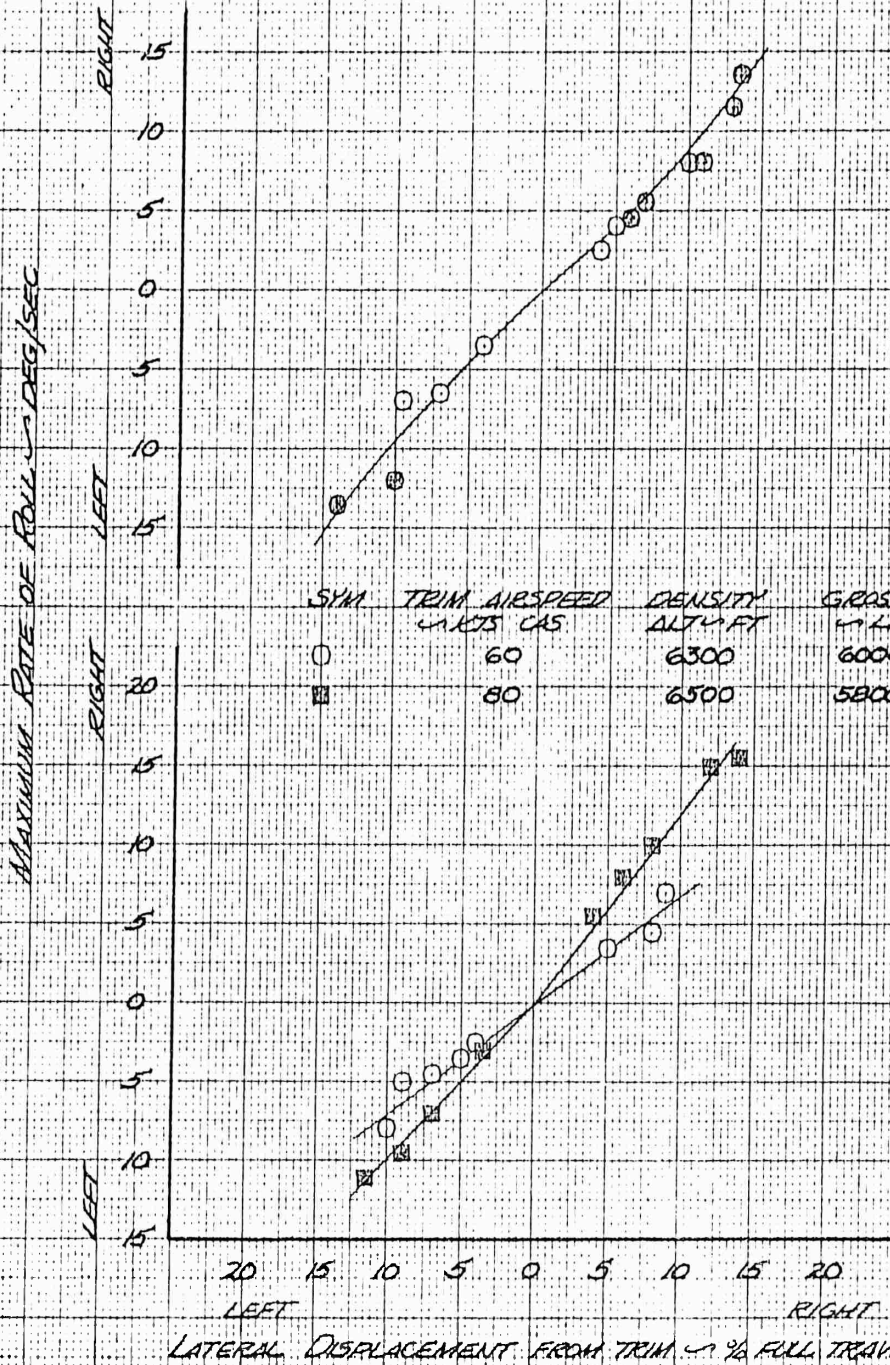

FIGURE NO 42  
 LATERAL RESPONSE  
 H-43B USAF SN 59-1548  
 RPM = 260/105%  
 LEVEL FLIGHT

- NOTES: MODIFIED EMPENNAGE
1. FULL LATERAL CONTROL TRAVEL = 14.4 INCHES
  2. COLORED SYMBOLS DENOTE DSAS "OFF"
  3. MAXIMUM RATE REACHED APPROXIMATELY 4.0 SECONDS FOLLOWING CONTROL DISPLACEMENT

SYM	TRIM	AIRSPEED	DENSITY	GROSS WT
↳	↳	↳ KTS CAS	↳ ACTUFT	↳ LB
○		40	2250	6100

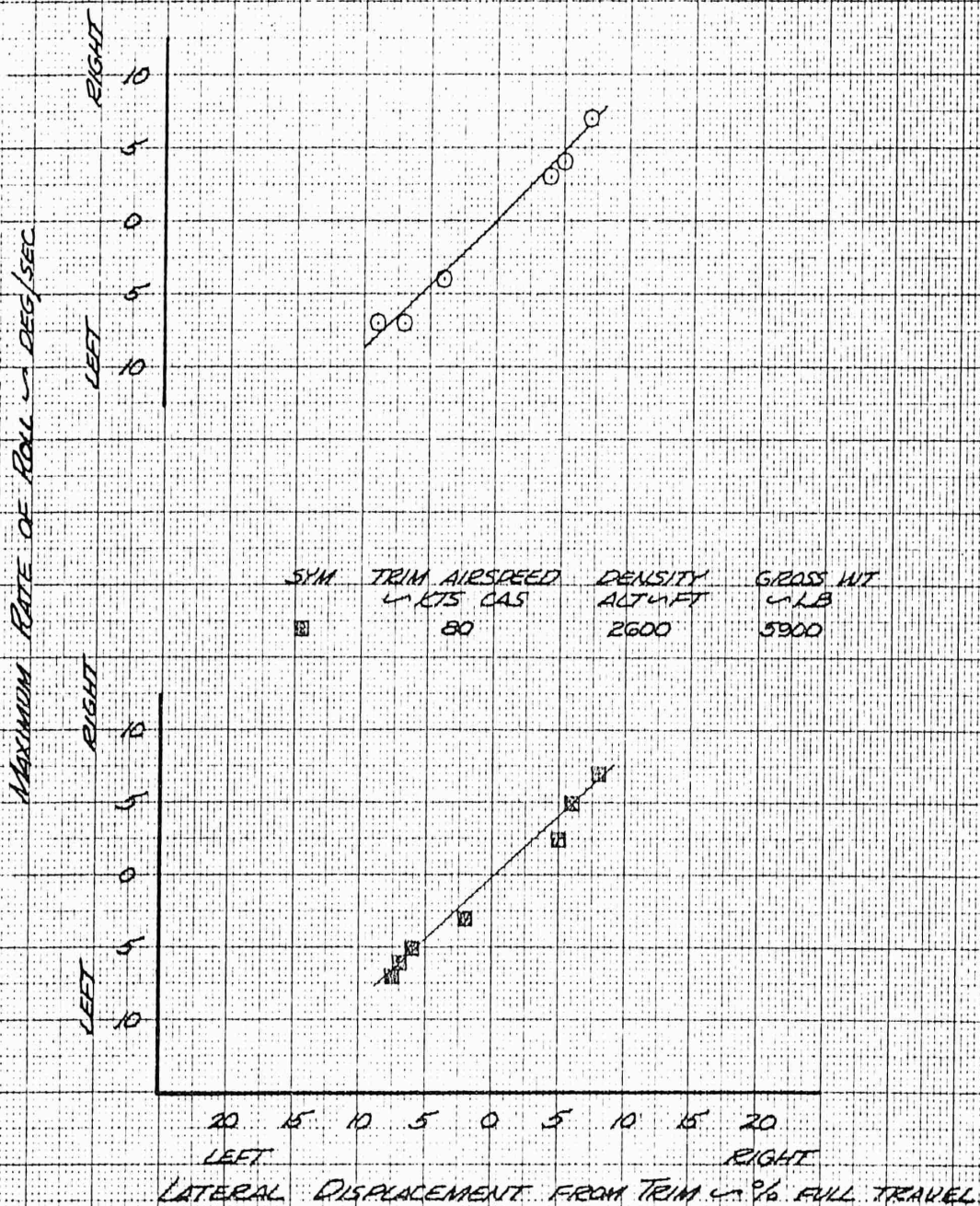

FIGURE No 43  
 DIRECTIONAL CONTROL SENSITIVITY  
 H-43B USAF # 50-1849  
 RPM = 260/105%  
 LEVEL FLIGHT

- NOTES: ORIGINAL EMPENNAGE
1. FULL DIRECTIONAL CONTROL TRAVEL = 6.5 INCHES
  2. COLORED SYMBOLS DENOTE DSAS "OFF"
  3. MAXIMUM ACCELERATION REACHED APPROXIMATELY 0.9 SECONDS FOLLOWING CONTROL DISPLACEMENT

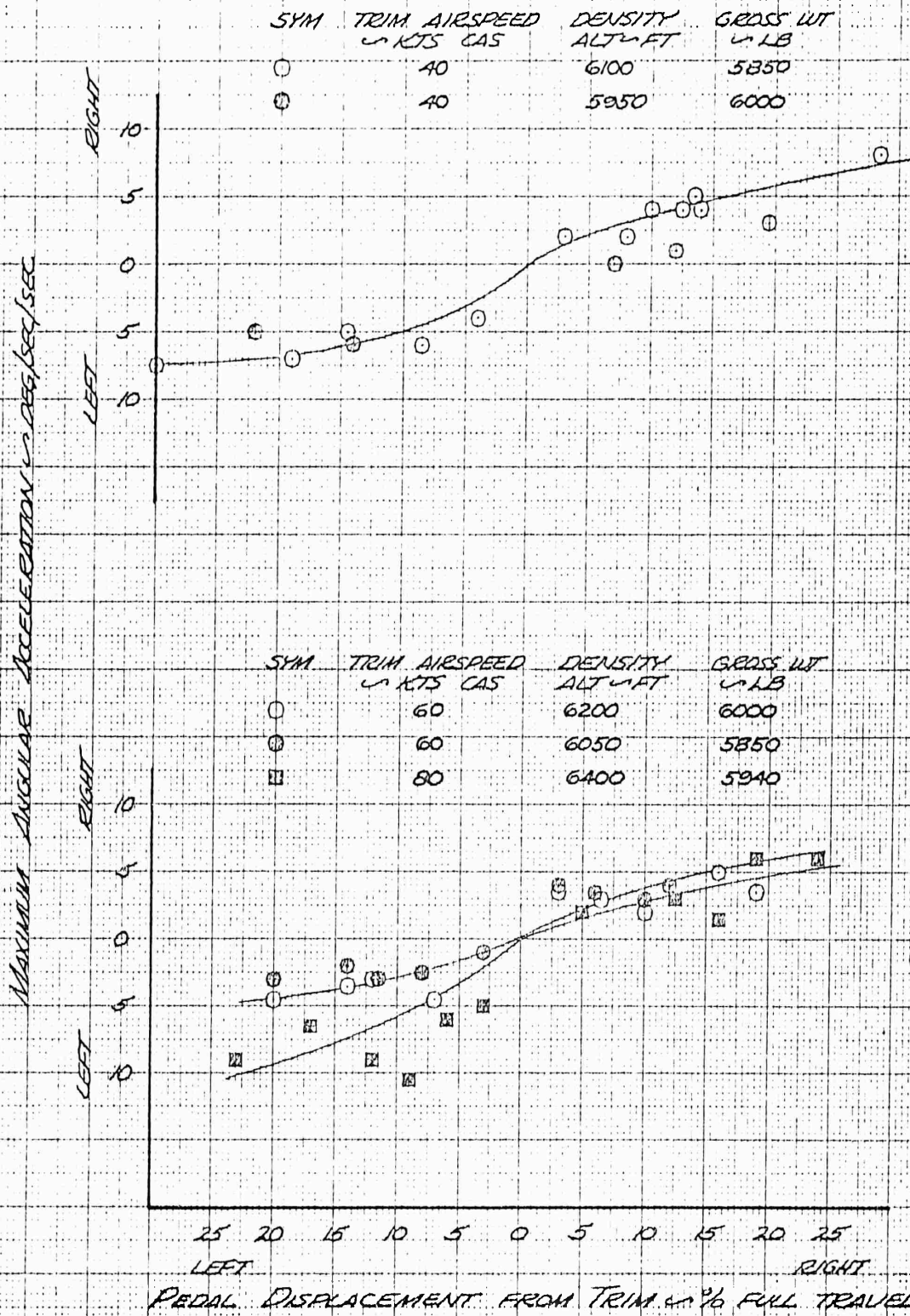

FIGURE No 44  
 DIRECTIONAL CONTROL SENSITIVITY  
 H-43B USAF SN 59-1849  
 RPM = 238/96%  
 LEVEL FLIGHT

- NOTES: ORIGINAL EMPENNAGE
1. FULL DIRECTIONAL CONTROL TRAVEL = 6.5 INCHES
  2. COLORED SYMBOLS DENOTE DSAS "OFF"
  3. MAXIMUM ACCELERATION REACHED APPROXIMATELY 0.9 SECONDS FOLLOWING CONTROL DISPLACEMENT

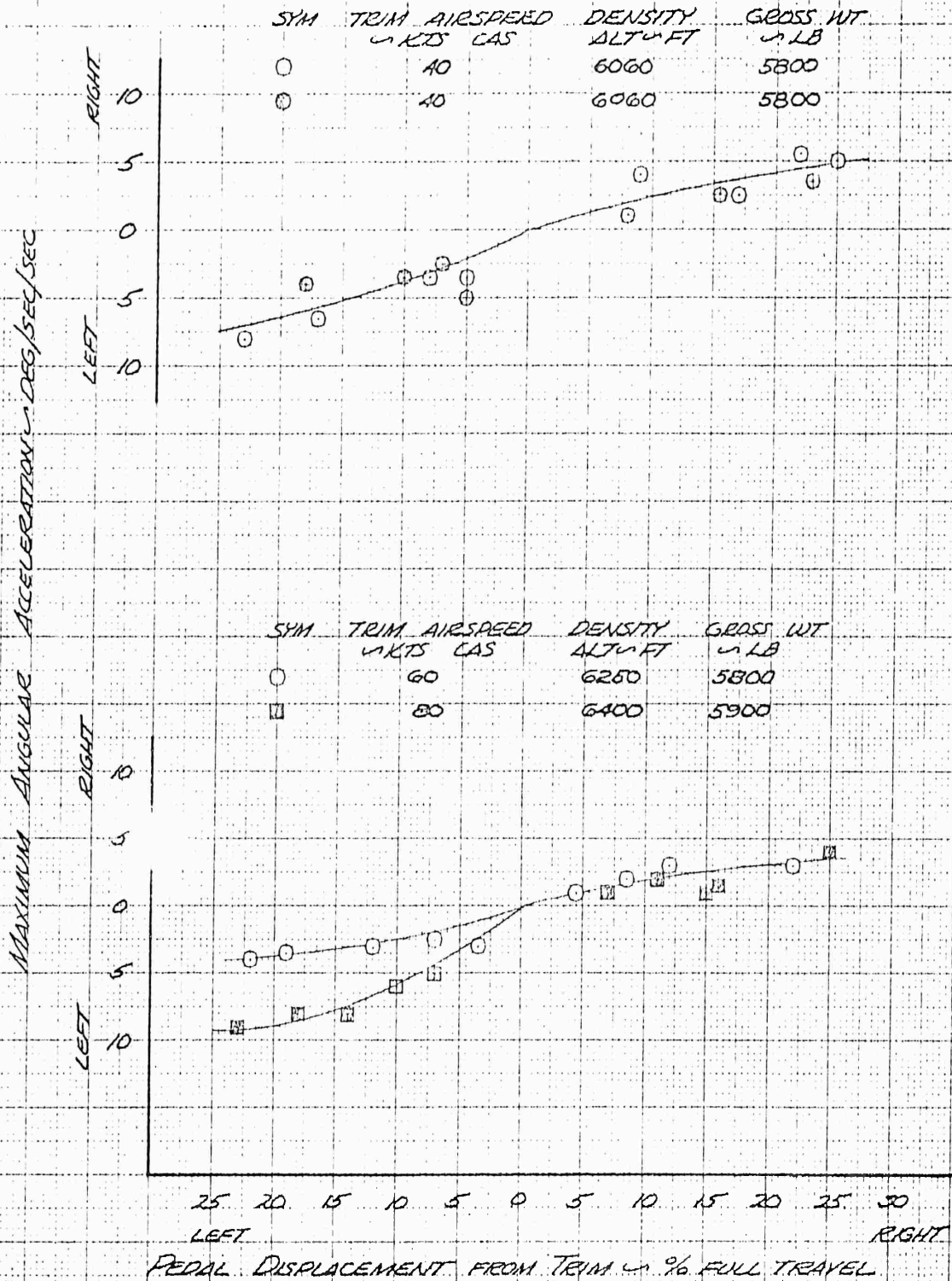
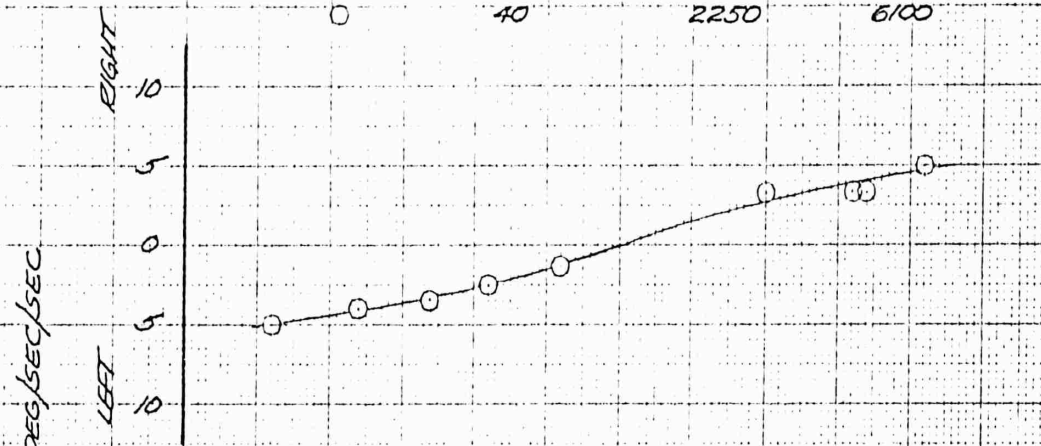

FIGURE No 45  
 DIRECTIONAL CONTROL SENSITIVITY  
 H-43B USAF SN 59-1548  
 RPM = 260/105%  
 LEVEL FLIGHT

- NOTES: MODIFIED EMPENNAGE
1. FULL DIRECTIONAL TRAVEL = 6.5 INCHES
  2. COLORED SYMBOLS DENOTE DSAS "OFF"
  3. MAXIMUM ACCELERATION REACHED APPROXIMATELY 1.3 SECONDS FOLLOWING CONTROL DISPLACEMENT

SYM	TRIM	AIR SPEED	DENSITY	GROSS WT
		KTS CAS	ALT-FT	LB
○		40	2250	6100



SYM	TRIM	AIR SPEED	DENSITY	GROSS WT
		KTS CAS	ALT-FT	LB
□		80	2600	5900

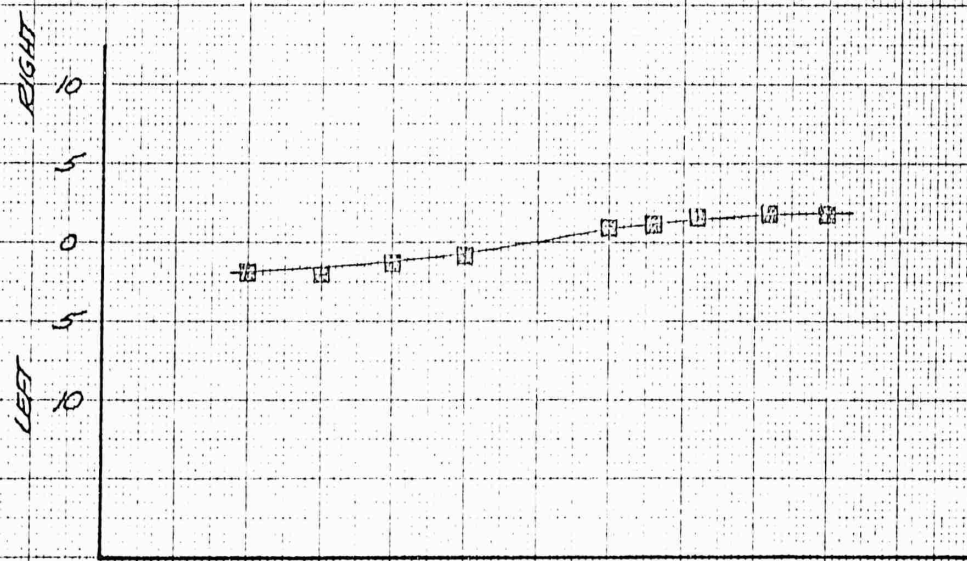

20 15 10 5 0 5 10 15 20  
 LEFT RIGHT  
 PEDAL DISPLACEMENT FROM TRIM % FULL TRAVEL

FIGURE NO 48  
 DIRECTIONAL RESPONSE  
 H-43B USAF 9A 59-1849  
 ORIGINAL EMPENNAGE

NOTES:

1. FULL PEDAL TRAVEL = 6.5 INCHES
2. COLORED SYMBOLS DENOTE DSAS "OFF"
3. MINIMUM RATE REACHED APPROXIMATELY 1.9 SECONDS FOLLOWING CONTROL DISPLACEMENT

SYM.	FLIGHT CONDITION	TRIM	AIRSPEED KTS CAS	DENSITY FT	ALT. FT	GROSS WT-LB	RPM
○	CLIMB		60		5440	5820	260/105%
□	AUTOROTATION		60		5440	5820	220/88.7%

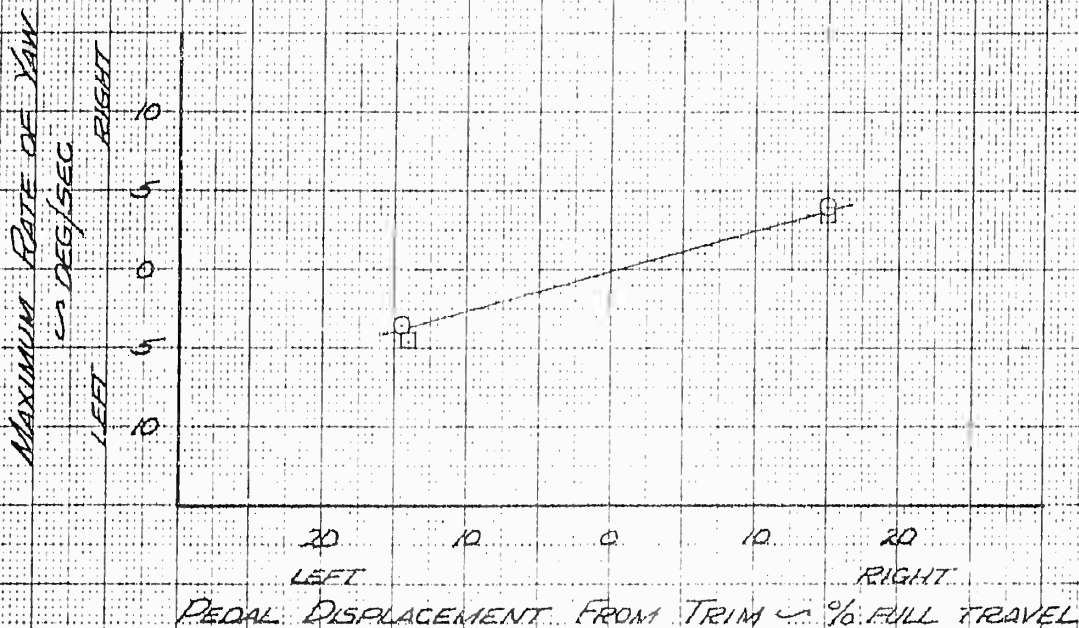

FIGURE No 47  
 DIRECTIONAL RESPONSE  
 H-13B USAF 5/11/59-1840  
 RPM = 260/105%

LEVEL FLIGHT

NOTES: ORIGINAL EMPENNAGE

1. FULL DIRECTIONAL CONTROL TRAVEL = 6.5 INCHES
2. COLORED SYMBOLS DENOTE CASAS "OFF"
3. MAXIMUM RATE REACHED APPROXIMATELY 1.9 SECONDS FOLLOWING CONTROL DISPLACEMENT

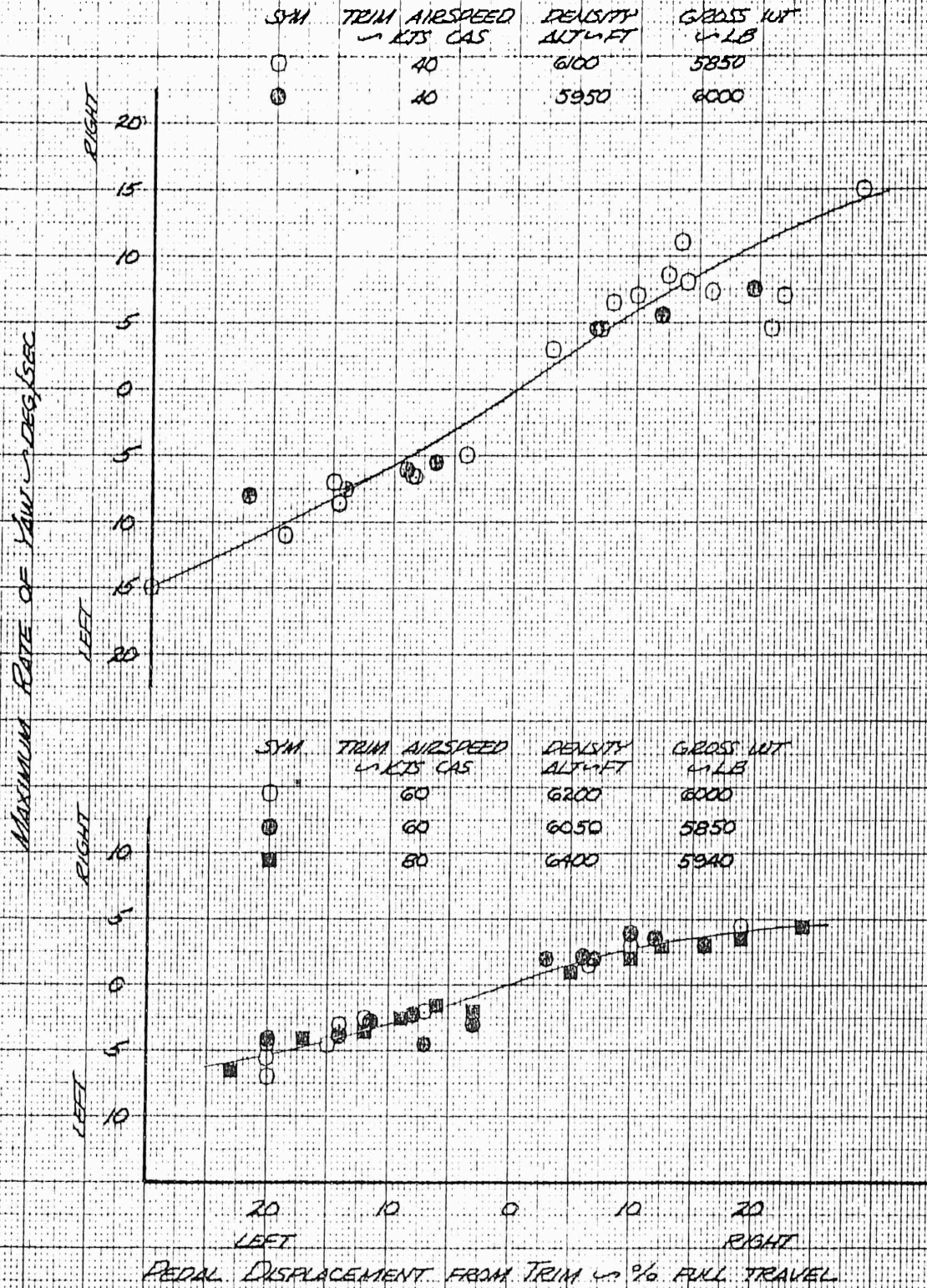

FIGURE NO 48  
 DIRECTIONAL RESPONSE  
 H-43B USAF 5W-59-1849  
 RPM = 238/96%  
 LEVEL FLIGHT

NOTES: ORIGINAL EMPENNAGE

1. FULL DIRECTIONAL CONTROL TRAVEL = 6.5 INCHES
2. COLORED SYMBOLS DENOTE DSAS "OFF"
3. MAXIMUM RATE REACHED APPROXIMATELY 19 SECONDS FOLLOWING CONTROL DISPLACEMENT

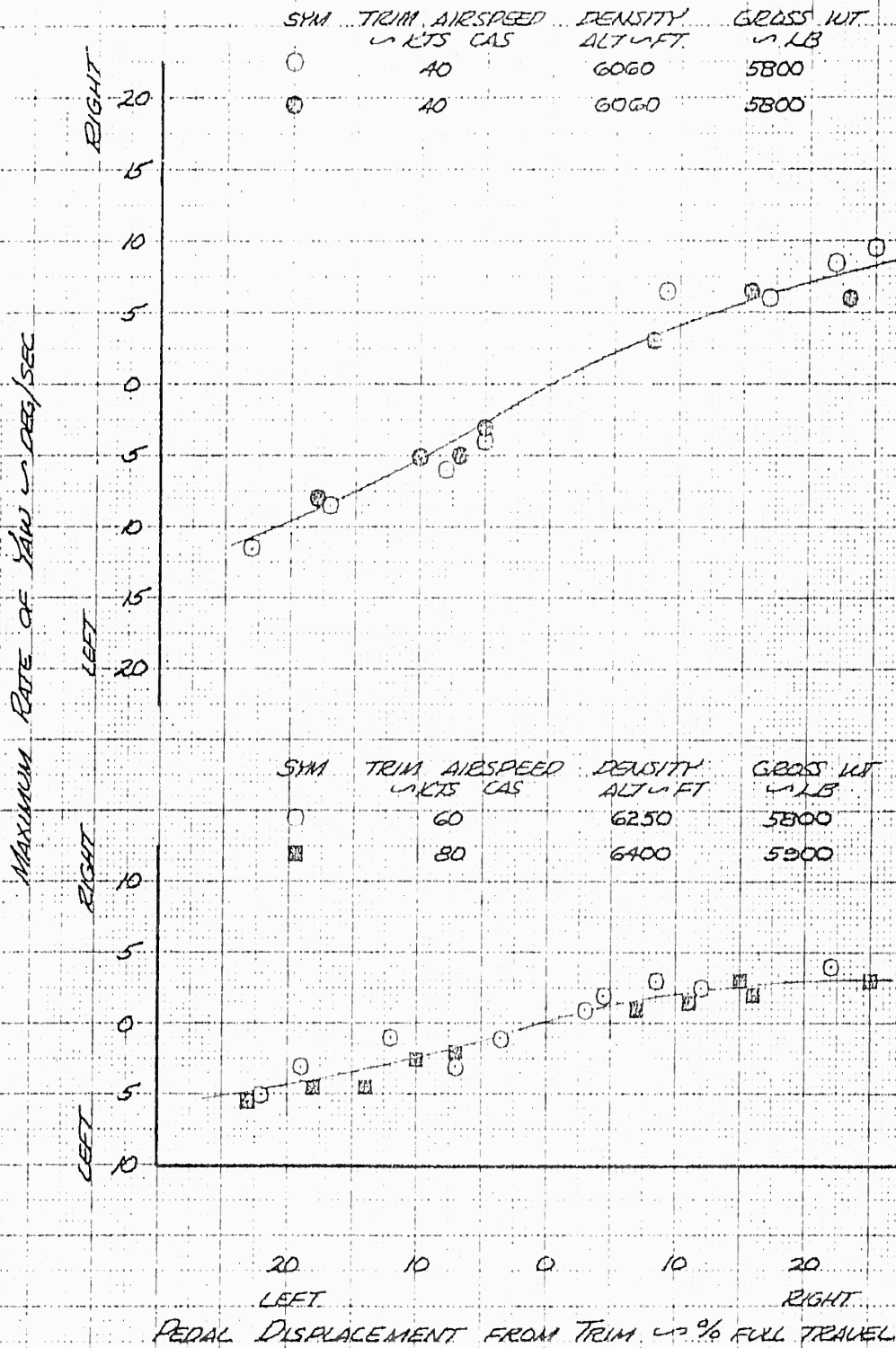
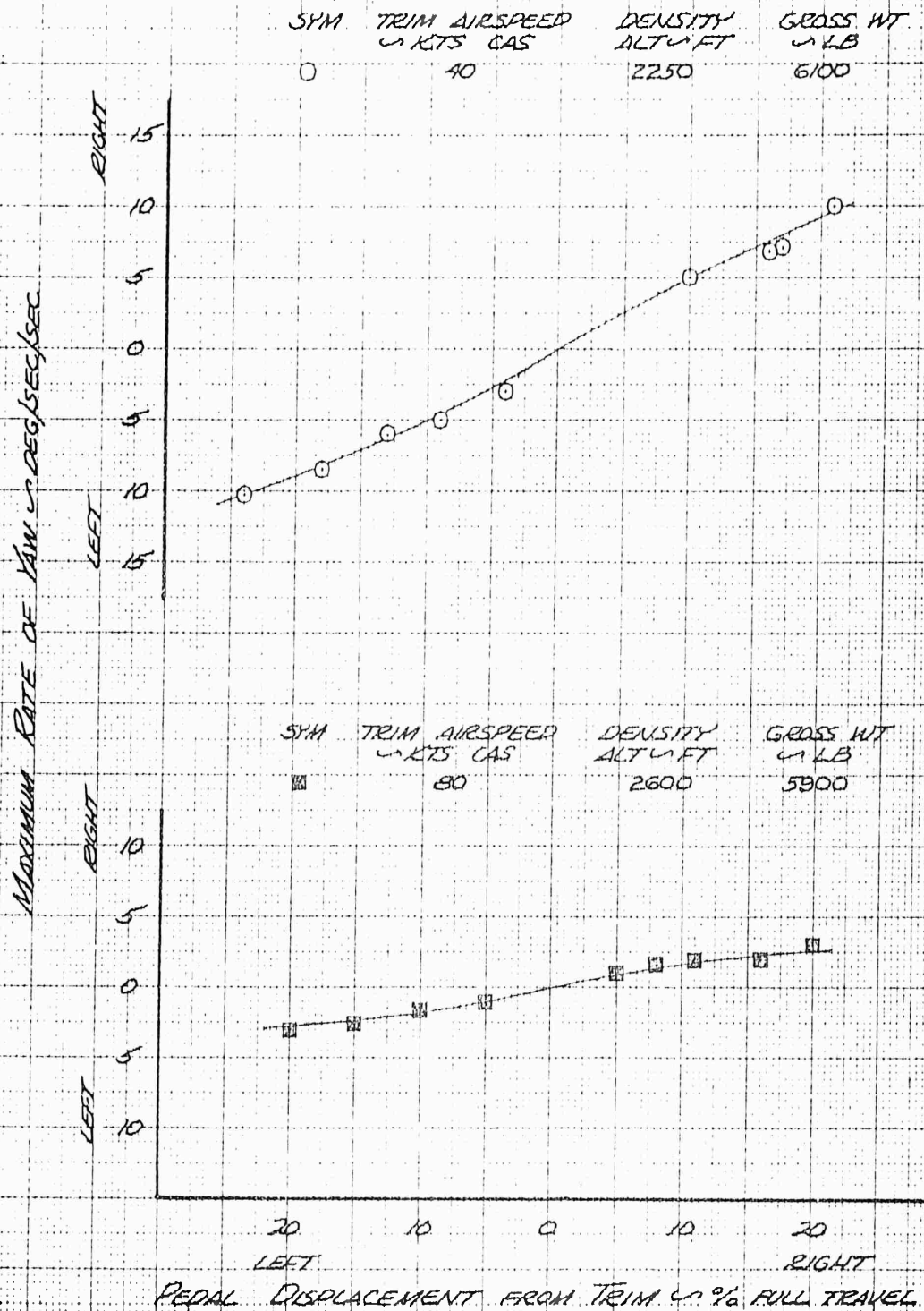

FIGURE No 49  
 DIRECTIONAL RESPONSE  
 H-43B USAF S/N 59-1548  
 RPM = 260/105%  
 LEVEL FLIGHT

- NOTES: MODIFIED EMPENNAGE
1. FULL DIRECTIONAL TRAVEL = 6.5 INCHES
  2. COLORED SYMBOLS DENOTE DSAS "OFF"
  3. MAXIMUM RATE REACHED APPROXIMATELY 2.8 SECONDS FOLLOWING CONTROL DISPLACEMENT



THIS PAGE LEFT BLANK FOR CONVENIENCE IN PRESENTING PLOTS

FIGURE No. 50

RESPONSE TO A LONGITUDINAL STEP  
 H-43B USAF 59-1849  
 TRIM AIRSPEED = 60 KNOTS CAS  
 DENSITY ALTITUDE = 5000 FEET  
 GROSS WEIGHT = 5960 LB  
 C.G. LOCATION = MID (STATION 119)  
 RPM = 260/105%

CLIMB  
 DSAS-ON

ORIGINAL EMPENNAGE

PITCH \_\_\_\_\_  
 ROLL - - - - -  
 YAW - - - - -

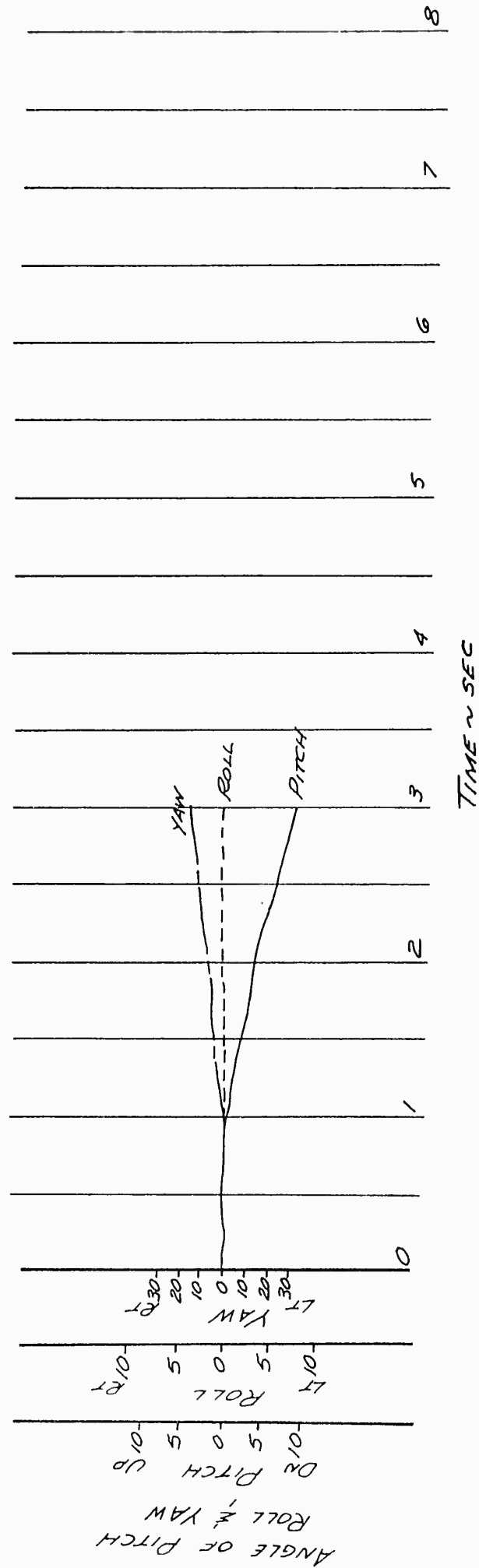

TIME ~ SEC

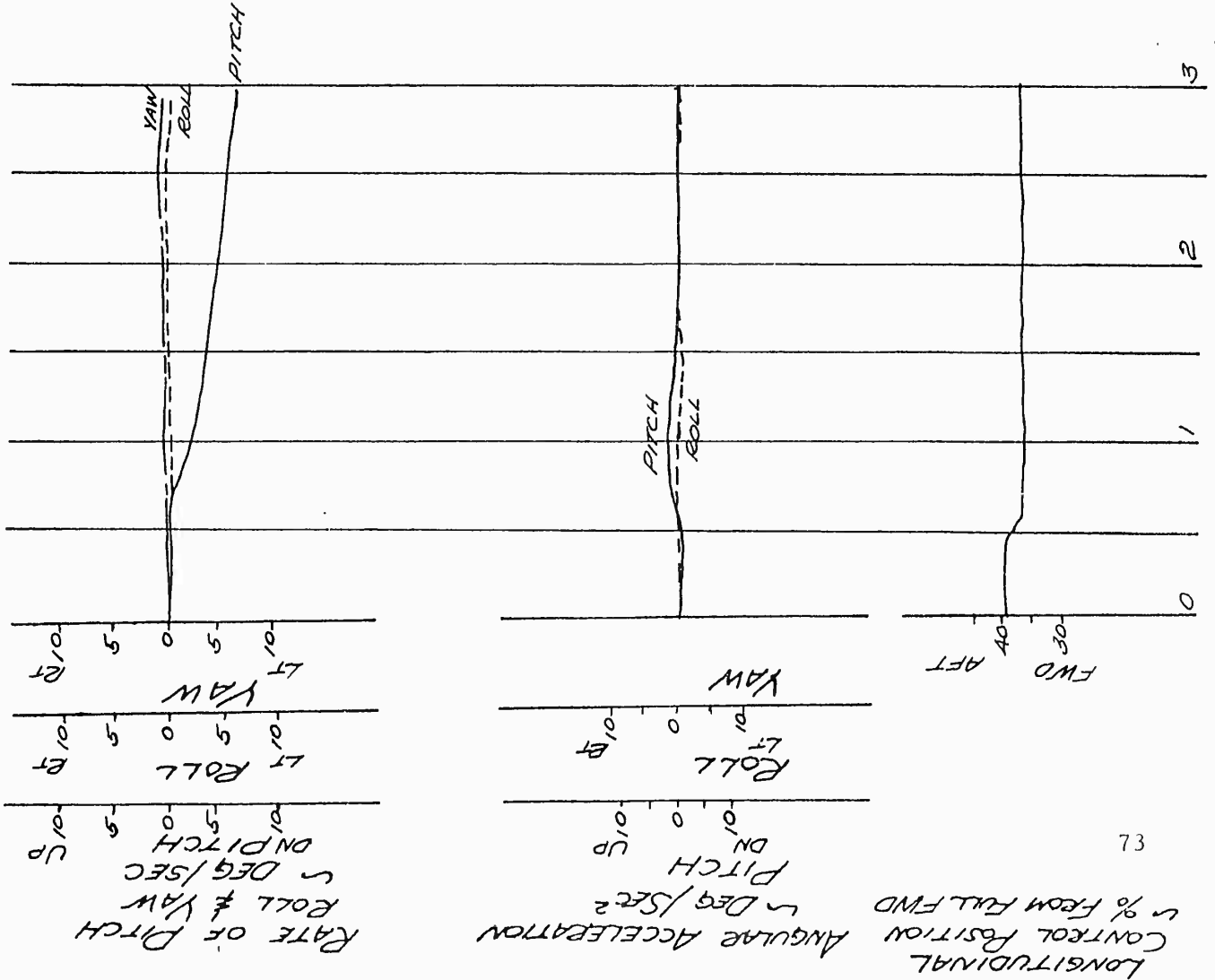

LONGITUDINAL CONTROL POSITION ~ % FROM FULL FWD

ANGULAR ACCELERATION ~ DEG/SEC<sup>2</sup>

RATE OF PITCH ~ DEG/SEC

ROLL ~ DEG/SEC

YAW ~ DEG/SEC

UP DOWN

LT RT

LT RT

LT RT

LT RT

LT RT

LT RT

LT RT

LT RT

LT RT

LT RT

LT RT

LT RT

LT RT

LT RT

LT RT

LT RT

LT RT

LT RT

FIGURE No. 51

RESPONSE TO A LATERAL STEP  
 H-43B USAF 59-1849  
 TRIM AIRSPEED = 60 KNOTS CAS  
 DENSITY ALTITUDE = 5450 FEET  
 GROSS WEIGHT = 5800 LB  
 CG LOCATION = MID (STATION 119)  
 RPM = 260/105%  
 CLIMB  
 DSAS-ON

ORIGINAL EMPENNAGE

PITCH \_\_\_\_\_  
 ROLL - - - - -  
 YAW - - - - -

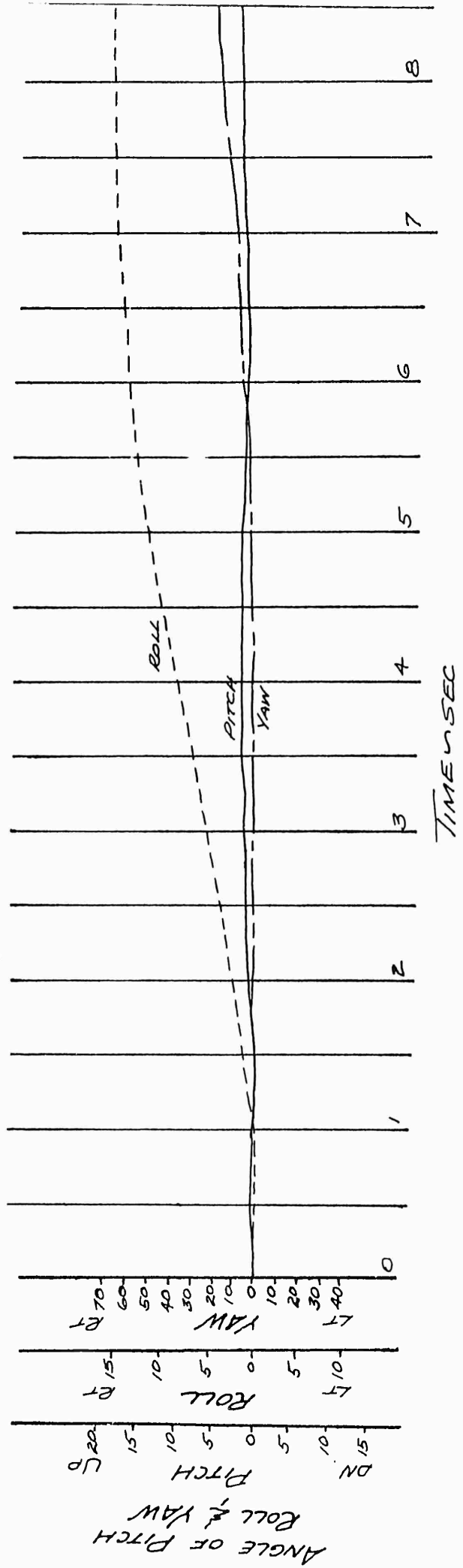

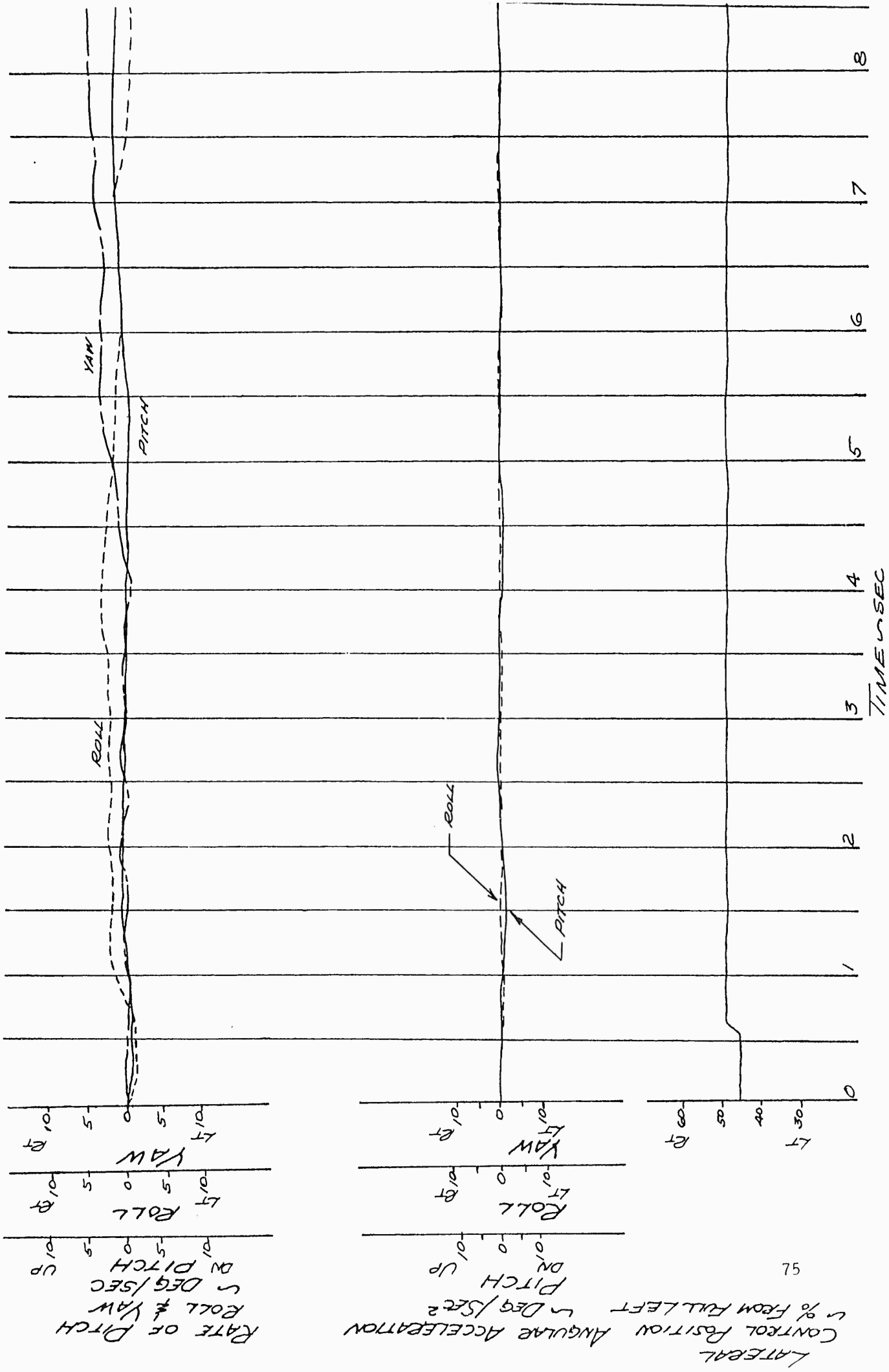
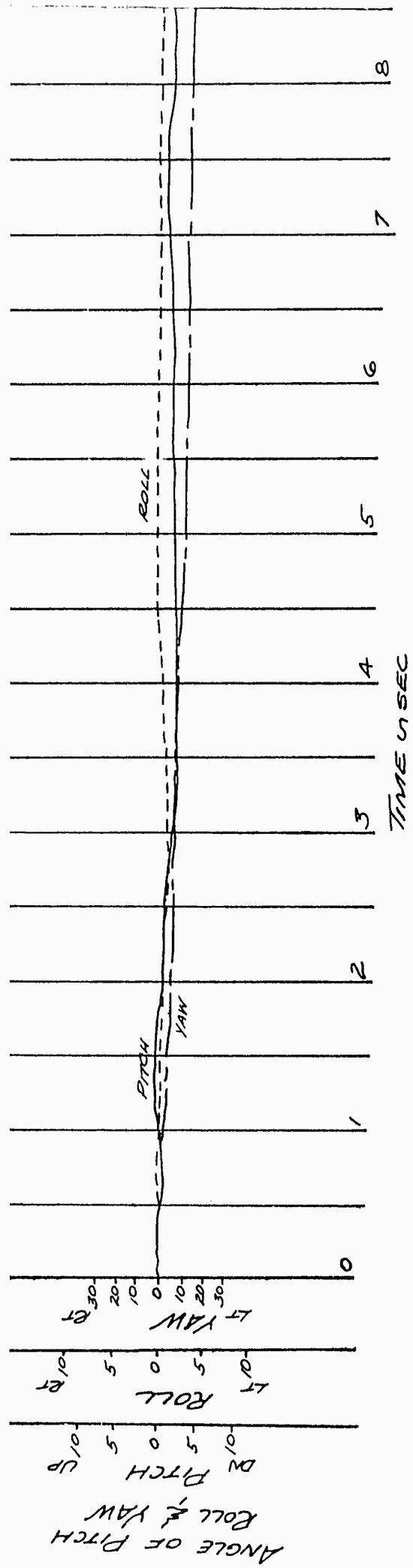

FIGURE No. 52

RESPONSE TO A PEDAL STEP  
 H-43B USAF 59-1849  
 TRIM AIRSPEED = 60 KNOTS CAS  
 DENSITY ALTITUDE = 5450 FEET  
 GROSS WEIGHT = 5800 LB  
 CG LOCATION = MID (STATION 119)  
 RPM = 260/105%  
 CLIMB  
 DSAS - ON

PITCH  
 ROLL  
 YAW

ORIGINAL EMPENNAGE



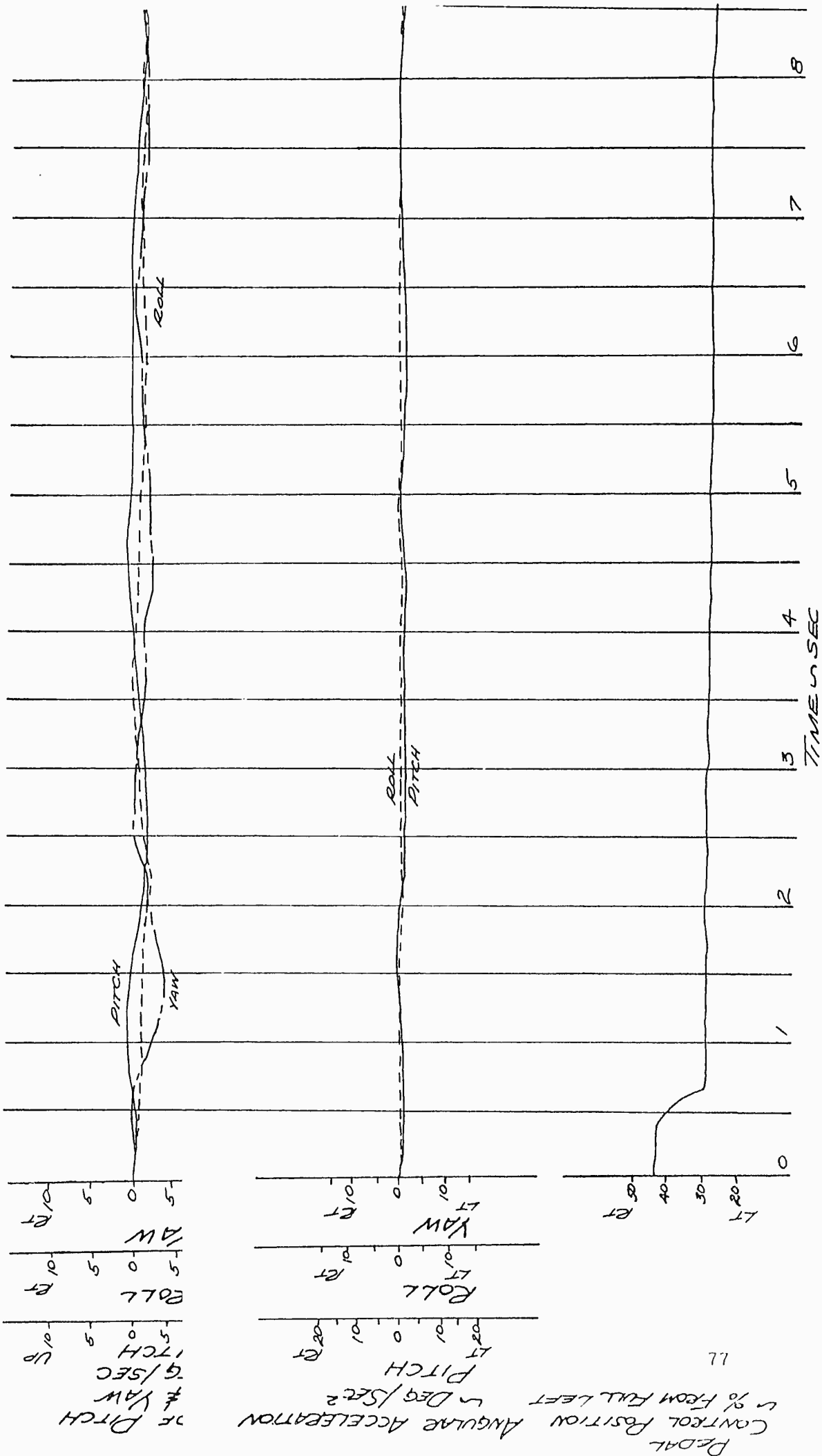

LL

PEDAL POSITION  
 CONTROL POSITION ANGULAR ACCELERATION  
 % FROM FULL LEFT  
 IN DEG/SEC<sup>2</sup>

% PITCH  
 # YAW  
 DEG/SEC  
 UP

PITCH  
 5  
 0  
 5  
 10  
 15  
 20

ROLL  
 5  
 0  
 5  
 10

YAW  
 5  
 0  
 5  
 10

FIGURE No. 53

RESPONSE TO A LONGITUDINAL PULSE  
 H-43B USAF SN 59-1849  
 TRIM AIRSPEED = 60 KNOTS CAS  
 DENSITY ALTITUDE = 5700 FEET  
 GROSS WEIGHT = 6150 LB  
 CG LOCATION = MID (STATION 119)  
 RPM = 260/105%  
 LEVEL FLIGHT  
 D3A5 - ON

PITCH \_\_\_\_\_  
 ROLL - - - - -  
 YAW - - - - -

ORIGINAL EMPENNAGE

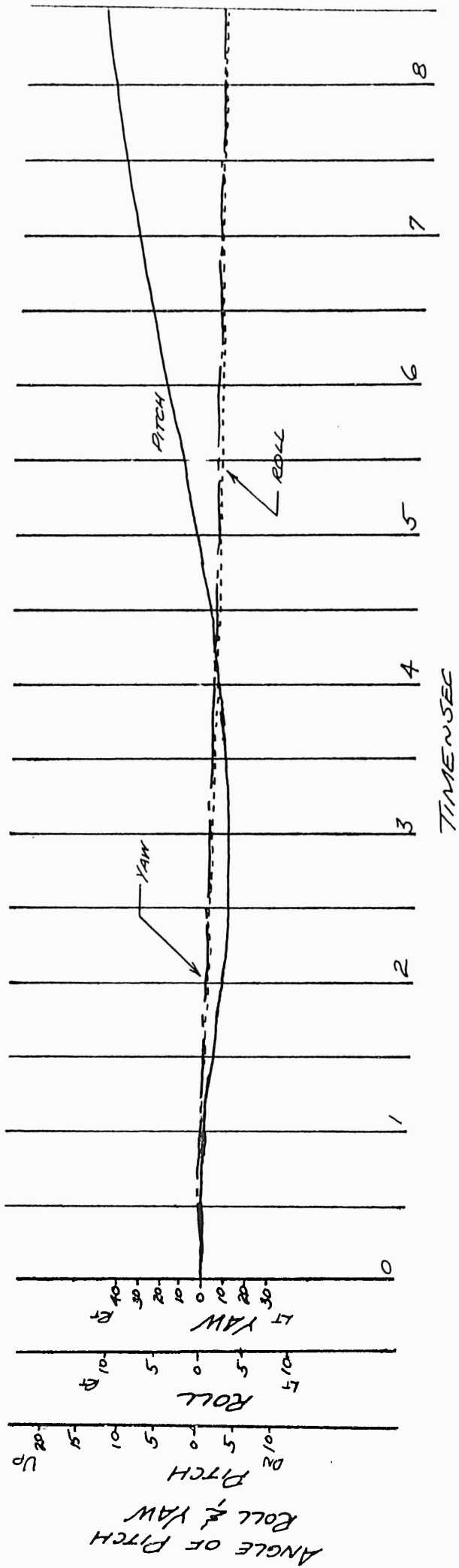

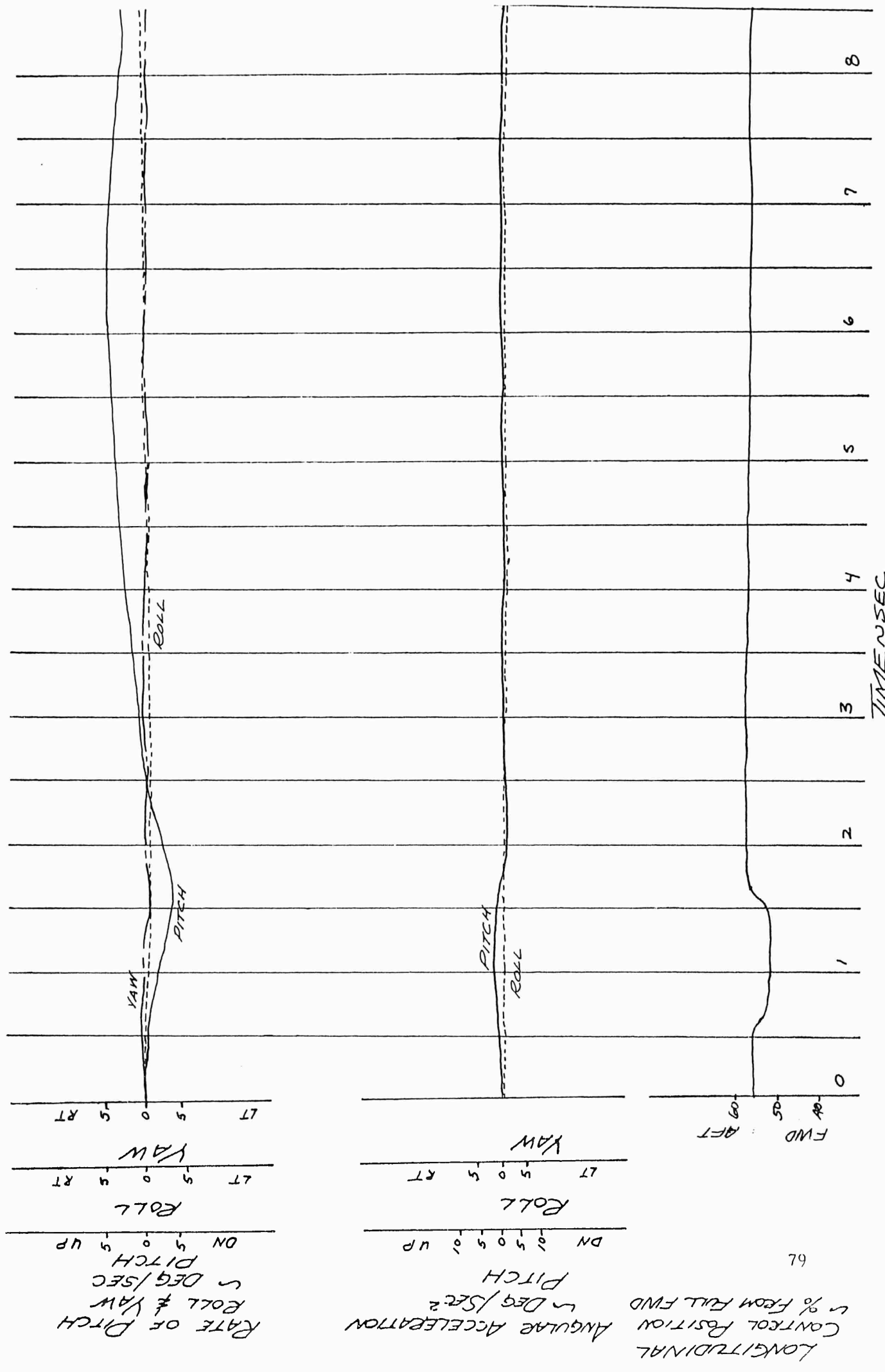

67

FIGURE No. 54

RESPONSE TO A LONGITUDINAL PULSE  
 H-R3B USAF 59-1849  
 TRIM AIRSPEED = 80 KNOTS CAS  
 DENSITY ALTITUDE = 5700 FEET  
 GROSS WEIGHT = 6150 LB  
 C.G. LOCATION = MID (STATION 119)  
 RPM = 260/105%  
 LEVEL FLIGHT  
 DSAS-OFF

PITCH ———  
 ROLL - - -  
 YAW - - -

ORIGINAL EMPENNAGE

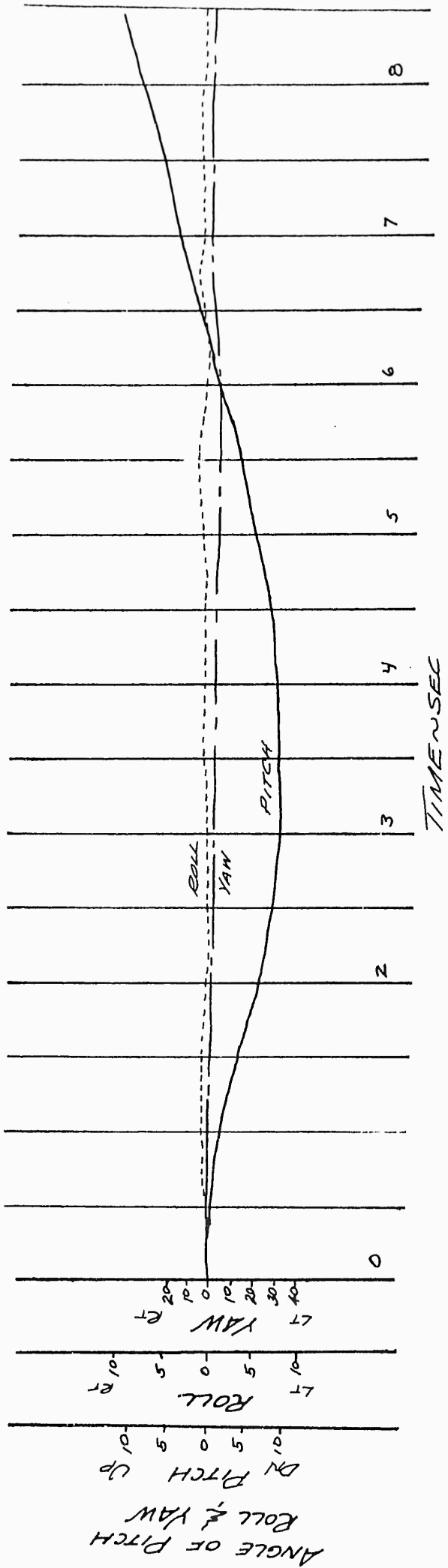

8

7

6

5

4

3

2

1

0

TIME IN SEC

LONGITUDINAL  
CONTROL POSITION  
% FROM FULL FWD

18

ANGULAR ACCELERATION  
% DEG/SEC<sup>2</sup>  
PITCH

RATE OF PITCH  
% DEG/SEC  
ROLL & YAW

FWD  
0%  
5%  
10%  
AFT

ROLL  
5  
0  
5  
LT  
RT

ROLL  
5  
0  
5  
LT  
RT

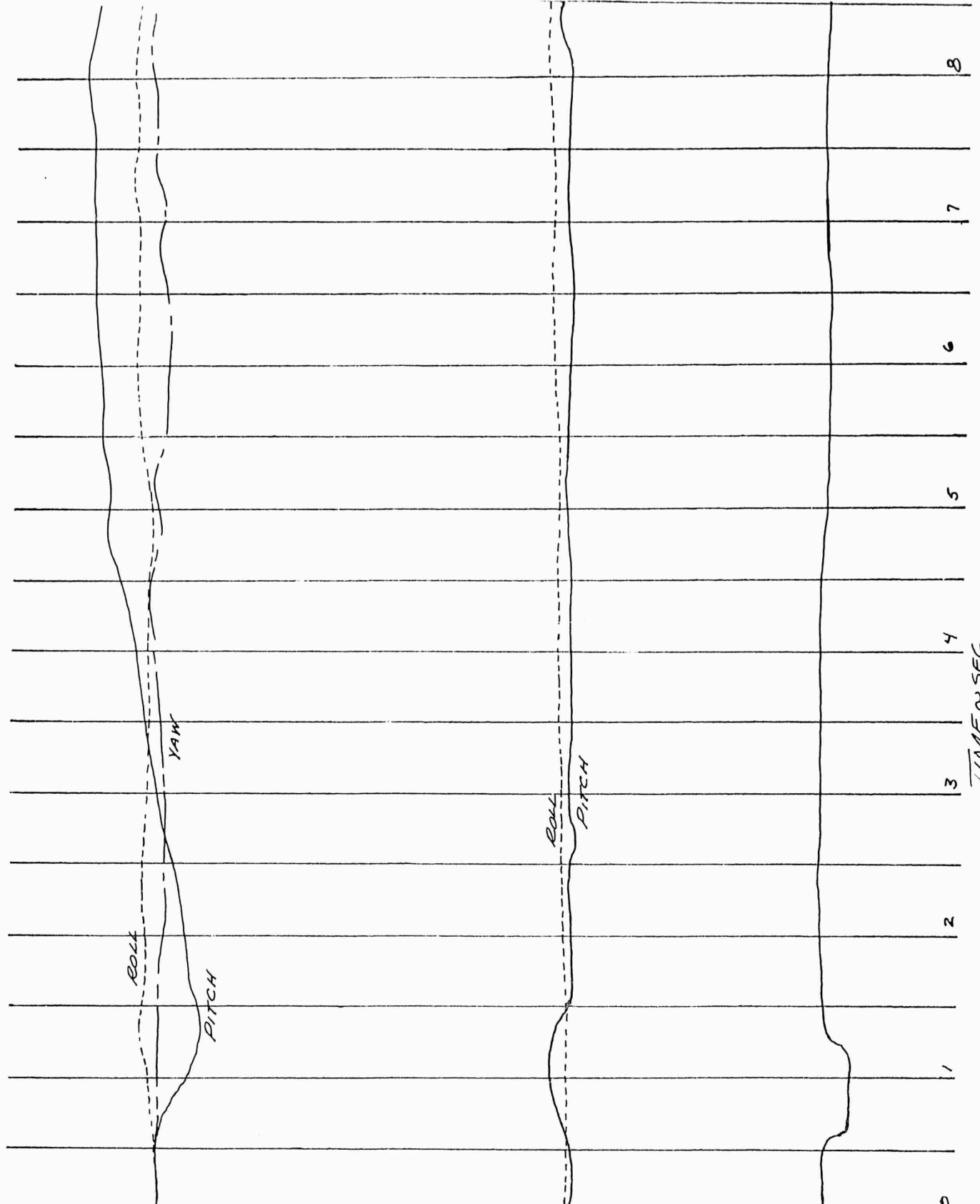
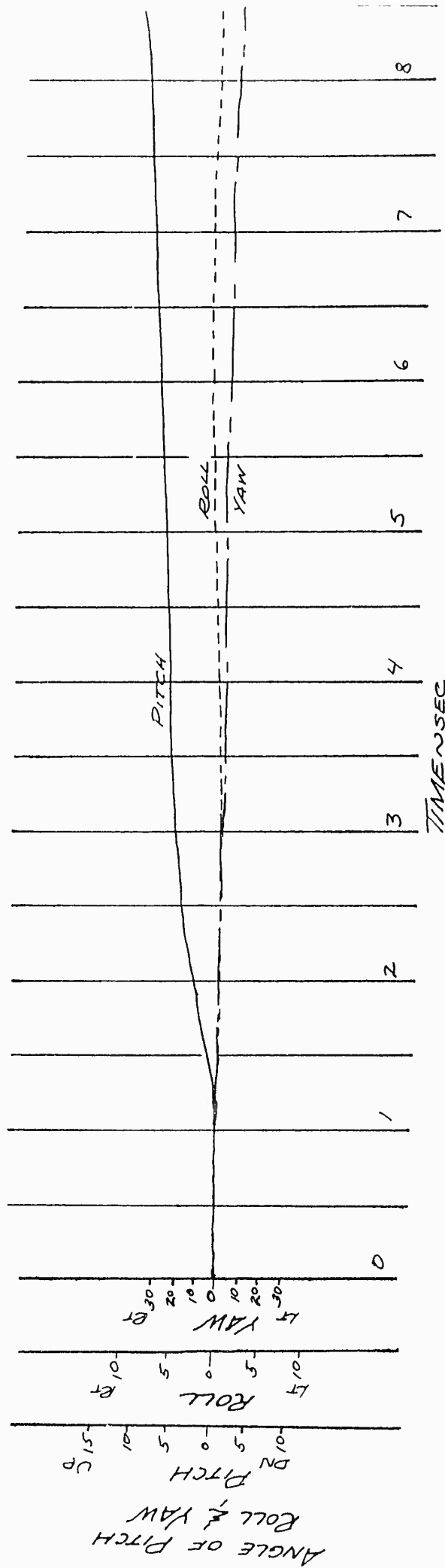

FIGURE No. 55

RESPONSE TO A LONGITUDINAL PULSE  
 H-43B USAF s/n 59-1849  
 TRIM AIRSPEED = 40 KNOTS CAS  
 DENSITY ALTITUDE = 5700 FEET  
 GROSS WEIGHT = 6150 LB  
 C G LOCATION = MID (STATION 119)  
 RPM = 260/105%  
 DSAS-ON  
 LEVEL FLIGHT

PITCH \_\_\_\_\_  
 ROLL - - - - -  
 YAW - - - - -

ORIGINAL EMPENNAGE



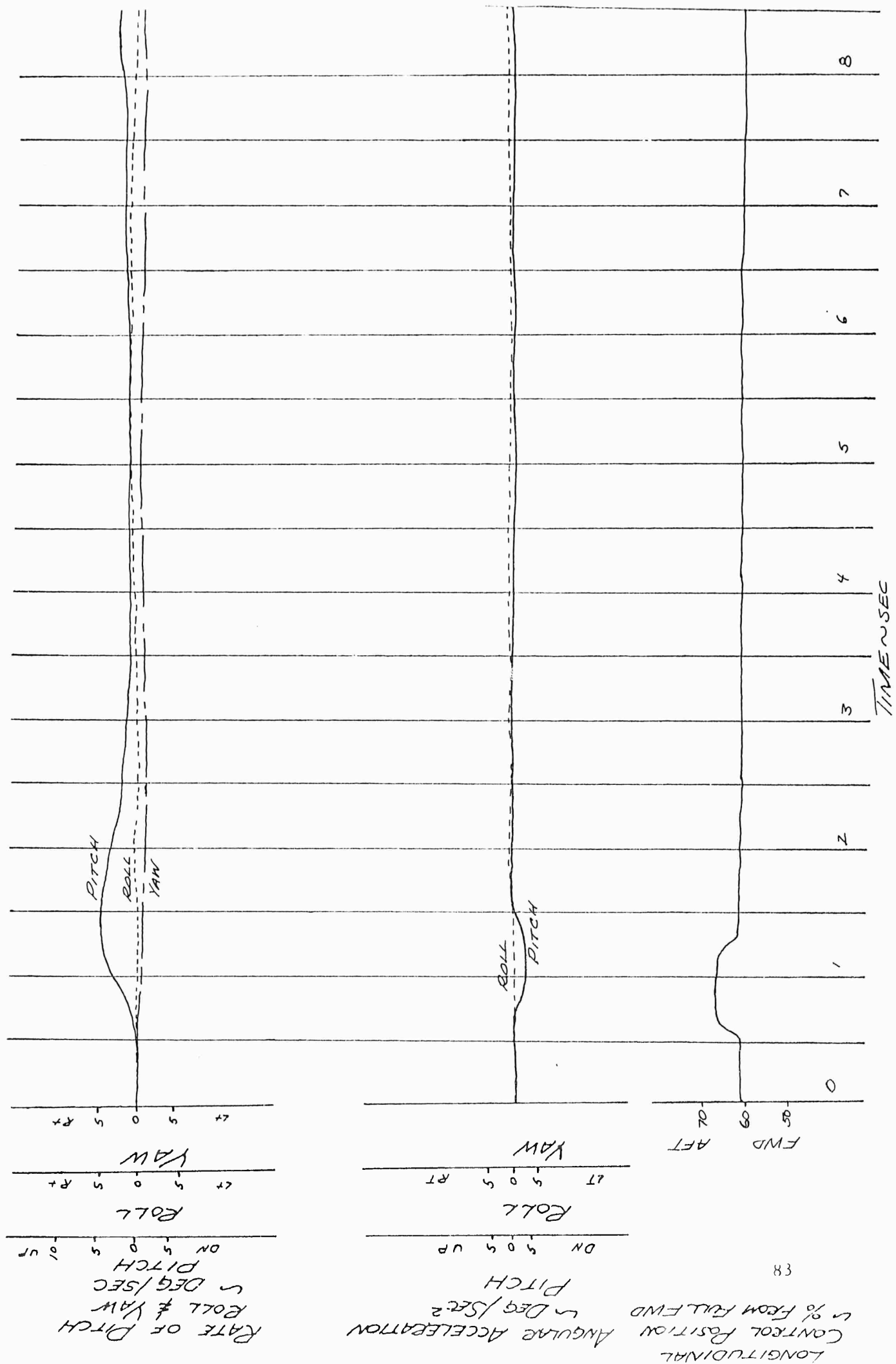

83

LONGITUDINAL CONTROL POSITION  
 ~ % FROM FULL FWD

ANGULAR ACCELERATION  
 ~ DEG/SEC²  
 PITCH  
 ~ DEG/SEC

RATE OF ROLL  
 ~ DEG/SEC  
 RATE OF YAW  
 ~ DEG/SEC

ROLL  
 DN UP  
 5 0 5  
 YAW  
 LT RT  
 5 0 5

ROLL  
 DN UP  
 5 0 5  
 YAW  
 LT RT  
 5 0 5

FWD AFT  
 0 5 10

FIGURE No. 56

RESPONSE TO A LONGITUDINAL PULSE  
 H-43B USAF SN 59-1849  
 TRIM AIRSPEED = 60 KNOTS CAS  
 DENSITY ALTITUDE = 5700 FEET  
 GROSS WEIGHT = 6150 LB  
 C G LOCATION = MID (STATION 119)  
 RPM = 260/105%  
 LEVEL FLIGHT  
 DSAS - ON

PITCH \_\_\_\_\_  
 ROLL \_\_\_\_\_  
 YAW \_\_\_\_\_

ORIGINAL EMPENNAGE

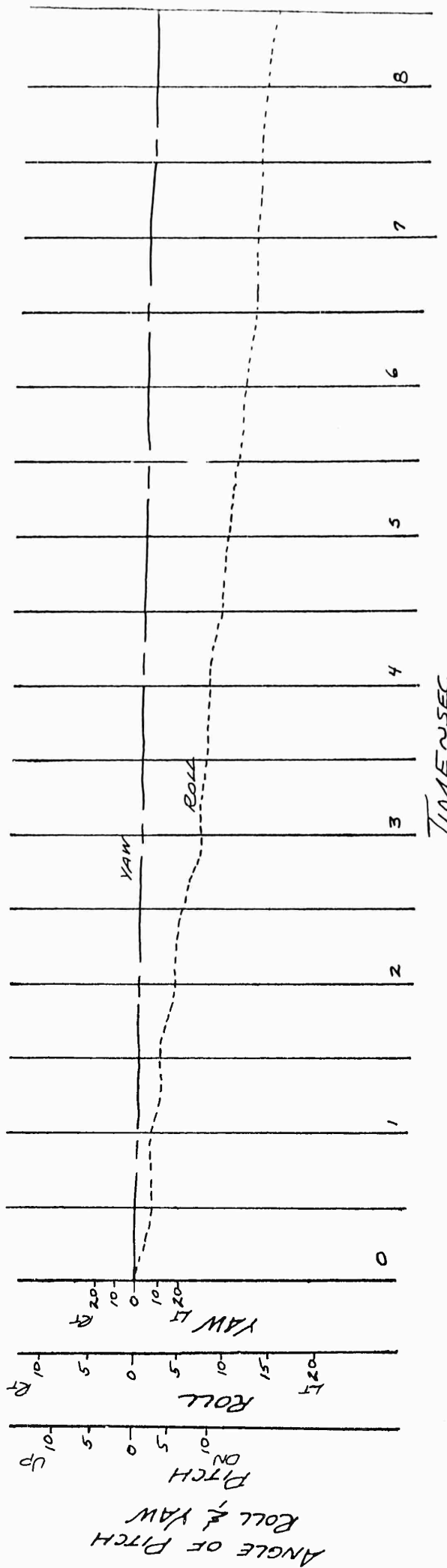

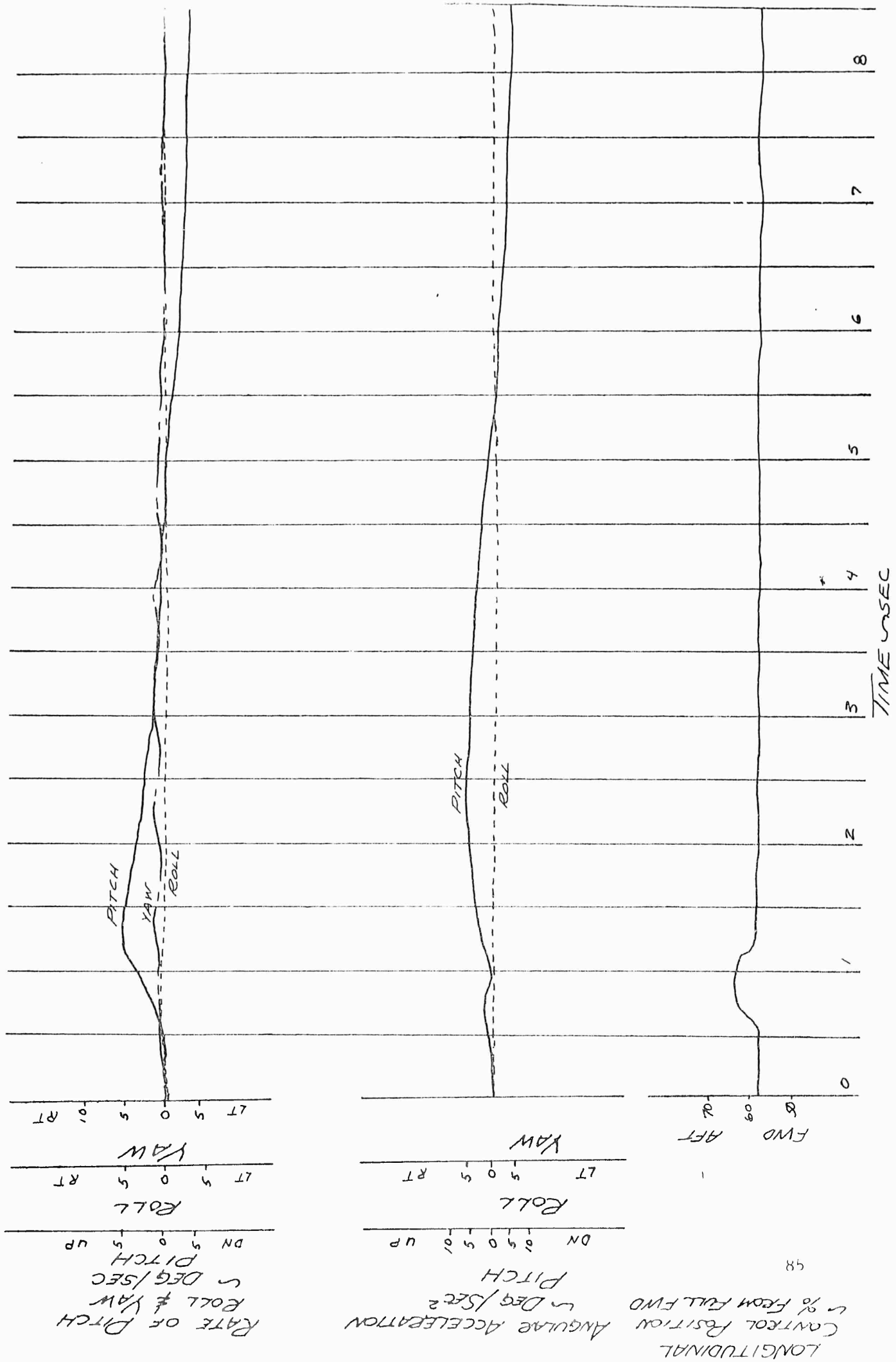

98

LONGITUDINAL CONTROL POSITION (% FROM FULL FWD)

ANGULAR ACCELERATION (DEG/SEC<sup>2</sup>)

RATE OF PITCH (DEG/SEC)

PITCH UP 5 0 5 DN  
 ROLL UP 5 0 5 DN  
 YAW RT 5 0 5 LT

PITCH UP 5 0 5 DN  
 ROLL UP 5 0 5 DN  
 YAW RT 5 0 5 LT

FWD 5 0 5 AFT  
 ROLL UP 5 0 5 DN  
 YAW RT 5 0 5 LT

PITCH  
 YAW  
 ROLL

PITCH  
 ROLL

8  
7  
6  
5  
4  
3  
2  
1  
0

FIGURE No. 57

RESPONSE TO A LONGITUDINAL PULSE  
 H-43B USAF 59-1548  
 TRIM AIRSPEED = 80 KNOTS CAS  
 DENSITY ALTITUDE = 2300 FEET  
 GROSS WEIGHT = 6000 LB  
 C.G. LOCATION = MID (STATION 119)  
 RPM = 260/105%

MODIFIED EMPENNAGE

PITCH \_\_\_\_\_  
 ROLL - - - - -  
 YAW - - - - -

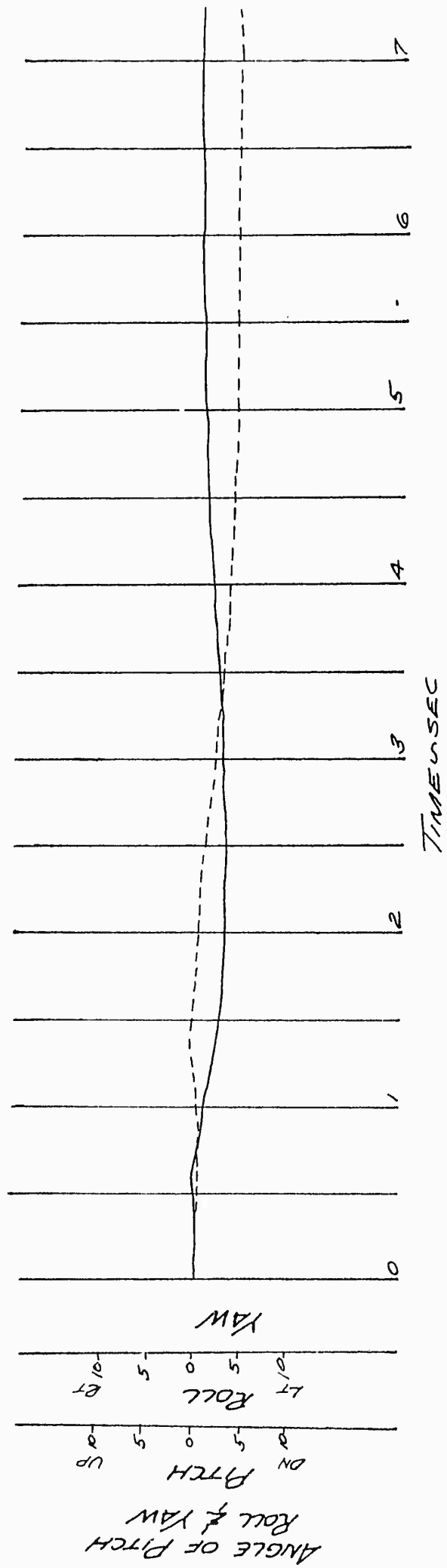

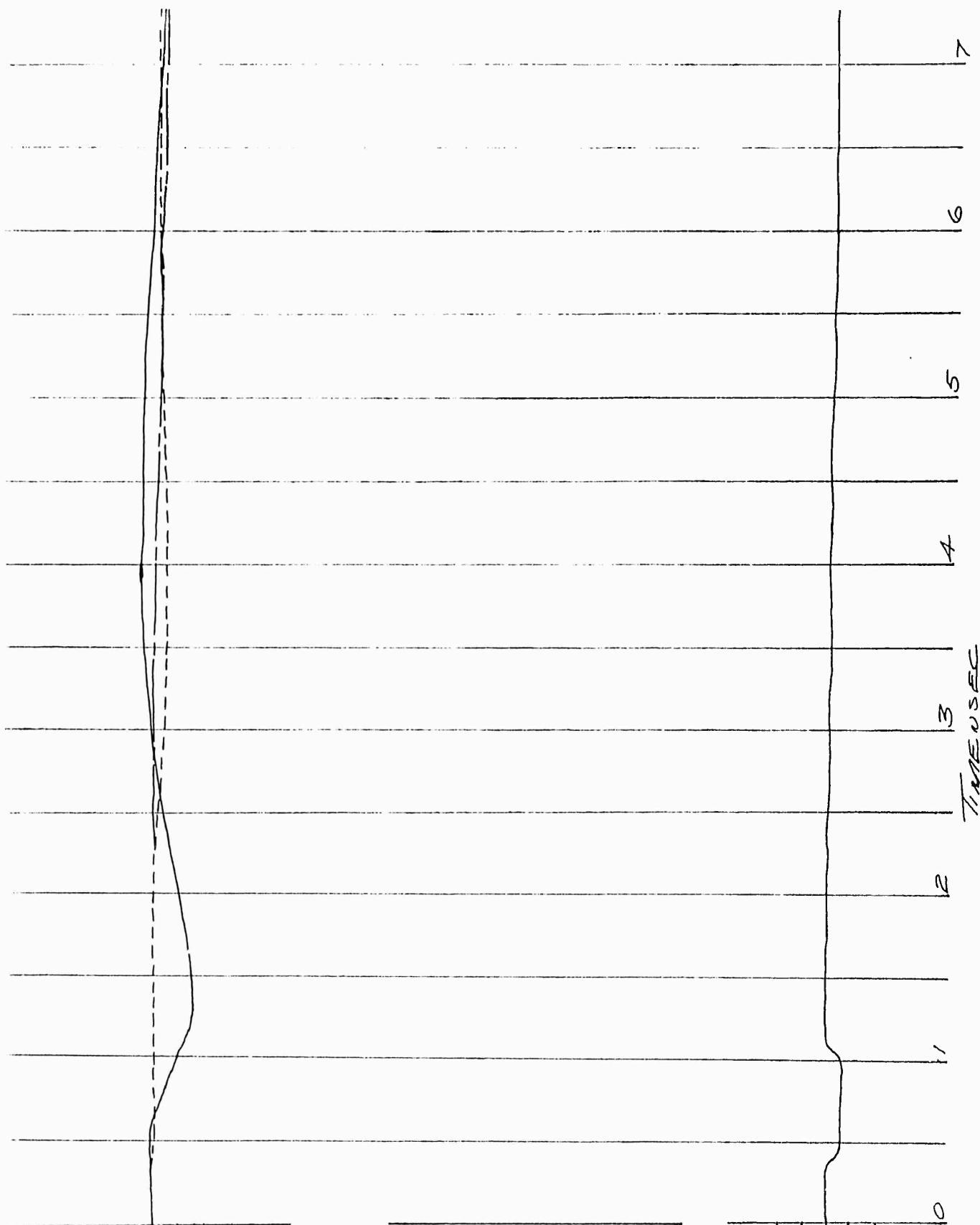

TIME IN SEC

LONGITUDINAL  
CONTROL POSITION  
% FROM FULL FWD

ANGULAR ACCELERATION  
DEG/SEC<sup>2</sup>

RATE OF PITCH  
DEG/SEC

ROLL & YAW  
DEG/SEC

ROLL RATE  
LT RT

YAW RATE  
LT RT

FWD  
50 60 70  
AFT

8 6 4 2 0 2 4 6 8  
LT RT

0

1

2

3

4

5

6

7

FIGURE No. 58

RESPONSE TO A LATERAL PULSE  
 H-43B USAF SN 59-1849  
 TRIM AIRSPEED = 80 KNOTS CAS  
 DENSITY ALTITUDE = 6040 FEET  
 GROSS WEIGHT = 6120 LB  
 C G LOCATION = MID (STATION 119)  
 RPM = 200/105%  
 LEVEL FLIGHT  
 DSAS-OFF

ORIGINAL EMPENNAGE

PITCH \_\_\_\_\_  
 ROLL - - - - -  
 YAW - - - - -

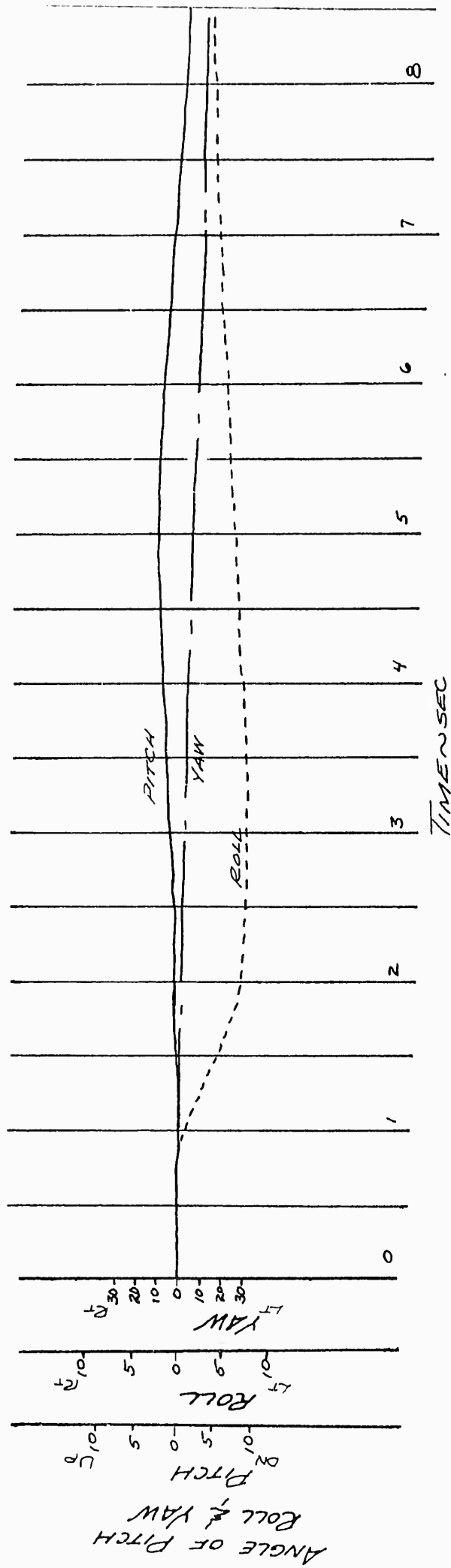

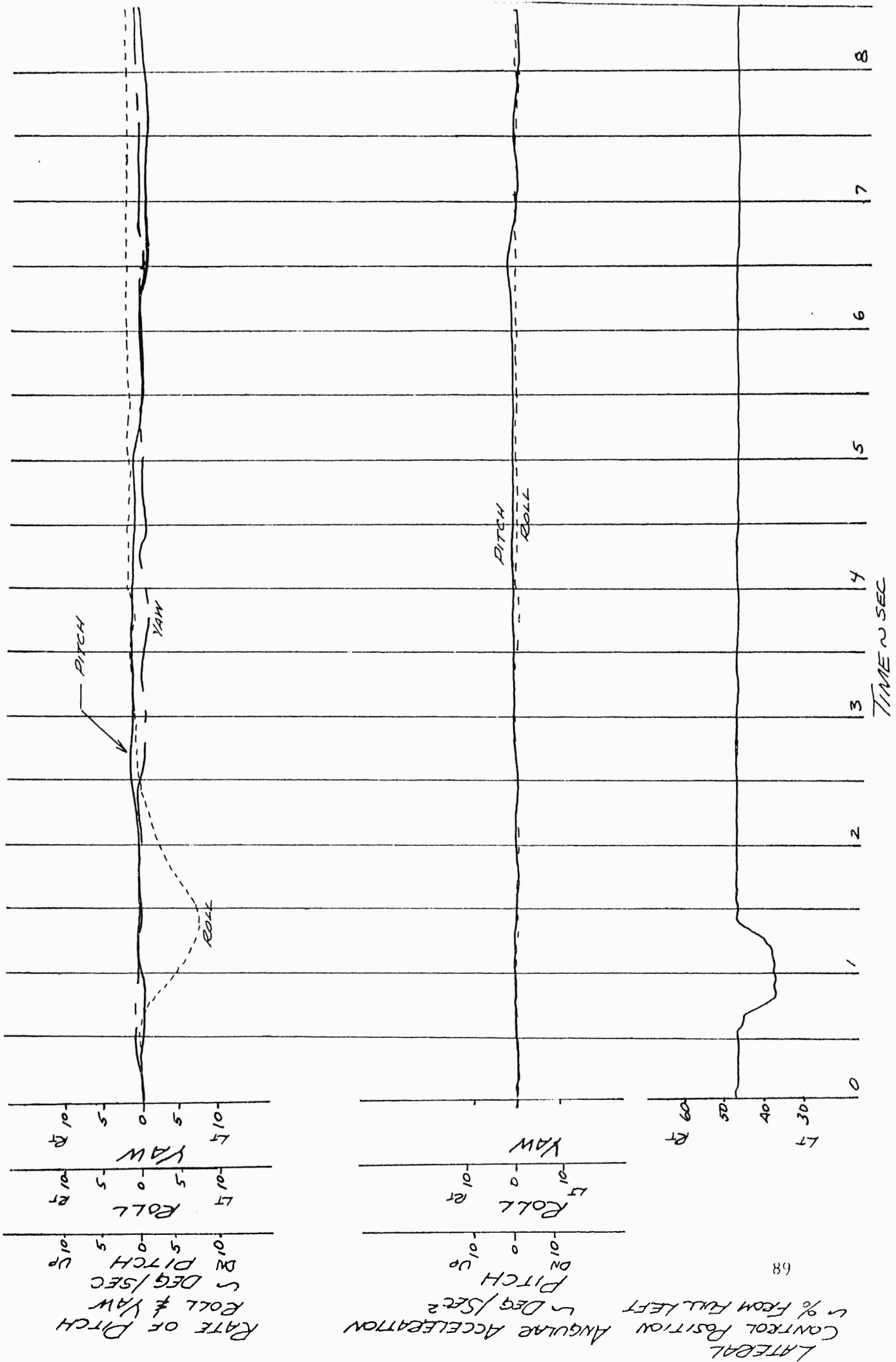

FIGURE No. 59

RESPONSE TO A LATERAL PULSE  
 H-43B USAF SN 59-1849  
 TRIM AIRSPEED = 40 KNOTS CAS  
 DENSITY ALTITUDE = 6040 FEET  
 GROSS WEIGHT = 6120 LB  
 C G LOCATION = MID (STATION 119)  
 RPM = 260/105%

LEVEL FLIGHT  
 DSAS-ON

PITCH ———  
 ROLL - - -  
 YAW - - -

ORIGINAL EMPENNAGE

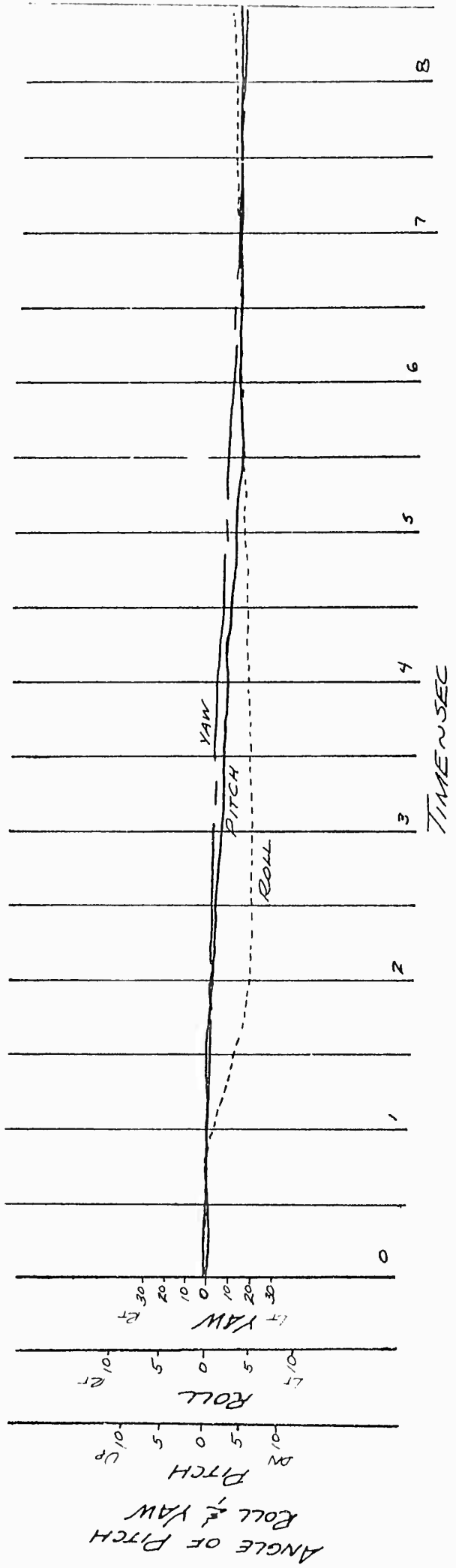

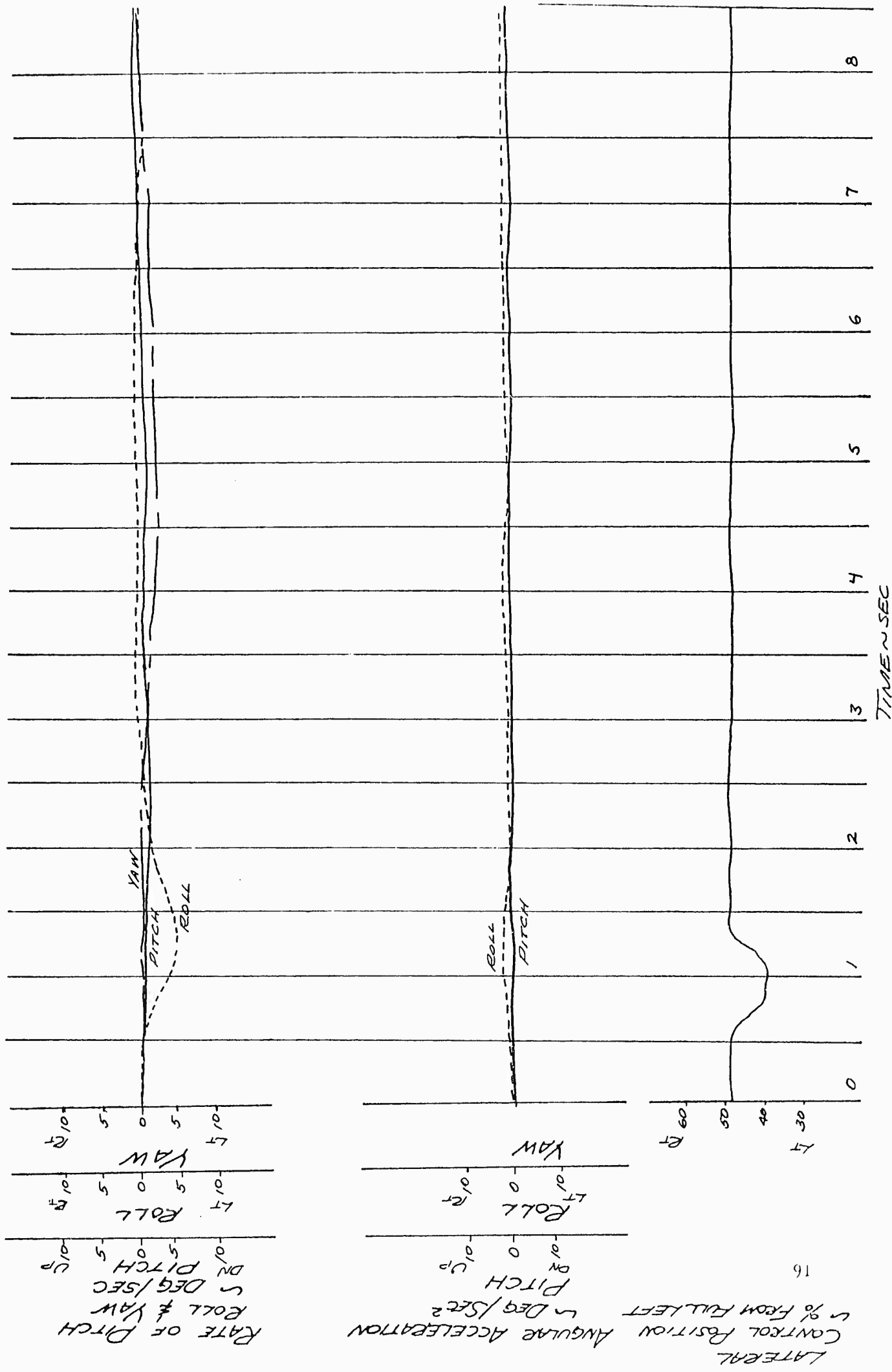
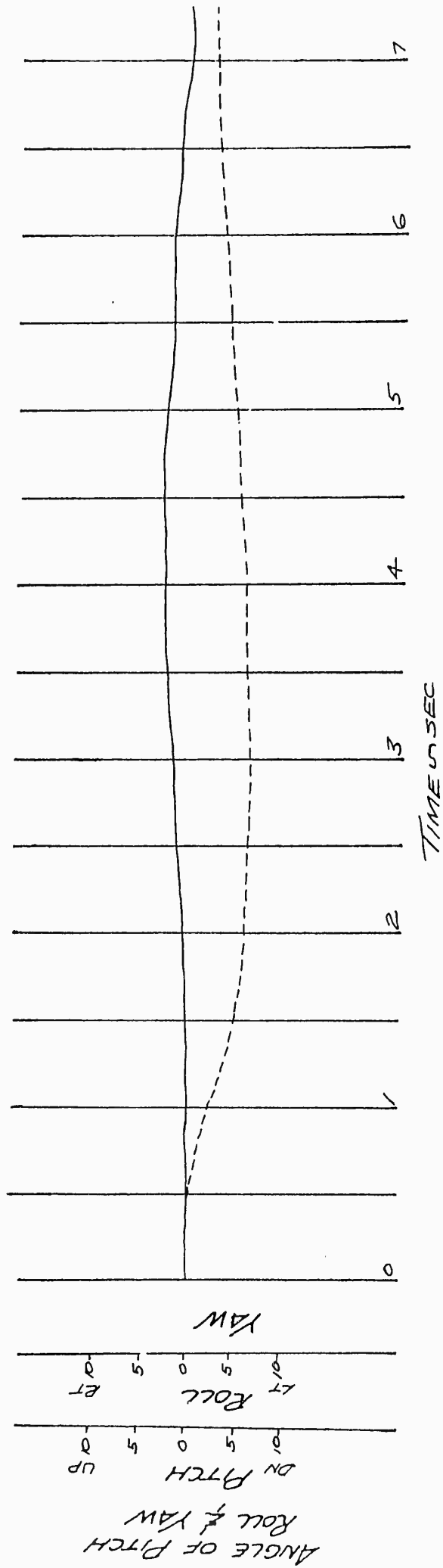

FIGURE No. 60

RESPONSE TO A LATERAL PULSE  
 H-43B USAF 59-1548  
 TRIM AIRSPEED = 80 KNOTS CAS  
 DENSITY ALTITUDE = 2300 FEET  
 GROSS WEIGHT = 6000 LB  
 CG LOCATION = MID (STATION 119)  
 RPM = 260/105%

MODIFIED EMPENNAGE

PITCH  
 ROLL  
 YAW



TIME IN SEC

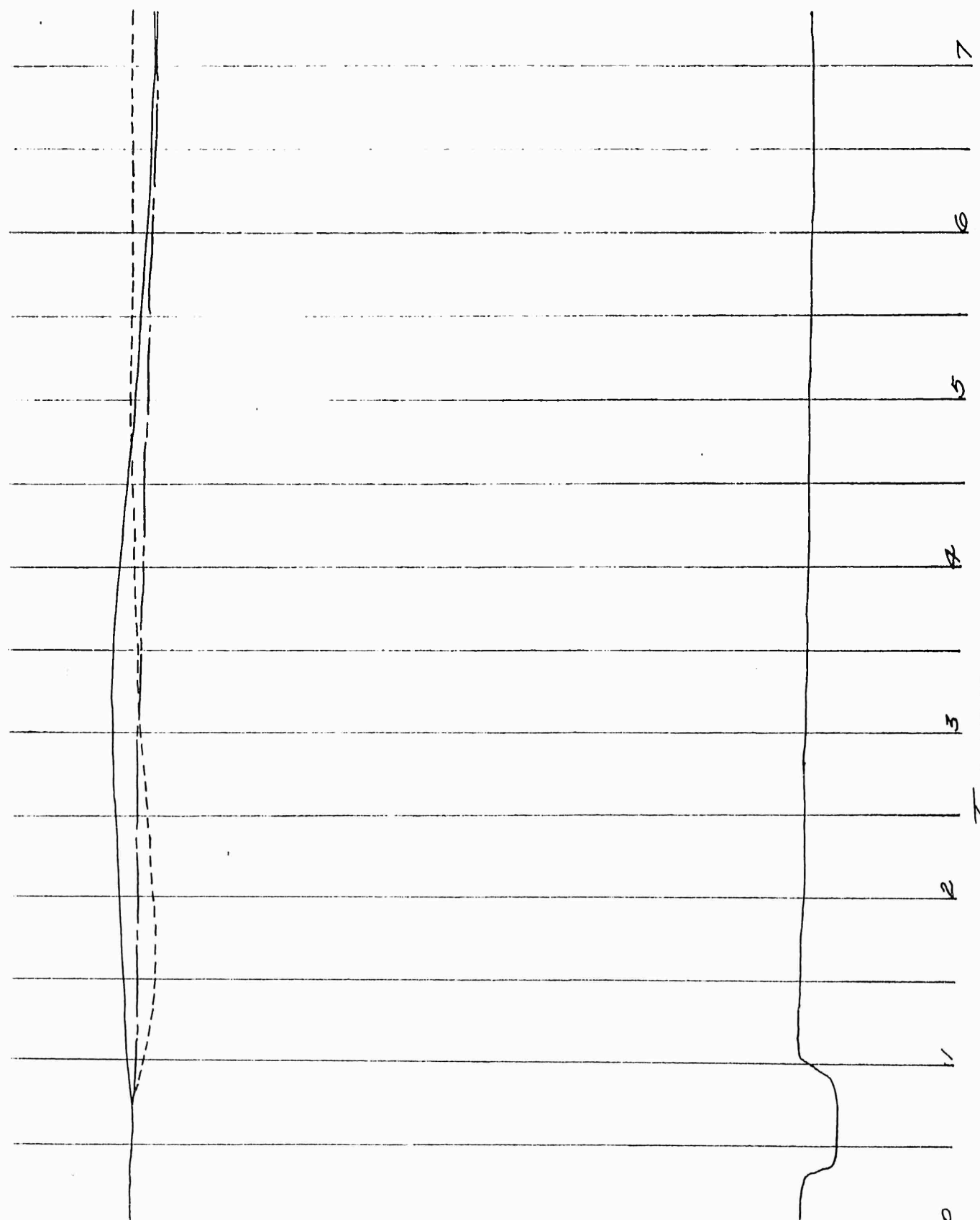

RATE OF PITCH  
 ROLL & YAW  
 DEG/SEC  
 DITCH  
 UP  
 L R  
 10 5 0 5 10  
 ROLL  
 L R  
 6 4 2 0 2 4 6 8  
 YAW  
 L R  
 6 4 2 0 2 4 6 8

LATERAL  
 CONTROL POSITION ANGLE ACCELERATION  
 % FROM FULL LEFT  
 DEG/SEC  
 PITCH  
 L R  
 40 30 20 10 0 10 20 30 40

FIGURE No. 61

RESPONSE TO A LATERAL PULSE  
 H-43B USAF 59-1548  
 TRIM AIRSPEED = 40 KNOTS CAS  
 DENSITY ALTITUDE = 2100 FEET  
 GROSS WEIGHT = 6170 LB  
 C.G. LOCATION = MD (STATION 119)  
 RPM = 260/105%

PITCH \_\_\_\_\_  
 ROLL - - - - -  
 YAW - - - - -

MODIFIED EMPENNAGE

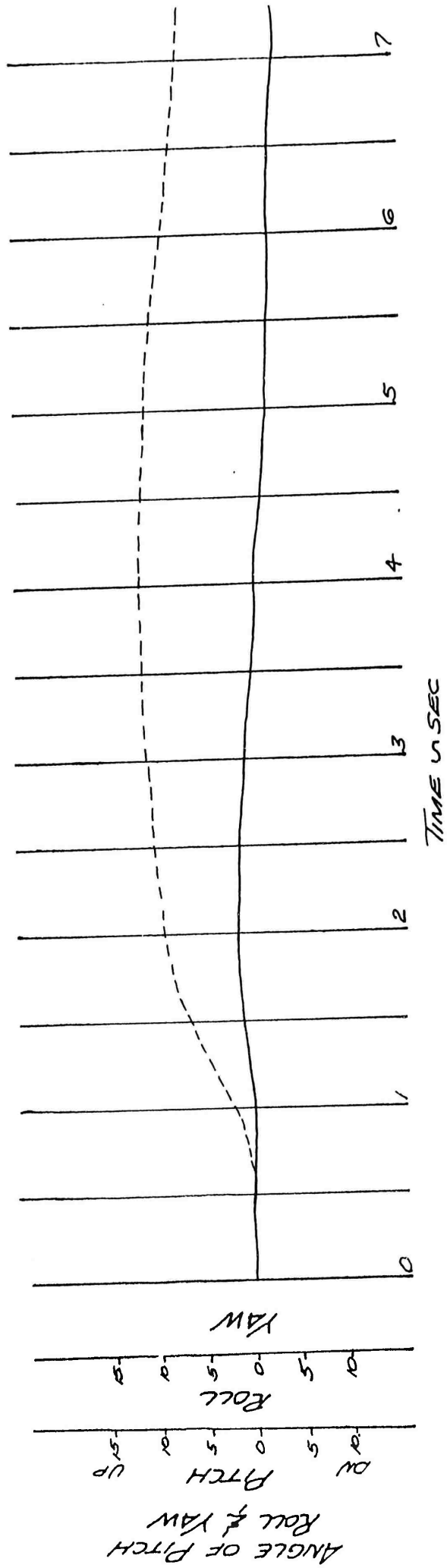

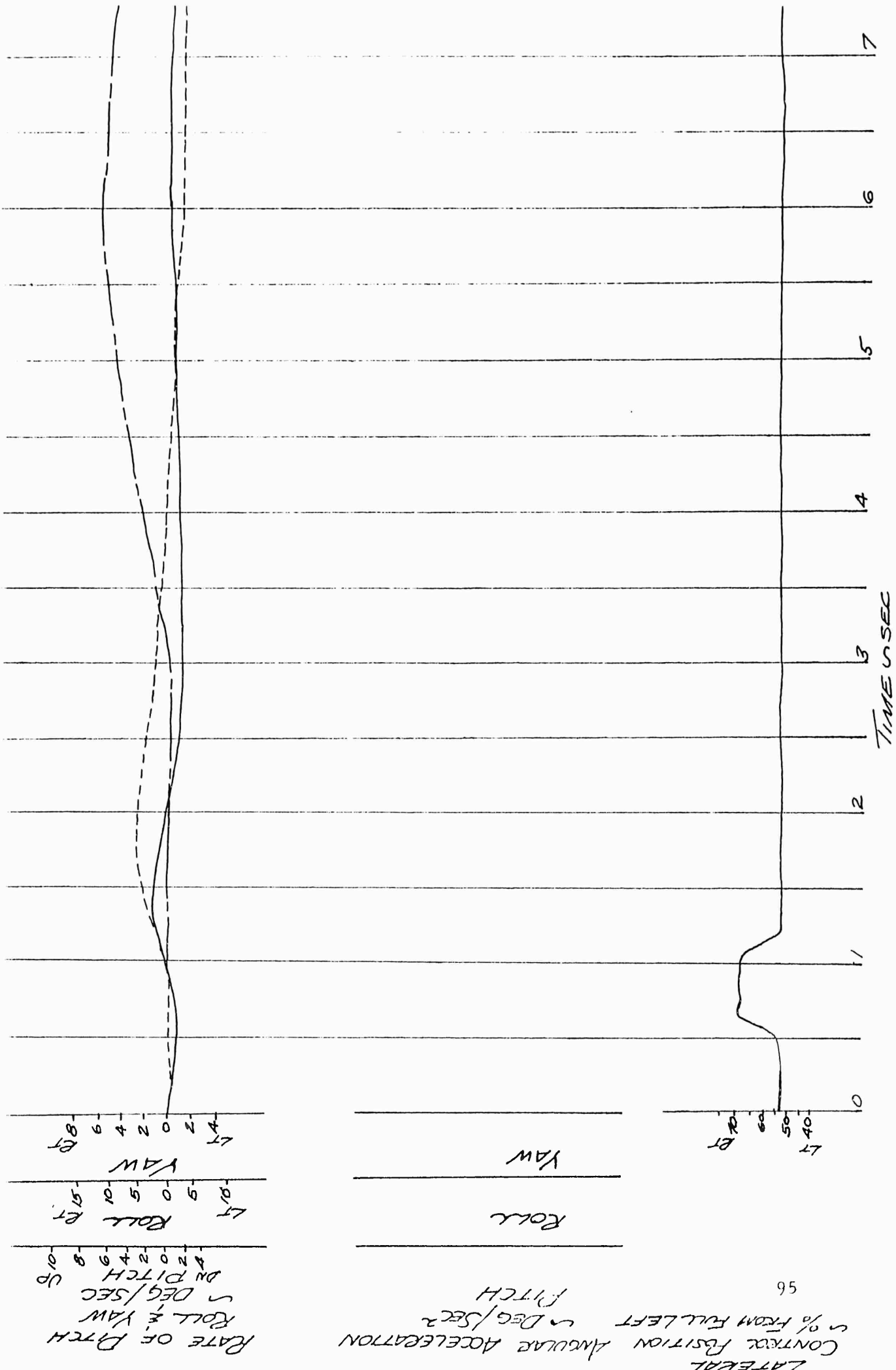

LATERAL CONTROL POSITION ANGULAR ACCELERATION  
 % FROM FULL LEFT  
 DEG/SEC<sup>2</sup>  
 PITCH

RATE OF PITCH  
 Roll & Yaw  
 DEG/SEC  
 UP  
 DN  
 PITCH

FIGURE No. 62

RESPONSE TO A PEDAL PULSE  
 H-43B USAF SN 59-1849  
 TRIM AIRSPEED = 80 KNOTS CAS  
 DENSITY ALTITUDE = 6260 FEET  
 GROSS WEIGHT = 6160 LB  
 CG LOCATION = MID (STATION 119)  
 RPM = 260/105%  
 LEVEL FLIGHT  
 DSAS-OFF

PITCH  
 ROLL  
 YAW

ORIGINAL EMPENNAGE

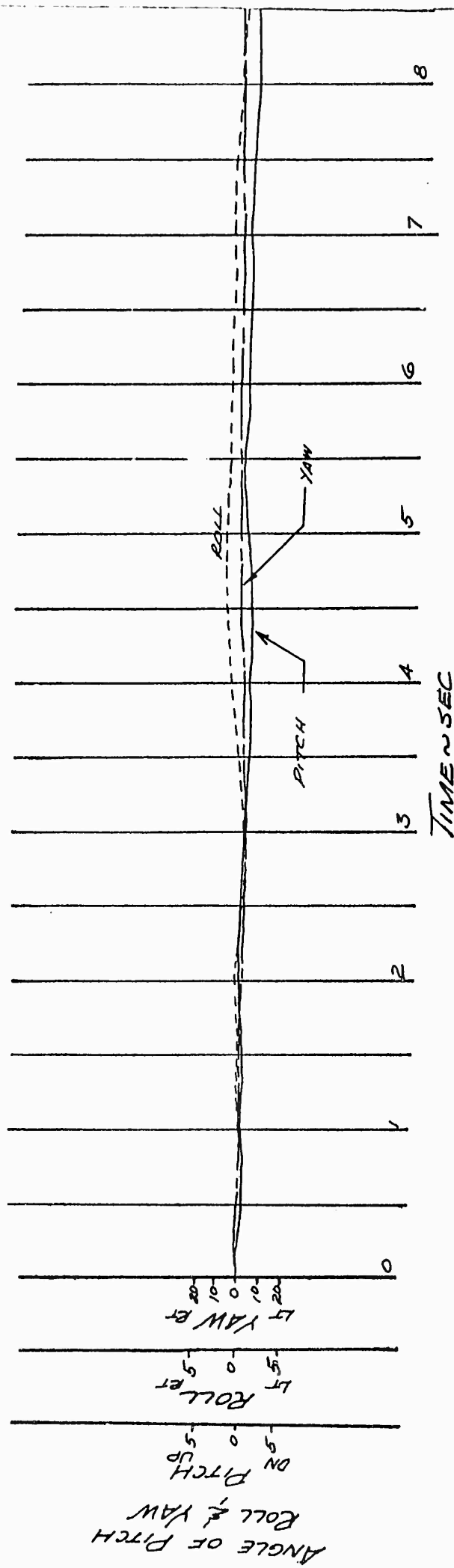

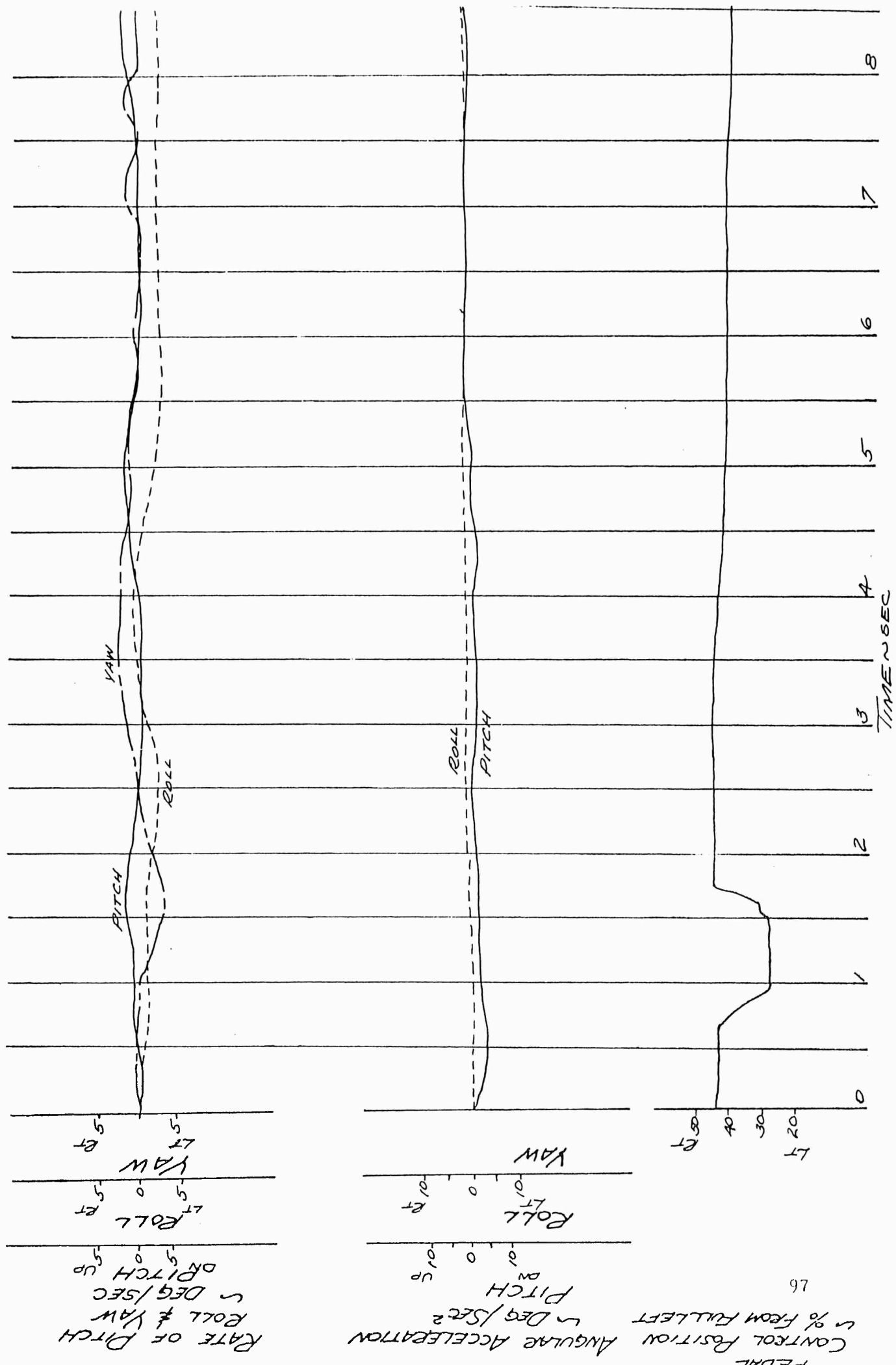

26

PEDAL POSITION ANGULAR ACCELERATION  
 % FROM FULL LEFT  
 DEG/SEC<sup>2</sup>  
 ROLL  
 PITCH

RATE OF PITCH  
 ROLL & YAW  
 DEG/SEC  
 PITCH  
 UP  
 DOWN

FIGURE No. 63

RESPONSE TO A PEDAL PULSE  
 H-43B USAF SN 59-1849  
 TRIM AIRSPEED = 40 KNOTS CAS  
 DENSITY ALTITUDE = 6260 FEET  
 GROSS WEIGHT = 6160 LB  
 CG LOCATION = MID (STATION 119)  
 RPM = 260/105 %

LEVEL FLIGHT  
 DSAS - OFF

PITCH \_\_\_\_\_  
 ROLL \_\_\_\_\_  
 YAW \_\_\_\_\_

ORIGINAL EMPENNAGE

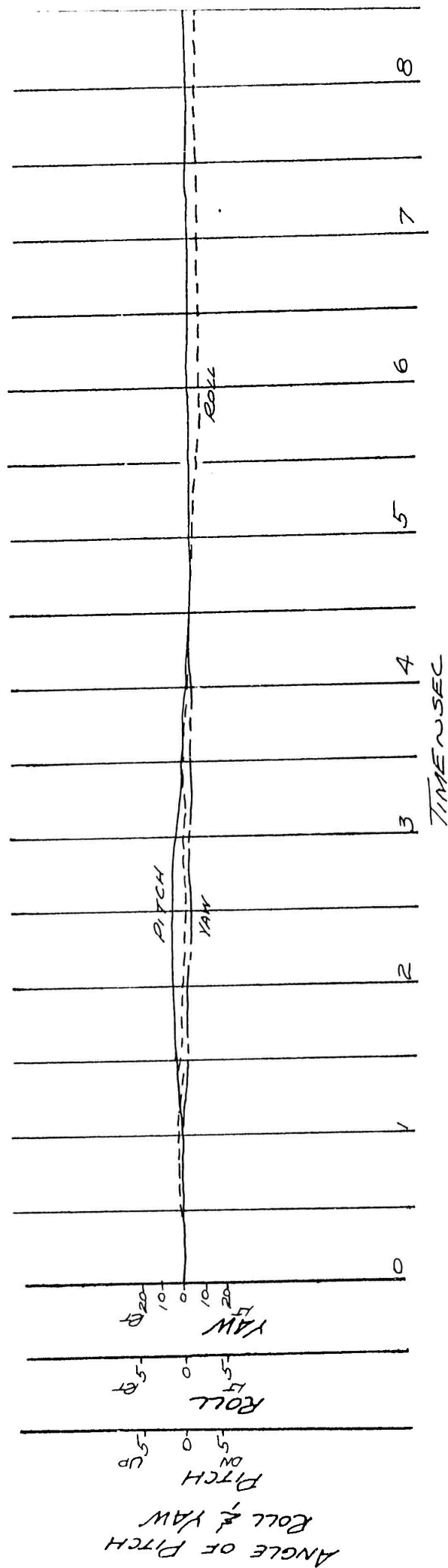

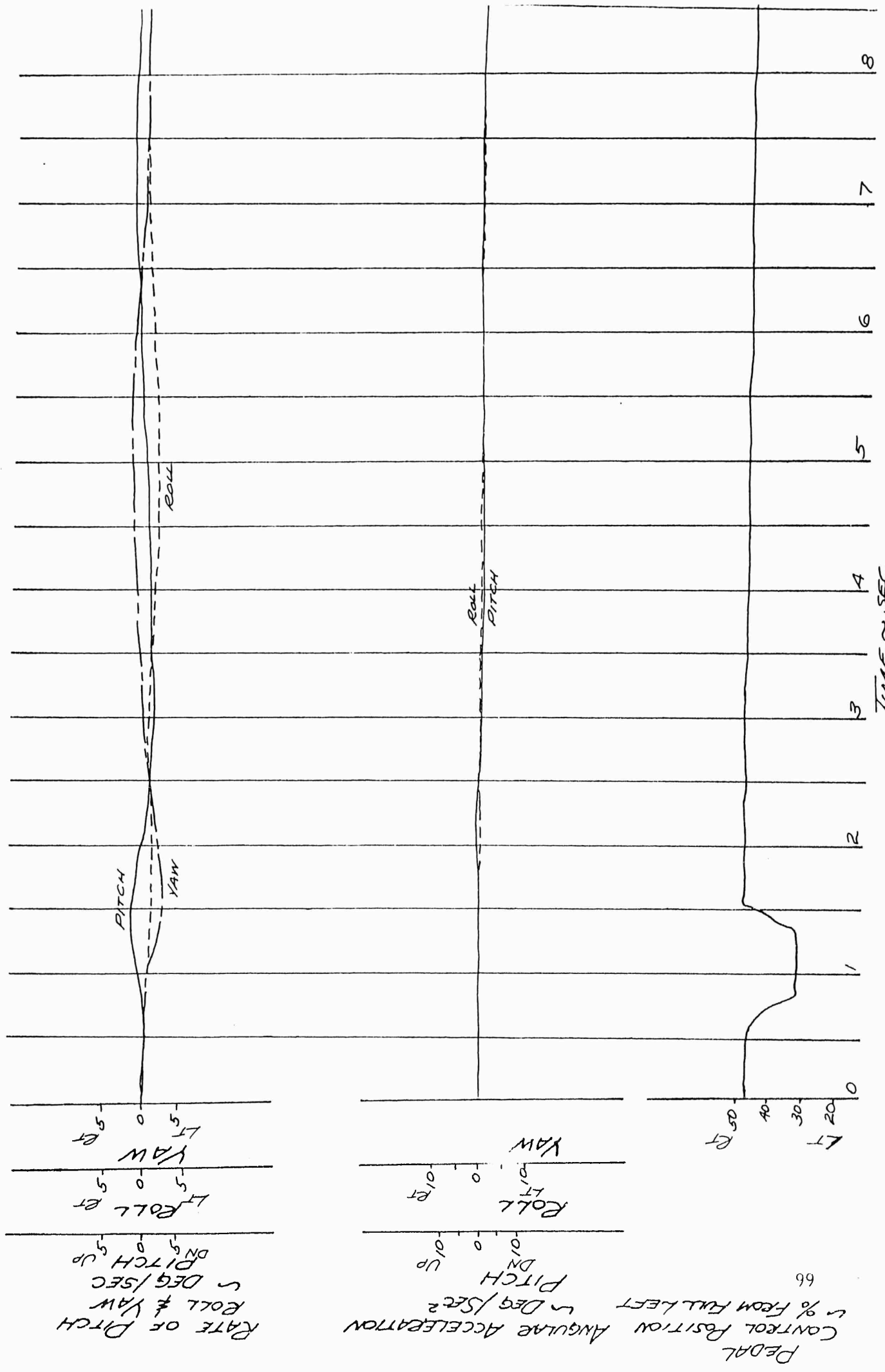

RATE OF PITCH  
 ~ DEG/SEC  
 ROLL & YAW

PEDAL POSITION ANGLE ACCELERATION  
 ~ DEG/SEC²  
 ~ % FROM FULL LEFT

FIGURE No. 64

RESPONSE TO A PEARL PULSE  
 H-43B USAF SN 59-1849  
 TRIM AIRSPEED = 40 KNOTS CAS  
 DENSITY ALTITUDE = 6260 FEET  
 GROSS WEIGHT = 6160 LB  
 C.G. LOCATION = MID (STATION 119)  
 RPM = 260/105%  
 LEVEL FLIGHT  
 DSAS - ON

PITCH \_\_\_\_\_  
 ROLL - - - - -  
 YAW - - - - -

ORIGINAL EMPENNAGE

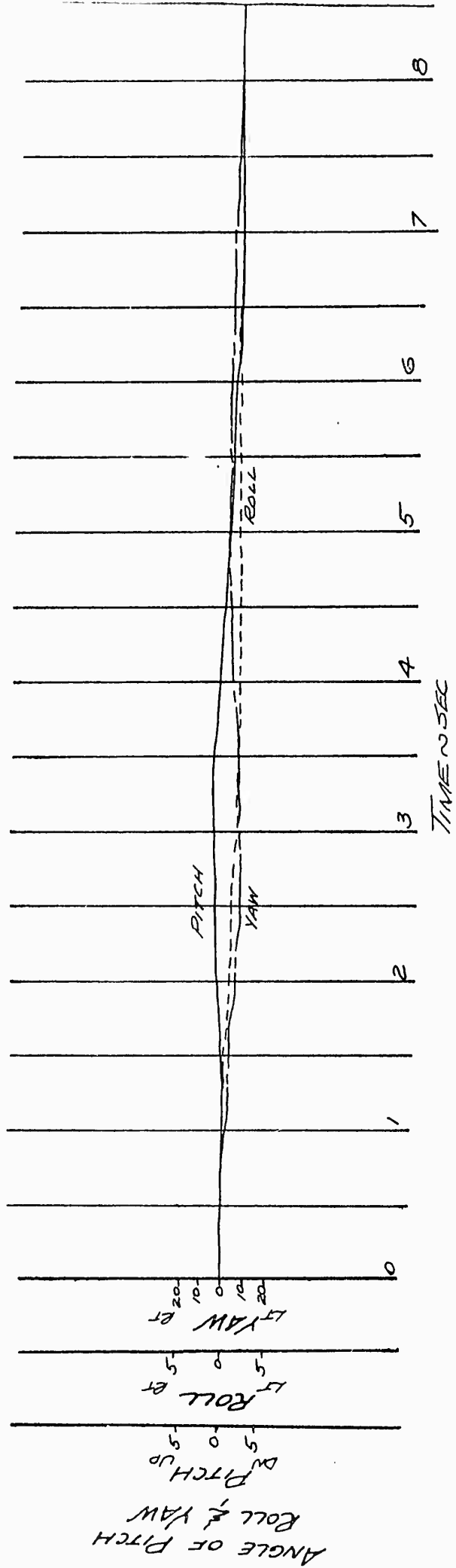

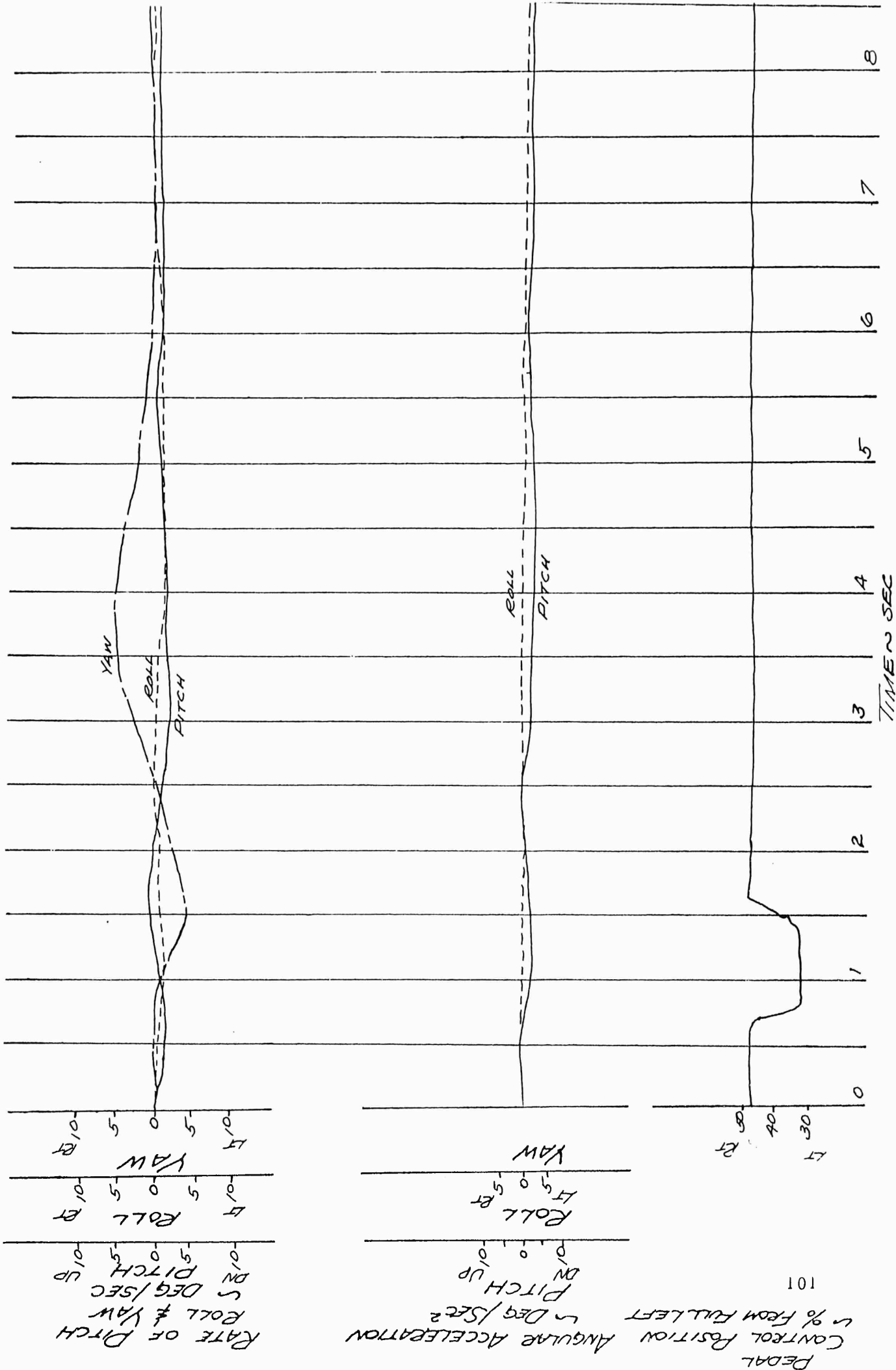

101

PEDAL CONTROL POSITION  
 % FROM FULL LEFT

ANGULAR ACCELERATION  
 DEG/SEC<sup>2</sup>

RATES OF PITCH  
 ROLL & YAW  
 DEG/SEC

FIGURE No. 65

RESPONSE TO A PEDAL PULSE  
 H-43B USAF 59-1548  
 TRIM AIRSPEED = 40 KNOTS CAS  
 DENSITY ALTITUDE = 2100 FEET  
 GROSS WEIGHT = 6170 LB  
 CG LOCATION = MID (STATION 119)  
 RPM = 260/105%

PITCH ———  
 ROLL - - -  
 YAW - - -

MODIFIED EMPENNAGE

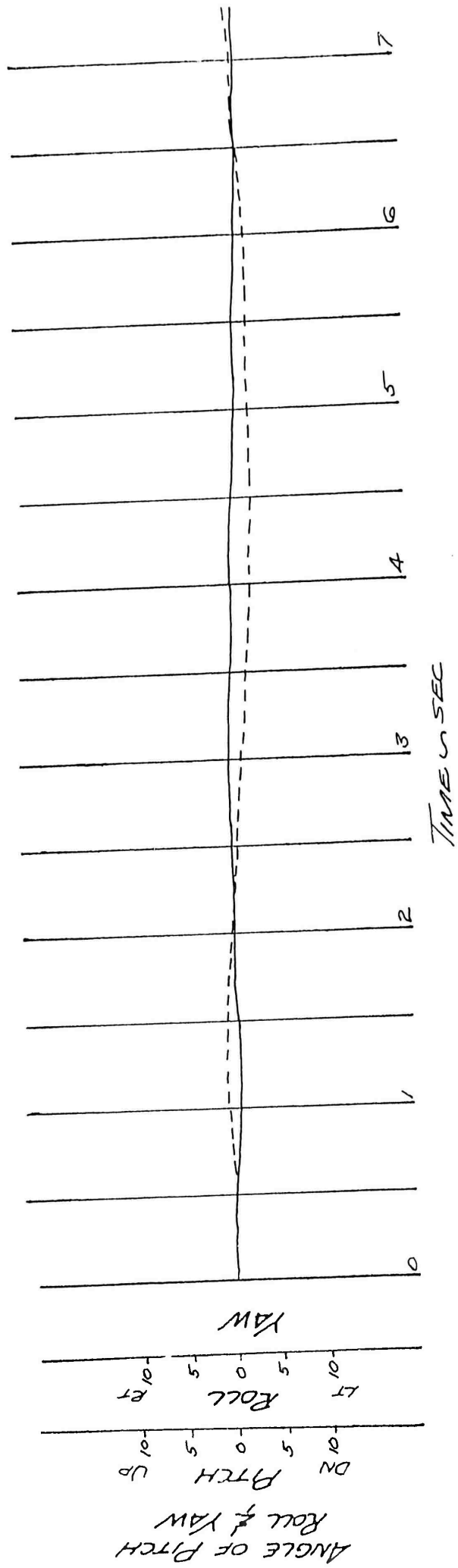

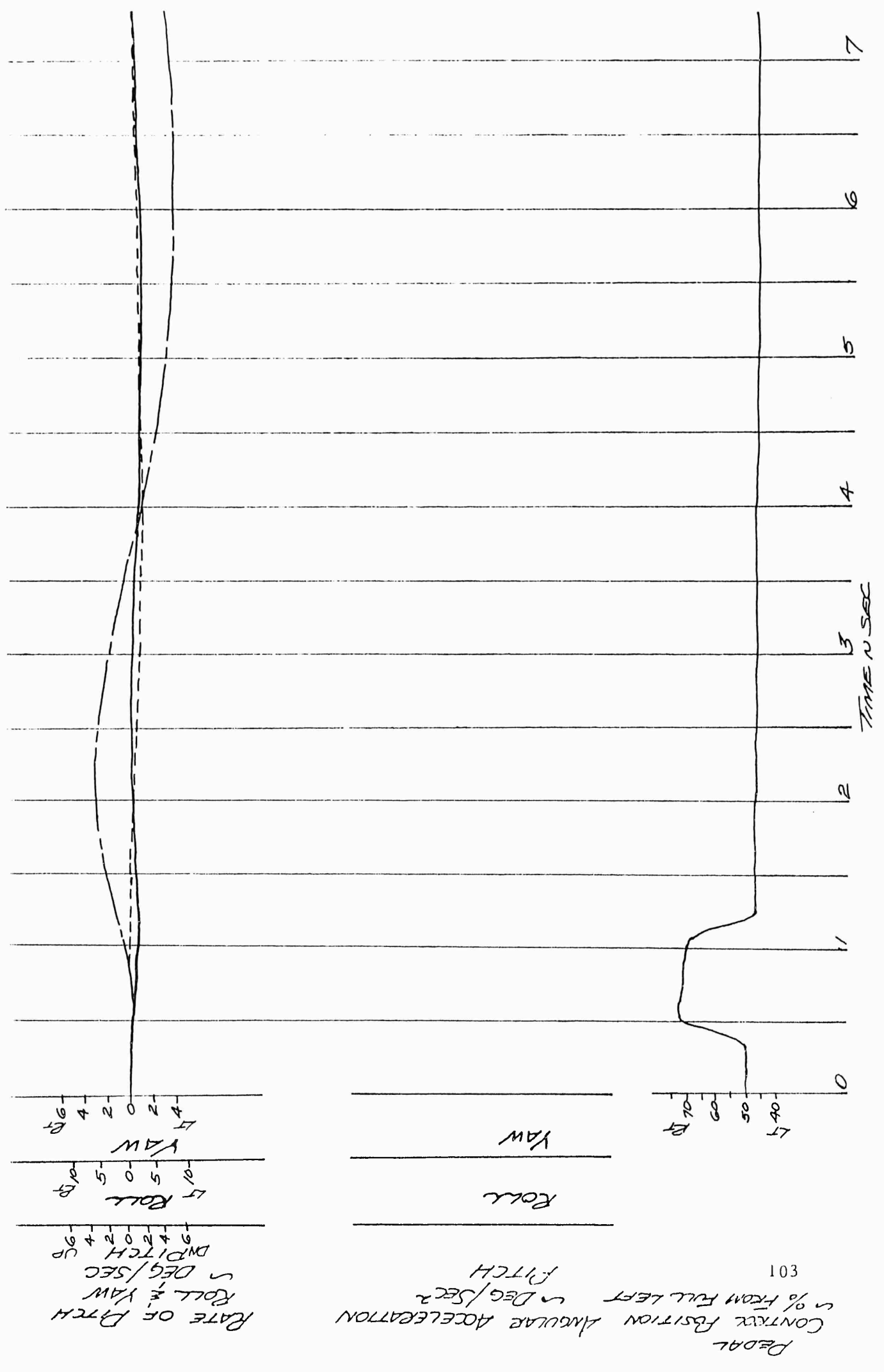

Pedal Position Angular Acceleration  
 % from Full Left ~ Deg/Sec<sup>2</sup>  
 103

Rate of Pitch  
 Roll & Yaw  
 ~ Deg/Sec  
 ~ Pitch  
 UP

Roll

Yaw

TIME IN SEC

FIGURE No. 66

RESPONSE TO A PEDAL PULSE  
 H-43B USAF 59-1548  
 TRIM AIRSPEED = 80 KNOTS CAS  
 DENSITY ALTITUDE = 2500 FEET  
 GROSS WEIGHT = 6000 LB  
 C.G. LOCATION = MID (STATION 119)  
 RPM = 260/105%

PITCH \_\_\_\_\_  
 ROLL - - - - -  
 YAW - - - - -

MODIFIED EMPENNAGE

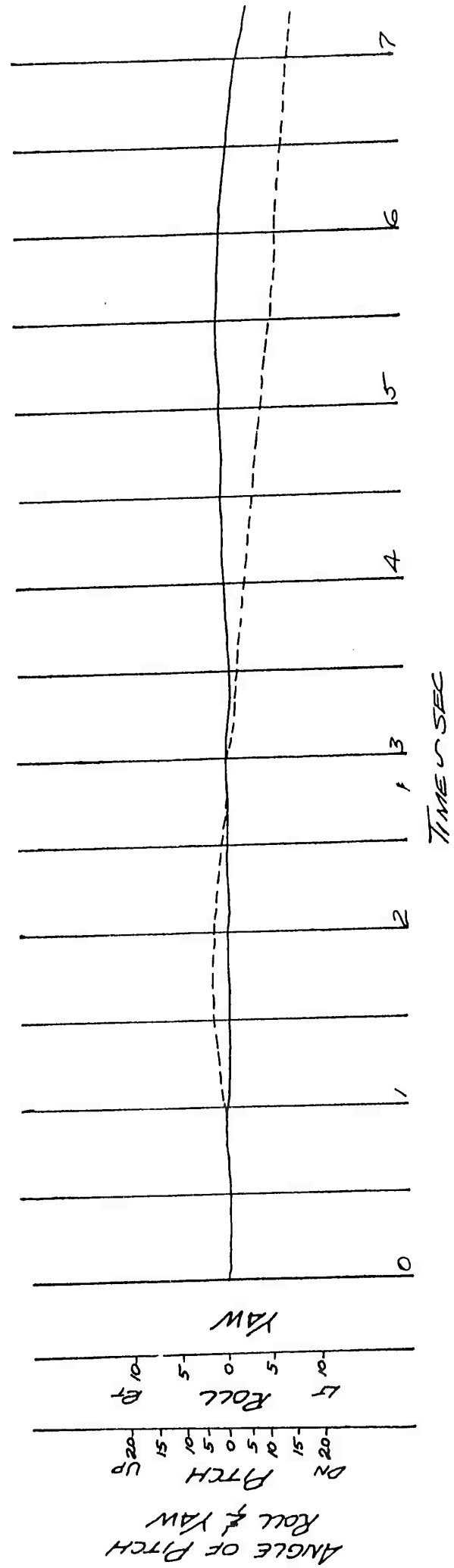

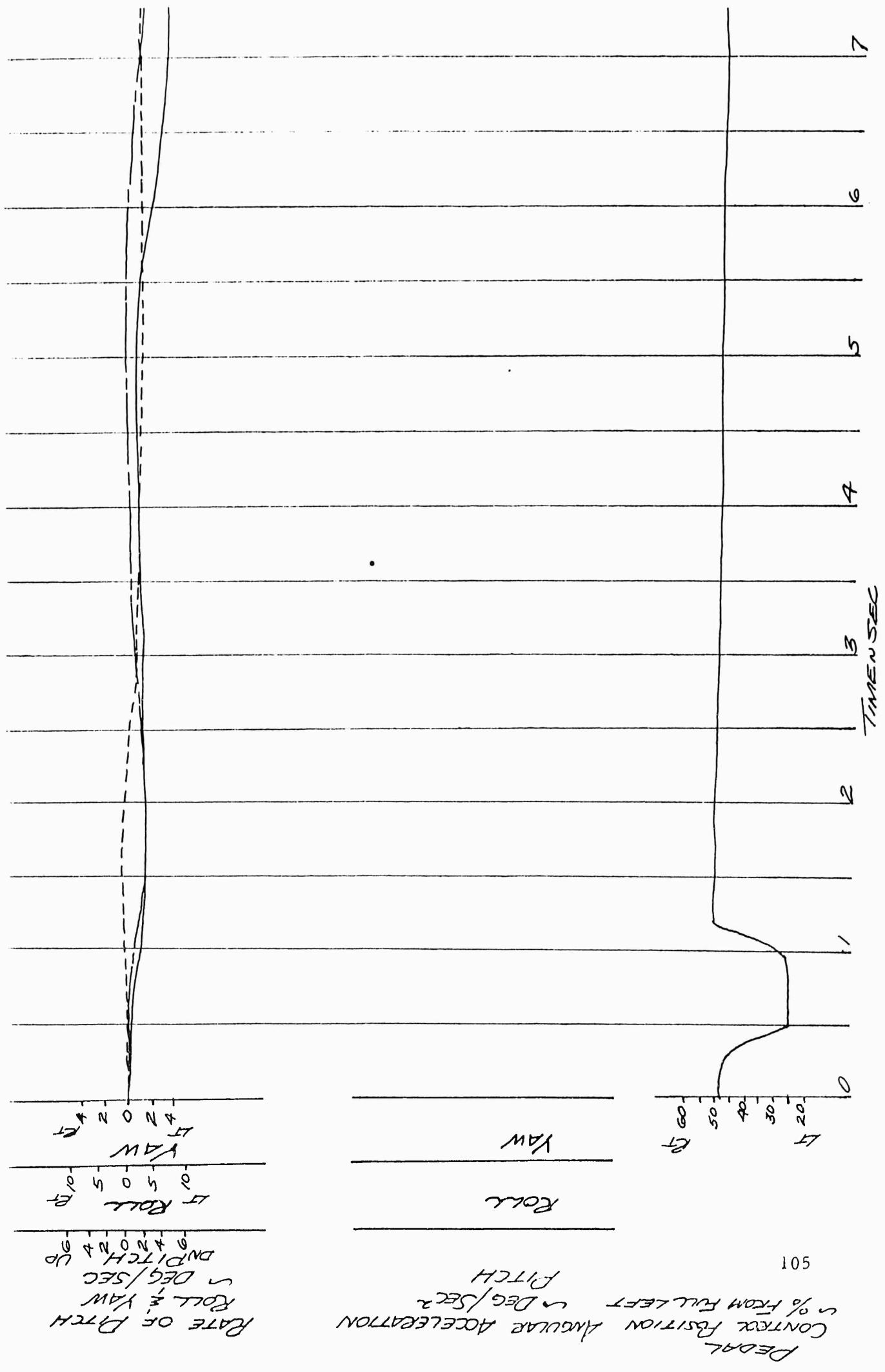

FIGURE No. 67

RESPONSE TO A LONGITUDINAL STEP  
 H-43B USAF #N 59-1849  
 TRIM AIRSPEED = 40 KNOTS CAS  
 DENSITY ALTITUDE = 6040 FEET  
 GROSS WEIGHT = 6184 LB  
 C.G. LOCATION = MID (STATION 119)  
 RPM = 260/105%

LEVEL FLIGHT  
 DSAS - ON

PITCH \_\_\_\_\_  
 ROLL - - - - -  
 YAW - - - - -

ORIGINAL EMPENNAGE

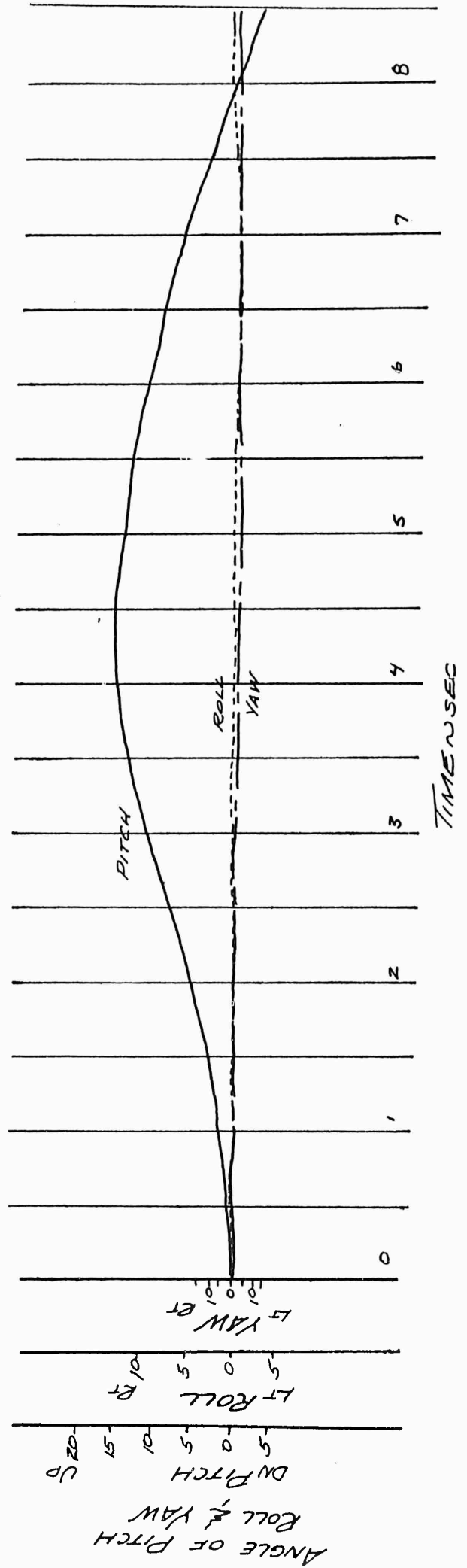

LONGITUDINAL CONTROL POSITION % FROM FULL FWD

ANGULAR ACCELERATION DEG/SEC<sup>2</sup>

RATE OF PITCH ROLL & YAW DEG/SEC

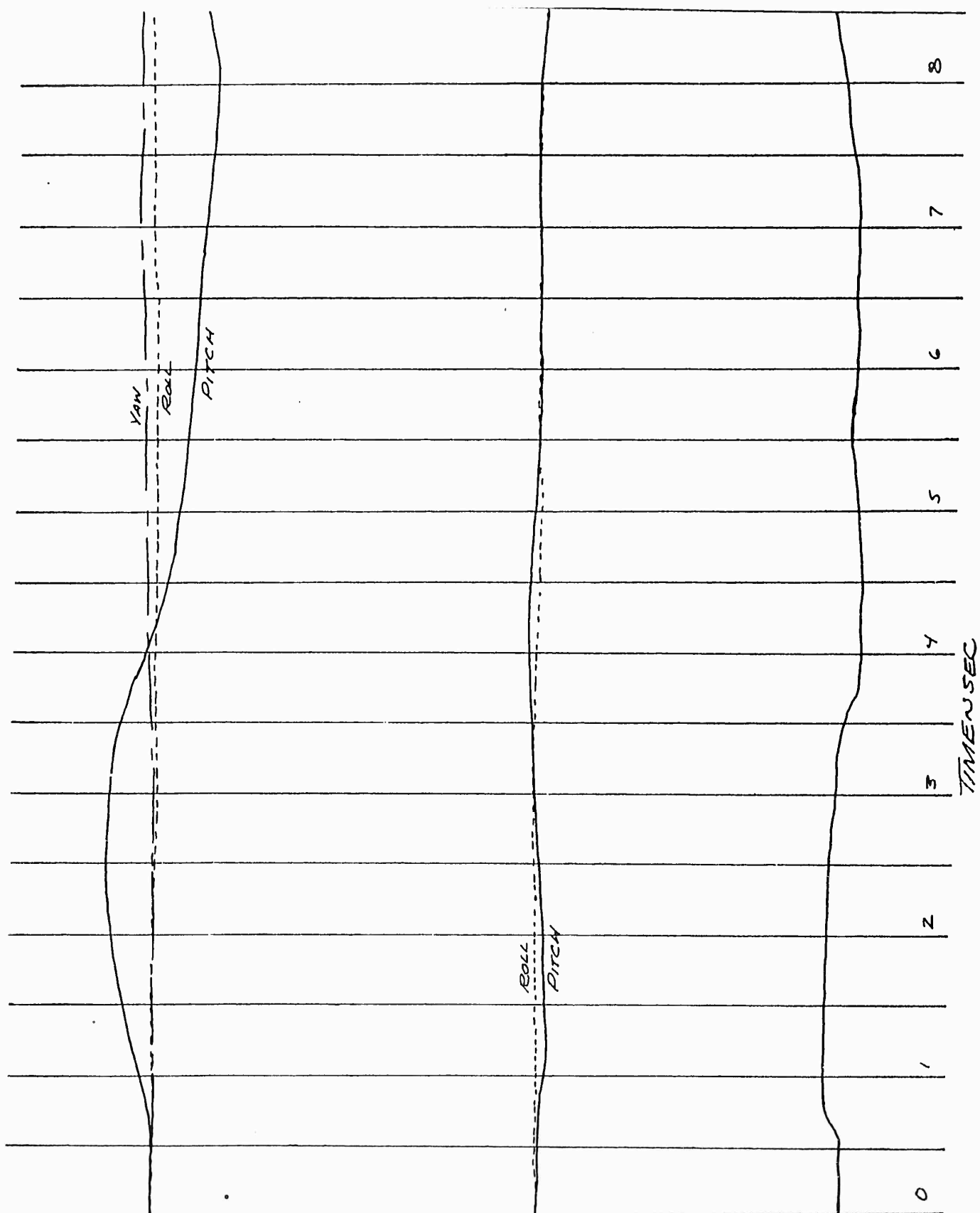

8

7

6

5

4

3

2

1

0

TIME IN SEC

FWD

0.4

0.3

0.2

0.1

YAW

ROLL

0.5

PITCH

0.5

YAW

ROLL

0.5

0.5

0.5

0.5

0.5

0.5

0.5

0.5

0.5

0.5

0.5

0.5

0.5

0.5

0.5

0.5

0.5

0.5

0.5

0.5

0.5

0.5

0.5

0.5

0.5

0.5

0.5

0.5

0.5

0.5

0.5

0.5

0.5

0.5

0.5

0.5

0.5

0.5

0.5

0.5

0.5

0.5

0.5

0.5

0.5

0.5

0.5

0.5

0.5

0.5

0.5

0.5

0.5

0.5

0.5

0.5

0.5

0.5

0.5

0.5

0.5

0.5

0.5

0.5

0.5

0.5

0.5

0.5

0.5

0.5

0.5

0.5

0.5

0.5

0.5

0.5

0.5

0.5

0.5

0.5

0.5

0.5

0.5

0.5

0.5

0.5

0.5

0.5

YAW

ROLL

PITCH

ROLL

PITCH

FIGURE No. 68

RESPONSE TO A LONGITUDINAL STEP  
 H-43B USAF SN 59-1849  
 TRIM AIRSPEED = 40 KNOTS CAS  
 DENSITY ALTITUDE = 6040 FEET  
 GROSS WEIGHT = 6180 LB  
 CG LOCATION = MID (STATION 119)  
 RPM = 260/105%  
 LEVEL FLIGHT  
 DSAS-ON

PITCH \_\_\_\_\_  
 ROLL - - - - -  
 YAW - - - - -

ORIGINAL EMPENNAGE

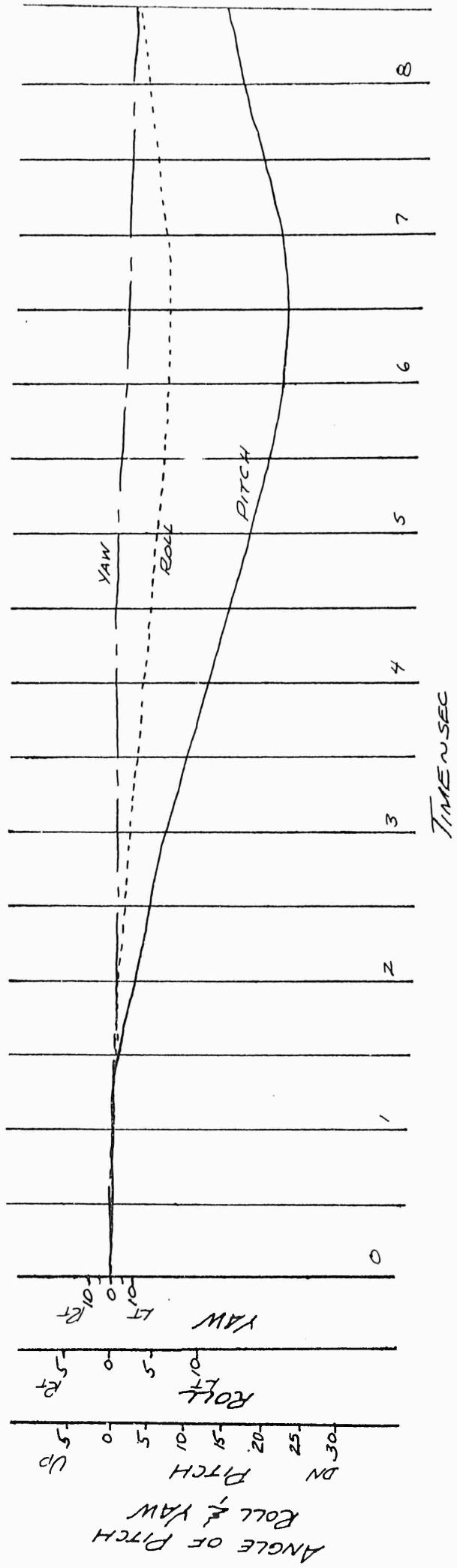

TIME IN SEC

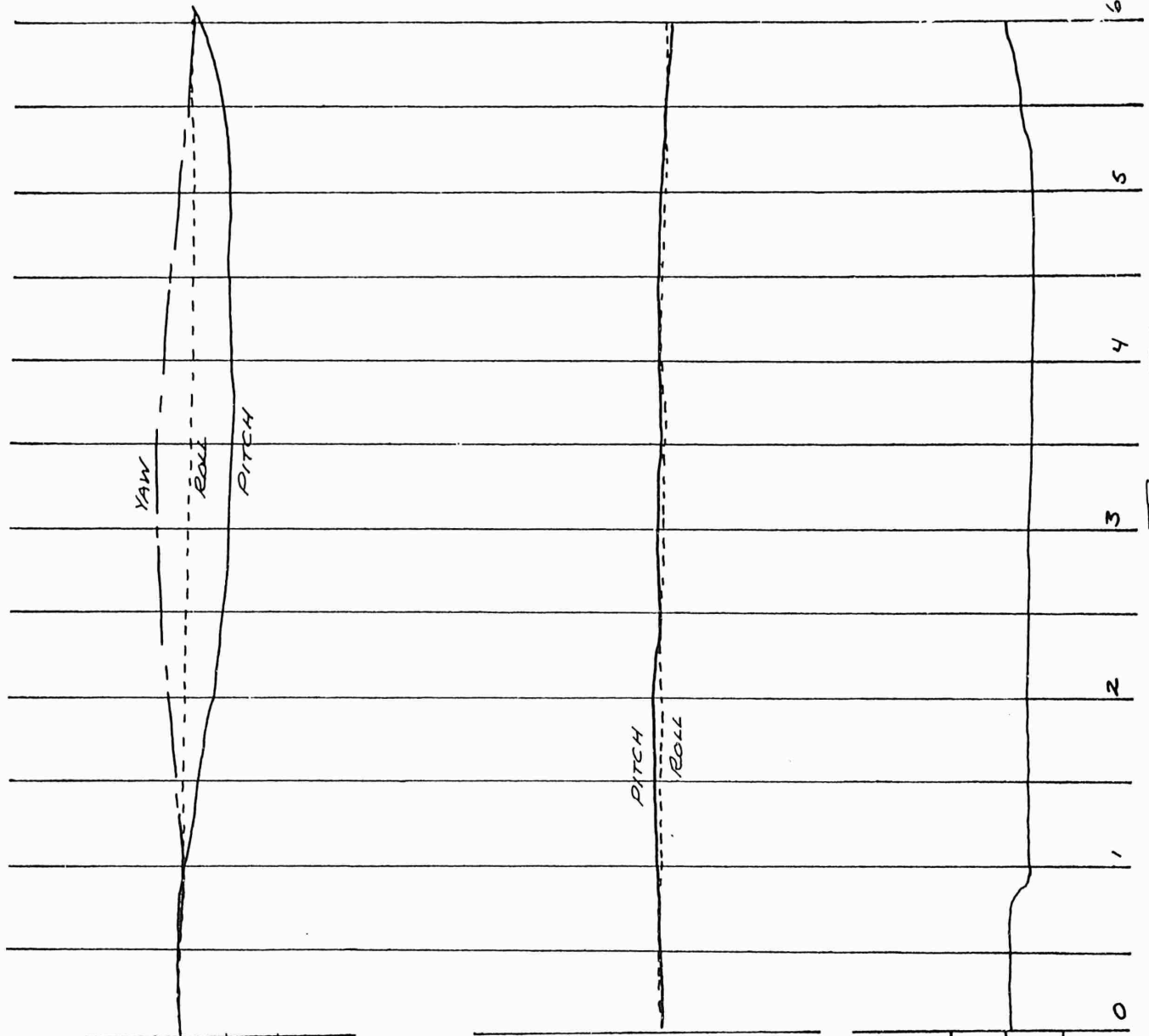

LONGITUDINAL CONTROL POSITION % FROM FULL FWD

ANGULAR ACCELERATION DEG/SEC<sup>2</sup>

RATE OF PITCH

ROLL & YAW DEG/SEC

ON PITCH UP

ROLL RT

ROLL LT

YAW RT

YAW LT

FWD

AFT

RT

LT

UP

DN

FIGURE No. 69

RESPONSE TO A LONGITUDINAL STEP

H-43B USAF 59-1849  
 TRIM AIRSPEED = 60 KNOTS CAS  
 DENSITY ALTITUDE = 6040 FEET  
 GROSS WEIGHT = 6180 LB  
 C G LOCATION = MID (STATION 119)  
 RPM = 260/105%

LEVEL FLIGHT  
 DSAS-ON

PITCH \_\_\_\_\_  
 ROLL - - - - -  
 YAW - - - - -

ORIGINAL EMPENNAGE

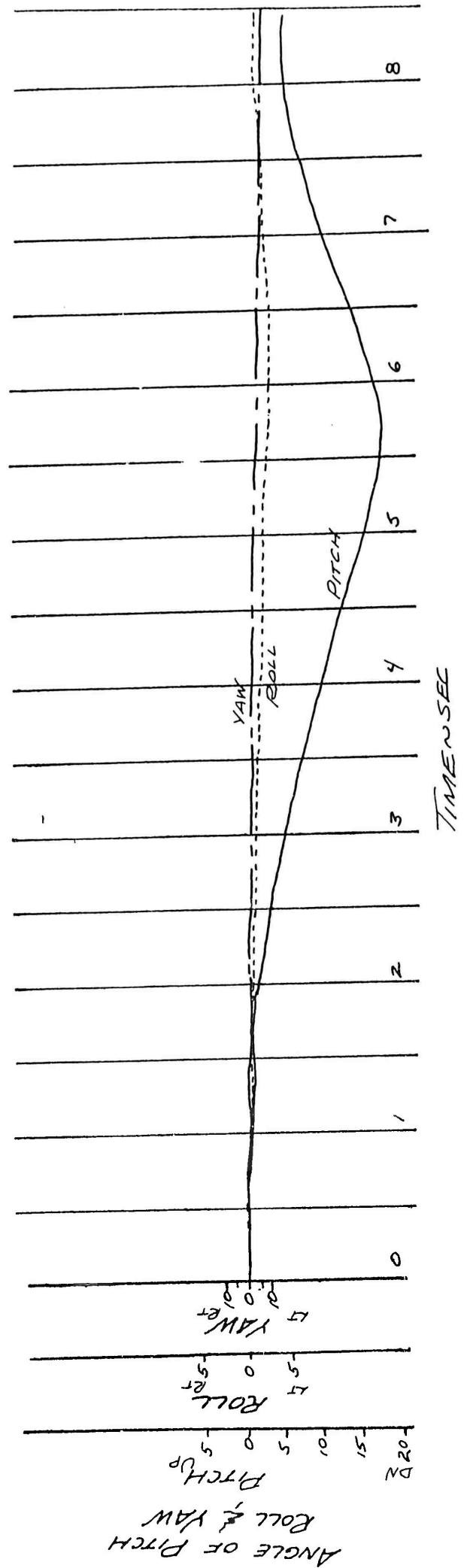

8

7

6

5

4

3

2

1

0

TIME ~ SEC

LONGITUDINAL CONTROL POSITION ~ % FROM FULL FWD

111

ANGULAR ACCELERATION ~ DEG/SEC<sup>2</sup>

RATE OF PITCH ~ DEG/SEC

FWD  
0.5  
0.9  
AFT

PITCH  
DN  
0  
UP

RATE OF PITCH  
DN  
0  
UP

ROLL  
LT  
0  
RT

ROLL  
LT  
0  
RT

YAW  
LT  
0  
RT

YAW  
LT  
0  
RT

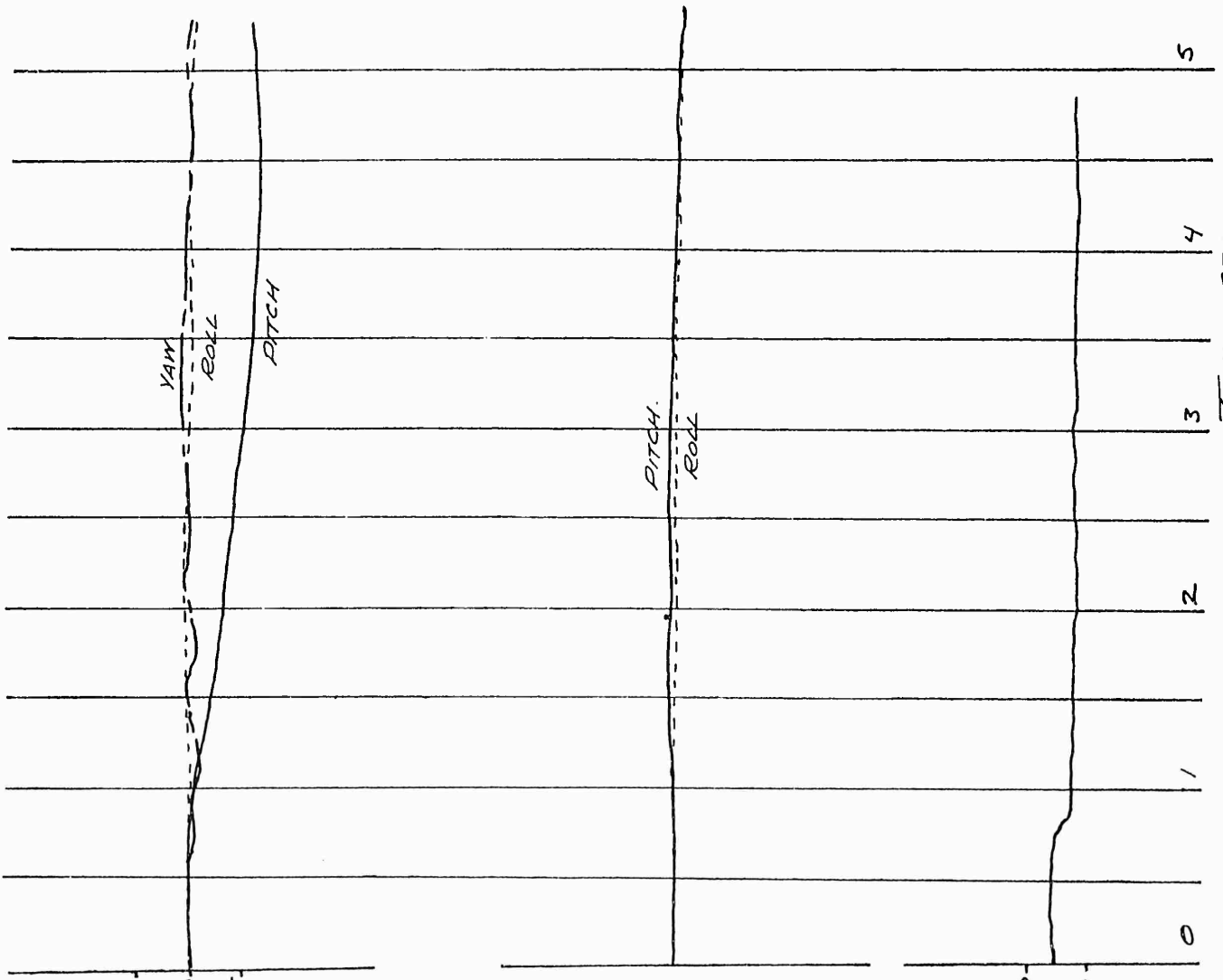
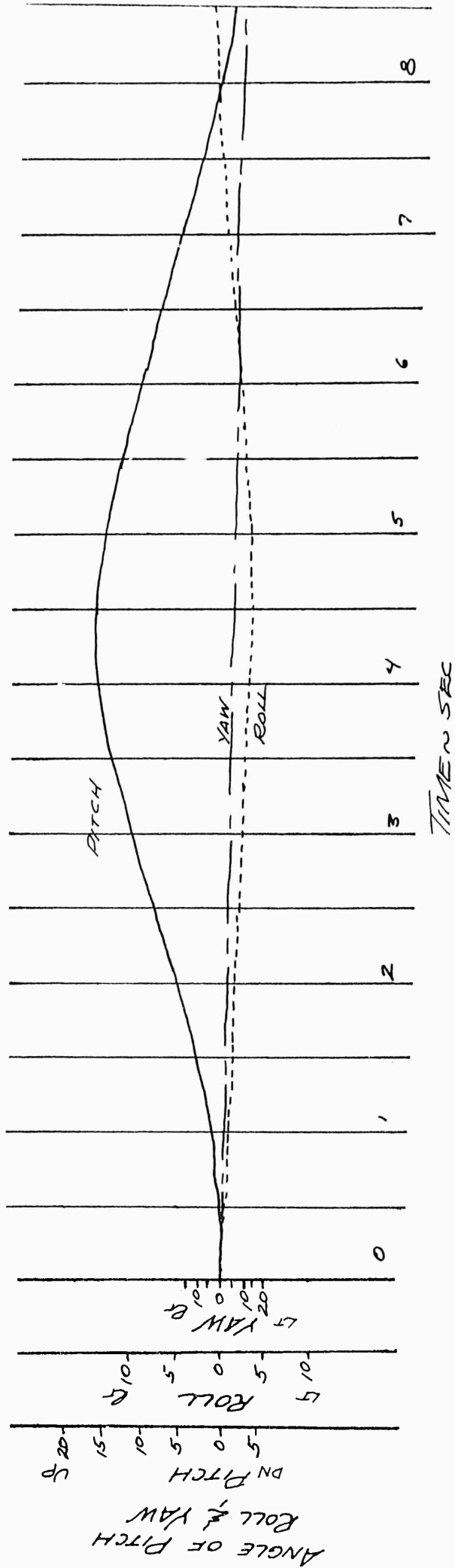

FIGURE No. 70

RESPONSE TO A LONGITUDINAL STEP  
 H-43B USAF 59-1849  
 TRIM AIRSPEED = 60 KNOTS CAS  
 DENSITY ALTITUDE = 6040 FEET  
 GROSS WEIGHT = 6184 LB  
 C.G. LOCATION = MID (STATION 119)  
 RPM = 260/105%  
 LEVEL FLIGHT  
 DSAS - ON

PITCH \_\_\_\_\_  
 ROLL - - - - -  
 YAW - - - - -

ORIGINAL EMPENNAGE



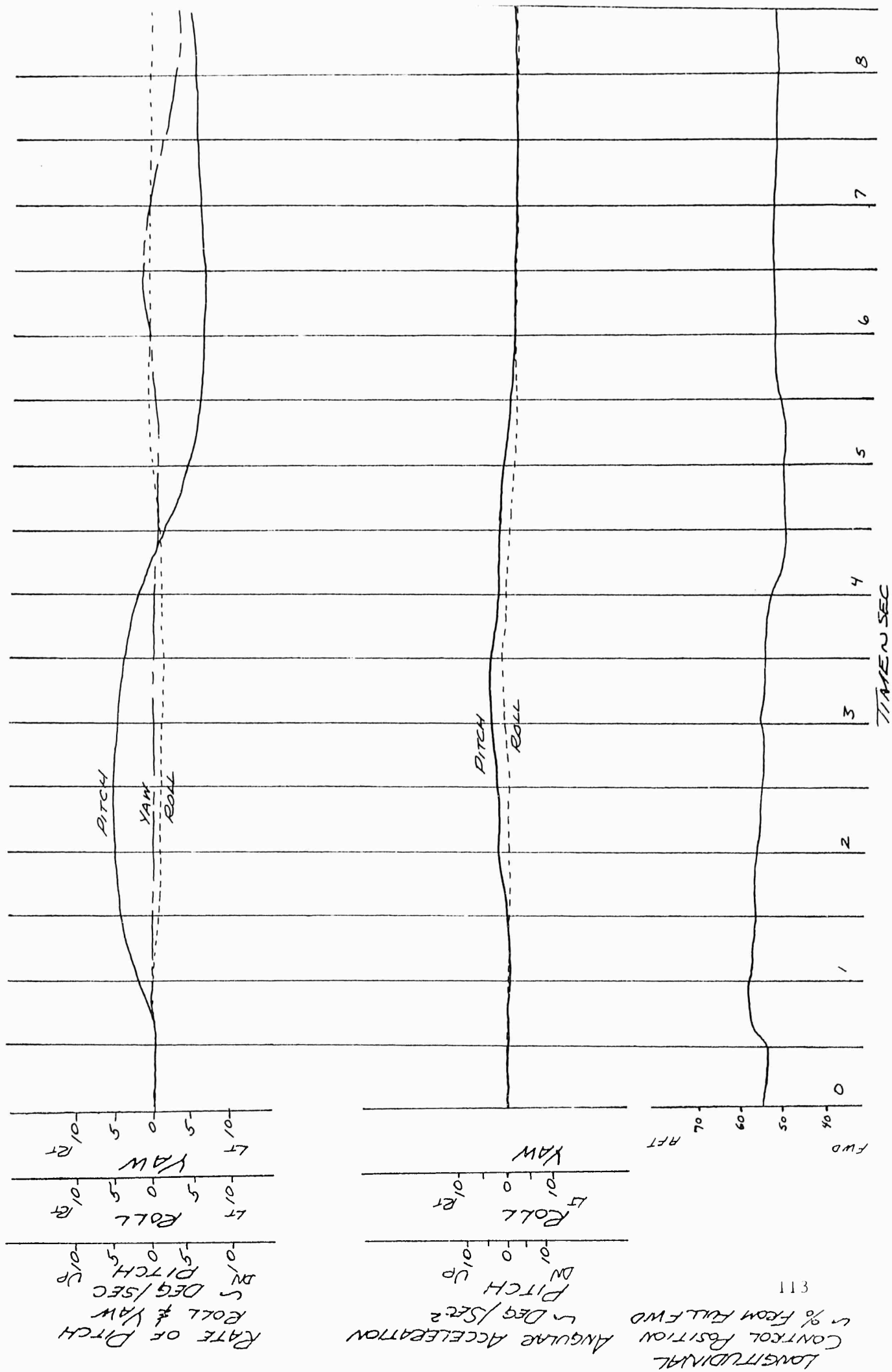

113

LONGITUDINAL CONTROL POSITION % FROM FULL FWD

ANGULAR ACCELERATION DEG/SEC²

RATE OF PITCH DEG/SEC

FIGURE No. 71

RESPONSE TO AN AFT LONGITUDINAL STEP  
 H-43B USAF 59-1548  
 TRIM AIRSPEED = 40 KNOTS CAS  
 DENSITY ALTITUDE = 2150 FEET  
 GROSS WEIGHT = 6080 LB  
 C.G. LOCATION = MID (STATION 119)  
 RPM = 260  
 DSAS = 00

MODIFIED EMPENNAGE

PITCH  
 ROLL  
 YAW

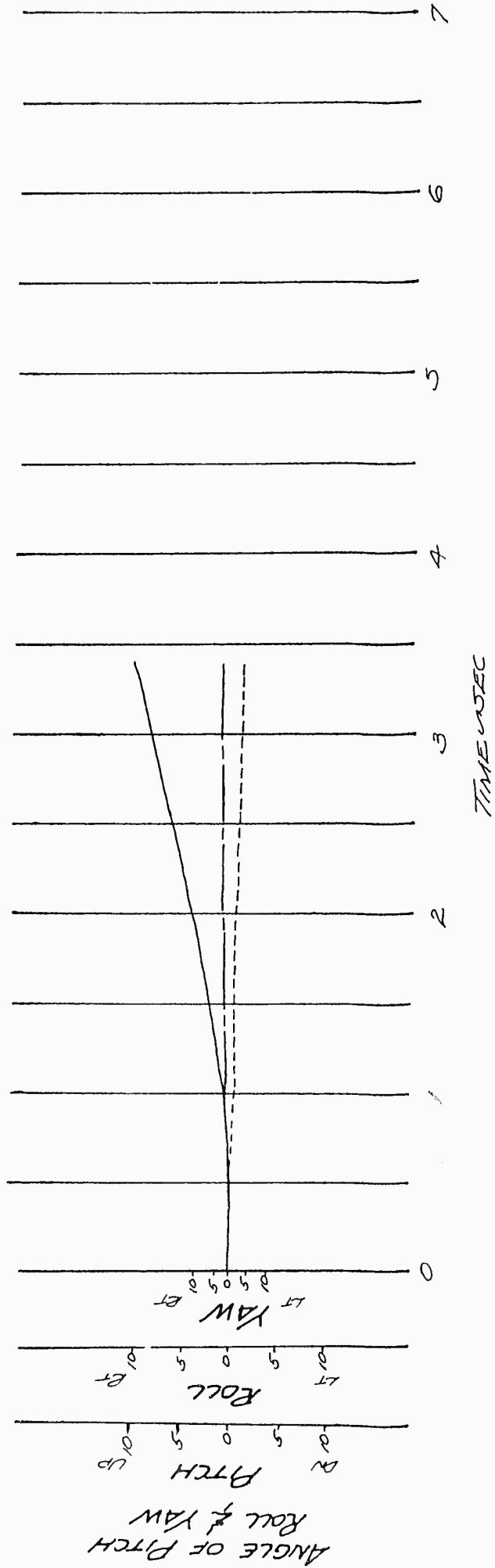

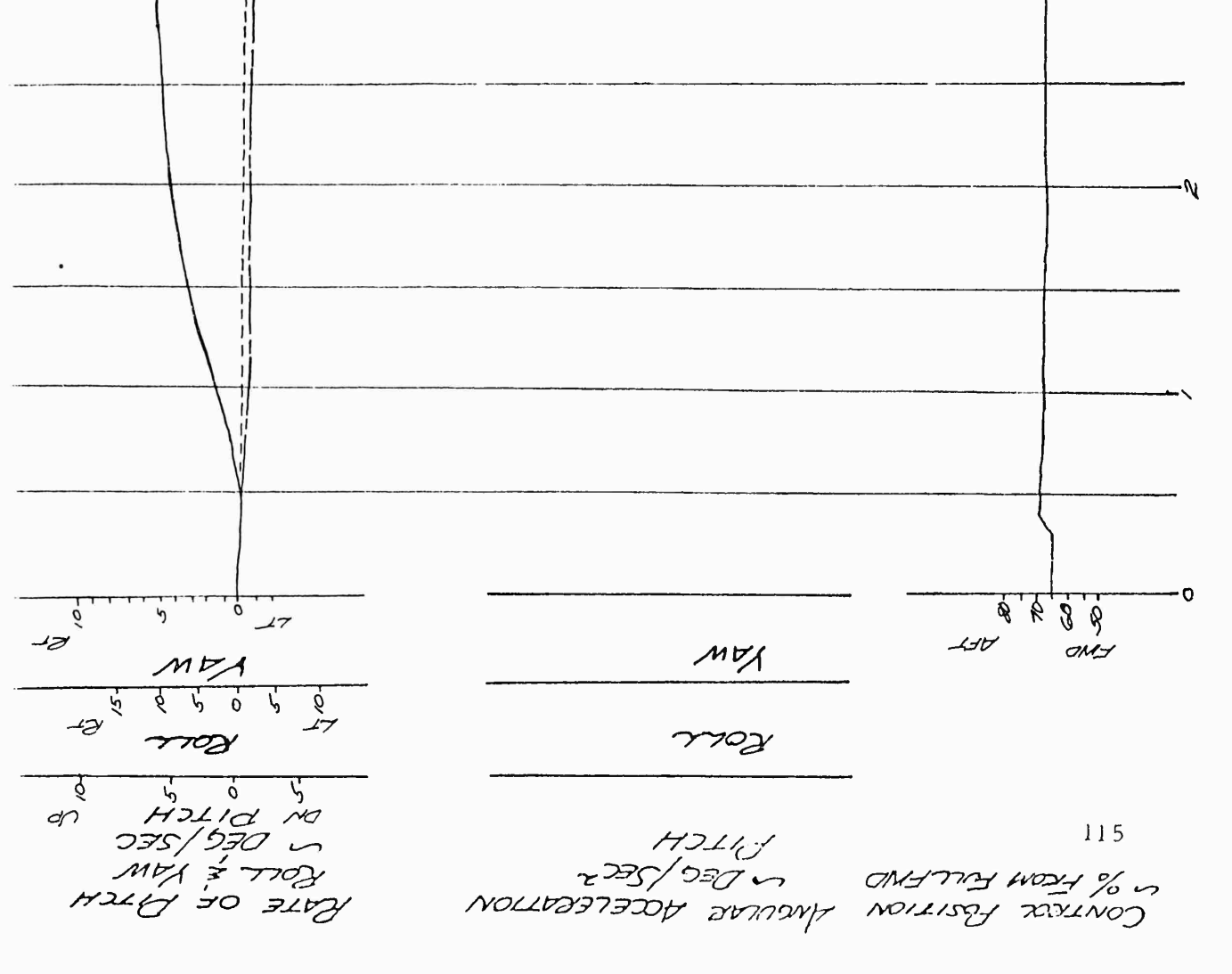
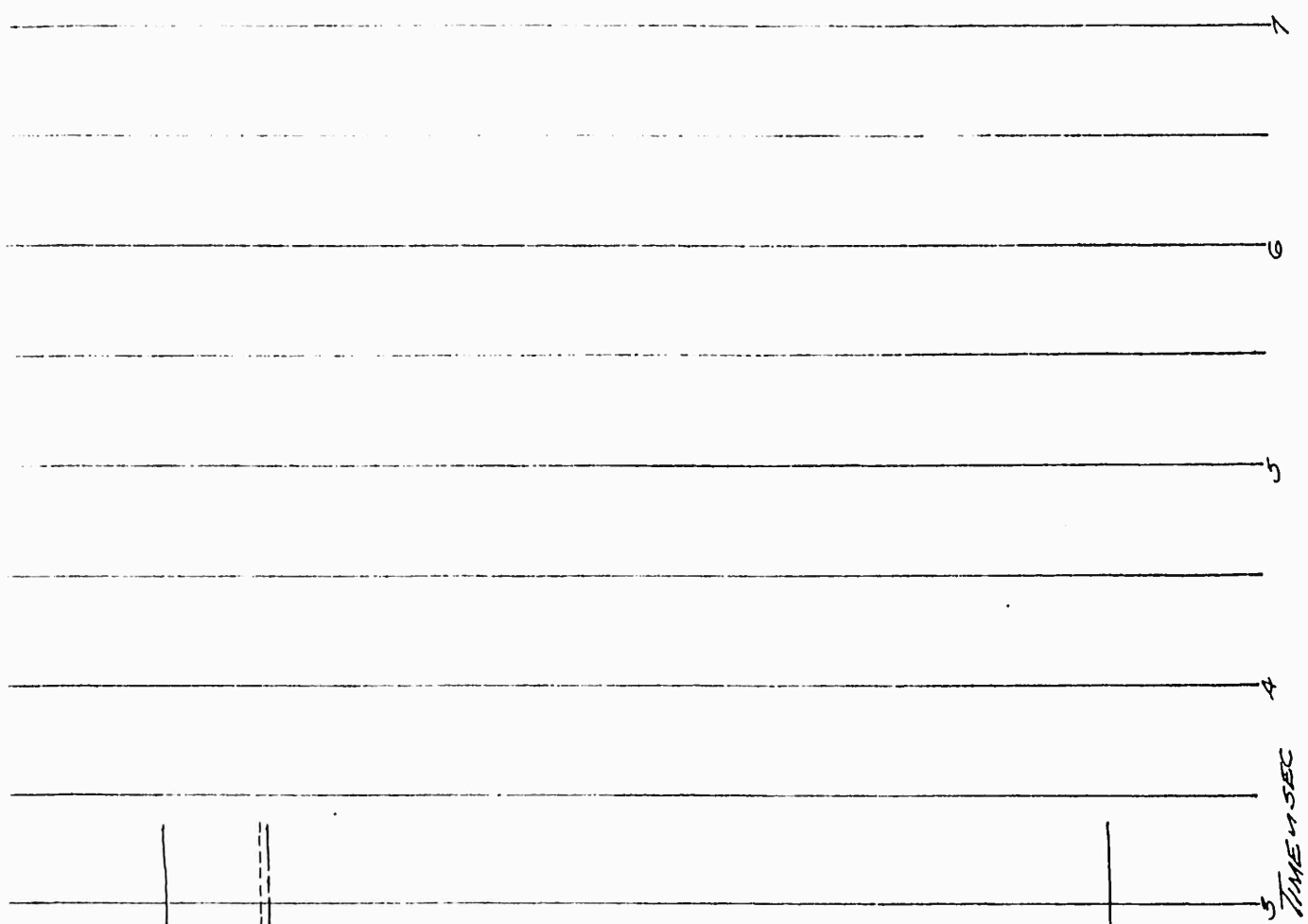

115

RATE OF PITCH  
 ROLL & YAW  
 DEG/SEC  
 UP  
 DN PITCH  
 0  
 5  
 10  
 15  
 20  
 25  
 30  
 35  
 40  
 45  
 50  
 LT  
 RT

ANGULAR ACCELERATION  
 DEG/SEC<sup>2</sup>  
 PITCH  
 0  
 5  
 10  
 15  
 20  
 25  
 30  
 35  
 40  
 45  
 50  
 LT  
 RT

CONTEXT POSITION  
 % FROM FULL FWD  
 0  
 5  
 10  
 15  
 20  
 25  
 30  
 35  
 40  
 45  
 50  
 FWD  
 AFT

FIGURE No. 72

RESPONSE TO A FINO LONGITUDINAL STEP  
 H-43B USAF SN 59-1548  
 TRIM AIRSPEED = 40 KNOTS CAS  
 DENSITY ALTITUDE = 2150 FEET  
 GROSS WEIGHT = 6000 LB  
 C.G. LOCATION = MID (STATION 119)  
 RPM = 260  
 DSAS = 00

PITCH \_\_\_\_\_  
 ROLL - - - - -  
 YAW - - - - -

MODIFIED EMPENNAGE

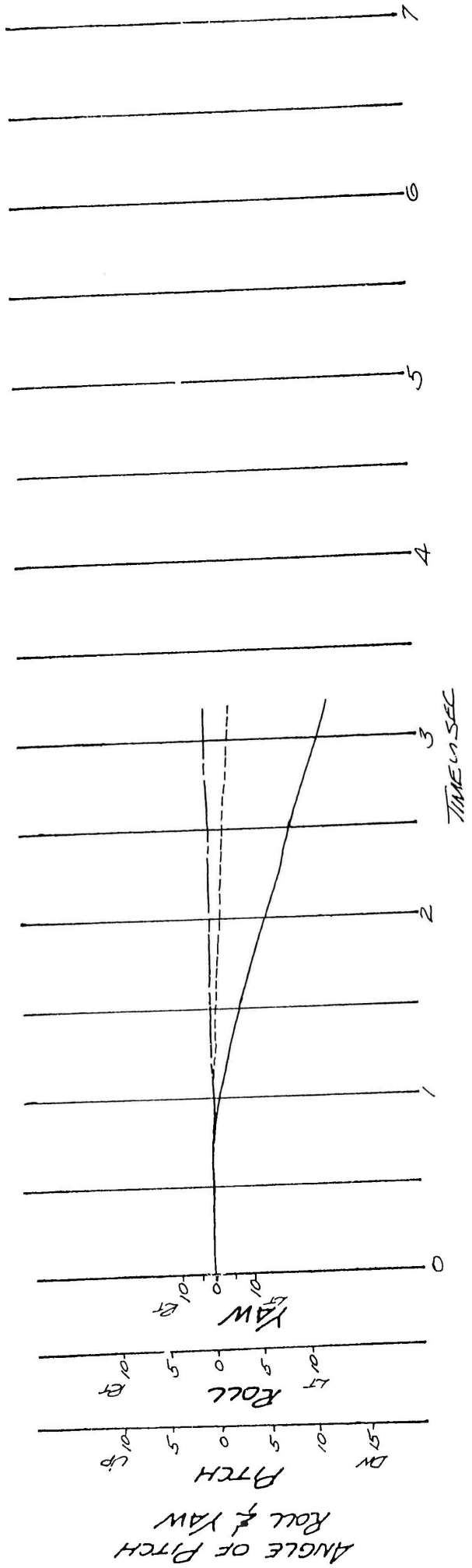

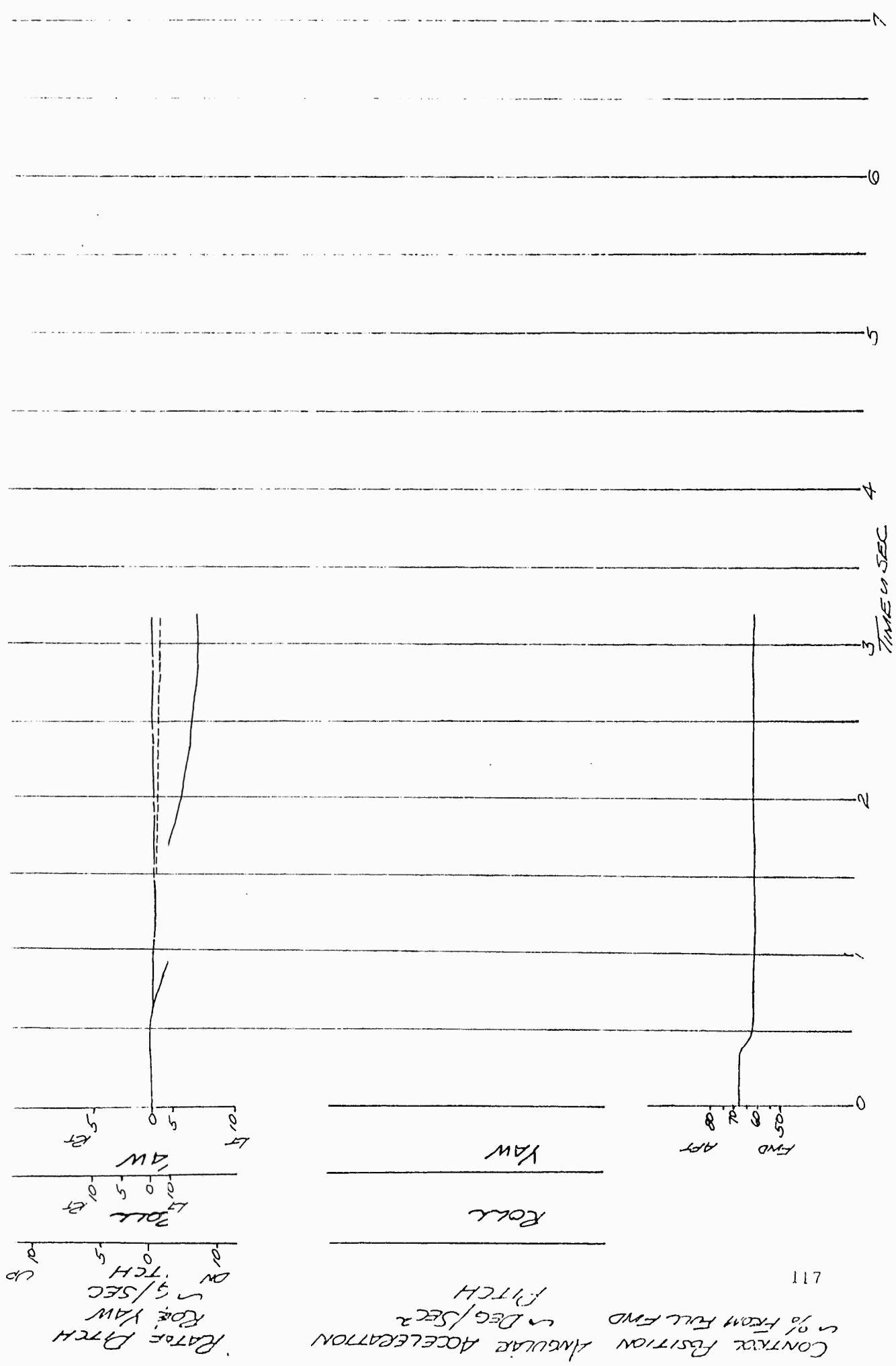

CONTROL POSITION % FROM FULL FWD  
 ~ DEG/SEC<sup>2</sup> PITCH  
 ~ DEG/SEC<sup>2</sup> ROLL  
 ~ DEG/SEC<sup>2</sup> YAW

FIGURE No. 73

RESPONSE TO A LATERAL STEP  
 H-43B USAF 59-1849  
 TRIM AIRSPEED = 60 KNOTS CAS  
 DENSITY ALTITUDE = 6280 FEET  
 GROSS WEIGHT = 6160 LB  
 CG LOCATION = MID (STATION 119)  
 RPM = 269/105%

LEVEL FLIGHT  
 DSAS - ON

PITCH \_\_\_\_\_  
 ROLL \_\_\_\_\_  
 YAW \_\_\_\_\_

ORIGINAL EMPENNAGE

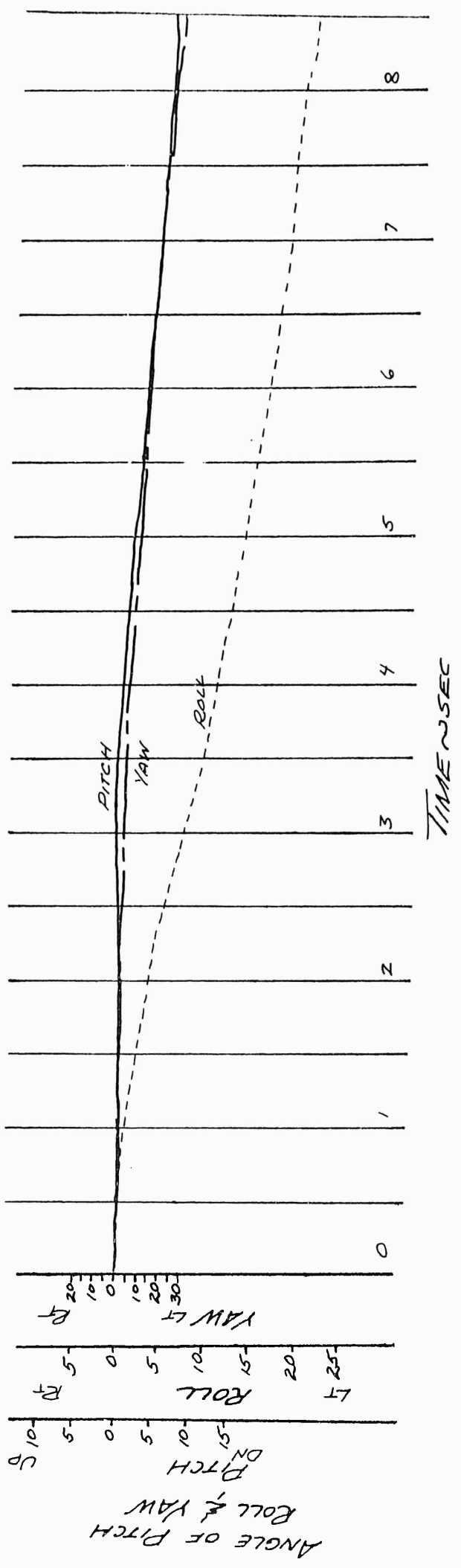

611

LATERAL CONTROL POSITION % FROM FULL LEFT  
ANGULAR ACCELERATION  
PITCH ~ DEG/SEC<sup>2</sup>  
ROLL ~ DEG/SEC<sup>2</sup>

RATE OF PITCH  
ROLL & YAW  
~ DEG/SEC  
DN PITCH UP

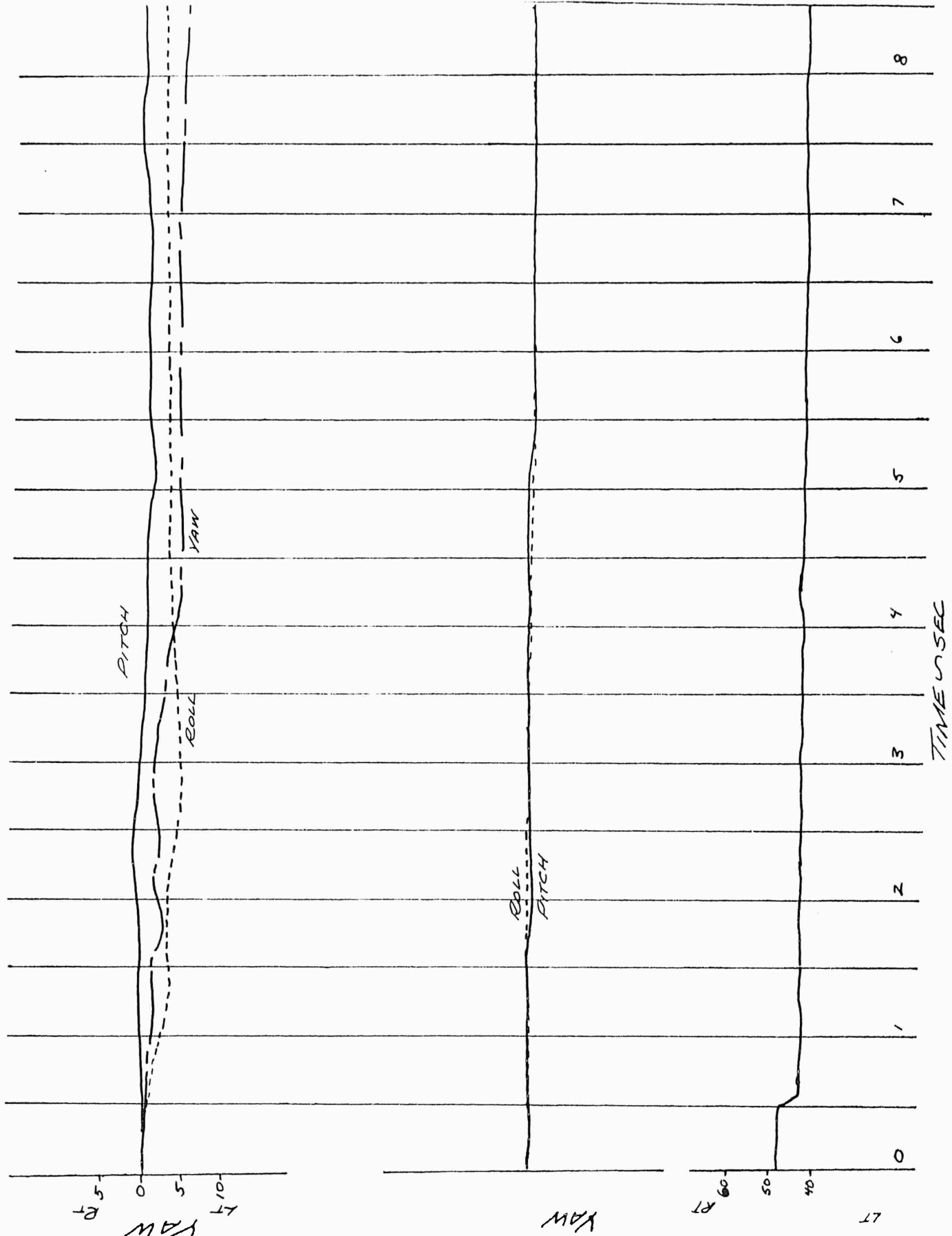

TIME IN SEC

8

7

6

5

4

3

2

1

0

LT

0.4  
0.5  
0.9

YAW

ROLL

DN  
UP

YAW

ROLL

PITCH

YAW

ROLL

DN  
UP

FIGURE No. 74

RESPONSE TO A LATERAL STEP  
 H-43B USAF SN 59-1849  
 TRIM AIRSPEED = 40 KNOTS CAS  
 DENSITY ALTITUDE = 6280 FEET  
 GROSS WEIGHT = 6160 LB  
 C.G. LOCATION = MID (STATION 119)  
 RPM = 260/105%

LEVEL FLIGHT  
 DSAS-ON

PITCH \_\_\_\_\_  
 ROLL \_\_\_\_\_  
 YAW \_\_\_\_\_

ORIGINAL EMPENNAGE

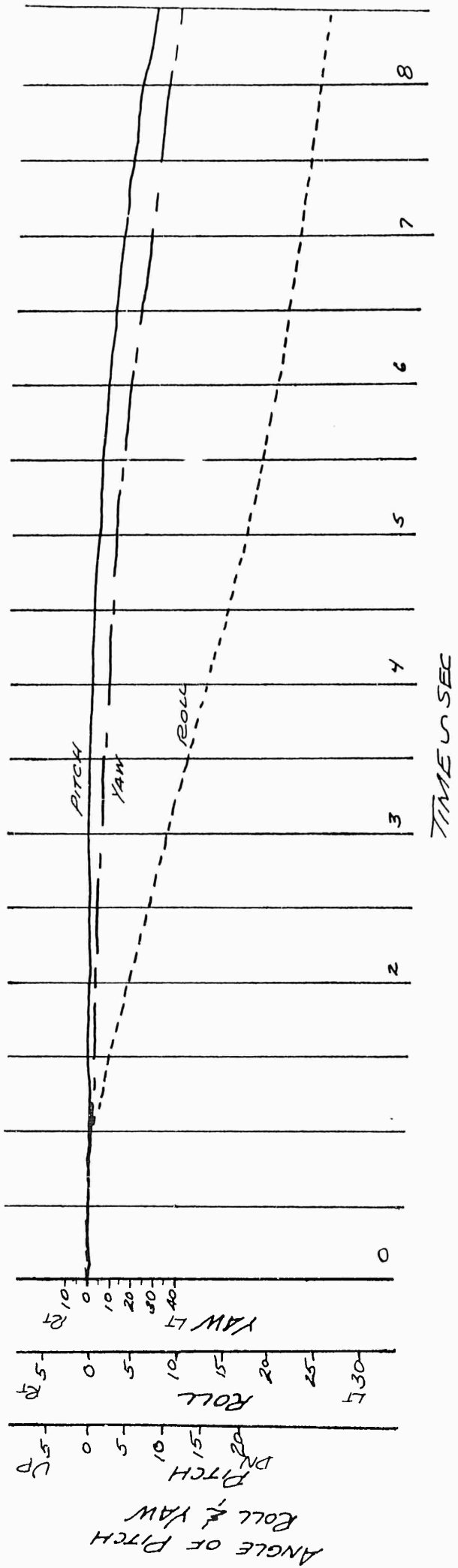

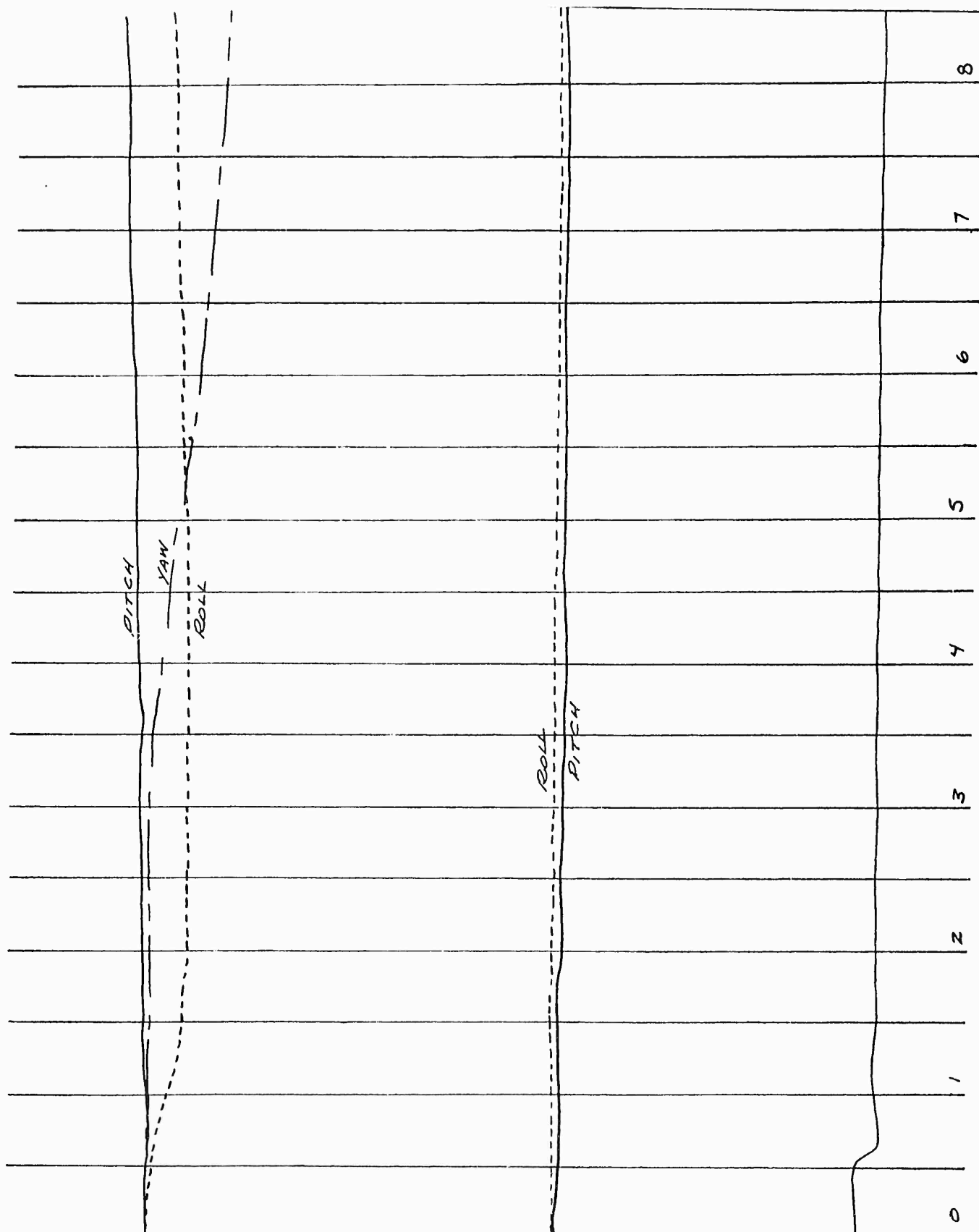

RATE OF PITCH  
 ROLL & YAW  
 DEG/SEC  
 UP  
 01  
 05  
 10  
 15  
 20  
 25  
 30  
 35  
 40  
 45  
 50  
 55  
 60  
 65  
 70  
 75  
 80  
 85  
 90  
 95  
 100  
 105  
 110  
 115  
 120  
 125  
 130  
 135  
 140  
 145  
 150  
 155  
 160  
 165  
 170  
 175  
 180  
 185  
 190  
 195  
 200  
 205  
 210  
 215  
 220  
 225  
 230  
 235  
 240  
 245  
 250  
 255  
 260  
 265  
 270  
 275  
 280  
 285  
 290  
 295  
 300  
 305  
 310  
 315  
 320  
 325  
 330  
 335  
 340  
 345  
 350  
 355  
 360  
 365  
 370  
 375  
 380  
 385  
 390  
 395  
 400  
 405  
 410  
 415  
 420  
 425  
 430  
 435  
 440  
 445  
 450  
 455  
 460  
 465  
 470  
 475  
 480  
 485  
 490  
 495  
 500  
 505  
 510  
 515  
 520  
 525  
 530  
 535  
 540  
 545  
 550  
 555  
 560  
 565  
 570  
 575  
 580  
 585  
 590  
 595  
 600  
 605  
 610  
 615  
 620  
 625  
 630  
 635  
 640  
 645  
 650  
 655  
 660  
 665  
 670  
 675  
 680  
 685  
 690  
 695  
 700  
 705  
 710  
 715  
 720  
 725  
 730  
 735  
 740  
 745  
 750  
 755  
 760  
 765  
 770  
 775  
 780  
 785  
 790  
 795  
 800  
 805  
 810  
 815  
 820  
 825  
 830  
 835  
 840  
 845  
 850  
 855  
 860  
 865  
 870  
 875  
 880  
 885  
 890  
 895  
 900  
 905  
 910  
 915  
 920  
 925  
 930  
 935  
 940  
 945  
 950  
 955  
 960  
 965  
 970  
 975  
 980  
 985  
 990  
 995  
 1000

LATERAL  
 CONTROL POSITION  
 ANGULAR ACCELERATION  
 DEG/SEC<sup>2</sup>  
 UP  
 01  
 05  
 10  
 15  
 20  
 25  
 30  
 35  
 40  
 45  
 50  
 55  
 60  
 65  
 70  
 75  
 80  
 85  
 90  
 95  
 100  
 105  
 110  
 115  
 120  
 125  
 130  
 135  
 140  
 145  
 150  
 155  
 160  
 165  
 170  
 175  
 180  
 185  
 190  
 195  
 200  
 205  
 210  
 215  
 220  
 225  
 230  
 235  
 240  
 245  
 250  
 255  
 260  
 265  
 270  
 275  
 280  
 285  
 290  
 295  
 300  
 305  
 310  
 315  
 320  
 325  
 330  
 335  
 340  
 345  
 350  
 355  
 360  
 365  
 370  
 375  
 380  
 385  
 390  
 395  
 400  
 405  
 410  
 415  
 420  
 425  
 430  
 435  
 440  
 445  
 450  
 455  
 460  
 465  
 470  
 475  
 480  
 485  
 490  
 495  
 500  
 505  
 510  
 515  
 520  
 525  
 530  
 535  
 540  
 545  
 550  
 555  
 560  
 565  
 570  
 575  
 580  
 585  
 590  
 595  
 600  
 605  
 610  
 615  
 620  
 625  
 630  
 635  
 640  
 645  
 650  
 655  
 660  
 665  
 670  
 675  
 680  
 685  
 690  
 695  
 700  
 705  
 710  
 715  
 720  
 725  
 730  
 735  
 740  
 745  
 750  
 755  
 760  
 765  
 770  
 775  
 780  
 785  
 790  
 795  
 800  
 805  
 810  
 815  
 820  
 825  
 830  
 835  
 840  
 845  
 850  
 855  
 860  
 865  
 870  
 875  
 880  
 885  
 890  
 895  
 900  
 905  
 910  
 915  
 920  
 925  
 930  
 935  
 940  
 945  
 950  
 955  
 960  
 965  
 970  
 975  
 980  
 985  
 990  
 995  
 1000

LATERAL  
 CONTROL POSITION  
 % FROM FULL LEFT  
 RT  
 05  
 10  
 15  
 20  
 25  
 30  
 35  
 40  
 45  
 50  
 55  
 60  
 65  
 70  
 75  
 80  
 85  
 90  
 95  
 100  
 105  
 110  
 115  
 120  
 125  
 130  
 135  
 140  
 145  
 150  
 155  
 160  
 165  
 170  
 175  
 180  
 185  
 190  
 195  
 200  
 205  
 210  
 215  
 220  
 225  
 230  
 235  
 240  
 245  
 250  
 255  
 260  
 265  
 270  
 275  
 280  
 285  
 290  
 295  
 300  
 305  
 310  
 315  
 320  
 325  
 330  
 335  
 340  
 345  
 350  
 355  
 360  
 365  
 370  
 375  
 380  
 385  
 390  
 395  
 400  
 405  
 410  
 415  
 420  
 425  
 430  
 435  
 440  
 445  
 450  
 455  
 460  
 465  
 470  
 475  
 480  
 485  
 490  
 495  
 500  
 505  
 510  
 515  
 520  
 525  
 530  
 535  
 540  
 545  
 550  
 555  
 560  
 565  
 570  
 575  
 580  
 585  
 590  
 595  
 600  
 605  
 610  
 615  
 620  
 625  
 630  
 635  
 640  
 645  
 650  
 655  
 660  
 665  
 670  
 675  
 680  
 685  
 690  
 695  
 700  
 705  
 710  
 715  
 720  
 725  
 730  
 735  
 740  
 745  
 750  
 755  
 760  
 765  
 770  
 775  
 780  
 785  
 790  
 795  
 800  
 805  
 810  
 815  
 820  
 825  
 830  
 835  
 840  
 845  
 850  
 855  
 860  
 865  
 870  
 875  
 880  
 885  
 890  
 895  
 900  
 905  
 910  
 915  
 920  
 925  
 930  
 935  
 940  
 945  
 950  
 955  
 960  
 965  
 970  
 975  
 980  
 985  
 990  
 995  
 1000

121

FIGURE No. 75

RESPONSE TO A RIGHT LATERAL STEP  
 H-43B USAF 59-1548  
 TRIM AIRSPEED = 40 KNOTS CAS  
 DENSITY ALTITUDE = 2150 FEET  
 GROSS WEIGHT = 6050 LB  
 CG LOCATION = MID (STATION 119)  
 RPM = 260  
 Q545 = 0W

PITCH ———  
 ROLL - - -  
 YAW ———

MODIFIED EMPENNAGE

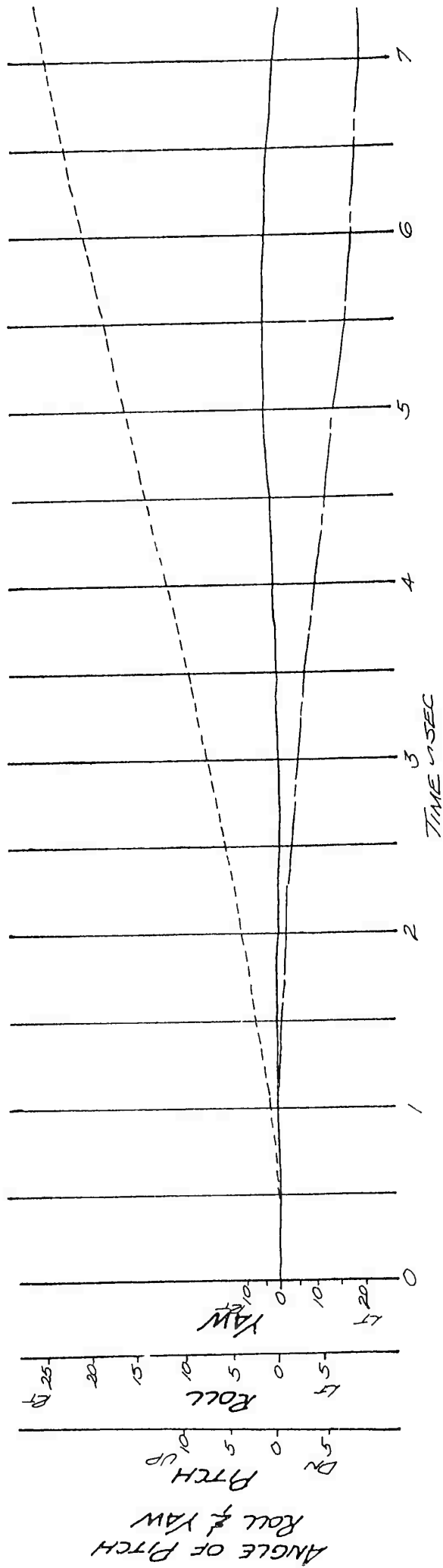

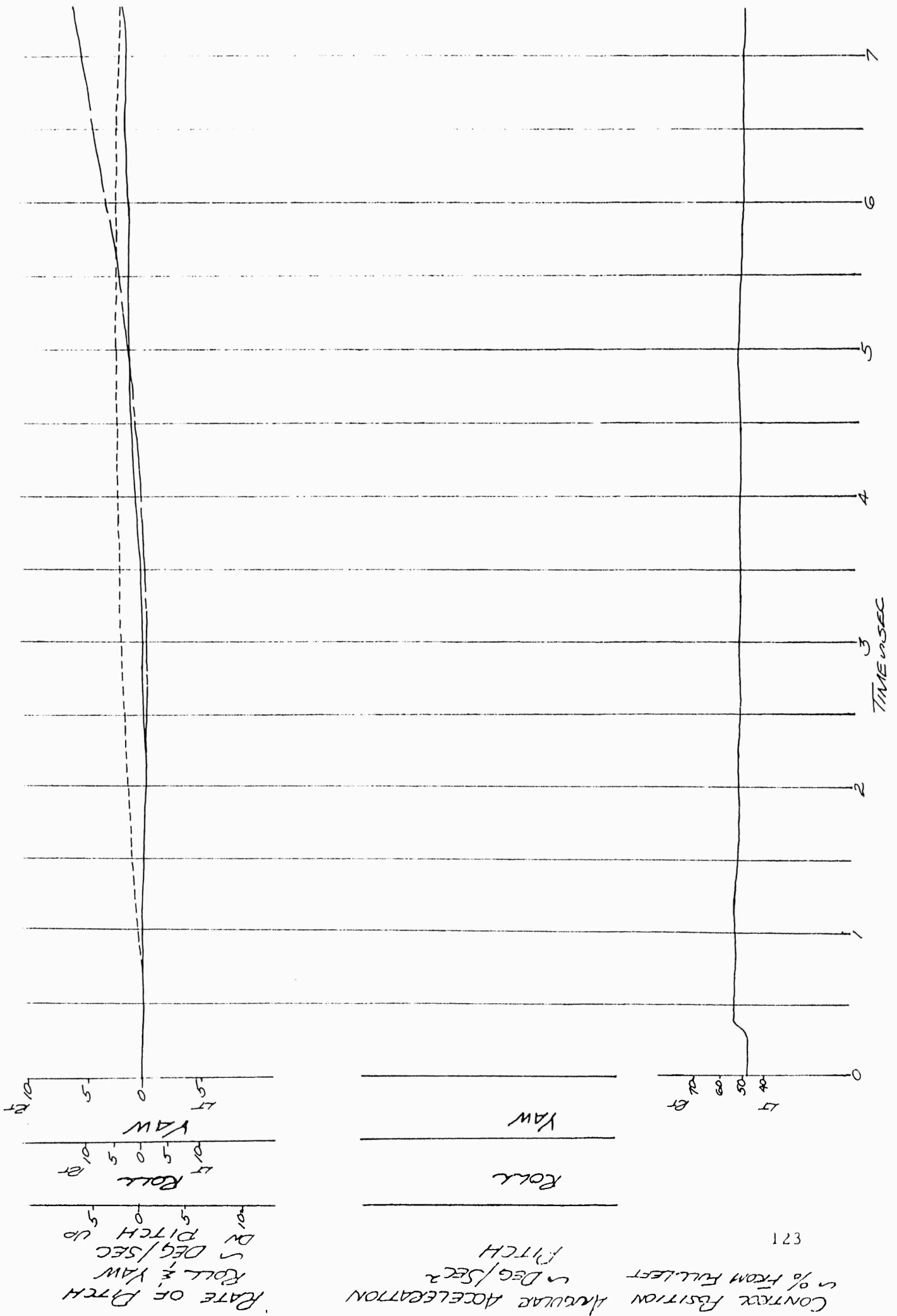

123

CONTROL POSITION % FROM FULL LEFT  
 DEG/SEC<sup>2</sup>  
 ANGULAR ACCELERATION  
 PITCH

RATE OF PITCH  
 DEG/SEC  
 UP  
 DOWN  
 PITCH

ROLL  
 DEG  
 UP  
 DOWN

YAW

YAW

ROLL

1.0  
 0.5  
 0.0  
 0.5  
 1.0

10  
 5  
 0  
 5  
 10

TIME IN SEC

7

6

5

4

3

2

1

0

FIGURE No. 76

RESPONSE TO A LEFT LATERAL STEP  
 H-43B USAF 59-1548  
 TRIM AIRSPEED = 40 KNOTS CAS  
 DENSITY ALTITUDE = 2150 FEET  
 GROSS WEIGHT = 6030 LB  
 CG LOCATION = MID (STATION 119)  
 RPM = 260  
 DEAS = ON

PITCH  
 ROLL  
 YAW

MODIFIED EMPENNAGE

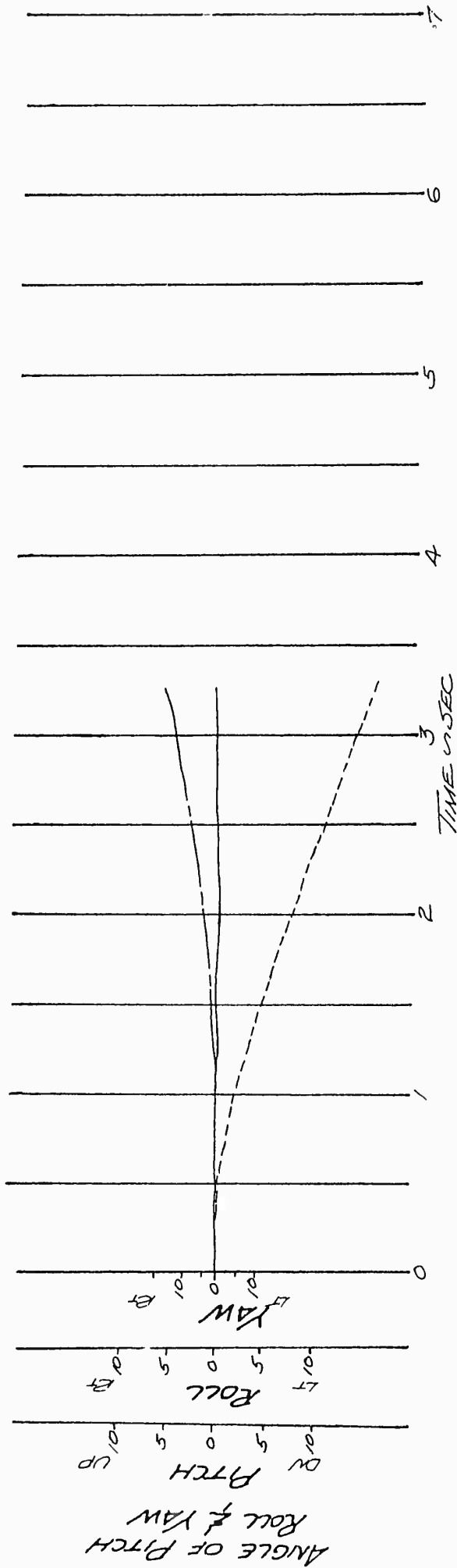

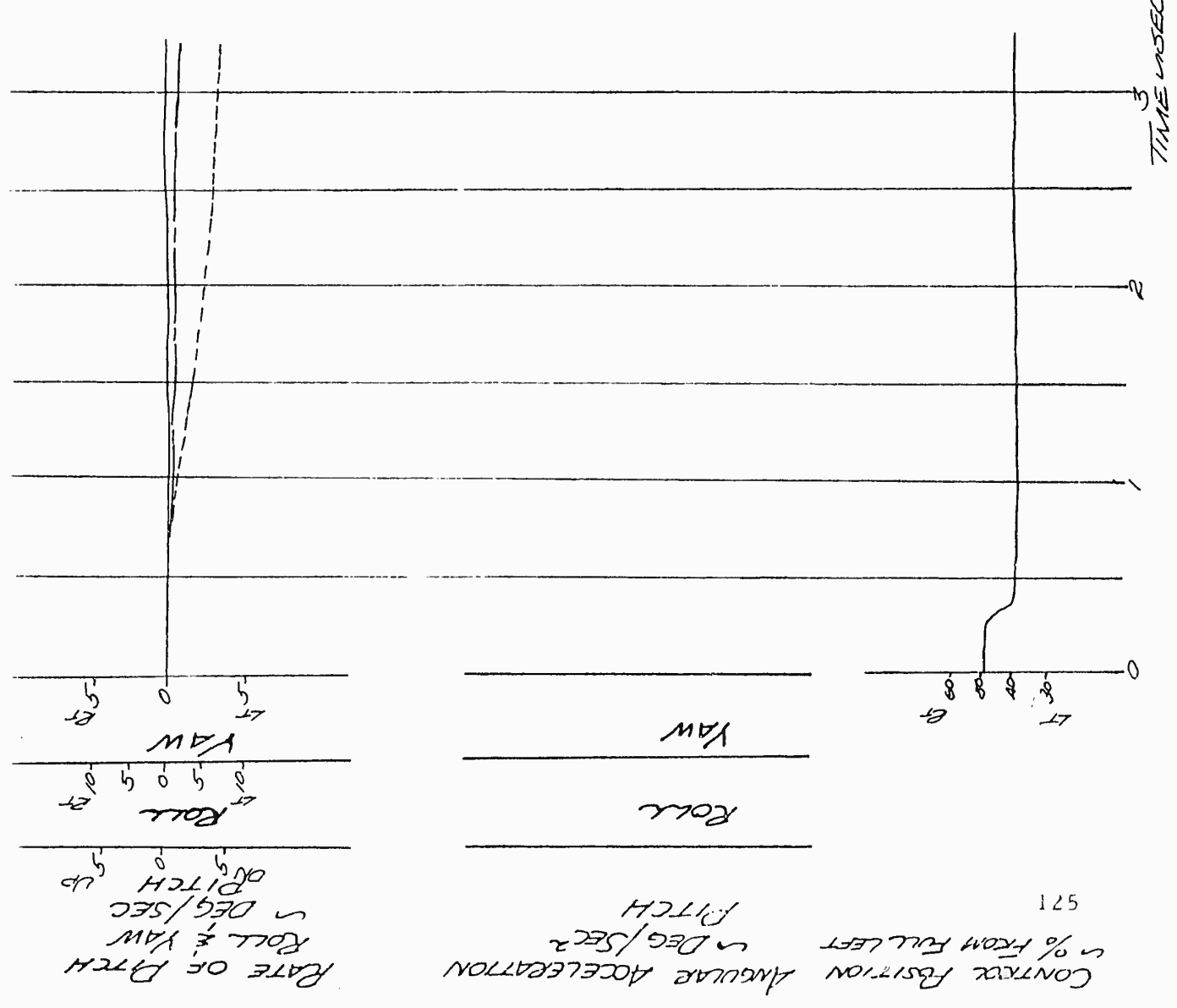
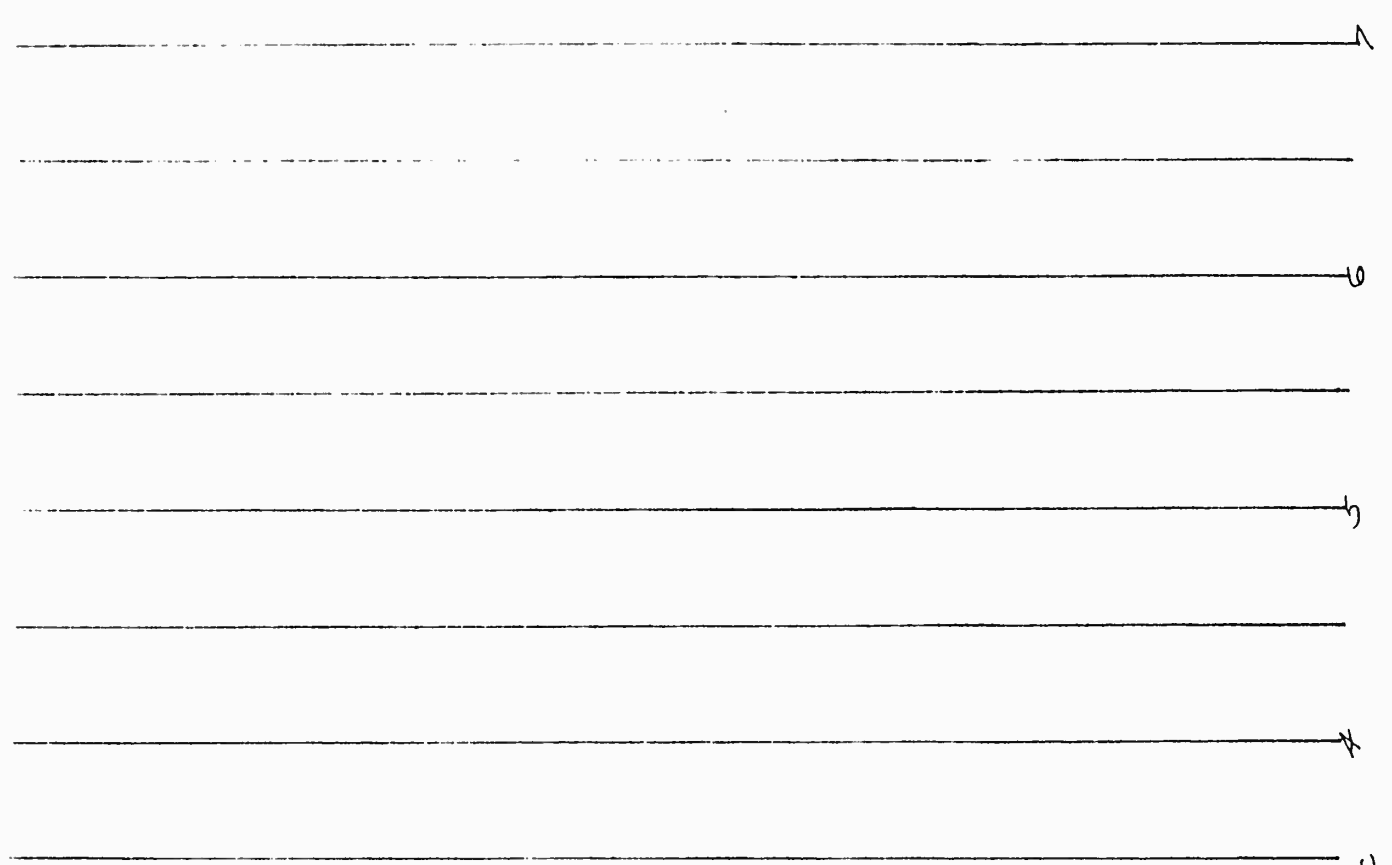

RATE OF PITCH  
 ~ DEG/SEC  
 ROLL & YAW  
 ~ DEG/SEC  
 UP

ANGULAR ACCELERATION  
 ~ DEG/SEC<sup>2</sup>  
 PITCH

CONTROL POSITION  
 ~ % FROM FULL LEFT

571

FIGURE No. 77

RESPONSE TO A PEDAL STEP  
 H-43B USAF SN 59-1849  
 TRIM AIRSPEED = 40 KNOTS CAS  
 DENSITY ALTITUDE = 6280 FEET  
 GROSS WEIGHT = 6160 LB  
 CG LOCATION = MID (STATION 119)  
 RPM = 260/105%  
 LEVEL FLIGHT  
 DSAS - ON

ORIGINAL EMPENNAGE

PITCH \_\_\_\_\_  
 ROLL - - - - -  
 YAW - - - - -

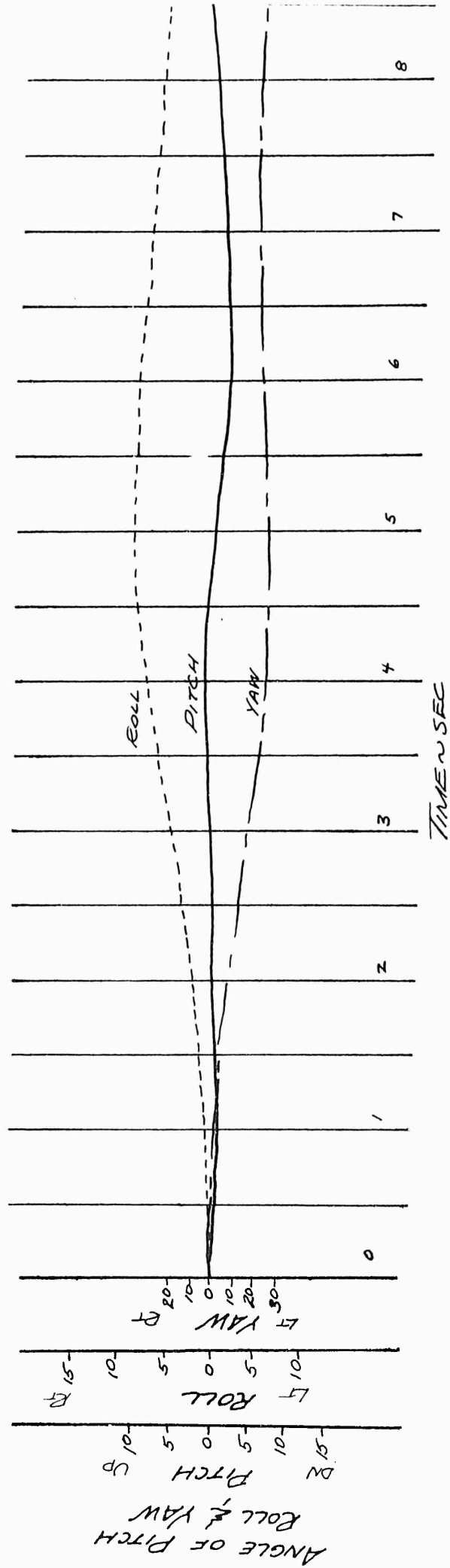

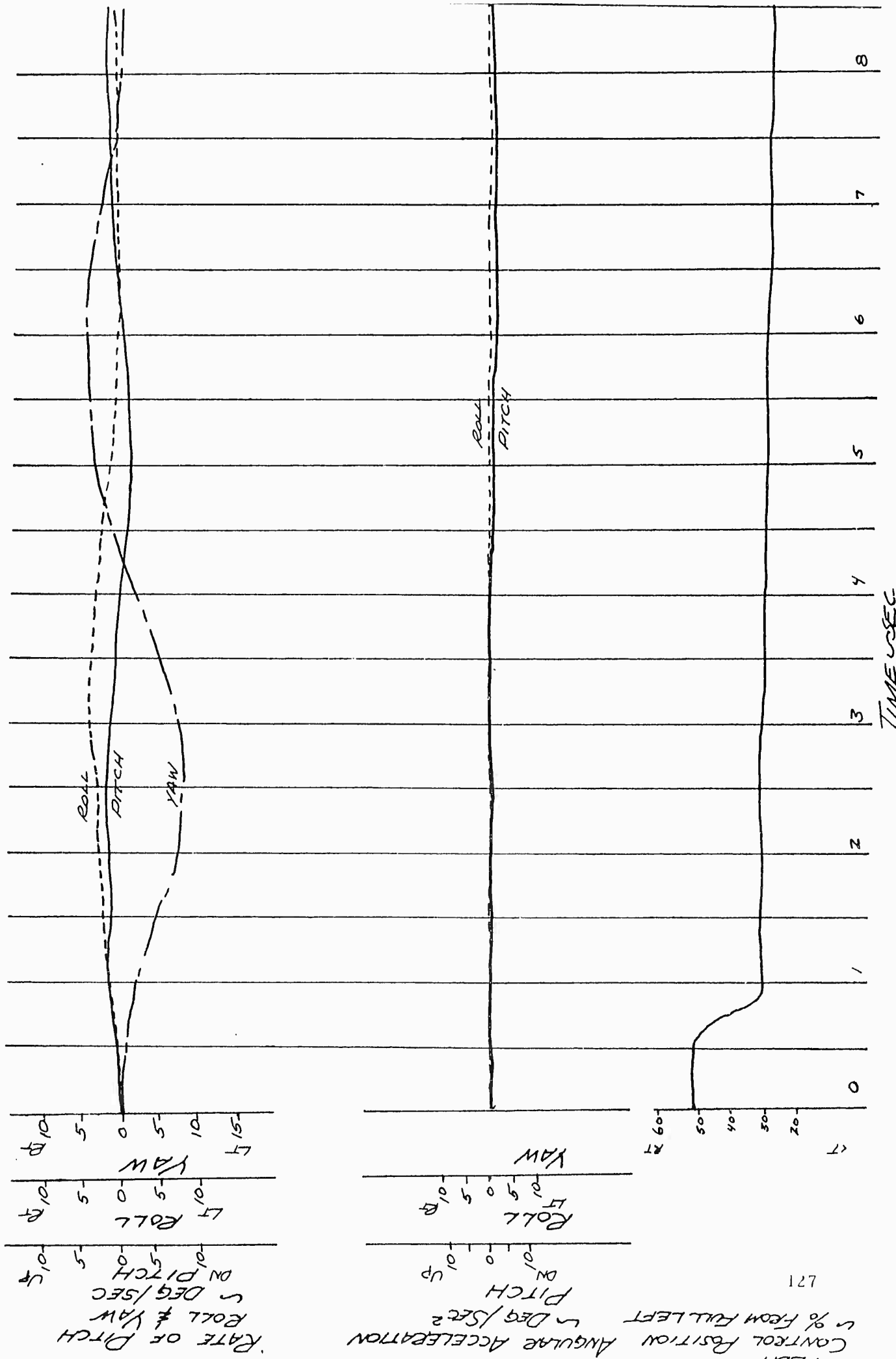

121

FIGURE No. 78

RESPONSE TO A PEDAL STEP  
 H-43B USAF SN 59-1849  
 TRIM AIRSPEED = 40 KNOTS CAS  
 DENSITY ALTITUDE = 5940 FEET  
 GROSS WEIGHT = 6150 LB  
 CG LOCATION = MID (STATION 119)  
 RPM = 238/96%

LEVEL FLIGHT  
 DSAS - ON

PITCH ———  
 ROLL - - -  
 YAW - - -

ORIGINAL EMPENNAGE

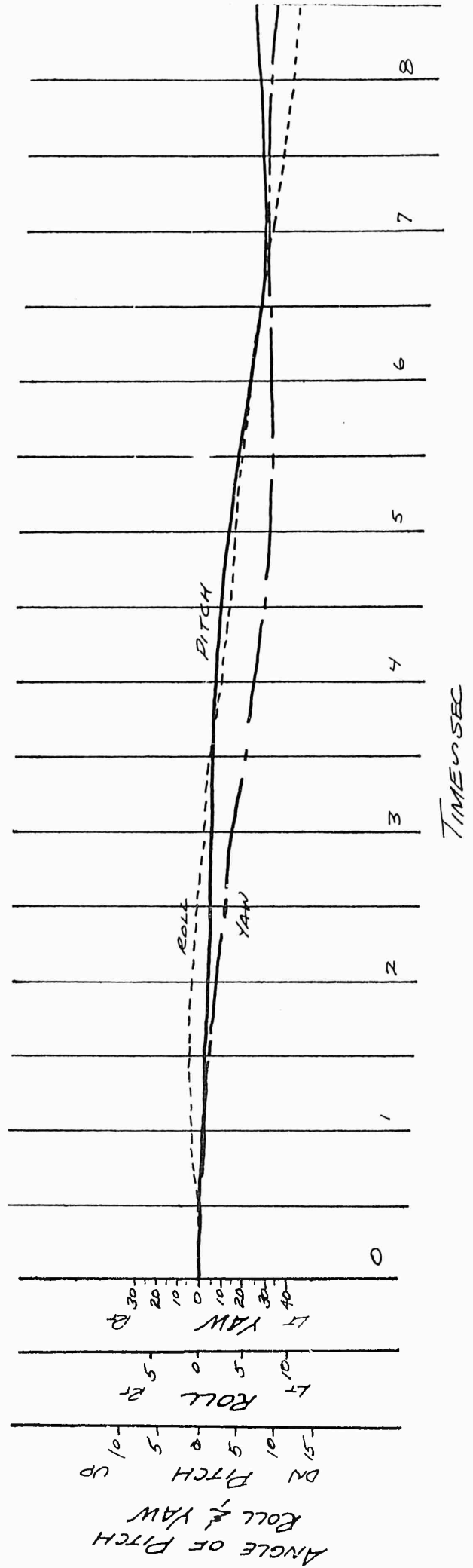

TIME IN SEC

8

7

6

5

4

3

2

1

0

PEDAL

CONTROL POSITION

% FROM FULL LEFT

621

ANGULAR ACCELERATION

PITCH

ROLL

YAW

LT

RT

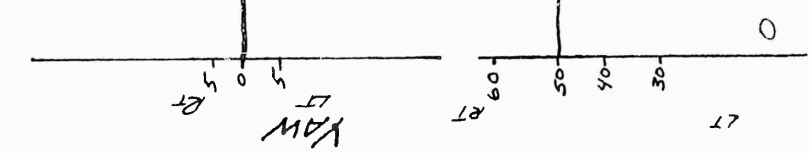

RATE OF PITCH

ROLL & YAW

DEG/SEC

DOWN

UP

LT

RT

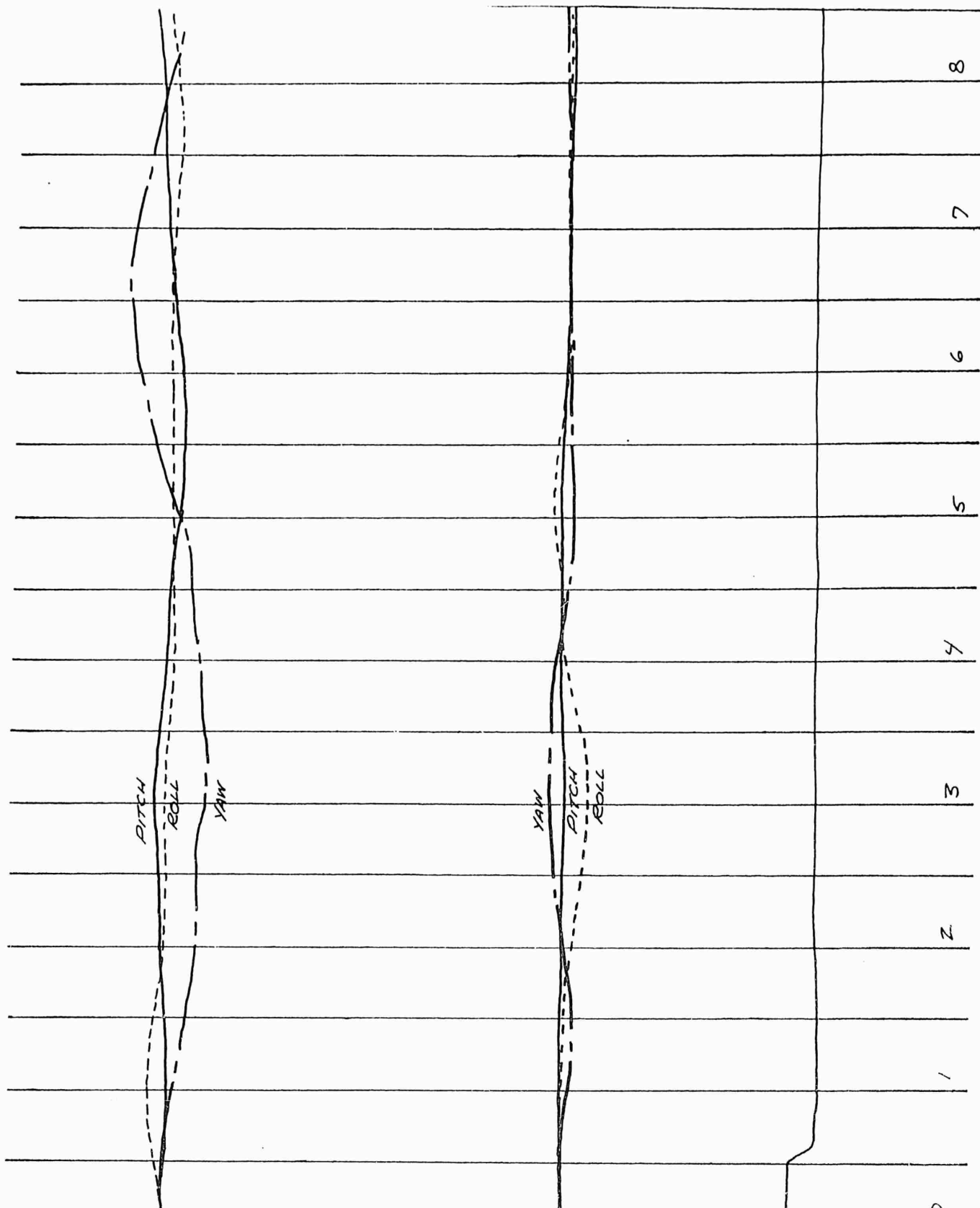
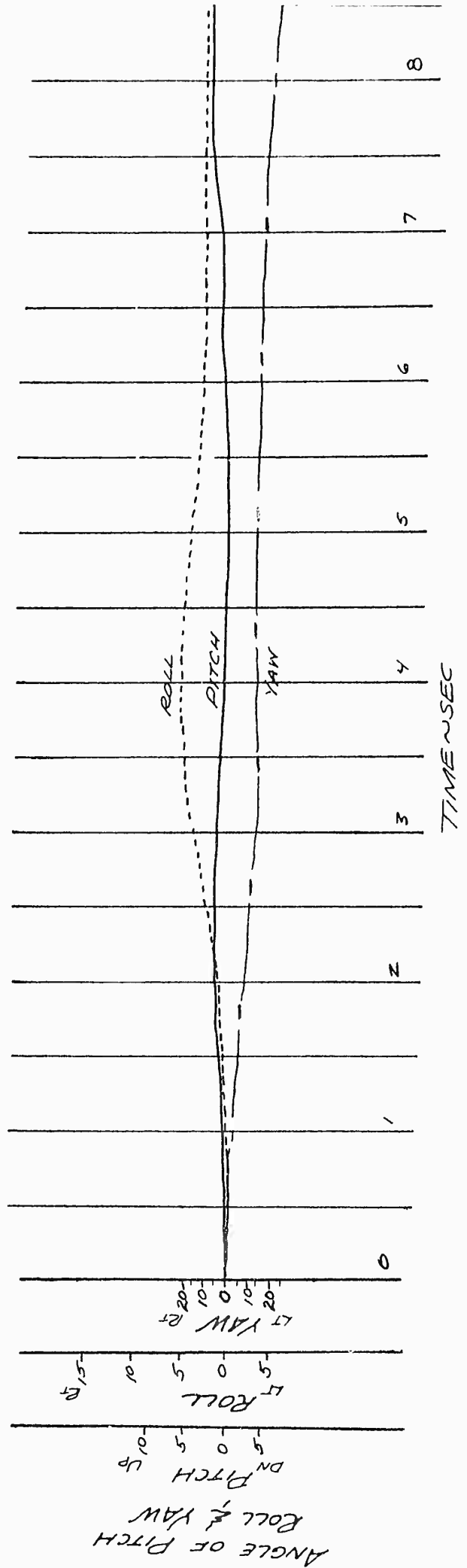

FIGURE No. 79

RESPONSE TO A PEDAL STEP  
 H-43B USAF SN 59-1849  
 TRIM AIRSPEED = 60 KNOTS CAS  
 DENSITY ALTITUDE = 6280 FEET  
 GROSS WEIGHT = 6160 LB  
 C G LOCATION = MID (STATION 119)  
 RPM = 260/105%  
 LEVEL FLIGHT  
 D5A5-ON

PITCH  
 ROLL  
 YAW

ORIGINAL EMPENNAGE



PEDAL CONTROL POSITION % FROM FULL LEFT

ANGULAR ACCELERATION DEG/SEC<sup>2</sup>

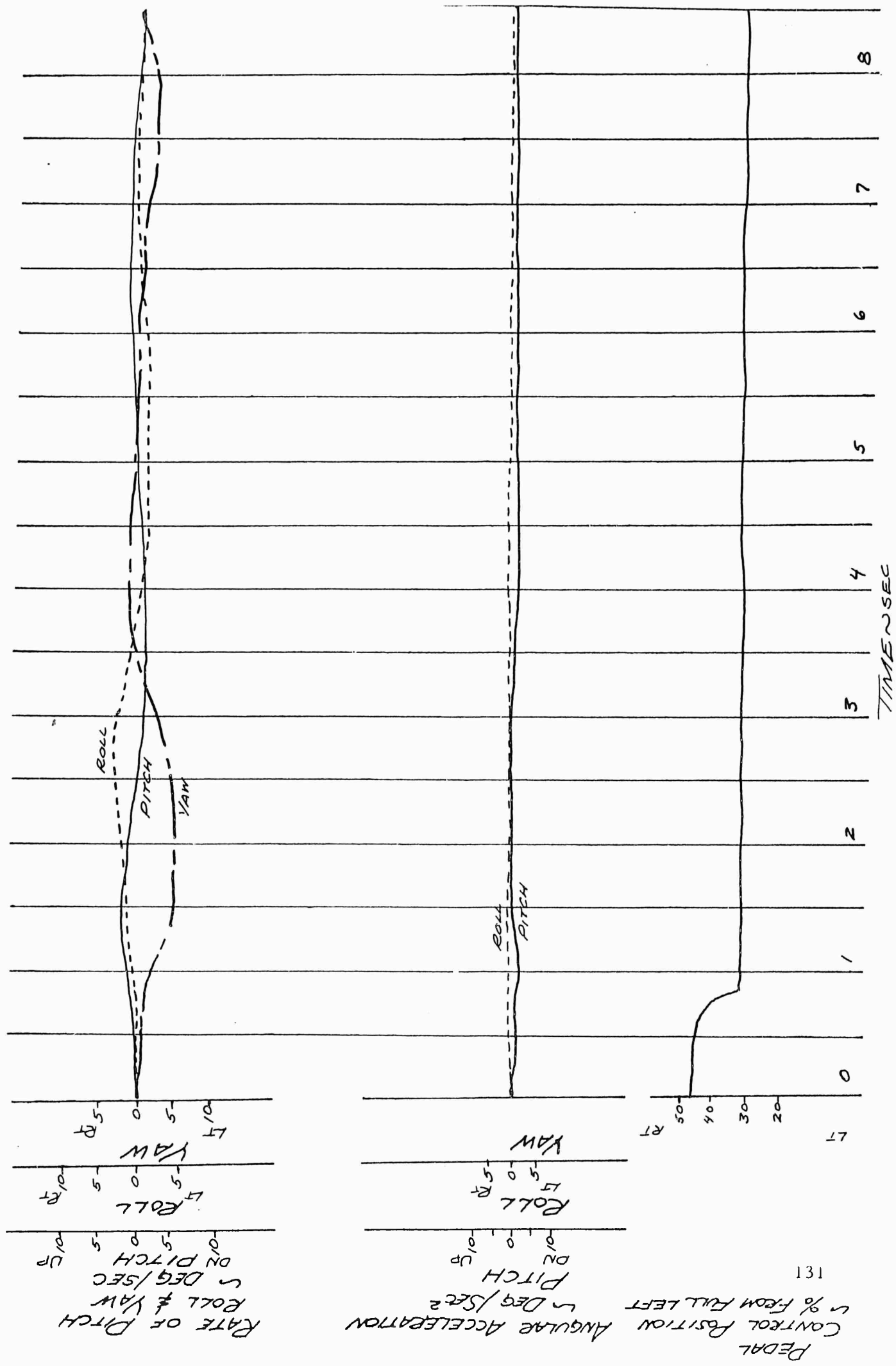
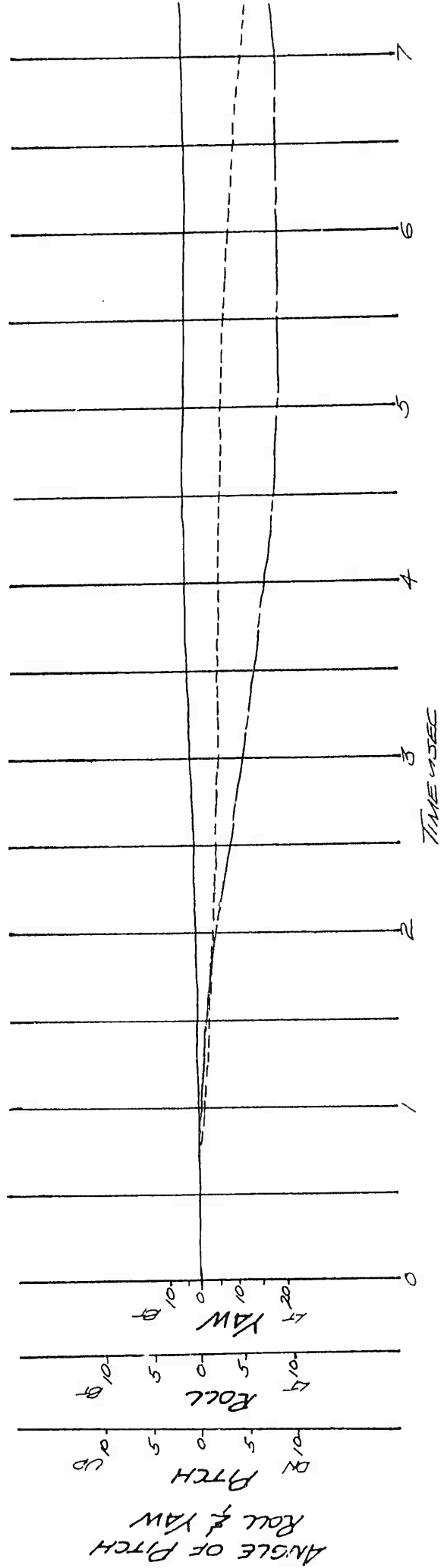

FIGURE No. 80

RESPONSE TO A LEFT PEDAL STEP  
 H-43B USAF 59-1548  
 TRIM AIRSPEED = 40 KNOTS CAS  
 DENSITY ALTITUDE = 2100 FEET  
 GROSS WEIGHT = 6000 LB  
 CG LOCATION = 1110 (STATION 115)  
 RPM = 260  
 DSAS = 0U

MODIFIED EMPENNAGE

PITCH \_\_\_\_\_  
 ROLL - - - - -  
 YAW - - - - -



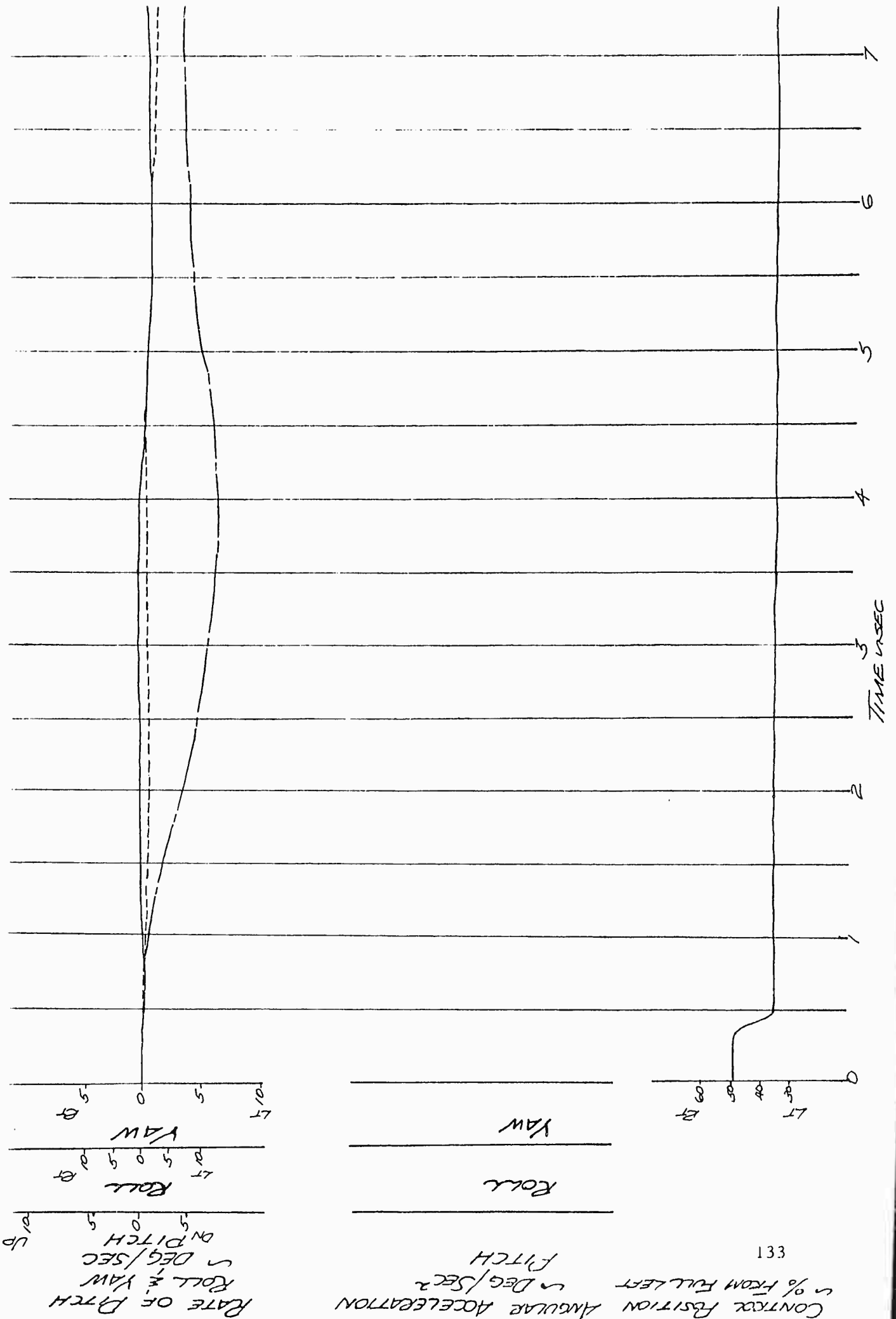

133

CONTROL POSITION ANGLE ACCELERATION  
 % FROM FULL LEFT  
 DEG/SEC<sup>2</sup>  
 PITCH

RATE OF PITCH  
 Roll & Yaw  
 DEG/SEC  
 DN PITCH  
 UP

FIGURE No. 81

RESPONSE TO A EIGHT DEGREE STEP  
 H-43B USAF 59-1548  
 TRIM AIRSPEED = 40 KNOTS CAS  
 DENSITY ALTITUDE = 2150 FEET  
 GROSS WEIGHT = 6050 LB  
 C.G. LOCATION = 1110 (STATION 119)  
 RPM = 260  
 DEAS = ON

MODIFIED EMPENNAGE

PITCH  
 ROLL  
 YAW

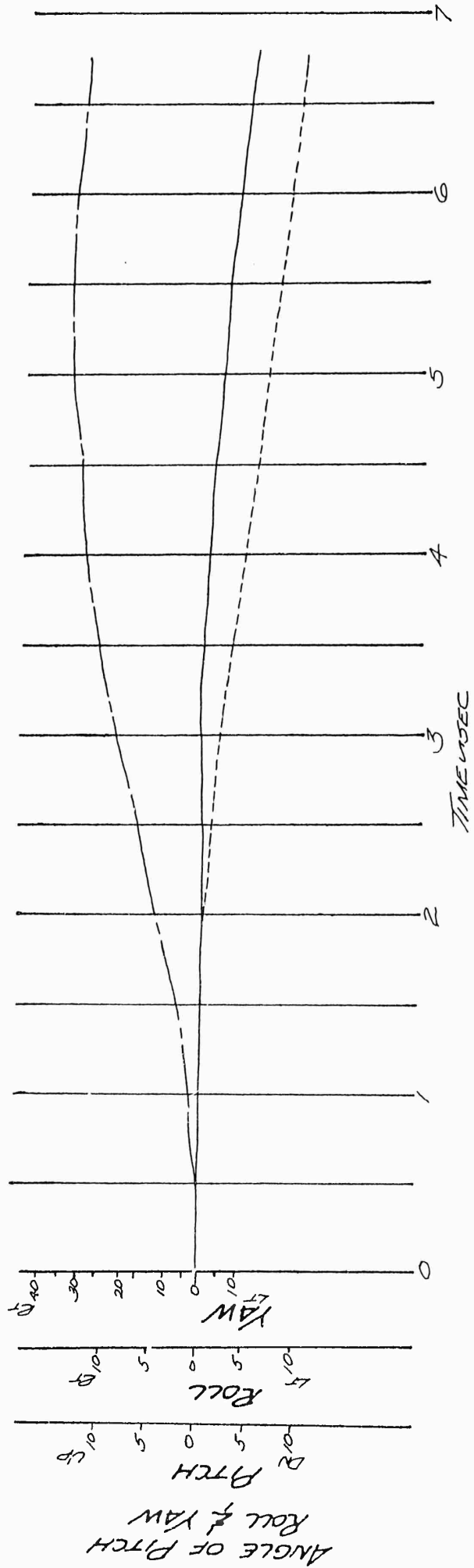

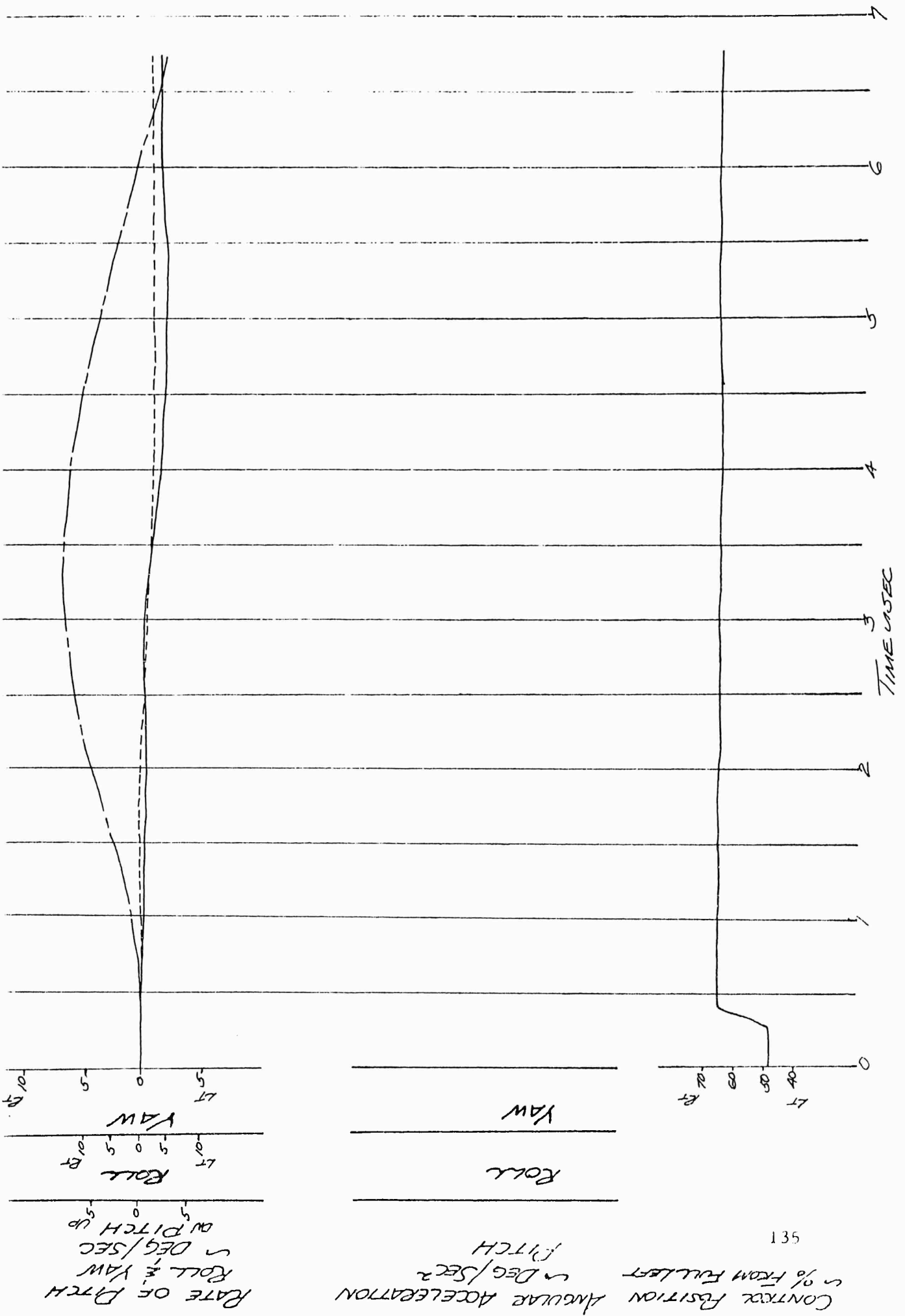
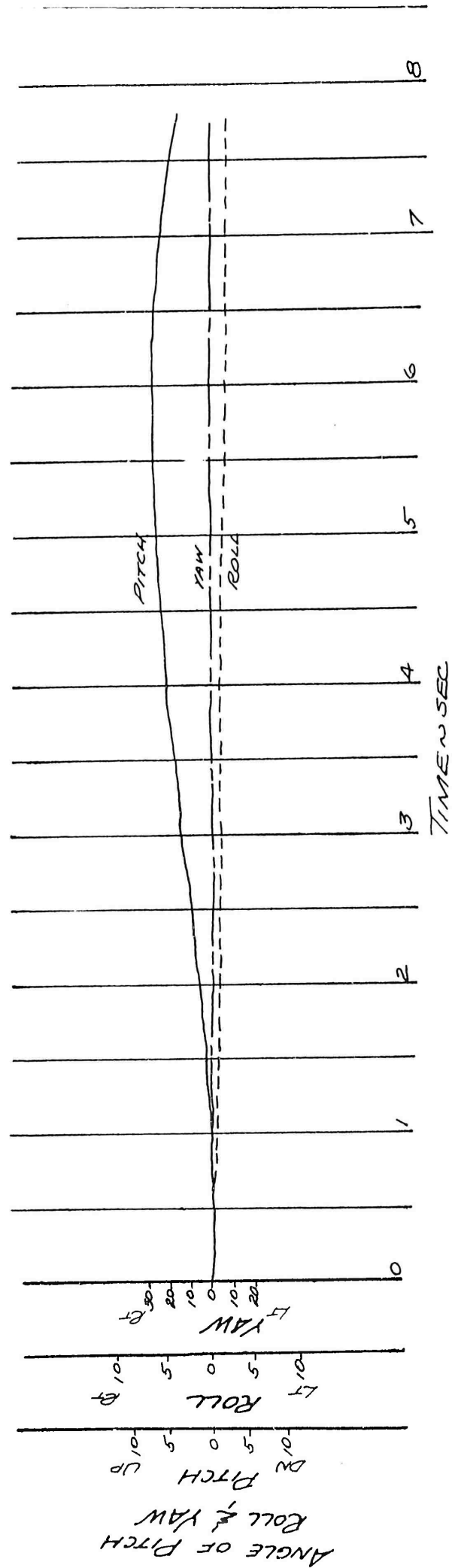

FIGURE No. 82

RESPONSE TO A LONGITUDINAL STEP  
 H-43B USAF 59-1849  
 TRIM AIRSPEED = 60 KNOTS CAS  
 DENSITY ALTITUDE = 5000 FEET  
 GROSS WEIGHT = 5960 LB  
 C.G. LOCATION = MID (STATION 119)  
 RPM = 220/88%  
 AUTOREOTATION  
 DSAS - ON

PITCH \_\_\_\_\_  
 ROLL - - - - -  
 YAW - - - - -

ORIGINAL EMPENNAGE



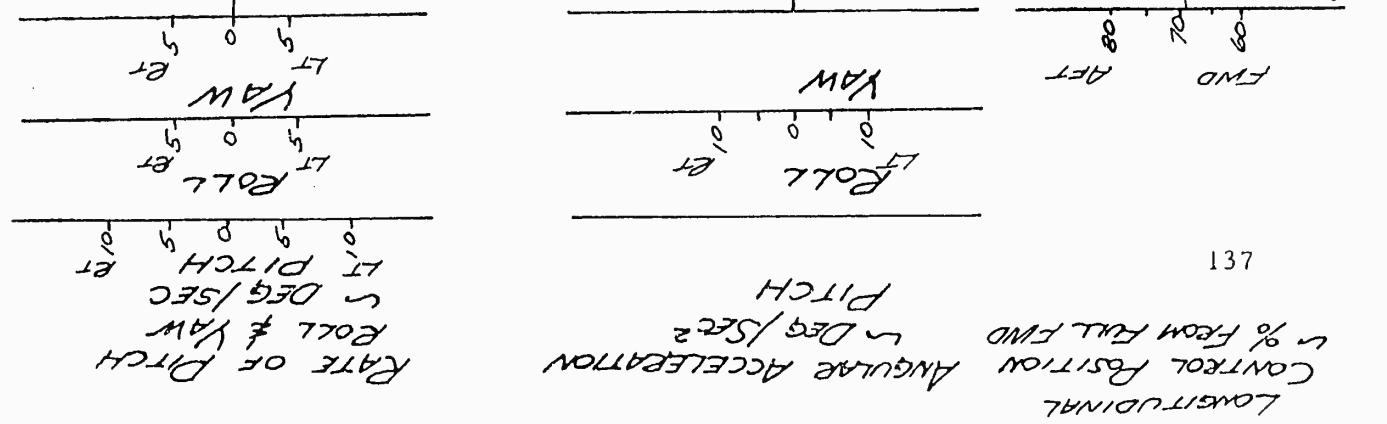
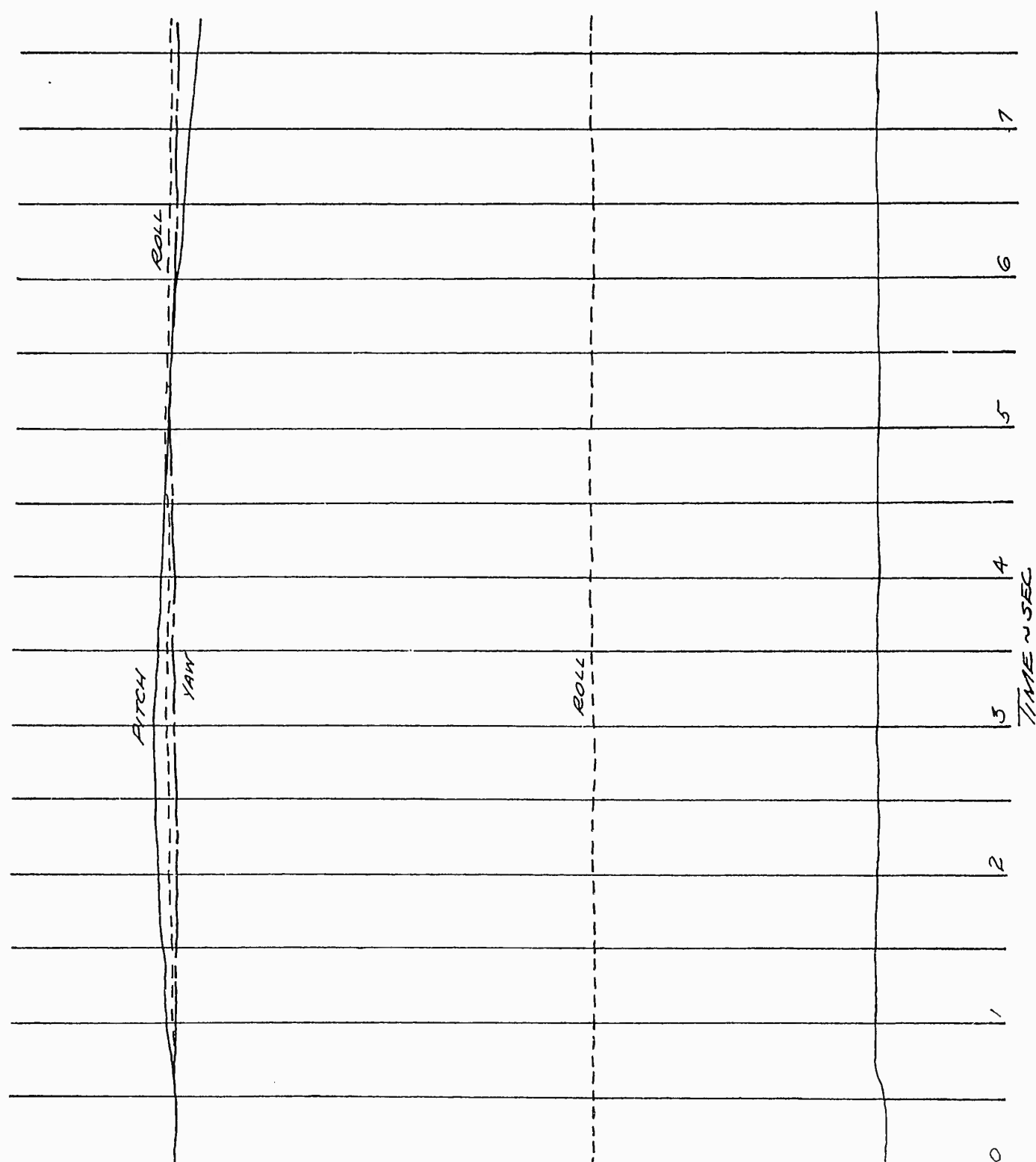

RATE OF PITCH  
 ROLL & YAW  
 ~ DEG/SEC  
 LT PITCH RT  
 0 5 9  
 LT ROLL RT  
 0 5 9  
 LT YAW RT  
 0 5 9

ANGULAR ACCELERATION  
 ~ DEG/SEC<sup>2</sup>  
 LT ROLL RT  
 0 1  
 LT YAW RT  
 0 1

LONGITUDINAL  
 CONTROL POSITION  
 ~ % FROM FULL FWD  
 FWD  
 0 1 2 3 4 5 6 7 8 9  
 AFT

FIGURE No. 83

RESPONSE TO A LATERAL STEP  
 H-43B USAF 59-1849  
 TRIM AIRSPEED = 60 KNOTS CAS  
 DENSITY ALTITUDE = 5450 FEET  
 GROSS WEIGHT = 5800 LB  
 C.G. LOCATION = MID (STATION 119)  
 RPM = 220/88%

AUTOROTATION  
 DSAS - ON

PITCH \_\_\_\_\_  
 ROLL - - - - -  
 YAW - - - - -

ORIGINAL EMPENNAGE

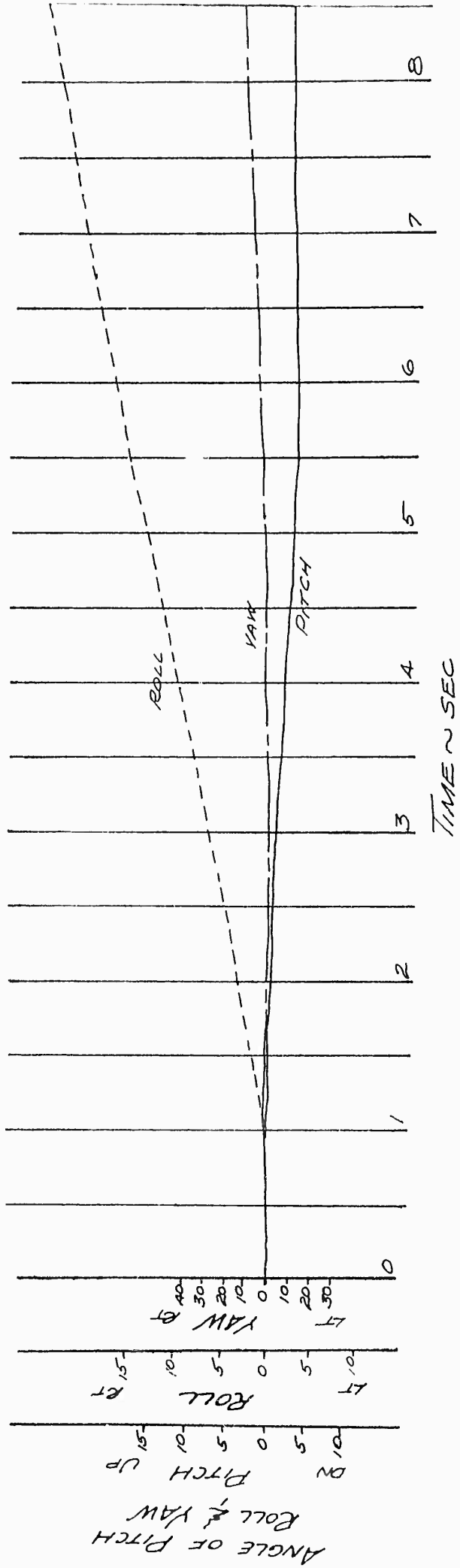

LATERAL

CONTROL POSITION % FROM FULL LEFT

ANGULAR ACCELERATION

PITCH ~ DEG/SEC<sup>2</sup>

ROLL ~ DEG/SEC<sup>2</sup>

YAW ~ DEG/SEC<sup>2</sup>

LT RT

UP DN

RATE OF PITCH

ROLL ~ DEG/SEC

YAW ~ DEG/SEC

PITCH ~ DEG/SEC

UP DN

LT RT

ROLL

YAW

PITCH

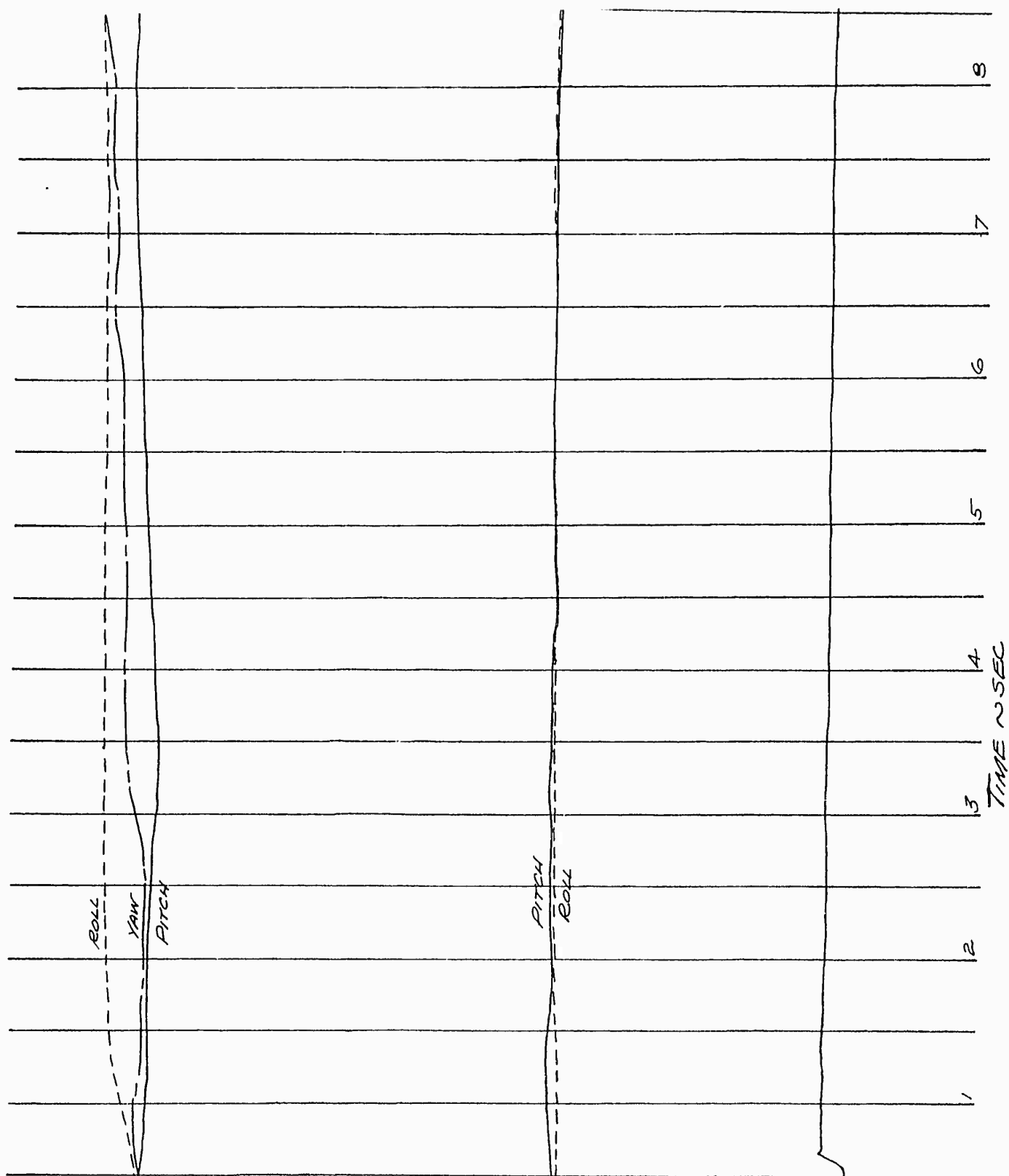

9  
7  
6  
5  
4  
3  
2  
1  
0  
TIME ~ SEC

ROLL  
YAW  
PITCH

PITCH  
ROLL

RATE OF PITCH  
 ~ DEG/SEC  
 ROLL ~ DEG/SEC  
 YAW ~ DEG/SEC  
 PITCH ~ DEG/SEC  
 UP DN  
 LT RT  
 ROLL  
 YAW  
 PITCH

CONTROL POSITION  
 % FROM FULL LEFT  
 ANGULAR ACCELERATION  
 PITCH ~ DEG/SEC<sup>2</sup>  
 ROLL ~ DEG/SEC<sup>2</sup>  
 YAW ~ DEG/SEC<sup>2</sup>  
 LT RT  
 UP DN  
 PITCH  
 ROLL  
 YAW

FIGURE No. 84

RESPONSE TO A PEDAL STEP  
 H-43B USAF 59-1849  
 TRIM AIRSPEED = 60 KNOTS CAS  
 DENSITY ALTITUDE = 5450 FEET  
 GROSS WEIGHT = 5800 LB  
 CG LOCATION = MID (STATION 119)  
 RPM = 220/88%  
 AUTOROTATION  
 DSAS = ON

PITCH  
 ROLL  
 YAW

ORIGINAL EMPENNAGE

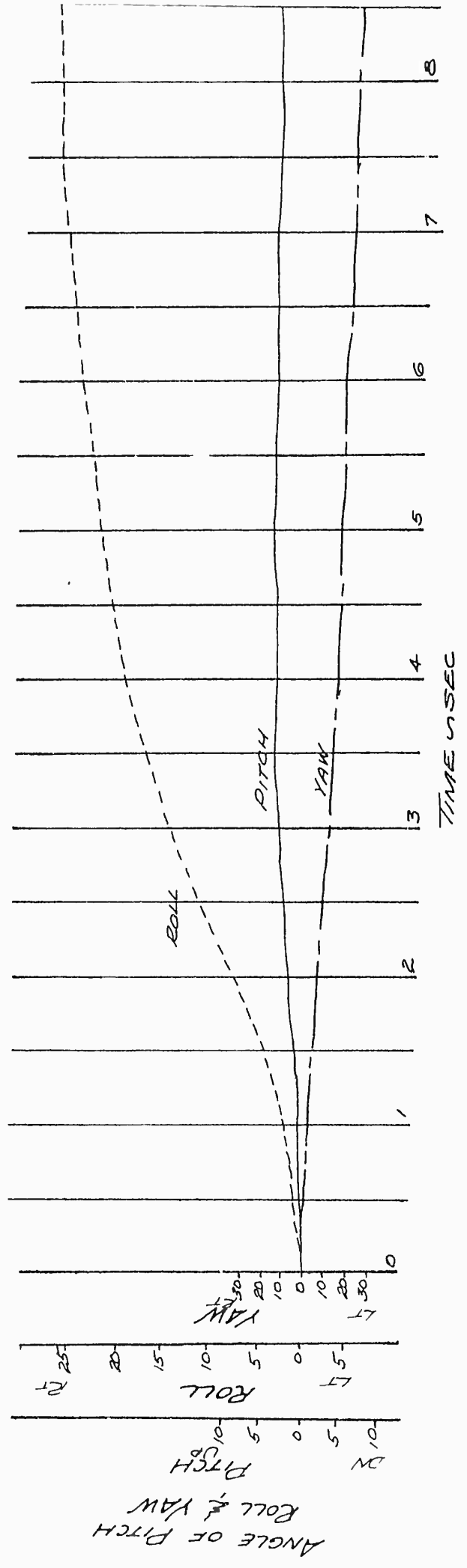

Pedal Position Angular Acceleration  
% From Full Left

LT  
RT  
0  
20  
40  
60

PITCH  
DN  
UP  
0  
0.1  
0.2

ROLL  
LT  
RT  
0  
0.1  
0.2

PITCH  
ROLL

Rate of Pitch  
Roll & Yaw  
Deg/Sec

LT  
RT  
0  
5  
10

LT  
RT  
0  
5  
10

LT  
RT  
0  
5  
10

PITCH  
ROLL  
YAW

TIME IN SEC  
0  
1  
2  
3  
4  
5  
6  
7  
8

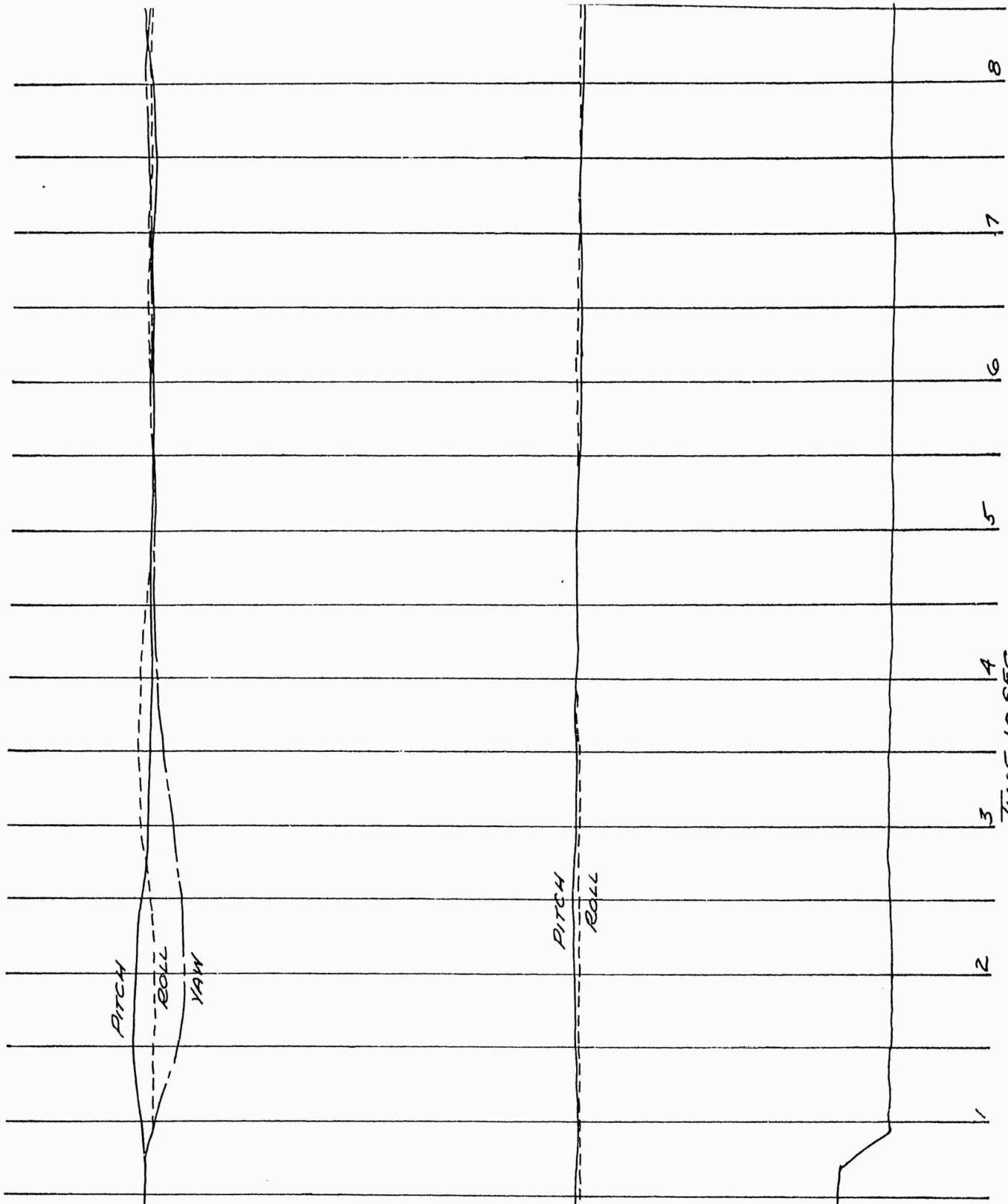

# APPENDIX II

## general aircraft information

### CONTROL SYSTEM

Conventional helicopter flight controls are provided in the right hand forward cabin area for the pilot and on the left hand side for the co-pilot. Longitudinal and lateral control is obtained in a conventional manner by fore, aft and lateral tilting of the rotor discs. The cyclic stick is connected to the azimuth assemblies which are attached to the bottom of the rotor transmission assembly. Two control rods run from each azimuth assembly (which has the same function as a conventional swash plate assembly) through the rotor shafts to the rotor hub. A control rod then runs spanwise through each blade to the servo flap. Cyclic actuation of these servo flaps is then utilized to tilt the rotor tip path plane. Two hydraulic dampers are connected to the longitudinal cyclic bell cranks ahead of the azimuth assembly. The dampers are intended to minimize any feedback to the cyclic stick. A lateral limiting device is installed in the control system to limit the inboard lateral tilt of the trailing rotor in sideward flight or any flight condition requiring large lateral tilt of the rotors. This limiting device is necessitated by blade to hub interference conditions.

A longitudinal and lateral cyclic control stick trim system is incorporated to provide control feel and reduce the forces required to hold the cyclic stick in a specific position. Two types of trim controls are provided. The cyclic stick trim switch (fine trimmer) consists of a four-way switch located on the console that operates electric actuators which slowly introduce trim into the cyclic system. The cyclic trim release switch (centering button) located on the pilot's cyclic stick, when depressed, is designed to rapidly release all forces on the cyclic stick. When a new stick position has been established, releasing the switch establishes the new trim setting (zero reference).

Application of the directional pedals results in two simultaneous reactions. The following reactions occur as a result of a right pedal input:

1. An increase in collective pitch and tilting of the tip path plane forward in the left rotor.
2. A decrease in collective pitch and tilting the tip path plane rearward in the right rotor.

The difference in collective pitch results in a turning and rolling moment on the aircraft because of the unbalance of torque between the two rotors. In order to retain the same directional control in autorotational flight as in powered flight (i. e., right pedal means right turn) a "reverser" and "shifter" are included in the control linkages from the directional controls. The reverser is installed in the differential collective system to reverse the differential collective pitch in the rotor blades. This is necessary because of the reversal in torque reaction when the rotors are driving the rotor shafts instead of being driven by the engine. At collective settings from 7 to 35 percent from full down, the reverser is in a neutral or low torque area called the dwell zone. At this condition, directional control becomes weaker since it is obtained only by differential cyclic tilt of the rotors (DSAS off) which are at a low collective angle. At collective settings above or below this "dwell zone" directional control becomes more effective. To increase directional control in the "dwell zone," a differential cyclic "shifter" is installed in the differential cyclic control system to vary the amount of cyclic pitch differential in the rotors for a given amount of pedal movement as a function of collective pitch position. This is necessitated by the change in the turning effectiveness of differential collective pitch with collective pitch position.

The rudder surfaces are controlled by a directional stabilization system. Horizontal and vertical control surfaces are incorporated into the tail and influence the pitch attitude as well as the directional stability and control in various flight regimes. These are discussed in the following sections of this Appendix.

#### DIRECTIONAL STABILITY SYSTEM

The purpose of the directional stability augmentation system (DSAS) in the H-43B helicopter is to provide positive static directional stability in all flight conditions. The directional stability

augmentation system consists primarily of the following items:

1. Pedal position transducer
2. Pressure switches
3. Stability control unit

The stability control unit includes a lateral accelerometer, yaw rate transducer, summing circuitry, airspeed voltage attenuator, and a servo amplifier. The various components in the directional stability augmentation system are shown in the following block diagram.

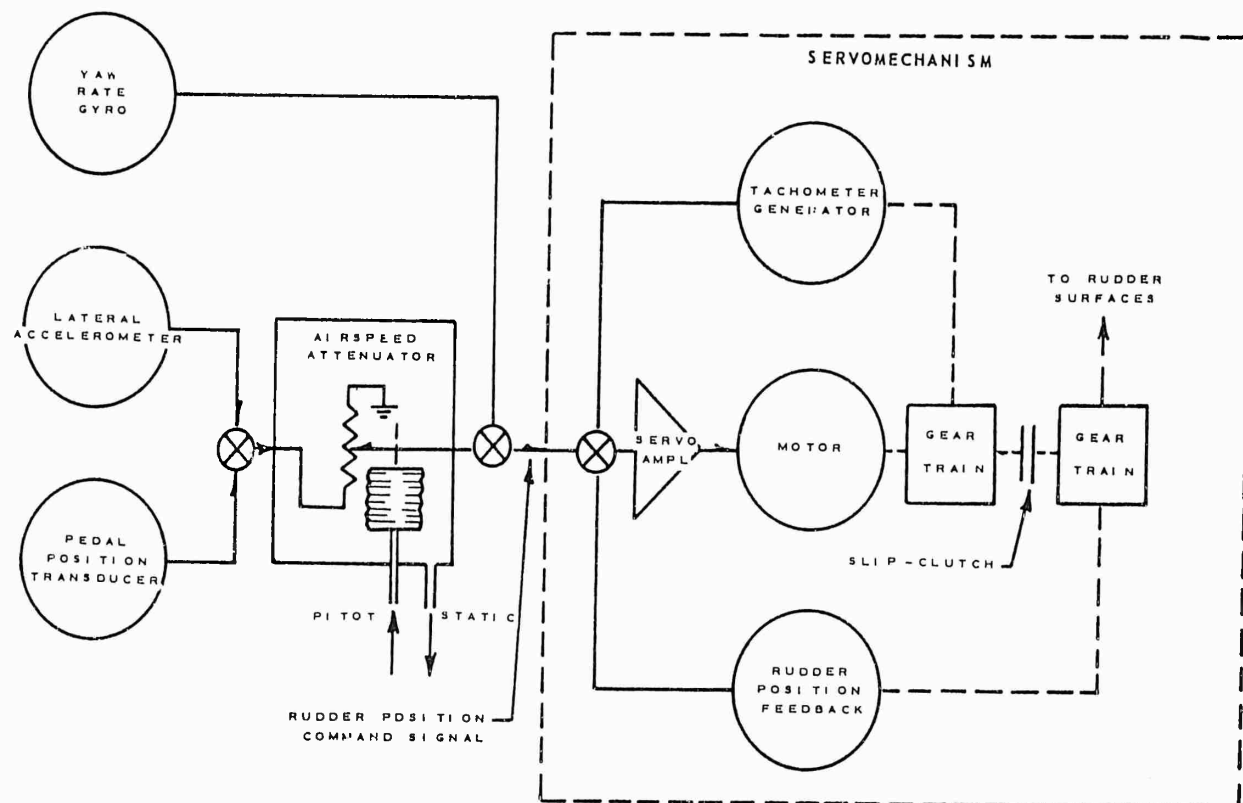

FIGURE 1:  
DIRECTIONAL STABILITY SYSTEM,  
SIMPLIFIED BLOCK DIAGRAM

The components and their location in the aircraft are illustrated in the figure below.

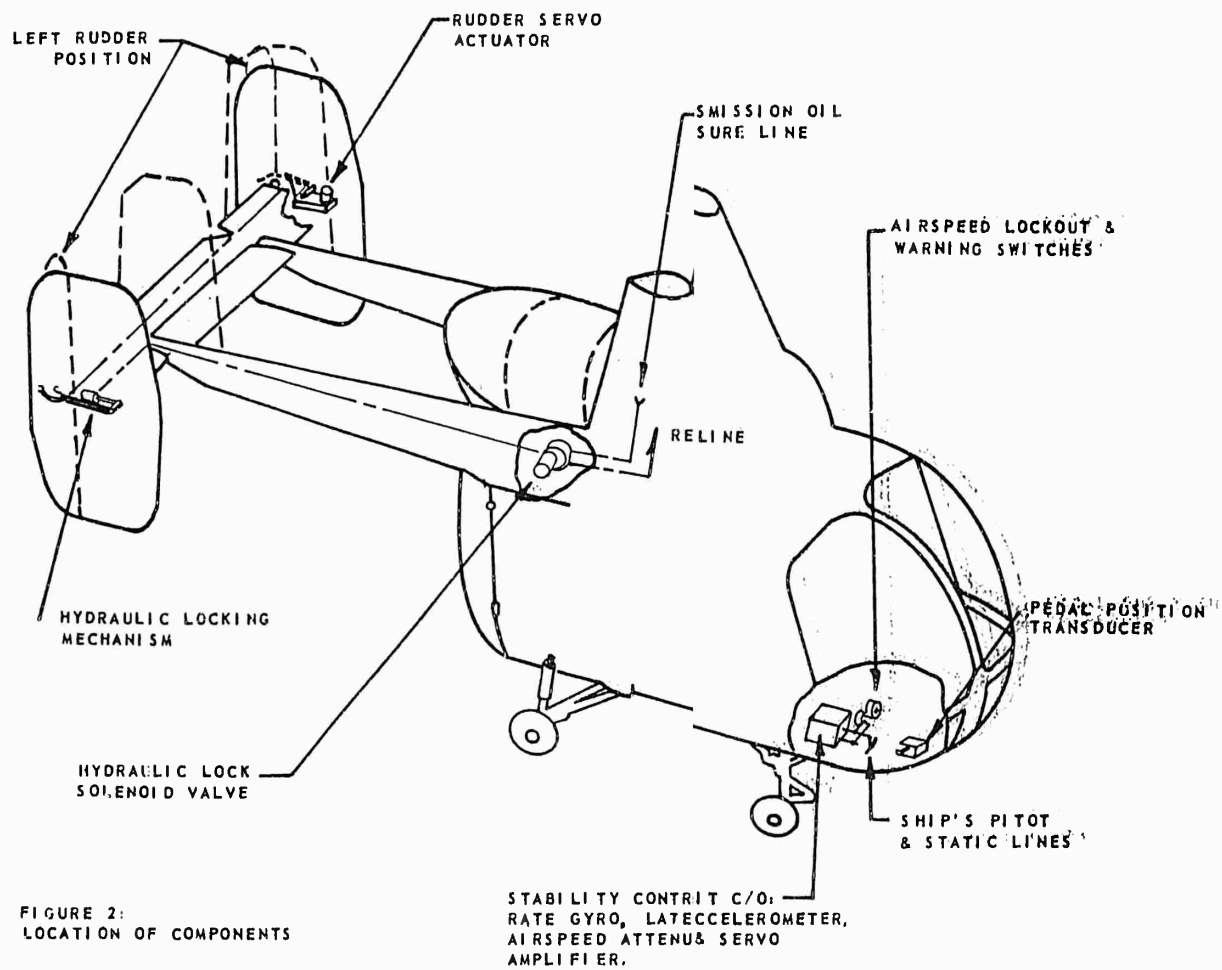

FIGURE 2:  
LOCATION OF COMPONENTS

lateral  
 accel  
 skidding or a  
 non-rod to introduce  
 corron. The function  
 of thecer (gyro) is to  
 sensenroduce damping  
 action to improve the  
 dynanthe yaw axis.

tioned by a servo  
 actua; a signal from  
 the stement of the  
 pedalidition, will  
 transi "stability control  
 unit. 'ontrol unit"  
 transignal to the  
 actuate rudders. This  
 modifselly proportional  
 to thee higher the air-  
 speeders will move for  
 a givence rudder  
 effecth airspeed, the

airspeed voltage attenuator is used to  
 reduce the effectiveness of the  
 accelerometer and the pedal transducer.  
 There is no mechanical linkage between  
 the rudder pedals and the rudders. The  
 DSAS becomes inoperative above  
 approximately 80 knots IAS and the rudders  
 will be automatically (pressure switches)  
 hydraulically and electrically locked in  
 the neutral position. In the event of an  
 electrical failure, the rudders will also  
 be locked in the neutral position.

#### ORIGINAL TAIL

The original H-43B tail assembly is  
 mounted on two booms extending aft from  
 the fuselage. The tail assembly is free  
 floating and consists of two inboard  
 vertical stabilizers (dorsal fins) and two  
 outboard rudders. The outboard rudders  
 are mounted on a horizontal stabilizer

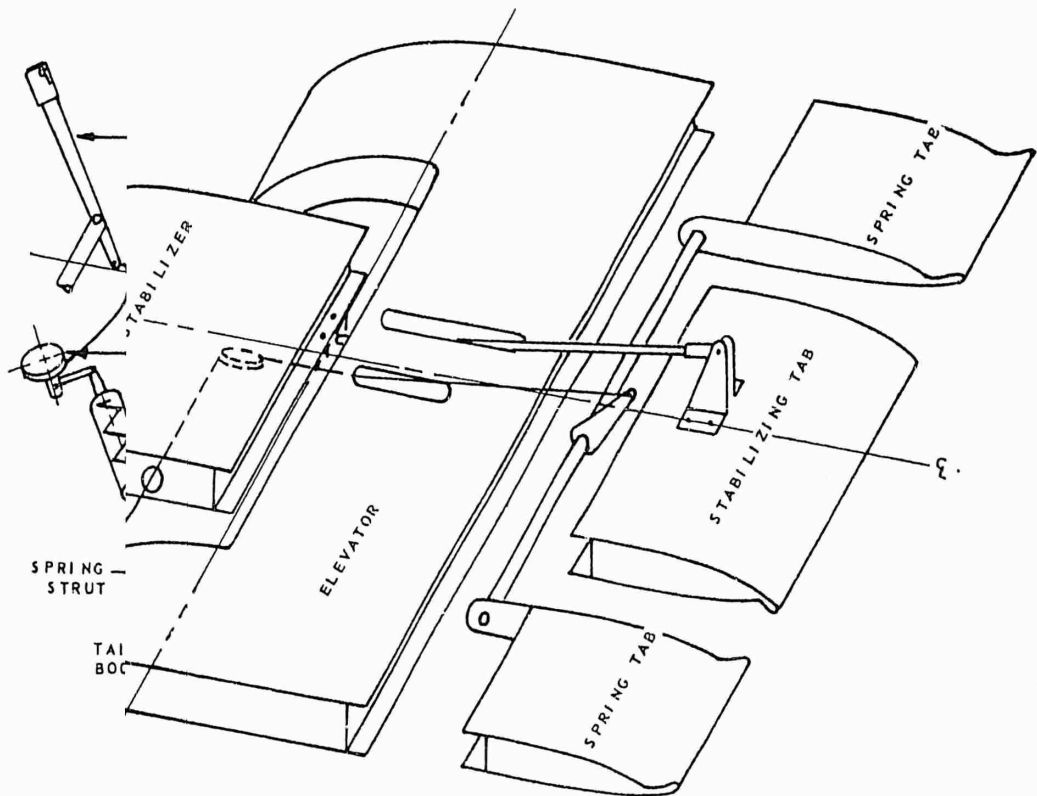

ORIGINAL TAIL CONFIGURATION

which is attached to the booms. The arrangements of the surfaces and their dimensions are shown in the accompanying photograph and drawing. The upper 12 inches of each vertical surface is constructed of frangible material to minimize damage should blade to tail interference occur. All surfaces other than the frangible tips are constructed of sheet aluminum. The horizontal stabilizer moves up and down through a total travel of 20 degrees. The stabilizer movement cannot be controlled directly from the cockpit. The position and movement is controlled by the aerodynamic forces contributed by the various surfaces.

Movement of the collective stick moves two spring tabs on the horizontal tail which control the position of the floating tail assembly. The trailing edge of the horizontal stabilizer is divided spanwise into three sections; the center section, or stabilizing tab, and two outboard sections, or spring tabs. The position of the center tab is determined

by deflection of the elevator with respect to the aircraft and by ground adjustment of the tab. The system linkage is such that deflection of the elevator rotates the tab. The stabilizing tab trailing edge is deflected downward 18 degrees and is generally deflected trailing edge down with respect to the main surface. The outboard spring tabs are linked to the collective pitch through a spring. The trailing edge of these outboard tabs is deflected upward 15 degrees, and with respect to the main surface the tabs are always deflected upward. When an increase in collective pitch is applied the reaction to the increased torque causes the nose to pitch up. To counteract this force, upward movement of the collective pitch also moves the tabs on the horizontal stabilizer causing the stabilizer to increase its angle of incidence since it is free floating. This increased angle of incidence applies a nose down moment on the aircraft to counteract the torque reaction. This application is reversed with downward

#### ORIGINAL EMPENNAGE CONFIGURATION



movement of the collective pitch stick when entering autorotation. Since these tabs are spring loaded, they deflect as a function of airspeed against the spring, which may be pre-loaded to any desired value at zero airspeed conditions.

#### MODIFIED TAIL

To provide additional blade to tail clearance, the inboard fins (dorsal fins) were removed and the vertical height of the outboard stabilizers were decreased

#### MODIFIED EMPENNAGE CONFIGURATION

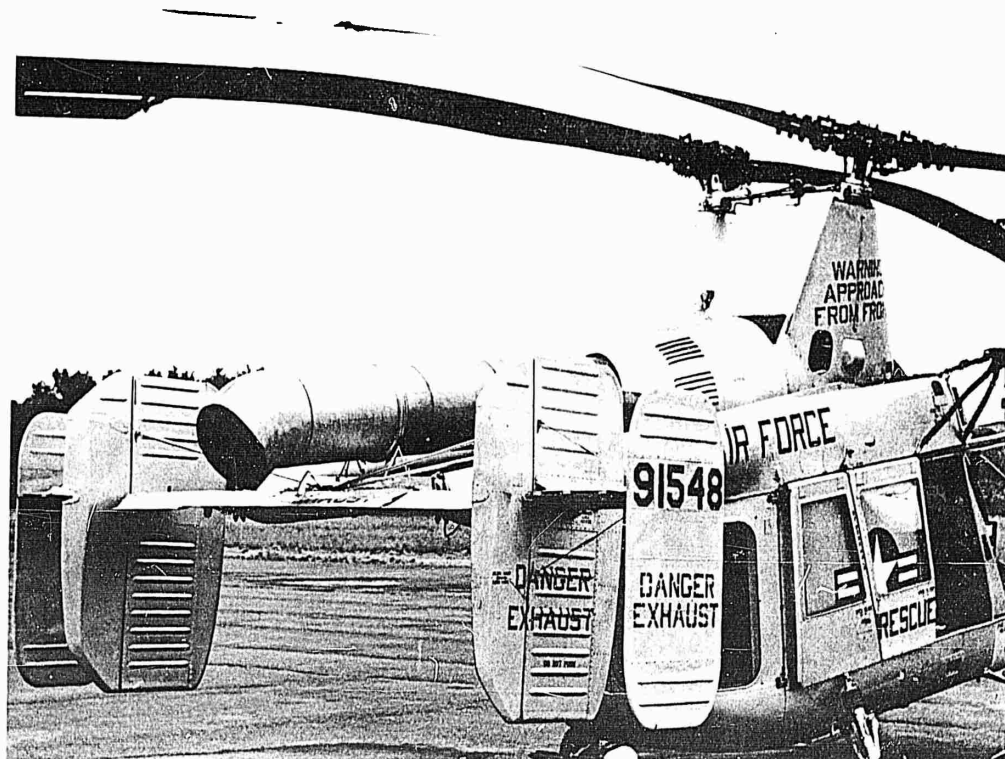

14 inches. Additional vertical stabilizers were mounted outboard of the original rudders in order to prevent deterioration of the directional flying qualities. The modified tail configuration is shown in the following figure.

As can be seen, additional horizontal surfaces were added on either side of the rudders. In addition, the upper and lower 10 inches of each vertical surface

is constructed of fiberglass material to minimize damage in the event of blade to tail interference or a low tail landing.

The horizontal stabilizer moves up and down through a total travel of 20 degrees and, as on the standard tail, cannot be controlled directly from the cockpit. The position and movement of the tail are controlled by the aerodynamic forces contributed by the various surfaces.

Additional physical differences between the two tails are:

1. The "droop" leading edge (generally for delaying stall) of the floating elevator has been eliminated.
2. A centering bungee has been attached between the tail boom and floating elevator.

In addition, the adjustment was changed on the bungee located between the floating elevator and the outboard tabs. This bungee pulls the tabs to the full down position with full down collective pitch. The overall operation of the modified tail and its contribution to the aircraft stability and control characteristics are the same as for the standard tail.



MODIFIED EMPENNAGE  
SHOWING INCREASED BLADE  
TO TAIL CLEARANCE

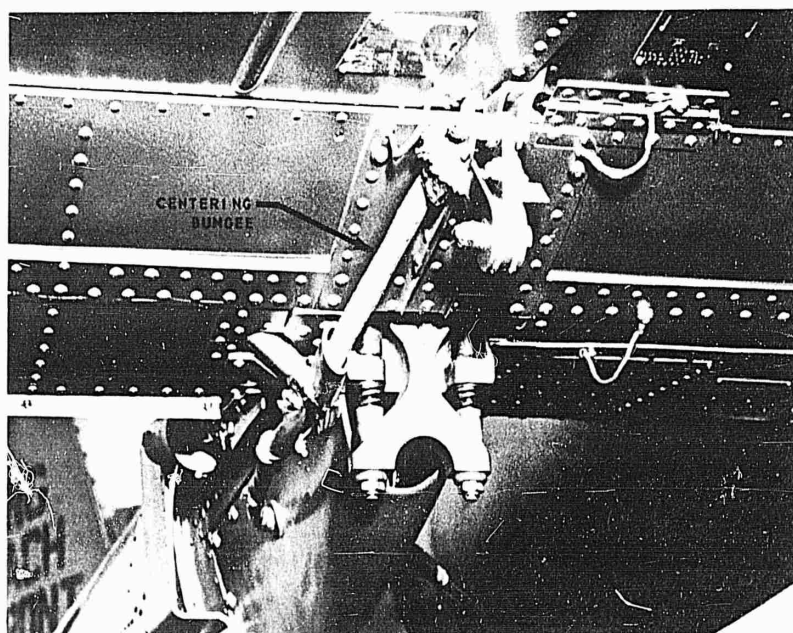

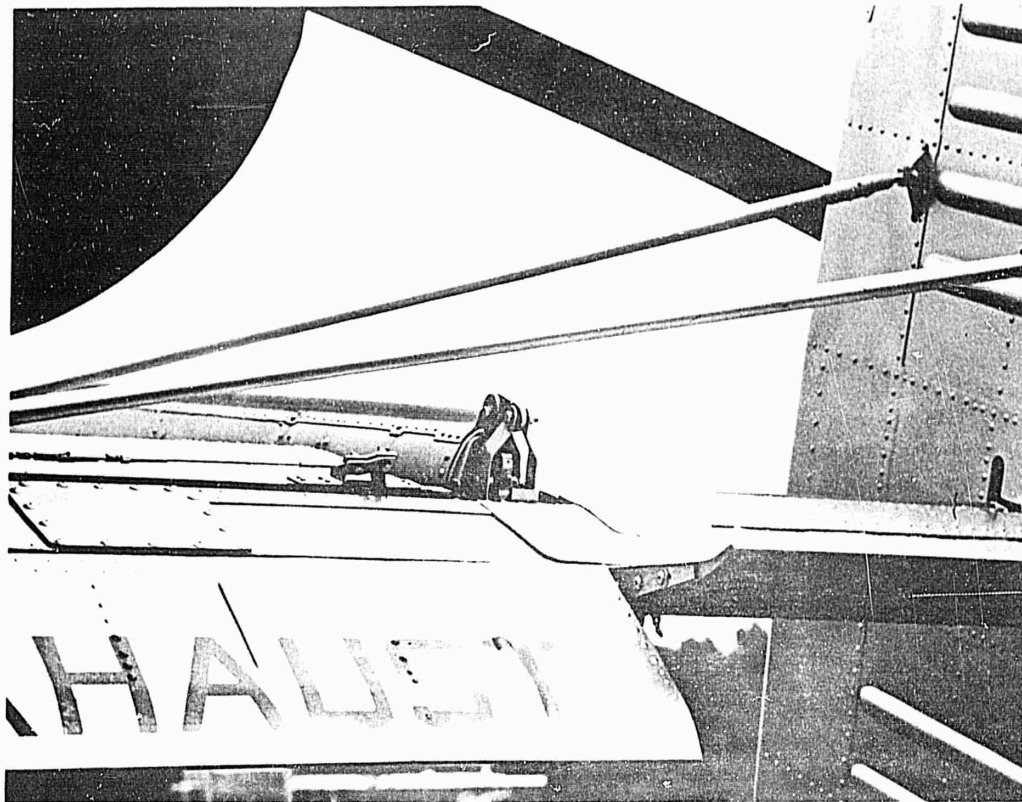

**SPRING TAB POSITION  
WITH COLLECTIVE DOWN**

**SPRING TAB POSITION  
WITH UP COLLECTIVE**

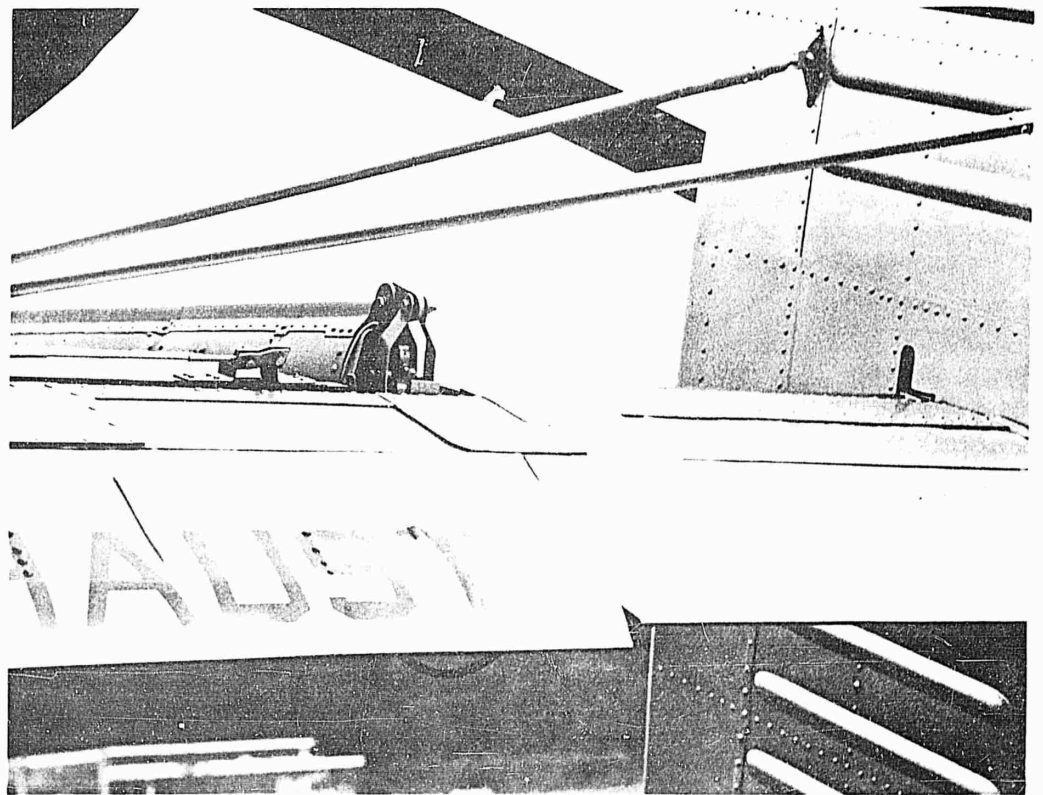

**ASTIA DOCUMENT NO. AD-**

**Air Force Flight Test Center  
Flight Test Engineering Division  
Edwards AFB, California**

H-43B Modified Empennage Evaluation, by Kenneth R. Ferrell, Project Engineer, and Jimmie S. Honaker, Captain, USAF, Project Pilot. 149 Pages. May 1961. Addendum 1 to AFFTC-60-21.

This report presents a comparative evaluation of rotor blade-to-tail clearance and stability and control of the original reproduction H-43B and one with a modified empennage with the vertical stabilizers lowered 14 inches and equipped with 19 inch fiberglass tips.

The modified empennage provides increased blade to vertical tail clearance and makes the possibility of interference very remote. Flying qualities of this helicopter with the modified empennage are acceptable for service use with the directional stability augmentation system (DSAS) operative at the optimum setting utilized.

Vibration levels during high speed level flight and longitudinal stability (static and dynamic) are improved with the modified empennage. During autorotation the static directional stability is poor with the DSAS operative and unsatisfactory with it inoperative. Autorotation is also

**ASTIA DOCUMENT NO. AD-**

**Air Force Flight Test Center  
Flight Test Engineering Division  
Edwards AFB, California**

H-43B Modified Empennage Evaluation, by Kenneth R. Ferrell, Project Engineer, and Jimmie S. Honaker, Captain, USAF, Project Pilot. 149 Pages. May 1961. Addendum 1 to AFFTC-60-21.

This report presents a comparative evaluation of rotor blade-to-tail clearance and stability and control of the original reproduction H-43B and one with a modified empennage with the vertical stabilizers lowered 14 inches and equipped with 19 inch fiberglass tips.

The modified empennage provides increased blade to vertical tail clearance and makes the possibility of interference very remote. Flying qualities of this helicopter with the modified empennage are acceptable for service use with the directional stability augmentation system (DSAS) operative at the optimum setting utilized.

Vibration levels during high speed level flight and longitudinal stability (static and dynamic) are improved with the modified empennage. During autorotation the static directional stability is poor with the DSAS operative and unsatisfactory with it inoperative. Autorotation is also

**ASTIA DOCUMENT NO. AD-**

**Air Force Flight Test Center  
Flight Test Engineering Division  
Edwards AFB, California**

H-43B Modified Empennage Evaluation, by Kenneth R. Ferrell, Project Engineer, and Jimmie S. Honaker, Captain, USAF, Project Pilot. 149 Pages. May 1961. Addendum 1 to AFFTC-60-21.

This report presents a comparative evaluation of rotor blade-to-tail clearance and stability and control of the original reproduction H-43B and one with a modified empennage with the vertical stabilizers lowered 14 inches and equipped with 19 inch fiberglass tips.

The modified empennage provides increased blade to vertical tail clearance and makes the possibility of interference very remote. Flying qualities of this helicopter with the modified empennage are acceptable for service use with the directional stability augmentation system (DSAS) operative at the optimum setting utilized.

Vibration levels during high speed level flight and longitudinal stability (static and dynamic) are improved with the modified empennage. During autorotation the static directional stability is poor with the DSAS operative and unsatisfactory with it inoperative. Autorotation is also

**ASTIA DOCUMENT NO. AD-**

**Air Force Flight Test Center  
Flight Test Engineering Division  
Edwards AFB, California**

H-43B Modified Empennage Evaluation, by Kenneth R. Ferrell, Project Engineer, and Jimmie S. Honaker, Captain, USAF, Project Pilot. 149 Pages. May 1961. Addendum 1 to AFFTC-60-21.

This report presents a comparative evaluation of rotor blade-to-tail clearance and stability and control of the original reproduction H-43B and one with a modified empennage with the vertical stabilizers lowered 14 inches and equipped with 19 inch fiberglass tips.

The modified empennage provides increased blade to vertical tail clearance and makes the possibility of interference very remote. Flying qualities of this helicopter with the modified empennage are acceptable for service use with the directional stability augmentation system (DSAS) operative at the optimum setting utilized.

Vibration levels during high speed level flight and longitudinal stability (static and dynamic) are improved with the modified empennage. During autorotation the static directional stability is poor with the DSAS operative and unsatisfactory with it inoperative. Autorotation is also

accompanied by low lateral and directional control sensitivity and response as well as a large nose down pitching tendency following a throttle chop or a sudden reduction in collective pitch. Additional deficient stability and control areas result from forward speed being restricted by longitudinal cyclic available in level flight.

accompanied by low lateral and directional control sensitivity and response as well as a large nose down pitching tendency following a throttle chop or a sudden reduction in collective pitch. Additional deficient stability and control areas result from forward speed being restricted by longitudinal cyclic available in level flight.

accompanied by low lateral and directional control sensitivity and response as well as a large nose down pitching tendency following a throttle chop or a sudden reduction in collective pitch. Additional deficient stability and control areas result from forward speed being restricted by longitudinal cyclic available in level flight.

accompanied by low lateral and directional control sensitivity and response as well as a large nose down pitching tendency following a throttle chop or a sudden reduction in collective pitch. Additional deficient stability and control areas result from forward speed being restricted by longitudinal cyclic available in level flight.

**ASTIA DOCUMENT NO. AD-**

**Air Force Flight Test Center  
Flight Test Engineering Division  
Edwards AFB, California**

H-43B Modified Empennage Evaluation, by Kenneth R. Ferrell, Project Engineer, and Jimmie S. Honaker, Captain, USAF, Project Pilot. 149 Pages. May 1961. Addendum 1 to AFFTC-60-21.

This report presents a comparative evaluation of rotor blade-to-tail clearance and stability and control of the original reproduction H-43B and one with a modified empennage with the vertical stabilizers lowered 14 inches and equipped with 19 inch fiberglass tips.

The modified empennage provides increased blade to vertical tail clearance and makes the possibility of interference very remote. Flying qualities of this helicopter with the modified empennage are acceptable for service use with the directional stability augmentation system (DSAS) operative at the optimum setting utilized.

Vibration levels during high speed level flight and longitudinal stability (static and dynamic) are improved with the modified empennage. During autorotation the static directional stability is poor with the DSAS operative and unsatisfactory with it inoperative. Autorotation is also

**ASTIA DOCUMENT NO. AD-**

**Air Force Flight Test Center  
Flight Test Engineering Division  
Edwards AFB, California**

H-43B Modified Empennage Evaluation, by Kenneth R. Ferrell, Project Engineer, and Jimmie S. Honaker, Captain, USAF, Project Pilot. 149 Pages. May 1961. Addendum 1 to AFFTC-60-21.

This report presents a comparative evaluation of rotor blade-to-tail clearance and stability and control of the original reproduction H-43B and one with a modified empennage with the vertical stabilizers lowered 14 inches and equipped with 19 inch fiberglass tips.

The modified empennage provides increased blade to vertical tail clearance and makes the possibility of interference very remote. Flying qualities of this helicopter with the modified empennage are acceptable for service use with the directional stability augmentation system (DSAS) operative at the optimum setting utilized.

Vibration levels during high speed level flight and longitudinal stability (static and dynamic) are improved with the modified empennage. During autorotation the static directional stability is poor with the DSAS operative and unsatisfactory with it inoperative. Autorotation is also

**ASTIA DOCUMENT NO. AD-**

**Air Force Flight Test Center  
Flight Test Engineering Division  
Edwards AFB, California**

H-43B Modified Empennage Evaluation, by Kenneth R. Ferrell, Project Engineer, and Jimmie S. Honaker, Captain, USAF, Project Pilot. 149 Pages. May 1961. Addendum 1 to AFFTC-60-21.

This report presents a comparative evaluation of rotor blade-to-tail clearance and stability and control of the original reproduction H-43B and one with a modified empennage with the vertical stabilizers lowered 14 inches and equipped with 19 inch fiberglass tips.

The modified empennage provides increased blade to vertical tail clearance and makes the possibility of interference very remote. Flying qualities of this helicopter with the modified empennage are acceptable for service use with the directional stability augmentation system (DSAS) operative at the optimum setting utilized.

Vibration levels during high speed level flight and longitudinal stability (static and dynamic) are improved with the modified empennage. During autorotation the static directional stability is poor with the DSAS operative and unsatisfactory with it inoperative. Autorotation is also

**ASTIA DOCUMENT NO. AD-**

**Air Force Flight Test Center  
Flight Test Engineering Division  
Edwards AFB, California**

H-43B Modified Empennage Evaluation, by Kenneth R. Ferrell, Project Engineer, and Jimmie S. Honaker, Captain, USAF, Project Pilot. 149 Pages. May 1961. Addendum 1 to AFFTC-60-21.

This report presents a comparative evaluation of rotor blade-to-tail clearance and stability and control of the original reproduction H-43B and one with a modified empennage with the vertical stabilizers lowered 14 inches and equipped with 19 inch fiberglass tips.

The modified empennage provides increased blade to vertical tail clearance and makes the possibility of interference very remote. Flying qualities of this helicopter with the modified empennage are acceptable for service use with the directional stability augmentation system (DSAS) operative at the optimum setting utilized.

Vibration levels during high speed level flight and longitudinal stability (static and dynamic) are improved with the modified empennage. During autorotation the static directional stability is poor with the DSAS operative and unsatisfactory with it inoperative. Autorotation is also

accompanied by low lateral and directional control sensitivity and response as well as a large nose down pitching tendency following a throttle chop or a sudden reduction in collective pitch. Additional deficient stability and control areas result from forward speed being restricted by longitudinal cyclic available in level flight.

accompanied by low lateral and directional control sensitivity and response as well as a large nose down pitching tendency following a throttle chop or a sudden reduction in collective pitch. Additional deficient stability and control areas result from forward speed being restricted by longitudinal cyclic available in level flight.

accompanied by low lateral and directional control sensitivity and response as well as a large nose down pitching tendency following a throttle chop or a sudden reduction in collective pitch. Additional deficient stability and control areas result from forward speed being restricted by longitudinal cyclic available in level flight.

accompanied by low lateral and directional control sensitivity and response as well as a large nose down pitching tendency following a throttle chop or a sudden reduction in collective pitch. Additional deficient stability and control areas result from forward speed being restricted by longitudinal cyclic available in level flight.