

UNCLASSIFIED

AD 264 092

*Reproduced
by the*

ARMED SERVICES TECHNICAL INFORMATION AGENCY
ARLINGTON HALL STATION
ARLINGTON 12, VIRGINIA



UNCLASSIFIED

NOTICE: When government or other drawings, specifications or other data are used for any purpose other than in connection with a definitely related government procurement operation, the U. S. Government thereby incurs no responsibility, nor any obligation whatsoever; and the fact that the Government may have formulated, furnished, or in any way supplied the said drawings, specifications, or other data is not to be regarded by implication or otherwise as in any manner licensing the holder or any other person or corporation, or conveying any rights or permission to manufacture, use or sell any patented invention that may in any way be related thereto.

264 092

PROGRESS REPORT

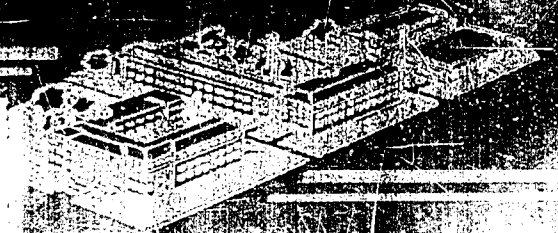
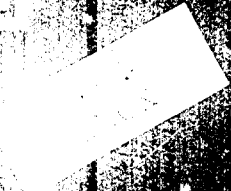
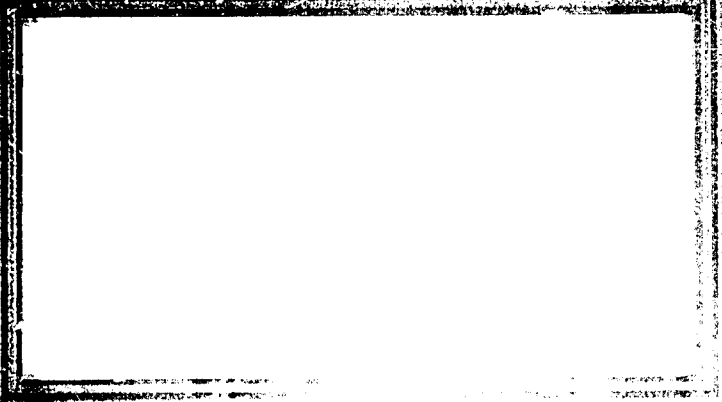

MEMORIAL INSTITUTE

9/64

9815-1622 (53)

1000 15098

Mar 24 53

~~CONFIDENTIAL~~
~~CONFIDENTIAL~~
~~CONFIDENTIAL~~

EIGHTH MONTHLY PROGRESS REPORT

on

A STUDY AND EVALUATION OF LIQUID-
LEVEL AND LIQUID-VOLUME CONTROLS
FOR SHELL-, ROCKET-, AND BOMB-
FILLING MACHINES

ETF 080-15/8
to
Copy 6
ARMY CHEMICAL CENTER

February 27, 1953

Dr. Colonel Franklin
British Liaison Officer
Army Chemical Center, Md.

Contract No. DA 18-108-CML-3965

9 SEP 1953

by

Thomas M. Boland, William H. Peake, Edward G. Thurston,
William Hecox, Roger L. Merrill, and Robert C. McMaster

The information contained herein will not be re-
leased to any other nation without specific approval
of the United States. For the purpose of this pro-
vision, the United Kingdom, the British Dominions,
and India are considered to be separate nations. Ex-
cept that interchange of the technical information
between Canada and the United Kingdom authorized
by the Chemical Corps provided that said information
when released by the United Kingdom to Canada, or
Canada to the United Kingdom, will not be further
released from that nation in any other nation than
Canada or the United Kingdom without the specific
approval of the United States.
The information will be afforded subject to
the same degree of security afforded by the United
States.
The information will not be reported for use
in other than military purposes.
The information will not be reported for use
in the development of nuclear energy.
The information will not be reported for use
in the development of nuclear energy.
The information will not be reported for use
in the development of nuclear energy.

109700

BATTELLE MEMORIAL INSTITUTE
505 King Avenue
Columbus 1, Ohio

ASTIA
SEP 27 1953
MADR A

Reproduced From
Best Available Copy

TECHNICAL LIBRARY
ARMY CHEMICAL CENTER
MARYLAND

wrc 15008

820 776

Battelle Memorial Institute

5 0 5 K I N G A V E N U E C O L U M B U S , O H I O

March 12, 1953

Commanding Officer
Chemical Corps Chemical and
Radiological Laboratories
Army Chemical Center, Maryland

Attention Mr. Curt Hesdoerffer
Project Officer

Dear Sir:

We are enclosing six copies of the Eighth Monthly Progress Report on "A Study and Evaluation of Liquid-Level and Liquid-Volume Controls for Shell-, Rocket-, and Bomb-Filling Machines". This report covers the work period from February 2, to February 27, 1953.

A preliminary analysis of measuring munition-cavity volumes by sonic or ultrasonic methods has been completed and is presented in this report. Further progress on modification of the Annin valve drive mechanism is described, and a device for accomplishing specific-gravity compensation by remote operation is suggested.

Yours very truly,



Thomas M. Boland
Electrical Engineering Division

TMB:mpk
Enc. (6)

R E S E A R C H F O R I N D U S T R Y

TABLE OF CONTENTS

	<u>Page</u>
SUMMARY	1
INTRODUCTION	2
WORK IN PROGRESS	2
Sonic Volume Measurements	2
Cavity-Resonance Method	3
First Method	3
Accuracy and Design Parameters of First Method	6
Second Method	8
Specific-Gravity Compensation	8
Improvement of Annin Valve	10
FUTURE WORK	14

EIGHTH MONTHLY PROGRESS REPORT

on

A STUDY AND EVALUATION OF LIQUID-LEVEL AND
LIQUID-VOLUME CONTROLS FOR SHELL-, ROCKET-,
AND BOMB-FILLING MACHINES

to

ARMY CHEMICAL CENTER

Contract No. DA 18-108-CML-3965

from

BATTELLE MEMORIAL INSTITUTE

by

Thomas M. Boland, William H. Peake, Edward G. Thurston,
William Hecox, Roger L. Merrill, and Robert C. McMaster

February 27, 1953

SUMMARY

In this report, a preliminary analysis of the use of sonic or ultrasonic techniques for the determination of munition-cavity volume is presented. Results of this analysis indicate that a device of this type may be suitable as a check for volume measurements of both empty and filled munitions. Preliminary calculations pertaining to a 2600-ml shell volume are included.

A method of compensation for variations in the specific gravity of the liquid agent is proposed in this report. This device would add or subtract weight to or from the balance arm by a chain attached to the counterweight outrider. Remote control would be provided for the chain-adjusting mechanism.

Further improvements toward better Annin valve performance have also been made during February.

BATTELLE MEMORIAL INSTITUTE

INTRODUCTION

This is the Eighth Monthly Progress Report on "A Study and Evaluation of Liquid-Level and Liquid-Volume Controls for Shell-, Rocket-, and Bomb-Filling Machines", covering the period from February 2, to February 27, 1953.

The research program of this project is directed toward the development of a filling machine that will deposit accurate repeatable volumes of liquid agent into munition of various sizes. The machine being developed weighs this desired amount of agent in an intermediate chamber and then releases the agent into the munition cavity.

WORK IN PROGRESS

The work in progress during the month of February consisted of the following:

1. An evaluation of the use of sonic techniques for cavity-volume measurements as applied to the filling of munitions.
2. Preliminary considerations of a device to compensate for specific-gravity variations in the liquid agent.
3. Improving the operation of the Annin valve-plug positioning mechanism.

Sonic Volume Measurements

During the latter part of January, Mr. Hesdoerffer and Mr. Gruen of the Army Chemical Center visited Battelle. Inspection of the constant-volume filling device was made by them at that time.

It was suggested by them that Battelle perform a preliminary investigation of a method of measuring volumes by sonic or ultrasonic means. The purpose of this process would be to accomplish a volumetric check of filled munitions, thereby determining the per cent of the cavity occupied by the liquid agent. It is required that the volume of void remaining after filling be between 8 and 12 per cent of the total munition cavity.

Cavity-Resonance Method

The purpose of the following analysis is to demonstrate by theory the feasibility of determining the volume of munition cavities by the use of acoustical cavity resonance.⁽¹⁾

Consider a cavity of volume V (see Figure 1), the interior of which is connected to the air of density ρ by a tube of length " ℓ " and cross-sectional area " S ". The plug of air in the tube, of acoustic inertance $\rho\ell/S$, (where ℓ is the effective tube length and is some function of the actual tube length, its radius, and the conditions of termination) vibrates under the action of a restoring force of acoustic compliance $\frac{V}{\rho c^2}$ (where c is the velocity of sound) due to the compressibility of the air within the cavity. The resonant frequency of the cavity is then $f_0 = \frac{c}{2\pi} \sqrt{\frac{S}{\ell^2 V}}$. The Q factor of the cavity at resonance is defined to be $Q = \frac{2\pi f_0}{R} \left(\frac{\rho\ell'}{S} \right)$ where R , the radiation resistance of the orifice, will probably lie between the value $R = \frac{\rho c k^2}{2\pi}$ for a simple source mounted in an infinite baffle and the value $R = \frac{\rho c k^2}{4\pi}$ for an isolated simple source, where $K = \frac{2\pi}{\lambda}$.

First Method. The simplest way of using the cavity resonance to measure volume is shown in Figure 2. The cavity is closed by tube of known dimension, the mouth of which is excited by a nearby loudspeaker driven at constant amplitude by a variable-frequency oscillator. A microphone, suspended within the cavity, indicates the internal sound pressure and thus indicates the condition of resonance.

Another approach which should be investigated is to use the change of electrical impedance experienced by the driving speaker at resonance as an indication of this condition. This would eliminate the need for an additional probe microphone and is often done in other applications. Unfortunately, only experiment will determine realistically the acceptability of this method as far as accuracy is concerned, since the sharpness of such an indication

⁽¹⁾ Kinsler and Frey, Fundamentals of Acoustics, Chap. 8, John Wiley and Sons, Inc., New York, 1950.

Circular tube of area "S"

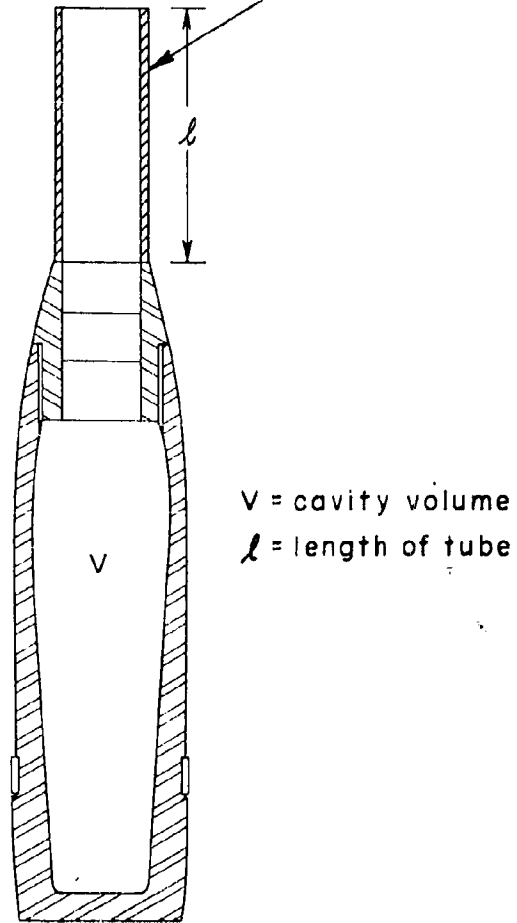

FIGURE I. CAVITY - RESONANCE METHOD OF VOLUME DETERMINATION

A - 5038

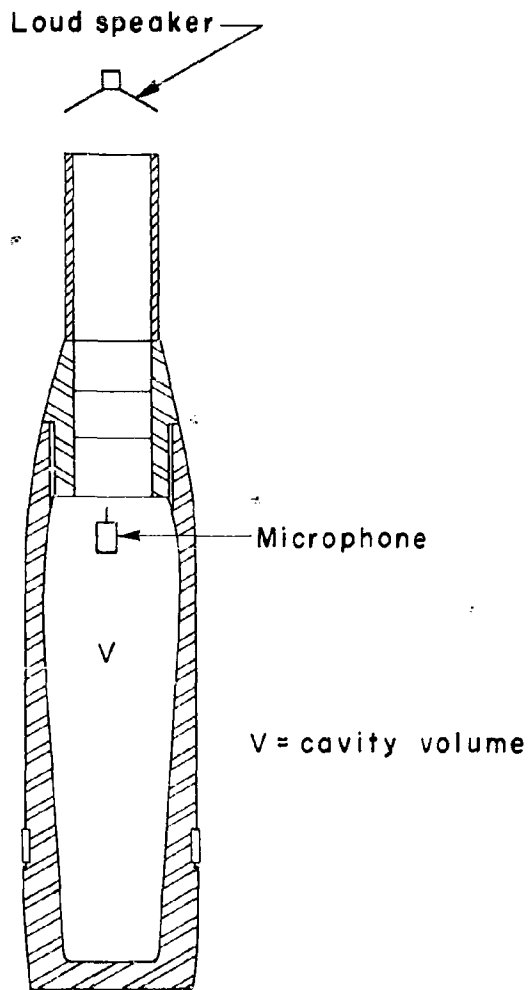

FIGURE 2. FIRST METHOD OF RESONANCE DETECTION

A - 5039

would be somewhat affected by the internal losses of the driver in a manner which is not readily amenable to simple analysis.

Accuracy and Design Parameters of First Method. The basic equations for the cavity

$$f_o = \frac{c}{2\pi} \sqrt{\frac{S}{\lambda'^2 V}} \quad (1)$$

$$Q = 2\pi \sqrt{\frac{(\lambda')^3 V}{S^3}} \quad (2)$$

in which the radiation resistance has been taken as $\frac{\rho c k^2}{2\pi}$ can be combined to give

$$f_o = \frac{c}{(4\pi^2 V Q)^{1/3}} \quad (3)$$

$$Q = \left(\frac{1}{2\pi}\right)^2 \left(\frac{c}{f_o}\right)^3 \frac{1}{V} \quad (4)$$

$$\frac{S}{\lambda'^2} = V \left(\frac{2\pi f_o}{c}\right)^2 \quad (5)$$

from which it is clear from Equation 4 that once the volume V is fixed, by the nature of the cavity to be measured, and if the Q is determined by the accuracy requirements as explained below, the resonant frequency is necessarily determined. Furthermore, when the volumes of resonant frequency are thus chosen, then the ratio $\frac{S}{\lambda'}$ is uniquely determined. Figure 3 gives illustrative design curves for $V = 2600$ cc.

The accuracy with which the frequency must be measured in order that the volume may be known to $\frac{dV}{V}$ is $\frac{df}{f} = -\frac{1}{2} \frac{dV}{V}$, i.e., the fractional error in volume.

Now a conservative criterion for determining resonance by frequency measurements is that $\frac{df}{f} = \frac{1}{Q}$ so that $\frac{dV}{V} = -\frac{2}{Q}$.

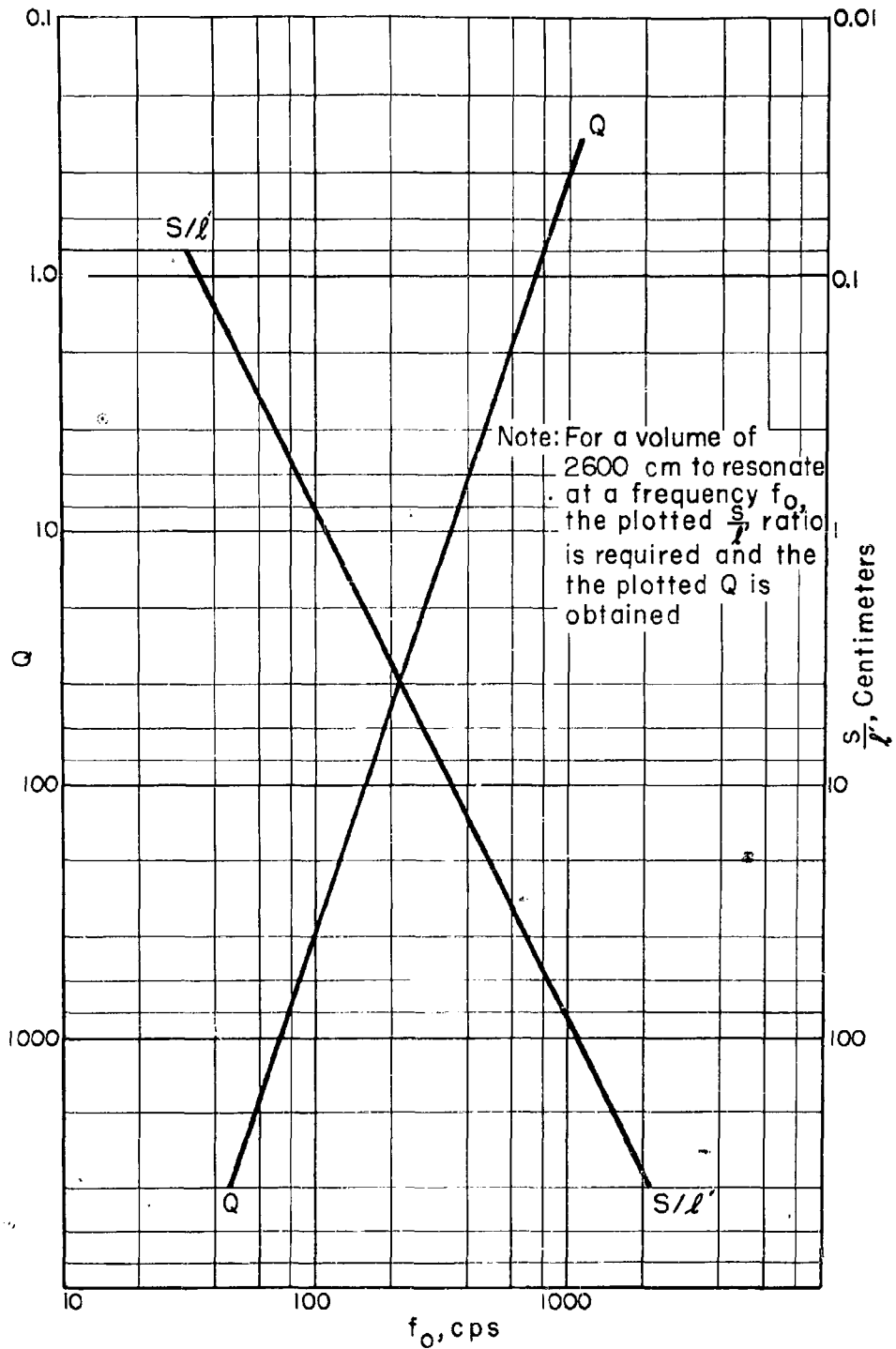

FIGURE 3. DESIGN CURVES FOR $V=2600 \text{ cc}$

C-5040

As a practical illustration, if $\frac{dV}{V}$ is to be 2 per cent, then Q must be around 100 if the volume to be measured is about 2600 cc. The curves of Figure 3 indicate that the required accuracy will be achieved for a frequency $f_0 \leq 157$ cps and a tube having $\frac{S}{\lambda} \leq 2.05$. This indicates that such an accuracy should be possible practically.

Second Method. A second method of using the cavity resonance as a measure of volume is shown in Figure 4. Sound of frequency f_0 is transmitted down a pipe of cross-sectional area A to which the cavity is attached by a tube of effective length λ' and cross section S. At the resonant frequency of the cavity, as given in the previous section, nearly all power is reflected back up the pipe, and the power transmitted to the receiver becomes nearly zero. It can be shown that in this case⁽¹⁾ the Q factor is, approximately, for $Q \gg 1$,

$$Q = \frac{Ac}{\pi f_0 V} = 2A \sqrt{\frac{\lambda'}{VS}}$$

where, as before,

$$f_0 = \frac{c}{2\pi} \sqrt{\frac{S}{\lambda'V}}$$

Clearly, for fixed A, an increase in Q will require a decrease in f_0 .

If, as before, the volume is to be accurate to 2 per cent, i.e., the Q is to be >100 , then the frequency cannot be greater than $f_0 = .0417 A$ (where A is in sq cm). For any reasonable size of pipe, (say $A < 400 \text{ cm}^2$), the difficulty of measuring frequencies of a few cycles per second with an accuracy of one per cent make this method decidedly less interesting than the first.

Specific-Gravity Compensation

Mr. Hesdoerffer also suggested during his visit that methods of compensation for specific-gravity changes of the agent be investigated, and, if time permits, to incorporate such a device into the filling machine.

(1) Kinsler and Frey, loc cit.

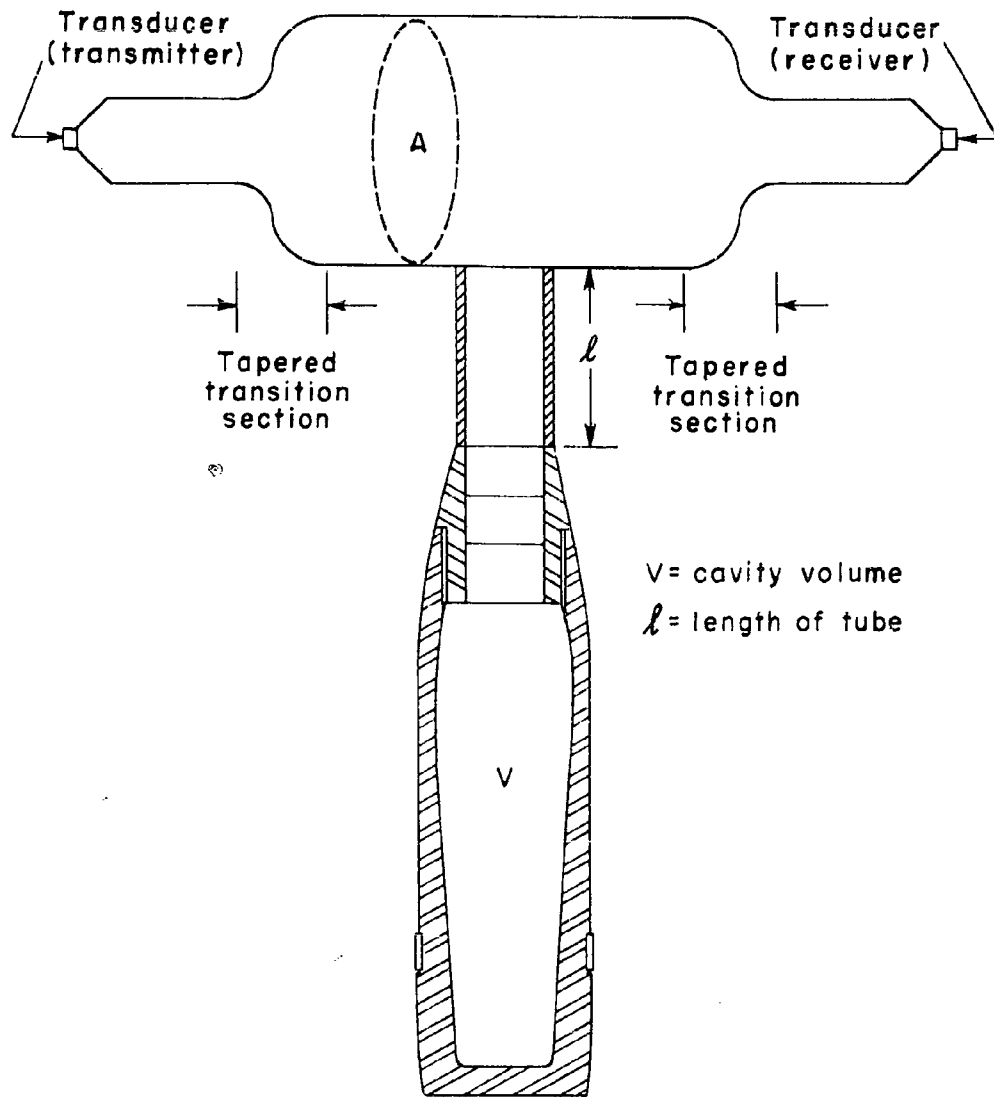

FIGURE 4. SECOND METHOD OF DETERMINING RESONANCE

A-5041

A compensating device is required because the liquid agent is supplied in batch quantities. The specific-gravity variance from batch to batch is from 1.07 to 1.08 grams per cc.

Two methods for accomplishing a correction for this variance were discussed during Mr. Hesdoerffer's visit:

1. Compensation could be achieved by mounting a motor-driven traveling poise on the Shadograph balance arm. Following the determination of the specific gravity of a given batch, the poise could be remotely positioned according to previous calibration.

2. Compensation might also be obtained by mounting on the balance arm a chain as shown in Figure 5. The length of chain in suspension is varied by the rotation of the motor-driven drum on which the chain is wound.

By the use of two selsyns, remote indication is available. The transmitter selsyn is mounted on the chain drum shaft; the receiver selsyn and calibration indicator at the location of the motor-control station. Thus, instantaneous indication of chain weight applied on the balance is available to the operator of the motor-driven chain drum.

With selsyn indicators, it is necessary that the total arc travelled by the transmitter-selsyn shaft be less than 360°. With the selsyn mounted in common with the chain drum shaft, the chain drum's travel is thereby limited to 360°. With this in mind, the following calculations were made:

Maximum specific-gravity variation -- .01 g/cc
For 2600 ml: total maximum variation is $2600 \times .01 = 26$ grams

By using chain whose weight is 4 grams per inch, a maximum of 6.5 inches of chain would be required to hang from the balance. The total to be wound on the drum would be 13 inches. Thus:

Drum circumference = 13 inches
Drum diameter = $13/\pi = 4.1$ inch

The chain could be attached directly to the counterweight outrider.

Improvement of Annin Valve

Because the torque required to operate the original Annin valve and gear train was nearly as large as the output torque of the servomotor, it was necessary that friction losses be reduced. The first step toward the

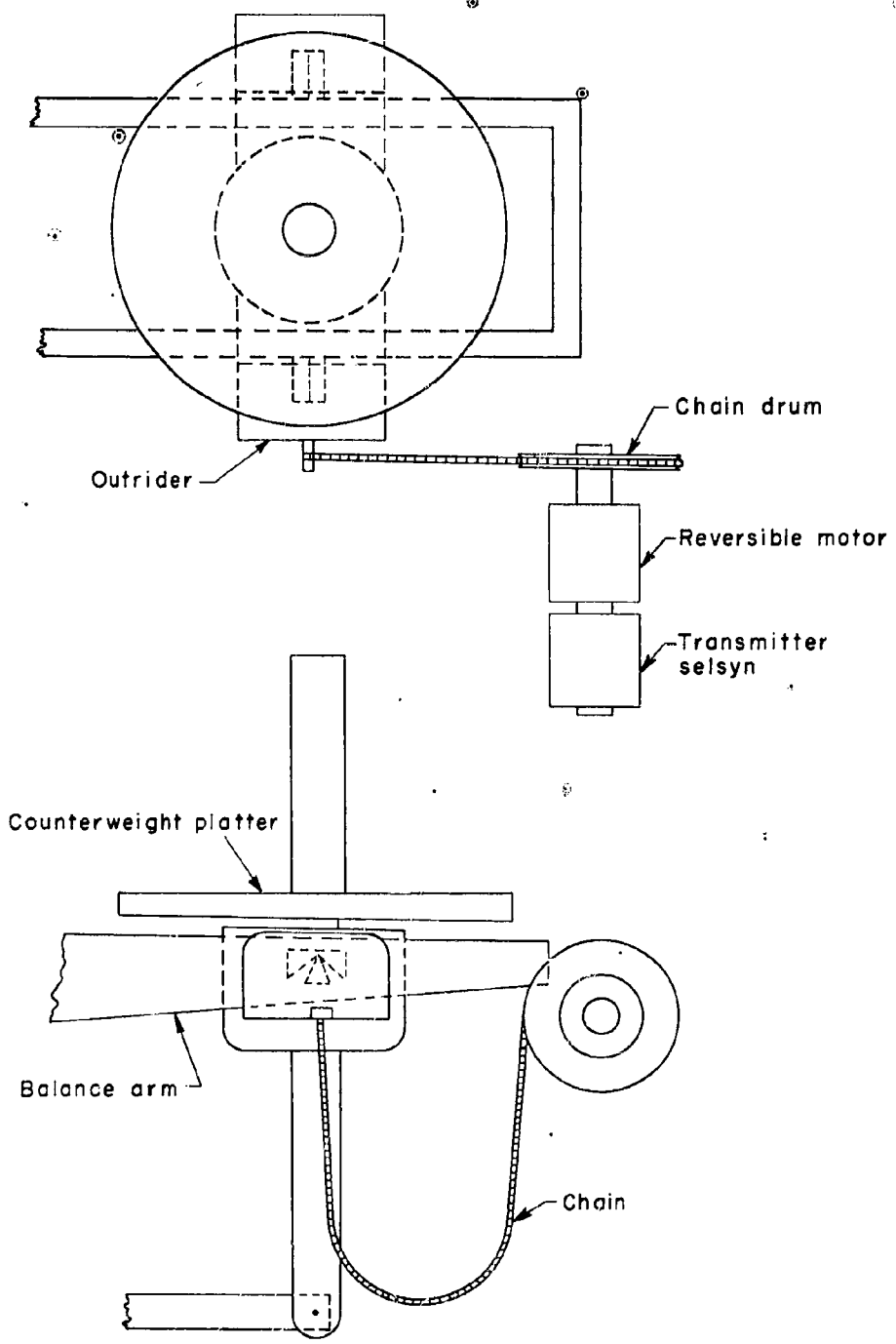

FIGURE 5. TOP AND SIDE VIEWS OF CHAIN-TYPE SPECIFIC GRAVITY COMPENSATION DEVICE

A-5042

reduction of these losses was the aligning of the servomotor-drive mechanism as described in the previous report. This included alignment of the servomotor, gear reduction unit, and rate generator.

Tests run following this improvement showed that revamping of the valve-drive parts was also necessary. A section drawing of the improved valve is shown in Figure 6.

Friction between the shaft coupling the valve plug to the gear box and the valve yoke was the source of most of the drag on the servomotor. Ball bearings were introduced as shown to alleviate this condition.

Further improvements were made in the following areas:

1. New threads were provided for positioning of the valve plug.
2. A more rigid construction was incorporated to prohibit the turning of the valve plug as it was moved.
3. The valve differential-transformer mounting was reworked, and it now provides more accurate positioning to the core and coils of this transformer.

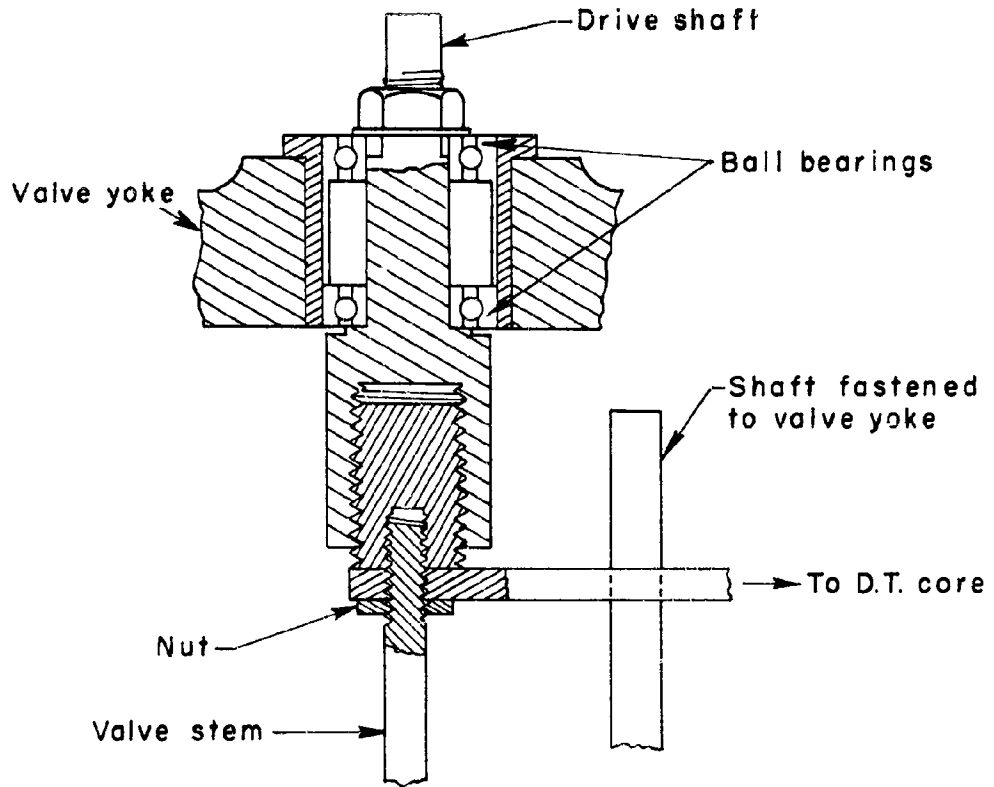

FIGURE 6. SECTIONAL VIEW OF ANNIN VALVE DRIVE MECHANISM

A - 5043

FUTURE WORK

Future work will include:

1. Tests on the modified filling machines leading toward improvement of accuracy and control.
2. Addition of leaf springs for making the scale "stiffer", the more the lever arm is unbalanced. This, it is hoped, will reduce overfilling and permit more accurate fill control.
3. Increasing the voltage gain of the servo amplifier. This also will improve control and accuracy.

TMB:WHP:EGT:WH:RLM:RCM/mpk
March 9, 1953

UNCLASSIFIED

UNCLASSIFIED