

UNCLASSIFIED

AD 264 093

*Reproduced
by the*

ARMED SERVICES TECHNICAL INFORMATION AGENCY
ARLINGTON HALL STATION
ARLINGTON 12, VIRGINIA



UNCLASSIFIED

NOTICE: When government or other drawings, specifications or other data are used for any purpose other than in connection with a definitely related government procurement operation, the U. S. Government thereby incurs no responsibility, nor any obligation whatsoever; and the fact that the Government may have formulated, furnished, or in any way supplied the said drawings, specifications, or other data is not to be regarded by implication or otherwise as in any manner licensing the holder or any other person or corporation, or conveying any rights or permission to manufacture, use or sell any patented invention that may in any way be related thereto.

264 093

XEROX

* 1.60

RH

APR 20 1953

ORIGINAL MAY 1953
HEADQUARTERS

NINTH MONTHLY PROGRESS REPORT

on

A STUDY AND EVALUATION OF LIQUID-
LEVEL AND LIQUID-VOLUME CONTROLS
FOR SHELL-, ROCKET-, AND BOMB-
FILLING MACHINES

to

ARMY CHEMICAL CENTER

ETF 080 - 15/9 Copy 6
March 31, 1953

Contract No. DA 18-108-CML-3965

by

Thomas M. Boland, William Hecox,
Roger L. Merrill, and Robert C. McMaster

BATTELLE MEMORIAL INSTITUTE
505 King Avenue
Columbus 1, Ohio

TECHNICAL LIBRARY
ARMY CHEMICAL CENTER
COLUMBUS, OHIO

TABLE OF CONTENTS

	<u>Page</u>
SUMMARY	1
INTRODUCTION	2
WORK IN PROGRESS	2
"Rate" Circuit Control	2
Addition of Leaf Springs	4
Filling-System Accuracy Tests	4
Redesign of Chamber Release Valve	6
FUTURE WORK.	8

NINTH MONTHLY PROGRESS REPORT

on

A STUDY AND EVALUATION OF LIQUID-LEVEL AND
LIQUID-VOLUME CONTROLS FOR SHELL-, ROCKET-,
AND BOMB-FILLING MACHINES

to

ARMY CHEMICAL CENTER

Contract No. DA 18-108-CML-3965

from

BATTELLE MEMORIAL INSTITUTE

by

Thomas M. Boland, William Hecox,
Roger L. Merrill, and Robert C. McMaster

March 31, 1953

SUMMARY

In this report, the latest improvements added to the weigh filler are described. These involve a new circuit, and also a device which positions leaf springs so that they engage the Shadograph lever arm as it moves away from balance.

Tests of the filling system made following the addition of these improvements showed that its accuracy was better than one per cent for 500-gram fill and also for 1000-gram fill. Results of these checks are included in this report.

Drawings of the redesigned chamber release valve are presented.

**Reproduced From
Best Available Copy**

BATTELLE MEMORIAL INSTITUTE

INTRODUCTION

This is the Ninth Monthly Progress Report on "A Study and Evaluation of Liquid-Level and Liquid-Volume Controls for Shell-, Rocket-, and Bomb-Filling Machines", covering the work period from March 2 to March 31, 1953.

The major effort of this research program is directed toward the development of a munition-filling device which fills the munitions with a constant volume of liquid agent. The filling machine being built at Battelle weighs this given amount of agent in an intermediate chamber and then releases the agent into the munition.

WORK IN PROGRESS

The work in progress during March consisted of:

1. Addition of a "Rate" circuit which improves the control of the servomotor drive.
2. Attaching various leaf springs to the Shadograph frame, thereby reducing the balance arm deflection when the weigh chamber is empty.
3. Testing the accuracy of the volume weigh filler following the inclusion of the above improvements.
4. Redesigning and constructing the chamber release valve.

"Rate" Circuit Control

To increase the response speed of the servomotor driving the Annin valve, a "Rate" circuit was added to the servo-amplifier input. The diagram of the "Rate" circuit is shown in Figure 1.

The rate generator consists of a two-winding A-C generator, the windings of which are equal, except that they are physically displaced by 90°. One winding is excited by 6.3 volts, and the other is connected in series with the secondaries of the two differential transformers.

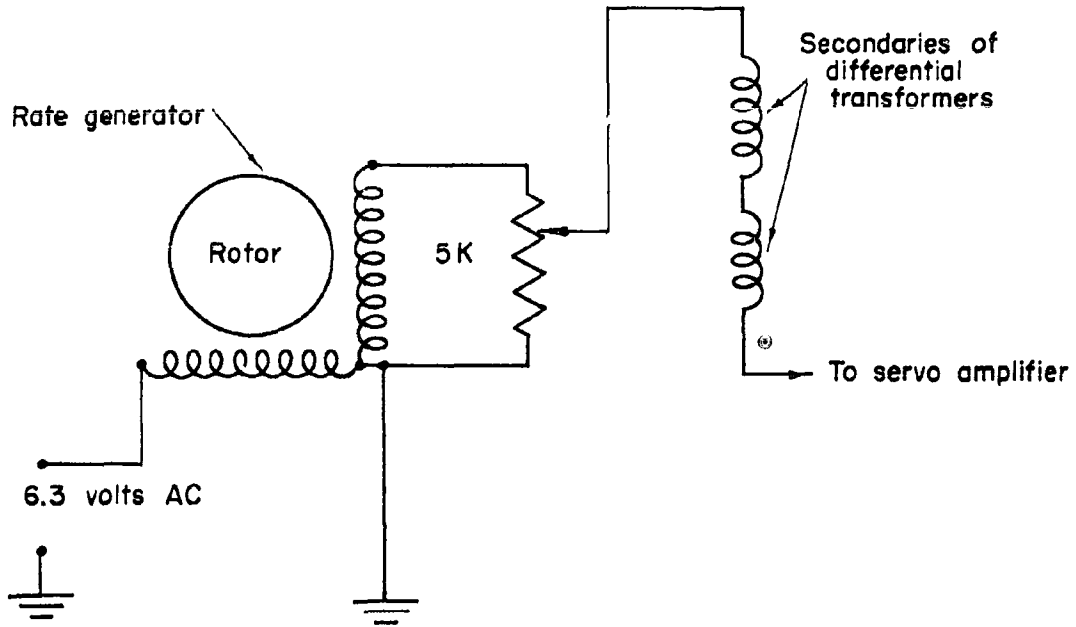

FIGURE 1. "RATE" CIRCUIT
A-5166

The rotor of the rate generator is coupled directly on the servomotor shaft.

The operation of the rate generator is as follows: The voltage generated by its winding in series with the differential transformers is proportional to the rotor speed. This voltage is connected in such a manner as to oppose the velocity that generates it. Thus, the faster the servomotor runs, the greater the damping voltage becomes, and the servo system, in this manner, may be brought to balanced condition (zero input to the servo amplifier) more rapidly. When the servomotor slows down as null is approached, the rate voltage drops also.

The advantages of this circuit are:

1. More rapid response, that is, the servomotor drives the valve to balanced position more rapidly.
2. Smoother control. A smaller voltage unbalance of the two differential transformers drives the servomotor.

3. Oscillation of the servomotor is overcome. The servomotor will not now be driven too far in one direction, then too far in the other. Rather it will operate only as fast as is required to keep the system balanced.

Addition of Leaf Springs

As another method of increasing fill accuracy and control, a device for holding leaf springs was fixed to the Shadograph base as illustrated in Figure 2.

These leaf springs are mounted so that they are not in contact with the lever arm at the balance position. Thus, accuracy of the Shadograph at balance is not affected.

As the lever arm moves away from balance, the leaf spring engages the outrider. This makes the scale system "stiffer", that is, the deflection of the lever arm is reduced for a given amount of weight unbalance.

The leaf springs are mounted so that their vertical position may be varied, thereby allowing adjustment of the space between the outrider and leaf spring at balance.

Since the balance-arm deflection is now reduced, the voltage output of the scale differential transformer is also reduced for a given amount of weight unbalance. The servomotor speed is thus kept more constant, because the change in error voltage is slower until the region of balance is approached.

Filling-System Accuracy Tests

After the installation of the "Rate" circuit and the leaf springs, accuracy tests were run on the filling system. Following are the data of these tests:

Weight required for balance (chamber empty) - 1570 grams.

Fluid used as agent simulant - water.

Length of leaf spring - 1.625 in.

Leaf-spring cross section - .021" x 1".

Leaf spring adjusted to engage outrider at 3 grams off balance (under).

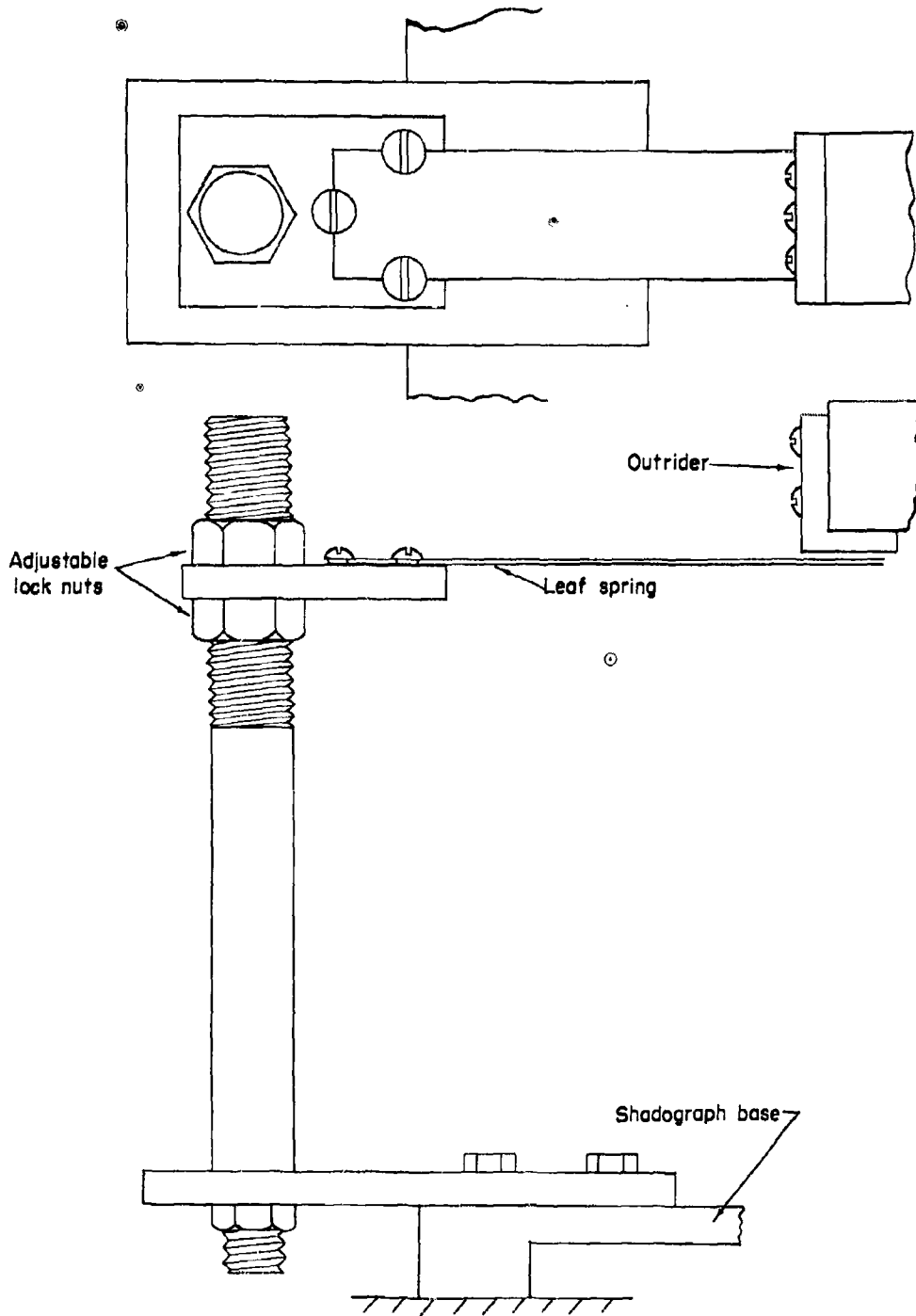

FIGURE 2. LEAF SPRING POSITIONER

A-5167

<u>Fill Desired, grams</u>	<u>Fill Weight, grams</u>	<u>Fill Desired, grams</u>	<u>Fill Weight, grams</u>
500	500.5	1000	1000.6
⊙	501.6		1001.2
	500.0		1000.8
	496.5		1001.0
	500.8		999.0
	496.2		1000.1
	500.4		1000.5
	500.0		995.0
	499.0		1000.0
	500.7		999.4
	497.8		1000.0
	500.1		1000.6

The greatest error incurred for the 500-gram fill was 3.8 grams underfill. In per cent, this is

$$\frac{3.8}{500} \times 100 = 0.76\%$$

The greatest error incurred for 1000-gram fill was 5 grams underfill.

$$\frac{5}{1000} \times 100 = 0.5\%$$

These are both under the 1% fill accuracy desired of the liquid-volume filling machine.

Redesign of Chamber Release Valve

The original chamber release valve constructed at Battelle proved unsatisfactory on two counts:

1. Drip-tight cut off was not achieved.
2. Liquid flow rate was too slow.

A second release valve has been built and, in tests undergone thus far, its performance has been acceptable. Tight shutoff has been obtained.

A cross-section drawing and top view of this valve are shown in Figure 3.

One problem with this valve is that the entire liquid load is not discharged from the weigh chamber. It is expected that by some combination

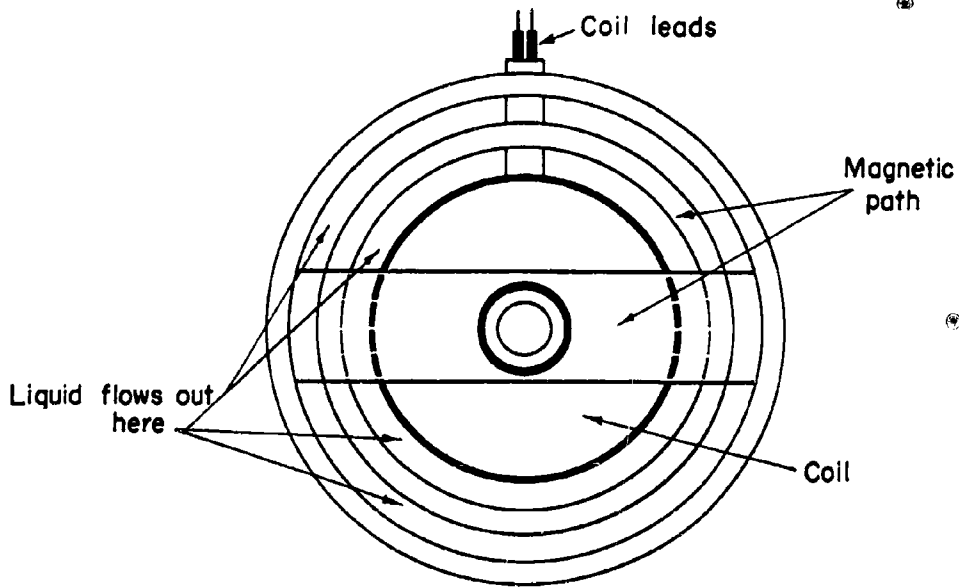
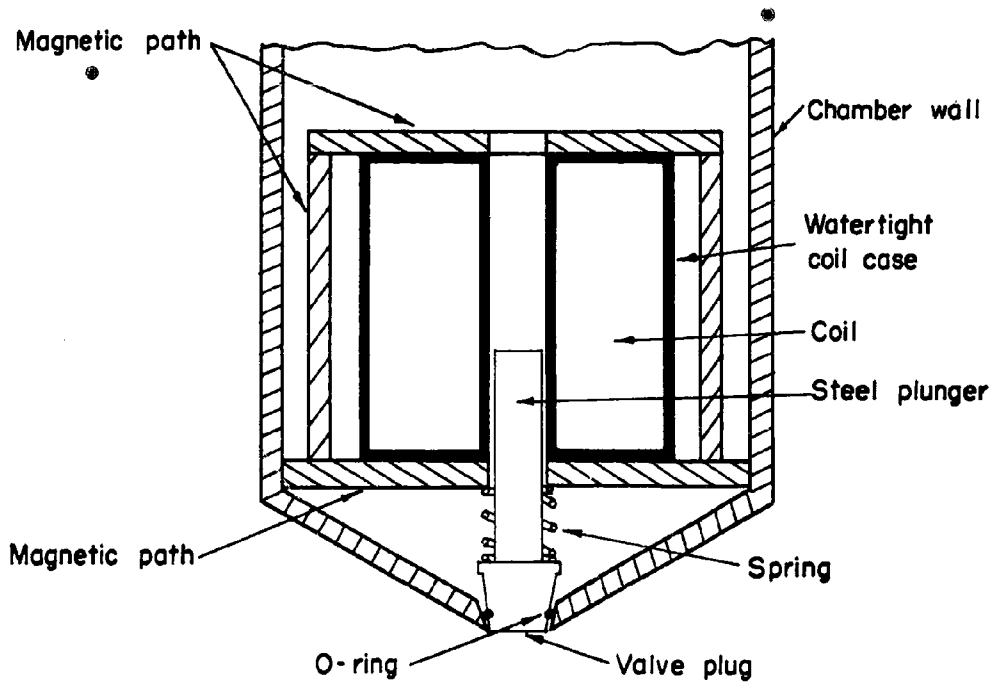

FIGURE 3. REDESIGNED CHAMBER RELEASE VALVE

A-5198

of shields, and/or reshaping of parts, this fault will be eliminated. Rusting of the iron parts of the valve also presents a minor problem.

FUTURE WORK

Further work on the weigh filler will include:

1. Achieving constant emptying of the weigh chamber for each fill.
2. Obtaining other data on fill accuracy, time of filling operation, etc.
3. Continued effort toward improvement of the Annin valve driving mechanism.

It is also expected that work on the level control device will be renewed during April.

TMB:WH:RLM:RCM/bep
April 6, 1953

UNCLASSIFIED

UNCLASSIFIED