

UNCLASSIFIED

---

---

AD 264 095

*Reproduced  
by the*

ARMED SERVICES TECHNICAL INFORMATION AGENCY  
ARLINGTON HALL STATION  
ARLINGTON 12, VIRGINIA



---

---

UNCLASSIFIED

NOTICE: When government or other drawings, specifications or other data are used for any purpose other than in connection with a definitely related government procurement operation, the U. S. Government thereby incurs no responsibility, nor any obligation whatsoever; and the fact that the Government may have formulated, furnished, or in any way supplied the said drawings, specifications, or other data is not to be regarded by implication or otherwise as in any manner licensing the holder or any other person or corporation, or conveying any rights or permission to manufacture, use or sell any patented invention that may in any way be related thereto.

264 095

7

# PROGRESS REPORT

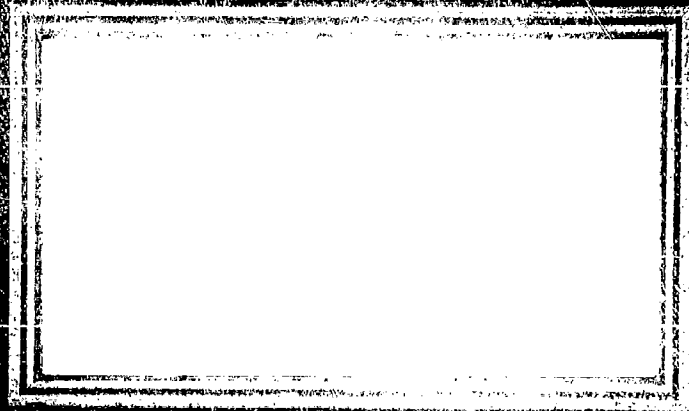

264 095



BATTELLE MEMORIAL INSTITUTE

264 095

Jun 18 1953

ORIGINAL CONTAINS COLOR PLATES: ALL ASTIA  
REPRODUCTIONS WILL BE IN BLACK AND WHITE.  
ORIGINAL MAY BE SEEN IN ASTIA HEADQUARTERS.

ELEVENTH MONTHLY PROGRESS REPORT

on

A STUDY AND EVALUATION OF LIQUID-  
LEVEL AND LIQUID-VOLUME CONTROLS  
FOR SHELL-, ROCKET-, AND BOMB-  
FILLING MACHINES

to  
ETF 080-15/11  
ARMY CHEMICAL CENTER

June 1, 1953 *Copy 6*

Contract No. DA 18-108-CML-3965

by

Thomas M. Boland, William Hecox, E. C. Foudriat,  
Roger L. Merrill, and Robert C. McMaster

109 700  
BATTELLE MEMORIAL INSTITUTE  
505 King Avenue  
Columbus 1, Ohio

ASTIA  
TECHNICAL LIBRARY  
ARMY CHEMICAL CENTER  
MARYLAND

(9)

TABLE OF CONTENTS

	<u>Page</u>
SUMMARY . . . . .	1
INTRODUCTION . . . . .	2
WORK IN PROGRESS . . . . .	2
Weigh-Filler Tests . . . . .	2
Specific-Gravity-Compensation Device . . . . .	3
Liquid-Level Filling System . . . . .	3
Electronic Control Circuit . . . . .	4
Water Filling System . . . . .	4
Probe-Head Design . . . . .	4
FUTURE WORK . . . . .	8

ELEVENTH MONTHLY PROGRESS REPORT

on

A STUDY AND EVALUATION OF LIQUID-LEVEL AND  
LIQUID-VOLUME CONTROLS FOR SHELL-, ROCKET-,  
AND BOMB-FILLING MACHINES

to

ARMY CHEMICAL CENTER

Contract No. DA 18-108-CML-3965

from

BATTELLE MEMORIAL INSTITUTE

by

Thomas M. Boland, William Hecox, E. C. Foudriat,  
Roger L. Merrill, and Robert C. McMaster

June 1, 1953

SUMMARY

Accuracy tests on the improved weigh filler were run during May, and the results proved very favorable. For 500-gram fill weights, the maximum error was 0.3 per cent; for 1000-gram fill weights, 0.35 per cent.

A device for specific-gravity compensation was built and installed on the weigh filler. Its operation is satisfactory.

Progress on the liquid-level filling control includes construction of a flow system with suitable valve-control circuits and the design of a probe head to detect the agent level during filling.

BATTELLE MEMORIAL INSTITUTE

INTRODUCTION

This is the Eleventh Monthly Progress Report on "A Study and Evaluation of Liquid-Level and Liquid-Volume Controls for Shell-, Rocket-, and Bomb-Filling Machines", covering the work period from May 1 to May 31, 1953.

The research program of this project is directed toward the development of a filling machine that will deposit accurate, repeatable weights of liquid agent into munitions. A further object of this project is the development of a machine to fill munitions to a given, accurate level.

WORK IN PROGRESS

The work on this project during May consisted of the following:

1. Further tests were run on the weigh filler.
2. The device to compensate for changes in the specific gravity of the agent was built and installed.
3. The electrical circuit and water system for the liquid-level filler have been constructed.
4. A conductance probe was designed and is under construction.

Weigh-Filler Tests

During May, further accuracy tests were run on the weigh filler. These tests were run to recheck the test results antedating the improvements made on the Annin-valve driving mechanism.

The results of the recent accuracy tests follow.

<u>Fill Desired,</u> <u>grams</u>	<u>Fill Weight,</u> <u>grams</u>	<u>Fill Desired,</u> <u>grams</u>	<u>Fill Weight,</u> <u>grams</u>
500.0	501.5	1000.0	1001.5
	501.0		1000.0
	501.0		1001.0
	501.2		996.5
	499.3		999.0
	499.6		1000.2
	499.7		1000.0
	500.5		1000.2
	499.1		999.6
	499.0		1000.4

The maximum error for the 500-gram fill was 1.5 grams overfill. This is:

$$\frac{1.5}{500} \times 100 = 0.3 \text{ per cent.}$$

The maximum error for the 1000-gram fill was 3.5 grams underfill. This is:

$$\frac{3.5}{1000} \times 100 = 0.35 \text{ per cent.}$$

These accuracies are considerably better than the one per cent accuracy desired of this filling machine.

#### Specific-Gravity-Compensation Device

A device has been built to compensate for the variation in the liquid agent's specific gravity. It is very similar to the compensation device described in the Eighth Monthly Progress Report. The present device has been installed on the weigh filler and operates in a very satisfactory manner.

The capacity of the intermediate chamber of the prototype model is 1000 grams of water and, therefore, the compensation device was designed to add a maximum weight of 10 grams to the counterweight end of the balance arm. Since the variation of the specific gravity is 0.01 g/cc, 10 grams will adequately compensate for the maximum variation for a 1000-gram fill.

A Brown servomotor and speed reducer was selected as the driving motor for the compensation device. In conjunction with this motor, a 100-to-1 gear box is also used, thus making the speed of the output shaft 0.54 rpm. It is on this shaft that the chain sprocket and the selsyn indicator are mounted.

#### Liquid-Level Filling System

As stated in the previous monthly report, a two-step filling method using a conductance electronic probe has been selected for test and evaluation. During this report period, an electronic circuit to detect the level and actuate the solenoids has been designed, constructed, and tested; a water system with constant head pressure designed and built; and a probe head designed which is now under construction.

### Electronic Control Circuit

Figure 1 shows the electronic circuit to slow and stop the flow of water when a probe signal is received. By momentarily closing S, the filling process is started and continues until the liquid level specified by the probe head is reached. Then the circuit is returned to its original state so that the same filling process can be repeated by closing S again.

The thyratron grids are biased by the 6.3-volt windings of T<sub>2</sub> and T<sub>3</sub> so that they are 180 degrees out of phase with the 110-volt plate windings. Thus, as the plate goes positive, the grid goes negative and the thyratrons remain nonconductive. However, when the probe makes contact with the liquid, very little of the 6.3-volt bias is placed between grid and cathode. The tubes can ignite and energize the relays, which in turn close the solenoid valves and halt the filling process.

In tests, successful operation of the circuit was obtained when a 100K-ohm resistor was substituted for the probe resistance. This simple test shows that the circuit is quite sensitive and should operate even though the resistivity of the liquid is quite high.

### Water Filling System

A water system has been designed and constructed. The system, shown in Figure 2, uses a large vessel with an overflow to obtain a constant head pressure. This constant-head tank was believed necessary, since the line water pressure in the laboratory varies considerably. The filling rate for both the fast-fill and the slow-fill lines can be controlled and varied by the needle valves.

In constructing the system, the solenoid valves have been kept as close as possible to the shell casing. The raised level of the drain pipes tends to halt the flow quickly after the solenoids have been closed.

The design in the previous report showed baffles on the drain which tended to reduce splash and waves. These have not been included in the design, since a probe has been designed which tends to limit these effects. Also, it is desired to study the amount of error caused by these factors.

### Probe-Head Design

A test probe has been designed and is being constructed. The unit consists of a long, ceramic rod with two holes through its length and a teflon fitting on the end. The design of the fitting is shown in Figure 3. The slow probe emerges 1/8 inch from the fitting, while the stop probe is housed in the 5/32-inch hole so that its end is 3/8 inch from the end of the fitting. The 1/32-inch ports allow air to escape as water flows up the hole. It is hoped that this type of design will make the effect of splash and wave negligible without resorting to baffles in the flow line.

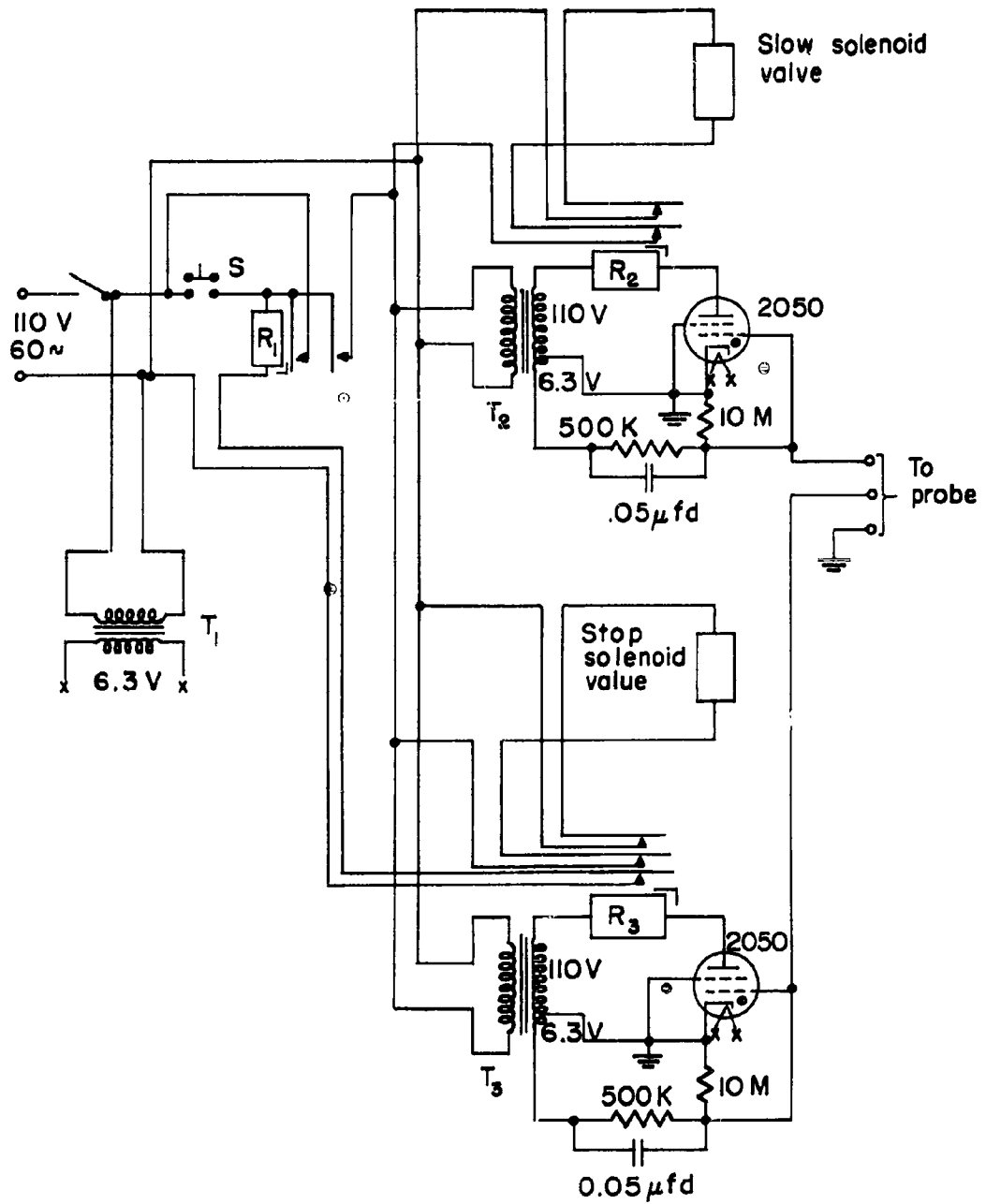

FIGURE I. ELECTRONIC CIRCUIT FOR LEVEL-CONTROL FILLER

A-5809

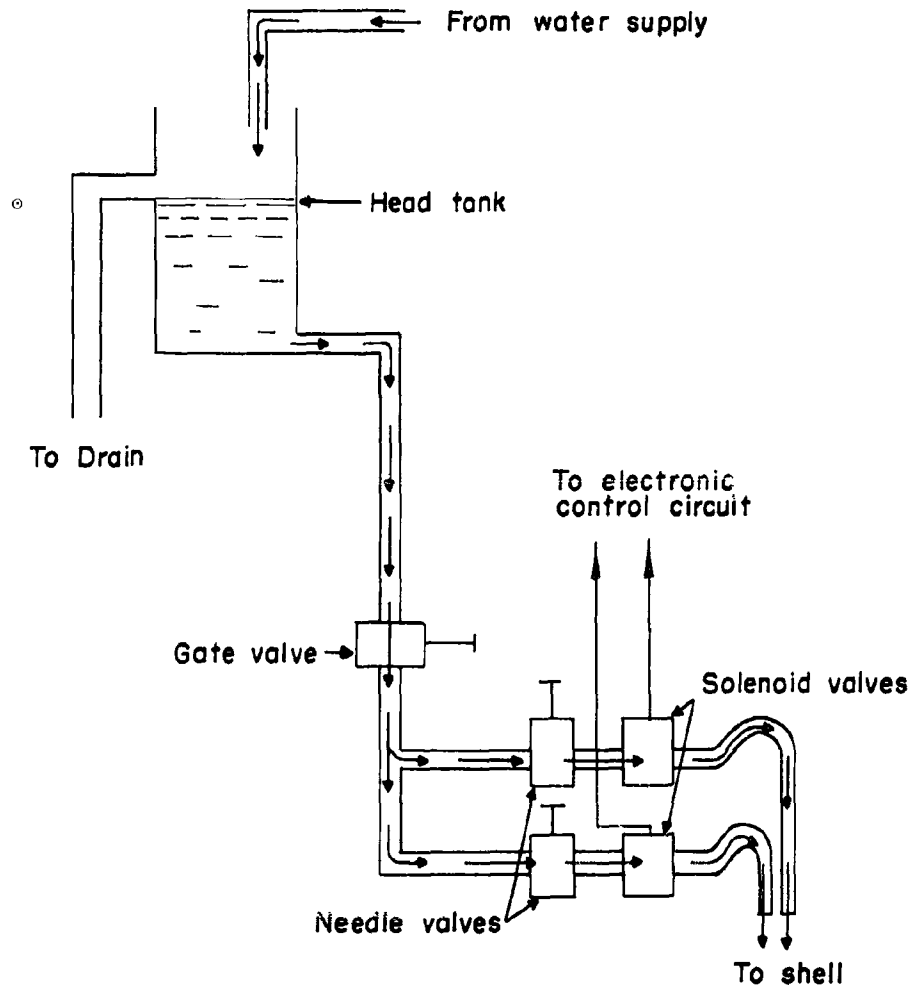

FIGURE 2. WATER SYSTEM FOR LIQUID-LEVEL-CONTROL TEST SETUP  
A-5810

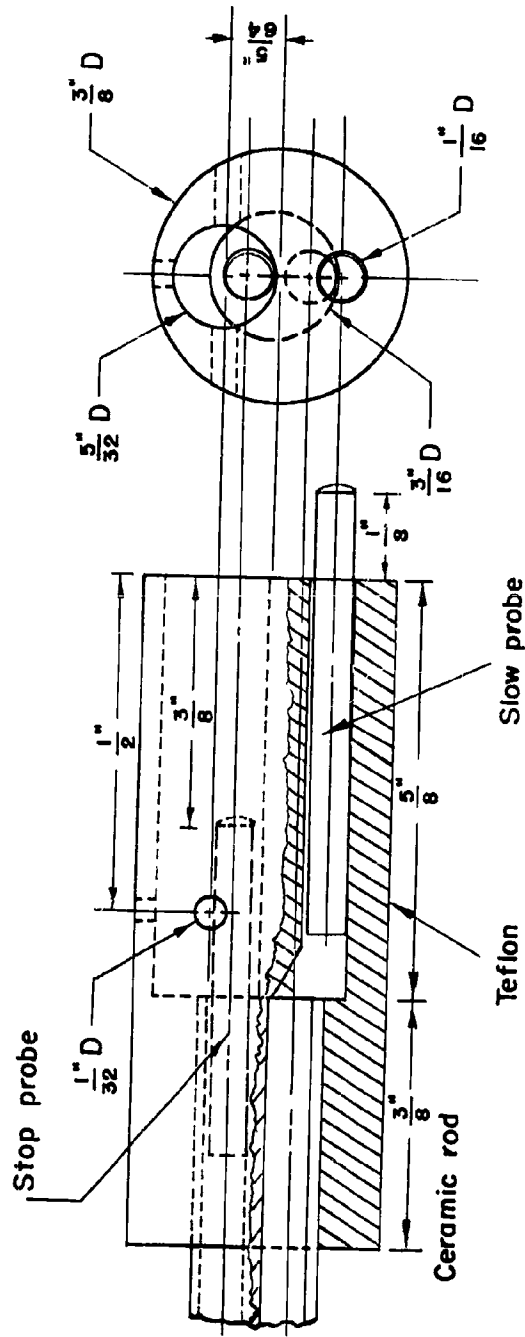

FIGURE 3. PROBE-HEAD FITTING

A-5811

FUTURE WORK

Future work will include:

1. Mounting the servo amplifier on a compact chassis.
2. Testing the accuracy of the liquid-level filling system and testing to determine the cause of errors obtained for various filling rates.
3. Arranging for a suitable visit by Chemical Center personnel to Battelle to inspect the filling systems constructed.
4. Preparing the Final Report of the work done on this project.

TMB:WH:ECF:RLM:RCM/lek  
June 4, 1953

UNCLASSIFIED

UNCLASSIFIED