

UNCLASSIFIED

AD **264 560**

*Reproduced
by the*

ARMED SERVICES TECHNICAL INFORMATION AGENCY
ARLINGTON HALL STATION
ARLINGTON 12, VIRGINIA



UNCLASSIFIED

NOTICE: When government or other drawings, specifications or other data are used for any purpose other than in connection with a definitely related government procurement operation, the U. S. Government thereby incurs no responsibility, nor any obligation whatsoever; and the fact that the Government may have formulated, furnished, or in any way supplied the said drawings, specifications, or other data is not to be regarded by implication or otherwise as in any manner licensing the holder or any other person or corporation, or conveying any rights or permission to manufacture, use or sell any patented invention that may in any way be related thereto.

CATALOGED BY ASTIA
AS AD No. 264560

51



41-4-V
NOX

ASTIA
RECEIVED
OCT 18 1961
KELLETT CO
TIPDR

KELLETT
1929
Aircraft
CORPORATION



AN INVESTIGATION OF
VTOL OPERATIONAL PROBLEMS

DUE TO DOWNWASH EFFECTS
Released to ~~ASTIC~~ by
Bureau of **NAVAL WEAPONS**
without restriction.

DATE 12 June 1961 REPORT NO. 179T80-2

Contract No. NOW 60-0450-f

Sponsored Jointly by
U. S. Navy, Bureau of Naval Weapons, and
U. S. Army, Transportation Research Command

PREPARED

R. Pruyn

R. Pruyn
Head, Aerodynamics Section

Leonard Goland
Leonard Goland
Vice President, Engineering

APPROVED

Leonard Goland
Leonard Goland
Vice President, Engineering

NO. OF PAGES

FOREWORD

The work described herein was accomplished by Kellett Aircraft Corporation for the Bureau of Naval Weapons, U. S. Navy and the U. S. Army Transportation Research Command. The work was accomplished under Contract No. NOW 60-0450-f. Mr. James Jones of Kellett Aircraft Corporation was project engineer and Mr. Benjamin Stein, RAAD, U. S. Navy, administered the project.

ABSTRACT

Operational problems of VTOL type aircraft caused by downwash effects have been investigated utilizing a 3500 horsepower engine and a 15 foot diameter propeller mounted on a 20 ton crane. Results are presented for various propeller disc loadings up to 60 pounds per square foot, for several types of terrain and for various propeller heights and orientation above the terrain. The effects on pilot vision, ground personnel, equipment, aircraft and on aircraft concealment are presented. The effects of downwash were found to be a major operational problem which could limit the operational utility of VTOL aircraft.

TABLE OF CONTENTS

	Page
Foreword	ii
Abstract	iii
List of Illustrations	vi
Symbols	viii
I. Introduction	1
II. Test Apparatus and Procedures	3
A. Test Rig	3
B. Test Objects, Debris and Exposed Personnel	3
C. Instrumentation	4
D. Test Procedures	5
E. Test Conditions	5
III. Test Results	8
A. Qualitative Results	8
1. Grading System	9
2. Definitions of Operational Limitations	9
3. Discussion	15
B. Quantitative Results	18
1. Downwash Velocity at Ground	18
2. Static Pressure Survey	19
3. Radial Distribution of Downwash Near Propeller	19
4. Engine Ingestion	20

	Page
5. Water Spray Height	21
IV. Conclusions	22
V. References	24

LIST OF ILLUSTRATIONS

Figure		Page
1	Basic Test Rig for Downwash Study	25
2	Propeller Blade Characteristics	26
3	Plastic Face Mask and Protective Goggles used by Ground Personnel	27
4	Close-Up View of Sod Terrain	27
5	Close-Up View of Earth Terrain	28
6	Test Area for Clay Terrain	28
7	Geometry of Water Test Pool (Showing location of Projection of Propeller Disc along Propeller shaft Axis at the Ground)	29
8	Test Set-Up for Operations over Water Test Pool	30
9	Test Set-Up for Operations over Sand Terrain	30
10	Particle Size Data for Sand used in Downwash Impingement Study	31
11	Close-Up View of Gravel and Stone Terrain	32
12	Test Set-Up Test Objects on Snow Covered Surface	32
13	Zones of Operational Limitations for Personnel and Equipment	33
14	Vertical Gradient of Downwash Dynamic Pressure	34
15	Static Pressure at the Ground Due to Downwash with the Propeller Axis Vertical	35
16	Static Pressure at the Ground Due to Downwash with the Propeller Axis inclined 30 Degrees to Vertical	36
17	Downwash Velocity Measurements Near the Propeller at Various Radial Positions for a Disc Loading of 30 pounds per square foot	37

Figure		Page
18	Particles Collected on Engine Air Filter When Operating over Earth	38
19	Height at which Water Spray was Observed for Various Surface Dynamic Pressures	39

LIST OF SYMBOLS

D	Propeller Diameter	Feet
DL	Disc Loading	Pounds per square foot
q_{sMAX}	Maximum Surface Dynamic Pressure based on Theory and Data from Reference 1	Pounds per square foot
R	Propeller Radius	Feet
X	Distance from Point of Intersection of Propeller Axis and Ground, Negative when in Direction of Propeller thrust	Feet
Z	Distance from Ground to Plane of Propeller	Feet
θ	Thrust Axis Inclination Angle	Degrees
U,L,T,S	Unacceptable, Limited, Tolerable, Satisfactory, Severity Grading Symbols (See Text for Definitions)	

LIST OF TABLES

Table No.	Title	Page
I	Description, Weight and Dimensions of Test objects	40
II	Terrain: Water	41
III	Terrain: Dry Snow	42
IV	Terrain: Wet Sand	43
V	Terrain: Sod	44
VI	Terrain: Clay	45
VII	Terrain: Earth	46
VIII	Terrain: Gravel & Stone	47
IX	Terrain: Hard Surface, Debris Strewn	48

INTRODUCTION

Present experiences with existing vertical take-off and landing type aircraft have demonstrated that certain operational problems arise due to the effects of aerodynamic downwash when operating in the vicinity of terrain. These experiences have for the most part, been restricted to aircraft of relatively low disc loading and, therefore, concern has been centered on new aircraft designs, such as the Tri-Service VTOL, which are of much higher disc loadings. Kellett Aircraft Corporation in cooperation with the U. S. Navy Bureau of Naval Weapons and the U. S. Army Transportation Research Command consequently foresaw the necessity of full scale operational experience in this area to assist in the development of this type of vehicle.

The principal objective of this program was to obtain experience in the following five areas under various conditions of propeller disc loading, terrain, propeller height and orientation above terrain:

1. Pilot's Vision
2. Personnel (ground crew and disembarking troops)
 - a. Vision
 - b. Risk of injury
 - c. Restriction of motion
3. Equipment
4. Aircraft
 - a. Propeller
 - b. Engine
 - c. Airframe
5. Concealment

As an economical, realistic approach to obtaining this experience, a program using an engine-propeller combination mounted on a crane was conceived. The combination consisted of a Pratt and Whitney 3500 horsepower Model R 4360 engine and a Hamilton Standard 15.0 foot diameter four-bladed propeller, mounted on a boom of a 20 ton Bay City crane (Figure 1).

References 1 and 2 describe certain small scale experimental data pertaining to this problem. It would appear that the data (e.g. pressure, velocity, etc.) concerned with the flow over smooth ground should be independent of size (above a critical value). Representative measurements have been made in this program for comparison with the above references. However, it should be realized that since terrain particles and personnel cannot be "scaled down" effectively, the objectives of this program have to be obtained by full scale tests.

A much better appreciation of the effects of downwash has been achieved from these tests. Of course, a large part of the results are of a qualitative nature and, therefore, an attempt has been made herein to define, as carefully as possible, the criteria which were used in the evaluation of these results. It is expected that further experience in this area will establish a more detailed basis for this evaluation.

The present program as presented herein pertains chiefly to the reporting of conditions which were experienced without taking any precautions which could alleviate the problems when they arose. It is expected that the use of the results and further experience with operations of full scale equipment as presented herein will aid in alleviating the more disturbing conditions.

A film supplement to this report is available. This film presents the highlights of the test operations.

TEST APPARATUS AND PROCEDURES

A. Test Rig

A 20-ton Bay City truck crane was modified to support an engine-propeller combination consisting of a Hamilton Standard 15.0 foot diameter four-bladed propeller and a Pratt and Whitney 3500 horsepower Model R4360 20 WCT engine, as shown in Figure 1. The engine-propeller combination was mounted on a boom extension of the Bay City crane to allow for raising and lowering the propeller.

The crane was capable of positioning the propeller at heights from 40 feet above the ground to within 11 feet above the ground. Also, the propeller could be tilted to an angle of 30° with the vertical in the above height range.

The propeller had blade characteristics as shown in Figure 2. The propeller pitch mechanism was locked for all tests with a pitch setting of 16 degrees at 72 inch radius. Various disc loadings were possible from 10 to 68 psf by variation of the engine rpm.

B. Test Debris, Objects and Exposed Personnel

Various objects were placed on the ground near the propeller and were subjected to the downwash. The objects included:

1. Oil drums, empty and full
2. Crates, with and without equipment
3. Automotive equipment
4. Humans
5. Miscellaneous structural material
6. Rocks and debris

The description, density and frontal area of the test objects is given in Table I.

The personnel who were exposed to the downwash also took velocity measurements with hand held instruments, (clay terrain condition). Pilots crash helmets with face shields (U. S. Navy APH-5) and heavy coveralls were worn by these personnel. The use of plastic face masks and protective goggles shown in Figure 3 were also evaluated by these personnel.

C. Instrumentation

1. Provisions were made for recording the propeller position as follows:

- a. Height above the ground
- b. Angle of inclination of the propeller thrust

2. Four Baldwin-Lima-Hamilton load cells were provided to measure the propeller thrust. The thrust was indicated on a microammeter which was read directly.

3. Engine data was recorded from the panel within the operator's cab. Data taken included:

- a. Engine rpm
- b. Cylinder head temperature
- c. Manifold pressure
- d. Oil pressure
- e. Oil Temperature

4. A static pressure tube assembly was used to determine the ground pressure distribution. This information was recorded directly from a multiple tube manometer.

5. A hot wire anemometer was provided to sense and indicate airflow velocities near the ground level. This meter was read directly.

6. Two motion picture cameras were provided to afford integrated motion picture coverage of the experimental tests from two different vantage points.

- a. Close up view of the affected area - view toward engine from crane-cab, near ground height.
- b. Remote from the affected area - view inward toward center.

D. Test Procedure

1. The propeller was set at a given height and thrust axis inclination angle over the test terrain.
2. The identification and location of all major debris items; large rocks, oil cans, crates, equipment, et cetera, was established.
3. Moving picture cameras were loaded and set.
4. Engine was started and run at idle.
5. Cameras were started and the engine rpm was increased at a uniform rate of approximately 75 rpm per second to develop desired thrust.
6. Static pressure and flow velocity measurements were made, when required.
7. Test personnel noted how much their vision was obscured due to the disturbance of the terrain for later correlation with the moving pictures.
8. When the test engineer noted that the disturbance had reached a steady state condition, the test was terminated. The engine and cameras were stopped.
9. Eroded areas of the terrain were measured.
10. Major debris items were located and the position relative to the propeller was measured for comparison with Item #2 above.
11. Test equipment was prepared for the next test.
12. Engine and APU air filters were checked for accumulation of terrain particles at the end of each day's testing. Accumulation of terrain particles on engine, propeller or engine support rig was noted at completion of each test.

E. Test Conditions

A test condition was defined by the following parameters:

1. Propeller height (0.73, 1.67 or 2.67 times the propeller diameter).

2. Propeller thrust axis inclination (vertical or inclined 30 degrees from vertical).

3. Disc loading (10, 30 or 60 psf)

4. Terrain type and configuration

Almost every possible combination of the above parameters were tested. Test conditions which would cause severe damage to the test rig were omitted.

The terrains which were tested may be defined as follows:

1. Sod

This series of tests were conducted on an unmowed grass covered area of clay soil. The grass was moderately dense and of 3 inch average height as shown in Figure 4.

2. Earth

The sod of the previous test series was plowed with a rotary tiller to a depth of 10 inches over a 30 by 60 foot area. The earth was soft from previous rains and therefore, tilling produced clumps of soft soil. The earth type of terrain is shown in Figure 5.

3. Clay

The tilled soil of the earth test was scraped away leaving clay with a density of 142 pounds per cubic foot and a moisture content of 23 percent. The clay on the surface was fairly smooth and was not packed down. This type of terrain is shown in Figure 6.

4. Water

To simulate operation of VTOL aircraft on water, a specially constructed water test pool was prepared as

illustrated in Figure 7. The average depth of water was 22 inches. The sides of the test bed were sloped 3 to 1 in order to reduce unwanted wave action. A graduated bar was placed in the water to determine the amount of water which was blown away during each test. A photograph of the test set up for operations over water is presented as Figure 8.

5. Snow

Snow tests were performed as weather conditions permitted. Therefore, the conditions of the snow varied from day to day. Snow conditions varied from very dry and powdery, to wet and packed. Tests were performed in snow from 1/2 inch to 4 feet in depth. The powdery snow tested had a specific gravity of 0.27.

6. Sand

A test bed was prepared to simulate operation over sandy terrain. The test bed was 30 feet wide by 50 feet in length with an average sand depth of 10 inches. A photograph of the test set up for testing over sand is presented as Figure 9. The average moisture content of the sand was 4 percent and the average density of the wet sand was 85 pounds per cubic foot. The particle size graduation from a standard sieve analysis of the sand is shown in Figure 10.

7. Gravel and Stone

The gravel and stone test bed consisted of a man made area which had been exposed to the elements for several years. A typical sample of the gravel mixture had a density of approximately 110 pounds per cubic foot. A close up photograph of this terrain is shown in Figure 11.

8. Debris on Hard Surface Terrain

The test objects described previously and as listed in Table 1 were arranged in a predescribed manner on a macadam or a packed snow covered surface. A photograph of the test set up for operation with the propeller at 25 foot height and with a 30 degree thrust axis inclination is shown in Figure 12. Various patterns of test objects were utilized to best suit the test condition.

TEST RESULTS

The results of this program are of both a qualitative and a quantitative nature and are presented in the form of contemplated operational limitations data and downwash velocity, pressure and terrain disturbance data respectively. These results are presented and discussed in the following sections of this report.

In presenting results, it was decided not to include still photographs of the disturbance in this report. The evaluation of this data from still photographs is difficult for the following reasons:

1. The effects of the disturbance are of a somewhat random nature.
2. Lighting and background influence the pictured results.
3. Quality of the reproduction influences one's opinion of the results.

Not including these photographs will prevent misinterpretation. A moving picture film is available which presents the results in such a way as to avoid these difficulties.

A. Qualitative Results

The large portion of the results of this program are of a qualitative nature. In the presentation of qualitative results, it is necessary to closely define the language that is used. For this purpose, it appeared necessary to define a general grading system followed by more specific definitions of operational limitations. It is appreciated that the data available for use in establishing these limits is rather **sparse** and therefore, the limits proposed are somewhat open to argument. However, the definitions which have been used were established with consideration given to the accuracy of the present data. As further test programs are conducted, and as operational experience becomes available, the limitations which are proposed can be more closely defined and may require revision.

1. Grading System:

A coarse grading system is required before further detail is considered. The grading system which has been used is as follows:

a. Unacceptable - based on present day VTOL design and operational techniques and equipment, the specified function cannot, in general, be performed (with equipment as listed in operational limitations definition).

b. Limited - the specified function may be performed in a limited manner under emergency or combat conditions.

c. Tolerable - disturbance may be endured but is disconcerting and will reduce efficiency.

d. Satisfactory - the specified function can be performed unimpeded.

2. Definitions of Operational Limitations

The coarse grading system is not adequately defined for the establishment of operational limitations and therefore, further definitions are required. The problem areas are:

- a. Pilot's vision
- b. Personnel (ground)
- c. Equipment
- d. Aircraft
- e. Concealment

In this section, the definitions required to establish limitations in each of these areas are given. Since the severity of the problem will depend somewhat on the equipment which is available, certain equipment has been assumed to be available and is listed under the definition which is influenced.

Operational limitations for personnel or equipment depends on the location of the personnel or equipment. Therefore, zones were established to give a general location. The zones consist of concentric rings about the point of intersection of the propeller axis with the ground as shown in Figure 13. It should be noted that for operations

with the propeller axis inclined, the operational problems are not quite as severe to either side as they are in the direction of the inclination.

a. Pilot's Vision

It is assumed that the pilot will be located between one and two diameters from the propeller center and will be a distance of about 1/4 of the propeller diameter below the plane of the propeller. It is further assumed that the configuration of the pilot's windshield will be provided with adequate washers and wipers to provide a clear view through the windshield. With these assumptions, the proposed operational limitations, based on pilot's vision, have been defined as follows:

1) Unacceptable - no visual contact with any reference point.

2) Limited - objects distinguishable at 30 feet distance from the pilot but horizon not perceptible.
NOTE: Automatic stabilization equipment is assumed to be available and the aircraft is likely to suffer damage during landing under these conditions.

3) Tolerable - ground objects larger than 3 feet diameter are clearly distinguishable at 100 feet distance and a horizon is always perceptible.

4) Satisfactory - vision unimpeded.

b. Personnel

The personnel which are considered include ground crew and disembarking troops.

1) Vision of Personnel

It is assumed in considerations given to the vision problem that personnel will have eye protection such as goggles or a face shield. The proposed operational limitations based on ground crew vision are as follows:

a) Unacceptable - ground objects larger than three feet diameter not distinguishable beyond ten feet from the crewman.

b) Limited - ground objects distinguishable at distances up to 50 feet.

c) Tolerable - objects distinguishable at distances up to 200 feet.

d) Satisfactory - vision unimpaired.

2) Risk of Injury from Disturbed Terrain or Debris

If the personnel are adequately equipped with protective clothing, the risk of injury is small. Further study will be required to determine the amount of protection required. However, three limitations definitions were utilized, based on the protection required, as follows:

a) Unacceptable - personnel will require extraordinary protection to insure that they will not be injured.

b) Limited - personnel will require padded clothing and face shield.

c) Satisfactory - personnel would not risk injury when wearing only standard ground crew clothing.

3) Motion Restricted due to Aerodynamic Forces

Personnel functions may be made difficult due to downwash even though there is no disturbance of the terrain. The following limitations were devised to evaluate these conditions:

a) Unacceptable - personnel would not be able to stand under these conditions.

b) Limited - personnel would be able to be in area and would be capable of locomotion.

c) Tolerable - motion would be slightly impeded.

d) Satisfactory - no effect.

c. Equipment

The equipment which has been considered in the limitation devised for this problem area include:

- 1) Ground power units
- 2) Vehicles
- 3) Housing
- 4) Stored equipment
- 5) Parked aircraft

It is assumed that this equipment will not be damaged by aerodynamic pressure loading and will be secured as required to prevent equipment from blowing away.

With these assumptions, limitations were devised as follows:

1) Limited - equipment will be subjected to severe environmental problems.

2) Satisfactory - no perceptable change to operational environmental due to downwash.

d. Aircraft

Due to the downwash, debris and terrain particles may be set in motion. These particles can cause physical damage to the aircraft. This damage includes:

- 1) Denting and abrasion of propeller
- 2) Engine ingestion
- 3) Denting and abrasion of airframe

The proposed operational limitations for these problem areas have been defined as given below.

1) Propeller

It was assumed that the aircraft will have metal propellers. The limitations which were used are as follows:

a) Unacceptable - risk of damage to propeller which would cause further operations to be unsafe.

b) Limited - propeller is subjected to abnormal environmental conditions which may reduce propeller performance.

c) Tolerable - not applicable

d) Satisfactory - no damage or abrasion to propeller.

2) Engine

The engine problems will be much different for engines with an intake filter than for engines without such filter. Some quantitative data on the size and amount of particles which should be removed by the filter was obtained in this program, as will be discussed in a following section. However, for the qualitative operational limitations, it was assumed that a filter will be used. The limitations which were used were defined as follows:

a) Unacceptable - risk that terrain being recirculated may clog filter and stop engine.

b) Limited - terrain being recirculated may reduce engine performance.

c) Satisfactory - no apparent effect on engine operation.

3) Airframe

It was assumed that the aircraft will consist of a light metal monocoque structure and will have helicopter type landing gear. Since the sensitivity of the airframe to damage will depend on the configuration of the structure, the severity of the damage cannot be estimated at this time. Therefore, limitations were based on the occurrence of damage as follows:

a) Limited - risk that damage may occur to airframe

b) Satisfactory - no risk of damage to airframe

e. Concealment

It was assumed that only one aircraft was in operation in the area. Limits were defined based on the maximum height of the cloud of disturbed terrain as follows:

1) Unacceptable - 100 feet or more

2) Limited - less than 100 feet but more than 25 feet

3) Tolerable - less than 25 feet height but a cloud is formed

4) Satisfactory - no cloud formed

These definitions have been used to prepare tables of operational limitations and are presented herein. The results are summarized and will be discussed in following sections of this report.

3. Discussion

In the utilization of the qualitative data it should be noted that there were certain limitations inherent in this data due to the geometry of the test rig and due to the method of testing. Compromises were required which were not truly representative of a VTOL aircraft. However, it is believed that these data are a good first order approximation of VTOL operations, and as was discussed previously, the limitations of this data have been considered in the evaluation of results. The reasoning used in evaluating these limitations is presented in the following discussion.

a. Geometry of Test Rig

These tests were conducted with a single propeller which, of course, is not representative of a VTOL aircraft. The number of propellers may have a large influence on the data, but could not be considered in this program. It is believed that multi-propeller operations will cause more severe downwash problems than is reported herein for the following reasons:

1) The interaction of the downwash from two or more adjacent propellers will cause an upwash at the region of the intersection of the downwash wakes and the ground. It is believed that this upwash will increase terrain particle recirculation and thereby increase vision and ingestion problems.

2) Most of the terrain particles are eroded from an annular area surrounding the periphery of the projection of the propeller disc on the ground. At the same disc loading and for a given thrust, use of a larger number of smaller propellers will result in more propeller peripheral length. Thus, since most of the erosion occurs at the periphery and there is more periphery with a larger number of propellers, it is reasonable to expect that the severity of problems due to terrain erosion will increase as the number of propellers which are used is increased.

Further tests should be performed to determine the significance of these multipropeller effects and to determine means for alleviating the downwash problems which result from these effects.

The test rig was also somewhat limited for use in the determination of the significance of the pilot vision limitations. This was mostly due to the fact that there was no provision made for having the test personnel at the expected location of the pilot of a VTOL aircraft. Therefore, the severity of the vision problem was estimated by personnel located in the cab of the crane, by ground personnel and from a study of the motion pictures which were taken during testing. It should also be noted that the evaluation of the vision problem is influenced by the lighting and by the background. Further test programs should provide instrumentation or other means for determining visibility without these limitations.

The geometry of the test pool used in the water tests may have limited the applicability of this data. As will be discussed in the following section of this report, the height of the water particle cloud was much less than would be expected from an extrapolation of the small scale test data obtained by other investigators. Further testing should be performed with a full scale test rig mounted over a large body of water to determine the significance of this pool geometry effect.

b. Test Operations

There have been questions concerning the applicability of the essentially steady-state testing as conducted in this test program to the dynamic landing and take-off maneuvers of a VTOL aircraft. Also, there is an influence of fixed pitch operation on the test data.

In relating the test operations to the VTOL, it must first be established what is expected of the VTOL. The maneuvers expected with this aircraft are as follows:

- 1) Ground Engine Operation: It is expected that constant speed turbine engine controls will be utilized with adjustable propeller collective pitch, such as used on helicopters. Due to the large pitch adjustment required for high speed operation, it is expected that the design will be compromised to allow a significant propeller pitch at the minimum pitch setting. It is, therefore, expected that a rather large propeller thrust will be produced with the engines idling and with the aircraft on the ground. This thrust may be as large as 25 percent of the gross weight of the aircraft.

2) Take Off: The increase in thrust from that developed at ground idle to the thrust that is required for vertical flight is expected to be fairly gradual. The VTOL will be rather sensitive to center of gravity position and therefore, it is expected that good pilotage would require a similar caution in leaving the ground as is presently necessary with a large transport helicopter. It is also possible that the pilot's vision will be obstructed by a cloud of disturbed terrain during takeoff and, therefore, the pilot should have his aircraft in trim and under precise control as it leaves the ground. Once clear of the ground, the aircraft can easily fly clear of any dust cloud that may have been created.

3) Approach to Landing: It is expected that the approach to landing will be made along a steep glide path and at airspeeds on the order of 20 knots.

4) Hovering: Since the VTOL aircraft will have the capability of hovering, it is expected that it will hover.

5) Landing: Run-on landings are expected to be the usual procedure; however, landings would probably be from a hover on rough, rocky or very soft terrain such as could be expected on an unprepared site. All landings were expected to be made into the wind.

It is believed that this test program is a good representation of a VTOL aircraft with these expected characteristics. The propeller of the test rig developed a disc loading of nearly ten pounds per square foot at idle. This operation removed the light dust from the surface and in some cases started the formation of a dust cloud. For these tests, the engine speed was increased from idle to the maximum allowable speed in approximately 25 seconds. This resulted in an increase in disc loading to 60 pounds per square foot. It is believed that this rate of increase in thrust is of the same order as that which will be used in the VTOL aircraft. Once a steady state operation is reached, the testing was representative of hovering.

There is a question as to the dynamic effects on the downwash which will result from landing and take-off maneuvers. It is believed that these effects will make the downwash problems more severe for the following reasons:

1) A sudden increase in thrust could cause a transient vortex motion in the downwash similar to a starting vortex. It was noted in the test program that the starting vortex aggravated the recirculation of terrain through the propeller.

2) A sudden impingement of the downwash on the ground will cause a large amount of terrain particles to be disturbed at once rather than over the rather long period of erosion as was experienced in the test program. It was noted on numerous occasions that terrain disturbance problems were more severe if something prevented the erosion of the terrain and then the obstruction to erosion was suddenly removed. This condition would be similar to the sudden impingement of the downwash on the terrain during landing.

In summary, it is believed that the testing which was conducted is representative of VTOL operations. Certain geometric limitations influence the applicability of this data and require further investigation. However, the data presented include consideration of these effects and are believed to be a good first-order approximation to the conditions which will be experienced with VTOL aircraft.

B. Quantitative Results

In this program emphasis was placed on obtaining operational experience and, therefore, the quantitative data obtained is rather sparse. The data which was obtained was directed toward determining scale effects and obtaining data which would aid in assessing operational problems.

1. Downwash Velocity at Ground

The vertical gradient of downwash velocity was measured at a radial distance of 1.5 and 2.0 times the propeller radius. These measurements were taken at a propeller height to diameter ratio of 0.7 at a disc loading from 15 to 60 pounds per square foot. The data which was obtained is presented in Figure 14 with small scale test data from Reference 2. Fair agreement was found between the data from Reference 2 for a 5 foot diameter propeller and the data obtained from this test program. The Reference 2 downwash dynamic pressure data was about 0.05 times the disc loading larger than the Kellett data. There was no indication of a mixing or boundary layer in the measurements and therefore, it was concluded that there is no apparent scale effect on the downwash velocity gradient near the ground.

2. Static Pressure Survey

The static pressure at the ground was measured with the propeller axis vertical and inclined at 30 degrees from vertical. This data is shown in Figures 15 and 16 respectively. Similar data from References 2 and 3 are also shown in Figure 15, and a rather poor comparison is indicated. This poor comparison may be due to the difference between the geometry of the propeller and nacelle which was used in these tests.

It was also found that there is an area which is subjected to negative (gage) static pressure due to the downwash. This area is not indicated in the referenced data and therefore, the test data was initially suspected as being erroneous. However, the mechanism of erosion of terrain from this area indicates that there should be a negative static pressure since the erosion leaves pockets in the ground as a result of particles being lifted by a static pressure differential across each particle. This could only result from a negative static pressure at the ground. It is also found from potential flow theory that the static pressure at the ground would become a negative gage pressure. Also, this test was repeated and the negative static pressure measurements were confirmed.

When the propeller axis is inclined, the ground static pressure field is similar to the field when the propeller axis is vertical. The peak download is of similar magnitude, but the magnitude and area of the negative static pressure region is reduced. The positive static pressure is not centered on the point of intersection of the propeller axis and the ground, but is skewed toward the direction of inclination of the thrust axis.

3. Radial Distribution of Downwash Near Propeller

A radial survey of downwash velocity was also made at a height of 0.5 and 0.18 times the distance of the propeller from the ground. A disc loading of 30 pounds per square foot was being developed during this survey, and the propeller height

was 0.7 of the propeller diameter. The resulting data is shown in Figure 17. The measured velocity at 0.5 of the height is fairly uniform. It appears from this data, from a brief smoke study and from the vapor trails caused by the blade tip on moist days that the outer edge of the downwash is about 0.9 times the propeller radius at this height. This is reasonable considering the effect of the ground in preventing the contraction of the downwash. The measurements taken at 0.18 of the propeller height show reduced downwash velocities especially inboard near the engine.

4. Engine Ingestion

The significance of the engine ingestion problem was briefly studied during tests over earth terrain. The engine air filter was removed after an interval of testing and the accumulated particles from the filter were knocked loose and collected. These particles weighed 0.02 pounds. The propeller was operating at 30 pounds per square foot disc loading for 8 minutes and 60 pounds per square foot for 11 minutes during the time in which this sample was being collected in the filter. For these tests, the propeller height-diameter ratio was 0.73. Since the filter was of rather coarse mesh and did not fit tightly, it is believed that a significant portion of the terrain entering the filter was not collected by the filter. Therefore, the ingestion problem is, apparently, somewhat more severe than the 0.02 pounds per 19 minutes operation mentioned above, but it is unlikely that it is more severe than twice this ingestion rate when operating over moist earth terrain. Operation over a non-cohesive terrain such as dry sand would cause a much worse ingestion problem than was experienced over moist earth. The distribution of particle size of the terrain which was collected was determined and this data is shown in Figure 18.

The ingestion problem is, of course, worse for inlets near the ground. Some ingestion data was obtained for the auxiliary power unit (APU) during operation over sand. The APU was located at ground level at the side of the crane approximately 35 feet from the intersection of the propeller axis and the ground. During operations at various disc loadings from 10 to 60 pounds per square foot for 28 minutes at a propeller height of 1.67 times the diameter, there was 0.06 pounds of sand collected in the APU air filter. Similar operation for 20 minutes at a propeller height ratio of 0.71

resulted in 0.14 pounds of sand collected. This APU had an engine displacement of 61 cubic inches, and operated at 2400 rpm. An oil bath air cleaner was provided on this engine. While greatly increased maintenance was required to remove the collected sand from the APU inlet air filter, there was no noticeable influence of this ingestion rate on the APU engine performance.

5. Water Spray Height

Operation of the propeller at disc loading of 10 psf or higher over water causes an opaque spray cloud. The height of the top of this opaque cloud was estimated from the motion pictures taken during this testing. These data are shown in Figure 19 with comparative small scale data from Reference 1 and 4. To provide a basis for comparison, these data are plotted against the theoretical maximum surface dynamic pressure as used and defined in Reference 1. The referenced data indicates that the spray problem is more severe than the test data from this program. This may be due to one or more of the following reasons:

- a) The test pool used in this program was rather small. The small pool may have had significant edge effects which reduced the height of the spray.
- b) There may have been a difference in the method of estimating the edge of the cloud. For this program, the upper edge of the opaque cloud was measured. Spray projecting above this opaque cloud was not considered significant. The determination of the edge of the opaque portion of the spray cloud is considerably influenced by the lighting, the background, and is somewhat the opinion of the viewer.
- c) There is also a possibility that the magnitude of the water cloud is reduced by scale effects.
- d) The referenced data was for ducted propellers or a nozzle. These devices may cause more spray than an open propeller.

Further testing should be accomplished with a full scale test rig over a large body of water to ascertain the severity of the water cloud problem.

CONCLUSIONS

Based on the data and experience acquired in this program, a guide is presented herein as to the contemplated operational limitations of VTOL aircraft which have 10 to 60 pounds per square foot disc loadings. The results are presented for various disc loadings, terrain conditions and propeller heights and orientation above the terrain. The effects on pilot vision, ground personnel, equipment, aircraft and concealment are presented. It is to be appreciated that the practical design and operational techniques of VTOL aircraft are yet to be established. Nevertheless, by consideration of the results presented herein, the problem area may be minimized.

It is reasonable to expect that the design of propeller type VTOL vehicles will specify disc loadings above 30 pounds per square foot and that the ground static height of the propellers will be less than two diameters from the terrain. For these conditions, the following can generally be concluded:

1. Operation over water, snow and sand will cause severe vision problems to both pilot and ground crew in the neighborhood of the aircraft. Operation over sod, clay, earth or gravel presents no vision difficulties.
2. All debris and equipment in the neighborhood of the operating aircraft must be restrained from motion in order to prevent injury to personnel in the vicinity.
3. Movement of personnel in the vicinity of the aircraft will be impeded. Face shields and protective clothing will be required.
4. Hovering over snow or sand will make it difficult to conceal the aircraft from the enemy.
5. Damage to the engine and aircraft can result due to erosion, ingestion and flying debris.
6. The effects of downwash on terrain should receive one of the major considerations in the design of VTOL type aircraft.

7. It is expected that through careful design and operational techniques, the limitations mentioned herein can be minimized. However, it is strongly recommended that more direct methods of solution be investigated such as lightweight ground covers, flow separators, and methods for increasing soil cohesion.

REFERENCES

1. Kuhn, R., E., An Investigation to Determine Conditions Under Which Downwash From VTOL Aircraft Will Start Surface Erosion From Various Types of Terrain, NASA TND-56, September, 1959.
2. Morse, A., VTOL Downwash Impingement Study, - Velocity Survey, Hiller Aircraft Corporation Report No. 60-15, August, 1960.
3. Fradenburgh, E., A., Flow Field Measurements For a Hovering Rotor Near the Ground, Paper Presented at The American Helicopter Society, Fifth Annual Western Forum, September, 1958.
4. Morse, A., VTOL Downwash Impingement Study, Surface Erosion Tests, Hiller Aircraft Corporation, Report No. 60-84, October, 1960.

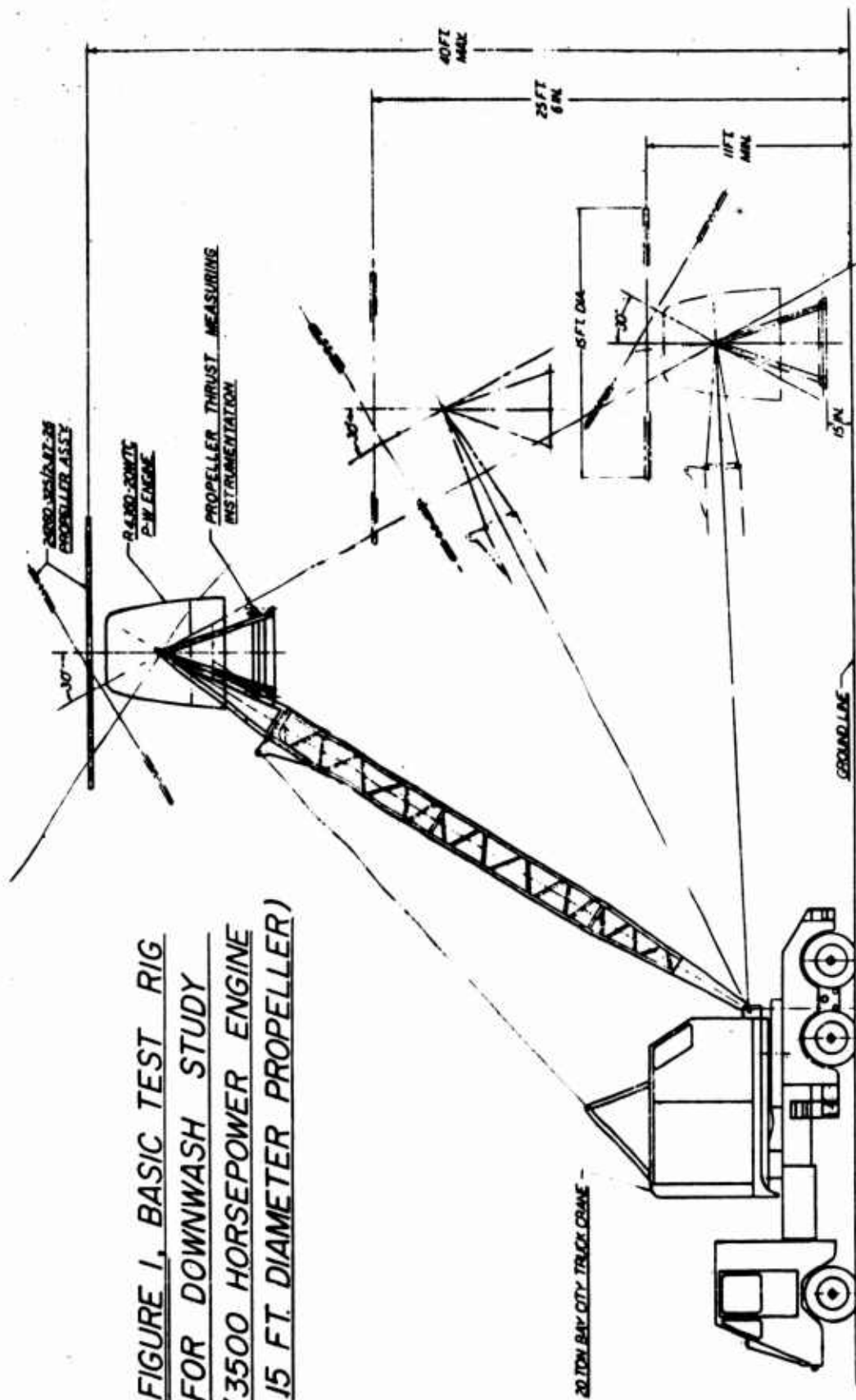

FIGURE 1. BASIC TEST RIG
FOR DOWNWASH STUDY
(3500 HORSEPOWER ENGINE
15 FT. DIAMETER PROPELLER)

Hamilton Standard Propeller 2J1763

Blade - NACA 16-64,
Blade Diameter - 15 ft.

AF = 120

CL = 0.46

$\Delta\theta = 2$

$(h/b)_{.15} = .068$

R = blade radius
h = blade thickness
b = blade chord
D = blade diameter

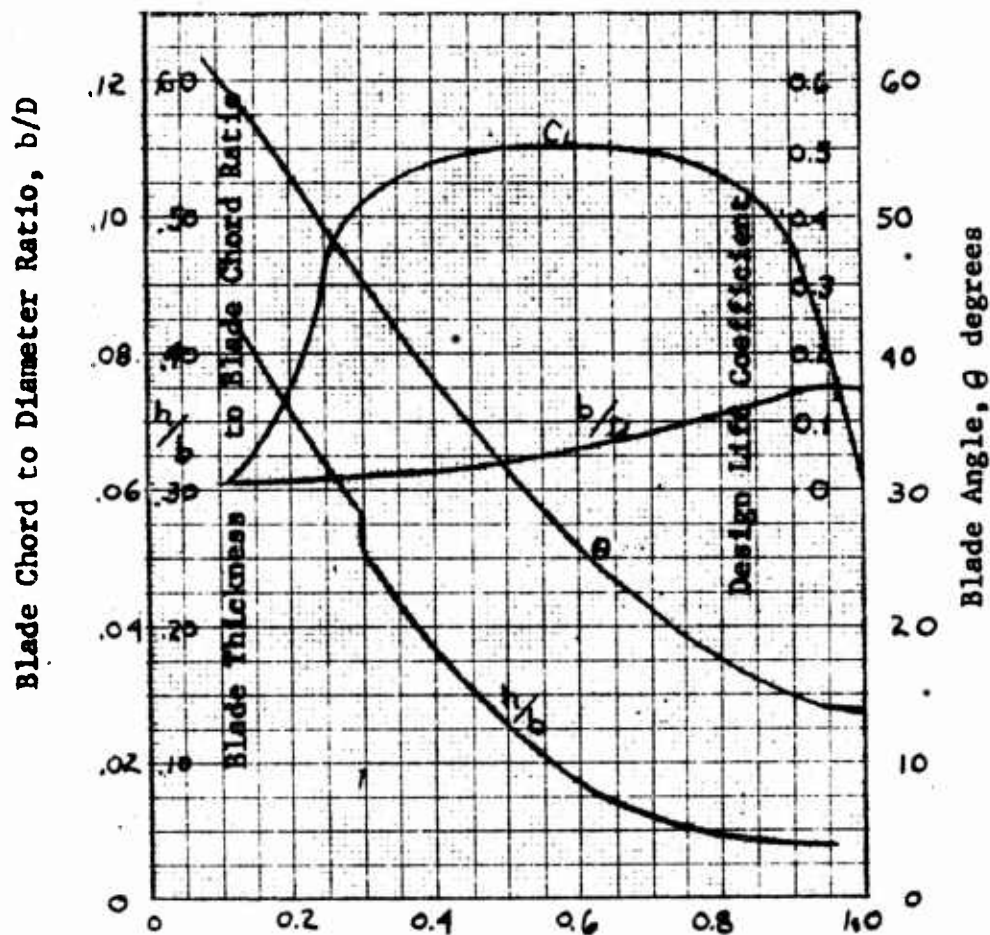

Blade Station to Blade Tip Ratio, r/R

Figure 2: PROPELLER BLADE CHARACTERISTICS

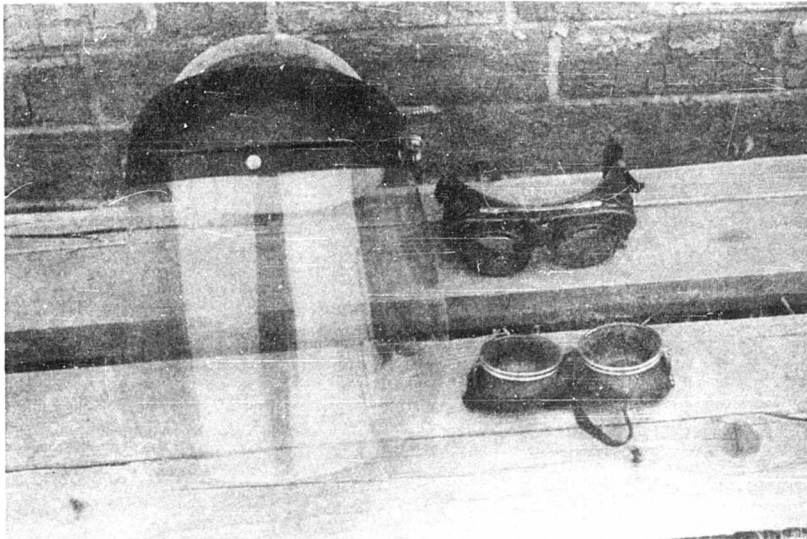

Figure 3: PLASTIC FACE MASK AND PROTECTIVE GOGGLES USED BY GROUND PERSONNEL

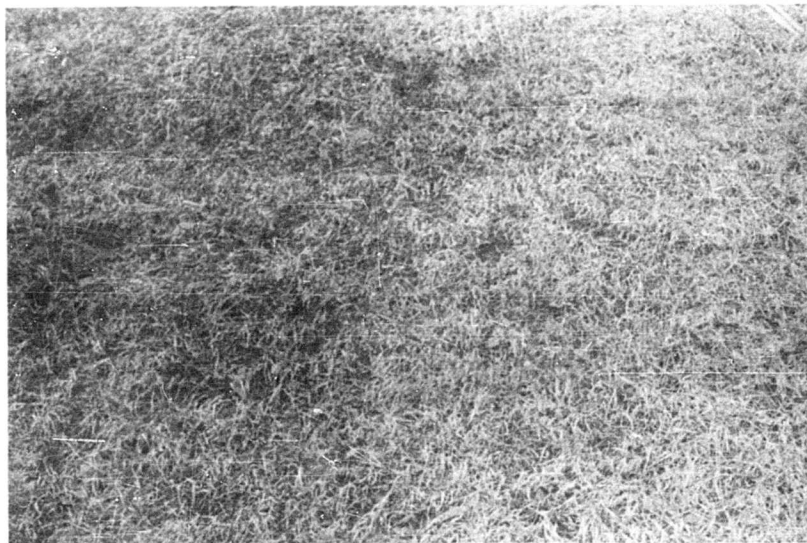

Figure 4: CLOSE-UP VIEW OF SOD TERRAIN



Figure 5: CLOSE-UP VIEW OF EARTH TERRAIN

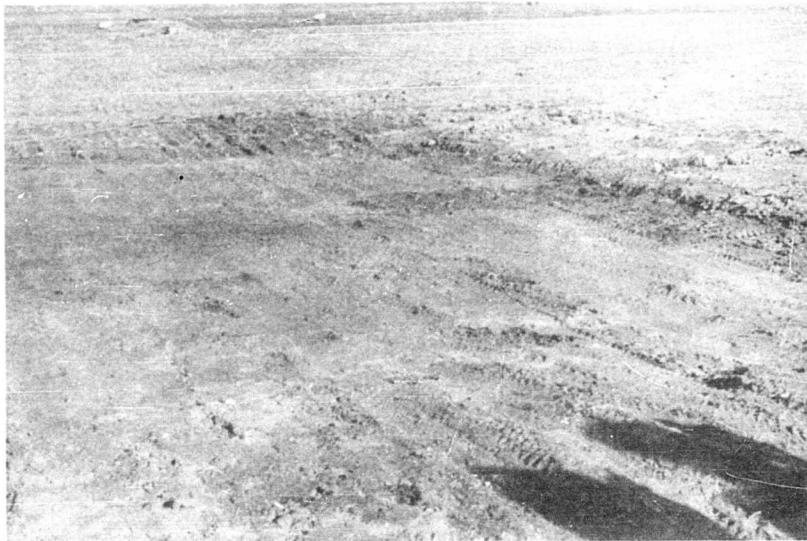

Figure 6: TEST AREA FOR CLAY TERRAIN

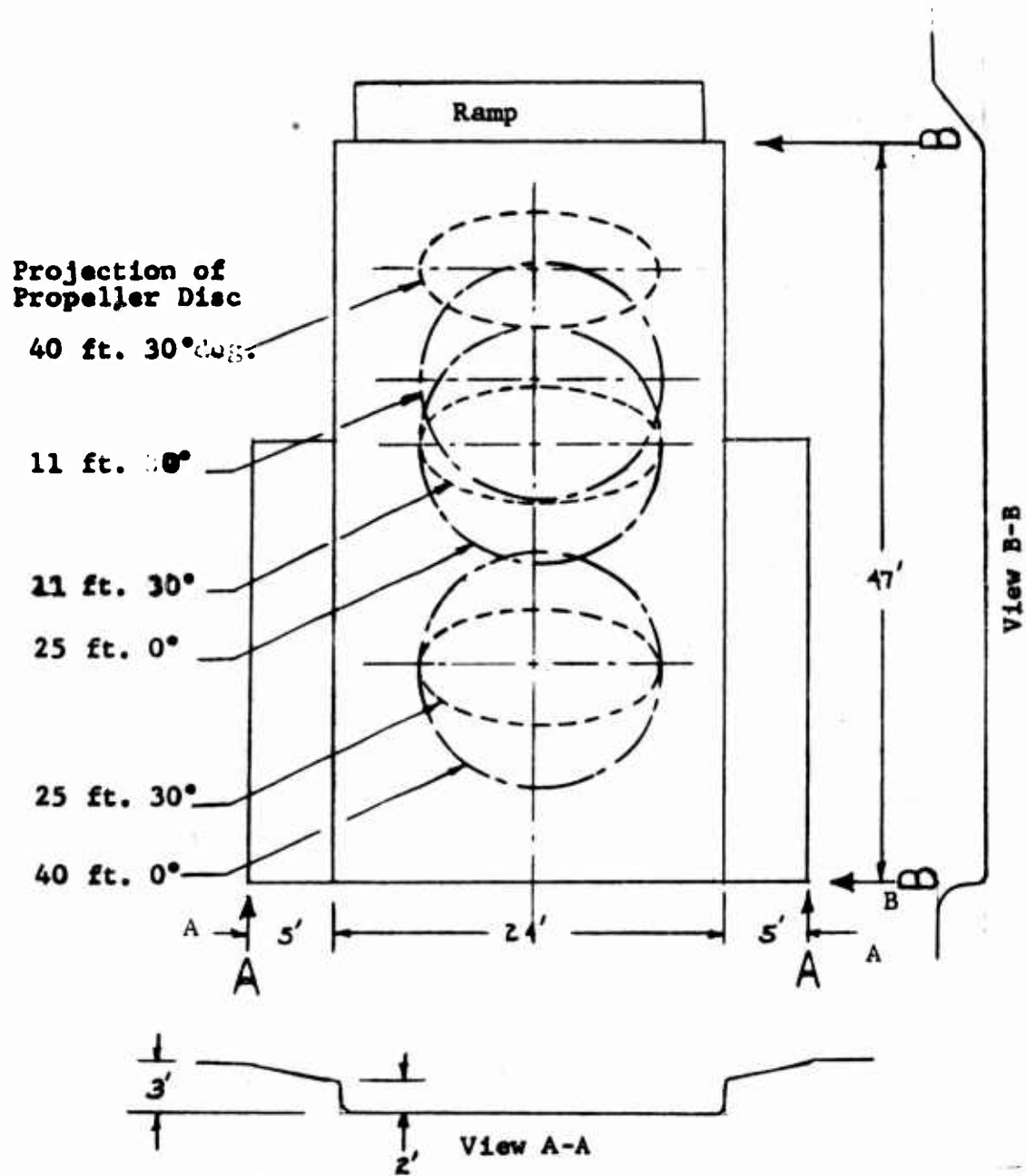

Figure 7: GEOMETRY OF WATER TEST POOL (SHOWING LOCATION OF PROJECTION OF PROPELLER DISC ALONG PROPELLER SHAFT AXIS AT THE GROUND).



Figure 8: TEST SET-UP FOR OPERATIONS OVER
WATER TEST POOL



Figure 9: TEST SET-UP FOR OPERATIONS OVER
SAND TERRAIN

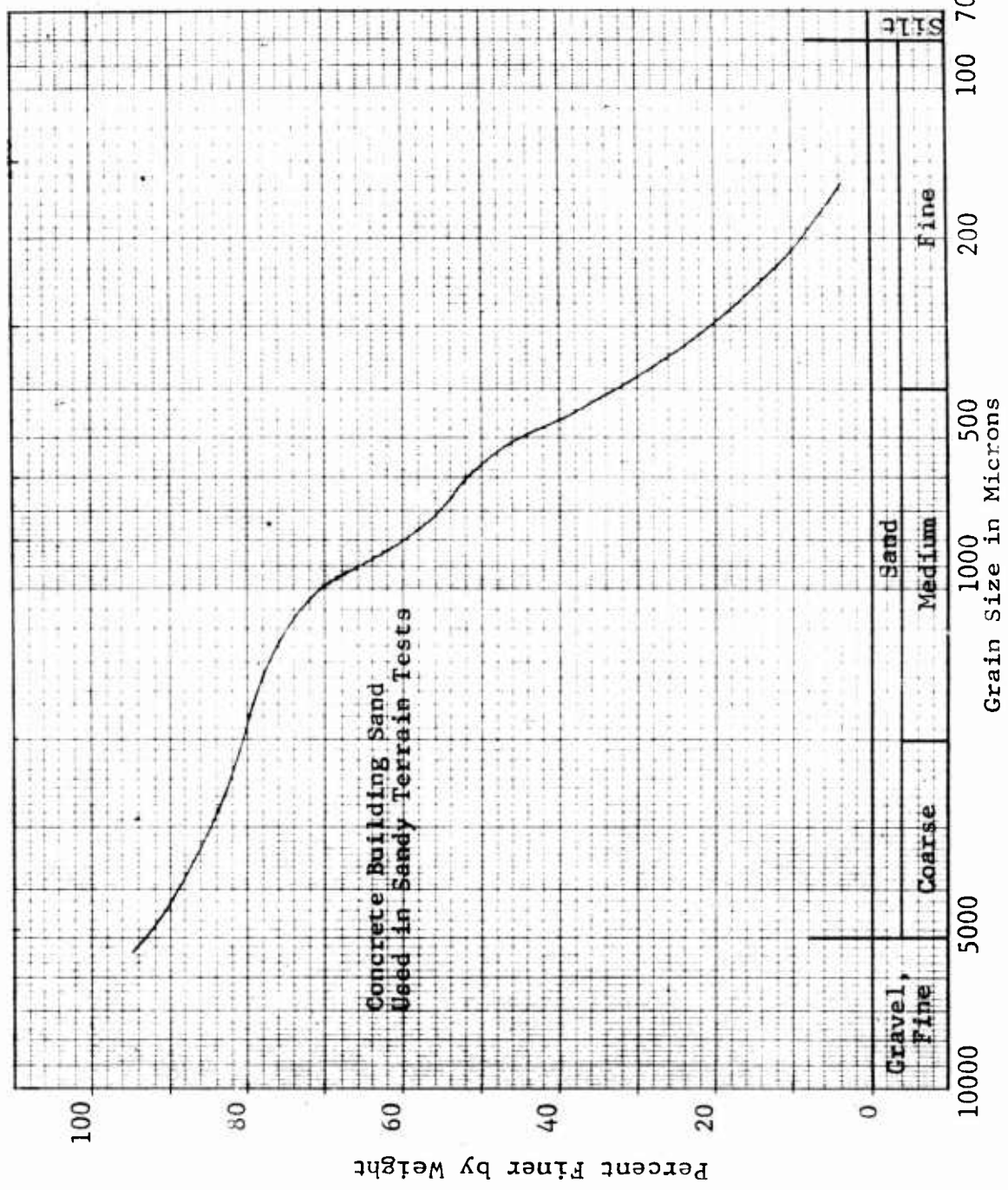

Figure 10: PARTICLE SIZE DATA FOR SAND USED IN DOWNWASH IMPINGEMENT STUDY



Figure 11: CLOSE-UP VIEW OF GRAVEL AND
STONE TERRAIN



Figure 12: TEST SET-UP TEST OBJECTS ON
SNOW COVERED SURFACE

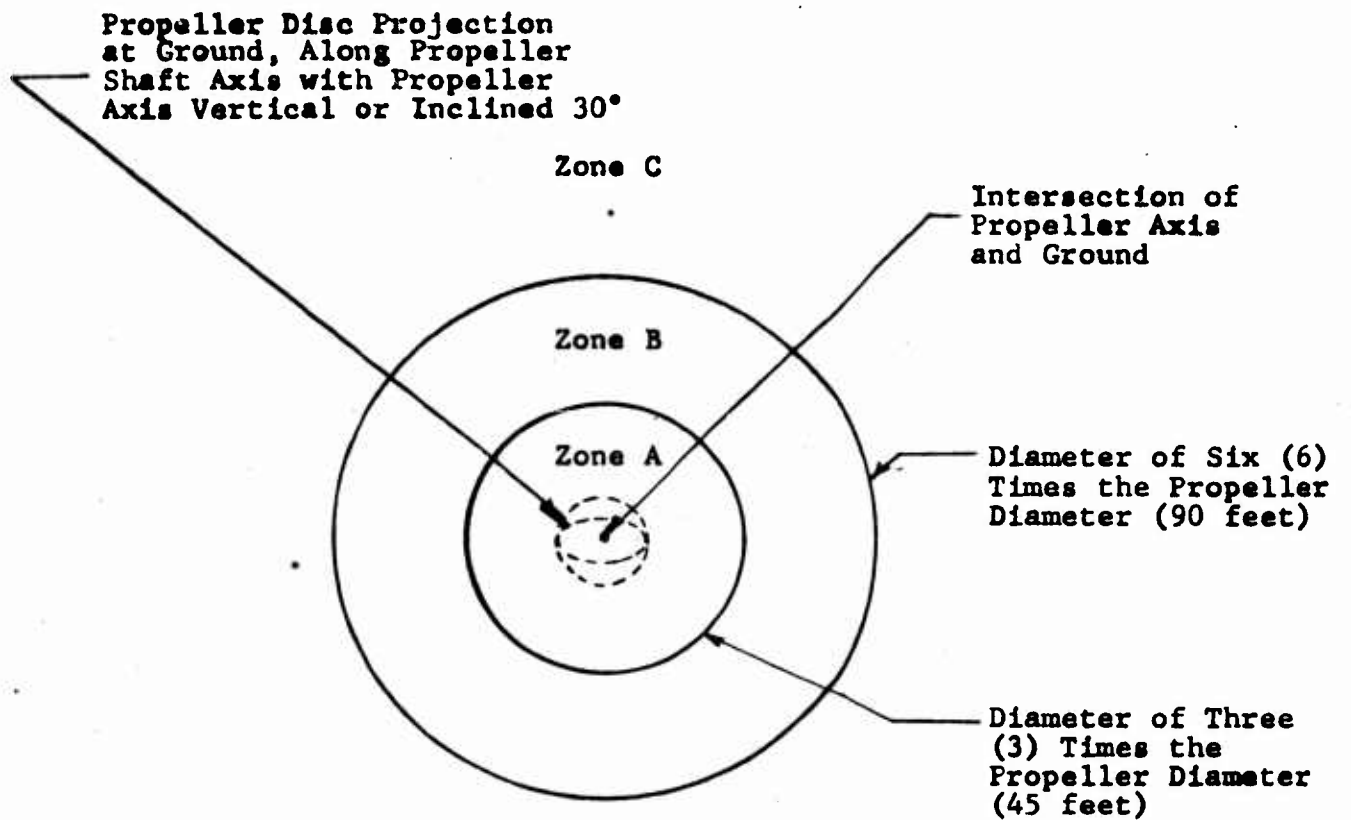

**Figure 13: ZONES OF OPERATIONAL LIMITATIONS
FOR PERSONNEL AND EQUIPMENT**

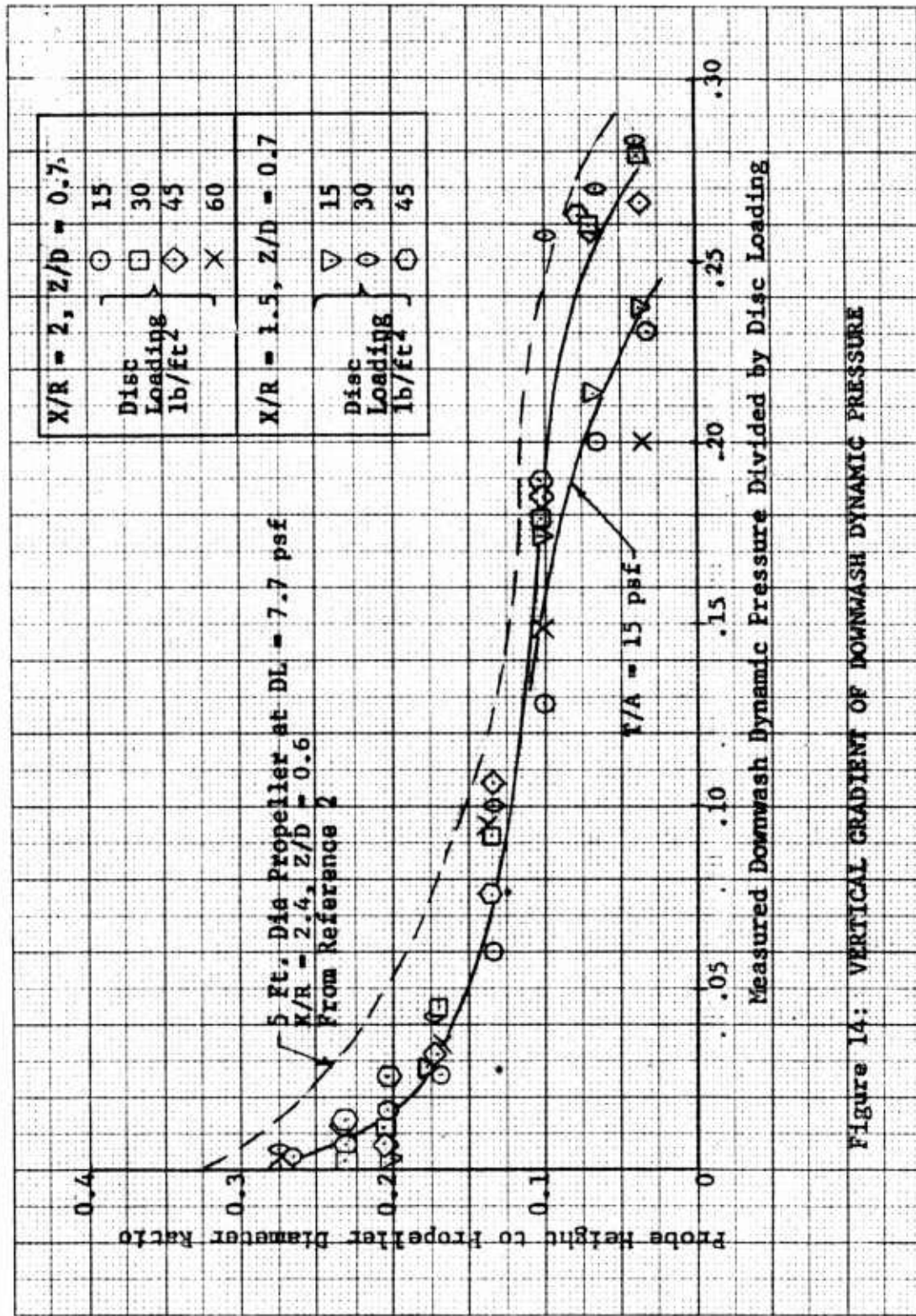

Figure 14: VERTICAL GRADIENT OF DOWNWASH DYNAMIC PRESSURE

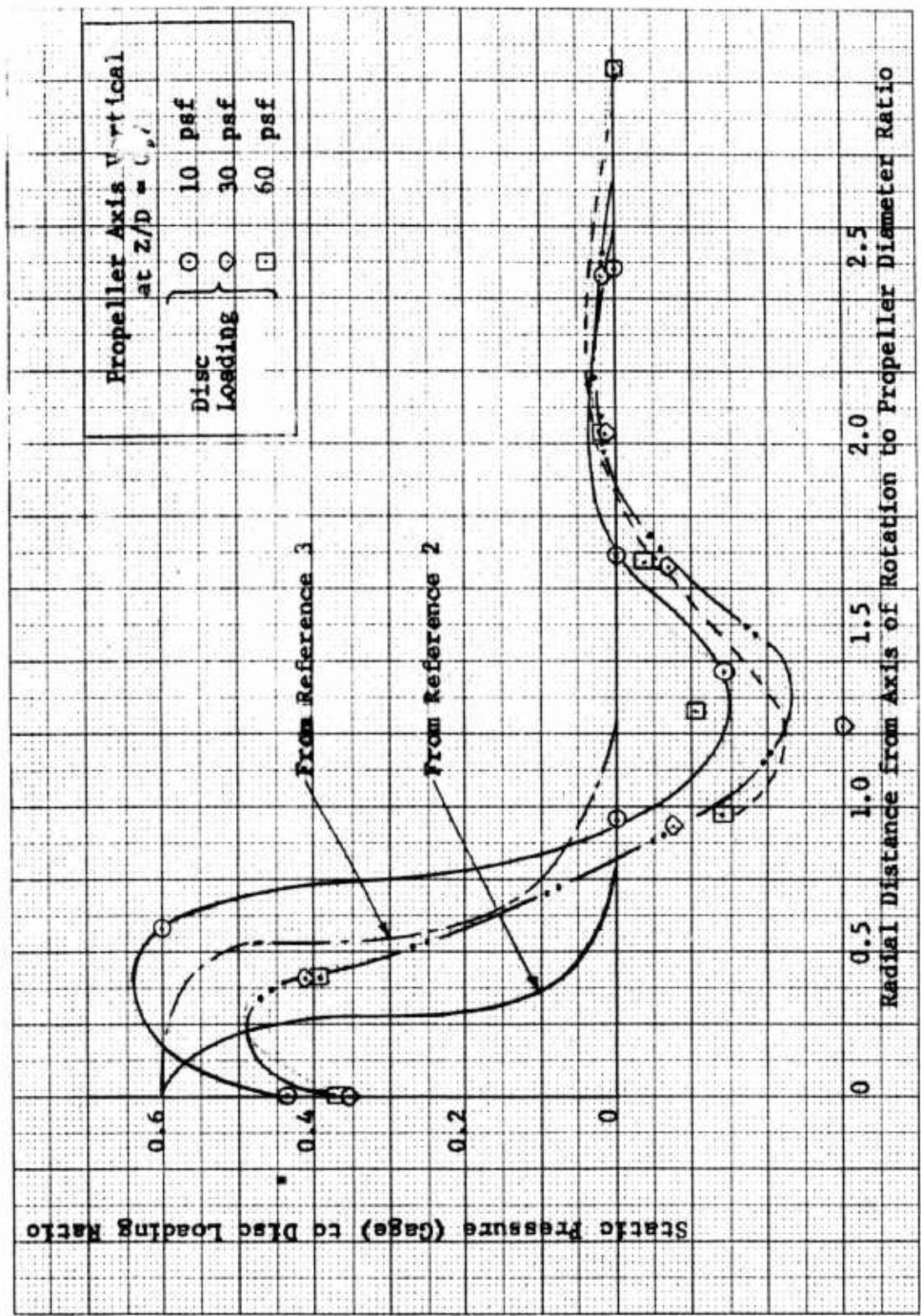

Figure 15: STATIC PRESSURE AT THE GROUND DUE TO DOWNWASH WITH THE PROPELLER AXIS VERTICAL

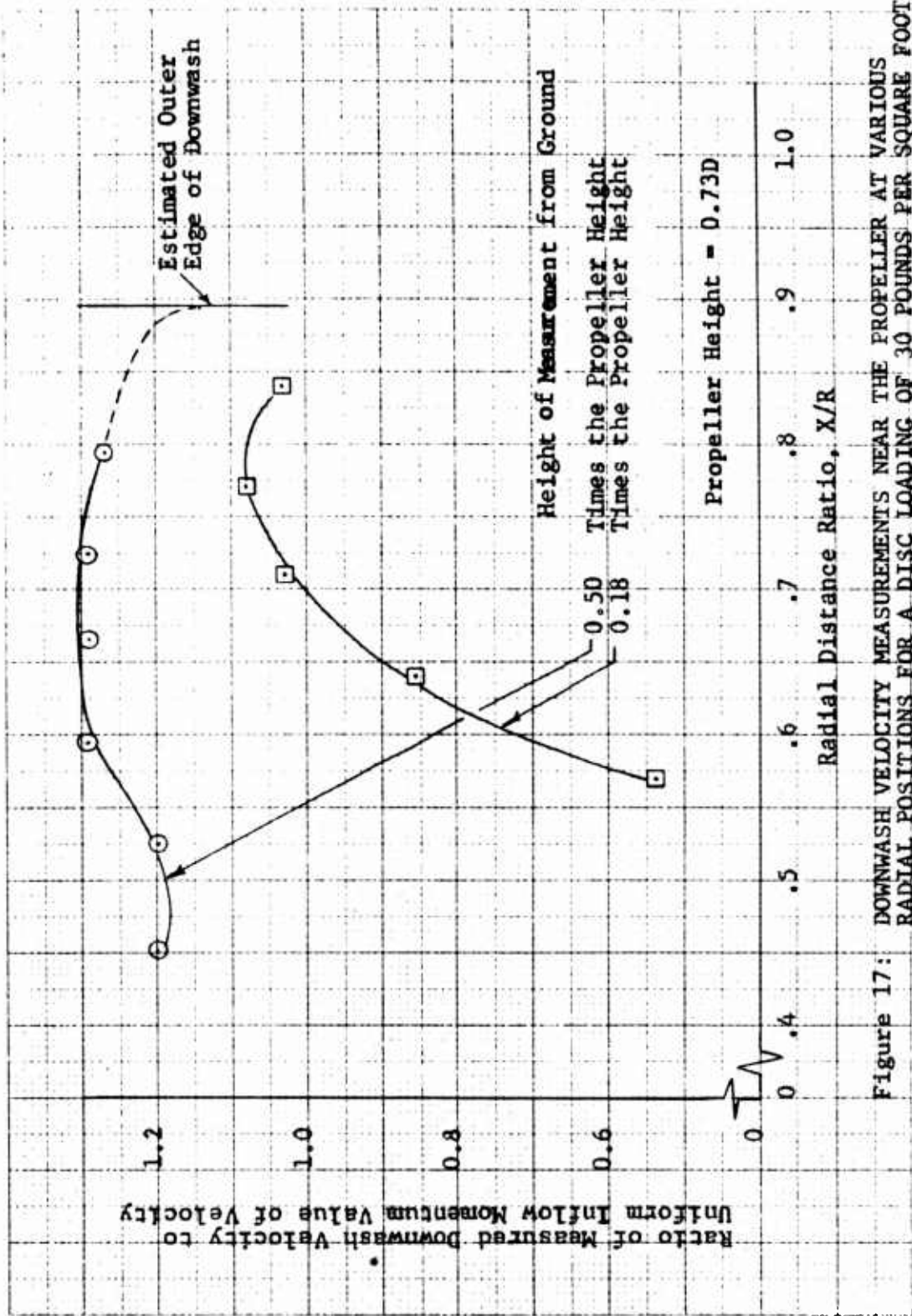

Figure 17: DOWNWASH VELOCITY MEASUREMENTS NEAR THE PROPELLER AT VARIOUS RADIAL POSITIONS FOR A DISC LOADING OF 30 POUNDS PER SQUARE FOOT

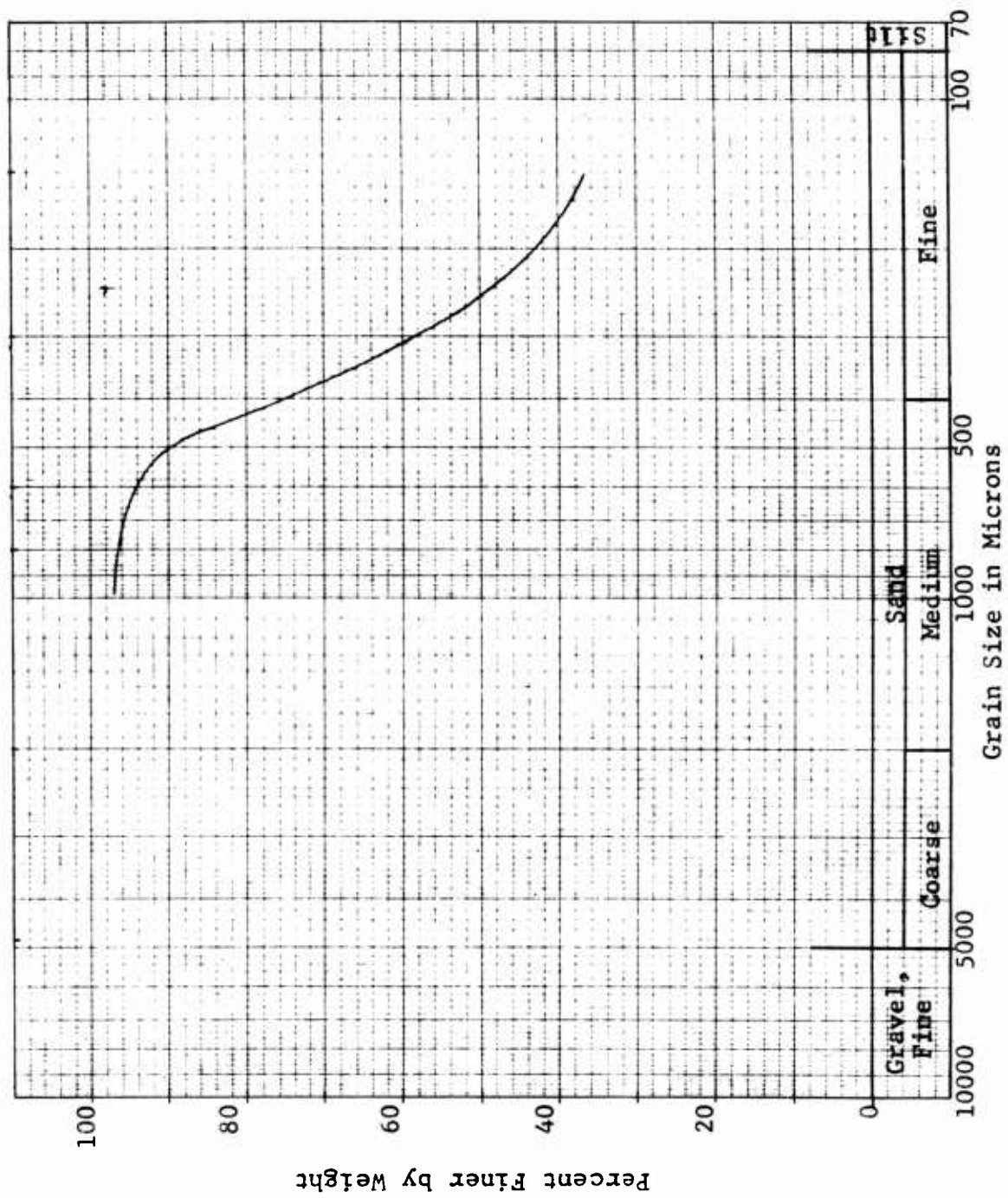

Figure 18: PARTICLES COLLECTED ON ENGINE AIR FILTER WHEN OPERATING OVER EARTH

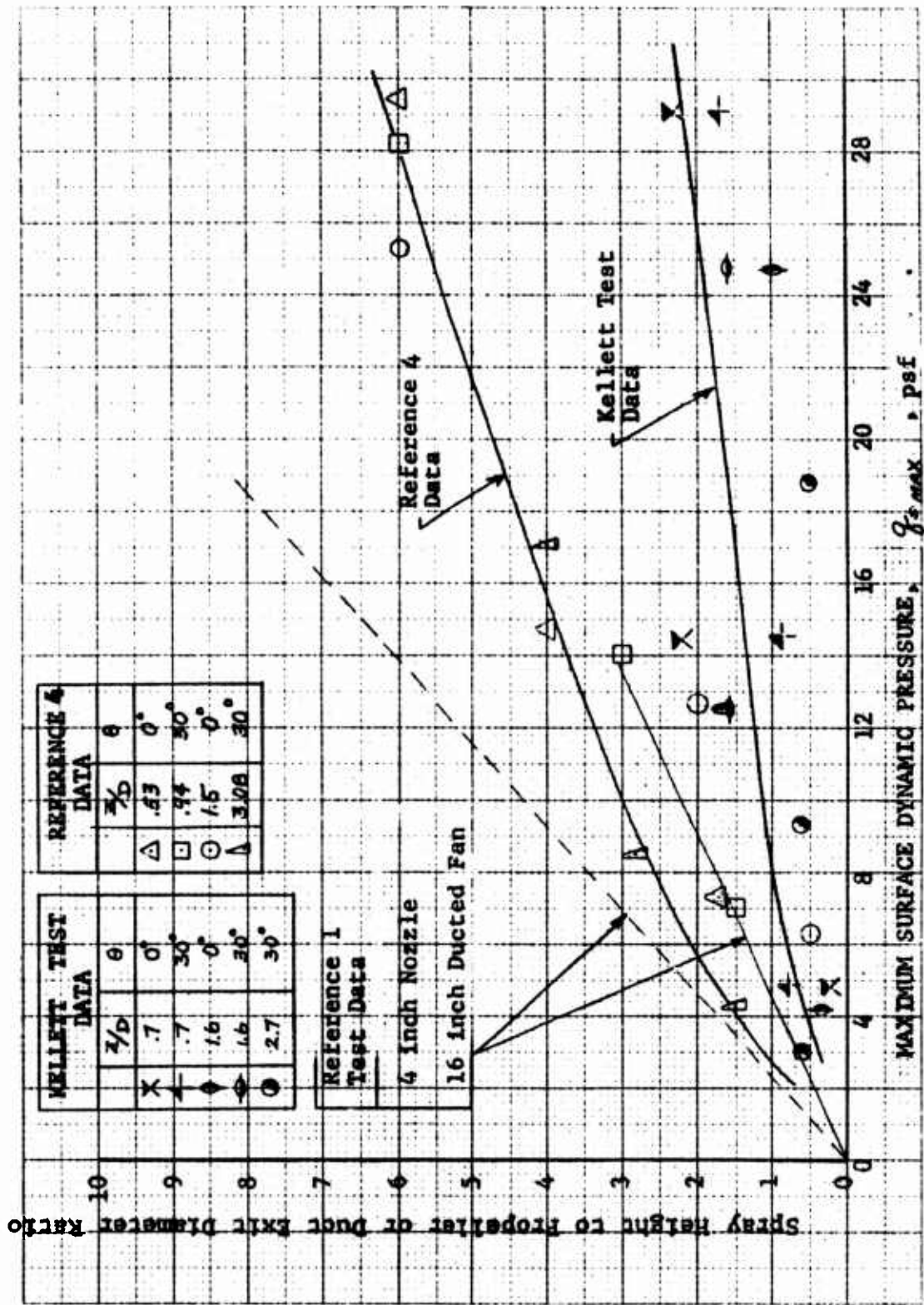

Figure 19: HEIGHT AT WHICH WATER SPRAY WAS OBSERVED FOR VARIOUS SURFACE DYNAMIC PRESSURES

Article	Item Number	Weight (lb)	Dimensions (inches)	Frontal Area ft ²
Box	1	24	16 x 25 x 15	1.65
Box	2	65	39 x 24 x 25	4.2
Box	8	23	48 x 12 x 8	2.7
Lumber	7	10	29 x 1.5 x 3.5	0.9
Auto Tire	3	17	7 x 26 Dia.	1.26
Large Drum	6A 6B	50	35 x 23 Dia.	5.6
Medium Drum	5	25	29 x 18.5 Dia.	3.7
Small Drum	4, 13, 17	18	26 x 14 Dia.	2.5
Card-board Barrel	12	6	32 x 17 Dia.	3.8
Small Drum Full Water	14	162	26 x 14 Dia.	2.5
Small Drum 3/4 full Water	15	127	26 x 14 Dia.	2.5
Small Drum 1/2 full Water	16	90	26 x 14 Dia.	2.5

Table 1: DESCRIPTION, WEIGHT AND DIMENSIONS OF TEST OBJECTS

Table II TERRAIN: WATER

Disc Loading psf	Propeller Height Ratio Z/D	Propeller Inclina- tion	Pilot Vision	OPERATIONAL LIMITATION												Conceal- ment	
				Personnel						Equipment			Aircraft				
				Zone A		Zone B		Zone C		Zone A	Zone B	Zone C	Propel- ler	En- gine	Air- frame		
				Vision	Injury	Motion	Vision	Injury	Motion	Vision	Injury	Motion					
60	0.73	Vertical	U	L(1)	L(2)	L	L	L	S	S	T	S	S	S	S	L	
		30	↓		L(2)		L		L								
	1.67	Vertical	L		L					S							
		30	↑		L		↑										
	2.67	Vertical	T	L	T	T	T	T									T
		30		L	T	T	T	T									
30	0.73	Vertical	L	U	L(2)	L	L	L	L								
		30	T	U	L(2)	L	L	L			↑						
	1.67	Vertical	T	L	T	T	T	T	S			S					
		30	S	L					T								
	2.67	Vertical		T		S											
		30															
10	0.73	Vertical															S
		30	↓														
	1.67	Vertical	S														
		30															
	2.67	Vertical			S												
		30															

Grading Code
 U - Unacceptable
 L - Limited
 T - Tolerable
 S - Satisfactory

NOTES: 1. Face shield and waterproof clothing would be required due to spray.
 2. Conditions directly under propeller are unacceptable.

Table III TERRAIN: DRY SNOW - See Note (1)

Disc Loading psf	Propeller Height Ratio Z/D	Propeller Inclination	Pilot Vision	OPERATIONAL LIMITATION												Concealment			
				Zone A			Zone B			Zone C			Equipment				Aircraft		
				Vision	Injury	Motion	Vision	Injury	Motion	Vision	Injury	Motion	Zone A	Zone B	Zone C		Propeller	Engine	Airframe
				U	L(2)	L(3)	U	L(2)	L	U	L(2)	L	S	S	S		S	L	S
60	0.73	Vertical	U	L(2)	L(3)	U	L(2)	L	U	L(2)	T	S	S	S	S	S	U		
		30			L(3)				U										
	1.67	Vertical			L				L										
		30			L														
	2.67	Vertical	L	T	T	L	T												
		30			T														
30	0.73	Vertical			L(3)														
		30			L(3)														
	1.67	Vertical	T	T	T	T	S										L		
		30																	
	2.67	Vertical	T																
		30																	
10	0.73	Vertical	U	L		L	L										T		
		30		L			L												
	1.67	Vertical	L	T		T													
		30		L															
	2.67	Vertical	T		S														
		30		T		S													

Grading Code
 U = Unacceptable
 L = Limited
 T = Tolerable
 S = Satisfactory

- NOTES: 1. When wet, packed, or frozen snow is present, conditions will be similar to clay or sand.
 2. Personnel require blizzard protection.
 3. Conditions directly under propeller are unacceptable

Table IV TERRAIN: WET SAND

Disc Loading psf	Propeller Height Ratio Z/D	Propeller Inclina- tion	Pilot Vision	OPERATIONAL LIMITATION												Conceal- ment			
				Personnel						Equipment			Aircraft						
				Zone A			Zone B			Zone C			Zone A	Zone B	Zone C		Propel- ler	En- gine	Air- frame
				Vision	Injury	Motion	Vision	Injury	Motion	Vision	Injury	Motion	Vision	Injury	Motion				
60	0.73	Vertical	T	U	L	L(1)	U	L	L	L	T	L	L	L	L	L	L	T	
		30		U		L(1)	U												
		Vertical		L		L	L												
		30		L		L	L												
		Vertical		T		T	T						S	S	S	S	S	S	
		30				T													
30	0.73	Vertical	S			L(1)					S							T	
		30				L(1)													
		Vertical				L(1)													
		30				L(1)													
		Vertical				T				S	S	S	S	S	S	S	S	S	
		30																	
10	0.73	Vertical																	
		30																	
		Vertical																	
		30																	
		Vertical																	
		30																	

NOTES: 1. Conditions directly under propeller are unacceptable.

Grading Code
 U = Unacceptable
 L = Limited
 T = Tolerable
 S = Satisfactory

Table V TERRAIN: SOD

Disc Loading psf		OPERATIONAL LIMITATION																				Conceal- ment	
		Propeller Height Ratio Z/D	Propeller Inclina- tion	Pilot Vision	Personnel						Equipment			Aircraft									
					Zone A		Zone B		Zone C		Zone A	Zone B	Zone C	Propel- ler	En- gine frame								
					Vision	Injury	Motion	Vision	Injury	Motion						Vision	Injury	Motion					
60	0.73	Vertical	S	L	L(L)	S	L	L	S	S	S	S	S	S	S	S	S	S	S	S	S	S	
		30			L(L)																		
	1.67	Vertical			L																		
		30				L																	
	2.67	Vertical		S	T	T	S	T	T														
		30				T																	
30	0.73	Vertical			L(L)																		
		30			L(L)																		
	1.67	Vertical			L(L)																		
		30			L(L)																		
	2.67	Vertical			T																		
		30				T																	
10	0.73	Vertical																					
		30																					
	1.67	Vertical																					
		30																					
	2.67	Vertical				S																	
		30				S																	

NOTES: 1. Conditions directly under propeller are unacceptable.
 2. Terrain containing loose vegetation may present an unacceptable condition.

Grading Code
 U - Unacceptable
 L - Limited
 T - Tolerable
 S - Satisfactory

Table VI TERRAIN: CLAY - See Note (1)

Disc Loading psf	Propeller Height Ratio Z/D	Propeller Inclination	Pilot Vision	OPERATIONAL LIMITATION												Concealment										
				Zone A			Zone B			Zone C			Equipment				Aircraft									
				Vision	Injury	Motion	Vision	Injury	Motion	Vision	Injury	Motion	Zone A	Zone B	Zone C		Propeller	Engine frame								
60	0.73	Vertical	S	T	L	L(2)	T	L	L	L	S	L	L	T	S	S	S	S	S	S	S					
		30		T		L(2)	T																			
	1.67	Vertical		S		L																				
		30				L																				
	2.67	Vertical			S	T		S	T																	
		30			S	T		S																		
30	0.73	Vertical			L	L(2)		L																		
		30			L	L(2)		L																		
	1.67	Vertical			S	T		S																		
		30																								
	2.67	Vertical																								
		30																								
10	0.73	Vertical																								
		30																								
	1.67	Vertical																								
		30																								
	2.67	Vertical																								
		30																								

NOTES: 1. When clay dust is present conditions will be similar to dry snow.
 2. Conditions directly under propeller are unacceptable.

Grading Code
 U = Unacceptable
 L = Limited
 T = Tolerable
 S = Satisfactory

Table VII TERRAIN: EARTH (moist) - See Note (1)

Disc Loading psi	Propeller Height Ratio Z/D	Propeller Inclination	OPERATIONAL LIMITATION															Concealment							
			Pilot Vision	Zone A						Zone B			Zone C			Equipment			Aircraft						
				Injury		Motion		Vision		Injury		Vision	Motion	Injury	Vision		Zone A		Zone B	Zone C	Propeller	Engine	Airframe		
				Vision	Injury	Motion	Vision	Injury	Motion	Vision	Injury	Motion	Vision	Injury	Motion	Vision	Injury		Motion	Vision	Injury	Motion	Vision	Injury	Motion
60	0.73	Vertical	S	L	L	L(2)	L	L	L	L	L	L	S	S	T	S	S	S	S	S	S	S	S		
		30		L	L(2)	L																			
	1.67	Vertical		T	L	L	T	T	T	T	T	T	S	S	T	S	S	S	S	S	S	S	S	S	
		30		T	L	L	T	T	T	T	T	T	S	S	T	S	S	S	S	S	S	S	S	S	S
	2.67	Vertical		S	S	T	T	S	S	S	T	T	S	S	T	S	S	S	S	S	S	S	S	S	S
		30		S	S	T	T	S	S	S	T	T	S	S	T	S	S	S	S	S	S	S	S	S	S
30	0.73	Vertical		L	L	L(2)	L	L	L	L	L	L	L	L	L	L	L	L	L	L	L	L	L	L	L
		30		L	L(2)	L																			
	1.67	Vertical		L	L	L(2)	L	L	L	L	L	L	L	L	L	L	L	L	L	L	L	L	L	L	L
		30		L	L(2)	L																			
	2.67	Vertical		S	T	T	T	S	S	S	T	T	S	S	T	S	S	S	S	S	S	S	S	S	S
		30		S	T	T	T	S	S	S	T	T	S	S	T	S	S	S	S	S	S	S	S	S	S
10	0.73	Vertical																							
		30																							
	1.67	Vertical																							
		30																							
	2.67	Vertical																							
		30																							

Grading Code
 U = Unacceptable
 L = Limited
 T = Tolerable
 S = Satisfactory

NOTES: 1. When dry earth is present conditions will be similar to dry snow.
 2. Conditions directly under propeller are unacceptable.

Table IX TERRAIN: HARD SURFACE TERRAIN, DEBRIS STREAM

		OPERATIONAL LIMITATION																										
Disc Loading psf	Propeller Height Ratio Z/D	Propeller Inclination	Pilot Vision	Zone A						Zone B				Zone C			Equipment			Aircraft		Concealment						
				Vision		Injury		Motion		Vision		Injury		Motion		Vision		Injury		Motion			Zone A	Zone B	Zone C	Propeller	Engine	Airframe
				U	S	U	S	L(1)	L(1)	L	L	T	T	L(1)	L(1)	T	T	U	S	U	S							
	0.73	Vertical	S	S	U	L(1)	S	U	L	L	S	U	S	U	S	L	L	S	L	L	S	S	S	L	S			
	1.67	Vertical				L																						
	2.67	Vertical				L																						
	0.73	Vertical				T			T																			
	1.67	Vertical				T																						
	2.67	Vertical				L(1)																						
	0.73	Vertical				L(1)																						
	1.67	Vertical				L(1)																						
	2.67	Vertical				T			S																			
	0.73	Vertical				S																						
	1.67	Vertical																										
	2.67	Vertical				S																						
	0.73	Vertical				S																						
	1.67	Vertical																										
	2.67	Vertical				S																						
	0.73	Vertical				S																						
	1.67	Vertical																										
	2.67	Vertical				S																						

Grading Code
 U = Unacceptable
 L = Limited
 T = Tolerable
 S = Satisfactory

NOTES: 1. Conditions directly under propeller are unacceptable

ANALYSIS OF DATA FROM AN INVESTIGATION OF VTOL
OPERATIONAL PROBLEMS DUE TO DOWNWASH EFFECTS

(Supplement to Kellett Aircraft Corporation Report 179T80-2
of 12 June 1961)

The operational problem severity data presented in the body of this report shows definite trends which can be presented in graphical form. With the data presented in this manner the necessity of correlating the data and of determining logical reasons for the trends shown becomes obvious. Therefore, a brief first order analysis of this data has been made based on the existing flow field data and is presented. It is believed that this analysis provides a means for presenting the data in a more readily digested manner and indicates the parameters which are of importance.

I. The Downwash Flow Field

The downwash flow field data measured in this program and as presented in Reference 1, 2 and 3 (of KAC Report 179T80-2) is plotted in Figure 1S to show the effect of radial distance on the peak surface dynamic pressure near the ground (q_s) for various propeller height to diameter ratios. This data shows that at a radial distance of about one diameter, the gradient of surface dynamic pressure with propeller height is quite large.

At radial distances of two diameters or more the surface dynamic pressure is almost independent of propeller height. This data is shown in Figure 2S for the mid-radius of the test zones considered in the test program. It may be noted that the peak surface dynamic pressure is almost linear with propeller height in Zone A, but is almost independent of propeller height in Zone C. Also, the peak surface pressure is about one-half as large in Zone B as in Zone A, and about one-seventh as large in Zone C as in Zone A. These effects should be considered in the interpretation of the test data.

II. Operational Problems Which Are Independent of Terrain

A. Personnel, Motion Restricted Due to Aerodynamic Forces

The data obtained on the personnel motion problem are presented in Figures 3S, 4S and 5S. The upper limit of the tolerable zone seems to follow the trend of the peak surface dynamic pressure except that there is a considerable influence of propeller height on the data in Zone C. The severity of the problem is shown to be similar in Zones A and B.

III. Visual Problems Due to Terrain

Visual problems are caused by the creation of an opaque cloud of terrain particles by the downwash. This depends on the number, size, density and shape of the terrain particles, and the local downwash dynamic pressure at the particle. The

tendency for a particle to become entrained in the downwash will be greater if the weight of the particle is small in comparison with its aerodynamic drag area. The ratio of these factors can be estimated by assuming the particles are spheres and have a drag coefficient of unity. Thus, the particle weight to drag area ratio can be estimated as:

$$W/C_D A = (41.6) (S.G.) d$$

where

W	=	Weight of the particle, lb.
C_D	=	Drag coefficient of particle
A	=	Frontal area of particle, ft. ²
S.G.	=	Specific gravity of particle
d	=	Particle diameter, ft.

This weight to drag area ratio and the number of terrain particles available for the formation of a cloud should provide a first order correlation of the visual problem data.

The particle size, average diameter and specific gravity of the terrains tested have been measured or estimated and are presented in Table 1S. The terrains are subdivided into groups depending on the number of particles which are available to the downwash per unit area of the ground surface. Since the terrains which have a large number of particles have about the same size it would be expected that the specific gravity of the terrain is the parameter which will provide correlation of the

visual problems with these terrains. It may also be noted from Table 1S that the product of specific gravity and size of the particles of the terrains which have few particles per unit area is at least a factor of ten larger than the terrains with a large number of particles. Therefore, it would be expected that these terrains (earth, debris, gravel and stone) would not tend to become entrained in the downwash even if there were a large number of particles present.

These conclusions as to the effects of the terrain characteristics on visual problems will be applied to the specific problem areas in the following discussion.

A. Pilot's Vision

There is a problem of pilot's vision only for operations over the terrains with a large number of particles per unit area (water, sand and snow). As shown in Figure 6S, the data correlate fairly well with the product of the propeller height-diameter ratio and the specific gravity of the terrain. This indicates that the data are consistent and can be extrapolated to other terrain with some confidence. The cloud which obscures the pilot's vision is apparently created in a region where the downwash intensity is fairly linear with propeller height.

B. Personnel, Vision

The data on the ground personnel vision problem is not

consistent. This apparently is due to having a too finely divided grading system for the accuracy of the test method as well as specific problems that were more severe than the problem due to the terrain particle cloud. For example, when operations were over clay, earth and wet sand, terrain particles would stick to the face shields of ground personnel and obscure their vision. This caused a visual problem since cleaning the face shields was found to be not feasible in this environment.

The data which were obtained are shown in Figures 7S, 8S and 9S. Considerable overlap of the data is shown. The best correlation was obtained in Zone A when the specific gravity of the terrain was not considered. Data obtained for Zones B and C correlated best with consideration given to the specific gravity of the terrain.

Further testing should be made with more accurate testing methods to determine the severity of this problem. The problem area may also have to be defined more carefully for these tests.

C. Concealment

The problem of concealment also is concerned with the opaque terrain particle cloud and therefore is also a visual problem. As shown in Figure 10S, the data on the severity of this problem correlates for various terrains when the product of

the propeller height-diameter ratio and the specific gravity is used as a parameter. As with the pilot's vision problem, the terrains that were troublesome had a large number of particles per unit ground surface.

It may be noted from a comparison of Figures 6S and 10S that the problem of pilot's vision is more severe than the concealment problem.

IV. Problems of Damage due to Terrain.

The potential of a terrain particle for doing damage depends on its weight-drag area ratio (as defined previously) which will indicate the tendency of the particle to become entrained in the downwash. Also, once the particle is entrained its momentum per unit frontal area will indicate the damage which the particle can cause if it collides with the aircraft or other equipment.

If the particles are assumed to be spheres the momentum per unit area can be estimated as follows:

$$mv/A = (37.4) (S.G.)d \sqrt{q_s}$$

where

m = Mass of particle, slugs

v = Velocity of particle, fps

A = Frontal area of particle, ft.²

S.G. = Particle specific gravity

d = Particle diameter, ft.

q_s = Local downwash dynamic pressure, psf

A comparison of this relation with the relation given previously for the weight to drag area ratio shows that if the particle specific gravity or diameter is increased its potential for doing damage is increased, but the tendency for the particle to become entrained in the downwash is reduced. It would, therefore, be expected that there is a certain size of particle which would cause the most damage and particles which are larger or smaller would cause less damage.

The hardness and shape of the particle will also influence the damage which can be caused. There is some data on this subject available in NASA TN D-238 for metal particles. This NASA data can also be used to show the expected magnitude of the damage which would be caused by particles entrained by downwash. For example, the momentum per unit frontal area of a particle is $0.027 \text{ lb. sec/in.}^2$ if the following parameters are assumed:

$$d = 0.08 \text{ inches}$$

$$\text{S.G.} = 2$$

$$q_s = 60 \text{ psf}$$

From the data of TN D-238 it is found that steel projectiles with this momentum per unit area, will penetrate aluminum plates to a depth of 0.001 inches. This is of the same order of magnitude as the depth of the pitting of aluminum equipment by

sand particles which occurred during testing.

In general, it would be concluded from this discussion that the problem of damage caused by particles is more sensitive to particle size than the visual problems. However, other factors such as particle hardness will also be significant.

A. Personnel, Risk of Injury from Terrain Particles

The risk of injury to personnel depends to a considerable extent on the particle size. In general, particles which are large enough to cause serious injury such as debris are too large to become entrained in the downwash. However, these objects bounce along the ground and achieve considerable velocity when the propeller is at low height and high disc loading. As shown in Figures 11S, 12S and 13S, debris presents an unusual problem in that the particles are so large that the damage which they can cause would require extraordinary protection for the personnel.

For gravel and stone, sand and snow, personnel will require some protection for all conditions of propeller height and disc loadings tested and, therefore, conditions are limited. These smaller particles (only the smaller particles of gravel) become entrained in the downwash but are not large enough to cause injury to adequately protected personnel. Conditions which prevail when operating over earth, clay, sod and water are as shown in Figures 11S, 12S and 13S.

B. Possible Damage to Airframe

There was a risk of damage to the airframe when operating over sand, debris, gravel and stone. The data which was obtained is shown plotted in Figure 14S. This data was consistent for the three terrains which were troublesome.

C. Possible Damage to Propeller

Operation over sand and gravel and stone terrain caused a risk of damage to the propeller at the higher disc loadings and lower propeller heights. This data is shown in Figure 15S.

D. Evaluation of Risk of Engine Ingestion

The data obtained in the evaluation of ingestion problems is shown in Figure 16S. Only the wet sand terrain is shown to be a problem. Snow was evaluated as limited for all conditions. Also it should be noted that loose vegetation may present an unacceptable condition. It is likely that operations over salt water would be graded as a limited condition.

E. Damage to Equipment

The risk of damage to equipment can be plotted on one curve to show the severity of the problem for the terrains which caused damage; sand, debris, and gravel and stone. An effective propeller height parameter was used for this purpose which was defined as the actual propeller height-diameter ratio times the average radius of a zone divided by the average radius of Zone A. This factor is fairly consistent with the peak surface

downwash dynamic pressure data given previously. The actual propeller height-diameter ratio was multiplied by the following factors:

Zone A = 1.00

Zone B = 2.25

Zone C = 4.50

The resulting data is shown in Figure 17S.

a. Terrain with a Large Number of Particles per Unit Ground Area

TERRAIN	SPECIFIC GRAVITY	PARTICLE SIZE (Average), inches	(S.G.)(SIZE)
Water	1.00	0.10 (estimated)	0.10
Sand	1.45	0.08 (measured)	0.12
Snow	0.27	0.15 (estimated)	0.04

b. Terrain with Few Particles per Unit Ground Area

TERRAIN	SPECIFIC GRAVITY	PARTICLE SIZE (Average), inches	(S.G.)(SIZE)
Gravel & Stone	2.5	1/2 to 3 (measured)	1.2
Debris	0.3	23 (measured)	6.9
Earth	1.6	1 (estimated)	1.6

c. Terrain with No Significant Particles

TERRAIN
Sod
Clay

TABLE 1S: TERRAIN PARTICLE PARAMETERS

NOTE: $D_e = 0.707 D$ Open Propeller

$q_n =$ Disc Loading for Open Propeller

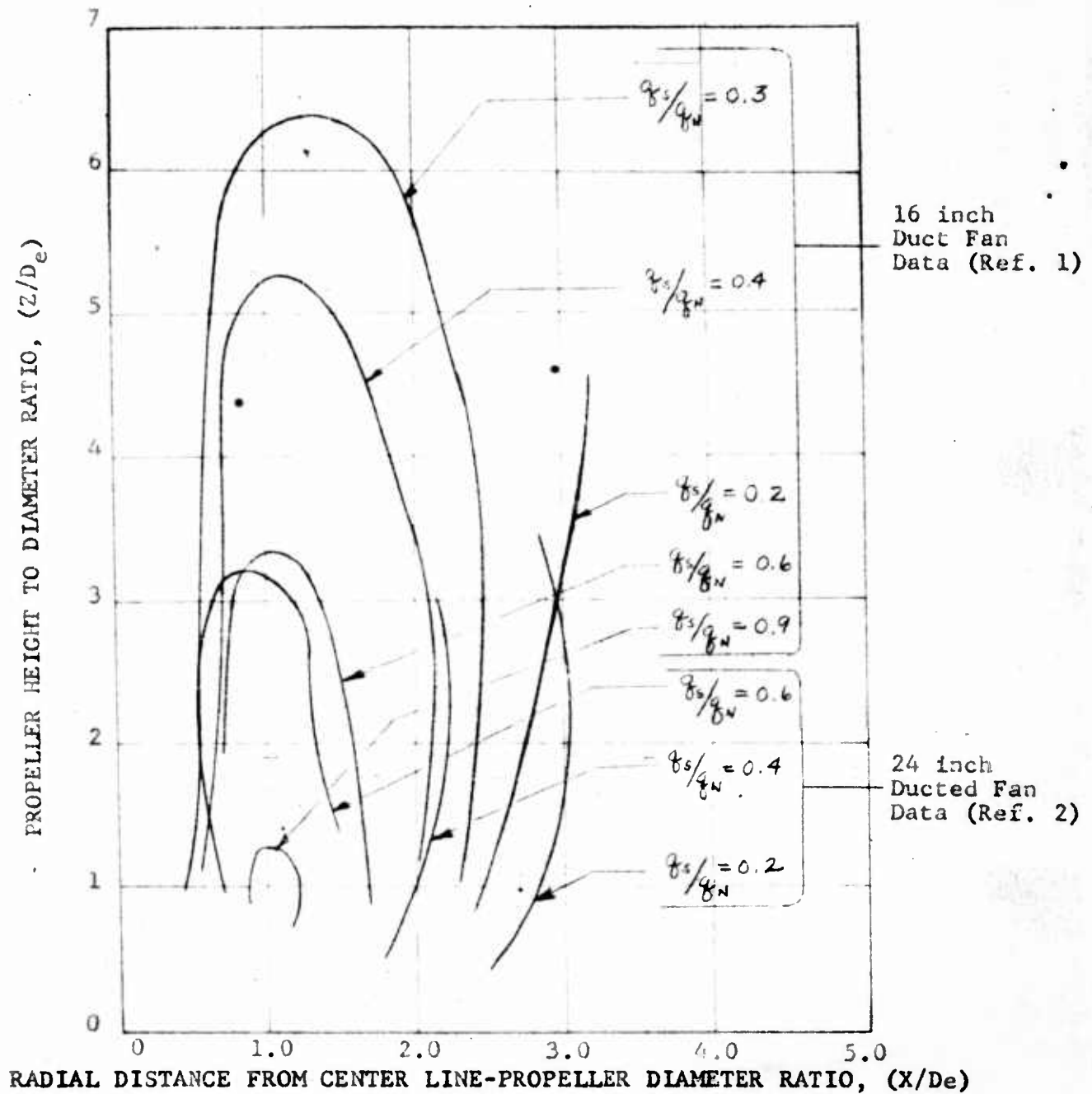

FIGURE 18: EFFECT OF PROPELLER HEIGHT ON MAXIMUM DOWNWASH DYNAMIC PRESSURE (PARALLEL AND NEAR TO GROUND) AT A RADIAL DISTANCE FROM THE PROP CENTER LINE.

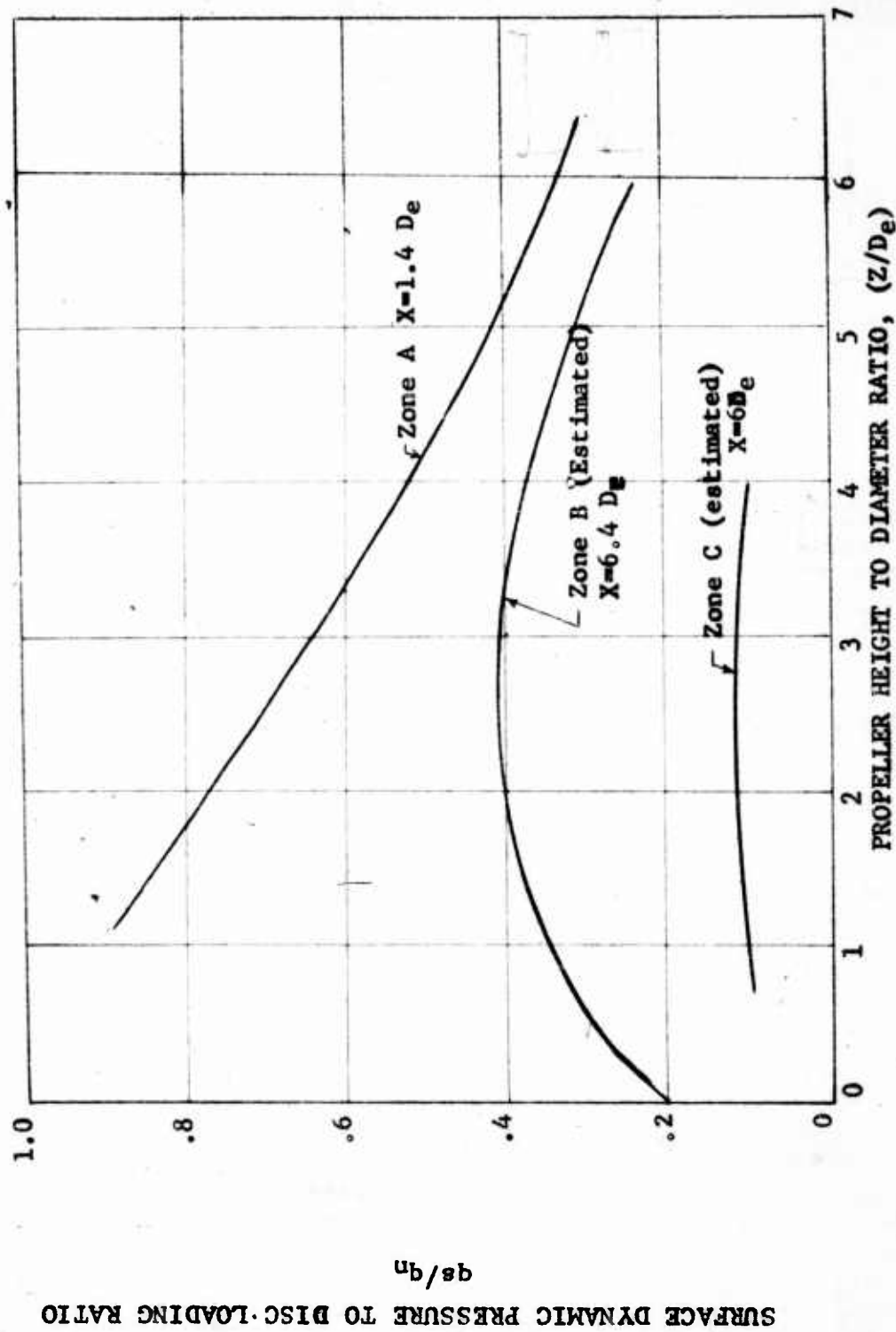

FIGURE 2S EFFECT OF PROPELLER HEIGHT ON SURFACE DYNAMIC PRESSURE FOR THE GROUND AREA ZONES CONSIDERED IN THE TEST PROGRAM.

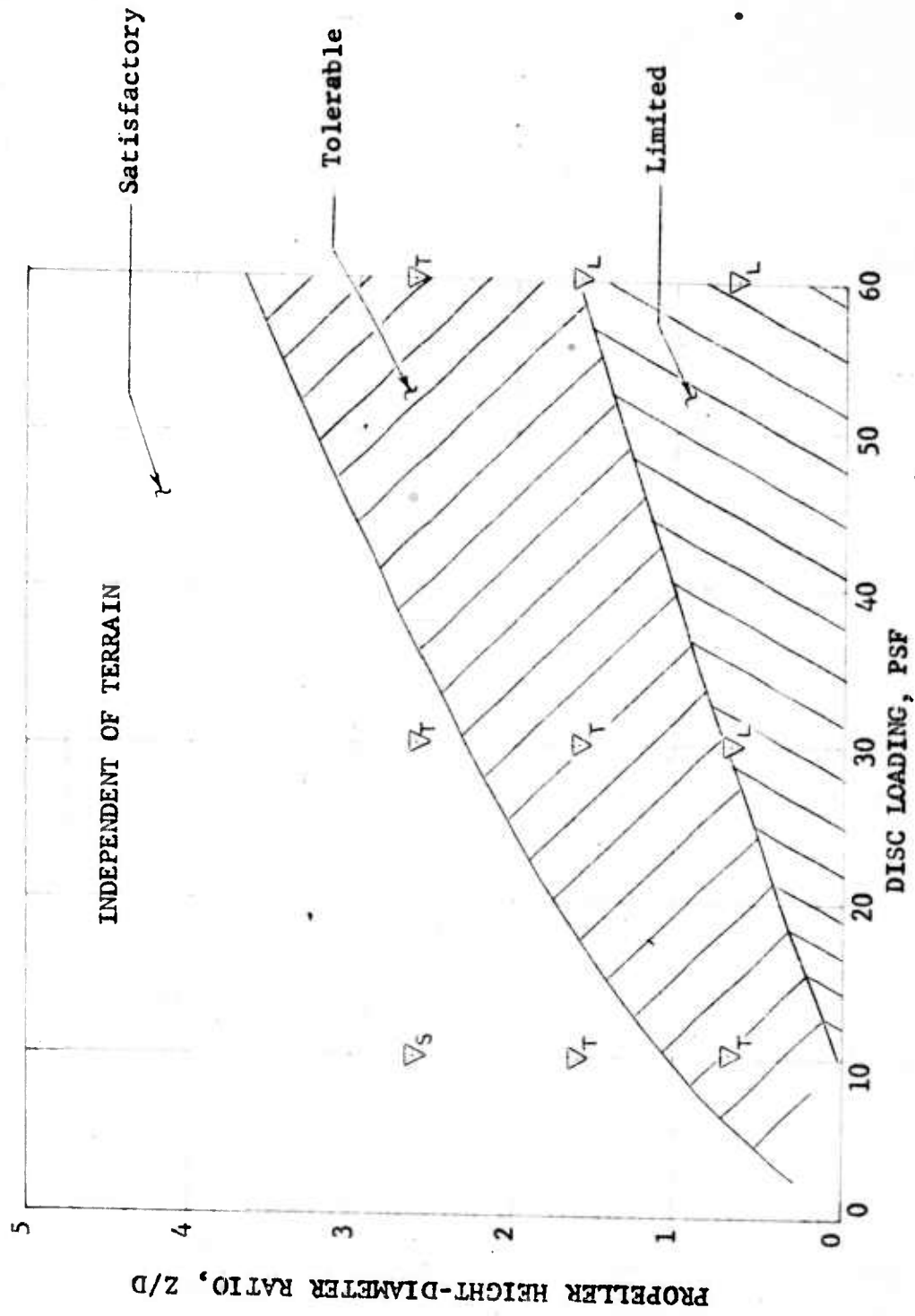

FIGURE 3S: RESTRICTION OF PERSONNEL MOTION BY DOWNWASH AERODYNAMIC FORCES IN ZONE A

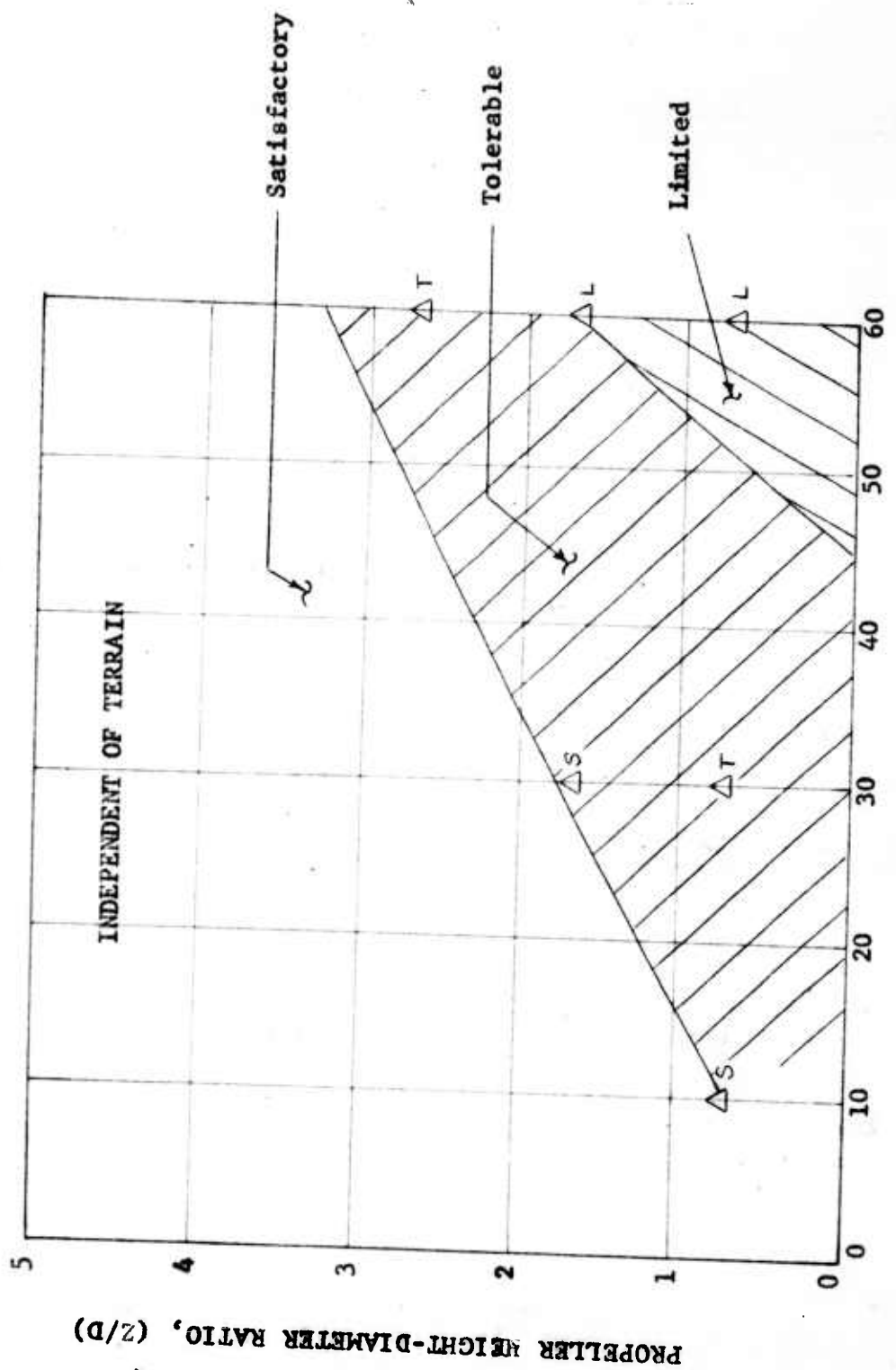

FIGURE 4S: RESTRICTION OF PERSONNEL MOTION BY DOWNWASH AERODYNAMIC FORCES IN ZONE B

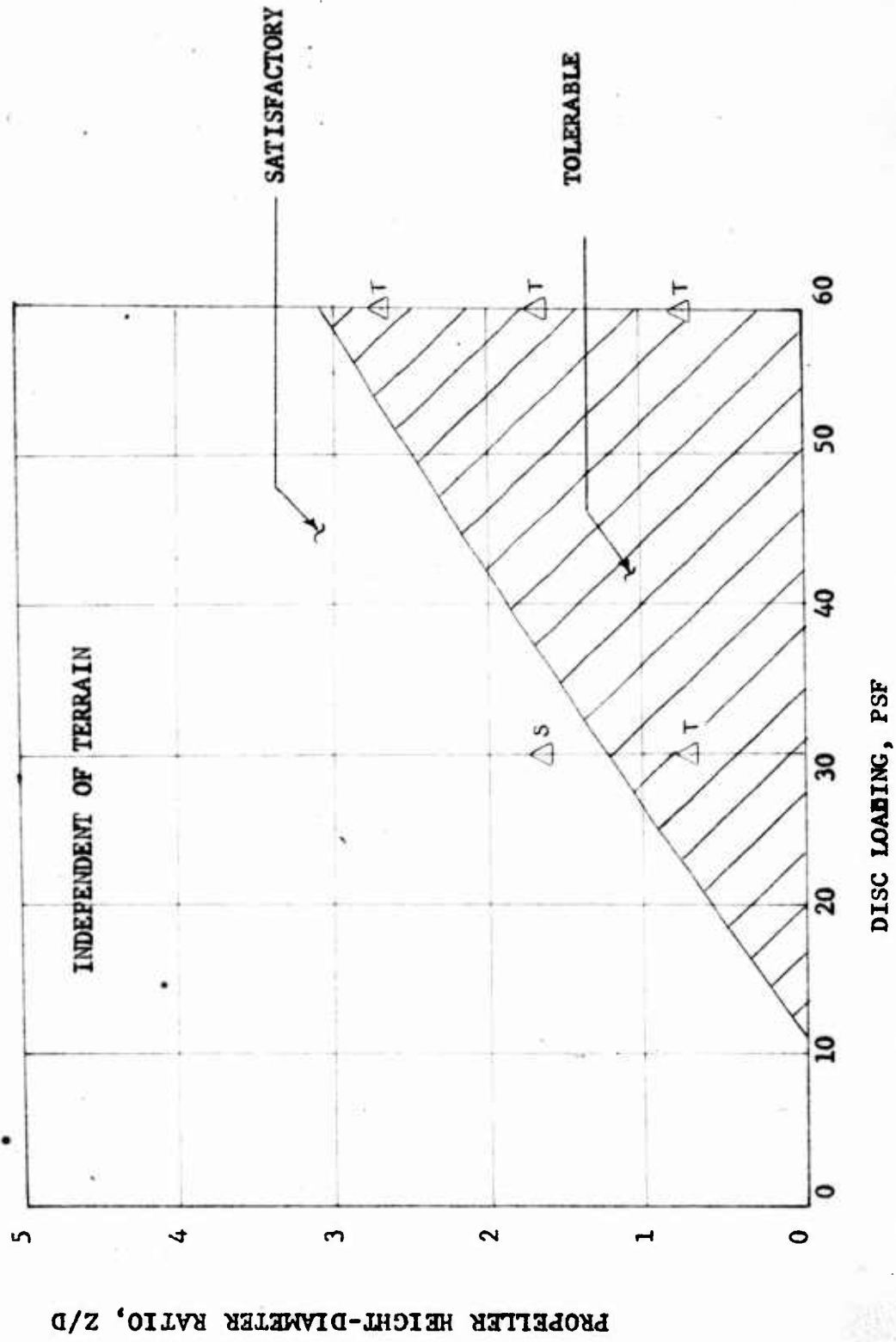

FIGURE 5S: RESTRICTION OF PERSONNEL MOTION BY DOWNWASH AERODYNAMIC FORCES IN ZONE C

Terrain	○
Water	△
Snow	□
Band	■

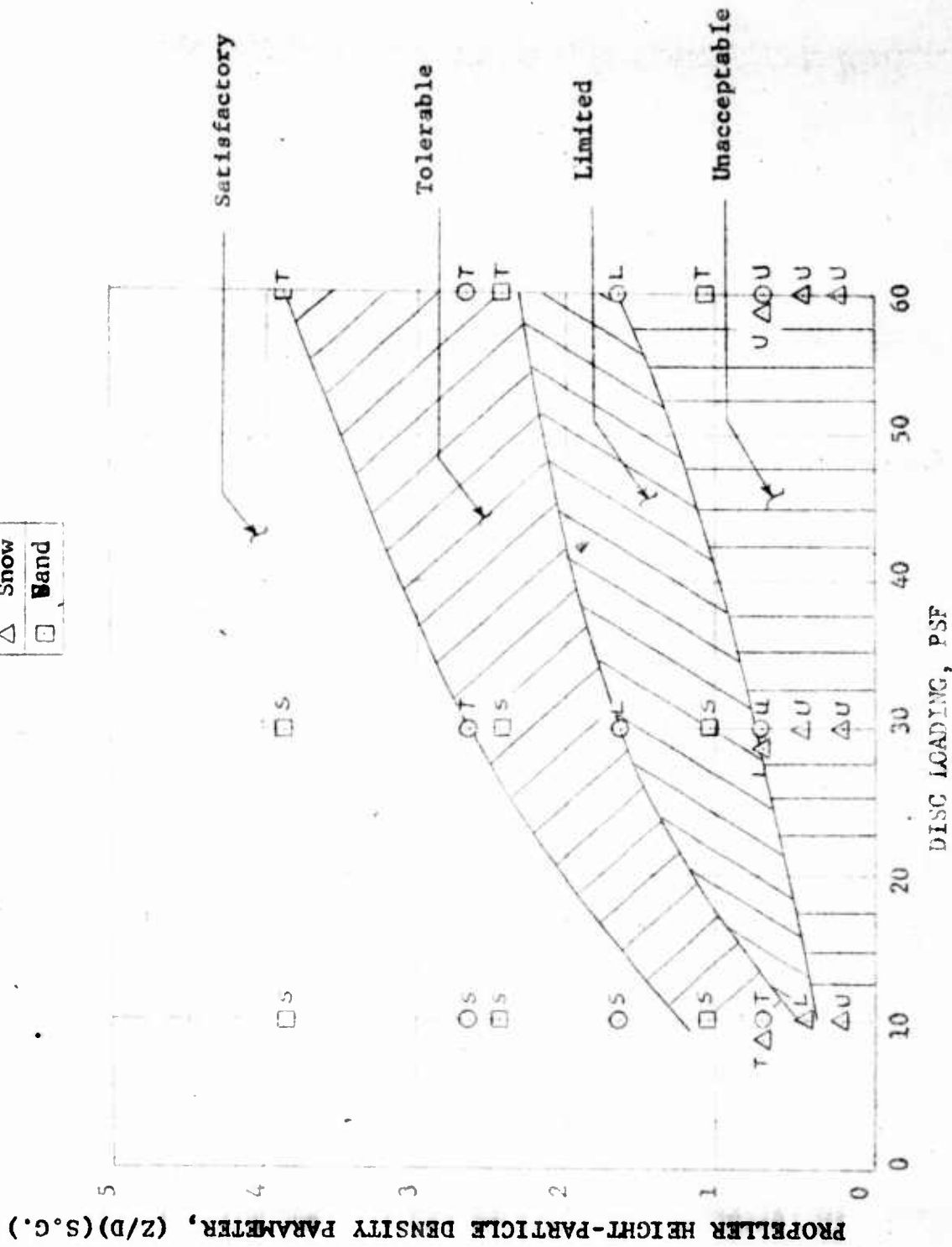

FIGURE 6S: PILOT'S VISION OBSTRUCTION DUE TO DOWNWASH

Terrain	
○	Water
□	Wet Sand
◻	Clay
◇	Earth
△	Dry Snow

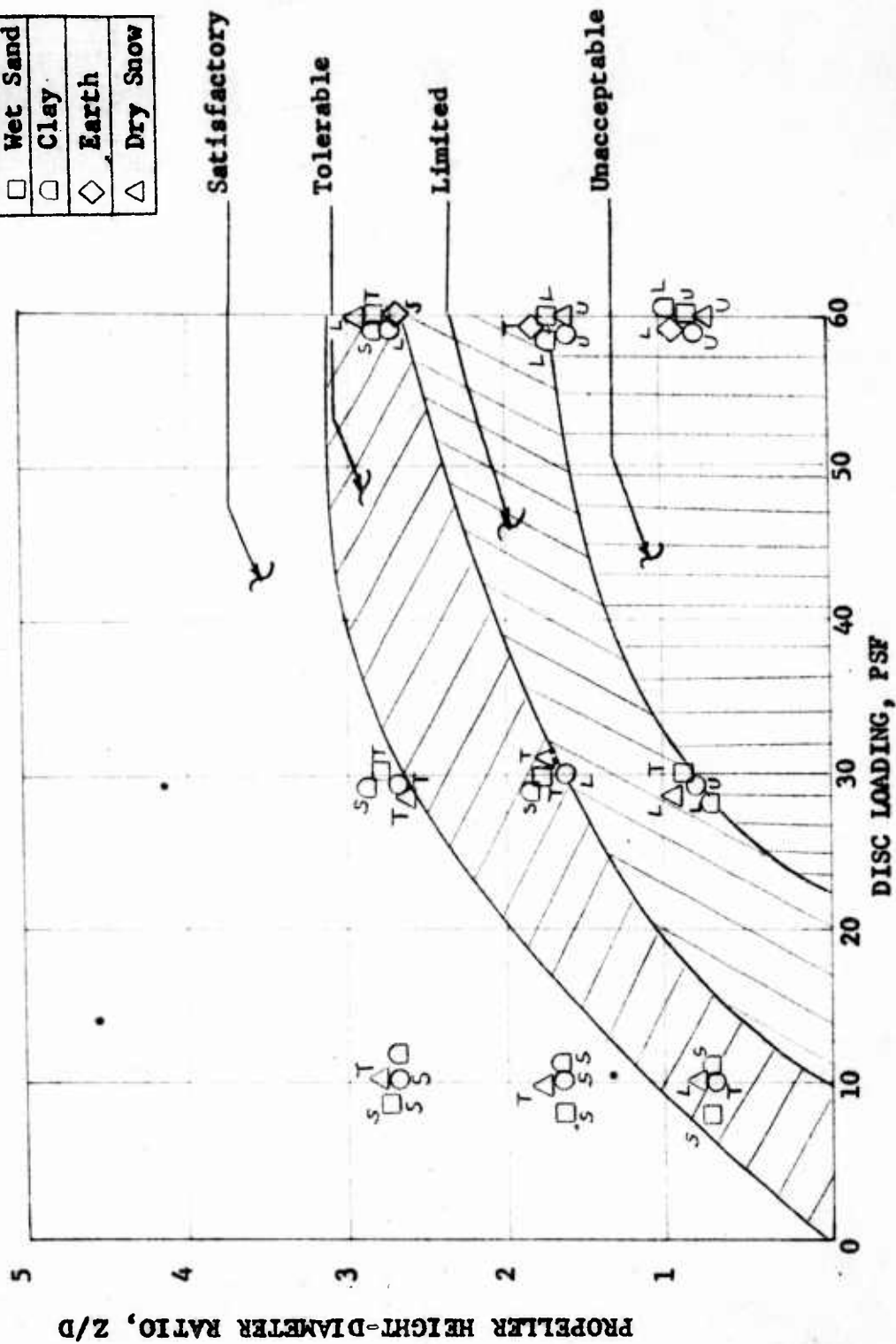

FIGURE 7S: PERSONNEL VISION PROBLEMS IN ZONE A

PROPELLER HEIGHT-PARTICLE DENSITY PARAMETER, (Z/D) (S.O)

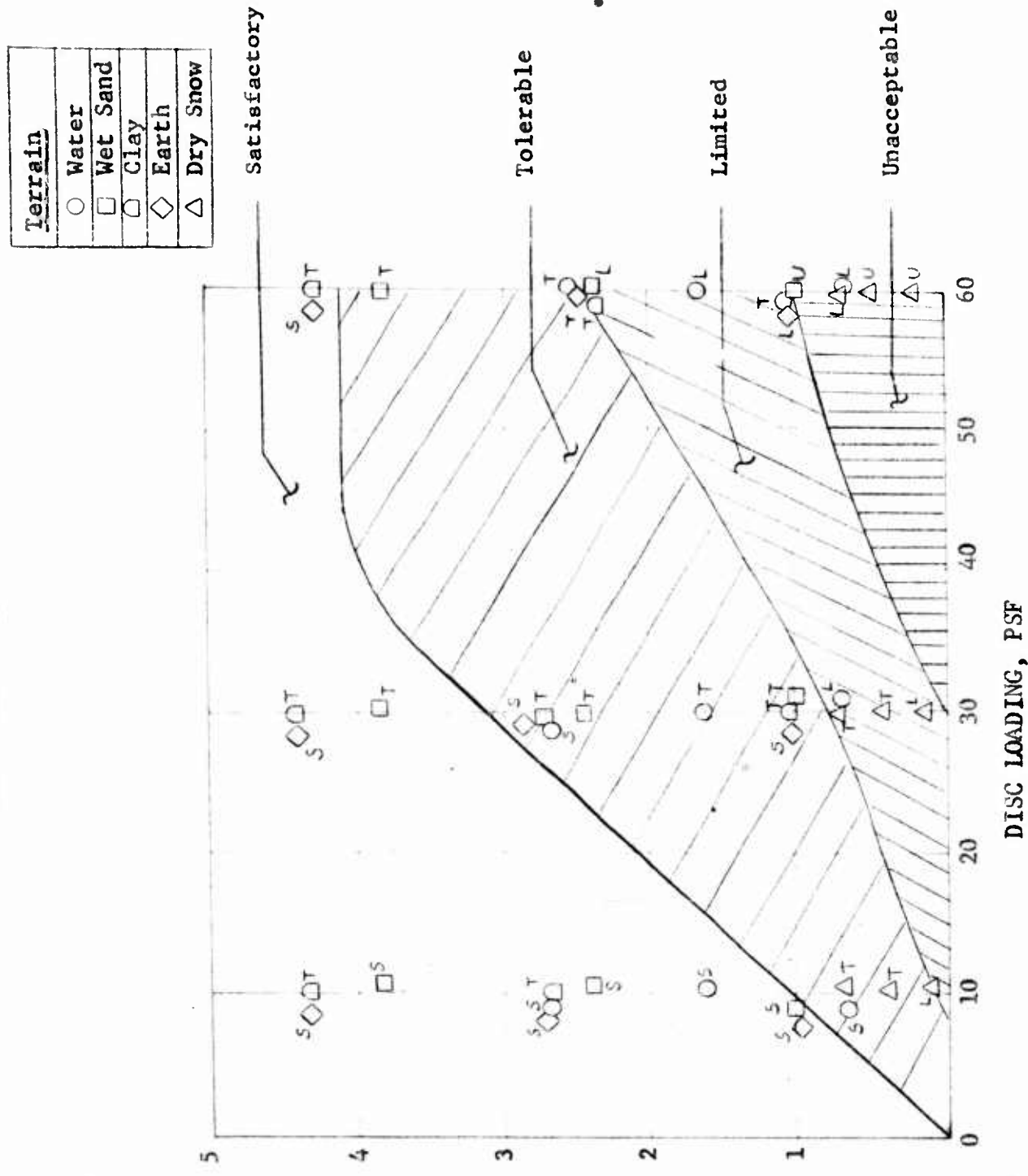

FIGURE 8S: PERSONNEL VISION PROBLEMS IN ZONE B

PROPELLER HEIGHT-PARTICLE DENSITY PARAMETER, (Z/D)(S.G.)

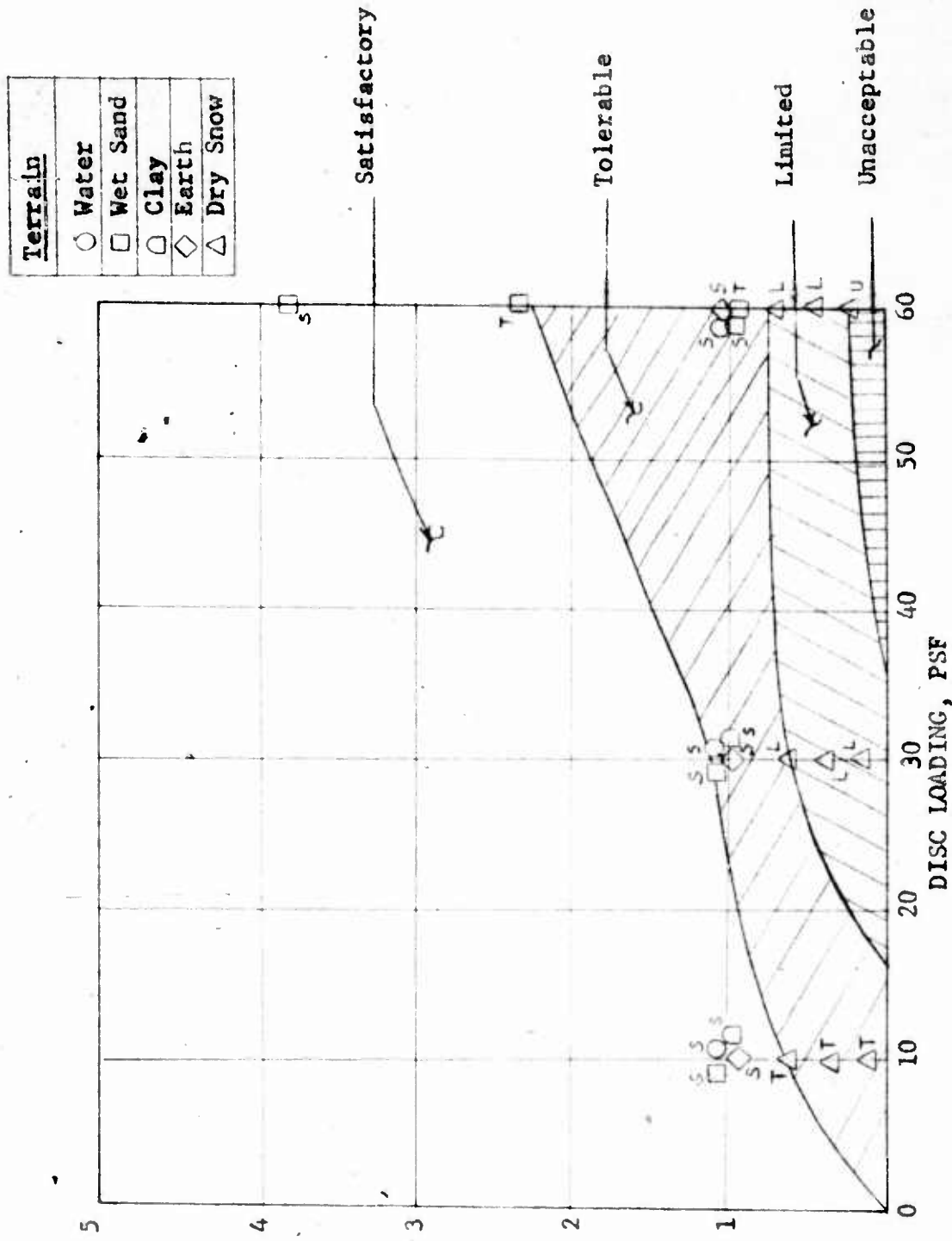

FIGURE 9S: PERSONNEL VISION PROBLEMS IN ZONE C

PROPELLER HEIGHT-PARTICLE DENSITY PARAMETER, (Z/D)(S.G.)

Terrain	
□	Sand
△	SNOW
○	Water

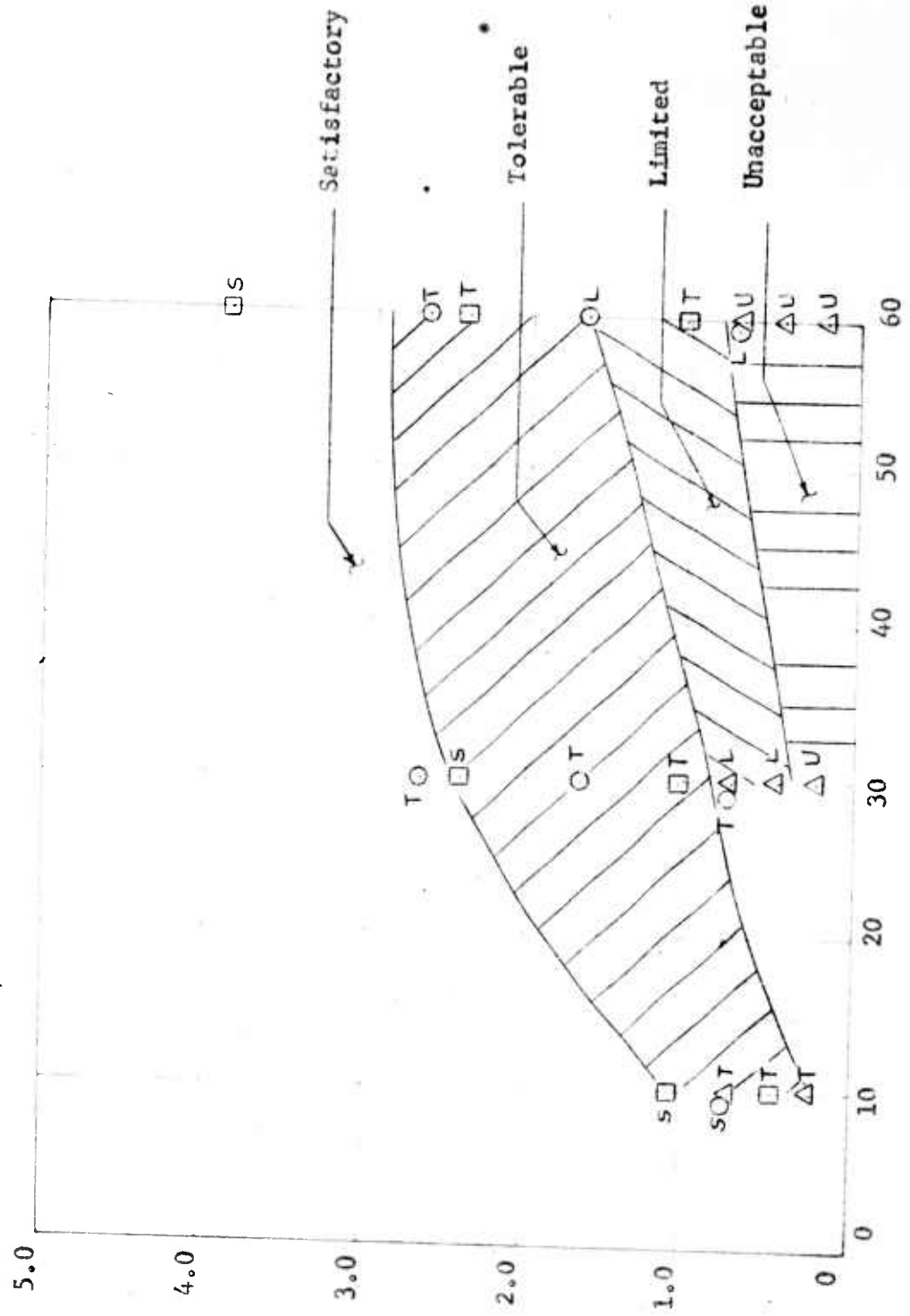

FIGURE 10S: SEVERITY OF CONCEALMENT PROBLEM
DISC LOADING, PSF

Terrain	
○	Water
◇	Earth
×	Sod
◊	Debris
□	Clay

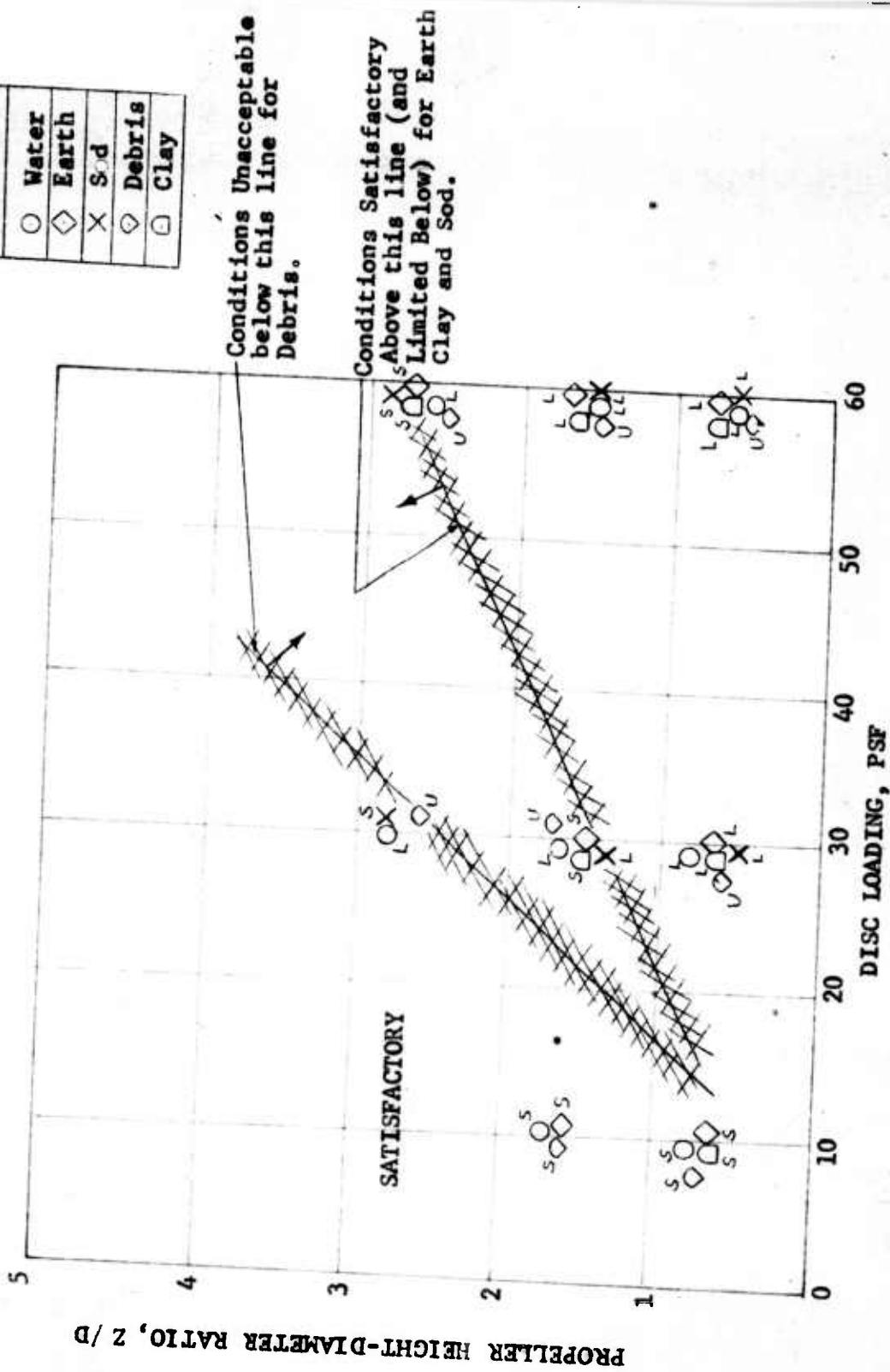

FIGURE 11S: PERSONNEL-RISK OF INJURY IN ZONE A

Terrain	
○	Water
◇	Earth
X	Sod
◊	Debris
□	Clay

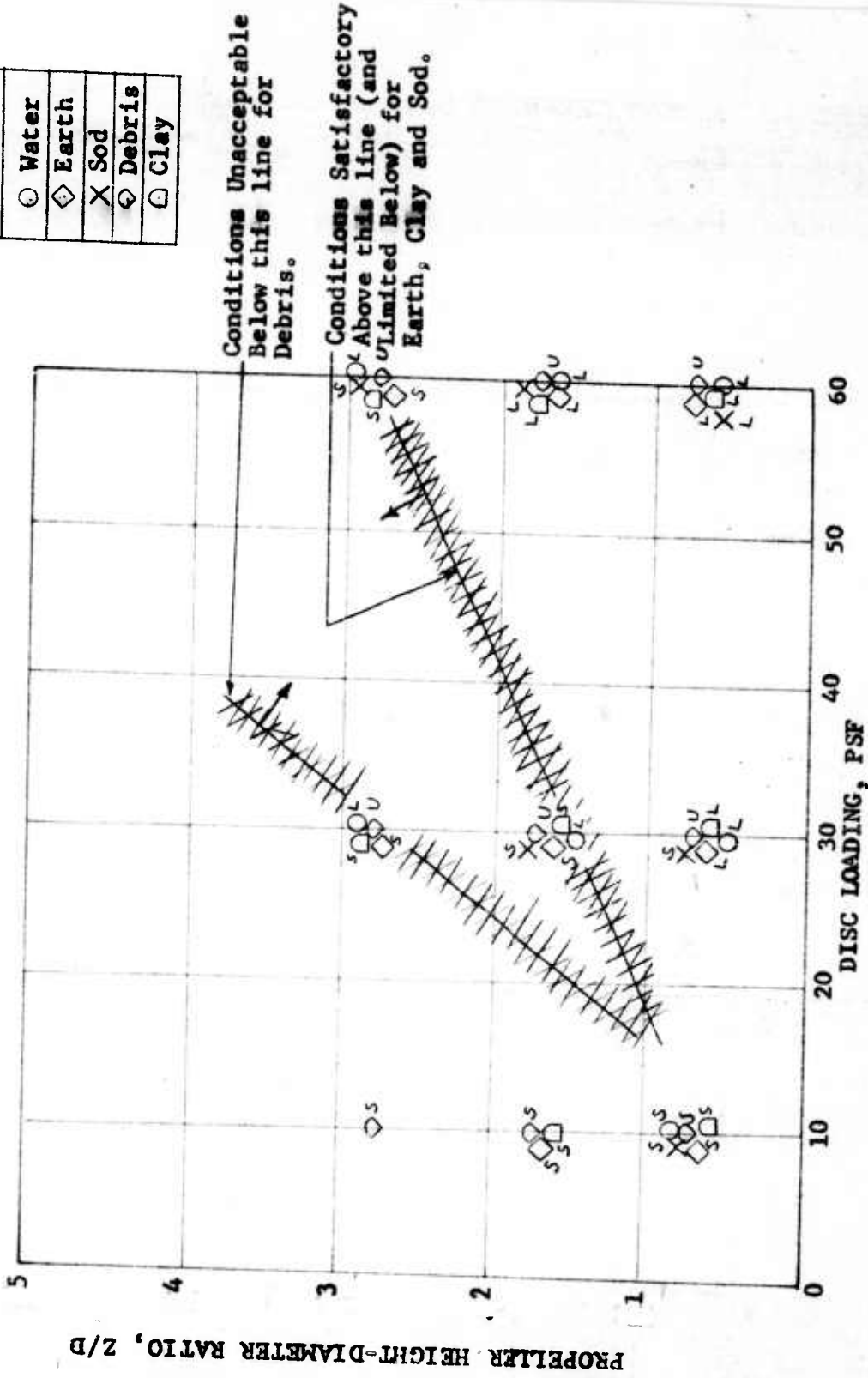

FIGURE 12S: PERSONNEL-RISK OF INJURY IN ZONE B

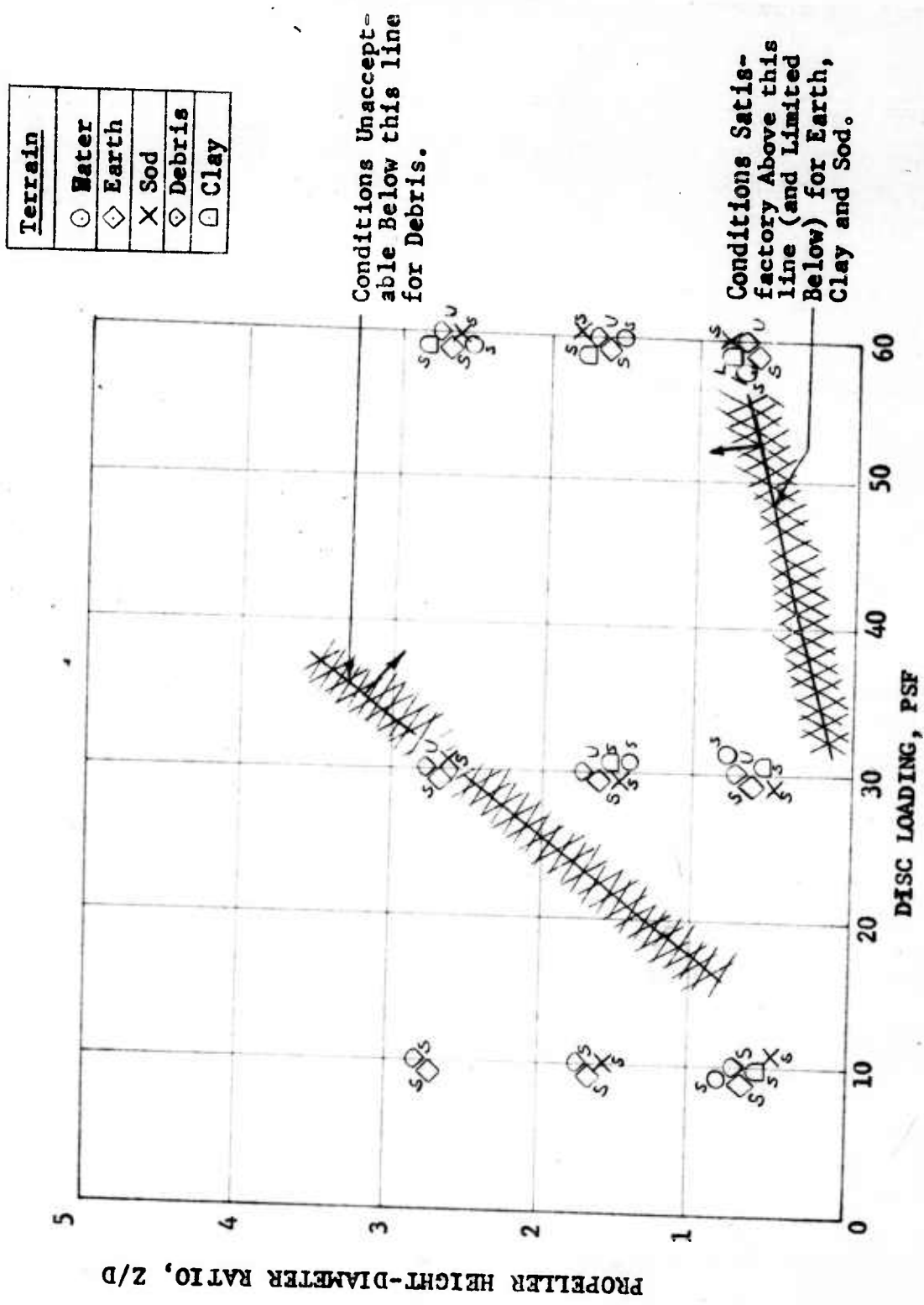

FIGURE 13S: PERSONNEL-RISK OF INJURY IN ZONE C

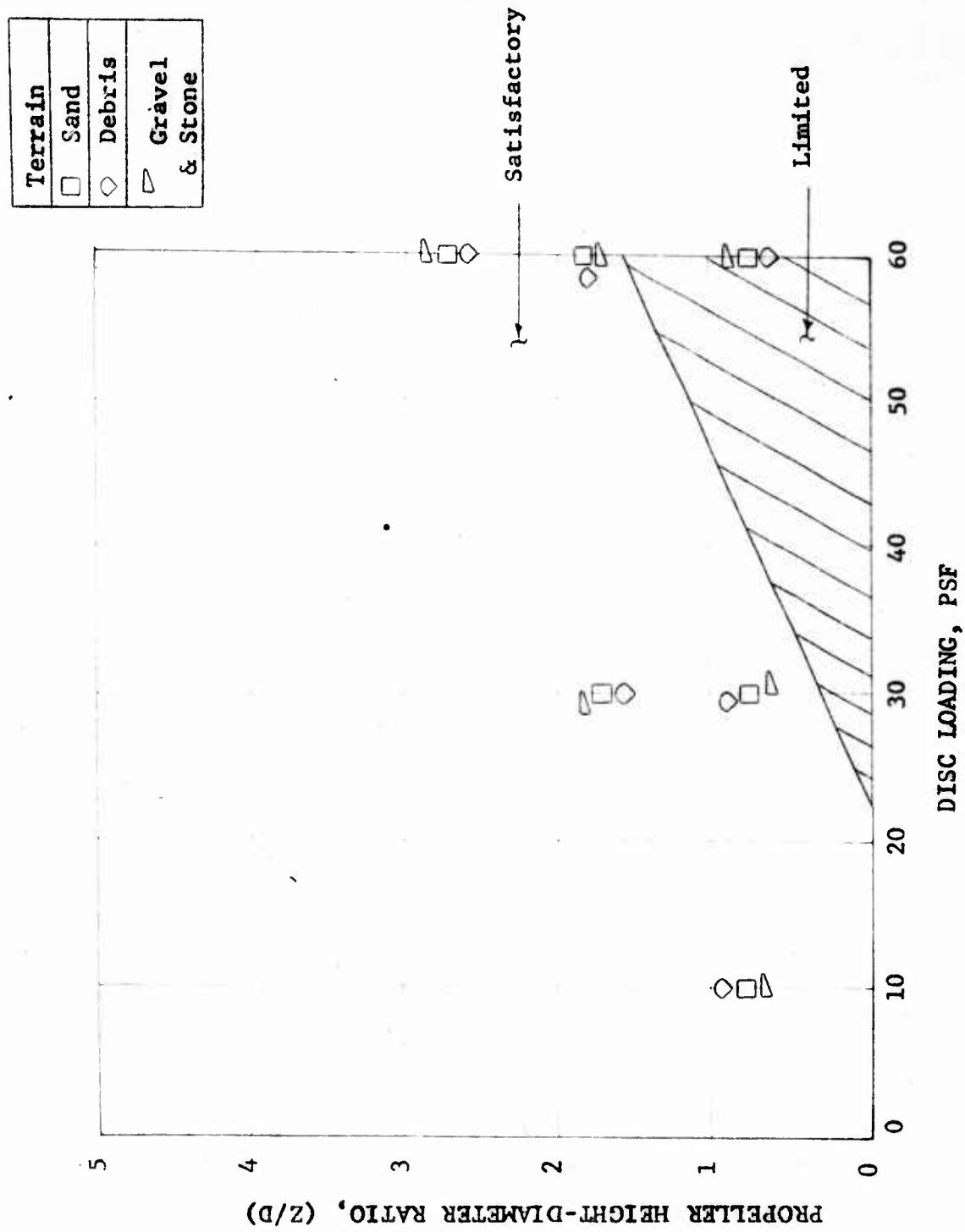

FIGURE 14S: EVALUATION OF POSSIBLE DAMAGE TO AIRFRAME

Data shown are for wet sand terrain.
All conditions are limited for snow.
All conditions are satisfactory for other terrains tested.
Loose vegetation may present unacceptable condition.

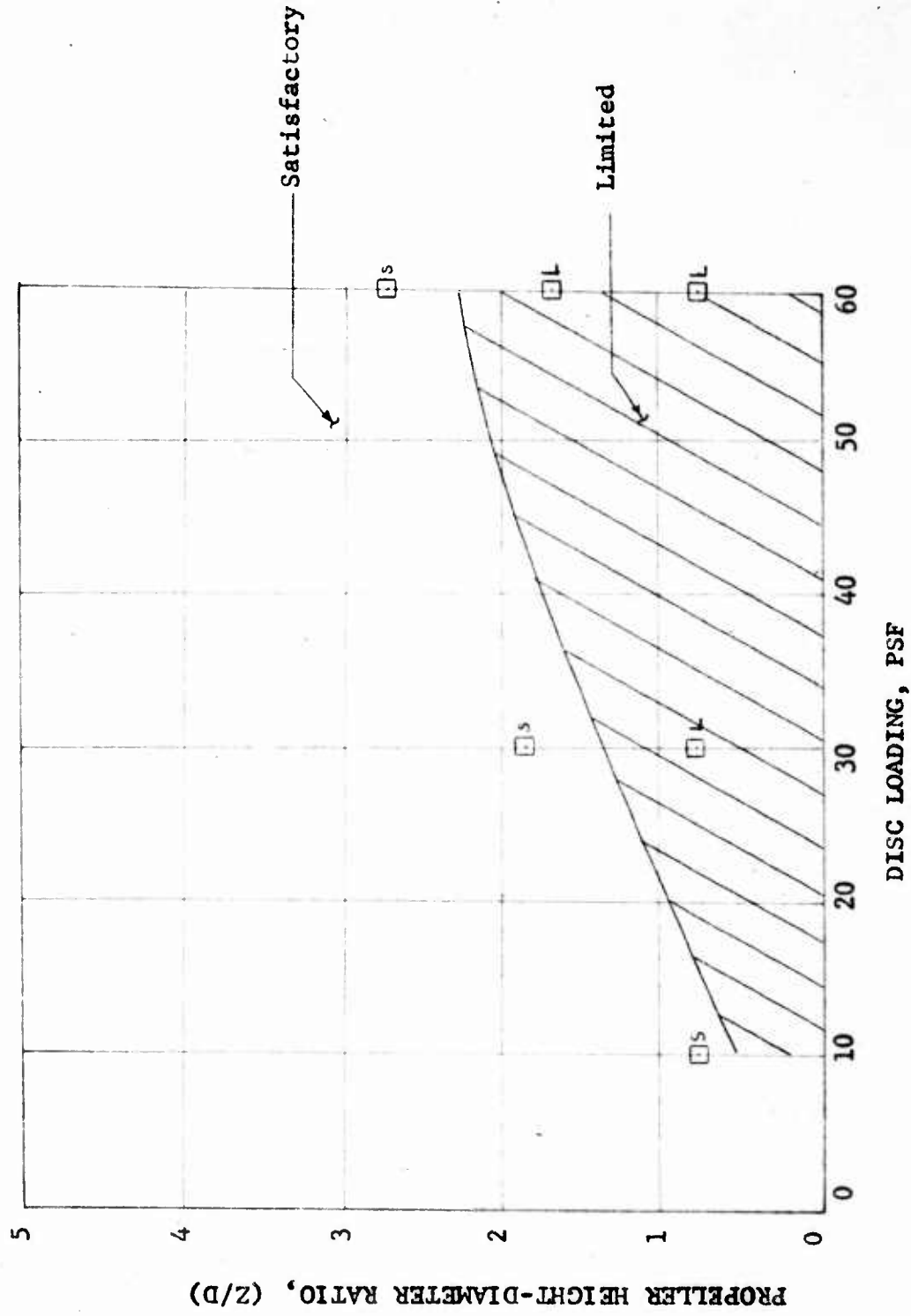

FIGURE 16S: EVALUATION OF DAMAGE TO ENGINE BY TERRAIN INGESTION

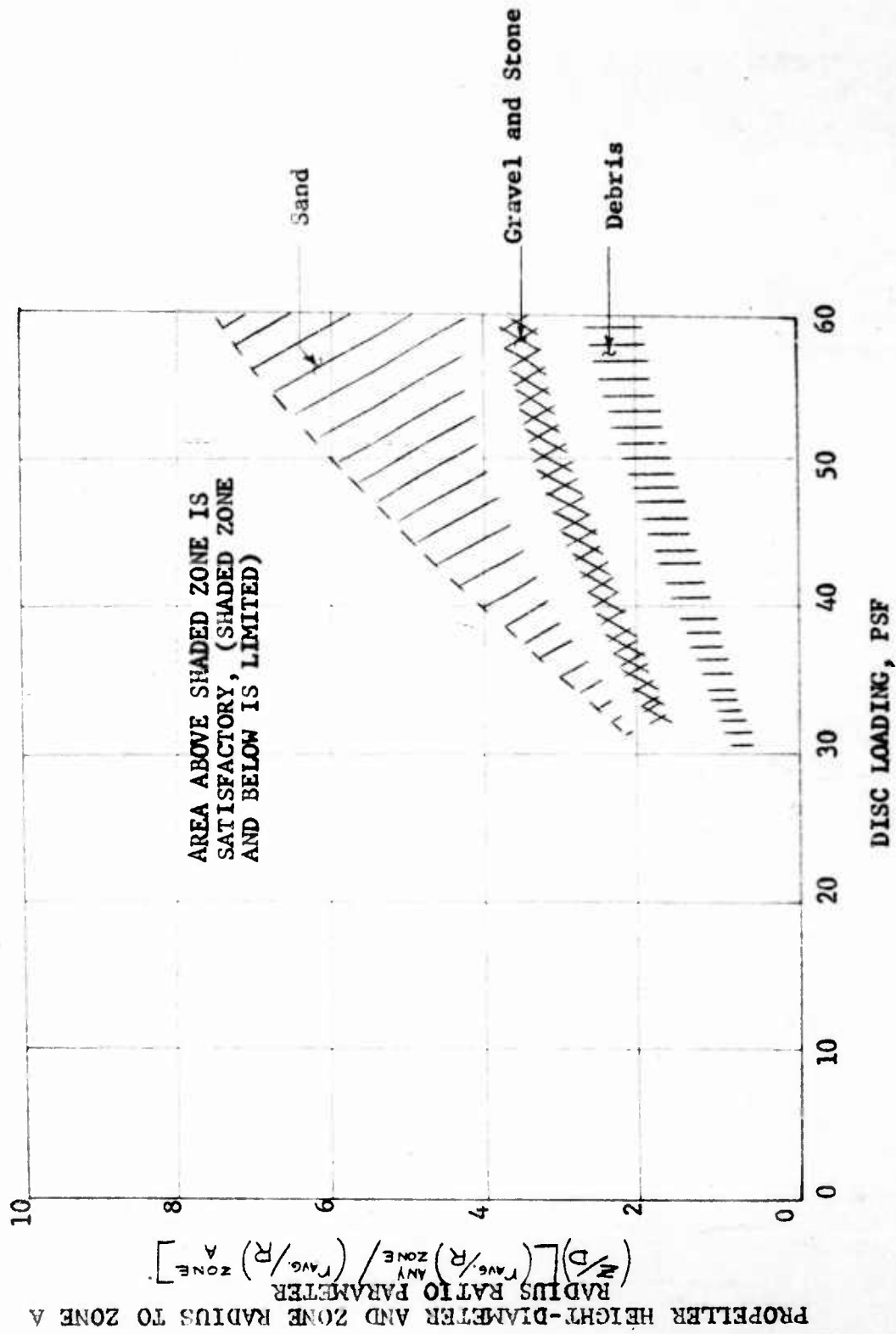

FIGURE 17S: POSSIBLE DAMAGE TO EQUIPMENT DUE TO DOWNWASH - ZONES A, B AND C.

UNCLASSIFIED

711

UNCLASSIFIED