

**UNCLASSIFIED**

---

---

**AD 265 000**

---

*Reproduced  
by the*

**ARMED SERVICES TECHNICAL INFORMATION AGENCY  
ARLINGTON HALL STATION  
ARLINGTON 12, VIRGINIA**



---

---

**UNCLASSIFIED**

NOTICE: When government or other drawings, specifications or other data are used for any purpose other than in connection with a definitely related government procurement operation, the U. S. Government thereby incurs no responsibility, nor any obligation whatsoever; and the fact that the Government may have formulated, furnished, or in any way supplied the said drawings, specifications, or other data is not to be regarded by implication or otherwise as in any manner licensing the holder or any other person or corporation, or conveying any rights or permission to manufacture, use or sell any patented invention that may in any way be related thereto.

NOLC REPORT 556

1 NOVEMBER 1961

ASTIA  
CATALOGUED BY  
AS AD NO. 265 000

**MONITORING THE MECHANICAL OPERATION  
OF FUZE SAFETY-ARMING MECHANISMS**

L. V. CRAYCRAFT

E. E. BARILOTTI

FUZE DEPARTMENT

NOV 2 1961  
NOX

ASTIA  
RECEIVED  
NOV 2 1961  
JIPDR



**NAVAL ORDNANCE LABORATORY CORONA**

CORONA, CALIFORNIA

# NAVAL ORDNANCE LABORATORY CORONA

W. R. KURTZ, CAPT., USN  
Commanding Officer

F. S. ATCHISON, Ph.D.  
Technical Director

## FOREWORD

The monitoring device developed at the Naval Ordnance Laboratory Corona and described in this report has proved reliable for measuring the timing sequences that take place inside certain safety-arming mechanisms (S-A's). Contractors producing and evaluating S-A's use the device to monitor and adjust S-A timing.

Several commercially procured items were employed in the device; however, neither the use of the commercial items nor the mention in this report of the suppliers' names constitutes an endorsement of the product of one manufacturer over a similar product of another, and should not be so construed.

B. F. HUSTEN  
Head, Fuze Department

## ABSTRACT

Described in this report is a monitoring system that detects and records the mechanical operations taking place inside a safety-arming device (S-A) while it is being tested within a rotary accelerator. A ruggedized miniature crystal accelerometer, fastened to the case of the S-A, responds to internal vibrations caused by pallet clatter on the gear train, solenoid plunger bottoming, and g-weight movement. The resulting signals are converted to electrical energy and fed to an amplifier, also on the centrifuge arm, from which they are conducted through slip rings to a recorder. In addition, records are made of the time of S-A switch operations as well as the time of voltage application to the launch-latch solenoid.

## CONTENTS

	<u>Page</u>
Foreword . . . . .	Inside front cover
Abstract . . . . .	Inside front cover
Introduction . . . . .	1
History of Development . . . . .	2
Physical Layout and Installation . . . . .	3
Operating Characteristics . . . . .	6
Performance Testing . . . . .	8
Conclusions . . . . .	10

## INTRODUCTION

A safety-arming mechanism (S-A) is used in a guided missile fuze to (1) prevent premature firing of the missile by keeping the fuze firing system in safe condition during transportation and handling, and (2) provide the fuze with proper arming sequences during flight of the missile. Since the total flight time of a tactical guided missile is very short (several seconds for some missiles), the timing sequence of the S-A in preflight tests must be measured very accurately. These measurements are normally made on the S-A while it is attached to the arm of the centrifuge and the centrifuge is exerting between 5 and 100 g on the S-A.

In general, a monitoring device for making such measurements must:

1. Measure the S-A commit-to-arm time (1 to 3 seconds) within a tolerance of 1 percent.
2. Give an accurate indication of the S-A launch-latch solenoid operation.
3. Measure the S-A self-destruct time sequence (20 to 30 seconds).
4. Provide some means of helping to identify trouble if failure or faulty operation occurs in the S-A.

Measurements can be recorded by a commercial electrical-input system such as a slow-speed pen recorder or, for better resolution, a fast-speed oscillograph. In either case, the monitoring device must convert the internal mechanical operations of the S-A into electrical energy that can be recorded by the system. The device must be small enough to fit on the arm of the centrifuge near the S-A and rugged enough to operate correctly under the varied acceleration forces of the centrifuge. In addition, the monitoring device should be simple to operate and use during the tests.

A monitoring device developed at this Laboratory meets the above requirements and is now being used during evaluation tests of certain S-A's. Below are a brief discussion of the history of the device; a description of the device and its operating characteristics, physical layout, and construction; and finally, some data on performance testing.

## HISTORY OF DEVELOPMENT

The "commit-to-arm" time in research and development models of some S-A's is recorded with a telemetering system during flight tests of the missile. This time is measured by recording d-c voltages applied through normally open and normally closed switches mounted in the S-A for this purpose. Such a method of measuring the commit-to-arm time is also used in the Laboratory when S-A's are tested on the centrifuge. If the S-A operates satisfactorily during centrifuge testing, the switching action gives an accurate measurement of the commit-to-arm time.

However, if faulty switch action or incorrect gear-train movement occurs in the S-A, there is no way of indicating what is causing the faulty operation without X-ray examination or removal of the S-A from its housing for visual inspection. Moreover, telemetering switches are not always installed in production and preproduction S-A's. Needed, therefore, is a device which can monitor the internal mechanical operation of the S-A from an external source during laboratory acceleration tests.

Various methods were tried in an attempt to develop such a device. A phonograph crystal pickup was attached to the S-A fixture mounted on the centrifuge arm. The pickup was then adjusted to provide contact of the stylus with the S-A metal housing. The electrical output from the pickup was fed through the slip rings of the centrifuge to an external recording system. When the S-A gear train was cycled by hand, the pickup sent a distinct electrical signal through the centrifuge slip rings to the recorder, but when the centrifuge was operated the electrical signals became very erratic. Adjustment of the pickup stylus contact with the S-A was very critical and had to be changed each time an S-A was removed from the fixture. Different types of phonograph crystal pickups were tried in an effort to obtain suitable contact with the S-A, but none proved satisfactory.

A second method used a hearing-aid microphone and a transistor amplifier.<sup>1</sup> The microphone, being attached to the mounting fixture of the S-A, responded to noise caused by the clatter of the gear train and pallet movement as well as noise from the solenoid plunger. This noise was converted to electrical energy by the microphone and amplified by the hearing-aid amplifier, which was mounted close to the S-A. The output from the amplifier was then fed through the slip rings of the centrifuge to the recording device.

---

<sup>1</sup> For a detailed description see NOLC Technical Memorandum 55-59, Description and Operation of an Acoustic Transducer and Recording System for Monitoring Fuze Safety and Arming Device Operation.

This system works satisfactorily when the S-A is tested on a quiet centrifuge and at low g levels. At high g levels acoustical background noise from the centrifuge is high. Since this noise is also picked up by the microphone, it is difficult to distinguish between centrifuge noise and signals from the mechanical operations of the S-A. To eliminate this unwanted noise numerous methods were tried, such as bandpass filtering, shock mounting the specimen on the centrifuge arm, and using a two-channel monitoring system. None of these methods produced a satisfactory signal when the S-A was run on a typically noisy centrifuge at the higher g levels.

A third method, employing the device described in this report, uses a ruggedized miniature crystal accelerometer attached to the S-A mounting fixture by a 1/4-28 mounting stud, which makes physical contact with the case of the S-A. This accelerometer is insensitive to acoustical noise but very responsive to mechanical vibrations of the S-A. It therefore gives a well-defined electrical output signal from the vibration caused by internal movements, such as pallet clatter on the gear train, solenoid plunger bottoming, and g-weight movement. From the accelerometer the output signal is fed into a transistorized amplifier-rectifier. The output from the amplifier-rectifier is then fed through the slip rings of the centrifuge to a recording system.

Because the third method minimizes the acoustical noise problem and gives good signal-to-noise output to the recorder, a number of such monitoring devices have been constructed and are being used by this Laboratory.

#### PHYSICAL LAYOUT AND INSTALLATION

Physical layout and installation of the monitoring device are shown in Figures 1 and 2.

The amplifier-rectifier is housed in a 4- by 4- by 2-in. aluminum box. Layout of the chassis is not critical; however, special precautions normally associated with transistor circuitry should be followed. Placement of circuit components is as follows:

1. The 22-1/2 volt battery is attached to the bottom cover plate of the amplifier-rectifier box.
2. The gain-control potentiometer and the on-off switch are attached to the top cover plate.
3. The resistors, capacitors, transistors, diodes, and output transformer are all mounted on a circuit board, which is also attached to the top cover plate.

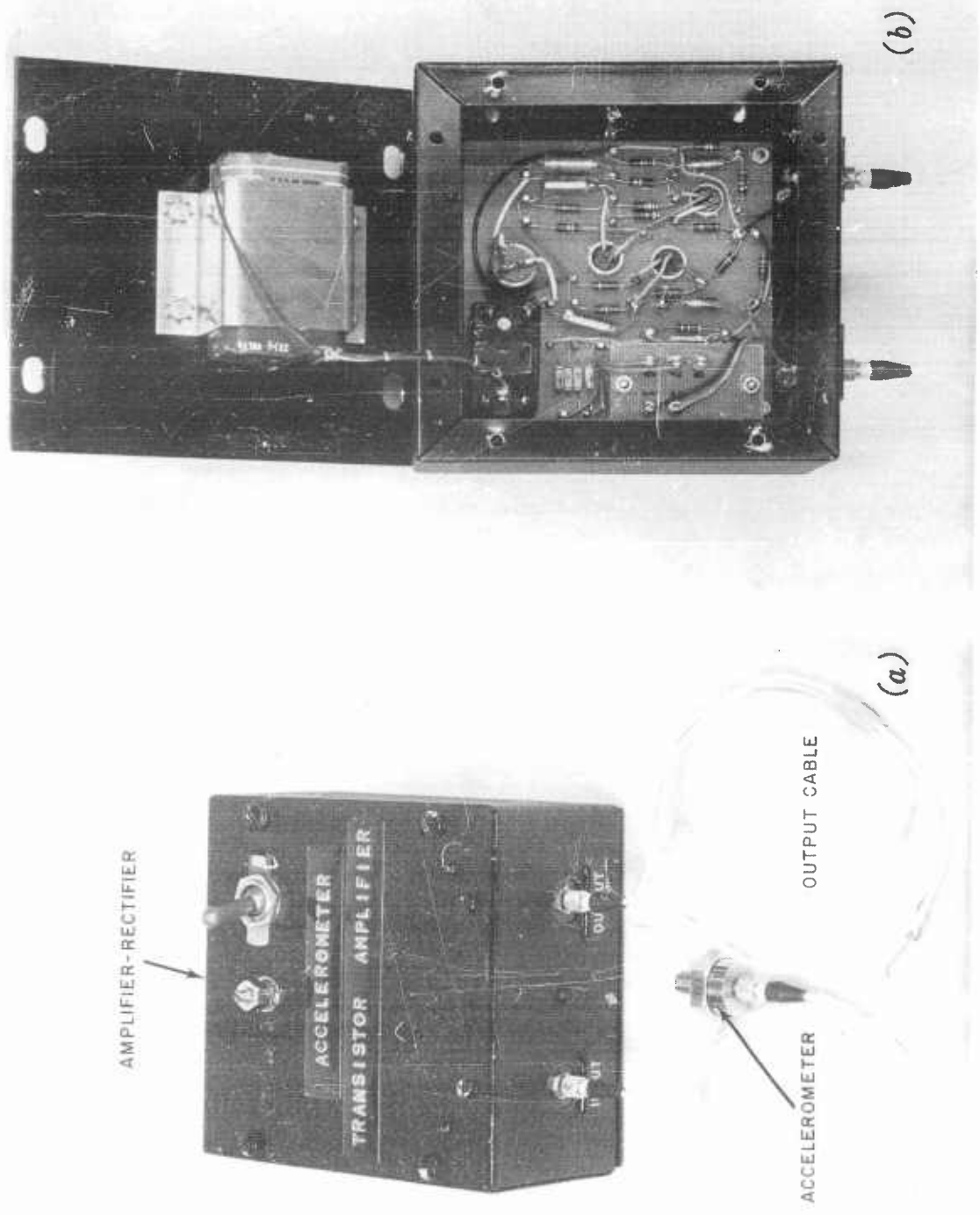

FIGURE 1. Accelerometer Monitoring Device. (a) Components; (b) internal view of amplifier-rectifier.

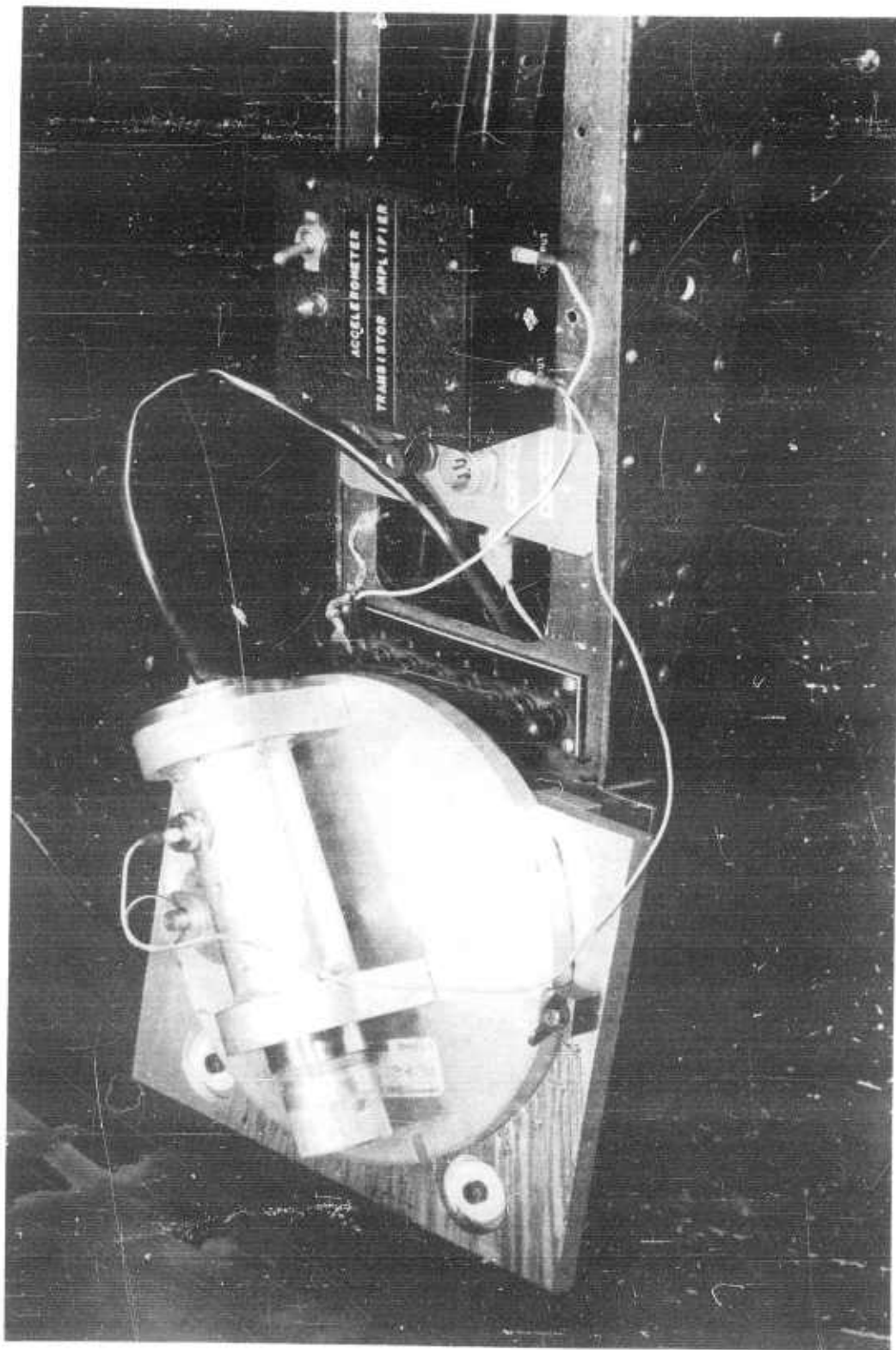

FIGURE 2. S-A and Monitoring Device Mounted on Centrifuge Arm

The amplifier-rectifier box can be installed on the centrifuge arm by means of angle brackets attached to the cover plate. Plane or position of mounting is not critical.

The accelerometer dimensions are 3/4 in. in diameter and 1/2 in. in height, the 1/4-28 stud extending another 1/2 in. below the accelerometer. Since the accelerometer is manufactured commercially, it requires no special layout. Its stainless steel housing and stud make it very rugged and long-lasting, even when used under extreme test conditions.

The coaxial cables are approximately 18 in. long. Each is attached to the amplifier-rectifier box by means of a chassis-type connector (Microdot No. 3201).<sup>2</sup>

### OPERATING CHARACTERISTICS

The monitoring device consists of (1) a crystal accelerometer for converting mechanical motion to electrical energy; (2) an amplifier-rectifier for amplifying and rectifying the electrical energy; and (3) two miniature coaxial cables, one for connecting the accelerometer to the input of the amplifier, the other for connecting the output of the amplifier to the centrifuge slip rings. A schematic diagram of the circuit is shown in Figure 3.

The accelerometer used (Columbia Model 410) was chosen because of its high output sensitivity (approximately 50 mv per g), effective mounting stud (the 1/4-28 stud gives excellent metal contact with the S-A housing when the S-A is inserted in the centrifuge test fixture), rugged construction, and light weight (8.7 gm). Other features are a frequency response of 1 cps to 20 kc and an acceleration range of 0.03 to 40,000 g. A miniature low-noise coaxial cable (Microdot) connects the output of the accelerometer to the input of the amplifier.

The input stage of the amplifier-rectifier is a two-transistor amplifier utilizing both positive and negative feedback loops to provide a stabilized voltage gain of 5 and an input impedance of approximately 1 megohm. The output stage is a stabilized feedback amplifier with a voltage gain of 20; it is followed by a matching output transformer, a bridge rectifier, and a filter circuit.

---

<sup>2</sup> Throughout this report, allusion to a manufacturer does not constitute an endorsement of the product of one manufacturer over a similar product of another.



Frequency response of the amplifier-rectifier is approximately 1500 cps to 40 kc. Since the upper frequency-response limit of the accelerometer is 20 kc, the response of the monitoring system is in the frequency range of 1500 cps to 20 kc. The low-frequency cutoff, which is necessary to eliminate unwanted low-frequency vibrations such as those caused by the centrifuge arm, can be varied by changing the size of the coupling capacitor in series with the primary of the output transformer.

The full-wave bridge rectifier rectifies the a-c output from the amplifier and gives a d-c step function which can be recorded on a slow-speed pen recorder as well as a high-speed oscillograph recorder. The sharpness of the trace can be controlled by varying the R-C filter combination across the rectifier output.

The amplifier is powered by the single 22-1/2 volt battery.

#### PERFORMANCE TESTING

Figure 4 shows the external instrumentation layout normally used at NOLC for recording the output from the monitoring device and for furnishing power to the S-A. This system uses:

1. A low-voltage, high-current power supply (Sorensen SR-100) for operating a launch-latch solenoid.
2. A high-voltage power supply (Hewlett-Packard 712B) for telemetering switch operations.
3. An audio amplifier (Bogen AC-10) and speaker for aurally monitoring vibration signals.
4. A recorder system (Sanborn 150) for recording electrical outputs from the monitoring device and the telemetering switches.
5. A control box for switching the high and low voltages on.
6. A centrifuge (Genisco) for producing the required acceleration during S-A arming tests.
7. A frequency counter (Hupp 130) for accurately recording the rpm of the centrifuge arm.

Performance capability of the monitoring device was determined from simultaneous recordings on two channels of the Sanborn recorder. One channel recorded commit-to-arm time as indicated by the monitoring device; the other channel recorded the commit-to-arm time as produced by two telemeter switches installed in the S-A. Several hundred S-A's have been tested in this manner on the centrifuge. In each test

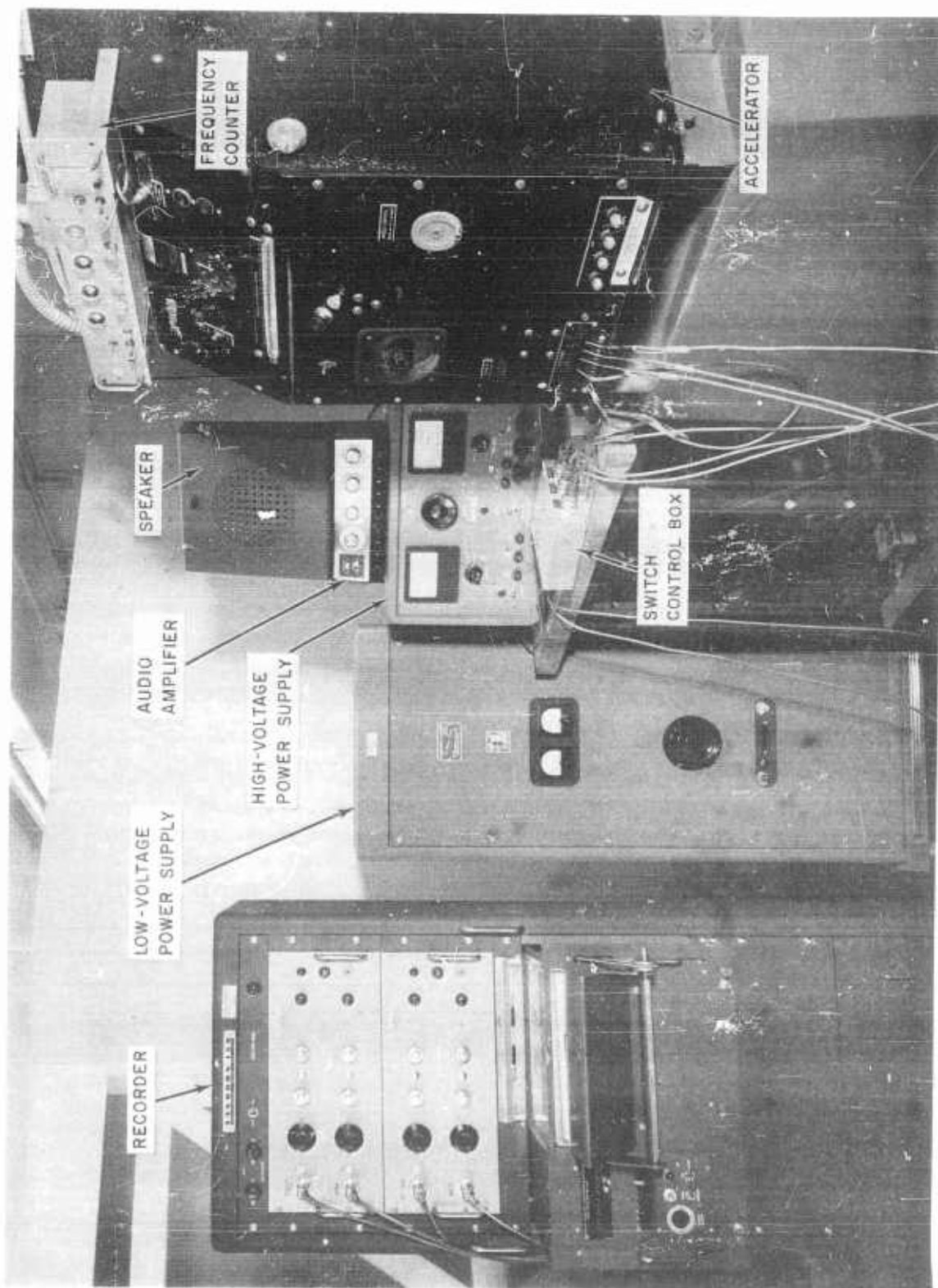

FIGURE 4. External Instrumentation for S-A Monitoring

made, within the error limits of the recording and timing techniques used, the two methods of measurement showed identical commit-to-arm times.

Figure 5 shows the wiring arrangement and Figures 6 and 7 the recorded results obtained during Laboratory evaluation tests of typical S-A's. The traces on Channels 1 and 2 of Figure 6 show commit-to-arm times that are identical within a few milliseconds. The voltage applied to the launch-latch solenoid was recorded on Channel 3. Figure 7 shows that a telemeter switch of Channel 2 failed to indicate commit-to-arm time; therefore, in this instance, the record reproduced from the accelerometer monitoring device (Channel 1) was relied upon. Figure 7 also shows good accelerometer monitoring of solenoid and gear train operation.

### CONCLUSIONS

The monitoring device developed at NOLC meets the requirements listed in the introduction of this report and has proved reliable for measuring the timing sequences that take place inside certain S-A mechanisms. Performance capability of the device was proved by comparison of the commit-to-arm time measurements made by this device with commit-to-arm time measurements made by monitoring the telemetering switches of research and development models of the S-A's.

- To summarize, this device has the following desirable features:
1. It provides a simple and accurate external means of measuring arming or commit-to-arm time.
  2. It gives a good indication of launch-latch solenoid operation during acceleration tests.
  3. It measures the timing of the self-destruct mechanisms used in some types of S-A's.
  4. The complete monitoring device is small, rugged, and self-powered, and requires no external power or circuitry except some type of recorder for reproducing the output signals fed from the device through the slip rings of the centrifuge.
  5. The output from the monitoring device can be fed through an audio amplifier and speaker system for aural monitoring if desired.

If monitoring of acoustical noise from a specimen is desired instead of mechanical vibration, a high-impedance crystal microphone could be substituted for the crystal accelerometer.

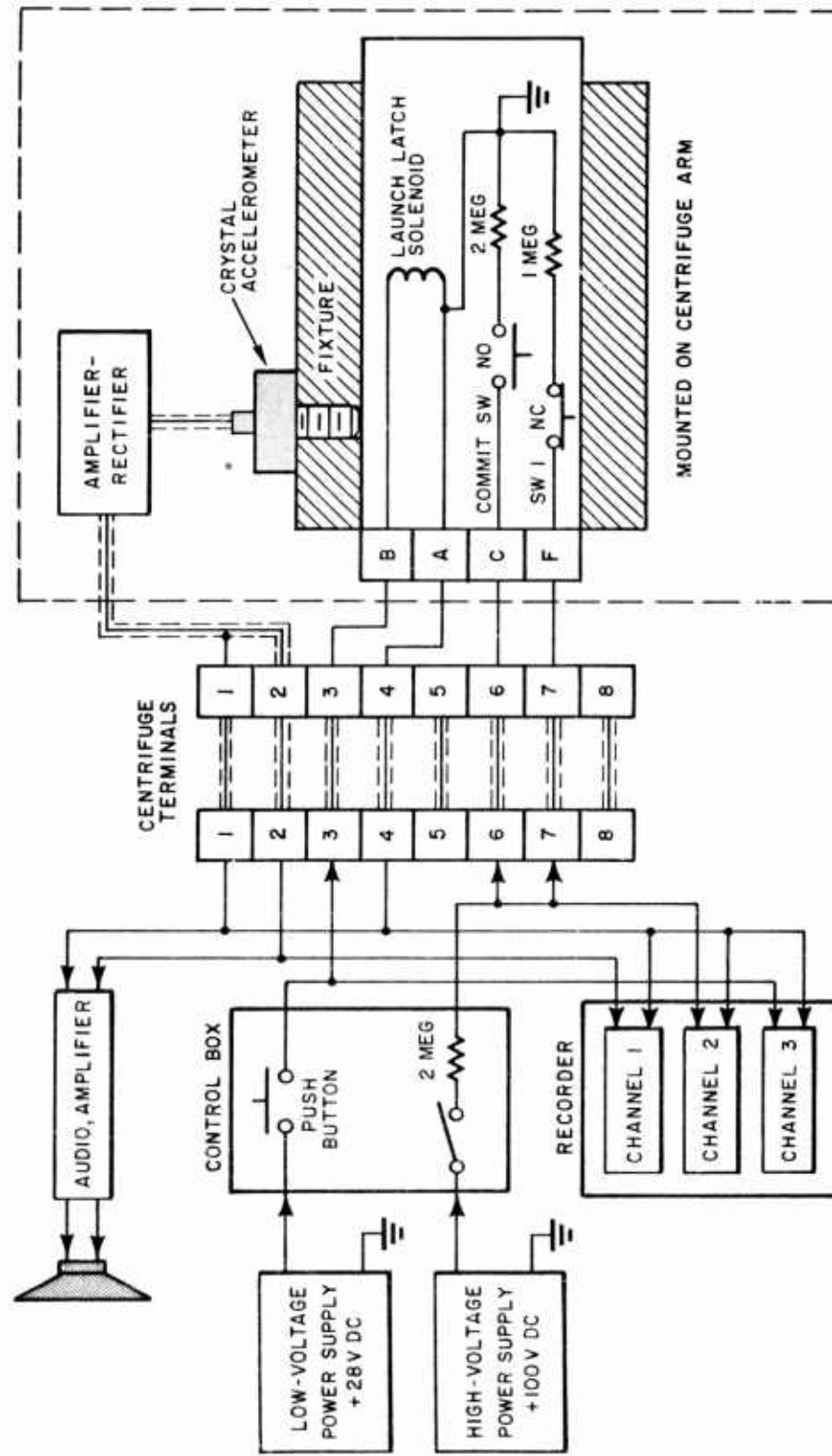

FIGURE 5. Centrifuge Instrumentation for S-A Monitoring

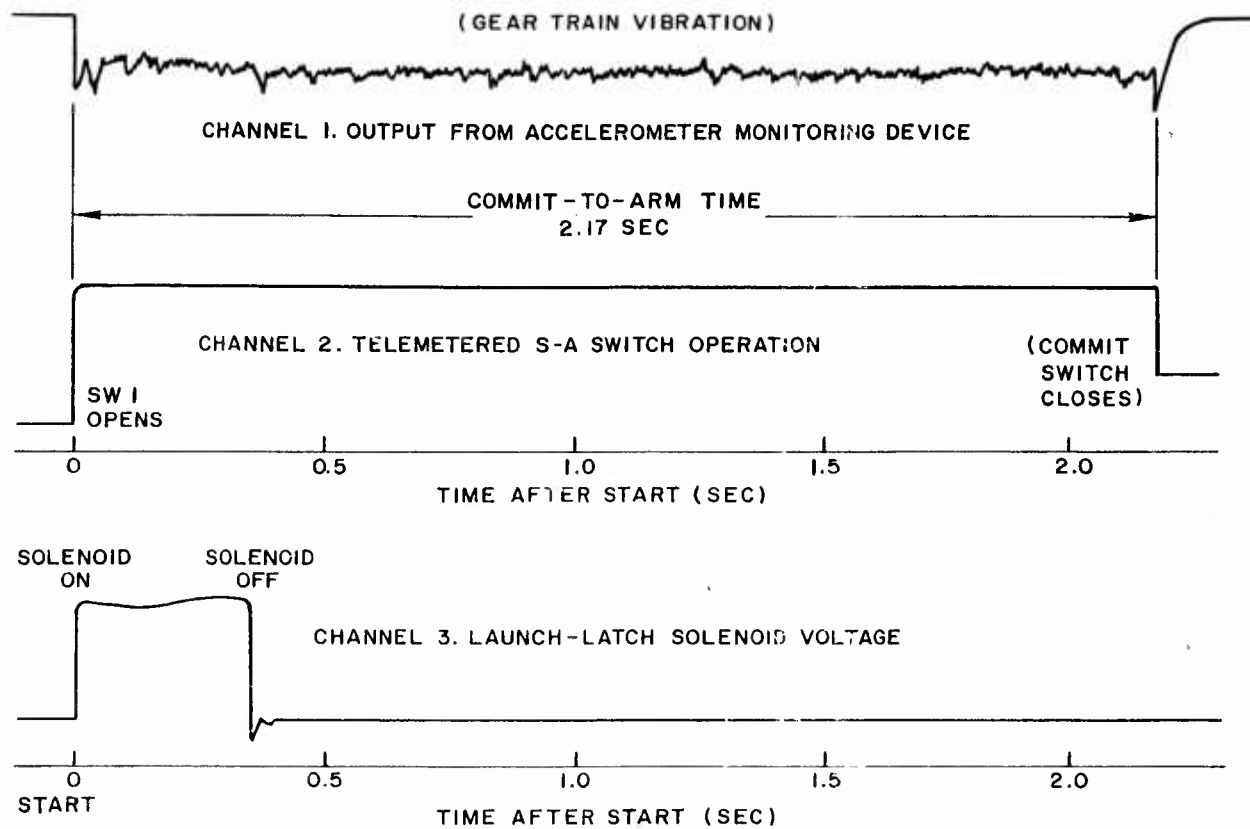

FIGURE 6. Monitoring Record Showing Satisfactory S-A Operation

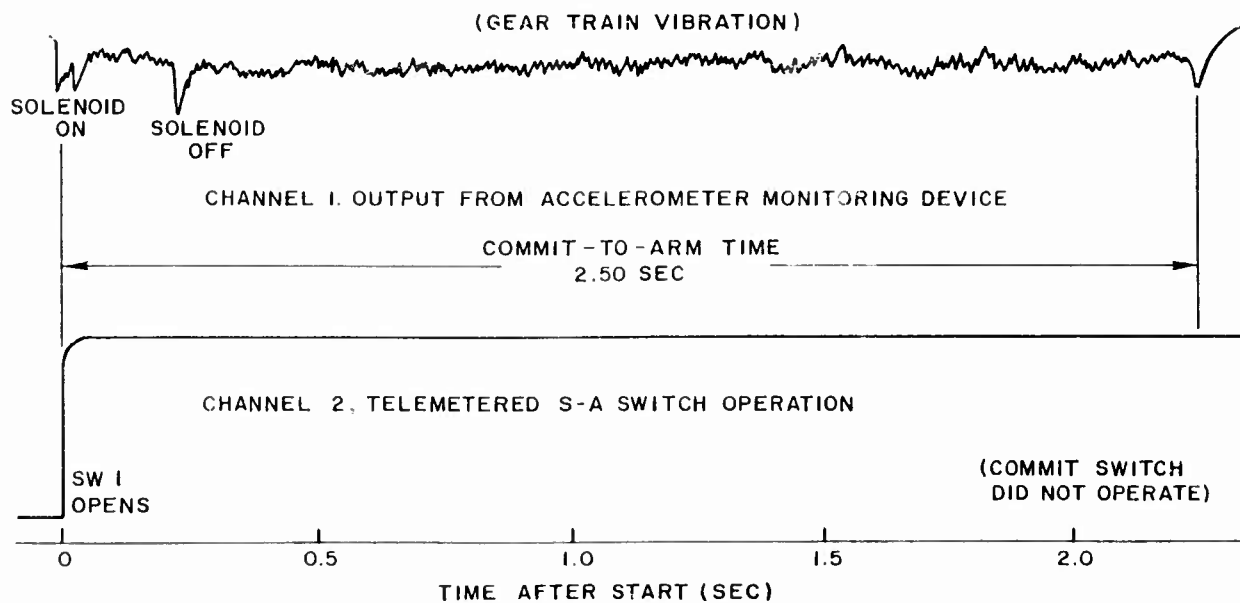

FIGURE 7. Monitoring Record Showing Telemetering Switch Failure

INITIAL DISTRIBUTION

	<u>Copies</u>		<u>Copies</u>
Chief, Bureau of Naval Weapons Navy Department Washington 25, D. C. Attn: Code DLI-31 RMMO	4 2	Commanding Officer Naval Ordnance Plant Macon, Ga.	1
Chief of Naval Operations Navy Department Washington 25, D. C. Attn: Code Op03EG	1	Commanding Officer Diamond Ordnance Fuze Laboratory Washington 25, D. C. Attn: ORDTL	1
Superintendent Naval Weapons Plant Washington 25, D. C. Attn: Code 752	1	Commanding General Frankford Arsenal Box 7989 Philadelphia 1, Pa. Attn: Library	1
Commanding Officer Naval Ordnance Test Station China Lake, Calif. Attn: Code 753	2	Commanding Officer Picatinny Arsenal Dover, N. J.	1
Commander Naval Ordnance Laboratory White Oak Silver Spring 19, Md. Attn: Library	2	Commanding Officer U. S. Naval Weapons Evaluation Facility Kirtland Air Force Base Albuquerque, N. Mex. Attn: Library	1
NOLC Washington Office Naval Ordnance Laboratory White Oak Silver Spring 19, Md. Attn: W. F. Stuart	2	Armed Services Technical Information Agency Arlington Hall Station Arlington 12, Va. Attn: TIPCA	10
Commanding Officer Naval Ammunition Depot Crane, Ind.	2	Aerojet General Corporation 11711 Woodruff Avenue Downey, Calif.	1
Commanding Officer Naval Weapons Laboratory Dahlgren, Va.	1	Bulova Research and Development Laboratory Prototype Department 7520 Flushing 70, N. Y.	1

	<u>Copies</u>		<u>Copies</u>
Eastman Kodak Company Apparatus and Optical Division 121 Lincoln Avenue Rochester, N. Y.	1	United Testing Laboratories 573 Monterey Pass Road Monterey Park, Calif. Attn: Ordnance Div.	1
Elgin National Watch Company West Coast Division 21001 Nordhoff Street Chatsworth, Calif.	1	NOLC: C. R. Hamilton, Code 55 R. W. Taylor, Code 551 R. R. Emerson, Code 561 L. V. Craycraft, Code 562	3 1 2 1
Elgin National Watch Company Micronics Division 366 Bluff City Boulevard Elgin, Ill.	1	E. E. Barilotti, Code 562 T. E. Tate, Code 563 Library, Code 234	1 1 2
General Sintering Corporation 1830 N. 32nd Avenue Melrose Park, Ill.	1		
Hamilton Watch Company W. End and Columbia Avenue Lancaster, Pa.	1		
Obex Manufacturing Company 163 Denton Avenue Lynbrook, N. Y.	1		

<p>Naval Ordnance Laboratory Corona. (NOLC Report 556)</p> <p>MONITORING THE MECHANICAL OPERATION OF FUZE SAFETY-ARMING MECHANISMS, by L. V. Craycraft and E. E. Barilotti, Fuze Department, 1 November 1961. 14 pp.</p> <p>UNCLASSIFIED</p> <p>Described in this report is a monitoring system that detects and records the mechanical operations taking place inside a safety-arming device (S-A) while it is being tested within a rotary accelerator. A ruggedized miniature crystal accelerometer, fastened to the case of the S-A, responds to internal vibrations caused by pallet clatter on the gear train, solenoid plunger bottoming, and g-weight movement. The resulting signals are converted to electrical energy and fed to an amplifier, also on the centrifuge arm, from which they are conducted through slip rings to a recorder. In addition, records are made of the time of S-A switch operations as well as the time of voltage application to the launch-latch solenoid.</p>	<p>1. Safety-arming devices— Testing I. Craycraft, L. V. II. Barilotti, E. E. III. Title</p>	<p>Naval Ordnance Laboratory Corona. (NOLC Report 556)</p> <p>MONITORING THE MECHANICAL OPERATION OF FUZE SAFETY-ARMING MECHANISMS, by L. V. Craycraft and E. E. Barilotti, Fuze Department, 1 November 1961. 14 pp.</p> <p>UNCLASSIFIED</p> <p>Described in this report is a monitoring system that detects and records the mechanical operations taking place inside a safety-arming device (S-A) while it is being tested within a rotary accelerator. A ruggedized miniature crystal accelerometer, fastened to the case of the S-A, responds to internal vibrations caused by pallet clatter on the gear train, solenoid plunger bottoming, and g-weight movement. The resulting signals are converted to electrical energy and fed to an amplifier, also on the centrifuge arm, from which they are conducted through slip rings to a recorder. In addition, records are made of the time of S-A switch operations as well as the time of voltage application to the launch-latch solenoid.</p>	<p>1. Safety-arming devices— Testing I. Craycraft, L. V. II. Barilotti, E. E. III. Title</p>
<p>----- This card is UNCLASSIFIED -----</p>			
<p>Naval Ordnance Laboratory Corona. (NOLC Report 556)</p> <p>MONITORING THE MECHANICAL OPERATION OF FUZE SAFETY-ARMING MECHANISMS, by L. V. Craycraft and E. E. Barilotti, Fuze Department, 1 November 1961. 14 pp.</p> <p>UNCLASSIFIED</p> <p>Described in this report is a monitoring system that detects and records the mechanical operations taking place inside a safety-arming device (S-A) while it is being tested within a rotary accelerator. A ruggedized miniature crystal accelerometer, fastened to the case of the S-A, responds to internal vibrations caused by pallet clatter on the gear train, solenoid plunger bottoming, and g-weight movement. The resulting signals are converted to electrical energy and fed to an amplifier, also on the centrifuge arm, from which they are conducted through slip rings to a recorder. In addition, records are made of the time of S-A switch operations as well as the time of voltage application to the launch-latch solenoid.</p>	<p>1. Safety-arming devices— Testing I. Craycraft, L. V. II. Barilotti, E. E. III. Title</p>	<p>Naval Ordnance Laboratory Corona. (NOLC Report 556)</p> <p>MONITORING THE MECHANICAL OPERATION OF FUZE SAFETY-ARMING MECHANISMS, by L. V. Craycraft and E. E. Barilotti, Fuze Department, 1 November 1961. 14 pp.</p> <p>UNCLASSIFIED</p> <p>Described in this report is a monitoring system that detects and records the mechanical operations taking place inside a safety-arming device (S-A) while it is being tested within a rotary accelerator. A ruggedized miniature crystal accelerometer, fastened to the case of the S-A, responds to internal vibrations caused by pallet clatter on the gear train, solenoid plunger bottoming, and g-weight movement. The resulting signals are converted to electrical energy and fed to an amplifier, also on the centrifuge arm, from which they are conducted through slip rings to a recorder. In addition, records are made of the time of S-A switch operations as well as the time of voltage application to the launch-latch solenoid.</p>	<p>1. Safety-arming devices— Testing I. Craycraft, L. V. II. Barilotti, E. E. III. Title</p>
<p>----- This card is UNCLASSIFIED -----</p>			