

UNCLASSIFIED

AD **265 096**

*Reproduced
by the*

ARMED SERVICES TECHNICAL INFORMATION AGENCY
ARLINGTON HALL STATION
ARLINGTON 12, VIRGINIA



UNCLASSIFIED

NOTICE: When government or other drawings, specifications or other data are used for any purpose other than in connection with a definitely related government procurement operation, the U. S. Government thereby incurs no responsibility, nor any obligation whatsoever; and the fact that the Government may have formulated, furnished, or in any way supplied the said drawings, specifications, or other data is not to be regarded by implication or otherwise as in any manner licensing the holder or any other person or corporation, or conveying any rights or permission to manufacture, use or sell any patented invention that may in any way be related thereto.

CATALOGED BY ASTIA 265096
AS AD 110

XEROX
62-1-1

I. E. R.
TECH. REPT. 140-46

CLOSELY SPACED PILES AS A BREAKWATER

BY
R. L. WIEGEL

ASTIA
RECORDED
OCT 81 1961
TIPPER



HYDRAULIC ENGINEERING LABORATORY
WAVE RESEARCH PROJECTS

UNIVERSITY OF CALIFORNIA
BERKELEY

University of California
Hydraulic Engineering Laboratory
Wave Research Projects

Submitted under Contract NBy - 3139
with the Bureau of Yards & Docks, U. S. Navy

Institute of Engineering Research
Technical Report
Series 140, Issue 44

CLOSELY SPACED PILES AS A BREAKWATER

by

R. L. Wiegel

Note: Reproduction for any purpose of the United States Government
is permitted.

Berkeley, California
May, 1961

CLOSELY SPACED PILES AS A BREAKWATER

by

R. L. Wiegel

One possible solution to the problem of creating an area sheltered from wave action is the use of closely spaced piles. This possibility is usually considered when a pile supported pier is needed and it is desired to obtain double use from the structure. Theory and laboratory studies show that this is not a practical solution.

Consider a single row of piles of diameter D and distance between piles b . As an approximation it can be assumed that the portion of the power transmitted past the pile structure is proportional to the gap portion of the pile structure:

$$P_T/P_I = b/(b + D)$$

where P_T is the power transmitted past the structure and P_I is the power transmitted by the incident waves. The wave height is proportional to the square root of the wave power, so

$$H_T/H_I = \sqrt{P_T/P_I} = \sqrt{b/(b + D)}$$

where H_T is the transmitted wave height and H_I is the incident wave

height.

As an example, if a row of 14 inch diameter piles were placed with 10 inches between piles the transmitted wave height would be 63% of the incident wave height. If the same piles were placed with only 3 inches between them the transmitted wave height would be 42% of the incident wave height, and if the space were reduced to only 1-1/2 inches, the transmitted height would still be 31% of the incident wave height. A 1:12 scale model study by the author showed the values of H_T/H_I of 0.83, 0.53, and 0.43, respectively for these pile arrangements. It is believed that diffraction effects are responsible for the fact that the measured transmitted wave heights were nearly 25% greater than the simple theory predicts. Tests made with the line of piles at a 45 degree angle with the waves showed this to be less effective as a breakwater than when the line of piles was normal to the direction of advance of the incident waves.

The phenomenon is more complicated when the pile array consists of more than one row of piles. The second row of piles transmits a portion of the wave power that gets through the first row of piles and reflects a portion of the power, the relative amounts depending upon the geometry of the array. The reflected portion is partially transmitted back through the first line of piles and partially reflected by it, but with a phase lag between this and the original wave. This wave is then partially transmitted through the second pile line and partially reflected again, with a phase shift from the original

transmitted and reflected waves, etc. In addition, a portion of the energy is dissipated by skin and form drag.

Costello (1952) made a laboratory study of several arrays of piles, Fig. 1. The number of piles used in experimental set-up (b) is the same as in (a) and (c) although the number of rows of piles in the direction of wave advance is only one-half that in (a) and (c). For a given number of piles, there does not appear to be any appreciable difference in the effect of the various array configurations upon the effectiveness of the structures as a breakwater. It can be seen that the steeper the wave (the greater H_I/L , where L is the incident wave length) the lower is the transmitted wave height, all other factors being the same. It is evident that such an array is not effective as a breakwater.

The use of a row of closely spaced piles appears to be illusory as a relatively cheap breakwater, as is also the case for a vertical thin barrier extending from the bottom up to a short distance beneath the water surface (Wiegel, 1960). Furthermore, it is ineffective for the same reason--namely, that the wave height is proportional to the square root of the wave power. Thus, if a structure permitted only 4% of the wave power to be transmitted it would transmit a wave 20% as high as the incident wave.

Costello, R. D., Damping of water waves by vertical circular cylinders, Trans. Amer. Geophys. Union, Vol. 33, No. 4, pp 513-519, Aug. 1952.

Wiegel, R. L., Transmission of waves past a rigid vertical thin barrier, Jour. Waterways and Harbors Div., Proc. ASCE, Vol. 86, No. WW1, pp. 1-12, March 1960.

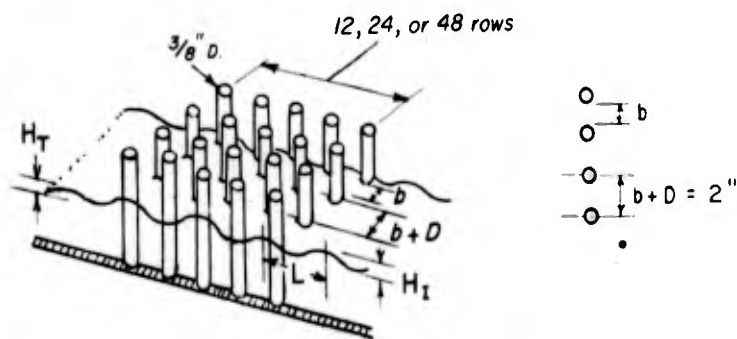
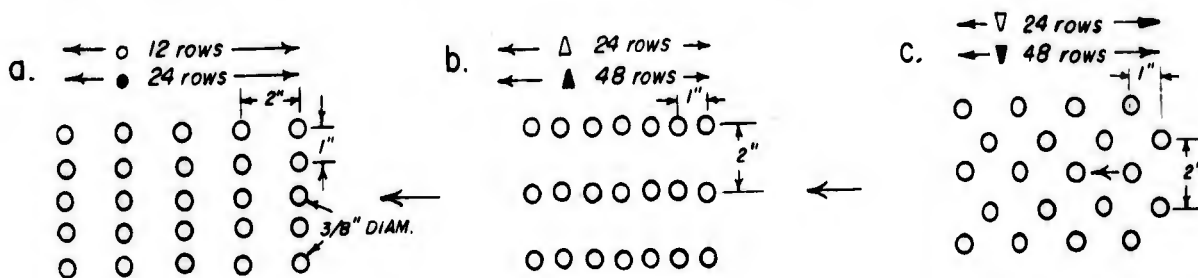
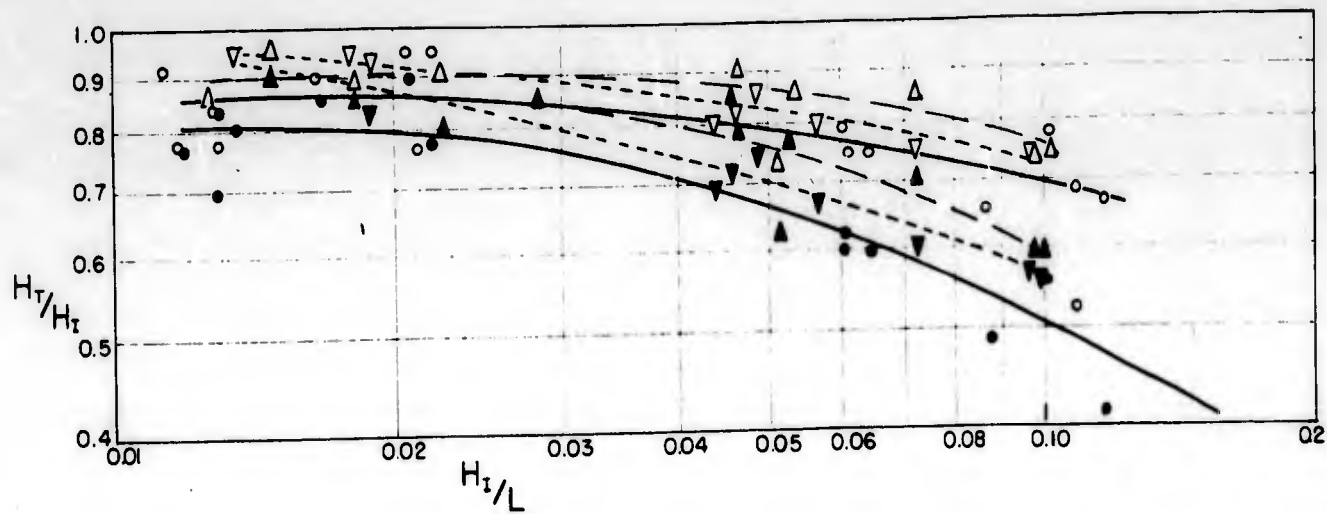

FIGURE 1- RELATIONSHIPS AMONG INITIAL WAVE STEEPNESS, PILE ARRAY AND WAVE ATTENUATION.

HYD-8581

(After Costello, 1952)

FIGURE 1

UNCLASSIFIED

UNCLASSIFIED