

UNCLASSIFIED

AD 265 369

*Reproduced
by the*

ARMED SERVICES TECHNICAL INFORMATION AGENCY
ARLINGTON HALL STATION
ARLINGTON 12, VIRGINIA



UNCLASSIFIED

Best Available Copy

NOTICE: When government or other drawings, specifications or other data are used for any purpose other than in connection with a definitely related government procurement operation, the U. S. Government thereby incurs no responsibility, nor any obligation whatsoever; and the fact that the Government may have formulated, furnished, or in any way supplied the said drawings, specifications, or other data is not to be regarded by implication or otherwise as in any manner licensing the holder or any other person or corporation, or conveying any rights or permission to manufacture, use or sell any patented invention that may in any way be related thereto.

CATALOGED BY ASTIA
AS AD No. 265369

AID Report 61-130

15 September 1961

SOVIET NUCLEAR INSTRUMENTATION AND
CONTROL FOR PROPULSION

AID Work Assignment No. 15c

Report 7

Science and Technology Section

Air Information Division

DISCLAIMER NOTICE

THIS DOCUMENT IS BEST QUALITY PRACTICABLE. THE COPY FURNISHED TO DTIC CONTAINED A SIGNIFICANT NUMBER OF PAGES WHICH DO NOT REPRODUCE LEGIBLY.

AID Report 61-130

15 September 1961

SOVIET NUCLEAR INSTRUMENTATION AND
CONTROL FOR PROPULSION

AID Work Assignment No. 16c

Report 7

The publication of this report does not constitute approval by any U. S. Government organization of the inferences, findings, and conclusions contained herein. It is published solely for the exchange and stimulation of ideas.

Science and Technology Section

Air Information Division

SUBJECT: Monthly Report - AID Work Assignment No. 16c

PERIOD : 10 Jul 1961 - 10 Aug 1961

This is the seventh in a report series reviewing Soviet and Soviet-bloc developments in nuclear instrumentation and control for propulsion. It is based on materials made available at the Air Information Division during the period 10 Jul to 10 Aug 1961. Items have been selected with a view to the possible applicability of their subject matter to problems of instrumentation and control of nuclear propulsion, although such applicability is, of course, rarely mentioned in Soviet-bloc open literature.

Materials in this report deal with the following topics:

- II. Detectors
- III. Control components
 - 2. Pneumatic
- IV. Miscellaneous related subjects

SUBJECT. Monthly Report - AID Work Assignment No. 16c

PERIOD : 10 Jul 1961 - 10 Aug 1961

TOPIC II. DETECTORS

- 1.) Celiński, Z. Device for measuring excess reactivity in a reactor. Nukleonika, v. 6, no. 4, 1961, 261-266.

A device (see illustration) developed and put into operation by the Reactor Operations Department of the Institute of Nuclear Research, Polish Academy of Sciences, Warsaw, gives a direct reading of excess reactivity in a nuclear reactor. It consists of two basic units: 1) a summation unit consisting of resistors as well as potentiometers R_0 , R_{10} , and R_{11} , which are coupled with the control rod drive systems and are individually fed from special transformer windings, and 2) a measuring unit consisting of a magnetoelectric millivoltmeter V , a rectifier G , and a range selector P .

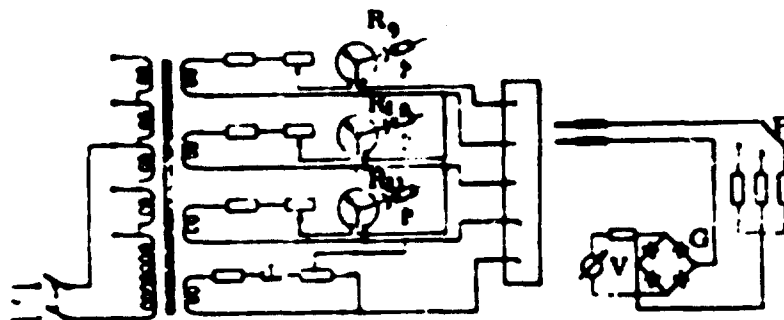

Basic circuit diagram of the device
for measuring excess reactivity

The potentiometers are designed in such a way that their characteristics are nonlinear and correspond to those of the control rods. Thus, the total voltage of the output of the potentiometers is directly proportional to the total excess reactivity in the reactor. The device which measures the output of the potentiometers is calibrated to give a direct reading of excess reactivity in percentages with an accuracy of 5%. The device makes possible the measurement of the excess reactivity of individual control rods or a group of rods inserted in a reactor core. (Author's association: Institute of Nuclear Research, Warsaw)

SUBJECT: Monthly Report - AID Work Assignment No. 16c

PERIOD 10 Jul 1961 - 10 Aug 1961

TOPIC II. DETECTORS

- 2.) Grebenskiy, R. S., T. V. Timofeyeva, S. P. Khormushko, and O. S. Tsvetkov. On increasing the efficiency of a slow-neutron scintillation detector. IN: Akademiya nauk SSSR. Izvestiya. Seriya fizicheskaya, v. 25, no. 4, 1961, 500-503.

In a study of the means for improving the efficiency of slow-neutron scintillation detectors, the relationship between the neutron-counting efficiency ∂_n , the grain size, and the thickness of a scintillator was determined for various contents of boric acid enriched with the B^{10} isotope. Differential curves of pulse amplitude distribution for slow neutrons and γ -rays were also obtained. Plain dispersion-type detectors with scintillators composed of ZnS-Ag and H_2BO_3 compounds (natural and enriched with the B^{10} isotope) were studied. The scintillators were obtained 1) by firing the mixture of ZnS-Ag with H_2BO_3 , and 2) by the method described by K. H. Sun, P. R. Malmberg, and F. A. Pecjak [Nucleonics, v. 14, July-Dec. 1956, 46-49]. Results are shown in the Table and Figs. 1 and 2.

It was found that with an increase in H_2BO_3 content the scintillator efficiency also increases until it reaches its peak value at the H_2BO_3 content of 30-34% (by weight) and then drops. The curves showing the relationship between the efficiency and thickness also pass through their respective maxima, which are more pronounced and displaced in the direction of smaller thickness for scintillators with a higher B^{10} content. With an increase in grain size the efficiency of a scintillator with a given thickness and H_2BO_3 content strongly increases until it reaches a certain limit at the grain size of 800-1000 μ . For example, the efficiency of a scintillator with a thickness of 100 mg/cm² and a content of 30% H_2BO_3 (enriched with B^{10} to 87%) increased 5, 14, and 25% with increases in grain size from 50-100, 150-300, and 750-1000 μ respectively. At the same time the corresponding optimal thickness increased from 50 to 110 mg/cm². For a scintillator of the same composition but with natural H_2BO_3 at the grain size of 750-350 μ , the optimal thickness amounted to 160 mg/cm². The efficiency of the scintillators shown in the table was increased by a factor of 1.6-2.0 by increasing the grain size from 185 to 800 μ . Their respective optimal thicknesses were also increased by a factor of 1.9-2.0. The differential curves shown in Fig. 2 were obtained by using a 100-channel type AM-100 "Raduga" pulse analyzer. The experimental and theoretical determination of a gamma-ray counting efficiency ∂_γ with gamma energy $E_\gamma = 2.62$ Mev and pulse discrimination from gamma rays with the energy $E_\gamma = 1.76$ Mev, have shown that ∂_γ is lower than the neutron-counting efficiency ∂_n by a factor of three. A scin-

illator whose characteristics are represented by curve 1 in Fig. 2 is recommended for neutron detection at high-gamma background.

Grain size	Scintillator 1		Scintillator 2		Scintillator 3		Scintillator 4		Scintillator 5	
	l_0 mg.cm ⁻¹	α	l_0 mg.cm ⁻¹	α	l_0 mg.cm ⁻¹	α	l_0 mg.cm ⁻¹	α	l_0 mg.cm ⁻¹	α
175 ± 150	100	0.55	100	0.55	110	0.89	110	0.89	100	0.69
175 ± 180	-	-	130	0.69	130	0.69	90	0.85	70	0.57
185 ± 100	100	0.40	80	0.51	80	0.51	60	0.75	55	0.43

Table 1. Data on scintillators studied. l_0 - scintillator optimal thickness; α - relative efficiency based on the scintillator with 34% natural K_2CO_3 ; thickness: $l = 80 \text{ mg.cm}^{-1}$; grain size: 185μ ; neutron-counting efficiency θ_n : $5.4 \pm 0.4\%$, i.e., $\theta_n = 1 \times 5.4\%$; α - efficiency of thermal neutron capture.

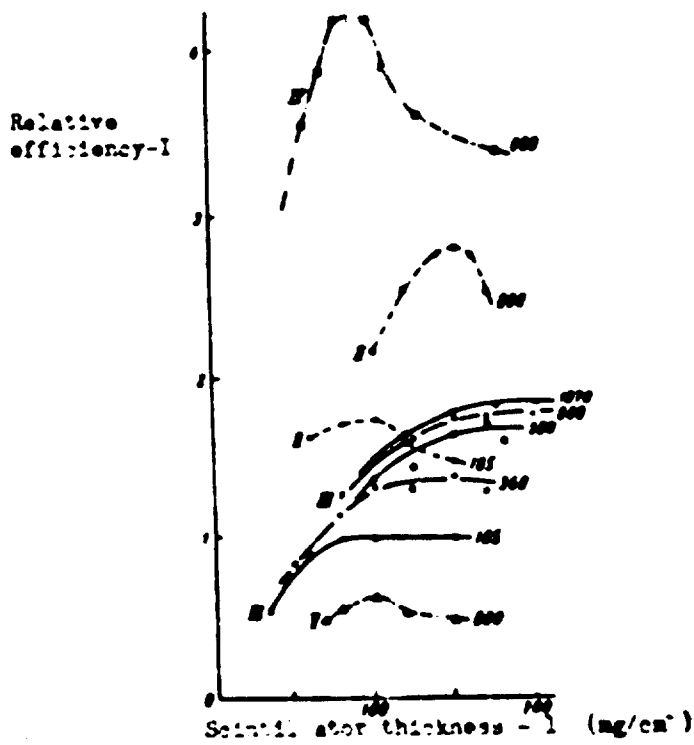

Fig. . Relationship between relative neutron counting efficiency and scintillator thickness for scintillators I to IV. Numbers indicate grain sizes in μ .

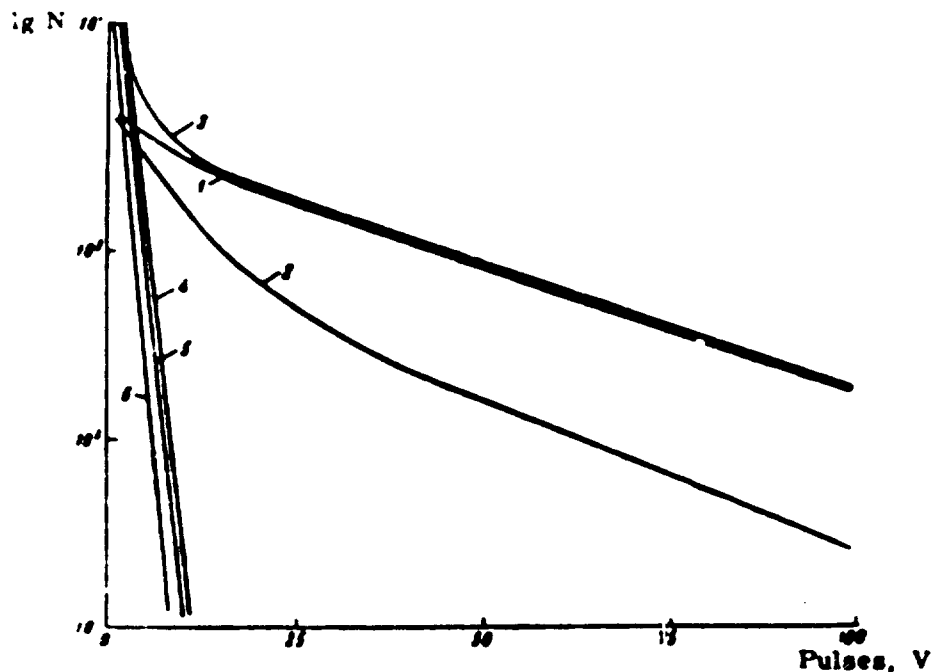

Fig. 2. Differential curves of pulse amplitude distribution for slow neutrons and γ -rays

1 - slow neutron pulse distribution for a scintillator containing 30% H_2BO_3 enriched with B^{10} to 87%; scintillator thickness 1: 100 mg cm^{-2} ; grain size: $750-1000 \mu$; σ_n - neutron-counting efficiency: 25%; 2 - same for scintillator with 34% natural H_2BO_3 ; 1- 200 mg cm^{-2} ; grain size: $750-1000 \mu$; $\sigma_n=10\%$; 3 - total distributions of pulses from neutrons and gamma rays for the first detector; 4, 5, and 6 - distribution of pulses from γ -rays of $RaTh$ ($E_\gamma=2.62 \text{ Mev}$), Ra ($E_\gamma=1.76 \text{ Mev}$) and C_3^{10} ($E_\gamma=661 \text{ Kev}$) respectively.

SUBJECT Monthly Report - AID Work Assignment No. 16c

PERIOD 10 Jul 1961 - 10 Aug 1961

TOPIC III. 2. PNEUMATIC CONTROL COMPONENTS

- 1.) Design elements. IN: Boshnyak, L. L., and L. N. Byzov. Izmereniye malykh raskhodov zhidkostey (Measuring small flow rates of fluids). Moskva, Mashgiz, 1961, 43-45.

During 1958-1959 the Leningrad Mechanical Institute developed two flowmeters for measuring small flow rates. The flowmeters have the following characteristics: 1) Flow-rate range: from 3.5 to 35 cm³/sec; 2) pipeline diameter: 4 mm; 3) pipeline fluid pressure: up to 250 kg/cm²; 4) output parameter (electric signal frequency) from 50 to 500 cps; 5) minimum signal voltage: 20 mv; 6) time constant: less than 0.03 sec; and 7) principal error: $\pm 0.35\%$.

The $\Delta P-2E-I$ flowmeter (Fig. 1) consists of a sensor-rotor located in a fluid stream, and a pulse transducer, designed for converting rotor rpm into the measuring signal. The rotor assembly 13 (Fig. 1) consists of a rotor proper, made of nonmagnetic-type CH-4J7 , TY5211-56 [Nimonic 80A] steel, a magnetic plate 15 made of type 2X13 [AISI-321] steel, and a plate-fastening pin made of type LAMBHT [AISI-321] steel. The bearings for supports 2 are made of synthetic ruby.

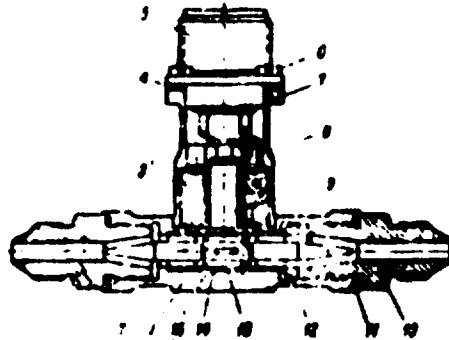

- Fig. 1. $\Delta P-2E-I$ flowmeter. 1 - body; 2 - supports; 3 - coil; 4 - washer; 5 - plug; 6 - screw; 7 - cup; 8 - washer; 9 - magnet; 10 - connecting pipe; 11 - packing ring; 12 - nut; 13 - rotor; 14 - bushing; 15 - magnetic plate.

The body 1, supports 2, and bushing 14 are made of nonmagnetic-type 1X18H9T [AISI-321] steel, and the pressure nut 12 and connection pipe 10 are made of type 2X13 ГОСТ 5949-51 [AISI-420] steel. The pulse transducer consists of a permanent magnet 9 and a coil 3, whose terminals are connected with a plug 5. The interaction of the permanent magnet and magnetic plate mounted in the rotor induces a signal with a frequency equal to twice the rotor rps.

The type ПР-2Б-III flowmeter (Fig. 2) is a modified design of the ПР-2Б-I meter. The pulse transducer has been replaced with an induction-type tachometer consisting of a coil wound on a permalloy toroidal core. The magnetic plate in the rotor has been replaced with a permanent magnet whose interaction with the toroidal coil induces a signal with a frequency equal to the rotor rps.

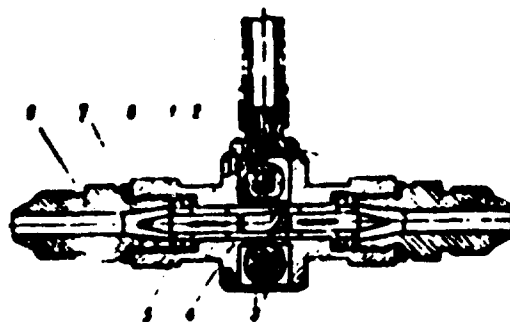

Fig. 2. ПР-2Б-III flowmeter. 1 - Body; 2 - cover;
3 - toroidal coil; 4 - rotor; 5 - support;
6 - connecting pipe; 7 - packing ring; 8 - nut.

SUBJECT: Monthly Report - AID Work Assignment No. 18c

PERIOD : 10 Jul 1961 - 10 Aug 1961

TOPIC III. 2. PNEUMATIC CONTROL COMPONENTS

- 2.) Filters and pressure regulators. IN: Berklayd, I. M., A. P. Kurochkin, A. V. Lyakhovskiy, A. M. Snetkov, and V. A. Chudov. Daichiki i izmeritel'nyye golovki (Transducers and measuring heads). Moskva, Mashgiz, 1960, 79-83.

The Bureau of Interchangeability has conducted comparative studies of a number of Soviet and non-Soviet filters, filtering materials, and pressure regulators used in pneumatic control and measuring systems. The efficiency of filtering materials and filters was determined by means of nephelometric analysis. It was found that the type $\Phi 111$ -15-1.5 filtering material, (with glass fiber 0.0015 μ in diameter as a base, and perchlorvinyl as a binder) developed by Professor I. Petryanov, had the highest filtering efficiency, was nonwetable, and was resistant to chemically aggressive substances. At a load of $1 \text{ cm}^3/\text{sec}/\text{cm}^2$ the 1.5mm-thick layer of this filtering material has a pressure drop of 1.5 mm water column. One of the shortcomings of this material is its nonresistance to oil-saturated media.

The study resulted in the design of a new type T Φ -17-11 filter and a type T Φ -17-12 pressure regulator. The first stage of the new filter is made of glass fiber; type $\Phi 111$ -15-1.5 filtering material is used in the second stage. The area of both stages insures optimal air-flow velocities. The filter, which has been successfully tested, has the following specifications: 1) Air supply line pressure: 3-6 kg/cm^2 ; 2) maximum air flow at a supply pressure of 3 kg/cm^2 8 m^3/hour ; 3) filtering efficiency: 99.93%; 4) pressure drop: does not exceed 500 mm water column; 5) outside dimensions: 98 mm in diameter, 180 mm high; and 6) weight: 0.93 kg.

A schematic diagram of the new type T Φ -17-12 pressure regulator is shown in the illustration. The constant working pressure at the regulator's outlet 13 is maintained by means of a ball valve 1, which is actuated by diaphragm 12 and a servomotor. The pressure regulator has undergone successful laboratory and industrial testing and can be used in both differential and nondifferential pneumatic systems. It has the following specifications: 1) air supply line pressure: 3-6 kg/cm^2 ; 2) working pressure regulation range: 0-2 kg/cm^2 ; 3) pressure stabilisation error at supply pressure variation from 3 to 6 kg/cm^2 in the working pressure range from 0-2 kg/cm^2 : does not exceed 0.02 kg/cm^2 ; 4) outside dimensions: 90 mm in diameter, 170 mm high; and 5) weight: 1.540 kg. The filter and pressure regulator can be assembled as a single unit 98 mm in diameter, 208 mm high, and weighing 2.170 kg.

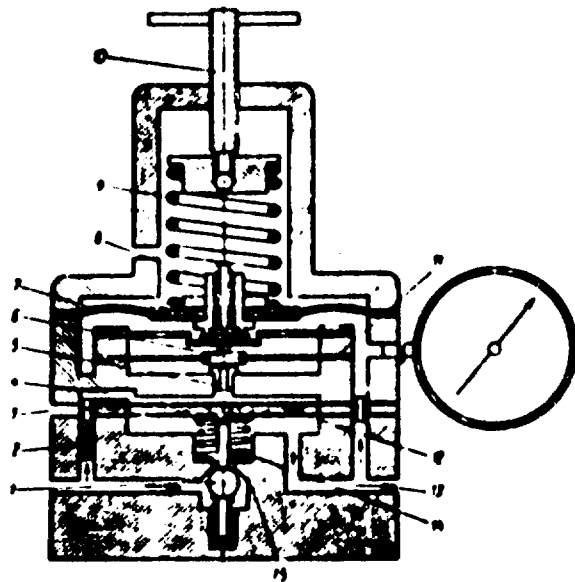

The TO-17-12 pressure regulator

1 - ball valve; 2 - nozzle; 3 - exhaust port; 4 - amplifier chamber;
 5 - nozzle; 6 - plate; 7 - diaphragm; 8 - safety valve; 9 - spring;
 10 - screw; 11 - diaphragm; 12 - double-layer diaphragm; 13 - out-
 let port; 14 - spring; 15 - exhaust port.

SUBJECT: Monthly Report - AID Work Assignment No. 16c

PERIOD : 10 Jul 1961 - 10 Aug 1961

TOPIC IV. MISCELLANEOUS RELATED SUBJECTS

- 1.) Andronov, G. G. , and N. K. Komarova. Cleaning corrosion products from the reactor circuit. IN: Gerasimov, V. V. (ed.) Korroziya reaktornykh materialov; sbornik statey (Corrosion of reactor materials; collection of articles). Moskva, Atomizdat, 1960, 277-282.

In spite of various protective measures, it is extremely difficult to prevent contamination of the surfaces of reactor parts during their manufacture and assembling, and while the nuclear reactor is in operation. Small chips or pieces of metal can be deposited on the surfaces of the part during various machining operations, and during polishing and sand-blast cleaning. The contamination of reactor parts increases the nonhomogeneity of metal surfaces as well as their corrosion rate. Corrosion products washed from the metal surfaces by cooling water are trapped and accumulated in the reactor at points of increased resistance, e. g., in the heat-exchanger tubing and filters. It is very difficult to clean the inner surfaces of the reactor circuit from corrosion products and other contaminations by mechanical methods. These deposits, however, can easily be removed by dissolving them in acid solutions and washing them away with a distillate water. The acid solutions used in chemical cleaning must be able to dissolve corrosion products but should not affect the base metal. In this connection numerous acid solutions were tested to determine their effect on materials widely used in the construction of nuclear research reactors. Corroded and uncorroded specimens were tested. In order to obtain deposits of corrosion products on specimens made of aluminum alloys or stainless steels the specimens were placed in a solution consisting of CaCl-65 mg/l, Mg-30 mg/l, and FeCl-27 mg/l and held at room temperature for a long period of time. The following solutions were used as etching agents: 1) 8% nitric acid; 2) 30% nitric acid; 3) chromic anhydride-20 g/l + 35 ml/l of phosphoric acid with a density of 1.68 g/cm³; and 4) a solution containing 15% phosphoric acid, 35% monomanganese phosphate, and 5% butyl alcohol. The results showed that the solution of CrO₃ and H₂PO₄ completely removed corrosion products from surfaces of aluminum alloys and stainless steels without corroding the base metal and welded joints. The use of the 8% HNO₃ solution is not recommended since this solution dissolves the base metal and causes intergranular corrosion in the weld zone. The latter is responsible for the formation of a film on the surface in the temperature-affected region, which may become a contamination source for the heat-transfer agent (water). The solution of phosphoric acid, monomanganese phosphate, and butyl alcohol removes corrosion deposits from stainless-steel surfaces but cannot be used for cleaning aluminum-alloy parts since aluminum alloys are intensively dissolved in this solution.

A solution of chromic anhydride - 20 g/l and phosphoric acid (with a density of 1.68 g/cm³) - 35 ml/l is recommended for cleaning the circuit of the type BBP-C reactor.

SUBJECT: Monthly Report - AID Work Assignment No. 16c

PERIOD : 10 Jul 1961 - 10 Aug 1961

TOPIC IV. MISCELLANEOUS RELATED SUBJECTS

- 2.) Komarovskiy, A. N. Protective coatings in radioactive installations. Atomnaya energiya, v. 10, no. 6, June 1961, 597-605.

One of the most serious problems encountered in the construction of buildings for nuclear reactors and for radiochemical plants and installations is that concerned with the protective coating of walls, floors, ceilings, and other surfaces exposed to radioactive radiations or in contact with radioactive fluids or gases. Floors and ceilings are usually lined with a stainless sheet steel 2-3 mm thick. The same type of steel is also being used for the facing of structures carrying piping with radioactive or chemically aggressive fluids at pressures above 2 atm. At lower pressures, and at fluid radioactivities below 10^{-2} g. ekv/cm³ [where g. ekv/cm³ is defined as a radiation dose rate equivalent to the γ -radiation produced by 1 mg Ra] (regardless of pressure) a special type 57-40 plasticized polyvinylchloride is presently being used in Soviet reactor practice. The type 57-40 plasticized polyvinylchloride which has been developed jointly by several organizations as a result of long experimental research has the following basic characteristics: 1) density: 1.3-1.4 g/cm³; 2) tensile strength: 160-180 kg/cm²; 3) relative elongation at rupture: 200-210%; 4) resistance to frost: -20° C; 5) coefficient of linear expansion: $8 \times 10^{-6} \frac{1}{C}$; 6) maximum operational temperature: + 60° C; 7) thermal dissociation: + 200° C; 8) electric resistivity 1.6×10^{10} ohm/cm; and 9) residual contamination: 1.5%. Plasticized polyvinylchloride produced in the form of sheets has a considerable resistance to radiation. When heated with a gas burner it will melt and smolder but will not ignite. Plasticized polyvinylchloride can easily and reliably be butt- and lap-welded. Its resistance to various chemical agents is shown by the following data: 1) 35% hydrochloric acid (up to 70° C) -- resistant; 2) 90% sulfuric acid (up to 40° C) -- relatively resistant; 3) 35% nitric acid (up to 20° C) -- relatively resistant; 4) mixture of diluted sulfuric and nitric acids (up to 65° C) -- relatively resistant; 5) 40% sodium hydrate (up to 60° C) -- resistant; 6) 32% fluosilicic acid (up to 60° C) -- resistant; 7) 100% acetic acid (up to 40° C) -- relatively resistant; 8) 35% chromic acid (up to 60° C) -- relatively resistant; 9) 84% hydrogen peroxide (up to 20° C) -- relatively resistant; and 10) 100% phosphoric acid (up to 60° C) -- resistant. Currently the type 57-40 plasticized polyvinylchloride is being produced in 1 m² sheets 3 mm thick, and in strips 0.5-1 and 2.2 mm thick, up to 1.2 m wide, and 15 m long. Special welding apparatus and methods for welding the polyvinylchloride have been developed. Surfaces exposed to aggressive media at temperatures up to 400° C are covered with LX18H2T [AISI-321] steel. With highly aggressive media and temperatures above 400° C,

X18H12N2T (AISI-316T) and X18H12N3T (AISI-317 T) steels are used. For facing special storehouses and pools, a 4-6-cm-thick double-layer clad steel consisting of a 1.5-2mm layer of stainless X18H9T or X18H12N3T steels and a layer of type 3 or 10 carbon steel (1.3% C or 1.0% C) is being widely used. At a temperature of 60°C and with low radioactivity levels, the exposed surfaces are coated with chemically stable type XCG pervinylchloride enamels.

SUBJECT: Monthly Report - AID Work Assignment No. 18c

PERIOD 10 Jul - 10 Aug 1961

BIBLIOGRAPHY

- 1.) Andronov, G. G., and N. K. Komarova. Cleaning corrosion products from the reactor circuit. IN: Gerasimov, V. V. (ed.) Korrosiya reaktornykh materialov; sbornik stat'yi (Corrosion of reactor materials, collection of articles). Moskva, Atomizdat, 1960, 277-282.
- 2.) Berklayd, I. M., A. P. Kurochkin, A. V. Lyakhovskiy, A. M. Snetkov, and V. A. Chudov. Datchiki i izmeritel'nyye golovki (Transducers and measuring heads). Moskva, Mashgiz, 1960, 79-83.
- 3.) Boshnyak, I. L., and L. N. Bysov. Izmereniye malyykh rashkhodov zhidkostey (Measuring small flow rates of fluids). Moskva, Mashgiz, 1961, 43-45.
- 4.) Celinski, Z. Device for measuring excess reactivity in a reactor. Nukleonika, v. 6, no. 4, 1961, 261-266.
- 5.) Grebenskiy, B. S., T. V. Timofeyeva, S. P. Khermushko, and O. T. Tsvetkov. On increasing the efficiency of a slow-neutron scintillation detector. IN: Akademiya nauk SSSR. Izvestiya. Seriya fizicheskaya, v. 25, no. 4, 1961, 500-503.
- 6.) Komarovskiy, A. N. Protective coatings in radioactive installations. Atomnaya energiya, v. 10, no. 6, June 1961, 597-605.