



**EXPERIMENTAL STUDY OF THE HEATING
OF GAS FLOW BY HIGH-FREQUENCY DISCHARGE**

By

James C. Williams, III, Paul C. Wilber, Philip O. Johnson
and Frederick O. Smetana

ENGINEERING CENTER
UNIVERSITY OF SOUTHERN CALIFORNIA

September 1961

**ARNOLD ENGINEERING
DEVELOPMENT CENTER**

AIR FORCE SYSTEMS COMMAND



Additional copies of this report may be obtained from

ASTIA (TISVV)
ARLINGTON HALL STATION
ARLINGTON 12, VIRGINIA

note

Department of Defense contractors must be established for ASTIA services, or have their need-to-know certified by the cognizant military agency of their project or contract.

**EXPERIMENTAL STUDY OF THE HEATING
OF GAS FLOW BY HIGH-FREQUENCY DISCHARGE**

By

**James C. Williams, III, Paul C. Wilbur, Philip O. Johnson
and Frederick O. Smetana**

**ENGINEERING CENTER
UNIVERSITY OF SOUTHERN CALIFORNIA
Los Angeles 7, California**

September 1961

AFSC Program Area 750A, Project 8952, Task 895203

**(The reproducible copy supplied by the University of Southern
California was used in the reproduction of this report.)**

**The research reported herein was performed at the Engineering
Center of the University of Southern California under
AEDC sponsorship - Contract AF 40(600)-857.**

ABSTRACT

An experimental investigation has been carried out to determine the feasibility of using a radio-frequency discharge to heat a supersonic gas stream. Experiments were conducted with both axisymmetric and two-dimensional supersonic nozzles with the RF discharge created in the supersonic gas flow. Temperature measurements in the flow field downstream of the discharge indicate a definite temperature rise in the decaying plasma. Calorimetry measurements show that it is possible to add up to 40% of the energy available at the discharge plates to the gas stream. It is concluded that radio-frequency discharge heating is a feasible method of heating a supersonic gas stream.

ACKNOWLEDGEMENTS

The present work is a summary of experimental investigations carried out over the past two years in the study of heating a supersonic gas stream by a radio-frequency discharge. A number of persons, other than the joint authors of this report, have been of invaluable assistance in carrying out these investigations. The authors wish to thank all those who have helped in these investigations and, specifically, express their appreciation to Dr. David Robinson who obtained and analyzed the spectrographic plates, Mr. Herbert Pass who conducted the microwave investigations, Mr. J. G. Everton who coordinated and assisted in carrying out a number of the experiments, and to Messrs. R. Aland, L. Morris and K. Yost who were responsible for most of the detailed design, construction and setting up of the experimental apparatus.

TABLE OF CONTENTS

	Page
ABSTRACT	ii
ACKNOWLEDGEMENTS	iii
I. INTRODUCTION	1
II. DESCRIPTION OF EQUIPMENT	
A. EXPERIMENTS WITH AN AXISYMMETRIC NOZZLE	4
B. EXPERIMENTS WITH TWO-DIMENSIONAL NOZZLES	6
III. RESULTS AND DISCUSSION	
A. EXPERIMENTS WITH AN AXISYMMETRIC NOZZLE	11
1. Feasibility of Teflon as a Nozzle Material	11
2. General Characteristic of the RF Discharge- Created Plasma	13
3. Energy Added to the Gas Stream by an RF Discharge	14
4. Composition of the Discharge-Produced Plasma	16
B. EXPERIMENTS WITH TWO-DIMENSIONAL NOZZLES	18
1. Nozzle Material	18
2. Calorimetry Experiments	22
3. Characteristics of the Discharge	27
IV. APPLICATION TO A FULL SIZE TUNNEL	29
V. CONCLUDING REMARKS	45

APPENDIX I — USE OF THE CONTOURED NOZZLE BLOCKS AS ELECTRODES IN A RADIO-FREQUENCY DISCHARGE NOZZLE	47
--	----

APPENDIX II — MEASUREMENTS OF POWER IN A RADIO-FREQUENCY DISCHARGE	50
---	----

REFERENCES	55
------------	----

Table I—Result Of Calorimetry Measurements.	57
---	----

LIST OF ILLUSTRATIONS

Figure		Page
1	Details Of Axisymmetric Nozzle Construction.	58
2	Teflon Axisymmetric Nozzle RF Heating Apparatus.	59
3	View Of Plasma Tunnel Showing Microwave Interferometer.	60
4	Details Of Two-Dimensional Nozzle Construction.	61
5	Calorimeter Arrangement For Two-Dimensional Nozzle Studies, RF Heating Studies.	62
6	Petrolatum Oil Bath With Nozzle Blocks In Place.	63
7	Two-Dimensional Nozzle RF Heating Apparatus.	64
8	View Of Teflon Axisymmetric Nozzle After Testing.	65
9	Self-Luminous Flow Of Supersonic Argon Over A Wedge.	66
10	Temperature Measurements In A Decaying Nitrogen Plasma.	67
11	Typical Spectrographic Plate For Nitrogen And Argon Discharge.	68
12	Supramica Nozzle Components After Failure.	69
13	Effect Of Discharge Pressure On The Distribution Of Energy In Calorimetry Measurements.	70-72
14	Results Of Calorimetry Measurements In Segmented Calorimeters.	73
15	Characteristics Of The RF Discharge In Two-Dimensional Nozzles.	74

Figure		Page
16	Effect Of Static Pressure On The Electrical Conductivity Of The Discharge Created Plasma.	75
17(a)	Variation Of Breakdown Voltage With Gap Length Between Plates In Air At Different Frequencies (Data from Ref. 11).	76
17(b)	Breakdown Voltage Curves In Argon As A Function Of Frequency. The Dotted Curves Give The Calculated Values (Data from Ref. 11).	76
17(c)	Variation Of Breakdown Voltage With Gap Length Between Plates In Air At 200 Mc./s. For Different Gas Pressures (Data from Ref. 11).	77
17(d)	Breakdown In Air. Solid Line, Theory; ● Data Of Herlin and Brown; ○ Data of Pim; + "pure" Air (Data from Ref. 15, p. 567).	77
18(a)	Maximum Pressure For Breakdown Between Plates In Air As A Function Of Gap Distance.	78
18(b)	Effective Gap Distance For Contoured Nozzle Block Electrodes.	78
19	Location Of High-Frequency Discharge In A Supersonic Nozzle.	79
20	Electronic Mean Free Path In N_2 As A Function Of Pressure For Various Average—Electron Energies.	80
21	Oscillation Amplitude Limit In Air Expressed As $f_{min} = f(p)$ For Parallel Plates Having Various Separation Distances, L' , And Geometries Such That $L' \approx 2\Lambda$ Where Λ Is The Characteristic Diffusion Length.	81

I. INTRODUCTION

The attainment of the high energy gas streams required for the simulation of hypersonic flight has for several years now been the subject of intensive study by physicists and engineers. It is now generally conceded that the laboratory attainment of such high energy gas streams will require some form of conversion of electrical, or electromagnetic energy into thermal and kinetic energy in the stream. Various schemes have been proposed for this purpose. These range from various forms of d. c. and a. c. discharges to the more recent schemes employing magnetohydrodynamic principles such as crossed field acceleration and traveling wave pumps.

For the past two and one-half years, the Engineering Center of the University of Southern California has been involved in the study of one of these schemes, namely, the heating of a supersonic gas stream by using a high-frequency electromagnetic field to break down the gas and thereby add energy, in the form of potential energy of electron-ion separation, to the gas stream. As the gas flows downstream from the discharge region, the electrons and ions recombine and some of the potential energy of electron-ion separation is converted to thermal energy in the gas stream.

The advantages of this high-frequency discharge heating scheme lie in the fact that the energy can be added in the supersonic portion of the gas stream, thereby circumventing the throat heating problem

associated with the addition of large quantities of thermal energy upstream of the throat, and in the fact that it is not necessary to have the discharge electrodes in direct contact with the gas, thereby eliminating the electrode erosion problem so prominent in direct current arc heating schemes.

The initial studies of high-frequency discharge heating of a supersonic gas stream were analytical in nature and concentrated on studies of the mechanisms of the discharge (Refs. 1, 2 and 3), and on the mechanisms involved in the decay of the ionized gas and the conversion of the ionization energy into thermal energy (Refs. 3 and 4). These analytical studies have given considerable insight into the mechanisms of both the discharge and the decay. However, out of these analytical studies, there arose other questions which could only be answered empirically. For example, the analytical studies showed that the feasibility of high-frequency discharge heating was very dependent upon the pressure at which the discharge was created, since at low pressures the time required for the decay, at least in nitrogen, could be excessive. It was not possible to determine analytically, however, the maximum pressure at which the discharge could be created, nor was it possible to determine analytically the portion of the energy added to the gas stream in the discharge which could be converted to thermal energy in the decay. It therefore became obvious that what was needed was an experimental investigation of the possibility of heating a gas stream by high-frequency electromagnetic discharge.

Some experimental investigations of high-frequency electromagnetic discharge heating had been carried out simultaneously with the above analytical studies (Refs. 5 and 6), however, these were of limited scope. More comprehensive experimental studies have been carried out during the past year and a half. The objective of this more comprehensive program was to determine experimentally the feasibility range of application and energy conversion efficiency of heating a supersonic gas stream by means of an electrodeless RF discharge. It is the purpose of this report to summarize the results obtained in these studies.

Certainly the results set forth in this report will point up the fact that this experimental program has not, as yet, met with the degree of success originally hoped for. Some consolation for this fact can be derived from the knowledge that this work has pressed the limits of existing knowledge in the fields of materials, electromagnetic breakdown and nonequilibrium gasdynamics. The work continues, and it is hoped that the questions still unresolved will be answered in the near future.

II. DESCRIPTION OF EQUIPMENT

A. EXPERIMENTS WITH AN AXISYMMETRIC NOZZLE

The earliest experiments conducted in this program were carried out using an axisymmetric (conical) nozzle. Details of the nozzle construction are presented in Fig. 1. The nozzle was constructed of teflon because of the ease of obtaining and fabricating this material. Provisions were made to cool the nozzle, by circulating a low loss dielectric through internal passages in the nozzle, in an attempt to avoid the severe erosion, softening and collapsing of uncooled teflon nozzles which had been used previously (Ref. 6). The heat absorbed by this liquid was measured and removed by passing a constant flow of cooling water through the liquid reservoir. The temperature rise of the cooling water was measured and taken as an indication of the heating of the nozzle by the discharge. The nozzle cone angle of 12° was selected to put as much gas volume under the discharge coil as possible and still stay within material and aerodynamic size limitations.

The discharge was obtained by using a coil type electrode wound on the outside of the axisymmetric nozzle.

The plenum chamber was provided with discharge electrodes, encased in teflon, and extending into the chamber. It was intended to use these electrodes to create a discharge in the plenum chamber and

thereby increase the electron density in the expanding portion of the nozzle and thus enable more power to be absorbed in the supersonic discharge. Unfortunately, the electrode geometry and matching network chosen did not permit a discharge to be obtained at pressures above 1 mm.Hg. so that this scheme was abandoned.

The conical nozzle described above discharged into a cylindrical teflon test section some 32 inches long with an outside diameter of approximately 7-1/2 inches. This test section was equipped with 6 quartz windows on each side through which the discharge could be viewed.

Downstream of the teflon test section were two heat exchangers employed to cool the discharge heated gas stream before it entered the low-density wind tunnel. The first of these was an aluminum-walled, water-jacketed, heat exchanger; the second employed 34 (1/4-inch) water filled copper tubes traversing the gas stream to cool the gas stream. Provisions were made to measure the water flow rates through these heat exchangers and the water inlet and outlet temperatures in order to have some measure of the thermal energy added to the gas stream by the discharge. In addition to this crude form of calorimetry, thermometers were immersed in the gas stream at various points in an attempt to measure the total temperature of the gas stream.

Flow was maintained through the axisymmetric nozzle by using the USCEC low-density wind-tunnel cryopump to maintain vacuum on the downstream side of the apparatus. The general arrangement of the

plenum chamber, nozzles, coil electrode, test section, heat exchangers, and miscellaneous experimental apparatus is shown in Fig. 2.

A small Bausch and Lomb quartz spectrometer placed next to the quartz windows of the test section was used to examine the emission from the discharge-created plasma in the visible and near ultraviolet regions of the spectrum.

A K-band microwave interferometer was used in an attempt to determine the electron density in the plasma at various distances downstream of the nozzle exit plane. This apparatus is shown in position during a test in Fig. 3.

Additional detailed descriptions of the axisymmetric nozzle and attendant equipment is given in Ref. 7, and additional description of the microwave interferometer and experimental results obtained with this apparatus is presented in Ref. 8.

B. EXPERIMENTS WITH TWO-DIMENSIONAL NOZZLES

The later experiments in this program were carried out using two-dimensional nozzles and two-dimensional discharge apparatus. Four two-dimensional nozzles were constructed at various times during the program. The construction details of these nozzle systems and the individual nozzle contours are presented in Fig. 4. The contoured walls

of these nozzles were constructed, respectively, of teflon and Supramica 620 for the first two nozzles, and of aluminum for the latter two. For each of these nozzles, the sidewalls were quartz plates.

In the first two nozzles (teflon and Supramica 620) the discharge is created with flat plate-type electrodes which discharge through the quartz sidewalls; in the last two nozzles, the aluminum contoured nozzle blocks act as the electrodes for creating the discharge. The use of the countoured nozzle blocks as electrodes for the RF discharge is considered qualitatively in Appendix I.

As a result of the early experience with the axisymmetric nozzle and the 2.5 kw. generator, it was evident that in order to obtain any reasonable power density in the gas stream, it would be necessary to have a larger power supply. To this end, a new RF power generator was purchased to replace the 2.5 kw. unit previously used. This new RF power generator is a commercial type dielectric heater unit manufactured by the Peeco Corporation of Los Angeles. The unit consists of a single stage power oscillator of the Colpitts type and is capable of delivering 12 kilowatts of RF power at approximately 13 megacycles. This type of power oscillator is extremely flexible and can be matched into a wide variety of load impedances.

The power output of the generator is not all consumed in the load (in the present case, the RF discharge in the nozzle), since there are line losses and losses in the electronic coupling circuits between the

generator and the load. It was therefore necessary to develop an instrument capable of measuring the power dissipated in the load. The method chosen to measure the power dissipated in the RF discharge is known as the "three-ammeter method". The theory of the three-ammeter method for measuring power dissipated in an RF circuit is outlined briefly in Appendix II and is presented in more detail in Refs. 9 and 10. Basically, this method employs three ammeters, two capacitors and an inductance in the circuit with the load (RF discharge). The readings on the three ammeters, together with knowledge of the circuit constants, then is indicative of the power dissipated in the discharge.

An attempt was made to measure the power added to the gas stream by the RF discharge. In order to perform this measurement, a system of water-jacketed calorimeters was introduced downstream of the two-dimensional nozzle and discharge apparatus as shown schematically in Fig. 5. Several modifications to this system were made during the experimental program; the system in its final form is shown in Fig. 5. The first calorimeter was constructed of a teflon inner wall and an outer wall of micarta. The second heat exchanger was constructed with both inner and outer walls of copper. Each of these two heat exchangers has been segmented (see Fig. 5) into three parts so as to give some indication of the heat absorbed in the calorimetry as a function of the distance from the discharge. The third calorimeter was a large (4' long by 8" diameter) fire-tube-type heat exchanger. This heat

exchanger was employed to give a large surface area for heat transfer from the gas stream to the cooling water, while maintaining a relatively small pressure drop through the heat exchanger. The fourth, and final, calorimeter consisted of a cylinder with 34 (1/4-inch) water-filled copper tubes running diagonally across the inside of the cylinder (see Fig. 5). Thus, in this calorimeter, the gas passes over and around the 34 tubes and gives heat energy to the cooled tubes.

For each calorimeter, or segment of a calorimeter, there is a venturi meter and attendant manometer for measuring the water flow rate and a thermometer for measuring the temperature of the water at the outlet of the calorimeter. The inlet water temperature, which is common to all calorimeters, is measured at one point in the inlet water system. Water inlet and outlet temperatures were measured on standard ASTM Gas Calorimetry Thermometers with divisions of 0.2°F and 0.1°F , respectively. At times not all of the energy of the gas stream was recovered in the calorimetry. An attempt was made to determine the excess quantity of thermal energy in the gas stream downstream of the calorimeters by measuring the stagnation temperature of the gas at this point with an ASTM Bomb Calorimeter Thermometer, and comparing this with the temperature of the gas upstream of the discharge (unheated gas).

In the high-frequency electromagnetic discharge in a supersonic nozzle, there is a large amount of energy dissipated in the form of heat at the electrodes. In the later experiments, to be reported here, it was decided to immerse the nozzle and electrodes in a bath of liquid petrolatum to cool nozzle and electrodes. It was further decided to measure the rate of temperature rise in the petrolatum to obtain some crude estimate of the power dissipated in heat at the electrodes. The oil bath, as built, contained approximately 28 liters of liquid petrolatum. Forced circulation of the petrolatum around the nozzle and electrodes was obtained by using a small air motor-driven propeller to circulate the oil. The temperature of the oil was measured on a standard ASTM Bomb Calorimeter Thermometer with division of 0.2°C . The oil bath with the nozzle (nozzle number 4) in place is shown in Fig. 6.

Since larger mass flows were pumped through the two-dimensional nozzle system than through the axisymmetric nozzle system, it was not possible to use the low-density wind-tunnel cryopump as a vacuum source for the two-dimensional systems. For these systems, mass flow was maintained by using a Kenny KDH 150 single stage mechanical vacuum pump on the downstream side of the system.

At various points in the system, it was desirable to measure the static pressure of the gas. At some points this was accomplished by using mercury manometers; at other points, by using Wallace and Tiernan dial-type vacuum gages.

The entire experimental setup, including plenum chamber, discharge nozzle (nozzle number 4), calorimeters and accessory equipment is shown in Fig. 7.

III. RESULTS AND DISCUSSION

A. EXPERIMENTS WITH AN AXISYMMETRIC NOZZLE

The results of the experiment made with an axisymmetric nozzle have, for the most part, been reported elsewhere (Ref. 7) and will only be briefly reviewed here. From these experiments come information on: (1) The feasibility of using teflon as a nozzle material for plasma heating of a supersonic gas stream, (2) the general character of the RF discharge-produced plasma, (3) some measure of the energy added in the discharge, and (4) the composition of the discharge-produced plasma.

1. Feasibility of Teflon as a Nozzle Material

It was pointed out in Ref. 7 that the material used in a nozzle employing RF discharge heating of the gas stream should have the following characteristics:

- (a) Low electrical loss.
- (b) Good resistance to the eroding action of the discharge and gas flow.

(c) Formability in the necessary shape.

(d) Sufficient mechanical strength to withstand one atmosphere pressure differential across the wall plus additional axial load under operating conditions without deforming.

(e) Good thermal shock properties.

A number of nozzle materials were considered and it was decided to build the nozzle of teflon. While teflon has low electrical loss, is easily formed in the desired shape, has good thermal shock properties, and is further readily obtained; it is relatively weak, is difficult to cool because of its low thermal conductivity and has low softening and vaporizing temperatures. Teflon represents then, a compromise in the requirements for a RF discharge nozzle.

Provisions were made to cool the nozzle by circulating a low loss dielectric through internal passages in the nozzle in an attempt to avoid the severe erosion, softening and collapsing of uncooled teflon nozzles which had been used previously.

In spite of this attempt to cool the nozzle, this nozzle failed after approximately 10 hours of use. The main failure occurred when distortion of the downstream section of the nozzle became so severe that it was impossible to seal the nozzle to the test section. A close inspection of the nozzle revealed that there had been severe erosion of the teflon in the throat of the nozzle and somewhat less severe erosion in the region under the coil electrode. Erosion had caused the throat diameter to

increase from 0.188 inches to approximately 0.392 inches. The throat showed fissures and spalling in addition to being charred to a depth of about 1/32-inch. Fig. 8 is a cutaway section of this nozzle showing the erosion in the vicinity of the throat and the distortion of the downstream lip of the cone.

It was concluded from the experience, that teflon properly cooled, is a satisfactory nozzle material with a short service life.

2. General Characteristic of the RF Discharge-Created Plasma

Three different gases; argon, nitrogen and octofluorocyclobutane (C_4F_8), were used in the experiments with the axisymmetric nozzle. Application of the discharge made the flow visible. The discharge in argon was blue-white in color, in nitrogen it was a bright orange, and in C_4F_8 the discharge appeared a bright bluebird-blue color (Ref. 7).

The conical nozzle was designed to give a Mach number of 7.9 in inviscid flow. Without a discharge, the nozzle could only attain a Mach number of from 4.9 to 5.2 with stagnation pressures ranging from 50 to 900 mm. Hg. The failure of the conical nozzle to attain anywhere near its full theoretical Mach number at the exit plane was attributed in Ref. 7 to viscous effect, although this conclusion is open to question. A core flow was readily discernible when the discharge was applied, and the size of this core could be identified by the extent of a shock wave produced on a small body immersed in the stream. To obtain an

indication of the Mach number in the gas, a small 20° micarta wedge was placed in the argon flow. Measurements from photographs indicate that the Mach number in the argon stream with discharge applied varies from 1.7 to 2.4 depending upon the power. A representative photograph of this wedge and the shock wave on the wedge is shown in Fig. 9.

3. Energy Added to the Gas Stream by an RF Discharge

The heat removed from the experimental apparatus in the liquid cooling of the nozzle, and in the two heat exchangers downstream of the teflon test section, was measured in an effort to obtain some measure of the thermal energy added to the gas stream by the RF discharge. In addition to these crude calorimetry measurements, thermometers were immersed in the gas stream at various points in the system in an attempt to determine the temperature rise of the gas stream as the discharge-produced plasma decayed back to its neutral state.

For nitrogen gas in the nozzle it was estimated, on the basis of the calorimetry measurements, that of the 2000 to 2500 watts of power applied by the power supply, from 27 to 40% is actually supplied to the gas; from 18 to 25% is supplied to the gas but is lost in heating the nozzle walls; and the remainder is lost at the generator plates, in radiation to the room, and in transmission to the discharge coil. Based on the power taken off the transmission lines, the overall efficiency of the apparatus

is estimated at 10%. This figure is arrived at by considering the losses between the transmission lines and the generator and considering a generator efficiency of approximately 50%.

For argon gas in the nozzle and again on the basis of the experimental calorimetry measurements, it is estimated that of the power applied at the power supply 24 to 35% is actually supplied to the gas downstream of the nozzle, from 31 to 36% is supplied to the gas but is lost in heating the nozzle walls; the remainder is lost at the generator plates, in radiation to the room and in transmission. Again, the overall efficiency was estimated at from 10 to 15 percent. The detailed results of these calorimetry measurements are presented in Ref. 7.

The insertion of a thermometer into a supersonic stream will of course disturb the stream by causing a bow shock wave ahead of the thermometer. The existence of this bow shock wave in a closed channel causes a transition to subsonic flow within a short distance of the thermometer; this transition undoubtedly changes the rate of decay of the discharge-produced plasma. Furthermore, a bulb thermometer inserted into the stream does not measure the actual stagnation temperature of the stream but measures a lower temperature because its recovery factor is on the order of 0.85. For these reasons, the measurements made with bulb thermometers immersed in the gas stream only give an indication of the temperature distribution along the channel. Results of these measurements in nitrogen are presented in Fig. 10 as the ratio of

measured temperature to the upstream stagnation temperature as a function of distance from the nozzle exit plane. It is interesting to note that the introduction of a contaminate gas (in this case C_4F_8) to the gas stream has a very noticeable effect on the rate of heating of the gas. Also, there appears to be a definite effect of the upstream stagnation pressure on the rate of heating but more data is needed to establish a definite trend.

4. Composition of the Discharge-Produced Plasma

Spectrographic plates were made of the plasma in the test section for typical nitrogen and argon discharges. A typical spectrographic plate is shown in Fig. 11. A study of the spectrum shows clearly the following features:

(a) No evidence of ionization products of the discharge in the flow of either gas.

(b) In the nitrogen flow the afterglow is clear, arising from the reaction:



The radiation emitted is observed as the Nitrogen First and Second Positive Systems.

(c) Traces of oxygen impurity are observed from the appearance of the $N\theta\gamma$ System. This system is very often found in nitrogen afterglows with the smallest amount of oxygen present.

(d) No observed argon lines.

The excited states of argon have a very short lifetime and have decayed before the expansion of the flow at the nozzle.

(e) Impurity CN Violet and Red Systems.

These systems are also very common in nitrogen afterglows. Since the argon discharge was run shortly after the nitrogen discharge the presence of nitrogen is not unexpected. The presence of carbon is explained because the pilot tunnel discharge section was constructed of teflon for better matching to the radio-frequency discharge source.

These preliminary experiments show that the state of the gas flow is very close to that desired; that is, a neutral molecular gas, except for the presence of some atomic nitrogen.

A K-band microwave interferometer was used to determine the order of magnitude of the electron density in the plasma. For nitrogen these measurements indicate that the electron density in the test section was less than 10^{10} electrons/cm³, the minimum density which the interferometer could measure with any accuracy. The measurements in argon indicate electron densities from 10^{10} to 4.6×10^{11} electrons/cm³. An analysis of this data has been carried out in Ref. 8. This analysis indicates an electron recombination rate in argon on the order of 1.6×10^{-8} cm³/sec at 100 microns static pressure.

B. EXPERIMENTS WITH TWO-DIMENSIONAL NOZZLES

It was clear from the experimental results obtained with the axisymmetric nozzle that much additional work was necessary in order to determine the feasibility of plasma heating of a supersonic gas stream. It was decided, however, that further experiments should be made with two-dimensional nozzles since the discharge can be created in a constant area, constant pressure, and constant Mach number region with a two-dimensional nozzle; whereas the discharge in the axisymmetric nozzle was created in a region of varying area, varying pressure, and varying Mach number. Furthermore, if the discharge is created with capacitive-type electrodes at the sidewalls of a two-dimensional nozzle, one has a certain amount of flexibility in that the electrode spacing can be varied, and thus the electric field strength can be changed over a wide range of values.

1. Nozzle Material

Several two-dimensional nozzles of various materials were constructed and tested during the experimental program. The first of these was a teflon nozzle (Nozzle 1, Fig. 4) in which integral cooling passages were drilled in order to supply sufficient cooling to avoid the difficulties encountered with the axisymmetric teflon nozzle. The nozzle was constructed from a single piece of teflon into which was machined the desired nozzle contour. The nozzle employed quartz sidewalls and

the discharge was created by using capacitive-type electrodes discharging through these sidewalls. It was found, after only a few preliminary runs, that the teflon nozzle had insufficient strength even with cooling and became badly distorted under the action of both the pressure differential between the test section and the surroundings, and the radio-frequency heating.

Next, a nozzle (Nozzle 2, Fig. 4) of Supramica 620, a glass bonded mica, which was used because it is machinable, has good electrical properties and has a high melting temperature. In this nozzle, only the countoured walls were of Supramica 620, and the nozzle end pieces were made of boron nitride. (See Fig. 4 for construction details.) Quartz sidewalls were used and again the discharge was created by using capacitive-type electrodes located outside the sidewalls.

Three runs at an estimated power input of 3 kw. were made with this nozzle. The results of these tests are presented in Table I as runs A1, A2, and A3 and will be discussed later.

During the third run, a catastrophic failure occurred in the quartz sidewalls and the Supramica nozzle blocks due to excessive heating. This is shown in Fig. 12. It will be noted that the Supramica was cracked and chipped, and that a hole at approximately 45° to the direction of the field was actually burned through the upper block. The quartz plates had also been caused to boil in this area, had cracked, and had been blown through. The plates were also etched for a considerable distance along

the line of juncture with the blocks. The area of main failure was almost 3/4" to 1" upstream from the downstream end of electrodes at the time and was therefore not evident until after it occurred. The failure is thought to have resulted from localized, surface ion-electron recombination which caused localized heating. The heated area then absorbed more electrical energy from the field, became hotter and finally melted.

During the period when the above experiments were being conducted, it was postulated that it might be possible to use the metal contoured nozzle blocks both as tunnel walls and as discharge electrodes. This postulate was based on the considerations which are presented in Appendix I. These considerations show that if the nozzle stagnation pressure is high enough, the discharge can be maintained in the supersonic section of the nozzle (and not in the throat where the field strength is highest) because of the pressure variation along the nozzle. With this in mind, a new set of aluminum blocks was constructed to replace the Supramica 620 nozzle blocks. Again, the nozzle end pieces were of boron nitride and the nozzle sidewalls were quartz plates. The discharge is created between the electrodes which are themselves the contoured nozzle walls. This design represents a departure from the original concept of a high-frequency discharge in which the electrodes are not in direct contact with the gas stream. However, with the complete lack of

materials which possessed the characteristics required for a discharge nozzle, it was felt that such a departure was warranted, at least at present.

The first of the aluminum nozzles (Nozzle 3, Fig. 4) was constructed with the same nozzle contours and had been used previously in the teflon and Supramica nozzles. In designing this contour, an attempt had been made to obtain a constant pressure in the downstream portion of the nozzle by continuously expanding the nozzle area to account for the wall boundary layer growth and for the change in gas stream pressure due to the discharge. Unfortunately, there was an over compensation for these effects and as a result, the pressure continuously dropped along the nozzle length. At low stagnation pressures, the discharge took place in the nozzle throat as would be expected (see Appendix I), but at high stagnation pressure—because of the continuous pressure drop along the nozzle—the discharge was confined to the far downstream end of the nozzle.

The fourth and final set of nozzle blocks were also constructed of aluminum but no allowance was made for boundary layer displacement effects. The nozzle contour was a normal contour for a Mach number 3.24 nozzle. The flow in the nozzle became supersonic and approached 3, but near the end of the nozzle there was some type of boundary layer shock wave interaction such that a system of shock waves developed and the flow became subsonic very shortly after leaving the nozzle area.

Nevertheless, this nozzle was used throughout the remaining portion of the last program. In addition to the shock wave boundary layer interaction already noted, two other problems with this nozzle were noted. First, because of the several different parts of the nozzle blocks end pieces, and sidewalls, sealing of the nozzle against leaks was never successfully accomplished. The problems in sealing occurred because of the necessity of using end seals (see Fig. 4) in the present design, and because of the difficulty in cooling the seals in the small nozzle used. It is felt, however, that these problems can be overcome by clever design, especially in larger nozzles than used here.

The second problem with this nozzle configuration was evident in the severe pitting of the nozzle surface area near the end of the nozzle. It is believed that this pitting was due to sputtering of the nozzle surface due to the collision of the high energy electrons and the surface. It may be possible to avoid this problem in the future by using other electrode materials or by coating the electrodes with a ceramic material.

2. Calorimetry Experiments

The main purpose for the experiments conducted with two-dimensional nozzles was to determine, by means of calorimetry, the quantity of energy added to the gas stream by the electromagnetic discharge. In order to make this measurement, a system of water-jacketed calorimeters was introduced downstream of the two-dimensional nozzles

and discharge apparatus as shown schematically in Fig. 5. Thus, the hot, energized gas stream transferred thermal energy through the calorimeter walls and into the cooling water which was circulated through the calorimeters. Measurement of the water flow rate through each calorimeter or segment of a calorimeter and the water temperature rise on passing through the calorimeter gave the energy transferred from the gas stream to the calorimeter.

In addition to the calorimetry measurements above, the quantity of heat dissipated at the nozzle electrodes and transferred to the oil bath and the radiant energy absorbed from the discharge by the oil bath, was determined by measuring the rate of temperature rise of the liquid petroleum oil bath. Knowledge of the mass of petroleum in the oil bath, the specific heat of petrolatum and the rate of temperature rise of the petroleum gives the power absorbed in cooling the discharge electrodes.

Finally, the quantity of energy carried downstream of the calorimeters in the gas flow was determined by immersing a thermometer into the gas stream downstream of the calorimeters and measuring the temperature difference between the temperature in the plenum chamber and this thermometer station.

The results of all of these calorimetry measurements are presented in Table I. Inspection of the data presented in the table indicates that:

(a) In general, the power extracted in the separate segments of the two segmented calorimeters, decreased from one segment to the next in the downstream direction (this will be considered in more detail later).

(b) The residual thermal energy remaining in the gas stream downstream of all calorimeters is very small.

(c) The percentage of energy recovered in the calorimeters varies from 9% to about 47%. In two cases the measurements indicated that more than 50% of the input energy was recovered in the calorimetry, but these results do not appear logical in light of theoretical considerations. *

* If it is assumed that the recombination process is described by

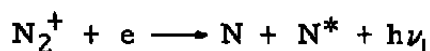

9.7 ev ~ 5 ev

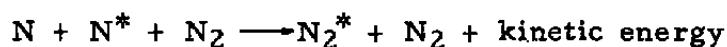

~ 2 ev ~ 7 ev

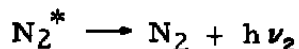

~ 2 ev

where the numbers below the various symbols represent the energy involved in the formation of the product or in the described radiation, then of the approximately 15.5 ev. required to form the ionized pair (N_2^+ and e) only about 7 ev can be recovered in kinetic energy of the gas. Thus one would not expect efficiencies greater than 50%, based on the input energy.

The data from Table I for the distribution of the recovered and unaccounted for energy is presented graphically in Fig. 13. In the limited pressure range over which these experiments were conducted, and although there is considerable scatter in the data, it appears that:

(a) There is no discernible effect of pressure on the percent of input power recovered in the calorimeters [Fig. 13(a)].

(b) There is a decrease in the percent of power recovered in the oil bath with increased discharge pressure [Fig. 13(b)]. This seems logical since at low pressures more of the discharge products (ions and electrons) may diffuse to and recombine on the nozzle walls resulting in heating of the nozzle oil bath. At higher pressures the diffusion to the walls and consequent wall recombination and wall heating is inhibited.

(c) There is an increase in the percent of power unaccounted for with increased pressure [Fig. 13(c)]. It was initially felt that this effect might be due to the fact that the pressure range involved corresponded to the pressures on the right-hand side of the Paschen curve for nitrogen. Thus, at higher pressures, higher voltages would be required to maintain the discharge. Higher voltages would result in greater losses due to electromagnetic radiation from the nozzle blocks and from the electrical leads to the nozzle blocks. In an effort to check this speculation, the discharge voltages were listed beside each data point in Fig. 13(c). It is seen that the highest loss is associated with the highest voltage (1260 volts)

and that the lowest loss is associated with the lowest discharge voltage (182 volts). In between these points, however, the data is quite scattered and it is impossible to make any definite conclusions regarding the cause for the increase in unaccounted for power with pressure.

To obtain a more detailed indication of the manner in which the gas is heated by the decaying discharge-produced plasma, the first two calorimeters were segmented as has been mentioned previously. The power extracted in each segment, divided by the area exposed to the gas stream for that segment, has been calculated and plotted in Fig. 14 as a function of the distance of the midpoint of the segment from the end of the nozzle blocks. The data from all runs is presented here and although there is some scatter in the data of each run, in general, the data follow the trends of the typical run, Run B3, for which a curve has been drawn through the data. The energy transfer to the third segment of heat exchanger 1 is always less than the energy transfer to the first segment of heat exchanger 2. This effect may be due to either the difference in catalytic effect of the heat exchanger walls (heat exchanger 1 has inner walls of teflon, and heat exchanger 2 has inner walls of copper) in wall recombination, or to the difference in the thermal conductivity of the heat exchanger walls, or possibly a combination of these factors.

There is a definite decrease of heating rate with increased distance from the nozzle (and discharge). This type of energy distribution is characteristic of a recombination process where the energy release is proportional to the recombination rate and the recombination rate decreases as the flow proceeds downstream due to the loss (recombination) of dissociated or ionized particles by recombination. It is impossible to tell from these experiments what portion of the energy recovered in the calorimetry is due to wall recombination, and what portion is due to volume recombination heating the gas,

with the hot gas then heating the walls. It does appear, however, because of the distances involved (the plasma is still heating the walls in one way or another at distance of over 100 cm. from the discharge) that the recombination process is a three-body process. Furthermore, since the volume of gas confined by the channel walls goes up as the square of the channel diameter while the wall surface area is directly proportional to the diameter, it seems logical that the wall recombination effects could be minimized by increasing the diameter of the channel. The question arises as to whether or not a large portion of the heat transfer to the walls was due to normal convective heat transfer through the compressible boundary layer on the wall without plasma heating as on a high speed missile. This possibility can be discounted since, first, the boundary layer recovery temperature without plasma heating was generally very close to the cooling water temperature and, second, since in each test run the calorimeters were allowed to come to equilibrium with the gas flowing through the apparatus before the electrical discharge was turned on.

3. Characteristics of the Discharge

Photographs of the discharge were taken at various times during the program. Fig. 15 is a set of three of these taken with nozzle number 4 at various pressures and various plate voltages. Fig. 15(a) shows the discharge at a static pressure of 4 mm. Hg. (upstream total pressure of 35 mm. Hg.). The discharge extends upstream to the throat section of the nozzle at this pressure and is a lavender color throughout the entire discharge. Fig. 15(b) is typical of discharges at slightly higher

pressures; in this case, a static pressure of 9 mm.Hg. and an upstream total pressure of 139 mm.Hg. The front of the discharge now lies downstream of the throat and is lavender to pink in this region. Further downstream the lavender-pink color fades into a bright white with a very blue layer immediately adjacent to the electrodes. At higher pressures, as in Fig. 15(c) (static pressure 55 mm.Hg. and total pressure 433 mm.Hg.), the discharge is confined entirely to the constant area section of the nozzle. The discharge front is again lavender but fades rapidly to a bright white. Again there is a thin blue layer adjacent to the electrodes.

Using the three-ammeter method, described in Appendix II, it was possible to measure not only power input to the discharge but, also, the voltage drop across the discharge. From these two measurements it is possible to calculate the real part of the conductivity of the gas in the discharge region. The power input, P , voltage drop, V , and real part of the conductivity, σ_r , are related by:

$$P = |V|^2 \frac{A}{L} \sigma_r$$

where A is the surface area of the electrodes

L is the electrode spacing.

The real part of the gas conductivity, determined in this manner, is shown in Fig. 16 to be on the order of 4×10^{-4} mho/cm. Furthermore, over the pressure range tested, there appears to be no discernible effect of pressure on the conductivity of the discharge-created plasma.

IV. APPLICATION TO A FULL SIZE TUNNEL

The heating of a cold ionized gas by the process of plasma decay introduces no application problems, other than that of relaxation time, which have not been considered previously in studies of the more conventional techniques of heating a wind tunnel stream. Therefore, the additional problems which appear in the application of the high-frequency discharge heating technique described in this report to actual operational facilities arise in the establishment and maintenance of the discharge under the prescribed conditions. This section will limit itself to consideration of these problems which are peculiar to this new technique.

As indicated above these special problems may be divided into those concerned with establishing the discharge and those pertaining to its maintenance. Since electrical breakdown of a gas depends upon applying a sufficiently high voltage and since initial cost and operating expenses of high-voltage equipment vary roughly as the square of the voltages produced, the first case is concerned with minimizing the required field (voltage).

For high-frequency discharges the maintenance field is generally tens to hundreds of volts-per-centimeter lower than the breakdown field; therefore the problem in the second case only need be concerned with supplying the desired amount of power to the gas through the discharge.

These can be divided into consideration of efficient coupling of the electrical generator to the discharge, and study of the operational survival of the discharge section from the heat-transfer point of view.

In order to discuss these problems the basic features of the various types of high-frequency discharge must be presented. Depending upon the geometry of the discharge region, frequency and strength of the applied field, static pressure of the stream, and nature of the working gas, various physical processes will be responsible for initiating the discharge. These are best described in terms of the characteristic diffusion length of the discharge region, L , the dimension of the discharge region in the direction of the field, L^{\parallel} , the electron mean free path, λ , and the oscillation amplitude, A , of the electron in the given gas under the influence of the given field.

When $\lambda \geq L$ and $A = L^{\parallel}$, the electron population is increased by secondary emission from the walls. This process is called secondary-electron resonance and has been described by Gill and von Engel (Ref. 12). For $\lambda \ll L$ and $A = L^{\parallel}$, breakdown results from production of primary electrons in electron avalanches moving in the field direction. Pim (Ref. 13) describes this phenomenon and refers to it as the "double" electron avalanche process. If $\lambda < L$ and other conditions are such that an average electron obtains ionizing energy at the end of one mean free path the situation is explained by Hale (Ref. 14) in his single mean free path theory. Finally, when $\lambda < L$, $A < L^{\parallel}$, and diffusion is the

only electron loss mechanism, then the diffusion controlled breakdown process described by Brown (Ref. 15) applies. The basic criterion for this process is that the rate of production of primary electrons by inelastic collisions of electrons with gas particles just equals the rate of loss by diffusion.

Since the process described by Gill and von Engel is one of secondary emission from the walls it should be avoided in practical facilities. The other processes all appear feasible as means for producing the discharge. Figs. 17(a), 17(b), and 17(c) supply information from which starting voltages for two of the discharge types can be estimated. Since the diffusion-controlled breakdown as described by Brown is the most efficient process from the standpoint of power required for initiating a discharge and hence requires lowest field strength, the maximum breakdown voltage from the above figures will fix an upper limit on the maximum required voltage regardless of power.

From the breakdown point of view any applied voltage which does not cause breakdown over a path external to the wind tunnel at ambient pressure is practical. However, since the effective L and L' of an external path might be such as to allow a diffusion-controlled breakdown at a field value less than or equal to that of the interior field, care must be taken to minimize the field exterior to the discharge. Also, from the operational point of view, high breakdown voltages indicating large energy losses due to electron drift and diffusion mean poor efficiency of energy

transfer and excessive wall heating and should be avoided, especially at high-power input levels. In terms of the discharge limits this means that the mean free path and, more particularly, the oscillation amplitude limit should not be exceeded.

The case of a high-frequency discharge between parallel plates, besides being directly applicable to practical problems, can be studied theoretically with relative ease and the results extended to the axisymmetric case (where the exciting field is produced by oscillating currents in a coil) through Maxwell's equations. Because of its importance this case will be discussed in the following paragraphs with the idea of providing useful engineering information.

Curves for estimating the mean free path and the conditions just satisfying the oscillation amplitude limit for low-energy electrons in nitrogen or air between parallel plates are given in Figs. 20 and 21 respectively. The effect of electron energy on the mean free path is seen by comparing the various curves in Fig. 20. In Fig. 21 the solid lines indicate for various plate separations the minimum frequencies of the exciting field as functions of pressure at which the average electron will not cross the boundaries of the breakdown region when the strength of the applied field is just sufficient to cause breakdown and Maxwellian distribution of electron energies is assumed. The dotted lines in the same figure indicate the minimum pressure as a function of plate

separation at which the mean free path limit is not exceeded. The region above and to the right of each pair of the curves in Fig. 21 is that of diffusion-controlled breakdown.

A special case of diffusion-controlled breakdown occurs when the pressure is sufficiently high that energy loss from diffusion becomes negligible and all other loss processes, except that by elastic collisions, can also be ignored. This is a most important case since it applies to many facilities presently operating or contemplated. For this case an expression for the breakdown field as a function of pressure can be derived which is sufficiently accurate to provide useful information for application considerations. In this case the breakdown criterion is that the energy input to the electron from the field must reach a value which replaces all that lost by the electron in elastic collisions with neutral particles. The general form of the equation is

$$E^{\dagger} = 4.56 \times 10^{-8} \left(\frac{u_i}{A} \right)^{\frac{1}{2}} \nu_m$$

where

$$E^{\dagger} = E \left[1 + \left(\frac{\omega}{\nu_m} \right)^2 \right]^{\frac{1}{2}}$$

or E^{\dagger} = the effective rms field in volts-per-meter that produces the same rate of energy transfer to the electron under elastic collision as a steady field

ω = radian frequency of the applied field

ν_m = electron collision frequency for momentum transfer in c. p. s.

u_i = ionization potential of gas particles in ev.

A = atomic or molecular weight of gas particles

For nitrogen, $u_i = 15.576$ ev., $A = 28.02$, and experimental results (Ref. 15) indicate $\nu_m = 4.3 \times 10^9$ p, thus

$$E'_{N_2} = 1.46 \times 10^2 p$$

where p is pressure in mm. Hg. In this derivation only energy loss by elastic collisions has been considered as effective. However, for nitrogen, besides some loss by drift and diffusion, the molecules have a first resonance potential of 6.1 ev. with an excitation function* of around 10^{-2} and hence a very large radiation loss from excited states should be expected.

Assuming a normal energy distribution, a constant for the amount of energy the electron gains from the field for any pair of successive collisions, and taking the "ionization function" equal to the "excitation function" leads to an estimate of 50 as the number of equivalent 6.1 ev. excitation per ionization. If it is further assumed that all radiation from excited states is lost to the gas, then the above expression for E'_{N_2} should be raised by a factor of 20. Hence

$$E'_{N_2} \cong 3.0 \times 10^3 p$$

* A. von Engel, "Ionized Gases", (1955) 38.

Also expanding $\left[1 + \left(\frac{\omega}{\nu_m}\right)^2\right]^{\frac{1}{2}}$ shows that $E' = E$ to within 10% if

$$f \leq 306 \times 10^6 p$$

where f = frequency of the applied field in c. p. s.

E = the actual rms value of the applied field.

At lower pressures where diffusion becomes the dominant loss mechanism the above relation between E and p no longer applies. The point of failure can be estimated by requiring that the electron must suffer a large number of collisions before it diffuses out of the discharge region; that is,

$$\lambda \ll L$$

where λ and L are as defined previously. Replacing \ll by $\leq \frac{1}{100}$ and expressing λ in terms of p , T and P_c (the collision probability) yields

$$\frac{pL}{T} \geq \frac{0.37}{P_c}$$

For nitrogen, and $\bar{u} = \frac{u_1}{3}$, the value of P_c is $3.3 \times 10^3 \text{ m}^{-1} (\text{mm. Hg.})^{-1}$.

Hence

$$\frac{pL}{T} \geq 1.1 \times 10^{-4}$$

where

p is pressure in mm. Hg.

T is gas temperature in $^{\circ}\text{K}$

L is characteristic diffusion length in meters

\bar{u} is average electron energy.

In the low-pressure region the electron continuity equation must be solved to obtain a relation between E and p . If electron attachment is also an effective energy loss mechanism, then for any given p a still higher value of E will be required. Brown (Ref. 15) derived the following breakdown condition from the continuity equation including both diffusion and attachment for parallel plate breakdown:

$$\frac{\alpha}{p} = \frac{\beta}{p} + \frac{2}{3} \frac{\bar{u} \pi}{\left(\frac{E'}{p}\right) (pL')^2}$$

where

α = Townsend first ionization coefficient

β = number of electrons per electron attached in a path of one centimeter

L' = plate separation in cm.

E' = effective field in volts per cm.

The quantities $\frac{\alpha}{p}$, $\frac{\beta}{p}$ and \bar{u} are all functions of $\frac{E'}{p}$ and depend upon the energy distribution function. They are most easily evaluated experimentally. For air, measurements by Harrison and Geballe (Ref. 16), yield values for $\frac{\alpha}{p}$ and $\frac{\beta}{p}$ as functions of $\frac{E}{p}$ while

data obtained by Healey and Reed (Ref. 17) provide $\bar{u} = \bar{u} \left(\frac{E}{p} \right)$. Using the experimental data $\frac{E^1}{p}$ as a function of pL as predicted by the above equation is plotted as the solid line in Fig. 17(d). Since oxygen has a high electron attachment cross section and, therefore, air too, whereas the corresponding cross section for nitrogen is negligible; the breakdown field for air given by Fig. 17(d) will be somewhat higher than the corresponding field for nitrogen. The curve thus provides a conservative estimate for applications using nitrogen.

Once the discharge is initiated the feasibility problem then becomes one of how to put power into the discharge; in particular, how to put maximum power in. However, before discussing this problem an estimate of the minimum length of the discharge region which will still satisfy maximum power requirements will be made. After the conditions for breakdown have been met, the actual breakdown and subsequent build-up of charge density in the discharge is a rate problem; that is

$$\frac{dn_1}{dt} = kn_1$$

or

$$n_1(t) = n_{i_0} e^{kt}$$

where

k is the ionization rate coefficient

n_{i_0} is the number density of electrons just prior to breakdown.

The value of k can be determined by dividing the electron collision frequency by the number of collisions N_i an average electron suffers before causing an ionization. An estimate of N_i is made by taking the ratio of the first ionization potential of the gas particles to the rate (per collision) of energy transfer from the field to the electron and correcting it for the probability that a given collision of a sufficiently energetic electron will cause an ionization. For nitrogen

$$N_{iN_2} \cong 10^6$$

and

$$\nu_m = 4.3 \times 10^9 \text{ p}$$

therefore

$$k \cong \frac{4.3 \times 10^9 \text{ p}}{10^6} = 4.3 \times 10^3 \text{ p.}$$

The condition for maximum power input to the stream occurs when the pressure and degree of ionization are at their maximum values. For most facilities these maxima will not exceed one atmosphere and ten percent respectively. At one atmosphere the background density of electrons resulting from the statistical distribution of energies and the various random ionization processes is $n_{i_0} \approx 10^2$. Therefore,

$$\ln \left[\frac{0.1 \times 3 \times 10^{19}}{10^2} \right] \cong 4.3 \times 10^3 \times 760 \text{ t}$$

or

$$t \cong 1.2 \times 10^{-5} \text{ sec.}$$

Minimum discharge length which meets the above requirements will then correspond to maximum Mach number. An extreme upper limit for Mach number which provides a much more conservative design estimate of discharge length than a more realistic value of Mach number would, is $M = 20$. The corresponding velocity at room temperature is approximately $U = 6.6 \times 10^5$ cm/sec. Thus minimum discharge length is

$$L_{\min} \cong 6.6 \times 10^5 \times 1.2 \times 10^{-5} \cong 8 \text{ cm.}$$

which should be acceptable for most installations.

The transfer of power from an electrical generator to the discharge depends upon the electrical nature of the discharge. Since the density of power delivered to an arbitrary load is equal to the real part of the product of its conductivity by the square of the applied field the problem requires knowledge of conductivity in the discharge. In addition, at the higher power levels, matching the discharge to the generator gains in importance, as it becomes necessary to optimize the efficiency of energy transfer from source to load.

The problem of putting the desired power into the discharge has been carefully studied at the University of Southern California Engineering Center by Smetana, and his work is presented in Ref. 6. Since our experiments have shown that no difficulties arise in supplying and controlling power to the discharge up to that indicated level which corresponds to an energy density of 1000 Joules per cubic meter per mm.Hg. at 300° K, the results and conclusions of Smetana's study will be summarized here only insofar as they apply to maximizing energy input to the discharge.

If the electron density is assumed to be constant an approximation for the conductivity of a discharge produced by a sinusoidally varying uniform field is provided by the solution of the Langevin Equation for the motion of the average electron. The result is

$$\sigma = \frac{n e^2}{m(\nu_m^2 + \omega^2)} (\nu_m - j\omega) = \frac{n e^2}{m} (B - jD)$$

where n , e , and m are the number density, charge and mass respectively of the electrons. The quantities B and D are functions both of the gas pressure and frequency of the applied field and are in the same direct proportion to the magnitudes of the real and imaginary parts of the conductivity respectively. As long as the pressure and field strength are fixed the above assumption of constant electron density should be valid.

If the field is uniform and the cross section of the discharge region transverse to the field direction is constant, the impedance of the discharge is easily shown to be

$$Z = \frac{L'}{\sigma A}$$

Here L' is the distance across which the field acts and A is the cross-sectional area of the discharge region.

As was indicated in the discussion of breakdown, when the number density of electrons is treated as a function only of pressure the result is a function which has a maximum between the low and high

pressure regions. This maximum occurs at a pressure which corresponds to a ν_m , the collision frequency for momentum transfer, that is approximately equal to ω , the frequency of the applied field.

The study of power dissipated in a discharge in terms of the above results leads to the following conclusions. If the discharge conditions are such that $\omega = \nu_m$ (which is desirable from the breakdown point of view) then either increasing or decreasing ω by itself reduces the power input. The decrease is greater for increasing ω since B as well as n is decreasing. Reducing the pressure causes B to fall still faster and the decrease in power is even more serious. Raising the pressure above that corresponding to $\nu_m = \omega$ may or may not increase the power absorbed, depending on whether B rises faster than n falls. This is a function of the particular working gas.

Increasing the field strength produces a very large increase in the power since besides producing a large direct change thru the factor E^2 it also increases σ by producing increases in both n and B . However, theory indicates, and experiments seem to bear it out, that the largest change in E for a given gasdynamic situation that can be produced electrically without causing undesirable effects (such as severe wall heating or arcing) is not more than about 15 percent. Also, if conditions are such that the discharge operates near the oscillation amplitude limit an increase in E may produce a drop in power actually delivered to the gas because of drift losses. Of course, breakdown, by definition, means

large changes in current occur for small changes in field; hence, as long as the generator has not reached its output-current limit, additional power is added to the discharge by supplying more current.

Input of high power to a full scale wind tunnel stream requires a high applied voltage regardless of the mode in which the discharge is operated. To keep power losses from radiation to the surroundings, dielectric heating in the transmission line, and plate dissipation in the generator from becoming excessively large under this high voltage condition, it is necessary to match the impedance of the load to that of the generator. The above results indicate that this matching problem should be minimized when the RF generator is operated under conditions where the reactive impedance is 1 to 2 times the real impedance. For these conditions the impedance is approximately constant over a considerable range of pressures and decreases with increasing field strength in most cases.

In addition, it is generally good practice to design the matching circuit to reflect as little of the load impedance changes to the generator as possible since changes in what the generator sees may affect its output which may in turn affect the discharge, etc. This state of affairs can lead to relaxation-type oscillations which put undesirable loads on the generator and might seriously affect operation of the tunnel.

The structural survival of the discharge section under conditions of continuous operation appears to be concerned with two problems—erosion and excessive heating. Although they appear to be separate problems, our experiments indicated that they are merely two separately observed results of the same physical process; namely, the transport of energy from the body of the discharge to the tunnel walls by the various active species (i. e., electrons, ions, dissociated atoms, excited particles, and photons as compared to the unexcited neutral molecules).

Since the erosion results almost entirely from bombardment of the walls by charged particles accelerated up to sufficiently high energies the remark made in the discussion of breakdown also applies here. That is, conditions should be so chosen as to avoid exceeding the mean free path and oscillation amplitude limits. Obviously, this remark applies even more strongly to the wall heating where particles with much lower energies are also effective.

However, the wall heating is also a strong function of both wall recombination of dissociated atoms and radiation absorption. The effects of recombination are best minimized by placing the walls as far as possible from the main body of the gas. Thus the discharge region should have a maximum cross-sectional area with minimum wetted perimeter. Further minimization is obtained by using materials for

the walls which have as little catalytic effect upon the recombination as possible. In general such materials are nonmetallic and relatively inactive chemically; good examples being the ceramics and glasses.

Relative to the effects of radiation absorption the best method for their minimization is to have the surfaces as near to perfectly reflecting as possible. Another method which is satisfactory from the structural point of view but lowers the efficiency of energy transfer would be to have the walls perfectly transparent. At the present, the most practical method appears to be to make the surfaces in contact with the discharge from high temperature materials which have high emissivities and coefficients of thermal conductivity that are as low as possible. The best examples of such materials are the various ceramic forms.

An additional heating phenomenon which may be active is that of the walls absorbing energy from the electromagnetic field either by induction or dielectric heating. By using nonconductors with high breakdown potentials induction heating is eliminated. Further, if materials are so selected as to have minimum loss tangents then the dielectric heating can be reduced to the point of unimportance.

Regardless of the level of power input to the gas precautions should be taken to keep the discharge conditions as far from the oscillation amplitude and mean path limits as possible so as to minimize erosion. However, since wall heating to a degree compatible with the

structural limit of the materials used in the tunnel is in many cases permissible, and perhaps in some cases desirable, the question of where it becomes critical is difficult to answer. From a purely structural point of view our experiments indicate that facilities can be built from materials presently in existence which will not fail from wall heating while enclosing discharges in nitrogen streams having energy densities of 4×10^4 Joules per cubic meter.

V. CONCLUDING REMARKS

An experimental study has been carried out to determine the feasibility of using the electrodeless high-frequency discharge as a method of heating a supersonic gas stream. These experiments indicate that:

1. It is possible, using the electrodeless high-frequency discharge, to introduce up to 40% of the power supplied at the discharge electrodes into a supersonic gas stream.
2. One of the principal problems associated with the application of this method to heating supersonic gas streams is that of obtaining nozzle materials with the desired characteristics. Teflon, when properly cooled, is a satisfactory nozzle material with short service

life. For longer life, it is possible to use metal nozzle blocks which serve both as the contoured nozzle walls and electrodes. Experience with this type of nozzle electrode configuration has been good although there was some pitting of the electrodes. This might be eliminated by coating the electrodes with ceramic materials.

3. There is a definite temperature rise in the plasma decay as evidenced in the temperature measurements along the test section used with the axisymmetric nozzle.

4. In the calorimetry measurements, there was an energy distribution in the calorimeters which indicated a three-body recombination. The energy recovered in the calorimeters was probably due to the combined effects of wall recombination and volume recombination. The wall recombination, which is undesirable, can be minimized by increasing the ratio of gas volume to wall surface area.

5. The upper limit in pressure, at which the discharge can be produced and maintained, is dependent only upon the dimensions of the discharge vessel and the electric field strength which can be obtained.

APPENDIX I

USE OF THE CONTOURED NOZZLE BLOCKS AS ELECTRODES IN A RADIO-FREQUENCY DISCHARGE NOZZLE

One of the most severe problems encountered in the experimental program was that of obtaining materials for the two-dimensional nozzles. At the outset it was felt that the nozzle-contoured walls should be of a dielectric material and that the discharge should be applied with capacitive type electrodes discharging through the quartz sidewalls. The failure of the teflon and Supramica 620 nozzles and the lack of any suitable machinable materials made it imperative that a new design be developed for the two-dimensional nozzles. Most of the materials problems can be circumvented if the nozzle-contoured walls could be constructed of a metal and used as the discharge electrodes. One would expect, however, that for nozzle-shaped electrodes, electrical breakdown of the gas would always occur in the nozzle throat where the electrode separation is smallest, and hence, the electric field (for constant plate voltage) is highest. Indeed this would be the case if there were no pressure gradient (flow) through the nozzle. With a pressure gradient in the nozzle, the situation is quite different since the breakdown voltage for the gas is strongly dependent upon the pressure as well as plate separation distance.

Rough calculation can be made to determine the possibility of obtaining a breakdown of the gas stream in the supersonic portion of the stream instead of at the throat. Consider the data presented in Ref. 11 and reproduced in Fig. 17(c) as representative of the variation of breakdown voltage in air with pressure and gap width between flat plate type electrodes. From data such as this one can construct curves of the maximum pressure at which breakdown can occur at a given field strength and frequency as a function of gap distance. Typical curves of this type are shown in Fig. 18(a). Also, if the desired nozzle contour is shown, one has the effective gap distance between the nozzle-contoured walls as a function of distance along the nozzle [Fig. 18(b)]. Now if one combines the curve of Fig. 18(b) with the appropriate curve of Fig. 18(a), it is possible to construct a curve of the maximum discharge pressure at a given plate voltage at each point along the nozzle. Such a curve is presented in Fig. 19 for a breakdown voltage of 1000 volts. For a given upstream stagnation pressure, it is possible to construct a curve of the static pressure variation through the nozzle. Typical static pressure variations are also shown in Fig. 19 for four different stagnation pressures.

If the static pressure in the gas stream is greater than the maximum discharge pressure (at fixed plate voltage), no discharge can occur; if the static pressure is less than the maximum pressure for which breakdown can occur, a discharge is possible. Thus,

the intercepts of the static pressure curves and the maximum pressure for discharge curve are the locus of the most forward points in the nozzle at which discharge can be obtained, and discharges may only be maintained to the right of these intercepts.

From Fig. 19 it is clear that at low stagnation pressures a discharge may be obtained at the throat or even upstream of the throat in the plenum chamber. As the stagnation pressure is increased, however, the discharge must move further downstream. At sufficiently high stagnation pressure the discharge is seen to be confined entirely to the supersonic portion of the stream.

It has been tacitly assumed in the above analysis that the trends shown in Fig. 17(c) for the variation of breakdown voltage with gap distance and with pressure at the frequency shown are applicable in other cases where the gap distance varies and where the field frequency is different from that of Fig. 17(c). Thus, the most that can be expected from the above analysis are qualitatively correct results. In the present experimental studies, qualitative verification of the above analysis has been obtained; for it was noted that at low stagnation pressures, the discharge was obtained in the throat region and even upstream of the throat. As the stagnation pressure was increased, the discharge region moved into the supersonic region of the nozzle and at even higher pressures, the discharge was confined to the downstream region of the nozzle; compare Figs. 15(a) and 15(c).

APPENDIX II
 MEASUREMENTS OF POWER IN A
 RADIO-FREQUENCY DISCHARGE

In order to describe the energy transfer through gaseous discharges one needs to know, first of all, the heat evolved, as determined by calorimetric measurements; however, for a complete accounting of the energy one would like to measure the power supplied to the discharge. Measurements of the power supplied by the RF generator have been made using three RF ammeters in a method discussed by P. M. Honnel and E. B. Ferrell in Ref. 10.

For the sake of completeness, a derivation of the method used is included. The circuit may be represented by the load Z , the capacitive impedance X_c , and the ammeters as shown. The load Z

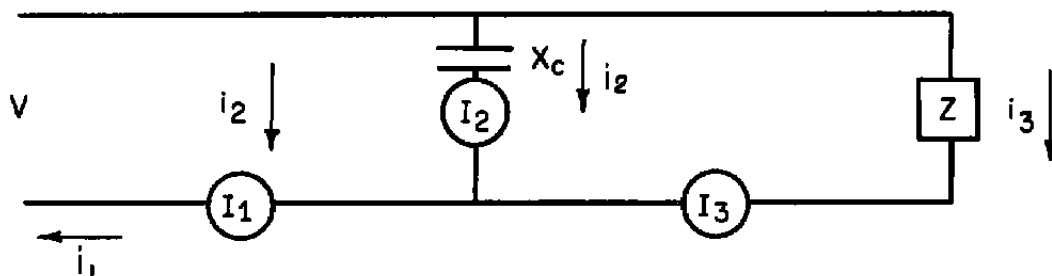

included a parallel LC tank circuit, used for fine adjustments of the applied voltage. The complex equations for the network are:

$$V = -i_2(jX_c), \text{ and } V = i_3Z, \text{ where } j^2 = -1$$

These give the complex currents passing through the meters:

$$i_1 = i_2 + i_3 = V \left(\frac{1}{Z} - \frac{1}{jX_c} \right),$$

$$i_2 = -V \left(\frac{1}{jX_c} \right),$$

$$i_3 = V \left(\frac{1}{Z} \right).$$

The magnitudes of these currents, which are the quantities indicated by the ammeters, are

$$I_1 = V \sqrt{\left[\frac{1}{2} \left(\frac{1}{Z} + \frac{1}{Z^*} \right) \right]^2 - \left[\frac{1}{2} \left(\frac{1}{Z} - \frac{1}{Z^*} \right) + \frac{j}{X_c} \right]^2} \quad (1)$$

$$I_2 = V/X_c \quad (2)$$

$$I_3 = V/\sqrt{ZZ^*} \quad (3)$$

where Z^* is the complex conjugate of Z . The power supplied to the load Z is given by:

$$P = \frac{1}{2} (Z + Z^*) I_3^2 = \frac{V^2}{2} \left(\frac{1}{Z} + \frac{1}{Z^*} \right). \quad (4)$$

A relation which will be needed is the identity:

$$\frac{1}{ZZ^*} = \left[\frac{1}{2} \left(\frac{1}{Z} + \frac{1}{Z^*} \right) \right]^2 - \left[\frac{1}{2} \left(\frac{1}{Z} - \frac{1}{Z^*} \right) \right]^2$$

Substitution of this relation in the expression for I_1 , Eq.(1), leads to:

$$I_1 = V \sqrt{\frac{1}{ZZ^*} - \frac{j}{X_c} \left(\frac{1}{Z} - \frac{1}{Z^*} \right) + \frac{1}{X_c^2}} \quad (5)$$

Let us now form term $S = \frac{1}{2} (I_1 + I_2 + I_3)$, and investigate the quantity $S(S - I_1) (S - I_2) (S - I_3)$:

$$\begin{aligned}
 S(S-I_1)(S-I_2)(S-I_3) &= \frac{1}{16} (I_2+I_3+I_1) (I_2+I_3-I_1) [I_1-(I_1-I_3)] [I_1+(I_2-I_3)] \\
 &= \frac{1}{16} [(I_2+I_3)^2 - I_1^2] [I_1^2 - (I_2-I_3)^2] \\
 &= \frac{1}{16} [2I_2I_3 - (I_1^2 - I_2^2 - I_3^2)] [2I_2I_3 + (I_1^2 - I_2^2 - I_3^2)] \\
 S(S-I_1)(S-I_2)(S-I_3) &= \frac{1}{16} [4I_2^2I_3^2 - (I_1^2 - I_2^2 - I_3^2)^2] \tag{6}
 \end{aligned}$$

Substitution of Eqs. (5), (2), and (3) for I_1 , I_2 and I_3 in Eq. (6) gives:

$$\begin{aligned}
 S(S-I_1)(S-I_2)(S-I_3) &= \frac{v^4}{16} \left\{ \frac{4}{ZZ^*X_c^2} - \left[\frac{1}{ZZ^*} - \frac{j}{X_c} \left(\frac{1}{Z} - \frac{1}{Z^*} \right) + \frac{1}{X_c^2} - \frac{1}{X_c^2} - \frac{1}{ZZ^*} \right]^2 \right\} \\
 &= \frac{v^4}{16X_c^2} \left[\frac{4}{ZZ^*} + \left(\frac{1}{Z} - \frac{1}{Z^*} \right)^2 \right] \\
 &= \frac{v^4}{16X_c^2} \left(\frac{1}{Z} + \frac{1}{Z^*} \right)^2
 \end{aligned}$$

Substitution of Eq. (4) in this relation gives:

$$S(S - I_1) (S - I_2) (S - I_3) = \frac{P^2}{4X_c^2} \tag{7}$$

Rewriting this to give power directly:

$$P = 2X_c \sqrt{S(S - I_1) (S - I_2) (S - I_3)}. \tag{8}$$

This is a symmetrical form which will reduce to the same equation regardless of which current is factored from the radical. Relabelling the currents I_L , I_M , and I_S for large, medium and small currents, and substituting Eq. (6) in (8) we have:

$$P = \frac{1}{2} X_c I_L^2 \sqrt{4 \left(\frac{I_M}{I_L} \right)^2 - \left[\left(\frac{I_S}{I_L} \right)^2 - \left(\frac{I_M}{I_L} \right)^2 - 1 \right]^2} \quad (9)$$

$$\text{Let } \left(\frac{I_M}{I_L} \right)^2 = u^2 + v^2, \quad \text{and } \left(\frac{I_S}{I_L} \right)^2 - \left(\frac{I_M}{I_L} \right)^2 - 1 = 2v,$$

$$\begin{aligned} \text{then } P &= X_c I_c^2 u, & \text{and } \left(\frac{I_S}{I_L} \right)^2 &= 2v + \left(\frac{I_M}{I_L} \right)^2 + 1 \\ & & &= 2v + u^2 + v^2 + 1 \\ & & &= u^2 + (v + 1)^2 \end{aligned}$$

These results allow a graphical solution for u , of the form:

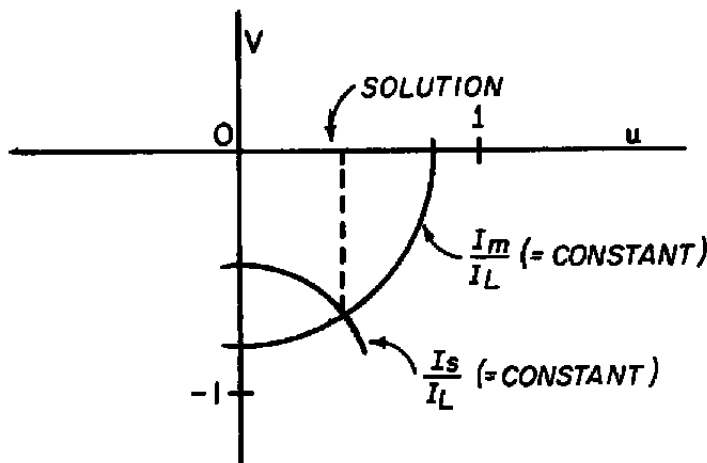

A chart for this solution has been made, with ranges of $\frac{I_S}{I_L}$ from zero to one, and $\frac{I_M}{I_L}$ from one-half to one. Thus measurements of the three ammeter currents and the value of the capacitance have been used to determine the power supplied to the gaseous discharge in the experiments described in this report.

REFERENCES

1. Chuan, Raymond L., "Plasma Heating of Hypersonic Gas Flow", USCEC Rept 56-202, AFOSR TN 57-762, AD 136-751, December 1957.
2. Chuan, Raymond L., "A Note on the Addition of Heat to a Gas Through Electrical Discharge", AEDC TN 59-51, January 31, 1959.
3. Williams, James C., III, Wilber, Paul C., and Chuan, Raymond L., "Analytical Study of the Heating of Hypersonic Air Flow by Electrodeless High-Frequency Discharge", USCEC Rept 68-101, AEDC TR 59-23, July 1959.
4. Williams, James C., III, "One-Dimensional Flow of a Decaying Nitrogen Plasma", USCEC Rept 68-201, AEDC TN 59-50, AD-215021, May 1959.
5. Chuan, Raymond L., "Preliminary Results of Plasma Heating of High Speed Air Flow", AFOSR TN 58-680, ASTIA AD 162-182, July 1958.
6. Smetana, Frederick O., "Some Further Results on Heating a Supersonic Gas Stream with Radio Frequency Discharge", AFOSR TN 59-1127, November 1959.
7. Smetana, Frederick O., "Studies in the Heating of a Supersonic Gas Stream by a Radio Frequency Discharge", USCEC Rept 56-214, AFOSR TN 60-648, 15 July 1960.
8. Pass, Herbert R., "K-Band Microwave Interferometer Description and Initial Experiments in a Pilot Model of the U.S.C. Low-Density Wind Tunnel", USCEC Rept 56-217, AFOSR TN 60-1087, August 1960.
9. Hollis, J. L., "Measuring RF Power with Three Ammeters". *Electronics*, Vol. 18, p.142, June 1945.
10. Hannel, P. M., and Ferrell, E. B., "The Measurement of Harmonic Power Output of a Radio Transmitter". *Proc. Inst. Radio Engrs.*, Vol. 22, p. 1181, October 1934.

11. Meek, J. M., and Craggs, J. D., "Electrical Breakdown in Gases", Oxford University Press, London, 1953.
12. Gill, E. W. B., and von Engel, A., Proc. Roy. Soc., Series A, Vol. 192 (1948), p. 446.
13. Pim, J. A., J. Inst. Elec. Engrs., Part III, Vol. 96 (1949), p. 117.
14. Hale, Donald H., Phys. Rev., Vol. 73 (1948), p. 1046.
15. Brown, Sanborn C., Hand. d. Phyk., Vol. 22 (1956), p. 531.
16. Harrison, M. A., and Geballe, R., Phys. Rev., Vol. 50 (1953), p. 1.
17. Healey, R. H., and Reed, F. W., "The Behavior of Slow Electrons in Gases". Sidney (1941).

TABLE I

RESULT OF CALORIMETRY MEASUREMENTS

Test	Nozzle	Power Extracted in Calorimeter 1 (watts)			Power Extracted in Calorimeter 2 (watts)			Power Extracted in Calorimeter 3 (watts)	Power Extracted in Calorimeter 4 (watts)	Total Power Extracted in Calorimetry	Power Extracted in Oil Bath (watts)	Residual Power in Gas (watts)	Input Power (watts)	Percent Input Power Extracted in Calorimetry	Percent Input Power Extracted in Oil Bath	Percent Input Power Unaccounted For	Discharge Voltage (volts)	Discharge Static Pressure (mm. Hg.)	Wind Tunnel Stagnation Pressure (mm. Hg.)
		Segment 1	Segment 2	Segment 3	Segment 1	Segment 2	Segment 3												
A1	2	24.3	20.5	263.5	—	—	—	—	—	—	—	—	—	—	—	—	—	51.0	688.0
A2	2	19.9	16.7	13.8	—	—	—	—	—	—	—	—	—	—	—	—	—	88.0	892.0
A3	2	—	—	—	—	—	—	—	—	—	—	—	—	—	—	—	—	77.0	884.0
B1	4	18.4	14.4	12.2	30.0	27.0	20.8	100.7	22.1	245.6	198.0	0	580.0	42.3	34.2	23.5	465.0	9.0	116.5
B2	4	12.3	9.3	5.0	26.0	17.0	14.1	88.0	0	171.7	270.0	0	696.0	19.6	38.8	44.6	475.0	6.0	124.0
B3	4	10.6	8.0	6.8	37.4	25.2	19.9	115.1	0	223.0	202.5	1.8	720.0	31.2	28.1	40.7	468.0	23.0	125.0
B4	4	8.5	5.3	4.7	30.0	21.4	17.7	85.0	0	172.6	172.9	0.7	682.0	23.6	25.0	49.3	460.0	21.0	120.0
B5	4	8.5	4.5	2.8	49.0	32.1	27.7	95.0	0	219.6	180.0	6.5	985.0	23.0	18.3	58.7	582.0	51.0	312.0
B6	4	18.4	14.1	14.0	42.6	33.6	27.7	123.0	26.9	300.3	164.2	1.5	646.0	46.6	25.3	27.9	470.0	18.0	118.0
B7	4	10.5	7.1	5.1	38.5	23.4	19.8	40.0	0	144.4	212.5	1.2	842.0	17.3	25.3	57.5	470.0	18.0	118.0
B8	4	27.4	20.1	19.4	42.4	33.8	36.2	142.2	78.8	400.3	144.1	0.4	648.0	61.7	22.3	16.1	482.0	21.0	119.0
B9	4	9.40	7.3	4.5	54.1	38.0	32.2	140.0	6.70	292.2	242.0	8.8	1150.0	27.2	21.05	52.8	625.0	42.0	357.0
B10	4	—	—	—	—	—	—	—	—	—	—	—	1005.0	—	—	—	516.0	22.0	163.8
B11	4	24.0	12.1	12.0	63.8	54.5	41.7	193.5	14.2	415.8	359.4	15.8	2910.0	14.81	12.3	72.8	1260.0	44.0	362.2
B12	4	24.7	9.1	9.0	38.3	28.0	26.1	139.8	0	275.0	372.5	1.7	1093.0	25.1	34.1	40.8	426.0	21.0	128.0
B13	4	17.5	4.6	1.6	32.9	17.7	17.3	96.3	0	187.9	305.5	0.4	840.0	22.4	36.4	41.2	420.0	20.0	121.5
B14	4	25.8	39.5	8.8	91.5	76.0	62.9	147.0	3.4	454.9	217.0	18.7	1297.0	35.1	18.2	46.2	735.0	51.0	345.5
B15	4	19.4	2.1	4.6	35.1	30.3	24.1	190.5	0	306.1	236.0	6.6	861.0	35.6	27.4	36.8	541	10.0	129.0
B16	4	38.9	16.3	15.5	17.5	12.4	41.8	186.5	62.4	391.3	48.4	0.6	517.4	75.6	9.4	15.0	182.0	9.0	86.5

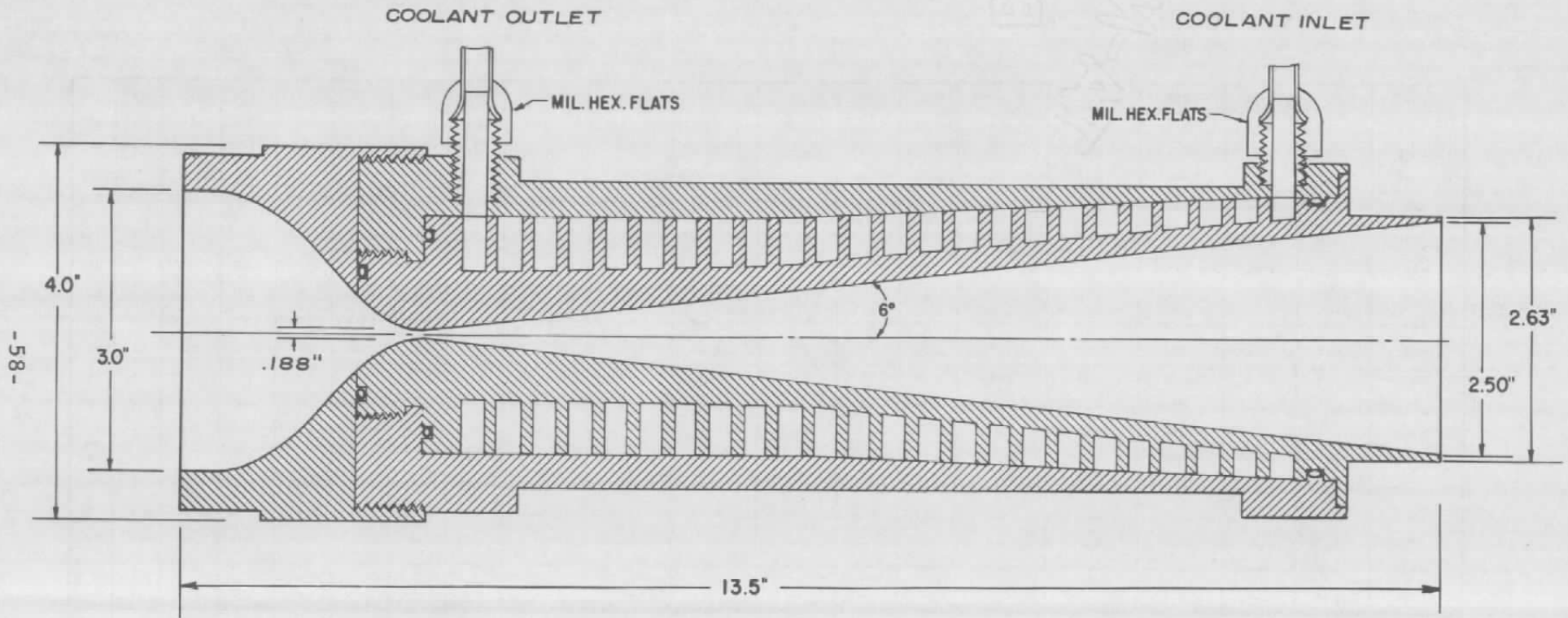

Fig. 1 Details Of Axisymmetric Nozzle Construction

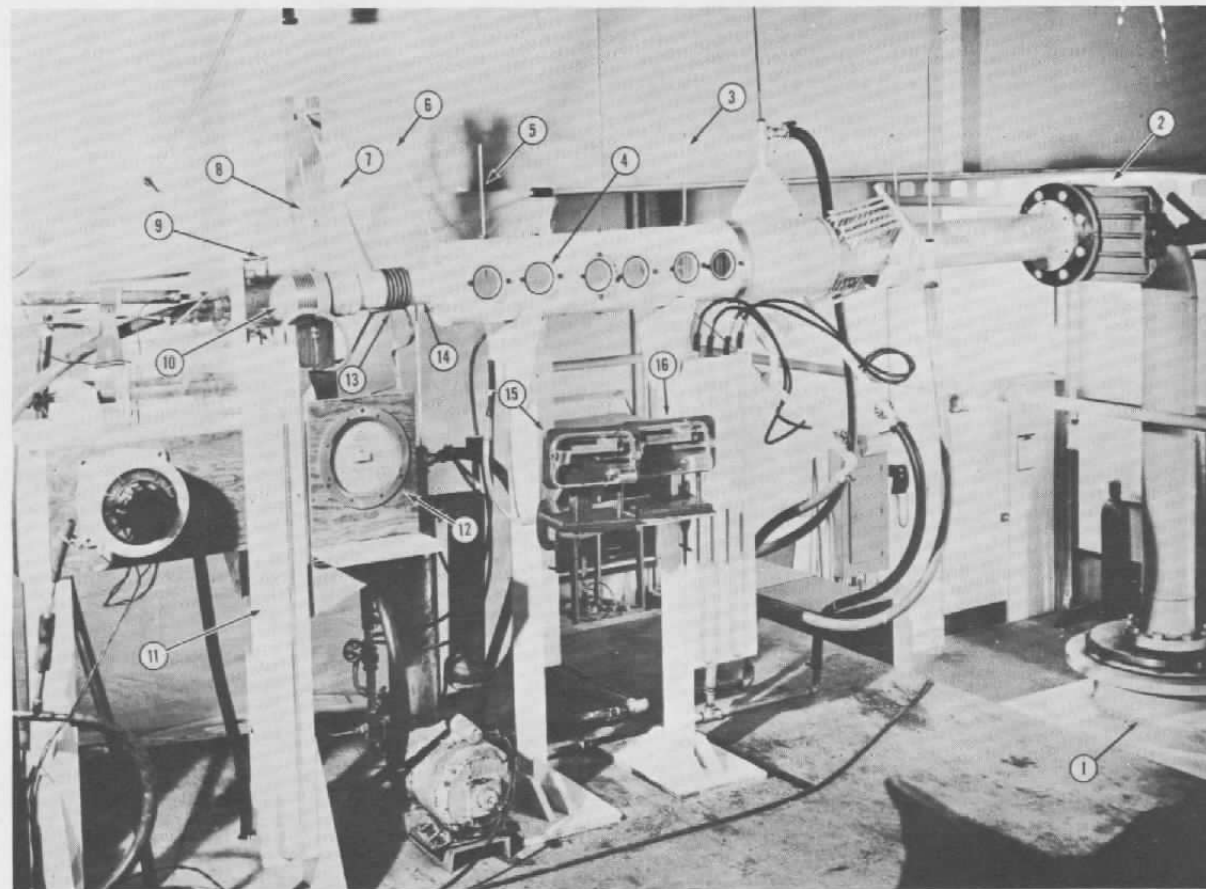

Fig. 2 Teflon Axisymmetric Nozzle RF Heating Apparatus

NOMENCLATURE

1. Low Density Wind Tunnel (Used as a Vacuum Source)
2. Six Inch Quick Opening Vacuum Valve
3. Gas Stream Thermometer No. 3, 20°F to 760°F, 2°F Increments
4. Quartz Window
5. Gas Stream Thermometer No. 2, 20°F to 760°F, 2°F Increments
6. Heat Exchanging Medium (4 pts. $\text{CCl}_2\text{F}-\text{CCl}_2\text{F}$ and 1 part $\text{CClF}_2-\text{CCl}_2\text{F}$) Supply Line to Nozzle (Supplies Cooling to Nozzle)
7. Heat Exchanging Medium Return Line
8. Gas Stream Thermometer No. 1, 20°F to 760°F
9. Plenum Discharge Electrode
10. Plenum Chamber - Aluminum
11. Coarse Plenum Chamber Pressure Gauge, 0-1600 mm Hg.
12. Fine Plenum Chamber Pressure Gauge, 0-100 mm Hg.
13. Discharge Electrode
14. Nozzle Assembly - Teflon
15. McLeod Gauge For Nozzle Exit Pitot Tube, 1-5000 μHg .
16. McLeod Gauge For Downstream Pitot Tube, 1-5000 μHg .

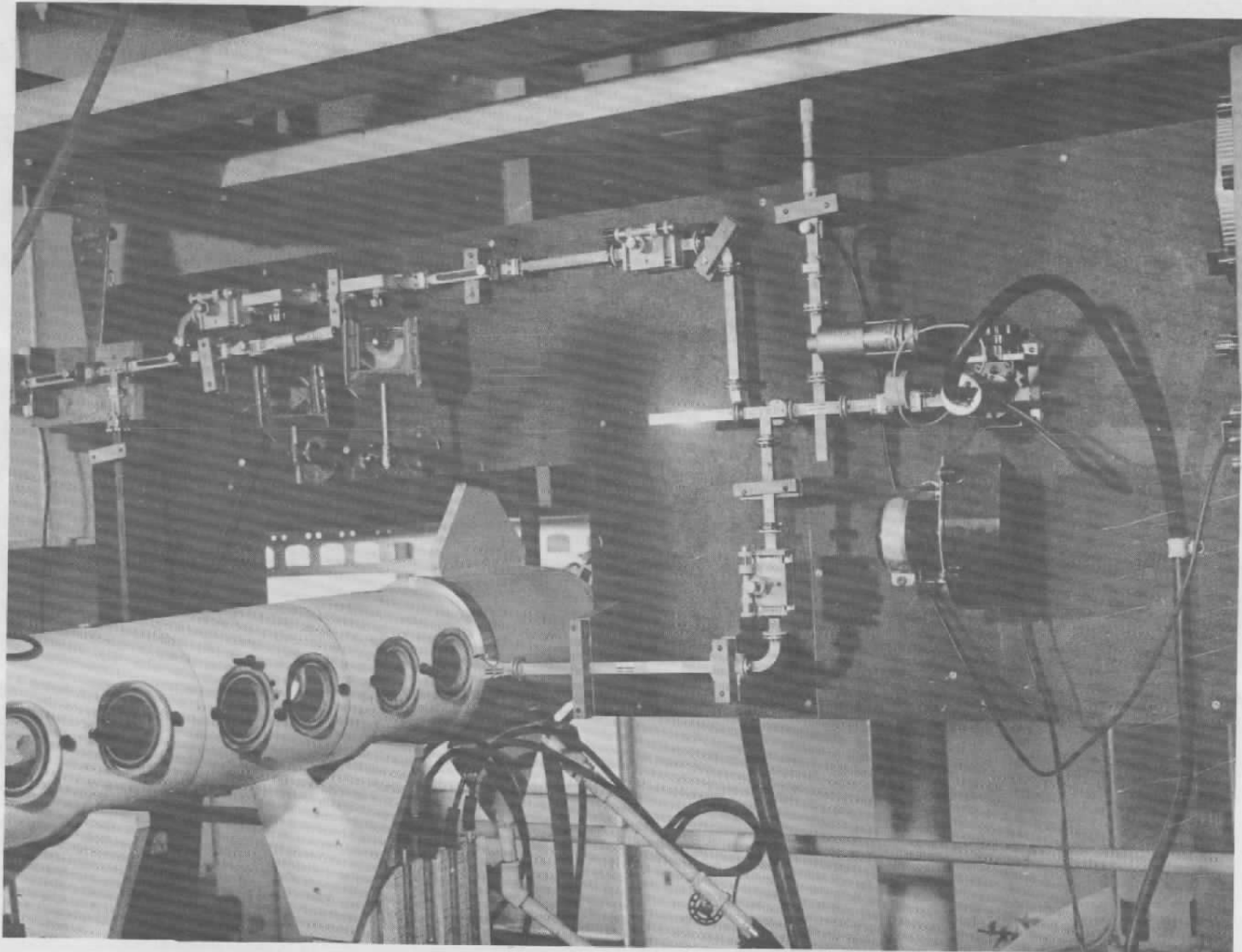
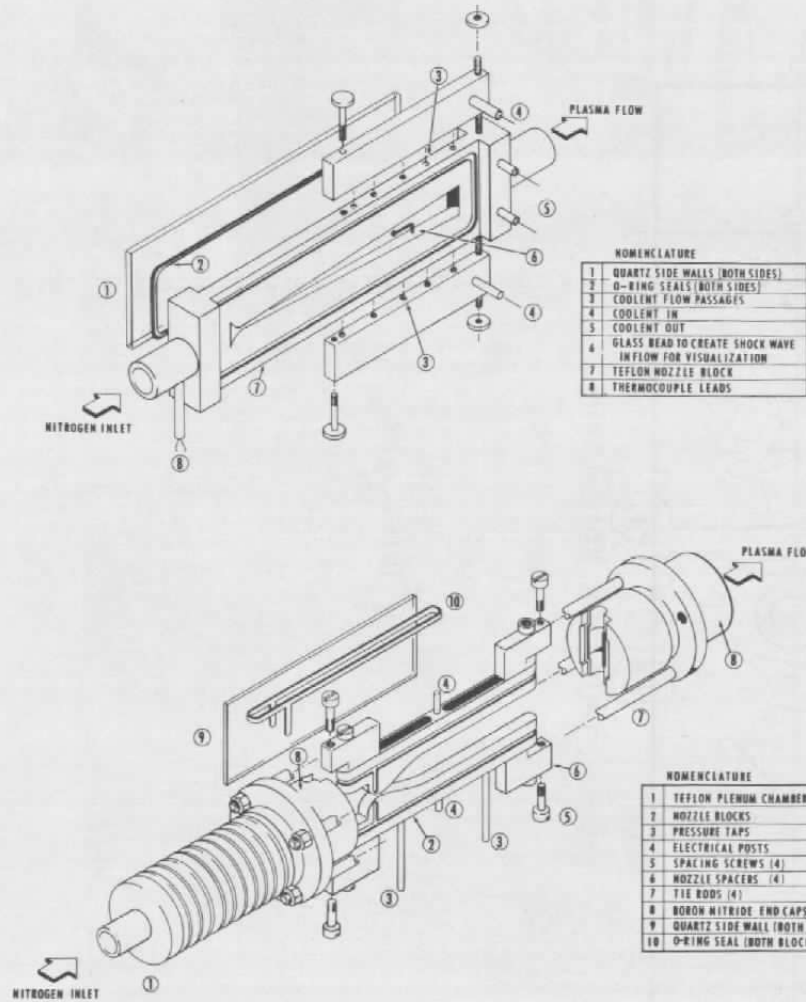
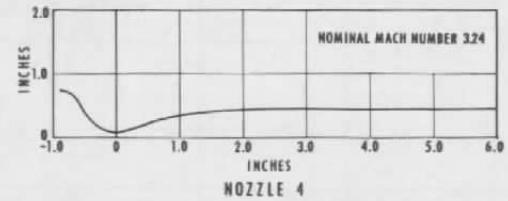
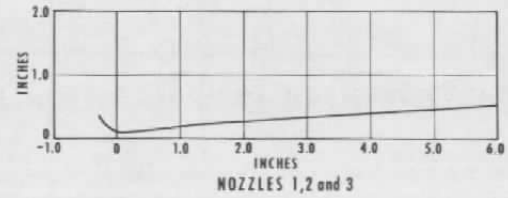

Fig. 3 View Of Plasma Tunnel Showing Microwave Interferometer



NOZZLE CONTOURS



NOZZLE	MATERIAL	DISCHARGE
1	TEFLON	THROUGH QUARTZ SIDEWALL
2	SUPRAMICA 620	" " "
3	ALUMINUM	FROM CONTOURED WALLS
4	ALUMINUM	" " "

Fig. 4 Details Of Two-Dimensional Nozzle Construction

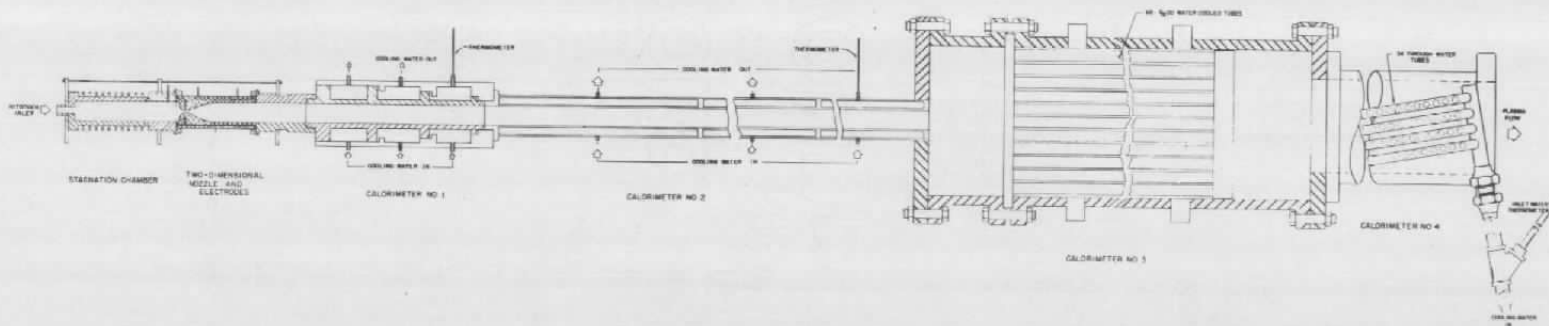

Fig. 5 Calorimeter Arrangement For Two-Dimensional Nozzle Studies, RF Heating Studies

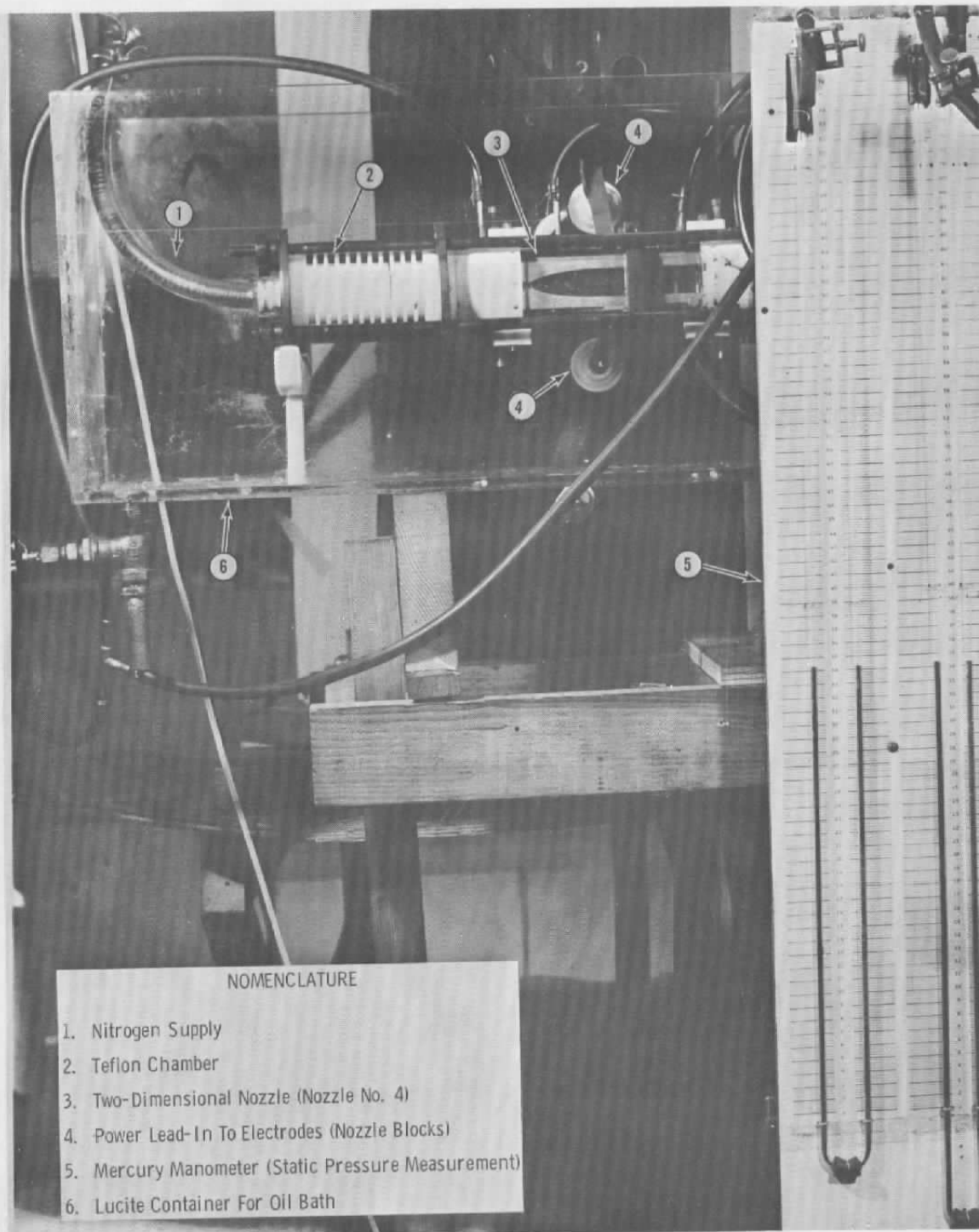

Fig. 6 Petrolatum Oil Bath With Nozzle Blocks In Place

NOMENCLATURE

1. Three Ammeters (Power Measurements)
2. Two-Dimensional Nozzle
3. Copper Water-Jacketed Calorimeter
4. Large Calorimeter (Fire-Tube Boiler Type)
5. Manometer For Water Flow Rate Measurement
6. Mercury Manometer (Static Pressure Measurement)
7. Lucite Container For Oil Bath
8. Mercury Manometer (Stagnation Pressure Measurement)

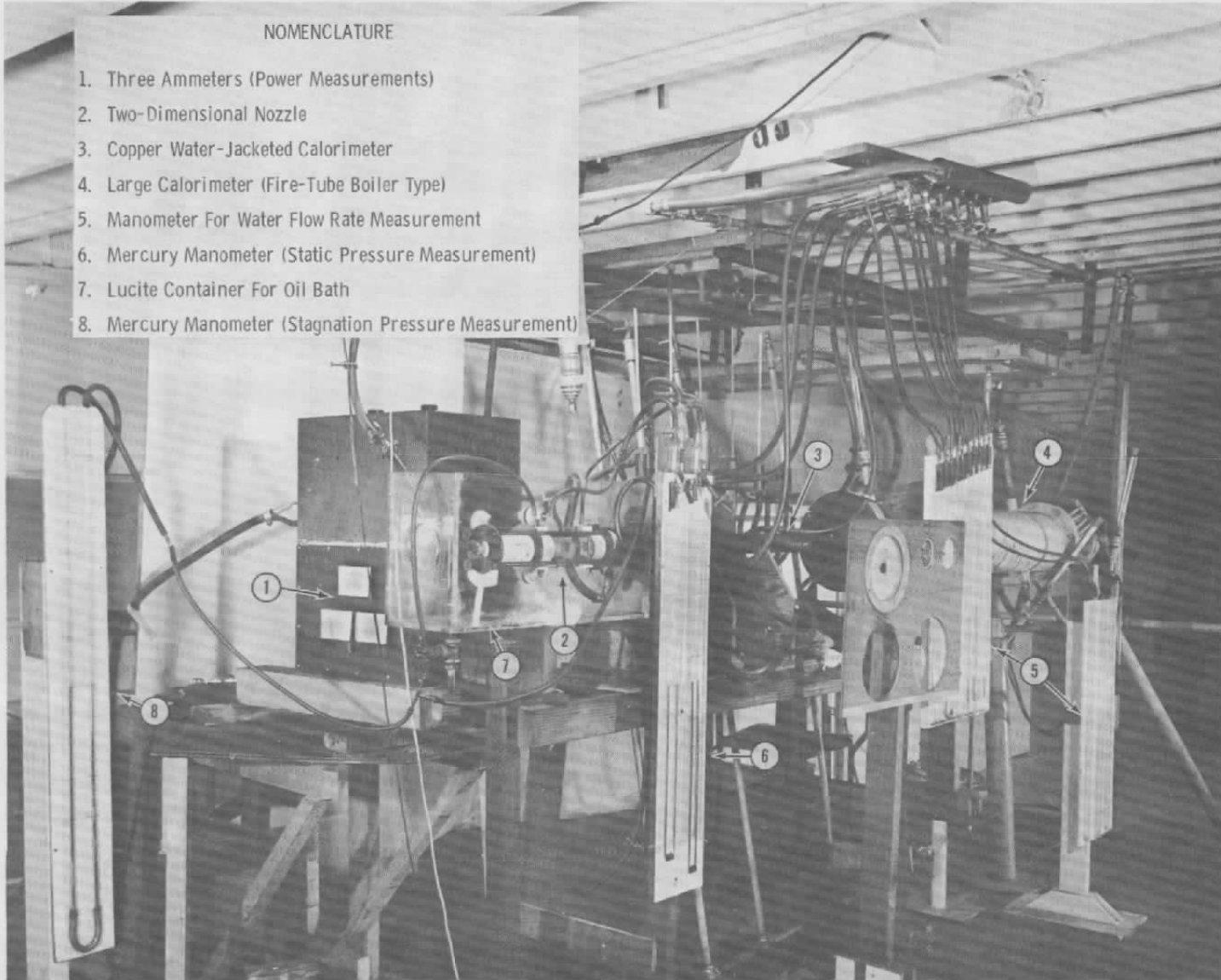

Fig. 7 Two-Dimensional Nozzle RF Heating Apparatus

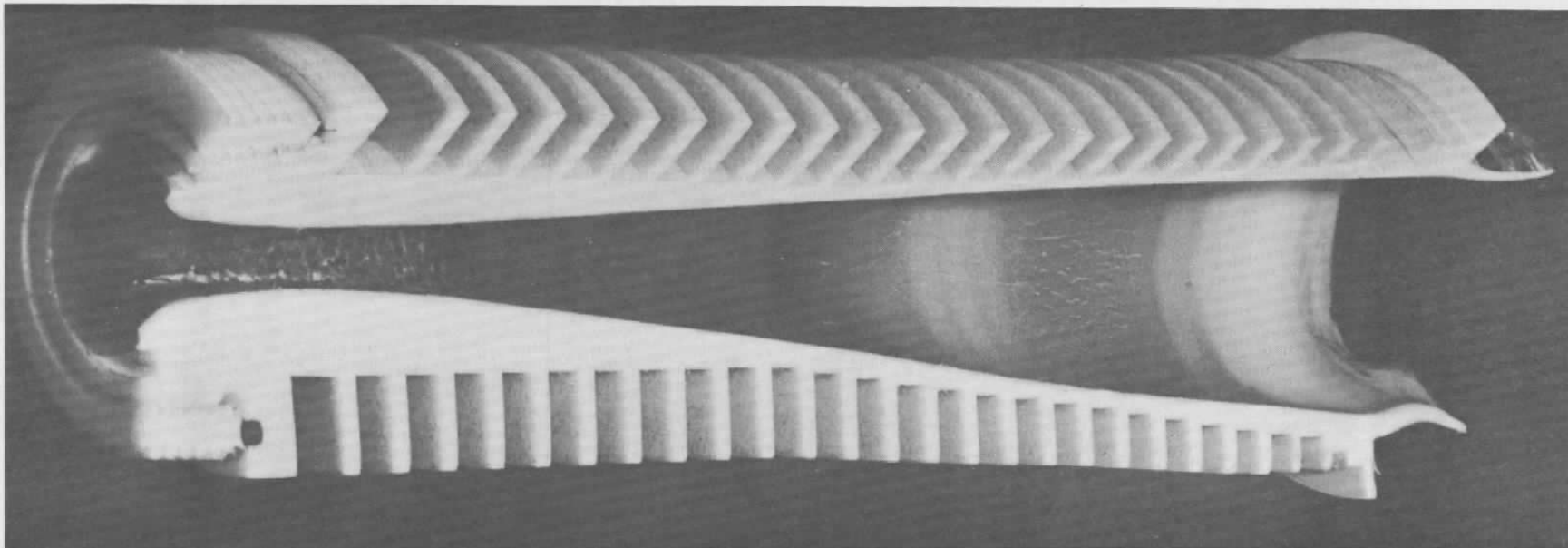

Fig. 8 View Of Teflon Axisymmetric Nozzle After Testing

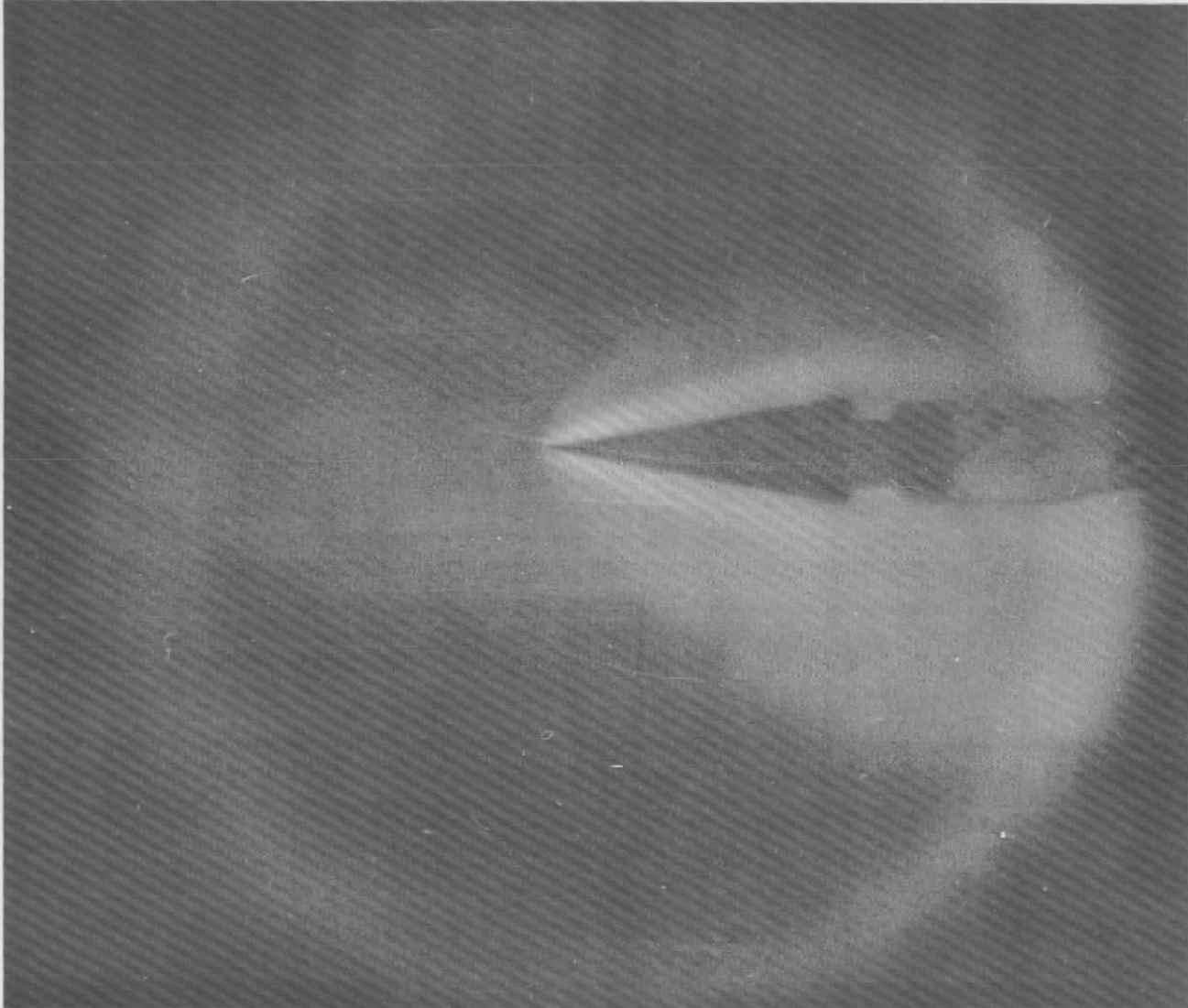

Fig. 9 Self-Luminous Flow Of Supersonic Argon Over A Wedge

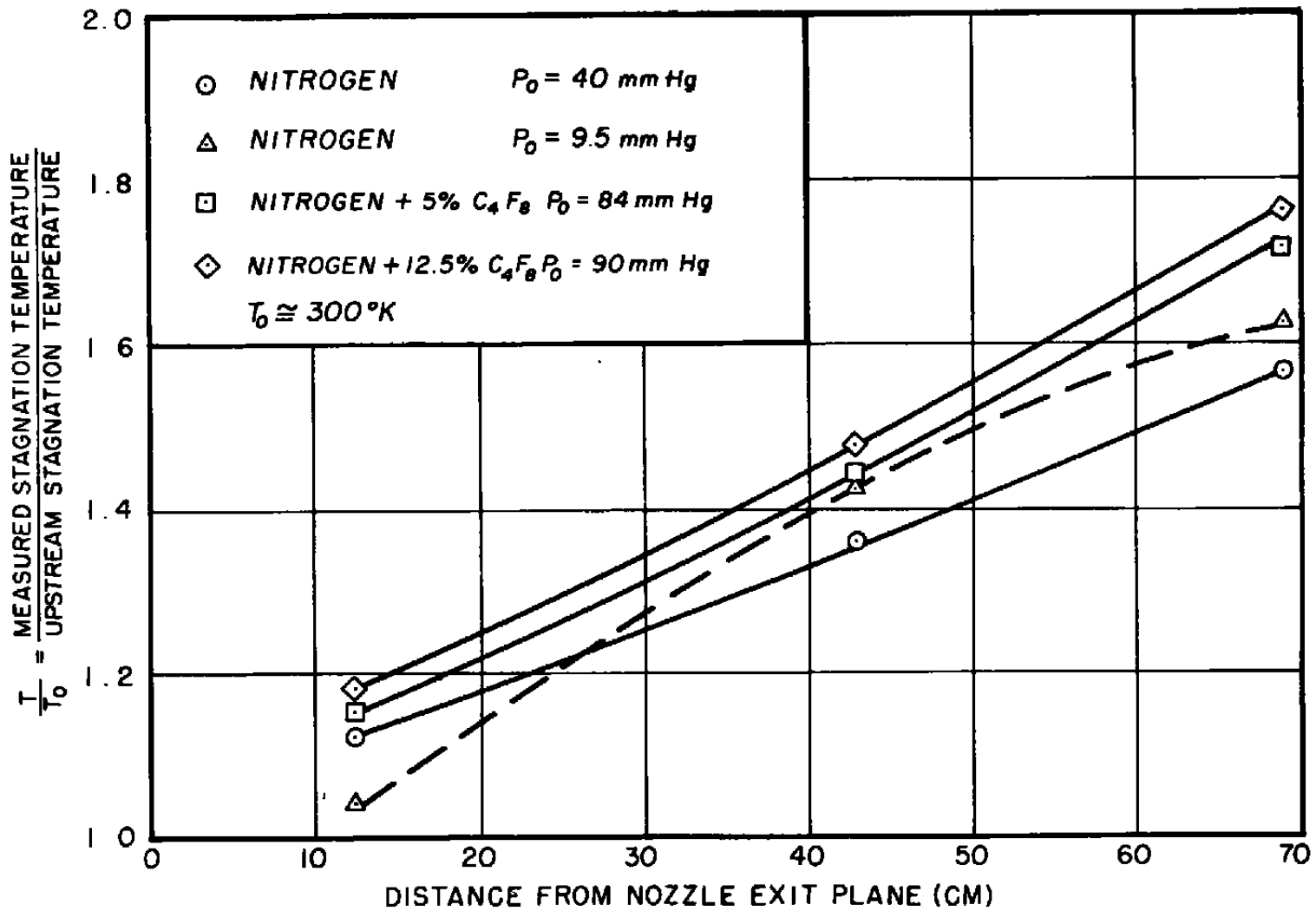

Fig. 10 Temperature Measurements In A Decaying Nitrogen Plasma

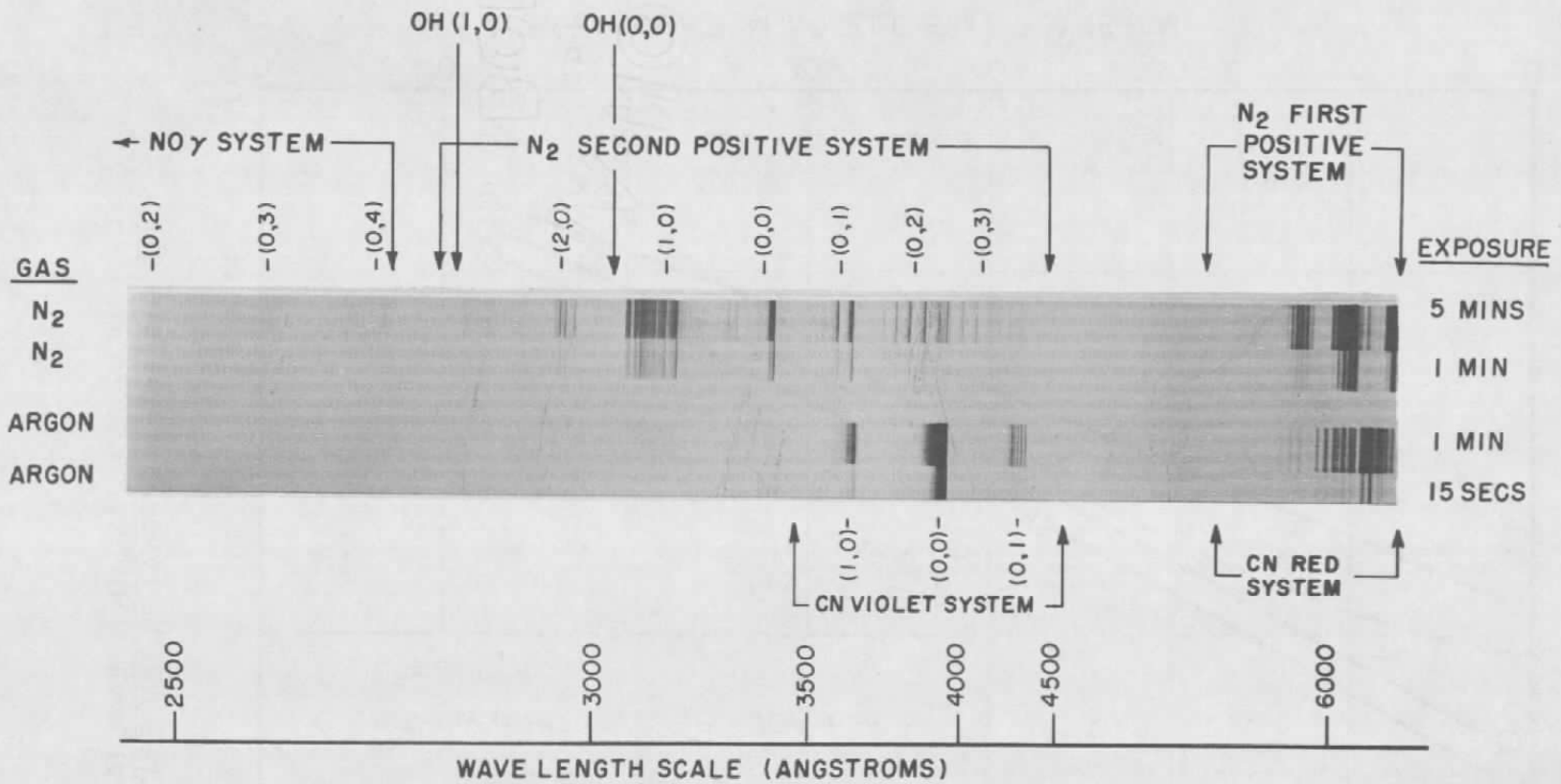

Fig. 11 Typical Spectrographic Plate For Nitrogen And Argon Discharge

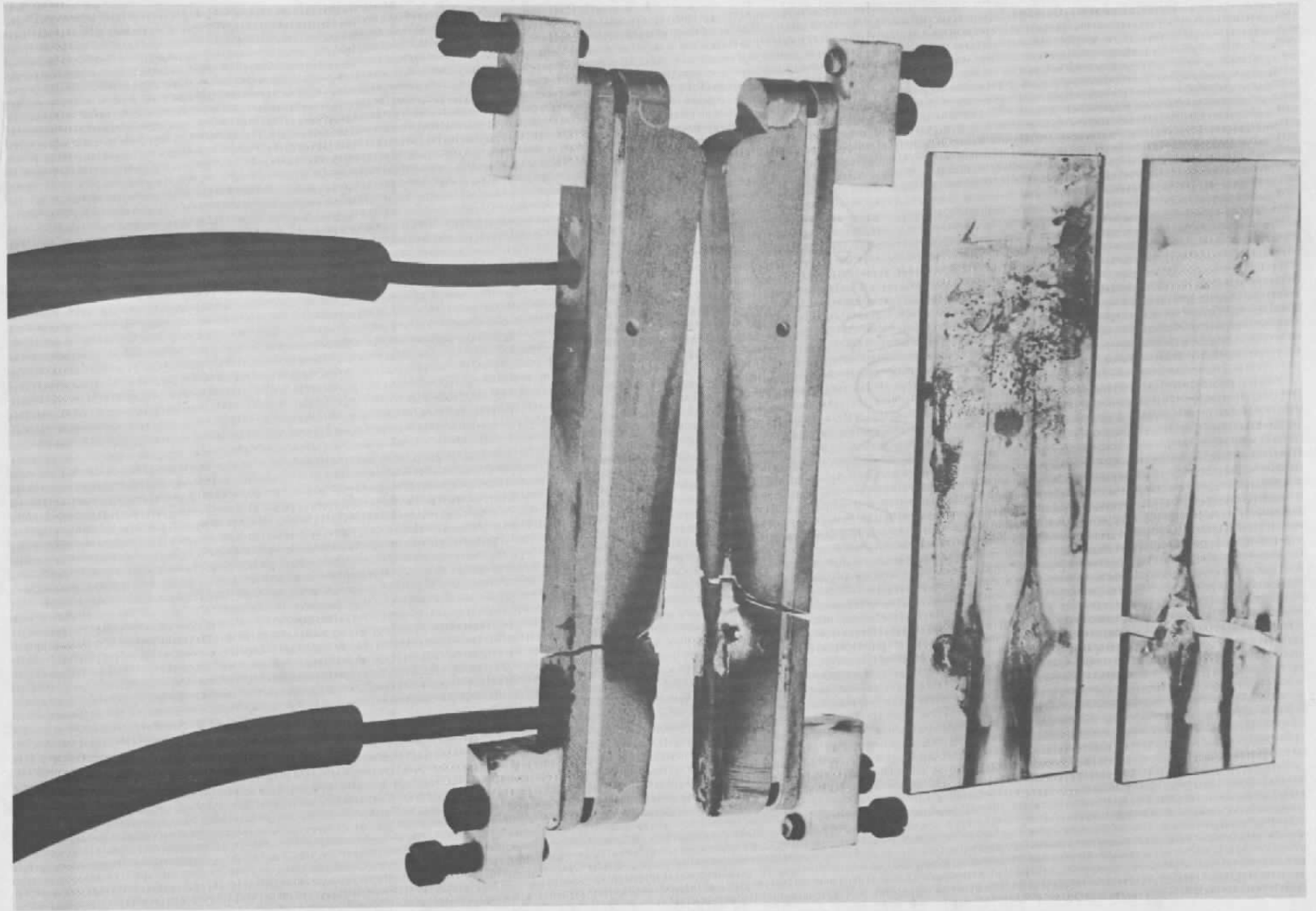

Fig. 12 Supramica Nozzle Components After Failure

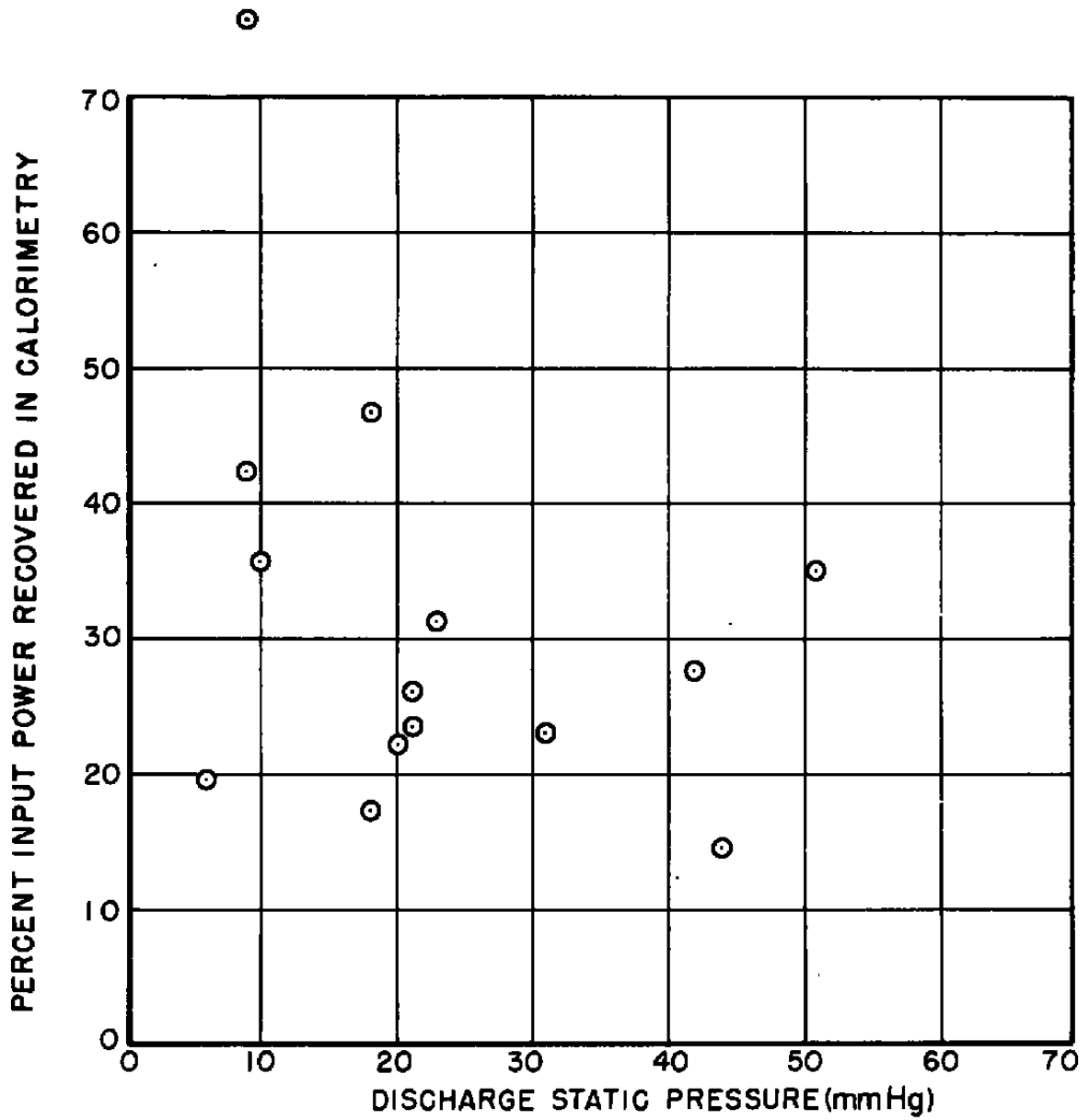

Fig. 13(a) Effect Of Discharge Pressure On The Distribution Of Energy In Calorimetry Measurements

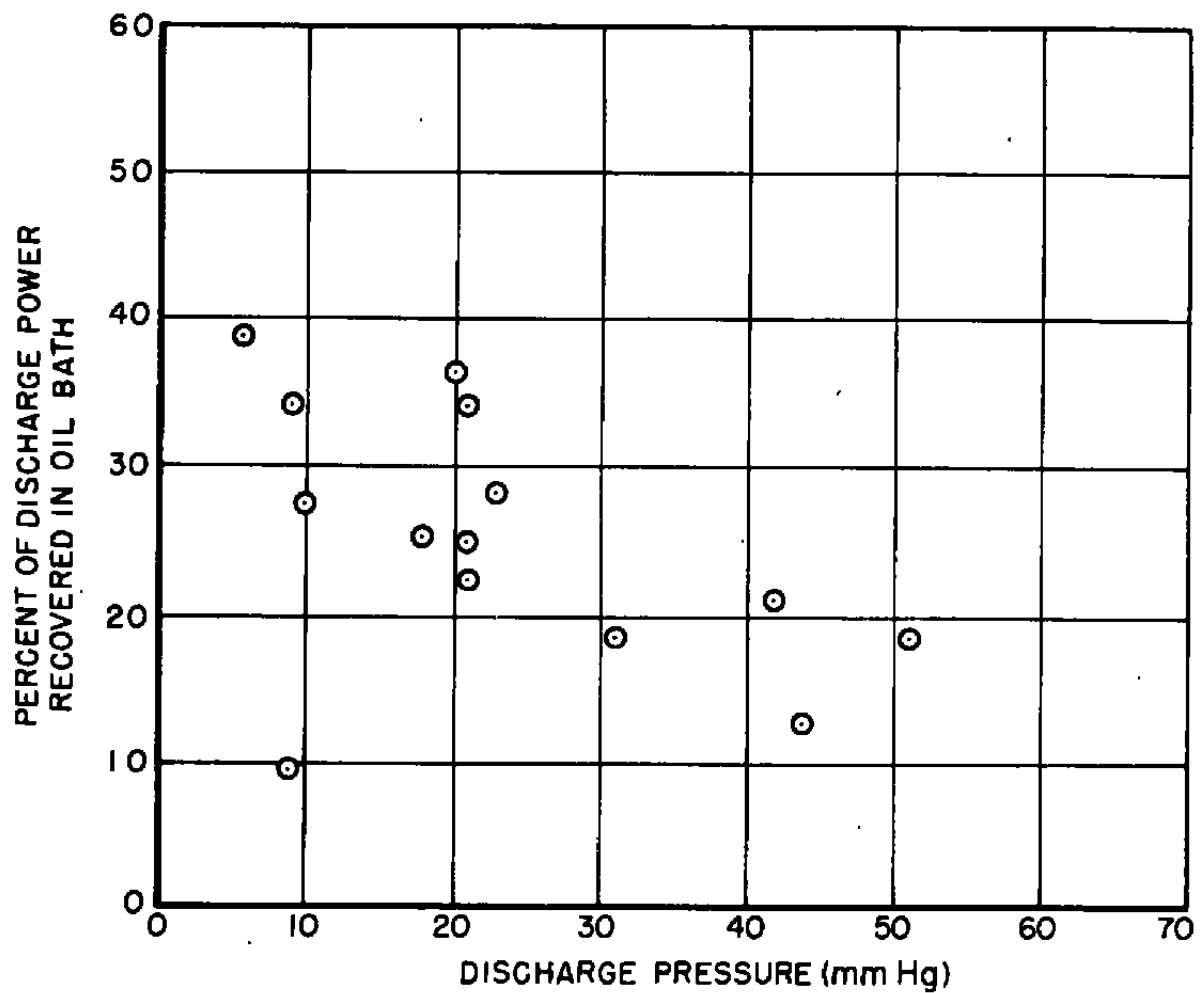

Fig. 13(b)

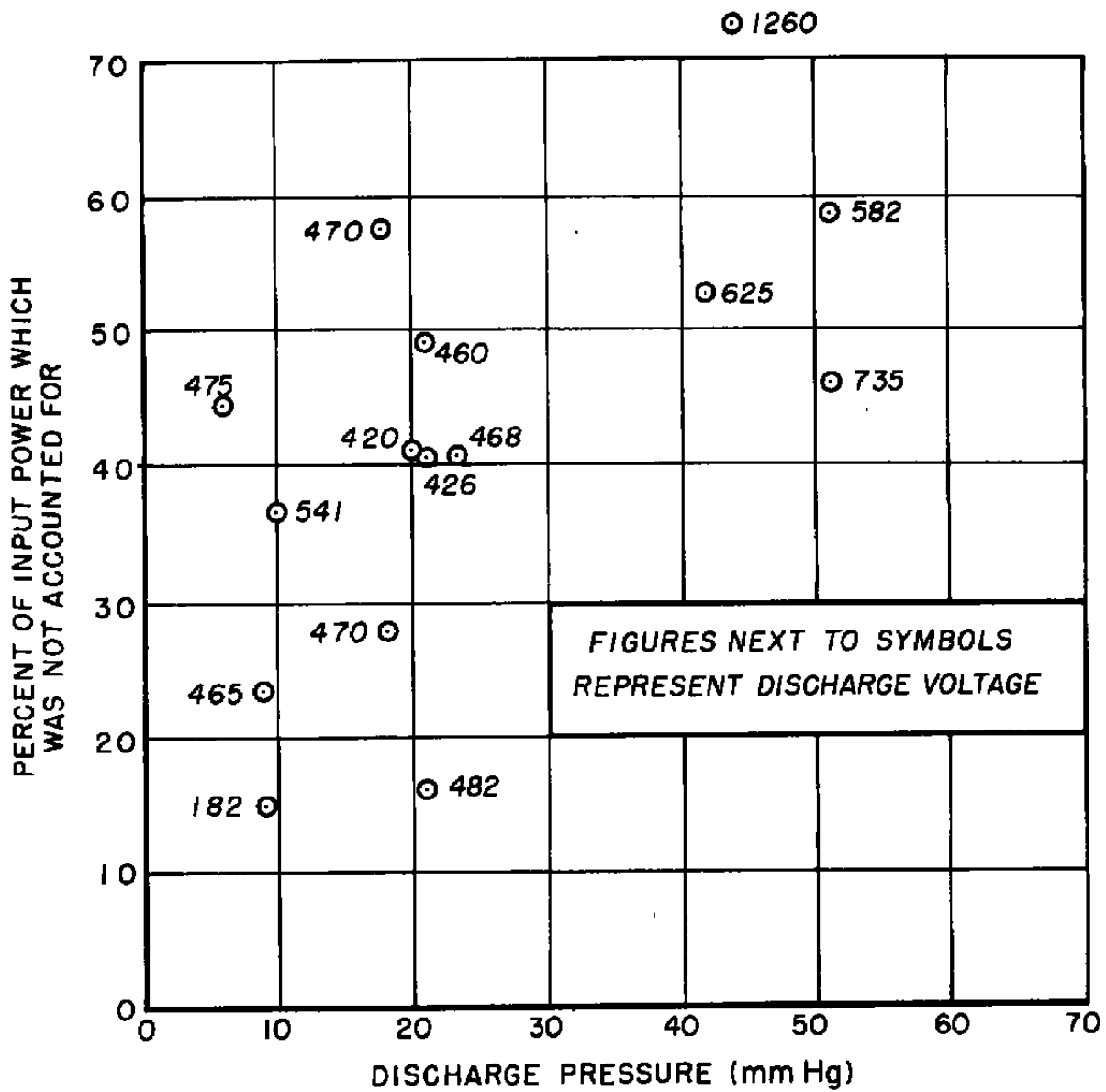

Fig. 13(c)

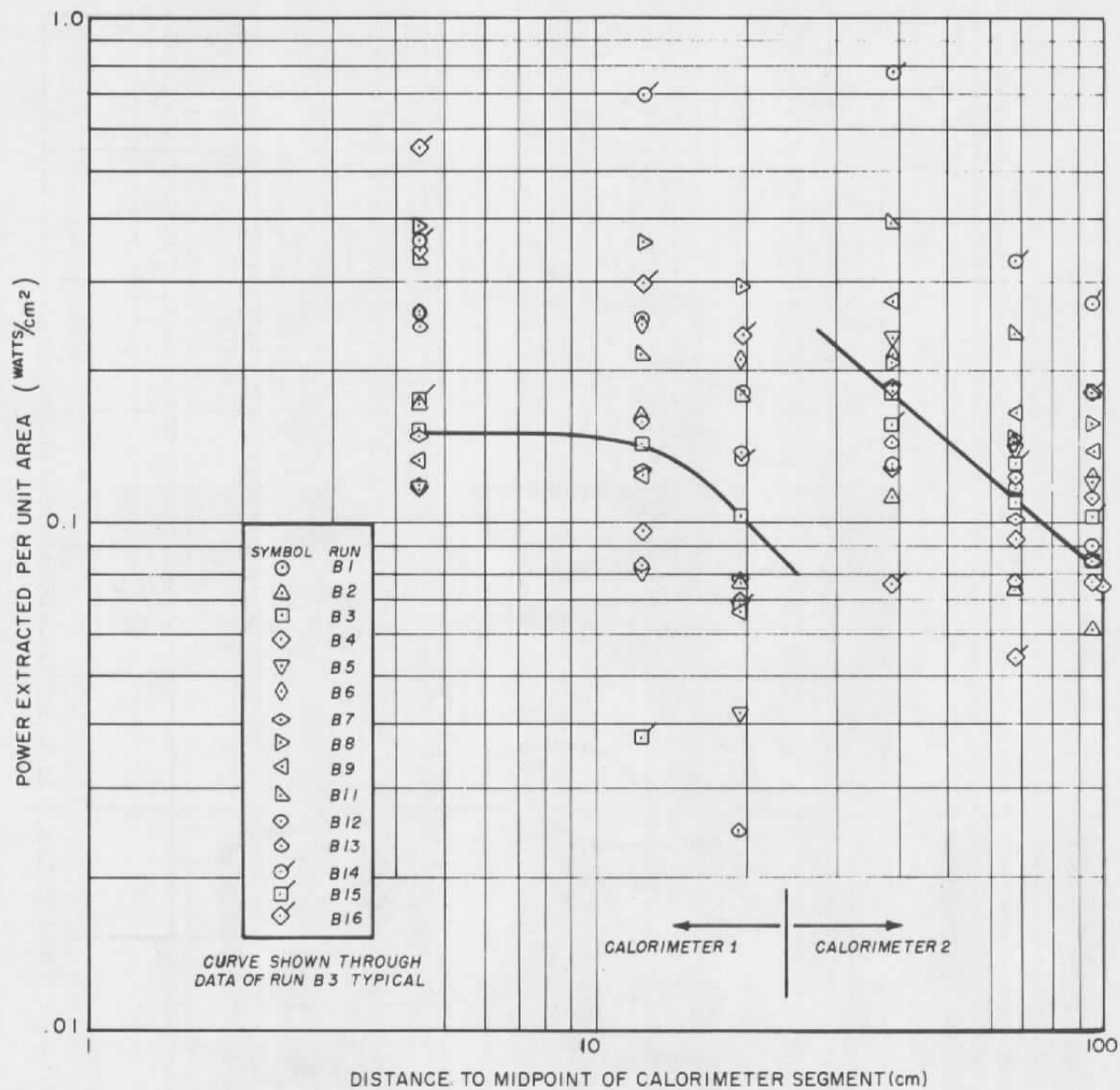
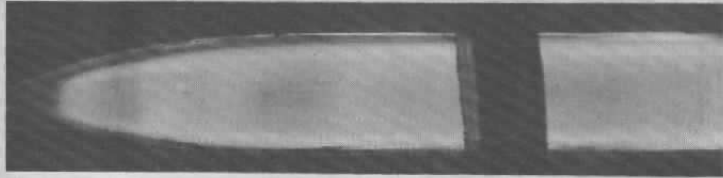
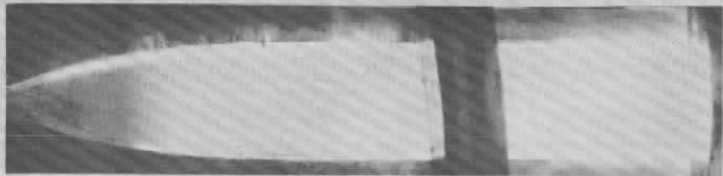

Fig. 14 Results Of Calorimetry Measurements In Segmented Calorimeters



(a)

STATIC PRESSURE = 4 mm Hg
STAGNATION PRESSURE = 35 mm Hg
PLATE VOLTAGE = 377 VOLTS



(b)

STATIC PRESSURE = 9 mm Hg
STAGNATION PRESSURE = 139 mm Hg
PLATE VOLTAGE = 648 VOLTS

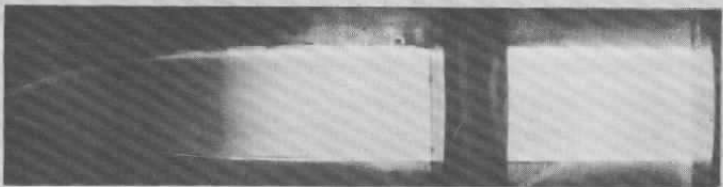

(c)

STATIC PRESSURE = 55 mm Hg
STAGNATION PRESSURE = 433 mm Hg
PLATE VOLTAGE = 996 VOLTS

Fig. 15 Characteristics Of The RF Discharge In Two-Dimensional Nozzles

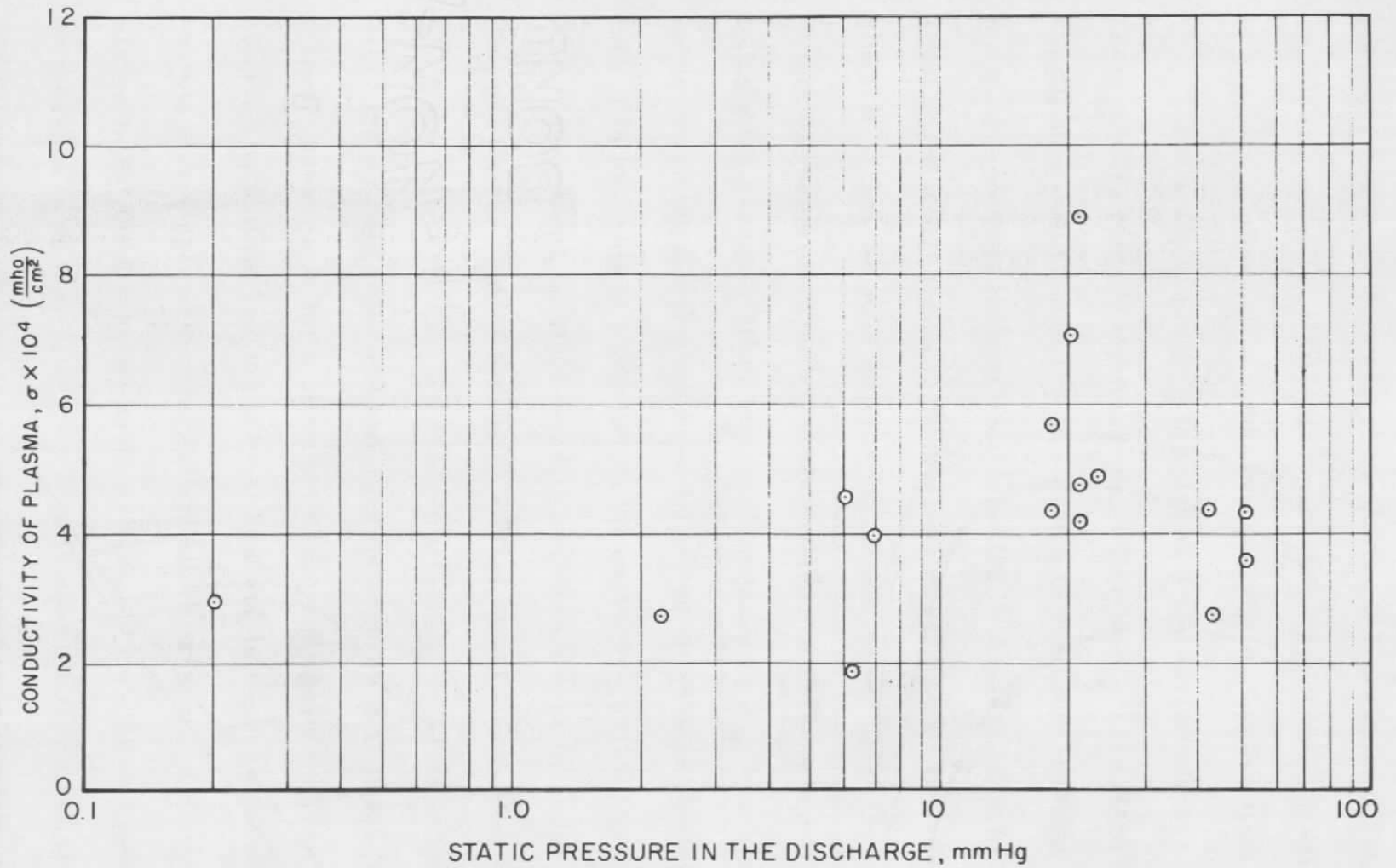

Fig. 16 Effect Of Static Pressure On The Electrical Conductivity Of The Discharge Created Plasma

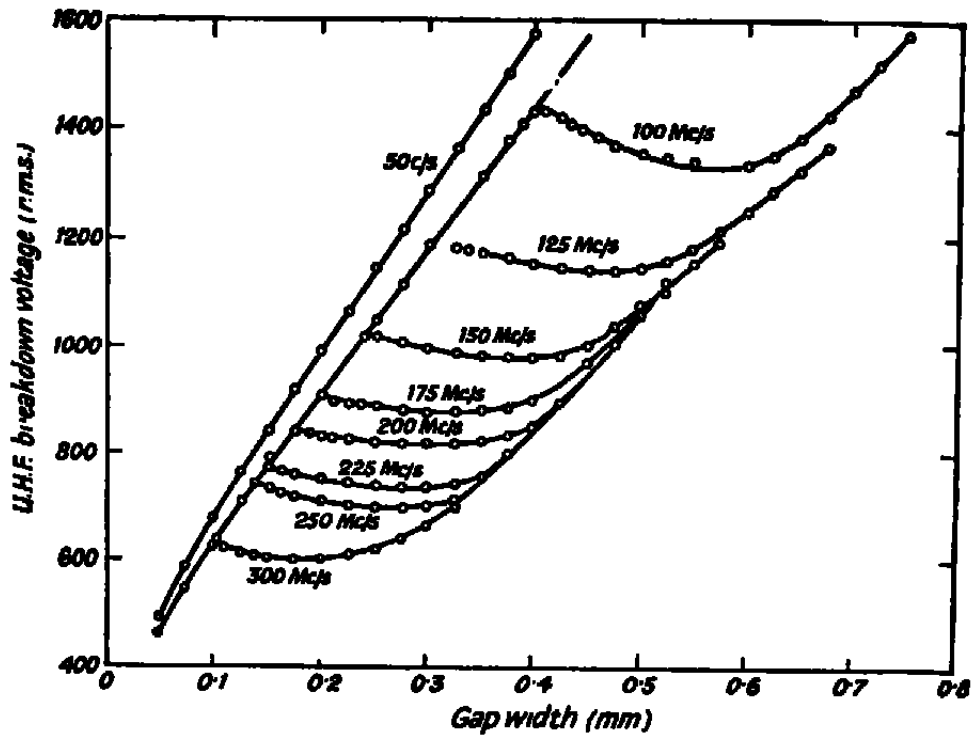

Fig. 17(a) Variation Of Breakdown Voltage With Gap Length Between Plates In Air At Different Frequencies (Data From Ref. 11)

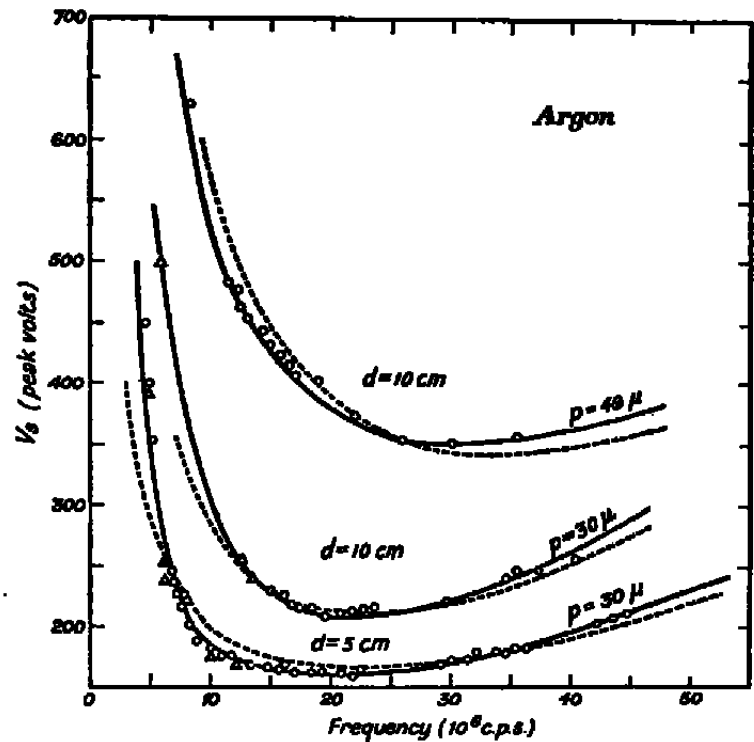

Fig. 17(b) Breakdown Voltage Curves In Argon As A Function Of Frequency. The Dotted Curves Gives The Calculated Values (Data From Ref. 11)

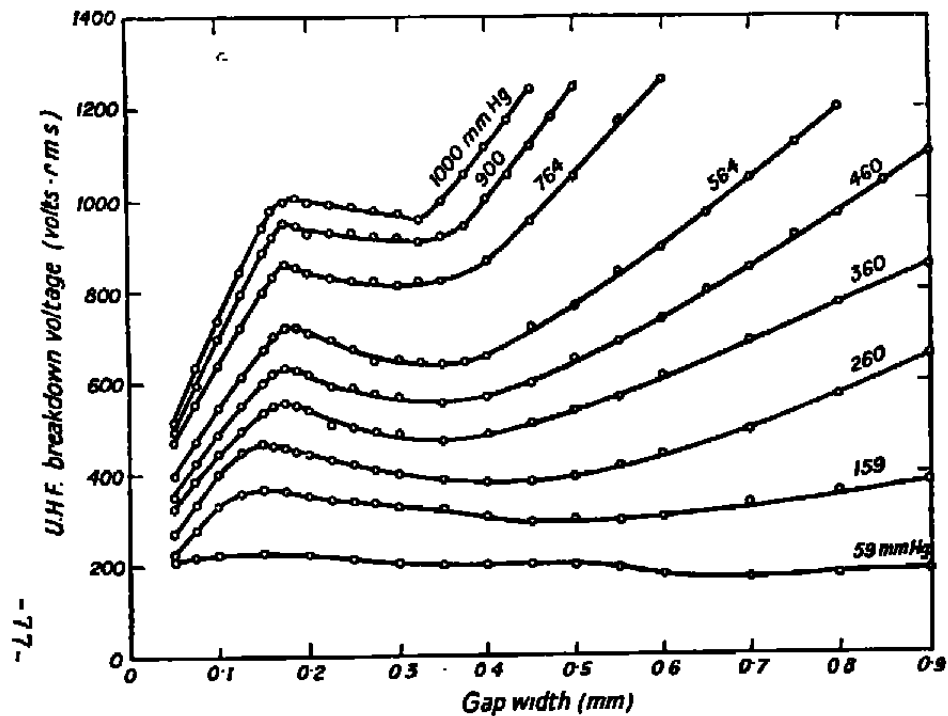

Fig. 17(c) Variation Of Breakdown Voltage With Gap Length Between Plates In Air At 200 Mc./s. For Different Gas Pressures (Data From Ref. 11)

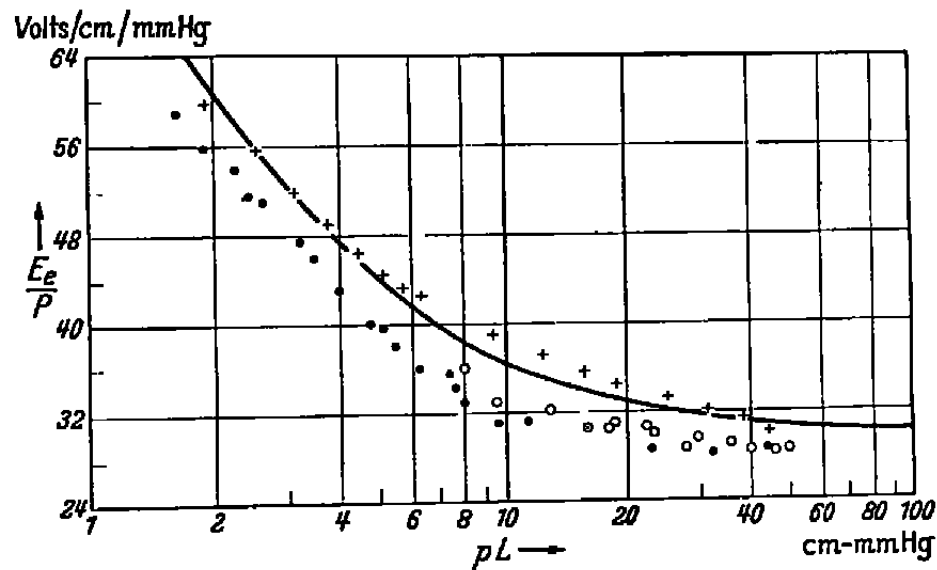

Fig. 17(d) Breakdown In Air. Solid Line, Theory; ● Data Of Herlin and Brown; ○ Data Of Pim; + "pure" Air (Ref. 15, p.567)

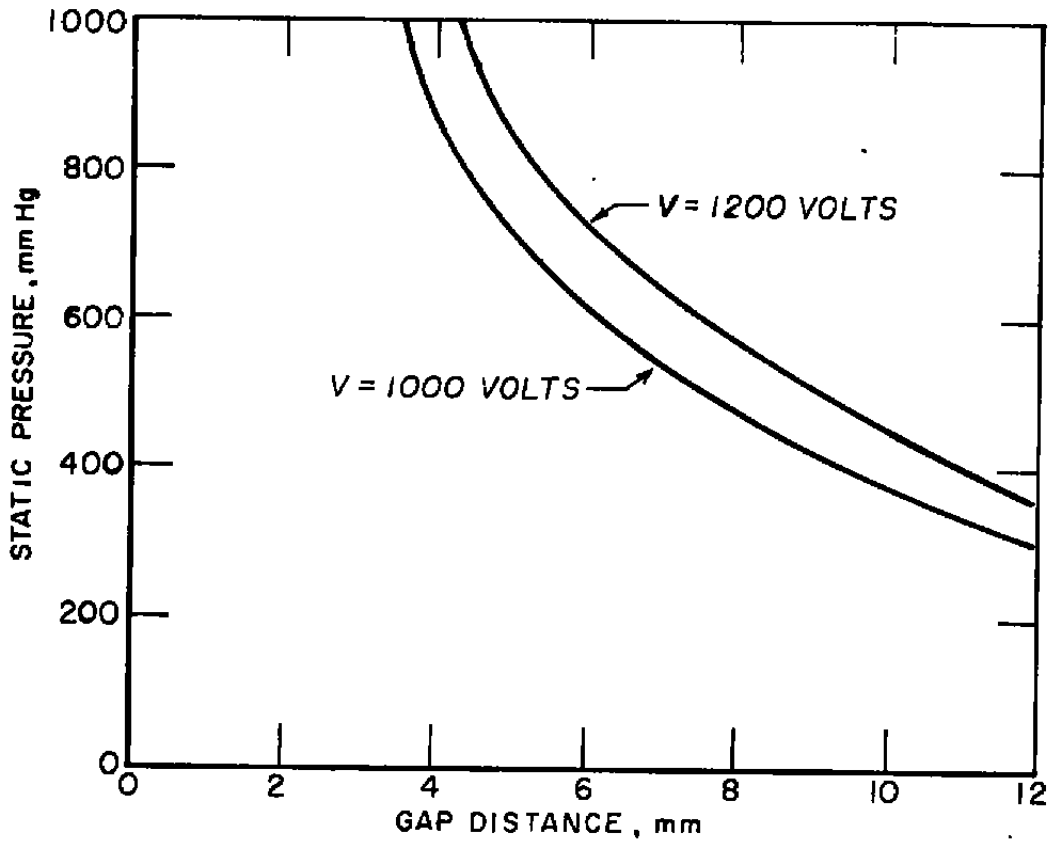

Fig. 18(a) Maximum Pressure For Breakdown Between Plates In Air As A Function Of Gap Distance

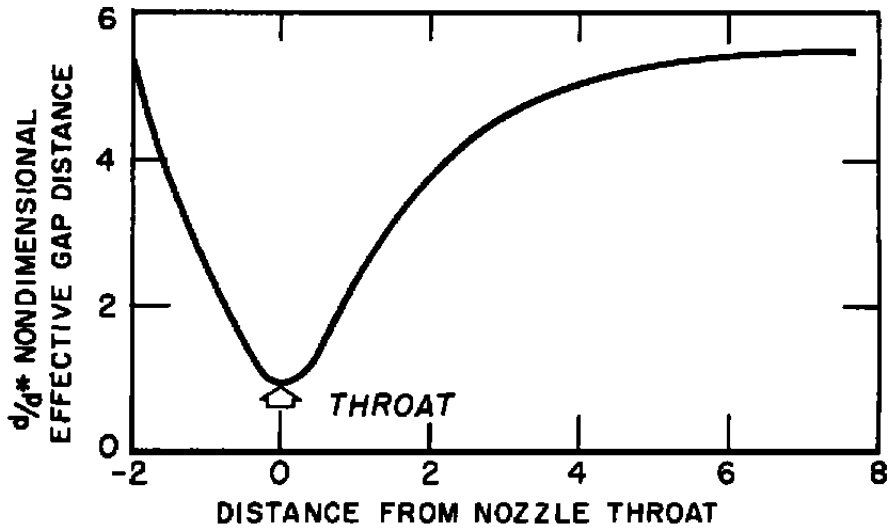

Fig. 18(b) Effective Gap Distance For Contoured Nozzle Block Electrodes

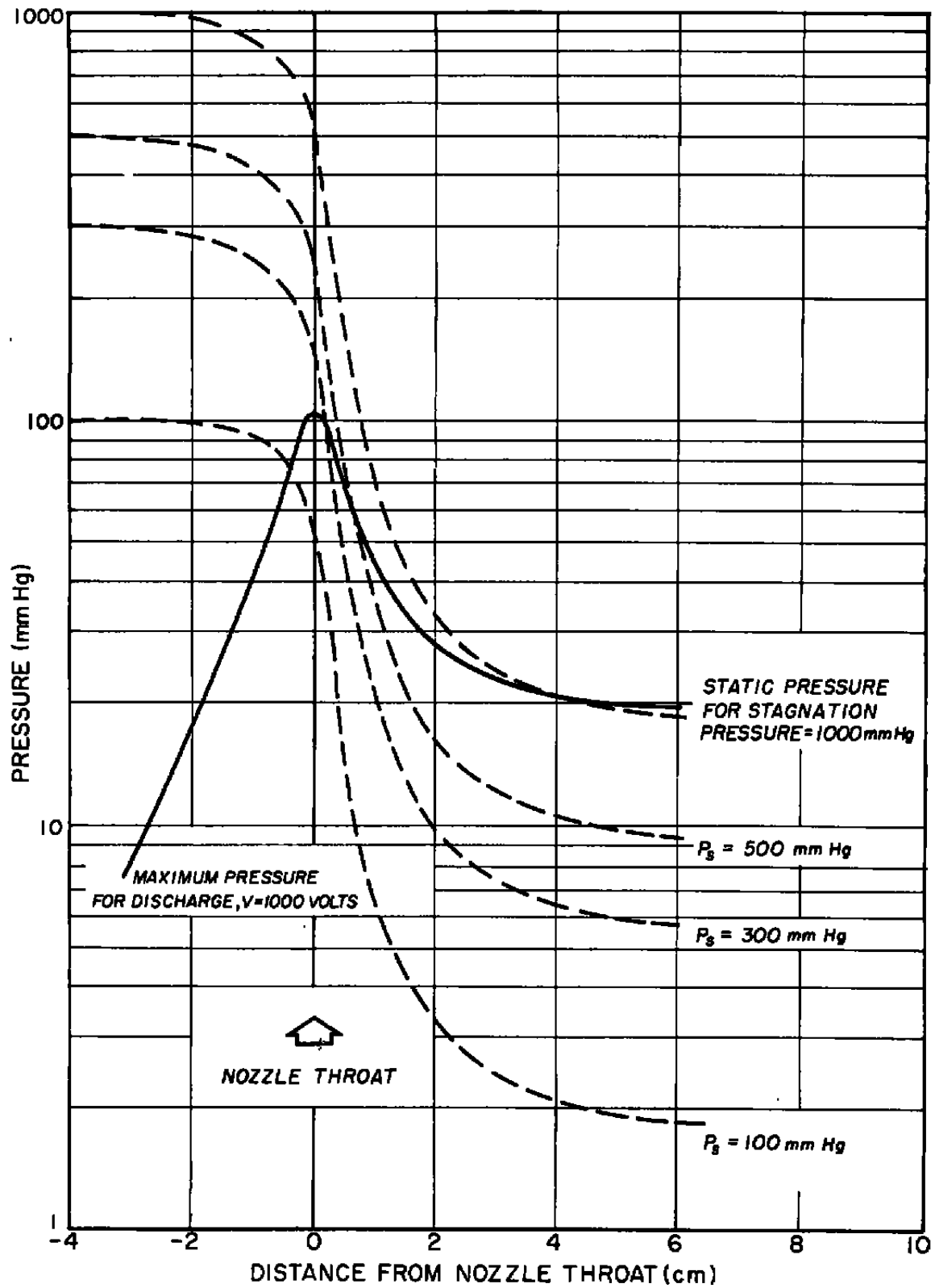

Fig. 19 Location Of High Frequency Discharge In A Supersonic Nozzle

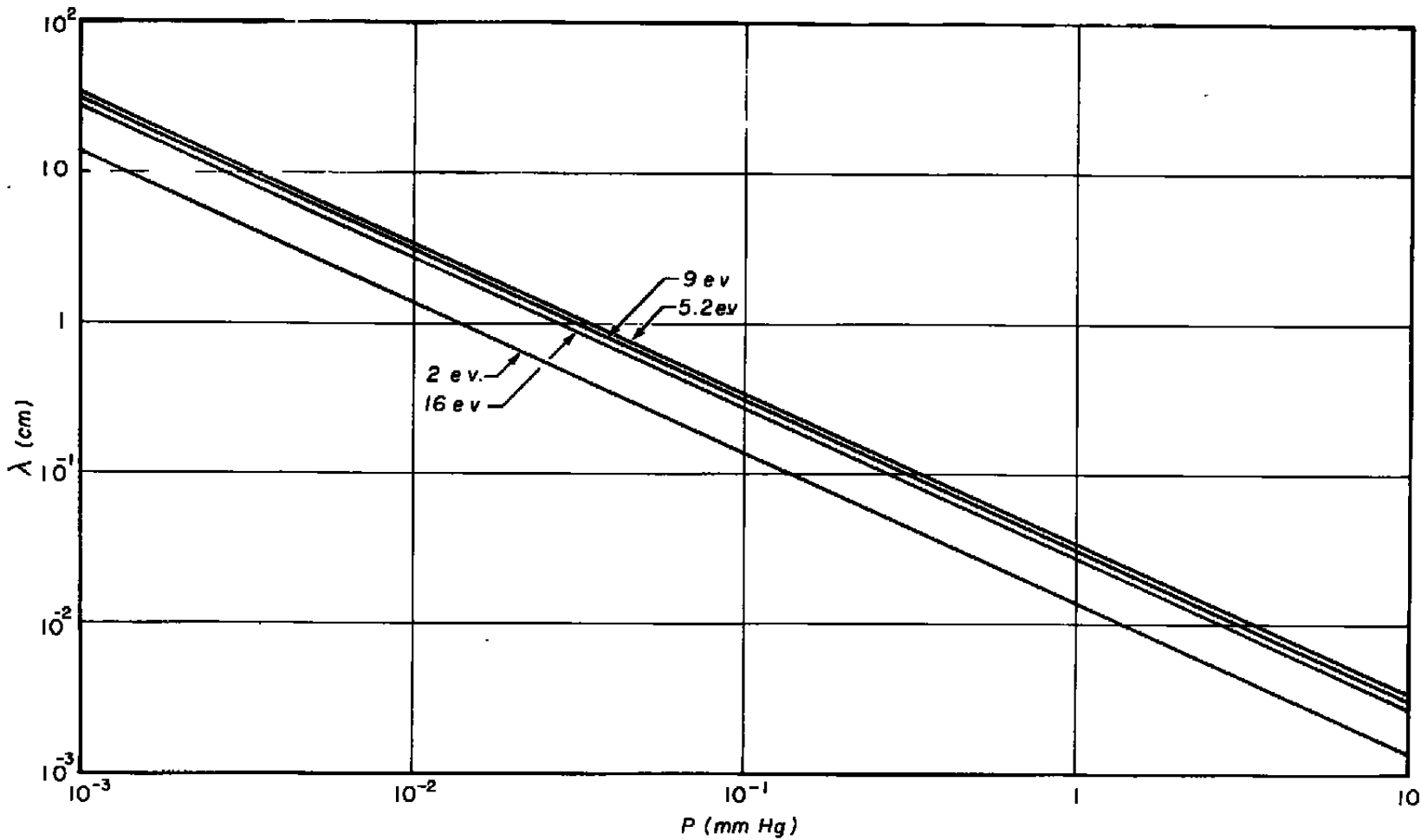

Fig. 20 Electronic Mean Free Path In N₂ As A Function Of Pressure For Various Average - Electron Energies

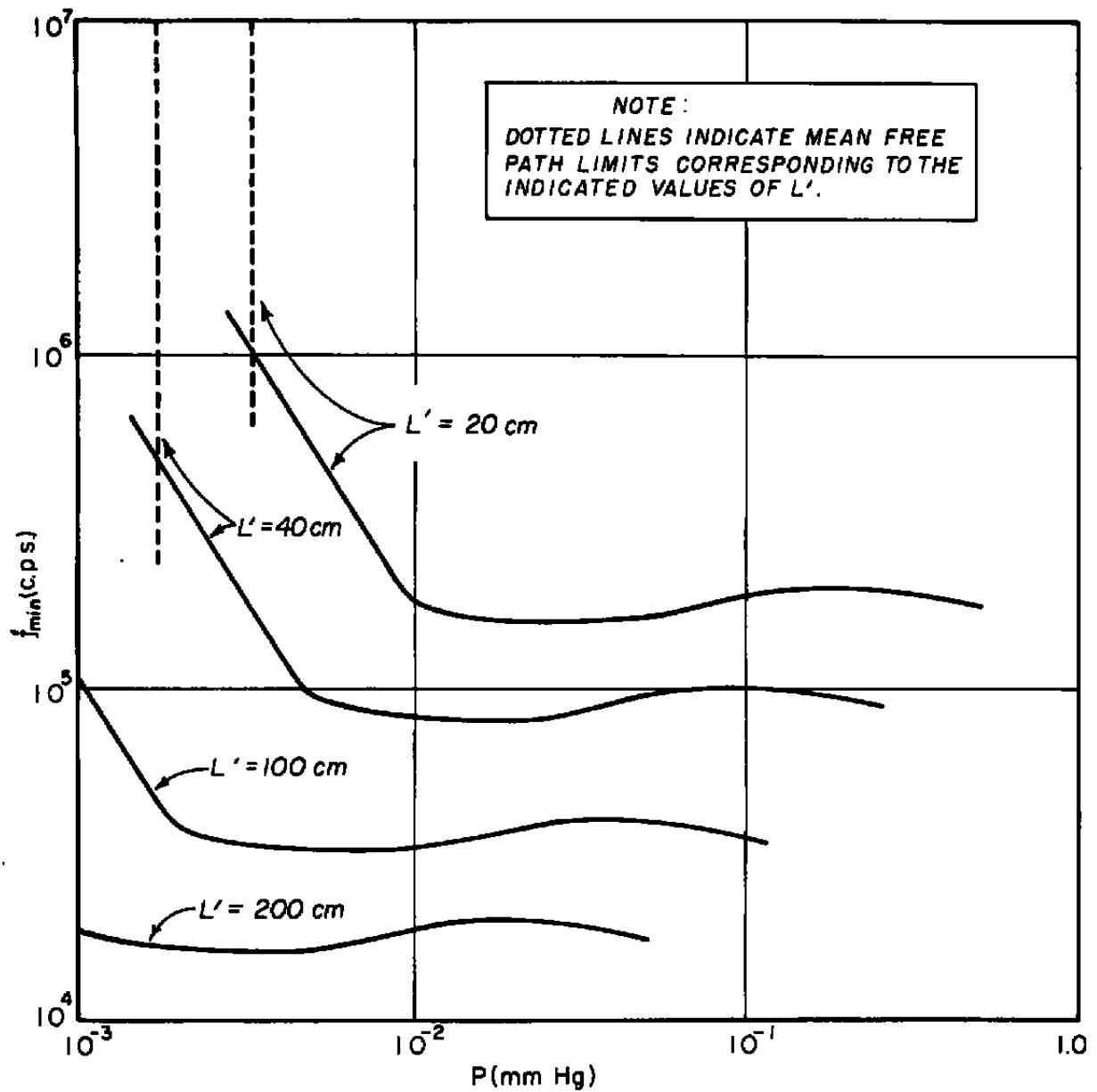

Fig. 21 Oscillation Amplitude Limit In Air* Expressed As $f_{\min.} = f(p)$ For Parallel Plates Having Various Separation Distances, L' , And Geometries Such That $L' \approx 2\Lambda$ Where Λ Is The Characteristic Diffusion Length

* Based on data contained in AEDC TR 59-23, p. 55, Fig. 2

AEDC-TR-61-11

Engineering Center, University of Southern California, Los Angeles 7, California
EXPERIMENTAL STUDY OF THE HEATING OF GAS FLOW BY HIGH-FREQUENCY DISCHARGE by James C. Williams, III, Paul C. Wilber, Philip O. Johnson, and Frederick O. Smetana, September 1961. 81 pp. (AFSC Program Area 750A, Project 8852, Task 895203) (AEDC-TR-61-11) (Contract No. AF 40(600)-857). Unclassified
 17 references

An experimental investigation has been carried out to determine the feasibility of using a radio-frequency discharge to heat a supersonic gas stream. Experiments were conducted with both axisymmetric and two-dimensional supersonic nozzles with the RF discharge created in the supersonic gas flow. Temperature measurements in the flow field downstream of the discharge indicate a definite temperature rise in the decaying plasma. Calorimetry measurements show that it is possible to add up to 40% of the energy available at the discharge plates to the gas stream. It is concluded that radio-frequency discharge heating is a feasible method of heating a supersonic gas stream.

UNCLASSIFIED

1. Gas flow--Heating
 2. Supersonic flow--Heating
 3. Radiofrequency discharges
 4. Plasmas--Decay
 5. Supersonic nozzles--Test results
- I. Williams, James C., III
 - II. Wilber, Paul C.
 - III. Johnson, Philip O.
 - IV. Smetana, Frederick O.
 - V. Arnold Engineering Development Center, ARO, Inc. (Contract AF 40(600)-857)

UNCLASSIFIED

AEDC-TR-61-11

Engineering Center, University of Southern California, Los Angeles 7, California
EXPERIMENTAL STUDY OF THE HEATING OF GAS FLOW BY HIGH-FREQUENCY DISCHARGE by James C. Williams, III, Paul C. Wilber, Philip O. Johnson, and Frederick O. Smetana, September 1961. 81 pp. (AFSC Program Area 750A, Project 8852, Task 895203) (AEDC-TR-61-11) (Contract No. AF 40(600)-857). Unclassified
 17 references

An experimental investigation has been carried out to determine the feasibility of using a radio-frequency discharge to heat a supersonic gas stream. Experiments were conducted with both axisymmetric and two-dimensional supersonic nozzles with the RF discharge created in the supersonic gas flow. Temperature measurements in the flow field downstream of the discharge indicate a definite temperature rise in the decaying plasma. Calorimetry measurements show that it is possible to add up to 40% of the energy available at the discharge plates to the gas stream. It is concluded that radio-frequency discharge heating is a feasible method of heating a supersonic gas stream.

UNCLASSIFIED

1. Gas flow--Heating
 2. Supersonic flow--Heating
 3. Radiofrequency discharges
 4. Plasmas--Decay
 5. Supersonic nozzles--Test results
- I. Williams, James C., III
 - II. Wilber, Paul C.
 - III. Johnson, Philip O.
 - IV. Smetana, Frederick O.
 - V. Arnold Engineering Development Center, ARO, Inc. (Contract AF 40(600)-857)

UNCLASSIFIED

AEDC-TR-61-11

Engineering Center, University of Southern California, Los Angeles 7, California
EXPERIMENTAL STUDY OF THE HEATING OF GAS FLOW BY HIGH-FREQUENCY DISCHARGE by James C. Williams, III, Paul C. Wilber, Philip O. Johnson, and Frederick O. Smetana, September 1961. 81 pp. (AFSC Program Area 750A, Project 8852, Task 895203) (AEDC-TR-61-11) (Contract No. AF 40(600)-857). Unclassified
 17 references

An experimental investigation has been carried out to determine the feasibility of using a radio-frequency discharge to heat a supersonic gas stream. Experiments were conducted with both axisymmetric and two-dimensional supersonic nozzles with the RF discharge created in the supersonic gas flow. Temperature measurements in the flow field downstream of the discharge indicate a definite temperature rise in the decaying plasma. Calorimetry measurements show that it is possible to add up to 40% of the energy available at the discharge plates to the gas stream. It is concluded that radio-frequency discharge heating is a feasible method of heating a supersonic gas stream.

UNCLASSIFIED

1. Gas flow--Heating
 2. Supersonic flow--Heating
 3. Radiofrequency discharges
 4. Plasmas--Decay
 5. Supersonic nozzles--Test results
- I. Williams, James C., III
 - II. Wilber, Paul C.
 - III. Johnson, Philip O.
 - IV. Smetana, Frederick O.
 - V. Arnold Engineering Development Center, ARO, Inc. (Contract AF 40(600)-857)

UNCLASSIFIED

AEDC-TR-61-11

Engineering Center, University of Southern California, Los Angeles 7, California
EXPERIMENTAL STUDY OF THE HEATING OF GAS FLOW BY HIGH-FREQUENCY DISCHARGE by James C. Williams, III, Paul C. Wilber, Philip O. Johnson, and Frederick O. Smetana, September 1961. 81 pp. (AFSC Program Area 750A, Project 8852, Task 895203) (AEDC-TR-61-11) (Contract No. AF 40(600)-857). Unclassified
 17 references

An experimental investigation has been carried out to determine the feasibility of using a radio-frequency discharge to heat a supersonic gas stream. Experiments were conducted with both axisymmetric and two-dimensional supersonic nozzles with the RF discharge created in the supersonic gas flow. Temperature measurements in the flow field downstream of the discharge indicate a definite temperature rise in the decaying plasma. Calorimetry measurements show that it is possible to add up to 40% of the energy available at the discharge plates to the gas stream. It is concluded that radio-frequency discharge heating is a feasible method of heating a supersonic gas stream.

UNCLASSIFIED

1. Gas flow--Heating
 2. Supersonic flow--Heating
 3. Radiofrequency discharges
 4. Plasmas--Decay
 5. Supersonic nozzles--Test results
- I. Williams, James C., III
 - II. Wilber, Paul C.
 - III. Johnson, Philip O.
 - IV. Smetana, Frederick O.
 - V. Arnold Engineering Development Center, ARO, Inc. (Contract AF 40(600)-857)

UNCLASSIFIED

<p>AEDC-TR-61-11</p> <p>Engineering Center, University of Southern California, Los Angeles 7, California</p> <p>EXPERIMENTAL STUDY OF THE HEATING OF GAS FLOW BY HIGH-FREQUENCY DISCHARGE by James C. Williams, III, Paul C. Wilber, Philip O. Johnson, and Frederick O. Smetana, September 1961. 81 pp. (AFSC Program Area 750A, Project 8952, Task 895203) (AEDC-TR-61-11) (Contract No. AF 40(600)-857). Unclassified</p> <p>17 references</p> <p>An experimental investigation has been carried out to determine the feasibility of using a radio-frequency discharge to heat a supersonic gas stream. Experiments were conducted with both axisymmetric and two-dimensional supersonic nozzles with the RF discharge created in the supersonic gas flow. Temperature measurements in the flow field downstream of the discharge indicate a definite temperature rise in the decaying plasma. Calorimetry measurements show that it is possible to add up to 40% of the energy available at the discharge plates to the gas stream. It is concluded that radio-frequency discharge heating is a feasible method of heating a supersonic gas stream.</p>	<p>UNCLASSIFIED</p> <ol style="list-style-type: none"> 1. Gas flow--Heating 2. Supersonic flow--Heating 3. Radiofrequency discharges 4. Plasmas--Decay 5. Supersonic nozzles--Test results <ol style="list-style-type: none"> I. Williams, James C., III II. Wilber, Paul C. III. Johnson, Philip O. IV. Smetana, Frederick O. V. Arnold Engineering Development Center, ARO, Inc. (Contract AF 40(600)-857) <p>UNCLASSIFIED</p>	<p>AEDC-TR-61-11</p> <p>Engineering Center, University of Southern California, Los Angeles 7, California</p> <p>EXPERIMENTAL STUDY OF THE HEATING OF GAS FLOW BY HIGH-FREQUENCY DISCHARGE by James C. Williams, III, Paul C. Wilber, Philip O. Johnson, and Frederick O. Smetana, September 1961. 81 pp. (AFSC Program Area 750A, Project 8952, Task 895203) (AEDC-TR-61-11) (Contract No. AF 40(600)-857). Unclassified</p> <p>17 references</p> <p>An experimental investigation has been carried out to determine the feasibility of using a radio-frequency discharge to heat a supersonic gas stream. Experiments were conducted with both axisymmetric and two-dimensional supersonic nozzles with the RF discharge created in the supersonic gas flow. Temperature measurements in the flow field downstream of the discharge indicate a definite temperature rise in the decaying plasma. Calorimetry measurements show that it is possible to add up to 40% of the energy available at the discharge plates to the gas stream. It is concluded that radio-frequency discharge heating is a feasible method of heating a supersonic gas stream.</p>	<p>UNCLASSIFIED</p> <ol style="list-style-type: none"> 1. Gas flow--Heating 2. Supersonic flow--Heating 3. Radiofrequency discharges 4. Plasmas--Decay 5. Supersonic nozzles--Test results <ol style="list-style-type: none"> I. Williams, James C., III II. Wilber, Paul C. III. Johnson, Philip O. IV. Smetana, Frederick O. V. Arnold Engineering Development Center, ARO, Inc. (Contract AF 40(600)-857) <p>UNCLASSIFIED</p>
<p>AEDC-TR-61-11</p> <p>Engineering Center, University of Southern California, Los Angeles 7, California</p> <p>EXPERIMENTAL STUDY OF THE HEATING OF GAS FLOW BY HIGH-FREQUENCY DISCHARGE by James C. Williams, III, Paul C. Wilber, Philip O. Johnson, and Frederick O. Smetana, September 1961. 81 pp. (AFSC Program Area 750A, Project 8952, Task 895203) (AEDC-TR-61-11) (Contract No. AF 40(600)-857). Unclassified</p> <p>17 references</p> <p>An experimental investigation has been carried out to determine the feasibility of using a radio-frequency discharge to heat a supersonic gas stream. Experiments were conducted with both axisymmetric and two-dimensional supersonic nozzles with the RF discharge created in the supersonic gas flow. Temperature measurements in the flow field downstream of the discharge indicate a definite temperature rise in the decaying plasma. Calorimetry measurements show that it is possible to add up to 40% of the energy available at the discharge plates to the gas stream. It is concluded that radio-frequency discharge heating is a feasible method of heating a supersonic gas stream.</p>	<p>UNCLASSIFIED</p> <ol style="list-style-type: none"> 1. Gas flow--Heating 2. Supersonic flow--Heating 3. Radiofrequency discharges 4. Plasmas--Decay 5. Supersonic nozzles--Test results <ol style="list-style-type: none"> I. Williams, James C., III II. Wilber, Paul C. III. Johnson, Philip O. IV. Smetana, Frederick O. V. Arnold Engineering Development Center, ARO, Inc. (Contract AF 40(600)-857) <p>UNCLASSIFIED</p>	<p>AEDC-TR-61-11</p> <p>Engineering Center, University of Southern California, Los Angeles 7, California</p> <p>EXPERIMENTAL STUDY OF THE HEATING OF GAS FLOW BY HIGH-FREQUENCY DISCHARGE by James C. Williams, III, Paul C. Wilber, Philip O. Johnson, and Frederick O. Smetana, September 1961. 81 pp. (AFSC Program Area 750A, Project 8952, Task 895203) (AEDC-TR-61-11) (Contract No. AF 40(600)-857). Unclassified</p> <p>17 references</p> <p>An experimental investigation has been carried out to determine the feasibility of using a radio-frequency discharge to heat a supersonic gas stream. Experiments were conducted with both axisymmetric and two-dimensional supersonic nozzles with the RF discharge created in the supersonic gas flow. Temperature measurements in the flow field downstream of the discharge indicate a definite temperature rise in the decaying plasma. Calorimetry measurements show that it is possible to add up to 40% of the energy available at the discharge plates to the gas stream. It is concluded that radio-frequency discharge heating is a feasible method of heating a supersonic gas stream.</p>	<p>UNCLASSIFIED</p> <ol style="list-style-type: none"> 1. Gas flow--Heating 2. Supersonic flow--Heating 3. Radiofrequency discharges 4. Plasmas--Decay 5. Supersonic nozzles--Test results <ol style="list-style-type: none"> I. Williams, James C., III II. Wilber, Paul C. III. Johnson, Philip O. IV. Smetana, Frederick O. V. Arnold Engineering Development Center, ARO, Inc. (Contract AF 40(600)-857) <p>UNCLASSIFIED</p>

<p>AEDC-TR-61-11</p> <p>Engineering Center, University of Southern California, Los Angeles 7, California</p> <p>EXPERIMENTAL STUDY OF THE HEATING OF GAS FLOW BY HIGH-FREQUENCY DISCHARGE by James C. Williams, III, Paul C. Wilber, Philip O. Johnson, and Frederick O. Smetana, September 1961. 81 pp. (AFSC Program Area 750A, Project 8952, Task 895203) (AEDC-TR-61-11) (Contract No. AF 40(600)-857). Unclassified</p> <p>17 references</p> <p>An experimental investigation has been carried out to determine the feasibility of using a radio-frequency discharge to heat a supersonic gas stream. Experiments were conducted with both axisymmetric and two-dimensional supersonic nozzles with the RF discharge created in the supersonic gas flow. Temperature measurements in the flow field downstream of the discharge indicate a definite temperature rise in the decaying plasma. Calorimetry measurements show that it is possible to add up to 40% of the energy available at the discharge plates to the gas stream. It is concluded that radio-frequency discharge heating is a feasible method of heating a supersonic gas stream.</p>	<p>UNCLASSIFIED</p> <ol style="list-style-type: none"> 1. Gas flow--Heating 2. Supersonic flow--Heating 3. Radiofrequency discharges 4. Plasmas--Decay 5. Supersonic nozzles--Test results <ol style="list-style-type: none"> I. Williams, James C., III II. Wilber, Paul C. III. Johnson, Philip O. IV. Smetana, Frederick O. V. Arnold Engineering Development Center, ARO, Inc. (Contract AF 40(600)-857) <p>UNCLASSIFIED</p>	<p>AEDC-TR-61-11</p> <p>Engineering Center, University of Southern California, Los Angeles 7, California</p> <p>EXPERIMENTAL STUDY OF THE HEATING OF GAS FLOW BY HIGH-FREQUENCY DISCHARGE by James C. Williams, III, Paul C. Wilber, Philip O. Johnson, and Frederick O. Smetana, September 1961. 81 pp. (AFSC Program Area 750A, Project 8952, Task 895203) (AEDC-TR-61-11) (Contract No. AF 40(600)-857). Unclassified</p> <p>17 references</p> <p>An experimental investigation has been carried out to determine the feasibility of using a radio-frequency discharge to heat a supersonic gas stream. Experiments were conducted with both axisymmetric and two-dimensional supersonic nozzles with the RF discharge created in the supersonic gas flow. Temperature measurements in the flow field downstream of the discharge indicate a definite temperature rise in the decaying plasma. Calorimetry measurements show that it is possible to add up to 40% of the energy available at the discharge plates to the gas stream. It is concluded that radio-frequency discharge heating is a feasible method of heating a supersonic gas stream.</p>	<p>UNCLASSIFIED</p> <ol style="list-style-type: none"> 1. Gas flow--Heating 2. Supersonic flow--Heating 3. Radiofrequency discharges 4. Plasmas--Decay 5. Supersonic nozzles--Test results <ol style="list-style-type: none"> I. Williams, James C., III II. Wilber, Paul C. III. Johnson, Philip O. IV. Smetana, Frederick O. V. Arnold Engineering Development Center, ARO, Inc. (Contract AF 40(600)-857) <p>UNCLASSIFIED</p>
<p>AEDC-TR-61-11</p> <p>Engineering Center, University of Southern California, Los Angeles 7, California</p> <p>EXPERIMENTAL STUDY OF THE HEATING OF GAS FLOW BY HIGH-FREQUENCY DISCHARGE by James C. Williams, III, Paul C. Wilber, Philip O. Johnson, and Frederick O. Smetana, September 1961. 81 pp. (AFSC Program Area 750A, Project 8952, Task 895203) (AEDC-TR-61-11) (Contract No. AF 40(600)-857). Unclassified</p> <p>17 references</p> <p>An experimental investigation has been carried out to determine the feasibility of using a radio-frequency discharge to heat a supersonic gas stream. Experiments were conducted with both axisymmetric and two-dimensional supersonic nozzles with the RF discharge created in the supersonic gas flow. Temperature measurements in the flow field downstream of the discharge indicate a definite temperature rise in the decaying plasma. Calorimetry measurements show that it is possible to add up to 40% of the energy available at the discharge plates to the gas stream. It is concluded that radio-frequency discharge heating is a feasible method of heating a supersonic gas stream.</p>	<p>UNCLASSIFIED</p> <ol style="list-style-type: none"> 1. Gas flow--Heating 2. Supersonic flow--Heating 3. Radiofrequency discharges 4. Plasmas--Decay 5. Supersonic nozzles--Test results <ol style="list-style-type: none"> I. Williams, James C., III II. Wilber, Paul C. III. Johnson, Philip O. IV. Smetana, Frederick O. V. Arnold Engineering Development Center, ARO, Inc. (Contract AF 40(600)-857) <p>UNCLASSIFIED</p>	<p>AEDC-TR-61-11</p> <p>Engineering Center, University of Southern California, Los Angeles 7, California</p> <p>EXPERIMENTAL STUDY OF THE HEATING OF GAS FLOW BY HIGH-FREQUENCY DISCHARGE by James C. Williams, III, Paul C. Wilber, Philip O. Johnson, and Frederick O. Smetana, September 1961. 81 pp. (AFSC Program Area 750A, Project 8952, Task 895203) (AEDC-TR-61-11) (Contract No. AF 40(600)-857). Unclassified</p> <p>17 references</p> <p>An experimental investigation has been carried out to determine the feasibility of using a radio-frequency discharge to heat a supersonic gas stream. Experiments were conducted with both axisymmetric and two-dimensional supersonic nozzles with the RF discharge created in the supersonic gas flow. Temperature measurements in the flow field downstream of the discharge indicate a definite temperature rise in the decaying plasma. Calorimetry measurements show that it is possible to add up to 40% of the energy available at the discharge plates to the gas stream. It is concluded that radio-frequency discharge heating is a feasible method of heating a supersonic gas stream.</p>	<p>UNCLASSIFIED</p> <ol style="list-style-type: none"> 1. Gas flow--Heating 2. Supersonic flow--Heating 3. Radiofrequency discharges 4. Plasmas--Decay 5. Supersonic nozzles--Test results <ol style="list-style-type: none"> I. Williams, James C., III II. Wilber, Paul C. III. Johnson, Philip O. IV. Smetana, Frederick O. V. Arnold Engineering Development Center, ARO, Inc. (Contract AF 40(600)-857) <p>UNCLASSIFIED</p>