

UNCLASSIFIED

AD 267 562

*Reproduced
by the*

ARMED SERVICES TECHNICAL INFORMATION AGENCY
ARLINGTON HALL STATION
ARLINGTON 12, VIRGINIA



UNCLASSIFIED

NOTICE: When government or other drawings, specifications or other data are used for any purpose other than in connection with a definitely related government procurement operation, the U. S. Government thereby incurs no responsibility, nor any obligation whatsoever; and the fact that the Government may have formulated, furnished, or in any way supplied the said drawings, specifications, or other data is not to be regarded by implication or otherwise as in any manner licensing the holder or any other person or corporation, or conveying any rights or permission to manufacture, use or sell any patented invention that may in any way be related thereto.

DISCLAIMER NOTICE

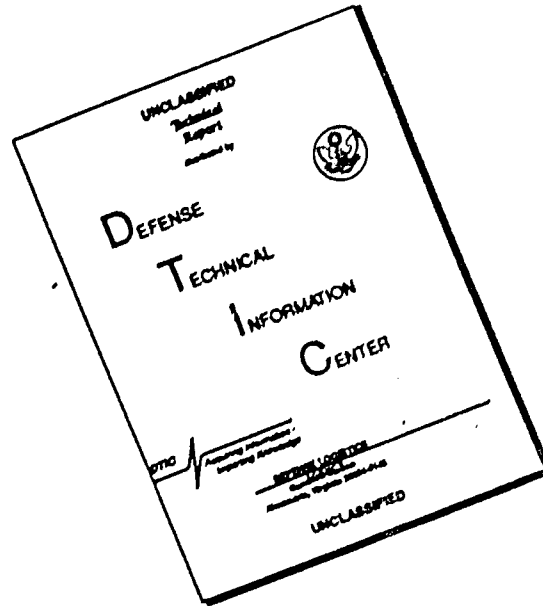

THIS DOCUMENT IS BEST QUALITY AVAILABLE. THE COPY FURNISHED TO DTIC CONTAINED A SIGNIFICANT NUMBER OF PAGES WHICH DO NOT REPRODUCE LEGIBLY.

267 562

U. S. A R M Y
TRANSPORTATION RESEARCH COMMAND
FORT EUSTIS, VIRGINIA

TECHNICAL REPORT 61-72

STUDY TO ESTABLISH REALISTIC ACOUSTIC
DESIGN CRITERIA FOR FUTURE ARMY-AIR CRAFT

REPORT NUMBER: TR-61-117-54

CONTRACT NUMBER: DA-36-100-562

Prepared by



DISCLAIMER NOTICE

When Government drawings, specifications, or other data are used for any purpose other than in connection with a definitely related Government procurement operation, the United States Government thereby incurs no responsibility nor any obligation whatsoever, and the fact that the Government may have formulated, furnished, or in any way supplied the said drawings, specifications, or other data is not to be regarded by implication or otherwise as in any manner licensing the holder or any other person or corporation, or conveying any rights or permission to manufacture, use, or sell any product or invention that may in any way be related thereto.

* * *

CIA AVAILABILITY NOTICE

Individuals desiring to obtain copies of this report from

the Central Intelligence Agency
Central Intelligence Agency
Washington Hall Station
Arlington 12, Virginia

* * *

This report has been referred to the Office of Technical Services,
U. S. Department of Commerce, Washington 25, D. C., for sale to the
general public.

* * *

This report and its contents will not be used for advertising pur-

* * *

The findings and recommendations contained in this report are those
of the contractor and do not necessarily reflect the views of the Chief
of Training and the Department of the Army.

Task 9R38-01-017-54

Contract DA 44-177-TC-562

June 1961

STUDY TO ESTABLISH
REALISTIC ACOUSTICAL DESIGN CRITERIA
FOR FUTURE ARMY AIRCRAFT

REPORT 192

Prepared By
VERTOL DIVISION
THE BOEING COMPANY
MORTON, PENNSYLVANIA

FOR
U.S. ARMY TRANSPORTATION RESEARCH COMMAND
FORT EUSTIS, VIRGINIA

FOREWORD

This report was prepared by H. Sternfeld, Jr., R. H. Spencer and E. G. Schaeffer of the Vertol Division of The Boeing Company, under Contract DA44-177-TC-562, Task 9R38-01-017-54. It was funded by the U. S. Army Transportation Research Command, and was carried out under the technical cognizance of Mr. J. Everette Forehand, U.S. Army TRCOCOM, Ft. Eustis, Virginia.

Consultation in design and interpretation of the pilot opinion survey was provided by Dr. Roy Hackman of the Temple University Department of Psychology, and by Dr. L. L. Beranek, Dr. K. D. Kryter and Mr. Laymon N. Miller of Bolt, Beranek, and Newman.

A program of this nature cannot be carried out without the cooperation of many individuals and organizations. Special credit is due the TATSA Organization, Ft. Rucker, Alabama, under the direction of Lt. Col. G. Shea; Messrs. D. Reed and C. Snakespeare of Vertol who assisted in the field measurements; and Mrs. C. H. Boehmer who analyzed the data.

CONTENTS

	<u>Page</u>
FOREWORD	iii
LIST OF ILLUSTRATIONS	vi
LIST OF TABLES	ix
LIST OF SYMBOLS	x
SUMMARY AND CONCLUSIONS	1
INTRODUCTION	4
NOISE LEVEL SURVEY	6
I Introduction - Task I	6
II Instrumentation	6
Data Acquisition	6
System Calibration	7
Analysis	8
III Test 1 - Determination of External Noise Field	9
IV Test 2 - Takeoff and Landing Noise	9
V Test 3 - Ground Level Flight Noise	10
VI Test 4 - Internal Noise Levels	10
VII Narrow Band Analysis	11
ESTABLISHMENT OF ACOUSTICAL CRITERIA	12
I Introduction - Task II	12
II Pilot Opinion Survey	12
Survey Design	12
Results	13
Pilot Experience	15
Subjective Evaluation of Responses	16
III Correlation with Measured Data	17
Development of Specification	17
Significance of Response	17
Correlation of Fatigue, Noise and Vibration	18
IV Correlation with Existing Standards	19
Correlation with MIL-A-8806	19
Correlation with Medical Limits	20
Correlation with other Acoustical Criteria	21
Proposed Specifications	22

CONTENTS (continued)

	<u>Page</u>
V Application to Aircraft Interiors	23
Design Principles	23
Design Applications	26
1. General	26
2. H-21	26
3. H-23	31
4. H-37	34
5. HU-1A	39
6. YHC-1A	40
Performance Penalties	43
RECOMMENDATION FOR REVISED ACOUSTICAL CRITERION	50
I Introduction - Task III	50
II Comparison with MIL-A-8806 (ASG)	50
III Effect of Acoustical Treatments	52
BIBLIOGRAPHY	53
APPENDIX I - Illustrations	55
APPENDIX II - Data Sheets	241
APPENDIX III - List of Instrumentation	307
APPENDIX IV - Pilot Opinion Survey	308
APPENDIX V - List of Army Installations	319
DISTRIBUTION	320

ILLUSTRATIONS

<u>Figure</u>		<u>Page</u>
1	Calibration Chamber	56
2	Calibration System	56
3	System Calibration Curves	57
4	Sound Level Recording Equipment	58
5	Technical Products Wave Analyzer	59
6	Block Diagram - Technical Products Wave Analyzer. . .	60
7	Characteristic Curves	60
8	Measurement Locations - Test 1	61
9-20	Variation of Sound Pressure Level Surrounding Aircraft	62-73
21	Microphone Locations - Test 2	74
22-33	Maximum Sound Pressure Levels During Takeoff and Landing	75-86
	Measurement Locations - Test 3	87
35-66	Maximum External Sound Pressure Levels Measured at Ground Station	88-119
67-103	Maximum Internal Sound Pressure Levels	120-156
104	Sample Narrowband Analysis Chart.	157
105-135	Narrowband Analyses	158-188
136-143	Aircraft Rating - Pilot Opinion Survey	189-196
144	Experience Distribution: Groups 1-20	197
145	Aircraft Rating for Three Experience Groups	198
146-149	Correlation of Pilot Opinion with Loudness from Measured Data	199-202
150	Pilot Acceptance Level - Based on Question 7	203
151	Pilot Acceptance Level - Based on Questions 2 and 6 . .	204

ILLUSTRATIONS (continued)

<u>Figure</u>		<u>Page</u>
152	Correlation of Ranked Pilot Opinion with Ranked Sound Pressure Level in Octave Band	205
153	Comparison of MIL-A-8806 with Pilot Acceptance Level	206
154	Comparison of Accepted Pilot Limit with Acceptable and Unacceptable Aircraft Scatterbands	207
155	Comparison of Ratings	208
156	Comparison of Noise Specifications	209
157	Comparison of MIL-A-8806 with Proposed Specification	210
158	Test Schematic for Theoretical Source - Receiver Combination	211
159	Transmission Loss for PF-195 Fiberglass	212
160	Mass Law Transmission Loss for Lirp Panels	212
161	Acoustical Blanket Design Curves, Vinyl - Fiberglass Combinations	213
162	Acoustical Blanket Design Curves, Aluminum - Fiberglass Combinations	214
163-171	Identification of Noise Sources	217-225
172	H-21 Internal Sound Pressure Levels	226
173	H-21 Acoustical Blanket Locations	228
174	H-23 Internal Sound Pressure Levels	229
175	H-23 Acoustical Blanket Locations	230
176	H-37 Internal Sound Pressure Levels	231
177	H-37 Acoustical Blanket Locations	233
178	HU-1A Internal Sound Pressure Levels	234
179	HU-1A Acoustical Blanket Locations	235

ILLUSTRATIONS (continued)

<u>Figure</u>		<u>Page</u>
180	YHC-1A Internal Sound Pressure Levels	236
181	YHC-1A Acoustical Blanket Locations	237
182	Effect of Acoustical Treatment on Performance	238
183	Summary of Army Aircraft Noise Levels (Internal). . .	239
184	Summary of Army Aircraft Noise Levels (External). . .	240

TABLES

<u>TABLE</u>	<u>PAGE</u>
I Transmission Loss Data - Limp Panel	215
II Transmission Loss Data - Rigid Panel	216
III H-21 Forward Rotor Transmission Noise Reduction	27
IV H-21 Aft Curtain Treatment	28
V H-21 Drive Shaft Transmission Enclosure	29
VI H-21 Cabin Noise Reduction Treatment	30
VII H-21 Cockpit Treatment	30
VIII H-23 Engine Muffler	32
IX H-23 Rotor Transmission Enclosure	33
X H-23 Total Noise Reduction	34
XI H-37 Rotor Transmission Enclosure	35
XII H-37 Aft Cabin Treatment	35
XIII H-37 General Cabin Treatment	36
XIV H-37 Clamshell Doors	37
XV H-37 Cockpit Window Area	38
XVI H-37 Cockpit Blanket Area	38
XVII HU-1A Cabin Treatment	39
XVIII HU-1A Cockpit Window Area	40
XIX YHC-1A Aft Cabin Treatment	41
XX YHC-1A Fwd Rotor Transmission Treatment	41
XXI YHC-1A General Cabin Treatment	42
XXII YHC-1A Cockpit Treatment	42
XXIII H-21 Weight Calculation - H-21 Acoustical Treatment	44
XXIV H-23 Weight Calculation - H-23 Acoustical Treatment	45
XXV H-37 Weight Calculation - H-37 Acoustical Treatment	46
XXVI HU-1A Weight Calculation - HU-1A Acoustical Treatment	47
XXVII YHC-1A Weight Calculation - YHC-1A Acoustical Treatment	48
XXVIII Effect of Acoustical Treatment on Range	49

SYMBOLS

A	Area
C	Transmission loss correction factor
c	Velocity of sound propagation
D	Difference in rank between paired items
f	Frequency
ρ	Specific surface weight
h	Height
L	Length, characteristic cabin dimension
N	Number of ranked groups
R	Receiver
S	Source
V	Cavity volume
w	Width
\underline{w}	Weight
X	Mean pilot experience
α	Average statistical absorption coefficient
λ	Wave length
ρ	Spearman's rank correlation coefficient
σ	Standard deviation

SUBSCRIPTS

a	Ambient corrections to T.L.
n	Receiving space size correction
o	Initial reference
1, 2, 3	Small, medium, large receiving space

LIST OF ABBREVIATIONS

db	Decibel
L.L.	Loudness level
N.R.	Noise reduction
PNdb	Perceived noise level
S.I.L.	Speech interference level
S.F.L.	Sound pressure level
T.L.	Transmission loss
PWL	Sound power level

SUMMARY AND CONCLUSIONS

As a result of this study, it has been concluded that MIL-A-8806 (ASG), the Military Specification for noise levels in aircraft should be amended for Army Aircraft during normal cruise power by the addition of a Table V.

TABLE V

Frequency Bands and Acceptable Noise Level
at Normal Cruise Power

Frequency Bands, cps	Acceptable Noise Levels, db
Overall	106
37.5 - 75	104
75 - 150	104
150 - 300	104
300 - 600	96
600 - 1200	90
1200 - 2400	86
2400 - 4800	75
4800 - 9600	75

It is recommended that Paragraph 3.1.4 of Specification MIL-A-8806 (ASG) dated 25 October 1956 shall be amended by the addition of a Table V and rewording of the existing paragraph as follows (underlines indicate added or changed wording).

3.1.4 Normal cruise power - The acceptable noise level in any part of the aircraft intended for occupancy by the crew or other personnel shall not exceed the values shown in Table IV or V (whichever is applicable) under conditions of NORMAL CRUISE POWER.

Table IV is applicable to all Naval aircraft procurement and to Air Force and Army fixed wing aircraft procurement when so stated in the aircraft detail specification. Table V is applicable to all Army rotary wing and VTOL/STOL aircraft procurement when so stated in the aircraft detail specification.

Figures 183 and 184 summarize the internal and external noise environments which were encountered in the fixed and rotary wing aircraft tested. The two VTOL test beds were excluded because of the lack of directly comparable data. For purposes of providing a condensed summary which retained more significance than just the over-all, or peak, sound levels the arithmetic averages of what have arbitrarily been defined as the low (20-75 and 75-150), middle (150-300, 300-600

and 600-1200) and high (1200-2400 , 2400-4800, and 4800-10,000 cps) octave bands are presented. This has the advantage of preserving some description of frequency distribution. It is noteworthy that the relative noise levels internally and externally are not directly comparable. For example, the low frequency internal data for the H-13 are greater than for any other aircraft while the comparable external data are the lowest of all aircraft tested. Such a condition is indicative of a local condition within the aircraft such as either a structural or an air cavity resonance which is apparently amplifying a particular exciting frequency within the aircraft.

Correlation of pilot comment with measured data shows that Army pilots require additional relief from noise at high frequencies over that afforded by Table IV of MIL-A-8806 (ASG) dated 25 October, 1950, when flying rotary wing aircraft (Ref. Fig 157). It further appears that most aircraft being operated by the Army do not comply with Table IV of MIL-A-8806.

Treatments which would insure pilot satisfaction can be achieved at nominal penalties averaging about 1% of gross weight and 10% of range.

Greater efficiency in noise control can be achieved by reduction at the source. Such achievement will require research into several basic mechanisms of aircraft noise.

In view of the meager amount of data, especially internal, which is available on the newer types of VTOL/STOL aircraft it is recommended that the Army keep the inventory of acoustical data acquired in Task I up to date by addition of all new aircraft and test beds as soon as their stage of development will permit satisfactory completion of the required flight program.

During interviews conducted during the Task II survey many Army personnel expressed concern about the tactical and operational limitations which must often be placed on aircraft due to external noise. It is recommended that the external data obtained during the Task I program be used as a basis for establishing a specification for external noise levels to be applied to Army combat aircraft.

It is apparent that the most efficient acoustical control is that which can be applied at the source. Studies of sources leading to major pilot discomfort indicate the great potential weight saving and value of reducing transmission noise by gear and/or case design and by reducing turbine inlet and compressor noise. It appears that research in these areas will have to be pursued if weight allocations for noise reduction are not to become excessive.

Rotor noise, which with the advent of the gas turbine definitely becomes the major external noise problem has, up to now, been relatively neglected. Wind tunnel and whirl tower studies aimed at better understanding the causes of rotor blade noise and studying the effects of blade design on the noise generated should be carried on if helicopters are to realize their full military potential.

INTRODUCTION

This study of the problem of aircraft noise and its effect on Army operation and utilization of equipment is divided into three tasks:

Task I

A sound pressure level measurement program which was carried out on twelve of the Army's aircraft inventory. (Specifically, the L-20, L-23, U-1A, H-13, H-21, H-23, H-34, H-37, HU-1A, VHC-1A, Doak 16 and Vertol 76 Aircraft.)

Task II

A study of the effect of aircraft noise on Army aircraft operations as limited by the noise environment to which pilots are exposed, and performance limits which might be imposed on the aircraft by additional soundproofing treatments.

Task III

A review of Specification MIL-A-8806 for adequacy and applicability to Army aircraft, in light of the findings of Task II. This will include recommendations, if warranted, for revisions or addenda.

Consideration of acoustic design and application of noise control measures to military aircraft have, for a long time, been relegated to a relatively minor role in overall design considerations. The resulting high noise levels which have, unfortunately, become associated with these vehicles were long regarded merely as undesirable working conditions with which flight and ground crews have had to contend. The development of new higher performance aircraft, however, resulted in further increases in noise levels to the point where action has, in many cases, become mandatory.

The benefits derived from good noise control, however, far exceed those of hearing preservation alone. Low internal noise reduces pilot fatigue, permits good radio and intercommunication system operation, and generally improves physical response and morale of flight crews.

External noise level problems are of extreme importance in limiting the tactical utilization of many troop-carrying aircraft. A far-carrying and distinctive noise can, for example, completely cancel the advantage of surprise assault available with troop-carrying helicopters operating behind hills or below "treetop level".

Community relations, in non-combat areas, in recent years has become an area of increasing problem. Location of airports and flight operational procedures have, in many cases, been dictated largely by noise. It is, therefore, most desirable that the aircraft itself be designed such that its utilization need not later be restricted.

In order to arrive at aircraft with optimum noise characteristics without paying undue penalties in weight, performance, etc., it is necessary to establish criteria which, when satisfied, will permit unrestricted operation with high crew efficiency and still not be conservative to a penalizing degree. It is the purpose of this program to arrive at such criteria for the types of aircraft operated by the U.S. Army and to consider the effects of such control on the aircraft itself.

NOISE LEVEL SURVEY

I. INTRODUCTION - Task I

This section specifically covers the Task I work and comprises an objective sound pressure level measurement program which was conducted to establish the internal and external noise levels incurred during operation of each aircraft. Subjective responses, or the effects of these sound pressures on the human, will be treated in the Task II Report.

Throughout the program every effort was taken to insure consistency and comparability of data by choosing identical or similarly open terrain, operating in similar climatic conditions, (and only in low winds), and utilizing only equipment of excellent construction which had been calibrated correctly.

Measurements were made on the following aircraft: Sabana (i-20, L-23, G-12, P-13, and L-14), F-30, F-47, H-1, Lockheed, FB, California (Vertol 70), General Electric, Farmington, Vermont, Batavia, Virginia (Doak 16), and the Bell Helicopter, Pennsylvania State Collegeport, New Jersey, (YHC 13).

II. INSTRUMENTATION

Data Acquisition

The fundamental technique used for the collection of acoustical data in this program was the use of a series of sound reproductions of the sound on magnetic tape and then subjected to the most appropriate analysis. In the conduct of this program the following equipment and techniques were employed:

A General Radio Type 4020 Condenser Microphone System, consisting of an Altec 21-B3-15 microphone and a wicker-generated power supply for providing preamplifier, preamplifier, filament power as well as a polarizing voltage for the microphone, was employed as a sensing element. Preamplification was provided by a 6A6 miniature tube housed in the microphone base.

Microphone output was fed to a Model Model 501 tape recorder which had been modified to replace the continuously variable rotary input attenuator with a stepped attenuator which had been designed to provide 10 db increments between steps.

As frequent intervals during the tests a calibrating signal of 121 db at a frequency of 430 cycles per second was recorded. This signal was generated by a General Radio Type 1502-B Sound Level Calibrator which was powered by a type 1502 transistor oscillator. Directly preceding this series of tests the calibrators were returned to the

manufacturer for check. One was found to be exactly correct while the other was found to be only .4 db low. The first calibrator was then placed in storage (as a master) and the second used for field operations. At the conclusion of the testing the two calibrators were again compared and no shift noted. The .4 db variance was then compensated for in analysis, and correct and consistent calibration insured.

System Calibration

Since the 400 cps calibration is only a single frequency check on the system gain, a complete system calibration was performed as follows:

1. The microphone was connected to its preamplifier and the 400 cps GR type 1552-B calibrating speaker placed on the microphone. The resulting open circuit voltage from the preamp output was measured as .295 volt for 121 db input. This agreed within 1 db with the voltage output predicted from the microphone calibration curves. For use later in this calibration procedure, the open circuit voltage at 100 db was calculated to be .026 volts.
2. A test chamber (Figure 1) was constructed and the circuit of Figure 2 connected. The calibrating speaker was placed over the microphone (dotted circuit) and the octave band analyzer adjusted to read 121 db. In this case and in the following calibrations the recorder was in the "tape mode," i.e., the signal was recorded on the tape and the octave band analyses made from the taped signal. This procedure insured that the characteristics of the recording head and playback system were accounted for.
3. The signal generator (solid circuit) was then set at each frequency to be calibrated and its output adjusted so that the open circuit voltage of the microphone preamp output was .026 volts (100 db). The microphone was then connected into the circuit and the output read on the octave band analyzer. At each frequency the calibration was made for several attenuator settings as shown in Figure 3.
4. Examination of Figure 3 shows that linearity of response is very dependent on signal level. The high frequency cutoff exhibited with the low attenuation setting (5) is evidence of amplifier saturation. While the amplification obtained at attenuator settings 7 and 8 agree closely with the microphone characteristic curve, attenuator 6 at 100 db apparently compensates well and provides optimum response. By noting the position of the V.U. meter during calibration, it was possible to select attenuator settings in the field so as to record at this same level, thereby assuring input corresponding to the calibration at attenuator 6. This removed any necessity for compensation in the analysis. All 120 db field calibrations were made at attenuator 8 to correspond with the optimum recording level equivalence of 100 db at attenuator 6.

5. The recording technique was:
- a. Record 121 db 400 cps tone generated by calibrating speaker at attenuator 8 (equivalent to 100 db at attenuator 6).
 - b. Adjust attenuation in actual noise field such that V.U. meter reading closely approximates that during calibration.
 - c. Make recordings, insuring that:
 - (1) Neither technician nor equipment provides undue shielding from, or reverberation of, subject sound.
 - (2) Microphone does not make direct physical contact with vibrating structure.

(Figure 4 shows the test equipment mounted in the back of a truck for external noise level testing.)

Analysis

In describing noise, it is necessary to specify both amplitude and frequency. Since the audio range is quite broad, it is often convenient to deal with groups of frequencies and integrate the amplitudes. Perhaps the most common audio frequency grouping is by octave bands. All data taken in this program was analyzed by playing the tape through a General Radio Type 1550-A Octave-Band Noise Analyzer, utilizing the recorded calibration tone at 400 cps for reference and reading the sound pressure levels in the 20-75, 75-150, 150-300, 300-600, 600-1200, 1200-2400, 2400-4800, 4800-10,000 cps bands.

When it is necessary to identify particular noise sources of discrete frequency and to determine their intensities, it is then necessary to turn to more complex equipment. The analyses required for this portion of the program were carried out on a Technical Products Wave Analyzer (Figure 5) consisting of a TP 626 Oscillator and a TP 627 Analyzer, with output recorded on a General Radio 1521-A Graphic Level Recorder. Figure 6 shows a block diagram of this system which is basically a heterodyne type in which all filtering is done at a frequency of 97 kc with bandwidths of either 2 cps or 20 cps available. The filters have optimum characteristics as displayed by Figure 7, which shows the high rejection and fiat top required for beat analysis. Means are available for selecting time constant and paper speeds to permit optimization of the record presentation consistent with faithful results.

III. TEST 1 - DETERMINATION OF EXTERNAL NOISE FIELD

The purpose of this test was to determine the shape and intensity of the noise field surrounding the aircraft for the purpose of identifying noise sources and defining problems which might affect those persons required to work in the area immediately adjacent to ground operations.

In each case the aircraft was either hovered in ground effect (for helicopters) or run at cruise power (for fixed wing aircraft) while records were taken at given radii from the intersections of center-lines of longitudinal symmetry and power plant.

Records were taken at the locations shown in Figure 8 with the following exceptions:

- H-37 & YHC-1A 50 ft radius (Points 13, 14, 15, 16) - omitted due to proximity to aircraft.

- Doak 16 and Data for the two VTOL aircraft are given
Vertol 76 on a 100 ft. radius in Figures 19 and 20
 because of previously mentioned limitations
 in the amount of such data compiled.

- Doak 16 Points 12, 1, 2, 3, and a point halfway be-
 tween 4 and 5 were the only ones obtained
 because of limited aircraft availability.

All data taken are tabulated in Appendix II, pages 242 through 306.

Since the 200 ft. data generally give the clearest definition of the sound pattern, these data are presented in polar plot form in Figures 9 through 18.

IV. TEST 2 - TAKE-OFF AND LANDING NOISE

Noise levels generated by aircraft during take-off and landing procedures are significant both from the standpoint of insuring safety for airbase personnel and also from tactical considerations, particularly with regard to helicopters which may often be required to operate out of unprepared sites in combat areas where minimum detection is essential.

Records were made during take-offs in which the aircraft were required to clear a 50 ft. (imaginary) obstacle in 250 ft., and normal landings at the locations illustrated in Figure 21. In the case of fixed wing aircraft, landing noise was found very low and is not considered.

It should be kept in mind that the sound pressure levels shown in Figures 22 through 33 and data presented in Pages 264 through 275 are the maximum recorded and do not necessarily occur at the same instant in time, but represent a profile of the maximum levels in each band during a given operation.

V TEST 3 - GROUND LEVEL FLIGHT NOISE

The ease with which an aircraft can be detected from the ground often determines the operational limitations which may be imposed on operations in hostile areas. Obviously a vehicle which makes its presence known long before actual arrival, places itself in a vulnerable position by permitting the enemy maximum time to prepare countermeasures. Noise, therefore, can become a limiting factor to the proximity which an observation aircraft can approach or the minimum speed at which it can fly in carrying out its mission.

In the case of troop-carrying aircraft, where maximum surprise is important, the distance from the enemy at which troops may be safely disembarked is a function of the detectability of the aircraft. Here again external flight noise may limit the effectiveness of the "Sky Cavalry" concept.

During this test each aircraft was flown at its basic design cruise speed and at various altitudes from 25 to 500 ft. and at horizontal distances from 0 to 500 ft. from the microphone, as illustrated in Figure 34.

Although operation beyond 500 ft. is also most important, it was found that under the ambient conditions available at the test sites (particularly due to operation of other aircraft in the area) much data would be contaminated. Extrapolation of the data obtained to much greater distances, however, is relatively simple and could be carried out. Reference 1, for example, outlines the analytic method for such predictions.

Once again the octave band analyses, Figures 35 through 66, and Pages 276 through 277 are the maxima independent of time or position of the aircraft.

VI. TEST 4 - INTERNAL NOISE LEVELS

Flight sound pressure levels were recorded in each aircraft, the test procedure being identical with those used for ground work. In each aircraft, records were made at the pilot's ear location and where applicable, at passenger locations during typical flight conditions including hover, take-off, cruise, high speed forward flight, and autorotations. At the cruise condition, records were made at many locations in the aircraft, in order to identify sound sources and to provide information required to proportion acoustical treatments properly.

Most of the aircraft were essentially in an "as delivered" configuration. In some cases, however, this was not the case, and where deviations from the standard configuration occurred, they are noted.

Illustrations showing microphone locations and internal sound pressure levels are presented in Figures 67 through 103. All data are tabulated on Pages 288 through 306 .

VII. NARROW BAND ANALYSIS

In order to determine which components (propeller, rotor, gear box, power plant, etc.) are the prime contributors to either overall or any specific octave of the total noise, it is necessary to do a discrete frequency analysis. The equipment used for this work was described on Page 8 ; its output is automatically reproduced in strip chart form. Figure 104 shows a portion of a typical chart and illustrates how predominant source identifications can be made. Several of the larger peaks are immediately identifiable with harmonics of engine and main rotor frequencies, E and M respectively, while the subscript denotes harmonic order. Note that with a six-cylinder four-stroke engine such as used in the H-13, three cylinders receive a power stroke with each crankshaft revolution. As a result third harmonic and multiple integers of it are predominant. Harmonics shown have been identified E₃ and E₆. Also identifiable are multiple integers of the two-bladed main rotor, M₆, M₈, and M₁₀.

Figures 105 through 135 present charts made from internal and external recordings in each aircraft. Internal locations were selected to provide maximum information regarding noise at pilot and passenger locations. External locations were selected from Test 1 data at the azimuth of maximum overall noise.

The finest filter (2 cps Bandwidth) was selected in order to preclude masking of sources generating frequencies close to each other.

This collection of data is considered to be essentially an inventory from which more detailed analyses may be made without recourse to field measurements, and much of it will be utilized in the latter tasks of this project.

ESTABLISHMENT OF ACOUSTICAL CRITERIA

I. INTRODUCTION

This section covers Task II and deals primarily with the subjective response of pilots to aircraft noise and the correlation of these responses with measured data.

It has been well established, by several investigators, that human hearing is frequency sensitive, i.e. equal sound pressure levels do not sound equally loud at all frequencies. The work of Fletcher and Munson (Ref. 2, Pg. 399) is generally accepted as one of the more fundamental in this area. It is thus obvious that suitable consideration of frequency, as well as absolute level is required since human reaction to noise is a subjective response and criteria based on measurements or medical limitations alone will not necessarily result in pilot satisfaction.

The approach taken in this study was to go to Army pilots themselves, by means of an opinion survey, to correlate their responses with flight data, and thus arrive at a preliminary specification limit which represents an envelope of sound pressure levels (at various frequencies) which the pilots are willing to tolerate. This preliminary specification is then reviewed in the light of known medical and psychological limits to ensure that the limits set by the pilots themselves are not injurious.

In order to assure that a specification which satisfies the above requirements is realistic with respect to the penalties which its application might impose, sample calculations will be made of the acoustical treatments which will be required. Finally, estimates of the concomitant weight and performance penalties will be made.

II. PILOT OPINION SURVEY

Survey Design

The fundamental concept of the pilot opinion survey was to extract from the men who operate the aircraft their opinions regarding the noise environment to which they are exposed, and in what manner, if any, noise adversely affects their performance. A second objective was to ascertain the upper limits which can be tolerated.

Since the Task I work included measurements made at pilot's ear level, correlation between comment obtained on the actual aircraft tested and the recorded data can be used as the basis for transforming abstract opinion into numbers.

Survey design and wording is, in itself, a technical specialty. Many instances of invalid conclusions have resulted from improper wording and/or a format which tends to lead responses into a given pattern. In order to ensure compliance with the latest thinking in public opinion sampling, an expert in this field, Dr. Roy Hackman, Professor of Psychology, Temple University, Philadelphia, Pennsylvania, was retained in an advisory capacity throughout the phase of work dealing with survey design and evaluation. Dr. Karl Kryter and Mr. Laymon Miller of the acoustical consulting firm Bolt, Beranek, and Newman also consulted on question content.

The survey itself, which is reproduced in its entirety in Appendix IV was forwarded to TRÉCOM, and from there to 249 pilots in 14 units. (See Appendix V.)

Results

Upon receipt of the completed surveys each question was tabulated by dividing the response scale into ten equal parts, by means of an overlay as indicated by the dotted lines shown in Appendix IV. The responses, along with information regarding the respondents base and flight experience were then punched in IBM cards. A cross tabulation of response rating against aircraft was then made for each question and the mean rating determined. The rating distributions are shown in Figs. 136-144 with the location of the mean indicated by a dotted bar. These are also indicated by the locations of the check marks on the sample survey of Appendix IV.

The questions used in the survey follow with a brief explanation of each

Question 1. Hearing Loss and Discomfort

"Do noise levels in the following aircraft cause you any temporary hearing loss, discomfort, or pain during or after flight?"

This question which is interded to probe such problems as temporary hearing loss and similar sensations which are often reported in terms of hearing the noise for hours (or in some cases days) after the flight. From Fig. 136 it can be seen that only the large helicopters such as the H-21, H-34, and H-37 evoke any comment indicative of difficulty.

Question 2. Speech Interference

"Do you encounter difficulty in conversing with other occupants without the use of intercommunication equipment?"

In general, pilots were more critical of this factor than of any other specific manifestation of noise on which they were questioned. Only

the L-23 and RU-1A (Fig. 137) were actually classified in the no problem area. Comparison with Fig. 136 shows that although the relative rankings with regard to both Questions 1 and 2 are similar, the range is greatly extended.

Comparison with measured data and calculated speech interference levels will be found in Section IV.

Question 3. Radio Communication

"Do you encounter any difficulty communicating via either radio or intercommunication equipment?"

Evidently radio communication is not a factor to be considered in evaluating aircraft noise problems. Several written comments, however, did criticize specific radio equipment as being technically inferior and therefore harder to understand.

Question 4. Judgment

"Does the noise, in the following aircraft, make it more difficult for you to make decisions as quickly and accurately as usual?"

This is a rather delicate question no matter how carefully phrased, and it might be assumed that a reluctance to admit difficulty in making judgments would affect the answers. Research which has been done in this area, however, generally tends to substantiate pilot statements. In Reference 3, Chapter 10, Broadbent reports that choice and judgment tests run at 90 db and 115 db noise fields showed no difference and that performance of intellectual tasks was, if anything, slightly faster in high noise fields.

Question 5. Coordination

"Does the noise, in the following aircraft, make coordination and actual flying more difficult for you?"

This question and the expected responses are in many ways analogous to those of Question 4. Once again, however, experimental data supports the pilots comments. Reference 3, Chapter 10, also reports no effects on reaction time, body sway and similar responses in tests of simulated aircraft noise up to 115 db.

Question 6. Fatigue

"Does the noise in the aircraft make you feel tired?"

When discussing the manifestations of noise with pilots they often refer to fatigue. Actually it is virtually impossible to separate the independent effects of noise, vibration, and flying qualities.

From the responses to this question it is evident that while the larger helicopters are more tiring to fly there are no strong conclusions which may be drawn.

Question 7. Noise

"Rate the following aircraft with regard to your opinion of its general noise environment."

As might be suspected, this is the fundamental question of the entire survey. The opinions were well spread and, as will be discussed in Section IV, form the basis for the actual specification determination.

Question 8. Vibration

"Rate the following aircraft with regard to your opinion of physical vibration."

Since noise and physical vibration often produce similar reactions the information gained from this question will be used to separate the factors and thus preclude possible errors in judging the effect of noise alone on pilot comment.

Pilot Experience

In evaluating survey responses two factors which might color the pilot comments were investigated. Firstly, the answers from each base were evaluated against those of the composite group. Any bases with significantly poorer ratings than the others would have been discounted as an assumption of either a morale or equipment problem. Actually no such deviations were required and all bases were included.

Secondly, consideration was given to pilot experience and its effect on validity of comment. Provision was made in the program for inclusion of experience weighting factors. To investigate this parameter pilot flight experience as presented in Fig. 144 was examined. Based on total experience, the mean experience (\bar{X}) was found to be 860 hours and the standard deviation (σ) 547 hours. The group was then divided into three experience groups:

Average	$= \bar{X} \pm 1/2 \sigma$
Inexperienced	$< \bar{X} - 1/2 \sigma$
Experienced	$> \bar{X} + 1/2 \sigma$

Rounding these numbers off to $\bar{X} = 900$, and $\sigma = 600$, the groups would divide:

Average = 600 - 1200 hours

Inexperienced < 600 hours

Experienced > 1200 hours

As illustrated in Fig. 145, Question 7 was examined for responses to two aircraft (L-23 and H-21) and one aircraft (H-21) was examined for two questions (1 and 7) by experience group response. Examination of Fig. 145 leads to no consistent conclusion regarding the type of answer which may be expected from a given group, hence all answers were given equal weight.

Subjective Evaluation of Responses

It is perhaps obvious that if one were able to ask precisely the right question of the right group, only one question would be required and the sample could be quite small. Unfortunately one can have no assurance prior to the survey itself, exactly which questions will prove most valuable. Therefore, it is necessary to ask several questions and then edit them on the basis of usefulness of response.

The primary objective of the survey was to determine the limit of pilot acceptability with regard to aircraft noise. In order to ascertain this, it is necessary to establish where the subjective center of the rating scale (i.e. the division between acceptable and unacceptable) lies.

To establish such limits one can use only those questions which show a great enough diversity of response to show both favorable and unfavorable pilot comment for at least some of the aircraft tested. Taking those aircraft with distributed responses, and summing the response distributions, will yield a composite distribution curve of responses to that question which resulted in diverse pilot comment. The mean value of this new curve would then be the subjective center of pilot opinion for that question, or the division point between acceptability and unacceptability. Distributions of this type are to be found in responses to Questions 2, 6 and 7. As will be shown in Section III., Questions 2 and 6 evoked less critical and significant answers than did Question 7 and only the latter will be discussed here.

Examining Fig. 142 it is evident that reasonably normal distributions were obtained for the L-20, L-23, U-1A, H-13, and H-23 with good division and distribution of responses. Thus the limit of acceptability, or criteria, is to be established from these five of the seventy-two ratings given.

Summing the responses of the above mentioned five aircraft at each rating and establishing a new mean, based on the summed data, established the value 5.8 as the subjective center or limit of acceptability. That is, all aircraft with ratings lower than 5.8 are assumed unacceptable and all those rating higher than 5.8 are assumed acceptable to the majority of Army pilots.

III. CORRELATION WITH MEASURED DATA

Development of Specification

It now remains to take this acceptability limit of 5.8, and, utilizing data which was measured at pilot ear level in the same aircraft for which the limit was established, convert these opinions into measurable acoustical data. As previously mentioned, the human being is quite frequency sensitive and his evaluation of a given noise environment will not be reflected by sound pressure level alone. This has long been recognized and several subjective ratings have been established. One of the fundamental ones is the expression of Loudness Level as defined by S. S. Stevens in Reference 4. In order to assure the best possible statistical correlation between pilot rating and measured data, the S.P.L. in each octave band was converted to loudness in sones and then plotted for each octave band, the point having been defined by the coordinates of mean pilot rating (abscissa) and loudness level in the octave band (ordinate). The best straight line is then fit to the data by the method of least squares (Reference 5). By entering the resulting chart at the limiting rating of 5.8 one can read out the corresponding limiting loudness levels (Figs. 146 through 149). This is then converted back to sound pressure level in db to establish the final criteria.

It should be pointed out that the same procedure could have been applied directly to sound pressure level and would have yielded the same results. The reason for using the subjective rating was to preserve physical sense in the numbers as related to physical response. Fig. 150 presents the envelope of pilot acceptance in terms of both sound pressure level (db) and loudness (sones). In order to permit direct application to measured data only the db scale will be utilized.

Application of similar methods to Questions 2 and 6 would have resulted in the criteria shown in Fig. 151, thus confirming the earlier statement that Question 7 yields the most critical specification.

Significance of Response

Responses to all questions are ranked in order of pilot preference, and the measured data ranked in order of acceptability. A feeling for the correlation between pilot opinion and measured data can then

be gained by the application of Spearmans rank correlation coefficient, Reference 6, Page 685.

$$\rho = 1 - \frac{6 \sum D^2}{N(N^2-1)}$$

ρ \triangleq correlation coefficient

D \triangleq difference in rank between paired items in the two series

N \triangleq number of ranked groups

It can easily be seen that if, for example, the ranking by pilot and data were exactly the same for all aircraft, that $\sum D^2$ would be zero and $\rho = 1$ or, in other words, perfect correlation would be obtained. Generally a ρ greater than 0.75 is quite significant and one larger than 0.90 indicates extremely strong correlation.

Fig. 152 presents the Spearman rank correlation coefficient obtained in each octave band. Note the extremely high correlation between pilot comment and the sound pressure levels in the highest three bands. This indicates that the pilot comment is based entirely on the high frequency noise content, as is even more strongly evidenced by the very poor correlation in the lower octave bands which are evidently playing no role in the evaluation.

Correlation between Fatigue, Noise, and Vibration

The rank difference correlation coefficient can also be used to evaluate the significance of relative ratings obtained from responses to different questions as well as for correlating subjective correlations with data. This technique is especially valuable in evaluating the response to Question 6 regarding fatigue.

In discussing aircraft noise problems one often hears the statement that noise is extremely fatiguing. Although this statement is undeniably true it must be recognized that physical vibration, as well as other factors, also directly affect fatigue. Indeed there is added confusion regarding the ability to separate the effects of airborne sound with that caused by physical vibration of the ear mechanism. An interesting insight, if not clarification, of this problem is afforded by determining the correlation coefficients for relative rankings of Question 6 (fatigue) with the rankings of Question 7 (noise) and Question 8 (vibration). In both cases $\rho = .934$. This indicates that either the pilots are unable to distinguish between noise and vibration as primary in inducing fatigue, or that the vibration levels and noise levels of the different aircraft have perfect correlation with respect to each other. Vibration measurement was not within the scope of this program and thus no definite conclusion can be reached except the obvious one that it is not possible to directly attribute pilot fatigue

problems to ambient noise. Further research in this area which could be carried out utilizing the results of this program in conjunction with recorded vibration data would prove most beneficial in resolving this question.

IV CORRELATION WITH EXISTING STANDARDS

Correlation with MIL-A-8806

Military Specification MIL-A-8806 (ASG), 25 October 1956, entitled "Acoustical Noise Level in Aircraft, General Specification for" provides internal sound pressure limits which are generally invoked in detail aircraft specification negotiations by the military services. One of the purposes of this study is to examine the applicability of the specification to the specific types of aircraft and missions being flown by the U. S. Army. Perhaps the greatest operational change since the adoption of this specification is the ever increasing use of rotary wing aircraft, which provide a noise environment, and require pilot performance of a nature which probably did not merit full consideration in the past.

MIL-A-8806 specifies maximum noise level envelopes for four different flight conditions:

Table I - Maximum continuous power

Table II - Short duration conditions

Table III - Maximum continuous power with protective helmets

Table IV - Normal cruise power

The results of this study are most directly comparable with the specification of Table IV since the pilot opinions are based on their integrated flight experience which would be predominately cruise. Fig. 153 shows the comparison between the results of the subject study and the limits prescribed in Table IV of MIL-A-8806. It readily shows that the Army pilots require additional relief at the higher frequencies than is afforded by the currently applicable specification. It would also appear that the pilots indicate that aircraft which in the lower frequency bands are even in excess of those currently permitted could be completely acceptable to them. Whether they should, in fact, be permitted to subject themselves to such pressure levels will be discussed in the following sections.

Dividing the aircraft into two groups acceptable and unacceptable as defined by the borderline rating of 5.8 and comparing the spectra scatter-bands with: 1) the existing specification and 2) the proposed revision as shown in Fig. 154 clearly shows, once again, that

indeed it is only the higher frequency components which display clearly defined differences. Note the area of unsatisfactory aircraft which are currently acceptable by specification but would require additional soundproofing to satisfy the revised requirement.

It is interesting to note that most of the aircraft tested did not even meet the currently applicable MIL-A-8806. While it is probably true that some of them were not procured to this specification it is suspected that in normal military usage the sound reducing treatments and installations deteriorate rapidly and, since relatively small noise leaks can greatly reduce the effectiveness of any treatment, the pilot in the field is generally not being afforded the environment which exists at the time the aircraft is delivered.

It can also be seen that none of the helicopters are able to meet the low frequency requirements of 104 db in the first three octave bands. This is due to the high pressure levels generated as rotational and vortex noise from the lifting rotors. Apparently at the present stage it is necessary to grant deviations from this specified limit for rotary wing aircraft.

Correlation with Medical Limits

Much work has been done by many researchers to establish the effect of noise on hearing impairment. A great part of this has been with regard to industrial noise and its effect upon workers. Recent interpretations of liability under workmens' compensation laws makes it mandatory that each operation be evaluated in the light of its noise environment and rated against potential for producing hearing difficulties. Whenever environments are found which exceed safe limits these situations must be remedied or else protective devices such as ear plugs, sound attenuating headsets, and the like must be employed. References 7 through 12 report some of the work which has been carried out in this field.

The military too have had their noise problems and have also conducted research in this area. In order to establish the view of the U. S. Army on this matter a meeting has held with Major James Albrite, Director, Mr. R. Edwin Shutts, Assistant Director and Mr. David M. Resnick, Supervisor Bioacoustics Section, Army Audiology and Speech Center, Walter Reed Army Hospital, Washington, D. C.

It was decided that the establishment of a criteria would have to be based on the following assumptions:

1. Average daily flying time is 4 hours.
2. No helmets or headsets are worn.
3. No allowance is made for extremely susceptible individuals with regard to noise induced hearing loss.

Based on these assumptions it was recommended that noise levels above 300 cps should not exceed 95 db re 0.0002 dynes/cm². With regard to noise levels in the lower three octave bands no absolute recommendation was given. It is noted, however, that the higher frequency limit coincides with that of Fig. 18.6, Reference 10.

It further appears that loss of hearing of Army pilots who are flying aircraft which comply with MIL-A-8806 have constituted no real problem and that the existing specification itself represents at least a satisfactory although perhaps slightly conservative upper limit.

Correlation with Other Acoustical Criteria

It is perhaps obvious that if one were able to come up with a single number which would express the loudness, or noisiness, or annoyance of a given noise in a single number, this number would then become a very convenient method of expressing a specification.

There have been several attempts made to arrive at such indexes and it is necessary to investigate their applicability to the problem in order to determine what form the final proposed specification should take.

This can best be done by determining the ranked correlation coefficient between pilot rating and each of the evaluation methods.

The following ratings were investigated:

1. Overall noise level in decibels
2. Speech interference level (defined as the arithmetic average of the sound pressure levels in the 600-1200, 1200-2400, and 2400-4800 cps octave bands, Reference 2).
3. Loudness level in phons (Reference 4).
4. Perceived noise level in PNdb (Reference 13).

For Question 7 responses these compare with the sound pressure levels in the top three bands by themselves as shown in Fig. 155.

Obviously then, a simple octave by octave criteria in the high frequencies better supports the pilot opinions than do any of the common rating systems, and therefore an octave band envelope as currently used in MIL-A-8806 is recommended as the best form for future noise level specifications.

One of the problems encountered in applying the above ratings is the presence of discrete frequency or pure tone components such as may be generated by highly loaded gearing, gas turbines, and the like. These are often difficult to define in terms of analytical numbers

even when narrow band spectra (Figs. 105 through 135) are available. Many researchers believe, however, that the tolerance to such pure tones is about 10 db less than for that of a multifrequency noise. The aircraft rated were reviewed in light of Figs. 105 through 135 as well as known primary gear frequencies, compressor frequencies, etc. and 10 db was added to any octave band believed to have its level determined by a single frequency and the correlation with loudness level and PNdb recalculated. Loudness level ρ increased from -.26 to +.18 and PNdb from -.13 to +.67 (Fig. 155). It should be stated that the authors of Reference 13 make no claim of applicability of their rating to anything other than external aircraft noise, however, with proper adjustment this rating method appears more applicable than loudness level.

Loudness level was originally determined on the basis of apparent loudness of different frequencies while perceived noise level was determined on the basis of noisiness or annoyance. This difference, although subtle, is evidently quite important in evaluating pilot reaction.

It remains obvious, however, that at the present time no single rating number system exists which will correlate as well as the sound pressure levels in those octave bands which are determining the pilot comment.

Proposed Specification

Fig. 156 shows: 1) the limits imposed by MIL-A-8806 Table IV, 2) the medical limitations acceptable to the Army Medical Staff, and 3) the environment which the pilots have indicated they should have. If MIL-A-8806 is also accepted as a low frequency medical limit then it appears that at frequencies below 600 cps the pilots will permit higher sound pressure levels than are safe and the existing specification should be invoked.

Above 2400 cps, however, the Army pilots feel that they require about 7 db lower noise field than is currently afforded.

It is therefore proposed that the limits presented in Fig. 157 be invoked in procurement of future aircraft intended for use by the United States Army.

V. APPLICATION TO AIRCRAFT INTERIORS

Design Principles

To insure that the specification proposed in Section IV-D is realistic in that it will not impose unreasonable weight penalties, approximate sound reducing treatments will be developed for the following representative group of Army aircraft:

<u>Designation</u>	<u>Name</u>	<u>G.W. (lbs)</u>	<u>Power Plant</u>		<u>Rotor(s)</u>
			<u>Number</u>	<u>Type</u>	
H-21	Shawnee	13,900	1	Reciprocating	Tandem
H-23	Raven	2,700	1	Reciprocating	Single
H-37	Mojave	30,842	2	Reciprocating	Single
HU-1A	Iroquois	5,383	1	Turbine	Single
YHC-1A		15,750	2	Turbine	Tandem

In any calculation of the soundproofing for an aircraft cabin it becomes essential to maintain the weight of material to an absolute minimum in order that the design mission of that aircraft be efficiently accomplished. Of necessity this weight must be consumed either directly in payload, or indirectly, in the mission range.

In order to achieve an optimum design, much information is required. First, there is no substitute for a complete acoustic evaluation of the untreated aircraft. Such a study should include sound pressure levels recorded inside and outside the fuselage, skin vibration studies, and application of other special techniques such as the construction of compartments within the aircraft to aid the study of airborne sound. There must be available completely detailed information regarding such items as fuselage construction, equipment, ducting installations and power plant mounting, etc. Detailed studies of this type are extremely costly and time consuming, and are beyond the scope of this effort.

It is possible, however, to arrive at a reasonably accurate estimate of the general nature, and therefore weight, of a treatment which will achieve the desired objectives using only data which was obtained during Task 1 measurements.

Structural changes to the aircraft will not be considered as part of the design objective. Where acoustical materials presently exist and where further noise reduction is necessary, recommendations will be made for additional sound proofing material to be added; and, where blankets do not exist at all, suitable treatments will be designed. However, before determining the noise reduction required in each aircraft, it is necessary

to first define those terms used in the calculations. In addition, some discussion of the acoustical blankets and their properties is necessary.

Noise reduction, or the actual sound pressure level attenuation achieved by introducing a barrier in a noise path, is less than that which would be predicted by transmission loss alone and is generally written:

$$NR = TL_0 + C_n + C_a$$

where NR = Noise Reduction

TL₀ = Reference transmission loss

C_n = Correction for type of receiving space
(always negative)

C_a = Correction for ambient conditions (positive
or negative)

A more thorough discussion of this concept may be found on Page 78 of Reference 14. In the case of the types of aircraft included in this study, C_a is generally very small due to relatively limited temperature and altitude extremes, and will be discounted.

Transmission loss may be described as the difference in sound power level measured at each side of the wall shown in Fig 158. The wall is assumed to extend sufficiently so that all pressure waves radiating from the source, S, must pass through the barrier B-B in order to reach Receiver, R. In addition, no wave reflections are allowed to return to the receiver, and this restriction is usually achieved only in free space or in a specially designed nonreverberant (anechoic) chamber. The sound intensity measured in a chamber which is reverberant will be somewhat higher than this and the noise reduction will not equal the transmission loss but will be resultingly lower by an amount, C_n.

$$NR - TL_0 = C_n$$

C_n is a correction which is a function of, among other things, the receiving space size, stiffness, and absorption, and is always negative.

That is, if the receiving space characteristics are not anechoic, the noise reduction achieved will be less than the transmission loss through the panel itself.

Transmission loss is achieved either by addition of mass or by use of certain materials which have other means of attenuating acoustical energy, generally by friction. The most common material used in aircraft is Fiberglass, and all designs in this study will be based on Type PF-105 which is a grade commonly used in military and commercial aircraft. Transmission loss for this material is shown in Fig. 159. Since Fiberglass is effective only at the higher frequencies it is

generally necessary to add mass to the treatment in order to satisfy lower frequency requirements. In addition to reducing the noise coming through the side wall it is necessary to reduce the reverberation, or echo, by use of an absorptive cabin lining. It is often possible to do this by utilizing the same blanketing employed for building up the transmission loss. This is achieved by construction of a blanket consisting of an impervious septum of some material such as vinyl film, and a Fiberglas blanket covered with a suitable porous trim. In cases where very large attenuation is required the impervious septum may actually be an aluminum sheet and a double wall Fiberglas filled construction employed. In such cases, it is necessary to add an additional absorptive lining, but whenever possible, absorption is provided by the same blanketing employed for transmission loss.

An optimum transmission loss-weight combination should be used for an efficient design, and to insure proper selection of the blanket it is valuable to plot T.L. as a function of weight. To do this, it is necessary to know the transmission loss which can be expected for the blanket material considered for each frequency. Several thicknesses and therefore several weights are shown in Fig. 159. In addition Fig. 160 gives the transmission loss which may be expected from the mass properties of limp panels and Fig. 13.7, Reference 14, those of a rigid septum as a function of the surface weight, (g), of the panel or septum, as well as the frequency, (f), incident upon it. It is valuable to consider several blanket-septa combinations and to plot the transmission loss as a function of weight. This is shown in Fig. 161 and 162, each curve representing individual octave bands with like symbols representing similar septa thicknesses and like shadings representing similar Fiberglas thicknesses. Fig. 161 predicts the transmission loss for a limp-panel blanket, such as vinyl-backed, while Fig. 162 is for a rigid (aluminum) panel. Tables I and II show the detail numbers and identify the symbols of Figs. 161 and 162 respectively. Thus, all that is necessary to obtain the optimum blanket-septum combination to give the greatest noise reduction for the least weight is a knowledge of the noise reduction required in each of the octave bands. As an example, consider the following conditions: It is desired to achieve a 20 db transmission loss in the 600-1200 cps band through a cabin sidewall with a blanket-septum combination. Referring to Fig. 161, it is seen that for a 20 db transmission loss the optimum blanket weighs $.257 \text{ lbs/ft}^2$ and is represented by the symbol \blacklozenge . Referring to Table I, note that this symbol indicates a combination 0.016' vinyl septum with 3" of Fiberglas. Also, it may be seen that approximately the same transmission loss (21 db) could have been obtained at a significantly higher cost in surface weight (0.28 lbs/ft^2). Thus, the optimum weight-transmission loss ratio is readily apparent.

Some difficulty may be encountered in achieving efficient noise reduction in the low frequency bands where the glass fiber material becomes ineffective in providing the required transmission loss. In these

lowest octaves (20-75, 75-150 and 150-300) noise reduction by mass properties alone is the only practical means of obtaining the required transmission loss. Even this approach leaves much to be desired from a weight stand-point, and in order to realize a 10 db noise reduction at a frequency of 210 cps (center frequency 150-290 cps octave) a surface mass of .547 lbs/ft² is required. This, converted into an aluminum sheet, represents a thickness of about .040". At half that frequency (105 cps) a similar noise reduction requires a surface weight of 1.1 lbs/ft² or approximately 0.180" thick aluminum sheet. In the 20-75 cps band (39 cps) a 10 db reduction requires 2.95 lbs/ft² or 0.205" thick sheet aluminum. In many cases it is not practical to consider such drastic treatments and at the present it appears that noise reduction at the lower frequencies will have to be achieved at the source rather than by conventional sound reducing treatments. Until such reductions are achieved it will often be necessary to grant deviations below the 300-600 cps band and such deviations will be assumed in some of the following designs rather than pursuing a completely academic and impractical treatment.

Design Application

1. General

In order to examine the sources of noise in an aircraft cabin and isolate those sources which are determining factors in setting noise levels, it is necessary to have a knowledge of three qualities relating these sources. These are: (1) frequency, (2) sound pressure level, and (3) location. These may be determined in part by plotting the sound pressure level for various cabin locations along the longitudinal as well as transverse axis of the fuselage. With this information it is possible to determine which frequency predominates in each area of the aircraft. Furthermore, it is necessary to identify these frequencies with their respective sources, so that, where required, specific treatments for soundproofing may be prescribed. This identification process is accomplished with the aid of the narrow band (continuous spectrum) analysis, Figs. 105-135. Fundamental frequencies and harmonics for each suspect noise source can be calculated and identified with the corresponding frequencies shown on the narrow band analysis. These are presented in Fig. 163 through 171.

2. H-21

The sound pressure level in each octave band has been plotted for various cabin locations along the longitudinal axis of the fuselage (see Fig. 175) in order to identify those noise sources which significantly contribute to the interior noise level of the H-21. The identification numbers refer to those presented in Fig. 80. Fig. 172 a and b show the sound pressure level variation along the centerline ceiling, centerline ear level, centerline floor level, sidewall, and drive shaft locations.

It will be necessary to design or improve local area treatments for the forward transmission, the existing curtain which closes off the aft end of the cabin, and the drive shaft guard. It will then be possible to design a general treatment for the cabin sidewalls which will result in attaining the desired specification.

Forward Transmission

The noise level associated with the forward transmission is presented in Column 1 of Table III and was measured at Position 4, Fig. 80. Reference to Figs. 163 and 164 show that forward transmission noise is predominant in the 600-1200 cps band. Since Location 4 shows the highest levels in this band, measurements at this location will be used as typical of the forward transmission.

Since the forward gear case is directly adjacent to the pilot, the enclosure must be designed to attenuate airborne noise to the specified level (Column 4).

Column 2 of Table III shows the weight of treatment required and Column 3 that predicted as selected from the chart of Fig. 162.

In order to achieve the high T.L. required, care must be taken to insure no leakage, since even a very small amount will render such treatment relatively ineffective. It is expected that a similar surface weight of soundproofing material will be required for the forward bulkhead area to insure an efficient noise seal in the cockpit.

TABLE III
FORWARD TRANSMISSION

Octave Band	SPL	Transmission Loss		SPL* Treated
	Initial	Required	Predicted	(100% Encl.)
	1	2	3	4
20-75	107	3	-	107
75-150	111	5	2	109
150-300	108	12	6	102
300-600	102	11	10	92
600-1200	111	21	21	90
1200-2400	103	17	29	86
2400-4800	93	15	40	53
4800-10kc	79	26	51	28

*Treatment ○ Weight 0.60 lb/ft² - Reference Table II

Aft Curtain

The noise level recorded at the aft curtain (Position 19) is listed in Column 1, Table IV. The noise level at Position 18 (ear level) is similar, if somewhat less in several frequency bands, so that the higher level will design the soundproofing.

Column 2 lists the T.L. required for the desired noise reduction of the local acoustical treatment. The reasons for not designing treatments to the 75-150 cps band have previously been stated and, therefore, a treatment of .50 lbs/ft² has been used for the surface weight of the curtain.

TABLE IV
H-21 AFT CURTAIN

Octave Band cps	SPL	Transmission Loss		SPL*	SPL
	Initial	Required	Predicted	Treated (100% Encl)	Predicted (98% Encl)
	1	2	3	4	5
20-75	107	3	-	107	107
75-150	111	5	6	105	105
150-300	107	10	10	97	97
300-600	106	10	16	90	92
600-1200	101	2	24	77	85
1200-2400	113	11	32	81	95
2400-4800	105	13	40	65	89
4800-10kc	96	9	50	46	80

*Treatment O Weight 0.60 lb/ft² - Reference Table II

The transmission loss provided by this surface weight is shown in Column 3. This P.L. results in the sound pressure level shown in Column 4 which is modified for assumed leakage in Column 5.

Drive Shaft

In similar manner sound pressure levels recorded at the drive shaft (location 14) are shown as column 1 of Table V. Calculations are carried out similar to those required to establish the previous designs.

TABLE V
H-21 DRIVE SHAFT

Octave Band cps	SPL	Transmission Loss		SPL*	SPL
	Initial	Required	Predicted	Treated (100% Encl)	Predicted (98% Encl)
	1	2	3	4	5
20-75	110	6	-	110	110
75-150	114	8	6	108	108
150-300	108	4	10	98	98
300-600	99	3	16	83	85
600-1200	99	9	24	75	83
1200-2400	102	16	32	70	85
2400-4800	92	17	40	52	76
4800-10kc	87	12	50	37	71

*Treatment ○ Weight 0.60 lb/ft² - Reference Table II

Uniform Cabin Treatment

Column 2, Table VI shows the noise reduction required in the cabin area. A treatment of .180 lb/ft² will give the added transmission loss required, which when corrected for receiving space effects (Column 3) will indicate the SPL shown in Column 4 and 5. This resulting sound pressure level is that which would be attained if the uniform treatment were added to all existing treatments as well as completely covering the side walls. An investigation into the affects of the window area has shown that, in all octaves, they afford more transmission loss than the surrounding treatment and have no adverse effect on the sound pressure level indicated in Column 5.

TABLE VI
H-21 UNIFORM TREATMENT

Octave Band cps	SPL	Noise Reduction		SPL*	SPL
	Initial	Required	Predicted	Treated	Predicted
	1	2	3	(100% Encl)	(98% Encl)
				4	5
20-75	104	-	-	104	104
75-150	106	2	-	106	106
150-300	97	-	3	94	94
300-600	96	-	6	90	90
600-1200	99	9	13	86	87
1200-2400	102	16	20	82	87
2400-4800	92	17	22	70	75
4800-10kc	87	12	42	45	67

*Treatment Weight 0.18 lb/ft² - Reference Table I

TABLE VII
H-21 COCKPIT TREATMENT

Octave Band cps	SPL	Noise Reduction		SPL*	SPL
	Initial	Required	Predicted	Treated	Predicted
	1	2	3	(100% Encl)	(98% Encl)
				4	5
20-75	105	1	-	105	105
75-150	99	-	-	99	99
150-300	98	-	-	98	98
300-600	94	-	-	94	94
600-1200	95	5	5	90	90
1200-2400	92	6	7	85	75
2400-4800	88	13	15	73	75
4800-10kc	80	5	24	56	64

*Treatment Weight 0.063 lb/ft² - Reference Table I

Measured sound levels in the H-21 cockpit are tabulated in Column 1 of Table VII. A blanket weighing .063 lbs/ft² (composed of 1" Fiberglas with a .002" vinyl backing) applied to the bulkhead directly behind the pilot and copilot seats, provides the noise reduction shown in Column 3. Noise levels of the forward rotor transmission have been treated in the cockpit area as well as the cabin by application of the soundproofing shown in Table III. For this reason it is predicted that the cockpit treatment proposed will reduce the noise level to that of Column 5. Fig. 173 illustrates the composite treatment for the H-21.

3. H-23

The sound treatment of the H-23 differs substantially from that of the H-21 in that a large portion of the passenger enclosure is constructed of a transparent material, for visibility. Obviously any treatment of an opaque nature would void its primary purpose and is not considered in this study.

Although increasing the thickness of the transparent enclosure would increase its transmission loss such treatments would rapidly become prohibitively heavy. It is questionable whether such measures would prove valuable in any event since the extreme lack of absorption will tend to minimize any benefits derived.

Furthermore it seems to be general practice to fly aircraft of the H-13, H-23 type with doors removed in many areas where weather permits. Indeed many pilots feel that for certain operations requiring extreme side or rearward vision, and for missions such as carrying external litters, operation without doors is greatly preferred. Since the doors occupy about 20% of the enclosure their effect is substantial. It, therefore, appears most advisable to achieve the required noise reduction at the sources rather than the passenger enclosure.

Column 1 of Table VIII shows the noise level measured at a typical cockpit position during the Task 1 measurement program (Figs. 84 and 174). The level is virtually uniform throughout the entire enclosure. Column 2 lists the attenuation required to comply with the proposed specification. Review of Fig. 165 shows that main and tail rotor noise by themselves will just about comply with this specification.

TABLE VIII
H-23 ENGINE MUFFLER

Octave Band cps	SPL		Attenuation		SPL
	Initial	Required	Predicted	Treated	
	1	2	3	4	
20-75	105	1	3	102	
75-150	107	3	10	97	
150-300	111	7	11	100	
300-600	104	8	14	90	
600-1200	96	6	-	96	
1200-2400	90	4	-	90	
2400-4800	83	8	-	83	
4800-10kc	74	-	-	74	

Below 600 cps the problem is almost solely engine, and above 600 cps, transmission noise predominates. The approach then is to reduce sound pressure levels of these two items at their respective sources.

Engine noise can be most effectively reduced by means of a suitable muffler, probably of the resonant chamber type. One such muffler was designed by Northrop Aircraft, Inc. (Reference 15) for their company owned and operated Bell Model 47J and not only provided very significant reductions in peak sound pressure levels, but actually improved performance slightly due to a small decrease in back pressure. This muffler weighed about 25 pounds. Since the H-23 and Bell Model 47J engines are very similar, it has been assumed that such a muffler could also be tuned to the former aircraft with equally good results. Column 3 of Table VIII is taken from Fig. 1 of Reference 15. Column 4 is the predicted SPL after incorporation of the muffler.

TABLE IX
H-23 ROTOR XMSN ENCLOSURE

Octave Band cps	SPL	Transmission Loss		SPL*
	Initial	Required	Predicted	Treated
	1	2	3	4
20-75	105	-	-	105
75-150	107	-	-	107
150-300	111	-	-	111
300-600	104	-	8	96
600-1200	96	2	11	85
1200-2400	90	1	6	84
2400-4800	83	6	8	75
4800-10kc	74	-	9	65

*Treatment Weight 0.40 lb/ft² - Reference Table II

Sound pressure levels with the muffler installed are predicted to predominate in the transmission frequency. The remaining enclosure has been designed to meet the requirements of strength as well as acoustic requirements of the transmission frequency band. This enclosure consists of an aluminum panel for rigidity, with a 0.009" impervious vinyl backing on a one inch blanket of Fiberglas. Column 1 of Table IX is a relisting of the measured SPL. The transmission loss provided by the aluminum-vinyl-Fiberglas combination is listed in Column 3 of Table IX. These numbers assume 10% uncoverable area and were obtained by use of Fig. 52 of Reference 14.

In predicting the final sound pressure level which will be experienced, the reduction which will be achieved from application of both recommended treatments is shown in Table X. At 300-600 cps it is assumed that the lower of the two TL's predicted in Tables VIII and IX (that due to the transmission enclosure) will determine the final sound pressure level. Fig. 175 illustrates the composite treatment for the H-23.

TABLE X
H-23 NOISE REDUCTION IN CABIN

Octave Band cps	SPL	Noise Reduction		SPL
	Initial	Required	Predicted	Treated
	1	2	3	4
20-75	105	1	3	102
75-150	107	3	10	97
150-300	111	7	11	100
300-600	104	8	8	96
600-1200	96	6	11	85
1200-2400	90	4	6	84
2400-4800	83	8	8	75
4800-10kc	74	-	9	66

4. H-37

The H-37 configuration is divisible into three separate general areas, and requires three separate treatments: the cockpit, the forward cabin or clamshell door area beneath the cockpit, and the main cabin itself.

In the main cabin area particularly high levels are found in the vicinity of the main transmission (Position 14, Fig. 90 and Fig. 176) and at the aft end of the cabin (Position 23, Fig. 90). These are treated separately to bring local levels down to those measured in the general cabin area (Position 7, Fig. 90). Tables XI and XII develop the local treatments required to handle these two items.

TABLE XI
H-37 ROTOR TRANSMISSION ENCLOSURE

Octave Band cps	SPL Initial	Transmission Loss		SPL* Treated (100% Encl)	SPL Predicted (98% Encl)
		Required	Predicted		
		1	2		
20-75	100	-	-	108	108
75-150	109	3	-	109	109
150-300	111	1	-	111	111
300-600	112	4	3	109	109
600-1200	118	11	12	106	106
1200-2400	114	11	19	95	100
2400-4800	106	10	30	76	89
4800-10kc	99	10	41	58	82

*Treatment ⊗ Weight 0.18 lb/ft² - Ref. Table I

TABLE XII
H-37 AFT CABIN TREATMENT

Octave Band cps	SPL Initial	Transmission Loss		SPL* Treated (100% Encl)	SPL Predicted (98% Encl)
		Required	Predicted		
		1	2		
20-75	108	-	-	108	108
75-150	107	1	6	101	101
150-300	118	8	10	108	108
300-600	115	7	16	99	101
600-1200	116	9	24	92	100
1200-2400	112	9	32	80	94
2400-4800	107	11	40	67	91
4800-10kc	99	10	50	49	83

*Treatment ○ Weight 0.60 lb/ft² - Ref. Table II

Since the aircraft as delivered has no blanketing installed, the treatment for the cabin area must credit the increase in absorption as was the case with the H-21 discussed in Part 2 of this section. It should be noted that in the general cabin, if one were to comply completely with requirements in the lower three bands, a doubling of weight would be required over the entire general area. As previously discussed it is considered advisable to grant deviation in such cases and the .16 lb/ft² treatment, Table XIII will be assumed acceptable. Window area of the H-37 cabin is about 4% and has a higher T.L. than the treatment and, therefore, will have no adverse effect.

Forward cabin treatments are developed in Table XIV.

TABLE XIII
H-37 GENERAL CABIN TREATMENT

Octave Band cps	SPL	Noise Reduction		SPL*	SPL
	Initial	Required	Predicted	Treated (100% Encl)	Predicted (98% Encl)
	1	2	3	4	5
20-75	109	5	-	109	109
75-150	106	2	-	106	106
150-300	110	6	2	108	108
300-600	108	12	13	95	96
600-1200	107	17	23	84	91
1200-2400	103	17	26	77	86
2400-4800	96	21	37	59	70
4800-10kc	89	14	48	41	74

*Treatment ● Weight 0.16 lb/ft² - Ref. Table I

TABLE XIV
H-37 CLAMSHELL DOORS

Octave Band cps	SPL Initial	Noise Reduction		SPL* Treated (100% Encl)	SPL Predicted (98% Encl)
		Required	Predicted		
		1	2		
20-75	111	7	2	113	113
75-150	102	-	2	100	100
150-300	108	4	4	104	104
300-600	103	7	8	95	95
600-1200	100	10	17	83	85
1200-2400	98	12	19	79	84
2400-4800	92	17	28	64	76
4800-10kc	84	9	38	46	69

*Treatment Δ Weight 0.077 lb/ft² - Ref. Table I

The cockpit area is almost entirely enclosed in plexiglass and therefore is not amenable to absorption treatment. Since cabin levels, untreated, are lower than those in the cockpit, it can not be expected that the cabin treatment will have much effect on reducing cockpit noise. The only course available appears to be incorporation of thicker windows and heavier blanketing to build up the T.L. of the cockpit enclosure.

Column 1 of Table XV presents the sound pressure level at the cockpit window (Position 1) and Column 2, the additional T.L. required. The present window weighs .76 lb/ft², and Column 2 is the T.L. required of a replacement window. Assuming no resonances and applying rigid panel mass law, the new plexiglass (about 3/4" thick) will weigh 4.4 lb/ft². Similarly the nontransparent area T.L. will be treated as shown in Table XVI.

TABLE XV
H-37 COCKPIT WINDOW AREA

Octave Band cps	SPL	Noise Reduction		SPL
	Initial	Required	Predicted	Treated
	1	2	3	4
20-75	112	8	10	102
75-150	105	1	14	91
150-300	104	-	16	88
300-600	105	9	14	91
600-1200	100	10	14	86
1200-2400	96	10	15	81
2400-4800	89	14	16	73
4800-10kc	81	6	15	66

TABLE XVI
H-37 COCKPIT BLANKET AREAS

Octave Band cps	SPL	Noise Reduction		SPL*	SPL
	Initial	Required	Predicted	Treated (100% Encl)	Predicted (98% Encl)
	1	2	3	4	5
20-75	110	6	-	110	110
75-150	104	-	6	98	98
150-300	107	3	10	97	97
300-600	108	12	16	92	94
600-1200	104	14	24	80	86
1200-2400	97	11	32	65	79
2400-4800	90	15	40	50	74
4800-10kc	81	6	50	31	64

*Treatment ○ Weight 9.60 lb/ft² - Ref. Table II

It is perhaps true that a somewhat lighter treatment could have been arrived at by use of a double enclosure with an air gap between the panes. While acoustically more efficient the manufacturing problems inherent in the production of curved double panels and the glare and distortion problems which would be encountered preclude their recommendation. Fig. 177 illustrates the composite treatment for the H-37.

5. HU-1A

Sound pressure levels throughout this aircraft are essentially uniform with a slight increase at the aft cabin locations (Fig. 94 and 178). The treatment, therefore, consists of blanketing designed to aft cabin requirements and heavier plexiglass panels as derived in Tables XVII and XVIII. The absorption due to additional blanketing remain essentially unchanged and thus no direct benefit beyond transmission loss can be realized. The windows (Table XVII) are designed for the 600-1200 octave band rather than the much higher weight dictated by the 20-75 cps band.

TABLE XVII
HU-1A CABIN TREATMENT

Octave Band cps	SPL	Noise Reduction		SPL*	SPL
	Initial	Required	Predicted	Treated (100% Encl)	Predicted (98% Encl)
	1	2	3	4	5
20-75	118	14	-	118	118
75-150	113	9	2	112	112
150-300	109	5	6	103	103
300-600	105	9	10	95	95
600-1200	95	5	18	77	81
1200-2400	88	2	26	62	71
2400-4800	80	5	34	46	63
4800-10kc	70	-	44	26	54

*Treatment Weight 0.31 lb/ft² - Ref. Table II

TABLE XVIII
 HU-1A COCKPIT WINDOW AREA

Octave Band cps	SPL	Noise Reduction		SPL
	Initial	Required	Predicted	Treated
	1	2	3	4
20-75	112	8	4	108
75-150	108	4	4	104
150-300	105	1	6	99
300-600	102	6	7	95
600-1200	96	6	6	90
1200-2400	86	-	5	81
2400-4800	79	4	7	72
4800-10kc	75	-	5	70

Fig. 179 illustrates the composite treatment for the HU-1A

6. YHC-1A

The YHC-1A affords a unique opportunity in that test data and noise reduction treatment details are available for the aircraft as initially designed and later as modified to comply with MIL-A-8806. Since the latter treatment also complies with the proposed specification, measured data will be used throughout. This information will be most useful in evaluating the efficiency of the analytical designs used for the other four aircraft studied.

Tables XIX through XXII show in Column 1 the SPL recorded in the aircraft as initially configured. Column 2 is the reduction required to comply with the proposed specification and Column 4 is measured data after treatment. Column 3, in this case, was obtained by subtracting Column 4 SPL from those of Column 1.

Figure 181 illustrates the composite treatment for the YHC-1A.

TABLE XIX
YHC-1A AFT CABIN TREATMENT

Octave Band cps	SPL	Transmission Loss		SPL
	Initial	Required	Measured	Treated
	1	2	3	4
20-75	109	5	7	102
75-150	112	8	11	101
150-300	101	-	13	98
300-600	112	16	22	90
600-1200	101	11	13	87
1200-2400	93	7	15	78
2400-4800	90	15	14	76
4800-10kc	93	18	21	72

TABLE XX
FORWARD ROTOR TRANSMISSION TREATMENT

Octave Band cps	SPL	Transmission Loss		SPL
	Initial	Required	Measured	Treated
	1	2	3	4
20-75	103	-	-	103
75-150	102	-	4	98
150-300	100	-	8	92
300-600	111	15	15	96
600-1200	105	15	15	90
1200-2400	96	10	18	78
2400-4800	92	17	21	71
4800-10kc	84	9	23	61

TABLE XXI
YHC-1A GENERAL CABIN TREATMENT

Octave Band cps	SPL	Noise Reduction		SPL
	Initial	Required	Measured	Treated
	1	2	3	4
20-75	108	4	3	105
75-150	105	1	1	104
150-300	102	-	8	94
300-600	104	8	12	92
600-1200	98	8	14	84
1200-2400	91	5	13	79
2400-4800	89	14	13	76
4800-10kc	85	10	13	72

TABLE XXII
YHC-1A COCKPIT TREATMENT

Octave Band cps	SPL	Noise Reduction		SPL
	Initial	Required	Measured	Treated
	1	2	3	4
20-75	108	4	10	98
75-150	101	-	8	93
150-300	92	-	2	90
300-600	102	6	9	93
600-1200	107	17	10	97
1200-2400	99	13	12	87
2400-4800	91	16	14	77
4800-10kc	81	6	16	65

Performance Penalties

Tables XXIII through XXVII present calculations of the weight penalties which would be incurred by adoption of the proposed specification. All areas are estimated from drawings or by measurement on actual aircraft. Weights of existing treatments were supplied by the customer. In each case both weight increment and total weight required are shown. It is important to note that most of the aircraft tested failed to comply with the limits set forth in Table IV of MIL-A-8806. However, the weight of acoustical treatment required to achieve this compliance would be virtually the same as that which is necessary to meet the proposed specification.

Table XXVIII and Fig. 182 summarize the weight and range penalties incurred. It may at first appear paradoxical that the HU-1A which was well liked by the pilots requires the highest treatment in percentage of gross weight while the H-37 which was considered very objectionable requires the least. There are two explanations for this: First, the H-37, as delivered, has no noise attenuating treatment installed, and thus the improvement derived is more impressive than that which could be obtained by adding a similar weight to existing treatments. Second, the HU-1A displays very low sound pressure levels at high frequencies, and it is this low level which creates favorable pilot comment. The low frequency noise however has quite high sound pressure levels, and the treatment (Table XVIII) is dictated by the 300-600 cps octave band. As has been discussed previously, the lower the frequency, the higher the mass requirement. Furthermore, since a large portion of the enclosed area is plexiglass it is not possible to assist the transmission loss by absorption.

It is also noteworthy that the YHC-1A weight and range penalties which were determined from, and validated by flight test data are directly in line with those calculated for the other aircraft, thus justifying the analytical methods employed in this report.

TABLE XXIII

WEIGHT CALCULATIONS - H-21 ACOUSTICAL TREATMENT

<u>Treatment</u>	<u>Reference Table</u>	<u>Symbol</u>	<u>Unit Weight (lbs/ft²)</u>	<u>Area (ft²)</u>	<u>Added W (lbs)</u>	<u>Existing Weight (lbs)</u>	<u>Total W (lbs)</u>
Forward Rotor Transmission	III		.60	15	9.0		
Aft Curtain (MID XMSN)	IV		0.60	36	21.6		
Drive Shaft Guard	V		0.60	42	25.2		
Uniform Treatment	VI		0.180	366	66.0		
Cockpit	VII		0.063	24	1.5		
Total					123.7	58.9	182.6

TABLE XXIV

WEIGHT CALCULATIONS - H-23 ACOUSTICAL TREATMENT

<u>Treatment</u>	<u>Reference Table</u>	<u>Symbol</u>	<u>Unit Weight (lbs.)</u>	<u>Area (ft²)</u>	<u>Added W (lbs.)</u>	<u>Existing Weight (lbs.)</u>	<u>Total W (lbs.)</u>
Engine Muffler	VIII	—	.25	—	25	-	25
Rotor XMSN Treatment	IX	—	0.400	23	9.2	-	9.2
Total					34.2		34.2

TABLE XXV

WEIGHT CALCULATION - H-37 ACOUSTICAL TREATMENT

<u>Treatment</u>	<u>Reference Table</u>	<u>Symbol</u>	<u>Unit Weight (lbs.)</u>	<u>Area (ft.²)</u>	<u>Added W (lbs.)</u>	<u>Existing Weight (lbs.)</u>	<u>Total W (lbs.)</u>
Rotor XMSN Enclosure	XI		0.18	61	11	--	
Aft Cabin Treatment	XII		0.61	9	5.5	--	
General Cabin Treatment	XIII		0.16	684	110	--	
Clamshell Doors	XIV		0.077	69	5.3	--	
Cockpit Window Area	XV		4.4	37	135	28	135
Cockpit Blanket Area	XVI		0.60	12	7.2	--	
Total					274.0		

TABLE XXVI
WEIGHT CALCULATION - HU-1A ACOUSTICAL TREATMENT

<u>Treatment</u>	<u>Reference Table</u>	<u>Symbol</u>	<u>Unit Weight (lb/ft²)</u>	<u>Area (ft²)</u>	<u>Added W (lbs)</u>	<u>Existing Weight (lbs.)</u>	<u>Total W (lbs)</u>
Cabin Treatment	XVII		0.31	86	25.6	7.4	34.0
Window Area	XVIII		1.6	56	47.5	42.5	90
Total					74.1		124

TABLE XXVII
WEIGHT CALCULATION - YHC-1A ACOUSTICAL TREATMENT

<u>Treatment</u>	<u>Reference Table</u>	<u>Symbol</u>	<u>Unit Weight (lbs/ft²)</u>	<u>Area (ft²)</u>	<u>Added W (lbs)</u>	<u>Existing Weight (lbs.)</u>	<u>Total W (lbs)</u>
Aft Cabin Treatment	XIX				18.1	7.4	25.5
Fwd. Rotor XMSN Treatment	XX				8.5	—	8.5
General Cabin Treatment	XXI				117.9	9.8	127.7
Cockpit Treatment					5.7	18.6	24.3
Total					150.2	35.9	186.0

TABLE XXVIII

EFFECT OF ACOUSTICAL TREATMENTS ON RANGE

Aircraft	Total W (lbs)	*G.T.O. (lbs)	% G.W.*	Added W (lbs)	*W Fuel (lbs)	*Range (N.Miles)	Range Red. (N.Miles)	% Range Red. MIL-A-880b
H-21	182.5	14,379	1.2	124	1620***	239	18	7.7
H-23	34	2,478	1.4	34	252***	177	24	13
H-37	273	31,000	0.9	273	2160***	127	16	12.7
HU-1A	124	5,402	2.3	74	747***	**	--	9.9
YHC-1A	186	15,550	1.2	150	1694***	**	--	8.9

* Reference 16

** Not Available

*** Does Not Include 10% Reserve

RECOMMENDATION FOR REVISED ACOUSTICAL CRITERIA

I. INTRODUCTION - Task III

This section specifically covers the Task III work and reviews Military Specification MIL-A-8806 (ASG), 25 October 1956 in the light of the findings of Tasks I and II.

The primary purpose of this report is to establish acoustical criteria for procurement of future Army aircraft. This implies not only new airplanes and helicopters but also VTOL/STOL aircraft with propulsion systems and lifting mechanisms which at the present have experienced little or no flight time. Obviously, aircraft of these types (such as tilt wings, ducted fans, etc.) have been flown by a very few pilots and insufficient comment on noise is available to permit their direct inclusion in the study. It is necessary, therefore, to apply criteria based on existing aircraft to the newer types of VTOL/STOL aircraft.

II. COMPARISON WITH MIL-A-8806(ASG)

MIL-A-8806(ASG) dated 25 October 1956 titled "Military Specification - Acoustical Noise Level in Aircraft, General Specification for," specifies noise level limits under four separate flight conditions:

1. Paragraph 3.1.1 specifies noise levels at maximum continuous power.
2. Paragraph 3.1.2 specifies noise levels for short duration conditions, not exceeding five minutes.
3. Paragraph 3.1.3 specifies noise levels at maximum continuous power in aircraft in which personnel must necessarily wear helmets at all times and communicate by electronic means.
4. Paragraph 3.1.4 specifies noise levels during conditions of normal cruise power.

As stated in Paragraph 6.2.5 the limits prescribed in MIL-A-8806 were developed from considerations of damage to hearing, speech communication requirements, and effects on crew performance. The study carried on under this program essentially constitutes a re-evaluation of these factors in light of the latest medical thinking, and incorporating pilot reaction gained on more modern aircraft. This is most important due to the great advancements in rotary wing aircraft made during the 1956-1960 period.

Paragraphs 3.1.1 through 3.1.3 of MIL-A-8806(ASG) apply to short duration exposure only and as such were not directly researched in that all pilot responses to the Task II survey are assumed based on the cruise environment in which the pilot spends the majority of his time. Interrogation of medical personnel was also primarily based on the cumulative effects of exposures averaging about four hours per day. For exposures of approximately five minute duration there is little question that the levels prescribed in Paragraphs 3.1.1 - 3.1.3 are acceptable.

It is essentially the limits set forth in Paragraph 3.1.4 and Table IV of MIL-A-8806(ASG) which have been re-evaluated by this current program. Medically, the Department of Speech and Audiology at Walter Reed Army Hospital feels that even these limits are perhaps excessive (Ref. Task II, Section IV-B) but there is little evidence from actual field experience to indicate that the present environment in which Army pilots find themselves is resulting in a significant amount of hearing damage. Admittedly, some cases have been reported, but since there is a wide scatter of susceptibility to hearing damage, which is impossible to predetermine, it can be safely assumed that continuation of specifications no higher than those currently applicable will be satisfactory.

The crux of the matter then lies in the pilot reaction to noise environment in the cruise condition. A comparison of the results of this study is made with Table IV of MIL-A-8806(ASG) in Fig. 157. As is indicated there is an expression of requirement for additional relief above 2400 cps. The major sources of noise in this higher frequency range are predominantly harmonics of transmission gear contact frequencies, and turbine inlet and compressor stages. These are generally manifested as discrete frequencies or pure tones which are considerably more irritating than an equal level of broadband noise.

If it were possible to develop an easily measurable and simply interpretable criteria which were based on pure tones, it would be strongly advisable to use such a concept as the basis for formulating future criteria. Unfortunately no absolute measurement or criteria exists for this rather intangible quality and even close scrutiny of the narrow band analyses (Figs. 105-135) fails to clearly convey, in all cases, the presence of particularly annoying sounds. However, the rotary wing aircraft included in this study all possess to some degree pure tone components in their acoustical spectra. There is an indirect inclusion of this effect in the octave band level limits. It is believed that the primary reason that more high frequency relief is sought by today's pilots as contrasted with that required in 1956 is that the characteristic of the high frequency noise to which they are being subjected has changed in character from broadband to discrete frequency peaks.

III. EFFECT OF ACOUSTICAL TREATMENTS

A review of Section V, Task II will reveal the acoustical treatments required in Army aircraft are nearly always dictated by requirements between 300 cps and 1200 cps. This is established by the crossover of source intensities which generally decrease in the higher octaves and treatment efficiency which improves rapidly with frequency. Since the resulting treatments generally show an excess attenuation, over that required, in the highest octave bands it might appear that compliance with the present Table IV of MIL-A-8806(ASG) will also insure automatic compliance with the specification resulting from this study. This would be true if it were not for two factors: Firstly, the high attenuations at high frequencies predicted by calculation often fall far short of those actually attained. This is not so much a lack in the analysis as unavoidable imperfection of application which permits short circuiting of the treatment by flanking paths. Secondly, and most important, is the fact that these treatments were all applied to aircraft of the current day fixed and rotary wing types. The purpose of this program is to designate a specification for procurement of future Army aircraft which may have radically different acoustical signatures from those currently experienced. Some valuable insight into this problem can be gained by examination of Figs. 36, 39, 42, 45, 48, 51, 54, 57, 60, 63, and 65 each of which shows external noise levels generated during flybys of various aircraft tested. When compared on the basis of 100 ft. altitude directly over the microphone the first ten aircraft (airplanes and helicopters) all display maximum amplitude in or below the 150-300 cps band while the last which is a ducted fan VTOL peaks in the 600-1200 cps band. From all present indications the newer propulsion systems and lifting devices can be expected to shift future frequency spectra upward placing increased importance on the proposed departure from MIL-A-8806 as currently existent.

BIBLIOGRAPHY

1. Werner, Francis W., "Sound Propagation Outdoors," Noise Control, July 1958.
2. Beranek, L. L., "Acoustics," McGraw Hill Book Co., Inc. 1954.
3. Harris, D. N., "Handbook of Noise Control," McGraw Hill Book Co., Inc., 1957.
4. Stevens, S. S., "Calculating Loudness," Noise Control, September, 1957.
5. Wylie, G. R., "Advanced Engineering Mathematics," McGraw Hill Book Co., Inc., 1951.
6. Croxton, F. G. and Cowden, D. J., "Applied General Statistics," Prentice Hall, 1939.
7. American Academy of Ophthalmology and Otolaryngology, "Guide for Conservation of Hearing in Noise," Los Angeles, California.
8. Air Force Regulation 160-3A, "Hazardous Noise Exposure," May 1960.
9. Kryter, K. D., "The Effects of Noise on Man," The Journal of Speech and Hearing Disorders, Monograph Supplement 1, 1950.
10. Rosenblith, W. A., Stevens, K. N., "Handbook of Acoustic Noise Control, Volume II - Noise and Man," WADC TR-52-204, June 1953.
11. Beranek, L. L., "Noise Reduction," McGraw Hill Book Co., Inc., 1960.
12. McFarland, R. A., "Human Factors in Air Transportation," McGraw Hill Book Co., Inc., New York, 1953.
13. Beranek, L. L., Kryter, K. D., and Miller, L. N., "Reaction of People to Exterior Aircraft Noise," Noise Control, Volume 5, No. 5, September 1959.
14. Franken, P. A. and Kerwin, E. M., Jr. "Methods of Flight Vehicle Noise Prediction," WADC TR-58-343 ASTIA Document No. AD 205776.
15. Northrop Aircraft, Inc., "HM-1A Muffler Installation, Helicopter, Bell Model 47," NAI-58-612, 7 August 1958.
16. U. S. Army Transportation School, "Aircraft Characteristics," Ft. Eustis, Virginia.

17. Kryter, K. D., "Noise Control Criteria for Buildings." Noise Control, Volume 3, No. 6 14-20, November 1957.
18. Beranek, L. L., "Criteria for Office Quieting Based on Questionnaire Rating Studies," Journal of the Acoustical Society of America, Volume 28, No. 5 833-52, September 1956.
19. Beranek, L. L., "Revised Criteria for Noise in Buildings," Noise Control, Volume 3, No. 1 19-27, January 1957.
20. Peterson, A. P. G., and Beranek, L. L., "Handbook of Noise Measurement, (3rd Ed.)", General Radio Co., 1956.
21. Bolt, Lukasik, Nolle, and Frost, "Handbook of Acoustical Noise Control, Volume I Physical Acoustics," WADC TR-52-204, December 1952.
22. Route, W. D., "Gear Design for Noise Reduction," Paper presented at SAE Summer Meeting, Edgewater Beach Hotel, Chicago, Illinois, June 5-10, 1950.
23. Beranek, L. L. and Rudmose, H. W., "Airplane Quieting I - Measurement of Sound Levels in Flight" ASME Transactions 1947 Volume 69, Pages 89-95.
24. Beranek, L. L. and Rudmose, H. W., "Airplane Quieting II - Specification of Acceptable Noise Levels," ASME Transactions, 1947, Volume 69, Pages 97-100.
25. Military Specification, "Acoustical Noise Level in Aircraft, General Specifications For, MIL-A-8806 (ASC)," 25 October 1956.
26. Knudsen, V. O., "Acoustics in Comfort and Safety," J. Acoustical Society of America, Volume 21, No. 4, July 1949.
27. Beranek, L. L., "Acoustics in Comfort and Safety," J. Acoustical Society of America, Volume 21, No. 4, July 1949.
28. Exploratory Subcommittee Z24-X-2 of the American Standards Association Z24 Sectional Committee on Acoustics, Vibration, Mechanical Shock; Acoustical Society of America, 1954, "The Relations of Hearing Loss to Noise Exposure."

APPENDIX 1

ILLUSTRATIONS

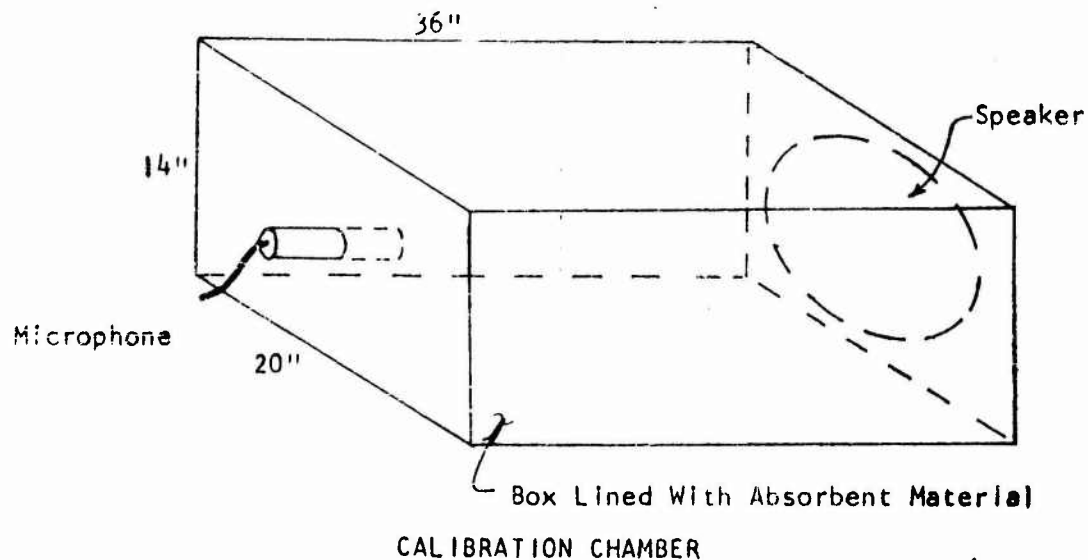
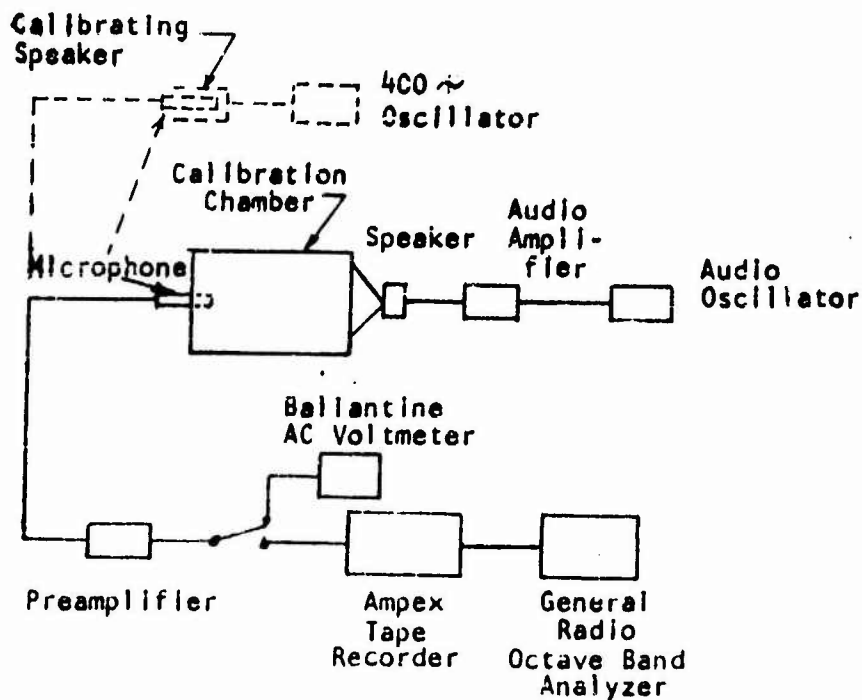

FIGURE 1



CALIBRATION SYSTEM

FIGURE 2

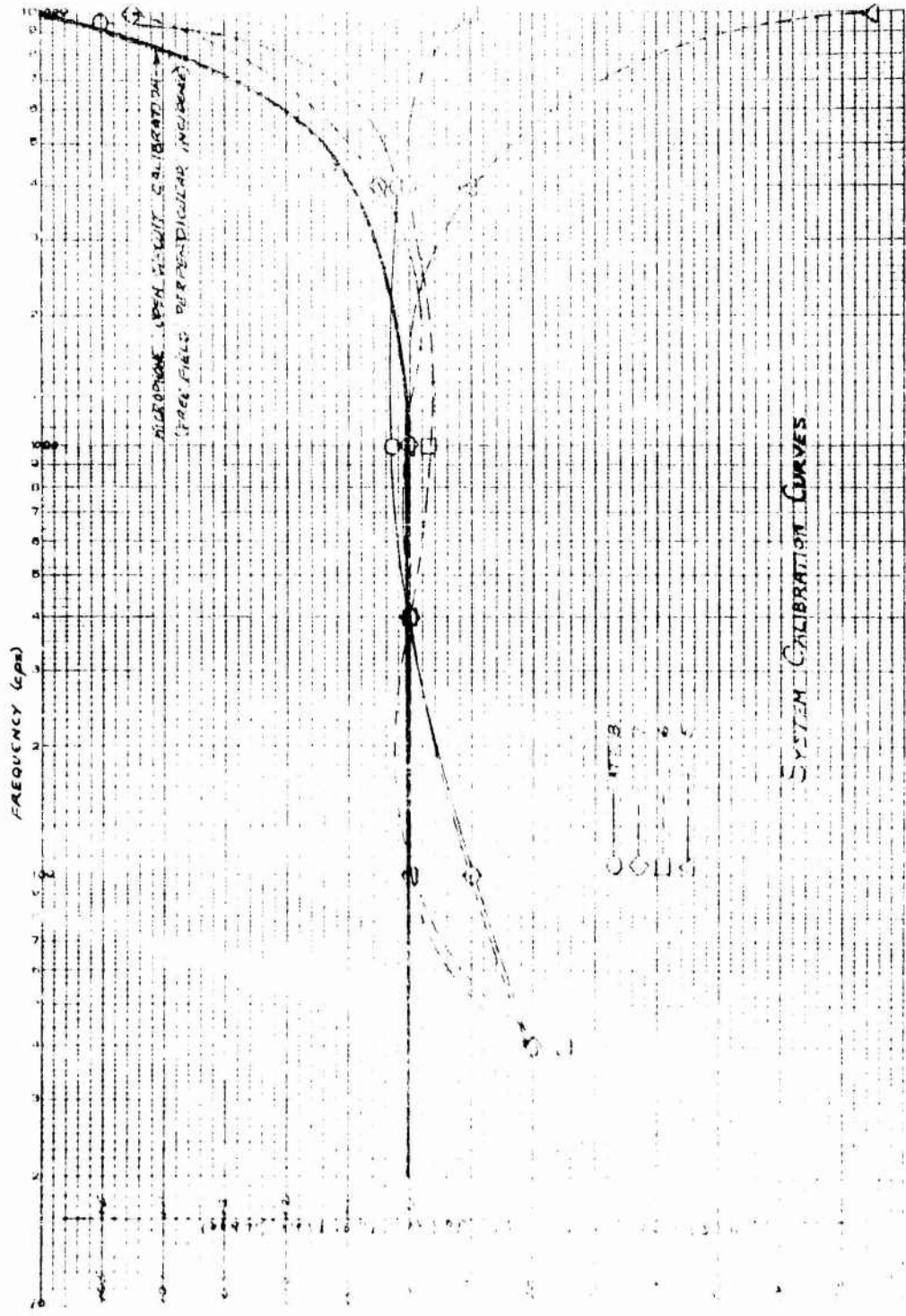
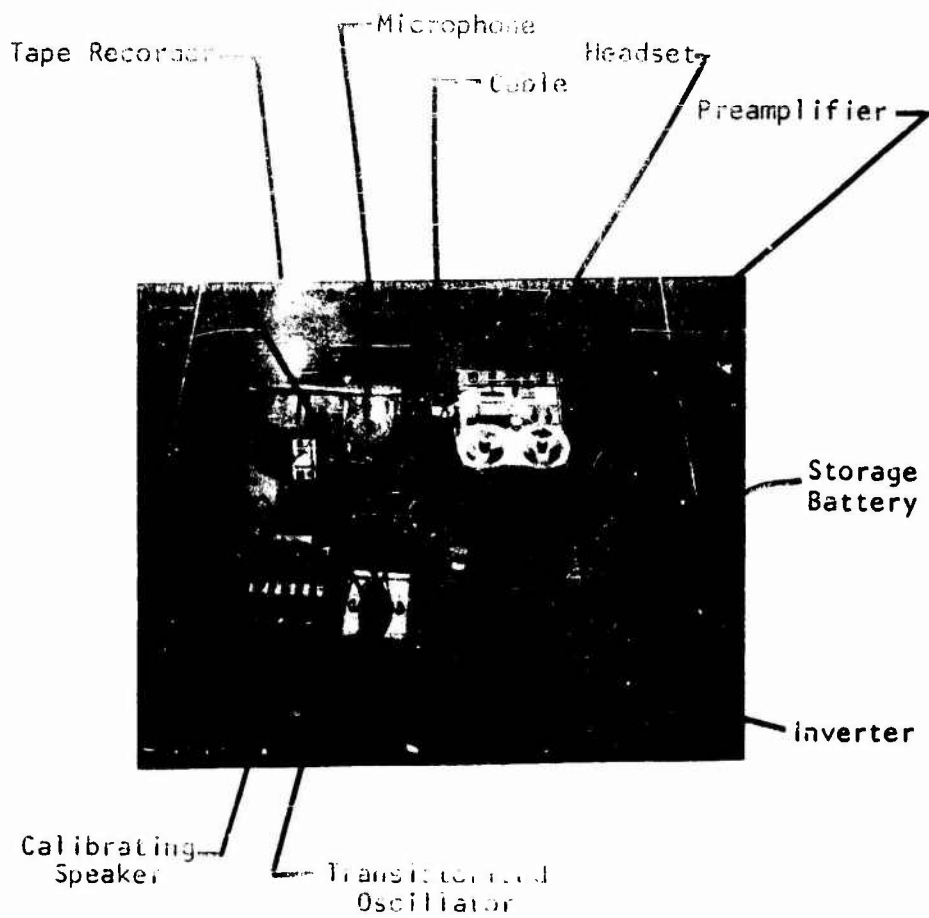
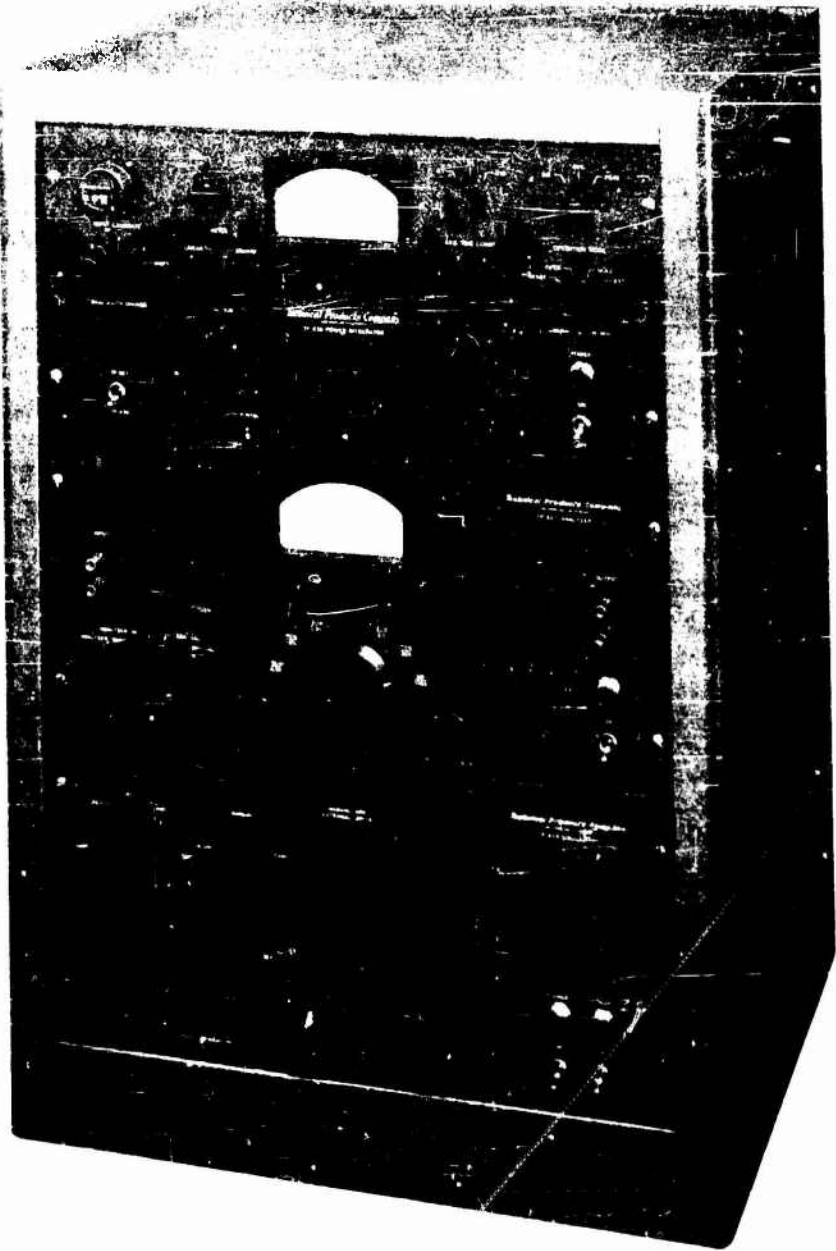

FIGURE 3



SOUND LEVEL RECORDING EQUIPMENT



TECHNICAL PRODUCTS WAVE ANALYZER

FIGURE 5

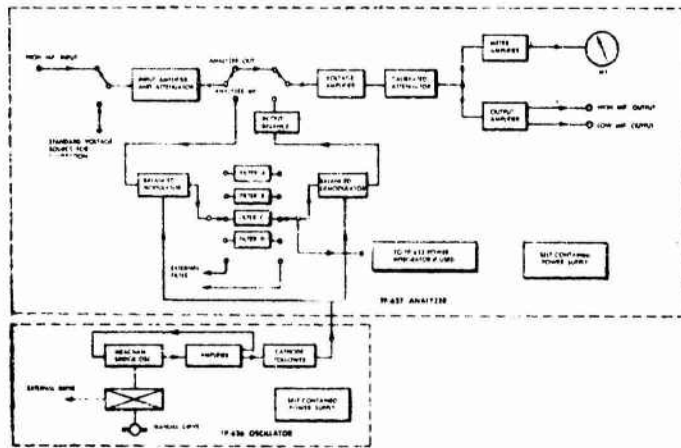

BLOCK DIAGRAM - TECHNICAL PRODUCTS WAVE ANALYZER

FIGURE 6

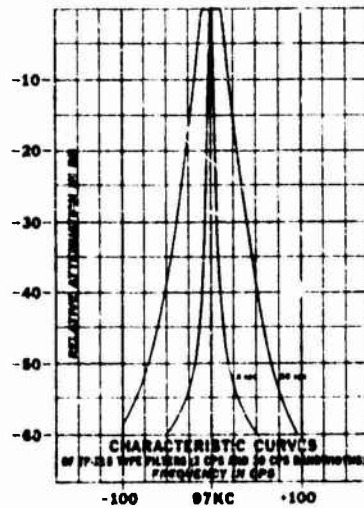
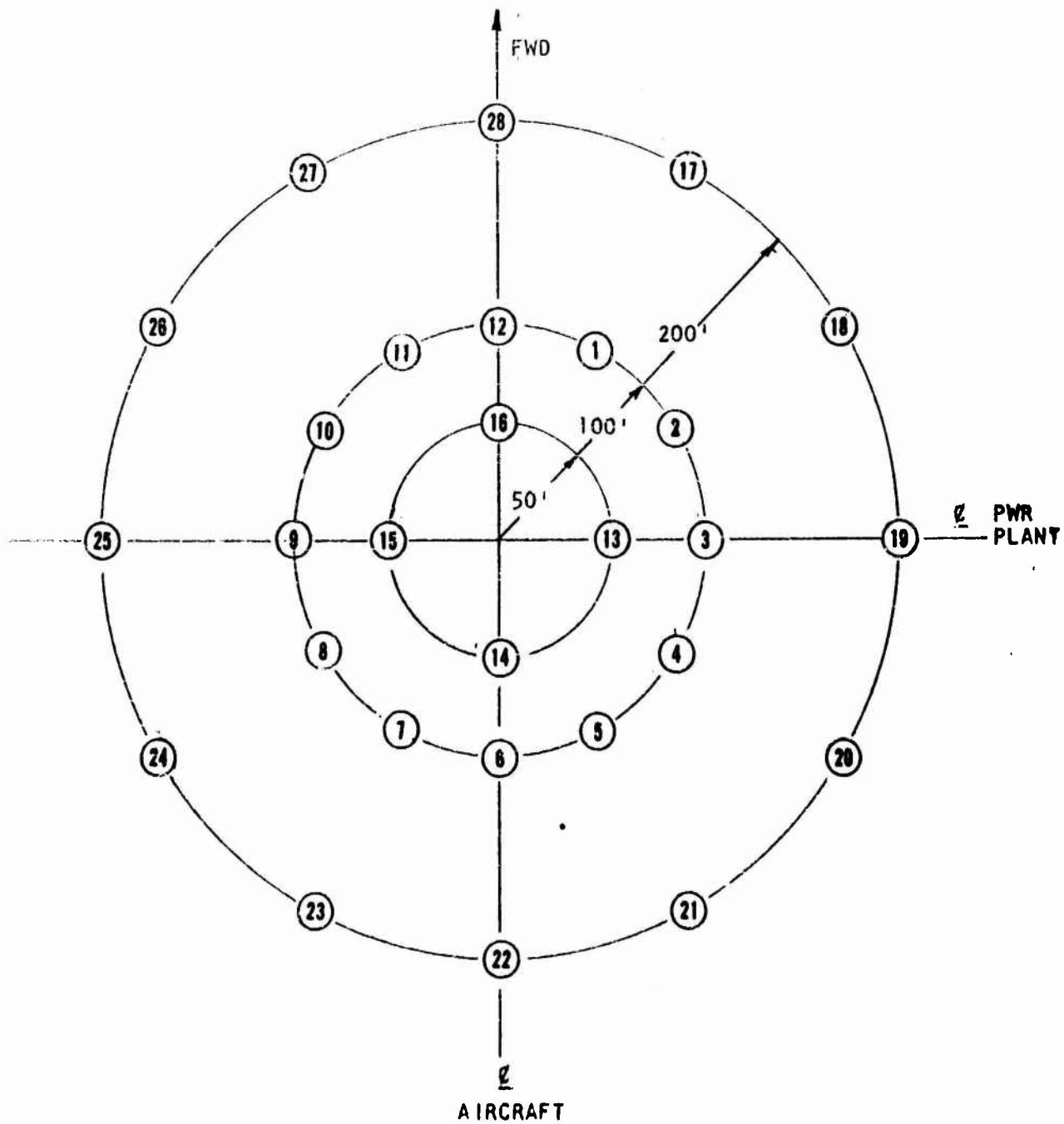

FIGURE 7

NOTE: Figures 6 and 7 are reproduced with permission of the Technical Products Company, Los Angeles, California.



MEASUREMENT LOCATIONS - TEST 1

FIGURE 8

A/C - TEST

VARIATION OF SOUND
PRESSURE LEVEL AT
200 FT. RADIUS

L-20-1

ENGINE SPEED 1800 rpm

ROTOR SPEED rpm

MAP 28 in. Hg

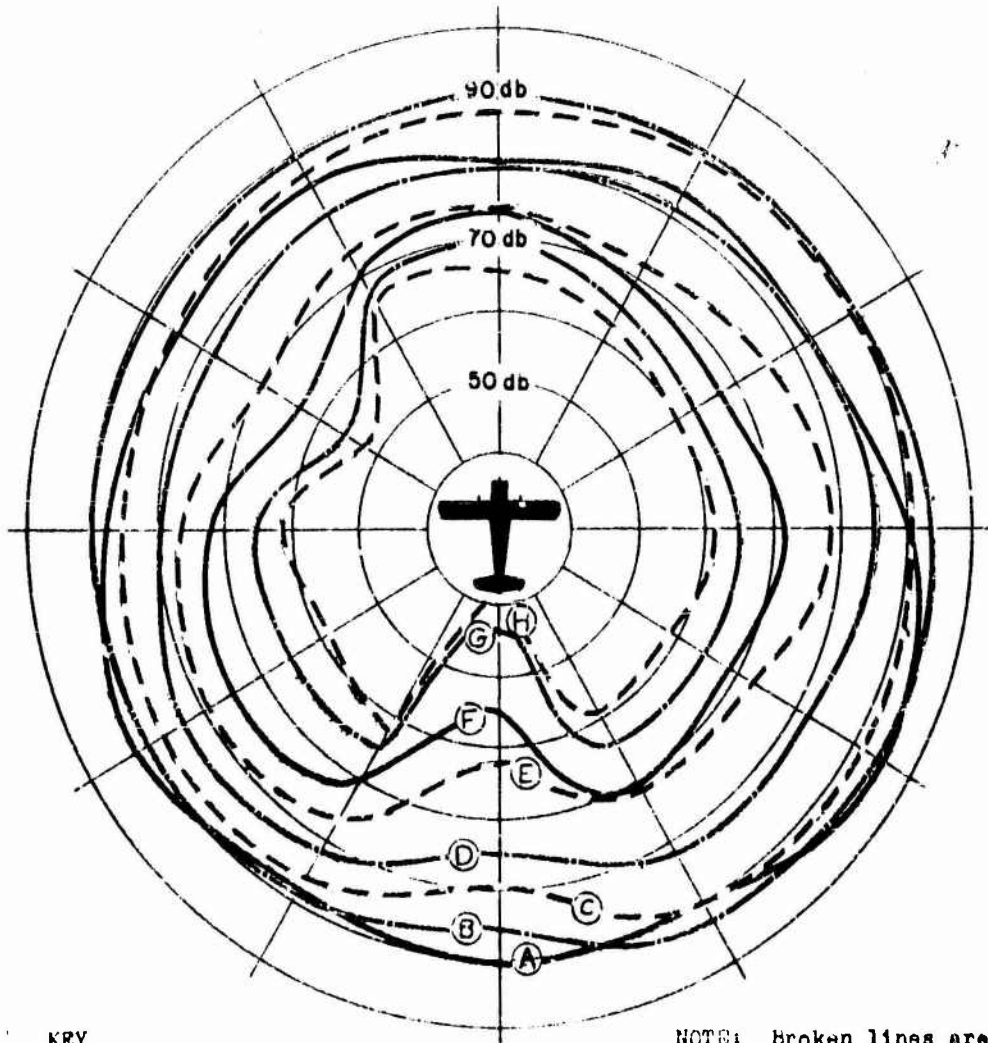

KEY

Symbol	Octave band - CPS
A	20-75
B	75-150
C	150-300
D	300-600
E	600-1200
F	1200-2400
G	2400-4800
H	4800-10 KC

NOTE: Broken lines are for clarity only.

FIGURE 9

VARIATION OF SOUND
PRESSURE LEVEL AT
200 FT. RADIUS

ENGINE SPEED 2600 rpm ROTOR SPEED rpm MAP 30 in. Hg

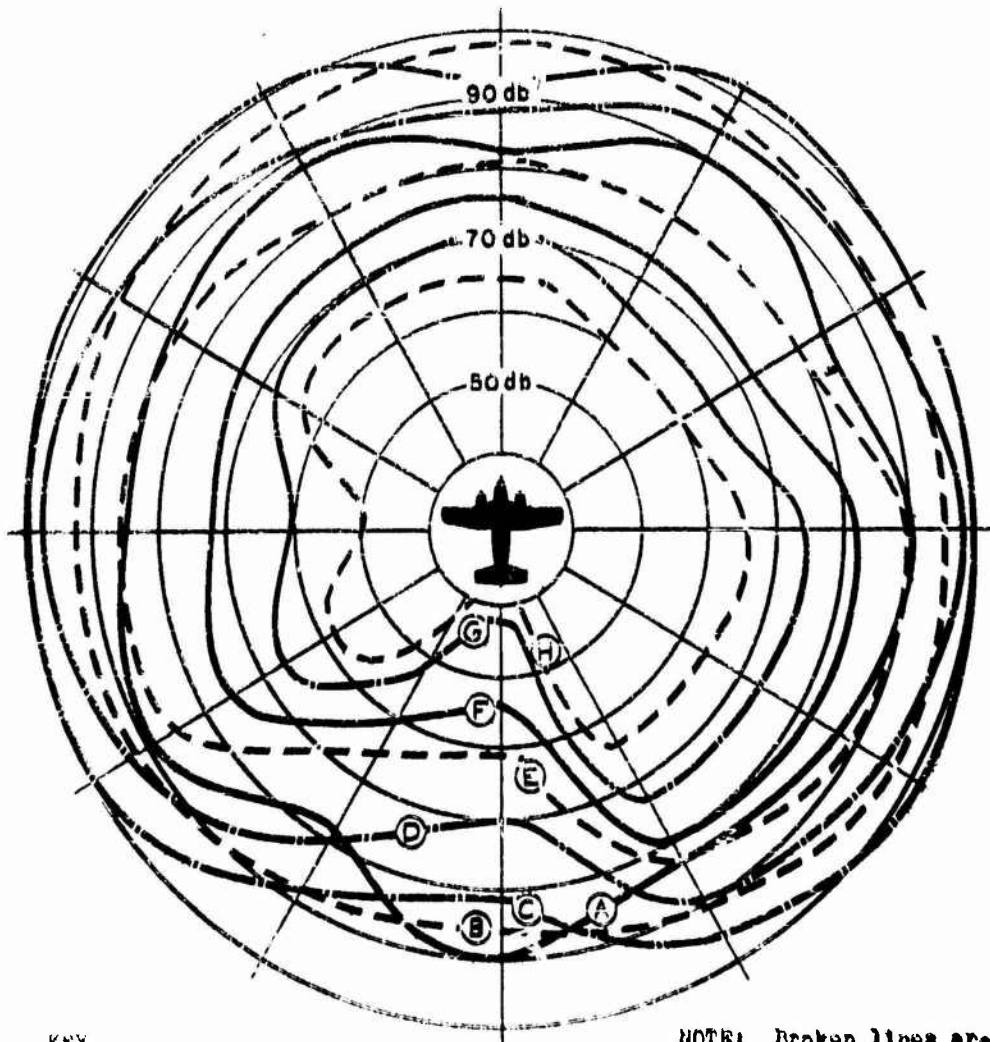

KEY	SYMBOL	Octave Band - CPB
	A	20-75
	B	75-150
	C	150-300
	D	300-600
	E	600-1200
	F	1200-2400
	G	2400-4800
	H	4800-10 KC

NOTE: Broken lines are for clarity only.

FIGURE 10

A/C - TEST

VARIATION OF SOUND
PRESSURE LEVEL AT
200 FT. RADIUS

U-1A-1

ENGINE SPEED 1750 rpm ROTOR SPEED _____ rpm MAP 28 in. Hg

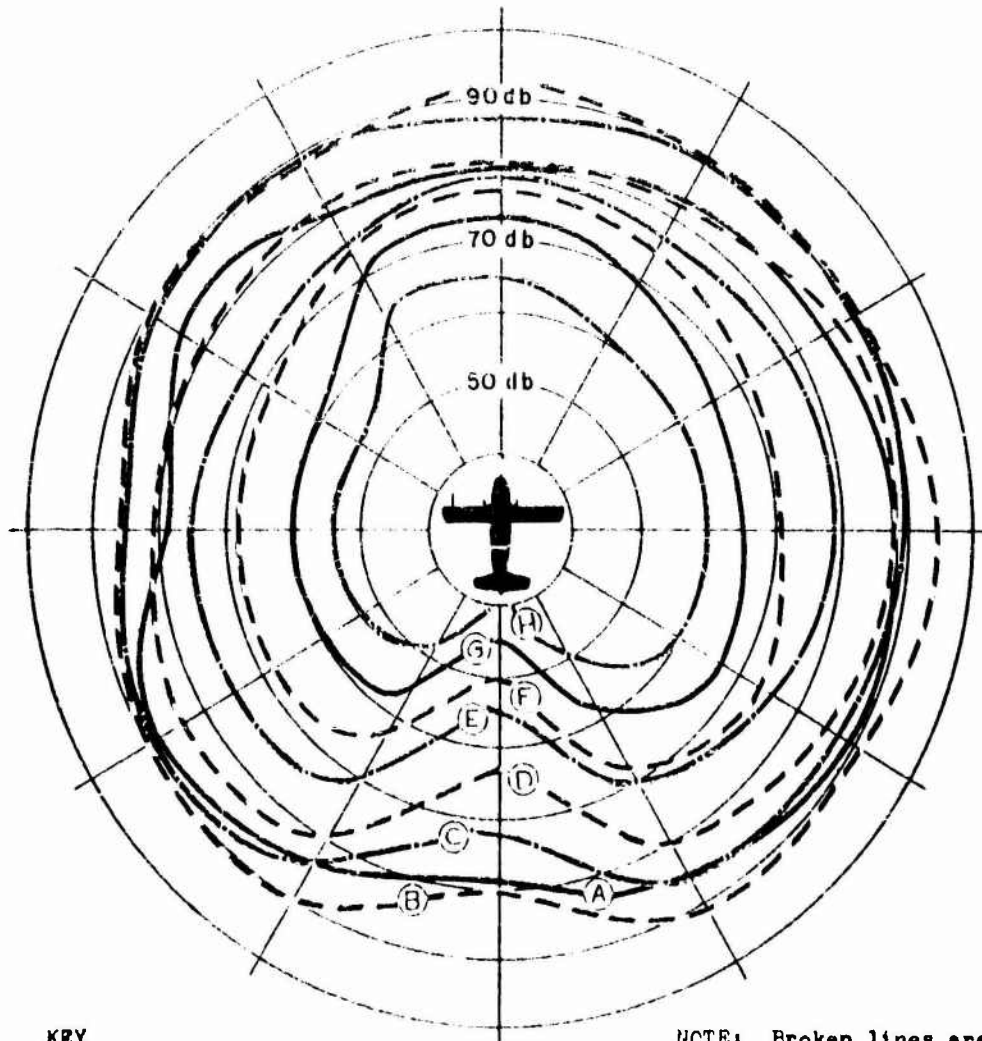

KEY

Symbol	Octave Band - CPS
A	20-75
B	75-150
C	150-300
D	300-600
E	600-1200
F	1200-2400
G	2400-4800
H	4800-10 K.

NOTE: Broken lines are for clarity only.

FIGURE 11

VARIATION OF SOUND
PRESSURE LEVEL AT
200 FT. RADIUS

ENGINE SPEED 3100 rpm ROTOR SPEED 345 rpm MAP 24 in. Hg

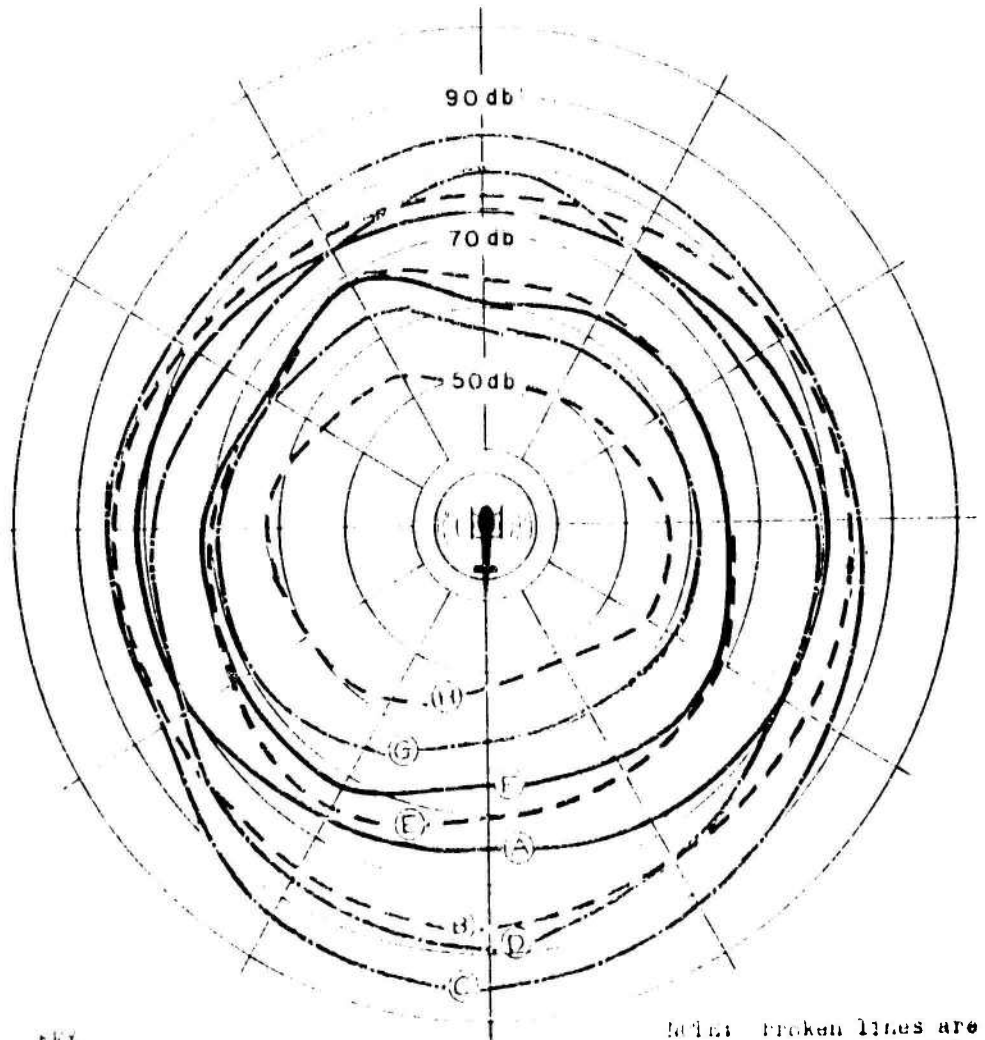

KEY
Symbol indicate Band - CIG

A	40-70
B	70-100
C	100-130
D	130-160
E	160-190
F	190-220
G	220-250
H	250-280

Note: Broken lines are
for clarity only.

FIGURE 12

A/C - TEST

VARIATION OF SOUND
PRESSURE LEVEL AT
200 FT. RADIUS

H-21-1

ENGINE SPEED 2500 rpm ROTOR SPEED 260 rpm MAP 34 in. Hg

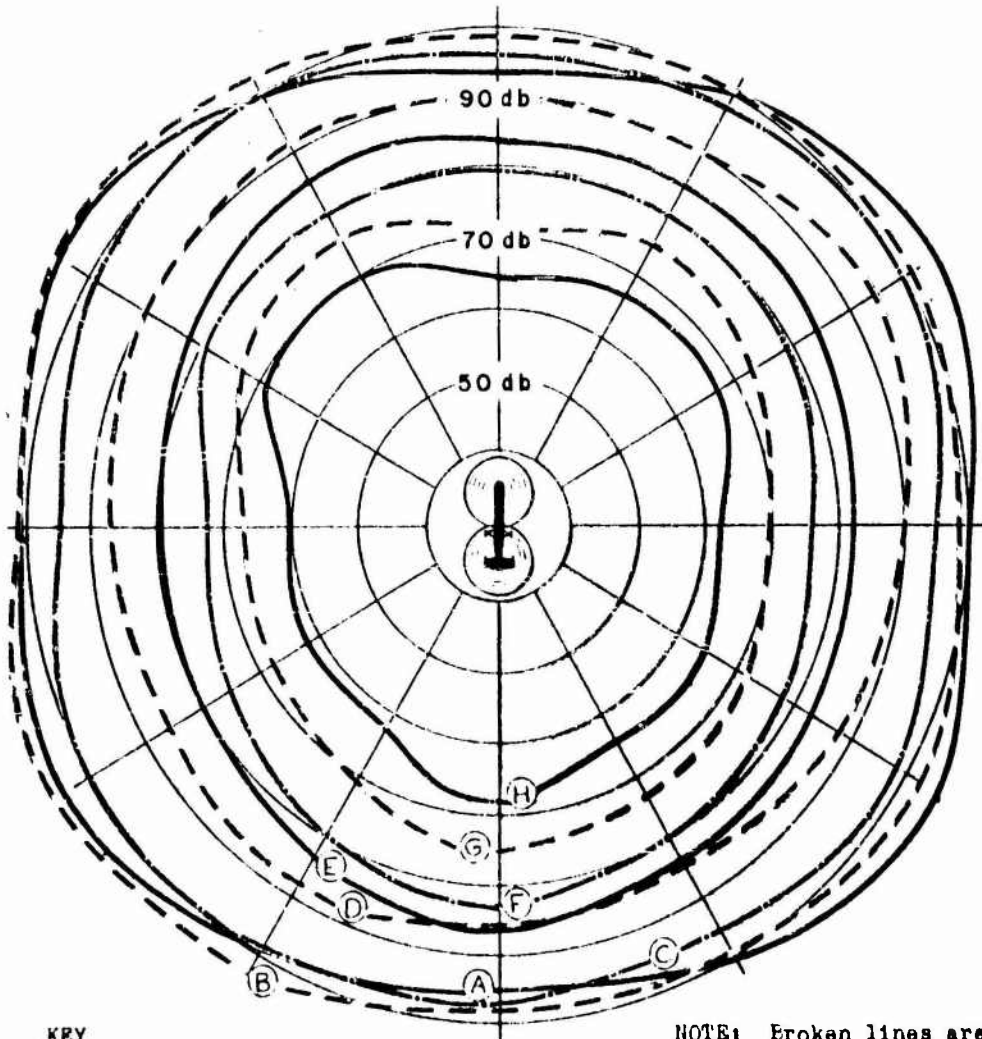

KEY

Symbol	Octave Band - CFS
A	20-75
B	75-150
C	150-300
D	300-600
E	600-1200
F	1200-2400
G	2400-4800
H	4800-10 KC

NOTE: Broken lines are
for clarity only.

FIGURE 13

H-23-1

VARIATION OF SOUND
PRESSURE LEVEL AT
200 FT. RADIUS

ENGINE SPEED 3200 rpm ROTOR SPEED 370 rpm MAP 25 in. Hg

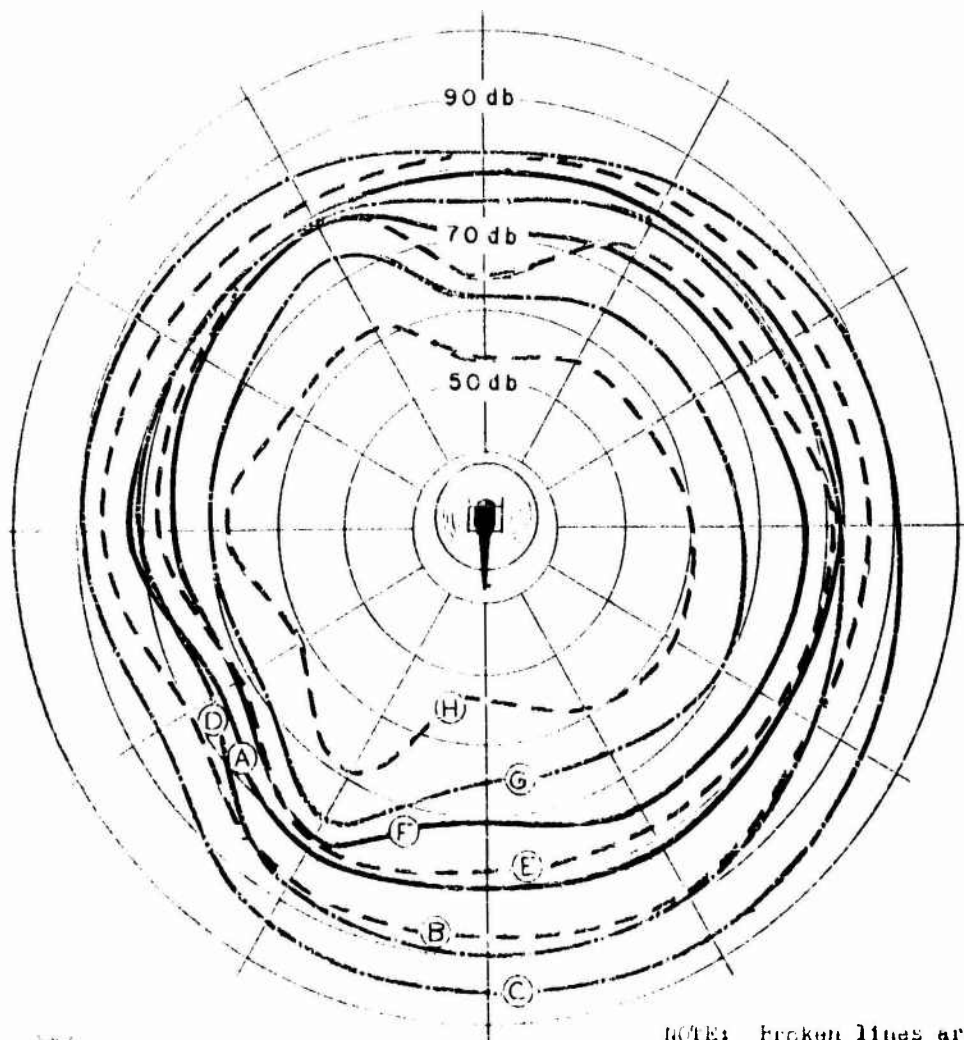

FIG. 1
Symbol Octave Band - OLS

A	20-25
B	25-35
C	35-50
D	50-70
E	70-100
F	100-150
G	150-200
H	200-315

NOTE: Broken lines are
for clarity only.

FIGURE 14

A/C - TEST

H-34-1

VARIATION OF SOUND
PRESSURE LEVEL AT
200 FT. RADIUS

ENGINE SPEED 2500 rpm ROTOR SPEED 220 rpm MAP 37 in. Hg

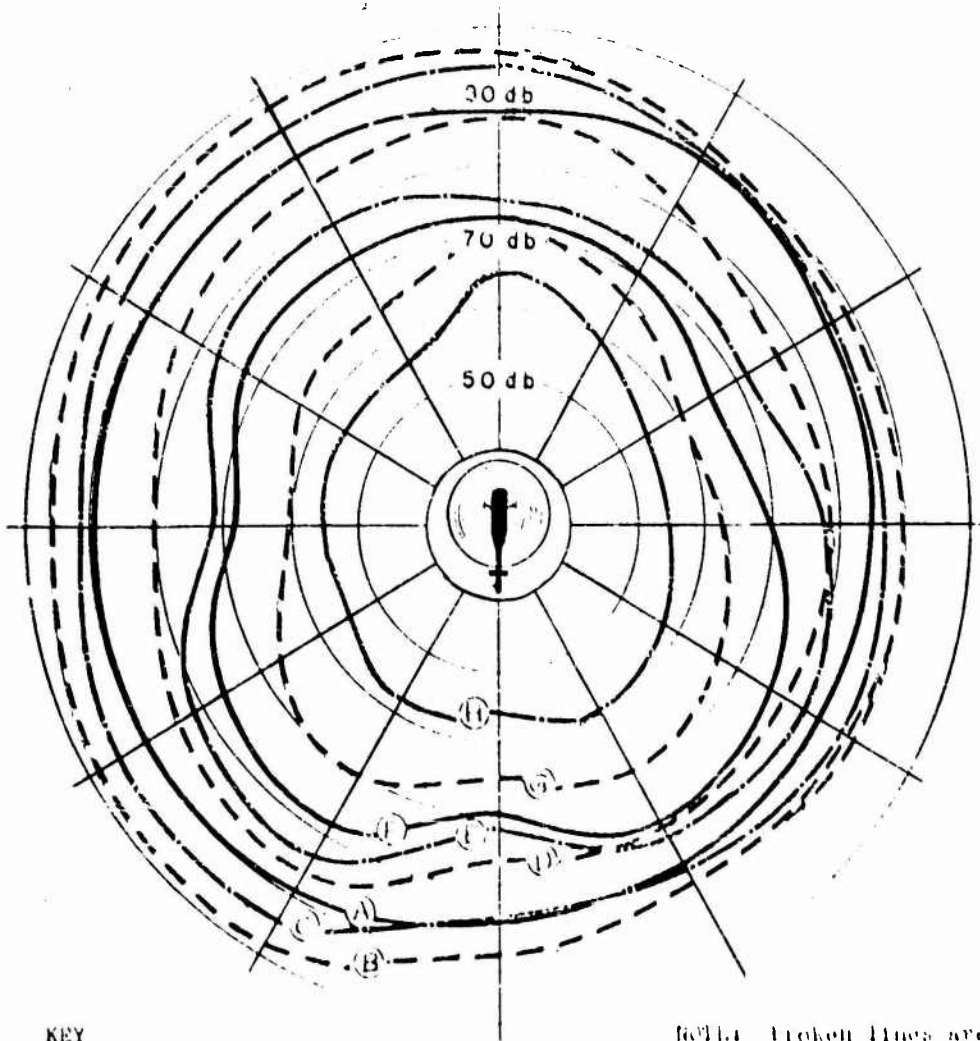

KEY

Symbol	Octava Band - C15
A	30-75
B	75-150
C	150-300
D	300-600
E	600-1,200
F	1,200-2,400
G	2,400-4,800
H	4,800-10,000

NOTE: Broken lines are for clarity only.

FIGURE 15

A/C - TEST

VARIATION OF SOUND
PRESSURE LEVEL AT
200 FT. RADIUS

H-37-1

ENGINE SPEED 2600 rpm ROTOR SPEED 185 rpm MAP in. Hg

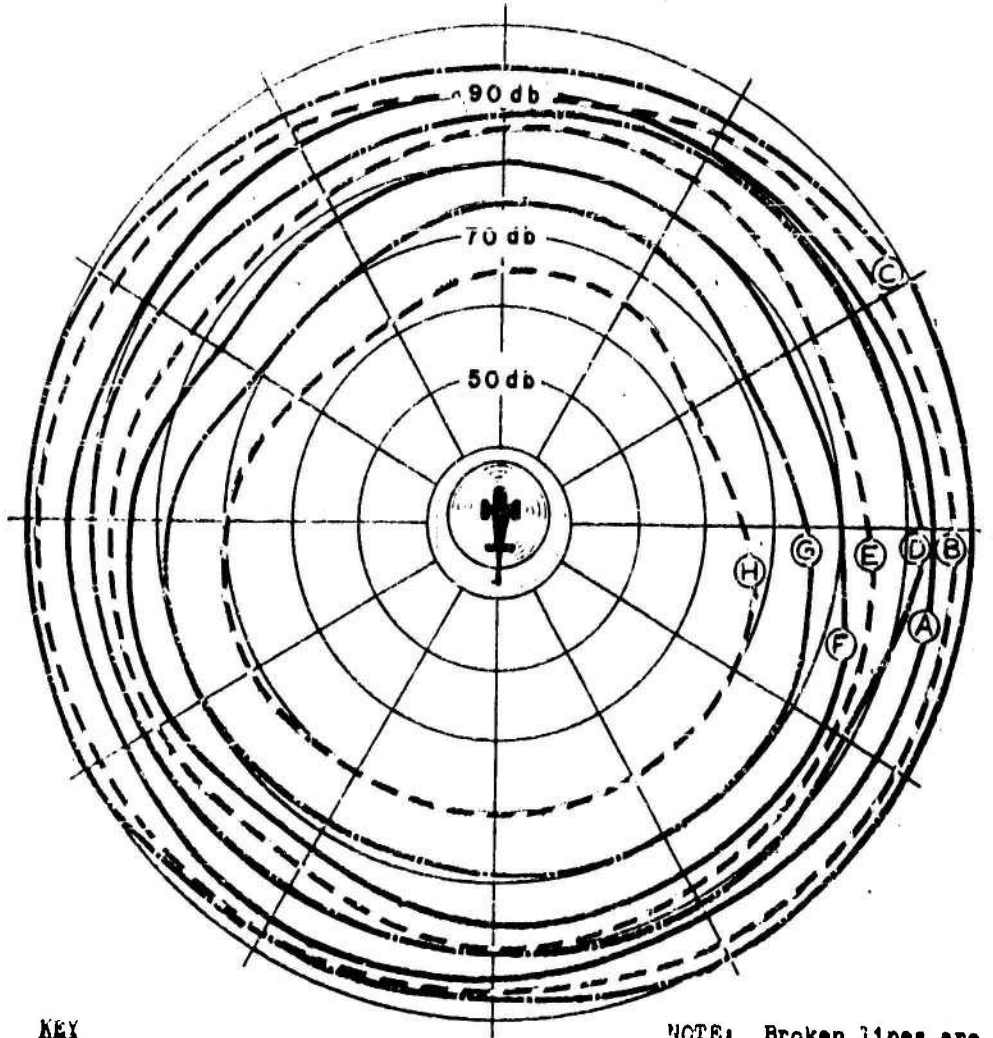

KEY

Symbol	Octave Band - CPS
A	20-75
B	75-150
C	150-300
D	300-600
E	600-1200
F	1200-2400
G	2400-4800
H	4800-10 KC

NOTE: Broken lines are for clarity only.

FIGURE 16

A/C - TEST

VARIATION OF SOUND
PRESSURE LEVEL AT
200 FT. RADIUS

HU-1A-1

ENGINE SPEED 6300 rpm ROTOR SPEED 310 rpm MAP in Hg

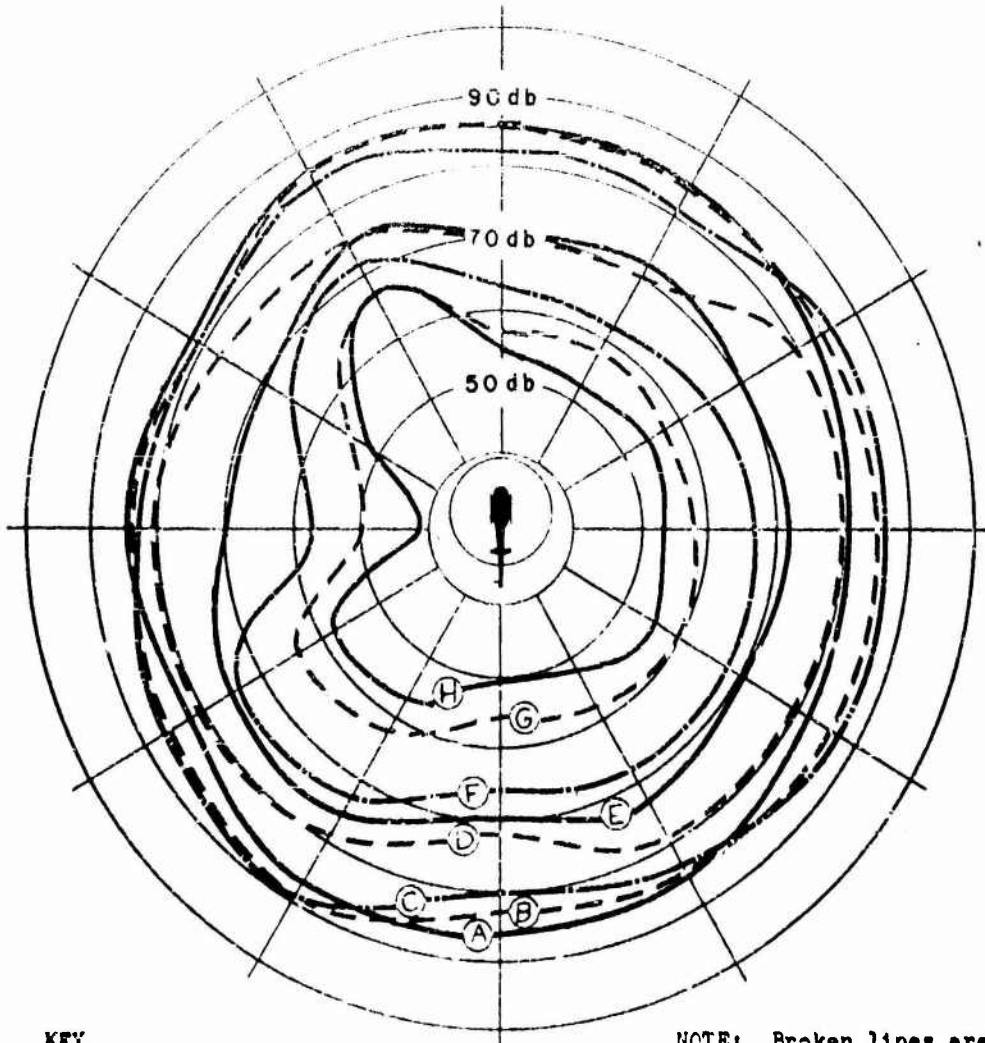

KEY

Symbol	Octave Band - CPS
A	20-75
B	75-150
C	150-300
D	300-600
E	600-1200
F	1200-2400
G	2400-4800
H	4800-10 KC

NOTE: Broken lines are for clarity only.

FIGURE 17

A/C - TEST

YHG-IA

VARIATION OF SOUND
PRESSURE LEVEL AT
200 FT. RADIUS

ENGINE SPEED 2500 rpm ROTOR SPEED 260 rpm MAP in. Hg

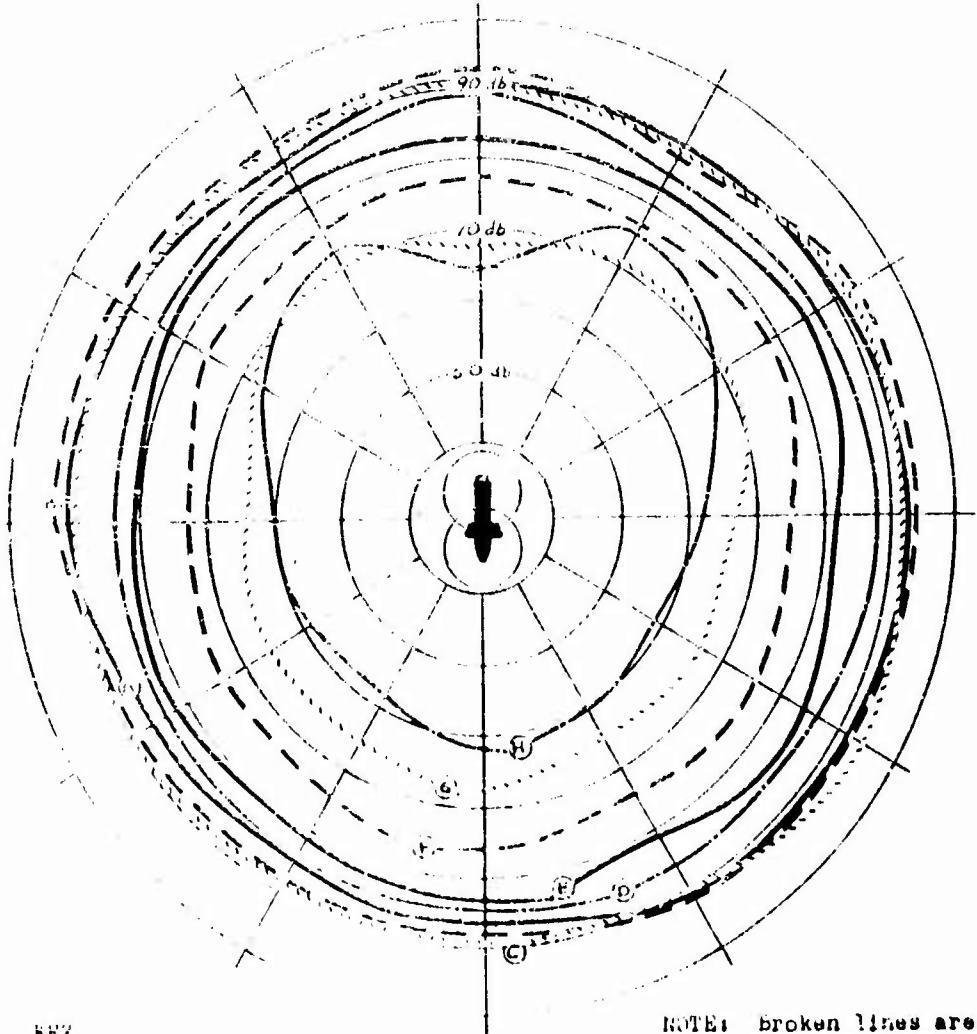

KEY

Symbol	Octave Band - CFB
A	20-75
B	75-150
C	150-300
D	300-600
E	600-1200
F	1200-2400
G	2400-4800
H	4800-10 K

NOTE: Broken lines are for clarity only.

FIGURE 10

VARIATION OF SOUND
PRESSURE LEVEL AT
100 FT. RADIUS

Doak-16-1.

ENGINE SPEED _____ rpm FAN SPEED 4800 rpm MAP _____ in. Hg

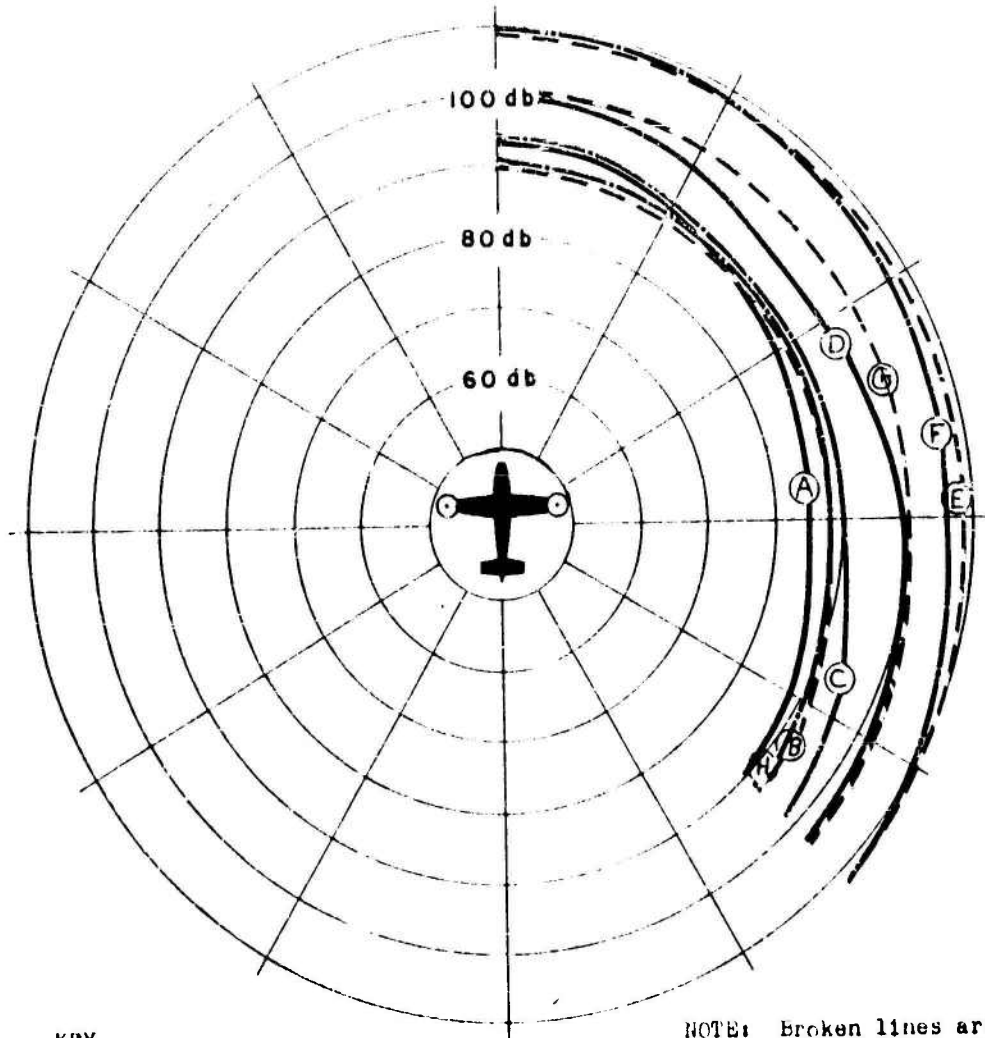

KEY

Symbol	Octava Band - C/s
A	20-75
B	75-150
C	150-300
D	300-600
E	600-1200
F	1200-2400
G	2400-4800
H	4800-10 KC

NOTE: Broken lines are for clarity only.

FIGURE 19

VARIATION OF SOUND
PRESSURE LEVEL AT
100 FT. RADIUS

Vertol-76-1

ENGINE SPEED 5850 rpm ROTOR SPEED 1410 rpm MAP in. Hg

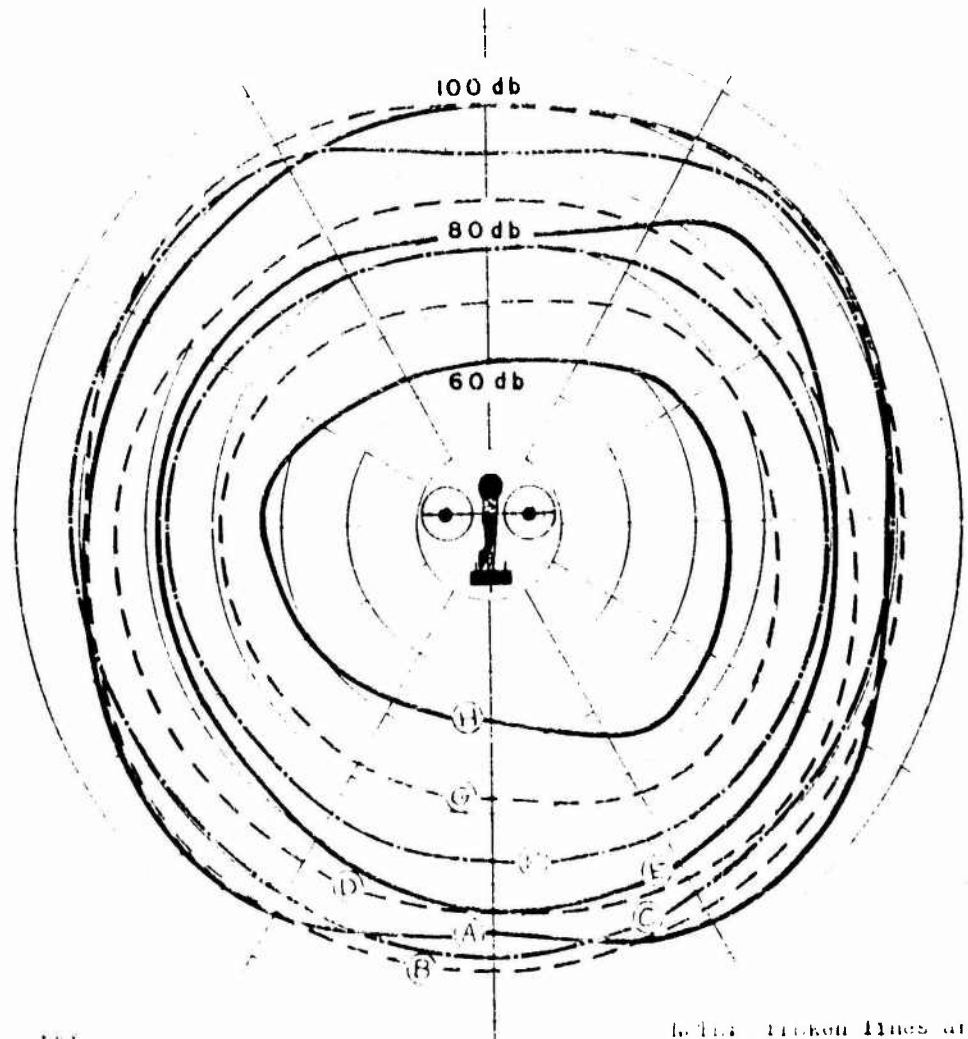

- DEFINITION OF LETTERS:
- A 12 O'clock
 - B 1:30
 - C 3:00
 - D 4:30
 - E 6:00
 - F 7:30
 - G 9:00
 - H 10:30

(The broken lines are for clarity only.)

FIGURE 20

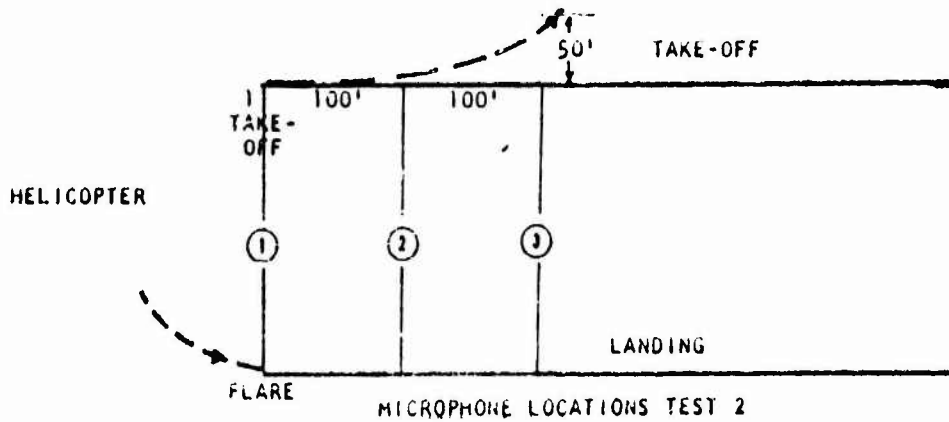
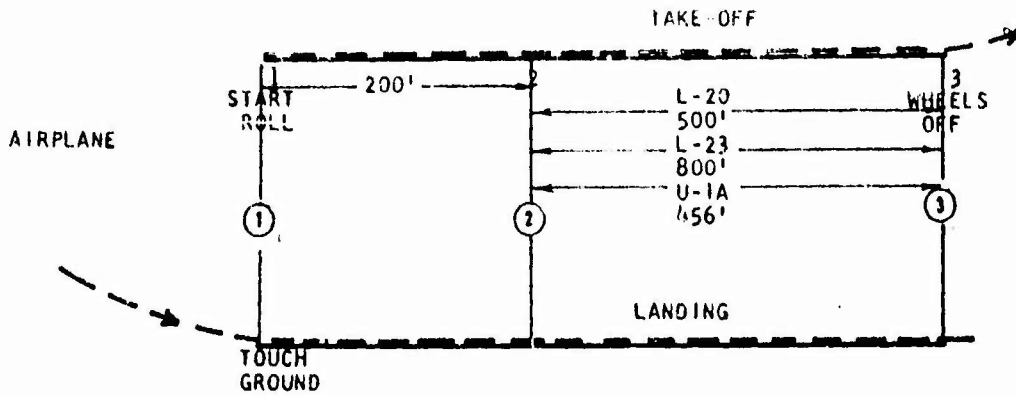
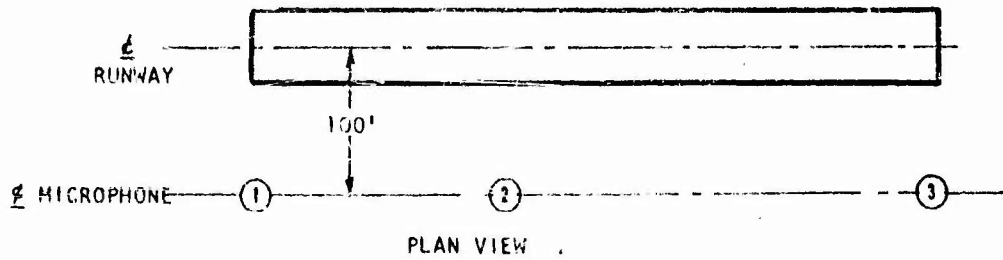

FIGURE 21

MAXIMUM SOUND PRESSURE LEVELS
DURING TAKEOFF AND/OR LANDING

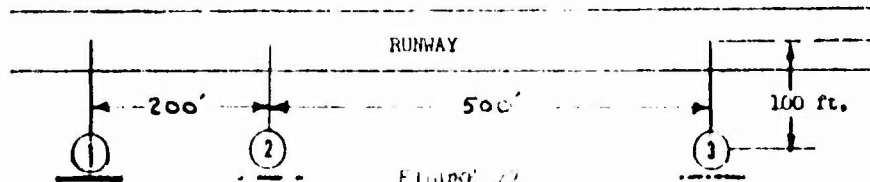
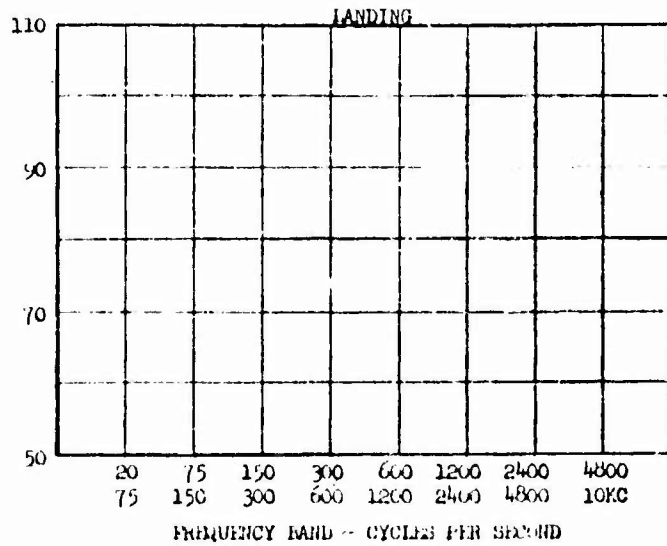
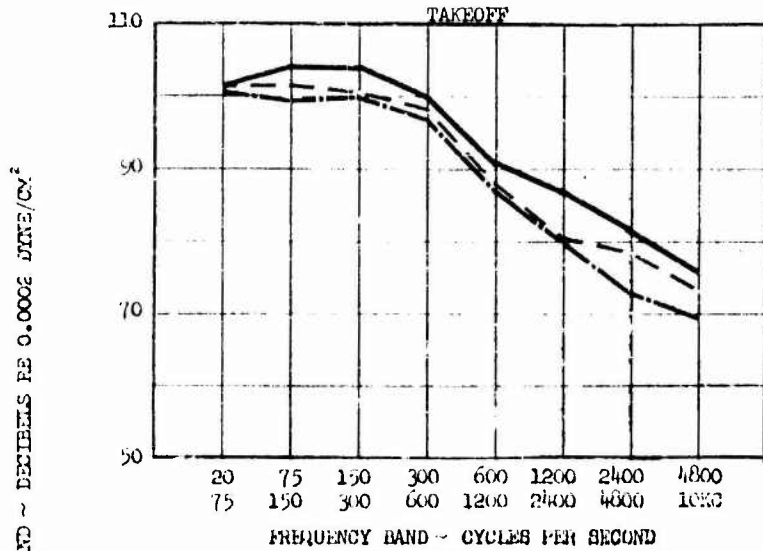
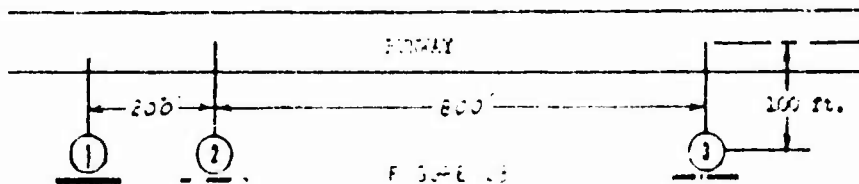
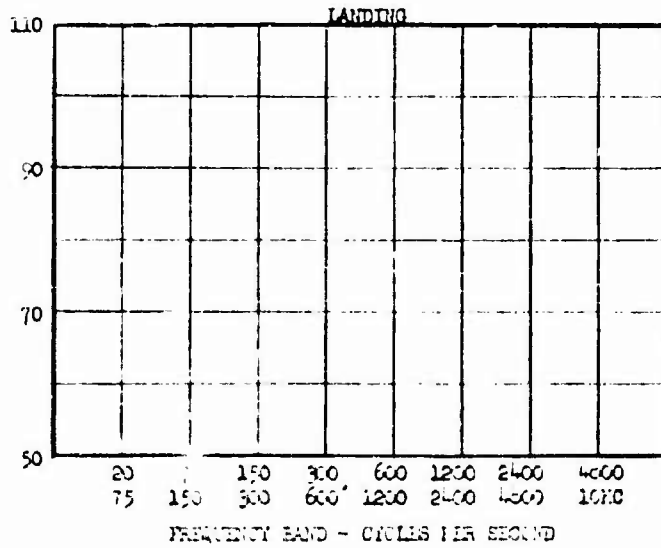
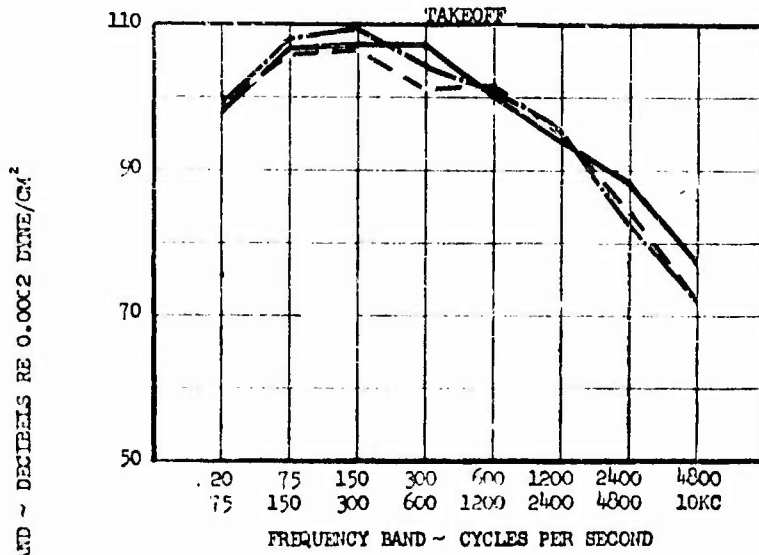

FIGURE 22

MAXIMUM SOUND PRESSURE LEVELS
DURING TAKEOFF AND/OR LANDING



A/C-TEST
U-1A-2;

MAXIMUM SOUND PRESSURE LEVELS DURING TAKEOFF AND/OR LANDING

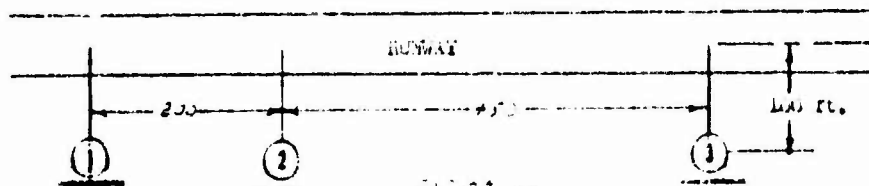
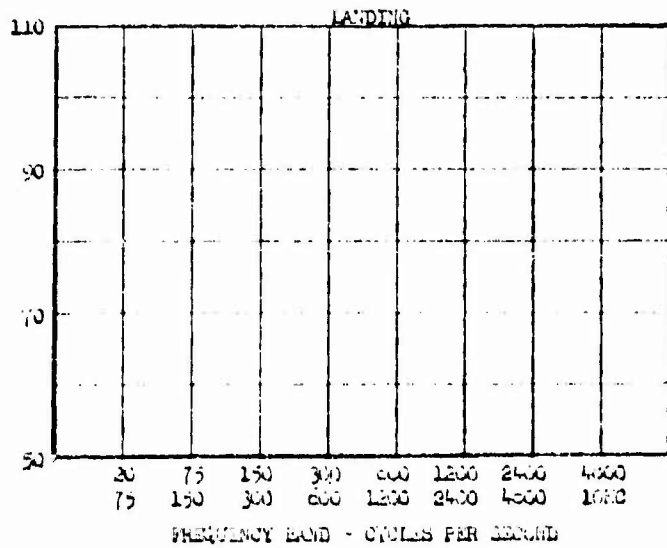
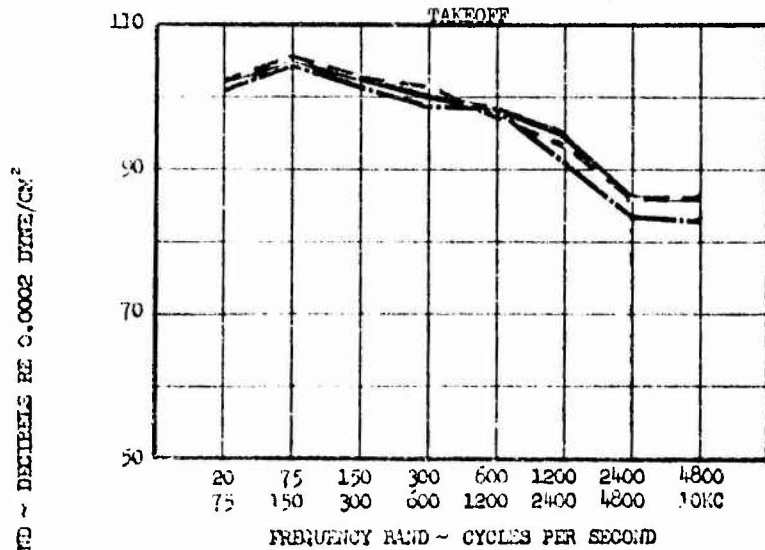

MAXIMUM SOUND PRESSURE LEVELS
DURING TAKEOFF AND/OR LANDING

SOUND PRESSURE LEVEL IN BAND ~ DECIBELS RE 0.0002 DYNE/CM²

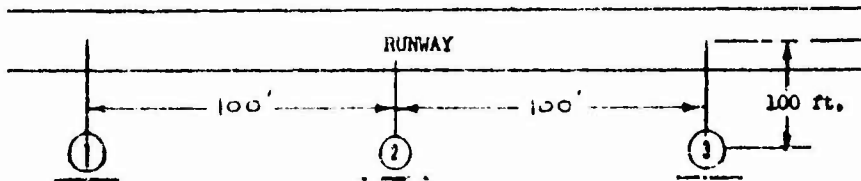
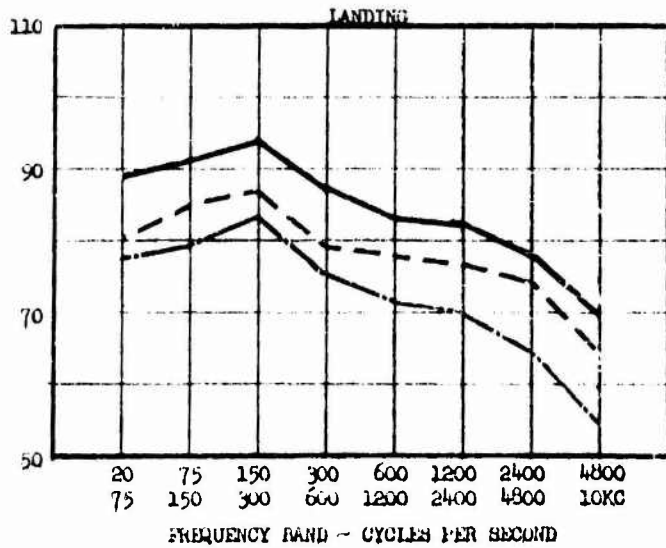
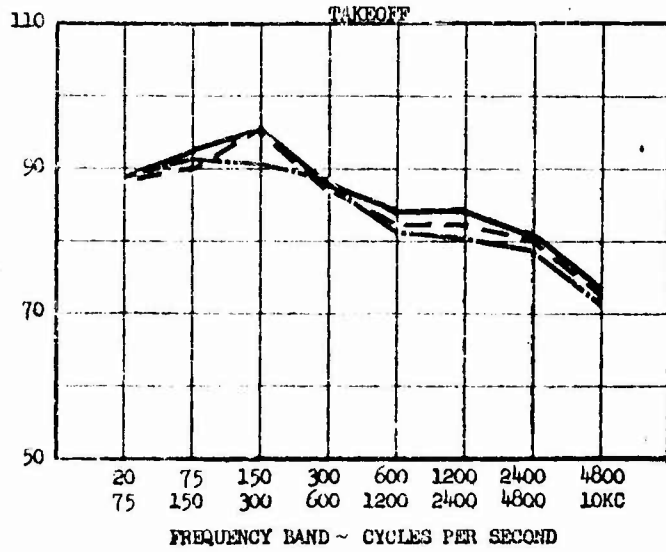

FIGURE 25

MAXIMUM SOUND PRESSURE LEVELS
DURING TAKEOFF AND/OR LANDING

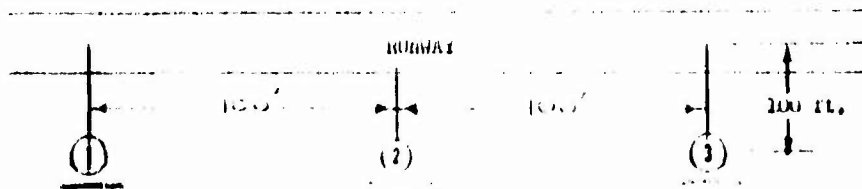
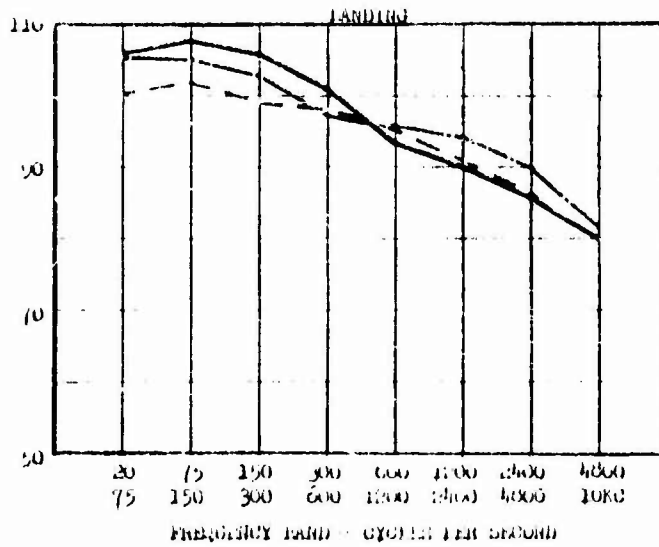
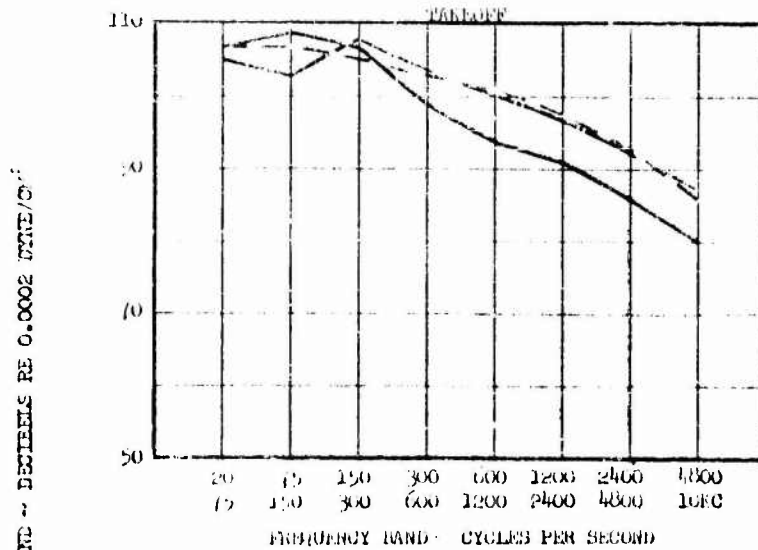

FIGURE 20

MAXIMUM SOUND PRESSURE LEVELS
DURING TAKEOFF AND/OR LANDING

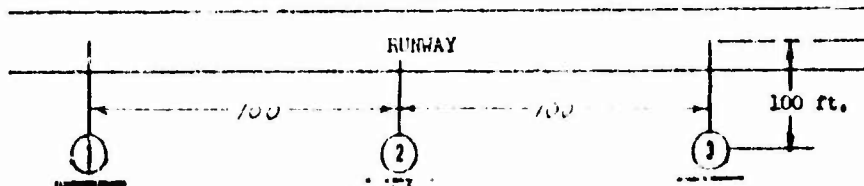
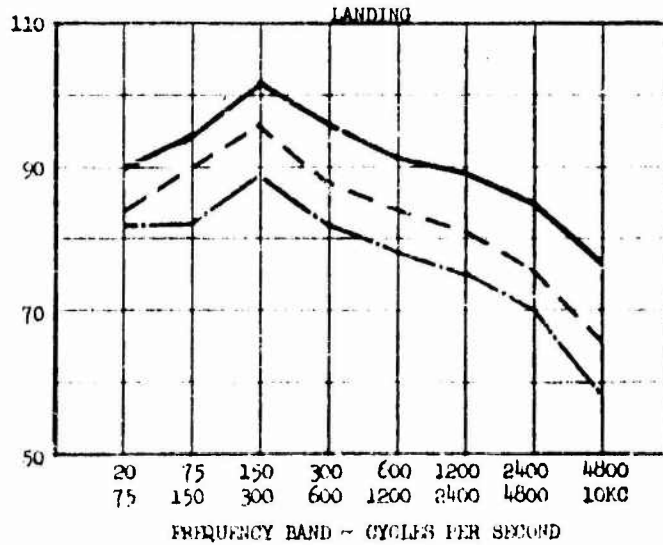
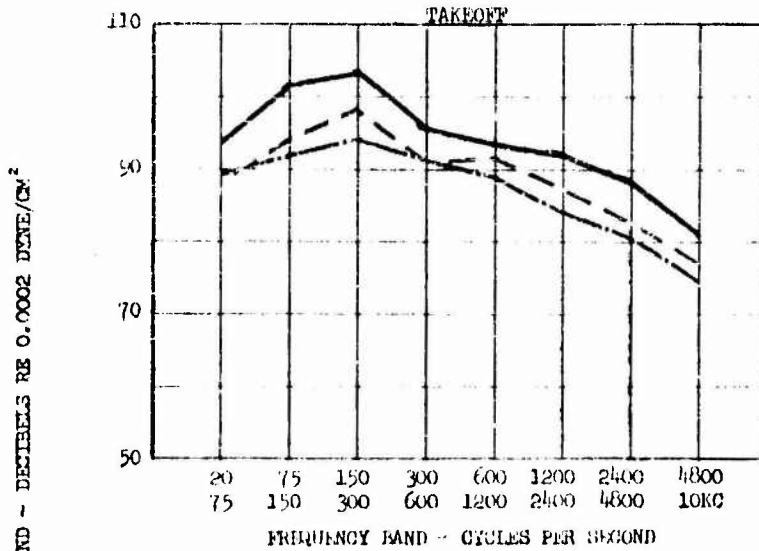

FIGURE 27
- 30 -

MAXIMUM SOUND PRESSURE LEVELS
DURING TAKEOFF AND/OR LANDING

SOUND PRESSURE LEVEL IN BAND ~ DECIBELS RE 0.0002 DYNE/CM²

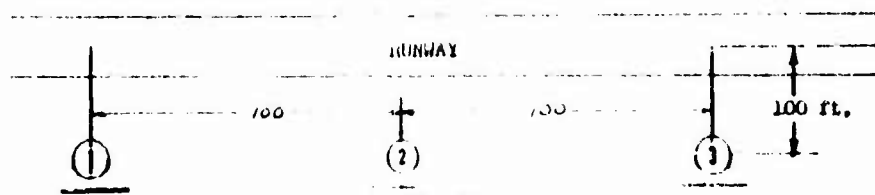
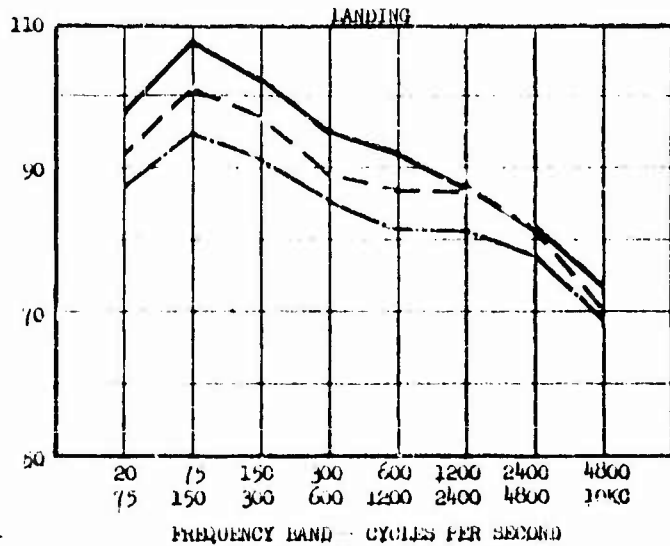
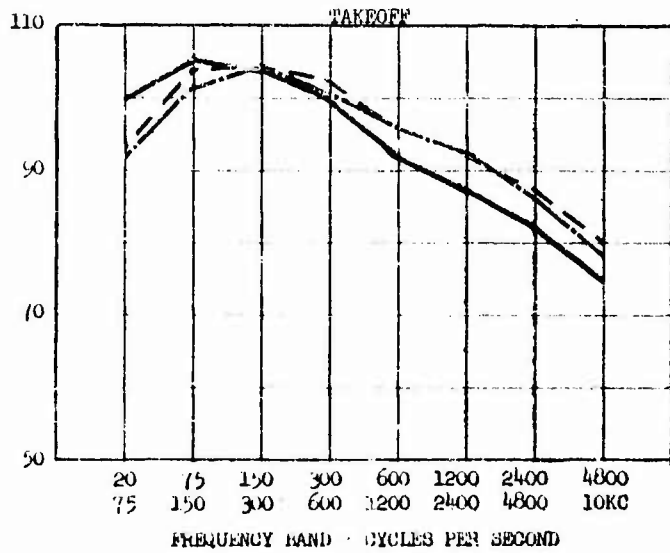

FIGURE 28

MAXIMUM SOUND PRESSURE LEVELS
DURING TAKEOFF AND/OR LANDING

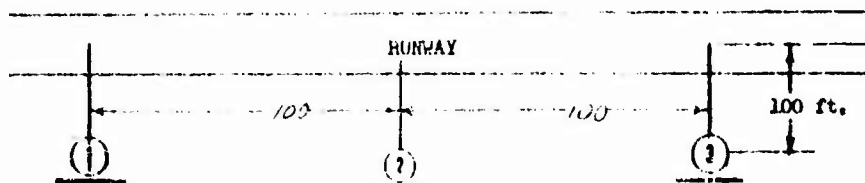
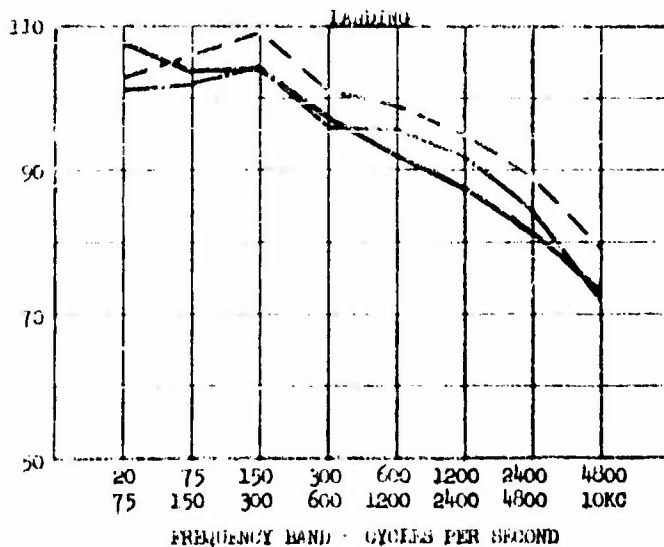
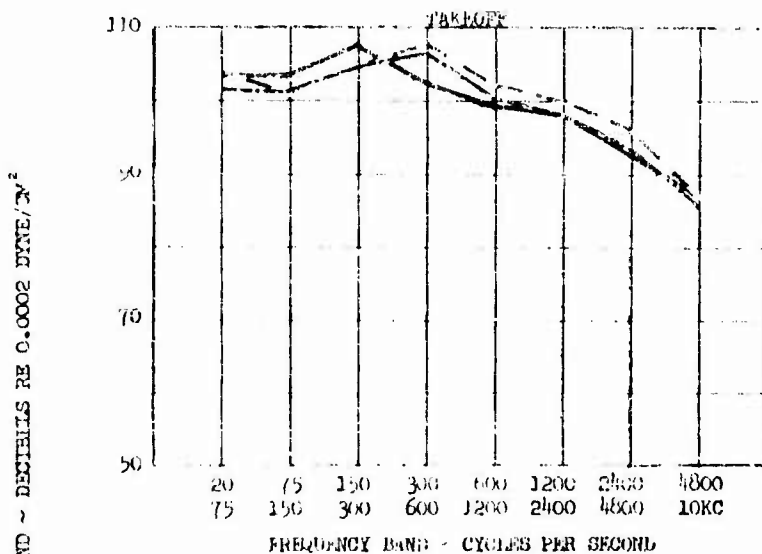

FIGURE 29

MAXIMUM SOUND PRESSURE LEVELS
DURING TAKEOFF AND/OR LANDING

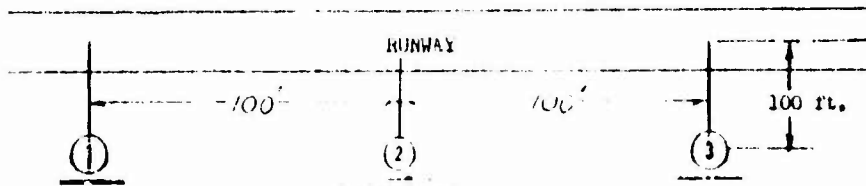
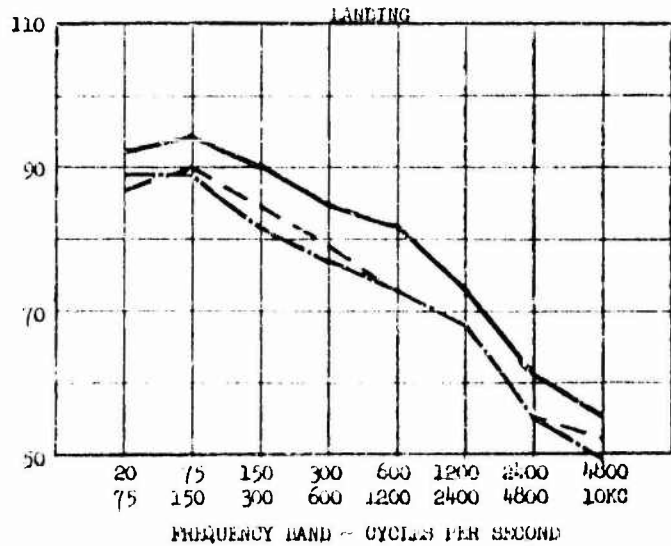
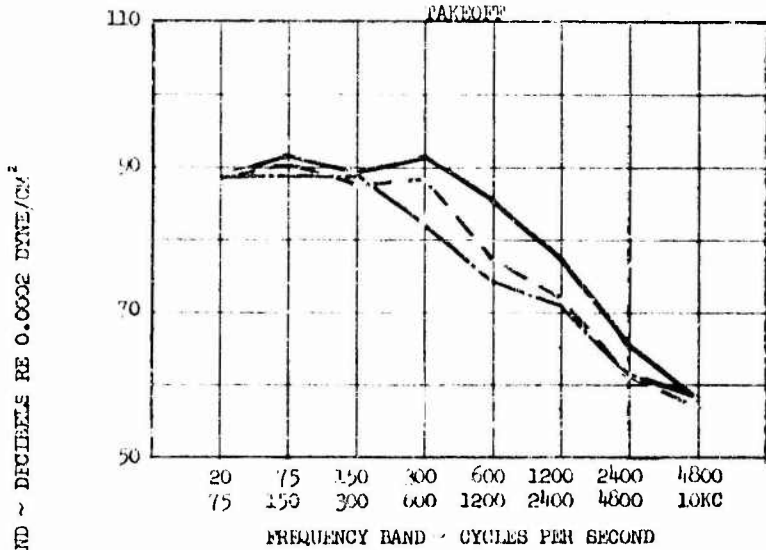

FIGURE 30

MAXIMUM SOUND PRESSURE LEVELS
DURING TAKEOFF AND/OR LANDING

SOUND PRESSURE LEVEL IN BAND ~ DECIBELS RE 0.0002 DYNE/CM²

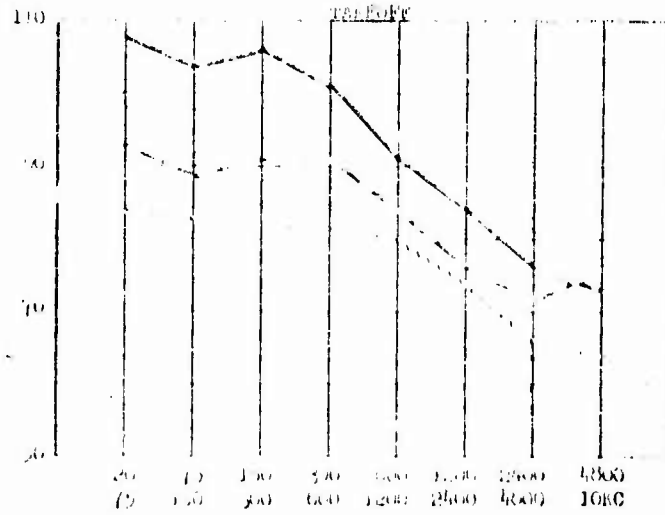

FIG. 1. TAKEOFF - CYCLES PER SECOND

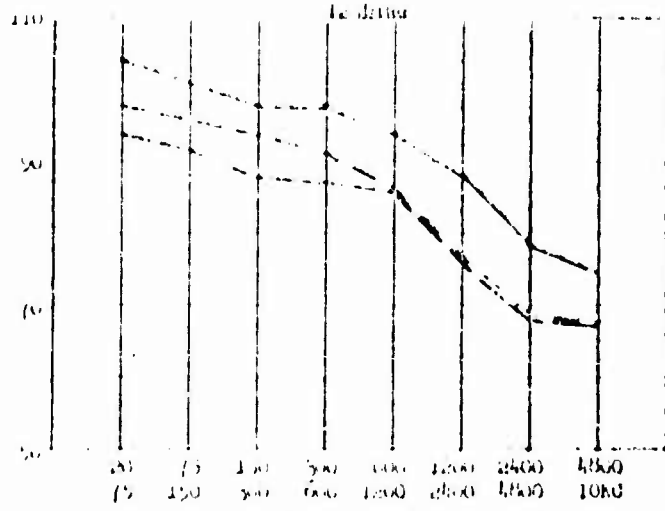

FIG. 2. LANDING - CYCLES PER SECOND



FIG. 3A-1

MAXIMUM SOUND PRESSURE LEVELS
DURING TAKEOFF AND/OR LANDING

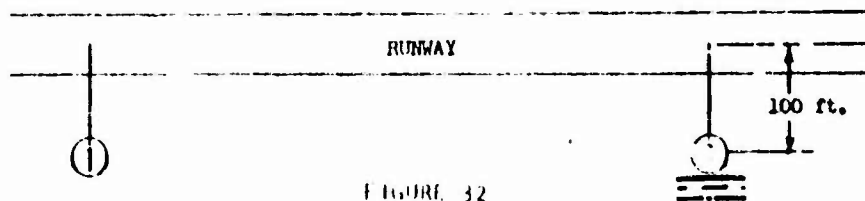
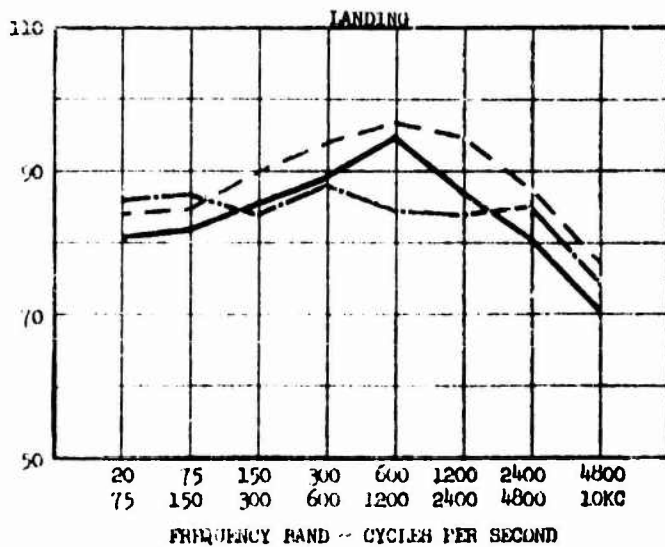
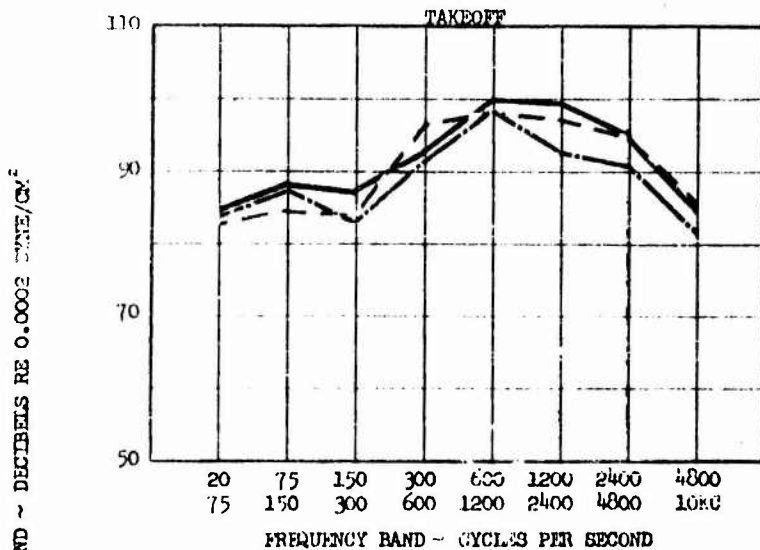

FIGURE 32

A/C-TEST
VERTOL
76-2

MAXIMUM SOUND PRESSURE LEVELS
DURING TAKEOFF AND/OR LANDING

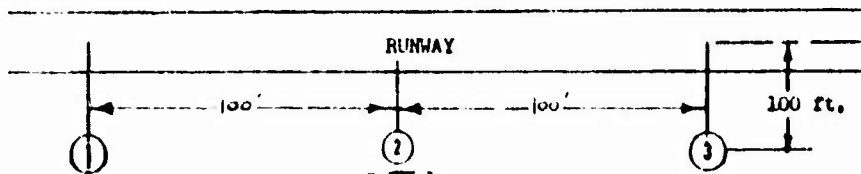
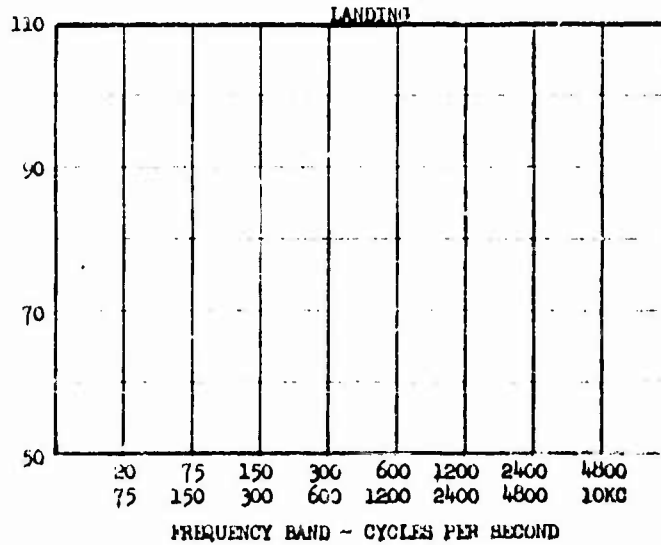
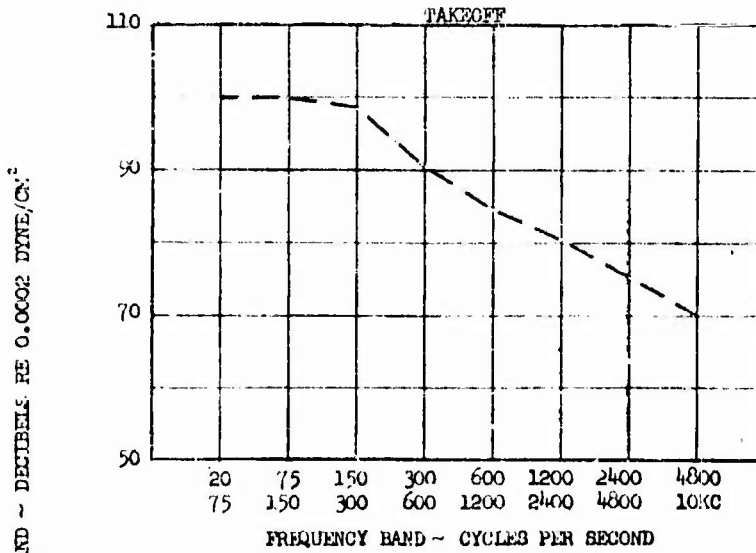
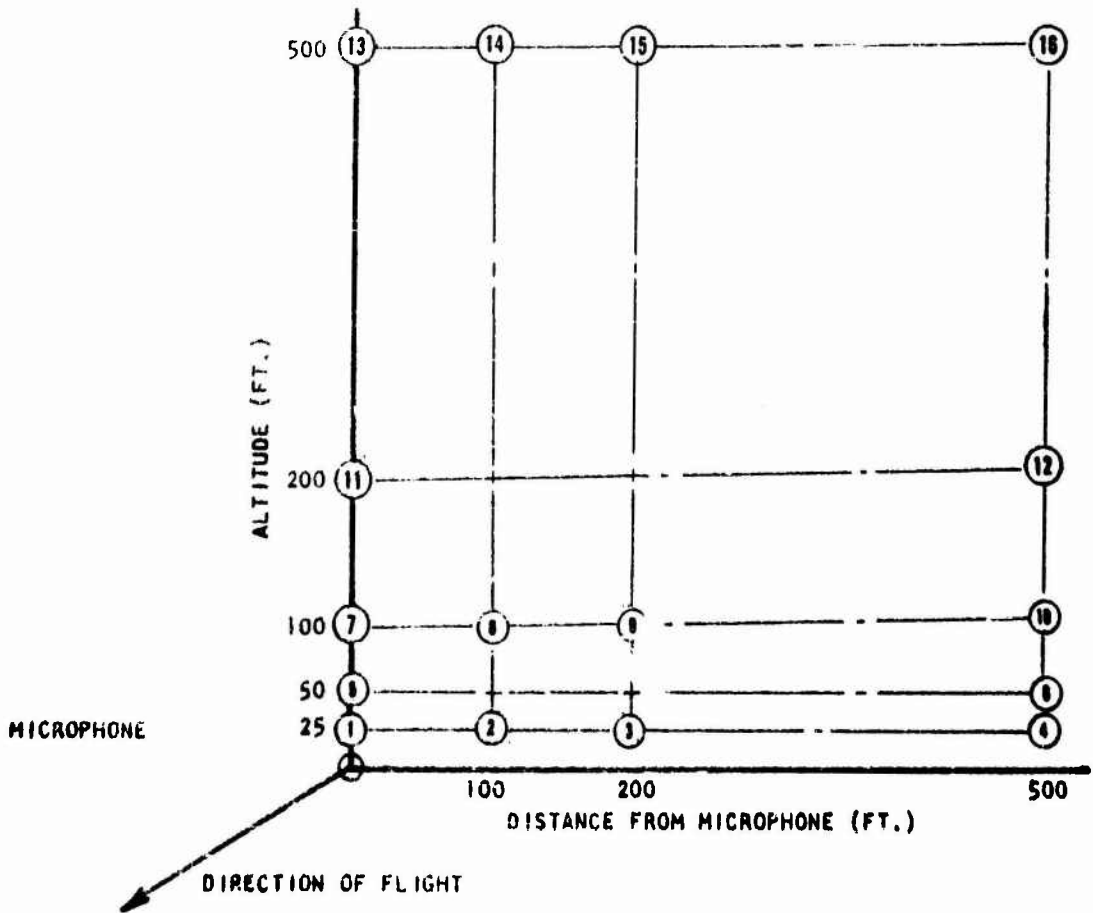

FIGURE 33



MEASUREMENT LOCATIONS - TEST 3

FIGURE 34

MAXIMUM EXTERNAL SOUND PRESSURE
LEVELS MEASURED AT GROUND STATION

L-20-3

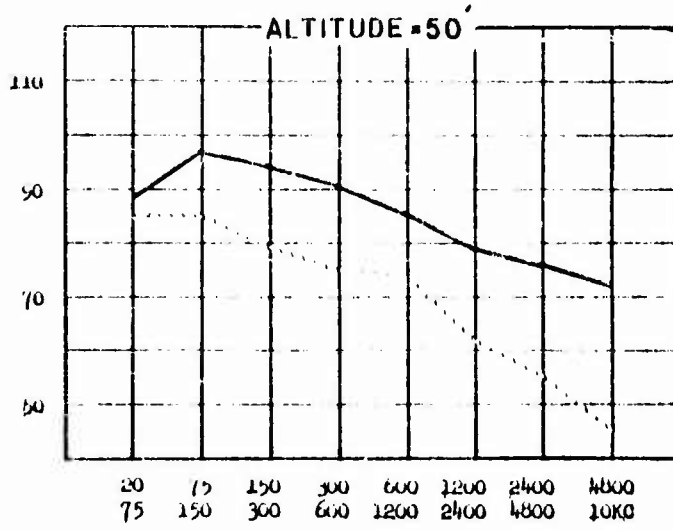
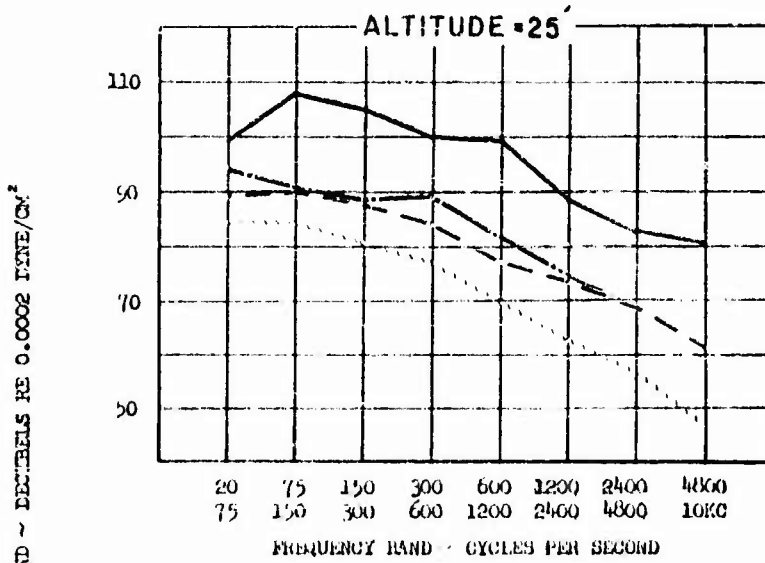

DISTANCES

- 0' ————
- 100' - - - -
- 200' - - - -
- 500' ······

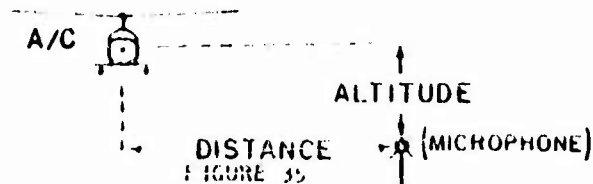
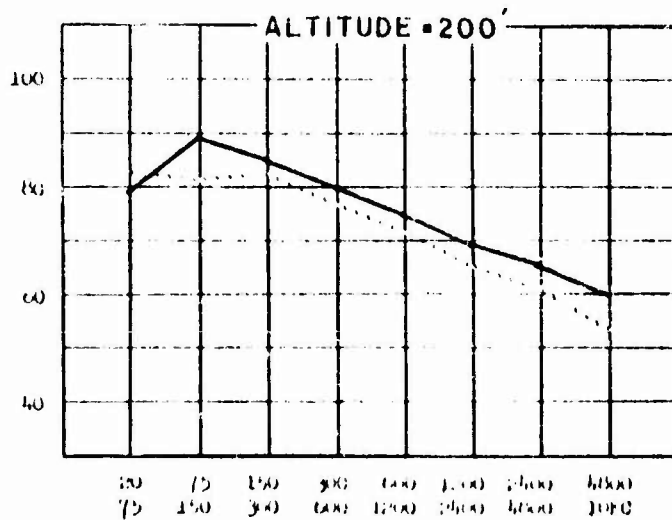
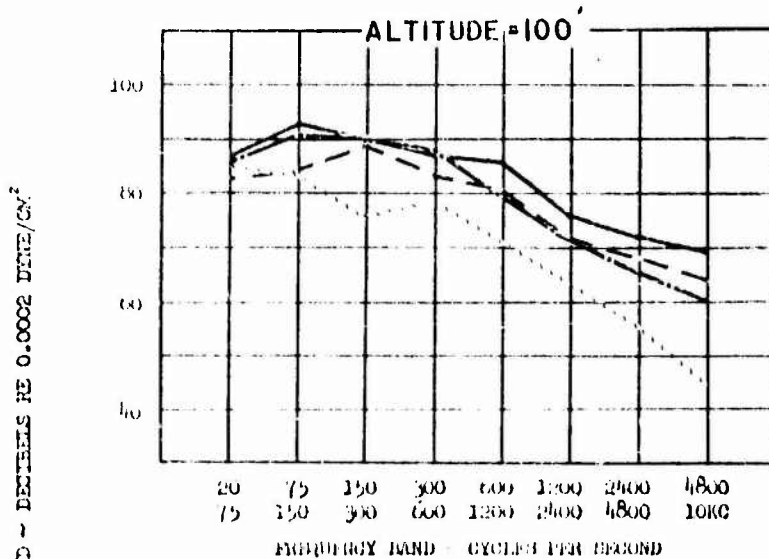

FIGURE 35

MAXIMUM EXTERNAL SOUND PRESSURE
LEVELS MEASURED AT GROUND STATION

L-20-3



DISTANCES

- 0' ————
- 100' - - - -
- 200' - - - -
- 500' ······

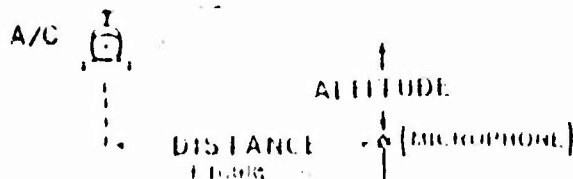

MAXIMUM EXTERNAL SOUND PRESSURE
LEVELS MEASURED AT GROUND STATION

A/C - TEST

L-20-3

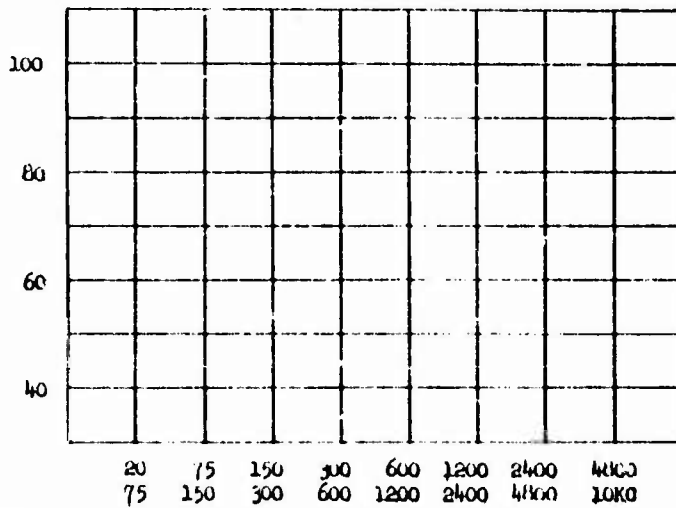
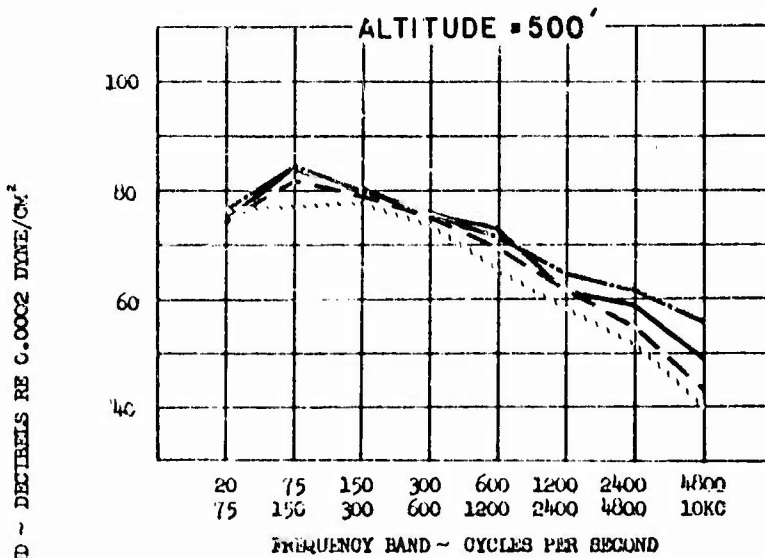

DISTANCES

- 0' —————
- 100' - - - - -
- 200' - - - - -
- 500' ·······

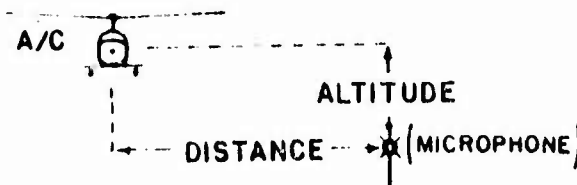
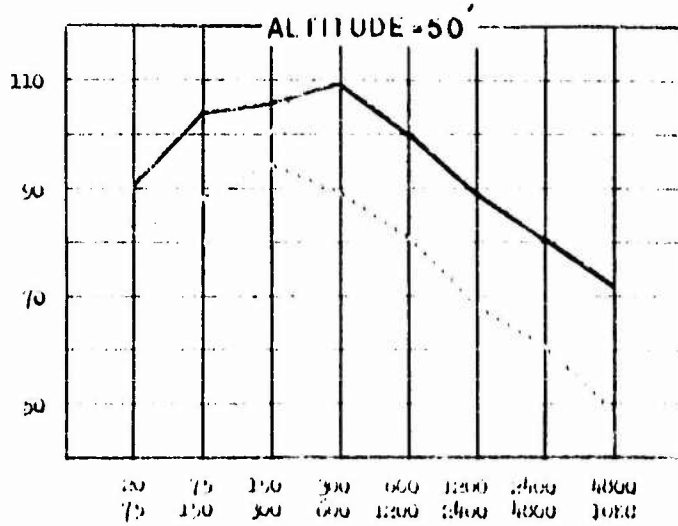
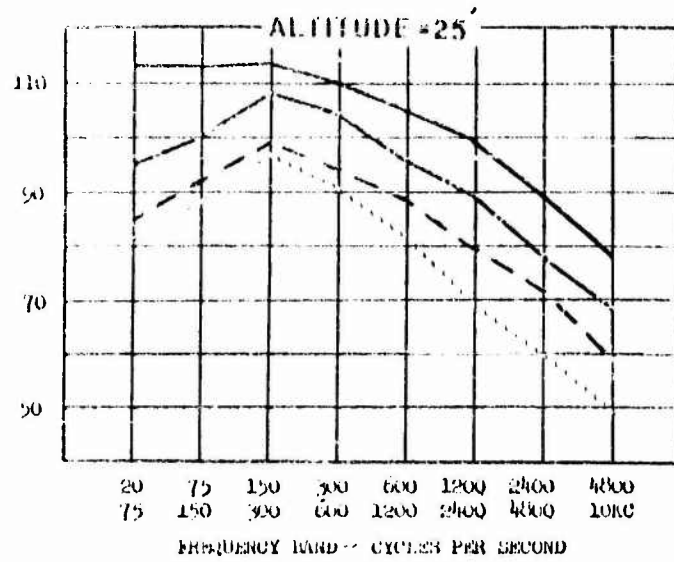

FIGURE 3/

MAXIMUM EXTERNAL SOUND PRESSURE
LEVELS MEASURED AT GROUND STATION

L-23-3

SOUND PRESSURE LEVEL IN BAND ~ DECIBELS RE 0.0002 DYNE/CM²



DISTANCES

- 0' —————
- 100' - - - - -
- 200' ······
- 500' - - - - -

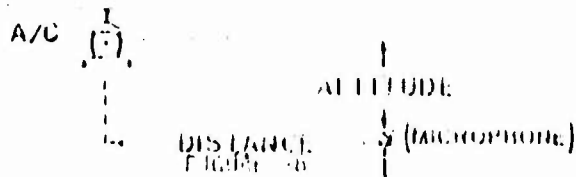

MAXIMUM EXTERNAL SOUND PRESSURE
LEVELS MEASURED AT GROUND STATION

L-23-3

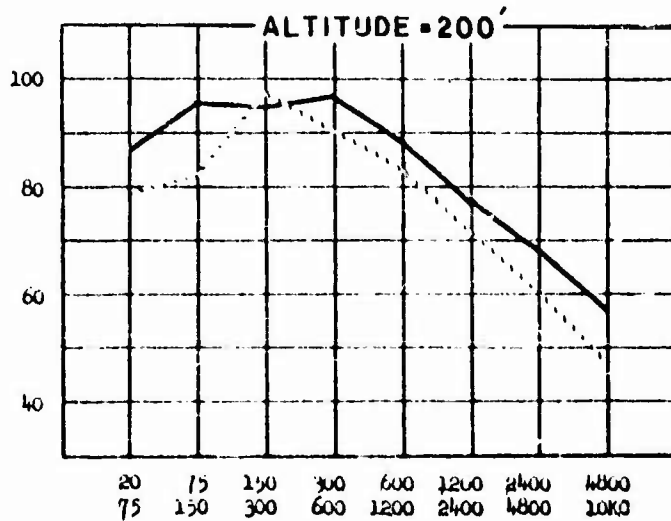
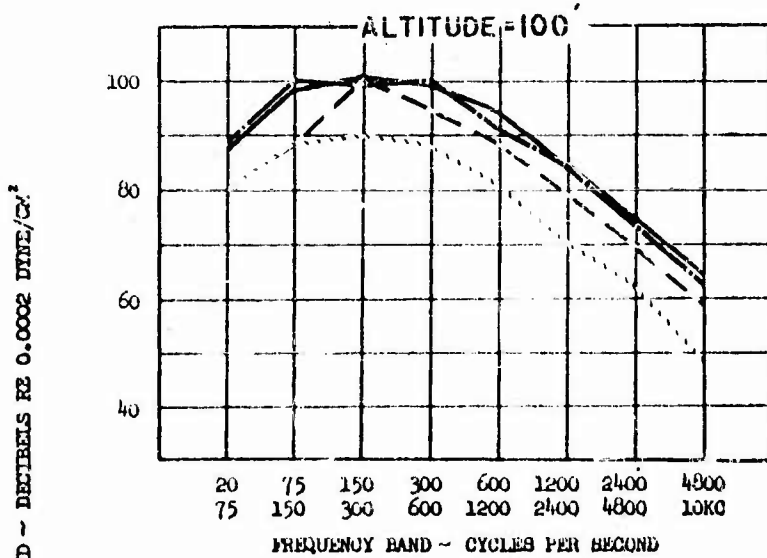

DISTANCES

- 0' ———
- 100' - - - -
- 200' - - - -
- 500' ·····

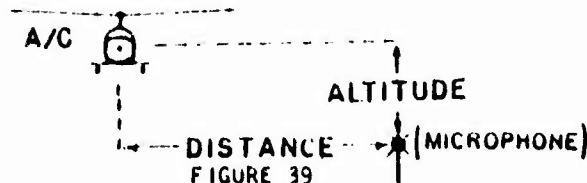

MAXIMUM EXTERNAL SOUND PRESSURE
LEVELS MEASURED AT GROUND STATION

A/C - TEST

L-23-3

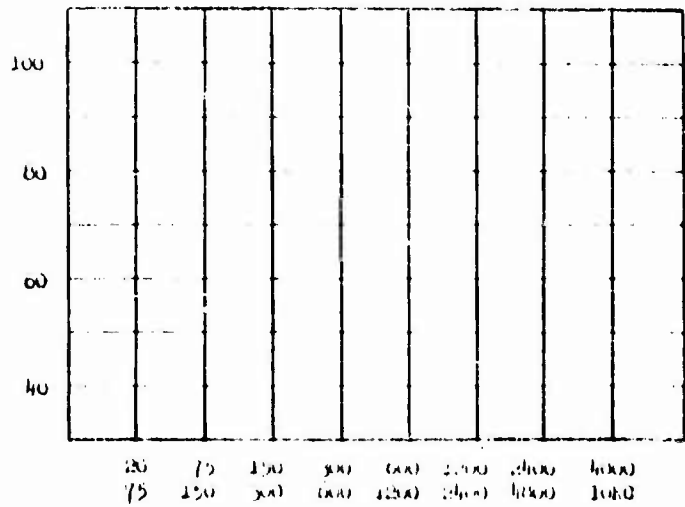
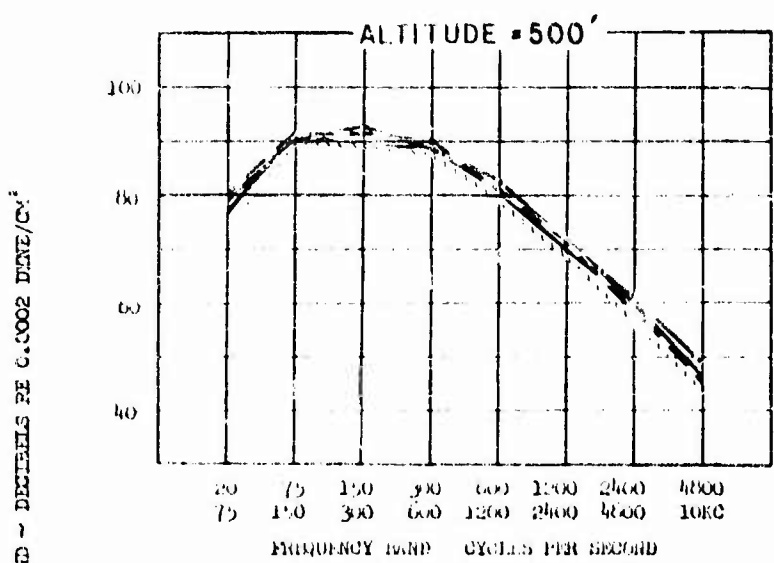

DISTANCES

- 0' —————
- 100' - - - - -
- 200' - - - - -
- 500' ······

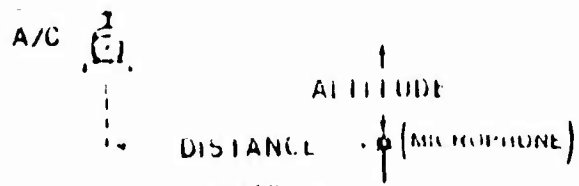

FIGURE 50

A/C-TEST

MAXIMUM EXTERNAL SOUND PRESSURE
LEVELS MEASURED AT GROUND STATION

U-1A-3

SOUND PRESSURE LEVEL IN BAND - DECIBELS RE 0.0002 DYNE/CM²

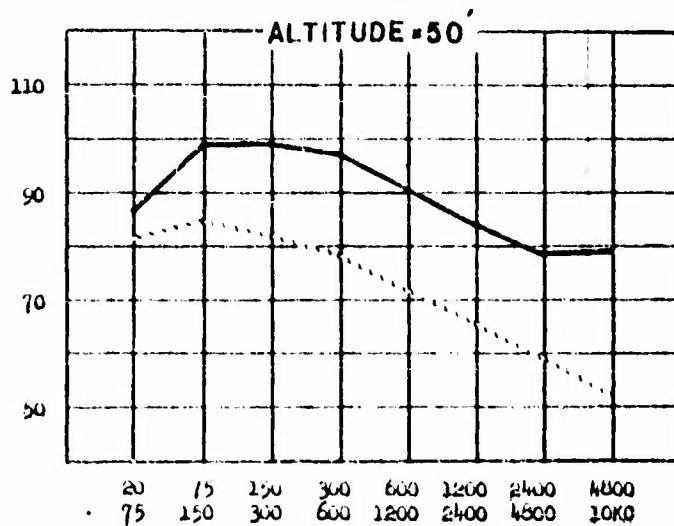
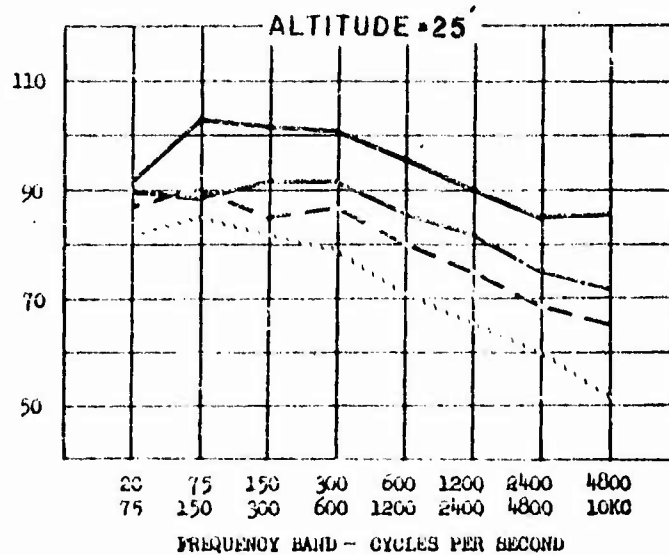

DISTANCES

100' —————
 200' - - - - -
 500' ······

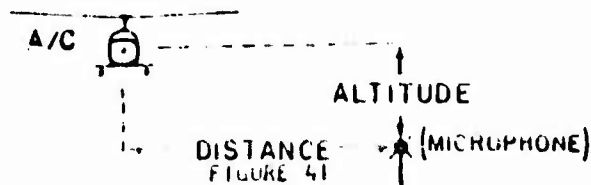

MAXIMUM EXTERNAL SOUND PRESSURE
LEVELS MEASURED AT GROUND STATION

SOUND PRESSURE LEVEL IN BAND - DECIBELS RE 0.0002 DYNE/CM²

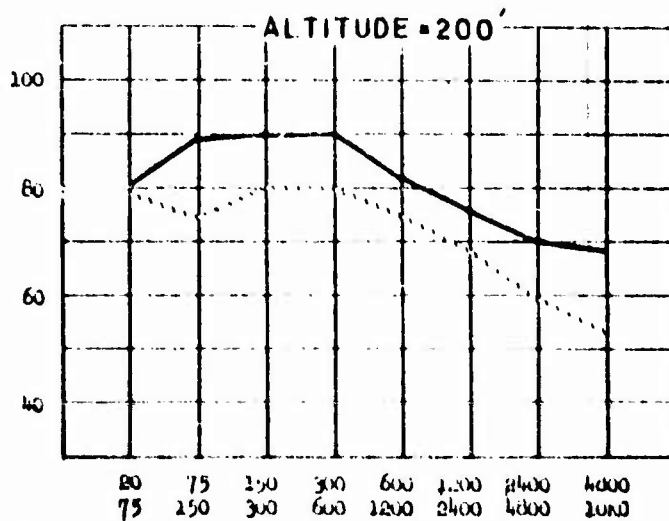
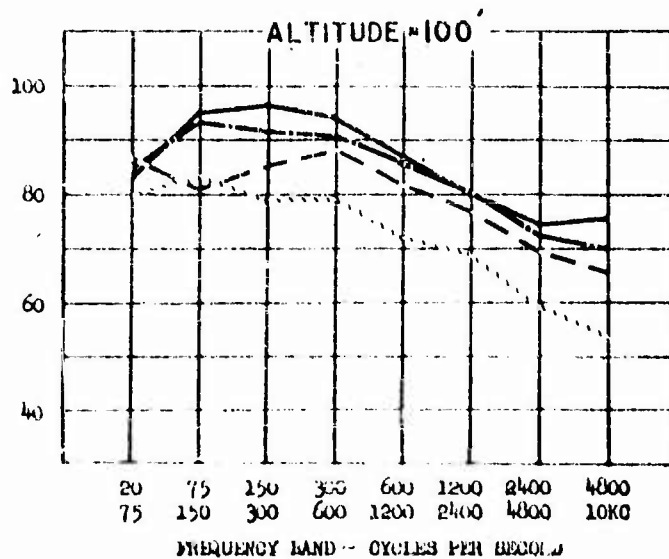

DISTANCES

- 0' —————
- 100' - - - - -
- 200' - - - - -
- 600' ······

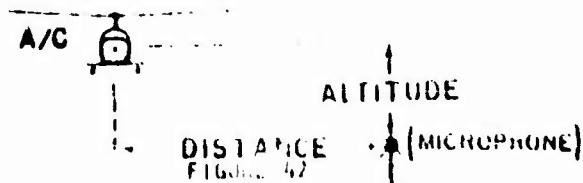
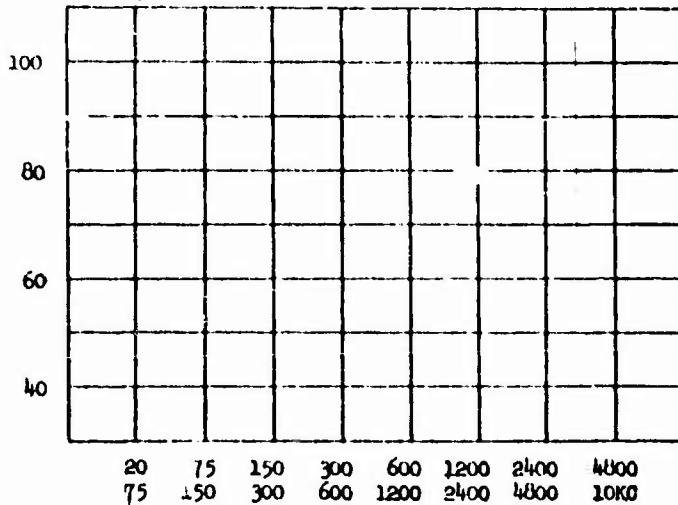
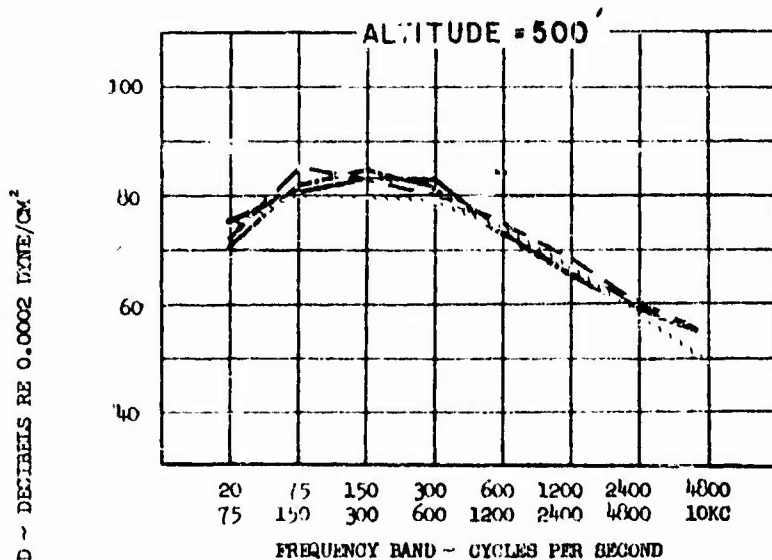

FIGURE 42

MAXIMUM EXTERNAL SOUND PRESSURE
LEVELS MEASURED AT GROUND STATION

A/C - TEST

U-1A-3



DISTANCES

- 0' —————
- 100' - - - - -
- 200' - - - - -
- 500' ·······

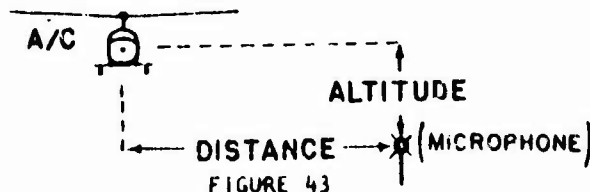
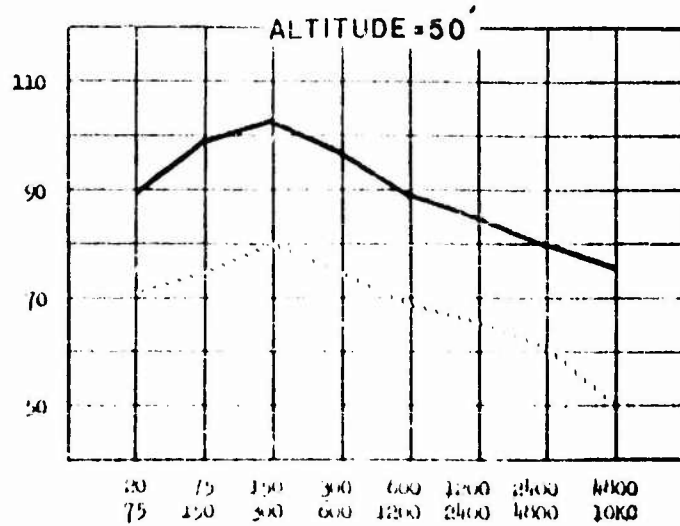
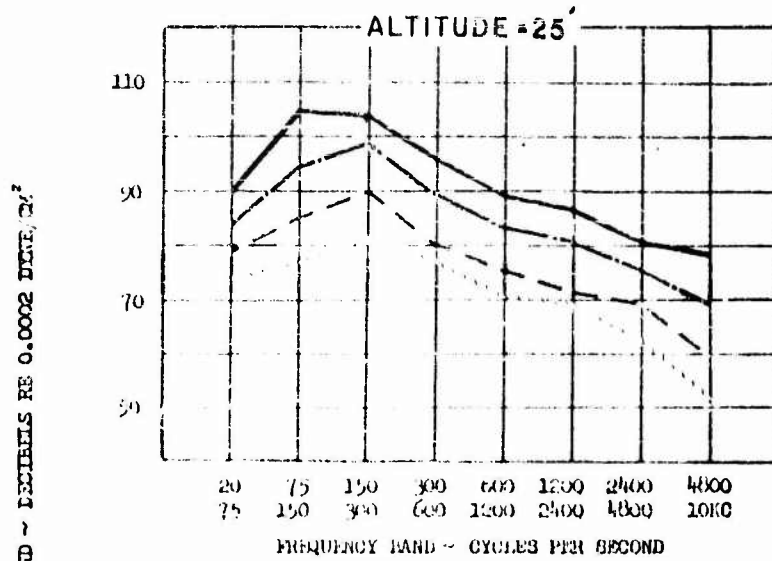

FIGURE 43

MAXIMUM EXTERNAL SOUND PRESSURE
LEVELS MEASURED AT GROUND STATION

H-13-3



DISTANCES

- 0' ————
- 100' - - - -
- 200' - - - -
- 500' ······

A/C



DISTANCE
FEET

↑
ALTITUDE

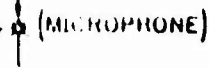

MAXIMUM EXTERNAL SOUND PRESSURE
LEVELS MEASURED AT GROUND STATION

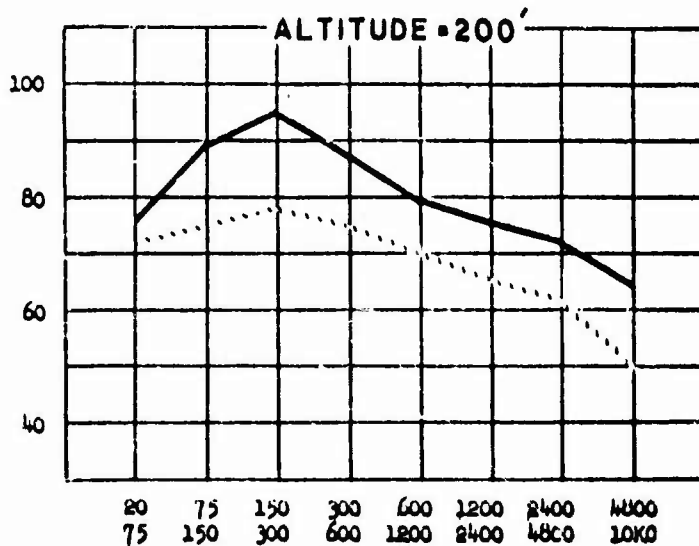
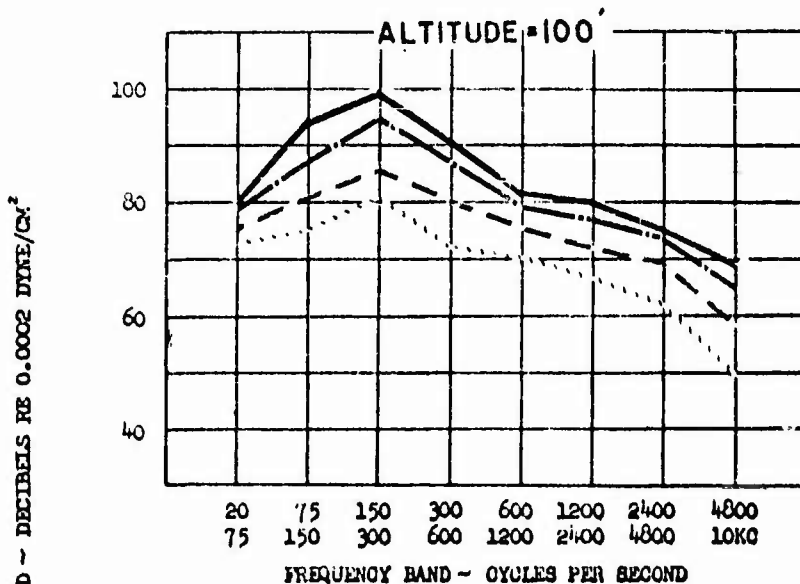

DISTANCES

- 0' —————
- 100' - - - - -
- 200' - - - - -
- 500' - - - - -

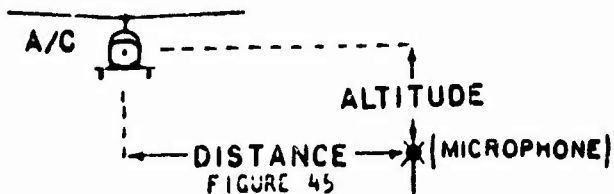
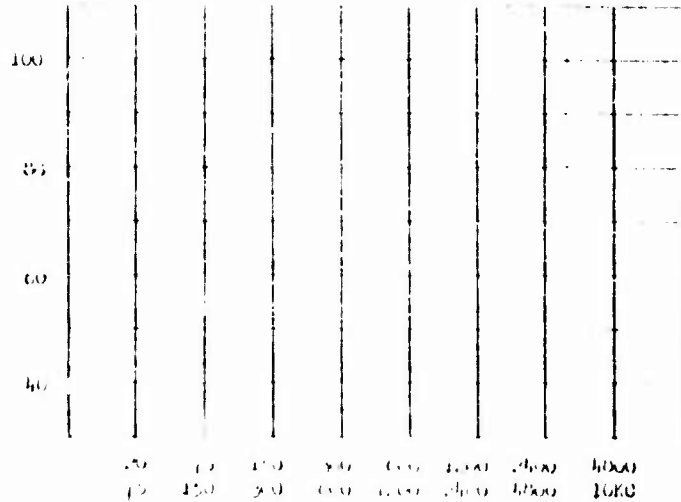
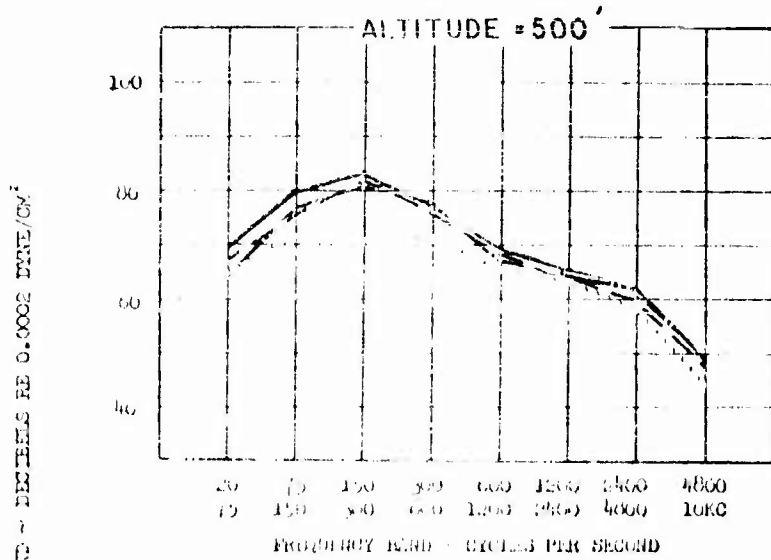

FIGURE 45

MAXIMUM EXTERNAL SOUND PRESSURE
LEVELS MEASURED AT GROUND STATION

A/C - TEST

H-13-3



DISTANCES

- 0' ————
- 100' - - - -
- 200' - · - · -
- 500' - · · · ·

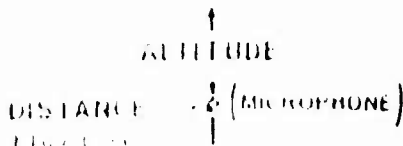
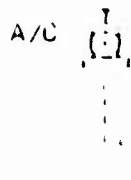

MAXIMUM EXTERNAL SOUND PRESSURE
LEVELS MEASURED AT GROUND STATION

H-21-3

SOUND PRESSURE LEVEL IN BAND ~ DECIBELS RE 0.0002 DYNE/CM²

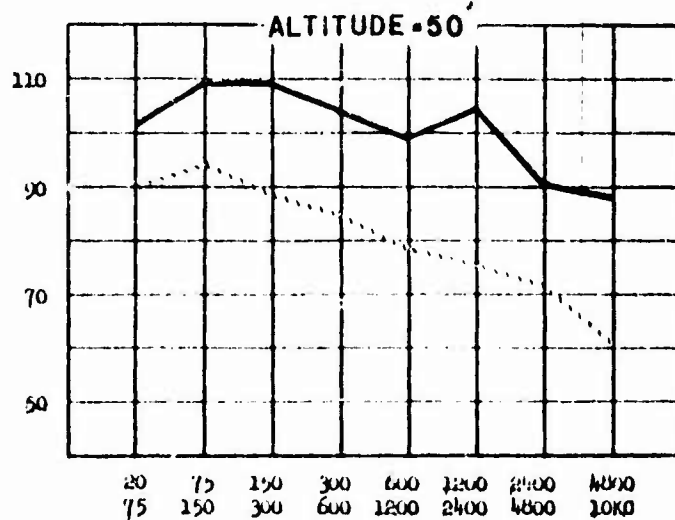
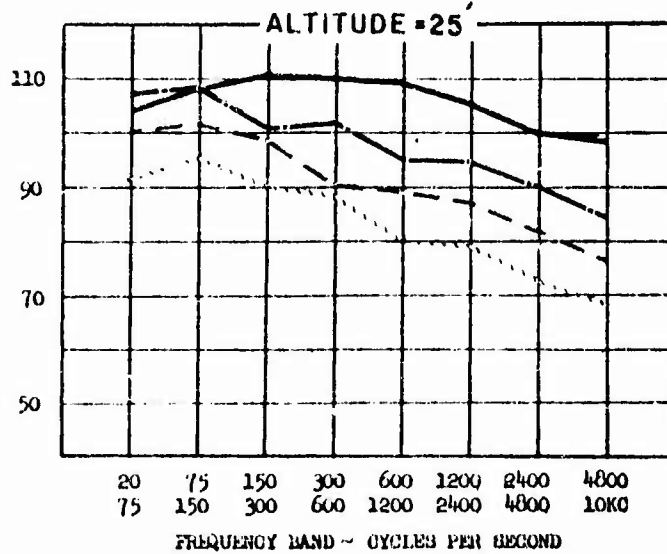

DISTANCES

- 0' —————
- 100' - - - - -
- 200' - - - - -
- 500' ·······

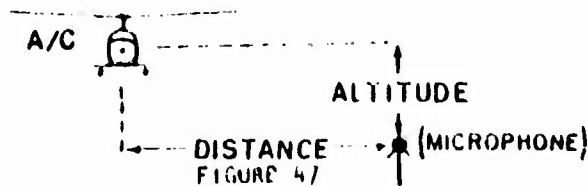
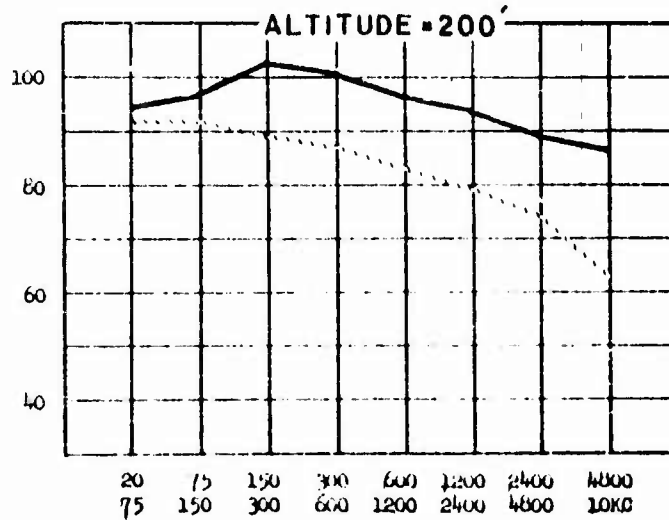
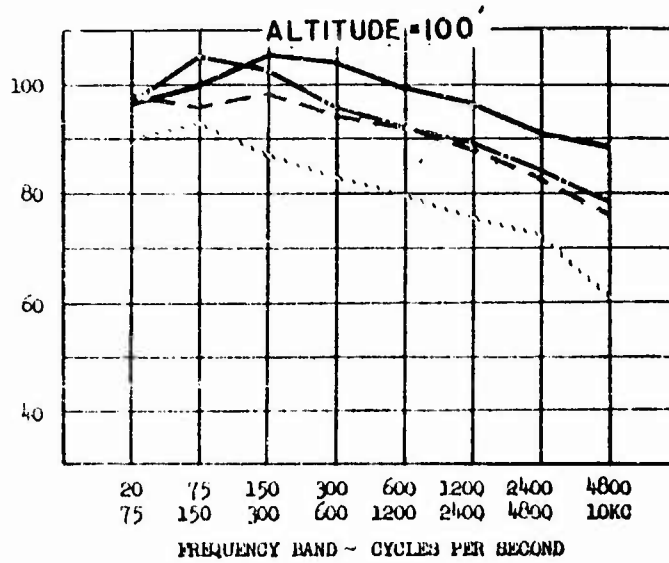

FIGURE 47

MAXIMUM EXTERNAL SOUND PRESSURE
LEVELS MEASURED AT GROUND STATION

H-21-3

SOUND PRESSURE LEVEL IN BAND ~ DECIBELS RE 0.0002 DYNE/CM²



DISTANCES

- 0' —————
- 100' - - - - -
- 200' - - - - -
- 500' ·······

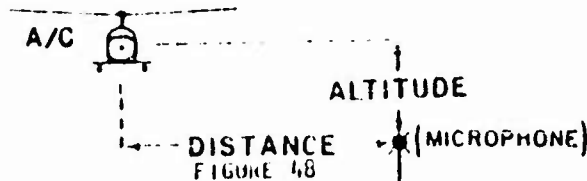

MAXIMUM EXTERNAL SOUND PRESSURE
LEVELS MEASURED AT GROUND STATION

A/C - TEST

H-21-3

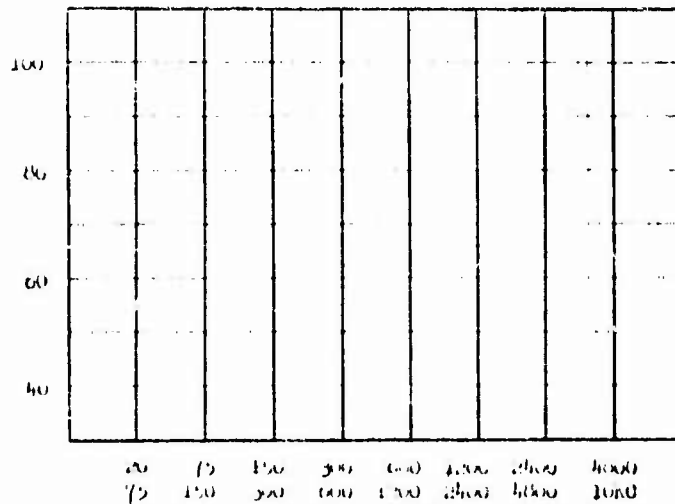
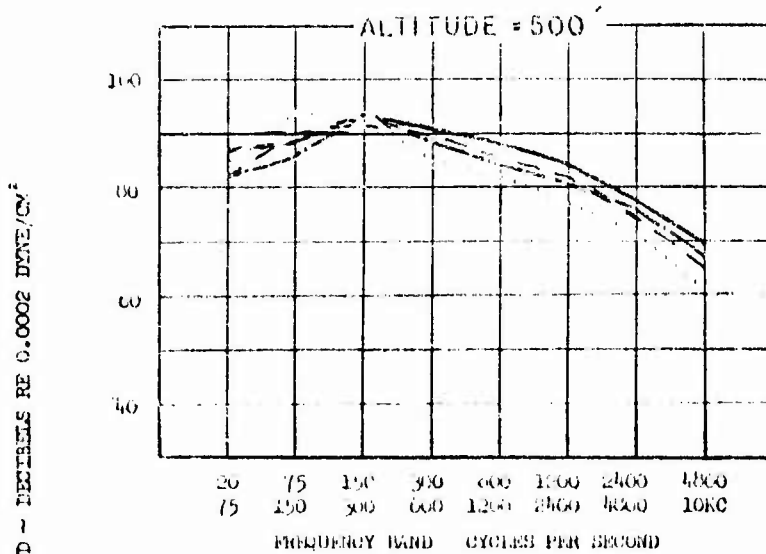

DISTANCES

- 0' —————
- 100' - - - - -
- 200' - - - - -
- 500' ······

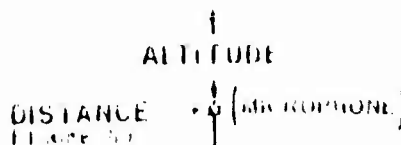
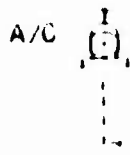

MAXIMUM EXTERNAL SOUND PRESSURE
LEVELS MEASURED AT GROUND STATION

H-23-3

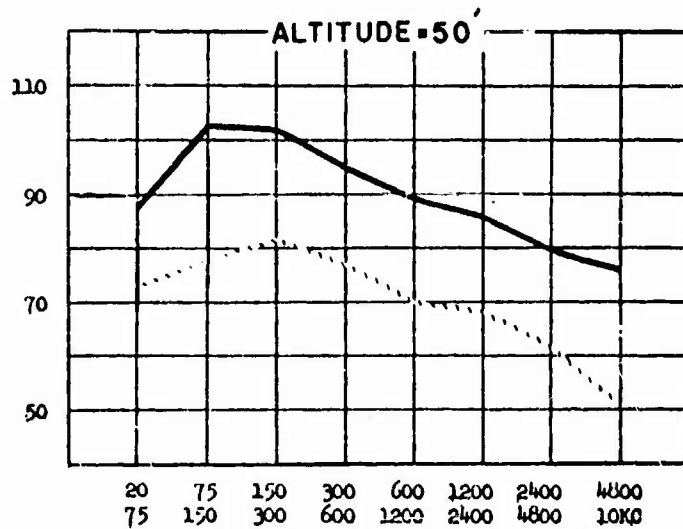
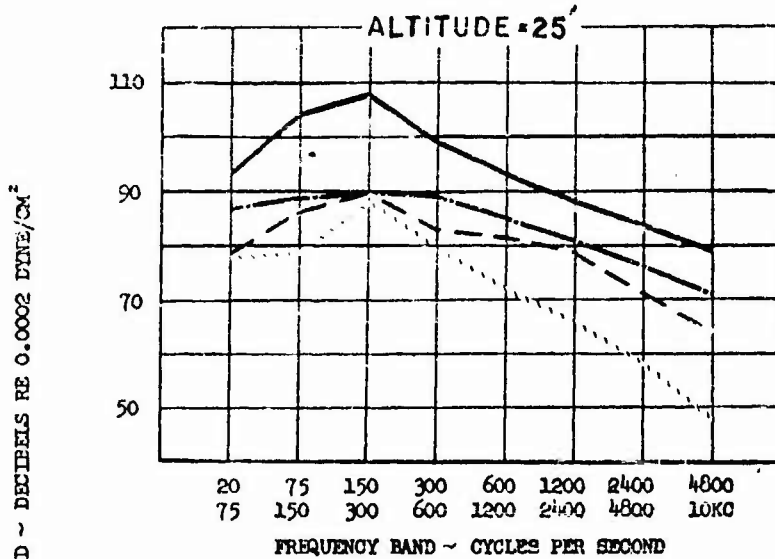

DISTANCES

- 0' —————
- 100' - - - - -
- 200' - - - - -
- 500' ·······

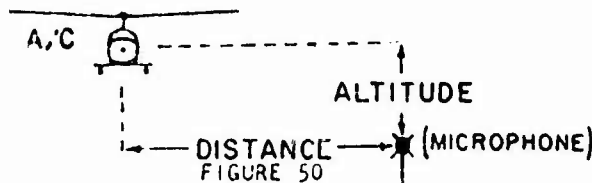

MAXIMUM EXTERNAL SOUND PRESSURE
LEVELS MEASURED AT GROUND STATION

A/C-TEST
H-23-3

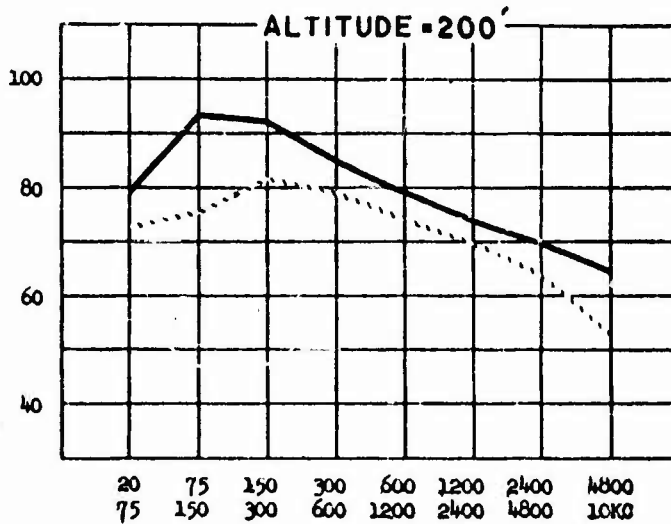
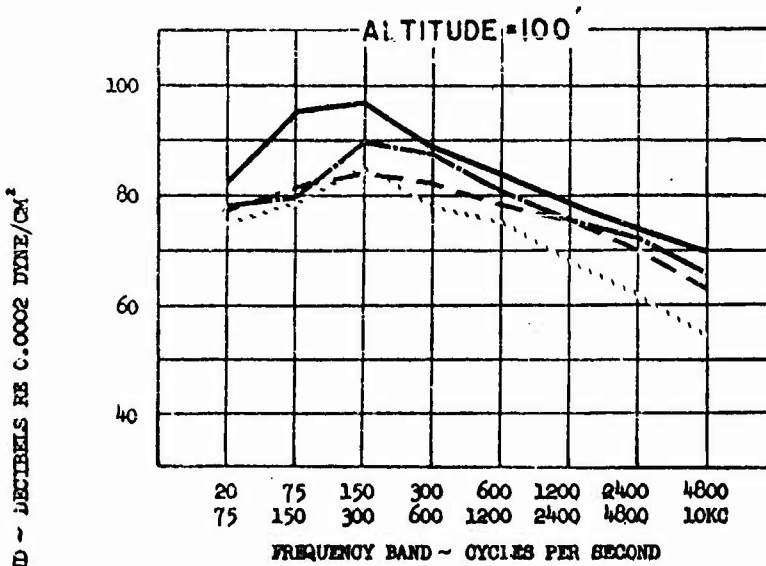

DISTANCES

- 0' ————
- 100' - - - -
- 200' - - - -
- 500' ······

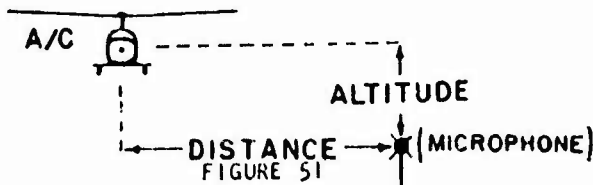
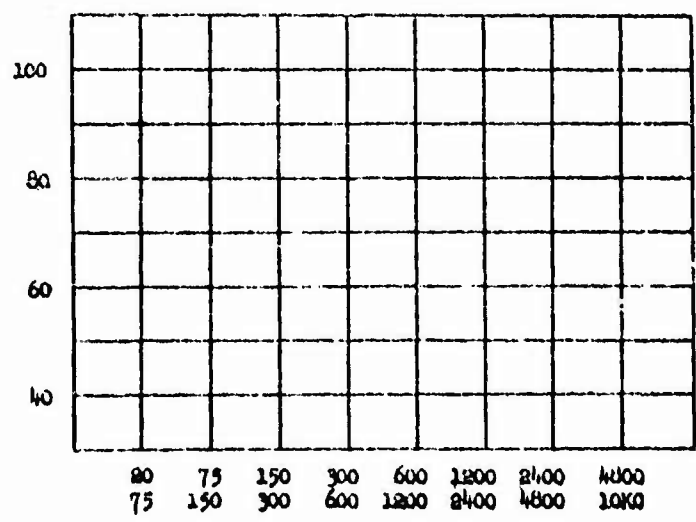
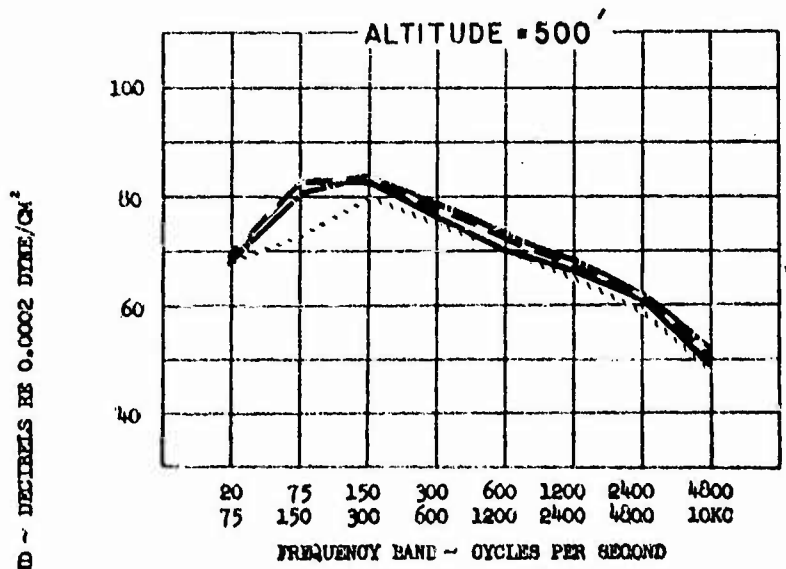

FIGURE 51

A/C - TEST

MAXIMUM EXTERNAL SOUND PRESSURE
LEVELS MEASURED AT GROUND STATION

H-23-3



DISTANCES

- 0' —————
- 100' - - - - -
- 200' ······
- 500' ······

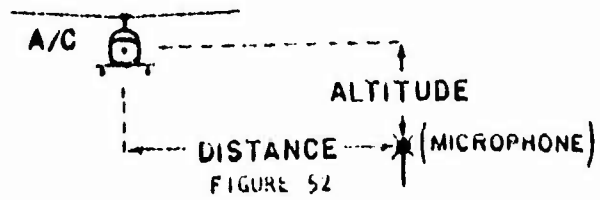
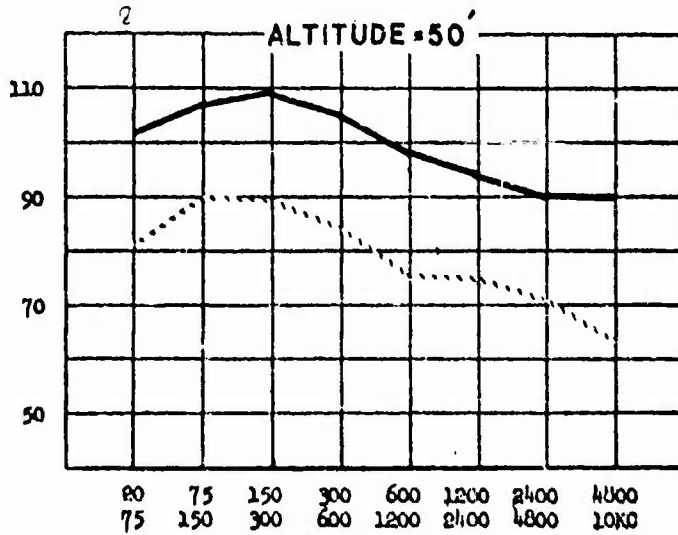
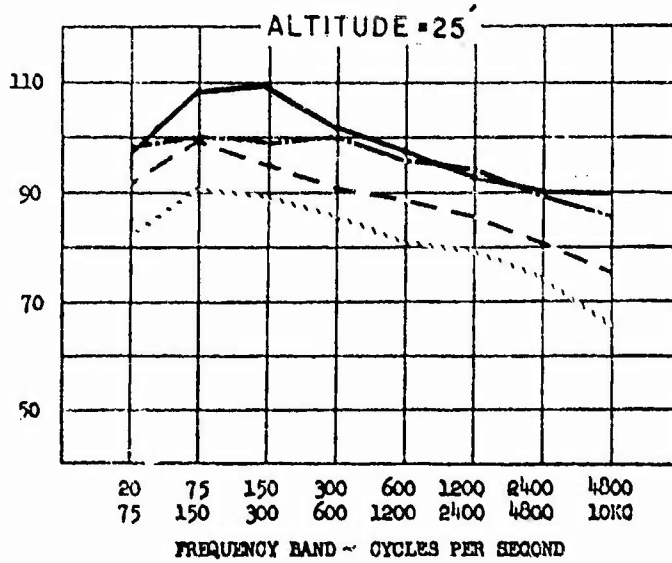

FIGURE 52

MAXIMUM EXTERNAL SOUND PRESSURE
LEVELS MEASURED AT GROUND STATION

H-34-3

SOUND PRESSURE LEVEL IN BAND ~ DECIBELS RE 0.0002 DYNE/CM²



DISTANCES

- 0' —————
- 100' - - - - -
- 200' - - - - -
- 500' ········

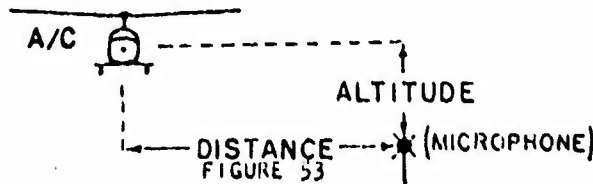

MAXIMUM EXTERNAL SOUND PRESSURE
LEVELS MEASURED AT GROUND STATION

H-34-3

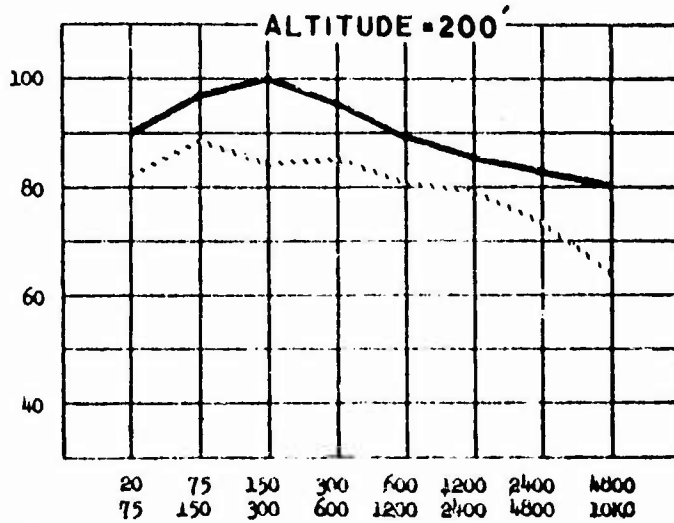
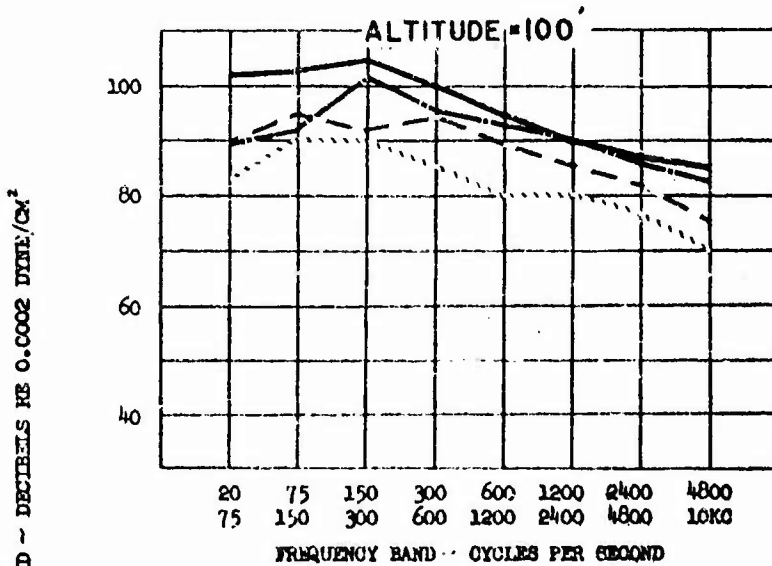

DISTANCES

- 0' ————
- 100' ————
- 200' - - - -
- 500' ······

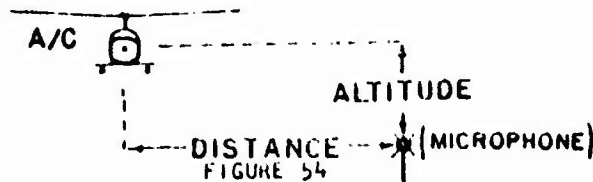

MAXIMUM EXTERNAL SOUND PRESSURE A/C - TEST
 LEVELS MEASURED AT GROUND STATION H-34-3

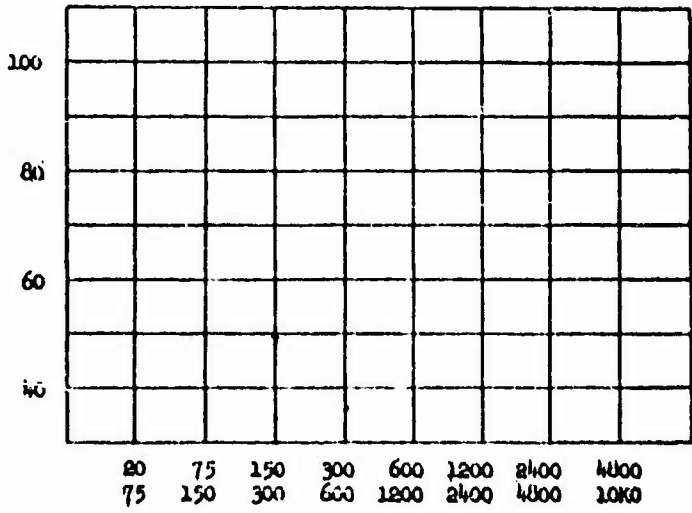
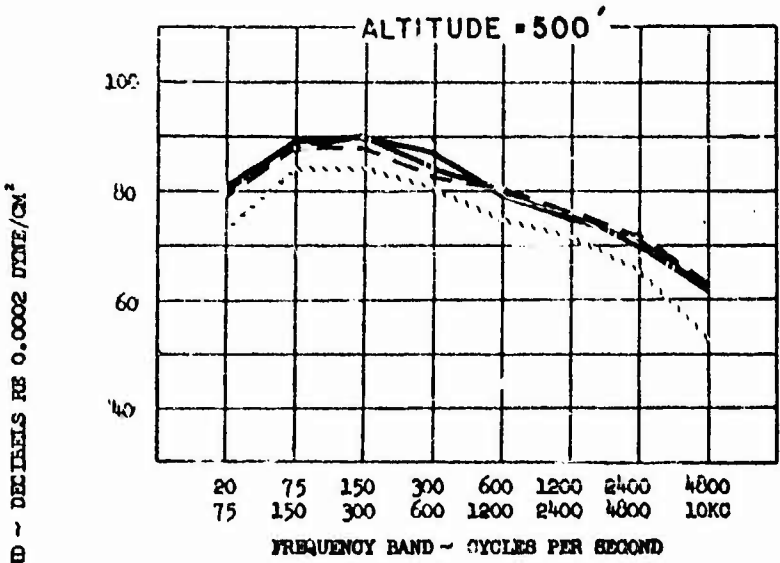

DISTANCES

- 0' ————
- 100' ————
- 200' - - - -
- 500' ······

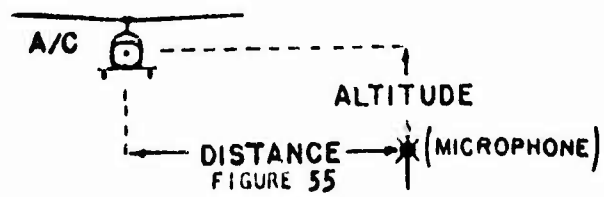

MAXIMUM EXTERNAL SOUND PRESSURE
LEVELS MEASURED AT GROUND STATION

H-37-3

SOUND PRESSURE LEVEL IN BAND ~ DECIBELS RE 0.0002 DYNE/CM²

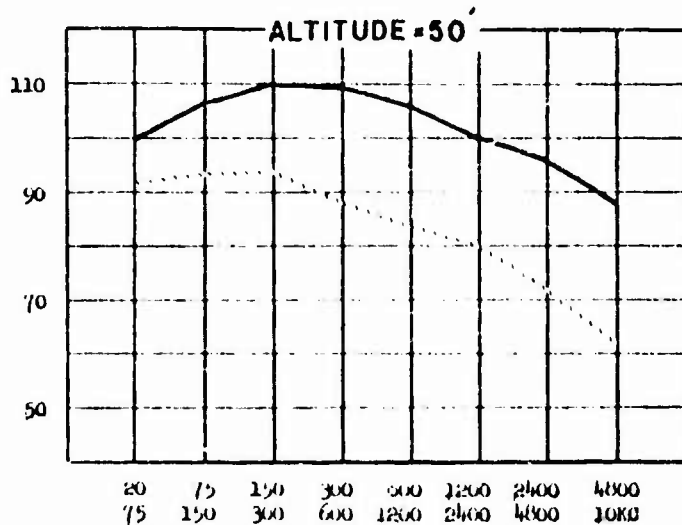
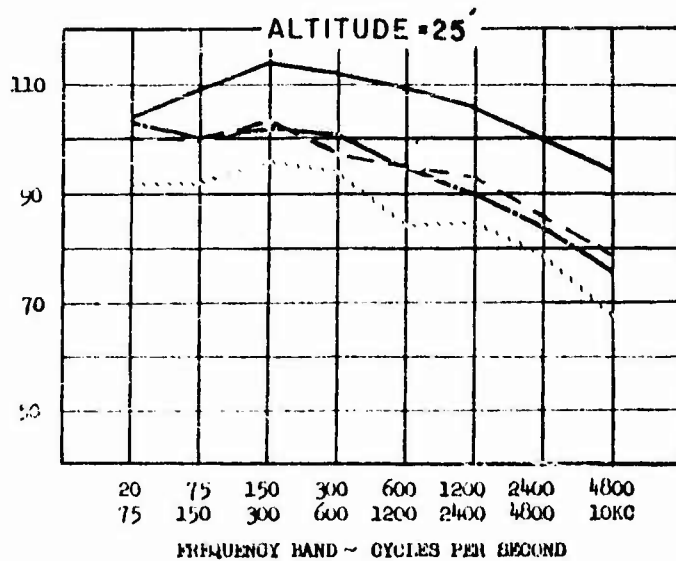

DISTANCES

- 0' ————
- 100' - - - -
- 200' - - - -
- 500' ······

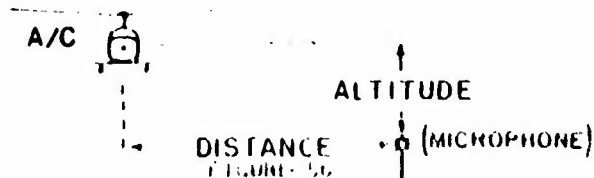

**MAXIMUM EXTERNAL SOUND PRESSURE
LEVELS MEASURED AT GROUND STATION**

**A/C-TEST
H-37-3**

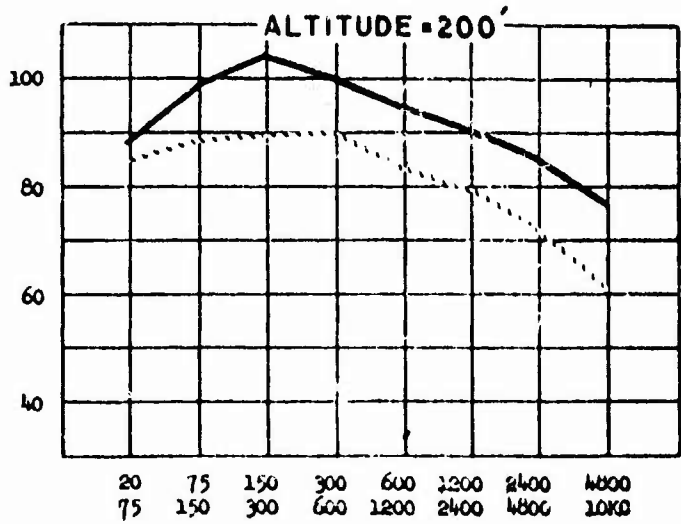
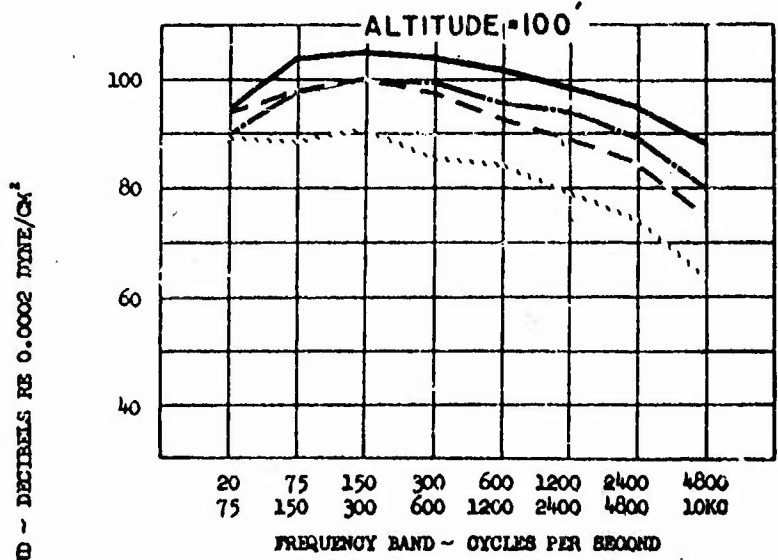

DISTANCES

- 0' ———
- 100' - - -
- 200' - - -
- 500' ·····

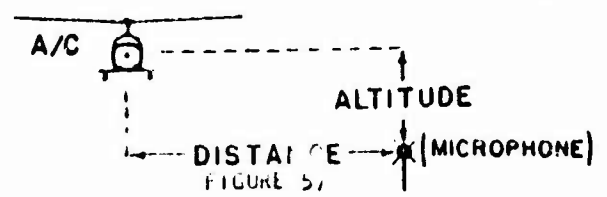
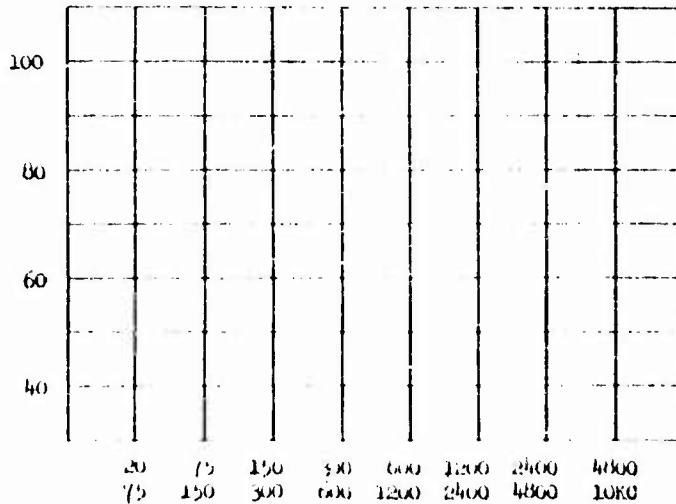
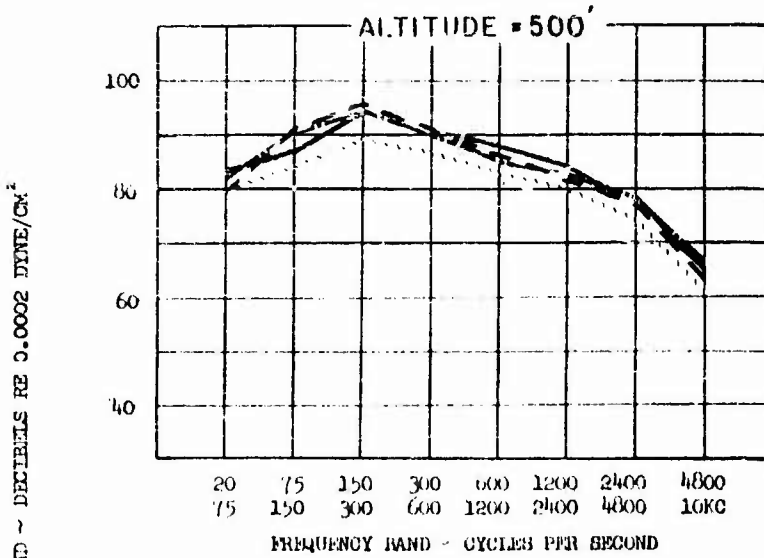

FIGURE 57

MAXIMUM EXTERNAL SOUND PRESSURE
LEVELS MEASURED AT GROUND STATION

A/C - TEST
H-37-3



DISTANCES

- 0' ———
- 100' - - - -
- 200' - - - -
- 500' ·····

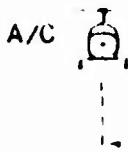

↑
AL.TITUDE

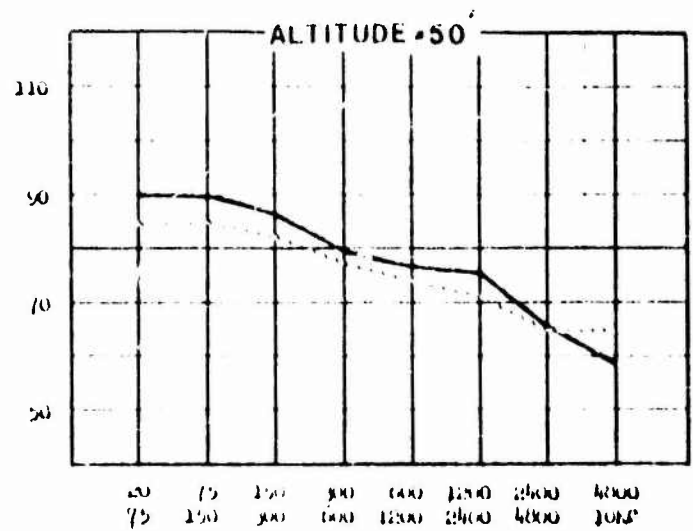
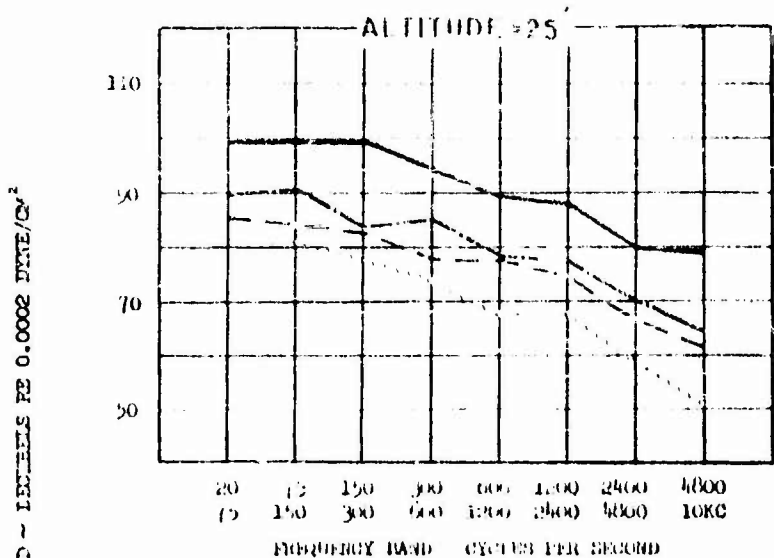

FIGURE 58

A/C-TEST

MAXIMUM EXTERNAL SOUND PRESSURE
LEVELS MEASURED AT GROUND STATION

HU-1A-3



DISTANCES

0' —————

100' - - - - -

200' - - - - -

500' ·······

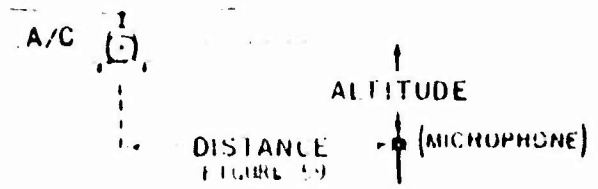
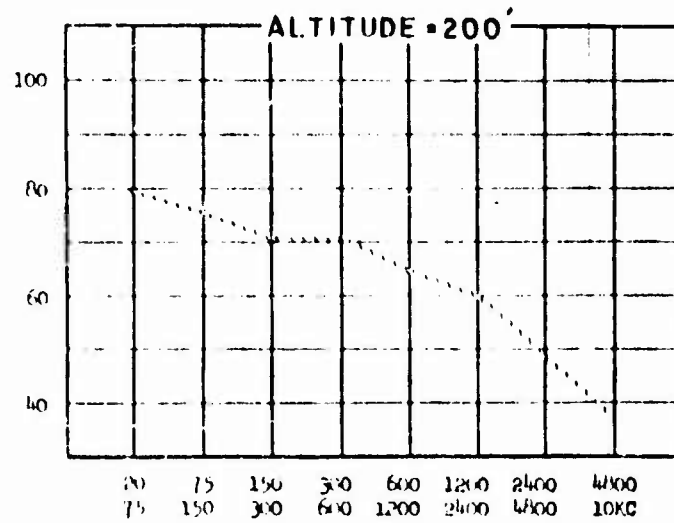
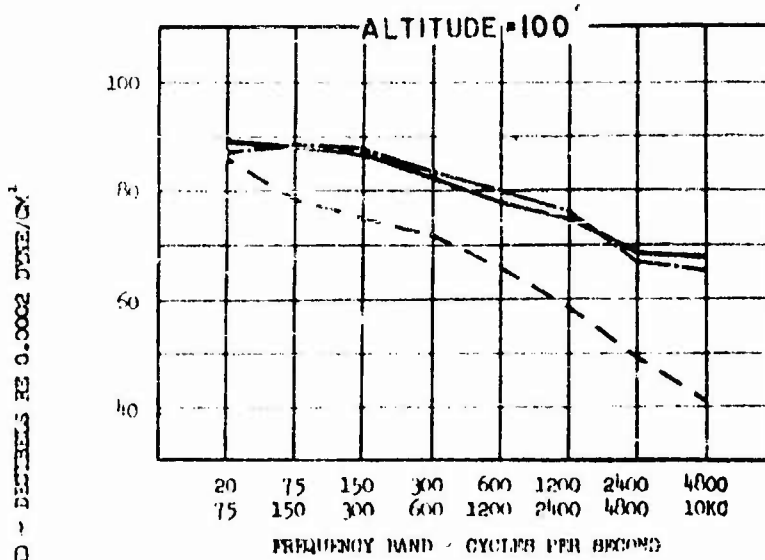

FIGURE 59

MAXIMUM EXTERNAL SOUND PRESSURE
LEVELS MEASURED AT GROUND STATION

HU-1A-3



DISTANCES

- 0' ———
- 100' - - - -
- 200' - - - -
- 500' ·····

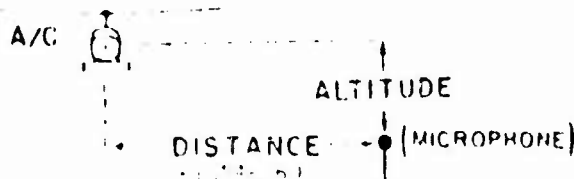

MAXIMUM EXTERNAL SOUND PRESSURE
 LEVELS MEASURED AT GROUND STATION

A/C - TEST
 HU-IA-3

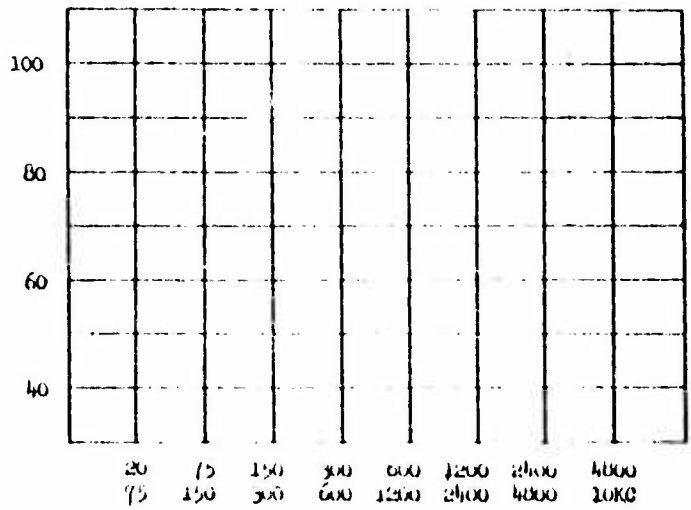
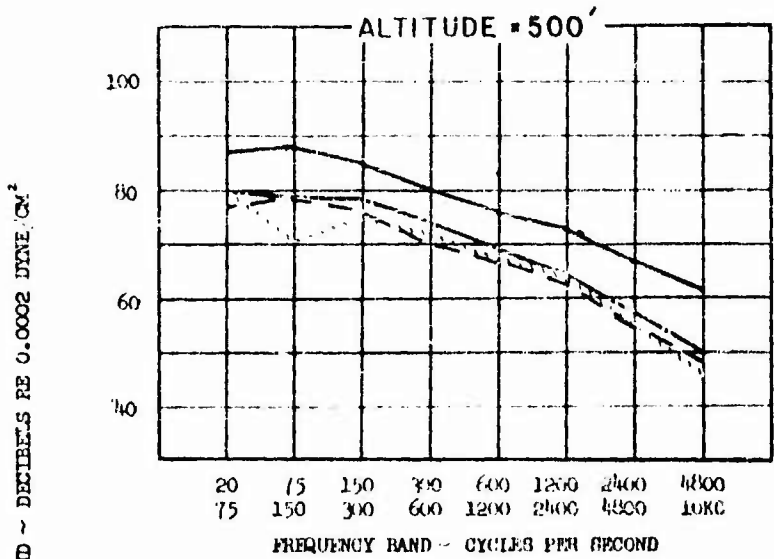

DISTANCES

- 0' ———
- 100' - - - -
- 200' - - - -
- 500' ·····

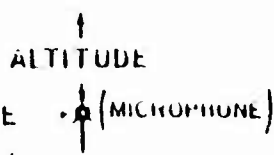
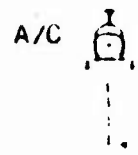
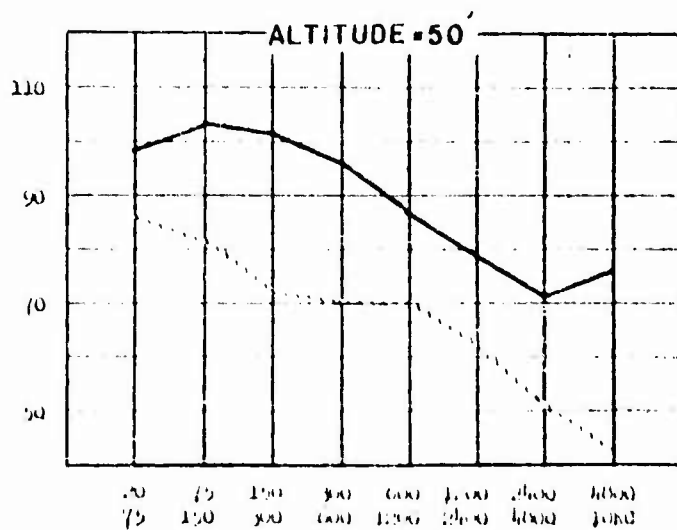
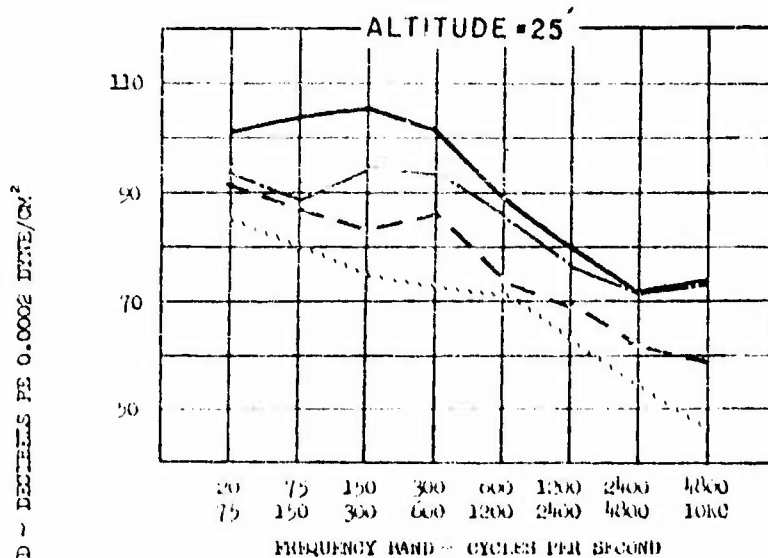

FIGURE 11

MAXIMUM EXTERNAL SOUND PRESSURE
LEVELS MEASURED AT GROUND STATION

A/C-TEST
YHC-1A

3



DISTANCES

- 0' ———
- 100' - - - -
- 200' ······
- 500' - - - -

A/C



↑
ALTITUDE

↓
DISTANCE
FROM A/C



MAXIMUM EXTERNAL SOUND PRESSURE
LEVELS MEASURED AT GROUND STATION

A/C-TEST
YHC-1A
3

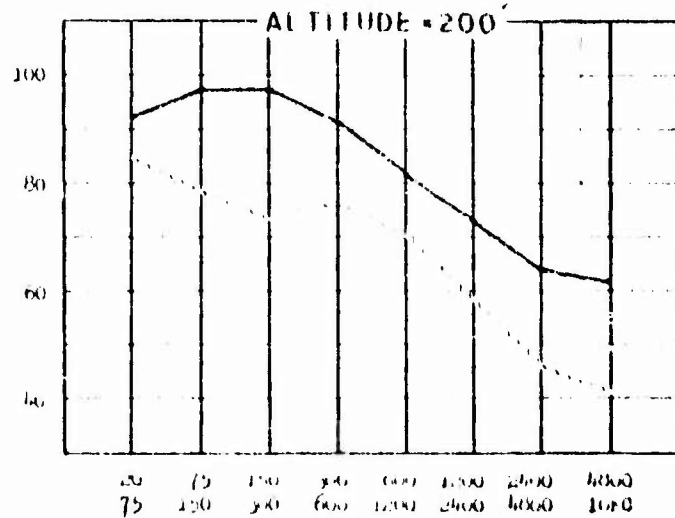
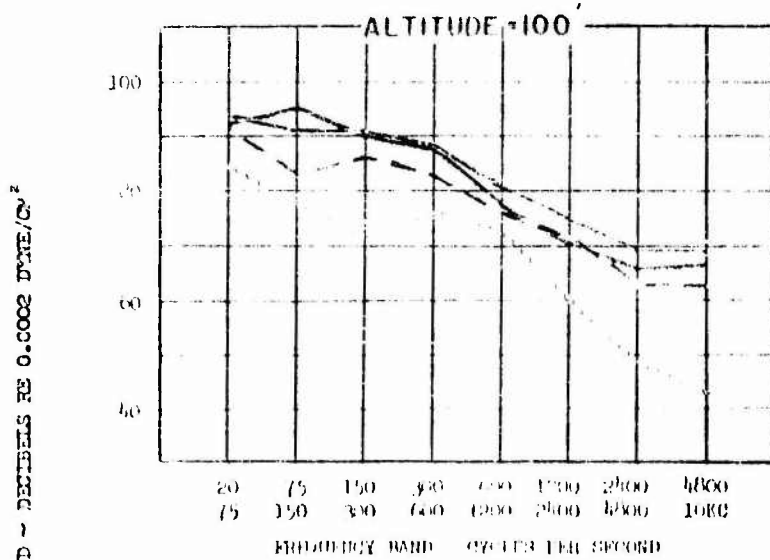

DISTANCES

- 0' - - - - -
- 100' - - - - -
- 200' - - - - -
- 500' - - - - -

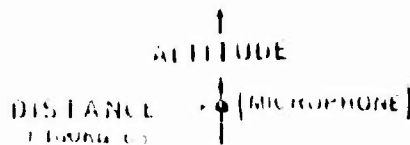
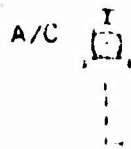

MAXIMUM EXTERNAL SOUND PRESSURE
LEVELS MEASURED AT GROUND STATION

A/C - TEST
YHC-1A

3

SOUND PRESSURE LEVEL IN BAND ~ DECIBELS RE 0.0002 DYNE/CM²

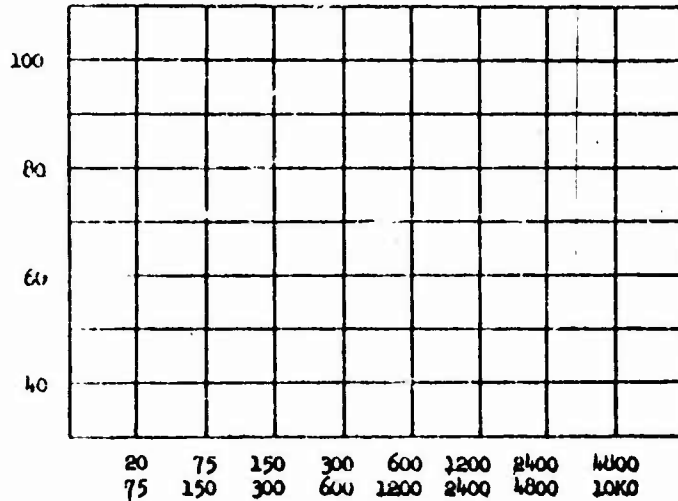
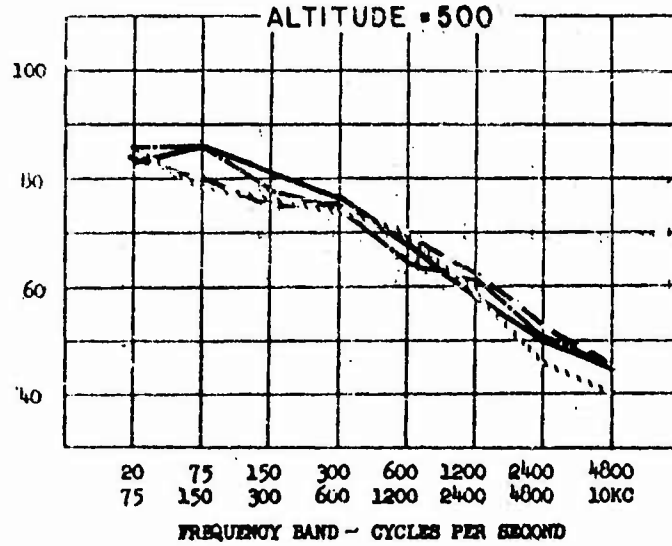

DISTANCES

- 0' —————
- 100' - - - - -
- 200' -
- 500' ········

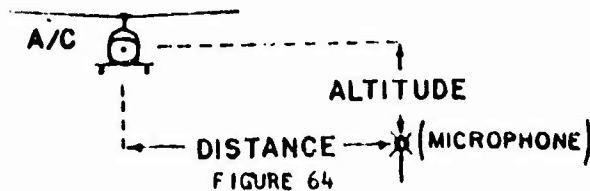
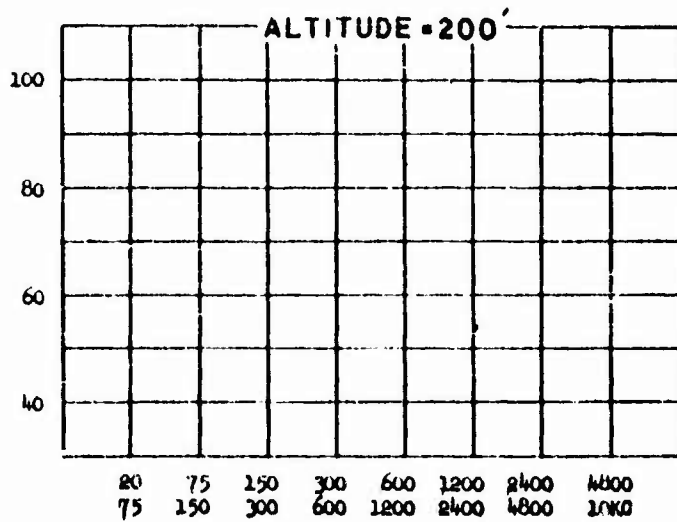
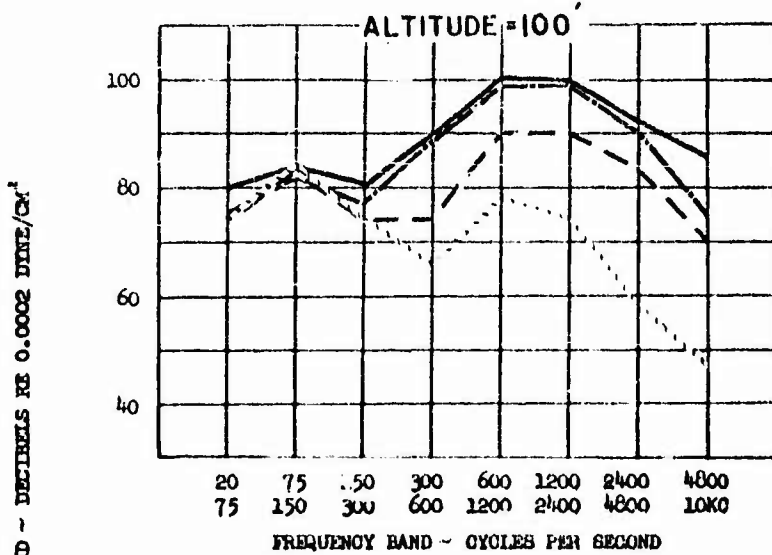

FIGURE 64

MAXIMUM EXTERNAL SOUND PRESSURE
LEVELS MEASURED AT GROUND STATION

Doak-16

3



DISTANCES

- 0' —————
- 100' - - - - -
- 200' - - - - -
- 500' ·······

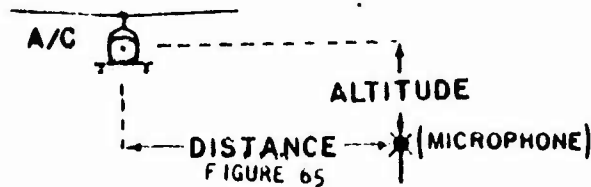

MAXIMUM EXTERNAL SOUND PRESSURE
LEVELS MEASURED AT GROUND STATION

Vertol-76

3

SOUND PRESSURE LEVEL IN BAND - DECIBELS RE 0.0002 DINE/CM²

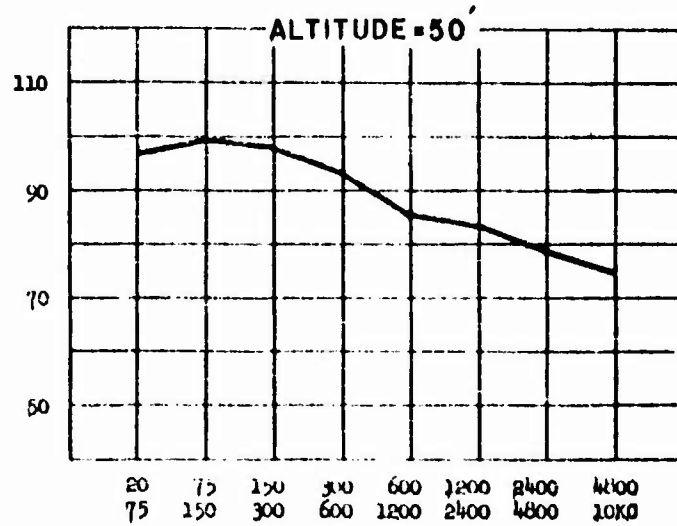
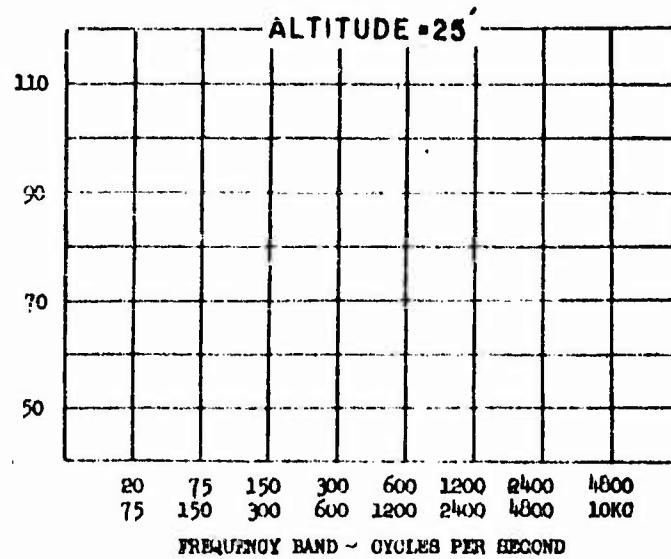

DISTANCES

50' —————

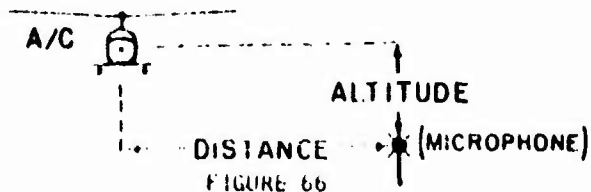

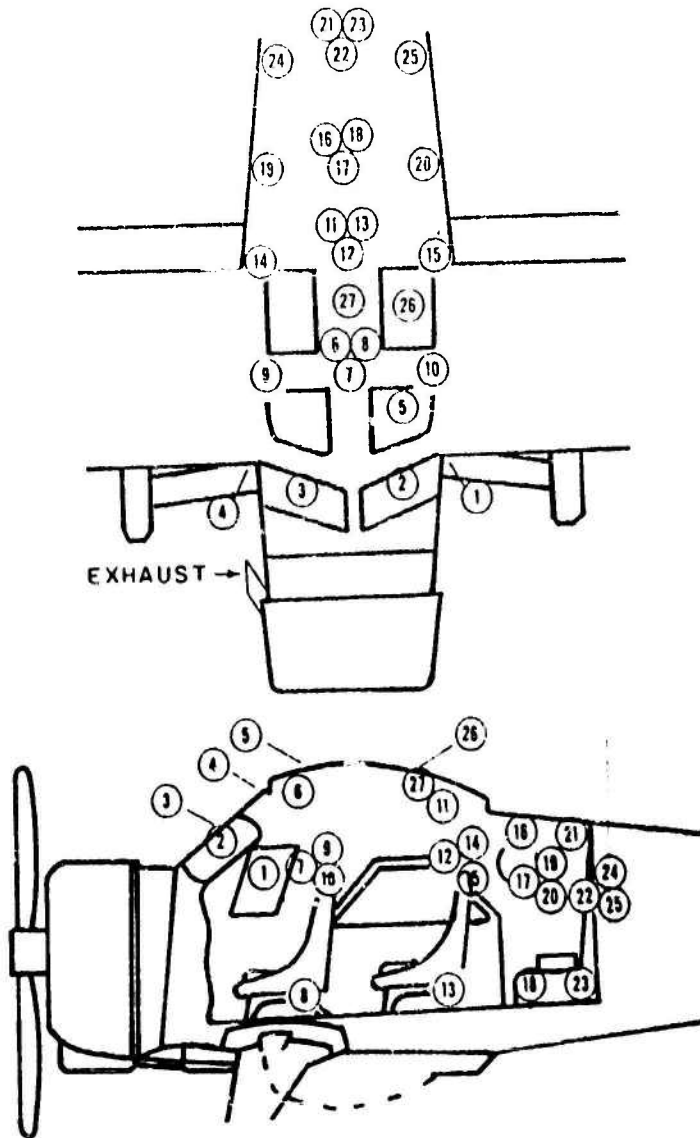

APPROXIMATE MICROPHONE POSITIONS USED FOR
VARIOUS NOISE MEASUREMENTS INSIDE AIRCRAFT

PILOT'S EAR LEVEL LOCATION-①

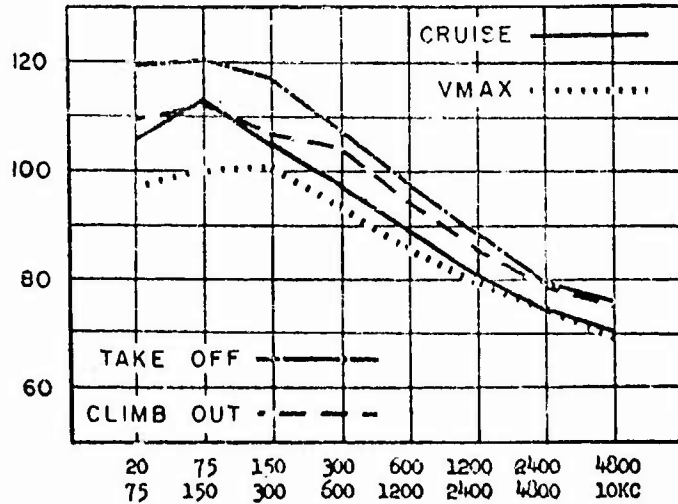

SOUND PRESSURE LEVEL IN BAND - DECIBELS RE 0.0002 DYNE/CM²

WINDOW LOCATIONS

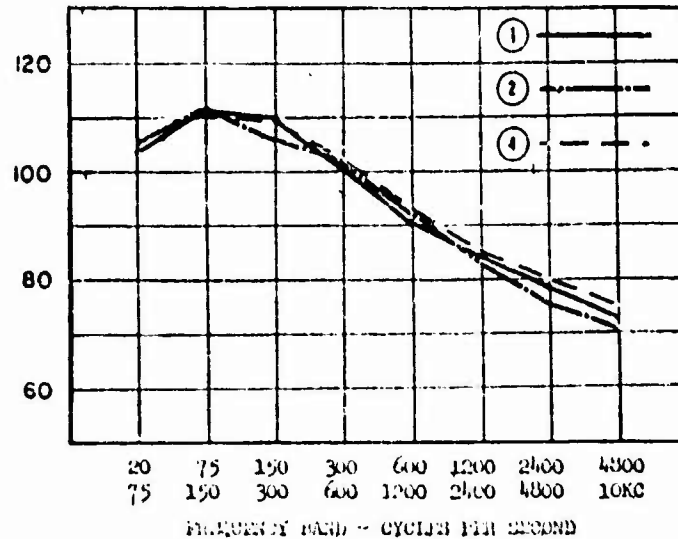

FIGURE 35

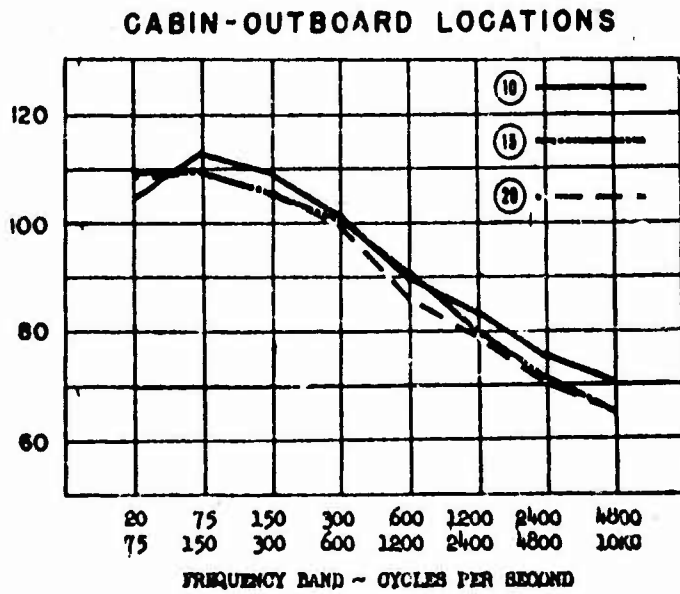
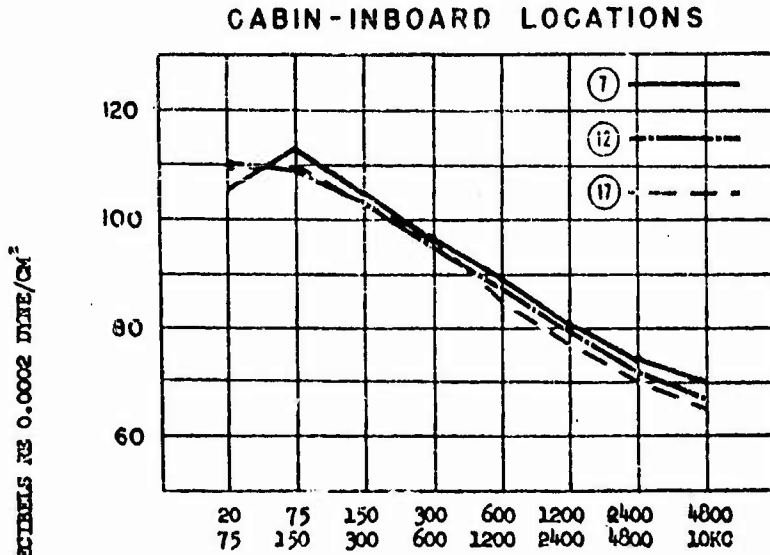

FIGURE 69

VARIOUS LOCATIONS - WINDOWS OPEN

SOUND PRESSURE LEVEL IN BAND ~ DECIBELS RE 0.0002 DYNES/CM²

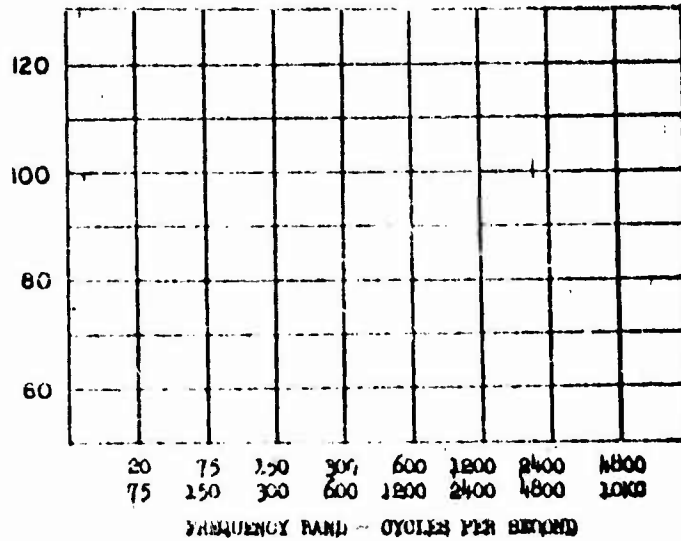
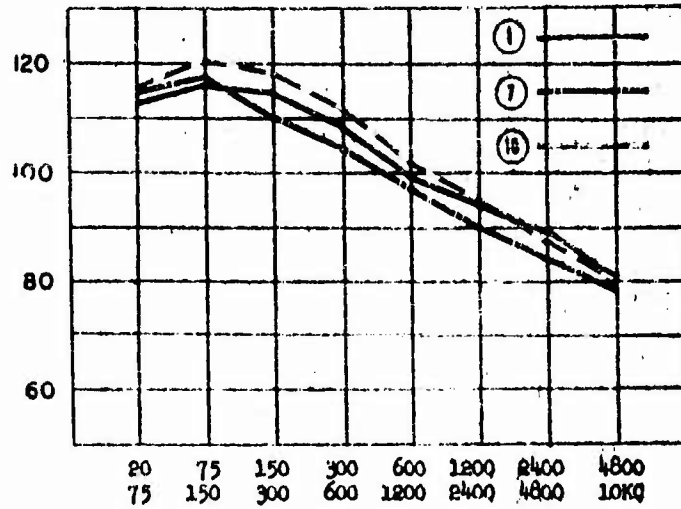
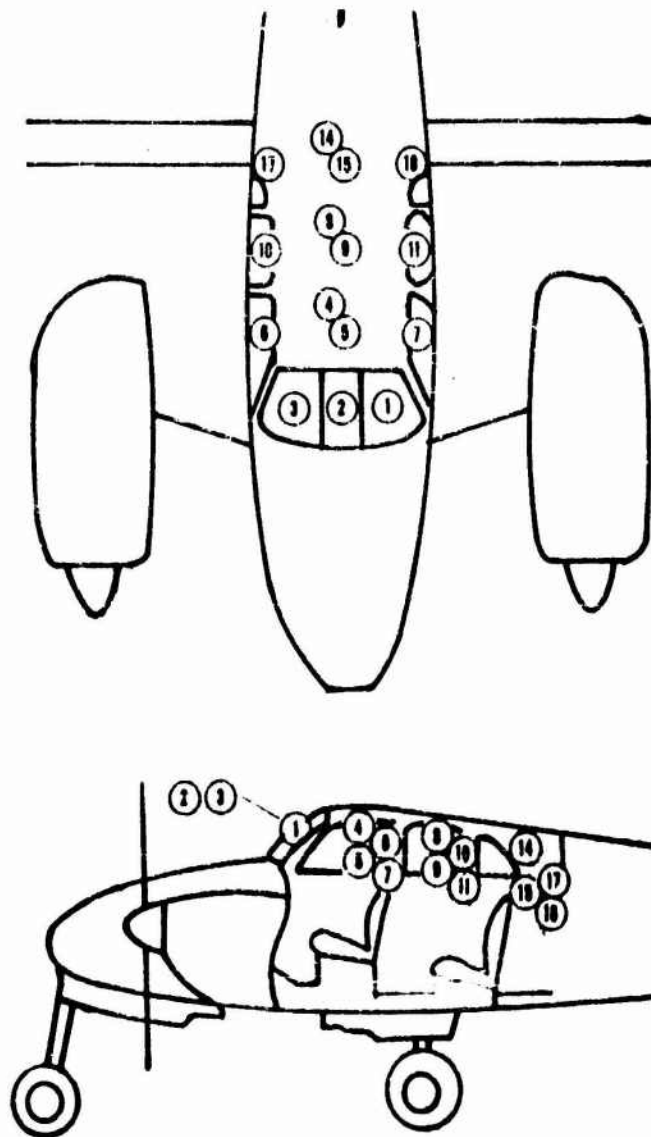

FIGURE 70



APPROXIMATE MICROPHONE POSITIONS USED FOR
VARIOUS NOISE MEASUREMENTS INSIDE AIRCRAFT

FIGURE 71

PILOT'S EAR LEVEL LOCATION-(1)

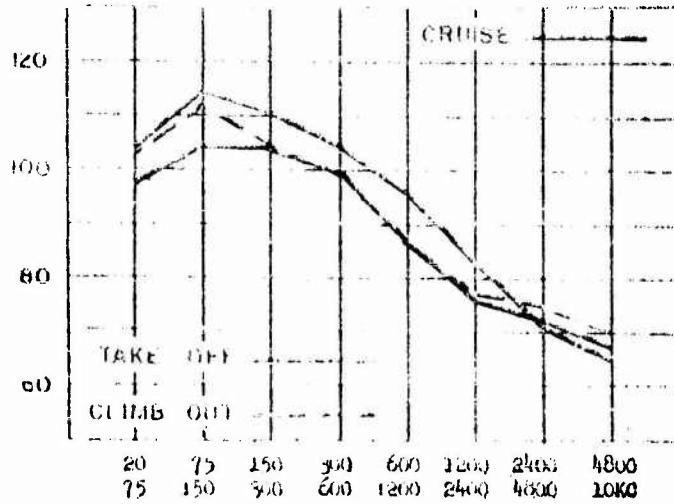

WINDOW LOCATIONS

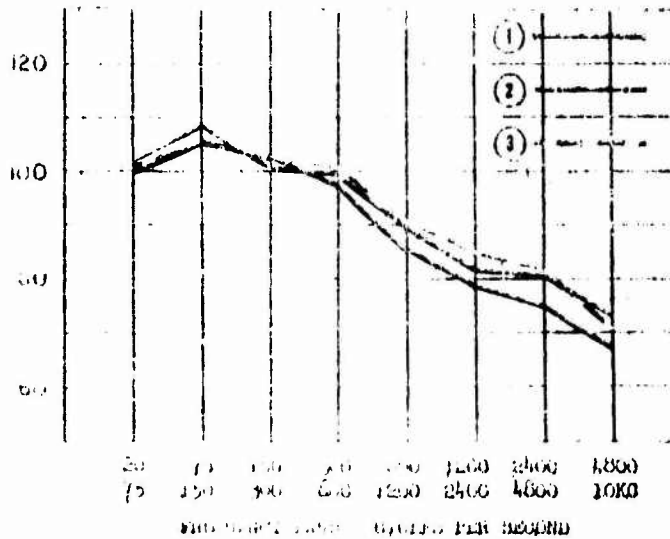

CABIN - INBOARD LOCATIONS

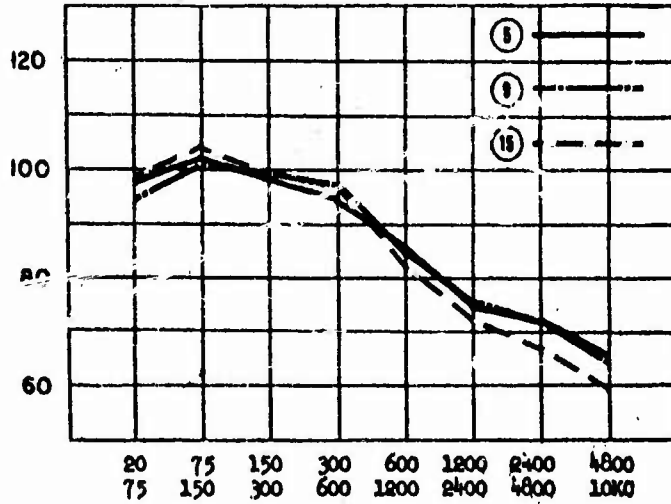

SOUND PRESSURE LEVEL IN BAND ~ DECIBELS RE 0.0002 DYNE/CM²

CABIN - OUTBOARD LOCATIONS

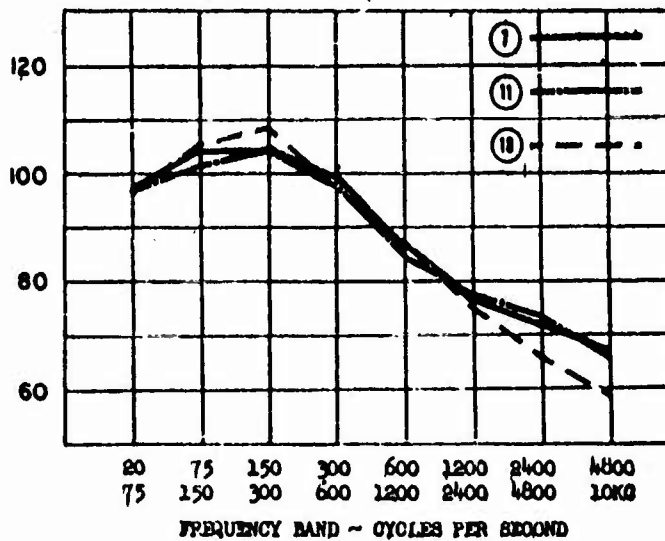
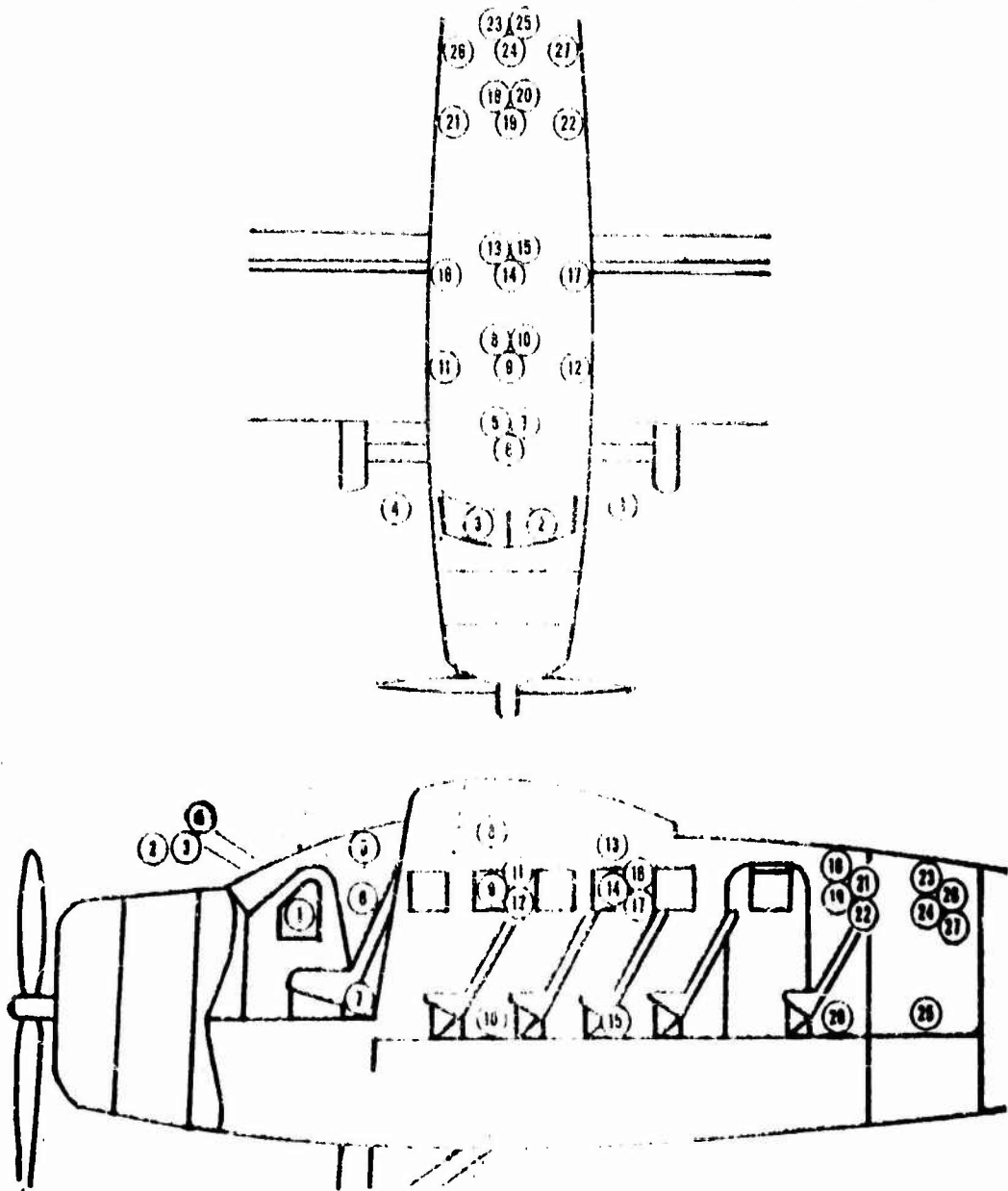

FIGURE 73

A/C-TEST

U-1A-4



APPROXIMATE MICROPHONE POSITIONS USED FOR
VARIOUS NOISE MEASUREMENTS INSIDE AIRCRAFT

SOUND PRESSURE LEVEL IN BAND - DECIBELS RE 0.0002 MICRO/C.M.²

PILOT'S EAR LEVEL LOCATION--①

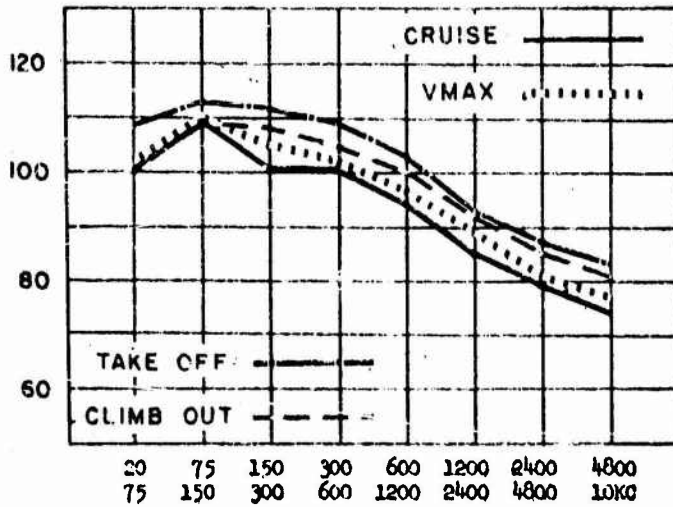

WINDOW LOCATIONS

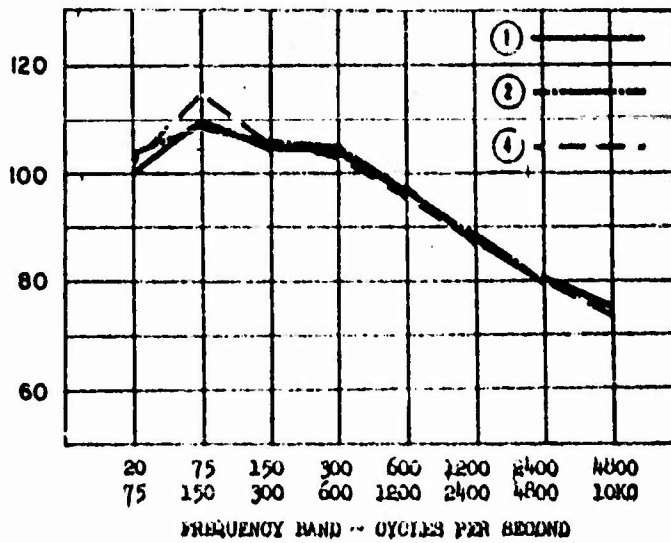
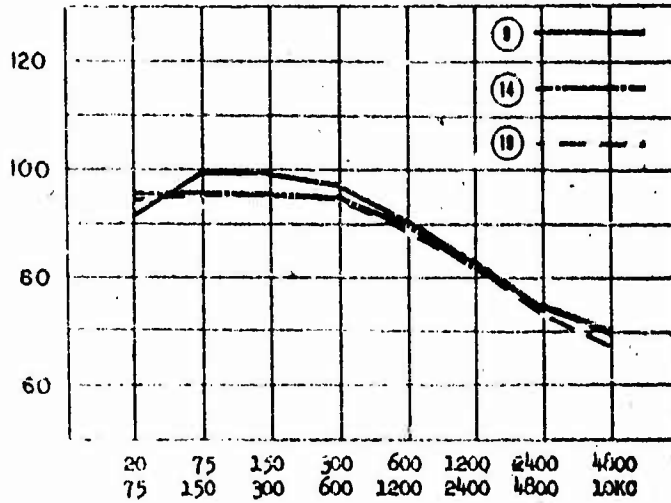

FIGURE 75

CABIN-INBOARD LOCATIONS



SOUND PRESSURE LEVEL IN BAND ~ DECIBELS RE 0.0002 DYNE/CM²

CABIN-OUTBOARD LOCATIONS

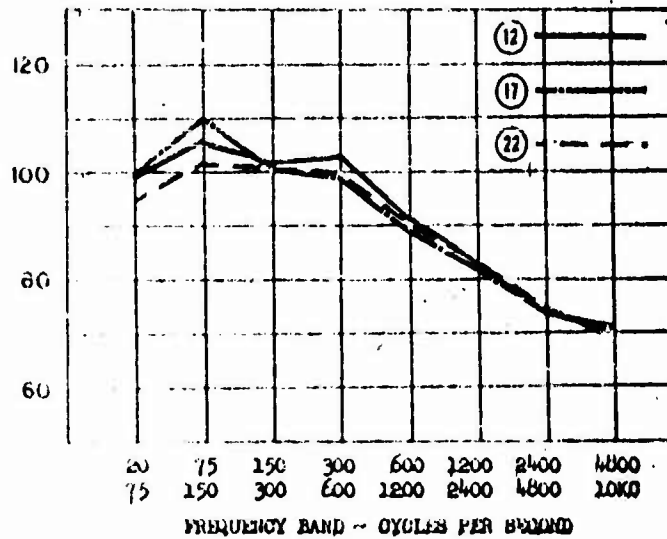

FREQUENCY BAND ~ CYCLES PER SECOND

FIGURE 76

VARIOUS LOCATIONS - WINDOWS OPEN

SOUND PRESSURE LEVEL IN BAND - DECIBELS RE 0.0002 DYNE/CM²

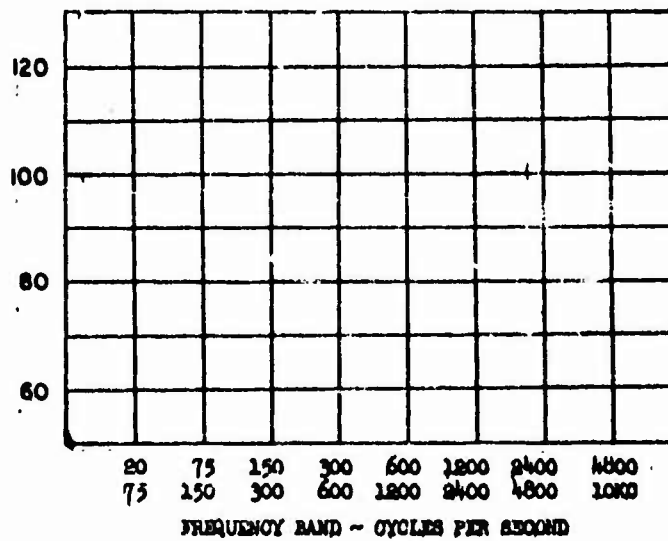
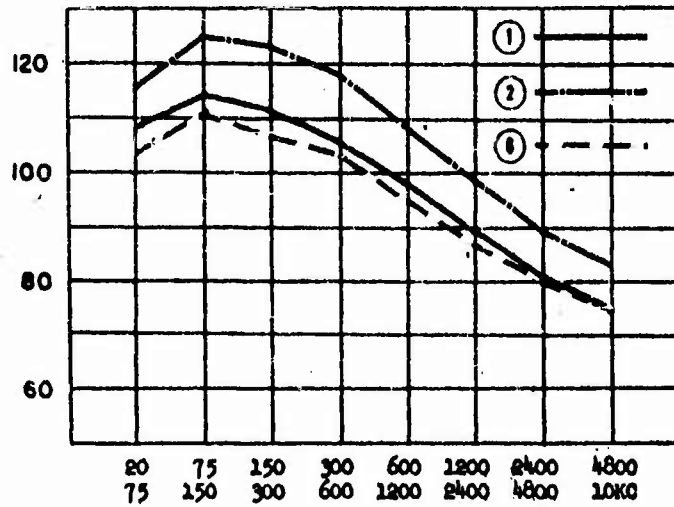
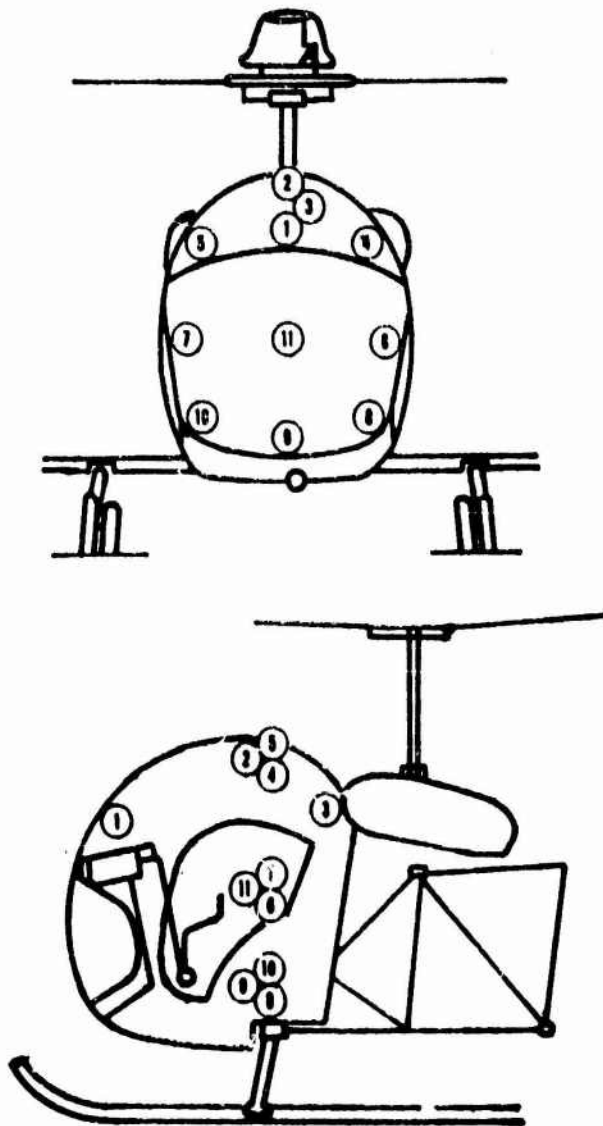

FIGURE 77

A/C-TEST

H-13-4



APPROXIMATE MICROPHONE POSITIONS USED FOR
VARIOUS NOISE MEASUREMENTS INSIDE AIRCRAFT

FIGURE 78

SOUND PRESSURE LEVEL IN BAND ~ DECIBELS RE 0.0002 DYNE/CM²

PILOT'S EAR LEVEL LOCATION-①

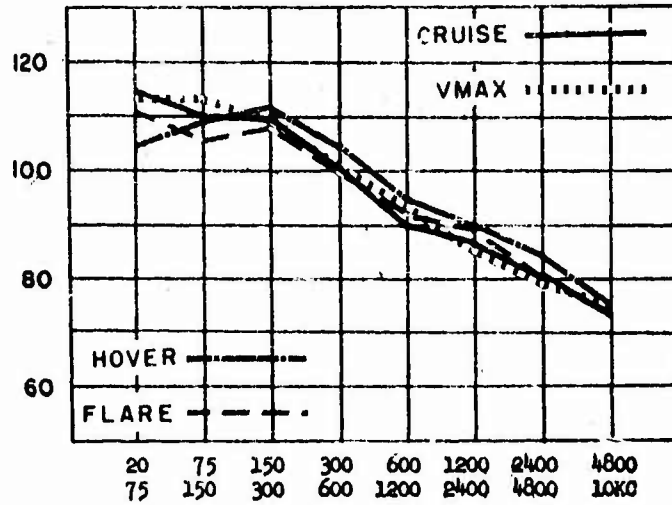

CREW'S EAR LEVEL LOCATIONS

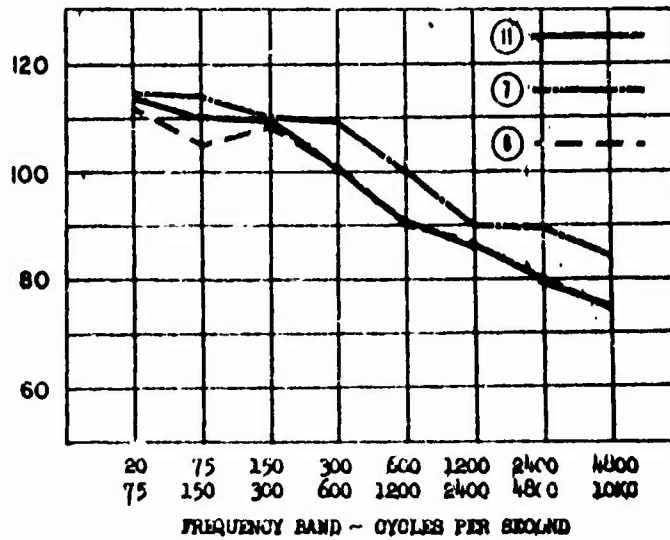
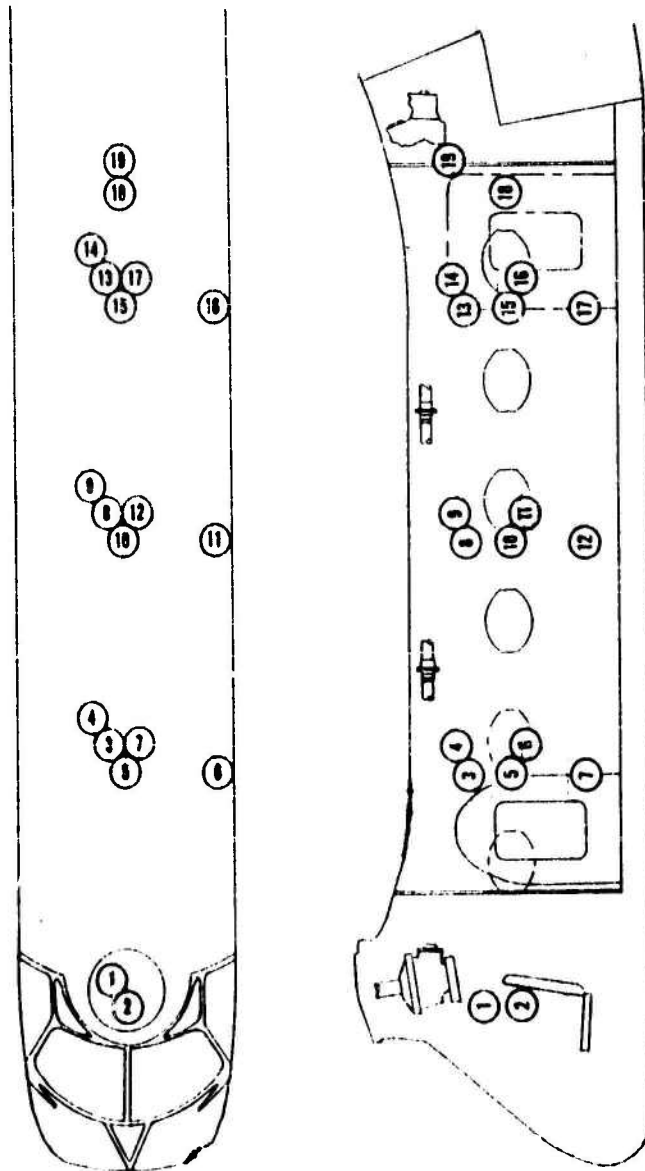

FIGURE 79



APPROXIMATE MICROPHONE POSITIONS USED FOR
VARIOUS NOISE MEASUREMENTS IN THE AIRCRAFT

FIGURE 80

SOUND PRESSURE LEVEL IN BAND ~ DECIBELS RE 0.0002 DYNE/CM²

PILOT'S EAR LEVEL LOCATION ②

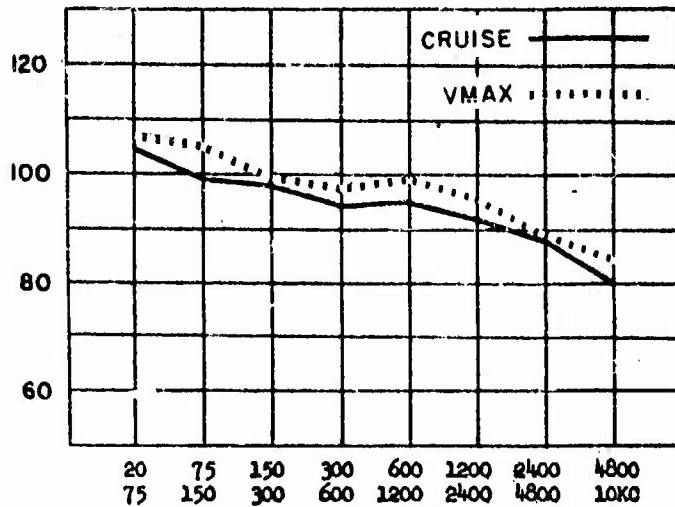

CENTER OF CABIN LOCATION ⑩

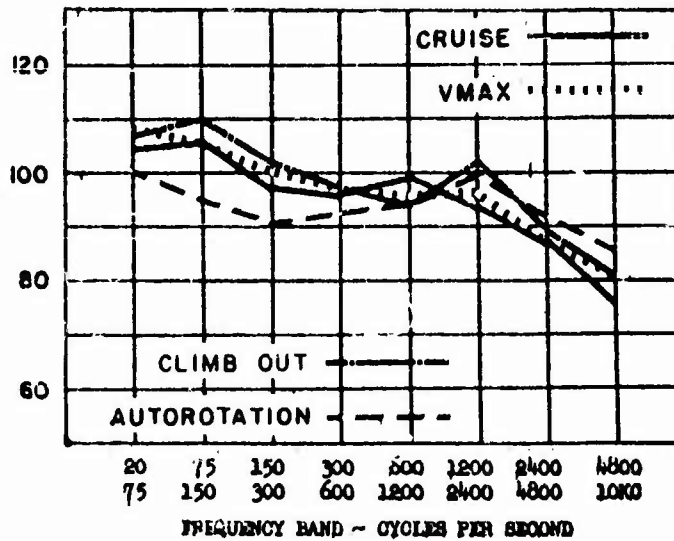
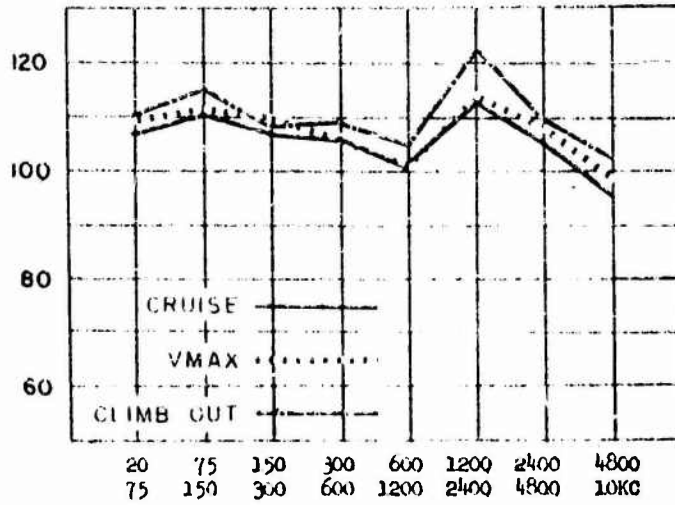

FIGURE 81

SOUND PRESSURE LEVEL IN BAND ~ DECIBELS RE 0.0002 DYNE/CM²

CABIN LOCATION

(19)



CABIN - INBOARD LOCATIONS

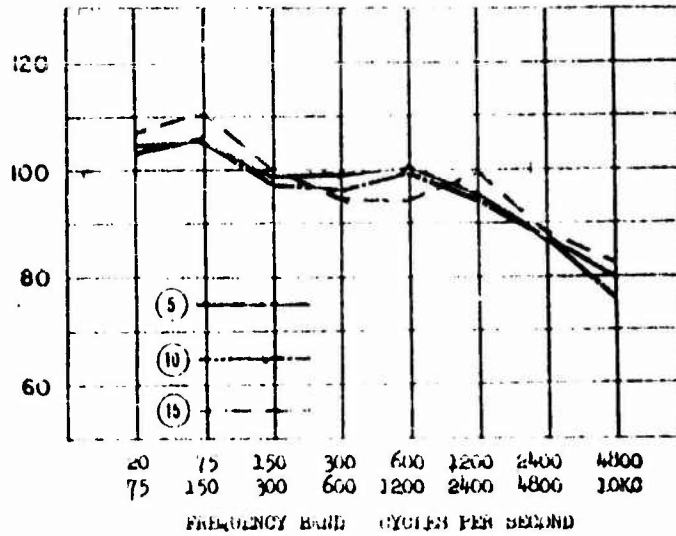
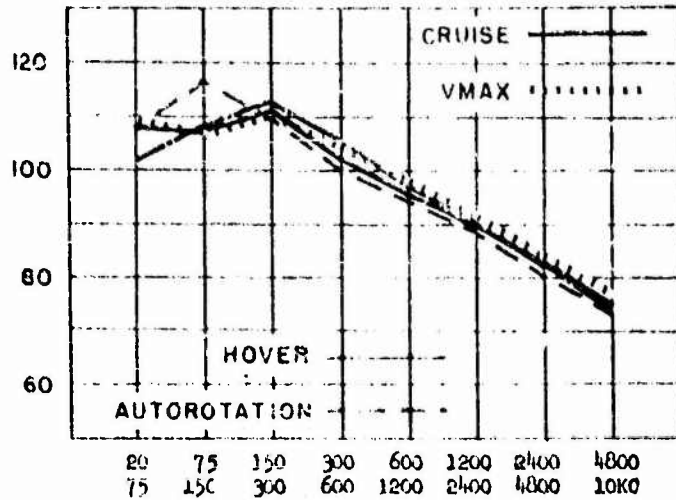

FIGURE 82

PILOT'S EAR LEVEL LOCATION -- (II)



SOUND PRESSURE LEVEL IN BAND - DECIBELS RE 0.0002 DYNE/CM²

CREW'S EAR LEVEL LOCATIONS

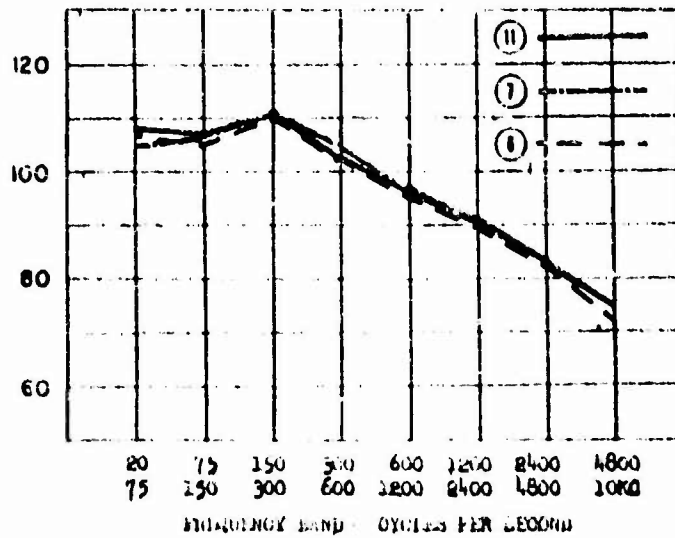
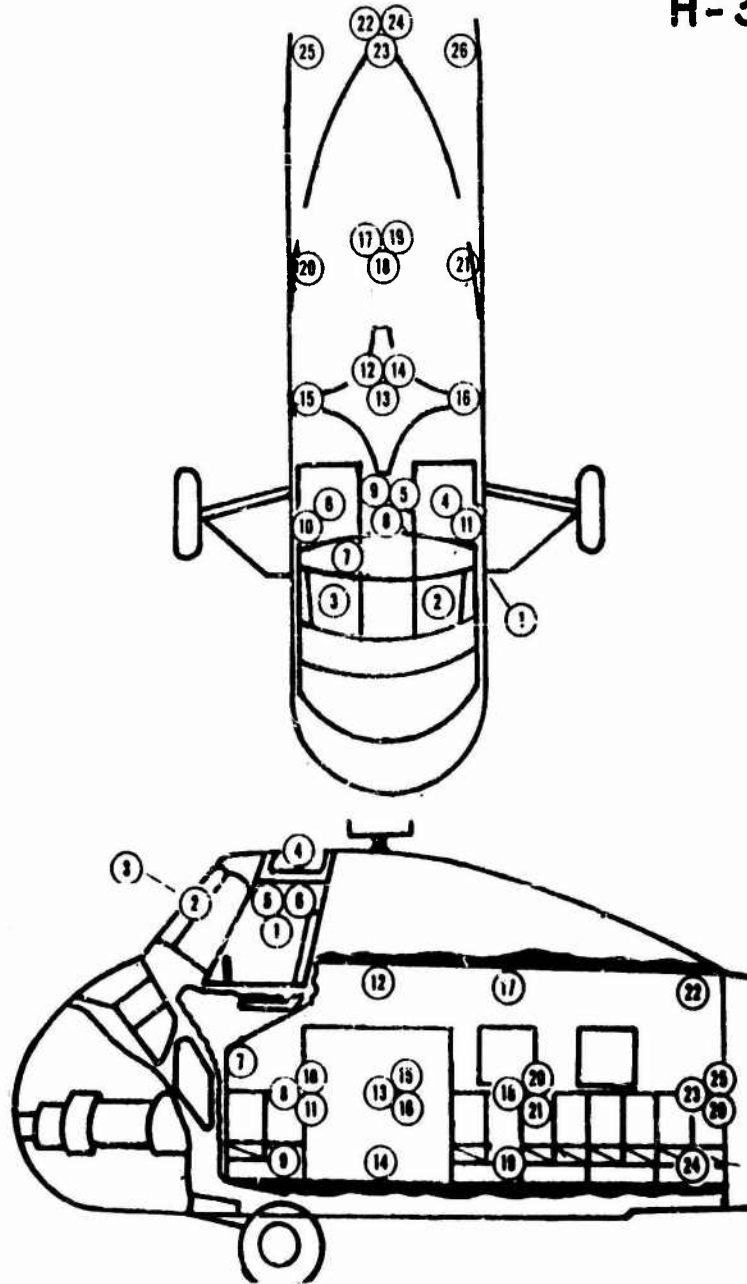

FIGURE 25

10-100



APPROXIMATE MICROPHONE POSITIONS USED FOR
VARIOUS NOISE MEASUREMENTS INSIDE AIRCRAFT

FIGURE 86

SOUND PRESSURE LEVEL IN BAND ~ DECIBELS RE 0.0002 DYNE/CM²

PILOT'S EAR LEVEL LOCATION ⑤

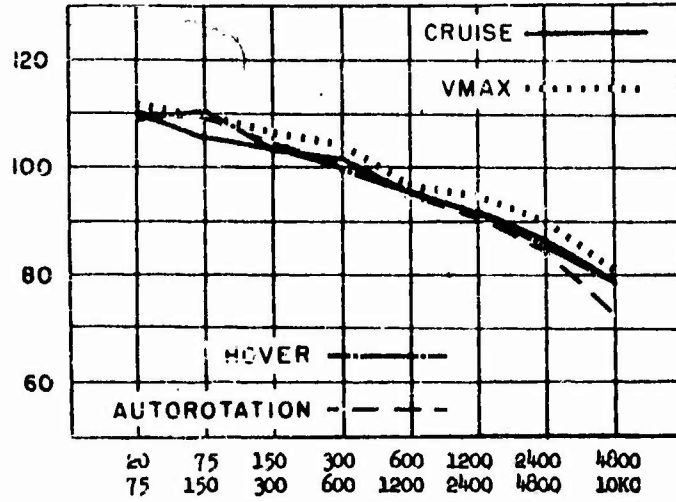

CENTER OF CABIN LOCATION ⑩

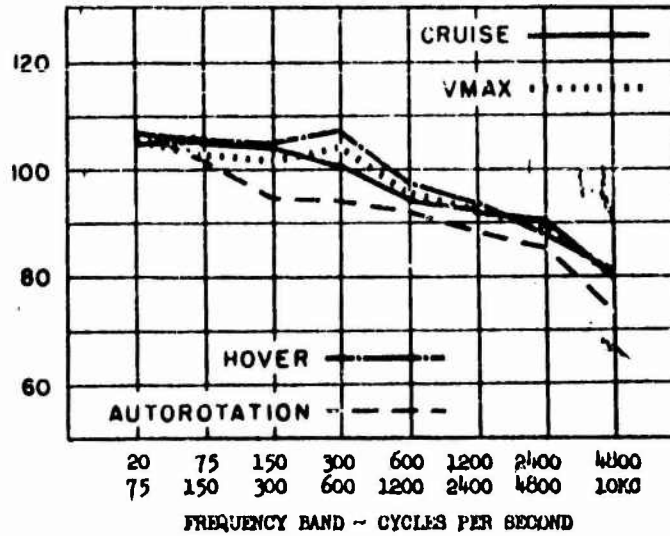

FREQUENCY BAND ~ CYCLES PER SECOND

FIGURE 87

SOUND PRESSURE LEVEL IN BAND ~ DECIBELS RE 0.0002 DYNE/CM²

CABIN - INBOARD LOCATIONS

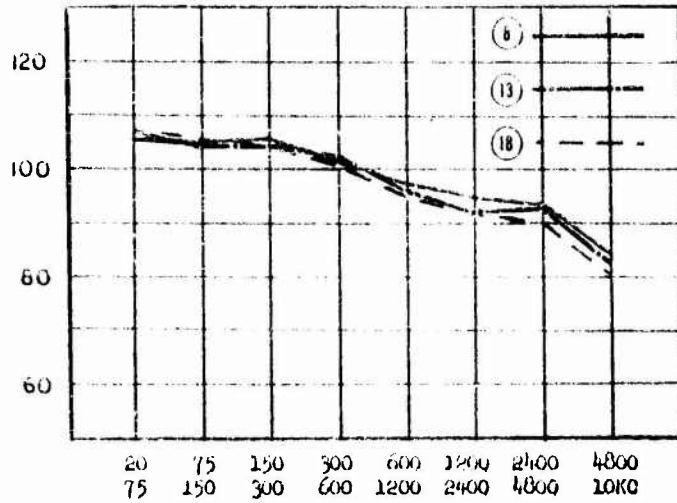

CABIN - OUTBOARD LOCATIONS

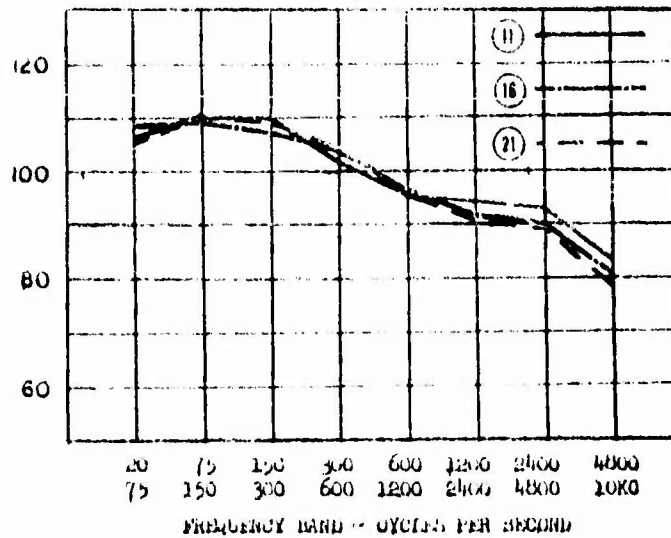

FREQUENCY BAND - CYCLES PER SECOND

FIGURE 88

WINDOW LOCATIONS

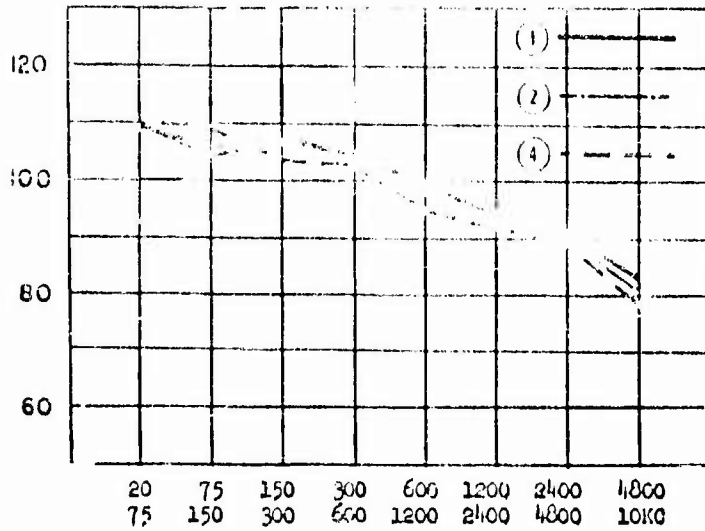

SOUND PRESSURE LEVEL IN BAND - DECIBELS RE 0.0002 DYNE/CM²

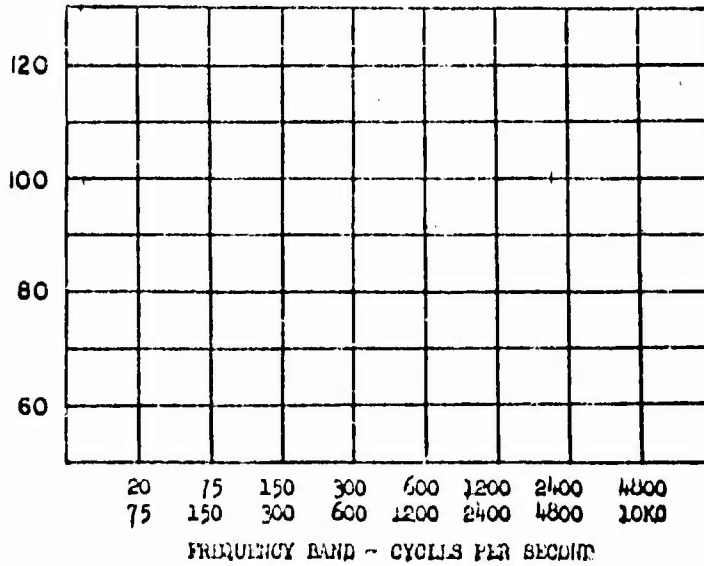
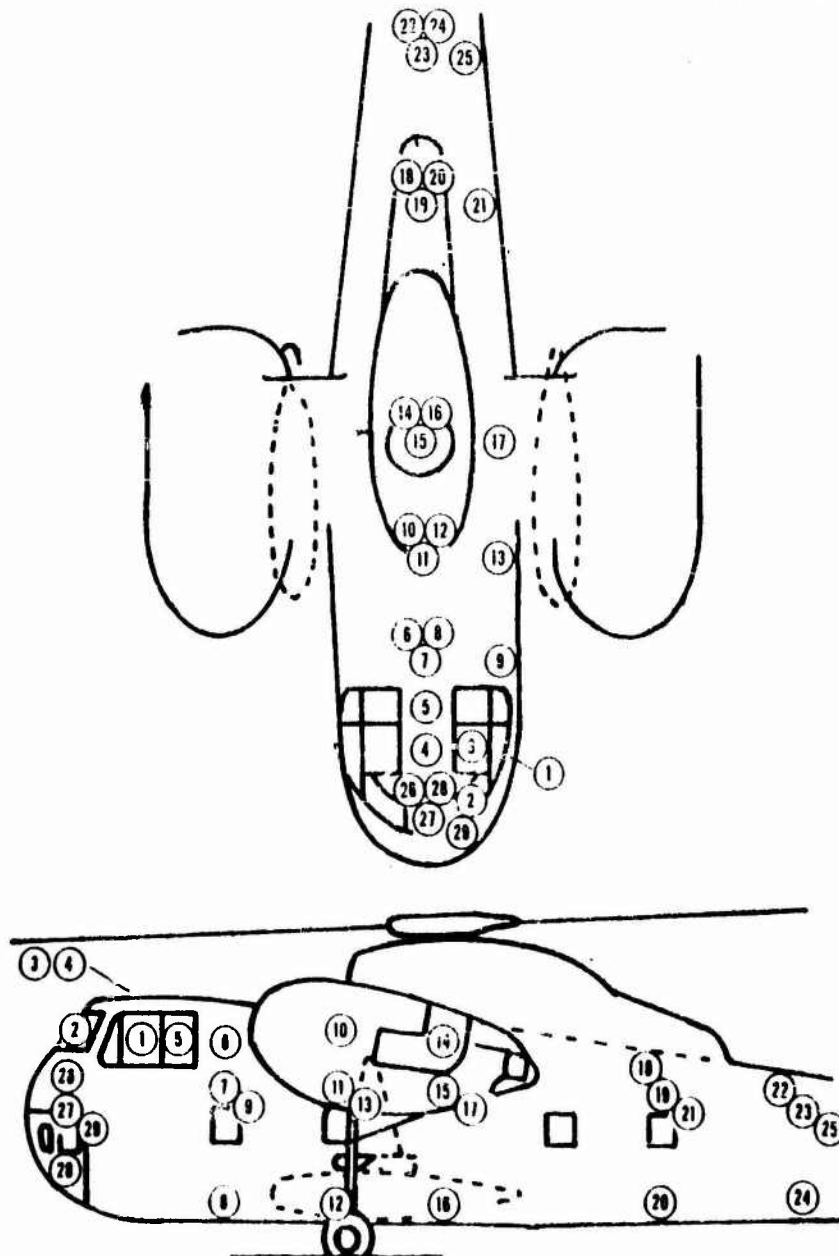

FIGURE 89



APPROXIMATE MICROPHONE POSITIONS USED FOR
VARIOUS NOISE MEASUREMENTS INSIDE AIRCRAFT

FIGURE 90

SOUND PRESSURE LEVEL IN BAND - DECEIBELS RE 0.0002 DYNE/CM²

PILOT'S EAR LEVEL LOCATION (9)

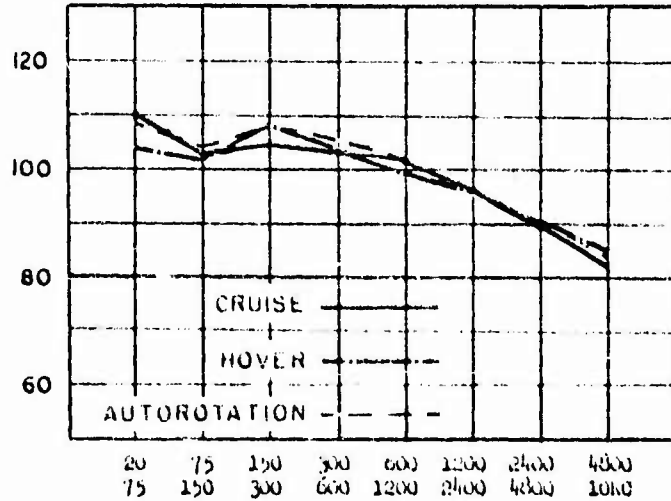

CENTER OF CABIN LOCATION (15)

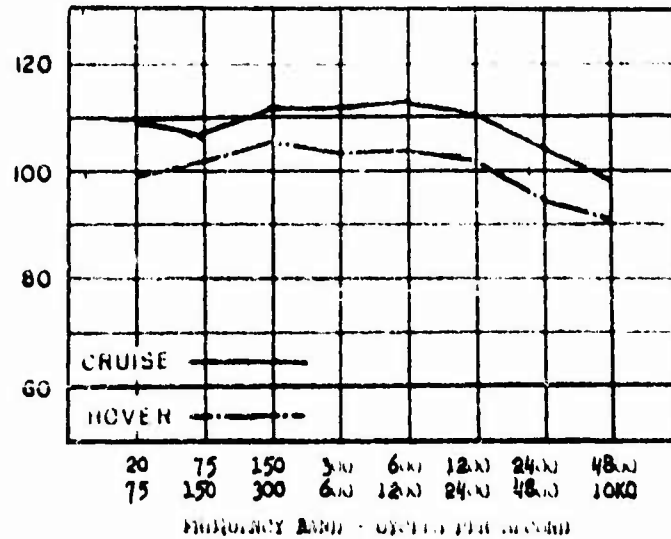
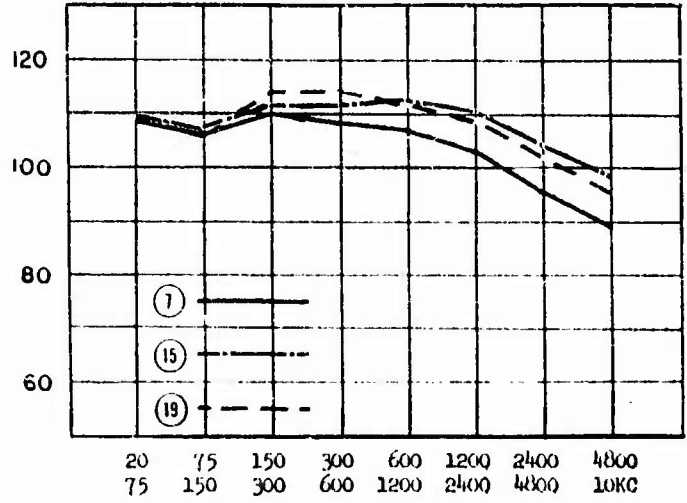

FIGURE 91

SOUND PRESSURE LEVEL IN BAND ~ DECIBELS RE 0.0002 DYNE/CM²

CABIN - INBOARD LOCATIONS



CABIN - OUTBOARD LOCATIONS

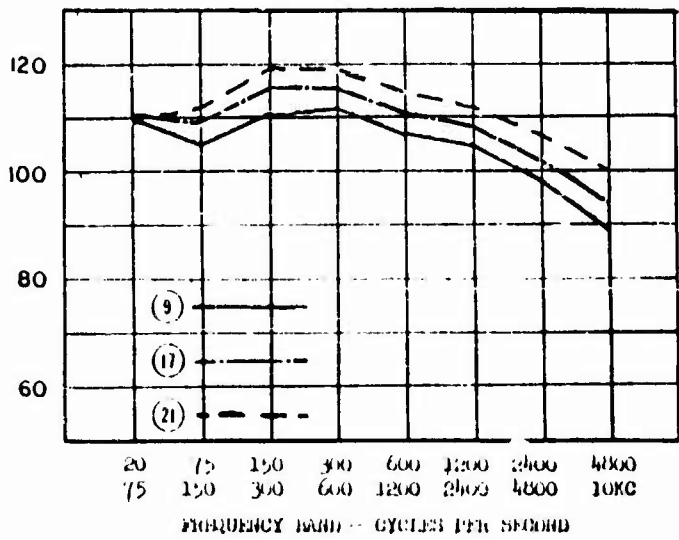
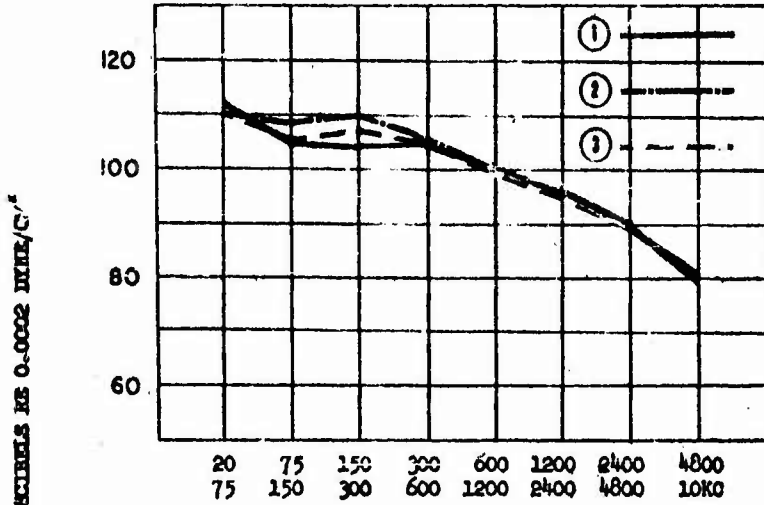

FIGURE 92

WINDOW LOCATIONS



SOUND PRESSURE LEVEL IN DB - DECIBELS RE 0.0002 DYNE/C.M²

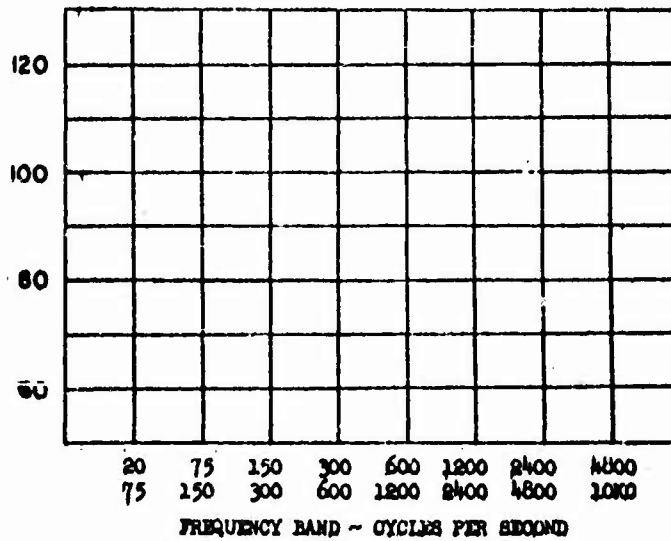
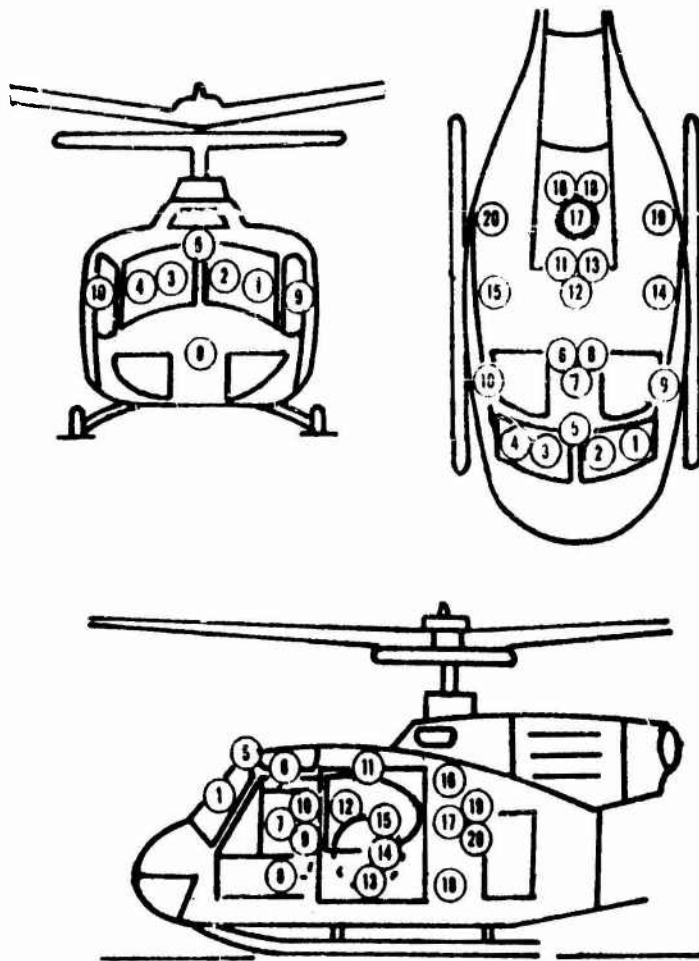

FIGURE 93



APPROXIMATE MICROPHONE POSITIONS USED FOR
VARIOUS NOISE MEASUREMENTS INSIDE AIRCRAFT

FIGURE 94

SOUND PRESSURE LEVEL IN MIND - DECIBELS RE 0.0002 DYNE/CM²

PILOT'S EAR LEVEL LOCATION ①

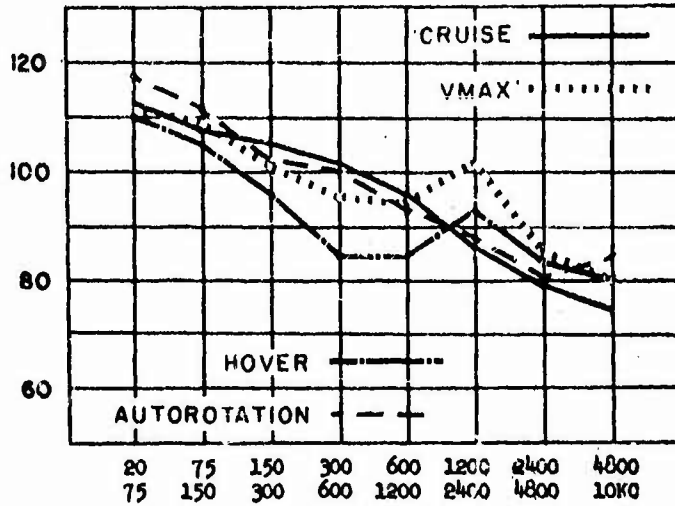

WINDOW LOCATIONS

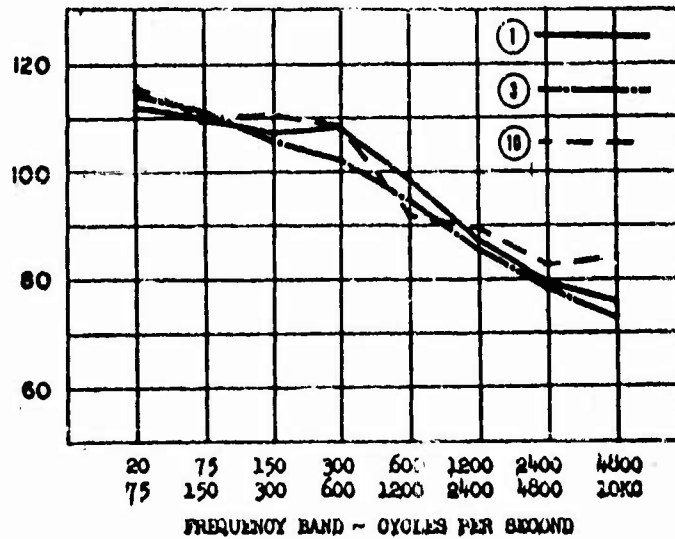

FIGURE 95

SOUND PRESSURE LEVEL IN BAND ~ DECIBELS RE 0.0002 DYNE/CM²

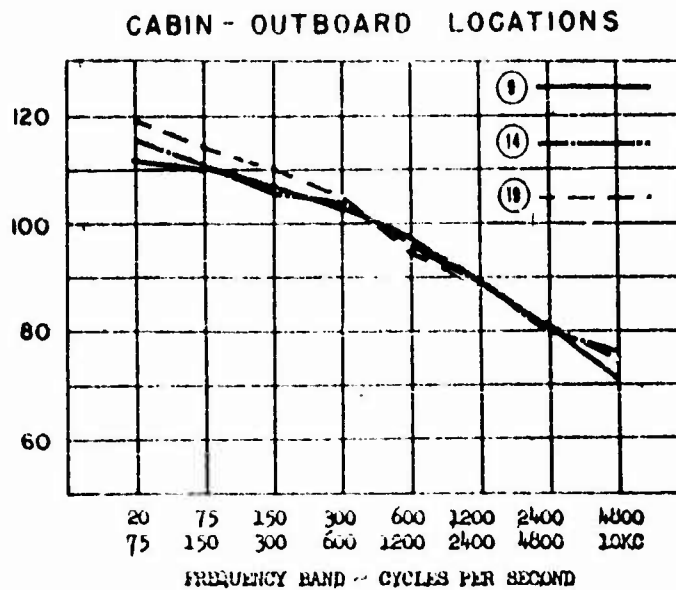
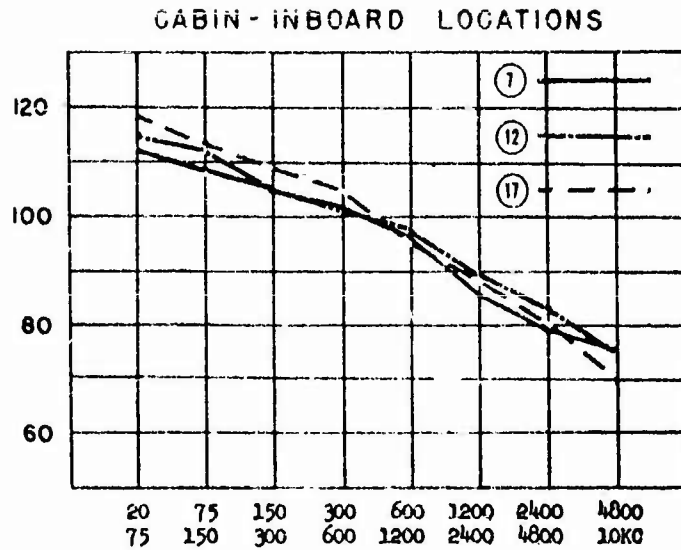

FIGURE 96

VARIOUS LOCATIONS - WINDOWS OPEN

SOLID PRESSURE LEVEL IN BAND - DECIBELS RE 0.0002 INCH/CM²

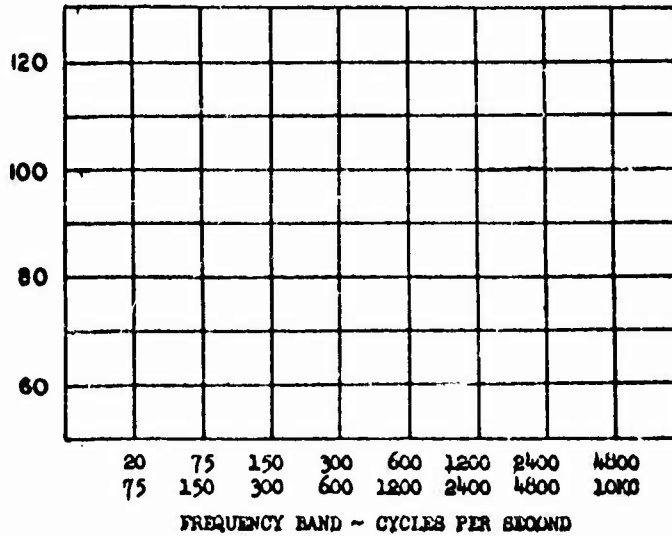
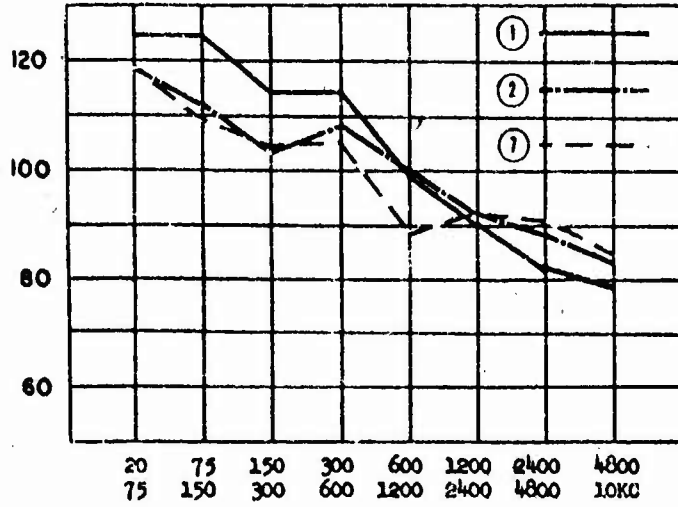
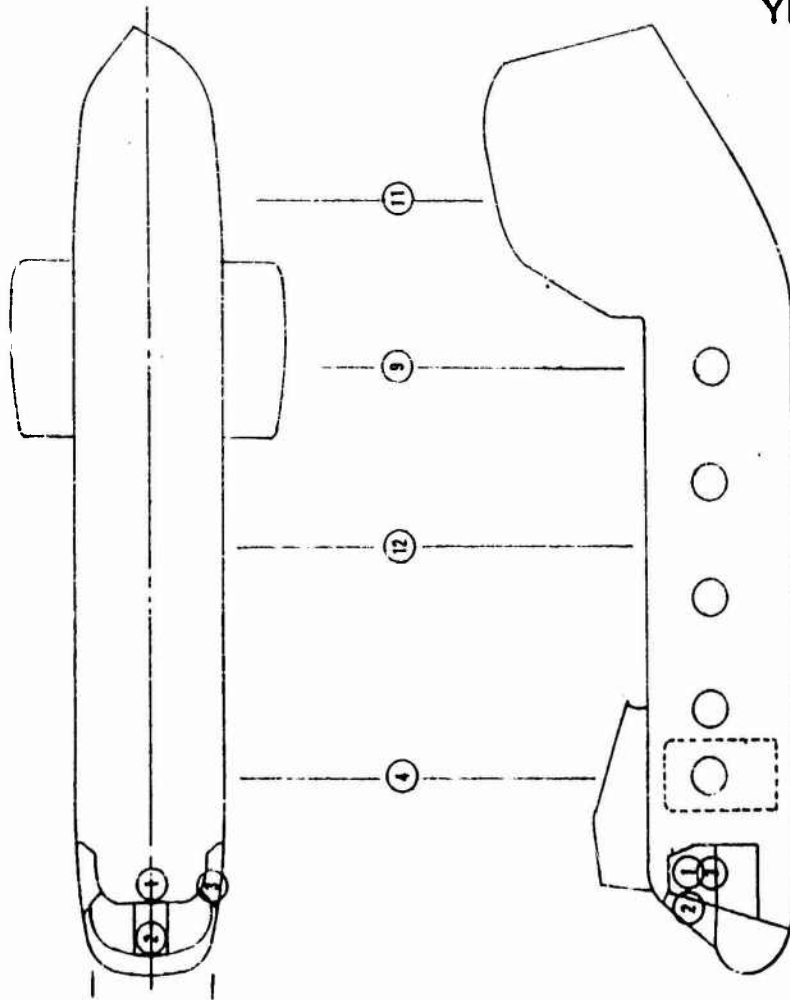

FIGURE 97



APPROXIMATE MICROPHONE POSITIONS
USED FOR
VARIOUS NOISE MEASUREMENTS
INSIDE AIRCRAFT

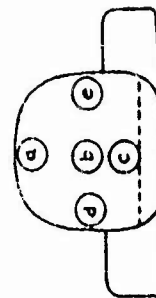
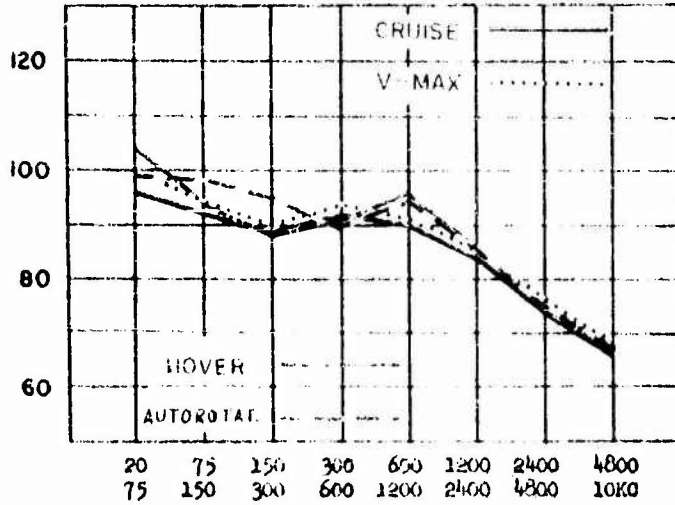

FIGURE 98

SOUND PRESSURE LEVEL IN BAND ~ DECIBELS RE 0.0002 MICRO/CM²

PILOT'S EAR LEVEL LOCATION-1



CENTER OF CABIN LOCATION-12b

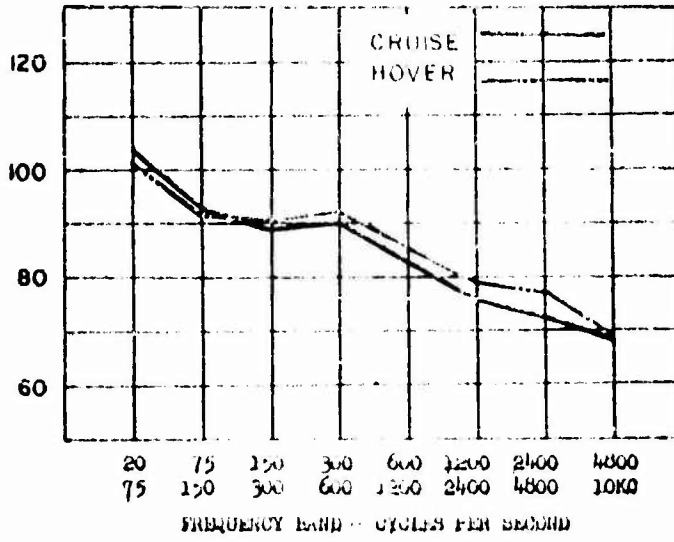
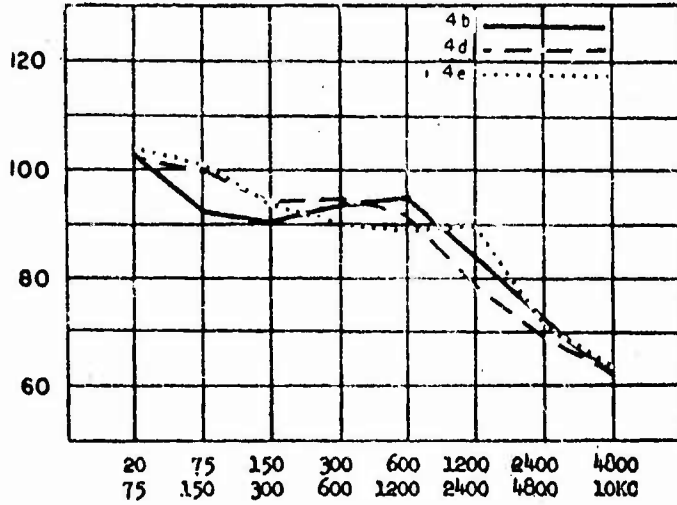

FIGURE 99

FORWARD CABIN LOCATION - CRUISE

SOUND PRESSURE LEVEL IN BAND ~ DECIBELS RE 0.0002 DYNE/CM²



CENTER CABIN LOCATION - CRUISE

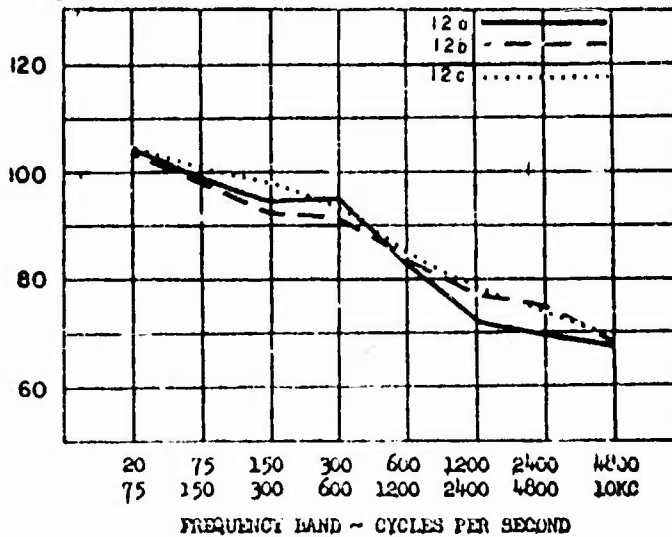

FIGURE 100

A/C-TEST
 YHC-1A

INBOARD CABIN LOCATIONS -- CRUISE

SOUND PRESSURE LEVEL 1L BAND - DECIBELS RE 0.0002 DINE/CM²

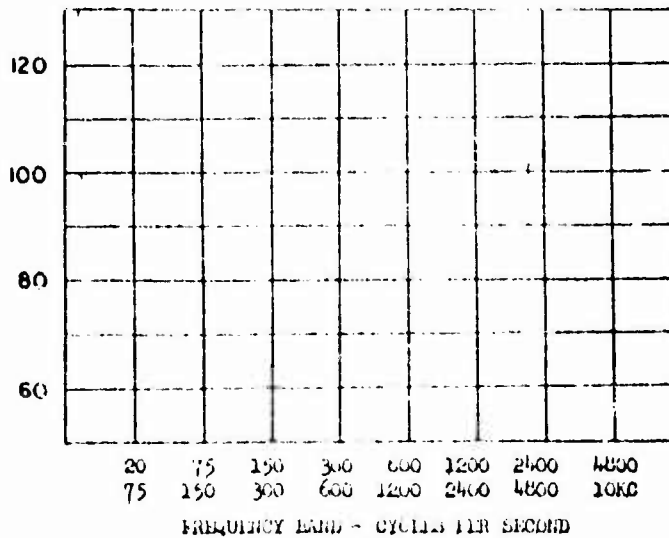
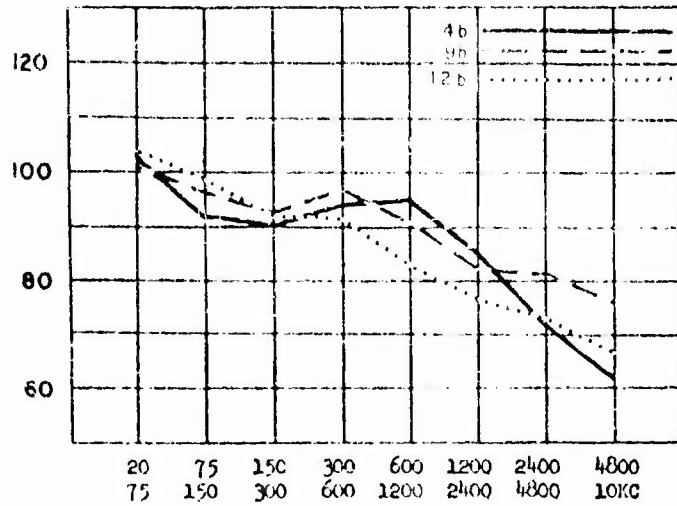
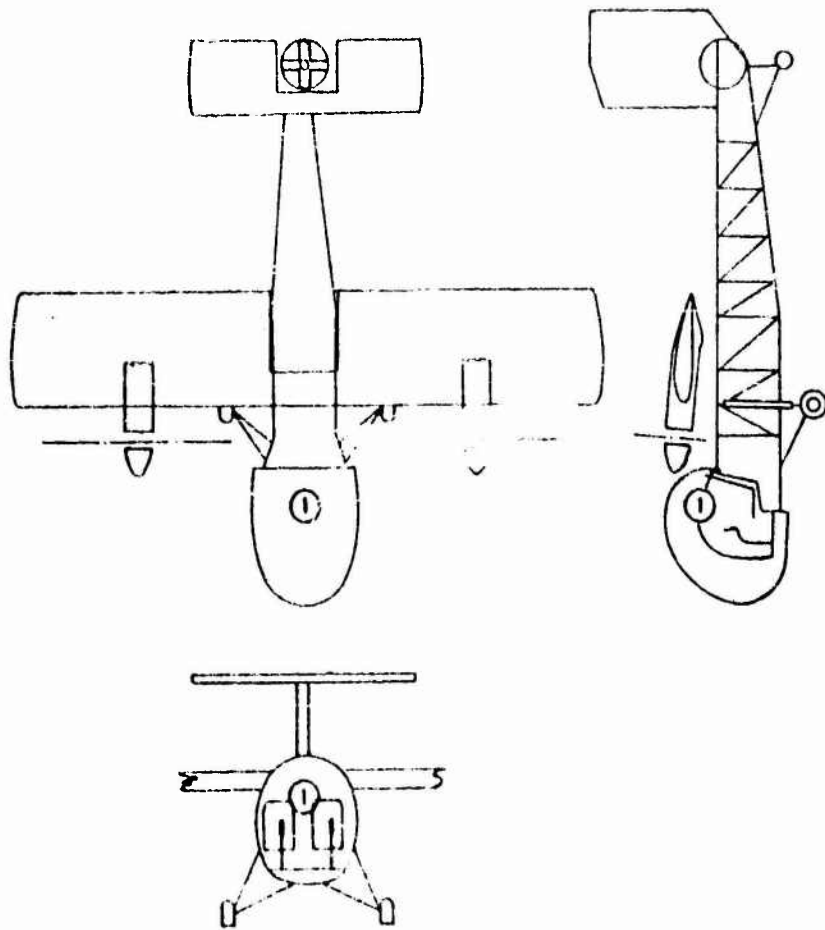

FIGURE 101



APPROXIMATE MICROPHONE POSITIONS USED FOR
VARIOUS NOISE MEASUREMENTS INSIDE AIRCRAFT

FIGURE 102

Vertol-76

4

PILOT'S EAR LEVEL LOCATION

SOUND PRESSURE LEVEL IN BAND - DECIBELS RE 0.0002 DYNE/CM²

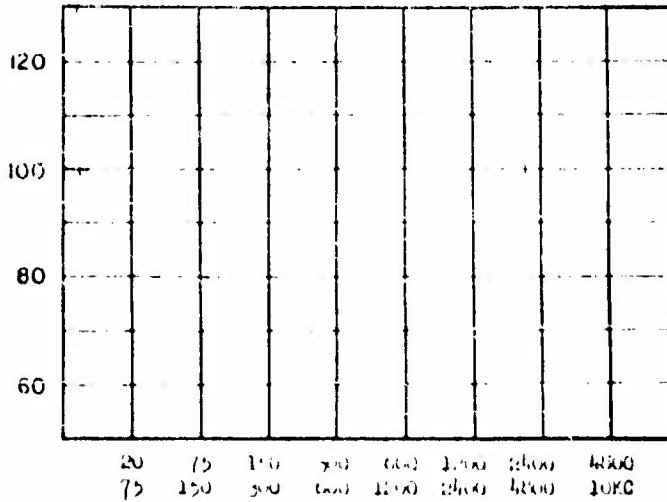
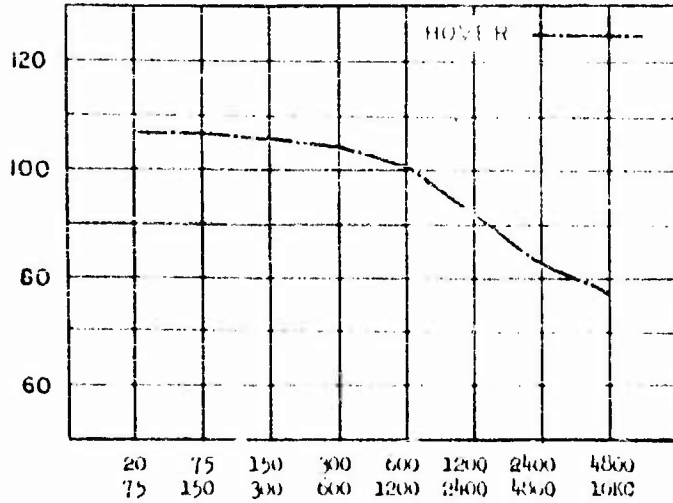

FREQUENCY BAND - CENTER FREQ. (CYCLES PER SECOND)

FIGURE 103

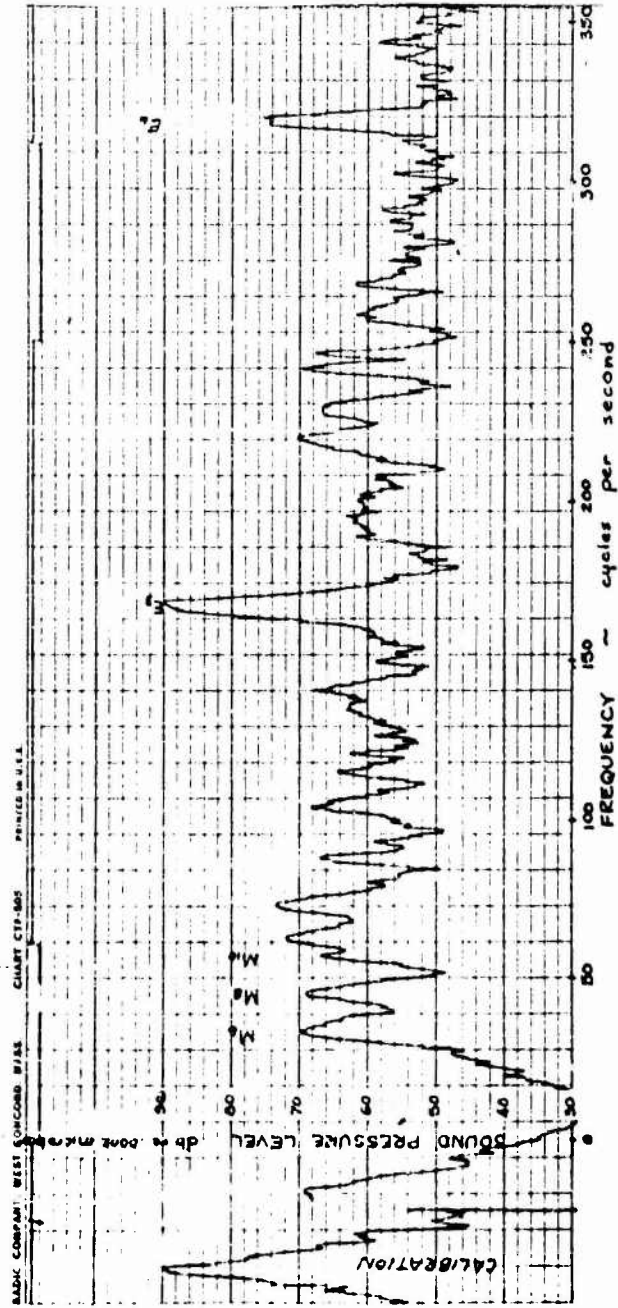

H-13 NARROWBAND ANALYSIS CHART

FIGURE 104

L-20 NOISE SPECTRUM

POSITION 7 PILOT'S EAR LEVEL

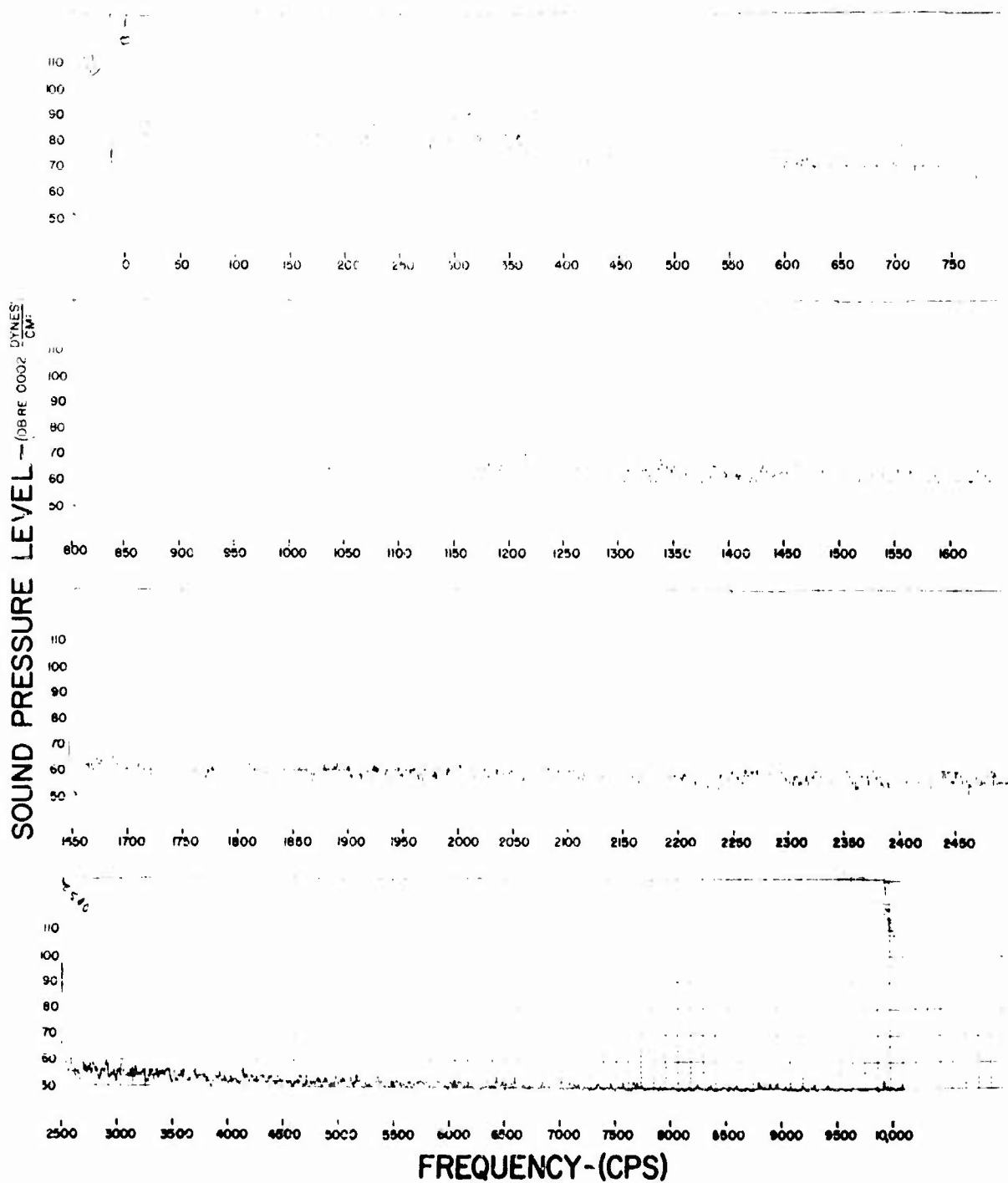

FIGURE 105

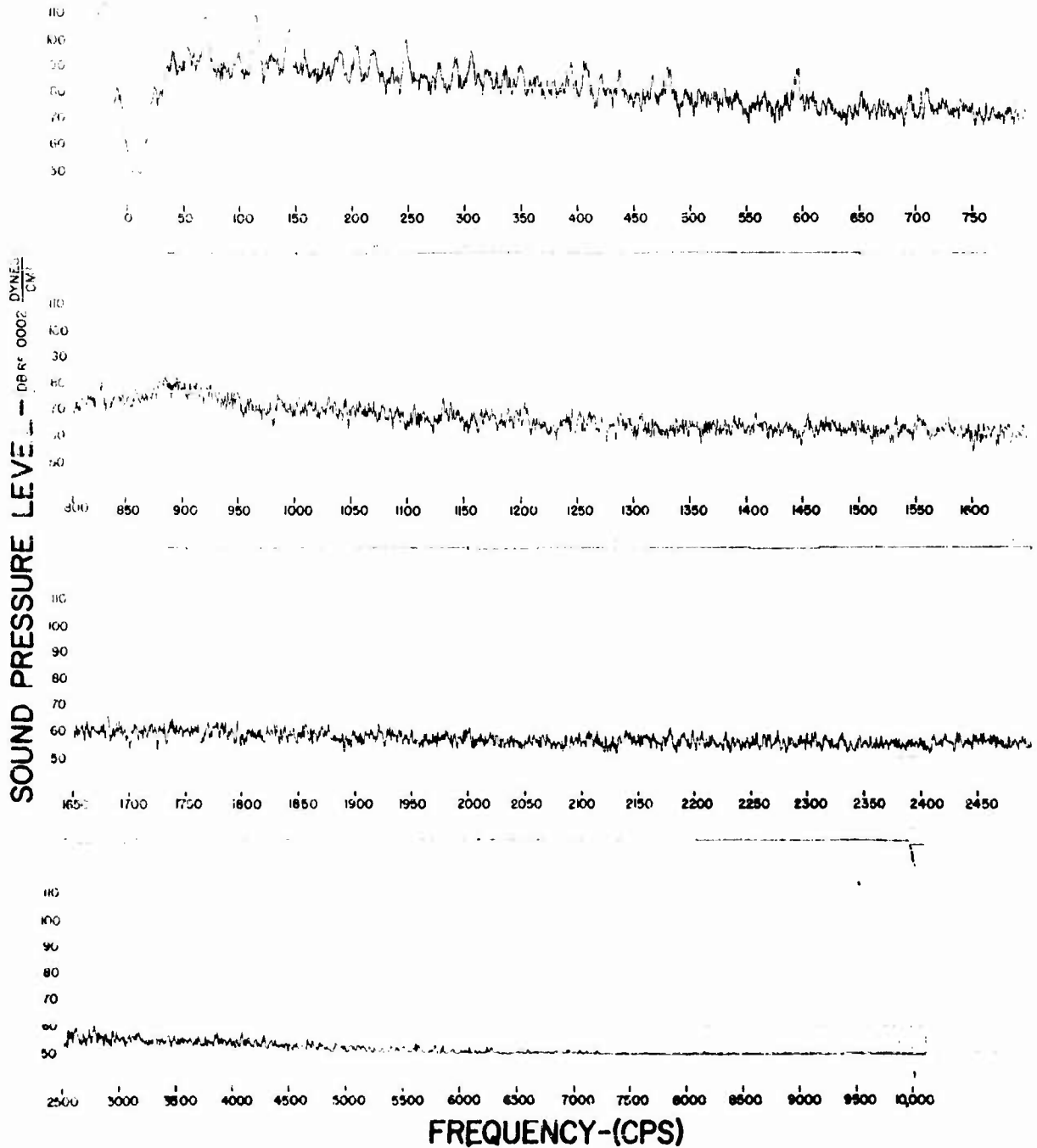

FIGURE 106

L-20 NOISE SPECTRUM

POSITION 20 EXTERNAL

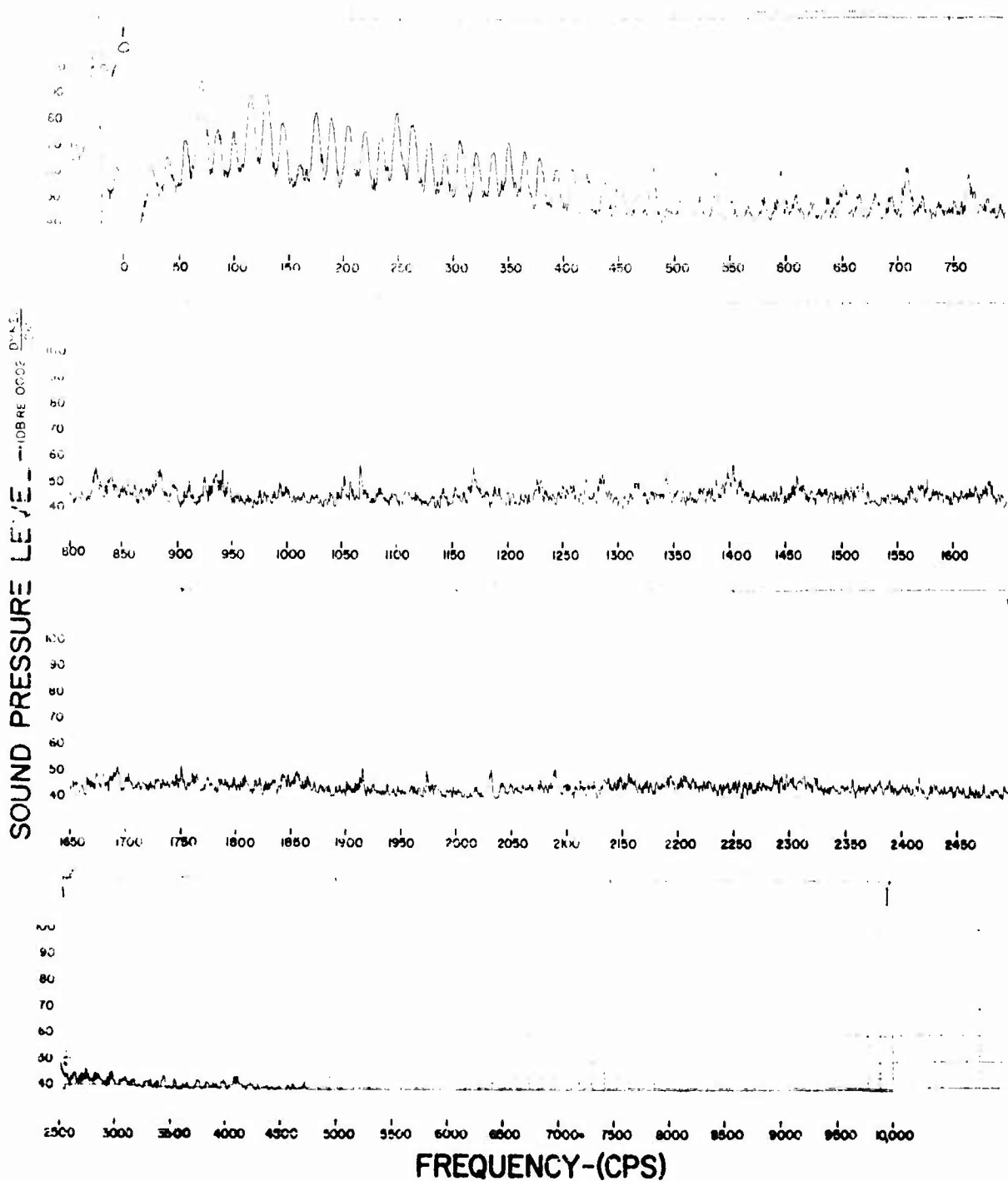

FIGURE 107

L-23 NOISE SPECTRUM

POSITION 7 PILOT'S EAR LEVEL

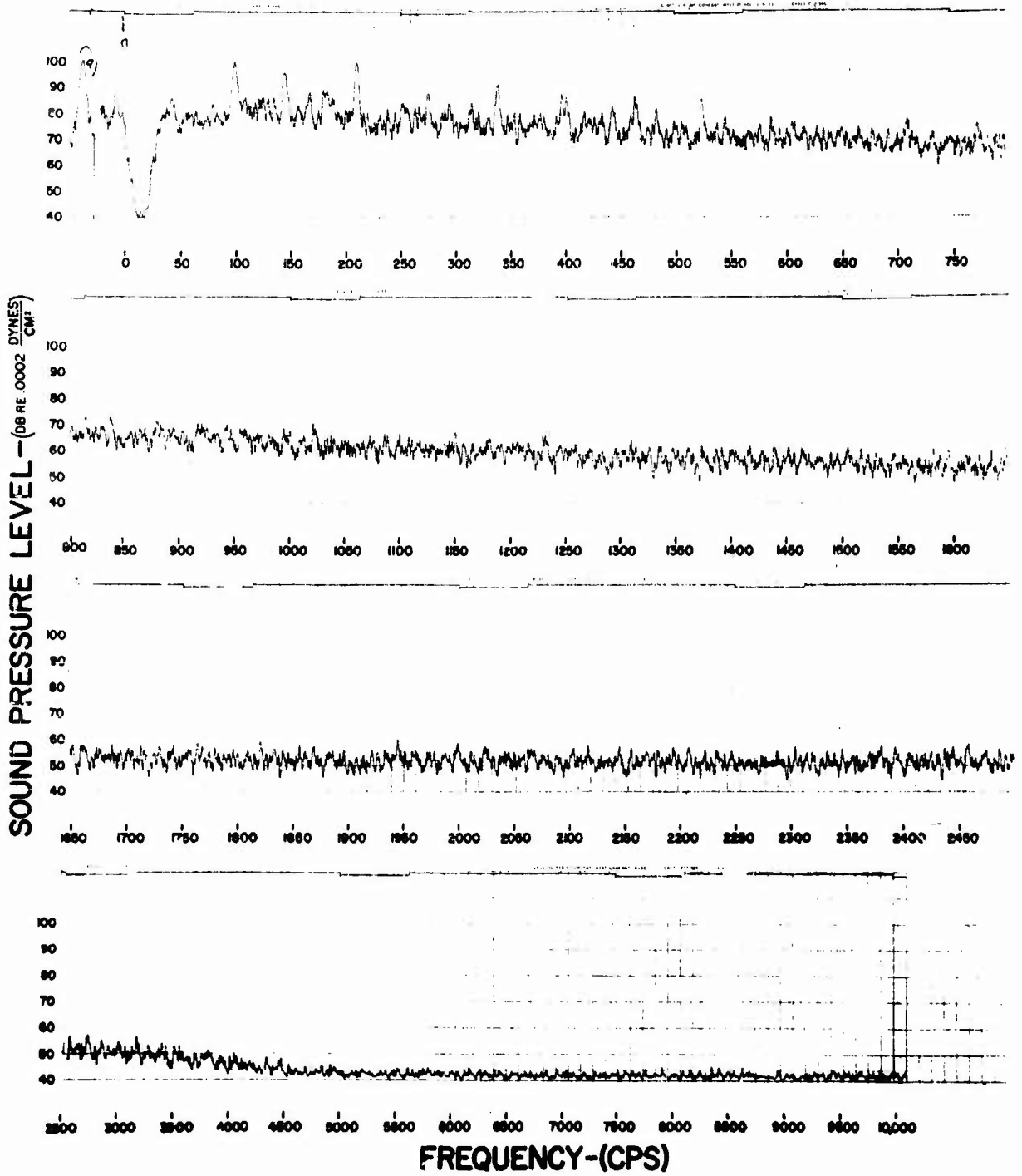

FIGURE 108

L-23 NOISE SPECTRUM

POSITION II CABIN

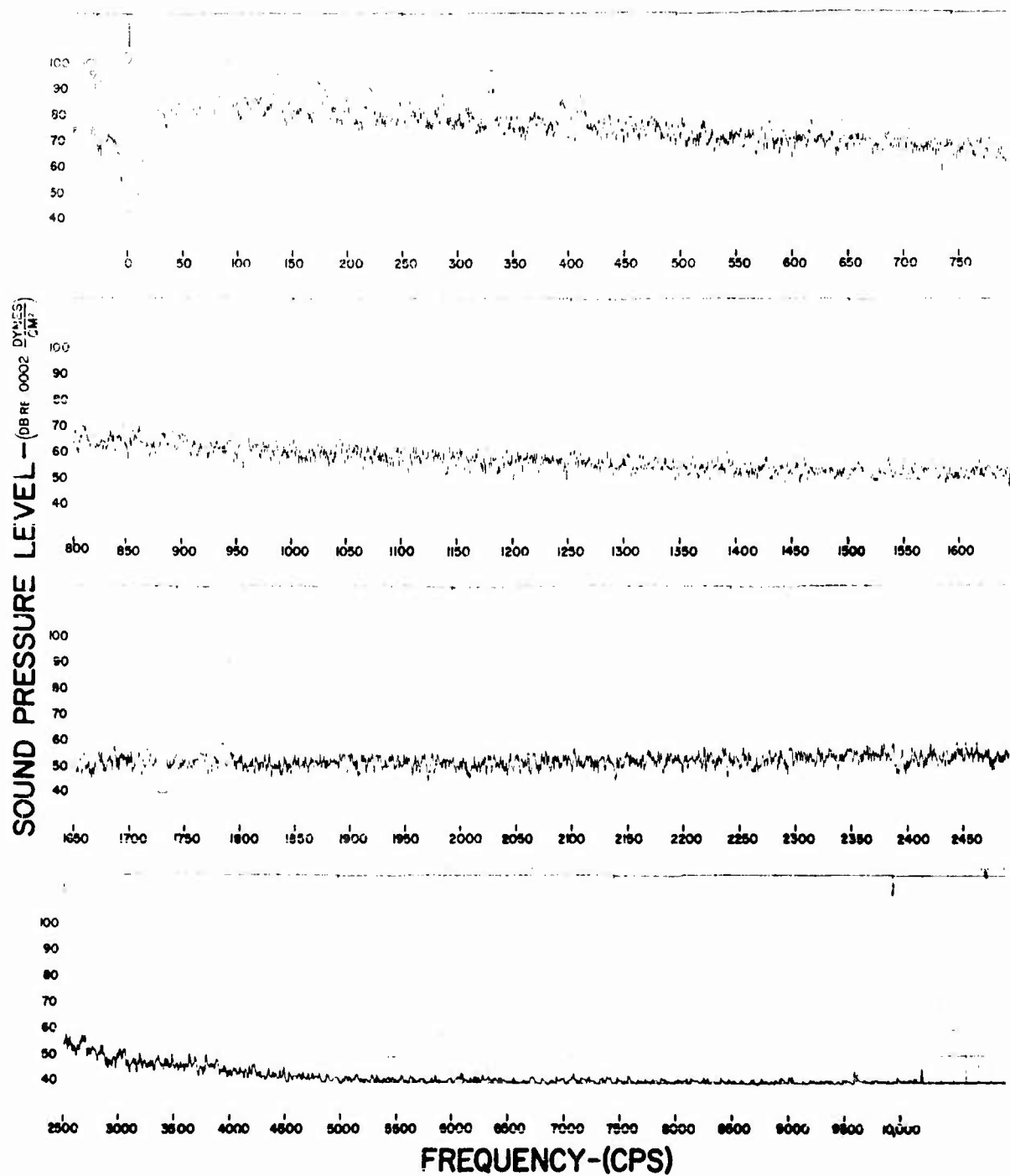

FIGURE 109

L-23 NOISE SPECTRUM

POSITION 20 EXTERNAL

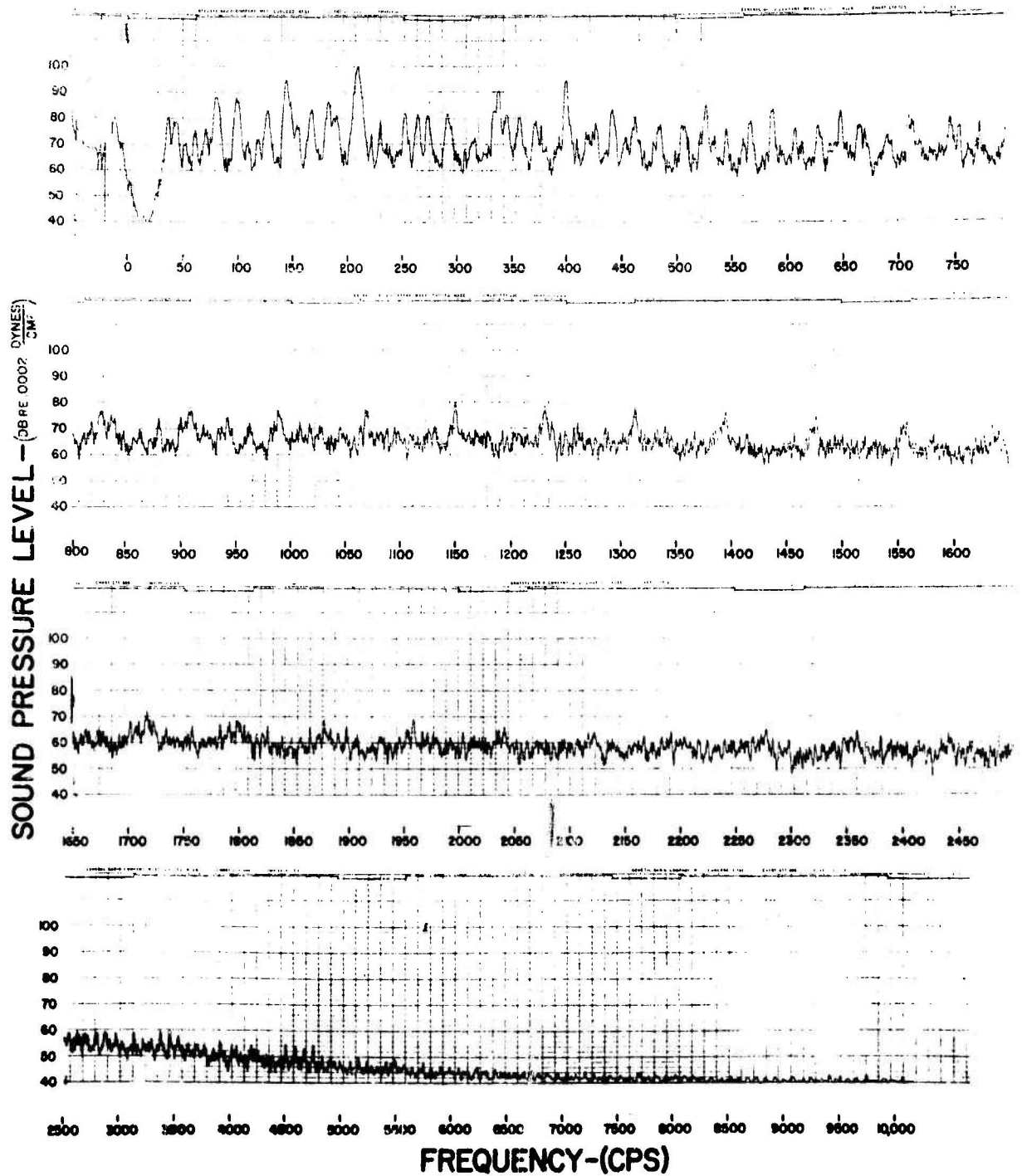

FIGURE 110

U-1A NOISE SPECTRUM

POSITION 6 PILOT'S EAR LEVEL

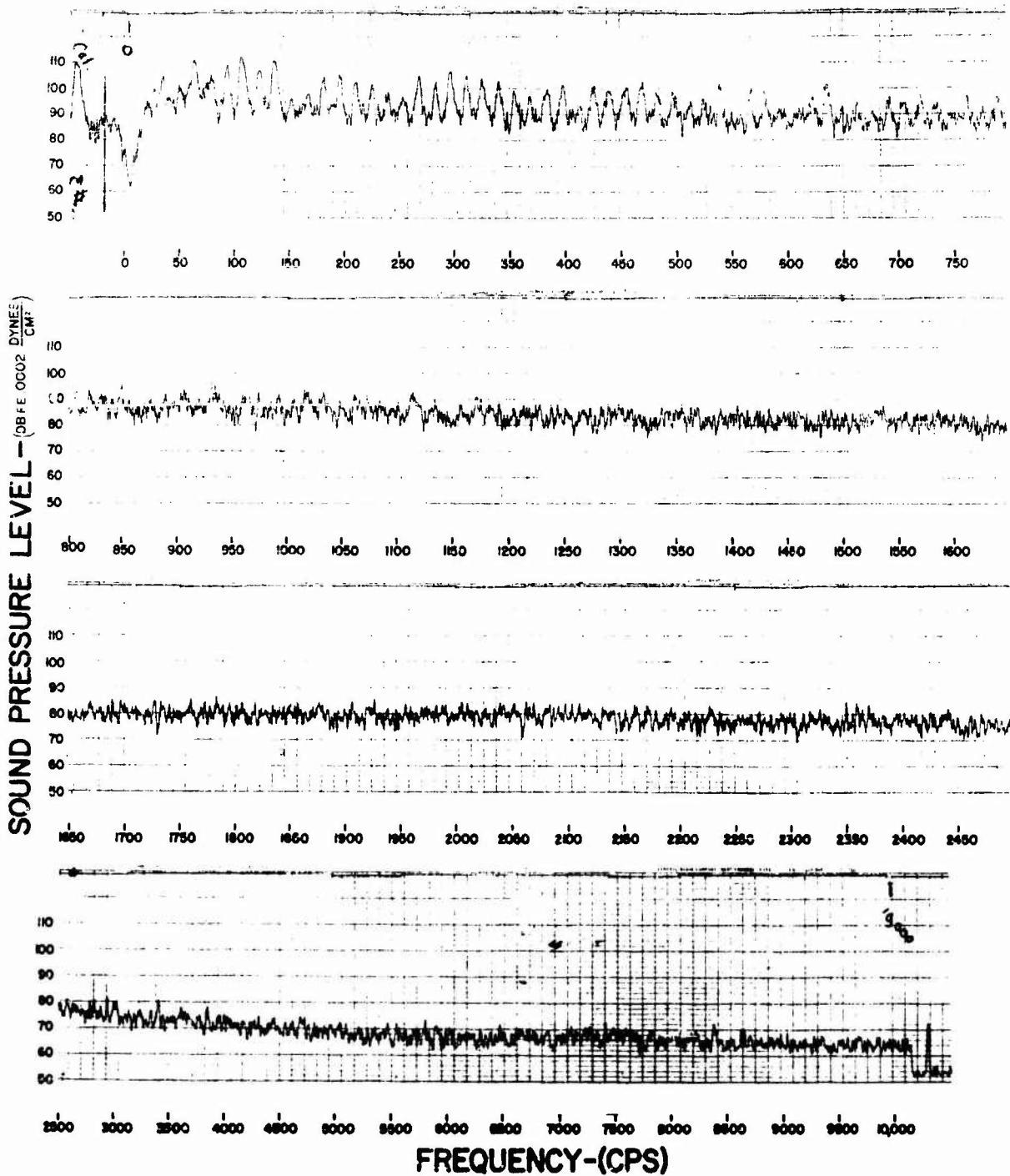

FIGURE 111

U-1A NOISE SPECTRUM

POSITION 17 CABIN

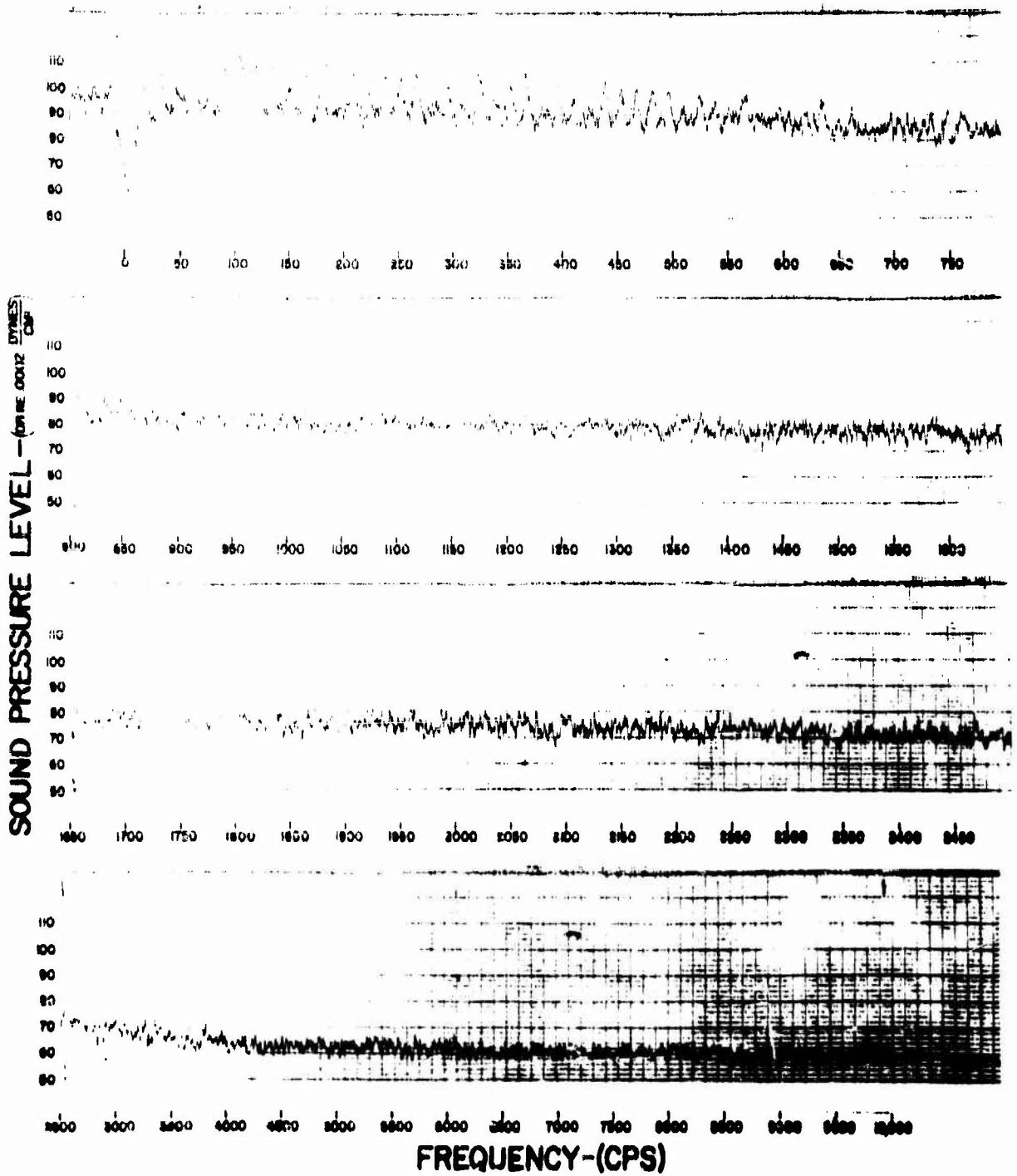

FIGURE 112

U-1A NOISE SPECTRUM

POSITION 19 EXTERNAL

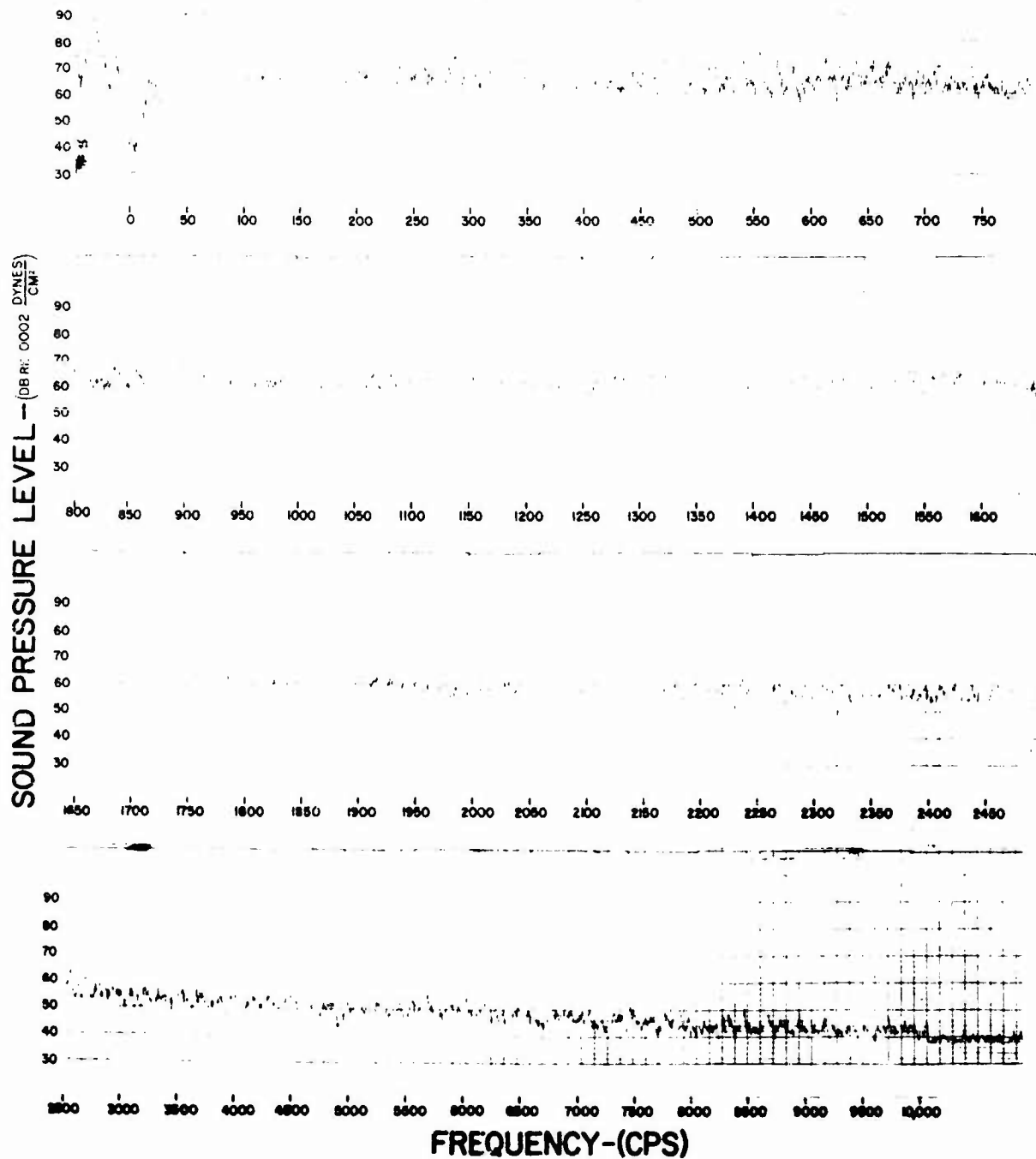

FIGURE 113

H-13 NOISE SPECTRUM

POSITION II PILOTS EAR LEVEL

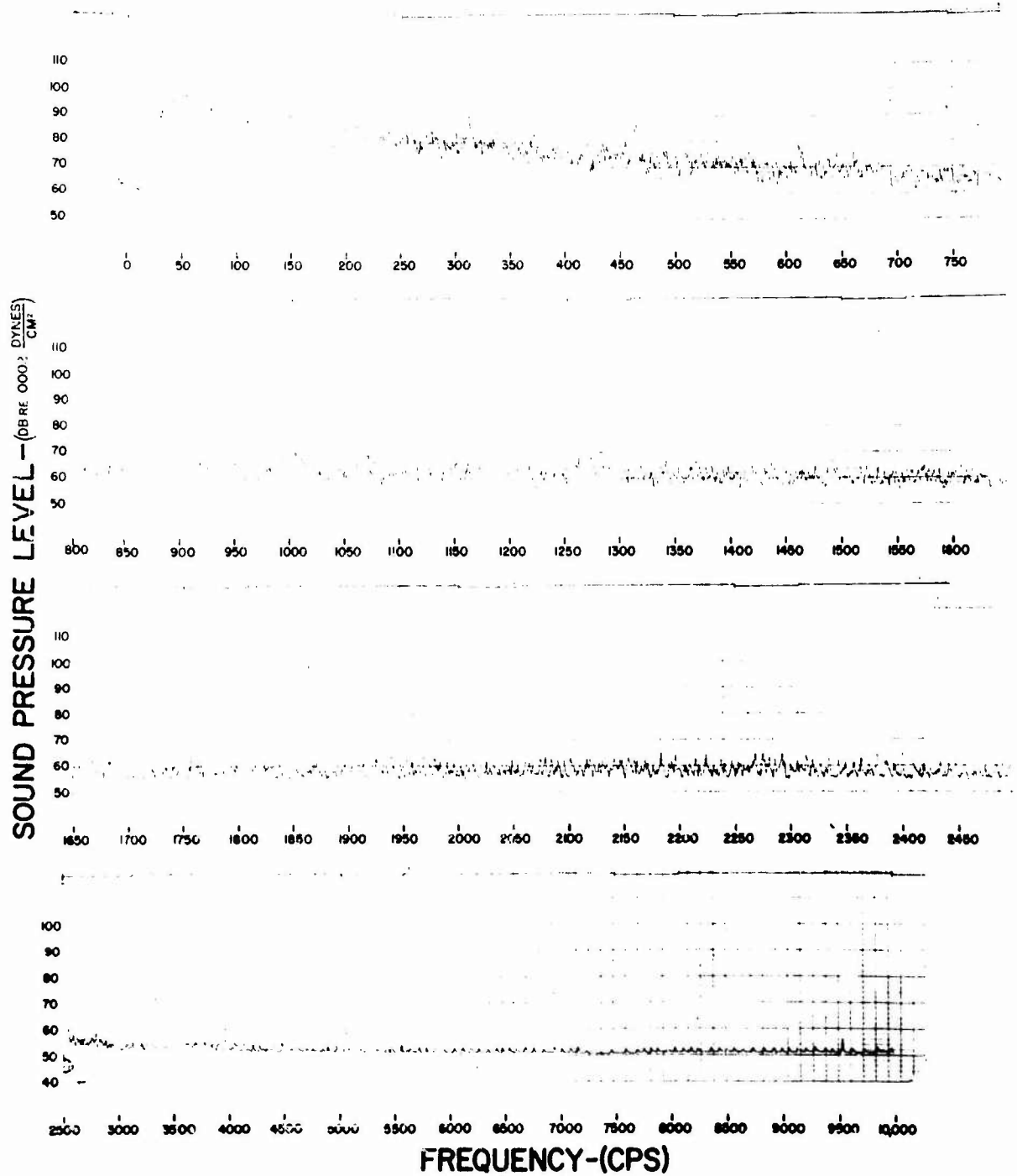

FIGURE 114

H-13 NOISE SPECTRUM

POSITION 22 EXTERNAL

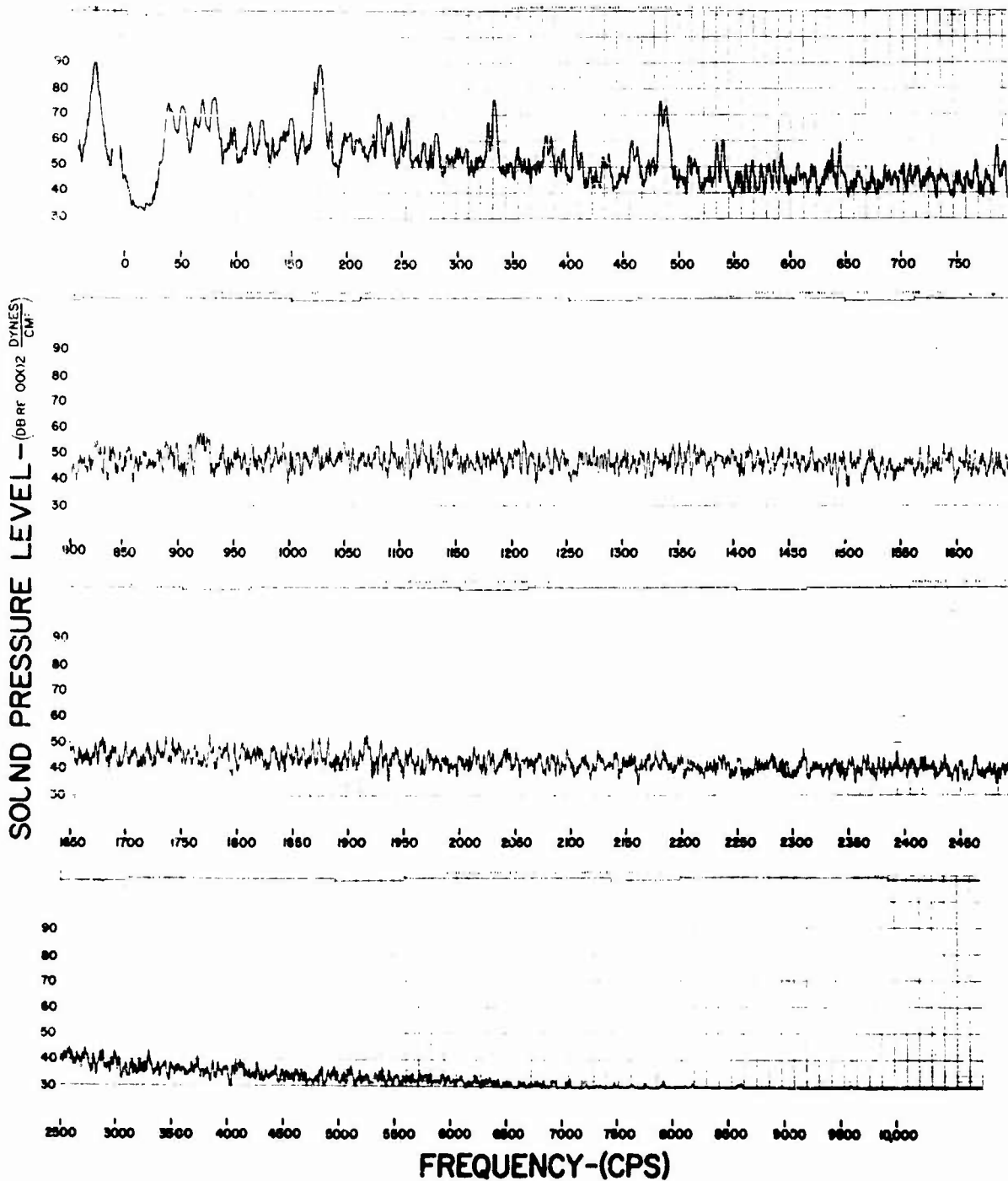

FIGURE 11.

H-21 NOISE SPECTRUM

POSITION 2 PILOTS EAR LEVEL

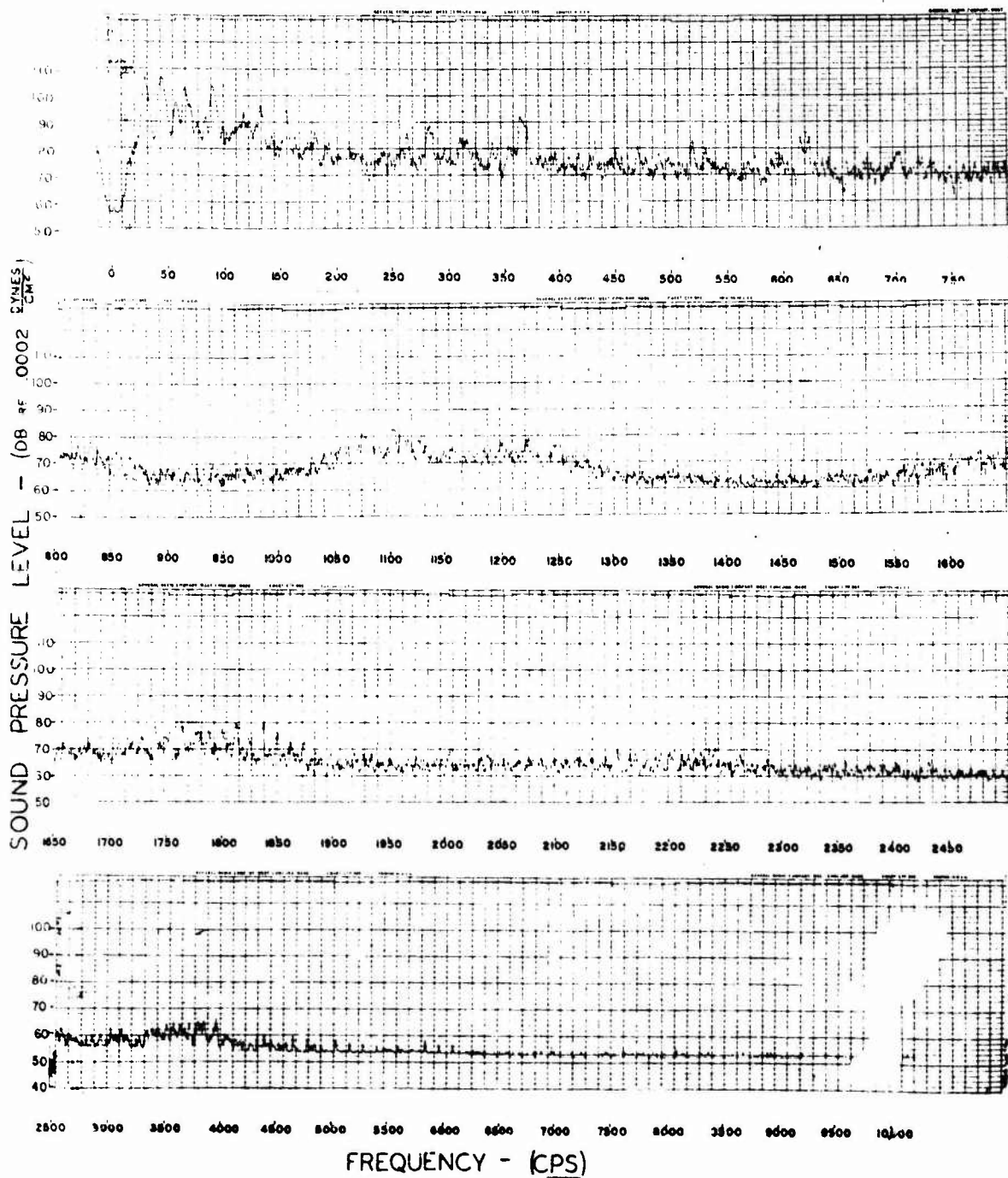

FIGURE 116

H-2i NOISE SPECTRUM

POSITION II CABIN

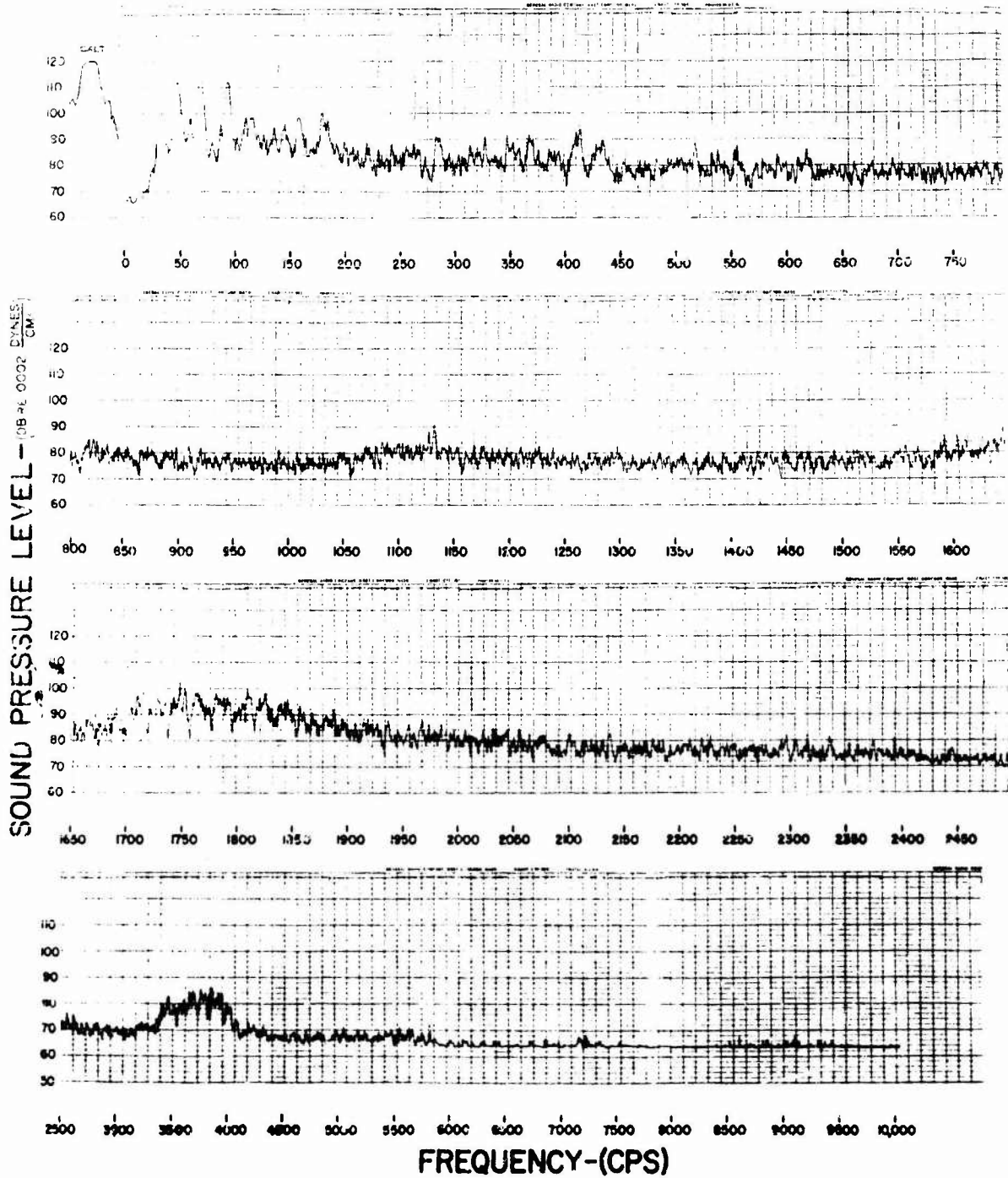

FIGURE 117

H-21 NOISE SPECTRUM

POSITION 27 EXTERNAL

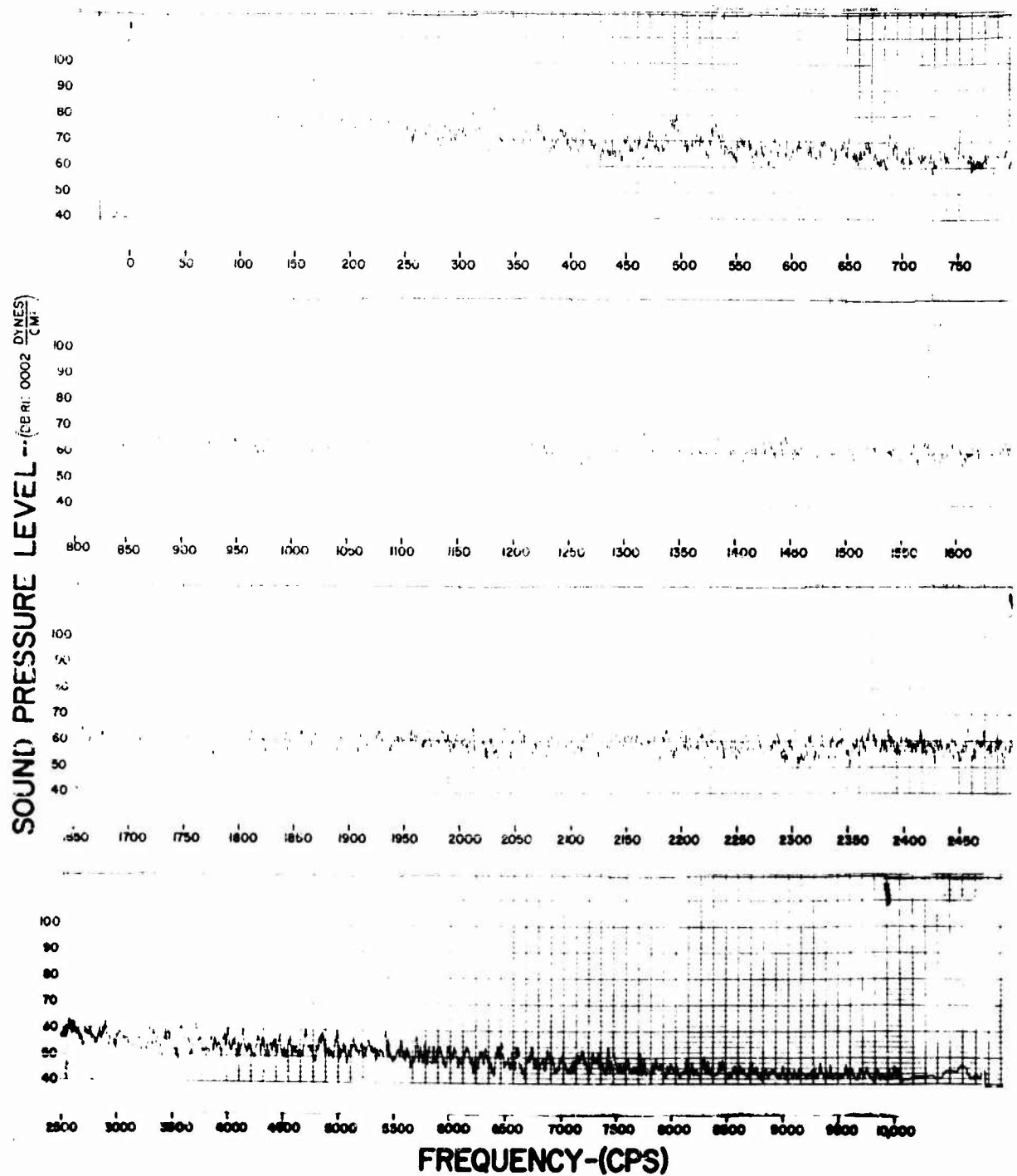

FIGURE 118

H-23 NOISE SPECTRUM

POSITION II PILOT'S EAR LEVEL

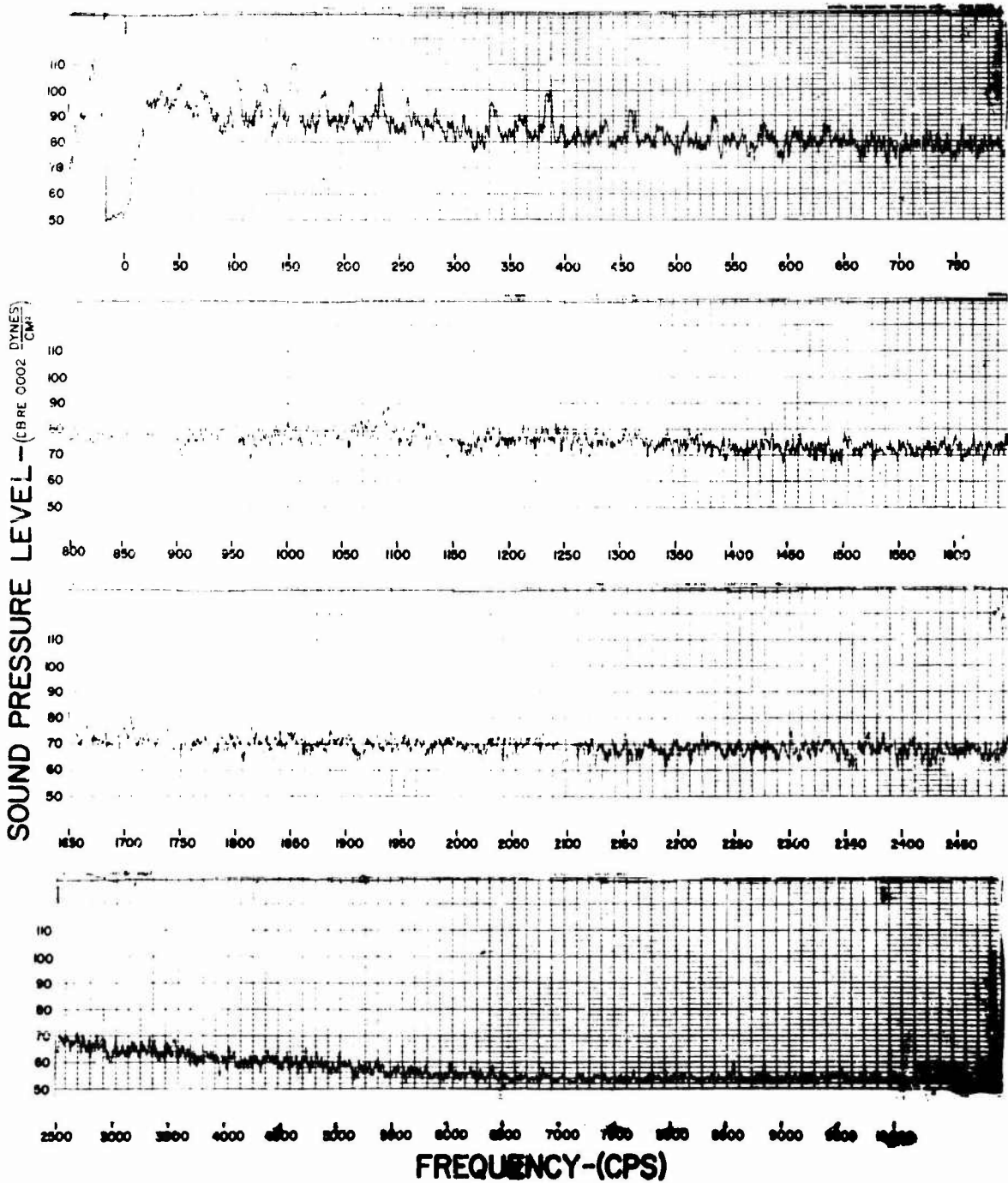

FIGURE 119

H-23 NOISE SPECTRUM

POSITION 21 EXTERNAL

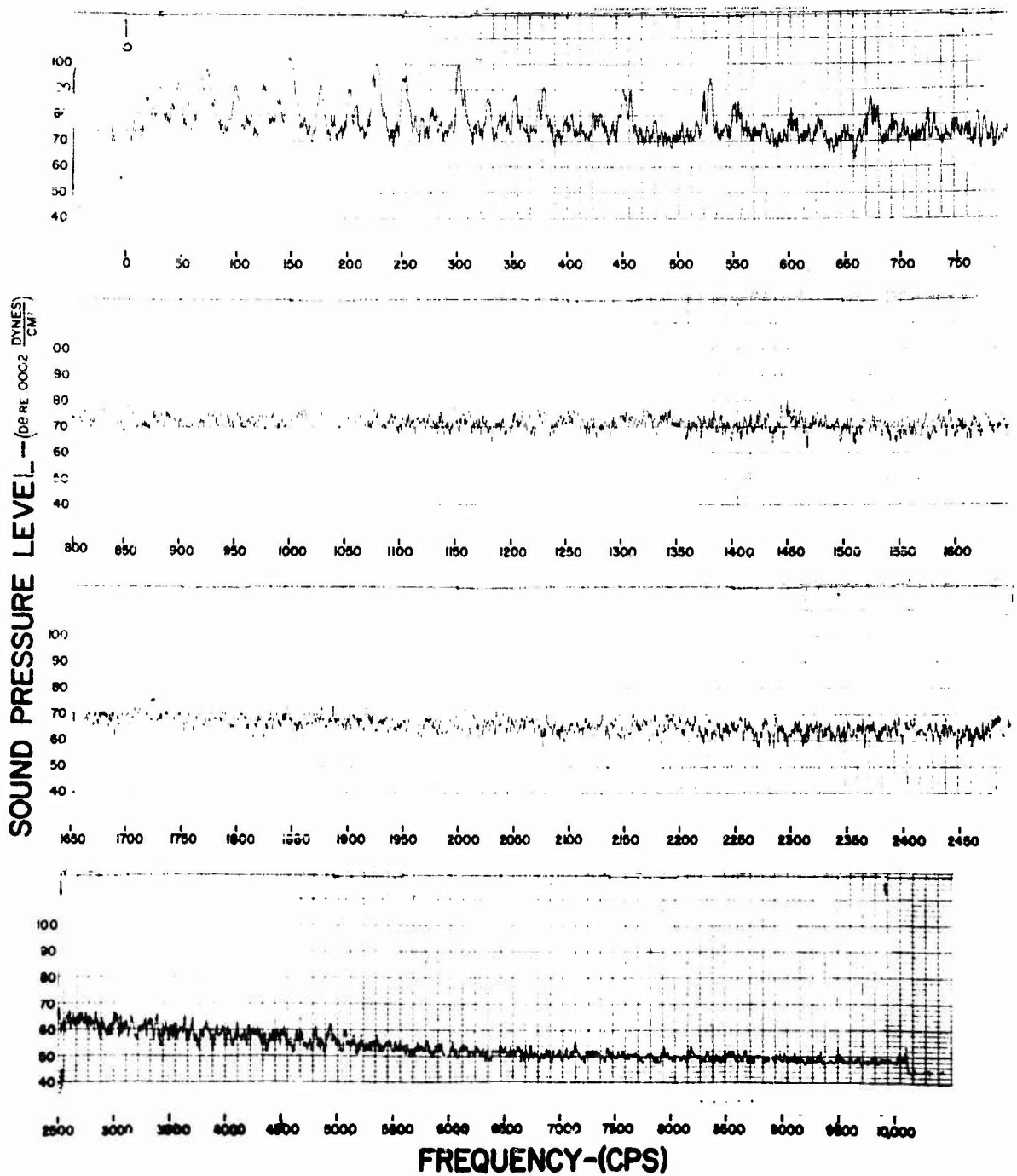

FIGURE 120

H-34 NOISE SPECTRUM

POSITION 5 PILOT'S EAR LEVEL

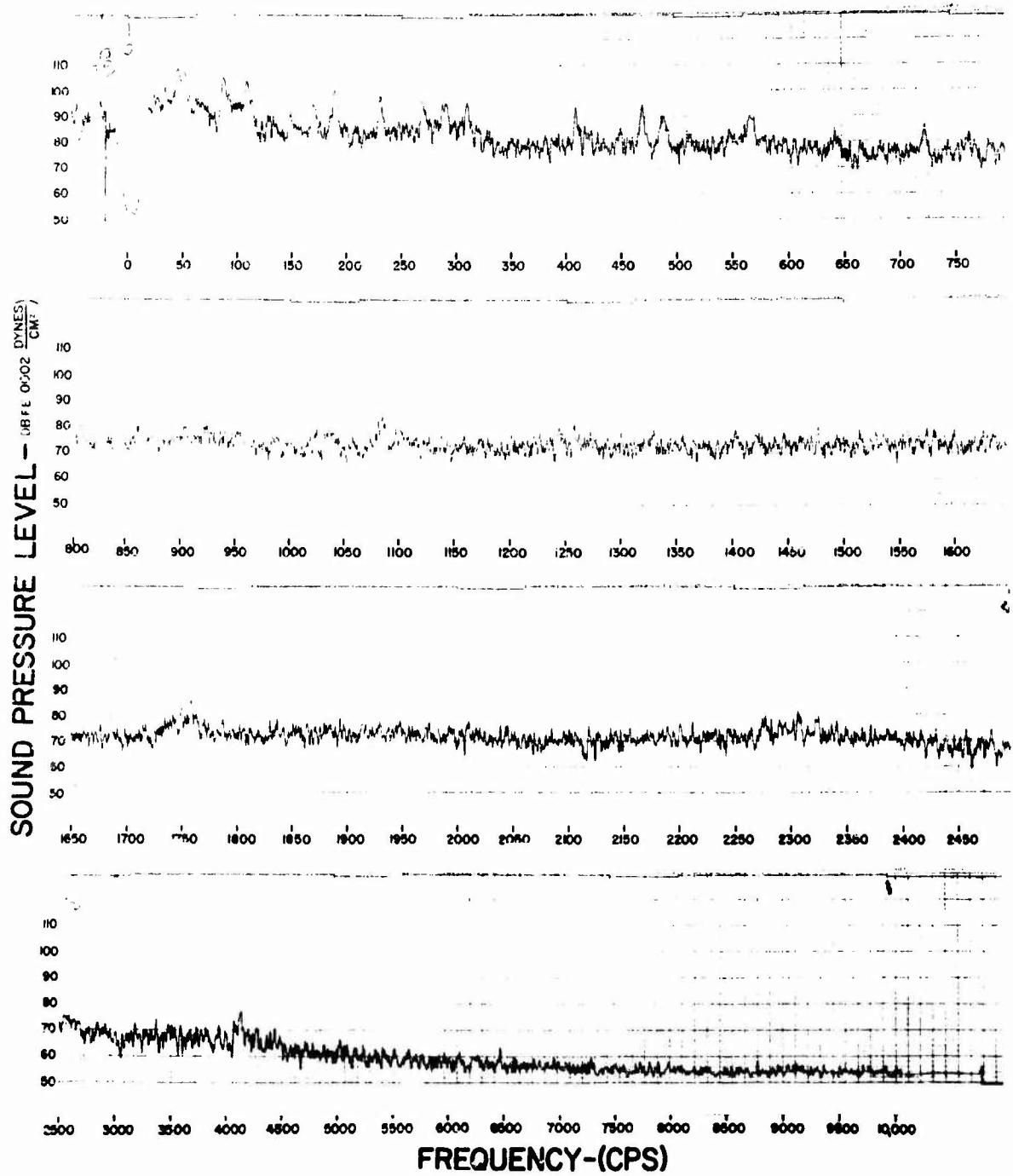

FIGURE 121

H-34 NOISE SPECTRUM

POSITION 16 CABIN

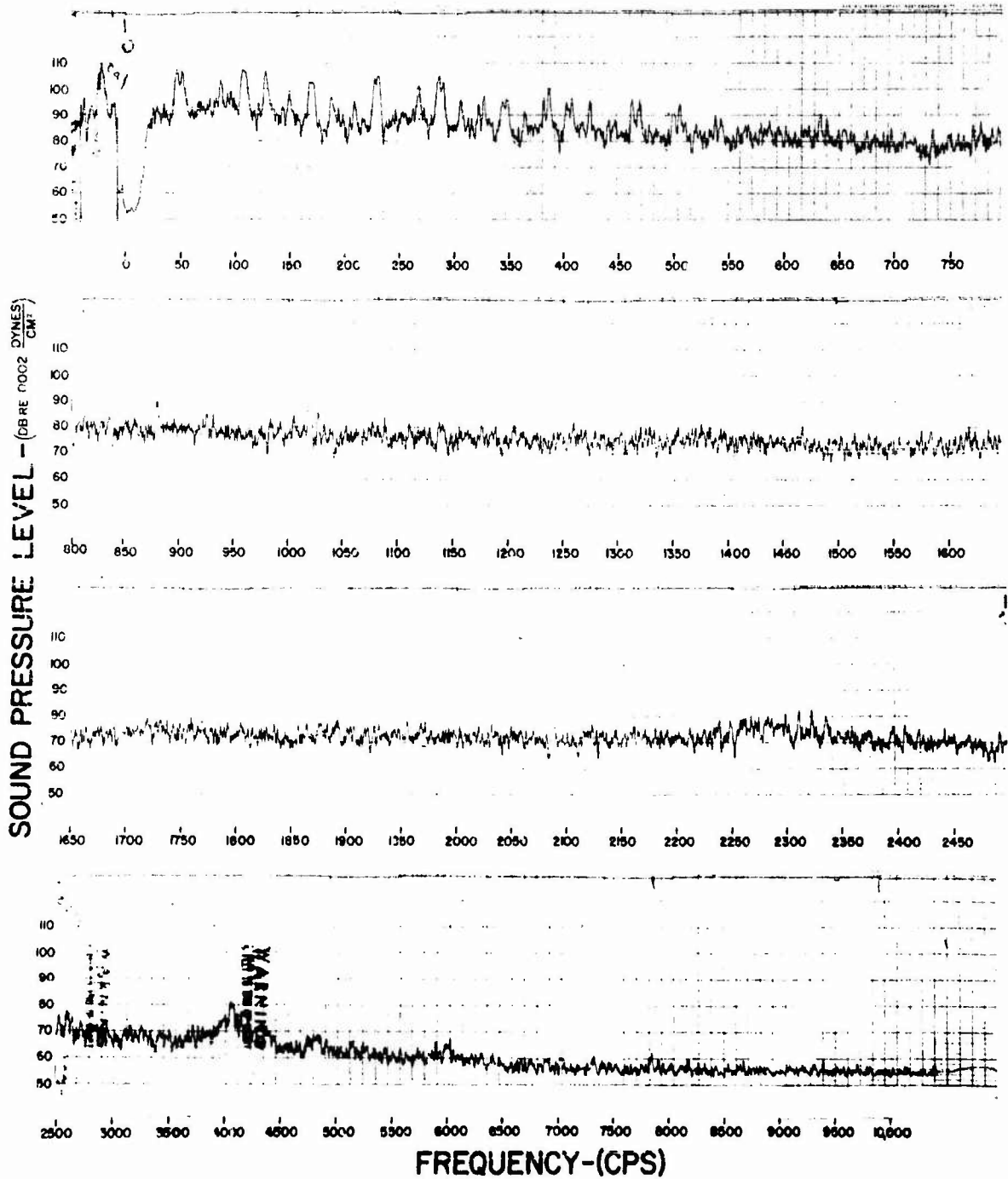

FIGURE 122

H-34 NOISE SPECTRUM

POSITION 23 EXTERNAL

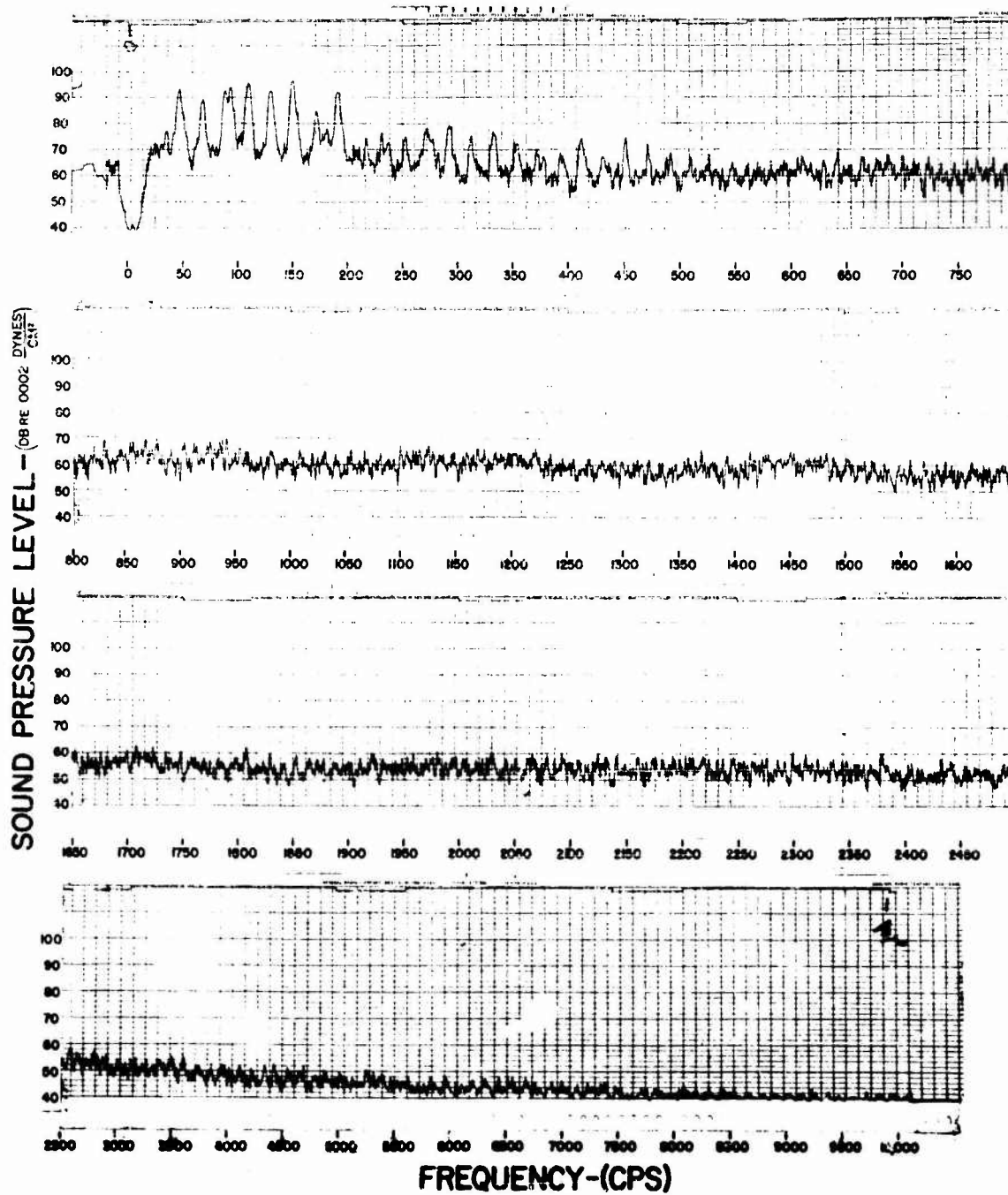

FIGURE 123

H-37 NOISE SPECTRUM

POSITION 5 PILOTS EAR LEVEL

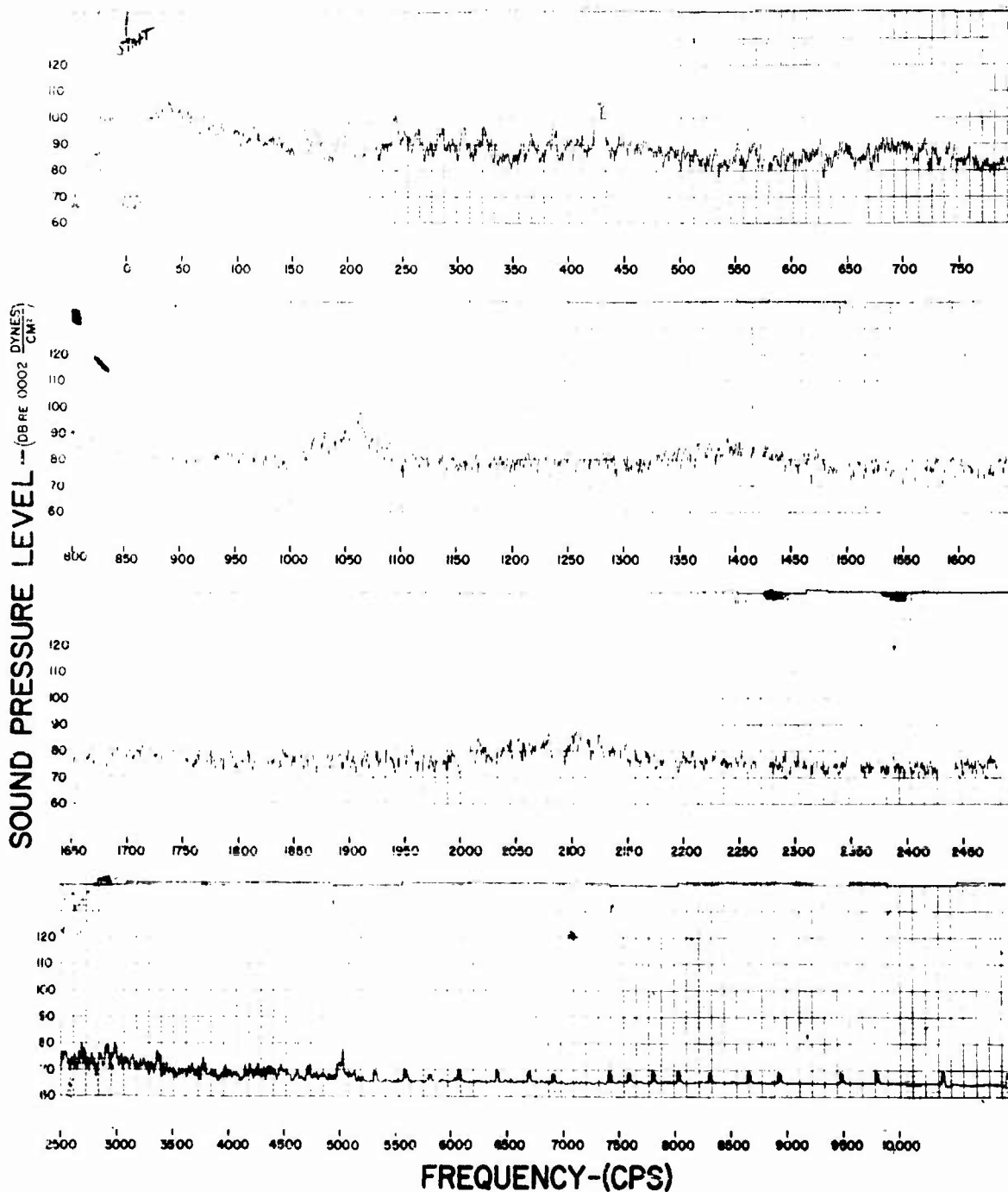

FIGURE 124

H-37 NOISE SPECTRUM

POSITION 17 CABIN

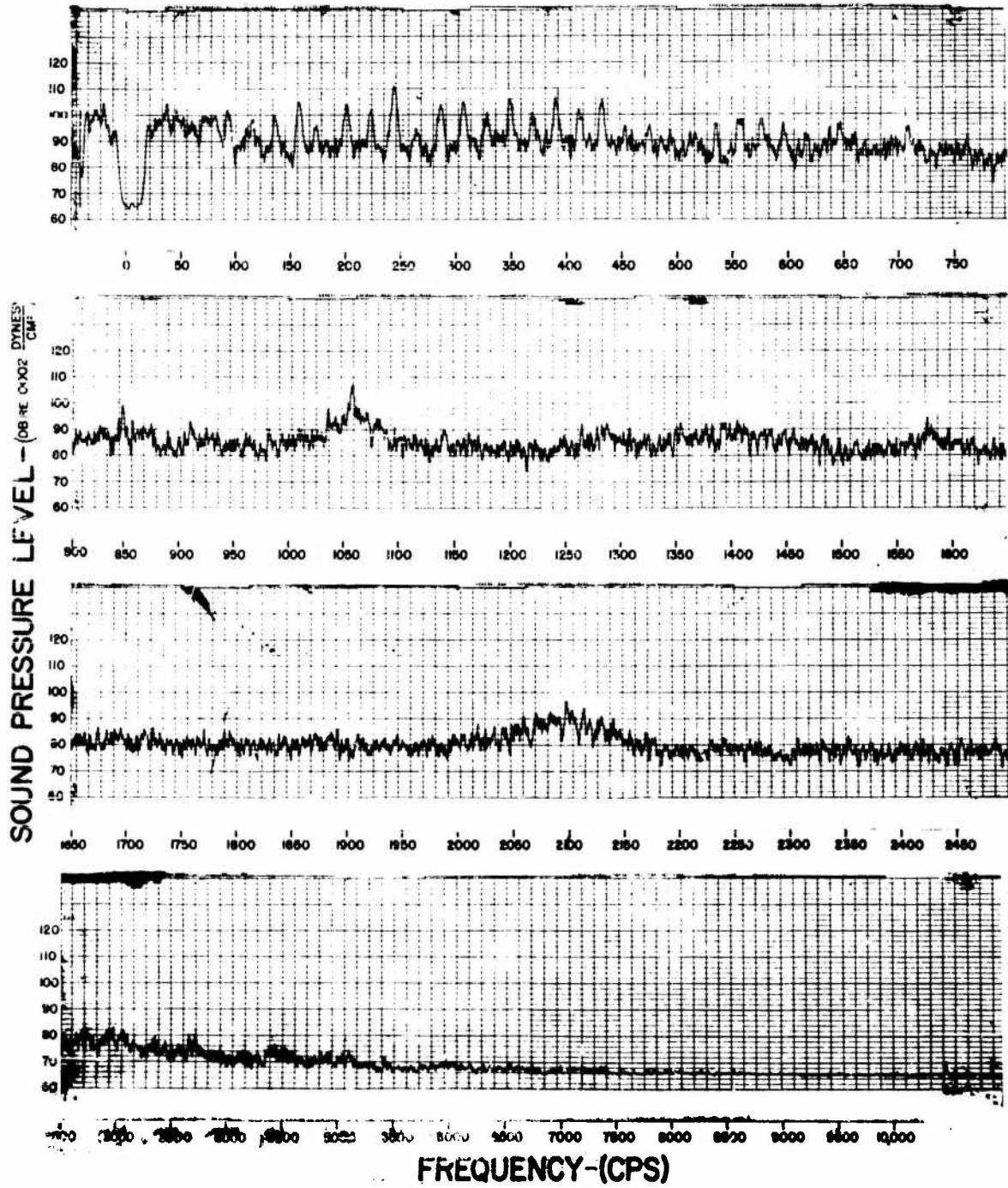

FIGURE 125

H-37 NOISE SPECTRUM

POSITION 21 EXTERNAL

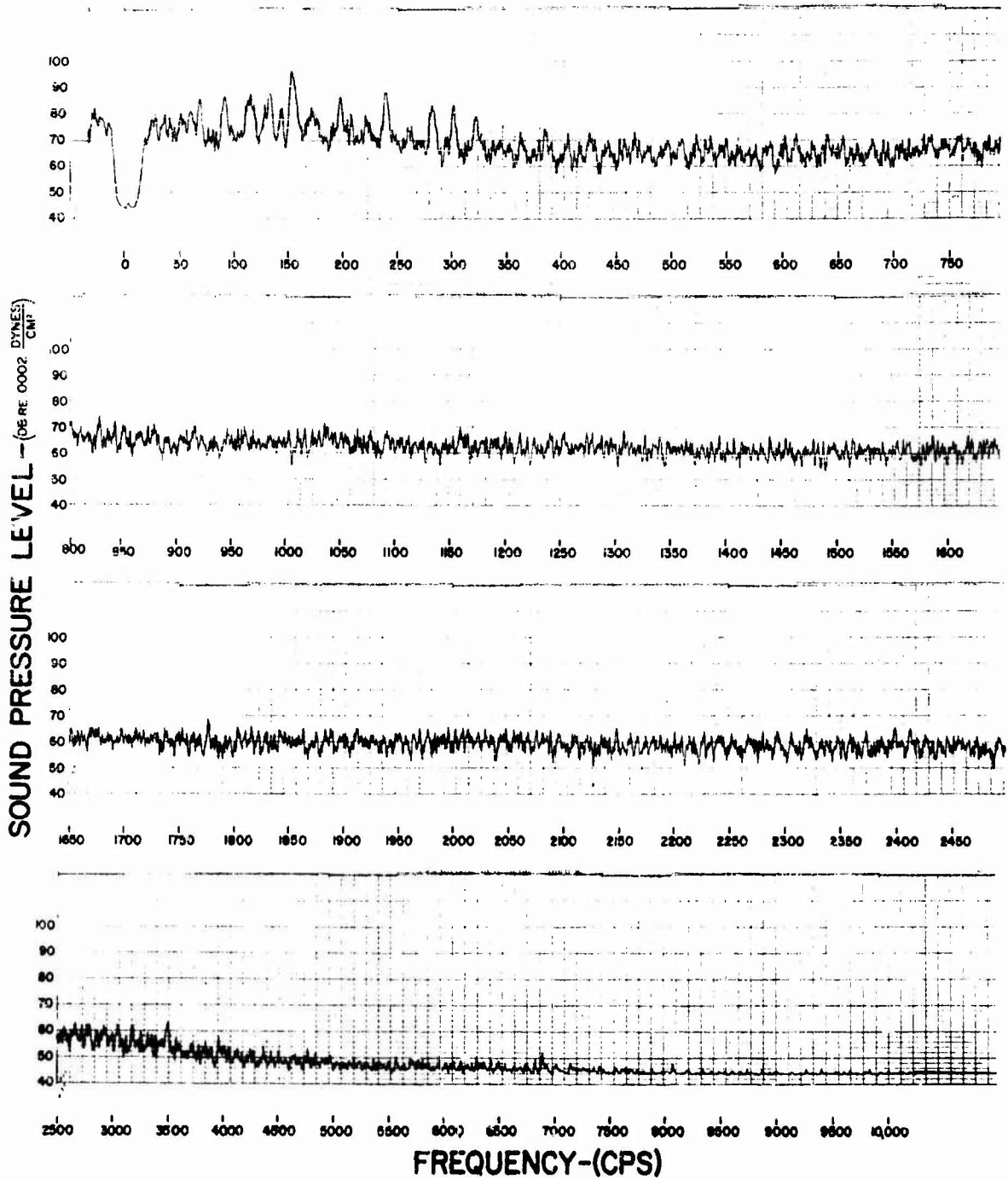

FIGURE 126

HU-1A NOISE SPECTRUM

POSITION 7 PILOT'S EAR LEVEL

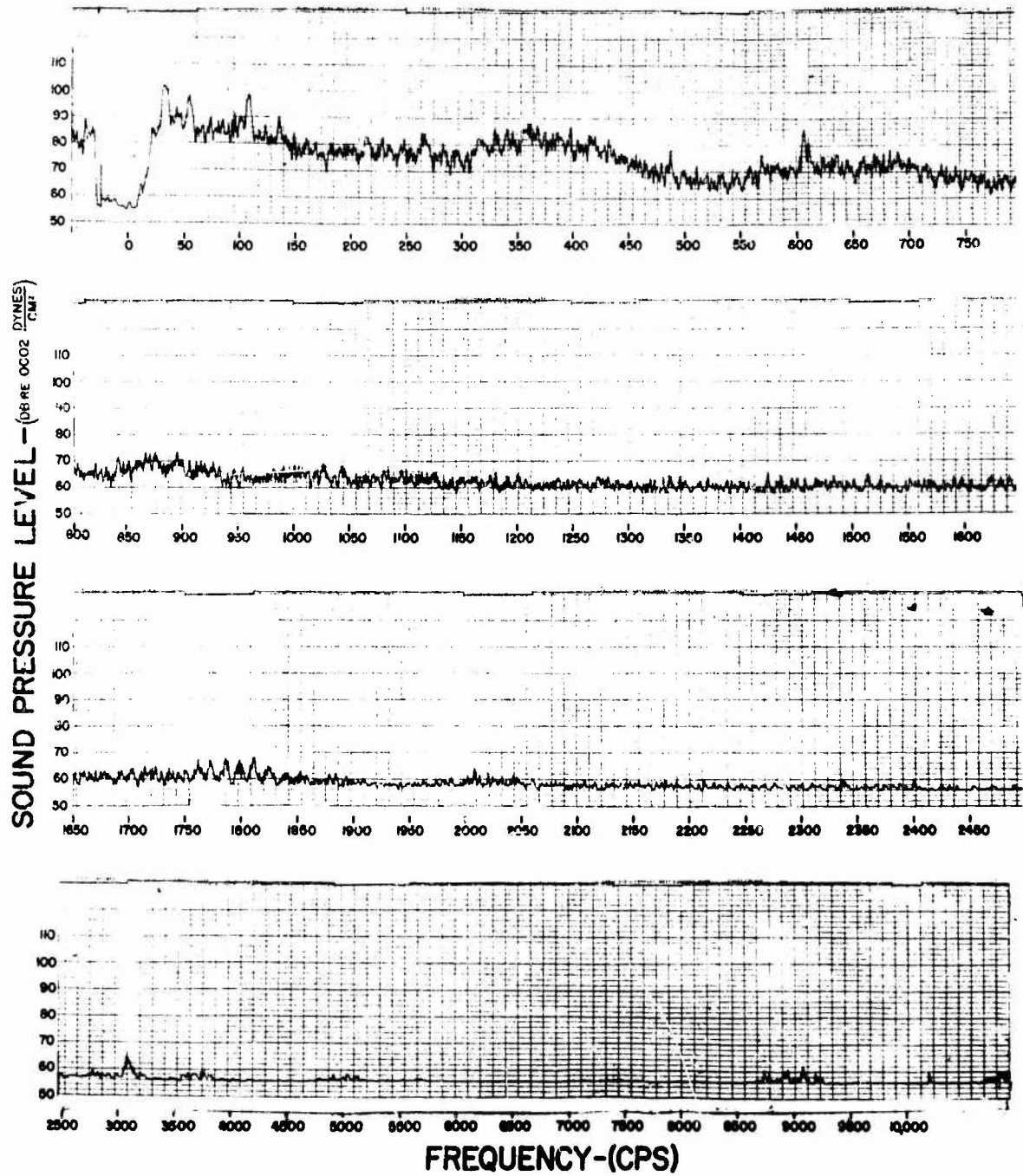

FIGURE 127

HU-1A NOISE SPECTRUM

POSITION 19 CABIN

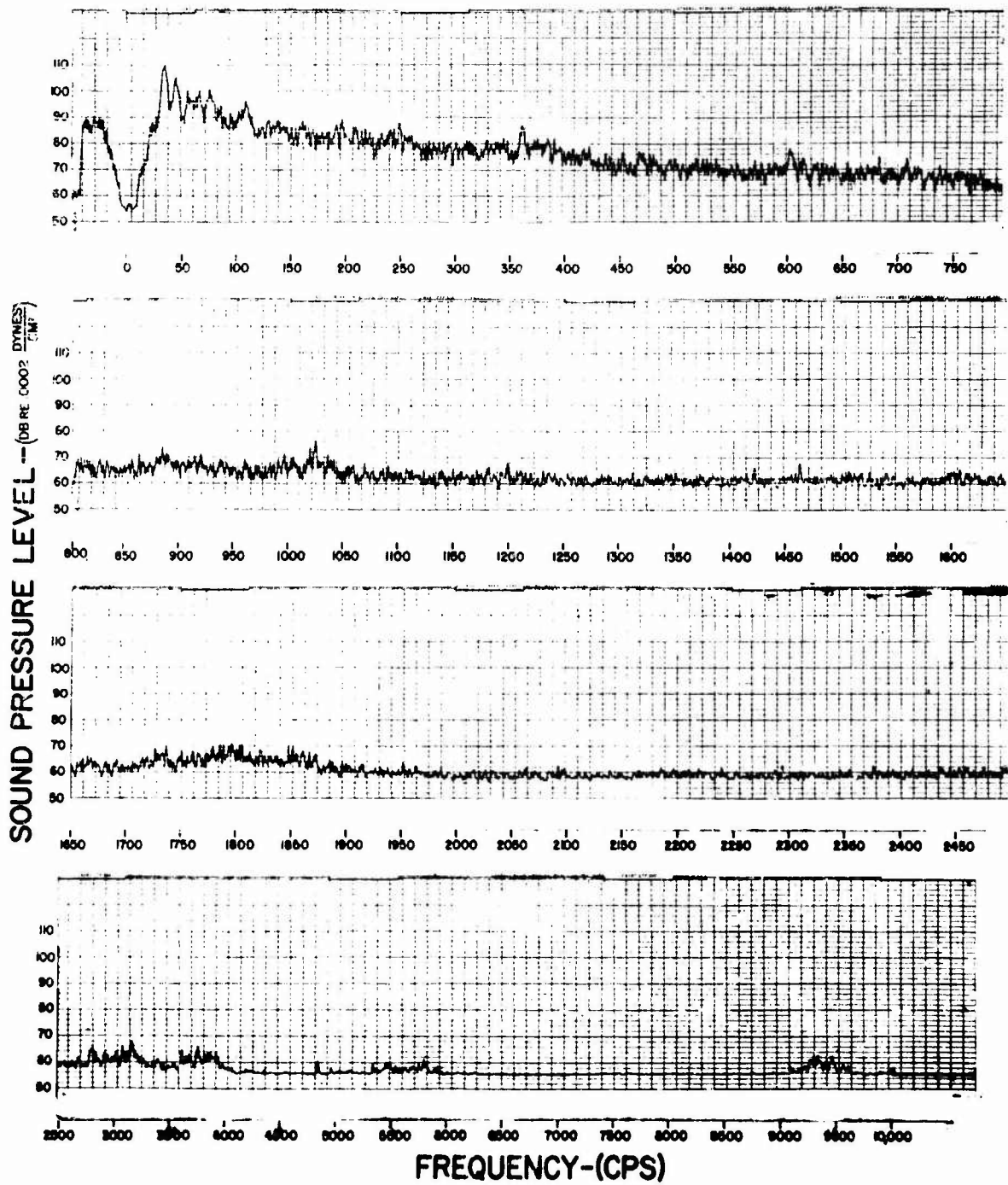

FIGURE 128

HU-1A NOISE SPECTRUM

POSITION 23 EXTERNAL

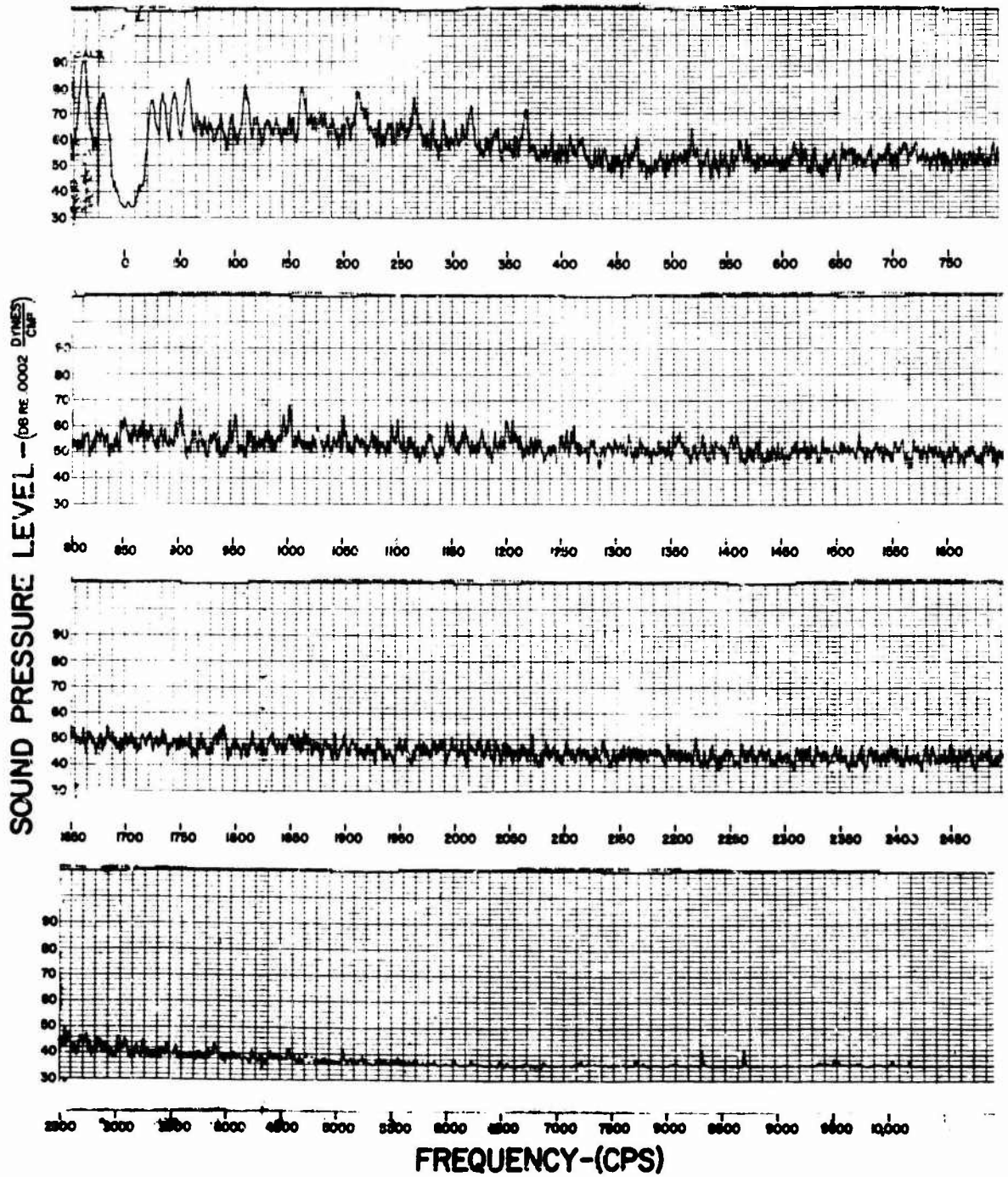

FIGURE 129

YHC-1A NOISE SPECTRUM

POSITION 1 PILOT'S EAR LEVEL

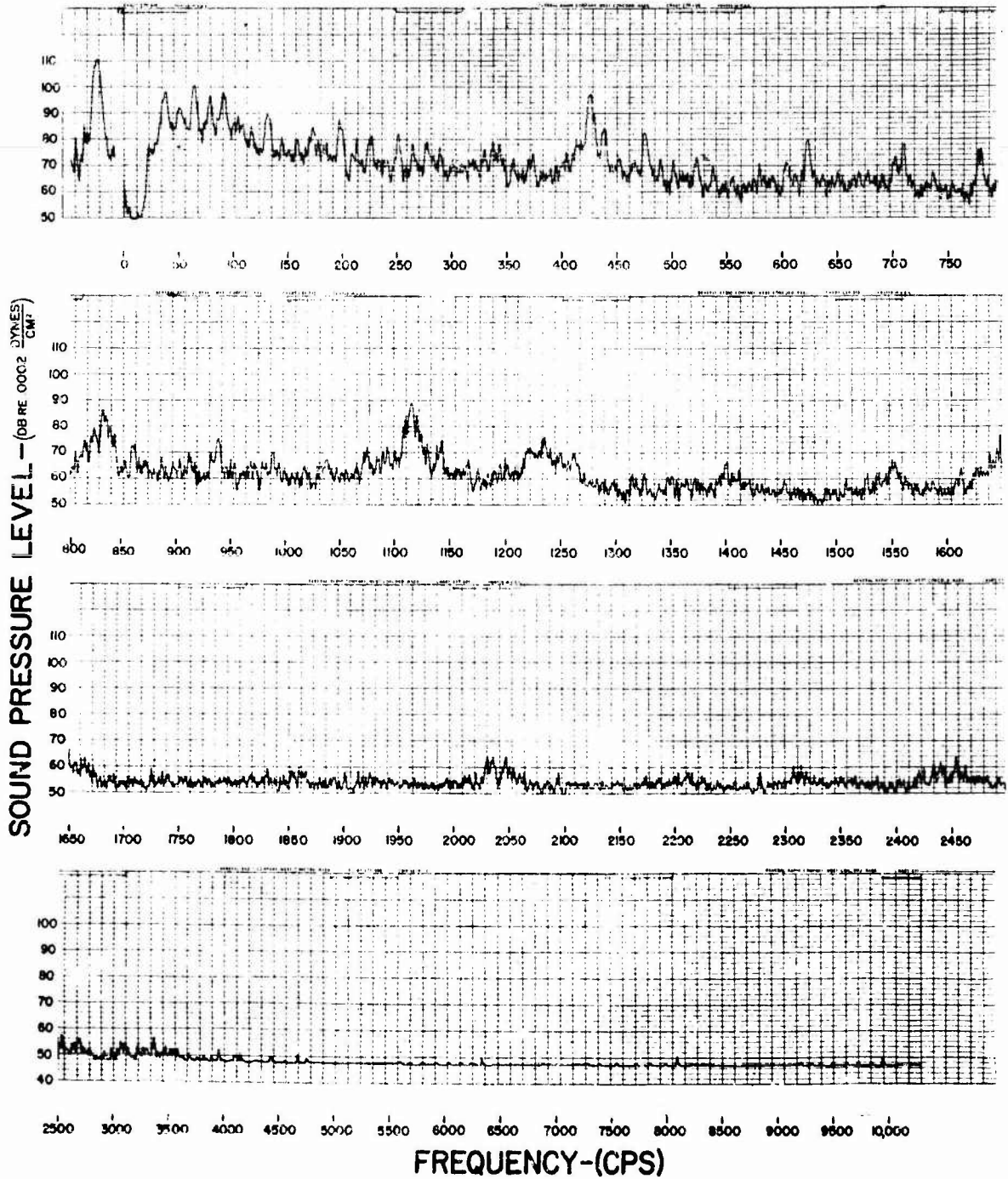

FIGURE 130

YHC-1A NOISE SPECTRUM

POSITION 12 CABIN

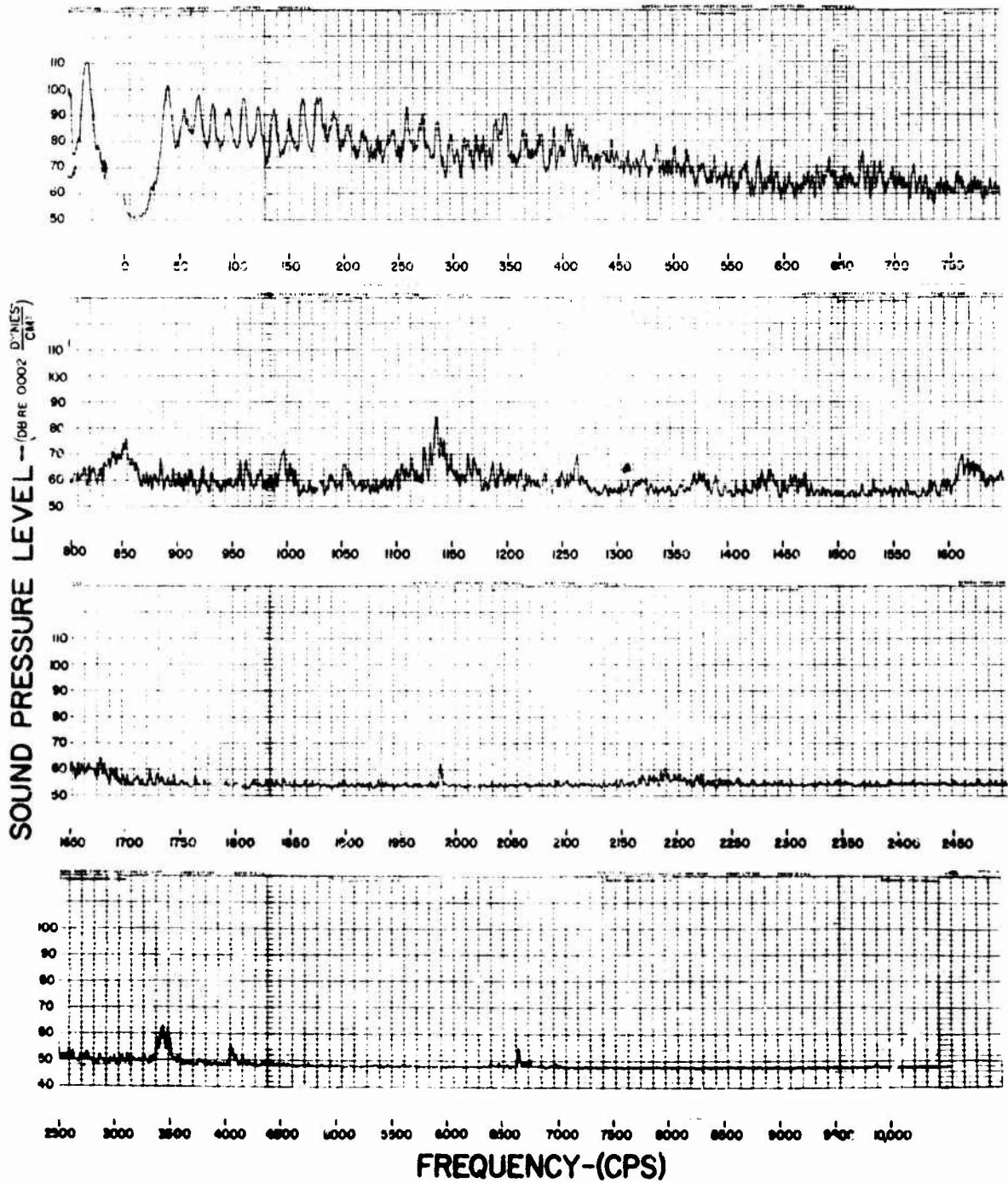

FIGURE 131

YHC-1A NOISE SPECTRUM

POSITION 25 EXTERNAL

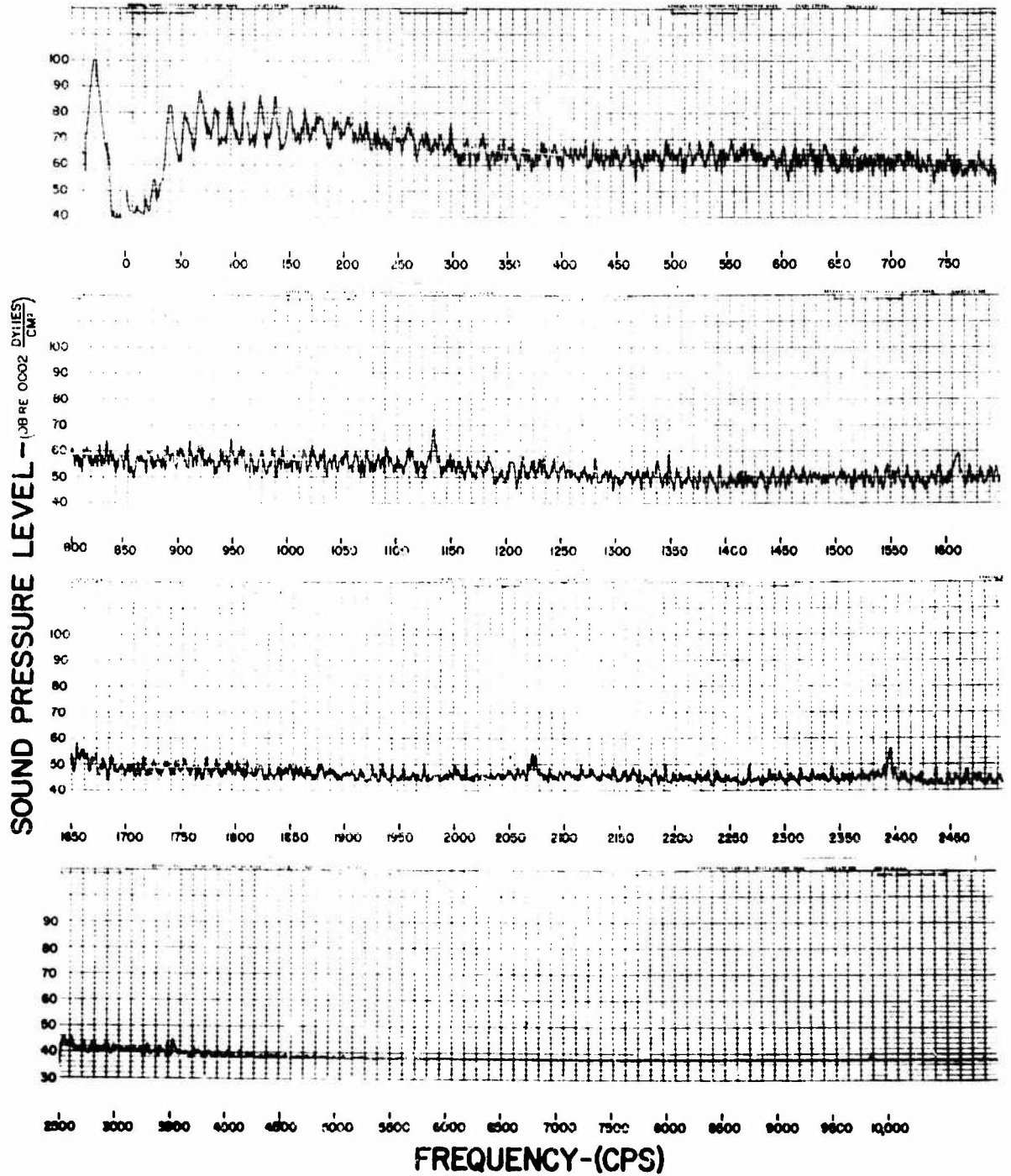

FIGURE 132

DOAK 16 NOISE SPECTRUM

POSITION 12 EXTERNAL

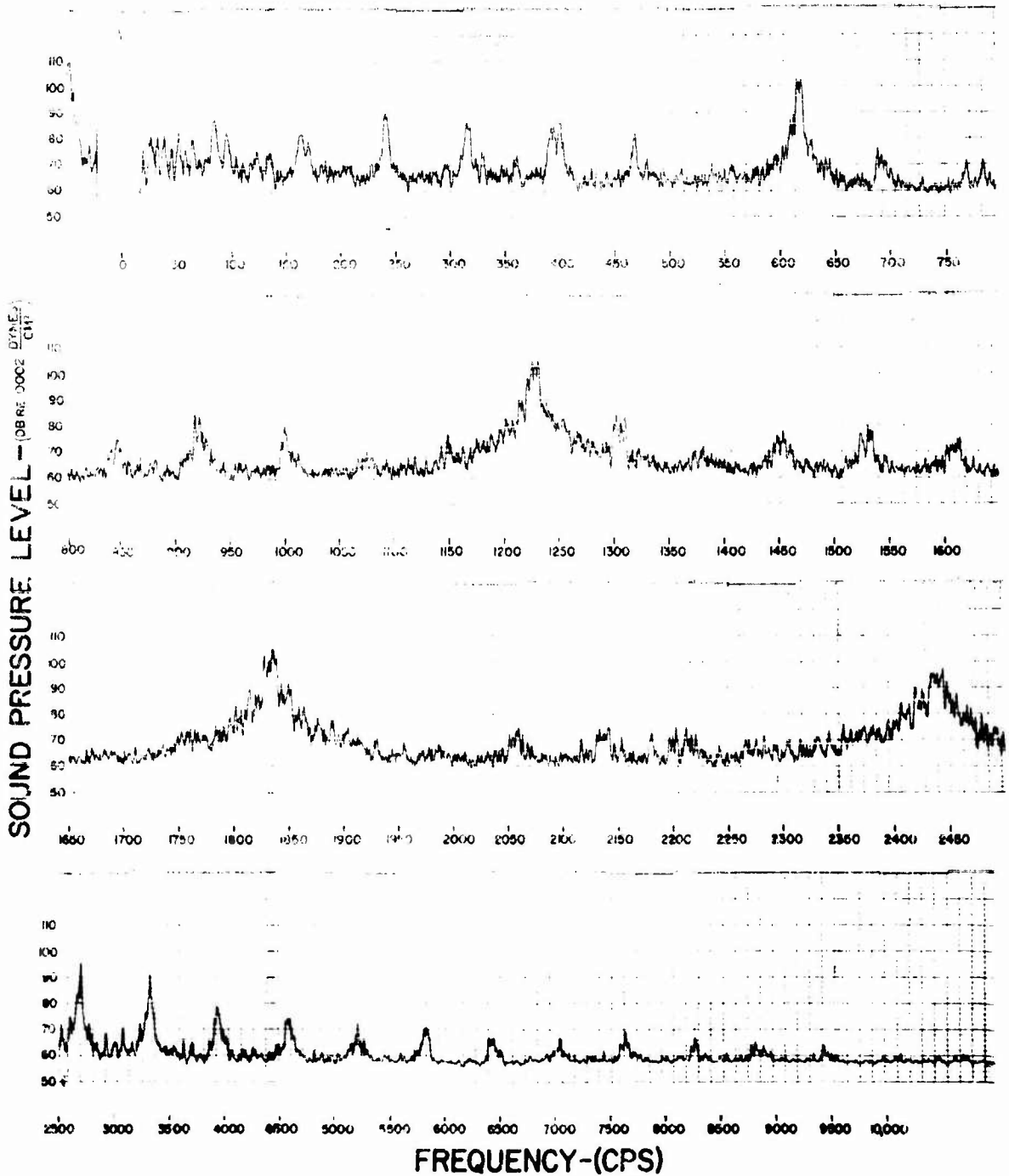

FIGURE 133

VERTOL 76 NOISE SPECTRUM

POSITION PILOT'S EAR LEVEL

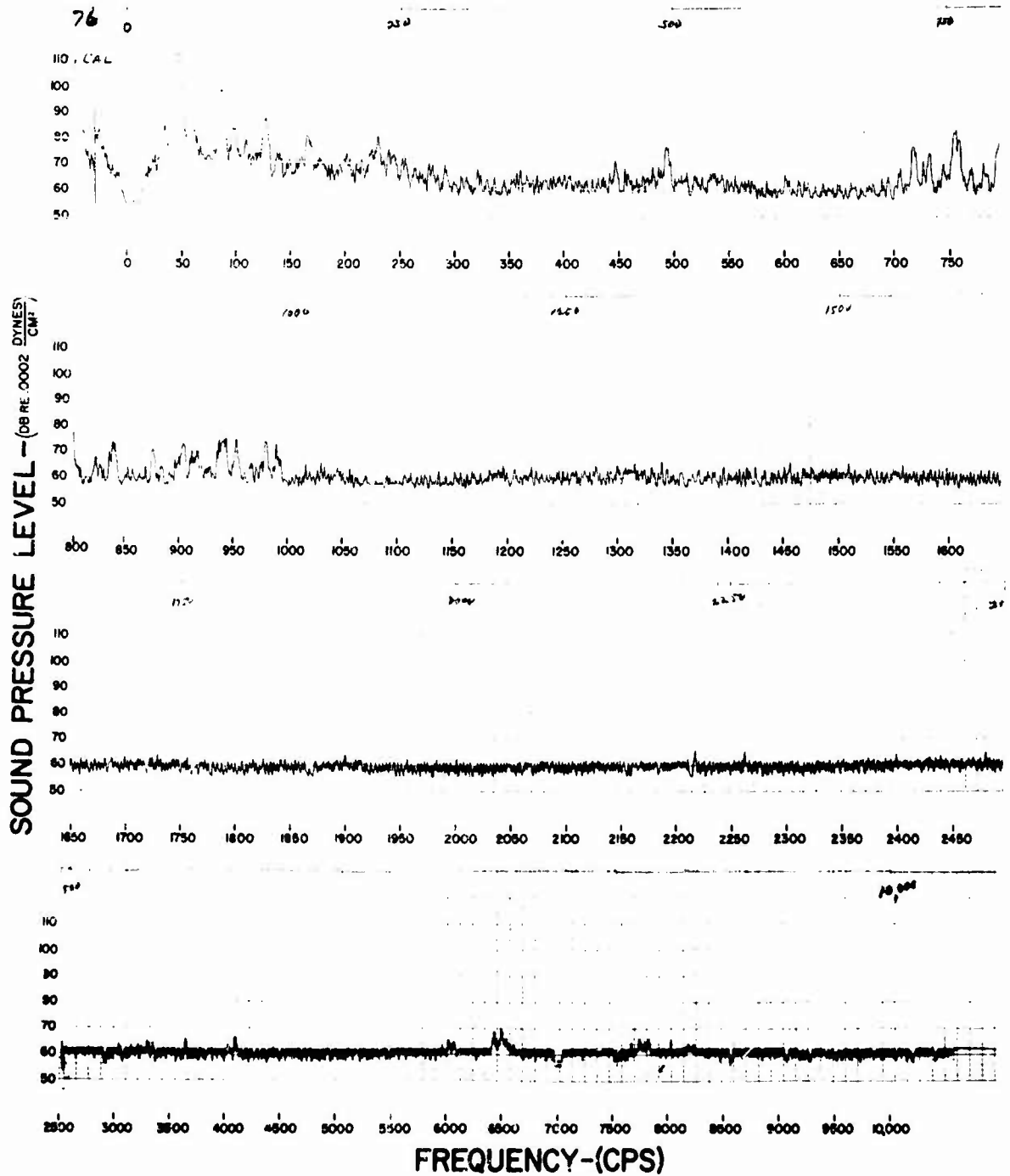

FIGURE 134

VERTOL 76 NOISE SPECTRUM

POSITION 4 1/2 EXTERNAL

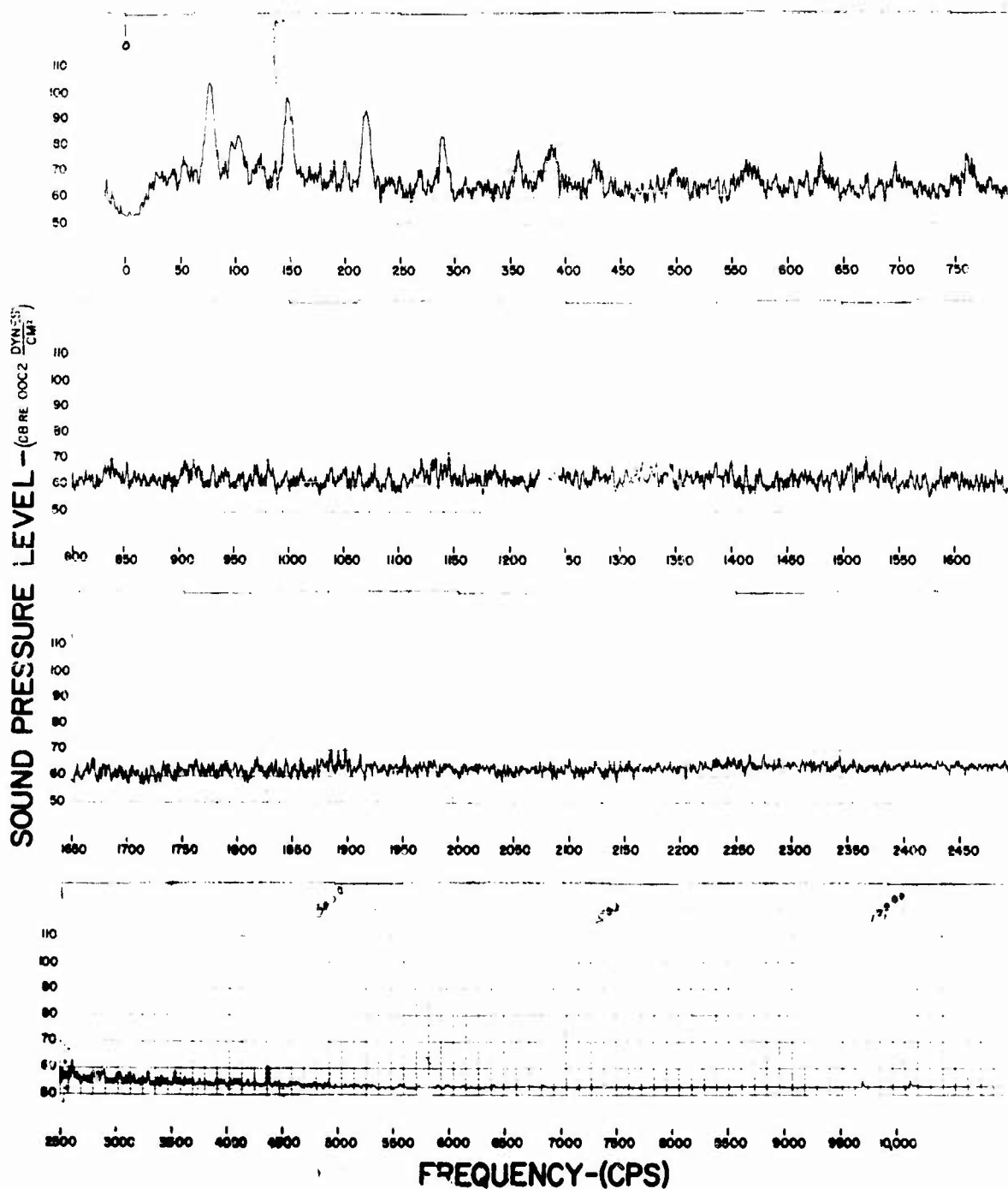

FIGURE 135

AIRCRAFT RATING PILOT OPINION SURVEY

QUESTION 1 HEARING LOSS AND DISCOMFORT

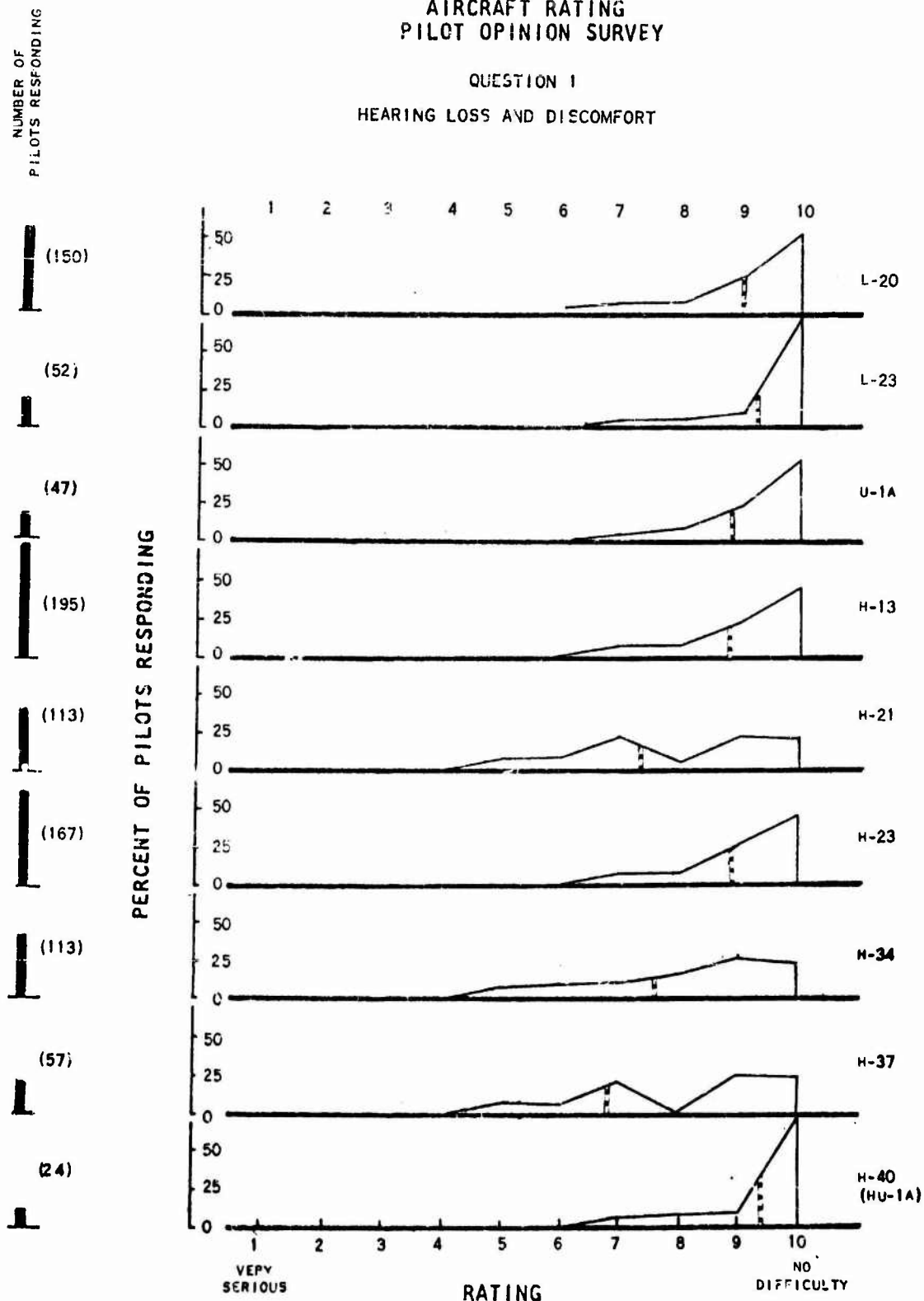

FIGURE 136

AIRCRAFT RATING PILOT OPINION SURVEY

QUESTION 2 SPEECH INTERFERENCE

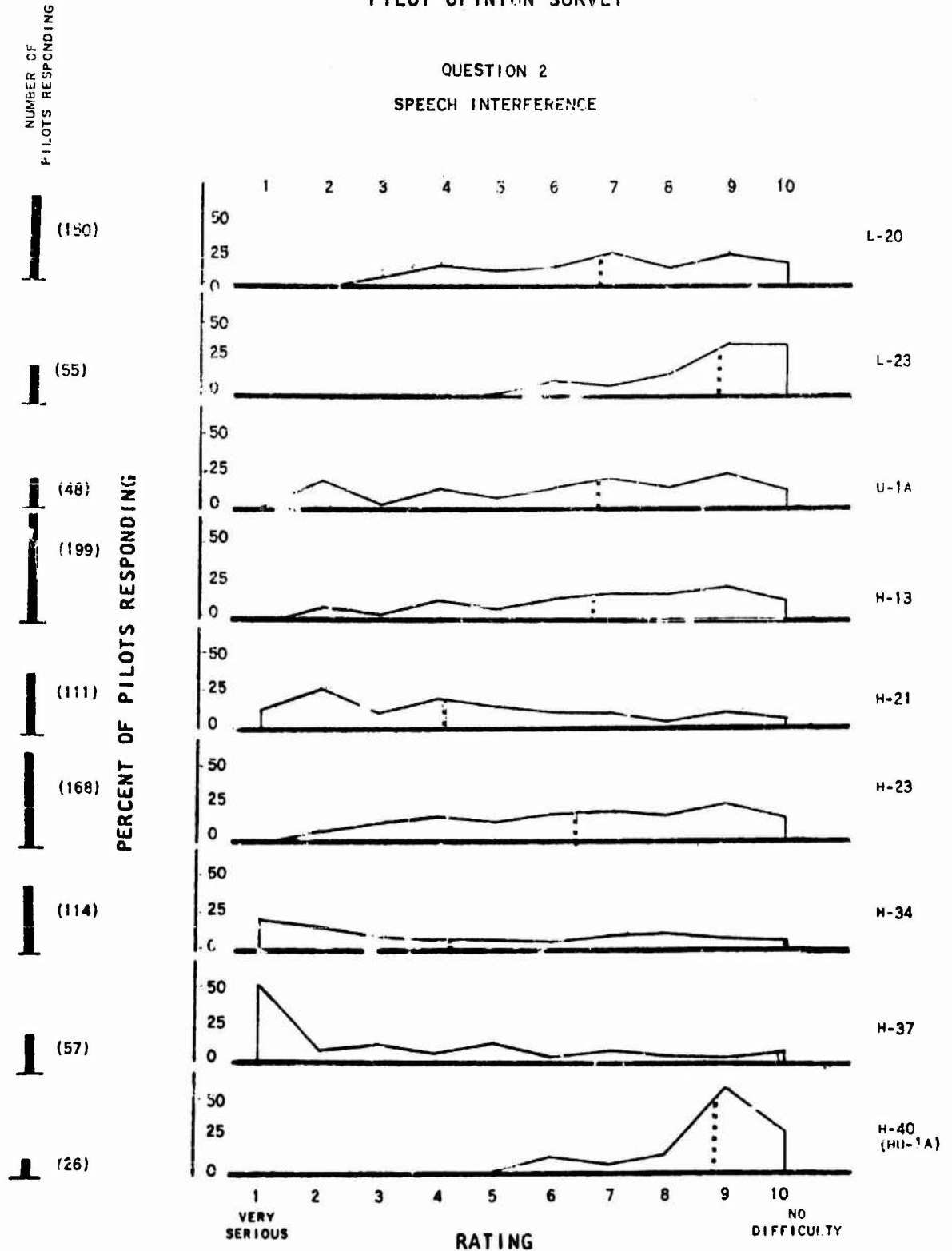
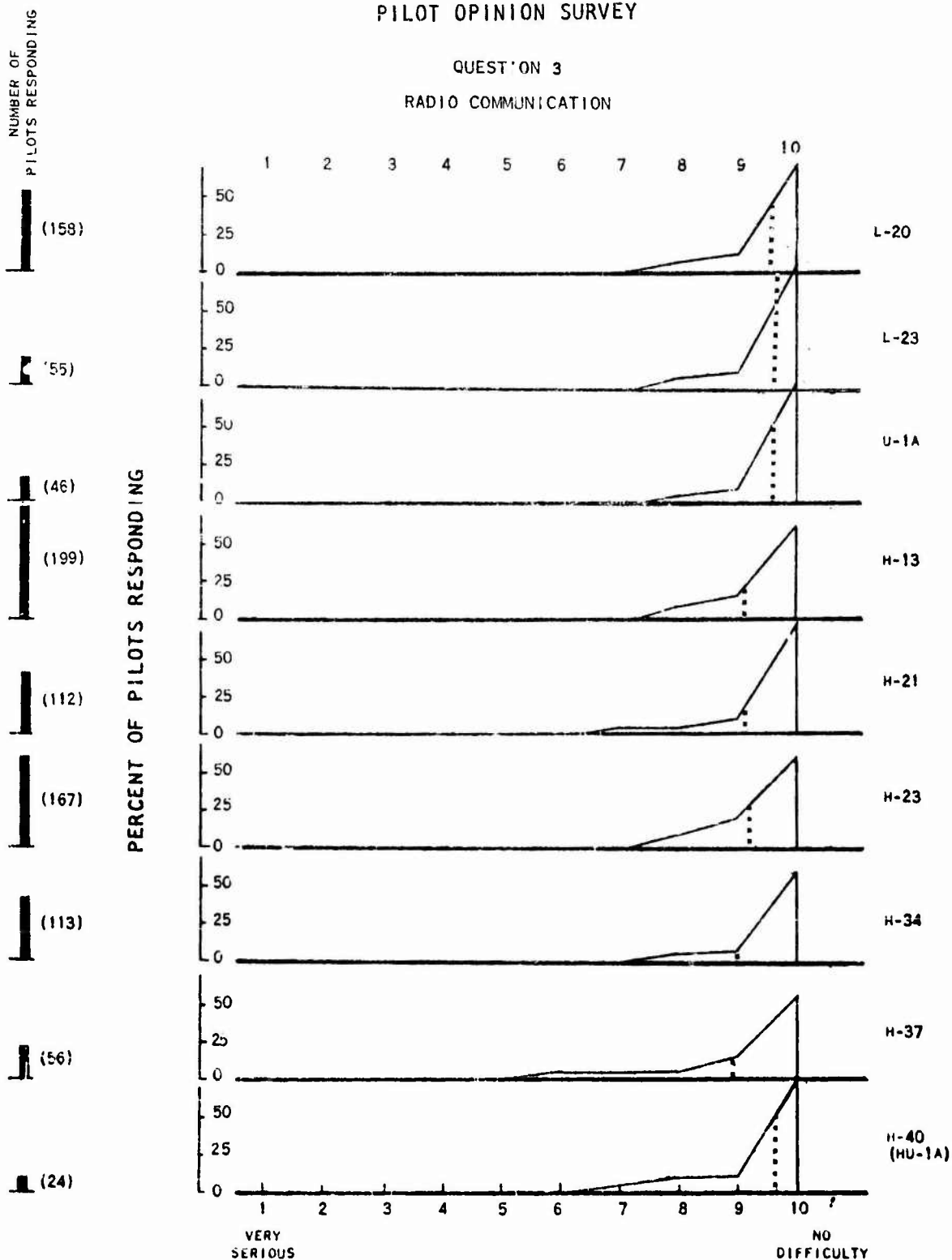

FIGURE 137

AIRCRAFT RATING PILOT OPINION SURVEY

QUEST'ON 3

RADIO COMMUNICATION



RATING

FIGURE 138

AIRCRAFT RATING PILOT OPINION SURVEY

QUESTION 4

JUDGMENT

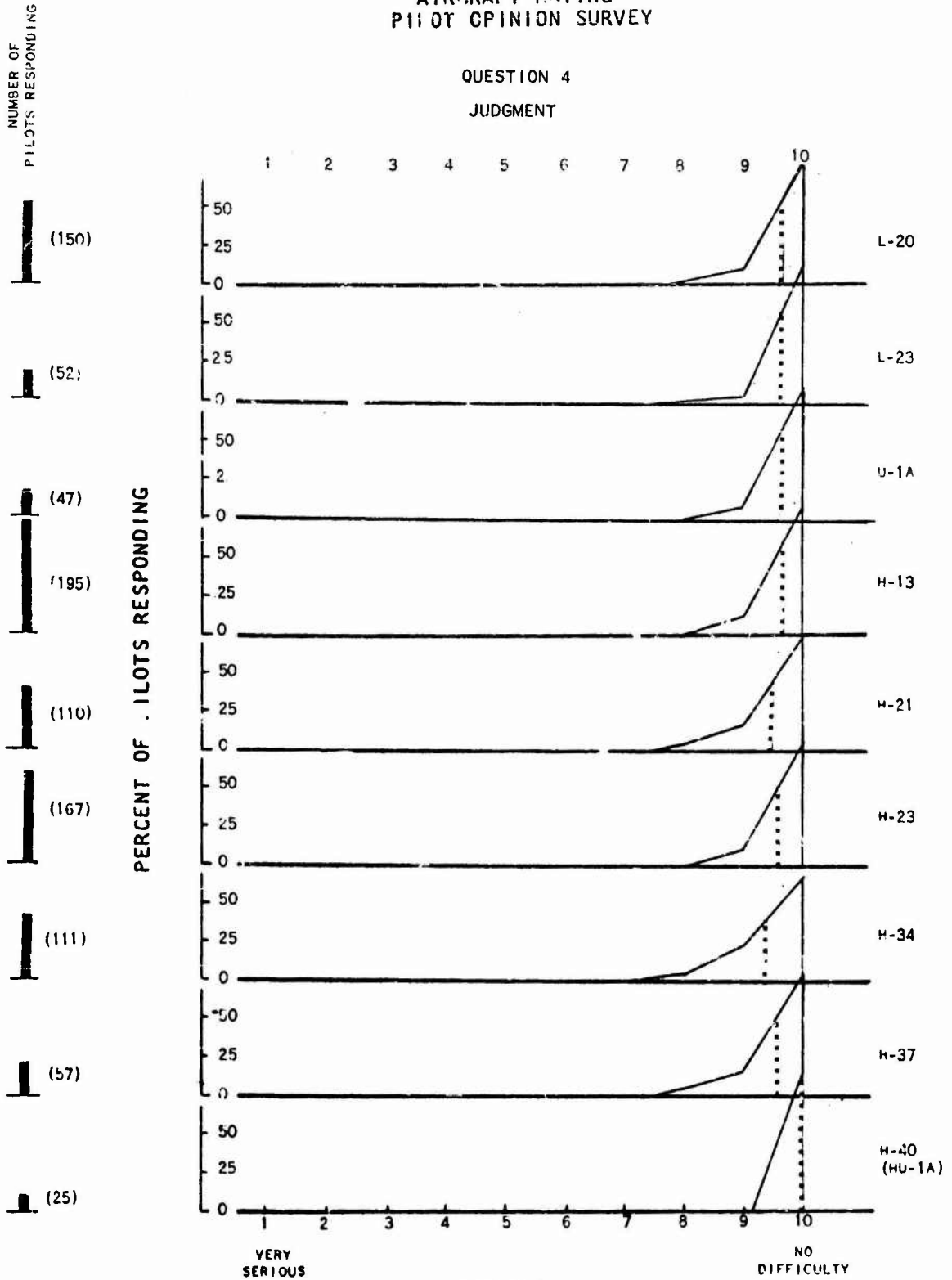

FIGURE 139

AIRCRAFT RATING PILOT OPINION SURVEY

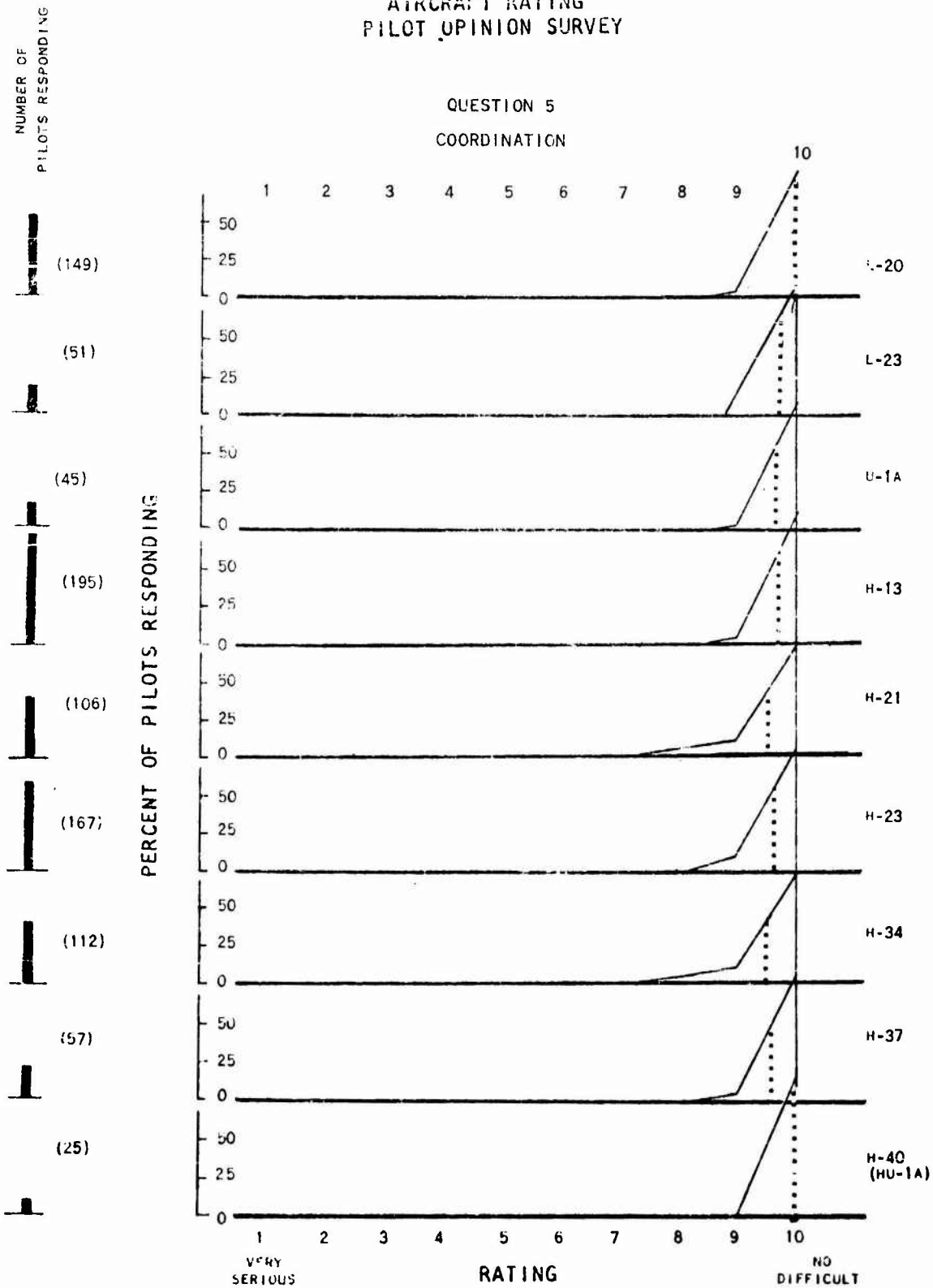

FIGURE 140

AIRCRAFT RATING PILOT OPINION SURVEY

QUESTION 6

FATIGUE

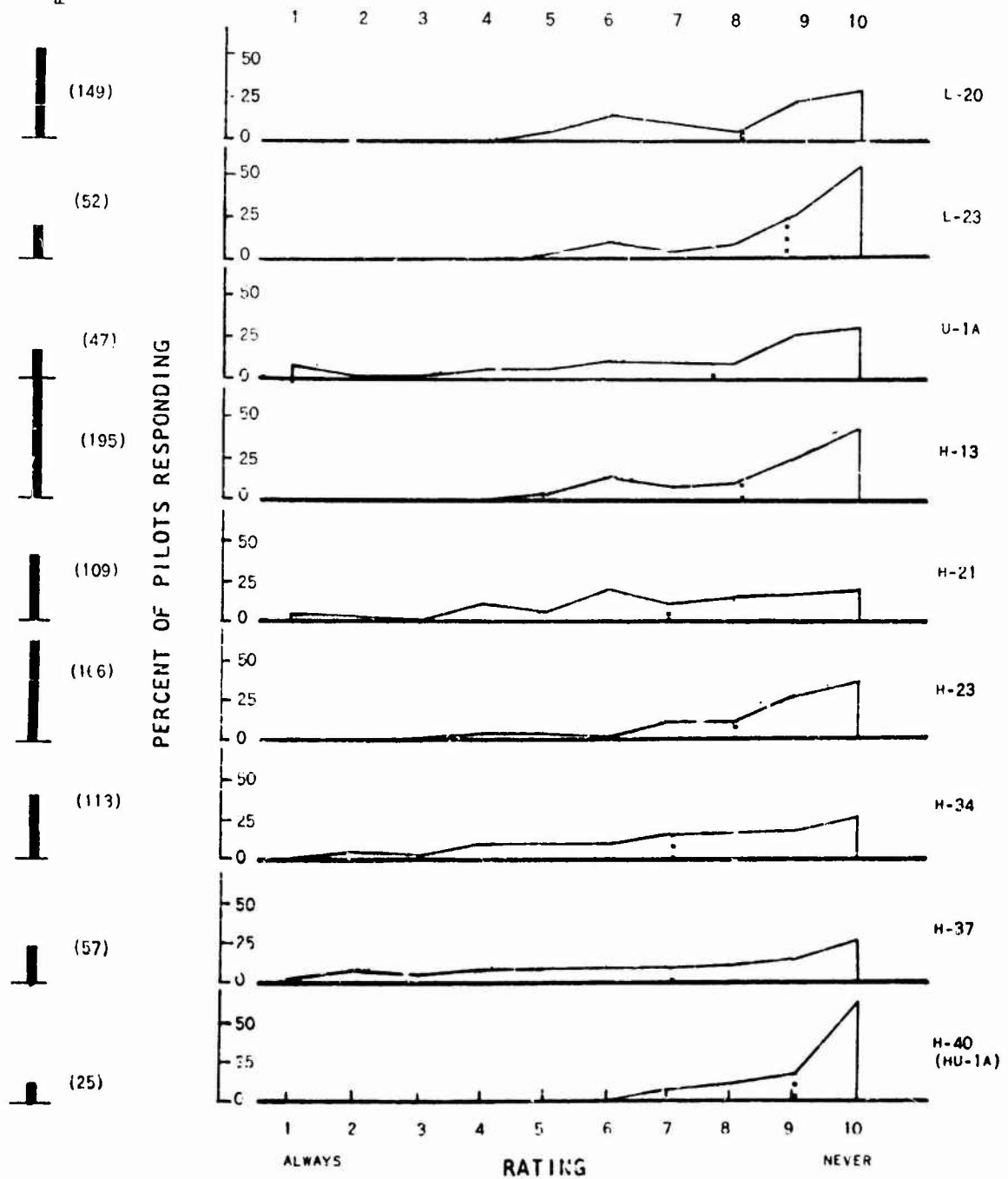

FIGURE 141

AIRCRAFT RATING PILOT OPINION SURVEY

QUESTION 7

NOISE

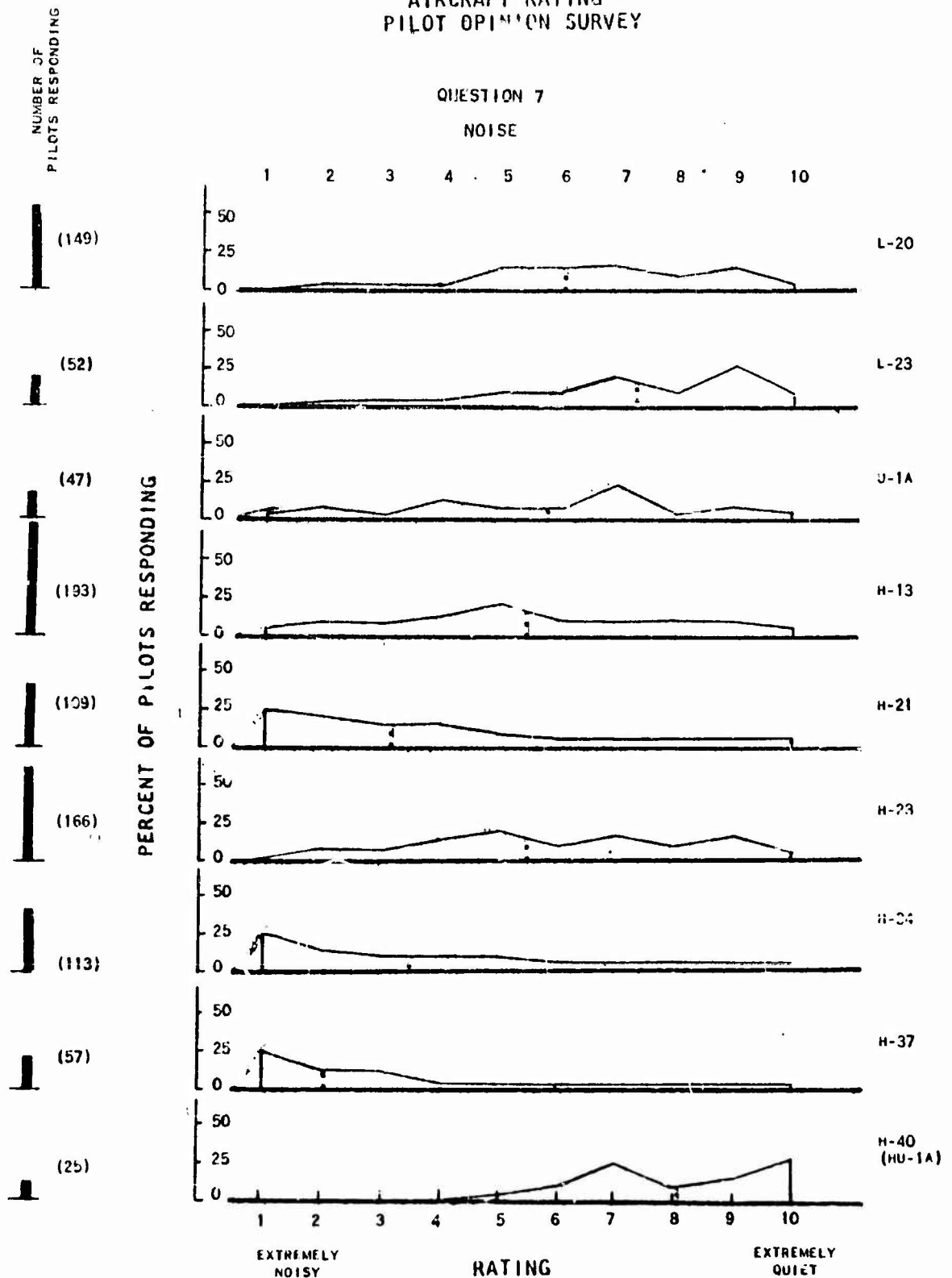

FIGURE 142

AIRCRAFT RATING PILOT OPINION SURVEY

QUESTION 8

VIBRATION

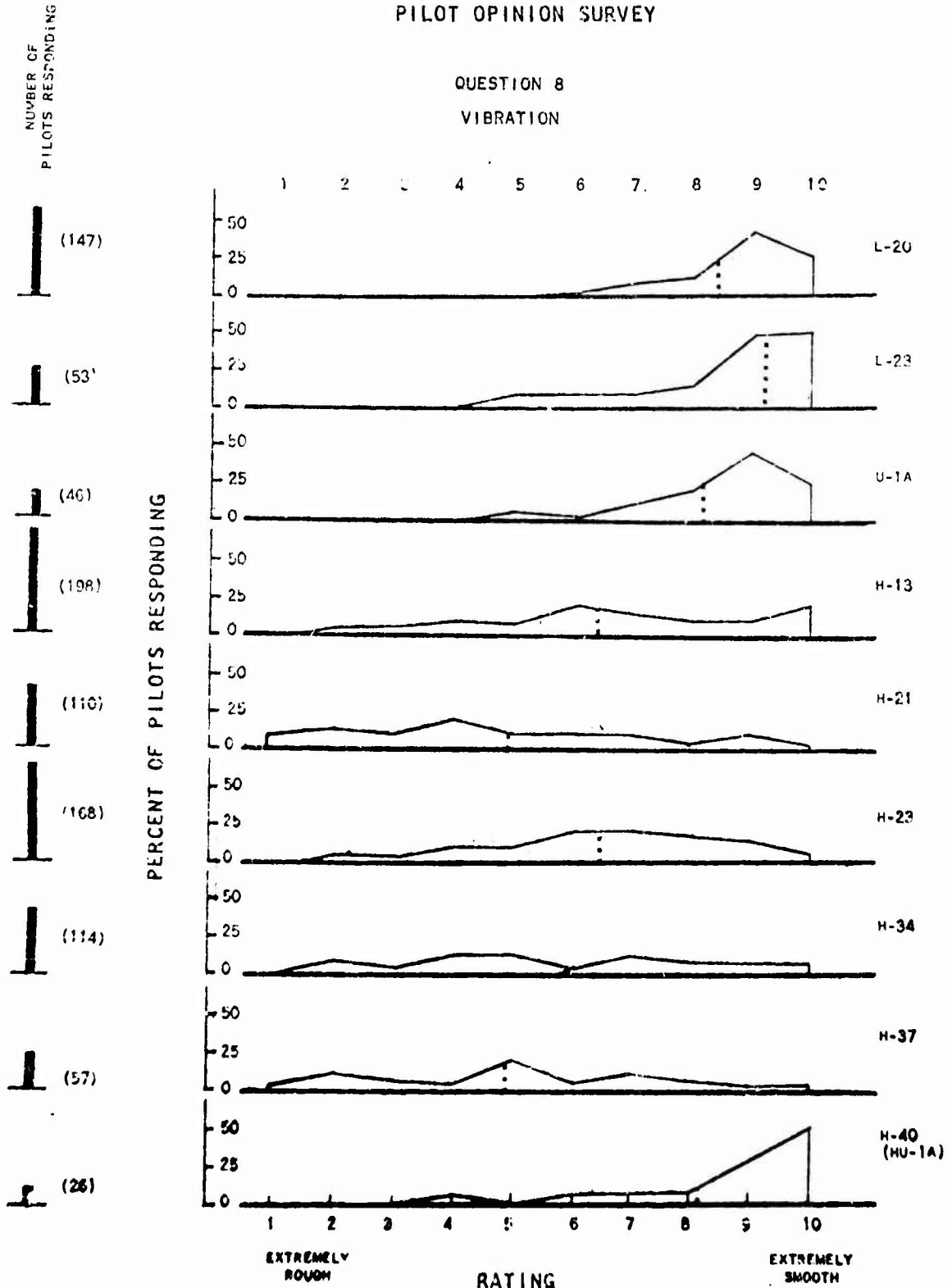
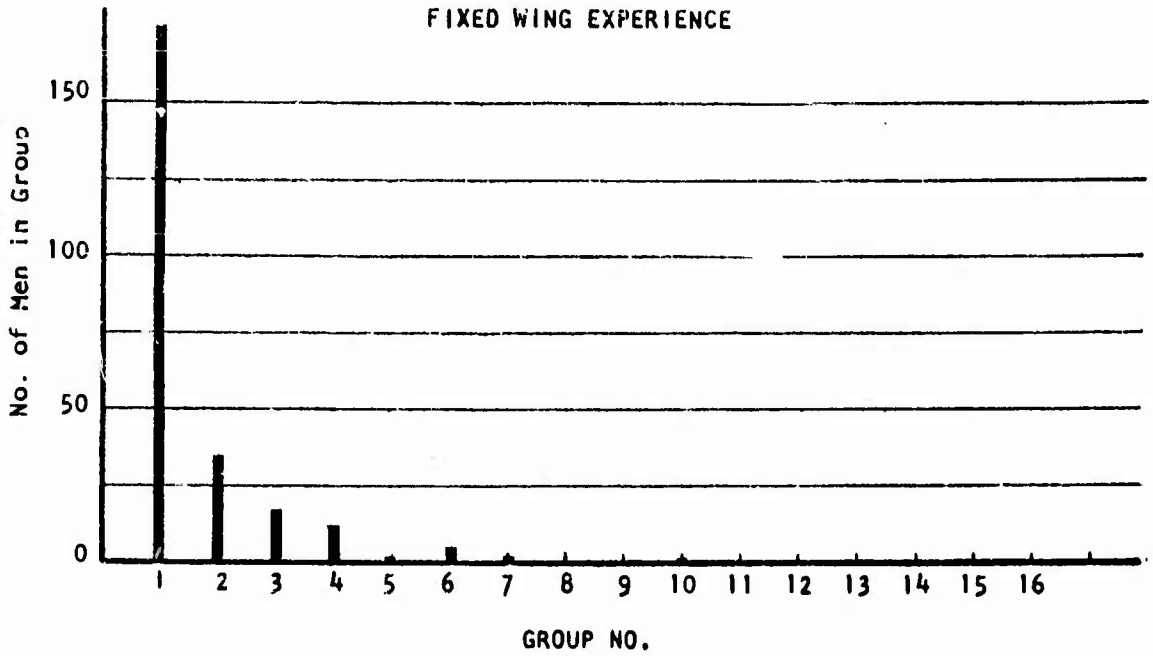

FIGURE 14.3

EXPERIENCE DISTRIBUTION: GROUPS 1-20

PILOT OPINION SURVEY

FIXED WING EXPERIENCE



ROTARY WING EXPERIENCE

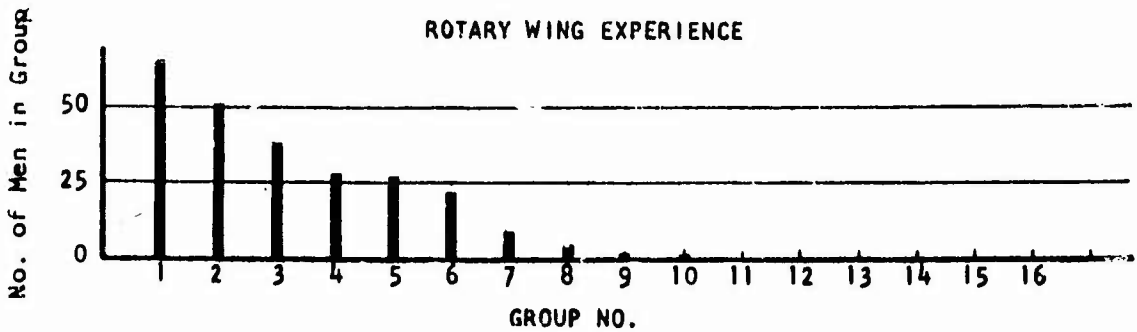

TOTAL EXPERIENCE

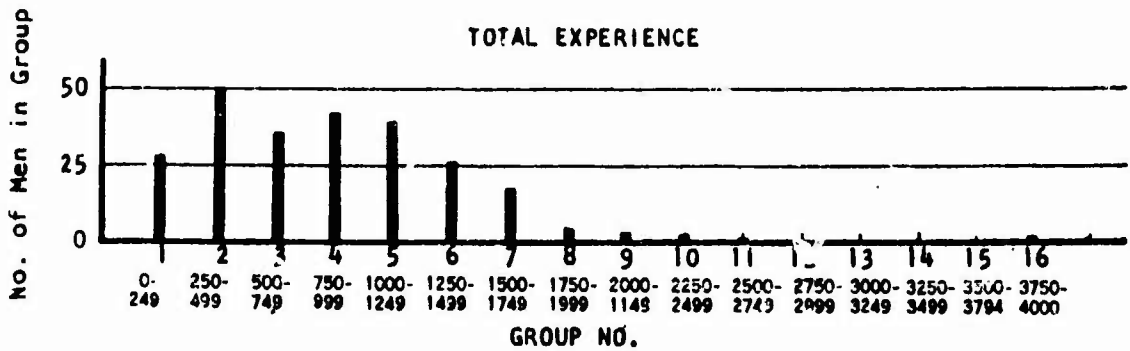

FIGURE 14a

CORRELATION OF PILOT OPINION
WITH LOUDNESS FROM MEASURED DATA

QUESTION 7 - NOISE

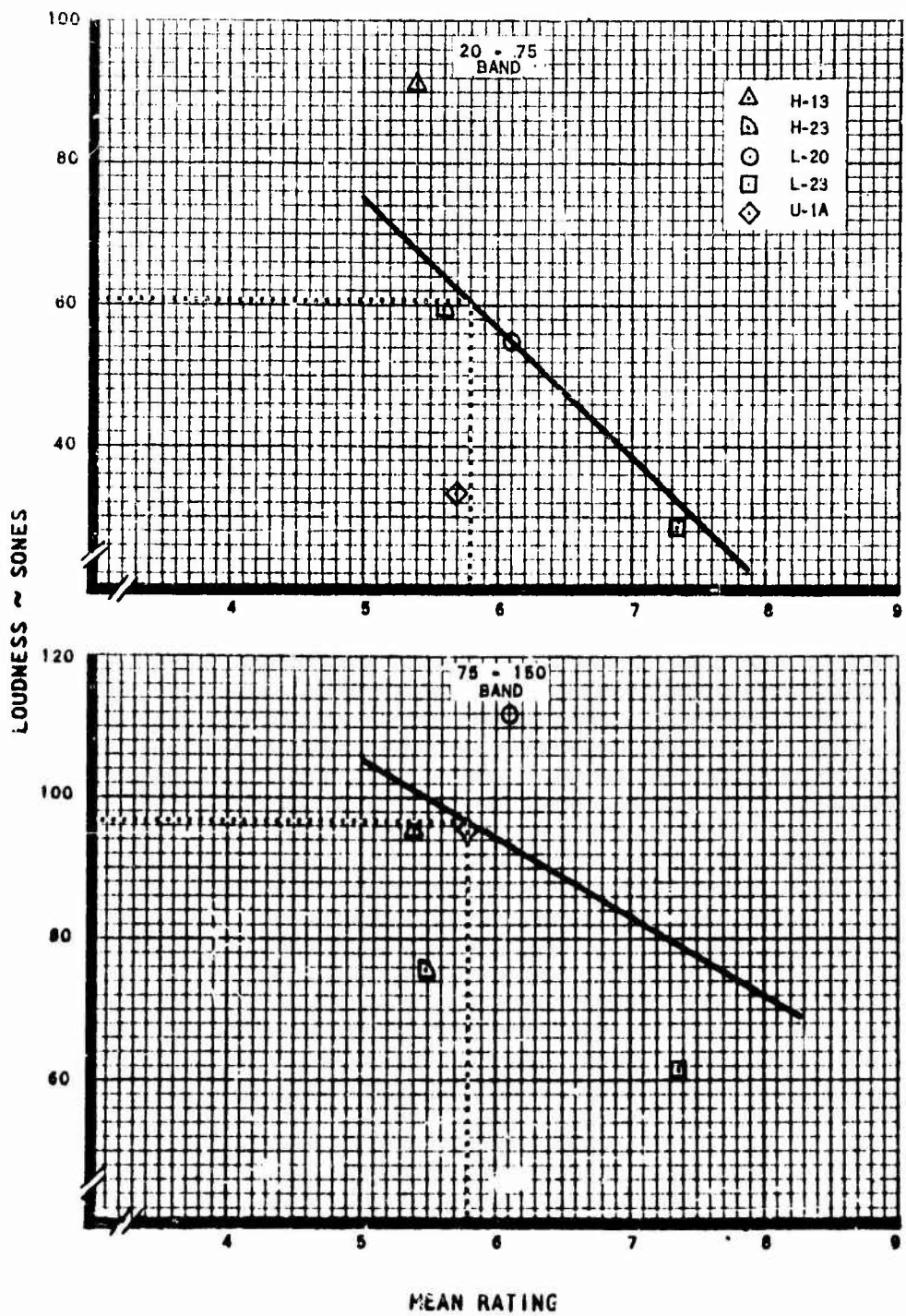
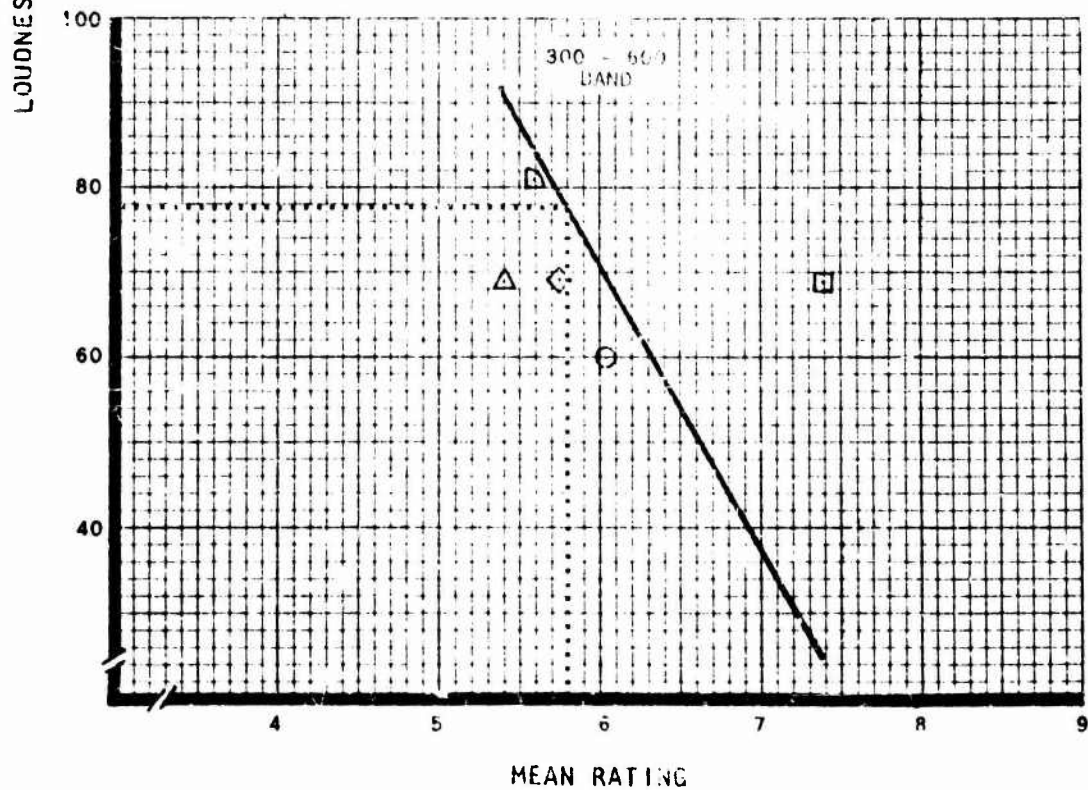
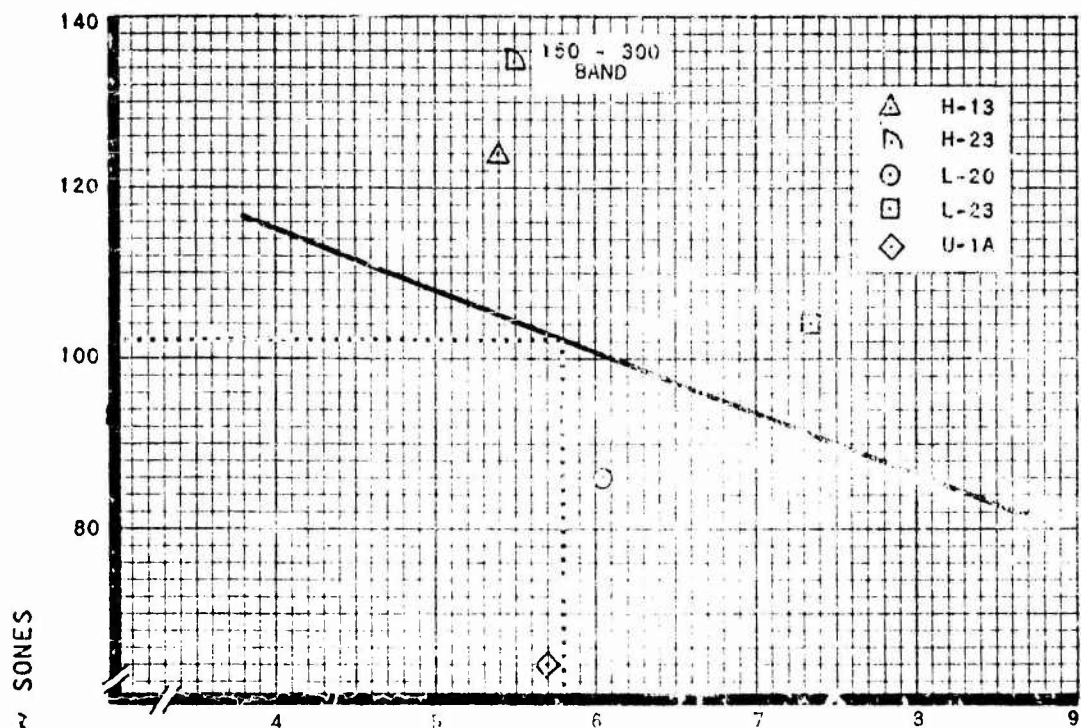

FIGURE 146

CORRELATION OF PILOT OPINION
WITH LOUDNESS FROM MEASURED DATA

QUESTION 7 - NOISE



MEAN RATING

CORRELATION OF PILOT OPINION
WITH LOUDNESS FROM MEASURED DATA

QUESTION 7 - NOISE

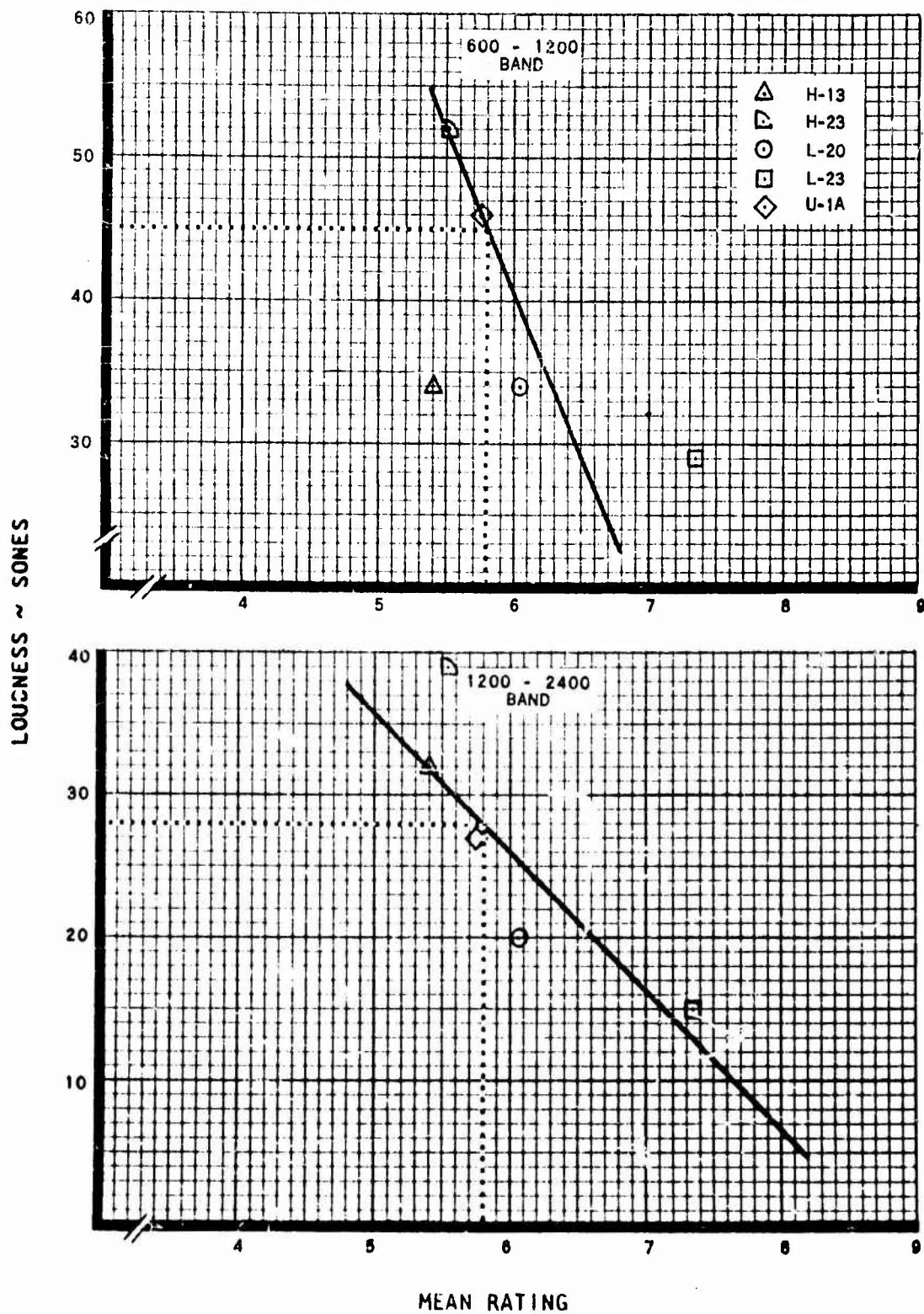
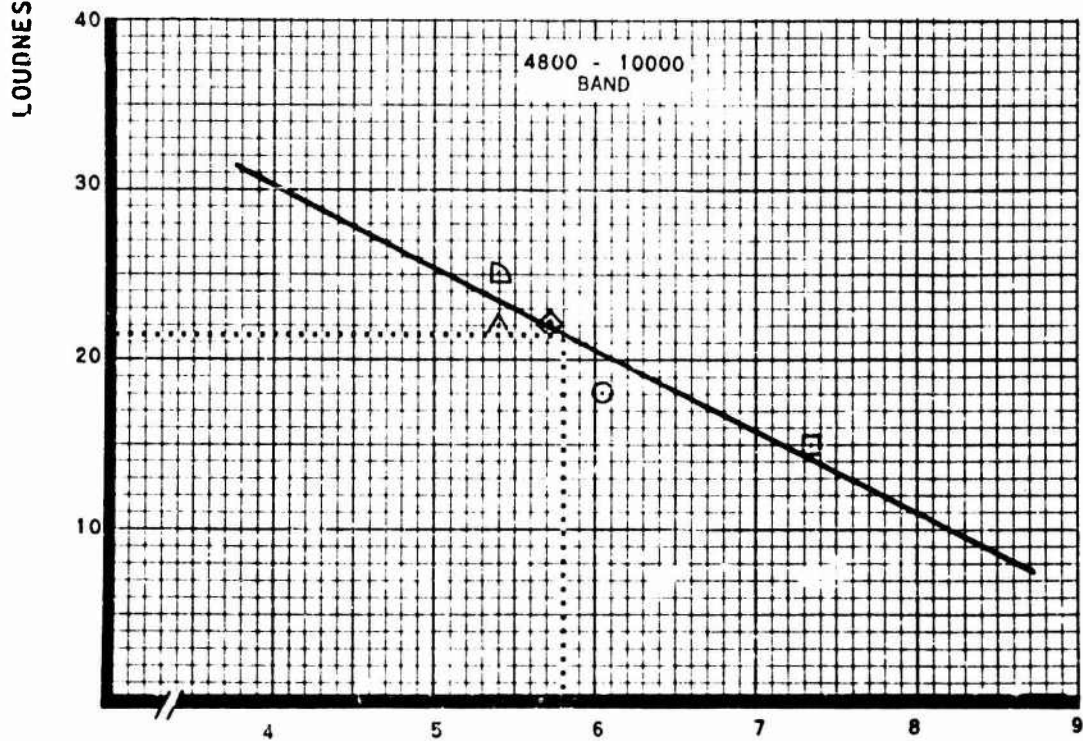
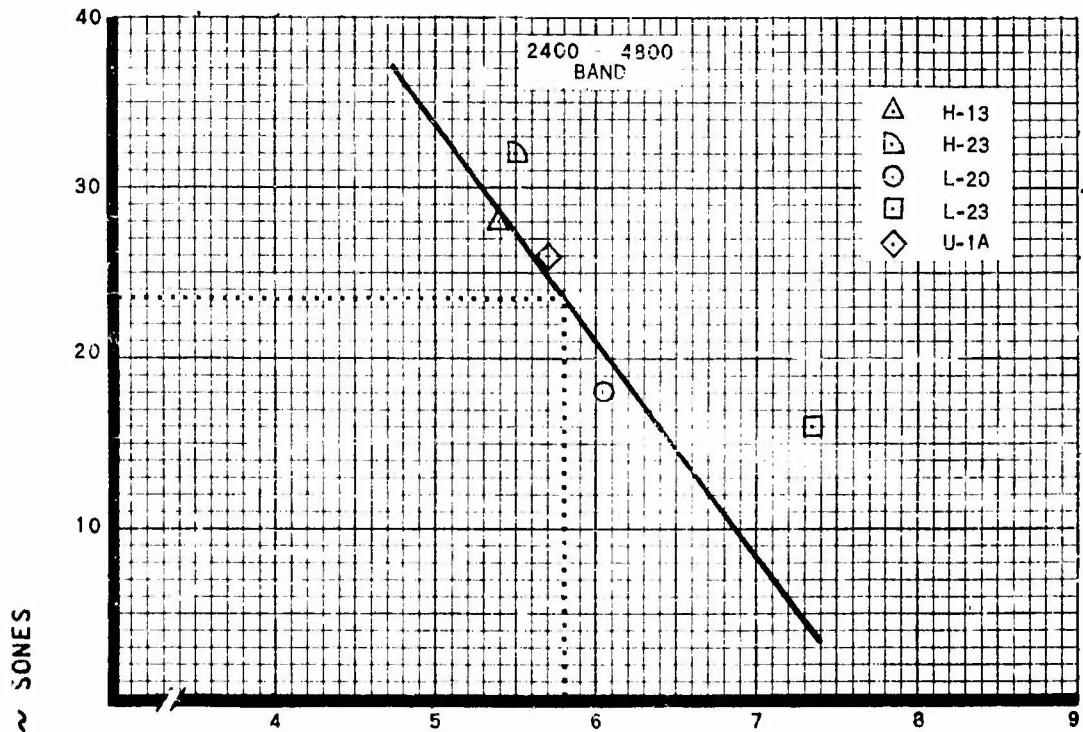

FIGURE 148

CORRELATION OF PILOT OPINION
WITH LOUDNESS FROM MEASURED DATA

QUESTION 7 - NOISE



MEAN RATING

FIGURE 149

PILOT ACCEPTANCE LEVEL

BASED ON QUESTION #7

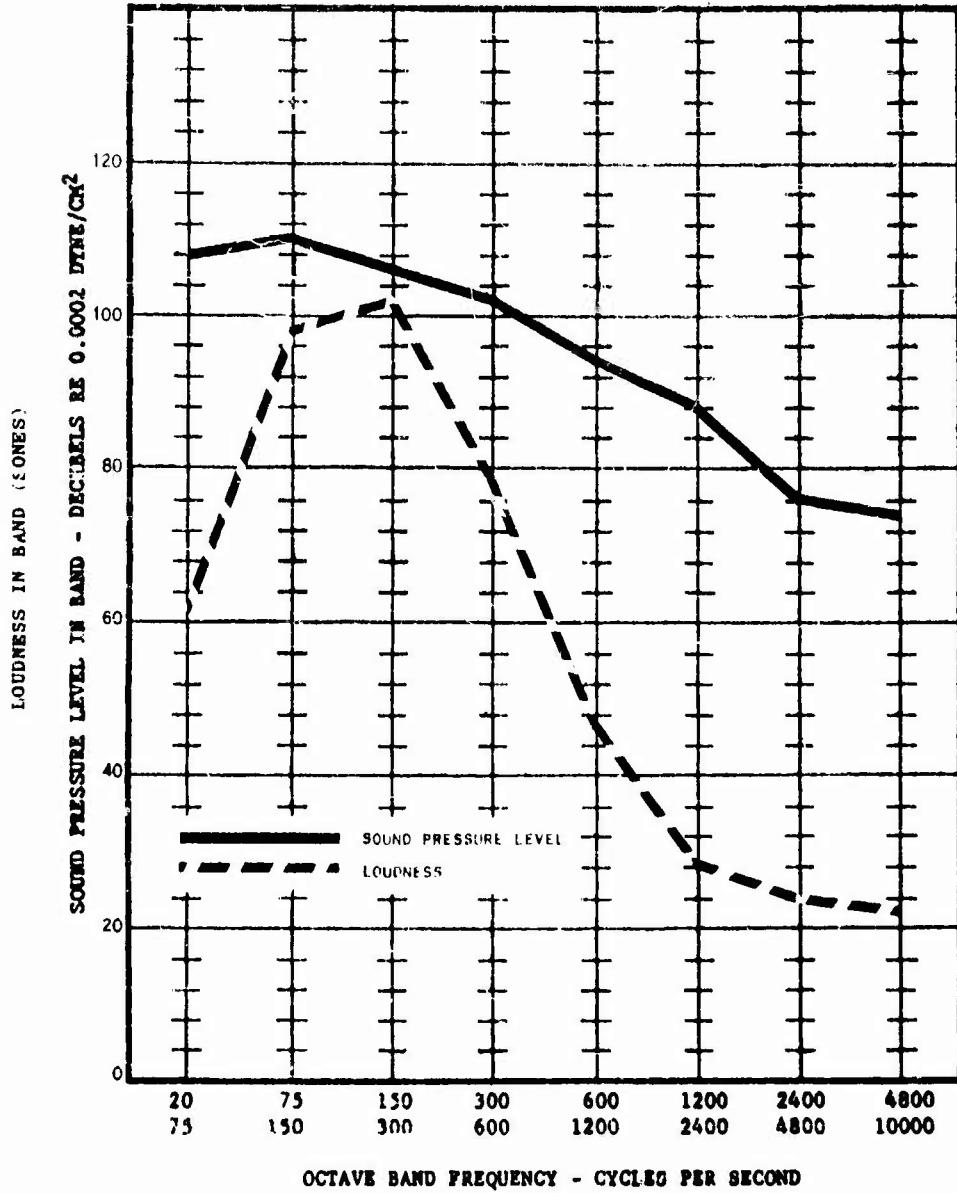

FIGURE 159

PILOT ACCEPTANCE LEVEL

DETERMINED FROM SURVEY QUESTIONS

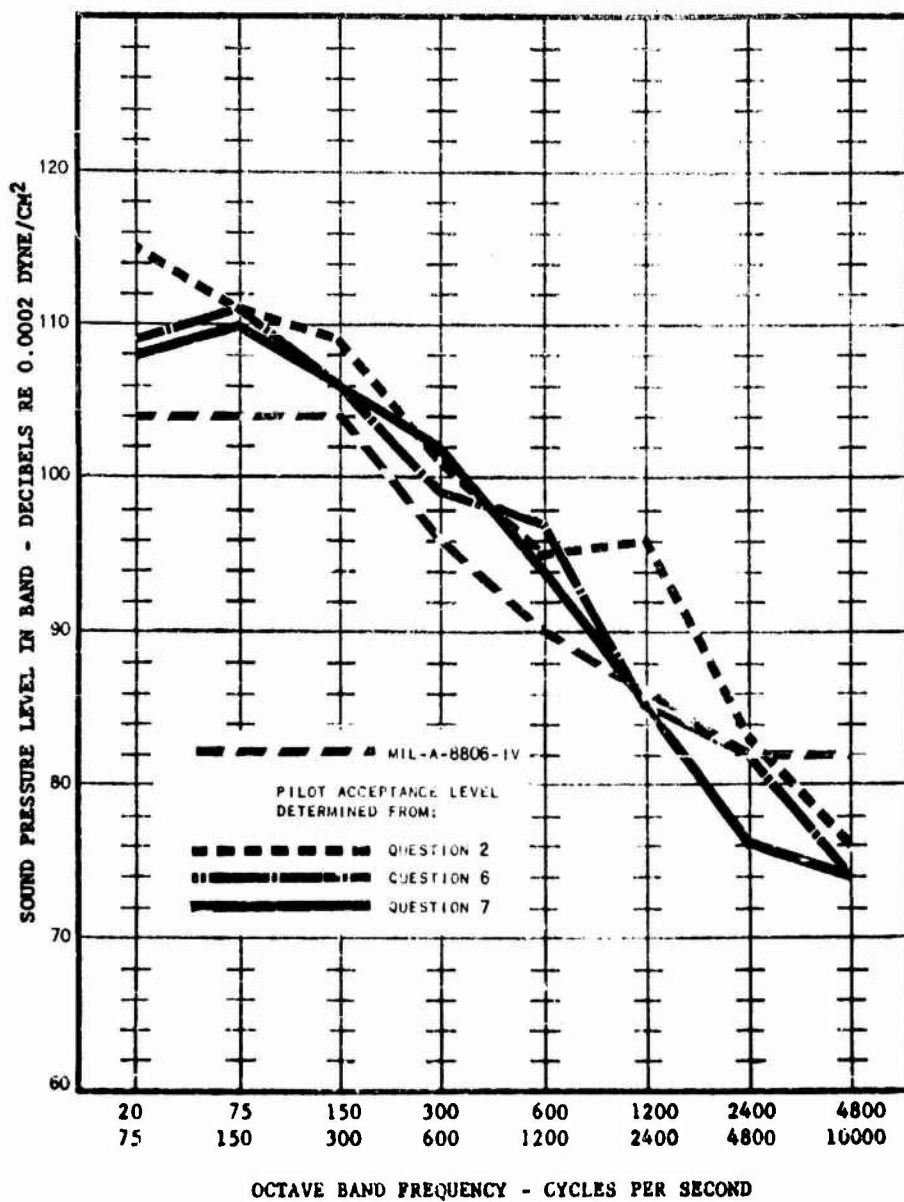

FIGURE 151

CORRELATION OF RANKED PILOT OPINION WITH
 RANKED SOUND PRESSURE LEVEL IN OCTAVE BAND
 QUESTION #7 - NOISE

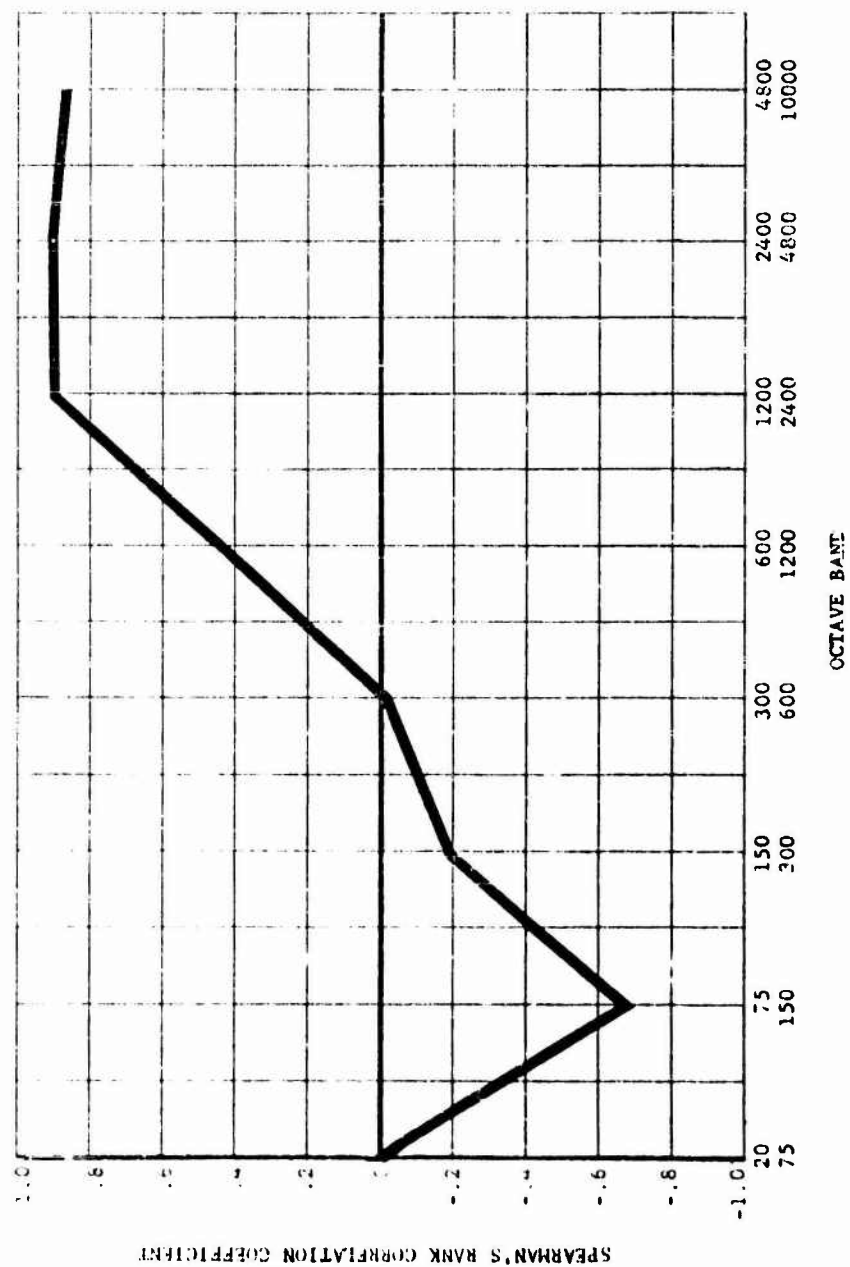

FIGURE 152

COMPARISON OF MIL-8806 IV WITH
PILOT ACCEPTANCE LEVEL (QUESTION #7)

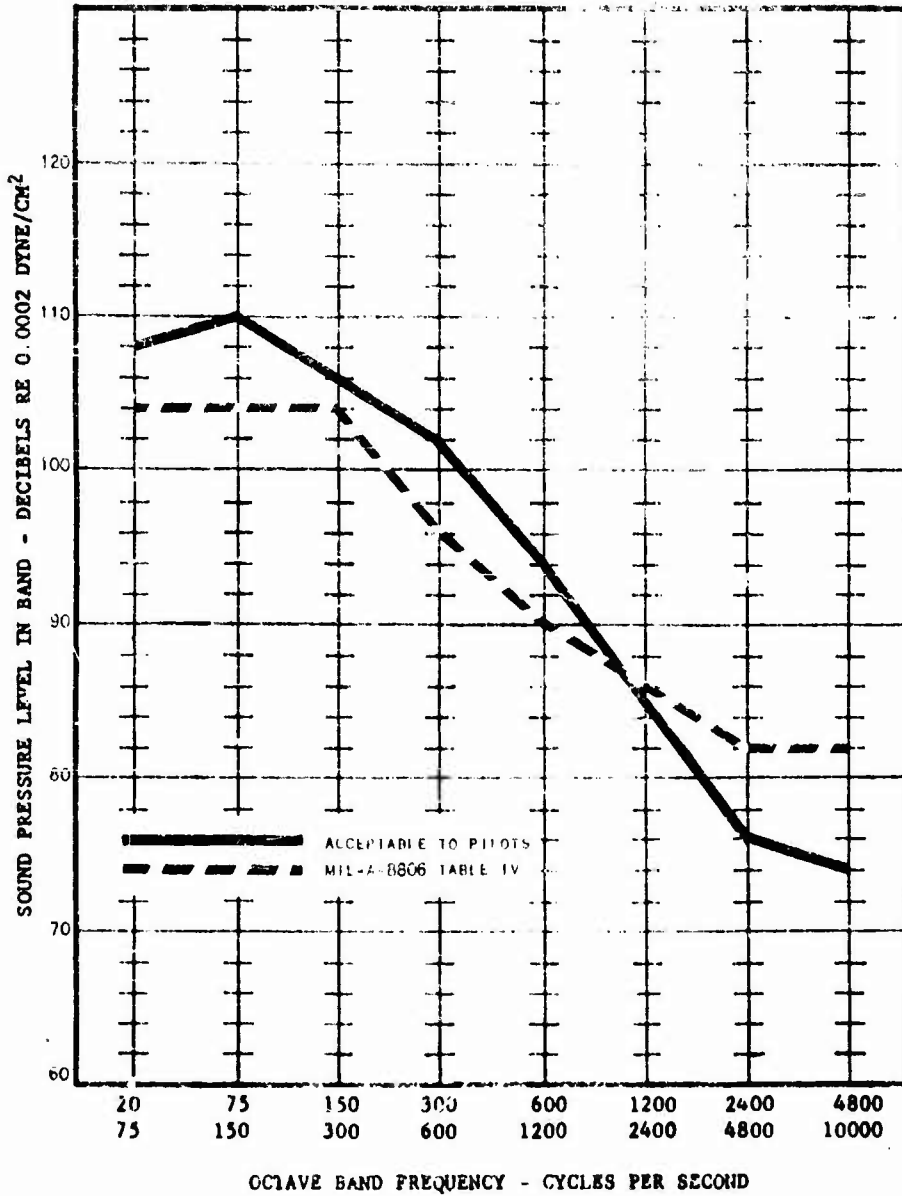
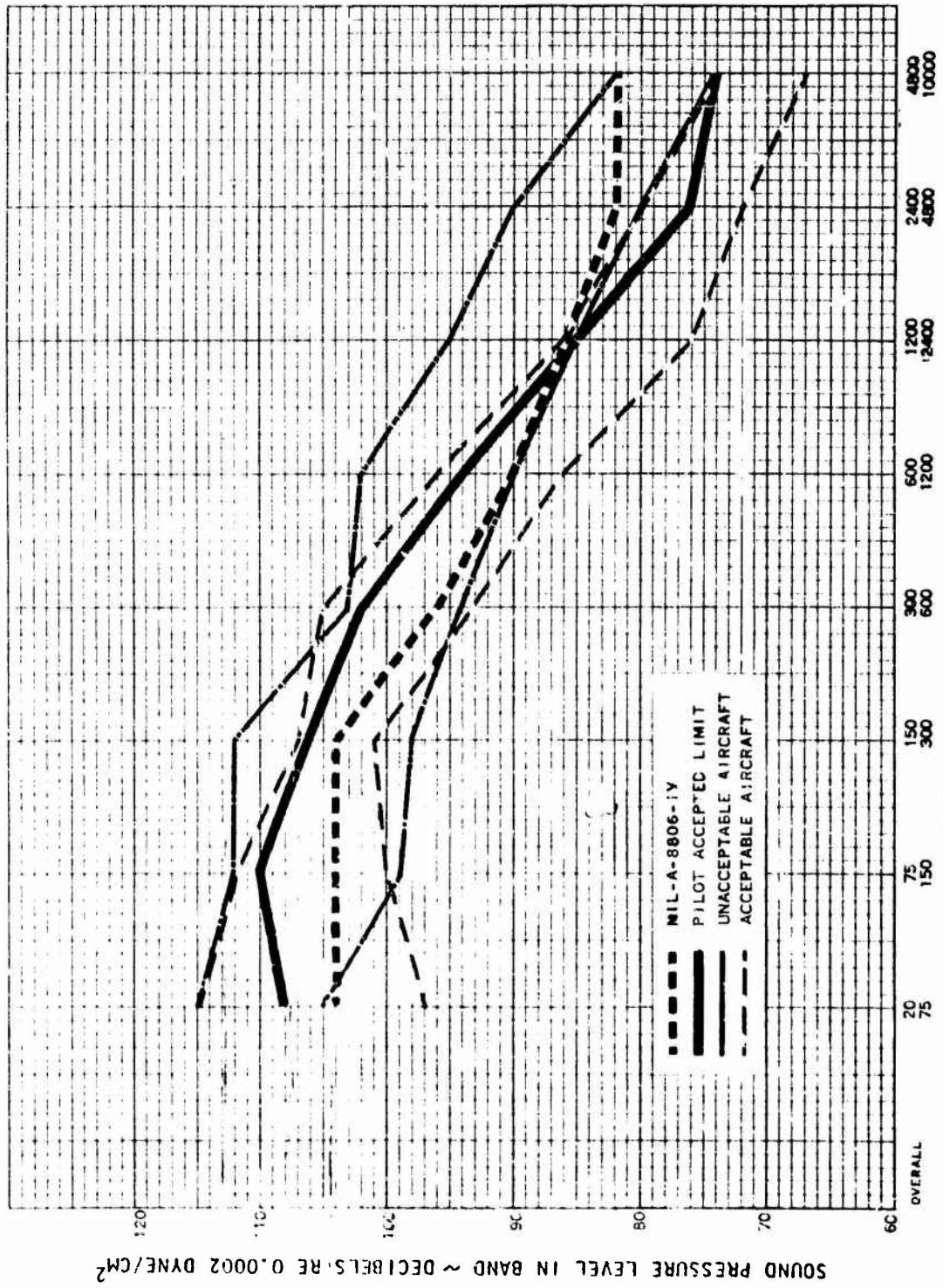

FIGURE 154

COMPARISON OF ACCEPTED PILOT LIMIT WITH
ACCEPTABLE AND UNACCEPTABLE AIRCRAFT SCATTERBANDS:



FREQUENCY BAND CYCLES PER SECOND
FIG. 15a

COMPARISON OF RATINGS

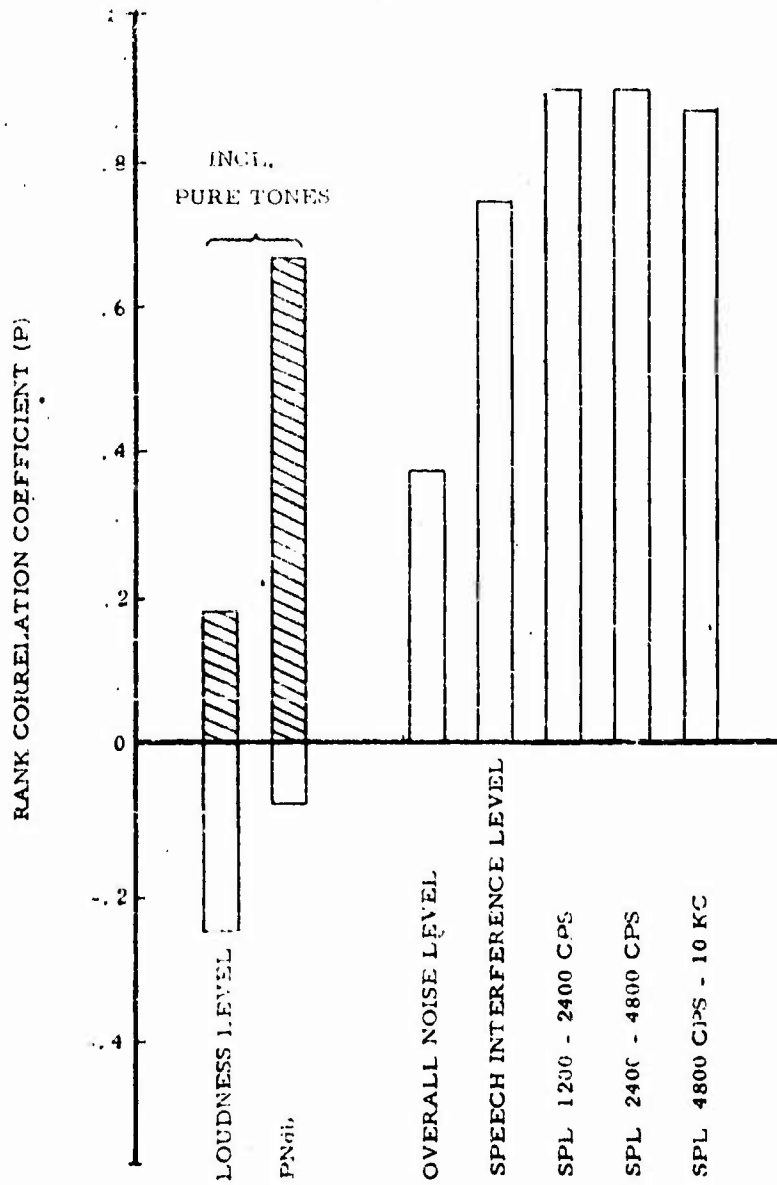

FIGURE 155

COMPARISON OF NOISE SPECIFICATIONS

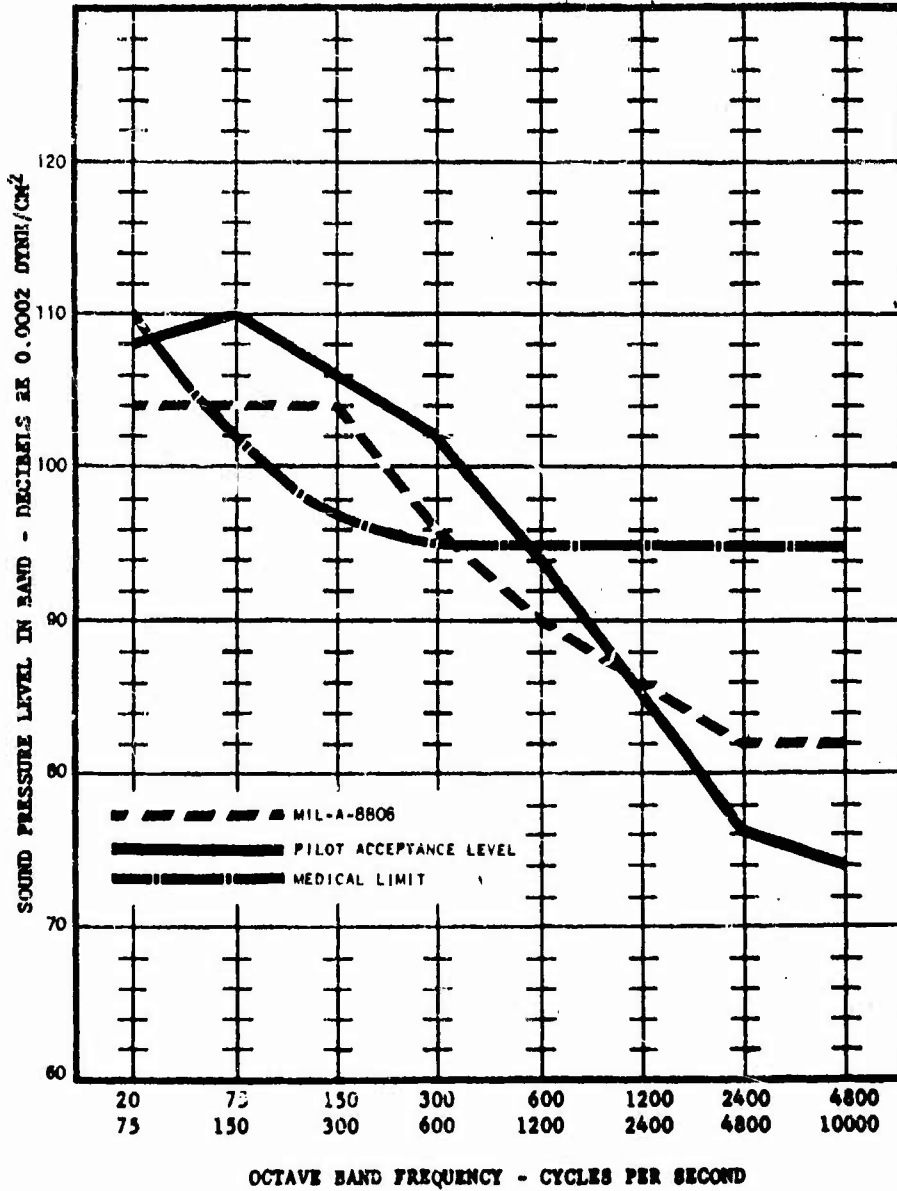

FIGURE 156

COMPARISON OF MIL-A-8806
WITH PROPOSED SPECIFICATION

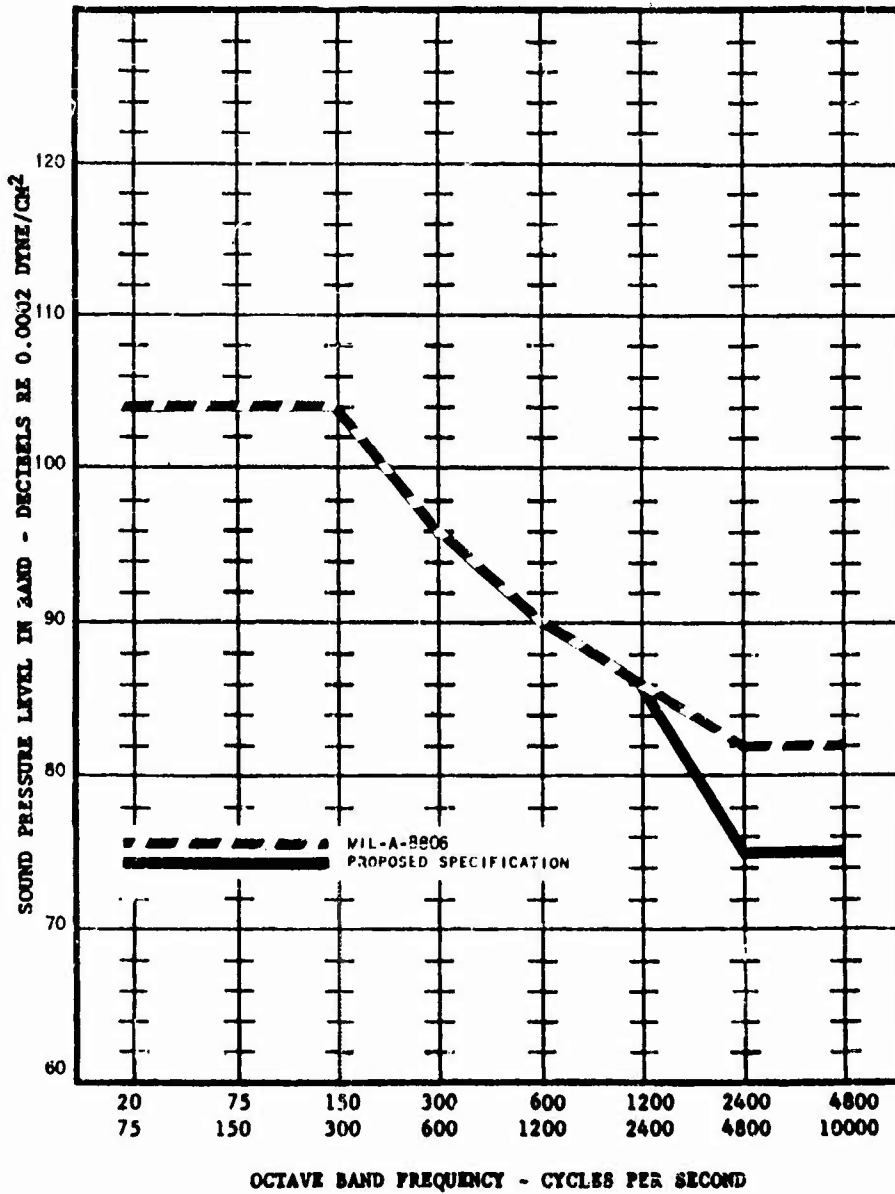

FIGURE 157

TEST SCHEMATIC FOR THEORETICAL
SOURCE - RECEIVER COMBINATION

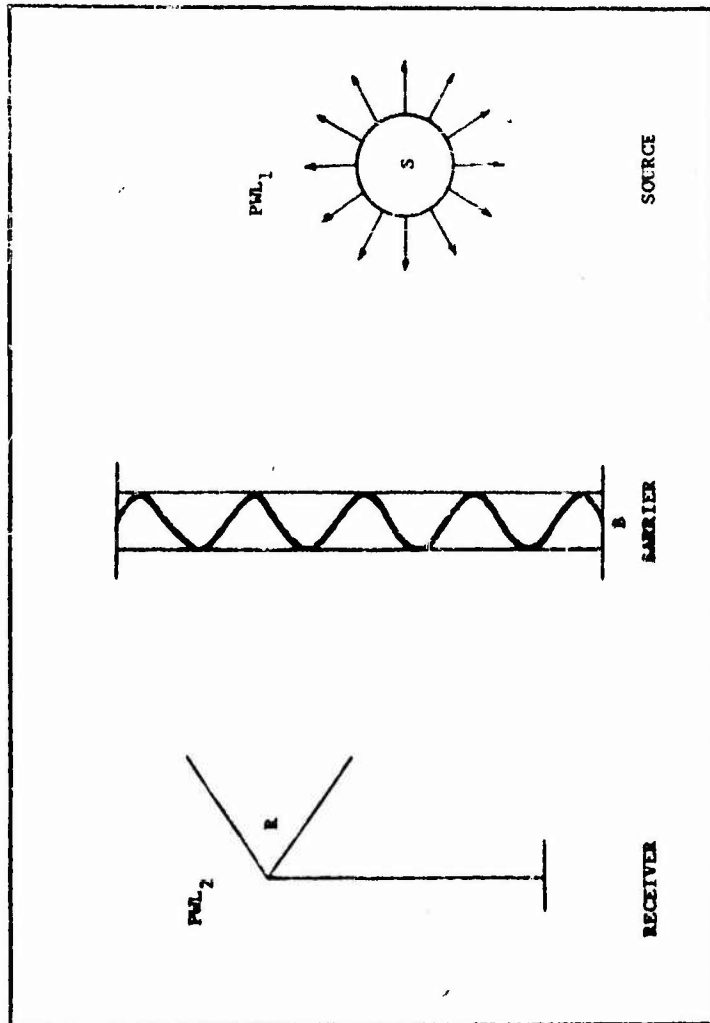
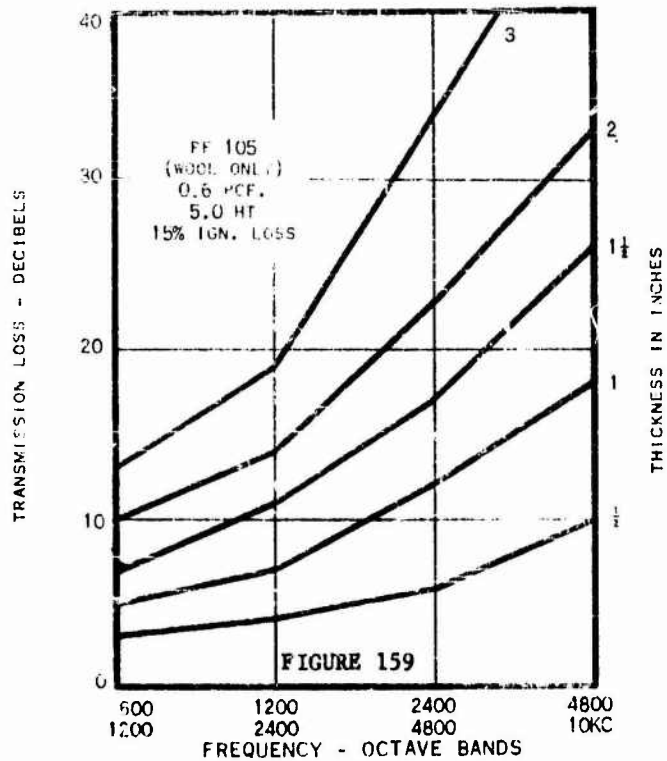
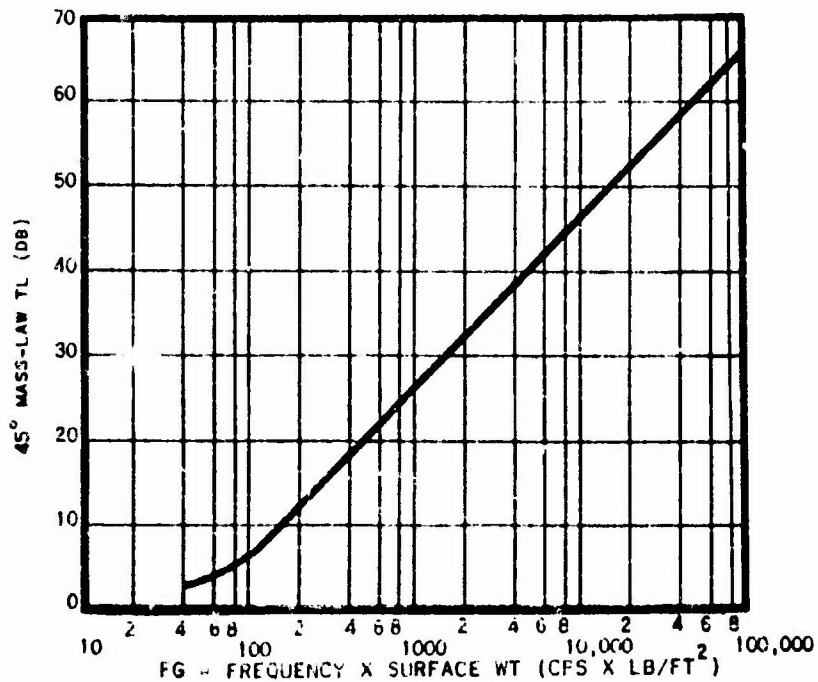

FIGURE 158



TRANSMISSION LOSS FOR PF-105 FIBERGLAS
(Courtesy Owens-Corning Fiberglas Corp.)



MASS LAW TRANSMISSION LOSS FOR LIMP PANELS

FIGURE 160

ACOUSTICAL BLANKET DESIGN CURVES
FOR VINYL-FIBERGLAS BLANKETS

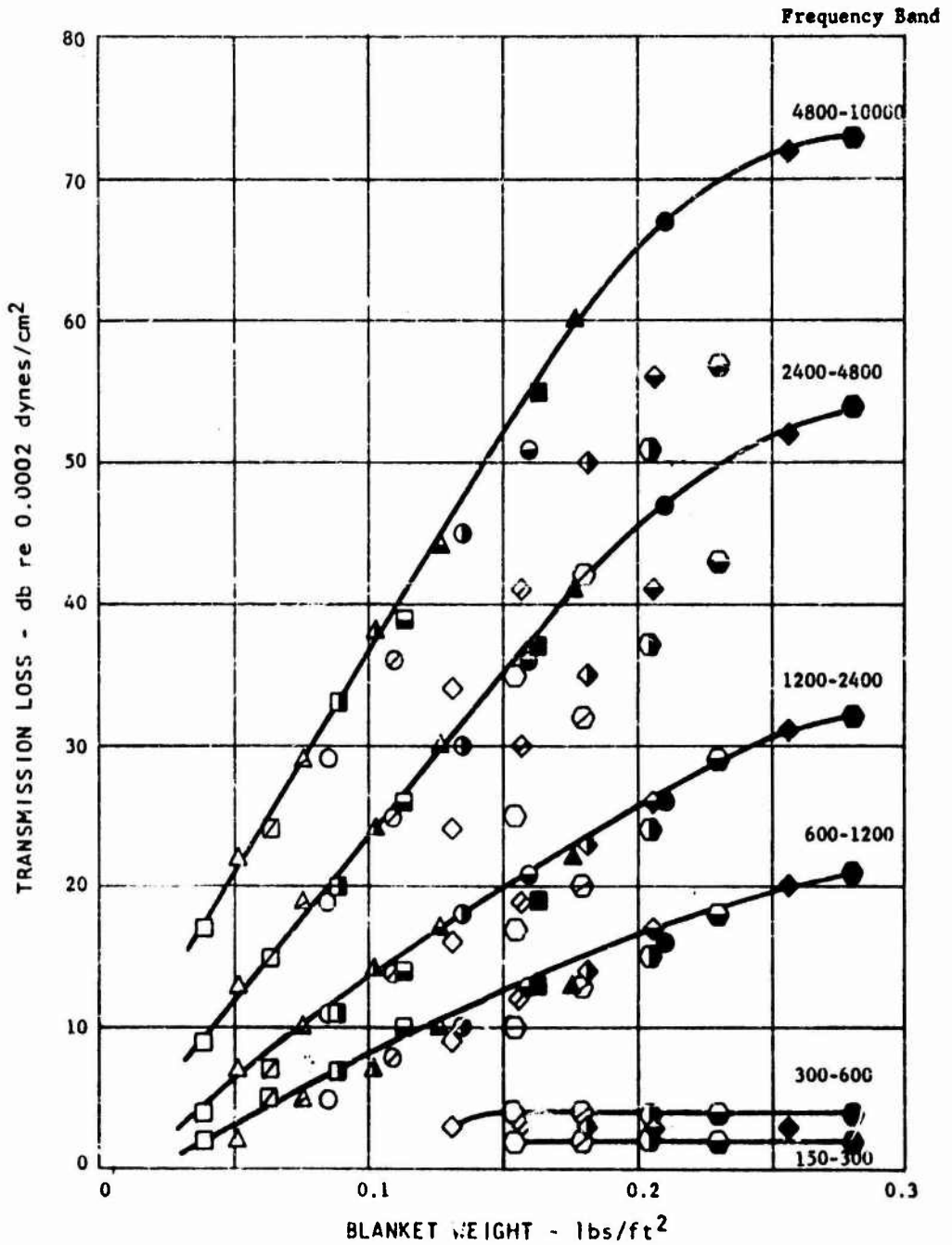

FIGURE 161

ACOUSTICAL BLANKET DESIGN CURVES
FOR ALUMINUM-FIBERGLAS BLANKETS

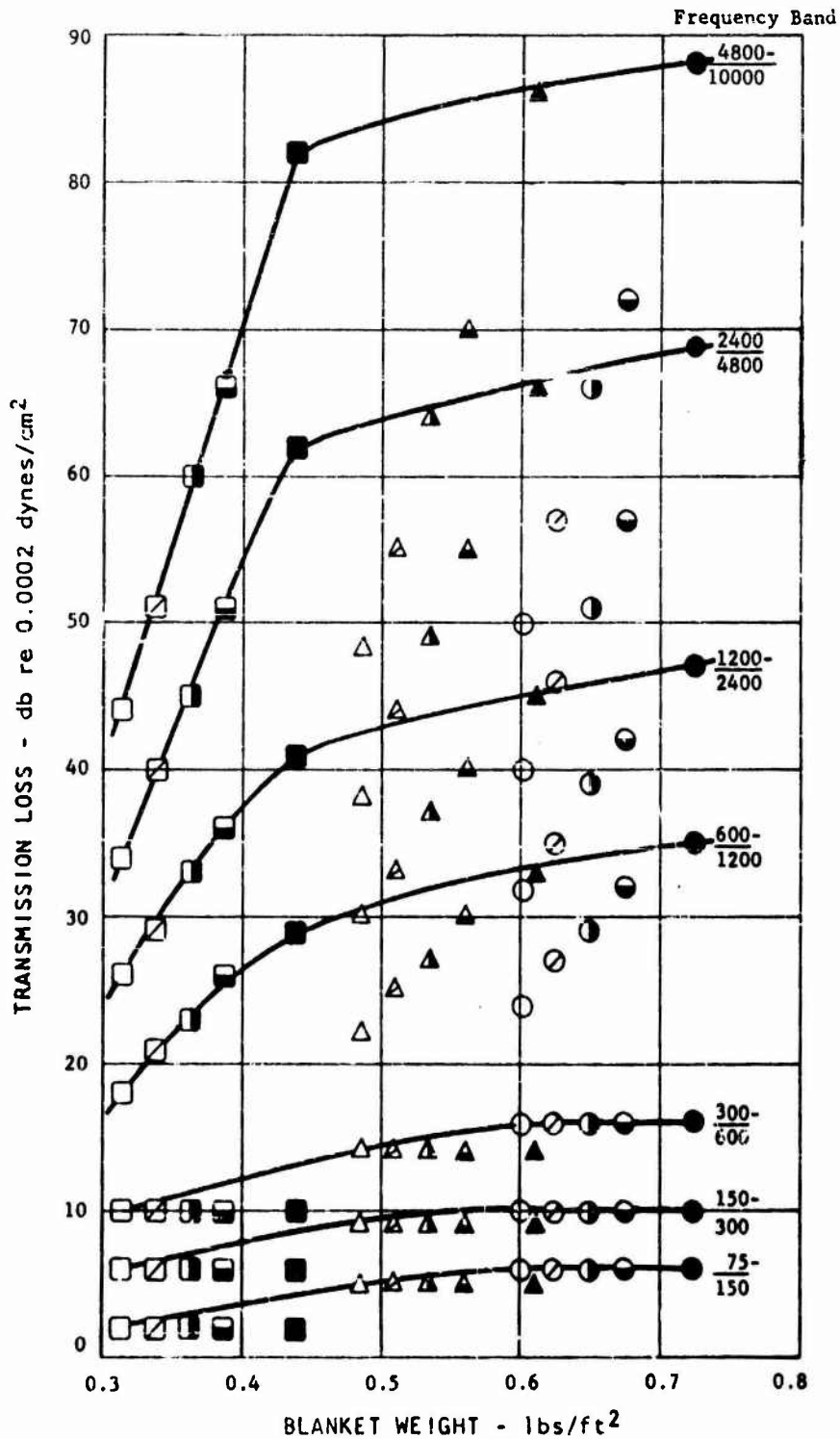

FIGURE 162

TABLE I
TRANSMISSION LOSS FOR VINYL-FIBERGLAS COMBINATIONS

Vinyl Thickness Fiberglass Thickness Weight lbs/sq ft Ident.	0.002"					0.004"					0.009"				
	0.5"	1.0"	1.5"	2.0"	3.0"	0.5"	1.0"	1.5"	2.0"	3.0"	0.5"	1.0"	1.5"	2.0"	3.0"
20-75	--	--	--	--	--	--	--	--	--	--	--	--	--	--	--
75-150	--	--	--	--	--	--	--	--	--	--	--	--	--	--	--
150-300	--	--	--	--	--	--	--	--	--	--	--	--	--	--	--
300-600	--	--	--	--	--	--	--	--	--	--	--	--	--	--	--
600-1200	2	5	7	10	13	2	5	7	10	13	5	8	10	13	16
1200-2400	4	7	11	14	19	7	10	14	17	22	11	14	18	21	26
2400-4800	9	15	20	26	37	13	19	24	30	41	19	25	30	36	47
4800-10000	17	24	33	39	55	22	29	38	44	60	29	36	45	51	67
	0.020"														
	0.016"					0.020"									
	0.5"	1.0"	1.5"	2.0"	3.0"	0.5"	1.0"	1.5"	2.0"	3.0"	0.5"	1.0"	1.5"	2.0"	3.0"
	.132	.157	.182	.207	.257	.155	.180	.205	.230	.280					
	◇	◇	◇	◇	◇	◇	◇	◇	◇	◇	◇	◇	◇	◇	◇
20-75	--	--	--	--	--	--	--	--	--	--	--	--	--	--	--
75-150	--	--	--	--	--	--	--	--	--	--	--	--	--	--	--
150-300	--	--	--	--	--	2	2	2	2	2	2	2	2	2	2
300-600	3	3	3	3	3	4	4	4	4	4	4	4	4	4	4
600-1200	9	12	14	17	20	10	13	15	18	21	10	13	15	18	21
1200-2400	16	19	23	26	31	17	20	24	29	32	17	20	24	29	32
2400-4800	24	30	35	41	52	25	32	37	43	54	25	32	37	43	54
4800-10000	34	41	50	56	72	35	42	51	57	73	35	42	51	57	73

FREQUENCY BAND
CYCLES/SECOND

FREQUENCY BAND
CYCLES/SECOND

TABLE 11
TRANSMISSION LOSS FOR ALUMINUM-FIBERGLAS COMBINATIONS

Aluminum Thickness	.020"						.032"						.040"					
	0.5"	1.0"	1.5"	2.0"	3.0"	3.0"	0.5"	1.0"	1.5"	2.0"	3.0"	3.0"	0.5"	1.0"	1.5"	2.0"	3.0"	
Fiberglass Thickness																		
Weight lbs/sq ft																		
Identification	□	▣	▢	▤	▥	▦	△	▴	▲	▲	▲	○	⊙	⊙	⊙	⊙	●	
20-75	--	--	--	--	--	--	--	--	--	--	--	--	--	--	--	--	--	
75-150	2	2	2	2	2	2	5	5	5	5	5	6	6	6	6	6	6	
150-300	6	6	6	6	6	6	9	9	9	9	9	10	10	10	10	10	10	
300-600	10	10	10	10	10	10	14	14	14	14	14	16	16	16	16	16	16	
600-1200	18	21	23	26	29	29	22	25	27	30	33	24	27	29	29	32	35	
1200-2400	26	29	33	36	41	41	30	33	37	40	45	32	35	39	39	42	47	
2400-4800	34	40	45	51	62	62	38	44	49	55	66	40	46	51	51	57	69	
4800-10000	44	51	60	66	82	82	48	55	64	70	86	50	57	66	66	72	98	

FREQUENCY BAND
CYCLES/SECOND

IDENTIFICATION OF NOISE SOURCES

H-21

P. LOTS EAR LEVEL POSITION 2

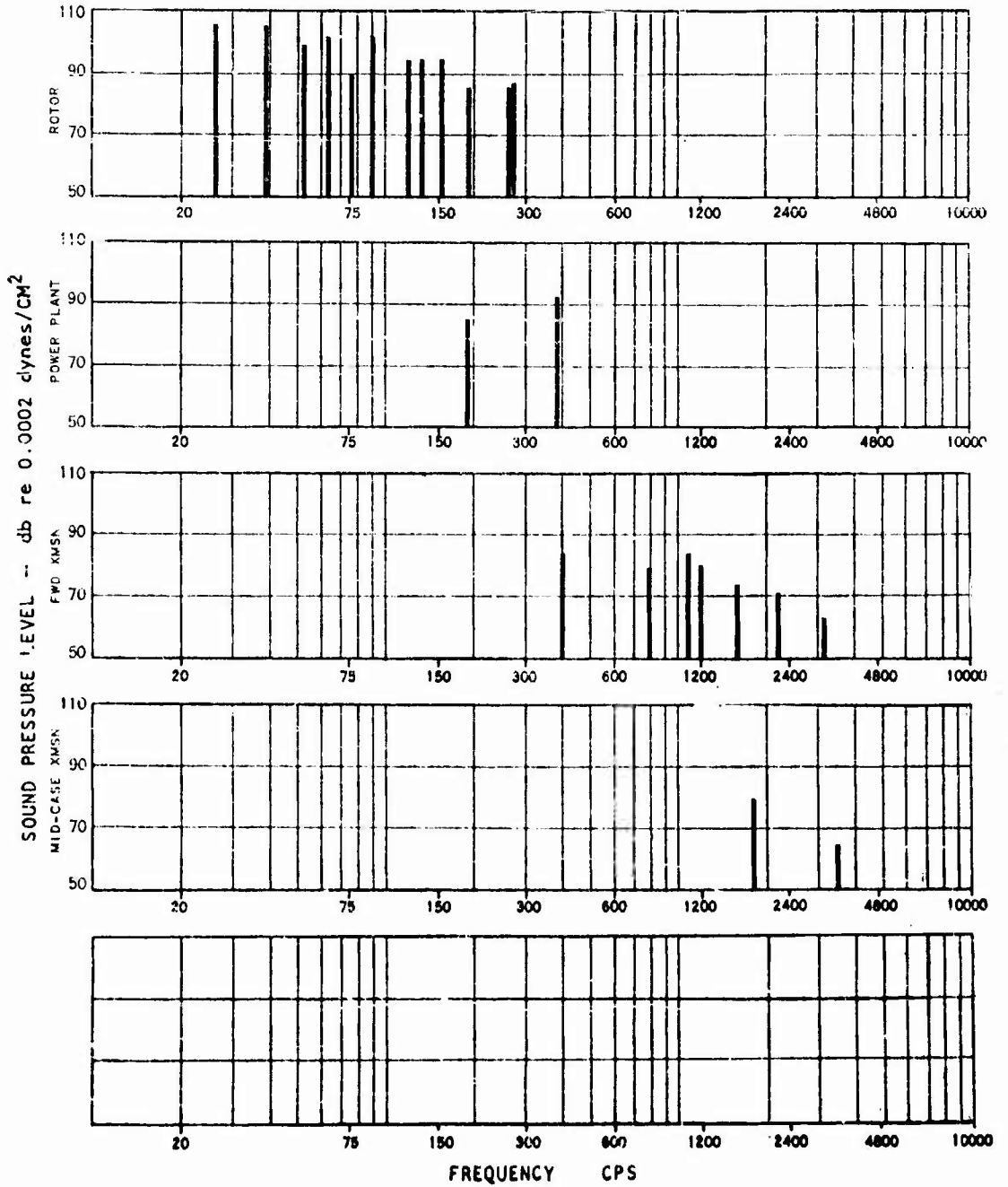

FIGURE 163

IDENTIFICATION OF NOISE SOURCES

H-21

CABIN POSITION 11

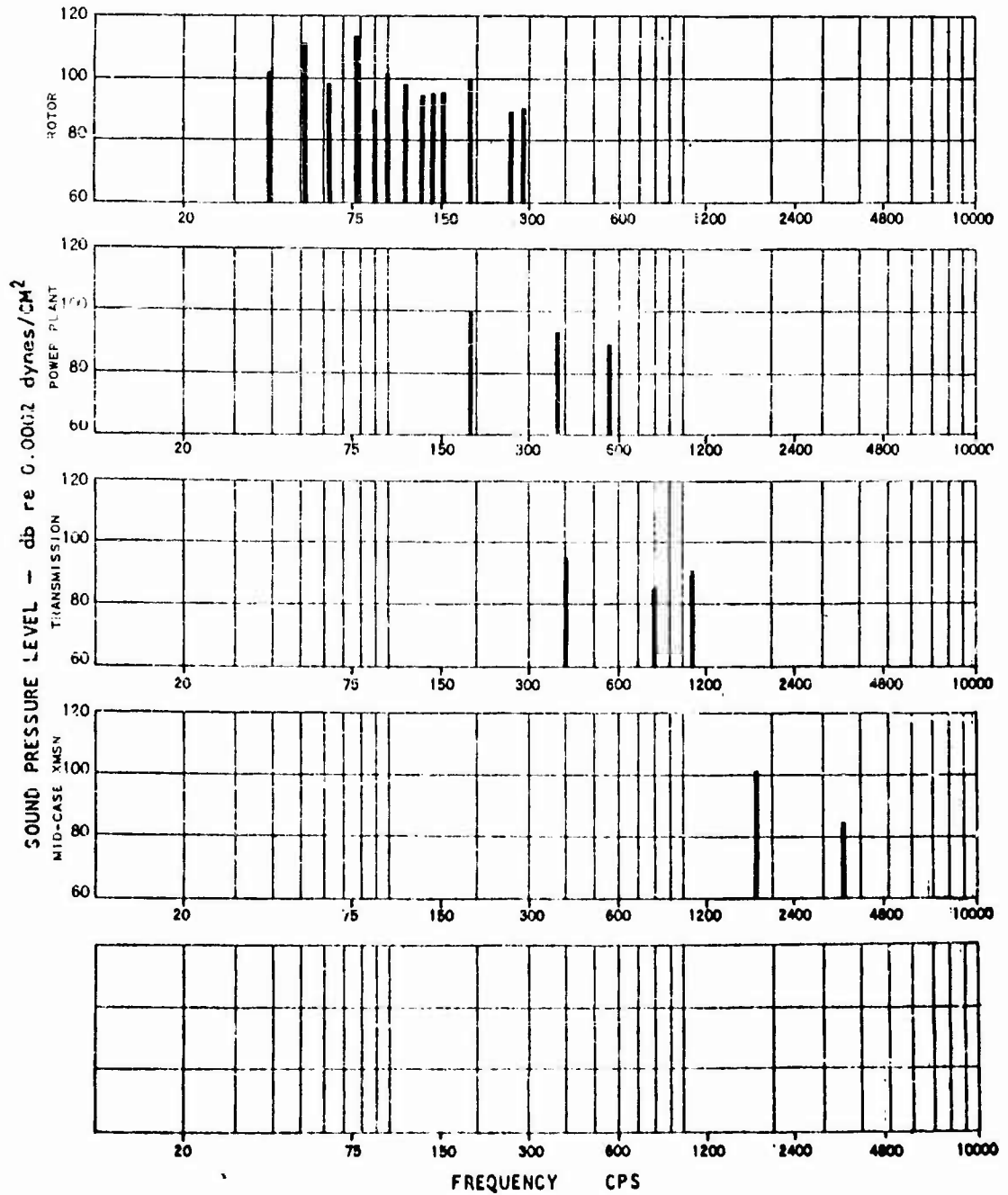

FIGURE 164

IDENTIFICATION OF NOISE SOURCES

H-23

INTERNAL POSITION 11

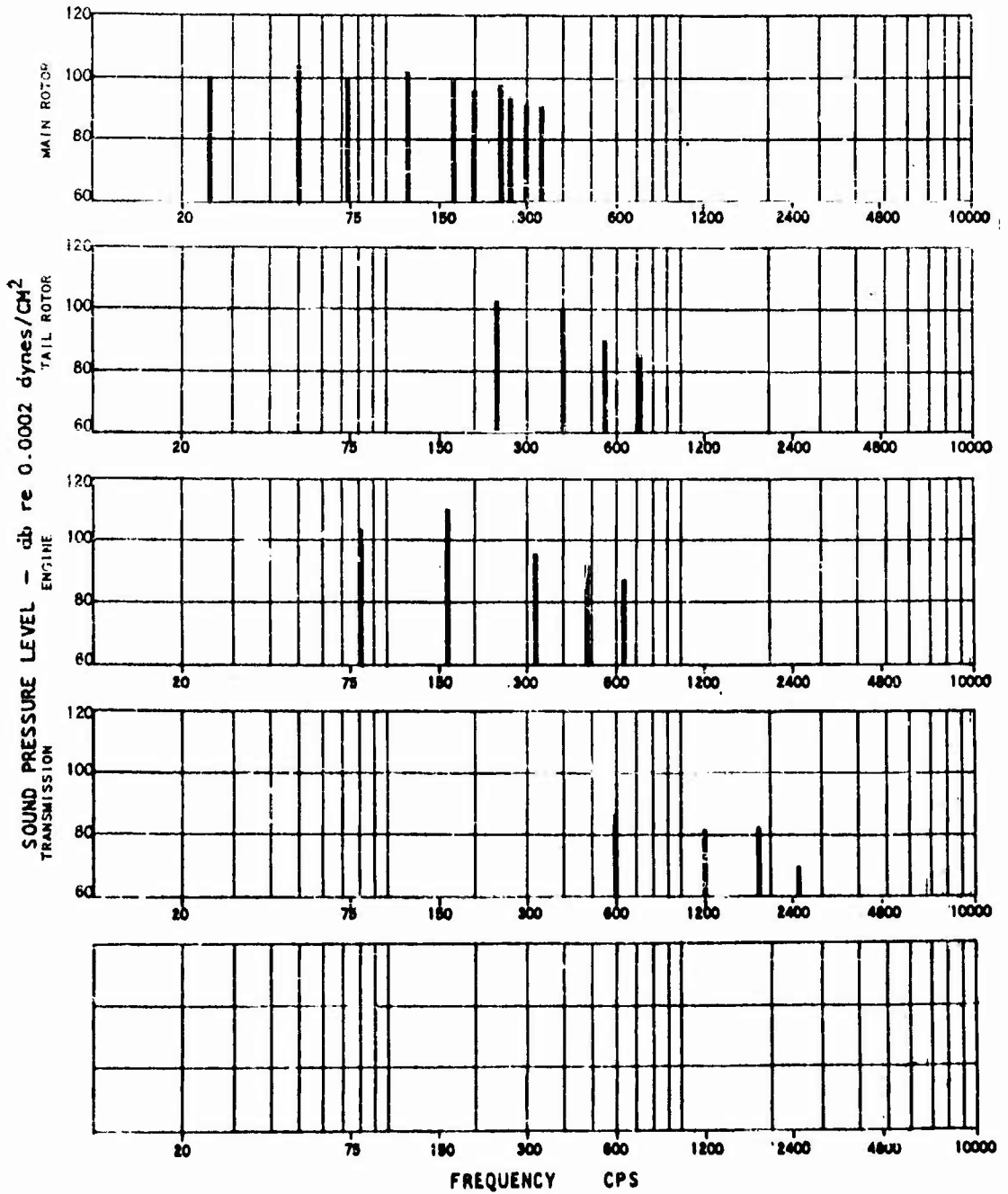

FIGURE 165

IDENTIFICATION OF NOISE SOURCES

H-37

PILOTS EAR LEVEL POSITION 5

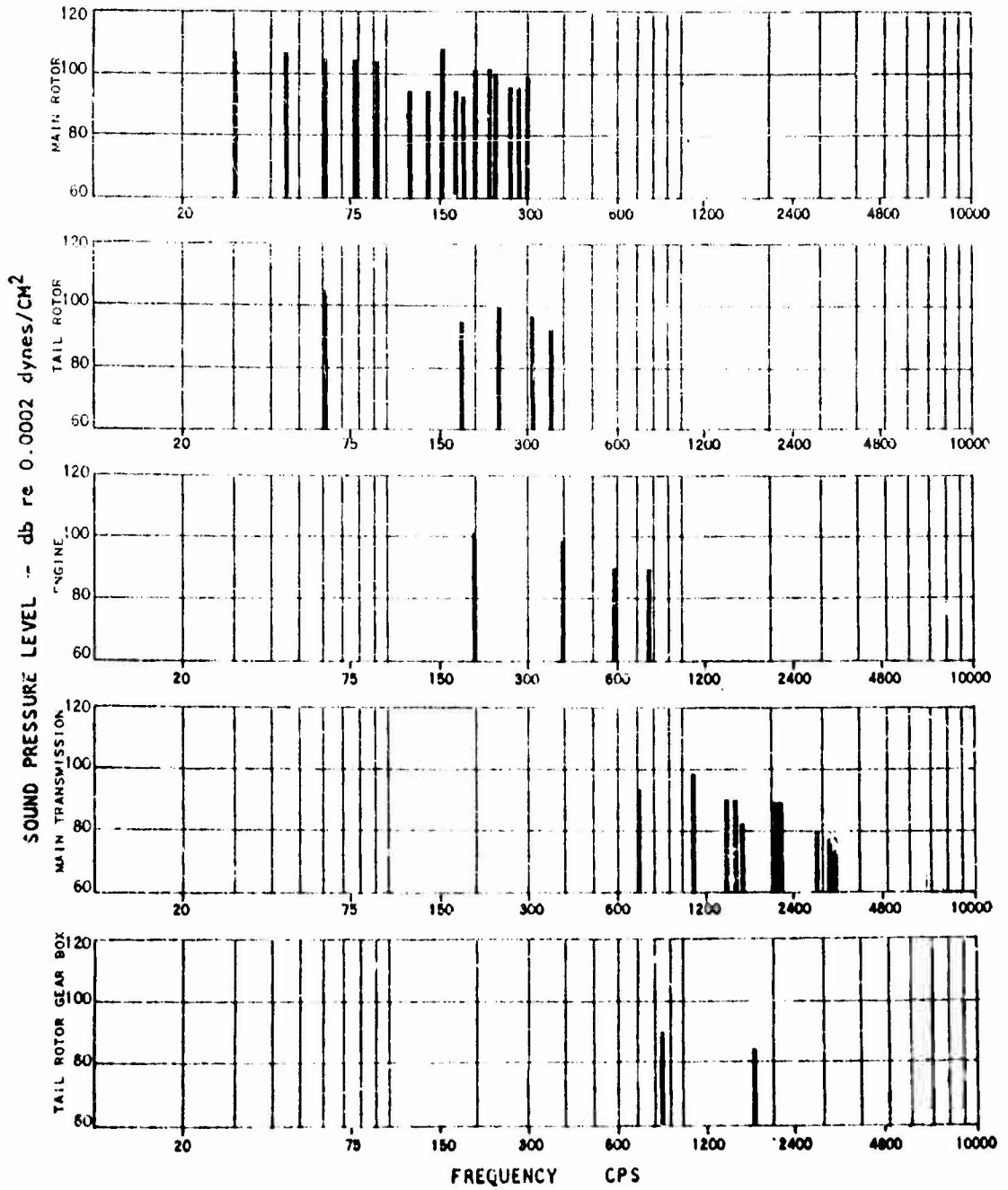

FIGURE 166

IDENTIFICATION OF NOISE SOURCES

H-37

CABIN POSITION 17

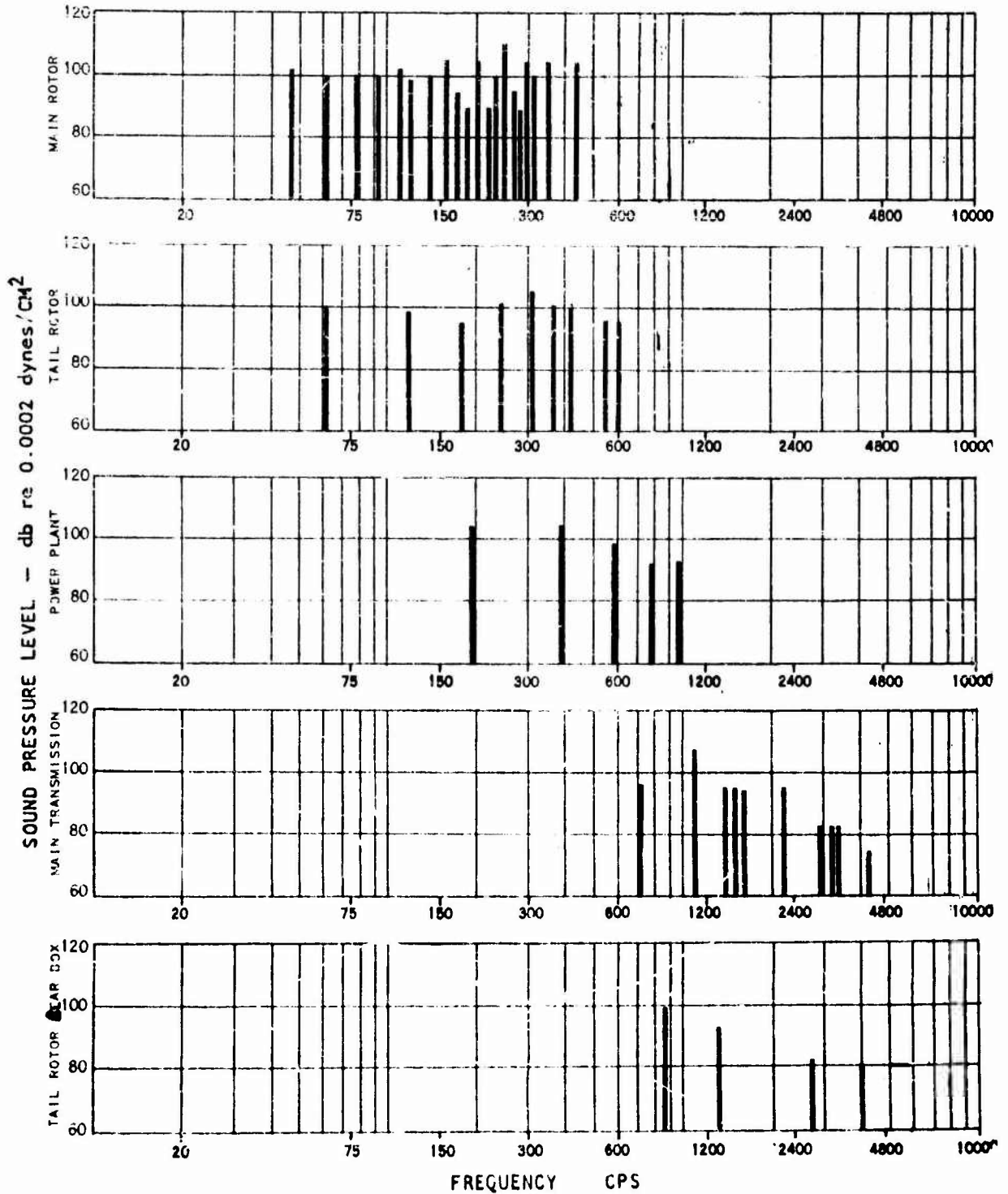

FIGURE 167

IDENTIFICATION OF NOISE SOURCES

HU-1A

PILOTS EAR LEVEL POSITION 2

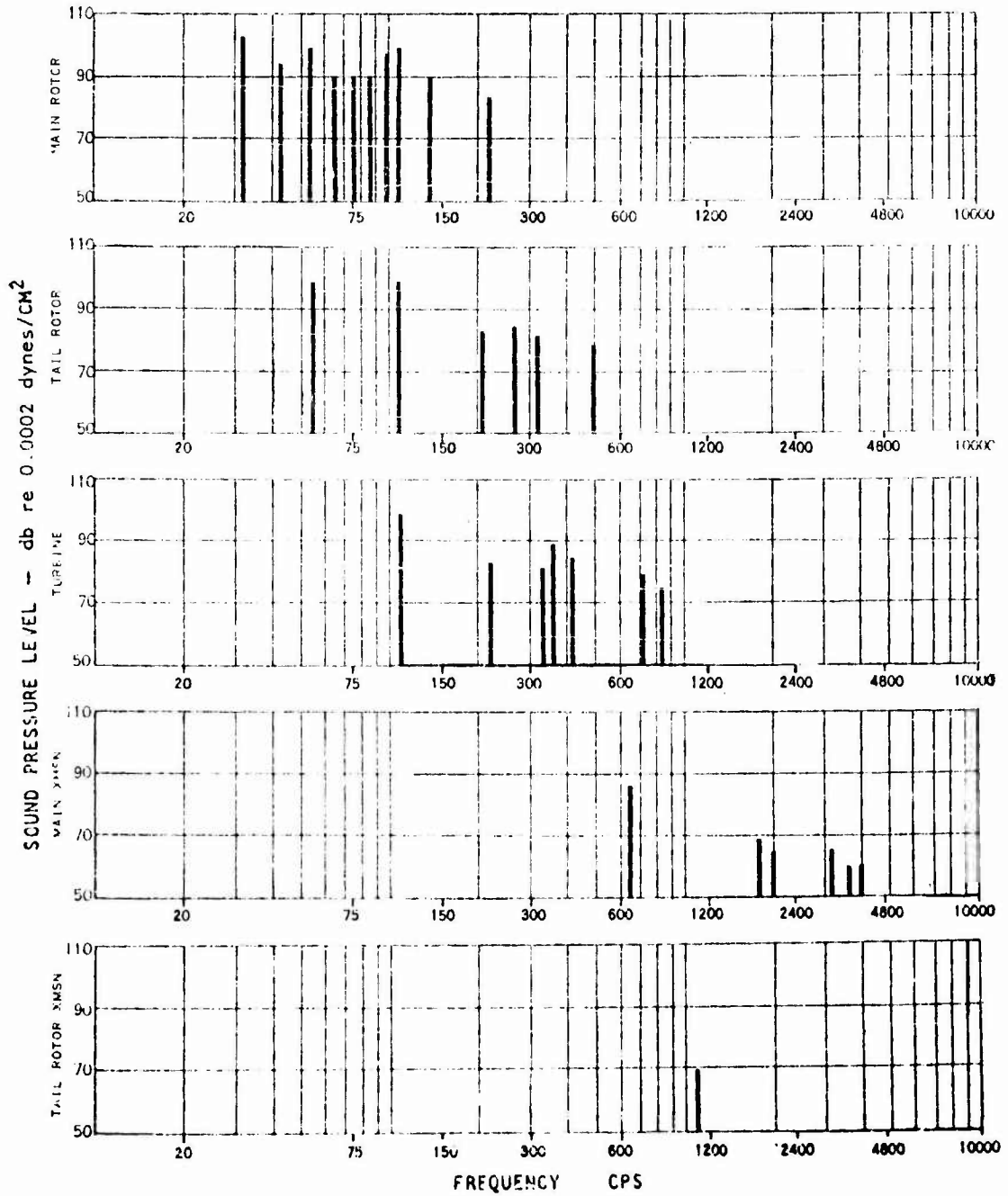

FIGURE 168

IDENTIFICATION OF NOISE SOURCES

EU-1A

CABIN POSITION 19

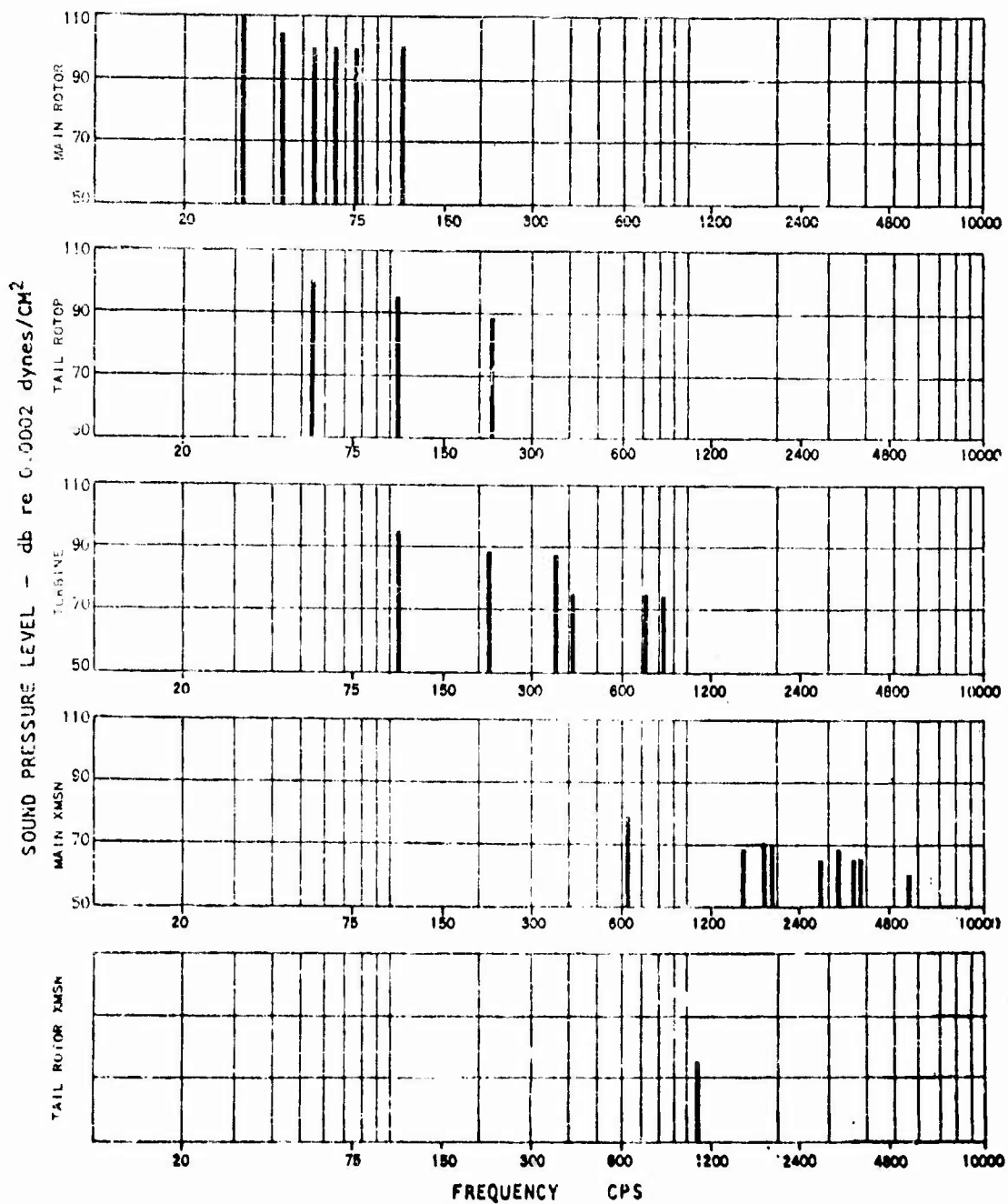

FIGURE 169

IDENTIFICATION OF NOISE SOURCES

YHC-1A

PILOTS EAR LEVEL POSITION 1

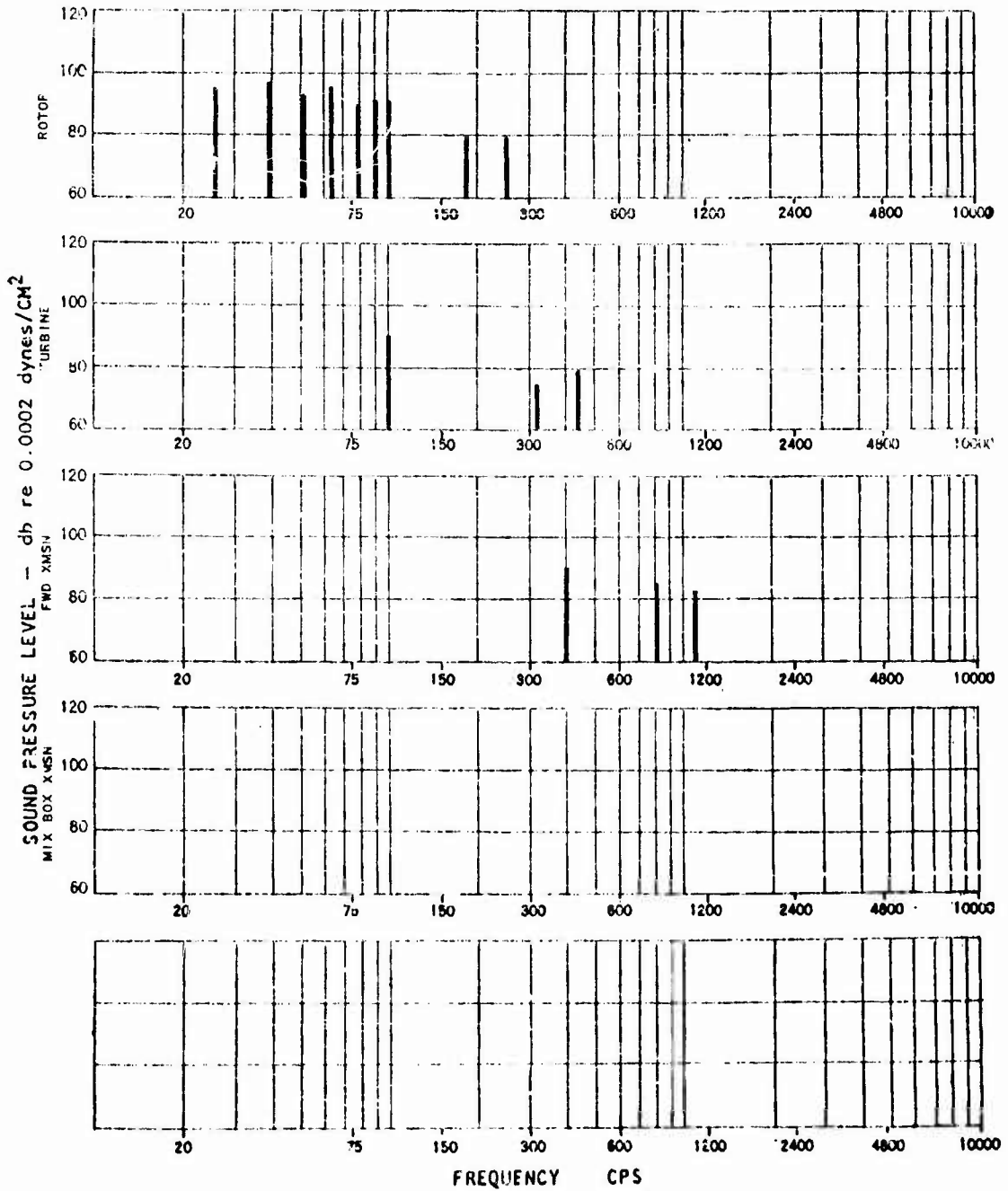

FIGURE 170

IDENTIFICATION OF NOISE SOURCES

YHC-1A

CABIN POSITION 12

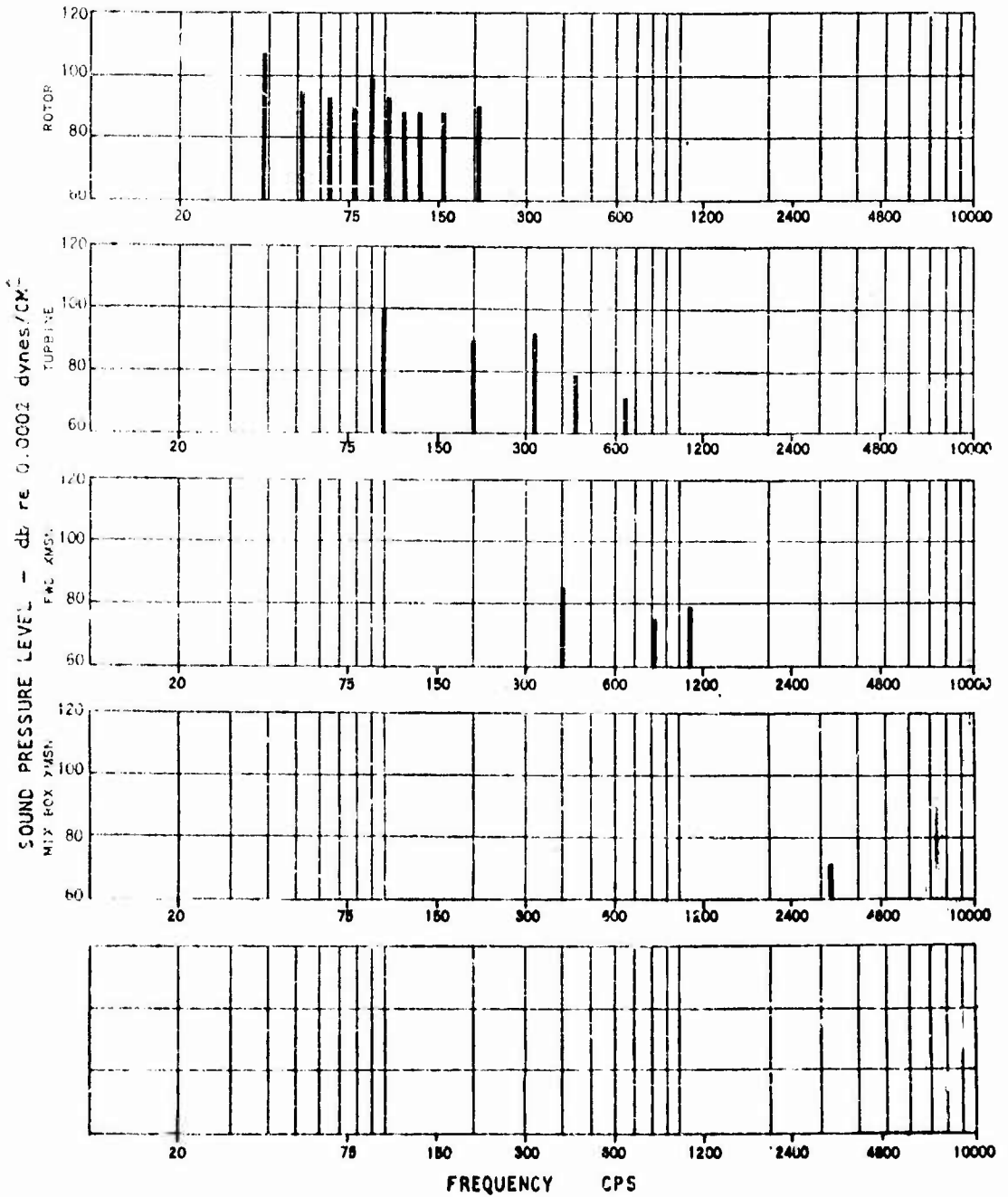

FIGURE 171

H-21 INTERNAL SOUND PRESSURE LEVELS

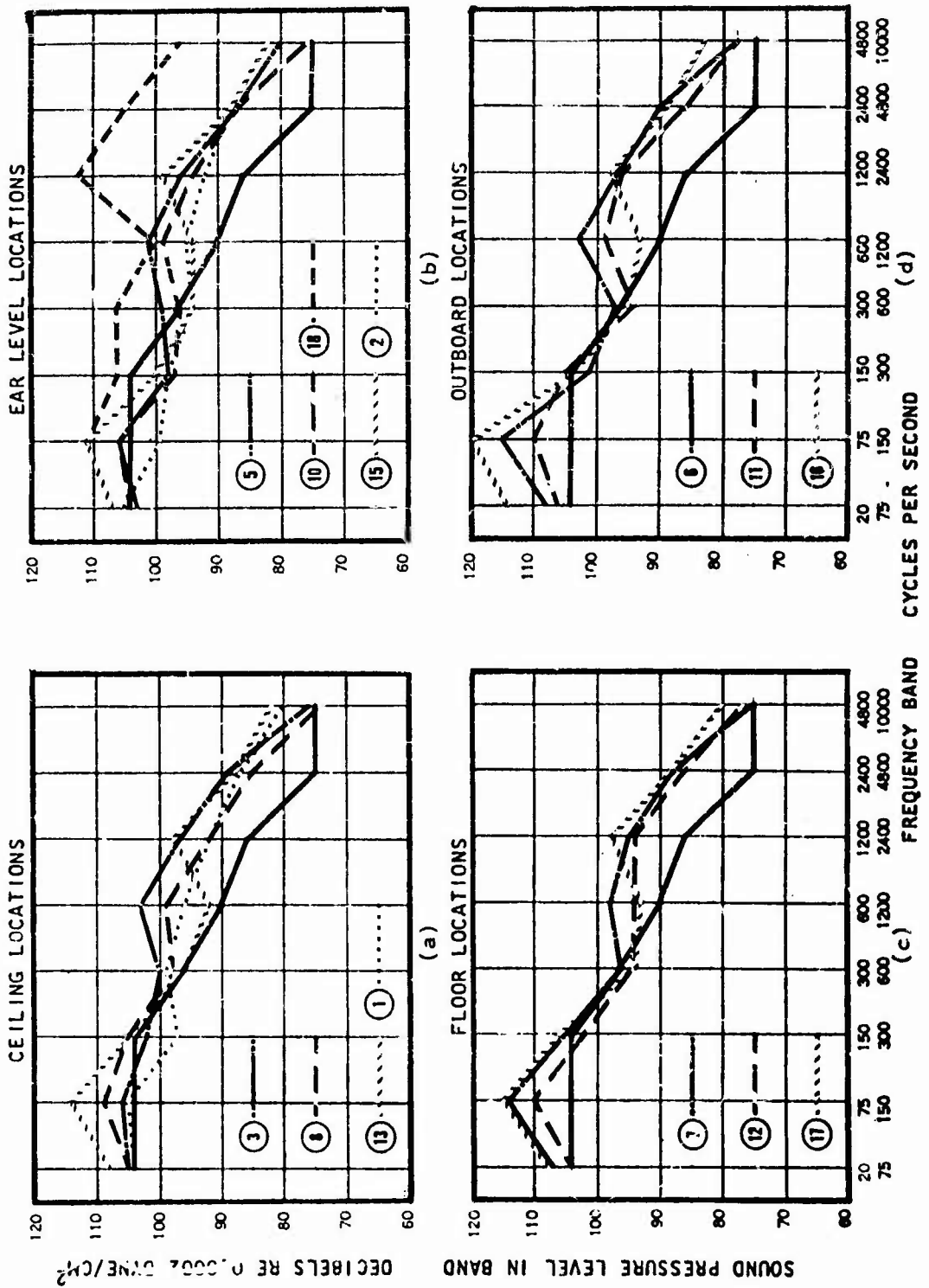
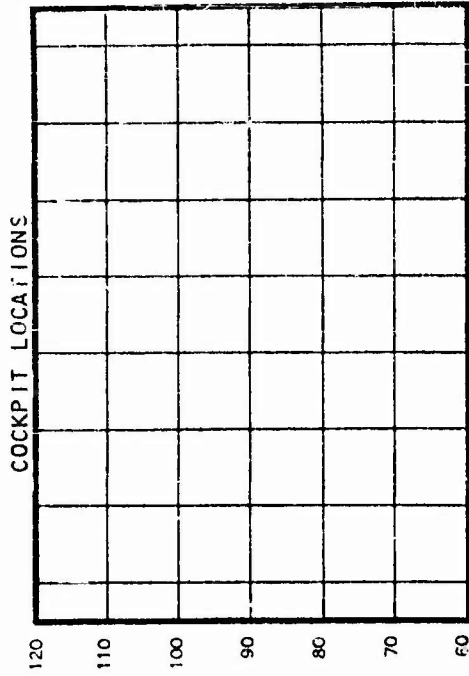
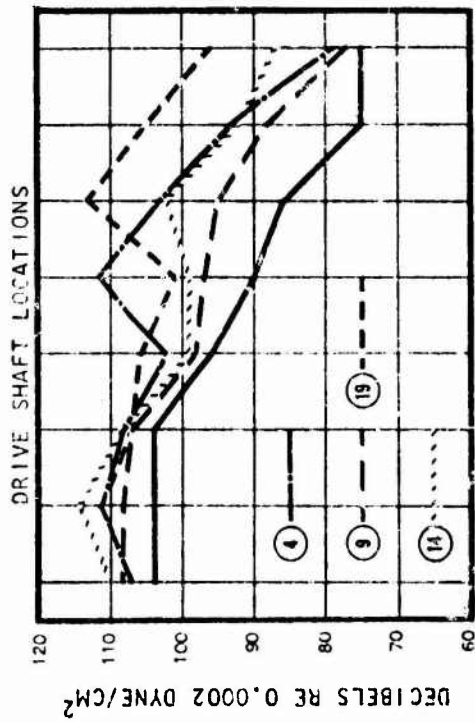

FIGURE 172 (a)

H-21 INTERNAL SOUND PRESSURE LEVELS



(e)

(f)

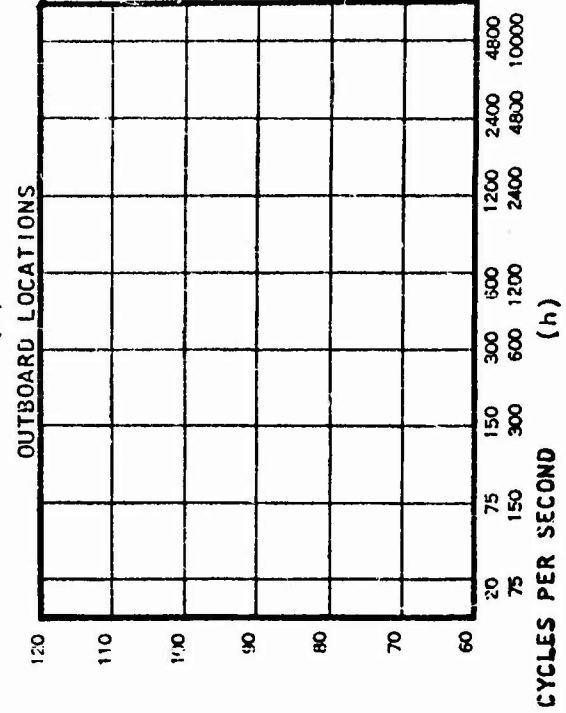
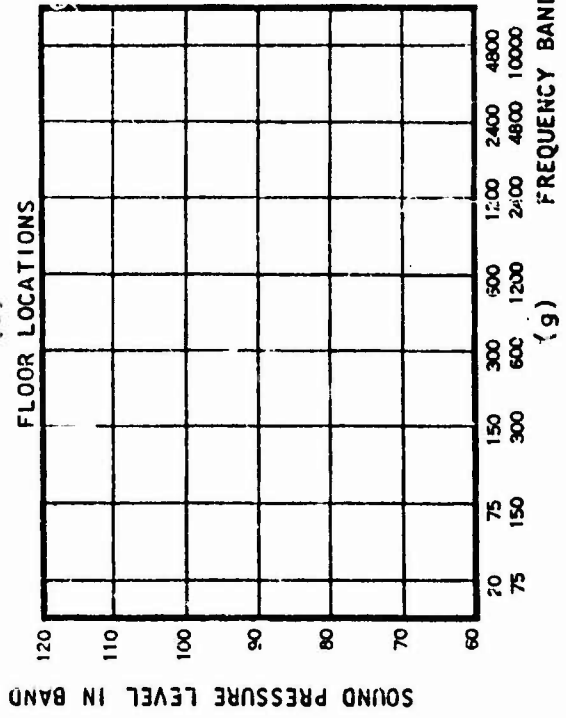

(g)

(h)

FIGURE 172 (b)

H-21 ACOUSTICAL TREATMENTS AND LOCATIONS

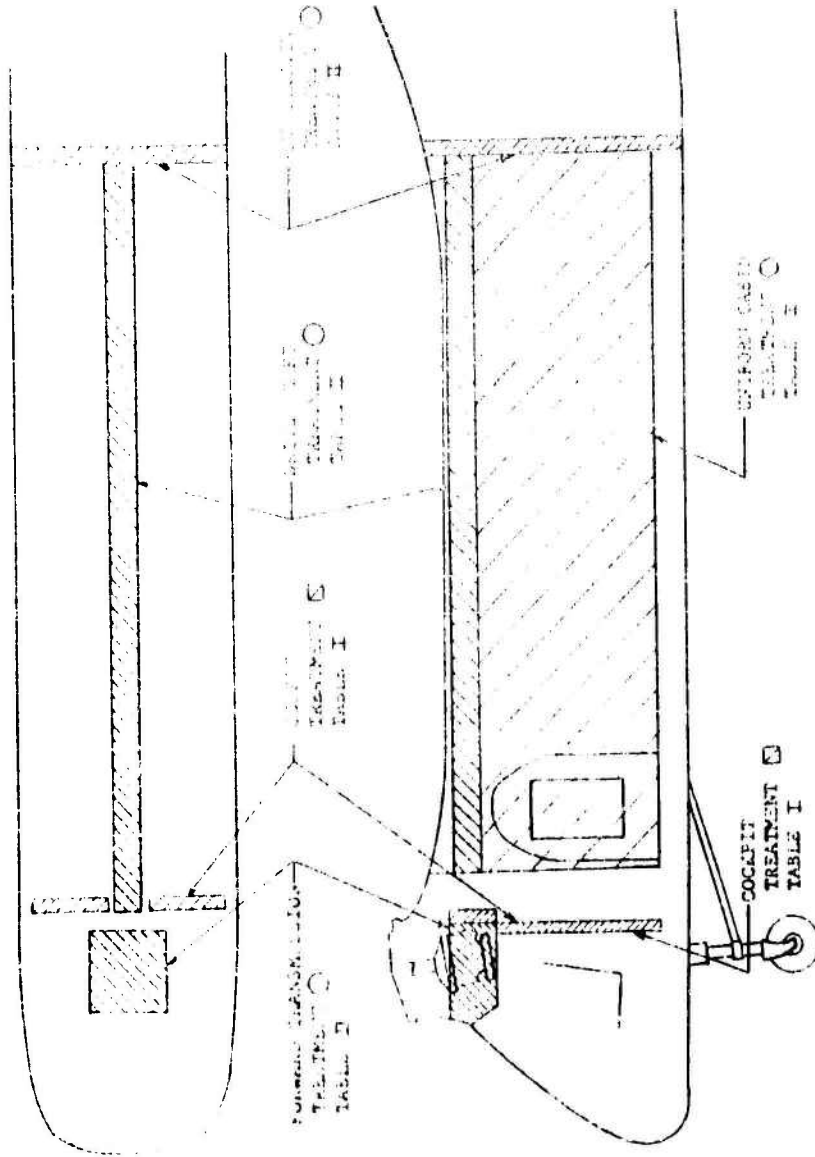

FIGURE 179

H-23 INTERNAL SOUND PRESSURE LEVELS

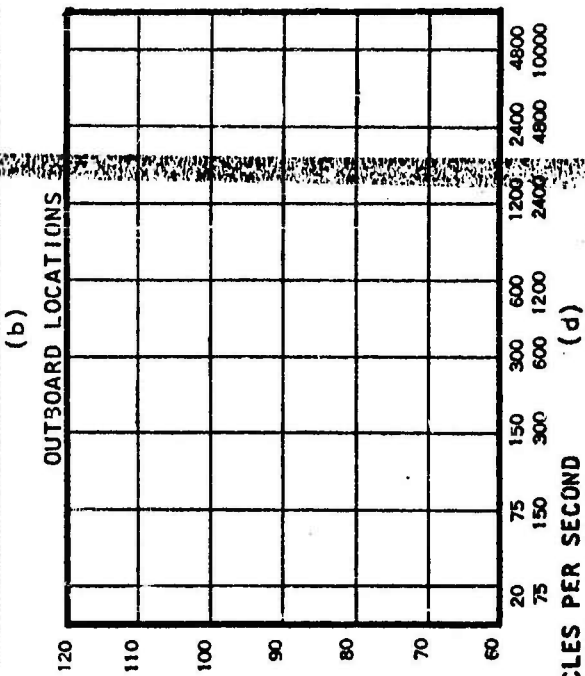
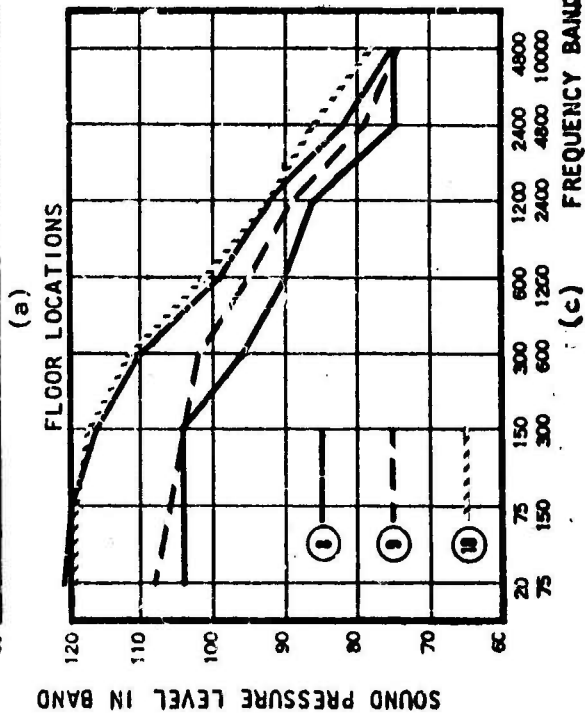
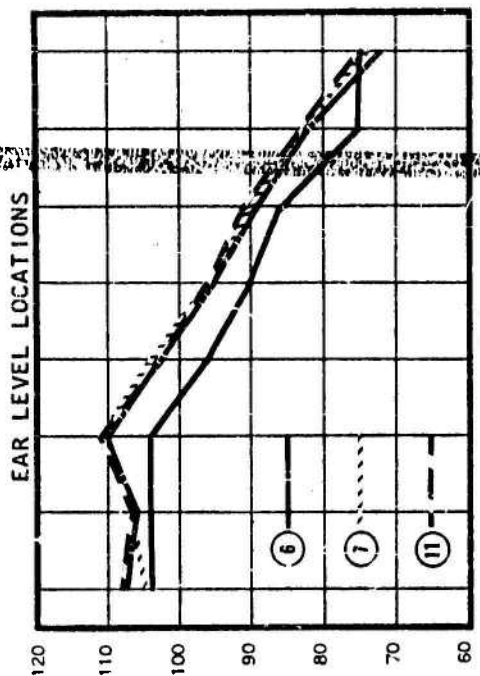
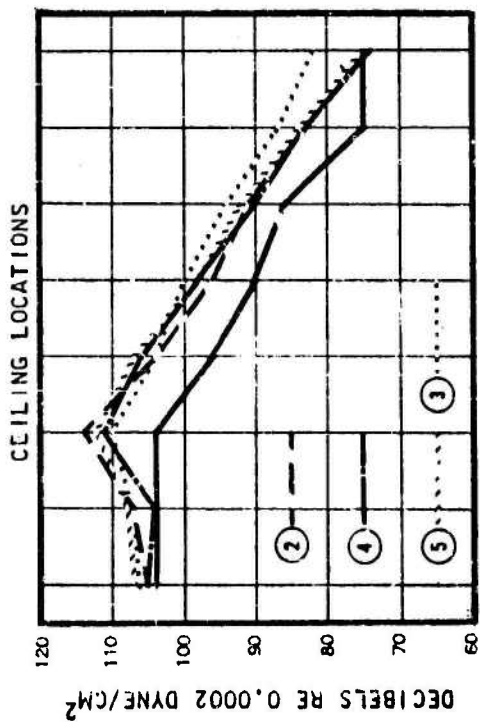

FIGURE 174

H-23 ACOUSTICAL TREATMENTS AND LOCATIONS

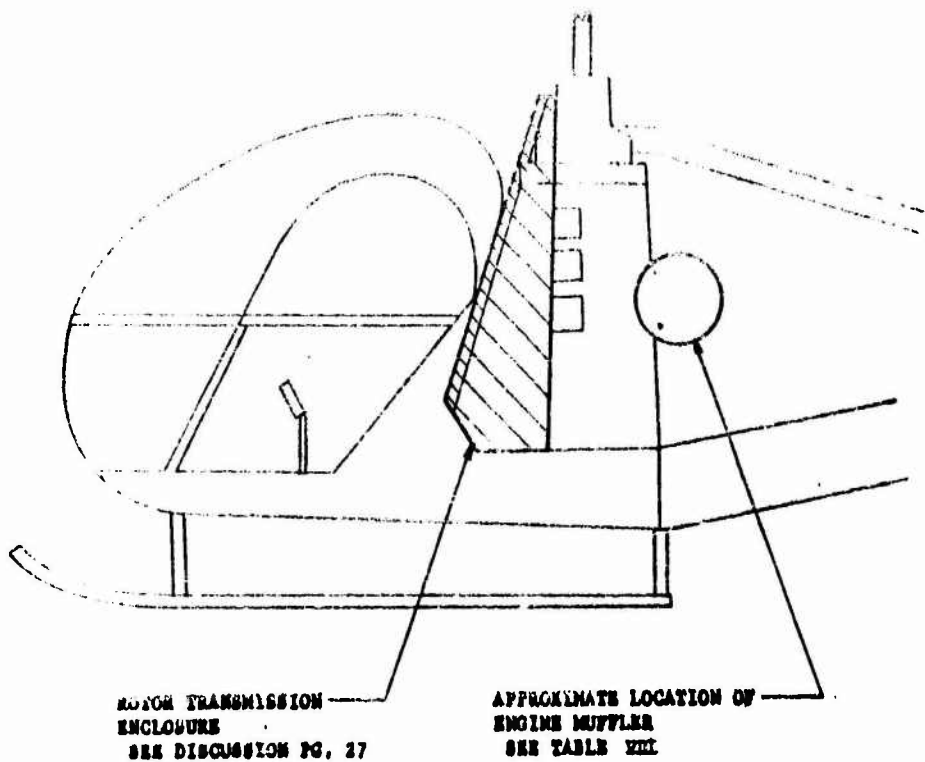
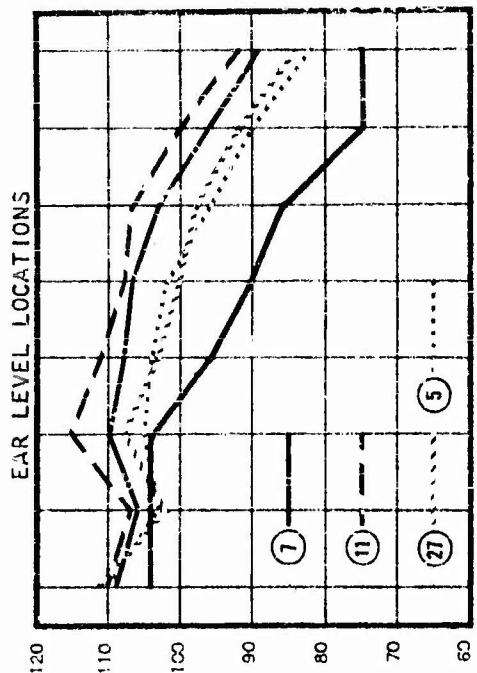
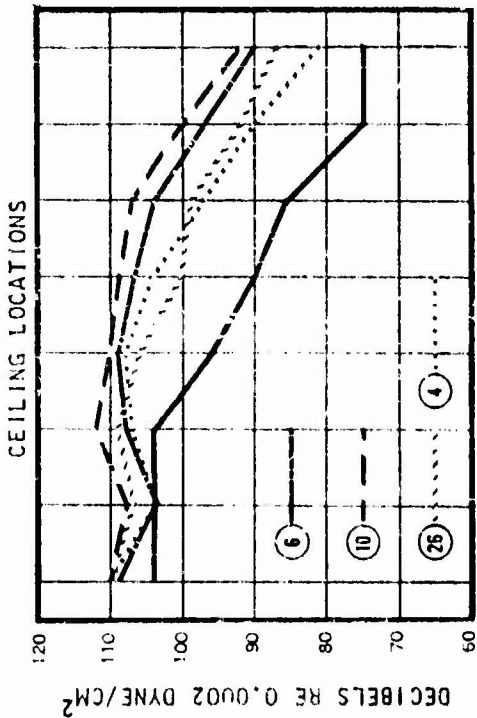

FIGURE 175

H-37 INTERNAL SOUND PRESSURE LEVELS

FORWARD POSITIONS



(a)

(b)

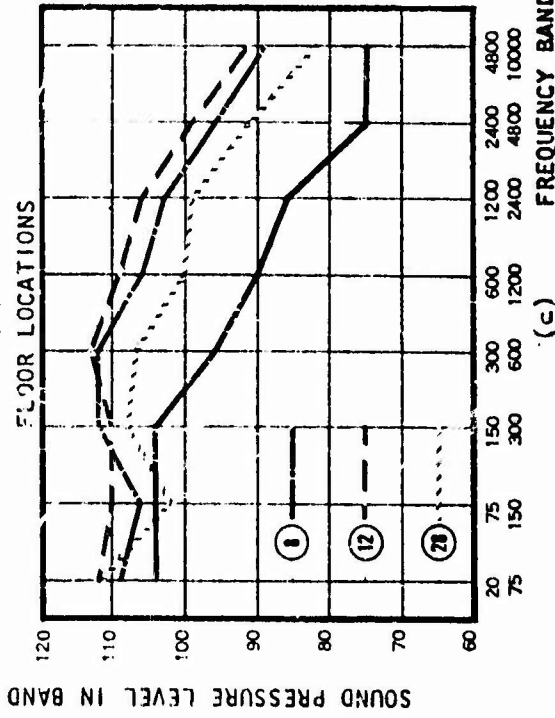

(c)

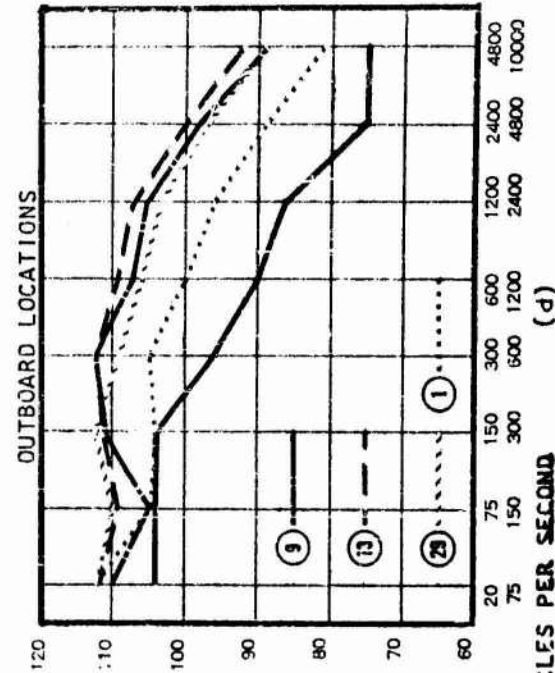

(d)

FIGURE 176 (a)

1-37 INTERNAL SOUND PRESSURE LEVELS

APT POSITIONS

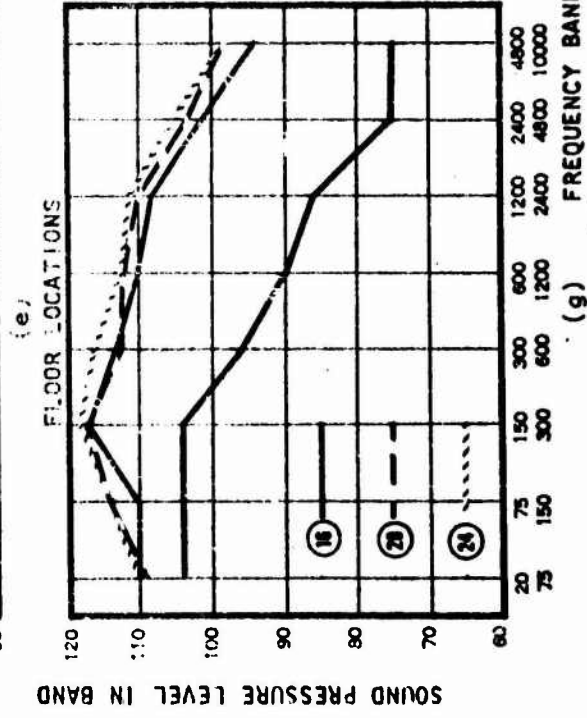
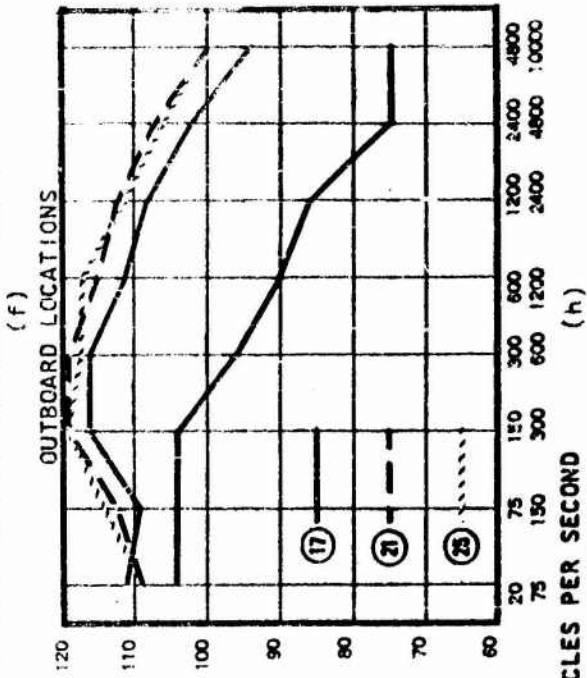
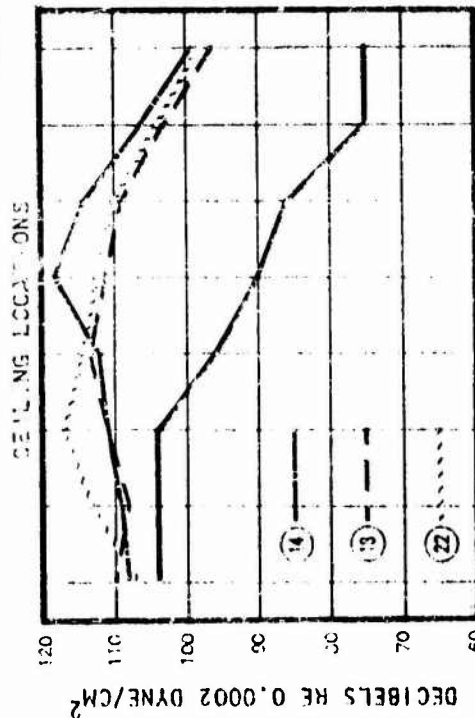
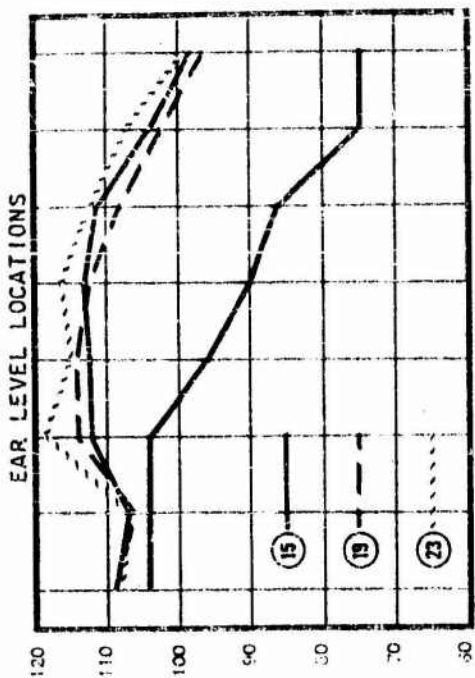

FIGURE 176 (b)

H-37 ACOUSTICAL TREATMENTS AND LOCATIONS

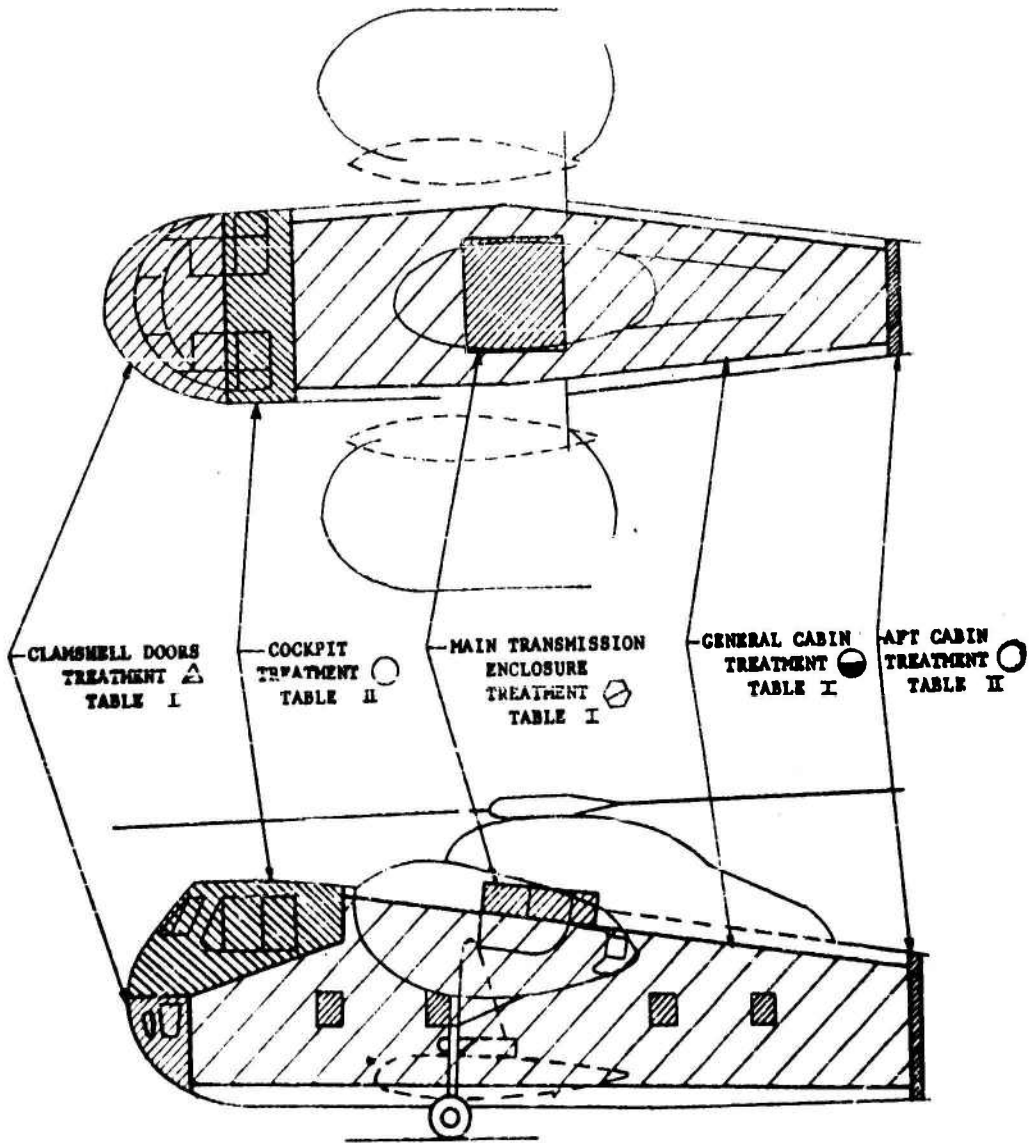
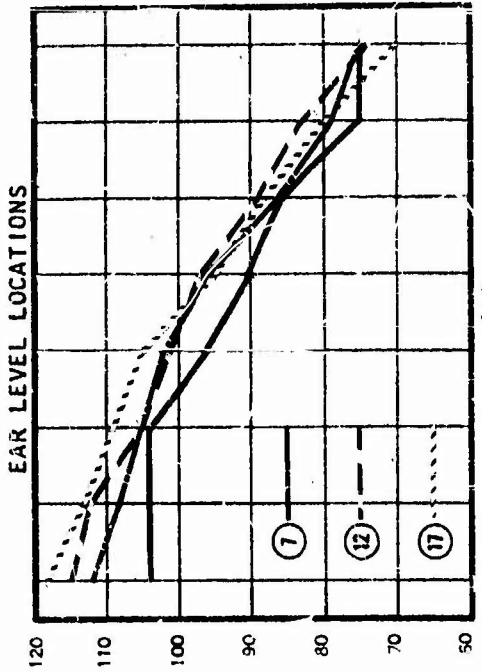
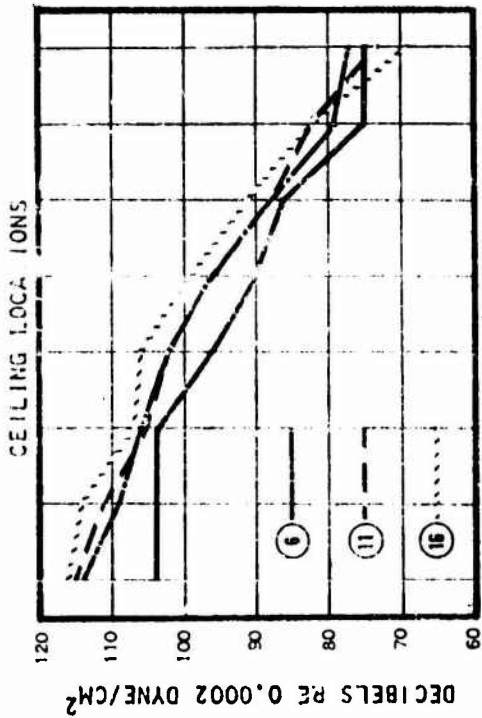

FIGURE 177

INTERNAL SOUND PRESSURE LEVELS



(a)

(b)

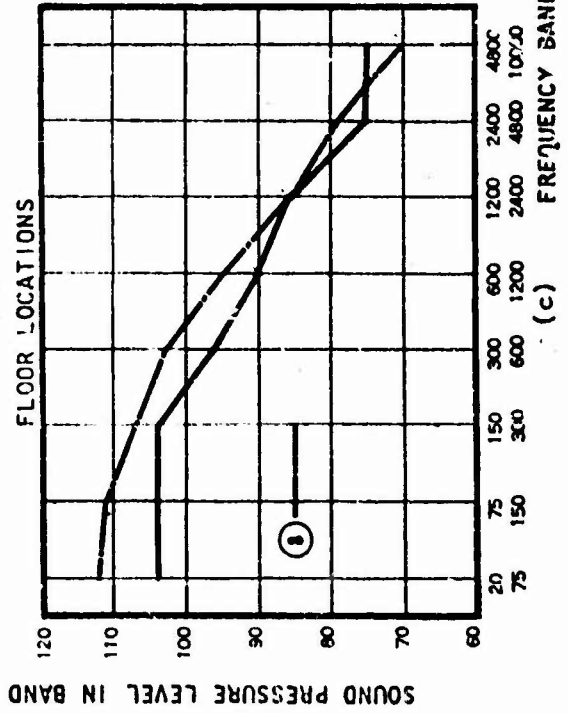

(c)

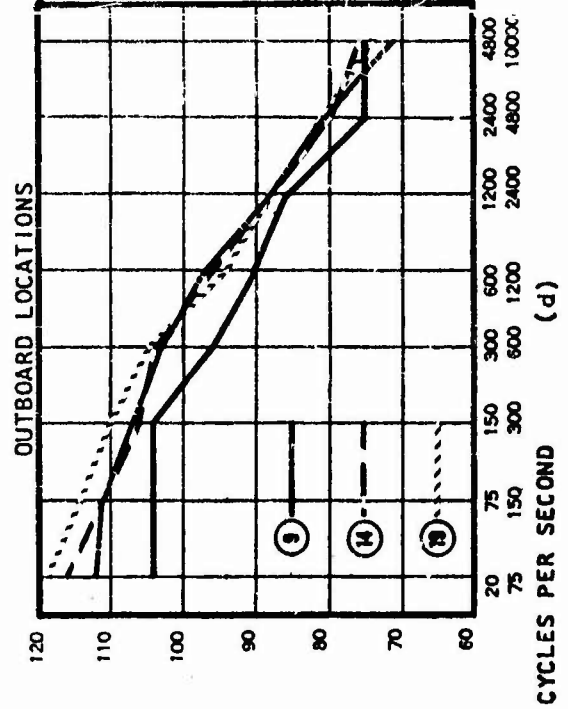

(d)

FIGURE 178

HU-1A ACOUSTICAL TREATMENTS AND LOCATIONS

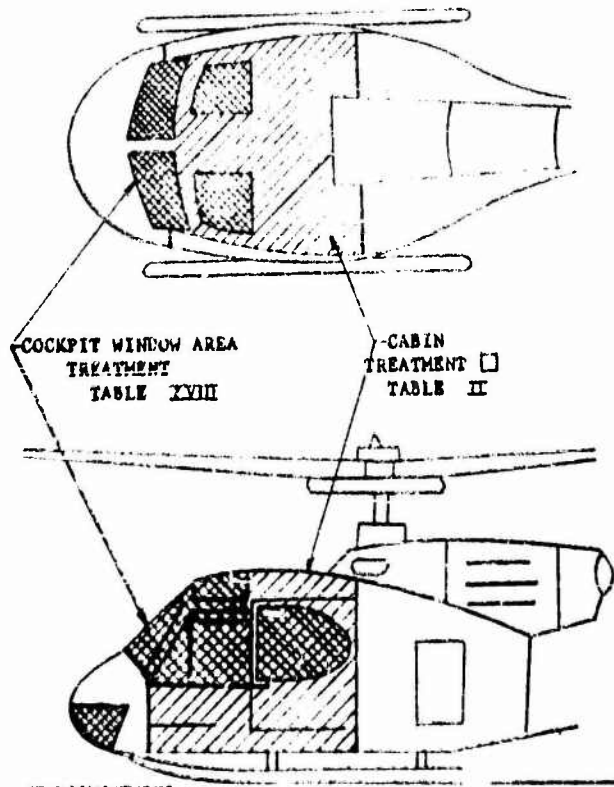

FIGURE 179

FIG-1A INTERNAL SOUND PRESSURE LEVELS

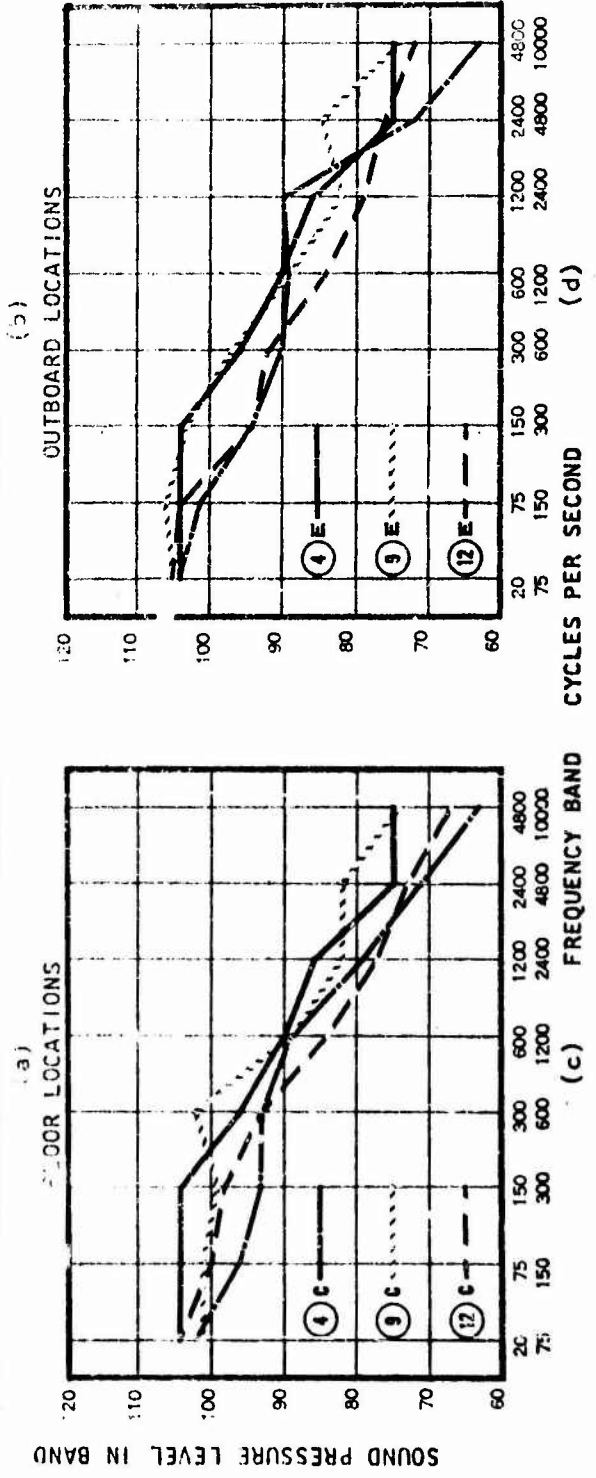
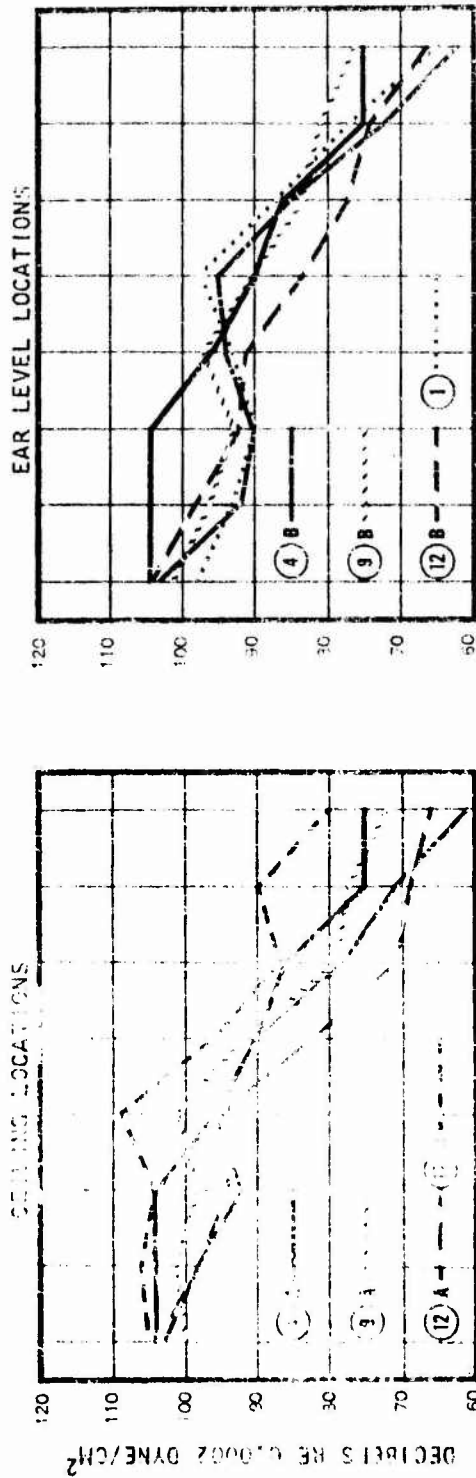

FIGURE 180

YHC-1A ACOUSTICAL TREATMENT AND LOCATIONS

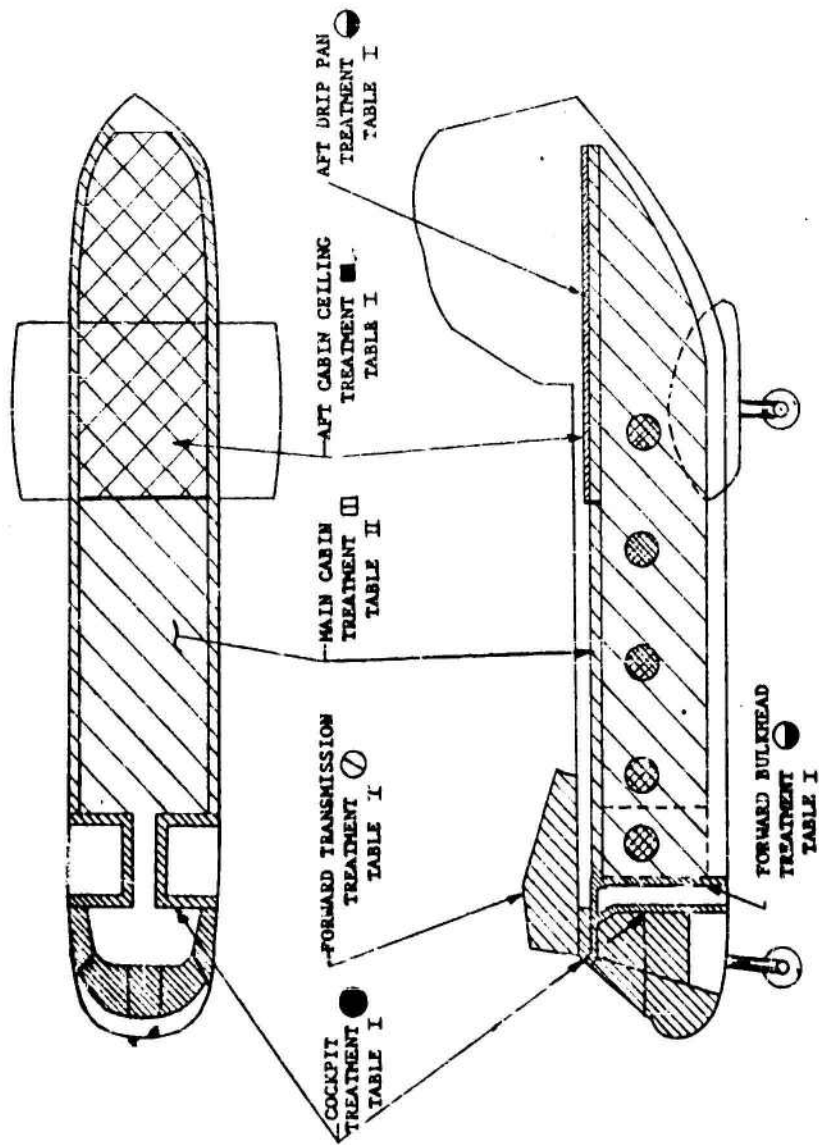

FIGURE 181

EFFECT OF ACOUSTIC TREATMENT
ON PERFORMANCE

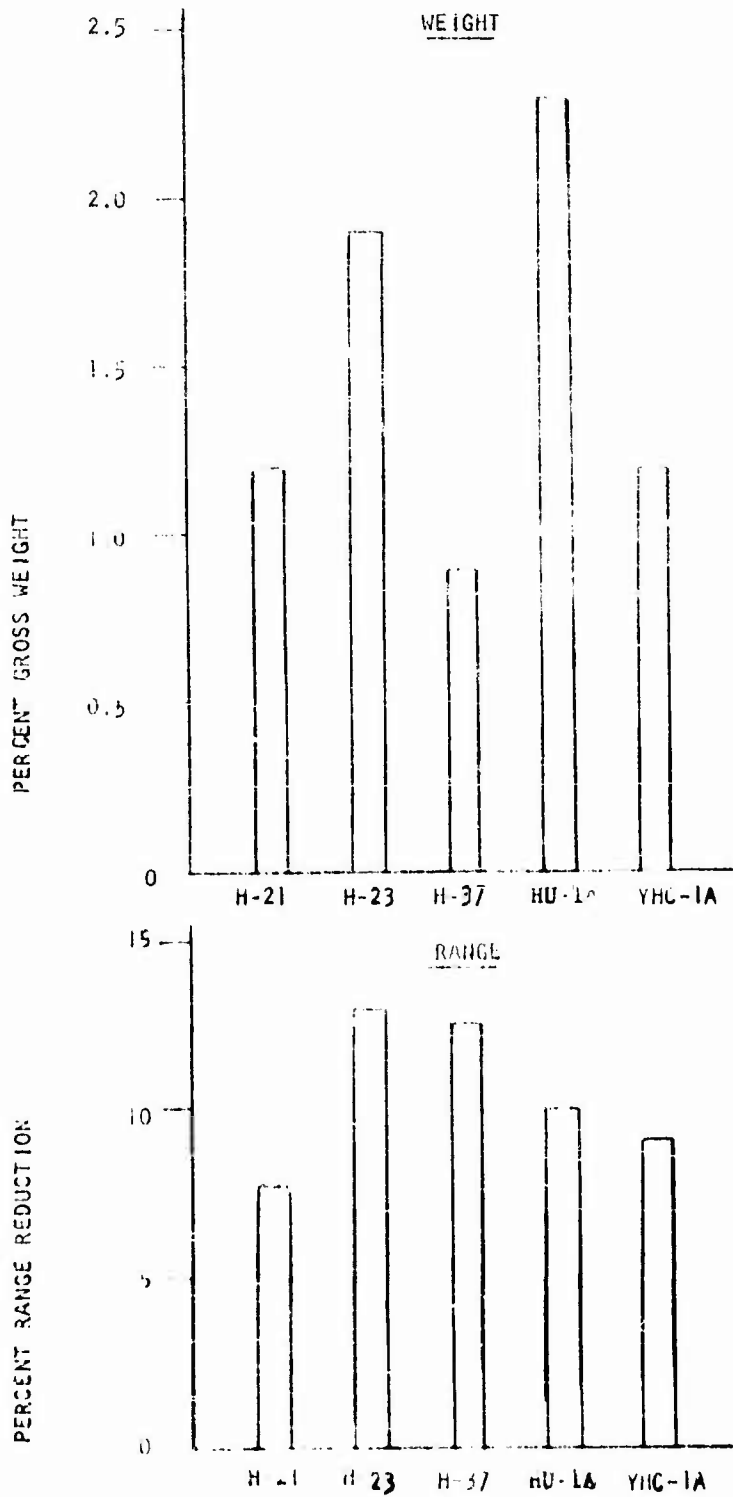

FIGURE 18.

SUMMARY OF ARMY AIRCRAFT NOISE LEVELS

SOUND PRESSURE LEVEL AVERAGE FOR OCTAVE BANDS SHOWN

PILOTS' EAR LEVEL POSITION - CRUISE

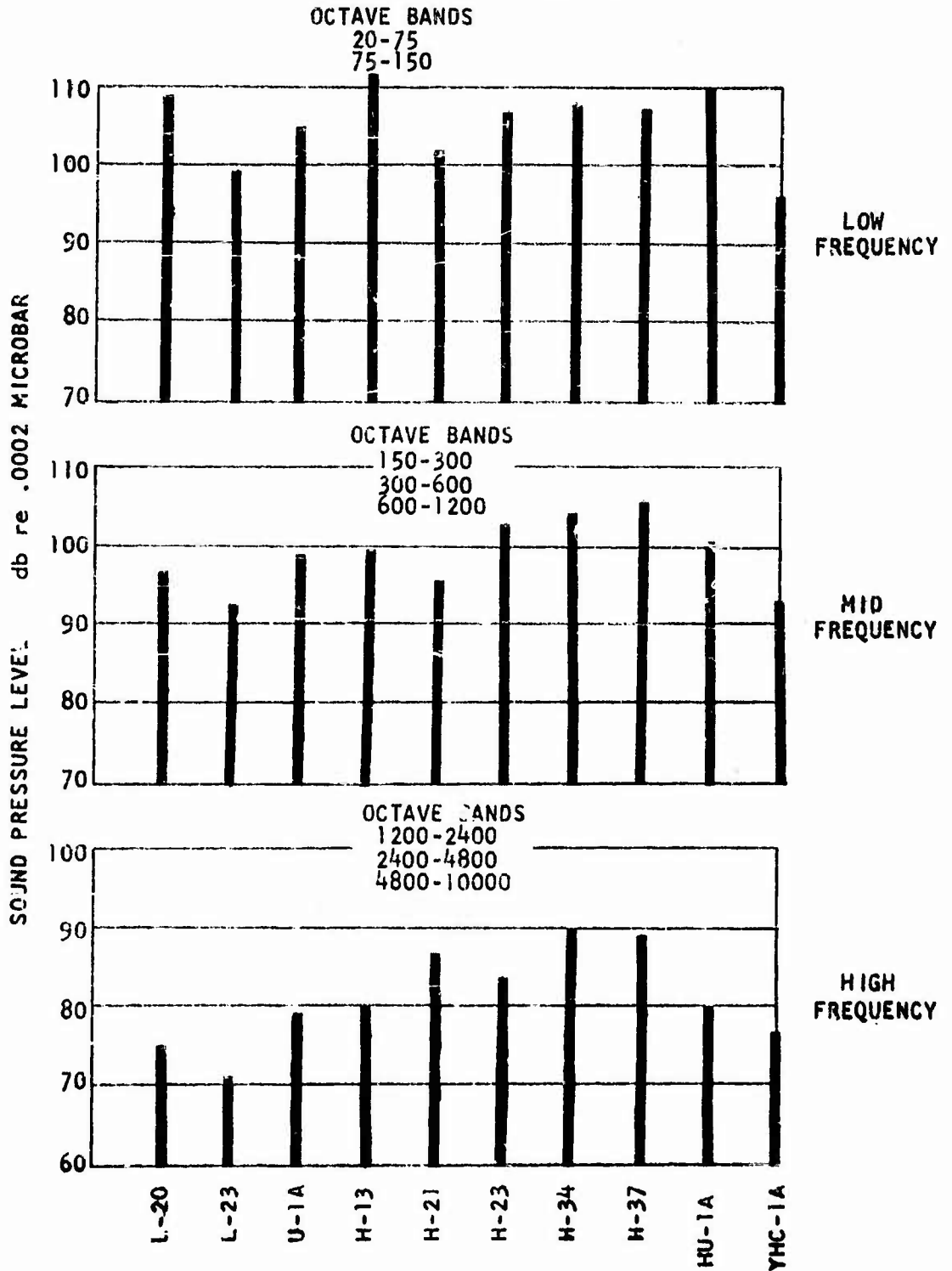

FIGURE 183

SUMMARY OF ARMY AIRCRAFT NOISE LEVELS

SOUND PRESSURE LEVEL AVERAGE FOR OCTAVE BANDS SHOWN

OVERHEAD FLY BY - 100' ALTITUDE - POSITION 7

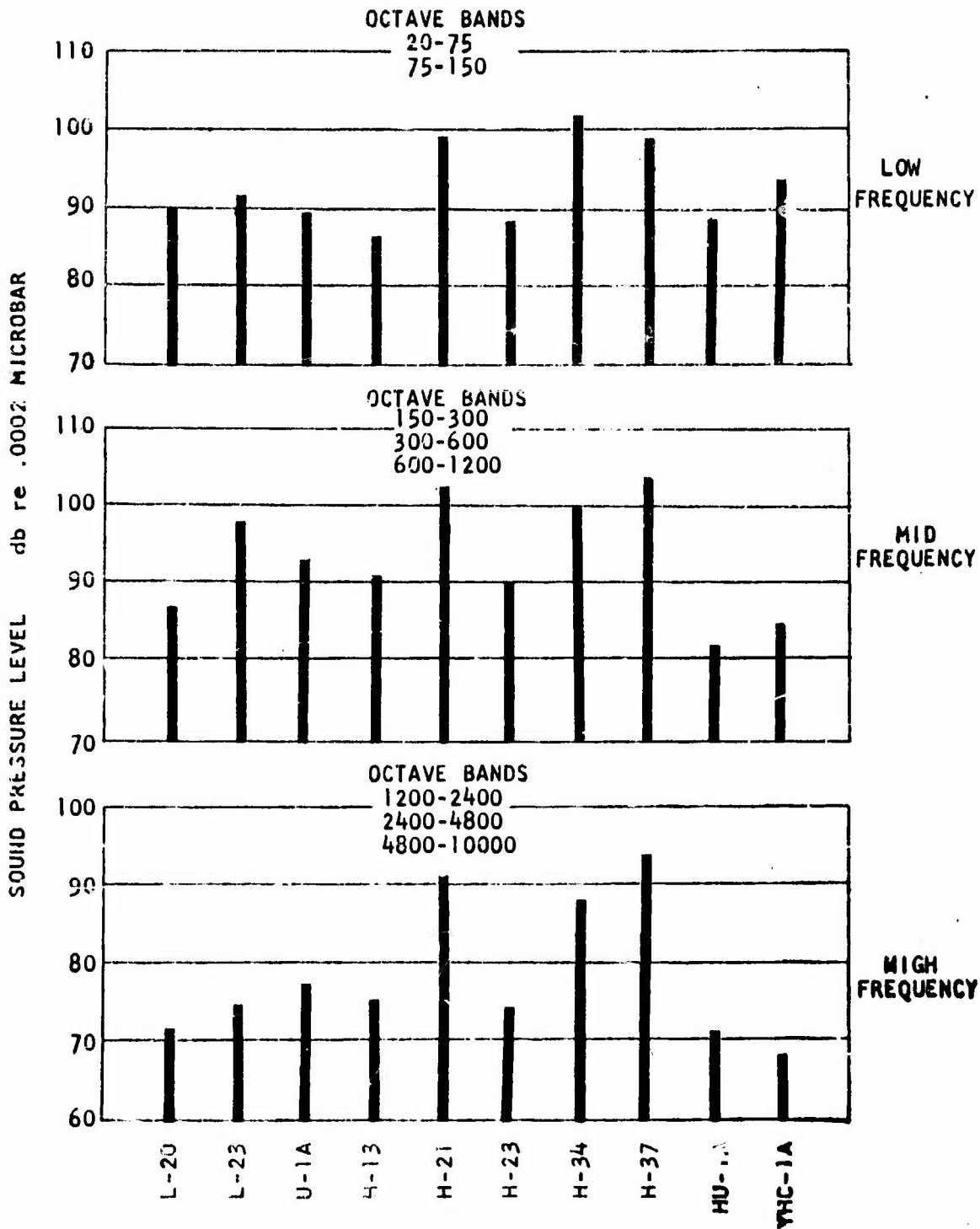

FIGURE 154

APPENDIX II

DATA SHEETS

OCTAVE-BAND ANALYSIS SHEET

Analyzed By _____ DATE _____

LOC.	COND.	Octave-Band Pressure Levels Re. .0002 microbar								
		20-75	75-150	150-300	300-600	600-1200	1200-2400	2400-4800	above 4800	
1	GROUND RUN	88	98	96	91	86	80	75	72	
2		89	97	96	89	84	79	73	74	
3		96	97	95	89	83	80	74	73	
4		99	98	94	89	81	79	73	69	
5		93	96	94	86	81	76	68	65	
6		100	92	87	78	67	60	51	47	
7		95	93	88	86	82	78	71	69	
8		98	96	94	94	94	87	79	73	
9		96	97	93	92	91	86	79	74	
10		86	96	92	92	90	86	80	76	
11		91	95	94	92	89	84	78	73	
12		88	95	96	91	88	86	79	73	
13		103	104	103	96	89	87	84	82	
14		109	105	99	90	86	80	69	65	
15		102	104	102	99	103	98	90	80	
16		95	103	103	100	97	89	82	80	
17		84	91	89	82	72	69	66	63	
18	GROUND RUN	83	91	91	83	76	67	63	60	

REV

OCTAVE-BAND ANALYSIS SHEET

Analyzed By _____ DATE _____

LOC.	COND.	Octave-Band Pressure Levels Re. .0002 microbar								
		20-75	75-150	150-300	300-600	600-1200	1200-2400	2400-4800	above 4800	
19	GROUND RUN		91	94	91	86	79	72	66	62
20			96	95	92	82	72	68	64	58
21			90	93	91	83	72	71	64	59
22			91	86	79	75	62	55	43	38
23			88	89	87	83	77	70	65	62
24			92	90	87	84	79	75	65	58
25			88	90	86	80	77	72	66	62
26			84	89	85	78	69	63	55	52
27			85	89	87	81	74	71	68	67
28	GROUND RUN		81	90	88	80	74	73	69	66

REV

OCTAVE-BAND ANALYSIS SHEET

Analyzed By _____

DATE _____

LOC.	COND.	Octave-Band Pressure Levels Re. .0002 microbar								
		20-75	75-150	150-300	300-600	600-1200	1200-2400	2400-4800	above 4800	
1	GROUND RUN	95	104	110	103	96	86	79	72	
2		95	98	107	106	96	86	78	71	
3		99	103	110	106	100	93	81	72	
4		94	100	110	104	90	83	71	70	
5		88	96	99	91	82	79	69	62	
6		100	96	90	87	78	71	62	52	
7		90	98	104	99	92	83	73	64	
8		98	102	110	106	98	85	76	67	
9		96	100	108	106	95	83	71	63	
10		96	105	110	104	95	82	73	67	
11		96	104	108	101	94	87	77	71	
12		96	102	106	99	92	88	79	72	
13		107	110	118	112	105	99	88	80	
14		113	109	104	102	92	85	75	65	
15		105	108	115	111	99	91	81	75	
16		96	108	108	105	100	94	85	77	
17		90	97	102	95	80	73	66	60	
18	GROUND RUN	84	95	100	94	80	72	65	60	

REV

OCTAVE-BAND ANALYSIS SHEET

Analyzed By _____ DATE _____

LOC.	COND.	Octave-Band Pressure Levels Re. .0002 microbar								
		20-75	75-150	150-300	300-600	600-1200	1200-2400	2400-4800	above 4800	
19	GROUND RUN	91	95	100	98	90	82	74	66	
20	↑	87	97	102	95	89	82	73	64	
21		83	91	96	90	83	80	73	64	
22		90	86	81	70	61	54	42	35	
23		78	88	88	80	66	61	52	44	
24		89	92	100	93	86	76	67	58	
25		85	92	100	98	86	72	60	49	
26		86	95	102	96	85	74	68	63	
27	↓	88	96	101	91	80	75	69	65	
28	GROUND RUN	82	98	92	88	81	76	71	64	

REV

OCTAVE-BAND ANALYSIS SHEET

Analyzed By _____

DATE _____

LOC.	COND.	Octave-Band Pressure Levels Re. .0002 microbar								
		20-75	75-150	150-300	300-600	600-1200	1200-2400	2400-4800	above 4800	
1	HOVER	95	97	97	94	88	84	76	71	
2	↑	96	98	97	95	86	80	73	68	
3		95	101	97	95	87	78	72	68	
4		96	98	96	97	90	84	76	73	
5		91	99	95	92	84	82	77	65	
6		103	99	92	83	72	65	59	52	
7		87	97	90	90	82	80	71	62	
8		92	99	98	96	92	86	78	73	
9		93	102	99	93	86	79	72	66	
10		87	98	97	95	92	84	76	67	
11		87	96	95	93	92	85	76	68	
12		84	98	94	91	88	84	76	69	
13		103	107	103	102	91	86	80	74	
14		112	109	107	96	87	80	74	67	
15		101	109	106	103	100	92	83	77	
16		102	105	103	103	96	91	84	77	
17	↓	83	90	89	82	77	75	69	61	
18	HOVER	85	91	91	87	78	72	66	60	

REV

OCTAVE-BAND ANALYSIS SHEET

Analyzed By _____ DATE _____

LOC.	COND.	Octave-Band Pressure Levels Re. .0002 microbar								
		20-75	75-150	150-300	300-600	600-1200	1200-2400	2400-4800	above 4800	
19	HOVER	88	94	89	88	79	71	65	60	
20	↑	89	91	87	85	76	74	67	60	
21		86	92	87	81	71	68	58	49	
22		78	80	72	63	54	50	45	38	
23		84	91	84	80	70	63	56	48	
24		88	90	89	84	75	68	59	53	
25		78	86	85	81	76	68	61	54	
26		84	90	89	81	73	68	61	53	
27	↓	80	88	89	82	76	75	71	64	
28	HOVER	80	92	87	81	79	77	73	65	

REV

OCTAVE-BAND ANALYSIS SHEET

Analyzed by _____

DATE _____

LOC.	COND.	Octave-Band Pressure Levels Re. .0002 microbar								
		20-75	75-150	150-300	300-600	600-1200	1200-2400	2400-4800	above 4800	
1	HOVER		81	85	90	84	82	80	76	65
2	↑		84	88	90	85	83	82	76	67
3			86	89	90	86	82	81	77	72
4			87	91	95	89	87	83	79	73
5			84	92	100	94	87	83	76	70
6			83	93	101	96	85	78	70	63
7			84	91	100	92	87	85	77	70
8			85	90	96	89	89	88	85	77
9			86	88	91	84	82	84	80	73
10			84	87	89	85	83	79	76	68
11			80	82	89	82	81	83	76	67
12			79	85	93	88	75	70	62	56
13			93	95	96	94	89	89	86	79
14			94	100	108	105	94	90	82	74
15			95	96	98	94	91	90	86	79
16			90	90	98	91	85	80	72	66
17	↓		74	78	83	74	64	63	58	51
18	HOVER		77	81	82	73	65	65	59	52

KEY

OCTAVE-BAND ANALYSIS SHEET

Analyzed By _____

DATE _____

LOC.	COND.	Octave-Band Pressure Levels Re. .0002 microbar								
		20-75	75-150	150-300	300-600	600-1200	1200-2400	2400-4800	above 4800	
1	HOVER	109	108	105	103	94	91	84	78	
2		110	109	105	102	95	88	81	75	
3		111	109	106	105	95	86	80	74	
4		110	109	106	99	94	87	81	75	
5		107	106	103	99	90	87	82	76	
6		102	105	106	102	93	93	88	81	
7		106	110	105	98	92	87	81	74	
8		109	111	106	99	90	85	79	71	
9		110	109	105	98	89	82	76	70	
10		109	111	106	102	96	89	82	75	
11		107	110	108	102	92	88	82	77	
12		106	106	104	100	92	88	82	76	
13		119	116	112	108	100	94	88	81	
14		111	114	114	109	109	103	99	93	
15		117	117	113	104	96	92	86	79	
16		106	109	114	110	102	99	93	88	
17		101	101	98	90	84	80	75	67	
18	HOVER	106	102	100	96	85	79	73	67	

OCTAVE-BAND ANALYSIS SHEET

Analyzed By _____ DATE _____

LOC.	COND.	Octave-Band Pressure Levels Re. ,0002 microbar								
		20-75	75-150	150-300	300-600	600-1200	1200-2400	2400-4800	above 4800	
19	HOVER	100	98	95	90	82	76	69	62	
20	↑	106	103	99	88	83	78	72	65	
21		101	99	96	84	83	80	73	64	
22		95	98	97	86	87	83	75	68	
23		99	103	99	88	83	80	71	62	
24		104	106	101	86	80	75	68	62	
25		101	101	94	87	79	72	67	60	
26		105	106	99	90	82	80	73	69	
27	↓	100	103	101	92	86	80	76	70	
28	HOVER	93	98	96	89	83	79	71	64	

REV

OCTAVE-BAND ANALYSIS SHEET

Analyzed By _____

DATE _____

LOC.	COND.	Octave-Band Pressure Levels Re. .0002 microbar								
		20-75	75-150	150-300	300-600	600-1200	1200-2400	2400-4800	above 4800	
1	HOVER		85	87	91	86	82	77	70	63
2	↑		88	90	95	89	86	81	73	67
3			90	93	96	91	87	82	77	73
4			88	93	100	93	87	81	77	69
5			86	93	102	97	86	80	72	64
6			90	97	105	100	89	81	72	67
7			89	95	105	99	92	88	81	73
8			88	92	101	94	92	90	85	78
9			88	93	98	92	90	88	83	75
10			88	92	96	90	89	84	79	69
11			85	87	91	86	84	80	76	67
12			85	86	91	84	79	75	67	60
13			96	99	106	99	97	92	88	83
14			97	103	110	104	90	88	79	71
15			98	100	106	99	96	93	87	82
16			95	96	102	98	93	88	81	73
17	↓		81	83	86	79	75	73	66	57
18	HOVER		82	85	89	79	75	73	66	57

REV

OCTAVE-BAND ANALYSIS SHEET

Analyzed By _____

DATE _____

LOC.	COND.	Octave-Band Pressure Levels Re. .0002 microbar								
		20-75	75-150	150-300	300-600	600-1200	1200-2400	2400-4800	above 4800	
19	HOVER	83	87	91	83	82	77	68	61	
20	↑	81	86	94	86	79	76	70	62	
21		82	89	97	90	78	75	66	59	
22		80	87	95	90	77	71	65	53	
23		82	87	94	88	81	80	77	69	
24		74	79	85	76	71	72	68	61	
25		83	87	91	82	78	76	70	67	
26		81	85	89	81	78	77	71	62	
27	↓	80	82	87	80	79	79	74	62	
28	HOVER	79	82	82	76	64	71	62	53	

REV

OCTAVE-BAND ANALYSIS SHEET

Analyzed By _____

DATE _____

LOC.	COND.	Octave-Band Pressure Levels Re. .0002 microbar								
		20-75	75-150	150-300	300-600	600-1200	1200-2400	2400-4800	above 4800	
1	HOVER		98	99	100	93	86	84	79	70
2	↑		98	97	97	89	85	79	74	67
3			97	96	95	90	88	81	74	67
4			100	98	96	90	90	82	74	66
5			98	94	94	91	89	83	74	68
6			100	98	95	91	85	80	77	70
7			95	103	101	94	92	85	77	70
8			98	103	99	90	86	78	72	64
9			100	106	103	94	88	82	76	70
10			101	106	105	98	94	85	78	70
11			99	106	105	98	87	87	81	75
12			95	102	100	95	84	82	80	76
14			97	106	105	103	95	93	87	81
15			116	115	112	104	103	94	87	78
16			102	109	109	102	98	94	90	85
17			89	92	90	82	74	71	67	59
18	↓		86	89	87	77	72	66	60	54
19	HOVER		85	90	87	79	78	70	63	55

REV

OCTAVE-BAND ANALYSIS SHEET

Analyzed By _____

DATE _____

LOC.	COND.	Octave-Band Pressure Levels Re. .0002 microbar								
		20-75	75-150	150-300	300-600	600-1200	1200-2400	2400-4800	above 4800	
20	HOVER	84	91	88	78	82	76	67	58	
21	↑	84	87	85	78	80	77	69	60	
22		86	90	85	76	72	69	64	55	
23		90	99	95	87	84	78	71	58	
24		90	98	95	84	82	76	67	54	
25		89	96	91	80	71	68	60	56	
26		89	98	94	85	78	73	64	56	
27	↓	89	98	94	85	78	73	64	56	
28	HOVER	88	97	94	87	76	73	70	65	

REV

OCTAVE-BAND ANALYSIS SHEET

Analyzed By _____

DATE _____

LOC.	COND.	Octave-Band Pressure Levels Re. .0002 microbar								
		20-75	75-150	150-300	300-600	600-1200	1200-2400	2400-4800	above 4800	
1	HOVER	107	101	103	99	91	85	78	69	
2	↑	105	100	105	99	90	86	79	79	
3		104	103	107	101	92	86	78	68	
4		103	104	106	100	92	86	80	69	
5		100	101	102	99	90	82	75	63	
6		106	103	102	98	92	81	78	67	
7		108	105	107	103	99	92	84	72	
8		104	104	103	105	102	98	90	81	
9		108	105	106	103	103	98	91	80	
10		101	102	105	98	94	89	79	69	
11		98	96	100	95	88	84	76	68	
12		101	98	99	94	89	83	76	66	
17		91	93	96	89	86	80	74	66	
18		92	95	98	89	83	78	71	62	
19		94	97	100	92	84	80	74	66	
20		95	98	97	88	87	86	79	70	
21	↓	93	98	101	92	88	86	80	71	
22	HOVER	94	96	97	91	91	86	79	71	

REV

OCTAVE-BAND ANALYSIS SHEET

Analyzed By _____

DATE _____

LOC.	COND.	Octave-Band Pressure Levels Re. .0002 microbar								
		20-75	75-150	150-300	300-600	600-1200	1200-2400	2400-4800	above 4800	
1	HOVER		95	90	89	83	80	76	69	70
2	↑		96	91	92	90	82	78	70	69
3			94	95	94	87	82	79	69	69
4			95	92	98	93	82	79	70	67
6			96	94	96	90	82	80	70	63
7			95	94	97	88	87	82	71	66
8			97	92	96	94	85	83	75	71
9			92	91	94	90	81	79	71	65
10			96	90	91	89	82	77	72	70
11			95	92	88	81	80	76	69	68
12			92	91	88	72	73	70	65	67
13			104	102	101	94	91	88	81	81
15			104	99	98	96	91	87	80	77
16			104	100	98	92	89	83	76	74
17			85	84	81	70	72	62	58	52
18			83	84	86	80	70	65	57	54
19	↓		81	85	86	80	72	67	58	53
20	HOVER		82	86	87	79	71	68	60	56

REV

OCTAVE-BAND ANALYSIS

Analyzed By _____

DATE _____

LOC.	COND.	Octave-Band Pressure Levels Re. .0002 microbar								
		20-75	75-150	150-300	300-600	600-1200	1200-2400	2400-4800	above 4800	
21	HOVER	86	85	84	79	73	68	58	52	
22	↑	86	83	80	72	69	66	56	51	
23		87	89	89	79	76	73	62	57	
24		82	86	87	81	75	74	64	58	
25		85	84	83	81	69	57	49	41	
26		82	81	81	77	69	65	55	52	
27	↓	87	87	85	76	75	72	67	67	
28	HOVER	86	86	82	69	70	63	57	54	

REV

OCTAVE-BAND ANALYSIS SHEET

Analyzed By _____ DATE _____

LOC.	COND.	Octave-Band Pressure Levels Re. .0002 microbar								
		30-75	75-150	150-300	300-600	600-1200	1200-2400	2400-4800	above 4800	
1	HOVER	99	98	98	102	90	82	74	83	
2	↑	102	100	102	102	94	87	78	80	
3		99	96	92	91	86	78	68	63	
4		101	100	100	99	91	83	75	69	
5		99	98	97	97	90	82	73	67	
6		99	95	95	97	92	84	76	72	
7		95	95	96	97	91	83	76	73	
8		93	96	95	92	88	81	73	69	
9		98	98	96	96	89	82	72	67	
10		105	101	99	100	92	85	75	73	
11		97	98	97	99	92	86	79	82	
12		101	100	98	100	94	86	76	76	
17		90	88	88	85	83	77	71	76	
18		91	94	93	87	85	79	71	70	
19		93	94	93	88	82	75	67	62	
20		92	92	95	87	84	76	67	59	
21	↓	91	91	91	86	81	74	65	61	
22	HOVER	87	88	89	85	83	76	68	62	

REV

OCTAVE-BAND ANALYSIS SHEET

Analyzed By _____

DATE _____

LOC.	COND.	Octave-Band Pressure Levels Re. .0002 microbar								
		20-75	75-150	150-300	300-600	600-1200	1200-2400	2400-4800	above 4800	
1-1/2	HOVER	103	103	102	88	95	84	78	70	
3	↑	98	101	99	93	91	89	82	74	
4-1/2		106	103	100	98	94	91	85	77	
6		97	103	101	94	94	87	78	67	
7-1/2		104	103	99	94	88	85	78	69	
9		99	99	102	95	88	87	79	73	
10-1/2	↓	97	103	101	88	86	82	75	65	
12	HOVER	98	98	92	85	80	78	71	62	

REV

OCTAVE-BAND ANALYSIS SHEET

Analyzed By _____

DATE _____

LOC.	COND.	Octave-Band Pressure Levels Re. .0002 microbar								
		20-75	75-150	150-300	300-600	600-1200	1200-2400	2400-4800	above 4800	
1	TAKE OFF	85	88	87	93	100	99	95	85	
1	LAND	81	82	85	89	95	87	81	71	
1	TAXI	81	82	82	89	73	66	62	68	
2	TAKE OFF	83	85	84	97	98	97	95	86	
2	LAND	84	84	90	94	97	94	87	77	
3	TAKE OFF	84	87	83	92	98	93	91	82	
3	LAND	86	87	84	88	94	94	95	75	

REV

OCTAVE-BAND ANALYSIS SHEET

Analyzed By _____

DATE _____

LOC.	COND.	Octave-Band Pressure Levels Re. .0002 microbar								
		20-75	75-150	150-300	300-600	600-1200	1200-2400	2400-4800	above 4800	
1		99	108	106	100	99	88	83	81	
2		94	91	88	89	82	75	68	62	
3		89	90	87	84	77	74	68	62	
4		84	84	81	77	70	63	57	47	
5		88	97	94	91	86	79	76	72	
6		85	85	79	75	74	62	56	46	
7		87	93	90	87	86	76	72	69	
8		86	94	90	88	79	72	66	60	
9		83	84	89	83	81	72	68	64	
10		85	83	76	78	71	63	56	45	
11		79	89	85	80	75	69	66	60	
12		83	82	83	77	72	66	61	53	
13		74	84	80	76	73	62	58	49	
14		77	84	80	76	72	65	62	56	
15		74	82	79	76	69	62	55	43	
16		77	77	78	74	66	58	52	40	

REV

OCTAVE-BAND ANALYSIS SHEET

Analyzed By

DATE

LOC.	COND.	Octave-Band Pressure Levels Re. ,0002 microbar								
		20-75	75-150	150-300	300-600	600-1200	1200-2400	2400-4800	above 4800	
1		83	83	84	85	86	87	88		
2		89	88	87	86	85	84	83	82	
3		86	85	84	83	82	81	80	79	
4		87	86	85	84	83	82	81	80	
5		85	84	83	82	81	80	79	78	
6		83	82	81	80	79	78	77	76	
7		81	80	79	78	77	76	75	74	
8		88	87	86	85	84	83	82	81	
9		80	79	78	77	76	75	74	73	
10		80	79	78	77	76	75	74	73	
11		82	81	80	79	78	77	76	75	
12		80	79	78	77	76	75	74	73	
13		77	76	75	74	73	72	71	70	
14		79	78	77	76	75	74	73	72	
15		81	80	79	78	77	76	75	74	
16		78	77	76	75	74	73	72	71	

REV

OCTAVE-BAND ANALYSIS SHEET

Analyzed By _____

DATE _____

LOC.	COND.	Octave-Band Pressure Levels Re. .0002 microbar								
		20-75	75-150	150-300	300-600	600-1200	1200-2400	2400-4800	above 4800	
1		92	102	102	101	96	90	85	86	
2		90	88	92	92	86	82	75	72	
3		87	90	85	87	80	75	68	65	
4		82	85	82	79	71	66	60	52	
5		87	99	99	97	91	84	78	79	
6		82	85	82	78	72	66	59	52	
7		83	96	97	94	87	80	74	76	
8		84	94	92	91	86	80	72	70	
9		86	81	86	88	82	77	69	66	
10		80	83	78	79	72	69	59	54	
11		81	89	90	90	82	76	70	68	
12		79	74	80	80	74	66	59	53	
13		75	81	83	83	73	66	60	54	
14		71	83	85	82	73	66	59	54	
15		72	85	83	80	75	68	60	54	
16		74	81	80	79	74	67	58	49	

REV

OCTAVE-BAND ANALYSIS SHEET

Analyzed By _____

DATE _____

LOC.	COND.	Octave-Band Pressure Levels No. ,0002 microbar								
		20- 75	75- 150	150- 300	300- 600	600- 1200	1200- 2400	2400- 4800	above 4800	
1		90	106	104	96	89	87	81	78	
2		84	94	98	89	83	81	76	69	
3		78	85	86	80	76	72	69	59	
4		74	77	82	77	71	69	63	52	
5		89	99	103	97	88	85	80	76	
6		71	75	80	75	68	66	61	50	
7		80	94	99	91	82	80	76	69	
8		79	87	95	87	79	77	74	65	
9		76	81	86	80	76	72	69	58	
10		73	75	81	72	70	67	62	50	
11		76	89	95	87	79	76	72	64	
12		72	75	78	75	70	66	62	50	
13		69	80	83	77	69	66	62	49	
14		65	77	81	78	67	65	62	49	
15		67	76	82	77	68	64	60	48	
16		65	72	71	72	66	64	59	44	

REV

OCTAVE-BAND ANALYSIS SHEET

Analyzed By _____

DATE _____

LOC.	COND.	Octave-Band Pressure Levels Re. 1000 microbar								
		20-75	75-150	150-300	300-600	600-1200	1200-2400	2400-4800	above 4800	
1		106	108	110	110	109	106	100	98	
2		107	108	110	111	96	95	90	84	
3		100	102	104	105	85	87	82	76	
4		92	94	96	85	80	79	73	68	
5		102	103	104	104	99	105	90	88	
6		90	94	98	85	78	76	72	61	
7		97	98	100	104	99	97	91	88	
8		97	97	103	96	92	89	84	78	
9		98	98	98	94	92	88	83	76	
10		90	93	87	83	80	76	72	61	
11		94	97	103	101	97	94	89	87	
12		92	97	84	87	83	79	74	63	
13		87	88	93	91	88	84	78	70	
14		82	86	93	88	84	81	76	67	
15		82	90	92	90	85	82	75	65	
16		85	94	93	85	82	77	72	61	

REV

OCTAVE-BAND ANALYSIS SHEET

Analyzed By _____

DATE _____

LOC.	COND.	Octave-Band Pressure Levels Re. .0002 microbar								
		20-75	75-150	150-300	300-600	600-1200	1200-2400	2400-4800	>4800	
1		93	104	108	99	83	88	65	75	
2		87	89	90	89	84	81	76	71	
3		79	86	90	85	80	75	70	64	
4		78	79	83	80	77	67	59	58	
5		87	82	91	91	89	86	80	76	
6		72	77	81	77	76	68	62	51	
7		82	95	97	89	84	79	74	70	
8		78	80	80	87	81	76	72	66	
9		79	81	84	82	79	75	70	63	
10		75	78	85	78	75	68	62	54	
11		79	93	92	85	79	74	70	64	
12		72	75	81	79	74	69	64	53	
13		69	82	82	76	70	66	61	49	
14		68	81	84	78	73	68	62	52	
15		69	82	83	77	72	67	61	51	
16		68	72	80	75	70	65	59	48	

REV

WATER RESOURCES DIVISION

1965

LOG.	COND.	Oeative Band Pressure Levels (Res. ORZ) microbar								
		20-75	75-150	150-300	300-600	600-1200	1200-2400	2400-above 4000	above 4800	
1							97	93	90	90
2							96	94	89	86
3							82	86	81	76
4								74	66	
5							88	94	90	90
6							76	75	71	63
7							85	96	87	86
8							82	90	86	83
9							89	86	82	76
10							77	80	77	70
11							89	86	83	80
12							87	79	73	64
13							79	75	72	63
14							80	76	70	62
15							87	80	76	63
16							80	72	66	53
17										
18										

REV

A/C - TEST

YHC-1A-3

OCTAVE-BAND ANALYSIS SHEET

Analyzed By _____

DATE _____

LOC.	COND.	Octave-Band Pressure Levels Re. .0002 microbar								
		20-75	75-150	150-300	300-600	600-1200	1200-2400	2400-4800	above 4800	
1		101	104	106	101	89	80	71	73	
2		94	89	95	94	86	77	71	73	
3		92	87	85	86	74	69	62	59	
4		86	80	75	73	72	63	54	46	
5		99	104	102	76	87	79	71	76	
6		86	81	72	76	70	62	51	43	
7		92	95	90	87	77	70	66	67	
8		94	91	91	88	81	75	69	69	
9		91	83	86	84	76	71	64	63	
10		85	78	77	76	73	60	49	44	
11		92	97	97	91	82	73	64	62	
12		85	79	74	76	70	59	46	41	
13		84	86	81	77	68	58	50	45	
14		86	86	78	75	65	61	50	45	
15		84	80	76	77	69	62	53	45	
16		86	79	78	76	69	59	46	40	

REV

OCTAVE-BAND ANALYSIS SHEET

Analyzed By _____

DATE _____

LOC.	COND.		Octave-Band Pressure Levels Re. .0002 microbar							
			20-75	75-150	150-300	300-600	600-1200	1200-2400	2400-4800	above 4800
1	CRUISE	1800 RPM 28.0' MAF 120 MPH	104	112	109	101	90	84	78	73
2	↑	↑	106	112	106	102	92	83	76	71
3			106	112	108	104	93	86	77	71
4			106	111	109	102	93	86	80	75
5			106	113	109	103	93	84	77	70
6			107	114	107	101	91	81	72	69
7			106	113	105	97	89	81	74	70
8			103	107	104	99	90	81	74	68
9			104	112	107	102	91	83	75	71
10			104	113	109	101	90	83	76	71
11			109	110	104	97	90	81	72	67
12			110	109	103	95	87	79	72	67
13			106	105	105	100	89	79	71	65
14			111	109	107	99	89	80	71	65
15			109	109	106	100	91	79	71	65
16			109	110	104	97	86	77	69	64
17	CRUISE	1800 RPM 28.0' MAF 120 MPH	109	110	103	97	85	77	70	65

OCTAVE-BAND ANALYSIS SHEET

Analyzed by _____

DATE _____

LOC.	COND.	Octave-Band Pressure Levels Re. ,0002 microbar								
		20-75	75-150	150-300	300-600	600-1200	1200-2400	2400-4800	above 4800	
18	UP	800 RPM 36.5 MAX	69	78	76	90	86	77	69	65
19	↑		6	04	75	88	85	78	70	65
20	↑		08	04	06	77	81	78	70	65
21	↑		06	05	06	6	69	73	69	64
22	↑		06	10	08	97	87	77	70	65
23	↑		08	04	04	93	88	76	67	64
24	↑		06	12	06	101	89	78	69	65
25	↑		05	0	06	100	87	77	69	64
26	↑		6	5	08	99	90	81	72	65
27	↑		7	2	10	92	93	82	76	66
7	V MAX	36.5 MAX	97	00	0	93	86	79	74	69
1	CHOISE	WINDOWS OFFEN	83	6	15	108	99	94	89	81
4	↑		19	14	14	108	101	95	90	84
7	↑		15	17	10	104	97	90	84	78
9	↓		20	14	16	111	99	92	85	78
10	ERUINE	WINDOWS OFFEN	10	2	18	112	102	95	87	80
7	TAKE OFF	2250 RPM 36.5 MAX	19	7	17	107	97	88	79	76
7	TAKE OFF		19	7	17	104	94	86	78	75

REV

OCTAVE-BAND ANALYSIS SHEET

Analyzed By _____

DATE _____

LOC.	COND.		Octave-Band Pressure Levels Re. .002 microbar							
			20-75	75-150	150-300	300-600	600-1200	1200-2400	2400-4800	above 4800
1	CRUISE	2600 RPM 29.0' MAP 1A-150RTS	100	106	103	97	85	78	75	67
2	↑	↑	102	108	101	99	89	82	81	73
3			101	106	103	101	91	85	82	71
4			97	103	101	96	86	76	75	68
5			97	102	98	95	85	75	72	66
6			96	105	102	98	88	86	86	75
7			97	105	104	99	87	76	72	67
8			94	98	100	95	85	77	76	65
9			94	101	99	97	84	76	72	64
10			95	101	103	99	87	80	75	65
11			97	102	104	97	85	77	73	66
14			97	104	99	99	84	74	71	68
15		↓	98	104	99	97	82	72	67	59
17	↓	AFT CURTAINS CLOSED IN	97	103	107	100	86	75	70	60
18	CRUISE	FRONT OF WINDOWS	97	106	108	97	87	75	66	58
7	TAKE OFF	3400 RPM 40.0' MAP	104	115	111	104	96	83	71	65
7	CLIMB OUT	3000 RPM 40.0' MAP	103	112	105	99	87	77	75	70

OCTAVE-BAND ANALYSIS SHEET

Analyzed By _____

DATE _____

LOG.	COND.		Octave-Band Pressure Levels Re. 10002 microbar							
			20-75	75-150	150-300	300-600	600-1200	1200-2400	2400-4800	above 4800
0	TAKE OFF	2200 RPM 24.0 MAP	108	103	100	100	103	93	87	83
6	CLIMB	2220 RPM 30.0 MAP	100	109	108	105	101	92	85	81
1	CRUISE	1750 RPM 28.0 MAP WASCHKTS.	106	109	105	103	97	87	80	75
1	BELOW CRUISE SPEED	WINDOWS OPEN 1750 RPM	108	104	105	105	98	89	81	75
2	CRUISE	2911 MAN. 24.0 MAP KTS.	103	108	108	104	97	88	80	75
2	BELOW CRUISE SPEED	WINDOWS OPEN 1750 RPM	106	124	123	108	108	98	89	83
3	CRUISE	2911 MAN. 25.0 MAP KTS.	104	111	109	105	98	87	79	74
4	↑	↑	102	104	105	103	96	87	80	73
5	↓	↓	102	105	105	104	95	86	80	75
6	CRUISE	↓	101	108	107	103	94	85	79	74
6	BELOW CRUISE SPEED	WINDOWS OPEN 1750 RPM	103	111	107	103	95	87	80	74
6	V-MAX	2900 RPM 30.0 MAP WASCHKTS.	102	110	105	102	97	89	81	77
7	CRUISE	↑	99	105	105	106	96	89	82	77
	↑	↑	103	107	104	104	98	89	82	76
8	↑	↑	100	106	100	101	94	86	76	71
9	↓	↓	100	105	98	97	90	83	74	70
10	CRUISE	↓	104	101	96	96	89	83	74	70

REV

OCTAVE-BAND ANALYSIS SHEET

Analyzed By _____

DATE _____

LOC.	COND.	Octave-Band Pressure Levels Re. .0002 microbar								
		20-75	75-150	150-300	300-600	600-1200	1200-2400	2400-4800	above 4800	
11	CRUISE		97	107	104	102	91	84	74	70
12	↑		99	106	102	103	91	83	74	71
13			95	101	98	98	90	83	73	69
14			96	96	96	95	89	82	74	69
15			97	100	96	92	88	81	72	68
16			101	110	103	100	90	81	74	70
17			100	110	101	99	88	82	74	70
18			89	96	96	96	88	81	73	67
19			94	96	96	95	88	82	73	67
20			95	100	96	96	86	81	71	65
21			102	102	101	101	88	82	73	67
22			95	102	101	100	90	83	75	68
23			98	100	97	96	88	82	74	65
24			99	98	95	96	88	82	73	66
25			100	98	92	95	89	82	72	65
26	↓		99	99	96	95	89	83	73	65
27	CRUISE		101	99	96	95	88	81	72	64

REV

OCTAVE-BAND ANALYST'S SHEET

Analyzed By _____

DATE _____

LOC.	COND.	Octave-Band Pressure Levels Re. .0002 microbar							
		20-75	75-150	150-300	300-600	600-1200	1200-2400	2400-4800	above 4800
1	CRUISE	111	107	109	100	92	89	83	77
2	↑	110	109	112	104	92	91	82	75
3		111	109	112	102	94	88	84	77
4		109	106	110	101	93	89	82	75
5		110	106	109	100	93	88	82	75
6		112	106	108	101	90	87	80	74
7		115	114	110	109	90	80	79	74
8		113	109	110	100	92	90	80	73
9	↓	112	107	106	99	91	87	81	72
11	CRUISE	114	110	105	101	90	87	80	74
11	LANDING (FLARE)	111	106	108	100	92	89	80	74
11	HOVER	104	108	112	104	94	90	84	76
11	V MAX	113	113	109	101	93	86	79	76

REV

OCTAVE-BAND ANALYSIS SHEET

Analyzed By _____

DATE _____

LOC.	COORD.		Octave-Band Pressure Levels Re. .0002 microbar							
			20-75	75-150	150-300	300-600	600-1200	1200-2400	2400-4800	above 4800
1	CRUISE	2500 RPM IAS: 85KTS	104	105	97	99	96	92	87	80
2	↑		105	99	98	94	95	92	88	80
3			105	106	102	100	103	97	89	76
4			107	111	108	102	111	103	93	79
5			103	106	98	99	101	96	87	80
6			108	115	101	97	103	97	90	78
7			107	114	105	96	98	95	88	75
8			105	109	105	98	99	92	85	74
9			108	108	107	98	97	95	88	77
10			104	106	97	96	99	94	87	76
11			106	110	105	94	99	96	86	78
12			104	110	102	94	94	94	86	77
13			108	114	105	96	94	98	88	82
14			110	114	108	99	99	102	92	87
15			107	111	100	94	94	99	88	82
16	↓		114	120	103	95	93	98	89	83
17	CRUISE		108	115	106	94	93	98	88	80

OCTAVE-BAND ANALYSIS SHEET

Analyzed By _____

DATE _____

LOG.	COND.		Octave-Band Pressure Levels Re. .0002 microbar							
			20-75	75-150	150-300	300-600	600-1200	1200-2400	2400-4800	above 4800
18	CRUISE	2500 RPM IAS 85 KTS	107	111	106	106	100	112	105	96
19	CRUISE	↑	107	111	107	106	101	113	105	96
2	V MAX	2500 RPM IAS 80 KTS	107	105	99	97	99	96	89	84
3	↑	↑	103	109	105	100	106	103	88	78
15			105	109	100	98	100	97	90	79
8			107	108	100	100	95	100	87	78
10			108	106	100	97	96	97	87	81
13			108	112	108	98	95	97	90	83
15			108	110	103	98	98	99	90	82
19	V MAX	↓	109	112	110	106	101	114	108	98
10	TAKE OFF	2700 RPM IAS 60 KTS	107	110	102	97	94	102	89	81
18	POWER CL MB	↑	114	122	110	101	98	107	95	92
19	TAKE OFF POWER CL MB	↓	110	115	108	109	105	122	109	102
10	ROYAL ON DESCENT	ROTOR SPEED 258 RPM IAS 70 KTS	100	95	91	92	94	99	92	86

REV

OCTAVE BAND ANALYSIS SHEET

Analyzed By _____

DATE _____

LOC.	COND.		Octave-Band Pressure Levels Re. .0002 microbar							
			20-75	75-150	150-300	300-600	600-1200	1200-2400	2400-4800	above 4800
1	CRUISE	3150 RPM 220" MAN. 14500 KTS	106	107	112	104	95	91	83	75
2	↑	↑	104	107	118	104	96	91	83	74
3			106	107	110	104	100	94	87	82
4			105	104	111	106	98	90	83	74
5			107	108	112	107	98	92	84	75
6			107	106	110	102	95	89	82	72
7			105	107	111	104	96	90	83	74
8			105	106	116	110	99	92	82	75
9			108	106	104	102	95	89	79	74
10	↓	↓	109	109	117	111	101	92	86	78
11	CRUISE	3150 RPM 220" MAN. 14500 KTS	108	107	111	102	96	91	83	75
11	HOVER	↓	107	108	112	105	97	91	83	74
11	CLIMB OUT	3200 RPM 250" MAN.	103	107	111	105	97	92	83	75
11	V MAX	3200 RPM 270" MAN. 14500 KTS	109	107	110	104	98	92	84	77
11	AUTO- STOP	↑	108	117	109	100	94	88	80	73
11	DESCEN		109	108	112	102	96	90	83	75
11	START- ING FLARE	↓	104	107	114	105	95	89	81	73

OCTAVE-BAND ANALYSIS SHEET

Analyzed by

DATE

LOC.	COND.		Octave-Band Pressure Levels Re. ,0002 microbar							
			20-75	75-150	150-300	300-600	600-1200	1200-2400	2400-4800	above 4800
1	CRUISE	2500 REM 20.5 STAGE TASBUNTS	104	106	107	107	99	95	91	83
2	↑		95	94	107	107	98	95	90	81
3			104	101	107	107	99	92	87	78
4			104	103	107	107	99	92	87	78
5			104	103	107	107	99	92	87	78
6			104	102	107	107	97	93	86	75
7			104	103	107	107	98	94	97	86
8			95	97	107	107	97	95	94	84
9			104	106	107	107	97	97	94	87
10			95	99	107	107	97	94	94	83
11			96	100	107	107	96	94	93	83
12			96	98	107	107	96	91	92	83
13			107	104	107	107	96	92	93	82
14			97	108	107	107	95	92	90	86
15			97	103	107	107	95	93	95	82
16	↓		97	99	107	107	97	92	90	81
17	CRUISE		97	98	108	108	95	90	87	78

REV

OCTAVE BAND ANALYSIS SHEET

Analyzed by _____

DATE _____

LOG.	COND.		Octave-Band Pressure Levels Re. .0002 microbar							
			20-75	75-150	150-300	300-600	600-1200	1200-2400	2400-4800	above 4800
18	CRUISE	2500 RPM 34.5" MAP TAS 80 KTS	107	106	104	101	95	92	90	80
19	↑	↑	06	09	106	99	94	90	89	79
20			07	10	09	10	94	91	88	78
21			104	101	09	104	96	91	89	78
22			103	108	08	102	95	90	88	78
23			104	08	103	100	95	90	86	77
24			09	107	107	98	93	89	85	76
25			06	07	0	103	93	89	86	76
26			05	109	100	101	93	89	86	76
		LEVER RADIC. CH. AFT OF	109	104	09	00	94	89	89	75
1	Y	CARIN COCKPIT	110	108	104	112	106	106	102	95
5	CRUISE	WINDOW OPEN	102	102	09	07	102	98	92	85
5	AUTO- ROTATION DESCEN		110	109	105	101	95	91	84	72
5	HOVER	2500 RPM 34.0" MAP	109	10	104	100	95	92	86	78
18	HOVER	↑	105	106	105	107	97	93	88	81
5	TAFF OFF AND CLIMB		10	07	107	102	97	94	88	80
18	CLIMB OUT	Y	08	06	104	106	99	93	90	82

REV

OCTAVE-BAND ANALYSIS SHEET

Analyzed By _____

DATE _____

LOC.	COORD.		Octave-Band Pressure Levels Re. .0002 microbar							
			20-75	75-150	150-300	300-600	600-1200	1200-2400	2400-4800	above 4800
1	CRUISE	IASBORIS	102	105	104	105	100	96	89	81
2	↑	↑	100	108	100	106	100	96	89	80
3			100	106	107	105	99	95	89	81
4			100	104	107	108	104	97	90	81
5			110	103	105	104	102	96	90	82
6			109	104	108	109	107	104	97	90
7			104	106	110	108	107	103	96	89
8			105	106	112	112	106	103	96	89
9			110	104	111	112	107	105	98	89
10			110	108	112	110	109	107	100	92
11			110	107	115	111	108	107	100	92
12			112	110	110	113	109	106	99	91
13			112	109	111	112	109	107	100	92
14			108	109	111	112	118	114	106	99
15			109	107	112	112	113	111	104	98
16			110	110	117	113	110	108	101	94
17	CRUISE	IASBORIS	111	109	116	116	111	108	102	94

OCTAVE BAND ANALYSIS SHEET

Analyzed By _____

DATE _____

LOC.	COND.		Octave-Band Pressure Levels: Re. 1000 microbar							
			20-75	75-150	150-300	300-600	600-1200	1200-2400	2400-4800	above 4800
18	↑	IAS-80%	108	108	108	108	111	108	103	96
19	↑	↑	109	106	108	108	112	108	102	96
20	↑	↑	109	106	108	108	112	110	103	98
21	↑	↑	109	106	108	108	112	112	107	100
22	↑	↑	107	103	107	106	112	110	104	98
23	↑	↑	106	107	108	106	110	112	107	99
24	↑	↑	108	104	108	108	112	111	105	98
25	↑	↑	109	104	108	107	117	111	106	100
26	↑	↑	108	107	108	108	100	99	92	87
27	↑	↑	108	107	108	108	100	98	92	84
28	↓	↓	108	102	108	107	100	99	91	82
29	↑	IAS-80%	112	110	112	109	106	103	97	89
5	ROTATION		108	104	108	106	102	96	91	84
5	HOVER		104	102	108	104	99	96	91	84
15	HOVER	↑	99	102	106	103	104	102	95	91

REV

OCTAVE BAND ANALYSIS SHEET

Analyzed By _____

DATE _____

LOC.	COND.	Octave-Band Pressure Levels Re. .0002 microbar								
		20- 75	75- 150	150- 300	300- 600	600- 1200	1200- 2400	2400- 4800	above 4800	
1	CRUISE	102	100	107	108	98	87	79	76	
2	↑	108	100	107	106	96	85	79	74	
3		104	100	106	107	94	86	78	73	
4		102	100	105	102	93	83	76	76	
5		104	100	106	103	95	84	76	72	
6		100	09	102	102	96	88	79	77	
7		100	108	105	102	96	86	79	75	
8		100	100	100	103	95	86	79	70	
9		102	100	100	103	97	88	81	71	
10		100	100	100	108	92	89	83	74	
11		105	100	100	102	96	88	82	73	
12		100	100	100	101	97	89	83	74	
14		106	100	105	104	96	88	80	76	
15		105	100	105	105	98	90	84	73	
16		106	100	107	106	99	91	82	69	
17		108	100	107	105	95	88	80	70	
19	CRUISE	109	100	110	105	84	88	81	74	

REV

OCTAVE-BAND ANALYSIS SHEET

Analyzed by _____

DATE _____

LOC.	COND.	Octave-Band Pressure Levels Re. .0002 microbar								
		20-75	75-150	150-300	300-600	600-1200	1200-2400	2400-4800	above 4800	
1	CLIMB OUT	102	96	89	96	92	83	74	63	
1	V-MAX 120KTS IAS	101	94	92	96	96	86	77	67	
1	CRUISE 100KTS IAS	98	93	90	93	97	87	77	65	
1	HOVER	103	97	89	98	96	89	76	66	
1	AUTO- ROTA- TION	99	98	95	90	94	86	75	67	
4A	CRUISE	103	98	92	96	90	78	71	61	
4B	A	103	92	90	94	95	85	72	62	
4C		102	96	93	93	89	79	71	63	
4D		102	100	94	95	92	78	69	62	
4E		104	101	94	90	89	90	72	63	
9A		100	101	98	101	92	79	77	72	
9B		101	96	93	97	90	83	81	76	
9C		101	101	99	102	89	82	82	74	
9D		105	104	99	101	90	80	83	74	
9E		105	106	103	97	89	82	85	74	
11A	CRUISE	105	106	104	109	96	87	90	80	

REV

APPENDIX III

LIST OF INSTRUMENTATION

Microphone - General Radio Condenser Microphone System Type 1551-P1-25 consisting of: Microphone S/N 507, Preamplifier S/N 420.

Calibrating Speaker - General Radio Type 1552-B, S/N 1571.

Transistorized Oscillator - General Radio Type 1307-A, S/N 1571.

Tape Recorder - Ampex Model 601, S/N 8B-128.

Octave Band Analyzer - General Radio Type 1550-A, S/N 703.

Voltmeter A.C. - Ballantine Model 300, S/N 12917.

Audio Oscillator - Hewlett Packard Model 200CD, S/N 3969.

Playback System: Preamplifier - Fisher Chassis 30-C, S/N 10612-A;
Power Amplifier - Fisher Model 100, S/N 130915; Speaker System -
Altec A-7.

Wave Analyzer System: Technical Products Model 625 consisting of:
Oscillator Type TP-626, S/N 161; Analyzer Type TP-627, S/N 187; Power
Integrator Type TP-633, S/N 154.

APPENDIX IV

PILOT OPINION SURVEY

PILOT OPINION SURVEY
AIRCRAFT NOISE LEVELS
CONTRACT DA44-177-TC-562

This questionnaire is part of a scientific study which is being made, by a private organization, to evaluate noise problems associated with Army aircraft. Your opinion is being sought to assist in the selection of realistic noise criteria.

The benefits derived from good noise control far exceed those of hearing preservation alone. Low internal noise reduces pilot fatigue, permits good radio and intercommunication system operation, and generally improves physical response and morale of flight crews. Unnecessarily strict criteria, however, would cause designs which were too heavy and result in undue performance penalties. It is, therefore, most important to consider the opinions of pilots, regarding current aircraft, in setting future design standards.

For each aircraft listed below, please indicate the approximate number of flight hours you have either as a pilot or copilot.

L-20 (Beaver)	_____	hrs.
L-23 (Seminole)	_____	hrs.
U-1A (Otter)	_____	hrs.
H-13 (Sioux)	_____	hrs.
H-21 (Shawnee)	_____	hrs.
H-23 (Raven)	_____	hrs.
H-34 (Choctaw)	_____	hrs.
H-37 (Mojave)	_____	hrs.
HU-1A (Iroquois)	_____	hrs.

You are asked to rate, on the following pages, only those aircraft with which you have indicated personal experience. Space is left at the bottom and reverse side of each sheet for any additional comments you might care to make.

This evaluation was made by _____
(Signature may be omitted if desired)

SAMPLE QUESTION:

Suppose you are being asked to rate the flavor of several brands of canned food:

- I. Place a check mark (✓) on each line opposite your opinion of the flavor.
- II. Draw a circle around those ratings (⊗) which, in your opinion, are not acceptable for Army use.

	VERY POOR	POOR	FAIR	GOOD	EXCELLENT
Brand X	-----	-----	-----	-----	-----
Brand Y	-----	-----	-----	-----	-----
Brand Z	-----	-----	-----	-----	-----
Brand Q	-----	-----	-----	-----	-----
Brand R	-----	-----	-----	-----	-----

Detailed description of the rating scale: The scale consists of five horizontal lines, one for each brand (X, Y, Z, Q, R). Above the lines are five labels: 'VERY POOR', 'POOR', 'FAIR', 'GOOD', and 'EXCELLENT'. Each line has 11 tick marks. Brand X has a checkmark (✓) between 'GOOD' and 'EXCELLENT'. Brand Y has a circled X (⊗) between 'POOR' and 'FAIR'. Brand Z has a checkmark (✓) between 'EXCELLENT' and the next tick mark. Brand Q has a circled X (⊗) between 'VERY POOR' and 'POOR'. Brand R has no marks.

- NOTE:**
1. You may place your mark anywhere on the scale, not just at the indicated ratings.
 2. In the above example Brand R had never been sampled.

SAMPLE QUESTION:

Suppose you are being asked to rate the flavor of several brands of canned food:

- I. Place a check mark (✓) on each line opposite your opinion of the flavor.
- II. Draw a circle around those ratings (⊗) which, in your opinion, are not acceptable for Army use.

	VERY POOR	POOR	FAIR	GOOD	EXCELLENT
Brand X	-----✓-----				
Brand Y	-----⊗-----				
Brand Z	-----✓-----				
Brand Q	-----⊗-----				
Brand R	-----				

- NOTE:**
1. You may place your mark anywhere on the scale, not just at the indicated ratings.
 2. In the above example Brand R had never been sampled.

DIRECTIONS:

1. Rate each aircraft, with which you have had experience, by placing a check mark (✓) on each scale indicating your own opinion.
2. For each aircraft, circle those ratings (⊗) where you feel the noise makes the aircraft unacceptable for Army use. (By "unacceptable" we mean that the condition interferes with operation of the aircraft.)

I. HEARING LOSS & DISCOMFORT

Do noise levels, in the following aircraft, cause you any temporary hearing loss, discomfort, or pain during or after flight?

	VERY SERIOUS	QUITE SERIOUS	FAIRLY SERIOUS	MODERATE DIFFICULTY	SOME DIFFICULTY	NO DIFFICULTY
L-20 (Beaver)					✓	
L-23 (Seminole)						✓
U-1A (Otter)					✓	
H-13 (Sioux)					✓	
H-21 (Shawnee)				✓		
H-23 (Raven)					✓	
H-34 (Choctaw)				✓		
H-37 (Mojave)				✓		
HU-1A (Iroquois)						✓

ADDITIONAL COMMENTS _____

DIRECTIONS:

1. Rate each aircraft, with which you have had experience, by placing a check mark (✓) on each scale indicating your own opinion.
2. For each aircraft, circle those ratings (⊙) where you feel the noise makes the aircraft unacceptable for Army use. (By "unacceptable") we mean that the condition interferes with operation of the aircraft.

2. SPEECH INTERFERENCE

Do you encounter difficulty in conversing with other occupants without the use of intercommunication equipment?

	VERY SERIOUS	QUITE SERIOUS	FAIRLY SERIOUS	MODERATE DIFFICULTY	SOME DIFFICULTY	NO DIFFICULTY
L-20 (Beaver)				✓		
L-23 (Seminole)						✓
U-1A (Otter)				✓		
H-13 (Sioux)				✓		
H-21 (Shawnee)			✓			
H-23 (Raven)				✓		
H-34 (Choctaw)			✓			
H-37 (Mojave)		✓				
HU-1A (Iroquois)						✓

ADDITIONAL COMMENTS _____

DIRECTIONS:

1. Rate each aircraft, with which you have had experience, by placing a check mark (✓) on each scale indicating your own opinion.
2. For each aircraft, circle those ratings (⊙) where you feel the noise makes the aircraft unacceptable for Army use. (By "unacceptable" we mean that the condition interferes with operation of the aircraft.)

3. RADIO COMMUNICATION

Do you encounter difficulty in communicating via either radio or inter-communication equipment?

	VERY SERIOUS	QUITE SERIOUS	FAIRLY SERIOUS	MODERATE DIFFICULTY	SOME DIFFICULTY	NO DIFFICULTY
L-20 (Beaver)					✓	
L-23 (Seminoe)					✓	
U-1A (Otter)					✓	
H-13 (Sioux)					✓	
H-21 (Shawnee)					✓	
H-23 (Raven)					✓	
H-34 (Choctaw)					✓	
H-37 (Mojave)					✓	
HU-1A (Iroquois)					✓	

ADDITIONAL COMMENTS _____

DIRECTIONS:

1. Rate each aircraft, with which you have had experience, by placing a check mark (✓) on each scale indicating your own opinion.
2. For each aircraft, circle those ratings (⊙) where you feel the noise makes the aircraft unacceptable for Army use. (By "unacceptable") we mean that the condition interferes with operation of the aircraft.

4. JUDGEMENT

Does the noise, in the following aircraft, make it more difficult for you to make judgements as quickly and accurately as usual?

	VERY SERIOUS	QUITE SERIOUS	FAIRLY SERIOUS	MODERATE DIFFICULTY	SOME DIFFICULTY	NO DIFFICULTY
L-20 (Beaver)					✓	
L-23 (Seminoe)					✓	
U-1A (Otter)					✓	
H-13 (Sioux)					✓	
H-21 (Shawnee)					✓	
H-23 (Raven)					✓	
H-34 (Choclaw)					✓	
H-37 (Mojave)					✓	
HU-1A (Iroquois)					✓	

ADDITIONAL COMMENTS _____

DIRECTIONS:

1. Rate each aircraft, with which you have had experience, by placing a check mark (✓) on each scale indicating your own opinion.
2. For each aircraft, circle those ratings (⊙) where you feel the noise makes the aircraft unacceptable for Army use. (By "unacceptable") we mean that the condition interferes with operation of the aircraft.

5. COORDINATION

Does the noise, in the following aircraft, make coordination and actual flying more difficult for you?

	VERY SERIOUS	QUITE SERIOUS	FAIRLY SERIOUS	MODERATE DIFFICULTY	SOME DIFFICULTY	NO DIFFICULTY
L-20 (Beaver)						✓
L-23 (Seminole)						✓
U-1A (Otter)						✓
H-13 (Sioux)						✓
H-21 (Shawnee)						✓
H-23 (Raven)						✓
H-34 (Choctaw)						✓
H-37 (Mojave)						✓
HU-1A (Iroquois)						✓

ADDITIONAL COMMENTS _____

DIRECTIONS:

1. Rate each aircraft, with which you have had experience, by placing a check mark (✓) on each scale indicating your own opinion.
2. For each aircraft, circle those ratings (○) where you feel the noise makes the aircraft unacceptable for Army use. (By "unacceptable" we mean that the condition interferes with operation of the aircraft.)

6. FATIGUE

Does the noise in the aircraft make you feel tired?

	ALWAYS	VERY FREQUENTLY	FREQUENTLY	OCCASIONALLY	VERY SELDOM	NEVER
L-2G (Beaver)					✓	
L-25 (Seminole)						✓
U-1A (Otter)					✓	
H-13 (Sioux)					✓	
H-21 (Shawnee)				✓		
H-23 (Raven)				✓		
H-34 (Choctaw)				✓		
H-37 (Mojave)				✓		
HU-1A (Iroquois)						✓

ADDITIONAL COMMENTS

DIRECTIONS:

1. Rate each aircraft, with which you have had experience, by placing a check mark (✓) on each scale indicating your own opinion.
2. For each aircraft, circle those ratings (⊙) where you feel the noise makes the aircraft unacceptable for Army use. (By "unacceptable" we mean that the condition interferes with operation of the aircraft.)

7. NOISE

Rate the following aircraft with regard to your opinion of its general noise environment.

	EXTREMELY NOISY	FAIRLY NOISY	MODERATELY NOISY	MODERATELY QUIET	FAIRLY QUIET	EXTREMELY QUIET
L-20 (Beaver)			✓			
L-23 (Seminole)				✓		
U-1A (Otter)			✓			
H-13 (Sioux)			✓			
H-21 (Shawnee)		✓				
H-23 (Raven)				✓		
H-34 (Choctaw)			✓			
H-37 (Mojave)		✓				
HU-1A (Iroquois)					✓	

ADDITIONAL COMMENTS _____

DIRECTIONS:

1. Rate each aircraft, with which you have had experience, by placing a check mark (✓) on each scale indicating your own opinion.
2. For each aircraft, circle those ratings (⊙) where you feel the noise makes the aircraft unacceptable for Army use. (By "unacceptable" we mean that the condition interferes with operation of the aircraft.)

8. VIBRATION

Rate the following aircraft with regard to your opinion of physical vibration.

	EXTREMELY ROUGH	FAIRLY ROUGH	MODERATELY ROUGH	MODERATELY SMOOTH	FAIRLY SMOOTH	EXTREMELY SMOOTH
L-20 (Beaver)					✓	
L-23 (Seminole)						✓
U-1A (Otter)					✓	
H-13 (Sioux)				✓		
H-21 (Shawnee)			✓			
H-23 (Raven)				✓		
H-34 (Choctaw)				✓		
H-37 (Mojave)			✓			
HU-1A (Iroquois)					✓	

ADDITIONAL COMMENTS _____

APPENDIX V

ARMY INSTALLATIONS SURVEYED

Aircraft noted in the pilot opinion survey were rated by pilots at the following Army bases:

Fort Belvoir, Virginia
Fort Benning, Georgia
Fort Campbell, Kentucky
Fort Carson, Colorado
Fort Devens, Massachusetts
Fort Eustis, Virginia
Fort Hood, Texas
Fort Knox, Kentucky
Fort Lewis, Washington
Fort Ord, California
Fort Riley, Kansas
Fort Rucker, Alabama
Fort Sill, Oklahoma

DISTRIBUTION LIST

Commanding General
United States Continental Army Command
ATTN: Materiel Developments
Fort Monroe, Virginia (2)

The Surgeon General
Department of the Army
Main Navy Building
Washington 25, D. C. (1)

Commanding General
United States Army Infantry Center
ATTN: Transportation Officer
Fort Benning, Georgia (1)

Commandant
U. S. Army Aviation School
ATTN: Combat Developments Office
Fort Rucker, Alabama (2)

President
United States Army Armor Board
Fort Knox, Kentucky (1)

President
United States Army Aviation Board
ATTN: ATBG-DG
Fort Rucker, Alabama (2)

headquarters
U. S. Army Aviation Test Office
ATTN: FTZAT
Edwards Air Force Base, California (1)

Deputy Chief of Staff for Logistics
ATTN: Requirements Division
Department of the Army
Washington 25, D. C. (2)

Deputy Chief of Staff for Military Operations
ATTN: Director of Organization and Training, Doctrines
and Combat Developments Division
Department of the Army
Washington 25, D. C. (1)

Army Research Office
Office of the Chief of Research and Development
ATTN: Research Support Division
Department of the Army
Washington 25, D. C. (1)

DISTRIBUTION LIST (Continued)

Office of Chief of R&D
ATTN: Air Mobility Division
Department of the Army
Washington 25, D. C. (1)

Officer in Charge
U. S. Army Transportation Aviation Field Office
ATTN: ALO - Room 1716
Bureau of Naval Weapons, Department of the Navy
Washington 25, D. C. (1)

Commander
Naval Air Test Center
ATTN: U. S. Army Liaison Officer (1)
ATTN: Technical Library (1)
Patuxent River, Maryland

Commanding General
U. S. Army Ordnance Missile Command
ATTN: ORDKM-T
Redstone Arsenal, Alabama (1)

Deputy President
The Ordnance Board
ATTN: Library
Aberdeen Proving Ground, Maryland (1)

Commanding General
Quartermaster Research and Engineering Command, U. S. Army
ATTN: Technical Library
Natick, Massachusetts (1)

President
U. S. Army Signal Board
Fort Monmouth, New Jersey (1)

Chief of Transportation
ATTN: TCDRD (2)
ATTN: TCAW (1)
ATTN: TCREG (1)
ATTN: TCSOP (1)
ATTN: TCCAD (1)
Department of the Army
Washington 25, D. C.

Commanding Officer
U. S. Army Transportation Combat Development Group
Fort Eustis, Virginia (1)

DISTRIBUTION LIST (Continued)

Commanding General
U. S. Army Transportation Materiel Command
ATTN: TCMAC-APU and Deputy for Aviation Engineering
P. O. Box 209, Main Office
St. Louis 66, Missouri (19)

Commandant
U. S. Army Transportation School
ATTN: Adjutant
Fort Eustis, Virginia (3)

Commanding Officer (1)
U. S. Army Transportation Research Command
ATTN: Executive for Programs (2)
ATTN: Research Reference Center (14)
ATTN: Editorial Branch (2)
ATTN: Aviation Directorate (5)
ATTN: Military Liaison & Advisory Office (4)
ATTN: Deputy Commander for Aviation (1)
Fort Eustis, Virginia

Commanding Officer
U. S. Army Transportation Research Command Liaison Office
ATTN: MCLATS
Wright-Patterson Air Force Base, Ohio (1)

Commander
Air Research & Development Command
ATTN: RDR-LA
Andrews Air Force Base
Washington 25, D. C. (1)

Commander
Wright Air Development Division (WWAD Library) (1)
ATTN: WCLSY-V (1)
Wright-Patterson Air Force Base, Ohio

Hq USAF (AFDFD)
Washington 25, D. C. (1)

Chief of Naval Research
Code 461, Maj. L. C. Robertson
Washington 25, D. C. (1)

Chief, Bureau of Naval Weapons (R-38)
Department of the Navy
Washington 25, D. C. (1)

DISTRIBUTION LIST (Continued)

Commandant
U. S. Army Transportation School
ATTN: Marine Corps Liaison Officer
Fort Eustis, Virginia (1)

Commandant
U. S. Coast Guard
ATTN: Chief, Testing and Development Division
1300 "E" Street, N.W.
Washington 25, D. C. (1)

National Aviation Facilities Experimental Center
ATTN: Library
Atlantic City, New Jersey (1)

National Aeronautics and Space Administration
ATTN: Bertram A. Mulcahy
Assistant Director for Technical Information
1520 H Street, N.W.
Washington 25, D. C. (2)

British Joint Services Mission (Army Staff)
ATTN: Lt. Col. R. J. Wade, RE
DAQMG (Mov & Tn)
3100 Massachusetts Avenue, N. W.
Washington P, D. C. (3)

Commander
Armed Services Technical Information Agency
ATTN: TIPCR
Arlington Hall Station
Arlington 12, Virginia (10)

Office of Technical Services
Acquisition Section
Department of Commerce
Washington 25, D. C. (2)

Librarian
Langley Research Center
National Aeronautics & Space Administration
Langley Field, Virginia (3)

Ames Research Center
National Aeronautics and Space Agency
ATTN: Library
Moffett Field, California (1)

DISTRIBUTION LIST (Continued)

National Aeronautics & Space Administration
Lewis Research Center
ATTN: Library
21000 Brookpark Road
Cleveland 35, Ohio (1)

Dr. C. B. Cambrell, Chairman
Department of Industrial Engineering
Arizona State University
Tempe, Arizona (1)

Douglas Aircraft Company, Incorporated
El Segundo, California
ATTN: Advanced Design Section (1)

National Aircraft Noise Abatement Council
Room 413, Associations Building
1145 19th Street, N.W.
ATTN: Jack R. Cram, President
Washington 6, D. C. (1)

Bell Helicopter Company
Fort Worth, Texas (1)

Doak Aircraft Company, Incorporated
22309 South Western Avenue
Torrance, California (1)

Hiller Aircraft Corporation
Palo Alto, California (1)

Sikorsky Aircraft Division
United Aircraft Corporation
Stratford, Connecticut (1)

Chief, Aviation Medicine Division
United States Army Hospital
Fort Rucker, Alabama (1)

Commanding Officer
U. S. Army Medical Research & Development Command
ATTN: Neuropsychiatry & Psychology Branch
Washington 25, D. C. (1)

Commanding General
U. S. Army Quartermaster Research & Engineering Command
ATTN: Environmental Protection Research Division
Natick, Massachusetts (1)

DISTRIBUTION LIST (Continued)

Director
National Aeronautical Space Administration
Langley Research Center
ATTN: Mr. Harvey Hubbard
Hampton, Virginia (1)

Chief of Research & Development
Office, Chief of Staff
Department of the Army
ATTN: Executive Secretary, Army Scientific Panel
Washington 25, D. C. (1)

Engineering Data Services
North American Aviation Incorporated
4300 East 5th Avenue
Columbus 16, Ohio
ATTN: RFD 30184 (1)

Chief
U. S. Army R&D Liaison Group (9851 DU)
ATTN: USATRECOM Liaison Officer
APO 757, New York, New York

Director
Human Resources Research Office
Washington 7, D. C. (1)

U. S. Army Transportation Research Command Liaison Office
Airborne & Electronic Board
Fort Bragg, North Carolina (1)

President
U. S. Army Transportation Board
Fort Eustis, Virginia (1)

Vertical Division, The Boeing Company
Aircraft Division
10000 North East 10th Street
Seattle, Washington 98148
Telephone: (206) 426-4000
Fax: (206) 426-4001
Internet: http://www.boeing.com
E-mail: boeing@boeing.com

Vertical Division, The Boeing Company
Aircraft Division
10000 North East 10th Street
Seattle, Washington 98148
Telephone: (206) 426-4000
Fax: (206) 426-4001
Internet: http://www.boeing.com
E-mail: boeing@boeing.com

Vertical Division, The Boeing Company
Aircraft Division
10000 North East 10th Street
Seattle, Washington 98148
Telephone: (206) 426-4000
Fax: (206) 426-4001
Internet: http://www.boeing.com
E-mail: boeing@boeing.com

Vertical Division, The Boeing Company
Aircraft Division
10000 North East 10th Street
Seattle, Washington 98148
Telephone: (206) 426-4000
Fax: (206) 426-4001
Internet: http://www.boeing.com
E-mail: boeing@boeing.com

Vertical Division, The Boeing Company
Aircraft Division
10000 North East 10th Street
Seattle, Washington 98148
Telephone: (206) 426-4000
Fax: (206) 426-4001
Internet: http://www.boeing.com
E-mail: boeing@boeing.com

Vertical Division, The Boeing Company
Aircraft Division
10000 North East 10th Street
Seattle, Washington 98148
Telephone: (206) 426-4000
Fax: (206) 426-4001
Internet: http://www.boeing.com
E-mail: boeing@boeing.com

