

UNCLASSIFIED

AD. 269 348

*Reproduced
by the*

**ARMED SERVICES TECHNICAL INFORMATION AGENCY
ARLINGTON HALL STATION
ARLINGTON 12, VIRGINIA**



UNCLASSIFIED

NOTICE: When government or other drawings, specifications or other data are used for any purpose other than in connection with a definitely related government procurement operation, the U. S. Government thereby incurs no responsibility, nor any obligation whatsoever; and the fact that the Government may have formulated, furnished, or in any way supplied the said drawings, specifications, or other data is not to be regarded by implication or otherwise as in any manner licensing the holder or any other person or corporation, or conveying any rights or permission to manufacture, use or sell any patented invention that may in any way be related thereto.

BSC29064

Copy No. _____

CATALOGED BY ASTIA
AS AD NO. 269348

269 348



NOT
6-1-68

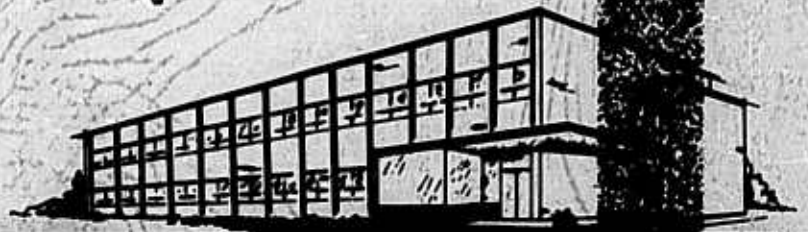

THE *Bendix* CORPORATION

BENDIX SYSTEMS DIVISION • ANN ARBOR, MICHIGAN

ASTIA
RECORDED
JAN 15 1962
RECEIVED
TIPDS

SKYSCRAPER Airborne Instrumentation

System Laboratory Tests

BSR-604

1 December 1961

AFCRL 1085

Contract No. AF 19(604)-6129

Project No. 4904

Task No. 4904-2

ARPA Order 30-61

Scientific Report No. 3

**Prepared
for**

**GEOPHYSICS RESEARCH DIRECTORATE
AIR FORCE CAMBRIDGE RESEARCH LABORATORIES
OFFICE OF AEROSPACE RESEARCH
UNITED STATES AIR FORCE
BEDFORD, MASSACHUSETTS**

**BENDIX SYSTEMS DIVISION
OF
THE BENDIX CORPORATION
Ann Arbor, Michigan**

NOTICES

Requests for additional copies by Agencies of the Department of Defense, their contractors, and other Government agencies should be directed to the:

**ARMED SERVICES TECHNICAL INFORMATION AGENCY
ARLINGTON HALL STATION
ARLINGTON 12, VIRGINIA**

Department of Defense contractors must be established for ASTIA services or have their "need-to-know" certified by the cognizant military agency of their project or contract.

All other persons and organizations should apply to the:

**U. S. DEPARTMENT OF COMMERCE
OFFICE OF TECHNICAL SERVICES
WASHINGTON 25, D. C.**

**LIST OF SCIENTISTS AND ENGINEERS
WHO CONTRIBUTED TO THIS REPORT**

P. Hasell,	System Project Engineer
R. Blythe,	Radiation-Measuring Subsystem Scientist
F. Benning, *	Optical Tracking Subsystem Engineer
G. Johnston,	Data Handling Subsystem Engineer
D. Lewis,	Electrical Engineer
R. Drake,	Physicist
D. Kucera,	Electrical Engineer
R. Kistler,	Electrical Engineer
R. Flack, *	Electrical Engineer
R. Cuny,	Optical Designer

* Employed at Space Technology Laboratories, Inc., Canoga Park Division, subcontractor for design and fabrication of the optical tracking subsystem

PREVIOUS PUBLICATIONS UNDER SPONSORSHIP OF THIS CONTRACT

1. **Bendix Systems Division, "SKYSCRAPER Airborne Radiation-Measuring System Quarterly Status Report No. 1," BSR-225, 1 December 1959 - 29 February 1960 (SECRET).**
2. **Bendix Systems Division, "SKYSCRAPER Airborne Radiation-Measuring System Preliminary Design Study Report," BSR-270, 1 December 1959 - 31 May 1960 (SECRET).**
3. **Bendix Systems Division, "SKYSCRAPER Airborne Instrumentation System Final Design Report," BSR-440, 28 February 1961 (SECRET).**
4. **Bendix Systems Division, "SKYSCRAPER Airborne Radiation-Measuring System Cavity Temperature and Air Flow Control Analysis," BSR-445, February 1961 (UNCLASSIFIED).**
5. **An Airborne Spectroradiometer, August 1960, Presented in December 1960 Issue of Journal of the Optical Society of America, Volume 50, Number 12, pp 1187-1192 (UNCLASSIFIED).**
6. **Scan Pattern Analysis With Application to SKYSCRAPER, ITM-62, 1 June 1960, Presented on 25 October 1960 in Baltimore, Maryland at 7th East Coast Conference, IRE (UNCLASSIFIED).**

TABLE OF CONTENTS

	<u>Page</u>
1. INTRODUCTION	1-1
2. LABORATORY TESTS OF SYSTEM	2-1
2.1 ELECTRICAL AND MECHANICAL MATING	2-1
2.2 FUNCTIONAL OPERATION	2-4
3. RADIATION MEASURING SYBSYSTEM TESTS	3-1
3.1 OBJECTIVES	3-1
3.2 METHODS AND RESULTS	3-2
3.2.1 Alignment of Spectroradiometer With Tracker	3-2
3.2.2 Foreoptics	3-4
3.2.3 Electronics	3-6
3.2.4 Mechanical Components and Controls	3-11
3.2.5 Spectrometers	3-14
3.2.6 Radiometers	3-29
4. OPTICAL TRACKING SUBSYSTEM TEST REPORT	4-1
4.1 10" OPTICS AND SLIT MIRROR TESTS	4-1
4.2 SERVO SYSTEM TESTS	4-11
4.2.1 Track Mode	4-11
4.2.2 Acquisition Mode	4-14
4.2.3 Search Mode	4-15
4.3 SENSITIVITY TEST	4-15
4.4 SUBSYSTEM TESTING WITH ALL UNITS ON PLATFORM	4-18
4.4.1 Search Loop Stability Tests	4-18
4.4.2 Track and Acquisition Loop Stability Tests	4-19
4.4.3 Tracking Accuracy and Repeatability	4-19
4.4.4 Search Loop Frequency Response	4-20
4.4.5 Multiple Target Tests	4-20
4.4.6 Dynamic Tests of System	4-23

TABLE OF CONTENTS (CONT.)

	<u>Page</u>
5. DATA HANDLING SUBSYSTEM TESTS	5-1
5.1 COMPUTER INPUT-OUTPUT SERVO UNITS	5-1
5.2 POINTING COMPUTER	5-4
5.3 TIME GENERATION UNIT	5-4
5.4 DATA RECORDING UNIT	5-4
5.5 SYSTEM TESTS	5-8
5.6 ASSOCIATED AIRBORNE PLATFORM EQUIPMENT	5-11
5.6.1 Manual Optical Director	5-11
5.6.2 Pilot's Display	5-13
5.6.3 Attitude Gyro and Controls	5-13
APPENDIX A SKYSCRAPER Test Plans	A-1
APPENDIX B SKYSCRAPER Test Specification	B-1
APPENDIX C SKYSCRAPER Optical Tracking Subsystem Test Plan	C-1

LIST OF ILLUSTRATIONS

<u>Figure</u>	<u>Title</u>	<u>Page</u>
1-1	Model of SKYSCRAPER System	1-2
2-1	Electronic Rack Assembly	2-2
2-2	Rigid Platform Assembly	2-3
2-3	5° Diameter Rosette Search Pattern	2-6
2-4	Boresight Film Strips of System Tracking Aircraft Landing Light, 16 Flames/sec, ~ 12° FOV	2-7/2-8
3-1	Spectroradiometer Mounted on Tracker	3-3
3-2	Spectroradiometer Optics	3-5
3-3	Electronics for Spectroradiometer	3-7
3-4	Block Diagram of Signal Electronics	3-8
3-5	Signal Amplifier Bandwidths for Spectroradiometer	3-10
3-6	Short Wavelength Spectra	3-15/3-16
3-7	Short Wavelength Spectrometer Calibration	3-17
3-8	Intermediate Wavelength Spectra	3-19/3-20
3-9	Intermediate Wavelength Spectrometer Calibration	3-22
3-10	Interference Filter Spectrum	3-23
3-11	Long Wavelength Spectra	3-25/3-26
3-12	Long Wavelength Spectrometer Calibration	3-28
3-13	Photomultiplier Noise Equivalent Power	3-30
3-14	Radiometer Filter Transmissions	3-32
4-1A	Slit Mirror Elevation Angle vs Tracker Elevation Angle	4-3
4-1B	Slit Mirror Azimuth Angle vs Tracker Azimuth Error Angle	4-4
4-2A	S/M Elevation Angle vs Output Elevation Position Voltage	4-5
4-2B	S/M Azimuth Angle vs Output Azimuth Position Voltage	4-6
4-3A	Polar Error Signal (Track) vs Tracker Elevation Error Angle	4-7
4-3B	Polar Error Signal (Track) vs Tracker Azimuth Error Angle	4-8
4-4A	Elevation Position Error Signal vs Elevation Tracker Error Angle	4-9

LIST OF ILLUSTRATIONS (CONT.)

<u>Figure</u>	<u>Title</u>	<u>Page</u>
4-4B	Azimuth Position Error Signal vs Azimuth Tracker Error Angle	4-10
4-5A	Polar Error Signal (Acq.) vs Tracker Elevation Error Angle	4-12
4-5B	Polar Error Signal (Acq.) vs Tracker Azimuth Error Angle	4-13
4-6A	Elevation Error Angle vs Angular Frequency for Various Input Angular Excursions (Search Mode)	4-21
4-6B	Azimuth Error Angle vs Angular Frequency for Various Input Angular Excursions (Search Mode)	4-22
4-7	Wide Angle Boresight Camera View of Daylight Tracking	4-24
4-8	Narrow Field Boresight Camera View of Spectrometer Entrance Slit During Daylight Tracking	4-25
5-1	Computer I/O Unit	5-2
5-2	CP-209	5-5
5-3	Time Generator	5-6
5-4	Manual Optical Director	5-12
5-5	Pilot's Display	5-14

LIST OF TABLES

<u>Table</u>	<u>Title</u>	<u>Page</u>
3-1	Overall Amplifier Gain at 1/2 Scan Per Minute	3-9
5-1	Pointing Computer Servo Response Data	5-7
5-2	Computer/Tracker Servo Response Data	5-10
5-3	Azimuth Calibration, Computer Input vs Panel Digital Readout	5-16

SECTION 1

INTRODUCTION

This document is the third technical report on the SKYSCRAPER airborne instrumentation system, and marks the completion of fabrication, assembly, and laboratory test of the equipment. The SKYSCRAPER airborne instrumentation system was described in the Final Design Report, BSR-440, February 1961. (It is anticipated that the reader of this report is familiar with BSR-440; consequently, this document discusses test results without describing the system itself.)

The KC-135 aircraft is presently being modified by the Hayes Corporation of Birmingham, Alabama. Figure 1-1 illustrates how the equipment will be arranged in the aircraft after installation during December 1961. The system will undergo functional checkout at the Hayes Corporation during January 1961, and will be delivered to the Air Force early in February.

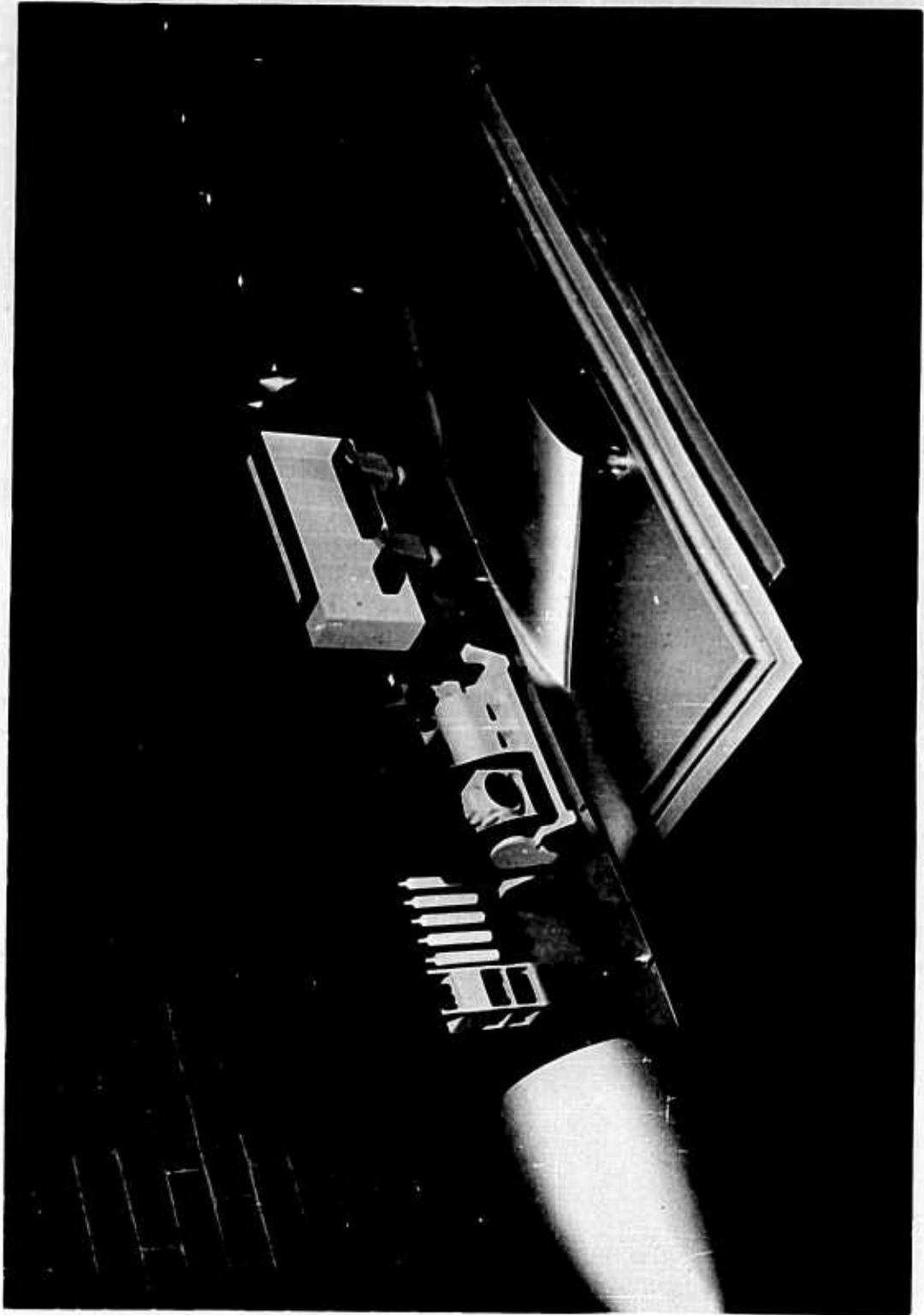

Figure 1-1 Model of SKYSCRAPER System

SECTION 2

LABORATORY TESTS OF SYSTEM

The prime objective of the system laboratory tests was to confirm the electrical and mechanical mating of equipments, and to establish the functional operation of the integrated partial¹ system prior to the equipment installation in the modified aircraft. The secondary goal was to achieve specified performance from the equipment undergoing tests. The primary objective was achieved completely, and the secondary one partially.

2.1 ELECTRICAL AND MECHANICAL MATING

Most of the laboratory test time was spent in obtaining satisfactory mating and alignment of components, subassemblies and assemblies. Extreme care was taken to complete the checkout of each subassembly before it was integrated with others. Each new combination of subassemblies was operationally checked as the assembly grew so that discrepancies could be quickly isolated and repaired. Thus, by the time an assembly was completed, its functional test required little additional effort.

Many components required rework, either by the supplier or Bendix, because of faulty operation or faulty mounting provisions. Most of the difficulty was with nonstandard, one-of-a-kind type components especially fabricated for the SKYSCRAPER system. A few of the optical components were acceptable for inclusion in the system only because they were the best available under the program schedule. It would be desirable to replace some of these components whenever the opportunity arises in some later phase of the program. However, all components were successfully mated, both mechanically and electrically (see Figures 2-1 and 2-2).

Figure 2-1 shows the front panel and operator positions for six of the seven racks of electronics which comprise the SKYSCRAPER system. The seventh rack (containing the optical tracker electronics) is shown in the center background of Figure 2-2. It will be the rearmost part of the longitudinal seven rack assembly in the aircraft. The spectroscopist's position

¹The complete SKYSCRAPER System includes a modified KC-135 aircraft and associated equipment which will be operated in support of the partial system undergoing laboratory tests.

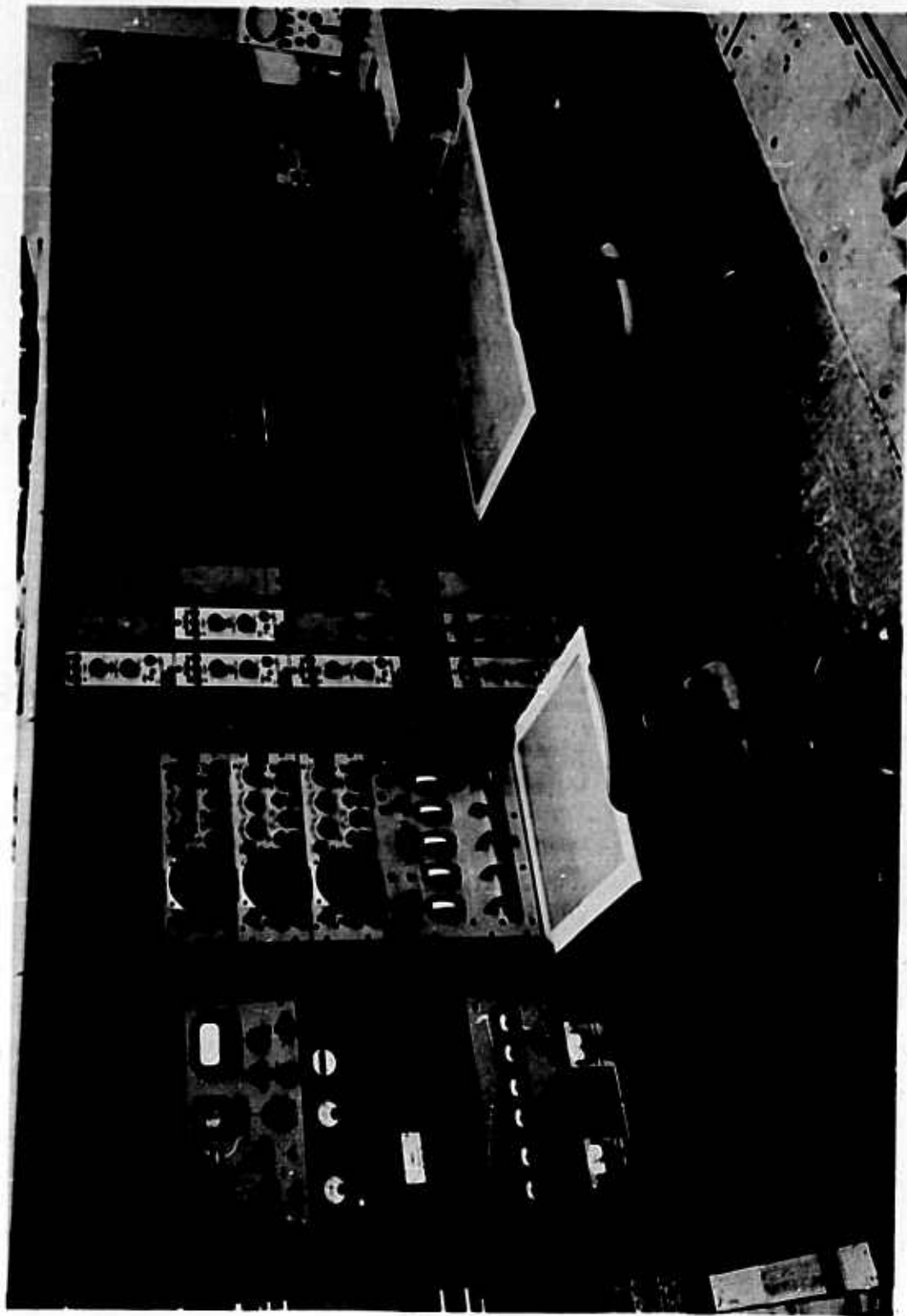

Figure 2-1 Electronic Rack Assembly

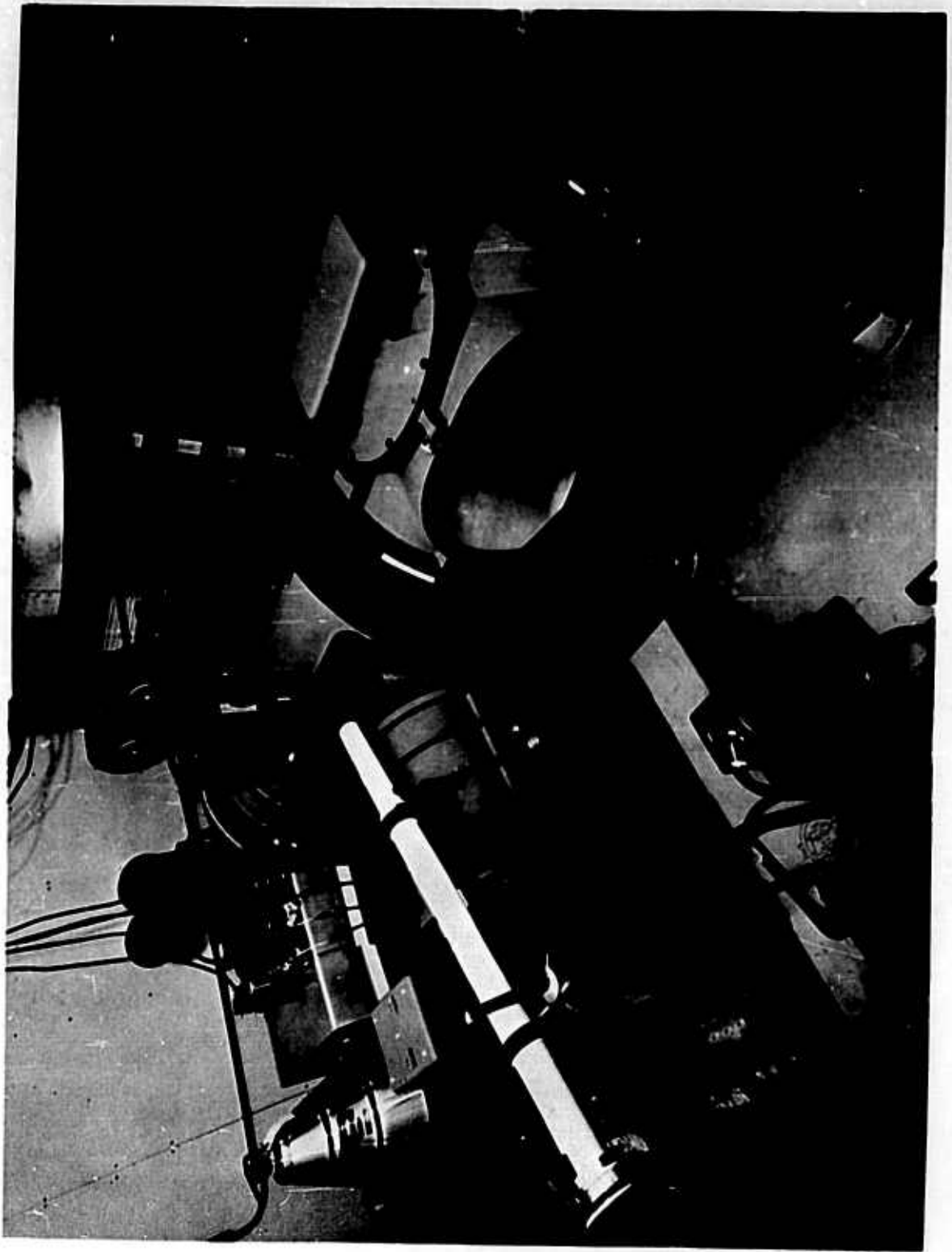

Figure 2-2 Rigid Platform Assembly

is opposite the measurement controls and displays shown in the second rack from the left of Figure 2-1. To his left are power supplies and test equipment, and to his right are the signal amplifiers for the five measurement channels.

The track operator's position is shown opposite rack number four which includes the tracker control panel, communications panel, computer controls, tape recorder controls, and the manual inputs to the pointing computer. To his right are the time generation equipment and time display, attitude gyro erection controls, and the tape deck for the recorder.

Figure 2-2 is a view of the rigid platform assembly from the forward starboard position looking aft. The unpressurized cavity enclosure in the aircraft will encompass the large mirror gimbal assembly, the backside of which is shown in the right foreground. The joystick control (for the manual optical director) and attitude gyro unit are shown in the left foreground. Immediately behind them is the 10-inch diameter optical collector and tracking head. The 20-inch diameter optical collector, with attached wide field-of-view boresight camera and visual telescope, are shown in the left center. The spectroradiometer unit with top mounted detectors and the narrow field boresight camera are shown in the left background.

2.2 FUNCTIONAL OPERATION

Five experiments were planned and executed to demonstrate the performance capabilities of the integrated partial system. Prior to these experiments, each subsystem had undergone separate alignment and tests to determine their individual performance characteristics. These characteristics are discussed in Sections 3, 4, and 5.

The step-by-step procedure for accomplishing the experiments is presented in Appendix A. A general discussion of results will follow in this section with specific performance recorded in the appropriate subsystem test sections.

Experiment 1 was primarily a check on the performance of the spectroradiometer using its own internal calibration references as radiation sources. The degree of compliance of this unit to its design parameters is discussed in Section 3. In general, everything operated as designed except for lower sensitivity and higher noise in the measurement channels than anticipated.

Experiment 2 brought the remainder of the partial system into operation under static conditions. The collimator, mounted to the rigid platform but outboard of the large track mirror, was used as a static target source to be acquired in track by manual direction of the tracker through the joystick control. The spectroradiometer recorded the radiation of this target source for analysis. The operation of the tracker and the pointing computer were monitored to determine their performance, which is reported in Sections 4 and 5, respectively.

Experiment 3 introduced target motion into the tests through operation of the system in the search mode against a static target provided by a laboratory collimator. The recording of the search patterns was not done as described in Section 3, Appendix A, since a much simpler way became apparent during the earlier tests. The static target source was focused on a chart held perpendicular to the visual telescope axis inches away from the eyepiece. As the tracker was programmed through the search pattern by the computer, the fixed source centered in the search field of view traced the pattern on the chart. The rosette search pattern is shown in Figure 2-3. The reason for the collapsing leaves along the horizontal axis is under investigation. The path should continue as shown by the dotted line.

The prime purpose of experiment 4 was to demonstrate the multiple target tracking capability of the optical tracker. The large laboratory collimator was used with an assortment of masks with single and multiple holes placed in front of the radiation source to simulate various target complexes. The target switching and centering in the spectroradiometer entrance aperture was satisfactory. This performance is described in detail in Section 4. Occasionally a false second target was indicated in the track field because of the high noise level on all circuits during lab tests. A concentrated effort in noise reduction after equipment installation in the aircraft should remedy this undesirable feature.

The fifth and final experiment was a dynamic exercise of the entire partial system in a simulated operational test. The target was the landing light on a light aircraft, since none of the other potential radiation sources were available. The target range was governed by the angle limits set by the opening in the lab wall, line of sight over a tree opposite the opening, and the altitude ceiling of the airplane. Thus, tracking was limited to in-bound runs from about 10 miles out. Although the aircraft landing light

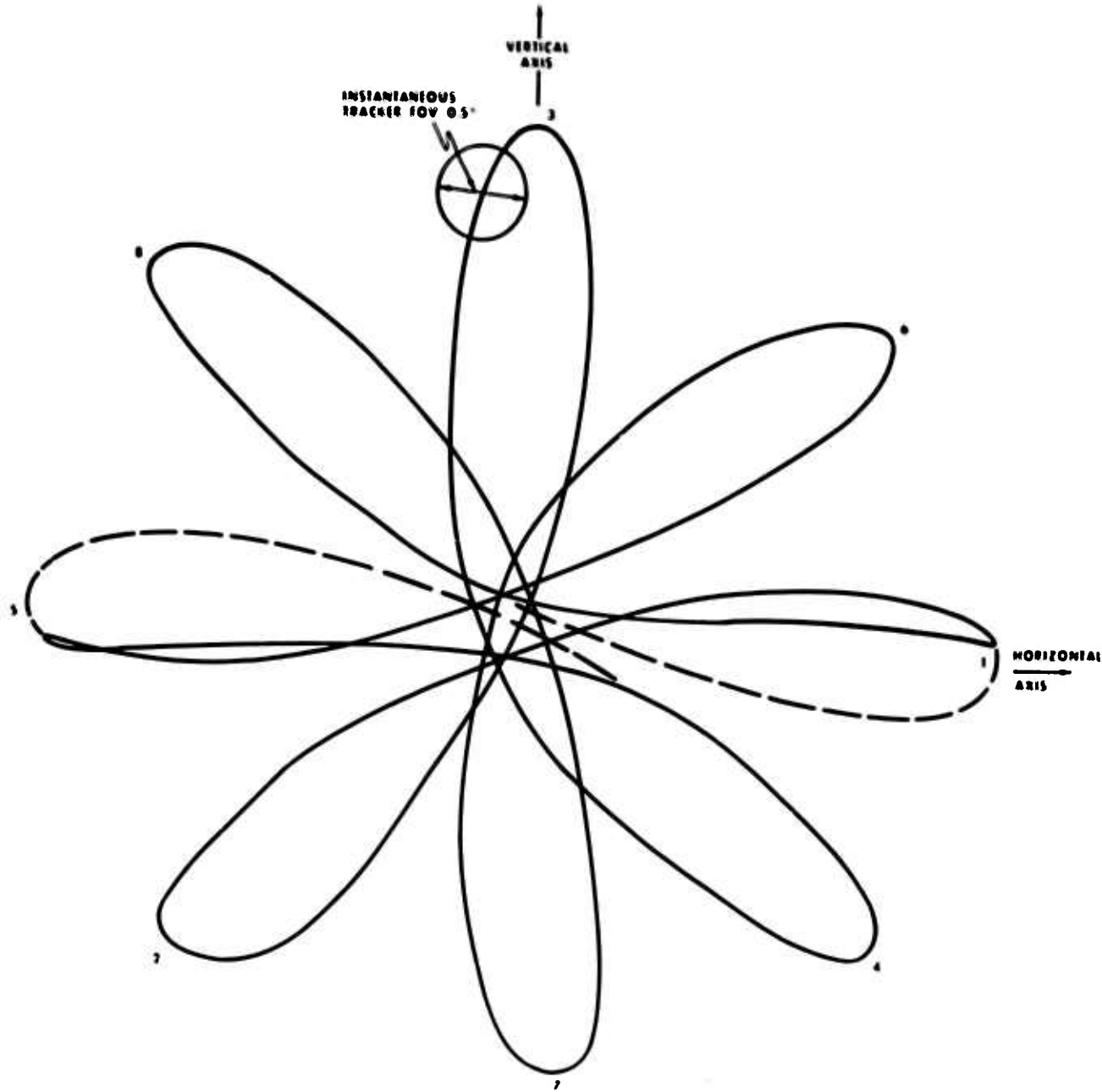

Figure 2-3 5° Diameter Rosette Search Pattern

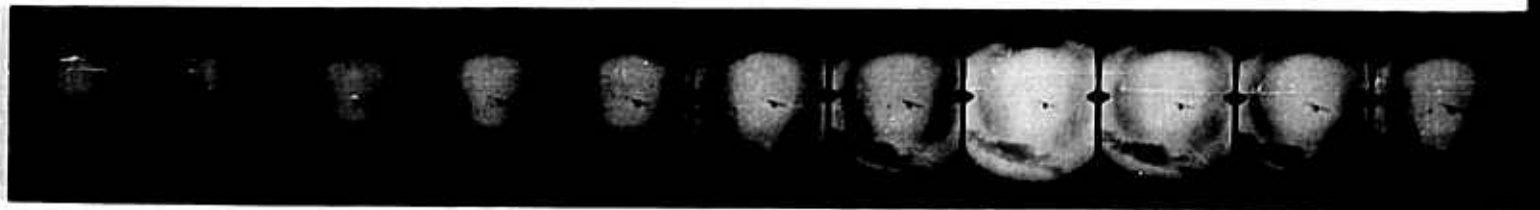
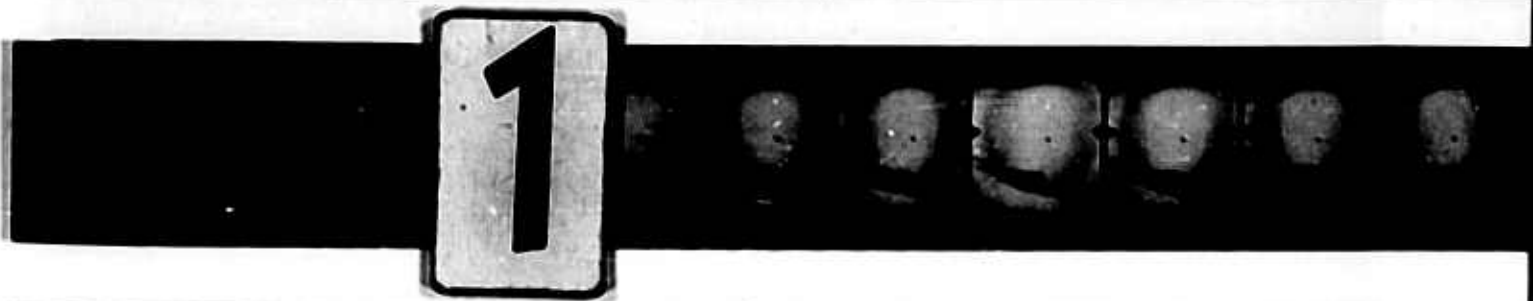
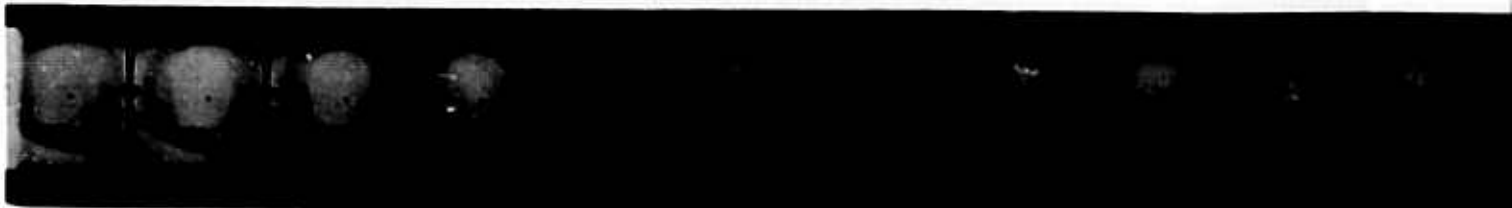



Figure 2-4 Boresight Film Strips of System Tracking Aircraft Landing Light
16 Frames/sec, $\sim 12^\circ$ FOV

(200 watts) was bright to the eye, only a small portion was received by the PbS track cells because of the 0.3μ wavelength pass band between plexiglass attenuation of the landing light radiation (upper cutoff about 1.5μ) and field-lens attenuation at the detector (lower cutoff about 1.2μ). Nevertheless, tracking was quite smooth and manual acquisition of the target was not difficult. Automatic acquisition of the target from the search pattern was satisfactory only about 20% of the time. The possible reasons for this difficulty and the efforts underway to remedy the situation are discussed in Section 5.

Film strips from the 35-mm, wide-angle boresight camera are shown in Figure 2-4 to illustrate the appearance of the aircraft in the system field of view. The boresight camera was not centered perfectly as shown by the fiducial marks and examination of the target position in the cine film strip. The target tracking, with only the large mirror positioning being registered by this camera, was impressively good. Noise pickup from various sources caused target jitter in the slit control mirror, but the extent of the jitter was difficult to measure from the narrow field of view boresight film because the landing light image was bigger than the slits at these short target ranges. Also, the narrow field of view camera happened to be out of focus during these runs.

Radiation data outputs from these tests with the aircraft were displayed but not recorded for analysis.

SECTION 3

RADIATION MEASURING SUBSYSTEM TESTS

3.1 OBJECTIVES

The purpose of these subsystem tests was to ensure that the radiation measuring subsystem is compatible with the other SKYSCRAPER subsystems, and that the performance does (or can be made to) satisfy the specified design requirements. This entails determination (for the radiation measuring subsystem as a whole) of the alignment and compatibility with the rest of the SKYSCRAPER System and the proper working of optical, mechanical, and electrical components. The equipment tests included the following:

1. Spectroradiometer: alignment with tracker and entrance optics
2. Subsystem Foreoptics:
 - a. Mirror tests
 - b. Internal alignment
 - c. Chopper flatness and alignment
3. Electronics:
 - a. Temperature control
 - b. Reduction of electrical interference
 - c. Amplifier gain and noise
 - d. Amplifier BW

4. Mechanical Components and Controls:

- a. Chopper**
- b. Ambient BB flag**
- c. Radiometer mirror**
- d. Filter wheel**
- e. Camera flag**
- f. Littrow mirrors**
- g. Wavelength potentiometer**
- h. Filter potentiometer**
- i. Camera controls**

5. Spectrometers: (Short, Intermediate, and Long Wavelength)

- a. Wavelength range, calibration, and resolution**
- b. NEP**
- c. NEFD**

6. Radiometers: (Ultraviolet and Infrared) Wavelength range, calibration, NEP, NEFD

3.2 METHODS AND RESULTS

3.2.1 Alignment of Spectroradiometer With Tracker

Figure 3-1 illustrates the spectroradiometer and the entrance optics housing. In the alignment, the main tracking mirror was adjusted so that when the incoming radiation was centered on the tracker reticle; the radiation to the spectroradiometer was directed through the center of the target-field stop. Visual observation of the radiant energy to the

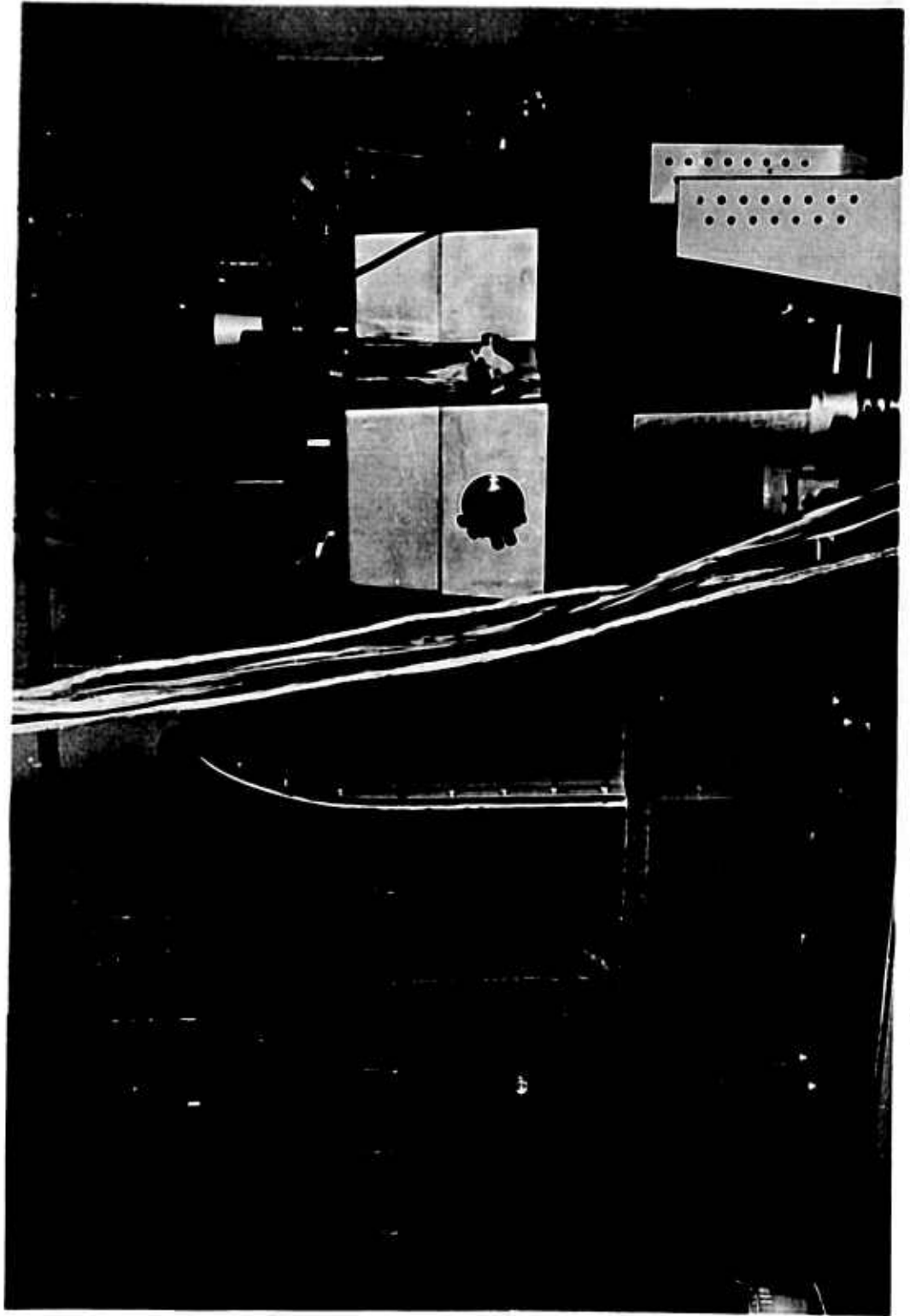

Figure 3-1 Spectroradiometer Mounted on Tracker

short wavelength radiometer and the short wavelength spectrometer enabled the position of the spectroradiometer in elevation and azimuth to be monitored. The spectrometer was adjusted until maximum energy from the primary collecting optics was observed to come through the entrance slits of the radiometer and spectrometer.

The primary collecting optics was illuminated by a 60-inch focal length collimator having a 0.003-inch object aperture. The size of the spot of light focused on the entrance field stop of the spectroradiometer by the 100-inch focal length collector was of the order of 0.007 inches. Moreover, previous measurements had shown that the 1:1 foreoptics ellipsoids imaged the entrance field stops on the spectrometer entrance slits with negligible image distortion. Thus, when the spot of light was centered in the entrance field stop and the spectroradiometer was adjusted to give maximum light transmission, it can be safely assumed that essentially all the energy from the 0.007-inch image entered the 0.020-inch wide spectrometer entrance slits, except for mirror reflectivity and scattering losses.

3.2.2 Foreoptics

Figure 3-2 illustrates the spectroradiometer with the covers removed. The foreoptics can be seen at the right hand side of the picture.

The two matched pairs of foreoptics ellipsoids were tested by a modified Ronchi test, using a 0.005-inch aperture at one focus and a standard 100-line Ronchi ruling at the other. After the object and image points were determined precisely, the Ronchi fringes were found to be straight and parallel down to complete illumination. This indicated that the mirrors were true ellipsoids to better than $1/4$ wavelength of visible light in terms of the geometry used.

After this test, the ellipsoids were placed on the spectroradiometer base and observed with a microscope focused on the image position and an illuminated 0.020 inch square aperture placed at the object position. After proper adjustment was obtained, the 0.020-inch square entrance aperture was imaged by the two consecutive ellipsoids to an image not measurably larger than 0.020 inch square.

The double reflecting chopper (illustrated in Figure 3-2) is a photo-ceram etched disk 0.038 inch thick. It was optically lapped and polished

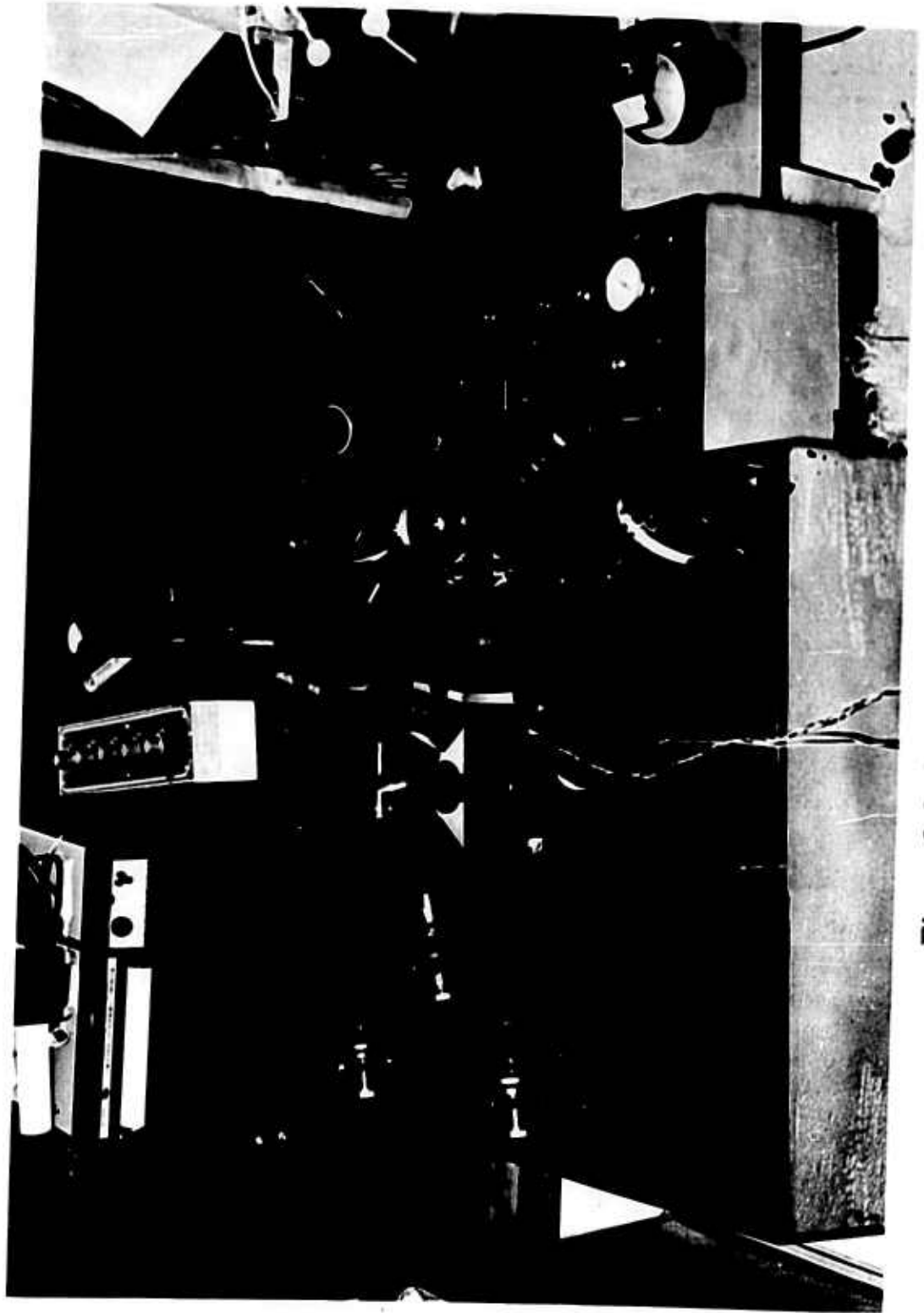

Figure 3-2 Spectroradiometer Optics

using a strain-relieving pitch transfer process. It was mounted in a steel mandrel whose flatness was determined to be within one wavelength of visible light. After the mandrel with its chopper was mounted in ABEC-5 bearings, aligned, and rotated, the reflected image of one foreoptics ellipsoid mount was superimposed over the symmetrically-opposite ellipsoid mount. No variation of image to object position could be seen, dynamically or statically.

On the basis of these tests and the observed fact that the light entered the spectrometer entrance slits with almost imperceptible vignetting, it was concluded that the foreoptics are performing properly. However, complete background cancellation has not yet been achieved. Hence, further adjustments will be necessary before the specified equipment performance can be realized.

3.2.3 Electronics

Figure 3-3 shows most of the radiation measuring subsystem electronics. Other electronic assemblies not shown are the blackbody power regulator located in Rack 6, the blackbody rack (which will be mounted on the aircraft bulkhead near the spectroradiometer), and the detector pre-amplifiers located on the spectroradiometer.

During the laboratory test period, all electronic controls and drive mechanisms functioned satisfactorily. The signal amplifier channels were operative, but performance was limited by electrical interference and feedback problems in the bandpass amplifiers. These difficulties are being resolved at present; it is expected that they will be cleared up before installation of the equipment in the aircraft.

The present configuration of the radiation measurement subsystem signal electronics is shown in block diagram form in Figure 3-4; this arrangement reflects very few changes from that reported in the Final Design Report, BSR-440.

The overall gains of the five main amplifier channels are shown in Table 3-1. These gains are for the slow scan rate and are in agreement with design specs.

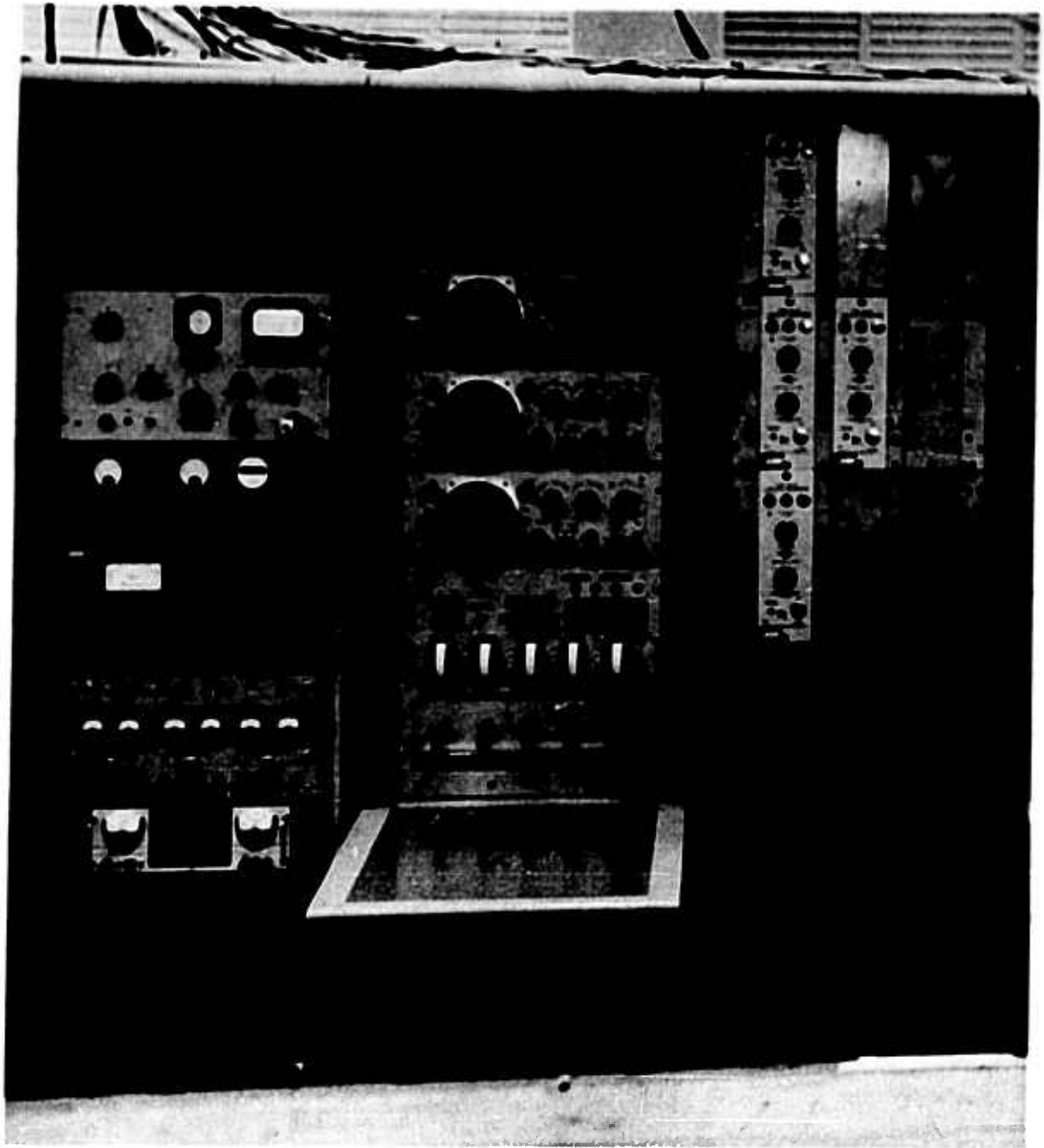

Figure 3-3 Electronics for Spectroradiometer

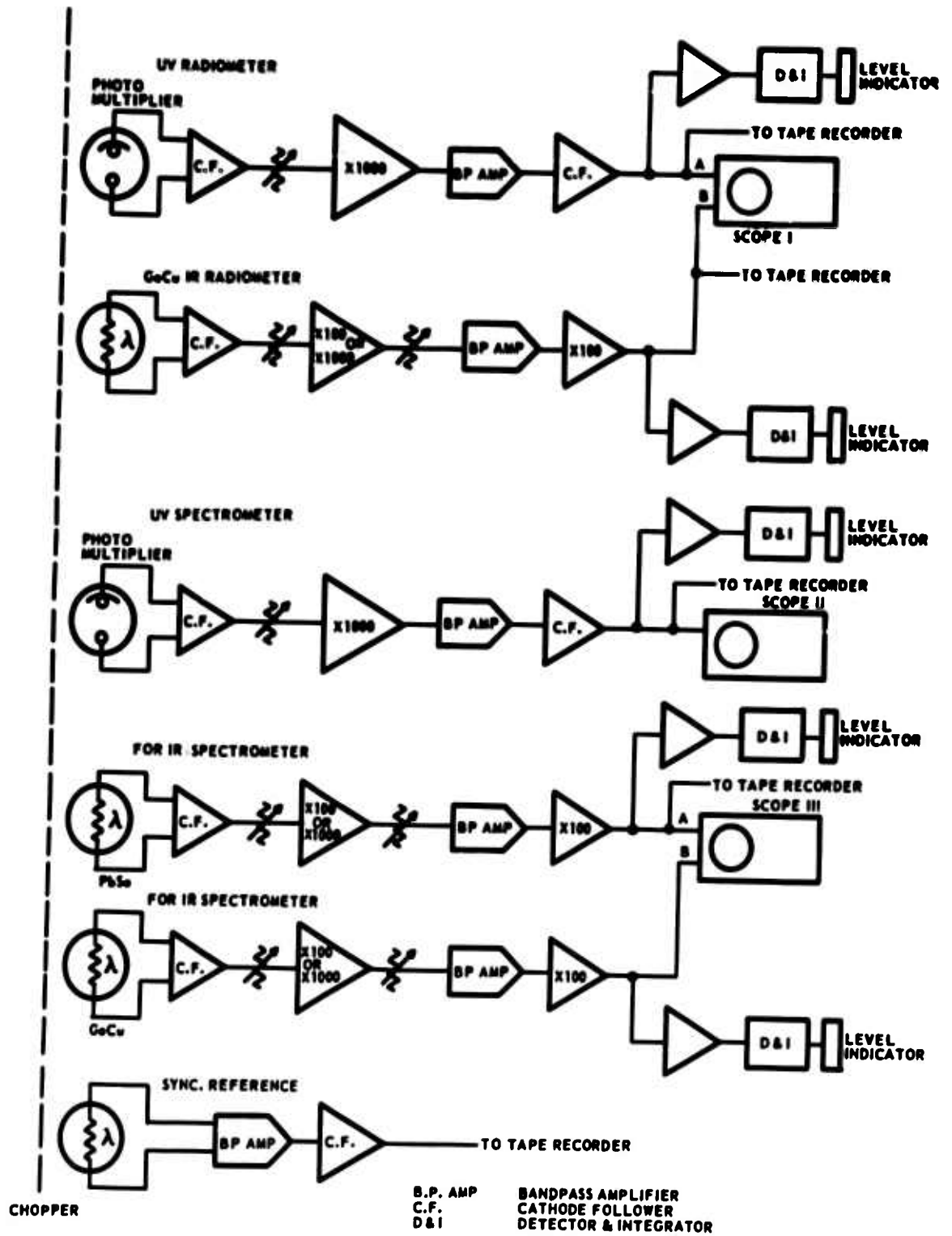

Figure 3-4 Block Diagram of Signal Electronics

TABLE 3-1

OVERALL AMPLIFIER GAIN AT 1/2 SCAN PER MINUTE

<u>Measurement channel</u>	<u>Overall Amplifier Gain</u>
UV Radiometer	1.0×10^4
IR Radiometer	1.3×10^5
UV Spectrometer	1.1×10^4
Near IR Spectrometer	0.82×10^5
Far IR Spectrometer	1.0×10^5

The results of tests conducted to determine the overall bandwidth of each of the five main amplifier channels are illustrated in Figure 3-5. The bandpasses are plotted to the 3-db and 6-db points and are shown for each of the four scan rates. The bandwidths obtained approximate the specified design performance.

It has not yet been possible to obtain reasonable noise measurements for the amplifier channels because of 400-cps leakage and other electrical interference. These interference problems are being corrected.

The following sources of interference were found:

1. Switching transients, both internal and external
2. The 28 VDC laboratory power source: this power source had a 5-volt ripple content of about 2000 cps, which is the same frequency as the chopper and bandpass amplifiers; the aircraft power supply is expected to have less ripple
3. Camera frame counter contacts
4. 400-cps leakage from primary power circuits.

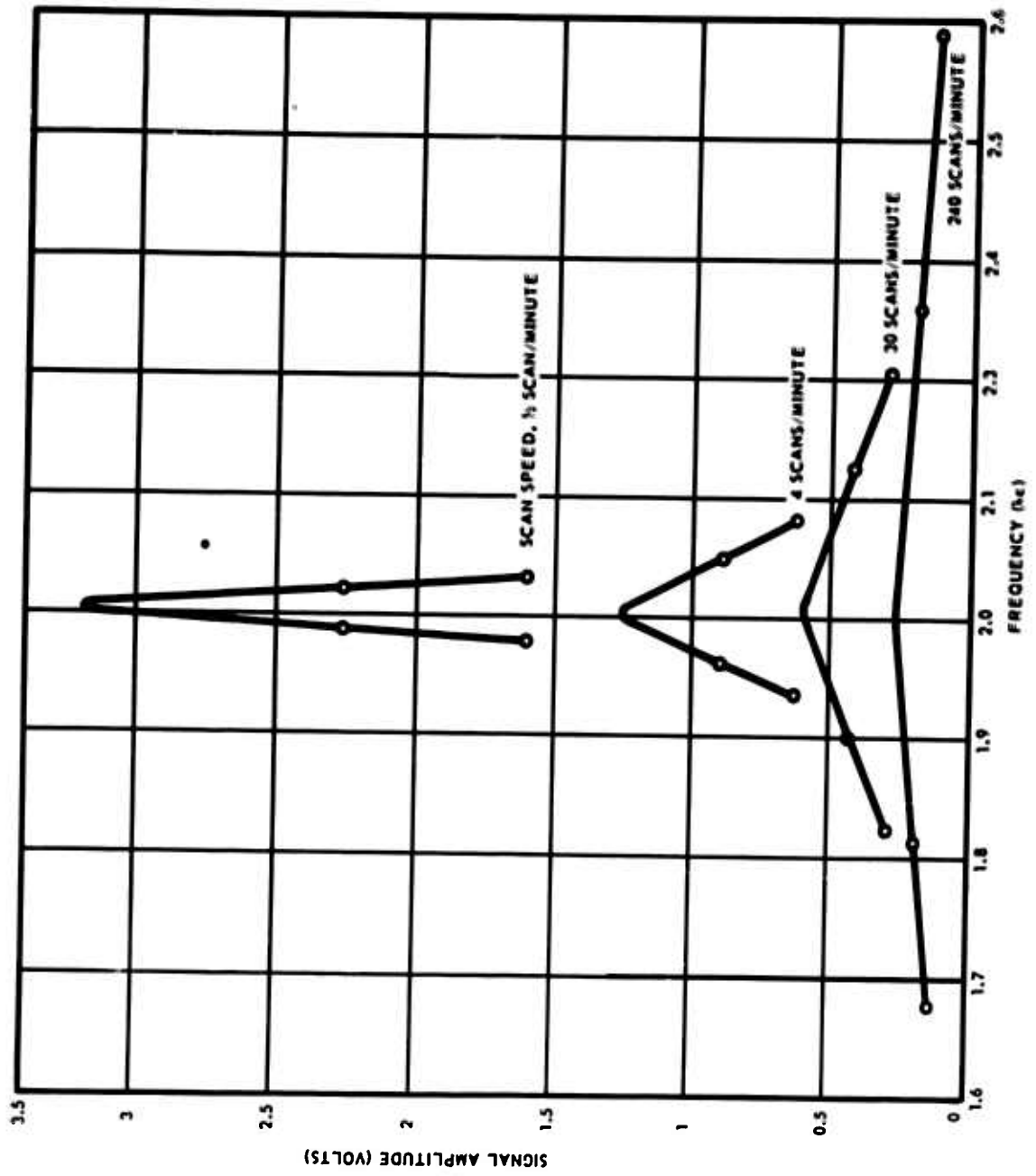

Figure 3-5 Signal Amplifier Bandwidths for Spectroradiometer

The reduction of noise from the switching transients and the camera frame counter contacts has been successful. Transients and 400 cps leakage will remain a problem until the complete system is debugged after installation in the aircraft.

Changes have been made to the layout of circuitry, and filters have been added to decrease the 28 volt main power ripple from being a problem in the aircraft.

Cross talk, which was discovered in the cathode follower preamplifiers for each detector, has been attributed to the interaction in the detector bias and plate supply voltages common to the detector/preamplifiers. The problem will be resolved by isolating the detector bias with its own battery source.

The precision oscillator and power amplifier, the power source for the spectroradiometer chopper motor, performed satisfactorily under laboratory conditions. The frequency determining source is a tuning fork resonator tuned to 400 cps with an accuracy of 0.01% and wave form distortion less than 8%.

Because of the restricted ambient temperature ranges in the laboratory, the temperature controller for the spectroradiometer was not tested to the extremes of its design capability; however, it did function properly in the laboratory. Temperature and humidity control inside the spectroradiometer is necessary because some of the optical components are hygroscopic, and because of expansion and mechanical stability problems with the critical optical alignment.

The controller consists of four heaters mounted in a housing with a blower attached and a bimetal thermo regulator with an accuracy of $\pm 0.05^{\circ}\text{C}$. Three of the four heaters are controlled by individual switches on the heater control panel located above the display oscilloscopes. The fourth heater is controlled by the thermo regulator located in the spectroradiometer and a variable auto transformer which is mounted on the heater control panel.

3.2.4 Mechanical Components and Controls

3.2.4.1 Chopper

As mentioned in Section 3.2.2, the optical quality and mechanical runout of the double reflecting chopper rotating freely in its bearings

was very satisfactory. A further indication of this was that no image shift occurred at the spectrometer entrance slits as the chopper transferred the incident energy from direct to reflected beam positions. However, the chopper driving pulley is eccentric, thereby causing a modulation in the chopping frequency and unnecessary vibration. This pulley is being repaired.

3. 2. 4. 2 Ambient Blackbody Flags

By throwing the "target flag" switch to the "on" position, the ambient blackbody flag on the target side was rotated into its position in the target beam. Reversing the switch removed the flag. By following the same procedure for the "blackbody flag" switch, the ambient blackbody flag in the background position was made to position itself in and to remove itself from the background beam.

3. 2. 4. 3 Radiometer Mirror

As the radiometer mirror control was switched through its sequence N-R-S-R, the actuating relay rotated the mirror through the positions non-reflecting, reflecting, semi-reflecting, and reflecting. The semi-reflecting position reflects 20% of the energy to the long wavelength radiometer by partially intercepting the converging beam of radiation. In this mode, 80% passes directly to the short and intermediate wavelength spectrometers.

3. 2. 4. 4 Filter Wheel

When the littrow drive mechanism was turned on, the gear driven filter wheel rotated in synchronism (once per sweep) with the wavelength scan, as designed.

3. 2. 4. 5 Camera Flag

The camera flag is geared to the littrow drive in such fashion that it covers the entrance field stops once for each spectral scan. It is phased mechanically so that these coverings occur during the "dead" time on the long and short wavelength turnaround positions of the littrow mirrors.

When the littrow drive was energized, the camera flag was observed to rotate as designed and in the proper phase. Its surface quality,

is not as good as that to be expected from a glass mirror, however, and efforts to obtain a new higher optical quality metal flag are underway.

3. 2. 4. 6 Littrow Mirrors

The littrow mirrors are driven by connecting rods from adjustable crank pins located on geared pulleys and make one back-and-forth rocking motion per pulley revolution. The mechanism was adjusted for the closest possible fit consistent with free running. No backlash was perceptible.

When the littrow drive was energized from the spectroscopist's control panel, the mechanism operated properly at each of the four speeds (0.5, 4, 30, and 240 scans per minute).

3. 2. 4. 7 Wavelength Potentiometer

After the wavelength potentiometer was mechanically phased to the littrow mirror positions, the voltage output (with the energizing voltage applied) was observed on the trace produced by Consolidated Electrodynamics recording galvanometer. The trapezoidal trace was regular, repeatable, and linear to within 2%, but not yet symmetrical for the two directions of scan. The symmetry will be improved as soon as possible. With calibration, however, the wavelength potentiometer output will give wavelength position to better than 1%.

3. 2. 4. 8 Filter Potentiometer

The sawtooth trace produced by the voltage tapped off the filter potentiometer was linear to within about 2%. It was also regular and repeatable to the limits of observability of the record produced by the CEC recording galvanometer.

3. 2. 4. 9 Camera Controls

The two Flight Research IV E data cameras were tested, one in the boresight position at the spectroradiometer, and the other at the wide-field-of-view position at the tracker.

The spring on the takeup spool was found to be loose on the boresight camera. This caused the film to jam when the spring slipped at the

splice joint. A new spring has been ordered. However, some data was recorded on the positioning of the aircraft landing lights on the spectroradiometer entrance field stop by the tracker. Initially both cameras were actuated when either camera control was turned on. Independent operation of these cameras has been achieved.

The camera in the wide FOV position performed properly in all modes: single frame, cine burst, cine, external sync, and internal sync. Pictures of the tracker tracking the aircraft were taken in daylight using Plus X film, and at night using Tri-X film.

It is to be noted that although the boresight camera was focused on the entrance field stops, lack of time and the film jamming did not permit a complete check of precise alignment of the combination of tracker and boresight camera together. This will be checked during the initial phases of SKYSCRAPER operations.

3. 2. 5 Spectrometers

The spectrometer for the visible-UV range uses a DuMont 2114 photomultiplier having an S-13 spectral response, an average cathode luminous sensitivity of $50 \mu\text{a/L}$, and a maximum dark current (105 v/stage) of 5×10^{-8} amperes.

Figure 3-6 is a reproduction of some spectra taken with this spectrometer. Figure 3-6, Trace a, is the output of a tungsten lamp at a temperature of about 2600°K . Wavelength increases to the right, indicated by the rising wavelength potentiometer trace. On the gain setting used to prevent excessive saturation, the signal wavelength covers the range from about $320\text{m}\mu$ to $580\text{m}\mu$.

Figure 3-6, Trace b, is a spike produced at $537\text{m}\mu$ by a filter between the lamp and the spectrometer.

Figure 3-6, Trace c, is the recorded output of an NBS calibrated didymium oxide filter in combination with the lamp.

Figure 3-6, Trace d, is the recorded output of an AH4 mercury lamp. The wavelengths were plotted versus littrow position as shown in Figure 3-7. From this and the output of the $650\text{-m}\mu$ filter, it can be seen that

1

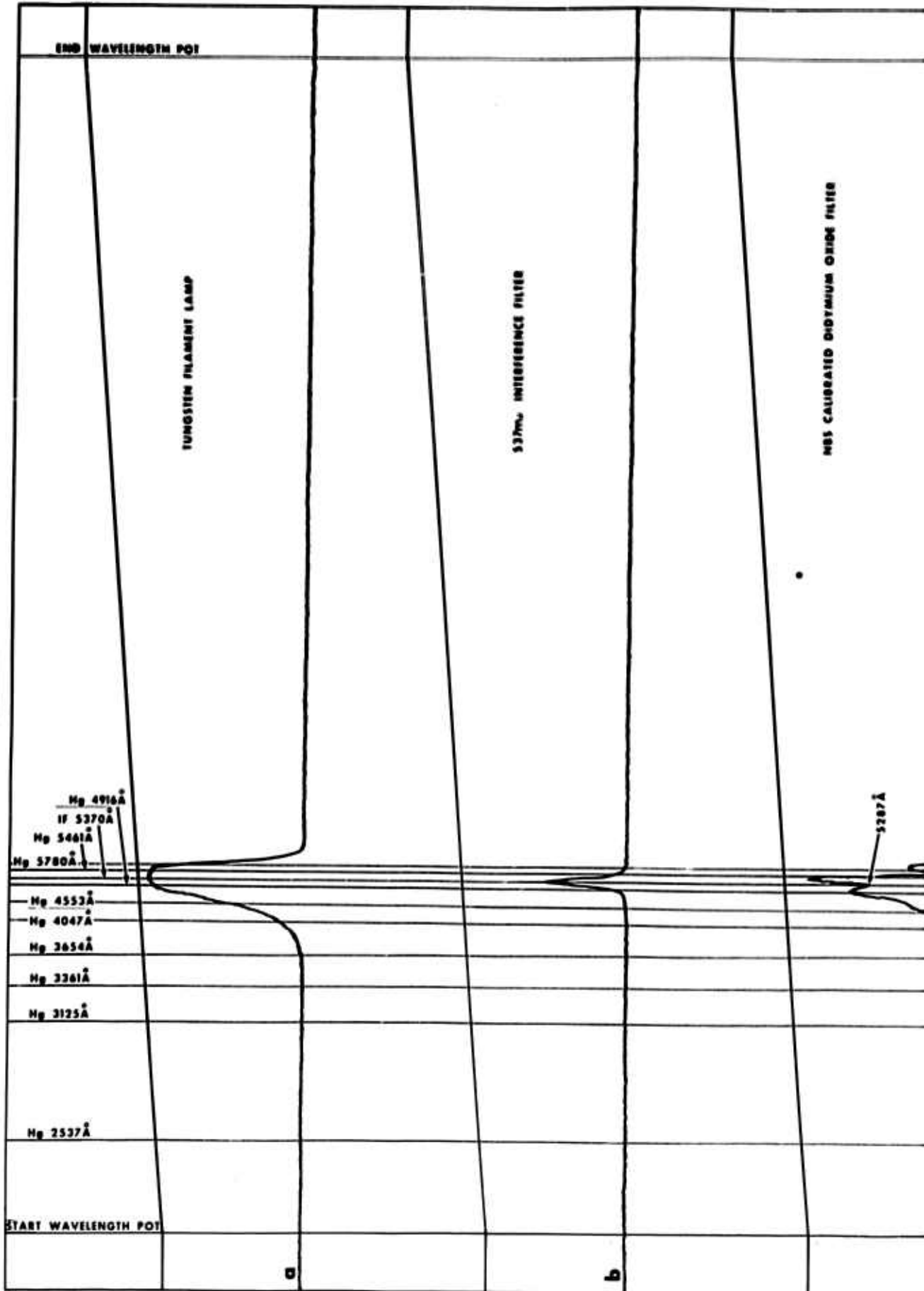

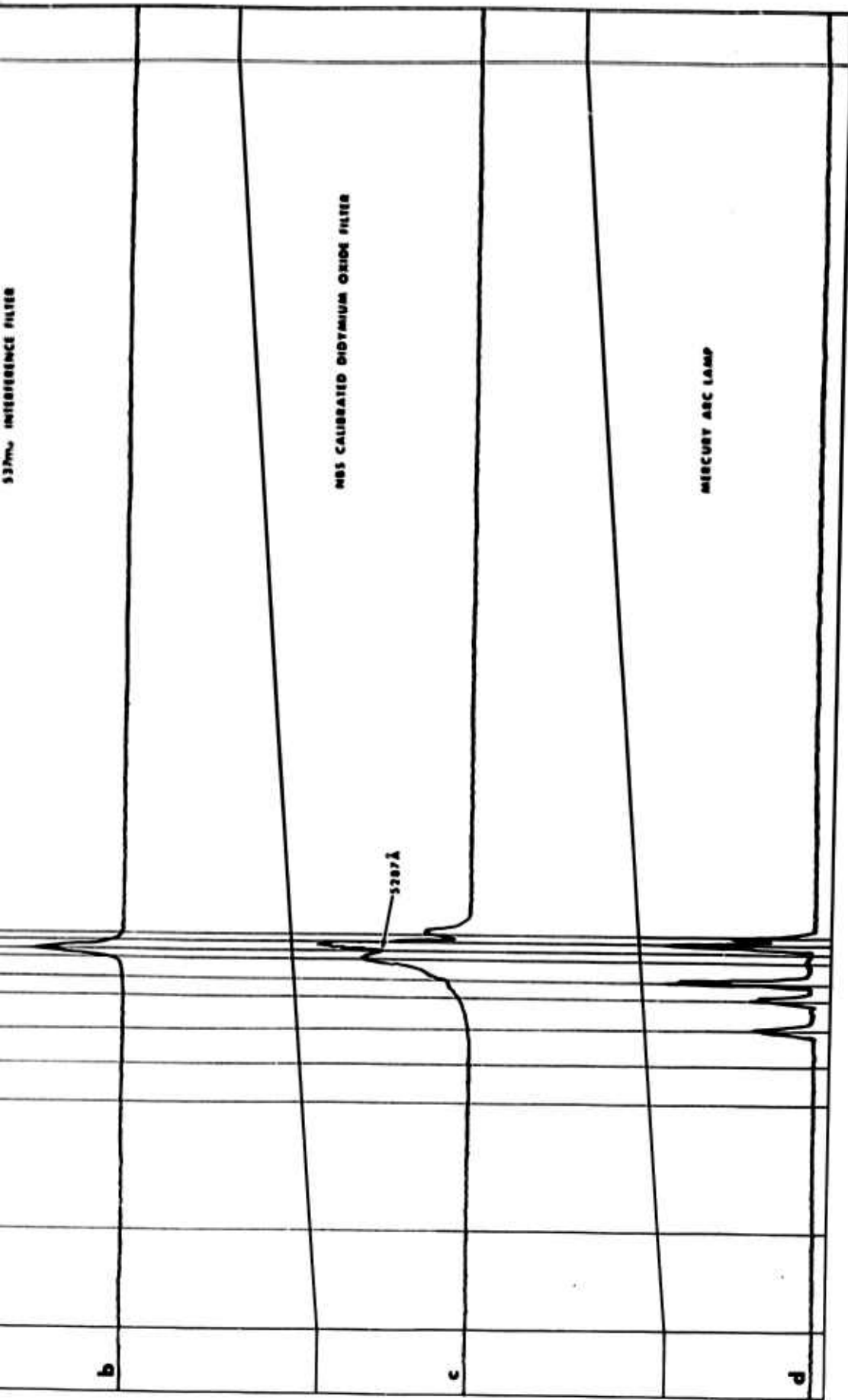

2

Figure 3-6 Short Wavelength Spectra

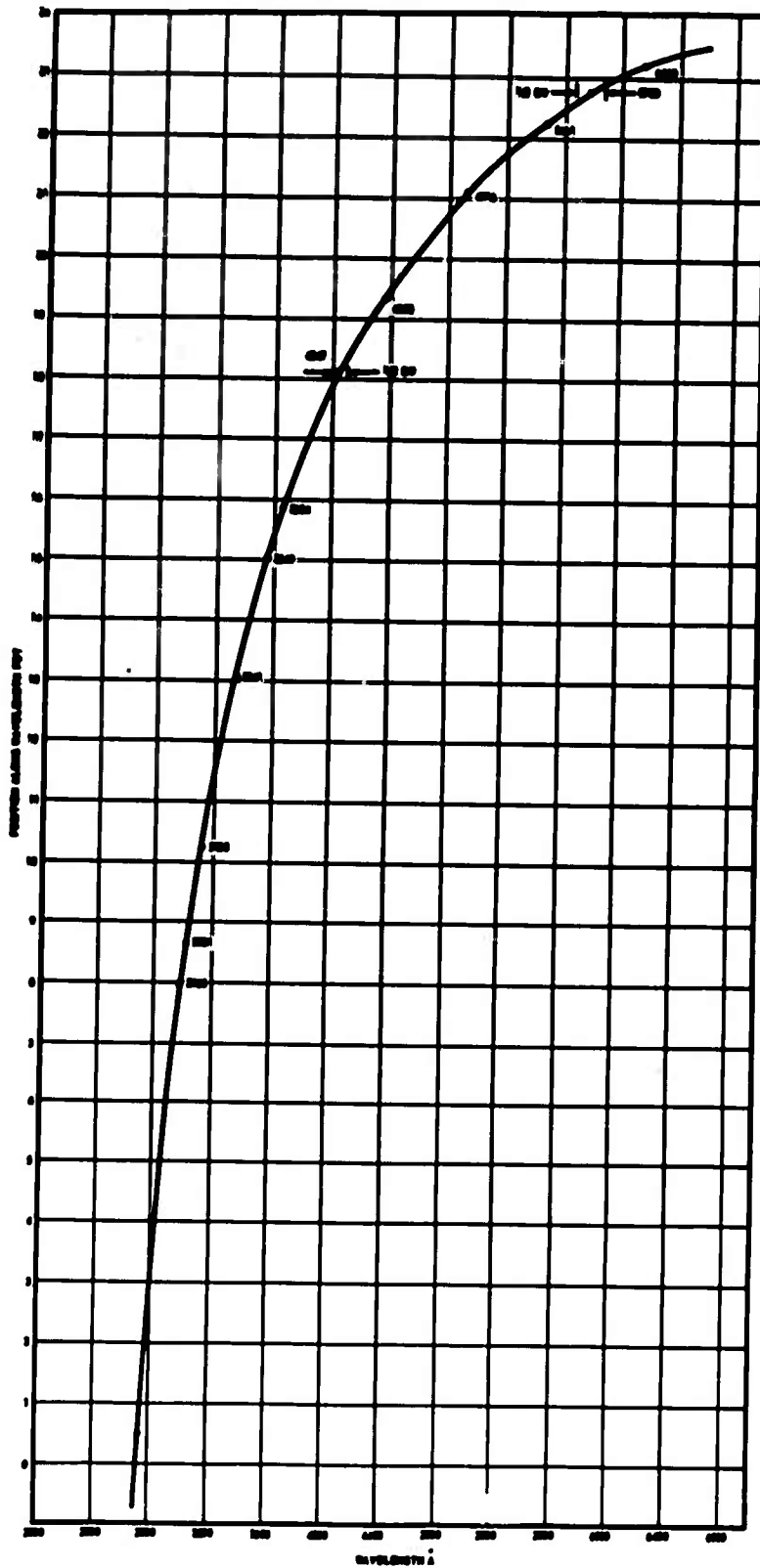

Figure 3-7 Short Wavelength Spectrometer Calibration

the recorded wavelength range runs from approximately 250 μ to beyond 650 μ . The recorded wavelength positions fall very accurately on a smooth curve, indicating smooth, even Littrow mirror travel. The wavelength scanned is about 19% of the total Littrow travel, as designed.

The wavelength resolution (line half-width) is about 10 μ at 404.7 μ and about 30 μ at 578 μ . The resolution increases at shorter wavelengths, due to increased dispersion of the LiF prism, so that the average resolution, within the limits of measurements made to date, appears to be at least as good as the 0.014 μ desired.

From Figure 3-6, Trace a, the signal to noise from the lamp is about 300. The power to the detector in the 30 μ bandwidth is about 2×10^{-8} watts. With correction for the bandwidth of the slowest scan to be used, the NEP at the entrance field stops is about 2.6×10^{-11} watts. For a 1500 cm² collector, this produces an NEFD of about 1.7×10^{-14} watts for a 30 μ bandwidth, or an NEFD of the order of $5 \times 10^{-13} \frac{\text{w}}{\text{cm}^2 \mu}$.

To the accuracy of the measurements and for the 2114 photomultiplier sensitivity, this is about an order of magnitude less sensitive than the design value at 578 μ . However, much of this was due to lowering the voltage to the photomultiplier to 500 volts in order to prevent extreme saturation of the amplifying and recording equipment.

3. 2. 5. 1 Intermediate Wavelength Spectrometer

The intermediate wavelength spectrometer was designed to cover the wavelength interval from about 1.0 μ to 5.0 μ using a lead selenide detector. Although two such detectors were purchased, one developed an open circuit. The other, which was used to take the data, had a higher resistance and lower D^* (about 1×10^{10} cm cps^{1/2} watt⁻¹) than originally specified, but still within the range of acceptability. Primarily as a result of the high and varying detector resistance (varying from 3 to 30 megohms) limited data was obtained in this region. It was possible to obtain data only when the cold resistance of the PbSe cell was of the order of 3 to 6 megohms.

Figure 3-8 is a set of reproductions of some spectra taken with this spectrometer. Figure 3-8, Trace a, shows the output of the cell with a 2000°K Nernst glower as a source. The absorption in the neighborhood of 2.6 μ is caused by the water vapor in about a 3-foot optical path at a relative humidity of 30%.

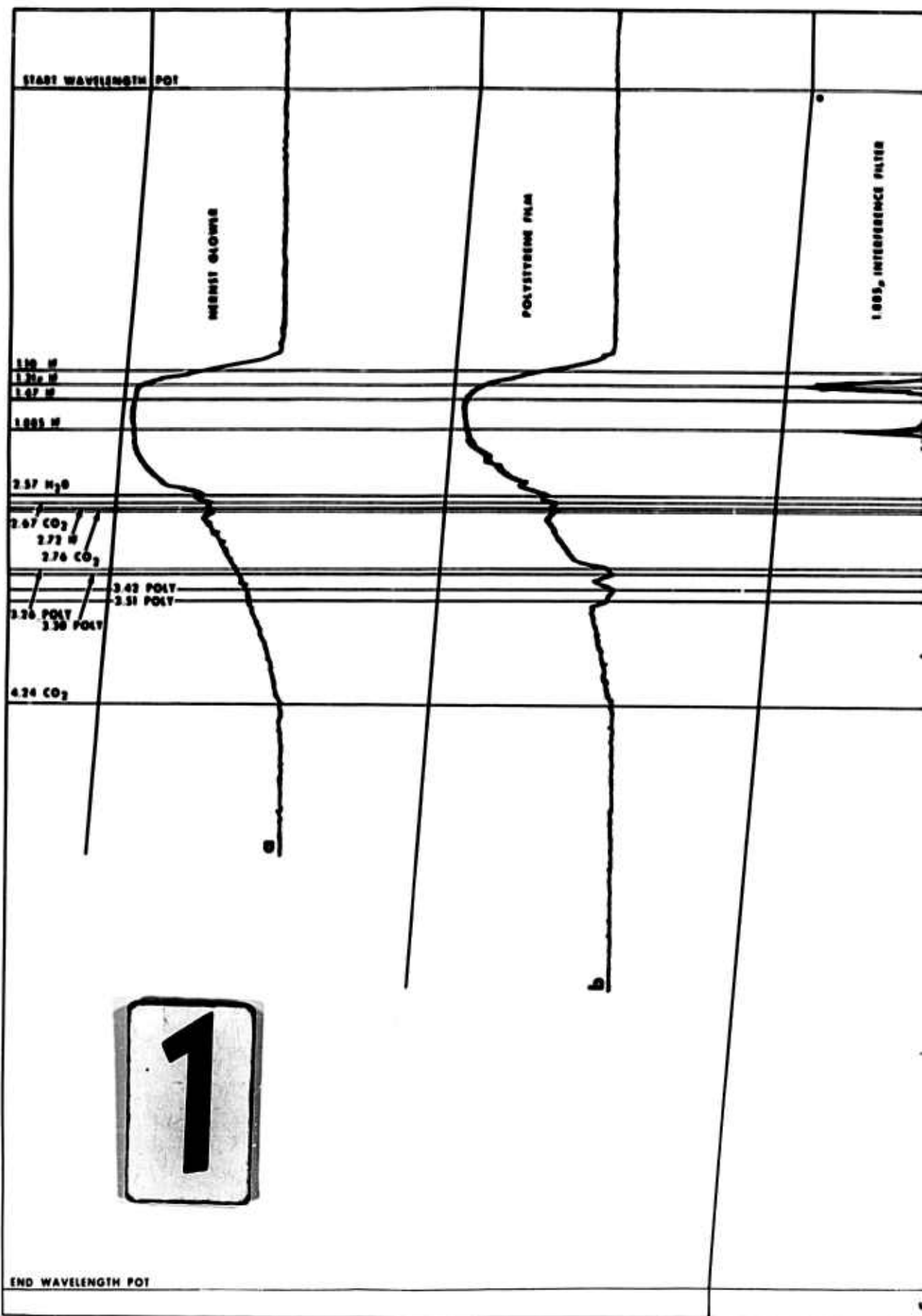

1

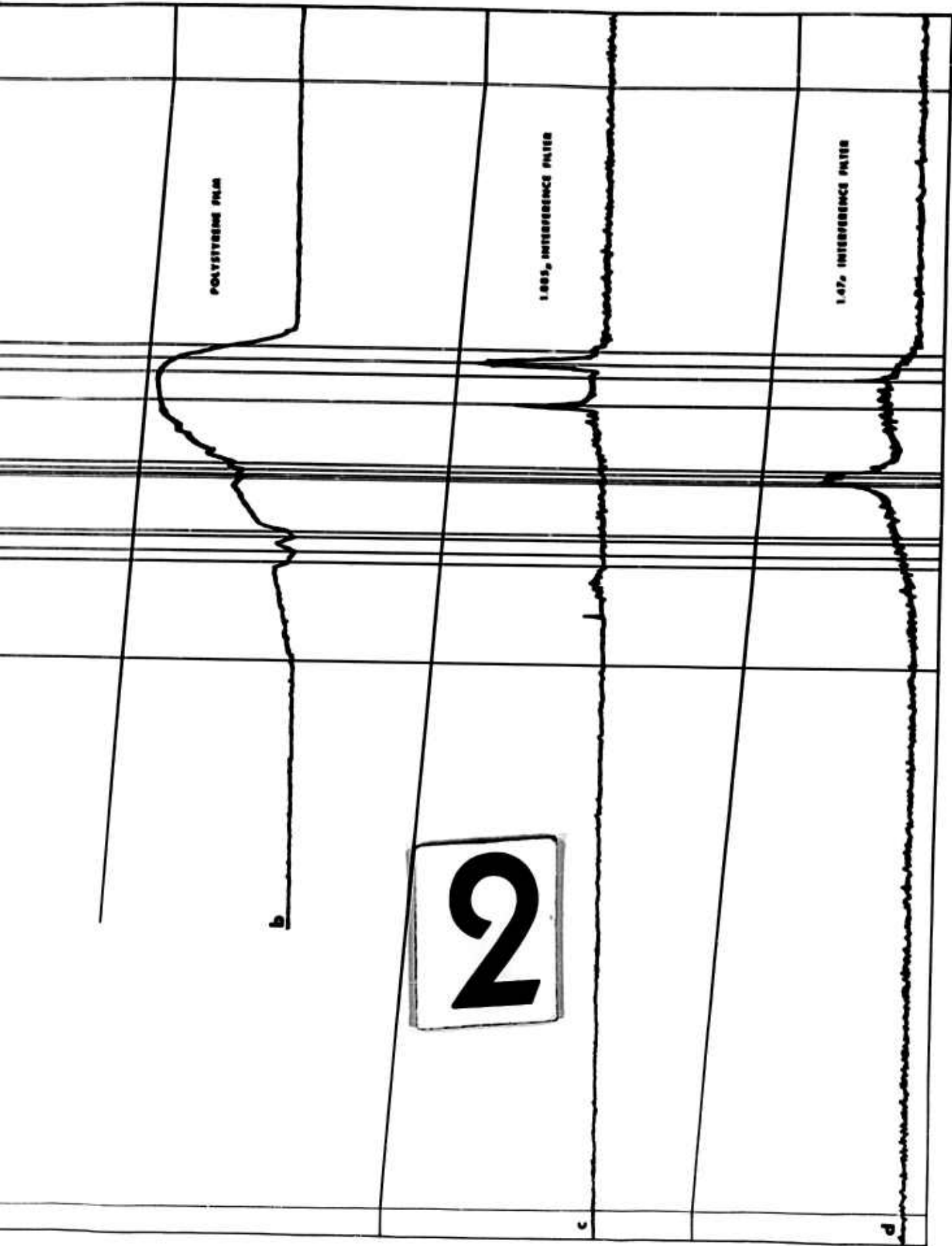

Figure 3-8 Intermediate Wavelength Spectra

The wavelength region observed at a single gain setting ran from 1.0 to 4.25 μ , and, as shown in Figure 3-9, all the wavelength values fit a smooth curve when plotted against the output voltage of the wavelength potentiometer. The output at the peak of the spectrum had a S/N of about 400. The power to the detector in the 0.05 μ bandwidth used was about 10⁻⁵ watts. Correcting for the electrical signal bandwidth used at the slowest scan rate, and for the fact that the energy input did not fill the f/5 cone of rays, the noise equivalent power (NEP) at the entrance field stop was estimated to be 6 x 10⁻⁹ watts. From this, the noise equivalent flux density at the tracker entrance aperture was about 4 x 10⁻¹² w/cm² for a 0.05 μ bandwidth in the neighborhood of 2 μ . This is about three orders of magnitude below the ultimate sensitivity to be expected from the spectrometer, but is not by any means a system limitation. Three changes are to be made to increase the sensitivity:

1. The present final ellipsoidal mirror used to image the spectrometer output slit on the detector has rather serious aberrations. It was not possible to obtain such a special mirror having good image quality in time for these tests. It is expected that a good quality replacement mirror will improve the NEFD by nearly an order of magnitude.
2. Replacement of the present PbSe detector cell with a detector having a better D*, impedance, and time constant should improve this spectrometer NEFD by a factor of 3 or more.
3. Improving the noise figure of the cell-amplifier combination and better shielding of all electronics to decrease the pickup level should further greatly increase the S/N, and thus NEFD.

Figure 3-8, Trace b, shows, in addition to the 2.6 μ water vapor band, the 3.3, 3.4 and 3.5 μ absorptions due to polystyrene.

Figure 3-8, Trace c, shows transmission peaks at 1.1, 1.31, 1.9 and 3.9 μ passed by an interference filter. Figure 3-10 shows the spectral output of the same filter produced by a Beckman recording spectrophotometer.

Figure 3.8, Trace d, shows the spectral transmission of a filter at 1.47 and 2.72 μ .

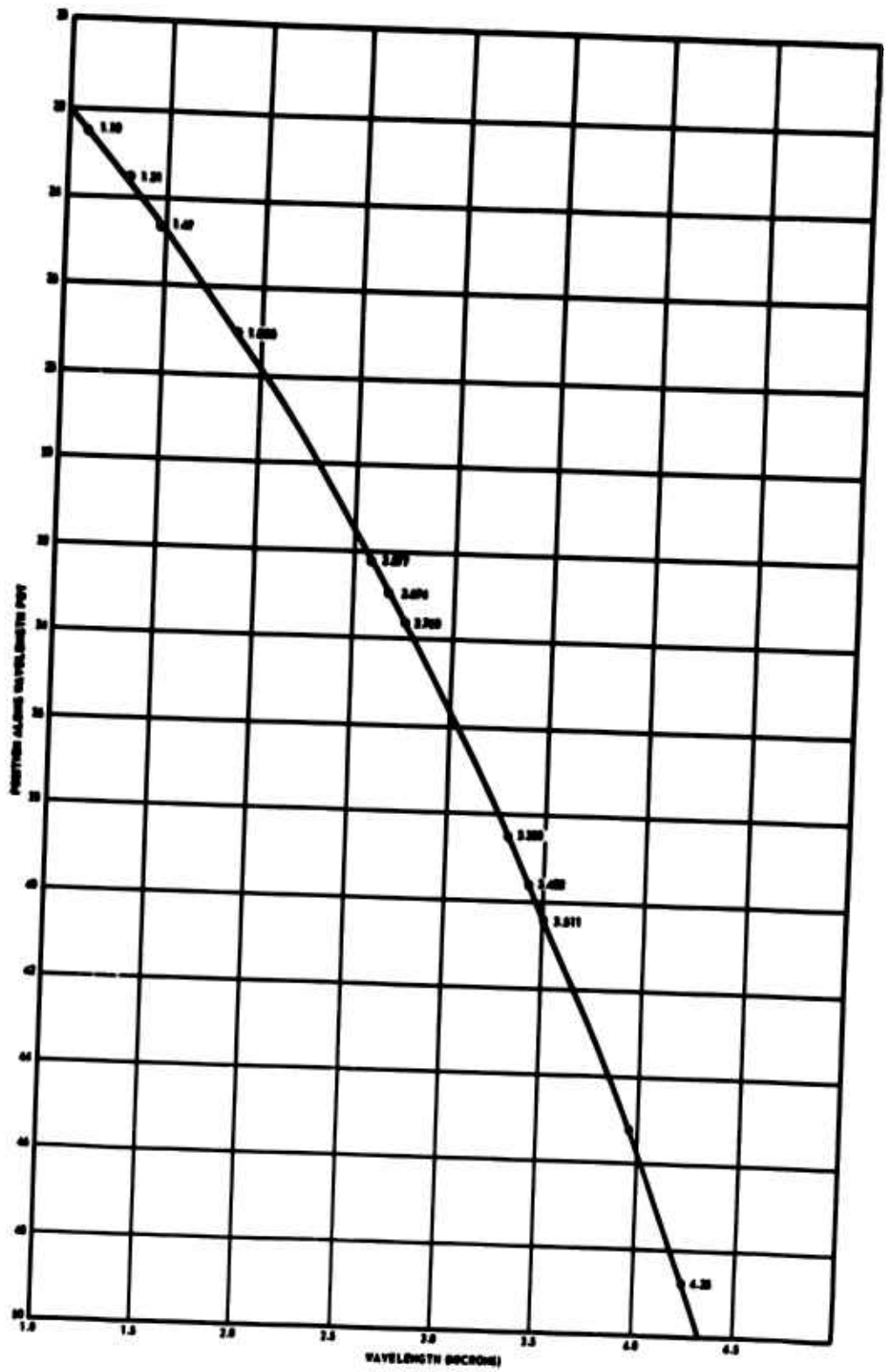

Figure 3-9 Intermediate Wavelength Spectrometer Calibration

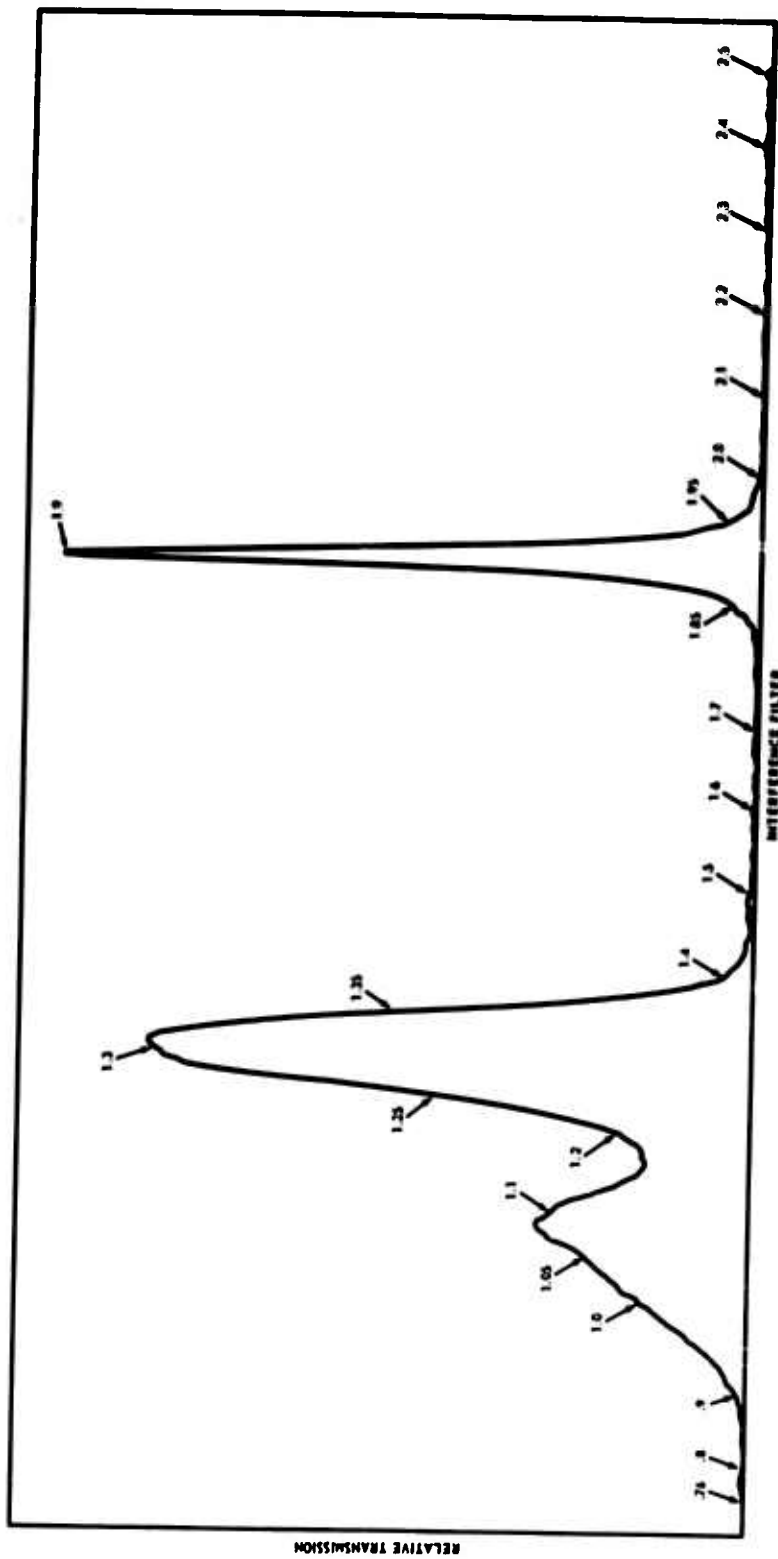

Figure 3-10 Interference Filter Spectrum

It was mentioned previously that the resolution in the 2.0μ region was about 0.05μ . This was checked by taking the half-width of the 1.9μ line and referring back to the wavelength calibration curve of Figure 3-9. It is thought that insufficiently precise wavelength points are available at present to produce measured resolution as a function of wavelength. A better estimate of resolution will be attained later as further debugging of and measurements with the system are made.

3.2.5.2 Long Wavelength Spectrometer

The detector for the long wavelength spectrometer is a helium-cooled, copper-doped germanium cell 0.5×0.5 mm in size having a measured D^* (500, 1800 ~) of 2.25×10^{10} cm cps $^{1/2}$ watt $^{-1}$.

Figure 3-11 is a reproduction of the long wavelength spectrometer output response to a 2160° K blackbody source. Figure 3-11, Trace a (in which a polystyrene filter was used), illustrates that the S/N ratio in the neighborhood of 9μ is approximately 200. Since the power, in a 0.1μ band at 9μ , from the blackbody into the entrance slits is about 10^{-6} watts, the NEP in this region for this spectrometer is about 5×10^{-9} watts after correction is made for the final bandwidth to be used with the slow speed scan. This gives an NEFD of the order of 3×10^{-12} watts/cm 2 for the spectral resolution obtained (0.1μ) or 3×10^{-11} watts/cm $^2 \mu$. This is over two orders of magnitude lower than the design estimate.

In this case, it appears that the cell itself is not the primary cause of the high noise and resulting low S/N. The cell responsivity was rechecked in a quiet (electrically and mechanically) environment and was found to be of the order of 2×10^{10} cm cps $^{1/2}$ watt $^{-1}$. However, when it was placed in the spectrometer, rather large amplitude voltages having frequencies associated with the mechanical vibration of the chopper pulley appeared. In addition, about 20 microvolts of wide band noise, possibly associated with current or variable contact type noise appeared. It is planned that these sources of noise will be thoroughly investigated and eliminated to the maximum extent possible in subsequent phases of the work.

A known cause for low signal to noise is the signal reduction resulting from the inadequate optical quality of the exit ellipsoidal mirror. Although the foreoptics ellipsoidal mirrors and spectrometer paraboloids are of truly fine optical quality, the final ellipsoid used to image the spectrometer exit slit on the cell at a 2 to 1 reduction had a blur circle of over

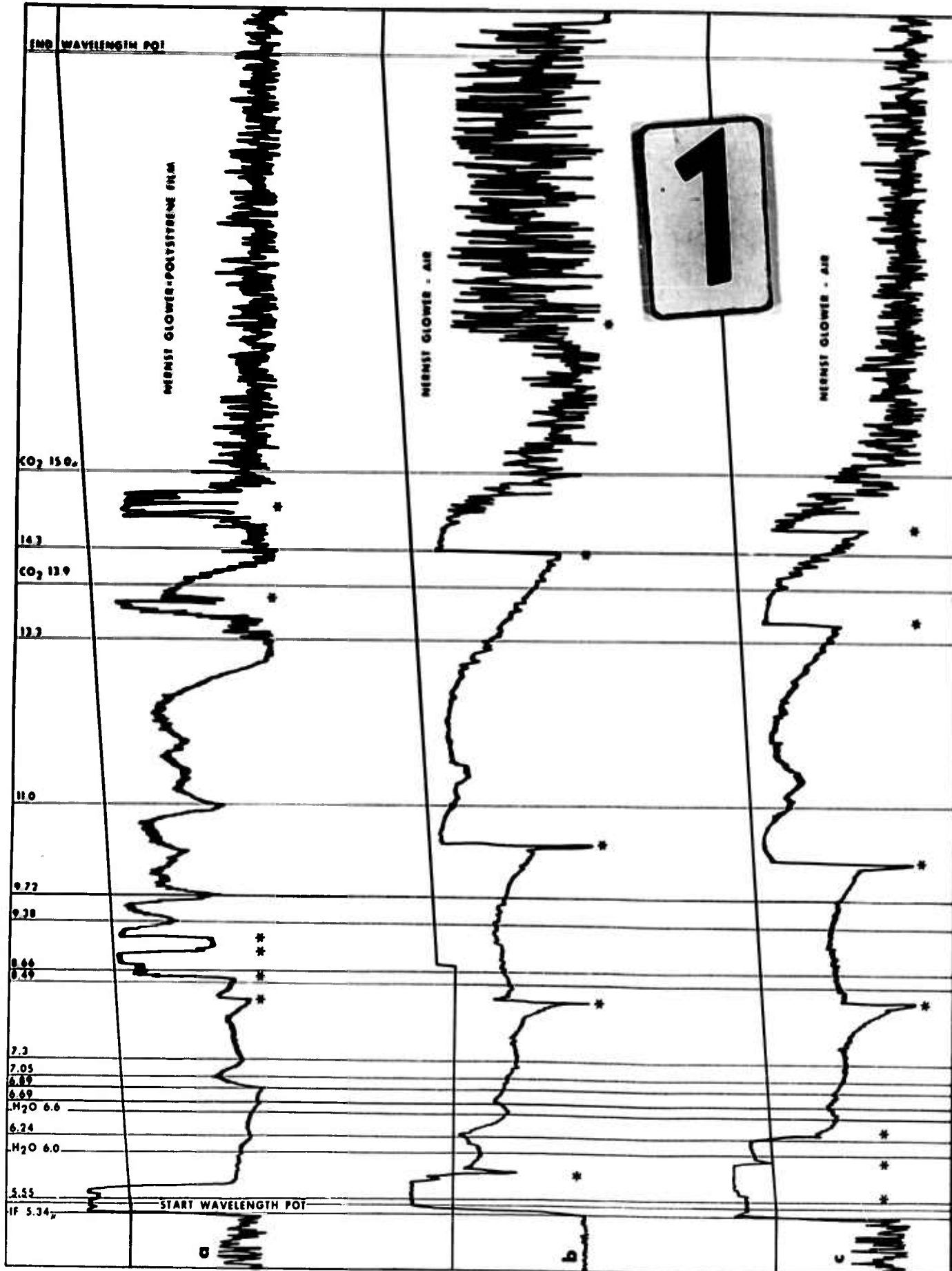

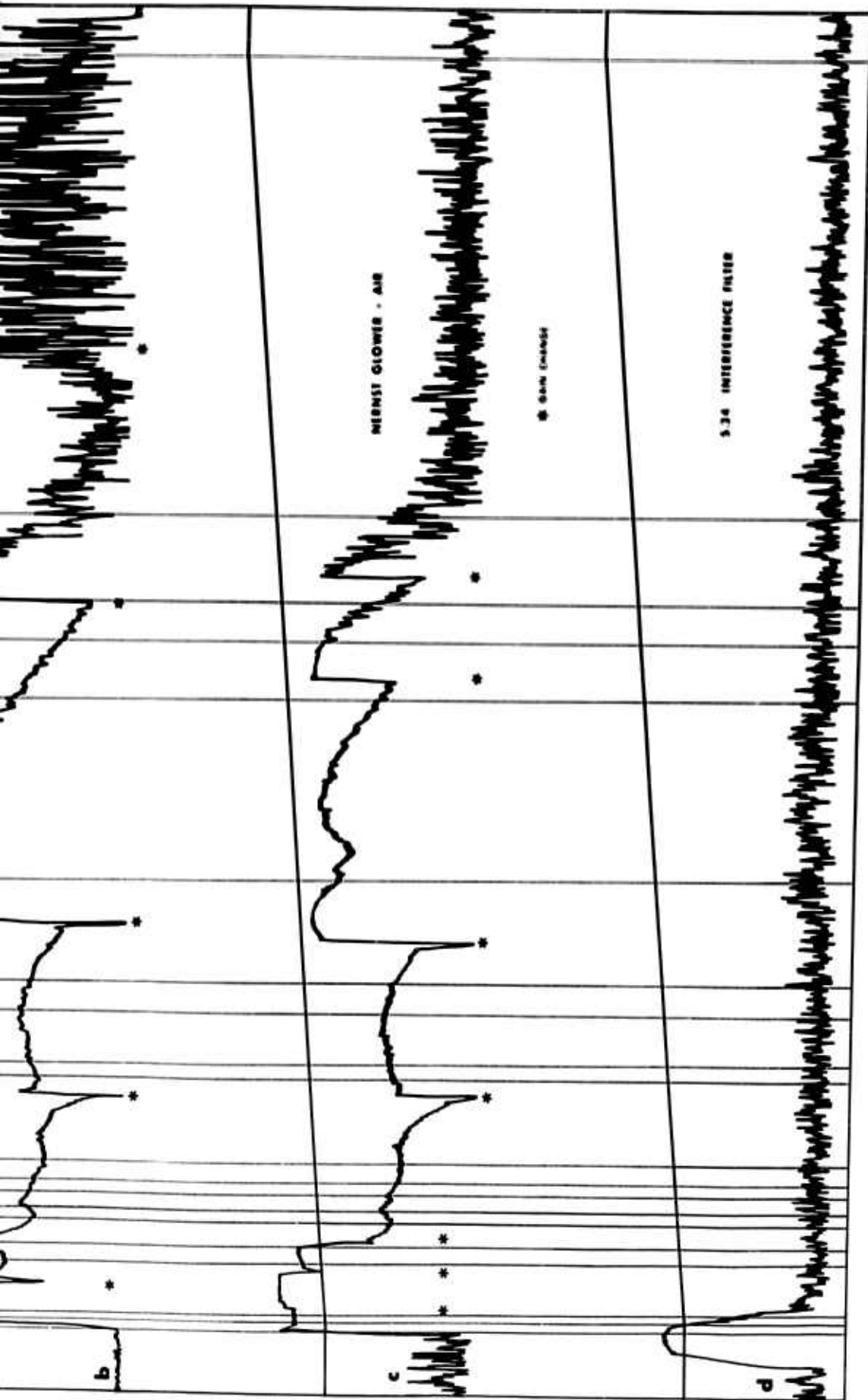

2

Figure 3-11 Long Wavelength Spectra

0.020 in. This causes some energy loss. Of all the many optical manufacturers contacted, only the L. H. Sampson Company is able to produce diffraction limited ellipsoids. This final ellipsoidal mirror will eventually be replaced by a high quality one produced by this vendor when operational spares are ordered for the system.

Figure 3-11, Trace a, also shows a number of other features. The wavelength range covered goes from 5.34 to 15 μ . The cutoff below 5.34 μ is caused by a slight misphasing of the littrow mirror. This can easily be corrected, now that the wavelength values are known. A number of water vapor, polystyrene filter, and CO₂ absorptions with their wavelengths are indicated. And, as in all the spectra of this set, the extreme energy variations over the wide spectral range covered required that manual gain control be used during the scan. The resultant voltage changes appear as the large scale vertical discontinuities in the recorded spectra.

Figures 3-11, Traces b and c, show primarily the 6.6 μ H₂O and 13.9 μ CO₂ absorptions. No filter was used.

Figures 3-11, Trace d, shows the output after the energy was passed through a 5.3 μ interference filter. The slight littrow misphasing causes cutoff before the peak of the filter is reached (the dotted portion of the curve indicates transmission if cutoff did not occur) but the complete curve is sketched in for clarity. The noise at high gain is also shown.

Figures 3-12 is a wavelength calibration curve of this spectrometer. It should be noted that all wavelength points fit the curve quite well.

A check of relative line width at half power indicates that the resolution is probably better than 0.1 μ at 9.7 μ . This is in agreement with the design goal.

It has been determined that the spectroradiometer operates and that it has the proper resolution and approximately proper wavelength range. There remain yet some improvements to be incorporated, such as improving the concentricity of the chopper drive pulley, replacing the final ellipsoidal mirrors in the long and intermediate wavelength spectrometers, obtaining a less microphonic long wavelength spectrometer cell, and obtaining a lower resistance, improved intermediate wavelength cell. It would also be desirable to try some photomultipliers having envelopes with a minimum of potassium 40 impurity.

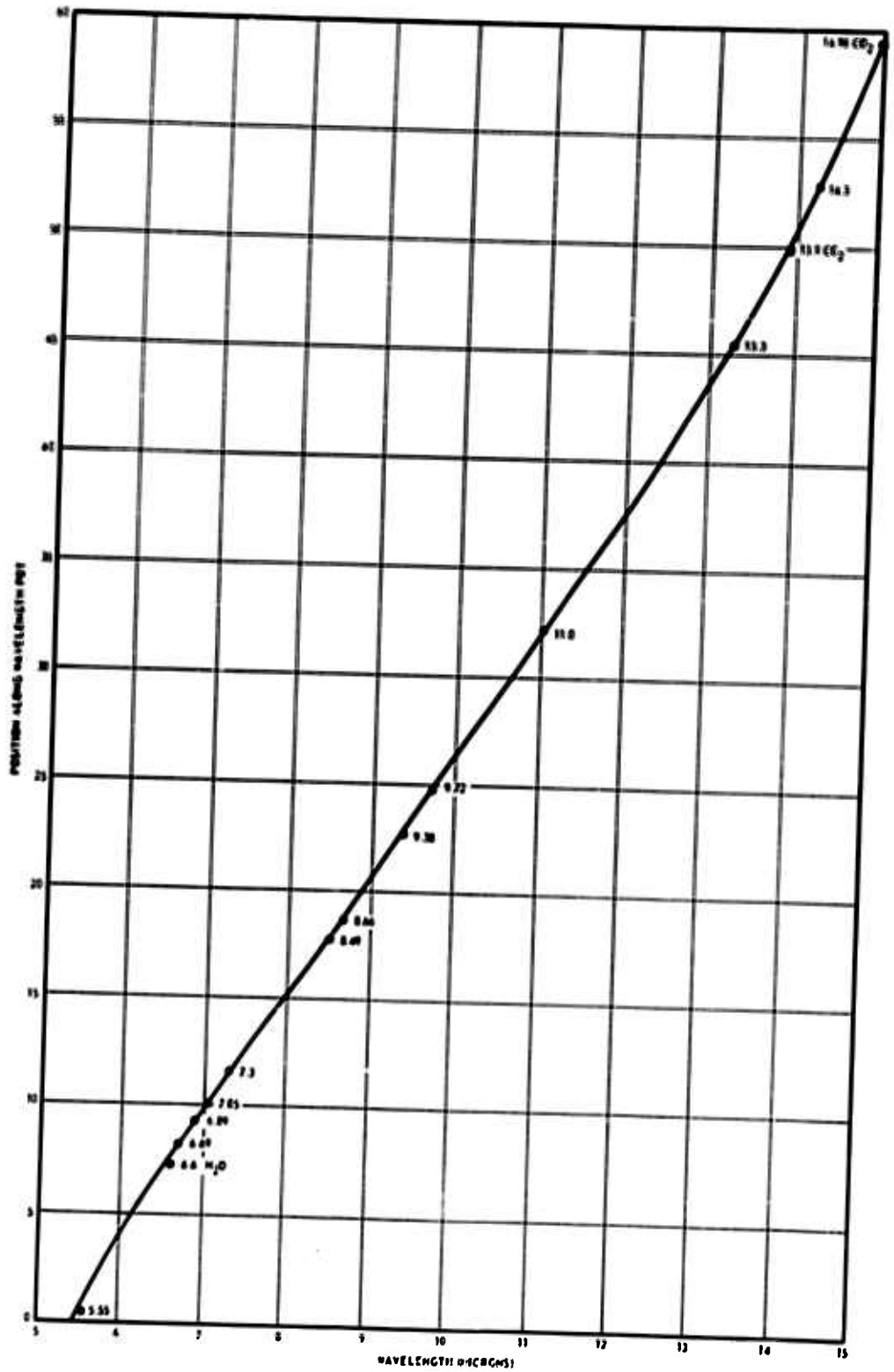

Figure 3-12 Long Wavelength Spectrometer Calibration

Beyond the foregoing problems, the future problems of the present system appear, at present, to be electronic in nature. These are shielding, grounding, and general reduction of the minute, but significant, electrical noises that degrade the signals at such extremely low energy levels.

It would be desirable also, as soon as possible, to incorporate good logarithmic amplifiers. Figure 3-11 gives ample evidence of the justification for this improvement.

3.2.6 Radiometers

Visible-Ultraviolet Radiometer

The 0.25 to 0.6 μ radiometer uses a nitrogen cooled DuMont #2114 photomultiplier having an S-13 spectral response. The average cathode luminous sensitivity is 50 μ amps/lumen and a maximum dark current of 5×10^{-2} μ amperes. The foregoing data is from the manufacturer's specifications at 25° C. Cooling a photomultiplier in liquid nitrogen (77°K) produces a factor of 40 or better reduction in dark current noise.

Figure 3-13 is a graph of noise equivalent power with wavelength. Because of difficulty with the electronic signal processing equipment, output curves are not available. The unit did perform well during the target tracking program and output values were obtained on the oscilloscope monitor. The short wavelength spectrometer, which uses an identical photomultiplier, performed satisfactorily. Spectral output curves for this photomultiplier are listed in the previous section on spectrometers.

3.2.6.1 Long Wavelength Radiometer

The long wavelength radiometer uses a copper-doped germanium detector cooled with liquid helium (4.2° K). An intensive in-house detector measurement program was conducted to verify the detector manufacturer's ratings.

These cells were tested using a 500° K Barnes blackbody source with an aperture of 0.200 inches. The blackbody was located 20 inches from the detector. The bias current was varied to produce maximum S/N ratio. A cathode follower preamplifier and a battery powered Tektronix 122 amplifier provided signal amplification. Signal levels were measured using a Hewlett-Packard Wave Analyzer. A 2-megohm impedance match was used in the preamplifier. Tests were conducted on the Texas Instrument and Santa Barbara Research detectors.

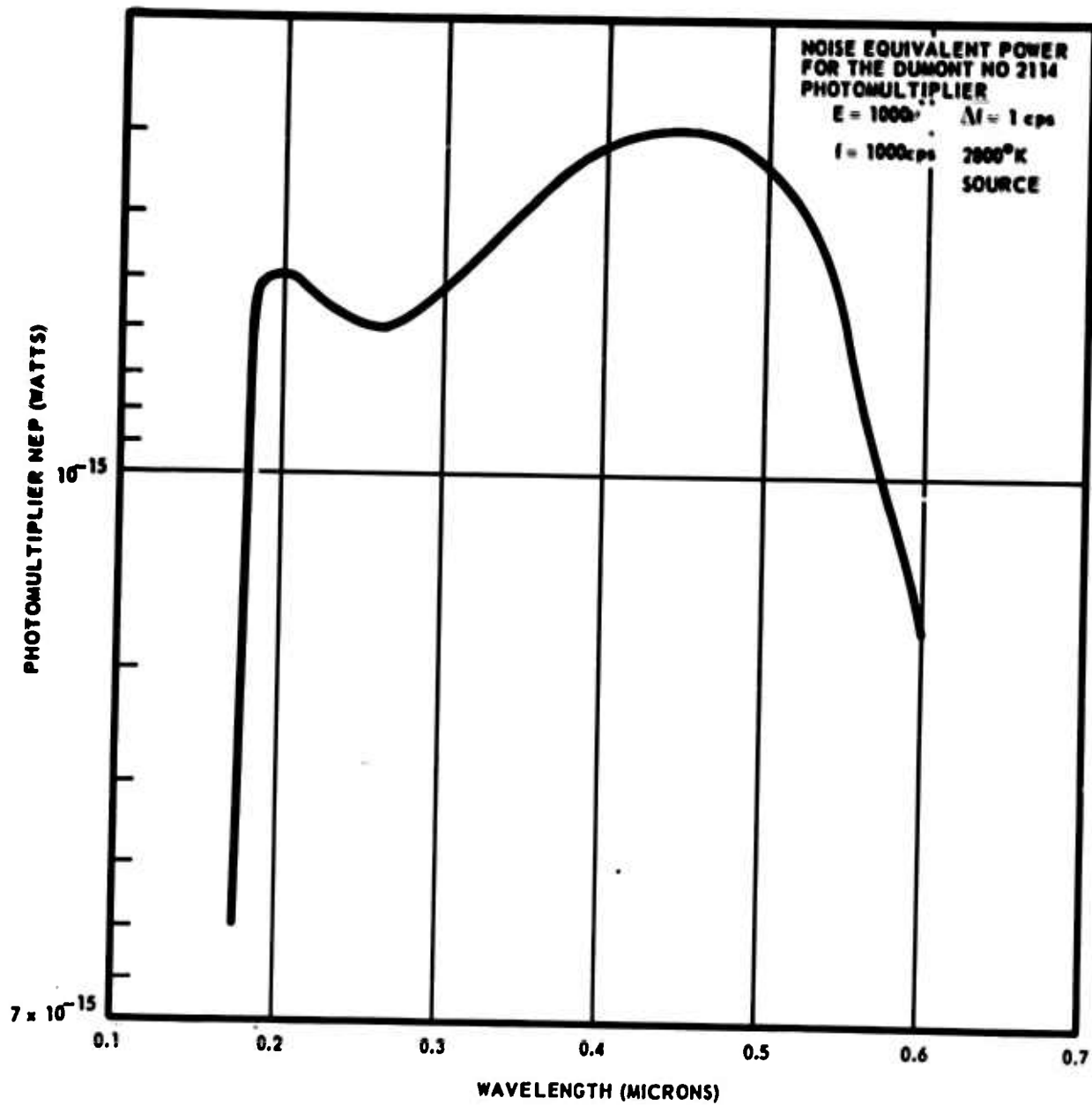

Figure 3-13 Photomultiplier Noise Equivalent Power

The following is the measurement data followed by the D^* calculated from the data.

<u>Measurement Data</u>	<u>Texas Inst.</u>	<u>Santa Barbara</u>
Bias current (μ amps)	15	2
Chopping frequency (cps)	1800	1800
Cell resistance at 4.2° K (megohms)	1.8	8
Calculated D^* (500, 1000, 1)	2×10^{10}	2.25×10^{10}
Manufacturer's rated D^* (500, 1000, 1)	2.6×10^{10}	2.2×10^{10}

Because of time and mechanical fit problems, no data were obtained with this radiometer, the major effort during this time being expended toward obtaining spectrometer data.

Preliminary filters have been selected for the radiometer filter wheel. These are intended to approximate the PbS and PbSe detector ranges. Figure 3-14 is a graph of their transmission vs. wavelength characteristics.

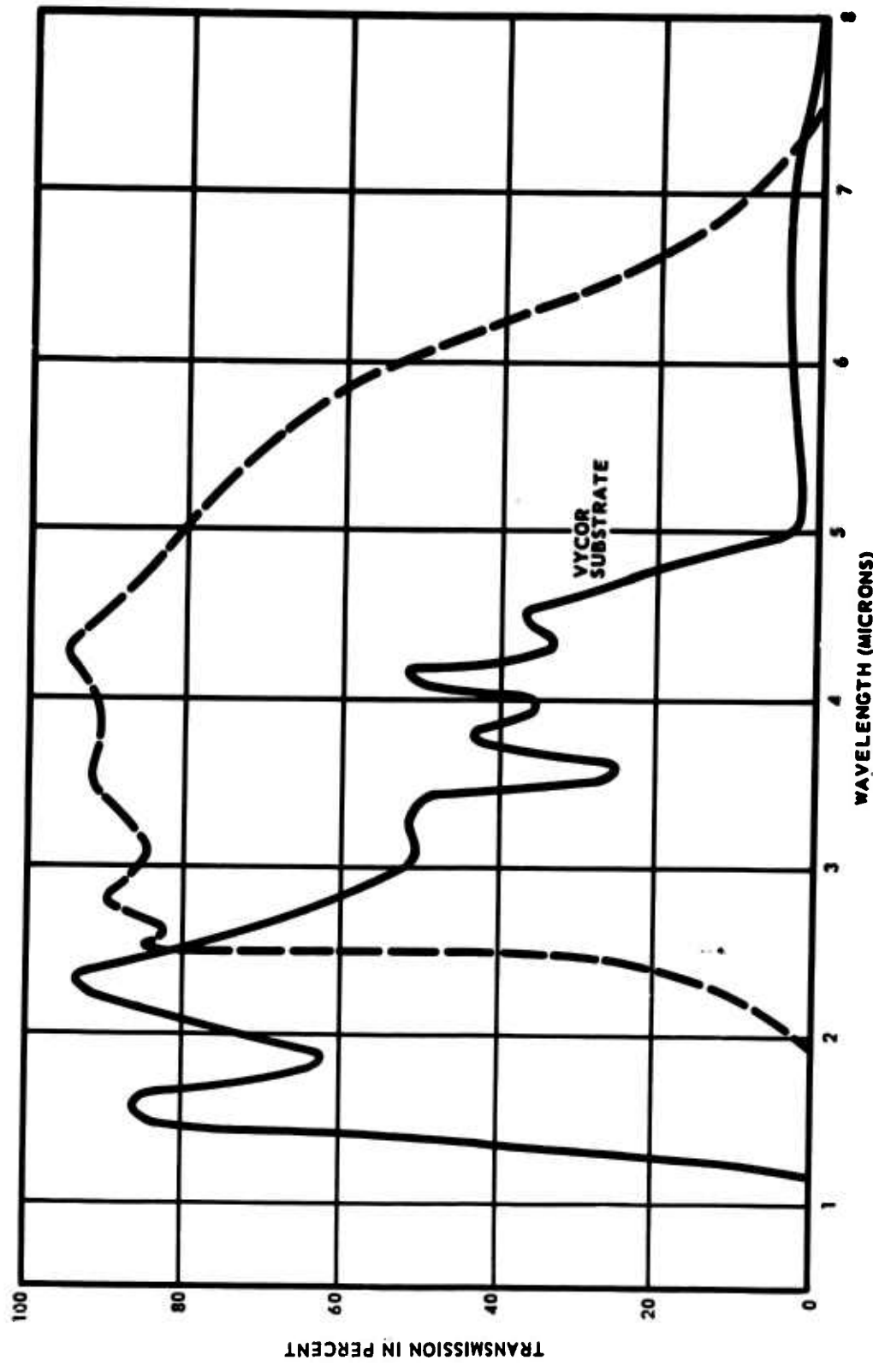

Figure 3-14 Radiometer Filter Transmissions

SECTION 4

OPTICAL TRACKING SUBSYSTEM TEST REPORT

The testing of this subsystem was performed by personnel of Space Technology Laboratories, Inc., with the cognizance of Bendix personnel. The tests were conducted at both STL and Bendix facilities. The outline of tests are noted in Appendix C with test results discussed in this section.

4.1 10" OPTICS AND SLIT MIRROR TESTS

The 10" optics assembly was mounted on the alignment jig and indexing head. These fixtures had been previously mounted on a steel topped table, weighing approximately 300 lbs, which served as a stable work surface. The 12" diameter collimator was oriented with respect to the 10" optical tracker in such a manner as to completely illuminate the tracker with the collimated beam of energy. A single target aperture was placed in the collimator and illuminated with a light source. The size of the aperture was chosen small enough to insure a target size that could be efficiently chopped by the tracker reticles. In this case, because both collimator and 10" optical unit have the same 60" focal length, a .004" diameter target aperture was sufficiently small.

The tracker error signal was nulled by moving the 10" optical unit with the indexing head. Indicating dials were used to indicate the angular deviation from the nulled position. The indication dials were placed 10" from the index heads center of rotation such that one minute of arc was indicated by a .0029" displacement at the indicator. A positive azimuth angular error (positive defined as target position to the right) of less than 3 minutes of arc, was introduced. The mounting screws of the K-mirror resolver were loosened and the resolver body rotated until the output of the elevation slit mirror detectors were 0 VDC and the output of the azimuth slit mirror was a positive DC voltage.

The tracker was then re-nulled and a positive elevation (defined as target position up) introduced by rotating the tracker head down. The outputs of the slit mirror synchronous detectors were again checked for a zero

in the azimuth channel and a positive DC voltage in the elevation channel. This completed the nulling of the K-mirror resolver and the mounting screws were re-tightened. During these tests care was exercised to insure that no motion was introduced into the orthogonal axis of the tracker.

With the above phasing complete, the slit control mirror channel was tested. This consisted of again introducing a target error angle into one axis of the tracker, by moving the tracker and indexing head, and measuring the amount of angular motion introduced into the slit mirror. Electrical position indication was given by the voltages appearing between pins 7J3-G and 7J3-J (azimuth) and 7J3-H and 7J3-J (elevation). These calibrated voltages are sent to the data recording and display equipments. The angular motion of the slit mirror was measured by auto-collimating on the mirror surface with a theodolite. The angular error introduced into the tracker was again measured by indicator dials placed on the indexing head at 10" radii. Figure 4-1A is a plot of the data taken showing the motion of the slit mirror vs. elevation error angle and Figure 4-1B is the same plot for an azimuth error angle. These plots contain data taken from two separate runs and demonstrate that the linearity is within the acceptable limits of ± 1.07 minutes for azimuth and ± 1.52 minutes for elevation. These plots also demonstrate that the repeatability of the slit mirror system is within acceptable limits (same as above) for both axes. Figure 4-2A and 4-2B are plots of the slit mirror position voltage for the elevation and azimuth axes respectively. Here again these plots reflect two separate data runs and serve to indicate the repeatability and linearity along with the output scale factors.

Two additional voltage outputs were also recorded, as functions of tracker error angle. These are the output of the data processing electronics, and the position error signal into the system rate loops. Recording this information serves to verify the scale factors required in the system for proper performance of the servo system; i. e. position error signal gain, system velocity constant, signal linearity, etc. Figures 4-3A and 4-3B are plots of the output of the data processing electronics for the elevation and azimuth channels respectively. The scale factors should theoretically be the same at this point and these agree within the accuracy of the measuring technique. The repeatability and linearity of the error signal is, in general, quite good and since these deviations occur within the loop of a feedback type system, they are not too critical. Figures 4-4A and 4-4B are plots of the DC position error signals into the system rate loops. This

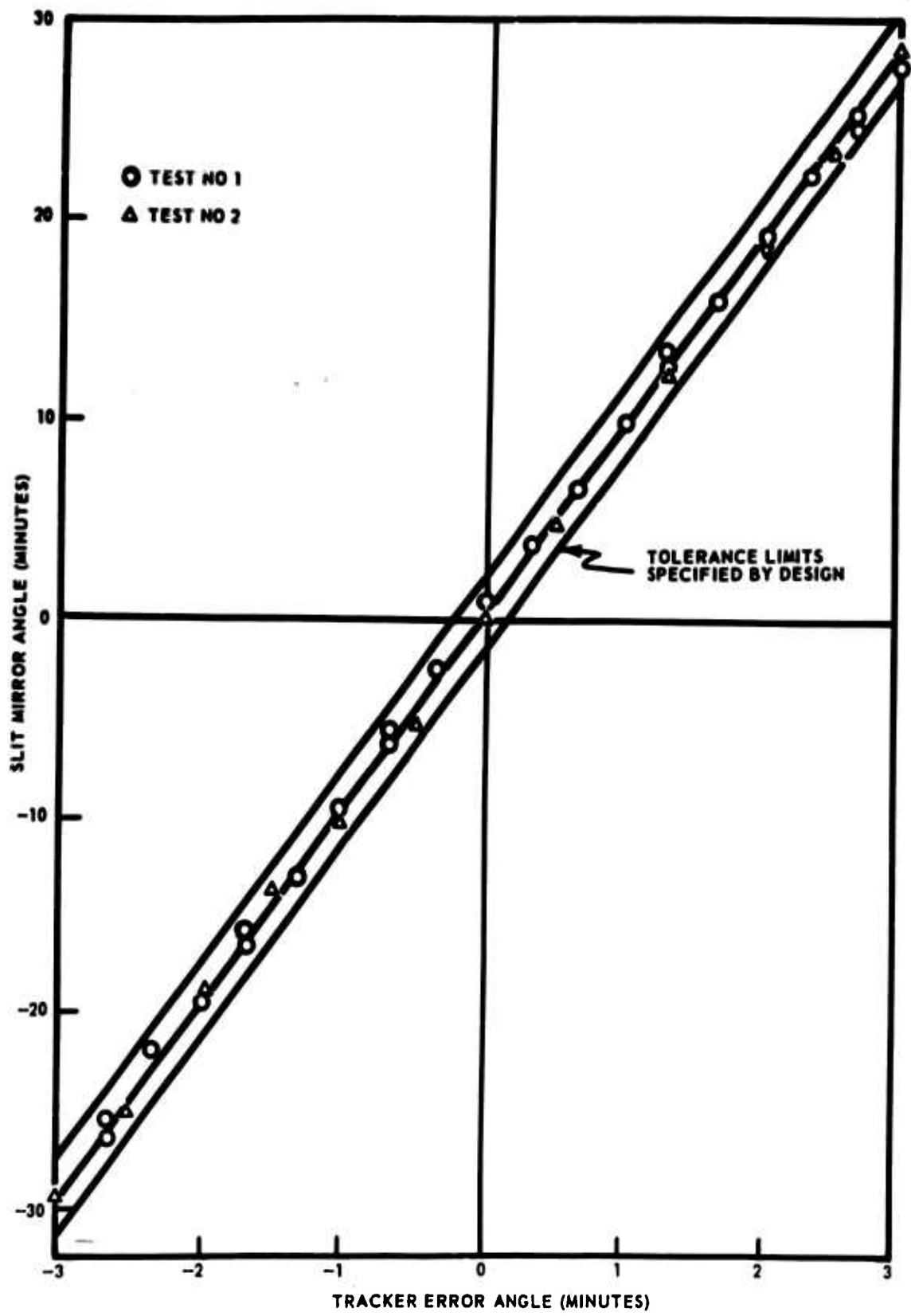

Figure 4-1A Slit Mirror Elevation Angle vs Tracker Elevation Angle

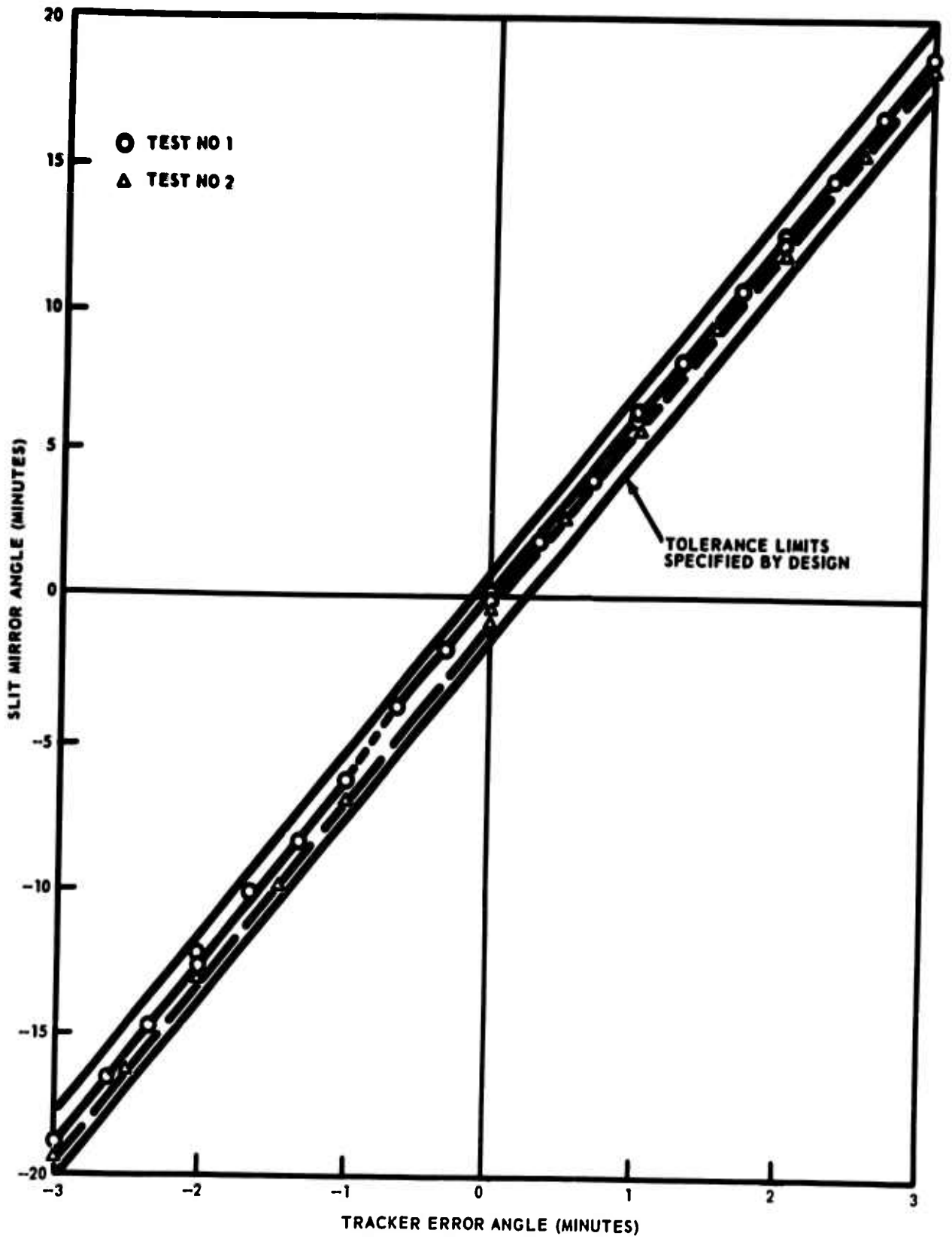

Figure 4-1B Slit Mirror Azimuth Angle vs Tracker Azimuth Error Angle

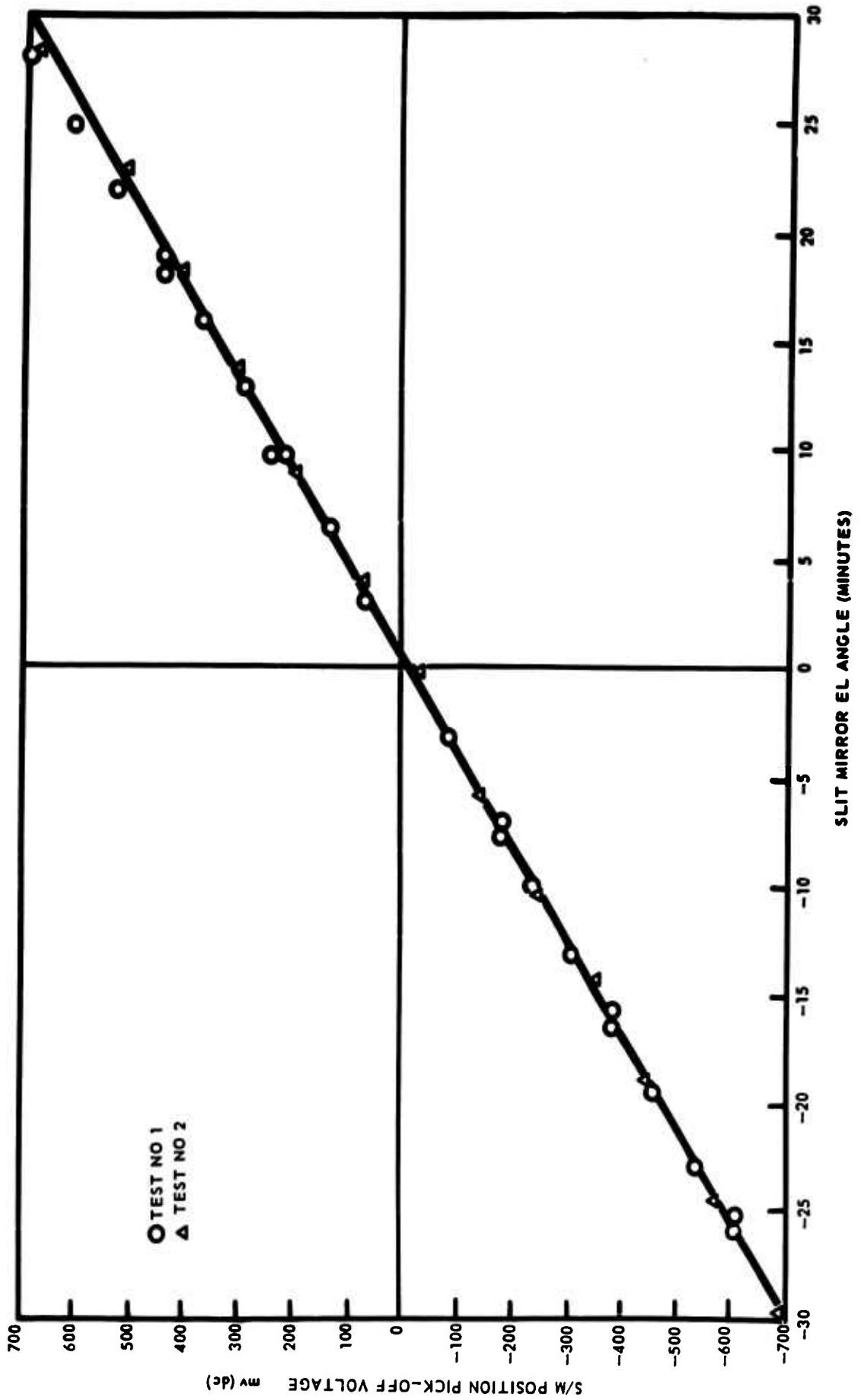

Figure 4-2A S/M Elevation Angle vs Output Elevation Position Voltage

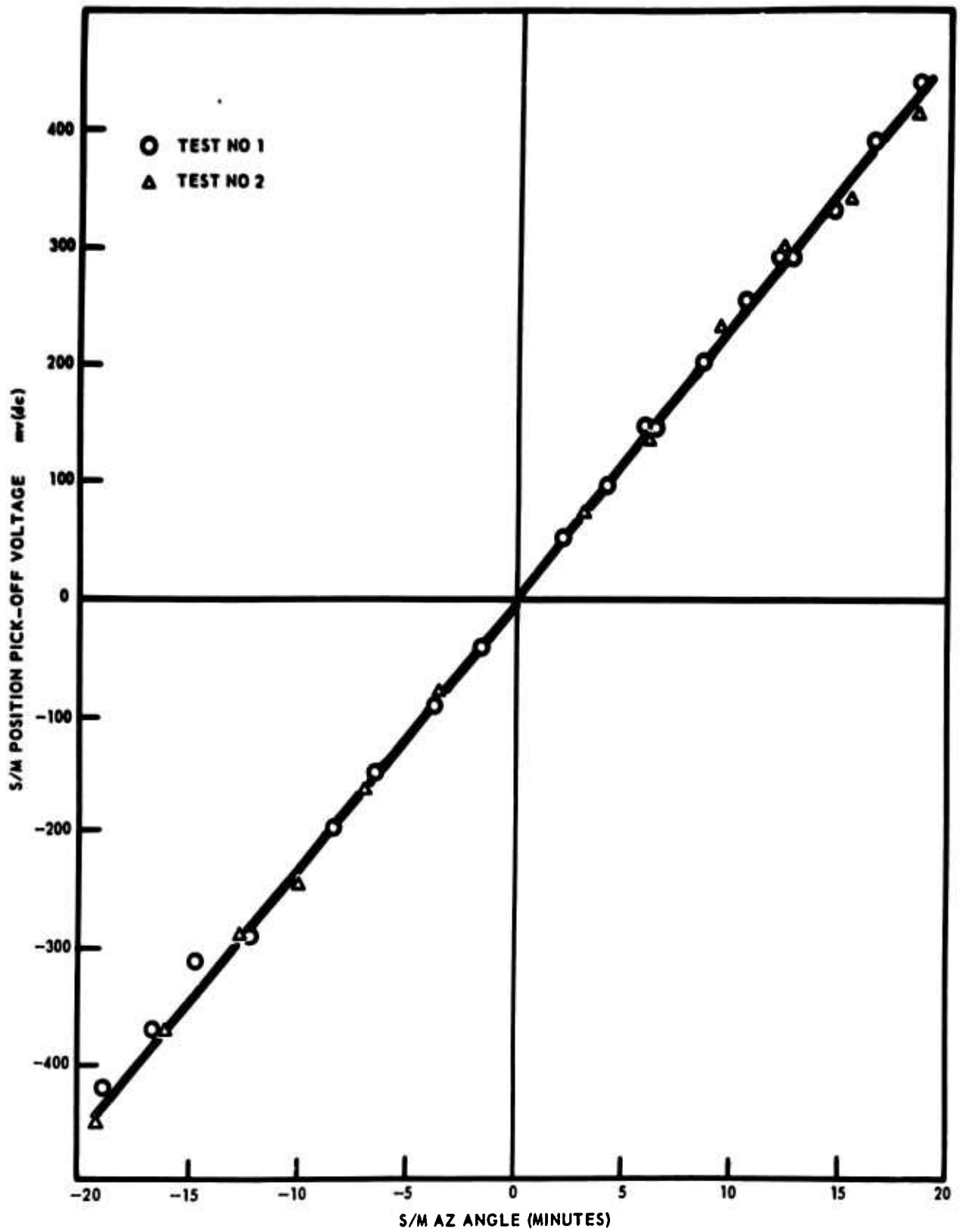

Figure 4-2B S/M Azimuth Angle vs Output Azimuth Position Voltage

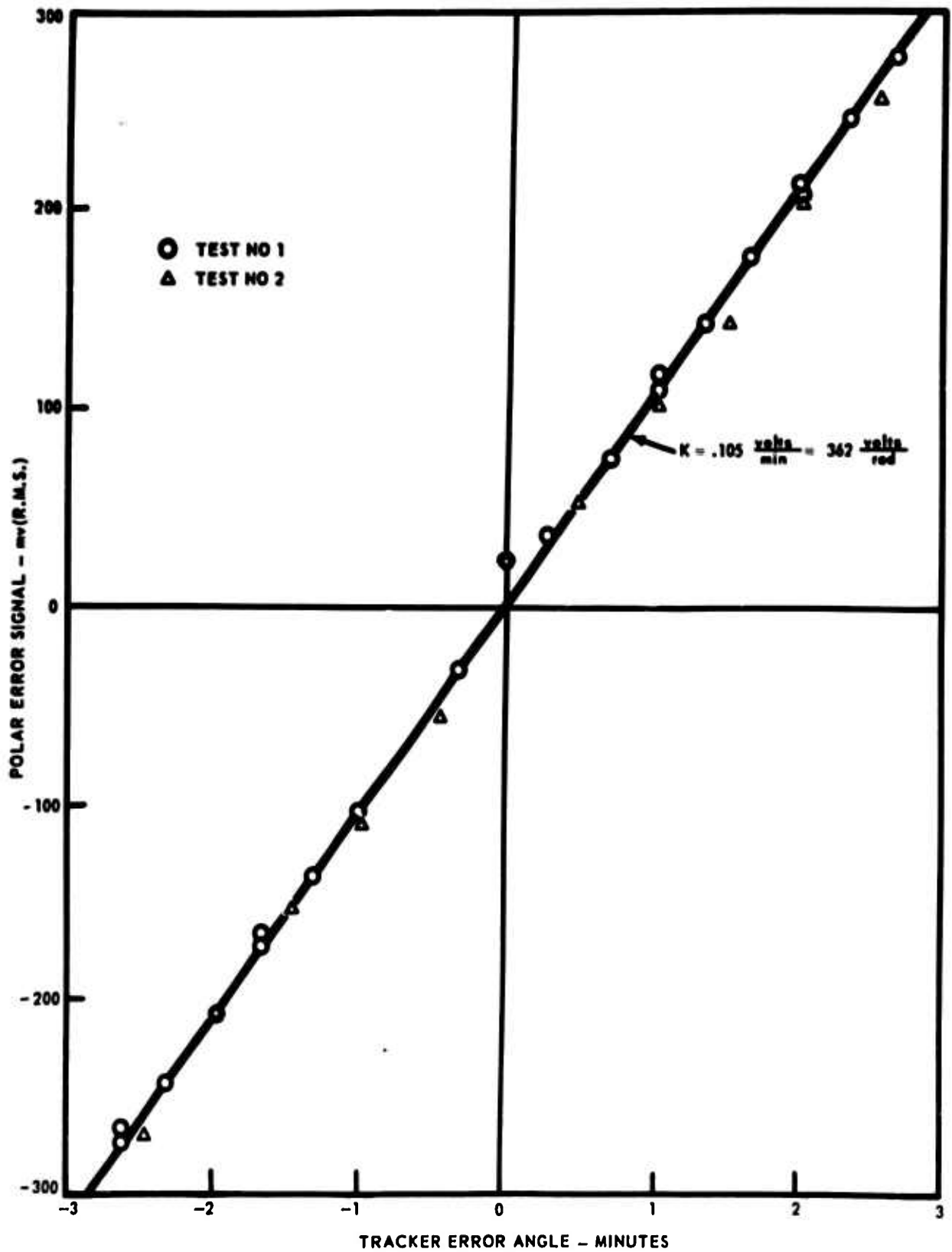

Figure 4-3A Polar Error Signal (Track) vs Tracker Elevation Error Angle

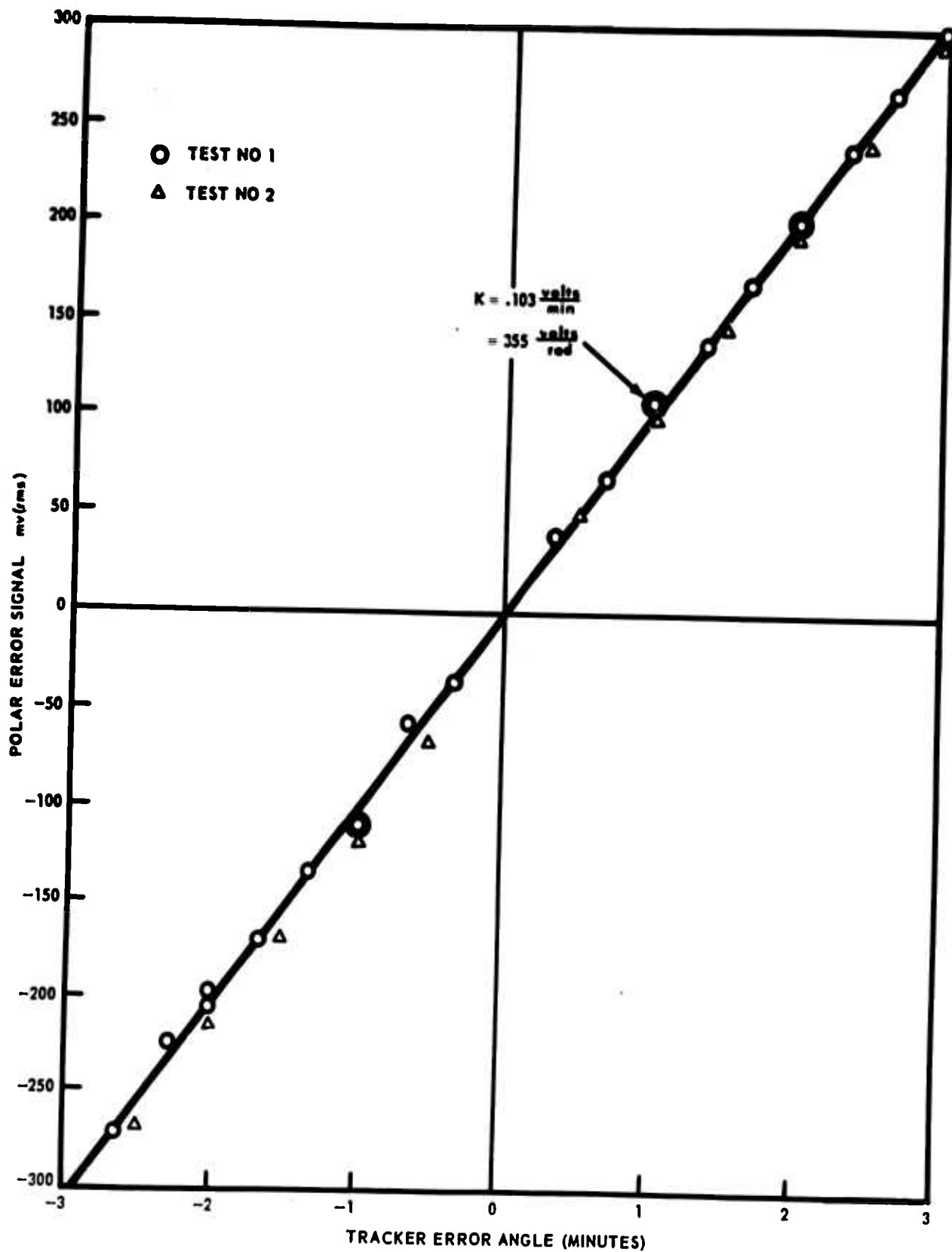

Figure 4-3B Polar Error Signal (Track) vs Tracker Azimuth Error Angle

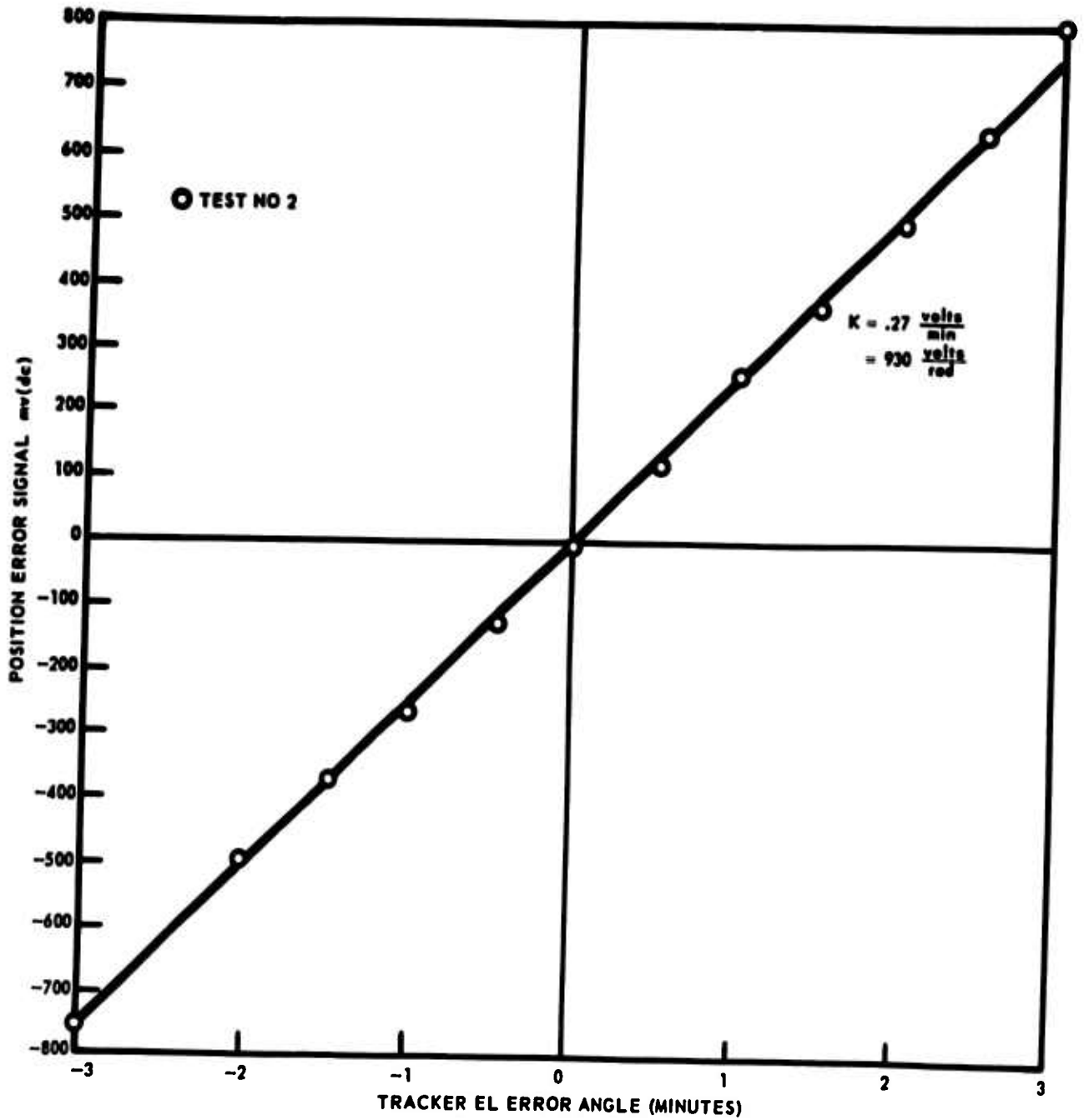

Figure 4-4A Elevation Position Error Signal vs Elevation Tracker Error Angle

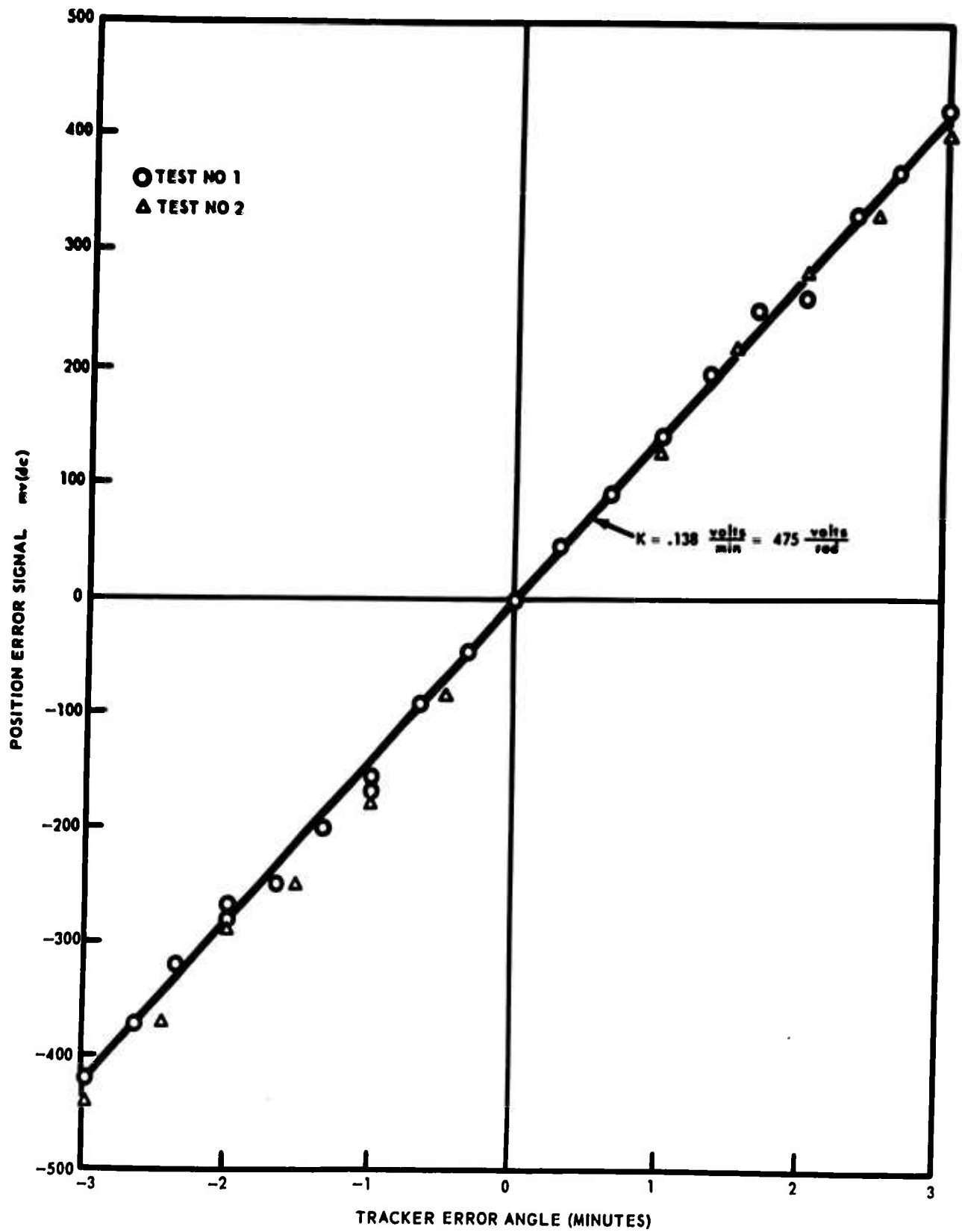

Figure 4-4B Azimuth Position Error Signal vs Azimuth Tracker Error Angle

signal is derived by amplifying the polar error signal into its azimuth and elevation components. The linearity shown is again adequate for proper system performance since this signal is also within the system feedback loop.

In the same manner as the one just described, the polar error signal from the acquisition field of view was recorded as a function of tracker error signal. Figures 4-5A and 4-5B are plots of the resultant data. The scale factors for this mode are high as shown (310 volts/radian) but were adjusted at a later time to the proper value (140 volts/radian). The acquisition voltage serves to develop an error signal which slews the target into the track field of view. This signal is amplified by an amplifier which is also used in the track channel. The resulting factor (the position error signal, in the acquisition mode) is 400 VDC/radian (elevation) and 200VDC/radian (azimuth).

4.2 SERVO SYSTEM TESTS

Because a collimated source of infrared energy, that could be moved in a programmed manner, was not available, a dynamic error angle test could not be made for the acquisition and track modes. Using the scale factors just derived along with the scale factors for the system rate loops the system velocity constants, K_v , may be calculated for each of the three modes; Track, Acquisition, and Search. From these constants the system angular errors in each channel, may be calculated for the peak specified input rates. These will be accurate only for steady-state rates.

4.2.1 Track Mode

From the scale factors shown in Figures 4-4A and 4-4B the system velocity constants, for the track mode, may be calculated. Multiplying the scale factors shown in Figures 4-4A and 4-4B with the scale factor for the system rate loops, .188 radians/second/volt, gives the azimuth and elevation velocity constant;

$$K_v = \frac{\dot{\theta}_{in}}{\theta_{error}} = 930 \frac{\text{volts}}{\text{rad.}} \times .188 \frac{\text{rad/sec}}{\text{volt}} = 175 \text{ sec}^{-1} \text{ (Elevation)}$$

$$= 475 \frac{\text{volts}}{\text{rad.}} \times .188 \frac{\text{rad/sec}}{\text{volt}} = 89 \text{ sec}^{-1} \text{ (Azimuth)}$$

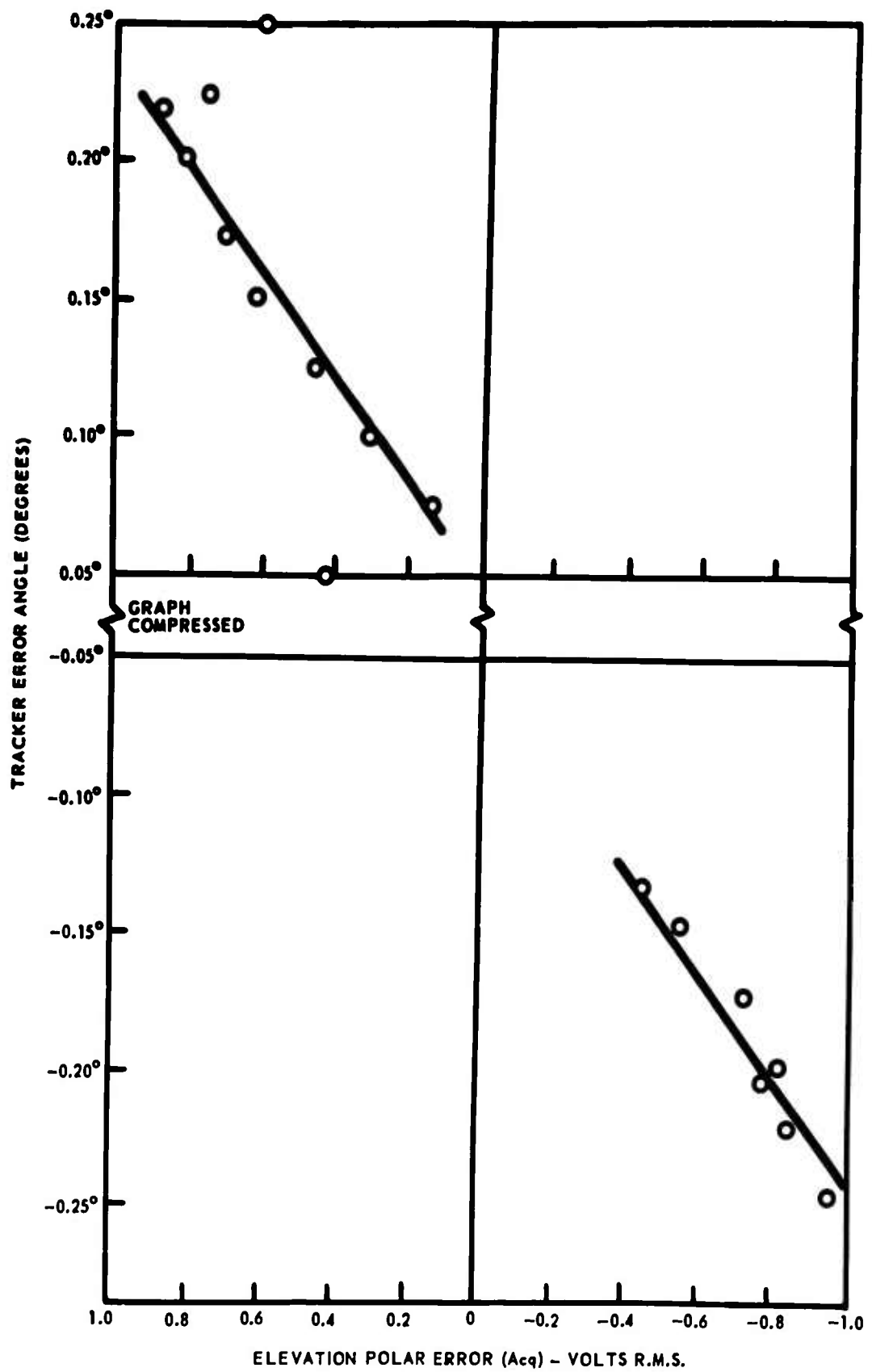

Figure 4-5A Polar Error Signal (Acq.) vs Tracker Elevation Error Angle

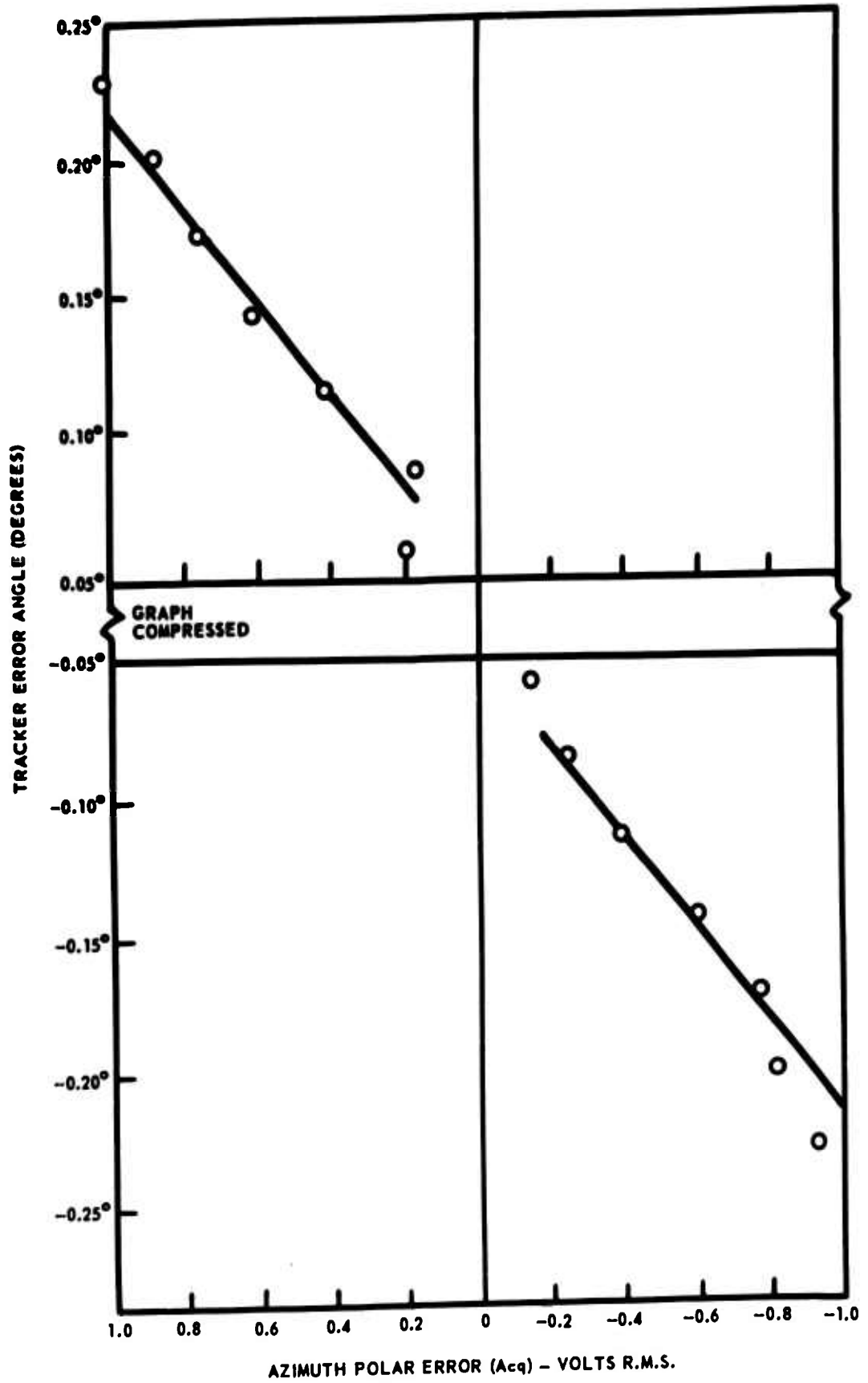

Figure 4-5B Polar Error Signal (Acq.) vs Tracker Azimuth Error Angle

Having derived the system velocity constants the maximum error angle may be derived for peak specified input target rates. For elevation,

$$K_v = \frac{\dot{\theta}_{in}}{\theta_{error}} \quad \theta_{error} = \frac{\dot{\theta}_{in}}{K_v} = \frac{3 \text{ deg/sec}}{175} = .017 \text{ degrees.}$$

Since the radius of the track field of view is .05 degrees, this calculation shows that the target will remain well within the track FOV for the peak rate. In a like manner azimuth is computed. Here, however, the peak rate is 1.5 deg/sec (3 degrees/sec optical time of sight).

$$\theta_{error} = \frac{\dot{\theta}_{in}}{K_v} = \frac{1.5 \text{ degrees/sec}}{89} = .017 \text{ degrees.}$$

This calculation also shows that the target will remain well within the FOV for peak input rates.

4.2.2 Acquisition Mode

The velocity constants and error angles, for steady-state rate inputs in the acquisition mode, are calculated in the same manner.

$$\begin{aligned} K_v &= \frac{\dot{\theta}_{in}}{\theta_{error}} = 200 \frac{\text{volts}}{\text{radian}} \times .188 \frac{\text{radians/sec}}{\text{volt}} = 37.5 \text{ sec}^{-1} \text{ (azimuth)} \\ &= 400 \frac{\text{volts}}{\text{radian}} \times .188 \frac{\text{radians/sec}}{\text{volt}} = 75 \text{ sec}^{-1} \text{ (elevation)} \end{aligned}$$

The system errors angles are given, for the acquisition mode, by:

$$\begin{aligned} \theta_{error} &= \frac{\dot{\theta}_{in}}{K_v} = \frac{3 \text{ deg/sec}}{75} = .04 \text{ degrees (elevation)} \\ &= \frac{1.5 \text{ deg/sec}^*}{37.5} = .04 \text{ degrees (azimuth)} \end{aligned}$$

* 1.5 deg/sec at the gimbal = 3 deg/sec optical line-of-sight rate.

4.2.3 Search Mode

Although the gain adjustments for the search mode were not made during this period, but prior to system tests, the velocity constants will be calculated at this point. The gain of the error amplifiers in the search channels, had been previously set to $K=26$ for azimuth channel and $K=52$ for the elevation channels. The scale factors of the resolver error voltages is 10 volts/radian. The velocity constants for the search mode are then:

$$K_v = 10 \frac{\text{volts}}{\text{radian}} \times 26 \frac{\text{volt}}{\text{volt}} \times .188 \frac{\text{rad/sec}}{\text{volt}} = 49 \text{ sec}^{-1} \text{ (azimuth)}$$
$$= 10 \frac{\text{volt}}{\text{rad}} \times 52 \frac{\text{volt}}{\text{volt}} \times .188 \frac{\text{rad/sec}}{\text{volt}} = 98 \text{ sec}^{-1} \text{ (elevation)}$$

These are close enough to the design values of 50 and 100 respectively.

4.3 SENSITIVITY TEST

With the 10" optical unit mounted on indexing head and aligned with the collimator a sensitivity test was conducted for the lead sulphide detector installation. A special chopping mechanism was employed at the focal plane of the collimator so that the black body could be chopped at the carrier frequency of the electronics. This allowed checking the sensitivity using external modulation or the system reticle modulation.

The test set up conditions were as follows:

1. Collimator - 12" clear aperture, 60" focal length

Target aperture size $A_1 = .029"$ when using collimator chopper

$A_2 = .0047"$ when using system track reticle

Black Body Temperature - 500°C

Collimator Efficiency - 80% with two reflections

2. 10" Optical Unit Under Test

Unit aligned for zero target position

Noise and Signal measured at preamp output (7 A1 J101 pin 16)

1000 x Attenuator on for collimator chopping
off for system chopping

4000 cps carrier frequency

1.2 - 2.8 μ spectral pass band

Calculations:

Total Black Body Flux = .65 watts/cm² steradian

Amount in spectral pass band = 10% = W = .065 w/cm² steradian

Area of aperture $A_1 = \frac{\pi}{4} (.029)^2 (2.54)^2 = 4.26 \times 10^{-3} \text{ cm}^2$

$$A_2 = \frac{\pi}{4} (.0047)^2 (2.54)^2 = 1.12 \times 10^{-4} \text{ cm}^2$$

Focal length of collimator $f = (60) (2.54) = 152.4 \text{ cm.}$

Flux at exit of collimator = B

$$B = \frac{WA}{f^2} \times \text{efficiency}$$

$$B_1 = \frac{(.065) (1.12) (10^{-3})}{(152)^2} (.80) = 9.58 \times 10^{-9} \text{ watt/cm}^2$$

$$B_2 = \frac{(.065) (1.12) (10^{-4})}{(152)^2} (.80) = 2.52 \times 10^{-10} \text{ watt/cm}^2$$

In the first case where the black body flux is chopped at the collimator and additional attenuation of 50% from the stationary track reticle must be taken into account. This comes from the fact that the large aperture size results in a similarly large image size at the track reticle - one that covers many spokes and spaces.

This makes an effective flux for the first case

$$B_1 \text{ eff} = 4.29 \times 10^{-9} \text{ watt/cm}^2$$

3. Measurements

Case 1 - Black Body or Collimator Chopping

Attenuation on Signal of 1000 x

Signal + Noise = 7.8 mv)

) Broad band measured with V. T. V. M.

Noise = 0.4 mv)

$$\frac{S + N}{N} = \frac{7.8}{.4} = 19.5 \quad \frac{S}{N} = 18.5$$

$$\text{Without Attenuator } \frac{S}{N} = 18.5 \times 10^3$$

Case 2 - Track Reticle

No attenuation of signal

Signal + Noise = 900 mv

Noise = 13 mv

$$\frac{S + N}{N} = 69.2 \quad \frac{S}{N} = 68.2$$

4. Sensitivity

$$\text{Case 1} \quad \text{N. E. F. D.}_1 = \frac{0.58 \times 10^{-9}}{18.5 \times 10^3} = 5.2 \times 10^{-13} \text{ w/cm}^2$$

$$\text{Case 2} \quad \text{N. E. F. D.}_2 = \frac{2.52 \times 10^{-10}}{68.2} = 3.67 \times 10^{-12} \text{ w/cm}^2$$

The main reason that Case 2 does not agree is that the aperture size was not small enough to insure 100% modulation efficiency in the reticle. With a .0047" aperture the blur circle at the reticle was approximately .0067". With .0040" spokes this will result in a modulating efficiency of less than 30%.

The remaining factor of two difference comes from the fact that the attenuator calibration may not have been correct due to non-linearity in the detector. This is because the attenuator works on the detector bias.

In either case, however, the sensitivity compares favorably with the predicted sensitivity of 2×10^{-12} w/cm².

This completed that portion of the system testing wherein the tracker was mounted on the indexing head. It was removed for installation on the platform.

4.4 SUBSYSTEM TESTING WITH ALL UNITS ON PLATFORM

With the tracker mounted on the platform the alignment of all optics, on the platform, was completed. This included optically positioning the tracking mirror gimbals to zero position with respect to the platform. With the tracking mirror pinned to the position, the phasing of all synchros and resolvers on the two gimbal axes, was completed. With this phasing completed, the alignment of the elevation and azimuth rate gyros was completed.

4.4.1 Search Loop Stability Tests

A 10 volt (rms) signal was applied to the X input of the gimbal resolver and the Y and Z inputs were shorted together. This simulates a pointing command of zero degrees for both azimuth and elevation. The elevation servo amplifier was removed and the system energized in the search mode. The MOD (Manual Optical Director) joystick adds a signal in series with the error signal in each channel. These signals are derived from potentiometers mounted on the MOD stick. It has two scale factors; one for producing $\pm 8^\circ$ total gimbal motion and one for producing $\pm 4^\circ$. A switch is provided for selecting the desired sensitivity. Step functions were introduced into the azimuth axis by moving the gimbal off slightly in azimuth with the MOD stick and switching the sensitivity switch back and forth. The capacitors of the compensation networks were adjusted until the azimuth axis exhibited about one and one-half overshoots of the position error signal or a relative damping of about 0.4. The elevation servo amplifier was replaced and the azimuth servo amplifier removed. The process was repeated with the elevation axis for approximately the same results.

4.4.2 Track and Acquisition Loop Stability Tests

The 12" collimator was again oriented with respect to the tracking mirror in such a manner as to completely illuminate the 10" tracker. A single target aperture, of .004" diameter, was placed in the focal plane of the collimator, and illuminated with a visible light source. The elevation servo amplifier was removed and the system energized. By means of the MOD and the optical telescope the system was "locked on" the target appearing in the collimator. There is no convenient way to apply a step function change to the target's position, because of the size and weight of the collimator. However, the scanner could be impulsed, or very nearly so, by striking the tracking mirror gimbal sharply. Using this technique the capacitors of the azimuth compensation network in the acquisition track channel were adjusted until the system demonstrated a relative damping ratio of approximately 0.4. The elevation servo amplifier was replaced and the azimuth servo amplifier removed. The procedure was repeated for the same results in the elevation channel. Since the acquisition mode uses the same error amplifier and compensation networks as the track channel, there is no adjustment of acquisition compensation networks.

4.4.3 Tracking Accuracy and Repeatability

The tracking mirror gimbal was pinned in the zero position. The aperture in the collimator was centered, in the track field of view, by means of thumbscrews which allow small motions of the position of the aperture in the focal plane of the collimator. The center position is indicated by a null in the track polar error signal. This null was 18 mv (rms) magnitude and consisted primarily of residual noise from the track channel data processing electronics. Acquiring the target several times by means of the MOD stick and telescope showed an average steady-state polar error signal of 22 mv (rms) which is signal plus noise. Assuming the signal and noise add in an rms manner the static resolution or tracking accuracy may be calculated.

$$\begin{aligned} N &= 18 \text{ mv} \\ \sqrt{S^2 + N^2} &= 22 \text{ mv} \\ (S^2 + N^2) &= 484 \text{ and } N^2 = 324 \\ S^2 &= (S^2 + N^2) - N^2 = 484 - 324 = 160 \\ S &\approx 13 \text{ mv} \end{aligned}$$

The scale factors shown in Figures 4-3A and 4-3B are approximately 350 volts/radian or 350 millivolts/milliradian. The residual 13 millivolt signal is then equivalent to an angular error of:

$$\frac{13}{350} = .037 \text{ milliradians} = 8 \text{ seconds of arc}$$

4.4.4 Search Loop Frequency Response

A frequency response of the system search mode was made next. Signals from a Servoscope were injected into the Y and Z inputs of the gimbal resolvers simulating azimuth and elevation input commands respectively. The input amplitudes were adjusted to produce three separate command excursions of $\pm 2.5^\circ$, $\pm 1^\circ$ and $\pm 0.5^\circ$. The error signal was measured and recorded just ahead of the compensation networks and these reduced to error angles by dividing the recorded error voltage by the search position error scale factors of 260 volts/radian for azimuth and 520 volts/radian for elevation. Figure 4-6A and 4-6B are plots of the resulting data for each axis. These plots show the error angle vs. frequency for the three input amplitudes. The curves prove that the error angle is much less than the referenced FOV for all frequencies below 1 cps which includes all frequencies of interest.

4.4.5 Multiple Target Tests

The single target aperture in the collimator was replaced with a three target aperture. The three targets are separated from one another by a known dimension and the apertures are of a known relative hole size, this had been previously determined using a traveling microscope. Since the focal length of the collimator is known (60") the separation of the target apertures can be reduced to an angular separation. Also, since the relative hole size of the apertures is known and they are illuminated by a common source of known black body temperature their intensities and relative intensities were calculated. The strongest of the three targets was acquired by means of the MOD stick and the telescope. The readings of the T_1 , T_2 and A position meters were compared to the calculations discussed above and found to agree within about 5%. Also, the intensity meters agreed with the calculations within approximately this figure.

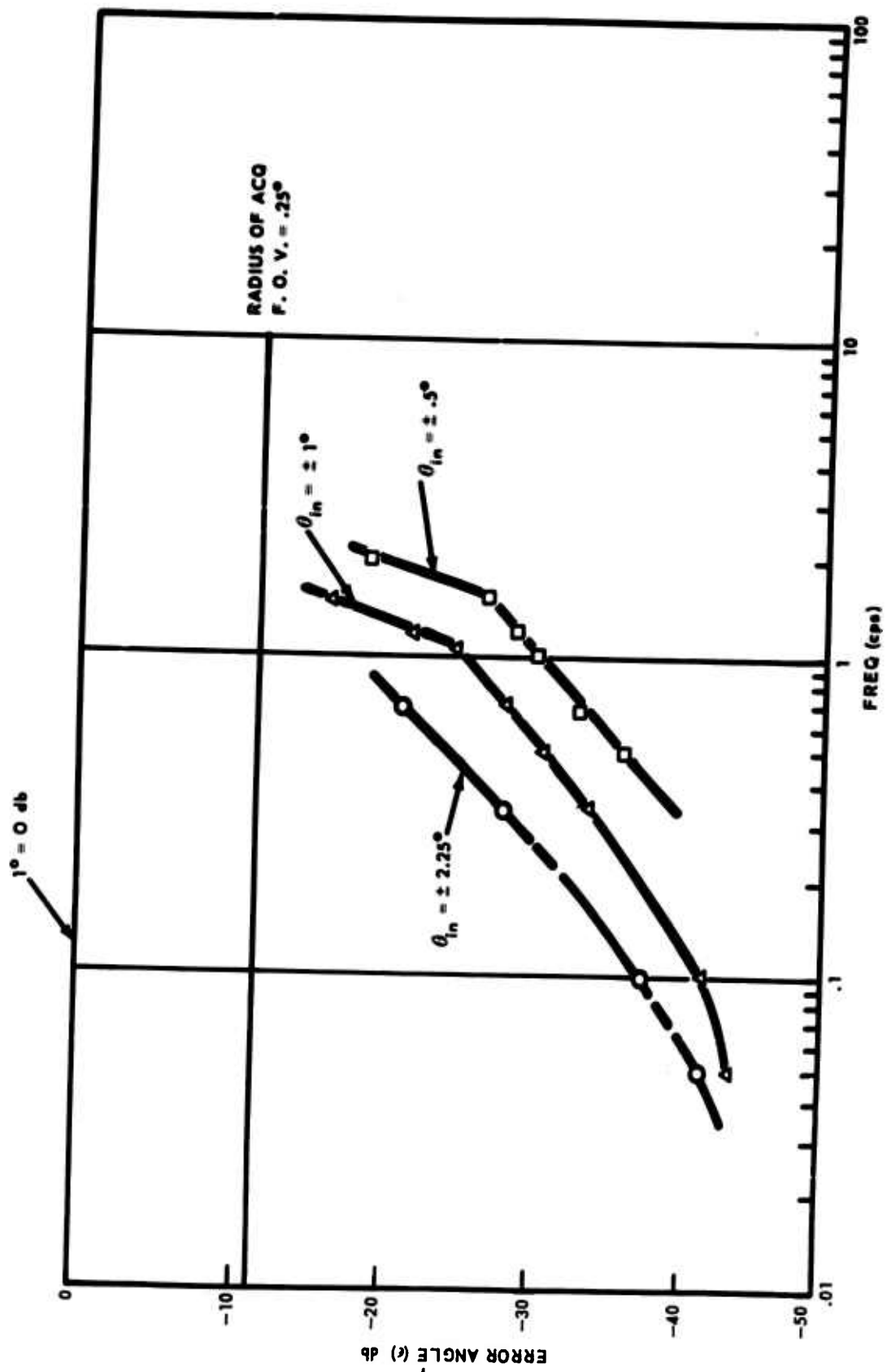

Figure 4-6A Elevation Error Angle vs Angular Frequency for Various Input Angular Excursions (search Mode)

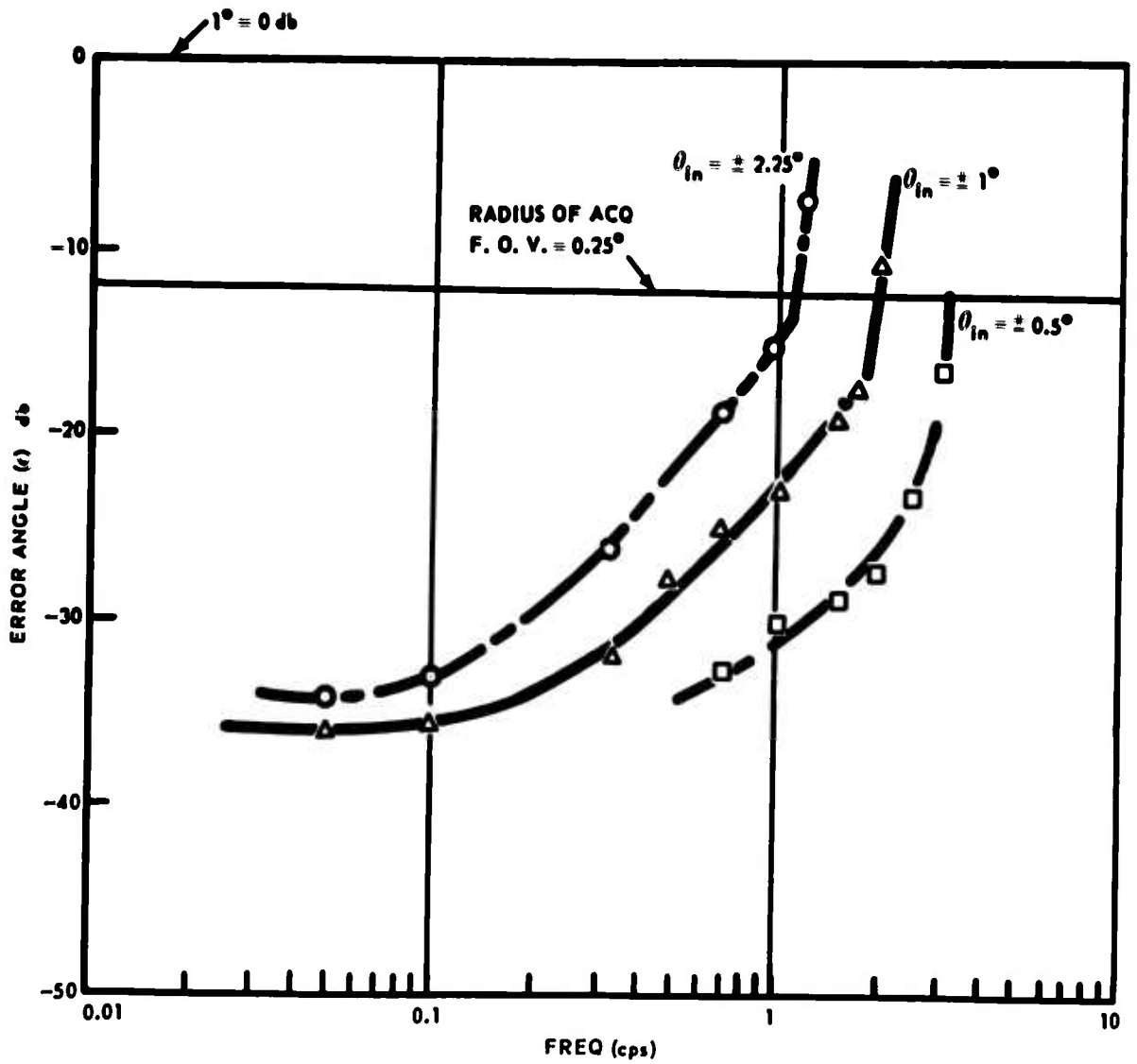

Figure 4-6B Azimuth Error Angle vs Angular Frequency for Various Input Angular Excursions (search Mode)

The energy from each of the three targets was then sequenced into the slit of the spectrometer by each of two methods; the manual provided on the control panel and by simulating the grounding signal from the computer with a push-button switch. In each case the energy was focused entirely within the slit.

4.4.6 Dynamic Tests of System

The last test to be performed with the tracking subsystem was that of tracking the landing light of a small airplane. The tests were performed during both daylight and night. The airplane would climb to altitude and turn to point its landing light at the test setup. The light was acquired by means of the MOD stick and the optical telescope. The longest daylight range tested was approximately 5 miles. The longest night range tested was approximately 6 miles. The tracking of the subsystem was successful on all occasions and continued tracking up to elevation angles of approximately 45 degrees. Figure 4-7 is a photograph taken with a boresight camera through the tracker optics. Figure 4-8 is another photograph taken through a second boresight camera through the slit mirror optics. The reason the target energy is not contained entirely within the slit is that the target size was much larger than the slit opening at the time the picture was taken. In addition the final focusing of the collimator slit had not been completed at the time of these tests.

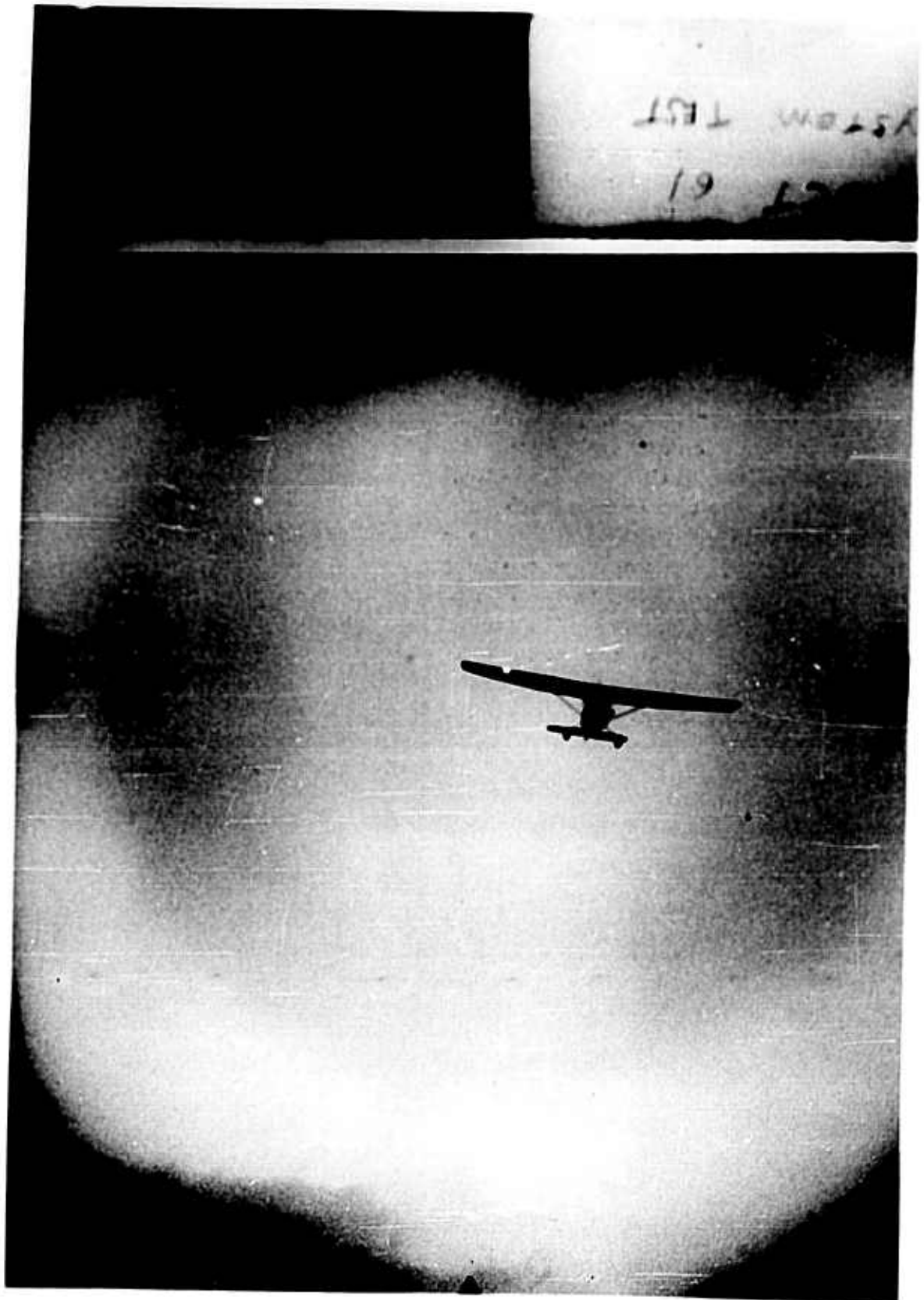

Figure 4-7 Wide Angle Boresight Camera View of Daylight Tracking

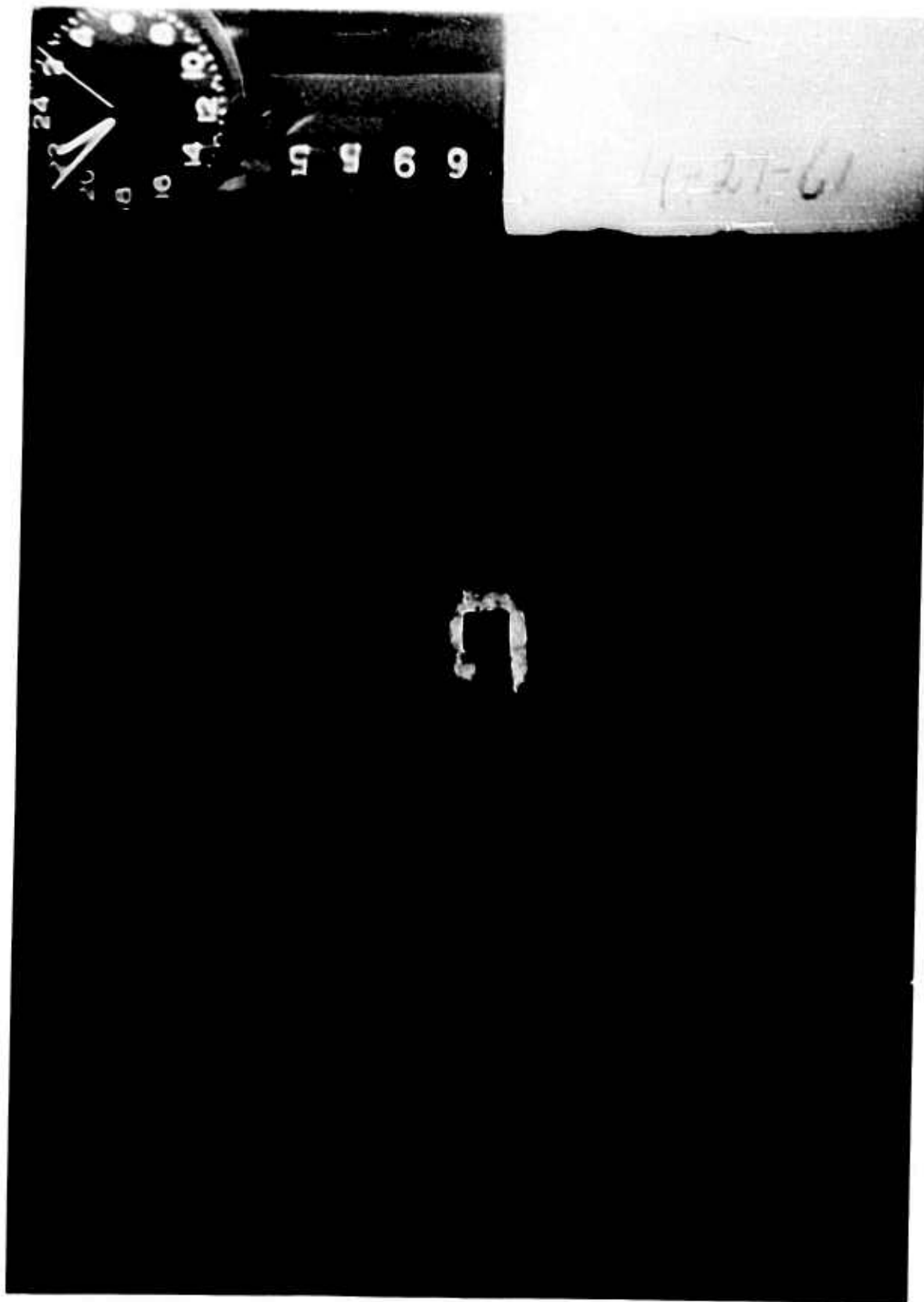

Figure 4-8 Narrow Field Boresight Camera View of Spectrometer Entrance Slit During Daylight Tracking

SECTION 5

DATA HANDLING SUBSYSTEM TESTS

This section records the results of those tests performed on the data handling subsystem prior to installation in the aircraft. The data handling subsystem includes the pointing computer, computer input/output units, the time generator, and data recording equipment. The procedures for tests performed before equipment integration into the SKYSCRAPER system are outlined in Appendix B. Additional testing was done on certain components to assure satisfactory performance. Unless exceptions are noted in the discussion of results, all equipments successfully met the test specifications. Certain changes and modifications arising from the test program have resulted in altered performance characteristics of the system differing from those predicted on earlier configurations. A discussion of additional changes which may be desirable is also included.

5.1 COMPUTER INPUT/OUTPUT SERVO UNITS

A number of gearing changes were made in the computer I/O servo units as a result of tests for slow speed compatibility with the Librascope CP-209 computer. These servo units are pictured in Figure 5-1. In all cases, the changes consisted of increasing slow speed until the following conditions were met:

1. Data input maximum slew rates were set close to (but less than) the maximum rate at which the computer could accept data.
2. Data output rates were set above the maximum rate which the computer could command.

The necessity for condition 1 arises from the incremental operation of the computer, wherein all input data arriving in excess of a fixed number of increments per unit time are ignored by the computer, leading to erroneous solutions of the problem. It was considered advisable to prevent such erroneous solutions by limiting the rate of data input to below the critical value for each input. Condition 2 represents the desirability

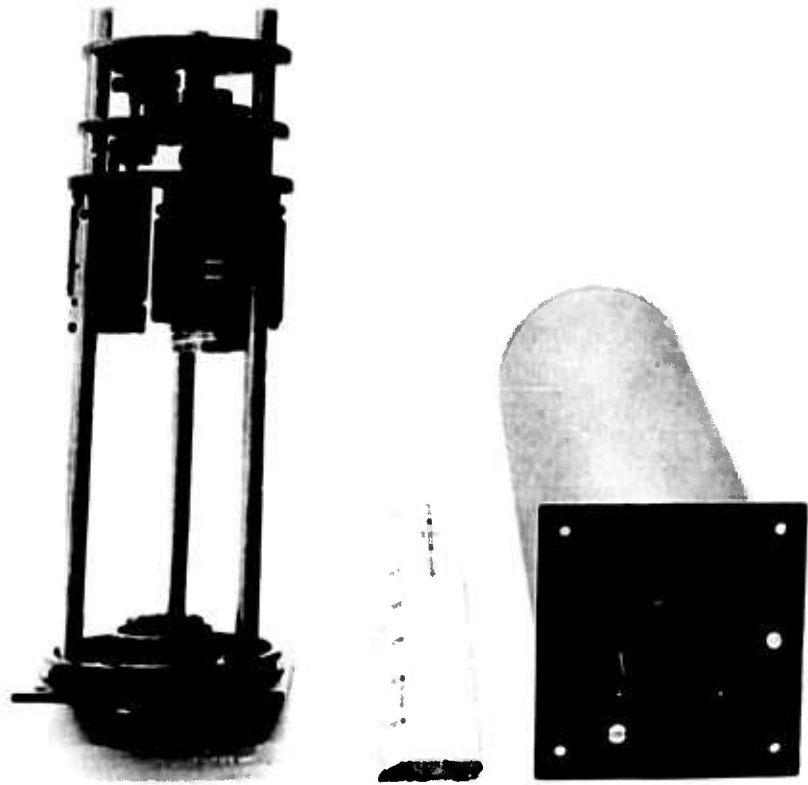

A. SERVO CAN ASSEMBLY

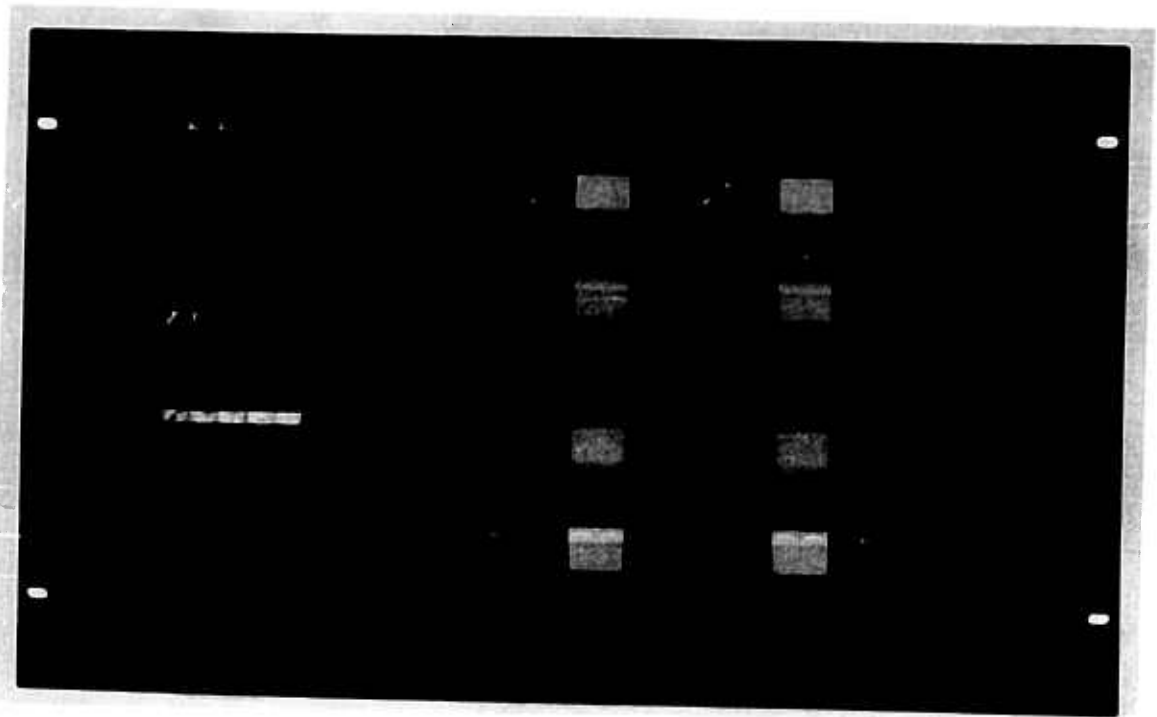

B. MANUAL INSERTION CONTROL PANEL

Figure 5-1 Computer I/O Unit

of having the computer solution rate and not the output servo speed control the maximum rate of data output. It was found necessary to limit aircraft attitude input rates to the following maximum values:

1. Roll: $4^{\circ}/\text{sec.}$
2. Pitch: $3^{\circ}/\text{sec.}$
3. Heading: $1^{\circ}/\text{sec.}$

Gearing changes were made in the direction cosine outputs in order to accomplish the following objectives:

1. Satisfy condition 2, above
2. Provide upper and lower stops which were compatible with maximum and minimum computer values of direction cosines
3. Add slip clutches to protect servo motors and gearing when operating against the stops
4. Provide uniform gearing for all these direction cosines and allow X_p to go to -1.

Condition 2 was satisfied by increasing slew speed by an average of 75 times; also, slip clutches were introduced between the motor and the output potentiometers. Adjustment of gear ratios between shaft encoders and potentiometers allowed the pot end stops to function as output limit stops, giving a maximum range of from 1.1 to +1.1 for the outputs. (Except during warmup, the computer will not normally command an output in excess of ± 1 .) Excitation of the minus end of the X_p potentiometer was provided so as to balance the load on the excitation transformer, and to allow a more simple calibration technique.

The changes outlined above assure that the computed pointing vector will have minimum dynamic error during normal flight and that the computer will not lose the problem during rapid changes in aircraft attitude. The pointing vector will not follow the target during such transients, but neither will the computer be overloaded, after a transient has subsided, the solution will again be correct.

That portion of dynamic pointing error arising in the pointing computer system can be obtained from measured data which correlate direction cosine outputs to aircraft attitude inputs. For example, a roll input of $R \sin 2 \pi f$, where $R = 2^\circ$ and $f = 0.3$ cycles/sec would have a maximum pointing error of about 0.25° . For larger roll angles and/or higher frequencies of roll oscillation, the roll input would be velocity limited, and increased errors will occur during portions of the roll cycle. For smaller roll angles and/or lower frequencies, the error will be reduced. Measured data showing correlation between various input-output pairs are included in Table 5-1.

5.2 POINTING COMPUTER

The CP-209 computer was tested at the factory (Librascope Division of General Precision, Glendale, California) to US Navy Factory Acceptance Test 340-D-101 prior to being programmed for the SKYSCRAPER problem. Subsequent testing using SKYSCRAPER peripheral equipment (computer controller, I/O units, etc.) was conducted to demonstrate satisfactory solution of the SKYSCRAPER problem. The computer was accepted by Bendix Systems Division upon completion of the second series of tests. It is pictured in Figure 5-2.

5.3 TIME GENERATION UNIT

During construction of the time generator, (see Figure 5-3), the vibration resistance of the logic packages was questioned. Accordingly, vibration tests were run on representative samples. Results were good; the major problem was susceptibility to electrical noise inputs, which was observed during the operation of the vibration monitoring equipment. The noise problem has been dealt with by filtering of input power lines and shielding of critical signal leads. While vibration did not appear to be a serious problem, the logic mounting chassis was constructed of extra heavy gage sheet metal, and stiffening braces were installed, to reduce chassis transmissibility. Operational tests over a seven hour period showed accumulated errors of less than one second.

5.4 DATA RECORDING UNIT

The data handling subsystem contains an Ampex Model 800 tape recording system, which has a total of 14 recording tracks. Eleven FM amplifiers are provided for data recording, one AM channel is used for voice

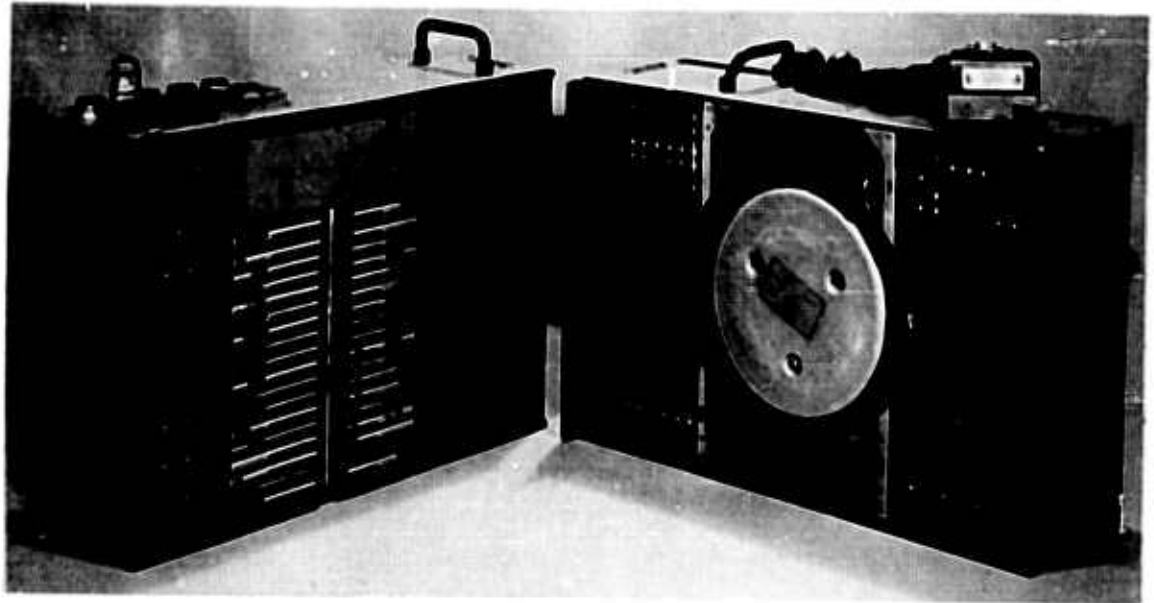

A. COMPUTER OPENED

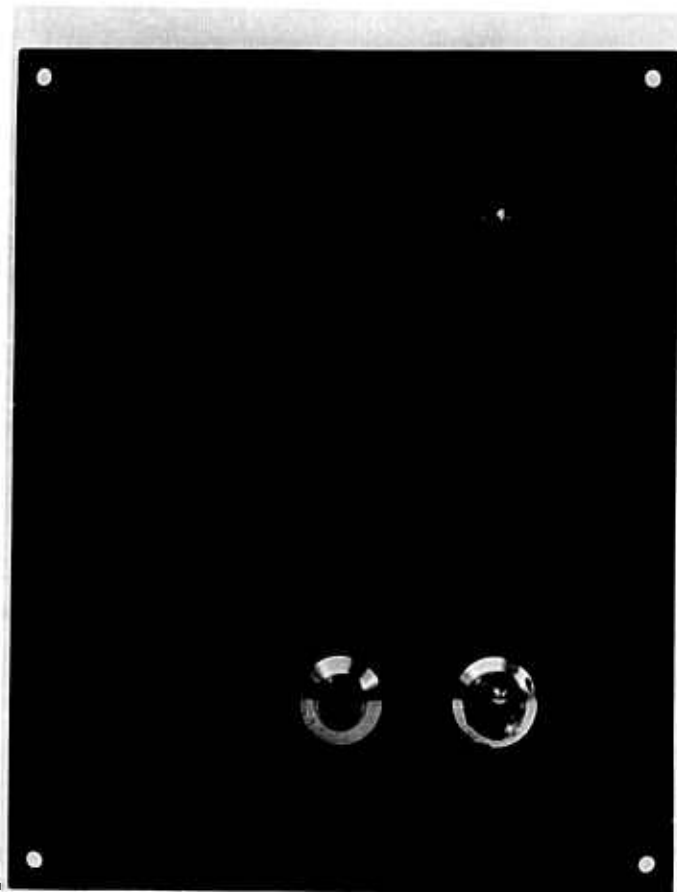

B. COMPUTER CONTROL PANEL

Figure 5-2 CP-209

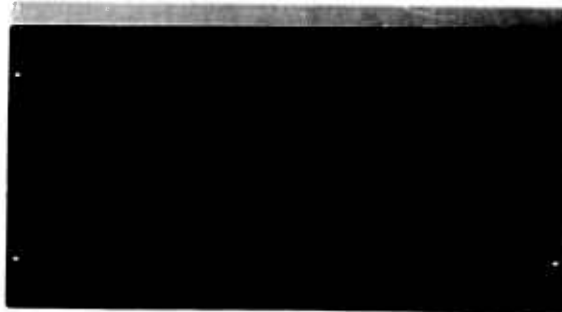

A. TIME DISPLAY PANEL

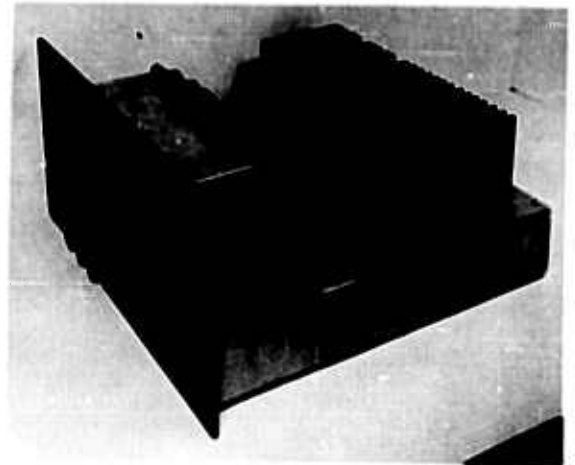

B. TIME DISPLAY CHASSIS

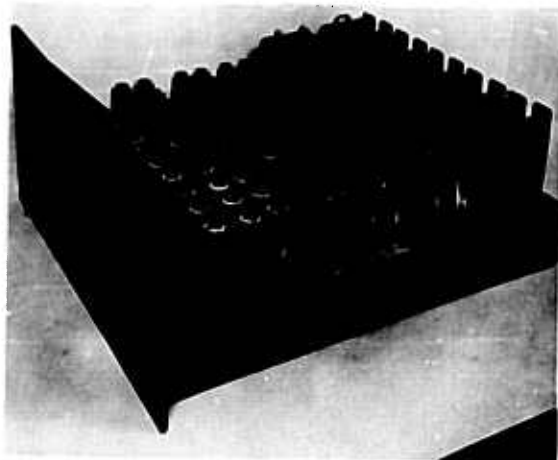

C. TIME GENERATOR CHASSIS

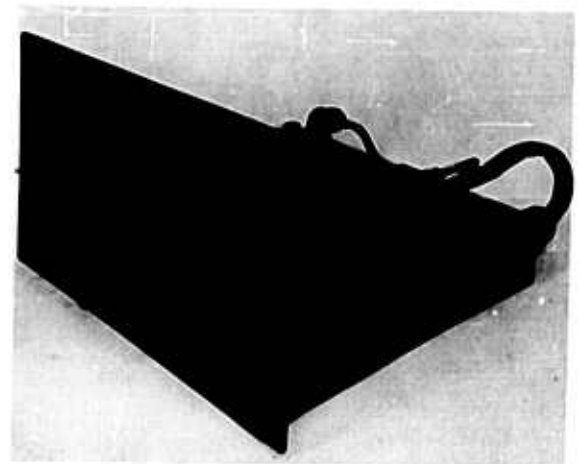

D. COMMUTATOR UNIT

Figure 5-3 Time Generator

TABLE 5-1
POINTING COMPUTER - SERVO RESPONSE DATA

f cps	Zp Out/Roll In		Yp Out/Head In		Zp Out/Pitch In		Xp Out/Roll In	
	db	ϕ	db	ϕ	db	ϕ	db	ϕ
0.01	0	-4°	0	-4°	0	-8°	0	-6°
0.02	0	-4°	0	-6°	0	-10°	0	-6°
0.04	0	-4°	0	-10°	0	-12°	0	-6°
0.07	0	-8°	0	-14°	0	-14°	0	-6°
0.10	0	-12°	0	-20°	0	-20°	0	-10°
0.15	0	-30°	-0.5	-30°	-0.5	-40°	0	-18°
0.20	0	-46°	-1	-40°	-1	-50°	0	-30°
0.30	0	-60°	-2	-56°	-2	-62°	0	-35°
0.40	-1	-60°	-3	-70°	-4	-84°	0	-52°
0.50	-2	-82°	-	-110°	-	-94°	0	-75°
0.60	-6	-105°	-	-140°	-	-120°	-1	-95°
0.70	-	-	-	-	-	-	-3	-
0.80	-	-	-	-	-	-	-	-
1.0	-	-	-	-	-	-	-	-

Line of sight out	Line of sight in	Line of sight in	Line of sight in	Line of sight in	Line of sight in	Line of sight in	Line of sight in
left wing	left wing	left wing	straight ahead	straight ahead	straight ahead	straight ahead	down
right out	right out	right out	straight ahead	straight ahead	straight ahead	straight ahead	down
left wing	left wing	left wing	straight ahead	straight ahead	straight ahead	straight ahead	down
right out	right out	right out	straight ahead	straight ahead	straight ahead	straight ahead	down

Maximum slew rates	Computer max. input rate
Inputs	
Roll	5°/sec
Pitch	4°/sec
Heading	1.5°/sec
Outputs	
Xp	6°/sec
Yp	3°/sec
Zp	6°/sec

recording, and two PDM channels are available. One PDM channel is used for recording time signals from the time generator and the other is not used. Spectral and radiometric target data are recorded directly on five FM channels. Spectrometer and radiometer attenuator and wavelength data are sampled by a commutator (see Figure 5-3) and recorded on one FM channel, while the commutator reference and radiometer chopper reference signals are put on two additional FM channels. One FM channel is used for tracker gimbal angles (corrected to space coordinates by the computer) which are sampled alternately and recorded in serial binary form. Other FM channels are used for wave filter and Littrow mirror settings. The tape transport holds eight minutes of tape and operates at 60 ips. Provisions are available for 30 ips operations, which requires lower frequency FM oscillators and doubles the recording time.

5.5 SYSTEM TESTS

Following check out, the input/output servos, pointing computer, time generator, and data recording units were installed in SKYSCRAPER racks and interconnected with the other portions of the system. System tests generally followed the program outlined in Appendix A, with occasional lapses to correct interface problems. Such problems were generally minor in nature, but time-consuming to locate and correct. For the most part, they consisted of incorrect rotation sense, reversed excitation polarities, and misplaced null positions. The solution in most instances consisted of reversing electrical connections and/or adjusting positioning clamps. It was necessary to add two diodes to the computer controller to eliminate sneak circuits in the tracker mode controls.

When operating the CP209 computer, it is necessary to return to a fixed set of initial conditions at the start of each new problem solution. The initial conditions are stored in the memory and are entered into the computer by an operation called subfill, which occurs whenever the subfill command button is depressed. A time interval of up to 20 minutes can occur after subfill is commanded (depending on the particular problem), during which the computer outputs are not meaningful to the problem to be solved. As delivered from the factory, the computer provided no indication as to the presence or absence of the subfill condition. Because of the long subfill period required for certain problems, some indication of the state of the computer was desirable. As designed, the computer mode indicator showed conditions as follows:

1. Hold and compute lamps off: computer is in warm-up
2. Hold lamp on: computer is in hold
3. Compute lamp on: computer is in subfill or compute mode.

The addition of a separate subfill lamp was indicated, but practical difficulties ruled this course out. It was decided, therefore, to change the existing mode indicators to the following:

1. Hold and compute lamps off: computer is in warm-up or subfill
2. Hold lamp on: computer is in hold
3. Compute lamp on: computer is in compute mode.

Since warm-up occurs only when the computer is turned on and lasts for a maximum of five minutes, the ambiguous indication is not expected to be a handicap. Implementation of the change required the addition of a logical comparison circuit, a relay driver amplifier, and a relay to interrupt the compute lamp current when in subfill mode. The necessary components were mounted on a plug-in module which was put in a spare socket in the computer.

Results of dynamic testing over the entire pointing command loop from aircraft-attitude inputs to tracker gimbal-angle outputs indicate that performance is essentially defined by the pointing computer limitations. Data for gyro heading input to tracker azimuth output, and for roll input to tracker elevation output are included in Table 5-2. Comparison of these data with corresponding data for the pointing computer alone indicates that only at input frequencies in excess of 0.4 cps do the tracker gimbal servos begin to contribute noticeable phase lag errors.

Maximum slew speeds are limited by the command signals from the computer and are therefore the same as listed in Table 5-1 for the computer input units.

The possibility of providing two additional modes of search operation became evident during system tests. Since only small changes are required in wiring and components, it is suggested that the following functions be made available:

1. Search mode with no scan pattern
2. Manual optical director (MOD) command with superimposed raster or rosette scan pattern.

Provision of these additional functions would not alter any of the presently available modes of operation.

TABLE 5-2

COMPUTER/TRACKER SERVO RESPONSE DATA

f cps	TR-AZ/Heading		TR-EL/Roll	
	db	ϕ	db	ϕ
0.01	0	-4°	0	-2°
0.02	0	-5°	0	-4°
0.04	0	-8°	0	-6°
0.07	0	-12°	0	-8°
0.1	-.5	-20°	0	-14°
0.15	-.5	-30°	-.5	-22°
0.2	-.5	-38°	-.5	-30°
0.3	-1.0	-53°	-1	-48°
0.4	-2.0	-72°	-2	-65°
0.6	-5.0	-106°	-4	-88°
0.8			-8	-112°
1.0				-132°

The major problem encountered during system tests was the difficulty of obtaining a track lock-on from either of the search scan patterns when the target appeared near the center of the pattern. In such cases, the tracker would sense a target presence and would signal the computer to stop the scan pattern. However, the tracker would come to rest with the target outside of the acquisition field, and a track lock-on would not result. Examination of the observed behavior of the system indicated that a position lag of the order of 0.5° occurs between the angle which the computer is commanding and the actual angle of the line of sight. Upon receipt of the stop-scan order, the computer commands a steady angle which is 0.5° ahead of the line of sight at the time of command. The tracker settles out to this angle, thus moving the target out of the acquisition field. An investigation is underway to determine the source of, and to correct, this error.

5.6 ASSOCIATED AIRBORNE PLATFORM EQUIPMENT

5.6.1 Manual Optical Director

The manual optical director (MOD) consists of an 8-power, 8°-FOV telescope looking out through the tracker optics, and a joystick control which adds azimuth and elevation bias voltages to the computer-generated pointing vector. The telescope and joystick are shown mounted on the platform in Figure 5-4.

The joystick portion of the MOD was connected to the tracker during subsystem testing at Canoga Park, California. The unit functioned exactly as predicted by design calculations, both in scale factor and rotational sense.

During system test the telescope was mounted and boresighted, using the external collimator for alignment. No boresighting difficulties were encountered.

The MOD was used extensively during system testing and proved extremely valuable for manual acquisition of static targets in the collimator and of the moving aircraft. It was also used as a monitoring device for automatic target sequencing.

In the course of the six-week test period several operational defects in the MOD were uncovered. The maximum deviation of $\pm 8^\circ$ about center allowed by the joystick electronics proved inadequate for some tests. The physical motion limits of the joystick (whereby the elevation travel was only half that of azimuth) gave the operator trouble; also, the generally poor mechanical condition of the GFE supplied joystick led to continual operator frustrations as miscellaneous hardware kept falling off. The gun-laying reticle in the telescope did not suit the MOD application, while the beam-splitter shifted the boresight center-line as viewed in the telescope when it was changed from "all telescope" to "half telescope, half wide-angle camera" position.

A series of modifications has been accomplished on the MOD since completion of the system test. A new switch with a shunting resistor for the potentiometer voltage divider has been added to the MOD base. This switch doubles the present $\pm 4^\circ$ and $\pm 8^\circ$ azimuth limits when it is on. The mechanical limit stops for elevation motion were removed, giving a total travel in elevation about 70% that in azimuth which appears to be adequate.



Figure 5-4 Manual Optical Director

A newer joystick of the same type has been requested as GFE. The old reticle in the telescope is being replaced with one specially designed for SKYSCRAPER. The beamsplitter is being studied to determine why it changes the angle of light incident on the telescope when it is used with the wide angle camera, and how this shift can be either corrected or compensated for.

5.6.2 Pilot's Display

One of the functions of the pointing computer is to provide signals to the aircraft pilot indicating a flight attitude such that the tracker line of sight will be unoccluded in the observation window. The front of the pilot's display is shown in Figure 5-5. Both heading and roll angles are so indicated. Operation of this function was checked during system tests and the sensitivities adjusted so as to give full scale deflections on the pilots display at roll and heading angles corresponding to line of sight deviations of $\pm 10^\circ$ from the center of the window. Changes in sensitivities can be made by screw driver adjustments should different values be desired.

5.6.3 Attitude Gyro and Controls

The attitude gyro, installed on the rigid platform for angular reference, is a Bendix type 19005-1-A, three-axis displacement gyro. The control panel in rack 6 provides power, erection, and torquing control. Earth-rate correction to the gyro is provided by the control unit from a J-4 compass system and a battery. The KC-135 secondary compass system provides a synchro output of magnetic heading which is turned into true heading by a differential synchro and displayed on a digital readout. The gyro heading is also displayed on a digital readout and the two are matched by torquing controls.

The earth-rate correction circuitry worked well, but a higher voltage than predicted had to be inserted at the latitude correction potentiometer, presumably as a result of resistance in the cabling between the rack and platform.

The gyro outputs were connected to the computer and the gyro was physically moved in each of the three axes. It proved necessary to rotate some stator leads and to switch rotor leads in the digital readout unit at the control panel for correct rotational sensing.

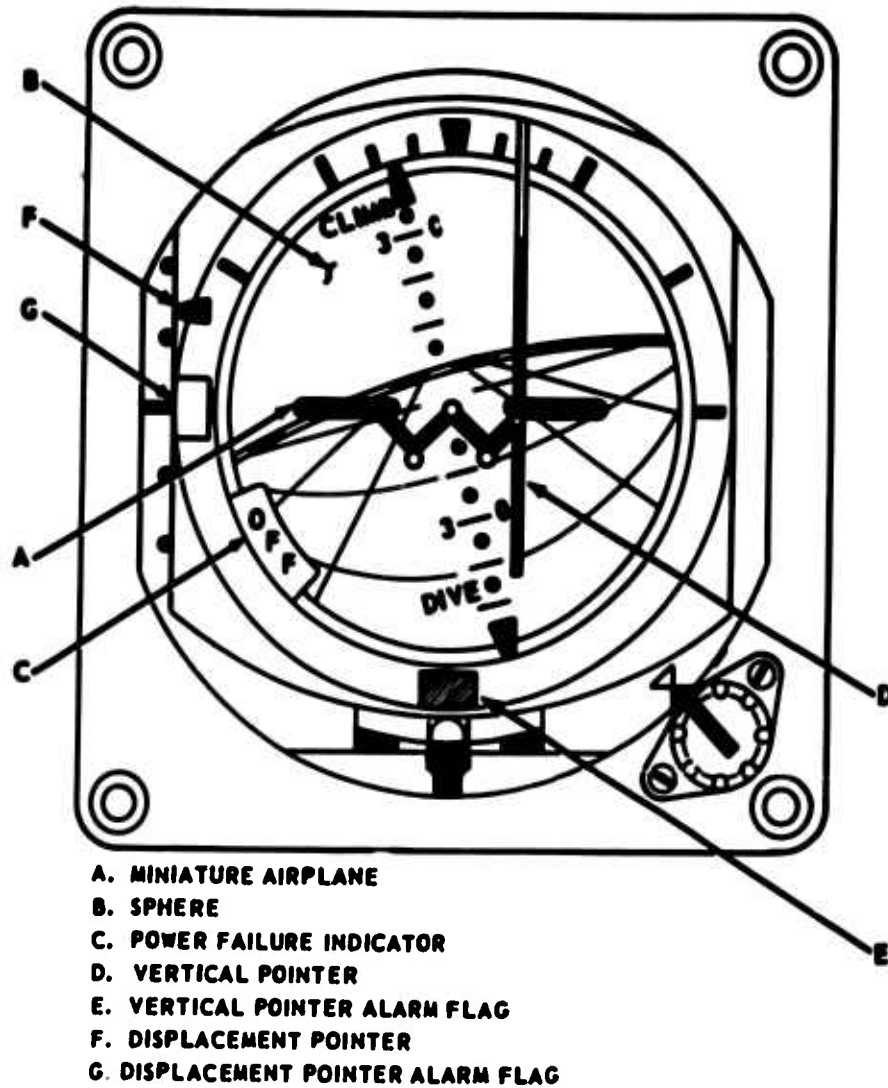

Figure 5-5 Pilot's Display

An azimuth calibration run was made between the computer and panel digital readout unit by torquing the gyro through 360° ; the results were unsatisfactory. A combination of synchro errors and eccentricity in the common shaft linking the gyro synchro transmitters number 1 (to computer) and number 2 (to readout) yielded peak errors of approximately 54 minutes of arc. Satisfactory operation was obtained by connecting both the computer and readout to azimuth transmitter number 1 (which is rated for use by up to four control transformers of this type) with results as shown in Table 5-3.

After the gyro had run for approximately 20 hours during system test, a pronounced jitter appeared at the digital readout unit. The unit was checked out and no malfunctions were detected. The input line voltage at the synchro rotor was checked for noise and the cables were investigated for poor connections and interference. No positive faults were located. The synchro output was checked at the gyro and found to be the source of the jitter. This output, when viewed on an oscilloscope, indicated a noisy slip ring. After completion of system tests, the gyro was returned to the manufacturer for repair of the intermittent synchro output.

TABLE 5-3

AZIMUTH CALIBRATION, COMPUTER INPUT VS
PANEL DIGITAL READOUT

<u>Computer*</u>	<u>Panel Readout**</u>	<u>Error</u>
0°	359° 58'	2'
45°	45° 3'	3'
90°	90° 2'	2'
135°	135° 1'	1'
180°	180° 7'	7'
225°	225° 7'	7'
270°	270° 0'	0'
315°	315° 2'	2'
360°	0° 0'	0'
315°	314° 53'	7'
270°	269° 55'	5'
225°	224° 58'	2'
180°	179° 58'	2'
135°	134° 54'	6'
90°	89° 55'	5'
45°	44° 52'	8'
0°	359° 56'	4'

* Readout resolution 6 min

** Readout resolution 0.5 min

APPENDIX A

SKYSCRAPER

Laboratory Test Plans

Contract No. AF 19(604)-6129

Air Force Cambridge Research Laboratories

22 September 1961

**Bendix Systems Division
of
The Bendix Corporation
Ann Arbor, Michigan**

SKYSCRAPER Laboratory Tests

Objective

The objective of the SKYSCRAPER Laboratory Tests is to ensure that the subsystems are compatible and that the performance of the integrated partial system¹ satisfies the specified design requirements. The tests will be initiated after the subsystem tests have been completed and the subsystems have been integrated into the partial radiation measuring system.

The initial tests will be relatively simple and will determine the interface compatibility between the subsystems. The later tests will be more complex and will be designed to evaluate the overall performance of the SKYSCRAPER System.

¹The complete SKYSCRAPER System includes a modified KC-135 aircraft and its associated equipment which will be operated in support of the partial system undergoing laboratory test.

1.0 INTERNAL CALIBRATION REFERENCES USED AS RADIATION SOURCES

1.1 OBJECTIVES - to check the following:

- 1.1.1 Temperature control of spectroradiometer.**
- 1.1.2 Operation of spectroradiometer mechanical components - i. e. chopper, ambient black body flag, spectrometer/radiometer reflecting wheel, filter wheel, camera flag, etc.**
- 1.1.3 Alignment of spectroradiometer optics.**
- 1.1.4 Wavelength calibration.**
- 1.1.5 Approximate calibration of spectrometers and radiometers.**
- 1.1.6 Alignment and operation of narrow field camera.**
- 1.1.7 Operation of attenuators.**
- 1.1.8 Evaluation of design parameters listed in Section 1.4.**

1.2 METHOD

During this test the standard calibrated tungsten lamp and the Barnes black body calibration references will be used as radiation sources. Since these sources are inserted between the spectroradiometer and the entrance optics, it will not be necessary to operate the tracker and data handling equipment during this test. The oscillograph recorder will be used to record the data outputs from the spectroradiometer.

Filters will be placed in front of the calibration sources to check the wavelength calibration and wavelength range capability of the spectroradiometer. The tungsten and black body calibration sources will be inserted separately to check the spectral irradiance calibration of the three spectrometers and the irradiance calibration of the two radiometers. Calculations can then be made to determine the effects of the collecting optics so that apparent radiances measured at the entrance to the spectroradiometer can be converted to target irradiances at the primary collecting optics.

1.3 EQUIPMENT REQUIRED FOR TESTS

1.3.1 Spectroradiometer.

1.3.2 Oscillograph recorder.

1.3.3 National Bureau of Standards tungsten calibrated lamps #U-33, E-55 & E-69.

1.3.4 Barnes Model 1A 500°K black body calibration source.

1.3.5 Filters for wavelength calibration check.

1.4 DESIGN PARAMETERS EVALUATED

1.4.1 Spectroradiometer

1.4.1.1 Short wavelength spectrometer Calculated

a. Spectral region (μ)	0.25 - 0.6
b. Peak sensitivity (watts/cm ² /micron)	1.5×10^{-15}
c. Wavelength resolution not to exceed 0.02 microns between 0.25 and 0.6 microns (μ)	\leq < 0.02
d. Bandwidths (cps) at 0.5 scans/min	20
4.0 scans/min	60
30.0 scans/min	500
240.0 scans/min	2000

1.4.1.2 Medium wavelength spectrometer

a. Spectral region (μ)	0.6 - 5.0
b. Peak sensitivity (watts/cm ² /micron)	1.9×10^{-14}

c. Wavelength resolution not to exceed
0.10 microns between 0.6 and 5.0
microns (μ) $\bar{=}$
 < 0.10

d. Bandwidths (cps) - same as Section
1.4.1.1

1.4.1.3 Long wavelength spectrometer

a. Spectral region (μ) 5.0 - 15

b. Peak sensitivity (watts/cm²/micron) 3.8×10^{-14}

c. Wavelength resolution not to exceed
0.27 microns between 5 and 10
microns (μ) $\bar{=}$
 < 0.27

d. Wavelength resolution not to exceed
0.10 microns between 10 and 15
microns (μ) $\bar{=}$
 < 0.10

e. Bandwidth (cps) - same as Section
1.4.1.1

1.4.1.4 Short wavelength radiometer

a. Spectral region (μ) 0.25 - 0.6

b. Peak sensitivity (watts/cm²/ μ) 9.3×10^{-17}

c. Bandwidths (cps) - same as Section
1.4.1.1

1.4.1.5 Long wavelength radiometer

a. Spectral region (μ) 0.6 - 15

b. Peak sensitivity (watts/cm²/ μ) 1.7×10^{-14}

c. Bandwidths (cps) - same as Section
1.4.1.1

- 1. 4. 2 Tracker (no evaluation)
- 1. 4. 3 Data handling (no evaluation)
- 1. 5 CONTROLS
 - 1. 5. 1 Spectroradiometer
 - 1. 5. 1. 1 Chopper motor switch (ON-OFF)
 - 1. 5. 1. 2 Background reference switches (SKY-AMBIENT)
 - 1. 5. 1. 3 Spectrometer/radiometer mirror (4 positions)
 - 1. 5. 1. 4 Spectroradiometer heater control (ON-OFF)
 - 1. 5. 1. 5 Attenuator ganging mode control (MANUAL-GANGED)
 - 1. 5. 1. 6 Attenuator controls - Spectrometers A, B and C
 - Radiometers A and B
 - 1. 5. 1. 7 Attenuator ganged control
 - 1. 5. 1. 8 Narrow field camera switch
 - 1. 5. 1. 9 Narrow field camera mode control
 - 1.5.1.10 Narrow field camera MANUAL pushbutton
 - 1. 5. 2 Tracker (no controls used)
 - 1. 5. 3 Data handling (no controls used)
- 1. 6 DISPLAYS
 - 1. 6. 1 Spectroradiometer
 - 1. 6. 1. 1 Recording level intensity meters - Spectrometers A, B and C
 - 1. 6. 1. 2 Recording level intensity meters - Radiometers A and B

- 1. 6. 1. 3 Irradiance - Radiometers A and B (Oscilloscope #1)**
- 1. 6. 1. 4 Spectral irradiance - Spectrometer A (Oscilloscope #2)**
- 1. 6. 1. 5 Spectral irradiance - Spectrometers B and C (Oscilloscope #3)**
- 1. 6. 2 Tracker (no displays used)**
- 1. 6. 3 Data handling (no displays used)**
- 1. 7 RECORDED DATA OUTPUTS**
- 1. 7. 1 Spectroradiometer (data recorded on oscillograph recorder)**
 - 1. 7. 1. 1 Littrow mirror wavelength**
 - 1. 7. 1. 2 Spectral irradiance - Spectrometer A**
 - 1. 7. 1. 3 Spectral irradiance - Spectrometer B**
 - 1. 7. 1. 4 Spectral irradiance - Spectrometer C**
 - 1. 7. 1. 5 Irradiance - Radiometer A**
 - 1. 7. 1. 6 Irradiance - Radiometer B**
- 1. 7. 2 Tracker (no recorded outputs)**
- 1. 7. 3 Data handling (no recorded outputs)**

2.0 INTERNAL COLLIMATOR USED AS TARGET SOURCE

2.1 OBJECTIVES - to check the following:

- 2.1.1 Optical alignment of tracker and spectroradiometer.**
- 2.1.2 Operation of manual optical director joystick.**
- 2.1.3 Operation of tracker during search, locate, acquisition and track modes.**
- 2.1.4 Operation of computer during the locate mode.**
- 2.1.5 Accuracy of tracking mirror elevation and azimuth outputs.**
- 2.1.6 Operation of T₁ target condition lights and meters.**
- 2.1.7 Ability of fine track mirror to center the energy from the collimator in the spectroradiometer entrance field stop under static conditions.**
- 2.1.8 Evaluation of the design parameters listed in Section 2.4.**

2.2 METHOD

The manual optical director joystick will be used to drive the tracking mirror to an azimuth of approximately 0° and an elevation angle of approximately -15° so that the internal collimator will appear within the tracker 0.5° field of view. When the A TARGET PRESENCE light comes on, the joystick trigger will be released and the tracker will be allowed to track the static target.

The operation of the computer, under static target and platform conditions, will be noted during the locate mode. The operation of the tracker will be monitored during the search, locate, acquisition and track modes, under the static conditions discussed above.

The output of the fine track mirror will be monitored to determine the ability of the mirror to center the energy from the collimator in the spectroradiometer field stop. Once the successful operation of the fine track mirror has been assured, the tracker and spectroradiometer data outputs will be monitored by means of the oscillograph recorder, an external oscilloscope and voltmeters, depending upon the form of the data output.

2.3 EQUIPMENT REQUIRED FOR TESTS

- 2.3.1 Tracker.**
- 2.3.2 Spectroradiometer.**
- 2.3.3 Data handling equipment (excluding magnetic tape recorder).**
- 2.3.4 Oscillograph recorder.**
- 2.3.5 Filters for wavelength calibration check.**

2.4 DESIGN PARAMETERS EVALUATED

- 2.4.1 Spectroradiometer**
 - 2.4.1.1 Short wavelength spectrometer**

	<u>Calculated</u>
a. Spectral region - limited at shorter wavelength (μ)	0.35 - 0.6
b. Wavelength resolution checks between 0.35 and 0.6 μ (μ)	\leq 0.02
 - 2.4.1.2 Medium wavelength spectrometer**

a. Spectral region (μ)	0.6 - 5
b. Wavelength resolution checks between 0.6 and 5 μ (μ)	\leq 0.10

2.4.1.3 Long wavelength spectrometer

Evaluation not possible due to collimator wavelength limitations in far infrared

2.4.1.4 Short wavelength radiometer

a. Spectral region - limited at shorter wavelength (μ) 0.35 - 0.6

2.4.1.5 Long wavelength radiometer

a. Spectral region - limited at upper wavelength (μ) 0.6 - 6

2.4.2 Tracker

2.4.2.1 Beam geometry

a. Tracking mirror elevation angle (degrees) -15

b. Tracking mirror azimuth angle (degrees) 0

2.4.2.2 Tracking capabilities

a. Tracking accuracy at the spectroradiometer entrance field stop (m. radians) ≤ 0.1

b. Angular deviation limits of central ray from the optical axis of the spectroradiometer (degrees) ± 2

c. Target capture time (seconds) 0.5

2.4.2.3 Detectors

a. Sensitive wavelength of PbS detector (μ) 1.2 - 2.7

- 2. 5. 1. 10 Narrow field camera MANUAL pushbutton
- 2. 5. 1. 11 Wide field camera switch (ON-OFF)
- 2. 5. 1. 12 Wide field camera MODE control
- 2. 5. 1. 13 Wide field camera MANUAL pushbutton
- 2. 5. 2 Tracker
- 2. 5. 2. 1 Intensity range switch (HI-LO)
- 2. 6 DISPLAYS
- 2. 6. 1 Spectroradiometer
- 2. 6. 1. 1 Recording level intensity meters - Spectrometers A and B
- 2. 6. 1. 2 Recording level intensity meters - Radiometers A and B
- 2. 6. 1. 3 Irradiance - Radiometers A and B (Oscilloscope #1)
- 2. 6. 1. 4 Spectral irradiance - Spectrometer A (Oscilloscope #2)
- 2. 6. 1. 5 Spectral irradiance - Spectrometers B and C (Oscilloscope #3)
- 2. 6. 2 Tracker
- 2. 6. 2. 1 Tracking mirror azimuth angle (degrees) 0
- 2. 6. 2. 2 Tracking mirror elevation angle (degrees) -15
- 2. 6. 2. 3 T_1 azimuth angle relative to primary tracking mirror (Minutes) ± 3
- 2. 6. 2. 4 T_1 elevation angle relative to primary tracking mirror (Minutes) ± 3
- 2. 6. 2. 5 T_1 RADIANT INTENSITY meter

2.6.2.6	T ₁ TARGET PRESENCE light	
2.6.2.7	T ₁ UNDER SPECTRAL TEST light	
2.6.3	Data handling	
2.6.3.1	Real time decimal display (seconds)	
2.7	RECORDED DATA OUTPUTS	
2.7.1	Spectroradiometer	<u>Data Display</u>
2.7.1.1	Spectral irradiance - Spectrometer A	Oscillograph recorder
2.7.1.2	Spectral irradiance - Spectrometer B	Oscillograph recorder
2.7.1.3	Irradiance - Radiometer A	Oscillograph recorder
2.7.1.4	Irradiance - Radiometer B	Oscillograph recorder
2.7.1.5	Littrow mirror wavelength (0-10 VDC)	Oscillograph recorder
2.7.1.6	Radiometer B filter wheel position (0 - 10 VDC)	Oscillograph recorder
2.7.1.7	Phase reference for chopper mirror (2 KC)	Oscilloscope
2.7.1.8	Commutated signals	
	a. Attenuator - Spectrometer A (12 increments)?	Voltmeter
	b. Attenuator - Spectrometer B (12 increments)	Voltmeter
	c. Attenuator - Radiometer A (12 increments)	Voltmeter
	d. Attenuator - Radiometer B (12 increments)	Voltmeter

- e. Sky background reference-
ON (10 VDC)
OFF (5 VDC) Voltmeter
- f. Spectral scan rate (2, 4, 6, 8, 10 VDC) Voltmeter
- g. Ambient flag reference-
ON (10 VDC)
OFF (5 VDC) Voltmeter
- h. Spectrometer/radiometer mirror
-N (10 VDC) Voltmeter
-R₂ (7.5 VDC)
-S (5 VDC)
-R₄ (2.5 VDC)

Data Display

- 2.7.2 Tracker
 - 2.7.2.1 Tracker azimuth angle Control panel indicator
 - 2.7.2.2 Tracker elevation angle Control panel indicator
 - 2.7.2.3 Commutated signals
 - a. T₁ offset azimuth angle (0 - 10 VDC) Voltmeter
 - b. T₁ offset elevation angle (0 - 10 VDC) Voltmeter
- 2.7.3 Data handling (data not displayed)

3.0 EXTERNAL GRID PATTERN USED AS PHOTOGRAPHIC OBJECT DURING THE SEARCH MODE

3.1 OBJECTIVE - to check the following:

3.1.1 Mutual optical alignment of the narrow field camera, the wide field camera and the telescope.

3.1.2 Operation of the manual optical director.

3.1.3 Operation of the computer during the search mode for various tracking mirror azimuth and elevation angles.

3.1.4 Operation of the tracker during the search mode for various tracking mirror azimuth and elevation angles.

3.1.5 Operation and field of view of narrow field camera.

3.1.6 Operation and field of view of wide field camera.

3.1.7 Telescope field of view.

3.2 METHOD

A rectangular grid will be marked on a large surface area and a small collimator will be placed in the center of the grid. The grid will be placed in front of the tracking mirror and positioned such that it is perpendicular to the tracking mirror optical axis and centered relative to the tracking mirror optical axis when the tracking mirror is locked at zero azimuth and elevation angles.

The narrow field camera, wide field camera and telescope will be boresighted relative to the tracker optical axis with the tracking mirror in the pinned position. It will also be possible to check the field of view of both the wide angle camera and the telescope.

After the tracking mirror has been unlocked, the tracker will be operated in the search mode at various azimuth and elevation angles and the camera will be operated to determine the quality of both the raster and rosette search patterns. The manual

optical director joystick will be used to control the tracking mirror and again the operation of the tracker will be checked by observing the grid through the telescope.

By means of the manual optical director joystick and the telescope the tracker will be directed to look at a distant object whose dimensions and distance from the tracking mirror are known. In this manner the field of view of the wide field camera may be checked.

3. 3 EQUIPMENT REQUIRED FOR TESTS

- 3. 3. 1 Spectroradiometer (including narrow field camera)**
- 3. 3. 2 Tracker (including wide field camera)**
- 3. 3. 3 Data handling equipment (excluding magnetic tape recorder)**
- 3. 3. 4 Rectangular grid for photographic object (including a small collimator)**

3. 4 DESIGN PARAMETERS EVALUATED

- 3. 4. 1 Spectroradiometer**
 - 3. 4. 1. 1 Narrow field camera field of view**
 - 3. 4. 2 Tracker**
 - 3. 4. 2. 1 Wide field camera field of view**
 - 3. 4. 2. 2 Telescope field of view**
 - 3. 4. 3 Data handling (none)**
- ### **3. 5 CONTROLS**
- 3. 5. 1 Spectroradiometer**
 - 3. 5. 1. 1 Narrow field camera switch (ON-OFF)**

- 3. 5. 1. 2 Narrow field camera **MODE** control
- 3. 5. 1. 3 Narrow field camera **MANUAL** pushbutton
- 3. 5. 1. 4 Wide field camera switch (**ON-OFF**)
- 3. 5. 1. 5 Wide field camera **MODE** control
- 3. 5. 1. 6 Wide field camera **MANUAL** pushbutton
- 3. 5. 2 Tracker (none)
- 3. 5. 3 Data handling
 - 3. 5. 3. 1 Manual optical director joystick
- 3. 6 **DISPLAYS**
 - 3. 6. 1 Spectroradiometer (none)
 - 3. 6. 2 Tracker
 - 3. 6. 2. 1 Tracking mirror azimuth angle (degrees) ± 15
 - 3. 6. 2. 2 Tracking mirror elevation angle (degrees) -15 to +75
 - 3. 6. 2. 3 Gimbal limit stop light
 - 3. 6. 3 Data handling
 - 3. 6. 3. 1 Real time decimal display (seconds)
- 3. 7 **RECORDED DATA OUTPUTS**
 - 3. 7. 1 Spectroradiometer
 - 3. 7. 1. 1 Narrow field camera field of view Data Display
35 mm film
 - 3. 7. 2 Tracker

3. 7. 2. 1	Tracker azimuth angle	Control panel indicator
3. 7. 2. 2	Tracker elevation angle	Control panel indicator
3. 7. 2. 3	Wide field camera field of view	35 mm film
3. 7. 3	Data handling (none)	

4.0 TWELVE INCH COLLIMATOR, WITH SINGLE AND MULTIPLE SLITS, USED AS A SINGLE AND MULTIPLE TARGET SOURCE

4.1 OBJECTIVES - to check the following:

- 4.1.1 Optical alignment of tracker and spectroradiometer**
- 4.1.2 Operation of manual optical director**
- 4.1.3 Operation of tracker during search, locate, acquisition and track modes under static and dynamic conditions.**
- 4.1.4 Operation of tracker with various multiple target combinations.**
- 4.1.5 Operation of the tracker with small target movements.**
- 4.1.6 Operation of the computer during search and locate modes.**
- 4.1.7 Ability of the fine track mirror to center the energy from the collimator into the spectroradiometer entrance field stop, with multiple target switching.**
- 4.1.8 Operation of T_1 , T_2 and A target selection modes.**
- 4.1.9 Operation of T_1 , T_2 and A target condition lights and meters.**
- 4.1.10 Operation of narrow field camera.**
- 4.1.11 Operation of wide field camera.**
- 4.1.12 Operation of magnetic tape recorder.**
- 4.1.13 Elevation of design parameters listed in Section 4.4.**

4.2 METHOD

A single slit plate will be inserted into the 12 inch collimator and the collimator will be placed in front of the tracking mirror such that the optical axis of the collimator will be aligned with the optical axis of the tracking mirror, for a specified angular

position of the tracking mirror. The target will be acquired by (1) using the manual optical director joystick, (2) searching with a raster search pattern, and (3) searching with a rosette search pattern.

Once the target has been successfully acquired and tracked under static conditions, the SKYSCRAPER rigid platform will be moved both vertically and laterally to determine the ability of the tracker to search, acquire and track the target when the platform is in motion. The boresight cameras and telescope will be used to determine the ability of the tracker to track the target when the platform is subjected to random motions. The spectroradiometer irradiance data outputs will be monitored during this test to ensure that the fine track mirror centers the energy from the collimator in the spectroradiometer entrance field stop under the above dynamic conditions.

It will be possible to simulate small target motions by moving the slit slightly inside the collimator. Again the ability of the tracker to track the target and center the target radiation in the spectroradiometer entrance field stop will be evaluated.

Upon completion of successful tests with the single target source, slit plates with various combinations of multiple targets will be inserted into the collimator. The tracker will be put into operation to ensure that it will acquire and track a preselected target. The tracker will be instructed to select individual targets in both the AUTO and MANUAL target selection modes. Again the spectroradiometer outputs will be monitored to ensure that the radiation from each target selected for measurement enters the spectroradiometer.

The output data will be monitored on meters and oscilloscopes and will be recorded on the oscillograph recorder as in the previous tests. However, since this is the first test where data outputs will occur on all channels the output data will also be recorded on the magnetic tape recorder. Although the data retrieval equipment has not been designed for the tape recorder, as many channels as possible will be played back by means of existing play-back equipment available at Bendix Systems Division.

4.3 EQUIPMENT REQUIRED FOR TESTS

4.3.1 Spectroradiometer

4.3.2 Tracker

4.3.3 Data handling equipment (including magnetic tape recorder)

4.3.4 12" collimator with multiple slits

4.3.5 Oscillograph recorder

4.4 DESIGN PARAMETERS EVALUATED

4.4.1 Spectroradiometer Calculated

4.4.1.1 Short wavelength spectrometer

a. Spectral region - limited at lower wavelength (μ) 0.35-0.60

4.4.1.2 Medium wavelength spectrometer

a. Spectral region (μ) 0.60-5.0

4.4.1.3 Long wavelength spectrometer

a. Spectral region (μ) 5.-15

4.4.2 Tracker

4.4.2.1 Tracking capabilities

a. Number of simultaneously tracked targets (acquisition field) 1

b. Number of simultaneously tracked targets (track field) 2

c. Time to switch targets (seconds) 0.4

d.	Capture time (seconds)	0.5
4.4.2.2	Inputs to tracking subsystem	
a.	Completion of radiation measurement	
4.4.3	Data handling	
4.4.3.1	Pointing computer inputs	
a.	Tracker mode indicators (search, locate, acquire)	
4.4.3.2	Magnetic tape recorder operation will be evaluated	
4.4.3.3	Time reference generator	<u>Calculated</u>
a.	Accuracy in setting to real time (seconds)	0.5
b.	Stability	5 parts in 10^5
4.5	CONTROLS	
4.5.1	Spectroradiometer	
4.5.1.1	Chopper motor switch (ON-OFF)	
4.5.1.2	Background reference switches (SKY-AMBIENT)	
4.5.1.3	Spectrometer/radiometer mirror control (4 positions)	
4.5.1.4	Spectroradiometer heater control (ON-OFF)	
4.5.1.5	Attenuator ganging mode control (MANUAL-GANGED)	
4.5.1.6	Attenuator controls - Spectrometers A, B and C	
	- Radiometers A and B	

- 4. 5. 1. 7 Attenuator ganged control
- 4. 5. 1. 8 Narrow field camera switch (ON-OFF)
- 4. 5. 1. 9 Narrow field camera MODE control
- 4. 5. 1. 10 Narrow field camera MANUAL pushbutton
- 4. 5. 1. 11 Wide field camera switch (ON-OFF)
- 4. 5. 1. 12 Wide field camera MODE control
- 4. 5. 1. 13 Wide field camera MANUAL pushbutton
- 4. 5. 2 Tracker
 - 4. 5. 2. 1 Target MODE SELECTOR pushbuttons
 - 4. 5. 2. 2 SELECT FOR SPECTRAL TEST pushbuttons
 - 4. 5. 2. 3 RETURN TO SEARCH pushbutton
 - 4. 5. 2. 4 Radiation INTENSITY RANGE switch
- 4. 5. 3 Data handling
 - 4. 5. 3. 1 Manual optical director joystick
 - 4. 5. 3. 2 Tape recorder control
- 4. 6 DISPLAYS
 - 4. 6. 1 Spectroradiometer
 - 4. 6. 1. 1 Recording level intensity meters - Spectrometers A, B, and C
 - Radiometers A and B
 - 4. 6. 1. 2 Irradiance displays - Radiometers A and B (Oscilloscope #1)

- 4. 6. 1. 3 Spectral irradiance display - Spectrometer A (Oscilloscope #2)
- 4. 6. 1. 4 Spectral irradiance displays - Spectrometers B and C (Oscilloscope #3)
- 4. 6. 2 Tracker
 - 4. 6. 2. 1 Tracking mirror azimuth angle (degrees) ± 15
 - 4. 6. 2. 2 Tracking mirror elevation angle (degrees) -15 to +75
 - 4. 6. 2. 3 GIMBAL LIMIT STOP light
 - 4. 6. 2. 4 Target azimuth angle relative to primary tracking mirror (meters for targets A, T₁ and T₂)
 - 4. 6. 2. 5 Target elevation angle relative to primary tracking mirror (meters for targets A, T₁ and T₂)
 - 4. 6. 2. 6 RADIANT INTENSITY meters (targets A and T₁)
 - 4. 6. 2. 7 RELATIVE RADIANT INTENSITY meter (target T₂)
 - 4. 6. 2. 8 TARGET PRESENCE lights (targets A, T₁ and T₂)
 - 4. 6. 2. 9 UNDER SPECTRAL TEST lights (targets T₁ and T₂)
 - 4. 6. 2. 10 Target selection MODE display
 - 4. 6. 2. 11 TARGET CONDITION display
 - 4. 6. 2. 12 Radiant intensity magnification lights (targets A and T₁)
- 4. 7 RECORDED DATA OUTPUTS

All the data listed below will be recorded on the magnetic tape recorder in addition to the records or displays noted below.

		<u>Magnetic Tape Channel</u>	<u>Data Display</u>
4. 7. 1	Spectroradiometer		
4. 7. 1. 1	Spectral irradiance - Spectrometer A	6	Oscillograph Recorder
4. 7. 1. 2	Spectral irradiance - Spectrometer B	8	Oscillograph Recorder
4. 7. 1. 3	Spectral irradiance - Spectrometer C	10	Oscillograph Recorder
4. 7. 1. 4	Irradiance - Radiometer A	7	Oscillograph Recorder
4. 7. 1. 5	Irradiance - Radiometer B	9	Oscillograph Recorder
4. 7. 1. 6	Littrow mirror wavelength	12	Oscillograph Recorder
4. 7. 1. 7	Radiometer B filter wheel position (0 - 10 VDC)	2	Oscillograph Recorder
4. 7. 1. 8	Phase reference signal for chopper mirror (2 KC)	5	Oscilloscope
4. 7. 1. 9	Commutated signals	4	
	a. Attenuator - Spectrometer A (12 increments)		Voltmeter
	b. Attenuator - Spectrometer B (12 increments)		Voltmeter
	c. Attenuator - Spectrometer C (12 increments)		Voltmeter
	d. Attenuator - Radiometer A (12 increments)		Voltmeter

	<u>Magnetic Tape</u> <u>Channel</u>	<u>Data</u> <u>Display</u>
e. Attenuator - Radiometer B (12 increments)		Voltmeter
f. Sky background reference -ON (10 VDC) -OFF (5 VDC)		Voltmeter
g. Spectral scan rates (2, 4, 6, 8, 10 VDC)		Voltmeter
h. Ambient flag reference - ON (10 VDC) - OFF (5 VDC)		Voltmeter
i. Spectrometer/radiometer mirror -N (10 VDC) -R ₂ (7.5 VDC) -S (5 VDC) -R ₄ (2.5 VDC)		Voltmeter
4. 7. 2 Tracker		
4. 7. 2. 1 Tracker azimuth angle	11	Control panel indicator
4. 7. 2. 2 Tracker elevation angle	11	Control panel indicator
4. 7. 2. 3 Commutated signals	4	
a. Target shift pulse (5 and 10 v)		Voltmeter
b. Offset azimuth angle A		Voltmeter
c. Offset azimuth angle T ₁		Voltmeter
d. Offset azimuth angle T ₂		Voltmeter
e. Offset elevation angle A		Voltmeter

	<u>Magnetic Tape</u> <u>Channel</u>	<u>Data</u> <u>Display</u>
f. Offset elevation angle T_1		Voltmeter
g. Offset elevation angle T_2		Voltmeter
4.7.3 Data handling		
a. Commutator sync	3	
b. Voice channel	14	

5.0 AIRCRAFT LANDING LIGHT, JET AIRPLANE EXHAUST OR PARACHUTE FLARE USED AS A MOVING TARGET

5.1 OBJECTIVES - to check the following:

- 5.1.1 Operation of the manual optical director**
- 5.1.2 Operation of the tracker during search, locate, acquisition and track modes with the target moving.**
- 5.1.3 Operation of the computer during search and locate modes with the target moving.**
- 5.1.4 Ability of the fine track mirror to center the target energy in the spectroradiometer field stop when the target is moving.**
- 5.1.5 Qualitative spectroradiometer measurement outputs from a specified target.**
- 5.1.6 Operation of narrow field camera.**
- 5.1.7 Operation of wide field camera.**
- 5.1.8 Operation of magnetic tape recorder.**
- 5.1.9 Evaluation of design parameters listed in Section 5.4.**

5.2 METHOD

An aircraft landing light, the jet exhaust from a jet airplane or a flare fired from an aircraft will be used as a target during this test. If time permits each one of these radiation sources will be used to evaluate the ability of the SKYSCRAPER System to acquire and track a moving target and record the radiation measurements obtained from this target.

The target will be acquired using the search mode (raster and rosette) and the manual optical director mode using the joystick to aim the tracker. The SKYSCRAPER rigid platform will be moved vertically and laterally during the search and tracking modes to check the performance of the tracker with both target

motion and random motions of the SKYSCRAPER platform. The angular motion of the targets relative to the tracker will be varied in order to change the elevation and azimuth tracking rates.

It will be possible to use Venus as a target if the test is conducted shortly before sunrise. Venus is seen as a morning "star" during the month of October and thus would provide a slowly moving target whose radiance is known.

5.3 EQUIPMENT REQUIRED FOR TESTS

- 5.3.1 Spectroradiometer
- 5.3.2 Tracker
- 5.3.3 Data handling equipment (including magnetic tape recorder)
- 5.3.4 Oscillograph recorder
- 5.3.5 Light airplane equipped with a landing light
- 5.3.6 Parachute flares and signal lights
- 5.3.7 Jet airplane such as a T-33

5.4 DESIGN PARAMETERS EVALUATED

- 5.4.1 Spectroradiometer
 - 5.4.1.1 Short wavelength spectrometer
 - a. Spectral region (μ) 0.35-0.6
 - 5.4.1.2 Medium wavelength spectrometer
 - a. Spectral region (μ) 0.6-5
 - 5.4.1.3 Long wavelength spectrometer
 - a. Spectral region (μ) 5-15

		<u>Calculated</u>	<u>Measured</u>
5. 4. 2	Tracker		
5. 4. 2. 1	Maximum azimuth track rate (deg/sec)	8	
5. 4. 2. 2	Maximum elevation track rate (deg/sec)	8	
5. 4. 2. 3	Time to switch targets (seconds)	0. 4	
5. 4. 2. 4	Capture time (seconds)	0. 5	
5. 4. 3	Data handling		
5. 4. 3. 1	Programmed data (for re-entry acquisition)		
	a. Predicted terminal position		
	b. Predicted terminal time		
	c. Terminal trajectory (velocity components)		
5. 4. 3. 2	Manual inputs		
	a. Re-computed terminal position		
	b. Re-computed velocity component		
	c. Re-computed arrival time		
5. 4. 3. 3	Electrical inputs		
	a. Aircraft latitude and longitude		
	b. Aircraft altitude		
	c. Rigid platform attitude		
	d. Rigid platform heading		
	e. Target mode indication (search, locate, acquisition)		

5. 5 CONTROLS

5. 5. 1 Spectroradiometer

5. 5. 1. 1 Chopper motor switch

5. 5. 1. 2 Background reference switches (SKY-AMBIENT)

5. 5. 1. 3 Spectrometer/radiometer mirror (4 positions)

5. 5. 1. 4 Spectroradiometer heater control (ON-OFF)

5. 5. 1. 5 Attenuator ganging mode control (MANUAL-GANGED)

5. 5. 1. 6 Attenuator controls - Spectrometers A, B and C

- Radiometers A and B

5. 5. 1. 7 Attenuator ganged control

5. 5. 1. 8 Narrow field camera switch (ON-OFF)

5. 5. 1. 9 Narrow field camera MODE control

5. 5. 1. 10 Narrow field camera MANUAL pushbutton

5. 5. 1. 11 Wide field camera switch (ON-OFF)

5. 5. 1. 12 Wide field camera MODE control

5. 5. 1. 13 Wide field camera MANUAL pushbutton

5. 5. 2 Tracker

5. 5. 2. 1 Target MODE SELECTOR pushbuttons

5. 5. 2. 2 SELECT FOR SPECTRAL TEST pushbuttons

5. 5. 2. 3 RETURN TO SEARCH pushbuttons

5. 5. 2. 4 Radiation INTENSITY RANGE switch

5. 6. 2. 9 UNDER SPECTRAL TEST lights (targets T_1 and T_2)

5. 6. 2. 10 Target selection MODE display

5. 6. 2. 11 TARGET CONDITION display

5. 6. 2. 12 Radiant intensity magnification lights (targets A and T_1)

5. 7 RECORDED DATA OUTPUTS

All the data listed below will be recorded on the magnetic tape recorder in addition to the records or displays noted below.

	<u>Magnetic Tape</u>	<u>Data</u>
	<u>Channel</u>	<u>Display</u>
5. 7. 1 Spectroradiometer		
5. 7. 1. 1 Spectral irradiance - Spectrometer A	6	Oscillograph Recorder
5. 7. 1. 2 Spectral irradiance - Spectrometer B	8	Oscillograph Recorder
5. 7. 1. 3 Spectral irradiance - Spectrometer C	10	Oscillograph Recorder
5. 7. 1. 4 Irradiance - Radiometer A	7	Oscillograph Recorder
5. 7. 1. 5 Irradiance - Radiometer B	9	Oscillograph Recorder
5. 7. 1. 6 Littrow mirror wavelength	12	Oscillograph Recorder
5. 7. 1. 7 Radiometer B filter wheel position (0 - 10 VDC)	2	Oscillograph Recorder
5. 7. 1. 8 Phase reference signal for chopper mirror (2 KC)	5	Oscilloscope
5. 7. 1. 9 Commutated signals	4	

- a. Attenuator - Spectrometer A
(12 increments) Voltmeter
- b. Attenuator - Spectrometer B
(12 increments) Voltmeter
- c. Attenuator - Spectrometer C
(12 increments) Voltmeter
- d. Attenuator - Radiometer A
(12 increments) Voltmeter
- e. Attenuator - Radiometer B
(12 increments)[^] Voltmeter
- f. Sky background reference
-ON (10 VDC) Voltmeter
-OFF (5 VDC)
- g. Spectral scan rates (2, 4, 6, 8, 10 VDC) Voltmeter
- h. Ambient flag reference - ON (10 VDC) Voltmeter
-OFF (5 VDC)
- i. Spectrometer/radiometer mirror Voltmeter
-N (10 VDC)
-R₂ (7.5 VDC)
-S (5 VDC)
-R₄ (2.5 VDC)

5. 7. 2 Tracker

- 5. 7. 2. 1 Tracker azimuth angle 11 Control panel
indicator
- 5. 7. 2. 2 Tracker elevation angle 11 Control panel
indicator
- 5. 7. 2. 3 Commutated signals 4

- a. Target shift pulse (5 and 10 v) Voltmeter
- b. Offset azimuth angle A Voltmeter
- c. Offset azimuth angle T_1 Voltmeter
- d. Offset azimuth angle T_2 Voltmeter
- e. Offset elevation angle A Voltmeter
- f. Offset elevation angle T_1 Voltmeter
- g. Offset elevation angle T_2 Voltmeter

5.7.3 Data handling

- a. Commutator sync 3
- b. Voice channel 14

APPENDIX B

SKYSCRAPER

Test Specification

Data Handling Subsystem

1 August 1961

7133-DPS-S-002

7133-DPS-S-002

This specification consists of the following individual tests and specifications:

SK-1572	Computer I/O Units
SK-1573	Computer I/O Units
SK-1574	Computer I/O Units
SK-1576	Computer Controller
SK-1583	Timing Set
SK-1584	Pointing Computer
SK-1585	Recorder Serializer

1.0 Introduction

1.1 Purpose

It is the purpose of this Test Plan to outline certain tests to be performed on individual Output Units in order to assure their proper performance in the SKYSCRAPER system.

1.2 Scope

This Test Plan details the tests to be performed and the data to be collected on those units having synchro outputs, and the performance required of a satisfactory unit.

1.3 Test Methods

Methods of test will be as called out in the detail specifications of paragraph 3 of this Test Plan. Each Output Unit shall be subjected to the tests of paragraph 3, and shall meet the requirements of paragraph 4.

2.0 Test Equipment and Power Requirements

2.1 Meters and Monitoring

2.1.1 Digital Readout Device - A device capable of indicating up to 19 bits of binary information and incorporating logic necessary to utilize V-scan discs shall be available. The readout device shall provide all excitation voltages required to interrogate the discs and to indicate the disc positions.

2.1.2 Null Meter - A vacuum tube voltmeter or similar device suitable for indicating null position of a synchro control transformer shall be provided.

2.1.3 Angle Indicating Device - A synchro angle indicating device shall be provided, consisting of a Kearfott type RS901-2 control transformer or equivalent, mounted in a dividing head or dial capable of indicating shaft angle to 10 min. of arc. The dial shall be capable of 360° of continuous rotation and shall be calibrated throughout this range. Dial zero shall correspond to C. T. electrical zero position.

2.2 Input Signals

input signals shall consist of positioning the synchro-encoder gear train by manual means.

2.3 Power

Excitation voltage shall be provided for the synchro transmitter in the Output Unit.

3.0 Test Methods

3.1 Visual Inspection - Each output unit shall be examined for conformance to applicable drawings and specifications, and shall show good workmanship in construction of the unit and in manufacture of the component parts.

3.2 Functional Checks - Before application of electrical power, each unit shall be checked for free rotation of shafts and the proper meshing of gears.

3.3 Encoder Zero Position Adjustment

3.3.1 The digital readout device of paragraph 2.1.1 shall be connected to the encoder and checked for operation by manual rotation of the encoder shaft.

3.3.2 With the Synchro Angle Indication Device of paragraph 2.1.3 electrically connected to the synchro transmitter, the Null Meter of paragraph 2.1.2 connected to the rotor of the Angle Indicating Device, and with the Angle Indicating Device dial set at zero, the shaft (or housing) of the synchro transmitter shall be rotated to ARINC high null position. This position will be defined as zero position.

3.3.3 With the synchro transmitter in the zero position, the encoder shaft shall be slipped with respect to the synchro shaft (or the encoder housing may be rotated) until the Digital Readout Device indicates the proper zero-position encoder output per the schedule of paragraph 4.1. Encoder and synchro shafts shall be locked together and housing clamps shall be tightened to this position.

3.4 Static Accuracy Test - The input signal of paragraph 2.2.2 shall be applied together with the power supply of paragraph 2.3. Encoder output as indicated by the Readout Device of paragraph 2.1.1 shall be compared to synchro transmitter angle θ for as many values of θ as are indicated in the schedule of paragraph 4.2.

4.0 Test Data and Performance Requirements

4.1 Zero Position Schedule

Encoder and synchro shafts and housings shall be locked according to the procedure of paragraph 3.3 when in the relative positions defined below for the various types of Output Unit.

	Synchro Angle	Encoder Output (Binary)	
4.1.1 1559 Heading Units	0°	0 000 000 000 000 000 000	
	Synchro Angle	Encoder Output (Binary)	Tolerance (Binary)
4.2.1 1559 Heading Units	180	0 000 000 010 000 000 000	±001
	360	0 000 000 100 000 000 000	±001

1.0 Introduction

1.1 Purpose

It is the purpose of this Test Plan to outline certain tests to be performed on individual Output Units in order to assure their proper performance in the SKYSCRAPER system.

1.2 Scope

This Test Plan details the tests to be performed and the data to be collected on those units having potentiometer outputs, and the performance required of a satisfactory unit.

1.3 Test Methods

Methods of test will be as called out in the detail specifications of paragraph 3 of this Test Plan. Each Output Unit shall be subjected to the tests of paragraph 3, and shall meet the requirements of paragraph 4.

2.0 Test Equipment and Power Requirements

2.1 Meters and Monitoring

2.1.1 Digital Readout Device - A device capable of indicating up to 19 bits of binary information and incorporating logic necessary to utilize V-scan discs shall be available. The Readout Device shall provide all excitation voltages required to interrogate the discs and to indicate the disc positions.

2.1.2 Precision Potentiometer - A potentiometer or precision voltmeter, with reference voltage source, shall be provided to check percent resistance of linear output potentiometers. Accuracy of 0.1% or better must be obtainable.

2.2 Input Signals

Input signals shall consist of positioning the synchro-potentiometer gear train by manual means.

2.3 Power

Electrical power is not required for the tests of this specification, other than that provided by meters and monitoring equipment.

3.0 Test Methods

3.1 Visual Inspection - Each output unit shall be examined for conformance to applicable drawings and specifications, and shall show good workmanship in construction of the unit and in manufacture of the component parts.

3.2 Functional Checks - Each unit shall be checked for free rotation of shafts and the proper meshing of gears.

3.3 Encoder Zero Position Adjustment

3.3.1 The Digital Readout Device of paragraph 2.1.1 shall be connected to the encoder and checked for operation by manual rotation of the encoder shaft.

3.3.2 With the precision potentiometer of paragraph 2.1.2 connected to the output potentiometer, the output potentiometer shaft (or housing) shall be rotated to the lowest percent resistance position obtainable. Care must be used to prevent rotating past the position at which the lowest resistance is first observed. This is defined as zero position for the output potentiometer.

3.3.3 With the output potentiometer in the zero position, the encoder shaft shall be slipped with respect to the potentiometer shaft (or the encoder housing may be rotated) until the encoder Readout Device indicates the proper zero-position encoder output per the schedule of paragraph 4.1. Encoder and potentiometer shafts shall be locked together and housing clamps shall be tightened in this position.

3.4 Static Accuracy Test - The input signal of paragraph 2.2 shall be applied. Encoder output as indicated by the Readout Device of paragraph 2.1.1 shall be compared to potentiometer percent resistance for as many values as are indicated in the schedule of paragraph 4.2.

4.0 Schedule of Test Requirements

4.1 Zero Setting Data

Output Units shall have the shafts of potentiometers and encoders locked according to the procedure of paragraph 3.3 when in the relative positions detailed below for the various types of Units.

	Potentiometer % Resistance ¹	Encoder Output (Binary)
4.1.1 1560 Direction Cosine X _P 12F-C	0	0 000 000 010 010 000 000
4.1.2 1561 Direction Cosine Y _P 12F-E	0	0 000 000 010 010 000 000
4.1.3 1562 Direction Cosine Z _P 12F-F	0	0 000 000 010 010 000 000
4.1.4 1556 Heading Error 9F-P	0	0 000 000 000 000 110 011
4.1.5 1557 EL. Error 9F-R	0	0 000 000 000 001 000 000

4.2 Static Accuracy Tests Schedule

Static positional accuracy as specified in paragraph 3.4 shall be according to the following schedule for the Output Units listed.

	Potentiometer % Resistance ¹	Encoder Output (Binary)	Tolerance (Binary)
4.2.1 1560 Direction Cosine X _P	90%	000 101 011	± 110

Note 1: Percent Resistance of these units measured from wiper to center tap (center tap ground)

	Potentiometer	Encoder Output (Binary)	Tolerance (Binary)
4.2.2 1561 Direction Cosine Y_p	-90% (CCW)	0 000 000 000 010 010 101	± 100
	+90% (CW)	0 000 000 100 000 101 011	± 100
4.2.3 1562 Direction Cosine Z_p	-90% (CCW)	0 000 000 000 010 010 101	± 100
	+90% (CW)	0 000 000 100 000 101 011	± 100
4.2.4 1556 Heading Error	-90% (CCW)	0 000 000 000 000 000 101	± 010
	+90% (CW)	0 000 000 000 001 100 001	± 010
4.2.5 1557 Elevation Error	-90% (CCW)	0 000 000 000 000 000 110	± 010
	+90% (CW)	0 000 000 000 001 111 010	± 010

1.0 Introduction

1.1 Purpose

It is the purpose of this Test Plan to outline certain tests to be performed on individual Input Units in order to assure their proper performance in the SKYSCRAPER system.

1.2 Scope

This Test Plan details the tests to be performed and the data to be collected on each unit, and the performance required of a satisfactory unit.

1.3 Test Methods

Methods of test will be as called out in the detail specification of paragraph 3, and shall meet the requirements of paragraph 4.

2.0 Test Equipment and Power Requirements

2.1 Meters and Monitoring Instruments

2.1.1 Digital Readout Device - A device capable of indicating up to 19 bits of binary information, and incorporating logic necessary to utilize V-scan discs shall be available. The readout device shall provide all excitation voltages required to interrogate the discs and to indicate the disc positions.

2.1.2 Indicating Device - An instrument capable of indicating phase and magnitude of the modulating waveform of a suppressed-carrier modulated wave shall be provided.

2.1.3 Null Meter - A vacuum tube voltmeter or similar device suitable for indicating null position of a synchro control transformer shall be provided.

2.1.4 Ohmmeter - A device capable of measuring resistance from 0 to 10,000 ohms and of indicating a change of 1 ohm in the range from 0 to 10 ohms shall be provided.

2.2 Input Signals

2.2.1 Modulated Input Signal - An input signal in the form of suppressed-carrier modulated 400 cps signal shall be available. The modulation shall

be sine wave and adjustable in frequency over the range from 0.01 to 20 cps. The peak amplitude of this signal shall be adjustable from 0 to 15 volts, independently of the modulation frequency. Provision shall be made to supply this signal to the servo amplifier in series with the signal received from the rotor of the control transformer contained in the Input Unit under test.

2.2.2 Positional Reference Input Signal - A three wire synchro position signal from the stator of a properly excited synchro transmitter of the proper type to drive the control transformer shall be available. The shaft of the transmitter shall be provided with a device capable of indicating angular position, θ , to 6 minutes of arc. An error correction table or chart shall be available for the synchro transmitter, such that transmitter output can be corrected to ± 2 minutes of arc at several points around a complete revolution of the synchro shaft.

2.3 Power - Power supplies capable of providing all reference and excitation voltages for the Input Unit servo system shall be provided.

3.0 Test Methods

3.1 Visual Inspection - Each Input Unit shall be examined for conformance to applicable drawings and specifications and shall show good workmanship in construction of the unit and in manufacture of the component parts.

3.2 Functional Checks - Before application of electrical power, each unit shall be checked for free rotation of shafts and the proper meshing of gears.

3.3 Encoder Zero Position Adjustment

3.3.1 The Digital Readout Device of paragraph 2.1.1 shall be connected to the encoder and checked for operation by manual rotation of the encoder shaft.

3.3.2 With the null meter of paragraph 2.1.3 connected to the rotor terminals of the control transformer, and with excitation voltage applied from the signal source of 2.2.2, set at $\theta = 0^\circ$, the control transformer shaft (or housing) shall be rotated to the angular position corresponding to ARINC high null. This position shall be defined as zero position.

3.3.3 With the control transformer in the zero position, the encoder shaft shall be slipped with respect to the C. T. shaft (or the encoder housing may be rotated) until the encoder Readout Device indicates the proper zero-position encoder output per the schedule of paragraph 4.1. Encoder, C. T. and pot shafts shall be locked and housing clamps shall be tightened in this position.

3.4 Static Accuracy Test - The input signal of paragraph 2.2.2 shall be applied together with the power supplies of paragraph 2.3. Encoder output as indicated by the Readout Device of paragraph 2.1.1 shall be compared to input angular position angle θ for as many values of θ as are indicated in the schedule of paragraph 4.2.

3.5 Dynamic Stability Tests

With power applied per paragraph 2.3 and indicating device per paragraph 2.1.2 connected to the rotor terminals of the control transformer, input signals per paragraph 2.2.1 and 2.2.2 shall be applied and a set of output amplitude-phase measurements obtained sufficient to check the closed loop gain and phase shift characteristics as called out in paragraph 4.3.

4.0 Schedule of Test Requirements

4.1 Zero Setting Data

Input units shall have the shafts of synchros, encoders, and pots locked according to the procedure of paragraph 3.3 when in the relative positions detailed below for the various types of unit.

<u>Unit Type</u>	<u>Synchro Angle</u>	<u>Encoder Output (Binary)</u>	<u>Potentiometer % Resistance¹</u>
4.1.1 1551 Latitude 16F G	0°	0 000 111 111 100 000 000	-
4.1.2 1552 Longitude 16V H	0°	0 000 000 000 000 000 000	-
4.1.3 1553 Roll 11F J	0°	0 000 000 000 111 000 000	-

¹Pot resistance measured from center tap to wiper.

		SK 1574		
<u>Unit Type</u>	<u>Synchro Angle</u>	<u>Encoder Output (Binary)</u>	<u>Potentiometer % Resistance</u>	
4.1.4 1554 Pitch 11F L	0°	0 000 000 000 101 100 000	-	
4.1.5 1555 Azimuth 12V N	0°	0 000 000 000 000 000 000	-	
4.1.6 1563 TR-AZ 11F K	0°	0 000 111 111 100 000 000	0	
4.1.7 1564 TR-EL 11F M	0°	0 000 000 000 110 000 000	-	
	120°	-	0	

4.2 STATIC ACCURACY DATA

Input units, when tested according to the procedure of paragraph 3.4, shall exhibit static accuracies according to the following tabulations.

	<u>Synchro Angle</u>	<u>Encoder Output (Binary)</u>	<u>Tolerance (Binary)</u>
4.2.1 1551 Latitude Units	-90° (CCW)	0 000 000 000 000 100 000	± 100
	0°	0 000 111 111 100 000 000	± 100
	$+90^{\circ}$	0 001 111 110 000 000 000	.
4.2.2 1552 Longitude Unit	0° (CCW)	0 000 000 000 000 000 000	± 010
	180°	0 001 000 000 000 000 000	± 010
	360°	0 010 000 000 000 000 000	± 010

	<u>Synchro Angle</u>	<u>Encoder Output (Binary)</u>	<u>Tolerance (Binary)</u>
4.2.3			
1553 Roll Units	-36° (CCW)	0 000 000 000 001 000 000	± 010
	0°	0 000 000 000 111 000 000	± 010
	$+36^{\circ}$	0 000 000 001 101 000 000	± 010
4.2.4			
1554 Pitch Units	-27° (CCW)	0 000 000 000 001 000 000	± 010
	0°	0 000 000 000 101 100 000	± 010
	$+27^{\circ}$	0 000 000 001 010 000 000	± 010
4.2.5			
1555 Heading Units	0°	0 000 000 000 000 000 000	± 010
	180°	0 000 000 100 000 000 000	± 010
	360°	0 000 001 000 000 000 000	± 010
4.2.6			
1563 Tracker Azimuth Units	-90° (CCW)	0 000 000 000 001 000 000	± 111
	0°	0 000 000 001 000 100 000	± 111
	$+90^{\circ}$	0 000 000 010 000 000 000	± 111

	<u>Synchro Angle</u>	<u>Encoder Output (Binary)</u>	<u>Tolerance (Binary)</u>
4.2.7 1564 Tracker Elevation Units	-60°	0 000 000 000 001 000 000	± 111
	0°	0 000 000 000 110 000 000	± 111
	+300°	0 000 000 011 111 000 000	± 111

4.3 DYNAMIC STABILITY DATA

When tested for closed loop characteristics per 3.5, each input unit shall display no evidence of instability. In addition, output errors and phase shifts shall be according to the following tabulation. Operation shall be within the nominal linear range at all times during these tests. Rate feedback on 1563 and 1564 shall be adjusted to .7 - .9 of critical damping prior to these tests.

Input Unit	Maximum Amp Error At:		Maximum Phase Lag At:	
	1 cps	2 cps	1 cps	2 cps
4.3.1 1551 Latitude				
4.3.2 1552 Longitude				
4.3.3 1553 Roll	± 1 db		45°	
4.3.4 1554 Pitch	± 1 db		45°	
4.3.5 1555 Azimuth	± 1 db		45°	
4.3.6 1563 Tracker - Azimuth	± 1 db	+3-1 db	45°	90°
4.3.7 1564 Tracker - Elevation	± 1 db	+3-1 db	45°	90°

**Test Specification
Computer Controller (SKYSCRAPER)**

SK 1576

1.0 Introduction

1.1 Purpose

It is the purpose of this test specification to specify those tests to be performed on the computer controller so as to assure its proper performance in the SKYSCRAPER system.

1.2 Scope

This Test Specification details the individual electrical tests to be performed, and the results necessary for proper operation of an acceptable unit.

1.3 Methods

Methods of testing, and required performance, shall be according to the detailed specifications of paragraph 3.

2.0 Test Equipment and Power

2.1 Meter

An ohmmeter of $\pm 10\%$ accuracy over the ranges of resistance from 0 to 10 ohms, and from 1 to 100 megohms shall be available for use as specified in paragraph 3.

2.2 Power

A power source supplying 28 ± 2 volts DC with a maximum ripple content of 2 volts shall be available for use as specified in paragraph 3.

2.3 Input Signals

Input signals shall consist of applying 28 volt power or ground to various connector pins and/or of measuring resistance between various pairs of connector pins.

2.4 Definitions

When open or short circuits are called out in paragraph 3, resistances of more than 10 megohms and less than 1 ohm, respectively, shall be construed as meeting the requirements. All references to pin numbers refer to 1533-J1.

3.0 Test Methods

3.1 Visual Inspection

Each computer controller shall be examined for conformance to applicable drawings and specifications, and shall show good workmanship in construction of the unit and in manufacture of the component parts.

3.2 Electrical Checks

Electrical testing shall be performed in the sequence indicated below, with particular attention being given to the position of all controls, shunts, etc. which may have been set in a step prior to the one being performed.

3.2.1 All controls shall be placed in the positions detailed below before application of power.

Control	Position
Pattern Select	Raster
Hold - Operate	Operate
Selection (back of chassis)	ACQ.
Time (back of chassis)	Not Time

3.2.2 Application of 28 volt power per 2.2 to pins D and h (h ground) shall cause the ACQ lamp to light. All lamps shall light when pushed to the test position.

3.2.3 Apply a shunt between f and g. No change in lamp indications shall occur. Continuity shall exist according to the following table:

T - Z	short
U - Z	open
V - b	short
W - Z	open
e - h	open
X - Z	short
R - L	short
P - N	short
P - M	open

3.2.4 Put the Hold-Operate switch in the Hold position. The Hold lamp shall light and continuity shall exist according to the following table:

T - Z	open
U - Z	open
V - b	open
W - Z	short
e - h	open
X - Z	open
R - L	open
P - N	open
P - M	short

3.2.5 Move Selection switch to Search position and Hold-Operate switch to Operate. ACQ lamp shall go out and Search lamp shall come on. Continuity shall exist according to the following table:

Same as 3.2.3, except:

T - Z	open
--------------	-------------

3.2.6 Move Selection switch to Track position. Search lamp shall go out and Track lamp shall come on. Continuity shall exist according to the following table:

Same as 3.2.3, except:

U - Z	short
e - h	short

3.2.7 Apply a shunt between d and h. Track lamp shall go out and ACQ lamp shall come on. Operation of the Selection switch to any position shall have no effect on indication lamps. Continuity shall exist according to the following table:

Same as 3.2.3, except:

e - h	short
--------------	--------------

3.2.8 Remove shunts from d - h and f - g. An open shall exist between F and V. Set Time switch to Time. A short shall exist between F and V.

3.2.9 A shunt applied between S and D (-28 VDC) shall cause compute lamp to light. Remove shunt.

3.2.10 A shunt applied between G and D shall cause Thermal Warning lamp to light. Remove shunt.

3.2.11 Continuity shall exist, as a function of the Reset switch, according to the following table:

	Reset normal	Reset depressed
L - R	short	open
J - K	short	open

3.2.12 Continuity shall exist, as a function of the Subfill switch, according to the following table:

	Subfill normal	Subfill depressed
L - R	short	open
M - R	open	short

3.2.13 Continuity shall exist, as a function of the display switch, according to the following table:

	Raster	Rosette
A - Y	short	open
A - Z		

1.0 Introduction

1.1 Purpose

It is the purpose of this test specification to detail certain tests to be performed on the SKYSCRAPER Timing Set in order to assure its satisfactory operation in the SKYSCRAPER System.

1.2 Scope

This Test Specification details the tests to be performed and the results required of a timing set consisting of one each of the following units, plus necessary interconnecting cables.

1.2.1 SK-1456 Time Generator

1.2.2 SK-1457 Time Display

1.2.3 SK-1460 Signal and Power Distribution Unit

1.3 Test Methods

Test methods will be as called out in paragraphs 3, 4, and 5 of this specification. The Timing Set shall be subjected to all tests of paragraphs 3, 4, and 5, and shall meet all requirements of these paragraphs. Tests shall be performed in the sequence of paragraphs 3, 4, and 5.

1.4 References

The following drawings shall be available for use during tests as required.

1.4.1 SK-1486 (2 pages) Logic Package Pin Numbers

1.4.2 SK-1483 Schematic - Time Display

1.4.3 SK-1473 Schematic - Signal & Power Unit

1.4.4 SK-1451 Interconnecting Wiring Diagram

1.4.5 SK-1450 Block Diagram - Timing Set

1.4.6 SK-1482 Schematic - Time Generator

2.0 Test Conditions

2.1 Power

2.1.1 115 VAC, 400 cps, 3 phase four wire power shall be available at 1460 J4 to supply prime power of about 100 VA total.

2.1.2 +28 VDC shall be available at 1460 J4 to supply 1 ampere.

2.2 Test Equipment

2.2.1 Oscilloscope - A tektronix type 545 or equivalent oscilloscope shall be available for observing wave forms.

2.2.2 Time Standard - A clock or other device capable of indicating an elapsed time of greater than 10 minutes with an accuracy of 1/4 second or better in 10 minutes.

2.2.3 Ohmmeter - An ohmmeter capable of measuring resistances in excess of 100 megohm and of less than 1 ohm shall be available.

2.2.4 Input Signals

A DC signal of 10-5⁺⁰ volts shall be available from a source impedance of less than 100 ohms for insertion into the test points of SK-1460 (pin jacks).

2.3 Definitions

For the purposes of this specification, an open circuit shall have a resistance of greater than 100 megohms and a closed circuit shall have a resistance of less than 1 ohm.

3.0 General

3.1 Visual Inspection - The Timing Set shall be examined for conformance to applicable drawings and specifications and shall show good workmanship in assembly of the various units, and in the manufacture of the component parts.

3.2 Conditions of Test

3.2.1 The units shall be interconnected with cabling per SK-1451, except that the following connectors need not be used, except as called out in paragraphs 4 and 5.

3.2.1.1 1460 J5

3.2.1.2 1460 J7

3.2.1.3 1460 J3

3.2.1.4 1460 J9

3.2.1.5 1460 J10

3.2.1.6 1460 J11

3.2.1.7 1456 J1

3.2.1.8 1456 J4

3.2.2 Power per 2.1 shall be connected to the Timing Set.

3.2.3 Switches and controls shall be put in the following positions at the start of the tests of paragraph 4.

	Control	Position
3.2.3.1	1460 AC Power	ON (up)
3.2.3.2	1460 DC Power	OFF (down)
3.2.3.3	1460 COMM Power	OFF (down)
3.2.3.4	1457 Power	ON (up)
3.2.3.5	1457 Time Set	OFF (down)
3.2.3.6	1456 Reset-Enable	ENABLE

3.3 The Timing Set shall be allowed to warm up for 15 minutes after which a comparison shall be made between the rate of change of the displays and the time standard of 2.2.2 for a time of at least 10 minutes. Differences of indication shall not exceed 1/2 second per 10 minutes of comparison time.

4.0 Time Generator & Display Tests

4.1 Display and Sequencing

These checks shall be made starting with the unit operating under the conditions of paragraph 3.2.

4.1.1 Pilot lamps associated with ON power switches shall be lighted. All other pilot lamps including ENABLE shall be out.

4.1.2 The SECONDS display shall be observed for a period of at least two minutes and shall count from 00 to 59 and repeat at a rate of one count per second. Coincident with each transition from 59 to 00, the MINUTES display shall increase by one count.

4.1.3 Depression of the SECONDS push button (below SECONDS display) shall cause the SECONDS display to indicate 00 for as long as the button is depressed. No other display shall change during the time the SECONDS button is held down.

4.1.4 Upon release of the SECONDS button, counting per 4.1.2 shall resume, starting with 00.

4.1.5 Depression of the MINUTES button shall cause the MINUTES display to count from 0 to 9 and repeat at a rate of one count per second. Coincident with the transitions from 9 to 0, the 10 MINUTES display shall increase by one count.

4.1.6 Upon release of the MINUTES button, counting per 4.1.2 shall resume, starting from the count at the time of the push button.

4.1.7 Depression of the 10 MINUTES button shall cause the 10 MINUTES display to count from 0 to 5 and repeat, at a rate of one count per second. Coincident with the transition from 5 to 0, the HOURS display shall increase by one count.

- 4.1.8** Upon release of the 10 MINUTES button, counting per 4.1.2 shall resume, starting from the count at the time of release of the 10 MINUTES push button.
- 4.1.9** Depression of the HOURS button shall cause the HOURS and 10 HOURS displays to count from 0 to 23 and repeat, at a rate of one count per second.
- 4.1.10** Upon release of the HOURS button, counting per 4.1.2 shall resume starting from the count at the time of release of the HOURS push button.
- 4.1.11** Depression of the 10 HOURS button shall cause the 10 HOURS display to count through the sequence 0, 1, 2, blank and repeat at a rate of one count per second.
- 4.1.12** Upon release of the 10 HOURS button, counting per 4.1.2 shall resume starting from the count at the time of release of the 10 HOURS push button.
- 4.1.13** Operation of the TIME SET switch to ON (up) shall cause the following results.
- 4.1.13.1** The SECONDS and 10 SECONDS displays shall count, according to the following sequence, at a rate of one count per second.
- a. From count at time of actuation of TIME SET switch to 59.
 - b. From 59 to (blank) 0 1 count
 - c. From (blank) 0 to (blank) 9 9 counts
 - d. From (blank) 9 to (blank) 0 1 count
 - e. Repeat c and d for 2 cycles 20 counts
 - f. Repeat c 9 counts
 - g. From (blank) 9 to 00 1 count
 - h. From 00 to 59 59 counts
 - i. Repeat b-h 100 counts

4. 1. 13. 2 No changes shall occur in the HOURS and MINUTES displays during the sequence of counts 4. 1. 13. 1.

4. 1. 13. 3 Operation of the various push buttons shall cause the displays to change according to paragraphs 4. 1. 3, 4. 1. 5, 4. 1. 7, 4. 1. 9 and 4. 1. 11. In each case, release of the push button shall cause the display of hours and minutes to hold the display at time of release of button indefinitely.

4. 2 Time Recording Signals

These checks shall be made with the unit operating under the conditions of paragraph 3. 2.

4. 2. 1 The oscilloscope of paragraph 2. 2. 1 shall be connected to the Timing Set, and have its controls set as follows:

4. 2. 1. 1	Triggering Mode	AC slow
4. 2. 1. 2	Trigger Slope	+ EXT
4. 2. 1. 3	Trigger Input	From del'd trig
4. 2. 1. 4	Time/CM (Main Sweep)	100 μ S x 1
4. 2. 1. 5	Horizontal Display	Delaying Sweep
4. 2. 1. 6	Time/CM (Del. Sweep)	5 mS
4. 2. 1. 7	Volts/CM	5 (Including Probe)
4. 2. 1. 8	Trig or Ext Sweep Slope	+
4. 2. 1. 10	Trig or Ext Sweep Atten	X1
4. 2. 1. 11	Vert Input - DC	1456-J4
4. 2. 1. 12	GND	GND to 1456-J4

4. 2. 1. 13 Other oscilloscope controls shall be set so as to produce a display consisting of 20 pulses spaced at 2 1/2 millisecond intervals and

rising approximately 8 volts positively from a base line which is at -10 VDC. These pulses will be referred to, in order from left to right, as START, Numbers 1 thru 18, and STOP. The oscilloscope shall sweep at a rate of 10 sweeps per second.

4.2.2 Each pulse shall be examined by the following procedure and shall conform to the requirements listed in paragraph 4.2.3.

4.2.2.1 Adjust DELAY-TIME MULTIPLIER to position bright marker over pulse to be examined.

4.2.2.2 Switch HORIZONTAL DISPLAY to MAIN SWEEP DELAYED. Center pulse on screen with DELAY-TIME MULTIPLIER, if necessary.

4.2.3 Pulse Characteristics

4.2.3.1 Pulses shall have duration and amplitude according to the following table. It is necessary to examine only one numbered pulse for width and amplitude.

Pulse	Width	Amplitude
START	320 ± 40 μS	+8 ± 1 V*
1-18 (0)	80 ± 10 μS	+8 ± 1 V*
1-18 (1)	170 ± 20 μS	+8 ± 1 V*
STOP	700 ± 80 μS	+8 ± 1 V*

4.2.3.2 Pulses No's 1 thru 18 shall be examined for correlation with the displays of seconds and minutes according to the following tables. Use of the tables is as follows:

- a. Select pulse to be examined by number and determine from table I the associated display, if any, sequence, and table II column.
- b. From table II, determine the sequence of 1's and 0's for the selected pulse, associated with the display numbers in column 0 of table II. For 9 sequence numbers, the displayed count is 0 to 9 and repeat, for 5 sequence numbers it is 0 to 5 and repeat.

*Above base line

- c. Compare the pulse widths (0 = 80 μ S, 1 = 170 μ S) with the displayed numbers. The display may be speeded up by depressing the appropriate push button if desired.

4.2.3.3

TABLE I

Pulse No.			Table II Column	Sequence
1	5	12	1	9
2	6	13	2	9
3	7	14	4	9
4	8	15	8	9
		9	1	5
		10	2	5
		11	4	5
0.1 Sec*				
Sec				
10 Sec				
Min				
10 Min				
Display				

4.2.3.3

TABLE II

0	1	2	4	8
0	0	0	0	0
1	1	0	0	0
2	0	1	0	0
3	1	1	0	0
4	0	0	1	0
5	1	0	1	0
6	0	1	1	0
7	1	1	1	0
8	0	0	0	1
9	1	0	0	1

*These numbers not displayed

4.3 Time Comparator

The time comparator function shall be checked with the unit operating under the conditions of paragraph 3.2, except that 1460 DC POWER and 1457 TIME SET switches shall be ON. The ohmmeter of 2.2.3 shall be connected between pins E and F of 1456-J3.

4.3.1 Minutes Check

4.3.1.1 Set 1456 ETA switches to 0:00:0.

4.3.1.2 Set MINUTES display to X9 by depressing push buttons. HOUR display may be ignored. X may be any number 0-9.

4.3.1.3 If ENABLE lamp is on, flick RESET-ENABLE switch to RESET and return. ENABLE lamp shall go out.

4.3.1.4 Momentarily depress SECONDS push button and set TIME SET switch OFF. ENABLE lamp shall light as display changes from 9:59 to 0:00.

4.3.1.5 Set ETA to 1:00:0 and turn ENABLE lamp off with RESET switch. An open circuit shall exist between pins E and F of 1456-J3. Return RESET switch to ENABLE. ENABLE lamp shall light and a closed circuit shall appear between pins E and F of 1456-J3 as display changes from 0:59 to 1:00.

4.3.1.6-13 Repeat 4.3.1.5 for ETA's of 2:00 thru 9:00.0. It is not necessary to repeat continuity check of 4.3.1.5.

4.3.2 Ten seconds check.

4.3.2.1 Set TIME Set switch to ON, and ETA to 0:10.0. Set displays to 00 minutes with push buttons.

4.3.2.2 Repeat 4.3.1.3.

4.3.2.3 Depress SECONDS push button momentarily, ENABLE lamp shall light as SECONDS display changes from 09 to 10.

4.3.2.4 Within ten seconds of 4.3.2.2, set ETA to 0:20.0 and turn ENABLE lamp off with RESET switch. Return RESET switch to ENABLE. ENABLE lamp shall light as seconds display changes from 19 to 20.

4.3.2.5-7 Repeat 4.3.2.4 for ETA's of 0:30.0 thru 0:50.0.

4.3.3 Seconds Check

4.3.3.1 Set TIME SET switch to ON and ETA to 0:01.0. Set display to 00 minutes with push buttons.

4.3.3.2 Repeat 4.3.1.3.

4.3.3.3 Depress SECONDS push button momentarily. ENABLE lamp shall light as display indicates 00:01.

4.3.3.4 Set ETA to 0:02.0 and repeat 4.3.1.3.

4.3.3.5 Repeat 4.3.3.3 for display indication of 00:02.

4.3.3.6-19 Repeat 4.3.3.4 and 4.3.3.5 for ETA's of 0:03.0 thru 0:09.0.

4.3.4 Tenth seconds check

4.3.4.1 Set TIME SET switch to ON and ETA to 0:05.1. Set display to 00 minutes with push button.

4.3.4.2 Repeat 4.3.1.3.

4.3.4.3 Depress SECONDS push button momentarily. ENABLE lamp shall light as display indicates 00:05.

4.3.4.4 Set ETA to 0:05.2 and repeat 4.3.1.3.

4.3.4.5 Repeat 4.3.4.3.

4.3.4.6-19 Repeat 4.3.4.4 and 4.3.4.5 for ETA's of 0:05.3 thru 0:05.9. ENABLE lamp shall light 0.1 second later on each successive test.

4.4 Timer Output Pulses

Certain timer output pulses shall be examined with the oscilloscope of 2.2.1, connected per 4.21 (except for 4.2.1.11, VERY INPUT), and shall display characteristics as indicated below when the vertical input is connected to the indicated terminals.

- 4.4.1 Pin A of 1456 J1: 8 ± 1 volt peak to peak, 200 cps square wave.
- 4.4.2 Pin B of 1456 J1: 8 ± 1 volt peak to peak 10 cps square wave.
- 4.4.3 Pin C of 1456 J1: $\pm 8 \pm 1$ volt pulses (measured from -10VDC base-line) 0.8 second wide at a repetition rate of 1 per second.
- 4.4.4 Pin N of 1460 J9: Same as 4.4.3.

5.0 Recording Commutator

5.1 Test Conditions

5.1.1 The Recording Commutator shall be tested under the operating conditions of paragraph 3.2, except that 1457 POWER switch shall be OFF, and 1460 DC POWER switch shall be ON.

5.1.2 Resistive loads of 10,000 ohms $\pm 5\%$ shall be connected from 1460 J5 to ground and from 1460-J7 to ground.

5.2 Continuity Checks - Closed circuits per 2.3 shall exist between the following pairs of points, when measured with the ohmmeter per 2.2.3.

J9 - Pin A	Test Point A4
B	A5
C	A6
D	A7
E	A8
F	B4
U	B5
H	B6
K	B7
G	A1
J10-Pin A	B8
B	B1
C	B2
D	B3
E	C1
F	C2
G	C3
H	C4

J
N
P

A1
A1
C5

5.3 The oscilloscope of paragraph 2.2.1 shall be connected to the Timing Set, and have its controls set, as follows:

5.3.1 TRIGGERING MODE	AC SLOW
5.3.2 TRIGGER SLOPE	+ EXT
5.3.3 TRIGGER INPUT	FROM DEL'D TRIG
5.3.4 TIME/CM (MAIN SWEEP)	100 μ S X 5
5.3.5 HORIZONTAL DISPLAY	DELAYING SWEEP
5.3.6 TIME/CM (Del. Sweep)	10 m S
5.3.7 VOLTS/CM	5 (Including Probe)
5.3.8 TRIG OR EXT SWEEP IN	FROM J7
5.3.9 TRIG OR EXT SWEEP SLOPE	+
5.3.10 TRIG OR EXT SWEEP ATTEN	X1
5.3.11 VERT INPUT - DC	1460-J5
5.3.12 GND	1460-J5

5.3.13 Other oscilloscope controls shall be set so as to produce a display consisting of a sweep 9 cm long, recurring at 10 sweeps per second.

5.4 The input signal 2.2.4 shall be applied to test points A4 and A1 (GND). A pulse output shall appear on the oscilloscope display starting at a point corresponding to 6 ± 1 mS delay after the start of the sweep.

5.5 The pulse of 5.4 shall be isolated and displayed by the technique of paragraph 4.2.2.

+0

5. 5. 1 Pulse amplitude shall be 10-1 volts DC.

5. 5. 2 Pulse width shall be 2.5 ± 2 mS

5. 6-39 Repeat 5. 4 and 5. 5 for the test points of paragraph 5. 40. Pulses shall appear delayed from the start of the sweep by the amount listed for each test point, and each pulse shall meet the requirements of paragraph 5. 5.

5. 40	TEST POINT	DELAY (± 1 mS)
	A5	10
	A6	13
	A7	17
	A8	20
	B4	23
	B5	27
	B6	30
	B7	33
	B8	37
	B1	40
	B2	43
	B3	47
	C1	50
	C2	53
	C3	57
	C4	60
	C5	63

5. 41 Correct the oscilloscope Vert Input to 1460 J7 (in parallel with trig in). Observed signal shall be a pulse of $10 \begin{smallmatrix} +0 \\ -1 \end{smallmatrix}$ volts DC having a width of 5.1 ± 5 m Sec and a repetition rate of 10 pps.

Test Specification SKYSCRAPER Pointing Computer

1.0 Introduction

1.1 Purpose

It is the purpose of this specification to outline those tests to be performed on the SKYSCRAPER pointing computer in order to assure proper operation in the SKYSCRAPER system.

1.2 Scope

This specification details the tests to be performed on the pointing computer subsystem, and the results required of a satisfactory unit.

1.3 Test Methods

1.3.1 Tests shall be performed as detailed in, and in the sequence of, paragraphs 3 and 4 of this specification.

1.3.2 All servo input and output units shall have passed the tests of SK-1572, SK-1573 or SK-1574, as appropriate, prior to this test.

1.3.3 The computer control unit (SK-1533) shall have passed the tests of SK-1576 prior to this test.

1.4 References

1.4.1 SK-1577 Pin Numbers, Junction Box

1.4.2 SK-1449 Wiring Diagram, Pointing Computer

2.0 Power and Test Equipment

2.1 Power

2.1.1 Prime power shall be available at 1538-J2 according to the following table:

A	115V 400 cps ϕ A	5A
B	115V 400 cps ϕ B	5A
C	115V 400 cps ϕ C	5A
D	AC GND	
E	+28 VDC	10A
F	DC GND	

2.1.2 115V 400 cps ϕ C shall be available for test signal excitation.

2.2 Input Signals

2.2.1 Synchro Input

A three wire synchro position signal from the stator of a properly excited synchro transmitter, of the proper type to match the control transformer being driven, shall be available. The shaft of the transmitter shall be capable of being set to any angular position with an accuracy of ± 10 minutes of arc. The synchro shall be excited with phase C voltage.

2.2.2 Modulated Input Signal

A suppressed carrier modulated 400 cps carrier signal shall be available. The modulation shall be sine and/or square wave and adjustable in frequency over the range from .005 to 20 cps. The peak amplitude of this signal shall be adjustable from .01 to 15 volts, independently of the modulating frequency. Carrier shall be phase C.

2.3 Monitoring Instruments

2.3.1 Digital Readout Device

A device capable of indicating up to 19 bits of binary coded data, and incorporating logic necessary to utilize V-Scan discs shall be available.

2.3.2 An instrument capable of measuring phase and amplitude of the modulating waveform of a suppressed carrier modulated wave shall be available.

2.3.3 Voltmeter

A DC voltmeter, accurate to $\pm .5\%$ over the range from -10 to +10 VDC, shall be available.

3.0 Static Accuracy Tests

3.1 Test Conditions

3.1.1 All tests shall be performed with the components of the Pointing Computer system interconnected with normal operating cables per SK-1449 or with cables which are electrically identical to the operating cables. (Exception: Cable 2106, Computer Controller, shall be the test cable allowing use of the TIME and MODE switches on the Computer Controller)

3.1.2 All tests shall be performed with power per 2.1.1 applied to the Pointing Computer system.

3.1.3 System controls shall be in the following positions before and during tests, except where otherwise indicated.

Control	Position
Mode	ACQ
Hold-Operate	Operate
Time	Time
Search Pattern	Raster

3.1.4 Manual and servoed inputs shall be positioned according to the following table at the beginning of tests:

Input	Position
LAT	0°
Long	0°
H _a	10,000 Yd.
X _o	6,985,500 Yd.
Y _o	100,000 Yd.
Z _o	0
X _g	0
Y _g	0
Z _g	0
K	1
Heading	0°
Pitch	0°
Roll	0°

3.2 Static Tests

3.2.1 With the conditions of paragraph 3.1, operation of the SUBFILL button shall result in the following outputs, * after steady state is attained:

X_p	+10 VDC
Y_p	0°
Z_p	0°
ψ	0°
ϵ_ψ	0°
E_s	0°
ϵ_e	-30°
A_s	270°

3.2.2 Change of Z_0 from 0 to 57,750 yards shall cause steady state outputs according to the following table:

X_p	+8.66 VDC
Y_p	+5.00 VDC
Z_p	0
ψ	30°
ϵ_ψ	30°
E_s	0
ϵ_e	-30°
A_s	300°

Return of Z_0 to 0 shall result in the outputs of 3.2.1.

* These signals can be observed at SK-1539, the system junction box. See SK-1577 for pin numbers.

3.2.3 Change of Latitude input from 0 to $- .474^{\circ}$ shall cause steady state outputs according to the table of 3.2.2. Return of Latitude input to 0 shall result in the outputs of 3.2.1.

3.2.4 Change of H_s input from 10,000 to 0 shall cause steady state outputs according to the following table:

X_p	+9.95 volt
Y_p	0
Z_p	- .099 volt
ψ	0
ϵ_{ψ}	0
E_s	5.7°
ϵ_e	-24.3°
A_s	270°

3.2.5 Change of X_o from 6,985,500 to 7,148,750 yards shall cause steady state outputs according to the following table:

X_p	+5.00 VDC
Y_p	0
Z_p	-8.66 VDC
ψ	0
ϵ_{ψ}	0
E_s	60°
ϵ_e	$+30^{\circ}$
A_s	270°

Return of X_o to 6,985,500 shall result in the outputs of 3.2.1.

3.2.6 Change of Roll (ϕ) input from 0 to -5.7° (left wing down) shall cause steady state outputs of 3.2.4. Return of ϕ to 0 shall result in the outputs of 3.2.1.

3.2.7 Change of Heading (A_Z) input from 0 to 330° (nose left wing down) shall cause steady state outputs of 3.2.2. Return of A_Z to 0 shall result in the outputs of 3.2.1.

3.2.8 Manual and servoed inputs shall be set according to the following table:

Lat	0°
Long	0°
H_a	10,000 Yd.
X_o	6,985,500 Yd.
Y_o	0
Z_o	-100,000 Yd.
\dot{X}	0
\dot{Y}	0
\dot{Z}	0
K	1
Heading	270°
Roll	0°
Pitch	0°

3.2.9 Operation of the SUBFILL button shall result in the following steady state outputs:

X_p	+10 VDC
Y_p	0
Z_p	0
ψ_p	270°
ϵ_ψ	0°
E_s	0°
ϵ_e	-30°
A_s	270°

3.2.10 Change of Longitude input from 0° to $.474^\circ$ (West) shall cause steady state outputs according to the following table:

X_p	+8.66 VDC
Y_p	-5.000 VDC
Z_p	0
ψ	270°
ϵ_ψ	-30°
E_s	0°
ϵ_e	-30°
A_s	240°

3.2.11 Change of Pitch input from 0 to $+25^\circ$ (nose up) shall cause steady state outputs according to the following table:

X_p	+8.66 VDC
Y_p	-4.53 VDC
Z_p	-2.11 VDC
ψ	270°
ϵ_ψ	27°
E_s	-19°
ϵ_e	11°
A_s	243°

Return of Pitch and Longitude inputs to 0 shall result in the outputs of 3.2.9.

3.3 Dynamic Response Tests

3.3.1 With inputs per 3.1.4 and the signal of 2.2.2 in series with the rotor of the control transformer in the Roll servo input unit, the system shall be subfilled and allowed to come to a steady state.

3.3.1.1 A plot shall be made of the Z_p output/Roll input gain-frequency characteristics over the range of frequency from .005 to 10 cps. Critical points shall be according to the table below:

Frequency	Min. Gain	Max. Phase Shift
.01	-0 db	-6°
.10	-.5 db	-15°
.20	-1 db	-36°
.30	-2 db	-50°

3.3.1.2 With a ramp input from the signal source of 2.2.2, the maximum slew rate for a roll input shall be determined. The maximum slew rate shall be greater than 2° /second and not more than 4° /second.

3.3.2 Repeat 3.3.1 with the input signal in series with the rotor of the Heading servo input unit control transformer.

3.3.2.1 A plot of X_p output/Heading input shall be according to the table below:

Frequency	Min Gain	Max. Phase Shift
.01	0 db	-6°
.10	-.5 db	-15°
.20	-1 db	-36°
.30	-2 db	-50°

3.3.2.2 Maximum slew rate for heading input shall be greater than 1° /second and not more than 3° /second.

3.3.3 Repeat 3.3.3 with the input signal in series with the rotor of the pitch servo input control transformer and with the inputs of 3.2.11.

3.3.3.1 A plot of Y_p output/pitch input shall be according to the Table below:

Frequency	Min Gain	Max. Phase Shift
.01	0 db	-6°
.10	-.5 db	-20°
.20	-1 db	-45°
.30	-2 db	-60°

3.3.3.2 Maximum slew rate for pitch input shall be greater than 2° /second and not more than 3.5° /second.

1.0 INTRODUCTION

1.1 Purpose

The purpose of this specification is to describe those tests to be performed on the Recorder Serializer to assure satisfactory operation in the SKYSCRAPER System.

1.2 Scope

The specification describes the tests to be performed and the results required of the Recorder Serializer and its associated cabling.

1.3 Test Methods

Test methods will be described in Sections 3.0 and 4.0 of this specification. The Recorder Serializer shall be subjected to the tests described and shall meet all requirements of Sections 3.0 and 4.0.

1.4 References

The following drawings shall be available for use during testing:

1.4.1 SK-1588, Encoder Drivers

1.4.2 SK-1589, Control Circuits

1.4.3 SK-1590, Driving Circuits

1.4.4 SK-1591, Over-all block diagram and intra-chassis connection.

2.0 Test Conditions

2.1 Power

2.1.1 No power shall be applied to the unit, except as specified in Section 4.0, Tests. 115 VAC, 400 cps, shall be available to supply _____ VA of power.

2.1.2 DC Power. DC Power is required as follows: -33 VDC \pm 1 VDC, 0.3 amp; + 7 VDC \pm 0.5 VDC, 0.3 amp.

2.2 Test Equipment

2.2.1 Oscilloscope - A Tektronix type 545 or equivalent shall be available for observing waveforms.

2.2.2 Oscilloscope - A Hughes Memoscope Type 304E or equivalent shall be available for reading serial outputs.

2.2.3 Pulse Source - A pulse source of 1 pps and 200 pps with amplitudes of 13 volts shall be available. These signals may be derived from the SKYSCRAPER Timing Set SK-1456.

2.2.4 Pulse Source - Two synchronous pulse sources of 200 pps, 140 micro-seconds at an amplitude of +18 volts at an offset, or normal output, of -18 volts shall be available. These may be derived from the β scan outputs of the CP-209 under control of its test panel.

2.2.5 Volt-Ohm Meter - A volt-ohm meter shall be available for measuring voltages and resistance. The ranges shall be 0-300 VAC, 400 cps, 0-20-100 VDC, 0-1 ohm and 0-100 megohms. This shall be a Simpson model 260 or equivalent.

2.3 Definitions

For purposes of this specification, an open circuit shall have a resistance of a greater than 100 megohms and a short circuit shall have a resistance of less than 1 ohm.

3.0 General

3.1 Visual Inspection - The Encoder Serializer shall be examined for conformance to applicable drawings and specifications and shall show good workmanship in assembly of the various units, and in the manufacture of component parts.

3.2 Conditions of Test

3.2.1 Interconnecting Cabling, Signals - The unit shall be connected to signal lines as follows (when so specified):

- 1. J2, e: 200 pps, 140 microseconds, 18 volt pulse (β -ES)**
- 2. J2, f: 200 pps, 140 microseconds, 18 volt pulse (β -AS)**
- 3. J2, K: 1pps, 1 sec period, 13 volt pulse (serialization repetition rate)**
- 4. J 2, W: 200 pps, squarewave, 13 volts (serial shift rate)**

3.2.2 Power

When power is to be applied to the unit it shall have prime power applied as follows:

J 1, B: 115 VAC, 400 cps (Gnd).

J 1, C: 115 VAC, 400 cps.

J 1, A: DC Gnd.

J 1, D: -33 VDC

J 1, E: + 7 VDC

J 1, G: DC Gnd.

Before prime power is applied, these voltages shall be tested at the connector of power cable.

3.2.2 Warm-up

Power shall be applied to the unit and the unit allowed to warm-up for 1 minute before tests are commenced.

4.0 Tests

4.1 Power Tests

4. 1. 1 Power Supply-Remove connectors P4 and P5 on the two servo packages. Power shall be supplied at J1, as specified in Section 3. 2. 2. The output of the power supply shall be measured and shall be -13 VDC \pm 1 VDC after warm-up.

4. 2 Serializer Tests

4. 2. 1 Serialization of Azimuth Encoder

4. 2. 1. 1 Initial Set-up - The serializer shall be set up for the test as follows:

- 1. Connect P4 of the Azimuth servo package cable to the test jig connector.**
- 2. Supply signals as specified in Section 3. 2. 1. 1 thru 3. 2. 1. 4.**
- 3. Connect the Hughes Memoscope signal input to J3. Connect the Memoscope Sync to Gate #1 and set the trigger selector for - slope. Set sweep rate at 1/sec.**

4. 2. 1. 2 Test

- 1. A serial pattern shall appear on the scope consisting of a series of 14 pulses of +13 volts on a base line voltage of -13 volts. Each pulse shall be 5 milliseconds wide and spaced 20 milliseconds apart as measured from the leading edge of the following pulse. A single gap shall always appear at the first bit position of each encoder serialization to mark the beginning of a serialization cycle.**
- 2. Apply a ground successively to each pin of the encoder cable using the test jig. These grounds shall be supplied as follows:**
 - 1. HH**
 - 2. GG**
 - 3. EE**

4. CC
5. AA
6. y
7. w
8. u
9. s
10. q
11. n
12. k
13. a

At each test the interval between pulses shall be successively removed, and shall be displaced from step to step to the right.

4.2.2 **Serialization of Elevation Encoder**

4.2.2.1 **Initial Setup**

1. Remove the test jig connector from P4 of the Azimuth encoder cable and connect it to P5 of the elevation encoder cable.
2. The remainder of this set-up is identical with Section 4.2.1.1.

4.2.2.2 **Test**

1. A serial pattern identical with that described in 4.2.1.2, 1), but displaced in time by 0.5 second, i. e. it should appear on the right half of the scope face. There should always be a "one" on the first position.
2. Apply grounds successively to the pins of the test jig as described in 4.2.1.2, 2). The successive movement of pulse interval removal shall again appear in the right-hand half of the scope face.

4. 2. 3 Over-all Test of Channel 1

4. 2. 3. 1 Initial Setup

1. Remove the cover of the #1 encoder assembly.
2. Connect the digital readout device (referred to in SK-1572) or a volt-meter to connector J-2 in the following manner:

Indicator	Pin	Indicator	Pin
2 ⁰	d	2 ⁸	y
2 ¹	g	2 ⁹	s
2 ²	c	2 ¹⁰	GG
2 ³	w	2 ¹¹	Z
2 ⁴	b	2 ¹²	BB
2 ⁵	EE	2 ¹³	k
2 ⁶	i		
2 ⁷	DD		

3. Connect P-4 to the encoder connector, J-4. (P-5 shall be left disconnected).
4. Apply power and signal voltages as in Section 3. 2. 1 and 3. 2. 2.
5. Connect the oscilloscope to the serial output (d-3) as in Section 4. 2. 1. 1, 3).

4. 2. 3. 2 Test

1. The indication of the binary indicator or voltmeter shall correspond to the serial output on the oscilloscope as described in Section 4. 2. 1. 2, 1).
2. Manually rotate the shaft encoder to a new position and reset the indicator and oscilloscope. The indicator and serial readout shall again correspond. This shall be done at least for readouts of all one's and all zero's.

4. 2. 4 Overall Test of Channel 2

4. 2. 4. 1 Initial Setup

1. Re-assemble the #1 encoder, removing its connector, P-4.
2. Remove the cover of the #2 encoder assembly.
3. The digital readout is connected as in Section 4. 2. 3. 1.
4. Connect P-5 to the encoder connector, J-5.
5. Apply power and signal voltages as in Section 3. 2. 1 and Section 3. 2. 2.
6. The oscilloscope is left as in 4. 2. 3. 1.

4. 2. 4. 2 Test

1. The test is identical with that of 4. 2. 3. 2.

APPENDIX C

SKYSCRAPER OPTICAL TRACKING SUBSYSTEM TEST PLAN

A. The following outline of Skyscraper Subsystem Testing assumes the following subunit tests have been completed and that the subunits are performing adequately.

1. 10" Optics
 - a. Optical Alignment Completed
 - (1) K-Mirror
 - (2) Primary Mirror
 - (3) Secondary Mirror
 - (4) Reticle and Cell Alignment
 - b. Mechanical
 - (1) K-Mirror Motor - operating at proper speed
 - (2) K-Mirror Resolver
 - (3) Reticle Drive Assembly - operating at proper speed
2. Electronic Equipment Rack
 - a. All Electronic Modules Operating Properly
 - b. All Rack Wiring Completed
3. Control Panel
 - a. Lights, Switches, and Meters Operating Properly
4. Interconnecting Cables
 - a. Completed

5. Platform

- a. All interconnecting wiring required on the platform completed. This need only be the cables connecting the Platform J-Box to: Tracking Mirror Assy. , 10" Optics Assy. , and Slit Mirror Assy.

B. 10" Optics (Tracker)

1. Assemble Tracker to Test Apparatus

- a. Alignment Jig
- b. Indexing Head
- c. Stable Work Surface

2. Align Tracker with Infrared Collimator

- a. Insert a Single Target Aperture in Collimator
- b. Null Output of T_1 F-M Discriminator by Moving Tracker with Indexing Head

3. Phasing K-Mirror Resolver

- a. Introduce Positive Azimuth Error by Rotating Index Head
 - (1) Positive Error - Move Index Head Left
 - (2) 3 Minutes - Maximum Rotation
- b. Rotate Body of K-Mirror Resolver
 - (1) Output of Slit Mirror Synchronous Detectors
 - (a) Elevation Signal Nulled
 - (b) Azimuth - Positive D/C Signal
- c. Re-zero Tracker as in 2. b.
- d. Introduce Positive Elevation Error with Indexing Head

- (1) Positive Error - Move Index Head Down
- (2) 3 Minutes - Maximum Rotation

e. Check Output of Slit Mirror Synchronous Detectors

- (1) Azimuth Nulled
- (2) Elevation - Positive D/C Signal

f. Re-zero Tracker as in 2. b.

4. Slit Mirror Checkout

a. Introduce Azimuth Error by Means of Rotating Index Head in Azimuth

b. Measure and Record Motion of Slit Mirror + BSD Position Output for at Least Two Complete Runs

- (1) Auto-collimate with Theodolite
- (2) Slit Mirror Motion Given By:

$$\theta = 18.75 \alpha \pm 1.07 \text{ minutes}$$

- (a) θ = Slit Mirror Angle
- (b) α = Input Error Angle

(3) Elevation Cross-Talk

c. Re-zero Index Head as in 2. b.

d. Introduce Elevation Error by Means of Rotating Index Head in Elevation

e. Measure and Record Motion of Slit Mirror and BSD Position Output for at Least Two Complete Runs

- (1) Auto-collimate with Theodolite
- (2) Slit Mirror Motion Given by:

$$\theta = 26.51 \alpha \pm 1.52 \text{ minutes}$$

- (a) θ = Slit Mirror Angle
- (b) α = Input Error Angle

f. Re-zero as in 2. b.

5. Sensitivity Check

a. Place Aperture of Known Hole Size in Collimator

(1) Single Target

b. Calculate Radiant Intensity Received by 10" Optics

c. Measure Track D/C AGC Voltage as a Function of Input Radiant Intensity

(1) Radiant Intensity may be Varied by Changing Aperture Hole Size

(2) Black Body Temperature Remains Constant

d. Rotate Index Head Through an Azimuth Angle of 9 Minutes

e. Repeat (a) Through (e) Above, but Measure Acquisition AGC Voltage as a Function of Input Radiant Intensity

C. Resolver Alignment - Platform

1. Establish Zero Position of Tracking Mirror - Optically

2. Align the Following Units

a. Azimuth Resolver

b. Azimuth Sight-Line Synchro

c. El. Resolver

d. Coordinate Rotation Resolver

e. El. Sight-Line Synchro

D. Track Loop Tests

- 1. The following tests assume that these subsystem alignments have been completed on the platform.**
 - a. 20" Optics**
 - b. Tracking Mirror (Gyros)**
 - c. 10" Optics**
 - d. Platform Wiring**
- 2. Place a Single Target Aperture in the Collimator**
- 3. Connect Manual Search Controller into Platform J-Box**
- 4. Acquire Target by Moving Azimuth and Elevation Controls on Search Controller. Note BSD Mode Indication Outputs and Compare with Control Panel. Determine Capture Time.**
- 5. Measure Static Tracking Accuracy**
 - a. Measure 15 Cycles Signal from Track (T_1) F-M Discriminator**
- 6. Complete Open Loop Frequency Response Tests of Azimuth and Elevation Servo Loops**
 - a. Inject Signal at Rate Summing Point**
 - b. Measure Loop Output at Notch Filter Output**

E. Search Loop

- 1. Complete Search Loop Frequency Response Tests - Azimuth and Elevation Loops**
 - a. Inject Signals from Servoscope into Follow-up Resolvers**
 - b. Measure Output of Position Filter and Rate Filters in the Appropriate Channels.**

2. Check the Slew Rates of 7.5 Deg/Sec in Azimuth and 15 Deg/Sec in Elevation

F. Stabilization Loops (Rate)

1. Complete Rate Loop Frequency Response Tests - Azimuth and Elevation Loops
 - a. Inject Signals into Summing Network
 - b. Measure Error Signals into Amplifier

G. Interface Checks

1. Place a Three Target Aperture in the Collimator
2. Compare the Following BSD Outputs with the Control Panel Meters
 - a. Azimuth Line of Sight Synchro
 - b. Elevation Line of Sight Synchro
 - c. A Azimuth
 - d. A Elevation
 - e. T_1 Azimuth
 - f. T_1 Elevation
 - g. T_2 Azimuth
 - h. T_2 Elevation
3. Change Targets Using the BSD Shift Track Command Input. Note the Results on the Control Panel Indicators and at the Sequence Command Output to BSD. Determine Time Required to Change Targets.
4. Check Amplitude and Phase of BSD Potentiometer Excitation

H. Subsystem Demonstration

- 1. Place a Three Target Aperture in the Collimator**
- 2. Move the Collimator Outside the Subsystem Field-of-View**
- 3. Using a Fixed Signal from the BSD Computer Cable, the Telescope and MOD, Acquire the Strongest Target**
- 4. Sequence the Targets Using the BSD Shift Track Command Input. Watch Target Motion at the Spectrometer Slit Position**
- 5. Move the Collimator at a Rate which Corresponds to Approximately 5 Deg/Sec. Watch Target Motion at the Spectrometer Slit Position. Repeat Item 4. with the Collimator in Motion.**

UNCLASSIFIED

UNCLASSIFIED