

UNCLASSIFIED

AD 269 541

*Reproduced
by the*

**ARMED SERVICES TECHNICAL INFORMATION AGENCY
ARLINGTON HALL STATION
ARLINGTON 12, VIRGINIA**



UNCLASSIFIED

NOTICE: When government or other drawings, specifications or other data are used for any purpose other than in connection with a definitely related government procurement operation, the U. S. Government thereby incurs no responsibility, nor any obligation whatsoever; and the fact that the Government may have formulated, furnished, or in any way supplied the said drawings, specifications, or other data is not to be regarded by implication or otherwise as in any manner licensing the holder or any other person or corporation, or conveying any rights or permission to manufacture, use or sell any patented invention that may in any way be related thereto.

269541

ARL 76

ANALYSIS OF STRUCTURAL LAMINATES

XEROX
62-1-6

AS AD NO.

S. B. DONG
R. B. MATTHIENEN
K. S. PISTER
R. L. TAYLOR

UNIVERSITY OF CALIFORNIA
BERKELEY, CALIFORNIA

SEPTEMBER 1961

AERONAUTICAL RESEARCH LABORATORY
OFFICE OF AEROSPACE RESEARCH
UNITED STATES AIR FORCE

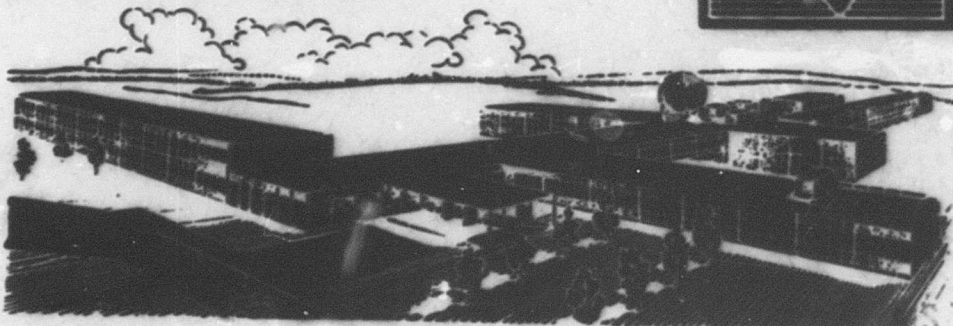

STIA
JAN 18 1962
1962

NOTICES

When Government drawings, specifications, or other data are used for any purpose other than in connection with a definitely related Government procurement operation, the United States Government thereby incurs no responsibility nor any obligation whatsoever; and the fact that the Government may have formulated, furnished, or in any way supplied the said drawings, specifications, or other data, is not to be regarded by implication or otherwise as in any manner licensing the holder or any other person or corporation, or conveying any rights or permission to manufacture, use, or sell any patented invention that may in any way be related thereto.

Qualified requesters may obtain copies of this report from the Armed Services Technical Information Agency, (ASTIA), Arlington Hall Station, Arlington 12, Virginia.

This report has been released to the Office of Technical Services, U. S. Department of Commerce, Washington 25, D. C. for sale to the general public.

Copies of ARL Technical Reports and Technical Notes should not be returned to Aeronautical Research Laboratory unless return is required by security considerations, contractual obligations, or notices on a specific document.

ARL 76

ANALYSIS OF STRUCTURAL LAMINATES

**S. B. DONG
R. B. MATTHIEN
K. S. PISTER
R. L. TAYLOR**

**INSTITUTE OF ENGINEERING RESEARCH
UNIVERSITY OF CALIFORNIA
BERKELEY, CALIFORNIA**

SEPTEMBER 1961

**CONTRACT No. AF 33(616)-6910
PROJECT 7063
TASK 70524**

**AERONAUTICAL RESEARCH LABORATORY
OFFICE OF AEROSPACE RESEARCH
UNITED STATES AIR FORCE
WRIGHT-PATTERSON AIR FORCE BASE, OHIO**

FOREWORD

This report was prepared by the Institute of Engineering Research, University of California, under USAF Contract No. AF 33(616)-6910. The work was administered under the direction of the Thermomechanics Research Branch, Aeronautical Research Laboratory. The authors are indebted to J. Frisch, Associate Professor of Mechanical Engineering, for supervision of the tests and analysis of the results described in Part III.

This report covers research conducted from 1 February 1960 through 31 January 1961.

ABSTRACT

A general small-deflection theory governing the elastostatic extension and flexure of thin laminated anisotropic shells and plates is formulated. The plate or shell structure may be composed of an arbitrary number of bonded layers, each of which may possess different thickness, orientation, and/or orthotropic elastic properties. Donnell-type equations for cylindrical shells and Poisson-Kirchhoff plate equations are explicitly discussed, along with procedures for determining stresses in an individual lamina. Several methods of solution of the system of equations governing extension and flexure of plates are discussed and illustrated with examples. Optimization of laminate configuration is treated briefly. The results of a limited number of crack propagation tests of flat plate aluminum foil laminates in uniaxial tension are presented.

TABLE OF CONTENTS

INTRODUCTION	1
PART I: THEORY OF THIN LAMINATED ANISOTROPIC PLATES AND SHELLS . .	2
1. GENERAL THEORY OF THIN LAMINATED ANISOTROPIC SHELLS	2
Stress-Strain Relations for a Lamina in Generalized Plane Stress	2
Stress-Strain Relations for an Orthotropic Lamina Referred to Arbitrary Axes	4
Surface Geometry of Shells	7
Assumptions in the Classical Theory of Shells	8
Displacement Vector	8
Strain-Displacement Equations	9
Stress-Resultants and Stress-Couples	10
Equations of Equilibrium and Compatibility	11
Boundary Conditions	12
2. DONNELL-TYPE EQUATIONS FOR LAMINATED ANISOTROPIC CYLINDRICAL SHELLS	15
Derivation of the Governing Differential Equations and Boundary Conditions	15
Determination of Stresses in an Individual Lamina and Interlaminar Shear Stresses	22
3. EQUATIONS FOR LAMINATED ANISOTROPIC PLATES	26
Derivation of the Governing Differential Equations and Boundary Conditions	26
Determination of Stresses in an Individual Lamina and Interlaminar Shear Stresses	32
4. METHODS OF SOLUTION	35
Reduction of the Coupled Equations to one Eighth Order Equation	35
Iterative Solution of the Coupled Equations	37

	Perturbation Solution of the Coupled Equations	38
	Specialization of the Plate Equations for Particular Orientations	43
	Specialization of the Shell Equations for Particular Orientations	46
PART II:	APPLICATIONS	49
5.	WEAK CYLINDRICAL BENDING AND EXTENSION OF A LONG RECTANGULAR LAMINATED PLATE OF ORTHOTROPIC MATERIAL	50
	Weak Cylindrical Bending of a Plate Strip	51
	Uniaxial Extension	53
	Superposition of Solutions	59
	Example of a Plate of 12 Orthotropic Laminas with Spiral Orientation	60
6.	DEFLECTION SURFACES FOR PRESCRIBED EDGE LOADS	70
	Uniform Tension	71
	Pure Shear	71
	Uniform Bending About One Axis	72
	Pure Twist	72
7.	BENDING OF ORTHOTROPIC LAMINATED PLATES	74
	Example of a Square Plate of 13 Layers with Pairwise 90° Equiangular Orientation	75
8.	APPLICATIONS OF THE PERTURBATION METHOD OF SOLUTION	79
	Clamped Circular Plate	79
	Simply-Supported Rectangular Plate	82
	Rectangular Plate with Two Opposite Edges Simply-Supported and the Other Two Edges Clamped	85
9.	OPTIMIZATION OF LAMINATE CONFIGURATION	91
	Cylindrical Bending of Long Rectangular Plates	91
	Rectangular Plates Simply-Supported on Two Opposite Edges	92

Effect of the Number of Layers for a Given Total Thickness.	96
PART III: DETERMINATION OF MATERIAL PROPERTIES AND CRACK PROPAGATION STUDIES	97
10. Determination of Elastic Coefficients of Individual Laminas	98
11. Experimental Studies of Crack Propagation in Foil Laminates	100
REFERENCES	132

LIST OF FIGURES

Figure		Page
1	Aluminum Foil Laminate Specimen	105
2a	Gross Area Stress vs Crack Length of 2-Ply 1100 H-19 Aluminum Foil Laminates	106
2b	Gross Area Stress vs Crack Length of 2-Ply 1100 H-19 Aluminum Foil Laminates	107
3a	Gross Area Stress vs Crack Length of 4-Ply 1100 H-19 Aluminum Foil Laminates	108
3b	Gross Area Stress vs Crack Length of 4-Ply 1100 H-19 Aluminum Foil Laminates	109
4a	Gross Area Stress vs Crack Length of 6-Ply 1100 H-19 Aluminum Foil Laminates	110
4b	Gross Area Stress vs Crack Length of 6-Ply 1100 H-19 Aluminum Foil Laminates	111
5a	Gross Area Stress vs Crack Length of 10-Ply 1100 H-19 Aluminum Foil Laminates	112
5b	Gross Area Stress vs Crack Length of 10-Ply 1100 H-19 Aluminum Foil Laminates	113
6a	Final Crack Length vs Number of Ply in 1100 H-19 Aluminum Foil Laminates	114
6b	Final Crack Length vs Number of Ply in 1100 H-19 Aluminum Foil Laminates	115
7a	Final Crack Length vs Initial Crack Length in 1100 H-19 Aluminum Foil Laminates	116
7b	Final Crack Length vs Initial Crack Length in 1100 H-19 Aluminum Foil Laminates	117
8a	Gross Area Initiation Stress vs Initial Crack Length in 1100 H-19 Aluminum Foil Laminates	118
8b	Gross Area Initiation Stress vs Initial Crack Length in 1100 H-19 Aluminum Foil Laminates	119
9a	Maximum Gross Area Stress vs Initial Crack Length in 1100 H-19 Aluminum Foil Laminates	120
9b	Maximum Gross Area Stress vs Initial Crack Length in 1100 H-19 Aluminum Foil Laminates	121

10a	Log-log Plot of Gross Area Initiation Stress vs Initial Crack Length in 1100 H-19 Aluminum Foil Laminates	122
10b	Log-log Plot of Gross Area Initiation Stress vs Initial Crack Length in 1100 H-19 Aluminum Foil Laminates	123
11a	Log-log Plot of Max. Gross Area Stress vs Initial Crack Length in 1100 H-19 Aluminum Foil Laminates	124
11b	Log-log Plot of Max. Gross Area Stress vs Initial Crack Length in 1100 H-19 Aluminum Foil Laminates	125
12a	Gross Area Initiation Stress vs Final Crack Length in 1100 H-19 Aluminum Foil Laminates	126
12b	Gross Area Initiation Stress vs Final Crack Length in 1100 H-19 Aluminum Foil Laminates	127
13a	Max. Gross Area Stress vs Final Crack Length in 1100 H-19 Aluminum Foil Laminates	128
13b	Max. Gross Area Stress vs Final Crack Length in 1100 H-19 Aluminum Foil Laminates	129
14a	Plastic Work Dissipation Rate vs Initial Crack Length in 1100 H-19 Aluminum Foil Laminates	130
14b	Plastic Work Dissipation Rate vs Initial Crack Length in 1100 H-19 Aluminum Foil Laminates	131

LIST OF TABLES

Table		Page
1	Summary of the Cylindrical Bending and Uniaxial Extension Problems	57
2	Computation of Elastic Constants A_{ij} , D_{ij}^* , and D_{ij}	63
3	Summary of the Rectangular Plate Strip Problem	67
4	Material Properties of 1100 H-19 Aluminum Foil Sheets	103
5	Summary of Results of Crack Propagation Tests	104

INTRODUCTION

Analysis and prediction of the mechanical behavior of structural laminates, with a view toward possible application in aircraft or missile structures is contingent upon obtaining basic information involving: (1) determination of mechanical properties of materials, (2) development of appropriate stress analysis procedures, and (3) establishment of suitable criteria for strength analysis.

This report describes a theory of behavior, for flat plate and cylindrical shell structures, appropriate to bonded laminate-type construction. The possibility of orthotropic elastic properties and arbitrary orientation of elastic axes of individual laminas is accounted for. The theory may be extended to include anisotropic layers with only slight modification. Preliminary experimental results of crack initiation and propagation studies for aluminum foil laminates in uniaxial tension are presented.

Manuscript released by the authors, March 31, 1961, for publication as an ARL Technical Documentary Report.

PART I: THEORY OF THIN ANISOTROPIC PLATES AND SHELLS

INTRODUCTION

A general theory for the flexural and extensional behavior of thin laminated anisotropic shells is developed in Part I. The theory is formulated within the framework of the classical shell theory predicated on the Kirchhoff-Love hypothesis. In this theory the effect of transverse shear deformation and transverse normal stress is neglected. Love's first approximation is employed in the derivation. The procedures in developing these governing equations are as follows. The stress-strain relations for an individual lamina in generalized plane stress are established. A brief discussion on surface geometry pertinent to the derivation is given. Stress-resultants and stress-couples are formulated by integration of the components of stress across the thickness of the shell. The condition of equilibrium is then imposed upon the shell. The additional equation for the compatibility of the reference surface is given. Boundary conditions associated with the boundary value problem are discussed. This system of general equations is then specialized for cylindrical shells and flat plates.

Much of the early work in laminated shells was devoted to symmetric sandwich-type construction of isotropic materials. A theory of laminated orthotropic shells was developed by S. A. Ambartsumyan (1), who restricted the elastic axes of all the laminae to run parallel to the coordinate axes. Other authors have studied problems which are governed by the same type of differential equations as for laminated plates and shells. Their work will be cited. Other methods of solution, such as perturbation and iteration, are also discussed.

1. GENERAL THEORY OF THIN LAMINATED ANISOTROPIC SHELLS

STRESS-STRAIN RELATIONS FOR A LAMINA IN GENERALIZED PLANE STRESS

To study laminate systems, it is first necessary to establish the stress-strain relations for a single lamina. Consider an individual lamina whose middle surface lies in the plane $z = 0$, with the axes 1 and 2 forming a right-handed orthogonal coordinate system. The strain-stress relations for a completely general anisotropic material in matrix notation assumes the form:

$$\begin{bmatrix} \epsilon_1 \\ \epsilon_2 \\ \gamma_{12} \end{bmatrix} = \begin{bmatrix} s_{11} & s_{12} & s_{16} \\ s_{12} & s_{22} & s_{26} \\ s_{16} & s_{26} & s_{66} \end{bmatrix} \begin{bmatrix} \sigma_1 \\ \sigma_2 \\ \tau_{12} \end{bmatrix} \quad (1.1)$$

In Eq (1.1), $(\sigma_1, \sigma_2, \tau_{12})$ and $(\epsilon_1, \epsilon_2, \gamma_{12})$ refer to the average normal and shearing stresses and strains, respectively, over the lamina thickness. Due to the symmetry of the compliance matrix s_{ij} , there are only six independent constants in generalized plane stress for an anisotropic material. If the material is orthotropic and the principal elastic axes coincide with the coordinate axes, the strain-stress relations reduce to the following:

$$\begin{bmatrix} \epsilon_1 \\ \epsilon_2 \\ 1/2\gamma_{12} \end{bmatrix} = \begin{bmatrix} s_{11} & s_{12} & 0 \\ s_{12} & s_{22} & 0 \\ 0 & 0 & 2s_{66} \end{bmatrix} \begin{bmatrix} \sigma_1 \\ \sigma_2 \\ \tau_{12} \end{bmatrix} \quad (1.2)$$

The matrix of coefficients s_{ij} in Eq (1.2) is related to the conventional elastic moduli and Poisson's ratio in the following manner:

$$\begin{aligned} s_{11} &= \frac{1}{E_1} & s_{12} &= s_{21} = -\frac{\nu_1}{E_1} = -\frac{\nu_2}{E_2} \\ s_{22} &= \frac{1}{E_2} & s_{66} &= \frac{1}{G} \end{aligned} \quad (1.3)$$

It is seen that the elastic properties of an orthotropic lamina are defined by four independent constants. The factors 2 and 1/2 in Eq (1.2) are inserted so as to make the matrix a tensor in order that tensorial transformations can be carried out in the sequel. Since most of the further work is devoted to orthotropic materials, subsequent discussion is restricted to orthotropic stress-strain relations. For convenience of application, it is frequently necessary to express Eq (1.2) in inverse form, i.e., as a stress-strain relation. Inversion of Eq (1.2) gives:

$$\begin{bmatrix} \sigma_1 \\ \sigma_2 \\ \tau_{12} \end{bmatrix} = \begin{bmatrix} c_{11} & c_{12} & 0 \\ c_{12} & c_{22} & 0 \\ 0 & 0 & 2c_{66} \end{bmatrix} \begin{bmatrix} \epsilon_1 \\ \epsilon_2 \\ 1/2\gamma_{12} \end{bmatrix} \quad (1.4)$$

where

$$\begin{aligned} c_{11} &= \frac{s_{22}}{s_{11}s_{22} - s_{12}^2} = \frac{E_1}{1 - \nu_1\nu_2} \\ c_{22} &= \frac{s_{11}}{s_{11}s_{22} - s_{12}^2} = \frac{E_2}{1 - \nu_1\nu_2} \\ c_{12} &= c_{21} = -\frac{s_{12}}{s_{11}s_{22} - s_{12}^2} = -\frac{E_2\nu_1}{1 - \nu_1\nu_2} = \frac{E_1\nu_2}{1 - \nu_1\nu_2} \end{aligned} \quad (1.5)$$

$$C_{66} = \frac{1}{S_{66}} = G \quad (1.5)$$

STRESS-STRAIN RELATIONS FOR AN ORTHOTROPIC
LAMINA REFERRED TO ARBITRARY AXES

In developing the theory associated with laminates composed of individual laminae in which the elastic axes are oriented at various angles relative to the major axis of the laminate proper, it is necessary to express the stress-strain relations for an individual lamina referred to orthogonal axes making an arbitrary angle relative to the elastic axes of the lamina. Referring to Figure 1.1, the elastic axes 1, 2, of the lamina are rotated through a positive angle θ relative to the arbitrary reference axes α , β .

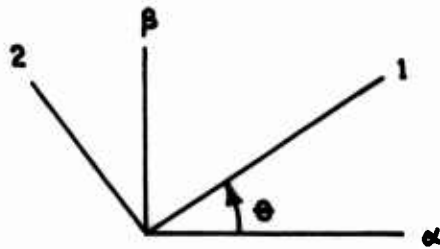

Figure 1.1

It is desired to express the stress-strain equations with respect to axes α , β . If the desired equations take the form

$$\begin{pmatrix} \sigma_{\alpha} \\ \sigma_{\beta} \\ \tau_{\alpha\beta} \end{pmatrix} = \begin{pmatrix} \bar{C}_{11} & \bar{C}_{12} & 2\bar{C}_{16} \\ \bar{C}_{12} & \bar{C}_{22} & 2\bar{C}_{26} \\ \bar{C}_{16} & \bar{C}_{26} & 2\bar{C}_{66} \end{pmatrix} \begin{pmatrix} \epsilon_{\alpha} \\ \epsilon_{\beta} \\ 1/2\gamma_{\alpha\beta} \end{pmatrix} \quad (1.6)$$

then the problem is to express the \bar{C}_{ij} matrix in terms of the C_{ij} matrix from Eq (1.4) and functions of the angle θ . This can be accomplished by utilizing appropriate transformations for stress and strain matrices as follows: It is easily verified that

$$C_{66} = \frac{1}{S_{66}} = G \quad (1.5)$$

STRESS-STRAIN RELATIONS FOR AN ORTHOTROPIC
LAMINA REFERRED TO ARBITRARY AXES

In developing the theory associated with laminates composed of individual laminae in which the elastic axes are oriented at various angles relative to the major axis of the laminate proper, it is necessary to express the stress-strain relations for an individual lamina referred to orthogonal axes making an arbitrary angle relative to the elastic axes of the lamina. Referring to Figure 1.1, the elastic axes 1, 2, of the lamina are rotated through a positive angle θ relative to the arbitrary reference axes α, β .

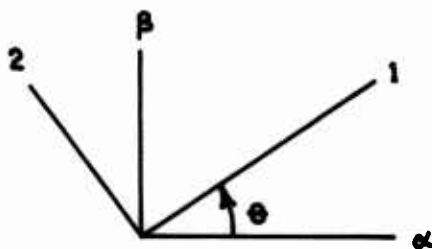

Figure 1.1

It is desired to express the stress-strain equations with respect to axes α, β . If the desired equations take the form

$$\begin{pmatrix} \sigma_{\alpha} \\ \sigma_{\beta} \\ \tau_{\alpha\beta} \end{pmatrix} = \begin{pmatrix} \bar{C}_{11} & \bar{C}_{12} & 2\bar{C}_{16} \\ \bar{C}_{12} & \bar{C}_{22} & 2\bar{C}_{26} \\ \bar{C}_{16} & \bar{C}_{26} & 2\bar{C}_{66} \end{pmatrix} \begin{pmatrix} \epsilon_{\alpha} \\ \epsilon_{\beta} \\ 1/2\gamma_{\alpha\beta} \end{pmatrix} \quad (1.6)$$

then the problem is to express the \bar{C}_{ij} matrix in terms of the C_{ij} matrix from Eq (1.4) and functions of the angle θ . This can be accomplished by utilizing appropriate transformations for stress and strain matrices as follows: It is easily verified that

$$\begin{bmatrix} \sigma_1 \\ \sigma_2 \\ \tau_{12} \end{bmatrix} = \begin{bmatrix} T \end{bmatrix} \begin{bmatrix} \sigma_\alpha \\ \sigma_\beta \\ \tau_{\alpha\beta} \end{bmatrix} \quad (1.7)$$

and

$$\begin{bmatrix} \epsilon_1 \\ \epsilon_2 \\ 1/2 \gamma_{12} \end{bmatrix} = \begin{bmatrix} T \end{bmatrix} \begin{bmatrix} \epsilon_\alpha \\ \epsilon_\beta \\ 1/2 \gamma_{\alpha\beta} \end{bmatrix} \quad (1.8)$$

where the matrix T is given by

$$\begin{bmatrix} T \end{bmatrix} = \begin{bmatrix} \cos^2 \theta & \sin^2 \theta & 2\sin \theta \cos \theta \\ \sin^2 \theta & \cos^2 \theta & -2\sin \theta \cos \theta \\ -\sin \theta \cos \theta & \sin \theta \cos \theta & \cos^2 \theta - \sin^2 \theta \end{bmatrix} \quad (1.9)$$

From Eq (1.4), (1.7), and (1.8) there results

$$\begin{bmatrix} \sigma_\alpha \\ \sigma_\beta \\ \tau_{\alpha\beta} \end{bmatrix} = \begin{bmatrix} T \end{bmatrix}^{-1} \begin{bmatrix} C \end{bmatrix} \begin{bmatrix} T \end{bmatrix} \begin{bmatrix} \epsilon_\alpha \\ \epsilon_\beta \\ 1/2 \gamma_{\alpha\beta} \end{bmatrix} \quad (1.10)$$

where $\begin{bmatrix} T \end{bmatrix}^{-1}$ denotes the inverse of $\begin{bmatrix} T \end{bmatrix}$. Comparing Eq (1.6) and (1.10) gives

$$\begin{bmatrix} \bar{C} \end{bmatrix} = \begin{bmatrix} T \end{bmatrix}^{-1} \begin{bmatrix} C \end{bmatrix} \begin{bmatrix} T \end{bmatrix} \quad (1.11)$$

Performing the matrix operations indicated by Eq (1.11) leads to the following expressions for the elements of the \bar{C} matrix.

$$\begin{aligned}
\bar{c}_{11} &= c_{11} \cos^4 \theta + 2(c_{12} + 2c_{66}) \sin^2 \theta \cos^2 \theta + c_{22} \sin^4 \theta \\
\bar{c}_{22} &= c_{11} \sin^4 \theta + 2(c_{12} + 2c_{66}) \sin^2 \theta \cos^2 \theta + c_{22} \cos^4 \theta \\
\bar{c}_{66} &= (c_{11} + c_{22} - 2c_{12} - 2c_{66}) \sin^2 \theta \cos^2 \theta + c_{66} (\sin^4 \theta + \cos^4 \theta) \\
\bar{c}_{12} &= (c_{11} + c_{22} - 4c_{66}) \sin^2 \theta \cos^2 \theta + c_{12} (\sin^4 \theta + \cos^4 \theta) \\
\bar{c}_{16} &= (c_{11} - c_{12} - 2c_{66}) \sin \theta \cos^3 \theta + (c_{12} - c_{22} + 2c_{66}) \sin^3 \theta \cos \theta \\
\bar{c}_{26} &= (c_{11} - c_{12} - 2c_{66}) \sin^3 \theta \cos \theta + (c_{12} - c_{22} + 2c_{66}) \sin \theta \cos^3 \theta
\end{aligned} \tag{1.12}$$

In the preceding equations, the elastic constants for stress-strain relations referred to arbitrary axes have been expressed in terms of the four independent orthotropic constants and functions of the angle θ .

It is convenient in application to deal with the conventional elastic moduli E_1 , E_2 , G and Poisson's ratios ν_1 , ν_2 instead of the elastic constants \bar{c}_{ij} . This can easily be accomplished by utilizing Eq (1.5), however, to simplify the final expressions for the general relationships, let the following definitions be introduced.

$$\begin{aligned}
E_1 &= E \\
E_2 &= kE \\
\nu_1 &= \nu && \text{where } k \text{ and } \lambda \text{ are} \\
\nu_2 &= k\nu && \text{arbitrary parameters} \\
G &= \frac{\lambda E}{1 - k\nu^2}
\end{aligned} \tag{1.13}$$

The four independent parameters which describe the material properties are now E , ν , k , and λ . Substituting Eq (1.13) into Eq (1.5) and in turn into Eq (1.12) gives:

$$\bar{c}_{11} = \frac{E}{1 - k\nu^2} \left[\cos^4 \theta + k \sin^4 \theta + (2k\nu + 4\lambda) \sin^2 \theta \cos^2 \theta \right] \tag{1.14}$$

$$\begin{aligned}
\bar{C}_{22} &= \frac{E}{1-k\nu^2} \left[k \cos^4 \theta + \sin^4 \theta + (2k\nu + 4\lambda) \sin^2 \theta \cos^2 \theta \right] \\
\bar{C}_{66} &= \frac{E}{1-k\nu^2} \left[\lambda (\sin^2 \theta - \cos^2 \theta)^2 + (1 - 2k\nu + k) \sin^2 \theta \cos^2 \theta \right] \\
\bar{C}_{12} &= \frac{E}{1-k\nu^2} \left[(1 + k - 4\lambda) \sin^2 \theta \cos^2 \theta + k\nu (\sin^4 \theta + \cos^4 \theta) \right] \quad (1.14) \\
\bar{C}_{16} &= \frac{E}{1-k\nu^2} \left[(k\nu - 1 + 2\lambda) \sin \theta \cos^3 \theta - (k\nu - k + 2\lambda) \sin^3 \theta \cos \theta \right] \\
\bar{C}_{25} &= \frac{E}{1-k\nu^2} \left[(k\nu - 1 + 2\lambda) \sin^3 \theta \cos \theta - (k\nu - k + 2\lambda) \sin \theta \cos^3 \theta \right]
\end{aligned}$$

SURFACE GEOMETRY OF SHELLS

Let α and β be orthogonal curvilinear coordinates which describe the surface whose cartesian coordinates are given by the equations:

$$\begin{aligned}
X &= X(\alpha, \beta) \\
Y &= Y(\alpha, \beta) \\
Z &= Z(\alpha, \beta)
\end{aligned} \quad (1.15)$$

The line element on the undeformed surface is

$$ds^2 = A^2 d\alpha^2 + B^2 d\beta^2 \quad (1.16)$$

where A and B are the surface metric coefficients defined by

$$\begin{aligned}
A^2 &= (X, \alpha)^2 + (Y, \alpha)^2 + (Z, \alpha)^2 \\
B^2 &= (X, \beta)^2 + (Y, \beta)^2 + (Z, \beta)^2
\end{aligned} \quad (1.17)$$

The comma in the subscript denotes partial differentiation. The principal radii of curvature R_1 and R_2 are related to the metric coefficients of the surface by the equations of Gauss and Codazzi:

$$\left(\frac{B, \alpha}{A}\right)_{, \alpha} + \left(\frac{A, \beta}{B}\right)_{, \beta} + \frac{AB}{R_1 R_2} = 0 \quad (1.18)$$

$$\left(\frac{B}{R_2}\right)_{,\alpha} = \frac{B_{,\alpha}}{R_1} ; \quad \left(\frac{A}{R_1}\right)_{,\beta} = \frac{A_{,\beta}}{R_2} \quad (1.19)$$

Let the variables α , β , z be the orthogonal curvilinear coordinates of the space surrounding the surface. The line element in this case is:

$$ds^2 = A^2 \left(1 + \frac{z}{R_1}\right)^2 d\alpha^2 + B^2 \left(1 + \frac{z}{R_2}\right)^2 d\beta^2 + dz^2 \quad (1.20)$$

ASSUMPTIONS IN THE CLASSICAL THEORY OF SHELLS

The following assumptions (2) are made in the classical theory of shells to simplify the mathematical model.

In the analysis of beams, the assumption for displacements is that plane sections remain plane before and after deformation. This notion was extended to plates by Kirchhoff and to shells by Love. This assumption, as interpreted for plates and shells, states that normals to the undeformed surface remain normal to the deformed surface and suffer no extension.

Another assumption in the classical shell theory is that the thickness of the shell is small in comparison to the lateral dimensions. As a consequence, the quantities $\frac{z}{R_1}$ and $\frac{z}{R_2}$ are small compared to unity and the variation of the radii of curvature over the shell thickness is neglected.

The component of stress normal to the reference surface is small in comparison to the other components of stress. This assumption stipulates a state of generalized plane stress.

Also the strains and displacements of second or higher order are neglected in comparison to their first order terms in the classical theory.

THE DISPLACEMENT VECTOR

Quantitatively, the Kirchhoff-Love hypothesis implies that the components of the displacement vector in orthogonal curvilinear coordinates are:

$$\begin{aligned} u(\alpha, \beta, z) &= u_0(\alpha, \beta) - \left(\frac{w_{,\alpha}}{A} - \frac{u_0}{R_1}\right) z \\ v(\alpha, \beta, z) &= v_0(\alpha, \beta) - \left(\frac{w_{,\beta}}{B} - \frac{v_0}{R_2}\right) z \\ w(\alpha, \beta, z) &= w_0(\alpha, \beta) \end{aligned} \quad (1.21)$$

In the above equations u_0 , v_0 , and w_0 are the displacement components of a point on an arbitrary reference surface.

STRAIN-DISPLACEMENT EQUATIONS

The strain-displacement equations for the linear theory of shells (also known as Love's first approximation) are:

$$\begin{aligned}\epsilon_\alpha &= \epsilon_{10} - z \chi_1 \\ \epsilon_\beta &= \epsilon_{20} - z \chi_2 \\ \gamma_{\alpha\beta} &= \gamma_{120} - 2z \chi_{12}\end{aligned}\tag{1.22}$$

where ϵ_{10} , ϵ_{20} , γ_{120} are the reference surface strains and χ_1 , χ_2 , χ_{12} are the changes of curvature and the twist of the surface. The reference surface strains are given by the same expressions for the middle surface strains in the theory of single-layer shells. These expressions are given, for example, by Novozhilov (3).

$$\begin{aligned}\epsilon_{10} &= \frac{1}{A} u_{0,\alpha} + \frac{v_0}{AB} A_{,\beta} + \frac{w}{R_1} \\ \epsilon_{20} &= \frac{1}{B} v_{0,\beta} + \frac{u_0}{AB} B_{,\alpha} + \frac{w}{R_2}\end{aligned}\tag{1.23}$$

$$\gamma_{120} = \frac{1}{A} v_{0,\alpha} + \frac{1}{B} u_{0,\beta} - \frac{1}{AB} (u_0 A_{,\beta} + v_0 B_{,\alpha})$$

The expressions for the changes of curvature* which are also given by Novozhilov (3) are:

$$\begin{aligned}\chi_1 &= \frac{1}{A} \left(\frac{1}{A} w_{,\alpha} - \frac{u_0}{R_1} \right)_{,\alpha} + \frac{1}{AB} A_{,\beta} \left(\frac{1}{B} v_{,\beta} - \frac{v_0}{R_2} \right) \\ \chi_2 &= \frac{1}{B} \left(\frac{1}{B} w_{,\beta} - \frac{v_0}{R_2} \right)_{,\beta} + \frac{1}{AB} B_{,\alpha} \left(\frac{1}{A} w_{,\alpha} - \frac{u_0}{R_1} \right)\end{aligned}\tag{1.24}$$

* These expressions ignore the extensional effects on the changes of curvature. According to Novozhilov (3), the effects are comparable to other effects which are neglected in this theory. The expressions which include extensional effects are given, for example, by Vlasov (4). For certain types of shells it appears that for computational purposes the expressions which include the extensional effects are more convenient to work with.

$$\begin{aligned} \chi_{12} = & \frac{1}{AB} (w_{,\alpha\beta} - \frac{1}{A} A_{,\beta} w_{,\alpha} - \frac{1}{B} B_{,\alpha} w_{,\beta}) \\ & - \frac{1}{R_1} (\frac{1}{B} u_{o,\beta} - \frac{u_o}{AB} A_{,\beta}) - \frac{1}{R_2} (\frac{1}{A} v_{o,\alpha} - \frac{v_o}{AB} B_{,\alpha}) \end{aligned} \quad (1.24)$$

STRESS-RESULTANTS AND STRESS-COUPLES

If the state of generalized plane stress is assumed to exist in the "k-th" lamina of the shell, the stress-strain relation for this condition is given by Eq (1.6). This equation rewritten for the "k-th" lamina is

$$\begin{bmatrix} \sigma_{\alpha}^{(k)} \\ \sigma_{\beta}^{(k)} \\ \tau_{\alpha\beta}^{(k)} \end{bmatrix} = \begin{bmatrix} \bar{c}_{11}^{(k)} & \bar{c}_{12}^{(k)} & \bar{c}_{16}^{(k)} \\ \bar{c}_{12}^{(k)} & \bar{c}_{22}^{(k)} & \bar{c}_{26}^{(k)} \\ \bar{c}_{16}^{(k)} & \bar{c}_{26}^{(k)} & \bar{c}_{66}^{(k)} \end{bmatrix} \begin{bmatrix} \epsilon_{\alpha} \\ \epsilon_{\beta} \\ \gamma_{\alpha\beta} \end{bmatrix} \quad (1.25)$$

The constants $\bar{c}_{ij}^{(k)}$ can be found for each lamina from Eq (1.12) or (1.14) by substituting the value of θ_k appropriate to the particular lamina "k."

Stress-resultants and stress-couples can be formulated in terms of the displacements by integrating Eq (1.25) across each lamina and summing the resulting expressions over n layers.

$$N_{\alpha}, N_{\alpha\beta} = \sum_{k=1}^n \int_{h_{k-1}}^{h_k} (\sigma_{\alpha}^{(k)}, \tau_{\alpha\beta}^{(k)}) (1 + \frac{z}{R_2}) dz \quad (1.26)$$

$$N_{\beta}, N_{\beta\alpha} = \sum_{k=1}^n \int_{h_{k-1}}^{h_k} (\sigma_{\beta}^{(k)}, \tau_{\alpha\beta}^{(k)}) (1 + \frac{z}{R_1}) dz$$

$$M_{\alpha}, M_{\alpha\beta} = \sum_{k=1}^n \int_{h_{k-1}}^{h_k} (\sigma_{\alpha}^{(k)}, \tau_{\alpha\beta}^{(k)}) z (1 + \frac{z}{R_2}) dz \quad (1.27)$$

$$M_{\beta}, M_{\beta\alpha} = \sum_{k=1}^n \int_{h_{k-1}}^{h_k} (\sigma_{\beta}^{(k)}, \tau_{\alpha\beta}^{(k)}) z (1 + \frac{z}{R_1}) dz$$

According to Love's first approximation, the quantities $\frac{z}{R_1}$ and $\frac{z}{R_2}$ are neglected. Therefore $N_{\alpha\beta} = N_{\beta\alpha}$ and $M_{\alpha\beta} = M_{\beta\alpha}$.

$$\begin{bmatrix} N_\alpha \\ N_\beta \\ N_{\alpha\beta} \end{bmatrix} = \begin{bmatrix} A_{11} & A_{12} & A_{16} \\ A_{12} & A_{22} & A_{26} \\ A_{16} & A_{26} & A_{66} \end{bmatrix} \begin{bmatrix} \epsilon_{10} \\ \epsilon_{20} \\ \gamma_{120} \end{bmatrix} - \begin{bmatrix} D_{11}^* & D_{12}^* & D_{16}^* \\ D_{12}^* & D_{22}^* & D_{26}^* \\ D_{16}^* & D_{26}^* & D_{66}^* \end{bmatrix} \begin{bmatrix} \chi_1 \\ \chi_2 \\ 2\chi_{12} \end{bmatrix} \quad (1.28)$$

$$\begin{bmatrix} M_\alpha \\ M_\beta \\ M_{\alpha\beta} \end{bmatrix} = \begin{bmatrix} D_{11}^* & D_{12}^* & D_{16}^* \\ D_{12}^* & D_{22}^* & D_{26}^* \\ D_{16}^* & D_{26}^* & D_{66}^* \end{bmatrix} \begin{bmatrix} \epsilon_{10} \\ \epsilon_{20} \\ \gamma_{120} \end{bmatrix} - \begin{bmatrix} D_{11} & D_{12} & D_{16} \\ D_{12} & D_{22} & D_{26} \\ D_{16} & D_{26} & D_{66} \end{bmatrix} \begin{bmatrix} \chi_1 \\ \chi_2 \\ 2\chi_{12} \end{bmatrix} \quad (1.29)$$

where the A_{ij} , D_{ij}^* , and D_{ij} are defined as

$$\begin{aligned} A_{ij} &= \sum_{k=1}^n \bar{c}_{ij}^{(k)} (h_k - h_{k-1}) \\ D_{ij}^* &= \frac{1}{2} \sum_{k=1}^n \bar{c}_{ij}^{(k)} (h_k^2 - h_{k-1}^2) \\ D_{ij} &= \frac{1}{3} \sum_{k=1}^n \bar{c}_{ij}^{(k)} (h_k^3 - h_{k-1}^3) \end{aligned} \quad (1.30)$$

EQUATIONS OF EQUILIBRIUM AND COMPATIBILITY

The five equations of equilibrium for a shell element and the compatibility equation for the in-plane strain components of the reference surface constitute the determinative system for this problem. These equations referred to the reference surface are:

$$\begin{aligned} (BN_\alpha)_{,\alpha} + (AN_{\alpha\beta})_{,\beta} + N_{\alpha\beta} A_{,\beta} - N_\beta B_{,\alpha} + \frac{AB}{R_1} Q_\alpha + AB q_\alpha &= 0 \\ (BN_{\alpha\beta})_{,\alpha} + (AN_\beta)_{,\beta} + N_{\alpha\beta} B_{,\alpha} - N_\alpha A_{,\beta} + \frac{AB}{R_2} Q_\beta + AB q_\beta &= 0 \\ (BQ_\alpha)_{,\alpha} + (AQ_\beta)_{,\beta} - AB \left(\frac{N_\alpha}{R_1} + \frac{N_\beta}{R_2} \right) + AB q_z &= 0 \\ (EM_\alpha)_{,\alpha} + (AM_{\alpha\beta})_{,\beta} + M_{\alpha\beta} A_{,\beta} - M_\beta B_{,\alpha} - AB Q_\alpha &= 0 \end{aligned} \quad (1.31)$$

$$(BN_{\alpha\beta}),_{\alpha} + (AN_{\beta}),_{\beta} + M_{\alpha\beta} B_{,\alpha} - M_{\alpha} A_{,\beta} - AB_{,\beta} = 0 \quad (1.31)$$

$$-\frac{\chi_1}{R_1} - \frac{\chi_2}{R_2} + \frac{1}{AB} \left[\frac{1}{A} \left\{ B \epsilon_{20,\alpha} + B_{,\alpha} (\epsilon_{20} - \epsilon_{10}) - \frac{A}{2} \gamma_{120,\beta}^{-A} \gamma_{120} \right\},_{\alpha} \right. \\ \left. + \frac{1}{AB} \left[\frac{1}{B} \left\{ A \epsilon_{10,\beta} + A_{,\beta} (\epsilon_{10} - \epsilon_{20}) - \frac{B}{2} \gamma_{120,\alpha} - B_{,\alpha} \gamma_{120} \right\},_{\beta} \right] \right] = 0 \quad (1.32)$$

In the above equations q_{α} , q_{β} , and q_2 are the external loads on the shell; Q_{α} and Q_{β} are the transverse shearing forces, and all other symbols have been previously defined.

BOUNDARY CONDITIONS

Associated with the system of Eq (1.31) and (1.32) are four boundary conditions to be satisfied on the contour of the shell. These boundary conditions arise from the physical requirements of support along the shell contour. Expressions of these conditions may be conveniently obtained by variational methods. Such an analysis leads to boundary conditions which are identical to those of the usual isotropic shell. However, it should be emphasized that in the present case all boundary forces and displacements are referred to the reference surface. If, in the physical problem, the boundary forces and displacements are given for some other surface, an equivalent reference surface system must be calculated.

The boundary conditions for shells are summarized in the following table.

	I	II
	Force Boundary Conditions	Displacement Boundary Conditions
1	$(N_n - \bar{N}_n)$	$(u_n - \bar{u}_n)$
2	$(N_{nt} + \frac{M_{nt}}{R_n} - \bar{N}_{nt} - \frac{\bar{M}_{nt}}{R_n})$	$(u_t - \bar{u}_t)$
3	$(M_n - \bar{M}_n)$	$(\frac{1}{A_n} w_{,n} - \frac{u_n}{R_n} - \bar{\Psi})$
4	$(Q_n + \frac{1}{A_n} M_{nt,t} - \bar{V}_n)$	$(w - \bar{w})$

(1.33)

where

- N_n - normal force
 N_t - in-surface shearing force
 Q_n - transverse shearing force
 M_n - bending moment
 M_{nt} - twisting moment
 V_n - effective shear given by

$$V_n = Q_n + \frac{1}{A_n} M_{nt,t}$$

- u_n - normal displacement
 u_t - tangential displacement
 w - deflection normal to surface
 Ψ - angle of rotation in the normal direction given by

$$\Psi = \frac{1}{A_n} w_{,n} - \frac{u_n}{R_n}$$

A_n - metric coefficient associated with the contour.

Bars over the quantities signify that they are the prescribed values at the boundaries.

In each of the four conditions, either the barred quantity in column I or II must be prescribed. For that force or displacement which is prescribed, the bracketed quantity must vanish. This means that the unbarred quantity (that force or displacement from the interior of the shell) must take on the prescribed value on the boundary.

Some examples of boundary conditions are:

Free edge:

$$N_n = 0, \quad N_{nt} + \frac{M_{nt}}{R_n} = 0, \quad M_n = 0, \quad Q_n + \frac{1}{A_n} M_{nt,t} = 0$$

Hinged edge with fixed support:

$$M_n = 0, \quad u_n = 0, \quad u_t = 0, \quad w = 0$$

Hinged edge with support free to move in the normal direction:

$$M_n = 0, \quad w = 0, \quad u_t = 0, \quad N_n = 0$$

Clamped edge:

$$u_n = 0, \quad u_t = 0, \quad w = 0, \quad \Psi = \frac{1}{A_n} w_{,n} - \frac{u_n}{R_n} = 0$$

The theory developed need not be restricted to shells comprised of orthotropic laminas. Because of possible rotation of the orthotropic elastic axes, the equations already involve six \bar{C}_{ij} , which, however, are not independent for a shell of orthotropic laminas. In the most general case, there can exist six independent constants \bar{C}_{ij} . It is then only necessary to regard these six constants as completely independent for a theory which involves a completely anisotropic material.

2. DONNELL-TYPE EQUATIONS FOR LAMINATED ANISOTROPIC CYLINDRICAL SHELLS

In this section, the general equations from the preceding section are specialized for a circular cylindrical shell using the Donnell approximations, which neglect certain terms in the changes of curvature and in the equilibrium equations. The justification for neglecting these terms can be argued by consideration of the configuration of the shell and the geometry of deformation. The Donnell Approximations simplify the mathematical model considerably, and the results obtained from this theory, as discussed in connection with isotropic cylindrical shells by Kempner (5), agree closely to the results obtained from a more exact theory, in most cases of technical interest.

DERIVATION OF THE GOVERNING DIFFERENTIAL EQUATIONS AND BOUNDARY CONDITIONS

The cartesian coordinates which describe a circular cylinder of radius a are:

$$\begin{aligned} X &= a \cos \psi \\ Y &= a \sin \psi \\ Z &= x \end{aligned} \tag{2.1}$$

Eq (2.1) has the form of Eq (1.15) with the variables $\alpha = x$ and $\beta = \psi$. The metric coefficients can be computed from Eq (1.17). The square of the line element in this system of curvilinear coordinates is then

$$ds^2 = dx^2 + a^2 d\psi^2 \tag{2.2}$$

The strains of the reference surface given by Eq (1.23) become for a cylindrical shell (recalling that $R_1 = \infty$)

$$\begin{aligned} \epsilon_{10} &= u_{0,x} \\ \epsilon_{20} &= \frac{1}{a} v_{0,\psi} + \frac{w}{a} \\ \gamma_{120} &= v_{0,x} + \frac{1}{a} u_{0,\psi} \end{aligned} \tag{2.3}$$

Donnell (6) proposed the following expressions for the changes in curvature by neglecting certain terms in the general expressions.

$$\begin{aligned} \chi_1 &= w_{,xx} \\ \chi_2 &= \frac{1}{a^2} w_{,\psi\psi} \\ \chi_{12} &= \frac{1}{a} w_{,x\psi} \end{aligned} \tag{2.4}$$

Stress-resultants and stress-couples are formulated as described in the previous section. These expressions for a cylindrical shell are:

$$\begin{bmatrix} N_x \\ N_\psi \\ N_{x\psi} \end{bmatrix} = \begin{bmatrix} A_{11} & A_{12} & A_{16} \\ A_{12} & A_{22} & A_{26} \\ A_{16} & A_{26} & A_{66} \end{bmatrix} \begin{bmatrix} u_{0,x} \\ \frac{1}{a} v_{0,\psi} + \frac{w}{a} \\ v_{0,x} + \frac{1}{a} u_{0,\psi} \end{bmatrix} - \begin{bmatrix} D_{11}^* & D_{12}^* & D_{16}^* \\ D_{12}^* & D_{22}^* & D_{26}^* \\ D_{16}^* & D_{26}^* & D_{66}^* \end{bmatrix} \begin{bmatrix} w_{,xx} \\ \frac{1}{a^2} w_{,\psi\psi} \\ \frac{2}{a} w_{,x\psi} \end{bmatrix} \quad (2.5)$$

$$\begin{bmatrix} M_x \\ M_\psi \\ M_{x\psi} \end{bmatrix} = \begin{bmatrix} D_{11}^* & D_{12}^* & D_{16}^* \\ D_{12}^* & D_{22}^* & D_{26}^* \\ D_{16}^* & D_{26}^* & D_{66}^* \end{bmatrix} \begin{bmatrix} u_{0,x} \\ \frac{1}{a} v_{0,\psi} + \frac{w}{a} \\ v_{0,x} + \frac{1}{a} u_{0,\psi} \end{bmatrix} - \begin{bmatrix} D_{11} & D_{12} & D_{16} \\ D_{12} & D_{22} & D_{26} \\ D_{16} & D_{26} & D_{66} \end{bmatrix} \begin{bmatrix} w_{,xx} \\ \frac{1}{a^2} w_{,\psi\psi} \\ \frac{2}{a} w_{,x\psi} \end{bmatrix} \quad (2.6)$$

The five equilibrium equations, which are also modified by a Donnell approximation, supplemented by the compatibility condition for the deformed reference surface of the shell constitute the determinative system of equations for the problem. These equations are:

$$\begin{aligned} N_{x,x} + \frac{1}{a} N_{x\psi,\psi} &= 0 \\ N_{x\psi,x} + \frac{1}{a} N_{\psi,\psi} &= 0 \\ Q_{x,x} + \frac{1}{a} Q_{\psi,\psi} + \frac{1}{a} N_\psi + q_z &= 0 \end{aligned} \quad (2.7)$$

$$\begin{aligned} M_{x,x} + \frac{1}{a} M_{x\psi,\psi} - Q_x &= 0 \\ M_{x\psi,x} + \frac{1}{a} M_{\psi,\psi} - Q_\psi &= 0 \end{aligned}$$

$$-\frac{1}{a} w_{,xx} + \epsilon_{20,xx} + \frac{1}{a^2} \epsilon_{10,\psi\psi} - \frac{1}{a} \gamma_{120,x\psi} = 0 \quad (2.8)$$

In the equilibrium Eq (2.7), the only external load which is considered is the normal load q_z . Q_x and Q_ψ appearing in the above equations can be eliminated by

appropriate differentiation and subsequent addition of the fourth and fifth equilibrium equations using the third equilibrium equation as an identity.

$$M_{x,xx} + \frac{2}{a} M_{x\psi, x\psi} + \frac{1}{2} M_{\psi, \psi\psi} + \frac{N_{\psi}}{a} + q_z = 0 \quad (2.9)$$

It is convenient to treat the transverse deflection w and the stress-resultants N_x , N_{ψ} , $N_{x\psi}$ as the primary dependent variables of the problem. Equations (2.5) and (2.6) rewritten in abbreviated matrix notation are:

$$N = A \epsilon_0 - D^* \chi \quad (2.5a)$$

$$M = D^* \epsilon_0 - D \chi \quad (2.6a)$$

Inversion of Eq (2.5a) gives:

$$\epsilon_0 = BN + BD^* \chi \quad (2.10)$$

where B is the inverse of A .

$$B = A^{-1} = \begin{pmatrix} B_{11} & B_{12} & B_{16} \\ B_{12} & B_{22} & B_{26} \\ B_{16} & B_{26} & B_{66} \end{pmatrix} \quad (2.11)$$

The components of the symmetric B matrix are:

$$B = \frac{1}{\Delta_A} \begin{pmatrix} A_{22}A_{66} - A_{26}^2 & A_{16}A_{26} - A_{12}A_{66} & A_{12}A_{26} - A_{16}A_{22} \\ A_{11}A_{66} - A_{16}^2 & A_{12}A_{16} - A_{11}A_{26} \\ A_{11}A_{22} - A_{12}^2 & \end{pmatrix}$$

where Δ_A is the determinant

$$\Delta_A = \begin{vmatrix} A_{11} & A_{12} & A_{16} \\ A_{12} & A_{22} & A_{26} \\ A_{16} & A_{26} & A_{66} \end{vmatrix}$$

Substituting Eq (2.10) into Eq (2.6a) gives:

$$M = bN + d\chi \quad (2.12)$$

where $b = D^*B$ and $d = D^*HD^* - D$.

The components of matrix b are:

$$b = \begin{bmatrix} b_{11} & b_{12} & b_{16} \\ b_{21} & b_{22} & b_{26} \\ b_{61} & b_{62} & b_{66} \end{bmatrix} \quad (2.13)$$

$$\begin{bmatrix} D_{11}^*B_{11} + D_{12}^*B_{12} + D_{16}^*B_{16}, & D_{11}^*B_{12} + D_{12}^*B_{22} + D_{16}^*B_{26}, & D_{11}^*B_{16} + D_{12}^*B_{26} + D_{16}^*B_{66} \\ D_{12}^*B_{11} + D_{22}^*B_{12} + D_{26}^*B_{16}, & D_{12}^*B_{12} + D_{22}^*B_{22} + D_{26}^*B_{26}, & D_{12}^*B_{16} + D_{22}^*B_{26} + D_{26}^*B_{66} \\ D_{16}^*B_{11} + D_{26}^*B_{12} + D_{66}^*B_{16}, & D_{16}^*B_{12} + D_{26}^*B_{22} + D_{66}^*B_{26}, & D_{16}^*B_{16} + D_{26}^*B_{26} + D_{66}^*B_{66} \end{bmatrix}$$

It should be noted that b is not symmetric, i.e. $b_{ij} \neq b_{ji}$. The ED^* matrix appearing in Eq (2.10) is defined as b' , the transpose of b . The components of the symmetric d matrix are:

$$d = \begin{bmatrix} d_{11} & d_{12} & d_{16} \\ d_{12} & d_{22} & d_{26} \\ d_{16} & d_{26} & d_{66} \end{bmatrix} \quad (2.14)$$

where

$$d_{11} = D_{11}^{*2}B_{11} + 2D_{11}^*D_{12}^*B_{12} + 2D_{11}^*D_{16}^*B_{16} + D_{12}^{*2}B_{22} + 2D_{12}^*D_{16}^*B_{26} + D_{16}^{*2}B_{66} - D_{11}$$

$$d_{12} = D_{11}^*D_{12}^*B_{11} + D_{12}^{*2}B_{12} + D_{12}^*D_{16}^*B_{16} + D_{11}^*D_{22}^*B_{12} + D_{12}^*D_{22}^*B_{22}$$

$$+ D_{16}^*D_{22}^*B_{26} + D_{11}^*D_{26}^*B_{16} + D_{12}^*D_{26}^*B_{26} + D_{16}^*D_{26}^*B_{66} - D_{12}$$

$$d_{16} = D_{11}^* D_{16}^* B_{11} + D_{12}^* D_{16}^* B_{12} + D_{16}^{*2} B_{16} + D_{11}^* D_{26}^* B_{12} + D_{12}^* D_{26}^* B_{22} \\ + D_{16}^* D_{26}^* B_{26} + D_{11}^* D_{66}^* B_{16} + D_{12}^* D_{66}^* B_{26} + D_{16}^* D_{66}^* B_{66} - D_{16}$$

$$d_{22} = D_{12}^{*2} B_{11} + 2D_{12}^* D_{22}^* B_{12} + 2D_{12}^* D_{26}^* B_{16} + D_{22}^{*2} B_{22} + 2D_{22}^* D_{26}^* B_{26} + D_{26}^{*2} B_{66} - D_{22}$$

$$d_{26} = D_{12}^* D_{16}^* B_{11} + D_{16}^* D_{22}^* B_{12} + D_{16}^* D_{26}^* B_{16} + D_{12}^* D_{26}^* B_{12} + D_{22}^* D_{26}^* B_{22} \\ + D_{26}^{*2} B_{26} + D_{12}^* D_{66}^* B_{16} + D_{22}^* D_{66}^* B_{26} + D_{26}^* D_{66}^* B_{66} - D_{26}$$

$$d_{66} = D_{16}^{*2} B_{11} + 2D_{16}^* D_{26}^* B_{12} + 2D_{16}^* D_{66}^* B_{16} + D_{26}^{*2} B_{22} + 2D_{26}^* D_{66}^* B_{26} + D_{66}^{*2} B_{66} - D_{66}$$

By way of recapitulation, Eq (2.10) and (2.12) are restated in terms of the components of the property matrices defined previously.

$$\epsilon_{10} = u_{0,x} = B_{11} N_x + B_{12} N_\psi + B_{16} N_{x\psi} + b'_{11} w_{,xx} + b'_{12} \frac{1}{a} w_{,\psi\psi} + 2b'_{16} \frac{1}{a} w_{,x\psi}$$

$$\epsilon_{20} = \frac{1}{a} v_{0,\psi} + \frac{w}{a} = B_{12} N_x + B_{22} N_\psi + B_{26} N_{x\psi} + b'_{21} w_{,xx} + b'_{22} \frac{1}{a} w_{,\psi\psi} \\ + 2b'_{26} \frac{1}{a} w_{,x\psi} \quad (2.10a)$$

$$\gamma_{120} = v_{0,x} + \frac{1}{a} u_{0,\psi} = B_{16} N_x + B_{26} N_\psi + B_{66} N_{x\psi} + b'_{61} w_{,xx} + b'_{62} \frac{1}{a} w_{,\psi\psi} \\ + \frac{2b'_{66}}{a} w_{,x\psi}$$

$$M_x = b_{11} N_x + b_{12} N_\psi + b_{16} N_{x\psi} + d_{11} w_{,xx} + \frac{d_{12}}{a} w_{,\psi\psi} + \frac{2d_{16}}{a} w_{,x\psi} \quad (2.12a)$$

$$M_\psi = b_{21} N_x + b_{22} N_\psi + b_{26} N_{x\psi} + d_{12} w_{,xx} + \frac{d_{22}}{a} w_{,\psi\psi} + \frac{2d_{26}}{a} w_{,x\psi}$$

$$M_{x\psi} = b_{61} N_x + b_{62} N_\psi + b_{66} N_{x\psi} + d_{16} w_{,xx} + \frac{d_{26}}{a} w_{,\psi\psi} + \frac{2d_{66}}{a} w_{,x\psi}$$

Introduction of the Airy stress function U defined in cylindrical coordinates

by

$$N_x = \frac{1}{a^2} U,_{\psi\psi} \quad , \quad N_\psi = U,_{xx} \quad , \quad N_{x\psi} = -\frac{1}{a} U,_{x\psi} \quad (2.15)$$

which identically satisfies the in-surface equilibrium equations, the first two equations of Eq (2.7), reduces the governing system to two primary dependent variables. Substitution of Eq (2.10) into Eq (2.8) using this definition of the Airy stress function gives:

$$\begin{aligned} & B_{22} U,_{xxxx} - \frac{2B_{26}}{a} U,_{xxx\psi} + \frac{(2B_{12} + B_{66})}{a^2} U,_{xx\psi\psi} - \frac{2B_{16}}{a^3} U,_{x\psi\psi\psi} \\ & + \frac{B_{11}}{4} U,_{\psi\psi\psi\psi} + b_{12} w,_{xxxx} + \frac{(2b_{62} - b_{16})}{a} w,_{xxx\psi} \\ & + \frac{(b_{11} + b_{22} - 2b_{66})}{a^2} w,_{xx\psi\psi} + \frac{(2b_{61} - b_{26})}{a^3} w,_{x\psi\psi\psi} + \frac{b_{21}}{a} w,_{\psi\psi\psi\psi} \\ & - \frac{1}{a} w,_{xx} = 0 \end{aligned} \quad (2.16)$$

Substitution of Eq (2.12) into Eq (2.9) again using Eq (2.15) gives:

$$\begin{aligned} & b_{12} U,_{xxxx} + \frac{(2b_{62} - b_{16})}{a} U,_{xxx\psi} + \frac{(b_{11} + b_{22} - 2b_{66})}{a^2} U,_{xx\psi\psi} \\ & + \frac{(2b_{61} - b_{26})}{a^3} U,_{x\psi\psi\psi} + \frac{b_{21}}{a} U,_{\psi\psi\psi\psi} + d_{11} w,_{xxxx} + \frac{4d_{16}}{a} w,_{xxx\psi} \\ & + \frac{2(d_{12} + 2d_{66})}{a^2} w,_{xx\psi\psi} + \frac{4d_{26}}{a^3} w,_{x\psi\psi\psi} + \frac{d_{22}}{a} w,_{\psi\psi\psi\psi} \\ & - \frac{1}{a} U,_{xx} = -q_z \end{aligned} \quad (2.17)$$

Equations (2.16) and (2.17) constitute the generalization of the Donnell equations of cylindrical shells to include the effect of anisotropy of the individual laminas. The presence of both dependent variables indicates coupling between membrane and bending effects.

The boundary conditions are given by Eq (1.33). They are summarized below to complete the formulation of the cylindrical shell problem.

	I	II
	Force Boundary Conditions	Displacement Boundary Cond.
1	$(N_n - \bar{N}_n)$	$(u_n - \bar{u}_n)$
2	$(N_{nt} + \frac{M_{nt}}{R_n} - \bar{N}_{nt} - \frac{\bar{M}_{nt}}{R_n})$	$(u_t - \bar{u}_t)$
3	$(M_n - \bar{M}_n)$	$(\frac{1}{A_n} w_{,n} - \frac{u_n}{R_n} - \bar{\Psi})$
4	$(Q_n + \frac{1}{A_n} M_{nt,t} - \bar{V}_n)$	$(w - \bar{w})$

(2.18)

where

N_n - normal force

N_t - in-surface shearing force

Q_n - transverse shearing force

M_n - bending moment

M_t - twisting moment

V_n - effective shear given by

$$V_n = Q_n + \frac{1}{A_n} M_{nt,t}$$

u_n - normal displacement

u_t - tangential displacement

w - deflection normal to surface

Ψ - angle of rotation in the normal direction given by $\Psi = \frac{1}{A_n} w_{,n} - \frac{u_n}{R_n}$

A_n - metric coefficient associated with the contour.

Bars over the quantities signify that they are the prescribed values at the boundaries.

Since the governing differential equations involve U and w , the boundary conditions must be expressed in terms of these variables in a given problem.

DETERMINATION OF STRESSES IN AN INDIVIDUAL LAMINA AND
INTER-LAMINAR SHEAR STRESSES

The stresses in the "k-th" lamina of a shell are given by Eq (1.6). They can be written in matrix form using the primary dependent variables U and w by substituting Eq (2.10) into Eq (1.22) and in turn into Eq (1.6). The expression for stresses in matrix notation then becomes:

$$\sigma = T^{(k)} N + (t^{(k)} - z\bar{C}^{(k)}) \chi \quad (2.19)$$

where

$$\sigma = \begin{bmatrix} \sigma_x^{(k)} \\ \sigma_\phi^{(k)} \\ \tau_{x\phi}^{(k)} \end{bmatrix}$$

and

$$T^{(k)} = \bar{C}^{(k)} B$$

$$T^{(k)} = \begin{bmatrix} T_{11}^{(k)} & T_{12}^{(k)} & T_{16}^{(k)} \\ T_{21}^{(k)} & T_{22}^{(k)} & T_{26}^{(k)} \\ T_{61}^{(k)} & T_{62}^{(k)} & T_{66}^{(k)} \end{bmatrix} =$$

$$\begin{bmatrix} \bar{C}_{11}^{(k)} B_{11} + \bar{C}_{12}^{(k)} B_{12} + \bar{C}_{16}^{(k)} B_{16} & \bar{C}_{11}^{(k)} B_{12} + \bar{C}_{12}^{(k)} B_{22} + \bar{C}_{16}^{(k)} B_{26} & \bar{C}_{11}^{(k)} B_{16} + \bar{C}_{12}^{(k)} B_{26} + \bar{C}_{16}^{(k)} B_{66} \\ \bar{C}_{12}^{(k)} B_{11} + \bar{C}_{22}^{(k)} B_{12} + \bar{C}_{26}^{(k)} B_{16} & \bar{C}_{12}^{(k)} B_{12} + \bar{C}_{22}^{(k)} B_{22} + \bar{C}_{26}^{(k)} B_{26} & \bar{C}_{12}^{(k)} B_{16} + \bar{C}_{22}^{(k)} B_{26} + \bar{C}_{26}^{(k)} B_{66} \\ \bar{C}_{16}^{(k)} B_{11} + \bar{C}_{26}^{(k)} B_{12} + \bar{C}_{66}^{(k)} B_{16} & \bar{C}_{16}^{(k)} B_{12} + \bar{C}_{26}^{(k)} B_{22} + \bar{C}_{66}^{(k)} B_{26} & \bar{C}_{16}^{(k)} B_{16} + \bar{C}_{26}^{(k)} B_{26} + \bar{C}_{66}^{(k)} B_{66} \end{bmatrix} \quad (2.20)$$

and

$$t^{(k)} = \bar{C}^{(k)} b,$$

$$t^{(k)} = \begin{bmatrix} t_{11}^{(k)} & t_{12}^{(k)} & t_{16}^{(k)} \\ t_{21}^{(k)} & t_{22}^{(k)} & t_{26}^{(k)} \\ t_{61}^{(k)} & t_{62}^{(k)} & t_{66}^{(k)} \end{bmatrix} =$$

$$\begin{bmatrix} \bar{c}_{11}^{(k)} b_{11} + \bar{c}_{12}^{(k)} b_{12} + \bar{c}_{16}^{(k)} b_{16} , & \bar{c}_{11}^{(k)} t_{21} + \bar{c}_{12}^{(k)} b_{22} + \bar{c}_{16}^{(k)} b_{26} , & \bar{c}_{11}^{(k)} b_{61} + \bar{c}_{12}^{(k)} b_{62} + \bar{c}_{16}^{(k)} b_{66} \\ \bar{c}_{12}^{(k)} b_{11} + \bar{c}_{22}^{(k)} b_{12} + \bar{c}_{26}^{(k)} b_{16} , & \bar{c}_{12}^{(k)} b_{21} + \bar{c}_{22}^{(k)} b_{22} + \bar{c}_{26}^{(k)} b_{26} , & \bar{c}_{12}^{(k)} b_{61} + \bar{c}_{22}^{(k)} b_{62} + \bar{c}_{26}^{(k)} b_{66} \\ \bar{c}_{16}^{(k)} b_{11} + \bar{c}_{26}^{(k)} b_{12} + \bar{c}_{66}^{(k)} b_{16} , & \bar{c}_{16}^{(k)} b_{21} + \bar{c}_{26}^{(k)} b_{22} + \bar{c}_{66}^{(k)} b_{26} , & \bar{c}_{16}^{(k)} b_{61} + \bar{c}_{26}^{(k)} b_{62} + \bar{c}_{66}^{(k)} b_{66} \end{bmatrix}$$

It should be noted that $T^{(k)}$ and $t^{(k)}$ are unsymmetric. The stresses written explicitly are:

$$\begin{aligned} \sigma_x^{(k)} = & \frac{T_{11}^{(k)}}{a^2} U_{,\varphi\varphi} + T_{12}^{(k)} U_{,xx} - \frac{T_{16}^{(k)}}{a} U_{,x\varphi} + (t_{11}^{(k)} - z\bar{c}_{11}^{(k)}) w_{,xx} \\ & + \frac{(t_{12}^{(k)} - z\bar{c}_{12}^{(k)})}{a^2} w_{,\varphi\varphi} + \frac{2(t_{16}^{(k)} - z\bar{c}_{16}^{(k)})}{a} w_{,x\varphi} \end{aligned} \quad (2.19a)$$

$$\begin{aligned} \sigma_\varphi^{(k)} = & \frac{T_{21}^{(k)}}{a^2} U_{,\varphi\varphi} + T_{22}^{(k)} U_{,xx} - \frac{T_{26}^{(k)}}{a} U_{,x\varphi} + (t_{21}^{(k)} - z\bar{c}_{12}^{(k)}) w_{,xx} \\ & + \frac{(t_{22}^{(k)} - z\bar{c}_{22}^{(k)})}{a^2} w_{,\varphi\varphi} + \frac{2(t_{26}^{(k)} - z\bar{c}_{26}^{(k)})}{a} w_{,x\varphi} \end{aligned}$$

$$\begin{aligned} \tau_{x\varphi}^{(k)} = & \frac{T_{61}^{(k)}}{a^2} U_{,\varphi\varphi} + T_{62}^{(k)} U_{,xx} - \frac{T_{66}^{(k)}}{a} U_{,x\varphi} + (t_{61}^{(k)} - z\bar{c}_{16}^{(k)}) w_{,xx} \\ & + \frac{(t_{62}^{(k)} - z\bar{c}_{26}^{(k)})}{a^2} w_{,\varphi\varphi} + \frac{2(t_{66}^{(k)} - z\bar{c}_{66}^{(k)})}{a} w_{,x\varphi} \end{aligned}$$

Although transverse shear deformation is neglected in the theory discussed, transverse shear resultants can be determined from the equilibrium equations, i.e. the last two equations of Eq (2.7), and are defined as:

$$Q_x = \sum_{k=1}^n \int_{h_{k-1}}^{h_k} \tau_{xz}^{(k)} dz \quad Q_\varphi = \sum_{k=1}^n \int_{h_{k-1}}^{h_k} \tau_{\varphi z}^{(k)} dz \quad (2.22)$$

In terms of the primary dependent variables U and w , these transverse shear resultants are:

$$Q_x = \frac{b_{61}}{a^3} U_{,\varphi\varphi\varphi} + \frac{(b_{11} - b_{66})}{a^2} U_{,x\varphi\varphi} + \frac{(b_{62} - b_{16})}{a} U_{,xxx\varphi} + b_{12} U_{,xxx} \\ + \frac{d_{26}}{a^3} w_{,\varphi\varphi\varphi} + \frac{(d_{12} + 2d_{66})}{a^2} w_{,x\varphi\varphi} + \frac{3d_{16}}{a} w_{,xxx\varphi} + d_{11} w_{,xxx} \quad (2.23)$$

$$Q_\varphi = \frac{b_{21}}{a^3} U_{,\varphi\varphi\varphi} + \frac{(b_{61} - b_{26})}{a^2} U_{,x\varphi\varphi} + \frac{(b_{22} - b_{66})}{a} U_{,xxx\varphi} + b_{62} U_{,xxx} \\ + \frac{d_{22}}{a^3} w_{,\varphi\varphi\varphi} + \frac{3d_{26}}{a^2} w_{,x\varphi\varphi} + \frac{(d_{12} + 2d_{66})}{a} w_{,xxx\varphi} + d_{16} w_{,xxx}$$

The inter-laminar shear stresses $\tau_{xz}^{(k)}$ and $\tau_{\varphi z}^{(k)}$ are formed by consideration of equilibrium in the x and φ directions. Summing the forces in the x -direction up to the (k -th) layer gives:

$$\tau_{xz}^{(k)} = - \sum_{j=1}^k \int_{h_{j-1}}^{h_j} (\sigma_{x,x}^{(j)} + \frac{1}{a} \tau_{x\varphi,\varphi}^{(j)}) dz + \tau_{xzo} \quad (2.24)$$

$$\tau_{\varphi z}^{(k)} = - \sum_{j=1}^k \int_{h_{j-1}}^{h_j} (\frac{1}{a} \sigma_{\varphi,\varphi}^{(j)} + \tau_{x\varphi,x}^{(j)}) dz + \tau_{\varphi zo}$$

Here τ_{xzo} and $\tau_{\varphi zo}$ are constants to be adjusted by conditions at the top and bottom shell surfaces. Using Eq (2.19a), these expressions become

$$\tau_{xz}^{(k)} = - \sum_{j=1}^k \int_{h_{j-1}}^{h_j} \left[T_{12}^{(j)} U_{,xxx} + \frac{(T_{62}^{(k)} - T_{16}^{(k)})}{a} U_{,xxx\varphi} + \frac{(T_{11}^{(j)} - T_{66}^{(j)})}{a^2} U_{,x\varphi\varphi} \right. \\ \left. + \frac{T_{61}^{(j)}}{a^3} U_{,\varphi\varphi\varphi} + (t_{11}^{(j)} - z\bar{c}_{11}^{(k)}) w_{,xxx} + \frac{(2t_{16}^{(j)} + t_{61}^{(j)} - 3z\bar{c}_{16}^{(j)})}{a} w_{,xxx\varphi} \right. \\ \left. + \frac{(t_{12}^{(j)} + 2t_{66}^{(j)} - z\bar{c}_{12}^{(j)} - 2z\bar{c}_{66}^{(j)})}{a^2} w_{,x\varphi\varphi} + \frac{(t_{62}^{(j)} - z\bar{c}_{62}^{(j)})}{a^3} w_{,\varphi\varphi\varphi} \right] dz \quad (2.25)$$

$$\begin{aligned}
\tau_{\psi z}^{(k)} = & - \sum_{j=1}^k \int_{h_{j-1}}^{h_j} \left[T_{62}^{(j)} U_{,xxx} + \frac{(T_{22}^{(j)} - T_{66}^{(j)})}{a} U_{,xx\psi} \right. \\
& + \frac{(T_{61}^{(j)} - T_{26}^{(j)})}{a^2} U_{,x\psi\psi} + \frac{T_{21}^{(j)}}{a^3} U_{,\psi\psi\psi} + (t_{61}^{(j)} - z\bar{c}_{16}^{(j)}) w_{,xxx} \\
& + \frac{(2t_{66}^{(j)} + t_{21}^{(j)} - 2z\bar{c}_{66}^{(j)} - z\bar{c}_{12}^{(j)})}{a} w_{,xx\psi} \\
& \left. + \frac{(t_{62}^{(j)} + 2t_{26}^{(j)} - 3z\bar{c}_{26}^{(j)})}{a^2} w_{,x\psi\psi} + \frac{(t_{22}^{(j)} - z\bar{c}_{22}^{(j)})}{a^3} w_{,\psi\psi\psi} \right] dz
\end{aligned} \tag{2.25}$$

3. EQUATIONS FOR LAMINATED ANISOTROPIC PLATES

An important area of application is that of laminated anisotropic plates. In this section, the general equations of Section 1 are specialized for rectangular plates.

DERIVATION OF THE GOVERNING DIFFERENTIAL EQUATIONS AND BOUNDARY CONDITIONS

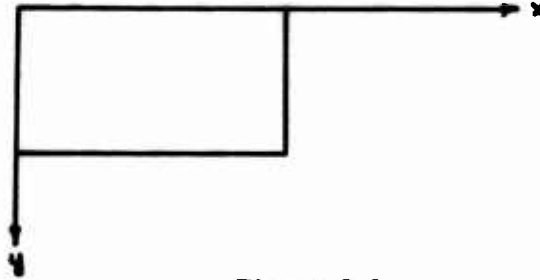

Figure 3.1

A plate is defined as a shell with no curvature; therefore, $R_1 = R_2 = \infty$ and the line element is given by:

$$ds^2 = dx^2 + dy^2 \quad (3.1)$$

where the change of variables of $\alpha = x$ and $\beta = y$ from Eq (1.16) has been made.

The reference surface strains given by Eq (1.23) reduce to the following for a plate:

$$\begin{aligned} \epsilon_{10} &= u_{0,x} \\ \epsilon_{20} &= v_{0,y} \\ \gamma_{120} &= u_{0,y} + v_{0,x} \end{aligned} \quad (3.2)$$

The expressions for the changes of curvature are now:

$$\begin{aligned} \chi_1 &= w_{,xx} \\ \chi_2 &= w_{,yy} \\ \chi_{12} &= w_{,xy} \end{aligned} \quad (3.3)$$

The stress-resultants and stress-couples, defined by Eq (1.26) and Eq (1.27), for rectangular plates become:

$$\begin{bmatrix} N_x \\ N_y \\ N_{xy} \end{bmatrix} = \begin{bmatrix} A_{11} & A_{12} & A_{16} \\ A_{12} & A_{22} & A_{26} \\ A_{16} & A_{26} & A_{66} \end{bmatrix} \begin{bmatrix} u_{0,x} \\ v_{0,y} \\ u_{0,y} + v_{0,x} \end{bmatrix} - \begin{bmatrix} D_{11}^* & D_{12}^* & D_{16}^* \\ D_{12}^* & D_{22}^* & D_{26}^* \\ D_{16}^* & D_{26}^* & D_{66}^* \end{bmatrix} \begin{bmatrix} w_{,xx} \\ w_{,yy} \\ 2w_{,xy} \end{bmatrix} \quad (3.4)$$

$$\begin{bmatrix} M_x \\ M_y \\ M_{xy} \end{bmatrix} = \begin{bmatrix} D_{11}^* & D_{12}^* & D_{16}^* \\ D_{12}^* & D_{22}^* & D_{26}^* \\ D_{16}^* & D_{26}^* & D_{66}^* \end{bmatrix} \begin{bmatrix} u_{0,x} \\ v_{0,y} \\ u_{0,y} + v_{0,x} \end{bmatrix} - \begin{bmatrix} D_{11} & D_{12} & D_{16} \\ D_{12} & D_{22} & D_{26} \\ D_{16} & D_{26} & D_{66} \end{bmatrix} \begin{bmatrix} w_{,xx} \\ w_{,yy} \\ 2w_{,xy} \end{bmatrix} \quad (3.5)$$

where A_{ij} , D_{ij}^* , and D_{ij} are defined by Eq (1.30).

The three equations of equilibrium for the plate element supplemented by the compatibility equation for the in-plane strain components at the reference surface of the plate constitute the determinative system of equations. These equations, as reduced from Eq (1.31) and Eq (1.32), are

$$N_{x,x} + N_{xy,y} = 0 \qquad N_{xy,x} + N_{y,y} = 0 \quad (3.6)$$

$$M_{x,xx} + 2M_{xy,xy} + M_{y,yy} = -q \quad (3.7)$$

$$\epsilon_{10,yy} + \epsilon_{20,xx} - \gamma_{120,xy} = 0 \quad (3.8)$$

It is convenient to regard the transverse displacement w and the stress-resultants N_x , N_y , and N_{xy} as the primary dependent variables for this system of equations. The moment and reference surface strains can be expressed in terms of these variables in the same manner as for cylindrical shells.

$$\begin{bmatrix} u_{0,x} \\ v_{0,y} \\ u_{0,y} + v_{0,x} \end{bmatrix} = B \begin{bmatrix} N_x \\ N_y \\ N_{xy} \end{bmatrix} + b' \begin{bmatrix} w_{,xx} \\ w_{,yy} \\ 2w_{,xy} \end{bmatrix} \quad (3.9)$$

$$\begin{bmatrix} M_x \\ M_y \\ M_{xy} \end{bmatrix} = b \begin{bmatrix} N_x \\ N_y \\ N_{xy} \end{bmatrix} + d \begin{bmatrix} w,_{xx} \\ w,_{yy} \\ 2w,_{xy} \end{bmatrix} \quad (3.10)$$

where B , b , b' , and d are defined by Eqs (2.11), (2.13), and (2.14). Eq (3.9) and Eq (3.10) written explicitly are:

$$\begin{aligned} \epsilon_{10} &= u_{0,x} = B_{11}N_x + B_{12}N_y + B_{16}N_{xy} + b'_{11}w,_{xx} + b'_{12}w,_{yy} + 2b'_{16}w,_{xy} \\ \epsilon_{20} &= v_{0,y} = B_{12}N_x + B_{22}N_y + B_{26}N_{xy} + b'_{21}w,_{xx} + b'_{22}w,_{yy} + 2b'_{26}w,_{xy} \\ \gamma_{120} &= u_{0,y} + v_{0,x} = B_{16}N_x + B_{26}N_y + B_{66}N_{xy} + b'_{61}w,_{xx} + b'_{62}w,_{yy} + 2b'_{66}w,_{xy} \end{aligned} \quad (3.9a)$$

$$\begin{aligned} M_x &= b_{11}N_x + b_{12}N_y + b_{16}N_{xy} + d_{11}w,_{xx} + d_{12}w,_{yy} + 2d_{16}w,_{xy} \\ M_y &= b_{21}N_x + b_{22}N_y + b_{26}N_{xy} + d_{12}w,_{xx} + d_{22}w,_{yy} + 2d_{26}w,_{xy} \\ M_{xy} &= b_{61}N_x + b_{62}N_y + b_{66}N_{xy} + d_{16}w,_{xx} + d_{26}w,_{yy} + 2d_{66}w,_{xy} \end{aligned} \quad (3.10a)$$

Introduction of the Airy stress function U defined in rectangular cartesian coordinates by:

$$N_x = U,_{yy} \quad N_y = U,_{xx} \quad N_{xy} = -U,_{xy} \quad (3.11)$$

which identically satisfies Eq (3.6) reduces the determinative equations to two primary dependent variables. Substituting Eq (3.9) into Eq (3.8) and using Eq (3.11) gives:

$$\begin{aligned} &B_{22}U,_{xxxx} - 2B_{26}U,_{xxxy} + (2B_{12} + B_{66})U,_{xxyy} - 2B_{16}U,_{xyyy} + B_{11}U,_{yyyy} \\ &+ b_{12}w,_{xxxx} + (2b_{62} - b_{16})w,_{xxxy} + (b_{11} + b_{22} - 2b_{66})w,_{xxyy} \\ &+ (2b_{61} - b_{26})w,_{xyyy} + b_{21}w,_{yyyy} = 0 \end{aligned} \quad (3.12)$$

Substituting Eq (3.10) into Eq (3.7) again using Eq (3.11) gives

$$\begin{aligned}
 & b_{12}U_{,xxxx} + (2b_{62} - b_{16})U_{,xxxxy} + (b_{11} + b_{22} - 2b_{66})U_{,xxxyy} \\
 & + (2b_{61} - b_{26})U_{,xyyy} + b_{21}U_{,yyyy} + d_{11}w_{,xxxx} + 4d_{16}w_{,xxxxy} \\
 & + 2(d_{12} + 2d_{66})w_{,xxxy} + 4d_{26}w_{,xyyy} + d_{22}w_{,yyyy} = -q
 \end{aligned} \tag{3.13}$$

Equations (3.12) and (3.13) are the generalizations of the Poisson-Kirchhoff equations to take into account the orthotropic properties of the laminas composing the plate. The presence of both dependent variables in each of the two equations indicates coupling between the in-plane forces and the deflection surface.

The boundary conditions, given by Eq (1.33), are summarized below to complete the formulation of the plate problem.

	I	II
	Force Boundary Conditions	Displacement Boundary Conds.
1	$(N_n - \bar{N}_n)$	$(u_n - \bar{u}_n)$
2	$(N_{nt} - \bar{N}_{nt})$	$(u_t - \bar{u}_t)$
3	$(M_n - \bar{M}_n)$	$(w_{,n} - \bar{w}_{,n})$
4	$(Q_n + M_{nt,t} - \bar{V}_n)$	$(w - \bar{w})$

(3.14)

where

- N_n - normal force
- N_{nt} - in-plane shearing force
- Q_n - transverse shearing force
- M_n - bending moment
- M_{nt} - twisting moment
- V_n - effective shear given by

$$V_n = Q_n + M_{nt,t}$$

- u_n - normal displacement
- u_t - tangential displacement
- w - transverse deflection
- $w_{,n}$ - slope in the normal direction.

Bars over the quantities signify that they are the prescribed values at the boundaries.

In each of the four conditions, either the barred quantity in column I or II must be prescribed. For that force or displacement which is prescribed, the bracketed quantity must vanish. This means that the unbarred quantity (that force or displacement from the interior of the plate) must take on the prescribed value on the boundary.

The boundary conditions corresponding to the physical restraint may be thought of in terms of those of the usual conditions for a bending problem (conditions 3 and 4) and an in-plane problem (conditions 1 and 2). Certain plate problems may be decomposed into these two separate problems and treated individually. However, in general the problem must be treated as a combined bending and in-plane problem since U and w are coupled in the governing differential equations and in the boundary conditions.

Some examples of boundary conditions for a rectangular plate are:

Clamped Edge - In a plate with a built-in edge both displacements u_0 and v_0 , the deflection w , and the slope $w_{,n}$ are zero. This condition along the x axis is

$$\begin{aligned} \bar{w} \Big|_{y=0} = 0 & \quad ; & \quad \bar{w}_{,y} \Big|_{y=0} = 0 \\ \bar{u}_0 \Big|_{y=0} = 0 & \quad ; & \quad \bar{v}_0 \Big|_{y=0} = 0 \end{aligned} \tag{3.15}$$

u_0 and v_0 may be expressed in terms of U and w in a specific problem by the integration of Eq (3.9a)

$$u_0 = \int (B_{11} U_{,yy} + B_{12} U_{,xx} - B_{16} U_{,xy} + b_{11} w_{,xx} + b_{21} w_{,yy} + 2b_{61} w_{,xy}) dx + f_1(y)$$

$$v_0 = \int (B_{12} U_{,yy} + B_{22} U_{,xx} - B_{26} U_{,xy} + b_{12} w_{,xx} + b_{22} w_{,yy} + 2b_{26} w_{,xy}) dy + f_2(x)$$

The arbitrary functions $f_1(y)$ and $f_2(x)$ may be evaluated by differentiating u_0 with respect to y and v_0 with respect to x and substituting into the third Eq (3.9a).

Free Edge - Along a free edge of a plate, the in-plane and transverse forces and the bending moment vanish. The displacements and slope, however, are unspecified. Along the x-axis, this condition is

$$\begin{aligned} M_y \Big|_{y=0} &= 0 & V_y \Big|_{y=0} &= Q_y + M_{xy,x} \Big|_{y=0} = 0 \\ N_y \Big|_{y=0} &= U_{,xx} \Big|_{y=0} = 0 & N_{xy} \Big|_{y=0} &= -U_{,xy} \Big|_{y=0} = 0 \end{aligned} \quad (3.16)$$

M_y and V_y may be expressed in terms of U and w by Eq (3.10a) and Eq (3.21).

$$\begin{aligned} M_y \Big|_{y=0} &= b_{21}U_{,yy} + b_{22}U_{,xx} - b_{26}U_{,xy} + d_{12}w_{,xx} + d_{22}w_{,yy} + 2d_{26}w_{,xy} \Big|_{y=0} = 0 \\ V_y \Big|_{y=0} &= b_{21}U_{,yyy} + (2b_{61} - b_{26})U_{,xyy} + (b_{22} - 2b_{66})U_{,xxy} + 2b_{62}U_{,xxx} \\ &+ d_{22}w_{,yyy} + 4d_{26}w_{,xyy} + (d_{12} + 4d_{66})w_{,xxy} + d_{16}w_{,xxx} \Big|_{y=0} = 0 \end{aligned} \quad (3.16a)$$

Simply Supported Edge - A simply supported edge permits rotation but no deflection. Since it is free to rotate, the bending moment is zero. For the in-plane boundary conditions, either a fixed (pinned) or a free (roller) condition may be prescribed depending on nature of the restraint. For a roller support which produces no in-plane forces along the x-axis, the boundary conditions are

$$\begin{aligned} w \Big|_{y=0} &= 0 & ; & & M_y \Big|_{y=0} &= 0 \\ N_y \Big|_{y=0} &= U_{,xx} \Big|_{y=0} = 0 & ; & & N_{xy} \Big|_{y=0} &= -U_{,xy} \Big|_{y=0} = 0 \end{aligned} \quad (3.17)$$

M_y in terms of U and w is given by Eq (3.16a).

DETERMINATION OF STRESSES IN AN INDIVIDUAL LAMINA AND
INTER-LAMINAR SHEAR STRESSES

The general expressions for the stresses in the "k-th" lamina are given in Eq (1.6). For the plate, this equation in terms of the primary dependent variables U and w becomes:

$$\begin{bmatrix} \sigma_x^{(k)} \\ \sigma_y^{(k)} \\ \tau_{xy}^{(k)} \end{bmatrix} = T^{(k)} \begin{bmatrix} U_{,xx} \\ U_{,yy} \\ -U_{,xy} \end{bmatrix} + (t^{(k)} - z\bar{c}^{(k)}) \begin{bmatrix} w_{,xx} \\ w_{,yy} \\ 2w_{,xy} \end{bmatrix} \quad (3.18)$$

where $T^{(k)}$, $t^{(k)}$, and $\bar{c}^{(k)}$ are previously defined by Eqs (2.20), (2.21), and (1.12), respectively. Equation (3.18) written explicitly are:

$$\begin{aligned} \sigma_x^{(k)} &= T_{11}^{(k)} U_{,yy} + T_{12}^{(k)} U_{,xx} - T_{16}^{(k)} U_{,xy} + (t_{11}^{(k)} - z\bar{c}_{11}^{(k)}) w_{,xx} \\ &\quad + (t_{12}^{(k)} - z\bar{c}_{12}^{(k)}) w_{,yy} + 2(t_{16}^{(k)} - z\bar{c}_{16}^{(k)}) w_{,xy} \end{aligned}$$

$$\begin{aligned} \sigma_y^{(k)} &= T_{21}^{(k)} U_{,yy} + T_{22}^{(k)} U_{,xx} - T_{26}^{(k)} U_{,xy} + (t_{21}^{(k)} - z\bar{c}_{12}^{(k)}) w_{,xx} \\ &\quad + (t_{22}^{(k)} - z\bar{c}_{22}^{(k)}) w_{,yy} + 2(t_{26}^{(k)} - z\bar{c}_{26}^{(k)}) w_{,xy} \end{aligned} \quad (3.18a)$$

$$\begin{aligned} \tau_{xy}^{(k)} &= T_{61}^{(k)} U_{,yy} + T_{62}^{(k)} U_{,xx} - T_{66}^{(k)} U_{,xy} + (t_{61}^{(k)} - z\bar{c}_{16}^{(k)}) w_{,xx} \\ &\quad + (t_{62}^{(k)} - z\bar{c}_{26}^{(k)}) w_{,yy} + 2(t_{66}^{(k)} - z\bar{c}_{66}^{(k)}) w_{,xy} \end{aligned}$$

Although transverse shear deformation is neglected in this theory, transverse shear resultants can be determined from equilibrium considerations. The resultants are defined as:

$$Q_x = \sum_{k=1}^n \int_{h_{k-1}}^{h_k} \tau_{xz}^{(k)} dz \quad Q_y = \sum_{k=1}^n \int_{h_{k-1}}^{h_k} \tau_{yz}^{(k)} dz \quad (3.19)$$

These stress resultants are determined from the moment equilibrium equations; i.e., the last two expressions of Eq (1.31):

$$Q_x = M_{x,x} + M_{xy,y} \quad Q_y = M_{xy,x} + M_{y,y} \quad (3.20)$$

Combining these equations with Eq (3.10) gives:

$$Q_x = b_{51}U_{,yyy} + (b_{11} - b_{66})U_{,xyy} + (b_{62} - b_{16})U_{,xxy} + b_{12}U_{,xxx} \\ + d_{26}w_{,yyy} + (d_{12} + 2d_{66})w_{,xyy} + 3d_{16}w_{,xxy} + d_{11}w_{,xxx} \quad (3.21)$$

$$Q_y = b_{21}U_{,yyy} + (b_{61} - b_{26})U_{,xyy} + (b_{22} - b_{66})U_{,xxy} + b_{62}U_{,xxx} \\ + d_{22}w_{,yyy} + 3d_{26}w_{,xxy} + (d_{12} + 2d_{66})w_{,xyy} + d_{16}w_{,xxx}$$

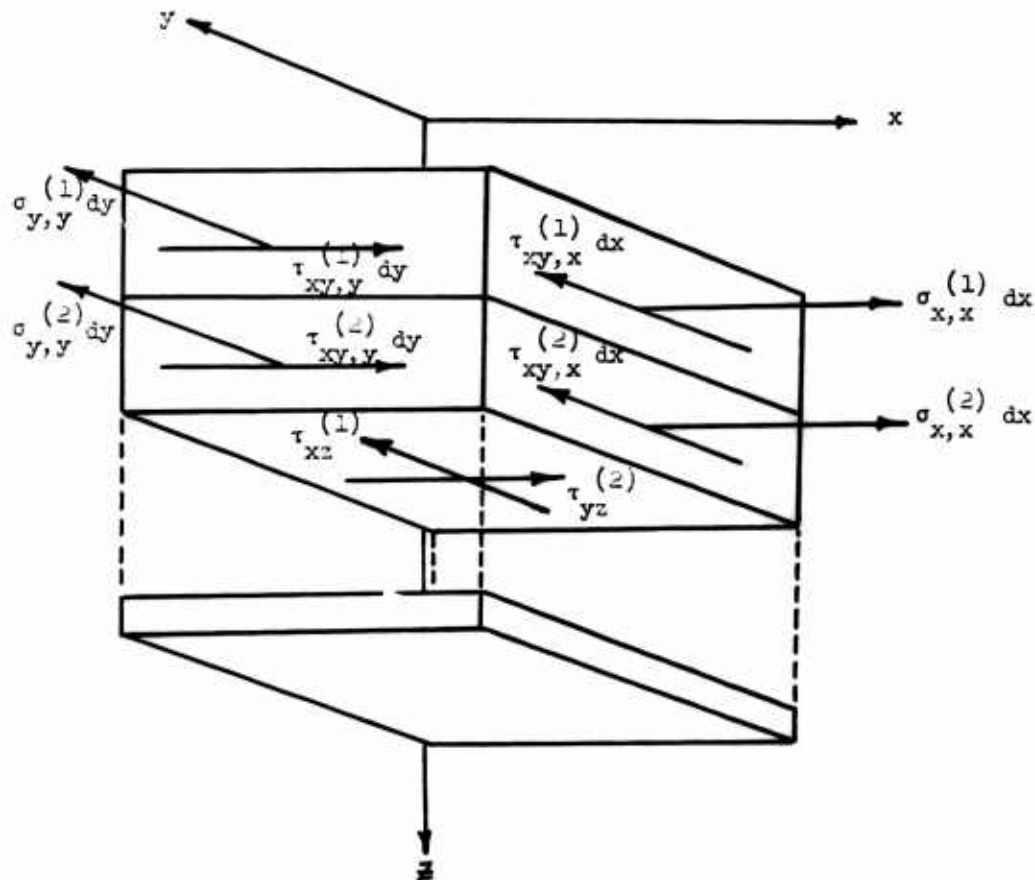

Figure 3.2

The inter-laminar shear stresses $\tau_{xz}^{(k)}$ and $\tau_{yz}^{(k)}$ are found by consideration of equilibrium in the x and y directions. Figure 3.2 shows only the change of the stresses in the x and y directions. Summing the forces in the x-direction up to the k-th layer gives

$$\tau_{xz}^{(k)} = - \sum_{j=1}^k \int_{h_{j-1}}^{h_j} (\sigma_{x,x}^{(j)} + \tau_{xy,y}^{(j)}) dz + \tau_{xzo} \quad (3.22)$$

$$\tau_{yz}^{(k)} = - \sum_{j=1}^k \int_{h_{j-1}}^{h_j} (\sigma_{y,y}^{(j)} + \tau_{xy,x}^{(j)}) dz + \tau_{yzo}$$

Here τ_{xzo} and τ_{yzo} are constants to be adjusted by conditions at the top and bottom plate surfaces. Using Eq (3.18a), these expressions become

$$\begin{aligned} \tau_{xz}^{(k)} = - \sum_{j=1}^k \int_{h_{j-1}}^{h_j} & \left[T_{12}^{(j)} U_{,xxx} + (T_{62}^{(j)} - T_{16}^{(j)}) U_{,xxy} + (T_{11}^{(j)} - T_{66}^{(j)}) U_{,xyy} \right. \\ & + T_{61}^{(j)} U_{,yyy} + (t_{11}^{(j)} - z\bar{c}_{11}^{(j)}) w_{,xxx} + (2t_{16}^{(j)} + t_{61}^{(j)} - 3z\bar{c}_{16}^{(j)}) w_{,xxy} \\ & \left. + (t_{12}^{(j)} + 2t_{66}^{(j)} - z\bar{c}_{12}^{(j)} - 2z\bar{c}_{66}^{(j)}) w_{,xyy} + (t_{62}^{(j)} - z\bar{c}_{62}^{(j)}) w_{,yyy} \right] dz \end{aligned} \quad (3.22a)$$

$$\begin{aligned} \tau_{yz}^{(k)} = - \sum_{j=1}^k \int_{h_{j-1}}^{h_j} & \left[T_{62}^{(j)} U_{,xxx} + (T_{22}^{(j)} - T_{66}^{(j)}) U_{,xxy} + (T_{61}^{(j)} - T_{26}^{(j)}) U_{,xyy} \right. \\ & + T_{21}^{(j)} U_{,yyy} + (t_{61}^{(j)} - z\bar{c}_{16}^{(j)}) w_{,xxx} + (2t_{66}^{(j)} + t_{21}^{(j)} - 2z\bar{c}_{66}^{(j)} - z\bar{c}_{12}^{(j)}) w_{,xxy} \\ & \left. + (t_{62}^{(j)} + 2t_{26}^{(j)} - 3z\bar{c}_{26}^{(j)}) w_{,xyy} + (t_{22}^{(j)} - z\bar{c}_{22}^{(j)}) w_{,yyy} \right] dz \end{aligned} \quad (3.22b)$$

4. METHODS OF SOLUTION

Several methods of obtaining solutions to the plate Eqs (3.12) and (3.13) are discussed in this section. First, a method which involves the combination of two fourth order equations into one eighth order is indicated. Then, iterative and perturbation schemes are discussed as other possible methods of attack. For special orientations of the individual laminas, the differential equations for plates and shells simplify, and an extensive amount of information for solving these simplified equations is available.

REDUCTION OF THE COUPLED EQUATIONS TO ONE EIGHTH ORDER EQUATION

A possible method of solution of the coupled system of equations is to combine the two equations into one eighth order equation using the technique which Vlasov used to solve shallow shell equations (7). For convenience, Eqs (3.12) and (3.13) are rewritten in operator notation:

$$L_1^{(4)}(U) + L_2^{(4)}(w) = 0 \quad (4.1)$$

$$L_2^{(4)}(U) + L_3^{(4)}(w) = -q \quad (4.2)$$

where operators $L_1^{(4)}$, $L_2^{(4)}$, $L_3^{(4)}$ are the following fourth order operators:

$$L_1^{(4)} = B_{22} \frac{\partial^4}{\partial x^4} - 2B_{26} \frac{\partial^4}{\partial x^3 \partial y} + (2B_{12} + B_{66}) \frac{\partial^4}{\partial x^2 \partial y^2} - 2B_{16} \frac{\partial^4}{\partial x \partial y^3} + B_{11} \frac{\partial^4}{\partial y^4} \quad (4.3)$$

$$L_2^{(4)} = b_{12} \frac{\partial^4}{\partial x^4} + (2b_{62} - b_{16}) \frac{\partial^4}{\partial x^3 \partial y} + (b_{11} + b_{22} - 2b_{66}) \frac{\partial^4}{\partial x^2 \partial y^2} + (2b_{61} + b_{26}) \frac{\partial^4}{\partial x \partial y^3} + b_{21} \frac{\partial^4}{\partial y^4}$$

$$L_3^{(4)} = a_{11} \frac{\partial^4}{\partial x^4} + 4a_{16} \frac{\partial^4}{\partial x^3 \partial y} + 2(a_{12} + 2a_{66}) \frac{\partial^4}{\partial x^2 \partial y^2} + 4a_{26} \frac{\partial^4}{\partial x \partial y^3} + a_{22} \frac{\partial^4}{\partial y^4}$$

If there exists a function Φ such that

$$v = L_1^{(4)} (\Phi) \quad (4.4)$$

$$U = - L_2^{(4)} (\Phi),$$

then Eq (4.1) is satisfied identically and Eq (4.2) becomes:

$$L_4^{(8)} (\Phi) = \left\{ [L_2^{(4)}]^2 - L_3^{(4)} L_1^{(4)} \right\} \Phi = q \quad (4.5)$$

where $L_4^{(8)}$ is the following eighth order operator:

$$\begin{aligned} L_4^{(8)} = & \left[b_{12}^2 - a_{11} B_{22} \right] \frac{\partial^8}{\partial x^8} + 2 \left[b_{12} (2b_{62} - b_{16}) + a_{11} B_{26} - 2a_{16} B_{22} \right] \frac{\partial^8}{\partial x^7 \partial y} \\ & + \left[2b_{12} (b_{11} + b_{22} - 2b_{66}) + (2b_{62} - b_{16})^2 - a_{11} (2B_{12} + B_{66}) \right. \\ & \left. 8a_{16} B_{26} - 2(a_{12} + 2a_{66}) B_{22} \right] \frac{\partial^8}{\partial x^6 \partial y^2} \\ & + 2 \left[b_{12} (2b_{61} - b_{62}) + (2b_{62} - b_{16})(b_{11} + b_{22} - 2b_{66}) + a_{11} B_{16} \right. \\ & \left. - 2a_{16} (2B_{12} + B_{66}) + 2(a_{12} + 2a_{66}) B_{26} - 2a_{26} B_{22} \right] \frac{\partial^8}{\partial x^5 \partial y^3} \\ & + \left[2b_{12} b_{21} + 2(2b_{62} - b_{16})(2b_{61} - b_{26}) + (b_{11} + b_{22} - 2b_{66})^2 \right. \\ & \left. - a_{11} B_{11} + 8a_{16} B_{16} - 2(a_{12} + 2a_{66})(2B_{12} + B_{66}) + 8a_{26} B_{26} - a_{22} B_{22} \right] \frac{\partial^8}{\partial x^4 \partial y^4} \\ & + 2 \left[b_{21} (2b_{62} - b_{16}) + (2b_{61} - b_{26})(b_{11} + b_{22} - 2b_{66}) + a_{22} B_{26} \right. \\ & \left. - 2a_{26} (2B_{12} + B_{66}) + 2(a_{12} + 2a_{66}) B_{16} - 2a_{16} B_{11} \right] \frac{\partial^8}{\partial x^3 \partial y^5} \quad (4.6) \\ & + \left[2b_{21} (b_{11} + b_{22} - 2b_{66}) + (2b_{61} - b_{26})^2 - a_{22} (2B_{16} + B_{66}) \right. \\ & \left. + 8a_{26} B_{16} + 2(a_{12} + 2a_{66}) B_{11} \right] \frac{\partial^8}{\partial x^2 \partial y^6} \\ & + 2 \left[b_{21} (2b_{61} - b_{26}) + a_{22} B_{16} - 2a_{26} B_{11} \right] \frac{\partial^8}{\partial x \partial y^7} + \left[b_{21}^2 - a_{22} B_{11} \right] \frac{\partial^8}{\partial y^8} \end{aligned}$$

The solution of Eq (4.5) may now be separated into a homogeneous and a particular solution. The particular solution should satisfy the loading condition but may not necessarily satisfy the boundary conditions. This solution may be determined by the use of trigonometric series. The homogeneous solution must be such that the sum of the particular and homogeneous solutions satisfies the boundary conditions. The latter condition may be satisfied in the same manner as that used by M. Suchar (8) to determine influence surfaces for anisotropic plates, or by other means.

ITERATIVE SOLUTION OF THE COUPLED EQUATIONS

Since Eqs (3.12) and (3.13) are based on small deflection theory, the coupling between the in-plane stress function, U , and the lateral deflection, w , generally will have a minor effect on the solutions. Hence, as a first approximation, the system can be treated as an uncoupled system by omitting from the equations the terms which contain the b_{ij} coefficients. Then, by substituting the first approximation into the terms containing the b_{ij} coefficients, a second approximation may be obtained. The process is then repeated to obtain higher order approximations.

Adopting the operator notation used previously, Eqs (3.12) and (3.13) may be written as:

$$L_1^{(4)}(U_n) = -L_2^{(4)}(w_{n-1}) \quad (4.7)$$

$$L_3^{(4)}(w_n) = -q - L_2^{(4)}(U_{n-1}) \quad (4.8)$$

where n represents the order of the approximation, w_0 and U_0 being equal to zero. It can be seen that this system is effectively uncoupled since the higher order approximations of one variable are coupled to the next lower order approximation of the other variable. Hence, the methods of solution applicable to the uncoupled equations given in the literature and summarized below may be applied to this system of equations.

Since coupling also exists in the expressions for moment and for in-plane strain, Eqs (3.9a) and (3.10a), which are used in stating the boundary conditions, these expressions must also be rewritten in iterative form:

$$u_{0,n,x} = B_{11}U_{n,yy} + B_{12}U_{n,xx} - B_{16}U_{n,xy} + b'_{11}w_{n-1,xx} + b'_{12}w_{n-1,yy} + 2b'_{16}w_{n-1,xy} \quad (4.9)$$

$$v_{0,n,y} = B_{12}U_{n,yy} + B_{22}U_{n,xx} - B_{26}U_{n,xy} + b'_{21}w_{n-1,xx} + b'_{22}w_{n-1,yy} + 2b'_{26}w_{n-1,xy}$$

$$\begin{aligned}
u_{o_{n,y}} + v_{o_{n,x}} = & B_{16} U_{n,yy} + B_{26} U_{n,xx} - B_{66} U_{n,xy} + b'_{61} w_{n-1,xx} \\
& + 2b'_{66} w_{n-1,xy} + b'_{62} w_{n-1,yy}
\end{aligned} \tag{4.9}$$

$$\begin{aligned}
M_{x_n} = & d_{11} w_{n,xx} + d_{12} w_{n,yy} + 2d_{16} w_{n,xy} + b_{11} U_{n-1,yy} + b_{12} U_{n-1,xx} \\
& - b_{16} U_{n-1,xy}
\end{aligned} \tag{4.10}$$

$$\begin{aligned}
M_{y_n} = & d_{12} w_{n,xx} + d_{22} w_{n,yy} + 2d_{26} w_{n,xy} + b_{21} U_{n-1,yy} + b_{22} U_{n-1,xx} \\
& - b_{26} U_{n-1,xy}
\end{aligned}$$

$$\begin{aligned}
M_{xy_n} = & d_{16} w_{n,xx} + d_{26} w_{n,yy} + 2d_{66} w_{n,xy} + b_{61} U_{n-1,yy} + b_{62} U_{n-1,xx} \\
& - b_{66} U_{n-1,xy}
\end{aligned}$$

PERTURBATION SOLUTION OF THE COUPLED EQUATIONS

For many materials of practical importance, the individual laminas will be only slightly orthotropic. In such cases, the operators in Eqs (3.12) and (3.13) will be only slightly different from those in the equations for isotropic plates. This suggests that such problems may be treated by a perturbation method of solution (9. 10); that is, the solution for a substitute isotropic material may be used as a first approximation, and then successive corrections may be obtained to account for the orthotropy.

To apply perturbation theory, Eqs (3.12) and (3.13) are written in a form such that they may be seen to be the equations for an isotropic plate modified by small corrective terms. To this end, the following parameters are defined:

$$\begin{aligned}
\nu_B = -\frac{B_{12}}{B} & & k_{26} = \frac{B_{26}}{B} \\
k_{11} = 1 - \frac{B_{11}}{B} & & k_{66} = 1 - \frac{1}{2(1+\nu_B)} \frac{B_{66}}{B} \\
k_{22} = 1 - \frac{B_{22}}{B} & & l_{ij} = \frac{b_{ij}}{B} \\
k_{16} = \frac{B_{16}}{B} & & m_{ij} = -\frac{b_{ij}}{D}
\end{aligned} \tag{4.11}$$

$$n_{11} = 1 - \frac{D_{11}}{D}, \quad n_{11}^* = \frac{d_{11} + D_{11}}{D}$$

$$n_{22} = 1 - \frac{D_{22}}{D}, \quad n_{22}^* = \frac{d_{22} + D_{22}}{D}$$

$$\nu_D = \frac{D_{12}}{D}, \quad n_{12}^* = \frac{d_{12} + D_{12}}{D}$$

$$n_{66} = 1 - \frac{2}{1-\nu_D} \frac{D_{66}}{D}, \quad n_{66}^* = \frac{2}{1-\nu_D} \frac{d_{66} + D_{66}}{D}$$

$$n_{16} = \frac{D_{16}}{D}, \quad n_{16}^* = \frac{d_{16} + D_{16}}{D}$$

$$n_{26} = \frac{D_{26}}{D}, \quad n_{26}^* = \frac{d_{26} + D_{26}}{D}$$

where B and D are the maximums of B_{11} , B_{22} , or $2B_{12} + B_{66}$, and D_{11} , D_{22} , or $D_{12} + 2D_{66}$, respectively. This latter condition guarantees that the parameters k_{ij} , l_{ij} , m_{ij} , n_{ij} , and n_{ij}^* are always less than 1.0 in magnitude. Four constants have been used to define the substitute isotropic material: B, ν_B , D, and ν_D . This has been done for convenience, since most problems will involve either an in-plane stress problem or a bending problem. The number of parameters has also been selected for convenience in the application of the method.

When Eqs (3.12) and (3.13) are expressed in terms of these parameters they become

$$\begin{aligned} (1 - k_{22})U_{,xxxx} - 2k_{26} U_{,xxyy} + \left[2 - 2(1 + \nu_B) k_{66} \right] U_{,xyyy} & \quad (4.12) \\ - 2k_{16} U_{,xyyy} + (1 - k_{11}) U_{,yyyy} + l_{12} w_{,xxxx} + (2l_{62} - l_{16}) w_{,xxyy} \\ + (l_{11} + l_{22} - 2l_{66}) w_{,xxyy} + (2l_{61} - l_{26}) w_{,xyyy} + l_{21} w_{,yyyy} = 0 \end{aligned}$$

$$\begin{aligned} m_{12} U_{,xxxx} + (2m_{62} - m_{16}) U_{,xxyy} + (m_{11} + m_{22} - 2m_{66}) U_{,xyyy} \\ + (2m_{61} - m_{26}) U_{,xyyy} + m_{21} U_{,yyyy} + (1 - n_{11} - n_{11}^*) w_{,xxxx} \\ + 4(n_{16} - n_{16}^*) w_{,xxyy} + \left[1 - n_{12}^* - (1 - \nu_D)(n_{66} + n_{66}^*) \right] w_{,xxyy} \\ + 4(n_{26} - n_{26}^*) w_{,xyyy} + (1 - n_{22} - n_{22}^*) w_{,yyyy} = \frac{q}{D} \end{aligned}$$

It may be seen that if the parameters k_{ij} , l_{ij} , m_{ij} , n_{ij} , and n_{ij}^* are so small that the terms containing them may be neglected, the equations for isotropic plates are recovered.

Since U and w may be considered to be continuous functions of the parameters k_{ij} , l_{ij} , m_{ij} , n_{ij} , and n_{ij}^* , they may be expanded in series in terms of powers of the parameters. However, from a computational standpoint, this method of solution is of practical value only when the terms containing squares, products, and higher powers of the parameters are negligible. Therefore, the power series expansions will be used in the following form:

$$\begin{aligned}
 U &= U_0 + k_{ij} U_{kij} + l_{ij} U_{lij} + m_{ij} U_{mij} + n_{ij} U_{nij} + n_{ij}^* U_{nij}^* \\
 w &= w_0 + k_{ij} w_{kij} + l_{ij} w_{lij} + m_{ij} w_{mij} + n_{ij} w_{nij} + n_{ij}^* w_{nij}^*
 \end{aligned}
 \tag{4.14}$$

The substitution of these expansions for U and w into Eqs (4.12) and (4.13) results in the following sets of equations when the coefficients of like powers of the parameters are equated:

$$\begin{aligned}
 \nabla^4 U_0 &= 0 \\
 \nabla^4 w_0 &= \frac{q}{D}
 \end{aligned}
 \tag{4.15}$$

$$\begin{aligned}
 \nabla^4 U_{k11} &= U_{0,yyyy} \\
 \nabla^4 U_{k22} &= U_{0,xxxx} \\
 \nabla^4 U_{k16} &= 2U_{0,xyyy} \\
 \nabla^4 U_{k26} &= 2U_{0,xxxy} \\
 \nabla^4 U_{k66} &= 2(1 + \nu_B) U_{0,xxyy}
 \end{aligned}
 \tag{4.16}$$

$$\begin{aligned}
 \nabla^4 U_{l11} &= -w_{0,xxyy} \\
 \nabla^4 U_{l12} &= -w_{0,xxxx} \\
 \nabla^4 U_{l16} &= +w_{0,xxxy}
 \end{aligned}
 \tag{4.17}$$

$$\begin{aligned}
\nabla^4 U_{l21} &= -w_{o,yyyy} \\
\nabla^4 U_{l22} &= -w_{o,xxxy} \\
\nabla^4 U_{l26} &= w_{o,xyyy} \\
\nabla^4 U_{l61} &= -2w_{o,xyyy} \\
\nabla^4 U_{l62} &= -2w_{o,xxxy} \\
\nabla^4 U_{l66} &= 2w_{o,xxxy}
\end{aligned}
\tag{4.17}$$

$$\begin{aligned}
\nabla^4 w_{m11} &= -U_{o,xxxy} \\
\nabla^4 w_{m12} &= -U_{o,xxxx} \\
\nabla^4 w_{m16} &= U_{o,xxxy} \\
\nabla^4 w_{m21} &= -U_{o,yyyy} \\
\nabla^4 w_{m22} &= -U_{o,xxxy} \\
\nabla^4 w_{m26} &= U_{o,xyyy} \\
\nabla^4 w_{m61} &= -2U_{o,xyyy} \\
\nabla^4 w_{m62} &= -2U_{o,xxxy} \\
\nabla^4 w_{m66} &= 2U_{o,xxxy}
\end{aligned}
\tag{4.18}$$

$$\begin{aligned}
\nabla^4 w_{n11} &= w_{o,xxxx} & \nabla^4 w_{n11}^* &= w_{o,xxxx} \\
\nabla^4 w_{n16} &= -4w_{o,xxxy} & \nabla^4 w_{n16}^* &= 4w_{o,xxxy}
\end{aligned}
\tag{4.19}$$

$$\begin{aligned}
\nabla^4 w_{n22} &= w_{o,yyyy} & \nabla^4 w_{n22}^* &= w_{o,yyyy} \\
\nabla^4 w_{n26} &= -4w_{o,xyyy} & \nabla^4 w_{n26}^* &= 4w_{o,xyyy} \\
\nabla^4 w_{n66} &= (1-\nu_D) w_{o,xxyy} & \nabla^4 w_{n12}^* &= w_{o,xxyy} \\
& & \nabla^4 w_{n66}^* &= (1-\nu_D) w_{o,xxyy}
\end{aligned} \tag{4.19}$$

Equations (4.15) are the differential equations of the first approximation. Equations (4.16), (4.17), (4.18), and (4.19) are the differential equations of the corrective terms forming the second approximation. It should be pointed out that the equations involving w_{kij} , w_{lij} , U_{nij} , and U_{mij} have been omitted from this summary since these equations are all of the form $\nabla^4(w, U) = 0$, and their solutions are identically zero.

Since the elastic constants appear in the expressions for the bending moments and in-plane strains, the boundary conditions for the above sets of equations will also be perturbed. When the bending moments are expressed in terms of the perturbation parameters, they become:

$$\begin{aligned}
M_x &= -D \left[m_{11} U_{,yy} + m_{12} U_{,xx} - m_{16} U_{,xy} + (1-n_{11} - n_{11}^*) w_{,xx} \right. \\
&\quad \left. + (\nu_D - n_{12}^*) w_{,yy} + 2n_{16} w_{,xy} \right] \\
M_y &= -D \left[m_{21} U_{,yy} + m_{22} U_{,xx} - m_{26} U_{,xy} + (\nu_D - n_{12}^*) w_{,xx} \right. \\
&\quad \left. + (1 - n_{22} - n_{22}^*) w_{,yy} + 2(n_{26} - n_{26}^*) w_{,xy} \right] \\
M_{xy} &= -D \left[m_{61} U_{,yy} + m_{62} U_{,xx} - m_{66} U_{,xy} + (n_{16} - n_{16}^*) w_{,xx} \right. \\
&\quad \left. + (n_{26} - n_{26}^*) w_{,yy} + (1 - n_{66} - n_{66}^*) w_{,xy} \right]
\end{aligned} \tag{4.20}$$

These moments must now be expanded in the same manner as for U and w , i.e.

$$M_x = M_{x0} + k_{ij} M_{xkij} + l_{ij} M_{xlj} + m_{ij} M_{xmi} + n_{ij} M_{xni} + n_{ij}^* M_{xni}^*$$

Substitution of the expansions for M , U , and w into Eq (4.20) leads to the following sets of equations:

$$\begin{aligned}
M_{x_0} &= -D \left[w_{0,xx} + \nu_D w_{0,yy} \right] \\
M_{y_0} &= -D \left[w_{0,yy} + \nu_D w_{0,xx} \right] \\
M_{xy_0} &= -D \left[(1 - \nu_D) w_{0,xy} \right]
\end{aligned} \tag{4.21}$$

$$\begin{aligned}
M_{xm11} &= -D \left[w_{m11,xx} + \nu_D w_{m11,yy} + U_{0,yy} \right] \\
M_{ym11} &= -D \left[w_{m11,yy} + \nu_D w_{m11,xx} \right] \\
M_{xym11} &= -D \left[(1 - \nu_D) w_{m11,xy} \right]
\end{aligned} \tag{4.22}$$

$$\begin{aligned}
M_{xn11} &= -D \left[w_{n11,xx} + \nu_D w_{n11,yy} - w_{0,xx} \right] \\
M_{yn11} &= -D \left[w_{n11,yy} + \nu_D w_{n11,xx} \right] \\
M_{xyn11} &= -D \left[(1 - \nu_D) w_{n11,xy} \right]
\end{aligned} \tag{4.23}$$

Similar expressions may be written for the remaining sets of equations.

SPECIALIZATION OF THE PLATE EQUATIONS FOR PARTICULAR ORIENTATIONS

The two governing Eqs (3.12) and (3.13) can be specialized for certain orientations of the laminas composing the laminated plate. In the following, the discussion is restricted to plates composed of laminas of identical thickness. Two general cases will be discussed: pairwise orientation with symmetry about the middle surface and spiral orientation. Methods of solution associated with each of the cases are indicated, and wherever the equations have already been solved, the literature is cited.

PAIRWISE ORIENTATION WITH SYMMETRY ABOUT THE MIDDLE SURFACE

This classification refers to a laminated plate made from pairs of the same orthotropic laminas. The laminas are situated such that one lamina of a pair is at the same distance above as the other is below the middle surface (which is also taken as reference surface). The principal axes of both laminas of the pair also run in the same direction.

This orientation uncouples the in-plane and bending effects since D_{ij}^* always vanishes. Equations (3.12) and (3.13) reduce to

$$B_{22} U_{,xxxx} - 2B_{26} U_{,xxxxy} + (B_{66} + 2B_{12}) U_{,xxyyy} - 2B_{16} U_{,xyyyy} + B_{11} U_{,yyyy} = 0 \tag{4.24}$$

$$D_{11} w_{,xxxx} + 4D_{16} D_{,xxxxy} + (2D_{12} + 4D_{66}) w_{,xxyy} + 4D_{26} w_{,xyyy} + D_{22} w_{,yyyy} = q(x,y) \quad (4.25)$$

Thus, the laminated plate is equivalent to a homogeneous anisotropic plate.

Further reduction of the A_{ij} is possible by having two pairs of laminae situated so that there exists symmetry about one of the coordinate axes (hence about both since the material considered here is orthotropic). In this case, which shall be called pairwise equiangular orientation, A_{16} and A_{26} are annihilated, thus B_{16} and B_{26} vanish in Eq (4.24). The equations in this case are orthotropic in the in-plane forces and anisotropic in bending.

A special case of the above, when all the pairs are either at plus or minus 45° from a coordinate axis, further reduces the equations. The elastic coefficients become

$$\begin{aligned} \bar{C}_{11} &= \bar{C}_{22} = \frac{1}{4} \left[C_{11} + C_{22} + 2C_{12} + 4C_{66} \right] \\ \bar{C}_{12} &= \frac{1}{4} \left[C_{11} + C_{22} + 2C_{12} - 4C_{66} \right] \\ \bar{C}_{16} &= \bar{C}_{26} = \pm \left[C_{22} - C_{11} \right] \quad \begin{array}{l} + \text{ for } + 45^\circ \\ - \text{ for } - 45^\circ \end{array} \\ \bar{C}_{66} &= \frac{1}{4} \left[C_{11} - 2C_{12} + C_{22} \right] \end{aligned}$$

The corresponding elastic constants associated with the plate problem reduce to

$$\begin{aligned} A_{11} &= A_{22} & A_{16} &= A_{26} = 0 \\ B_{11} &= B_{22} & B_{16} &= B_{26} = 0 \\ D_{11} &= D_{22} & D_{16} &= D_{26} \end{aligned}$$

Equations (4.24) and (4.25) become:

$$B_{11} U_{,xxxx} + (B_{66} + 2B_{12}) U_{,xxyy} + B_{11} U_{,yyyy} = 0 \quad (4.26)$$

$$D_{11} w_{,xxxx} + 4D_{16} w_{,xxxxy} + (2D_{12} + 4D_{66}) w_{,xxyy} + 4D_{26} w_{,xyyy} + D_{11} w_{,yyyy} = q(x,y) \quad (4.27)$$

These equations describe a special form of plate, orthotropic in the in-plane effect and anisotropic in bending.

Another similar special case when all the pairs are running either parallel or perpendicular to the coordinate axes permits simplification of the equations. The elastic coefficients in this case are

$$\bar{C}_{11} = C_{11} \cos^4 \theta + C_{22} \sin^4 \theta$$

$$\bar{C}_{22} = C_{11} \sin^4 \theta + C_{22} \cos^4 \theta$$

$$\bar{C}_{66} = C_{66}$$

$$\bar{C}_{12} = C_{12}$$

θ in this case is either 0° or 90° . All the A_{ij} and D_{ij} survive except the ones with subscripts 16 and 26. Consequently B_{16} and B_{26} also vanish. The governing equations here are

$$B_{22} U_{,xxxx} + (B_{66} + 2B_{12}) U_{,xxyy} + B_{11} U_{,yyyy} = 0 \quad (4.28)$$

$$D_{11} w_{,xxxx} + (2D_{12} + 4D_{66}) w_{,xxyy} + D_{22} w_{,yyyy} = q(x,y) \quad (4.29)$$

These equations describe a plate which is orthotropic in both in-plane and bending effects. Furthermore, if there are the same number of pairs in both directions, then $A_{11} = A_{22}$ and $B_{11} = B_{22}$; so that Eq (4.28) becomes the same as Eq (4.26).

Several authors have dealt with equations of the same form as Eqs (4.24) and (4.25) in connection with particular problems. Green (11) exhibited the method of solution to these equations in connection with an aeolotropic single-layer plate subjected to in-plane forces. Lekhnitskii (12), (13) also solved the same pair of equations. Both these authors used a technique involving complex variable theory. Pell (14) solved a problem of thermal stresses in a thin anisotropic plate. Luxenberg (15) solved a problem of the torsion of an anisotropic plate. Both of these problems were governed by an equation of the same form as Eq (4.25). Other authors, for example Green and Taylor (16) (17), Green (18, 19), Fridman (20), Okubu (21), Morris (22), have dealt with equations of the form of Eqs (4.28) and (4.29). They essentially used the same method as that used by Green and Lekhnitskii. Girkmann (23) discusses the solution to Eq (4.29) using a double Fourier Series in connection with an orthotropic single-layer plate; his method will be discussed in Section 7 of this report.

When the equations are of the form of Eqs (4.24) and (4.25), the distribution of stress near a hole in an infinite laminated anisotropic plate can be calculated using the technique presented by Savin (24) or, for the case of a circular hole in a laminated plate which behaves orthotropically, those presented by Green and Taylor(17). Savin extended the Muskhelishvili method for the solution of plane elasticity problems to solve the anisotropic plane problem for an infinite plate. Since in the absence of transverse loads, the differential equations for the plate and for plane elasticity are of the same form, the method is applicable to both

cases. The determination of general expressions for stresses is not practical since the stresses are determined from only the real part of the complex potentials which comprise the solution.

SPIRAL ORIENTATION

This classification refers to a layered plate made of laminas such that the elastic axes are distributed in the form of a spiral. Only the case denoted as equiangular spiral orientation will be discussed since all other cases are too complicated to be investigated on a general level. The equiangular spiral orientation describes a plate formed by alternating succeeding laminas from the middle surface at equal but opposite angles (one positive and one negative) from a coordinate axis. Each succeeding pair must have a larger angle than the previous pair. For this case all the A_{ij} and D_{ij} survive except those with subscripts 16 and 26. All the D_{ij}^* are annihilated except for the ones with subscripts 16 and 26. The determinative equations become

$$B_{22} U_{,xxxx} + (B_{66} + 2B_{12}) U_{,xxyy} + B_{11} U_{,yyyy} + \left[D_{16}^* (2B_{12} - B_{66}) + 2D_{26}^* B_{22} \right] w_{,xxyy} + \left[2D_{16}^* B_{11} + D_{26}^* (2B_{12} - B_{66}) \right] w_{,xyyy} = 0 \quad (4.30)$$

$$\left[D_{16}^* (2B_{12} - B_{66}) + 2D_{26}^* B_{22} \right] U_{,xxyy} + \left[2D_{16}^* B_{11} + D_{26}^* (2B_{12} - B_{66}) \right] U_{,xyyy} - D_{11} w_{,xxxx} + \left[D_{16}^* D_{26}^* (8B_{12} + 2B_{66}) + 4D_{16}^{*2} B_{11} + 4D_{26}^{*2} B_{22} - (2D_{12} + 4D_{66}) \right] w_{,xxyy} - D_{22} w_{,yyyy} = -q \quad (4.31)$$

These equations are partly coupled since both dependent variables appear in the equations.

The solutions to Eqs (4.30) and (4.31) may be found by raising the order of the differential equations up to the eighth order as was discussed in the beginning of this section.

SPECIALIZATION OF THE CYLINDRICAL SHELL EQUATIONS FOR PARTICULAR ORIENTATIONS

The two determinative Eqs (2.16) and (2.17) can be specialized for certain orientations of the laminas composing the layered shell. The following discussion will be restricted to cylindrical shells composed of laminas of the same thickness. Suppose that the laminas are situated such that one lamina of a pair is at the same distance above as the other is below the middle surface of the shell (now taken as the reference surface). Both laminas have the same orientation of their principal elastic axes. In this instance, the D_{ij}^* always vanish. Accordingly, Eqs (2.16) and (2.17) reduce to

$$B_{22} U_{,xxxx} - 2B_{26} U_{,xxyy} + (B_{66} + 2B_{12}) U_{,xxyy} - 2B_{16} U_{,xyyy} + B_{11} U_{,yyyy} - \frac{1}{a} w_{,xx} = 0 \quad (4.32)$$

$$\begin{aligned}
& D_{11} w_{,xxxx} + 4D_{16} w_{,xxxy} + 2(D_{12} + 2D_{66}) w_{,xxyy} + 4D_{26} w_{,xyyy} \\
& + D_{22} w_{,yyyy} + \frac{1}{a} U_{,xx} = q_z
\end{aligned} \tag{4.33}$$

In the above we have set

$$\frac{1}{a} \frac{\partial}{\partial \varphi} = \frac{\partial}{\partial y}$$

These equations indicate that the laminated shell is equivalent to a homogeneous anisotropic shell. Further simplification is possible by having two pairs of laminae situated so that there exists symmetry about the coordinate axes x, y . In this case (called pairwise equiangular orientation) $A_{16} = A_{26} = 0$, thus $B_{16} = B_{26} = 0$ in Eq (4.32). A further specialization results if all pairs are situated at plus or minus 45 degrees from the coordinate axes. In this instance

$$\begin{aligned}
A_{11} &= A_{22} & A_{16} &= A_{26} = 0 \\
B_{11} &= B_{22} & B_{16} &= B_{26} = 0 \\
D_{11} &= D_{22} & D_{16} &= D_{26}
\end{aligned}$$

Another special case arises when all pairs are situated either parallel or perpendicular to the coordinate axes. The governing equations here take the form

$$B_{22} U_{,xxxx} + (B_{66} + 2B_{12}) U_{,xxyy} + B_{11} U_{,yyyy} - \frac{1}{a} w_{,xx} = 0 \tag{4.34}$$

$$D_{11} w_{,xxxx} + 2(D_{12} + 2D_{66}) w_{,xxyy} + D_{22} w_{,yyyy} + \frac{1}{a} U_{,xx} = q_z \tag{4.35}$$

These equations describe a laminated cylindrical shell which is orthotropic in both in-plane and bending effects.

Equations (4.32) and (4.33), or the specializations discussed subsequently, are of the general form

$$L_1 U - \frac{1}{a} w_{,xx} = 0 \tag{4.36}$$

$$\frac{1}{a} U_{,xx} + L_2 w = q_z \tag{4.37}$$

where L_1 and L_2 are fourth order linear differential operators in x, y . Special forms of the operators occur for particular orientations of the laminae as described. A method of solving equations of this type has been suggested by

$$D_{11} w,_{xxxx} + 4D_{16} w,_{xxyy} + 2(D_{12} + 2D_{66}) w,_{xyyy} + 4D_{26} w,_{xyyy} + D_{22} w,_{yyyy} + \frac{1}{a} U,_{xx} = q_z \quad (4.33)$$

In the above we have set

$$\frac{1}{a} \frac{\partial}{\partial \phi} = \frac{\partial}{\partial y}$$

These equations indicate that the laminated shell is equivalent to a homogeneous anisotropic shell. Further simplification is possible by having two pairs of laminae situated so that there exists symmetry about the coordinate axes x, y . In this case (called pairwise equiangular orientation) $A_{16} = A_{26} = 0$, thus $B_{16} = B_{26} = 0$ in Eq (4.32). A further specialization results if all pairs are situated at plus or minus 45 degrees from the coordinate axes. In this instance

$$\begin{aligned} A_{11} &= A_{22} & A_{16} &= A_{26} = 0 \\ B_{11} &= B_{22} & B_{16} &= B_{26} = 0 \\ D_{11} &= D_{22} & D_{16} &= D_{26} \end{aligned}$$

Another special case arises when all pairs are situated either parallel or perpendicular to the coordinate axes. The governing equations here take the form

$$B_{22} U,_{xxxx} + (B_{66} + 2B_{12}) U,_{xxyy} + B_{11} U,_{yyyy} - \frac{1}{a} w,_{xx} = 0 \quad (4.34)$$

$$D_{11} w,_{xxxx} + 2(D_{12} + 2D_{66}) w,_{xxyy} + D_{22} w,_{yyyy} + \frac{1}{a} U,_{xx} = q_z \quad (4.35)$$

These equations describe a laminated cylindrical shell which is orthotropic in both in-plane and bending effects.

Equations (4.32) and (4.33), or the specializations discussed subsequently, are of the general form

$$L_1 U - \frac{1}{a} w,_{xx} = 0 \quad (4.36)$$

$$\frac{1}{a} U,_{xx} + L_2 w = q_z \quad (4.37)$$

where L_1 and L_2 are fourth order linear differential operators in x, y . Special forms of the operators occur for particular orientations of the laminae as described. A method of solving equations of this type has been suggested by

Vlasov (7). Assume the existence of a function $\Phi(x, y)$ defined such that

$$U = + \frac{1}{a} \Phi,_{xx} \quad (4.38)$$

$$w = L_1 \Phi$$

When Eq (4.38) is substituted into Eqs (4.36) and (4.37), the first equation is identically satisfied, and the second equation takes the form

$$L_1 L_2 \Phi + \frac{1}{a^2} \Phi,_{xxxx} = q_z \quad (4.39)$$

Stress-resultants, stress-couples or reference surface strains can be expressed in terms of Φ in a straight-forward manner.

For the case of a laminated orthotropic cylindrical shell, Eqs (4.34) and (4.35) are replaced by Eq (4.39) where L_1, L_2 take the form

$$L_1 = B_{22} ()_{,xxxx} + (B_{66} + 2B_{12}) ()_{,xxyy} + B_{11} ()_{,yyyy} \quad (4.40)$$

$$L_2 = D_{11} ()_{,xxxx} + 2(D_{12} + 2D_{66}) ()_{,xxyy} + D_{22} ()_{,yyyy}$$

Finally, for an isotropic shell,

$$L_1 = \frac{1}{Eh} \nabla^4 \quad (4.41)$$

$$L_2 = \frac{Eh^3}{12(1-\nu^2)} \nabla^4$$

where

$$\nabla^4 = ()_{,xxxx} + 2()_{,xxyy} + ()_{,yyyy}$$

And Eq (4.39) takes the well-known form

$$\nabla^8 \Phi + \frac{12(1-\nu^2)}{a^2 h^2} \Phi,_{xxxx} = q_z \quad (4.42)$$

where E, ν are modulus of elasticity and Poisson's ratio and h the plate thickness.

PART II: APPLICATIONS OF PLATE THEORY

INTRODUCTION

Several applications of the general theory for laminated anisotropic plates are discussed in this part. First, the equations of the plate theory are modified for the cylindrical bending and extension of long rectangular plates so that solutions may be obtained by integration or by transposition of known solutions from beam theory. One example is given to illustrate a step by step method of obtaining the elastic constants for a plate. Next, solutions are obtained by determining the edge loads which will cause the deflected surface to become a prescribed quadratic surface. The following examples are given: uniform tension, pure shear, uniform bending about one axis, and pure twist. As discussed under methods of solution, for certain orientations the general equations reduce to those of orthotropic plate theory. The solution for the uniformly-loaded simply-supported rectangular plate is presented. As illustrations of the solution of general equations by the perturbation method, three examples are given: the clamped circular plate (for which an exact solution can also be obtained), the simply-supported rectangular plate, and the rectangular plate simply supported on two opposite edges and clamped on the other two edges. Finally, the problem of obtaining the optimum arrangement and orientation of the layers so as to minimize the deflection in rectangular plates is discussed.

5. WEAK CYLINDRICAL BENDING AND EXTENSION OF A LONG
RECTANGULAR LAMINATED PLATE OF ORTHOTROPIC MATERIALS

A class of problems which deserves attention is that of extensional and flexural behavior of a long rectangular laminated plate composed of orthotropic material. When such a plate is loaded by a system of forces which does not vary in the y -direction, the deflected surface at some distance from the ends is cylindrical (i.e., it is also independent of y). Therefore, the displacement v is zero and the displacements u and w are independent of y . The plate may be investigated by studying a typical elemental strip bounded by two planes $y = \text{const.}$ (Figure 5.1). In essence the problem becomes one-dimensional, and the deflection curve resembles that of a deflected beam.

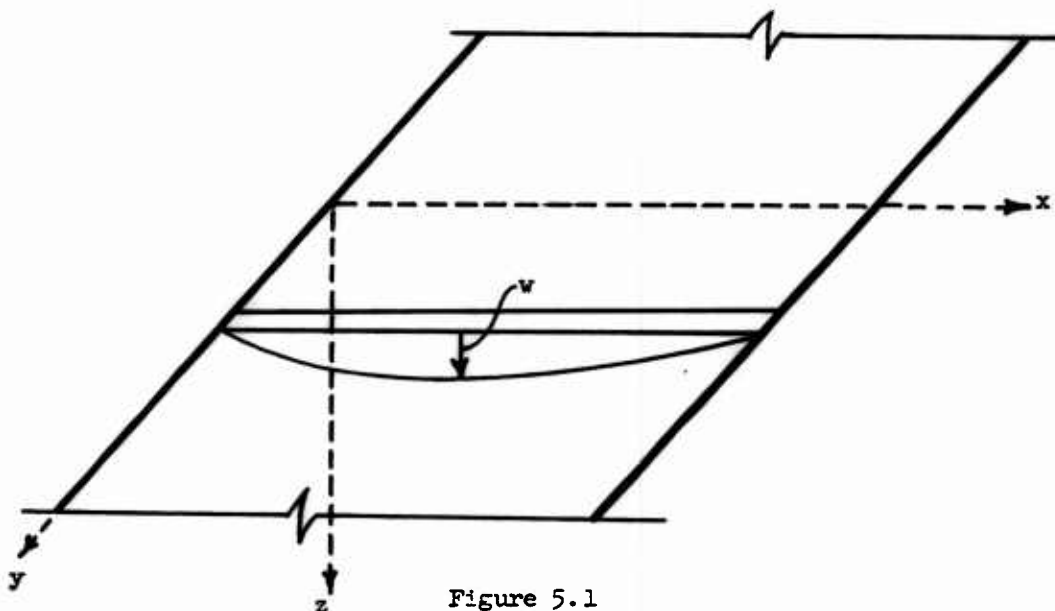

Figure 5.1

As a consequence of the type of displacements, $\epsilon_y = 0$ and $\gamma_{xy} = 0$. The stress-strain relations given by Eq (1.6) simplify considerably for the elemental plate strip.

$$\begin{aligned}\sigma_x^{(i)} &= \bar{c}_{11}^{(i)} \epsilon_x \\ \sigma_y^{(i)} &= \bar{c}_{12}^{(i)} \epsilon_x = \frac{\bar{c}_{12}^{(i)}}{\bar{c}_{11}^{(i)}} \sigma_x^{(i)} \\ \tau_{xy}^{(i)} &= \bar{c}_{16}^{(i)} \epsilon_x = \frac{\bar{c}_{16}^{(i)}}{\bar{c}_{11}^{(i)}} \sigma_x^{(i)}\end{aligned}\tag{5.1}$$

Corresponding simplification of the expressions for the stress-resultants and stress-couples may be seen. Equations (3.4) and (3.5) become:

$$\begin{aligned} N_x &= A_{11} u_{0,x} - D_{11}^* w_{,xx} \\ N_y &= A_{12} u_{0,x} - D_{12}^* w_{,xx} \\ N_{xy} &= A_{16} u_{0,x} - D_{16}^* w_{,xx} \end{aligned} \quad (5.2)$$

$$\begin{aligned} M_x &= D_{11}^* u_{0,x} - D_{11} w_{,xx} \\ M_y &= D_{12}^* u_{0,x} - D_{12} w_{,xx} \\ M_{xy} &= D_{16}^* u_{0,x} - D_{16} w_{,xx} \end{aligned} \quad (5.3)$$

For this plate strip, the differential equations for the transverse deflection w and the in-plane displacement u_0 can be uncoupled. Two general cases of loading will be discussed: weak cylindrical bending and uniaxial extension.

WEAK CYLINDRICAL BENDING OF A PLATE STRIP

Consider a simply supported plate strip of length L . The origin of the coordinate system is located at the left hand side of the plate strip. The x - y plane lies in the reference surface of the plate; the x and z axes are directed to the right and downward, respectively, as shown in Figure 5.2. This plate strip is loaded by an arbitrary system of transverse forces and moments M_1 and M_2 at the ends. The in-plane force N_x is taken to be zero.

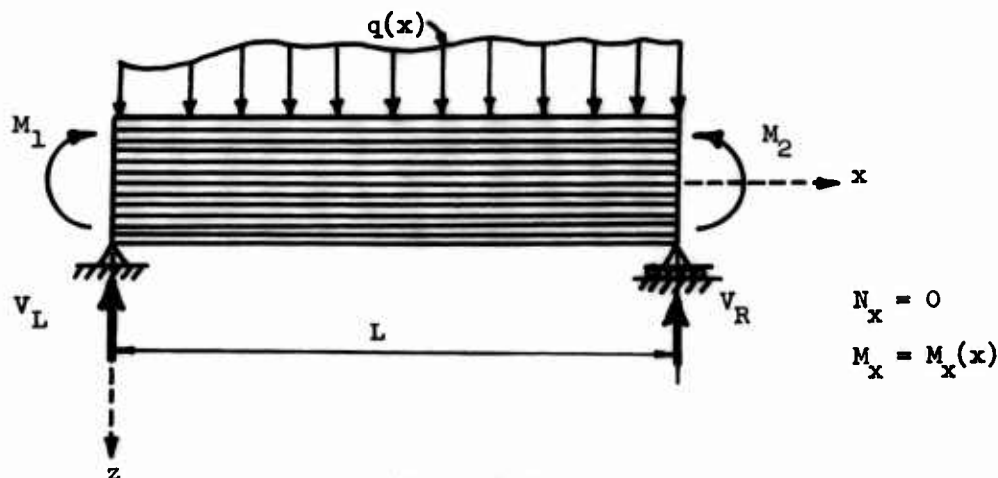

Figure 5.2

Under the action of the external loads, the plate strip deflects. The deflection curve can be determined in the following manner. Since K_x is zero, by setting the first of Eq (5.2) equal to zero, the following relation between u_0 and w is obtained.

$$u_0 = \frac{D_{11}^*}{A_{11}} w,_{xx} \quad (5.4)$$

Substitution of the above equation into the first of Eq (5.3) gives

$$w,_{xx} = \left[\frac{A_{11}}{(D_{11}^*)^2 - A_{11} D_{11}} \right] M_x(x) \quad (5.5)$$

Equation (5.5) is the governing differential equation for the deflection curve w and Eq (5.4) is the associated differential equation for the in-plane reference surface displacement u_0 . Equation (5.5) is of the same form as the equation for the deflection of an isotropic beam. Only the flexural rigidities are different.

The quantity $\frac{(D_{11}^*)^2 - A_{11} D_{11}}{A_{11}}$ replaces the usual flexural rigidity EI of the isotropic beam. Therefore, transposition of known solutions for isotropic beams with the corresponding loading conditions is possible. The solution may also be obtained by double integration if the expression for $M_x(x)$ is known.

The solution to Eq (5.4) may be obtained by direct integration

$$u_0(x) = \frac{D_{11}^*}{(D_{11}^*)^2 - A_{11} D_{11}} \int_0^x M(\xi) d\xi + k \quad (5.6)$$

The constant k is to be evaluated from a prescribed boundary condition. The boundary condition for u_0 can, however, be arbitrarily selected since it represents only a point from which the displacement is measured. Only the derivative $u_{0,x}$ which is the in-plane strain is of any interest in this problem. Therefore, let the boundary condition be taken as

$$u_0\left(\frac{L}{2}\right) = \frac{D_{11}^*}{(D_{11}^*)^2 - A_{11} D_{11}} \int_0^{\frac{L}{2}} M(\xi) d\xi + k = 0 \quad (5.7)$$

or

$$k = - \frac{D_{11}^*}{(D_{11}^*)^2 - A_{11} D_{11}} \int_0^{\frac{L}{2}} M(\xi) d\xi \quad (5.8)$$

Thus far the problem has proceeded as for the case of the cylindrical bending of a single-layer isotropic plate strip except for the different flexural rigidities. Now, however, unlike the single-layer isotropic plate strip, which requires only a transverse bending moment M_y to maintain the cylindrical deflection surface during bending, additional force and moment components (M_{xy} , N_y , N_{xy}) must be present to preserve the cylindrical surface for the laminated anisotropic plate strip. Unless these forces and moments are developed at the supports, the deflected surface will not remain cylindrical and warpage will occur along the y -direction. These forces and moments may be computed from Eqs (5.2) and (5.3). The stresses may be computed from Eq (3.13a).

UNIAXIAL EXTENSION

Consider the same simply supported plate strip with the coordinate system as shown in Figure 5.3. At the ends of this plate strip an in-plane extensional force of magnitude N is applied. The bending moment M_x is taken to be zero in this case.

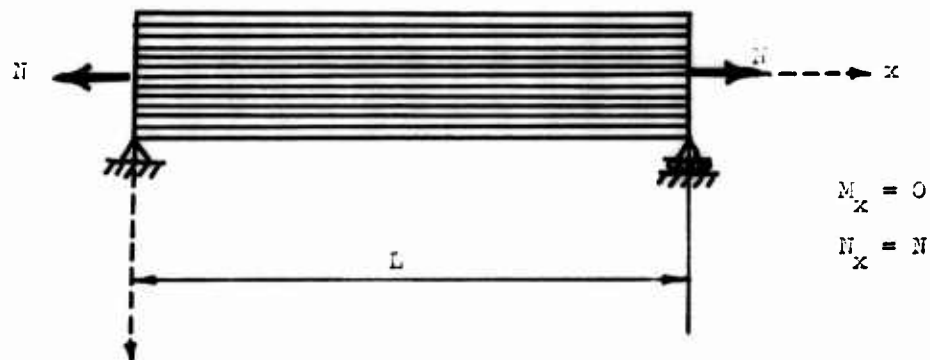

Figure 5.3

Because this force is applied at the reference surface (which is also the surface of the coordinate plane x - y), the plate strip will not only elongate but also may bend. This behavior occurs because the applied force may not coincide with the centroid for a tensile or compressive force (the point at which an axial force causes no bending) on this section. The deflection curve and the extension can be determined in a manner analogous to that used in the previous case. The first of Eq (5.3) is set equal to zero, from which

$$u_{0,x} = \frac{D_{11}}{D_{11}^*} w_{,xx} \quad (5.12)$$

Substituting Eq (5.12) into the first of Eq (5.2) gives the differential equation of the deflection curve w .

$$w,_{xx} = \left[\frac{D_{11}^*}{A_{11} D_{11} - (D_{11}^*)^2} \right] N \quad (5.13)$$

Again Eq (5.13) is of the same form as the equation for the deflection of an isotropic beam. Only the flexural rigidities are different. By replacing EI of the beam equation with $\frac{A_{11} D_{11} - (D_{11}^*)^2}{D_{11}^*}$ for the anisotropic laminated plate, known solutions from beam theory for corresponding loadings may be used.

The solution to Eq (5.12) is obtained by direct integration:

$$u_0(x) = \int \frac{D_{11}^* N}{A_{11} D_{11} - (D_{11}^*)^2} dx + k \quad (5.14)$$

Let the boundary condition for the evaluation of constant k be arbitrarily selected as

$$u_0(0) = -k_1 \quad (5.15)$$

The reason for such a specification will be apparent shortly. Therefore k is given by

$$k = k_1 \quad (5.16)$$

To maintain a flat surface during extension, a bending moment must be applied to cancel the deflection caused by the in-plane extensional force acting at the reference surface. Application of this bending moment may be thought of as the transfer of the applied force from the reference surface to the centroid for tension-compression of this section as shown in Figure 5.4.

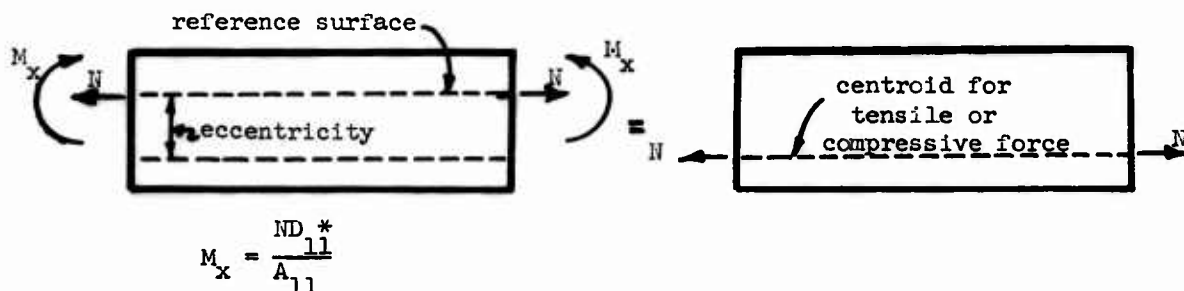

Figure 5.4

To remove the deflection curve, a moment of magnitude $M_x = \frac{N D_{11}^*}{A_{11}}$ is applied at the ends. Superposing both solutions of w then gives the condition of a flat plate.

$$w(x) = w_{\text{ext}}(x) + w_{\text{bend}}(x) = 0 \quad (5.17)$$

and

$$u_{\text{obend}}(x) = \left[\frac{D_{11}^* N}{A_{11} [(D_{11}^*)^2 - A_{11} D_{11}]} \right] x + k \quad (5.18)$$

The boundary condition for u_{obend} is taken as

$$u_{\text{obend}}(0) = k_1 \quad (5.19)$$

so that for the complete problem the displacement u_0 at $x = 0$ is zero. Therefore

$$k_{\text{bend}} = k_1 \quad (5.20)$$

and

$$u_{\text{obend}}(x) = \left[\frac{N (D_{11}^*)^2}{A_{11} [(D_{11}^*)^2 - D_{11} A_{11}]} \right] x + k \quad (5.21)$$

The superposition of $u_0(x)$ for extension and $u_0(x)$ for bending gives

$$u_0(x) = \frac{N}{A_{11}} x \quad (5.22)$$

As was mentioned previously the transfer of the in-plane extensional force to the centroid for tension-compression of this particular section gives the same result. The eccentricity of this centroid from the reference surface is given by the formula

$$\text{ecc}_{N_x} = \frac{M}{N} = \frac{D_{11}^*}{D_{11}} \quad (5.23)$$

When the load is applied at the centroid, no bending will occur.

As for the previous case of cylindrical bending, additional restraining forces and moments must be developed at the supports to prevent warpage along the y-direction. These quantities are again computed from Eqs (5.2) and (5.3) Stresses are given by Eq (3.18a).

Table I is a summary of the cylindrical bending and uniaxial extension problems.

TABLE 1: Summary of Cylindrical Bending and Uniaxial Extension Problems



	Cylindrical Bending	Uniaxial Extension
Sketch		
Boundary Conditions	$w(0) = w(L) = 0$ $u(\frac{L}{2}) = 0$	$w(0) = w(L) = 0$ $u(0) = 0$
$N_x(x)$	0	N
$M_x(x)$	$M_x(x)^*$	0
Remarks	Moment is applied about the reference surface.	Force is applied at distance $D_{11}^* D_{11}$ from reference surface.
N_y	$\left[\frac{A_{12} D_{11}^* - A_{11} D_{12}^*}{(D_{11}^*)^2 - A_{11} D_{11}} \right] M_x(x)$	$\frac{A_{12} N}{A_{11}}$
N_{xy}	$\left[\frac{A_{16} D_{11}^* - A_{11} D_{16}^*}{(D_{11}^*)^2 - A_{11} D_{11}} \right] M_x(x)$	$\frac{A_{16} N}{A_{11}}$
M_y	$\left[\frac{D_{11}^* D_{12}^* - A_{11} D_{12}}{(D_{11}^*)^2 - A_{11} D_{11}} \right] M_x(x)$	$\frac{D_{12}^* N}{D_{11}}$
M_{xy}	$\left[\frac{D_{11}^* D_{16}^* - A_{11} D_{16}}{(D_{11}^*)^2 - A_{11} D_{11}} \right] M_x(x)$	$\frac{D_{16}^* N}{D_{11}}$

TABLE 1: (cont.)

	Cylindrical Bending	Uniaxial Extension
$\sigma_x^{(k)}$	$\frac{M_x(x)}{(D_{11}^*)^2 - A_{11}D_{11}} \left[T_{12}^{(k)}(A_{12}D_{11}^* - A_{11}D_{12}^*) \right. \\ \left. + T_{16}^{(k)}(A_{16}D_{11}^* - A_{11}D_{16}^*) + (t_{11}^{(k)} - z\bar{c}_{11}^{(k)})A_{11} \right]$	$N \left[T_{11}^{(k)} + T_{12}^{(k)} \frac{A_{12}}{A_{11}} + T_{16}^{(k)} \frac{A_{16}}{A_{11}} \right]$
$\sigma_y^{(k)}$	$\frac{M_x(x)}{(D_{11}^*)^2 - D_{11}A_{11}} \left[T_{22}^{(k)}(A_{12}D_{11}^* - A_{11}D_{12}^*) \right. \\ \left. + T_{26}^{(k)}(A_{16}D_{11}^* - A_{11}D_{16}^*) + (t_{21}^{(k)} - z\bar{c}_{12}^{(k)})A_{11} \right]$	$N \left[T_{21}^{(k)} + T_{22}^{(k)} \frac{A_{12}}{A_{11}} + T_{26}^{(k)} \frac{A_{16}}{A_{11}} \right]$
$\tau_{xy}^{(k)}$	$\frac{M_x(x)}{(D_{11}^*)^2 - A_{11}D_{11}} \left[T_{62}^{(k)}(A_{12}D_{11}^* - A_{11}D_{12}^*) \right. \\ \left. + T_{66}^{(k)}(A_{16}D_{11}^* - A_{11}D_{16}^*) + (t_{61}^{(k)} - z\bar{c}_{16}^{(k)})A_{11} \right]$	$N \left[T_{61}^{(k)} + T_{62}^{(k)} \frac{A_{12}}{A_{11}} + T_{66}^{(k)} \frac{A_{16}}{A_{11}} \right]$

* see Steel Construction - Manual of the A.I.S.C., Fifth Ed., pp. 366 ff.

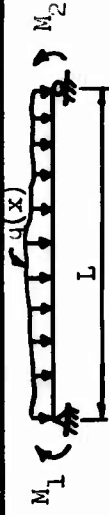
SUPERPOSITION OF SOLUTIONS

Many problems with different loadings and different support conditions may be found by superposing the previous cases. As an example, consider the following plate strip shown in Figure 5.5.

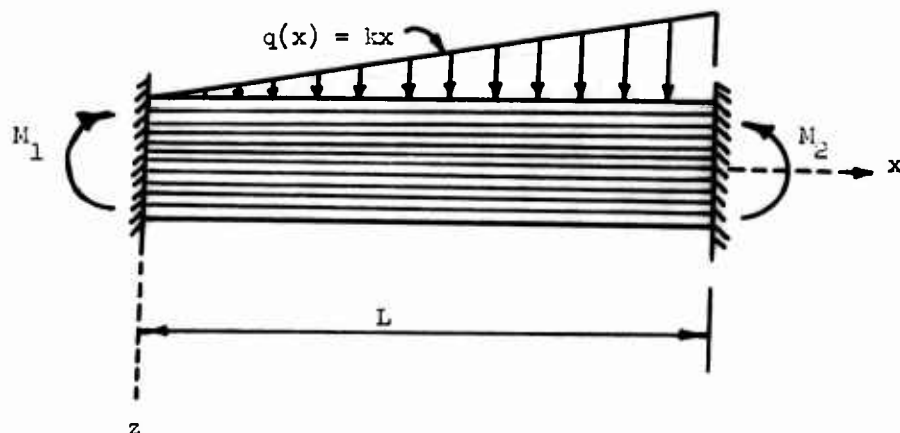

Figure 5.5

This problem may be solved by superposing the cases of a transversely loaded plate strip and bending by unequal moments. The bending moment for the bending problem is

$$M_x(x) = M_1 + \left(\frac{M_2 - M_1}{L}\right) x$$

The bending moment for the triangularly loaded plate strip is

$$M_x(x) = \frac{kL^2 x}{6} - \frac{kx^3}{6}$$

$w(x)$ for both cases can be obtained by double integration. Then these two solutions must be superposed in such a way that

$$w_{,x}(0) = 0 \quad \text{and} \quad w_{,x}(L) = 0$$

These two conditions determine the magnitudes of M_1 and M_2 .

$$w_{,x}(0) = - (M_2 + 2M_1) \frac{L}{6} - \frac{7kL^4}{360} = 0$$

$$w, x(L) = \frac{kL^4}{45} + \frac{M_1 L}{6} + \frac{M_2 L}{3} = 0$$

Solving these two equations gives

$$M_1 = -\frac{kL^3}{30}, \quad M_2 = -\frac{kL^3}{20}$$

Note that these end moments are the same as that for the isotropic beam of the same loading and boundary condition. Thus the solution could also have been obtained by transposition of the isotropic beam solution.

EXAMPLE OF A PLATE OF 12 ORTHOTROPIC LAMINAS WITH SPIRAL ORIENTATION

Consider a 12 layer laminated plate of spiral orientation. Each lamina has thickness h and is oriented such that the principal elastic axes are at either $+45^\circ$ or -45° with the coordinate axes. Let the reference surface be between the 6th and 7th layers as shown in Figure 5.6.

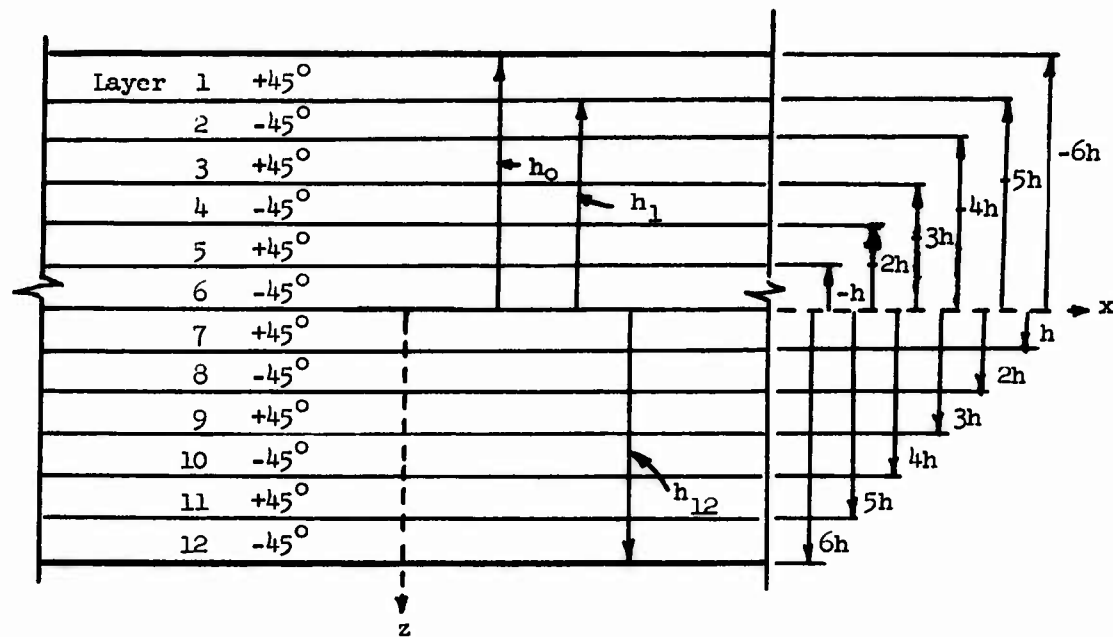

Figure 5.6

In this example let the four independent parameters be $E = E$, $k = 1.2$, $\nu = 0.3$, and $\lambda = 0.42$. The principal elastic constants are $C_{11} = 1.121E$, $C_{22} = 1.345E$, $C_{12} = 0.404E$ and $C_{66} = 0.471E$. The elastic constants \bar{C}_{ij} for the

rotated axes are computed using Eq (1.12).

$$\begin{array}{l} \text{For a lamina at } +45^\circ \\ \bar{C}_{ij} = E \begin{bmatrix} 1.29 & 0.35 & 0.06 \\ 0.35 & 1.29 & 0.06 \\ 0.06 & 0.06 & 0.41 \end{bmatrix} \end{array} \qquad \begin{array}{l} \text{For a lamina at } -45^\circ \\ \bar{C}_{ij} = E \begin{bmatrix} 1.29 & 0.35 & -0.06 \\ 0.35 & 1.29 & -0.06 \\ -0.06 & -0.06 & 0.41 \end{bmatrix} \end{array}$$

The coefficients A_{ij} , D_{ij}^* , and D_{ij} are computed from Eq (1.30) as shown in Table 2 and may be summarized as follows:

$$A_{ij} = Eh \begin{bmatrix} 15.48 & 4.20 & 0 \\ 4.20 & 15.48 & 0 \\ 0 & 0 & 4.92 \end{bmatrix}$$

$$D_{ij}^* = Eh^2 \begin{bmatrix} 0 & 0 & -0.36 \\ 0 & 0 & -0.36 \\ -0.36 & -0.36 & 0 \end{bmatrix}$$

$$D_{ij} = Eh^3 \begin{bmatrix} 185.76 & 50.44 & 0 \\ 50.44 & 185.76 & 0 \\ 0 & 0 & 59.08 \end{bmatrix}$$

With A_{ij} , D_{ij}^* , and D_{ij} known, B_{ij} , b_{ij} , $T_{ij}^{(i)}$, and $t_{ij}^{(i)}$ can be computed from Eqs (2.11), (2.13), (2.20), and (2.21).

$$B_{ij} = \frac{1}{Eh} \begin{bmatrix} 0.0697 & -0.0189 & 0 \\ -0.0189 & 0.0697 & 0 \\ 0 & 0 & 0.203 \end{bmatrix}$$

$$b_{ij} = h \begin{bmatrix} 0 & 0 & -0.073 \\ 0 & 0 & -0.073 \\ -0.018 & -0.018 & 0 \end{bmatrix}$$

$$T_{ij}^{(i)} = \frac{1}{h} \begin{pmatrix} 0.083 & 0.000+ & \pm 0.012 \\ 0.000+ & 0.083 & \pm 0.012 \\ \pm 0.003 & \pm 0.003 & 0.083 \end{pmatrix}$$

$$t_{ij}^{(i)} = Eh \begin{pmatrix} \mp 0.001 & \mp 0.001 & -0.119 \\ \mp 0.001 & \mp 0.001 & -0.119 \\ -0.007 & -0.007 & \mp 0.009 \end{pmatrix}$$

In the case where there are two signs, the upper sign is for an odd numbered layer and the lower sign is for an even numbered layer.

Three cases of the rectangular laminated plate strip for this spiral orientation have been computed:

- (1) Cylindrical bending by a uniform moment.
- (2) Uniaxial extensions: Since the eccentricity, ecc_{N_x} , is zero for this particular location of the reference surface, no shifting of the applied force is necessary.
- (3) Uniformly loaded plate strip.

All the results are obtained by substituting these numerical values into Table 1. The final results are summarized in Table 3. Plots of the stress distributions are shown in Figure 5.7 and Figure 5.8.

TABLE 2: Computation of the Elastic Constants A_{ij} , D_{ij}^* , and D_{ij}

Layer No.	1	2	3	4	5	6	7	8	9	10	11	12	13
$\bar{C}_{11}^{(i)}$	1.29	1.29	1.29	1.29	1.29	1.29	1.29	1.29	1.29	1.29	1.29	1.29	1.29
$\bar{C}_{22}^{(i)}$	1.29E	1.29E	1.29E	1.29E	1.29E	1.29E	1.29E	1.29E	1.29E	1.29E	1.29E	1.29E	1.29E
$\bar{C}_{66}^{(i)}$	0.41E	0.41E	0.41E	0.41E	0.41E	0.41E	0.41E	0.41E	0.41E	0.41E	0.41E	0.41E	0.41E
$\bar{C}_{12}^{(i)}$	0.35E	0.35E	0.35E	0.35E	0.35E	0.35E	0.35E	0.35E	0.35E	0.35E	0.35E	0.35E	0.35E
$\bar{C}_{16}^{(i)}$	0.06E	0.06E	0.06E	0.06E	0.06E	0.06E	0.06E	0.06E	0.06E	0.06E	0.06E	0.06E	0.06E
$\bar{C}_{26}^{(i)}$	0.06E	0.06E	0.06E	0.06E	0.06E	0.06E	0.06E	0.06E	0.06E	0.06E	0.06E	0.06E	0.06E
h_i	-5h	-4	-3	-2	-1	0	1	2	3	4	5	6	7
h_{i-1}	-6	-5	-4	-3	-2	-1	0	1	2	3	4	5	6
$h_{i-1} h_{i-1-1}$	h	h	h	h	h	h	h	h	h	h	h	h	h
$\frac{h_i^2 - h_{i-1}^2}{2}$	-5.5h ²	-4.5	-3.5	-2.5	-1.5	-0.5	0.5	1.5	2.5	3.5	4.5	5.5	6.5
$\frac{h_i^3 - h_{i-1}^3}{3}$	30.33h ³	20.33	12.33	6.33	2.33	0.33	0.33	2.33	6.33	12.33	20.33	30.33	48.33
$\bar{C}_{11}^{(i)} (h_i - h_{i-1})$	2x10	1.29Eh	1.29	1.29	1.29	1.29	1.29	1.29	1.29	1.29	1.29	1.29	1.29
Σ													15.48Eh

A_{11}

TABLE 2: (cont.)

1	14	15	16	17	18	19
Layer No.	$\bar{c}_{22}^{(i)}(h_i - h_{i-1})$	$\bar{c}_{66}^{(i)}(h_i - h_{i-1})$	$\bar{c}_{12}^{(i)}(h_i - h_{i-1})$	$\bar{c}_{16}^{(i)}(h_i - h_{i-1})$	$\bar{c}_{26}^{(i)}(h_i - h_{i-1})$	$\bar{c}_{11}^{(i)} \frac{h_i^2 - h_{i-1}^2}{2}$
	3x10	4x10	5x10	6x10	7x10	2x11
1	1.29Eh	0.41Eh	0.35Eh	0.06Eh	0.06Eh	-7.10Eh ²
2	1.29	0.41	0.35	-0.06	-0.06	-5.91
3	1.29	0.41	0.35	0.06	0.06	-4.52
4	1.29	0.41	0.35	-0.06	-0.06	-3.22
5	1.29	0.41	0.35	0.06	0.06	-1.94
6	1.29	0.41	0.35	-0.06	-0.06	-0.65
7	1.29	0.41	0.35	0.06	0.06	0.65
8	1.29	0.41	0.35	-0.06	-0.06	1.94
9	1.29	0.41	0.35	0.06	0.06	3.22
10	1.29	0.41	0.35	-0.06	-0.06	4.52
11	1.29	0.41	0.35	0.06	0.06	5.91
12	1.29	0.41	0.35	-0.06	-0.06	7.10
Σ	15.48Eh	4.92Eh	4.20Eh	0	0	0
	A ₂₂	A ₆₆	A ₁₂	A ₁₆	A ₂₆	D ₁₁ *

TABLE 2: (cont.)

1	20	21	22	23	24	25
Layer No.	$\bar{C}_{22}^{(i)} \frac{h_i^2 - h_{i-1}^2}{2}$	$\bar{C}_{66}^{(i)} \frac{h_i^2 - h_{i-1}^2}{2}$	$\bar{C}_{12}^{(i)} \frac{h_i^2 - h_{i-1}^2}{2}$	$\bar{C}_{16}^{(i)} \frac{h_i^2 - h_{i-1}^2}{2}$	$\bar{C}_{26}^{(i)} \frac{h_i^2 - h_{i-1}^2}{2}$	$\bar{C}_{11}^{(i)} \frac{h_i^3 - h_{i-1}^3}{3}$
	3x11	4x11	5x11	6x11	7x11	2x12
1	-7.10En ²	-0.23En ²	-0.49En ²	-0.33En ²	-0.33En ²	39.13En ³
2	-5.91	-0.18	-0.16	0.27	0.27	26.23
3	-4.52	-0.14	-0.12	-0.21	-0.21	15.91
4	-3.22	-0.10	-0.09	0.15	0.15	8.17
5	-1.94	-0.06	-0.05	-0.09	-0.09	3.01
6	-0.65	-0.02	-0.02	0.03	0.03	0.43
7	0.65	0.02	0.02	0.03	0.03	0.43
8	1.94	0.06	0.05	-0.09	-0.09	3.01
9	3.22	0.10	0.09	0.15	0.15	8.17
10	4.52	0.14	0.12	-0.21	-0.21	15.91
11	5.91	0.18	0.16	0.27	0.27	26.23
12	7.10	0.23	0.19	-0.33	-0.33	39.13
Σ	0	0	0	-0.36En ²	-0.36En ²	185.76En ³
	D ₂₂ *	D ₆₆ *	D ₁₂ *	D ₁₆ *	D ₂₆ *	D ₁₁

TABLE 1: (cont.)

1	26	27	28	29	30
Layer No.	$\bar{c}_{22}^{(1)}$	$\bar{c}_{66}^{(1)}$	$\bar{c}_{12}^{(1)}$	$\bar{c}_{16}^{(1)}$	$\bar{c}_{26}^{(1)}$
	$\frac{h^3-h^3_i}{3}$	$\frac{h^3-h^3_i}{3}$	$\frac{h^3-h^3_i}{3}$	$\frac{h^3-h^3_i}{3}$	$\frac{h^3-h^3_i}{3}$
	3x12	4x12	5x12	6x12	7x12
1	$39.13Eh^3$	$12.44Eh^3$	$10.62Eh^3$	$1.82Eh^3$	$1.82Eh^3$
2	26.23	8.34	7.12	-1.22	-1.22
3	15.91	5.06	4.32	0.74	0.74
4	8.17	2.60	2.22	-0.38	-0.38
5	3.01	0.96	0.82	0.14	0.14
6	0.43	0.14	0.12	-0.02	-0.02
7	0.43	0.14	0.12	0.02	0.02
8	3.01	0.96	0.82	-0.14	-0.14
9	8.17	2.60	2.22	0.38	0.38
10	15.91	5.06	4.32	-0.74	-0.74
11	26.23	8.34	7.12	1.22	1.22
12	39.13	12.44	10.62	-1.82	-1.82
Σ	$185.76Eh^3$	$59.03Eh^3$	$50.44Eh^3$	0	0
	D_{22}	D_{66}	D_{12}	D_{16}	D_{26}

Table 3: Summary of the Rectangular Plate Strip Problem

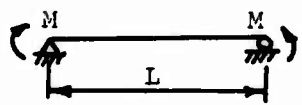
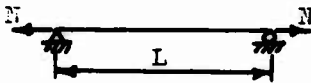
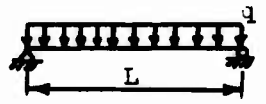
Case	Description	Boundary Conditions
1	Cylindrical Bending by Uniform Moment 	$w(0) = w(L) = 0$ $u_0(\frac{L}{2}) = 0$
2	Uniaxial Extension (ecc _{N_x} = 0) 	$w(0) = w(L) = 0$ $u_0(0) = 0$
3	Uniformly Loaded Plate Strip q=const. 	$w(0) = w(L) = 0$ $u_0(\frac{L}{2}) = 0$

	$N_x(x)$	$M_x(x)$	$u_0(x)$	$w(x)$
1	0	M	0	$\frac{M}{185.76Eh^3} (\frac{Lx}{2} - \frac{x^2}{2})$
2	N	0	$\frac{N}{15.43Eh} x$	0
3	0	$\frac{q}{2} (Lx - x^2)$	0	$\frac{q}{135.76Eh^3} (\frac{Lx^3}{24} - \frac{Lx^3}{12} - \frac{x^4}{24})$

	$N_y(x)$	$N_{xy}(x)$	$M_y(x)$	$M_{xy}(x)$
1	0	$0.00194 \frac{M}{h}$	+0.272M	0
2	0.271N	0	0	-0.023Nh
3	0	$-0.0010q (Lx-x^2)$	$0.135q (Lx-x^2)$	0

Table 3: (cont.)

$\sigma_x^{(i)}$	
1	$\frac{M}{185.76h^2} \left[\mp 0.000332 + 1.29 \frac{z}{h} \right]$
2	$0.075 \frac{N}{h}$
3	$\frac{q(Lx-x^2)}{371.52h^2} \left[\mp 0.00332 + 1.29 \frac{z}{h} \right]$

$\sigma_y^{(i)}$	
1	$\frac{M}{185.76h^2} \left[\mp 0.00332 + 0.35 \frac{z}{h} \right]$
2	$0.047 \frac{N}{h}$
3	$\frac{q(Lx-x^2)}{371.52h^2} \left[\mp 0.00332 + 0.35 \frac{z}{h} \right]$

$\tau_{xy}^{(i)}$	
1	$\frac{M}{185.76h^2} \left[0.03688 \pm 0.06 \frac{z}{h} \right]$
2	$\pm 0.003 \frac{N}{h}$
3	$\frac{q(Lx-x^2)}{371.52h^2} \left[0.03688 \pm 0.06 \frac{z}{h} \right]$

In the case of two signs (\pm or \mp), the upper sign is for an odd numbered layer and the lower sign is for an even numbered layer.

Stress Distributions for 45° Spiral Orientation

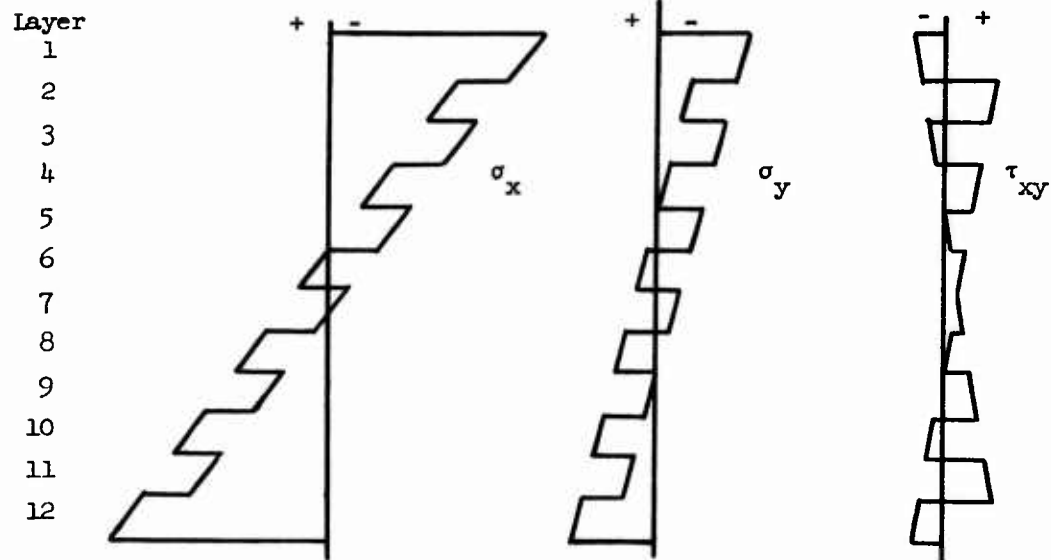

Figure 5.7 Typical Stress Distributions for Cylindrical Bending by a Uniform Moment and Uniformly Distributed Load

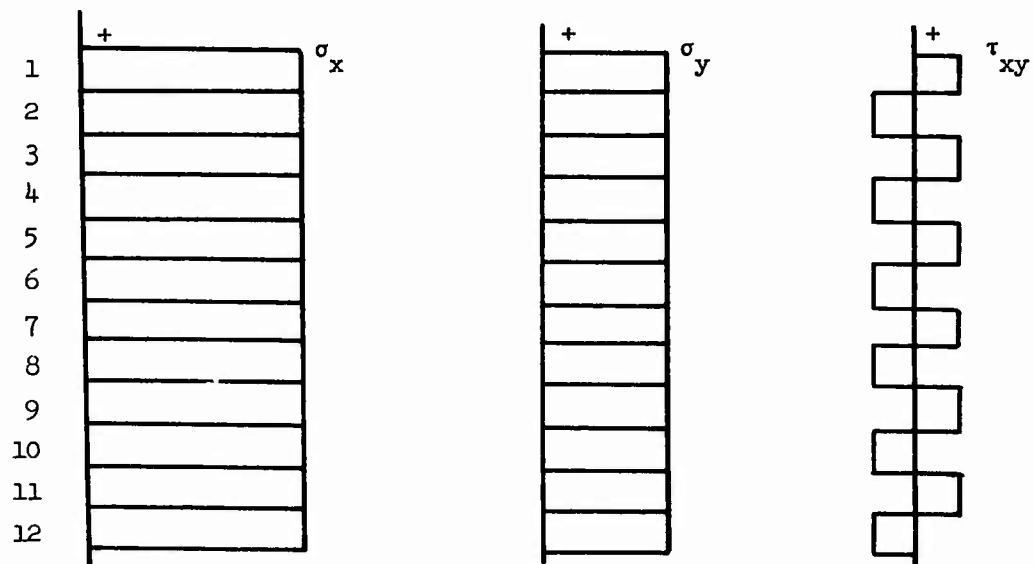

Figure 5.8 Typical Stress Distribution for Uniaxial Extension

6. DEFLECTION SURFACES FOR PRESCRIBED EDGE LOADS

In the absence of transverse loads (i.e., $q = 0$), the compatibility and equilibrium equations, Eqs (3.12) and (3.13), are both satisfied identically if U and w are assumed as:

$$\begin{aligned} U &= c_0 x^2 + c_1 y^2 + c_2 xy \\ w &= g_0 x^2 + g_1 y^2 + g_2 xy \end{aligned} \tag{6.1}$$

where the c_i are coefficients which describe the form of the stress function and the g_i are coefficients which describe the shape of the deflection surface.

The introduction of Eq (6.1) into Eqs (3.11) and (3.10a) leads to the following expressions for the in-plane forces and bending moments:

$$\begin{aligned} N_x &= U_{,yy} = 2c_1 \\ N_y &= U_{,xx} = 2c_0 \\ N_{xy} &= -U_{,xy} = -c_2 \end{aligned} \tag{6.2}$$

$$\begin{aligned} M_x &= 2c_1 b_{11} + 2c_0 b_{12} - c_2 b_{16} + 2g_0 d_{11} + 2g_1 d_{12} + 2g_2 d_{16} \\ M_y &= 2c_1 b_{21} + 2c_0 b_{22} - c_2 b_{26} + 2g_0 d_{12} + 2g_1 d_{22} + 2g_2 d_{26} \\ M_{xy} &= 2c_1 b_{61} + 2c_0 b_{62} - c_2 b_{66} + 2g_0 d_{16} + 2g_1 d_{26} + 2g_2 d_{66} \end{aligned} \tag{6.3}$$

Substituting the values of the c_i from Eq (6.2) into Eq (6.3) and writing the resulting equation in matrix form, one obtains:

$$M = bN + 2dg \tag{6.4}$$

where

$$g = \begin{pmatrix} g_0 \\ g_1 \\ g_2 \end{pmatrix} \tag{6.5}$$

From Eq (6.4), the deflection surface coefficients may be expressed in terms of the bending moments and in-plane forces.

$$g = \frac{1}{2} f \left[M - bN \right] \quad (6.6)$$

where the flexibility matrix, f , is related to the stiffness matrix, d , by:

$$f = d^{-1} \quad (6.7)$$

The shape of the deflection surface for several cases of edge loadings will now be considered.

UNIFORM TENSION

Let all force components be zero except N_x , then the g_i become:

$$\begin{aligned} g_0 &= -\frac{1}{2} N_x \left[f_{11} b_{11} + f_{12} b_{21} + f_{16} b_{61} \right] \\ g_1 &= -\frac{1}{2} N_x \left[f_{12} b_{11} + f_{22} b_{21} + f_{26} b_{61} \right] \\ g_2 &= -\frac{1}{2} N_x \left[f_{16} b_{11} + f_{26} b_{21} + f_{66} b_{61} \right] \end{aligned} \quad (6.8)$$

and the deflection surface is given by:

$$\begin{aligned} w = -\frac{1}{2} N_x \left[(f_{11} b_{11} + f_{12} b_{21} + f_{16} b_{61}) x^2 + (f_{12} b_{11} + f_{22} b_{21} + f_{26} b_{61}) y^2 \right. \\ \left. + (f_{16} b_{11} + f_{26} b_{21} + f_{66} b_{61}) xy \right] \end{aligned} \quad (6.9)$$

It must be recalled that all forces are applied at the reference surface and that it may be possible to change the form of the deflection surface by changing the location of the reference surface; that is, one of the coefficients of x^2 , y^2 , or xy may be made to vanish by a particular choice of the reference surface.

PURE SHEAR

Assume that the only non-zero force component is N_{xy} . The displacement surface coefficients are given by:

$$\begin{aligned} g_0 &= -\frac{1}{2} N_{xy} \left[f_{11} b_{16} + f_{12} b_{26} + f_{16} b_{66} \right] \\ g_1 &= -\frac{1}{2} N_{xy} \left[f_{12} b_{16} + f_{22} b_{26} + f_{26} b_{66} \right] \end{aligned} \quad (6.10)$$

$$g_2 = -\frac{1}{2} N_{xy} \left[f_{16} b_{16} + f_{26} b_{26} + f_{66} b_{66} \right] \quad (6.10)$$

and the displacement surface is

$$w = -\frac{1}{2} N_{xy} \left[(f_{11} b_{16} + f_{12} b_{26} + f_{16} b_{66}) x^2 + (f_{12} b_{16} + f_{22} b_{26} + f_{26} b_{66}) y^2 + (f_{16} b_{16} + f_{26} b_{26} + f_{66} b_{66}) xy \right] \quad (6.11)$$

As in the previous case, one of the coefficients of x^2 , y^2 , or xy may be made to vanish by an appropriate choice of reference surface.

UNIFORM BENDING ABOUT ONE AXIS

Let all of the force components be zero except M_x which is assumed to be constant. Then, the values of the g_i are given by:

$$\begin{aligned} g_0 &= \frac{1}{2} f_{11} M_x \\ g_1 &= \frac{1}{2} f_{12} M_x \\ g_2 &= \frac{1}{2} f_{16} M_x \end{aligned} \quad (6.12)$$

and the deflection surface becomes:

$$w = \frac{1}{2} M_x \left[f_{11} x^2 + f_{12} y^2 + f_{16} xy \right] \quad (6.13)$$

In this case, the only term which can possibly be made to vanish by changing the location of the reference surface is f_{16} . The other terms must exist for all possible choices of the reference surface and for all possible orientations of the laminas.

PURE TWIST

Assume that the only force component which exists is M_{xy} , then the g_i take on the form:

$$\begin{aligned} g_0 &= \frac{1}{2} f_{16} M_{xy} \\ g_1 &= \frac{1}{2} f_{26} M_{xy} \end{aligned} \quad (6.14)$$

$$g_2 = \frac{1}{2} f_{66} M_{xy} \quad (6.14)$$

The deflection surface is given by

$$w = \frac{1}{2} M_{xy} \left[f_{16} x^2 + f_{26} y^2 + f_{66} xy \right] \quad (6.15)$$

The only terms which might be made to vanish in this case are f_{16} and/or f_{26} . Both the location of the reference surface and the orientation of the laminae will affect the existence of these terms.

7. BENDING OF ORTHOTROPIC LAMINATED PLATES

As remarked in Section 4, the general determinative Eqs (3.12) and (3.13) governing the behavior of laminated plates can be specialized in certain instances of lamina orientation. In the particular case of a plate with pairwise orientation whose layers are 90 degrees relative to one another, the in-plane and bending effects are uncoupled. In this case a solution of Eq (3.13), now in the special form of Eq (4.29), may be obtained by the Navier method (see for example, Reference (23)). Recalling the form of this equation:

$$D_{11} w_{,xxxx} + (2D_{12} + 4D_{66}) w_{,xxyy} + D_{22} w_{,yyyy} = q(x,y) \quad (7.1)$$

if the load $q(x,y)$ is expanded in a double Fourier series

$$q(x,y) = \sum_{n=1}^{\infty} \sum_{m=1}^{\infty} q_{nm} \sin \frac{n\pi x}{a} \sin \frac{m\pi y}{b} \quad (7.2)$$

then the solution form of $w(x,y)$ for the simply supported plate may also be taken as a double Fourier series

$$w(x,y) = \sum_{n=1}^{\infty} \sum_{m=1}^{\infty} w_{nm} \sin \frac{n\pi x}{a} \sin \frac{m\pi y}{b} \quad (7.3)$$

where a and b are the lengths of the sides of the plate. The unknown coefficients w_{nm} may be found by substituting the two series back into Eq (7.1) and equating the like terms. The equation is satisfied for every value of n and m if

$$w_{nm} = \frac{q_{nm}}{\pi^4 \left[D_{11} \frac{n^4}{a^4} + (2D_{12} + 4D_{66}) \frac{n^2 m^2}{a^2 b^2} + D_{22} \frac{m^4}{b^4} \right]} \quad (7.4)$$

The complete solution of $w(x,y)$ is then,

$$w(x,y) = \frac{1}{\pi^4} \sum_{n=1}^{\infty} \sum_{m=1}^{\infty} \frac{q_{nm} \sin \frac{n\pi x}{a} \sin \frac{m\pi y}{b}}{D_{11} \frac{n^4}{a^4} + 2(D_{12} + 2D_{66}) \frac{n^2 m^2}{a^2 b^2} + D_{22} \frac{m^4}{b^4}} \quad (7.5)$$

for the special case of a uniform load $q = q_0$, q_{nm} is given by

$$q_{mn} = \frac{16 q_0}{\pi^2 mn} \quad \begin{array}{l} m = 1, 3, 5, \dots \\ n = 1, 3, 5, \dots \end{array} \quad (7.6)$$

The moments and stresses are calculated from Eqs (3.10a) and (3.18a). In-plane forces which are found from the solution to Eq (4.28) may be superimposed as a separate problem since the differential equations and boundary conditions are uncoupled for this particular orientation of the laminas.

EXAMPLE OF A SQUARE PLATE OF 13 LAYERS WITH PAIRWISE 90 DEGREE EQUIANGULAR ORIENTATION

Consider a 13 layer laminated plate of such an orientation that its behavior can be described by Eqs (4.28) and (4.29). Each lamina has thickness h and is orientated such that the principal elastic axes coincide with the coordinate axes. The length of the sides is a . Let the reference surface be the middle surface of the seventh layer.

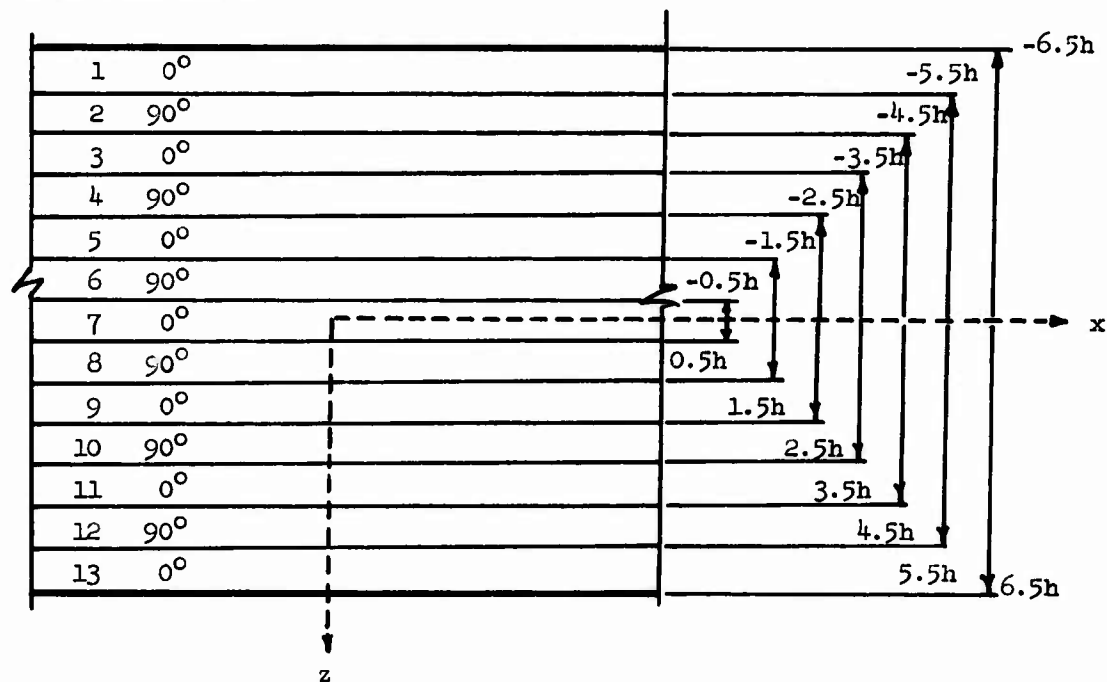

Figure 7.1

Let the four independent parameters be the same as that of the example in Section 5, $E = E$, $k = 1.2$, $\nu = 0.3$, and $\lambda = 0.42$. The \bar{C}_{ij} are given by Eq (1.14).

for an even numbered layer

$$\bar{C}_{ij} = E \begin{bmatrix} 1.345 & 0.404 & 0 \\ 0.404 & 1.121 & 0 \\ 0 & 0 & 0.471 \end{bmatrix}$$

for an odd numbered layer

$$\bar{C}_{ij} = E \begin{bmatrix} 1.121 & 0.404 & 0 \\ 0.404 & 1.345 & 0 \\ 0 & 0 & 0.471 \end{bmatrix}$$

The coefficients A_{ij} and D_{ij} are given by Eq (1.30). D_{ij}^* is zero for this orientation. A convenient form such as Table 2 of Section 5 may be used for the computation of these coefficients. The results are

$$A_{ij} = Eh \begin{bmatrix} 15.917 & 5.252 & 0 \\ 5.252 & 16.141 & 0 \\ 0 & 0 & 6.123 \end{bmatrix}$$

$$D_{ij} = Eh^3 \begin{bmatrix} 221.028 & 73.966 & 0 \\ 73.966 & 230.455 & 0 \\ 0 & 0 & 36.232 \end{bmatrix}$$

Knowing A_{ij} , the B_{ij} may be found.

$$B_{ij} = \frac{1}{Eh} \begin{bmatrix} 0.0704 & -0.0229 & 0 \\ -0.0229 & 0.0694 & 0 \\ 0 & 0 & 0.1633 \end{bmatrix}$$

The governing differential Eqs (4.28) and (4.29) become

$$\frac{1}{Eh} \left[0.0694 U_{,xxxx} + 0.1175 U_{,xxyy} + 0.0704 U_{,yyyy} \right] = 0$$

$$Eh^3 \left[221.028 w_{,xxxx} + 492.860 w_{,xxyy} + 230.455 w_{,yyyy} \right] = q(x,y)$$

Since these equations are uncoupled, their solutions may be taken independently. Only the bending problem will be considered here. If the plate has a uniform load $q = q_0$, then the solution for $w(x,y)$, which is given by Eq (7.5) and Eq (7.6) is

$$w(x,y) = \frac{16 q_0}{\pi^4 a^4 E h^3} \sum_{n=1}^{\infty} \sum_{m=1}^{\infty} \frac{\sin \frac{n\pi x}{a} \sin \frac{m\pi y}{a}}{221.028 n^5 m + 492.860 m^3 n^3 + 230.455 m^5}$$

(n = 1, 3, 5 - - - ; m = 1, 3, 5 - - -)

The moments are given by Eq (3.10a)

$$M_x = - (221.028 w_{,xx} + 73.966 w_{,yy}) E h^3$$

$$M_y = - (73.966 w_{,xx} + 230.455 w_{,yy}) E h^3$$

$$M_{xy} = - (172.464 w_{,xy}) E h^3$$

The stresses are given by Eq (3.18a). Since the in-plane forces and $t^{(i)}$ are zero, these equations reduce to

$$\sigma_x^{(i)} = -z \left[\bar{c}_{11}^{(i)} w_{,xx} + \bar{c}_{12}^{(i)} w_{,yy} \right]$$

$$\sigma_y^{(i)} = -z \left[\bar{c}_{12}^{(i)} w_{,xx} + \bar{c}_{22}^{(i)} w_{,yy} \right]$$

$$\tau_{xy}^{(i)} = -2z \bar{c}_{66}^{(i)} w_{,xy}$$

The deflections and the moments at the center of the plate, $x = \frac{a}{2}$, $y = \frac{a}{2}$, are summarized below

terms in series (nm)	w	M_x	M_y
11	$0.0000176 \frac{q_0 a^4}{E h^3}$	$0.0513 q_0 a^2$	$0.0530 q_0 a^2$
11, 13, 31, 33, 51, 15	$0.0000172 \frac{q_0 a^4}{E h^3}$	$0.0466 q_0 a^2$	$0.0481 q_0 a^2$

Additional terms are needed to obtain more exact values for the moments because their series representations converge slower than the series representation of the deflection.

The midspan stresses are

$$\sigma_x^{(i)} = \begin{cases} z \left(\frac{\pi a^2 q_0}{h^3} \right) (.0000766) & \text{for odd numbered layer} \\ z \left(\frac{\pi a^2 q_0}{h^3} \right) (0.0000879) & \text{for even numbered layer} \end{cases}$$

$$\sigma_y^{(i)} = \begin{cases} z \left(\frac{\pi a^2 q_0}{h^3} \right) (0.0000879) & \text{for odd numbered layer} \\ z \left(\frac{\pi a^2 q_0}{h^3} \right) (.0000766) & \text{for even numbered layer} \end{cases}$$

A plot of these stresses is shown in Figure 7.2.

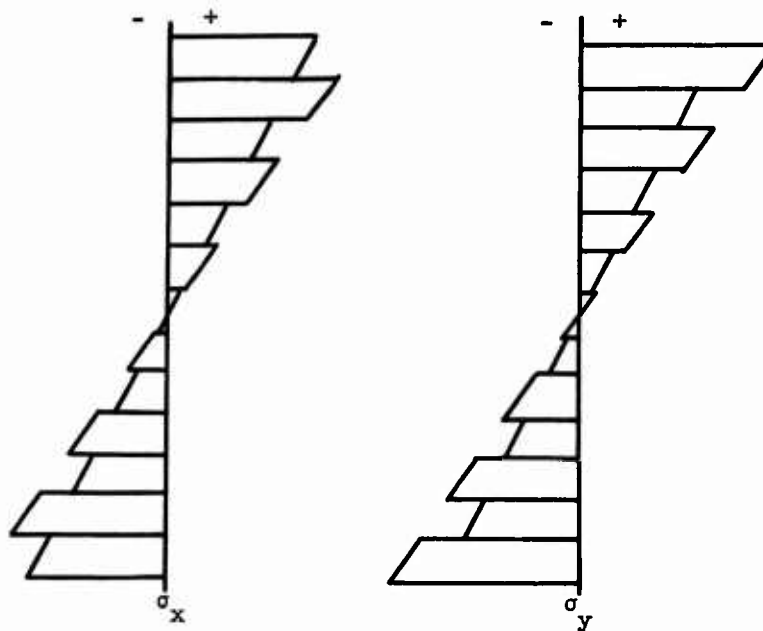

Figure 7.2

8. APPLICATIONS OF THE PERTURBATION METHOD OF SOLUTION

It should be recalled that the perturbation method of solution, as described in Section 4, is applicable when the squares, products, and higher powers of the perturbation parameters are negligibly small.

The perturbation method of solution may be applied to problems in which the boundaries are not rectangular with little more difficulty than arises in applying it to problems in which the boundaries are rectangular. This situation arises because the differential equations for the first approximation and for each correction term are of the same form as the equations for isotropic plates. Hence, any problem which has been solved for isotropic plates can be extended to laminated plates by the perturbation method. As an example of a problem for which the boundaries are not rectangular, the solution for a uniformly-loaded laminated circular plate with clamped edge is indicated below. An exact solution can be obtained for this case, so that a comparison can be made between the exact solution and the perturbation solution. In addition to this solution, the perturbation solutions for rectangular plates simply supported on all four edges or simply supported on two opposite edges and clamped on the other two edges are also indicated.

CLAMPED CIRCULAR PLATE

From Eq (4.15), the differential equations for the first approximation are the same as those for isotropic plates

$$\begin{aligned} \nabla^4 w_0 &= \frac{q}{D} \\ \nabla^4 U_0 &= 0 \end{aligned} \tag{8.1}$$

The boundary conditions for a clamped edge will be taken to be:

$$\begin{aligned} w \Big|_{r=a} &= w, r \Big|_{r=a} = 0 \\ \frac{1}{r} U, r + \frac{1}{r^2} U, \theta\theta \Big|_{r=a} &= N_r \Big|_{r=a} = 0 \end{aligned}$$

For a uniform load, the solutions of these differential equations in polar coordinates are: (see, for example, Reference (25))

$$\begin{aligned} w_0 &= \frac{q_0}{64D} (a^2 - r^2)^2 \\ U_0 &= 0 \end{aligned} \tag{8.2}$$

where q_0 is the magnitude of the load and a is the radius of the plate.

When Eqs (4.16), (4.17), (4.18), and (4.19) are transformed into polar coordinates, the following equations are obtained:

$$\begin{aligned}\nabla^4 U_{l11} &= \nabla^4 U_{l22} = -\frac{q_0}{8D} \\ \nabla^4 U_{l66} &= \frac{q_0}{4D} \\ \nabla^4 U_{l12} &= \nabla^4 U_{l21} = -\frac{3q_0}{8D}\end{aligned}\tag{8.3}$$

$$\begin{aligned}\nabla^4 w_{n11} &= \nabla^4 w_{n11}^* = \frac{3q_0}{8D} \\ \nabla^4 w_{n12}^* &= \frac{q_0}{8D} \\ \nabla^4 w_{n66} &= \nabla^4 w_{n66}^* = (1 - \nu_D) \frac{q_0}{8D} \\ \nabla^4 w_{n22} &= \nabla^4 w_{n22}^* = \frac{3q_0}{8D}\end{aligned}\tag{8.4}$$

The remaining equations are all of the form $\nabla^4 (U, w) = 0$, with their solutions identically equal to zero. The solutions of the above equations are:

$$\begin{aligned}U_{l11} &= U_{l22} = -\frac{q_0}{512D} (a^2 - r^2)^2 \\ U_{l66} &= \frac{q_0}{256D} (a^2 - r^2)^2\end{aligned}\tag{8.5}$$

$$\begin{aligned}U_{l12} &= U_{l21} = -\frac{3q_0}{512D} (a^2 - r^2)^2 \\ w_{n11} &= w_{n11}^* = \frac{3q_0}{512D} (a^2 - r^2)^2 \\ w_{n12}^* &= \frac{q_0}{512D} (a^2 - r^2)^2\end{aligned}\tag{8.6}$$

$$w_{n66} = w_{n66}^* = (1 - \nu_D) \frac{q_0}{512D} (a^2 - r^2)^2$$

$$w_{n22} = w_{n22}^* = \frac{3q_0}{512D} (a^2 - r^2)^2 \quad (8.6)$$

Therefore, the complete second approximation is:

$$w = \frac{q_0}{64D} (a^2 - r^2)^2 \left[1 + (n_{11} + n_{11}^* + n_{22} + n_{22}^*) \frac{3}{8} + n_{12}^* \frac{1}{8} + (n_{66} + n_{66}^*) \left(\frac{1 - \nu_D}{8} \right) \right] \quad (8.7)$$

$$U = \frac{q_0}{256D} (a^2 - r^2)^2 \left[l_{66} - (h_{11} + h_{22}) \frac{1}{2} - (h_{12} + h_{21}) \frac{3}{2} \right] \quad (8.8)$$

An exact solution for the uniformly-loaded clamped circular plate may be obtained by recognizing that the following forms of solution satisfy boundary conditions:

$$w = C_1 (a^2 - r^2)^2 \quad (8.9)$$

$$U = C_2 (a^2 - r^2)^2$$

Two simultaneous equations for the unknown constants C_1 and C_2 are obtained by substituting the above forms of solution into Eqs (3.12) and (3.13). The following solutions are obtained when the constants C_1 and C_2 have been determined:

$$w = -\frac{q_0}{8} (a^2 - r^2)^2 \left[\frac{3B_{22} + (2B_{12} + B_{66}) + 3B_{11}}{\Delta} \right] \quad (8.10)$$

$$U = \frac{q_0}{8} (a^2 - r^2)^2 \left[\frac{3b_{12} + (b_{11} + b_{22} - 2b_{66}) + 3b_{21}}{\Delta} \right]$$

where,

$$\Delta = \left[3B_{22} + (2B_{12} + B_{66}) + 3B_{11} \right] \left[3d_{11} + 2(d_{12} + 2d_{66}) + 3d_{22} \right] - \left[3b_{12} + (b_{11} + b_{22} - 2b_{66}) + 3b_{21} \right]^2$$

When this exact solution is expressed in terms of the perturbation parameters and the division is expressed in series form, the perturbation solution can be seen to consist of the first terms of the exact solution.

The solution for the simply supported circular plate can be obtained in a similar manner provided due care is taken in properly satisfying the boundary conditions.

SIMPLY-SUPPORTED RECTANGULAR PLATE

For the present, the load will be assumed to be sinusoidally distributed; that is

$$q = q_0 \sin \frac{\pi x}{a} \sin \frac{\pi y}{b} \quad (8.11)$$

where the coordinate system is as shown:

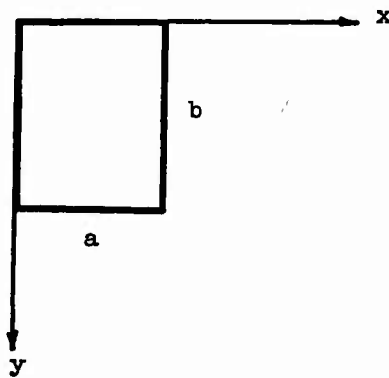

This will serve to illustrate the method, and will indicate that the solution for any load distribution may be obtained by expanding the load in a double Fourier series. For this load distribution, the solution to the first approximations, i.e., the isotropic case is: (see Reference (25), for example)

$$w_0 = \frac{q_0 a^4}{\pi^4 D (1 + \alpha^2)^2} \sin \frac{\pi x}{a} \sin \frac{\pi y}{b} \quad (8.12)$$

$$U_0 = 0$$

where $\alpha = a/b$, the aspect ratio.

Inserting these relationships into Eqs (4.16), (4.17), (4.18), and (4.19), the following equations are obtained:

$$\begin{aligned}
\nabla^4 U_{111} &= \nabla^4 U_{222} = -\frac{q_0 \alpha^2}{D(1+\alpha^2)^2} \sin \frac{\pi x}{a} \sin \frac{\pi y}{b} \\
\nabla^4 U_{166} &= \frac{2q_0 \alpha^2}{D(1+\alpha^2)^2} \sin \frac{\pi x}{a} \sin \frac{\pi y}{b} \\
\nabla^4 U_{112} &= -\frac{q_0}{D(1+\alpha^2)^2} \sin \frac{\pi x}{a} \sin \frac{\pi y}{b} \\
\nabla^4 U_{221} &= -\frac{q_0 \alpha^4}{D(1+\alpha^2)^2} \sin \frac{\pi x}{a} \sin \frac{\pi y}{b} \\
\nabla^4 U_{116} &= \frac{1}{2} \nabla^4 U_{162} = -\frac{q_0 \alpha}{D(1+\alpha^2)^2} \cos \frac{\pi x}{a} \cos \frac{\pi y}{b} \\
\nabla^4 U_{226} &= \frac{1}{2} \nabla^4 U_{261} = -\frac{q_0 \alpha^3}{D(1+\alpha^2)^2} \cos \frac{\pi x}{a} \cos \frac{\pi y}{b}
\end{aligned} \tag{8.13}$$

and

$$\begin{aligned}
\nabla^4 w_{n11} &= \nabla^4 w_{n11}^* = \frac{q_0}{D(1+\alpha^2)^2} \sin \frac{\pi x}{a} \sin \frac{\pi y}{b} \\
\nabla^4 w_{n16} &= -\nabla^4 w_{n16}^* = \frac{4q_0 \alpha}{D(1+\alpha^2)^2} \cos \frac{\pi x}{a} \cos \frac{\pi y}{b} \\
\nabla^4 w_{n12}^* &= \frac{q_0 \alpha^2}{D(1+\alpha^2)^2} \sin \frac{\pi x}{a} \sin \frac{\pi y}{b} \\
\nabla^4 w_{n66} &= \nabla^4 w_{n66}^* = \frac{(1-\nu_D) q_0 \alpha^2}{D(1+\alpha^2)^2} \sin \frac{\pi x}{a} \sin \frac{\pi y}{b} \\
\nabla^4 w_{n26} &= -\nabla^4 w_{n26}^* = \frac{4q_0 \alpha^3}{D(1+\alpha^2)^2} \cos \frac{\pi x}{a} \cos \frac{\pi y}{b} \\
\nabla^4 w_{n22} &= \nabla^4 w_{n22}^* = \frac{q_0 \alpha^4}{D(1+\alpha^2)^2} \sin \frac{\pi x}{a} \sin \frac{\pi y}{b}
\end{aligned} \tag{8.14}$$

The remaining equations are all of the form $\nabla^4(U,w) = 0$, with their solutions identically equal to zero.

The above equations are of two types:

$$(1) \quad \nabla^4 (\quad) = k_1 \sin \frac{\pi x}{a} \sin \frac{\pi y}{b} \quad (8.15)$$

$$\text{and (2)} \quad \nabla^4 (\quad) = k_2 \cos \frac{\pi x}{a} \cos \frac{\pi y}{b}$$

The solutions of these two types of equations are (see Reference (25), for example):

$$(1) \quad (\quad) = \frac{k_1 a^4}{\pi^4 (1 + \alpha^2)^2} \sin \frac{\pi x}{a} \sin \frac{\pi y}{b} \quad (8.16)$$

$$\text{and (2)} \quad (\quad) = \frac{k_2 a^4}{\pi^4 (1 + \alpha^2)^2} \sum_{m=2,4}^{\infty} \sum_{n=2,4}^{\infty} c_{nm} \sin \frac{m\pi x}{a} \sin \frac{n\pi y}{b}$$

$$\text{where} \quad c_{nm} = \frac{4mn}{(m^2 - 1)(n^2 - 1)}$$

Therefore, the complete second approximation is:

$$\begin{aligned} w = & \frac{q_0 a^4}{\pi^4 D(1 + \alpha^2)^2} \left\{ \left[1 + (n_{11} + n_{11}^*) \frac{1}{(1 + \alpha^2)^2} + n_{12}^* \frac{\alpha^2}{(1 + \alpha^2)^2} \right. \right. \\ & + \left. \frac{(1 - \nu_D) \alpha^2}{(1 + \alpha^2)^2} (n_{66} + n_{66}^*) + (n_{22} + n_{22}^*) \frac{\alpha^4}{(1 + \alpha^2)^2} \right] \sin \frac{\pi x}{a} \sin \frac{\pi y}{b} \\ & \left. + \frac{4}{(1 + \alpha^2)^2} \left[\alpha(n_{16} - n_{16}^*) + \alpha^3(n_{26} - n_{26}^*) \right] \sum_{n=2,4}^{\infty} \sum_{m=2,4}^{\infty} c_{mn} \sin \frac{\pi x}{a} \sin \frac{\pi y}{b} \right\} \quad (8.17) \end{aligned}$$

$$U = \frac{q_0 a^4}{\pi^4 D (1 + \alpha^2)^4} \left\{ \left[(l_{11} + l_{22} + 2l_{66})\alpha^2 - (l_{12} + l_{21})(1 + \alpha^4) \right] \sin \frac{\pi X}{a} \sin \frac{\pi Y}{b} \right. \\ \left. - \left[(l_{16} + 2l_{62})\alpha + (l_{26} + 2l_{61})\alpha^3 \right] \sum_{m=2,4}^{\infty} \sum_{n=2,4}^{\infty} c_{mn} \sin \frac{m\pi X}{a} \sin \frac{n\pi Y}{b} \right\} \quad (3.18)$$

RECTANGULAR PLATE WITH TWO OPPOSITE EDGES SIMPLY SUPPORTED
AND THE OTHER TWO EDGES CLAMPED

As in the previous case, a sinusoidal distribution of load will be assumed. For the coordinate system as shown,

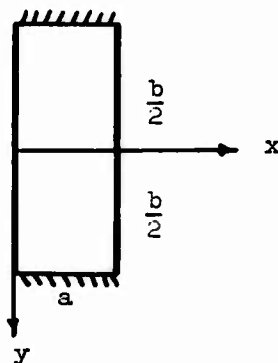

The equation for the load is:

$$q = q_0 \sin \frac{\pi X}{a} \cos \frac{\pi Y}{b} \quad (3.19)$$

To simplify the presentation, the arrangement of the layers will be assumed to be symmetrical with respect to the middle surface of the plate. An extension to a general arrangement of the layers can be readily obtained from the solution given.

The solution is assumed to consist of a particular and a homogeneous part; i.e., $w_0 = w_1 + w_2$. The particular solution is chosen so as to satisfy the loading condition, whereas the homogeneous solution is such that the sum of the two parts satisfies the boundary conditions. The particular solution is taken as that for the case when all edges are simply supported:

$$w_1 = \frac{q_0 a^4}{\pi^4 D (1 + \alpha^2)^2} \sin \frac{\pi X}{a} \cos \frac{\pi Y}{b} \quad (8.20)$$

where $\alpha = a/b$, the aspect ratio.

For symmetry with respect to the x axis, the homogeneous solution can be shown to be (see, for example, Reference (25)):

$$w_2 = \left[A \cosh \frac{\pi Y}{a} + B \frac{\pi Y}{a} \sinh \frac{\pi Y}{a} \right] \sin \frac{\pi X}{a} \quad (8.21)$$

where

$$A = - \frac{q_0 a^4}{\pi^4 D} \frac{\alpha}{(1 + \alpha^2)^2} \frac{\frac{\pi}{2\alpha} \sinh \frac{\pi}{2\alpha}}{\sinh \frac{\pi}{2\alpha} \cos \frac{\pi}{2\alpha} + \frac{\pi}{2\alpha}}$$

$$B = \frac{q_0 a^4}{\pi^4 D} \frac{\alpha}{(1 + \alpha^2)^2} \frac{\cosh \frac{\pi}{2\alpha}}{\sinh \frac{\pi}{2\alpha} \cosh \frac{\pi}{2\alpha} + \frac{\pi}{2\alpha}}$$

Therefore, the solution for the first approximation is:

$$w_0 = Q \sin \frac{\pi X}{a} \left[\cos \frac{\pi Y}{b} - K \left(\frac{\pi}{2\alpha} \sinh \frac{\pi}{2\alpha} \cosh \frac{\pi Y}{a} - \frac{\pi Y}{a} \cosh \frac{\pi}{2\alpha} \sinh \frac{\pi Y}{a} \right) \right] \quad (8.22)$$

where

$$Q = \frac{q_0 a^4}{\pi^4 D} \frac{1}{(1 + \alpha^2)^2}$$

and

$$K = \frac{\alpha}{\sinh \frac{\pi}{2\alpha} \cosh \frac{\pi}{2\alpha} + \frac{\pi}{2\alpha}}$$

Because of the simplifying assumption regarding symmetry with respect to the middle surface, the only differential equations for the corrective terms which need to be considered are Eq (4.18). Substitution of Eq (8.22) into Eq (4.18) leads to the following equations when the functions are expanded in suitable trigonometric series:

$$\nabla^4 w_{n11} = Q \frac{\pi^4}{a^4} \sin \frac{\pi X}{a} \left[\cos \frac{\pi Y}{b} - K \sum_{n=1,3}^{\infty} c_n^{(n11)} \cos \frac{n\pi Y}{b} \right]$$

where

$$c_n^{(n11)} = (-1)^{\frac{n-1}{2}} \left[\frac{8n \alpha^2}{\pi (1 + n^2 \alpha^2)^2} \cosh^2 \frac{\pi}{2\alpha} \right]$$

$$\nabla^4 w_{n16} = Q \frac{\pi^4}{a^4} \sum_{m=2,4}^{\infty} c_m^{(n16)} \sin \frac{m\pi x}{a} \left[\alpha \sum_{n=2,4}^{\infty} d_n^{(n16)} \sin \frac{n\pi y}{b} \right. \\ \left. + K \sum_{n=2,4}^{\infty} e_n^{(n16)} \sin \frac{n\pi y}{b} \right]$$

where

$$c_m^{(n16)} = \frac{4m}{\pi(m^2 - 1)}$$

$$d_n^{(n16)} = (-1)^{\frac{n}{2} - 1} \left[\frac{2n}{\pi(n^2 - 1)} \right]$$

$$e_n^{(n16)} = (-1)^{\frac{n}{2} - 1} \left[\frac{4n \alpha^2}{\pi(1 + n^2 \alpha^2)} \frac{(1 - n^2 \alpha^2)}{1 + n^2 \alpha^2} \text{Cosh} \frac{\pi}{2\alpha} \text{Sinh} \frac{\pi}{2\alpha} - \frac{\pi}{2\alpha} \right]$$

$$\nabla^4 w_{n66} = (1 - \nu_D) Q \frac{\pi^4}{a^4} \sin \frac{\pi x}{a} \left[\alpha^2 \cos \frac{\pi y}{b} - K \sum_{n=1,3}^{\infty} c_n^{(n66)} \cos \frac{n\pi y}{b} \right]$$

where

$$c_n^{(n66)} = (-1)^{\frac{n-1}{2}} \left[\frac{8n^3 \alpha^4}{\pi(1 + n^2 \alpha^2)^2} \text{Cosh}^2 \frac{\pi}{2\alpha} \right]$$

$$\nabla^4 w_{n26} = Q \frac{\pi^4}{a^4} \sum_{m=2,4,6}^{\infty} c_m^{(n26)} \sin \frac{m\pi x}{a} \left[\alpha^3 \sum_{n=2,4}^{\infty} d_n^{(n26)} \sin \frac{n\pi y}{b} \right. \\ \left. - K \sum_{n=2,4}^{\infty} e_n^{(n26)} \sin \frac{n\pi y}{b} \right]$$

where

$$c_m^{(n26)} = \frac{4m}{\pi(m^2 - 1)}$$

$$d_n^{(n26)} = (-1)^{\frac{n}{2} - 1} \left[\frac{2n}{\pi(n^2 - 1)} \right]$$

$$e_n^{(n26)} = (-1)^{\frac{n-1}{2}} \left[\frac{4n \alpha^2}{\pi(1+n^2 \alpha^2)} \left(\frac{1-3n^2 \alpha^2}{1+n^2 \alpha^2} \text{Cosh} \frac{\pi}{2\alpha} \text{Sinh} \frac{\pi}{2\alpha} - \frac{\pi}{2\alpha} \right) \right]$$

$$\nabla^4 w_{n22} = Q \frac{\pi^4}{a^4} \sin \frac{\pi x}{a} \left[\alpha^4 \cos \frac{\pi y}{b} + K \sum_{n=1,3}^{\infty} c_n^{(n22)} \cos \frac{n\pi y}{b} \right]$$

where

$$c_n^{(n22)} = -(-1)^{\frac{n-1}{2}} \left[\frac{8n \alpha^2}{\pi(1+n^2 \alpha^2)^2} \text{Cosh}^2 \frac{\pi}{2\alpha} \right]$$

The solutions to these equations, which are obtained in a manner similar to that used in the first approximation, are:

$$w_{n11} = Q \sin \frac{\pi x}{a} \left[\frac{1}{(1+\alpha^2)^2} \cos \frac{\pi y}{b} - K \sum_{n=1,3}^{\infty} \frac{c_n^{(n11)}}{(1+n^2 \alpha^2)^2} \cos \frac{n\pi y}{b} - L_{n11} \left(\frac{\pi}{2\alpha} \text{Sinh} \frac{\pi}{2\alpha} \text{Cosh} \frac{\pi y}{a} - \frac{\pi y}{a} \text{Cosh} \frac{\pi}{2\alpha} \text{Sinh} \frac{\pi y}{a} \right) \right]$$

where

$$L_{n11} = \frac{\left[\frac{\alpha}{(1+\alpha^2)^2} - K \sum_{n=1,3}^{\infty} (-1)^{\frac{n-1}{2}} \frac{n\alpha c_n^{(n11)}}{(1+n^2 \alpha^2)^2} \right]}{\text{Sinh} \frac{\pi}{2\alpha} \text{Cosh} \frac{\pi}{2\alpha} + \frac{\pi}{2\alpha}}$$

$$w_{n16} = -4Q \sum_{m=2,4}^{\infty} c_m^{(n16)} \sin \frac{m\pi x}{a} \left[\sum_{n=2,4}^{\infty} \frac{\alpha d_n^{(n16)}}{(m^2+n^2 \alpha^2)^2} \sin \frac{n\pi y}{b} - K \sum_{n=2,4}^{\infty} \frac{e_n^{(n16)}}{(m^2+n^2 \alpha^2)^2} \sin \frac{n\pi y}{b} - L_{n16} \left(\frac{\pi}{2\alpha} \text{Sinh} \frac{\pi}{2\alpha} \text{Cosh} \frac{\pi y}{a} - \frac{\pi y}{a} \text{Cosh} \frac{\pi}{2\alpha} \text{Sinh} \frac{\pi y}{a} \right) \right]$$

where

$$L_{n16} = \frac{\left[\sum_{n=2,4}^{\infty} (-1)^{\frac{n}{2}} \frac{n \alpha^2 d_n^{(n16)}}{(m^2 + n^2 \alpha^2)^2} - K \sum_{n=2,4}^{\infty} (-1)^{\frac{n}{2}} \frac{n \alpha e_n^{(n16)}}{(m^2 + n^2 \alpha^2)^2} \right]}{\text{Sinh } \frac{\pi}{2\alpha} \text{Cosh } \frac{\pi}{2\alpha} + \frac{\pi}{2\alpha}}$$

$$w_{n66} = (1 - \nu_D) Q \sin \frac{\pi x}{a} \left[\frac{\alpha^2}{(1 + \alpha^2)^2} \cos \frac{\pi y}{b} - K \sum_{n=1,3}^{\infty} \frac{c_n^{(n66)}}{(1 + n^2 \alpha^2)^2} \cos \frac{n\pi y}{b} \right. \\ \left. - L_{n66} \left(\frac{\pi}{2\alpha} \text{Sinh } \frac{\pi}{2\alpha} \text{Cosh } \frac{\pi y}{a} - \frac{\pi y}{a} \text{Cosh } \frac{\pi}{2\alpha} \text{Sinh } \frac{\pi y}{a} \right) \right]$$

where

$$L_{n66} = \frac{\left[\frac{\alpha^3}{(1 + \alpha^2)^2} - K \sum_{n=1,3}^{\infty} (-1)^{\frac{n-1}{2}} \frac{n \alpha c_n^{(n66)}}{(1 + n^2 \alpha^2)^2} \right]}{\text{Sinh } \frac{\pi}{2\alpha} \text{Cosh } \frac{\pi}{2\alpha} + \frac{\pi}{2\alpha}}$$

$$w_{n26} = -4Q \sum_{m=2,4}^{\infty} c_m^{(n26)} \sin \frac{m\pi x}{a} \left[\sum_{n=2,4}^{\infty} \frac{\alpha^3 d_n^{(n26)}}{(m^2 + n^2 \alpha^2)^2} \sin \frac{n\pi y}{b} \right. \\ \left. - K \sum_{n=2,4}^{\infty} \frac{e_n^{(n26)}}{(m^2 + n^2 \alpha^2)^2} \sin \frac{n\pi y}{b} \right. \\ \left. - L_{n26} \left(\frac{\pi}{2\alpha} \text{Sinh } \frac{\pi}{2\alpha} \text{Cosh } \frac{\pi y}{a} - \frac{\pi y}{a} \text{Cosh } \frac{\pi}{2\alpha} \text{Sinh } \frac{\pi y}{a} \right) \right]$$

where

$$L_{n26} = \frac{\left[\sum_{n=2,4}^{\infty} (-1)^{\frac{n}{2}} \frac{n \alpha^4 d_n^{(n26)}}{(m^2 + n^2 \alpha^2)^2} - K \sum_{n=1,3}^{\infty} (-1)^{\frac{n}{2}} \frac{n \alpha e_n^{(n26)}}{(m^2 + n^2 \alpha^2)^2} \right]}{\text{Sinh } \frac{\pi}{2\alpha} \text{Cosh } \frac{\pi}{2\alpha} + \frac{\pi}{2\alpha}}$$

$$w_{n22} = Q \sin \frac{\pi x}{a} \left[\frac{\alpha^4}{(1 + \alpha^2)^2} \cos \frac{\pi y}{b} - K \sum_{n=1,3}^{\infty} \frac{c_n^{(n22)}}{(1 + n^2 \alpha^2)^2} \cos \frac{n\pi y}{b} \right. \\ \left. - L_{n22} \left(\frac{\pi}{2\alpha} \text{Sinh } \frac{\pi}{2\alpha} \text{Cosh } \frac{\pi y}{a} - \frac{\pi y}{a} \text{Cosh } \frac{\pi}{2\alpha} \text{Sinh } \frac{\pi y}{a} \right) \right]$$

where

$$L_{n22} = \frac{\left[\frac{\alpha^5}{(1 + \alpha^2)^2} - K \sum_{n=1,3}^{\infty} (-1)^{\frac{n-1}{2}} \frac{n \alpha c_n^{(n22)}}{(1 + n^2 \alpha^2)^2} \right]}{\text{Sinh} \frac{\pi}{2\alpha} \text{Cosh} \frac{\pi}{2\alpha} + \frac{\pi}{2\alpha}}$$

It should be recalled that the second approximation is obtained by summing these separate solutions times the appropriate parameters:

$$w = w_0 + n_{11} w_{n11} + n_{16} w_{n16} + n_{66} w_{n66} + n_{26} w_{n26} + n_{22} w_{n22}$$

9. OPTIMIZATION OF LAMINATE CONFIGURATION

The question of obtaining the optimum orientation of the layers in a structural laminate can be considered from several viewpoints. There is the question of whether to optimize for minimum deformation (or minimum volume change in a pressure vessel), for equal stress in two directions, for maximum strength (which involves the question of a valid theory of failure), or for some other stress or deformation condition. In some cases two conditions may be satisfied by the same orientation, but it is not evident that this should be true in general. Then, the particular application for which the optimum structure is to be determined may be classified as to whether the stresses are statically determinate, as are the membrane stresses in a thin-walled pressure vessel, or whether the stresses are statically indeterminate, as in the bending of a plate. Thus, a general discussion of optimization would become quite involved. Only one aspect of the problem will be considered here.

The question of optimization for minimum deflection involves only a study of solutions to the differential equations presented in the first part of this report. This discussion of optimization will be limited to optimizing for minimum deflection in plate problems. Two classes of problem will be considered: the cylindrical bending and extension of long rectangular plates, and the bending of rectangular plates simply supported on two opposite edges.

CYLINDRICAL BENDING OF LONG RECTANGULAR PLATES

As shown in Section 5, in the cylindrical bending of long rectangular plates, the lateral deflection may be expressed in the following form:

$$w(x) = - \frac{1}{D_{11} - \frac{(D_{11}^*)^2}{A_{11}}} F(x) \quad (9.1)$$

where $F(x)$ may be obtained from the corresponding problem for the deflection of a beam. Similarly, the extension of a long rectangular plate may be expressed in the following form:

$$u_o(x) = \frac{1}{A_{11} - \frac{(D_{11}^*)^2}{D_{11}}} G(x) \quad (9.2)$$

It can be seen from the above expressions that in order to minimize the deflection or extension in the plate, it is necessary to maximize the expression

$\frac{(D_{11}^*)^2}{D_{11} - \frac{(D_{11}^*)^2}{A_{11}}}$ or $A_{11} - \frac{(D_{11}^*)^2}{D_{11}}$, respectively. For orientations which are

symmetrical with respect to the middle surface of the plate, the quantity D_{11}^* is zero. Therefore, it is obvious that the optimum orientation will be one which is symmetrical. For symmetrical orientations, the deflection or extension is minimized by maximizing the quantity D_{11} or A_{11} , respectively.

From the definitions of the quantities D_{11} and A_{11} :

$$D_{11} = \frac{1}{3} \sum_{k=1}^n \bar{c}_{11}^{(k)} (h_k^3 - h_{k-1}^3) \quad (9.3)$$

$$A_{11} = \sum_{k=1}^n \bar{c}_{11}^{(k)} (h_k - h_{k-1}),$$

it can be seen that in order to maximize these quantities, the quantity \bar{c}_{11} must be maximized for each layer. From the definition of \bar{c}_{11} :

$$\bar{c}_{11} = c_{11} \cos^4 \theta + 2(c_{12} + 2c_{66}) \sin^2 \theta \cos^2 \theta + c_{22} \sin^4 \theta \quad (9.4)$$

the conditions for maximizing \bar{c}_{11} can be found to be:

$$\begin{aligned} \sin \theta = 0, & \quad \text{when} \quad c_{11} > c_{12} + 2c_{66} \quad \text{and} \quad c_{11} > c_{22} \\ \cos \theta = 0, & \quad \text{when} \quad c_{22} > c_{11} \quad \text{and} \quad c_{22} > c_{12} + 2c_{66} \end{aligned} \quad (9.5)$$

$$\tan^2 \theta = \frac{(c_{12} + 2c_{66}) - c_{11}}{(c_{12} + 2c_{66}) - c_{22}}, \quad \begin{aligned} & \text{when} \quad c_{12} + 2c_{66} > c_{11} \\ & \text{and} \quad c_{12} + 2c_{66} > c_{22} \end{aligned}$$

The optimum orientation depends on the relative magnitudes of c_{11} and c_{22} . For $c_{11} = c_{22}$, the optimum orientation is 45° , as would be expected.

RECTANGULAR PLATES SIMPLY-SUPPORTED ON TWO OPPOSITE EDGES

From the solution given in Section 8, the maximum deflection of a sinusoidally loaded rectangular plate simply supported on all four edges can be shown to be:

$$\begin{aligned} w_{\max} = \frac{q_0 a^4}{\pi^4 D(1 + \alpha^2)^2} & \left[1 + (n_{11} + n_{11}^*) \frac{1}{(1 + \alpha^2)^2} + n_{12}^* \frac{\alpha^2}{(1 + \alpha^2)^2} \right. \\ & \left. + (n_{66} + n_{66}^*) \frac{(1 - \nu_D) \alpha^2}{(1 + \alpha^2)^2} + (n_{22} + n_{22}^*) \frac{\alpha^4}{(1 + \alpha^2)^2} \right] \end{aligned} \quad (9.6)$$

where $\alpha = a/b$ is the aspect ratio, D is the larger of D_{11} or $D_{12} + 2D_{66}$ or D_{22} , and the n_{ij} are small positive quantities defined by:

$$\begin{aligned}
n_{11} &= 1 - \frac{D_{11}}{D} & n_{11}^* &= \frac{d_{11} + D_{11}}{D} \\
\nu_D &= \frac{D_{12}}{D} & n_{12}^* &= \frac{d_{12} + D_{12}}{D} \\
n_{22} &= 1 - \frac{D_{22}}{D} & n_{22}^* &= \frac{d_{22} + D_{22}}{D} \\
n_{66} &= 1 - \frac{2}{1 - \nu_D} \frac{D_{66}}{D} & n_{66}^* &= \frac{2}{1 - \nu_D} \frac{d_{66} + D_{66}}{D}
\end{aligned} \tag{9.7}$$

From this solution, it can be seen that to minimize the deflection the quantity D should be maximized and the n_{ij} and the n_{ij}^* should be minimized. These two effects are not entirely independent since a change in orientation which decreases the n_{ij} will also decrease D . However, since for arrangements which are symmetrical with respect to the middle surface the n_{ij} will be zero, the optimum arrangement will be one which is symmetrical with respect to the middle surface.

For symmetrical arrangements of the layers, Eq (9.6) can be written as follows (assuming that $D_{11} \geq D_{22}$):

when $D_{11} > (D_{12} + 2D_{66})$, $D = D_{11}$

$$w_{\max} = \frac{q_0 a^4}{\pi^4 D_{11}} \frac{1}{(1 + \alpha^2)^2} \left[1 + \frac{2}{D_{11}} \frac{D_{11} - (D_{12} + 2D_{66})}{(1 + \alpha^2)^2} + \frac{D_{11} - D_{22}}{D_{11}} \frac{\alpha^4}{(1 + \alpha^2)^2} \right] \tag{9.3}$$

when $(D_{12} + 2D_{66}) > D_{11}$, $D = (D_{12} + 2D_{66})$

$$w_{\max} = \frac{q_0 a^4}{\pi^4 (D_{12} + 2D_{66})} \frac{1}{(1 + \alpha^2)^2} \left[1 + \frac{D - D_{11}}{D} \frac{1}{(1 + \alpha^2)^2} + \frac{D - D_{22}}{D} \frac{\alpha^4}{(1 + \alpha^2)^2} \right] \tag{9.9}$$

For long plates ($\alpha = 0$), it can be seen that the first of these equations reduces to one similar to that given in the previous discussion of long plates, whereas the second equation is different in form since two terms will be retained. From the previous discussion, it should be realized that the maximization of the D_{ij} depends on the relative magnitude of C_{11} and $C_{12} + 2C_{66}$ (C_{11} can always be defined to be greater than C_{22}).

Rather than attempt to continue in general terms, a series of numerical examples will be studied. First, consider the material in the layers to be such that $C_{11} = 1.0C$, $C_{12} + 2C_{66} = C_{22} = 0.8C$. (These values are chosen so that the n_{ij} will be less than 0.2, and their squares, products, and higher powers will be

negligible.) These layers may be oriented so as to maximize \bar{C}_{11} (thus maximizing D_{11}) or so as to maximize $\bar{C}_{12} + 2\bar{C}_{66}$ (maximizing $D_{12} + 2D_{66}$). When the layers are orientated so as to maximize \bar{C}_{11} (i.e., $\theta = 0$), it can be shown that

$$\bar{C}_{11} = 1.0C$$

$$\bar{C}_{12} + 2\bar{C}_{66} = 0.8C$$

$$\bar{C}_{22} = 0.8C$$

When these same layers are oriented so as to maximize $\bar{C}_{12} + 2\bar{C}_{66}$ (i.e., $\theta = 45^\circ$), it can be shown that:

$$\bar{C}_{11} = 0.85C$$

$$\bar{C}_{12} + 2\bar{C}_{66} = 0.95C$$

$$\bar{C}_{22} = 0.85C$$

For the first case ($\theta = 0^\circ$), Eq (9.8) becomes:

$$w_{\max} = \frac{q_0 a^4}{\pi^4 D} \frac{1}{(1 + \alpha^2)^2} \left[1 + 0.4 \frac{\alpha^2}{(1 + \alpha^2)^2} + 0.2 \frac{\alpha^4}{(1 + \alpha^2)^2} \right] \quad (9.10)$$

For the second case ($\theta = 45^\circ$), Eq (9.9) becomes:

$$w_{\max} = \frac{q_0 a^4}{\pi^4 D} \frac{1.05}{(1 + \alpha^2)^2} \left[1 + \frac{0.105}{(1 + \alpha^2)^2} + \frac{0.105 \alpha^4}{(1 + \alpha^2)^2} \right] \quad (9.11)$$

where

$$D = C \frac{t^3}{12}$$

Next, consider the material in the layers to be such that $C_{12} + 2C_{66} = 1.0C$, $C_{11} = C_{22} = 0.8C$. When these layers are oriented so as to maximize \bar{C}_{11} (i.e., $\theta = 45^\circ$), it can be shown that:

$$\bar{C}_{11} = 0.9C$$

$$\bar{C}_{12} + 2\bar{C}_{66} = 0.7C$$

$$\bar{c}_{22} = 0.90$$

When these layers are oriented so that $\bar{c}_{12} + 2\bar{c}_{66}$ is a maximum (i.e., $\theta = 0^\circ$), it can be shown that:

$$\bar{c}_{11} = 0.80$$

$$\bar{c}_{12} + 2\bar{c}_{66} = 1.00$$

$$\bar{c}_{22} = 0.80$$

For the first case ($\theta = 45^\circ$), Eq. (9.8) becomes:

$$w_{\max} = \frac{q_0 a^4}{\pi^4 D} \frac{1.111}{(1 + \alpha^2)^2} \left[1 + 0.444 \frac{\alpha^2}{(1 + \alpha^2)^2} \right] \quad (9.12)$$

For the second case ($\theta = 0^\circ$), Eq (9.9) becomes:

$$w_{\max} = \frac{q_0 a^4}{\pi^4 D} \frac{1}{(1 + \alpha^2)^2} \left[1 + \frac{0.2}{(1 + \alpha^2)^2} + \frac{0.2 \alpha^4}{(1 + \alpha^2)^2} \right] \quad (9.13)$$

As an indication of the effect of the aspect ratio, α , the maximum deflection has been evaluated from Eqs (9.10), (9.11), (9.12), and (9.13) for the limiting conditions $\alpha = 0$ (i.e., the long plate) and $\alpha = 1$ (i.e., the square plate). The results can be summarized as follows:

$w_{\max} / \frac{q_0 a^4}{\pi^4 D}$	$\alpha = 0$		$\alpha = 1$	
	D_{11} maximum	$D_{12} + 2D_{66}$ maximum	D_{11} maximum	$D_{12} + 2D_{66}$ maximum
$c_{11} = 1.00$ $c_{12} + 2c_{66} = 0.80$ $c_{22} = 0.80$	1.0 ($\theta = 0^\circ$)	1.16 ($\theta = 45^\circ$)	0.287 ($\theta = 0^\circ$)	0.276 ($\theta = 45^\circ$)
$c_{11} = 0.80$ $c_{12} + 2c_{66} = 1.00$ $c_{22} = 0.80$	1.111 ($\theta = 45^\circ$)	1.20 ($\theta = 0^\circ$)	0.309 ($\theta = 45^\circ$)	0.275 ($\theta = 0^\circ$)

From the left hand side of this table, it can be seen that for long plates ($\alpha = 0$) the layers should be oriented so as to maximize D_{11} (the same conclusion indicated previously). From the right hand side of this table, it can be seen that for square plates ($\alpha = 1$) the optimum orientation tends to be one which maximizes $D_{12} + 2D_{66}$, although the difference between the values in the first line, 0.287 and 0.276, is within the accuracy to be expected of the perturbation method of solution, (using orthotropic plate theory, which is applicable in this case, it can be shown that the value 0.287 should be 0.278).

Interpreting these results in terms of the angle of orientation, it appears that when C_{11} is greater than $C_{12} + 2C_{66}$ the angle of orientation of each layer should be zero. On the other hand, when $C_{12} + 2C_{66}$ is greater than C_{11} , it appears that for long plates the angle of orientation should be 45 degrees (for $C_{11} = C_{22}$), whereas for square plates the angle of orientation should be zero. The aspect ratio for which the optimum angle of orientation switches from 45 degrees to 0 degrees may be determined by setting Eq (9.8) equal to Eq (9.9). Such a computation for the material constants indicated in the second line of the above table gives an aspect ratio of 0.45. However, the accuracy of such a computation is somewhat questionable because of the approximate nature of the method of solution. The results may be checked by more accurate methods of solution (a refined perturbation method, orthotropic plate theory, or anisotropic plate theory), since only special orientations, for which these methods are applicable, need to be considered.

For the case of a rectangular plate simply supported on two opposite edges and clamped on the other two edges, a study of optimum orientations similar to that given above could be made. The conclusion that the optimum arrangement of the layers is one which is symmetrical with respect to the middle surface of the plate would be found to apply in this case also. Furthermore, the solution can be shown to reduce to be similar in form to that for long rectangular plates when $\alpha = 0$. However, it can be seen from the solution given in Section 8 that it will require extensive numerical calculations in order to arrive at specific conclusions regarding the optimum orientations for particular aspect ratios.

EFFECT OF THE NUMBER OF LAYERS FOR A GIVEN TOTAL THICKNESS

As indicated in the previous discussion, for many cases the deflection is minimized by orienting all of the layers in one direction. In these cases, if the effect of the glue layers is neglected and if the layers are all of the same material, there will be no effect of the number of layers. If the effect of the glue layers is considered, there will be a slight increase in the deflection as the number of layers increases.

PART III: DETERMINATION OF MATERIAL PROPERTIES, FRACTURE CRITERIA

INTRODUCTION

This part of the report contains a section describing a possible procedure which can be followed to determine the elastic properties of an individual orthotropic lamina. Such properties are necessary for use in the plate and shell theory developed in Part I. The final section presents a brief description and the results of a limited number of uniaxial crack propagation tests of laminated foil type laminates.

10. DETERMINATION OF ELASTIC COEFFICIENTS OF INDIVIDUAL LAMINAS

As described in Part I, Section 1, four independent elastic coefficients are required to specify the stress-strain relations for an orthotropic lamina. These are conveniently taken to be tensile moduli of elasticity E_L and E_T , shear modulus of elasticity G_{LT} and either value of Poisson's Ratio ν_{LT} or ν_{TL} . Since it appears to be difficult to measure the shear modulus of foil directly, an indirect method must be employed. One possible approach is to perform tensile stress-strain tests of a foil loaded uniaxially first in the L direction, then the T direction, and finally in one other direction (say 45 degrees). If the first two tests E_L , E_T and ν_{LT} or ν_{TL} can be measured, the value of G_{LT} can be calculated from the third test. The details of this procedure follow.

Following the steps outlined in Part I, Section 1, it is possible to write strain-stress equations for an orthotropic lamina referred to arbitrary axes x, y . Eq (1.2) then takes the more general form

$$\begin{pmatrix} \epsilon_x \\ \epsilon_y \\ \gamma_{xy} \end{pmatrix} = \begin{pmatrix} \bar{S}_{11} & \bar{S}_{12} & \bar{S}_{16} \\ \bar{S}_{12} & \bar{S}_{22} & \bar{S}_{26} \\ \bar{S}_{16} & \bar{S}_{26} & \bar{S}_{66} \end{pmatrix} \begin{pmatrix} \sigma_x \\ \sigma_y \\ \tau_{xy} \end{pmatrix} \quad (10.1)$$

The relationships between the S_{ij} and \bar{S}_{ij} and the angle θ are given by

$$\begin{aligned} \bar{S}_{11} &= S_{11} \cos^4 \theta + (2S_{12} + S_{66}) \sin^2 \theta \cos^2 \theta + S_{22} \sin^4 \theta \\ \bar{S}_{12} &= S_{12} (\cos^4 \theta + \sin^4 \theta) + (S_{11} + S_{22} - S_{66}) \sin^2 \theta \cos^2 \theta \\ \bar{S}_{22} &= S_{22} \cos^4 \theta + (2S_{12} + S_{66}) \sin^2 \theta \cos^2 \theta + S_{11} \sin^4 \theta \\ \bar{S}_{66} &= S_{66} (\cos^4 \theta + \sin^4 \theta) + 2(2S_{11} + 2S_{22} - 4S_{12} - S_{66}) \sin^2 \theta \cos^2 \theta \\ \bar{S}_{16} &= (2S_{11} - 2S_{12} - S_{66}) \cos^3 \theta \sin \theta - (2S_{22} - 2S_{12} - S_{66}) \cos \theta \sin^3 \theta \\ \bar{S}_{26} &= (2S_{11} - 2S_{12} - S_{66}) \cos \theta \sin^3 \theta - (2S_{22} - 2S_{12} - S_{66}) \cos^3 \theta \sin \theta \end{aligned} \quad (10.2)$$

The constants S_{11} and S_{22} can be obtained from tension tests with $\theta = 0^\circ$ and 90° respectively, since \bar{S}_{11} becomes:

for $\theta = 0^\circ$

$$\bar{S}_{11} \Big|_{\theta = 0^\circ} = S_{11} \quad (10.3)$$

and for $\theta = 90^\circ$

$$\bar{S}_{11} \Big|_{\theta = 45^\circ} = S_{22} \quad (10.4)$$

The remaining constants to be evaluated are S_{12} and S_{66} ; however, the only value which can be obtained directly by tension tests is the value $(2S_{12} + S_{66})$. If $\theta = 45^\circ$ in the expression for \bar{S}_{11} , then

$$(2S_{12} + S_{66}) = 4\bar{S}_{11} \Big|_{\theta = 45^\circ} - (S_{11} + S_{22}) \quad (10.5)$$

To obtain S_{66} , S_{12} must be experimentally measured. This involves the measurement of Poisson's Ratio. A possible procedure would involve measuring ν_{LT} and ν_{TL} , from which

$$2S_{12} = S_{12} + S_{21} = - \left[\frac{\nu_{LT}}{E_T} + \frac{\nu_{TL}}{E_L} \right] \quad (10.6)$$

Substituting Eq (10.6) and Eq (1.3) into Eq (10.5) gives

$$S_{66} = \frac{4}{E_{45^\circ}} - \left[\frac{1}{E_L} + \frac{1}{E_T} \right] + \left[\frac{\nu_{LT}}{E_T} + \frac{\nu_{TL}}{E_L} \right] \quad (10.7)$$

In this way the required elastic coefficients may be determined.

Preliminary tensile tests on 1100 - H19 aluminum foil of 0.0035 inch thickness indicate that mechanical property values can be obtained as described above. To obtain complete information, one must conduct tension tests in the longitudinal, transverse and 45 degrees directions from which moduli of elasticity E_L , E_T , and E_{45} degrees as well as Poisson's Ratios ν_{LT} and ν_{TL} can be determined.

The photogrid method which has been successfully applied to a number of deformation problems in metal sheets can be applied to the problem of determining the foregoing parameters.

11. CRACK PROPAGATION IN ALUMINUM FOIL LAMINATES *

Crack propagation tests of 4 x 10 inch specimens load in uniaxial tension was performed to study the fracture characteristics of foil-type laminates. The material used for making the laminated specimens was 1100 H-19 aluminum foil, 0.0037 inch thick. The ultimate tensile strength, 0.2 per cent tensile yield strength and elastic modulus were obtained from 1 x 4 inch specimens tested on an Instron (Model TT-BL) tensile testing machine. The results of the tests are shown in Table 4. Loading in the grain direction, across it as well as at 45 degrees to the grain direction of the foil, was done to determine the anisotropy of the aluminum foil.

The laminated specimens were made from 4 x 10 inch sheets of 1100 H-19 aluminum foil bonded with epoxy resin FM-47.** Measurements of the glue-line thicknesses showed that they were between 0.00004 to 0.00016 inch; these glue lines were achieved by applying a 3:2 thinner to epoxy resin mixture with a special spray gun. A typical specimen configuration is shown in Figure 1, and as can be seen, the initial crack was made by drilling a 1/8-inch hole and sawing a 0.008 inch slot of desired length through the entire thickness of the laminated specimens. Two, four, six, and ten-ply laminated sheets with the foil grain direction both parallel and perpendicular to the direction of the applied tensile load was tested. The specimens having initial crack lengths x_0 of 0.5, 0.6, 0.8, and 1.0 inches were tested in a Tate-Baldwin 60,000 pound tensile testing machine. A scale of 0.01 inch least count was used to measure crack extension during the slow load application until unstable crack lengths, i.e. sudden fracture, occurred.

The experimental results are summarized in Table 5 and are plotted in Figures 2, 3, 4, and 5 for 2-, 4-, 6-, and 10-ply laminated specimens respectively. The plots of gross area stress vs. crack length show the crack initiation and failure lines for specimens of varying crack length. During the course of the experiments, it was observed that upon reaching maximum load a brief discontinuous crack growth took place without the usual load drop experienced in tests of monolithic specimens. Although brief in nature, this critical propagation characteristic illustrates the temporary ability of the laminate to arrest propagation until loads beyond the maximum critical load are applied. In monolithic specimens, the crack extension after critical conditions are reached at loads below the maximum load. Both the monolithic sheets and foil laminates failed after formation of deep-necked bands in the plane of the sheet. The bands in the monolithic sheet specimens formed at 45 degrees to the applied tensile load, the bands in the laminate specimens were not as deep and formed on a fracture plane normal to the applied load. The lesser necking of the laminates in the fracture region means that reduction of cross sectional area is less than in monolithic sheets and consequently the load drop is also reduced. The values of net area initiation and fracture stress shown in Table 4 show that crack propagation initiates at a stress far below (less than 60 per cent) the ultimate strength of the material. The net area

* This section was prepared by J. Frisch, Associate Professor of Mechanical Engineering, University of California, Berkeley. The work reported formed part of a Master of Science Thesis in Mechanical Engineering, by C. D. Mote, Jr., June, 1960.

** Bloomingdale Ruber Company, Aberdeen, Maryland.

stress approaches the ultimate strength when the critical crack length is reached.

Figures 6a and 6b show plots of final crack length as a function of the number of foils in the laminate. The ability of 10-ply specimens to withstand longer final crack length, for particular initial crack length, than 2-, 4-, and 6-ply laminates is illustrated and can be directly correlated to the 10-ply laminate's greater load carrying capacity as shown in Table 4. However, direct comparison between 2- and 10-ply specimens should be done only with consideration of the more pronounced buckling, i.e., lower fracture strength, of the 2-ply specimens. The linear relationship between final and initial crack length for different laminates is shown in Figures 7a and 7b for with-grain and cross-grain loading conditions.

Gross area initial stress and maximum gross area stress as functions of initial crack length are shown in Figures 8 and 9, respectively. These data have been replotted on log-log coordinates in Figures 10 and 11 to test the theoretical relationship that the maximum gross area stress will vary inversely with the square root of the initial crack length. Figures 11a and 11b show that curves of slope 0.5 can be fitted to the experimental data of each specimen group and the power relationships are tabulated in Table 5. However, a similar attempt to relate the gross area initiation stress to initial crack length, shown in Figures 10a and 10b, gives no general relationship as indicated in Table 5, where the exponents vary from 0.147 to 0.663. The gross area crack initiation stresses and the maximum gross area stresses as functions of final crack length x_f before sudden fracture are plotted in Figures 12 and 13. Since the final crack length is related to the initial one as shown in Figure 7, the resultant decrease in strength with final crack length as shown in Figures 12 and 13 follows the patterns of the similar plots with respect to the initial crack length.

Of particular interest is the Griffith-Irwin (26) fracture criterion dW/dA , the dissipation rate of plastic work during fracture, shown as a function of initial crack length in Figures 14a and 14b. It can be observed that the values of dW/dA remain relatively constant for each laminated specimen group. The 6- and 10-ply specimens show a substantially greater value of dW/dA than do the 2- and 4-ply specimens. Since higher dissipation rates are associated with slower crack propagation rates before sudden fracture, it may be concluded that additional foil layers would be beneficial. However, as shown in Figure 14a the dissipation rate would be increased only slightly. The calculated values of dW/dA for each specimen and the average values for each specimen group are shown in Table 5. These calculated values incorporate the correction for the ratio of initial crack length to specimen width. It is noteworthy that the average value of dW/dA for any specimen group when substituted in the Griffith-Irwin equation for maximum gross area stress will yield essentially the same constant shown in Table 5 for the empirical power function between maximum gross area stress and initial crack length.

For example, the empirical equation, as shown in Table 5, for 2-ply laminates loaded in the cross-grain direction is

$$\sigma_{\max} = 13.0 x_0^{-0.475} \quad (\text{ksi})$$

The average value of $dW/dA = 30.8$ together with an elastic modulus of 10^7 psi when substituted in the Griffith-Irwin equation gives

$$\sigma_{\max} = 13.9 \times \sigma_0^{-0.500} \quad (\text{ksi})$$

which is sufficiently close to permit failure predictions based on dissipation rate values.

Table 4

Material Properties of 1100 H-19 Aluminum Foil Sheets

	Ultimate Tensile Strength ksi	0.2% Tensile Yield Strength ksi	Modulus of Elasticity psi x 10 ⁻⁶
Tensile Load with Grain Direction of Foil (with grain)	31.10	28.69	9.67
Tensile Load at 45° to Grain Direction of Foil	27.38	25.60	9.15
Tensile Load at 90° to Grain Direction of Foil (cross grain)	28.50	26.10	9.38

Table 5
Summary of Results of Crack Propagation Tests

SPECIMEN CG = CROSS GRAIN WG = WITH GRAIN	INITIAL CRACK LENGTH, x_0 (INCHES)	CRACK LENGTH AT MAXIMUM LOAD, x_f (INCHES)	GROSS AREA (t x B) (INCHES ²)	MAXIMUM GROSS AREA STRESS, σ_{MAX} (KSI)	GROSS AREA INITIATION STRESS σ_I (KSI)	RATE OF PLASTIC WORK DISSIPATED, $\frac{dA}{dW}$ (INCH-POUNDS / INCH ²)	AVERAGE RATE OF PLASTIC WORK DISSIPATED, $\frac{dA}{dW}$ (INCH-POUND / INCH ²)	EMPIRICAL EQUATION OF MAXIMUM STRESS ENVELOPE	EMPIRICAL EQUATION OF INITIATION STRESS ENVELOPE	NET AREA INITIATION STRESS (KSI)	NET AREA FRACTURE STRESS (KSI)
2 PLY LAMINATE LOADING: CG	0.485	0.630	0.0280	17.40	14.75	29.0	30.8	$\sigma_{MAX} = 13.0 x_0^{-0.475}$	$\sigma_I = 10.3 x_0^{-0.494}$	19.4	20.6
	0.700	0.845	0.0273	15.85	12.85	31.7				15.6	20.0
	0.805	1.145	0.0280	14.25	11.90	31.9				14.9	20.0
	1.075	1.225	0.0273	12.65	9.85	30.3				13.5	18.3
2 PLY LAMINATE LOADING: WG	0.575	0.710	0.0282	18.50	13.88	37.3	37.8	$\sigma_{MAX} = 13.7 x_0^{-0.488}$	$\sigma_I = 11.1 x_0^{-0.346}$	16.0	22.7
	0.667	0.955	0.0280	17.05	12.75	39.0				15.2	21.4
	0.800	1.020	0.0277	15.20	12.13	37.2				14.4	18.1
4 PLY LAMINATE LOADING: CG	0.575	0.700	0.0524	21.60	16.35	49.3	46.7	$\sigma_{MAX} = 15.6 x_0^{-0.560}$	$\sigma_I = 11.5 x_0^{-0.663}$	19.3	26.2
	0.612	0.870	0.0551	19.40	15.73	49.2				18.7	24.7
	0.800	0.975	0.0529	18.00	14.00	46.8				17.5	23.8
	1.000	1.225	0.0537	15.30	12.08	44.3				16.2	22.4
	1.200	1.445	0.0523	13.90	10.18	43.8				14.6	21.3
4 PLY LAMINATE LOADING: WG	0.500	0.680	0.0564	21.20	15.50	46.8	48.5	$\sigma_{MAX} = 16.3 x_0^{-0.441}$	$\sigma_I = 12.6 x_0^{-0.325}$	17.9	25.7
	0.640	0.855	0.0562	19.95	14.62	49.2				17.5	25.1
	0.830	1.070	0.0560	18.00	13.38	50.5				16.9	24.1
	1.000	1.315	0.0540	15.35	12.35	47.5				16.5	22.8
6 PLY LAMINATE LOADING: CG	0.545	0.815	0.0752	21.40	17.50	57.8	57.4	$\sigma_{MAX} = 17.0 x_0^{-0.510}$	$\sigma_I = 12.5 x_0^{-0.630}$	20.0	26.9
	0.645	0.835	0.0780	21.25	16.13	57.3				19.3	26.9
	0.845	1.130	0.0740	17.60	14.00	59.8				17.7	24.7
	1.040	1.230	0.0820	17.00	11.83	54.7				16.0	24.5
6 PLY LAMINATE LOADING: WG	0.585	0.815	0.0820	20.50	17.18	55.0	53.0	$\sigma_{MAX} = 17.7 x_0^{-0.456}$	$\sigma_I = 13.25 x_0^{-0.484}$	20.1	25.4
	0.830	1.110	0.0740	17.40	14.50	50.8				18.3	24.2
	1.020	1.325	0.0826	17.00	12.65	53.2				16.9	24.3
10 PLY LAMINATE LOADING: CG	0.535	0.700	0.1404	21.70	15.90	62.7	64.4	$\sigma_{MAX} = 17.75 x_0^{-0.510}$	$\sigma_I = 14.6 x_0^{-0.147}$	18.4	26.3
	0.835	1.215	0.1308	18.50	14.95	64.0				19.0	26.6
	1.000	1.580	0.1365	17.55	14.55	66.4				19.4	26.9
10 PLY LAMINATE LOADING: WG	0.500	0.895	0.1340	20.45	15.23	52.7	52.3	$\sigma_{MAX} = 16.75 x_0^{-0.418}$	$\sigma_I = 13.0 x_0^{-0.221}$	17.4	25.7
	1.030	1.500	0.1388	16.15	12.98	51.9				17.5	25.8

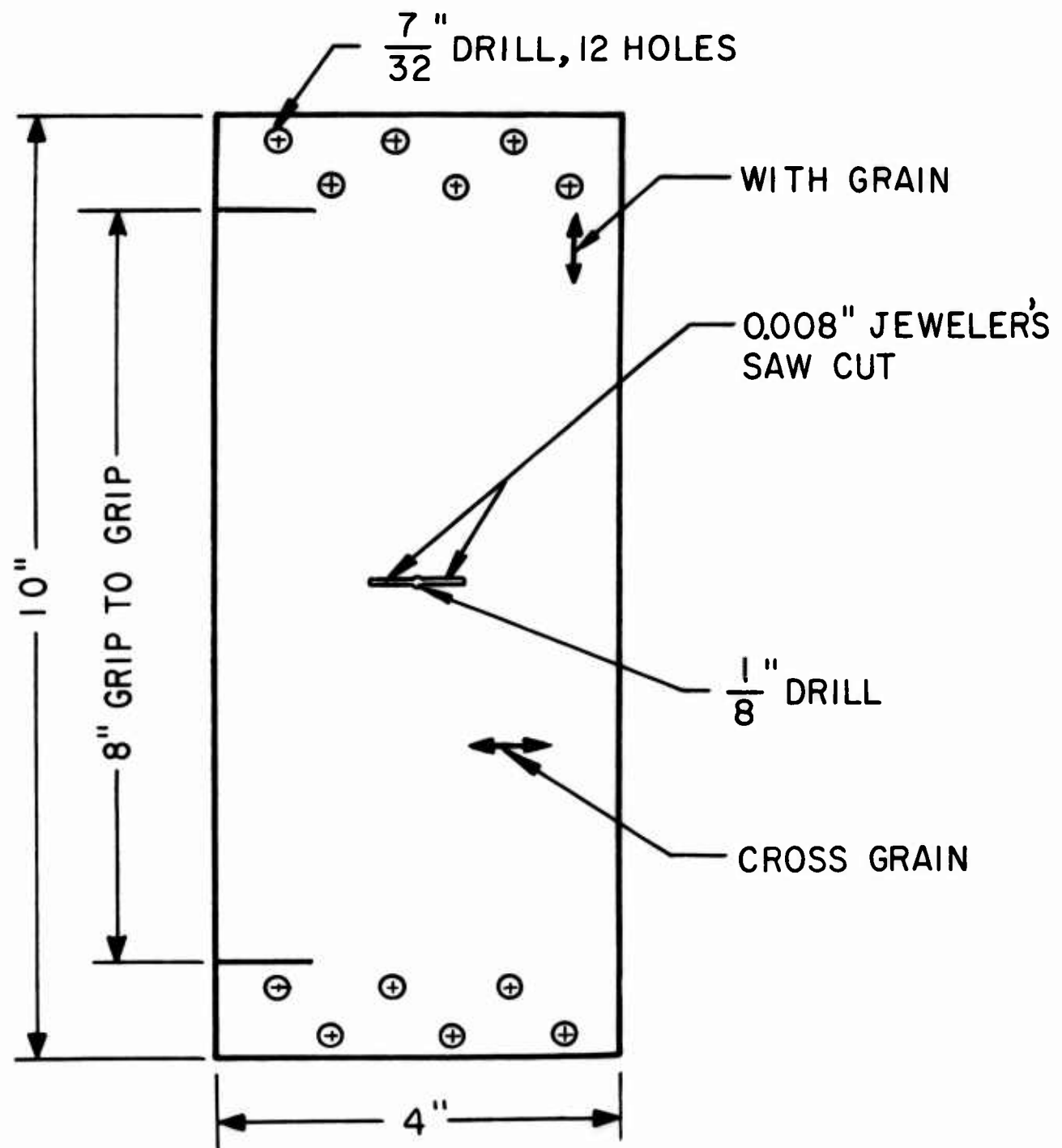

Figure 1. Aluminum Foil Laminate Specimen

Figure 2a. Gross Area Stress vs Crack Length of 2-Ply 1100 H-19 Aluminum Foil Laminates

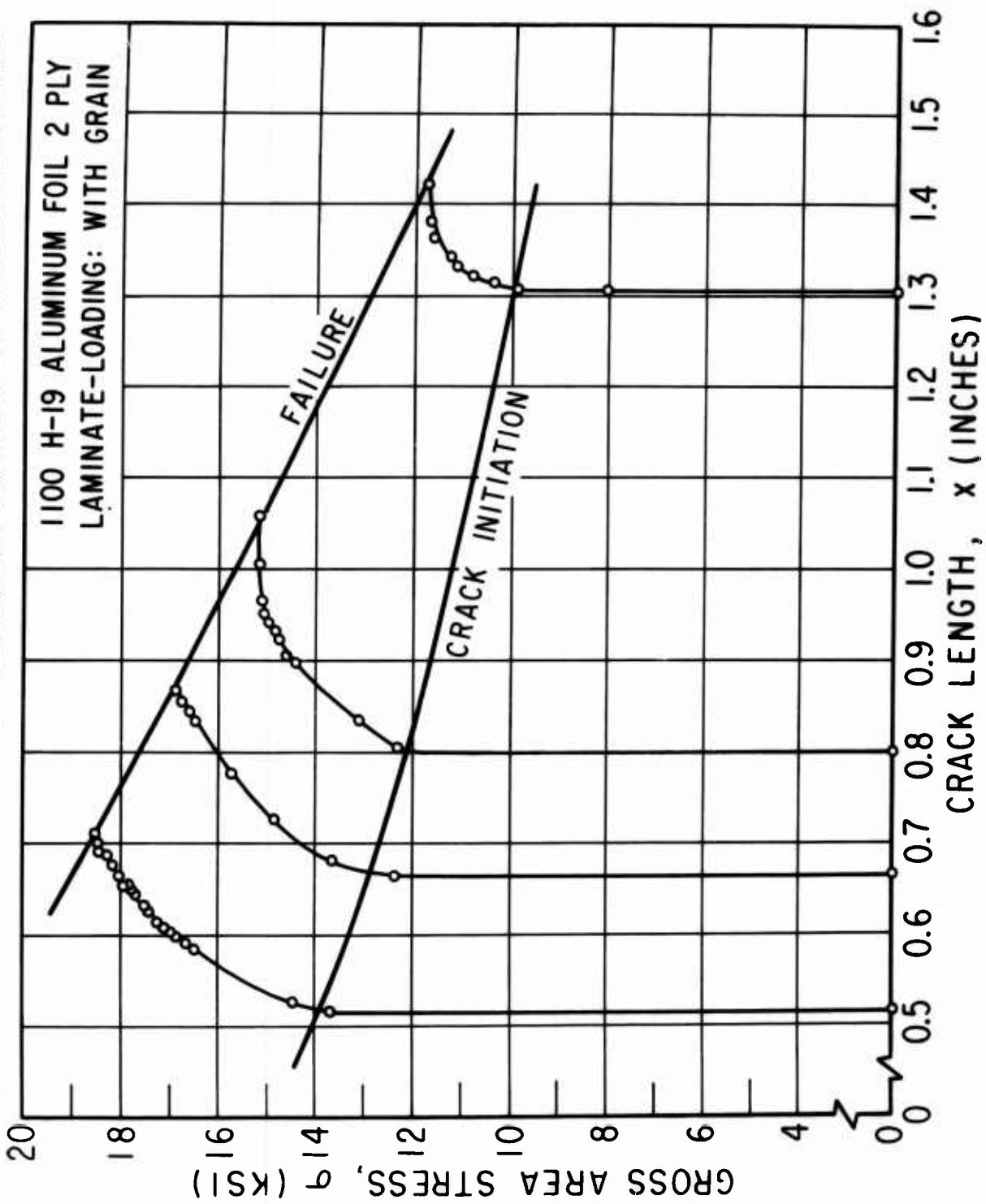

Figure 2b. Gross Area Stress vs Crack Length of 2-Ply 1100 H-19 Aluminum Foil Laminates

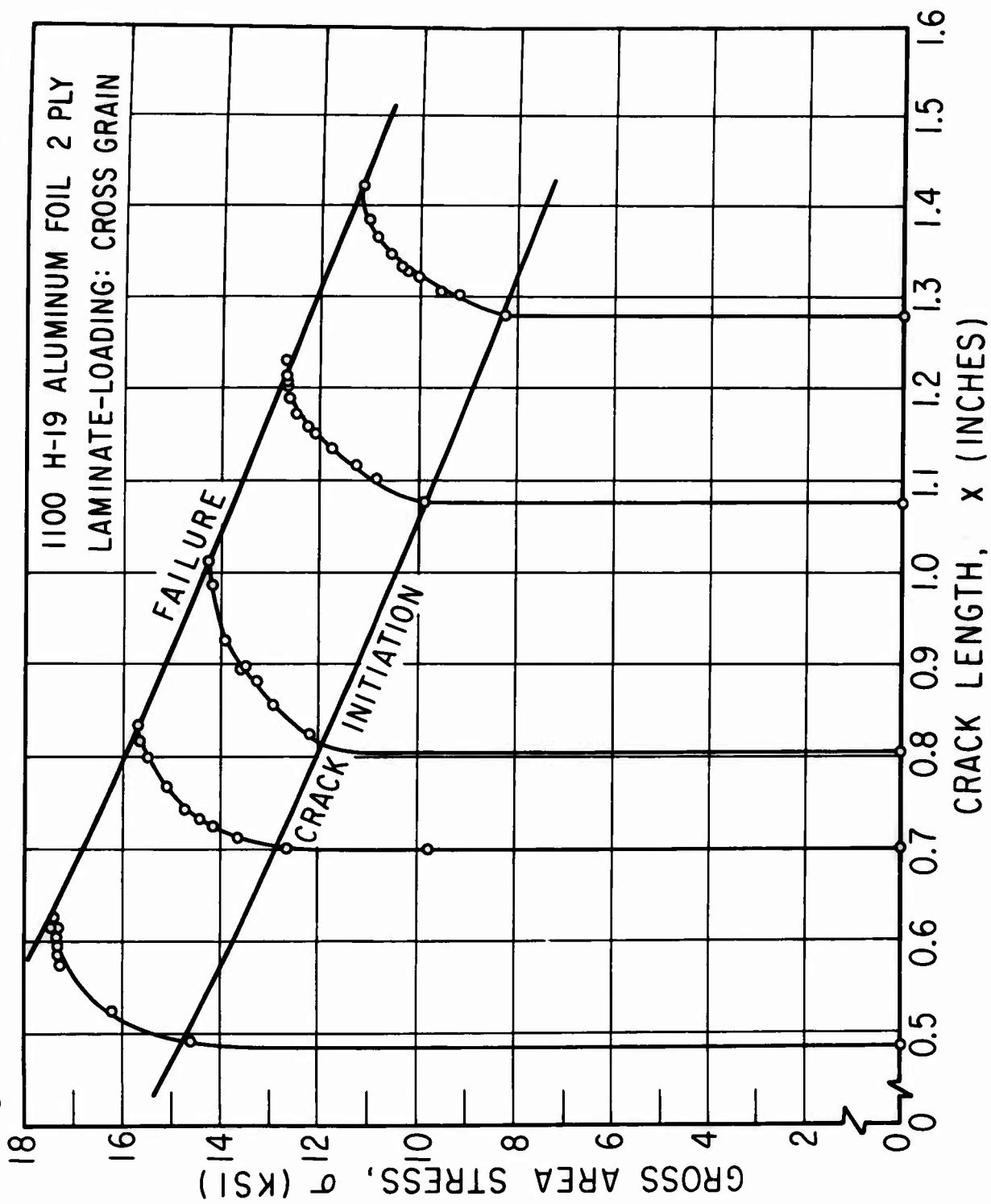

Figure 3a. Gross Area Stress vs Crack Length of 4-Ply 1100 H-19 Aluminum Foil Laminates

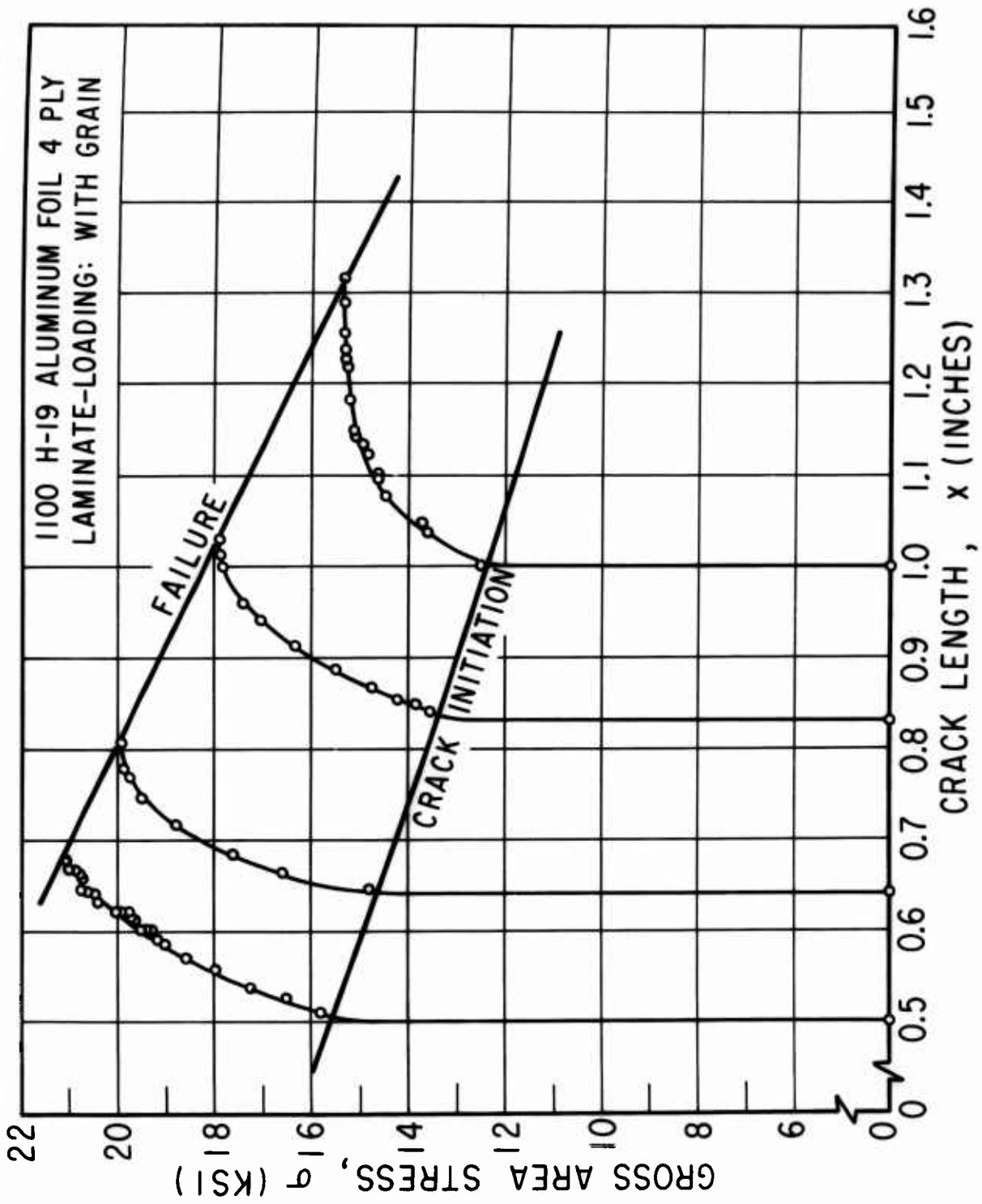

Figure 3b. Gross Area Stress vs Crack Length of 4-Ply 1100 H-19 Aluminum Foil Laminates

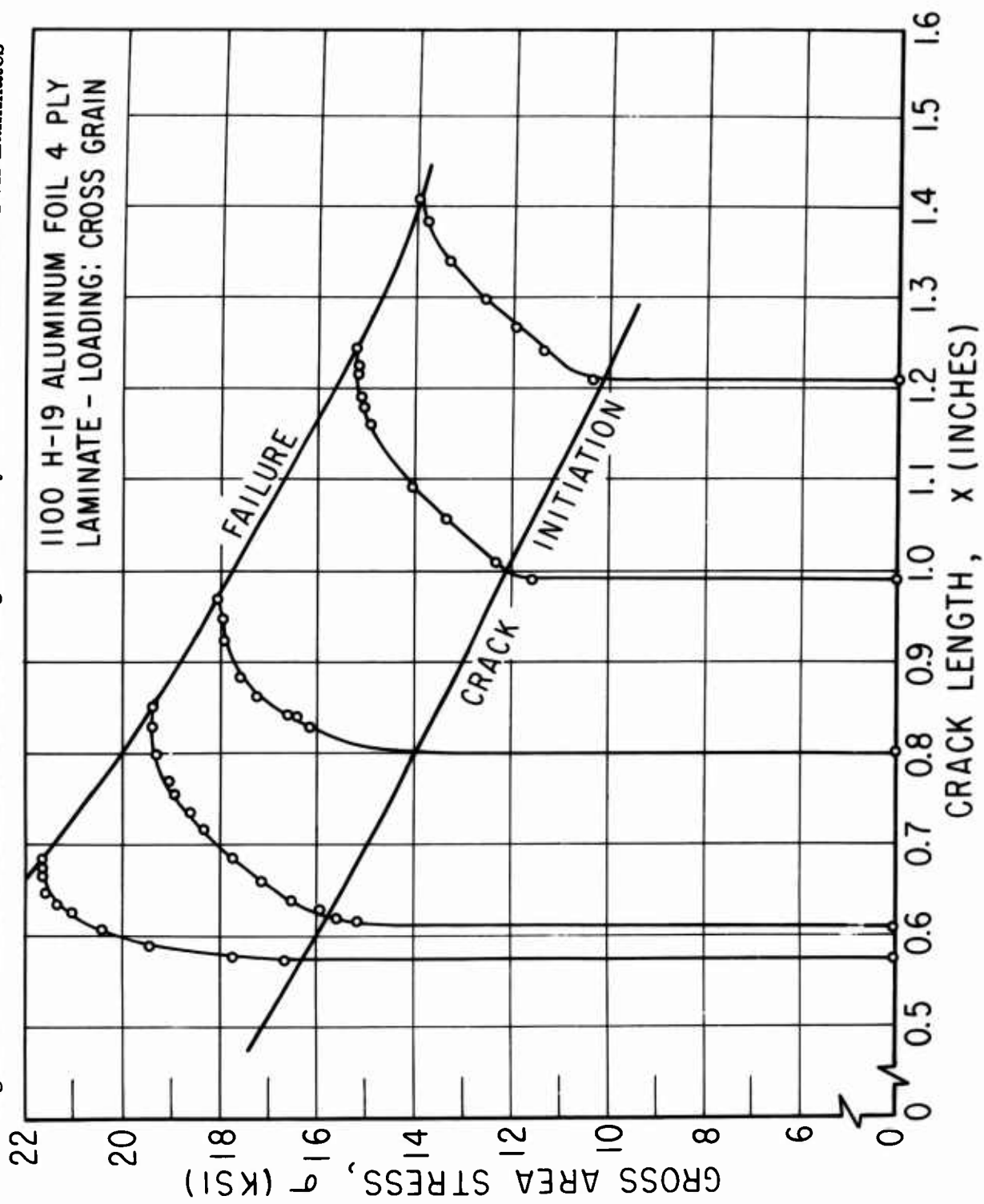

Figure 4a. Gross Area Stress vs Crack Length of 6-Ply 1100 H-19 Aluminum Foil Laminates

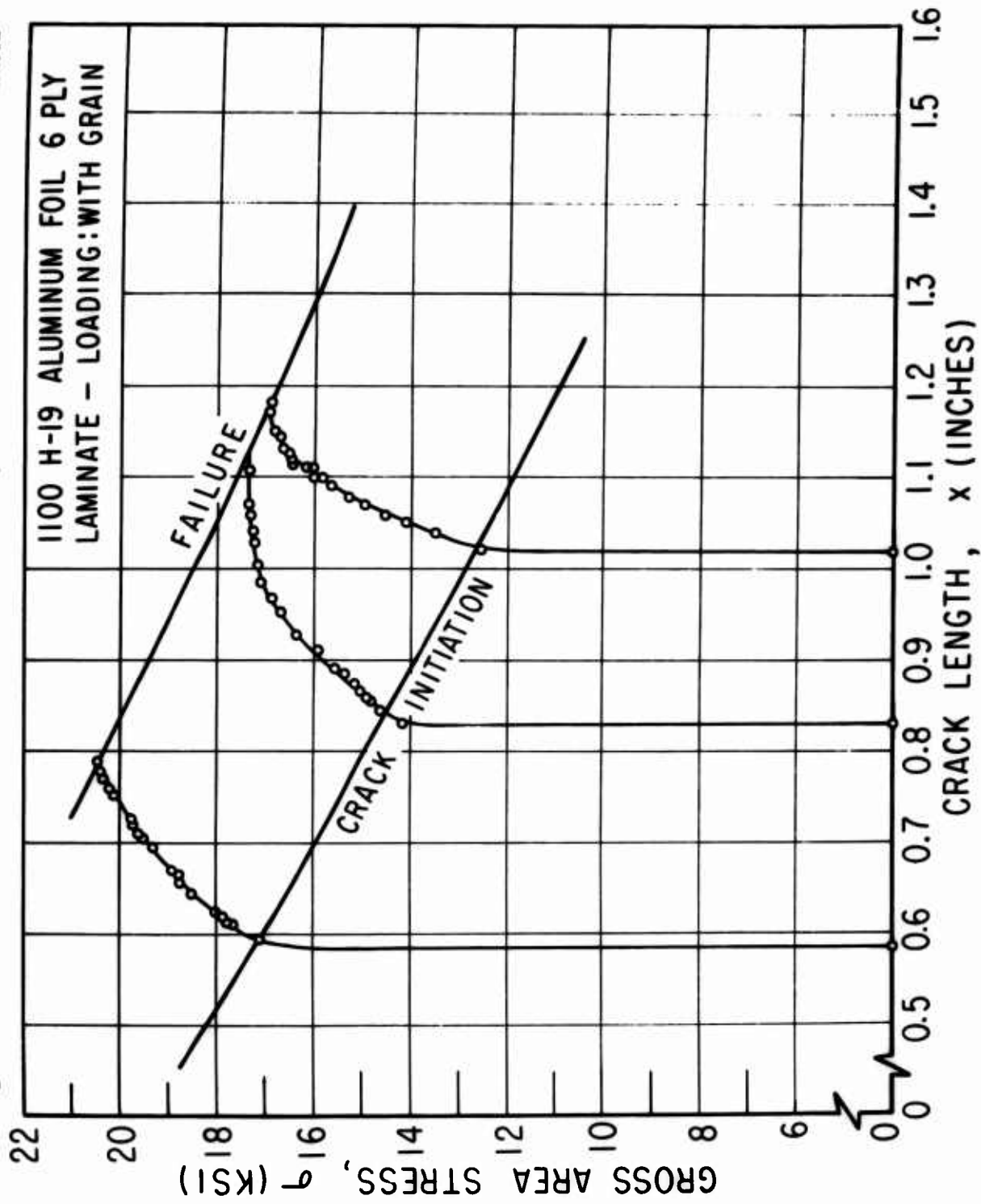

Figure 4b. Gross Area Stress vs Crack Length of 6-Ply 1100 H-19 Aluminum Foil Laminates

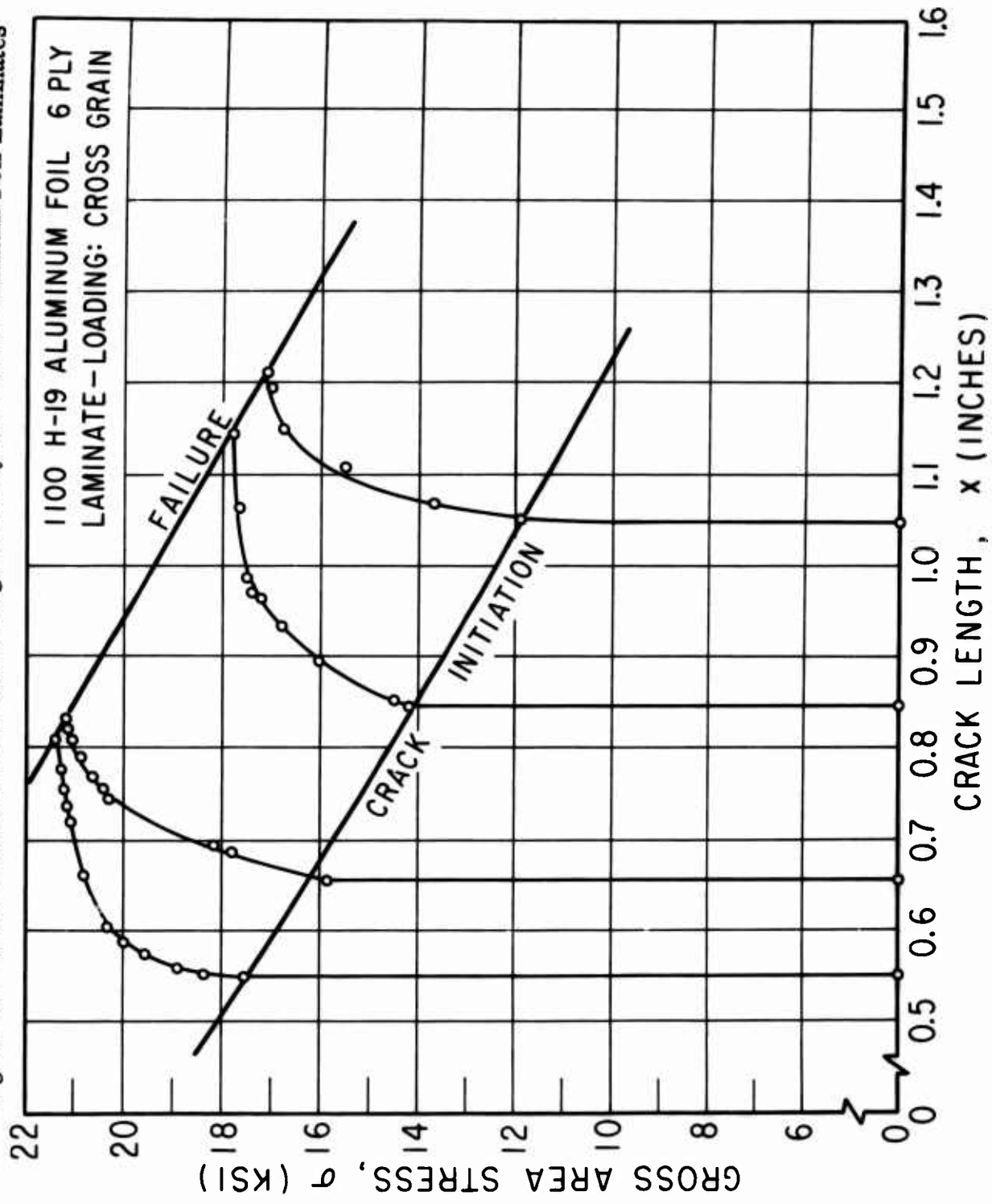

Figure 5a. Gross Area Stress vs Crack Length of 10-Ply 1100 H-19 Aluminum Foil Laminates

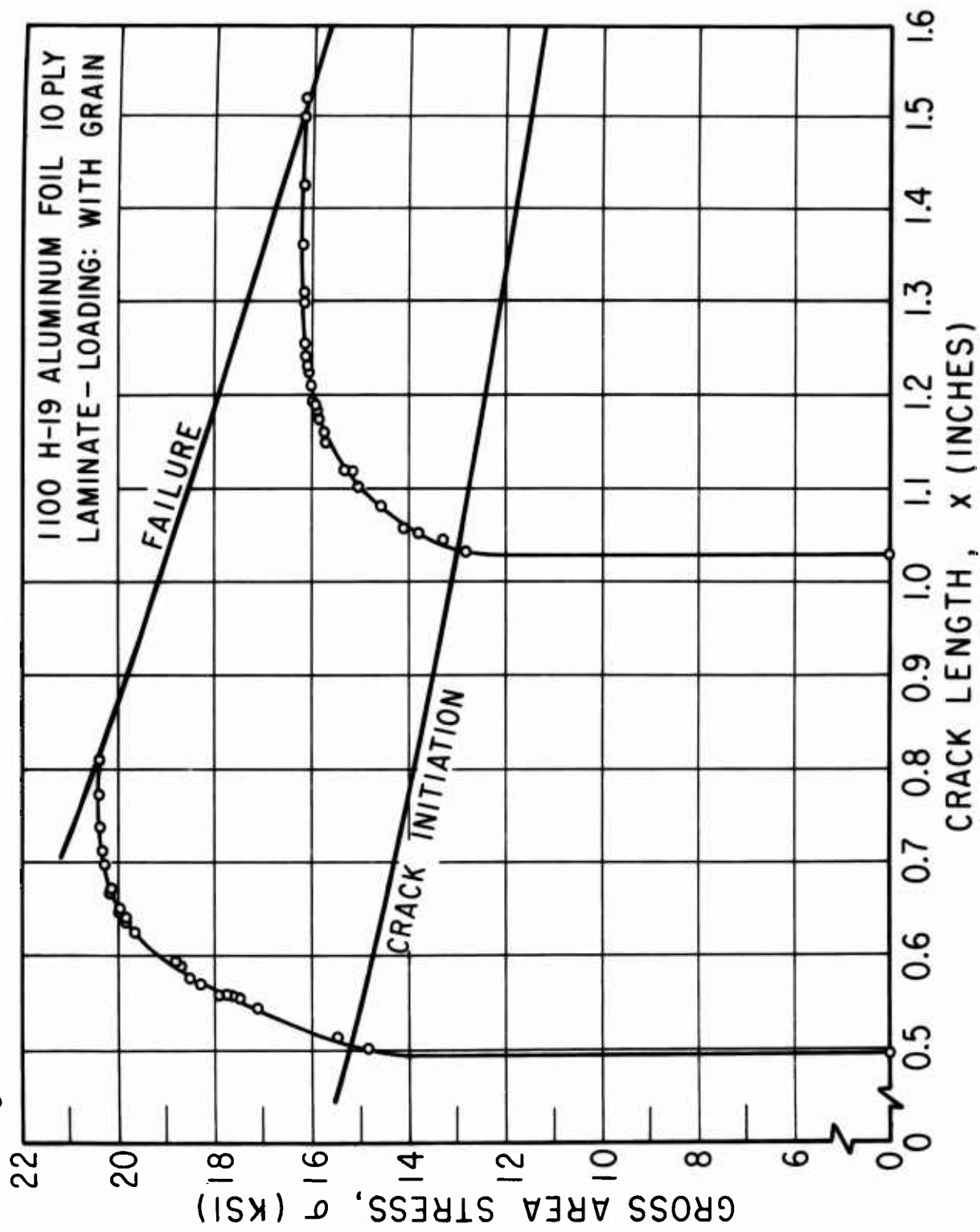
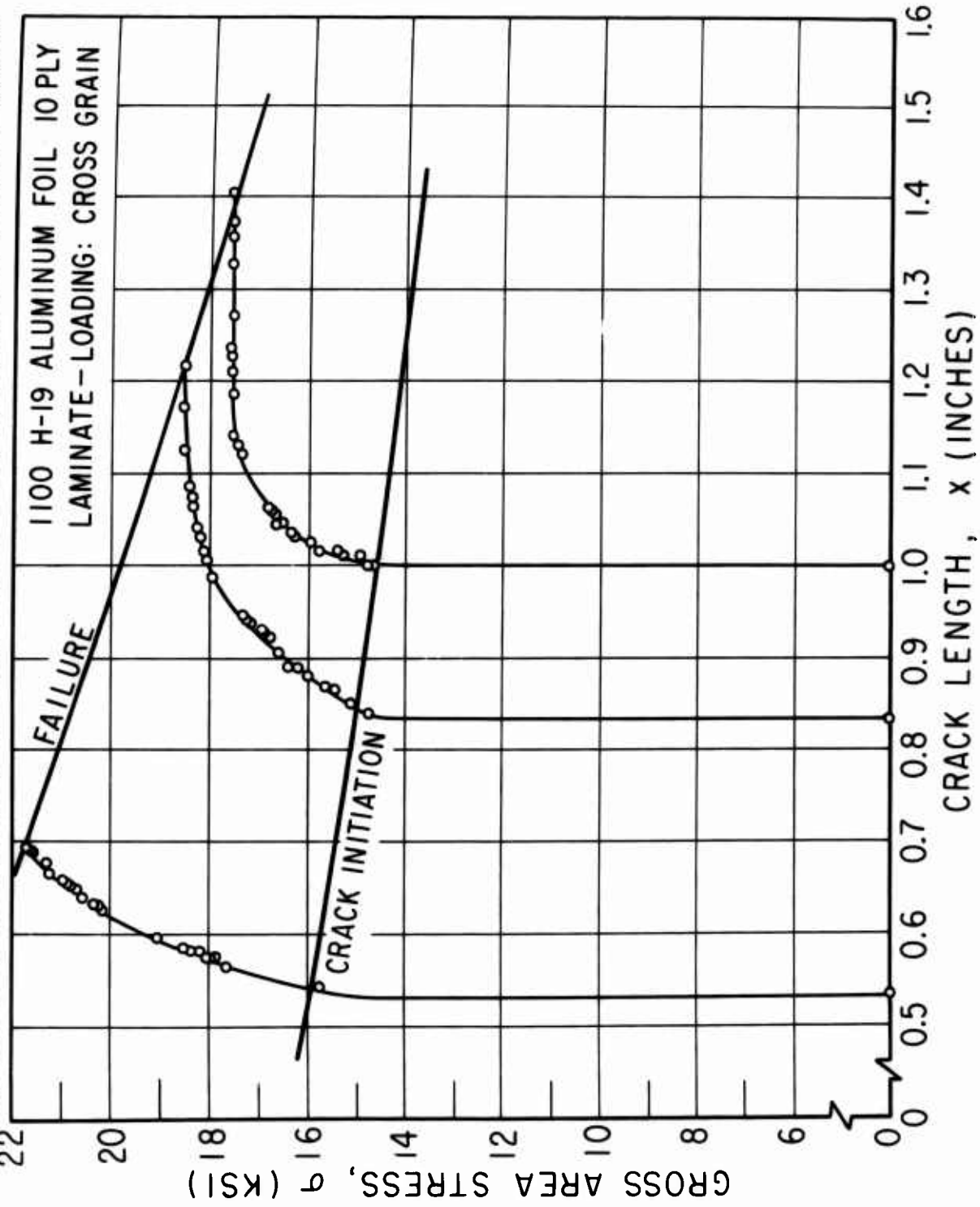

Figure 5b. Gross Area Stress vs Crack Length of 10-Ply 1100 H-19 Aluminum Foil Laminates



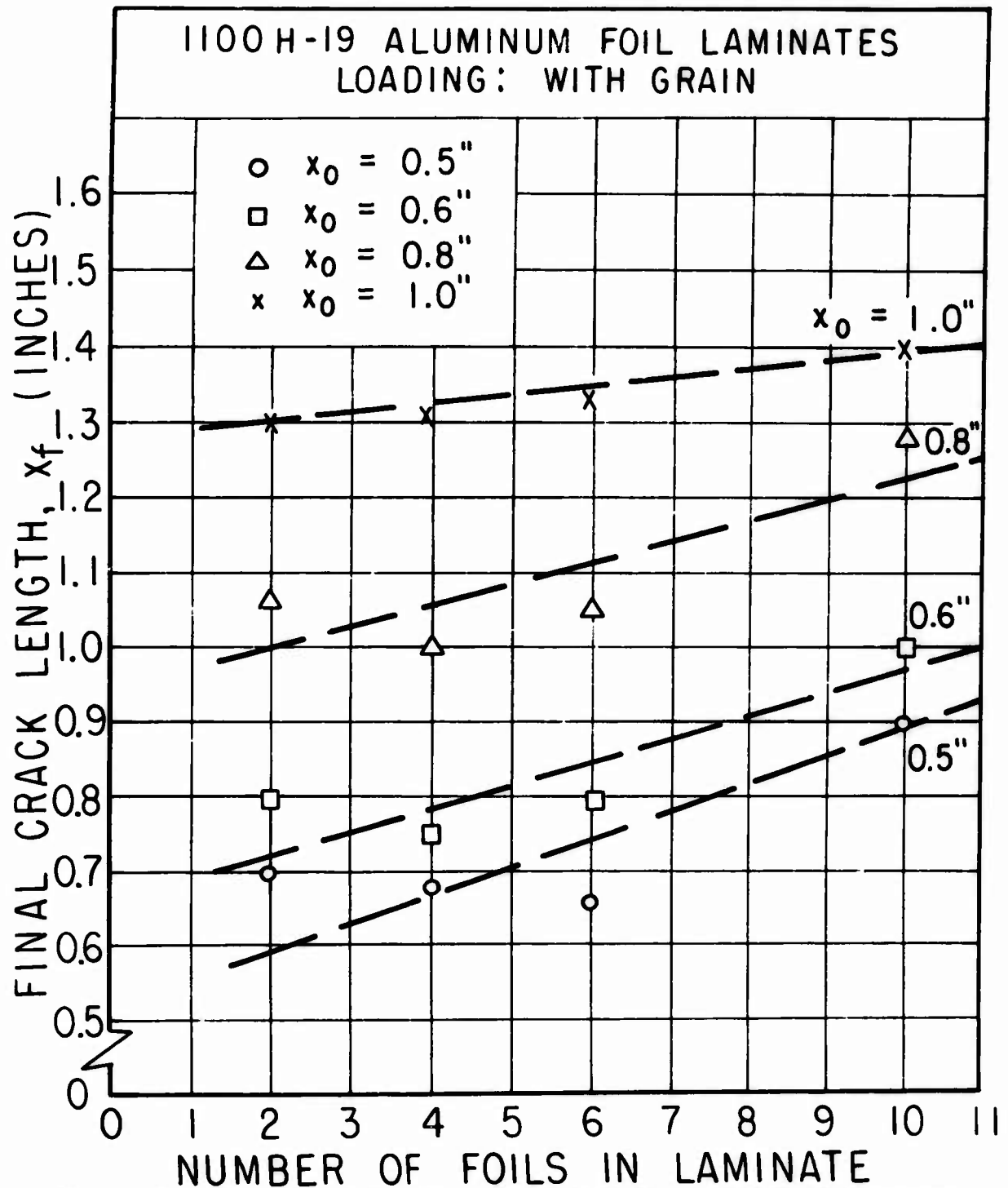

Figure 6a. Final Crack Length vs Number of Ply in 1100 H-19 Aluminum Foil Laminates

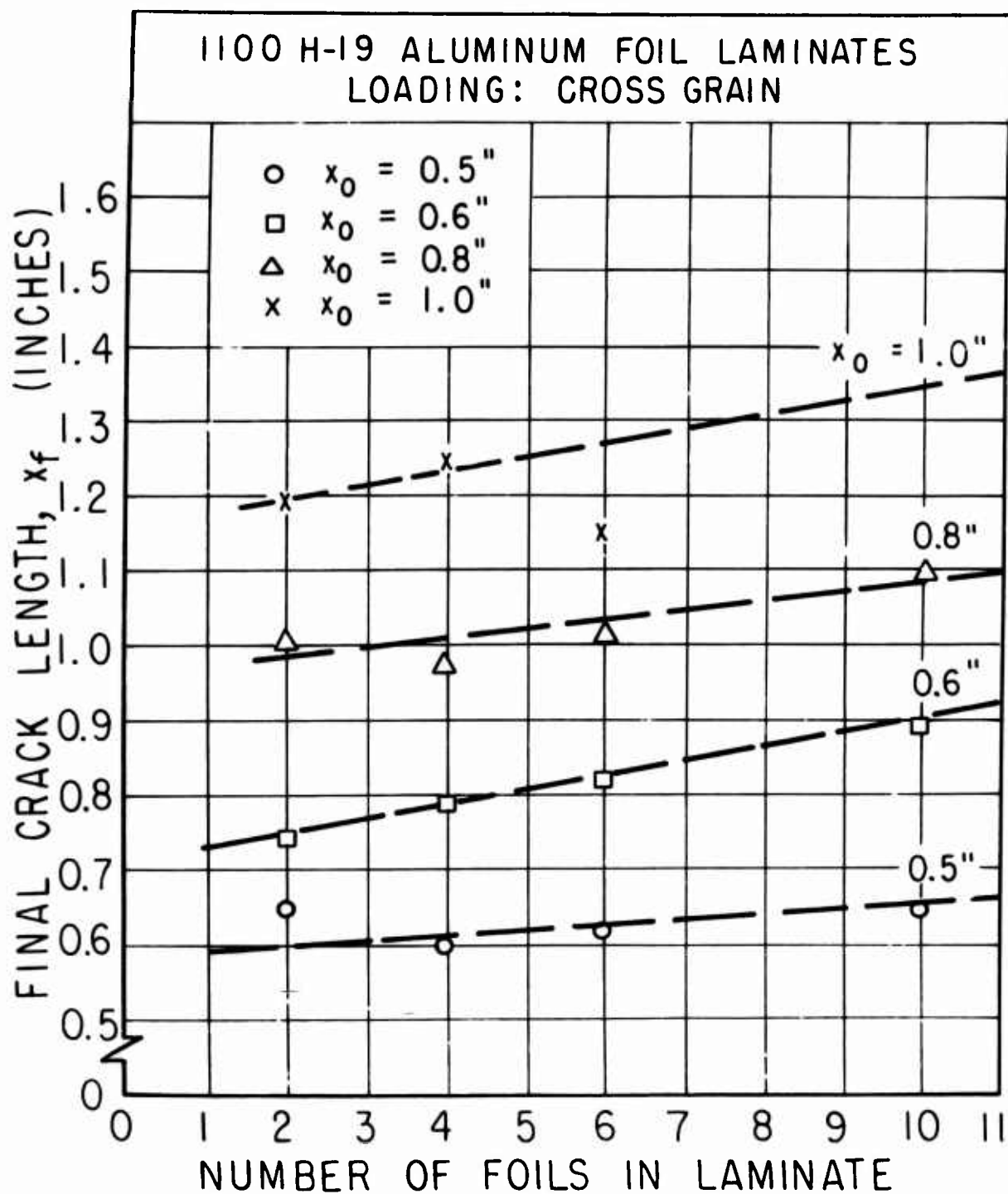

Figure 6b. Final Crack Length vs Number of Ply in 1100 H-19 Aluminum Foil Laminates

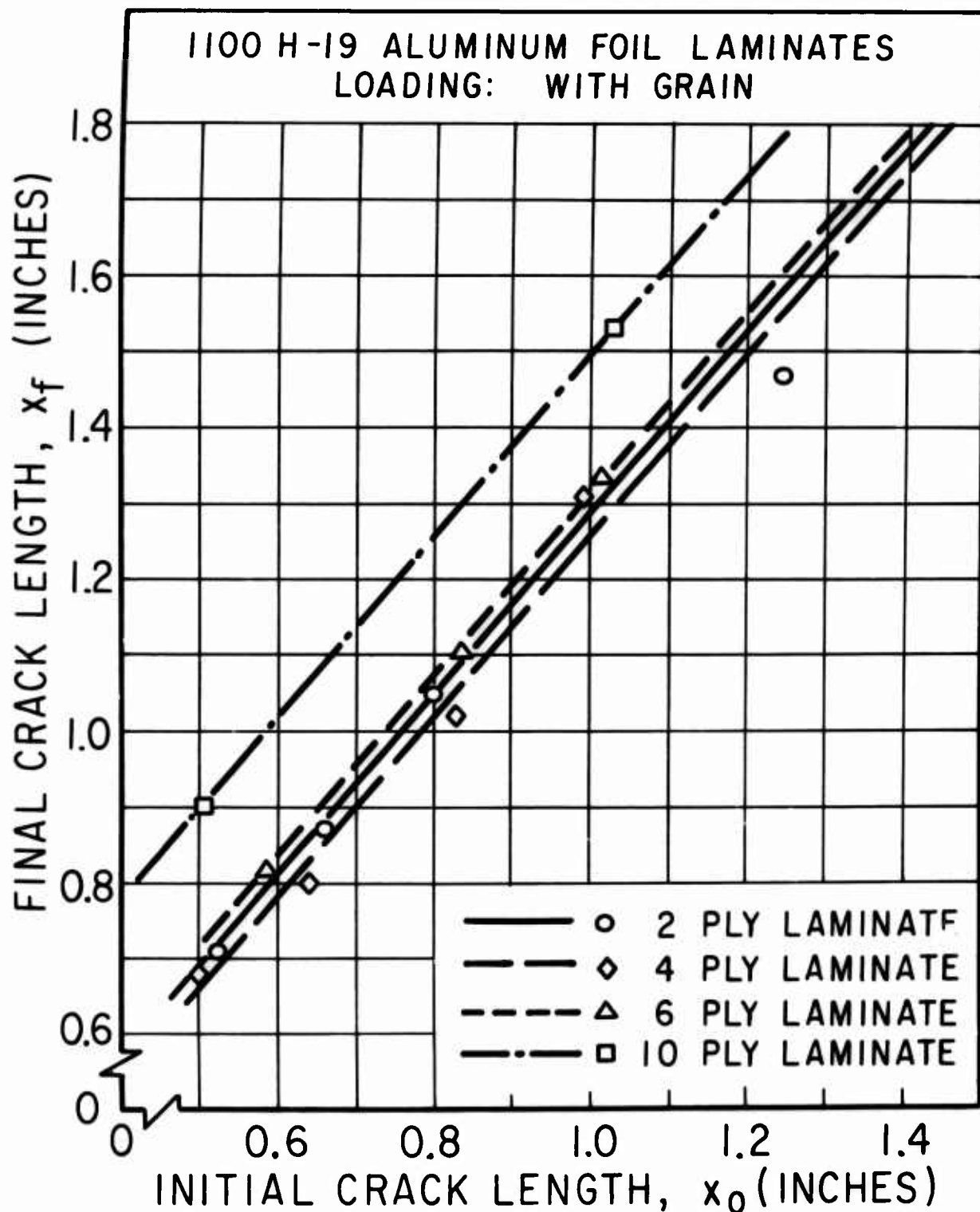

Figure 7a. Final Crack Length vs Initial Crack Length in 1100 H-19 Aluminum Foil Laminates

Figure 7b. Final Crack Length vs Initial Crack Length
in 1100 H-19 Aluminum Foil Laminates

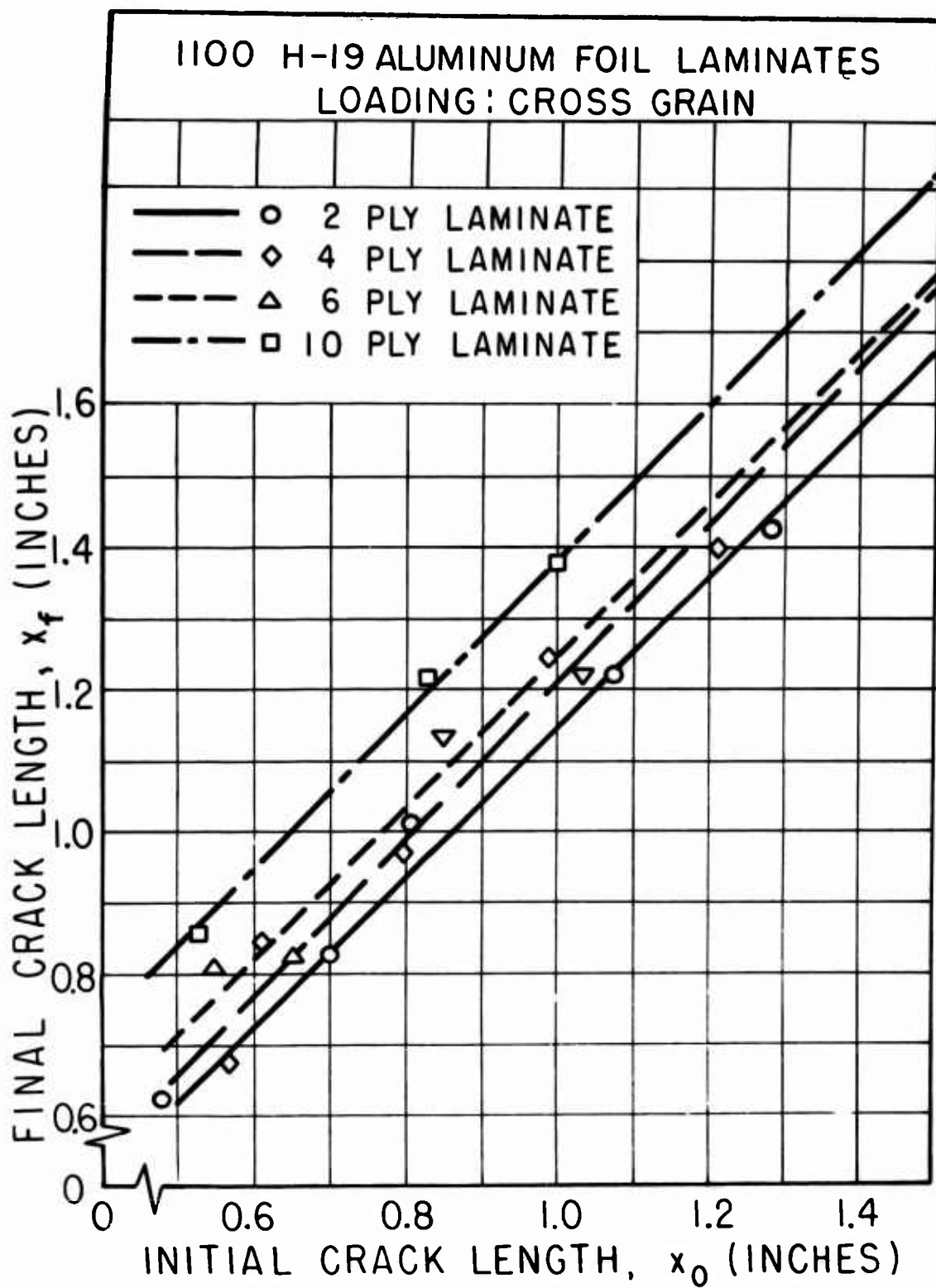
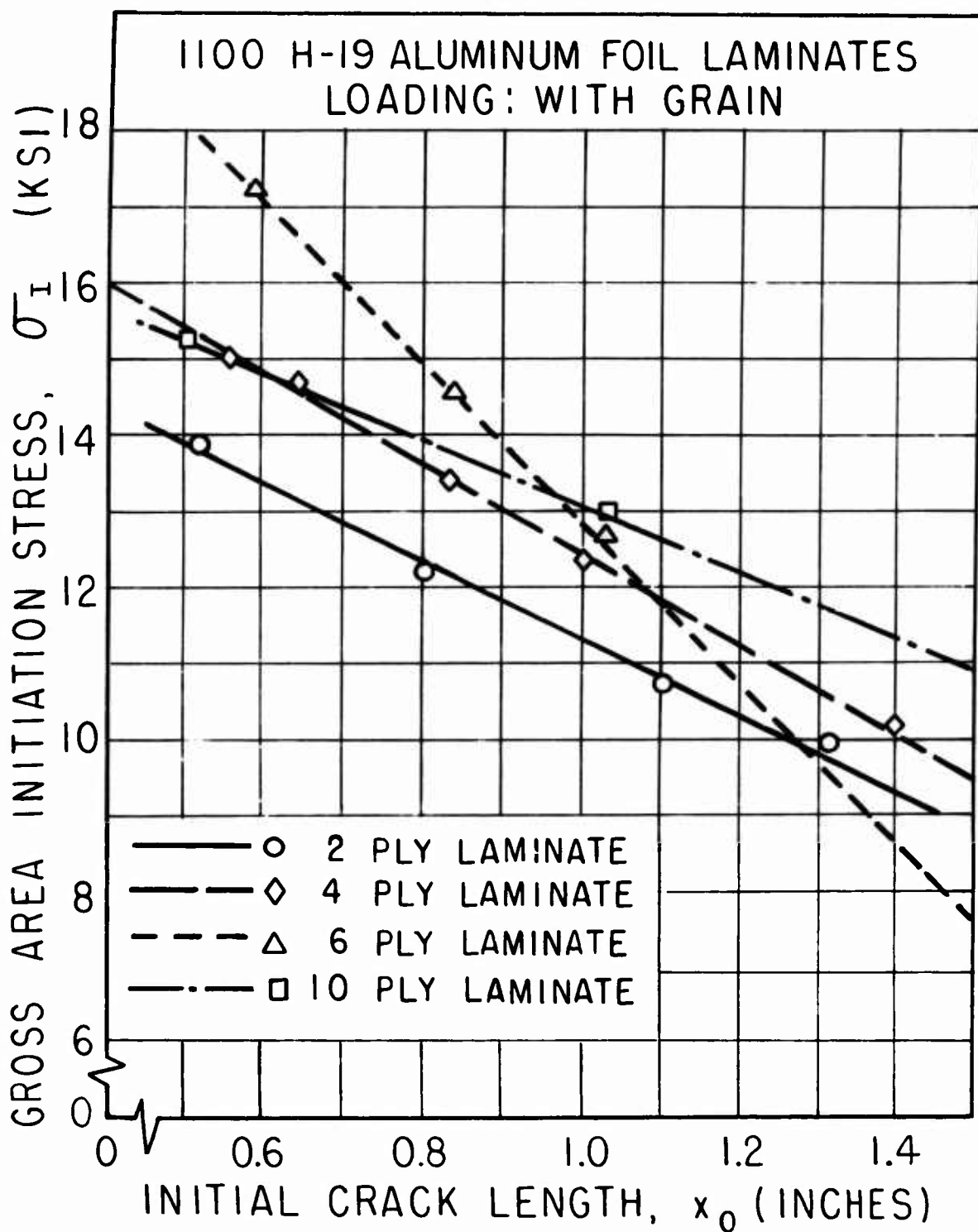

Figure 8a. Gross Area Initiation Stress vs Initial Crack Length
in 1100 H-19 Aluminum Foil Laminates



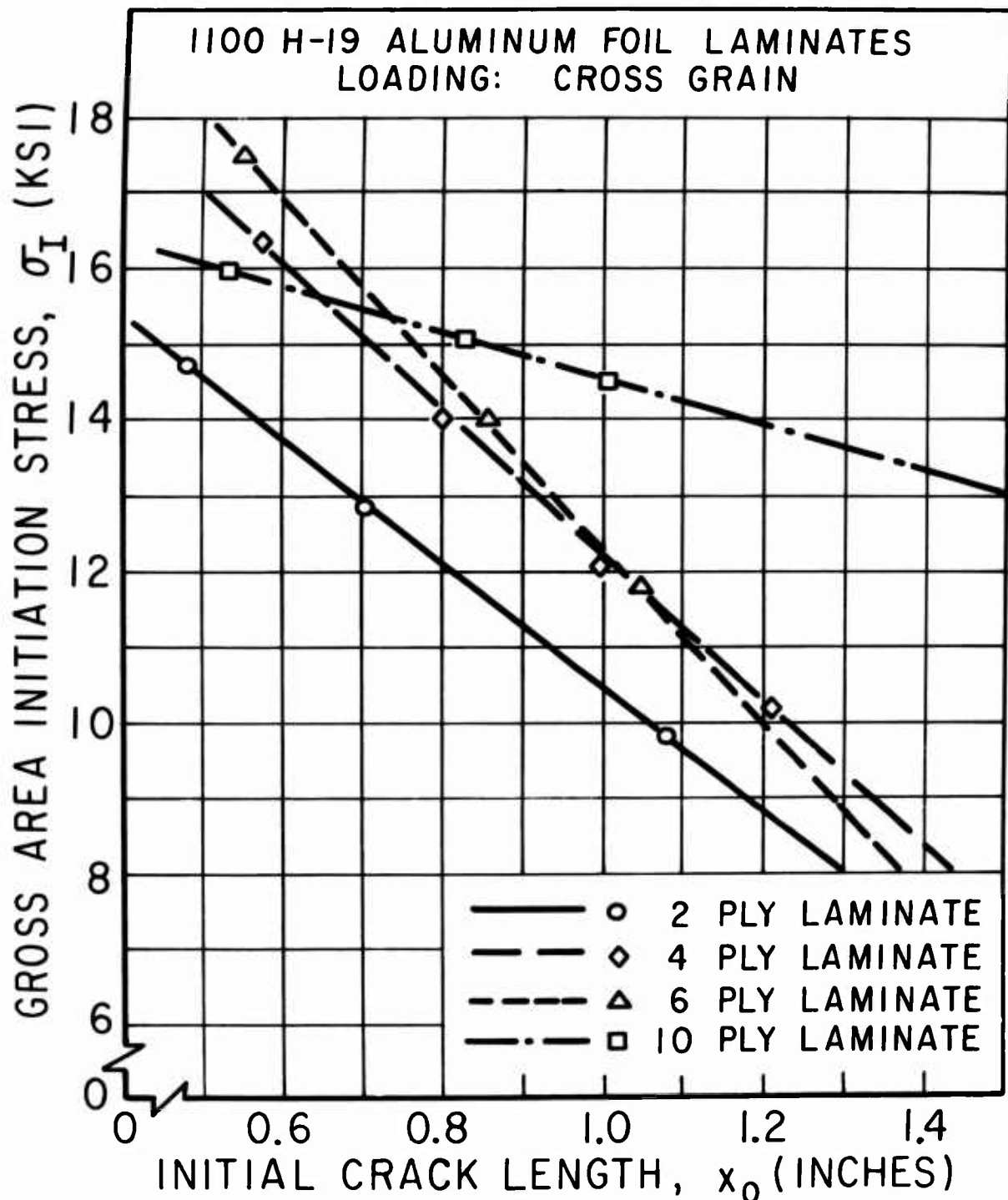

Figure 8b. Gross Area Initiation Stress vs Initial Crack Length in 1100 H-19 Aluminum Foil Laminates

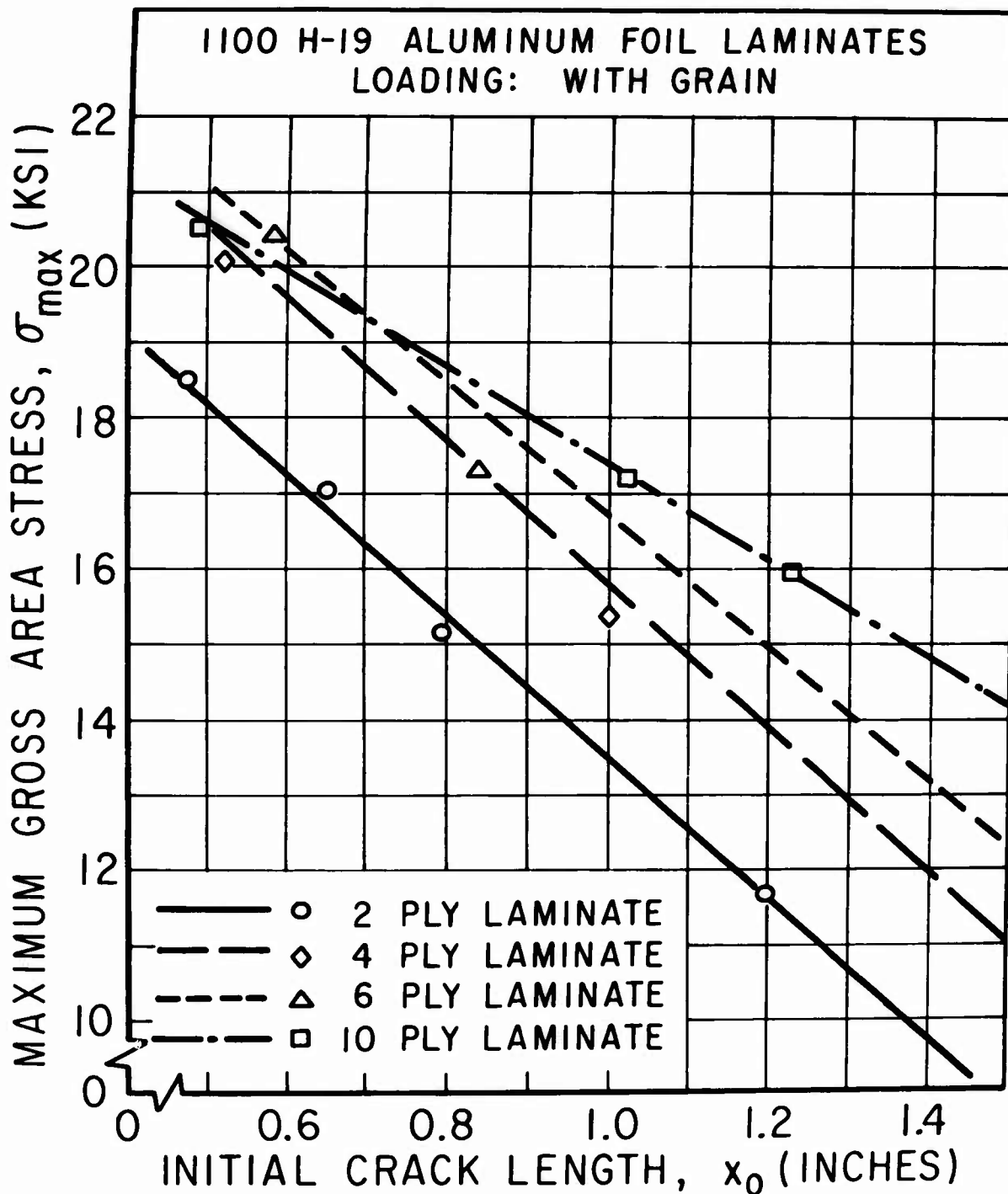
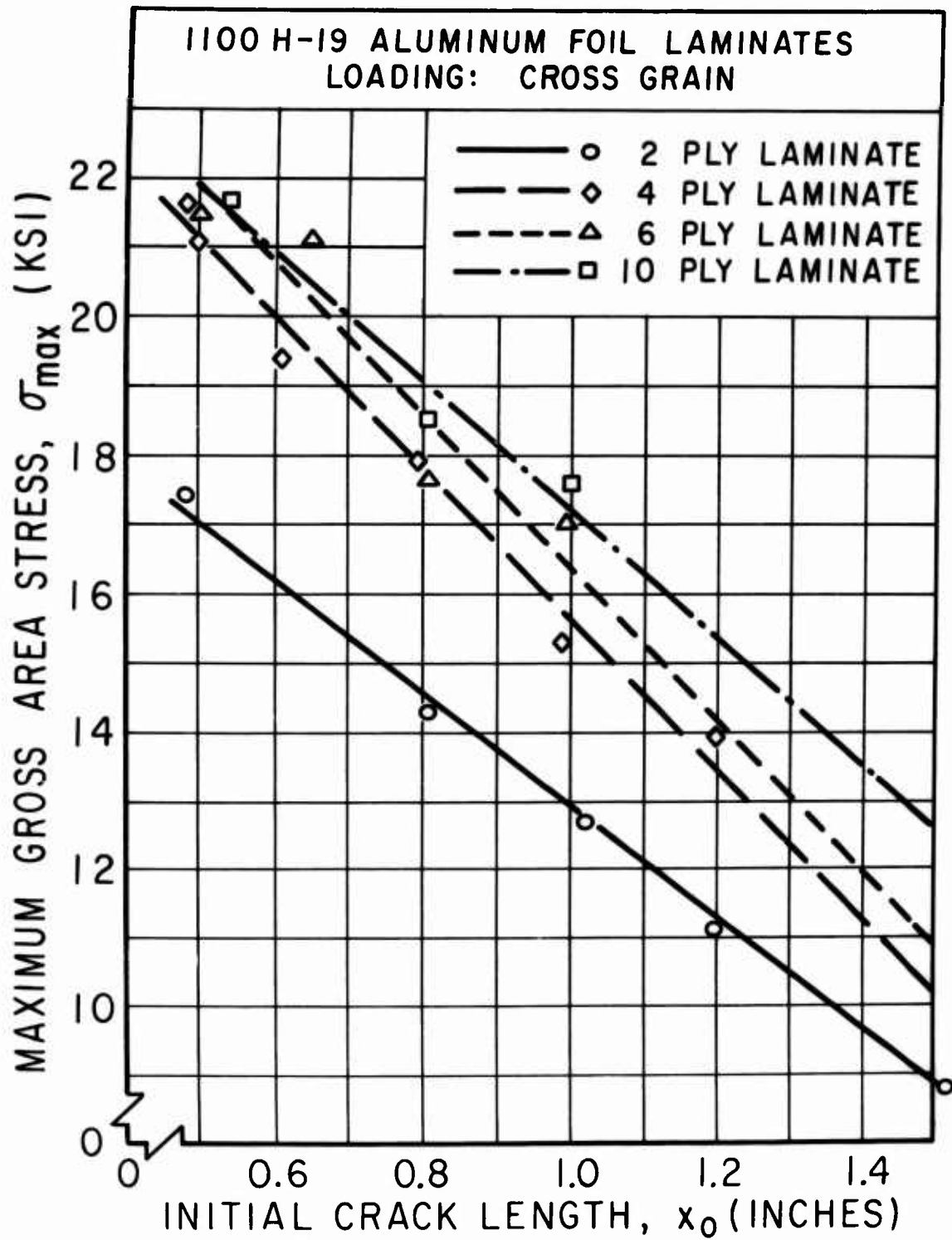

Figure 9a. Maximum Gross Area Stress vs Initial Crack Length in 1100 H-19 Aluminum Foil Laminates

Figure 9b. Maximum Gross Area Stress vs Initial Crack Length
in 1100 H-19 Aluminum Foil Laminates



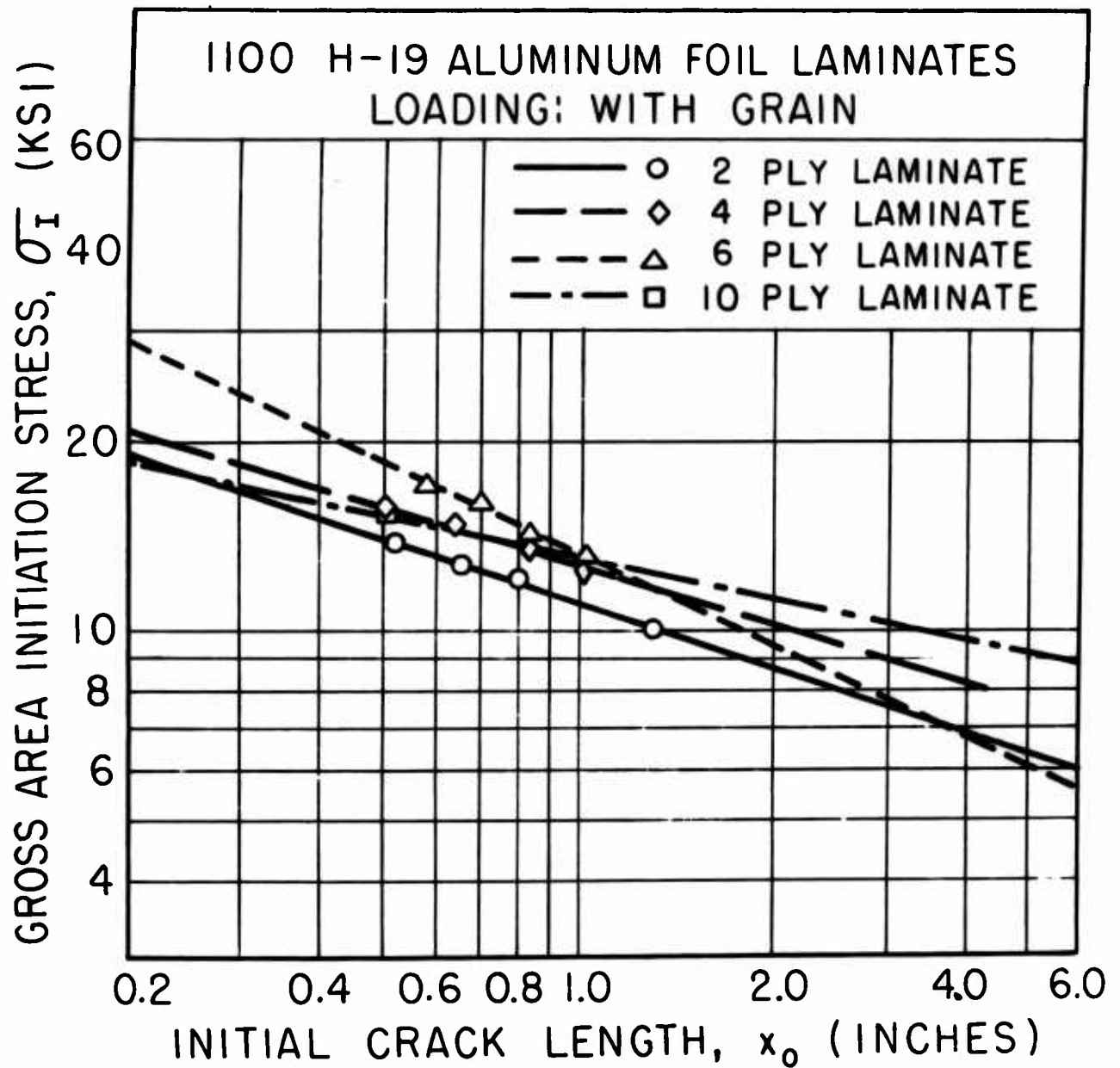

Figure 10a. Log-log Plot of Gross Area Initiation Stress vs Initial Crack Length in 1100 H-19 Aluminum Foil Laminates

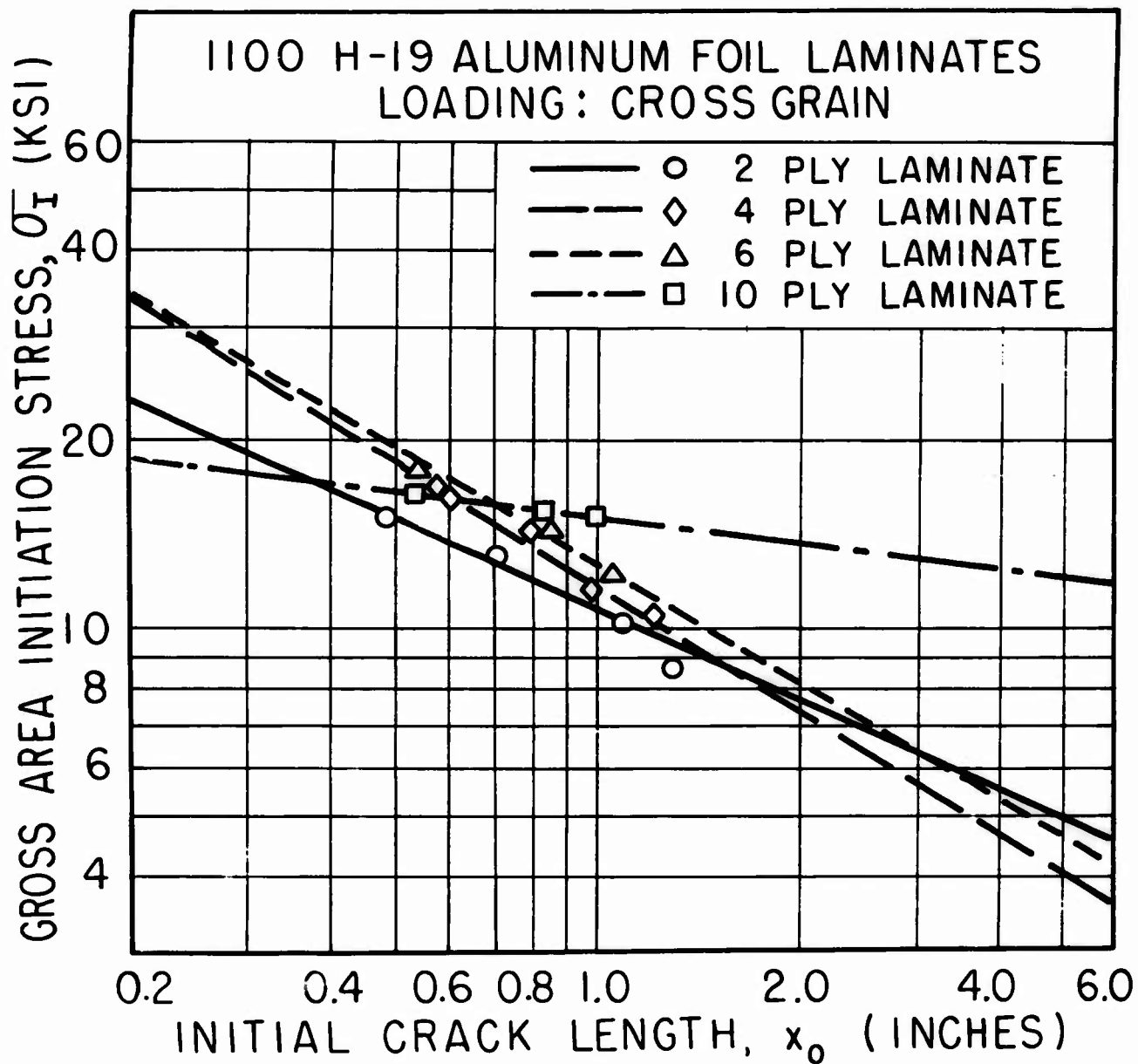

Figure 10b. Log-log Plot of Gross Area Initiation Stress vs Initial Crack Length in 1100 H-19 Aluminum Foil Laminates

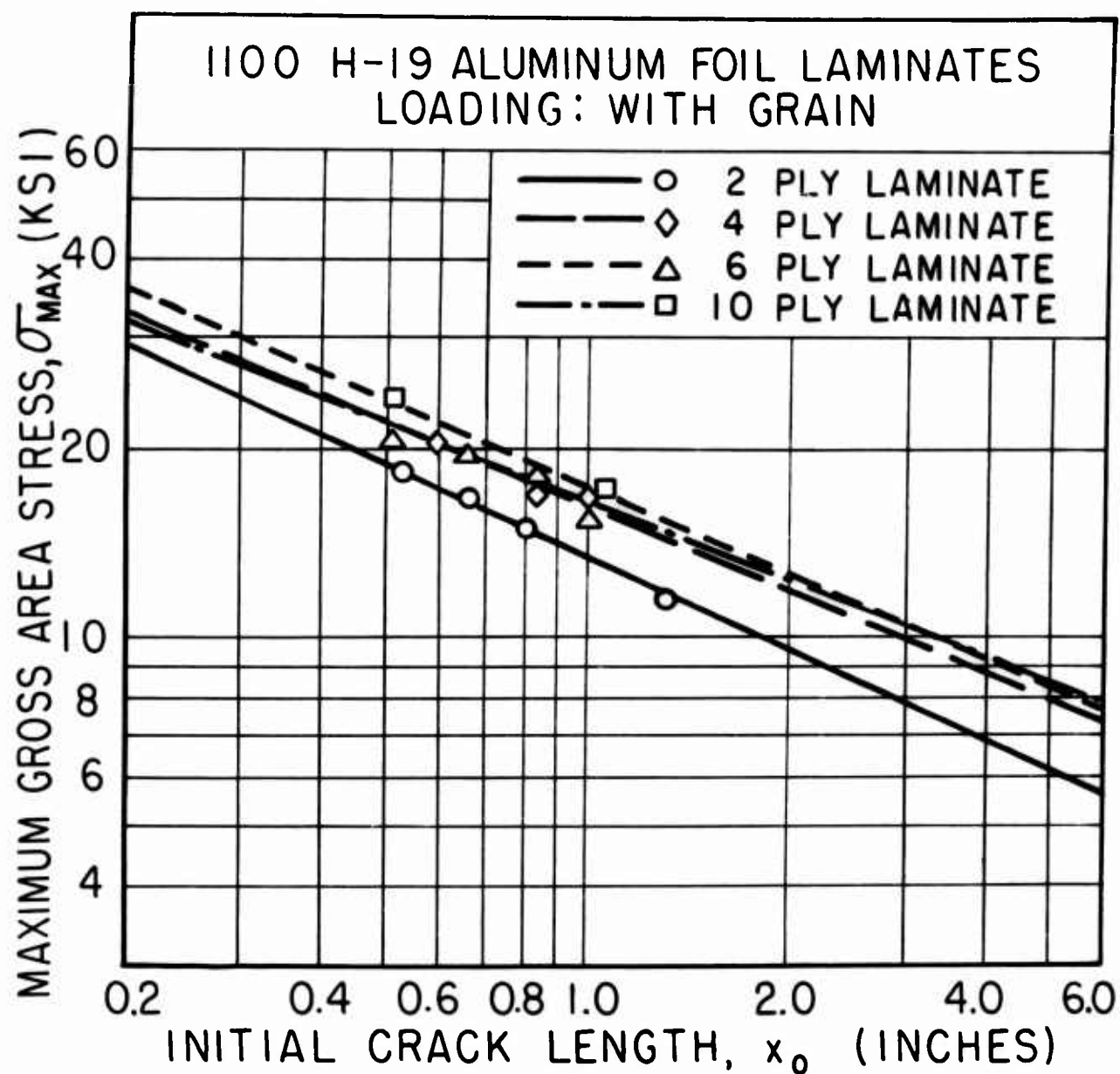

Figure 11a. Log-log Plot of Max. Gross Area Stress vs Initial Crack Length in 1100 H-19 Aluminum Foil Laminates

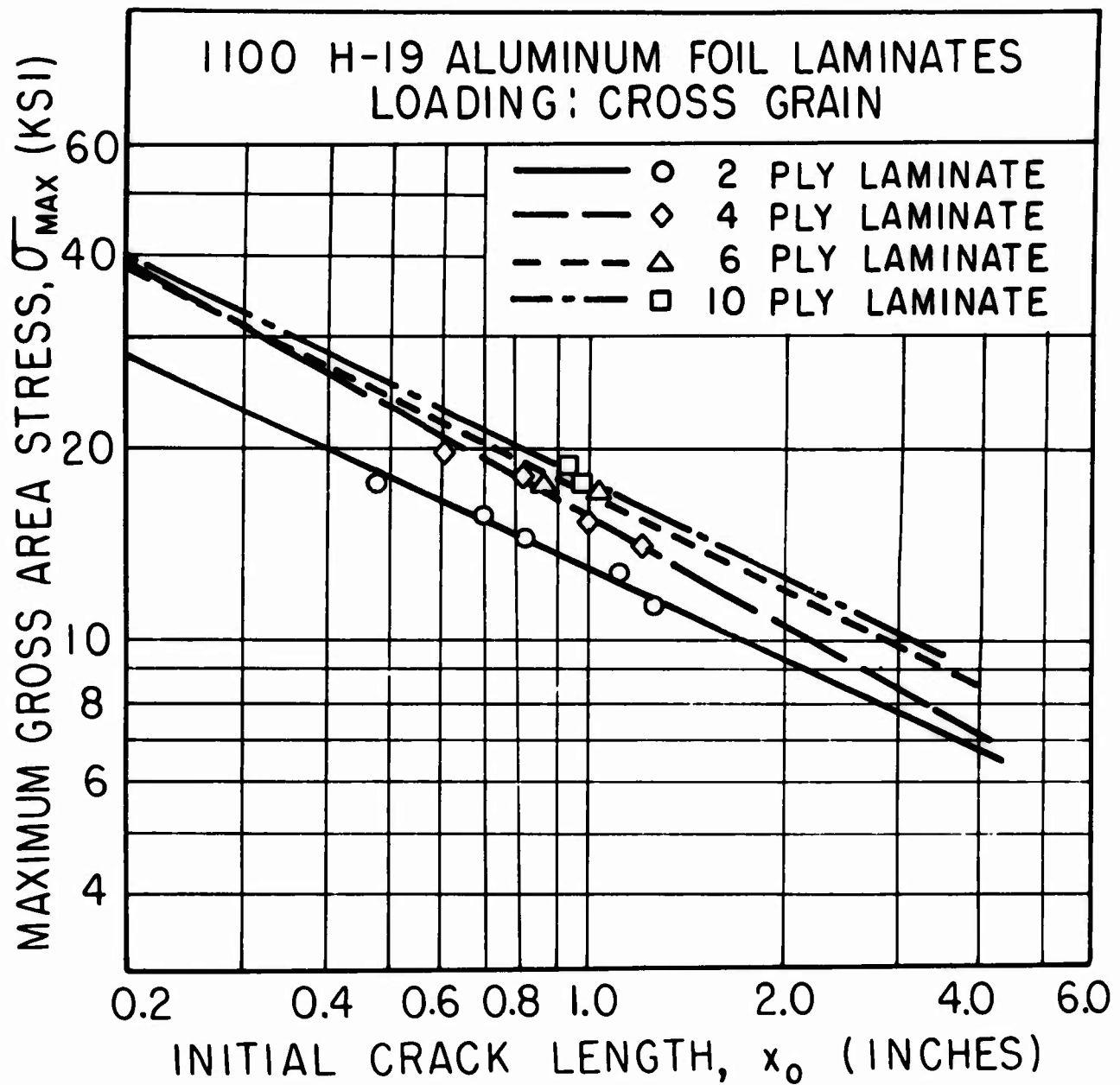

Figure 11b. Log-log Plot of Max. Gross Area Stress vs Initial Crack Length in 1100 H-19 Aluminum Foil Laminates

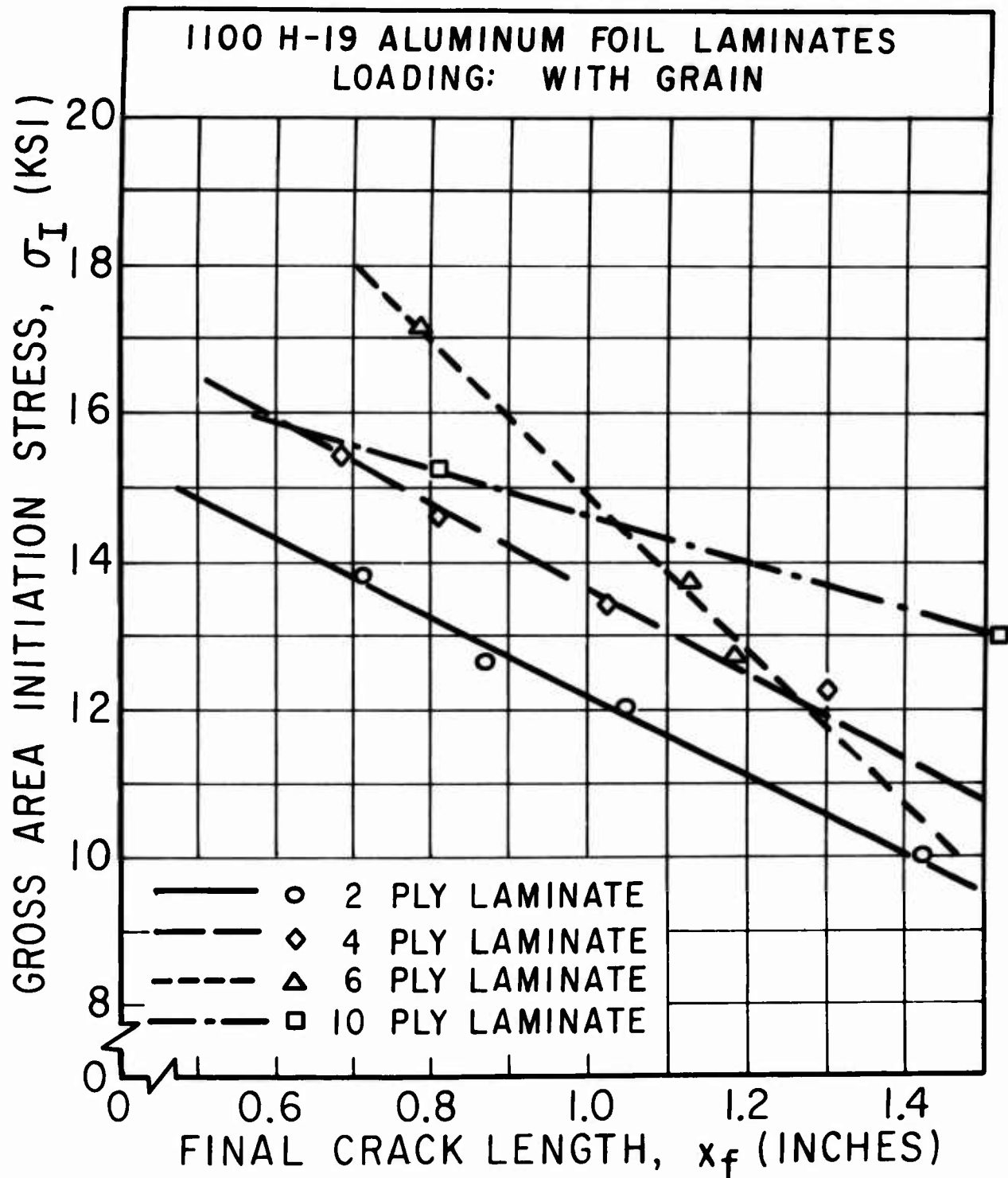

Figure 12a. Gross Area Initiation Stress vs Final Crack Length in 1100 H-19 Aluminum Foil Laminates

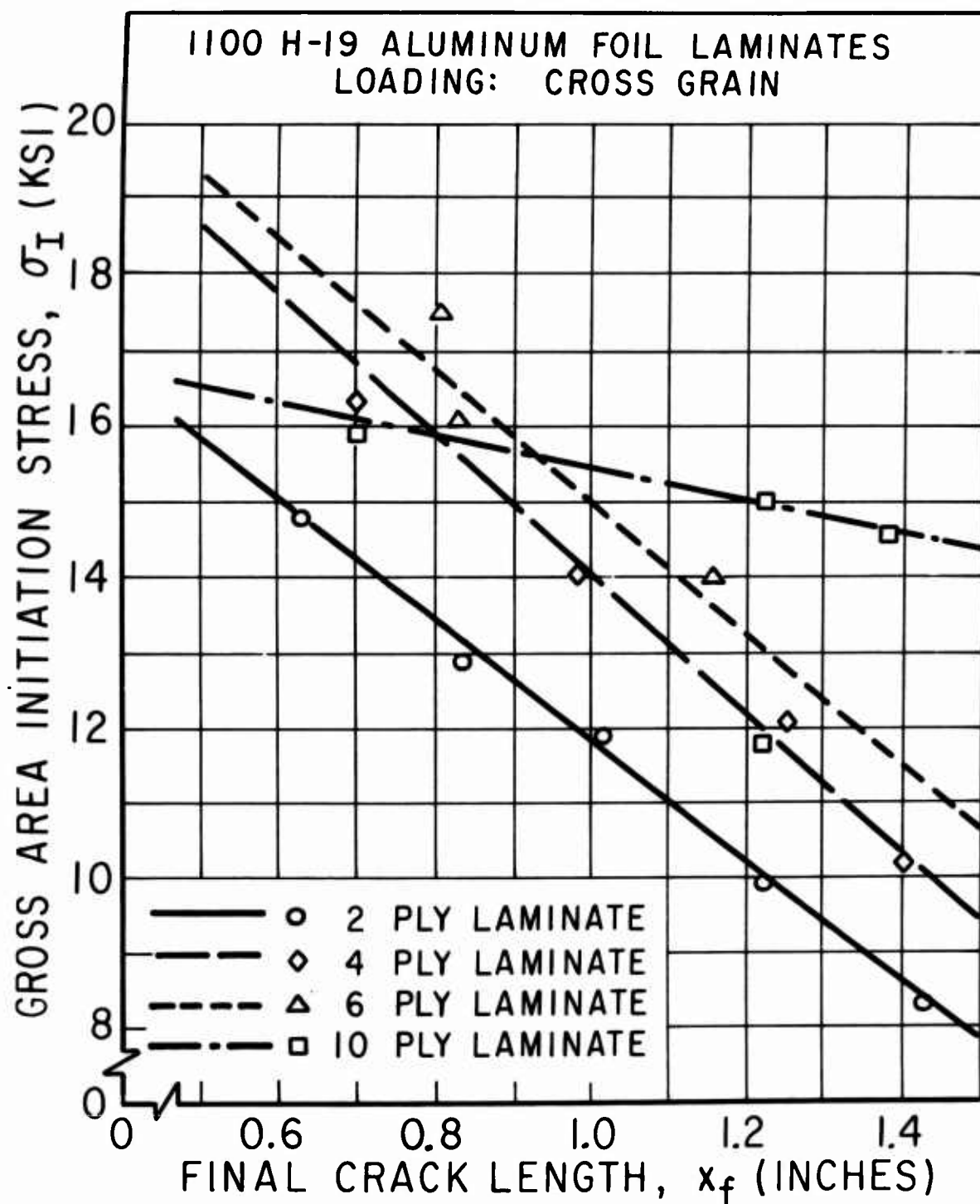

Figure 12b. Gross Area Initiation Stress vs Final Crack Length in 1100 H-19 Aluminum Foil Laminates

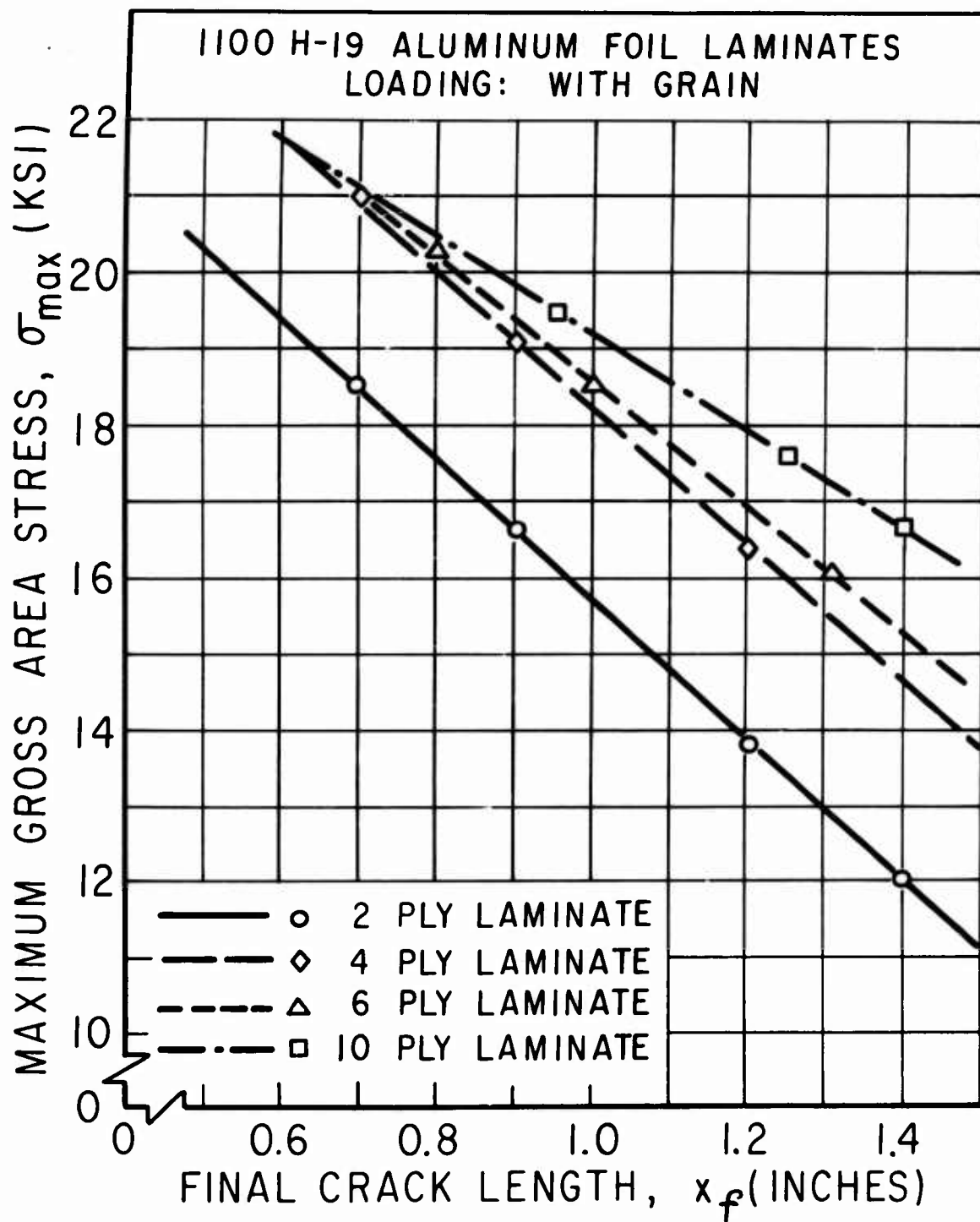

Figure 13a. Max. Gross Area Stress vs Final Crack Length in 1100 H-19 Aluminum Foil Laminates

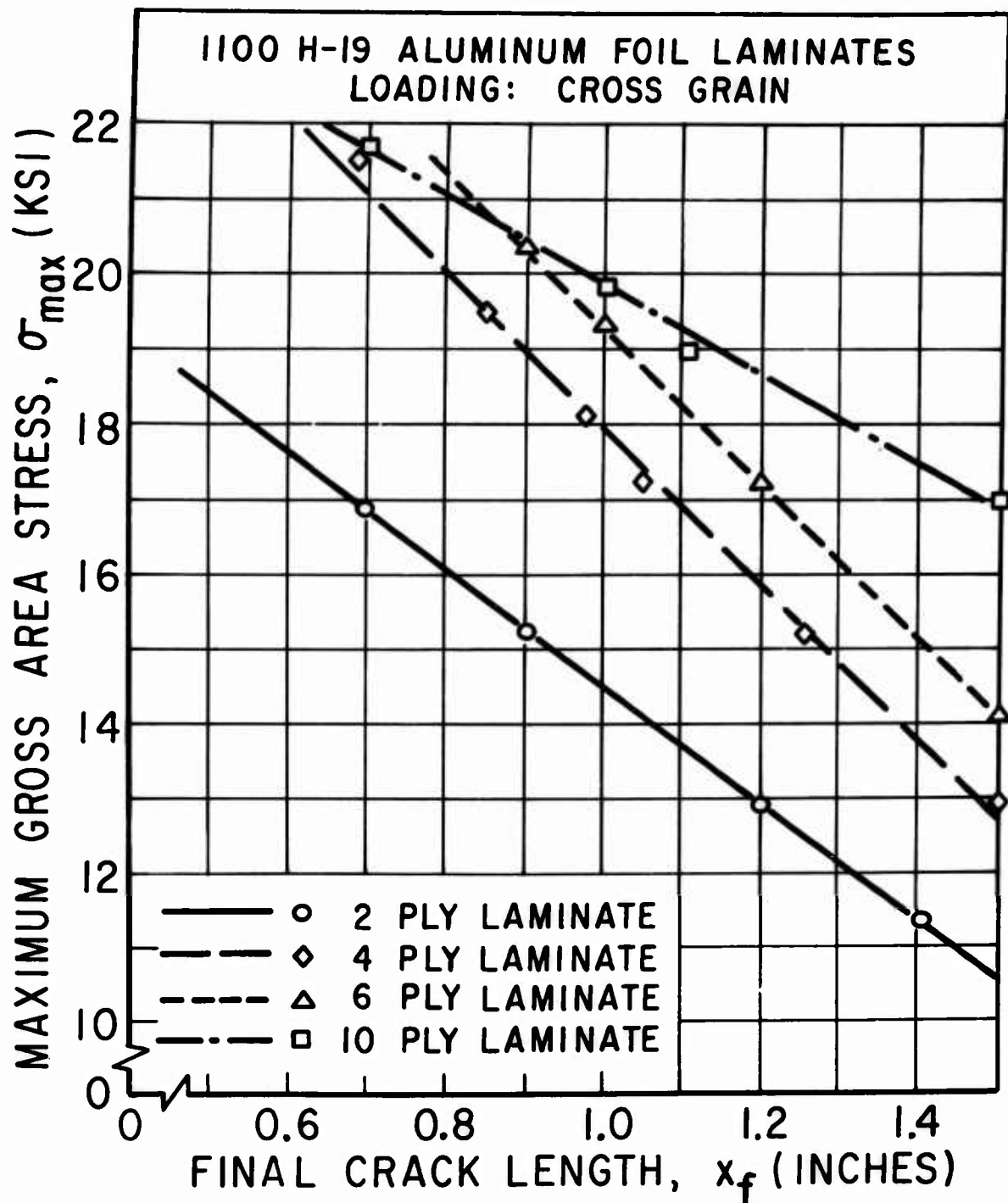

Figure 13b. Max. Gross Area Stress vs Final Crack Length in 1100 H-19 Aluminum Foil Laminates

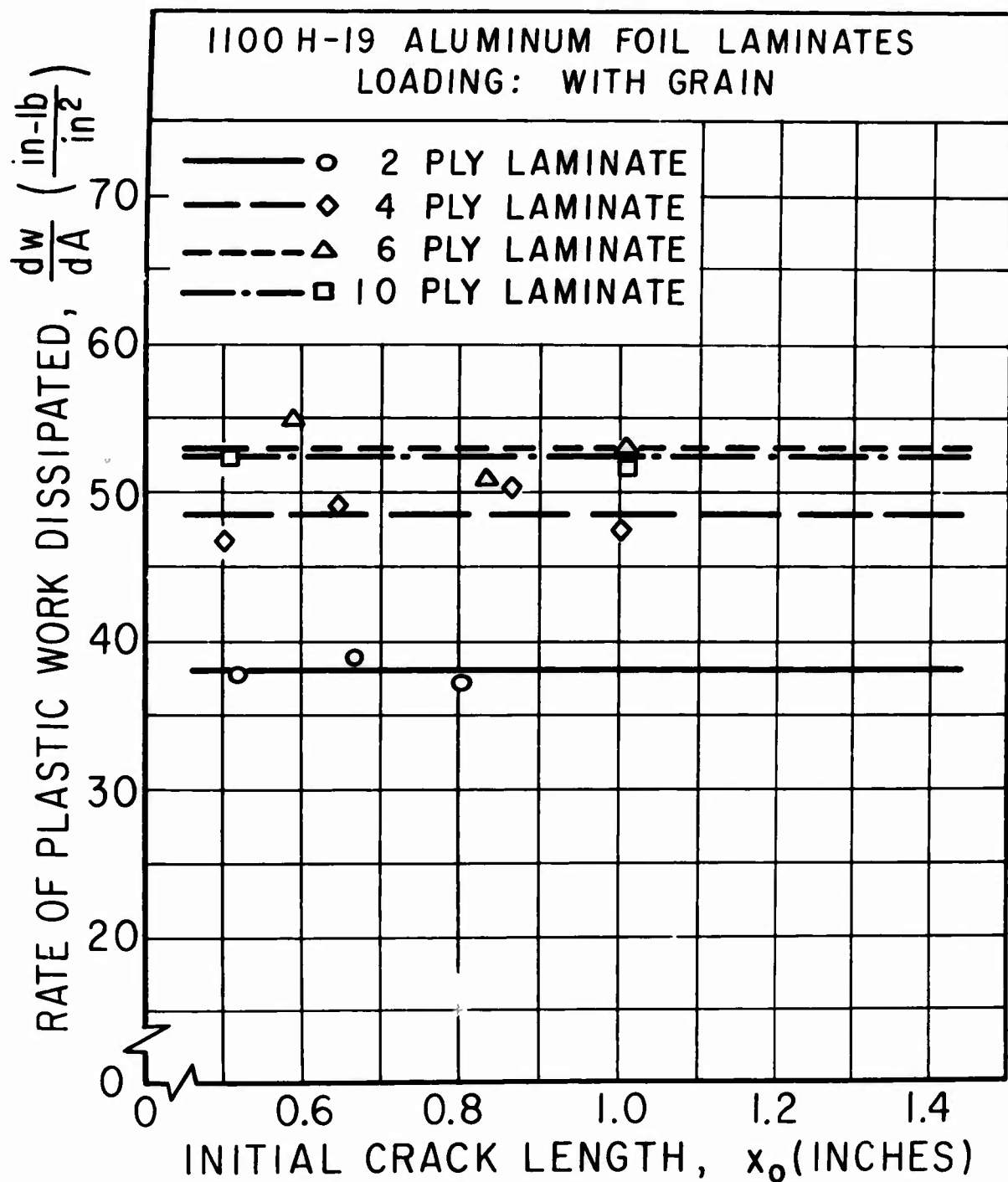

Figure 14a. Plastic Work Dissipation Rate vs Initial Crack Length in 1100 H-19 Aluminum Foil Laminates

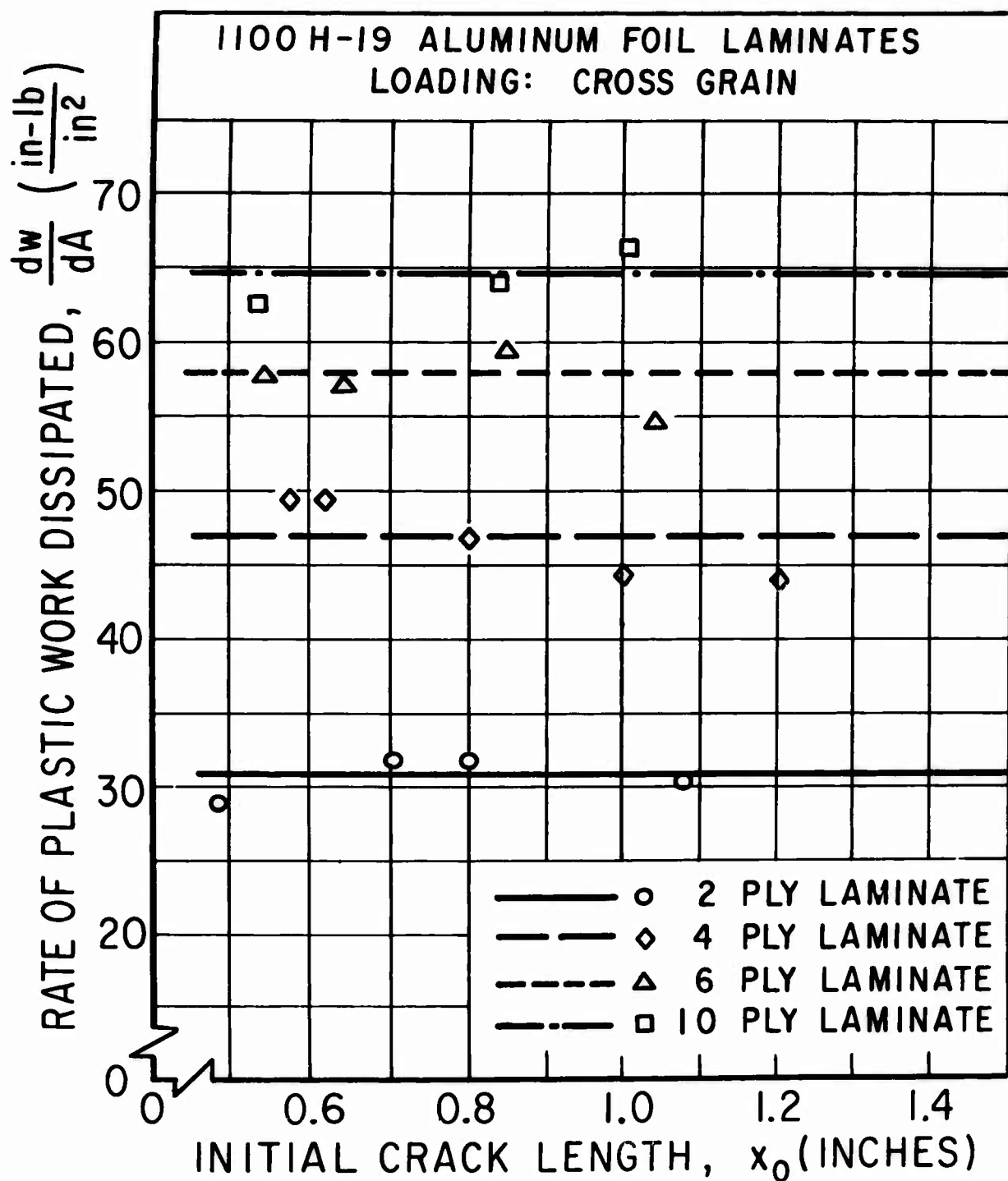

Figure 14b. Plastic Work Dissipation Rate vs Initial Crack Length in 1100 H-19 Aluminum Foil Laminates

REFERENCES

1. Ambartsumyan, S. A., "On the Problem of the Calculation of Laminated Anisotropic Shells," Izvestiia Akademii Nauk, Armyanskoi, S. S. R., Vol. 6, No. 3, 1953. (in Russian).
2. Naghdi, P. M., "On the Theory of Thin Elastic Shells," Quarterly of Applied Mathematics, Vol. 14, pp. 369-380, 1957.
3. Novozhilov, V. V., The Theory of Thin Elastic Shells, Translated from the Russian by P. G. Lowe and edited by J. R. M. Radok, P. Noordhoff Ltd., Groningen, The Netherlands, 1959.
4. Vlasov, V. S., "Basic Differential Equations in General Theory of Elastic Shells," N. A. C. A. TM 1241, 1951.
5. Kempner, J., "Remarks on Donnell's Equations," Journal of Applied Mechanics, Vol. 77, pt. 3, pp. 117-118, 1955.
6. Donnell, L. H., "Stability of Thin-Walled Tubes Under Torsion," N. A. C. A. Report No. 479, 1934.
7. Vlasov, V. S., Allgemeine Schalen Theorie und ihre Anwendung in der Technik, Akademie-Verlag, Berlin, 1958. (in German translated from the Russian).
8. Suchar, M., "Computation by Means of Polynomials of Influence Surfaces for Anisotropic Plates with Finite Dimensions," Arch. Mech. Stos., Vol. 10, pp. 615-634, 1958.
9. Sokolnikoff, I. S., "Approximate Methods of Solution of Two-dimensional Problems in Anisotropic Elasticity," Proceedings of the Symposia of Applied Mathematics, Vol. 3, pp. 1-11, 1953.
10. Morse, P. M. and H. Feshbach, Methods of Theoretical Physics, McGraw-Hill, New York, 1953.
11. Green, A. E., "A Note on Stress Systems in Aeolotropic Materials," Philosophical Magazine and Journal of Science, Vol. 34, pp. 416-422, 1943.
12. Lekhnitskii, S. G., Theory of Elasticity of an Anisotropic Body, Gosudarstvennoe Izdatel'stvo, Tekhiko-Teoreticheskoi Literaturi, Moscow-Leningrad, 1950. (in Russian).
13. Lekhnitskii, S. G., Anisotropic Plates, Gosudarstvennoe Izdatel'stvo, Tekhiko-Teoreticheskoi Literaturi, Moscow-Leningrad, 1950. (in Russian).
14. Pell, W. H., "Thermal Deflections of Anisotropic Thin Plates," Quarterly of Applied Mathematics, Vol. 4, pp. 27-44, 1946-47.
15. Luxenberg, H., "The Torsion of Anisotropic Elastic Cylinders by Forces Applied on the Lateral Surface," Journal of Research, National Bureau of Standards, Vol. 50, pp. 263-276, May, 1953.

16. Green, A. E. and Taylor, G. I., "Stress Systems in Aeolotropic Plates, I," Proceedings of the Royal Society of London, Vol. 173A, pp. 162-172, 1939.
17. Green, A. E. and Taylor, G. I., "Stress Systems in Aeolotropic Plates, III," Proceedings of the Royal Society of London, Vol. 184A, pp. 181-195, 1945.
18. Green, A. E., "Stress System in Aeolotropic Plates, II," Proceedings of the Royal Society of London, Vol. 173A, pp. 173-192, 1939.
19. Green, A. E., "Stress Systems in Aeolotropic Plates, IV," Proceedings of the Royal Society of London, Vol. 180A, pp. 173-208, 1942.
20. Fridman, M. M., "The Mathematical Theory of Elasticity of Anisotropic Media," Prikladnaya Matematika i Mekhanika, Akad. Nauk, S. S. S. R., Vol. 14, pp. 321-340, 1950. (in Russian).
21. Okubo, H., "The Stress Distribution in an Aeolotropic Circular Disk," Philosophical Magazine and Journal of Science, Vol. 27, pp. 508, 1939.
22. Morris, R. M., "Boundary Value Problems of Plane Stress," Quarterly of Mechanics and Applied Mathematics, Vol. 4, pp. 248, 1951.
23. Girkmann, K., Flächentragwerke, Springer-Verlag, Vienna, 1954. (in German).
24. Savin, G. N., Concentrations of Stress Around Holes, Gosudarstvennoe Izdatel'stvo, Tekhniko-Teoreticheskoi Literaturi, Moscow-Leningrad, 1951. (in Russian).
25. Timoshenko, S., Theory of Plates and Shells, McGraw-Hill, New York, 1940.
26. Irwin, G. R., and J. A. Kies, "Critical Energy Rate Analysis of Fracture Strength," Welding Journal, Research Supplement, April, 1954.

<p style="text-align: center;">UNCLASSIFIED</p>	<p style="text-align: center;">UNCLASSIFIED</p>
<p style="text-align: center;">UNCLASSIFIED</p>	<p style="text-align: center;">UNCLASSIFIED</p>
<p>Institute of Engineering Research, University of California, Berkeley, California. ANALYSIS OF STRUCTURAL LAMINATES, by S. B. Dong, R. B. Matthesen, K. S. Fister, et. al. March 1961. 133p. incl. illus. tables, 25 refs. (Proj. 7063; Task 70524) (Contract F 33(61b)-6910) Unclassified report</p> <p>A general small-deflection theory governing the elastostatic extension and flexure of thin laminated anisotropic shells and plates is formulated. The plate or shell structure may be composed of an arbitrary number of bonded layers, each of which may possess different thickness, orientation, and/or orthotropic elastic properties. Donnell-</p> <p style="text-align: right;">(over)</p>	<p>Institute of Engineering Research, University of California, Berkeley, California. ANALYSIS OF STRUCTURAL LAMINATES, by S. B. Dong, R. B. Matthesen, K. S. Fister, et. al. March 1961. 133p. incl. illus. tables, 25 refs. (Proj. 7063; Task 70524) (Contract AF 33(61b)-6910) Unclassified report</p> <p>A general small-deflection theory governing the elastostatic extension and flexure of thin laminated anisotropic shells and plates is formulated. The plate or shell structure may be composed of an arbitrary number of bonded layers, each of which may possess different thickness, orientation, and/or orthotropic elastic properties. Donnell-</p> <p style="text-align: right;">(over)</p>
<p style="text-align: center;">UNCLASSIFIED</p>	<p style="text-align: center;">UNCLASSIFIED</p>
<p style="text-align: center;">UNCLASSIFIED</p>	<p style="text-align: center;">UNCLASSIFIED</p>
<p style="text-align: center;">UNCLASSIFIED</p>	<p style="text-align: center;">UNCLASSIFIED</p>

Institute of Engineering Research, University of California, Berkeley, California. ANALYSIS OF STRUCTURAL LAMINATES, by S. B. Dong, R. B. Matthesen, K. S. Fister, et. al. March 1961. 133p. incl. illus. tables, 25 refs. (Proj. 7063; Task 70524) (Contract F 33(61b)-6910) Unclassified report

A general small-deflection theory governing the elastostatic extension and flexure of thin laminated anisotropic shells and plates is formulated. The plate or shell structure may be composed of an arbitrary number of bonded layers, each of which may possess different thickness, orientation, and/or orthotropic elastic properties. Donnell-

(over)

type equations for cylindrical shells and Poisson-Kirchhoff plate equations are explicitly discussed, along with procedures for determining stresses in an individual lamina. Several methods of solution of the system of equations governing extension and flexure of plates are discussed and illustrated with examples. Optimization of laminate configuration is treated briefly. The results of a limited number of crack propagation tests of flat plate aluminum foil laminates in uniaxial tension are presented.

Institute of Engineering Research, University of California, Berkeley, California. ANALYSIS OF STRUCTURAL LAMINATES, by S. B. Dong, R. B. Matthesen, K. S. Fister, et. al. March 1961. 133p. incl. illus. tables, 25 refs. (Proj. 7063; Task 70524) (Contract AF 33(61b)-6910) Unclassified report

A general small-deflection theory governing the elastostatic extension and flexure of thin laminated anisotropic shells and plates is formulated. The plate or shell structure may be composed of an arbitrary number of bonded layers, each of which may possess different thickness, orientation, and/or orthotropic elastic properties. Donnell-

(over)

type equations for cylindrical shells and Poisson-Kirchhoff plate equations are explicitly discussed, along with procedures for determining stresses in an individual lamina. Several methods of solution of the system of equations governing extension and flexure of plates are discussed and illustrated with examples. Optimization of laminate configuration is treated briefly. The results of a limited number of crack propagation tests of flat plate aluminum foil laminates in uniaxial tension are presented.

UNCLASSIFIED

UNCLASSIFIED

UNCLASSIFIED

UNCLASSIFIED

UNCLASSIFIED	<p>Institute of Engineering Research, University of California, Berkeley, California. ANALYSIS OF STRUCTURAL LAMINATES, by S. B. Dong, R. B. Matthiesen, K. S. Fister, et al. March 1961. 133p. incl. illus. tables, 25 refs. (Proj. 7003; Task: 70524) (Contract AF 33(616)-6910)</p> <p>Unclassified report</p> <p>A general small-deflection theory governing the elastostatic extension and flexure of thin laminated anisotropic shells and plates is formulated. The plate or shell structure may be composed of an arbitrary number of bonded layers, each of which may possess different thickness, orientation, and/or orthotropic elastic properties. Donnell-</p>	UNCLASSIFIED	UNCLASSIFIED
UNCLASSIFIED	<p>(over)</p> <p>type equations for cylindrical shells and Poisson-Kirchhoff plate equations are explicitly discussed, along with procedures for determining stresses in an individual lamina. Several methods of solution of the system of equations governing extension and flexure of plates are discussed and illustrated with examples. Optimization of laminate configuration is treated briefly. The results of a limited number of crack propagation tests of flat plate aluminum foil laminates in uniaxial tension are presented.</p>	UNCLASSIFIED	UNCLASSIFIED
UNCLASSIFIED		UNCLASSIFIED	UNCLASSIFIED

<p>Institute of Engineering Research, University of California, Berkeley, California. ANALYSIS OF STRUCTURAL LAMINATES, by S. B. Dong, R. B. Matthiesen, K. S. Fister, et al. March 1961. 133p. incl. illus. tables, 25 refs. (Proj. 7053; Task 70524) (Contract AF 33(616)-6910)</p> <p>Unclassified report</p> <p>A general small-deflection theory governing the elastostatic extension and flexure of thin laminated anisotropic shells and plates is formulated. The plate or shell structure may be composed of an arbitrary number of bonded layers, each of which may possess different thickness, orientation, and/or orthotropic elastic properties. Donnell-</p> <p>(over)</p>	<p>UNCLASSIFIED</p>	<p>UNCLASSIFIED</p> <p>Institute of Engineering Research, University of California, Berkeley, California. ANALYSIS OF STRUCTURAL LAMINATES, by S. B. Dong, R. B. Matthiesen, K. S. Fister, et al. March 1961. 133p. incl. illus. tables, 26 refs. (Proj. 7053; Task 70524) (Contract AF 33(616)-6910)</p> <p>Unclassified report</p> <p>A general small-deflection theory governing the elastostatic extension and flexure of thin laminated anisotropic shells and plates is formulated. The plate or shell structure may be composed of an arbitrary number of bonded layers, each of which may possess different thickness, orientation, and/or orthotropic elastic properties. Donnell-</p> <p>(over)</p>	<p>UNCLASSIFIED</p>
<p>type equations for cylindrical shells and Poisson-Kirchhoff plate equations are explicitly discussed, along with procedures for determining stresses in an individual lamina. Several methods of solution of the system of equations governing extension and flexure of plates are discussed and illustrated with examples. Optimization of laminate configuration is treated briefly. The results of a limited number of crack propagation tests of flat plate aluminum foil laminates in uniaxial tension are presented.</p>	<p>UNCLASSIFIED</p>	<p>type equations for cylindrical shells and Poisson-Kirchhoff plate equations are explicitly discussed, along with procedures for determining stresses in an individual lamina. Several methods of solution of the system of equations governing extension and flexure of plates are discussed and illustrated with examples. Optimization of laminate configuration is treated briefly. The results of a limited number of crack propagation tests of flat plate aluminum foil laminates in uniaxial tension are presented.</p>	<p>UNCLASSIFIED</p>
<p>UNCLASSIFIED</p>	<p>UNCLASSIFIED</p>	<p>UNCLASSIFIED</p>	<p>UNCLASSIFIED</p>

<p>Institute of Engineering Research, University of California, Berkeley, California. ANALYSIS OF STRUCTURAL LAMINATES, by S. B. Dong, R. B. Mathiesen, K. S. Fister, et. al. March 1961. 133p. incl. illus. tables, 26 refs. (Proj. 7003; Task 70524) (Contract AF 33(616)-6910)</p> <p style="text-align: right;">Unclassified report</p> <p>A general small-deflection theory governing the elastostatic extension and flexure of thin laminated anisotropic shells and plates is formulated. The plate or shell structure may be composed of an arbitrary number of bonded layers, each of which may possess different thickness, orientation, and/or orthotropic elastic properties. Donnell-</p>	<p style="text-align: center;">UNCLASSIFIED</p>	<p style="text-align: center;">UNCLASSIFIED</p>
<p style="text-align: center;">(over)</p> <p>type equations for cylindrical shells and Poisson-Kirchhoff plate equations are explicitly discussed, along with procedures for determining stresses in an individual lamina. Several methods of solution of the system of equations governing extension and flexure of plates are discussed and illustrated with examples. Optimization of laminate configuration is treated briefly. The results of a limited number of crack propagation tests of flat plate aluminum foil laminates in uniaxial tension are presented.</p>	<p style="text-align: center;">UNCLASSIFIED</p>	<p style="text-align: center;">UNCLASSIFIED</p>
<p style="text-align: center;">(over)</p> <p>type equations for cylindrical shells and Poisson-Kirchhoff plate equations are explicitly discussed, along with procedures for determining stresses in an individual lamina. Several methods of solution of the system of equations governing extension and flexure of plates are discussed and illustrated with examples. Optimization of laminate configuration is treated briefly. The results of a limited number of crack propagation tests of flat plate aluminum foil laminates in uniaxial tension are presented.</p>	<p style="text-align: center;">UNCLASSIFIED</p>	<p style="text-align: center;">UNCLASSIFIED</p>

UNCLASSIFIED

UNCLASSIFIED