

UNCLASSIFIED

AD 272 603

*Reproduced
by the*

ARMED SERVICES TECHNICAL INFORMATION AGENCY
ARLINGTON HALL STATION
ARLINGTON 12, VIRGINIA



UNCLASSIFIED

NOTICE: When government or other drawings, specifications or other data are used for any purpose other than in connection with a definitely related government procurement operation, the U. S. Government thereby incurs no responsibility, nor any obligation whatsoever; and the fact that the Government may have formulated, furnished, or in any way supplied the said drawings, specifications, or other data is not to be regarded by implication or otherwise as in any manner licensing the holder or any other person or corporation, or conveying any rights or permission to manufacture, use or sell any patented invention that may in any way be related thereto.

DISCLAIMER NOTICE

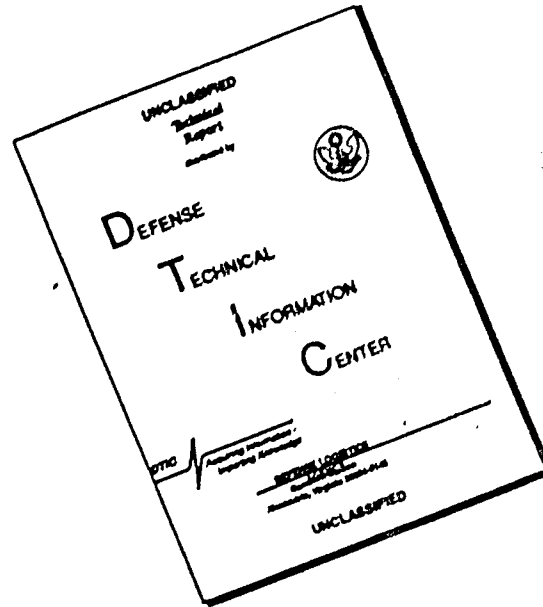

THIS DOCUMENT IS BEST QUALITY AVAILABLE. THE COPY FURNISHED TO DTIC CONTAINED A SIGNIFICANT NUMBER OF PAGES WHICH DO NOT REPRODUCE LEGIBLY.

27803

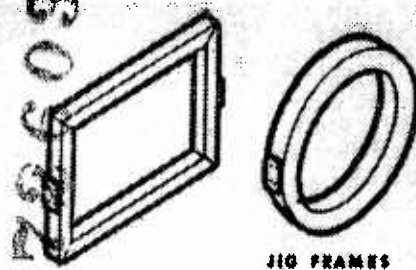

JIG FRAMES

STANDARDIZED UNIVERSAL TOOLING SYSTEM

W. Ahnert
D. Eklund
D. Kelleher

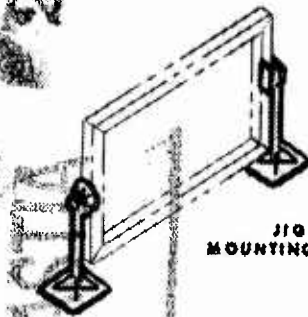

JIG FRAME MOUNTING EQUIPMENT

The Boeing Company
Aero-Space Division
Contract: AF 33(600)-41845
ASD Project: 7-829

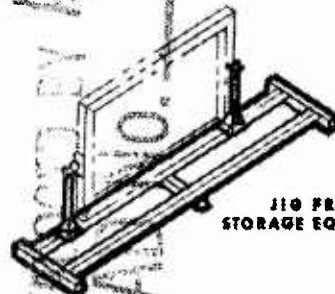

JIG FRAME STORAGE EQUIPMENT

DETAIL DESIGN SPECIFICATION

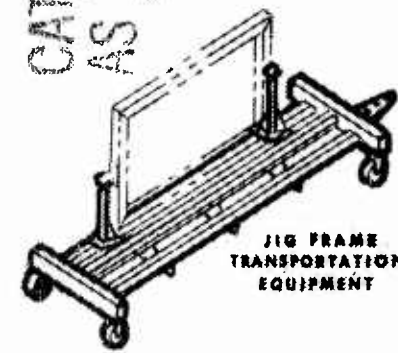

JIG FRAME TRANSPORTATION EQUIPMENT

This specification outlines the characteristics and performance requirements of the equipment items included in a standardized universal tooling system. The system is comprised of a series of incremental sized rectangular and round jig frames and related items of equipment for trunnion mounted support, storage, transportation, and hoisting of the frames in the fabrication, storage and assembly areas of plants. The hoisting equipment is also intended for lifting aircraft and missile components during manufacturing operations.

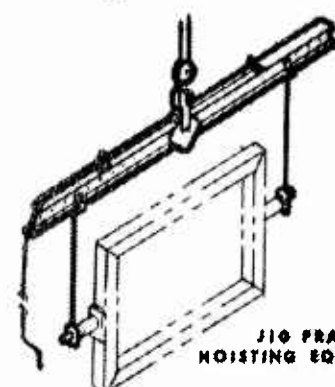

JIG FRAME HOISTING EQUIPMENT

MANUFACTURING TECHNOLOGY LABORATORY
Fabrication Branch (ASRCTF)

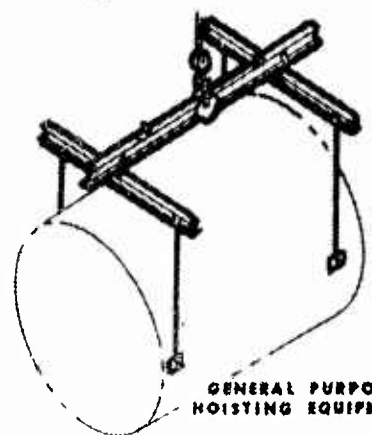

GENERAL PURPOSE HOISTING EQUIPMENT

ASD AERONAUTICAL SYSTEMS DIVISION
United States Air Force
Wright-Patterson Air Force Base, Ohio

DETAILED DESIGN SPECIFICATION

STANDARDIZED UNIVERSAL TOOLING SYSTEM

JIG FRAMES
AND RELATED MOUNTING, STORAGE, TRANSPORTATION
& HOISTING EQUIPMENT, & GENERAL PURPOSE HOISTING

USAF ASD PROJECT 7-829

CONTRACT: AF 33(600)-41845

MANUFACTURING TECHNOLOGY LABORATORY
FABRICATION BRANCH (ASRCTF)

ASD Aeronautical Systems Division
United States Air Force
Wright-Patterson Air Force Base, Ohio

Page 1 of 58

11 OCTOBER 1961

TABLE OF CONTENTS

	Page
SECTION 1 SCOPE	
1.1 Scope	7
1.2 Classification	7
1.2.1 Trunnion Mounted Jig Frame System	7
1.2.2 Storage System	8
1.2.3 Transportation System	8
1.2.4 Hoisting System	9
SECTION 2 APPLICABLE DOCUMENTS	
2.1 Government Documents	10
2.1.1 Federal	10
2.1.2 Military	10
2.2 Non-Government Documents	10
2.2.1 Boeing Drawings	11
2.2.2 Commercial Standards	13
SECTION 3 REQUIREMENTS	
3.1 Common Requirements	14
3.1.1 Welding	14
3.1.2 Protective Finishes	14
3.1.3 Standard Fasteners	14
3.1.4 Materials	14
3.1.5 Drawing Preparation	14
3.1.6 Part Identification	14
3.1.7 Workmanship	14
3.1.8 Environmental Requirements	14
3.1.9 Interchangeability	14
3.1.10 Structural Design Criteria	15
3.1.11 Fabrication	16
3.1.12 General Concepts	16
3.2 Trunnion Mounted Jig Frame System Equipment	18
3.2.1 General Description & Requirements	18
3.2.2 Equipment Items & Components	18
3.2.3 Detail Description & Requirements	19
3.2.4 Specific Standards	22
3.2.5 Materials	22
3.2.6 Design	22
3.2.7 Construction Requirements	22
3.2.8 Loads & Stresses	23
3.2.9 Performance Requirements	23
3.2.10 Environmental Requirements	26
3.2.11 Interchangeability	26
3.2.12 Radio Interference	26
3.2.13 Dimensions	26

SECTION 3 REQUIREMENTS - Continued

	3.2.14	Weights & Sizes	26
	3.2.15	Identification	28
	3.2.16	Workmanship	28
3.3		Jig Frame Storage Equipment	29
	3.3.1	Description & Requirements	29
	3.3.2	Components	29
	3.3.3	Specific Standards	29
	3.3.4	Design	29
	3.3.5	Construction Requirements	29
	3.3.6	Loads & Stresses	30
	3.3.7	Performance Requirements	31
	3.3.8	Environmental Requirements	31
	3.3.9	Interchangeability	31
	3.3.10	Radio Interference	31
	3.3.11	Dimensions	31
	3.3.12	Weight	31
	3.3.13	Identification	31
	3.3.14	Workmanship	31
3.4		Jig Frame Transportation Equipment	34
	3.4.1	Description & Requirements	34
	3.4.2	Components	34
	3.4.3	Specific Standards	34
	3.4.4	Design	34
	3.4.5	Construction Requirements	34
	3.4.6	Loads & Stresses	35
	3.4.7	Performance Requirements	36
	3.4.8	Environmental Requirements	36
	3.4.9	Interchangeability	36
	3.4.10	Radio Interference	36
	3.4.11	Dimensions	36
	3.4.12	Weight	37
	3.4.13	Identification	37
	3.4.14	Workmanship	37
3.5		Hoisting Systems Equipment	40
	3.5.1	General Description & Requirements	40
	3.5.2	Equipment Items	40
	3.5.3	Components & Sizes	41
	3.5.4	Specific Standards	42
	3.5.5	Design	43
	3.5.6	Construction Requirements	43
	3.5.7	Loads & Stresses	44
	3.5.8	Performance Requirements	44
	3.5.9	Environmental Requirements	46
	3.5.10	Interchangeability	46
	3.5.11	Radio Interference	46
	3.5.12	Dimensions & Tolerances	46
	3.5.13	Weights	46
	3.5.14	Identification	46
	3.5.15	Workmanship	46

SECTION 4 QUALITY ASSURANCE PROVISIONS

4.1	Classification of Tests	49
4.2	Acceptance Tests	49
4.2.1	Individual Tests	49
4.2.2	Component Tests	49
4.2.3	Receiving Inspection	49
4.2.4	Sampling Plan & Tests	50
4.2.5	Rejection & Retest	50
4.3	Test Conditions	50
4.3.1	Atmospheric Tests	50
4.3.2	Test Power	50
4.4	Test Methods	50
4.4.1	General Test Methods	50
4.4.2	Functional Tests	50
4.4.2.1	Overall Compatability	50
4.4.2.2	Jig Frame Mounting Equip.	50
4.4.2.3	Storage Equipment	52
4.4.2.4	Transportation Equipment	52
4.4.2.5	Hoisting Equipment	53
4.4.3	Load Tests - Hoisting Equipment	54
4.5	Preproduction Testing	55
4.5.1	Preproduction Test Samples	55
4.5.2	Preproduction Tests	55

SECTION 5 PREPARATION FOR DELIVERY

5.1	Preservation and Packaging	56
5.1.1	Immediate Use	56
5.1.2	Limited Storage	56
5.1.3	Extended Storage	56
5.2	Intermediate Packaging	56
5.3	Packaging	56
5.3.1	Immediate Use	56
5.3.2	Domestic Shipment	56
5.4	Physical Protection	56
5.5	Marking for Shipment and Storage	56

SECTION 6 NOTES

6.1	Specific Intended Use of the System	57
6.1.1	General	57
6.1.2	Trunnioned Jig Frame System	57
6.1.3	Storage & Transportation Equipment	58
6.1.4	Hoisting Systems	58
6.2	Ordering Equipment Items.	58

LIST OF ILLUSTRATIONS

	Page
FIGURE 1 TYPICAL LOADING CONDITION - STORAGE RACK STANCHIONS	32
FIGURE 2 GENERAL LOADING CONDITION - STORAGE RACK ASSEMBLY	33
FIGURE 3 TYPICAL LOADING CONDITION - TRANSPORTATION DOLLY STANCHIONS	38
FIGURE 4 GENERAL LOADING CONDITION - TRANSPORTATION DOLLY ASSEMBLY	39
FIGURE 5 HOISTING SYSTEM	47
FIGURE 6 JIG FRAME LIFTING - LOAD CONDITION	48
FIGURE 7 LOAD TEST OF HOISTING EQUIPMENT	55
TABLE I SIZES & WEIGHTS OF RECTANGULAR JIG FRAMES	26
TABLE II SIZES & WEIGHTS OF ROUND JIG FRAMES	27
TABLE III DESIGN LIMIT LOAD FACTORS, STORAGE EQUIPMENT	30
TABLE IV DESIGN LIMIT LOAD FACTORS, TRANSPORTATION EQUIPMENT	35

THE BOEING COMPANY

October 11, 1961

DETAILED DESIGN SPECIFICATION
STANDARDIZED UNIVERSAL TOOLING SYSTEM

1. SCOPE

1.1 SCOPE. - This specification outlines the characteristics and performance requirements of the equipment items included in a standardized universal tooling system.

1.1.1 Intended Use. - The tooling system is intended for utilization by producers of missiles and aircraft for assembly operations. The system is comprised of a series of incremental sized rectangular and round jig frames and related items of equipment for trunnion mounted support, storage, transportation, and hoisting of the frames in the fabrication, storage and assembly areas of plants. The hoisting equipment is also intended for lifting aircraft and missile components during manufacturing operations.

1.1.2 Specific Details. - See Section 6 "Notes" of this specification for specific details of intended use of the items of equipment defined herein.

1.2 CLASSIFICATION. - For purposes of this specification the equipment items of the overall tooling system shall be categorized in the following systems according to function:

1.2.1 Trunnion Mounted Jig Frame System. - This system shall include equipment items of the following types, classes and sizes:

1.2.1.1 Jig Frames - Trunnion Type.

1.2.1.1.1 Type I - Rectangular Jig Frames.

- a. Class I - 15 Sizes
- b. Class II - 30 Sizes
- c. Class III - 64 Sizes
- d. Class IV - 20 Sizes

1.2.1.1.2 Type II - Round Jig Frames.

- a. Class V - 3 Sizes
- b. Class VI - 3 Sizes
- c. Class VII - 3 Sizes

1.2.1.2 Trunnion Bearings - Jig Frames.

- a. Type I - Weldment - 2 Sizes
- b. Type II - Casting - 2 Sizes

1.2.1.3 Trunnion Shafts - Jig Frames.

- a. Type I - Gear Drive Coupling - 1 Size
- b. Type II - End Stop Collar - 2 Sizes
- c. Type III - Plain - 2 Sizes

1.2.1.4 Trunnion Stands - Jig Frames.

- a. Type I - Fixed Height - 1 Size
- b. Type II - Adjustable Height - 1 Size

1.2.1.5 Trunnion Gear Drive Assembly - Jig Frames.

One Type - 1 Size.

1.2.1.6 Indexing Equipment - Jig Frames.

- a. Lock Pin Assembly - 1 Type - 1 Size
- b. Index Plate - 1 Type - 1 Size

1.2.1.7 Counterbalance - Jig Frames. - The following equipment items shall be included in a counterbalancing sub-system as part of the jig frame mounting system:

- a. Counterweight - 5 Sizes
- b. Attach Rails - 5 Sizes
- c. Rail Spacer - 1 Size
- d. Eccentric Stop - 1 Size
- e. Outrigger Assembly - 1 Size

1.2.2 Storage System - Jig Frames. - This system shall include the items of equipment required for the storage of jig frames as follows:

- a. Storage Rack Frame - 1 Size
- b. Stanchion Assembly - 1 Size

1.2.3 Transportation System - Jig Frames. - This system shall include the items of equipment required for the transportation of jig frames as follows:

- a. Dolly Frame - 1 Size
- b. Stanchion Assembly - 1 Size

1.2.4 Hoisting System Equipment - General Purpose and Jig Frame Lifting. - This system shall include the items of hoisting equipment for 1500, 3000, and 6000 pound capacity hoisting systems. The systems shall include the equipment items of the following types and sizes:

1.2.4.1 Main Hoisting Beams - Adjustable.

- a. Type I - Short Flexible Drive Cable - 3 Sizes
- b. Type II - Long Flexible Drive Cable - 3 Sizes

1.2.4.2 Cross Beams.

One Type - 3 Sizes.

1.2.4.3 Cross Beam to Main Beam Hangers.

One Type - 3 Sizes.

1.2.4.4 Main Beam Load Dropper Fittings.

One Type - 3 Sizes.

1.2.4.5 Cross Beam Load Dropper Fittings.

One Type - 3 Sizes.

1.2.4.6 Lift Cable Assembly - Standard Jig Frame.

One Type - 3 Sizes.

2. APPLICABLE DOCUMENTS

2.1 **GOVERNMENT DOCUMENTS.**- The following government documents of the exact issue noted, together with the noted revisions thereto, constitute a part of this specification but only to the extent defined herein. In those cases where the document listed is not dated, the issue in effect on the date of contract effectivity shall form a part of this specification. Where conflicting requirements exist, the requirements of this specification shall govern. Vendors should review the below listed documents and request deviations wherein the requirements are not in line with standard acceptable commercial practices.

2.1.1 Specifications - Federal

- a. QQ-P-330 Phosphor Bronze Bars, Plates, Rods, Sheets, Strips, Flat Wire, and Structural and Special Shaped Sections.
- b. FED-STD-595 Colors
- c. TT-E-489 Enamel; Gloss, Synthetic
- d. QQ-L-171 Lead Pig
- e. PPP-B-676 Boxes, Set-up - Paperboard

2.1.2 Specifications - Military

- a. MIL-D-70327 Drawing Standards
- b. MIL-P-6889 Primer; Zinc Chromate for Aircraft Use.
- c. MIL-P-8585 Primer; Corrosion Inhibiting, Low Moisture Sensitivity
- d. MIL-P-116 Preservation, Methods of
- e. MIL-I-18331 Lead
- f. MIL-E-7729 Enamel; Gloss, Aircraft Application
- g. MIL-I-6868 Inspection Process; Magnetic Particle
- h. MIL-B-4229 Boxes, Paperboard, Metal Stayed
- i. MIL-STD-129 Marking for Shipment and Storage
- j. JAN-P-108 Boxes, Fiber
- k. JAN-P-120 Boxes, Folding Paperboard

2.2 **NON-GOVERNMENT DOCUMENTS.** - The following non-government documents and drawings of the exact issue shown, form a part of this specification to the extent specified herein. In those cases where the document is not dated, the latest issue in effect on the date of contract effectivity shall form a part of this specification.

2.2.1 Boeing Drawings

	<u>Drawing No.</u>	<u>Date</u>	<u>Title</u>
a.	55-20400	5-20-61	Index Drawing - Standard Jig Frames and Related Equipment.

2.2.1.1 Jig Frame Mounting System

a.	55-20401	5-20-61	General Arrangement Drawing - Jig Frame Mounting System, Standard Jig Frames and Related Equipment.
b.	55-20402	" "	Jig Frame Class I, Standard Rectangular Trunnioned Assembly.
c.	55-20403	" "	Jig Frame Class II, Standard Rectangular Trunnioned Assembly.
d.	55-20404	" "	Jig Frame Class III, Standard Rectangular Trunnioned Assembly.
e.	55-20405	" "	Jig Frame Class IV, Standard Rectangular Trunnioned Assembly.
f.	55-20406	" "	Jig Frame Class V, Standard Round Trunnioned Assembly.
g.	55-20407	" "	Jig Frame Class VI, Standard Round Trunnioned Assembly.
h.	55-20408	" "	Jig Frame Class VII, Standard Round Trunnioned Assembly.
i.	55-20409	" "	Trunnion Shaft - Large, Standard Jig Frame Assembly of.
j.	55-20410	" "	Trunnion Shaft - Small, Standard Jig Frame, Assembly of.
k.	55-20411	" "	Trunnion Bearing Assembly, Weldment, Standard Frame Support.
l.	55-20412	" "	Trunnion Bearing Assembly, Casting, Standard Frame Support.
m.	55-20413	" "	Adjustable Trunnion Stand-Assembly, Standard Jig Frame.

n.	55-20414	5-20-61	Fixed Trunnion Stand - Assembly, Standard Jig Frame.
o.	55-20415	" "	Gear Drive Assembly, Standard Jig Frame.
p.	55-20416	" "	Counterbalance Equipment, Standard Jig Frame.
q.	55-20422	" "	Lock Pin Assembly, Index- ing, Standard Frame.
r.	59-17300	" "	Index Plate - Standard Frame, Position Lock.
s.	59-17302	" "	Clamp, Adjustable, Quick Acting - Jig Plate Attach- ment.

2.2.1.2 Hoisting System

a.	55-20424	5-20-61	General Arrangement Draw- ing - Hoisting Equipment - Standard Jig Frame and General Purpose Lifting.
b.	55-20425	" "	Beam Assembly, Hoisting - Adjustable, General Pur- pose 1500# Capacity.
c.	55-20426	" "	Beam Assembly, Hoisting - Adjustable, General Pur- pose 3000# Capacity.
d.	55-20427	" "	Beam Assembly, Hoisting - Adjustable, General Pur- pose 6000# Capacity.
e.	55-20428	" "	Main Beam Assembly - Adjustable, General Pur- pose Hoisting Beam.
f.	55-20429	" "	Cross Beam - Adjustable, General Purpose Hoisting Beam.
g.	55-20430	" "	Lift Cable Assembly, Hoisting Beam, Standard Jig Frame.
h.	59-17303	" "	Load Dropper Assembly - Main Beam and Cross Beam, Hoisting Beam.
i.	59-17304	" "	Hanger Assembly - Cross Beam to Main Beam, Hoist- ing Beam.

2.2.1.3 Storage System

- a. 55-20419 5-20-61 General Arrangement Drawing - Storage Equipment, Standard Jig Frames.
- b. 55-20420 " " Storage Rack Assembly, Standard Jig Frames.
- c. 55-20421 " " Stanchion Assembly, Storage Rack, Standard Jig Frame.

2.2.1.4 Transportation System

- a. 55-20436 5-20-61 General Arrangement Drawing - Transportation Equipment Standard Jig Frames.
- b. 55-20437 " " Dolly Assembly, Transportation, Standard Jig Frame.
- c. 55-20438 " " Stanchion Assembly, Transportation Dolly, Standard Jig Frame.

2.2.2 Commercial Standards

- a. American Institute of Steel Construction Manual.
- b. American Society for Testing Materials Standards.
- c. Society of Automotive Engineers Yearbook.
- d. American Society of Mechanical Engineers. Engineering Reference Books.
- e. American Standards Association.
- f. Consolidated Freight Classification Rules.

3. REQUIREMENTS

The requirements set forth herein describe the items of equipment contained in the standardized universal tooling system listed under paragraphs 1.2.1 through 1.2.4.

3.1 COMMON REQUIREMENTS

All equipment items shall be designed and fabricated with the following requirements where applicable:

3.1.1 Welding. - All welding shall be per AWS specifications.

3.1.2 Protective Finishes. - Primer paint undercoat shall be type MIL-P-6889 or MIL-P-8585 zinc chromate. Type and color of finish coat at option of user. Anti-rust coat on machined surfaces shall be type MIL-P-116.

3.1.3 Standard Fasteners. - All bolts, nuts, washers, cotter pins, etc. shall be of standard commercial quality. Threads shall be of the unified series.

3.1.4 Materials. - All low carbon steel plates, rods, and bars shall be of type ASTM-A7, AISI-C 1045 or equivalent. All standard black pipe shall be of type ASTM-A-120. All rolled and formed structural steel shapes shall be of type ASTM-A7 structural quality.

3.1.5 Drawing Preparation. - All drawings shall be per MIL-D-70327 (MIL-STD-14, 15, 16, 23, 103, 106, and 129 are not used).

3.1.6 Part Identification. - All assemblies, sub-assemblies and end item details shall be steel stamped with their respective part number per drawing callout.

3.1.7 Workmanship. - The equipment items shall be fabricated and finished in a thoroughly workmanlike manner. Particular attention shall be given to accuracy of dimensions and freedom from blemishes, defects, burrs, and sharp edges.

3.1.8 Environmental Requirements. - All equipment items shall be produced to operate under normal shop conditions of temperature, humidity and pressure.

3.1.9 Interchangeability. - Equipment items manufactured in accordance with this specification shall be functionally, physically and structurally interchangeable and shall be

differentiated from all other equipment items not meeting the requirements of this specification by the assignment of specific part numbers. The part number shall be positive identification such that the item may be procured by the manufacturers part number alone without reference to this specification.

3.1.10 Structural Design Criteria. - The structural design criteria necessary to design the equipment items is as follows:

3.1.10.1 Structural Analysis. - In general, commercial practices customarily used in industry shall be considered for design solutions. The design limit loads used in the analysis are determined by applying the appropriate design limit load factors to the appropriate dead weights and, where applicable, combining these with the design limit loads resulting from consideration of other forces. The design limit loads are used in conjunction with the allowable working unit stress, as specified in paragraph 3.1.10.2, to determine structure required. A positive margin of safety shall be shown per paragraph 3.1.10.3.1.

3.1.10.1.1 An alternate method of design may be used: The design limit loads are determined by method stated above. The design limit loads are multiplied by a factor of safety to obtain design ultimate loads. The resulting design ultimate loads are used in conjunction with the proper allowable ultimate stresses, as specified in paragraph 3.1.10.2, to determine structure required. The design limit loads shall not cause detrimental yielding of the structural material. Allowable ultimate stresses shall be limited by the effects of buckling, crippling, etc., where applicable. The design limit loads and/or factors of safety shall be those specified in the applicable construction paragraphs of equipment items.

3.1.10.2 Materials and Allowables. - Allowable working unit stresses, or ultimate stresses to be used for design solutions, shall be those established in the commercial codes by American Institute of Steel Construction, American Society of Mechanical Engineers, American Society for Testing Materials, Society of Automotive Engineers and other standard engineering reference books. The determination of other materials, and/or material element allowables, shall be those specified in the applicable paragraphs of equipment items.

3.1.10.3 Definitions.

3.1.10.3.1 Margin of Safety. - All structure shall be designed to a positive margin of safety. The margin of safety is the percentage by which the ultimate (or yield) strength of

a member exceeds the ultimate (or limit) design load. The ultimate design load is the applied load or maximum probable load (limit load) multiplied by applicable Factor of Safety. The margin of safety shall be computed from the following formula:

$$MS = \frac{1}{R} - 1$$

Where R is the ratio of design load (or stress) to allowable load (or stress). In calculating the value of R, combined stresses shall be considered.

3.1.10.3.2 Ultimate Factor of Safety. - The ultimate factor of safety is the ratio of the design ultimate load to the design limit load.

3.1.10.3.3 Load Factor. - A load factor is the ratio by which the weight of a part, a force, or an external load is multiplied in order to obtain the limit or ultimate load action on a structure or a part thereof.

3.1.10.3.4 Transportation Factor. - A transportation factor is a load factor associated with transportation of the load.

3.1.11 Fabrication. - Wherever practical, equipment items shall be fabricated from commercially available structural steel shapes and plates, materials, and hardware requiring a minimum of alteration for incorporation into the article. Construction details shall be per applicable drawings of equipment items as specified.

3.1.12 General Concepts.

3.1.12.1 Producibility. - The design of the equipment items covered by this specification shall allow the use of such methods and processes as will result in maximum production with a minimum expenditure of manhours and materials, commensurate with the quality requirements.

3.1.12.2 Maintainability. - Maintainability shall be considered as a design factor along with other major design parameters. The design shall provide for simple installation or removal of components with an absolute minimum of special tools and equipment. Equipment designs must provide for rapid servicing and inspection.

3.1.12.3 Human Engineering. - Human engineering principles shall be applied to assure that equipment items can be operated and maintained safely, effectively, and with minimum human error.

3.2 **TRUNNION MOUNTED JIG FRAME SYSTEM EQUIPMENT -
COMPONENT PARTS AND SPECIFIC REQUIREMENTS OF**

3.2.1 General Description & Requirements. - The trunnion mounted jig frame system shall consist of jig frames and accessory mounting equipment for use in aircraft and/or missile assembly work. The system shall include a series of incremental sizes of rectangular and round jig frames encompassing the range of commonly used sizes. The accessory equipment items shall provide the means for trunnion supporting the jig frames and controlling their rotation for positioning during assembly operations. The support equipment shall include trunnion shafts, bearings, and stands. Accessory items shall include indexing equipment for indexing jig rotation, counter balancing equipment for balancing jigs, and a quick acting clamp for attachment of jig base plates to frames.

3.2.2 Equipment Items & Components. - The trunnion mounted jig frame system shall consist of the following equipment items:

3.2.2.1 Rectangular Jig Frames. - The rectangular jig frames shall be provided in 129 incremental sizes.

3.2.2.2 Round Jig Frames. - The round jig frames shall be provided in 9 incremental sizes.

3.2.2.3 Trunnion Shafts. - The trunnion shafts shall be provided in the following types and sizes:

- a. Type I With gear drive coupling slot and end stops (Large size only).
- b. Type II With end stops only (Large & small size).
- c. Type III Plain without stops (Large & small size).

3.2.2.4 Trunnion Bearings. - The trunnion bearings shall be provided in the following types and sizes:

- a. Type I Steel weldment (Large & small shaft size)
- b. Type II Gray cast iron (Large & small shaft size)

3.2.2.5 Trunnion Stands. - The trunnion stands shall be provided in the following types and sizes:

- a. Fixed Trunnion Stand. - One size for the smaller jig frames.
- b. Adjustable Trunnion Stand. - One size for the larger jig frames.

3.2.2.6 Gear Drive Assembly. - One size gear drive assembly shall be provided and shall consist of the following components:

- a. A mounting bracket assembly.
- b. A gear reduction unit.
- c. A shaft coupling.
- d. A hand crank assembly.

3.2.2.7 Counterbalance Equipment. - The counterbalance equipment shall consist of the following components and sizes:

- a. Counterweights - 5 sizes
- b. Attach rails - 5 sizes
- c. Rail spacer - 1 size
- d. Eccentric stop - 1 size
- e. Outrigger assembly - 1 size

3.2.2.8 Indexing Equipment. - The indexing equipment shall be provided in one size and one type and consist of the following components:

- a. An index plate.
- b. A lock pin assembly.

3.2.2.9 Adjustable Quick Acting Clamp. - The adjustable quick acting clamp shall be provided in 5 sizes of a single type.

3.2.3 Detail Description and Requirements. -
Trunnion Mounted Jig Frame System.

3.2.3.1 Rectangular Jig Frames. - The rectangular jig frames shall be used to fabricate or mount jigs for aircraft and/or missile component assembly. The frames shall be rigidly welded frames of square structural steel tubing with provisions for mounting and aligning trunnion shafts. The frame structures shall be suitable for accurate and rigid mounting of jig components. The jig component mounting surfaces shall be non-machined. The jig frame sizes shall be as established in Table I of paragraph 3.2.14.1.

3.2.3.2 Round Jig Frames. - The round jig frames shall be used to fabricate or mount jigs for aircraft and/or missile component assembly. The frames shall be rigidly welded circular structures composed of rolled inner and outer side plates and circular segmented cover plates welded into a square box section. The cover plates and/or mounting surfaces shall be machined flat and parallel. The cylindrical surfaces shall not be machined. The frame structures shall be suitable for accurate and rigid mounting of jig components. The frame shall have provisions for

mounting and aligning trunnion shafts. The jig frame sizes shall be as established in Table II of paragraph 3.2.14.2.

3.2.3.3 Trunnion Shafts. - Trunnion shafts shall be affixed to opposite sides of a jig frame for supporting frames in the trunnion bearings. The trunnion shafts shall be provided in two types of small sizes and three types of large sizes. They shall be comprised of a round pipe shaft and attach plate. The small size shall support the Class I, II, V and VI jig frames and the large sizes shall support Class III, IV and VII jig frames. One type of large shaft shall have a coupling slot and end stops, one type shall have end stops only, and one type shall be plain. One type of small shaft shall be plain and the other with end stops. All types shall have provisions for attachment to the hoisting beam lift cable assembly and shall be fabricated of a round pipe shaft and attach plate. The coupling slot shall mate with the gear drive coupling for rotating jig frames. The end stops shall attach to the exterior surface of the shaft to stop the shaft from horizontal movement when rotated in the trunnion bearing.

3.2.3.4 Trunnion Bearings. - A pair of trunnion bearings shall be used to mount jig frames from the shafts affixed to opposite sides of frame. Trunnion bearings shall be provided in two sizes. The small bearings shall be designed to support the lightweight jig frames to which the small trunnion shafts are attached. The large bearings shall be designed to support the heavier jig frames to which the large trunnion shafts are attached. Two types of trunnion bearings shall be designed for each size. One type shall be a steel weldment and the other type a gray iron casting. Both types of bearings shall be identical in size and form for interchangeability. They shall be of the split and hinged type to permit trunnion shaft removal and installation without the need for disassembly of bearing. A clamp screw device shall secure the bearing cap in place and when tightened the bearing halves shall act as a brake on the trunnion shaft. The bearing shall be fastened to the top of the trunnion stand by a single fastener and be capable of alignment through the use of a spherical base to allow for frame and floor variations and/or misalignment of shafts.

3.2.3.5 Trunnion Stands. - A pair of trunnion stands shall be used to support a jig frame from the assembly floor. The trunnion stands shall be provided in two types; a fixed type for mounting all classes of jig frames except Class IV, and an adjustable type for mounting all classes of jig frames. The fixed stand shall consist of a column of standard steel pipe welded to a floor base mounting plate. The adjustable trunnion stand shall consist of two telescoping pipe columns which can be locked together, with a single pin, at incremental heights to suit widths and working positions of jig frames. The adjustable trunnion stand shall have

5 incremental height adjustments and provisions for mounting the gear drive assembly near the upper end. The upper end of both type stands shall be machined to mate with the spherical mounting base of all trunnion bearings, and a single fastener shall be provided for securing the bearing to the stand. The stands shall be stable and provide attach holes through base plates for floor mounting.

3.2.3.6 Gear Drive Assembly. - The gear drive assembly shall be provided in one size and one type for use in conjunction with the large size coupling type trunnion shaft. It shall consist of a welded steel mounting bracket, a gear reduction unit, a hand crank assembly and a trunnion shaft coupling. The bracket shall mount the gear reduction unit and attach, through a hinge pin and lock pin, to the upper end of the adjustable trunnion stand. The gear box speed reducer shall be hand cranked and provide controlled rotation of a trunnioned jig frame. The coupling shall connect the gear drive shaft to the trunnion shaft. The gear drive assembly shall permit quick removal and installation of jig frames.

3.2.3.7 Counterbalance Equipment. - The counterbalance equipment shall be used to balance trunnion mounted jig frames about the axis of rotation. The equipment shall consist of lead billets which can be sub-divided into 10 lb. increments; a rail system consisting of rails, rail spacers and end stops for securing the lead billets to the jig frames; and an outrigger assembly which can mount weights at extended positions from frame sides to compensate for an extremely unbalanced condition. The outrigger shall be a hinge mounted steel weldment which can be folded against the jig frame side when not in use. The attach rails, rail spacer and stops shall allow weights to be readily removed or added to jig frames and outriggers. The equipment shall be used with all classes of jig frames.

3.2.3.8 Indexing Equipment. - The indexing equipment shall be used to locate and fix the position of trunnioned jig frames. The indexing equipment shall consist of an index plate attached to a jig frame and a mating lock pin assembly mounted to the trunnion bearing. The index plate shall provide jig frame indexing at 30° intervals. The lock pin shall be spring loaded to prevent inadvertent disengagement of pin and plate. The indexing equipment shall be adaptable to all sizes and types of jig frames and trunnion bearings.

3.2.3.9 Adjustable Quick Acting Clamp. - The adjustable quick acting clamp shall be used for mounting jig base plates of various thicknesses to the jig frames. It shall be a pin type clamp with a hand knob for screw adjustment of the pin grip length. The clamp shall be provided in 5 different basic pin grip lengths as

follows: 1, 1½, 2, 2½, and 3 inches. The grip length adjusting range shall be a minimum of one half inch. All clamp pins shall have the same diameter and be of the same type. The clamps shall be adaptable for use with all sizes and types of jig frames.

3.2.4 Specific Standards - Trunnion Mounted Jig Frame System

3.2.4.1 Finish. - Paragraph 3.1.2 shall apply on all jig frame mounting system equipment items except for the quick acting clamp to which no finish shall be applied.

3.2.4.2 Welding. - Paragraph 3.1.1 shall apply.

3.2.4.3 Drawing Preparation. - Paragraph 3.1.5 shall apply.

3.2.5 Materials - Trunnion Mounted Jig Frame System.

3.2.5.1 Common Materials. - The system equipment items shall be fabricated with the following material requirements where applicable:

- a. Low Carbon steel - Paragraph 3.1.4 shall apply.
- b. Standard Black steel pipe - 3.1.4 shall apply.
- c. Rolled and formed structural shapes - Paragraph 3.1.4 shall apply.
- d. Bolts, nuts, washers, etc - 3.1.3 shall apply.
- e. Anti-rust coat - Paragraph 3.1.2 shall apply.

3.2.5.2 Specific Materials.

- a. Trunnion Bearing Casting - Gray cast iron ASTM 48-48 No. 20 or 25.
- b. Gear Drive Assembly - Music wire SAE 1085.
- c. Counterbalance Equipment - Lead Antimony alloy MIL-L-18331 or QQ-L-171 Grade B.
- d. Indexing Equipment - Music wire SAE 1085.

3.2.6 Design - Trunnion Mounted Jig Frame System.

The design of the trunnion mounted jig frame system equipment items shall be adequate to obtain the required performance stated in 3.2.3 and 3.2.9.

3.2.7 Construction Requirements.- Trunnion Mounted Jig Frame System.

3.2.7.1 Fabrication. - The trunnion mounted jig frame system equipment items shall be fabricated per paragraph 3.1.11. Construction details shall be per respective equipment item drawings as listed in paragraph 2.2.1.1.

3.2.8 Loads and Stresses -
Trunnion Mounted Jig Frame System.

The equipment items shall be designed in accordance with requirements of paragraph 3.1.10.1. Allowable stresses shall be per paragraph 3.1.10.2. The equipment items shall be designed to sustain loads as specified in pertinent sub-paragraphs of paragraph 3.2.9.

3.2.9 Performance Requirements -
Trunnion Mounted Jig Frame System.

3.2.9.1 Jig Frames. - The largest frame in each class of jig frames shall be capable of supporting jig components and production parts of a weight equal to 20 pounds per square foot of frame plan form area without exceeding a deflection of .020 inches at any point while trunnion supported. All other frames within the class shall be loaded with the design load selected for the largest frame of that class. The frame stiffness shall be adequate to allow the total load to be concentrated at any point on a frame member. The effects of adding stiffening structural members to the frames shall be considered when analyzing load applications. Jig frames shall be compatible with the other equipment items of the system as specified in subsequent paragraphs of 3.2.9.

3.2.9.2 Trunnion Shafts.

3.2.9.2.1 General Performance. - All trunnion shaft pairs shall be capable of supporting the largest size jig frame (of the class to which they are mated), loaded to its maximum as specified in paragraph 3.2.14.3. All shafts shall provide for attachment of the hoisting beam lift cable assembly trunnion pins. The shafts shall be designed for safe, overhead lifting of loaded jig frames. All shafts shall mate with the trunnion bearings and the transportation and storage equipment stanchions. They shall have common provisions for pinning to the stanchions and lift cable assembly trunnion pins.

3.2.9.2.2 Specific Performance - Trunnion Shafts With Gear Drive Slot And/Or End Stops. - The gear drive coupling slot of the large shaft shall mate with the coupling of the gear drive assembly and be capable of rotating the largest size frame loaded as specified in paragraph 3.2.14.3. The end stops shall be compatible with the trunnion bearings and shall prevent axial movement of installed shafts during rotation of frames.

3.2.9.3 Trunnion Bearings. - The trunnion bearings shall be compatible with the trunnion stands, trunnion shafts and indexing equipment. They shall provide for clamping and/or braking the trunnion shafts against inadvertent rotation and permit ready installation and removal of the trunnion shafts. The trunnion

bearings shall allow ready attachment of the hoisting beam lift cable assembly to the installed trunnion shaft. They shall be capable of supporting the largest size loaded jig frame, as specified in paragraph 3.2.14.3., of the class to which they are mated. The bearings shall permit 360° rotation for all sizes of installed frames.

3.2.9.4 Trunnion Stands. - The trunnion stands shall be compatible with and provide for attachment of the trunnion bearings to upper end of column. They shall have a base for distribution of loads and attachment to the floor. They shall allow unrestricted rotation of the frames. The adjustable stand shall provide for gear drive assembly mounting and loading, and manual height adjustment of the unloaded stand. The stands shall be capable of supporting the largest size jig frame, loaded to its maximum as specified in paragraph 3.2.14.3, of the class to which they are matched.

3.2.9.5 Gear Drive Assembly. - The gear drive assembly shall be hinged and locked to the upper end of the trunnion stand, with its output shaft coupled to the large size slotted trunnion shaft in the locked position. The drive shaft coupling shall engage directly and positively to the trunnion shaft when the assembly is swung into the locked position. The coupling shall accommodate the maximum trunnion shaft misalignment resulting from drawing tolerance buildup of system equipment items. The hinged gear box support bracket shall be manually operated for engaging or disengaging the coupling and trunnion shaft. It shall allow installation of the jig frame lift cable assembly fittings to trunnion shaft when in the disengaged position. The gear box shall be of the self-locking gear type capable of manual operation with a minimum output torque of 1500 in-lbs and an output speed of one revolution per minute.

3.2.9.6 Counterbalance Equipment. - The counterbalance system shall be used to balance a loaded jig frame about its trunnion axis to facilitate rotation. The system equipment shall consist of a series of weights and the accessory items required to locate and affix them to jig frames of all sizes or types. Accessory attach equipment items shall include attach rails, end stops, rail spacers and an outrigger assembly. All items of the system shall be compatible with the overall jig frame mounting system.

3.2.9.6.1 The weights shall be provided in 10, 20, 30, 40, and 50 pound size lead billets of the same constant cross sectional shape and size. The multiple size weights shall be delineated and marked in 10 pound sizes so that they can be subdivided when specific weight combinations are required and/or when weights are to be separated for mounting on cylindrical surfaces of the round

jig frames. The weights shall attach along the sides of the frame member, at any accessible points, and along the outrigger arm. They shall be retained by track pairs fitted into the flanges formed by side grooves in the weights, and by an end stop at the ends of a string of weights.

3.2.9.6.2 The rails shall be provided in 5 sizes matched to the lengths of the billet sizes. Their cross sectional shape shall be fitted to side slots in the weights. The rails shall be flexible steel straps capable of being formed to the curvature of the smallest round jig frame when screw-attached along incremental spaced holes.

3.2.9.6.3 The rail spacers shall support the attach rails to provide flange clearance for the weights between the rails and mounting surface of jig frame or outrigger. The end stops shall provide the means to locate and hold a string of weights in position when proper balance is attained. The outrigger assembly shall be capable of bringing an extremely out-of-balance frame into balance. It shall mount along the jig frame side or end beams to extend counterweights out from the axis of rotation. The outrigger shall be hinged to fold against the frame to prevent damage while in storage or transportation, and to provide accessibility and clearances in work areas during assembly operations.

3.2.9.6.4 The counterbalance details and usage shall be as specified in paragraph 2.2.1.1 p.

3.2.9.7 Indexing Equipment. - The indexing equipment shall consist of an index plate and a mating spring-loaded lock pin assembly. The index plate shall fit around the trunnion shaft and be bolted to the jig frame side. It shall have 12 evenly spaced holes to provide for indexing and locking frames at 30° intervals. The lock pin assembly shall attach to the trunnion bearing lower half with screw fasteners. The spring load shall prevent inadvertent retraction of the pin from the index plate hole. The lock pin assembly shall be hand operated and provide for locking the pin in its retracted position. It shall be compatible with requirements of other system components.

3.2.9.8 Adjustable Quick Acting Clamp. - The adjustable quick acting clamp shall be capable of securing jig baseplates to the jig frames. It shall provide adjustment to allow for variations in jig plate thickness. The clamp shall be hand operated. It shall be capable of securing and releasing jig plates quickly without causing the user to become involved in complicated and time consuming mechanisms. It shall be capable of a single shear load of 16,000 pounds.

3.2.10 Environmental Requirements - Trunnion Mounted Jig Frame System. - The requirements of paragraph 3.1.8 shall apply to all equipment items of this system.

3.2.11 Interchangeability - Trunnion Mounted Jig Frame System. - The requirements of paragraph 3.1.9 shall apply to all equipment items of the system.

3.2.12 Radio Interference. - Not applicable.

3.2.13 Dimensions - Trunnion Mounted Jig Frame System. - The dimensions and tolerances for the trunnion mounted jig frame system equipment items shall be per their respective Boeing drawing numbers, as specified in 2.2.1.1.

3.2.14 Weight & Sizes - Trunnion Mounted Jig Frame System. - The weights and sizes of equipment items shall be taken as follows:

3.2.14.1 Rectangular Jig Frames. - The weight and sizes of rectangular jig frames are shown in the table below. The weights shown are in pounds and apply to basic frame structures.

FRAME CLASS	FRAME WIDTH - INCHES									FRAME LENGTH INCHES
	24	30	36	42	48	54	60	66	72	
CLASS I	80									24
	90	100								30
	100	110	120							36
	110	120	130	140						42
	120	130	140	150	160					48
CLASS II	180	195	210	225	240	255	270	285	300	54
	195	210	225	240	255	270	285	300	315	60
	210	225	240	255	270	285	300	315	325	66
	225	240	255	270	285	300	315	325	340	72
CLASS III	560	595	630	665	700	735	770	805	840	78
	595	630	665	700	735	770	805	840	875	84
	630	665	700	735	770	805	840	875	910	90
	665	700	735	770	805	840	875	910	945	96
			770	805	840	875	910	945	980	102
			805	840	875	910	945	980	1015	108
			840	875	910	945	980	1015	1050	114
			875	910	945	980	1015	1050	1085	120
CLASS IV					1300	1350	1400	1450	1500	126
					1350	1400	1450	1500	1550	132
					1400	1450	1500	1550	1600	138
					1450	1500	1550	1600	1650	144

TABLE I -
SIZES & WEIGHTS OF RECTANGULAR JIG FRAMES

3.2.14.2 Round Jig Frames. - The weights and sizes of round jig frames are shown below. The weights shown are in pounds and apply to basic frame structures.

FRAME CLASS	FRAME DIA - INCHES	FRAME WEIGHT LBS - APPROX.
V	24	105
	30	135
	36	145
VI	42	295
	48	325
	54	360
VII	60	685
	66	755
	72	820

TABLE II -
SIZES & WEIGHTS OF ROUND JIG FRAMES

3.2.14.3 Loaded Weights. - The weights of loaded frames shall, for the purpose of calculations, be the basic frame weight, plus attached trunnion shafts, plus jig component weight of an amount equal to 20 pounds per square foot of nominal jig frame plan form area of the largest frame within their class.

3.2.14.4 Trunnion Shaft. - 40 pounds.

3.2.14.5 Trunnion Bearing. - 60 pounds.

3.2.14.6 Trunnion Stands.

a. Fixed Stand. - 75 pounds.

b. Adjustable Stand. - 150 pounds.

3.2.14.7 Gear Drive Assembly. - 65 pounds.

3.2.14.8 Counterbalance Equipment.

a. Counterbalance Weights. - 10, 20, 30, 40
and 50 pounds.

b. Outrigger Assembly. - 25 pounds.

3.2.14.9 Indexing Equipment. - 30 pounds.

3.2.14.10 Adjustable Quick Acting Clamp. - 1/2 pound.

3.2.15 Identification - Trunnion Mounted Jig Frame System. -
The jig frame mounting system shall be identified per the requirements of paragraph 3.1.6.

3.2.16 Workmanship - Trunnion Mounted Jig Frame System. -
The quality of workmanship for the jig frame mounting system shall be that as specified in paragraph 3.1.7.

3.3 JIG FRAME STORAGE EQUIPMENT -
COMPONENT PARTS & SPECIFIC REQUIREMENTS OF

3.3.1 Description and Requirements of System. - The storage system shall be capable of storing various combinations of jig frames, with or without attached jiggling components, in their vertical planes. The storage system shall consist of a rack base assembly and stanchion assemblies. Jig frames shall be supported from the attached trunnion shafts by a pair of stanchions. The stanchions shall attach to the rack base structure in a manner which permits spacing to suit various combinations of sizes, types, and quantities of jig frames.

3.3.2 Components. - The storage system equipment items shall consist of the following components:

- a. A Storage Rack Base Assembly.
- b. Stanchion Assembly. - Quantities shall be per requirements of Boeing Drawing 55-20419.

3.3.3 Specific Standards - Storage Equipment. - The following requirements shall apply to storage equipment items:

3.3.3.1 Finish. - Paragraph 3.1.2 shall apply.

3.3.3.2 Welding. - Paragraph 3.1.1 shall apply.

3.3.3.3 Drawings. - Paragraph 3.1.5 shall apply.

3.3.3.4 Specific Material.

- a. Structural And Low Carbon Steel. - Paragraph 3.1.4 shall apply.
- b. Bolts, Nuts, Washers, Etc. - Paragraph 3.1.3 shall apply.

3.3.3.5 Protective Treatment. - Paragraph 3.1.2 shall apply.

3.3.4 Design. - Storage Equipment. - The design of the equipment items shall be adequate to obtain the required performance stated in 3.3.7.

3.3.5 Construction Requirements - Storage Equipment.

3.3.5.1 Fabrication - Construction Requirements. - The storage rack base assembly and the stanchion assembly shall be of welded steel construction.

3.3.5.2 Storage Rack Base Assembly Fabrication. - The rack base assembly shall consist of two independent and parallel rail sets joined together and supported from the floor by cross beams. The rails shall be fitted to the stanchion base in a manner that allows the stanchions to be spaced by sliding along the rail. Rails shall allow the stanchion base to be firmly clamped at all locations along its length. The rack base assembly shall be constructed per Boeing drawing 55-20420.

3.3.5.3 Stanchion Assembly Fabrication. - The stanchion assembly shall consist of a post with a base plate for rail attachment, and an upper vee block with fittings for nesting and securing standard jig frame trunnion shafts. The stanchion assembly shall be constructed per Boeing drawing 55-20421.

3.3.6 Loads and Stresses - Storage Equipment.

3.3.6.1 Equipment shall be designed in accordance with requirements of paragraph 3.1.10.1. Allowable stresses shall be per paragraph 3.1.10.2. Loaded frame weights shall be as specified in paragraph 3.2.14.3. Storage equipment items shall be designed at loaded gross weight for the following minimum design limit load factors:

CONDITION	APPLIED LOAD DIRECTION	DESIGN LIMIT LOAD FACTOR
1	Up	.25
2	Down	2.0
3	Side	.25
4	Fore and aft	.25

TABLE III -
DESIGN LIMIT LOAD FACTORS, STORAGE EQUIPMENT

Storage equipment items shall be designed for the following load conditions:

3.3.6.2 Stanchion Assembly Loads. - A pair of stanchions shall be capable of supporting the weight of the largest size loaded jig frame when attached to the rack base assembly as shown in Figure 1.

3.3.6.3 Storage Rack Base Assembly Loads. - The storage rack base assembly shall sustain all loads imparted to it through the loaded stanchion assemblies. The stanchion loads shall be of the magnitudes and applied as shown in Figure 2.

3.3.7 Performance Requirements - Storage Equipment.

3.3.7.1 Storage Rack Assembly. - The storage rack shall be capable of supporting and storing various combinations of sizes, shapes and quantities of the standard jig frame series. The rack shall provide attach fittings for use with the general purpose hoisting equipment, (Ref: Boeing drawing 55-20424) and shall be capable of fork truck and sling lifting in the unloaded condition, with trunnion assemblies attached.

3.3.7.2 Stanchion Assembly. - The stanchion assembly shall support the jig frames from the attached trunnion shafts (see Boeing drawings 55-20409 and 55-20410). It shall permit attachment of the jig frame lift cable trunnion pin to the nested trunnion shaft of the jig frame when another loaded stanchion is at the closest adjacent position. The supporting vee block shall nest the trunnion shaft and provide for securing it against rotation and movements in all directions.

3.3.8 Environmental Requirements - Storage Equipment. - The requirements of 3.1.8 shall apply to all equipment items of the system.

3.3.9 Interchangeability - Storage Equipment. - Requirements of paragraph 3.1.9 shall apply.

3.3.10 Radio Interference. - Not applicable.

3.3.11 Dimensions - Storage Equipment. - The dimensions and tolerances of equipment items shall be those specified on the applicable drawing as follows:

- a. Rack Base Assembly. - Drawing 55-20420 shall apply.
- b. Stanchion Assembly. - Drawing 55-20421 shall apply.

3.3.12 Weight - Storage Equipment. - The weight of equipment items shall be taken for purposes of calculations, as follows:

- a. Storage Rack Base Assembly. - 900 pounds.
- b. Each Stanchion Assembly. - 90 pounds.

3.3.13 Identification - Storage Equipment. - The storage equipment items shall be identified per the requirements of paragraph 3.1.6.

3.3.14 Workmanship - Storage Equipment. - The quality of workmanship for finished equipment items shall be that specified in paragraph 3.1.7.

A PAIR OF STANCHIONS SUPPORT A SINGLE JIG FRAME.

SEE PARAGRAPH 3.3.6 AND SUB-PARAGRAPHS FOR SPECIFIC LOAD MAGNITUDE, DIRECTION OF LOAD, LOAD FACTORS AND COMBINATIONS & ARRANGEMENTS OF STORAGE RACK STANCHIONS.

SEE FIGURE 2 FOR STANCHION SPACINGS AND LOCATIONS.

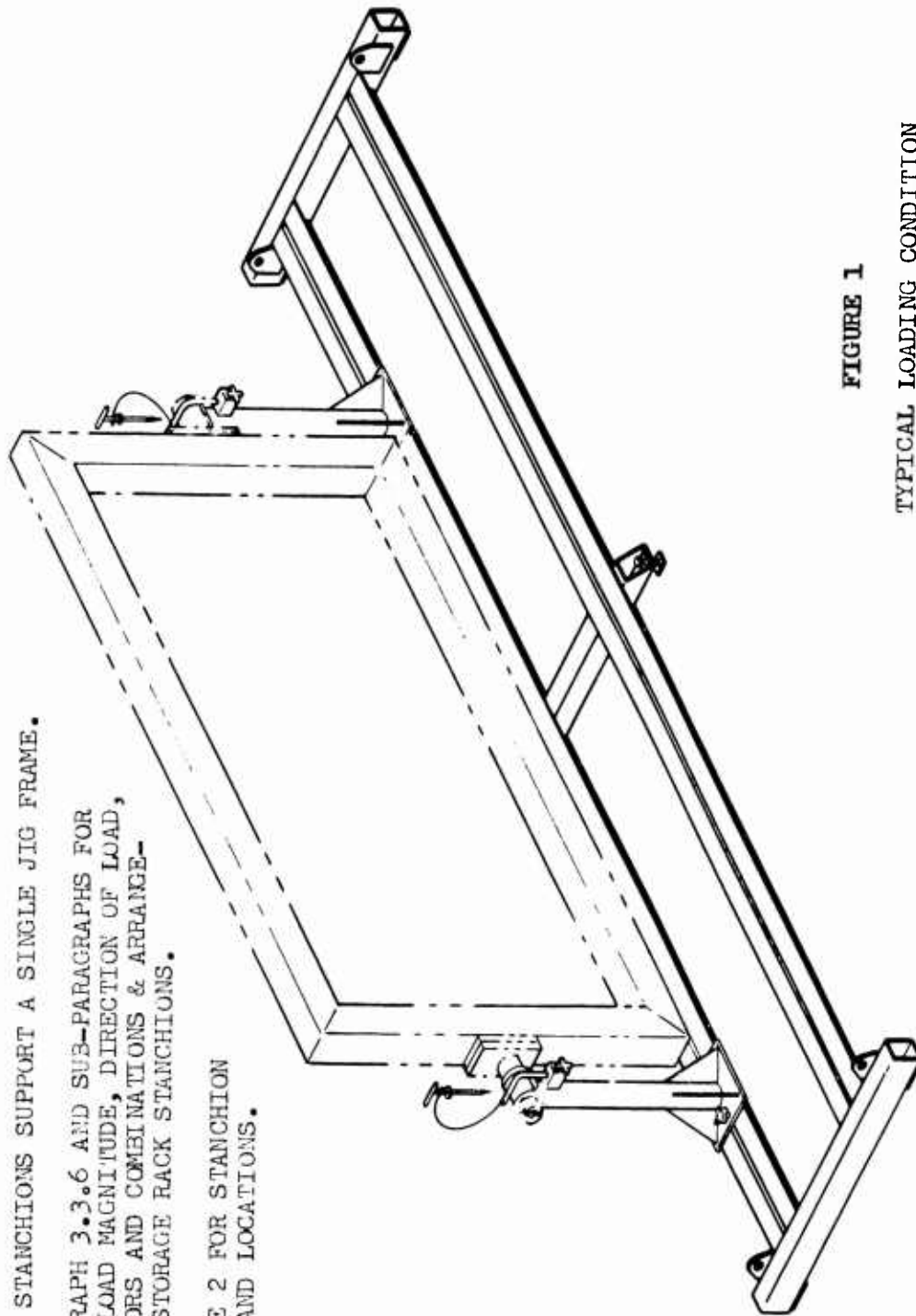
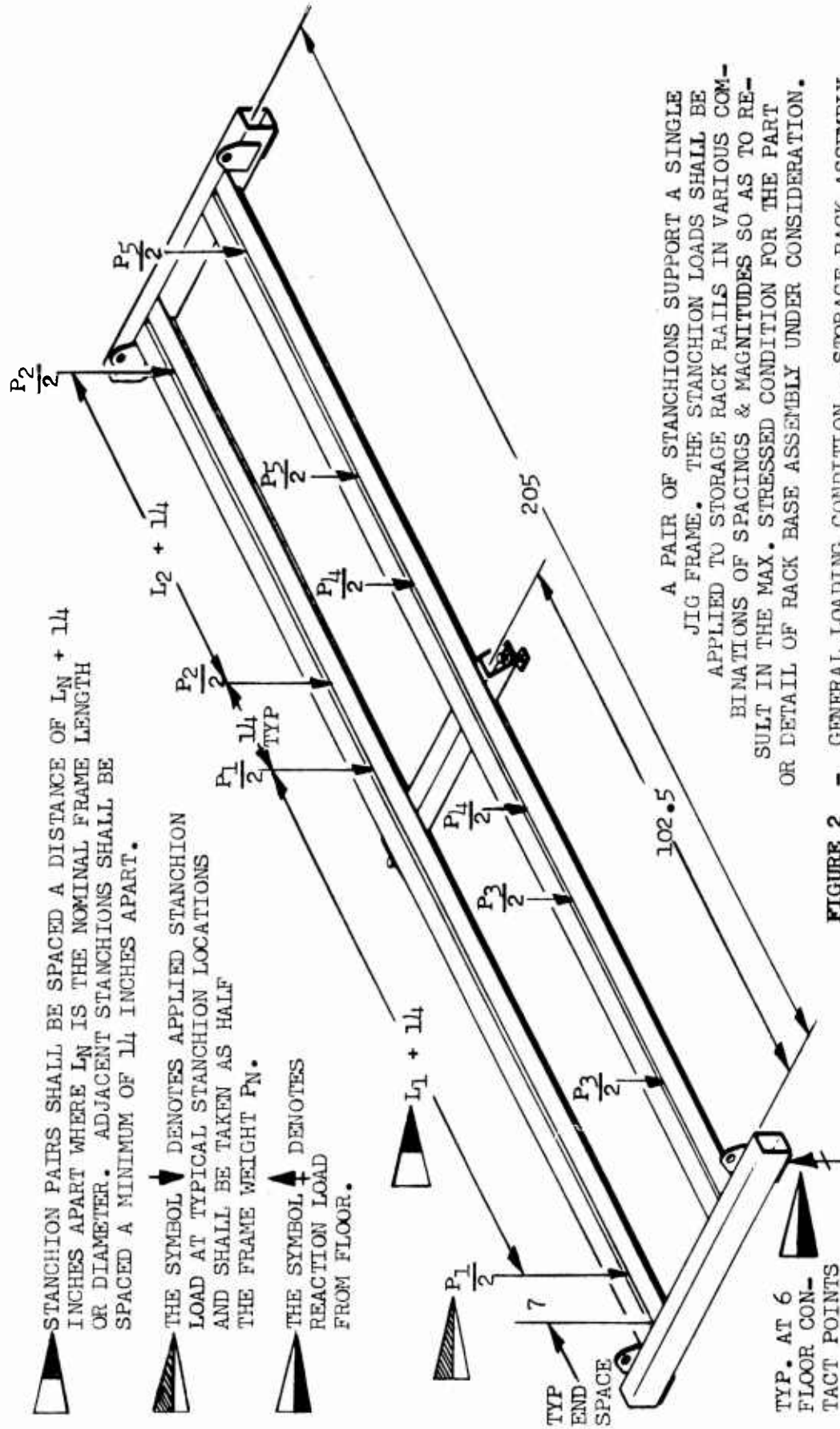

FIGURE 1

TYPICAL LOADING CONDITION
STORAGE RACK STANCHIONS



A PAIR OF STANCHIONS SUPPORT A SINGLE JIG FRAME. THE STANCHION LOADS SHALL BE APPLIED TO STORAGE RACK RAILS IN VARIOUS COMBINATIONS OF SPACINGS & MAGNITUDES SO AS TO RESULT IN THE MAX. STRESSED CONDITION FOR THE PART OR DETAIL OF RACK BASE ASSEMBLY UNDER CONSIDERATION.

FIGURE 2 - GENERAL LOADING CONDITION - STORAGE RACK ASSEMBLY

3.4 JIG FRAME TRANSPORTATION SYSTEM EQUIPMENT -
COMPONENT PARTS & SPECIFIC REQUIREMENTS OF

3.4.1 Description and Requirements. - The transportation system equipment shall be capable of transporting various combinations of jig frames, with or without attached jiggling components, between operating areas of jig frame fabrication, storage, and usage. The transportation system equipment shall consist of a dolly assembly and stanchion assemblies. Jig frames shall be supported from the attached trunnion shafts by a pair of stanchions. The stanchions shall attach to the dolly assembly structure in a manner which permits spacing to suit various combinations of sizes, types and quantities of jig frames.

3.4.2 Components - Transportation Equipment. - The transportation system equipment items shall consist of the following components:

- a. A Transportation Dolly Assembly.
- b. Stanchion Assembly. - Quantities shall be per requirements of Boeing Drawing 55-20436.

3.4.3 Specific Standards - Transportation Equipment. - The following requirements shall apply to transportation equipment items:

3.4.3.1 Finish. - Paragraph 3.1.2 shall apply.

3.4.3.2 Welding. - Paragraph 3.1.1 shall apply.

3.4.3.3 Drawings. - Paragraph 3.1.5 shall apply.

3.4.3.4 Specific Material.

- a. Structural And Low Carbon Steel. - Paragraph 3.1.4 shall apply.
- b. Bolts, Nuts, Washers, etc. - Paragraph 3.1.3 shall apply.

3.4.3.5 Protective Treatment. - Paragraph 3.1.2 shall apply.

3.4.4 Design - Transportation Equipment. - The design of the equipment items shall be adequate to obtain the required performance stated in 3.4.7.

3.4.5 Construction Requirements - Transportation Equipment.

3.4.5.1 Fabrication - Construction Requirements. - The dolly frame and stanchion assemblies shall be of welded steel construction.

3.4.5.2 Dolly Assembly Fabrication. - The dolly assembly shall consist of a rigid framework supporting two parallel rails. The frame shall be supported by casters and a towbar provided for powered towing. The rails shall adapt to the stanchion bases in a manner that permits longitudinal space adjustment between pairs of stanchion assemblies along the rails and which provides for clamping the stanchions firmly in place. The dolly assembly shall be constructed per Boeing Drawing 55-20437.

3.4.5.3 Stanchion Assembly Fabrication. - The stanchion assembly shall consist of a base adaptable to the dolly rails for sliding and clamping in position, and a support column with an upper vee block and fittings for nesting and securing standard jig frame trunnion shaft. The frame shall be restrained from rotating on trunnion shafts while being transported. The stanchion assembly shall be constructed per Boeing Drawing 55-20438.

3.4.6 Loads and Stresses - Transportation Equipment.

3.4.6.1 Equipment shall be designed in accordance with the requirements of paragraph 3.1.10.1. Allowable stresses shall be per paragraph 3.1.10.2. Loaded frame weights shall be as specified in paragraph 3.2.14.3. Transportation equipment items shall be designed at loaded gross weight for the following minimum transportation design limit load factors:

CONDITION	APPLIED LOAD DIRECTION	TRANSPORTATION LOAD FACTOR
1	Up	0.5
2	Down	2.0
3	Side	0.5
4	Fore and aft	1.0
5	Up	.25
	Side	.25
6	Down	1.0
	Fore and aft	.5
7	Down	1.0
	Side	.25

TABLE IV - TRANSPORTATION DESIGN LIMIT LOAD FACTORS

The transportation equipment items shall be designed for the following loads:

3.4.6.2 Stanchion Assembly Loads. - A pair of stanchions shall be capable of supporting the weight of the largest size loaded jig frame when secured to the dolly assembly as shown in Figure 3.

3.4.6.3 Dolly Assembly Loads. - The dolly assembly shall be capable of sustaining all loads imparted to it through the stanchions. The stanchion loads shall be applied to the dolly rails in the combination of spacing and load magnitudes and in the direction which results in the maximum stressed condition for the part or detail under consideration. Load spacings shall be as shown in Figure 4.

3.4.7 Performance Requirements - Transportation Equipment.

3.4.7.1 Transportation Dolly. - The transportation dolly shall be capable of supporting and transporting various combinations of sizes, shapes, and quantities of the standard jig frame series. The dolly shall be used with towing vehicles on normal factory aisleways and inter-plant roadways at speeds not to exceed ten miles per hour.

3.4.7.2 Stanchion Assembly. - The stanchion assembly shall support the jig frames from the attached trunnion shafts (see Boeing Drawings 55-20409 and 55-20410). It shall permit attachment of the jig frame when another loaded stanchion is at the closest adjacent position. The supporting vee block shall nest the trunnion shaft and provide for securing it against rotation and movements in all directions.

3.4.8 Environmental Requirements - Transportation Equipment. - The requirements of paragraph 3.1.8 shall apply to all equipment items of the system.

3.4.9 Interchangeability - Transportation Equipment. - The requirements of paragraph 3.1.9 shall apply to dolly and stanchion assembly.

3.4.10 Radio Interference. - Not applicable.

3.4.11 Dimensions - Transportation Equipment. - The dimensions and tolerances of equipment items shall be those specified on the applicable Boeing drawing as follows:

- a. Transportation Dolly Assembly. - Drawing 55-20437 shall apply.
- b. Stanchion Assembly. - Drawing 55-20438 shall apply.

3.4.12 Weight - Transportation Equipment. - The weights of equipment items shall be taken for purposes of calculations as follows:

- a. Dolly Frame. - 3000 pounds.
- b. Each Stanchion Assembly. - 120 pounds.

3.4.13 Identification - Transportation Equipment. - The transportation equipment shall be identified per the requirements of paragraph 3.1.6.

3.4.14 Workmanship - Transportation Equipment. - The quality of workmanship for the finished transportation dolly and stanchion assembly shall be that specified in paragraph 3.1.7.

A PAIR OF STANCHIONS SUPPORT A SINGLE JIG FRAME.

SEE PARAGRAPH 3.4.6 AND SUB-PARAGRAPHS FOR SPECIFIC LOAD MAGNITUDE, DIRECTION OF LOAD, LOAD FACTORS AND COMBINATIONS & ARRANGEMENTS OF DOLLY STANCHIONS.

SEE FIGURE 4 FOR STANCHION SPACINGS AND LOCATIONS.

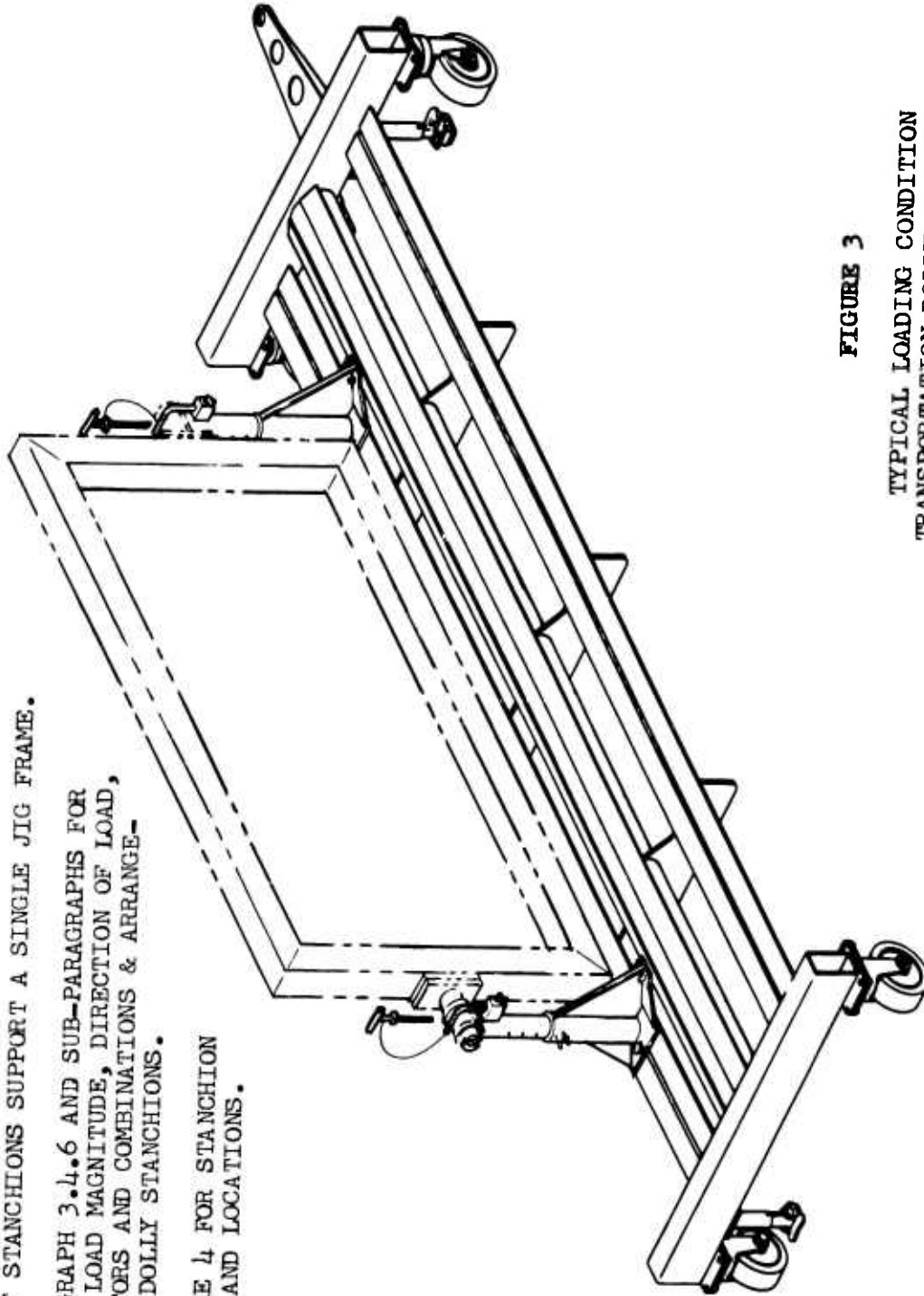
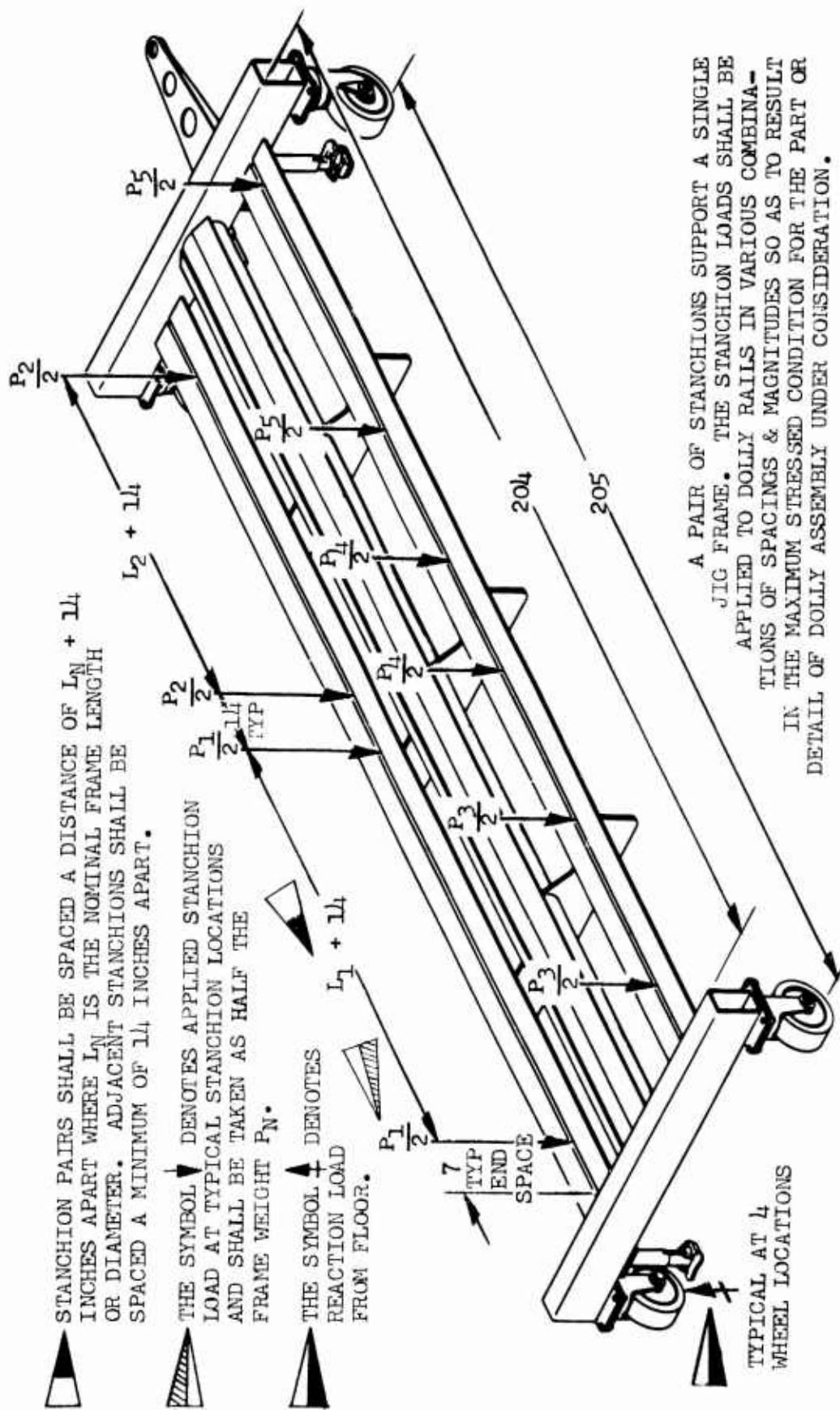

FIGURE 3

TYPICAL LOADING CONDITION
TRANSPORTATION DOLLY STANCHIONS



A PAIR OF STANCHIONS SUPPORT A SINGLE JIG FRAME. THE STANCHION LOADS SHALL BE APPLIED TO DOLLY RAILS IN VARIOUS COMBINATIONS OF SPACINGS & MAGNITUDES SO AS TO RESULT IN THE MAXIMUM STRESSED CONDITION FOR THE PART OR DETAIL OF DOLLY ASSEMBLY UNDER CONSIDERATION.

FIGURE 4 - GENERAL LOADING CONDITION - TRANSPORTATION DOLLY ASSEMBLY

3.5 HOISTING SYSTEMS EQUIPMENT - GENERAL PURPOSE AND JIG
FRAME LIFTING - COMPONENT PARTS & SPECIFIC REQUIREMENTS OF

3.5.1 General Description and Requirements.

3.5.1.1 The hoisting systems shall include the items of equipment for 1500, 3000, and 6000 pound capacity systems. The systems shall provide the means of hoisting the standard jig frames during operations involving fabrication, usage, storage, or transportation of frames. The hoisting systems shall also be capable of general purpose lifting operations involved in the production of missile and aircraft components.

3.5.1.2 All hoisting systems shall consist of the main hoisting beam, cross beams, main beam and cross beam load dropper attach fittings, cross beam to main beam hanger fittings, and jig frame lift cables. These equipment items shall be arranged and combined, within their respective systems, according to Boeing Drawing 55-20424; to perform the following specific operations:

a. Hoist any standard jig frame, listed under paragraph 1.2.1.1, whose size is included within the established dimensional limits of a main hoisting beam.

b. Perform general lifting operations within the established load rating capacities, dimensional limits, and adjusting ranges of equipment items by providing for multiple and adjustable load attach points and an adjustable positioned crane hook pickup point. Arrangements of equipment items may be varied so as to locate load droppers and lift point to suit configurations and structural limitations of the lifted aircraft or missile component.

3.5.2 Equipment Items of 1500, 3000, and 6000 Pound Capacity Hoisting Systems.

The nominal sizes of equipment items shall be as shown in Figure 5.

3.5.2.1 Main Beam Assemblies. - The main beam assemblies shall be structural steel beams with provisions for attachment of load droppers, cross beams and crane hook. The method of attachment shall provide for varying the positions of load droppers, cross beams, and crane hook pickup points to suit load requirements of general purpose lifting operations. The main beams shall be used in conjunction with a pair of lift cable assemblies to hoist and allow rotation of various size standard jig frames.

3.5.2.2 Cross Beams - General Purpose Hoisting. - The cross beams shall be single structural steel beams with provisions for attachment to main beams and attachment of the load droppers. The

method of attachment shall provide for varying the positions of load droppers and hanger fittings to suit conditions for general purpose lifting operations.

3.5.2.3 Lift Cable Assemblies - Standard Jig Frames. - The lift cable assemblies shall be single leg, wire rope slings with provisions for attaching terminal ends to main beams and jig frames. A pair of lift cable assemblies shall be used in conjunction with the main beam assembly to hoist and allow rotation of standard jig frames in assembly, fabrication and storage areas.

3.5.2.4 Main Beam Load Dropper Assemblies. - The main beam load dropper fittings shall provide the means of attaching to and positioning standard jig frame lift cable assemblies (or load droppers of the user's design) and cross beams along the main beam in various positions to accommodate different load lengths and/or provide multiple load attach points to the lifted part.

3.5.2.5 Cross Beam Load Dropper Assemblies. - The cross beam load dropper fittings shall provide the means of attaching load droppers of the user's design to the cross beam in various positions along the beam length in order to accommodate different load widths and/or provide multiple load attach points to the lifted part.

3.5.2.6 Cross Beam to Main Beam Hanger Assemblies. - The hanger assemblies shall provide the means for suspending cross beams from the main beam in various lateral positions along main beam length to suit general purpose lifting requirements for multiple and variable spaced load attach points.

3.5.3 Components and Sizes of Hoisting Systems Equipment.

3.5.3.1 The hoisting systems shall be load rated as 1500, 3000, and 6000 pound systems on the basis of main beam assembly load capacities. Each system shall consist of similar equipment items as described below. The types and quantities of items required for various arrangements of a system shall be selected per Boeing Drawing 55-20424 to suit the requirements of the lifting operation.

3.5.3.2 Main Hoisting Beam Assemblies. - The main hoisting beam assemblies shall consist of a rolled structural steel shape, a movable crane hook carriage assembly, and a flexible drive cable assembly. Two types of beam assemblies shall be included in each load rated system, and shall be identical in all respects except for the lengths of the flexible drive cable assemblies. These types shall be designated as follows:

Main Hoisting Beam Assemblies. -

- a. Type I Short Flex-drive 1500 pound capacity
- b. Type I Short Flex-drive 3000 pound capacity
- c. Type I Short Flex-drive 6000 pound capacity
- d. Type II Long Flex-drive 1500 pound capacity
- e. Type II Long Flex-drive 3000 pound capacity
- f. Type II Long Flex-drive 6000 pound capacity

3.5.3.3 Cross Beams - General Purpose Hoisting. - The cross beam shall consist of a single rolled structural steel shape altered to provide attach points for mated system components.

3.5.3.4 Lift Cable Assemblies - Standard Jig Frame Lifting. - The lift cable assemblies shall consist of an eyed cable dropper assembly, a lift pin plate, a trunnion pin, and all accessory fittings. A pair of lift cable assemblies shall be provided for use with each of the three main beam assemblies.

3.5.3.5 Main Beam Load Dropper Assemblies. - The load dropper assemblies shall consist of a steel plate, shaped to fit main beam cross-sectional shape and size, and accessory locating and attaching fittings.

3.5.3.6 Cross Beam Load Dropper Assemblies. - The cross beam load dropper assemblies shall consist of a steel plate, shaped to fit the cross beam cross-sectional shape and size, and accessory locating and attaching fittings.

3.5.3.7 Cross Beam - To - Main Beam Hanger Assemblies. - The hanger assemblies shall consist of a cross beam load dropper assembly (3.5.3.6) and a two-way swiveled coupling with swivel pins.

3.5.4 Specific Standards - Hoisting Equipment. - The following requirements shall apply to the equipment items of each hoisting system, unless otherwise specified.

3.5.4.1 Drawing Preparation. - Paragraph 3.1.5 shall apply.

3.5.4.2 Finishes. - Paragraph 3.1.2 shall apply.

3.5.4.3 Welding. - Paragraph 3.1.1 shall apply to main beam assemblies.

3.5.4.4 Material Requirements.

3.5.4.4.1 Common Materials. - The following requirements shall apply to the equipment items of each hoisting system:

- a. Low Carbon and Structural Steels. - Paragraph 3.1.4 shall apply.
- b. Bolts, Nuts, Washers, Screws, Cotter Pins. - Paragraph 3.1.3 shall apply.

3.5.4.4.2 Specific Materials - Main Beam Assembly.

- a. Phosphor Bronze - QQ-P-330 - Composition A.
- b. Spring Steel - SAE 1095
- c. Paint color per MIL-E-7729 or TT-E-489
 - Insignia Red - #11136 per FED STD 595
 - Yellow - #13538 per FED STD 595
 - Black - #17038 per FED STD 595
 - White - #17875 per FED STD 595

3.5.4.5 Protective Treatment. - Paragraph 3.1.2 shall apply to the equipment items of each hoisting system.

3.5.5 Design Requirements - Hoisting Equipment. - The design of all equipment items, for the systems, shall be adequate to obtain the required performance stated in 3.5.8 and shall be designed in accordance with the structural design criteria specified in 3.5.6.2. Designs shall take into consideration possible degradation of performance due to production variations and wear. In the interest of safety, consideration shall be given to the prevention of inadvertent mixing of equipment items of different load rated systems which could result in failure or damage to equipment and/or production parts, and injury to personnel.

3.5.6 Construction Requirements - Hoisting Equipment.

3.5.6.1 Fabrication. - Paragraph 3.1.11 shall apply to all equipment items of each hoisting system. Construction details shall be per applicable drawings as specified in paragraph 2.2.1.2.

3.5.6.2 Structural Requirements. - The structural design criteria, which shall be applied to the hoisting equipment items of each system, is as follows:

3.5.6.2.1 Structural Analysis. - The requirements of paragraph 3.1.10.1 shall apply to all hoisting equipment items. The design ultimate loads shall be obtained by multiplying the design limit load by a factor of safety. All components and detail parts are of either the multiple load path type (such as beams and bearing elements), or the single load path type (such as cables, chains, ties, and struts). Hoisting equipment components of the multiple

load path type shall be designed to sustain no detrimental yielding at two times the design limit load, and no failure at three times the design limit load. Hoisting equipment of the single load path type shall be designed to sustain no detrimental yielding at three times the design limit load and no failure at five times the design limit loads. Certain structural components of the items may have stiffness and functional requirements so that the strength criteria may not be based solely on weight considerations.

3.5.7 Loads and Stresses - Hoisting Equipment.

3.5.7.1 Allowable Working Stresses. - The requirements of 3.1.10.2 shall apply except that hardware items shall be taken at minimum rated strengths as stated by vendors, with a suitable factor of safety applied per 3.5.6.2.1.

3.5.7.2 Design Loads - General Purpose Lift Arrangement. - The design limit load "P" shall be taken as the rated load capacity of the main beam assemblies for systems when used for general purpose lifting. The load pick up point of the main beam and the components of the system shall be located in the position which results in the maximum stressed condition for the equipment item, or component part of the same, under consideration. Loads and dimensions shall be per Figure 5.

3.5.7.3 Design Loads - Standard Jig Frame Lift Arrangement. - The design limit load "W", for the system, shall be taken as the weight of the largest loaded jig frame which can be suspended by its attached trunnion shafts within the dimensional limits of the main beam assembly as shown on Figure 6. The loaded jig frame weights shall be taken as specified in paragraph 3.2.14.3. The design limit load shall be evenly shared by each lift cable assembly. The design ultimate loads for components shall be determined as specified in paragraph 3.5.6.2.1.

3.5.8 Performance Requirements - Hoisting Equipment.

3.5.8.1 Main Hoisting Beam Assemblies. - The main beam assemblies shall be capable of lifting all load combinations up to and including the rated capacity of the system that may be imparted to it through the load droppers and/or cross beams, with the crane hook carriage assembly at any position within the established range of adjustment. The suspended system shall be capable of being shifted relative to the crane hook carriage assembly by manual operation of the flexible cable driven lead screw so as to cause an unlevelled main beam to assume a horizontal position. This leveling operation shall be possible for the full rated load of the system with the main beam initially tilted not more than 20° from the horizontal position. Type I main beam assembly shall

have a flexible drive of sufficient length to permit manual operation from the floor or a stepstand when the widest jig frame is suspended from beam with lift cable assemblies. Type II main beam assembly shall have a flexible drive of sufficient length to permit manual operation from remote locations adjacent to the widest load handled by the cross beams. Load dropper attach points shall be incrementally spaced along beams for optimum utilization in performance of functions.

3.5.8.2 Cross Beam - General Purpose Hoisting. - The cross beam shall be capable of hoisting all load combinations within its rated capacity that may be imparted to it, when used in conjunction with the main beam for general purpose lift operations. The attach points for connection of load dropper assemblies and main beam hanger assemblies shall be spaced along beam length for optimum utilization in performance of functions.

3.5.8.3 Lift Cable Assemblies. - A pair of lift cable assemblies shall be capable of supporting all sizes and types of loaded jig frames which are to be lifted by a main beam assembly. The cable assembly pairs shall permit or prevent rotation of suspended jig frames as desired. The lift cable assembly terminal fittings shall be matched to the main beam load dropper assemblies, and to the standard trunnion shafts which are attached to the jig frame. The cable assembly shall be capable of installation or removal from a trunnion shaft when the jig frame is supported by trunnion stands, or by storage or transportation stanchions. The cable pairs shall utilize the incrementally spaced locations established for main beam fittings, to accommodate different length or diameter frames.

3.5.8.4 Main Beam Load Dropper Assemblies. - The main beam load dropper attach fittings shall be capable of sustaining the maximum load which may be imparted to them, when used in conjunction with the main beam assembly at rated load capacity. The fittings shall be capable of utilization at incrementally spaced positions along the length of the main beam without the need of hand tools to accomplish attachment to beam.

3.5.8.5 Cross Beam Load Dropper Assemblies. - The cross beam load dropper attach fittings shall be capable of sustaining the maximum load which may be imparted to them when used in conjunction with cross beams and main beam, with the system operating at rated load capacity. The fittings shall be capable of utilization at incrementally spaced positions along the length of the cross beam without the need of hand tools to accomplish attachment to beam.

3.5.8.6 Cross Beam to Main Beam Hanger Assemblies. - The hanger fitting shall be capable of transmitting the maximum cross beam load to the main beam which results from operation of the hoisting system at rated load capacity. The fittings shall be capable of utilization at incrementally spaced positions along the middle half of the cross beams and along the full length of the main beam without the need for hand tools to accomplish attachment to beams. The fittings shall permit limited rotation of the cross beams relative to the main beam in the vertical planes of the beams, to accommodate minor variations in load dropper lengths.

3.5.9 Environmental Requirements - Hoisting Equipment. - The requirements of 3.1.8 shall apply to all equipment items of the systems.

3.5.10 Interchangeability - Hoisting Equipment. - The requirements of 3.1.9 shall apply to all equipment items of the systems.

3.5.11 Radio Interference. - Not applicable.

3.5.12 Dimensions and Tolerances - Hoisting Equipment. - The dimensions and tolerances of equipment items shall be those specified by the applicable Boeing drawing, as shown in 2.2.1.2.

3.5.13 Weights - Hoisting Equipment. - The weights of all equipment items of the 1500, 3000, 6000 pound hoisting systems shall be taken as the values denoted on the applicable Boeing drawings listed under 2.2.1.2.

3.5.14 Identification - Hoisting Equipment. - The hoisting equipment items shall be identified per the requirements of paragraph 3.1.6.

3.5.15 Workmanship - Hoisting Equipment. - The quality of workmanship for finished equipment items shall be that specified in paragraph 3.1.7.

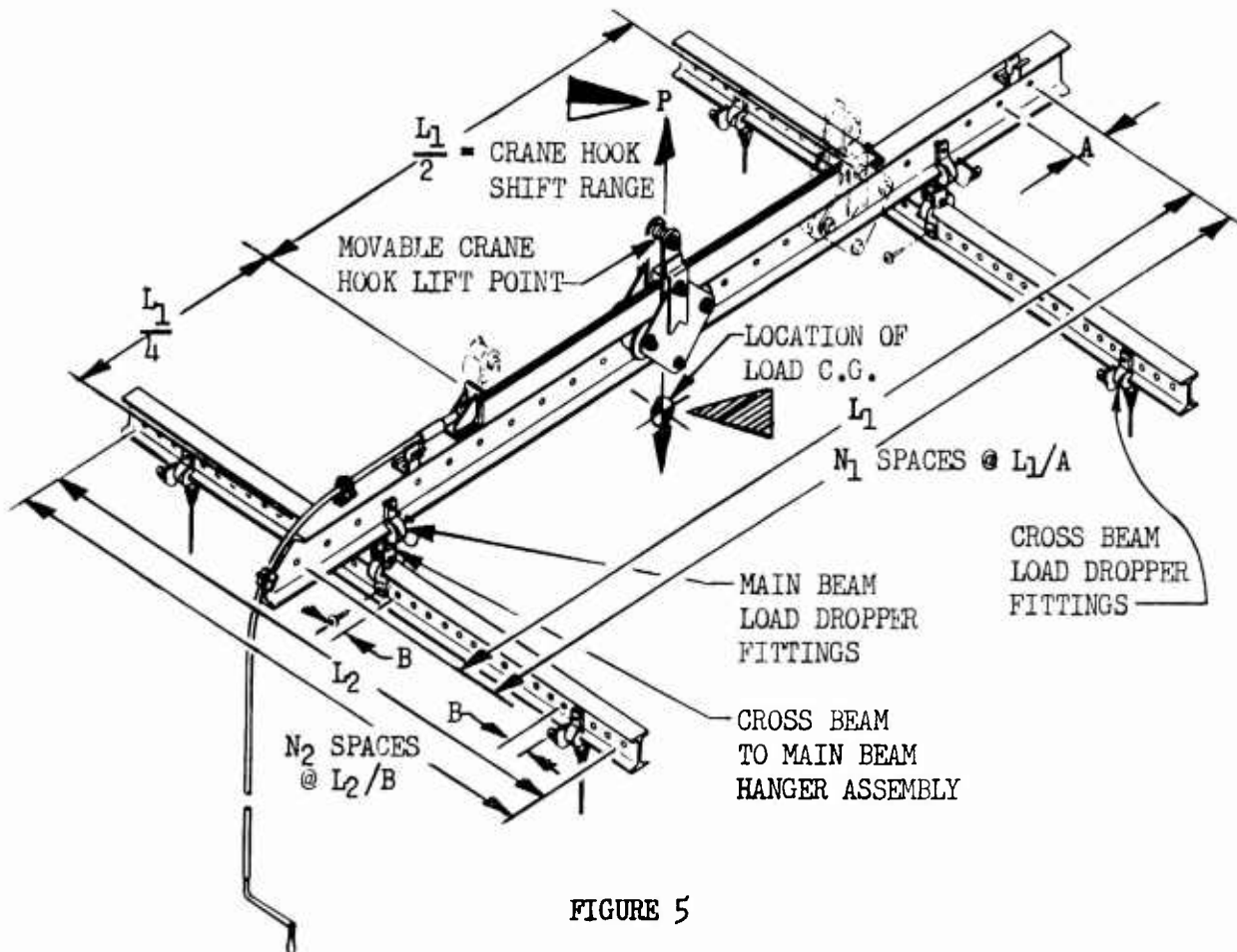



FIGURE 5

HOISTING SYSTEM

LOAD CAPACITY OF SYSTEMS	ALL DIMENSIONS IN INCHES			
	MAIN BEAM LENGTH, L_1	MAIN BEAM ATTACH POINT SPACING, A	CROSS BEAM LENGTH, L_2	CROSS BEAM ATTACH POINT SPACING, B
P = 1500 LBS	96	6	72	3
P = 3000 LBS	144	6	96	3
P = 6000 LBS	192	6	120	3

 RATED LOAD SHALL BE DISTRIBUTED TO CRANE HOOK PICKUP POINT THROUGH THE SYSTEM OF CROSS BEAMS AND/OR LOAD DROPPERS WHICH RESULTS IN THE MAXIMUM LOAD CONDITIONS OF ITEM, COMPONENT, OR PART UNDER CONSIDERATION.

 THE LOCATION OF LOAD MASS CENTER SHALL FALL WITHIN THE LONGITUDINAL SHIFT RANGE OF CRANE HOOK LIFT POINT IN THE VERTICAL PLANE AND WITHIN A DISTANCE OF $L_2/4$ FROM MAIN BEAM VERTICAL PLANE IN THE HORIZONTAL PLANE.

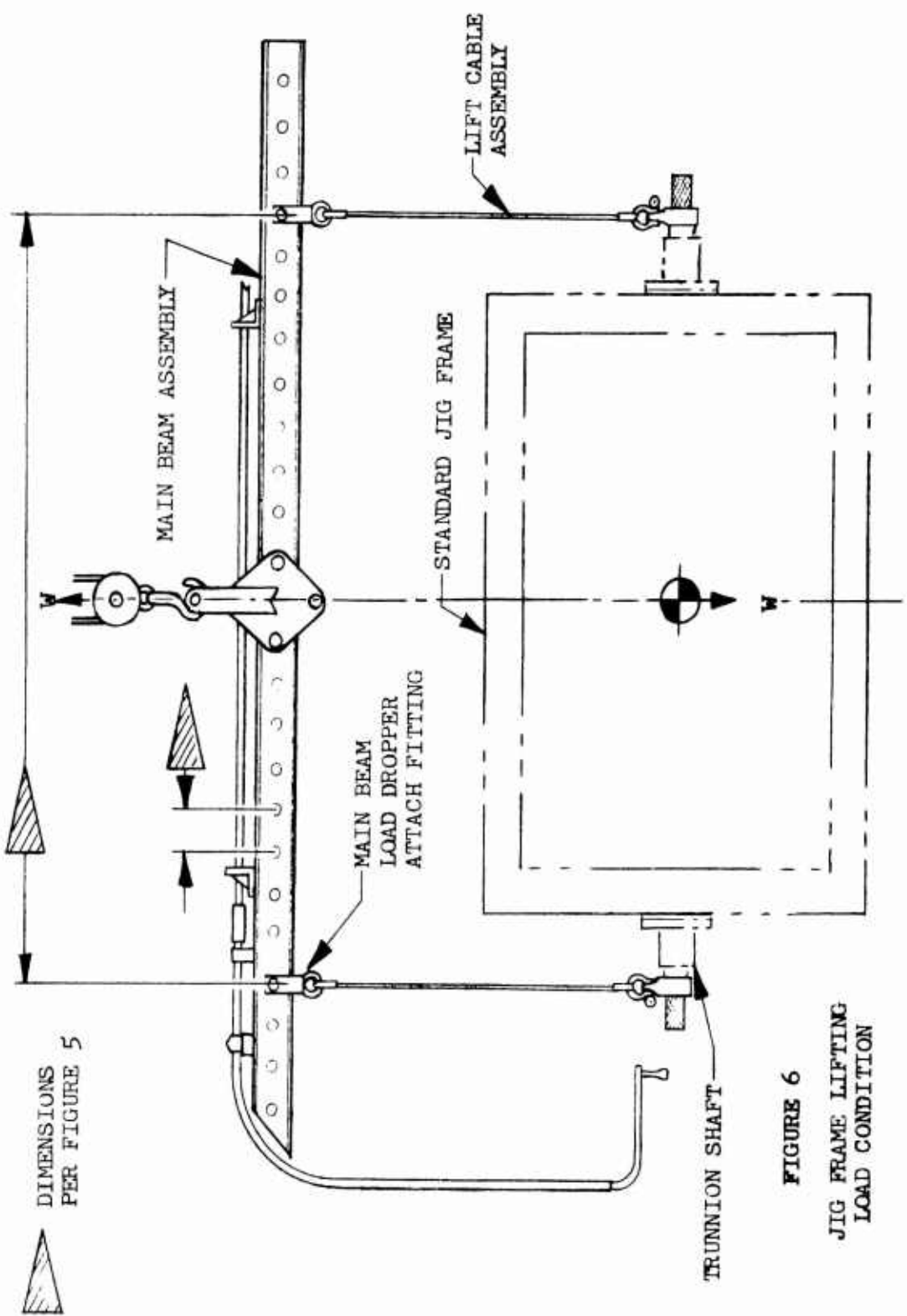

DIMENSIONS PER FIGURE 5

FIGURE 6
JIG FRAME LIFTING LOAD CONDITION

4.0 QUALITY ASSURANCE PROVISIONS

4.1 CLASSIFICATION OF TESTS

The inspection and testing of the equipment items listed under section 1.0 shall be classified as indicated in paragraphs 4.2 and 4.5 of this specification.

4.2 ACCEPTANCE TESTS

Acceptance Tests are those tests which shall be accomplished by the manufacturer of the equipment submitted for acceptance under contract. The purpose of these tests is to establish the ability to meet the requirements as specified in section 3.0. The Acceptance Tests shall be conducted as specified in paragraphs 4.2.1, 4.2.2, and 4.2.3.

4.2.1 Individual Tests. - Individual tests shall be conducted on each item of equipment included in the Standardized Universal Tooling System. The individual item tests shall be conducted as specified in paragraphs 4.2.1.1 and 4.2.1.2.

4.2.1.1 Examination of Product. - Each item of equipment shall be inspected to insure that it meets the requirements of this specification including workmanship, material, finishes, marking information, dimensional requirements, and proper and complete assembly.

4.2.1.2 Functional Tests. - The requirements of section 4.4 shall be applied where applicable. Each item of equipment shall be inspected to insure functioning of all components including freedom of movement and operating clearances.

4.2.2 Component Tests. - Component Tests shall be conducted on each self-contained component that makes up the equipment items as specified in section 3.0. The component tests shall be conducted as specified in paragraphs 4.2.2.1 and 4.2.2.2.

4.2.2.1 Examination of Product. - Each component shall be inspected visually to insure that it is assembled properly and completely and that it meets the specification requirements as specified in section 3.0.

4.2.2.2 Functional Tests. - Paragraph 4.2.1.2 shall apply.

4.2.3 Receiving Inspection. - All raw materials, detail items and purchased parts shall be inspected for freedom of flaws, warpage, distortion, breakage, and in addition, shall be inspected for completeness of parts.

4.2.4 Sampling Plan and Tests. - Does not apply.

4.2.5 Rejection and Retest. - When an equipment item fails to meet a requirement as specified herein, the inspector shall take action for the rejection and/or retest in accordance with provisions of the procurement contract.

4.3 TEST CONDITIONS

4.3.1 Atmospheric Conditions. - Unless otherwise specified, all tests required by this specification shall be made under normal shop conditions of temperature, humidity, and pressure.

4.3.2 Test Power. - Not applicable.

4.4 TEST METHODS

4.4.1 General Test Methods.

4.4.1.1 Examination of Product. - Paragraph 4.2.1.1 shall apply to all equipment.

4.4.1.2 Conformance to Drawings. - Each item of equipment shall be inspected for strict conformance to the pertinent drawings and specifications.

4.4.1.3 Lag Determination. - Does not apply.

4.4.1.4 Environmental Tests. - Does not apply.

4.4.2 Functional Tests.

4.4.2.1 The functional tests required to check fit and function, as well as overall compatibility of the equipment items of the standardized tooling system, shall be as specified in paragraphs 4.4.2.2 thru 4.4.2.5.

4.4.2.2 Functional Tests - Jig Frame Mounting System. - Functional tests shall be required for all first article(s) of the system for each single production run. Tests shall be conducted as follows:

1. Position and arrange equipment items per applicable arrangement view of Boeing drawing 55-20401. Trunnion stands shall be secured to a reasonably smooth, level surface.

2. Loosen trunnion bearing caps until trunnion shafts are free to rotate.
3. Disengage and lock out frame indexing lock pin.
4. Rotate jig frame in trunnion bearing - minimum of two revolutions by gear box or by hand. Check rotating frame and gear box handcrank for clearances, freedom of movement, and ease of operation.
5. Engage and disengage indexing lock pin in each index hole in the index plate through 360° of rotation. Check for pin alignment and ease of engagement and disengagement.
6. Support gear box support platform and remove gear box quick disconnect pin. Lower gear box assembly to limit of travel. Check freedom of disengaging drive shaft coupling. Raise gear box, engage coupling and install quick disconnect pin through gear box support platform and trunnion stand.
7. Open and close trunnion bearing cap and secure with clamp screw. Check for clearances and freedom of movement. Disengage gear box and check trunnion bearing braking action by tightening clamp screws. Brakes must hold frame in any desired rotational position with normal working pressure applied at outer edge of jig frame.
8. Remove the frame from the trunnion bearing per paragraph 4.4.2.5.
9. Hold adjustable trunnion stand upper section while removing quick disconnect pin holding upper section in place. Lower and raise upper section to limits of travel and reinstall pin. Check for freedom of movement of pin and upper section of the trunnion stand.
10. Disengage and engage gear box drive handle on gear box input shaft. Check for freedom of movement and ease of operation.

4.4.2.3 Functional Tests - Storage System Equipment - Standard Jig Frames. - Functional tests shall be required for all first run article(s) of the system for each single production run. Tests shall be conducted as follows:

1. Position and arrange equipment items per applicable arrangement view of Boeing drawing 55-20419. Storage rack shall be placed on a reasonably smooth level floor or surface. The center leveling screws shall be adjusted to contact the floor. Shimming may be required under corners of rack base.
2. Loosen star wheel clamp screws on stanchions and slide the stanchions the full length of both frame rails. Check for clearances and ease of sliding.
3. Place one large and/or small standard jig frame or sample frame with attached trunnion shafts in the stanchions. Secure the trunnion shaft hold down clamps and install the rotation lock pin. Check for freedom of movement and installation of clamp and lock pin. Handle frames per paragraph 4.4.2.5.

4.4.2.4 Functional Tests - Transportation Equipment - Standard Jig Frames. - Functional tests shall be required for all first run article(s) of the system for each single production run. Tests shall be conducted as follows:

1. Position and arrange equipment items per applicable arrangement view of Boeing drawing 55-20436.
2. Loosen star wheel clamp screws on stanchions and slide the stanchions the full length of both frame rails. Check for clearances and ease of sliding.
3. Place one large and/or small standard jig frame or sample frame with attached trunnion shafts in the stanchions. Secure the trunnion shaft hold down clamps and install the rotation lock pin. Check for freedom of movement and installation of clamp lock pin. Handle frames per paragraph 4.4.2.5.
4. Raise and lower towbar to maximum limits of travel. Check for freedom of movement and ease of operation.

5. Hitch dolly to towing vehicle and pull dolly a minimum of 200 feet, making a minimum of one left hand and one right hand turn. Check for handling and tracking during straight towing and through turns. Check casters for proper rotational function.
6. Engage and disengage floor position locks. Check for ease of operation and ability to hold dolly in place.

4.4.2.5 Functional Tests - Hoisting Equipment. - Functional tests shall be required for all first article(s) of the system for each single production run. Tests shall be conducted on applicable arrangements of equipment items as depicted on Boeing drawing 55-20424. Unless otherwise specified, the tests shall be applied on the 1500, 3000, and 6000 pound hoisting systems in a similar manner.

CAUTION: All equipment items shall have been previously load tested in accordance with the requirements of paragraph 4.4.3.

1. Suspend main beam assembly from crane hook pickup point with pickup point at beam mid-point. Shift pickup point, by cranking flexible drive to limit of adjusting range in each direction. Check flexible drive, lead screw and carriage movements for ease of operation, freedom from binding, and interferences. Equipment shall be lubricated in accordance with Boeing drawings 55-20425, 55-20426, and 55-20427.
2. Install two load dropper assemblies on main beam and slide dropper fittings full length of beam to check clearances. Install index pins of fittings at all index pin hole locations along main beam. Check all locations to insure that bearing surfaces of fittings and inside face of beam flanges are in contact with pins installed. Loads shall not be transmitted between beam and fittings by shearing action of the index pins.
3. Install lift cable fitting by connecting to load dropper fitting with shackle. Check pin clearance and swivel action for ease of operation.
4. Space lift cable assemblies equidistant on either side of main beam midpoint and to suit trunnion shaft spacing of a standard jig frame. Jig frame selected for this portion of test shall be largest

available frame within capacity of respective hoisting equipment, or a sample frame with attached trunnion shafts. Insert trunnion pins into ends of trunnion shafts full length, and lock with quick release lock pins. Remove lock pin from pin plate and trunnion pin and rotate frame 360°. Insert lock pin through pin plate and rotating pin. Check all pin clearances and mating action of parts for ease of operation and freedom of action. Shift crane hook pickup point through range of adjustment.

5. Install cross beam load dropper assembly and hanger assembly on cross beams and check per requirements of Step 2.
6. Connect cross beams, at their midpoints, to main beam by connecting the hanger assembly to the main beam load dropper assembly. Apply test loads per Figure 7. Operate flexible-drive to shift pickup point to position over center of gravity of loaded system and to minimize slope of main beam so that it is approximately horizontal. Check ease of operation for full shift range of pickup point. Interchange test load positions and repeat check.

4.4.3 Load Tests - Hoisting Equipment. - Load tests shall be conducted on all articles of specific hoisting equipment items as follows:

4.4.3.1 Main Hoisting Beam Assemblies

- a. 1500 pound capacity beam -- load test per diagram on Boeing drawing 55-20425.
- b. 3000 pound capacity beam -- load test per diagram on Boeing drawing 55-20426.
- c. 6000 pound capacity beam -- load test per diagram on Boeing drawing 55-20427.

4.4.3.2 Cross Beam - Hoisting Beams. - 1500, 3000, and 6000 pound capacity cross beams - load test per diagram on Boeing drawing 55-20429.

4.4.3.3 Hanger Assemblies - Hoisting Beam. - Load test hanger assemblies of the 1500, 3000, and 6000 pound capacity systems per diagram on Boeing drawing 59-17304.

4.4.3.4 Load Dropper Assemblies - Hoisting Beam. - Load test load dropper assemblies of the 1500, 3000, and 6000 pound capacity systems per diagram on Boeing drawing 59-17303.

4.4.3.5 Lift Cable Assemblies. - Load test the lift cable assemblies of the 1500, 3000, and 6000 capacity systems per diagram on Boeing drawing 55-20430.

4.5 PREPRODUCTION TESTING

4.5.1 Preproduction Test Samples. - Preproduction testing will be performed on all first article items as specified in paragraph 4.4, test methods. No representative samples are required for these tests.

4.5.2 Preproduction Tests. - Preproduction tests on all equipment items shall consist of all tests described under "test methods", per paragraph 4.4.

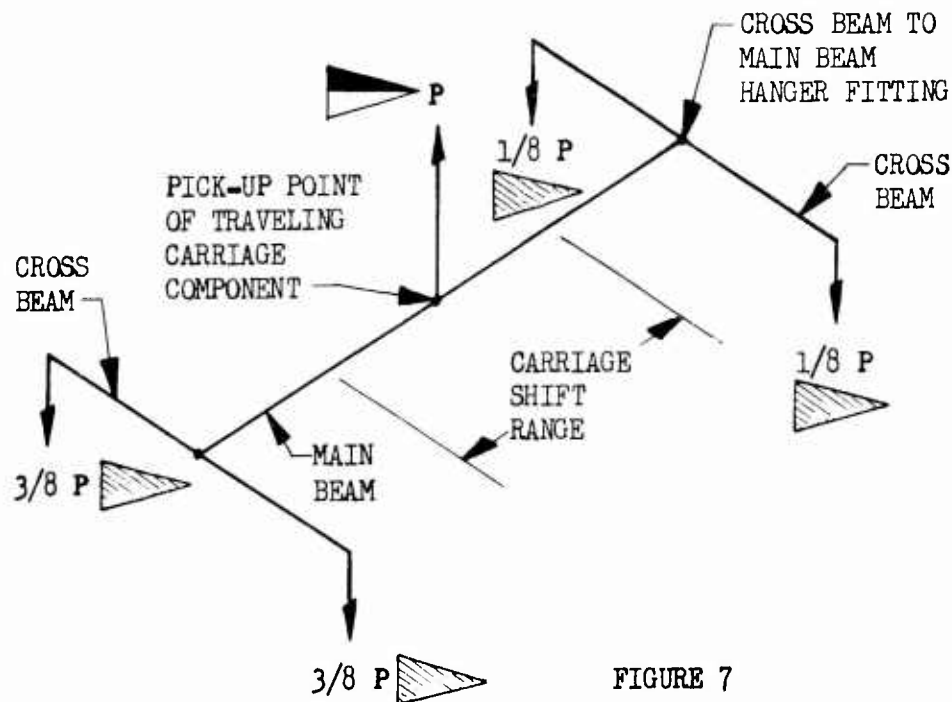

FIGURE 7

LOAD TEST OF HOISTING EQUIPMENT



"P" IS A 6000, 3000, OR 1500 POUND REACTIVE LOAD AND IS EQUAL TO THE SUM OF THE TEST LOADS TO BE APPLIED TO THE HOISTING SYSTEM OF A CORRESPONDING LOAD RATED CAPACITY. IT DOES NOT INCLUDE DEAD WEIGHTS OF EQUIPMENT ITEMS.



APPLIED LOADS ARE ON EXTREMITIES OF CROSS BEAMS. CROSS BEAMS ARE AT EXTREMITIES OF THE MAIN BEAM.

5.0 PREPARATION FOR DELIVERY

Section 5 of this specification covers the requirements for preserving, packaging, packing, and marking of the equipment items included in the standardized universal tooling system.

5.1 PRESERVATION AND PACKAGING

5.1.1 Immediate Use. - The standardized tooling equipment items shall be preserved and packaged in accordance with manufacturer's commercial practice.

5.1.2 Limited Storage. (For domestic shipment with maximum storage of 180 days.) The standardized tooling equipment items shall be preserved and packaged in accordance with the manufacturer's commercial practice. Unit quantities shall be as specified by the procuring activity.

5.1.3 Extended Storage. (For domestic shipment with more than 180 days storage.) The standardized tooling equipment items shall be preserved in accordance with MIL-P-116, Method III, and packed in containers in accordance with specification MIL-B-4229, JAN-P-120, PPP-B-676, or JAN-P-108 or as specified in the procurement contract. Unit quantities shall be as specified by the procuring activity.

5.2 INTERMEDIATE PACKAGING - Does not apply.

5.3 PACKAGING

5.3.1 Immediate Use. - Packages which require overpacking for acceptance by the carrier shall be packed in exterior-type shipping containers in a manner that will insure safe transportation at the lowest rate to the point of delivery. Containers shall meet Consolidated Freight Classification Rules, or regulations of other common carriers, as applicable to the mode of transportation.

5.3.2 Domestic Shipment. - Paragraph 5.3.1 shall apply.

5.4 PHYSICAL PROTECTION

Cushioning, blocking, bracing, and bolting as required shall be in accordance with manufacturer's commercial practice.

5.5 MARKING FOR SHIPMENT AND STORAGE

Packages and shipping containers shall be marked in accordance with MIL-STD-129. The nomenclature shall be as follows:
a. Part Number b. Nomenclature c. Quantity d. Date Packed

6.0 NOTES

This section contains information of a general nature to further explain the intended use and to give ordering data for the equipment items covered in this specification.

6.1 SPECIFIC INTENDED USE OF THE STANDARDIZED UNIVERSAL TOOLING SYSTEM

6.1.1 The tooling system is intended for use by manufacturers of aircraft and/or missiles to assemble and lift product components. Framed assembly jigs and hoisting beams used for these production operations on past programs, and involving different types and models of aircraft and missiles, have been essentially similar and differed mainly in details and the degree of matching sizes and shapes to those of the product. This standardized system is intended to eliminate repetitious solutions of design and fabrication problems by providing re-usable and multi-purpose standardized tooling items which can be applied throughout the aircraft and missile industry for routine assembly and lifting operations. The system is not intended to provide all solutions to operations of these types because of the many factors involved in tooling operations, but variations of the system can be employed by users to adapt to their particular needs.

6.1.2 Trunnioned Jig Frame System. - The sizes and shapes of the jig frame series encompass the range of present and predicted needs of the industry for these items. While primarily intended for trunnion mounting with the accessory support equipment, the frames may be rigidly mounted with support structure of the user's design. The frames may be incorporated as components of three dimensional floor jigs in addition to their intended use as a base for jig erection or multiple mounting of integral jig fixtures through use of tooling plates.

6.1.2.1 The supporting equipment can be used to trunnion mount the jig frames when it is desired to vary the working positions and/or when frames are to be re-cycled at frequent intervals. The frames are supported in split bearings from floor stands through the trunnion shafts which are affixed to opposite sides of the frames. By mounting one or both of the supports on a base with incrementally spaced attach holes, the supports can be adapted to re-cycling of frames of varying lengths or diameters. The frames may mount tooling plates, be counterbalanced, indexed and locked in various rotated positions, and rotated by use of the accessory equipment items as required by conditions and requirements for specific applications.

6.1.3 Storage and Transportation Systems. - The storage and transportation systems utilize a system of variable spaced support stanchions, which attach to the storage rack base or dolly, to accommodate different combinations of jig frame sizes and types. Frames are supported in these systems by the trunnion shafts affixed to the frames and may be installed with or without attached jig components.

6.1.4 Hoisting Systems. - The hoisting systems lift the frames by the affixed trunnion shafts using the main hoisting beam assembly and a pair of cable assemblies. The system is intended for all lifting operations involving jig frames such as the installation and removal of jig frames from trunnion stands and transportation and storage stanchions.

6.1.4.1 For general purpose lifting operations, the equipment items are intended to be combined so as to provide for attachment of load droppers to different size and shaped parts and to locate the crane hook pickup point over the mass center of the loaded system for a balanced lift. The equipment items of the 1500, 3000, and 6000 pound systems are not intended to be intermingled but partial or complete systems may be used in conjunction, such as for a two crane lift to accomplish lifts which exceed the capacities of a single system.

6.2 ORDERING EQUIPMENT ITEMS

Because the overall tooling system will allow the user to apply the equipment items or systems in the manner best suited to meet operation or program requirements, it may be difficult to determine orders for initial quantities. This may be particularly true of the storage and transportation equipment items and accessory types of equipment items since their usage is predicted on quantities, sizes and applications of the jig frames.