

**UNCLASSIFIED**

---

---

**AD 273 147**

*Reproduced  
by the*

**ARMED SERVICES TECHNICAL INFORMATION AGENCY  
ARLINGTON HALL STATION  
ARLINGTON 12, VIRGINIA**



---

---

**UNCLASSIFIED**

NOTICE: When government or other drawings, specifications or other data are used for any purpose other than in connection with a definitely related government procurement operation, the U. S. Government thereby incurs no responsibility, nor any obligation whatsoever; and the fact that the Government may have formulated, furnished, or in any way supplied the said drawings, specifications, or other data is not to be regarded by implication or otherwise as in any manner licensing the holder or any other person or corporation, or conveying any rights or permission to manufacture, use or sell any patented invention that may in any way be related thereto.

273147

273 147

CATALOGED BY ASTIA  
AS AD No.

# GAS TURBINE AND JET ENGINE FUELS

PROGRESS REPORT NO. 6

NAVY BUWEP CONTRACT NO. (W) 61-0590-D

JANUARY, 1962

36



Released to ASTIA by the  
Bureau of  
without restriction.

**PHILLIPS PETROLEUM COMPANY**

Progress Report No. 6  
Navy Contract NO(w)61-0590-d  
GAS TURBINE AND JET ENGINE FUELS

By  
W.L. Streets

36

-----  
S U M M A R Y

The sixth bimonthly period under Contract NO(w)61-0590-d has been spent continuing the study of the effects of sulfur in jet fuels and ingested sea water on the durability of engine "hot section" components. Efforts during this period have included: (1) Evaluation of the effect of the presence of guide vane test pieces on flame tube metal loss at 1600F (2-inch combustor), (2) study of the effect of sea water on 304 and 310 stainless steel flame tubes at 1600F with 1.0 per cent sulfur fuel (2-inch combustor), (3) evaluation of the effect of sulfur and sea water on Udimet 500 simulated turbine guide vanes at 1600F and 2000F (2-inch combustor), and (4) exploratory metal durability testing with a modified version of the Phillips Microburner using 304SS and Udimet 500 guide vane test pieces under conditions producing 2000F exhaust gas.

The results obtained during this reporting period indicate that: (1) the presence of guide vanes in the 2-inch combustor decreases flame tube metal loss, preventing comparison with earlier tests without vanes; (2) sea water caused an apparent increase in 310SS flame tube loss when guide vanes were present, but did not when vanes were absent; (3) 310SS flame tubes showed marked decrease in durability with increasing temperature from 1350-1650F with 1 per cent sulfur fuel; (4) Udimet 500 guide vanes were not adversely affected by either 1 per cent sulfur or sulfur plus ingested sea water at 1600F (2-inch combustor); (5) at 2000F Udimet 500 guide vanes were only slightly affected by 1 per cent fuel sulfur but were very adversely affected by increasing exhaust temperature from 1600F to 2000F; (6) at 2000F in the Microburner Udimet 500 guide vanes lost about one-half as much metal in 10 hours as 304 stainless steel in 3 hours (based on sulfur-free fuel runs) and were not detrimentally affected by 1 per cent added fuel sulfur.

-----  
FEB 23 1962

PHILLIPS PETROLEUM COMPANY

BARTLESVILLE, OKLAHOMA

Progress Report No. 6  
Navy Contract NO(w)61-0590-d  
GAS TURBINE AND JET ENGINE FUELS

I. INTRODUCTION

The sixth bimonthly period under Navy Contract NO(w)61-0590-d has been spent continuing the study of the effects of sulfur in jet fuels and ingested sea water on the durability of engine "hot section components". Efforts during this period have included (1) two-inch combustor tests on the effect of the presence of simulated turbine inlet guide vanes on flame tube metal loss in 1600F exhaust gas, (2) evaluation of the effect of sea water on flame tube metal loss in the two-inch combustor during operation with both 304 and 310 stainless steel flame tubes, 1.0 per cent sulfur fuel and under conditions producing 1600F exhaust gas, (3) evaluation of the effect of sulfur and sulfur plus sea water on the durability of Udimet 500 simulated turbine inlet guide vanes in the two-inch combustor under conditions producing 1600F and 2000F exhaust gas, (4) evaluation of metal losses from 304 stainless steel and Udimet 500 simulated turbine inlet guide vanes at 2000F using the Phillips Microburner, for comparison with similar tests conducted with the Phillips 2-Inch Research Combustor.

II. TEST METHODS AND APPARATUS

A. Phillips 2-Inch Research Combustor Tests

The Phillips 2-Inch Research Combustor, illustrated in Figure 1, has been described in previous reports (1). Briefly, this is a 2-inch diameter

axial flow combustor embodying the principal features of modern jet engine combustion systems. Air is supplied to this combustor from a compression and heating plant described in (1), while fuel is supplied to the swirl type nozzle by nitrogen pressurization. The design of the combustor provides for ready removal of flame tubes and turbine blading test pieces for weighing and inspection.

The test conditions employed were the same as those used for previous investigations of the effect of sulfur and sea water on flame tubes and turbine inlet guide vanes which have been reported on in (2). Combustor pressure was held at 350 in. Hg abs., inlet air temperature at 700F and inlet reference velocity at 100 fps, providing a severity level which is reasonably realistic for high compression ratio turbojets operating at relatively low altitudes. It will be recalled from Progress Report No. 3 that operation at a fuel/air ratio of 0.01 (exhaust gas temperature of approximately 1350F) resulted in the same guide vane metal loss (from 304SS pieces) regardless of the presence or absence of sulfur in the fuel. Therefore all subsequent testing has been done at fuel/air ratios of 0.015 lb. fuel/lb. air (exhaust gas temperature of approximately 1600-1650F) and 0.020 (exhaust temperature of approximately 1950-2050F). Under these conditions it has been found possible to observe significant differences in corrosion among the several fuel-contaminant combinations. The higher combustor exhaust gas temperatures (or turbine inlet temperatures) resulting from the increased fuel input are also more realistic in terms of the more advanced engine designs.

For investigations of metal loss from turbine blades no change was made to the combustor. The only change in apparatus was simply to add a six-inch spool piece downstream from the combustor and to cut a suitable holder cavity into its mating flange for the test pieces shown in Figure 2, placing these pieces in a position comparable to blading in an actual engine.

Weight losses from tubes and blades were measured following each of three consecutive two-hour test periods. During this reporting period both 304 and 310 stainless steel flame tubes have been tested in order to provide a comparison of these alloys and the effect of increasing fuel/air ratio from 0.010 to 0.015, as mentioned above. In the case of turbine guide vane pieces both 304SS and Udimet 500 (19 Cr-45 Ni-19 Co-4 Mo, w/Ti, Fe, Al) have been used. The tests on Udimet 500 represent the first of a series of tests to be conducted with practical turbine blading alloys.

Since previous investigations (2) had shown sulfur compound type to be unimportant as compared to gross sulfur content, it was decided to continue using ditertiary butyl disulfide as the sulfur contaminant since it is inexpensive and available at adequate purity. As in previous tests this compound was employed at sufficient concentration to realize a fuel sulfur content of 1.0 per cent. This exaggerated sulfur severity was considered desirable for research purposes. In the tests involving sea salts synthetic sea water formulated according to ASTM D665-60 was used. As in previous tests the synthetic sea water was injected at the rate of 1.0 lb/hr. or 5000 times the rate indicated in (3) as representative of airborne sea water vapor concentration at an altitude of 50 feet above the ocean surface. Tests at

realistic rates had shown no measurable effect of sea water.

The base fuel used in all tests reported herein, as in previous tests, was a JP-5 type isoparaffinic alkylate containing 0.005 per cent or less sulfur.

#### B. Phillips Microburner Guide Vane Metal Loss Tests

Exploratory testing has been carried on during this reporting period using the Phillips Microburner which has been adapted for measuring metal losses from (simulated) turbine inlet guide vanes. This apparatus has been described in detail in (4). Briefly, this apparatus is a 1.25 inch diameter atmospheric pressure tangential flow bench scale combustor. It is illustrated schematically in Figure 3. The exhaust system has been modified to allow placement of test materials in the exhaust stream. Simplified test pieces consisting of four 1/16" x 1/4" x 1 1/2" metal strips have been used. The position of these strips in the exhaust stream is illustrated in Figure 4. The holder containing the strips is clamped between the flanges shown in Figure 3. Exhaust gas temperature measurements are made by means of four equal area center thermocouples placed just upstream from the strips. The conditions of operation chosen for the exploratory tests were 500F inlet air temperature, 25 f.p.s. inlet reference velocity and 0.055 fuel/air ratio. This lean fuel/air ratio was chosen so as to provide a moderate amount of excess air (this burner uses no secondary air). However, since the running of these exploratory tests it has been discovered that a significant increase in fuel flow rate resulted from heating of the fuel rotometer during the tests. Indications are that the fuel/air ratio probably rose to near stoichiometric (0.07 approx.). The position of the the rotometer will be

changed in future tests. At any rate, under these conditions average exhaust gas temperatures from approximately 1930F to 2050F were obtained, simulating, in this respect, the most advanced engine designs.

Determination of weight losses from the test strips are made in the same way as in the 2-inch combustor tests. For these exploratory tests weighings have been made at one-hour intervals for a total test time of 10 hours, except in cases where severe corrosion prevented further testing. The data are reported herein as combined weight loss from all four test strips.

The testing conducted thus far with the modified Microburner has included runs with neat base fuel and base fuel plus 1.0 per cent sulfur (as ditertiary butyl disulfide) using 304 stainless steel and Udimet 500 strips. The same base fuel has been used for this series of tests as was used in the 2-inch high pressure combustor work. These data are intended to supplement the 2-inch combustor data and provide a means for a more rapid evaluation of sulfur and sea salt effects on a wide variety of practical alloys.

### III. DISCUSSION OF EXPERIMENTAL RESULTS

#### A. Flame Tube Metal Loss Tests in Phillips 2-Inch High Pressure Combustor

The flame tube metal loss data obtained during this reporting period are shown in Table I and in Figures 5 and 6 as plots of accumulated flame tube metal loss versus test hours. All of these data were obtained using 1.0 per cent sulfur fuel under conditions producing 1600F (approx.) exhaust gas. The objectives of these tests were three-fold; (1) to establish the effect, if any, of the presence of guide vane test pieces on flame tube metal loss,

(2) to evaluate the effect of sea water on flame tube durability during operation at 1600F on high sulfur fuel, and (3) to provide data for comparison of 304 and 310 stainless steels in sulfur plus salt atmosphere at 1600F.

Figure 5 shows effects of the presence of simulated turbine inlet guide vanes on flame tube metal loss, and the effects of sea water on 310 SS flame tubes with and without vanes installed. The purpose behind these runs was to establish whether or not flame tube metal loss data obtained concurrent with guide vane data could safely be compared with earlier data obtained without guide vane specimens installed. From Figure 5 it is apparent that such comparisons would not be valid. For some reason as yet unknown (but speculated to be the result of changes in flow characteristics in the flame tubes when vanes are installed) the presence of guide vane test specimens resulted in a significant decrease in flame tube metal loss. This was also true for the runs with sea water although to a lesser extent. With regard to sea water effects it is notable that sea water caused apparent increase in tube loss when vanes were installed while it did not when vanes were absent - again suggesting some change in flow characteristics caused by the vanes. This apparent increase from salt ingestion may very possibly lie within the range of experimental error, however. Nevertheless, it is noteworthy in that it is the first indication of increased flame tube metal loss caused by synthetic sea water which has been observed in this program. This should perhaps be followed up in future testing to be sure this point has not been missed in previous work which has been done without vanes in the exhaust stream.

Unfortunately, no directly comparable data are available on 310 stainless steel flame tubes at 1350F (0.010 ~~310~~). That is, the data available on 310 SS at 1350F were obtained under (otherwise) the same burner operating conditions but under a different test duration schedule - weighings were made at the end of three consecutive one-hour periods rather than two-hour periods, as in the present case. However, since the 1350F data show total losses of less than one gram after three hours with 1 per cent sulfur fuel it would appear that 310 SS is quite temperature sensitive.

Shown in Figure 6 are data comparing 304 and 310 stainless steel flame tubes during runs with 1.0 per cent sulfur fuel with and without sea water ingestion. These tests on 304 tubes were run to fill in a gap in background information. That is, data were needed on 304 tubes under conditions producing 1600F exhaust gases (all previous data on 304 were obtained at 1350F on a test schedule of three hours) in order to determine the significance of the observed increase in metal loss from 310 SS flame tubes at this higher temperature. As will be noted, it was necessary to terminate these 1600F tests after three hours because of extremely severe metal loss. These 304 tubes were considered as having failed completely at this time. Again, as in earlier tests at 1350F, synthetic sea water had no effect on 304 flame tubes under conditions producing 1600F exhaust gases. The same is true for the 310 flame tubes - synthetic sea water did not accelerate corrosion in the presence of a sulfurous atmosphere at 1600F. Surprisingly, the increase in metal loss resulting from increasing exhaust gas temperature from 1350F to 1600F was greater for 310 flame tubes than for 304 flame tubes. The 304 metal loss approximately doubled while 310 metal loss was about

20 times the value obtained at 1350F (304 yielded a three-hour average of 48 grams at 1350F; 310 about 1 gram at 1350F).

**B. Two-Inch Combustor Guide Vane Metal Loss Tests**

The data on metal loss from simulated turbine inlet guide vanes obtained with the Phillips 2-Inch Research Combustor during this reporting period are shown in Table I and Figure 7. Tests were run at two exhaust gas temperature levels: 1600F and 2000F. The former is representative of maximum turbine inlet temperatures in current operational engine designs, the latter is representative of maximum turbine inlet temperatures in engine designs of the near future. Efforts during this period have centered around evaluation of Udimet 500, the first in a series of actual turbine blading alloys to be studied. This material was subjected to both sulfur and sulfur plus sea water in addition to a base fuel run at 2000F.

From Figure 7 it may be seen that Udimet 500 was almost negligibly affected under conditions producing 1600F exhaust gas. Neither 1.0 per cent fuel sulfur nor 1.0 per cent sulfur plus 1 lb/hr. synthetic sea water appeared to affect the durability of Udimet 500 appreciably. Since the metal losses observed for these tests were so low, no attempt was made to run with the sulfur-free base fuel alone at 1600F. Instead, efforts were turned to obtaining data at 2000F exhaust gas temperature. The test runs at 2000F on Udimet 500 using base fuel and base fuel with 1.0 per cent sulfur added, shown in Figure 7, indicate that this alloy is only slightly affected by this relatively high concentration of sulfur, but is drastically affected by the rise in temperature from 1600 to 2000F. This indicated temperature sensitivity agrees, of course, with what has been observed

for the simpler Fe-Ni-Cr alloys in previous tests (5). Unfortunately, time was not available during this reporting period to evaluate the effect of sea water on Udimet 500 simulated guide vanes at this exhaust gas temperature. On the basis of the available data it would appear that: (1) Udimet 500 can tolerate as much as 1.0 per cent fuel sulfur without appreciable loss in durability and (2) Udimet 500 is markedly temperature sensitive in the range 1600F to 2000F.

### C. Phillips Microburner Guide Vane Metal Loss Tests

The results of a series of exploratory guide vane metal durability tests run with the modified Phillips Microburner are shown in Table II. As previously mentioned, the exact fuel/air ratio existing during these tests is unknown because of errors in fuel metering caused by rotometer heating during the tests. However, since the error should be constant test-to-test, these data are of value since they are representative of metal losses under conditions which produced 2000F to 2100F exhaust gas. Evaluations have been made thus far of 304 stainless steel and Udimet 500 strips with and without 1.0 per cent sulfur added to the essentially sulfur-free base fuel. These data are plotted as a function of operating time in Figure 8.

It will be immediately obvious from Figure 8 that 304 stainless steel guide vanes were severely attacked during three hours at 2000F in the Microburner. Additionally, even more attack was brought about by sulfur addition under these conditions. This is qualitatively in agreement with the results observed in the two-inch combustor at 12 atmospheres pressure. Udimet 500 vanes, on the other hand, were only rather moderately affected at 2000F in

three hours but, of course, as test time increased metal loss increased significantly. To gain some knowledge of the repeatability of this test method and apparatus, duplicate tests were run on Udimet 500 vanes (strips) with base fuel alone and base fuel doped with 1.0 per cent sulfur. These duplicate tests did not agree as well as expected or desired. It would appear that some increase in severity occurred between the first set of runs and the second set, since both sets of curves are displaced to about the same extent (based on 10-hour totals). This possibly is due to the variations in fuel flow caused by rotometer warm-up, although, if so, it was not reflected in exhaust gas temperatures. At any rate, it does appear as in the two-inch combustor tests, that Udimet 500 was not adversely affected by the sulfur added to the base fuel at these conditions.

It is believed that the metal durability work conducted thus far with the Microburner is encouraging because of relatively few operational problems and the fact that it is far less time-consuming. It is planned, therefore, to continue development of this test procedure and apparatus.

#### IV. CONCLUSIONS

Two-inch combustor data obtained during the present reporting period on the effects of sulfur and sea water on flame tubes and simulated turbine inlet guide vanes suggest the following conclusions:

1. Flame tube metal loss data obtained without guide vane specimens installed could not be compared directly with those obtained with vanes installed. The presence of vanes decreases flame tube metal loss for reasons as yet unknown.

2. Ingested sea water caused an apparent increase in metal loss from 310 stainless steel flame tubes when guide vane specimens were in place, while it did not when vanes were absent.
3. The durability of flame tubes fabricated from 310 stainless steel was found to be quite adversely affected by increasing exhaust gas temperature from 1350 to 1600F while operating with 1 per cent sulfur fuel.
4. The durability of simulated turbine inlet guide vanes fabricated from Udimet 500 was not adversely affected by either sulfur or sulfur and sea water in combination under conditions producing 1600F exhaust gas.
5. Guide vane metal loss tests conducted at an exhaust gas temperature of 2000F have indicated that Udimet 500 is only slightly affected by 1.0 per cent sulfur, but is very adversely affected by increasing exhaust temperature from 1600F to 2000F.

Exploratory turbine guide vane metal loss tests conducted with a modified version of the Phillips Microburner have indicated the following:

1. Under conditions producing 2000F exhaust gas temperature, calibration tests on 304 stainless steel test strips yielded very high metal losses on a sulfur-free alkylate base fuel. Addition of 1 per cent sulfur to the fuel increased the basic three-hour metal loss 64 per cent.

2. Udimet 500 test strips lost only about one-half as much metal in 10 hours running as 304 SS strips lost in three hours on the neat base fuel under conditions producing 2000F exhaust gas. One per cent sulfur had no detrimetal effect on Udimet 500 under these conditions.

#### V. OUTLINE OF PROJECTED WORK

Evaluation of the effects of fuel sulfur and ingested sea water on simulated turbine inlet guide vanes will be continued in the Phillips 2-Inch Research Combustor. Alloys planned for evaluation during the coming reporting period will include Waspalloy, Stellite 25 and Inconel X. Attempts are currently being made to procure quantities of Hastelloy R-235, René 41, Inconel 713, Udimet 700 and X-40 for inclusion in this test program. Initially these materials will be tested at 2000F. Additionally, it is planned to continue the metal durability studies begun with the modified Phillips Microburner apparatus. The alloys cited above will also be included in this phase of the test program. It is hoped that by use of this simpler less time-consuming apparatus the acquisition of data on a wide variety of alloys will be accelerated and at the same time data will be available for correlation with the 2-inch combustor which will yield information as to the advisability of employing such apparatus in future metal durability testing.

**REFERENCES**

1. Fromm, E. H.; "Design and Calibration of Phillips Jet Fuel Testing Facilities", Phillips Research Division Report 1252-55R, December 1955.
2. Kittredge, G. D. and Streets, W. L.; "Gas Turbine and Jet Engine Fuels", Summary Report for Navy Contract NOas 60-6009-c, Phillips Research Division Report 2760-61R, January 1961.
3. Woodstock, Alfred H. and Gifford, Mary M.; "Sampling Atmospheric Sea Salt Nuclei Over the Ocean", Journal of Marine Research, Volume VIII, 1949.
4. Streets, W. L.; "Phillips Microburner - A Tool for Evaluating the Burning Quality of Jet Fuels", Phillips Research Division Report No. 1793-57R, May 1957.
5. Streets, W. L.; "Gas Turbine and Jet Engine Fuels", Progress Report No. 3, Navy Contract NO(w)61-0590-d, Phillips Research Division Report 2959-61R, July 1961.

TABLE I

FLAME TUBE AND GUIDE VANE METAL DURABILITY TESTS IN PHILLIPS 2-INCH RESEARCH COMBUSTOR

Combustor Operating Conditions: P = 350 in. Hg abs; V = 100 f.p.s., IAT = 700F

Flame Tube Metal Type	Guide Vane Metal Type	Test Fuel Description*	Sea Water Input, lb/hr.**	F/A Ratio	Time, hrs.	Accum. Flame		Accum. Oxide		Avg. Exhaust Gas Temp., F
						Tube Metal Loss, %	Loss, %	Vane Metal Loss, %	Loss, %	
310SS	Udimet 500	Base Fuel + 1% Sulfur	None	0.015	2	1.6	0.0	0.0	0.0	1668
					4	14.8	3.2	3.2	3.2	1662
					6	31.1	10.2	10.2	10.2	1582
310SS	Udimet 500	Base Fuel + 1% Sulfur	1.0	0.015	2	2.0	0.0	0.0	0.0	1600
					4	20.0	0.0	0.0	0.0	1612
					6	43.9	0.0	0.0	0.0	1584
310SS	No Vanes	Base Fuel + 1% Sulfur	None	0.015	1.8	8.0	—	—	—	1553
					3.8	32.0	—	—	—	1570
					5.8	56.3	—	—	—	1606
310SS	No Vanes	Base Fuel + 1% Sulfur	1.0	0.015	2	12.4	—	—	—	1590
					4	34.1	—	—	—	1642
					6	61.7	—	—	—	1620
304SS	No Vanes	Base Fuel + 1% Sulfur	None	0.015	2	36.9	—	—	—	1600
					3	83.8	—	—	—	1587
304SS	No Vanes	Base Fuel + 1% Sulfur	1.0	0.015	2	18.3	—	—	—	1554
					3	79.0	—	—	—	1600
Inconel (No Weighings)	Udimet 500	Base Fuel	None	0.020	2	—	—	—	22.7	1946
					4	—	—	—	87.6	2016
					5.67	—	—	—	142.4	2042
Inconel (No Weighings)	Udimet 500	Base Fuel + 1% Sulfur	None	0.020	2	—	—	—	0.0	2004
					3.75	—	—	—	85.8	2018
					5.75	—	—	—	154.6	2022

\*Base fuel was 350-550F isoparaffinic alkylate. Sulfur contaminant was ditertiary butyl disulfide.

\*\*Synthetic sea water per ASTM D665-60.

**TABLE II**  
**SIMULATED TURBINE INLET GUIDE VANE DURABILITY TESTS IN THE PHILLIPS MICROBURNER**

Operating Conditions: P = atmospheric; V = 25 f.p.s.; IAT = 500F; F/A = (See Text)

Test No.	Metal Type	Test Fuel Description	Accumulated Guide Vane Metal Loss, mg. (4 Strips)										Avg. Exhaust Gas Temp., F			
			1 Hr.	2 Hr.	3 Hr.	4 Hr.	5 Hr.	6 Hr.	7 Hr.	8 Hr.	9 Hr.	10 Hr.				
1	304SS	Base Fuel (350-550F Alkylate)	251	593	1039											1928
2	304SS	Base Fuel + 1% Sulfur	449	1112	1701											2018
3	Udimet 500	Base Fuel	2	26	76	129	176	231	286	366	450	551				2050
4	Udimet 500	Base Fuel + 1% Sulfur	17	57	84	122	173	241	301	350	409	472				2024
5	Udimet 500	Base Fuel + 1% Sulfur	8	46	88	152	222	293	363	437	517	608				2044
6	Udimet 500	Base Fuel	28	72	133	211	277	334	398	486	573	676				2056

PHILLIPS PETROLEUM COMPANY  
RESEARCH DIVISION REPORT 3115-62R

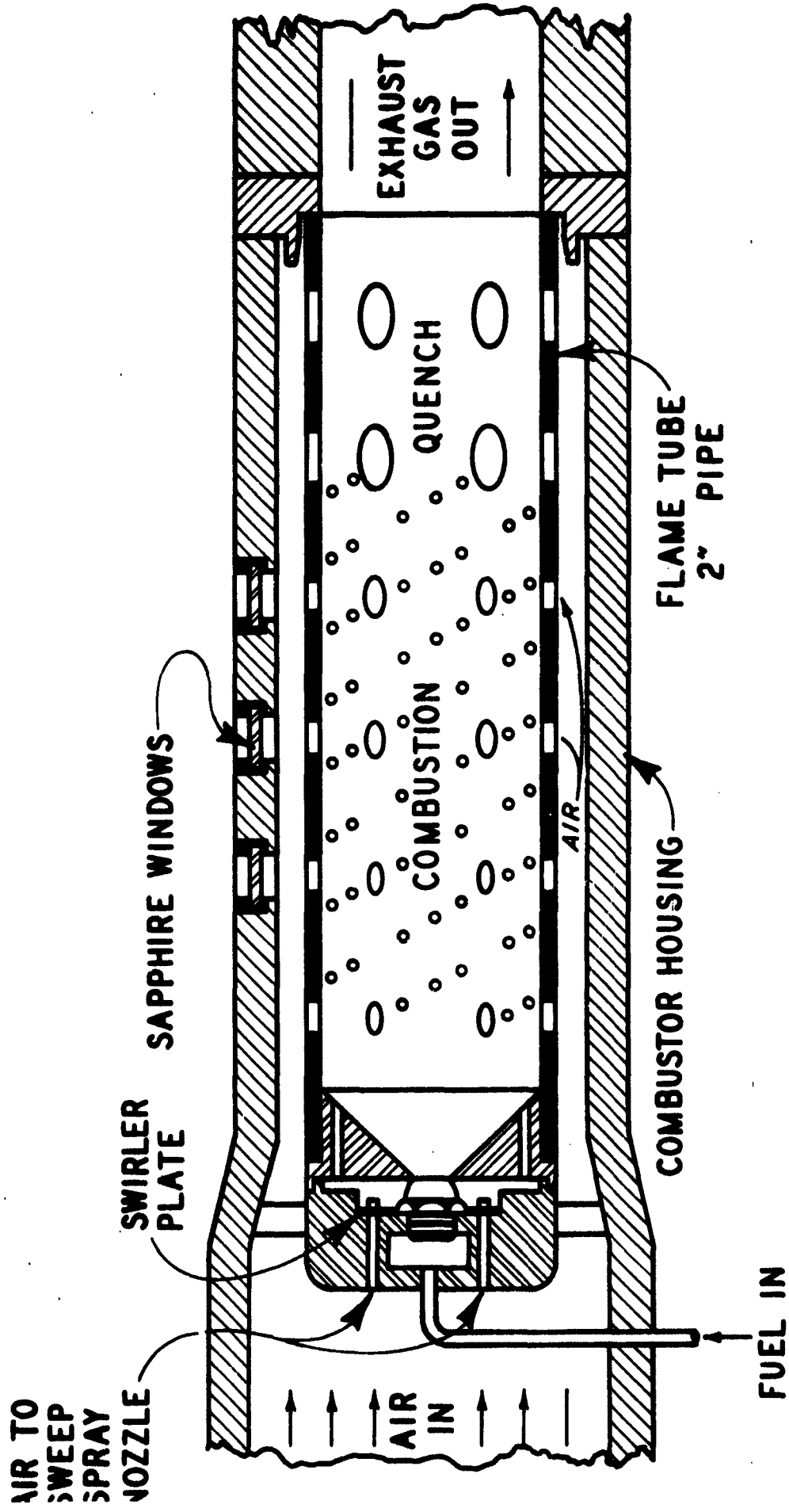
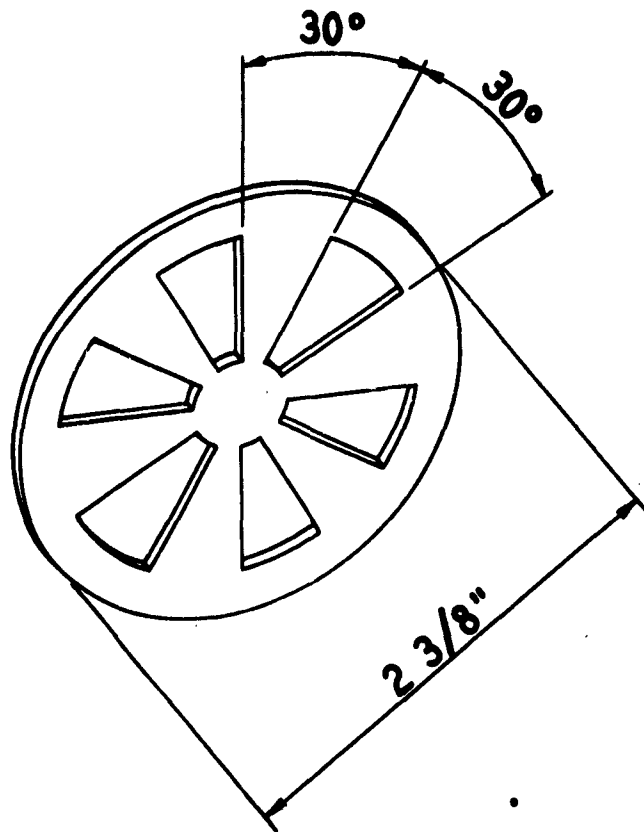

FIGURE I  
PHILLIPS LABORATORY SCALE TEST COMBUSTOR



**MATERIAL: VARIOUS TYPES OF TURBINE  
BLADING ALLOYS (16 GA. SHEET)**

**FIGURE 2  
SIMULATED TURBINE INLET GUIDE VANE INSERT FOR MEASUREMENT  
OF METAL LOSSES IN PHILLIPS 2- INCH RESEARCH COMBUSTOR**

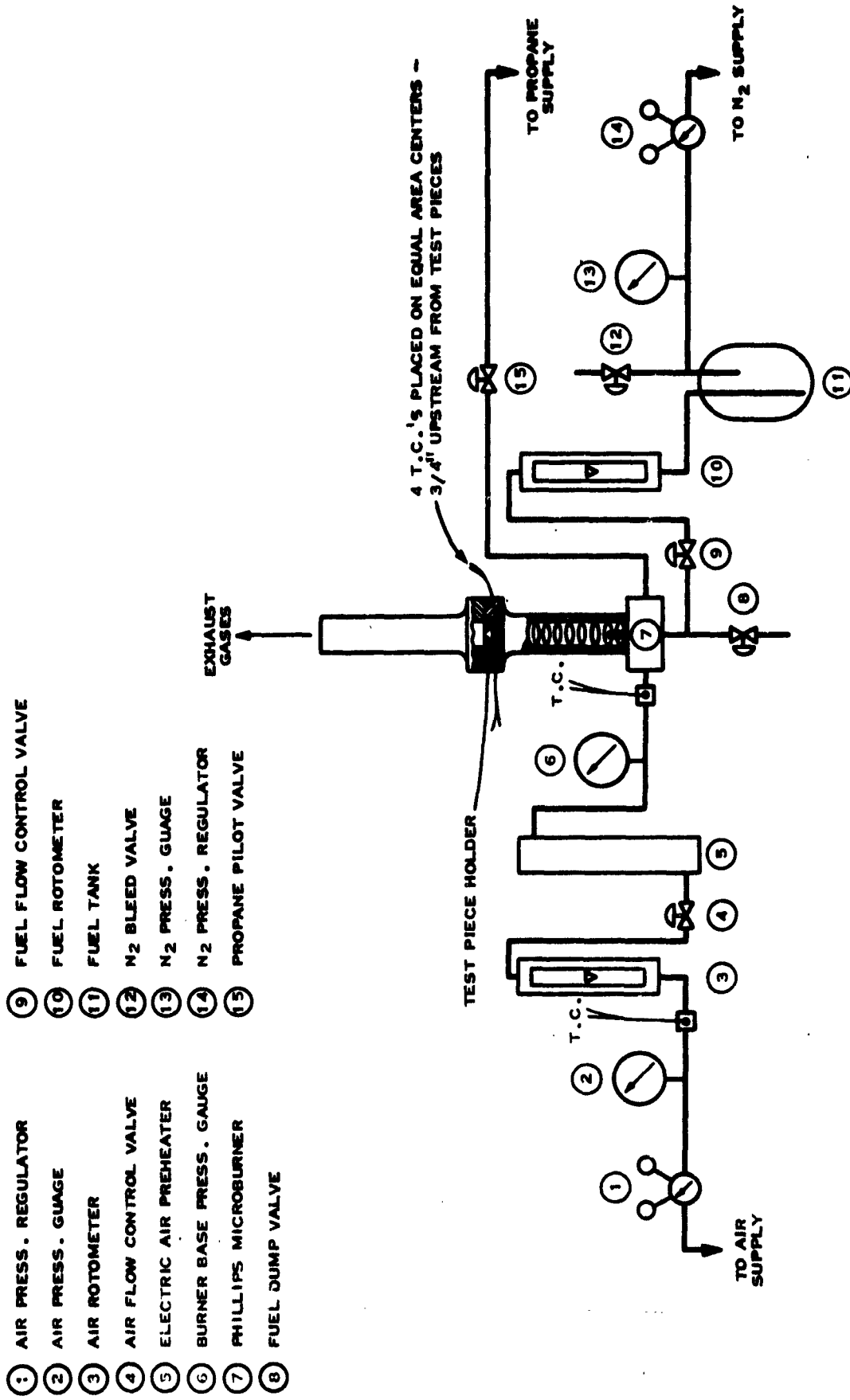
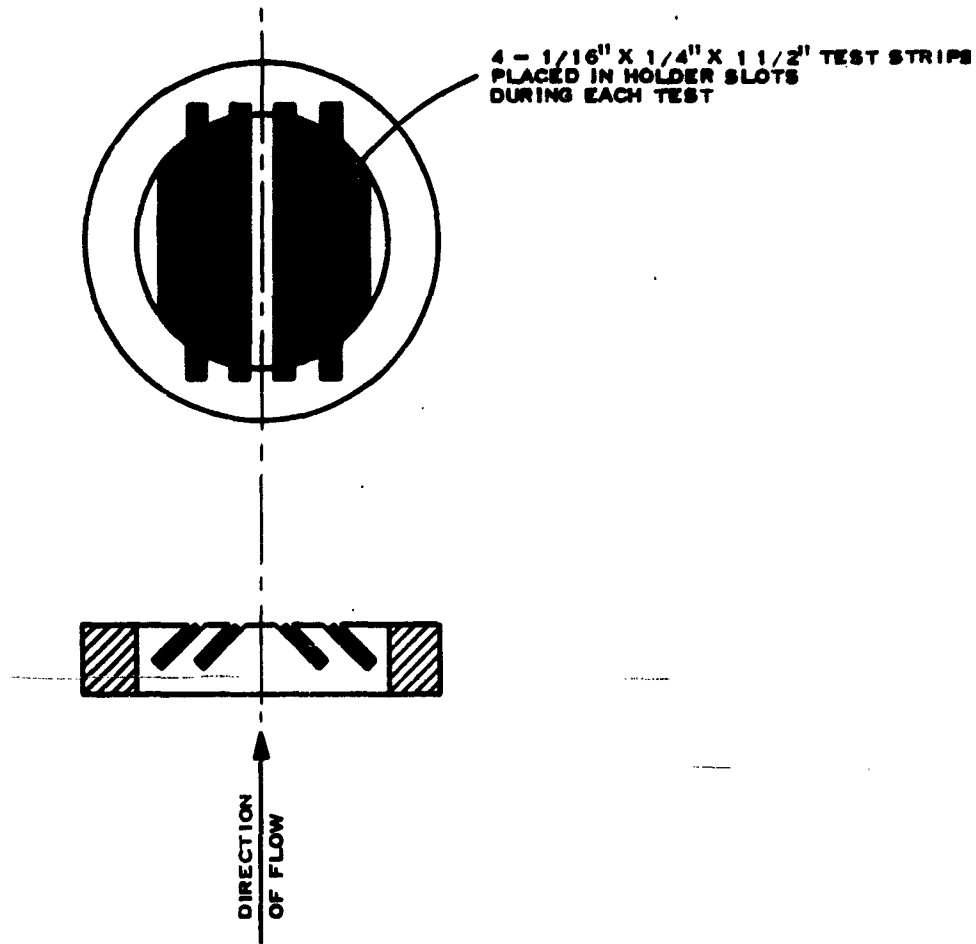

FIGURE 3  
 SCHEMATIC DIAGRAM OF PHILLIPS MICROBURNER ADAPTED FOR  
 MEASUREMENT OF TURBINE GUIDE VANE METAL DURABILITY



HOLDER MAT'L: 310SS; STRIP MAT'L: VARIOUS TURBINE BLADING ALLOYS

SCALE: FULL

FIGURE 4  
METAL DURABILITY SPECIMEN HOLDER FOR MICROBURNER APPARATUS

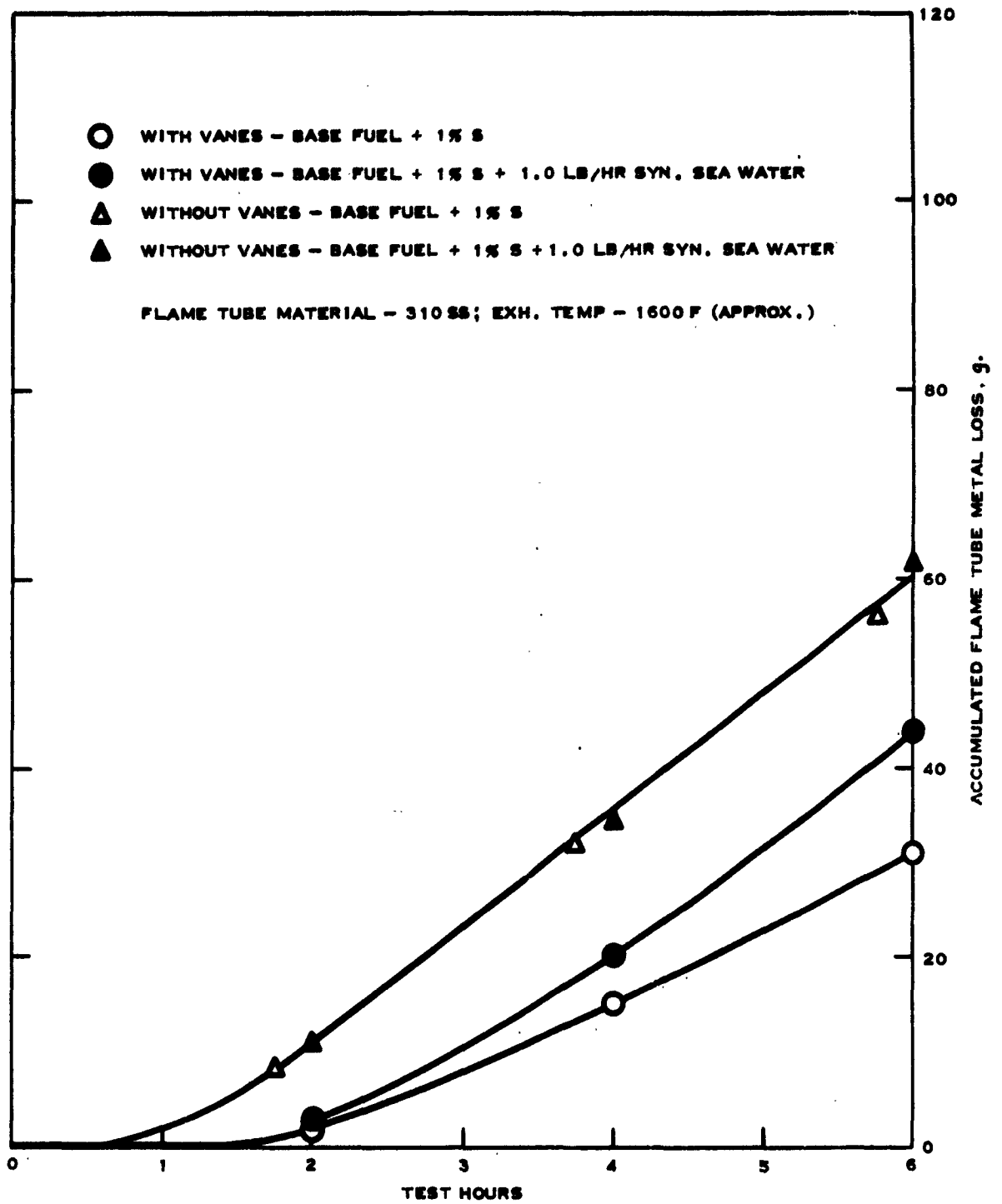

FIGURE 5  
EFFECT OF FUEL SULFUR AND INGESTED SEA WATER ON THE DURABILITY OF 310SS  
FLAME TUBES WITH AND WITHOUT GUIDE VANES INSTALLED  
IN THE PHILLIPS 2-INCH COMBUSTOR

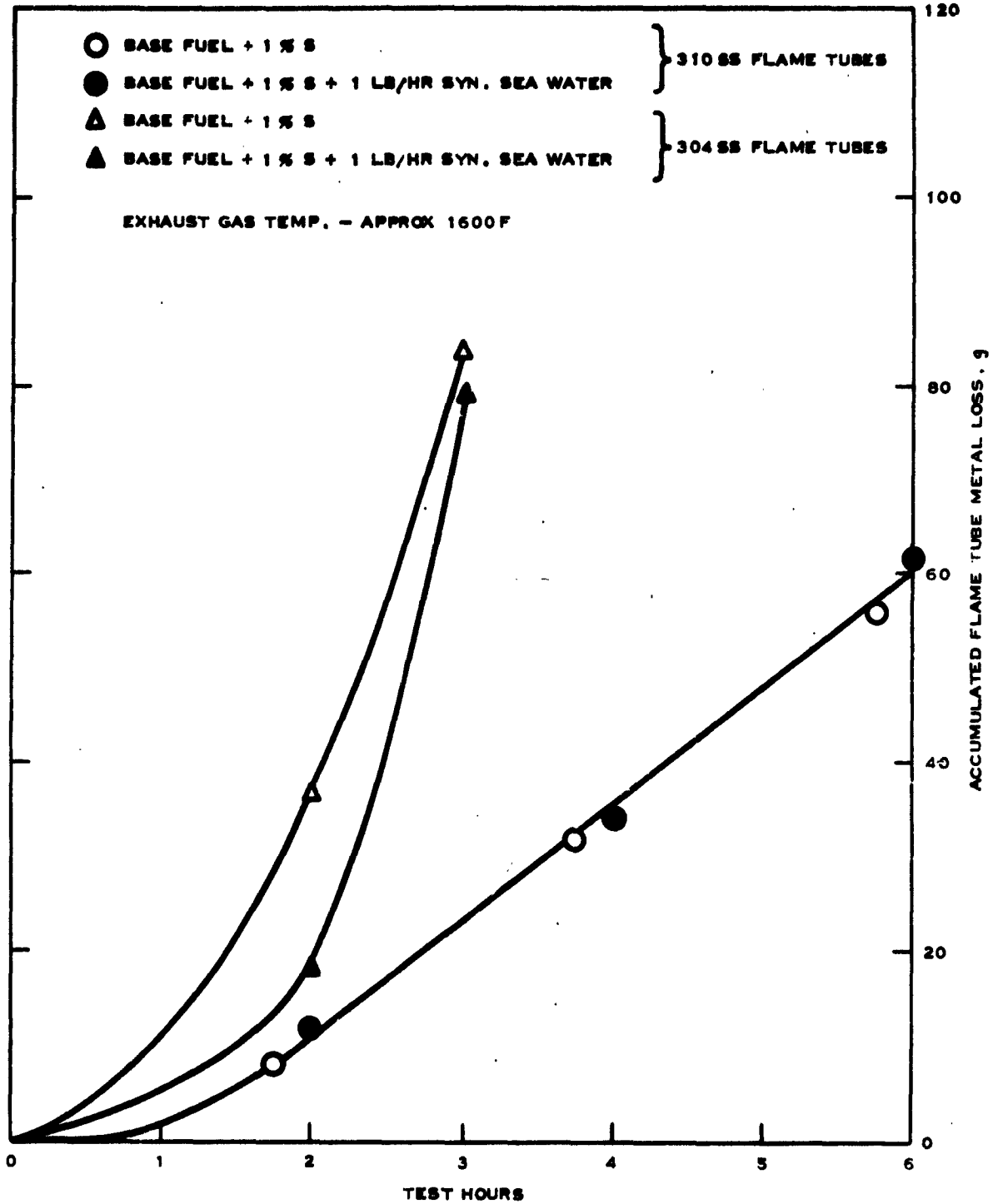

FIGURE 6  
EFFECT OF FUEL SULFUR AND INGESTED SEA WATER ON THE DURABILITY OF  
304 AND 310 STAINLESS STEEL FLAME TUBES - 2-INCH COMBUSTOR - NO VANES INSTALLED

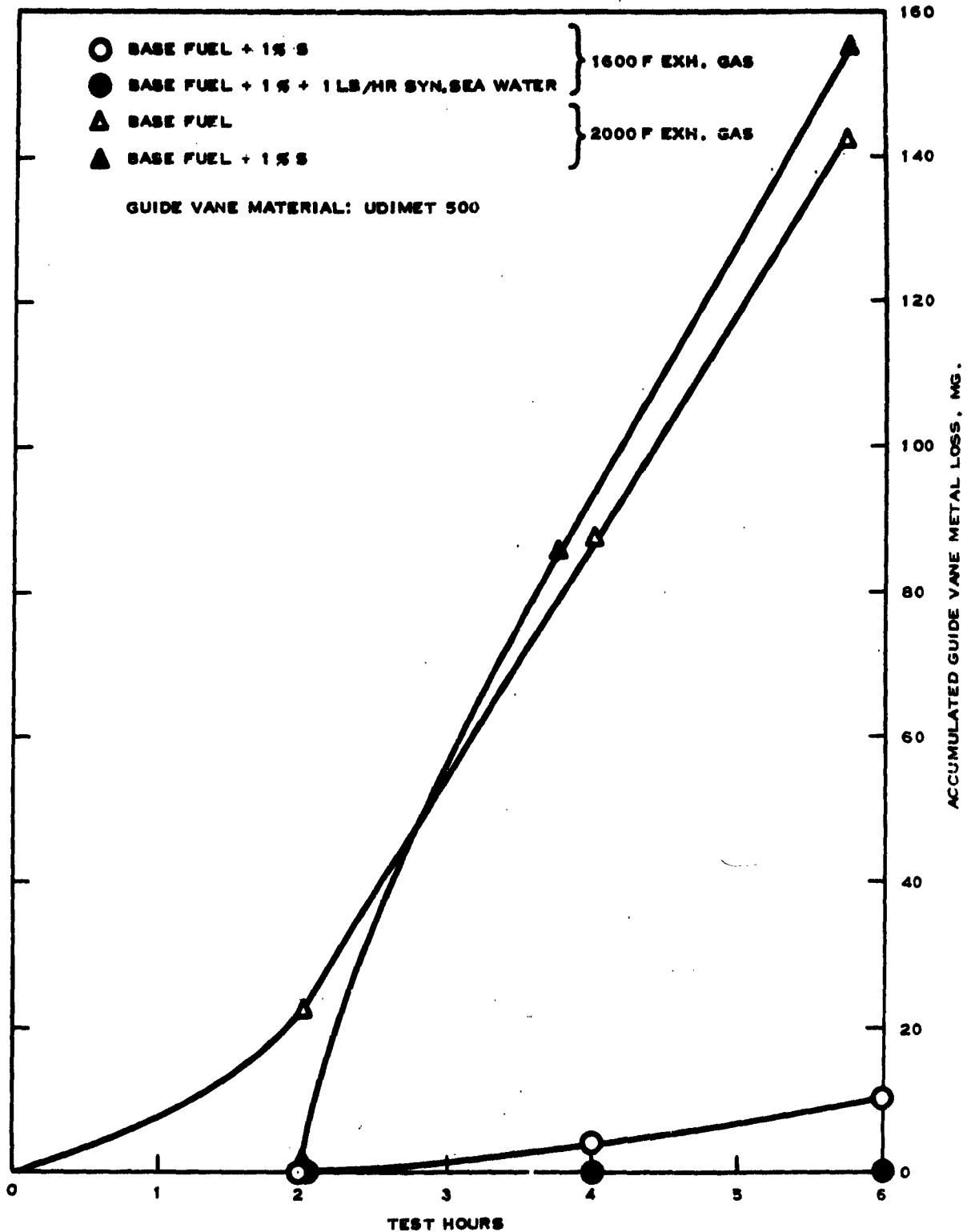

FIGURE 7  
EFFECT OF TEMPERATURE, SULFUR AND SEA WATER ON METAL LOSS FROM UDIMET 500  
GUIDE VANES IN THE PHILLIPS 2-INCH RESEARCH COMBUSTOR

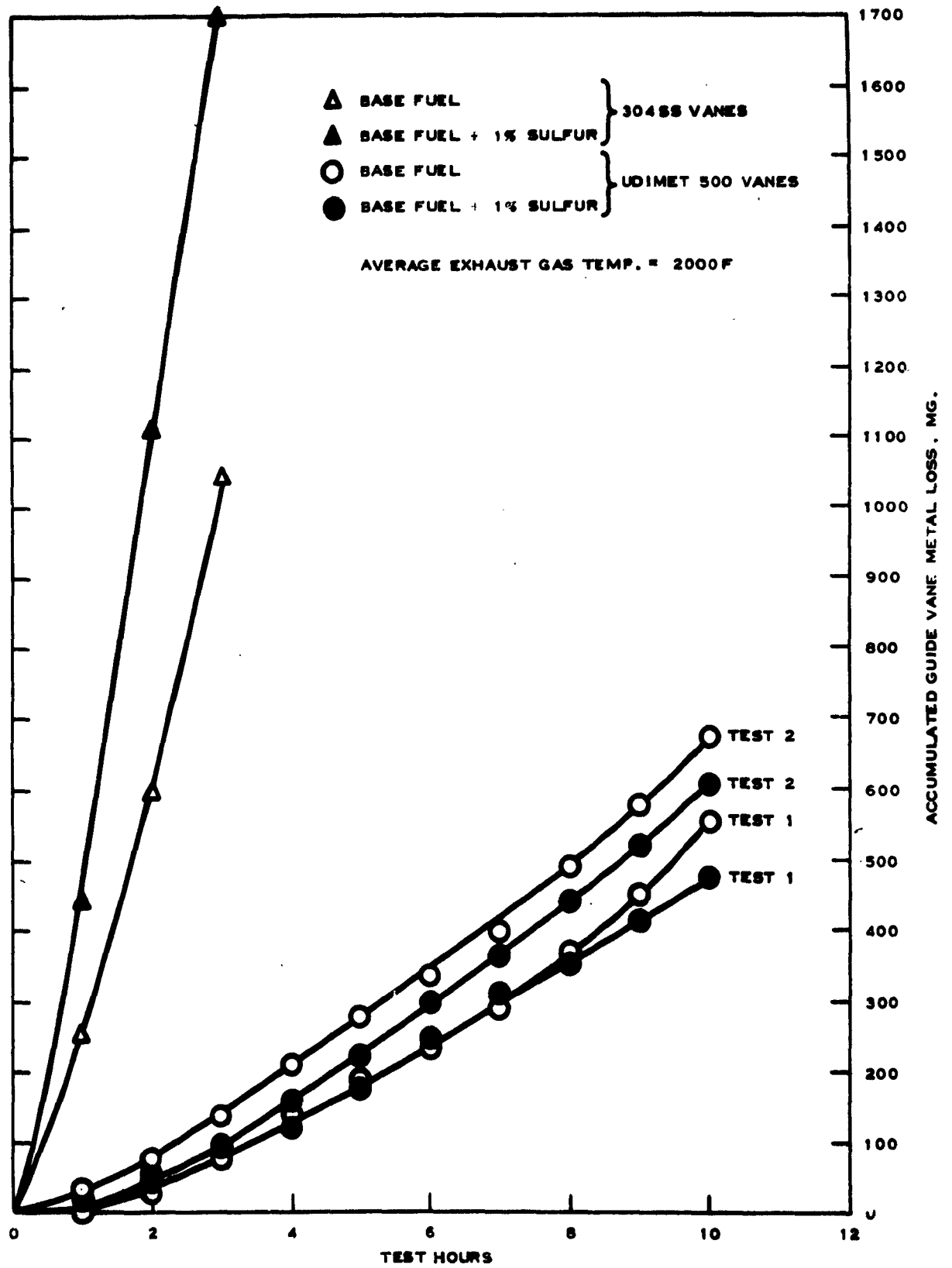

FIGURE 8  
EFFECT OF FUEL SULFUR CONTAMINATION ON THE DURABILITY OF  
304 STAINLESS STEEL AND UDIMET 500 SIMULATED TURBINE INLET GUIDE VANES  
IN THE PHILLIPS MICROBURNER