

**UNCLASSIFIED**

---

---

**AD 273 509**

*Reproduced  
by the*

**ARMED SERVICES TECHNICAL INFORMATION AGENCY  
ARLINGTON HALL STATION  
ARLINGTON 12, VIRGINIA**



---

---

**UNCLASSIFIED**

NOTICE: When government or other drawings, specifications or other data are used for any purpose other than in connection with a definitely related government procurement operation, the U. S. Government thereby incurs no responsibility, nor any obligation whatsoever; and the fact that the Government may have formulated, furnished, or in any way supplied the said drawings, specifications, or other data is not to be regarded by implication or otherwise as in any manner licensing the holder or any other person or corporation, or conveying any rights or permission to manufacture, use or sell any patented invention that may in any way be related thereto.

Unclassified

175

AFESD - TDR - 62-65

MASSACHUSETTS INSTITUTE OF TECHNOLOGY  
LINCOLN LABORATORY

PRECISION FREQUENCY CONTROL  
OF A HIGH-POWER MILLIMETER KLYSTRON

*C. M. STEINMETZ*

*Group 42*

TECHNICAL REPORT NO. 253

3 JANUARY 1962

*ABSTRACT*

This report describes the design and implementation of a stable 35-kMcps 30-watt CW transmitter that uses a floating-drift-tube klystron oscillator. The system both frequency and phase locks the klystron oscillator to a low-power stable oscillator. An analysis of the phase-locked system is made and schematic diagrams are presented for the complete system.

LEXINGTON

MASSACHUSETTS

Unclassified

# PRECISION FREQUENCY CONTROL OF A HIGH-POWER MILLIMETER KLYSTRON

## I. INTRODUCTION

Certain applications of millimeter waves require a high stability of the signal sources used in the system. In particular, those applications that allow very narrow predetection bandwidths (e.g., a pseudo-CW radar) exploit high transmitter frequency stability by reducing the receiver noise through the use of narrow-band filters. The stability at millimeter wavelengths should be comparable with that obtained by quartz crystal oscillators in the lower frequency portions of the electromagnetic spectrum. An application for a highly stable 8-mm transmitter arose at Lincoln Laboratory in conjunction with an 8-mm lunar radar project. Figure 1 is a simplified block diagram of this 8-mm lunar radar. It is a relatively simple system but contains many state-of-the-art components. A maser is used as the front-end preamplifier in order to obtain a low system noise temperature. The received signal is then mixed with a stable local oscillator to heterodyne the signal down to an intermediate frequency where it is amplified, detected and recorded. The same stable oscillator is used to stabilize the transmitter. The incoming and outgoing energy is duplexed to the antenna by means of a waveguide switch.

The system uses very long pulses of about 2 seconds' duration and a repetition rate of 0.2 pulse/sec. In order to reproduce the envelope of the return pulses faithfully, the receiver would require a bandwidth of only a few cycles per second. Aside from the broadening of the received signal spectrum due to the libration of the moon, however, the limiting factor on the bandwidth of the receiver is the stability of the transmitter and the local oscillator. The narrower the bandwidth of the system, the better the signal-to-noise ratio will be. For this particular system, a spectral width of less than 250 cps at 35 kMcps was desired. Measurements have shown that the spectral width of the 35-kMcps transmitter is about 25 cps with respect to the stable source. Exact measurements have not been made on the stable source but preliminary measurements show it to be within 50 cps, so the total spectral width should be much less than the design objective of 250 cps.

This report will cover in detail some of the problems associated with the transmitter and especially with its stabilization. It will also describe the generation of the source of stable power that is used for the transmitter and the local oscillator.

## II. KLYSTRON DESCRIPTION

The only tube currently available which will produce 30 watts of continuous power at 35 kMcps is manufactured by Elliott Brothers in England. It is a floating-drift-tube klystron oscillator. As can be seen from the specifications (Fig. 2), the tube requires a husky power supply since it is only 5 per cent efficient. Because of the stability desired, a well-regulated supply was needed to run the tube. Such a supply was not available on the market but had to be specially made.

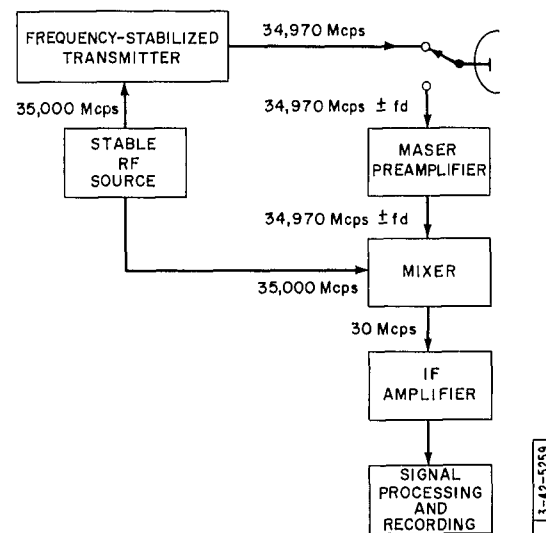
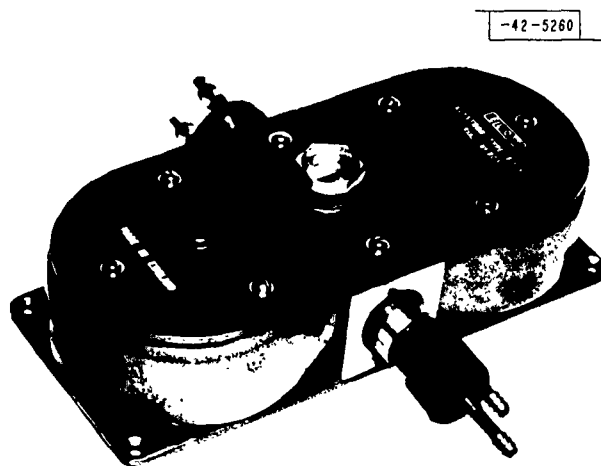

Fig. 1. Block diagram of the 8-mm lunar radar.



Frequency: Fixed tuned from 33 to 37 kMcps  
 Power output:  
 15 to 30 watts CW  
 Power input:  
 Beam, 4 kv negative, 150 r.  
 Focus, 1 kv negative, 1 ma  
 (with respect to beam)  
 Filament, 6.3 volts DC, 2.3 amp  
 (with respect to cathode)  
 Cooling: Water, 0.25 gal/min  
 Sensitivity to change in:  
 Beam voltage, 25 volts/Mcps  
 Focus voltage, 7 volts/Mcps  
 Water temperature, 0.5°/Mcps  
 Ambient temperature, 25°/Mcps

Fig. 2. Floating-drift-tube klystron oscillator (Elliott, 8FK1).

The tube can be electronically tuned over a small range without changing the output power by varying the beam or focus voltage. This feature makes it feasible to lock the tube to a stable, low-power source. Stability measurements were taken on the tube at room temperature with a well-regulated power supply. Figure 3 shows some of the results.

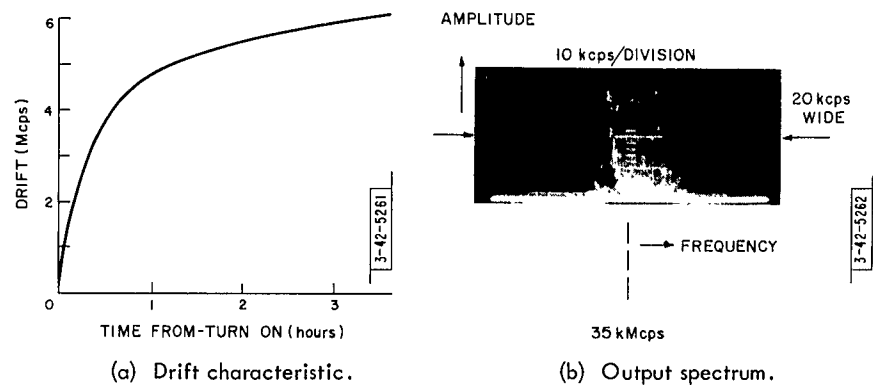

Fig. 3. Stability measurement results for the 8-mm klystron oscillator.

The klystron has a slow drift over many hours which is probably caused by the temperature change in the tube after it is turned on. This rise in tube temperature changes the internal dimensions of the tube, producing a shift in operating frequency. It is interesting to note that, at these frequencies, a change of only 20 millionths of an inch in a tuning cavity could change its center frequency 1 Mcps. It is easy to see why millimeter-wave sources are not inherently stable and need external circuitry for stability.

The 20-kcps width of the output spectrum as seen on the spectrum analyzer is probably due to microphonic and hum pickup from stray electric and magnetic fields. Since the environmental conditions on the antenna where the tube is to be mounted would probably be worse than those in the room where these measurements were taken, it was decided that the best way to stabilize the tube was to lock it to a low-power, stable, frequency source.

Frequency stabilization of the tube was considered first. It became apparent, however, that stabilization by means of a temperature-compensated cavity would not be adequate, nor would frequency locking to a stable signal source. The only method that would give the stability desired was phase locking the klystron to a stable source of RF power.

### III. THE PHASE-LOCKED LOOP

Figure 4 shows a block diagram of an elementary phase-locked loop. A small part of the output of the klystron is mixed with the stable local oscillator to form an IF signal. This signal is then compared in phase with another stable source, which is simply a crystal-controlled

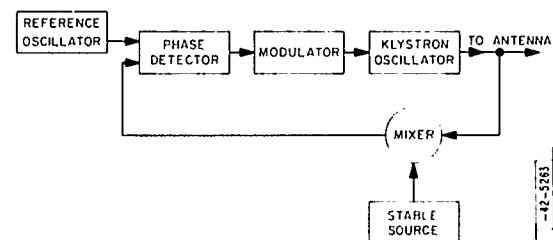

Fig. 4. Block diagram of an elementary phase-locked loop.

oscillator. The resulting output voltage from the phase detector, which is proportional to the phase difference between the two input signals, is applied as a correction voltage to the klystron oscillator.

Thus the klystron is synchronized with the two stable oscillators. The stability of both the reference oscillator and the stable source will determine the stability of the klystron oscillator. However, since the reference oscillator is a crystal oscillator at low frequency, the stable source is the unit that will determine the over-all stability of the system. This unit is described in Sec. VI.

An elementary phase-locked system that uses standard components will not completely stabilize the klystron. The following elementary equations describing the phase-locked system of Fig. 4 show this:

$$\begin{aligned} \text{Lock range} &= 2K \text{ rad/sec,} \\ \text{Noise sensitivity factor} &= \frac{f_n}{\sqrt{\frac{K^2}{39.5} + f_n^2}}, \\ K_{\text{max}} &\approx \frac{\omega_c}{4} \text{ rad/sec,} \\ \text{Maximum lock range} &\approx \frac{\omega_c}{2} \text{ rad/sec,} \end{aligned}$$

where  $K$  is the loop gain,  $\omega_c$  is the cutoff frequency of loop (3 db) and  $f_n$  is the noise frequency. The derivation of these equations is given in Appendix A.

One of the most important parameters describing the system is the lock range. This quantity is the maximum amount of drift the klystron can have without unlocking. It is just a function of the total loop gain  $K$  of the system.

Another important system parameter is the noise sensitivity factor. This is the ratio of the noise output of the phase-locked system to the noise output of the system when it is unlocked. It is a function of the total loop gain  $K$  and the frequency of the unwanted noise.

Both these equations indicate that the gain  $K$  should be made as large as possible; however, there is a limit imposed by the bandwidth of the loop on the maximum value of  $K$ . If a number of simplifying assumptions are made, it will be found that the maximum value of  $K$  which can be tolerated before the system becomes unstable is equal to the 3-db cutoff frequency of the loop divided by four. This determines the maximum lock range.

If some typical values are tried in these equations, one finds the following. If the amplifier system in the loop has a bandwidth flat from DC to a 3-db cutoff frequency at 1 Mcps, the maximum gain that the system can tolerate will give a maximum lock range of 500 kcps. This same amount of gain will attenuate any 60-cps hum in the system by 72 db, but higher frequency noise won't be attenuated as much. For example, 100-kcps noise will be reduced only 8.5 db. However, there are generally no noise components 100 kcps from the center frequency of the klystron.

Because of the maximum 500-kcps lock range, the elementary phase-locked system is not adequate since the slow drift of the klystron will cause the system to unlock after a very short time. It was decided to incorporate a second feedback loop in the system which would correct for the slow drift.

#### IV. FREQUENCY AND PHASE-LOCKED LOOP

Figure 5 is a block diagram of the final frequency and phase-locked system. The klystron is mounted in a cab behind the antenna so as to minimize the waveguide losses. The rest of the equipment is located in a penthouse a few hundred feet from the antenna. The phase-locked loop in this system consists of the stable source, mixer, amplifier, reference oscillator, phase detector, an amplifier-driver to drive the long cable to the antenna and the power supply modulator. The frequency loop comprises the stable source, mixer, IF amplifier, frequency discriminator, phase detector, integrator, amplifier-driver and modulator. The frequency loop derives its error voltage from two sources: the frequency discriminator and the phase detector. Logic circuitry in the integrator selects one of the two sources. The reason for this is as follows: When the transmitter is first turned on, the resultant IF signal will probably be within the 4-Mcps range of the frequency discriminator. The discriminator will produce an error voltage which will be integrated and applied to tune the klystron to the desired frequency. When the tube is in the capture range of the phase-locking loop, the system will phase lock. The output of the discriminator will then be zero. At this time the error voltage from the phase detector will be applied to the integrator by the switching network. As the klystron slowly drifts, the DC component from the phase detector will be integrated and this voltage will serve to hold the klystron within the lock range of the phase-locking loop. If the transmitter is switched off for a few seconds, as will be the case in normal operation, the integrator will hold its voltage and when the tube is turned on again, the same error voltage will be applied as when the tube was turned off. If the klystron is still within the phase lock range, it will lock immediately. If it has drifted out of the capture range, the frequency discriminator will retune the klystron back. This re-tuning process may take 100 msec or so.

This combination of frequency and phase-locked loops eliminates many of the practical drawbacks to a phase-locked system alone. The system will automatically lock and stay locked for as long as the tube can be electrically tuned. For the present system, the klystron will stay locked as long as the system is turned on.

#### V. SYSTEM PERFORMANCE

The output spectra (Fig. 6), as seen on a spectrum analyzer, show the performance of the system. Figure 6(a) shows the output of the klystron before the tube is locked. The width of the spectrum is about 20 kcps. The output of the tube after it is locked is shown in Fig. 6(b). It can be seen that the spectrum approaches a line, which indicates a single frequency. Now if this is blown up on the spectrum analyzer, the trace in Fig. 6(c) will be seen. This spectrum looks about 50 cps wide. However, when a known pure signal, which has a width of about a cycle per second, is applied to the analyzer (Fig. 6(d)), a similar display is shown. Hence one may conclude that the spectral width of the transmitter output is much less than that of the resolution of the spectrum analyzer, which is about 50 cps. A better analyzer was not readily available at the time. However, one thing should be noted here: these photographs show the spectrum of the transmitter with respect to the stable source. Frequency variations in the stable source would not show up on these traces.

Figure 7 shows the front control panel of the system. With these controls, it is possible to monitor the performance of the system while it is operating. Figure 8 displays some of the chassis which makes up the system.

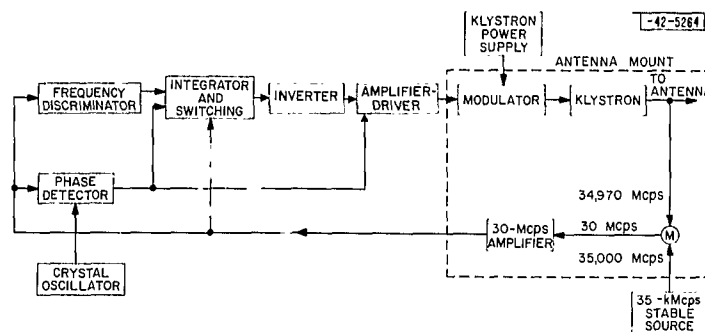

Fig. 5. Simplified block diagram of the 35-kMcps transmitter.

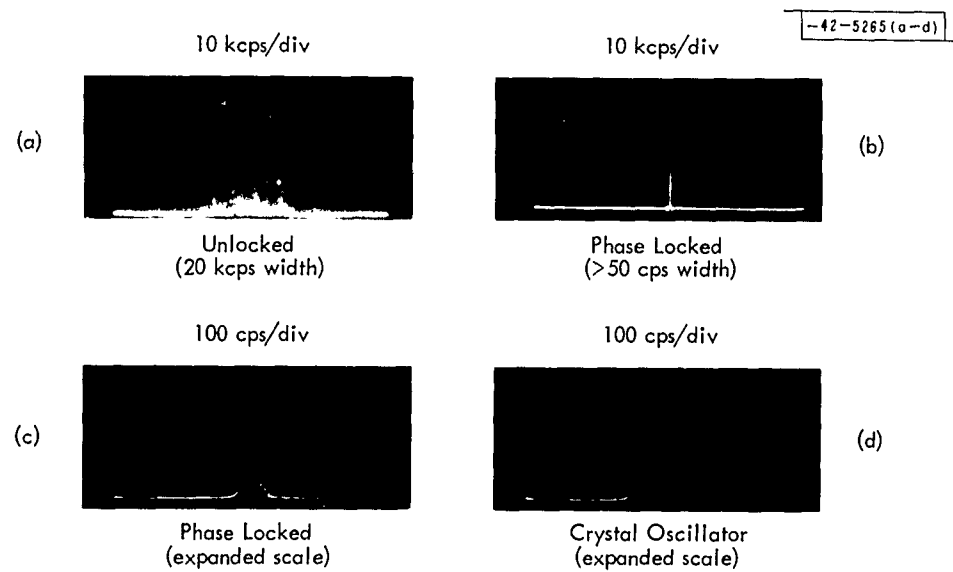

Fig. 6. Transmitter output spectra.

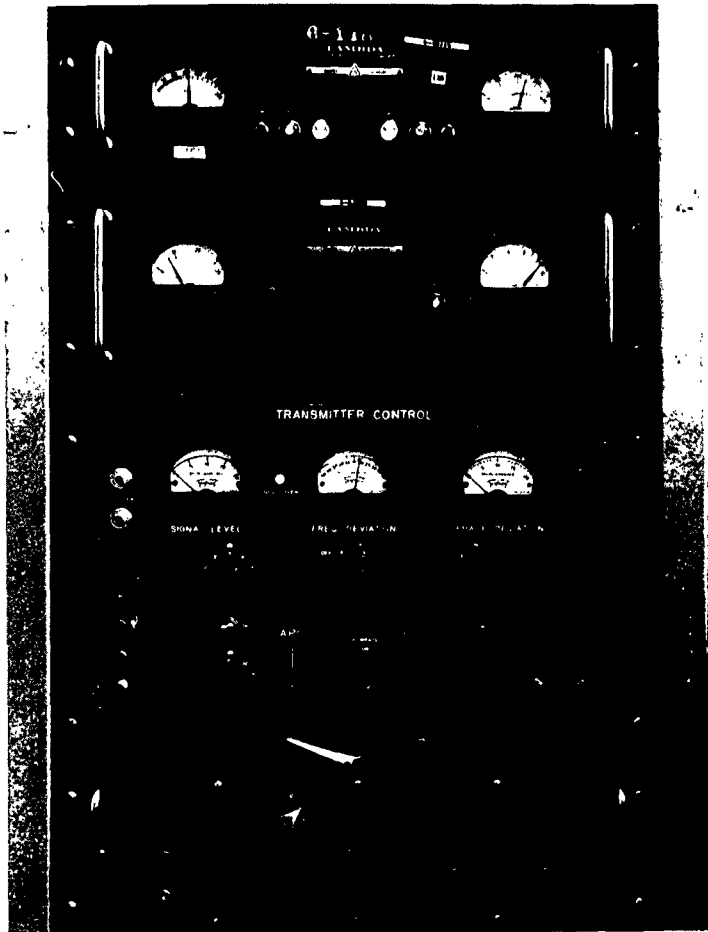

Fig. 7. Transmitter front control panel.

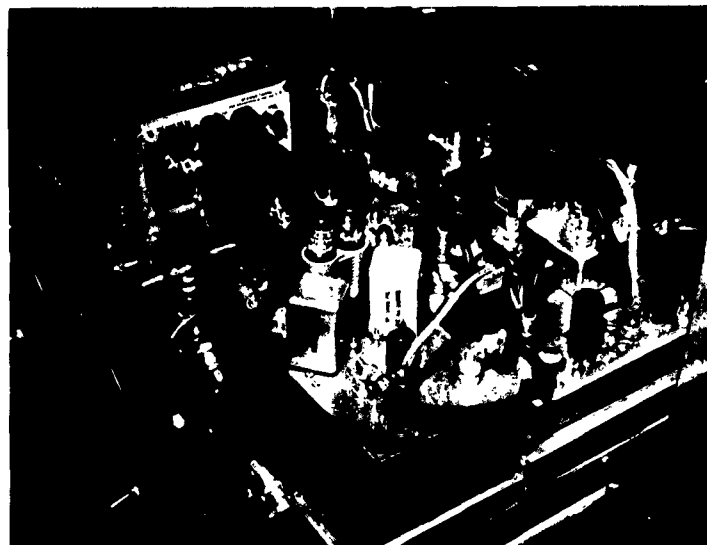

Fig. 8. Transmitter chassis.



Fig. 9. Klystron in maser rack.

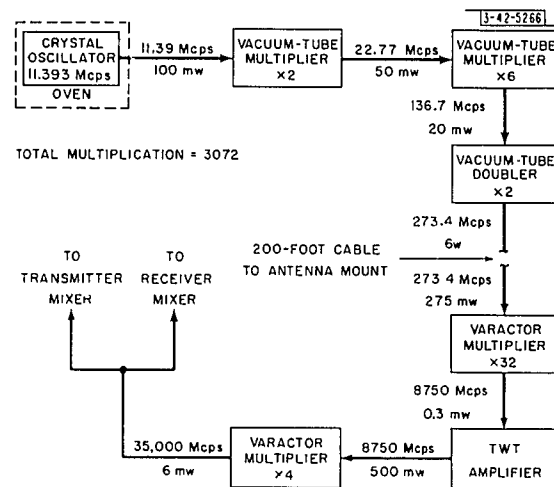

Fig. 10. Block diagram of stable source.

Figure 9 shows the transmitter klystron mounted in the rack along with the maser. This unit will be mounted right behind the antenna. When the radar is operating, this entire unit will have to be removed every day and the maser dewars filled with liquid helium and liquid nitrogen. When it is in the laboratory, however, it will make a convenient package for testing the receiver and transmitter.

## VI. DESCRIPTION OF THE STABLE SOURCE

Figure 10 is a block diagram of the stable source that furnishes a signal for use as the local oscillator in the receiver and provides a signal to mix the transmitter signal down to an intermediate frequency. This system obtains its stable output at 35 kMcps by direct multiplication without phase- or frequency-locking loops. A temperature-controlled crystal oscillator at 11.393 Mcps provides the basic stability. This is multiplied by vacuum-tube multipliers up to 273 Mcps. At this point, the signal is sent to the antenna mount through a long cable. It is then further multiplied by a varactor multiplier, amplified by a traveling-wave tube and finally multiplied by another varactor multiplier to obtain 6 mw of power at 35 kMcps. The total multiplication in this chain is 3072. With this system it is possible to obtain a signal output that has a spectrum output width of less than 50 cps. Measurements have not yet been made to determine the exact width.

It is interesting to note here how measurements of stability are made at these frequencies. Two similar but independent multiplier chains were built. The outputs of the two were heterodyned together to form an IF signal, and this was observed on the spectrum analyzer. The resulting spectrum is then caused by the instability of both the oscillators. To a very rough approximation, the spectrum output of a single oscillator can be assumed to be 70 per cent of the width of the two oscillators.

## VII. CONCLUSIONS

The performance of the entire stabilization system has surpassed the design objectives. The spectral width is about 50 cps, which is considerably better than the 250 cps originally chosen for the design objective. It is felt that, with additional work, the spectral width could be narrowed further. However, the radar system does not require such a narrow bandwidth and hence this has not been attempted.

APPENDIX A  
PHASE-LOCKED-SYSTEM ANALYSIS

I. INTRODUCTION

Many analyses of phase-locked systems have been made.\* However, most of them have been slanted toward the design of receiver phase-locked systems. In these systems the input signal (the reference oscillator of Fig. 4) is the noisy signal, and the controlled oscillator the "clean" signal. Although basically the two systems are the same, the physically realizable systems are different and emphasis in design is placed on different portions of the system. The following analysis attempts to pull together the important parameters in the design of a phase-locked system when the output oscillator is the unstable source.

II. ANALYTICAL

A block diagram of a phase-locked system in its most elementary form is shown in Fig. A-1. This is an ideal system and neglects some of the practical components found in the physical system, such as mixers, local oscillators and amplifiers. In the figure,  $e_r$  is the voltage from the reference oscillator, which is assumed to be a sinusoidal voltage of the general form  $\sin \phi_r(t)$ .

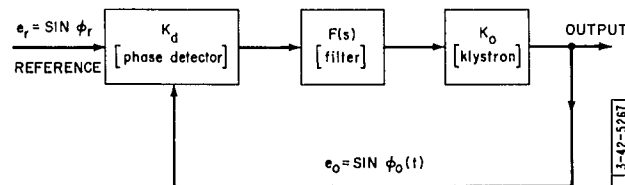

Fig. A-1. Block diagram of an elementary phase-locked system.

Similarly the output from the klystron oscillator is  $e_o$  and assumed to be sinusoidal with the form  $\sin \phi_o(t)$ . The output of the phase detector is assumed to be equal to  $K_d \sin [\phi_r(t) - \phi_o(t)]$ , where the constant  $K_d$  has the dimensions of volts. Since any physically realizable circuit has a finite bandwidth, an equivalent filter, shown in the figure with a transfer characteristic

$$F(s) = \frac{e_{out}(s)}{e_{in}(s)},$$

takes this into account. Physically it does not appear as a separate item in the actual circuit, but is formed by all the time constants of the other circuits. Finally  $K_o$  represents the conversion constant from volts change of the klystron-tube beam voltage to frequency change of its output.  $K_o$  then has the dimensions of radians/sec-volt.

The most important parameters of interest for this system are:

- (a) Phase error,
- (b) Lock range,
- (c) Capture range,
- (d) Maximum gain,
- (e) Sensitivity to klystron noise.

\*Please refer to References on p. 26.

The phase error is the amount of phase deviation between the reference signal and the klystron signal; the lock range is the total drift in unlocked output frequency for which the system can compensate. The capture range is the largest unlocked frequency difference  $\Delta\omega$  at which the system will pull in to lock. The maximum gain is the limit to which  $K_o K_d$  can be increased and still maintain system stability; the sensitivity to klystron noise is a measure of the performance of the system in reducing the unwanted noise and instability from the klystron output.

### A. Phase Error

For the purpose of analysis, the circuit diagram can be relabeled as in Fig. A-2. Here the reference frequency  $e_r$  is assumed to be a sine wave of frequency  $\omega_r$  rad/sec with a phase angle of  $\theta_r$  radians. The output frequency is divided into two parts to facilitate the following analysis.  $\omega_o$  is equal to the free-running oscillator frequency (with no control voltage applied to the oscillator).  $(\omega_o + \Delta\omega)$  is the frequency of the oscillator when the loop is closed. Finally  $-\theta_o$  is the phase angle of the klystron output voltage.

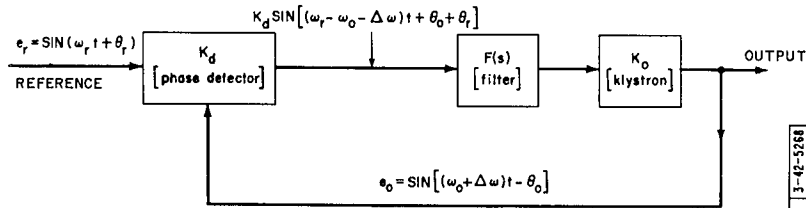

Fig. A-2. Block diagram of a phase-locked system.

For the following steady-state analysis,  $\theta_r$  will be assumed to be zero with no loss of generality and  $F(s)$  will be assumed equal to one. The phase-locked system can then be described by

$$(\omega_o + \Delta\omega) - \frac{d\theta_o}{dt} = K_o K_d \sin[(\omega_r - \omega_o - \Delta\omega) t + \theta_o] + \omega_o \quad (A-1)$$

$K_o$  and  $K_d$  can be lumped together and defined as  $K = K_o K_d$ . Then the equation can be rewritten as

$$\Delta\omega - \frac{d\theta_o}{dt} = K \sin[(\omega_r - \omega_o - \Delta\omega) t + \theta_o] \quad .$$

Assuming the system has locked and transients have ceased ( $t \rightarrow \infty$ , so  $d\theta_o/dt = 0$  and  $\omega_r - (\omega_o + \Delta\omega) = 0$ ), the following equation will apply:

$$\Delta\omega = K \sin \theta_o$$

or

$$\theta_o = \sin^{-1} \frac{\Delta\omega}{K} \approx \frac{\Delta\omega}{K} \quad (\text{for small angles}) \quad (A-2)$$

This equation says that the amount of phase error  $\theta_o$  in the steady state is proportional to the initial frequency difference between the klystron oscillator and the reference oscillator and inversely proportional to the gain constant  $K$ . The klystron will be locked "tighter" to the reference when the gain  $K$  is high and the initial frequency offset  $\Delta\omega$  is small (a carefully tuned, inherently stable klystron).

## B. Maximum Gain Limitations

To determine the gain of the system, Eq. (A-1) can be rewritten as

$$(\omega_o + \Delta\omega) - \frac{d\Theta_o}{dt} = K \sin[(\omega_r - \omega_o - \Delta\omega)t + \Theta_o + \Theta_r] + \omega_o \quad . \quad (A-3)$$

The equivalent filter  $F(s)$  is assumed not to be in the circuit ( $F(s) = 1$ ). If the system is locked, Eq. (A-3) becomes

$$-\frac{d\Theta}{dt} = K \sin[\Theta_r + \Theta_o] \quad . \quad (A-4)$$

If the small signal approximation  $\sin x = x$  is used for the phase detector, Eq. (A-4) becomes

$$-\frac{d\Theta}{dt} = K[\Theta_r + \Theta_o] \quad . \quad (A-5)$$

Now if we let the reference phase vary in a sinusoidal manner, i.e.,  $\Theta = \sin \omega_i t$ , Eq. (A-5) can be solved for  $\Theta_o$

$$\Theta_o = \frac{K}{\sqrt{\omega_i^2 + K^2}} \sin(\omega_i t - \beta) \quad \beta = \tan^{-1} \frac{\omega_i}{K} \quad . \quad (A-6)$$

Hence the magnitude of the transfer function of the system is

$$\left| \frac{\Theta_o(\omega)}{\Theta_i(\omega)} \right| = \frac{K}{\sqrt{K^2 + \omega_i^2}} \quad . \quad (A-7)$$

This indicates that output phase  $\Theta_o$  will equal the input phase  $\Theta_i$  only for low frequencies. High-frequency variation of phase by the input  $\Theta_i$  will not be shown on the output  $\Theta_o$ . This transfer function is similar to that of a simple low-pass RC filter with a time constant

$$RC = \frac{1}{K} \quad . \quad (A-8)$$

The equivalent 3-db cutoff frequency is

$$\omega_c = K \quad . \quad (A-9)$$

## C. Effect of Filter

In the physically realizable situation  $F(s)$  does not equal one but is some function of frequency. In the simplest case, the equivalent filter is equal to an RC low-pass filter. This is a very realistic case since there will be at least one component in the phase detector or its associated amplifiers which will limit the frequency response of the system because of stray capacity in the amplifiers. The transfer function of such an RC filter is

$$F(s) = \frac{e_{out}(s)}{e_{in}(s)} = \frac{1}{RCs + 1} \quad . \quad (A-10)$$

The transfer function of the entire phase-locked system can then be shown to be

$$\frac{\Theta_o(s)}{\Theta_i(s)} = \frac{K}{RC(s^2 + \frac{1}{RC}s + \frac{K}{RC})} \quad , \quad (A-11)$$

where  $s$  is the complex operator. The denominator has the general quadratic form

$$s^2 + 2\zeta\omega_n s + \omega_n^2, \quad (A-12)$$

where

$$\omega_n = \sqrt{\frac{K}{RC}} \quad (\text{resonant frequency}) \quad (A-13)$$

$$\zeta = \frac{1}{2\sqrt{RC}K} \quad (\text{damping ratio}) \quad (A-14)$$

Using the analogy with a series resonant circuit, three conditions can be defined:

$$\begin{aligned} \zeta = 1, \quad K &= \frac{1}{4RC} && (\text{critically damped}) \\ \zeta > 1, \quad K &< \frac{1}{4RC} && (\text{overdamped}) \\ \zeta < 1, \quad K &> \frac{1}{4RC} && (\text{underdamped}) \end{aligned} \quad (A-15)$$

If the constants of the circuit are adjusted so that it is underdamped, the system will tend to oscillate. Even though there is some damping ( $RC \neq \infty$ ), the circuit will show a small continuous oscillation or ringing due to a continuous excitation by the random noise input which is always present. Consequently the constants of the system should be adjusted to be near the critically damped case. This means that, for a given  $RC$  product (which defines a certain bandwidth), there is a limit to which  $K$  can be increased. In the physically realizable system, there are more time constants than just the one. Hence the value of  $K$  is more difficult to compute. In actual practice, the gain is increased until oscillations start to appear (as seen by a frequency discriminator on the output of the klystron) and then it is reduced a little. This has generally given good performance of the system.

#### D. Lock Range

From the system diagram it can be seen that the lock range is equal to the deviation of the klystron oscillator that is caused by the maximum voltage out of the phase detector. For the phase detector shown, the lock range is  $K_o K_d$  rad/sec. A phase difference change of  $\pi$  radians produces maximum voltage swing of  $2K_d$  volts out of the phase detector which, in turn, produces a change of  $2K_o K_d$  rad/sec in the klystron oscillator frequency.

#### E. Capture Range

If there are no time constants in the system ( $F(s) = 1$ ), the capture range will equal the lock range  $2K_o K_d$ . However, if  $F(s)$  is a low-pass filter, the capture range will be less than the lock range. An exact analysis is difficult because of nonlinearities in the system but has been attempted by others.\* It has been shown that the following relationship is true:

$$\frac{\text{Capture range}}{\text{Lock range}} = \frac{\omega_n}{K} \quad \text{for} \quad \omega_n \ll K \quad (A-16)$$

The capture range gets smaller as  $K_o K_d$ , or  $K$  gets smaller. This is what one would intuitively

---

\* See Ref. 8, p. 26.

expect. Since  $K$  is proportional to the lock range and the capture range has to be less than the lock range, as  $K_o K_d$  is reduced the capture range should also be reduced. Similarly, as the time constant of the equivalent filter is increased, it will lower  $\omega_n$  and consequently lower the capture range. This is also to be expected since the effective forward gain is being reduced at the higher difference frequencies ( $\Delta\omega$ ).

#### F. Sensitivity to Klystron Noise

In order to see the effect on the system of such klystron instabilities as hum, drift and tube noise, the circuit of Fig. A-3 can be drawn, where the voltage  $e_m$  causes the unwanted change of phase of the output. It will be assumed that the free-running frequency of the oscillator  $\omega_o$  is equal to the reference frequency  $\omega_r$  (i.e., the system is locked). The equation describing the frequency of the system is

$$\omega_r - \frac{d\theta_o}{dt} = K_o [K_d \sin(\theta_o) + e_m] + \omega_r \quad . \quad (A-17)$$

Now let  $e_m = E_m \sin \omega_m t$ . Then

$$-\frac{d\theta_o}{dt} = K_o [K_d \sin(\theta_o) + E_m \sin \omega_m t] \quad . \quad (A-18)$$

Assuming the phase detector is linear over a small range ( $\sin x = x$ ),

$$\frac{d\theta_o}{dt} + K_o K_d \theta_o = -K_o E_m \sin \omega_m t \quad . \quad (A-19)$$

This is a first-order linear differential equation which has the solution

$$\theta_o = \frac{-K_o E_m}{K_o^2 K_d^2 + \omega_m^2} (K_o K_d \sin \omega_m t - \omega_m \cos \omega_m t) \quad . \quad (A-20)$$

This can be simplified to

$$\theta_o = \frac{-K_o E_m}{\sqrt{K_o^2 K_d^2 + \omega_m^2}} \sin \left( \omega_m t - \tan^{-1} \frac{\omega_m}{K_o K_d} \right) \quad . \quad (A-21)$$

The magnitude of Eq. (A-21) can be written as

$$|\theta_o| = \frac{E_m}{\sqrt{K_d^2 + \frac{\omega_m^2}{K_o^2}}} \quad . \quad (A-22)$$

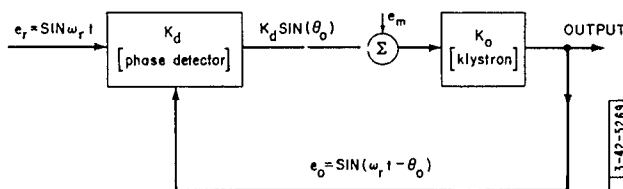

Fig. A-3. Phase-locked loop with added noise voltage.

If there is no feedback connected in the system,

$$|\theta_o|_{K_d=0} = \frac{E_m K_o}{\omega_m} \quad . \quad (A-23)$$

The ratio of noise output in the locked system to the noise output in the unlocked system is

$$\frac{|\theta|}{|\theta|_{K_d=0}} = \frac{1}{\sqrt{\frac{K_o^2 K_d^2}{\omega_m^2} + 1}} \quad . \quad (A-24)$$

This equation states that, if the noise is to be reduced, the gain  $K_d K_o$  has to be increased. Also, the higher the frequency of the noise, the more the gain has to be increased for a given amount of reduction. This is what one would intuitively expect from a phase-locked system. The faster the klystron tries to change the output frequency, the harder it is for the system to counteract this change. When the noise approaches DC (slow frequency drift in the tube), the system will completely eliminate it.

## APPENDIX B

### SPECIFICATION OF STABILITY

#### I. INTRODUCTION

During the design of the 8-mm transmitter, some confusion was encountered regarding the specification of the stability of an oscillator. Most of this, no doubt, was caused by the different methods of measurement which were used. Various methods of measurement will give different results, depending on the type of instability, i.e., how it varies as a function of time. It is important that the method of stability measurement be chosen carefully so that the measurement will be meaningful with respect to the final application of the oscillator.

#### II. DISCUSSION

Most of the different results occur because of the various time periods taken by the instruments in determining frequency. Three measuring instruments in common use are:

- (a) Frequency discriminator,
- (b) Counter,
- (c) Spectrum analyzer.

Let us review these instruments with regard to the measurement of stability.

A frequency discriminator measures the instantaneous frequency,  $d\phi/dt$ , as a function of time. If a continuous recording is made, this method will completely describe the frequency being measured at any instant of time. However, this may provide more information than can be utilized for most applications. Another way of using the discriminator output would be to record only the highest peak-to-peak deviation over a given period of time or to measure the rms deviation over a period of time. The specification of peak deviation is an important one if the oscillator is to be used for comparison with some other signal and the comparison measurement is to be made over a short period of time (e.g., of the order of a few cycles).

A counter simply counts the number of cycles in a given time period. Thus it measures the average frequency in the given counting period. This is a good measure of the slow drift of the oscillator, but does not give any information regarding the fast variations in frequency. If the oscillator is to be used in applications where short time stability is important, the counter is not a good performance indicator.

A spectrum analyzer measures the average power contained in a given unit bandwidth and displays the information as a function of frequency. This is done in the analyzer by sampling, rather than continuously, as could be done by a bank of comb filters. In a sampling analyzer this measurement takes time; hence a different portion of the spectrum is being measured at a different time. This may not be good if the spectrum changes as a function of the time during the analyzer sweep, but this is generally not the case.

Some typical stability measurements on oscillators with different forms of instability are given in Fig. B-1. It can be seen from the figure that various stability numbers can be obtained on a given oscillator. Hence the most thorough way to describe stability is to measure the stability in various ways and to describe each measurement system along with the results.

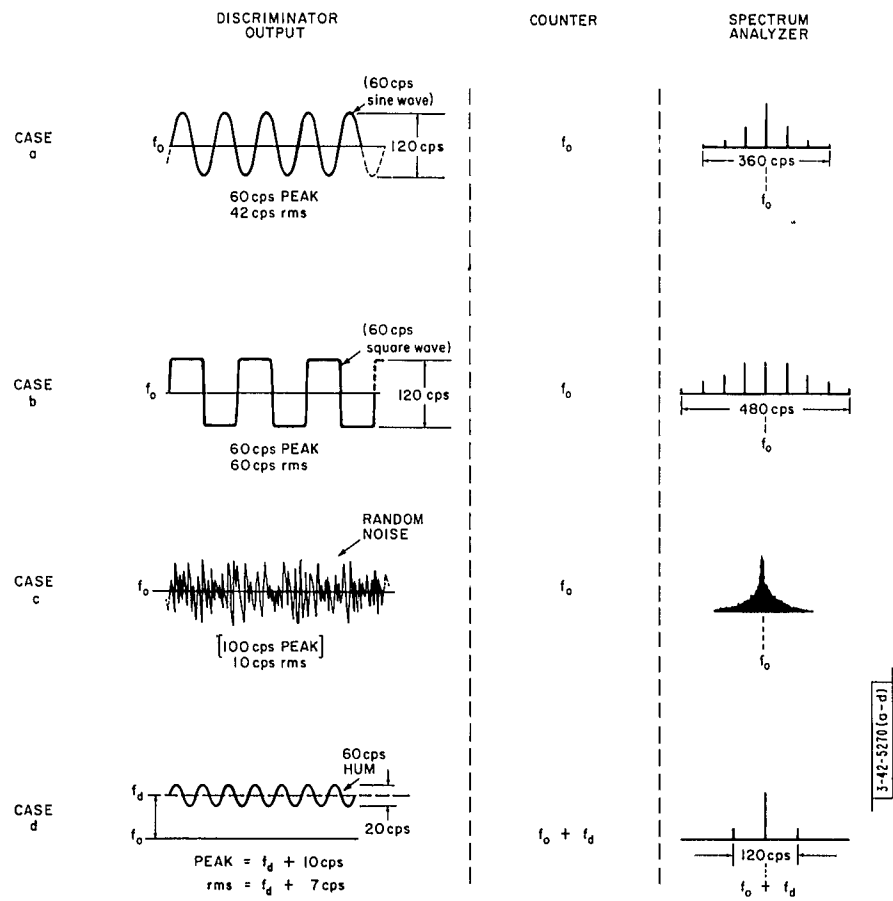

3-42-5270 (a-d)

Fig. B-1. Examples of measurements of stability.

### III. CONCLUSIONS

A recording of the instantaneous frequency vs time is the most informative of the measurements but is difficult to interpret because of the large amount of information. The counter provides only long-term averages of frequency. Any variation faster than the time the counting gate is open, may not be observed. Since this time is about a second in order to read frequency to six places in a typical megacycle counter, the counter is best used to measure slow drifts of average frequency over minutes and hours.

The spectrum analyzer provides a good measurement when one is trying to determine the bandwidth needed to pass the given oscillator signal. If one wants to determine what fraction of the total energy of the spectrum is contained within a specified bandwidth, the spectrum analyzer is the best measuring instrument.

Statements like "4 part in  $10^8$  stability" do not have much meaning; neither do statements like "5 parts in  $10^8$  per day." One may ask: does the oscillator maintain its frequency at all times during the day within 5 parts in  $10^8$ ? Undoubtedly it doesn't; the average frequency was probably measured in a 10-second interval and the measurements repeated a number of times in a day. It is, then, this series of numbers, and not the instantaneous frequency of the oscillator, which does not vary more than 5 parts in  $10^8$  per day. In order to describe an oscillator adequately, a more lengthy and precise statement must be given. The following is an example of such a specification:

Absolute Stability	Less than 1000-cps deviation from the <u>absolute</u> center frequency measured by counting cycles in 10-second intervals.
Long-Time Stability	Less than 1000-cps maximum variation during one day measured by counting cycles in 10-second intervals every minute.
Short-Time Stability	Instantaneous deviation no more than 5000 cps from absolute center frequency (measured by continuous observation of a frequency discriminator).
Spectrum	

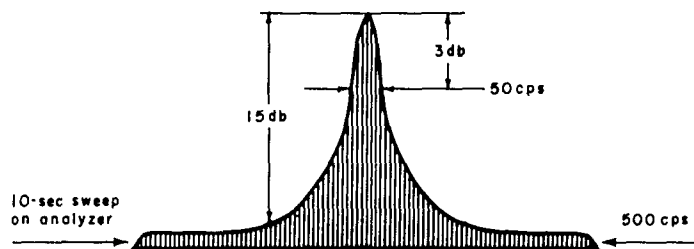

From this specification one can determine the utility of the oscillator for almost any application, whether the use requires long- or short-term stability.

## APPENDIX C

Figures C-1 through C-8 present a collection of schematic diagrams for various parts of the phase- and frequency-locked systems.

This system realization may not represent the optimum if size and power consumption are important. However, it is a configuration that works well and that lent itself readily to experimentation in the initial development of the system. It could have been made much smaller (possibly transistorized) if flexibility had not been one of the goals of the system.

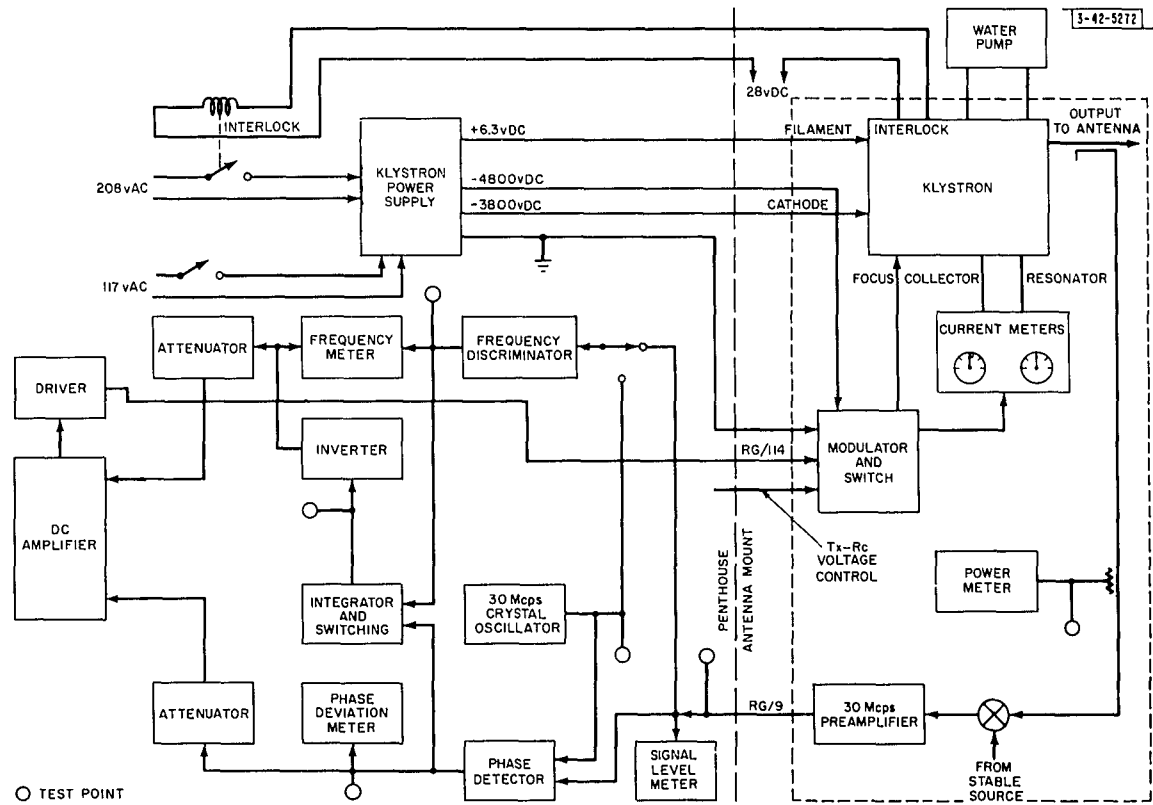

Fig. C-1. System block diagram of 35-kMcps transmitter.

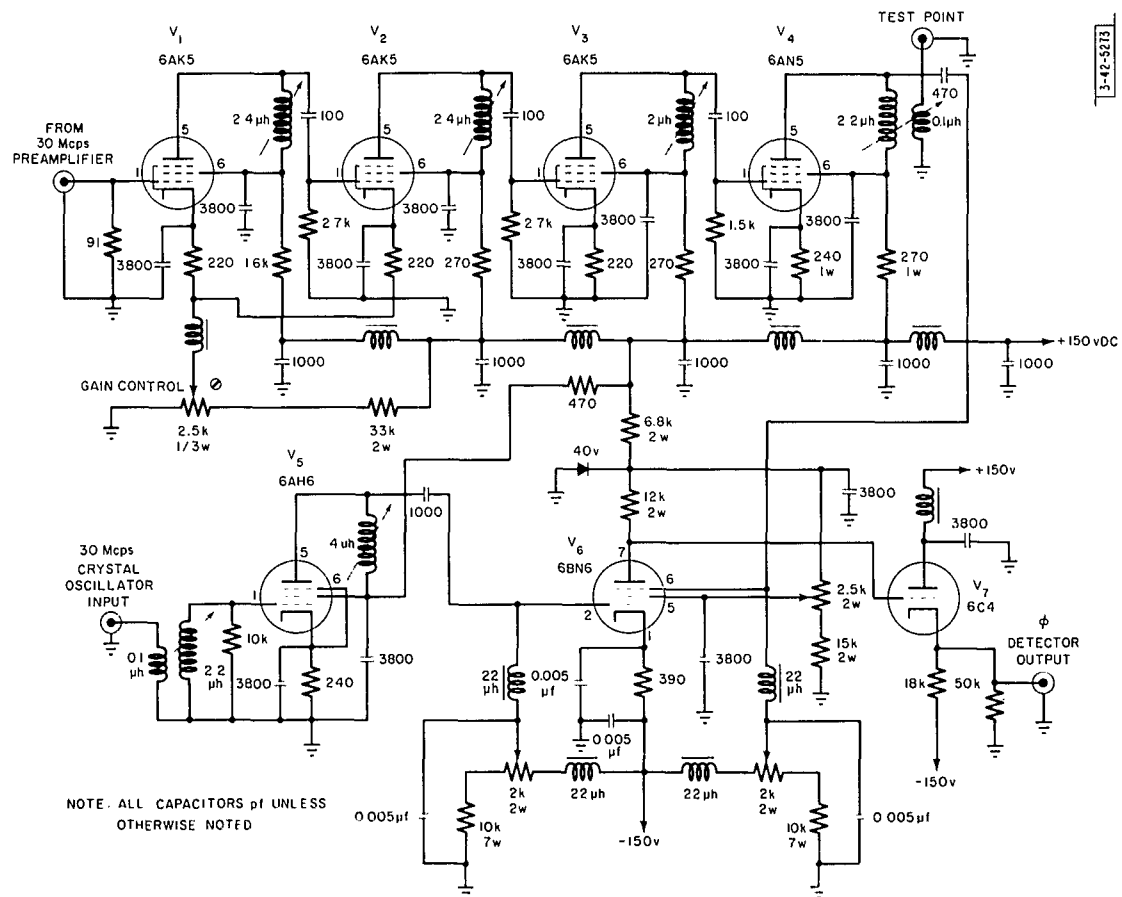

Fig. C-2. 30-Mcps phase detector.

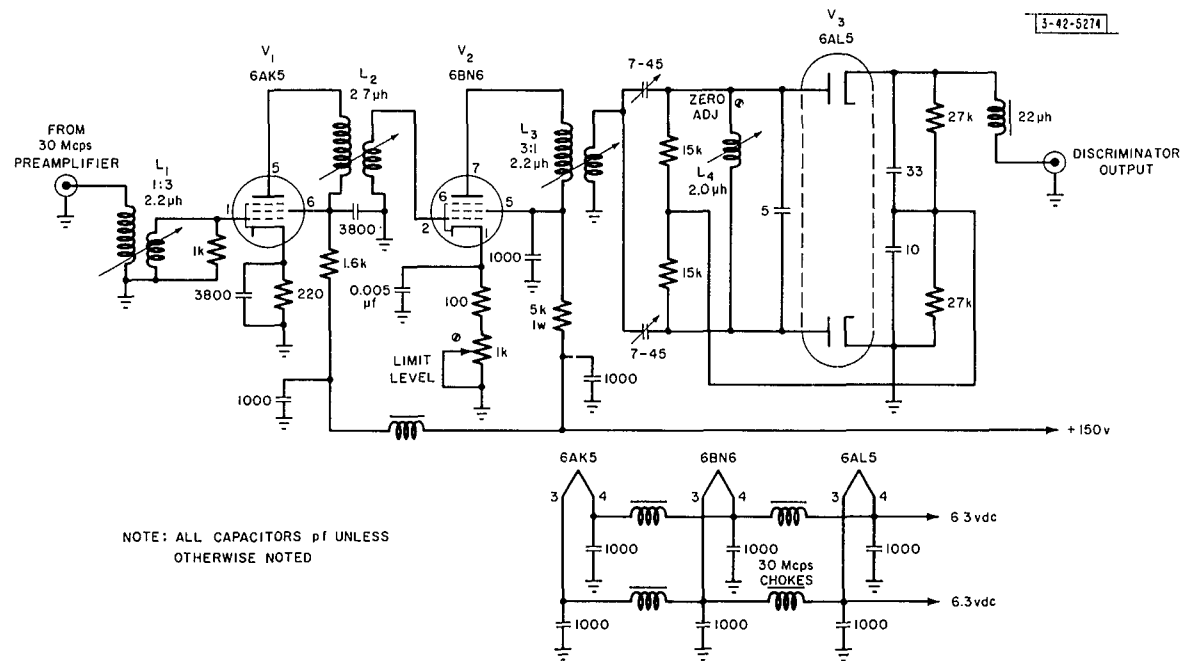

Fig. C-3. 30-Mcps frequency discriminator.

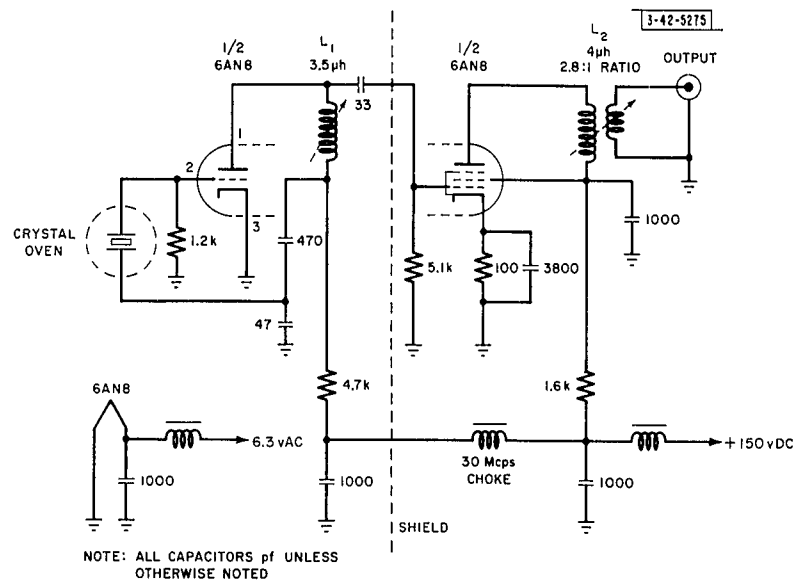

Fig. C-4. 30-Mcps crystal oscillator.

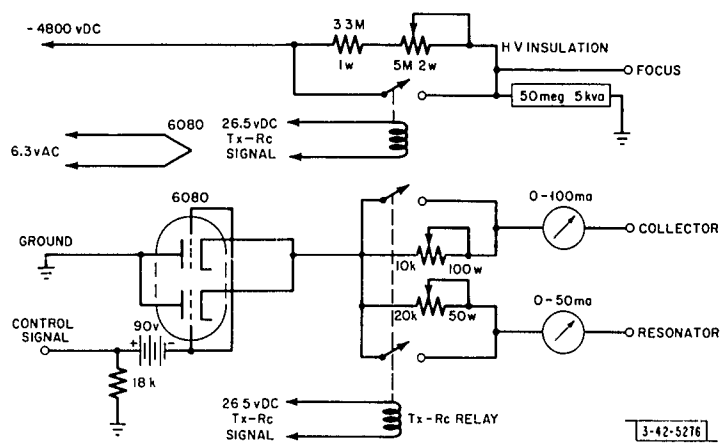

Fig. C-5. Klystron modulator and switching circuitry.

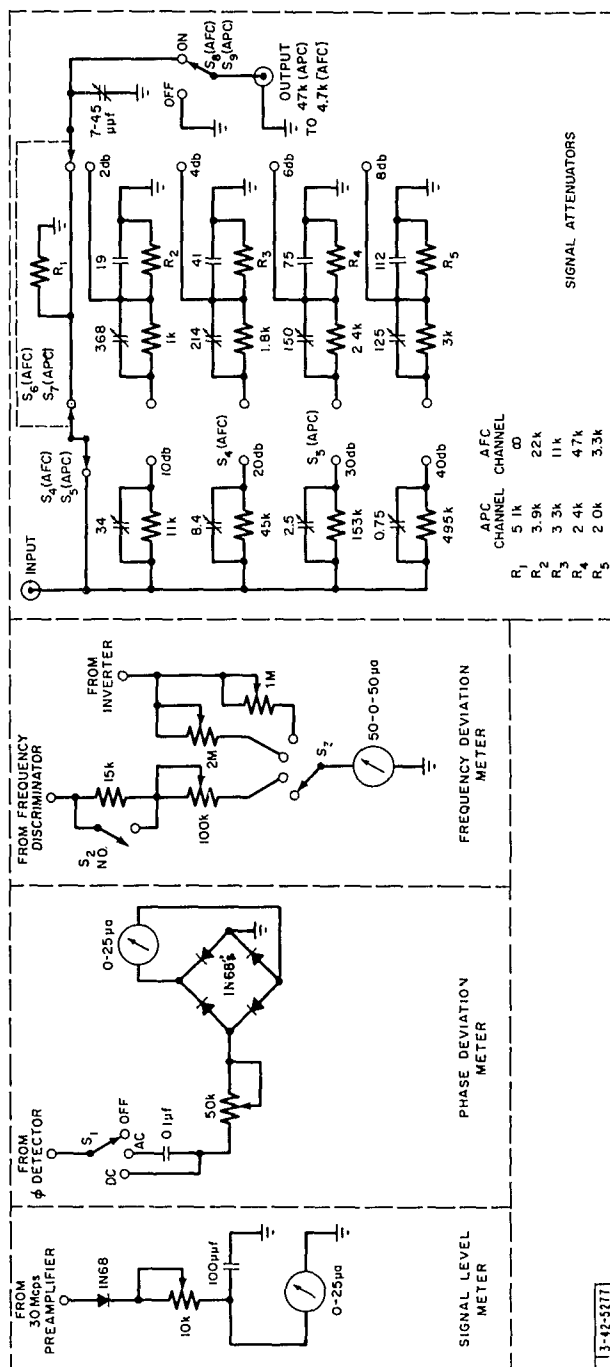

Fig. C-6. Metering and attenuator circuitry.

3-42-5271

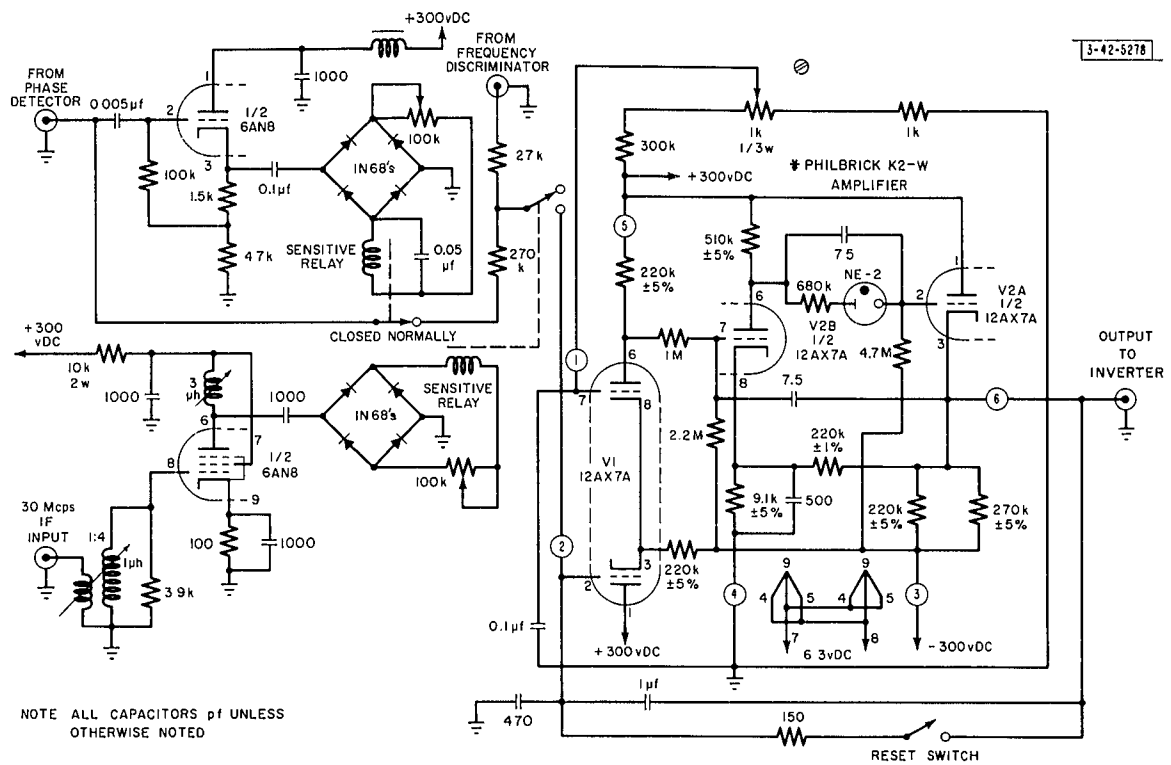

Fig. C-7. Integrator and switching diagram.

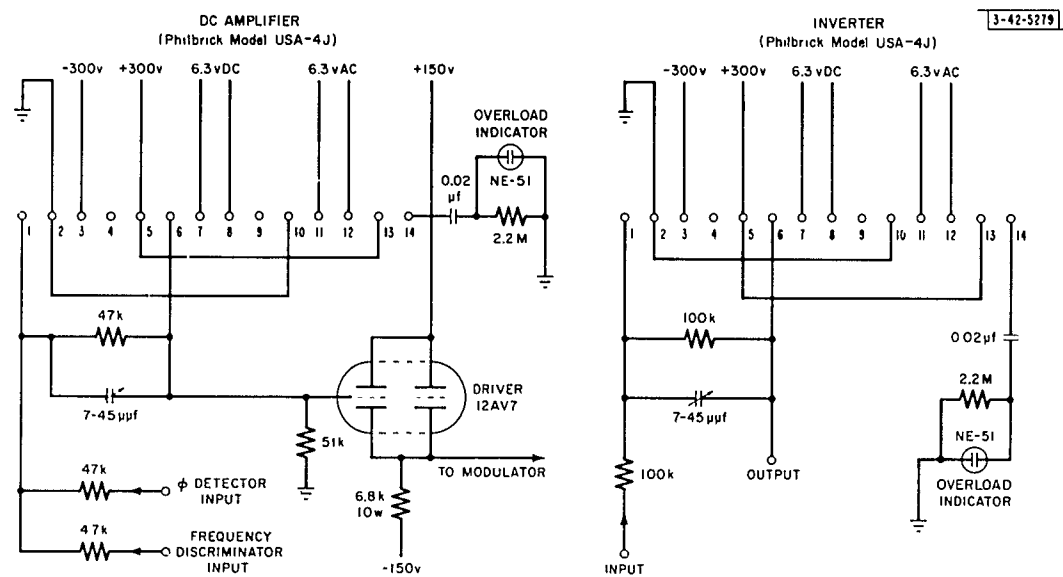

Fig. C-8. DC amplifier, driver and inverter diagrams.

\* George A. Philbrick Researches, Inc. 127 Clarendon Street, Boston 16, Massachusetts.

#### ACKNOWLEDGMENTS

The author is grateful for the suggestions and assistance of Mr. Verne L. Lynn. The author also acknowledges the help of Mr. Everett A. Crocker in providing the stable source used with the transmitting system.

#### REFERENCES

1. G. Preston and J. Tellier, "The Lock-In Performance of an AFC Circuit," Proc. IRE 41, 249 (1953).
2. D. Richman, "Color-Carrier Reference Phase Synchronization Accuracy in NTSC Color Television," Proc. IRE 42, 106 (1954).
3. M. Strandburg and M. Peter, "Phase Stabilization of Microwave Oscillators," Proc. IRE 43, 870 (1955).
4. H. McAleer, "A New Look at the Phase-Locked Oscillator," Proc. IRE 47, 1137 (1959).
5. T. J. Rey, "Effects of the Filter in Oscillator Synchronization," Technical Report No. 181 [U], Lincoln Laboratory, M.I.T. (14 May 1958), ASTIA 133854.
6. R. Ley, "Synchronisation en Phase D'un Oscillateur," Ann. Radioelec. 13, 212 (1958).
7. R. Leek, "Phase-Lock AFC Loop," Electronic Radio Eng. 34, 141-146 and 177-183 (April and May 1957).
8. W. Gruen, "Theory of AFC Synchronization," Proc. IRE 41, 1043 (1953).