

UNCLASSIFIED

AD 273 534

*Reproduced
by the*

**ARMED SERVICES TECHNICAL INFORMATION AGENCY
ARLINGTON HALL STATION
ARLINGTON 12, VIRGINIA**



UNCLASSIFIED

NOTICE: When government or other drawings, specifications or other data are used for any purpose other than in connection with a definitely related government procurement operation, the U. S. Government thereby incurs no responsibility, nor any obligation whatsoever; and the fact that the Government may have formulated, furnished, or in any way supplied the said drawings, specifications, or other data is not to be regarded by implication or otherwise as in any manner licensing the holder or any other person or corporation, or conveying any rights or permission to manufacture, use or sell any patented invention that may in any way be related thereto.

AFSWC-TR-61-67

SWC
TR
61-67

273534

**HEADQUARTERS
AIR FORCE SPECIAL WEAPONS CENTER
AIR FORCE SYSTEMS COMMAND
KIRTLAND AIR FORCE BASE, NEW MEXICO**

CATALOGED BY ASTIA
AS AD NO.

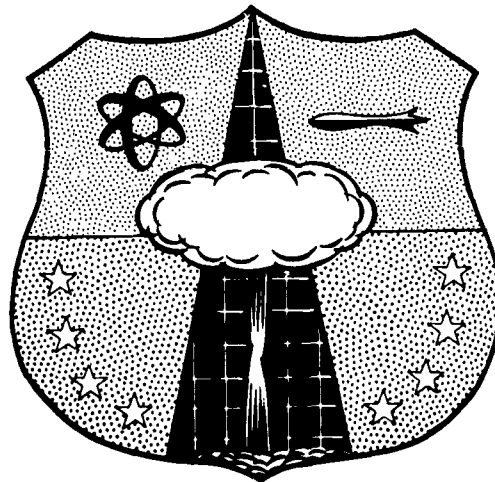

**A THEORETICAL STUDY OF RESPONSE OF SOLIDS
TO IMPULSIVE LOADS OF HIGH PRESSURE**

by

Joseph J. Poczatek

L. E. Fugelso

Final Report
October 1961

This research is a part
of Project DEFENDER
sponsored by the
Advanced Research
Projects Agency
Department of Defense

ASTIA
RECEIVED
MAR 10 1962
N-68-2-6
ASTIA

American Machine & Foundry Company
Mechanics Research Division
Niles, Illinois

HEADQUARTERS
AIR FORCE SPECIAL WEAPONS CENTER
Air Force Systems Command
Kirtland Air Force Base
New Mexico

When Government drawings, specifications, or other data are used for any purpose other than in connection with a definitely related Government procurement operation, the United States Government thereby incurs no responsibility nor any obligation whatsoever; and the fact that the Government may have formulated, furnished, or in any way supplied the said drawings, specifications, or other data, is not to be regarded by implication or otherwise as in any manner licensing the holder or any other person or corporation, or conveying any rights or permission to manufacture, use, or sell any patented invention that may in any way be related thereto.

This report is made available for study upon the understanding that the Government's proprietary interests in and relating thereto shall not be impaired. In case of apparent conflict between the Government's proprietary interests and those of others, notify the Staff Judge Advocate, Air Force Systems Command, Andrews AF Base, Washington 25, DC.

This report is published for the exchange and stimulation of ideas; it does not necessarily express the intent or policy of any higher headquarters.

Qualified requesters may obtain copies of this report from ASTIA. Orders will be expedited if placed through the librarian or other staff member designated to request and receive documents from ASTIA.

A THEORETICAL STUDY OF RESPONSE OF SOLIDS
TO IMPULSIVE LOADS OF HIGH PRESSURE

by

Joseph J. Poczatek

L. E. Fugelso

Final Report
October 1961

American Machine & Foundry Company
Mechanics Research Division
Niles, Illinois

Research Directorate
AIR FORCE SPECIAL WEAPONS CENTER
Air Force Systems Command
Kirtland Air Force Base
New Mexico

Approved:

DONALD I. PRICKETT
Colonel USAF
Director, Research Directorate

Project 4778
ARPA Order 6-58, Task 22
Contract AF 29(601)-2533
AMF-MRD Project MR 1134

FOREWORD

The Mechanics Research Division of American Machine and Foundry Company takes pleasure in presenting this technical report to the Physics Division, Research Directorate, of the Air Force Special Weapons Center, Kirtland AFB, N

This technical report contains the results of theoretical research on plastic deformation under high short duration loading. The research was carried out as a portion of Contract AF 29(601)-2533.

The remaining effort on this contract has resulted in a separate report, designated TDR-62-5, which treats the deformational behavior of solids under high impulsive pressures of significantly shorter time durations.

Acknowledgement is made to Mr. Joseph J. Poczatek, the project supervisor, and Dr. G.L. Neidhardt, both of American Machine and Foundry Company, Mechanics Research Division and Dr. S. Raynor, Northwestern University, Consultant to Mechanics Research Division, for stimulating conversations and discussions. J.D. Stein, H.M. Gruen, M.F. Darienzo and D.H. Duel performed the numerical computation, drew the graphs and proofread the report. Capt. Marvin Atkins of the Physics Division, AFSWC, was the technical monitor. The principal investigator on this portion of the project was L.E. Fugelso.

APPROVED:

J.J. Poczatek
J.J. Poczatek, Project Supervisor

Glen L. Neidhardt
G.L. Neidhardt, Group Leader
Engineering Mathematics Group

P. Rosenberg
P. Rosenberg, General Manager
Mechanics Research Division

Respectfully submitted,
AMERICAN MACHINE & FOUNDRY COMPANY
Mechanics Research Division

L.E. Fugelso
L.E. Fugelso
Research Engineer

A B S T R A C T

The response of materials and structures to pressures on the order of one megabar is considered. The problem is decomposed according to the characteristic response time for various failure modes. The short-time effects study analyzes propagation of these high-pressure pulses. General equations are developed for a solid under finite strain, with dissipation mechanism, heat conduction, and elasticity coefficients open to specification. Integral equations following motion of non-isentropic waves are obtained for uni-axial strain. Conditions for instantaneously forming finite discontinuities are delineated. Succeeding states are sought isentropically, resulting in a theoretical isentrope. A closed form family of isentropes is obtained for aluminum using the Hugoniot.

The long-time effects study develops dynamic elastic-plastic deformation theory of solids utilizing dislocation theory. Continuum equations for the elastic-plastic displacements and stresses are derived. Propagation of the plastic wave, apparent time-dependent increase in yield conditions, and other deformational characteristics are discussed. The elastic-plastic deformation equations are solved for three particular cases:

1. Propagation of a stress wave in a one-dimensional rod.
2. Deformation of a semi-infinite half space under a suddenly applied strip load.
3. Deformation of an infinitely long thin cylindrical shell under a suddenly applied strip load along a generator.

PUBLICATION REVIEW

This report has been reviewed and is approved.

John J. Dishuck
JOHN J. DISHUCK
Colonel USAF
Deputy Chief of Staff for Operations

PLASTIC DEFORMATION UNDER IMPACT LOADING

SUMMARY

A theoretical approach to the dynamic elastic-plastic deformation of polycrystalline solids is developed utilizing the theories of dislocations and irreversible thermodynamics.

In a solid body, stresses which are above the static yield condition may be developed under time dependent loading. If a state of stress which falls outside the yield conditions comes into existence, the solid body will react to alleviate this unstable state by the mechanism of moving dislocations.

Equations for the dynamic elastic-plastic displacements and stresses are derived on the basis of a model for a continuum density of dislocations. This model for elastic-plastic deformation is established by considering the dislocations as being randomly distributed. The physical properties of the dislocations and their reaction to applied stresses are derived following the basic geometrical theories of Kondo, Kröner, Taylor, and Bilby.

The elastic-plastic deformation equations are solved for three particular cases of interest. The first is the one-dimensional rod impacted at one end. The second is the elastic-plastic deformation of a semi-infinite half-space under a suddenly applied strip load. The dynamic plastic deformation of a cylindrical shell is the third problem studied. Numerical solutions for the half-space and the shell problems are given.

Several features of elastic-plastic stress wave propagation and stress states under time dependent loads are discussed in some detail. In particular, the propagation of the so-called plastic wave, the apparent increase in yield conditions under time dependent loads, and the course of deformation are discussed.

TABLE OF CONTENTS

<u>SECTION</u>	<u>Page</u>
FOREWORD	ii
SUMMARY	iv
TABLE OF CONTENTS	v
I. Introduction	1
II. Mathematical Theory of Dislocations	8
II.1 Geometrical Description of Dislocation	8
II.2 The Dislocation Density	17
II.3 Stress and Dislocations	21
II.4 Stresses and Moving Dislocations	25
III. Impact Plastic Deformation of a One Dimensional Rod	36
IV. Plastic Deformation of a Semi-Infinite Half Space Under a Suddenly Applied Load on the Surface	46
V. Impact Plastic Deformation - Cylindrical Shell Approximation	70
VI. Summary and Conclusions	94
BIBLIOGRAPHY	96

I. Introduction

When a material specimen is subjected to external loads, it deforms. If the loads are sufficiently small the resulting deformation is elastic, i.e., the deformation gradients are almost linear functions of the stresses developed internally. When the loads are higher than a specified level, the deformation ceases to be perfectly elastic. Normally the deformation increases more rapidly than the stress. The basic physical feature of the deformation is that the material slips along certain lines or planes within the body. This deformation is plastic deformation of the medium.

The problem of plastic deformation arises in many areas of engineering and applied science. Various impact problems, where the peak stresses rise far above the proportional limit, occur repeatedly; for example, the deformation of a plate under impact from a bullet. In seismology and the study of earthquakes, the deformation close to the focus of the earthquake is certainly in the plastic region.

The classical approach to the static problem⁽⁸⁾ ^{1/} is that there exists some relation among the stresses which cannot be exceeded. At incipient plastic deformation, the state of stress is at the maximum point or locus of this relation, called the yield condition. Insertion of this condition into the equation of equilibrium of an elastic solid yields a solution for the stress internal to the body.

When the stress field is caused by a load applied as a function of time, many difficulties ensue. This problem of dynamic elastic-plastic deformation has been treated by several authors, ^{(1), (10), (11), (21), (22), (23)}. The approach

^{1/} Superscripts refer to references listed in the bibliography.

to the dynamic plastic deformation is to assume a non-linear stress-strain⁽¹⁰⁾,
(11), (22) curve and insert this expression into the equations of motion for
an elastic body. Several difficulties arise immediately. First the equations
are non-linear and do not lend themselves to easy solution. Second, as pointed
out by Taylor,⁽²¹⁾ the non-linear stress-strain curve is a function of the rate
of loading.

In either approach to the problem of inelastic deformation, certain in-
adequacies are readily apparent. Particularly when the loads are applied
over a very short time duration or applied very rapidly, the experimental
evidence does not agree closely with the theoretical results. Under rapidly
applied loads, the yield point is raised and the deformation itself becomes
a function of strain rate or loading rate.⁽⁵⁾, (25)

To overcome these difficulties, the deformation of a solid body under
stresses which are in the region above the elastic stress stability region
is studied by examining the mechanism of deformation.

Above the yield stress, experimental evidence shows that for many metals,
the body has undergone deformation by slipping along certain lines or planes.

This slip mechanism for plastic deformation has been postulated as the
basic physical phenomenon underlying plastic deformation. In a time dependent
slip, it is unlikely that all the atoms along the slip plane move at once.
The energy requirements for this are many times the actual energy involved.
It becomes apparent that the slip occurs a little bit at a time to account
for the energy involved.

In 1934 Taylor,⁽²⁰⁾ Orowan,⁽¹⁶⁾ and Polanyi⁽²¹⁾ introduced the concept
of plastic deformation by the movement of dislocations and imperfections in
crystals. This basic concept remains as the foundation of plastic deformation.

These papers pointed out that when plastic flow occurs it is very unlikely that an entire plane of atoms move all at once, but rather the slip proceeds piecemeal along the slip plane. At the line in the slip plane where slip has occurred on one side but not in the rest of the slip plane, there is an imperfection in the crystal lattice.

The mechanism of plastic deformation may be explained simply. In a real crystal there exists a number of imperfections, either pre-existing or created during deformation, which interrupt the perfect crystal lattice. An example of this type of imperfection is where a row or plane of atoms is effectively missing from the perfect lattice. To take up the space and retain the crystal structure, the lattice distorts itself to accommodate the imperfection. The mechanism of plastic deformation may be stated qualitatively then as the formation of these types of imperfections and/or the subsequent movement or rearrangement of the dislocations.

The theory of plastic deformation by dislocations has advanced rapidly. Many properties of plastic deformation and other phenomena in the solid state may be described by appeal to dislocations. Among these are diffusion and precipitation in solids and some surface phenomena.

A qualitative description of plastic deformation by the dislocation movement is a necessary preliminary to further understanding and use of dislocations, Consider the two-dimensional picture of a square crystal lattice, Figure 1. Figure 1a represents the original undeformed lattice. Under stress, slip starts at some point in the lattice and proceeds, one atom slipping at a time, until an intermediate configuration (Figure 1b) is reached. The deformation proceeds, then, atom by atom, until the slip is complete (Figure 1c).

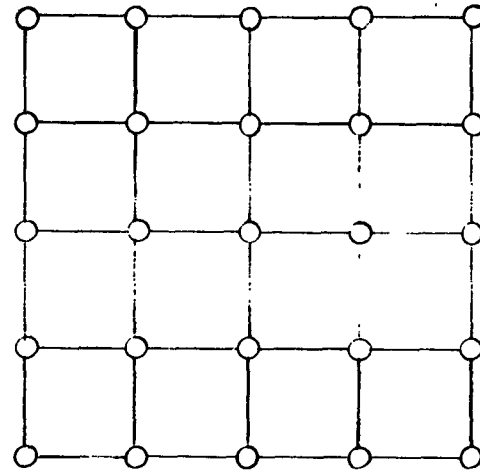

(a)

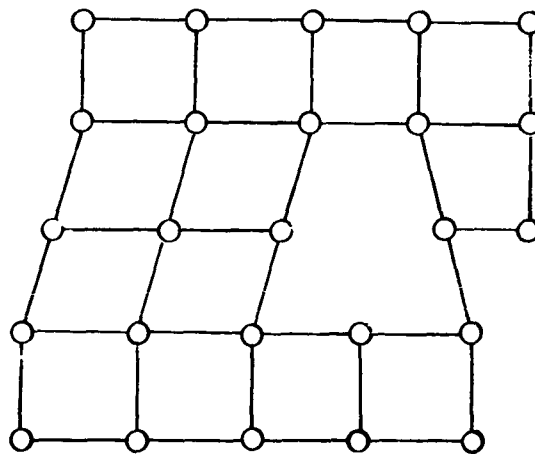

(b)

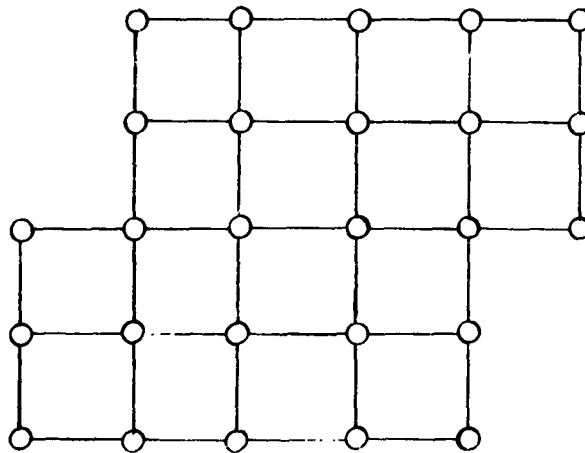

(c)

Dislocation Mechanism of Plastic Flow

Figure 1

This dislocation is called an edge dislocation. The displacement here is perpendicular to the line of the dislocation. Other types of dislocations are possible, the main one being the screw dislocation, in which the displacement in the slip plane is parallel to the edge of the dislocation.

Another class of imperfections which may be conveniently described by dislocations is the interface between two crystals in a polycrystalline specimen. If the angle between two different crystals is small, the mismatch at the boundary is described as a row of edge dislocations. Thus in a polycrystal, a natural source of dislocations is present.

In the theory of plastic flow developed by Taylor, the flow is due to movement and formation of dislocations. Treating these phases one at a time, the movement of dislocations will first be considered.

In order to move the dislocation a force must be applied to the atom on the undisturbed side of the dislocation. The atom, or more accurately speaking, a row of atoms along the dislocation line must be forced over an energy barrier. For a perfect crystal the stress corresponding to this is the stress which produces a shear strain of $1/2$. If a perfect crystal with but a single vacancy is considered, the strained atom must still have a strain of $1/2$ to come to the position of neutral equilibrium between the two possible sites. The stress that has to be applied to the atom is lower, however, as the vacancy causes a distortion of the lattice.

Similarly, a dislocation alters the strain energy around the dislocation. The presence of a dislocation in a crystal distorts the lattice surrounding the dislocation and alters the strain energy there. A quantitative expression for the stress due a dislocation, formulated by Cottrell is⁽⁵⁾

$$\sigma = \frac{\mu b}{2\pi r} f(\theta)$$

where r , θ are polar coordinates, b is the displacement due to the dislocation, and μ is the elastic shear modulus. $f(\theta)$ is the angular distribution and depends on the geometry of the lattice and the type of dislocation involved.

The explicit form of the stress around the dislocation is an involved problem and will not be considered here.

The stress required to move the dislocation then is of the form

$$\sigma = \sigma_0 - \frac{\mu b}{2\pi r} f(\theta)$$

where σ_0 is the stress required to move the dislocation from its original lattice site to the point of neutral equilibrium.

Thus, an approach to the problem of non-elastic deformation will be developed on the basis that the mechanism of the non-elastic or plastic deformation is the formation and movement of dislocations.

First, a detailed mathematical description of the geometry of dislocations will be presented and the relation of dislocations to internal stress and boundary conditions will be demonstrated. Then, the condition for movement of the dislocations through the solid will be formulated. A general form of the equations of motion based on this mechanism will be derived. Representative solutions for three important problems will be shown. The first solution is the one-dimensional rod. The second solution is for a strip load on an infinite half-space. The physical results are discussed in light of the features of the deformation sequence and observable quantities.

The third problem to be solved is the deformation of a thin cylindrical shell. Approximate equations for the plastic deformation under short duration loads will be set up and solved.

II. Mathematical Theory of Dislocations

II.1 Geometrical Description of Dislocation

The deformation of an imperfect crystal or polycrystalline medium has been recently studied utilizing the geometrical descriptions afforded by Riemannian and non-Riemannian geometry. The work of Kondo⁽¹²⁾, (13) in Japan, Kroner⁽¹⁴⁾ in Germany, and Bilby⁽²⁾ and co-workers in the United Kingdom have provided a great insight into the theories and mechanisms of plastic deformation. The basic mathematic tools that these investigators have utilized is the infinitesimal parallel displacement transformation which forms the corner stone of the general theory of relativity as developed by Einstein and Kaufmann⁽⁶⁾ and Cartan⁽³⁾.

In this approach to the studies of a plastically deformed crystal, the strained crystal, (its deformation consists of elastic strain plus added displacement due to dislocations) or the unstrained crystal, (with a localized internal strain due to the presence of dislocations) is viewed, with respect to a reference measuring coordinate system, under an infinitesimal parallel displacement. This transformation may be shown to be a function of the basic vectors of the reference system times a connection which does not have tensor properties. If the metric tensor of the crystal, whether under stress or not, is symmetric (indicating only elastic deformation) this connection is symmetric and shows no tensor properties whatsoever. However, if the metric tensor which describes the original configuration before parallel displacement is not symmetric, the connection is not symmetric. Under this condition the connection may be uniquely decomposed into a symmetric part which again has the properties of a connection and an antisymmetric part which is an antisymmetric tensor. This tensor, which is called the torsion

tensor after Cartan, ⁽³⁾ becomes an important quantity in describing the nature of plastic deformation.

To describe the deformation of a medium with dislocations, the connection and torsion tensor must be evaluated.

Consider a solid body which is defined in a reference Euclidian three-space. If the body is a perfect crystal, i.e., no imperfections of any nature are present, a Cartesian coordinate system may be attached to the medium. Under external forces, the medium goes over into a strained configuration. The Cartesian coordinate system maps into a curvilinear coordinate system. If the basic vectors of these two coordinate systems are denoted by \underline{x}_i for the Cartesian system and \underline{e}_i for the deformed system, metric tensors for these coordinates may be formed.

$$\delta_{ij} = \underline{x}_i \cdot \underline{x}_j \quad (\text{II.1.1})$$

$$g_{ij} = \underline{e}_i \cdot \underline{e}_j \quad (\text{II.1.2})$$

If the length of an element of arc in the original and deformed systems

$$ds_0^2 = \delta_{ij} dx^i dx^j \quad (\text{II.1.3})$$

$$ds^2 = g_{ij} dx^i dx^j \quad (\text{II.1.4})$$

are compared;

$$ds^2 - ds_0^2 = (g_{ij} - \delta_{ij}) dx^i dx^j \quad (\text{II.1.5})$$

The elastic strain tensor is defined naturally by

$$\epsilon_{ij} = \frac{1}{2} (g_{ij} - \delta_{ij})$$

If, however, the deformation occurs in a real crystal or in a polycrystalline aggregate, two sets of basic vectors are available. The first set in the Cartesian reference frame \underline{x}_i . The second set of basic vectors is given by the basic vectors of the crystal lattice, denoted by \underline{e}_λ . If there are no imperfections in the crystal or no grain boundaries, these two sets of basic vectors are identical. However, if the crystal is not perfect, either initially or at some later stage of the deformation process, the unique one-one correspondence is no longer there and these two sets are different. It becomes apparent, then, that the description of the deformation process is different in the two coordinate systems. If the deformation is described with respect to the Cartesian basic set, the total macroscopic strain will be shown. If the second set is used, the strain that is shown would be just the elastic distortion of the crystal.

Comparing these two, the difference in the descriptions should give a measure of deformation introduced by non-elastic means, i.e., the imperfections.

This difference for the displacements is established by considering an integral expression around a closed path in the real crystal and the corresponding path in an ideal or perfect crystal.

If \underline{dM} represents a vector from x^i to $x^i + dx^i$, then in terms of the lattice basis

$$\underline{dM} = \underline{e}_k \omega^k \quad (\text{II.1.6})$$

where

$$\underline{\omega}^k = \left[\frac{\partial e_k}{\partial x^i} \right] dx^i = A_i^k dx^i \quad (\text{II.1.7})$$

is the Pfaffian. The expression in the brackets may or may not be integrable.

The change in the lattice basis vector is

$$\underline{de}_\lambda = \underline{e}_k \omega_{\lambda=k} \Gamma_{\lambda\mu}^k \underline{e}_k$$

$$\underline{de}_\lambda = \underline{e}_k A_{\lambda}^\mu \Gamma_{\lambda\mu}^k dx^i$$

where the $\Gamma_{\lambda\mu}^k$ is the connection of parallel transformation from \underline{x}^i to \underline{e}_λ .

$$\Gamma_{\mu\lambda}^k = \frac{1}{2} g^{k\nu} (\partial_\mu g_{\nu\lambda} + \partial_\lambda g_{\mu\nu} - \partial_\nu g_{\mu\lambda})$$

then

$$\underline{e}_k = \frac{\partial \underline{M}}{\omega_k} = \frac{1}{A_{\lambda}^k} \frac{\partial \underline{M}}{\partial x^i}$$

Consider the expression

$$\frac{\partial^2 \underline{M}}{\partial x^i \partial x^j}$$

If the expression

$$\frac{\partial^2 \underline{M}}{\partial x^i \partial x^j} - \frac{\partial^2 \underline{M}}{\partial x^j \partial x^i} = \frac{\partial^2 \underline{M}}{\partial x^i \partial x^j} = 0$$

the deformation is compatible, i.e., there are no imperfections in the crystal.

Now

$$\frac{\partial \underline{M}}{\partial x^i} = e_k A^k{}_i \quad (\text{II.1.12})$$

$$\frac{\partial}{\partial x^j} \left(\frac{\partial \underline{M}}{\partial x^i} \right) = \frac{\partial e_k}{\partial x^j} A^k{}_i + e_k \partial_j A^k{}_i \quad \text{where } \partial_j A^k{}_i \equiv \frac{\partial A^k{}_i}{\partial x^j} \quad (\text{II.1.13})$$

$$= e_\lambda \frac{\partial \omega^\lambda{}_k}{\partial x^j} A^k{}_i + e_k \partial_j A^k{}_i \quad (\text{II.1.14})$$

$$= e_k [\Gamma^\lambda{}_{\lambda\mu} A^\mu{}_j A^\lambda{}_i + \partial_j A^k{}_i] \quad (\text{II.1.15})$$

If the vector \underline{dM} is integrable around the closed path

$$\partial_j A^k{}_i - \partial_i A^k{}_j + \Gamma^\lambda{}_{\lambda\mu} A^\mu{}_j A^\lambda{}_i - \Gamma^\lambda{}_{\lambda\mu} A^\mu{}_i A^\lambda{}_j = 0 \quad (\text{II.1.16})$$

If the vector \underline{dM} is not integrable around the closed path in the imperfect crystal

$$\frac{\partial^2 \underline{M}}{\partial x^i \partial x^j} = e_k \left[\Gamma^\lambda{}_{\lambda\mu} A^\mu{}_j A^\lambda{}_i + \partial_{[j} A^k{}_{i]} \right] \quad (\text{II.1.17})$$

The non-vanishing connection $\Gamma^\lambda{}_{\lambda\mu}$ is

$$\Gamma^\lambda{}_{\lambda\mu} = -A^i{}_\mu A^j{}_\lambda \partial_{[j} A^k{}_{i]} \quad (\text{II.1.18})$$

The component of normal curvature has been expressed in the original Euclidian coordinates. A similar expression may be derived for the normal curvature of the nature or lattice basis.

$$\frac{\partial^2 e_{\lambda}}{\partial x^j \partial x^i} = A_j^{\nu} A_i^{\mu} e_{\lambda k} (\partial_{\nu} \Gamma_{\mu\lambda}^k + \Gamma_{\mu\rho}^k \Gamma_{\rho\lambda}^{\mu} + A_{\nu}^k A_{\mu}^{\ell} \partial_{\ell} A_{\rho k}^{\rho} \Gamma_{\rho\lambda}^k) \quad (\text{II.1.19})$$

Computing

$$\frac{\partial^2 e_{\lambda}}{\partial x^j \partial x^i}$$

$$\frac{\partial^2 e_{\lambda}}{\partial x^j \partial x^i} = A_j^{\nu} A_i^{\mu} R_{\nu\mu k}^k \quad (\text{II.1.20})$$

Thus the antisymmetric part of the connection is not zero. This portion has tensor properties unlike its symmetric counterpart. Denote the tensor (the torsion tensor of Cartan),

$$\Gamma_{[\mu\lambda]}^k \equiv S_{\mu\lambda}^k$$

Since the basic mechanism of plastic deformation in the theory of Taylor involves the effects of a dislocation and/or the formation and transport of these dislocations through the medium, the question may be asked, what does this three-index tensor have to do with the deformation? Obviously, the formation and movement of the dislocation is not included in the formulation. Thus, this description must describe the dislocation itself.

The topology of the crystal is indicated by the difference in the outward normal vector of the perfect crystal circuit and the outward normal vector of

the corresponding vector in the imperfect crystal. This is the Burger's vector, which is defined as the difference between the outward normal vector of two circuits in the material (See Figure 2), the first circuit being a closed path in the imperfect material and the second the one-one corresponding path in the ideal crystal.

Consider these two circuits in the reference plane and the mapped plane. (Fig.

The transformation from imperfect to perfect crystals consists of the translation

$$\Delta \underline{x}^k = 2 S^k_{\mu\lambda} \omega_2^\mu \omega_1^\lambda \quad (\text{II.1.21})$$

plus the rotation

$$\Delta \underline{e}_\lambda = R^k_{\nu\mu\lambda} \underline{e}_k \omega^\nu \omega^\mu \quad (\text{II.1.22})$$

Then a vector $\underline{\xi}^k$ at x of the original frames goes into $\underline{\bar{\xi}}^k$ after one circuit in the perfect frame

$$\underline{\bar{\xi}}^k - \underline{\xi}^k = R^k_{\nu\mu\lambda} \underline{\xi}^\lambda \omega_1^\mu \omega_2^\nu + 2\Gamma^k_{[\mu\lambda]} \omega_1^\lambda \omega_2^\nu \quad (\text{II.1.23})$$

The Burger's vector is

$$\underline{b} = \underline{\bar{\xi}}^k - \underline{\xi}^k \quad (\text{II.1.24})$$

The quantities $\Gamma^k_{[\mu\lambda]}$ & $R^k_{\nu\mu\lambda}$, identify the torsion tensor and curvature, which define the imperfection.

If these quantities are examined separately the physical interpretation is obvious. Assuming that the metric is everywhere compatible, i.e., $R^k_{\nu\mu\lambda} = 0$.

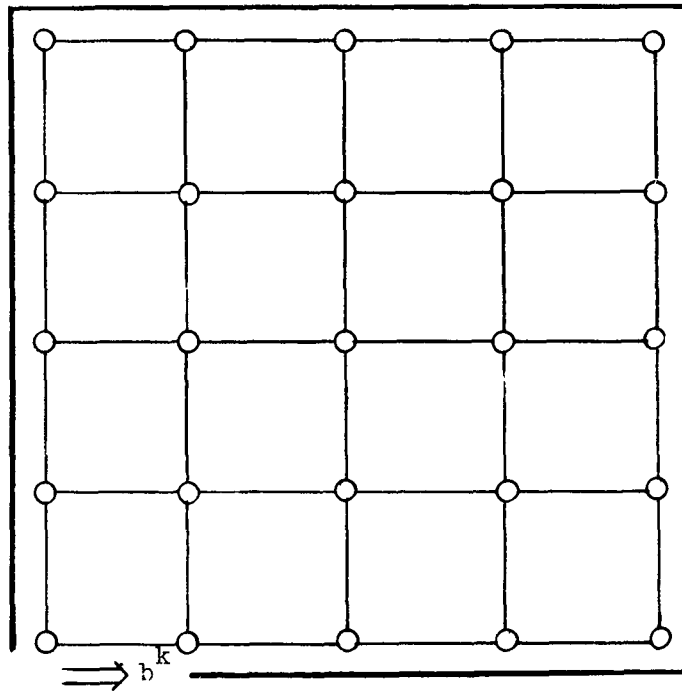
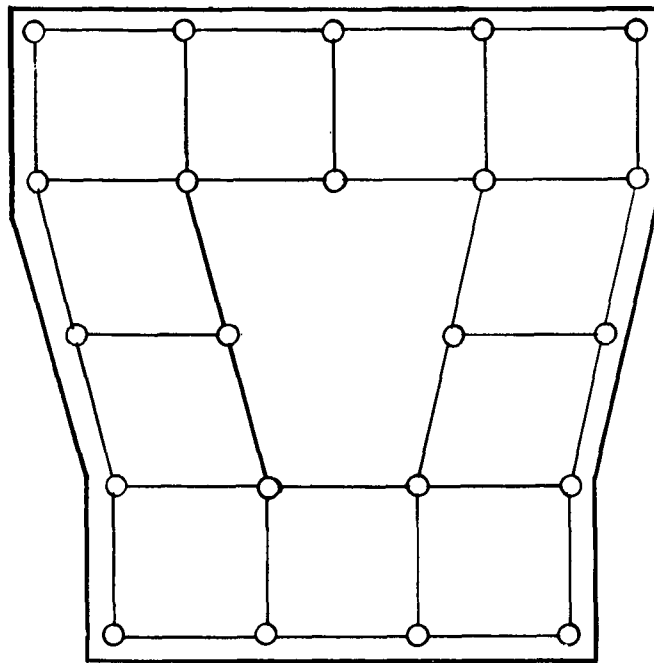

Burger's Circuits Around a Dislocation

Figure 2

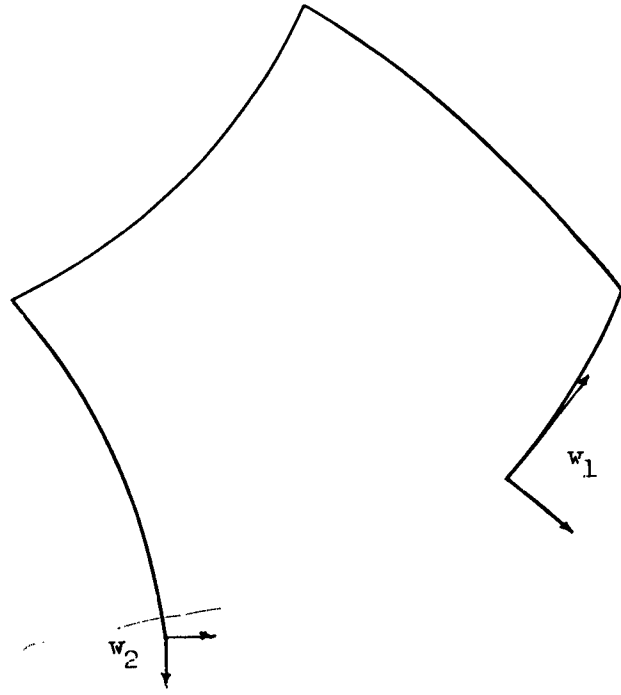
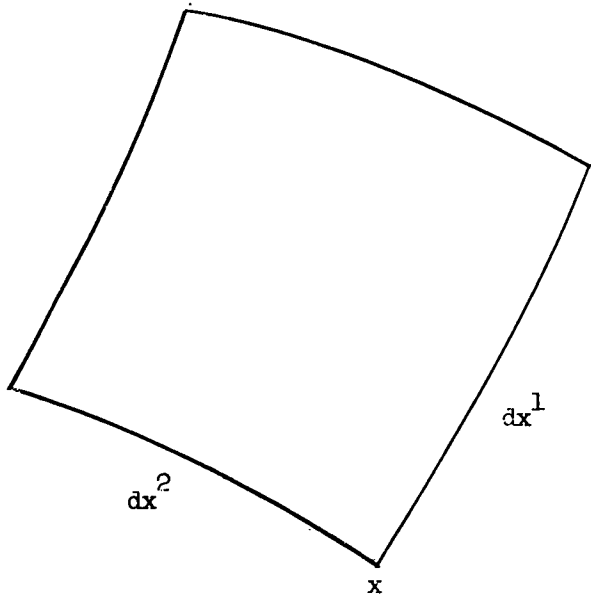

Figure 3

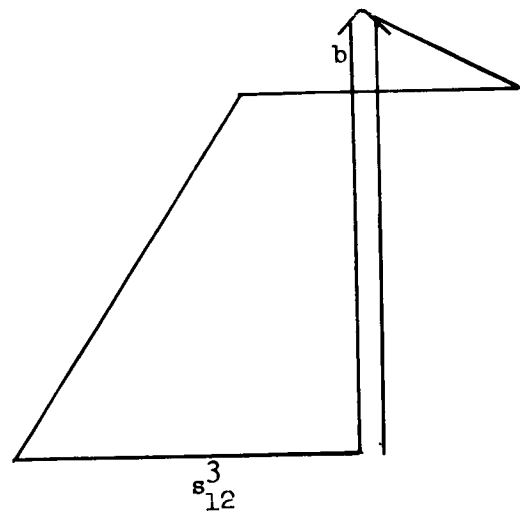
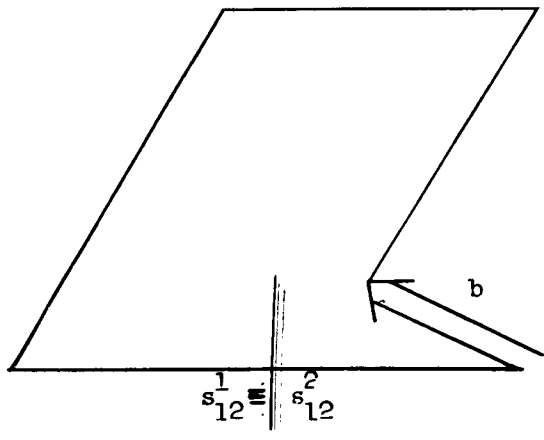

Figure 4

$$\underline{b}^k = 2 S_{\mu\nu}^k \omega_1^\nu \omega_2^\mu \quad (\text{II.1.25})$$

Only two essentially different components, $S_{\mu\nu}^k$, of the torsion tensor are noticed if the medium may be regarded as isotropic. ($S_{12}^1; S_{12}^2; S_{12}^3$) (See Fig. 4)

The torsion describes the local behavior. On the other hand, assume $R_{\nu\mu\lambda}^k \neq 0$. Then four cases arise (see Figure 5).

1. $R_{121}^1; R_{122}^2$
2. $R_{121}^3; R_{122}^3$
3. R_{123}^1
4. R_{123}^3

From the expression for the Burger's vector the first corresponds to the slip of an edge dislocation not parallel to the edge, the third corresponds to slip of an edge dislocation parallel to the edge and the second and fourth correspond to the slip of a screw dislocation not parallel to the edge of the screw, respectively.

The curvature term denotes imperfections in the large. (Figure 5).

II,2 The Dislocation Density

From the foregoing discussion, the curvature of the system denotes imperfections in the large. The torsion tensor denotes imperfections in the small and actually refers to the dislocation, which is the basis of the theory of plasticity. Noting that descriptions of plastic deformation usually do not involve descriptions in the large and that the material that is being deformed plastically maintains macroscopic continuity, the effects of a non-zero curvature will be ignored. Attention will be focused on the torsion tensor.

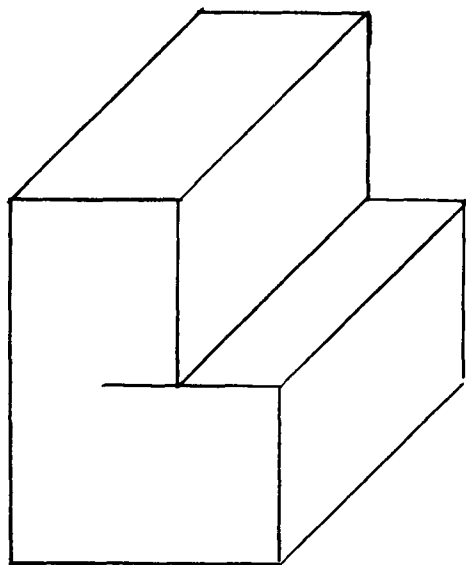

(a)

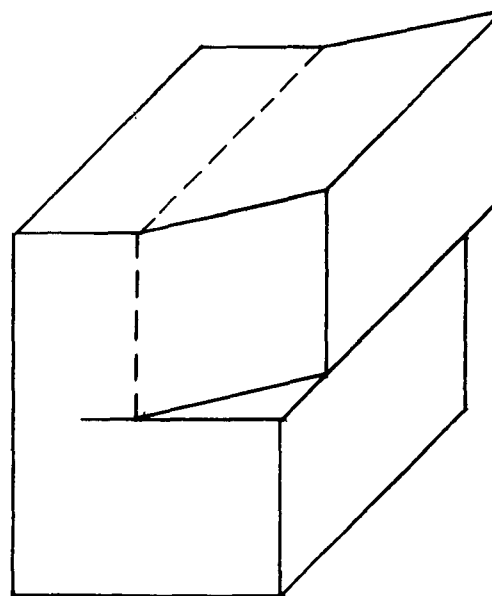

(b)

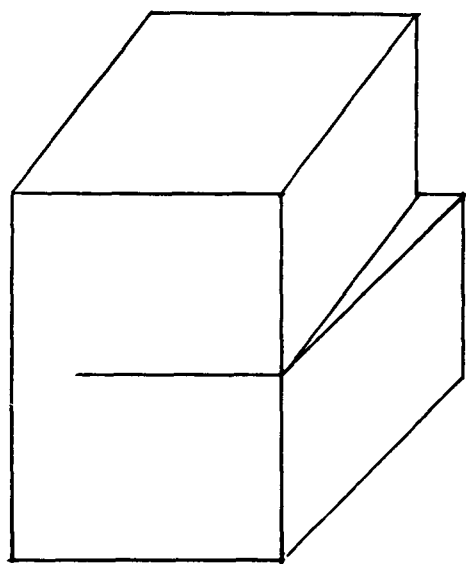

(c)

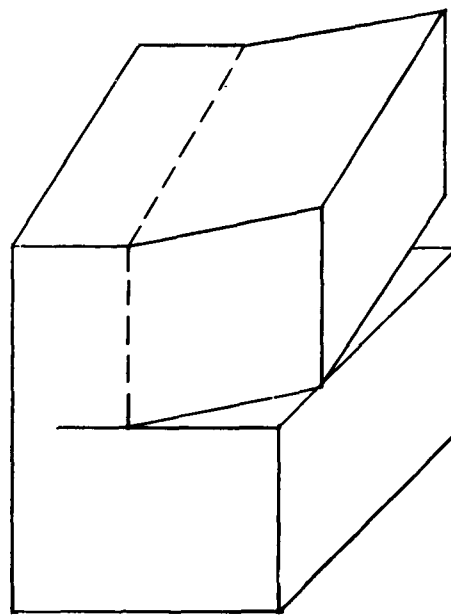

(d)

Configuration of Dislocation Movement

Figure 5

If the discrete lattice basis of the real crystal is replaced by a continuous lattice which has the same metric properties as the lattice basis, certain additional relations may be obtained by considering the differential relations concerning the Burger's vector.

The Burger's vector is

$$\underline{b}^k = S^k_{\mu\nu} \omega^\mu \omega^\nu \quad (\text{II.2.1})$$

The differential expression for the Burger's vector is

$$\underline{e}_k db^k = \underline{e}_k S^k_{\mu\nu} d[\omega^\nu \omega^\mu] \quad (\text{II.2.2})$$

Bilby⁽²⁾ and Kröner⁽¹⁴⁾ have demonstrated that this tensor may be written as the curl of second order tensor if the torsion tensor vanishes at infinity.

Introduce the term $L^{k\rho}$ defined by

$$L^{k\rho} = \epsilon^{\rho\mu\nu} S^k_{\mu\nu} \quad (\text{II.2.2})$$

where $\epsilon^{\rho\mu\nu}$ is the Eddington number

$$\epsilon^{\rho\mu\nu} = \begin{cases} 1 \\ -1 \\ 0 \end{cases} \quad \rho\mu\nu = \begin{cases} \text{even} \\ \text{odd} \\ \text{otherwise} \end{cases} \text{ permutation of } 1,2,3$$

Then

$$\underline{e}_k db^k = L^{k\rho} \underline{e}_\rho d\underline{e}_k \quad (\text{II.2.4})$$

The quantity $L^{k\rho}$ is a second order tensor relating the Burger's vector to the natural basis and is called the dislocation density. An analogous definition may be made with reference to the Cartesian reference basis. This quantity corresponds to the specification of an arbitrary distribution of dislocations in the medium.

The simple physical interpretation of the dislocation density is that it represents the Burger's vector in the k direction from a single dislocation which lies in the ρ direction.

The dislocation density is treated as a continuous function, defined by the limiting process above. Another interpretation which will have use in the application may be obtained if the dislocation density tensor is obtained by forming the torsion tensor around each discrete dislocation and then forming the dislocation density by the same limit process. This results in a sequence of non-zero values at isolated points. Then the complete dislocation density tensor may be formed by taking the average value.

$$\bar{L}^{k\rho} = \frac{\sum_{\nu} L(\nu)^{k\rho} \cos k_1 (x^1 - x^1_{(\nu)})}{\sum \cos k_1 (x^1 - x^1_{(\nu)})} \quad (\text{II.2.5})$$

where $L(\nu)^{k\rho}$ is the dislocation density associated with a discrete dislocation ν , k_1 is the reciprocal of the distance between dislocations in the 1 direction, x^1 is the reference coordinate, and $x^1_{(\nu)}$ is the coordinate of the dislocation.

Passing to the limit of a continuously dislocated crystal

$$L^{k\rho} = \frac{\int_{-\infty}^{\infty} L^{k\rho}(k_1) \cos(k_1 x^1) dk_1}{\int_{-\infty}^{\infty} \cos(k_1 x^1) dk_1} \quad (\text{II.2.6})$$

The operational significance of a derivative of some quantity containing the dislocation density in the reference plane now may be interpreted as division by the average distance between dislocations.

II.3 Stress and Dislocations

The next step in the development of dislocation theory of plastic deformation is to derive the relation between stress, elastic strain, the dislocations, and their relationship to boundary tractions.

The basic approach to the stress-dislocation relationship is made through the following procedure. Consider a perfect crystal with no surface tractions. There is no stress or strain in the interior of this crystal by definition. Now insert a dislocation into this crystal, keeping the surface tractions zero. Now there is a definite non-zero strain in the specimen. An internal stress which corresponds to the strain is generated. This is the internal stress due to the dislocation.

To demonstrate this mathematically, the deformation must be viewed from both the reference or macroscopic coordinate system and from the lattice of natural coordinate system. Thus the concept of shape or total deformation and lattice deformation is introduced.

From the definition of strain, the strain may be written in terms of the connection and the basis vectors of the reference coordinate system

$$\tau_{ij} = \Gamma_{jk}^i x^k \quad (\text{II.3.1})$$

From the above demonstration, the connection consists of a symmetric part and an antisymmetric part, thus giving rise to pure strain and rotation.

The strain in the lattice coordinate system has a similar development

$$\tau_{k\mu} = \Gamma_{\mu\nu}^k \underline{e}^\nu \quad (\text{II.3.2})$$

If this lattice strain is written in the reference coordinate system

$$\tau_{ij}^{(L)} = \Gamma^{(L)}_{ijk} \underline{x}^k \quad (\text{II.3.3})$$

where the connection is given by transformation of coordinates.

Since the total deformation consists of the lattice strain and dislocation, the deformation may be written as a sum

$$\tau_{ij}^T = \tau_{ij}^{(L)} + \tau_{ij}^{(D)} \quad (\text{II.3.4})$$

Introducing a similar connection for the deformation from the dislocations, it is readily seen that the connections are additive. The symmetric part of the connection gives rise to a strain and the antisymmetric part to a rigid rotation. Since the components of this decomposition are independent of the other component, it is evident that the total strain is a sum of the lattice strain and the strain is introduced by the dislocation.

To incorporate a discussion of stress into dislocation theory, it is reasonable to assume that the stress is a function of the lattice strain only.

$$\sigma_{ij} = M_{ij}^{kl} e_{kl}^{(L)} \quad (\text{II.3.5})$$

where M_{ij}^{kl} are elastic coefficients,

The lattice deformation is given by

$$\tau_{ij} = \Gamma_{jk}^i \underline{x}^k \quad (\text{II.3.6})$$

For differential increments of deformation

$$d\tau_{ij} = \Gamma_{jk}^i dx^k \quad (\text{II.3.7})$$

If the strains are small, the curvature is given by

$$R_{jkl}^i = \partial_k \Gamma_{jl}^i - \partial_l \Gamma_{jk}^i \quad (\text{II.3.8})$$

Associated with any Burger's circuit there is a change in lattice deformation

$$\Delta\tau_{ij} = -\frac{1}{2} R_{jkl}^i dx^{kl} \quad (\text{II.3.9})$$

where x^{kl} is the differential of area.

If the lattice strain may be written as a function of position, the curvature tensor may be contracted

$$R_{ij} = -\frac{1}{2} \epsilon_{i\alpha\beta} \epsilon_{j\mu\nu} \partial_\mu \Gamma_{\alpha\beta\nu} \quad (\text{II.3.10})$$

where

$$\Gamma_{\alpha\beta\nu} = g_{\alpha\lambda} \Gamma_{\beta\nu}^\lambda \quad (\text{II.3.11})$$

and ϵ is the Eddington symbol. Since the lattice strain and rotations are functions of the connections and since the connection may be written as a function of a second order tensor

$$de^{(\bar{L})}_{ij} = -\Gamma_{jk}^{(i)} dx^k \quad (\text{II.3.12})$$

$$d\omega^{(L)}_{ij} = \Gamma^{[ij]k} dx^k \quad (\text{II.3.13})$$

$$= \frac{1}{2} \delta_{ij} L - L_{ij} + \epsilon_{i\alpha\beta} \partial_\beta e^{(L)}_{\alpha j} \quad (\text{II.3.14})$$

The contracted curvature tensor is

$$R_{ij} = -\epsilon_{j\alpha\beta} \epsilon_{i\gamma\delta} \partial_\alpha \partial_\beta e^{(L)}_{\gamma\delta} - \epsilon_{j\alpha\beta} \partial_\alpha (\delta_{i\beta} L - L_{i\beta}) \quad (\text{II.3.15})$$

If both the lattice strain and lattice rotations are functions of position, the lattice deformation is compatible in the large and the curvature is zero. If the linear elastic stress-strain law is valid, a compatibility equation between stress and dislocation density follows

$$\epsilon_{i\alpha\beta} \epsilon_{j\gamma\delta} \frac{\partial}{\partial x^\alpha} \frac{\partial}{\partial x^\gamma} \sigma_{\beta\delta} = -\epsilon_{j\alpha\beta} \frac{\partial}{\partial x^\gamma} [\delta_{i\beta} L - L_{i\beta}] \quad (\text{II.3.16})$$

Solutions to this problem for arbitrary surface tractions and boundary conditions are given by the following procedure. For this it is assumed that the right hand side is known as a function of position. Denoting the right hand side by η_{ij} , the solution for the strain is given by⁽⁵⁾

$$e^L_{ij} = \frac{1}{4\pi} \int_V \frac{\eta_{ij}(r') - \eta_{kk}(r') \delta_{ij}}{(r - r')} dV \quad (\text{II.3.17})$$

Then the elastic stresses and strains for the perfectly elastic body of the same shape subject to the same boundary conditions are determined. Denoting this solution by e'_{ij} , the full solution is

$$e_{ij} = e'_{ij} + e^{(L)}_{ij} \quad (\text{II.3.18})$$

II.4 Stresses and Moving Dislocations

The foregoing discussion lays a detailed foundation for the study of plastic deformation. The introduction of the torsion tensor as a measure of the internal forces generated by a dislocation is a key point. This shows that the existence of dislocations in otherwise perfect crystals is possible and indeed quantitatively compatible with any discussion of inelastic deformation.

The foundation has been restricted to static deformation. As mentioned in the introduction, the basis of Taylor's original theory was that plastic deformation is basically caused by the movement of dislocations through the medium under stress.

A natural generalization to this development then is to introduce a quasi-torsion tensor which incorporates both the internal stress around the dislocation and the movement of the dislocation.

Consider the following three-index quantity,

$$H^k_{\mu\nu} = \frac{\partial^2 \mu^k}{\partial x^\mu \partial x^\nu} \quad (\text{II.4.1})$$

Let us examine the situation if several dislocations pass through a unit volume. Initially the volume contains one dislocation. Define the Burger's circuit as before. The tensor $H^k_{\mu\nu}$ is just the torsion tensor of the previous section.

$$H^k_{\mu\nu} = S^k_{\mu\nu} \quad (\text{II.4.2})$$

Now allow the dislocation to move through and out of the volume element, and let another dislocation enter into this volume and assume the same position (see Figure 6).

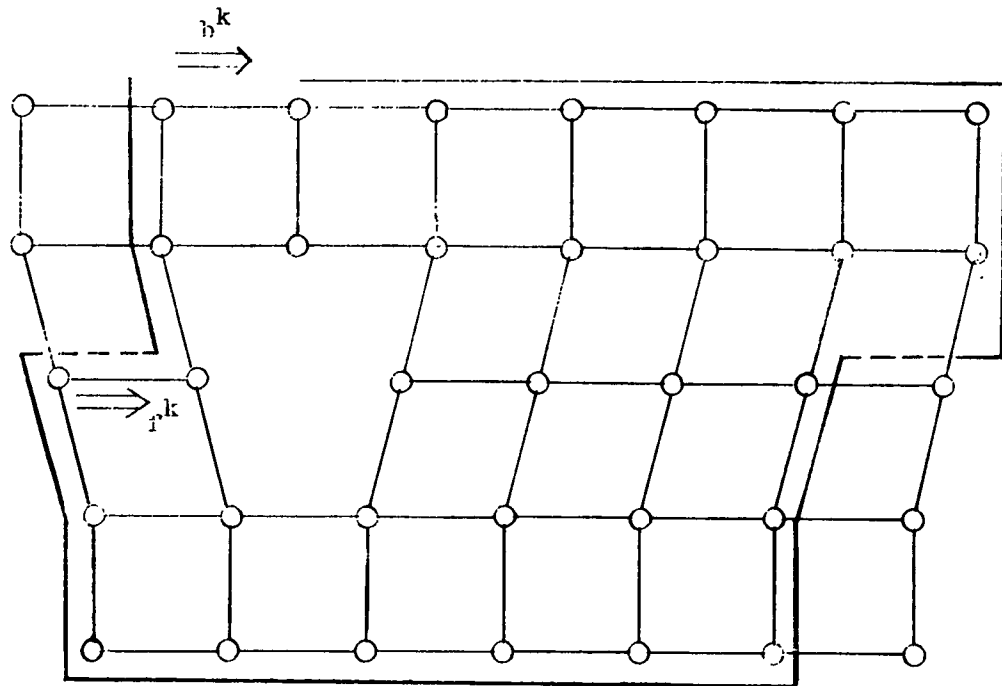
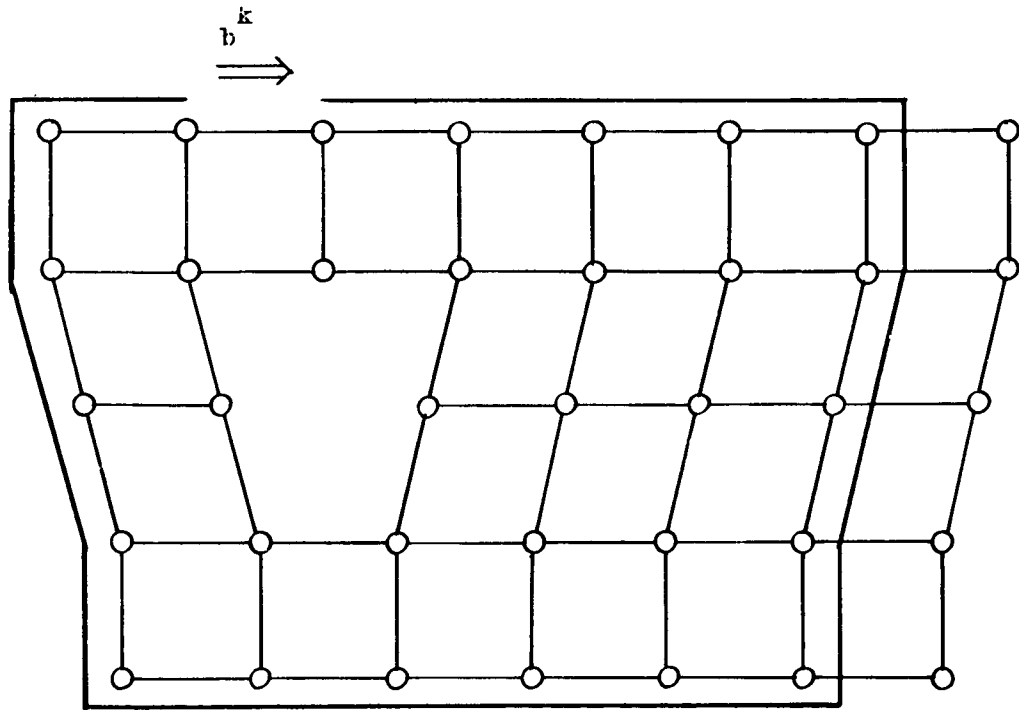

Burger's Circuits for Moving Dislocation

Figure 6

The original Burger's circuit has now become two separate non-closed paths. The Burger's vector of the dislocation has remained unchanged. However the displacement of the entire upper half of the volume is one lattice unit. Denote this displacement by a vector f^k .

The tensor $H_{\mu\nu}^k$ may be written then in terms of this vector, which has unit length per dislocation moved through the volume and the number of dislocations.

$$H_{\mu\nu}^k = S_{\mu\nu}^k + \eta_\nu \frac{\partial f^k}{\partial x^\mu} \quad (\text{II.4.3})$$

where n_ν is the number of dislocations that have moved in the ν th direction.

This quantity, $\eta_\nu \frac{\partial f^k}{\partial x^\mu}$, is the flux of dislocation in the ν -th direction times the strain caused by the elementary movement of a dislocation in the μ -th direction.

It is readily seen that, if many dislocations move through the body, the displacement arising from the flux term will be greater than the local strain induced by the presence of the dislocation.

Thus an approximation for plastic flow presents itself. The local strain field due to the presence of the dislocation is ignored and only the terms arising from the flux of the dislocation are retained.

If the general flux term is treated as a generalized flux in the Onsager sense, equations may be established for combined elastic-plastic deformation. The force that corresponds to this dislocation flux is taken by analogy to diffusion of point vacancies as gradient of the dislocation density.

The crux of the actual dynamic plastic mechanism is that the dislocations move under stress. If the dislocation is viewed end on, the movement

of the dislocation is analogous to diffusion under stress of a vacancy. It should then be seen that the movement of a dislocation should be dependent on the stress, the temperature, and the concentration gradients of dislocation. Somewhat heuristically, the movement of the dislocation will be treated similarly as a diffusing vacancy. The dislocation will move if the vibration of the atom on the edge of the dislocation is large enough in the direction of the lattice imperfection caused by the dislocation. In addition, all of the atoms along the dislocation must satisfy this requirement simultaneously. The probability is affected by the neighboring atoms which must move away sufficiently to allow passage of the atom. The probability that a dislocation will move under an applied stress field, then, is a compound probability, composed of the two factors:

1. The probability that one atom on the dislocation will move.
2. The probability that two adjacent atoms will have the same probability for a jump at the same time.

The diffusion coefficient of the dislocation may be written ⁽¹⁸⁾

$$D = \Gamma a^2 \quad (\text{II.4.4})$$

where Γ is the probability of a jump, and a is the jump distance

$$\Gamma = \bar{\nu} e^{-U_0/kT} \prod_1 e^{-U_i/kT} g_{oi} P_{oi} \quad (\text{II.4.5})$$

where $\bar{\nu}$ is a weighted thermal frequency, U_0 is the activation energy for the atom which is going to jump, U_i are the activation energy contributions caused by the neighboring atoms, g_{oi} is the pair interaction potential, and P_{oi} is the probability that the i -th atom will be in the same jump configuration.

The barrier U_0 is greatly reduced by a shearing stress. The probability of

the neighboring particle being in jump position increases as the shearing stress lowers its activation barrier. Assuming that the U_i are not affected by the shear, an approximate expression for the diffusion coefficient may be written if the barrier energy is a linear function of distance and P_{oi} is expanded in a Taylor series in the shearing stress. Retaining only the first term for P_{oi} .

$$D = D_0 \frac{\tau}{\tau_0} e^{\frac{-U_0}{kT} + \frac{\tau}{\tau_0}} \quad (\text{II.4.6})$$

where

$$D_0 = a^2 \bar{\nu} \Gamma_1 e^{-U_1/kT} g_{oi} \quad (\text{II.4.7})$$

τ is the shear stress, τ_0 is the shear stress corresponding to a strain which moves the atom to the top of the barrier.

$$\begin{aligned} \text{Since} \quad \Gamma &= \bar{\nu} \Gamma_1 e^{-\frac{U_1}{kT}} g_{oi} \frac{\tau}{\tau_0} e^{\frac{-U_0}{kT} + \frac{\tau}{\tau_0}} \\ &= \bar{\nu} g_{oi} \frac{\tau}{\tau_0} e^{\frac{-(U_0 + \sum U_i)}{kT} + \frac{\tau}{\tau_0}} \end{aligned} \quad (\text{II.4.8})$$

which is the probability, can never be greater than one, the diffusion coefficient has an upper value $D = D_0$ when the shear stress is greater than τ_0 .

The effect of hydrostatic stress or pressure on the yield strength of the material enters this expression by changing the magnitude of the potential barrier. To a first approximation.

$$U_0 (\sigma_1 + \sigma_2 + \sigma_3) = U_0 + \frac{\partial U_0}{\partial (\sigma_1 + \sigma_2 + \sigma_3)} (\sigma_1 + \sigma_2 + \sigma_3)$$

where $\sigma_1, \sigma_2, \sigma_3$ are the principal stresses and $\sigma_1 + \sigma_2 + \sigma_3$ is three times the hydrostatic pressure.

The exact form of this change may be quite involved and is not considered here.

A great number of dislocations are contained in a typical element of volume. The orientation of these dislocations for motion may be considered as randomly oriented. If this is the case, the macroscopic or effective diffusion coefficient will be different than the diffusion coefficient for a single dislocation. Assume an element of volume with applied stresses. Orient this volume so that the maximum shearing stress is along the X-axis. Denote the orientation of the dislocation movement line by θ measured from the X-axis. (Figure 7)

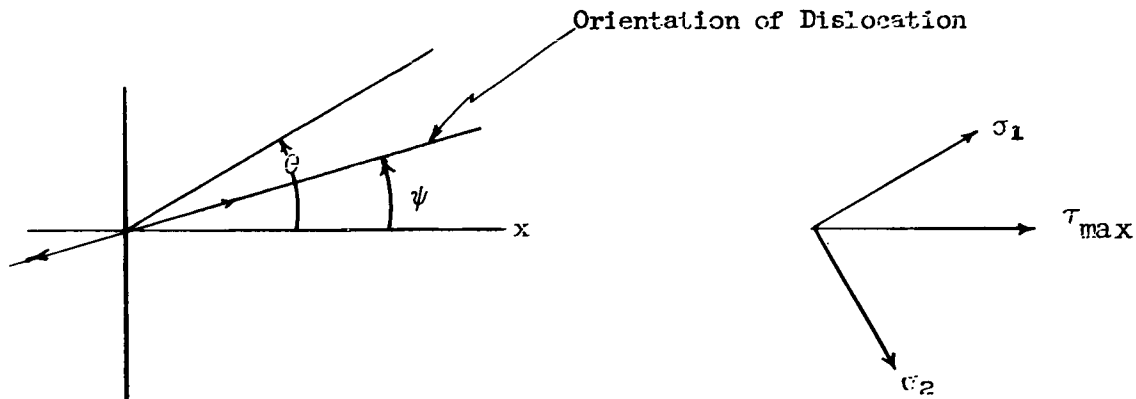

Figure 7

Since the shearing stress is zero for $\theta = 45^\circ$, there will be a restricted zone of orientation of dislocations that will move under this stress, say up to $\psi, \psi < \theta$. Then the macroscopic diffusion coefficient is given by averaging the component of D along the X-axis over all possible orientations. Then

$$\bar{D} = D_0 \frac{\sin \psi}{\psi} \quad (\text{II.4.9})$$

where \bar{D} is the macroscopic diffusion coefficient, and D_0 is the single dislocation diffusion. For $\psi < 45^\circ$ the value of $\frac{\sin\psi}{\psi}$ is between 0.9 and 1.0. Thus, for the purposes of this paper \bar{D} will be taken equal to D_0 ,

The equation of motion for the elastic plastic medium may be written

$$\rho \frac{\partial v_i}{\partial t} = \frac{\partial \sigma_{ij}}{\partial x^j} \quad (\text{II.4.10})$$

where v_i is the particle velocity in the i -th direction.

The equations of motion for an arbitrary body referred to a reference Cartesian system may be written

$$\sigma^{ij}{}_{;j} = \rho \frac{dv_i}{dt} \quad (\text{II.4.11})$$

where σ^{ij} are the contravariant components of the stress tensor given in the local metric; ij refers to total covariant differentiation, ρ is the density and $\frac{d}{dt}$ is the total or convective time derivative. The total covariant differentiation is defined as

$$\sigma^{ij}{}_{;j} = \sigma^{ij}{}_{,j} + \Gamma^i_{mn} \sigma^{mn} \quad (\text{II.4.12})$$

where the comma denotes partial derivatives and Γ^i_{mn} is the connexion of the metric space. In the case of dislocations, the metric tensor that describes the space is given by the lattice unit vectors. In the case where no dislocations are present, the lattice vectors coincide with the Cartesian reference system and the connexion is identically zero. If one or more dislocations are present, the lattice is distorted and the connexion is given by the Euler-Schouten tensor, $\Gamma^i_{mn} = S^i_{mn}$. If a dislocation has passed through an elementary volume in the original crystal lattice, the original coordinates are displaced by an integral

number of complete lattice units. This displacement is described by

$$F_{mn}^i = N_n \frac{\partial f_m^i}{\partial x^n} \quad (\text{II.4.13})$$

where N_n is the number of dislocations that have passed through the elementary volume in the n -th direction and $\frac{\partial f_m^i}{\partial x^n}$ is the projection of this displacement in the i -th direction. If no dislocations are present, the lattice metric coincides with Cartesian reference metric and the connexion is zero. If a dislocation is present, the connexion is given by the Euler-Schouten tensor. If a dislocation has passed through the region under some force and is no longer present, a residual three indexed tensor F_{mn}^i demonstrates that a slip has occurred. The resulting connexion is the sum of these two connexions

$$\Gamma_{mn}^i = S_{mn}^i + F_{mn}^i \quad (\text{II.4.14})$$

The amount of deformation due to the presence of a dislocation is small compared to the translatory movement caused by the passage of dislocations.

Now examine the contravariant derivative of the stress tensor

$$\sigma^{ij}{}_{;j} = \sigma^{ij}{}_{,j} + F_{mn}^i \sigma^{mn} \quad (\text{II.4.15})$$

If there are no applied surface tractions the stress at any interior point of the body is due to the elastic strain surrounding the dislocations. If this stress state is unstable thermodynamically, the dislocations will move. If the surface tractions are zero

$$\sigma^{ij}{}_{;j} = 0 \quad (\text{II.4.16})$$

and

$$\sigma^{ij}{}_{,j} = -F_{mn}^i \sigma^{mn} \quad (\text{II.4.17})$$

Thus a stress gradient on the interior of the body exists due to the moving dislocations. Since Hooke's law for elastic strains has been assumed, addition of surface tractions to the body adds stresses linearly to those in the body due to dislocations. Define now a stress tensor

$$s^{mn} = \sigma^{mn}$$

which denotes the stress due to the dislocations only, then the equation of motion may be written

$$\frac{\partial \sigma^{ij}}{\partial x^j} - \frac{\partial s^{im}}{\partial x^m} = \rho \frac{\partial v^i}{\partial t} \quad (\text{II.4.18})$$

The other equations necessary to complete the description of the deformation process are derived from energy and entropy considerations. Physically, it may be expected that the equation for motion of dislocations through a solid body will obey a diffusion equation. To investigate the transport properties of the dislocations, we note that the change in energy during this transport is proportional to the time rate of change of the total strain. Similarly the energy change may be written as a change in the connexion with position. Equating these two quantities should lead to the subsidiary equations necessary to complete the description of the motion.

The energy equation may be derived as follows: We consider the following differential expansion for the internal energy in terms of the lattice strain of the dislocated crystal,

$$dE = \sigma_{ij} d\epsilon_{ij} + TdS \quad (\text{II.4.19})$$

where E is the internal energy per unit mass, σ_{ij} is the stress, ϵ_{ij} is the lattice strain and S is the entropy per unit mass. The strain may be decomposed

into parts arising from surface tractions and the dislocations.

The lattice strains due to the movement of dislocation may be written as

$$de_{ij} = F^i_{jk} \underline{dx}^k \quad (\text{II.4.20})$$

where \underline{dx}^k is the basis vector.

If the strains are small, the strain may be written as

$$de_{ij} = \partial_l F^i_{jk} - \partial_k F^i_{lj} \quad dx^k \quad dx^l = R^i_{jkl} \quad dx^k \quad dx^l \quad (\text{II.4.21})$$

Since the medium under consideration is isotropic, we may contract the curvature term.

$$de_{ij} = R_{ijkl} \quad dx^k \quad dx^l = -\epsilon_{jmn} \epsilon_{isp} \partial_m \partial_n e_{np} \\ - \epsilon_{jmn} \partial_m (\delta_{in} L - L_{in}) \quad (\text{II.4.22})$$

where ϵ_{ijk} is the Eddington permutation symbol and L_{in} is the dislocation density.

If the reversible part of the strain energy is subtracted from the energy equation

$$T dS_{irr} = \epsilon_{jmn} \partial_m (\delta_{in} L - L_{in}) \quad (\text{II.4.23})$$

Since the process is diffusive in nature, we postulate

$$DT \frac{\partial^2 S_{irr}}{\partial x^k \partial x^k} = T \frac{\partial S_{irr}}{\partial t}$$

where D is the stress dependent diffusion coefficient for dislocation movement.

Inserting this expression for entropy and contracting indices

$$D \frac{\partial^2}{\partial x^2} (\delta_{ij} L - L_{ij}) = \frac{\partial}{\partial t} (\delta_{ij} L - L_{ij}) \quad (\text{II.4.24})$$

The dislocation density is proportional to the plastic strain as a first approximation and thus

$$D \frac{\partial^2 \epsilon_{ij}}{\partial x^k \partial x^k} = \frac{\partial}{\partial t} \epsilon_{ij} \quad (\text{II.4.25})$$

Resolving the strain into hydrostatic and deviator components

$$e_{ij} = \delta_{ij} \theta + d_{ij} \quad (\text{II.4.26})$$

and adding and subtracting

$$D_1 \frac{\partial^2 \epsilon_{ii}}{\partial x^k \partial x^k} = \frac{\partial}{\partial t} e_{ii} \quad (\text{II.4.27})$$

$$D_2 \frac{\partial^2 d_{ij}}{\partial x^k \partial x^k} = \frac{\partial}{\partial t} d_{ij} \quad (\text{II.4.28})$$

The equations of Motion are

$$\frac{\partial \sigma_{ij}}{\partial x_j} + \frac{\partial S_{im}}{\partial x_m} = \rho \frac{\partial v_i}{\partial t} \quad (\text{II.4.29})$$

$$D_1 \nabla^2 \epsilon_{ii} = \frac{\partial}{\partial t} \epsilon_{ii} \quad (\text{II.4.30})$$

$$D_2 \nabla^2 d_{ij} = \frac{\partial}{\partial t} d_{ij} \quad (\text{II.4.31})$$

III. Impact Plastic Deformation of a One Dimensional Rod

The first problem to be solved for dynamic plastic deformation is the case of a one dimensional rod impacted at the end. The rod is considered as a continuum extending from 0 to infinity in the x direction. A load is applied at the end $x = 0$ and is given by $\phi_0(t)$.

The equations for one dimensional dynamic plastic deformation, where the elastic strain is considered to be linear, are

$$M \frac{\partial^2 u}{\partial x^2} - \frac{\partial \sigma}{\partial x} = \rho \frac{\partial^2 u}{\partial t^2} \quad (\text{III.1})$$

$$D \frac{\partial^3 u}{\partial x^3} = \frac{\partial^2 u}{\partial x \partial t} \quad (\text{III.2})$$

where M is an elastic constant

ρ is the density

u is the displacement

D is a diffusion coefficient and

σ is the plastic driving force or the stress due to the dislocations defined by expanding this as a Taylor series in the total strain

$$\sigma = \alpha \frac{\partial^2 u}{\partial x^2} + \beta \frac{\partial u}{\partial x} \quad (\text{III.3})$$

and α and β are the constants relating the stress and dislocation density.

α , β and D are dependent upon material, temperature and stress configuration.

$$D = D_0 \frac{\tau}{\tau_0} \exp \left(- \frac{\Delta H}{RT} + \frac{\tau}{\tau_c} \right) \quad \tau \leq \tau_0 = \frac{\tau_c \Delta H}{RT} \quad (\text{III.4})$$

$$\alpha = \alpha_0$$

$$\beta = \beta_0$$

$$D = D_0$$

$$\tau > \tau_0 = \tau_c \frac{\Delta H}{RT} \quad (\text{III.5})$$

where τ is the maximum elastic shear stress. In this problem which is a case of plane strain, the lateral stresses are prescribed and thus the maximum shear stress in these expressions may be replaced by an equivalent expression in the elastic strain.

The first of the equations represents the balance of the forces due to elastic strain particle acceleration and the dislocations, and the second equation represents the dissipating of energy by motion of the dislocations through the crystal lattice. The energy that is dissipated shows up as thermal energy in the crystal. The internal stress or body force due to the presence of the dislocations is called the plastic driving force.

The diffusion coefficient may more accurately be called a kinematic viscosity but this distinction is semantic.

Thus the first equation may be written

$$\frac{M}{\rho} \frac{\partial^2 u}{\partial x^2} + \frac{\alpha}{\rho} \frac{\partial^3 u}{\partial x^3} - \frac{\beta}{\rho} \frac{\partial^2 u}{\partial x^2} = \frac{\partial^2 u}{\partial t^2} \quad (\text{III.6})$$

Multiply the second equation by $\lambda = \frac{\alpha}{\rho D}$

$$\lambda D \frac{\partial^3 u}{\partial x^3} = \lambda \frac{\partial^2 u}{\partial t \partial x} \quad (\text{III.7})$$

and subtract from the first equation.

Then

$$c^2 \frac{\partial^2 u}{\partial x^2} - \frac{\beta}{\rho} \frac{\partial^2 u}{\partial x^2} = \frac{\partial^2 u}{\partial t^2} - \lambda \frac{\partial^2 u}{\partial x \partial t} \quad (\text{III.8})$$

or
$$\left(\frac{\partial^2 u}{\partial t^2} - c^2 \frac{\partial^2 u}{\partial x^2} \right) + \left(\lambda \frac{\partial^2 u}{\partial x \partial t} + \frac{\beta}{\rho D} \frac{\partial^2 u}{\partial x^2} \right) = 0 \quad (\text{III.9})$$

The first term in this equation corresponds to the elastic wave equation.

By itself an undamped linear elastic wave would propagate down the rod.

The second term is the contribution from the dislocation movement.

Rewrite the second term as

$$\lambda \frac{\partial}{\partial x} \left(\frac{\partial u}{\partial t} + \frac{\beta}{\rho D \lambda} \frac{\partial u}{\partial x} \right) \quad (\text{III.10})$$

Since $\lambda = \frac{\alpha}{\rho D}$ the term becomes

$$\lambda \frac{\partial}{\partial x} \left(\frac{\partial u}{\partial t} + \frac{\beta D}{\alpha} \frac{\partial u}{\partial x} \right) \quad (\text{III.11})$$

Now the differential operator in front of the brackets may be interpreted as division by the average distance between dislocations.

$$\lambda \frac{\partial}{\partial x} = \frac{\Lambda}{d} = \frac{\alpha_o}{\rho_o D_o d} \quad (\text{III.12})$$

$$\frac{\Lambda}{d} \left(\frac{\partial u}{\partial t} + \alpha D \frac{\partial u}{\partial x} \right) \quad (\text{III.13})$$

However $\frac{D\beta}{dt}$ may be interpreted as the velocity of a moving dislocation.

$$\frac{\Lambda}{d} \left(\frac{\partial u}{\partial t} + \frac{v}{d} \frac{\partial u}{\partial x} \right) \quad (\text{III.14})$$

The differential equation of motion may be written

$$\left(\frac{\partial^2 u}{\partial t^2} - c^2 \frac{\partial^2 u}{\partial x^2} \right) + \frac{\Lambda}{d} \left(\frac{\partial u}{\partial t} + \frac{v}{d} \frac{\partial u}{\partial x} \right) = 0 \quad (\text{III.15})$$

Consider the problem under the restriction $c > v > -c$, $v > 0$. This is a problem which has been investigated fully by Whitham, ⁽²⁴⁾ The boundary condition is given

$$\begin{aligned} P &= \phi_0(t) & t &= 0 & x &= 0 \\ \frac{\partial u}{\partial t} &= u = 0 & t &= 0 & x &> 0 \end{aligned}$$

The second boundary condition, which is normally the displacement at infinity for the elastic wave propagation in the rod, is modified here. Since the plastic deformation is caused by freeing of dislocations under stress or strain, the other boundary condition must be given as a function of the incident stress wave, This condition will be explicitly evaluated later. It suffices here to state that the elastic wave from infinity is identically zero. The plastic wave is caused physically by the movement of dislocations freed by the state of elastic stress. This second boundary condition thus is an internal

boundary condition and is treated as a free boundary on the elastic wave front.

The first boundary condition is expressed as a pressure or stress. This affects only the elastic strain, not the total strain. The total strain is determined as the sum of elastic displacement and the flow due to dislocation movement. If the pressure is held constant the elastic strain is constant. When a dislocation, however, comes to the surface, an elastic rebound may be expected, and this rebound adds an elastic strain in addition to the strain already present due to the pressure. Because of the continuum notation for dislocations this rebound is very small for each individual dislocation, and is continuously spread out on the boundary. It is therefore indistinguishable from the already present elastic strain and can be safely ignored. This problem will crop up again in the two dimensional problem. There it will be stated that the stress due to dislocations is zero on the surface.

The displacement at $x = 0$ is composed of two parts, the first is the elastic strain and the other is the displacement caused by the movement of dislocation. Thus the boundary condition may be written as a displacement

$$u = u(t) = u_{\text{elas}}(t) + u_{\text{plas}}(t) \quad t > 0 \quad x = 0$$

Denote the one sided Laplace transform of the displacement by

$$\hat{u}(x, s) = s \int_0^{\infty} e^{-st} u(x, t) dt \quad (\text{III.16})$$

and the inverse Laplace transform by

$$u(x, t) = \frac{1}{2\pi i} \int_{\text{Br}} \frac{e^{st}}{s} \hat{u}(x, s) ds \quad (\text{III.17})$$

where Br denotes the Bromwich contour in the complex s -plane, the s in the denominator is the result of the Heaviside step function in the original two sided Laplace integral.

The differential equation in the transform variable may be written

$$\left(s^2 - c^2 \frac{\partial^2}{\partial x^2} \right) \hat{u} + \frac{\lambda}{d} \left(s - v \frac{\partial}{\partial x} \right) \hat{u} = 0 \quad (\text{III } 18)$$

The general solution of the transformed displacement is

$$\hat{u}(x, s) = A_1(s) e^{-f_1(s)x} + A_2(s) e^{-f_2(s)x} \quad (\text{III } 19)$$

where $f_1(s)$, $f_2(s)$ are solutions of the auxiliary equation.

$$c^2(f(s))^2 + \left(-\frac{\lambda v}{d} \right) f(s) - s\left(s + \frac{\lambda}{d}\right) = 0 \quad (\text{III.20})$$

For large s

$$\begin{aligned} f_1(s) &\approx -\frac{s}{c} \\ f_2(s) &\approx +\frac{s}{c} \end{aligned} \quad (\text{III.21})$$

so that for large distances from the end of the rod the first term represents an elastic wave propagating down the rod. The second term represents an incoming elastic wave from infinity.

For small s

$$\begin{aligned} f_1(s) &\approx +\frac{\lambda v}{dc^2} \\ f_2(s) &\approx -\frac{s}{v} \end{aligned} \quad (\text{III.22})$$

The first of these corresponds to a boundary layer at $x = 0$. This boundary layer expresses the difference in the actual displacement and the elastic component. This boundary layer term is necessary to fully complete the boundary conditions stated.

The second term corresponds to a "wave" being propagated backwards with the velocity of a moving dislocation.

The boundary conditions in terms of displacements may be further clarified. The presence of a boundary layer at $x = 0$ implies that two boundary conditions are necessary to specify the solution to the problem. The first of these boundary conditions is given by the elastic displacement which is a function of the stress applied at the surface. The difference between the actual displacement and the elastic displacement is given by the boundary layer.

This added displacement arises from the movement of dislocations under stress to the ends of the rod. These dislocations must have a starting point for motion. This starting point can be none other than the front of the elastic wave, for the rod does not know that the dislocations should move until the stress wave arrives.

Thus the second boundary condition at the surface may be replaced by a boundary condition along $x - ct$,

This boundary condition is just the displacement at the point (x, ct) . This means that the state of elastic strain on the interior of the rod determines the movement of a dislocation at that point.

It is seen then that the boundary condition that is applied at the surface is just the elastic displacement. The plastic component of displacement there is a consequence, rather than a restriction.

The coefficients A_1 and A_2 are evaluated in the following way. A_1 is evaluated by considering the boundary condition at $x = 0$

$$A_1(s) = s \int_0^{\infty} e^{-st} u_e(0, t) dt \quad (\text{III.23})$$

The coefficient A_2 must be formulated along the characteristic $x - ct$

$$A_2(s) = s \int_0^{\infty} e^{-st} u_e(ct, c) dt \quad (\text{III.24})$$

The displacement then is

$$u(x,t) = \frac{1}{2\pi i} \int_{Br} \hat{u}_e(o,s) e^{st-f(s)x} ds + \frac{1}{2\pi i} \int_{Br} \hat{u}_e\left(\frac{c}{s},s\right) e^{st-f_2(s)x} ds \quad (\text{III.25})$$

If this expression is now evaluated for large s

$$f_1(s) = -\frac{s}{c} + \frac{\lambda v}{2dc^2} + \Theta \frac{\lambda^2}{d^2 s} \quad (\text{III.26})$$

Thus the solution along $x + ct$ is

$$u(x,t) = u_e\left(t - \frac{x}{c}, t\right) \exp\left(-\frac{\lambda v}{2dc^2} x\right) \left[1 + \Theta \left(\frac{\lambda}{a} \left(t - \frac{x}{c}\right)\right)\right] \quad (\text{III.27})$$

Since v is negative with respect to the wave front this solution is the elastic wave at some distance from the end of the rod. The attenuation factor

$$k = \frac{\lambda v}{2dc^2}$$

gives the amount of damping in the elastic wave.

Inserting representative values of the parameters for stress loads near the yield limit for the metal aluminum

$$\lambda = \frac{\alpha}{\rho D^2} \quad \alpha = 10^2 / \text{cm}$$

$$D = 10^3 \text{ cm}^2 / \text{sec} \quad \rho = 2.7 \text{ gm/cm}^2$$

$$v = \alpha D = 10^5 \text{ cm/sec}$$

the average distance between dislocations d is taken as 10^{-6} cm and the sonic velocity is 5.3×10^5 cm/sec.

Then the attenuation coefficient is

$$k = \frac{10^2 (10^5)}{(2)(2.7)(10^{-6})(5.3 \times 10^5)^2 (10 + 6)} = 6.5 \times 10^{-6} / \text{cm} \quad (\text{III.28})$$

which is in reasonable agreement with experimental values of internal friction. (5)

On the other hand, if the expression for u is integrated for large t away from the elastic wave front, another wave front and the boundary layer will come into prominence. To evaluate the wave, consider the second term in the integral expression for u .

$$u(x,t) = \frac{1}{2\pi i} \int_{Br} u_e\left(\frac{c}{s}, s\right) e^{st - f_2(s)x} ds \quad (\text{III.29})$$

$$f_2(s) \approx \frac{s}{v}$$

Rewriting the variable in the exponential as

$$t \left(s - \frac{f_2(s)x}{t} \right)$$

$$u = \frac{1}{2\pi i} \int_{Br} u_e\left(\frac{c}{s}, s\right) e^{t \left(s - f_2(s) \frac{x}{t} \right)} ds \quad (\text{III.30})$$

This integral may be evaluated by the saddle point method for t large. The saddle point is at s_2 where

$$1 + f_2'(s_2) \frac{x}{t} = 0$$

The prime denotes differentiation with respect to s . The dominant term in the expansion is

$$u(x,t) = \frac{u\left(\frac{s_2}{c} - x, t^*\right) \exp\left[t\left(s_2 + \frac{x}{c} f_2(s_2)\right)\right]}{s_2 \sqrt{2\pi(x-x^*) f_2''(s_2)}} \quad (\text{III.31})$$

where x^* , t^* are the x , t points on the elastic wave front corresponding to this wave,

The exponential term is greatest for fixed t if $f_2(s_2) = 0$. From the expression for $f_2(s)$, this occurs at $s_2 = 0$

Thus

$$u(x, \tau) = \frac{1}{\sqrt{2\pi(x-x^*)}} \lim_{s \rightarrow 0} u \frac{\frac{s}{c} - x^*, t^*}{s}$$

$$f_2''(0) = 2 \frac{(c+v)(c-v)d}{v^3 \lambda} \quad (\text{III.32})$$

$$u(x, t) = \sqrt{\frac{v^3 \lambda}{4\pi(c^2 - v^2)(x-x^*)}} \int_0^\infty u_e(ct, t) dt$$

which is the value at the saddle point.

The propagation of stress waves down the elastic rod is seen to consist of a damped elastic wave which propagates at the sonic velocity and a number of dislocations which move backwards from the elastic wave front, carrying with them additional deformation. The boundary conditions at the end of the rod which are initially given as a single stress, decompose into an elastic displacement given by the linear stress-strain law and an added displacement, given mathematically by the boundary layer, which represents permanent plastic strain. Nowhere in this solution is there a forward propagating wave that moves at a velocity lower than the elastic sonic velocity.

IV. Plastic Deformation of a Semi-Infinite Half Space Under a Suddenly Applied Load on the Surface

In this section, the solution of the plastic and elastic deformation of an elastic half space with a continuous distribution of dislocations will be studied. The problem will be restricted for mathematical convenience to the plane strain problem. This corresponds to a load whose area of application extends to infinity in the one direction and is a prescribed function of position in another.

The equations of motion are

$$\frac{\partial \sigma_{ij}}{\partial x_j} + \frac{\partial s_{im}}{\partial x_m} = \rho \frac{\partial v_i}{\partial t_i} \quad (\text{IV.1})$$

$$D_1 \nabla^2 \epsilon_{ii} = \frac{\partial}{\partial t} \epsilon_{ii} \quad (\text{IV.2})$$

$$D_2 \nabla^2 d_{ij} = \frac{\partial}{\partial t} d_{ij} \quad (\text{IV.3})$$

Assuming Hooke's law for the elastic part

$$\sigma_{ij} = \lambda \epsilon_{kk} \delta_{ij} + 2\mu \epsilon_{ij} \quad (\text{IV.4})$$

$$\epsilon_{ij} = \frac{1}{2}(u_{i,j} + u_{j,i}) \quad (\text{IV.5})$$

$$d_{ij} = \epsilon_{ij} - \epsilon_{kk} \delta_{ij} \quad (\text{IV.6})$$

where λ, μ are Lamé's constants

Since the medium undergoing deformation is isotropic

$$s_{im} = s \delta_{im} + t_{im} \quad (\text{IV.7})$$

Restricting the equations to the case of plane strain, the equations of motion then are

$$\begin{aligned} \nabla^2 u - (2\eta-1) \frac{\partial \Delta}{\partial x} - \frac{1}{\mu} \frac{\partial t}{\partial x} \\ - \frac{1}{\mu} \frac{\partial t_{xx}}{\partial x} - \frac{1}{\mu} \frac{\partial t_{xz}}{\partial z} = \frac{1}{c_2^2} \frac{\partial^2 u}{\partial t^2} \end{aligned} \quad (\text{IV.8})$$

$$\begin{aligned} \nabla^2 w - (2\eta-1) \frac{\partial \Delta}{\partial z} - \frac{1}{\mu} \frac{\partial t}{\partial z} \\ - \frac{1}{\mu} \frac{\partial t_{xz}}{\partial x} - \frac{1}{\mu} \frac{\partial t_{zz}}{\partial z} = \frac{1}{c_2^2} \frac{\partial^2 w}{\partial t^2} \end{aligned} \quad (\text{IV.9})$$

$$D_1 \nabla^2 \epsilon_{11} = \frac{\partial}{\partial t} \epsilon_{11} \quad (\text{IV.10})$$

$$D_2 \nabla^2 d_{1j} = \frac{\partial}{\partial t} d_{1j} \quad (\text{IV.11})$$

Where u , w are the displacements in the x , z directions respectively,

$$\frac{\lambda + 2\mu}{\mu} = \eta$$

and Δ is the dilatation

$$\Delta = - \left(\frac{\partial u}{\partial x} + \frac{\partial w}{\partial z} \right)$$

These equations take on a more instructive form through the application of potential theory.

Introduce the potential functions ϕ , ψ , S , T defined by

$$u = \frac{\partial \phi}{\partial x} - \frac{\partial \psi}{\partial z} + z \frac{\partial S}{\partial x} - z \frac{\partial T}{\partial z} \quad (\text{IV.12})$$

$$w = \frac{\partial \phi}{\partial z} + \frac{\partial \psi}{\partial x} + z \frac{\partial S}{\partial z} + z \frac{\partial T}{\partial x} \quad (\text{IV.13})$$

Differentiating the first equation with respect to z and the second with respect to x , it is readily observed that the plastic driving stresses are harmonic functions

$$t = \frac{\partial S}{\partial z} - \eta \nabla^2 \phi \quad (\text{IV.14})$$

$$t_{xx} = \frac{\partial T}{\partial z} - \frac{\partial^2 \psi}{\partial y^2} \quad (\text{IV.15})$$

$$t_{yy} = \frac{\partial T}{\partial z} - \frac{\partial^2 \psi}{\partial x^2} \quad (\text{IV.16})$$

$$t_{xy} = \frac{\partial T}{\partial y} - \frac{\partial^2 \psi}{\partial x \partial y} \quad (\text{IV.17})$$

Inserting these values into the equations, the equations reduce to the following

$$\frac{1}{c_1^2} \frac{\partial^2 S}{\partial t^2} = \nabla^2 S \quad (\text{IV.18})$$

$$\frac{1}{c_2^2} \frac{\partial^2 T}{\partial t^2} = \nabla^2 T \quad (\text{IV.19})$$

$$\left(c_2^2 \nabla^2 - \frac{\partial^2}{\partial t^2} \right) \nabla^2 \psi + \left(D_2 \nabla^2 - \frac{\partial}{\partial t} \right) \nabla^2 \psi = 0 \quad (\text{IV.20})$$

$$\left(c_1^2 \nabla^2 - \frac{\partial^2}{\partial t^2} \right) \nabla^2 \phi + \left(D_1 \nabla^2 - \frac{\partial}{\partial t} \right) \nabla^2 \phi = 0 \quad (\text{IV.21})$$

where $c_1^2 = \frac{\lambda+2\mu}{\rho}$, $c_2^2 = \frac{\mu}{\rho}$

From the nature of these equations, four boundary conditions must be prescribed for the free surface.

The first two equations indicate the propagation of two elastic waves. The second pair of equations are the same form as the one dimensional plastic-elastic wave studied in a previous section. We recall a theorem derived therein; the derivative of a term involving the dislocation parameters may be replaced by division by the average spacing of the dislocations

$$D_1 \operatorname{div} = \frac{D_1}{k} = V \quad (\text{IV.22})$$

where V is the dislocation velocity. Then the second pair of equations is identical in form to the one dimensional case

$$\left(c_2^2 \nabla^2 - \frac{\partial^2}{\partial t^2} \right) \nabla^2 \psi + \left(v_2 \operatorname{grad} - \frac{\partial}{\partial t} \right) \nabla^2 \psi = 0 \quad (\text{IV.23})$$

$$\left(c_1^2 \nabla^2 - \frac{\partial^2}{\partial t^2} \right) \nabla^2 \phi + \left(v_1 \operatorname{grad} - \frac{\partial}{\partial t} \right) \nabla^2 \phi = 0 \quad (\text{IV.24})$$

The nature of these solutions is recapitulated here. One part of the stress wave propagates at sonic velocity, the wave front being damped by the action of the dislocations. The dislocations move away from the wave front and further displacement occurs behind the wave front and at the same time, the stress state is relieved.

Here the only difference is that the non-elastic behavior occurs in both the shear and dilatational modes. Since the diffusion coefficient that appears in these equations is dependent on the maximum shear stress, more plastic deformation is to be expected in the shear wave.

A detailed solution is evaluated for a simple dependence of the plastic driving force. In this simple case, the tensor components are all assumed to vanish with the exception of the scalar term.

Under this assumption, the equations of motion for elastic and plastic deformation of the half space are

$$\nabla^2 u - (2\eta-1) \frac{\partial \Delta}{\partial x} - \frac{1}{\mu} \frac{\partial \sigma}{\partial x} = \frac{1}{c_2^2} \frac{\partial^2 u}{\partial t^2} \quad (\text{IV.25})$$

$$\nabla^2 w - (2\eta-1) \frac{\partial \Delta}{\partial z} - \frac{1}{\mu} \frac{\partial \sigma}{\partial z} = \frac{1}{c_2^2} \frac{\partial^2 w}{\partial t^2} \quad (\text{IV.26})$$

$$D(t) \nabla^2 (\Delta) = \frac{\partial (\Delta)}{\partial t} \quad (\text{IV.27})$$

The boundary conditions are

$$\begin{array}{lll} \sigma_z = P_o(x,t) & z = 0 & t \geq 0 \\ \sigma = 0 & z = 0 & t \geq 0 \\ \tau_{xz} = 0 & z = 0 & t \geq 0 \end{array}$$

These boundary conditions state that a surface traction normal to the surface, given by P_o , is applied to the surface, that the surface is free of shear tractions, and that the driving force for plastic deformation and dislocation movement vanishes at the free surface.

These equations are similar to the equations of motion for deformation of a porous media. The following method of solution of these equations is by potential functions and the transform calculus. The method of solution follows very closely that of McNamee and Gibson⁽¹⁵⁾. Since the thermodynamic treatment of dislocation movement indicates that the dislocations move at nearly a constant velocity when

the shear stress is above the static yield stress, and that the velocity does not depend on the magnitude of the stress above the yield stress, little dependence on the transient inertial forces is expected. Therefore, the inertial forces are taken as zero in the following development of the equation.

$$\frac{\partial^2 u}{\partial t^2} = \frac{\partial^2 w}{\partial t^2} = 0 \quad (\text{IV.28})$$

The solution of these equations means that a static elastic stress field is established instantaneously after the load is applied. Then the plastic deformation ensues.

The equations of motion reduce to

$$\nabla^2 u - (2\eta-1) \frac{\partial \Delta}{\partial x} - \frac{1}{\mu} \frac{\partial \sigma}{\partial x} = 0 \quad (\text{IV.29})$$

$$\nabla^2 w - (2\eta-1) \frac{\partial \Delta}{\partial z} - \frac{1}{\mu} \frac{\partial \sigma}{\partial z} = 0 \quad (\text{IV.30})$$

$$D(t) \nabla^2 (\Delta) = \frac{\partial \Delta}{\partial t} \quad (\text{IV.31})$$

By differentiation of the first two equations,

$$\nabla^2 (\sigma + 2\mu\eta\Delta) = 0 \quad (\text{IV.32})$$

so that, if S is a harmonic function of x and z

$$\sigma = 2\mu \left(\frac{\partial S}{\partial z} - \eta\Delta \right) \quad (\text{IV.33})$$

Another potential function E may be introduced such that

$$\Delta = \nabla^2 E \quad (\text{IV.34})$$

The displacements u and w are related to these potential functions

$$u = - \frac{\partial E}{\partial x} + z \frac{\partial S}{\partial x} \quad (\text{IV.35})$$

$$w = - \frac{\partial E}{\partial z} + z \frac{\partial S}{\partial z} + S \quad (\text{IV.36})$$

Inserting these expressions in the equations of motion, the potential functions satisfy

$$D(t) \nabla^4 E = \nabla^2 \frac{\partial E}{\partial t} \quad (\text{IV.37})$$

$$\nabla^2 S = 0 \quad (\text{IV.38})$$

Utilizing the linear elastic stress-strain relations, the components of stress may be written in terms of the potentials

$$\frac{\sigma_x}{2\mu} = - \frac{\partial^2 E}{\partial z^2} - z \frac{\partial^2 S}{\partial x^2} + \frac{\partial S}{\partial z} \quad (\text{IV.39})$$

$$\frac{\sigma_z}{2\mu} = - \frac{\partial^2 E}{\partial x^2} - z \frac{\partial^2 S}{\partial z^2} + \frac{\partial S}{\partial z} \quad (\text{IV.40})$$

$$\frac{\tau_{xz}}{2\mu} = \frac{\partial^2 E}{\partial x \partial z} - z \frac{\partial^2 S}{\partial x \partial z} \quad (\text{IV.41})$$

$$\frac{\sigma}{2\mu} = \frac{\partial S}{\partial z} - \eta \nabla^2 E \quad (\text{IV.42})$$

These expressions identically satisfy the equation of motion.

Since the coefficient D is a function of the maximum shearing stress, it is more convenient to solve these equations in a non-dimensional form. The substitutions are

$$x = bx'$$

$$z = bz'$$

$$t = t'b^2/D$$

where b is a characteristic length dependent on the original load. This length will be clarified later.

This substitution introduces a non-uniform time scale into the problem, but will not introduce any serious difficulties.

The equations for the potentials become

$$\nabla^4 E' = \nabla^2 \frac{\partial E'}{\partial t'} \quad (\text{IV.43})$$

$$\nabla^2 S' = 0 \quad (\text{IV.44})$$

The superscript primes will be dropped as no confusion will be encountered. The boundary conditions become

$$\sigma_z = P_0(x, t)$$

$$\sigma = 0 \quad z = 0 \quad t \geq 0$$

$$\tau_{xz} = 0$$

The formal solutions of these equations will now be developed by the integral transform technique.

Introduce the Fourier-Laplace transform of the potentials

$$\hat{E}(\xi, z, p) = \int_0^{\infty} e^{-pt} dt \int_0^{\infty} \cos(\xi x) E(x, z, t) dx \quad (\text{IV.45})$$

$$\hat{S}(\xi, z, p) = \int_0^{\infty} e^{-pt} dt \int_0^{\infty} \cos(\xi x) S(x, z, t) dx \quad (\text{IV.46})$$

The differential relations of this transform are

$$\frac{\partial \hat{E}}{\partial t} = -p \hat{E} \quad (\text{IV.47})$$

$$\frac{\partial^2 \hat{E}}{\partial x^2} = -\xi^2 \hat{E} \quad (\text{IV.48})$$

$$\frac{\partial \hat{E}}{\partial t} = -\xi \hat{E}_s \quad (\text{IV.49})$$

where E_s is the corresponding Fourier sine transform.

The transform stresses and displacements may be written

$$\frac{\hat{\sigma}_x}{2\mu} = -\frac{\partial^2 \hat{E}}{\partial z^2} + z\xi^2 \hat{S} + \frac{\partial \hat{S}}{\partial z} \quad (\text{IV.50})$$

$$\frac{\hat{\sigma}_z}{2\mu} = \xi^2 \hat{E} - z \frac{\partial^2 \hat{S}}{\partial z^2} + \frac{\partial \hat{S}}{\partial z} \quad (\text{IV.51})$$

$$\frac{\hat{\tau}_{xz}}{2\mu} = -\xi \left(\frac{\partial \hat{E}_s}{\partial z} - z \frac{\partial \hat{S}_s}{\partial z} \right) \quad (\text{IV.52})$$

$$\frac{\hat{\sigma}}{2\mu} = \frac{\partial \hat{S}}{\partial z} - \eta \left(\frac{\partial^2}{\partial z^2} - \xi^2 \right) \hat{E} \quad (\text{IV.53})$$

$$\hat{u} = \xi \hat{E}_s - z \xi \hat{S}_s \quad (\text{IV.54})$$

$$\hat{w} = -\frac{\partial \hat{E}}{\partial z} + z \frac{\partial \hat{S}}{\partial z} - \hat{S} \quad (\text{IV.55})$$

The differential equation for the transform potentials become

$$\left(\frac{\partial^2}{\partial z^2} - \xi^2 - p \right) \left(\frac{\partial^2}{\partial z^2} - \xi^2 \right) \hat{E} = 0 \quad (\text{IV.56})$$

$$\left(\frac{\partial^2}{\partial z^2} - \xi^2 \right) \hat{S} = 0 \quad (\text{IV.57})$$

subject to the boundary conditions

$$\begin{aligned} \hat{\sigma} &= 0 \\ \hat{\sigma}_z &= \hat{P}_0(\xi, p) \\ \hat{\tau}_{xz} &= 0 \\ \hat{u} &\rightarrow 0 \quad \text{as } z \rightarrow \infty \end{aligned} \quad \begin{array}{l} z = 0 \\ t \geq 0 \end{array}$$

The general solutions for the transform potentials may be written

$$\hat{E} = A_1 e^{-z\xi} + A_2 e^{-z(\xi^2 + p)^{1/2}} \quad (\text{IV.58})$$

$$\hat{S} = B_1 e^{-z\xi} \quad (\text{IV.59})$$

The coefficients may be calculated by considering the values of the stresses at the boundaries.

$$\begin{aligned} \text{For } \hat{\sigma}_z &= \hat{P}_0 \text{ at } z = 0 \\ A_1 \xi^2 + A_2 \xi^2 - B_1 \xi &= \frac{\hat{P}_0}{2\mu} \end{aligned} \quad (\text{IV.60})$$

$$\begin{aligned} \text{For } \hat{\sigma} &= 0 \text{ at } z = 0 \\ A_2 \eta p + B_1 \xi &= 0 \end{aligned} \quad (\text{IV.61})$$

$$\begin{aligned} \text{For } \hat{\tau}_{xz} &= 0 \text{ at } z = 0 \\ A_1 \xi + A_2 (\xi^2 + p)^{1/2} &= 0 \end{aligned} \quad (\text{IV.62})$$

Thus

$$A_1 = - \frac{\hat{P}_0}{2\mu} \frac{\xi(\xi^2+p)^{1/2}}{Q} \quad (\text{IV.63})$$

$$A_2 = \frac{\hat{P}_0}{2\mu} \frac{\xi^2}{Q} \quad (\text{IV.64})$$

$$B_1 = - \frac{\hat{P}_0}{2\mu} \frac{\eta\xi p}{Q} \quad (\text{IV.65})$$

$$Q = -\xi^3(\xi^2+p)^{1/2} + \xi^4 + \eta p \xi^2 \quad (\text{IV.66})$$

If the change of scale

$$p = \xi^2 s$$

is made

$$A_1 = - \frac{\tilde{P}_0}{2\mu} \frac{(1+s)^{1/2}}{\xi^2 G} \quad (\text{IV.67})$$

$$A_2 = \frac{\tilde{P}_0}{2\mu \xi^2 G} \quad (\text{IV.68})$$

$$B_1 = - \frac{\tilde{P}_0 \eta s}{2\mu \xi G} \quad (\text{IV.69})$$

$$G = (1+\eta s) - (1+s)^{1/2} \quad (\text{IV.70})$$

The tilde on the pressure transform indicates that the transform is exposed as a function of the variables ξ and s .

The potential transforms may be written

$$\hat{E} = \frac{\tilde{P}_0}{2\mu} - \frac{(1+s)}{\xi^2 G} e^{-z\xi} + \frac{e^{-z\xi} (1+s)^{1/2}}{\xi^2 G} \quad (\text{IV.71})$$

$$\hat{S} = - \frac{\tilde{P}_0 \eta s}{2\mu \xi G} e^{-z\xi} \quad (\text{IV.72})$$

The original potentials are given by inverting the transforms

$$E = \frac{1}{4\pi\mu i} \int_{Br} e^{s\xi^2 t} ds \int_0^\infty \frac{P_0}{\xi^2 G} \left[-(1+s)^{1/2} e^{-z\xi} + e^{-z\xi(1+s)^{1/2}} \right] \cos(\xi x) d\xi \quad (IV.73)$$

$$S = \frac{\eta}{4\pi\mu i} \int_{Br} e^{s\xi^2 t} ds \int_0^\infty \frac{\tilde{P}_0 \xi s e^{-z\xi}}{G} \cos(\xi x) d\xi \quad (IV.74)$$

where Br denotes the Bromwich contour in the complex s-plane.

The components of stress and displacement may be formulated by inserting transform potentials in the expressions for the stresses and displacements, performing the indicated differentiations and inverting. After some manipulation, these are

$$\frac{\sigma_x}{2} = \frac{1}{4\pi\mu i} \int_{Br} e^{st\xi^2} ds \int_0^\infty \tilde{P}_0 \left[\frac{(1+s)^{1/2} - \eta s(z\xi-1)}{G} e^{-z\xi} - \frac{(1+s)}{G} e^{-z\xi(1+s)^{1/2}} \right] \cos \xi x d\xi \quad (IV.75)$$

$$\frac{\sigma_z}{2\mu} = \frac{1}{4\pi\mu i} \int_{Br} e^{st\xi^2} ds \int_0^\infty \tilde{P}_0 \left[\frac{e^{-z\xi} (1+s)^{1/2}}{G} - \frac{(1+s)^{1/2} + \eta s(z\xi-1)}{G} e^{-z\xi} \right] \cos(\xi x) d\xi \quad (IV.76)$$

$$\frac{\tau_{xz}}{2\mu} = \frac{1}{4\pi\mu i} \int_{Br} e^{st\xi^2} ds \int_0^\infty \tilde{P}_0 \left[\frac{(1+s)^{1/2} e^{-z\xi} (1+s)^{1/2}}{G} \right. \\ \left. + \frac{-(1+s)^{1/2} + \eta z \xi s}{G} e^{-z\xi} \right] \sin(\xi x) d\xi \quad (IV.77)$$

$$u = \frac{1}{2\pi\mu i} \int_{Br} e^{st\xi^2} ds \int_0^\infty \tilde{P}_0 \left[\frac{e^{-z\xi} (1+s)^{1/2}}{\xi G} \right. \\ \left. + \frac{\eta z s}{G} - \frac{(1+s)^{1/2}}{\xi G} e^{-z\xi} \right] \sin(\xi x) d\xi \quad (IV.78)$$

$$w = \frac{1}{2\pi\mu i} \int_{Br} e^{st\xi^2} ds \int_0^\infty \tilde{P}_0 \left[\frac{(1+s)^{1/2} e^{-z\xi} (1+s)^{1/2}}{\xi G} \right. \\ \left. + \frac{\eta s(1+z\xi) - (1+s)^{1/2}}{\xi G} e^{-z\xi} \right] \cos(\xi x) d\xi \quad (IV.79)$$

$$\frac{\sigma}{2\mu} = \frac{\eta}{4\pi\mu i} \int_{Br} e^{st\xi^2} ds \int_0^\infty \tilde{P}_0 \left[\frac{s}{G} e^{-z\xi} \right. \\ \left. + \frac{1 - (1+s)^{1/2}}{G} e^{-z\xi(1+s)^{1/2}} \right] \cos(\xi x) d\xi \quad (IV.80)$$

For later convenience in discussing the dynamic stress-strain curves, the formula for the linear strain $\partial w / \partial z$ is included

$$\frac{\partial w}{\partial z} = \frac{1}{2\pi\mu i} \int_{Br} e^{st\xi^2} ds \int_0^\infty \frac{\tilde{P}_0}{G} \left[(1+s)^{1/2} - \eta z \xi s \right] e^{-z\xi} \\ - (1+s) e^{-z\xi} (1+s)^{1/2} \left] \cos(\xi x) d\xi \quad (IV.81)$$

These integrals will be evaluated for a particular load. The load is a constant pressure on a strip of width $2b$ in the x direction on the surface $t = 0$. The load extends to infinity in the y direction. This load is applied suddenly on the surface at time $t = 0$. Thus the pressure is represented by the function

$$\begin{aligned}\sigma_z &= P_0 \cdot l(t) & x < b \\ \sigma_z &= 0 & x > b\end{aligned}$$

where $l(t)$ denotes Heaviside's unit function

$$l(t) = \begin{cases} 0 & t < 0 \\ 1 & t > 0 \end{cases}$$

If the dimensionless coordinates are introduced with b as the characteristic length, the pressure is

$$\begin{aligned}\hat{\sigma}_z(\xi, 0, p) &= \int_0^{\infty} e^{-pt} dt \int_0^{\infty} \sigma_z(x, 0, t) \cos(\xi x) d\xi & (IV.82) \\ &= \frac{2}{\pi} \frac{P_0}{b\xi} \sin \xi \\ &= \frac{2}{\pi} \frac{P_0}{\xi^2 s} \sin \xi\end{aligned}$$

Due to the complexity of the ensuing integrals, for arbitrary position, they will be evaluated here for $z = 0$, $x = 0$. By the boundary conditions $\sigma_z = P_0$, $\tau_{xz} = 0$. By invoking symmetry arguments on the horizontal displacement u , $u = 0$.

The other integrals to be evaluated are

$$w = \frac{P_0 \eta_1}{2\pi^2 \mu_1} \int_{Br} \frac{e^{st}}{G} ds \int_0^{\infty} \frac{\sin \xi}{\xi^2} d\xi \quad (IV.83)$$

$$\frac{\sigma x}{2\mu} = \frac{P_0}{4\pi^2 \mu i} \int_{\text{Br}} \frac{(1+s)^{1/2} + (\eta-1)s-1}{G} e^{st} ds \int_0^\infty \frac{\sin \xi}{\xi} d\xi \quad (\text{IV.84})$$

and

$$\frac{\partial w}{\partial z} = \frac{P_0}{2\pi^2 \mu i} \int_{\text{Br}} \frac{(1+s)^{1/2} - (1+s)}{G} e^{st} ds \int_0^\infty \frac{\sin \xi}{\xi} d\xi \quad (\text{IV.85})$$

with $t = \xi^2 t$

Since these integrals are convergent, either absolutely or in the Cesaro sense, the order of integration may be changed. The integrals may be written

$$w = \frac{P_0 \eta}{\mu \pi} \int_0^\infty \frac{\sin \xi}{\xi^2} I_1 d\xi \quad (\text{IV.86})$$

$$\frac{\sigma x}{2\mu} = \frac{P_0}{2\mu \pi} \int_0^\infty \frac{\sin \xi}{\xi} \left[I_2 + (\eta-1) I_1 - I_3 \right] d\xi \quad (\text{IV.87})$$

$$\frac{\partial w}{\partial z} = \frac{P_0}{\mu \pi} \int_0^\infty \frac{\sin \xi}{\xi} \left[I_2 - I_1 - I_3 \right] d\xi \quad (\text{IV.88})$$

where

$$I_1 = \frac{1}{2\pi i} \int_{\text{Br}} \frac{e^{sT}}{G} ds \quad (\text{IV.89})$$

$$I_2 = \frac{1}{2\pi i} \int_{\text{Br}} \frac{(1+s)^{1/2} e^{sT}}{G} ds \quad (\text{IV.90})$$

$$I_3 = \frac{1}{2\pi i} \int_{\text{Br}} \frac{e^{sT}}{sG} ds \quad (\text{IV.91})$$

The evaluation of the inverse Laplace transforms will be carried out for the explicit elastic parameter ratio $\eta = 1$. This corresponds to an elastically incompressible medium with Poisson's ratio $\nu = 0.5$

The integral for I_1 , is

$$I_1 = \frac{1}{2\pi i} \int_{Br} \frac{e^{s\tau}}{(1+s) - (1+s)^{1/2}} ds$$

This complex integral has two poles at $s = -1$ and $s = 0$ and a branch point at $s = -1$. Rewriting the integral

$$I_1 = \frac{1}{2\pi i} \int_{Br} \frac{[(1+s) + (1+s)^{1/2}]e^{s\tau}}{s(s+1)} ds$$

Applying the Laplace shift theorem

$$I_1 = \frac{e^{-\tau}}{2\pi i} \int_{Br} \frac{(s+s^{1/2})e^{s\tau}}{s(s-1)} ds$$

Then

$$I_1 = e^{-\tau} \left[e^{\tau} + e^{-\tau} \operatorname{erf} \tau^{1/2} \right]$$

$$I_1 = 1 + \operatorname{erf} \tau^{1/2}$$

Similarly

$$I_2 = 1 + \operatorname{erf} \tau^{1/2} + e^{-\tau}$$

$$I_3 = 1 + \operatorname{erf} \tau^{1/2}$$

The integrals for the vertical displacement and horizontal stress become

$$w = \frac{P_0}{\mu\pi} \int_0^{\infty} \frac{\sin\xi}{\xi^2} [1 + \operatorname{erf}(\xi t^{1/2})] d\xi \quad (\text{IV.98})$$

$$\frac{\sigma_x}{P_0} = \frac{1}{\pi} \frac{1}{(\pi t)^{1/2}} \int_0^{\infty} \frac{\sin\xi}{\xi^2} e^{-t\xi^2} d\xi \quad (\text{IV.99})$$

$$\frac{\partial w}{\partial z} = \frac{P_0}{\pi\mu} \frac{1}{(\pi t)^{1/2}} \int_0^{\infty} e^{-\xi^2 t} \frac{\sin\xi}{\xi^2} d\xi \int_0^{\infty} \frac{\sin\xi}{\xi^2} [1 + \operatorname{erf}(\xi t^{1/2})] d\xi \quad (\text{IV.100})$$

These integrals with respect to ξ do not converge absolutely. However, these integrals converge in the Cesaro sense and represent transform images of functions which are finite for finite, t , z and x . To demonstrate the convergence in the Cesaro sense, a term of the form $\frac{2P_0}{\pi\mu} \frac{\sin\xi}{\xi^2}$ is subtracted from each integral.

These integrals then tend to a finite value. These integrals then exist as Cauchy principle values and may be evaluated.

$$\frac{1}{\pi} \int_0^{\infty} \frac{\sin\xi}{\xi^2} \operatorname{erf}(\xi t^{1/2}) d\xi = (\pi t)^{1/2} \operatorname{erf} \frac{1}{2t^{1/2}} - \operatorname{Ei} \left(-\frac{1}{4t} \right) \quad (\text{IV.101})$$

$$\frac{1}{\pi} \int_0^{\infty} \frac{\sin\xi}{\xi^2} e^{-\xi^2 t} d\xi = (\pi t)^{1/2} \operatorname{erf} \left(\frac{1}{2t^{1/2}} \right) + \pi t \operatorname{Si} \left(\frac{1}{4t} \right) \quad (\text{IV.102})$$

where

$$- \text{Ei} (-x) = \int_x^{\infty} \frac{e^{-t}}{t} dt$$

$$\text{Si} (x) = \int_0^x \frac{\sin t}{t} dt$$

Inserting these expressions into the equations for the displacement and stress

$$\frac{\mu}{P_0} w = \pi^{1/2} t^{1/2} \text{erf} \left(\frac{1}{2t^{1/2}} \right) - \text{Ei} \left(- \frac{1}{4t} \right) \quad (\text{IV.103})$$

$$\frac{\sigma_x}{P_0} = \text{erf} \left(\frac{1}{2t^{1/2}} \right) + \pi^{1/2} t^{1/2} \text{Si} \left(\frac{1}{4t} \right) \quad (\text{IV.104})$$

$$\frac{\mu}{P_0} \frac{\partial u}{\partial z} = \text{erf} \left(\frac{1}{2t^{1/2}} \right) + \text{Si} \left(- \frac{1}{2t} \right) \quad (\text{IV.105})$$

These expressions are plotted in Figure 8. The maximum shearing stress, by symmetry given as

$$\tau_{\max} = \frac{|\sigma_x - \sigma_z|}{2}, \quad (\text{IV.106})$$

is also plotted.

The time scale is the dimensionless time scale. The actual time scale for aluminum is plotted under the following restrictions, $\sigma_z > 20\sigma_{\text{yield}}$ and above the yield shear stress $D_0 = 10^3 \text{ cm}^2/\text{sec}$.

For short times after the impulse little plastic deformation has taken place. Around $100 \mu \text{ sec}$ the plastic deformation becomes appreciable and the decay of the shear stress becomes rapid. The horizontal stress rises rapidly, approaching the value of the vertical stress. If the shear stress is allowed to decay all the way to zero, then the horizontal and vertical stresses are equal and a state of

Figure 8 - Stresses and Strains at $x = 0$ $z = 0$
 Strip Load of Width $2b$ on Semi-Infinite Halfspace

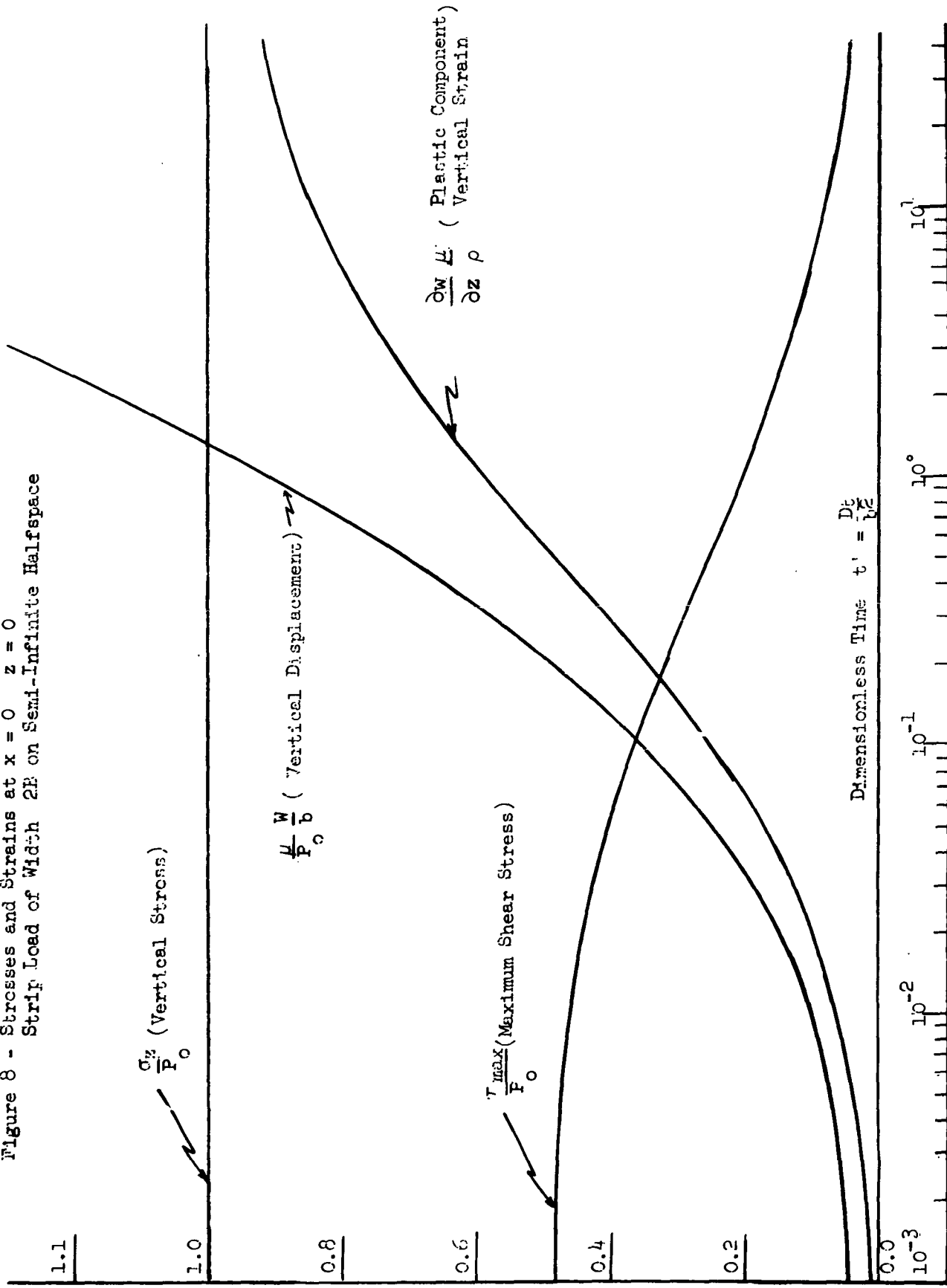

hydrostatic stress exists.

The stress-strain curve that is observed during deformation under rapid loading is not a unique curve. Its basic composition consists of two mechanisms, the first elastic and the second dislocation motion. The first mechanism responds instantaneously to the impulse while the second responds at a given rate characteristic of the medium.

The nature of this stress-strain relationship may be reasonably expected to vary at different points within the medium, since the original stress distribution will vary, and thus the average motion of the dislocation will vary. The relaxation of stress within the medium is of course dependent on the movement of the dislocations.

The stress and strain are functions of the dimensionless time variable

$$t' = \frac{Dt}{a}$$

To convert from the reduced time to actual time, the dependence of D on the maximum shear stress must be known. This was derived in the previous section.

$$D = \frac{\tau}{\tau_0} e^{\left[\frac{U_0}{kT} + \frac{\tau}{\tau_0} \right]} \quad \tau < \tau_0$$

$$D = D_0 \quad \tau > \tau_0$$

where τ_0 is the static yield stress, k is Boltzmann's constant and T is the absolute temperature. A representative diffusion coefficient is shown in Fig. 9.

Using the graphical solutions, the observed stress-strain curves were numerically calculated. These are shown in Figure 10 for various times after impact.

Figure 9
 Diffusion Coefficient For Dislocation Motion
 Versus
 Maximum Shear Stress

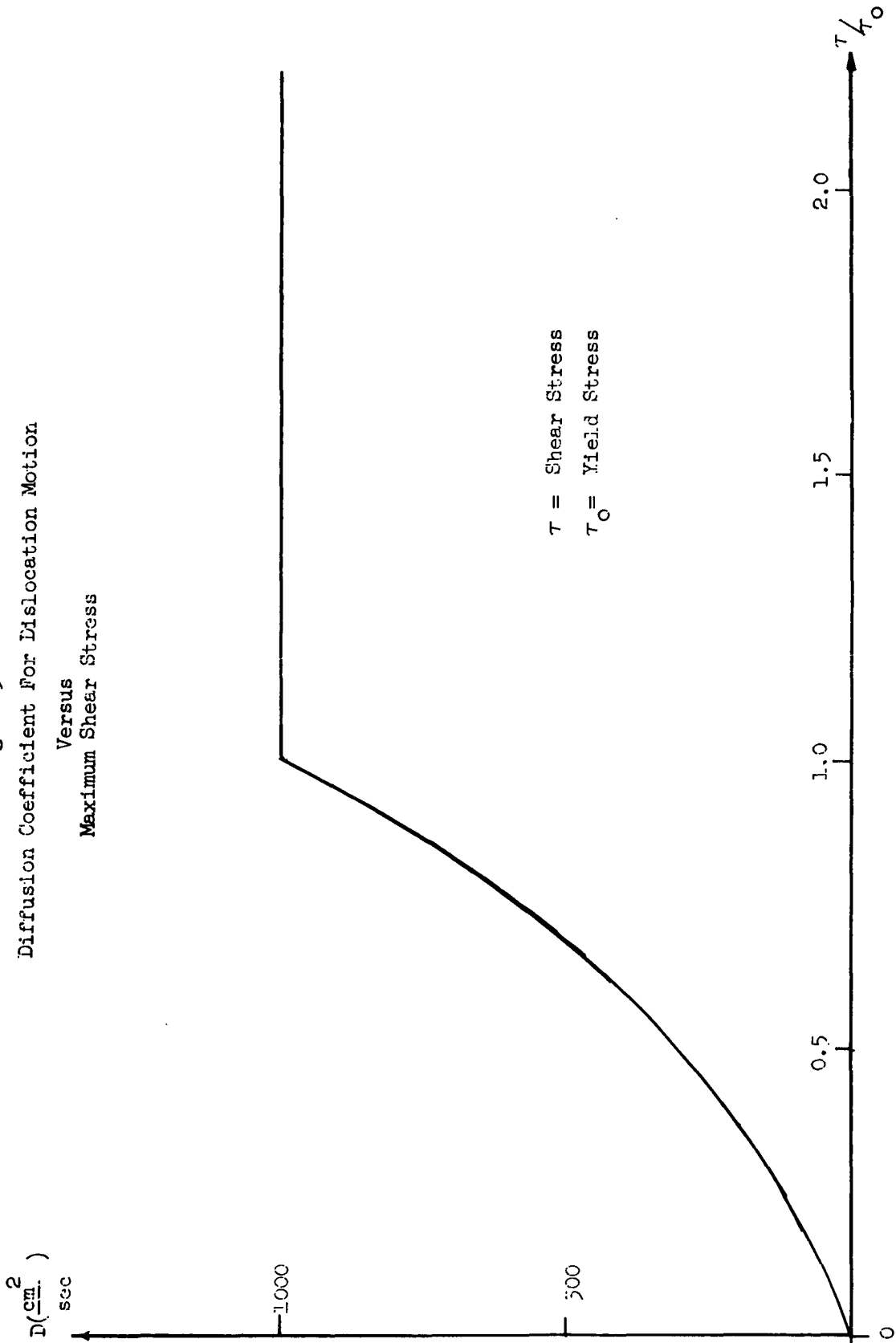

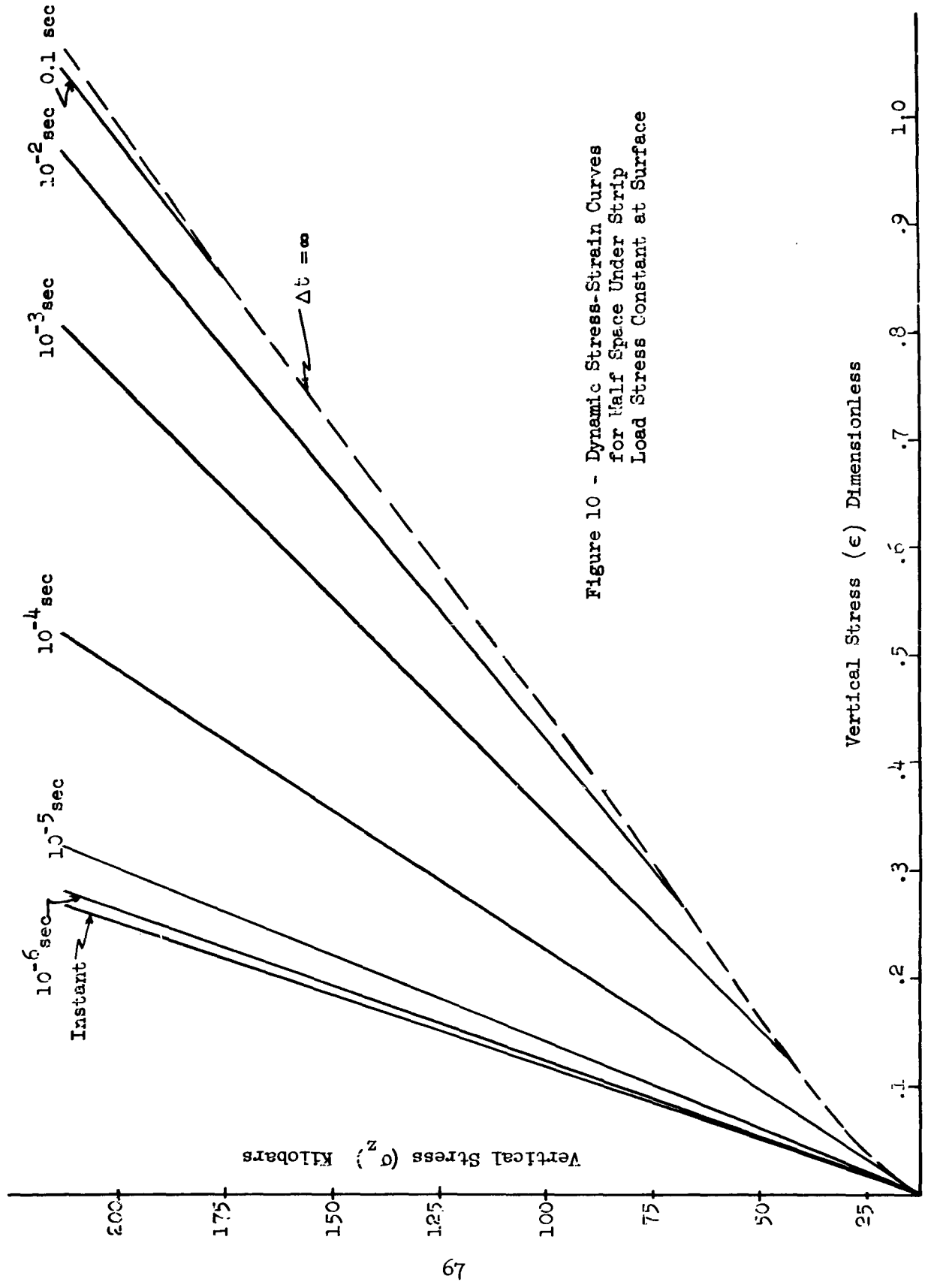

The stress-strain curve initially is a straight line corresponding to pure elastic deformation at very early times. At later times the stress-strain curve has a concave and a convex part. This is explained that below the yield stress, the original elastic stress strain curve is followed. Above the static yield stress, the strain component increases, but to a finite limit, while the stress is maintained. At points away from the boundary, the stress will change as a function of time in addition to the strain change. It is concluded that the observed stress-strain curve is very much dependent on the geometry of the system and where the relationship is measured.

Examine now the point on these stress-strain curves where the first concavity appears. A sharp turn is hard to describe and for this particular set of curves no actual sharp yield point is indicated. The two per cent offset curve, as good a definition of the dynamic yield point as any, is plotted as a function of time in Figure 11.

Figure 11
Apparent Yield Stress
Versus
Time Duration of Load
(2% Offset)
Aluminum Material

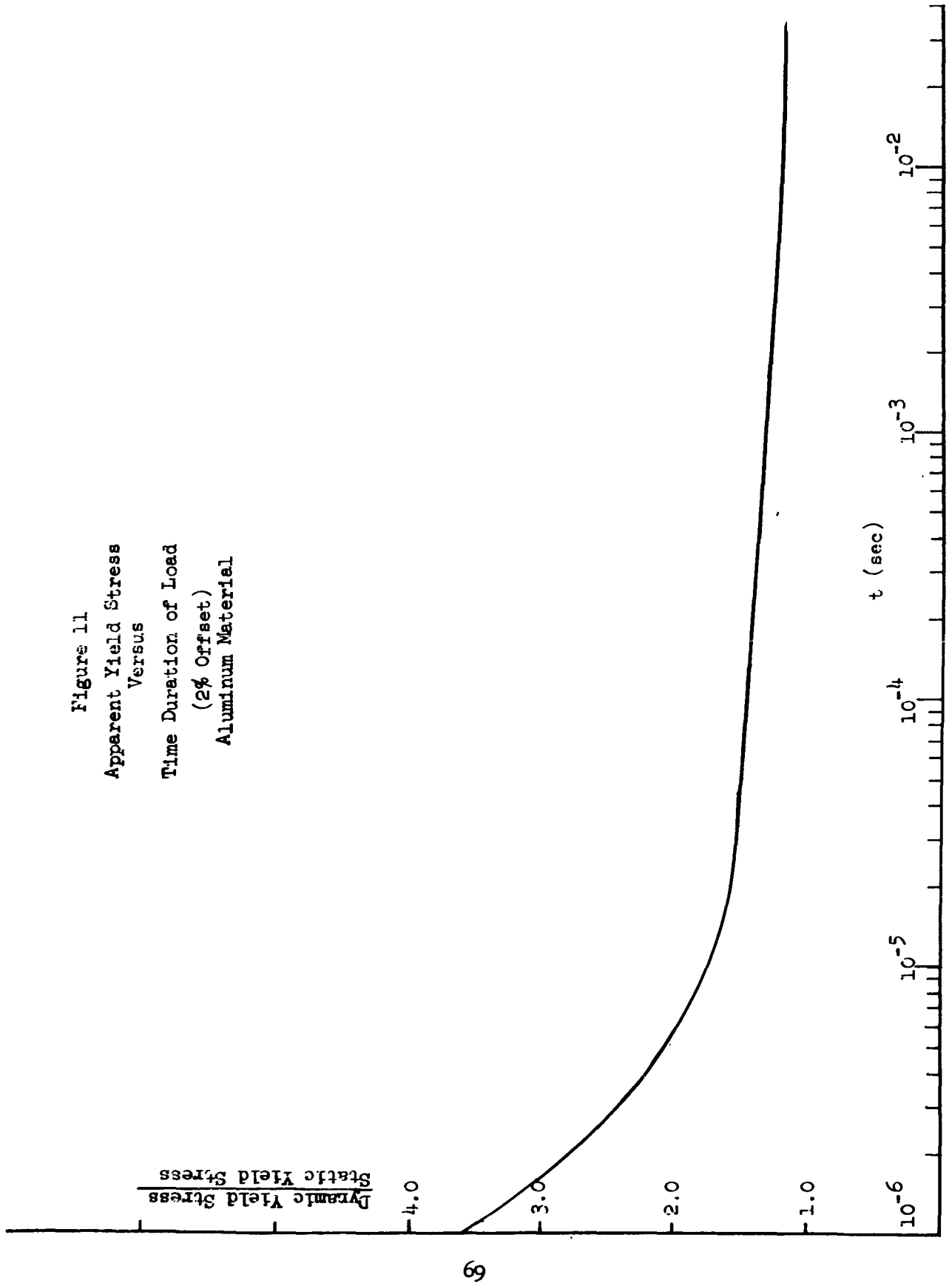

V. Impact Plastic Deformation - Cylindrical Shell Approximation

The equations of motion for dynamic plastic deformation are very cumbersome when applied to a cylindrical shell. The difficulty is caused by the nature of the transcendental integrands that occur when six boundary conditions must be satisfied.

To overcome the computational difficulties, a shell approximation is derived and the solution to the resulting set of equations is obtained. The establishment of the shell equations is guided by the elementary three dimensional equations previously derived,

The three dimensional solution indicates that the physical parameters in the equations of motion are the displacement gradients, (which may be resolved into elastic strains and permanent displacement gradients or plastic strain), the stresses associated with the elastic strain and a stress associated with the instability of the elastic strain configuration.

We therefore seek a formulation of the problem which will include the effect of these parameters. To accomplish this, a variational technique is used.

The formulation of a variational principle needs expressions for the kinetic and potential energy. No rigorous proof shall be given for the existence of such potentials. Their justification is based on an appeal by analogy to the results obtained in the three-dimensional case.

As in the previous solutions, the inertia terms will be omitted. The stress wave propagation across the thickness of the shell will be assumed to have occurred

many times and a quasi-steady state situation to be established.

The potential energy of the deformed shell consists of the elastic strain energy

$$\Sigma = \frac{1}{2} \sigma_{ij} \epsilon_{ij} \quad (V.1)$$

where σ_{ij} is the total stress and ϵ_{ij} is the geometric strain plus the potential energy due to the plastic driving force minus that plastic energy which is dissipated by the diffusive flow of dislocations. Since the plastic driving force in the three-dimensional equations is satisfied by a potential function, it is assumed that the potential energy associated with it may be written analogously to the elastic strain energy. The gradient of the plastic energy dissipates itself by the diffusive mechanism. Mathematically this may be formulated

$$V = \Sigma + \frac{p^2}{2M} - \frac{D}{2M_0} \int_0^t (p_{i,i}) dt \quad (V.2)$$

where M is a stress modulus which is taken as the yield stress in compression and D is the shear stress dependent diffusion coefficient for movement of the dislocations. A simple behavior of D with the maximum shear stress will be assumed. If the shear stress is greater than the static yield point

$$D = D_0$$

If the shear stress is lower than the static yield point

$$D = 0$$

Consider an infinite cylindrical shell of thickness h whose middle surface radius is R (Figure 12). The coordinate system is cylindrical polar. The formulation of the present equations is restricted to the case where there is no

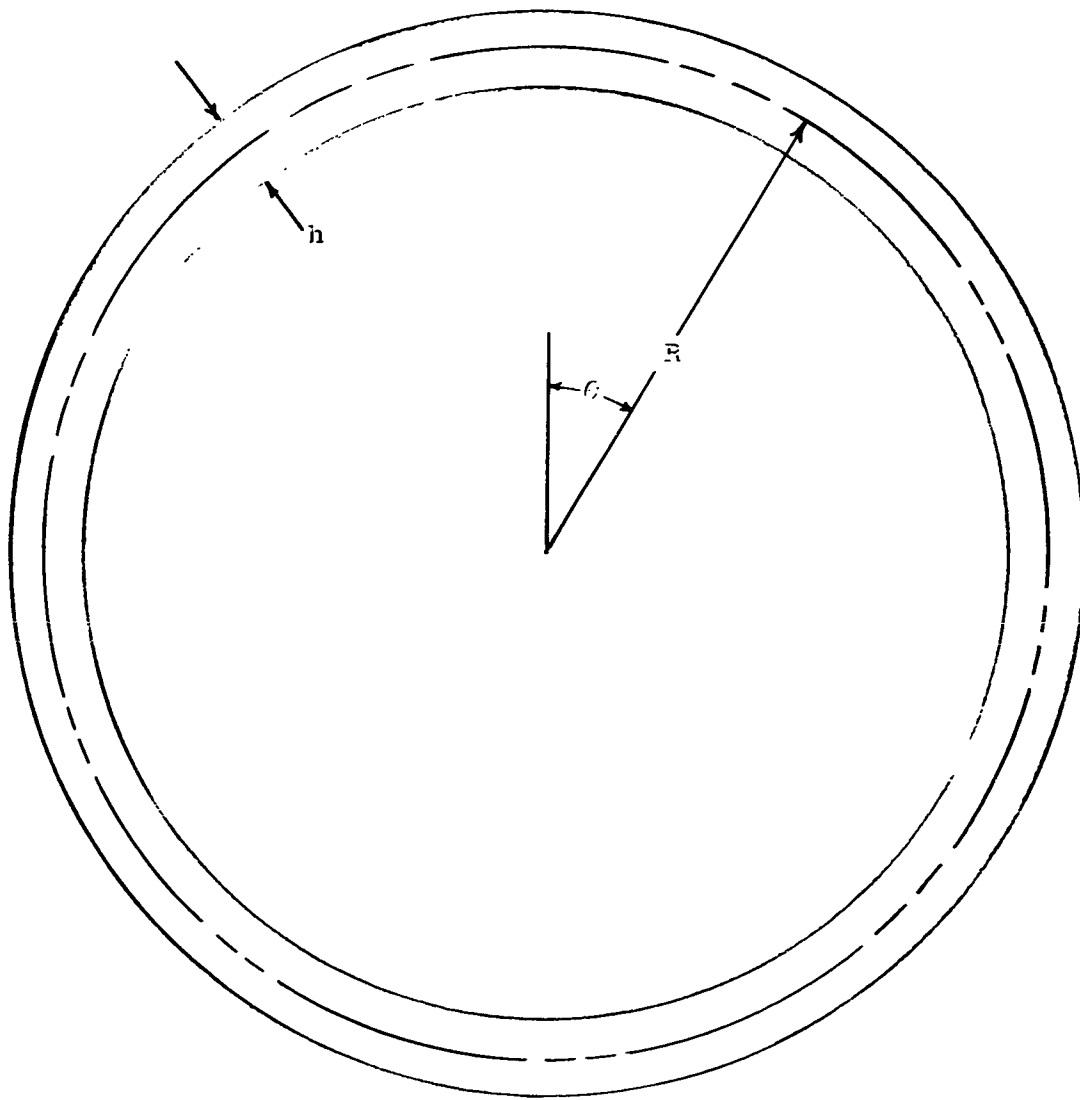

Figure 12
Geometry of Cylindrical Shell

displacement or variation of stresses in the direction of the generators, i.e.,

$$u \equiv 0 \quad \frac{\partial}{\partial z} \equiv 0. \quad (V.3)$$

Using the classic approach to shell theory, the only strain term that is considered is the strain along the middle surface in the tangential direction ϵ_0 . The strain in the radial direction is assumed to be negligibly small, as is the shear strain.

The linear approximation to the elastic strains and stresses will overestimate the elastic displacement. This error is not serious in the computation of the plastic strain as the main influence of the elastic stress state is to drive the plastic deformation at a given rate. The primary information needed about the elastic stress is to know when this stress exceeds the static yield condition. The strain is expanded as a function of the strain of the middle surface plus a linear term in r (7)

$$\epsilon_\theta = \epsilon_1 - \frac{1}{2} X_\theta r \quad (V.4)$$

$$\epsilon_1 = \frac{1}{R} \left(\frac{\partial v}{\partial \theta} - w \right) \quad (V.5)$$

$$X_\theta = \frac{1}{R^2} \left(\frac{\partial v}{\partial \theta} + \frac{\partial^2 w}{\partial \theta^2} \right) \quad (V.6)$$

where v is the tangential displacement and w is the radial displacement. ϵ_1 represents the membrane or extensional mode of deformation while $\frac{1}{2} X_\theta r$ represents the strain due to bending.

The elastic stress is given by

$$\sigma_\theta = \frac{E}{1-\nu} \epsilon_\theta \quad (V.7)$$

where E is Young's modulus

and ν is Poisson's ratio

The total stress is the sum of the elastic stress and the plastic stress.

$$\sigma = \frac{E}{1-\nu^2} \epsilon_{\theta} - p \quad (V.8)$$

The plastic driving force gradient is assumed constant across the thickness and the radial gradient then is zero.

$$p_{i, i} \cong \frac{1}{R} (p_{\theta} + p) \quad (V.9)$$

The potential energy may then be written using subscripts to denote differentiation.

$$\begin{aligned} V &= \frac{E}{2(1-\nu^2)} \int_{r_1}^{r_2} \int_0^{2\pi} \left[\frac{(v_{\theta} - w)^2}{R^2} + \frac{r^2}{4R^4} (v_{\theta} + w_{\theta\theta})^2 \right] R r dr d\theta \\ &- \int_{r_1}^{r_2} \int_0^{2\pi} \left[\frac{p}{R} (v_{\theta} - w) + \frac{r}{R^2} p (v_{\theta} + w_{\theta\theta}) \right] R r dr d\theta \\ &+ \int_{r_1}^{r_2} \int_0^{2\pi} \left[\frac{D}{2R^2 M} \int_0^t (p_{\theta} + p)^2 dt - \frac{p^2}{2M} \right] R r dr d\theta \\ &= - \int_0^{2\pi} F w R d\theta \quad (V.10) \end{aligned}$$

where F is the applied pressure in the inward radial direction.

Carrying the indicated integration with respect to r

$$\begin{aligned} V &= \frac{E}{2(1-\nu^2)} \int_0^{2\pi} \left[\frac{h}{R^2} (v_{\theta} - w)^2 + \frac{h^3}{12R^4} (v_{\theta} + w_{\theta\theta})^2 \right] R d\theta \\ &- \int_0^{2\pi} \left[\frac{p h}{R} (v_{\theta} - w) + \frac{h^2}{2R^2} p (v_{\theta} + w_{\theta\theta}) \right] R d\theta \\ &+ \int_0^{2\pi} \left[\frac{D h}{2R^2 M} \int_0^t (p + p_{\theta})^2 dt - \frac{h p^2}{2M} \right] R d\theta \\ &= - \int_0^{2\pi} F w R d\theta \quad (V.11) \end{aligned}$$

The differential equations of motion are evaluated by minimizing this integral. Applying the principles of the calculus of variations this is straight forward and the resulting equations are

$$\hat{D} \frac{h}{R} v_{\theta\theta} + \frac{\hat{D}h^3}{12R^3} v_{\theta\theta} - \frac{\hat{D}h}{R} w_{\theta} + \frac{\hat{D}h^3}{R^3} w_{\theta\theta\theta} - hp_{\theta} - \frac{h^2}{2R} p_{\theta} = 0 \quad (V.12)$$

$$\hat{D} \frac{h}{R} w + \frac{\hat{D}h^3}{12R^3} w_{\theta\theta\theta} - \hat{D} \frac{h}{R} v_{\theta} + \frac{\hat{D}h^3}{12R^3} v_{\theta\theta\theta} + hp - \frac{h^2}{2R} p_{\theta\theta} + FR = 0 \quad (V.13)$$

$$- h (v_{\theta} - w) - \frac{h^2}{2R} (v_{\theta} + w_{\theta\theta}) + \frac{Dh}{RM} \int_0^t (p_{\theta\theta} + 2p_{\theta} + p) dt - \frac{hpR}{M} = 0 \quad (V.14)$$

with $\hat{D} = \frac{E}{(1-\nu^2)}$

Introduce now the dimensionless displacements

$$v' = \frac{v}{R} \quad (V.15)$$

$$w' = \frac{w}{R}$$

and the dimensionless time

$$t' = \frac{Dt}{R^2} \quad (V.16)$$

The equations may now be written. The third equation is also differentiated with respect to time

$$D_1 (v'_{\theta\theta} - w'_{\theta}) + D_2 (v'_{\theta\theta} + w'_{\theta\theta\theta}) - (D_3 + D_4) p'_{\theta} = 0 \quad (V.17)$$

$$D_1 (w' - v'_{\theta}) + D_2 (w'_{\theta\theta\theta} + v'_{\theta\theta\theta}) + D_3 p' - D_4 p'_{\theta\theta} + \dot{F}' = 0 \quad (V.18)$$

$$-D_3 (v'_{\theta t} - w'_t) - D_4 (v'_{\theta t} + w'_{\theta\theta t}) + D_5 (p'_{\theta\theta} + 2p'_{\theta} + p) - D_6 p'_t = 0 \quad (V.19)$$

where

$$D_1 = \frac{E}{1-\nu^2}$$

$$D_2 = D_1 \frac{h^2}{12R^2} = \frac{Eh^2}{12(1-\nu^2)R^2}$$

$$D_3 = 1$$

$$D_4 = \frac{h}{2R}$$

$$D_5 = \frac{1}{M}$$

$$D_6 = \frac{1}{M}$$

The primes will now be dropped as no confusion can arise.

Solution

The solution to these equations will be sought in the transform space.

Denote the Laplace transform of the variables.

$$\hat{w}(s, \theta) = \int_0^{\infty} e^{-st} w(t, \theta) dt \quad (V.20)$$

$$\hat{v}(s, \theta) = \int_0^{\infty} e^{-st} v(t, \theta) dt \quad (V.21)$$

$$\hat{p}(s, \theta) = \int_0^{\infty} e^{-st} p(t, \theta) dt \quad (V.22)$$

Assume that the transform variables are separable and expand them in a Fourier series.

$$\hat{w}(s, \theta) = \sum_{n=0}^{\infty} \hat{w}_n(s) \cos n\theta \quad (V.23)$$

$$\hat{v}(s, \theta) = \sum_{n=0}^{\infty} \hat{v}_n(s) \sin n\theta \quad (V.24)$$

$$\hat{p}(s, \theta) = \sum_{n=0}^{\infty} \hat{p}_n(s) \cos n\theta \quad (V.25)$$

Utilizing the transform relations for derivatives, the equations in the transformed variables may be written

$$-n^2 (D_1 + D_2) \hat{v}_n + (nD_1 + n^3D_2) \hat{w}_n + n (D_3 + D_4) \hat{p}_n = 0 \quad (V.26)$$

$$(-nD_1 - n^3D_2) \hat{v}_n + (D_1 + n^4D_2) \hat{w}_n + (D_3 + n^2D_4) \hat{p}_n = \hat{f}_n \quad (V.27)$$

$$-ns (D_3 + D_4) \hat{v}_n - s (D_3 + n^2D_4) \hat{w}_n + (sD_6 - (n+1)^2D_5) \hat{p}_n = 0 \quad (V.28)$$

where

$$\hat{F}_n (s, \theta) = \sum_{n=0}^{\infty} \hat{F}_n (s) \cos n\theta \quad (V.29)$$

is the LaPlace Fourier transform of the applied pressure. The three equations are now reduced to a set of algebraic equations in the transform Fourier coefficients.

Using Cramer's rule

$$\hat{w}_n = -\hat{F}_n \frac{[-n^2 (D_1 D_6 + D_2 D_5) s + n^2 (D_3 + D_4)^2 + n^2 (D_1 D_5 + n^2 (nH)^2 D_2 D_5)]}{\Delta} \quad (V.30)$$

$$\hat{v}_n = \hat{F}_n \frac{(n D_1 D_6 + n^3 D_2 D_6) s - n^3 D_1 D_5 + n^3 (nH)^2 D_2 D_5}{\Delta} \quad (V.31)$$

where

$$\Delta = \begin{vmatrix} -n^2 (D_1 + D_2) & nD_1 + n^3D_2 & n(D_5 + D_4) \\ -nD_1 - n^3D_2 & D_1 + n^4D_2 & D_3 + n^2D_4 \\ -ns(D_3 + D_4) - s(D_3 + n^2D_4) & (sD_6 - (n+1)^2D_5) & \end{vmatrix} \quad (V.32)$$

$$\Delta = \left[(n^2+1)D_1D_4^2 + (n^2-1)D_1D_2D_6 + 2D_1D_3D_4 - (n^2+1) D_2D_3^2 - 2n^2D_2D_3D_4 \right] s - (n+1)^2 (n^2-1)^2 D_1D_2D_5 \quad (V.33)$$

For shells

$$D_1 > D_2$$

and for most materials

$$D_2 \gg D_3 > D_4$$

Thus the expressions for the displacements may be simplified

$$\hat{w}_n = \hat{P}_n \frac{[-n^2(D_1 D_6)s + n^4 D_1 D_5]}{(n^2-1) D_1 D_2 D_6 (s-\gamma_n)} \quad (V.34)$$

$$\hat{v}_n = \hat{P}_n \frac{n(D_1 D_6)s - n^3 D_1 D_5}{(n^2-1) D_1 D_2 D_6 (s-\gamma_n)} \quad (V.35)$$

where $\gamma_n = (n+1)^2$ (V.36)

These are the general transform solutions for the Fourier coefficients for an arbitrary applied pressure. A special case will now be examined.

Let us assume that a radial pressure of uniform magnitude is applied over a region of the cylinder surface and zero is outside that region (Figure 13),

$$\begin{aligned} F &= F(t) & -\alpha \leq \theta \leq \alpha \\ &= 0 & \text{elsewhere} \end{aligned} \quad (V.37)$$

The Fourier cosine expansion of this pressure is

$$F(\theta, t) = F_0(t) \left[\frac{\alpha}{\pi} + \frac{2}{\pi} \sum_{n=1}^{\infty} \frac{\sin n\alpha}{n} \cos n\theta \right] \quad (V.38)$$

The time dependence of the pressure on the surface will be a decaying exponential

$$F = F_0 e^{-\beta t} \quad (V.39)$$

The Laplace transform of the series is then given by

$$\hat{F}(s, \theta) = \frac{F_0}{s-\beta} \left[\frac{\alpha}{\pi} + \frac{2}{\pi} \sum_{n=1}^{\infty} \frac{\sin n\alpha}{n} \cos n\theta \right] \quad (V.40)$$

The transforms of the Fourier coefficients then are given by

$$D_2 \hat{w}_n = + \frac{2F_0 (ns - n^3) \sin n\alpha}{\pi (s-\gamma_n)(s-\beta)(n^2-1)} \quad (V.41)$$

Figure 13
 Response of Shell Displacements
 to a Unit Step Load

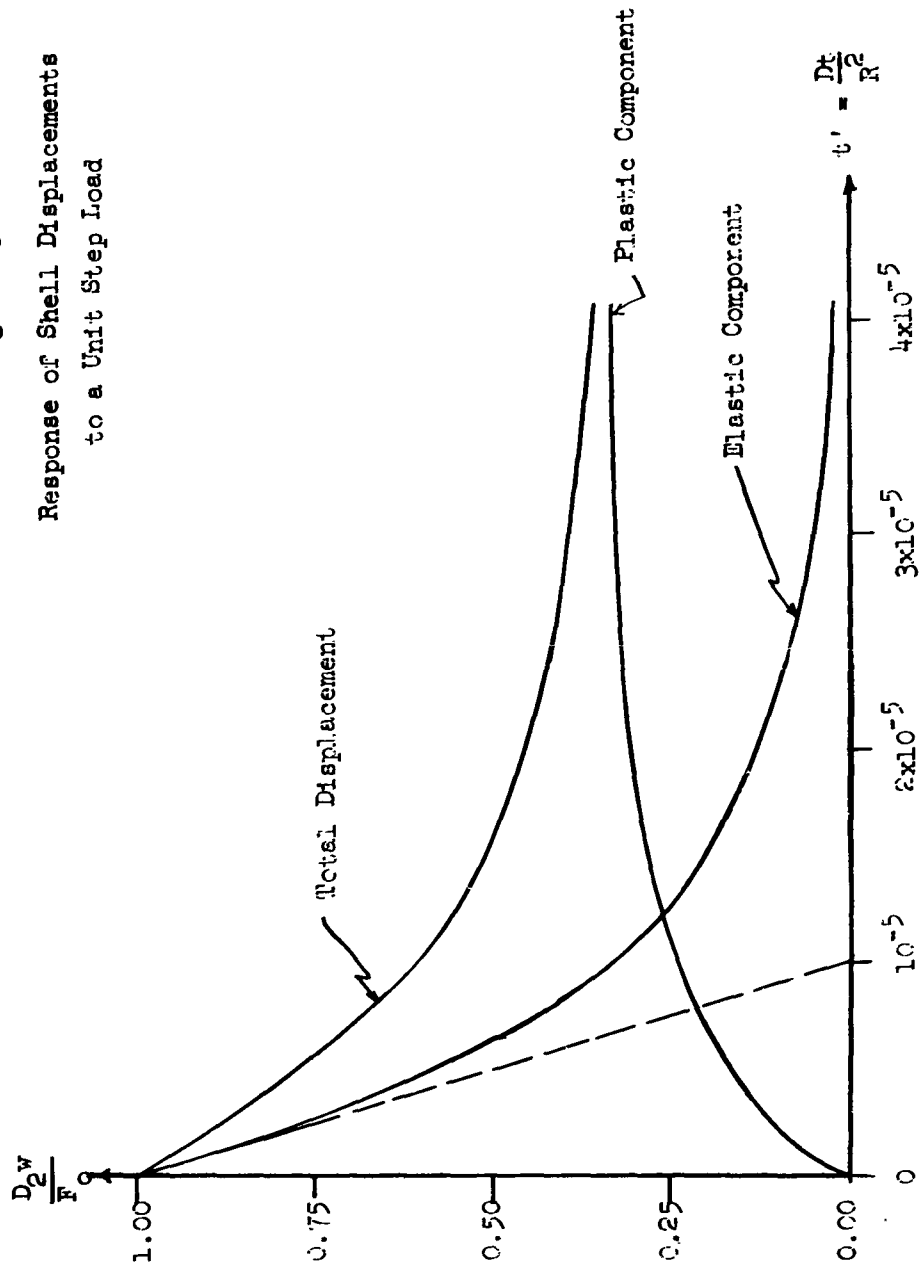

$$D_2 \hat{v}_n = -\frac{2F_0 (s-n^3) \sin n\alpha}{\pi (s-\gamma_n)(s-\beta)(n^2-1)} \quad (V.42)$$

Inverting these integrals

$$w_n(t)' = \frac{1}{2\pi i} \int_{c-i\infty}^{c+i\infty} \hat{w}_n(s) e^{st} ds \quad (V.43)$$

$$v_n(t) = \frac{1}{2\pi i} \int_{c-i\infty}^{c+i\infty} \hat{v}_n(s) e^{st} ds \quad (V.44)$$

by the values at the residues of the integrals

$$\frac{D_2}{F_0} w_n(t) = \frac{2n(\sin n\alpha)}{\pi(n^2-1)} \left[\frac{(\beta^2 - n^2 \gamma_n) e^{-\beta t}}{\beta - \gamma_n} - \frac{(n^2 \gamma_n - \gamma_n) e^{-\gamma_n t}}{\beta - \gamma_n} \right] \quad (V.45)$$

$$\frac{D_2}{F_0} v_n(t) = \frac{-2 \sin n\alpha}{\pi(n^2-1)} \left[\frac{(\beta^2 - n^2 \gamma_n) e^{-\beta t}}{\beta - \gamma_n} + \frac{(n^2 \gamma_n - \gamma_n) e^{-\gamma_n t}}{\beta - \gamma_n} \right] \quad (V.46)$$

These results will be regrouped to indicate the elastic and plastic components. To show how this is done, consider the case of the Heaviside unit pressure pulse i.e., $\beta = 0$

$$\frac{D_2}{F_0} w_n(t) = \frac{2n \sin n\alpha}{\pi(n^2-1)} \left[\frac{-n^2 \gamma_n}{\gamma_n} + \frac{(n^2 \gamma_n - \gamma_n)}{\gamma_n} e^{-\gamma_n t} \right] \quad (V.47)$$

or

$$\frac{D_2}{F_0} w_n(t) = \frac{2n \sin n\alpha}{(n^2-1)} \left[-e^{-\gamma_n t} - n^2 (1 - e^{-\gamma_n t}) \right] \quad (V.48)$$

At the instant of applied load no plastic deformation is present. Only elastic deformation can account for the initial displacement. At later times the elastic deformation decays and the plastic deformation increases as the dislocations have a chance to move. In the above expression the first term has its

maximum value at $t = 0$, and thereafter decreases while the second term starts at zero and increases with time. Thus we identify the first term with the elastic displacement and the second term with the permanent or plastic displacement, (Figure 14).

Taking a finite value of β , the same regrouping may be made.

$$\frac{D_2}{F_0} w_n(t) = \frac{2n \sin n\alpha}{\pi(n^2-1)} \left[\frac{\beta e^{-\beta t} - \gamma_n e^{-\gamma_n t}}{\beta - \gamma_n} - \frac{\gamma_n n^2 (e^{-\beta t} - e^{-\gamma_n t})}{\beta - \gamma_n} \right] \quad (V.49)$$

$$\frac{D_2}{F_0} v_n(t) = -\frac{2}{\pi} \frac{\sin n\alpha}{(n^2-1)} \left[\frac{\beta e^{-\beta t} - \gamma_n e^{-\gamma_n t}}{\beta - \gamma_n} - \frac{\gamma_n n^2 (e^{-\beta t} - e^{-\gamma_n t})}{\beta - \gamma_n} \right] \quad (V.50)$$

The solution for the zeroth mode requires special handling. This mode corresponds to a uniform pressure applied around the circumference. The transform equations for the radial displacement and the plastic driving stress for this mode are

$$D_1 \hat{w}_0 + D_3 \hat{p}_0 = \hat{F}_0 \quad (V.51)$$

$$-s D_3 \hat{w}_0 + (s D_6 - D_5) \hat{p}_0 = 0 \quad (V.52)$$

The solution for \hat{w}_0 is

$$\hat{w}_0 = \frac{\hat{F}_0 (s D_6 - D_5)}{D_1 (s D_6 - D_5) + D_3^2} \quad (V.53)$$

Inserting the value for \hat{F}_0

$$\frac{D_1}{F_0} w_0^{\rightarrow} = \frac{\alpha}{\pi} \frac{s D_6 - D_5}{\left[s D_6 - D_5 - \frac{D_3^2}{D_1} \right] (s - \beta)} \quad (V.54)$$

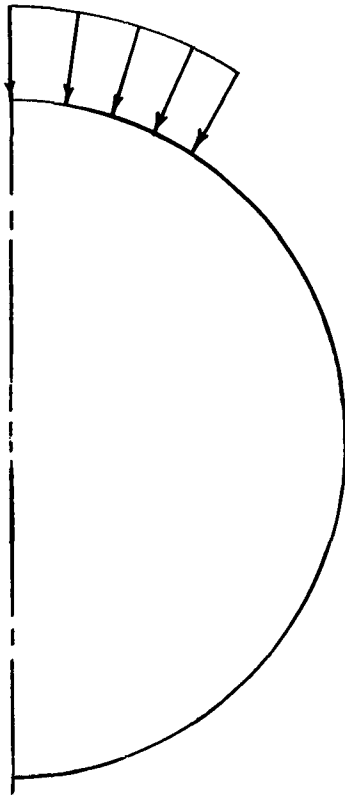
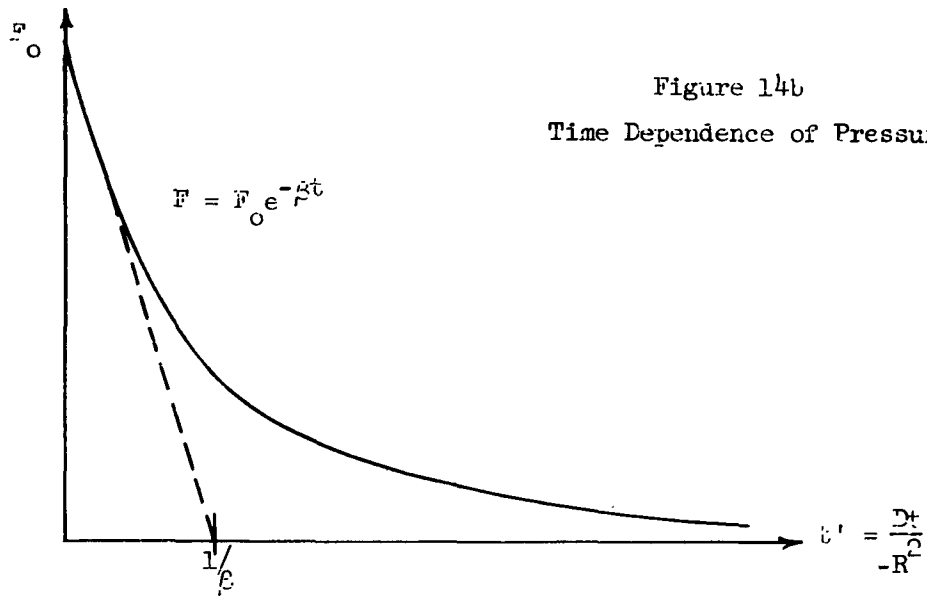

Figure 14a
Pressure Pulse on a
Cylindrical Shell



Inverting and using the fact that $D_5 = D_6$

$$\frac{D w_0}{F_0}(t) = \frac{a}{\pi} \left[\frac{\beta-1}{\beta-1-\delta} e^{-\beta t} - \frac{\delta e^{-(1+\delta)t}}{\beta-1-\delta} \right] \quad (V.55)$$

where $\delta = \frac{D_3^2}{D_1 D_5}$

For the particular example to be evaluated this term is small compared to the higher modes and will be neglected.

The first mode requires special handling for solution. This mode corresponds to the translation of the whole shell. No deformation is involved and therefore this mode is not evaluated.

We will now investigate the qualitative behavior of the deformation modes. The elastic portion starts at some initial value and decays to zero in a finite time. The plastic component starts at zero displacement and increases to a maximum at the same time the elastic part reaches zero. The solutions beyond this time are discarded as they imply that the plastic or permanent deformation does work to increase the elastic deformation. However the plastic part indicates an amount of energy which is permanently lost to the recoverable portion of the total energy of deformation. The solutions after this critical time indicate that this energy is recovered. Since we have made the identification of this displacement with nonrecoverable deformation, the solution beyond the critical time is meaningless.

The plastic deformation will increase until the maximum shear stress decreases to the static yield point. At this time the plastic deformation stops at that value. This may be shown by computing the actual time scale from the

$$\begin{aligned}
h &= 2 \text{ cm} \\
R &= 100 \text{ cm} \\
M &= 10 \text{ Kbars} \\
E &= 750 \text{ Kbars} \\
D &= 10^3 \text{ cm}^2/\text{sec}
\end{aligned}$$

A uniform pressure of 100 Kbars is applied over a 60° arc on the exterior of the shell, (Figure 14a) so that $\alpha = 30^\circ$. The time dependence of the load is a decaying exponential (Figure 14b)

$$F = F_0 e^{-\beta t}$$

In the actual time scale β is chosen as $10^5/\text{sec}$. In the reduced time scale

$$\beta = 10^6$$

The elastic displacement from the zeroth mode is negligible compared with the displacements of the second and third modes.

The first mode does not involve any distortion of the shell and is therefore neglected.

We retain only the first two modes. The two modes $n = 2, 3$ were computed.

The elastic portion of the solution for these two modes was calculated first (Figure 15 and 16). The maximum shearing stress was calculated at a number of points to determine the cutoff time, i.e., the time at which the diffusion coefficient went to zero. The plastic portion of the displacement for these two modes was calculated (Figure 17 and 18), and evaluated at the cutoff time. Table I shows the values of the cutoff points, the values of the plastic deformation at that time, and the computed values of the radial and tangential displacements.

Figure 15
Elastic Portion of Radial Displacement
Mode 2

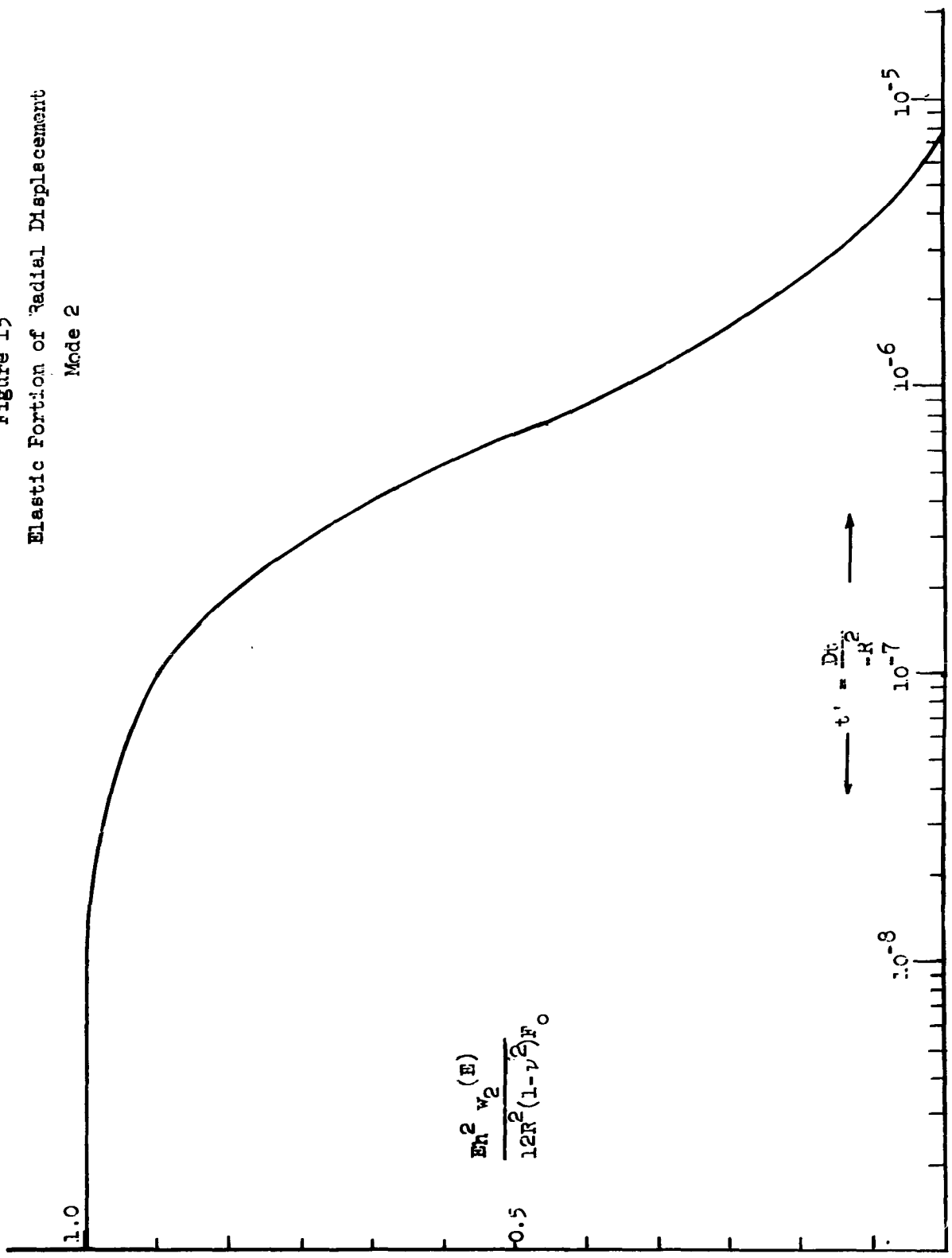

Figure 16
Elastic Portion of Radial Displacement
Mode 3

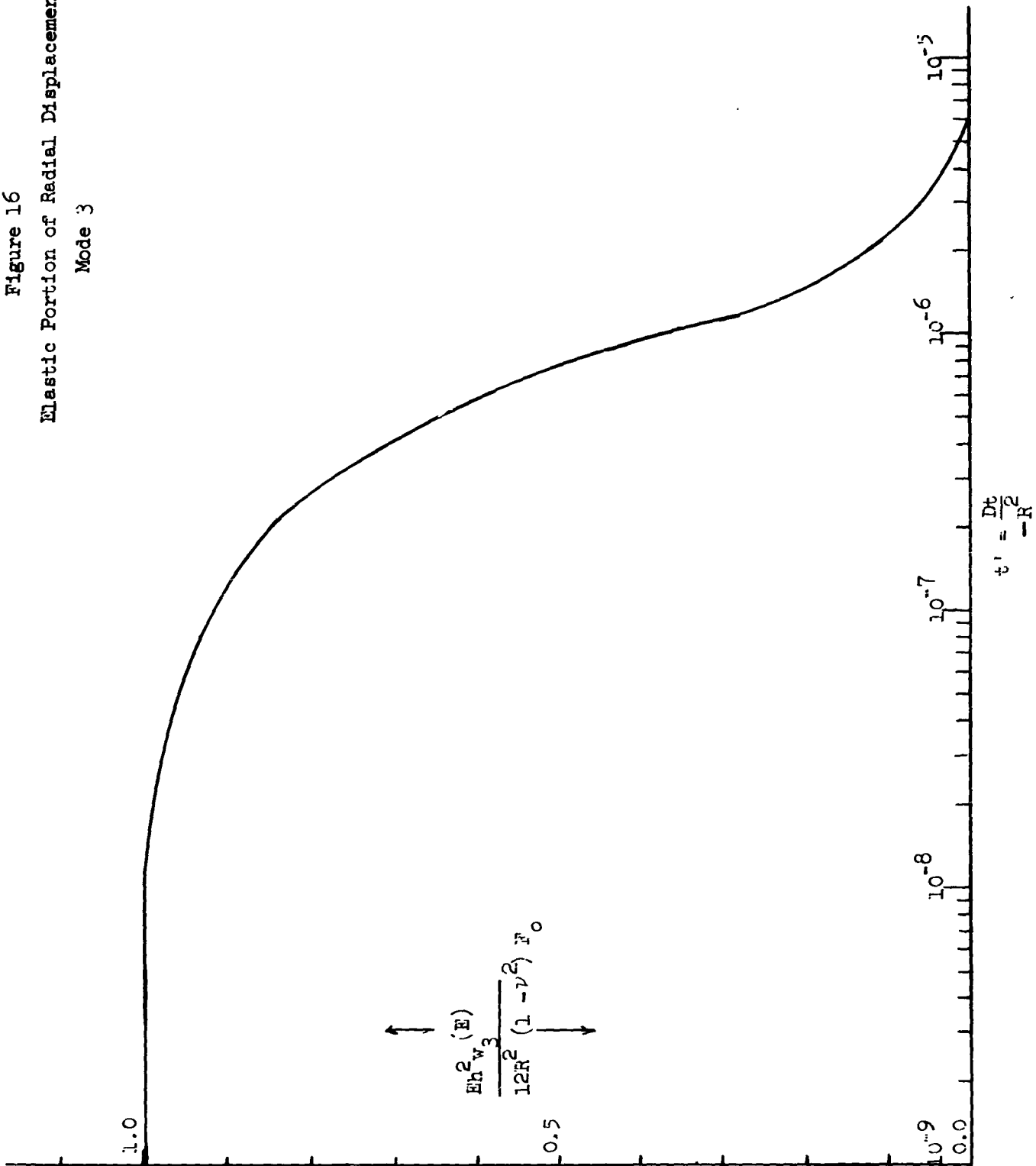

Figure 17
 Permanent Displacement vs. Time
 Mode 2

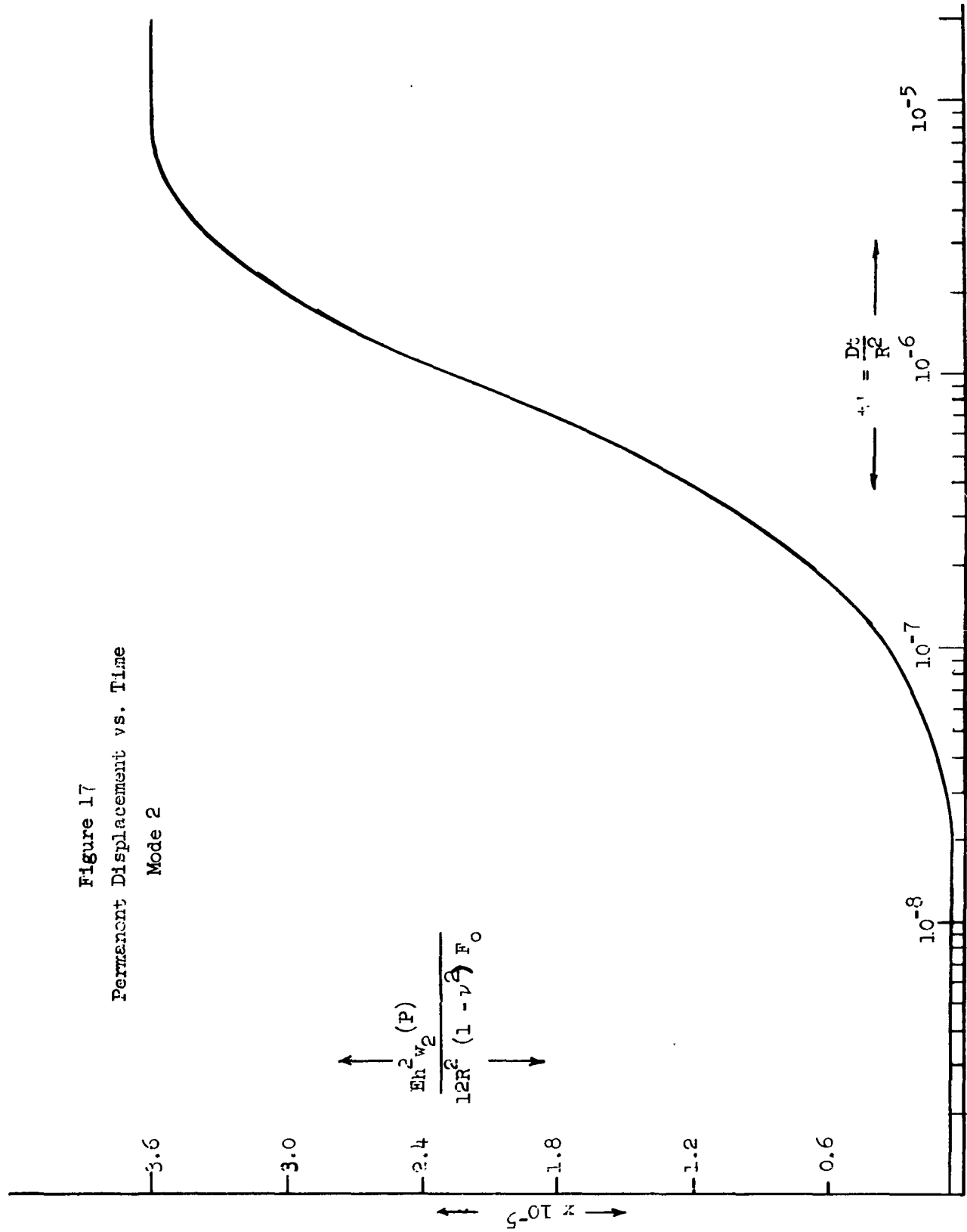

Figure 18
 Permanent Displacement vs. time
 Mode 3

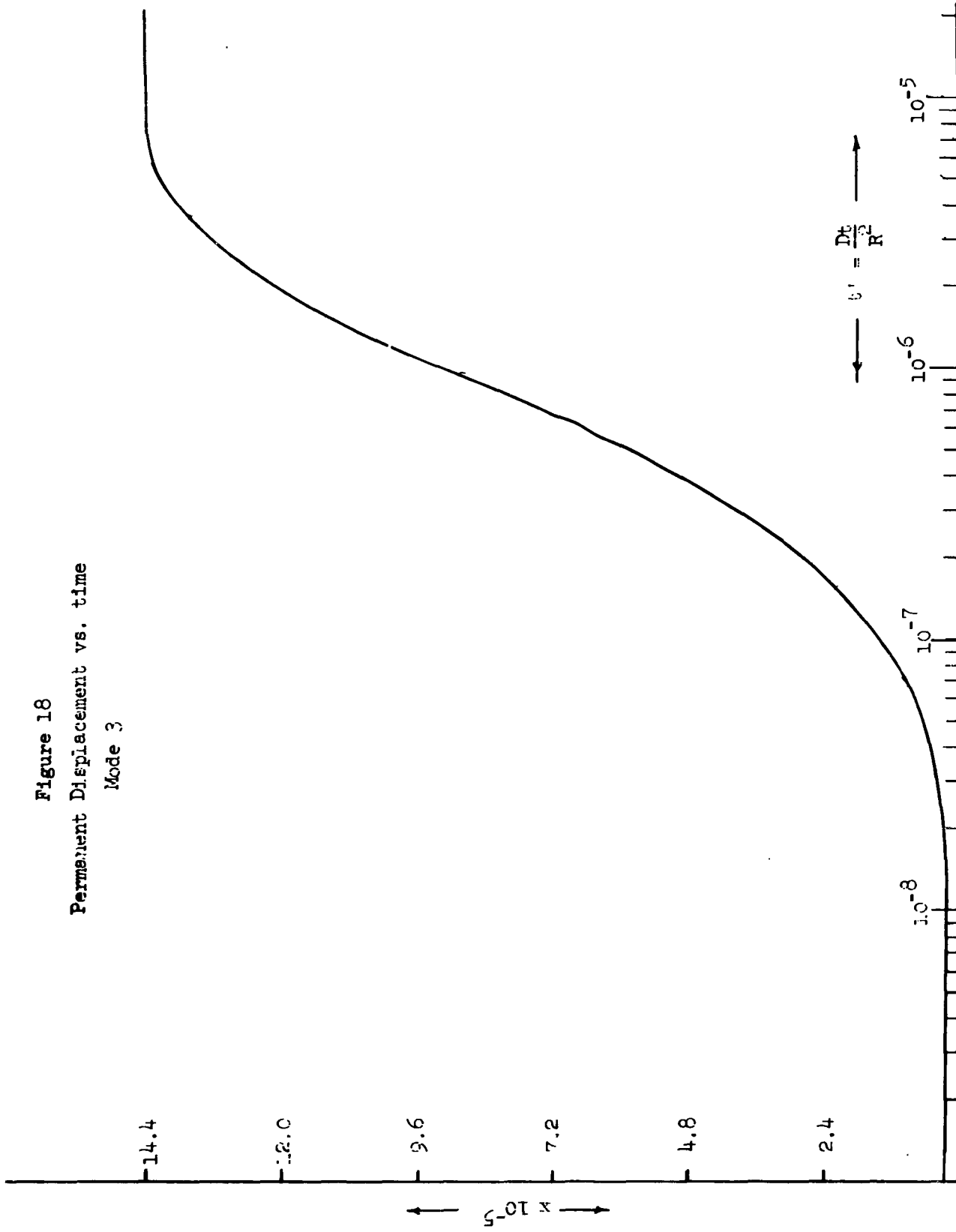

TABLE 1

PERMANENT DISPLACEMENTS FOR CYLINDRICAL SHELL

θ	t_c	$\frac{Eh^2}{12R^2F(1-\nu^2)} W_2^P$	$\frac{Eh^2}{12R^2F(1-\nu^2)} W_3^P$	$\frac{Eh^2}{12R^2F(1-\nu^2)} V$	$\frac{Eh^2}{12R^2F(1-\nu^2)} W$
0	2.3×10^{-6}	3.18×10^{-5}	1.272×10^{-4}	0	1.59×10^{-4}
15	1.8×10^{-6}	2.94×10^{-5}	1.176×10^{-4}	3.51×10^{-5}	1.09×10^{-4}
30	6.2×10^{-7}	1.62×10^{-5}	6.48×10^{-5}	2.86×10^{-5}	8.1×10^{-6}
45	5.0×10^{-7}	1.41×10^{-5}	5.64×10^{-5}	2.04×10^{-5}	-3.99×10^{-5}
60	1.7×10^{-6}	2.88×10^{-5}	1.152×10^{-4}	1.25×10^{-5}	-1.29×10^{-4}
75	1.8×10^{-6}	2.94×10^{-5}	1.176×10^{-4}	-2.04×10^{-5}	-1.09×10^{-4}
90	1.4×10^{-6}	2.64×10^{-5}	1.056×10^{-4}	-3.52×10^{-5}	-2.64×10^{-5}
105	4.8×10^{-7}	1.38×10^{-5}	5.52×10^{-5}	-1.65×10^{-5}	2.70×10^{-5}
120	0	0	0	0	0
135	4.7×10^{-7}	1.34×10^{-5}	5.36×10^{-5}	6.0×10^{-6}	3.79×10^{-5}
150	6.0×10^{-7}	1.59×10^{-5}	6.36×10^{-5}	1.43×10^{-5}	7.95×10^{-6}
165	3.7×10^{-7}	1.11×10^{-5}	4.44×10^{-5}	7.72×10^{-6}	-2.18×10^{-5}
180	2.4×10^{-7}	7.4×10^{-6}	2.96×10^{-5}	0	-2.22×10^{-5}

value of the dimensionless time

$$t = \frac{R^2}{D(\tau)} t' \quad (V.56)$$

When the shear stress is below the static yield value $t = \infty$.

To compute the value of the plastic strain, the time dependence of the maximum shear stress must be known.

$$\text{Now } \tau = \frac{1}{2} \left| \sigma_r - \sigma_\theta \right| \quad (V.57)$$

$$\tau = \mu \left| \epsilon_r - \epsilon_\theta \right| \quad (V.58)$$

where μ is the shear modulus. In the shell approximation, the radial strain is assumed zero so that

$$\frac{\tau}{\mu} = \left| \epsilon_\theta \right| \quad (V.59)$$

For very thin shells, the tangential strain is given by the membrane strain for low modes

$$\epsilon_\theta = v_\theta - w \quad (V.60)$$

For each Fourier component

$$\epsilon_\theta \cos n\theta = (n v_n - w) \cos n\theta \quad (V.61)$$

But

$$n v_n = -w_n \quad (V.62)$$

Thus

$$\frac{\tau}{2\mu} = \left| \sum_{n=0}^{\infty} w_n \cos n\theta \right| \quad (V.63)$$

A numerical example for the permanent deformation of a cylindrical shell under a high, rapidly decaying load is given. For this example, a shell with the following geometrical and physical properties is chosen

$$R = 100 \text{ cm}$$

$$h = 2 \text{ cm}$$

$$F_0 = 100 \text{ kbars} = E/6$$

$$\beta = 10^5 / \text{sec.}$$

Figure 19 shows the shape of the deformed shell.

Since this computation retained only two of the terms of a slowly converging Fourier series, the results show a great deal of wobble, particularly on the backside of the plate. Estimating the value of the elastic strain to 30 modes, the plastic deformation term is negligible beyond $\theta = 45^\circ$. Setting all of these permanent displacements equal to zero and retaining only the two mode approximation to the plastic deformation results in a more physically realizable picture. This deformation pattern is shown in Figure 20.

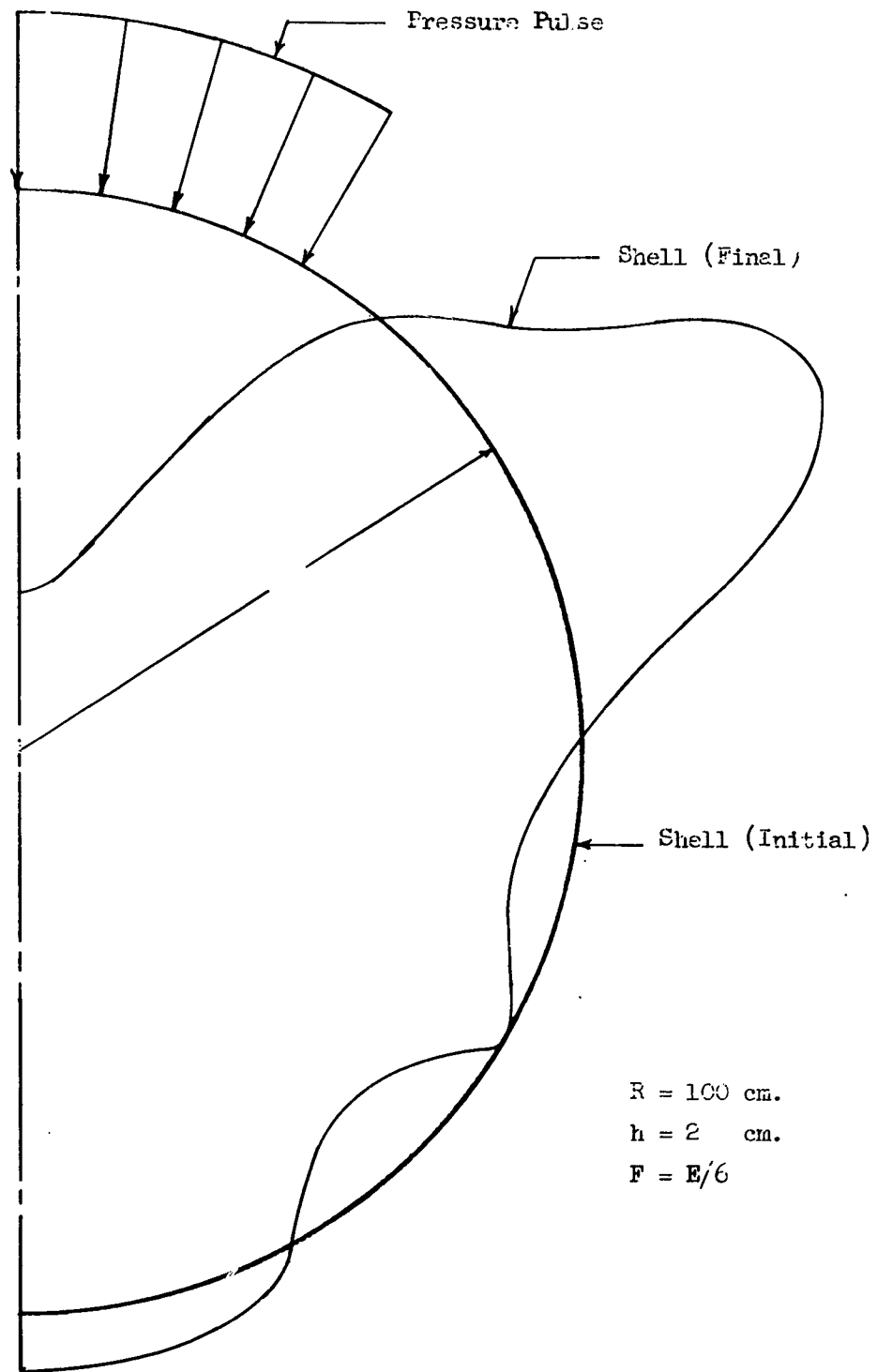

Figure 19
 Permanent Deformation of a Cylindrical
 Shell Under a Time Dependent Pressure Pulse
 (Modes 2 and 3 only)

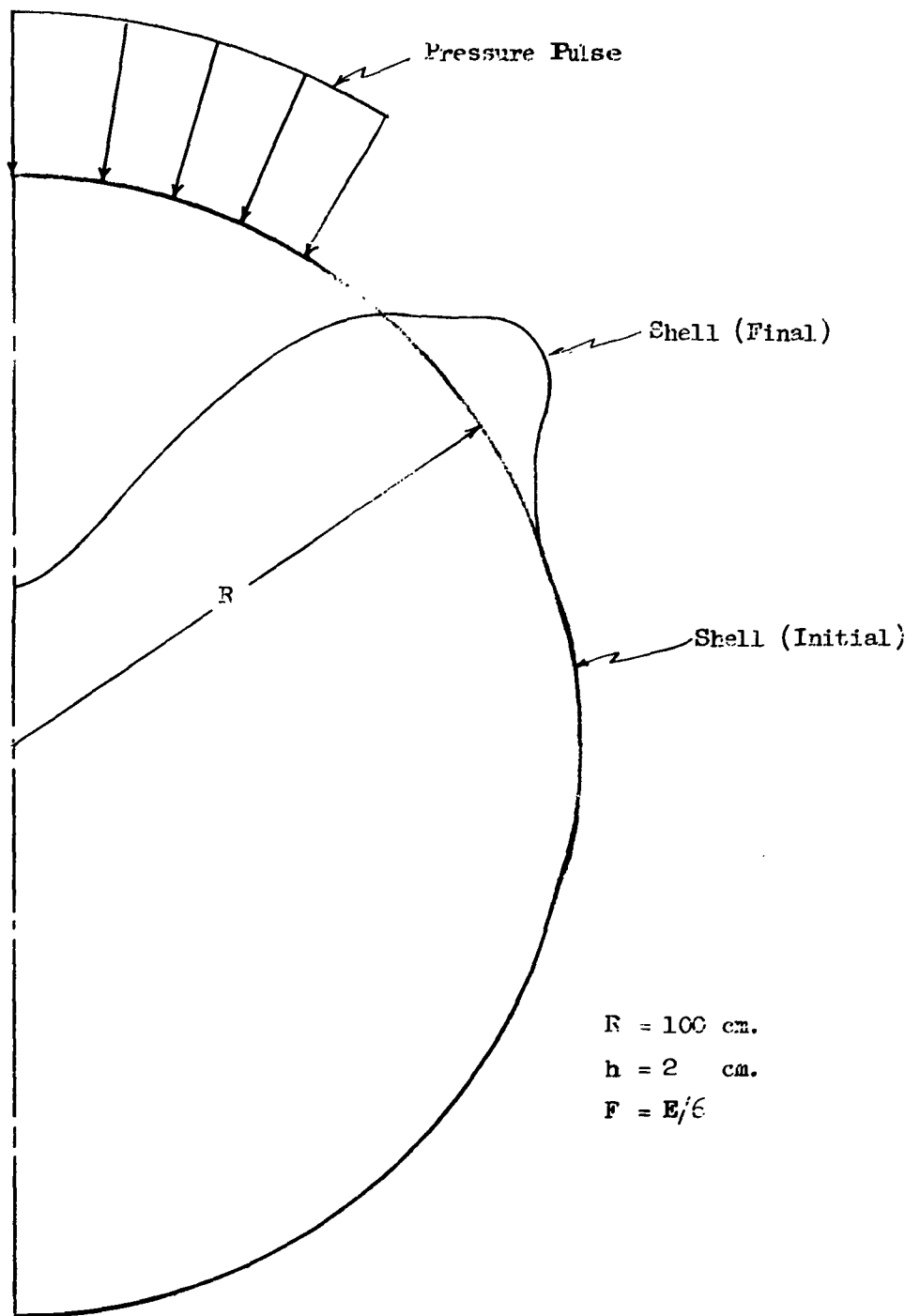

Figure 20
 Permanent Deformation of a Cylindrical
 Shell Under Time-Dependent Pressure Pulse
 Refined Approximation

VI Summary and Conclusions

The problem of plastic deformation under time dependent loads has been investigated from the viewpoint that at least two mechanisms work simultaneously in this process of deformation. In addition to the usual elastic deformation, further microscopic deformation by a specific microscopic mechanism has been studied. This mechanism is the motion of dislocations under an applied stress.

A set of equations of motion for a deforming body were derived under these assumptions of this physical model. These equations, when restricted to hydrostatic variation of the non-equilibrated driving force are identical with the equations of motion for a compacting porous medium. Formal solution of the equations of motion for a propagating stress wave where the material is stressed above the elastic limit indicates that a damped elastic wave propagates at the usual sonic velocity while further deformation occurs near the boundary due to diffusive flow of the dislocations.

A detailed analytical and numerical solution for two problems involving plastic deformation was carried out. The first problem solved was the deformation of a semi-infinite half space under a strip load. The displacements, stresses and total strains were analytically determined in integral form and were evaluated for a specific point. Several interesting conclusions were demonstrated.

1. The stress-strain curve that is observed is a function of time duration of load, level and rate of applied stress and the geometry of the problem.

2. The dynamic yield stress is explained simply as the first noticeable deviation from the pure elastic curve. The dynamic yield stress is a result of the process, rather than an explicit material property.

The equations of motion were applied to deformation of a cylindrical shell. A shell approximation including the effects of the dislocation movement were established and a numerical approximation calculated.

BIBLIOGRAPHY

1. Abramson, H.V., Plass, H.J., and Ripperger, E.A., *Adv. Appl. Mech.* 5, 111-193 (1958)
2. Bilby, B., *Prog. Solid Mech* 1, 331-346 (1960)
3. Cartan, E., *Oeuvres Completes*, partie 3, vol. 1, Gauthiers-Villars (1955)
4. Cinelli, G. and Fugelso, L.E., *Study of Ground Motion Produced by Nuclear Blasts*, Final Tech. Rept., AFSWC-TR-60-8 (1960)
5. Cottrell, A.H., *Dislocations and Plastic Flow in Solids*, Oxford U.P. (1953)
6. Einstein, A. and Kaufmann, *Ann. Math* 62, 128 (1955)
7. Eubanks, R.A., *Final Report Contract AF 33(616)2522 Vol. III (Unclassified)* 1958
8. Geiringer, H., *Mathematical Plasticity*, *Handbuch der Physik*, Bd6, (1955)
9. deGroot, S.R., *Irreversible Thermodynamics*, North Holland Publishing Co., (1951)
10. Von Karman, T., *On the Propagation of Plastic Deformation in Solids*, NRDC Report A-29 (1942)
11. Von Karman, T. and Duwez, P.E., *Jour. Appl. Phys.* 21, 232-237, (1950)
12. Kondo, K., *Research Association of Applied Geometry, Memoirs*, I, (1955)
13. Kondo, K., *Research Association of Applied Geometry, Memoirs*, II, (1958)
14. Kroner, E. *Kontinuumstheorie der Versetzungen und Eigenspannung*, Springer-Verlag (1958)
15. MacNamee, J. and Gibson, R.E., *Quart. Mech. Appl. Math.* 13, 98-111 (1960) and 13, 210-227, (1960)
16. Orowan, E., *Z. Phys.* 89, 605, (1934)
17. Polyani, M., *Z. Phys.* 89, 660, (1934)
18. Rice, S.A., *Phys. Rev.*, 112, 804, (1958)
19. Taylor, G.I., *Proc Roy Soc., Series A*, 145, 362, (1934)
20. Taylor, G.I., *The Plastic Wave in a Wire Extended by an Impact Load*, British R.C. Rept. 329, (1942)

21. Taylor, G.I., Proc Roy Soc. Series A, 194, 289-299 (1948)
22. White, M.P., and Griffis, L., Jour. Appl. Mech. 70, 256-259 (1948)
23. Whiffen, A.C., Proc Roy Soc. Series A, 194, 300-322 (1948)
24. Whitham, G.B., Comm. Pure Appl. Math., 11, 113-158 (1959)
25. Zener, C., and Holloman, J.H., J. Appl. Phys. 15, 22-32, (1944)

DISTRIBUTION

No. Cys

HEADQUARTERS USAF

1 Hq USAF (AFDAP), Wash 25, DC
 1 Hq USAF (AFORQ), Wash 25, DC
 1 Hq USAF (AFRDR-NU-1), Wash 25, DC
 1 Hq USAF (AFCIN), Wash 25, DC
 1 Hq USAF (AFTAC), Wash 25, DC
 AFOAR, Bldg T-D, Wash 25, DC
 1 (RROSA, Col Boreske)
 1 (RRN, Major Munyon)
 1 AFOAR, Aeronautical Research Lab, ATTN: RRLO, Mr. Cady,
 Wright-Patterson AFB, Ohio
 1 AFOSR (SREC), Bldg T-D, Wash 25, DC

MAJOR AIR COMMANDS

AFSC, Andrews AFB, Wash 25, DC
 1 (SCR)
 1 (SCR-2, Capt Ray Berrier)
 1 SAC (OAWS, Mr. England), Offutt AFB, Nebr
 1 Air Force Institute of Technology, MCLI, Wright-Patterson AFB,
 Ohio

AFSC ORGANIZATIONS

1 AFSC Regional Office (Maj Blilie), 6331 Hollywood Blvd., Los
 Angeles 28, Calif
 1 FTD (AFCIN 4F2A), Wright-Patterson AFB, Ohio
 ASD, Wright-Patterson AFB, Ohio
 1 (WWOOD, Tech Op. Div)
 1 (WWRDMS-12, Mr. Janik, Mr. Chinn)
 1 (WWRCPR, Mr. Salzberg)
 2 (ASAPRL)
 DCAS (Deputy Commander Aerospace Systems), AF Unit Post
 Office, Los Angeles 45, Calif
 2 (Tech Data Center)
 1 (WDTV, Col Middlekauff)
 1 (WDTV, Maj Fowler)
 1 (WDLA, Col Lulejian)
 1 (WDTD)

DISTRIBUTION (con't)

No. Cys

1 ARCRL, L. G. Hanscom Fld, Bedford, Mass
 1 RADC (RCOIL-2, Document Library), Griffiss AFB, NY
 KIRTLAND AFB ORGANIZATIONS
 AFSWC, Kirtland AFB, N Mex
 1 (SWEH)
 31 (SWOI)
 1 (SWV)
 1 (SWRPS)
 1 (SWRPT)
 1 (SWRPL)
 1 SAC Res Rep, AFSWC, Kirtland AFB, N Mex
 1 US Naval Weapons Evaluation Facility (NWEF) (Code 404),
 Kirtland AFB, N Mex

OTHER AIR FORCE AGENCIES

Director, USAF Project RAND, via: Air Force Liaison Office,
 The RAND Corporation, 1700 Main Street, Santa Monica, Calif
 2 (RAND Library)
 1 (Dr. Olen Nance)
 1 (Dr. A. Latter)
 1 (Lt Col Whitener)
 1 (Dr. Robert Lelevier)

ARMY ACTIVITIES

Chief of Research and Development, Department of the Army,
 Special Weapons and Air Defense Division, Wash 25, DC
 1 (Lt Col Conarty)
 1 (Major Baker)
 1 Commanding Officer, Diamond Ordnance Fuze Laboratories
 (ORDTL 010-235L), Wash 25, DC
 1 ARGMA Liaison Office, Bell Telephone Labs, ATTN: Lt Meek,
 ORDXR-SXR-BTL 15.04, Whippany, NJ
 1 Commander, Army Ballistic Missile Agency (Tech Library),
 Redstone Arsenal, Ala
 Director, Ballistic Research Laboratories, Aberdeen Proving
 Ground, Md
 1 (Library)
 1 (Dr. Robert Eichelberger)

DISTRIBUTION (con't)

No. Cys

- 1 (Mr. E. O. Baicy)
Commanding Officer, Picatinny Arsenal, Samuel Feltman
Ammunition Laboratories, Dover, NJ
- 1 (Mr. Murray Weinstein)
- 1 (ORDBB-TV8)
- 1 Commanding Officer, US Army Signal Research & Development
Laboratory, ATTN: Dr. W. Ramm, Fort Monmouth, NJ
ARGMA, Huntsville, Ala
- 1 (Tech Library)
- 1 (R. T. Moore, R&D Div, Exp. Programs Br., Term.
Eff. Sec)
- 1 Operations Research Office, Johns Hopkins University (Document
Control Ofc) 6935 Arlington Rd., Bethesda, Maryland, Wash 14, DC
- 1 US Army Office of Ordnance Research, ATTN: Herman Robl, Box
CM, Duke Station, Durham, NC

NAVY ACTIVITIES

- 1 Chief of Naval Operations, Department of the Navy, ATTN: OP-75,
Cdr Eaton, Wash 25, DC
Commanding Officer, Naval Research Laboratory, Wash 25, DC
- 2 (Tech Library)
- 1 (Mr. Walter Atkins, Code 6219)
- 1 (Dr. William Faust)
- 1 Commanding Officer, Naval Radiological Defense Laboratory (Tech-
nical Info Div), San Francisco 24, Calif
- 1 Director, Special Projects, Department of the Navy, ATTN: Dr.
Don Williams, Wash 25, DC

OTHER DOD ACTIVITIES

- 1 Commander, Field Command, Defense Atomic Support Agency,
FCWT, ATTN: Col Kiley, Sandia Base, N Mex
Director, Advanced Research Projects Agency, Department of
Defense, The Pentagon, Wash 25, DC
- 1 (Col William Innes)
- 1 (Lt Col Roy Weidler)
- 1 (Dr. Charles Cook)
- 1 (Mr. John Crone)

DISTRIBUTION (con't)

No. Cys

Chief, Defense Atomic Support Agency, Wash 25, DC

1 (Lt Col Ivan C. Atkinson)

1 (Lt Col S. E. Singer)

1 (Col Ledford)

1 (Lt Col Clinton)

10 ASTIA (TIPDR), Arlington Hall Sta, Arlington 12, Va

AEC ACTIVITIES

US Atomic Energy Commission, Wash 25, DC

1 (Technical Reports Library, Mrs. J. O'Leary for DMA)

1 (Dr. G. L. Rogosa)

President, Sandia Corporation, Sandia Base, N Mex

1 (Document Control Division)

1 (Dr. E. H. Draper)

1 (Dr. Lundergan)

1 (Mr. B. E. Bader)

1 Sandia Corporation, ATTN: Mr. W. J. Howard, P. O. Box 969, Livermore, Calif

1 Chief, Div of Technical Information Extension, US Atomic Energy Commission, Box 62, Oak Ridge, Tenn

Director, University of California Lawrence Radiation Laboratory, P. O. Box 808, Livermore, Calif

1 (Mr. Clovis Craig)

1 (Dr. Arnold Clark)

1 Director, Los Alamos Scientific Laboratory (Helen Redman, Report Library), P. O. Box 1663, Los Alamos, N Mex

OTHER

1 Aerojet-General Corporation, ATTN: Mr. Kreyenhagen, 6352 Irwindale Avenue, Azusa, Calif

1 General Electric Aerosciences Lab, ATTN: Dr. L. Steg, 3198 Chestnut Street, Philadelphia 4, Pa

1 Lockheed Missile & Space Division, ATTN: Dr. Roland E. Meyerott, 3251 Hanover Street, Palo Alto, Calif

1 E. H. Plessett Associates, ATTN: Dr. Harris Mayer, 1281 So. Westwood Blvd., Los Angeles 24, Calif

2 Stanford Research Institute, ATTN: Dr. D. L. Davenport and Dr. G. R. Fowles, Menlo Park, Calif

DISTRIBUTION (con't)

No. Cys

- 2 American Machine and Foundry Company, ATTN: J. J. Poczatek and L. E. Fugelso, 7501 North Natchez, Niles, Illinois
- 1 Boeing Airplane Company, Pilotless Aircraft Division, ATTN: Dr. Don Hicks, Seattle 14, Wash
- 1 Colorado School of Mines Research Foundation, Mining & Special Projects Division, ATTN: Dr. Rinehart, P. O. Box 112, Golden, Colo
- 1 AVCO Manufacturing Corporation, Research & Advanced Dev, ATTN: Dr. Malin, 201 Lowell Street, Wilmington, Mass
- 1 Lockheed Aircraft Corporation, Missile and Space Division, ATTN: Mr. E. W. Tice, Internal Systems, 81-62, P. O. Box 504, Sunnyvale, Calif
- 1 Kaman Aircraft Corporation, Nuclear Division, ATTN: Dr. A. P. Bridges, Colorado Springs, Colo
- 2 Space Technology Labs, ATTN: Dr. Herman Leon and Mr. Jackson Maxey, P. O. Box 95001, Los Angeles 45, Calif
- 1 General Electric Company, Aerosciences Lab., Mgr, Aerophysics Lab Ops, ATTN: Dr. Joseph Farber, 3750 D Street, Philadelphia 24, Pa
- 1 General Electric Company, Documents Library, Room 3446, ATTN: T. I. Chosen, Mgr. Library, Philadelphia 4, Pa
- 1 General Electric Company, Tempo, Advanced Earth Satellite Weapon System, ATTN: Mr. A. Deyarmond, Santa Barbara, Calif
- 1 Boeing Airplane Company, Advanced Earth Satellite System, ATTN: Mr. Charles Martin, Seattle, Wash
- 1 McAllister & Associates, Inc., 203-205 Truman, N. E., Albuquerque, N Mex
- Aerospace Corporation, P. O. Box 95085, Los Angeles 45, Calif
- 1 (Dr. Robert Cooper)
- 1 (Dr. D. Bitordo)
- 1 (Dr. George Welch)
- 1 Technical Operations, Inc., ATTN: Mr. V. E. Scherrer, Burlington, Mass
- 1 Official Record Copy (SWRPA)

<p>Air Force Special Weapons Center, Kirtland AF Base, New Mexico Rpt. No. AFSWC-TR-61-67. THEORETICAL STUDY OF RESPONSE OF SOLIDS TO IMPULSIVE LOADS OF HIGH PRESSURE. Final Report, October 1961. 107 pages Unclassified Report</p> <p>The response of materials and structures to pressures on the order of one megabar is considered. The problem is decomposed according to the characteristic response time for various failure modes. The short-time effects study analyzes propagation of these high-pressure pulses. General equations are developed for a solid under finite strain, with dissipation mechanism, heat conduction, and elasticity coefficients open to specification. Integral equations following motion of non-isentropic waves are obtained for uni-axial strain. Conditions for instantaneously forming finite discontinuities are delineated. Succeeding states are sought isentropically, (over)</p>	<p>UNCLASSIFIED</p> <ol style="list-style-type: none"> 1. Blast loading 2. Blast wave propagation 3. Defender 4. Kinematics 5. Plastic deformation 6. Pressure 7. Spalling 8. Stress and strain 9. Structural materials - effects of blast I. AFSC Project 4778, AFRA Order 6-58, Task 22 II. Contract AF29(601)-2533 III. American Machine and Foundry Co., Mechanics Research Div., Elles, Ill. 	<p>Air Force Special Weapons Center, Kirtland AF Base, New Mexico Rpt. No. AFSWC-TR-61-67. THEORETICAL STUDY OF RESPONSE OF SOLIDS TO IMPULSIVE LOADS OF HIGH PRESSURE. Final Report, October 1961. 107 pages Unclassified Report</p> <p>The response of materials and structures to pressures on the order of one megabar is considered. The problem is decomposed according to the characteristic response time for various failure modes. The short-time effects study analyzes propagation of these high-pressure pulses. General equations are developed for a solid under finite strain, with dissipation mechanism, heat conduction, and elasticity coefficients open to specification. Integral equations following motion of non-isentropic waves are obtained for uni-axial strain. Conditions for instantaneously forming finite discontinuities are delineated. Succeeding states are sought isentropically, (over)</p>	<p>UNCLASSIFIED</p> <ol style="list-style-type: none"> 1. Blast loading 2. Blast wave propagation 3. Defender 4. Kinematics 5. Plastic deformation 6. Pressure 7. Spalling 8. Stress and strain 9. Structural materials - effects of blast I. AFSC Project 4778, AFRA Order 6-58, Task 22 II. Contract AF29(601)-2533 III. American Machine and Foundry Co., Mechanics Research Div., Elles, Ill.
<p>Air Force Special Weapons Center, Kirtland AF Base, New Mexico Rpt. No. AFSWC-TR-61-67. THEORETICAL STUDY OF RESPONSE OF SOLIDS TO IMPULSIVE LOADS OF HIGH PRESSURE. Final Report, October 1961. 107 pages Unclassified Report</p> <p>The response of materials and structures to pressures on the order of one megabar is considered. The problem is decomposed according to the characteristic response time for various failure modes. The short-time effects study analyzes propagation of these high-pressure pulses. General equations are developed for a solid under finite strain, with dissipation mechanism, heat conduction, and elasticity coefficients open to specification. Integral equations following motion of non-isentropic waves are obtained for uni-axial strain. Conditions for instantaneously forming finite discontinuities are delineated. Succeeding states are sought isentropically, (over)</p>	<p>UNCLASSIFIED</p> <ol style="list-style-type: none"> 1. Blast loading 2. Blast wave propagation 3. Defender 4. Kinematics 5. Plastic deformation 6. Pressure 7. Spalling 8. Stress and strain 9. Structural materials - effects of blast I. AFSC Project 4778, AFRA Order 6-58, Task 22 II. Contract AF29(601)-2533 III. American Machine and Foundry Co., Mechanics Research Div., Elles, Ill. 	<p>Air Force Special Weapons Center, Kirtland AF Base, New Mexico Rpt. No. AFSWC-TR-61-67. THEORETICAL STUDY OF RESPONSE OF SOLIDS TO IMPULSIVE LOADS OF HIGH PRESSURE. Final Report, October 1961. 107 pages Unclassified Report</p> <p>The response of materials and structures to pressures on the order of one megabar is considered. The problem is decomposed according to the characteristic response time for various failure modes. The short-time effects study analyzes propagation of these high-pressure pulses. General equations are developed for a solid under finite strain, with dissipation mechanism, heat conduction, and elasticity coefficients open to specification. Integral equations following motion of non-isentropic waves are obtained for uni-axial strain. Conditions for instantaneously forming finite discontinuities are delineated. Succeeding states are sought isentropically, (over)</p>	<p>UNCLASSIFIED</p> <ol style="list-style-type: none"> 1. Blast loading 2. Blast wave propagation 3. Defender 4. Kinematics 5. Plastic deformation 6. Pressure 7. Spalling 8. Stress and strain 9. Structural materials - effects of blast I. AFSC Project 4778, AFRA Order 6-58, Task 22 II. Contract AF29(601)-2533 III. American Machine and Foundry Co., Mechanics Research Div., Elles, Ill.

<p>resulting in a theoretical isentrope. A closed form family of isentropes is obtained for aluminum using the Hugoniot. The long-time effects study develops dynamic elastic-plastic deformation theory of solids utilizing dislocation theory. Continuum equations for the elastic-plastic displacements and stresses are derived. Propagation of the plastic wave, apparent time-dependent increase in yield conditions, and other deformational characteristics are discussed. The elastic-plastic deformation equations are solved for three particular cases:</p> <ol style="list-style-type: none"> 1. Propagation of a stress wave in a one-dimensional rod. 2. Deformation of a semi-infinite half space under a suddenly applied strip load. 3. Deformation of an infinitely long thin cylindrical shell under a suddenly applied strip load along a generator. 	<p style="text-align: center;">UNCLASSIFIED</p> <p>IV. Joseph J. Poczatek, L. E. Fugelso Secondary Rpt. No. AMF-MRD MR 1134 VI. In ASTIA collection</p>	<p>resulting in a theoretical isentrope. A closed form family of isentropes is obtained for aluminum using the Hugoniot. The long-time effects study develops dynamic elastic-plastic deformation theory of solids utilizing dislocation theory. Continuum equations for the elastic-plastic displacements and stresses are derived. Propagation of the plastic wave, apparent time-dependent increase in yield conditions, and other deformational characteristics are discussed. The elastic-plastic deformation equations are solved for three particular cases:</p> <ol style="list-style-type: none"> 1. Propagation of a stress wave in a one-dimensional rod. 2. Deformation of a semi-infinite half space under a suddenly applied strip load. 3. Deformation of an infinitely long thin cylindrical shell under a suddenly applied strip load along a generator. 	<p style="text-align: center;">UNCLASSIFIED</p> <p>IV. Joseph J. Poczatek, L. E. Fugelso Secondary Rpt. No. AMF-MRD MR 1134 VI. In ASTIA collection</p>
<p>resulting in a theoretical isentrope. A closed form family of isentropes is obtained for aluminum using the Hugoniot. The long-time effects study develops dynamic elastic-plastic deformation theory of solids utilizing dislocation theory. Continuum equations for the elastic-plastic displacements and stresses are derived. Propagation of the plastic wave, apparent time-dependent increase in yield conditions, and other deformational characteristics are discussed. The elastic-plastic deformation equations are solved for three particular cases:</p> <ol style="list-style-type: none"> 1. Propagation of a stress wave in a one-dimensional rod. 2. Deformation of a semi-infinite half space under a suddenly applied strip load. 3. Deformation of an infinitely long thin cylindrical shell under a suddenly applied strip load along a generator. 	<p style="text-align: center;">UNCLASSIFIED</p> <p>IV. Joseph J. Poczatek, L. E. Fugelso Secondary Rpt. No. AMF-MRD MR 1134 VI. In ASTIA collection</p>	<p>resulting in a theoretical isentrope. a closed form family of isentropes is obtained for aluminum using the Hugoniot. The long-time effects study develops dynamic elastic-plastic deformation theory of solids utilizing dislocation theory. Continuum equations for the elastic-plastic displacements and stresses are derived. Propagation of the plastic wave, apparent time-dependent increase in yield conditions, and other deformational characteristics are discussed. The elastic-plastic deformation equations are solved for three particular cases:</p> <ol style="list-style-type: none"> 1. Propagation of a stress wave in a one-dimensional rod. 2. Deformation of a semi-infinite half space under a suddenly applied strip load. 3. Deformation of an infinitely long thin cylindrical shell under a suddenly applied strip load along a generator. 	<p style="text-align: center;">UNCLASSIFIED</p> <p>IV. Joseph J. Poczatek, L. E. Fugelso Secondary Rpt. No. AMF-MRD MR 1134 VI. In ASTIA collection</p>