

UNCLASSIFIED

---

---

AD 273 560

*Reproduced  
by the*

ARMED SERVICES TECHNICAL INFORMATION AGENCY  
ARLINGTON HALL STATION  
ARLINGTON 12, VIRGINIA



---

---

UNCLASSIFIED

NOTICE: When government or other drawings, specifications or other data are used for any purpose other than in connection with a definitely related government procurement operation, the U. S. Government thereby incurs no responsibility, nor any obligation whatsoever; and the fact that the Government may have formulated, furnished, or in any way supplied the said drawings, specifications, or other data is not to be regarded by implication or otherwise as in any manner licensing the holder or any other person or corporation, or conveying any rights or permission to manufacture, use or sell any patented invention that may in any way be related thereto.

09812 ASTIA 273580  
12 10 1962

## A PORTABLE, BLAST-CONTAINED, EXPLOSIVE LIGHT SOURCE FOR HIGH-SPEED SHADOWGRAPHS

by

Rolland Gallup  
*Weapons Development Department*

ABSTRACT. An explosive light source for shadowgraph use is described which employs a preassembled self-capping light bomb contained in a portable bomb chamber and overpressure housing. Its use is discussed in terms of an actual test, that of microsecond exposure shadowgraphs of a supersonic air flow through a two dimensional glass walled nozzle. Test results are presented.

Released to ASTIA for further dissemination with out limitations beyond those imposed by security regulations.



**U. S. NAVAL ORDNANCE TEST STATION**

**China Lake, California**

21 February 1962

**U. S. NAVAL ORDNANCE TEST STATION**

**AN ACTIVITY OF THE BUREAU OF NAVAL WEAPONS**

**C. BLENNAN, JR., CAPT., USN**      **WM. B. MCLEAN, PH.D.**  
*Commander*                              *Technical Director*

**FOREWORD**

The material in this report was obtained as part of a continuing instrumentation program conducted in support of explosive ordnance problems at the U. S. Naval Ordnance Test Station. These studies were performed on an intermittent basis between 1 August 1961 and 8 December 1961 and were supported by Bureau of Naval Weapons WEPTASK RMMO-42-004/216-1/F008-08-006.

This report was reviewed for technical accuracy by Mr. Robert G. S. Sewell and Wallace H. Allan.

**E. G. LOOMIS**  
Head, Technical Services Division

Released under the  
authority of:

**F. H. KNEMEYER**  
Head, Weapons Development Department

NOTS Technical Publication 2862  
NAVWEPS Report 7880

Published by ..... Weapons Development Department  
Manuscript ..... 40 MS/62-4  
Collation ..... Cover, 7 leaves, abstract cards  
First printing ..... 115 numbered copies  
Security classification ..... UNCLASSIFIED

## INTRODUCTION

Explosive light sources, which are commonly used in the field for shadowgraphs of transient events, have these disadvantages: (1) hazard to the film plate, subject matter, and unprotected personnel nearby from the explosive light source; (2) prolonged duration of light due to luminous air shock beyond the argon gap; and (3) cumbersome containment in an atmosphere of a hydrocarbon gas to quench the shock luminosity beyond the argon gap. These disadvantages are most serious when laboratory use is considered.

The requirement was to design a unit to overcome these disadvantages, and to provide a shadowgraph light source that was portable, yet contained and confined to the extent that neither the subject matter, the open film plate nor personnel nearby were endangered by blast pressures or fragments from the explosive light source. The light source was to be of microsecond range duration and triggerable by any conventional means. It was to be of considerable flexibility, usable for night tests in the field at distances of 20-30 feet or at distances of a few feet in any laboratory with minimum explosive limits.

## COMPONENTS OF LIGHT SOURCE ASSEMBLY

### POINT SOURCE LIGHT BOMB

Explosive-shocked argon gas was used to provide the illumination (Ref. 1-5). The detonation front, initiated by an electric detonator and a 0.25- x 0.25-inch cylindrical tetryl pellet, travelled through the confined atmosphere of argon producing a very intense light.

Tests were made with varying thicknesses of Plexiglas<sup>1</sup> to prevent the detonation wave from continuing into the air beyond the argon atmosphere, which would produce unwanted luminous shock and thereby lengthen the duration of the flash. The Plexiglas front (Fig. 1) was also necessary to contain and confine the detonation energy for safety. Light capping efficiency of the Plexiglas was increased by placing a single layer of "Saran Wrap"<sup>2</sup> in contact with the argon side of the Plexiglas.<sup>3</sup> This made the light cut off more quickly than when Plexiglas alone was used.

---

<sup>1</sup>Manufactured by Rohm & Haas Co., Philadelphia, Pennsylvania.

<sup>2</sup>Transparent plastic film, product of the Dow Chemical Co., Midland, Mich.

<sup>3</sup>Suggested by Dr. H. Dean Mallory of Research Department.

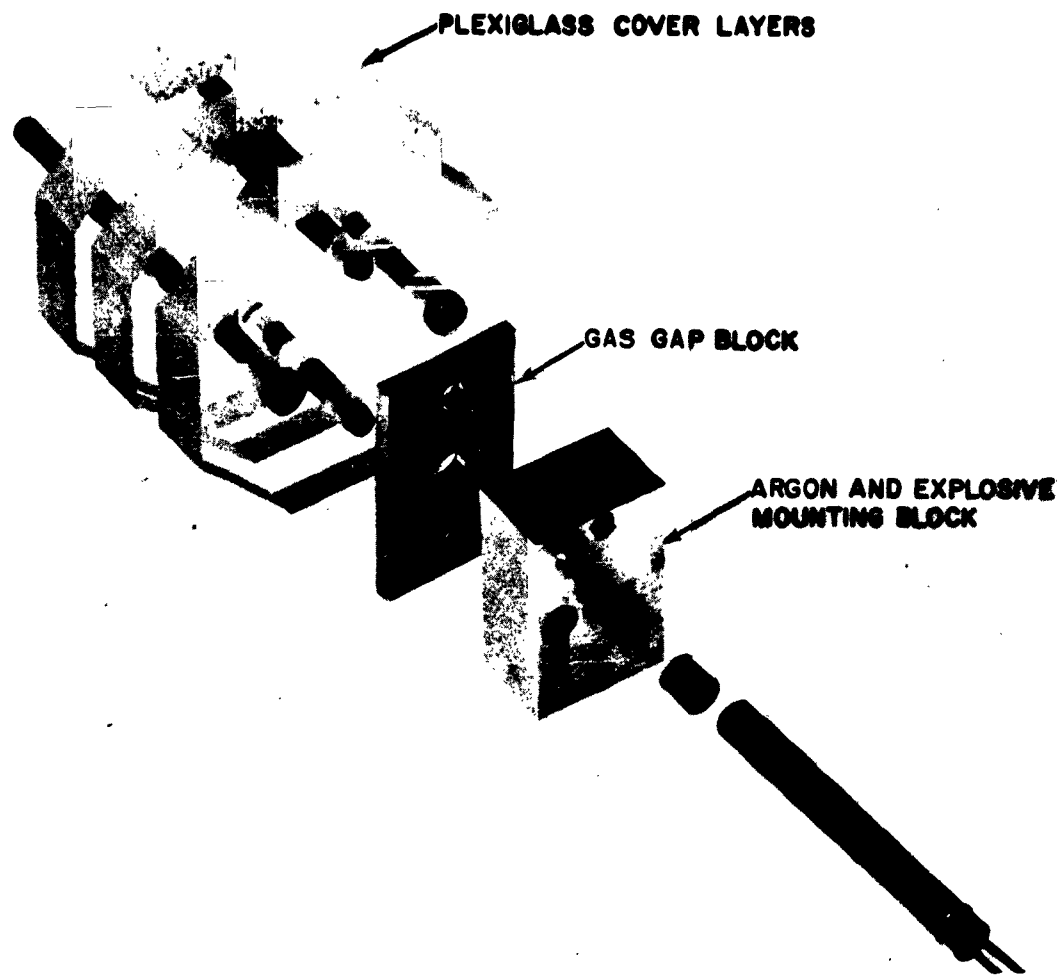

FIG. 1. Disassembled View of Explosively Shocked Argon Light Source with Plexiglas Blast Absorbing Front.

Argon gas was flushed through the system at very low pressure during firing. An aluminum disc slightly larger than the tetryl pellet and about 0.015 inch thick excluded most of the explosive light from mixing with the argon light (Fig. 2). Streak camera tests showed the total flash duration to be about 1 microsecond at 0.125-inch and 2 microseconds at 0.25-inch gap depth. The flash duration was controllable by varying the depth of the gas gap.

The light source can be made of a variety of materials and over a wide range of refinement. Machine shop facilities were utilized for making the light sources (Fig. 3) used in these tests, but this is not vital. For instance, the gas gap section can be of wood or layers of built-up masking tape, punched for the gas gap, with inflow and out-flow channels of cut-out strips of the built-up tape. The Plexiglas, gas gap, and detonator holder can also be cemented together, or bound together with tape. The aluminum disc can be omitted if the mixture of light is not objectionable for the test involved. The basic requirements are that (1) the detonation wave travels through the atmosphere

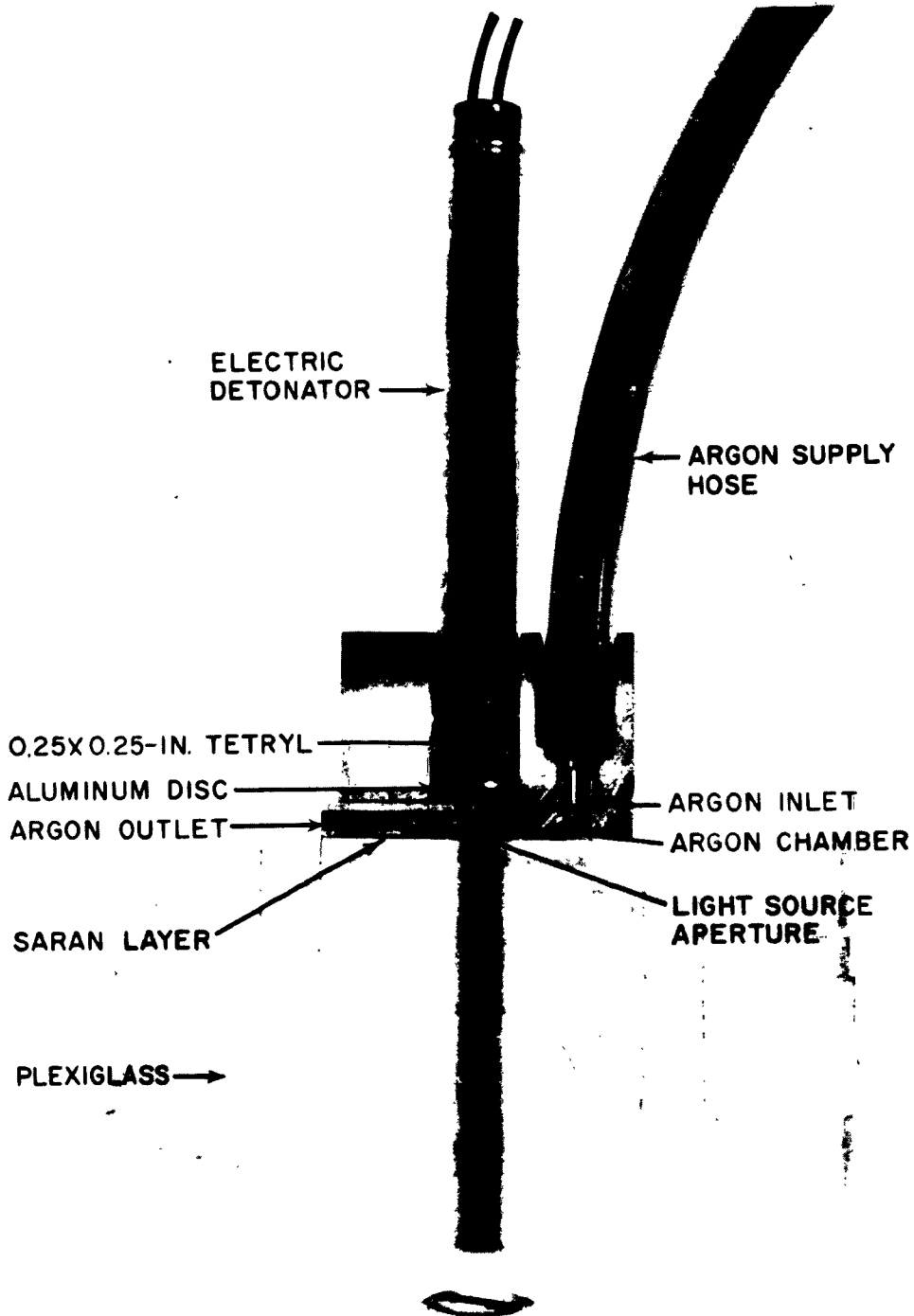

FIG. 2. Section View of Argon Light Source.

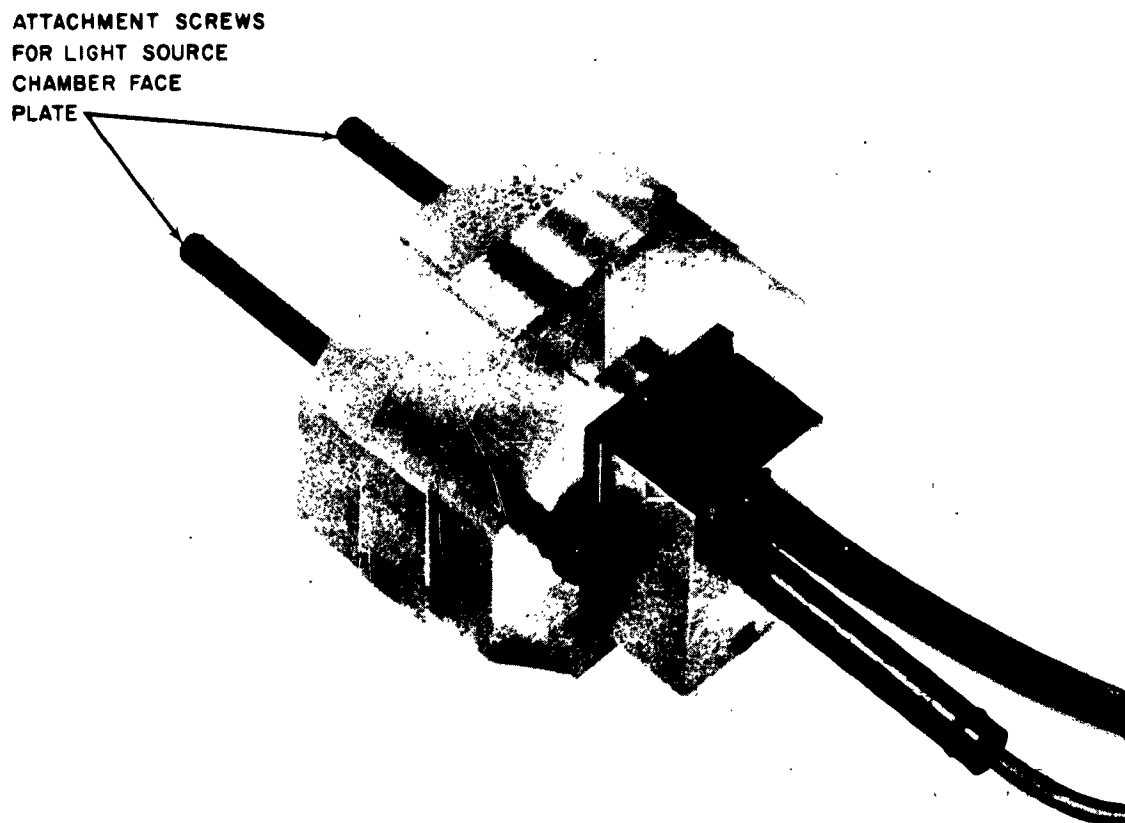

FIG. 3. Assembled Explosive Light Source.

of argon, (2) the argon gas gap is lined up on axis with the source container light hole, and (3) the Plexiglas with the Saran Wrap caps the light and contains the blast from the front.

The light source, which is the expendable part of the system, is small and self-contained. Several can be made up and stored ready for loading in a small space. Loading is simply a matter of inserting the argon hose, the tetryl pellet and the detonator, and fastening the light source into the source container.

#### THE LIGHT SOURCE CONTAINER

A metal container for repeated use with the light bomb is made of 1-inch steel (Fig. 4). Of vented cylindrical construction, the

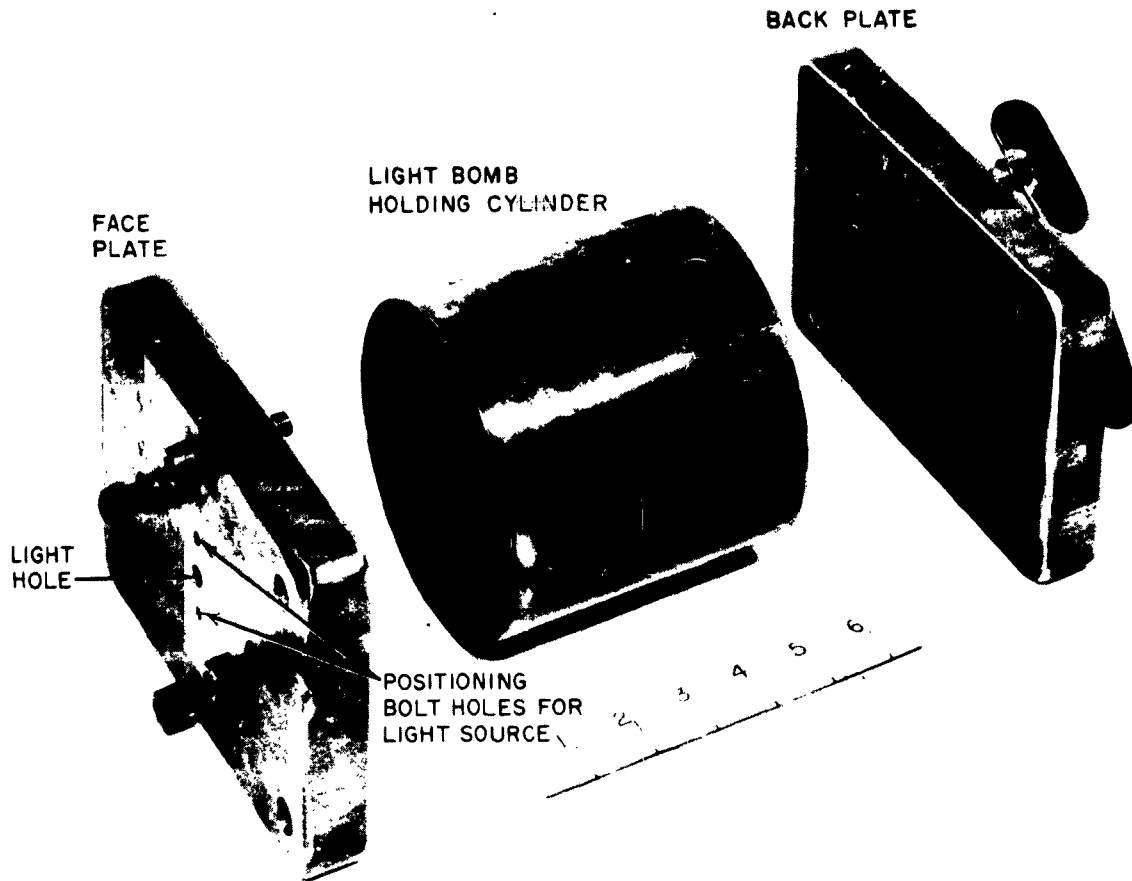

FIG. 4. Disassembled View of Light Source Container.

container serves three purposes: (1) it rigidly and accurately positions the light source for the test; (2) it contains the detonator and Plexiglas fragmentation; and (3) it provides venting for the blast pressures.

#### OVERPRESSURE HOUSING

A housing of steel-reinforced plywood (Fig. 5) was made to provide a stable mount for the light source and container, and to enclose and safely vent the overpressure through the baffles. A series of 2-inch holes in the housing are radially in line with the vents of the metal container. These holes are covered by 0.25-inch rubber sheeting, free at the edges to permit the escape of residual overpressure. All significant light is gone from the detonation by the time the overpressure vents itself through the rubber flaps.

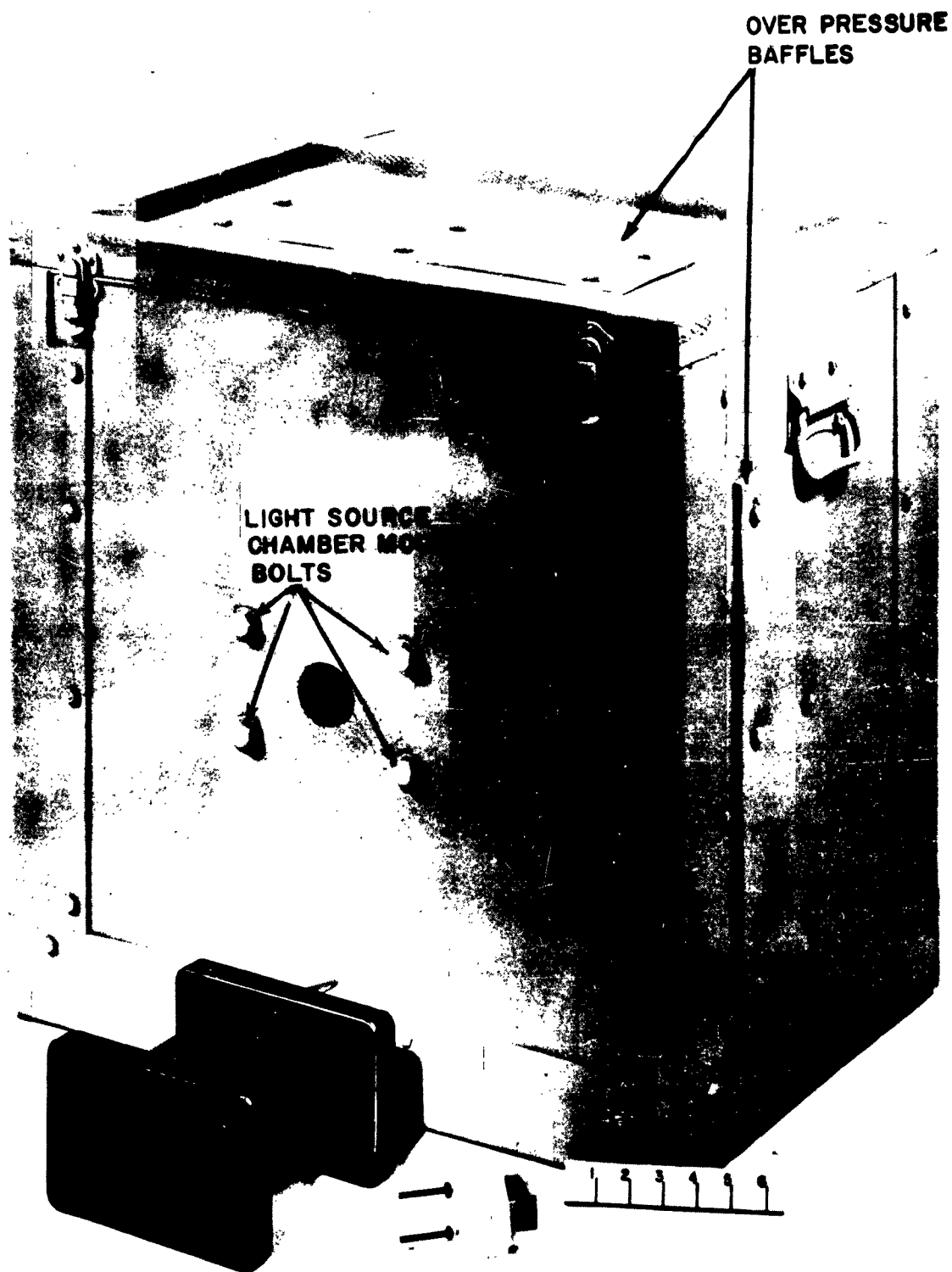

FIG. 5. Light Source (Before Loading), Source Container, and Overpressure Housing.

## TEST LIGHT

A tungsten light placed in the light bomb position is used for final alignment after the metal container and plywood housing are set-up in the test position. The test light (Fig. 6) approximates the shape of the explosive light source, so that the filament can be placed on axis with the future position of the explosive light source. The entire unit is then adjusted to center the light circle on the film behind the subject, assuring maximum illumination. The test light is removed and the explosive light source is put in its place for the test.

## TESTS AND RESULTS

Static exposure tests were made to determine the practical operating range of the system. A light bomb aperture of 0.0625 inch was found suitable for good resolution at distances of 3 feet and beyond, with 0.125- and 0.250-inch apertures becoming necessary at distances between 9 and 25 feet to produce sufficient illumination. Polaroid 400 or 3000 film yielded satisfactory density at various aperture and distance combinations.

The dynamic tests, schematically shown in Fig. 7 and 8, were conducted with the cooperation of the Aerothermochemistry Group, Research Department. A two-dimensional glass-walled nozzle with secondary injection at the Mach-2.5 station was shadowgraphed with a 0.0625-inch aperture light bomb. The distance from the light to the subject was 7.5 feet.

Shock wave sensitivity, which increases with the distance from the subject to the film, is shown in Fig. 9.

## CONCLUSIONS

The system described has met the basic requirements stated in the Introduction. Although the hazard of explosion or extreme shock-waves caused by certain types of subject matter remain unchanged, the similar hazards encountered with conventional explosive light sources have been eliminated, resulting in a safe, flexible test procedure where subject matter permits. The image quality of the shadowgraphs is adequate for scientific evaluation. The reloading operation is simple, taking about 5 minutes, to empty the bomb chamber of fragments from the previous shot, to check sighting alignment with the test light, and load a new light source. Depending on synchronization requirements, any number of firing arrangements

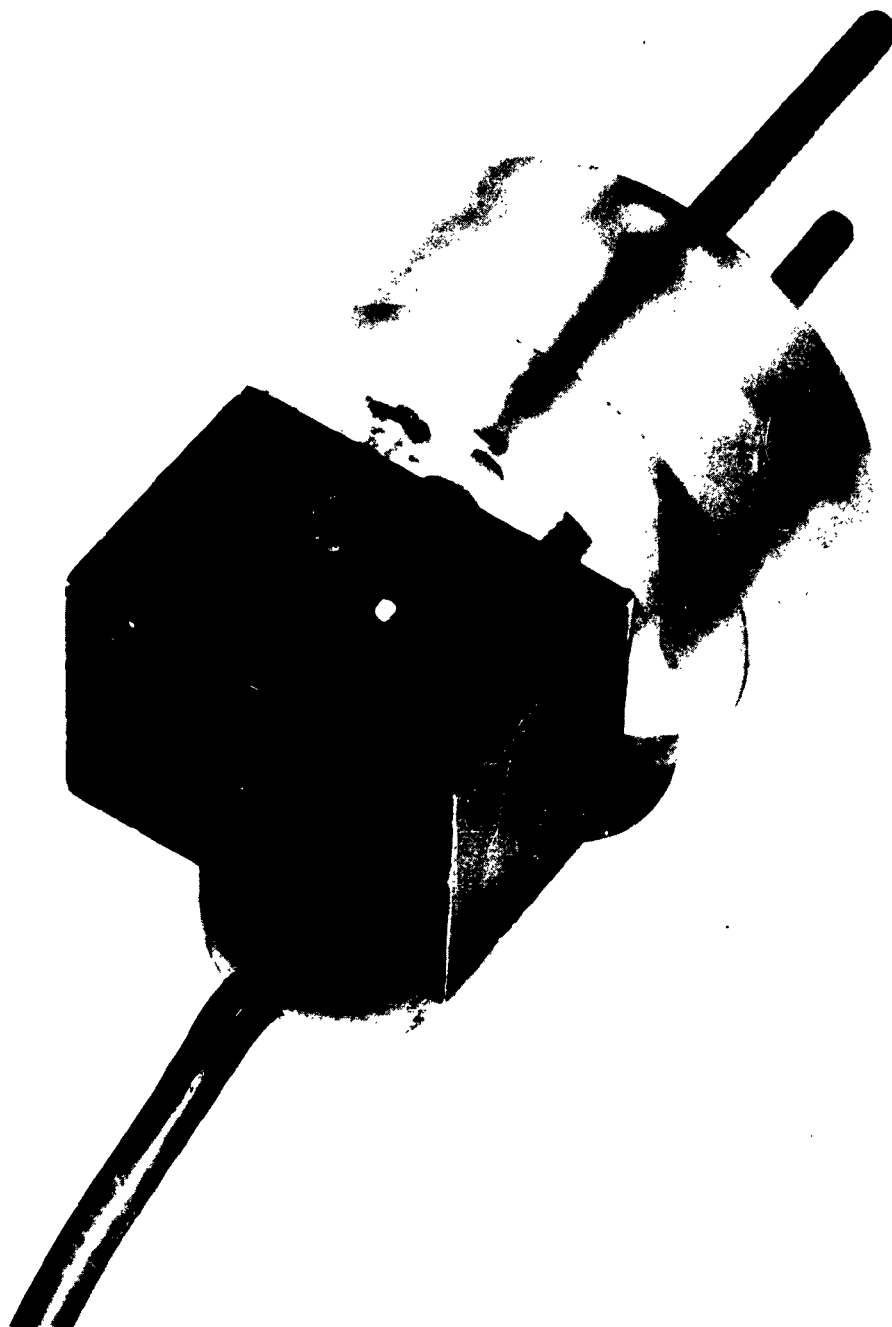

FIG. 6. Test Sighting Light Used to Align Light System with Film Prior to Loading Explosive Light Source.

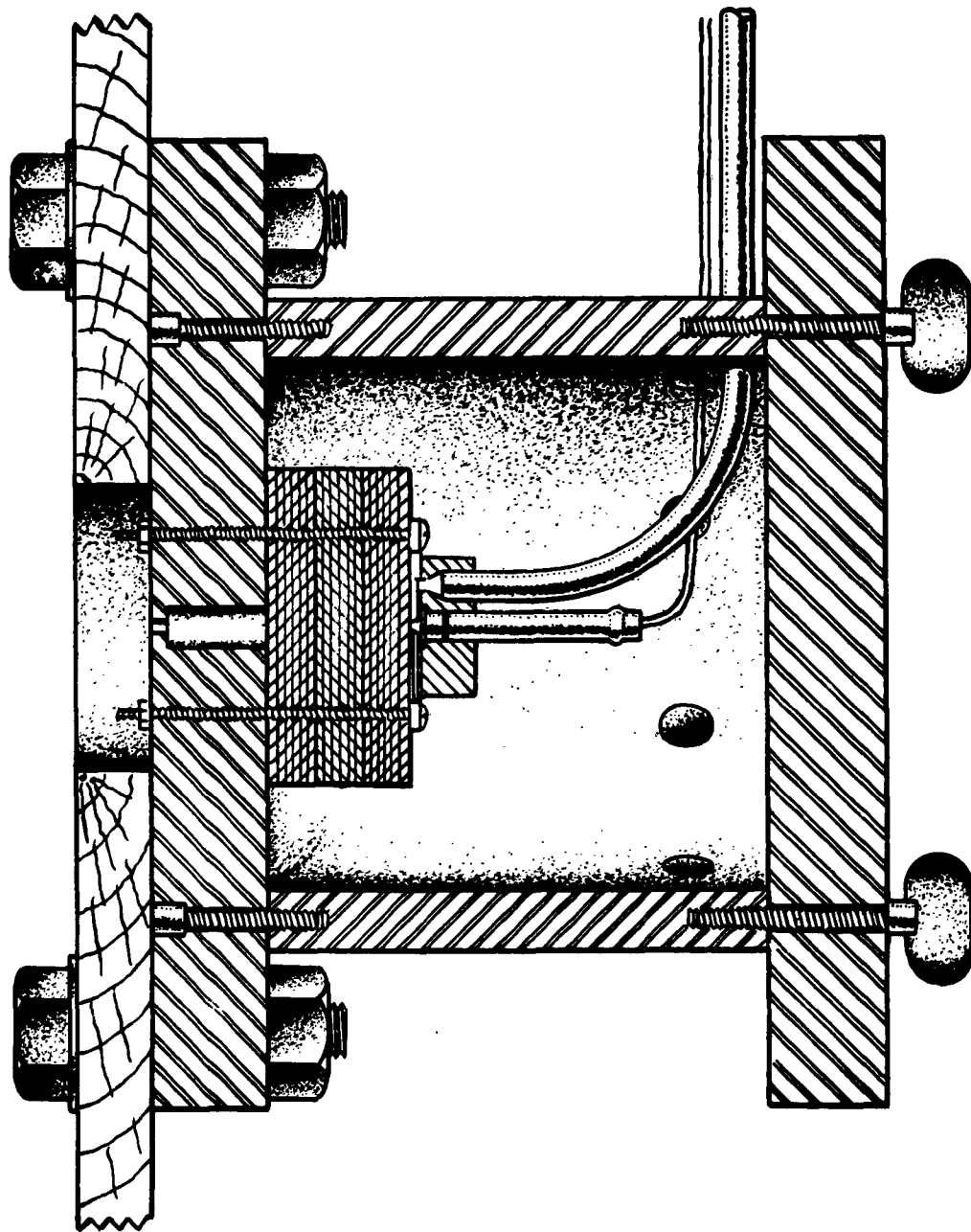

FIG. 7. Schematic of Shadowgraph Test Arrangement.

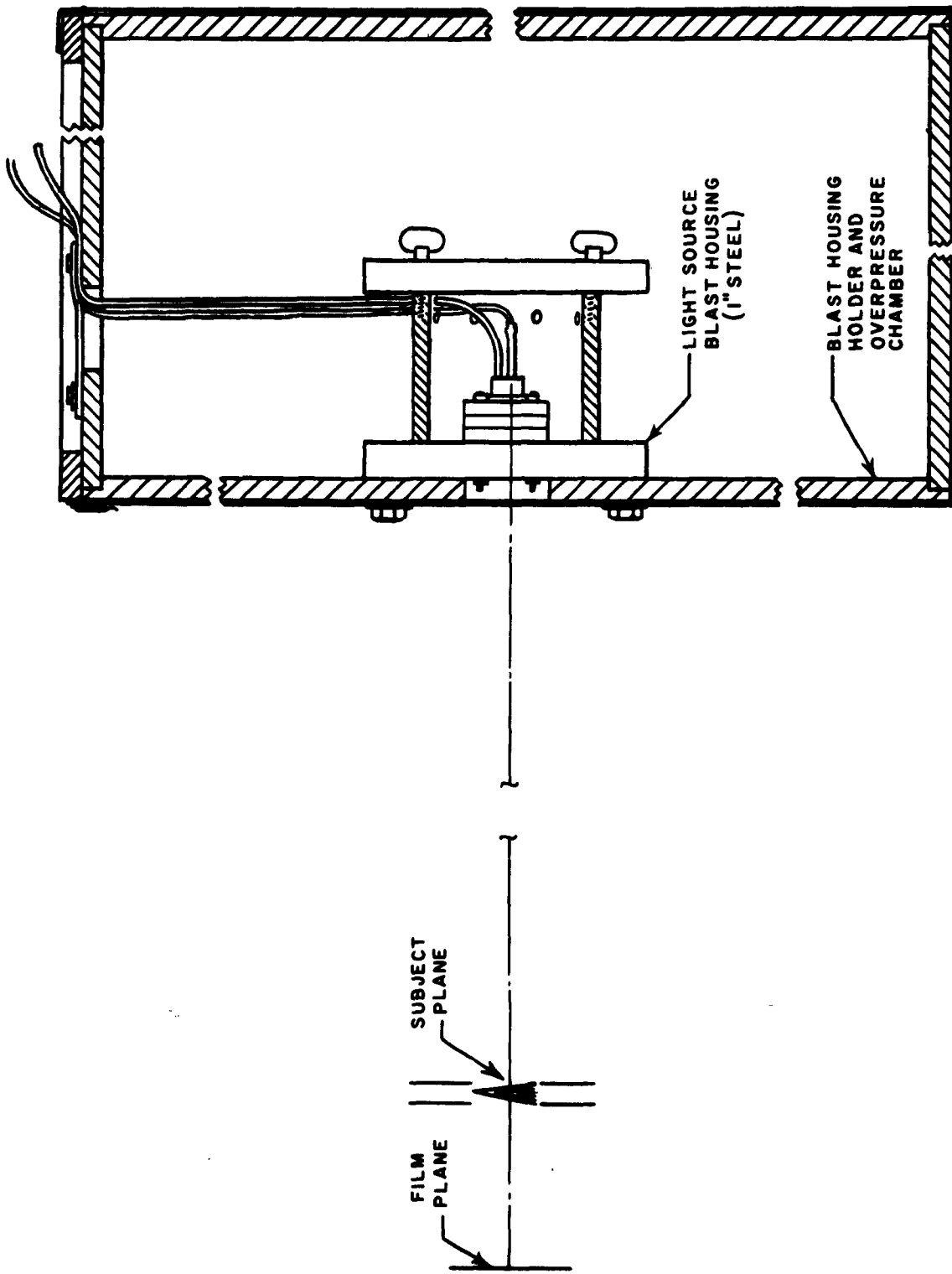
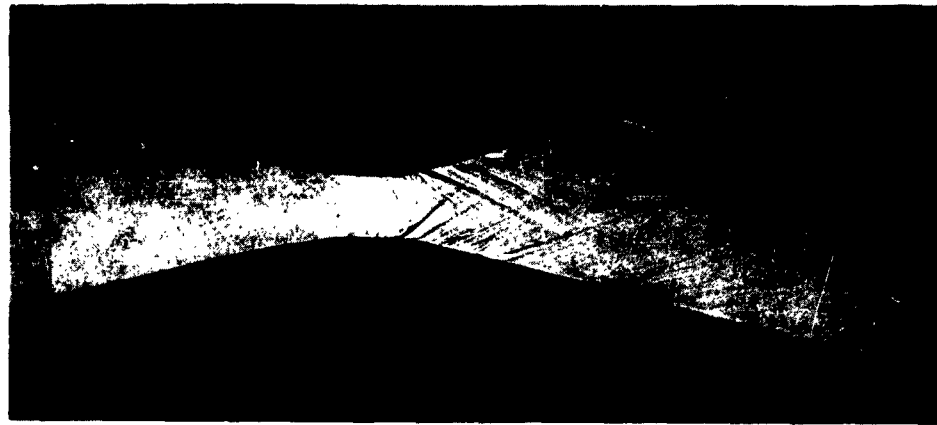
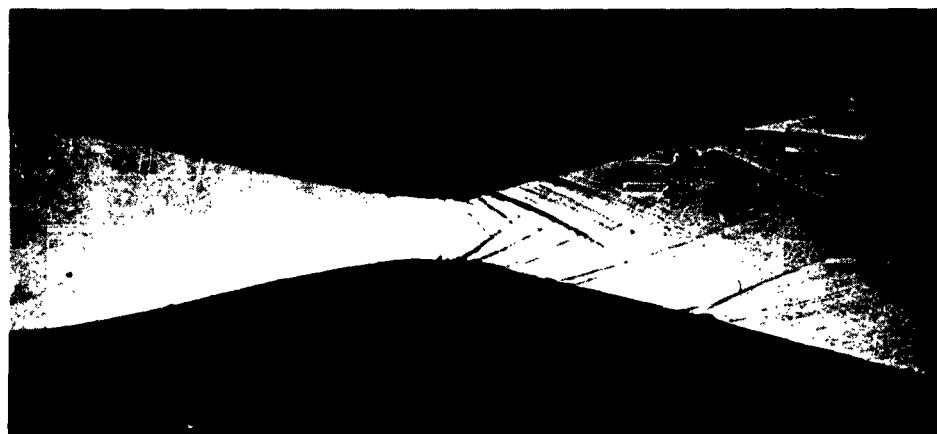

FIG. 8. Detailed Shadowgraph Test Arrangement.



2.5 INCHES



4.5 INCHES

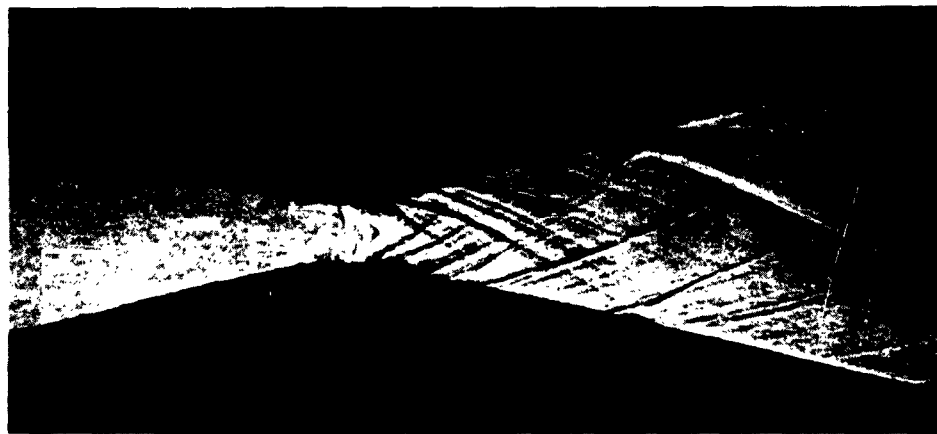

11.5 INCHES

FIG. 9. Shadowgraphs of Supersonic Air Flow Through Two-Dimensional Glass-Walled Nozzle with Secondary Injection at the Mach 2.5 Station. (Different distances from nozzle to film show different sensitivities to identical flow.)

can be used. For a continuous flow of supersonic gas through a nozzle, for example, no precise synchronization is required, and the light charge can be detonated manually by a "hell box" or dry cell. Electronic, adjustable, dual high-voltage-pulse systems or explosive-train-delay systems can be used to synchronize the light source with the event when necessary on events of short duration, or where a precise time instant of the event life is to be shadowgraphed. While a quantitative measurement of light output has not yet been made, the adequacy of the light upon Navy-stocked photographic emulsions has been established over a useful range of working distances.

## REFERENCES

1. R. G. S. Sewell, L. N. Cosner, H. W. Wedda, R. Gallup. "High Speed Explosive Argon-Flash Photography System", Journal SMPTE Vol. 66 (January 1957), pp 21-24.
2. C. H. Winning and H. E. Edgerton, "Explosive Argon Flashlamp". Journal SMPTE Vol. 59 (September 1952), pp 178-183.
3. P. M. Fye, "The High Speed Photography of Underwater Explosions", Journal SMPTE Vol. 55 (October 1950), pp 414-424.
4. G. A. Jones. High Speed Photography, New York, John Wiley and Sons, 1952.
5. W. D. Chesterman. The Photographic Study of Rapid Events, Oxford 1951.

INITIAL DISTRIBUTION

- 5 Chief, Bureau of Naval Weapons
  - DLI-31 (2)
  - RMGA-41 (1)
  - RRRE-3 (1)
  - RTSA-21 (1)
- 1 Chief of Naval Research (Code 104)
- 2 Naval Air Development Center, Johnsville
- 1 Naval Air Test Center, Patuxent River (Aeronautical Publications Library)
- 1 Naval Missile Center, Point Mugu
- 1 Naval Ordnance Laboratory, White Oak (Library)
- 1 Naval Ordnance Missile Test Facility, White Sands Proving Ground
- 2 Naval Weapons Laboratory, Dahlgren
  - Technical Library (1)
- 1 Naval Weapons Plant (Code 755)
- 2 Naval Weapons Services Office, Naval Weapons Plant
- 1 Aberdeen Proving Ground (Ballistic Research Laboratories)
- 1 Army Rocket & Guided Missile Agency, Redstone Arsenal (Technical Library, ORD XR-OTL)
- 1 Signal Corps Engineering Laboratories, Fort Monmouth
- 1 Aeronautical Systems Division, Wright-Patterson Air Force Base (ASAPRD-Dist)
- 1 Air Force Flight Test Center, Edwards Air Force Base
- 1 Air Force Missile Test Center, Patrick Air Force Base
- 1 Air Proving Ground Center, Eglin Air Force Base
- 1 Air Research and Development Command, Andrews Air Force Base
- 1 Holloman Air Force Base
- 1 Rome Air Development Center, Griffiss Air Force Base
- 10 Armed Services Technical Information Agency (TIPCR)
  - 1 Langley Research Center
  - 1 Aerojet-General Corporation, Azusa, Calif. via BuWepsRep
  - 1 Aerojet-General Corporation, Sacramento, via BuWepsRRep
  - 1 Applied Physics Laboratory, JHU, Silver Spring (Technical Document Center)
  - 1 AVCO Research Laboratory, Everett, Mass. (Document Control Center)
  - 1 Boeing Airplane Company, Seattle
  - 1 California Institute of Technology, Pasadena (Library)
  - 1 Hercules Powder Company, Bacchus Works, Bacchus, Utah
  - 1 Lockheed Aircraft Corporation, Missiles and Space Division, Palo Alto, Calif.
  - 1 Sandia Corporation, Albuquerque
  - 1 Thiokol Chemical Corporation, Utah Division, Brigham City

ABSTRACT CARD

U. S. Naval Ordnance Test Station

A Portable, Blast-Contained, Explosive Light Source for High-Speed Shadowgraphs, by Rolland Gallup. China Lake, Calif., NOTS, 21 February 1962. 14 pp. (NAVWEPS Report 7880, NOTS TP 2862), UNCLASSIFIED.

ABSTRACT. An explosive light source for shadowgraph use is described which employs a pre-assembled self-capping light bomb contained in a portable bomb chamber and overpressure housing. Its use is discussed in terms of an actual test, that of microsecond exposure shadowgraphs of a



(Over)  
1 card, 4 copies

U. S. Naval Ordnance Test Station

A Portable, Blast-Contained, Explosive Light Source for High-Speed Shadowgraphs, by Rolland Gallup. China Lake, Calif., NOTS, 21 February 1962. 14 pp. (NAVWEPS Report 7880, NOTS TP 2862), UNCLASSIFIED.

ABSTRACT. An explosive light source for shadowgraph use is described which employs a pre-assembled self-capping light bomb contained in a portable bomb chamber and overpressure housing. Its use is discussed in terms of an actual test, that of microsecond exposure shadowgraphs of a



(Over)  
1 card, 4 copies

U. S. Naval Ordnance Test Station

A Portable, Blast-Contained, Explosive Light Source for High-Speed Shadowgraphs, by Rolland Gallup. China Lake, Calif., NOTS, 21 February 1962. 14 pp. (NAVWEPS Report 7880, NOTS TP 2862), UNCLASSIFIED.

ABSTRACT. An explosive light source for shadowgraph use is described which employs a pre-assembled self-capping light bomb contained in a portable bomb chamber and overpressure housing. Its use is discussed in terms of an actual test, that of microsecond exposure shadowgraphs of a



(Over)  
1 card, 4 copies

U. S. Naval Ordnance Test Station

A Portable, Blast-Contained, Explosive Light Source for High-Speed Shadowgraphs, by Rolland Gallup. China Lake, Calif., NOTS, 21 February 1962. 14 pp. (NAVWEPS Report 7880, NOTS TP 2862), UNCLASSIFIED.

ABSTRACT. An explosive light source for shadowgraph use is described which employs a pre-assembled self-capping light bomb contained in a portable bomb chamber and overpressure housing. Its use is discussed in terms of an actual test, that of microsecond exposure shadowgraphs of a



(Over)  
1 card, 4 copies

NAVWEPS Report 7880



supersonic air flow through a two dimensional glass walled nozzle. Test results are presented.

NAVWEPS Report 7880



supersonic air flow through a two dimensional glass walled nozzle. Test results are presented.

NAVWEPS Report 7880



supersonic air flow through a two dimensional glass walled nozzle. Test results are presented.

NAVWEPS Report 7880



supersonic air flow through a two dimensional glass walled nozzle. Test results are presented.