

**UNCLASSIFIED**

---

---

**AD 273 707**

*Reproduced  
by the*

**ARMED SERVICES TECHNICAL INFORMATION AGENCY  
ARLINGTON HALL STATION  
ARLINGTON 12, VIRGINIA**



---

---

**UNCLASSIFIED**

NOTICE: When government or other drawings, specifications or other data are used for any purpose other than in connection with a definitely related government procurement operation, the U. S. Government thereby incurs no responsibility, nor any obligation whatsoever; and the fact that the Government may have formulated, furnished, or in any way supplied the said drawings, specifications, or other data is not to be regarded by implication or otherwise as in any manner licensing the holder or any other person or corporation, or conveying any rights or permission to manufacture, use or sell any patented invention that may in any way be related thereto.

**273 707**

ASD TECHNICAL REPORT 61-87

273 707

AS AD 110

**STRUCTURAL RESPONSE OF BERYLLIUM SHEET  
PRODUCED BY THREE FABRICATION METHODS**

*C. J. GIEMZA*

*THE MARTIN COMPANY  
BALTIMORE, MARYLAND*

*DECEMBER 1961*

**FLIGHT DYNAMICS LABORATORY  
AERONAUTICAL SYSTEMS DIVISION  
AIR FORCE SYSTEMS COMMAND  
UNITED STATES AIR FORCE  
WRIGHT-PATTERSON AIR FORCE BASE, OHIO**

## NOTICES

When Government drawings, specifications, or other data are used for any purpose other than in connection with a definitely related Government procurement operation, the United States Government thereby incurs no responsibility nor any obligation whatsoever; and the fact that the Government may have formulated, furnished, or in any way supplied the said drawings, specifications, or other data, is not to be regarded by implication or otherwise as in any manner licensing the holder or any other person or corporation, or conveying any rights or permission to manufacture, use, or sell any patented invention that may in any way be related thereto.

Qualified requesters may obtain copies of this report from the Armed Services Technical Information Agency, (ASTIA), Arlington Hall Station, Arlington 12, Virginia.

This report has been released to the Office of Technical Services, U. S. Department of Commerce, Washington 25, D. C., for sale to the general public.

Copies of ASD Technical Reports and Technical Notes should not be returned to the Aeronautical Systems Division unless return is required by security considerations, contractual obligations, or notice on a specific document.

**STRUCTURAL RESPONSE OF BERYLLIUM SHEET  
PRODUCED BY THREE FABRICATION METHODS**

*C. J. GIEMZA*

*THE MARTIN COMPANY*

*DECEMBER 1961*

FLIGHT DYNAMICS LABORATORY  
CONTRACT No. AF 33(600)-40648  
PROJECT No. 1368  
TASK No. 13928

AERONAUTICAL SYSTEMS DIVISION  
AIR FORCE SYSTEMS COMMAND  
UNITED STATES AIR FORCE  
WRIGHT-PATTERSON AIR FORCE BASE, OHIO

## FOREWORD

This report was prepared by the Research Department of The Martin Company under USAF Contract No. AF33(600)-40648, BPS No. 0-(1-1368-13928). The contract was initiated by The Aeronautical Systems Center, Air Material Command, with Mr. F. E. Barnett of the Flight Dynamics Laboratory, Wright Air Development Division, (presently designated Aeronautical Systems Division), acting as Project Engineer.

This is a final report summarizing the results of work performed from February 1960 to March 1961.

The Brush Beryllium Company is to be commended for their contribution of the hot-pressed and hot cross-rolled test material.

The Manufacturing and Materials Technology Division is to be commended for their foresight in the timely studies leading to a production process for fabricating beryllium sheet.

The author wishes to express his appreciation to Mr. E. Schottler for the structural analysis and to Messrs. M. J. Brown, R. Bowen and H. Hesselbein for the economy and general excellence achieved during the experimental phases of the investigation.

## ABSTRACT

Hot-pressed, hot-upset and hot cross-rolled beryllium sheet was examined to assess their differences and advantages from a structural design viewpoint.

Tension, notch tension, compression, bend ductility and box-beam tests, with the main emphasis on factors which tend to embrittle beryllium, were conducted.

The results show that hot cross-rolled beryllium sheet exhibits both high strength and high elongation in tensile tests but is relatively brittle when, as in bending, the stress is complex. Hot-pressed beryllium sheet, which is low in tensile strength and elongation, demonstrates an excellent capacity for accommodating complex stresses in bending without fracture. The hot-upset beryllium sheet exhibited the best characteristics possessed by both hot-pressed and hot cross-rolled beryllium, though to a lesser degree than the optimum of each.

The differences in mechanical behavior among the three groups are apparently a function of the degree of preferred orientation. However, the amounts of impurity elements which were reported could have contributed significantly to the embrittlement of the hot-pressed and hot cross-rolled beryllium sheet.

The data are presented as trend curves and, when appropriate, in tabular form.

## PUBLICATION REVIEW

This report has been reviewed and is approved.

FOR THE COMMANDER:

  
WILLIAM C. NIELSEN  
Colonel, USAF  
Chief, Flight Dynamics Laboratory

TABLE OF CONTENTS

	Page
I. Introduction. . . . .	1
II. Experimental Procedure . . . . .	2
A. Materials. . . . .	2
B. Test Specimens. . . . .	3
C. Test Equipment and Procedure . . . . .	3
III. Results and Discussion . . . . .	4
A. Tension Tests. . . . .	4
B. Notch Tension Tests . . . . .	5
C. Compression Tests . . . . .	5
D. Bend Ductility Tests . . . . .	5
E. Bulge Test. . . . .	7
F. Box-Beam Tests . . . . .	8
IV. Design Significance of Beryllium. . . . .	9
V. Conclusions and Recommendations . . . . .	10
A. Conclusions . . . . .	10
B. Recommendations . . . . .	10
VI. References . . . . .	11
Appendix A--Design Evaluation. . . . .	12
Appendix B--Tables and Illustrations. . . . .	15

## LIST OF FIGURES

FIGURE		PAGE
1	Tension Specimens, Specifications	23
2	Notch Tension Specimens, Specifications	24
3	Bend Ductility Specimens, Specifications	25
4	Bulge Test Specimen, Specifications	26
5	Box-Beam, Test Setup	27
6	Variation of Tensile Strength with Cross-Sectional Area, Hot-Pressed, Hot-Upset and Hot Cross-Rolled Beryllium Sheet	28
7	Average Tensile Stress-Strain Curves, Hot-Pressed Hot-Upset and Hot Cross-Rolled Beryllium Sheet	29
8	Variation of Notch Strength Ratio with Stress Concentration Factor, Hot-Pressed, Hot-Upset and Hot Cross-Rolled Beryllium Sheet	30
9	Variation of Maximum Bending Load with Thickness for the Beryllium Bend Ductility Specimens	31
10	Variation of Maximum Strain with Size in a Constant Moment Bend Test, Group 1, Beryllium Sheet (Hot Cross-Rolled)	32
11	Variation of Maximum Strain with Size in a Constant Moment Bend Test, Group 2, Beryllium Sheet (Hot-Pressed)	33
12	Variation of Maximum Strain with Size in a Constant Moment Bend Test, Group 3, Beryllium Sheet (Hot-Upset)	34
13	Comparison of Load Versus Strain in the Bend Ductility Test for 1-Inch Specimens, Hot-Pressed, Hot-Upset and Hot Cross-Rolled Beryllium Sheet	35
14	Comparison of Load Versus Strain in the Bend Ductility Test for 3-Inch Specimens, Hot-Pressed, Hot-Upset and Hot Cross-Rolled Beryllium Sheet	36
15a	Bend Ductility Specimens After Test, Hot-Pressed, Hot-Upset and Hot Cross-Rolled Beryllium Sheet	37
15b	Bend Ductility Specimens After Test, Hot-Pressed, Hot-Upset and Hot Cross-Rolled Beryllium Sheet	38
15c	Bend Ductility Specimens After Test, Hot-Pressed, Hot-Upset and Hot Cross-Rolled Beryllium Sheet	39

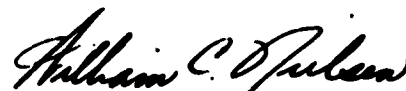
**LIST OF FIGURES (continued)**

<b>FIGURE</b>		<b>PAGE</b>
15d	<b>Bend Ductility Specimens After Test, Hot-Pressed, Hot-Upset and Hot Cross-Rolled Beryllium Sheet</b>	<b>40</b>
15e	<b>Bend Ductility Specimens After Test, Hot-Pressed and Hot Cross-Rolled Beryllium Sheet</b>	<b>41</b>
16	<b>Variation of Bending Load with Deflection for the Beryllium Box-Beams</b>	<b>42</b>
17	<b>Beryllium Box-Beams After Test</b>	<b>43</b>
18	<b>Beryllium Box-Beams After Test</b>	<b>44</b>
19	<b>Analytical Basis for Calculating Volume of Double Tapered Skins</b>	<b>45</b>
20	<b>Determination of Center of Gravity and Eccentricity for Arbitrary Wing Sections</b>	<b>46</b>
21	<b>Diagram for Calculating Moment of Inertia for Structural Analysis</b>	<b>43</b>
22	<b>Wing Structure Design</b>	<b>47</b>

## I. INTRODUCTION

In the course of studies relating to the development of beryllium, two approaches have been evolved for making sheet: hot cross-rolling and hot-upsetting. The development of the hot cross-rolling method is summarized in Refs. 1 and 2. The hot-upsetting sheet fabrication process, evolved as the consequence of crystallographic texture considerations rather than as a desirable method for sheet production, is discussed in Refs. 3, 4 and 5. The two techniques for sheet fabrication produce different crystallographic textures.

For structural applications of beryllium sheet, it was necessary to assess the comparative advantages and differences, with respect to mechanical behavior, of beryllium sheet fabricated by the two processes.

At the request of the Wright Air Development Division, an evaluation was made of beryllium sheet which was produced by hot cross-rolling and hot-upsetting; in addition, a third process (beryllium sheet machined from hot-pressed block) also was assessed.

The objective of this investigation centered, generally, on the determination of the relative superiority, in the structural sense, of the beryllium sheet produced by the aforementioned fabrication techniques. The main emphasis was given to those test conditions which would amplify the tendency of the beryllium sheet to embrittle. In addition, the feasibility of the bend ductility test was examined as a possible criterion for measuring the structural quality of beryllium sheet.

In order to avoid prejudgement during the investigation, knowledge of the processes by which the test material groups were fabricated was withheld. It was specified that the test specimens would be coded prior to submittal to The Martin Company.

---

Manuscript released by the author (June 1961) for publication as an ASD Technical Report.

## II. EXPERIMENTAL PROCEDURE

The test materials have been identified as Groups 1, 2 and 3; the box-beams as A, B and C; and the bulge specimens as 1, 2, 3 and 4.

### A. MATERIALS

#### 1. Hot-Upset Sheet

The hot-upset sheets were fabricated as follows. The beryllium powder was cold compacted to 50% theoretical density into steel cans. The steel cans were then sealed, except for a pinhole to permit outgassing, heated to 1850° F and forged into plates with a reduction of 7 to 1 based on theoretical density. Subsequent to the removal of the steel jacket material by pickling in a 50% aqueous solution of nitric acid, the plates were machined to the necessary thickness. After the mechanical test specimens and box-beam components were machined and formed when necessary, they were etched\* in a 10% aqueous solution of sulfuric acid and annealed at approximately 1400° F for one hour (see Refs. 3, 4 and 5).

Forming of the channel sections was carried out at about 950° F with one intermediate anneal at 1400° F for the 6-inch channels.

#### 2. Hot-Pressed Sheet

Slabs, approximately 3/16-inch thick, were sawed from a pressed and sintered beryllium block and machined to sheets with thicknesses of 0.080 and 0.060 inch. The sheets were cut so that the plane of the sheet was transverse to the pressing direction.

#### 3. Hot Cross-Rolled Sheet

Slabs cut transverse to the pressing direction from large hot-pressed blocks were clad in mild steel jackets and rolled at approximately 1400° F. The 0.050-inch sheet had a reduction ratio of 3.4 to 1 in the y direction\*\* and 4 to 1 in the x direction. The 0.070-inch sheet had a reduction ratio of 3.4 to 1 in the y direction and 3 to 1 in the x direction.

Both the hot-pressed and hot cross-rolled sheets were finish-ground with 240- and 600-grit abrasive paper.

---

\* Etching is considered essential to remove machining imperfections from the surface layer.

\*\* The directions of rolling and testing will be identified as:

- x = the longitudinal direction
- y = the transverse direction (in the plane)
- z = the thickness direction

Both hot-pressed and hot cross-rolled channels were formed at approximately 1400° F in heated dies; the forming time was approximately 30 seconds.

Although some precautions were necessary, drilling of beryllium sheet produced by any of the three fabrication techniques presented no difficulty. The methods employed for drilling are described in some detail in Refs. 2, 4 and 5.

After drilling and machining the hot-pressed and hot cross-rolled specimens, they were etched in a 10% and 2% aqueous solution of phosphoric acid and sulfuric acid, respectively, to remove the twinned microstructure at the surface.

## B. TEST SPECIMENS

Tensile specimens ranging from 1/4-inch to 1-1/2-inch gage width were employed (detailed dimensions are shown in Fig. 1). Notch tensile specimens with stress concentration values ( $K_T$ ) ranging from 1.28 to 2.43 were employed (detailed specifications are given in Fig. 2). Bend ductility specimens ranging from 1/4 inch to 5 inches in the variable dimension were employed (detailed specifications are given in Fig. 3). Specifications of the bulge test specimens are given in Fig. 4. The compression test specimens were 0.070 inch x 1 inch x 1 inch. The detailed specifications for the box-beam are given in Table 3.

## C. TEST EQUIPMENT AND PROCEDURE

The specimens were tested in a P.T.E. universal testing machine and, with the exception of the notch tensile specimens, all strain values were obtained with "metalfilm" foil strain gages. The gages were mounted back-to-back on the tension and compression specimens and the signal was fed to a null balancing instrument. Total elongation of the tension specimens was determined by measurement of the displacement of the 2-inch gage marks.

The box-beams were instrumented with back-to-back, transverse and longitudinal Budd Co. "metalfilm" electric strain gages. These were mounted in the constant stress section transverse to the principal stress on both covers. The box-beams were loaded in an FGT testing machine (shown in Fig. 5); the load-strain output was fed into a 50-channel oscillograph; deflection was measured with a 0.001-inch dial indicator.

### III. RESULTS AND DISCUSSION

The identity of the three beryllium groups was withheld during the reduction and interpretation of the data and up to the time of completion of the draft of the final report. Mr. F. E. Barnett, Project Engineer, WADD, then revealed the relation of the code to the material process to permit an explicit discussion and definitive conclusion. After receipt of the identification, the text was altered when necessary to establish coherency.

The identification is:

- Hot cross-rolled - Group 1, beam A and bulge specimens 1 and 4
- Hot-pressed - Group 2, beam C and bulge specimens 2 and 3
- Hot-upset - Group 3 and beam B

#### A. TENSION TESTS

The stress-strain curve is the general guide in the selection of materials for air frame structural design. However, interpretation of the values obtained from stress-strain curves is relative to the same or similar material for which experience records have been established.

Because structural design experience has not been accumulated for beryllium sheet, the specific values of mechanical properties would not, at this time, be significant. Furthermore, a specific production process or sheet material has not yet been selected for general use. However, the differences of stress-strain behavior among the three groups in comparison to other mechanical tests may provide a clue for obtaining the proper balance and a more rapid resolution between the manufacturing and structural design parameters.

Size effects do not appear to exert a major influence on the embrittlement of beryllium in a simple stress field (Ref. 4). However, in order to establish the significance of size in a tensile test, the specimen gage width was varied from 1/4 inch to 1-1/2 inches.

The variation of average maximum strength plotted against the log of cross-sectional area is shown in Fig. 6. The individual values of strength and elongation as well as qualifications are summarized in Table 4. Although Groups 1 and 3 produced the highest strength values, both scattered about the average value considerably more than did the lower strength Group 2 beryllium. Comparing the individual values of stress and strain at fracture for Groups 1 and 3 in Table 4, there is a relationship of stress at failure to the percent of elongation which is approximately linear. The low values are, in all probability, machining flaws and possibly load eccentricity developed during loading.

The average tensile stress-strain plots for the three beryllium groups are shown in Fig. 7. The most significant feature of these curves is the marked difference of the strain hardening rate between Group 1 beryllium and Groups 2 and 3. Groups 2 and 3 strain-harden at a rate approximately three times that of Group 1.

The work hardening coefficients were:

$0.45 \times 10^6$  psi for Group 1 (hot cross-rolled)

$1.4 \times 10^6$  psi for Group 2 (hot-pressed)

$1.55 \times 10^6$  psi for Group 3 (hot-upset).

## B. NOTCH TENSION TESTS

The notch tensile test is one measure of the ability of a metal to redistribute plastically the high local stresses generated as the consequence of notch geometry. Although beryllium has been regarded as an extremely notch-sensitive material, the data of this report and Ref. 4 show clearly an appreciable degree of notch strengthening for mild stress concentrations.

The notch-strength ratio (NSR)  $\frac{F_{TU \text{ notched}}}{F_{TU}}$ , based on average strength

plotted against the stress concentration factor is shown in Fig. 8. Although Group 1 NSR values scattered considerably, the trend of notch strengthening appeared to follow the more consistently notch-strengthened Group 3. Group 2 revealed the lowest values of NSR and fell below an NSR of one at a stress concentration factor of approximately 1.8.

The differences of NSR for the three groups probably are related to the differences in their crystallographic textures. However, the porosity, a twinned microstructure at the surface, machining imperfections and loading eccentricity could have reduced the values obtained and very probably contributed to the scatter.

## C. COMPRESSION TESTS

The compression tests did not provide sufficiently clear values to warrant construction of stress-strain curves. However, the maximum stresses, strains and average moduli of elasticity in compression are given in Table 5. Consistent with the tensile test results, the maximum stress values (at fracture) are equal for Groups 1 and 3 and approximately 50% higher than those obtained for Group 2. Unexpectedly, the total strain to fracture was approximately equal for the three groups.

## D. BEND DUCTILITY TESTS

The purpose of the bend ductility test was to examine the relative capacity among the three beryllium groups for withstanding complex stress. Beryllium derives its strength and elongation (tensile) by arranging the crystal structure in a preferred order. Within certain limits, both strength and elongation increase as the degree of anisotropy increases. (Refs. 3, 4, 5 and 6). However, it appears that a consequent reduction of ductility as manifested under a plane stress occurs.

In the case of a plate in simple bending, as the plane dimension transverse to the load line increases, the strain in the y direction undergoes a corresponding reduction for a given stress in the x direction and approaches the plane strain condition. As a consequence, a transverse stress of the same sign as the longitudinal stress is induced and its magnitude increases as the strain in the y direction decreases. The induced stress becomes significant when the longitudinal stress reaches magnitudes which, in simple tension, would become nonlinear.

In addition, in wrought forms of beryllium, the ability of the z direction to contribute to plastic flow diminishes rapidly as the degree of preferred orientation (anisotropy) increases. In Refs. 3 and 4, measurements of the z dimension of tensile and notch tensile specimens, after test, revealed no discernible change for strains in the x direction in excess of 9%. To satisfy the condition of constancy of volume, since the strain in the z direction was essentially zero, the plastic strain in the x direction was made up by an approximately equivalent strain in y. The plastic Poisson's ratio for this case becomes equal to one in the plane and 0 normal to the plane.

A third factor which contributes to the embrittlement of beryllium, particularly in combination with the plane strain condition and the preferred orientation, is the limitation for flow inherent in the beryllium system (Refs. 4, 5, 6 and 7).

The results of the bend ductility tests are summarized in Figs. 10, 11 and 12. The log of strain at maximum load or fracture is plotted against the log of the ratio of width to thickness. The ratio w/t was employed because of the variability of the specimen dimensions, particularly those of Group 3. However, a plot of unit load against specimen thickness revealed that a load-thickness proportionality did exist. Except for the unfractured Group 3 specimen, the data obtained from specimens of Groups 1 and 3 were coincident. Although the load-thickness relation for Group 2 is shown as a straight line, it may be nonlinear (Fig. 9).

The strain values for the x and y directions are related to maximum load or fracture and were obtained near one edge in the constant stress region of the specimens.

Specimens of Group 1 (Fig. 10) developed high strains at the lowest values of w/t but rapidly declined to strains of elastic order at fracture as w/t increased. In many instances, the y and x strains were approximately equal; this was indicative of the plane plastic phenomenon ( $\epsilon_{x_p} = \epsilon_{y_p}$ ,  $\epsilon_{z_p} = 0$ ) which appears to be a characteristic of textured sheet. In addition, Group 1 specimens revealed a characteristic fracture pattern with included angles of approximately 47° between intersecting cracks.

The Group 2 bend ductility data are shown in Fig. 11. In spite of the relatively low value of tensile elongation, the ability of this material to bend plastically is superior to the Group 1 beryllium sheet as w/t increased to large values. The more apparent divergence of the x and y strains indicates that the plastic strain in the x direction is compensated by metal flow from the y and z directions. Furthermore, the decline of maximum strain at fracture occurs at a moderate rate as w/t increases. The relatively low scatter of test points is typical of Group 2 data. The fractures which occurred in the Group 2 beryllium were transverse to the principal stress direction and simple in appearance.

The Group 3 bend ductility data, plotted in Fig. 12, revealed a marked superiority to Groups 1 and 2 for low values of w/t. Although the maximum strain values declined rapidly as w/t increased, the rate of decrease approached that of Group 2 beryllium. Group 3 was superior to Group 1 for all w/t examined. The strain difference for the x and y directions in some instances indicated some degree of three-dimensional flow. However, the test data indicated the plastic flow was primarily two dimensional, thus suggesting an anisotropic structure. Although the cracks of Group 3 beryllium were predominantly normal to the principal stress, occasionally a fracture pattern developed which exhibited included angles of approximately 30° between intersecting cracks.

The three groups exhibited load-carrying capacities which were generally proportional to their respective strengths and to sheet thickness. Apparently a direct correspondence exists between the strain-hardening rate or yield-to-ultimate strength ratio and an "embrittling rate".

Two sets of typical bend ductility data illustrating the differences among the three beryllium groups are shown in Figs. 13 and 14. In these illustrations, unit load is plotted against strain; the direction of strain as well as the location at which it was obtained is indicated by the diagram of strain gage locations.

It is noteworthy to point out here that Group 3, which shows the best combination of strength and ductility, did not fracture. In more than half of the tests, Group 3 specimens were loaded to the limiting strain capacity of the gages without failure. Group 2 occasionally sustained, without fracture, the limit of the strain gages; Group 1 began fracturing at low strain levels beyond specimen widths of about 0.75 inch.

The bend ductility specimens are pictured, after testing, in Fig. 15. The specimens which had fractured had been cemented together to provide a better impression of the strain magnitude as inferred from the permanent deflection. Group 3 is on the left, Group 2 is in the center and Group 1 is on the right. Because of a shortage of 4- and 5-inch Group 3 specimens, one figure contains only Groups 1 and 2. The small specimens (1/4 inch), one from each group, which are extensively deformed, were bent by hand after test; only the Group 3 specimen did not fracture. It is apparent (Fig. 15) that, as the size of the bend ductility specimens increased, Group 1 (hot cross-rolled) embrittled at a relatively rapid rate as compared to Groups 2 and 3.

Although increasing size has been emphasized as a factor contributing to the embrittlement of beryllium, it is necessary to recognize that increasing the thickness reduces the embrittling effect (Figs. 10, 11 and 12).

#### E. BULGE TEST

Because of the unavailability of hot-upset (Group 3) bulge test specimens, the results of this test will permit only limited conclusions. The maximum values of load, strain and deflection, obtained at fracture, are presented in Table 6. Although the loads at fracture did not differ appreciably, the hot-pressed sheet (Specs 2 and 3) developed approximately three times the strain and 50% more deflection than the hot cross-rolled sheet (Specs 1 and 4). These results conform with the greater ductility of Group 2 as compared to Group 1 in the bend ductility tests.

## F. BOX-BEAM TESTS

The box-beam tests were intended to provide the additional evidence of the relative differences of structural quality among the three beryllium groups. This experiment partially was successful. Unfortunately, box-beams A and C were not made to specification, and because of the nature of delivery, the element of time precluded the rectification of an omission during manufacture. In order to maintain identical test conditions, the vertical web reinforcements of Beam B, which would have prevented the low order web failure, were omitted. As a consequence, the design condition, failure in the tensile cover at maximum load, was not achieved. However, the data were adequate for classification of the general behavior of the materials.

The results are presented in the form of curves in which load is plotted against deflection (Fig. 16). The stresses, calculated on the basis of moment and strain, are presented in Table 7.

The significant difference among the beams was the maximum load for web failure. In the order of decreasing loads the results were:

- (1) Beam B (hot-upset) failed at 7,100 pounds.
- (2) Beam C (hot-pressed) failed at 4,700 pounds.
- (3) Beam A (hot cross-rolled) failed at 3,600 pounds.

Continued loading of Beam A produced a failure in the tension cover at 4,380 pounds. The load-deflection curves (Fig. 16) show that the total deflection at fracture was approximately proportional to maximum load for Beams A and B; however, the slope of the load-deflection curve of Beam C was significantly lower than that of Beams A and B. Similarly, in Fig. 9, the slope of the load-thickness curve for the hot-pressed beryllium (Group 2 and Beam C) was lower than that of the hot-upset and hot cross-rolled. The value of stress at 4,000 pounds for the tension cover of Beam C (Table 7) is at least 13,000 psi; therefore, since this value of stress exceeded the linear stress-strain region of the hot-pressed beryllium (Fig. 7), it may be concluded that plastic strain has contributed to the deflection. Beam B has exhibited a similar behavior and it can be attributed to the same cause. However, the nonlinear portion of the load-deflection curve for Beam A is most probably contributed by rigid body movement of the fractured web.

In general, the mode of failure and magnitudes of stress and strain are consistent with the bend ductility behavior of these three groups.

#### IV. DESIGN SIGNIFICANCE OF BERYLLIUM

Although, as a general rule, the ratio of strength to density is indicative of relative structural superiority, a design illustration is normally more accurate. Therefore, a hypothetical high performance wing was designed for an 800° F flight condition. The detailed analysis comparing beryllium to stainless steel and titanium is presented in Appendix A.

It is significant that although the strength values selected for beryllium were lower than those developed by Groups 1 and 3, the beryllium design was clearly superior to stainless steel and titanium.

## V. CONCLUSIONS AND RECOMMENDATIONS

### A. CONCLUSIONS

- (1) The tensile stress-strain curve may provide an important clue for characterizing the degree of embrittlement through the strain-hardening rate or, more generally, by the ratio of yield to ultimate strength.
- (2) Although the bend ductility test employed for the investigation has not achieved the desired precision due to specimen irregularities and possible inhomogeneity as well as lack of perfection of test methods, the trend of embrittlement as the specimen size increased was clearly established.
- (3) The test results, in aggregate, show that:
  - (a) Group 2 (hot-pressed) beryllium sheet is least acceptable because of its low strength, elongation and notch strength; however, it is generally homogeneous and can withstand complex stresses in bending.
  - (b) Group 1 (hot cross-rolled) beryllium sheet, which nominally exhibited the highest strength and ductility, suffers in comparison because of the marked embrittlement which it undergoes in bending.
  - (c) Group 3 (hot-upset) beryllium sheet appears to be superior because it manifests to a degree, the best qualities of both Groups 1 and 2.
- (4) It is evident from the results of this investigation that tensile elongation is an inadequate measure of structural quality for beryllium unless an inverse relation of elongation to embrittlement is employed. The specification should be based on the developed crystallographic structure.
- (5) Although the bend ductility test provided a more informed characterization of beryllium's ductile or brittle behavior as compared to the standard mechanical test, the stress concentrations generated in the regions of loading, and possible displacement of the test element on the supports during large deflections are undesirable.

### B. RECOMMENDATIONS

- (1) The bend test appears to offer the most informative and economical means for establishing the precise degree of embrittlement developed in beryllium. However, the experience gained in this investigation indicates that a cantilever beam test with a constant strength cross section may be superior because stress concentrations can be eliminated from the test region and the tapered specimen will provide a range of widths for increased test economy.
- (2) Certain features of each of the beryllium groups are desirable. For example, the high strength of Groups 1 and 3 and the resistance to embrittlement of Groups 2 and 3 are desirable. Therefore, the best features of each should be incorporated by undertaking a process development study which would be mainly concerned with the mechanical quality of beryllium sheet.

## VI. REFERENCES

1. Wikle, K. G., Armstrong, J. W. and Perrin, H. N., "Development of Beryllium Sheets Rolled Flat to Gauge," The Brush Beryllium Company, AMC TR 60-7-631, September 1930.
2. Wikle, K. G. and Glenn, G. M., "Production of Beryllium Sheets," Progress Reports 1 and 2, October - January 1958, AF 33(600)-35829.
3. Muvdi, B. B., "Structural Evaluation of Beryllium Produced by Several Processes," The Martin Company, WADC TR 58-162, 1958.
4. Giemza, C. J., "Development and Evaluation of Structural Beryllium," The Martin Company, WADC TR 59-349, 1959.
5. Yans, F. M. and Kaufman, A. R., "Third-Dimensional Ductility," Nuclear Metals, Inc., NMI 5003, 1958.
6. Greenspan, J., "Ductility in Beryllium Related to Grain Orientation and Grain Size," Nuclear Metals, Inc., NMI 1174, 1957.
7. Tuer, G. L., "Fundamental Mechanical and Physical Characteristics of Beryllium as Related to Single Crystal Studies," Thesis D. Sc., MIT, 1954.

## APPENDIX A

### DESIGN EVALUATION--COMPARISON OF BERYLLIUM, STAINLESS STEEL AND TITANIUM

This preliminary design study for a beryllium wing of a glide re-entry vehicle is not intended to be a definitive structural analysis. Its purpose is to show simply but clearly the margin of advantage that an experimental beryllium sheet possesses compared to two highly developed materials, PH 15-7 Mo RH 950 stainless steel and titanium 6 AL-4V. Furthermore, the wing design, on which the analysis is based, is not intended to satisfy aerodynamic requirements or to be identified with any particular practical concept. The materials selected for the comparison are typical and the mechanical properties are the maximum practical values given by standard reference sources. Properties for beryllium were taken from the Brush Beryllium Company's Progress Report No. 6 (AF33(616)-57-19) dated March 31, 1959 and do not represent the maximum values which have been attained.

Although paper design studies often neglect many practical problems associated with design, construction and service, the comparative advantage of one material over another on a simplified basis, such as the one employed in this case, is not invalid. Although the conventional design analysis employed here has neglected the detail, dynamic and thermal analyses which are necessarily beyond the scope of this preliminary design, major significance with respect to beryllium's weight-saving potential could not be attached to a more sophisticated design analysis. In fact, necessary presumptions would not only be erroneous but could obscure many meaningful results.

In the suggested applications (missiles, glide re-entry vehicles and satellites), the net advantage of one material over another is not only the relative weight saving but, more specifically, the saving in gross takeoff weight. The specific value of a factor which would be applied to arrive at a total weight saving would, of course, depend on the staging and mission.

Although beryllium is not presently employed as a structural material, in the manner of airframe materials, the advantage of the experimental beryllium sheet is clear for the conditions stated. Other experimental beryllium sheet has been produced with mechanical properties substantially in excess of those shown in Table 8.

#### A. STRUCTURAL ANALYSIS

##### Design conditions

Structural temperature	T = 800° F
Unit load	p = 50 lb/ft <sup>2</sup>
Ultimate load factor properties	(16g x 1.25) = 20
Properties	Table 8

Analysis of section at BLO (near rear spar) (Sk-46344 and Fig. 21)

$$\text{Area} = A_L = (102.5)(66.8) = 6850/144 = 47.6 \text{ ft}^2 \text{ (Fig. 21)}$$

$$\text{Ultimate load} = P = (47.6)(50)(20) = 47,600 \text{ lb uniformly distributed}$$

$$\text{Eccentricity} = e = 34.1 \text{ in. (Fig. 21)}$$

$$\text{Moment} = M_x = (47,600)(34.1) = 1.605 \times 10^6 \text{ lb-in.}$$

$$\text{Moment of inertia} = I_x = 3.45^2 + 3.85^2 + 4.2^2 + 4.45^2 + 4.7^2 + \frac{4.82^2}{4} 10 \\ \times 2 \times t^1*$$

$$= 1842t^1 \text{ in.}^4 \text{ where } t^1 = \text{skin thickness-in. (Fig. 20)}$$

$$\text{Maximum stress} = f_{\text{max}} = \frac{M c_{\text{max}}}{I} = \frac{1.605 \times 10^6 \times 4.8}{1842 t^1} = \frac{4220}{t^1} \text{ psi}$$

#### Case I Beryllium--Table 8

$$\text{Allowable compressive stress} = F_{CA} = (-41.6)(0.8)^{**} = -33.2 \text{ ksi}$$

$$\text{Compression skin} = t^1_{\text{top}} = \frac{4220}{33,200} = 0.127 \text{ in.}$$

$$\text{Allowable tensile stress } F_{TA} = (41)(0.8)^{***} = 32.8 \text{ ksi}$$

$$\text{Tension skin} = t^1_{\text{bottom}} = \frac{4220}{32,800} = 0.129 \text{ in.}$$

$$\text{Average skin thickness } t^1 = 0.128 \text{ in.}$$

Combined weight of upper and lower surfaces

$$\text{Total weight of covers } W = (175)(84)(0.0658)(0.07466) = 72.2 \text{ lb}^{****}$$

#### Case II Stainless Steel--PH 15-7 Mo Cond RH950

$$\text{Allowable compressive stress} = F_{CA} = (-154)(0.8)^{**} = -123 \text{ ksi}$$

$$\text{Compression skin} = t^1_{\text{top}} = \frac{4220}{123,000} = 0.0342 \text{ in.}$$

$$\text{Allowable tensile stress} = F_{TA} = (184)(0.8)^{***} = 147 \text{ ksi}$$

---

\*  $t^1$  includes the stiffener thickness

\*\* Compression factor--for optimum design condition

\*\*\* Tension factor--allowance for rivets and shear

\*\*\*\* See Fig. 19 for analytical basis

$$\text{Tension skin} = t^1_{\text{bottom}} = \frac{4220}{142,000} = 0.0287 \text{ in.}$$

$$\text{Total weight of covers} = W = (175)(84)(0.286)(0.0313) = 132 \text{ lb}$$

### Case III Titanium--6AL-4V

$$\text{Allowable compressive stress} = F_{CA} = (-93.5)(0.8)^{**} = -74.8 \text{ ksi}$$

$$\text{Compression skin} = t^1_{\text{top}} = \frac{4220}{74,800} = 0.0563 \text{ in.}$$

$$\text{Allowable tensile stress } F_{TA} = (115)(0.8)^{***} = 92 \text{ ksi}$$

$$\text{Tension skin} = t^1_{\text{bottom}} = \frac{4220}{92,000} = 0.0458 \text{ in.}$$

$$\text{Total weight of covers} = W = (175)(84)(0.164)(0.0448) = 107.5 \text{ lb}$$

Weight advantage of beryllium compared to stainless steel

$$\frac{132 - 72.2}{132} \times 100\% = 45.5 \%$$

Weight advantage of beryllium compared to titanium

$$\frac{107.5 - 72.2}{107.5} \times 100\% = 32.6 \%$$

The design illustration of a typical hypersonic wing structure comparing beryllium to stainless steel and titanium was based on limit load as the critical condition. In addition to the strength-density superiority of the beryllium wing design, added benefits accrue as the result of the stiffness-density difference of beryllium compared to stainless steel and titanium. Based on deflection theory and the design values obtained or specified for the three materials, the titanium wing would deflect approximately eight times more and the stainless steel wing would deflect approximately five times more than the beryllium wing. (The deflection of this wing, essentially, varies inversely with the product of skin thickness and modulus of elasticity.) Based on the buckling theory, the beryllium wing would show a similar superiority in buckling resistance compared to the stainless steel and titanium designs. (The buckling stress for a panel of this wing, essentially, varies directly with the product of the square of skin thickness and modulus of elasticity.)

Although the beryllium structure is clearly superior in strength-weight, stiffness and buckling resistance, the employment of these advantages will necessarily be based on economic and design considerations.

---

\*  $t^1$  includes the stiffener thickness

\*\* Compression factor--for optimum design condition

\*\*\* Tension factor--allowance for rivets and shear

\*\*\*\* See Fig. 19 for analytical basis

### CALCULATIONS FOR DOUBLE TAPERED BERYLLIUM COVERS

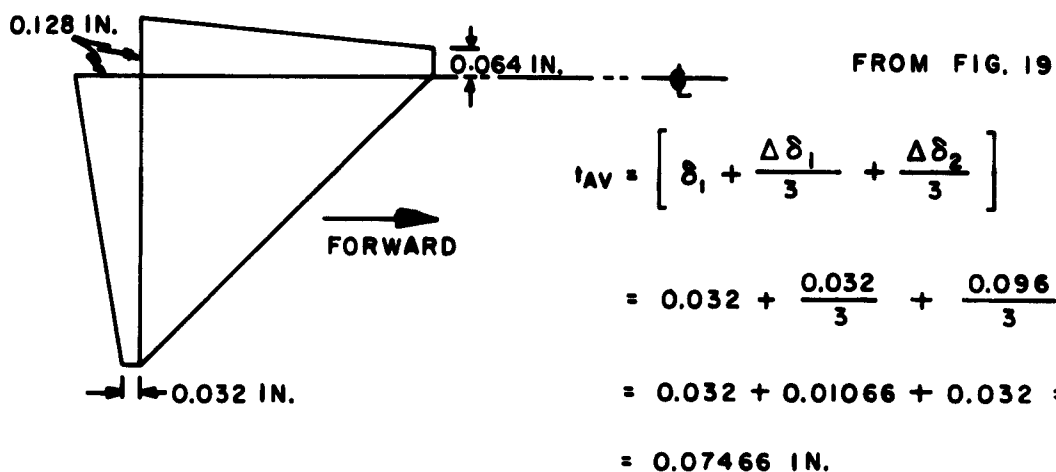

Calculations for steel covers based on constant thickness because the cover thickness, for this application, would not permit tapering.

### CALCULATIONS FOR SINGLE TAPERED TITANIUM COVERS

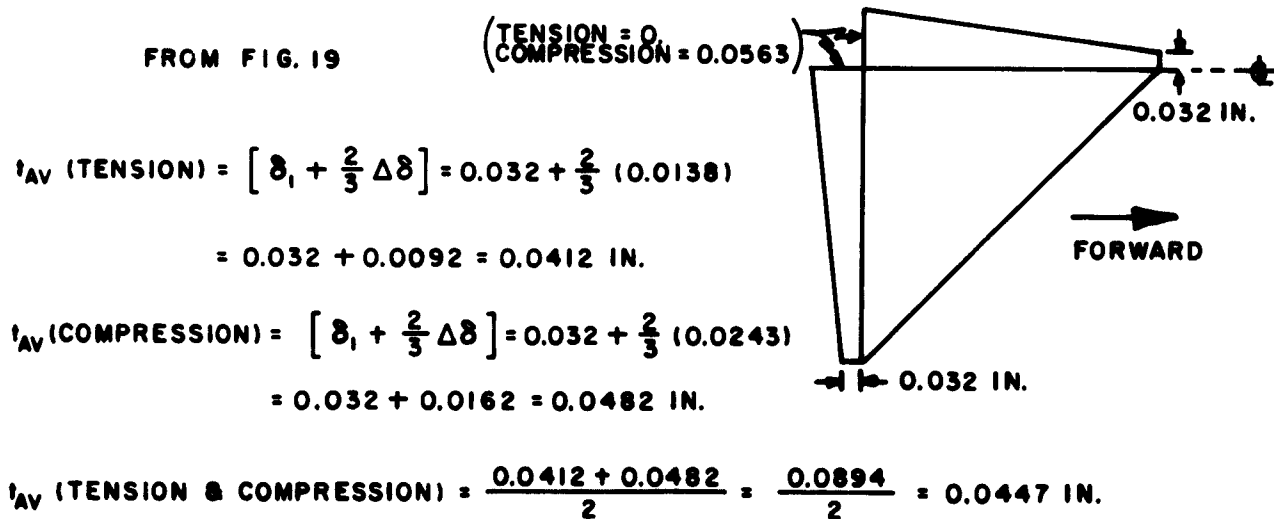

**APPENDIX B**  
**TABLES AND ILLUSTRATIONS**

**TABLE 1**  
**Chemical Analysis of Beryllium Powder for Hot-Upset Sheet**  
**(QMV-200 Mesh Powder--Brush Beryllium Company)**

<u>Element</u>	<u>Percent</u>
Be	98.5
BeO	0.88
C	0.09
Al	0.030
Fe	0.077
Mg	0.006
Si	0.025

**TABLE 2**  
**Chemical Analysis of Beryllium Powder for Both**  
**Hot-Pressed and Cross-Rolled Sheet**  
**(QMV-200 Mesh Powder--Brush Beryllium Company)**

<u>Element</u>	<u>Percent</u>
Be	98.2
BeO	1.59
C	0.15
Al	0.03
Fe	0.13
Mg	0.01
Si	0.02
Cr	0.01
Ni	0.01
Mn	0.01

**TABLE 3**  
**Box-Beam Specifications**

<u>Beam Number</u>	<u>Dimension (in.)</u>						
	<u>A</u>	<u>B</u>	<u>C</u>	<u>D</u>	<u>E</u>	<u>F</u>	<u>G</u>
A	4.968	0.072	0.073	0.073	2.390	0.054	1.00
B	5.031	0.074	0.068	0.068	2.390	0.057	1.00
C	4.890	0.073	0.069	0.069	2.390	0.051	1.00

Length of beams 15 in.  
 Weight of assembled beams 2.75 lb  
 Weight of beryllium 1.30 lb  
 Weight of fasteners (steel) 1.45 lb

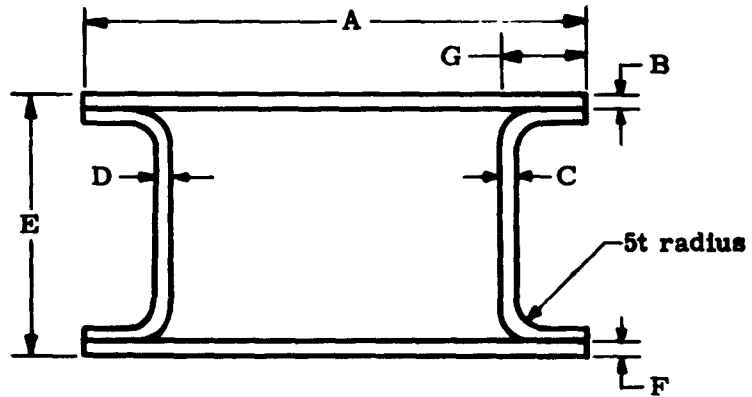

**TABLE 4**  
**Tensile Properties: Hot-Pressed, Hot-Upset and**  
**Hot Cross-Rolled Beryllium Sheet**

<u>Specimen No.</u>	<u>Gage (in.)</u>	<u>Width (in.)</u>	<u>Area (in.<sup>2</sup>)</u>	<u>F<sub>TU</sub> (psi)</u>	<u>Elongation (%)</u>	<u>Remarks</u>
<b>Group 1 (Hot Cross-Rolled)</b>						
T-1 -1	0.0697	0.2440	0.01701	70,300	4	
T-1 -2	0.0696	0.2463	0.01714	85,700	17	
T-1 -3	0.0690	0.4946	0.03413	76,100	--	Failed in grip section
T-1 -4	0.0707	0.4930	0.03486	82,800	9.5	Elong over 4 in.
T-1 -5	0.0707	0.7358	0.05202	66,400	1.0	
T-1 -6	0.0708	0.7389	0.05321	66,200	1.0	
T-1 -7	0.0707	0.9933	0.07023	85,400	15.0	
T-1 -8	0.0720	0.9948	0.07163	82,200	10.0	
T-1 -9	0.0725	1.4956	0.10843	85,500	9.0	Failed outside 2-in. gage marks
T-1 -10	0.0723	1.4970	0.10823	72,500	3.0	
<b>Group 2 (Hot-Pressed)</b>						
T-2 -1	0.0708	0.2464	0.01745	52,700	3.0	
T-2 -2	0.0702	0.2438	0.01711	49,400	2.5	
T-2 -3	0.0701	0.4960	0.03463	48,300	0.75	Elong over 4 in.
T-2 -4	0.0695	0.4954	0.03443	50,100	2.0	Failed outside gage marks
T-2 -5	0.0710	0.7450	0.05290	52,200	--	Failed outside gage marks
T-2 -6	0.0719	0.7450	0.05357	50,800	1.0	
T-2 -7	0.0714	0.9976	0.07123	55,600	1.0	
T-2 -8	0.0725	0.9958	0.07220	54,200	2.5	
T-2 -9	0.0728	1.4960	0.10891	43,400	1.0	
T-2 -10	0.0730	1.4998	0.10949	55,600	2.0	
<b>Group 3 (Hot-Upset)</b>						
T-3 -1	0.0755	0.2515	0.01899	72,800	3.5	
T-3 -2	0.0620	0.4940	0.03063	82,000	7.0	Failed outside gage marks

TABLE 4 (continued)

<u>Specimen No.</u>	<u>Gage (in.)</u>	<u>Width (in.)</u>	<u>Area (in.<sup>2</sup>)</u>	<u>F<sub>TU</sub> (psi)</u>	<u>Elongation (%)</u>	<u>Remarks</u>
T-3 -3	0.0574	0.4964	0.02849	88,600	12.0	
T-3 -4	0.0830	0.7383	0.06128	78,700	4.0	Failed outside gage marks
T-3 -5	0.1000	0.7470	0.07470	67,900	3.0	
T-3 -6	0.0565	0.9965	0.05630	74,000	2.0	
T-3 -7	0.0750	0.9955	0.07466	72,600	5.5	
T-3 -8	0.0640	1.4910	0.05420	67,400	2.0	
T-3 -9	0.0870	1.4940	0.12998	58,800		Failed in grip section before modification of grip area
				<u>Hot Cross-Rolled (T-1)</u>	<u>Hot-Pressed (T-2)</u>	<u>Hot-Upset (T-3)</u>
			Average F <sub>TU</sub> (psi)	77,300	51,200	75,600
			Average F <sub>TY</sub> (psi)	71,000	35,200	50,000
			Average elongation (%)	9	1.5	5
			Modulus of elasticity (psi)	42 x 10 <sup>6</sup>	42 x 10 <sup>6</sup>	42 x 10 <sup>6</sup>

**TABLE 5**  
**Compression Properties: Hot-Pressed, Hot-Upset  
and Hot Cross-Rolled Beryllium Sheet**

<u>Specimen No.</u>	<u>Gage (in.)</u>	<u>Width (in.)</u>	<u>Area (in.<sup>2</sup>)</u>	<u>Maximum Stress (psi)</u>	<u>Remarks</u>
C-1 -1	0.0735	1.006	0.0744	78,000	Fracture at maximum stress occurred after buckling and after at least 2% deformation
C-1 -2	0.0738	1.005	0.0742	83,300	
C-1 -3	0.0717	1.006	0.0722	75,800	
C-1 -4	0.0735	1.006	0.0740	76,400	
C-2 -1	0.0740	1.0005	0.0740	50,600	Fracture at maximum stress occurred after buckling and after at least 1.5% deformation
C-2 -2	0.0730	1.001	0.0730	48,000	
C-2 -3	0.0727	1.0005	0.0727	50,100	
C-2 -4	0.0740	1.0005	0.0740	50,100	
C-3 -1	0.0760	0.992	0.0754	72,100	Fracture at maximum stress occurred after buckling and after at least 2% deformation
C-3 -2	0.0745	0.988	0.0735	87,900	
C-3 -3	0.0769	0.9855	0.0756	67,450	
C-3 -4	0.0760	0.989	0.0750	72,500	

NOTE:  
 $E_c \geq 45 \times 10^6$  psi for the three material groups.

**TABLE 6**  
**Bulge Test Results for Beryllium Sheet**

<u>Specimen Number</u>	<u>Maximum Load (lb)</u>	<u>Average Maximum Strain (in./in.)</u>	<u>Maximum Deflection (in.) (1 in. from center)</u>
1	470	2700	0.021
2	450	8300	0.0265
3	485	9400	0.029
4	475	3000	0.018

**TABLE 7**  
**Calculated Stress Values for Beryllium Box Beams**

<u>Load (lb)</u>	<u>Beam Number</u>	<u>Location of Stress, <math>C_L</math></u>	<u>Stress Based on Load, <math>\sigma = \frac{M c}{I}</math> (psi)</u>	<u>Stress Based on Strain, <math>\sigma = \epsilon E</math> (psi)</u>
3000	A	Comp cover	-9,470	-7,890
		Tension cover	11,070	-8,610
	B	Comp cover	-9,470	-9,440
		Tension cover	11,070	10,330
	C	Comp cover	-9,470	-9,570
		Tension cover	11,070	11,110
4000	B	Comp cover	-12,630	-10,350
		Tension cover	14,750	11,110
	C	Comp cover	-12,630	-10,140
		Tension cover	14,750	13,550
6000	B	Comp cover	-18,940	-19,750
		Tension cover	22,130	21,940

TABLE 8  
 Properties at 600° F and 800° F for Beryllium,  
 PH15-7Mo Stainless and Titanium 6AL-4V

Material	RT		600° F						800° F															
	$F_{TU}$ (ksi)	$F_{TY}$ (ksi)	$F_{TU}$ (ksi)	Elong (%)	$E \times 10^{-6}$ (psi)	$F_{CY}$ (ksi)	$\rho = \text{lbs/in.}^3$	$F_{TY} \times 10^{-3}$ (in.)	$F_{CY} \times 10^{-3}$ (in.)	$\frac{F_{\Delta V}}{\rho} \times 10^{-3}$ (in.)	$\Delta^*$ (%)	$\Delta^{**}$ (%)	$F_{TU}$ (ksi)	$F_{TY}$ (ksi)	Elong (%)	$E \times 10^{-6}$ (psi)	$\rho = \text{lbs/in.}^3$	$F_{TY} \times 10^{-3}$ (in.)	$F_{CY} \times 10^{-3}$ (in.)	$\frac{F_{\Delta V}}{\rho} \times 10^{-3}$ (in.)	$\Delta^*$ (%)	$\Delta^{**}$ (%)		
Beryllium--extruded and cross-rolled 0.9% BeO	79.4	51.0	-46	40.1	36	0.0658	773	-702	737	0	-15.3													
	61.3	46.2	Est				702																	
Beryllium--extruded and cross-rolled 2.3% BeO	72.1	59.3	-55	40.5	36	0.0658	902	-837	870	18	0													
	69.0	55.0					837																	
Stainless steel PH15-7Mo, condition RH950	240	201	-205	5	26	0.286	703	-715	672	-8.8	-23.0													
	215	171					598																	
Titanium 6AL-4V	164	119	-102	18	12.5	0.164	725	-622	673	-8.7	-22.2													
	155	96					586																	
Beryllium--extruded and cross-rolled 0.9% BeO	79.4	41.0	-41.6	40	31	0.0658	633	-642	637	0	-12.7													
	61.3	40.4	Est				625																	
Beryllium--extruded and cross-rolled 2.3% BeO	72.1	48.2	-46.5	30	31	0.0658	743	-718	730	14.6	0													
	69.0	45.1					695																	
Stainless steel PH15-7Mo, condition RH950	240	184	-195	8	24.6	0.286	643	-682	621	-2.5	-15.1													
	215	154					538																	
Titanium 6AL-4V	164	115	-93.5	18	12	0.164	702	-570	636	~0	-12.9													
	155	96					548																	

\*Relative advantage based on strength-density ratio referred to 0.9% BeO extruded cross-rolled beryllium.

\*\*Relative advantage based on strength-density ratio referred to 2.3% BeO extruded cross-rolled beryllium.

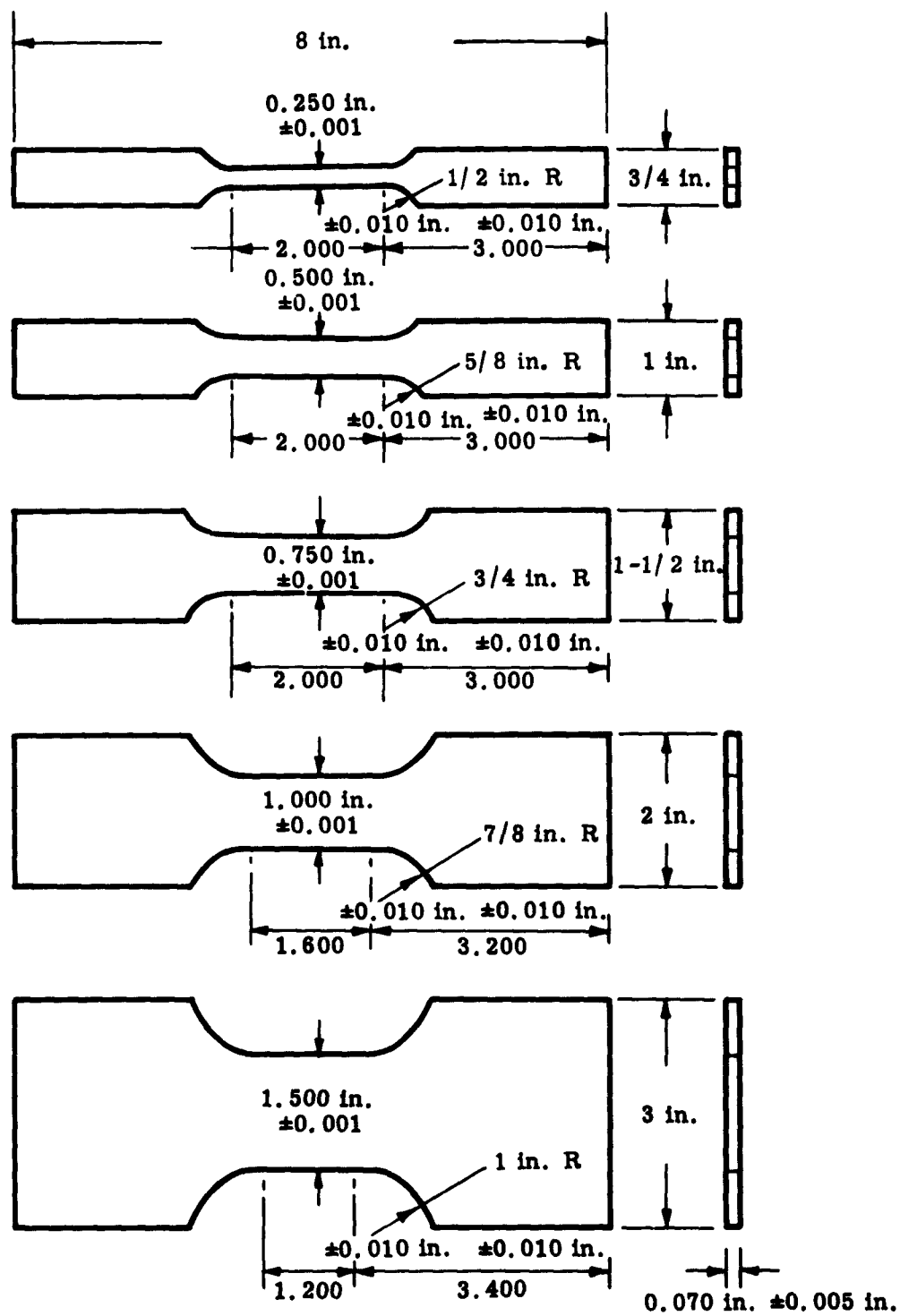
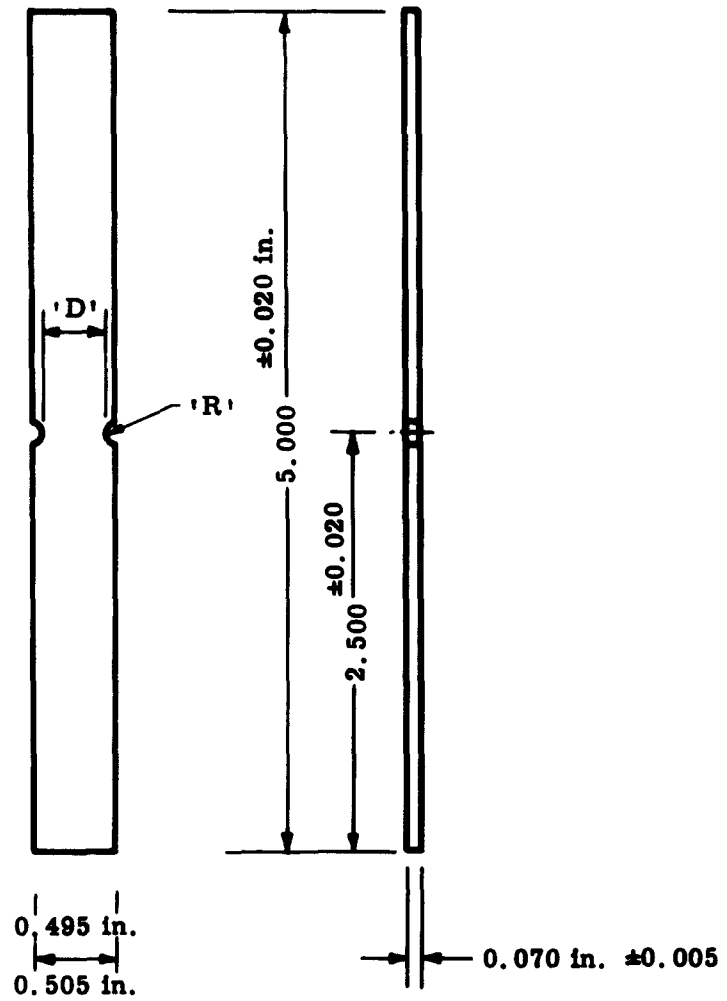
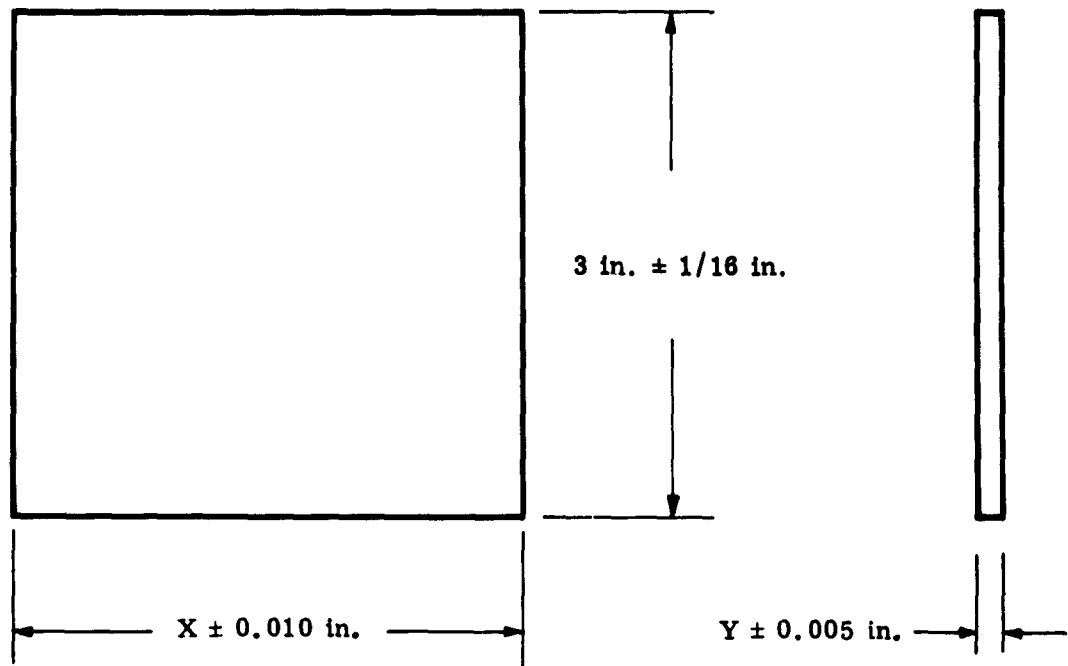

Fig. 1. Tension Specimens, Specifications



Specimen	No. Reqd	'D' (in.)	'R' (in.)
1	1	0.062	1/16
2	1	0.125	1/16
3	1	0.188	1/16
4	1	0.250	1/16
5	1	0.312	1/16
6	1	0.375	1/16
7	1	0.250	3/64
8	1	0.375	3/64

Fig. 2. Notch Tension Specimens, Specifications



Specimen	No. Required	X (in.)	Y (in.)
1	2	0.250	0.050
2	2	0.500	0.050
3	2	1.000	0.050
4	2	1.500	0.050
5	2	2.000	0.050
6	2	3.000	0.050
7	1	4.000	0.050
8	1	5.000	0.050
9	2	0.250	0.070
10	2	0.500	0.070
11	2	0.750	0.070
12	2	1.000	0.070
13	1	2.000	0.070
14	2	2.500	0.070
15	1	5.000	0.070

Fig. 3. Bend Ductility Specimens, Specifications

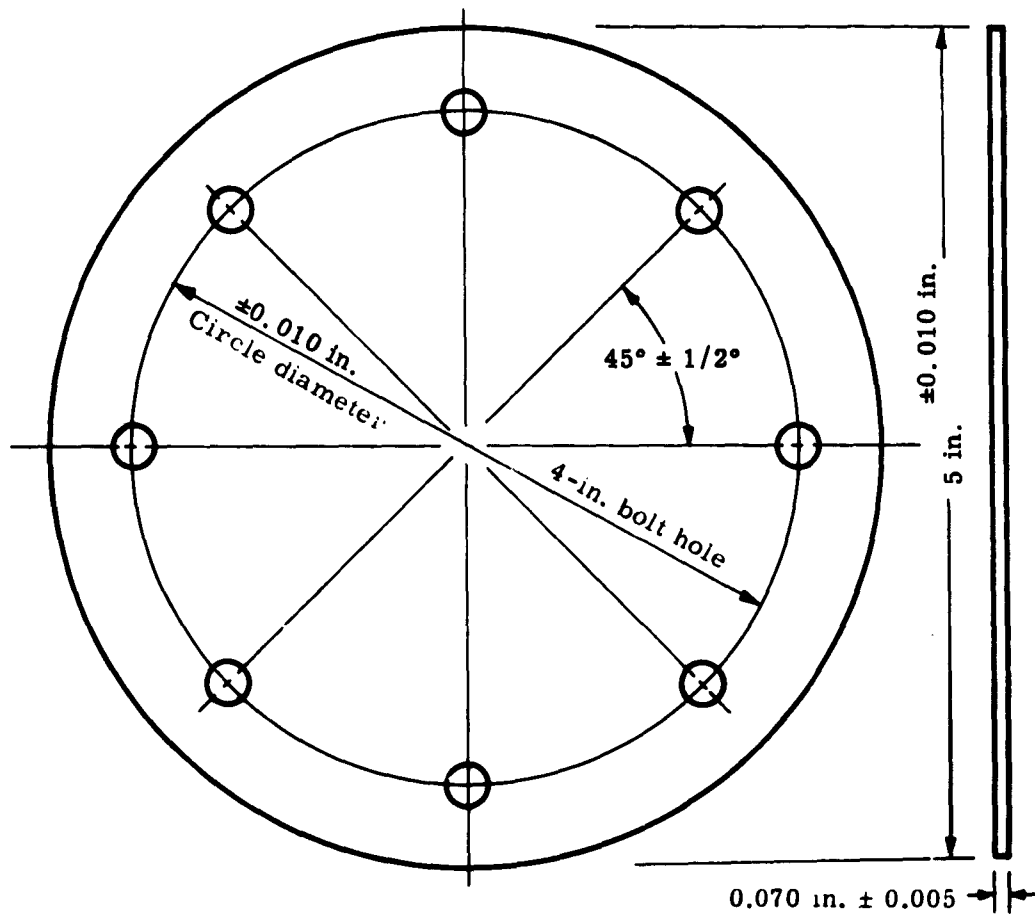
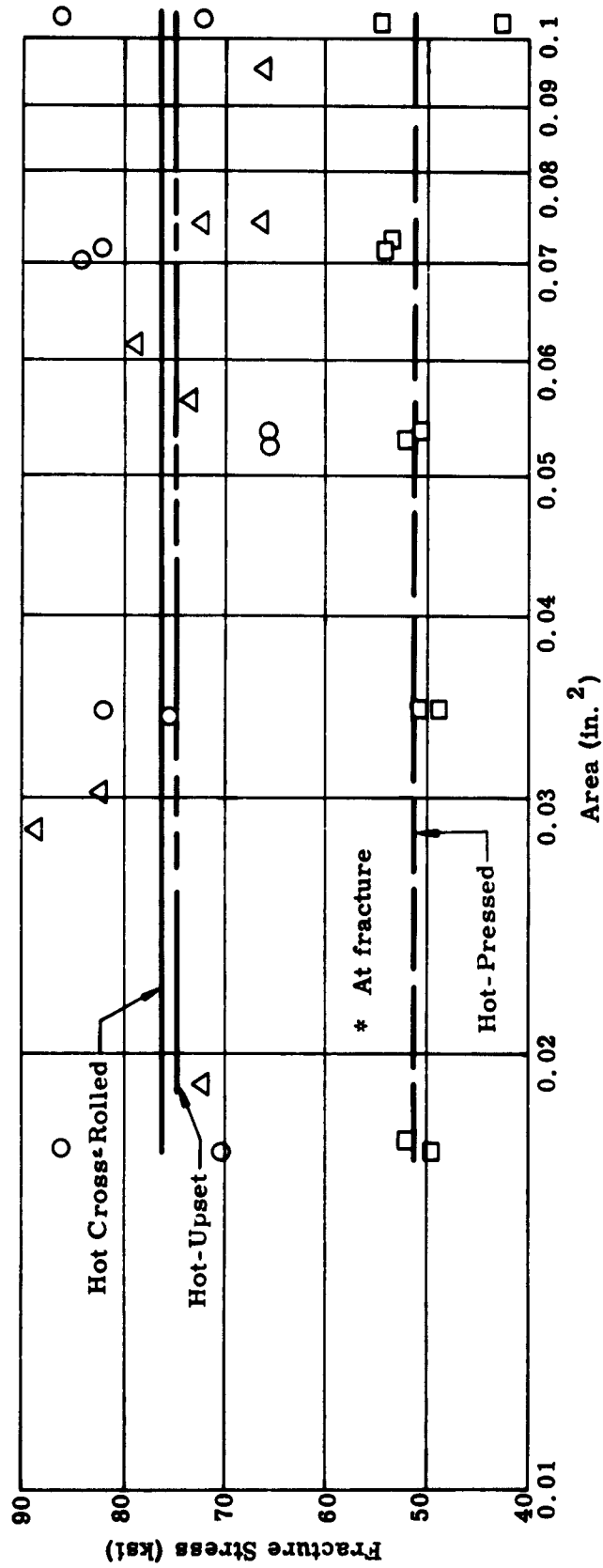

Fig. 4. Bulge Test Specimen, Specifications



Fig. 5. Box - Beam, Test Setup



(av) Elongation*	(av) Fracture Stress
9.0%	77,310 psi
1.5%	51,230 psi
5.0%	75,650 psi

Fig. 6. Variation of Tensile Strength with Cross-Sectional Area, Hot-Pressed Hot-Upset and Hot Cross-Rolled Beryllium Sheet

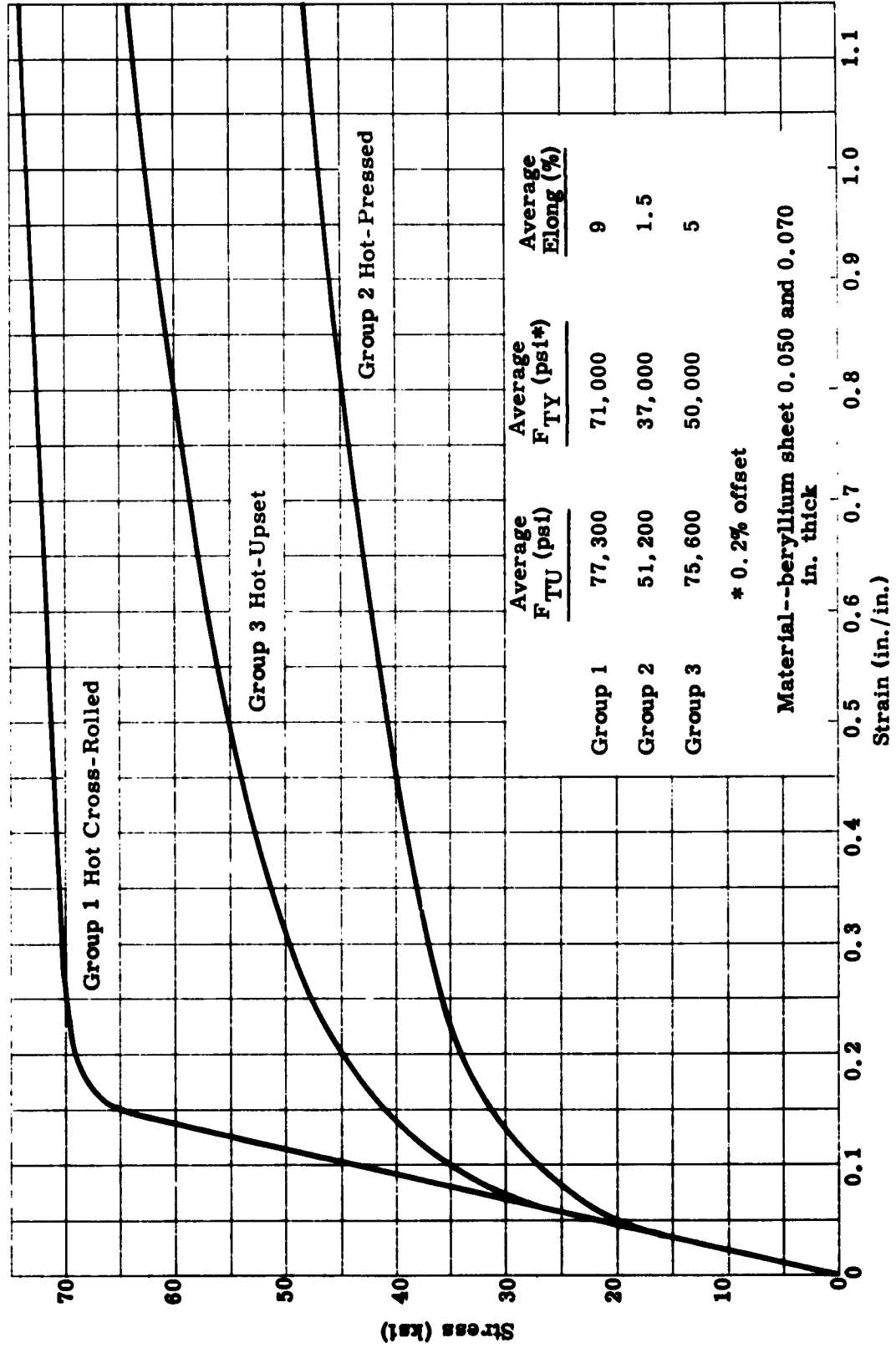

Fig. 7. Average Tensile Stress-Strain Curves, Hot-Pressed, Hot-Upset and Hot Cross-Rolled Beryllium Sheet

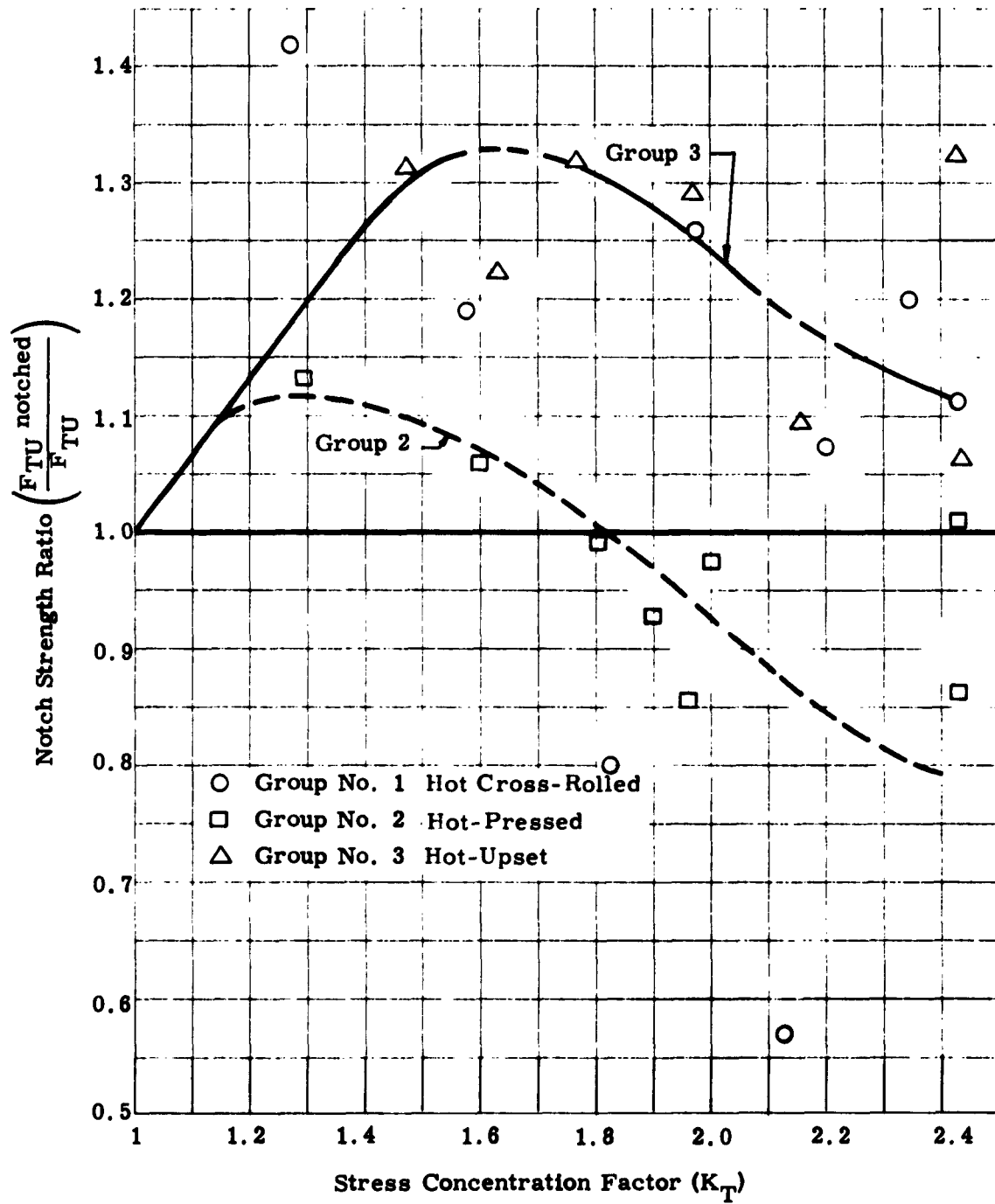

Fig. 8. Variation of Notch Strength Ratio with Stress Concentration Factor, Hot-Pressed, Hot-Upset and Hot Cross-Rolled Beryllium Sheet

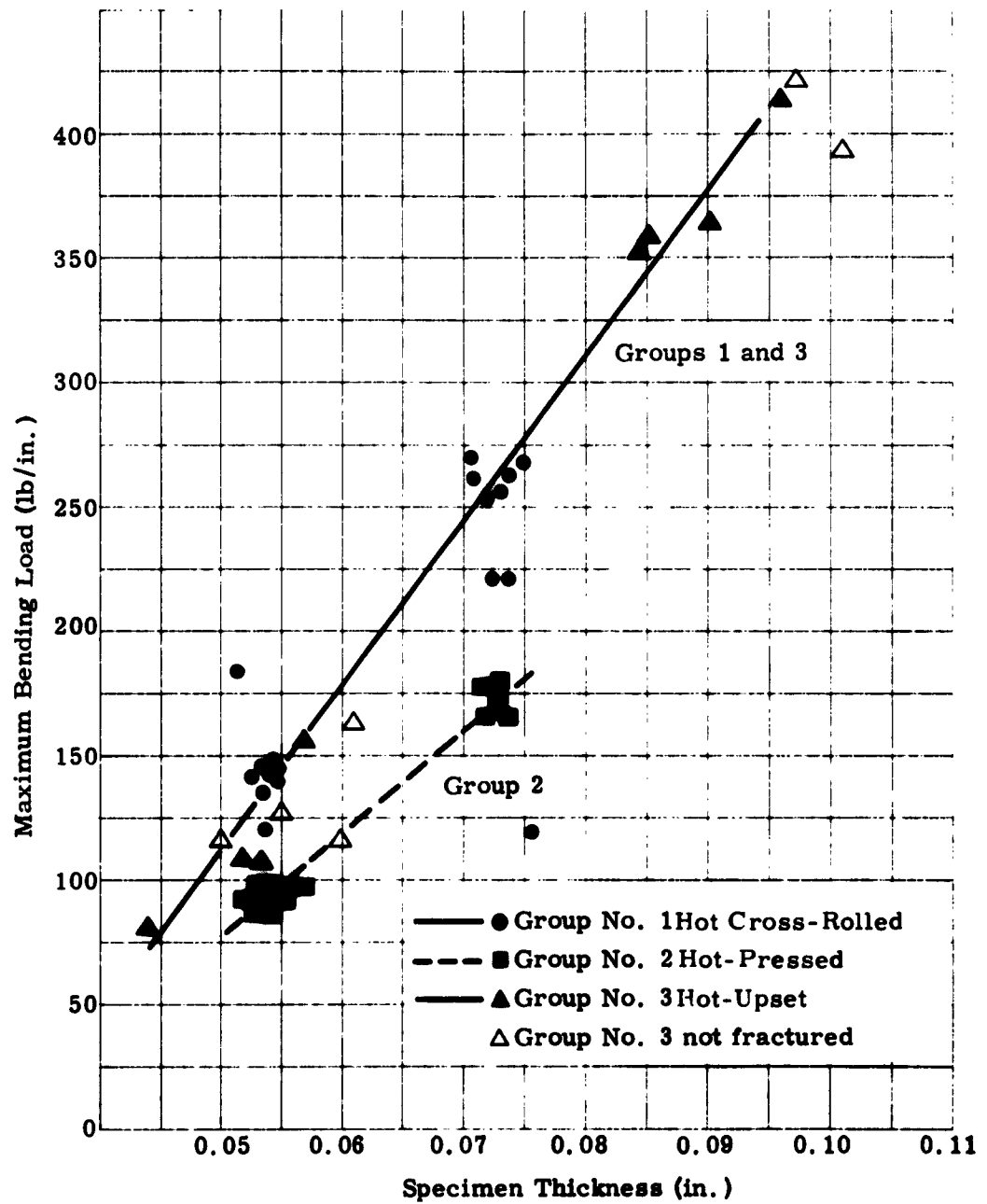

Fig. 9. Variation of Maximum Bending Load with Thickness for the Beryllium Bend Ductility Specimens

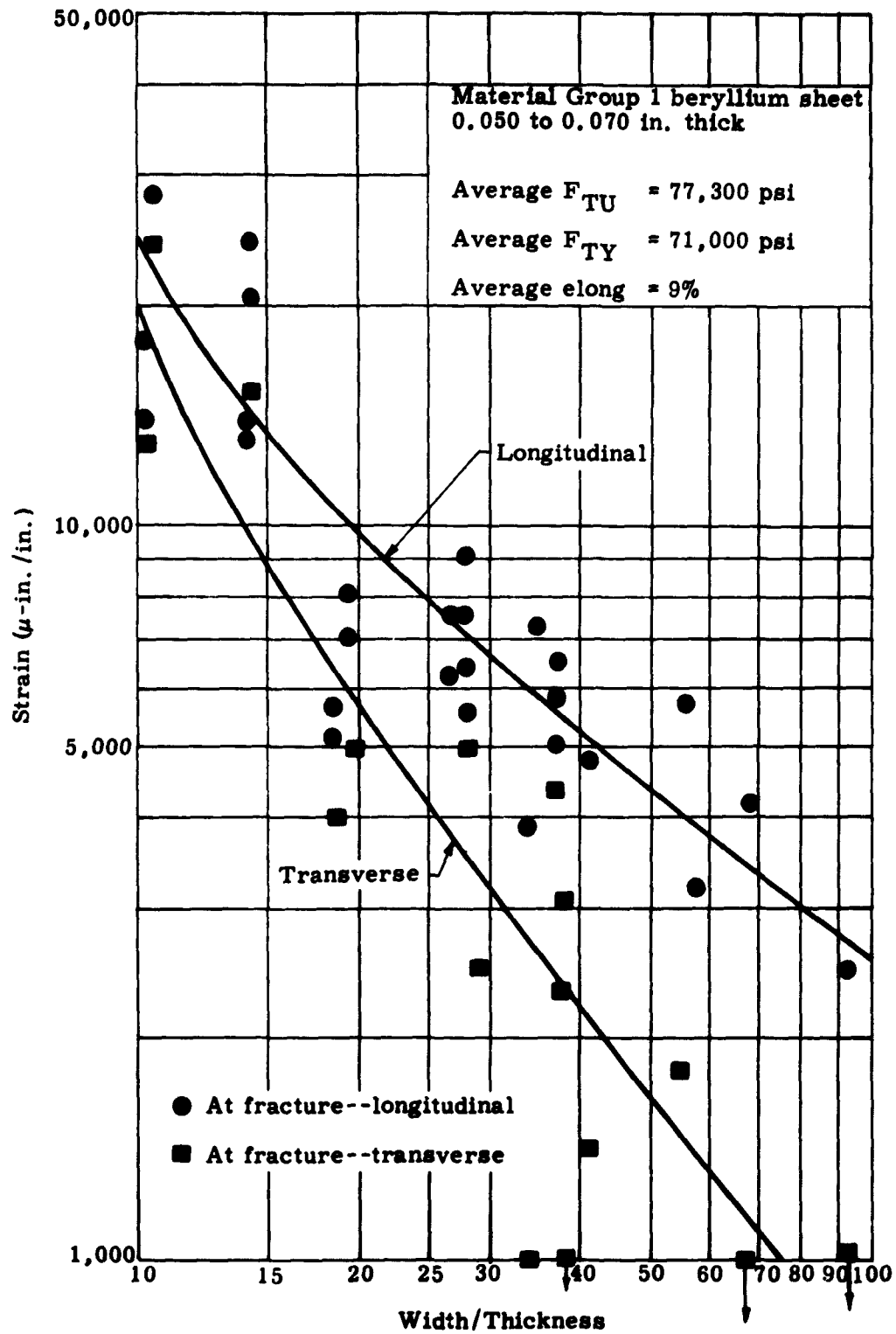

Fig. 10. Variation of Maximum Strain with Size in a Constant Moment Bend Test, Group 1, Beryllium Sheet (Hot Cross-Rolled)

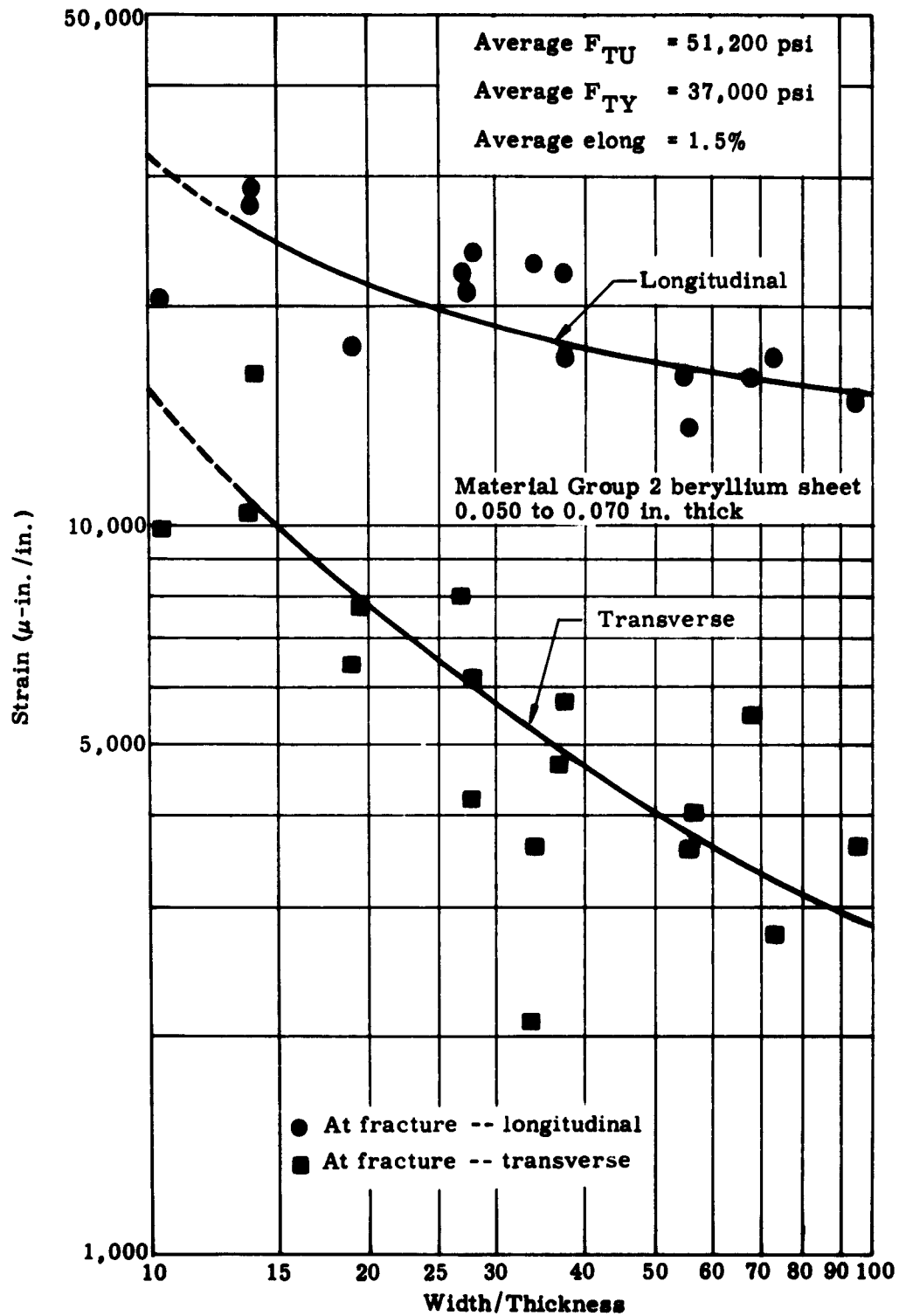

Fig. 11. Variation of Maximum Strain with Size in a Constant Moment Bend Test, Group 2, Beryllium Sheet (Hot-Pressed)

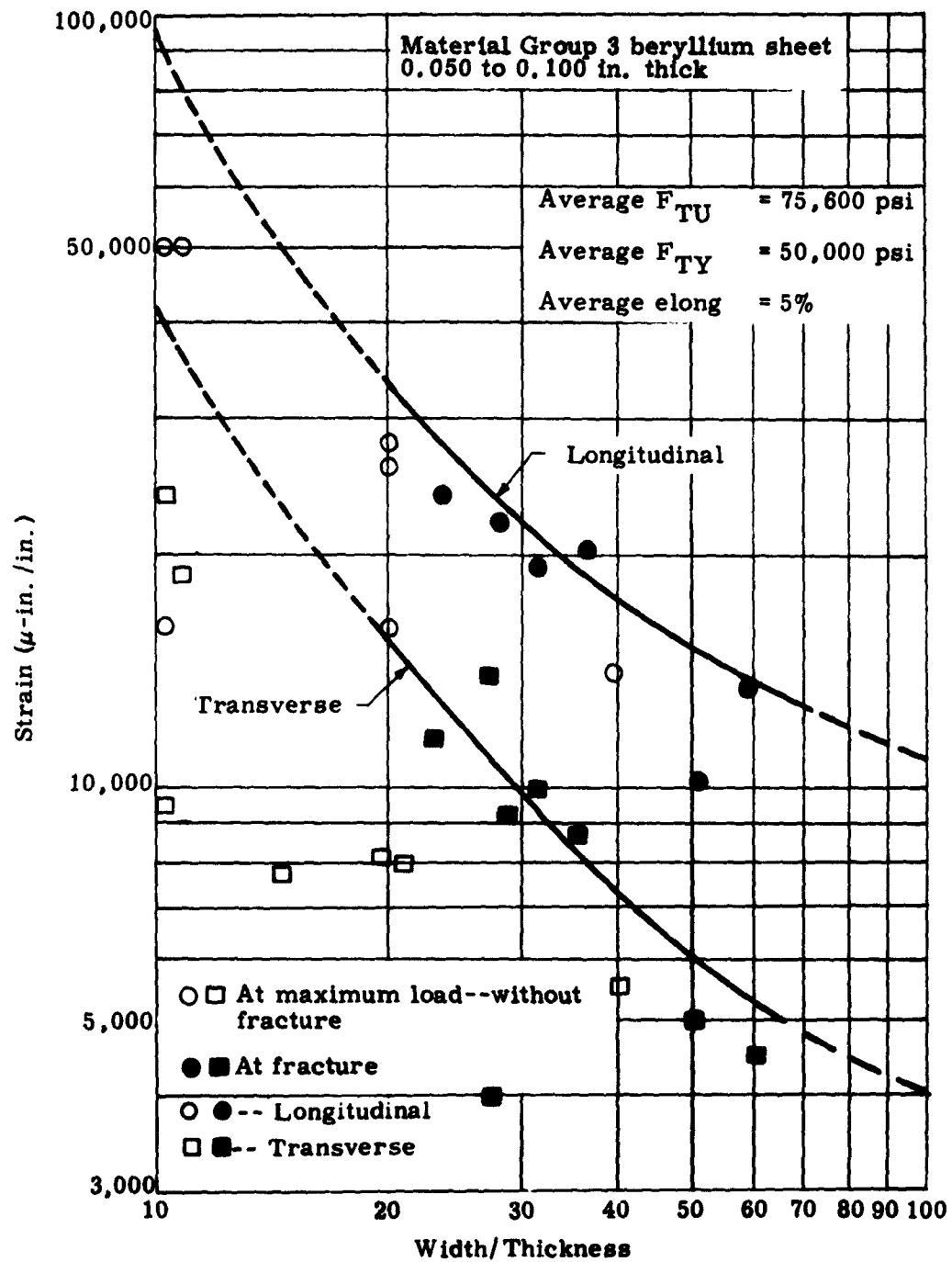
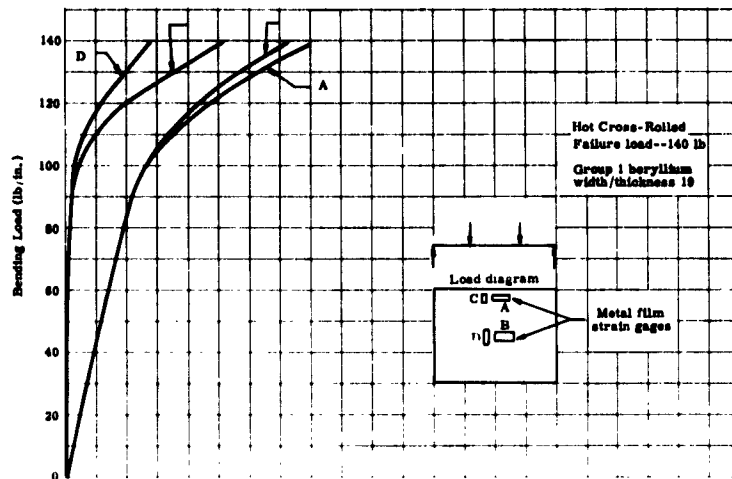
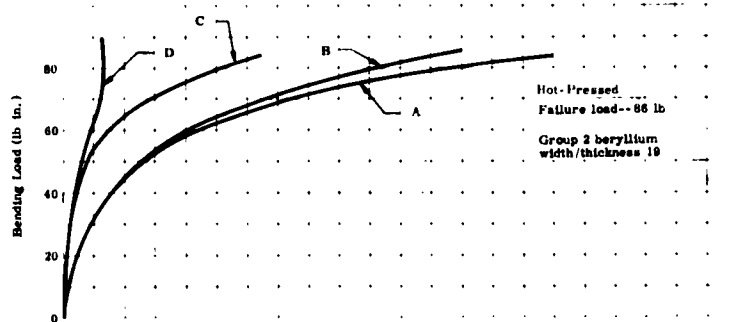

Fig. 12. Variation of Maximum Strain with Size in a Constant Moment Bend Test, Group 3, Beryllium Sheet (Hot-Upset)



a.



b.

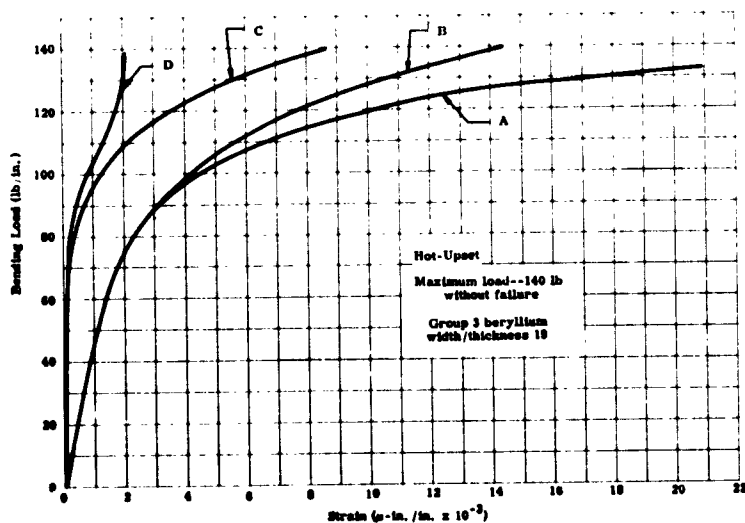

c.

Fig. 13. Comparison of Load Versus Strain in the Bend Ductility Test for 1-Inch Specimens, Hot-Pressed, Hot-Upset and Hot Cross-Rolled Beryllium Sheet

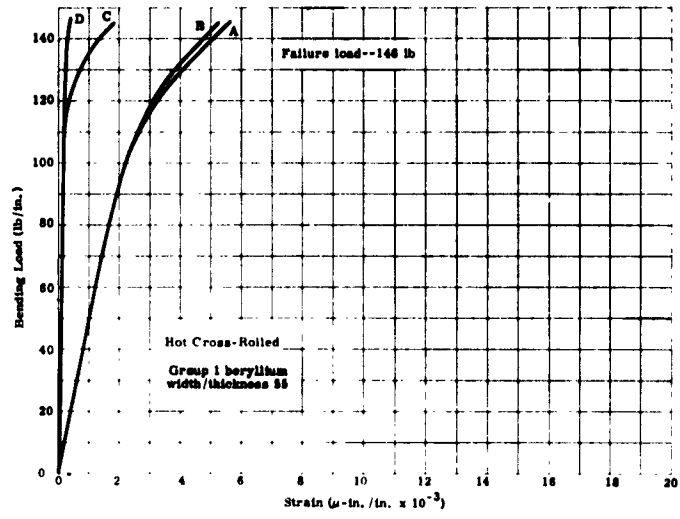

a.

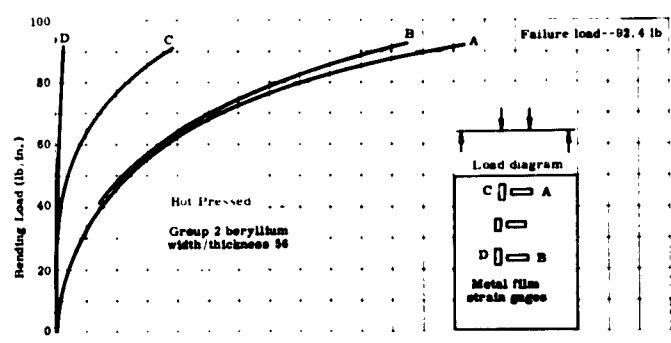

b.

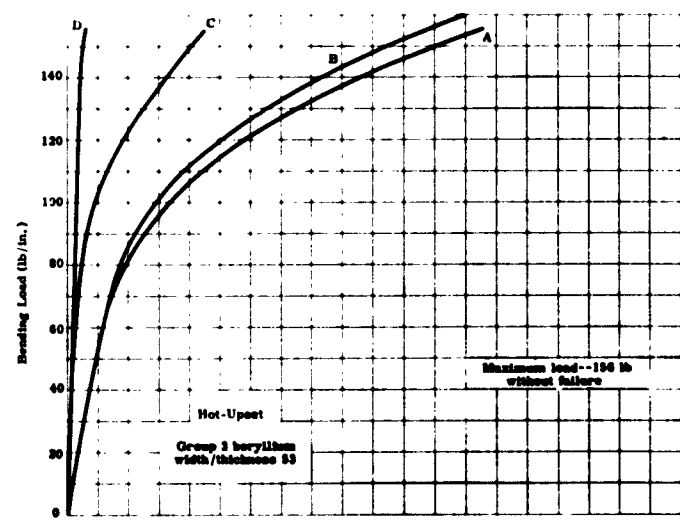

c.

Fig. 14. Comparison of Load Versus Strain in the Bend Ductility Test for 3-Inch Specimens, Hot-Pressed, Hot-Upset and Hot Cross-Rolled Beryllium Sheet



Group 1      Group 2      Group 3  
 Hot-Upset      Hot-Upset and      Hot-Upset  
 Hot Cross-Rolled      Hot Processed      and Hot Cross-Rolled  
 Fig. 15a. Bend Ductility Specimens After Fast, Hot Processing, Hot-Upset  
 and Hot Cross-Rolled Three-Diam Sheet



Group 1  
Hot Cross-Rolled

Group 2  
Hot-Pressed

Group 3  
Hot-Upset

Fig. 15b. Bend Ductility Specimens After Test, Hot-Pressed, Hot-Upset  
and Hot Cross-Rolled Beryllium Sheet

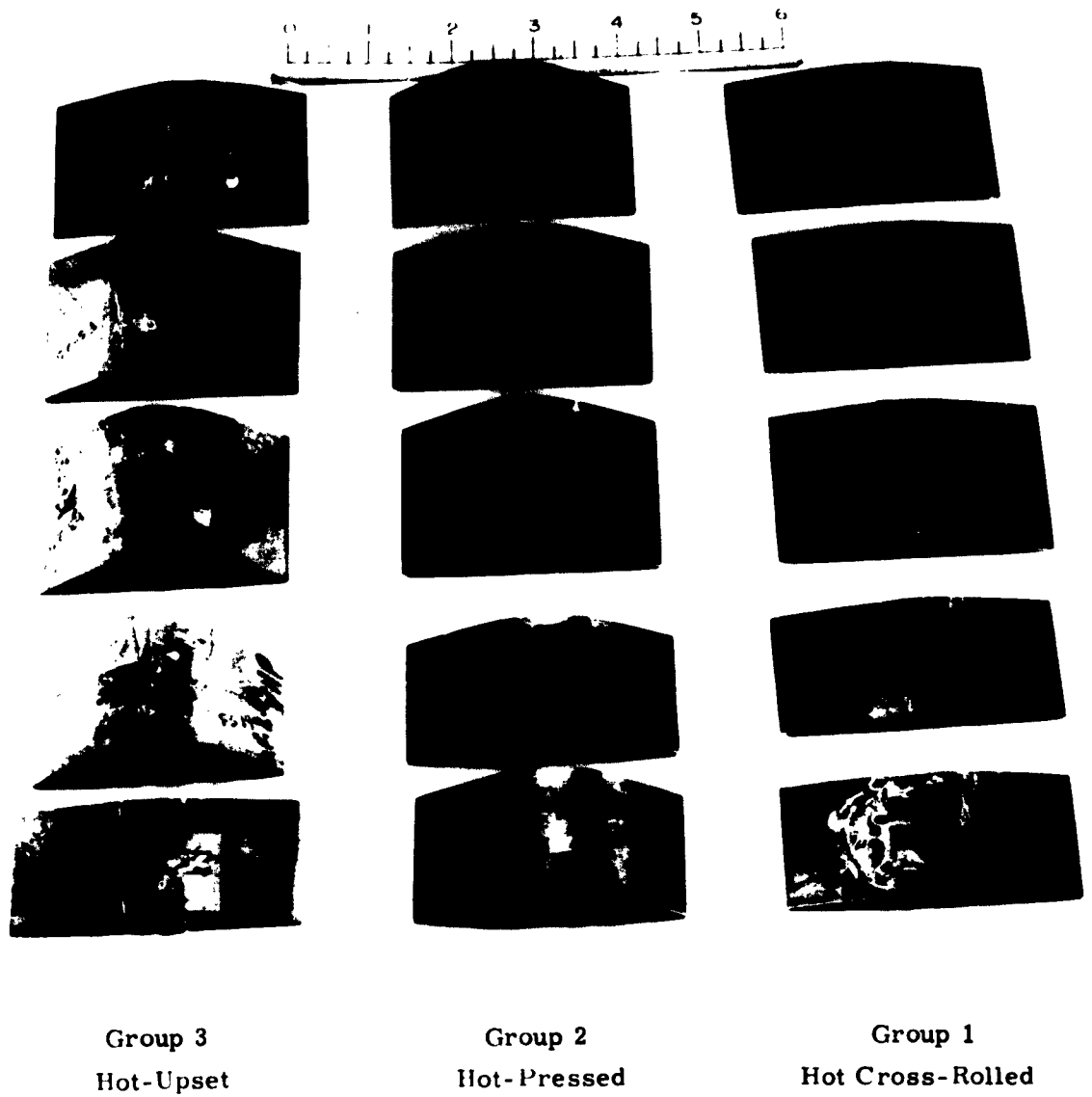
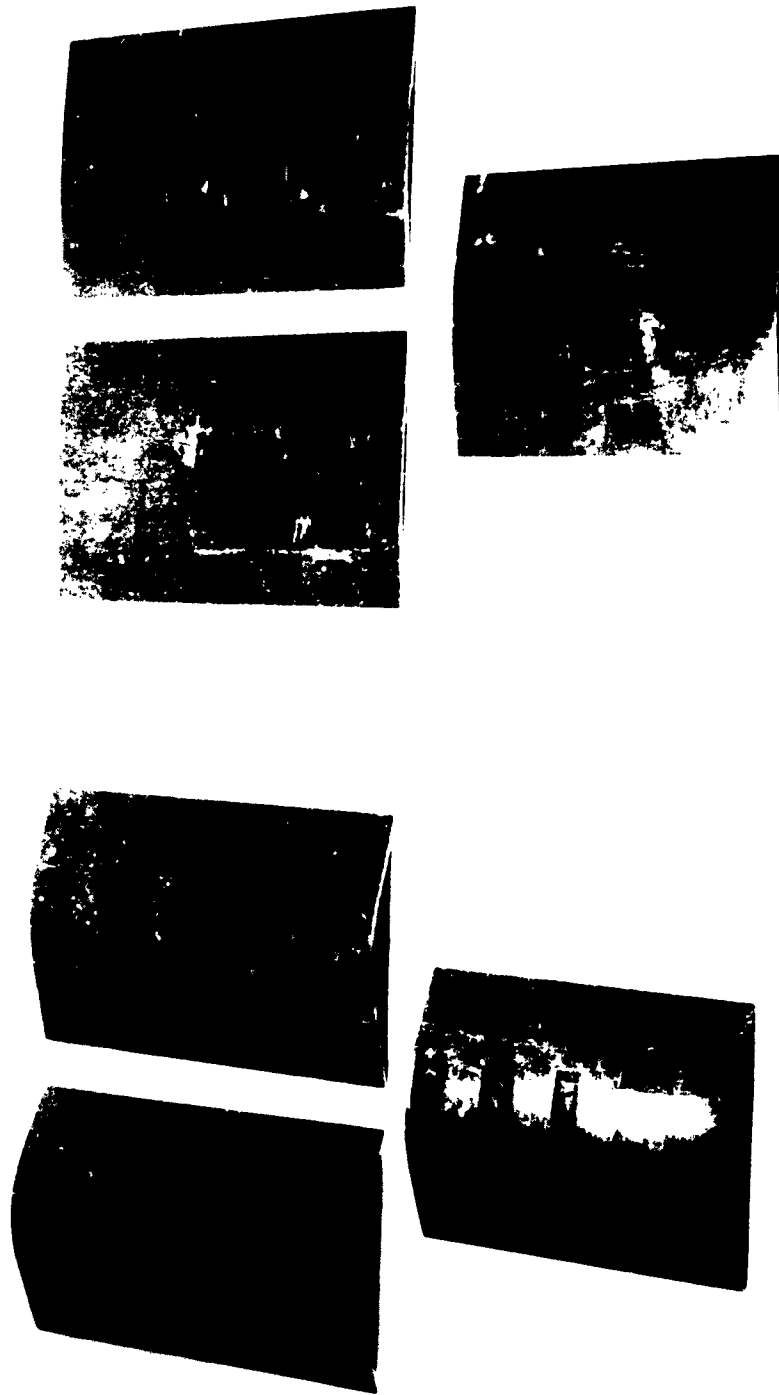

Fig. 15c. Bend Ductility Specimens After Test, Hot-Pressed, Hot-Upset and Hot Cross-Rolled Beryllium Sheet



Group 1  
 Hot-Cross-Rolled  
 Group 2  
 Hot-Pressed  
 Group 3  
 Hot-Upset  
**Fig. 15d.** Bend Ductility Specimens After Test, Hot-Pressed, Hot-Upset  
 and Hot Cross-Rolled Beryllium Sheet



**Group 2**  
 Hot-Pressed  
**Group 1**  
 Hot Cross-Rolled  
 Fig. 15e. Bend Ductility Specimens After Test, Hot-Pressed, Hot-Upset  
 and Hot Cross-Rolled Beryllium Sheet

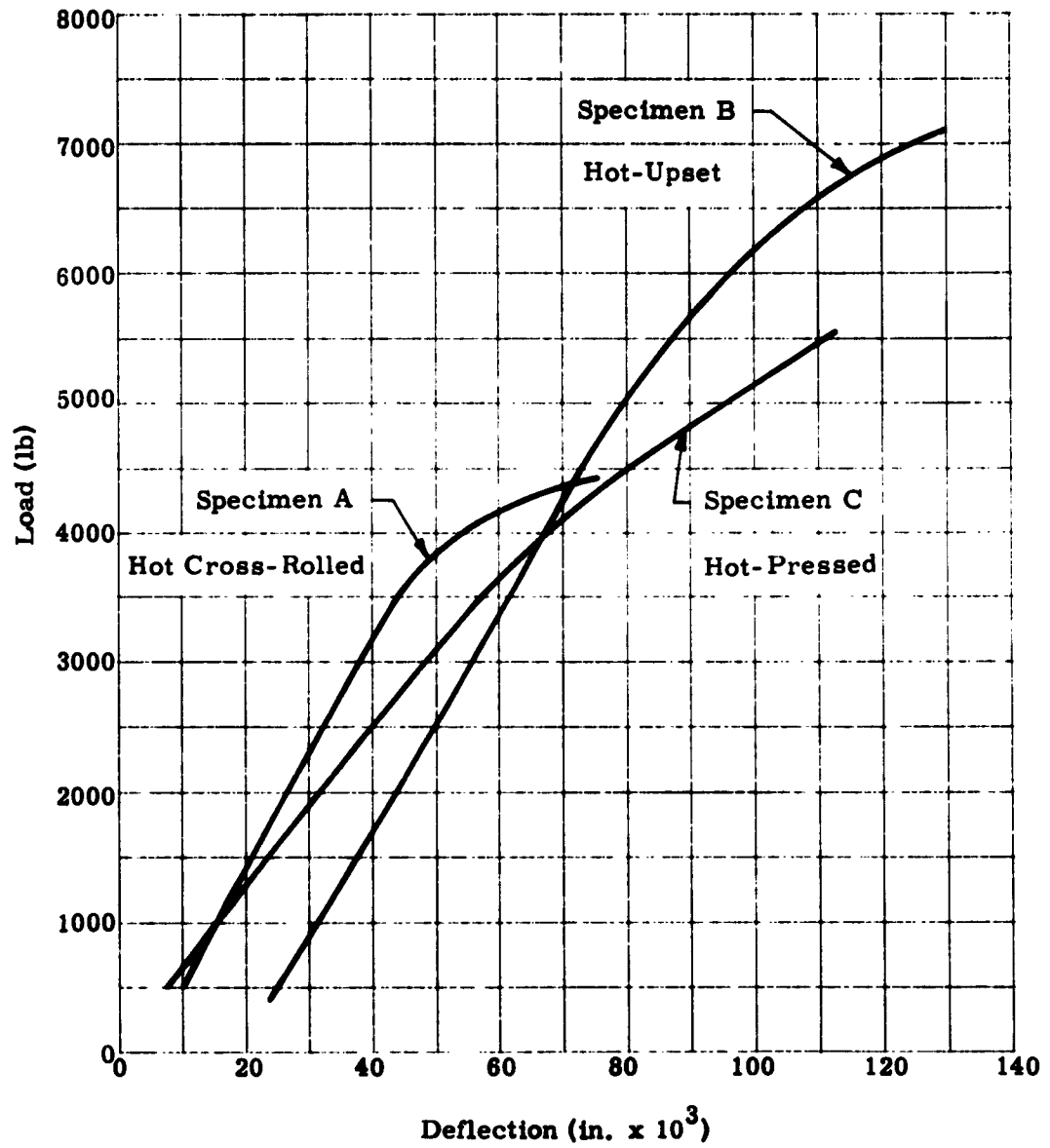

**Fig. 16. Variation of Bending Load with Deflection for the Beryllium Box-Beams**

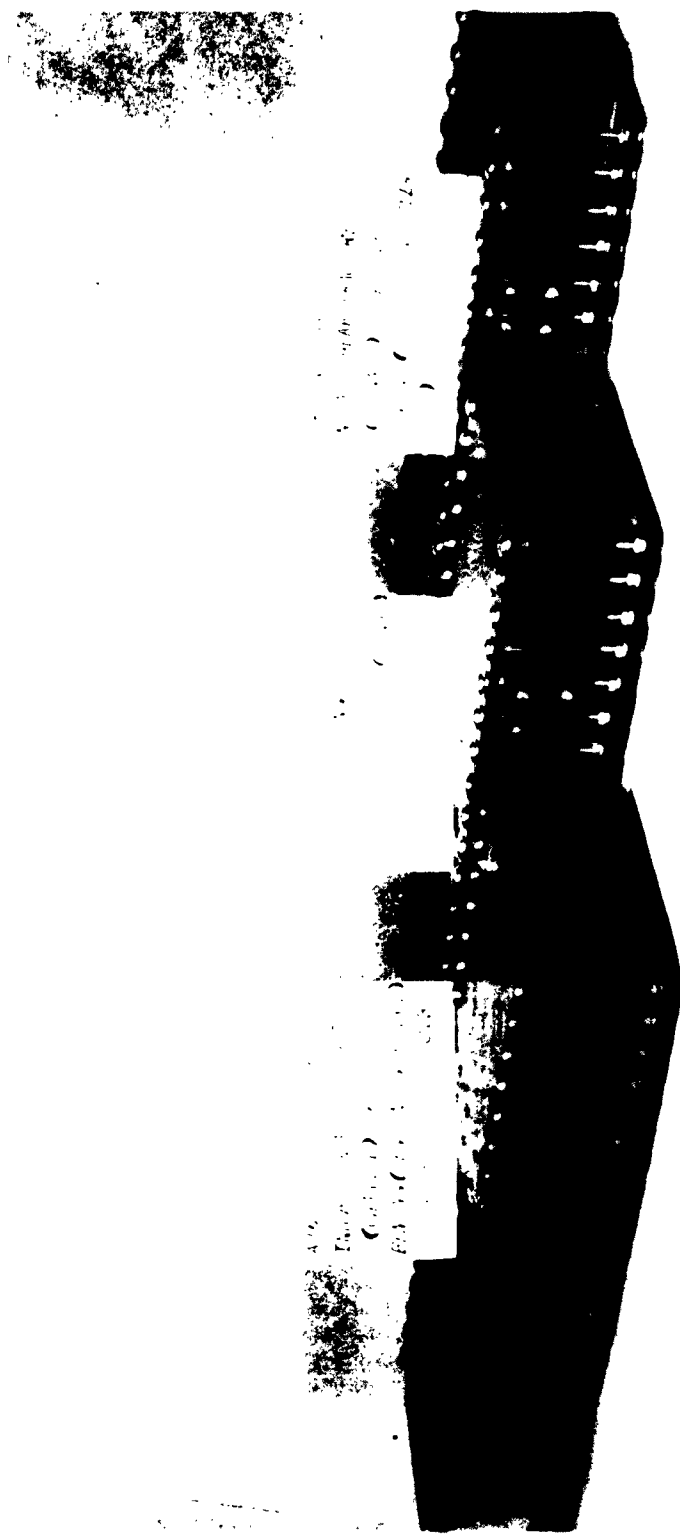

**Fig. 17. Beryllium Box-Beams After Test**

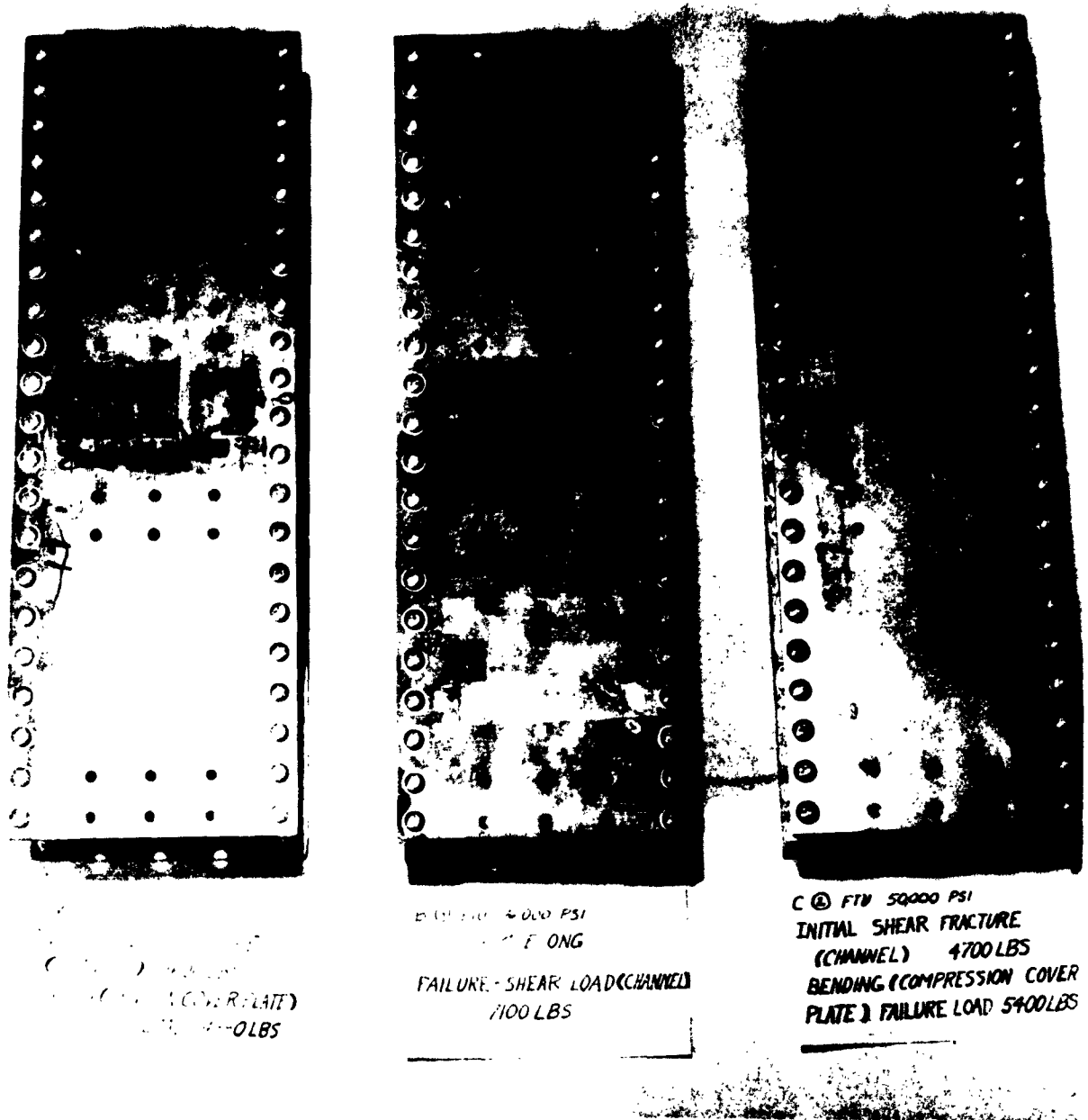
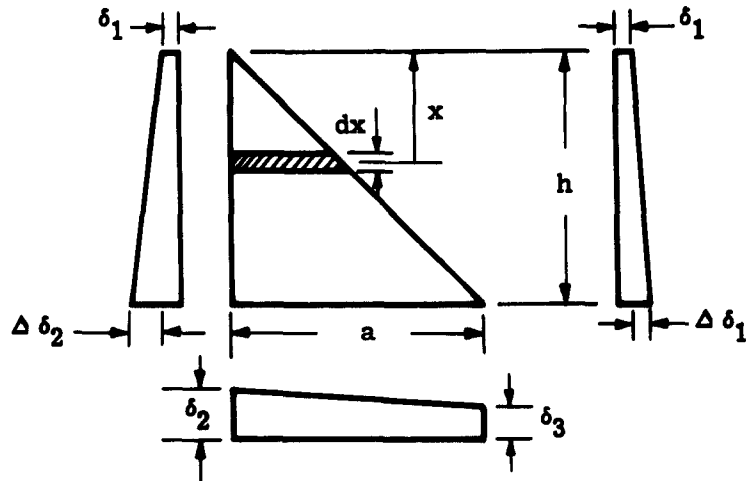

Fig. 18. Beryllium Box-Beams After Test



$$\begin{aligned}
 V &= \int_0^h a \frac{x}{h} \left[ \delta_1 + \frac{\Delta \delta_1 + \Delta \delta_2}{2} \frac{x}{h} \right] dx \\
 &= \frac{a}{h} \int_0^h \delta_1 x dx + \frac{\Delta \delta_1 a}{2h^2} \int_0^h x^2 dx + \frac{\Delta \delta_2 a}{2h^2} \int_0^h x^2 dx \\
 &= \frac{a}{h} \delta_1 \frac{h^2}{2} + \frac{\Delta \delta_1 a}{2h} \frac{\Delta \delta_2 a}{2h^2} \frac{h^3}{3} \\
 &= \frac{a h \delta_1}{2} + \frac{a h \Delta \delta_1}{6} + \frac{a h \Delta \delta_2}{6} \\
 &= \frac{a h}{2} \left[ \delta_1 + \frac{\Delta \delta_1}{3} + \frac{\Delta \delta_2}{3} \right]
 \end{aligned}$$

$$\delta_2 = \delta_1 + \Delta \delta_2$$

$$\delta_3 = \delta_1 + \Delta \delta_1$$

For  $\Delta \delta_1 = \Delta \delta_2 = \Delta \delta$

$$V = \frac{a h}{2} \left[ \delta_1 + \frac{2}{3} \Delta \delta \right]$$

Fig. 19. Analytical Basis for Calculating Volume of Double Tapered Skins

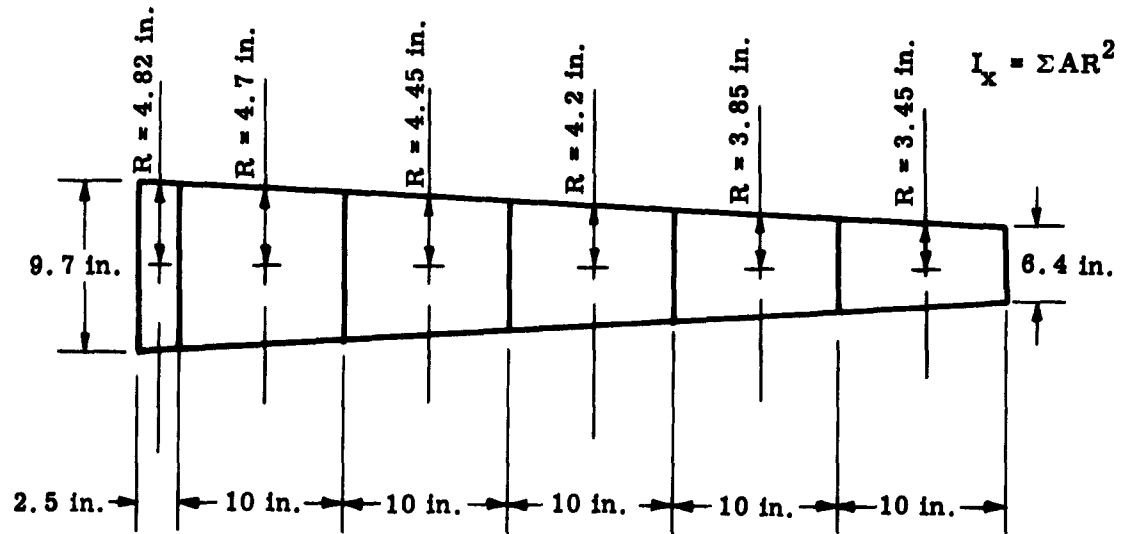

Fig. 20. Determination of Center of Gravity and Eccentricity for Arbitrary Wing Sections

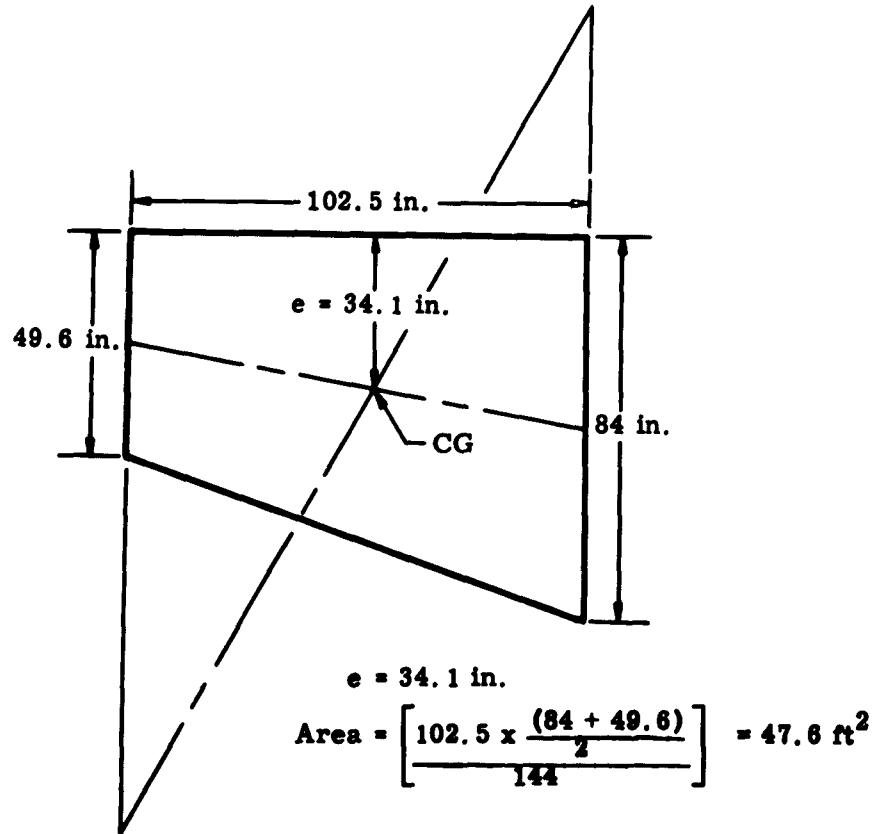

Fig. 21. Diagram for Calculating Moment of Inertia for Structural Analysis



<p>Aeronautical Systems Division, Wright-Patterson Air Force Base, Ohio. Rpt No. ASD TR 61-87. STRUCTURAL RESPONSE OF BERYLLIUM SHEET PRODUCED BY THREE FABRICATION METHODS. By C.J. Giemza, December 1961. 47p. incl. illus. and tables. Unclassified Report</p> <p>Hot-pressed, hot-upset and hot cross-rolled beryllium sheet is examined experimentally to determine mechanical behavior and relative structural superiority. Mechanical tests emphasizing factors which would tend to embrittle beryllium were employed. The data indicated that a high hardening rate and, not necessarily, high tensile elongation were associated with re-</p> <p style="text-align: right;">( over )</p>	<p>UNCLASSIFIED</p> <p>1. Beryllium--Hot-pressed, hot-upset and hot cross-rolled sheet</p> <p>2. Materials--Mechanical properties</p> <p>3. Materials--Brittle behavior</p> <p>I. Project 1368, Task 13928</p> <p>II. Contract AF33-(600)-40648 UNCLASSIFIED</p>	<p>UNCLASSIFIED</p> <p>1. Beryllium--Hot-pressed, hot-upset and hot cross-rolled sheet</p> <p>2. Materials--Mechanical properties</p> <p>3. Materials--Brittle behavior</p> <p>I. Project 1368, Task 13928</p> <p>II. Contract AF33-(600)-40648 UNCLASSIFIED</p>
<p>Aeronautical Systems Division, Wright-Patterson Air Force Base, Ohio. Rpt No. ASD TR 61-87. STRUCTURAL RESPONSE OF BERYLLIUM SHEET PRODUCED BY THREE FABRICATION METHODS. By C.J. Giemza, December 1961. 47p. incl. illus. and tables. Unclassified Report</p> <p>Hot-pressed, hot-upset and hot cross-rolled beryllium sheet is examined experimentally to determine mechanical behavior and relative structural superiority. Mechanical tests emphasizing factors which would tend to embrittle beryllium were employed. The data indicated that a high hardening rate and, not necessarily, high tensile elongation were associated with re-</p> <p style="text-align: right;">( over )</p>	<p>UNCLASSIFIED</p> <p>1. Beryllium--Hot-pressed, hot-upset and hot cross-rolled sheet</p> <p>2. Materials--Mechanical properties</p> <p>3. Materials--Brittle behavior</p> <p>I. Project 1368, Task 13928</p> <p>II. Contract AF33-(600)-40648 UNCLASSIFIED</p>	<p>UNCLASSIFIED</p> <p>1. Beryllium--Hot-pressed, hot-upset and hot cross-rolled sheet</p> <p>2. Materials--Mechanical properties</p> <p>3. Materials--Brittle behavior</p> <p>I. Project 1368, Task 13928</p> <p>II. Contract AF33-(600)-40648 UNCLASSIFIED</p>
<p>Aeronautical Systems Division, Wright-Patterson Air Force Base, Ohio. Rpt No. ASD TR 61-87. STRUCTURAL RESPONSE OF BERYLLIUM SHEET PRODUCED BY THREE FABRICATION METHODS. By C.J. Giemza, December 1961. 47p. incl. illus. and tables. Unclassified Report</p> <p>Hot-pressed, hot-upset and hot cross-rolled beryllium sheet is examined experimentally to determine mechanical behavior and relative structural superiority. Mechanical tests emphasizing factors which would tend to embrittle beryllium were employed. The data indicated that a high hardening rate and, not necessarily, high tensile elongation were associated with re-</p> <p style="text-align: right;">( over )</p>	<p>UNCLASSIFIED</p> <p>1. Beryllium--Hot-pressed, hot-upset and hot cross-rolled sheet</p> <p>2. Materials--Mechanical properties</p> <p>3. Materials--Brittle behavior</p> <p>I. Project 1368, Task 13928</p> <p>II. Contract AF33-(600)-40648 UNCLASSIFIED</p>	<p>UNCLASSIFIED</p> <p>1. Beryllium--Hot-pressed, hot-upset and hot cross-rolled sheet</p> <p>2. Materials--Mechanical properties</p> <p>3. Materials--Brittle behavior</p> <p>I. Project 1368, Task 13928</p> <p>II. Contract AF33-(600)-40648 UNCLASSIFIED</p>