

**UNCLASSIFIED**

---

---

**AD 273 961**

*Reproduced  
by the*

**ARMED SERVICES TECHNICAL INFORMATION AGENCY  
ARLINGTON HALL STATION  
ARLINGTON 12, VIRGINIA**



---

---

**UNCLASSIFIED**

NOTICE: When government or other drawings, specifications or other data are used for any purpose other than in connection with a definitely related government procurement operation, the U. S. Government thereby incurs no responsibility, nor any obligation whatsoever; and the fact that the Government may have formulated, furnished, or in any way supplied the said drawings, specifications, or other data is not to be regarded by implication or otherwise as in any manner licensing the holder or any other person or corporation, or conveying any rights or permission to manufacture, use or sell any patented invention that may in any way be related thereto.

CATALOGED BY ASTIA

AS AD NO. 273961

273 961

# RESEARCH STUDIES OF HIGH-DENSITY PLASMAS

## Quarterly Progress Report No. 1

Contract DA36-039-SC-87232  
Task No. 3A99-13-001-03

For the Period:  
15 September 1961 to 15 December 1961

U. S. Army Signal Research and Development Laboratory  
Fort Monmouth, New Jersey



ASTIA  
RECEIVED  
APR 10 1962  
4-62-3-1  
TISIA B

ELECTRICAL ENGINEERING RESEARCH LABORATORY  
ENGINEERING EXPERIMENT STATION  
UNIVERSITY OF ILLINOIS  
URBANA, ILLINOIS

<p>AD                    Accession No.                    Unclassified</p> <p>Electrical Engineering Research Laboratory University of Illinois, Urbana, Illinois</p> <p>INVESTIGATION OF THE ELECTRICAL AND OPTICAL PROPERTIES OF HIGH DENSITY PLASMAS by</p> <p>L. Goldstein, 15 September 1961 to 15 December 1961, 21 pgs., 9 illus., (Contract DA36-039-SC-87232) SC Task No. 3A99-13-001-03 Quarterly Progress Report No.1 Unclassified.</p> <p>I. L. Goldstein</p> <p><u>Abstract</u></p> <p>II. USASR&amp;D Lab. Ft. Monmouth, N.J.</p> <p>The fabrication of the apparatus required for the formation of a high density plasma is in progress. The instrumentation for the investigation of the properties of high density plasmas has been partially tested. For the formation of the high density plasma,</p>	<p>AD                    Accession No.                    Unclassified</p> <p>Electrical Engineering Research Laboratory University of Illinois, Urbana, Illinois</p> <p>INVESTIGATION OF THE ELECTRICAL AND OPTICAL PROPERTIES OF HIGH DENSITY PLASMAS by</p> <p>L. Goldstein, 15 September 1961 to 15 December 1961, 21 pgs., 9 illus., (Contract DA36-039-SC-87232) SC Task No. 3A99-13-001-03 Quarterly Progress Report No.1 Unclassified.</p> <p>I. L. Goldstein</p> <p><u>Abstract</u></p> <p>II. USASR&amp;D Lab. Ft. Monmouth, N.J.</p> <p>The fabrication of the apparatus required for the formation of a high density plasma is in progress. The instrumentation for the investigation of the properties of high density plasmas has been partially tested. For the formation of the high density plasma,</p>
<p>AD                    Accession No.                    Unclassified</p> <p>Electrical Engineering Research Laboratory University of Illinois, Urbana, Illinois</p> <p>INVESTIGATION OF THE ELECTRICAL AND OPTICAL PROPERTIES OF HIGH DENSITY PLASMAS by</p> <p>L. Goldstein, 15 September 1961 to 15 December 1961, 21 pgs., 9 illus., (Contract DA36-039-SC-87232) SC Task No. 3A99-13-001-03 Quarterly Progress Report No.1 Unclassified.</p> <p>I. L. Goldstein</p> <p><u>Abstract</u></p> <p>II. USASR&amp;D Lab. Ft. Monmouth, N.J.</p> <p>The fabrication of the apparatus required for the formation of a high density plasma is in progress. The instrumentation for the investigation of the properties of high density plasmas has been partially tested. For the formation of the high density plasma,</p>	<p>AD                    Accession No.                    Unclassified</p> <p>Electrical Engineering Research Laboratory University of Illinois, Urbana, Illinois</p> <p>INVESTIGATION OF THE ELECTRICAL AND OPTICAL PROPERTIES OF HIGH DENSITY PLASMAS by</p> <p>L. Goldstein, 15 September 1961 to 15 December 1961, 21 pgs., 9 illus., (Contract DA36-039-SC-87232) SC Task No. 3A99-13-001-03 Quarterly Progress Report No.1 Unclassified.</p> <p>I. L. Goldstein</p> <p><u>Abstract</u></p> <p>II. USASR&amp;D Lab. Ft. Monmouth, N.J.</p> <p>The fabrication of the apparatus required for the formation of a high density plasma is in progress. The instrumentation for the investigation of the properties of high density plasmas has been partially tested. For the formation of the high density plasma,</p>

a bank of capacitors is discharged through a one turn coil. Measurements of the magnetic field strength, uniformity and variation in time have been made. Testing of microwave equipment is proceeding and indicates that there is greater than 2% ionization in the plasma. Photomultiplier observations of the visible light emitted by the plasma have not yet shown satisfactory agreement between any two photomultiplier tubes. Spectroscopic investigations are also in progress. A laser is under construction for use as a diagnostic tool in very high density plasmas.

a bank of capacitors is discharged through a one turn coil. Measurements of the magnetic field strength, uniformity and variation in time have been made. Testing of microwave equipment is proceeding and indicates that there is greater than 2% ionization in the plasma. Photomultiplier observations of the visible light emitted by the plasma have not yet shown satisfactory agreement between any two photomultiplier tubes. Spectroscopic investigations are also in progress. A laser is under construction for use as a diagnostic tool in very high density plasmas.

a bank of capacitors is discharged through a one turn coil. Measurements of the magnetic field strength, uniformity and variation in time have been made. Testing of microwave equipment is proceeding and indicates that there is greater than 2% ionization in the plasma. Photomultiplier observations of the visible light emitted by the plasma have not yet shown satisfactory agreement between any two photomultiplier tubes. Spectroscopic investigations are also in progress. A laser is under construction for use as a diagnostic tool in very high density plasmas.

a bank of capacitors is discharged through a one turn coil. Measurements of the magnetic field strength, uniformity and variation in time have been made. Testing of microwave equipment is proceeding and indicates that there is greater than 2% ionization in the plasma. Photomultiplier observations of the visible light emitted by the plasma have not yet shown satisfactory agreement between any two photomultiplier tubes. Spectroscopic investigations are also in progress. A laser is under construction for use as a diagnostic tool in very high density plasmas.

RESEARCH STUDIES OF HIGH-DENSITY PLASMAS

Report No. 1

First Quarterly Progress Report

15 September 1961 to 15 December 1961

The objectives of these studies are a broader knowledge of the fundamental properties of high-density plasmas and the application of this knowledge to the utilization of high-density plasmas in gaseous electronic devices, with particular emphasis on methods for switching and controlling power.

Contract DA36-039 sc-87232

Technical Requirements - SCL-5826  
(17 November 1960)

Signal Corps Task No.3A99-13-001-03

Prepared by: E. Bialecke  
L. Dreyer  
D. Albares  
L. Slama  
L. Goldstein

CONTENTS

	Page
Purpose	
Abstract	
Publications, Lectures, Reports, and Conferences	
Factual Data	1
Conclusions	14
Plans for the Next Quarter	14
Personnel	15

## ILLUSTRATIONS

Figure Number		Page
1.	Schematic Diagram of Type I Capacitor Bank	3
2.	Sketch of the One Turn Coil and Header	4
3.	Block Diagram of System	5
4.	Timing Sequence for Present Apparatus	6
5.	Example of Magnetic Probe Output	7
6.	Plot of Magnetic Field vs Distance Along One Turn Coil	9
7.	Plot of Magnetic Field vs Capacitor Bank Voltage	9
8.	Schematic Diagram of Vacuum System	10
9.	Transmitted 67Gc & 8.8Gc Microwave Signals	12

## PURPOSE

This program covers the theoretical and research study of the fundamental properties of high-density plasmas to determine the discharge characteristics pertinent to the switching and controlling or relatively-large peak and average powers. Consideration shall be given to methods of producing and controlling these discharges and of determining such basic properties of a dense plasma as: ion, electron, and gas temperatures; energy distribution; loss mechanisms; and effect of gas fill (including hydrogen) and pressure. Information obtained shall be analyzed both from the viewpoint of its application to existing devices and to the conception of new devices.

## ABSTRACT

The fabrication of the apparatus required for the formation of a high density plasma is in progress. The instrumentation for the investigation of the properties of high density plasmas has been partially tested. For the formation of the high density plasma, a bank of capacitors is discharged through a one turn coil. Measurements of the magnetic field strength, uniformity and variation in time have been made. Testing of microwave equipment is proceeding and indicates that there is greater than 2% ionization in the plasma. Photomultiplier observations of the visible light emitted by the plasma have not yet shown satisfactory agreement between any two photomultiplier tubes. Spectroscopic investigations are also in progress. A laser is under construction for use as a diagnostic tool in very high density plasmas.

PUBLICATIONS, LECTURES, REPORTS, AND CONFERENCES

Publications:

None

Lectures:

None

Reports:

Monthly summary reports for October, November and December, 1961 have been issued.

Conferences:

None

## 1. INTRODUCTION

### Factual Data

In this quarter, instrumentation for some preliminary studies on the determination of the properties of high-density plasmas has been initiated. Using a rapidly changing magnetic field with preionization, a neutral gas is broken down to form a highly-ionized plasma.

Electromagnetic waves will be used as a diagnostic tool for some of these investigations. A known characteristic of propagation in a plasma of high-frequency ( $\omega$ ) electromagnetic waves is that no transmission occurs when  $\omega < \omega_p$ , the plasma frequency. This characteristic will be used to determine the order of electron densities attained in both the formation and decay of a transient plasma.

Light emission from the plasma will be observed by using photomultipliers. It may be possible, by using this technique, to determine the plasma's spatial distribution. Spectroscopic techniques will be used to observe the depth of excitation of the atoms used (spectrum of 0, 1, 2 -- n times ionized atoms). It will also enable us to identify the nature of the impurities present, if any.

## 2. DESCRIPTION OF PRESENT APPARATUS AND OF SOME PRELIMINARY STUDIES

### 2.1 Apparatus Used for the Formation of a High-Density Plasma

The formation of a high-density plasma having a geometry which would lend itself to an electromagnetic wave and optical study appears as the first problem to be solved. The use of internal electrodes in a plasma has long been a big source of contamination to the gas under study. From these and other considerations, it was decided to form the high-density plasma with the use of a rapidly changing magnetic field in a one-turn coil. This magnetic field is used to break down a gas contained in a glass tube placed inside the one-turn coil.

In this section, the equipment used to produce the magnetic field for some of the preliminary studies will be described.

The capacitor discharge energy source is the main component needed to produce the high magnetic field. Available for use are two banks of capacitors having the following specifications: (1) Type I Unit, 85 $\mu$ f capacitance, 20 kilovolt, 17,000 joule, 400,000 ampere peak current with 3.2  $\mu$ sec rise to peak; and (2) Type II Unit, 150  $\mu$ f capacitance, 20 kilovolt, 30,000 joules, 1,600,000 ampere peak current with 2.1  $\mu$ sec rise to peak. For the preliminary experiments, the Type I Unit was chosen. A schematic diagram of it is shown in Figure 1. A header (a unit for coupling the capacitor bank to the one turn coil) was fabricated. The header and the one turn coil are sketched in Figure 2. The necessary pulse equipment and control equipment were assembled to give the system shown in Figure 3. The timing sequence of the "firing" of the capacitor bank and of the triggering of auxiliary equipment is shown in Figure 4.

The magnetic field produced when the capacitor bank is discharged through the one turn coil has the form shown in Figure 5. The rise to peak is approximately 3.2  $\mu$ sec. A small search coil has been used to probe the field and with the use of an integrating circuit the magnitude of the field can be calculated from the formula

$$B = \frac{R C V}{A} \times 10^8 \text{ gauss,}$$

where R = value of the integrating resistor  
 C = value of the integrating capacitor  
 V = output voltage of the integrating circuit  
 and A = area of the magnetic probe coil (cm<sup>-3</sup>).

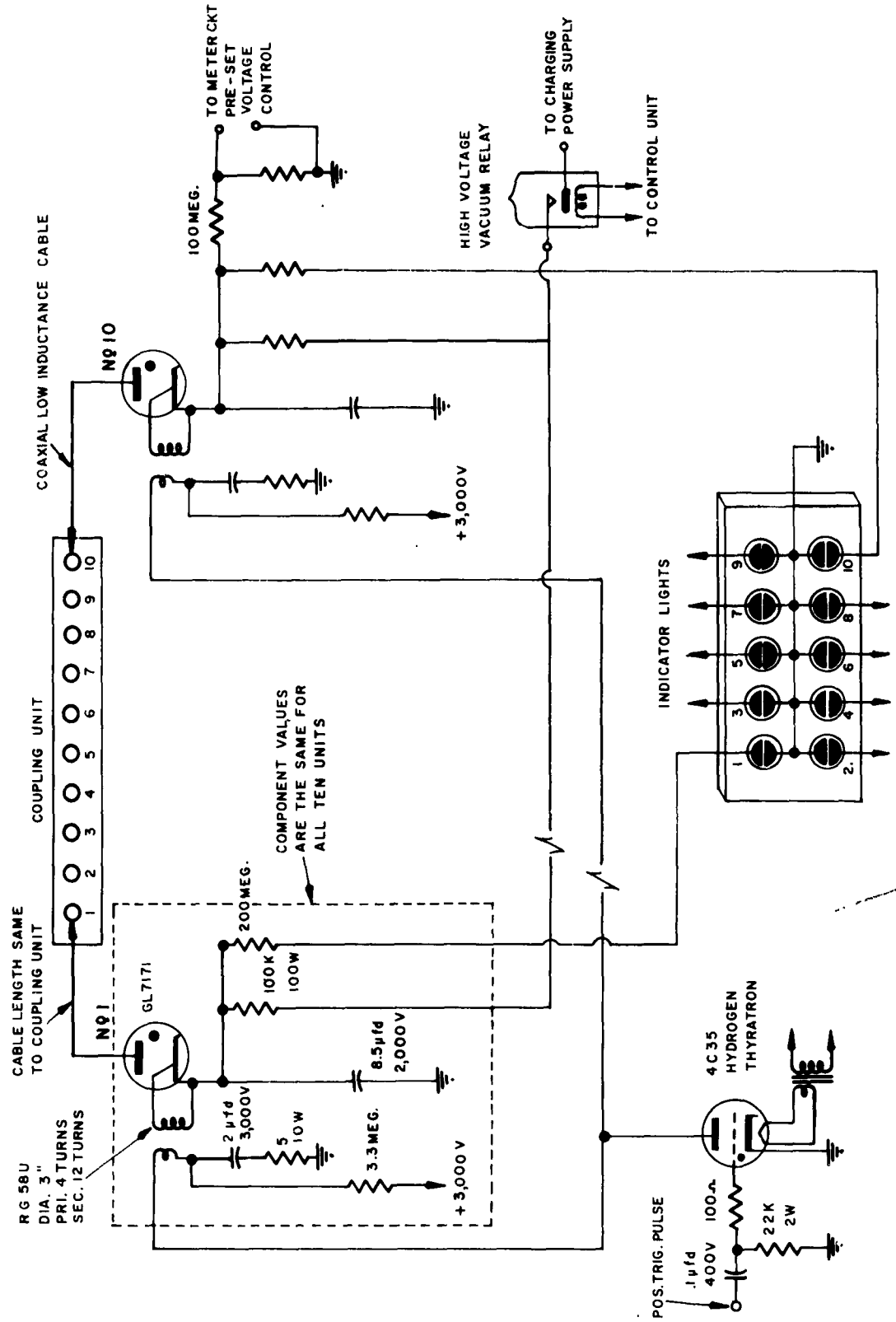

FIGURE 1. SCHEMATIC DIAGRAM OF TYPE I CAPACITOR BANK

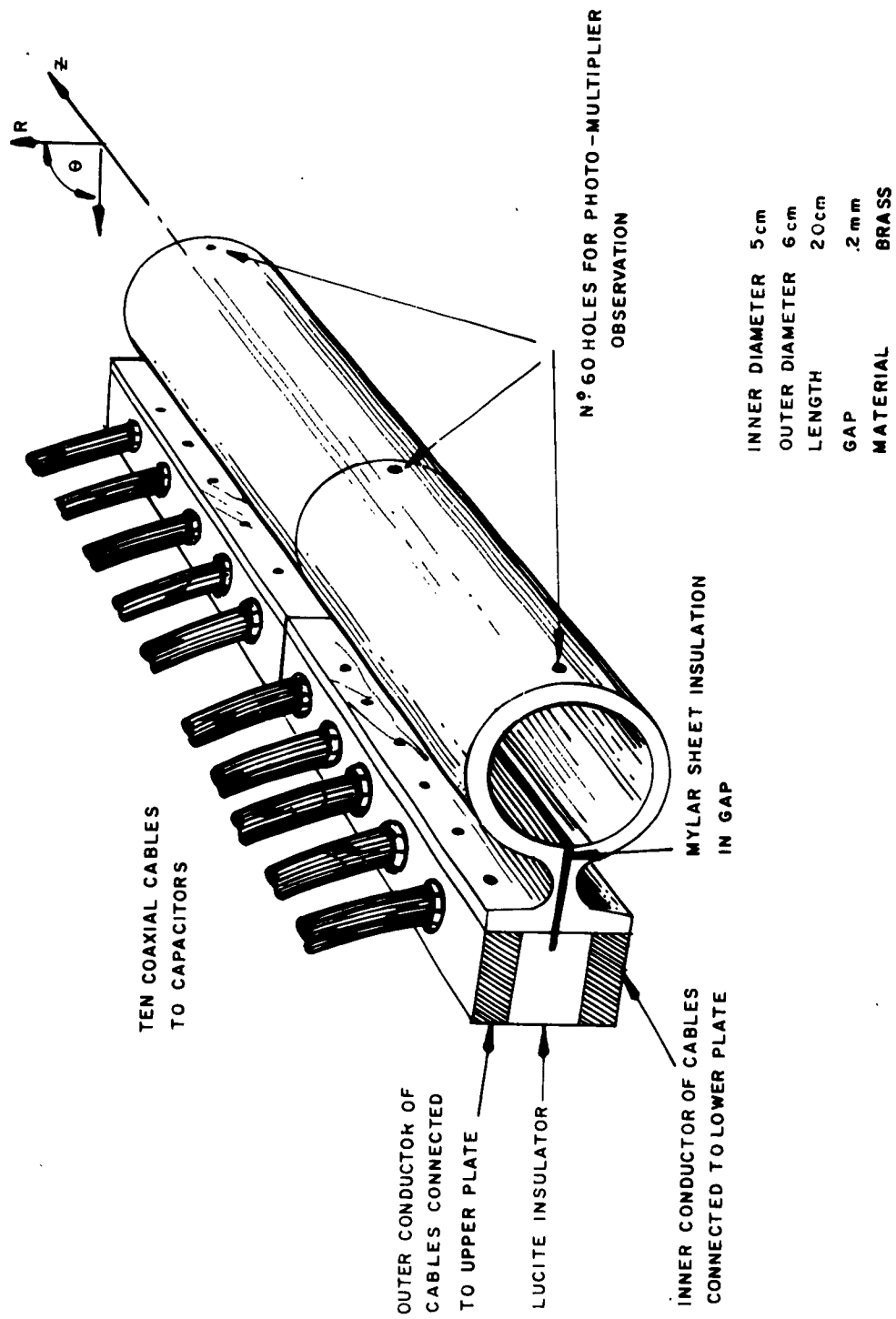

FIGURE 2. SKETCH OF THE ONE TURN COIL AND HEADER

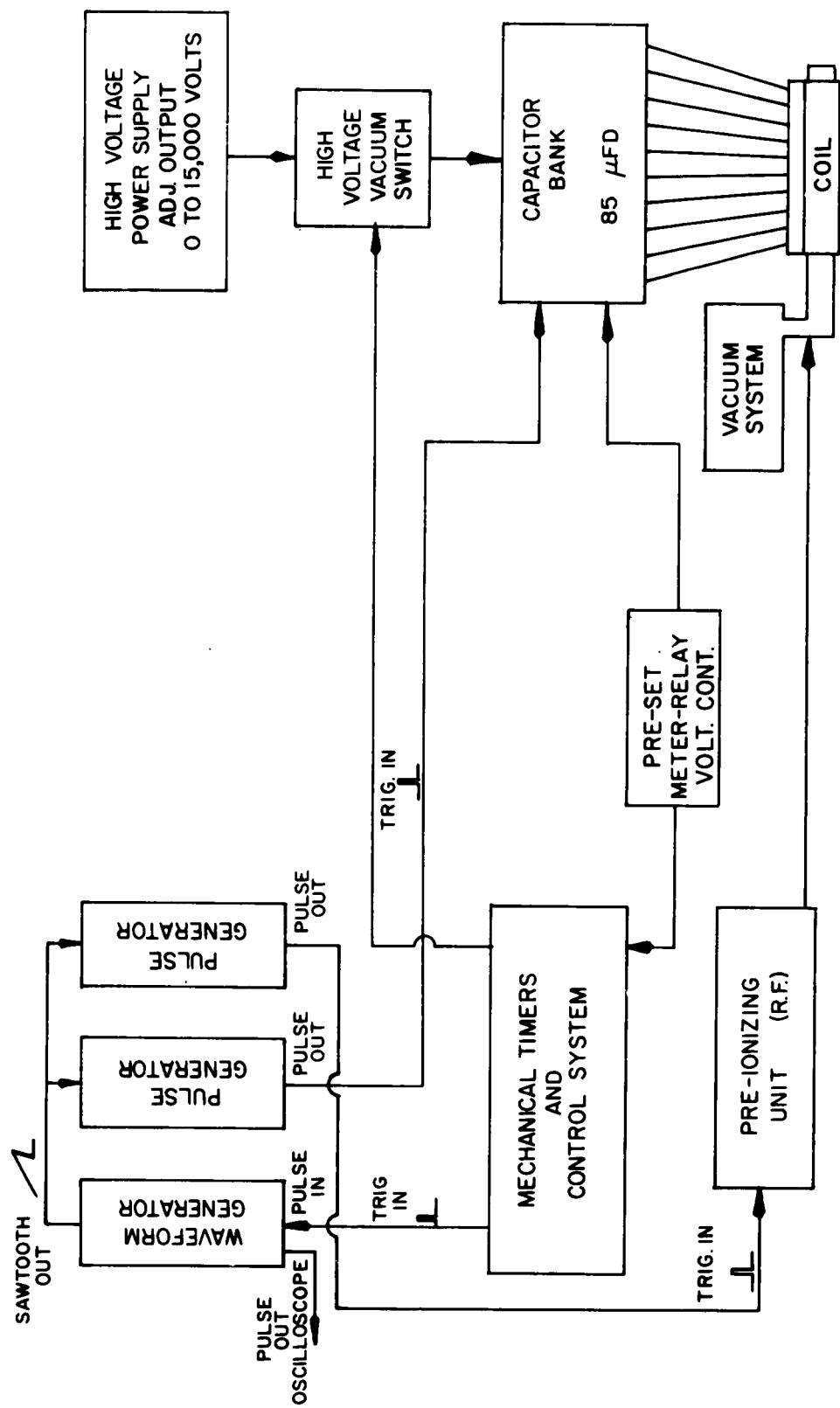
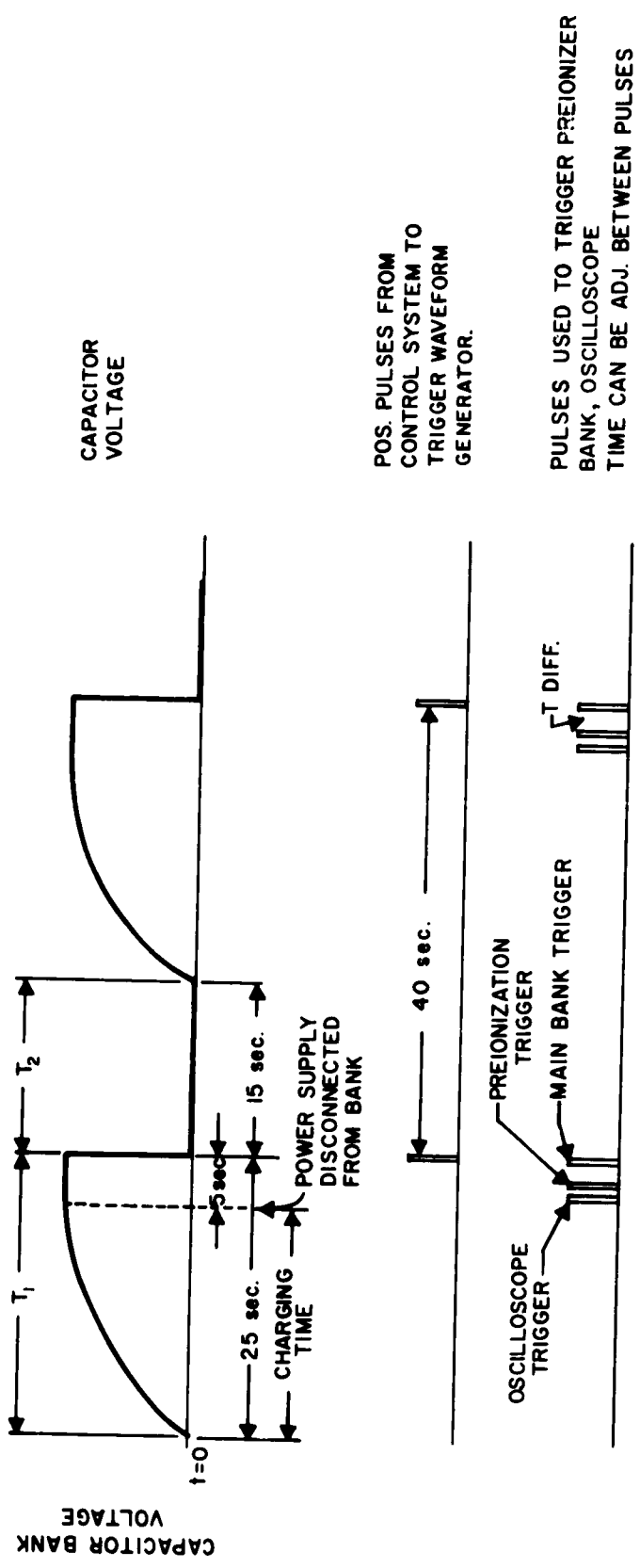

FIGURE 3. BLOCK DIAGRAM OF SYSTEM



During time  $T_1$  capacitor bank is charged till voltage on pre-set meter is reached. When level is reached power supply is disconnected from bank. At end of  $T_1$ . - A pulse is derived which triggers the waveform generator. With waveform generator and pulse generators, pulses to trigger oscilloscope preionization unit, capacitor bank can be derived with adjustable time delays between them.

FIGURE 4. TIMING SEQUENCE FOR PRESENT APPARATUS

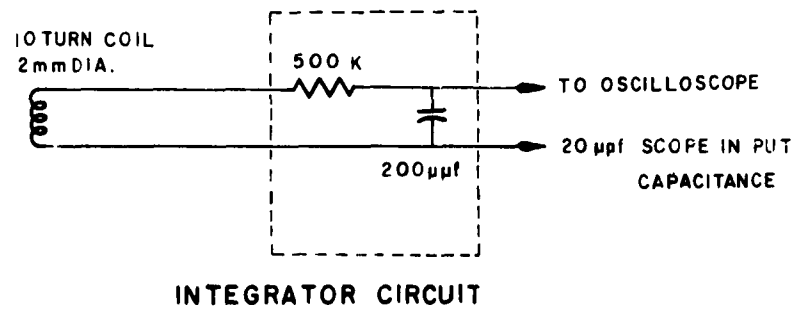
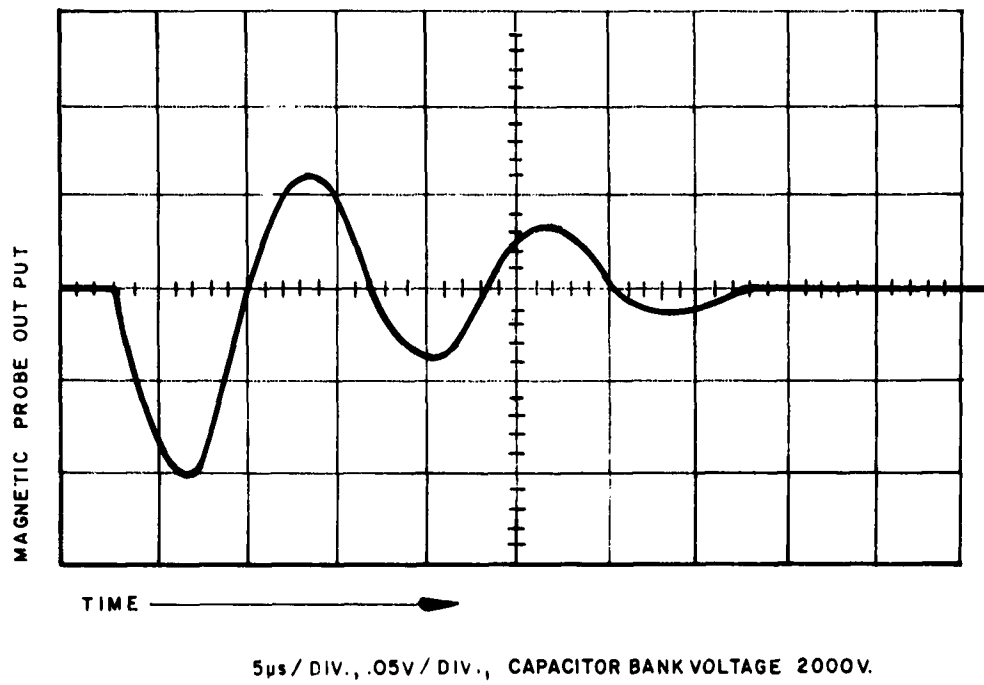

FIGURE 5. EXAMPLE OF MAGNETIC PROBE OUTPUT

A plot of the variation in the peak magnitude of the magnetic field as a function of length along the coil is shown in Figure 6. Other measurements showed that the field is uniform in the  $\theta$  and  $R$  directions inside the coil. The peak magnetic field as a function of the voltage applied to the capacitor bank is shown in Figure 7.

The decay of the magnetic field intensity can be determined from the plot shown in Figure 5. From this decay, the resistance and inductance of the capacitor discharge circuit can be calculated using the formulas

$$L \approx \frac{1}{4 \pi^2 f^2 C}$$

where  $f$  = the ringing frequency of the system and  $C$  = the capacitance of the bank, and

$$R = 2Lf \ln(a_1/a_2)$$

where  $a_1$  and  $a_2$  are two successive current peaks having the same sign. For the present system the resistance and inductance are .079 ohm and 0.56 $\mu$  henry, respectively. Reproducibility of the magnetic field from one "firing" to another is very good.

### 2.2 The Vacuum System

A vacuum system has been built and a schematic diagram of it is shown in Figure 8. The oil diffusion pump is cooled with water recirculating through a radiator and pump. The tube in which the plasma is contained is a circular cylinder 22 cm long and 38 mm in diameter with an exit port for pumping and filling with gas. Two thermocouple gauges have been calibrated for neon gas against a McLeod Gauge, in order to have a good measure of the gas pressure in the coming experiments.

### 2.3 Microwave Studies

The dielectric constant for an electromagnetic wave propagating through a plasma is given by

$$\epsilon = \epsilon_0 \left( 1 - \frac{\omega_p^2}{\nu^2 + \omega^2} \right)$$

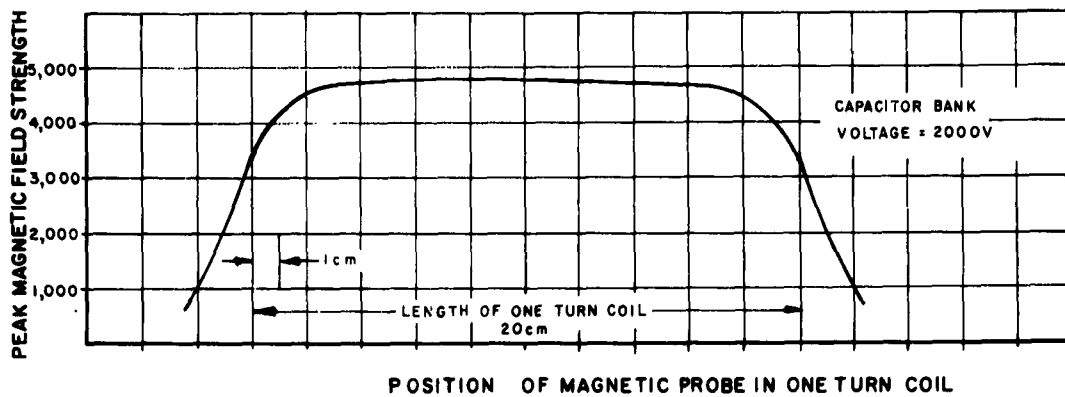

FIGURE 6. PLOT OF MAGNETIC FIELD VS DISTANCE ALONG ONE TURN COIL

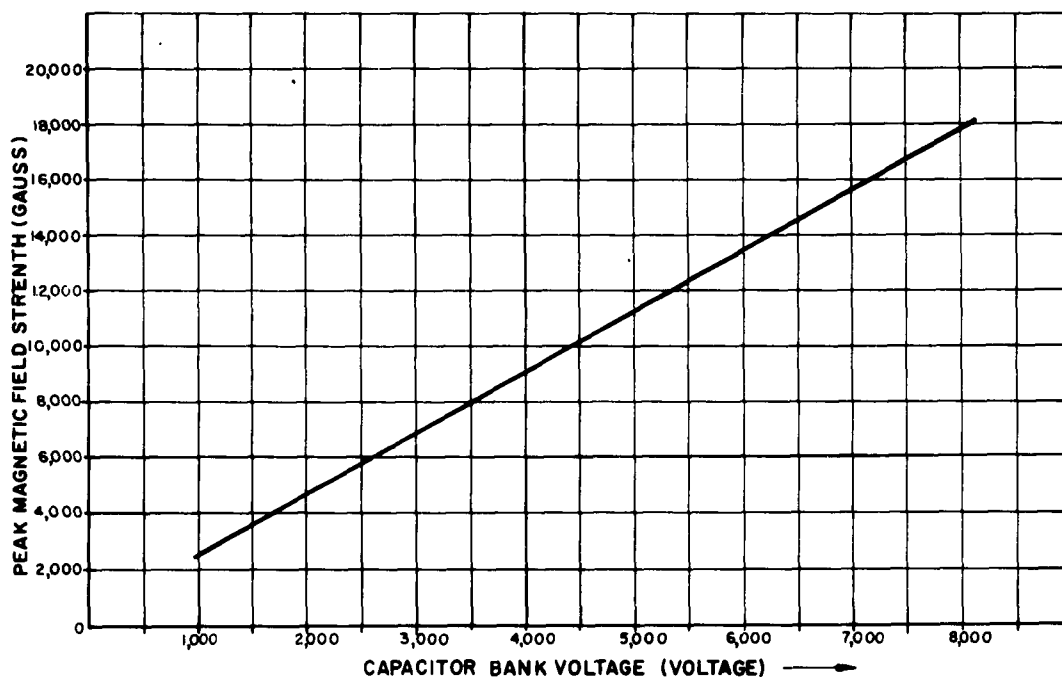

FIGURE 7. PLOT OF MAGNETIC FIELD VS CAPACITOR BANK VOLTAGE

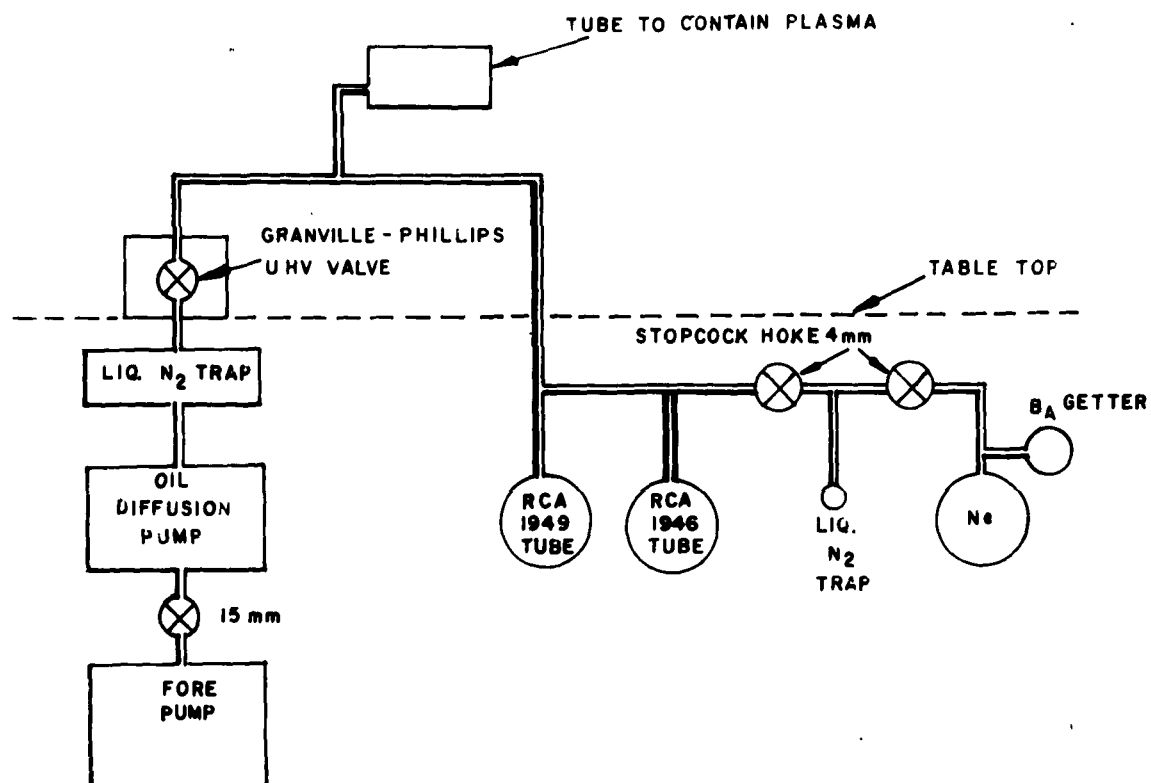

FIGURE 8. SCHEMATIC DIAGRAM OF VACUUM SYSTEM

where  $\omega_p/2\pi = f_p = 8,980 \sqrt{n_e}$  cps = the plasma frequency, and where  $n_e$  = electron density ( $\text{cm}^{-3}$ ). When the dielectric constant is zero, the plasma appears as a conductor to an electromagnetic wave, and there will be no propagation.

Thus, if  $\nu \ll \omega$ , there would be no transmission of a microwave signal when  $\omega \leq \omega_p$ . By simultaneously propagating several microwave frequencies, electron density variations can be determined by the different "cut-off" and "cut-in" points of the transmitted signals. This has been tested for the present method of forming a high-density plasma, using microwave frequencies of 67 Gc and 8.8 Gc. The transmitted signals observed are shown in Figure 9. Here the 67 Gc signal is cut off for about 100  $\mu\text{sec}$  and the 8.8 Gc signal is cut off for about 200  $\mu\text{sec}$ . This indicates that the electron density in this case was greater than  $10^{12}$  electrons/cc for 200  $\mu\text{sec}$  and greater than  $5 \times 10^{13}$  electrons/cc for 100  $\mu\text{sec}$ . Hence, the ionization was greater than 2% of the neutral gas (Neon) concentration for 100  $\mu\text{sec}$ .

Electron energies can be determined by a measurement of the microwave noise emitted by the plasma when it acts as a black-body radiator. Equipment has been gathered for this measurement, but the experiment itself has not yet been performed.

#### 2.4 Optical Studies

The instruments which have been used thus far to study the visible light spectrum are photomultiplier tubes and a grating spectrograph. The former are usually used with 0.7 mm diameter quartz fiber light pipes which will help in the spatial resolution of the light. As yet, the observations of the visible light emitted by the plasma by the photomultipliers have not shown satisfactory agreement between different tubes of the same type. The spectrograph has been used to obtain time integrated measurements of the spectrum radiated from the plasma.

In the study of dense plasmas by the means of electromagnetic waves we are led to the utilization of infrared or red light as a diagnostic method when the electron density is greater than  $10^{15}$  electrons/ $\text{cm}^{-3}$ . The coherent light from the now readily available lasers considerably broadens the present means of plasma diagnostics. The well known characteristics of a laser are monochromaticity, high power, and polarizability. These characteristics lend themselves very well to the following measurement techniques:

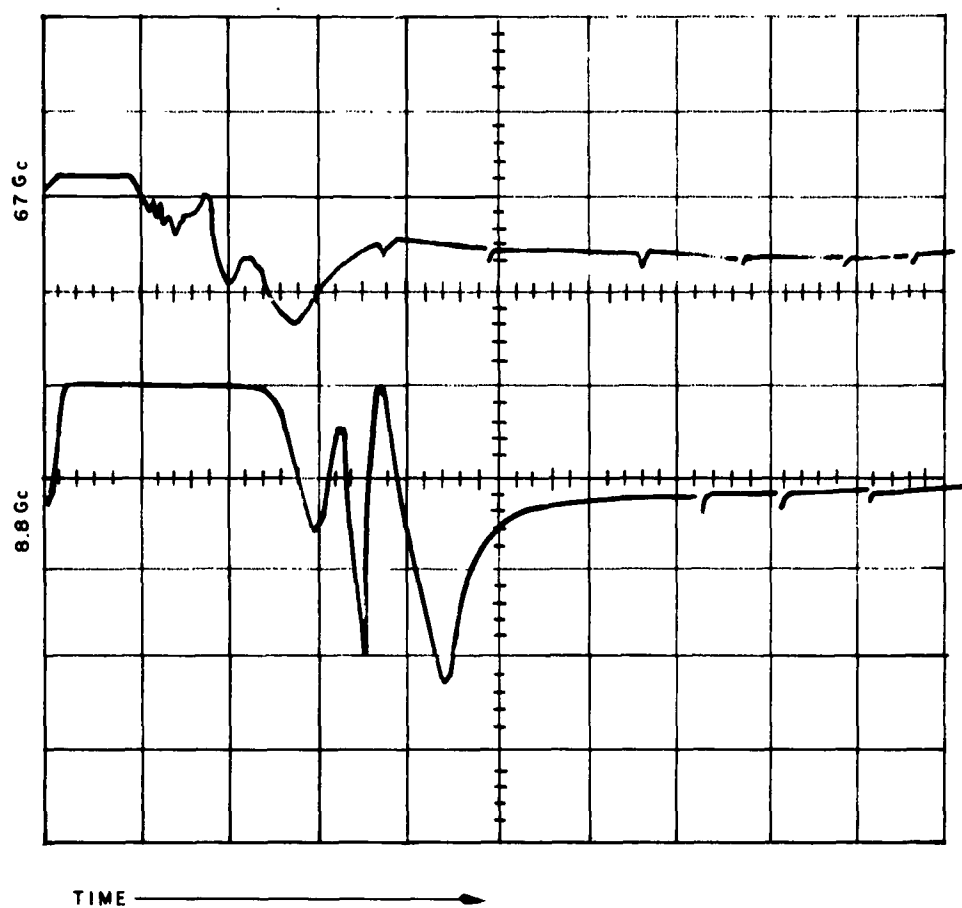

100 $\mu$ s/div., NEON GAS, 60 $\mu$ Hg PRESSURE,  
CAPACITOR BANK VOLTAGE 5,000V

FIGURE 9. TRANSMITTED 67Gc & 8.8Gc MICROWAVE SIGNALS

- 1) measurement of electron density of a plasma by interferometry
- 2) measurement of electron density of a plasma by observing the rotation of the plane of polarization (Faraday rotation)
- 3) measurement of electron and ion temperatures and the collision frequency by the study of the scattering of the incident beam.

These measurement techniques come immediately to mind because they are the familiar microwave measurements transposed into the optical range. Other properties of a dense plasma can be investigated with the use of a laser. Due to its short wavelength, a very fine analysis of a plasma could be made.

As a result of the above considerations a laser is now under construction. This will be a ruby laser with an elliptical configuration. This configuration results in a lower threshold value. One or two xenon flash lamps may be used for pumping. The use of two flash lamps has the following advantages:

- 1) If the "pumps" work together, almost double the pumping power results. This is useful because the quantity of energy each lamp can take is limited.
- 2) The threshold value of the laser can be reached with one pump. The other pump can then be flashed to trigger the emission.

Auxiliary electronic equipment is also under construction.

### 3. DISCUSSION AND CONCLUSIONS

A magnetic compression device has been assembled and tested using neon gas. The following have been observed: 1) With no preionization, breakdown does not occur. With a weak preionization, breakdown occurs at the beginning of the second half cycle of the magnetic field. With strong preionization, breakdown occurs at the beginning of the first half cycle. This is in qualitative agreement with the behavior of  $\theta$ -pinch type devices. 2) Microwave transmission through the plasma, along the axis of the one turn coil, has been studied at a few frequencies. Cut-off occurs in each case. 3) The spectral response of different photomultiplier tubes of the same type may impair the general usefulness of these devices in observing plasma behavior.

#### Plans for the Next Quarter

In the next quarter investigations will be directed toward the following:

- 1) Improvements will be made in the control of the initial gas pressure through the addition of the two calibrated thermocouple gauges to the vacuum system. A new glass tube to contain the plasma will be added to the system also, completely filling the one turn coil.
- 2) Improvements will be made in the apparatus for preionization. A pulsed rf source will be constructed to help eliminate the pick-up due to the present method of preionization.
- 3) Radio wave transmission tests will be repeated with waveguides designed to (a) launch waves of several frequencies (microwave as well as lower frequency rf) simultaneously into the plasma, and (b) to match the impedance of the coil and glass system more closely. The use of several frequencies will allow the measurement of electron density as a function of time for each transient plasma.
- 4) Emission of microwave noise from the plasma will be measured to ascertain the electron temperatures.
- 5) Microwave reflections will also be measured to determine to what extent the plasma behaves as a back-body radiator.
- 6) Faraday rotation will be sought as another method of determining electron densities.
- 7) Spectroscopic investigations of the degree of ionization attained in the plasma will be made, and
- 8) The components of the laser, and, perhaps, the laser itself may be ready for testing.

## 4. PERSONNEL

<u>Name</u>	<u>Position</u>	<u>Precent of Time</u>
Dr. Ladislav Goldstein, Project Director	Professor	10%
Lucien P. Slama	Visiting Research Associate	50%
Donald J. Albares	Research Assistant	67%
Edward Bialecke	Research Assistant	75% 1 Oct. - 15 Dec.
Carl L. Gruber	Research Assistant	25%
Leroy Dreyer	Electrical Engineer	50% 1 Sept. - 30 Oct. 75% 1 Nov. - 15 Dec.
Patricia Shafer	Clerk-Typist II	12%

Dr. Ladislav Goldstein

Dr. Goldstein received the B.S. degree from the University of Paris, France, in 1925; M.S. degree from the University of Paris, France in 1928 majoring in Physics; Ph.D. degree from the University of Paris, France in 1937.

From 1937-1939 Dr. Goldstein was an Assistant Professor at the University of Paris, France. From 1942-1944 he was associated with Canadian Radium and Uranium Corporation; from 1946-1951 he was Head of Research Laboratory, Federal Telecommunications Laboratory; from 1951-to date he has been associated with the Gaseous Electronics Group of the Electrical Engineering Research Laboratory of the University of Illinois.

Lucien P. Slama

Mr. Slama received the following scientific degrees:

Licence es Sciences (Physics) from the University of Paris in 1955 and  
Ingenieur de Telecommunications from the University of Paris in 1957.

He served two years in the French Navy as an Electronics Radar Officer. In 1960 he was employed as a physicist at the French Atomic Energy Commission working on plasma physics. Since September 15, 1961 he has been employed at the University of Illinois working as a Research Associate.

Donald J. Albares:

After receiving an A.B. degree in physics from Princeton University in 1954 and serving in the U.S. Navy, Mr. Albares spent one year at Convair Astronautics doing control systems electronic work. In 1958 he joined the Fusion Group at General Atomic engaged in physics research. During his three years at General Atomic he was involved with plasma diagnostics and studied the linear pinch effect. He pursued graduate work at San Diego State College until moving to the University of Illinois in September of 1961.

Edward P. Bialecke, Jr:

Mr. Bialecke received the degree of Bachelor of Science in Electrical Engineering from the University of Illinois in June, 1956. That same month he entered the graduate school at the University of Illinois. In September, 1956, he joined the Gaseous Electronics Laboratory of the Department of Electrical Engineering at the University as a Research Assistant. He received a Master of Science degree in June, 1951, for which he wrote a master's thesis entitled "Electron-Ion Recombination in Ionized Nitrogen Gas Studied by Microwave Techniques." He is currently working toward a degree of Doctor of Philosophy in the Electrical Engineering Department of the University of Illinois.

Carl Gruber:

Mr. Gruber received the B.S. degree in Electrical Engineering in January, 1960 from the University of Illinois. He entered graduate college at the University of Illinois in February, 1960 with a research assistantship in the Gaseous Electronics Laboratory. He received the M.S. degree in Electrical Engineering in June 1961, and is currently working toward his Ph.D. in the Gaseous Electronics Laboratory.

Leroy L. Dreyer

Mr. Dreyer served as an Aviation Electronics Tech. 1/C in the U.S. Navy from 1943 to 1946. He was employed by Western Electric Co. in the installation of central office telephone equipment and received the Associate of Arts in Pre-engineering in June 1950. Mr. Dreyer was then employed as Calibration Engineer for Emerson Electric Co. on radar and fire control equipment. He was then employed as Lab Engineer with the Bickers Electric Inc. on testing and development work on magnetic amplifier control systems. He joined the University of Illinois as a Sr. Electronics Tech in 1952 and worked in the Bioacoustics Lab, designing and fabricating experimental electronic instrumentation. In June 1956 he received the B.S. in E.E. from the University of Illinois. From 1956 to January 1959 he worked as a Research Assistant on Ultrasonic Neurosurgery Project (joint project with University of Iowa Medical College. He joined the Gaseous Electronics Group at the University of Illinois in January 1959 and is presently employed there as an Electronics Engineer.

Contract DA36-039 sc-87232  
University of Illinois

First Quarterly Progress Report  
15 September to 15 December 1961

DISTRIBUTION LIST

TO:

OASD (R&E), Rm 3E1065  
The Pentagon  
ATTN: Technical Library  
Washington 25, D.C.

Chief of Research and Development  
OCS, Dept. of the Army  
Washington 25, D.C.

Chief Signal Officer  
Department of the Army  
ATTN: SIGRD  
Washington 25, D.C.

Director, U.S. Naval Research Lab.  
ATTN: Code 2027  
Washington 25, D.C.

Commanding Officer and Director  
US Navy Electronics Laboratory  
San Diego 52, California

Commander  
Aeronautical Systems Division (2)  
ATTN: ASAPRL (1 copy)  
ASRNET-3 (Mr. V.L. Cartmell) (1 cy)  
Wright-Patterson Air Force Base, Ohio

Commander, AF Cambridge Research Labs  
L.G. Hanscom Field  
ATTN: CRO  
Bedford, Massachusetts

Commanding Officer, 9560th TSU  
US Army Signal Electronics Research Unit  
P.O. Box 205  
Mountain View, California

Commanding Officer  
US Army Signal Equipment Support Agency  
ATTN: SIGFM/ES-ADJ  
Fort Monmouth, New Jersey

Corps of Engineers Liaison Officer  
US Army Signal Research and Dev. Lab.  
Fort Monmouth, New Jersey

Marine Corps Liaison Office  
US Army Signal Research and Dev. Lab.  
Fort Monmouth, New Jersey

Commanding Officer (11)  
US Army Signal Research and Dev. Lab.  
Fort Monmouth, New Jersey  
ATTN: Logistics Division, Project  
Engineer (3 cys)  
Director of Research (1 cy)  
Technical Documents Center (1 cy)  
SIGRA/SL-PRG (Record Copy) (1 cy)  
Technical Information Div. (3 cys)  
(FOR RETRANSMITTAL TO ACCREDITED  
BRITISH AND CANADIAN GOVERNMENT  
REPRESENTATIVES)  
SIGRA/SL-PRG (Reports Distribution)  
(2 cys)

Commander, Rome Air Development Center  
Air Research and Development Command  
ATTN: RAOIL-2 (1 cy) (2)  
RALTP (Mr. H.L. Beard) (1 cy)  
Griffiss Air Force Base, New York

Commander  
Armed Services Technical Inf. Agency  
Arlington Hall Station (10)  
ATTN: TIPDR  
Arlington 12, Virginia

Commanding Officer  
Diamond Ordnance Fuze Labs.  
ATTN: Library, Rm 211, Bldg. 92 (1 cy) (2)  
R.E. Dorrell, Branch 930 (1cy)  
Washington 25, D.C.

Advisory Group on Electron Tubes  
346 Broadway (2)  
New York 13, New York

Commanding Officer  
Frankford Arsenal  
ATTN: ORDSA-FEL  
Philadelphia 37, Pa.

Chief, Bureau of Ships  
Department of the Navy  
ATTN: 691A  
Washington 25, D.C.

Chief of Ordnance  
ATTN: ORDTX-AR  
Washington 25, D.C.

Commanding General  
US Army Signal Supply Agency  
225 South 18th Street  
ATTN: SIGSU-R2a  
Philadelphia, Pa.

Chief, U.S. Army Security Agency  
Arlington Hall Station  
Arlington 12, Virginia

Deputy President  
U.S. Army Security Agency Board  
Arlington Hall Station  
Arlington 12, Virginia

Commanding General  
U.S. Army Signal Supply Agency  
ATTN: SIGSU-R4b  
225 South 18th Street  
Philadelphia 3, Pennsylvania

Edgerton, Germeshausen & Grier, Inc.  
160 Brookline Avenue  
Boston 15, Massachusetts  
ATTN: Mr. S. Goldberg

Kuthe Laboratories  
730 South 13th Street  
Newark, N. J.  
ATTN: Mr. A. Gordon

Chatham Electronics  
Division of Tung-Sol Electric, Inc.  
630 W. Mt. Pleasant Ave.,  
Livingston, New Jersey  
ATTN: Mr. W. W. Watrous

General Electric Company  
Power Tube Department  
1 River Road  
Schenectady 5, New York  
ATTN: Mr. W. Miller

(2)

This contract is supervised by the Special Tubes Branch, Electron Tubes Division, Electronic Components Department, USASRD, Fort Monmouth, New Jersey. For further technical information contact:

Mr. John E. Creedon

Project Advisor

Gaseous Electronics

Section

Tel. 201

Ext. 59-61437