

**UNCLASSIFIED**

---

---

**AD 274 172**

*Reproduced  
by the*

**ARMED SERVICES TECHNICAL INFORMATION AGENCY  
ARLINGTON HALL STATION  
ARLINGTON 12, VIRGINIA**



---

---

**UNCLASSIFIED**

**NOTICE:** When government or other drawings, specifications or other data are used for any purpose other than in connection with a definitely related government procurement operation, the U. S. Government thereby incurs no responsibility, nor any obligation whatsoever; and the fact that the Government may have formulated, furnished, or in any way supplied the said drawings, specifications, or other data is not to be regarded by implication or otherwise as in any manner licensing the holder or any other person or corporation, or conveying any rights or permission to manufacture, use or sell any patented invention that may in any way be related thereto.

NASA TN D-1351

CATALOGED BY ASTIA

AS AD NO. 274172

602 100

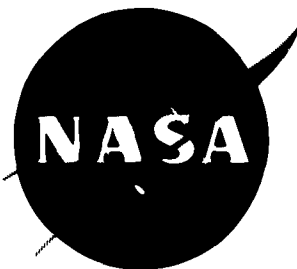

# TECHNICAL NOTE

D-1351

AN INVESTIGATION OF THE EFFECTS OF THE  
TIME LAG DUE TO LONG TRANSMISSION  
DISTANCE UPON REMOTE CONTROL

Phase II - Vehicle Experiments  
Phase III - Conclusions

By James L. Adams

Stanford University

ASTIA  
RECEIVED  
APR 17 1962  
N-62-3-1  
ASTIA

NATIONAL AERONAUTICS AND SPACE ADMINISTRATION  
WASHINGTON

April 1962

## PREFACE

This is the final report of the work done at Stanford University under NASA Contract No. NSG 111-61. The purpose of this work was to examine the effect upon remote control of the transport lag due to long transmission distances. The program consisted of three phases. The first was a series of tracking experiments incorporating a time delay in the loop. The second was a series of experiments with an actual remotely controlled vehicle. The third phase consisted of the correlation of the experimental data from the first two phases and the formulation of conclusions.

D  
1  
3  
5  
1

The three phases together represent a coherent unit of research and as such have been submitted to Stanford University in the form of a Dissertation in partial fulfillment of the requirements for the Ph. D. degree. However, because of the interest shown in the program and because of the impending schedule of Project Prospector, the results of the first phase of experimentation were submitted to NASA in June 1961 and have been published as NASA Technical Note D-1211 entitled "An Investigation of the Effects of the Time Lag Due to Long Transmission Distances upon Remote Control, Phase I - Tracking Experiments".

In order to minimize duplication, the tracking information will not be repeated completely in this report. It will be summarized in Chapter II. The remainder of the report will be concerned with Phases II and III. It is therefore suggested that the reader obtain a copy of NASA Technical Note D-1211 in order to have all of the information at his disposal.

## TABLE OF CONTENTS

	Page	
PREFACE . . . . .	1	
SUMMARY . . . . .	3	
<b>Chapter</b>		
I. BACKGROUND AND OBJECTIVES . . . . .	4	
General		
Previous Work		
Objectives and Approach		
II. TRACKING EXPERIMENTS . . . . .	10	
Summary of human operator work		
Experiments with simple human analogues		
III. VEHICLE EXPERIMENTS . . . . .	18	
Philosophy and Design of Experiments		
Description of Experiments		
Apparatus		
Conduct of Tests		
Experimental Results		
IV. DISCUSSION . . . . .	32	
Vehicle-Tracking Correlation		
V. LUNAR VEHICLE CONSIDERATIONS . . . . .	40	
General		
Problems		
Solutions		
Operator Aiding Schemes		
Future Work		
FULL-PAGE ILLUSTRATIONS . . . . .	53	
LIST OF REFERENCES . . . . .	64	
<b>Appendixes</b>		
1. TRACKING EXPERIMENT RESULTS . . . . .	66	
2. VEHICLE EXPERIMENT RESULTS . . . . .	76	

## TECHNICAL NOTE D-1351

AN INVESTIGATION OF THE EFFECTS OF THE  
TIME LAG DUE TO LONG TRANSMISSION  
DISTANCE UPON REMOTE CONTROL

Phase II - Vehicle Experiments

Phase III - Conclusions

By James L. Adams

## SUMMARY

An experimental program is undertaken to define the effects upon remote control of long transmission delays. Investigation centers around remote control of a ground vehicle, which is considered to be a representative remote control task.

A series of pursuit tracking tests is performed with transport lags ranging from 0 to 6 seconds between the control and the controlled quantity. Various target speeds are tracked with both velocity and acceleration controls. Two types of tracking are performed in an attempt to bracket the actual vehicle situation. In the first the operator attempts to follow the target with his controlled quantity in real time, using the delayed position and rates as feedback. In the second he attempts to follow the target with the delayed controlled quantity. In addition, tests are performed substituting simple electronic models for the human in an attempt to gain an understanding of human response with time delays in the control loop.

A series of tests with an actual vehicle are performed with the intent of relating the tracking tests to the actual situation of interest. Time delays of from 0 to 3 seconds are included in the control loop. Performance is scored at various speeds over both continuous and obstacle courses. Both two and four-wheel steering are investigated.

In the experiments the effects of all variables except delay magnitude and target complexity are minimized. Curves are obtained showing performance as a function of time delay and target complexity. These curves are discussed. Correlation of the tracking and vehicle experiments is discussed. Comments are made concerning the design of a minimum control system for a remotely controlled lunar roving vehicle.

CHAPTER I  
BACKGROUND AND OBJECTIVES

General

Man is unique in his ability to recognize patterns, adapt to unprogrammed situations, and make decisions based upon incomplete data. Therefore, in situations where a machine is liable to encounter unexpected phenomena we generally find a man exerting some degree of control. In these so-called "man-machine systems" we occasionally also find that for reasons of safety, convenience, or economy, the machine operates at some distance from the man.

Up to this date such "remote control" operations have not required special consideration because they have been possible without severely limiting the performance of the machine. This has been due to the gentle nature of the barrier between man and machine (usually no more than a few miles of atmosphere) and the relative lack of constraints on the amount of additional equipment allowable on the machine.

Electro-mechanical complexity has been the chief limitation in extending muscles and sensors from man to machine. The remoting of an aircraft, for instance, is mainly a problem of packaging the maze of hardware necessary to provide the remote eyes, ears, hands, and feet of the pilot and connect them with their real-life counterparts. Physically, the machine can accommodate and power the apparatus necessary to do everything from adjusting trim to reading tail-pipe temperature. The engineering problems are sometimes severe, but are generally within the realm of previous experience.

Recently, however, man has been confronted with more difficult remote control problems. This is because of his recently acquired ability to explore space. Whereas before it was physically impossible for him to place a machine more than a few thousand miles from the operator, he is now able to place machines several million miles away. The reasons for remote control are the same. The machines to be sent out into space will encounter unforeseen situations. A man must be present to tell them what to do. The man cannot be on board the machine for reasons of safety and economy. Therefore, he must control the machine from earth or some other hospitable site removed from the location of the machine.

This new barrier of space is no longer minor. It is expensive to transport objects across the barrier. It is expensive to convey intelligence through the barrier. The barrier distorts messages and delays their transmission. The optimum remote control system is no longer one which extends every nerve and muscle of the operator and allows unimpaired performance of the machine. The optimum system is now one which provides as good performance as possible with a strictly limited amount of additional equipment on the machine.

D  
1  
3  
5  
1

The purpose of the research covered in this report has been to investigate the effects of the delay in signal transmission due to long transmission distances upon remote control. This delay cannot be avoided since signals travel only at the speed of light and cannot be accelerated. However, in the past these delays have always been negligible. Even if the machine were as far as 1000 miles from the operator the delay would be only 6 milliseconds. This is certainly unimportant when compared to the operator's reaction time and the lags in most control systems.

Should the machine be on the surface of the moon, however, the signal transmission time will be approximately 1.3 seconds (earth-moon mean distance 239,000 miles). Since this delay will occur both in the control signal and in the feedback signal from moon to earth, the total signal delay in a closed loop remote control task between the earth and the moon will be slightly over 2.5 seconds. This is far from negligible. Since the moon is not very far away by space standards and since man will undoubtedly travel much further than the moon, it is apparent that the signal delay due to long transmission distances may exert seriously limiting effects upon certain remote control tasks in the future.

### Previous Work

A literature search at the beginning of the project showed little useful published work available. The available information fell into three categories: reports on successful remote control systems with short transmission distances; human engineering research; and control systems research. The first category was of interest largely from an electro-mechanical design sense. Complex remoting projects (Food Machinery's remote surf testing of amphibious tanks, Chance Vought's remote flight testing of the Regulus II missile, the remote controlling of target drones and models, the remote controlling of the

Scripps-U.S. Navy Project RUM) were in general examples of the sensor-muscle extension form of remote controlling. Time delays were in no cases present in the control loop, so that these experiences were of little help to the present research.<sup>1\*</sup>

In the second category, human engineering research, a great deal of experimentation has been done concerning the ability of a human to control various tasks with no time delay in the loop. "Tracking" experiments which require an operator to follow various targets with varying control dynamics, target paths, controls, displays, and frequencies, have resulted in rather complete coverage of the real-time field.<sup>2</sup> Some work has been done with time lags of an exponential form in the loop.<sup>3</sup> Work done by Warrick<sup>4</sup> actually considers a transmission-type lag in the loop but was carried out to a delay of one 1/3 second.

The third category, control systems research, was slightly more promising. Linear servo-mechanism theory<sup>5</sup> considers transport lags, which are the same as transmission lags. Unfortunately, it is rather difficult to fit the human into the world of transformed describing functions and harmonic responses. In order to use linear control theory, a linear describing function must be used for the human operator. The defining of such a function is a problem which has been plaguing control engineers for some time.

The attempt to describe a man by a mathematical model dates back to the work of Tustin in 1947.<sup>6</sup> Since that time the subject of human transfer functions has received ever-increasing emphasis due to the increasing complexity of systems containing man as a control device. However, man is not a mathematically simple device. If given extremely simple tasks he may operate in a simple, reasonably linear manner. As the tasks become more complex, he becomes increasingly non-linear and unpredictable.

McRuer and Krendel have published a report which indicates the status of the search for the human transfer function.<sup>7</sup> In brief, people can be described with some degree of success by what is sometimes referred to as a quasi-linear transfer function with a non-linear remnant. The quasi-linear transfer function is a linear transfer function whose parameters vary with the environment in which the human must operate, the nature of the controlled element, and the characteristics of his input. The non-linear remnant is the difference

\*Superscripts refer to publications listed in reference section.

between the quasi-linear transfer function and actual performance. Should this sound optimistic, the reader need only refer to any report seeking to define the parameters of the transfer function<sup>8, 9, 10</sup> to convince himself that a great deal more work is necessary before this relation becomes well enough known to be suitable for day-to-day use in control system work.

### Objectives and Approach

D  
1  
3  
5  
1

Since the literature search revealed no systems which had been operated with a transport lag in the loop, no work by human engineers which included transport lags in their work with humans (except for that by Warrick), and no work by control engineers which included humans in their work with transport lags, it was decided to undertake a program of exploratory nature. It was decided also that the human's extremely untidy mathematical format would render a theoretical approach both arduous and of dubious value. An experimental approach was therefore chosen.

In order to narrow the project down to a size compatible with the researcher, it was decided to concentrate upon distances on the order of that from the earth to the moon and to choose the remote controlled surface exploration vehicle as a typical task. In order to investigate some aspects of the effects of time delay, it was decided to measure the degree of success which the vehicle had in following its target as a function of only two variables, target complexity (vehicle forward speed and path wave shape) and delay magnitude. Since a vehicle is a complex machine and since it was desirable to consider only the variables of interest, all other quantities were held constant during the experimentation. A few violations of this policy were allowed in order to keep operators happy when it was obvious that the important results would not be adversely affected. However, quickening and aiding were not considered. Human factors quantities such as display size, knob size, room lighting, and so forth, were set at a reasonable value and then maintained unchanged. Vehicle television camera position, lens angle, and scan rate were treated likewise. Also ruled out of this investigation were methods of avoiding the problem of transmission delay altogether, such as operating open-loop with stops to allow the display to "catch up" to the control. It was assumed that there would be sufficient need for continuous motion of the controlled quantity to make it worthy of study.

It is apparent that a transport lag in a remote control loop adversely affects performance. It would be much harder to drive an automobile if the view of the road ahead were delayed by 1-1/4 seconds as it passed through the windshield and if the wheels waited 1-1/4 seconds before responding to steering wheel movements. However, the amount of effect the lag has is not so apparent. The experimental work was designed so as to quantitatively define the effects of the delay. It was assumed that the work necessary to define the effects would suggest methods of minimizing these effects in an actual system.

The chapters of this report correspond roughly to the phases of research. A two-sided experimental attack was used because of the non-linear nature of the human operator. These two families of experiments are discussed in chapters II and III. They are both necessary because a human operator in a complex situation cannot be relied upon to react to a given input in the same manner as he would react in a simplified situation. However, experimenting with a complex situation is inconvenient because of the number of variables involved. The first experiments (chapter II) were closely controlled and limited to the variables of interest only. The experimental situation was divorced somewhat from the actual remote vehicle control situation. It was essentially a series of tracking experiments incorporating a time delay in the loop. Tracking was chosen because of the ease of controlling and limiting the variables, because it was quite representative of human control tasks, and because of the great amount of work which had been done on tracking which might be usable in later generalization of the experimental results. A controlled experimental situation such as this had the advantage of allowing straightforward relating of cause and effect. However, since the human operator changes his transfer function with different jobs, it is necessary to relate the controlled experiments to the actual situation.

D  
1  
3  
5  
1

The second series of experiments (chapter III) represents the actual situation. They were performed with an actual vehicle. The experimental situation was somewhat cumbersome because of the many variables present. However, since it was an exact replica of the remote vehicle situation it could be expected to yield data which is typical of actual man-machine performance.

Chapter IV is a discussion of the results of chapters II and III. Chapter V is a discussion of possible design considerations to minimize the effects of the time lag. Also included are suggestions for possible future work in this field.

Due to the exploratory nature of this program, results are too broad in nature to allow a short concise statement of conclusions. However, the reader should have no trouble in finding conclusions in the main body of the report. The experimental results of chapters II and III, subject to the restraints discussed in chapter IV, give quantitative indications of maximum possible performance at various time delays, of penalties resulting from compromised vehicle dynamics, and of performance decrease from the real time situation due to time delays. In addition, chapter V contains qualitative conclusions arrived at by the researcher as a result of the experimental work.

D  
1  
3  
5  
1



Pure transport delays ranging from 0 to 6 seconds were placed between the operator's control and the simulated vehicle display. The target which the operator was to follow was the sum of 4 sinusoids of maximum frequency and amplitude as shown in Table I.

TABLE I  
TRACKING PROBLEM SINE WAVES

Resolver	Frequency (Cycles) Minute	Amplitude
No. 1	16.0	.4 volts
No. 2	12.6	.6 volts
No. 3	10.1	.6 volts
No. 4	3.8	.9 volts

The sine wave generators were geared together and mechanically driven through a variable speed device, so that although the frequency ratio and amplitudes of the 4 waves were fixed, the speed of the resulting wave could be varied between zero and the speed represented by Table No. 1.

Ideally this series of experiments would have required exactly the same mental processes from the operator as the actual remote vehicle situation. Because of the difficulty of simulating the type of perspective display seen from a moving vehicle, this was not accomplished. Instead two experimental situations were chosen which would utilize a conventional tracking display and hopefully would bracket the actual situation.

A typical pursuit tracking display was used. A vertical line on the bottom half of the scope face was driven horizontally by the problem. A vertical line on the top half of the scope face represented the delayed vehicle in all cases. Both Time on Target and Integrated Absolute Error types of scoring were used.

The first series of experiments was intended to simulate the vehicle situation with unobstructed and unimpaired forward vision. It was suspected that this series would place an upper limit on performance. The operator was instructed to follow the problem with his vehicle (the knob plus whatever dynamics were being used to simulate the vehicle) in real time and to use the delayed vehicle feed back on the scope for whatever purpose he desired. The scoring was between the problem and the real time vehicle as shown in Figure No. 1. This was known as Type I Tracking.

The second series of experiments was intended to simulate the vehicle situation with no forward vision. It was suspected that this series would place a lower limit on performance. The operator was instructed to follow the problem trace with the delayed vehicle trace. The scoring was between the problem and the delayed vehicle. This was known as Type II Tracking. In Type I Tracking the operator was not trying to match the two traces upon the scope. In Type II Tracking he was attempting to match them.

Two vehicle configurations were simulated. The first was the crab vehicle, an example of which would be a 4 wheeled vehicle with all 4 wheels steering together. This corresponded to a single integration on the vehicle analogue, or velocity control in the tracking task. The second was a higher order vehicle such as an automobile, which corresponded to a double integration on the vehicle analogue, or acceleration control in the tracking task. No inertial exponential lags were included during the experimental runs. Two operators were used. Time delays of 0, 1/4, 1/2, 1, 1-1/2, 2, 3, and 6 seconds were included in the loop. Problem speeds used were full speed, corresponding to the sum of the sine waves shown in Table I, 1/2 speed, 1/4 speed, 1/8 speed, and 1/16 speed. Operators were trained at each speed-delay point until their scores no longer improved so that any performance change was due to the experimental variables.

Appendix I contains 10 pages of curves showing the Time on Target and Integrated Total Error scores as a function of time lag for each target speed (solid curves). The performance of the two operators has been averaged. For further information as to the significance of the scoring and further discussion the reader is referred to NASA Tech Note D-1211.

### Experiments with Simple Human Analogues

The curves shown broken in Appendix I represent the data from a series of experiments which substituted a very simple electronic model for the human operator in the tracking experiments. These experiments were performed mainly because of the personal curiosity of the researcher, but are probably of sufficient interest to be included here. One curve is shown for each type of electronic model which was tested. The experimental set-up was identical to the tracking set-up except that a small analogue computer was substituted for the operator-control-vehicle analogue.

The literature search had revealed that many of the investigators who had worked on the human transfer function had used a quasi-linear transfer function of the form (in Laplacian notation).

$$Ke^{-st} \frac{(1 + T_1s)(1 + T_2s)}{(1 + T_3s)(1 + T_4s)}$$

The human operator always utilized the gain, K, and the reaction time delay,  $e^{-st}$ . The lags occurred in simpler tasks because of neuromuscular inertias and in more difficult tasks because of smoothing introduced by the operator to simplify his job. The leads were introduced in order to offset lags and integrations in the controlled quantity dynamics.

The first group of runs in this series was performed by substituting a 1/4 second delay for the display-operator-control-vehicle analogue combination. This would simulate an operator reaction time of 1/4 second, a control and a vehicle corresponding to pure gains, and an overall gain of the combination of unity. The net result was that the vehicle followed the input perfectly, except that it was delayed 1/4 second in time. When this 1/4 second delay was put into the experimental set-up it lumped indistinguishably with the experimental transmission time delay of 2 0 seconds. Scoring was, therefore, between the problem and the problem delayed 2 0 + 1/4 seconds. Experimental runs were made for all problem speeds and for 20 values of 0, 1/4, 3/4, 1-3/4, and 2-3/4 seconds (total transport delay of 1/4, 1/2, 1, 2 and 3 seconds). This scoring was, of

D  
1  
3  
5  
1

course, Type II, since it was between the delayed vehicle and the problem. Type I scoring in this case would give the values from the  $2\theta = 0$  seconds runs for all values of  $2\theta$ .

The second group of runs was performed substituting a transfer function of

$$e^{-1/4 t} \frac{(1 + Ts)}{(1 + 1/4s)}$$

for the display-operator-control-vehicle analogue combination. This would correspond to an operator reaction time of 1/4 second, an operator lag (exponential) with a time constant of 1/4 second, a lead term with a coefficient of T, a control and vehicle which were pure gains, and an overall gain of unity. Values for  $2\theta$  of 0, 3/4, 1-3/4, and 2-3/4 seconds were investigated. All speeds were used. T values used were 1/2, 1, and 2.

The electronic models used were of a quite unsophisticated nature. It should be noted that they were not used in direct competition with the human operator. Rather, they were substituted for the display-operator-control combination. If the results are to be considered as a direct comparison, it must be remembered that the operator (human) had a 1 or 2 integration disadvantage, depending upon whether he was given a velocity control or an acceleration control. The electronic model, therefore, never had as difficult a task as the human, since there were no integrations in the device it was to control. As an additional difference, it should be noted that human tests with the velocity control were scored both in the Type I and Type II manner, whereas with the acceleration control they were scored only in the Type I manner. All tests with the electronic models were scored in the Type II manner.

However, despite these factors it is of interest to examine the results one target speed at a time. Throughout this discussion keep in mind the facts that the human had a 1 or 2 integration disadvantage, depending upon the type of control, and that the 2 types of scoring were intended to set an upper and lower limit upon vehicle performance. Keep in mind, also, that the discussion concerns the comparison of electronic model and human operator, not the ability of either to control the controlled quantity. The effects of the time delay were, except for low target speeds, much greater than the

differences between model and human. Therefore, although the model might have been in some cases superior to the human, it still could not necessarily do an acceptable job of control.

Beginning with 1/16 full target speed (pages A-1 and A-6) it is apparent that at delays below 1/2 second, the simple reaction time model was slightly superior to the human, independently of the control and scoring mode. This is as would be expected since the human was encumbered with stick-slip friction and other mechanical imperfections while the model was not. However, at delays of a longer duration, the human became superior to the model. At a delay of 3/4 second, the two were comparable in time-on-target score even though the human was handicapped by an integration. At delays of 2 or 3 seconds, the human with 2 integrations was roughly comparable to the model. The human with only 1 integration was some 20 per cent better in time-on-target score. The lead-lag models attempted at this speed decreased performance to an even lower value.

D  
1  
3  
5  
1

The experimental runs at 1/8 full target speed were similar. The simple reaction time models were initially superior to the human with all control and scoring modes. However, once again by the time a delay of 3/4 second was reached, the human was equivalent to the model. At delays of 2 or 3 seconds the human, even with 2 integrations, was superior to the model. However, at this higher speed the lead-lag models showed more promise, although they were still inferior to the human in performance, except for the error scores of the T = 2 lead model at the 2 and 3 second delays. This model, at longer delays was roughly equivalent to the human with Type II scoring.

At 1/4 speed and no delay, the simple reaction time model was equivalent to the human with a single integration control. As the delay was increased, the performance of the model dipped below that of the human with velocity control and Type II scoring and approached the performance of the human with acceleration control and Type I scoring. At delays in excess of 1 second, the model and the human with acceleration control and Type I scoring performed similarly. The lead-lag model with T = 1/2 was slightly inferior to the simple reaction time model for delays between 1 and 2 seconds and then became better than the simple reaction time. At delays of 3 seconds, the T = 1/2 model had become slightly superior to the human with both the acceleration control and Type I scoring and the human with velocity control and Type II scoring. The T = 1

lead model was very similar to and slightly better than the human with velocity control and Type II scoring. The  $T = 2$  lead model was markedly superior to the human with velocity control and Type II scoring except for delays below 1-1/2 seconds.

For 1/2 speed runs, except for slightly poorer performance by the simple reaction time model at delays less than 1 second, the models all surpassed both the human with acceleration control and Type I scoring and the human with velocity control and Type II scoring. It should be considered at this point, however, that scores at delays of 2 and 3 seconds at 1/2 and full speeds lose some of their validity because of the asymptotic tendencies of the scoring systems. It should be noted that at 1/2 speed the lead-lag models fared better than the simple reaction time models for all values studied.

The comments of 1/2 speed also apply to full speed. However, at full speed some of the models exceeded the performance of the human, even with velocity control and Type I scoring. At delays in excess of 1/2 second, all models performed better than the human with velocity control and Type II scoring, except for the  $T = 2$  lead model, which was apparently ineffective at this speed.

In general, the scores attained by the human with the velocity control and Type I scoring were superior to those attained by the models. This is logical, since if Type I scoring had been used for the models, the results would have been horizontal lines passing through the zero delay points. With no delay in the experimental loop, the simple reaction time model very closely approximated the performance of the operator with the single integration control. At higher speeds the operator apparently used a small bit of lead to improve his no-delay scores, since his actual scores with 1 integration were superior to the scores attained by the reaction time model. The addition of another integration to the operator's control device caused his score to fall below that attainable by the simple reaction time model.

With delays, the operator performance depended upon both delay length and target speed. With 1/16 target speed, the operator was able to handle 1 integration with Type II scoring or 2 integrations with Type I scoring and still outperform all of the models. The reasons

D  
1  
3  
5  
1

probably were that the target rates were so low that the lead network was not effective, and that the model did not have the intelligence to maintain the continual lead which the operator did.

At 1/8 speed, the rates were higher and the lead term in the lead-lag models was much more effective. At delays of 2 and 3 seconds, the model with the  $T = 2$  lead term closely approximated the performance of the human with 1 integration and Type II scoring. The human was, therefore, apparently operating with a long lead term and was able to compensate for a single integration with no apparent trouble.

D  
1  
3  
5  
1

At 1/4 speed, the operator with 1 integration and Type II scoring could not do as well as the  $T = 2$  lead model at delays of over 1-1/2 seconds. He performed approximately as the  $T = 1$  lead model. Apparently at this speed the rates had increased to the point at which the integrations were becoming more difficult for the operator to handle. He could now only operate with a  $T$  of 1 and still compensate for the integration.

The increasing difficulty due to the integrations at higher speed became very apparent in the 1/2 speed and full speed cases. In both of these the operator was not able to compensate for his single integration and equal any of the model performances. The cumulative confusion resulting from these integrations apparently prevented the operator from operating as well as the simple linear model.

The point of interest here is that for no delay the operator, even with his 1 integration handicap, was able to equal or better the performance of the models at all speeds. With a delay of 2 or 3 seconds he could outperform the model at low speeds, but at high speeds the integration apparently prevented him from exercising the lead necessary to outperform the lead-lag models. It is possible that even without the integration he would have been unable to outperform the models. However, the fact that the operator was able to compensate for the integration at no delay, but apparently was not able to do so at 3 seconds of delay, suggests that the dynamics of devices intended for control with a time delay in the loop should be kept as simple as possible.

## CHAPTER III

### VEHICLE EXPERIMENTS

#### Philosophy and Design of Experiments

The object of this series of experiments was to achieve an exact simulation of the situation of interest by use of an actual remotely controlled surface vehicle. The purpose was to relate the previous tracking experiments to actuality. A full description of the vehicle will be found in the apparatus section of this chapter. In brief it was a four-wheeled cart which carried a television camera. Steering was with the front two wheels, with all wheels together, or with the front and the back wheels in opposition. Only the first two modes were used for experimentation. The television could either be fixed to the vehicle or turned with the steering wheels.

D  
1  
3  
5  
1

Every effort was made to continue the philosophy of limiting the number of variables to two: time delay and target speed. The display-control-vehicle system was kept as simple as possible. Standard television (30 frames per second, 525 line resolution) was used with a wide angle lens to avoid, as much as possible, considerations such as pan, tilt, scan, frame rate, resolution, and so on. The television display was not aided. Steering control time lags were small (see apparatus section), so that the experimental time delay effects were not masked by exponential lags in the machinery. The relationship of the steering knob to the wheel position was one-to-one. Vehicle speed was variable but was fixed for each run, rather than being operator controlled. Human factors variables were avoided by setting them at a reasonable value and then leaving them constant. By holding fixed as many parameters as possible, it was hoped that performance changes would be due to time delay and speed alone.

One of the major difficulties of an experimental program with an actual vehicle is the problem of obtaining data. It is not experimentally convenient to operate the vehicle over a random terrain typical of that which might be expected, for example, on the moon. It is necessary to control the terrain so that measures of success can be recorded. It was decided, for the purposes of these experiments, to use both a continuous course and an obstacle course on a flat surface for a terrain model.

The advantages of an obstacle course are that it cannot be easily learned and that it is most typical of off-the-road navigation, where the objective is usually to miss obstacles rather than follow an exact path. Learning is prevented by starting the vehicle each time from a different point and heading it in a different initial direction. The obstacles, therefore, have a different relationship for each run. Unfortunately with an obstacle course, the exact nature of the vehicle path is impossible to control and the only straightforward scoring technique is to record the number of obstacles hit.

On the other hand, a continuous course allows "time-on-target" scoring and allows the form of the problem to be set by the experimenter. Unfortunately, the course is a much more permanent thing physically than the sum of sinusoids used as a course in the tracking experiments. Since it must be marked upon the ground, it is not feasible to continuously change the course. The operator is therefore likely to learn the course to some extent. However, this does not invalidate the results since it is still necessary to drive foot-by-foot.

#### Description of Experiments

Two continuous courses and one obstacle course were marked upon a parking lot. They are shown both pictorially and diagrammatically in Figures 2 and 3. The long continuous course was used with the crab (all wheels steering plus camera) vehicle configuration. The course was modeled roughly after the four-sinusoid target used in the tracking experiments except that some hairpin turns were added to one end. The triple loop continuous course was used for experiments with two wheel steering. The vehicle in this configuration could not negotiate the tighter turns of the long course.

Since a radio link was not available for the control and television signals, the vehicle trailed a rather heavy umbilical cord. The television camera controls were also contained in a separate package which was not carried on the vehicle. An auxiliary hand-pushed cart was therefore used to follow the remotely controlled vehicle and carry the weight of the cable and the camera control unit. The outdoor end of the system, consisting of the vehicle and the auxiliary cart, is shown in Figure 4. Figure 5 is a photograph of the vehicle itself.

The vehicle was driven by an operator who was located in a building at the edge of the parking lot on which the course was marked.

All windows in the control room were blocked so that the operator could not see outside. The room was darkened to a degree considered optimum by the operator and no other persons were allowed in the room during test runs. The operator display was a standard television monitor. In the case of the obstacle course, the operator was asked to drive through the course and miss all of the obstacles. Scoring was accomplished by counting the number of obstacles the vehicle hit. A hit consisted of touching any of the circular obstacles with a wheel. For the continuous course runs, the vehicle was fitted with a 16 inch diameter disk mounted horizontally approximately 2 inches from the ground and in line with the verticle center line of the vehicle. The operator was asked to keep this disk over the course line. The total length of any run was recorded by stop watch. The amount of time the disk was over the course line was also recorded. Simple division then gave a per cent-of-time-on-target score.

D  
1  
3  
5  
1

### Apparatus

Figure No. 6 is a block diagram of the experimental apparatus. A description of each block in the diagram follows:

1. Display. The display was a Kay Labs model 1984 SM monitor with 14 inch screen.
2. Operator. The two subjects used in the tracking experiments were not available, so two other subjects were chosen. Subject No. 3 was a non-rated Air Force Captain. He was studying toward his M.S. in Mechanical Engineering. Subject No. 4 was a Navy Lieutenant who was a fighter pilot with a jet rating. He was completing his Engineer's Degree in Aeronautical Engineering and specializing in controls. Both subjects were well-coordinated, eager to participate, and had a very good understanding of the problem.
3. Steering Control. The same knob used in the tracking experiments was used. For 4-wheel steering the spring loading and detent were not used, as no "forward" existed. For 2-wheel steering, the spring loading and detent were used.
4. Speed Control. A rheostat with a 3 inch knob was used. However, the speed control function was never given to the operator as it was feared that it would be a confusion factor which was not desired in the experimentation.



most simple of dynamics, so the computer was not used to full potential. The computer was followed by a Philbrick cathode follower to provide the power necessary to excite the amplidyne.

7. Amplidyne. A General Electric 250-watt amplidyne was used to power the steering motor on the vehicle. It was excited by the error output from the analogue computer-cathode follower combination.

8. Vehicle. Figures 4 and 5 show the vehicle. Figure 7 shows the wiring diagram of the vehicle. The chassis was a welded box structure 2 feet square by 5 inches deep. The wheels were 16 inches in diameter and mounted at each corner with modified bicycle fork assemblies. The forks were shortened until about 1 inch of caster remained. The drive motor (or motors when 2 were used) were Dayton #4K862 gear motors with 5000 rpm full voltage armature speed and 238/1 gear reductions. The motors were operated as shunt wound motors with armature resistance speed control. The motors were mounted on the forks and drove the wheels directly through a chain drive. For very low vehicle speeds, the wheels were driven indirectly through a small drive wheel which contacted the tire. This drive wheel was driven directly from the motor. The highest vehicle speed used was 2.7 feet per second. The lowest was 0.4 feet per second.

Steering was done by a motor mounted approximately in the center of the frame. The steering motor was identical with the drive motors. The two front forks were linked together with a chain belt, as were the two back forks. The back forks could be pinned and the front ones steered; all could be steered; or the two could be steered in opposition. Steering was by means of timing belts from the steering motor.

The steering control system was a position loop between the steering forks and the steering knob. The error was obtained by taking the difference between the output of a 10-turn pot on the fork and one turned by the control knob. The 10-turn pots were necessary since a crab vehicle has very limited maneuverability if only one turn of steering is available. If a circular course is navigated, a complete turn is lost for every course circuit. With 10 turns of steering available, no problems were encountered with "running out of steering" during the testing, even though slip rings were required to transmit power to the drive wheels.

The control pot output was delayed by the amount of the experimental transmission lag before being compared to the vehicle pot

output. The difference was then amplified and used to excite the amplidyne, which fed the armature of the steering motor. A tachometer loop was necessary for damping. The tachometer was driven directly from the steering motor armature. The system gain was high enough so that the response to a control input appeared essentially instantaneous to the operator. The only difficulty with the system was that it was impossible to avoid a small amount (3 to 5 degrees) dead zone centered about the wheel position. This was due to stick-slip friction, gear backlash, and other mechanical imperfections. The motors used were not servo motors and were therefore not optimally designed for this use.

D  
1  
3  
5  
1

This dead zone was not noticeable when the vehicle was driven with no time delay in the system. However, with a delay it sometimes prevented extremely fine corrections as its presence could not be accurately predicted and could not be checked until the time lag had elapsed. The television camera was a Kay Labs model 1984 camera with a 10 mm. lens. It was mounted either on the steering motor pulley, which turned with the wheels, or on a bridge structure which cleared the drive pulley and held the camera stationary with respect to the chassis.

#### Conduct of Tests

A vehicle speed of 2.7 feet per second was chosen as the maximum vehicle speed to be used. This rather low speed (less than 2 m.p.h.) was chosen in deference to the operator of the follow-up cart, which was taking the weight of the umbilical and part of the television system. At longer time lags it was apparent that the motion of the vehicle might become extremely erratic. A higher speed would have resulted in extreme difficulties for the follow-up cart operator.

The low speed was also necessary because of the requirement to keep the physical course size down to match the 250 foot umbilical length. It was desirable to use low speeds and complex courses as much as possible. The courses were designed so that with no delay the operator could just barely achieve a perfect score. By placing time lags in the circuit, it was then possible to obtain curves of performance decay as a function of time lag. This was the hoped for result, as it would allow comparison with the tracking experiments.

The scores desired were those resulting from "fully trained" performance. This "fully trained" point was decided in a manner

similar to that used in the tracking experiments; that is, by operator opinion and scoring plateaus. After the operator had decided that he was not going to improve further and after the experimenter had decided likewise from the nature of the scores, a few more runs were taken to see if further improvement would result. If no noticeable improvement was observed, the operator was considered to be fully trained and his final scores were taken as a measure of his performance.

The majority of the testing was done with the vehicle in the crab configuration. All four wheels and the camera turned together. The long course was used for the first series of tests. The operators were told to keep the vehicle centered over the course line. They were then allowed to drive the vehicle back and forth over the course until they were fully trained and completely familiar with the vehicle. The scores were recorded and were near perfect as planned.

D  
1  
3  
5  
1

A time delay of  $1/2$  second was then introduced into the control loop and the process repeated. The same was then done for a time delay of 1 second and of 2 seconds. At this speed and with a delay of 2 seconds, the vehicle was no longer considered controllable (see chapter IV). The tracking experiments had indicated that to obtain comparable performance with a 3 second lag, it was necessary to cut speed to a value between  $1/4$  and  $1/8$  of the no delay speed. Therefore, the course was run at  $1/7$  of top vehicle speed. Again the same process was repeated. As a final test, the course was run in the same manner at  $1/3$  full vehicle speed.

After this program of experimentation was completed, the vehicle was run in a similar manner through the obstacle course. Before the beginning of each run it was placed in a new position and faced in a different direction. The lens cap was left on the television camera until a time before starting equivalent to the time delay. The operator was thereby given no chance to study the course before motion began. For each run the number of obstacles hit was recorded. The fully trained point was again reached for each time lag. After the vehicle was adjudged uncontrollable (again at 2 seconds), the speed was reduced to  $1/3$  full speed and delays of 2 and 3 seconds attempted.

The vehicle was then tested on the other continuous course while steering with front wheels only. Only one operator was used since performance of the two in previous tests had been sufficiently similar to suggest that either would be typical. The vehicle was initially run

with the camera fixed to the vehicle. However, after several runs it was decided to allow the camera to turn with the front wheels so as to effectively increase the field of view. (See discussion on page 27)

The experimental process used on the other continuous path was repeated for delays of 0, 1, and 2 seconds at the 2.7 feet per second top speed. The speed was then reduced to 1/3 of top speed and run with 3 seconds delay. The obstacle course was not used for this phase of the experimentation. A few runs were attempted but no scores were taken. The course was too complicated due to the slower turning response of the vehicle. With the crab configuration, the obstacle could be avoided up to the instant that the vehicle was on a collision course and less than the time delay away. However, with the automobile configuration, the turn had to be initiated at a much earlier point. A new course was not laid out because it was felt that enough information existed from the continuous path tests to allow comparison of the two vehicle configurations.

D  
1  
3  
5  
1

### Experimental Results

Appendix 2 contains the per cent-of-time-on-target scores for the various runs in tabular form. The first page presents scores for the crab vehicle at full speed with various time delays on the continuous course. Each score represents a run of 2 minutes and 50 seconds duration. The scores for each operator in each situation are shown in the order in which they were run. Note that in general learning seems to be complete after approximately 1/2 hour of scored run. The long series of runs at 1 second delay was taken in an attempt to verify the validity of the technique used to decide the fully trained point. It was decided that the technique was quite good for this particular type of learning. Perhaps, as in the case of the tracking experiments, hundreds of hours of additional practice with the situation might improve the ability of the operator to drive with a time lag. Unfortunately, it was not feasible to spend the hundreds of hours on each experimental point.

The data on page B2 represents the runs for the crab configuration at slower speeds with a 3 second lag and the runs over the continuous course with the 2-wheel steering vehicle. The crab runs at 0.4 feet per second totalled 2 minutes and 50 seconds in length for the first four runs, and seven times this, or 19 minutes and 50 seconds, for the last one. The runs at 0.9 feet per second all totalled 8 minutes and 30 seconds in length. The full speed runs with the automobile configuration totalled 2 minutes and 25 seconds each. At 1/3 speed (0.9 feet

per second) they totalled 7 minutes and 15 seconds each. The third page of data presents the scores for the vehicle in the crab configuration negotiating the obstacle course.

The vehicle experiments verified the fear that unwanted variables would exist. It was impossible during the experimentation to avoid the effects of a specific television camera mounting. Since no optional scan was available to the operator, since the course was necessarily rather complex, since the field of view was limited, and since errors were inherent with the time delay, a situation frequently resulted wherein the path was either not visible on the scope for a sufficient length ahead or not visible at all.

If the path had been straight, no difficulties would have existed since it would have been necessary only to keep the path centered on the screen. However, the path was necessarily quite complex. Even when the vehicle was following the path perfectly, the display would frequently appear as shown in Figure 8. The path was quite close to the edge of the monitor picture. Even with the wide-angle lens and perfect tracking, it was often impossible to see the entire path stretching out ahead. When the time delay was introduced, the path could no longer be followed perfectly. Mistakes could be costly. For instance, in the situation of Figure 8, a mistake to the left would cause the path to approach even closer to the edge of the monitor. If the mistake were big enough the path might leave the monitor altogether.

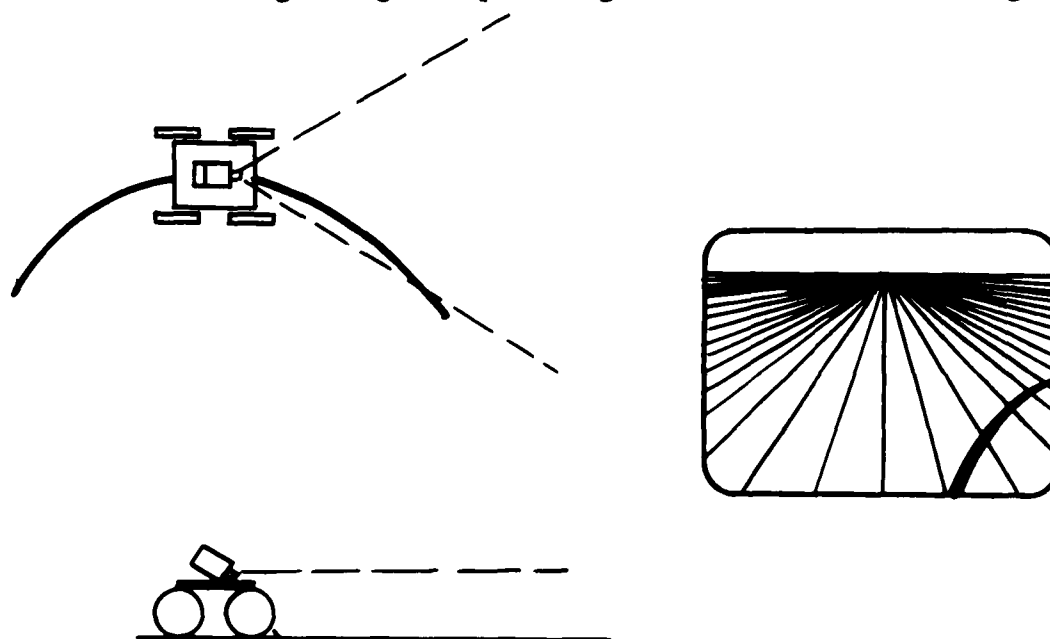

Figure 8 -- Effect of Path Curvature on Television Display

For these reasons, the path was frequently not visible for a distance ahead equal to the distance the vehicle would travel during the time delay. This, of course, made error inevitable. Such error was not strictly due either to the target complexity or to time delay and so was undesirable. However, no way was found to avoid it without going to an experimental system beyond the capabilities of the project.

D  
1  
3  
5  
1

The inability to see ahead was so important that the decision was made to drive the automobile configuration with the camera following the front wheel direction rather than fixed to the frame. A great deal of "feel" of vehicle position was thereby sacrificed. The effect was that the vehicle was much more responsive than it actually was. If a 15° left turn was desired, it could be put into the knob with the result that the camera would turn 15° (with the front wheels). Having apparently succeeded, the operator would then center the knob again, only to find that the vehicle itself may have turned only 5° in the time in which the wheels were turned.

However, once the operator became familiar with this configuration, it had the advantage of allowing a greater ability to "see" into turns. This was found to be of greater importance than the sacrificed "feel". For this reason all experimental runs with the two-wheel steering vehicle were done with the camera following the wheel direction. The fixed mounting on the frame is superior if the path can be kept in view. However, if the path cannot be seen, any configuration permitting better vision is an improvement, no matter how terrible the dynamics.

It was found that on their respective continuous paths scores for the two-wheel and four-wheel steering configurations were comparable for equal speeds and time delays. The gentler nature of the path for the automobile configuration compensated for the inferior control dynamics. However, the operators considered the automobile configuration more of a problem to control, even though scores were equivalent. The reason is the rather sluggish personality of the automobile in contrast to that of the crab. The crab seems extremely obedient in that it immediately (save for experimental delay) responds to direction changes. The automobile, on the other hand, responds only to rates of direction change. The automobile, therefore, seems more "difficult" to control.

With full vehicle speed and no time delay, some training was necessary for the operators to become accustomed to the response of the vehicle and the peculiarities of the display, which was slightly

distorted due to the wide angle of the camera lens. However, after training scores were close to 100% and, as one operator reported, "The situation was enjoyable and required an average amount of concentration and attention to the task."

The initial run with a 1/2 second delay introduced into the loop came as a bit of a shock to both operators. However, both soon learned to compensate for the delay to some degree. The path could easily be seen far enough ahead to pre-plan actions and was not lost for long enough periods to lose orientation. Mistakes were not serious, as the 1/2 second was not a long enough time period to wander far astray. In the words of one of the operators, "One-half second required more concentration than real time, but it finally became relatively easy." Scores were not as good as in the real time situation, but were still quite high.

With the introduction of the 1-second delay, the nature of the time delay became extremely apparent. It became necessary to concentrate both on the present situation (the display) and the future situation (what to put into the knob). Due to the delay itself and to accompanying errors, the path was frequently not visible on the screen for sufficient distances ahead. To quote from a report made by one of the operators:

"I found that three things were important about a turn: initiation, rate of turn, and amount of turn. I had to look at a turn from some distance away and estimate these three quantities while I could see the whole turn. When the vehicle got to the turn it was too late because I could no longer see the whole turn. Also, there were turns on the course which I never could see completely. These were the most difficult to navigate.

"When I had made my estimate of a turn I would try to steer them into the knob and then see what would happen. If I made a mistake on any one of the three, it was 1 second before I knew it and could make a correction and another second before I could evaluate my correction. Also any mistake I made aggravated the problem seriously because I then had to worry about getting the vehicle back on the path as well as preparing for the next turn. There were times when I could go through as many as 3 or 4 turns without making a serious error. But that first mistake was inevitable and I would eventually make it.

"The most frustrating part of this and the subsequent delay runs was that I would know that I had made an error but I could not correct it in time to help. It was because of this that I always felt I could do better. Each run I would try not to make that first mistake which threw me off so badly. But I would always make it and the scores would indicate I was not improving. Finally I had to admit I was not improving, no matter how sincerely I believed I could improve.

"I believe the greatest contributor to error in this series was not being able to see the path 1 second ahead while in a turn. This meant that by the time I saw the end of the turn I had already steered too much turn into the control causing an over turn. This made it very important to pre-plan the amount of turn correctly. Unfortunately, this was also the hardest of the three factors to estimate correctly. I got pretty good at initiation at all speeds and delays, fair at rate of turn, but I never did get really good at amount of turn.

"Therefore, the result of the 1-second runs was that control took the utmost concentration. Concentration which amounted to real physical work."

With 2 seconds of delay and full vehicle speed, another operator quote is quite indicative of the situation: "My attempts were more humorous than enlightening. It was at this time we realized that the speed must be reduced if the vehicle were to be controlled with a 3-second delay." Even at 2 seconds it was impossible to control the vehicle. The course could not be maintained on the display for more than a fraction of the time. The operators would lose their vehicle orientation completely, so that occasionally they would find the course, but start the vehicle along the path in the wrong direction.

Errors had become too costly. It was possible to get off of the path and by the time the error was discovered and corrected an entire path loop might have been missed. The operators had little success in keeping the path in view at all, much less for 2 seconds ahead.

With 3 seconds delay and vehicle speed reduced to 1/7 full speed, the operator, after some practice and using the crab configuration, had no trouble in accumulating scores comparable to, or better than, those from the runs with full speed and no delay. He was on target for essentially the entire run. In the final run of approximately 20 minutes, he

D  
1  
3  
5  
1

he was off for only 17 seconds. The delay was extremely evident. However, the speed was so low that the vehicle could not go far enough in 3 seconds to accumulate a dangerous amount of error. Also it was extremely responsive, in that control system response was unchanged from the full speed value.

With vehicle speed reduced to 1/3 full speed and 3 seconds delay, operator performance was roughly comparable to that with full speed and 1/2 second delay. Errors, once made, took a long time to correct, but speeds were again low enough that the performance did not suffer seriously.

With the obstacle course, the results are similar to those with the continuous courses with the difference that an obstacle course with an average spacing of  $x$  feet per obstacle is easier to drive than a continuous path with a wave length of  $2x$  feet. This is evident since one requires a continuous degree of precision, while the other requires only that certain points are missed. The obstacle course was laid out with a distance of about 5 feet as the closest obstacle interspacing. The crab vehicle could therefore go between any two obstacles. No clear paths were available which could be traversed without moving the control.

At full speed and no delay, a degree of competence was soon reached which allowed easy navigation of the course. An operator reported:

"I experienced no difficulty in navigating the course with the no lag, full speed test situation. The problem was much easier than the continuous path due to its discrete nature. This allowed much more time for continuous pre-planning, which became increasingly important in the delay situations.

"I found that the best procedure was to aim at an obstacle and then avoid it. I would try to just skirt around the obstacle I had been aiming at. In this way I found I did not have as many unpleasant surprises waiting for me when I turned. This became very important as delays were added to the system."

With full speed and 1/2 second delay the course was slightly more difficult. After practice it could just barely be navigated with no collisions. This means that hits occurred on occasional runs and near misses on most runs. It was found at this delay that if the vehicle were placed at the edge of the course with no lens cap on the camera,

the operator could study the course and plan his complete path by the time the vehicle was started. It was therefore decided to keep the lens cap on the camera and remove it at a time equivalent to the experimental delay before vehicle motion was started. This made the task more difficult as planning had to be done on the move. However, it did not seem to alter the score at this delay.

D  
1  
3  
5  
1

At full speed and 1 second of delay the situation was more difficult than the 1/2 second of delay situation. The vehicle more frequently hit an obstacle during a run than not. Generally, a hit would occur whenever the operator had gotten into a situation which required a sharp turn to avoid an obstacle. The turn would sometimes bring an obstacle into view too late for avoidance. Since the obstacle interspacing was at least twice the vehicle travel in a second this did not always happen.

At full speed and 2 seconds delay the obvious took place. The vehicle travel during the delay was approximately equal to the obstacle spacing. Therefore, the situation was almost one of "If you see it, you've hit it." In the words of an operator, "I was unable to avoid collisions at this speed and I felt completely helpless. The observers said it looked as though I was going out of my way to hit obstacles. This was not my intent but I could not prevent it. Needless to say, my score in this situation was very bad."

With 1/3 vehicle speed and 2 seconds delay, the obstacle course could be negotiated with fair assurance of no hits. At 1/3 speed and 3 seconds of delay the performance was slightly worse, but still slightly better than at full speed with 1 second of delay. An obstacle would be hit on about half of the runs. The operator felt that driving with 3 seconds of delay at 1/3 speed was approximately equal in difficulty to driving at full speed with somewhere between 1/2 and 1 second time delay.

## CHAPTER IV

## DISCUSSION

Vehicle-Tracking Correlation

Since it was so simple to obtain data from the tracking experiments and so difficult to obtain data from the vehicle tests, the intent of the vehicle experimentation was to make the rather copious tracking data usable by calibrating it with a small amount of data from an actual vehicle.

Figures 9, 10 and 11 contain the time-on-target and error scores from the tracking experiments and the vehicle tests in a form which allows easy comparison. Figure 9 is a plot of time-on-target scores plotted against time delay, with target speed as a curve parameter. The average (of both subjects) velocity Type I and velocity Type II scores appear as the top and bottom boundaries, respectively, of the crosshatched zones. The acceleration scores (average) are shown as heavy solid lines. The scores for the vehicle in crab configuration are shown circled and those for the vehicle in automobile configuration are enclosed in squares. The full-speed vehicle scores are connected by a heavy broken line. The two circled scores at the 3 second lag represent  $1/7$  and  $1/3$  of top vehicle speed for the crab vehicle. The boxed score at 3 seconds of lag represents  $1/3$  of top speed and automobile steering. Top speed for all vehicle tests was 2.7 feet per second.

Figure 10 presents exactly the same information as Figure 9 plotted on a semi-log plot. Figure 11 shows the error scores for the tracking experiments. The vehicle tests do not appear on this sheet since no error scores were taken. Again the average Type I and Type II velocity control scores appear as the boundaries of the crosshatched zones. This time the Type II scores form the top boundaries and the Type I scores the bottom ones. The acceleration scores are shown by heavy solid lines.

The tracking curves as plotted in Figure 9 are very well behaved. Their character suggests that they be plotted semi-logarithmically. Figure 10 is the result. The curves are quite linear in this form, except for an increasing curvature towards the low score end. However, as previously mentioned, low time-on-target scores are rather meaningless, since time-on-target can never become less than zero and the curves become asymptotic in nature no matter how uncontrolled the performance.

D  
1  
3  
5  
1

The tracking curves of Figure 9 can therefore be quite closely matched by a series of curves of the form  $\log_e P = mx + b$  where  $P$  is the time-on-target score and  $x$  is the time delay. Figure 12 gives  $m$  and  $b$  values for a series of curves of this sort which give  $P$  values in per cent and quite closely approximate the experimental curves. These curves appear on a semi-logarithmic plot as straight lines passing through the zero delay point on each curve and through the point where each curve intersects either the 2 second delay line or the 20% score line. The zero delay point was selected as a point of perfect matching because in all cases it is used as a reference. The 2 second delay line was chosen because of the resulting good fit with the experimental curves, which deviate slightly from linearity on the semi-log plot. The 20% boundary was used to avoid the sharply asymptotic nature of the experimental curves at extremely low scores.

The error curves of Figure 11 are seen to be quite linear as they are plotted. At low speeds a departure from linearity is apparent which appears to increase with increasing time delay. At higher speeds this curvature appears to disappear. At still higher speeds it reappears with reversed sign. This reversal is explained by the asymptotic nature of error curves at very high error values due to the fact that the target always remained upon the scope face during the tracking experiments. The asymptotic character is not as apparent as that of the time-on-target scores, as the ordinate includes error scores only up to 70, whereas an average error of 1/2 of the usable scope face would have resulted in an error of approximately 300. The region of obviously asymptotic behavior is therefore off of the graph. However, the effects of it could easily cause the observed curvature reversal. In spite of this curvature, the error curves can be matched quite well by a family of straight

lines of the form  $E = mx + b$  where  $E$  is the error and  $x$  is the time delay. A plot of  $m$  and  $b$  for this family of lines is found in Figure 13.

Before vehicle and tracking results can be further discussed, it is necessary to arrive at a relation between vehicle input and tracking input. This task is somewhat complicated by the use of a ground vehicle as a control situation. Terrains are usually mathematical only in a random sense. However, in order to negotiate a terrain it is usually necessary to make a series of turns. We will define a turn as being the period of vehicle progress during which its rate of change of direction goes from zero to some value and back again. With an automobile a turn would therefore be the period between the time the wheel was moved from its straight-ahead position until the time it was returned. With a crab vehicle the turn would last from the time knob-motion in one direction was initiated until it either stopped or changed to the other direction.

D  
1  
3  
5  
1

The continuous course used for experimentation with the crab configuration was considered to contain 28 major turns. The closed course used for the automobile vehicle contained what was considered to be 12 major turns. This is nowhere as near evident from the figure as the 28 turns of the longer course. However, it was necessary to make the closed course more gentle than the long course so that the vehicle could negotiate the turns in its automobile configuration. This resulted in a course shape as shown solid in Figure 14.

With the increased gentleness of the course the complexity was not high enough to sufficiently challenge the operator at the top speed condition with no delay. Therefore the "wiggles" shown dotted were added

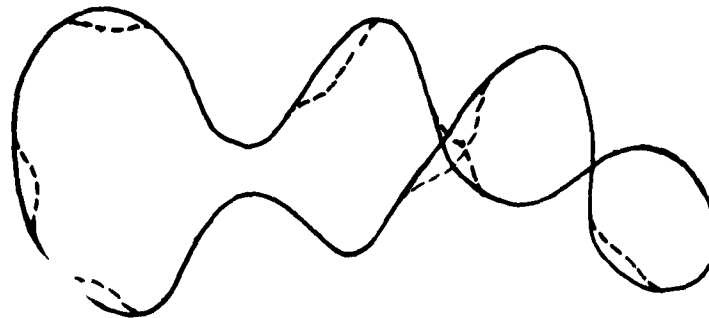

Figure 14 -- Course for Two-Wheel Steering

to the course. These were seven in number. However, they were considered equivalent to only approximately  $1/2$  a major turn. The result of adding these up is  $11-1/2$ , or to the precision being used in these experiments, 12 turns.

The tracking course was the sum of 4 sinusoids. Since a major turn was required at least for every half cycle of the fastest sinusoid, and since the fastest sine wave was 16 cycles per minute at top speed, the "turn rate" corresponding to top tracking speed was 32 turns per minute. Slower speeds corresponded to proportionately slower turn rates.

D  
1  
3  
5  
1

At top speed the vehicle negotiated the crab path in 2 minutes and 50 seconds. This corresponded to 28 turns in 170 seconds, or 9.9 turns per minute. This turn rate is therefore approximately  $1/3$  (0.31) that of the top tracking problem rate. Slower vehicle speeds correspond to proportionately lower turn rates.

The closed course required 2 minutes and 25 seconds for one circuit with the vehicle at top speed in automobile configuration. This corresponds to a turn rate of 12 turns in 145 seconds, or 5.0 turns per minute. This turn rate is approximately  $1/6$  that of the top tracking problem rate. Again, slower vehicle speeds correspond to proportionately lower turn rates.

Using this "turn rate" as the basis of comparison, it can be seen that the vehicle with four-wheel steering was tested at speeds corresponding to  $1/3$ ,  $1/21$  and  $1/9$  of full tracking speed. In the two-wheel steering configuration, it was tested at speeds corresponding to  $1/6$  and  $1/18$  of full tracking speed.

Figure 15 contains the curves of the form  $\log_e P = mx + b$  for tracking speeds of  $1/16$ ,  $1/8$ ,  $1/4$ ,  $1/2$  and full and time delays from 0 to 3 seconds. The Type I and Type II velocity control curves are shown as light solid lines and the acceleration control curves are shown as light broken lines. These curves correspond to the curves of Figure 13. In addition the plot contains velocity and acceleration control curves for tracking speeds of  $1/3$ ,  $1/6$ ,  $1/9$  and  $1/18$  as obtained from the above formula. The velocity control curves for

these speeds are connected by crosshatching, with the Type II curves at the lower boundaries. The acceleration curves are shown as heavy solid lines. The vehicle test data is the remaining information on the graph. It is identical to that in Figure 10.

In the design of the tracking experiment, velocity Type I performance and velocity Type II performance were intended to bracket crab vehicle performance. The extra integration (acceleration control) was to approximate a vehicle with automobile steering. Top speed crab performance appears as the heavy dotted line in Figure 15. It should correspond to 1/3 tracking speed by the above "turn rate" yardstick. With no time delay the vehicle score is some 10 per cent above the 1/3 tracking score with velocity control. This is due to the fact that the tracking experiment was designed to result in near perfect performance at full tracking speed and no delay, while the vehicle experiment was designed to result in near perfect performance at full vehicle speed and no delay. This no-delay difference could have easily been eliminated by use of a smaller target on the vehicle or a more complex vehicle path.

D  
1  
3  
5  
1

Of greater interest is the shape of the vehicle curve, which drops downward much more sharply than the tracking curves. For time delays in excess of 3/4 second, the vehicle scores are between the velocity Type I and velocity Type II 1/3 speed tracking scores, as originally hoped for. At a delay of 2 seconds, the vehicle score is located quite centrally between the Type I and Type II curves.

For 3 seconds delay tests the vehicle speed was reduced. A run at 1/7 of full vehicle speed with four-wheel steering resulted in the data point at 98% on the 3 second delay line. This point is a few per cent above the range plotted for 1/18 tracking speed with velocity control. The 1/7 vehicle speed actually corresponds to a 1/21 tracking speed, which would result in slightly better scores than the 1/18 tracking speed. However, improvements become asymptotically small as 100% is reached so that the vehicle score would presumably still remain slightly superior to the tracking score. Runs at 3 seconds lag and 1/3 vehicle speed resulted in a data point at 85%, which is 12% higher than the score obtained from the corresponding 1/9 tracking speed velocity control runs.

The same standard of comparison can be applied to the two-wheel steering vehicle. Full speed here corresponds to 1/6 tracking speed and 1/3 vehicle speed to 1/18 tracking speed. The automobile corresponds to the acceleration control. At no delay and full speed the vehicle scores are some 12% higher than the tracking scores. However, at 1 second delay the vehicle scores are equal to the tracking scores. No score was recorded for full vehicle speed and 2 seconds delay because the situation was so out of control that the vehicle could not be kept on the track. The score, if recordable, would have obviously been below the tracking score.

D  
1  
3  
5  
1

At the lower 1/3 vehicle speed and a 3 second delay, the vehicle score was 12% higher than that obtained from the tracking. Behavior from both crab and automobile configurations was therefore quite similar with respect to corresponding tracking performance. With no delay vehicle scores were roughly 10% higher than tracking scores due to target settings. At a delay of approximately 1 second, the vehicle scores were equal to the tracking scores with Type I scoring. At 2 seconds of delay, the vehicle scores were considerably lower. For the velocity tracking-crab vehicle case where Type II scoring was provided, the vehicle scores were approximately half way between Type I and Type II scores. At reduced vehicle speeds, the vehicle scores for 3 seconds of delay were once again superior to the tracking scores. In fact for 1/3 vehicle speed, the scores were once again roughly 10% higher than the tracking scores.

This lack of correlation is very easily explained by the limited field of view of the television camera. As discussed in Chapter III, this results in a frequent inability to see the target for the necessary time-delay-length ahead. This effect, of course, was much worse at longer delays and higher speeds. On runs where high performance was possible the target could be retained and little, if any, penalty was paid. On more difficult runs a severe driving difficulty was introduced. Lower scores, therefore, were affected more than higher scores. The result is the increased drop in the vehicle curve over the tracking curve. The "camera effect" did not exist in the tracking task as the target always remained in view.

This camera effect is very obvious in Figure 15. At small delays it was not noticeable so that the vehicle scores were approximately parallel to the tracking scores, and slightly higher as previously dis-

cussed. However, at a delay of 1 second where the "camera effect" was important vehicle scores were dropping off much more sharply than tracking scores with increased time lag. If the camera could have had 360° vision in some way, it is suspected that scores would have been slightly higher than the tracking scores for all delays and all speeds due to the initial bias.

Another check on vehicle-tracking correlation can be obtained from the rather cursory investigation of the tracking data performed in NASA Tech Note D-1211. For comparable performance in all the situations examined, 2-1/2 seconds of time delay required a speed reduction to a value between 1/4 and 1/8 of no-delay speed. The vehicle tests bear this out quite well. With four-wheel steering and 3 seconds of delay, 1/3 speed resulted in a score 17% lower than no delay and full speed. One-seventh speed and 3 seconds of delay resulted in a score 2% higher. The reduced speed for a score comparable to full speed-no delay operation is, therefore, clearly between 1/3 and 1/7 and probably about 1/6 speed. With two-wheel steering, 1/3 speed, and 3 seconds of delay, the score obtained is some 25% worse than that with no delay and full speed. Although no slower speed was attempted, it is assumed that a speed on the order of 1/8 speed would have resulted in a comparable score.

Since the variable limiting effects of the television lens explain the lack of correlation between the tracking scores and the vehicle scores, it is concluded that the data resulting from the tracking experiments is valid for remote control of a ground vehicle using television as a sensor providing:

1. The vehicle dynamics are equivalent to tracking dynamics, i. e. extremely fast steering response and one-to-one control knob-steering wheel position relationship.
2. No significant losses exist between control input and vehicle response, i. e. no ground slippage or terrain inputs to vehicle.
3. Vehicle is attempting to follow a course similar in nature to the tracking problem.
4. No aiding devices are used.

The Type I data simulates a situation in which the display gives at all times an indication of the vehicle-terrain relationship and an unimpeded view of the course ahead. The Type II data simulates a situation in which the display gives at all times an indication of the vehicle-terrain relationship but no view of the course ahead.

The above provisions outline an extremely ideal vehicle. For this ideal vehicle the Type I and Type II tracking data with velocity control bracket the crab performance. The data with the acceleration control approximates the automobile performance. Since the above idealizations are very difficult to achieve with a physical vehicle, the Type I tracking data in all cases represents an upper limit on vehicle performance for a similar continuous course. For an obstacle course less precision is required and the task is simpler (see chapter III).

A transport lag of the magnitude studied in these experiments is an extremely predominant factor in a control system. It tends to overpower to some degree minor changes in the dynamics of the other components of the system. The data from these experiments can therefore be used to gain an appreciation of time delay effects on tasks other than remote surface vehicle control. Performance attained in these experiments is, of course, higher than that attainable in control tasks with less ideal system dynamics. Exponential lags, additional integrations, seriously impaired television due to slow scans or low resolution, and other such factors impair man's ability to accomplish control tasks with time delays in the loop. How much cannot be known without a vastly increased experimental program (see chapter V).

D  
1  
3  
5  
1

CHAPTER V  
LUNAR VEHICLE CONSIDERATIONS

General

The design of a control system for a lunar vehicle which will be controlled from earth is quite a challenge at this time. Vehicles going to the moon in the near future will be intended solely for the support of scientific equipment. Because of the cost of getting the vehicles to the moon, the desire to minimize complexity in order to attain maximum reliability in a hostile environment, and the desire to maximize scientific weight, the optimum control system will require minimum hardware on the lunar end of the system. This means that the design will be oriented towards a minimum system as well as towards maximum performance. The first lunar vehicles will necessarily be far too spartan in nature to allow the use of inertial navigation systems and complicated guidance systems which would allow the vehicle to make its way automatically around obstacles.

Another difficulty in the design of the lunar vehicle control system is the unknown nature of the lunar terrain. The earth's atmosphere limits optical resolution to about 1/2 mile on the moon's surface, so that details of interest in controlling a ground vehicle have never been seen. Many theories exist about the nature of the lunar surface, but they are primarily concerned with the size of particles and the mechanical properties of the surface and differ widely upon many points. The Jet Propulsion Laboratory has established a lunar model based upon a composite of the best existing theories.<sup>11</sup> This is the model being used for preliminary designs for NASA's Project Prospector. However, it states only that protuberances greater than 10 cm., crevices, and rills may be avoided by maneuver.

We have no guarantee that the lunar vehicle will not be forced to pick its way through a "field of rocks" which are too large to surmount. Design must therefore be in the direction of a small, highly maneuverable vehicle. Since it is not the purpose of this

paper, the various merits of walking, running, rolling, hopping, and tracked machines will not be discussed. It will be assumed that the vehicle will be wheeled, although future comments will also apply to vehicles with tracks or feet, should such systems be developed with sufficient simplicity and efficiency to compete with wheels for this application. It is further assumed that guidance will be through use of television, since a television will be on board in any case for scientific reasons.

D  
1  
3  
5  
1

The experimental data from the project is applicable in many ways to the design of such a vehicle. It first of all can be used as an indication of the upper limit of performance. It can also be used to evaluate various "trade-offs" which must be made between performance and scientific cargo. It allows the prediction of performance with a time delay in the loop on the basis of known performance with no time delay. Finally, it can be used rather qualitatively to indicate design rules. Several general comments can be made from the results of the experimental program.

### Problems

The problems associated with control which were encountered in the experimentation fell into two categories. The first included the problems involved with determining the vehicle-terrain relationship at the time the control signal would affect it. The second included the problems involved with determining what control signal to send. The first, of course, had to be solved before the second could be attacked. The solution of the second required the solving of the first, and the solving of the problems associated with accurately determining the future course of the vehicle.

The solution of the first category of problems requires that the operator, either alone or with help, go through the process of using his last  $2\theta$  (where  $\theta$  represents the transmission delay) seconds of control input to update the time  $t - \theta$  vehicle-terrain relationship to time  $t + \theta$ . The  $t + \theta$  relationship is the desired one for control because any signal sent at time  $t$  will not arrive at the vehicle site until  $t + \theta$ . This "updating" process requires, first of all, a clear

indication of the  $t - \theta$  situation. It then requires that some computing be done. Finally, it requires that the results of the computation be added onto the  $t - \theta$  situation.

The solution of the second category of problems requires that the operator must be familiar with the vehicle response to various control inputs. Since his feedback is essentially delayed, he will be forced to drive without a continuous check on vehicle reaction to his control inputs. If he is going to be successful, he must be able to make his inputs solely on the knowledge of the desired vehicle response.

In order to accurately determine the future vehicle course, the operator must be able to see the future course on his display. He must be able to see the terrain at the point where the vehicle will be at time  $t + \theta$  and for far enough beyond so that he can reasonably be expected to drive. During the experimental runs, the inability to always see sufficiently far ahead was a serious problem (see chapter IV).

In addition to being able to predict his vehicle response and see ahead, the operator must be able to measure distances accurately. This is a problem because of the lack of normal distance cues. Man has three different methods of judging distances. The first is the binocular effect due to two eyes; the second is the monocular technique of size comparison; the third is the trigonometric method of noting where objects or their projections intercept the ground surface. In the experimental situation the only method available was the third one, since stereo television was not available and no objects of known size could be seen on the display. This third method depends upon a knowledge of ground shape and a feel for camera height. The experimental terrain was flat, and therefore was not a problem. Camera height, however, was only 32 inches. As a result, distances could be qualitatively seen, but not judged accurately enough to allow full use of the operator's knowledge of his vehicle response. Once accustomed to the vehicle forward speed, the operators could lead sufficiently so that the vehicle would begin the turn at the proper point on the path. After some practice they could also judge the rate of turn fairly well. However, they could not tell an  $80^\circ$  left turn from

a 100° left turn. Thus, they would turn too much or too little, and since it was 20 seconds before they realized it and before they could correct, the effects could be quite serious.

If stereo television is available on the lunar vehicle, some binocular effect will be present which will improve the situation. However, the terrain character will not be as well known, so distance perception to the desired accuracy will still be a problem, especially since no atmospheric light diffusion will be present and the horizon will be much closer.

Still another problem which exists, although it is slightly outside the scope of either of the two categories, is that of retaining a sense of vehicle direction. An operator who is working on negotiating a complex obstacle course with a time delay in his control loop is so saturated mentally that he usually forgets in what direction he is heading. Without the availability of many obvious landmarks he is hard-pressed to maintain a given net direction of travel.

### Solutions

The first remotely controlled lunar exploration vehicles should be "driven" directly by the operator. They should be devoted mainly to scientific and propulsion equipment and should not be burdened with automatic control devices, multiple television cameras, and other refinements. Once channel of continuous (at least 8 frames per second) television should be provided for the alternate purposes of control and scientific observation. By concentrating on the previously mentioned problems, this system can be made sufficiently controllable for the purpose of the mission. Continuous speeds may be used which should add to the efficiency of the vehicle. Should the vehicle be forced to navigate terrain which would require it to maneuver to the limit of its capability, speeds on the order of 1/8 mile an hour might be necessary. In no cases, should speeds of over 10 miles an hour be considered. The vehicle speeds should remain fixed at one of two or three values so as to not add extra confusion to the already confused mind of the operator.

D  
1  
3  
5  
1

Since humans are known to be weaker than machines in certain respects, it is always tempting to seek improved performance in a man-machine system by aiding the human in these areas. An earth-based aiding scheme will be discussed later in this chapter. However, as with many human-aiding devices, this scheme will be a big help in some situations and a hindrance in others. The operator should have the discretion of using such aiding devices only if he chooses, as for example the aircraft automatic pilot, which would never be used in an emergency or combat situation. The value of aiding schemes can only be determined by an experimental program. However, since situations could conceivably arise where they would be valueless, lunar vehicle control system design should proceed on the assumption of an unaided human operator. The aiding devices should be considered as frosting on the cake.

Considering the problems in order, the first is that of clearly defining the vehicle-terrain relationship at time  $t - \theta$ . This is the relationship which appears on the operator display. Driving requires knowledge of position, direction, and rates of change of both of these. These can be provided most effectively by assuring that the camera-vehicle relationship is exceedingly simple. If possible, the display should include some reference point on the vehicle in direct contact with, or very close to, the terrain. Alternatively, the vehicle-camera relationship should be so simple that the operator can know exactly his vehicle position, direction, and rates merely by looking through the eye of the camera. The experimental vehicle case is an example of this latter type of operator orientation. The operator was able to see neither the scoring target nor the wheels of the vehicle on his display. In a sense, he could not see his pointer. However, the pointer-camera relationship was so simple that he could soon learn where his pointer was in relation to his display presentation. Direction was no problem since the camera direction corresponded to the direction of the vehicle velocity vector.

The automobile configuration with the fixed camera was also simple because the camera represented the vehicle position and direction. The automobile camera following the front wheels was a good deal more difficult, but still simple enough to be learned. However, any further attempt to loosen the camera from the vehicle could be seriously detrimental to performance. An operator controlled scan, for instance, would in all probability be sufficiently confusing to cause the operator to lose control of the vehicle completely if employed

in a difficult situation with the time delay also existing in the scan control loop. A separately controlled scan should probably be available for exploration and observation purposes, but it should not be used for control. The vehicle should either be stopped or driven blind while it is being used.

D  
1  
3  
5  
1

A simple vehicle-camera relationship minimizes the problem of establishing the  $t - \theta$  vehicle-terrain situation. Similarly, a simple control-vehicle relationship minimizes the problem of updating this  $t - \theta$  situation. It is necessary to keep the control dynamics of the task simple enough so that the operator can perform his mental computations satisfactorily. The control-input vehicle response must be straightforward. An example of a good system is again the instantly-responding crab vehicle used in the experimentation. In order to update his display, it was only necessary for the operator to do a minimum amount of thinking. If he had turned his control knob  $x$  degrees to the left in the last  $2\theta$  seconds, he knew that the vehicle would be heading  $x$  degrees to the left of the direction indicated by the display at the time a control signal would reach the moon. By remembering the rate at which he had put the turn into the knob and knowing the vehicle speed, the operator could do a fair job of predicting the vehicle position at the time  $t + \theta$ .

However, in the case of the two-wheel steering vehicle, the operator's task was not so easy. The  $x$  degree turn now corresponded to a change in front wheel direction. The change in vehicle direction depended upon the forward velocity and the rate at which the  $x$  degrees had been put into the knob, as well as upon the value of  $x$ . The position change of the vehicle was obviously a more complex function.

As an example of an even more difficult situation, imagine that the vehicle wheels no longer responded instantaneously to the control signal. A simple exponential lag in steering would require the operator to compute the vehicle steering response to his control input and then run through the previous mental work with this vehicle steering response. As a final example of increasing difficulty, consider the simple form of steering utilizing a steering motor and an open loop forward-reverse command to the motor. The motor, when commanded, either turns the vehicle wheels to the right, to the left, or not at all.

A control input now causes a rate of front wheel steering, or if inertias are present, the exponential initiation of a rate of front-wheel steering. The direction and position change will then have to be computed using this rate of front-wheel steering rather than the position of front-wheel steering. Computations such as these, involving speeds, wheelbases, dynamic responses, and several integrations are obviously far too difficult for the human operator to carry out while he is simultaneously driving the vehicle.

The influence of complex system dynamics is much more serious with a time delay than without one. The above left-right steering system has been used very successfully in rather complex vehicles. However, it was used in real time. It was found in the experimentation that if no time delay existed, the operators were comparatively unaffected by sick control dynamics. At one point in the vehicle testing, a malfunction caused the error signal to become asymmetrically amplified. The control system was, consequently, extremely responsive in one direction and extremely sluggish in the other. The operator noticed this behavior immediately, but with no time delay his scores were not affected. However, with time delays the operators were continually claiming that non-linearities existed in the system--even when they did not. When they did creep into the loop, even in small amounts, they would immediately affect the performance, since they could not be compensated for in the control movements until the time delay had elapsed.

Simple control dynamics allow the operator to minimize the mental processing of rates, which he is much less suited to process than quantities. A further simplification can be accomplished by limiting the number of control inputs he may make. It may be difficult to sum up the past 20 seconds of control movements with a continuous knob, but it would obviously be quite simple with an on-off switch. By providing a discrete control device, such as a detented knob or a keyboard by which the operator could select turn increments, his mental bookkeeping could be simplified.

Simple control responses also minimize the problems of familiarity with vehicle response mentioned in the second category. If vehicle actions are simple functions of control movements, the operator can easily use his desired response to compute the necessary input. Keeping

the future course on the display, however, is another problem. It is immediately obvious, upon attempting to drive a maneuverable vehicle with a time delay along a complex path, that a wide angle field of view is necessary. In general, the wider the field, the better. Even though the picture becomes distorted at the edges, the distorted information is better than no information at all. Once the field of view is established, precautions must be taken so that the operator's projected vehicle position at the time the control signal will reach the moon is never outside of the picture. If the lunar surface is very gentle and the angle of the lens is  $90^\circ$  or more, this will probably never happen. If the vehicle is not maneuverable enough to turn  $45^\circ$  in 20 seconds, no problem exists. If the vehicle is as maneuverable as the experimental crab, it may be necessary to include a circuit which will stop the vehicle should the operator ever put over  $45^\circ$  (or half of the lens angle) turn into the vehicle in 20 seconds. This would effectively prevent him from turning outside of his picture. This is a rather drastic method of solving the problem since it limits maneuverability. It may be preferable to allow the operator to drive blind for small periods rather than limit maneuverability.

D  
1  
3  
5  
1

It is possible to increase field of view beyond that obtainable with the widest practical lens angle by scanning. As previously mentioned, problems arise with scanning due to the "loosening" of the camera from the vehicle. Scanning has more disadvantages in the case of a minimum control system. Presumably, some sort of mechanism is necessary to actually do the scanning, whether the entire camera is scanned, the lens, a mirror, or a prism. In order to allow the operator some vehicle orientation the scanning would probably be done rapidly and repeatedly by an automatic device. This device would have to be extremely precise and therefore would not be too good a risk for the lunar landing and subsequent operations. Also, power is required to do the scanning and to transmit the increased band width back to earth.

A solution both to the angle of view problem and the "measurement" problem to be discussed next would be a plan view display, which would give an "aerial" view of the vehicle and the terrain. This would be mechanically more complicated, but the possible advantages are attractive enough to warrant further work. The difficulty in achieving

such a display lies in elevating the sensor to a large enough height to allow it to see the terrain at some distance ahead. A promising approach is to mount the camera on the vehicle and direct it upward at a mirror. By properly shaping the mirror, any view desired could be obtained. Distortion could be completely eliminated, or alternatively it could be utilized to provide a large scale view of the terrain of interest for control and a reduced scale view of the remaining terrain. No problems should exist with using a mirror for such an application, as no moisture exists to fog the surface, and dust lacks the necessary air for flotation and would not be likely to "splash" to the height necessary for the mirror. One disadvantage would be the decreased information as to obstacle height from such a display. Another would be the necessity of stabilizing the mirror in some manner. In any case, some suspension system will probably be necessary, either on the camera mount or on the vehicle, to stabilize the camera to some extent. It should have enough inertia so that the camera will ignore small imperfections in the surface, enough damping so that the camera will not oscillate, and enough spring force so that the camera will retain its relationship to the vehicle.

The problems of accurately measuring distances could, of course, be easily accomplished if a plan view were available. Distances are easily measured on aerial views. If such a plan view is not available, distance measurement can be simplified by increasing the camera height. Any height which can be gained is an advantage. If some picture resolution can be sacrificed, or if sufficient power is available to allow the transmission of a larger bandwidth, stereo television should be used. Methods of using the size-comparison method of distance measurement are possible, but the messiness of placing known references on an unknown and mechanically hostile terrain is definitely a disadvantage.

#### Operator Aiding Schemes

Two suggested operator aiding schemes will be outlined. These schemes are "free", in that they require only a negligible amount of extra equipment on the vehicle and no power from the vehicle. They are by no means the only possible schemes, but are considered typical, possible, and sufficient. It is doubtful whether any additional informa-

D  
1  
3  
5  
1

tion beyond that produced by these schemes could be assimilated by the operator during the mentally-saturating process of driving a vehicle with transmission delays. The first aiding scheme is intended to provide a "compass" for the driver. The second scheme is a "prediction" scheme, which is intended to aid the operator in the mental task of "updating" his displayed vehicle-terrain situation.

D  
1  
3  
5  
1

One solution to the direction problem is to use two operators, one to decide upon overall directions and long range plans and relay these decisions verbally to the other operator, who would be attempting only to keep the vehicle from hitting obstacles. However, even in this case, a direction indication would be extremely useful. Compasses are quite ineffectual on the moon since no magnetic field seems to exist. The most economical substitute yet encountered seems to be a sun dial. A sketch of such a system is shown in Figure 16. Presuming that the sun (or earth in the case of earth-light operation) would not be directly overhead, the shadow of the vertical rod would cast a shadow on the translucent plate. The bottom of the translucent plate, showing the shadow, would appear in one corner of the display screen. Knowing the date and the time of day, it would be quite easy to compute the sun's position with respect to the location of the lunar vehicle. Knowing this, the sun dial, as shown on the display, could be calibrated as to north or whatever coordinate axis is to be used. The driver could then use the sun dial like a compass. This additional information on the display would not adversely affect the driver because it would be in the corner of the picture and only referred to when necessary.

The second aiding scheme to be suggested is a "prediction" device. This device is to take over some of the computations of display updating, which are of a nature more easily done by machine than by man. The intended result is a prediction of the vehicle-terrain situation at the time a control signal will reach the moon. This aiding can be done on the basis of the control information for the past 20 seconds, the vehicle transfer function (both known), the nature of the terrain, and the amount of slip between the vehicle and the ground (both partly known, partly assumed). If these quantities can all be exactly determined, a very good mathematical model of the lunar vehicle can be made which will react identically

to the actual vehicle. Should the vehicle be operating through a gentle course on flat terrain the slippage will probably be small, control commands will be executed extremely well, no inputs to the system will exist other than those commanded by the operator (no deflections due to rough terrain), and a very good model can be made. In inhomogeneous, irregular terrain over complex courses, the model will be considerably less valid.

The predictor could consist of an electronic model which would duplicate, as closely as possible, the actual vehicle behavior for any control input. Because of the nature of electronic models, this model could be run through an entire range of control commands in very short time. Therefore, it would be orders of magnitude "faster" than the actual vehicle. The model would repeatedly be given the control signals sent to the lunar vehicle between time  $t - 2\theta$  and time  $t$ . In other words, the model would continually be carrying out the commands sent to the lunar vehicle, but not yet shown on the display. The performance of the model would then be superimposed on the  $t - \theta$  situation of the actual vehicle as shown on the display. If the model is good, the vehicle situation would be accurately updated to the time at which a control signal would reach the moon.

Because of the speed of the model, the prediction would be brought up to date continually and errors would not be additive. Any lack of confidence in the model could be shown by including a questionable zone with the prediction which would increase in width with longer predictions and resulting greater error. Superimposing this prediction on the display could be done as shown in Figure 17. A perspective coordinate system is necessary for the predicted position information. This coordinate system must be superimposed upon the lunar terrain so that the swath appears to be drawn directly upon the surface. If the lunar terrain is flat, this requires only a horizon alignment. If the terrain is not flat, either a correction will be necessary in the prediction perspective or an error will have to be tolerated. The terrain on the display and the swath will change continually as the vehicle progresses. The swath increases in width as it goes forward in order to compensate for model uncertainties. As a possible further refinement, the "bug" appears

D  
1  
3  
5  
1

at the end of the swath at the model position. Radiating from this bug are heading lines which indicate the effects of control inputs. The heading lines also appear in perspective.

This scheme, if available, could obviously offer a great deal of aid to the operator. At high speeds and gentle terrain with few obstacles, the predicted swath should be extremely accurate, and it should be necessary only to drive the bug and ensure that the swath did not contact any obstacles. The time delay problem would be essentially eliminated. The predictor would also allow the use of vehicles with more complex control dynamics, since the computer instead of the man could be burdened by the extra calculation. Unfortunately, rolling terrain would make it extremely difficult to align the prediction perspective with the lunar terrain. At low ground speeds, local irregularities would cause some discrepancy as to where the swath actually was on the ground. With many obstacles, the system might lack the necessary precision to serpentine around them with low speeds and small clearances. Therefore, in the situations where the system would be most useful, it might not be adequate. However, since it is "free" with respect to vehicle requirements, it would be well worth having it available for the use of the operator should he so desire.

D  
1  
3  
5  
1

#### Future Work

A great deal of investigation is needed before the problems encountered in remote control with long transmission delays are even understood, much less solved. The major goal in this program was to study the effects of the time delay itself upon remote control. Target speed was considered as an unavoidable variable. However, every effort was made to ignore all other variables. Many of these ignored variables are both important and unavoidable with actual roving vehicles and therefore are deserving of further study. Experimental programs should be undertaken to investigate the effects of these variables at various time delays. As an example, an actual vehicle is affected by inputs other than those made by the operator. Traction losses, vehicle slippages due to surface irregularities, deflections due to collisions with small objects, and other such disturbances

cause "noise" in the system. The causes may or may not be apparent to the operator. In any case, the noise must be isolated and identified for proper vehicle control. This is simple with no delay in the loop. However, in the few cases where such noise sneaked into the experimental situation, it was found to be an extremely severe problem. A program should be undertaken to define the effects of such noise and devise methods of alleviating the problem.

In a similar manner, the effects of various vehicle dynamics should be studied. Also the effects of slower television frame rates. Stereo television should be examined. Also some effort should be spent on the effects of various camera positions, lens angles, and possible scan techniques. An aiding device such as the predictor discussed earlier in this chapter should be designed, built, and tested. Considerable design problems would arise in developing a refined enough predictor to be useful. However, no unsurmountable obstacles intervene, and the result would be extremely interesting and informative.

Stanford University  
Stanford, Calif., January 24, 1961

D  
1  
3  
5  
1

D-1351



Figure No. 2 - Vehicle Test Courses

L-62-53

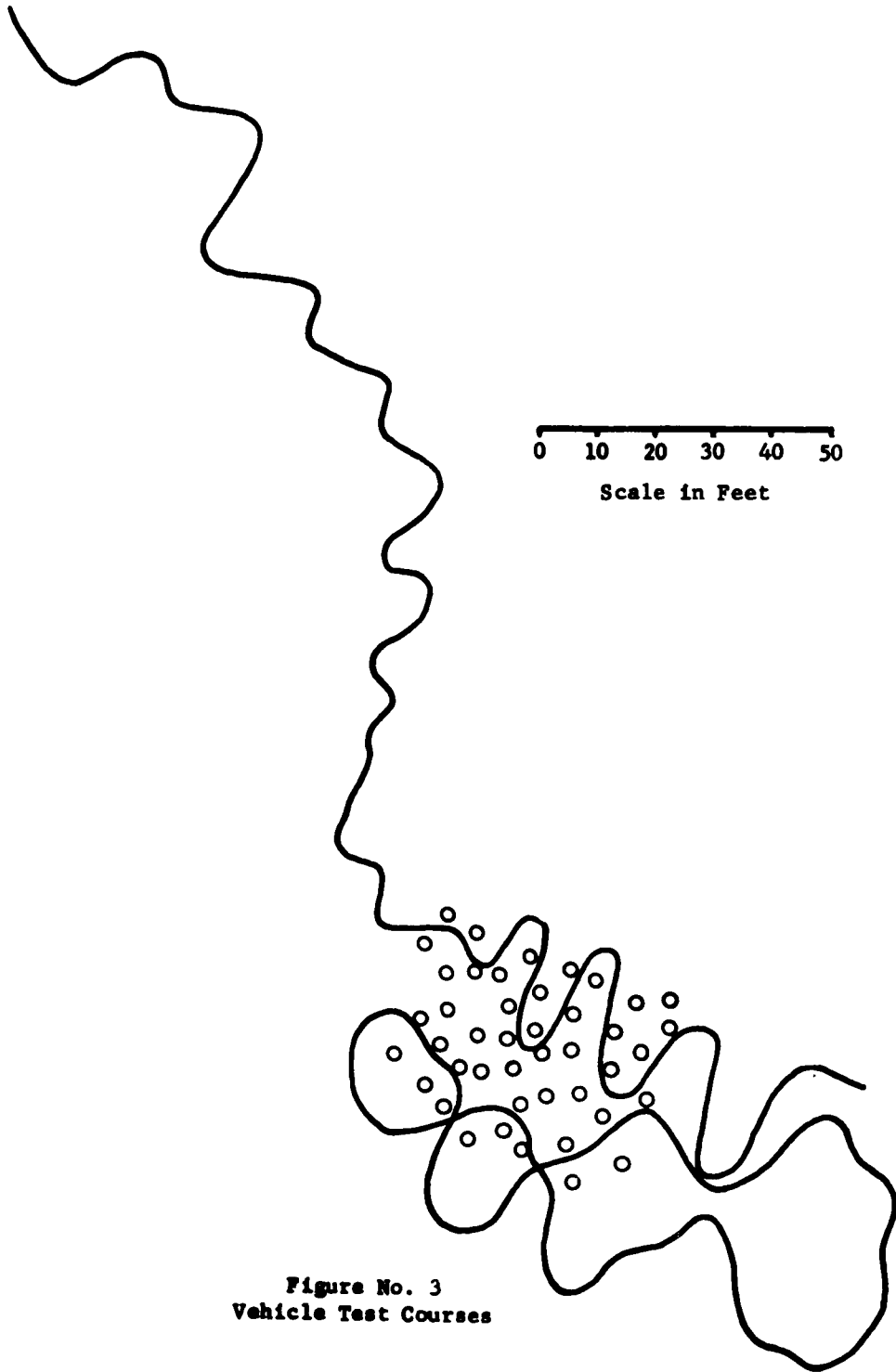

**Figure No. 3**  
**Vehicle Test Courses**

D-1351

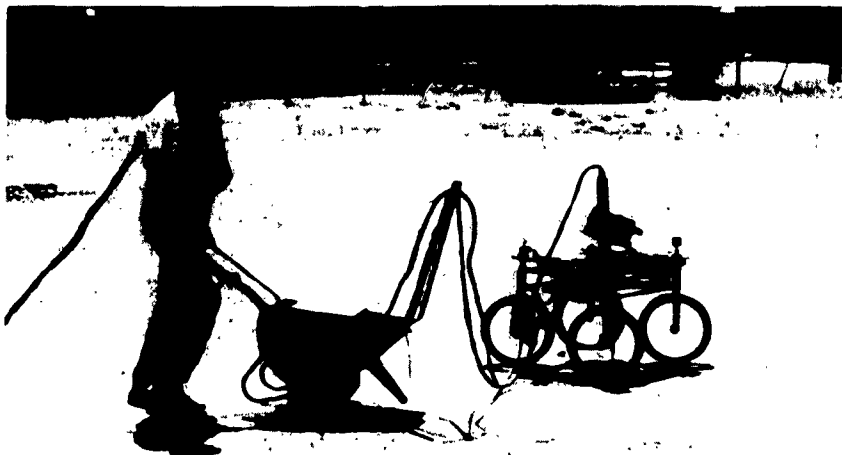

Figure No. 4 - Experimental Vehicle and Cart L-62-54

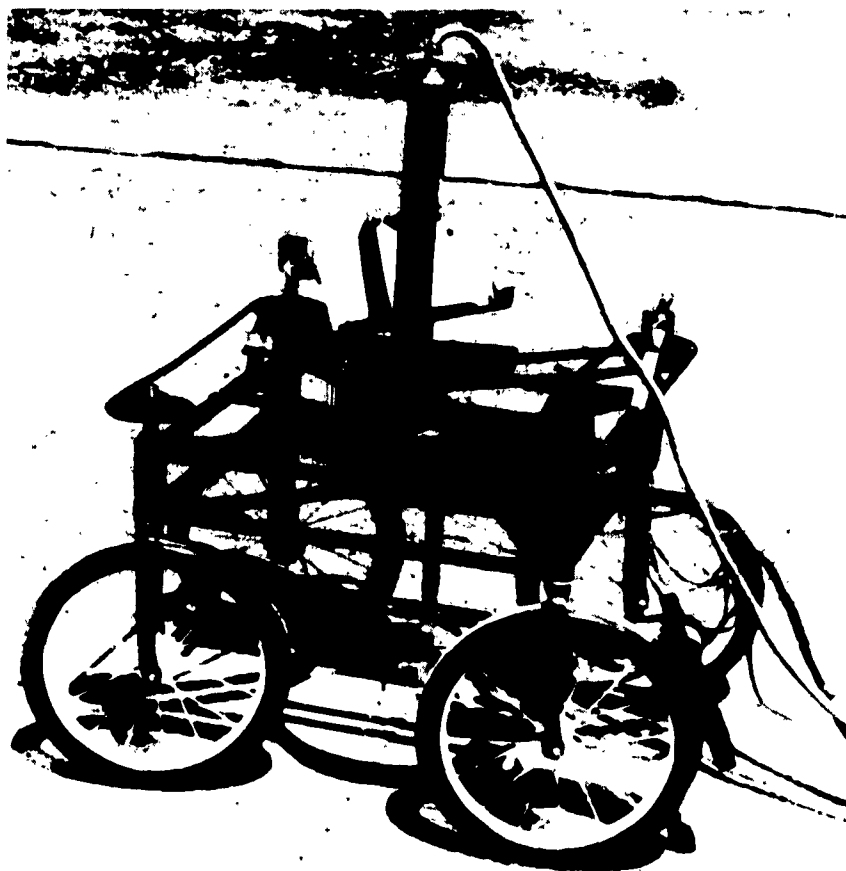
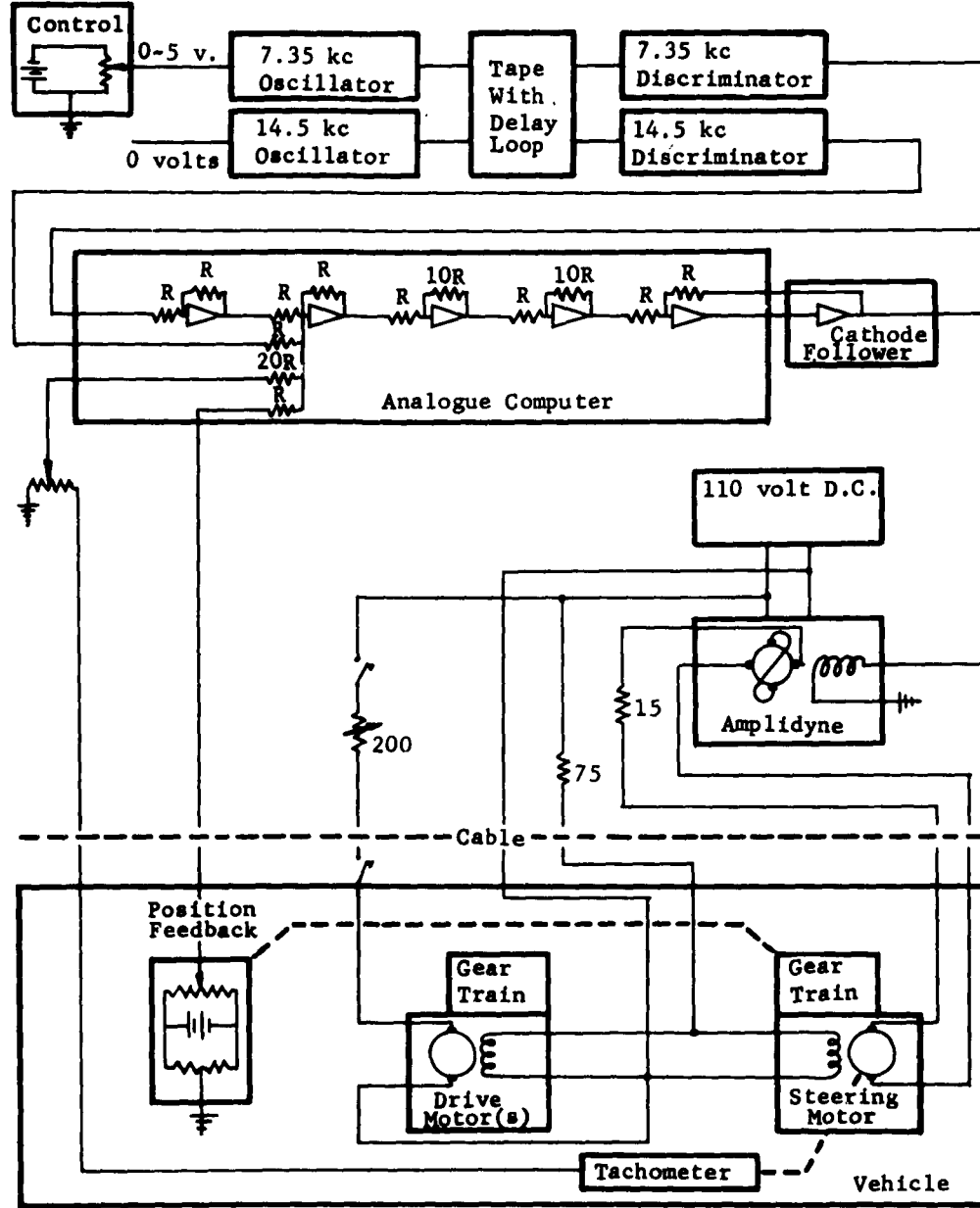

Figure No. 5 - Experimental Vehicle

L-62-55



D-1351

Figure No. 7  
Experimental Vehicle Wiring Diagram

D-1351

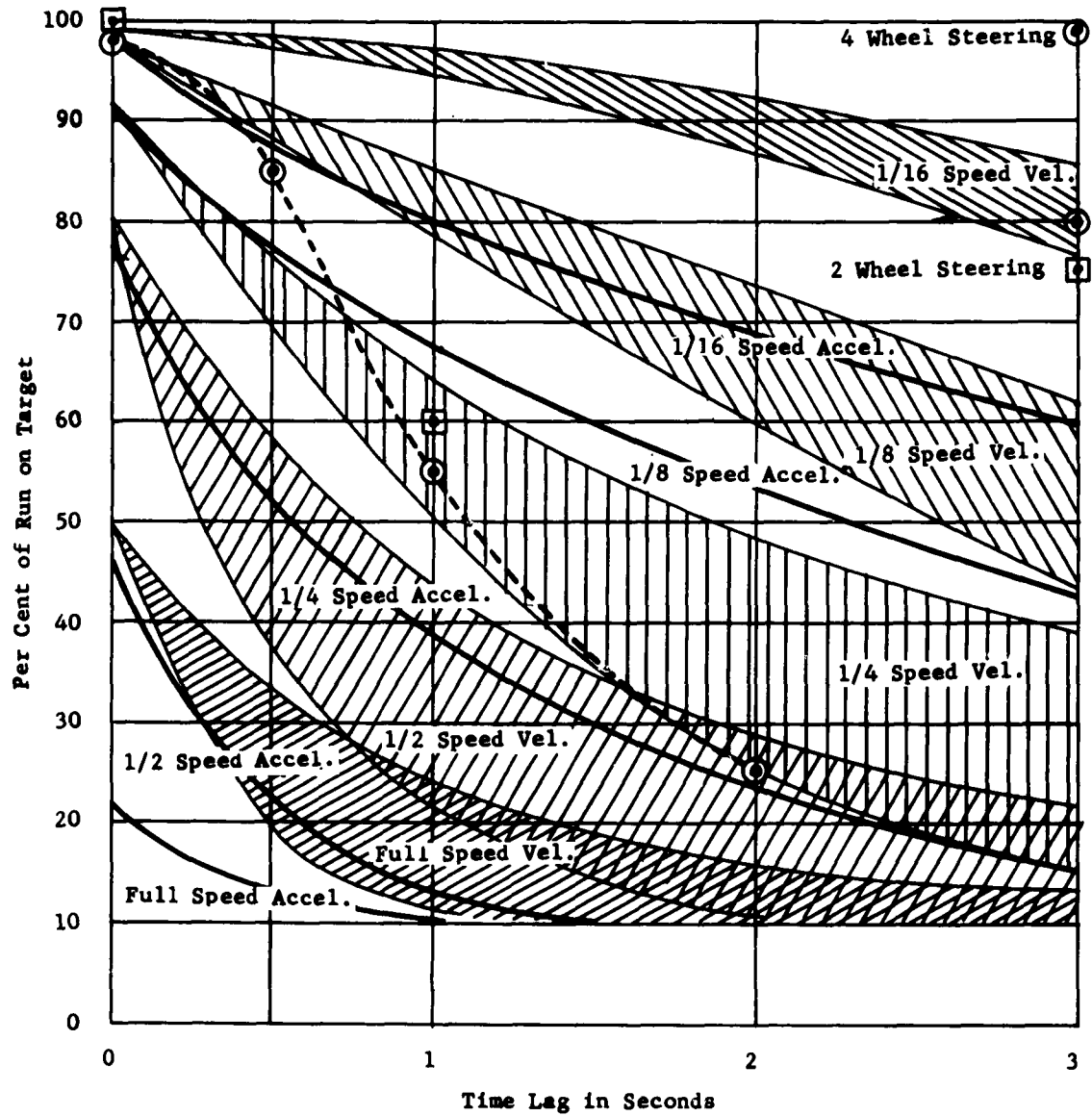
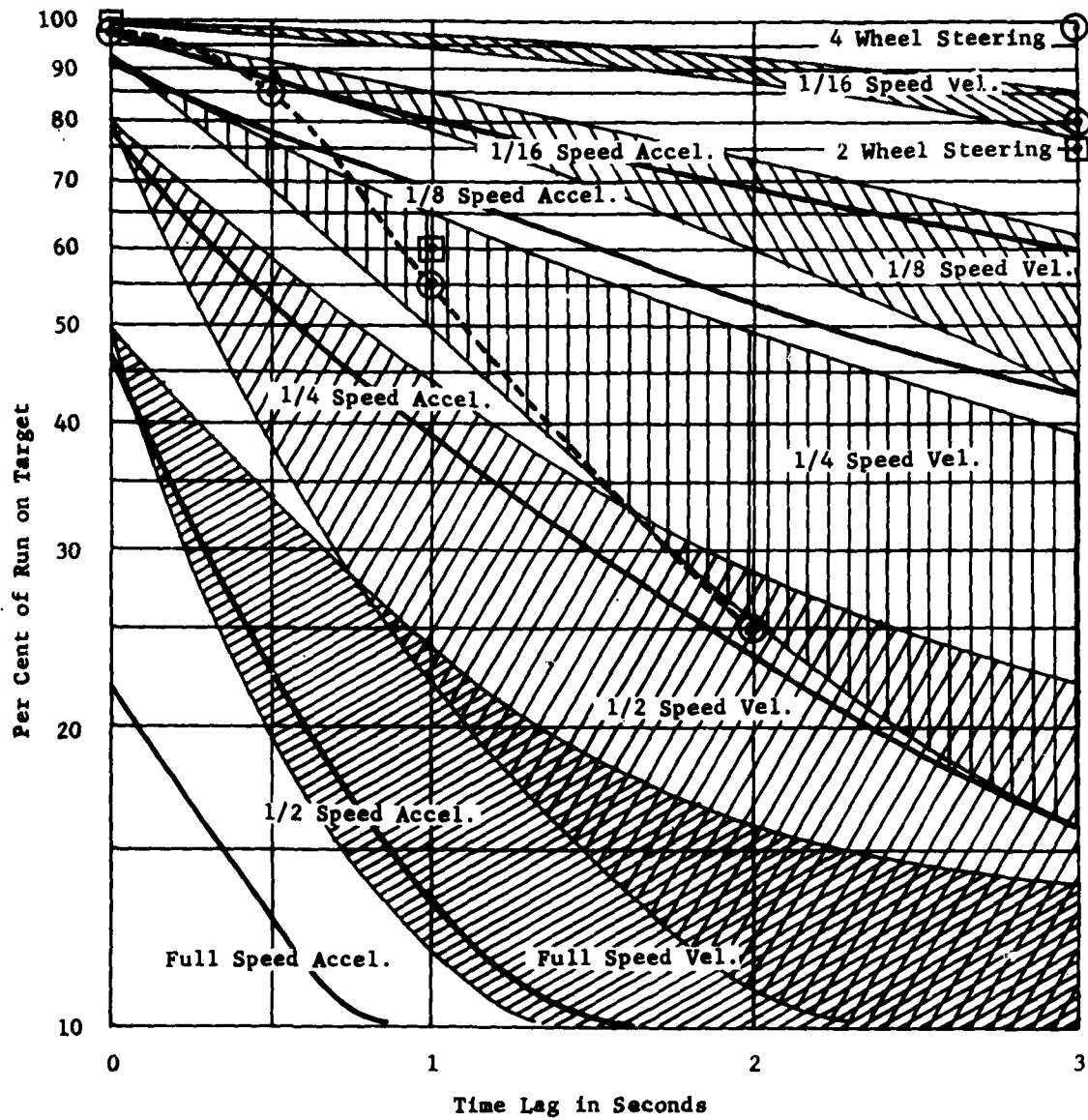

Figure No. 9  
Time on Target vs. Lag  
Linear Plot



D-1351

Figure No. 10  
Log Time on Target vs. Lag

D-1351

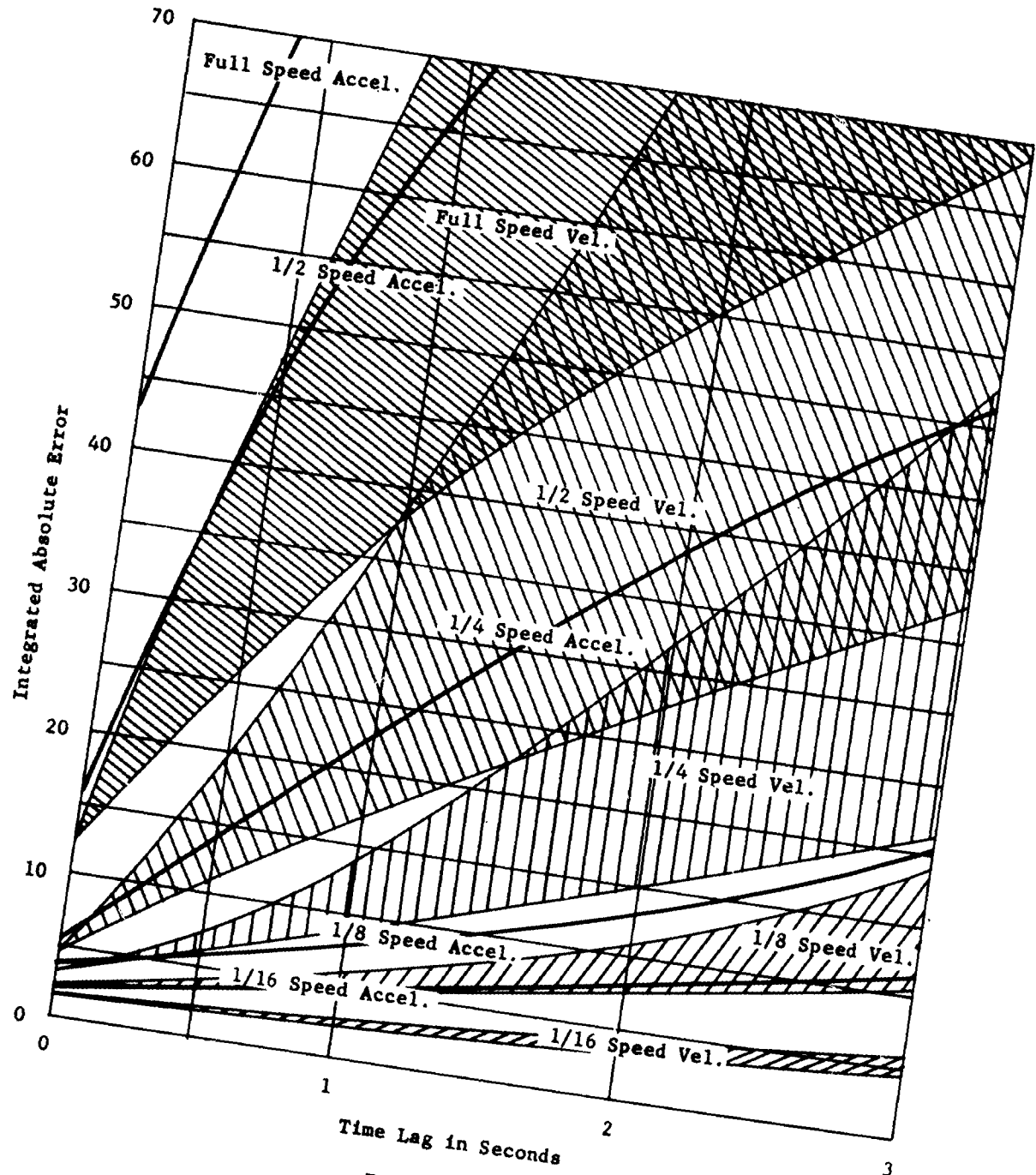

Time Lag in Seconds

Figure No. 11  
Error vs. Lag

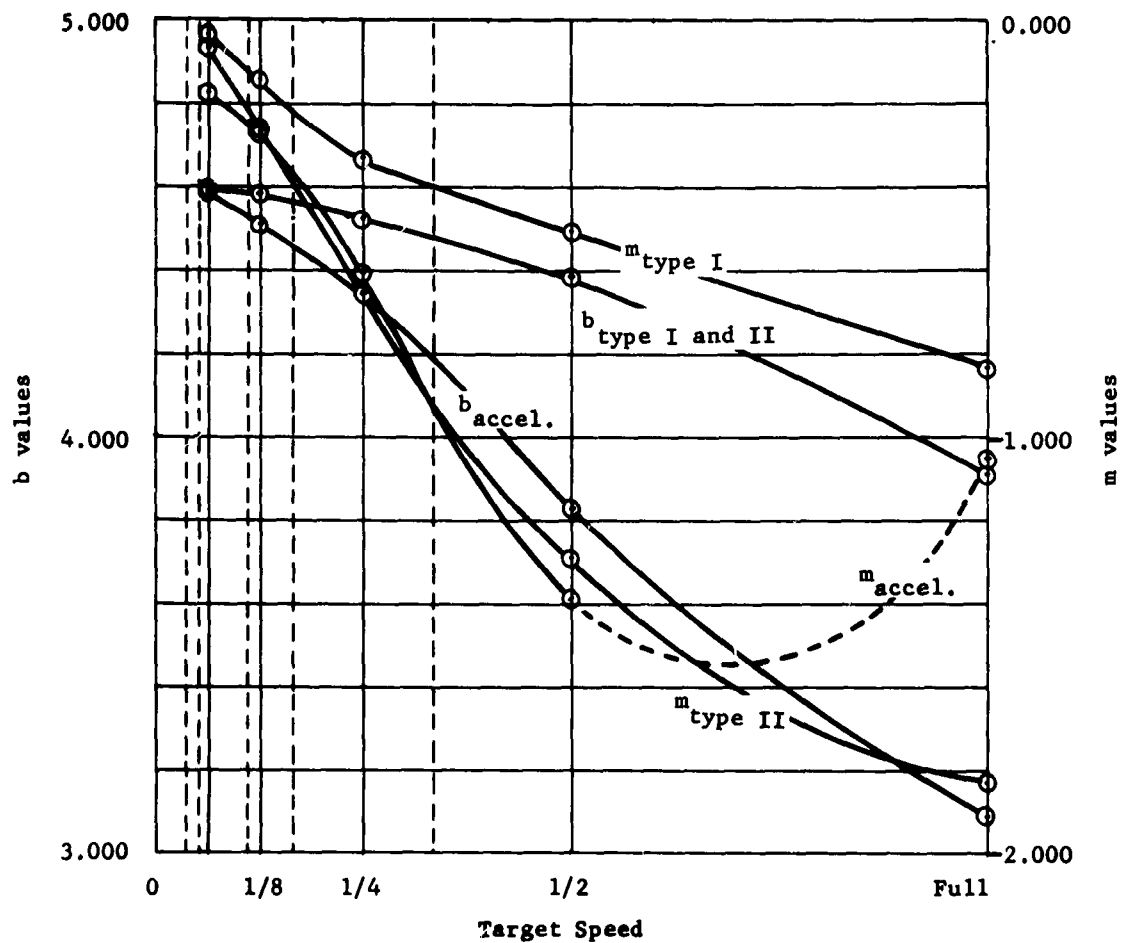

Figure No. 12  
 $m$  and  $b$  Values  
 For Curves of Form  
 $\text{Log}_e P = mx + b$

D-1351

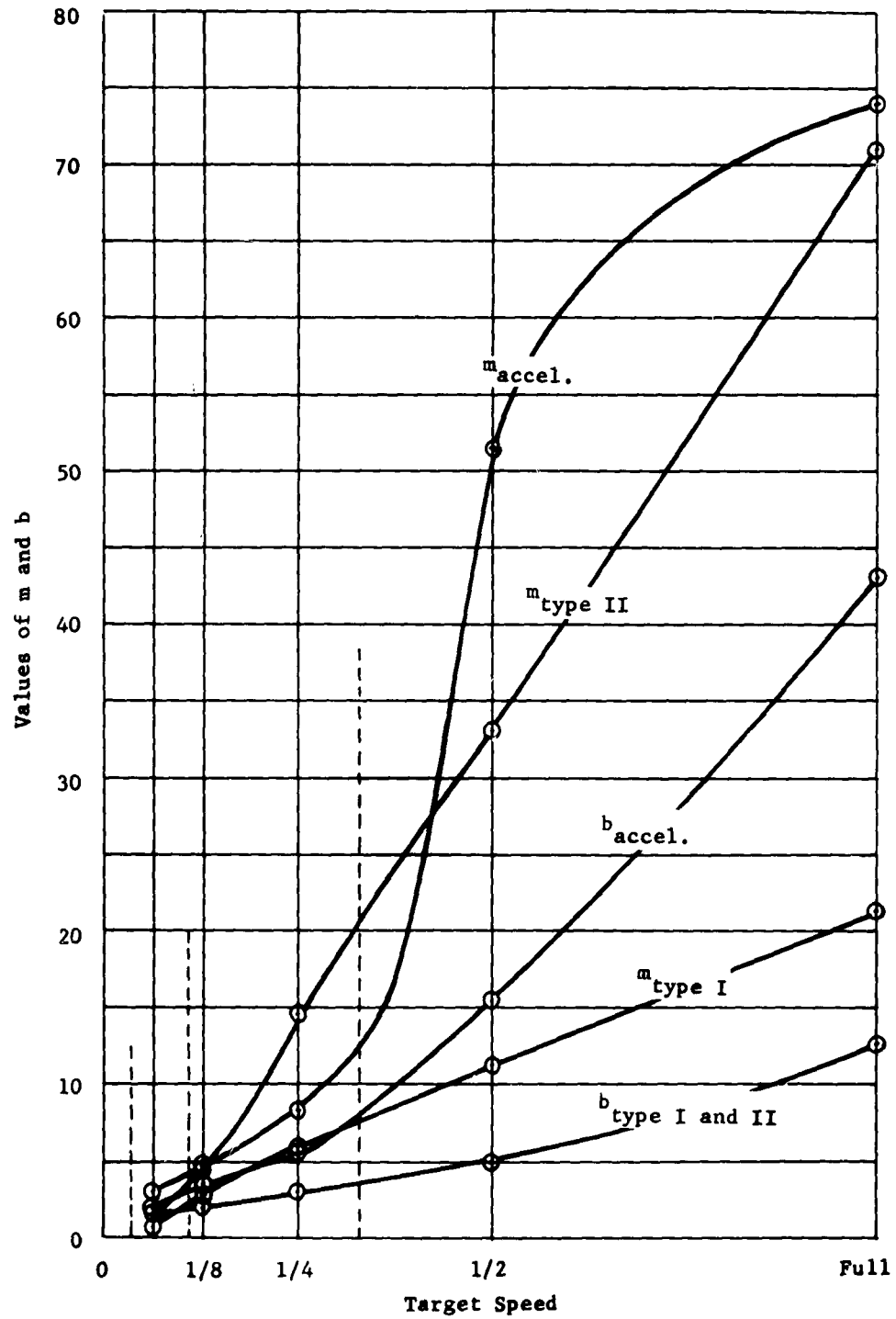
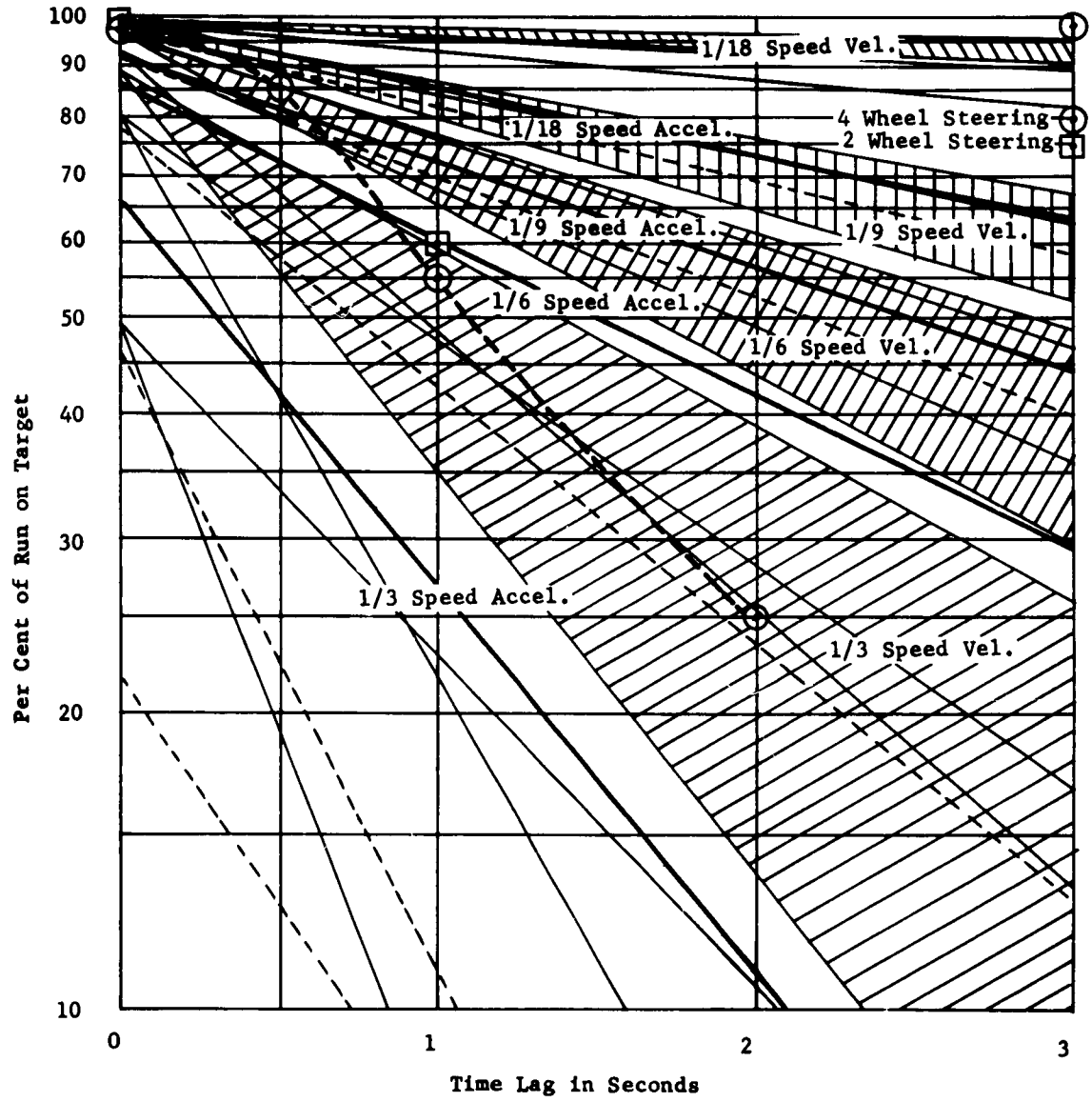

Figure No. 13  
 m and b values  
 For Curves of Form  
 $E = mx + b$



D-1351

Figure No. 15  
 Log Time on Target vs. Lag  
 Vehicle - Tracking Comparison

D-1351

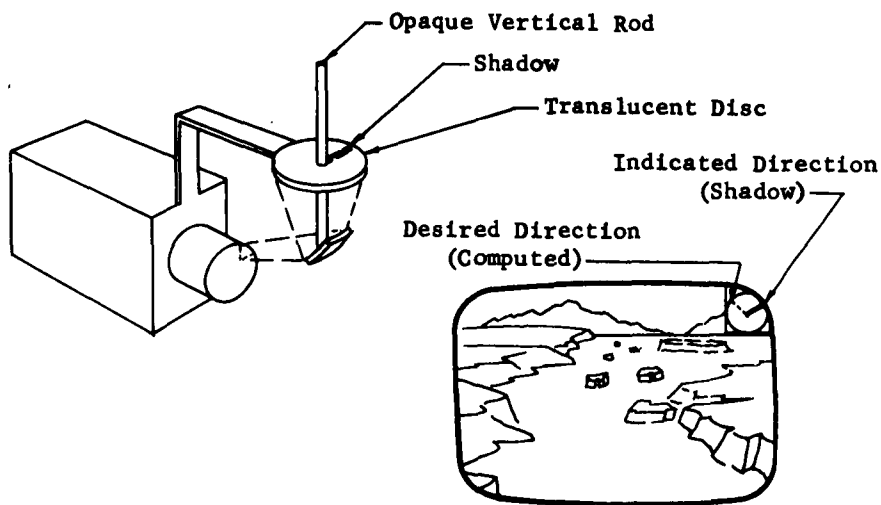

Figure No. 16 - Direction Indicator Aiding Device

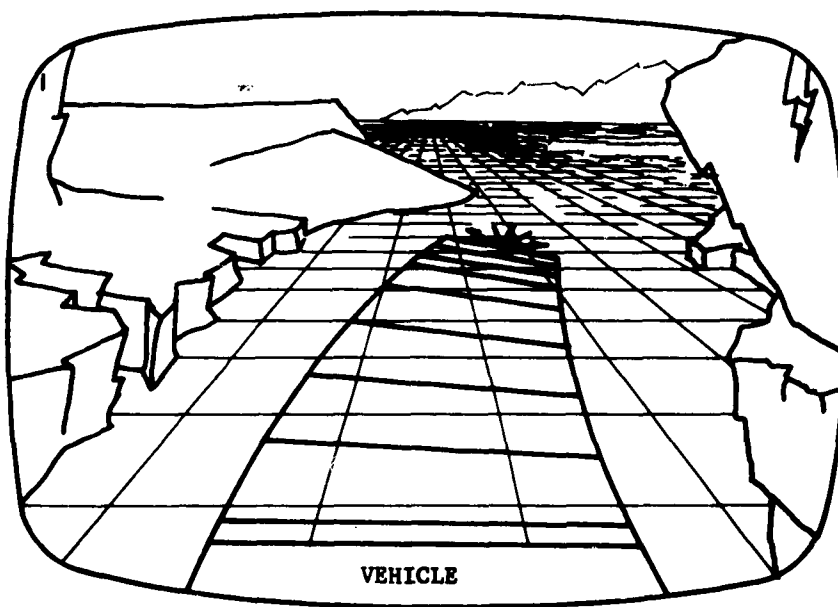

Figure No. 17 - Prediction Aiding Device

## REFERENCES

1. Moler, C. G. and Brown, G. L. "Closed Circuit Television Vehicle Driving: I. A Preliminary Investigation", U. S. Army Ordnance Human Engineering Laboratories Technical Memorandum 10-60, 1961.
2. Lockard, R. B. "Bibliography of Human Engineering Reports on Tracking", NAVORD Report No. 5257.
3. McFadden, N. M. "A Flight Study of Longitudinal Control System Dynamic Characteristics by the Use of a Variable Control System Airplane", Ames Research Laboratory Report CRM A57L10, 1958.
4. Warrick, Melvin J. "Effect of Transmission-Type Control Lags on Tracking Accuracy", USAF Technical Report No. 5916, 1949.
5. Bower, J. L. and Schultheiss, P. M. Introduction to the Design of Servomechanisms. Wiley and Sons, 1958.
6. Tustin, A. "The Nature of the Operator's Response in Manual Control Systems and Its Implication for Controller Design", Journal I.E.E. , vol. 94, part IIA, No. 2, 1947.
7. McRuer, D. T. and Krendel, E. S. "Dynamic Response of Human Operators", WADC Technical Report No. 56-524, 1957.
8. Hall, I. A. M. "Effect of Controlled Element on the Human Pilot", Princeton University Department of Aeronautical Engineering Report No. 389, 1958.
9. "Investigation of Control 'Feel' Effects on the Dynamics of a Piloted Aircraft System", Goodyear Aircraft Corporation Report GER 6726, 1955.

D  
1  
3  
5  
1

10. Sheridan, T. B. "Time-Variable Dynamics of Human Operator Systems", AFCRC Technical Note 60-169, 1960.
11. Buwalda, P. "The Lunar Environment", California Institute of Technology Jet Propulsion Laboratory Technical Release No. 34-159.

D  
1  
3  
5  
1

Appendix page A-1

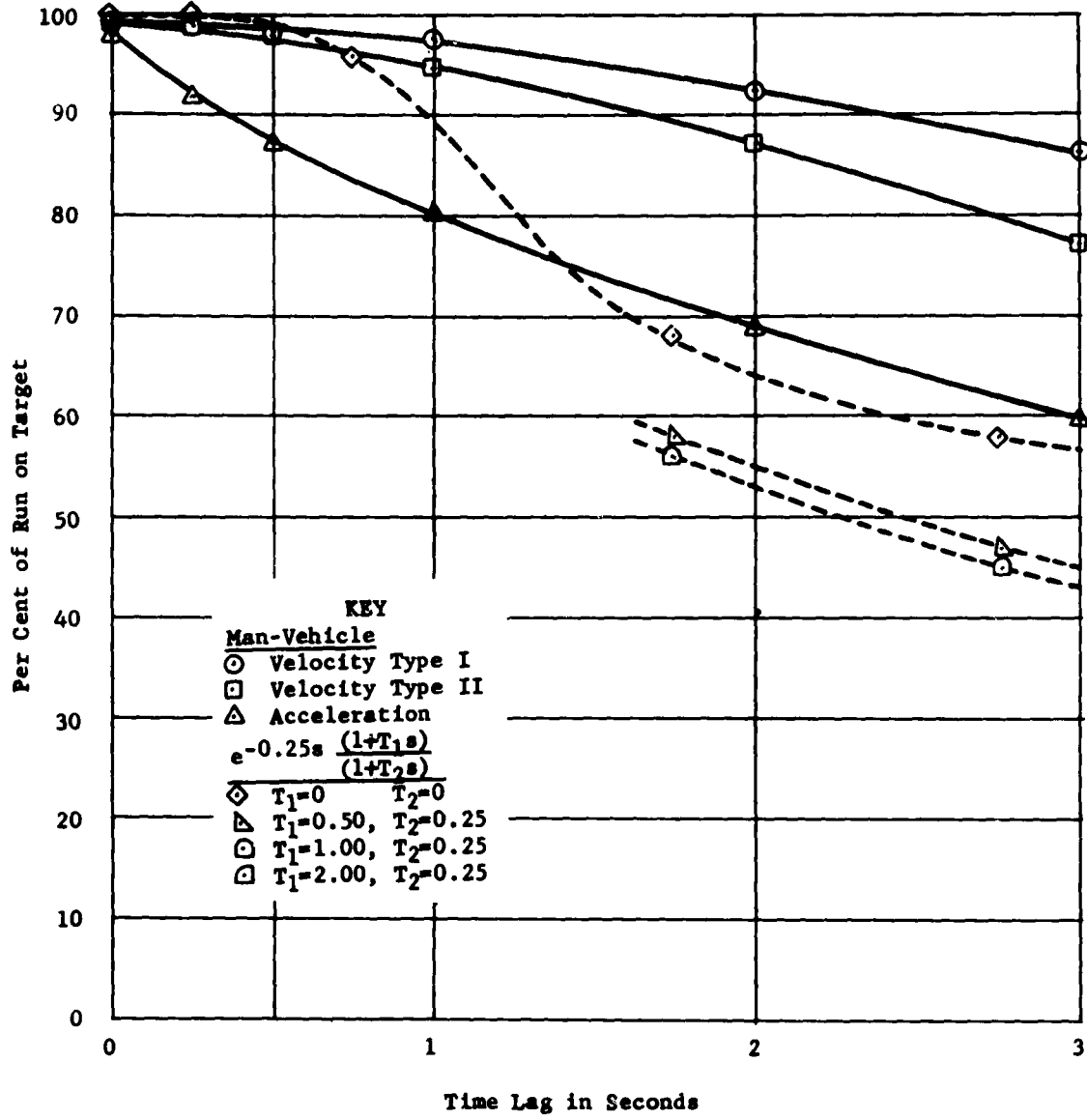

Time on Target vs. Lag  
 1/16th Target Speed

D-1351

Appendix page A-2

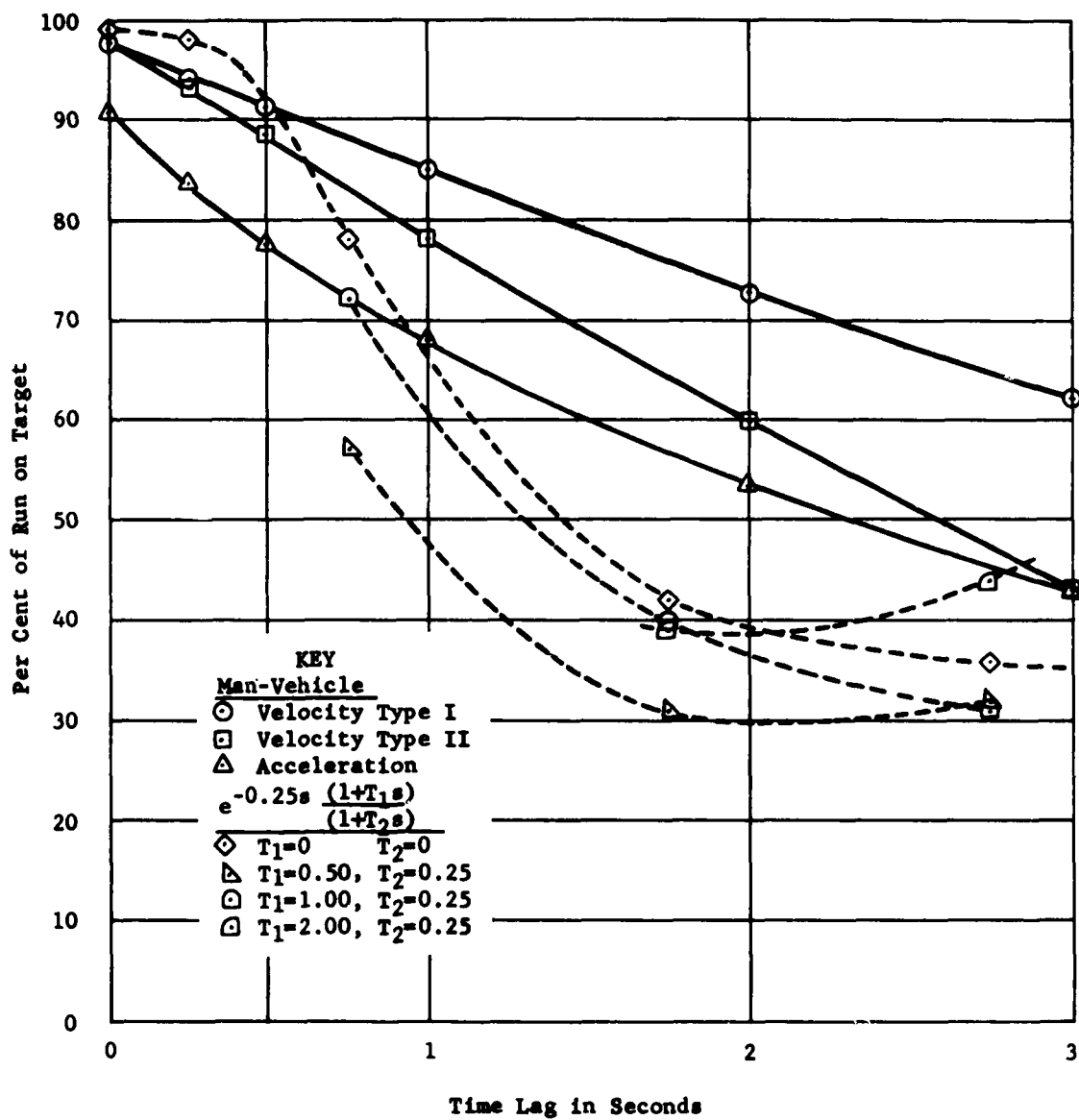

Time on Target vs. Lag  
 1/8th Target Speed

Appendix page A-3

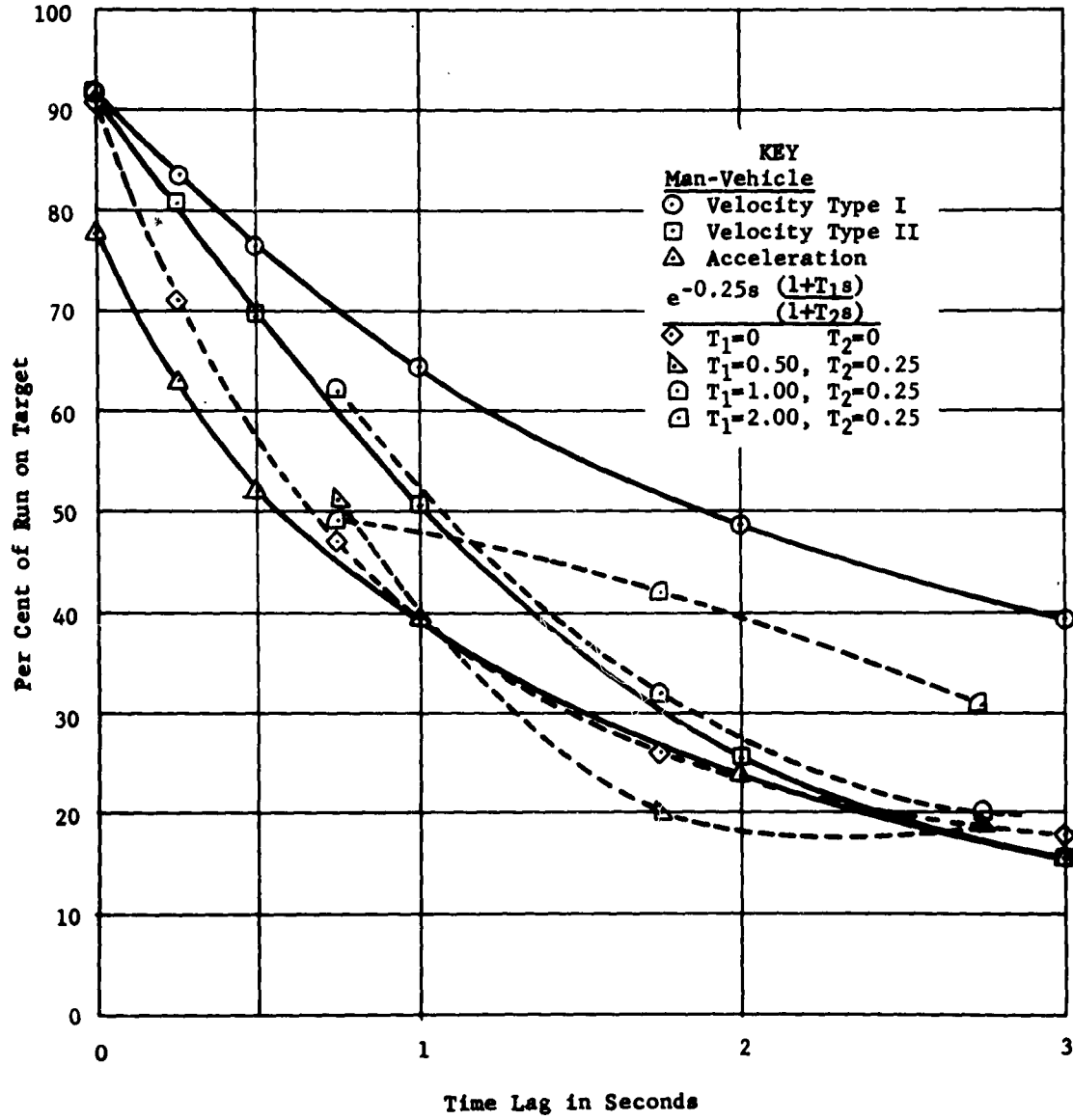

Time on Target vs. Lag  
1/4 Target Speed

## Appendix page A-4

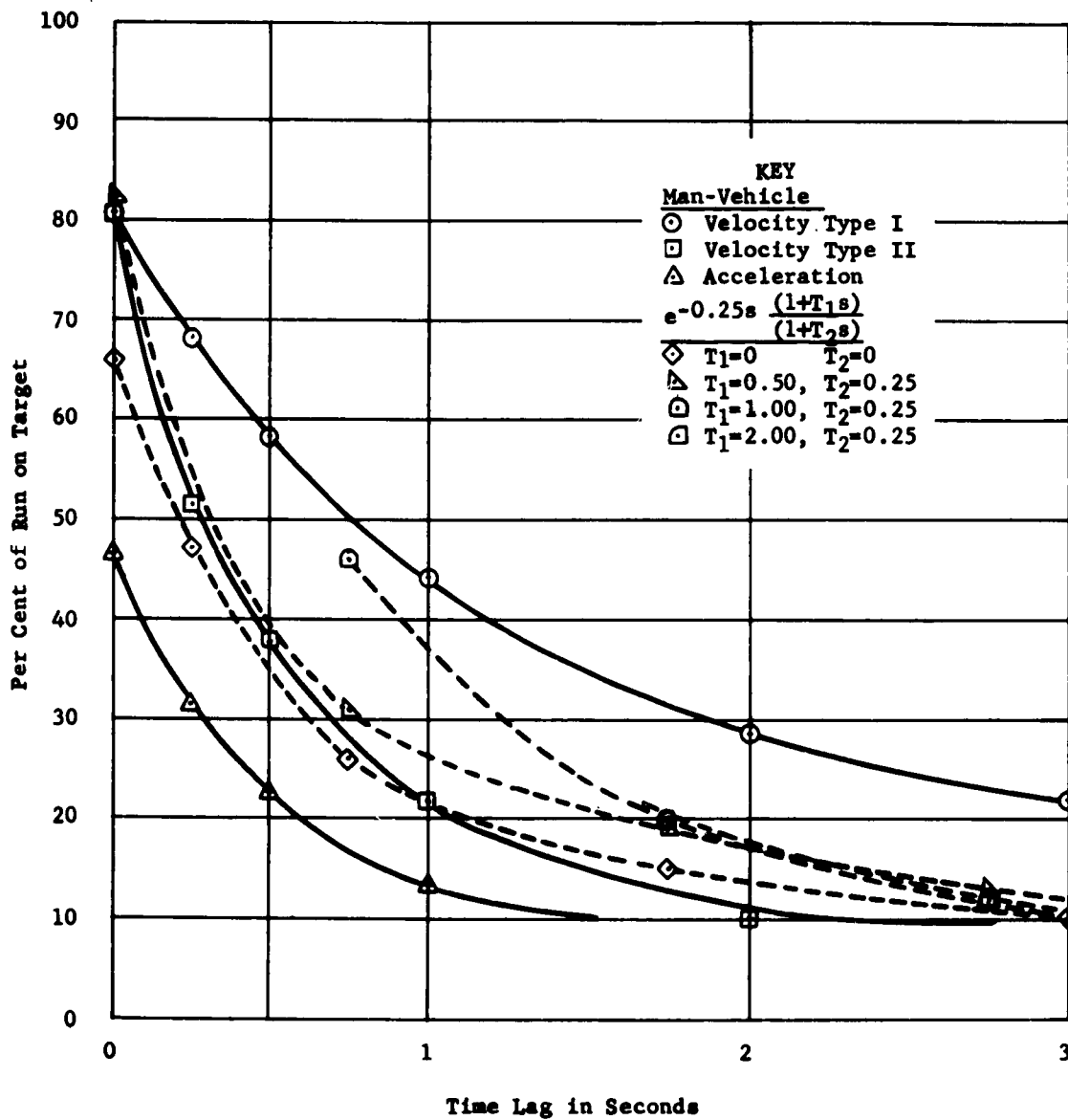

Time on Target vs. Lag  
1/2 Target Speed

Appendix page A-5

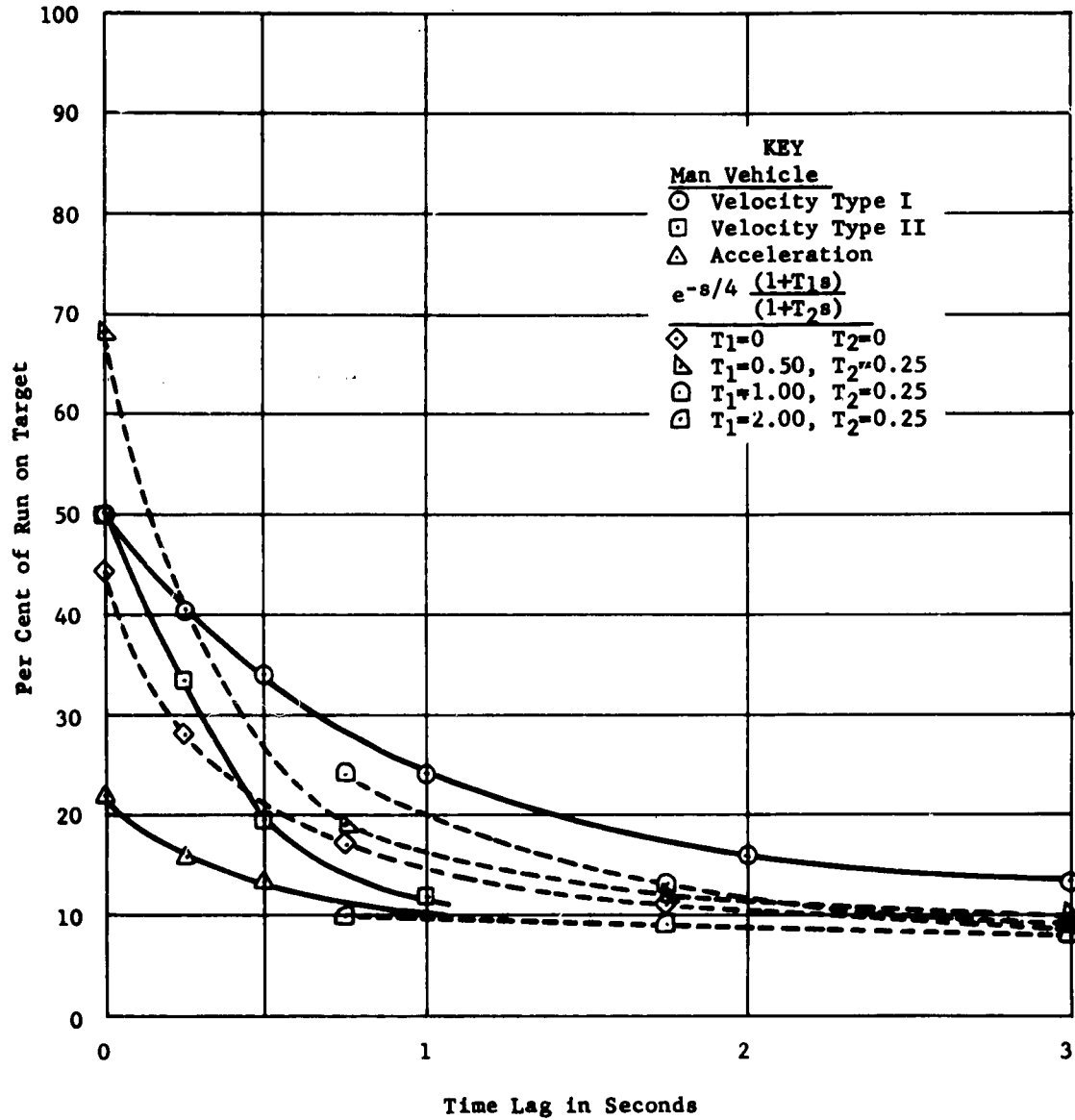

Time on Target vs. Lag  
Full Target Speed

D-1351

## Appendix page A-6

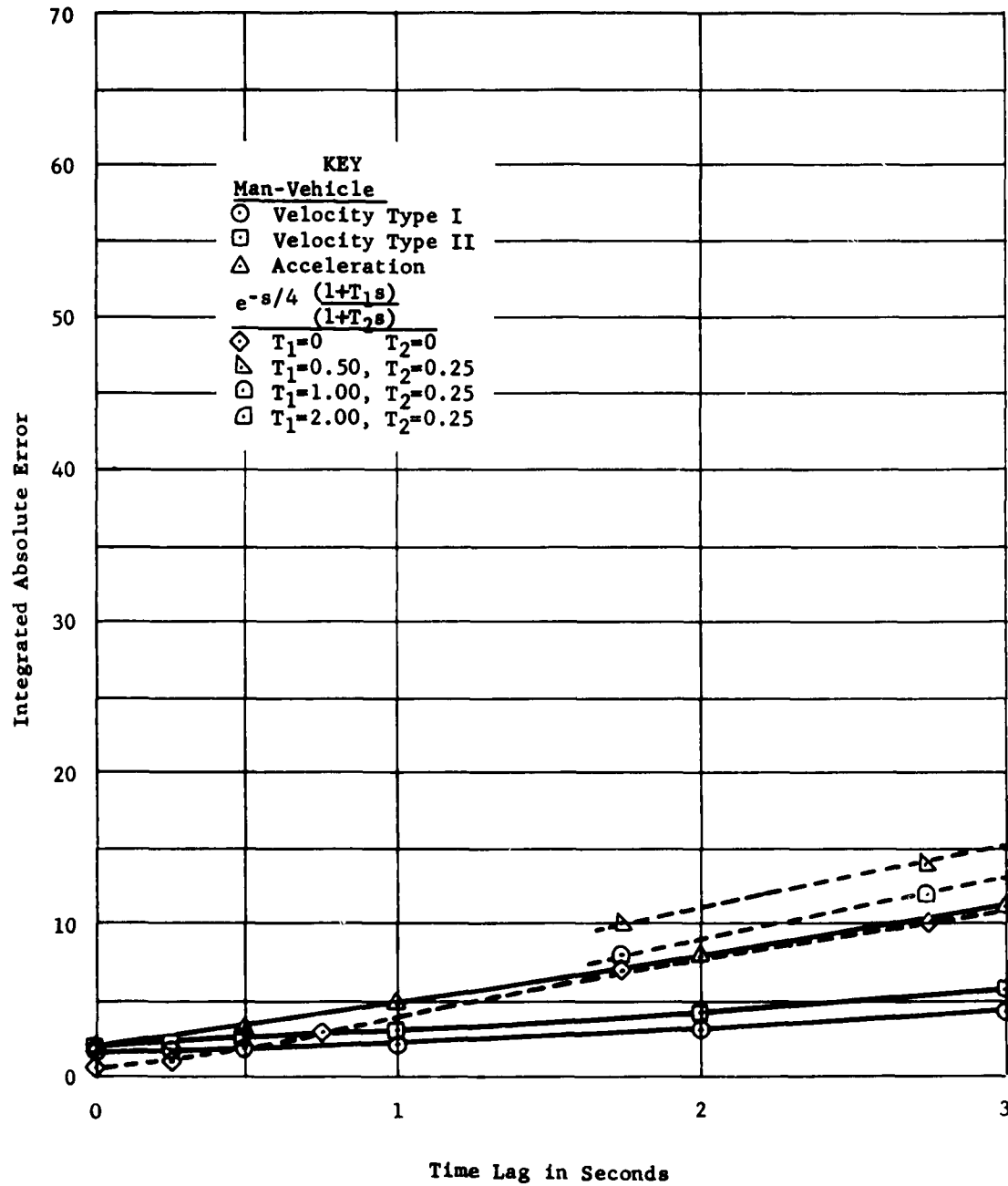

Error vs. Lag  
 1/16th Target Speed

D-1351

## Appendix page A-7

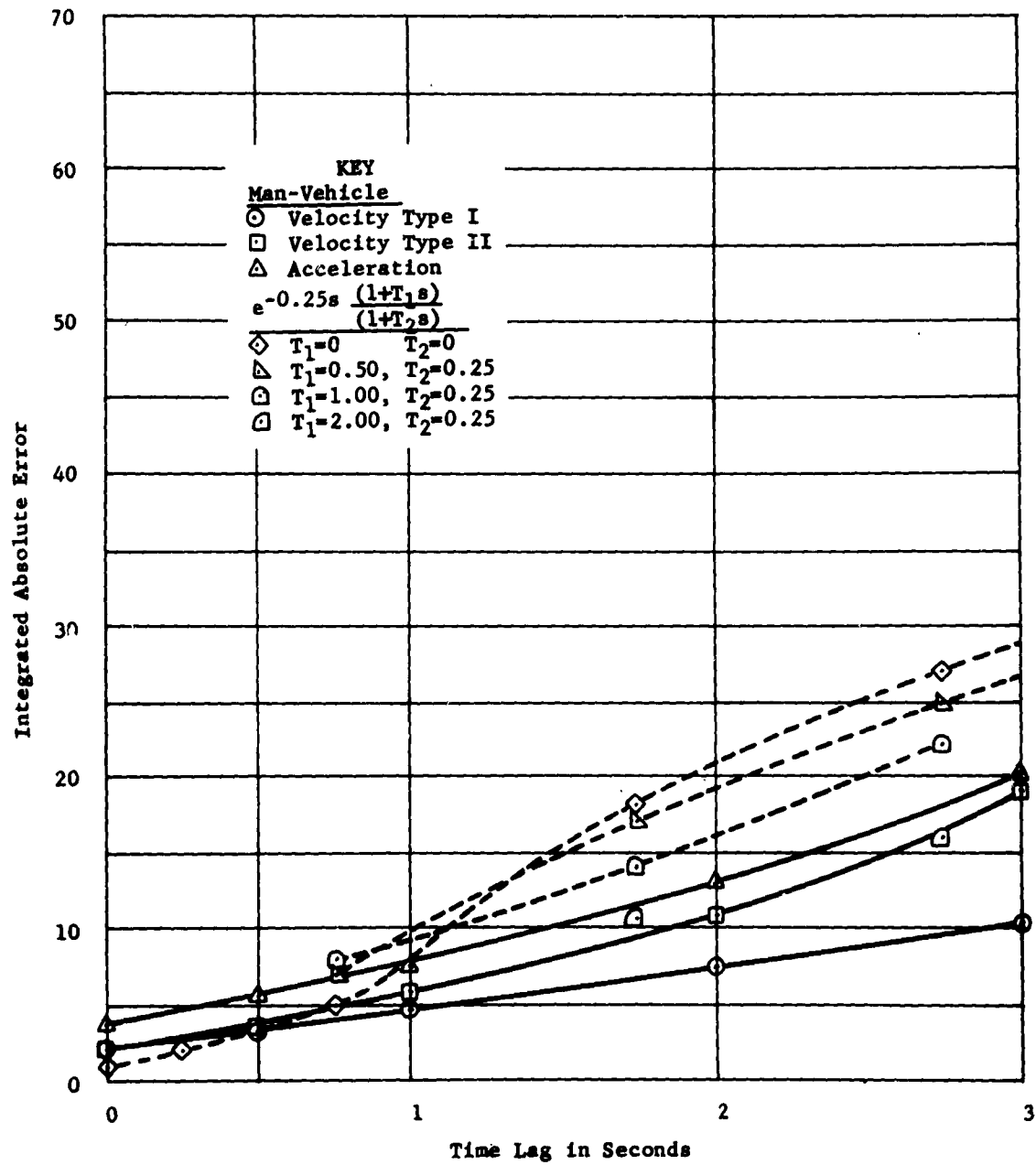

## Appendix page A-8

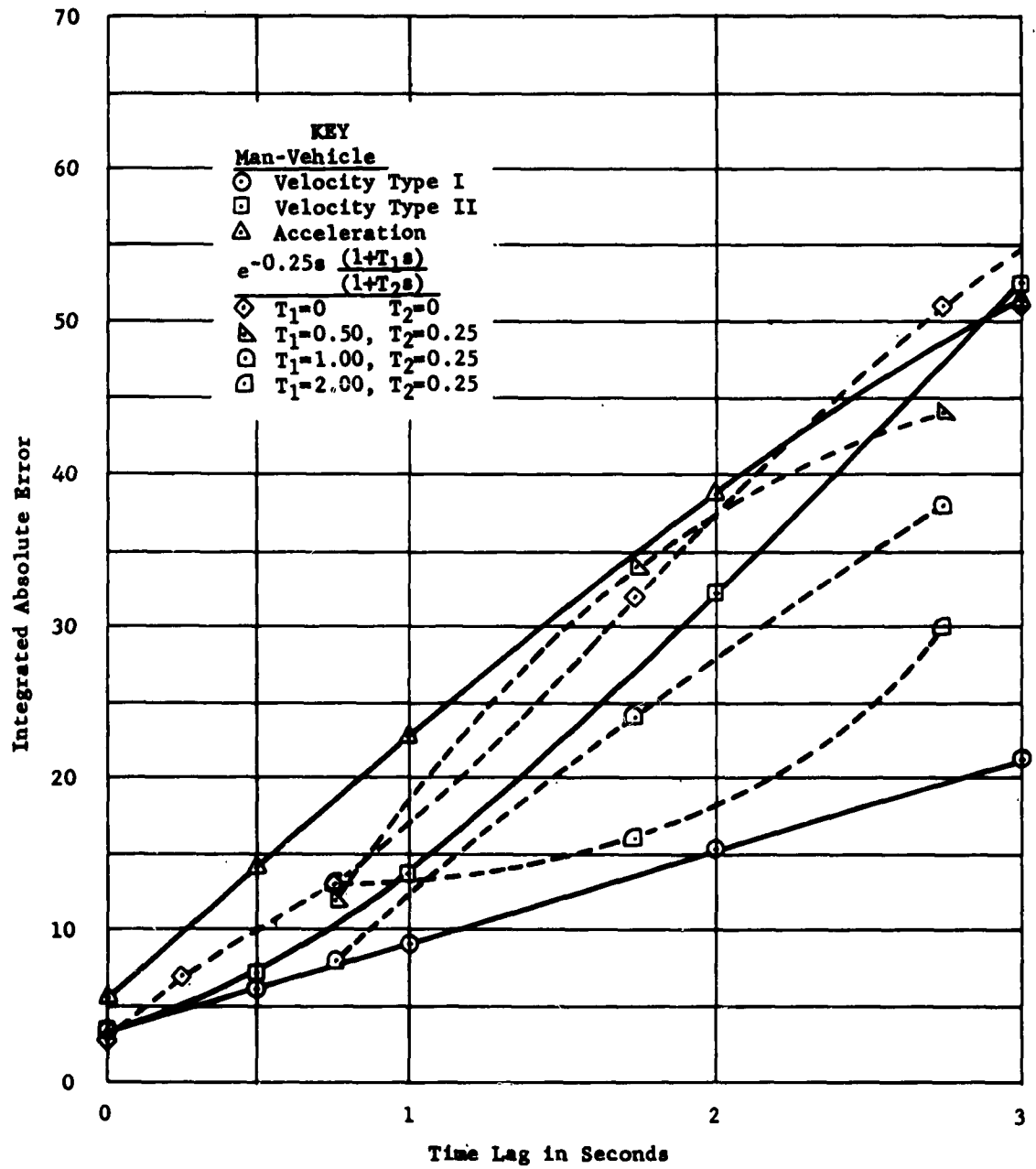

Error vs. Lag  
1/4 Target Speed

D-1351

Appendix page A-9

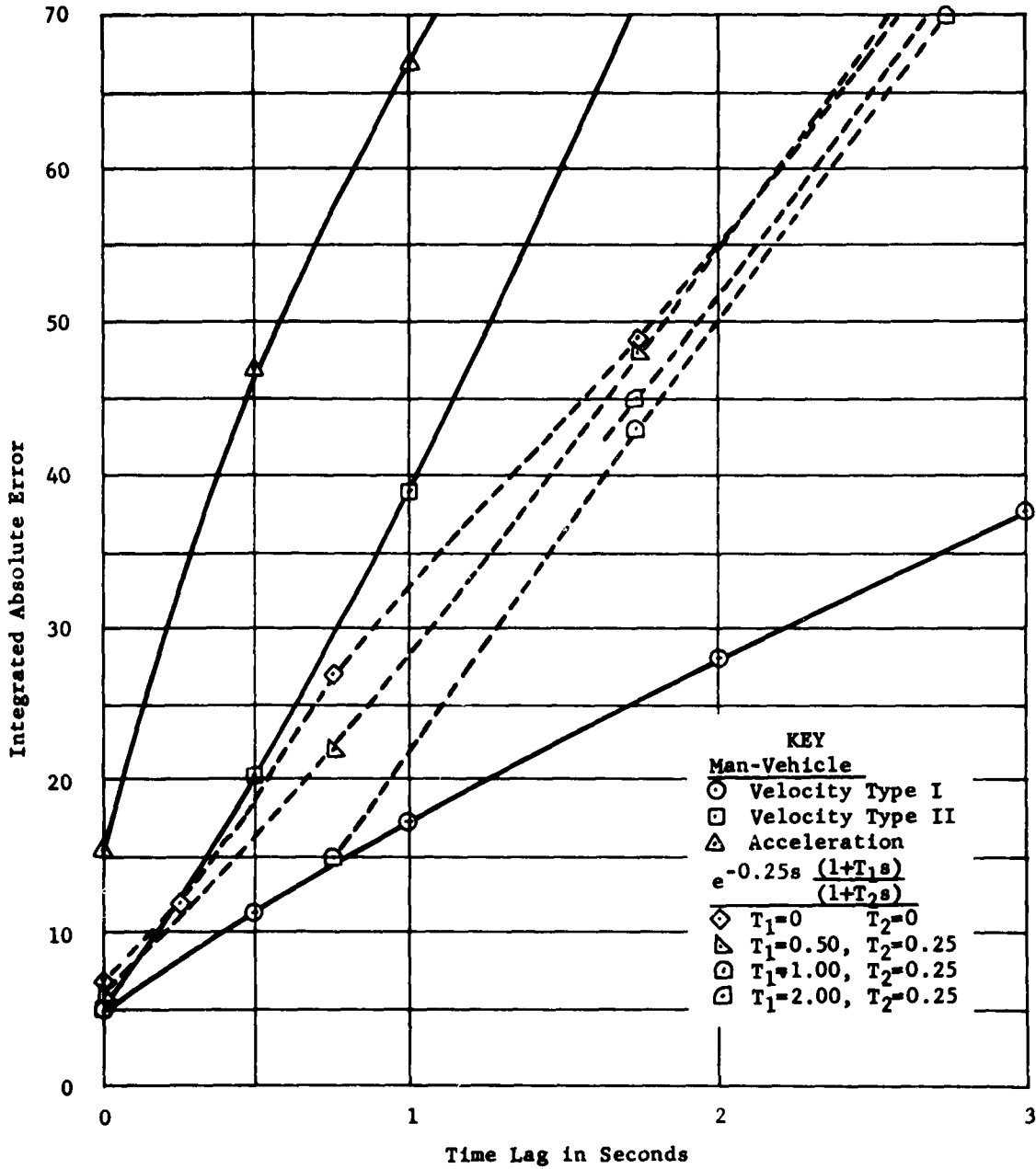

Error vs. Lag  
1/2 Target Speed

D-1351

## Appendix page A-10

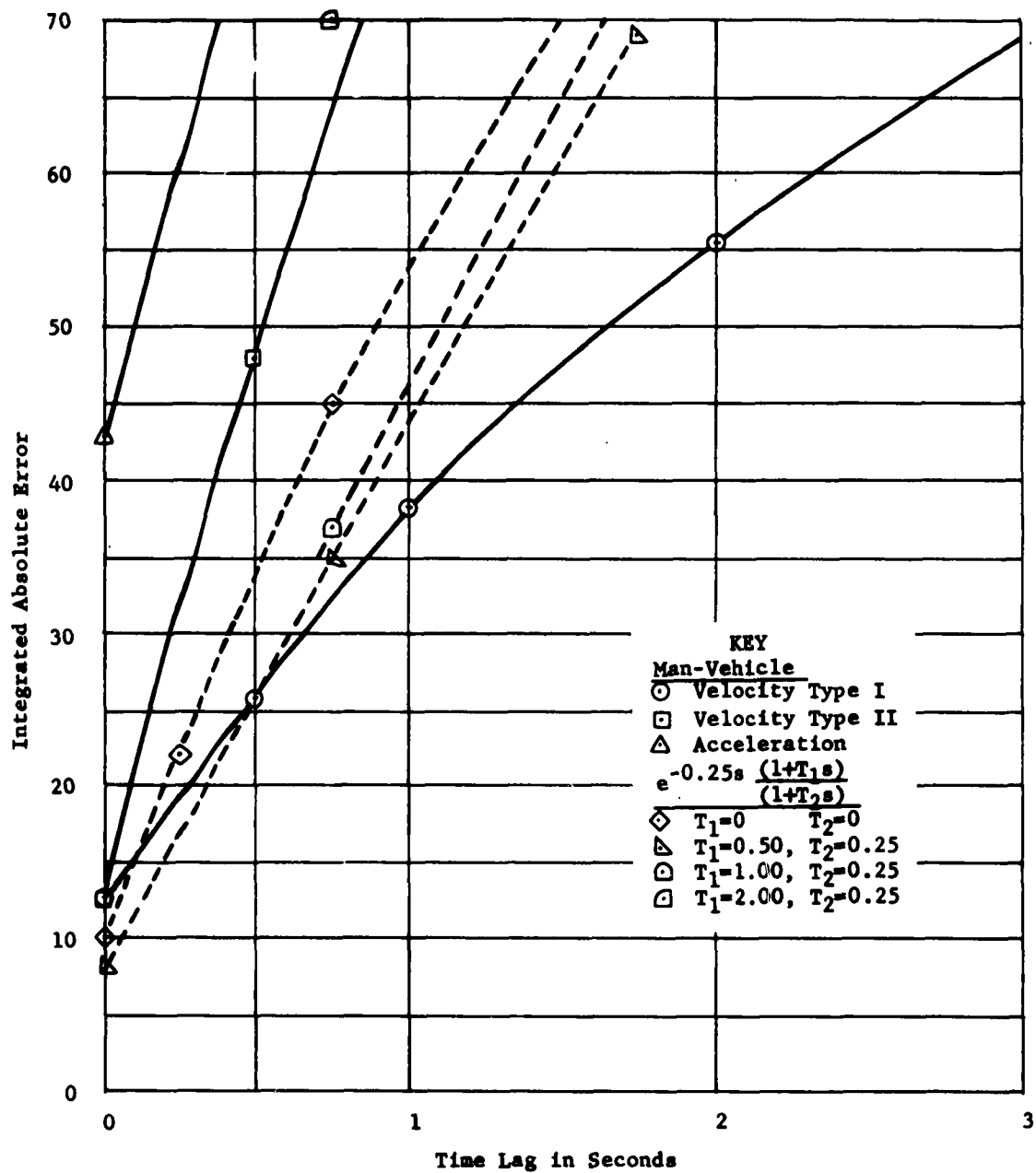

Error vs. Lag  
Full Target Speed

APPENDIX PAGE B-1

VEHICLE SCORING - CONTINUOUS PATH

Vehicle Speed	- - - - -2.7 feet per second- - - - -							
Steering Mode	- - - - -Four wheels plus camera- - - - -							
Operator	3	4	3	4	3	4	3	4
Seconds Lag	0	0	1/2	1/2	1	1	2	2
% Time on Target	93	88	35	46	28	35	15	23
	98	95	62	82	38	40	18	27
	95	96	50	81	50	41	15	21
	99	97	69	80	48	43	25	26
	98	98	85	86	52	39	19	21
	98	98	86	86	50	46	15	
	99	96	83	86	44	68		
	99	97	86	87	48	50		
	99	98	88	85	52	51		
	98	99	88		54	51		
			100		50	58		
			98		47	49		
			98		54	46		
				89	73	55		
					63			
					57			
					59			
					58			
					48			
					50			
				53				
				47				
				49				
				47				
				60				
				74				
				55				
				63				
				52				
				60				
Approximate average % TOT	98%		85%		55%		25%	

D  
1  
3  
5  
1

U  
N  
C  
O  
N  
T  
R  
O  
L  
L  
A  
B  
L  
E



APPENDIX PAGE B-3

VEHICLE SCORING - OBSTACLES

Vehicle Speed	2.7 feet/sec						0.9 feet/sec			
Steering Mode	Four wheels plus camera									
Operator	3	4	3	4	3	4	3	3	4	
Seconds Lag	0	1/2	1/2	1	1	2	2	2	3	3
No. Obstacles Hit	0	2	3	1	2	5	3	0	1	1
	0	3	2	1	1	3	4	0	1	3
	0	1	3	2	3	3	5	0	0	1
	0	2	1	2	3	6	4	0	0	1
		1	2	1	2			1	2	0
		1	0	1	1			0	0	0
		0	1	2	0				1	1
		0	2	0	2				1	0
		1	1	4	0				0	1
		0	0	4	0				1	1
		0	0	2	1				0	0
		0	1	1	1				1	1
		1	0	1	0				0	0
		0		2	1				1	
		0		2	1					
		0		2	0					
		0		1	2					
				0	1					
				1	0					
				2	0					
				1	1					
				2	1					
				2	0					
				1	1					
				2	1					
				2	0					
				1	1					
				2	1					
				0	1					
				1	1					
				3						
				2						
				0						
				1						
				2						
				1						
				0						

D  
1  
3  
5  
1

NASA TN D-1351  
National Aeronautics and Space Administration.  
AN INVESTIGATION OF THE EFFECTS OF THE  
TIME LAG DUE TO LONG TRANSMISSION DISTANCE  
UPON REMOTE CONTROL. PHASE II - VEHICLE  
EXPERIMENTS. PHASE III - CONCLUSIONS.  
James L. Adams, Stanford University. (Final report  
on NASA Contract NSG 111-61.) April 1962. 78p.  
OTS price, \$2.00.  
(NASA TECHNICAL NOTE D-1351)

An experimental program is undertaken to define the effects upon remote control of long transmission delays. Investigation centers around remote control of a ground vehicle, which is considered to be a representative remote control task.

Copies obtainable from NASA, Washington

- I. Adams, James L.
- II. NASA TN D-1351
- III. Stanford U.

(Initial NASA distribution:  
8, Behavioral studies;  
9, Biomedicine;  
17, Communications and sensing equipment, flight;  
18, Communications and tracking installations,  
ground; 19, Electronics;  
22, Guidance and homing systems; 29, Navigation and navigation equipment;  
46, Space mechanics;  
48, Space vehicles;  
49, Simulators and computers;  
53, Vehicle performance.)

NASA

NASA TN D-1351  
National Aeronautics and Space Administration.  
AN INVESTIGATION OF THE EFFECTS OF THE  
TIME LAG DUE TO LONG TRANSMISSION DISTANCE  
UPON REMOTE CONTROL. PHASE II - VEHICLE  
EXPERIMENTS. PHASE III - CONCLUSIONS.  
James L. Adams, Stanford University. (Final report  
on NASA Contract NSG 111-61.) April 1962. 78p.  
OTS price, \$2.00.  
(NASA TECHNICAL NOTE D-1351)

An experimental program is undertaken to define the effects upon remote control of long transmission delays. Investigation centers around remote control of a ground vehicle, which is considered to be a representative remote control task.

Copies obtainable from NASA, Washington

- I. Adams, James L.
- II. NASA TN D-1351
- III. Stanford U.

(Initial NASA distribution:  
8, Behavioral studies;  
9, Biomedicine;  
17, Communications and sensing equipment, flight;  
18, Communications and tracking installations,  
ground; 19, Electronics;  
22, Guidance and homing systems; 29, Navigation and navigation equipment;  
46, Space mechanics;  
48, Space vehicles;  
49, Simulators and computers;  
53, Vehicle performance.)

NASA

NASA TN D-1351  
National Aeronautics and Space Administration.  
AN INVESTIGATION OF THE EFFECTS OF THE  
TIME LAG DUE TO LONG TRANSMISSION DISTANCE  
UPON REMOTE CONTROL. PHASE II - VEHICLE  
EXPERIMENTS. PHASE III - CONCLUSIONS.  
James L. Adams, Stanford University. (Final report  
on NASA Contract NSG 111-61.) April 1962. 78p.  
OTS price, \$2.00.  
(NASA TECHNICAL NOTE D-1351)

An experimental program is undertaken to define the effects upon remote control of long transmission delays. Investigation centers around remote control of a ground vehicle, which is considered to be a representative remote control task.

Copies obtainable from NASA, Washington

NASA TN D-1351  
National Aeronautics and Space Administration.  
AN INVESTIGATION OF THE EFFECTS OF THE  
TIME LAG DUE TO LONG TRANSMISSION DISTANCE  
UPON REMOTE CONTROL. PHASE II - VEHICLE  
EXPERIMENTS. PHASE III - CONCLUSIONS.  
James L. Adams, Stanford University. (Final report  
on NASA Contract NSG 111-61.) April 1962. 78p.  
OTS price, \$2.00.  
(NASA TECHNICAL NOTE D-1351)

An experimental program is undertaken to define the effects upon remote control of long transmission delays. Investigation centers around remote control of a ground vehicle, which is considered to be a representative remote control task.

Copies obtainable from NASA, Washington

- I. Adams, James L.
- II. NASA TN D-1351
- III. Stanford U.

(Initial NASA distribution:  
8, Behavioral studies;  
9, Biomedicine;  
17, Communications and sensing equipment, flight;  
18, Communications and tracking installations,  
ground; 19, Electronics;  
22, Guidance and homing systems; 29, Navigation and navigation equipment;  
46, Space mechanics;  
48, Space vehicles;  
49, Simulators and computers;  
53, Vehicle performance.)

NASA

- I. Adams, James L.
- II. NASA TN D-1351
- III. Stanford U.

(Initial NASA distribution:  
8, Behavioral studies;  
9, Biomedicine;  
17, Communications and sensing equipment, flight;  
18, Communications and tracking installations,  
ground; 19, Electronics;  
22, Guidance and homing systems; 29, Navigation and navigation equipment;  
46, Space mechanics;  
48, Space vehicles;  
49, Simulators and computers;  
53, Vehicle performance.)

NASA