

UNCLASSIFIED

---

AD 274 245

*Reproduced  
by the*

ARMED SERVICES TECHNICAL INFORMATION AGENCY  
ARLINGTON HALL STATION  
ARLINGTON 12, VIRGINIA



---

UNCLASSIFIED

NOTICE: When government or other drawings, specifications or other data are used for any purpose other than in connection with a definitely related government procurement operation, the U. S. Government thereby incurs no responsibility, nor any obligation whatsoever; and the fact that the Government may have formulated, furnished, or in any way supplied the said drawings, specifications, or other data is not to be regarded by implication or otherwise as in any manner licensing the holder or any other person or corporation, or conveying any rights or permission to manufacture, use or sell any patented invention that may in any way be related thereto.

STIA

274 245

FOR M...

Best Available Copy

FINAL REPORT ON THE  
FEASIBILITY AND DESIGN STUDY  
FOR COLLECTIVE PROTECTION  
EQUIPMENT FOR THE  
AN/MSG-4 SYSTEM  
A STUDY REPORT  
CONTRACT DA 18-108 CML-6618

15 MARCH 1962

FD 62-75

HUGHES

GROUND SYSTEMS  
ENGINEERING LABORATORIES  
HUGHES AIRCRAFT COMPANY  
FULLERTON, CALIFORNIA

DOCUMENT ID: 100-100000  
 DATE: 10/10/00  
 PAGE: 100

TABLE OF CONTENTS

	<u>Paragraph</u>	<u>Page</u>
Section I. Introduction.....		1
Nature of Program.....	1	1
General Summary of Program...	2	2
II. Requirements of Collective Protection Equipment.....		3
Environment.....	3	3
Degree of Protection.....	4	4
Transportability.....	5	5
Base of Installation.....	6	6
Contractual Requirements.....	7	7
III. Assumptions.....		7
Air Leakage Rates.....	8	7
Heating Requirements.....	9	8
IV. Collective Protection System...		9
General Comments on Air Distribution.....	10	9
Control System.....	11	11
Power Requirement.....	12	12
V. Collective Protection Equipment Design Philosophy.....		13
Protective Entrance.....	13	15
Filter Unit.....	14	17
Remote Control Panel.....	15	23

	<u>Paragraph</u>	<u>Page</u>
VI. Integration of Air Filtration Equipment with AN/MSQ-4 System Shelters/Vehicle.....		25
AN/MSQ-28 (except AN/MPS-23 Radar Antenna Trailer).....	16	25
AN/MPS-23 Radar Antenna Trailer.....	17	27
AN/MSQ-18 Vehicles.....	18	30
AN/TSQ-38 Shelters.....	19	32
AN/GSS-1D Shelter.....	20	33
VII. Evaluation of Mockups.....		37
Protective Entrance.....	21	37
400 CFM Filter Unit.....	22	43
800 CFM Filter Unit.....	23	45
VIII. Conclusions.....		47
Filter Unit Models.....	24	47
Protective Entrance Models...	25	48
Capacity of Air Conditioners.	26	48
IX. Recommendations.....		49
Additional Testing Required..	27	49
AN/MSQ-28 R & D Vehicles.....	28	49
Phase II.....	29	50
X. Miscellaneous Information.....	30	51

1  
 2  
 3  
 4  
 5  
 6  
 7  
 8  
 9  
 10  
 11  
 12  
 13  
 14  
 15  
 16  
 17  
 18  
 19  
 20  
 21  
 22  
 23  
 24  
 25  
 26  
 27  
 28  
 29  
 30  
 31  
 32  
 33  
 34  
 35  
 36  
 37  
 38  
 39  
 40  
 41  
 42  
 43  
 44  
 45  
 46  
 47  
 48  
 49  
 50  
 51  
 52  
 53  
 54  
 55  
 56  
 57  
 58  
 59  
 60  
 61  
 62  
 63  
 64  
 65  
 66  
 67  
 68  
 69  
 70  
 71  
 72  
 73  
 74  
 75  
 76  
 77  
 78  
 79  
 80  
 81  
 82  
 83  
 84  
 85  
 86  
 87  
 88  
 89  
 90  
 91  
 92  
 93  
 94  
 95  
 96  
 97  
 98  
 99  
 100

LIST OF ILLUSTRATIONS

	<u>Page</u>
Figure 1 Protective Entrance Design Concept.....	16
Figure 2 Filter Unit Design Concept.....	18
Figure 3 400 CFM Filter Unit Mockup.....	19
Figure 4 400 CFM Filter Unit with Aerosol Filter Partially Removed.....	20
Figure 5 400 CFM Filter Unit Mockup arranged for Horizontal Mounting.....	21
Figure 6 800 CFM Filter Unit Mockup.....	29
Figure 7 Protective Entrance Mockup Components Less Coupling.....	38
Figure 8 Protective Entrance Mockup Partially Installed.....	39
Figure 9 Protective Entrance Mockup Installed but Unpressurized.....	40
Figure 10 Protective Entrance Mockup Installed and Pressurized.....	41
Figure 11 Actual Operating Pressure of AN/MSQ-28 WMC..	53
Figure 12 Typical Construction of Aerosol and Gas Filters.....	55

		<u>Page</u>
Figure 13	Category A Collective Protection Equipment for WMC, RDPC, and RET (AN/MPS-23) Vehicles.	57
Figure 14	Category A Collective Protection Equipment for Maintenance Vehicles (AN/MSM-34 and AN/MSM-55).....	59
Figure 15	Schematic Control Diagram for 400 CFM Filter Unit.....	61
Figure 16	AN/MSQ-28 Vehicle Modification Required for Filter Unit Control System.....	63
Figure 17	Category B Collective Protection Equipment for AN/MPS-23 Radar Antenna Trailer.....	65
Figure 18	Category A Collective Protection Equipment for OC & CDG Vehicles (AN/MSQ-18).....	67
Figure 19	AN/MSQ-18 Vehicle Modifications Required for Filter Unit Control System.....	69
Figure 20	Category A Collective Protection Equipment for OC and CDG Shelters (AN/TSQ-38).....	71
Figure 21	AN/TSQ-38 Shelter Modifications Required for Filter Unit Control System.....	73
Figure 22	Category A Collective Protection Equipment for AN/GSS-1D Shelter.....	75

Approved for Release by NSA on 05-08-2014 pursuant to E.O. 13526

## Section I INTRODUCTION

### 1. NATURE OF PROGRAM

The purpose of this study program was to evaluate the feasibility of developing and installing collective protection equipment on the various subsystems of the AN/MSG-4 Antiaircraft Defense System, and to evolve the optimum designs required. The collective protection equipment for study consideration included: a chemical, bacteriological, and radiological (CBR) filter for filtering irritating, noxious, and toxic gases and aerosols from the air; a pressure-control device to maintain a safe positive pressure within the protected shelter to prevent backdrafts; and an air lock to permit personnel to make safe entry and exit from the shelters/vehicle. Collective Protection Equipment, therefore, serves to safeguard operating personnel from chemical, bacteriological and radiological contaminants.

The term "collective" indicates, however, that protection is afforded to a large group or area, in contrast to an individual in the open. The basic principle studied is to protect personnel or equipment by an enclosure which is not originally contaminated by these agents, and to further prevent the enclosure from becoming contaminated by pressurizing it so that outside contaminants cannot leak in. The principle further provides for decontamination of all air used for the shelter pressurization and ventilation processes for protective purposes. This study also considered the Protective Entrance which permits personnel to enter and leave a protected area without admitting contaminants or adversely disturbing the pressurization. Upon entering a protected area from a contaminated

atmosphere, personnel are required to shed contaminated clothing in the protective entrance, dispose of it to the outside, and cleanse themselves with decontaminating agents before making final entry into the safeguarded area.

For planning purposes, the study was termed "Phase I" of a tentative Chemical Corps program to develop complete collective protection for mobile elements of the Field Army Air Defense.

## 2. GENERAL SUMMARY OF PROGRAM

In June 1961 the Ground Systems Group of Hughes Aircraft Company was awarded a contract to conduct the Phase I study program. The study program was started 1 July 1961 and was completed 15 February 1962.

All major subsystems of the AN/MSG-4 Defense System were considered in the study together with the AN/GSS-1D Radar Surveillance Central.

The first part of the program was devoted to studying principles of CBR protection and methods of adapting suitable equipment to the various subsystems. At approximately the midpoint of the program, designs were formulated for representative equipment. The concluding portion of the program was comprised of mockup construction of CBR equipment for evaluation by the Army Chemical Center, and as a basis for future planning for Phase II. Phase II will yield prototypes for test and field evaluation.

The application of the Collective Protection Equipment to the AN/MSG-4 subsystem vehicles was found to be feasible. The study revealed that the necessary modifications can be made to the subsystems to accommodate the control system, air inlet connections, and the support attachments. The power available from GFP generators in common usage with various subsystems is adequate, although somewhat marginal for the Operations Central in both the AN/MSQ-18 and AN/TSQ-38 subsystems.

During this Study Program, the contractor produced a mockup of a filter unit for evaluation. The evaluation of the mockup demonstrated that further development of the equipment is practical, that it will adequately safeguard all portions of the AN/MSG-4 System, and that the equipment is adaptable for application to all subsystems with the modifications described herein.

In the course of this Study Program, the contractor developed a unique and practical construction principle for a Protective Entrance which can be used with all types of collective protection systems. A mockup of the Protective Entrance was built from materials closely approximating those which will be used in later

production hardware. Evaluation of this item gave full indication that the principle is practical and completely adaptable, with additional development, to all subsystems of the AN/MSG-4 System.

The following sections of this report present full details of the study, design of applicable equipment, and the nature of modifications required to adapt the equipment to the various vehicles and shelters.

## Section II REQUIREMENTS OF COLLECTIVE PROTECTION EQUIPMENT

### 3. ENVIRONMENT

The purpose of the collective protection equipment is to safeguard the lives of the personnel operating the AN/MSG-4 Antiaircraft Defense System when the ambient atmosphere contains chemical, bacteriological, and radiological agents. Seasons of the year or terrain do not limit the need of such protection and, therefore, the collective protection equipment must be capable of operating under the same conditions prescribed for the AN/MSG-4 System. This includes ambient operating temperatures from +130°F to -65°F and elevations from sea level to 10,000 feet, under all conditions imposed by outdoor environment.

### 4. DEGREE OF PROTECTION

The Filter Unit, at rated air flow, provides protection against CBR agents comparable to the protection provided by a standard gas mask. The Filter Unit offers adequate protection against chemicals and bacteria, and partial protection against radiation, because it is capable of preventing fallout particles from entering the vehicle/shelter, but does not prevent fallout from settling on the vehicle. Particles which are only harmful when the fallout touches the skin, or when swallowed or inhaled, will be stopped by the outer surface of the vehicle or the Filter Unit. Additional shielding would be required to completely protect personnel and equipment within the vehicles from all radiation sources.

## 5. TRANSPORTABILITY

Appendix A of Contract DA 18-108-CML-6618 states that the collective protection equipment shall be capable of being transported in kit form by vehicles no larger than the standard 2 1/2 ton truck. Transportation in kit form in smaller vehicles such as the 1/4 ton truck and/or trailer is desirable. It is anticipated that all collective protection items will fall within the latter category.

## 6. EASE OF INSTALLATION

Ease of installation was a primary design guideline and is reflected in the simplicity of designs evolved. Design details are described in the appropriate sections.

## 7. CONTRACTURAL REQUIREMENTS

The work performed in Phase I consisted of evaluating the application of collective protective equipment to the following R & D and production subsystems.

- AN/MSQ-28 RDPC
- AN/MSQ-28 WMC
- AN/MSQ-28 SMES (AN/MSM-34)
- AN/MSQ-28 RET (AN/MPS-23)
- AN/MSQ-28 Maintenance (AN/MSM-55)
- AN/MSQ-28 Antenna Trailer (AN/MPS-23)
- AN/MSQ-18 OC
- AN/MSQ-18 CDG
- AN/TSQ-38 OC
- AN/TSQ-38 CDG
- AN/GSS-1D Radar Surveillance Central

Mockups were provided of a basic 400 cfm Filter Unit module, an 800 cfm Filter Unit, and a Protective Entrance. The two Filter Units will serve all of the subsystems with the exception of the AN/GSS-1D Radar Surveillance Central. The Protective Entrance was designed for the AN/MSQ-28 RDPC and WMC vehicles but is substantially representative of the five models required for all of the AN/MSG-4 Subsystems.

The AN/GSS-1D Radar Surveillance Central is not listed as an applicable system in Phase I Contract DA 18-108-CML-6618, but was added by the request of the U.S. Army Chemical Center. The contractor agreed to undertake a study of the AN/GSS-1D within the available remaining time and funding.

### Section III ASSUMPTIONS

#### 8. AIR LEAKAGE RATES

On 14 August 1961, the head of the Air Filtration Branch, U.S. Army Chemical Center, Maryland, visited the Hughes Aircraft Company. The major problem discussed was the establishment of air delivery rates for the Filter Units.

The Army Chemical Center had previously performed a feasibility study of Collective Protection Equipment for several different vehicles of the AN/MSG-4 System to aid in establishing the air leakage rates. The contractor was supplied with Technical memorandum #32-52, which gives the data from the tests, and planned to use the data in this memorandum to determine the required air flow capacity of the CBR Filters. However, analysis of the data revealed that the test methods used to measure the leakage rates did not provide a true indication of leakage that could occur within subsystems of the AN/MSG-4 under actual operating conditions, because the air conditioners were not in operation during the air leakage tests. System pressures during actual operation vary widely within a given vehicle, and also differ greatly from the nominal 1/2" and 1" water gage pressures used during the leakage test. To illustrate, figure 11 shows actual operating pressures within a WMC vehicle. Inasmuch as the test results do not reflect actual operating conditions, and no vehicles were available for test, the decision was made to base the Filter Unit design on assumed values. The U.S. Army Chemical Center had previously initiated design of a Filter Unit for the AN/MSQ-28 vehicles (Antenna Trailer excepted) based on an air delivery rate of 400 cfm, which in their best judgment would adequately cover vehicle leakage rates and make-up air to the Protective Entrance. The

decision was made to continue the study based on an air delivery rate of 400 cfm, with the intent of bringing leakage rates of all using vehicles within the required limits by subsequent modification. Technical Memorandum #32-52 indicated that the air leakage rates for the AN/MSQ-18 vehicles exceeded the air leakage rates for the R & D AN/MSQ-28 vehicles. It was concluded, however, that the larger leakage rate was caused primarily by the air conditioner cabinet seals, and could be reduced to a level comparable to that of the R & D AN/MSQ-28 vehicles. The 400 cfm Filter Unit delivery rate was, therefore, also selected for the AN/MSQ-18 vehicles.

The U.S. Army Chemical Center had previously furnished air filtration equipment for a shelter and air conditioner combination similar to the AN/TSQ-38 system. The shelter in that case had required 125 cfm of make-up air to maintain the proper pressurization of the shelter. It was therefore concluded that a Filter Unit with a 300 cfm air rate would be satisfactory, as 125 cfm would be available for make-up air to this shelter, and 175 cfm would be available for scavenging the Protective Entrance.

The Production AN/MSQ-18 vehicles with air conditioners, at this time, were months away from completion and therefore unavailable for testing. The AN/MSQ-18 vehicles had already been delivered, and the AN/TSQ-38 shelters were shipped upon completion. It was therefore necessary to make the above assumptions.

The air delivery rate was not established at the 14 August 1961 meeting for the Shelter Unit covering the AN/MSQ-18 Shelter Antenna Trailer and the report had not been made to include the AN/CS3-1D Shelter in the feasibility and design study.

#### 9. HEATING REQUIREMENTS

It was assumed that the Protective Entrance would not require a heated air supply, because personnel would wear extra layers of clothing during severe weather conditions and would remove only the contaminated outer layers of clothing before entering the shelter/vehicle. U.S. Army Chemical Center representatives approved this assumption following the evaluation of the Protective Entrance mockup on the 10th and 11th of January 1962.

Best Available Copy

8

## Section IV COLLECTIVE PROTECTION SYSTEM

### 10. GENERAL COMMENTS ON AIR DISTRIBUTION

The proposed Category A Collective Protection Equipment for all subsystems except the AN/GSS-1D consists of a Filter Unit complete with an automatic pressure regulating device, a Protective Entrance and stowage facilities. Only the air required for ventilation and pressurization of the shelter/vehicle is delivered to the shelter/vehicle and the scavenging air is delivered directly to the Protective Entrance. The scavenging air is provided directly to the Protective Entrance to prevent overloading the cooling and heating portions of the air conditioning systems. The following discussion outlines the reasons for this approach:

a. Reduction of Cooling Load. Table 1 entitled "Cooling Requirement Tabulation" was prepared to guide the selection of the air distribution method. Column A is the calculated system cooling load in btu per hour including the cooling of 400 cfm of filtered air. Column B is the calculated cooling load based on bypassing 175 cfm of filtered air directly to the Protective Entrance. Column C is the rated capacity of the air conditioning systems used with various shelter/vehicles. Column D is the calculated maximum cooling load when the Filter Unit is not in operation. It is evident from this tabulation that the air conditioners on the AN/MSQ-18 and AN/T5Q-38 systems would be seriously overloaded if all of the filtered air were admitted to the air conditioning system allowing the scavenging air to enter the Protective Entrance through the CBR port in the vehicle door. It should be noted that the capacity (Table I) of some air conditioners is marginal when the ambient temperature is 125°F. In these cases it may be necessary to increase the air conditioning capacity at the time of installation of Collective Protection Equipment.

TABLE I  
 COOLING REQUIREMENT TABULATION (125°F Ambient Temperature)

Subsystem	A (Calculated Cooling Load BTU/HR with Air Conditioner(s) and Collective Protection Equipment. No By-Pass)	B (Calculated Cooling Load BTU/HR with Air Conditioner(s) and Collective Protection Equipment. W/By-Pass)	C (Rated Cooling Capacity of Air Conditioning Equipment BTU/HR)	D (Calculated Cooling Load BTU/HR With Air Conditioner(s) Only)
AN/MSQ-28				
WMC	109,515	98,215	120,000	92,615
RDFC	121,465	110,175	120,000	109,475
AN/MSM-34	72,815	61,525	60,000	53,475
AN/MPS-23	139,340	128,050	120,000	120,000
AN/MSM-55	72,815	61,525	60,000	53,475
AN/MSQ-18				
OC	59,700	48,410	36,000	36,000
CDG	47,600	36,300	36,000	23,000
AN/TSQ-38				
OC	59,700	48,410	36,000	36,000
CDG	47,600	36,300	36,000	23,000

b. Reduction of Heating Load. A further consideration in the selection of the air distribution method was the heating cycle of operation. If all of the filtered air is admitted to the air conditioning system, considering an air density of 0.1 lb per cubic foot (which would correspond to sea level conditions at minus 65°F), an additional heatload of 34,200 btu per hour would be imposed for heating the air to a final temperature of 70°F. With this method, the filtered air would be supplied to the Protective Entrance at approximately 70°F thru a port located in the door of the vehicle being protected. With an ambient temperature of minus 65°F the resulting air temperature within the Protective Entrance would be approximately 0°F, based on an overall U factor (heat transmission coefficient) of 1.47 btu/hr/°F/ft<sup>2</sup>. The additional heat would overload all heating systems. In addition, it must be noted that most shelter/vehicle air conditioning systems are designed in such a manner that relatively cold air will enter the occupied compartment from the Filter Unit in low ambient temperature operation. This condition can be alleviated by supplying the scavenging air directly to the Protective Entrance.

c. Selection of Shelter/Vehicle Filtered Air Inlet Location. The GFP air conditioner supplied for the AN/MSQ-28 vehicles is equipped with CBR inlets for the admittance of filtered air directly into the blower inlet plenum. The air conditioners provided for the AN/MSQ-18 and AN/TSQ-38 systems cannot be modified conveniently to admit the filtered air into the blower inlet plenum chambers which are generally the lowest pressure point in the system, and the filtered air must be admitted elsewhere. In the case of the AN/MSQ-18 vehicles, it is proposed to install a CBR port in the front bulkhead of the M-109 van to provide filtered air directly into the air conditioner return air plenum. The air conditioner for the AN/TSQ-38 system is mounted separate from the shelter and is connected by flexible ducting. It is proposed to install a "T" shaped coupling between the air conditioner and the return air duct into which the filtered air is admitted.

## 11. CONTROL SYSTEM

During collective protection operation, it is essential that the minimum pressure within the shelter/vehicle and collective protection system downstream from the pressurization blower be maintained above +0.3 inches water gage over atmospheric pressure. Higher internal pressure will prevent infiltration of contaminated air. When the shelter/vehicles are equipped with air conditioners, the minimum pressure within the collective protection system normally will be found at the suction side of the blower within the air conditioner. With Filter Unit operating, the pressure at this point will be raised to approximately +0.5 inches water gage by the Filter Unit blower which has slightly more than the required air delivery and pressure capacity. Pressure at all these points in the system will be raised accordingly. Control of system pressure will be fully automatic and will be accomplished by components

of the Filter Unit. Minimum system pressure will be sensed by a Dwyer pressure switch which will control a reversible damper actuator motor. An additional back draft damper will not be required on any of the systems. In fact, it should not be used as it will increase air leakage rates. In most cases it will be necessary to reduce the leakage rate of the shelter/vehicles to obtain proper pressurization. In the case of the AN/GSS-1D system however, the cooling of the electronic equipment is accomplished normally by using ambient air. Therefore, the air flow required may exceed the amount used for pressurization. In this case a backdraft damper may be required along with a calibrated discharge opening. The minimum pressure in the AN/GSS-1D shelter will be found in the occupied area and the pressure switch controlling the Filter Unit dampers will monitor the difference in pressure between the occupied area of the shelter and the ambient air.

## 12. POWER REQUIREMENTS

The subsystem vehicles are supplied power as follows:

<u>Subsystem</u>	<u>Voltage</u>	<u>Phase</u>	<u>Frequency-cps</u>
AN/MSQ-28			
WMC	208	3	60
	208	3	400
RDFC	208	3	60
	208	3	400
AN/MSM-34	208	3	60
	208	3	400
REF (AN/MPS-23)	416	3	60
	416	3	400
AN/MSM-55	416	3	60
	416	3	400
Radar Antenna Trailer	416	3	60
AN/MSQ-18			
OC	208	3	60
CDG	208	3	60
AN/TSQ-38			
OC	208	3	60
CDG	208	3	60
AN/GSS-1D			
Radar Surveillance Central	120	3	400
	28	1	dc

The power selected to operate the Filter Unit blower serving the above subsystems (except the AN/GSS-1D) is 208 volts, 3 phase, 60 cps. This requires that the Radar Equipment Trailer (RET), AN/MSM-55, and the Radar Antenna Trailer be equipped with 416/208 volt transformers. The AN/GSS-1D Radar Surveillance Central does not have sufficient dc power available to power additional equipment and thus will be designed for 120 volt, 3 phase, 400 cps blower operation.

## Section V COLLECTIVE PROTECTION EQUIPMENT DESIGN PHILOSOPHY

### 13. PROTECTIVE ENTRANCE

a. Shape. The two considerations that influenced the design of the Protective Entrance were the requirements for rapid installation and minimum stowage space. A cylindrical shape was chosen in order to eliminate the rigid framework normally required to maintain a square or rectangular shape when the entrance is pressurized. A full size mockup was fabricated and installed on an AN/MSQ-28 RDPC vehicle. From tests conducted by the contractor, as described later, it was concluded that the cylindrical shape was effective and practical. The fabric assembly was constructed of neoprene-coated nylon fabric weighing 16 oz. per square yard. It folds into a shape 24 inches long by 14 inches wide by 11 inches high, thus greatly reducing the required stowage space. The fabric assembly weighs approximately 25 pounds.

b. Single Point Suspension. The Protective Entrance is supported from a single point on top using a cantilevered support attached to the shelter. The support includes a pulley for raising the Protective Entrance into position. Future models will be equipped with an automatic latching device at the pulley to secure the Entrance after erection.

c. Coupling and Door Frame. As a means of further reducing the installation time, the Protective Entrance is furnished with a coupling, or transition piece, which is permanently attached to the shelter/vehicle. The Protective Entrance is then zipper-connected to the coupling. Figure 1 depicts the Protective Entrance suspended from its top and coupled to the door frame of a vehicle.

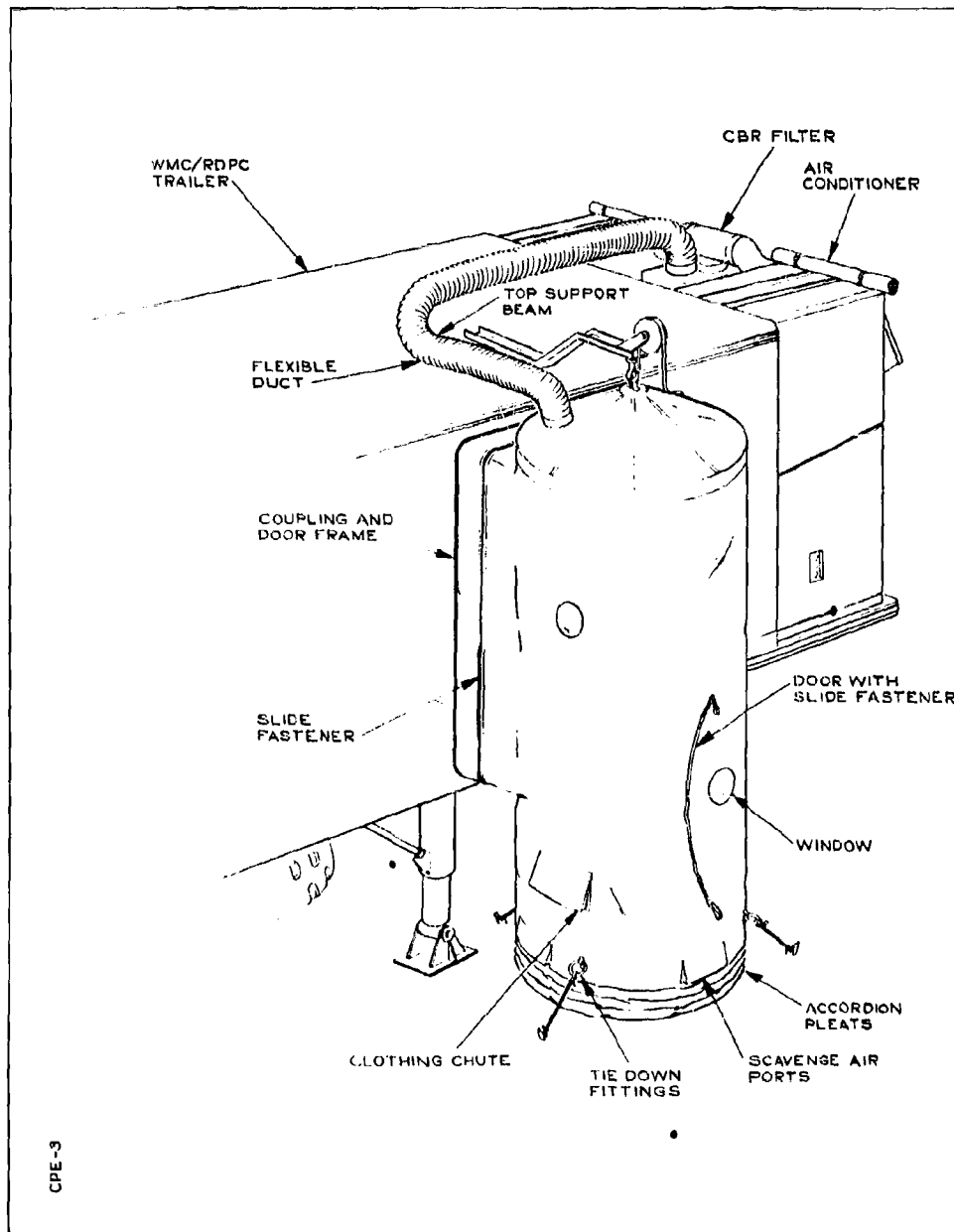

Figure 1 Protective Entrance Design Concept

d. Top Plenum. Filtered air is delivered to the top of the Protective Entrance and is evenly distributed through the porous fabric ceiling within the entrance. The air travels down through the cylindrical shape giving the piston action desired for scavenging contaminants from the Protective Entrance through exhaust ports located around the periphery near the bottom.

e. Door. The door will be a crescent shape opening secured by a slide fastener (zipper). The zipper is equipped with two sliders which permit opening or closing of any portion of the door from either direction. The zipper opening in the mockup has a rectangular shape. The zipper used was found to be too long, and the shape of the door inconvenient. Subsequent designs will be provided with a smaller door of crescent shape in accordance with the wishes of the U.S. Army Chemical Center personnel who evaluated the mockup.

f. Scavenging Air Leakage Ports. The scavenging air leakage ports are provided around the periphery near the bottom of the Protective Entrance. The ports are designed to provide control of the pressure within the Protective Entrance and are covered with gusseted flaps on the outside to protect against backdrafts.

g. Spreader Bars. The spreader bar is located directly under the porous ceiling and attaches to a web belt which is in turn attached to the support ring at the top of the Protective Entrance. The primary purpose of the spreader bar is to maintain the circular shape when the Protective Entrance is not pressurized.

h. Tiedowns. Tiedown stakes are provided to maintain a circular shape at the bottom of the Protective Entrance and to hold it in place under wind conditions and when the entrance is not pressurized.

#### 14. FILTER UNIT

a. General. The basic Filter Unit includes a pre-filter, two aerosol filters, two particulate filters, a blower, an automatic pressure regulating system, two manual dampers, motor starter, start-stop switch, and an inlet air weather shield. Refer to Figures 2 through 5 for diagrammatic and photographic representations of the Filter Unit Design.

b. Pre-Filter. The pre-filter is an inexpensive, cleanable filter with metallic filter media. Its function is (1), to prevent large objects from entering the Filter Unit thereby preventing damage to the blower and (2), filtering out larger particles, thus extending the useful life of the aerosol (particulate) filter.

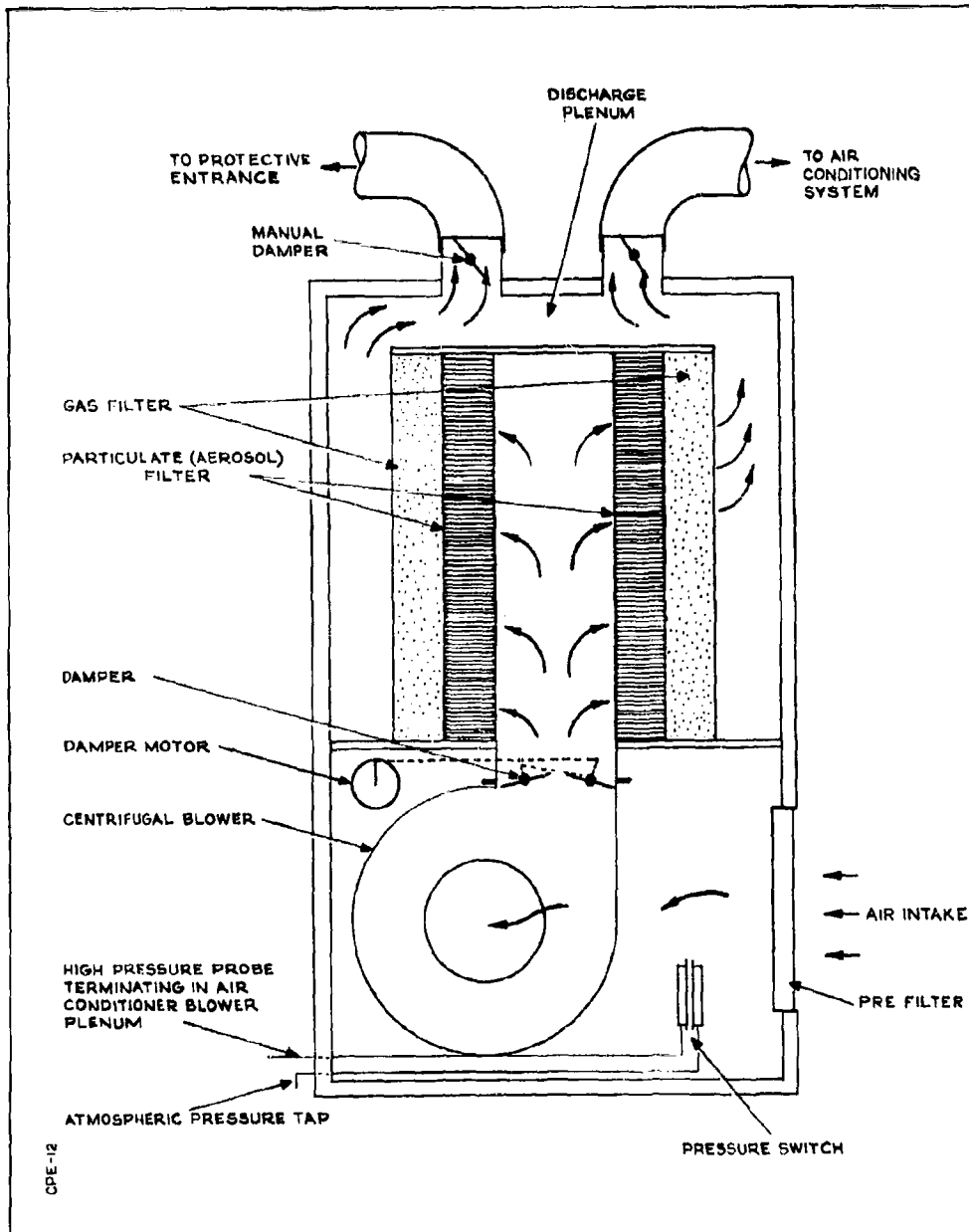
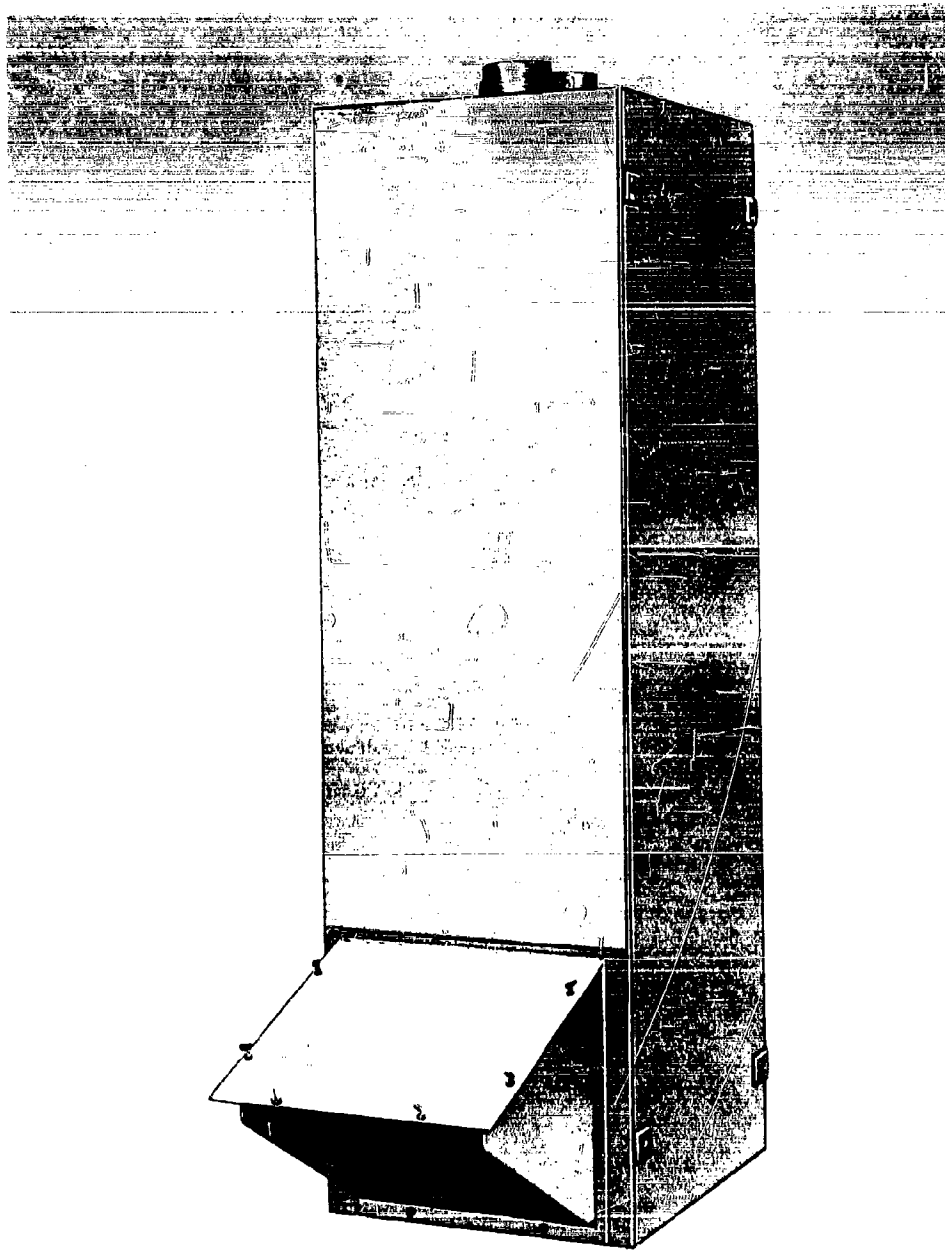
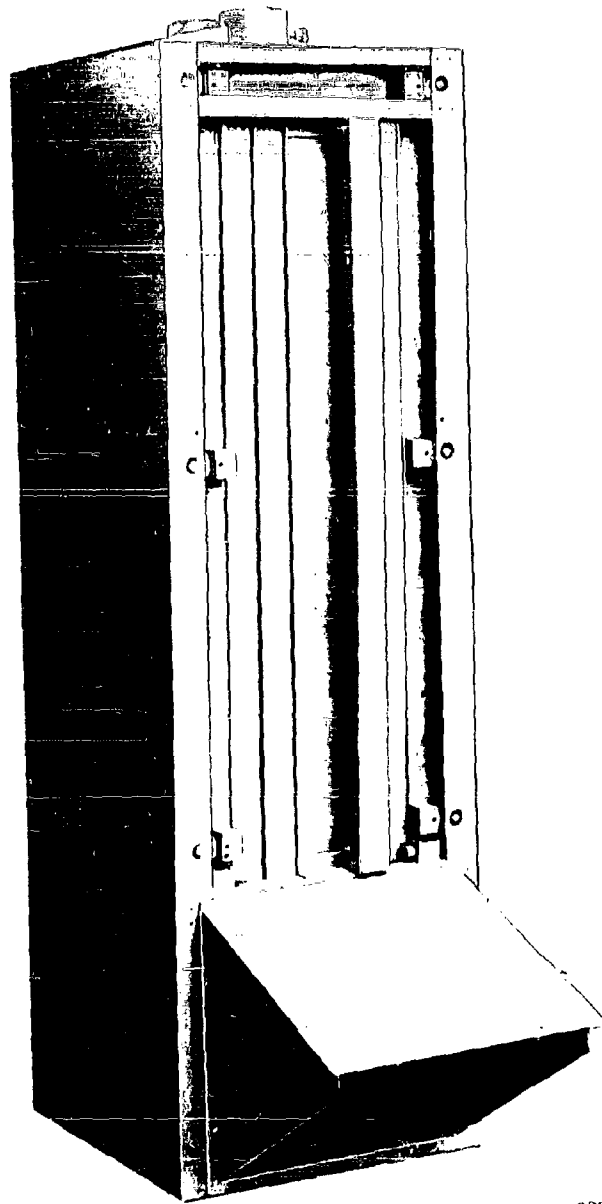

Figure 2 Filter Unit Design Concept



CPE-13

Figure 3 400 CFM Filter Unit Mockup



CPE-16

Figure 4 400 CFM Filler Unit with Aerogel Filter Partially Removed

E  
L  
L  
L  
L

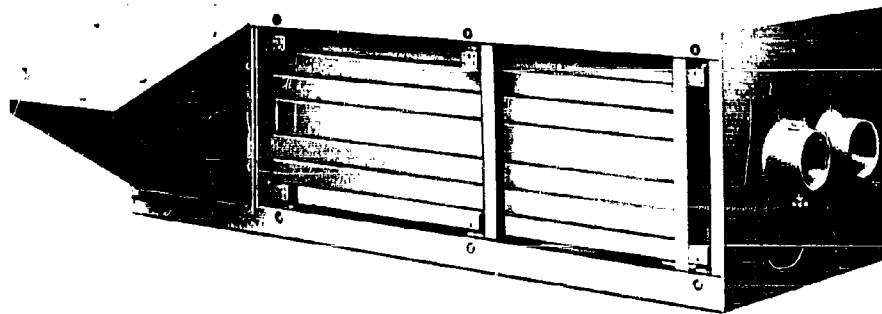

CPE-15

Figure 1. 400 CFM Filter Unit Mockup arranged for Horizontal Mounting.

c. Aerosol Filter. Aerosols are fine dust particles and very minute accumulations of airborne liquid (similar to a dispersed fine spray). This category of contaminant can carry chemical, radiological, and bacteriological elements that may affect the human via the lungs or the skin. With respect to radiological contaminants, the aerosol filter would prevent charged particles from entering the shelter, but could offer no protection against the Gamma rays of any fallout on the shelter/vehicle.

The aerosol filter media will be either Type 6 filter paper, pleated and separated by fluted Kraft paper, or a pleated glass mat separated by fluted aluminum separators. The pleated and separated filter media assembly is bonded to the frame with 3 M brand adhesive, Type EC 750, Type B847 or Type L236 (Minnesota Mining and Mfg. Co.). The basic 400 cfm Filter Unit module contains two aerosol filters operating in parallel, one on each side of the center plenum. Figure 12 shows the proposed construction of the aerosol and gas filters.

d. Gas Filter. The gas filter removes the irritating, noxious, and toxic gases in the contaminated air, including aerosols which sometime re-evaporate into the gaseous state. The possibility of re-evaporation of aerosols dictates that the gas filter be placed downstream of the aerosol filter.

The filter media is ASC Whetlerik, an activated carbon or 12 to 30 mesh which is impregnated with certain salts. The filter media is retained by glass mats which, in turn, are retained by perforated metal plates attached to the frames.

e. Blower. The blower selected for the 400 cfm Filter Unit module must be of small diameter to fit the very limited space. To create the required static head, the necessarily small blower wheel must be driven at approximately 7500 rpm, which requires the use of a speed increaser gear box between the blower and the 3660 rpm, 2-pole, 60-cps ac motor.

In order to provide for operation of the Filter Unit in either the vertical or horizontal position, the breather vent in the gear box was located so that the blower, gear box, and motor assembly can be rotated 90° clockwise about its axis (looking at the blower inlet) without obstructing the vent hole with lubricating oil.

The blower has not been selected for the AN/GSS-1D Filter Unit. The power source is 400 cps and therefore the gear box may not be required as higher motor speeds can be achieved with 400 cps power.

f. Automatic Damper System. The purpose of the automatic damper system is to maintain the desired minimum pressure within the protected system. As the filters become loaded, the resistance to air flow increases. The Dwyer pressure switch senses the drop in the minimum pressure differential and starts the damper motor, which begins to open the damper (air valve). When the pressure differential reaches the desired level, the damper motor stops. When the filters are clean, the damper imposes a static head penalty of 1 inch water gage which gradually decreases to 0 inch water gage as the filters become loaded. When the dampers become fully opened, a warning light on the remote control panel is energized to indicate that the filters should be checked.

Consideration was originally given to locating the damper immediately downstream of the pre-filter. However, the face area of the damper was determined to be too large for good control of the airflow and pressure, and the damper was later redesigned and relocated to the discharge side of the blower. The damper will be of the opposed blade type with two blades.

g. Weather Shield. The air inlet weather shield was designed for mounting in two positions, to properly protect the 400 cfm Filter Unit when operating in either the horizontal or vertical position. The start-stop switch is mounted on the weather shield frame and therefore will always remain in the same position regardless of the operating position of the Filter Unit. The start-stop switch is also covered when the weather shield is closed.

The pre-filter holding frame forms an integral part of the weather shield and can be easily removed and replaced with the weather shield open.

h. Manual Dampers. A manual damper is installed in both supply air outlets on the 400 cfm Filter Unit to assist in properly distributing the air to the shelter/vehicles and the Protective Entrance. A spring-loaded key held by slots on a quadrant permits the blades to be locked at 10 degree intervals between the fully opened and fully closed positions.

#### 15. REMOTE CONTROL PANEL

a. General. The nature of the CBR atmosphere requires provisions for operating the Filter Unit in the safety of the protected shelter/vehicle. To assure this measure of safety, several features are included in the control circuit and are located by necessity on the remote control panel which will be operated from inside the shelter/vehicle. The panel will contain a circuit breaker, warning lights, pressure indicator, and means for over-riding the pressure switch and manually operating the damper motor.

The proposed remote control panel will be a portable unit to eliminate the high cost of unique installations for the various vehicles. The portable remote control panel can be placed in any convenient spot within the shelter/vehicle and placed in operation by making the proper connections. By virtue of the portable design, the remote control panel will be identical for all AN/MSQ-28, AN/MSQ-18, and AN/MSQ-38 vehicles.

b. Circuit Breaker. To obtain proximity to the power source and resulting maximum wiring protection, the circuit breaker is included on the remote control panel.

c. Pressure Gage. So that operating personnel can be assured of proper system pressures, a pressure gage is included on the remote control panel to monitor the difference in pressure between atmospheric pressure and the pressure at the inlet of the blower in the air conditioner.

d. Manual Control of Automatic Pressure Regulating Dampers. Under normal operation, the Dwyer pressure switch (located within the Filter Unit) monitors the same pressure difference as is monitored by the pressure gage on the remote control panel. The pressure controls the operation of the automatic damper to assure the maintenance of the proper pressure differential. In the event the pressure gage indicated a pressure switch malfunction, the operator can use the override switch to remove the pressure switch from the control circuit, and then control the damper by a separate "increase-off-decrease" type switch. The dampers can be opened or closed as required until the proper operating pressure differential has been reached.

e. Warning Lights. As the filters become loaded with contaminants, the automatic dampers will open normally to adjust for this increased impedance to air flow. When the dampers have reached the fully opened position, a warning light will indicate that the filter elements require attention. Another warning light is provided to indicate failure of the blower motor.

Approved for Release by NSA on 05-08-2014 pursuant to E.O. 13526

Section VI INTEGRATION OF AIR FILTRATION EQUIPMENT  
WITH AN/MSQ-4 SYSTEM SHELTERS/VEHICLES

16. AN/MSQ-28 (EXCEPT AN/MSQ-33 RADAR ANTENNA TRAILER)

a. General. In accordance with the requirement of the Contract, the R & D vehicles were included in this study. Originally, application of the Collective Protection Equipment was not included in the R & D systems design, and therefore no space was provided. Based on the study effort, it was determined that the Filter Unit could be mounted under the frame of the trailer, but the fording requirements would require that the filter unit be protected by a water tight case. In addition to being watertight, the case would have to be strong enough structurally to resist the forces that would exist if the trailer became bogged in heavy mud. In addition to the above design considerations, it is anticipated that the two R & D systems will soon be replaced by Production Systems. Therefore, it is recommended that the R & D vehicles not be considered for Collective Protection Equipment.

Design of the production AN/MSQ-28 vehicles anticipated the future addition of Collective Protection Equipment and some provisions were made during vehicle design for future application of this equipment. Figures 13 and 14 indicate the general mounting arrangement of Collective Protection Equipment on two representative types of vehicles in this system.

b. Protective Entrance. The Protective Entrance mockup provided for design evaluation by the U.S. Army Chemical Center was made specifically to fit the AN/MSQ-28 WMC and RDC vehicles. Figures 7 through 10 show the Protective Entrance at various stages of installation.

It is noted that personnel entering the vehicle through the Protective Entrance are required to ascend a ladder after they dispose of their outer garments. When personnel ascend the ladder, it is expected that further decontamination will take place since the contaminants are driven to the bottom of the Protective Entrance and expelled.

c. Filter Unit. The Filter Unit employed on all AN/MSQ-28 vehicles is the 400 cfm Filter Unit. The mockup provided for U.S. Army Chemical Center evaluation simulated this unit. Refer to figures 3 and 4. The 400 cfm Filter Unit module will be used on all shelter/vehicles comprising the AN/MSG-4 System with the exception of the AN/GSS-1D Radar Surveillance Central.

d. Mounting Provisions. The Filter Unit will mount on the front platform of the trailer adjacent to or between the air conditioners as dictated by the trailer served. However, this will require relocation of the gas tank which provides fuel for the vehicle heaters. If relocation of the gas tank is not desirable, the alternative is to mount the Filter Unit beneath the frame of the vehicle, with the resulting design problems described for the R & D vehicles.

The vehicle curbside door frame is provided with a system of camloc receptacles. The door frame provided by the contractor as a part of the Protective Entrance coupling attaches to this system of camloc receptacles. It is intended that the door frame and coupling be permanently mounted on the vehicle after the system is deployed and located on a given site to assure rapid installation of the Protective Entrance in cases of emergency. The beam for supporting the Protective Entrance will be mounted on top of the vehicle. It will fasten to blind rivnuts inserted in the structural members above the top of the door.

e. Stowage Provisions. A stowage box for the collective protection equipment is located underneath the AN/MSQ-28 vehicles. The box has adequate stowage capacity for the collective protection equipment not permanently installed on the vehicle.

f. Method of Admitting Filtered Air for Vehicle Protection. The AN/MSQ-28 System air conditioners are provided with CBR ports for the filtered air to be delivered directly to the blower inlet plenum of the air conditioner.

g. Control System. The schematic diagram for the 400 cfm Filter Unit, figure 15, includes the wiring for the Filter Unit, the remote control panel, and the interconnecting wiring. The operation of the Filter Unit and the remote control panel is described in paragraphs 11, 14, and 15.

h. Vehicle Modifications. Figure 16 shows the basic vehicle modifications required to accommodate the control and power wiring, the tubing for the remote pressure gage, and the pressure probe into the blower inlet plenum of the air conditioner.

#### 17. AN/MPS-23 Radar Antenna Trailer

a. General. Category B Collective Protection Equipment is specified for the AN/MPS-23 Radar Antenna Trailer. Category B equipment does not include the Protective Entrance. The Antenna Trailer is unmanned and cannot be entered as long as the antenna is radiating. The Filter Unit is required to prevent contamination within the radome. The radome is provided with an airlock, which is required for pressure equalizing purposes, so that the personnel access port into the radome can be opened. If it becomes necessary to enter the radome from a contaminated atmosphere, a certain amount of personnel decontamination will take place in the airlock and also as personnel enter the radome by virtue of the high velocity air from the radome passing through these areas.

A test was made to determine the required air delivery capacity for the Filter Unit. Basic objectives of the test were:

- (1) To determine if the radome could be maintained in a fully inflated condition with only one radome blower in operation.
- (2) To determine the maximum air delivery capacity of one radome blower while maintaining pressure in the radome.

The method used to determine the first objective was to open the personnel access port in the radome for 15 seconds and measure the radome pressure at the end of the 15-second time interval. The 15-second time interval was selected as ample for normal ingress and egress. The external zippered opening in the airlock was closed while the radome access port was opened. The pressure fell from 6.2 inches of water gage to 4.4 inches of water gage, which is safely above the pressure level at which the antenna is automatically prevented from rotating. With the data obtained from this test the radome blower performance curve was reviewed and the maximum blower capacity was determined to be 640 cfm.

The test results suggested the use of two 400 cfm units operating in parallel to satisfy the air requirements of the antenna trailer. A blower-system balance curve was plotted on this basis to determine feasibility. The curve indicated that the pressure within the radome would rise from a normal pressure of 6.2 inches of water gage to approximately 8.0 inches of water gage, and that the blower system will deliver approximately 760 cfm

of air when the filters are clean. The condition described is for stable operation.

Figure 17 indicates the general mounting arrangement of the collective protection equipment for the AN/MPS-23 Radar Antenna Trailer.

b. Filter Unit. The proposed 800 cfm Filter Unit was described in the 6th monthly progress report and is shown in Figure 6. It consists of two 400 cfm Filter Unit modules stacked and mounted horizontally on a skid base with a stowage box mounted directly above the top filter module. The 800 cfm Filter Unit has a discharge header into which both 400 cfm modules deliver filtered air. As a result of the U.S. Army Chemical Center personnel evaluation of the 800 cfm Filter Unit mockup, the discharge header will be eliminated and, instead of using a single 8-inch diameter flexible duct for delivering filtered air to the antenna trailer, two 5-inch diameter flexible ducts will be used, one from each of the Filter Unit modules.

c. Stowage and Cartage. A stowage box is provided which mounts above the top 400 cfm Filter Unit module. It will stow the two 5-inch diameter supply ducts and the power and control intercabling required to operate the Filter Unit.

The AN/MPS-23 Radar Antenna Trailer does not have stowage space for the 800 cfm Filter Unit. Therefore, means of carting the Filter Unit will have to be provided by the using agency. The Radar Antenna Trailer is equipped with a towing pintle and it is recommended that a trailer be provided for cartage of the Filter Unit.

d. Method of Admitting Filtered Air for Vehicle Protection. The fresh air inlet, provided as standard equipment on the AN/MPS-23 Radar Antenna Trailer, admits air from the underside of the trailer, filters the air and delivers it to the suction plenum of the two parallel blowers within the radome. The fresh air opening is square in shape and has a total free area of four square feet. A cover plate is presently provided to prevent mud and dirt from entering the vehicle during transit. The cover plate is held in place by camloc fasteners. For adaptation of the CBR Filter Unit, the cover plate can be replaced by a cover plate containing two 5-inch diameter hose couplings with protective caps. The two 5-inch diameter flexible ducts will connect between the Filter Units and the duct couplings on the cover plate, and will deliver filtered air to the Antenna Trailer blower suction plenum.

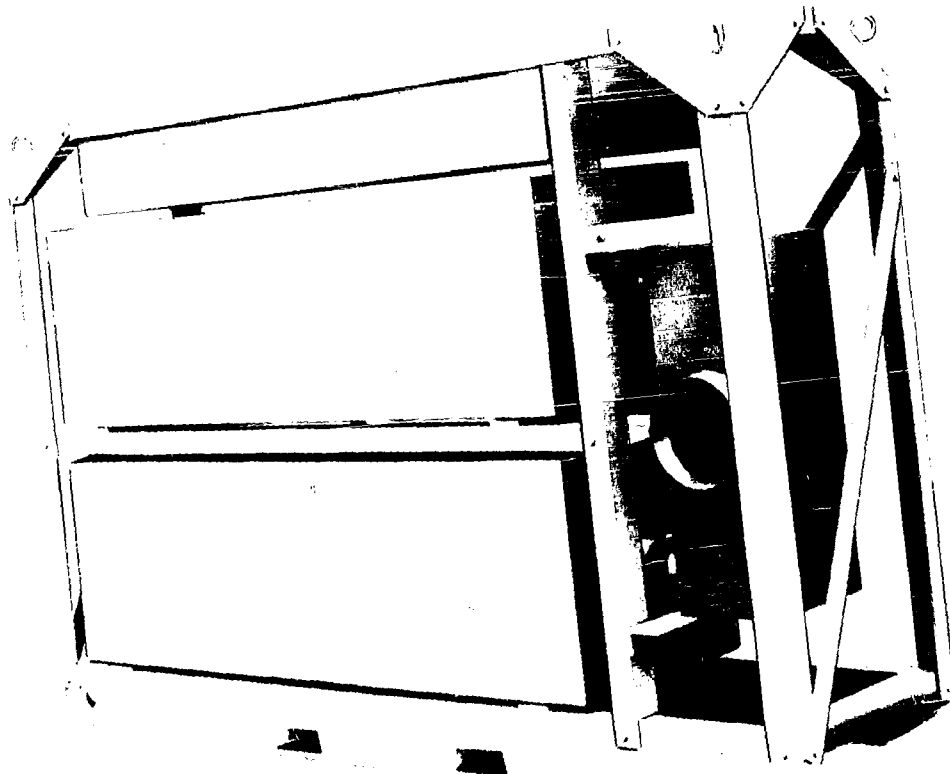

CPE-16

Figure 6. 800 CFM Filter Drill Backup

e. Control System. The Filter Unit modules will contain the standard automatic damper systems to provide interchangeability. However, the intention is to permit the dampers to remain in the fully opened position and let the pressure in the radome decrease as the filters become loaded. This operational simplification is possible because the radome air flow requirement will never exceed the safe filtering capacity with the Filter Unit dampers open.

The remote control panel will not be required with the 800 cfm Filter Unit as the radome is unmanned. The individual modules comprising the Filter Unit will be started and stopped manually by the switches provided on the modules.

f. Vehicle Modifications. The proposed alterations required for the AN/MPS-23 Radar Antenna Trailer are relatively simple and consist primarily of; (1) the addition of a transformer to reduce the available power from 416 volts, 3 phase, 60 cycle power to 208 volt, 3 phase, 60 cycle power, (2) provision for prevention of the No. 2 radome inflation blower from operating, and (3) provision for the necessary wiring and connectors to bring the 208 volt power to a convenient point on the underside of the vehicle.

#### 18. AN/MSQ-18 VEHICLES

a. General. The AN/MSQ-18 System is comprised of two types of vehicles, the Operations Central (OC), and the Coder-Decoder Group (CDG). Although the CDG may be operated as an unmanned vehicle, therefore, Category A Collective Protection Equipment is required. The electronic equipment of both the OC and CDG Systems is mounted in an M-109 van body which is mounted on a type M-35, 2 1/2-ton truck chassis. The vehicles are self-propelled and are not intended for heli-lift operations.

A complete operational AN/MSQ-18 System is comprised of one OC and four CDG vehicles. There are 8 R & D systems and 19 production systems in existence. These have all been deployed to the field, and no basic differences exist between the R & D and Production models.

The general arrangement of the Category A Collective Protection Equipment on the vehicles is shown in figure 18.

b. Protective Entrance. The Protective Entrance for the AN/MSQ-18 vehicles is similar in design to the Protective Entrance used on the AN/MSQ-28 vehicles, as shown in figures 7 through 10. To enter the vehicle, personnel will leave the bottom area containing the maximum amount of contaminants and ascend the ladder to a contaminant free area.

c. Filter Unit. The Filter Unit intended for use on the AN/MSQ-18 vehicles is the same basic 400 cfm Filter Unit module intended for use on the AN/MSQ-28 vehicles. The Filter Unit will be mounted in a horizontal position on a skid base similar to that required for the 800 cfm Filter Unit. Figure 5 shows the 400 cfm Filter Unit mockup arranged for horizontal mounting.

d. Stowage and Cartage. Attached to the top of the 400 cfm module will be a stowage box to provide stowage for the Protective Entrance, the spreader bars, the support beam, the Protective Entrance door frame coupling, and the interconnecting control cabling.

The original intention was to mount the Filter Unit above the cab of the truck and immediately in front of the horizontal air conditioner. Stowage facilities were also to be provided at the same location. However, further investigation revealed that the addition of weight to either vehicle would not be permitted by vehicle specifications, and it would be difficult to provide a single modification kit capable of structurally supporting the Filter Units on all vehicles. The van bodies were made by several manufacturers over a span of years. Modifications were made to the forward bulkheads for the application of the air conditioner and other equipment, and the records of these modifications are incomplete or non-existent. It is recommended that the Filter Unit be skid-mounted and that the means of carting the Filter Unit and accessories be furnished by the using agencies.

e. Method of Admitting Filtered Air for Vehicle Protection. On the air conditioners used with the AN/MSQ-18 vehicles it is not feasible to introduce filtered air into the blower inlet plenum, as the air conditioner would require extensive rework. Therefore, an alternate location has been selected. The selected inlet location is in the forward bulkhead of the M-109 van, leading directly into the return air duct which supplies the recirculated air to the air conditioner. This location considerably reduces the amount of modification required. Satisfactory pressurization of the vehicle will be accomplished. However, the filter assembly will be required to operate against a back pressure higher than that of other systems where air is introduced into the lowest pressure area. Pressure sensing will be at the blower inlet plenum.

f. Control System. The control system is the same as the one used on the AN/MSQ-28 vehicles (par. 16g).

g. Vehicle Modification. Figure 19 shows the basic vehicle modifications required to accommodate the control and power wiring for the operation of the filter unit, the addition of tubing to provide for the hookup of the remote pressure gage, and the modifications required in equipping the air conditioner with a static pressure tap.

## 19. AN/TSQ-38 SHELTERS

a. General. The OC and CDG subsystems comprising the AN/TSQ-38 System contain the same electronic equipment as their counterparts in the AN/MSQ-18 System vehicles. The equipment was repackaged in a heli-hut type shelter for deployment by helicopters to inaccessible areas.

The air conditioner is separate from the heli-hut, and is connected by means of flexible ducting. The arrangement of the category A Collective Protection Equipment is shown in figure 20.

b. Protective Entrance. The proposed design of the Protective Entrance for the AN/TSQ-38 vehicles has gone through several stages of design evolution. It was originally intended that the Protective Entrance be similar in design to that proposed for the AN/MSQ-28 vehicles and the AN/MSQ-18 vehicles, except that the portion extending below the vehicle door opening would be shortened considerably, inasmuch as the heli-huts are sometimes placed on the ground. However, this design did not reflect the philosophy that entering personnel would ascend a ladder into an area of pure air providing for a greater degree of decontamination prior to their entering the vehicle. It was therefore planned to divide the Protective Entrance into two compartments. The outer compartment would be used for first stage decontamination such as removal of contaminated clothing and use of the decontaminants agents. The inner compartment with higher pressure would provide final decontamination.

A later revision reflects a considerable change in design philosophy. In addition to being deployed by helicopters, the AN/TSQ-38 shelters are designed to mount on an M-35 truck. It was the original intent to supply a support platform for the Protective Entrance when the heli-huts are truck-mounted. Because it is a natural requirement to provide stowage space for any components furnished, it was decided that the platform would be a stowage burden. For truck usage, a third Protective Entrance concept was considered. This concept is similar to the AN/MSQ-28 entrance, built to extend to the ground. Two access openings are provided. The upper opening can be used when the shelter is set on the ground, and the lower opening can be used when the shelter is mounted on the M-35 truck. With the shelter set on the truck, the Protective Entrance will function in a manner similar to that of the AN/MSQ-28 and AN/MSQ-18 Protective Entrances. A further development would provide a readily removable lower section which will not be used when the heli-hut shelter is on the ground. With this section removed, the bottom (floor) assembly, which includes the scavange air outlets, would be connected directly to the top portion of the entrance. Since a stairway to the shelter will not be necessary under these conditions, a "snap in" type inner partition would be provided to divide the entrance into two compartments. The assembly would then function the same as the two compartment design already described.

c. Filter Unit. The Filter Unit proposed for the AN/TSQ-38 System vehicles is the same as the one proposed for the AN/MSQ-18 vehicles. It consists of a 400 cfm module mounted horizontally on a skid base, and with a stowage box mounted directly above the Filter Unit module.

d. Stowage and Cartage. Stowage of the Protective Entrance, door frame and coupling, support beam, spreader bars, intercabling and remote control panel is provided by stowage box on the Filter Unit assembly.

The Filter Unit is designed to be heli-lifted to make it compatible with the operational requirements of the system it serves. When the AN/TSQ-38 shelters are transported on M-36 trucks, the Filter Unit can be set between the air conditioner and the heli-hut, as shown on figure 20. A separate means of transporting the Filter Unit should not be required providing the M-36 truck is used to transport the shelter. Means of securing the filter unit to the M-36 truck will be furnished by the using agency.

e. Method of Admitting Filtered Air for Vehicle Protection. The most effective place to admit the filtered air to the AN/TSQ-38 OC and CDG Systems is the blower inlet plenum in the air conditioner. This would cause a decrease in the pressure drop through the cooling coil by virtue of passing a smaller amount of air through the coil, with a resulting decrease in pressure throughout the system. However, a major modification to the air conditioner would be required and, therefore, another method of admitting the filtered air was sought. A decision was made to introduce the filtered air into a "q" duct section inserted between the air conditioner and the flexible return air duct. The only air conditioner modification required is to provide for introduction of the static pressure probe in the blower suction plenum.

f. Control System. The control system for the AN/TSQ-38 OC and CDG systems is identical to that described for the AN/MSQ-28 systems.

g. Vehicle Modifications. Figure 21 shows the proposed vehicle modifications required to accommodate the power and control wiring, and the tubing for the pressure switch and remote pressure gage.

## 20. AN/GSS-1D SHELTER

a. General. The AN/GSS-1D Radar Surveillance Central Shelter is divided into two sections by a partition comprised of three sliding panels. One section is the personnel area, and the other, located behind the sliding panels, is the equipment compartment. Located in the equipment area are the power supply (PP-674/TPS-1D), signal comparator (CM-36/TPS-1b), radar modulator (MD-144/TPS-1D),

receiver-transmitter (RT-212/TPS-1D), antenna base (AB-221/TPS-1D), and the azimuth-range indicator (1P-141/TPS-1D). Ambient air is used to cool the equipment and is drawn into the compartment through ventilators near the corner where the roadside and forward walls meet. The air is drawn through the compartment and exhausted by a centrifugal blower which has the suction side connected by a flexible duct to the equipment compartment. The blower is located in the shelter and discharges the air to the ambient atmosphere. An identical centrifugal blower draws air directly from the personnel section of the shelter and exhausts it to the atmosphere. When the personnel blower is in operation, ambient air is drawn through a louvered ventilator in the curbside wall of the shelter. A remote air conditioner can be supplied for cooling the personnel space in lieu of using ambient air. Two air conditioner duct adapters are provided which attach to the curbside window and the operator's compartment ventilator.

The shelter is heated with a 60,000 BTU gasoline-burning heater using 28 volt dc power for blower operation and ignition. Fresh air enters the fan plenum section through a louvered ventilator on the roadside wall. Recirculation air from the operator's space mixes with the fresh air in the fan intake plenum. A decontamination opening is provided in the curbside wall to which the filtered air can be ducted from the CBR Filter Unit.

The general arrangement of the Category A Collective Protection Equipment proposed for this system is shown in figure 22.

b. Protective Entrance. The AN/GSS-1D Radar Surveillance Central can be transported by helicopter, M-35 truck or M8E2 cargo carrier. It is similar to the AN/TSQ-38 shelters in this respect. The description in paragraph 19b of the AN/TSQ-38 Protective Entrance therefore also applies to the AN/GSS-1D Protective Entrance.

c. Filter Unit. The Phase I study time and funds did not permit completion of the AN/GSS-1D Filter Unit design concept and air delivery requirements. The final Filter Unit configuration must be determined in Phase II. The study effort expended to date indicates that the filtered air must be heated before admitting it to the shelter, and that, unlike the other filter units, 120 volt, 3 phase, 400 cycle power must be used for blower operation because of power availability. The trailer-mounted gasoline engine generator set (PU-253/U) that supplies power to the AN/GSS-1D System is comprised of two gasoline engine generator sets (PU-107/U) mounted in a type M-105 two-wheel trailer. The PU-107/U generator has a 400 cps, 3 phase output of 118-120 volts, 10 kw, 10<sup>4</sup> amp (maximum) and a dc output of 28 volts, 2.5 kw, 90 amp. The specification power requirement for the AN/GSS-1D Radar Surveillance Central is 7.82 kw at 115 volts, 400 cps, and 1.4 kw at 28 volts dc.

Sufficient dc power is not available for Filter Unit motor blower operation. However, 400 cps power is available for Filter Unit operation if both PU-107/U generators are used.

d. Stowage and Cartage. The design concept of the Filter Unit has not been established but it is presently the intent to include a box to provide stowage for such items as the Protective Entrance, door and coupling, support beam, spreader bars, electrical cables, and ducts.

The Filter Unit cannot be attached to the shelter and space is not available on the M-35 truck or M9E2 cargo carrier. A separate means of conveying the Filter Unit must be provided by the using agencies.

e. Method of Admitting Filtered Air for Vehicle Protection. In the 5th monthly progress report it was proposed to admit air to the personnel section of the shelter through the CBR port provided. The air will be drawn into the equipment compartment through a new port in the curbside sliding panel, and then exhausted to the atmosphere by the equipment compartment fan. This will admit high velocity air to the personnel compartment, possibly creating an uncomfortable condition. Ducting the air from the CBR port to the proposed port in the curbside sliding panel is not practical as the duct will interfere with the radar operator. Further study is required to determine the best method for admitting the filtered air.

f. Control System. The control system will be similar in function to the basic collective protection control system except for the added heating capability.

g. Vehicle Modifications. An air conditioner will not be used for cooling the personnel in the shelter when the collective protection system is in operation. The minimum system pressure will therefore be found within the shelter, and the static pressure probe from the air control pressure switch will be within the shelter. The control modification to the shelter will be very similar to the modifications shown for the other systems.

## SECTION VII EVALUATION OF MOCKUPS

### 21. PROTECTIVE ENTRANCE

The full-sized Protective Entrance described in the 6th Monthly Progress Report was evaluated by HAC for design effectiveness. The points considered were:

- (1) Ease of installation
- (2) Ease of entry
- (3) Ability to maintain shape
- (4) Storage requirements
- (5) Air leakage

a. Ease of Installation. With the door frame coupling and support beam installed on the trailer as they would be when the system is deployed on site, the installation procedure consists of; (1) installing the spreader bars in the fabric assembly, (2) hoisting and securing the fabric assembly to the support beam, (3) connecting the fabric assembly to the coupling, and (4) attaching the supply air duct. The assembly was installed by one person in six minutes. The time required to disassemble the Protective Entrance will be somewhat less than the installation time. The installation and disassembly are easily and quickly accomplished. Refer to Figures 7, 8, 9, and 10.





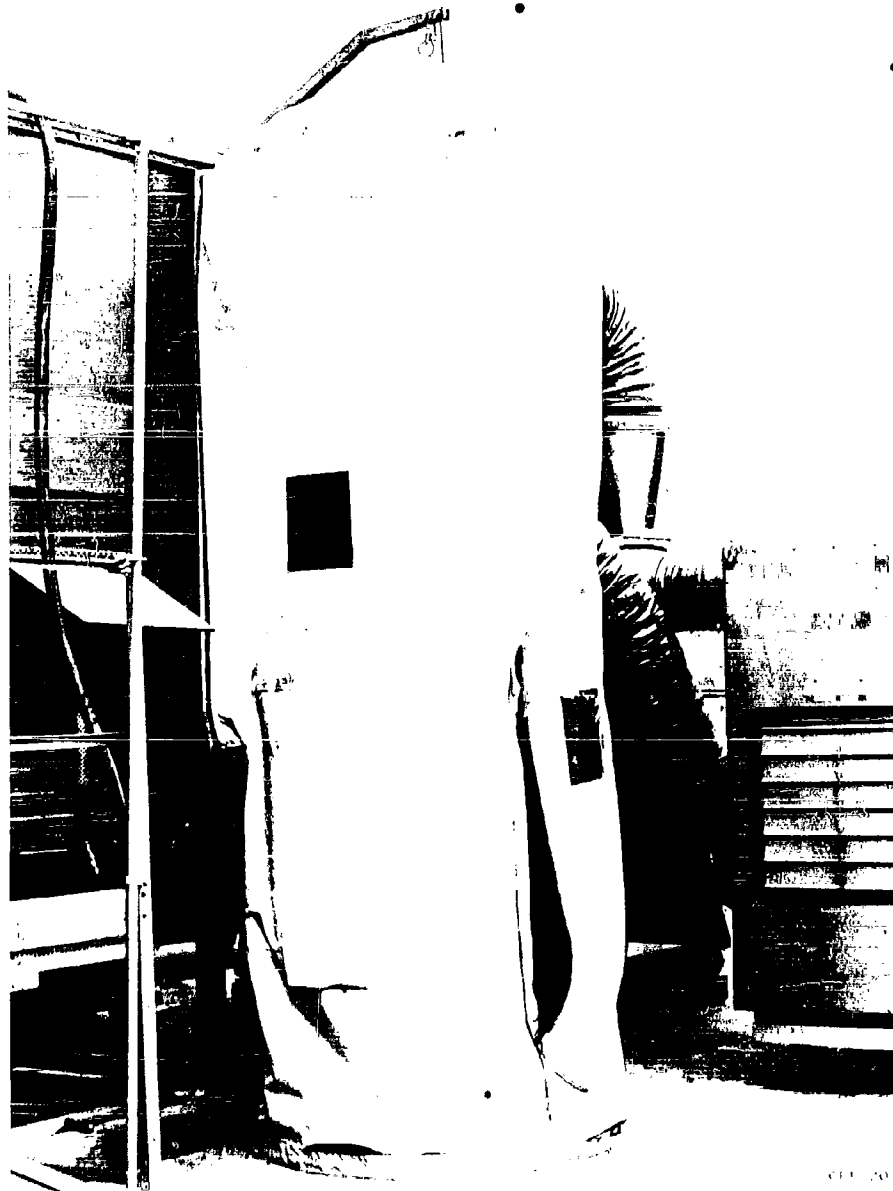
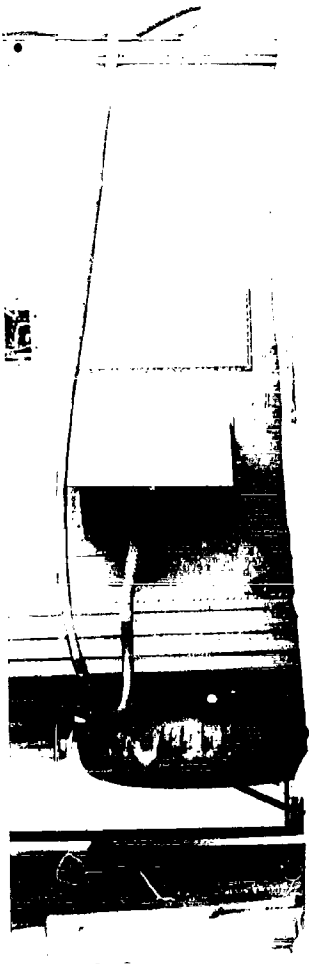

Figure 1. A person in a white protective suit standing in a room.



b. Ease of Entry. Entry to and exit from the Protective Entrance is easily accomplished. It was concluded, however, that pull tabs should be strategically sewn on the fabric assembly to assist in closing and opening the zipper on the door. The Protective Entrance was easily entered even when buffeted by high winds.

c. Ability to Maintain Shape. The evaluation took place over a span of time that included periods of calm weather and periods of high winds estimated at 40 mph. Under all conditions of weather, the entrance shape was maintained when inflated. During windy conditions it was necessary to secure the bottom of the Protective Entrance with tie-down stakes to maintain the proper shape.

d. Stowage Requirements. The fabric assembly was folded into a shape 24 inches long by 14 inches wide by 11 inches high. It weighs approximately 25 pounds. The item requiring the greatest amount of stowage space is the door frame coupling which, when folded, is 75 inches long by 18 inches wide and approximately 3 inches thick. The spreader bars fold into a shape 7 inches in diameter and 26 inches long. The support beam is 63 inches long and requires very little stowage space.

e. Air Leakage. The primary sources of leakage were the sealing flaps covering the zippers. These were not properly cut and would not seal as well as intended. To test the effects of the leakage, the Protective Entrance was pressurized by admitting air at a rate of 180 cfm. A pressurization of 0.6 inches of water gage was achieved with the scavenge air ports completely open. This compares favorably with the expected operating pressure required for the AN/MSQ-28, AN/MSQ-18, and AN/GSS-1D shelter/vehicles. The zipper sealing flaps will have to be revised to permit operation of the Protective Entrance at the pressures required by the AN/TSQ-38 shelters.

The U. S. Army Chemical Center representatives examined the mockup and made the following suggestions and recommendations.

(1) The 12" x 12" windows are too large and should be reduced in size to approximately 3" diameter. Recent cold chamber tests have shown that the windows become brittle at low temperatures and break when flexed. The smaller sized windows reduce the hazard.

(2) The accordion plent at the bottom of the Protective Entrance, designed to allow for ground level irregularities, was not considered absolutely necessary by the customer. However, the variations in vehicle level are respectfully pointed out by this contractor, with the recommendation that it not be eliminated from the final designs.

(3) The door of the mockup is rectangular in shape and secured by a slide fastener (zipper). The slide fastener is equipped with two sliders which allow any portion of the slide fastener to be opened or closed from either direction. It was suggested that a crescent shape rather than a rectangular shape would provide a more convenient door opening and that the slide fastener be shortened.

(4) The opening provided in the side of the Protective Entrance for ejecting contaminated clothing should be enlarged to accommodate the passage of heavy winter clothing. The design of the anti-backdraft flap covering the opening was found to be satisfactory but will be improved by the addition of the side gussets which will allow the flap to fit more securely against the Protective Entrance. The same type of gusseted flaps will be used to protect the scavenging air outlets, at the bottom and around the periphery of the Protective Entrance, against backdrafts.

(5) The contractor was asked to consider the addition of an electric light within the Protective Entrance.

The above recommendations will be incorporated in the final design with the exception of No. 2 and No. 5. The addition of an electric light would complicate the design, and a battery-powered light is recommended.

## 22. 400 CFM FILTER UNIT

The 400 cfm Filter Unit mockup provided for evaluation is a full size unit incorporating much of the actual hardware planned for the production unit. The mockup is complete with air inlet weather shield, toggle switches, Dwyer pressure switch, automatic damper system complete with mockup damper motor, manual damper hardware in the outlet stacks, mockup of the filters made from wood and cardboard, plenums, and blower assembly.

The contractor's evaluation of the mockup considered the following:

- (1) Effectiveness of filter clamping devices
- (2) Ease of replacing filters
- (3) Method used to hold the air inlet weather shield open
- (4) Accessibility of components

a. Effectiveness of Filter Clamping Devices. A visual inspection indicated that the sealing gaskets were evenly loaded. The physical act of loading the cams used in the filter clamping device was relatively easy, and it is concluded that filters and headers can be securely held together by the method employed in the mockup. Operation of the clamping device is accomplished from the front of the Filter Unit.

b. Ease of Replacing Filters. The filters are conveniently removed from the front of the Filter Unit. From operation of the mockup, it was observed that handles should be installed on the filters to assist in their removal.

c. Method Used to Hold Air Inlet Weather Shield Open. The top of the weather shield is supported by the sides of the shield when open for filter unit operation. On the mockup assembly, it was held in place by gravity. Evaluation of the shield resulted in the conclusion that production models should be equipped with a positive latching device to prevent a shock or a strong wind from accidentally closing the shield.

d. Accessibility of Components. All of the mechanical components are located in the blower compartment and are readily accessible by removing the side panels of the Filter Unit.

The U. S. Army Chemical Center representatives examined the mockup and made the following suggestions and recommendations.

(1) The manual damper control switches on the Filter Unit are not considered necessary, and it was recommended that they be removed to simplify the control system.

(2) To provide an additional degree of safety, it was requested that the automatic damper system be driven through a clutch mechanism which would allow the dampers to be manually positioned without having to remove the operating linkage.

(3) It was suggested that the Dwyer pressure switch be mounted from the inlet air weather shield, so that the pressure switch will always be mounted in the same position relative to ground, regardless of the vertical or horizontal position of the filter assembly.

Contractor will comply with items (1) and (2), and a survey will be made to determine the feasibility of complying with item (3).

### 23. 800 CFM FILTER UNIT

A full scale 800 cfm Filter Unit mockup was provided for evaluation. It consists of a skid base with two 400 cfm Filter Unit modules stacked horizontally, with a stowage box mounted above the top module. A structural frame supports the top module, the stowage box, and the discharge header, into which the modules deliver air. The four top corners of the frame are fitted with lifting eyes, and the skid base has an opening provided for insertion of forks of a lift truck. Holes are provided in the end of the skid base runners for the insertion of towing hooks.

The contractor's evaluation of the mockup considered the following:

- (1) Type and placement of lifting eyes
- (2) Provisions for lift truck handling
- (3) Size of stowage box

a. Type and Placement of Lifting Eyes. The frame of the Filter Unit is designed so that the fixed lifting eyes do not protrude past the projected dimensions of the Filter Unit. Evaluation of the design indicated high manufacturing costs, consequently a different type of lifting eye will be considered for future development.

b. Provisions for Lift Truck Handling. Two openings are provided in the skid base to insert the lifting forks. Examination revealed that these are too small and too closely spaced to allow handling by larger lift trucks. Additional development will be accomplished in this area during subsequent phases of this program.

c. Size of Stowage Box. The stowage box was designed to hold the 8-inch diameter ducts. During Phase II an investigation will be made to see if it is practical to make the stowage box identical to the one used on the skid base proposed for the AN/MSQ-28 and AN/TSQ-38 Filter Units.

The U. S. Army Chemical Center representatives examined the mockup and made the following suggestions and recommendations.

(1) Instead of running one 8-inch diameter flexible duct from the header of the Filter Unit to the AN/MPS-23 Radar Antenna Trailer, the header should be eliminated and two 5-inch diameter ducts should be connected directly to the Filter Unit modules.

(2) The structural frame should be eliminated, with the top Filter Unit module bolted to the bottom module. The stowage box should, in turn, bolt to the top module. The eye bolts, or similar lifting provisions, should be provided on the skid base.

The recommendation to eliminate the header will be accepted and incorporated in the final design. The recommendation to eliminate the structural frame will be accepted providing the weight of the Filter Unit can be reduced sufficiently by doing so. The elimination of the structural frame would necessitate strengthening the modules in order to withstand rough handling and associated shock, with consequent increase of the 400 cfm Filter Unit module weight and cost.

## SECTION VIII CONCLUSIONS

### 24. FILTER UNIT MODELS

Only two basic Filter Unit applications are required for the 11 different shelter/vehicles considered in the study. One unique filter is required for the AN/GSS-1D Radar Surveillance Central and for all others, the 400 cfm Filter Unit used singly and in multiples will satisfy the requirements based on the original air leakage assumptions.

The design concept of the basic 400 cfm Filter Unit module provides great utilization versatility. The speed increaser gear box required for blower operation is especially designed for Filter Unit operation in either the vertical or horizontal position. The inlet air weather shield can be oriented to accommodate the operating position of the Filter Unit module. When used to protect the AN/MSQ-28 vehicles (AN/MPS-23 Radar Antenna Trailer excepted), the basic module is mounted in the vertical position. When it is used to protect the AN/MSQ-1B and AN/TSQ-28 shelter/vehicles, a module is mounted horizontally on a skid base. The 800 cfm Filter Unit used to protect the AN/MPS-23 Radar Antenna Trailer is comprised of two modules mounted similarly on a skid base. This modular, or building block design, has resulted in development cost savings. It will also facilitate large cost savings for quantity production programs, and will reduce future stocking and logistics problems.

On the basis of the work performed to date, including the mockups which have been evaluated, it is concluded that these design concepts can be developed into practical and workable production hardware.

## 25. PROTECTIVE ENTRANCE MODELS

The evaluation testing of the Protective Entrance mockup (truly a prototype) revealed the novel design concept to be very practical. While only one of the five ultimate models was produced in mockup, the evaluation indicates that the concept will apply successfully throughout. Further development will produce a practical and workable production series of Protective Entrances.

## 26. CAPACITY OF AIR CONDITIONERS

Table I (Section IV) shows that some air conditioners have marginal capacities and the subsystems served by them cannot be expected to operate satisfactorily at temperature as high as 125°F when the Collective Protection Equipment is also in operation. In these cases it may be necessary to provide for higher air conditioner capacities by means of a field modification at the time of installation of the Collective Protection Equipment.

## SECTION IX RECOMMENDATIONS

### 27. ADDITIONAL TESTING REQUIRED

The Phase I study is based on the assumptions outlined in paragraph 8. It was necessary to base the Phase I study on reasonable assumptions for lack of vehicle availability for testing. The U. S. Army Chemical Center has concurred with the contractors recommendation that representative vehicles of each type be tested for leakage rate, and is requesting assignment of vehicles to HAC from other agencies for test purposes. The testing should consist of introducing the correct amount of air into the shelter/vehicle while the air conditioner system is in operation. The pressure differential between the air conditioner blower inlet plenum and the atmosphere should be monitored. If the assumed leakage rate is correct, the critical pressure differential will increase until it reaches +0.5 inches of water gage. Conversely, the inability to obtain proper pressurization would indicate that the leakage rate is too high, requiring appropriate corrective vehicle fixes. The corrective vehicle leakage fixes should be developed as a part of a separate program and should be suitable for field installation by the users.

### 28. AN/MSQ-28 R & D VEHICLES

It is recommended that the AN/MSQ-28 R & D vehicles not be equipped with Collective Protection Equipment, based on the understanding that these vehicles will soon be phased out and replaced by production vehicles.

29. PHASE II

It is recommended that the development program be continued to provide for complete development of working prototypes for performance testing and field evaluation in accordance with the recently submitted contractor Phase II proposal.

SECTION X MISCELLANEOUS INFORMATION

30. APPLICABLE CONFERENCES AND REPORTS

The following is a list of subject, locations, and dates of conferences pertinent to this study.

<u>Date</u>	<u>Location</u>	<u>Subject</u>
11 July 1961	Edgewood, MD.	Design Information on Collective Protective Equipment
14 August 1961	Hughes Aircraft Co. Fullerton, Calif.	Filter Unit Air Delivery Rates
3 & 4 October 1961	Hughes Aircraft Co. Fullerton, Calif.	Review of Design Concepts of 400 CFM Filter Unit and Protective Entrance
14 & 15 November 1961	Hughes Aircraft Co. Fullerton, Calif.	Review of Layout Drawing of 400 CFM Filter Unit and Protective Entrance
10 & 11 January 1962	Hughes Aircraft Co. Fullerton, Calif.	Review of Mockups of 400 CFM Filter Unit and Protective Entrance
13 & 14 February 1962	Hughes Aircraft Co. Fullerton, Calif.	Review of Mockup of 800 CFM Filter Unit and Protective Entrance

The following reports were issued during the course of the Study Contract:

<u>Type</u>	<u>Publication Date</u>	<u>Report Reference Number</u>	<u>Classification</u>
Monthly Progress Report	21 August 1961	1610.30/141 SD61-137	U
Monthly Progress Report	21 September 1961	1610.30/149 SD61-159	U
Monthly Progress Report	21 October 1961	1610.30/159 SD61-175	U
Monthly Progress Report	9 November 1961	1610.30/163 SD61-186	U
Monthly Progress Report	1 December 1961	1610.30/170 SD61-212	U
Monthly Progress Report	21 January 1962	1610.30/26 SD62-10	U
Monthly Progress Report	19 February 1962	1663.10/203 SD62-10	U

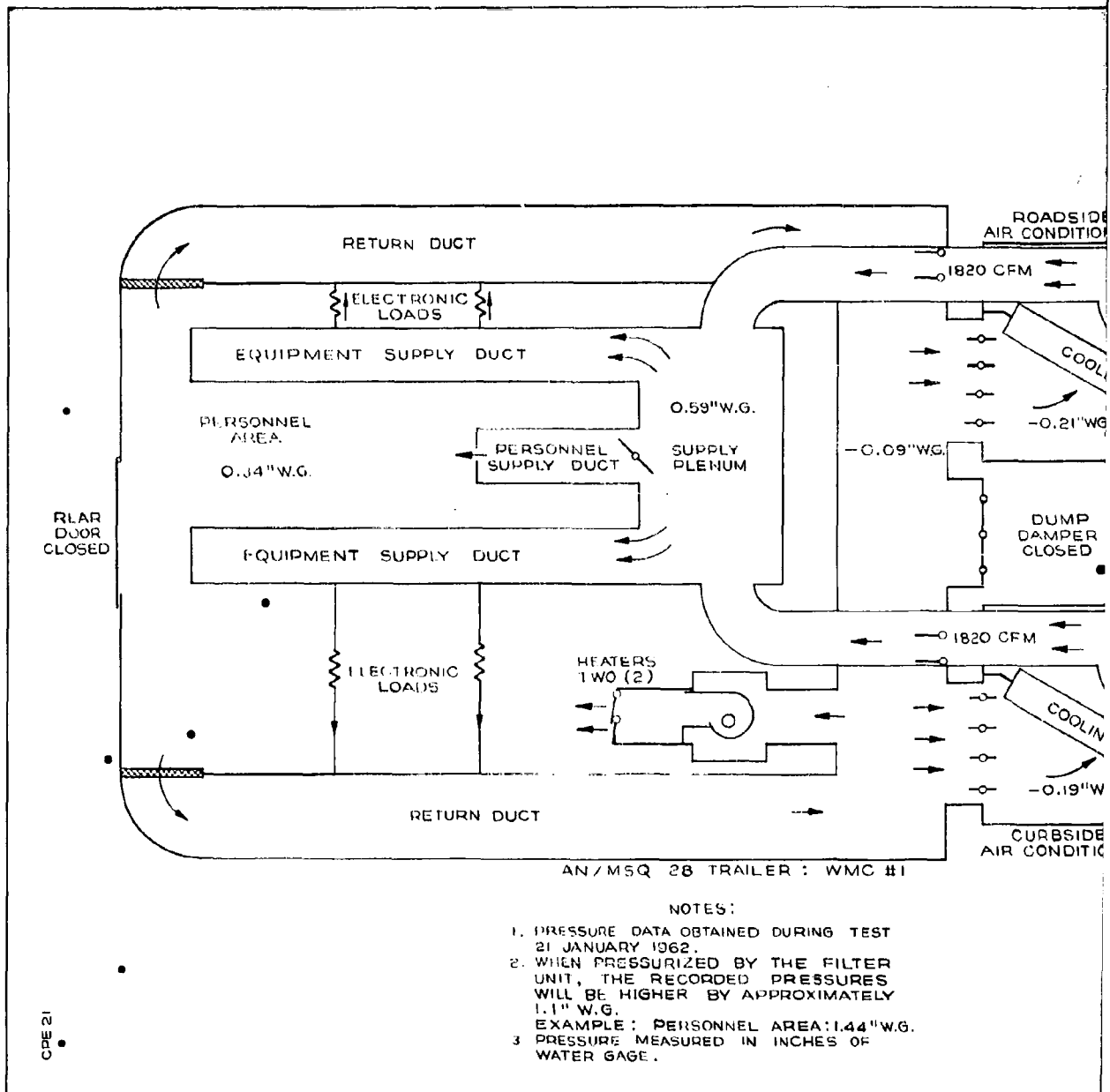

CPE 21



Figure 11 Actual Operat

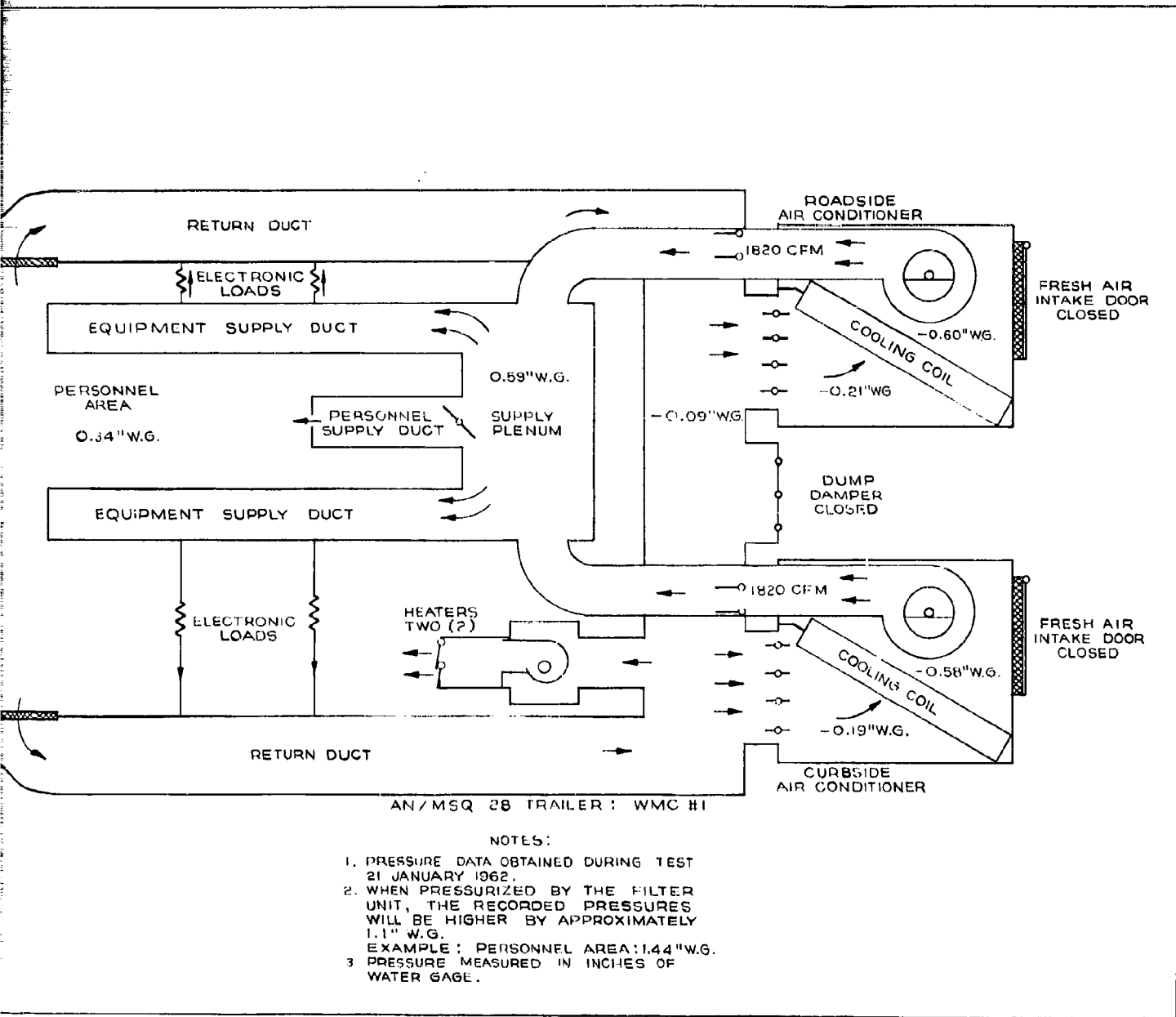
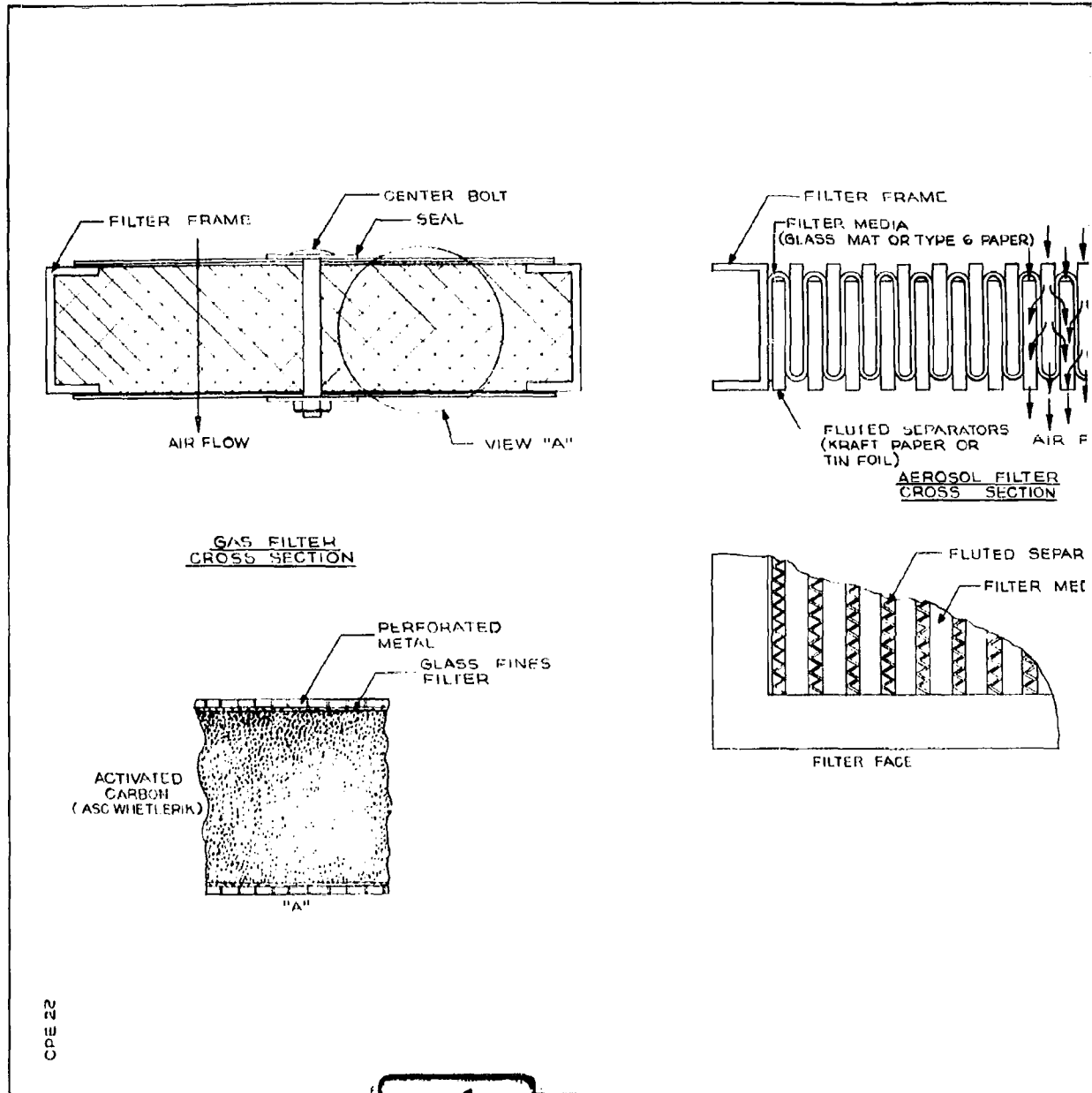

Figure 11 Actual Operating Pressure of AN/MSQ-28 WMC

2



1

Figure 12 Typical Construction of Aero

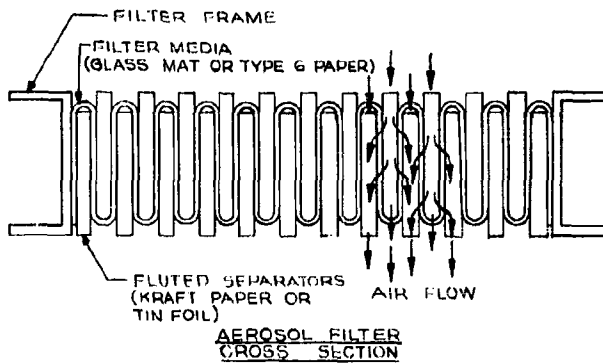
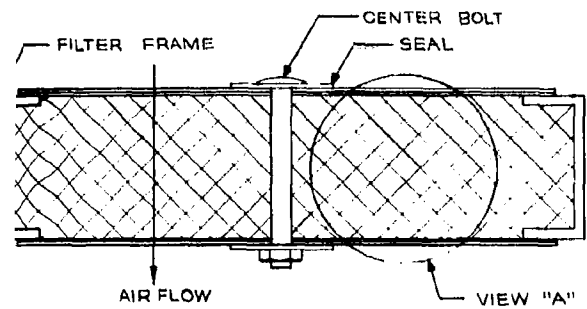

GAS FILTER CROSS SECTION

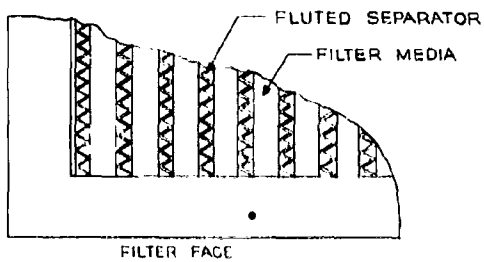
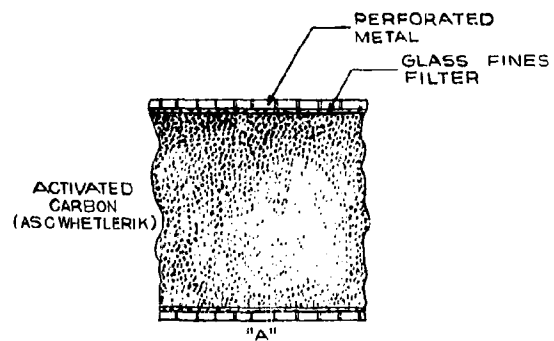

2

Figure 12 Typical Construction of Aerosol and Gas Filters

SLIDE FASTENER

TRAILER

CPE-6

1

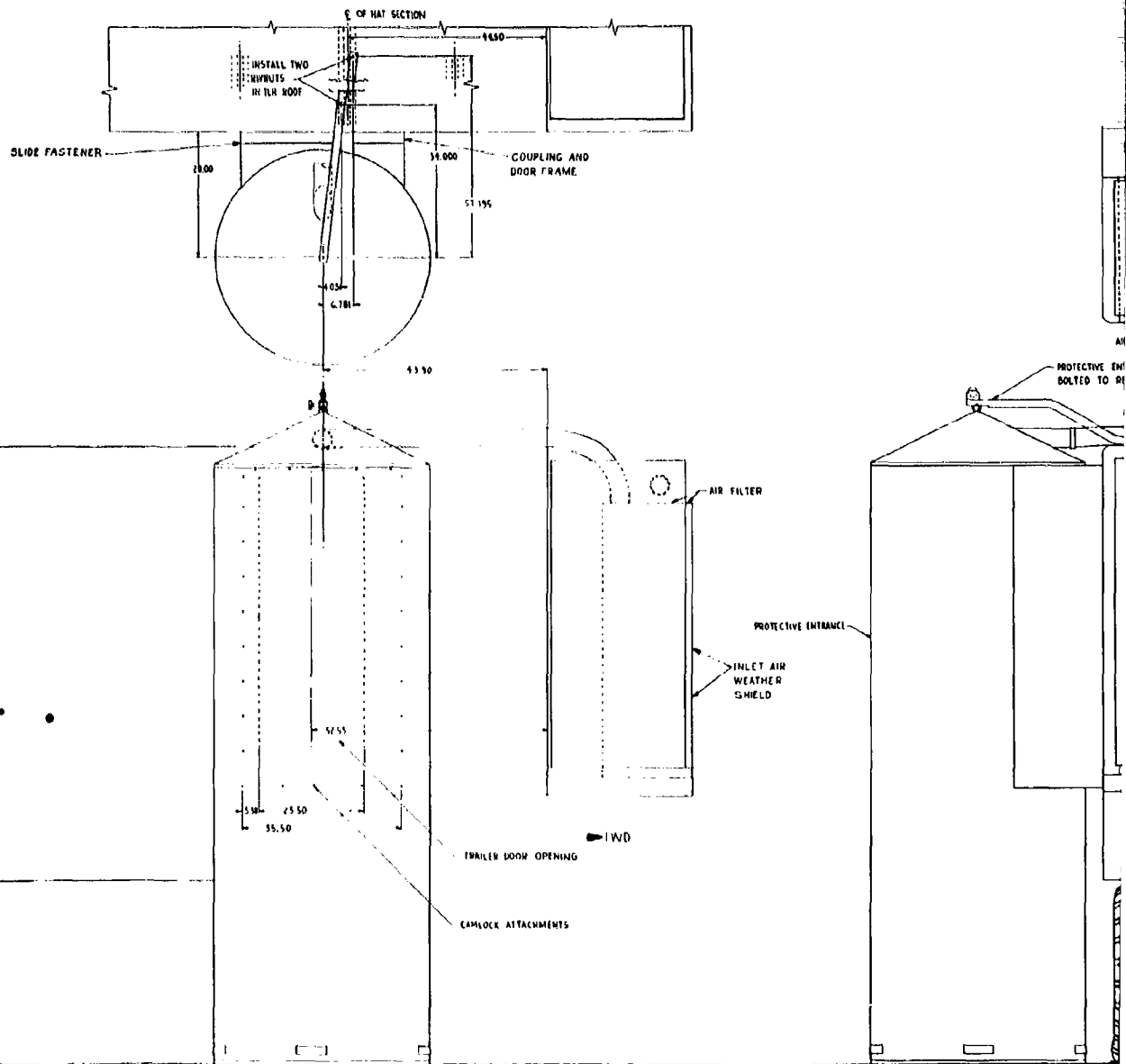

2

Figure 13 Category A Collective Protection

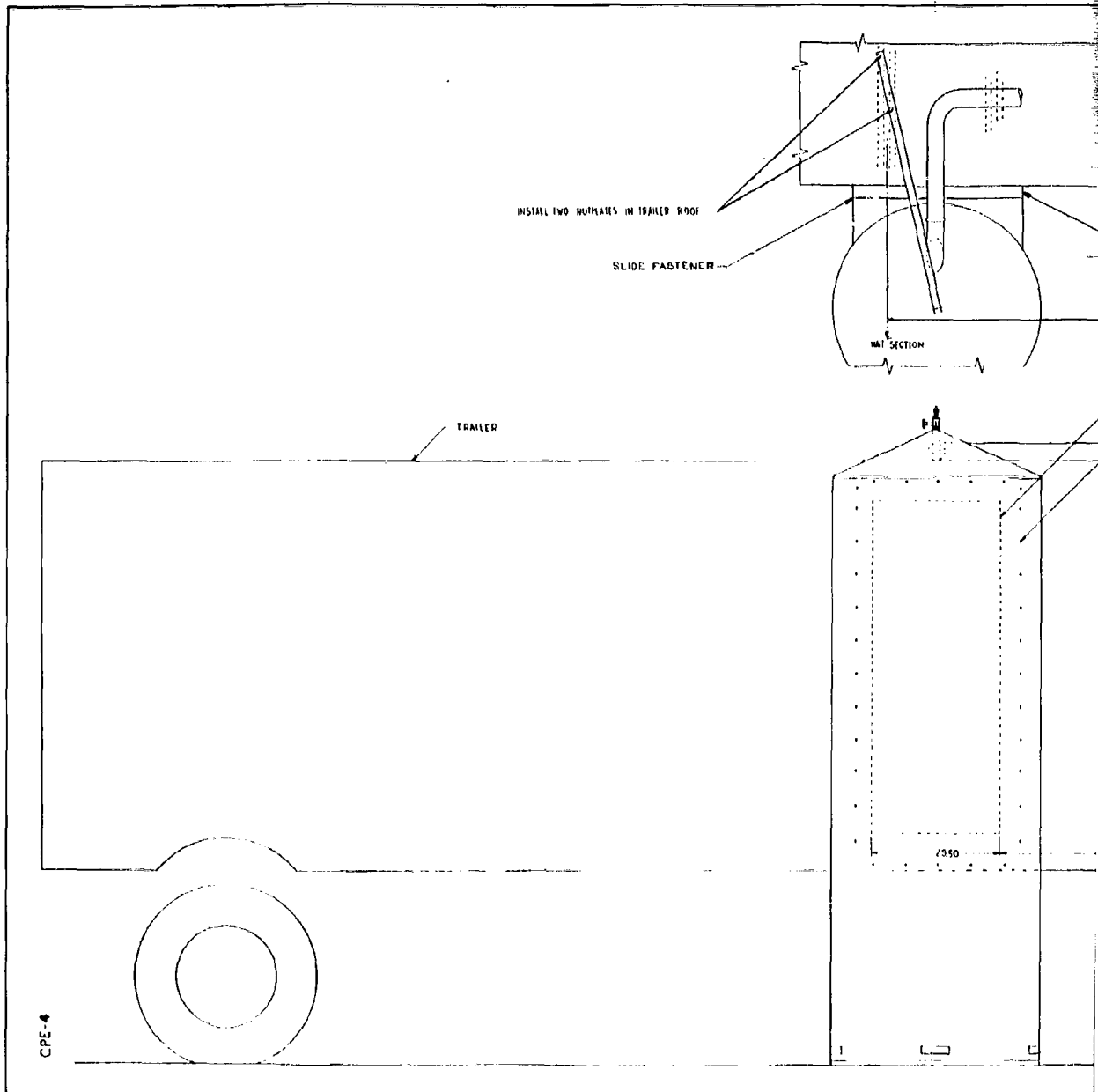

1

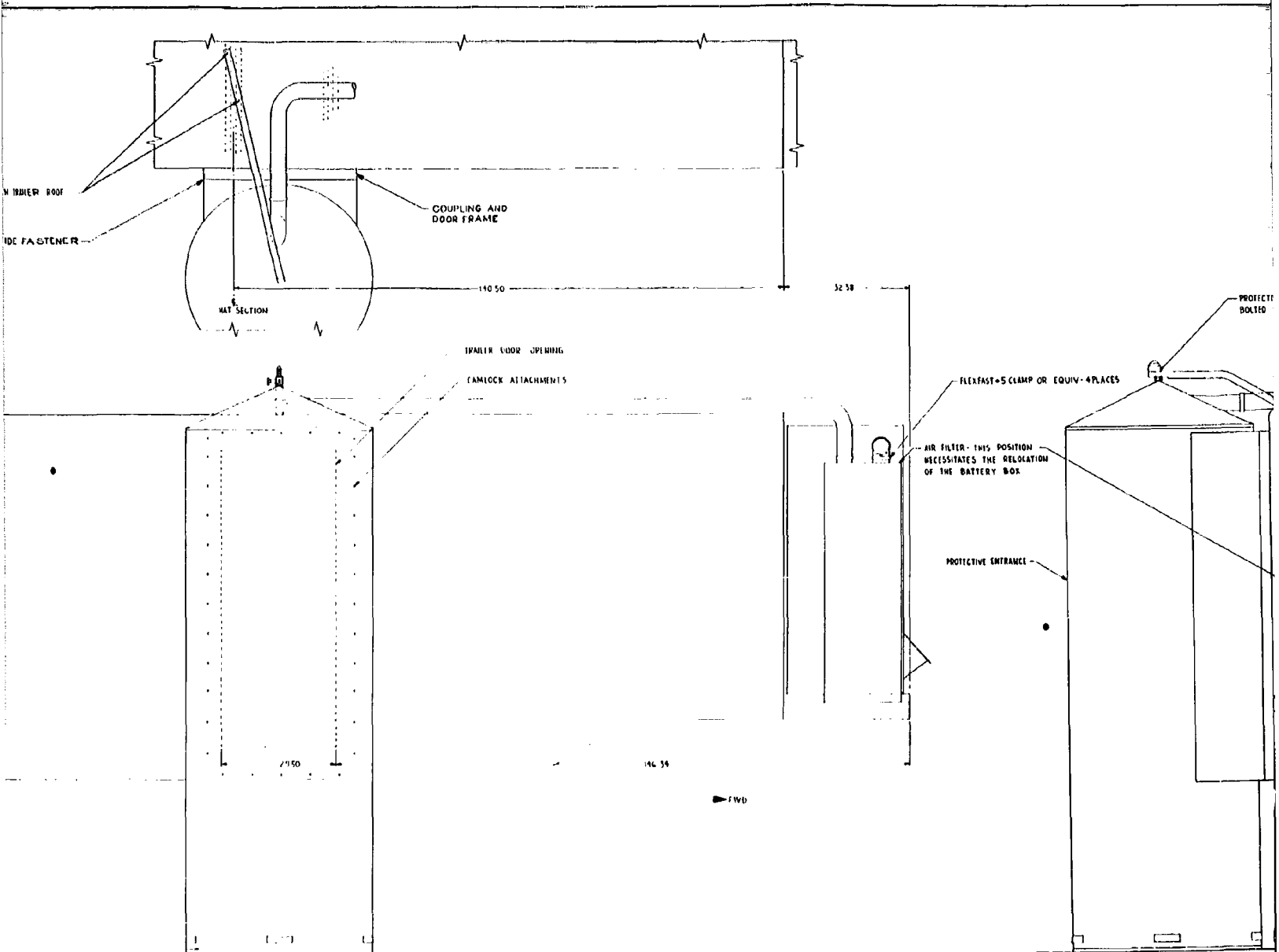

2

Figure 1  
for M

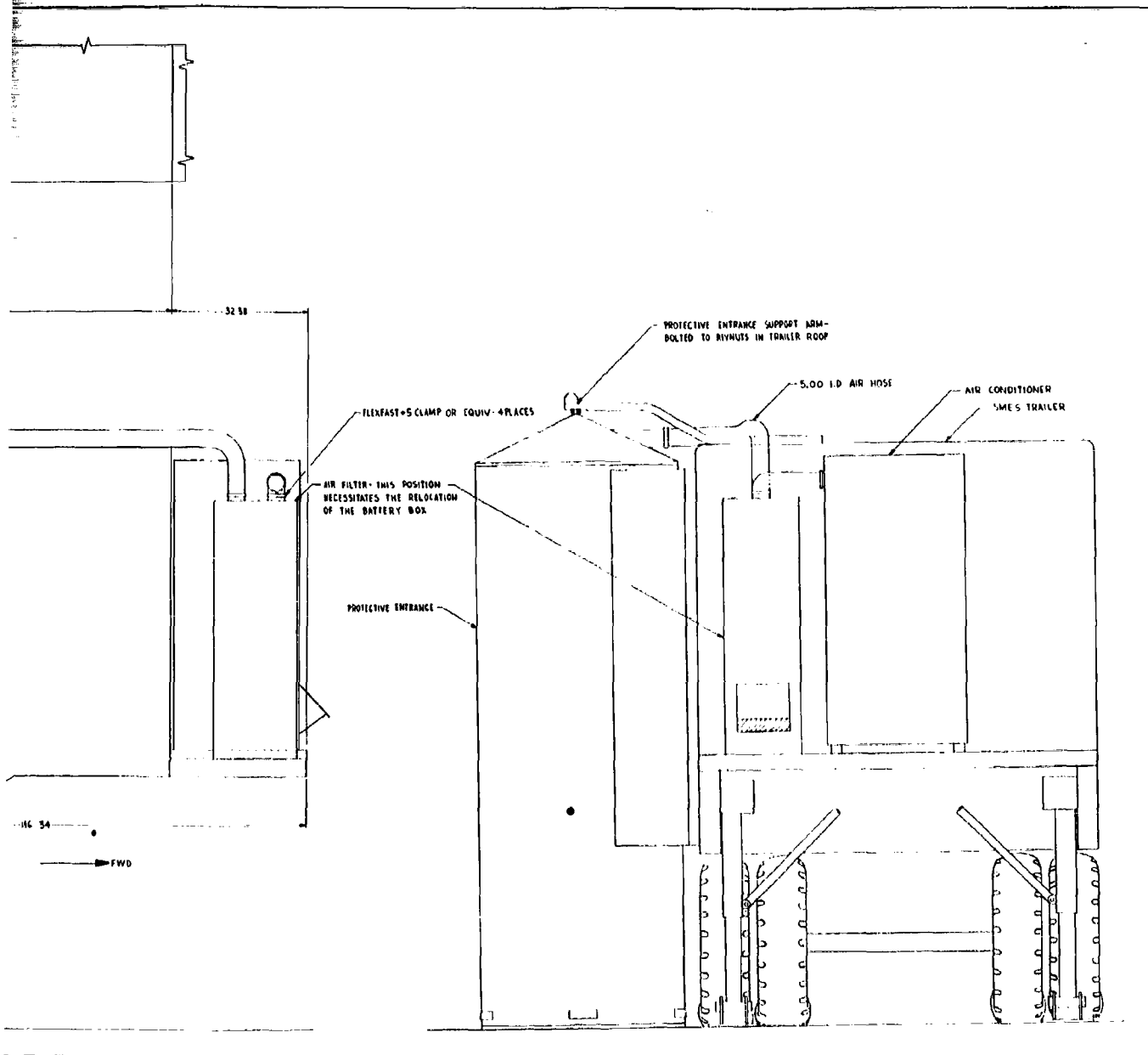
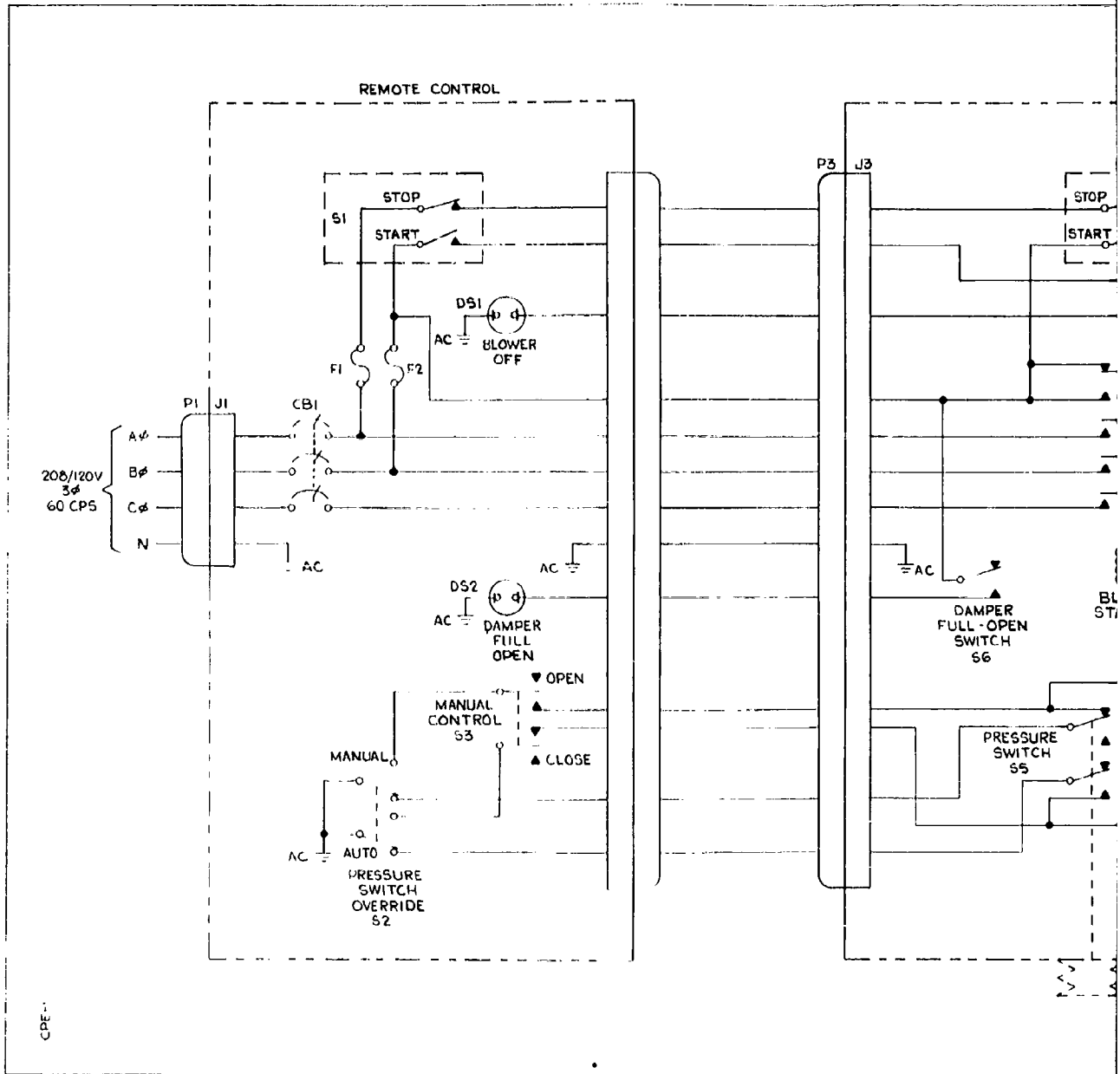

Figure 14 Category A Collective Protection Equipment  
for Maintenance Vehicles (AN/MSM-34 and AN/MSM-35)

3



1

Figure 15 Sc

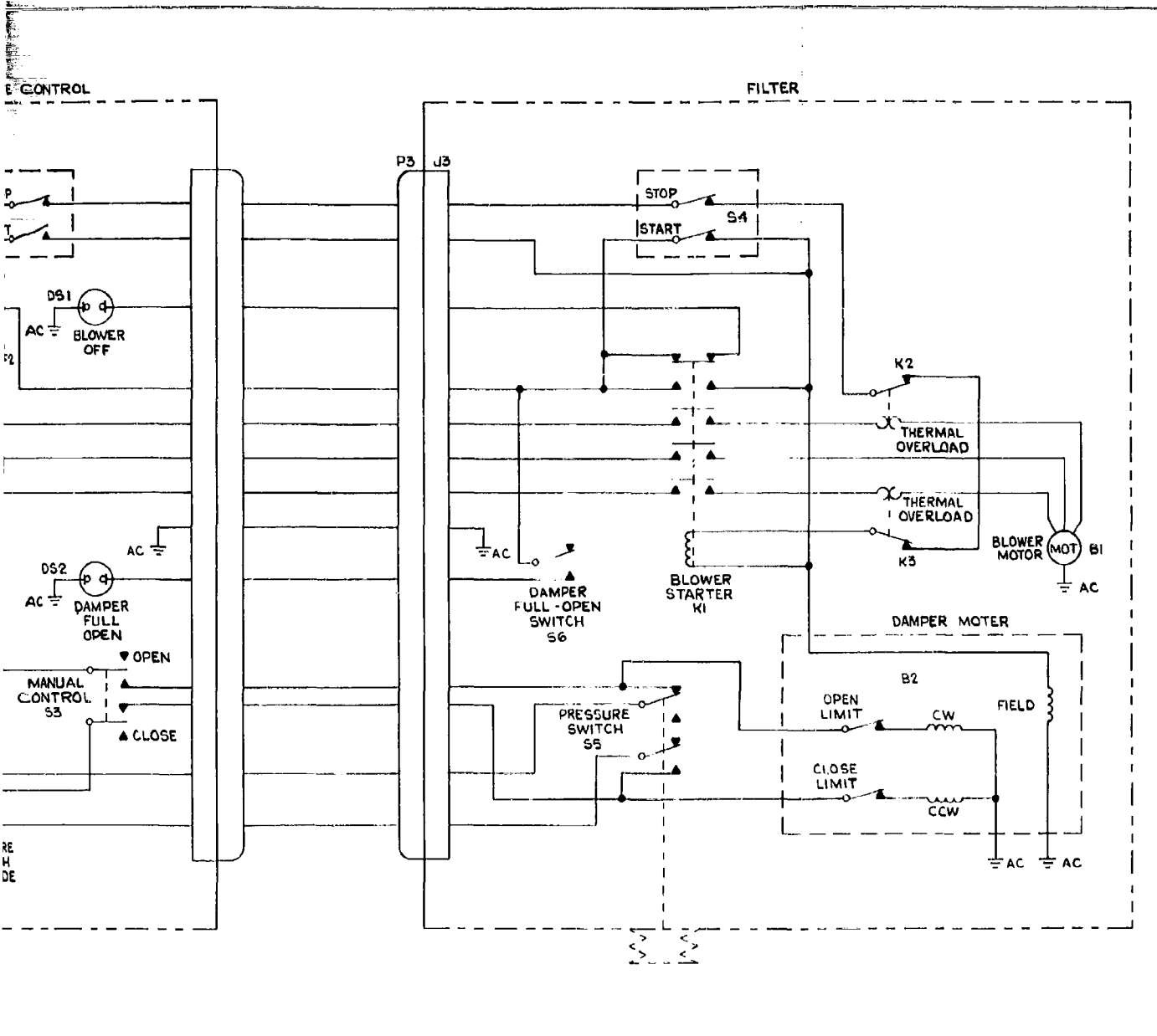

2

Figure 15 Schematic Control Diagram for 400 CFM Filter Unit

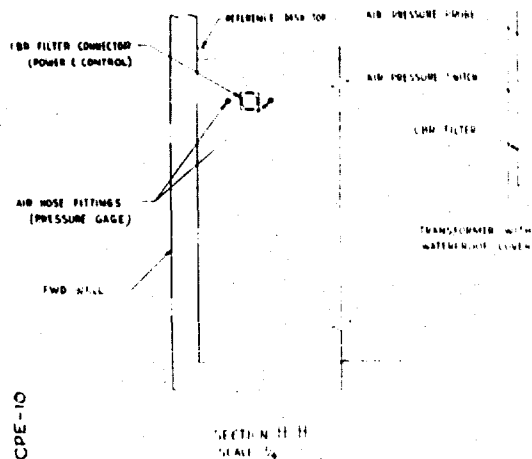
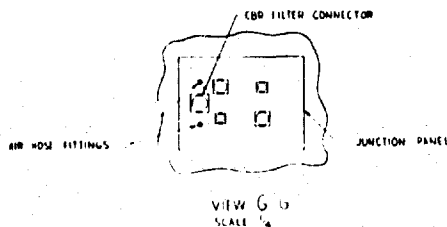

VIEW D C AND D W IN TRAILER  
SAGAN MAINTENANCE TRAILER

CPE-10

Best Available Copy

1

ANEL

AIR CONDITIONER  
 AIR PRESSURE PROBE  
 2 PLACES  
 AIR PRESSURE SWITCH  
 CBD FILTER  
 AIR CONDITIONER  
 FRONT PANEL  
 CBD FILTER CONNECTION

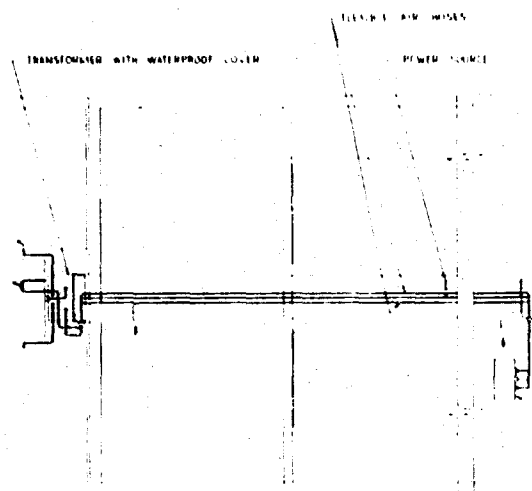

VIEW LOOKING DOWN ON TRAILER  
 RADAR EQUIPMENT TRAILER

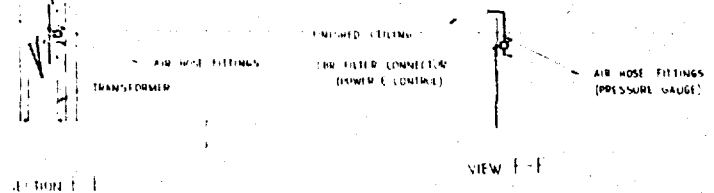

SECTION F-F

VIEW F-F

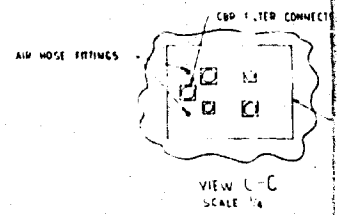

RETIENE GROUP

PORTABLE CONTROL PANEL

FRONT PANEL  
 AIR CONDITIONER  
 AIR PRESSURE PROBE  
 AIR PRESSURE SWITCH  
 CBD FILTER

2

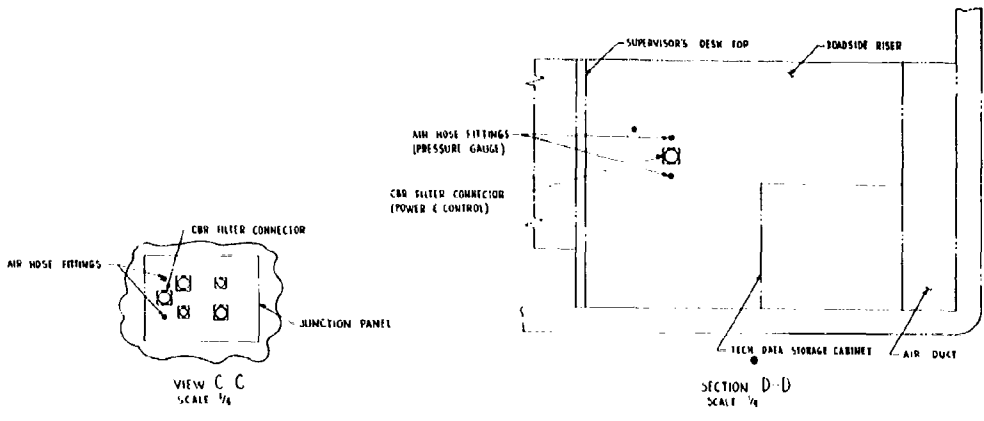

AIR HOSE FITTINGS (PRESSURE GAUGE)  
CBR FILTER CONNECTOR (POWER & CONTROL)

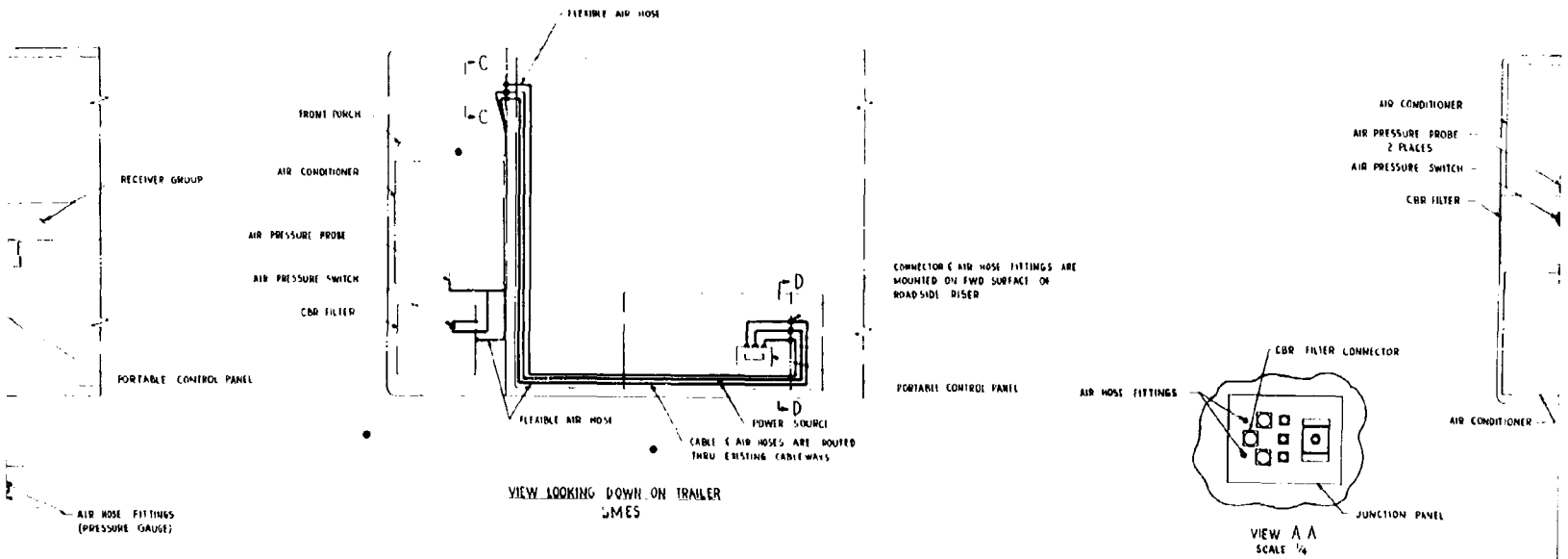

F-F

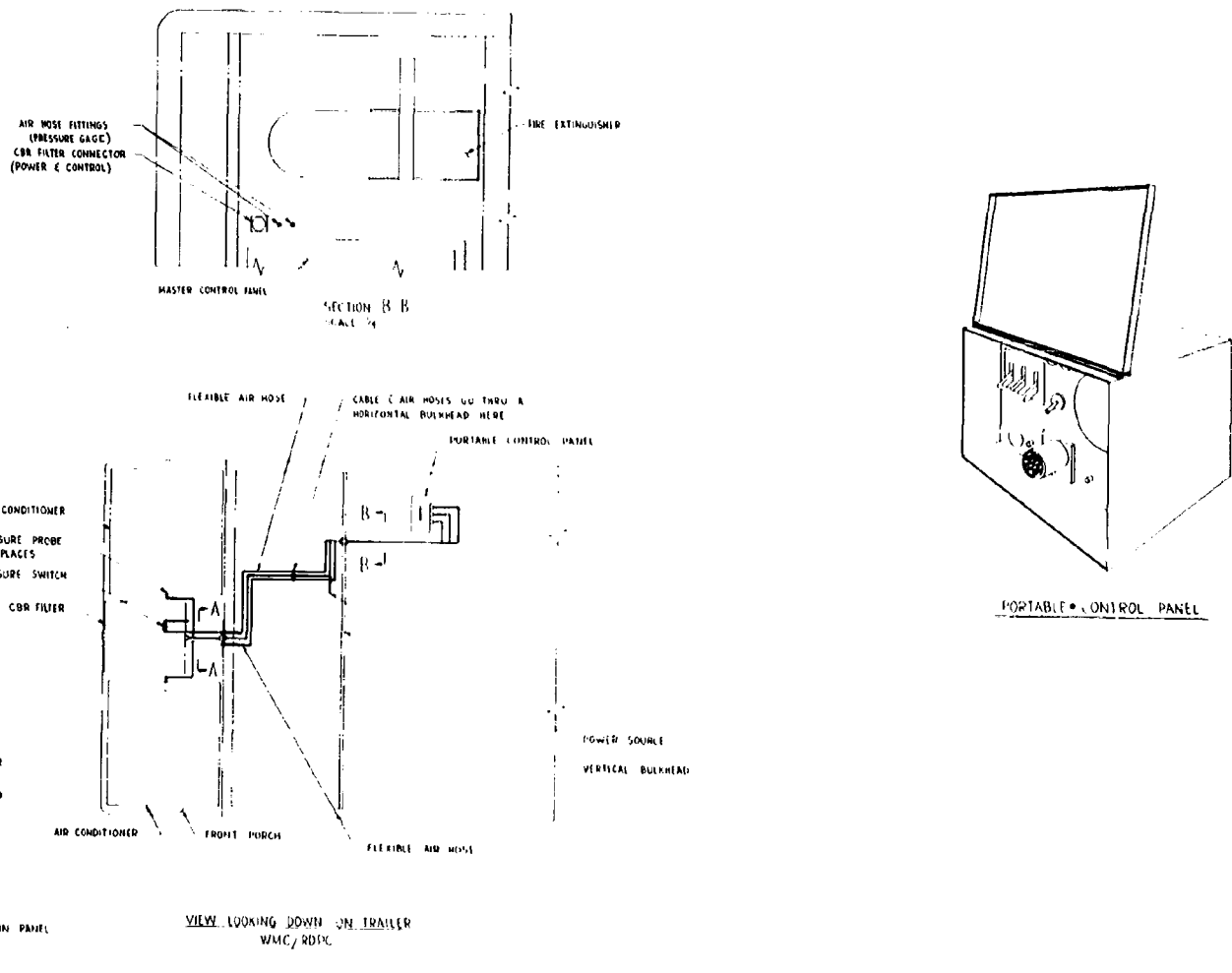
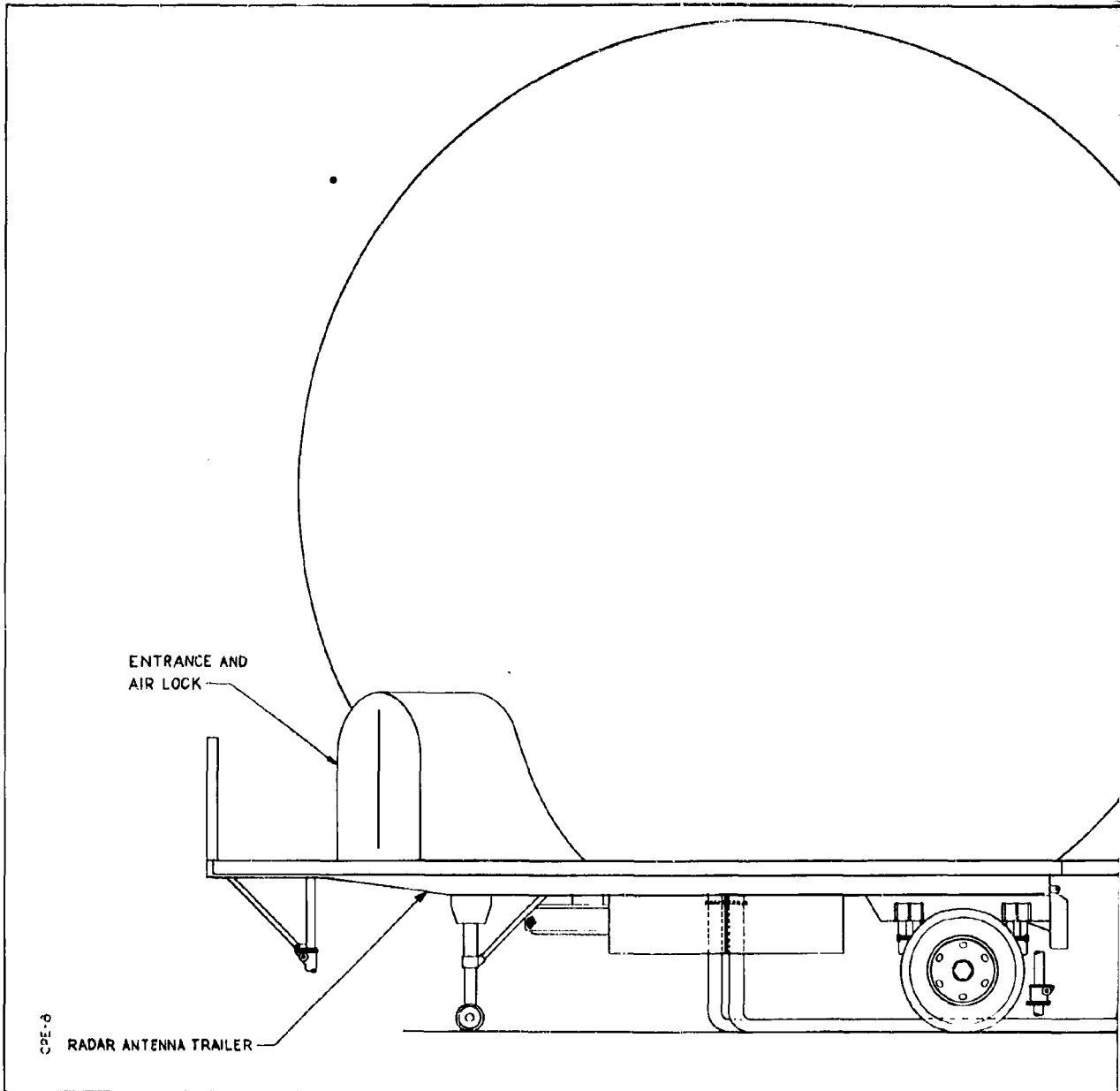

Figure 16 AN/MSQ-28 Vehicle Modifications Required for Filter Unit Control System



1

Figure 17 Category B Collective Prot

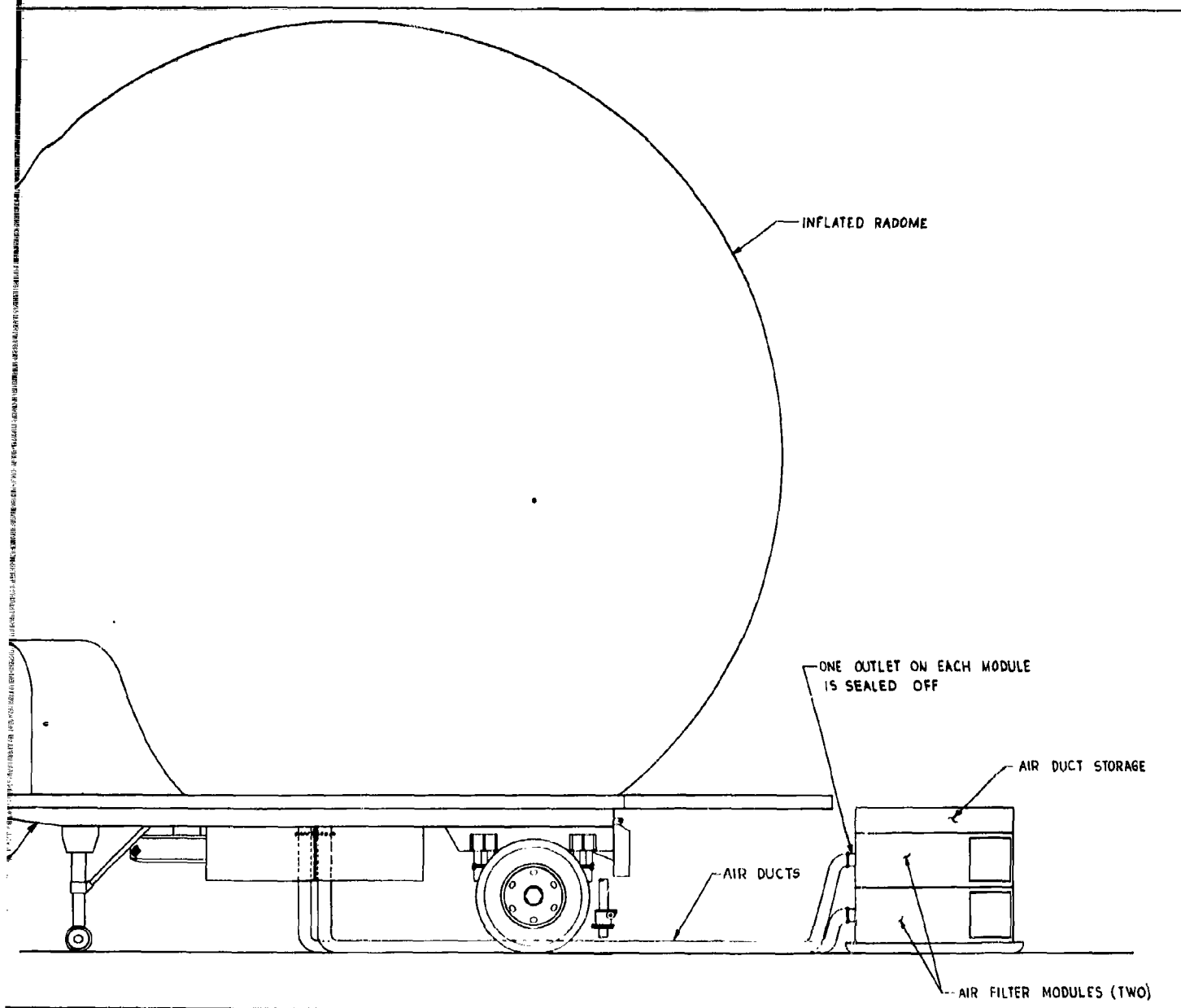
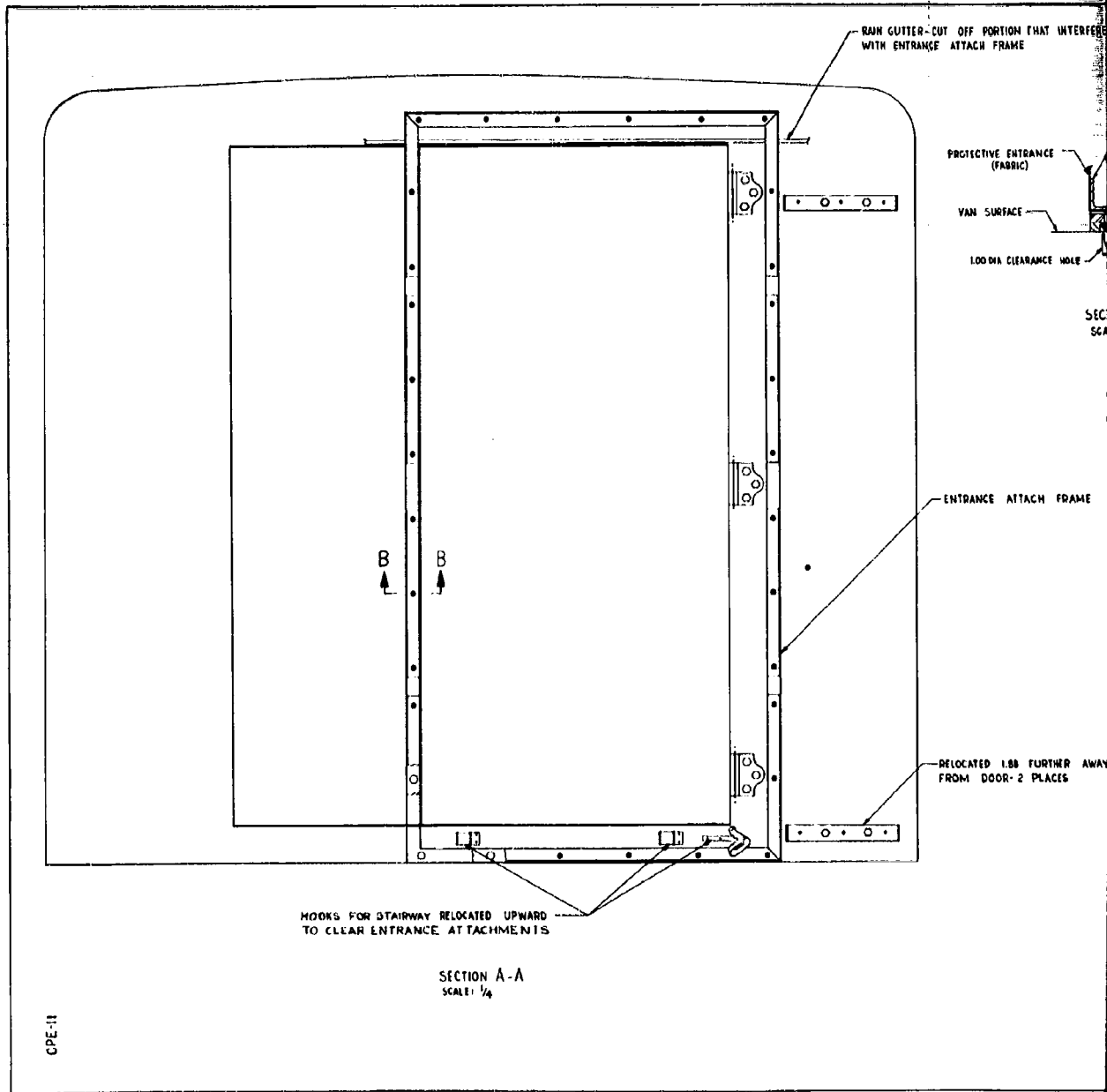

Figure 17 Category B Collective Protection Equipment for AN/MP8-23 Radar Antenna Trailer



1

RAIN GUTTER - CUT-OFF PORTION THAT INTERFERES WITH ENTRANCE ATTACH FRAME

PROTECTIVE ENTRANCE (FABRIC)  
VAN SURFACE  
LOGGING CLEARANCE HOLE  
16015B-9 AL EXTR  
ENTRANCE ATTACH FRAME - RIVETED TO .050 SHEET WITH FABRIC BETWEEN  
4002-18 CAMLOCK STUD, 4002-0 GROMMET, R46 SNAP RING  
.050 AL SHEET  
.25 THICK 760200 RUBBER, BOND TO .050 SHEET USING 760087 PER 760041-1  
.250 AL PLATE WITH SLOTS FOR MOUNTING OF CAMLOCK RECEPTACLE  
RIVETED TO TRAILER  
244-22C CAMLOCK RECEPTACLE

SECTION B-B  
SCALE 1/4

ENTRANCE ATTACH FRAME

RELOCATED 1.88" FURTHER AWAY FROM DDDR-2 PLACES

5.00 O.D. COUPLING INSTALL FRONT VAN WALL

AIR CONDITIONER

5.00 I.D. AIR

FLEXFAST #5 CLAMP OR EQUIVALENT 4 PLACES

2

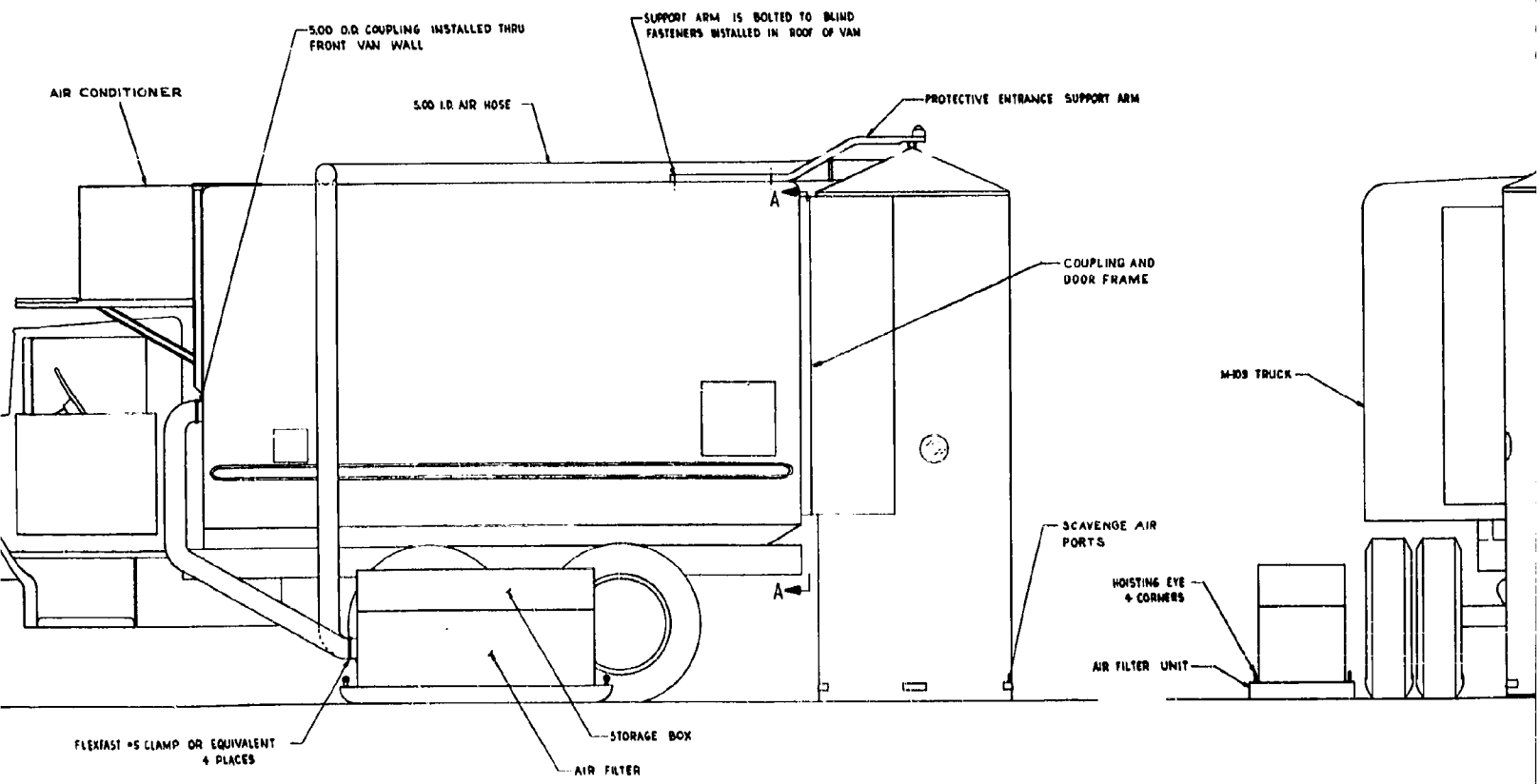

3

Figure 18 Category A Collective Protection Equipment

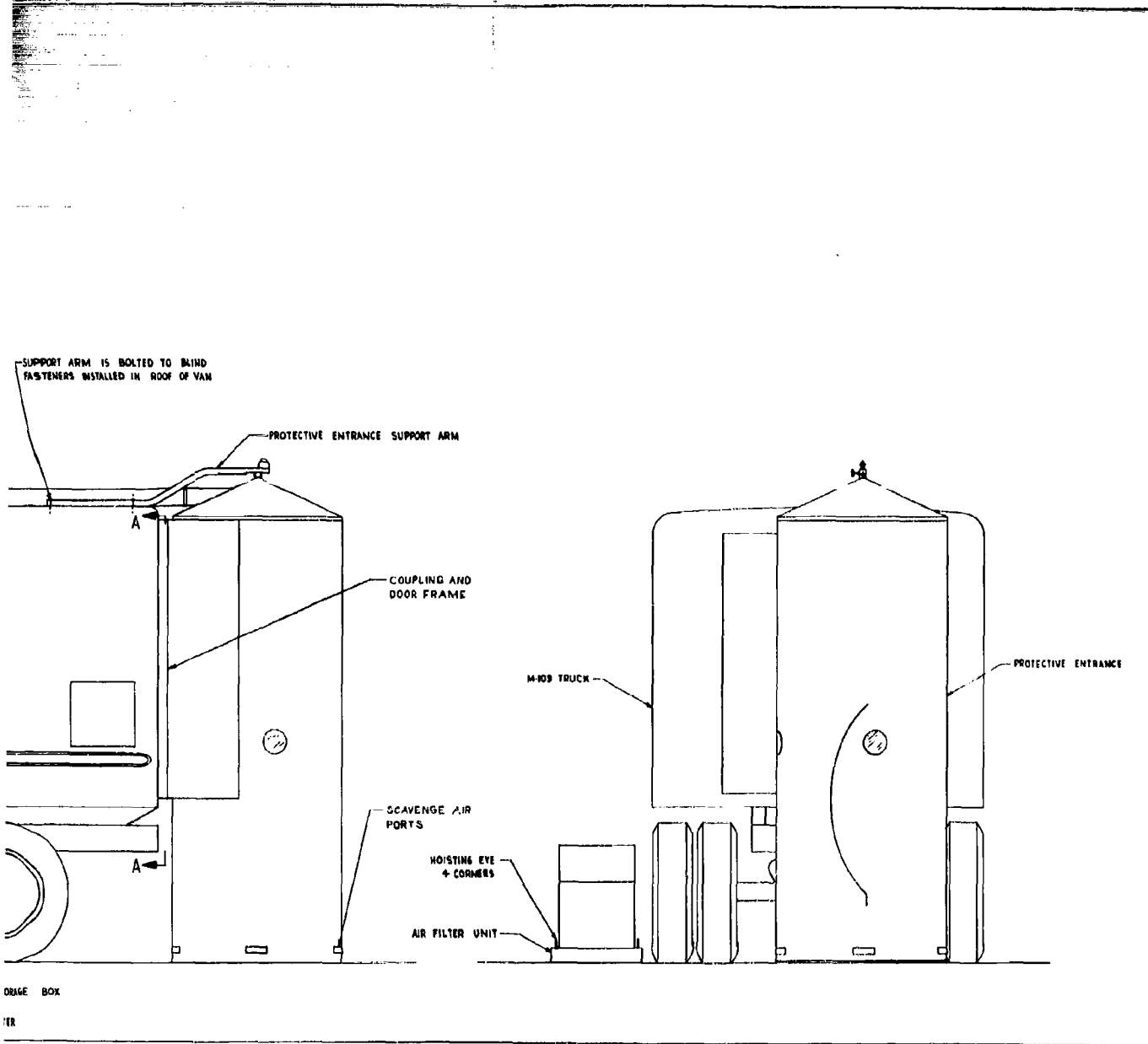
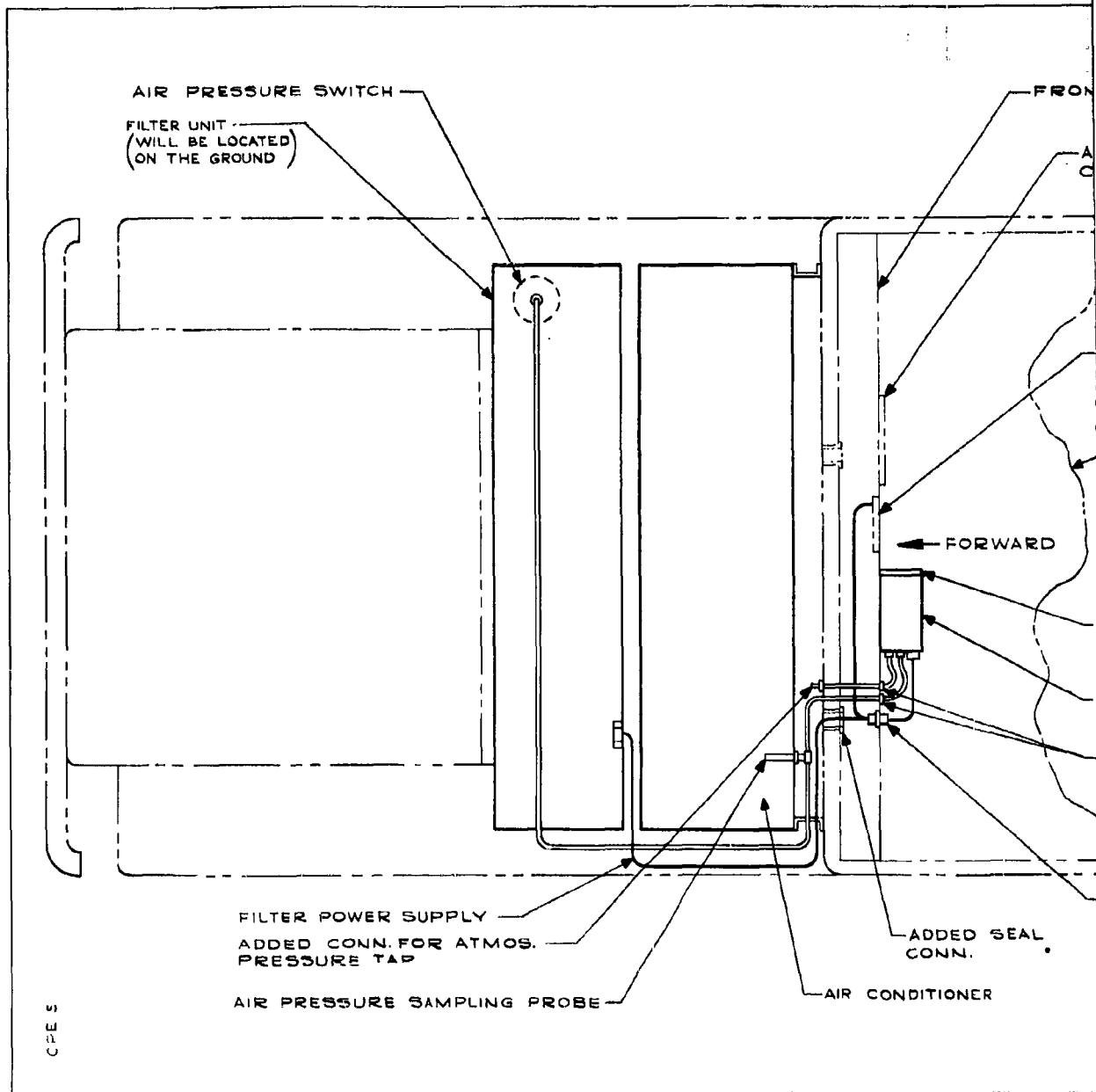

Figure 18 Category A Collective Protection Equipment for OC & CDG Vehicles (AN/MSQ-18)

4



1

Figure 19 AN/MSQ-18 Vehicle Modifications Required for Filter

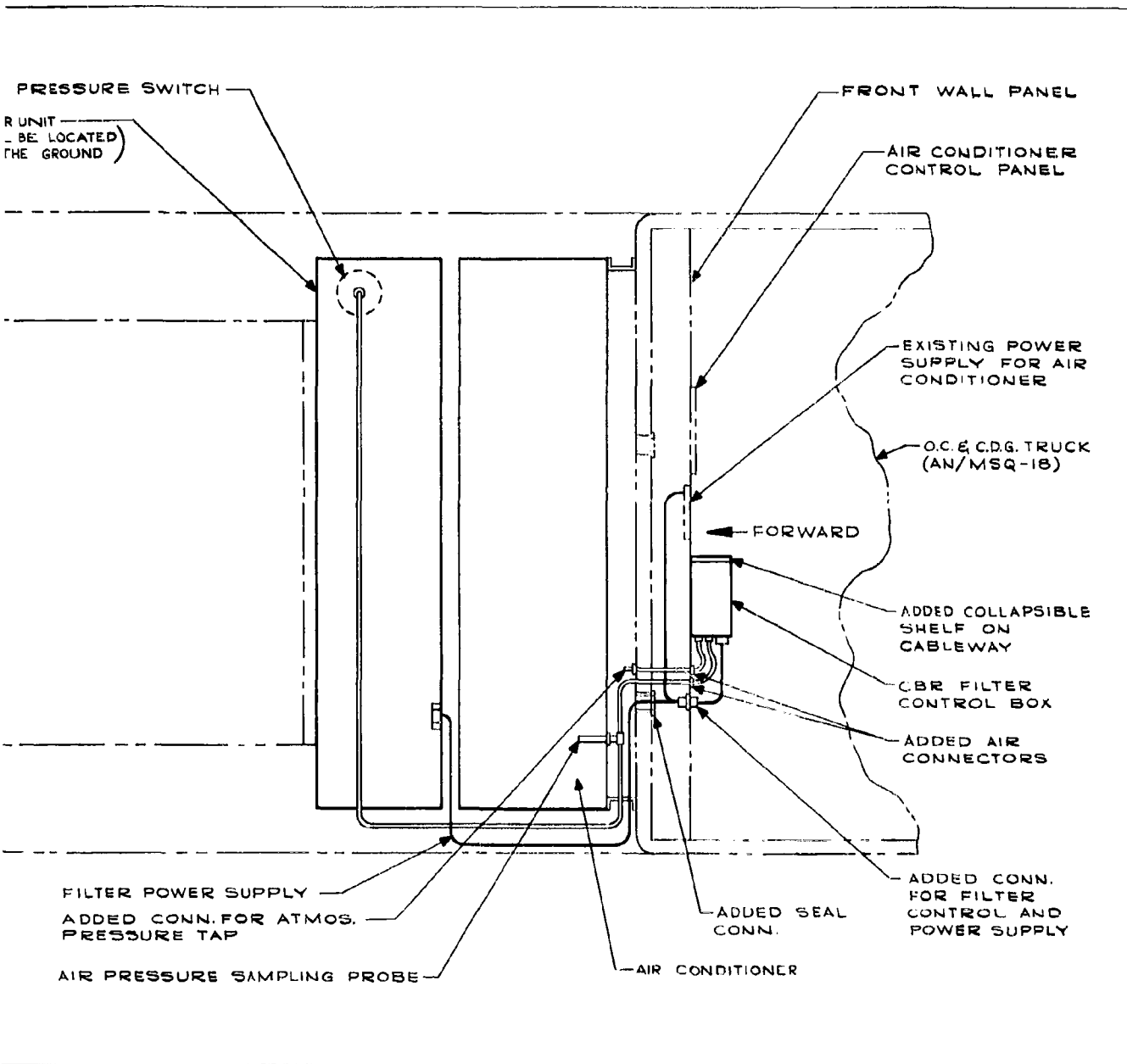

2

Figure 19 AN/MSQ-18 Vehicle Modifications Required for Filter Unit Control System

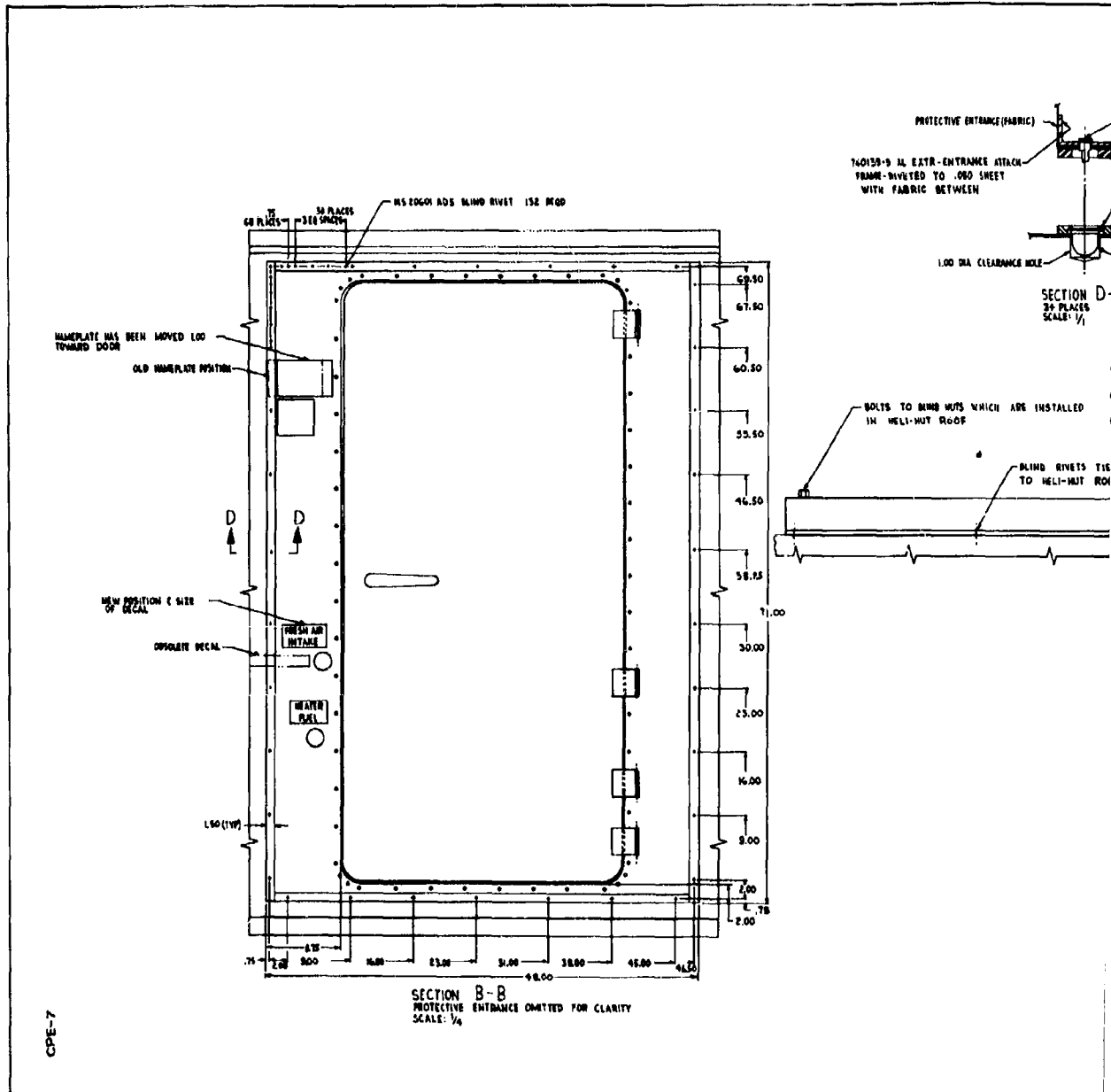

1

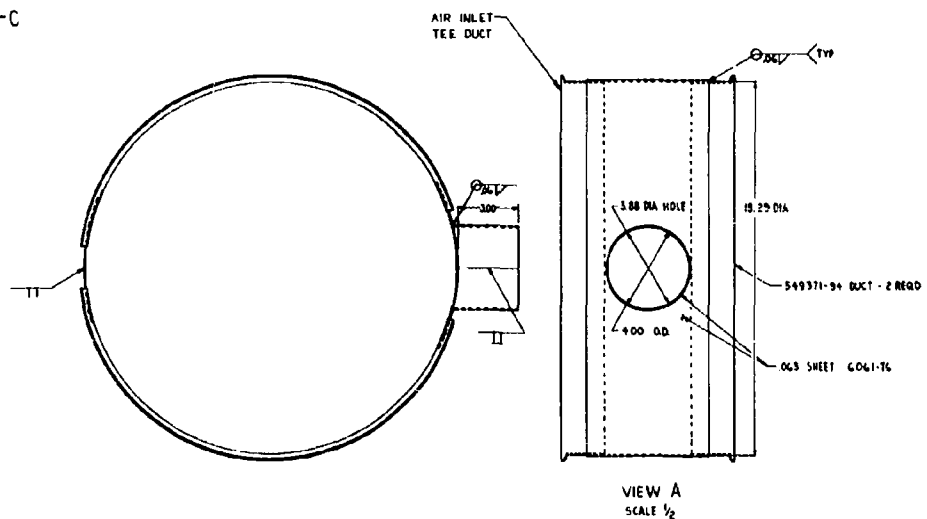
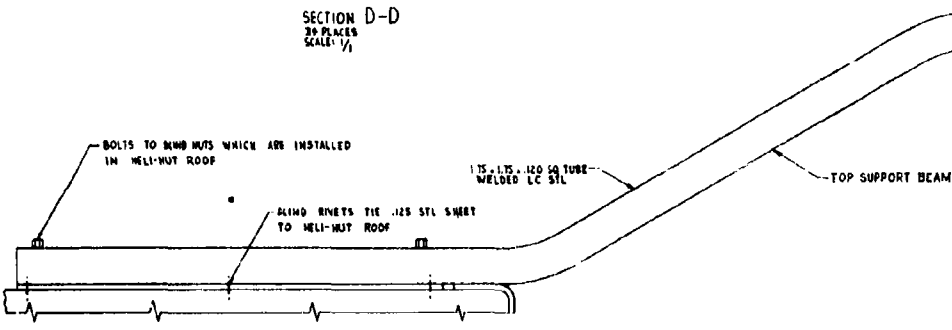
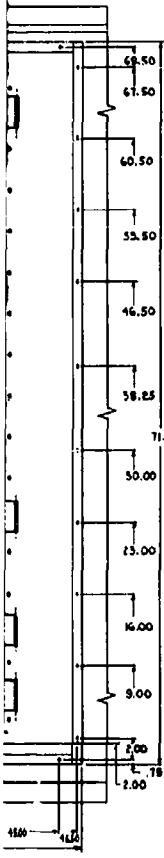
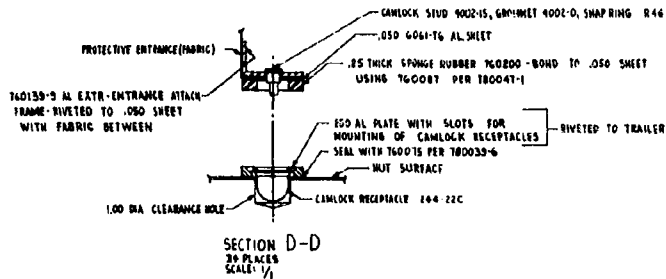

2

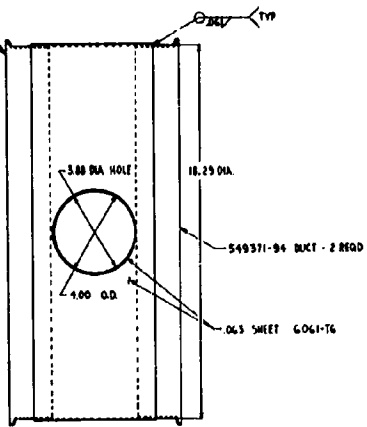
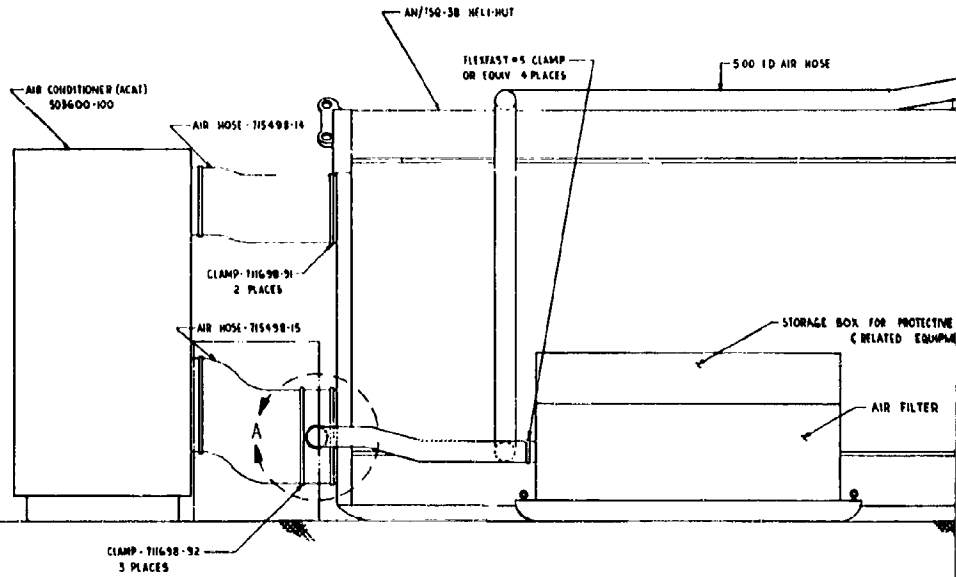
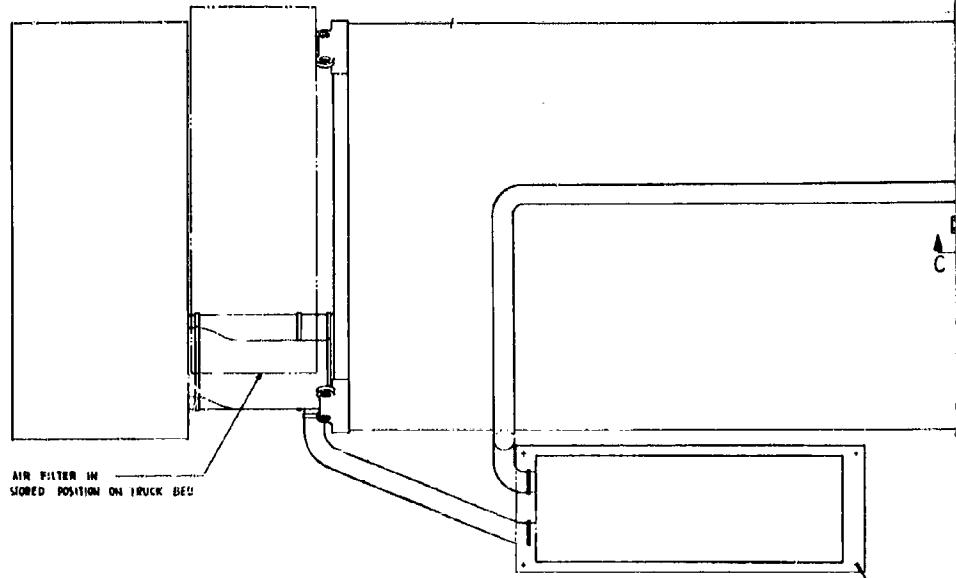
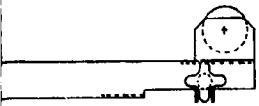

VIEW A  
SCALE 1/2

3

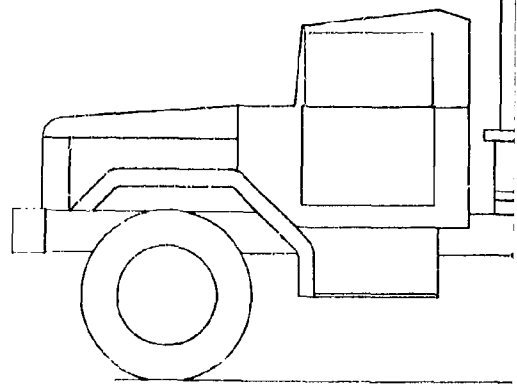
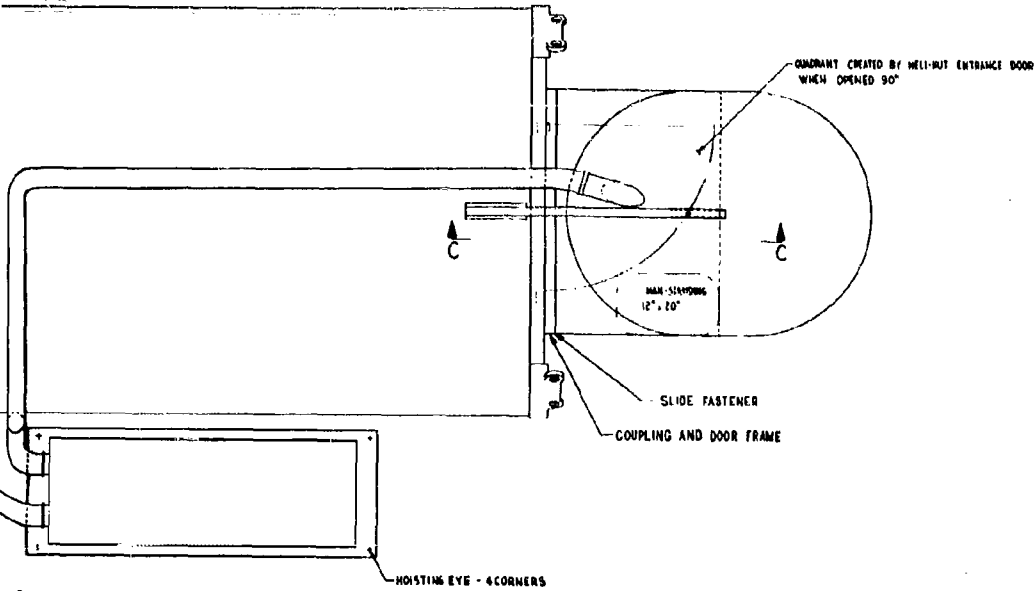

LHMUT

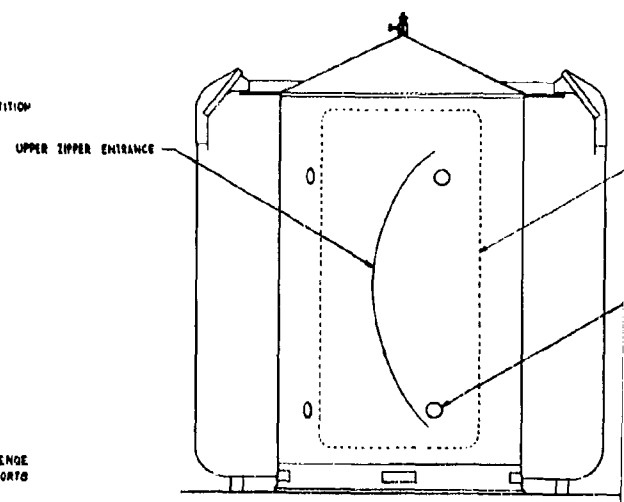
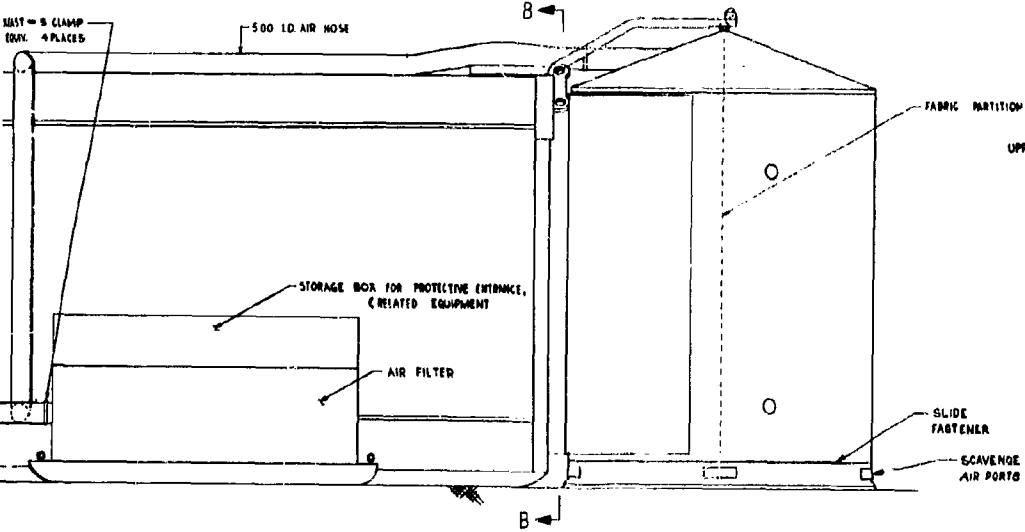

4

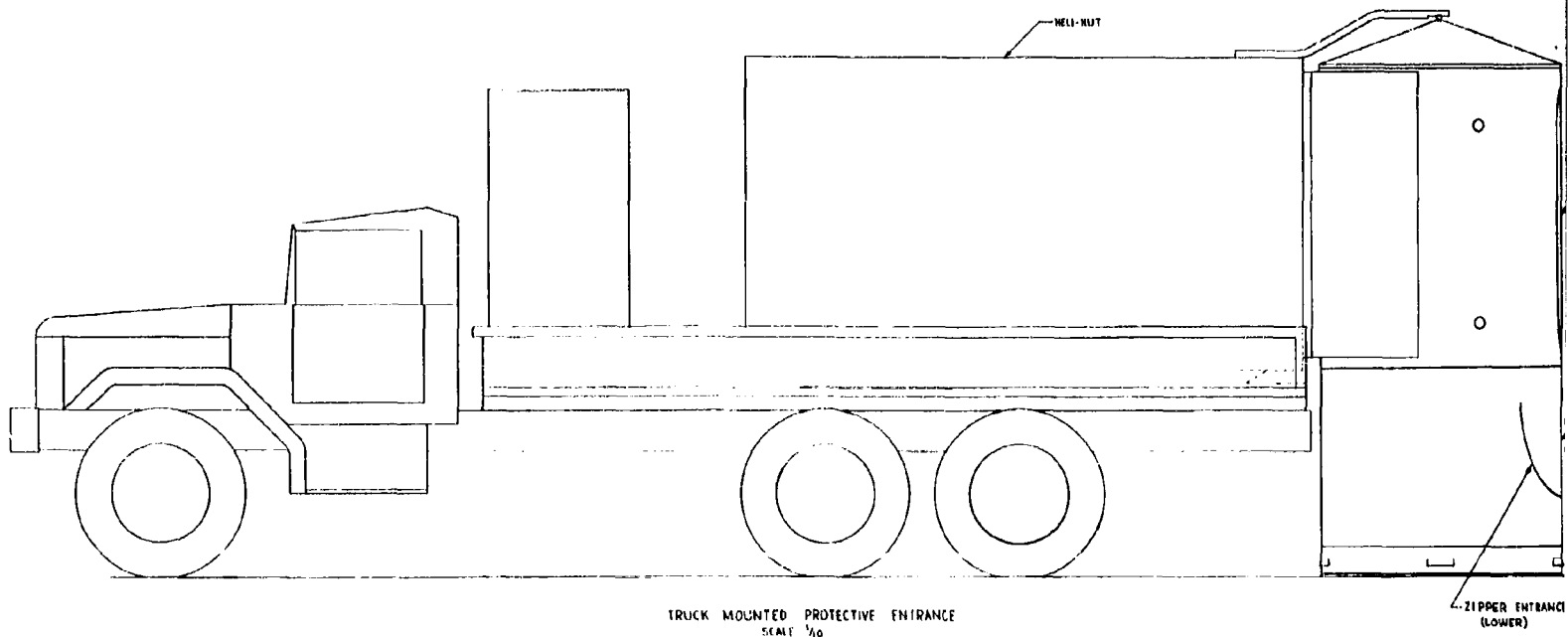

TRUCK MOUNTED PROTECTIVE ENTRANCE  
SCALE 1/10

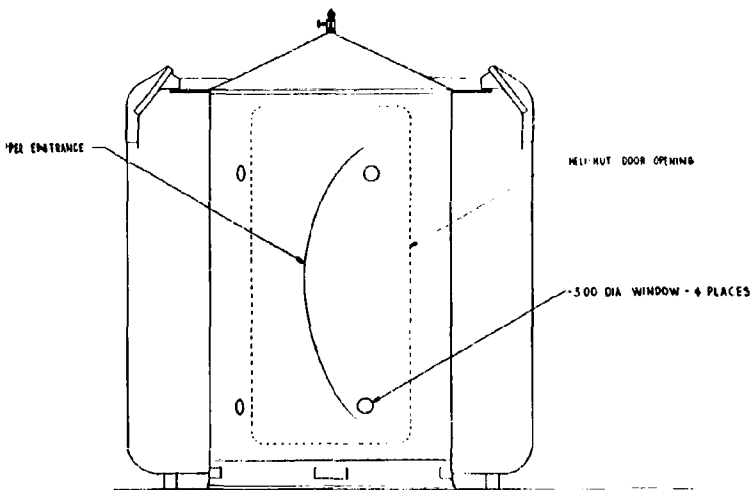
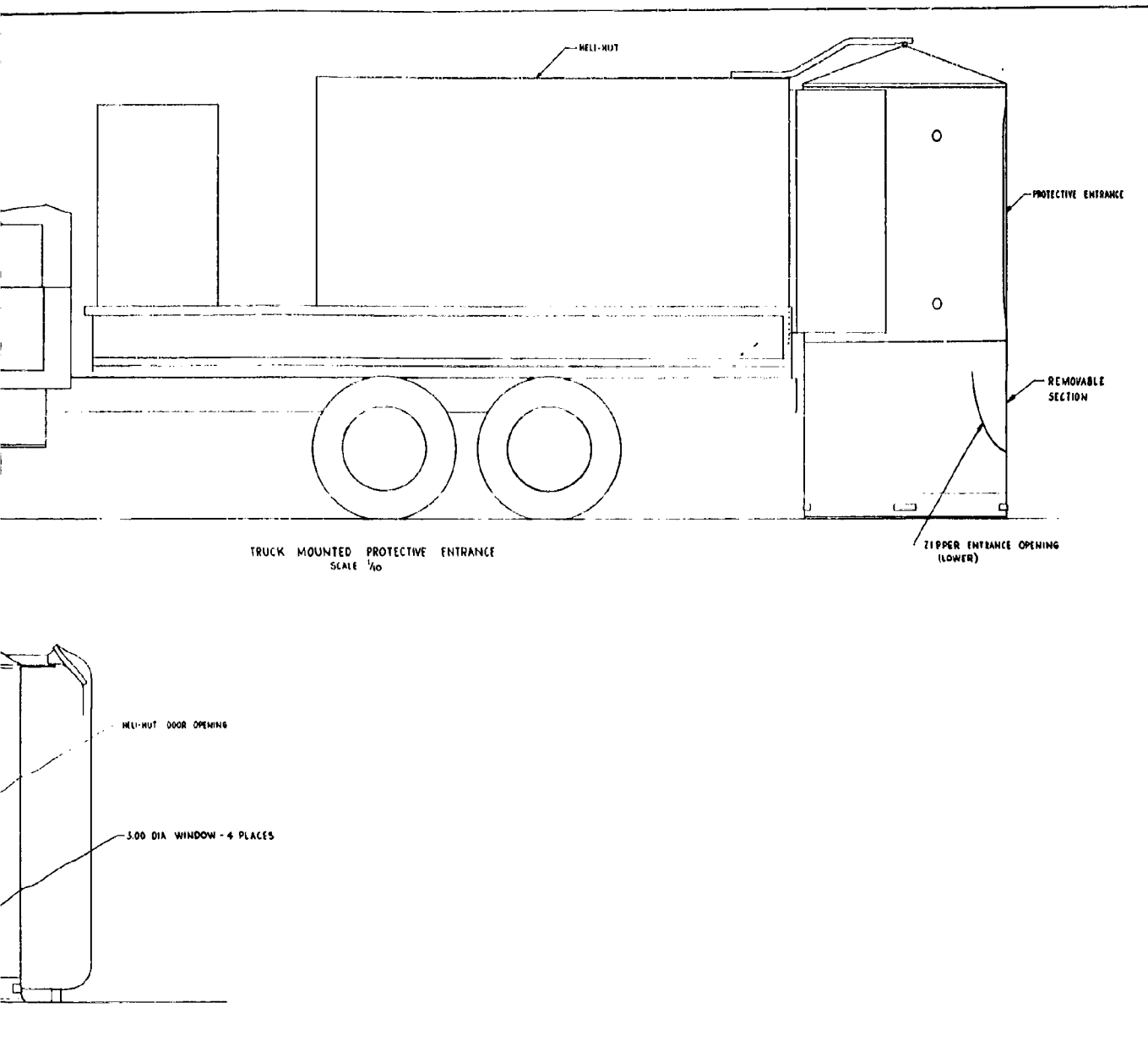

Figure 20 Category A Collective Protection Equipment for OC and CDG Shell

5



6

Figure 20 Category A Collective Protection Equipment for OC and CDG Shelters (AN/TSQ-38)

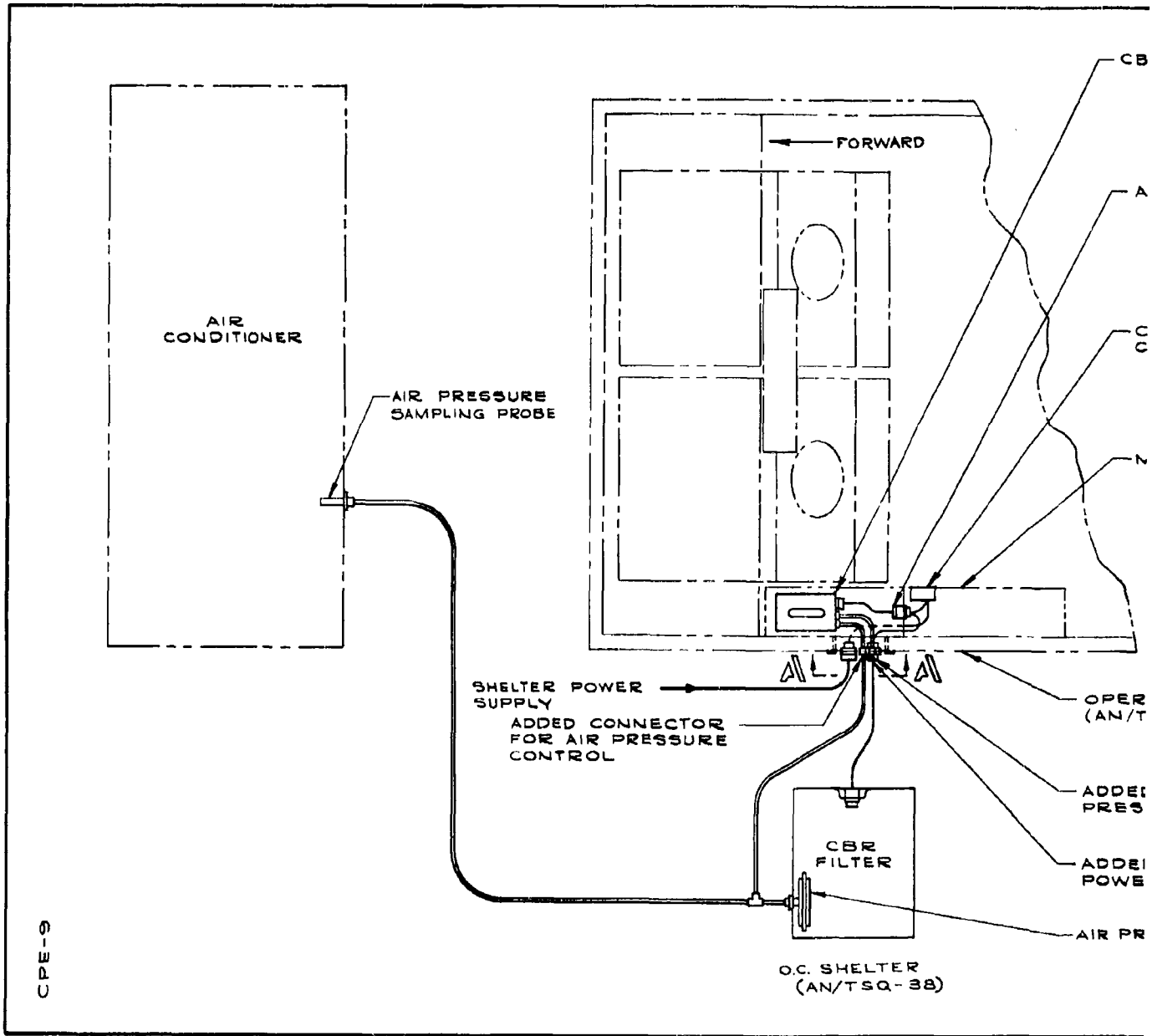

CPE-9

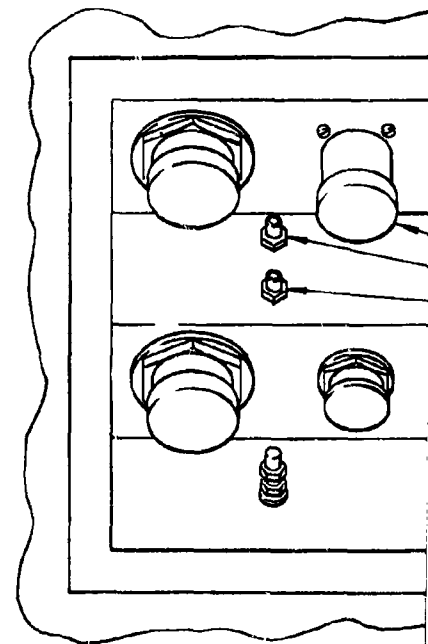
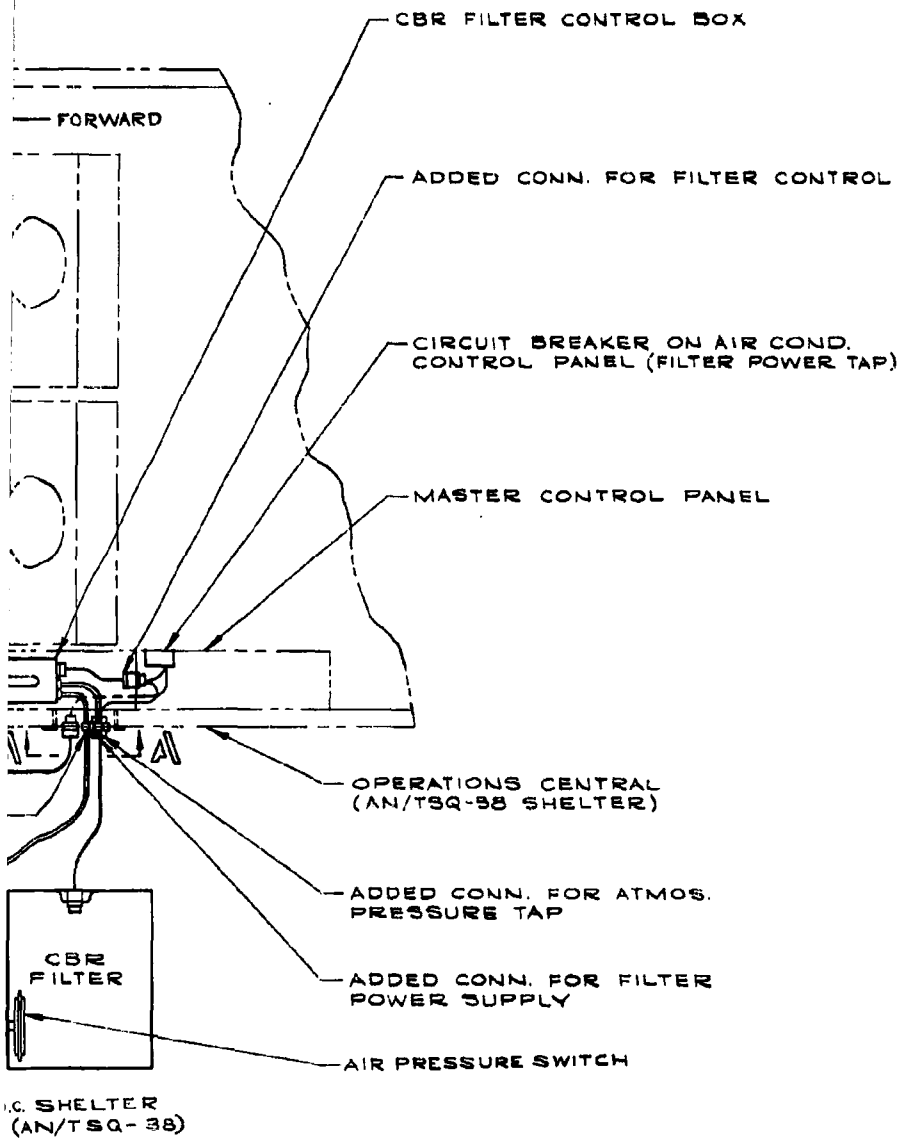

VIEW A-A  
SHOWING LEFT SIDE POW

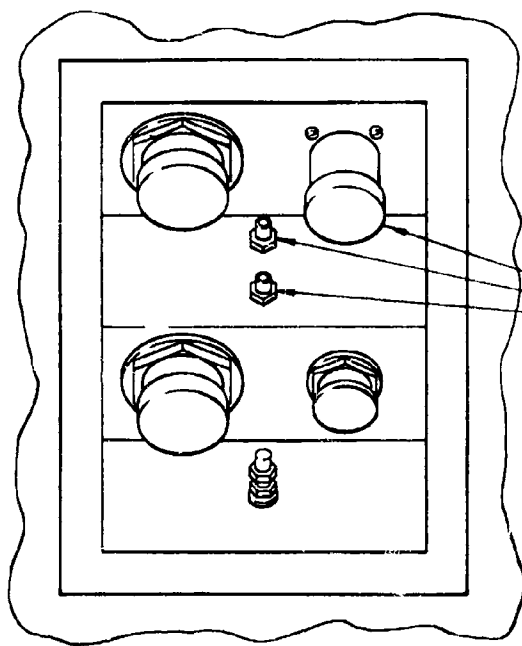

ADDED CONNECTORS

VIEW A-A  
SHOWING LEFT SIDE POWER PANEL

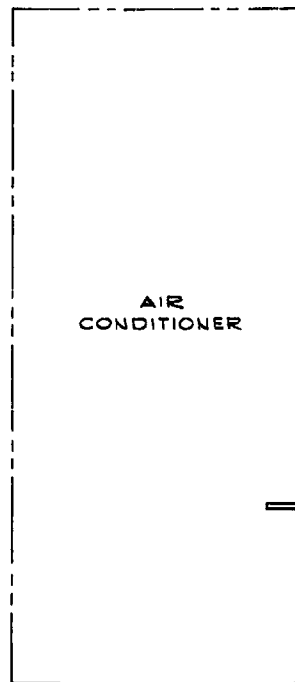

3

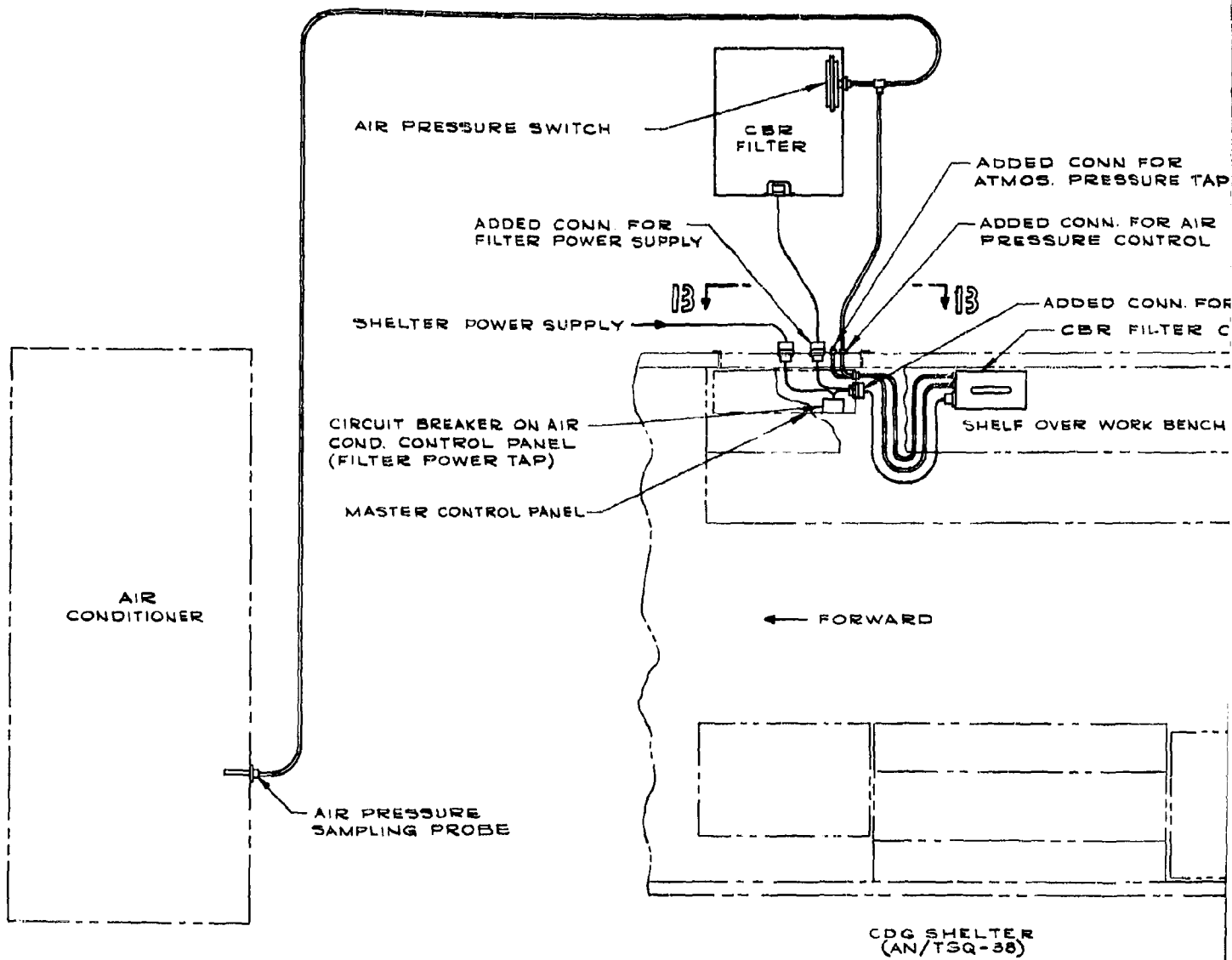

4

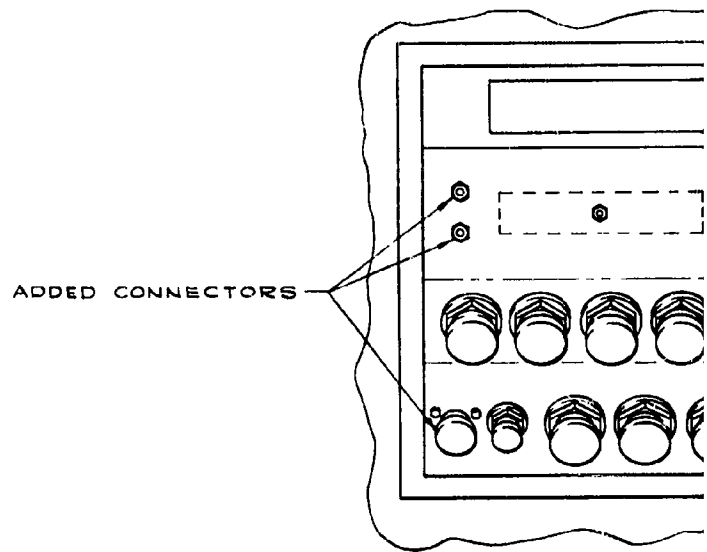
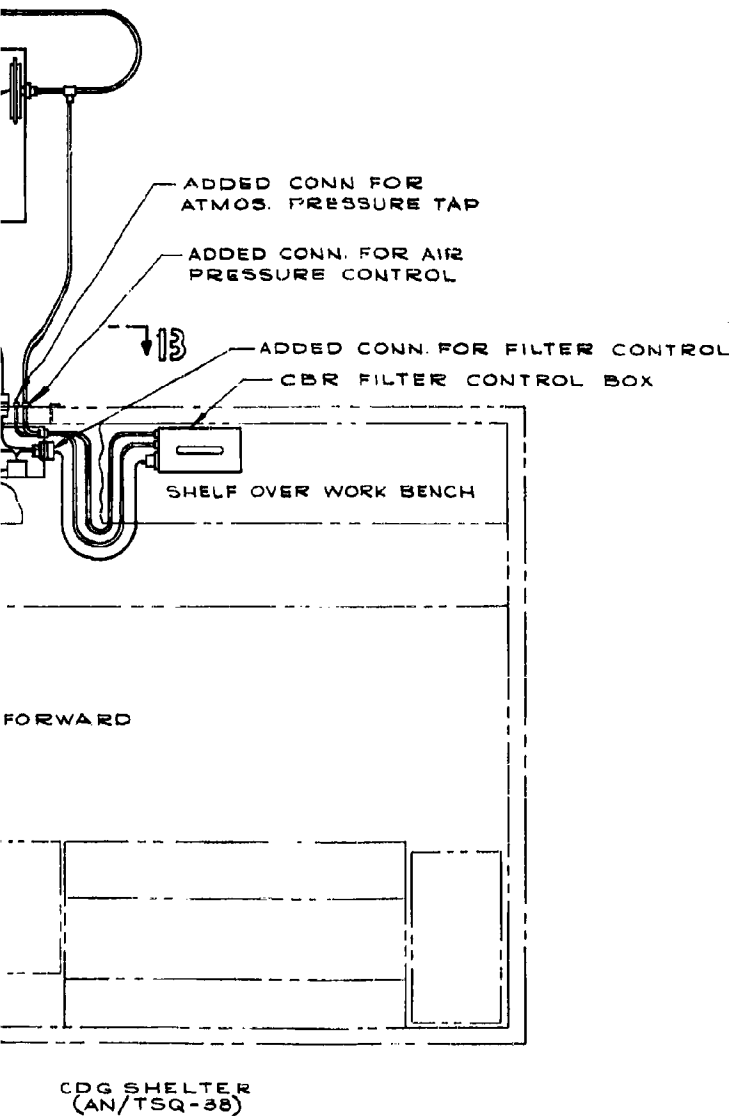

VIEW 13-13  
ROTATED 180°  
SHOWING RIGHT SIDE PORT

5

Figure 21 AN/TSQ-38 Shelter Modifications Required

CONTROL  
BOX

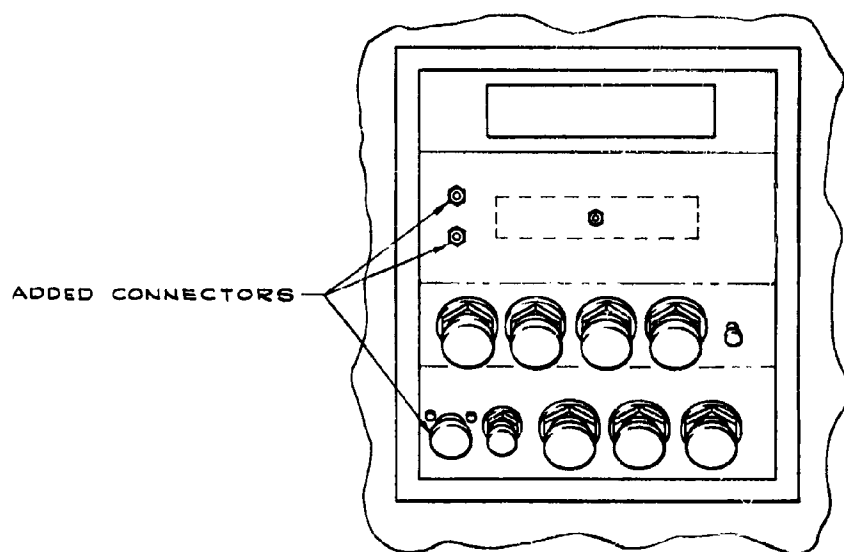

VIEW 13-13  
ROTATED 180°  
SHOWING RIGHT SIDE POWER PANEL

6

Figure 21 AN/TSQ-38 Shelter Modifications Required for Filter Unit Control System

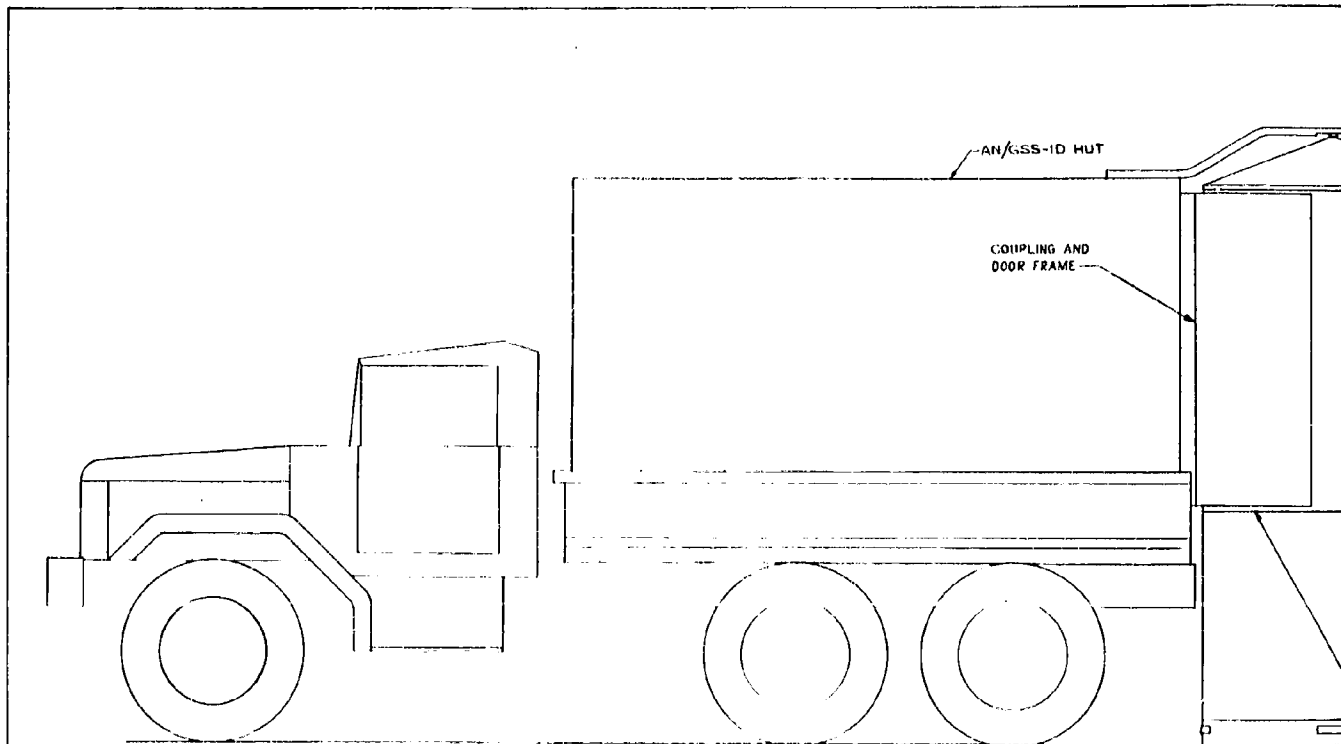

TRUCK MOUNTED PROTECTIVE ENTRANCE  
SCALE 1/40

CPE-2

1

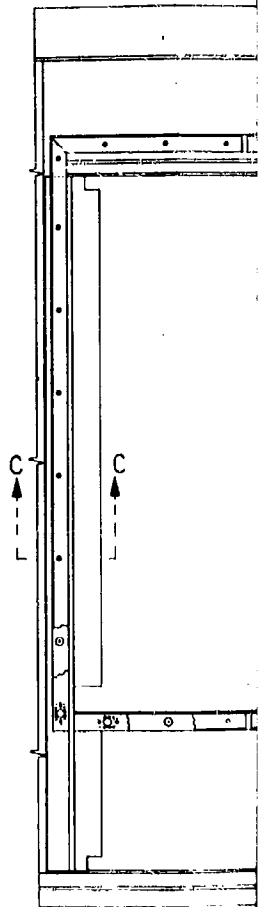
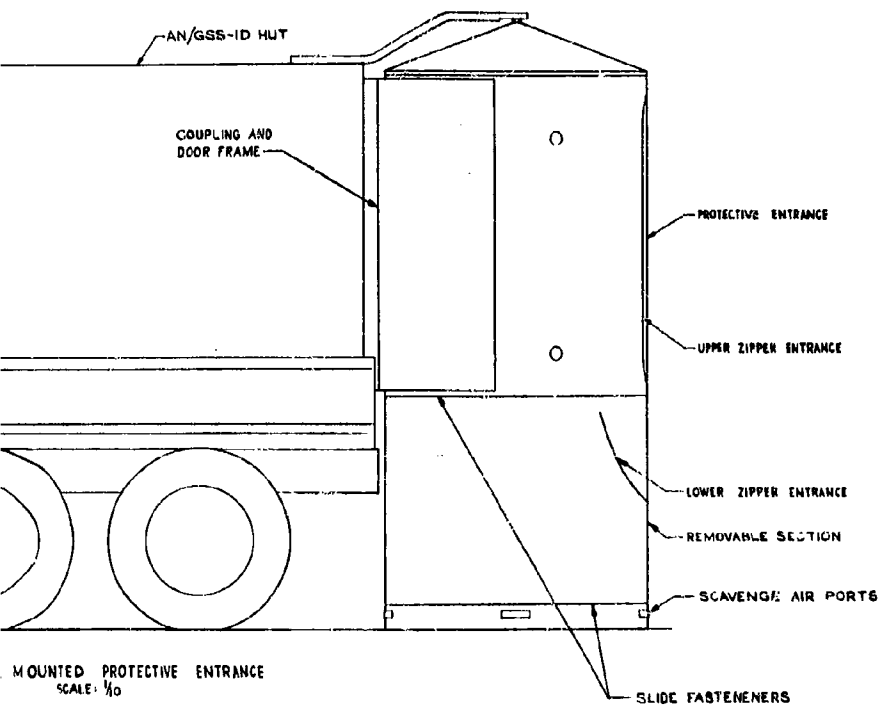

2

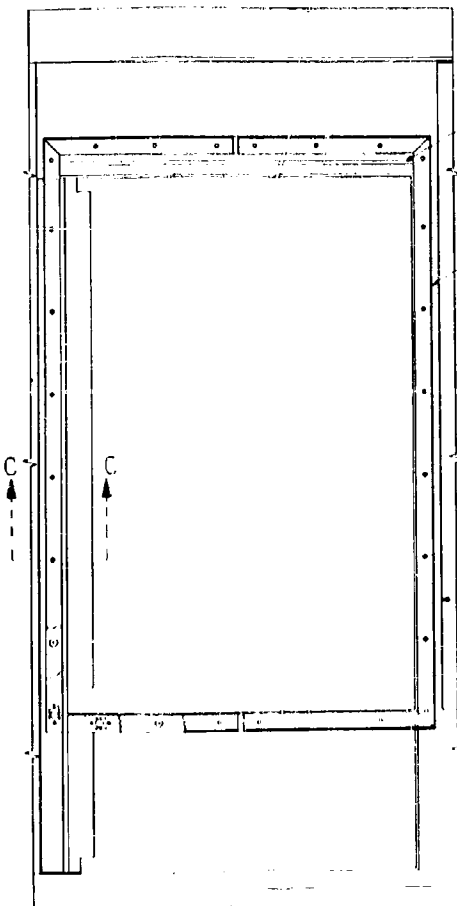

SECTION B-B  
SCALE: 3/4

RAIN GUTTER-CUT OFF ENDS TO ELIMINATE INTERFERENCE WITH ENTRANCE ATTACH FRAME

ENTRANCE ATTACH FRAME

LADDER

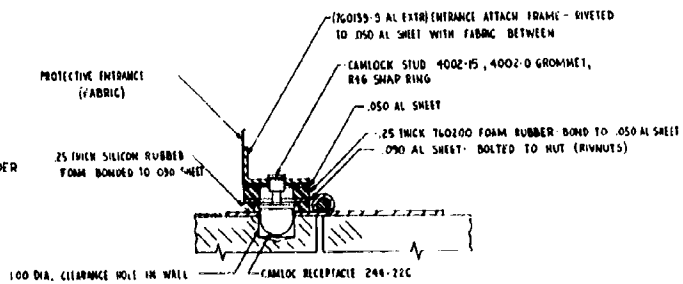

SECTION C-C  
SCALE: 1/2

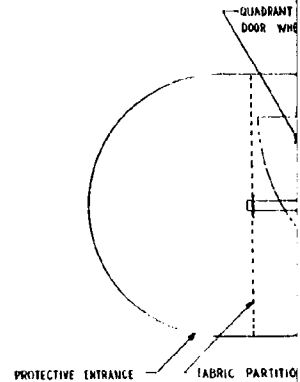

ENTRANCE SUPPORT ARM - BOLTED TO BLIND FASTENERS INSTALLED IN ROOF OF HUT

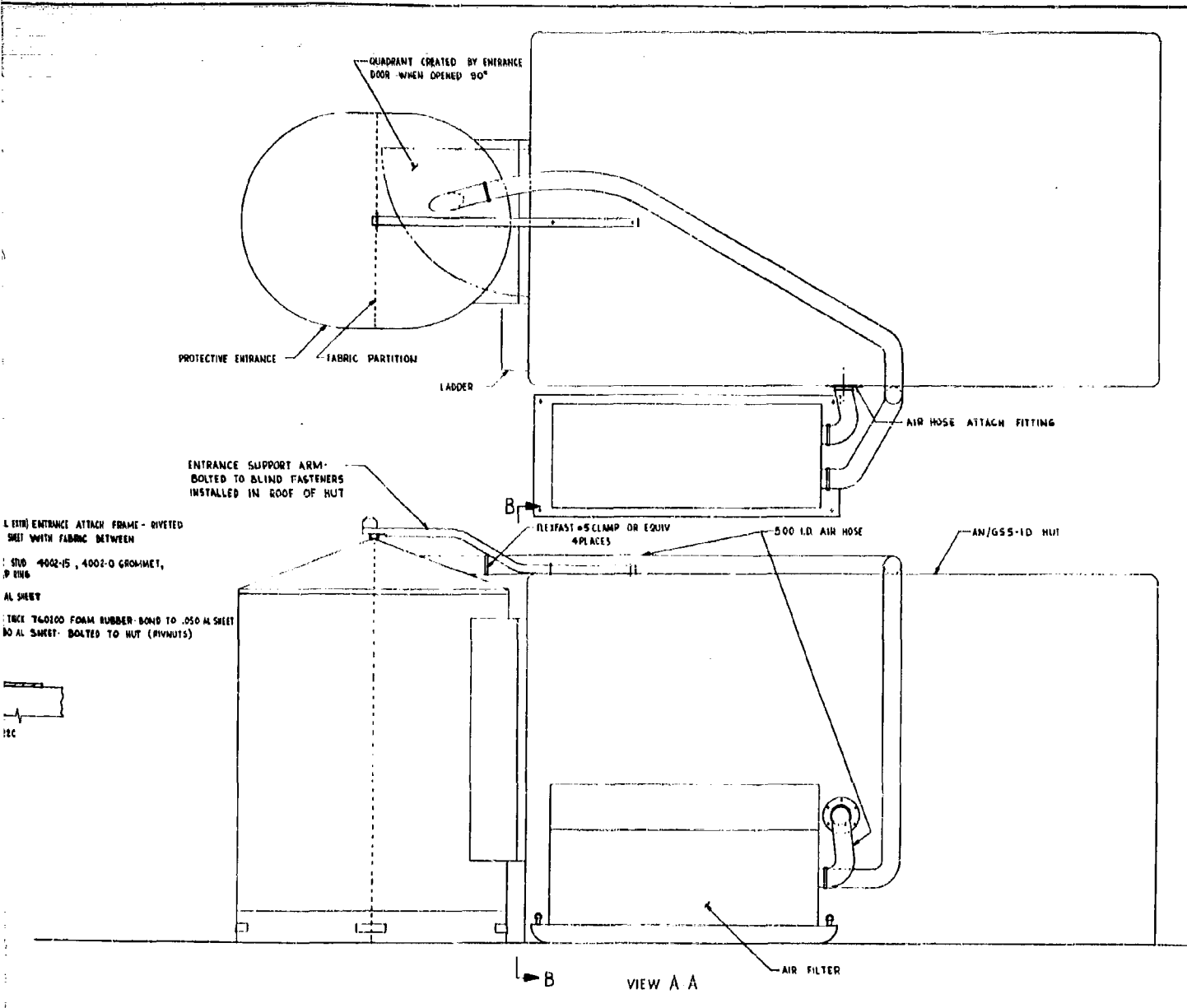

4

Figure 22

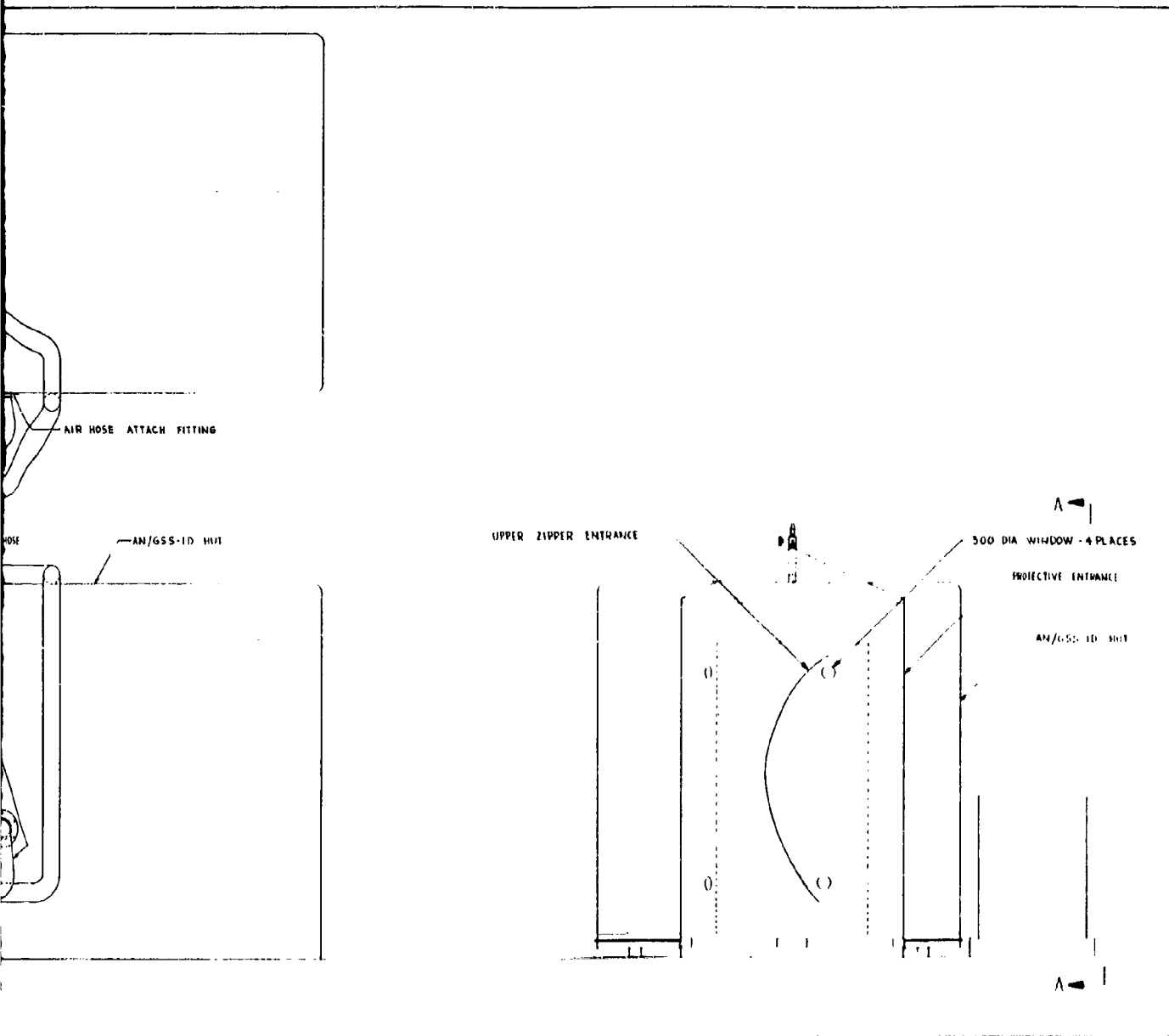

Figure 22 Category A Collective Protection Equipment for AN/GSS-1D Shelter