

UNCLASSIFIED

AD 274 295

*Reproduced
by the*

**ARMED SERVICES TECHNICAL INFORMATION AGENCY
ARLINGTON HALL STATION
ARLINGTON 12, VIRGINIA**



UNCLASSIFIED

NOTICE: When government or other drawings, specifications or other data are used for any purpose other than in connection with a definitely related government procurement operation, the U. S. Government thereby incurs no responsibility, nor any obligation whatsoever; and the fact that the Government may have formulated, furnished, or in any way supplied the said drawings, specifications, or other data is not to be regarded by implication or otherwise as in any manner licensing the holder or any other person or corporation, or conveying any rights or permission to manufacture, use or sell any patented invention that may in any way be related thereto.

274 295

ARL 156

274295

INTRAMOLECULAR ENERGY TRANSFER: LUMINESCENCE PHENOMENA IN THE GROUP IV TETRAPHENYLS

S. R. LA PAGLIA, 1/LT., USAF
CHEMISTRY RESEARCH BRANCH

DECEMBER 1961

AERONAUTICAL RESEARCH LABORATORY
OFFICE OF AEROSPACE RESEARCH
UNITED STATES AIR FORCE

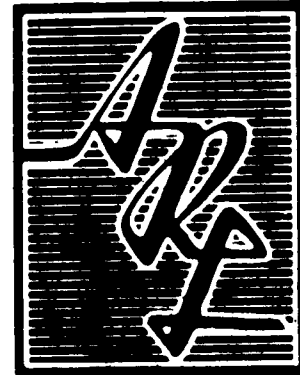

AS AD NO. _____

NOTICES

When Government drawings, specifications, or other data are used for any purpose other than in connection with a definitely related Government procurement operation, the United States Government thereby incurs no responsibility nor any obligation whatsoever; and the fact that the Government may have formulated, furnished, or in any way supplied the said drawings, specifications, or other data, is not to be regarded by implication or otherwise as in any manner licensing the holder or any other person or corporation, or conveying any rights or permission to manufacture, use, or sell any patented invention that may in any way be related thereto.

Qualified requesters may obtain copies of this report from the Armed Services Technical Information Agency, (ASTIA), Arlington Hall Station, Arlington 12, Virginia.

This report has been released to the Office of Technical Services, U. S. Department of Commerce, Washington 25, D. C. for sale to the general public.

Stock available at OTS \$1.00.

Copies of ARL Technical Reports and Technical Notes should not be returned to Aeronautical Research Laboratory unless return is required by security considerations, contractual obligations, or notices on a specific document.

4	<p>Aeronautical Research Laboratory, Wright-Patterson Air Force Base, Ohio. INTRA-MOLECULAR ENERGY TRANSFER: LUMINESCENCE PHENOMENA IN THE GROUP IV TETRAPHENYLS by S. R. La Paglia, 1/Lt. USAF. December 1961. 28 p. incl. illus. (Project 7013; Task 70346) (ARL 156) Unclassified Report</p> <p>The absorption, emission and excitation spectra, crossing ratios and lifetimes of phosphorescence of the group iv tetraphenyls are presented and discussed from the viewpoint of the theory of intramolecular energy transfer processes.</p> <p>(ever)</p>	UNCLASSIFIED	UNCLASSIFIED
4	<p>Aeronautical Research Laboratory, Wright-Patterson Air Force Base, Ohio. INTRA-MOLECULAR ENERGY TRANSFER: LUMINESCENCE PHENOMENA IN THE GROUP IV TETRAPHENYLS by S. R. La Paglia, 1/Lt. USAF. December 1961. 28 p. incl. illus. (Project 7013; Task 70346) (ARL 156) Unclassified Report</p> <p>The absorption, emission and excitation spectra, crossing ratios and lifetimes of phosphorescence of the group iv tetraphenyls are presented and discussed from the viewpoint of the theory of intramolecular energy transfer processes.</p> <p>(ever)</p>	UNCLASSIFIED	UNCLASSIFIED
4	<p>Aeronautical Research Laboratory, Wright-Patterson Air Force Base, Ohio. INTRA-MOLECULAR ENERGY TRANSFER: LUMINESCENCE PHENOMENA IN THE GROUP IV TETRAPHENYLS by S. R. La Paglia, 1/Lt. USAF. December 1961. 28 p. incl. illus. (Project 7013; Task 70346) (ARL 156) Unclassified Report</p> <p>The absorption, emission and excitation spectra, crossing ratios and lifetimes of phosphorescence of the group iv tetraphenyls are presented and discussed from the viewpoint of the theory of intramolecular energy transfer processes.</p> <p>(ever)</p>	UNCLASSIFIED	UNCLASSIFIED

**INTRAMOLECULAR ENERGY TRANSFER:
LUMINESCENCE PHENOMENA IN THE GROUP IV
TETRAPHENYLS**

*S. R. LA PAGLIA
1/LT. USAF*

CHEMISTRY RESEARCH BRANCH

DECEMBER 1961

**PROJECT No. 7013
TASK No. 70346**

**AERONAUTICAL RESEARCH LABORATORY
OFFICE OF AEROSPACE RESEARCH
UNITED STATES AIR FORCE
WRIGHT-PATTERSON AIR FORCE BASE, OHIO**

FOREWORD

This report was prepared by Dr. S. R. La Paglia of the Chemistry Research Branch, Aeronautical Research Laboratory. The work reported herein was accomplished under Project 7013, "Research on Combustion Kinetics", and Task 70346, "Research on Molecular Energy Transfer". The author gratefully acknowledges the tenure of a National Academy of Sciences-National Research Council Postdoctoral Research Associateship during 1960-1961.

ABSTRACT

The absorption, emission and excitation spectra, crossing ratios and lifetimes of phosphorescence of the group IV tetraphenyls are presented and discussed from the viewpoint of the theory of intramolecular energy transfer processes.

TABLE OF CONTENTS

<u>Section</u>	<u>Page</u>
I. INTRODUCTION	1
II. INTRODUCTION TO THE THEORY OF INTRAMOLECULAR PROCESSES IN POLYATOMIC MOLECULES	2
III. LUMINESCENT PROPERTIES OF THE GROUP IV TETRAPHENYLS	4
A. Absorption Spectra	4
B. Emission Spectra	5
C. Excitation Spectra	7
D. Kinetic Analysis	7
E. Discussion	9
(a) crossing ratios	
(b) lifetimes	
F. Singlet-Triplet Absorption Spectra	11
IV. PROBABILITY OF SINGLET-TRIPLET TRANSITIONS	15
Appendix I. Materials	20
Appendix II. Lifetime Measurements	22
Appendix III. Spectra	25

LIST OF FIGURES

<u>Figure</u>	<u>Page</u>
1. Absorption spectra of carbon, and silicon tetraphenyl and benzene	4
2. Absorption spectra of germanium, tin and lead tetraphenyl	5
3. Typical emission spectrum, germanium tetraphenyl	6
4. Conventional energy level scheme	7
5. S-T absorption of lead tetraphenyl	12
6. S-T absorption of germanium tetraphenyl	13
7. S-T absorption of tin tetraphenyl	14
8. Electrical Circuits	22
9. Optical Arrangement	23
10. Spectrophotofluorometer	25
11. SPF Response	26

SECTION I

INTRODUCTION

In the elucidation of the luminescent behavior of polyatomic molecules, hypotheses have been advanced on the nature of the states and processes involved. Although by now well established, these suggestions are confirmed by the luminescence characteristics of the group IV tetraphenyls. Specifically, the tetraphenyls emit two types of luminescence, the variation of which with atomic number of the central atom and physical environment, forms the topic of the present report.

Although hypothesized many years ago the radiationless transition is still the object of extensive research and conjecture. In Section II we give a short descriptive introduction to the theory of intramolecular processes, including an approach to radiationless transitions. In Section III the results of our investigations are presented and discussed. In the last section we apply the theory of spin-orbit coupling in polyatomic molecules, in some detail, in order to explain these observations.

SECTION II

INTRODUCTION TO INTRAMOLECULAR PROCESSES IN POLYATOMIC MOLECULES

Since the suggestion by Lewis and Kasha, and Terenin on the nature of the phosphorescent state in complex molecules (1943-44) our understanding of luminescent phenomena has been greatly increased. Recent reviews have been given by M. Kasha, H. Sporer, C. Reid and G. Porter (Ref. 1-4). In this section we assume the reader is familiar with these reviews, we merely discuss one or two points which are occasionally glossed over. Dissociation phenomena, here ignored are treated in the reviews (Ref. 5).

After the initial act of absorption of a photon the molecule finds itself in an excited electronic state with a lifetime which does not necessarily depend wholly on the transition probability. For example, if the excited state is other than the lowest lying state of that multiplicity, radiationless deactivation to a lower state of the same multiplicity occurs within 10^{-11} to 10^{-13} sec. For very high lying states this has been visualized as a cascade process whereby electronic energy is converted into nuclear motions. This has led to a statement which is well borne out by experiment, that after the absorption of non-ionizing radiation the emitting state is the lowest lying excited state of that multiplicity (Ref. 6). If two emissions are observed they therefore correspond to excited states of different multiplicity. Complex molecules then, possess a very efficient mechanism for the relaxation of electronic energy. But, by analogy with the diatomic molecule, it is conventional to think of these radiationless transitions in terms of the intersection of potential energy surfaces. Here it must be remembered that for a complex molecule the potential energy surface is of $3n-6$ dimensions so that the intersecting surfaces will also in general be hyperdimensional (up to $3n-6$). For the diatomic molecule the probability of these non-adiabatic transitions has been calculated by Landau and Zener (Ref. 7, 8). Teller (Ref. 9) extended these considerations to the polyatomic molecule. In the diatomic molecule only states which differ in symmetry or excitation can cross since the one available parameter (the internuclear distance) cannot bring about a complete degeneracy (Ref. 9). However, the large number of available parameters of different symmetry in a complex molecule can always bring about such a degeneracy. This is what we mean when we say the states are mixed by vibrations of appropriate symmetry. Teller treated the case of two parameters ("double conical" crossing) and three parameters, and obtained reasonable transition probabilities.

In view of the difficulties inherent in this approach for complex molecules, it is useful to have a scheme for visualizing the fast electronic relaxation. We note that the cascade qualitatively resembles exciton migration and may be termed an intramolecular exciton phenomenon. While the exciton propagates in 3 dimensional space the intramolecular exciton moves in the polydimensional space of electrons and nuclei. That is, the absorption of a photon creates an exciton which is scattered from state to state (after partial thermalization) by phonons of appropriate symmetry. The exciton is finally either completely thermalized (ground electronic state) or localized (lowest excited state of that multiplicity). The affect* of the medium in which the molecule finds itself is on vibrational relaxation. The intramolecular process also differs from the intermolecular one in that the coupling mechanism in the latter (Ref. 10) is a multipole-multipole interaction while in the former it is a vibrational perturbation of the electronic state.

However, both are resonance phenomena and can be treated by the time dependent perturbation theory. From Schiff (Ref. 11) the transition probability per unit time is,

$$\omega(\text{sec}^{-1}) = \sum_k \frac{2\pi}{\hbar} \rho(k) |H'_{km}|^2 \quad (1)$$

where m is the initial state, k is the final state and $\rho(k)$ is the density of final states. H'_{km} is the matrix element of the perturbation between these states. The sum is over final states of nearly the same energy but different H'_{km} . That is, the excitation may be scattered to a variety of vibronic states.

Robinson (Ref. 12) has written down the same expression for the radiationless transition probability,

$$P \approx \frac{4\pi^2}{\nu} I_{12}^2 V_{12}^2 \quad (2)$$

where I_{12} is a product of vibrational overlap integrals and V_{12} is the purely electronic matrix element. (Note that (1) reduces to (2), as it must, under certain assumptions about the matrix element H'_{km} and the density of final states.) We refer the reader to Reference 12 for further discussion of radiationless transitions and some actual examples. The non-adiabatic transition here discussed, is not a "tunnelling phenomenon" at least not as the expression has been used heretofore. Albrecht (Ref. 13) has also touched on this question. The first use of the analogy between scattering phenomena (time dependent perturbation theory) and the coupling of vibrational and electronic energy in a polyatomic molecule was made by Liehr (Ref. 14) in connection with the Jahn-Teller effect in benzene positive ion.**

We must add, for the sake of understanding the results which follow, that because of the energetic isolation of the ground state from states of the same multiplicity in most molecules, the intramolecular exciton has a small probability of being thermalized via the first excited singlet state. Indeed, it is commonly found that intersystem crossing to the lowest triplet state is competitive with both emission and internal conversion of the first excited singlet. This leads to two more processes, emission from the triplet (phosphorescence) and thermalization via the triplet. Luminescence observations of the tetraphenyls show the last process to be important, at least in certain cases.

*Of course, in the case of rare gas solvents with high nuclear charge or other electronically perturbing solvents the effect of the medium is more than merely thermal. Here we are thinking of inert media, in the true sense.

**In the J-T phenomenon electronic states which are degenerate by symmetry are split by vibrations of appropriate symmetry, while in the radiationless transition, vibrations bring about a vibronic degeneracy.

SECTION III

LUMINESCENT PROPERTIES OF THE GROUP IV TETRAPHENYLS

ABSORPTION SPECTRA

Absorption spectra of the tetraphenyls and of benzene are given in Figures 1 and 2.

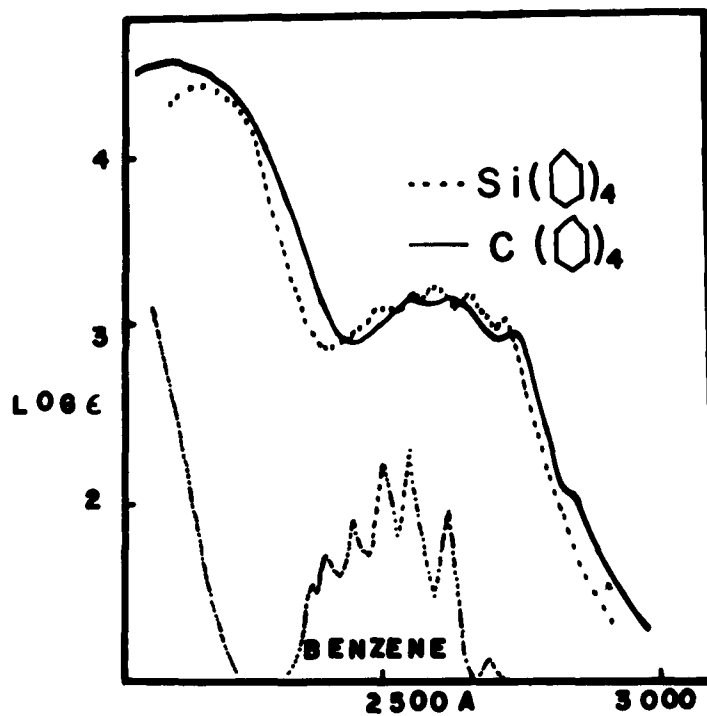

Figure 1. Absorption spectra of carbon and silicon tetraphenyl and of benzene. Iso-octane used as solvent.

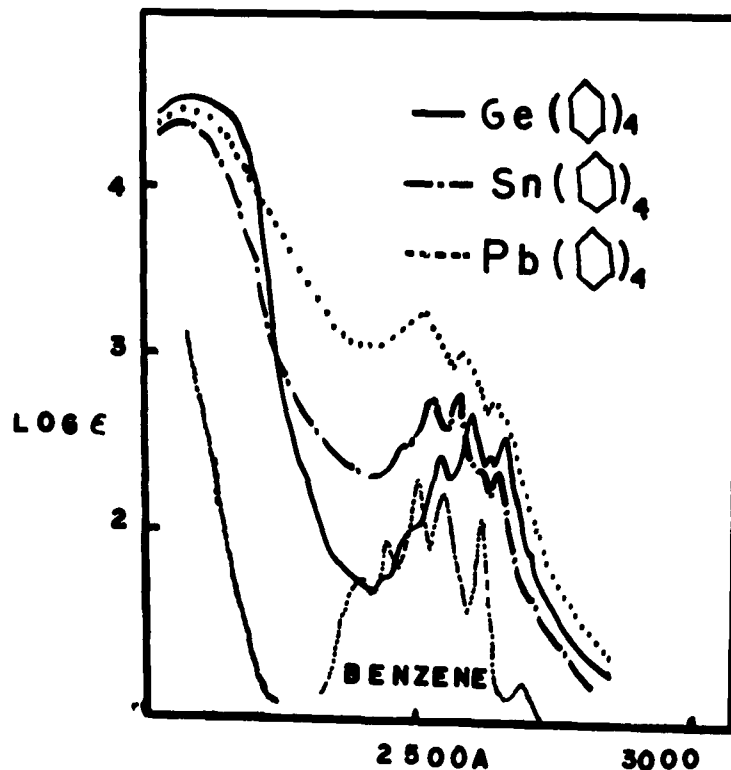

Figure 2. Absorption spectra of germanium, tin, and lead tetraphenyl in iso-octane solvent.

The similarity to the absorption spectra of benzene and benzene derivatives is evident. The two electronic transitions observed (2600 and 2100Å) are analogous to the forbidden ${}^1B_{2g} \leftarrow {}^1A_{1g}$ and ${}^1B_{1g} \leftarrow {}^1A_{1g}$ transitions of benzene. The blue shift which results from substitution of group IV atoms of higher nuclear charge, together with the simultaneous marked decrease of the intensity of the 0-0 transition, which is forbidden in benzene by symmetry, has been interpreted as indicating a decreasing perturbation of the "normal benzene charge distribution", (Ref. 15 and 18).

EMISSION SPECTRA

Emission spectra of the tetraphenyls are given in Figure 3 and Table I. Experimental details are found in Appendix III.

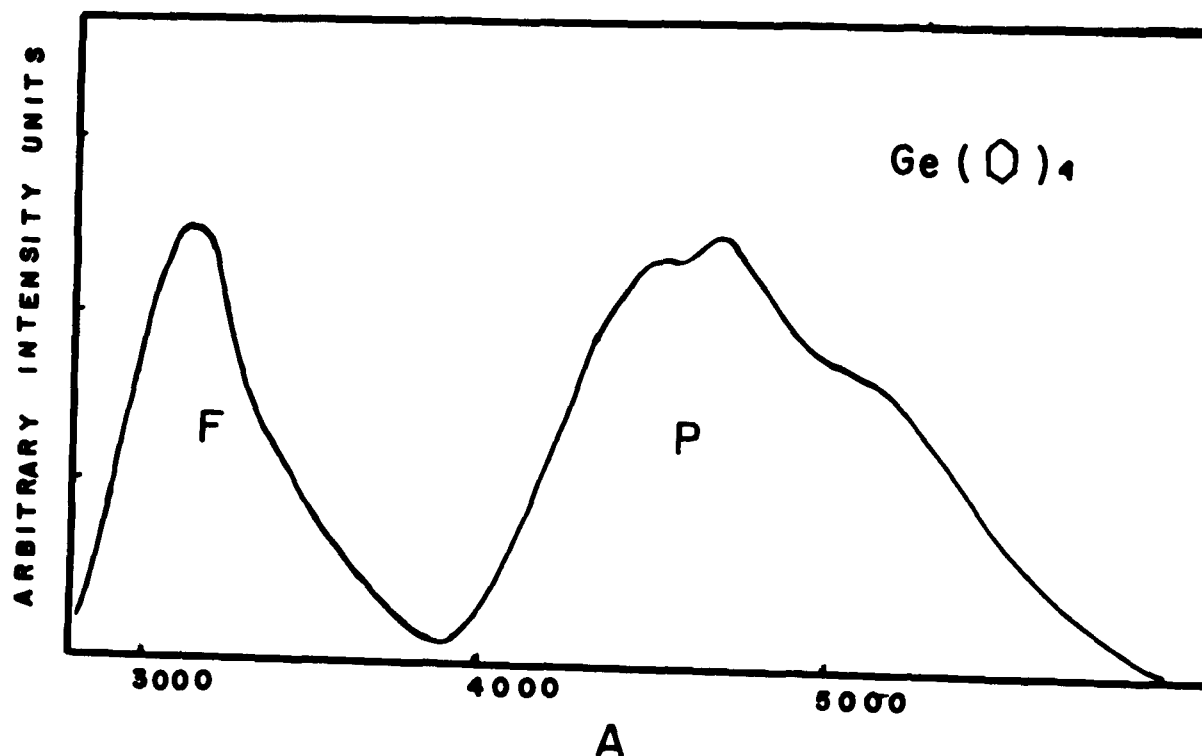

Figure 3. Emission spectrum of germanium tetraphenyl.

Emission consists of two broad bands. A short wavelength band (F band), which overlaps the 0-0 transition region (2700Å), is ascribed to transitions from the vibrationless first excited state to vibrational levels of the ground state. In solution at room temperature this is the only emission which occurs. A longer wavelength band (P band) is the source of the blue-green phosphorescence observed in all these molecules in the crystalline state at room temperature, or 77°K, or in solid solution at 77°K. A noticeable decrease in the lifetime of phosphorescence with increasing atomic number of the central atom has served to classify this emitting state as a triplet state of lower energy than the first excited singlet. This emission should correspond to the well studied phosphorescence of benzene. In benzene the F band possesses vibrational structure and occurs in the region 2500-3000Å. The P band (3400-4700Å) also occurs with extensive vibrational structure. Sponer et al. (Ref. 19) classify the P emission as ${}^3B_{1g} \rightarrow {}^1A_{1g}$ (or possibly ${}^3B_{2g} \rightarrow {}^1A_{1g}$). F emission is of course ${}^1B_{2g} \rightarrow {}^1A_{1g}$.

TABLE I
EMISSION SPECTRA OF THE GROUP IV TETRAPHENYLS

	$C(C_6H_5)_4$	$Si(C_6H_5)_4$	$Ge(C_6H_5)_4$	$Sn(C_6H_5)_4$	$Pb(C_6H_5)_4$
F Band Maxima	3200Å	3100	3200	3200	weak
P Band Maxima	4500, 4700 5100	4300, 4600	4500, 4700 5100	4500, 4700	4250, 4550

EXCITATION SPECTRA

The emission spectra were found to be independent of the wavelength of the exciting light (2000-3000Å). The intensity of emission does vary with the absorption coefficient at the exciting wavelength. It would be interesting to investigate the relative yield of phosphorescence and fluorescence as a function of exciting wavelength and temperature using solid solutions. Interesting results have been obtained in studies of dye solutions, which indicate the relative yields are temperature and wavelength dependent (Ref. 20); other cases are also known.

KINETIC ANALYSIS

In the following analysis we ignore the possible existence of thermal effects of the kind just mentioned, which would involve a consideration of vibrational excitation and relaxation, and instead consider the usual 3 level scheme.

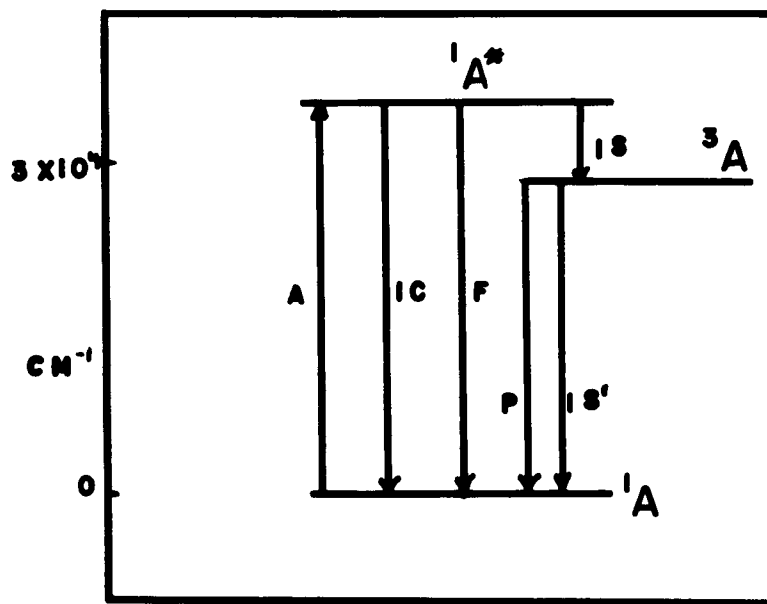

Figure 4. Conventional level scheme with possible processes.

<u>Rate Constant</u>		<u>Process</u>	
	$1_A + h\nu \longrightarrow 1_A^*$	Absorption	(3)
k_f	$1_A^* \longrightarrow 1_A + h\nu$	Fluorescence	(4)
k_{is}	$1_A^* \longrightarrow 3_A$	Intersystem Crossing	(5)
k_p	$3_A \longrightarrow 1_A + h\nu'$	Phosphorescence	(6)
k_{is}'	$3_A \longrightarrow 1_A$	Intersystem Crossing	(7)
k_{ic}	$1_A^* \longrightarrow 1_A$	Internal Conversion	(8)

The inverse lifetimes of phosphorescence and fluorescence are then,

$$1/\tau_p = k_p + k_{is}', \quad 1/\tau_f = k_f + k_{ic} + k_{is} \text{ and by radiative lifetimes we mean, } 1/\tau_p^0 = k_p, \quad 1/\tau_f^0 = k_f \quad (9)$$

The scheme given above will apply only under certain conditions. In particular, we have ignored all possible bimolecular processes. Those often suggested are,



We may also mention sensitized fluorescence, in which case the quencher Q in Equation (10) or Equation (11) later emits. Equations (11) and (12) prohibit the observation of 3_A emission in non-rigid media. Livingston and Jackson (Ref. 21) present evidence^A, specifically for anthracene, that Equation (11) and Equation (12) are temperature and viscosity dependent. It is also clear that because of the long lifetime of 3_A , very small quantities of quenching impurities* ($10^{-7}M$) are sufficient to appreciably lower the lifetime. These bimolecular processes are

*The rate of disappearance of 3_A may be written,

$$-d3_A/dt = k_1 (3_A) + k_2 (3_A)^2$$

where $k_1 = k_1^0 + k_1^Q (Q) \exp -E/RT$, $1/k_1^0$ is the unimolecular lifetime and

minimized in rigid, dilute, solid solutions at low temperatures. It should be noted that Equations (6), (7), (11) and (12) give first and second order rate constants which are both viscosity dependent (compare Ref. 22).

In dilute, solid solution at 77°K, the quantum yields of fluorescence, intersystem crossing and phosphorescence are given by,

$$\bar{\Phi}_F = k_f / (k_f + k_{ic} + k_{is}) \quad (14)$$

$$\bar{\Phi}_{is} = k_{is} / (k_{is} + k_{ic} + k_f) \quad (15)$$

$$\bar{\Phi}_P = \bar{\Phi}_{is} k_p / (k_p + k_{is}') \quad (16)$$

$$\bar{\Phi}_P = k_p k_{is} / (k_p + k_{is}') (k_{is} + k_{ic} + k_f)$$

$$\bar{\Phi}_P / \bar{\Phi}_F = \frac{k_{is}}{k_f} \left(\frac{k_p}{k_p + k_{is}'} \right) \quad (17)$$

DISCUSSION

If k_{is}' is zero, $\bar{\Phi}_P / \bar{\Phi}_F = \frac{k_{is}}{k_f}$ Kasha's Crossing Ratio, Equation (16)

Taking the case of carbon tetraphenyl where Equation (18) is a very bad approximation, but better than in the case of the other tetraphenyls, we have,

$$\bar{\Phi}_P / \bar{\Phi}_F \leq 0.1, \quad k_f \sim 10^8, \text{ then } k_{is} \sim 10^6 \text{ or } 10^7 \text{ sec}^{-1}$$

as Kasha expected (Ref. 6) for an essentially aromatic molecule containing only carbon atoms. $\bar{\Phi}_P / \bar{\Phi}_F$ ratios have been estimated for the other tetraphenyls to be, Si(0.1), Ge(1), Sn(10), Pb($\gg 10$).**

$1/k_1$ is the observed lifetime. Therefore k_1^0 is 10^5 to 1 sec^{-1} or smaller. Taking $k_1 \exp -E/RT = 10^9 \text{ l.mole}^{-1} \text{ sec}^{-1}$, then (4) may be 10^{-5} to 10^{-9} moles l.^{-1} in order to exert quite an observable effect.

**Method of estimation is dealt with in Appendix III.

Relative yields are difficult to estimate for the lead compound since the F band has almost disappeared, which is to say it was not observable in our experiments. This compound also shows the weakest P band, as seen below, this is all to be expected.

The change in crossing ratio shows the expected trend with increasing atomic number of the central atom. That is, k_{is} in Equation (14) is markedly increased by heavy atom substitution, reducing the fluorescence yield.* It would be somewhat illogical to have the heavy atom affect k_{is} and not k_{is}' . In this regard we note that a decreasing Φ_p can only be produced by an increasing k_{is}' since Φ_{is} and k_p can only increase under the same circumstances, Equations (15) and (16).* This is what is observed. At 77°K in dilute solid solution or at room temperature in the crystalline state Φ_p decreased markedly and smoothly in going from carbon to lead tetraphenyl.

This is an important observation since some have doubted the existence of (is') or claimed it was viscosity dependent and therefore totally inhibited under these conditions.** The difference between k_{is} and k_{is}' is expressed in Equations (1) and (2) and may be mainly caused by vibrational overlap.

Of course the crossing ratio will show the correct behavior with increasing atomic number even if Φ_p is decreasing, simply because Φ_f must decrease much faster. From Equation (17) we see that with k_f constant, the increasing k_{is} and k_p are multiplicative while the increasing k_{is}' and k_p are merely additive.

To estimate the radiationless rates more information is needed, specifically, both the observed lifetime of phosphorescence and the radiative lifetime, Equation (9). The lifetimes of phosphorescence in rigid glasses at 77°K were measured (experimental details in Appendix 11).

	C	Si	Ge	Sn	Pb
$\tau_p(\text{sec})$	2.9	1.1	0.055	0.003	(0.0008)

* k_{ic} , if it is not zero, is assumed to be constant as a function of the atomic number of the central atom. This assumption is strengthened by the nearly identical extinction coefficients (constant k_f) and similar band shapes observed in the tetraphenyls. The lack of sharp vibrational structure in the absorption spectra of carbon and lead tetraphenyl may have very different origins. In the former the transition will not be localized in the ring, while in the latter we will find that k_{is} is so large, of the order of a vibrational frequency, that the vibronic levels may suffer in sharpness because of the uncertainty principle.

A fall in quantum yield of luminescence may always be attributed to photodecomposition. However, in no case do we have evidence of photodecomposition products, i.e., the occurrence of new emission or absorption bands upon irradiation.

In Section IV we examine the theory of spin-orbit coupling in polyatomic molecules more closely, in order to estimate the radiative lifetimes.***

SINGLET-TRIPLET ABSORPTION SPECTRA

The radiative lifetime, $\tau_p^0 = 1/k_p$, may be determined directly if singlet-triplet absorption bands can be observed. The radiative lifetime is calculated from the equation,

$$\int \epsilon \, d\nu = \frac{10.41 \times 10^8}{\nu^2 \tau_p^0} \quad \nu \text{ in cm}^{-1}$$

We searched for S-T absorption bands in the tetraphenyls. Our efforts were hampered by the small solubility of these compounds in hydrocarbon and hydroxylic solvents. However, chloroform was found to be a good solvent. The S-T absorption spectra are displayed in Figures 5 to 7.

As was expected the intensity of the S-T absorption increased with the atomic number of the central atom. In germanium tetraphenyl the S-T absorption is the long tail of the S-S absorption with a mere indication of structure. In the silicon compound S-T absorption was not detected under the present conditions.

By plotting the data as molecular extinction coefficient versus wave numbers and performing the integration we obtain,

	Ge	Sn	Pb
τ (sec)	.003	.0006	.00008

Although the germanium value suffers from uncertainty due to difficulty in separating singlet-singlet from singlet-triplet absorption, this is not true of the others. It is evident that these lifetimes are shorter, by at least an order of magnitude, than the observed lifetimes of phosphorescence in rigid solution. Clearly, these lifetimes cannot represent molecular quantities, but rather, are characteristic of both the molecule and the solvent. We are observing transitions which seem to derive a great deal of their intensity from collisional perturbation by the heavy atom solvent (an effect first reported by M. Kasha) and, to some lesser extent, dissolved oxygen (see the papers of D. F. Evans). Although this removes all quantitative significance from lifetimes so derived, qualitatively the absorption curves and relative intensities are of interest since they support the other types of observation.

**See for example, W. Kauzmann, "Quantum Chemistry", Academic Press, 1957, p. 700-703, and references given therein.

***Radiative lifetimes could be obtained from singlet-triplet absorption coefficients, or as Equations (14), to (17) show from measured yields of fluorescence and phosphorescence.

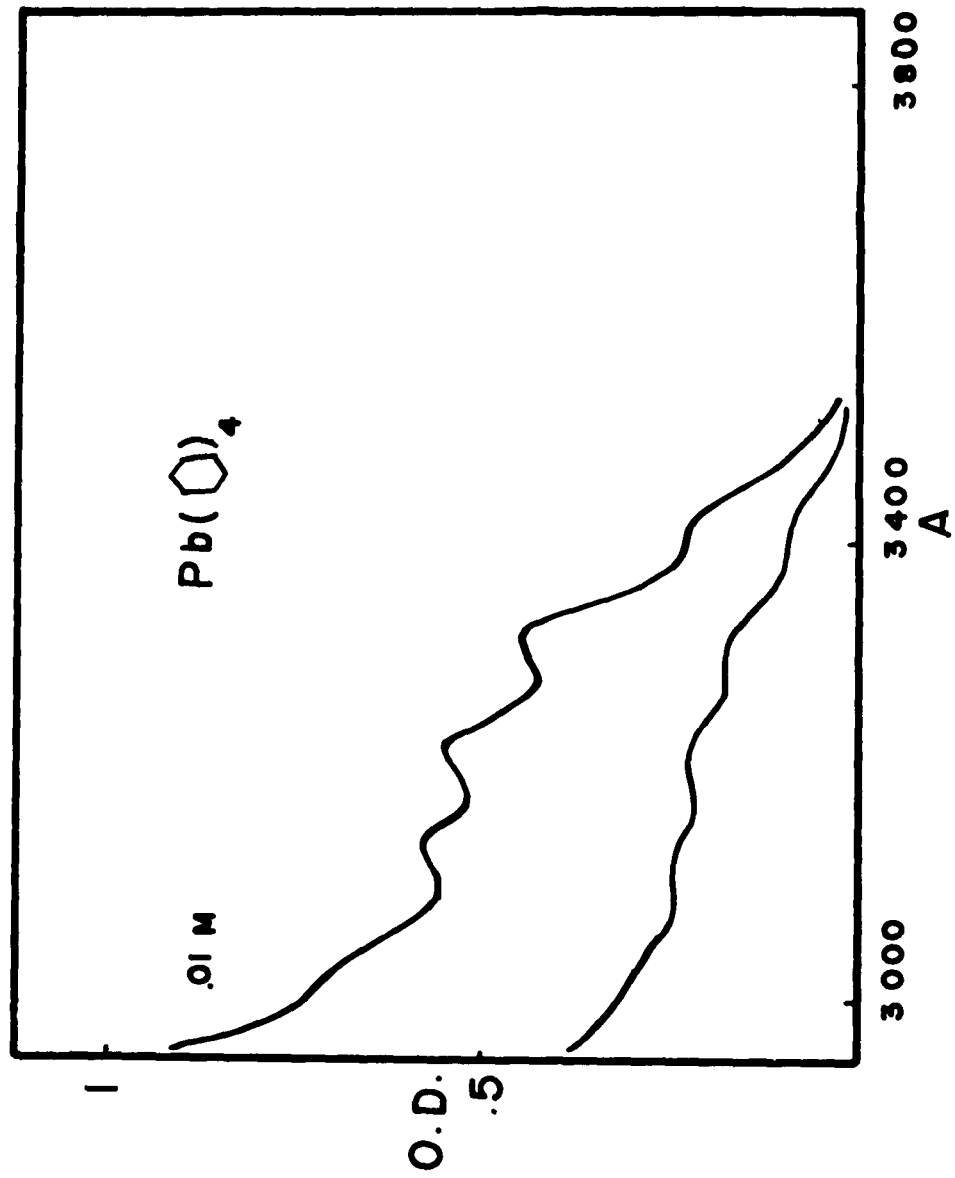

Figure 5. S-T absorption spectrum of lead tetraphenyl in CHCl_3

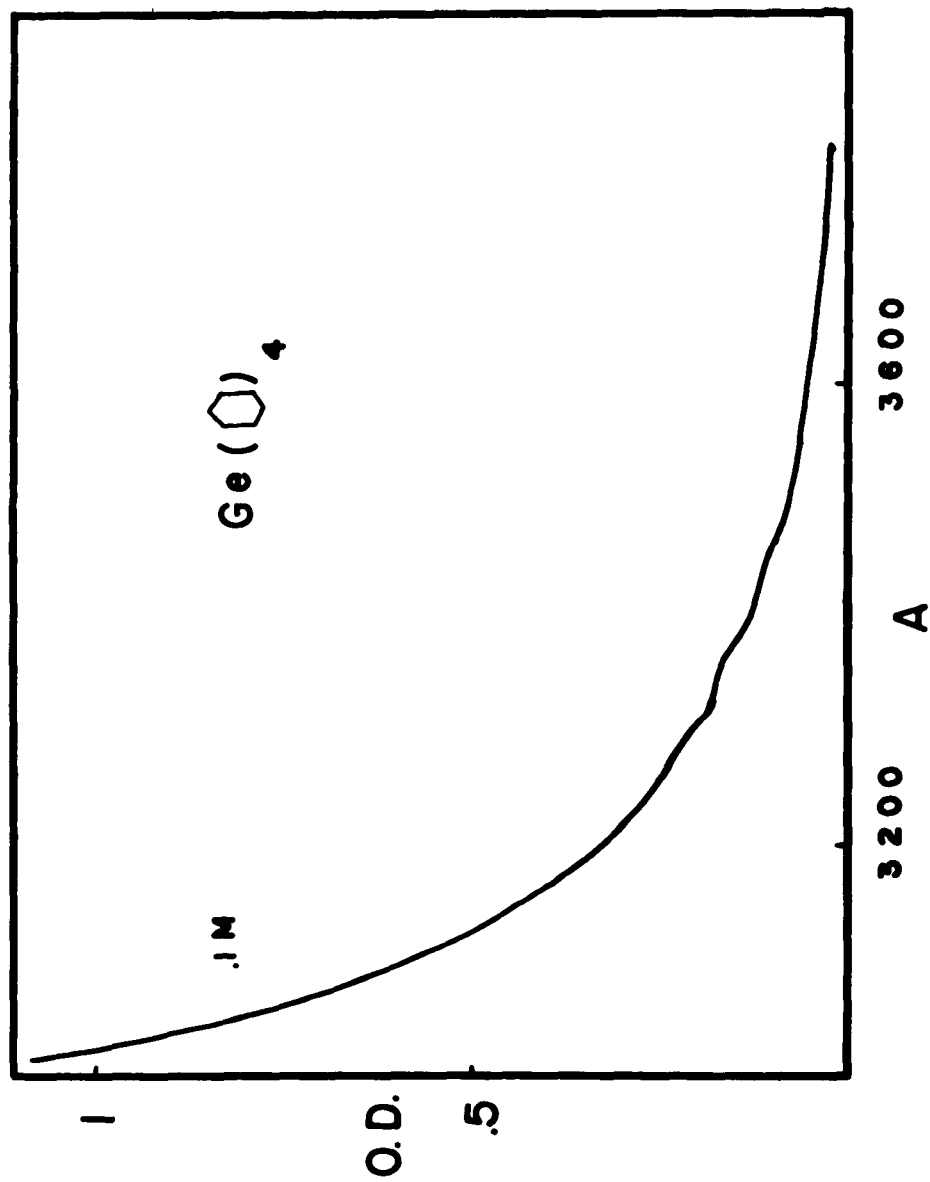

Figure 6. S-T absorption of germanium tetraphenyl in CHCl_3

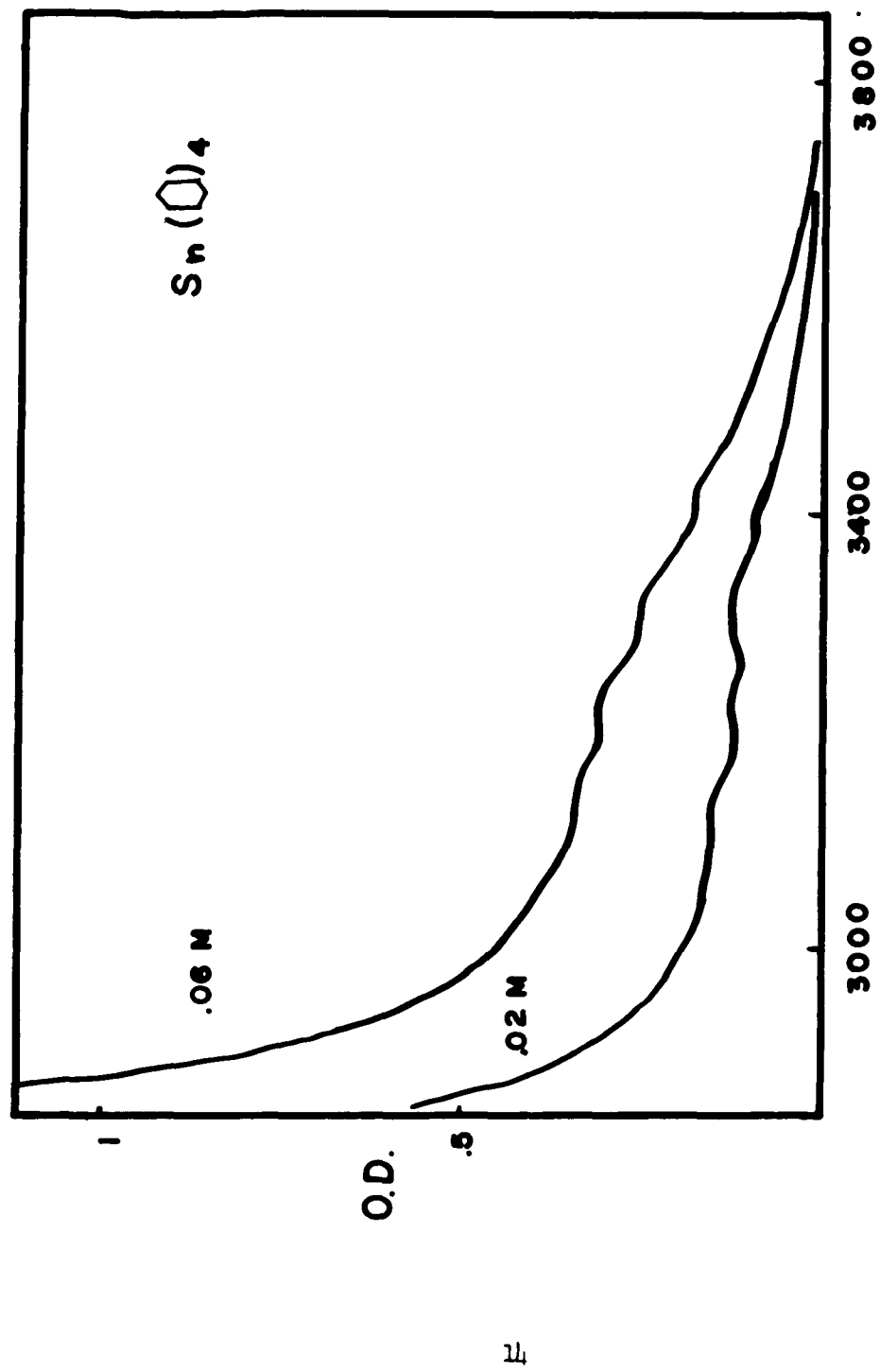

Figure 7. S-T absorption of tin tetraphenyl in CHCl_3

SECTION 1V

PROBABILITY OF SINGLET-TRIPLET TRANSITIONS

Actual calculation of radiative lifetimes for triplet-singlet emission have been carried out in only a few cases, e.g., carbonyl emission (Sidman, Hamcka and Oosterhoff) and benzene (Mizushima and Koida, Clementi, Hamcka and Oosterhoff) (Ref. 23 to Ref. 26). The methods used in these studies differ in detail, but all make use of the first order perturbation theory. This reduces to the calculation (or more properly, estimation) of the matrix element of the perturbing spin-orbit Hamiltonian between the triplet state and a nearby excited singlet state. Possible mixing of the ground state with excited triplet states is ignored. Slater type orbitals are used, which are not distinguished for their ability to represent the wave function in the region of the nucleus.

Results of calculations referring to the same phosphorescence differ widely among themselves and are in very poor agreement with experiment. However a more refined approach seems neither feasible nor necessary at the present time since part of the difficulty lies in obtaining true radiative lifetimes from experiment. This should be clear from various sections of this report.*

In the following we propose to treat the singlet-triplet transition probability in the group IV tetraphenyls from the viewpoint of a normal benzene ring perturbed by a heavy atom. This model has the virtues of simplicity and generality. If the heavy atom is a halogen, we have the halogen benzenes (also phosphorescent), and if it is a rare gas atom, our model closely approximates that chosen by G. W. Robinson for the phosphorescent benzene-rare gas complex, which he studied at 4.2°K in crystalline rare gas solvents (Ref. 12).

Our interest lies in the states which arise from the lowest excited configuration of benzene, $(\phi_0)^2(\phi_{z1})^2(\phi_{z2})^2$.

where the ϕ_i are linear combinations of $2p_z$ carbon functions, z axis perpendicular to the molecular plane. This configuration gives rise to 16 Slater determinants. The linear combinations of these determinants which are eigenfunctions of S^2 , S_z and the operations of D_{6h} represent the low lying excited pi states of benzene, $1,3B_{1u}$, $1,3B_{2u}$, $1,3E_{1u}$. In the model chosen (benzene perturbed by a heavy atom) the symmetry is C_{2v} . Wilson, Decius and Cross (Ref. 27) give the correlation table for C_{2v} as a sub-group of D_{6h} . (The correlation is made on the basis of the C_2 axis being along a C-H bond, which is the C_2' axis in D_{6h} symmetry.)

*An added complication in the case of benzene is that the observed phosphorescence arises from a transition which is both spin and symmetry forbidden.

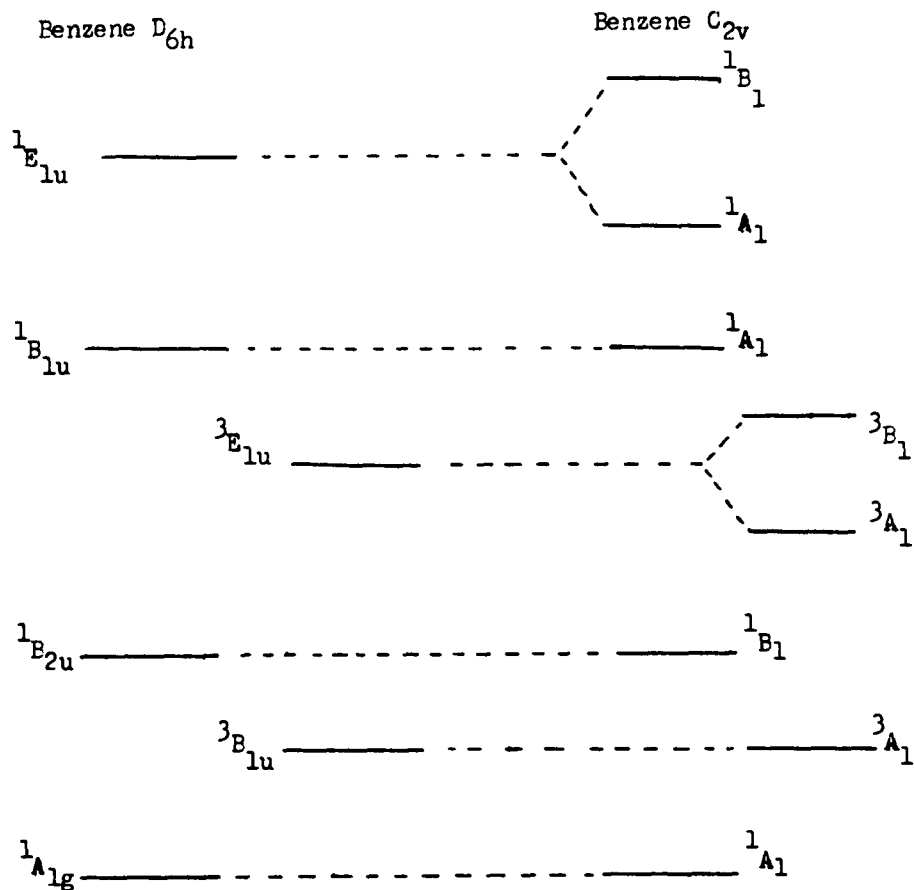

The possible perturbation of the states of benzene in going from D_{6h} to C_{2v} is taken in two parts. We first consider the correction to the zero order Hamiltonian which mixes states of the same multiplicity. This corresponds to mixing of states in the same vertical column in the above diagram. If the total Hamiltonian (ignoring spin-orbit coupling), be separated into two parts, H^0 referring to the isolated benzene ring and H' representing the perturbation, other than spin-orbit, brought about by substituting a heavy atom for hydrogen (electrostatic, multipole-multipole, exchange), then the first order correction to the energy of the state Ψ_l^0

$$\text{is,} \quad E(\Psi_l) = E^0 + H'_{ll}, \quad \text{where} \quad H'_{ll} = \langle \Psi_l^0 | H' | \Psi_l^0 \rangle \quad (19)$$

The actual shifts in the 0-0 transition of $1B_1 \leftarrow 1A_1$ relative to benzene are, C(500 cm^{-1}), Si(350), Ge(40), Sn(40), Pb(110); indicating, at least for the heavier tetraphenyls, a small shift or small parallel shift in energy levels. The first order correction to the wave function is given by the mixing coefficients,

$$\left\langle \sum_{k \neq l} \frac{H'_{kl}}{E_k^0 - E_l^0} \Psi_k^0 \right\rangle \Psi_l^0 \quad (20)$$

The denominators of the mixing coefficients are of the order of several thousand cm^{-1} and increase rapidly for higher states. We conclude that Ψ_l^0 is appreciably mixed by H' only with the nearest states of the same multiplicity.

Similarly, with the correction to the zero order Hamiltonian which mixes states of differing multiplicity, H_{so} , the transition energies differ little from benzene, although the transition moments may be changed appreciably. Explicitly, the probability of the intercombination ${}^3\Psi_l \leftarrow {}^1\Psi_k$ is given by,

$$P = \frac{1}{3\hbar^2} \langle {}^3\Psi_l | e\vec{r} | {}^1\Psi_k \rangle \quad \text{or}$$

$$P = \frac{1}{3\hbar^2} \left\langle {}^3\Psi_{l,n}^0 + \sum_m \frac{\langle {}^1\Psi_m^0 | H_{so} | {}^3\Psi_{l,n}^0 \rangle}{{}^3E_l^0 - {}^1E_m^0} {}^1\Psi_m^0 \middle| e\vec{r} \middle| {}^1\Psi_k^0 + \sum_{m,n} \frac{\langle {}^1\Psi_k^0 | H_{so} | {}^3\Psi_{m,n}^0 \rangle}{{}^1E_k^0 - {}^3E_{m,n}^0} {}^3\Psi_{m,n}^0 \right\rangle^2 \quad (21)$$

Ignoring the possible mixing of the ground state, dropping the sum over components of the triplet state (which are not observable), allowing the triplet to mix with only the nearby singlet, 1B_1 ("perturbing singlet"), and converting to inverse radiative lifetime, we have,

$$1/\tau_p^0 = \frac{32\pi^2\nu^3}{3hc^2} \left\{ \frac{\langle {}^1\Psi_m^0 | H_{so} | {}^3\Psi_l^0 \rangle}{{}^3E_0 - {}^1E_0} \right\}^2 \langle {}^1\Psi_k^0 | e\vec{r} | {}^1\Psi_m^0 \rangle^2 \quad (22)$$

Equation (22) reduces to,

$$1/\tau_p^0 = \frac{(\nu_p/\nu_s)^3}{\tau_s^0(E_s - E_t)^2} M^2 \quad \begin{array}{l} {}^1\Psi_m^0 = {}^1E_1 \\ {}^1\Psi_k^0 = {}^1A_1 \\ {}^3\Psi_l^0 = {}^3A_1 \end{array} \quad (23)$$

where τ_s^0 is the radiative lifetime of the perturbing singlet.

ν_p and ν_s are the 0-0 bands of transition to triplet and perturbing singlet respectively.

$E_s - E_t$ is the energy separation, triplet-perturbing singlet.

M is the matrix element of the spin-orbit Hamiltonian between these states.

Presumably everything is known in Equation (23) except M^2 , certainly the factor before M^2 is the same for all the tetraphenyls, and the problem reduces to

evaluating M^2 . This discussion follows McClure (Ref. 28 and Ref. 29). We write the operator H_{so} , for the i th electron,

$$(H_{so})_i = e^2/2m^2c^2 \sum_f (Z_{fi}/r_{fi}^3)(L_i \cdot S_i) \quad (24)$$

where L_i is the orbital angular momentum of the i th electron relative to the f th nucleus, S_i is the intrinsic spin of the i th electron, r_{if} is the distance of the i th electron from the f th nucleus and Z_{if} is the effective charge of the f th nucleus seen by the i th electron. Equation (24) expresses the interaction between the intrinsic magnetic moment of the electron due to its spin and the magnetic moment due to its motion in the molecule. (In a coordinate system in which the electron is at rest it sees the nuclei and other electrons rotating about it, Equation (24) expresses the interaction of its spin magnetic moment with the moment which results from such a circulation of charge.) Note that Equation (24) has the property of a one electron operator, so interaction with the moments produced by the other circulating electrons is ignored. The other electrons are accounted for electrostatically by using an effective nuclear charge Z_{if} . Since H_{so} is a sum of one electron operators M vanishes if the determinants differ by more than one set of quantum numbers (see Slater (Ref. 30).) That is, the determinants do not differ by more than the assignment of one electron to a different orbital. Since the molecular orbitals are themselves linear combinations of atomic orbitals, M reduces to the evaluation of the matrix elements of Equation (24) between atomic orbitals. These integrals can at most be three center. Because of r_{if} and Z_{if} the interaction is largest near the nuclei; therefore 2 and 3 center integrals will be small due to the small overlap of atomic orbitals at adjacent nuclei and the very small combined overlap at a third nucleus. However in the present discussion it is the multicenter integrals which are important, since the pi electrons are believed to be localized in the ring and it is the effective nuclear charge of the group IV atom which makes the major contribution to the Hamiltonian. Although the Hamiltonian shows a linear dependence on Z_{if} the actual dependence of the matrix elements is greater. (In the case of an A. O. centered on f the average r_{if} varies inversely as Z_{if} , giving a spin-orbit interaction which varies as Z_{if}^2 .)^{*} The importance of the 3 center integral is noteworthy since in the following we estimate the interaction from one center quantities, these must be taken as upper limits to the true interaction.

Following McClure (Ref. 28) the spin-orbit interaction is estimated from the atomic spin-orbit matrix elements of the heaviest atom in the molecule. Condon and Shortley give,

$$\langle A | H_{so} | A' \rangle = \pm \hbar^{-2} \zeta_{nl} \langle a | L \cdot S | a' \rangle \quad (25)$$

where a and a' are the only sets of quantum numbers by which A and A' differ.

ζ_{nl} determines the degree of spin-orbit coupling. For any given configuration the electrostatic energies are added to the spin-orbit matrices and the secular equations solved, the energy levels are expressed in terms of ζ_{nl} . ζ_{nl} is then determined from the observed multiplet spectra. Of course ζ_{nl} depends on the atomic configuration. The values given here (Condon and Shortley, p. 274) are for the lowest configuration.

		p ² configuration				
		Cl	SiI	GeI	SnI	PbI
$\left. \begin{array}{l} \sum_{nl} \\ \sum_k \end{array} \right\} 2(\text{cm}^{-1})$	(7.84x10 ²)**	2.016x10 ⁴	7.74x10 ⁵	4.39x10 ⁶	5.32x10 ⁷	
	5.49x10 ³	2.49x10 ⁴	7.79x10 ⁵	4.39x10 ⁶	5.32x10 ⁷	

The second line of the table gives the sum of \sum^2 over the atoms which make up the molecule, since the perturbation is additive in the nuclei, Equation (24).

McClure has shown that substituting the appropriate quantities into Equation (23), and using \sum^2 for M^2 , gives $\tau_p^0 \sim 0.003$ sec for a molecule composed entirely of carbon atoms. The latest information indicates that this prediction is probably wrong by a factor of at least 10²! For other carbon containing molecules the agreement is probably fair. The difficulty is that \sum is a one center parameter while in the aromatics all one center integrals in M vanish from symmetry (Ref. 4 and Ref. 30). The difficulty is compounded when the transition is also space forbidden.

In the case of benzene measurements of the true radiative lifetime have themselves been a function of the time, varying over 3 orders of magnitude since 1940. However, Craig, Hollas and King (Ref. 36) have searched for the singlet-triplet absorption of oxygen-free benzene. Their efforts place a lower limit of 300 sec on τ_p^0 ***

This implies that, to within the accuracy of the experiments, the observed lifetime of phosphorescence of benzene and carbon tetraphenyl is entirely $1/k_{is}$ '. Assuming the radiative lifetimes of the heavy tetraphenyls are proportional to

\sum^2 we apply an empirical correction for its one center character and the fact that it accounts for spin forbiddenness only, obtaining for τ_p^0 , Si(66sec), Ge(2.1), Sn(0.38), Pb(0.031). These are lower limits since the lifetime of benzene may be much greater than 300 sec and the true matrix elements may increase more slowly than \sum^2 . These results indicate that in every case the observed lifetime is essentially due to intersystem crossing to the ground state. Using Equation (17), and taking k_f as 10⁸, we have that k_{is} is of the order, Si(10⁸sec⁻¹), Ge(10⁹) and Sn(10¹¹). Intersystem crossing between excited singlet and triplet remains much more efficient than crossing to the ground state from the triplet, but the latter is hardly negligible. Also note that for the heavier tetraphenyls, we have rates of intersystem crossing which are comparable to radiationless transition rates between states of the same multiplicity.

*Since the matrix element M appears as the square in Equation (23), the total effect of Z_{if} on the probability of the transition is Z_{if}^0 , in this particular case.

**Estimated in Ref. 28.

***Robinson would make it shorter (Ref. 12), calculations by Hamerka (Ref. 24) would have it longer.

APPENDIX I

MATERIALS

TETRAPHENYLS

Carbon tetraphenyl (Monsanto), silicon tetraphenyl (synthesized at ARL), germanium tetraphenyl (Anderson), tin tetraphenyl (Thermit) and lead tetraphenyl (synthesized at ARL) were purified by recrystallization. The criterion of purity was the spectrum of the material in emission and absorption. These spectra are quite characteristic and should not vary on successive purifications.

SOLVENTS

Matheson spectroscopic solvents were used. Even this grade contains what appears to be a high concentration of fluorescent and phosphorescent material when exposed to the full intensity of a mercury arc. This has been noted by others. Extensive purification procedures were used to eliminate these substances, since they might interfere with the luminescence of the molecules of interest. This is especially important when the luminescent materials under study are only weakly soluble, as in the present case. Also, the triplet state is known to be very sensitive to quenchers because of its long lifetime (see Section II).

Hydrocarbons (Ref. 31, 32) were shaken with concentrated sulfuric acid, washed with distilled water containing NaOH and washed with water many times. They were dried over calcium chloride for several days and distilled, taking a middle fraction, then passed over silica gel several times. (Silica gel is activated by heating for several hours at 200°C and allowing to cool in a dry place.)

Ether was shaken with 10 percent sodium bisulfite, washed with saturated NaCl solution, shaken with concentrated sulfuric acid and washed with basic (NaOH) KMnO_4 solution. It was then washed many times with water and dried over CaCl_2 , passed through silica gel, distilled over sodium and stored over sodium.

Alcohols were distilled with concentrated sulfuric, refluxed for hours with AgNO_3 solution and a little NaOH, and distilled. They were then refluxed with CaCl_2 , passed through silica gel once and fractionally distilled.

The solvents thus obtained were appreciably improved over the starting materials, they were sufficiently non-luminescent for our purposes. However, when exposed to the full intensity of the Hg arc for 10 seconds they still clearly show a phosphorescence of the order of seconds. Solvents were found to deteriorate with time and for best results should be distilled before use.

RIGID GLASSES

The following combinations were found to produce rigid clear glasses at 77°K with little, if any, fracture. Given in parts by volume.

3 ether, 3 iso-octane, 1 iso-propyl alcohol
3 ether, 1 iso-propyl alcohol

Ethyl alcohol may be substituted for iso-propyl, or either may be used alone, with more fracture resulting.

1 iso-pentane, 4 methyl cyclohexane

1 iso-propyl alcohol, 3 iso-octane, 3 methyl cyclohexane

The well known EPA is 5 ether, 5 iso-pentane, 2 ethyl alcohol.

APPENDIX II

LIFETIME MEASUREMENTS

Phosphorescent lifetimes were measured by following the decay on an oscilloscope after flash excitation.

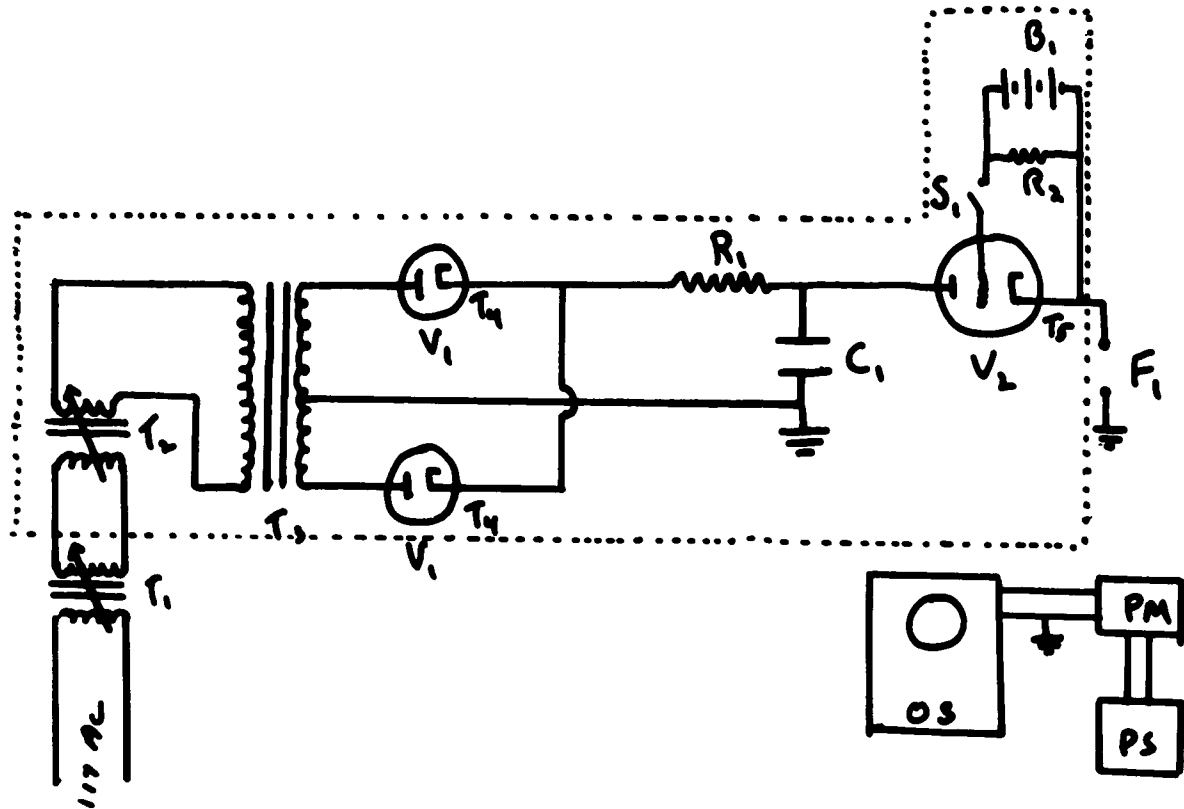

Figure 8. Schematic diagram of electrical circuits for flash excitation and monitoring of decay.

R₁ 9 Meg, 3000v (Westinghouse)
 R₂ 165K
 T₁, T₂ variac, 20a
 T₃ 9.5kv, 4kva (GE)
 T₄ 5.0v, 16a
 T₅ 6.3v, 11.6a
 C₁ 10-20kv, 0.25-.5 mfd (GE pyranol)
 PS Furst regulated power supply
 PM photomultiplier (935-A, 1P21, 1P28)
 and voltage divider network which
 drops 1 kv across the dynodes.

B₁ 135v
 S₁ tapping switch
 F₁ FX-12 (Edgerton, Germeshausen
 and Grier) or of our design,
 see further.
 V₁ 575-A rectifier
 V₂ 5C22 hydrogen thyatron
 OS Tektronix 545 or equivalent
 oscilloscope

In Figure 8 the dotted line indicates grounded copper screening. Although several grounds are indicated they should be common to avoid ground loops. The operation of the apparatus is simple and trouble-free. The hydrogen thyratron is put into a conducting state by merely closing S₁ momentarily, F₁ then fires if sufficient voltage has been applied across C₁. Operated under conditions of maximum sensitivity, and C₁ at 0.25 mfd, the intensity of the flash decayed to essentially zero in 2x10⁻³ sec. With the internal RC of the oscilloscope equal to 4.7x10⁻⁵ (C = 4.7x10⁻¹¹), the largest resistance consonant with the lifetime of the phenomenon to be measured should be placed across the input terminals of the oscilloscope, in order to maximize the voltage drop produced by the photocurrent. (Useful references are 33-35.)

A flash lamp which has a low breakdown voltage, short lifetime and good intensity, was made by mounting 2 tungsten rods in 2mm ID quartz tubing and filling to 8 cm Hg of Argon. The electrode separation was 7 mm.

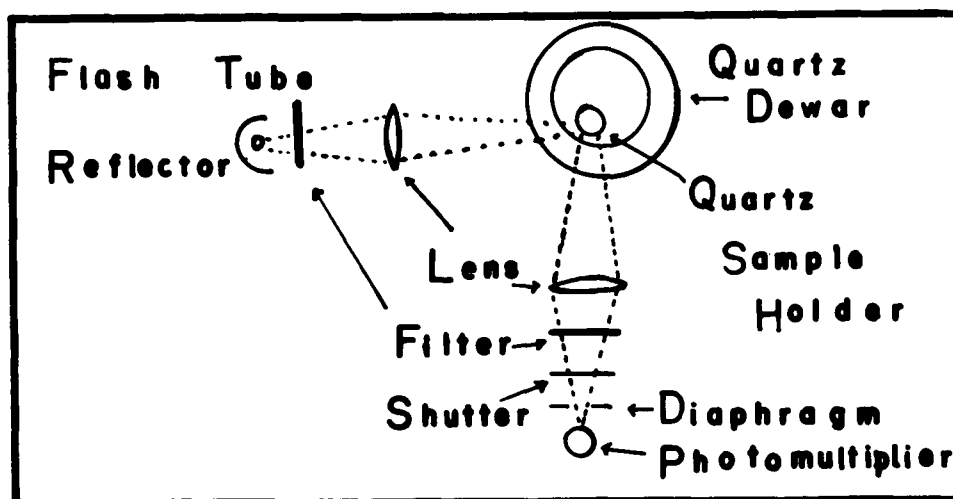

Figure 9. Optical arrangement of apparatus.

The solute was dissolved in the chosen mixture of solvents. The solution was then outgassed on a vacuum line from the quartz sample holder. With the sample holder still evacuated, it was plunged into liquid nitrogen contained in a quartz dewar. The decay of the solute luminescence was displayed on the oscilloscope screen. One sweep being triggered by the flash itself. The decay curve, time scale and zero intensity base line were photographed with an oscilloscope camera. The scope was calibrated against the 60 cycle line. The photographic image was projected onto graph paper and carefully copied at a more manageable size. The decay of the log of the intensity was plotted versus time. The straight line which resulted indicated a largely first order process for the decay. The mean lifetime was determined from these plots by,

$$\tau(\text{sec}) = \frac{t_2 - t_1}{\ln(I_1/I_2)}$$

ln indicates the natural log.

The phosphorescent lifetimes of the pure crystalline tetraphenyls at room temperature and at 77°K were also determined by a phosphoroscopic method. The flash and phosphoroscope values were found to agree to within one part in 50. The following results may be of interest,

	C	Si	Ge	Sn	Pb
crystal room T	2.0 sec	1.3	0.2	0.04	---
crystal 77°K	3.0	2.0	0.4	0.09	---
solution 77°K	2.9	1.1	0.06	0.003	0.0008

Although the precision (or internal consistency) of the lifetime measurements is satisfactory we would not claim an accuracy greater than 10 - 30 percent. This is not conservative in view of the numerous unevaluated effects which beset this type of work, illustrated above and in the solvent difficulties enumerated previously. Experience shows that where great accuracy is claimed, especially without statistical analysis, then it is the precision of the experiments that is meant. However, in the present case we can check 3 of the 5 lifetimes against the results obtained previously (Ref. 29). We find that the lifetimes of silicon and tin agree to within 10 percent but the value for lead (0.01 sec), cannot be correlated with the present results. This phosphorescence is very weak and short lived. Increasing the intensity of the source causes it to cover the emission. In the present experiments the decay constant was determined from the tail of the emission decay. Although it therefore suffers an increased uncertainty, we can say that a longer value is, theoretically, not to be expected, and experimentally, was not observed.

APPENDIX III

SPECTRA

Ultraviolet absorption spectra were taken with both a Jarrell-Ash grating instrument and the Cary recording spectrophotometer. Carefully measured amounts of the tetraphenyls were dissolved in spectroscopic solvents (iso-octane, CHCl_3).

Emission spectra and excitation spectra were recorded by the Aminco-Bowman spectrophotofluorometer, Figure 10.

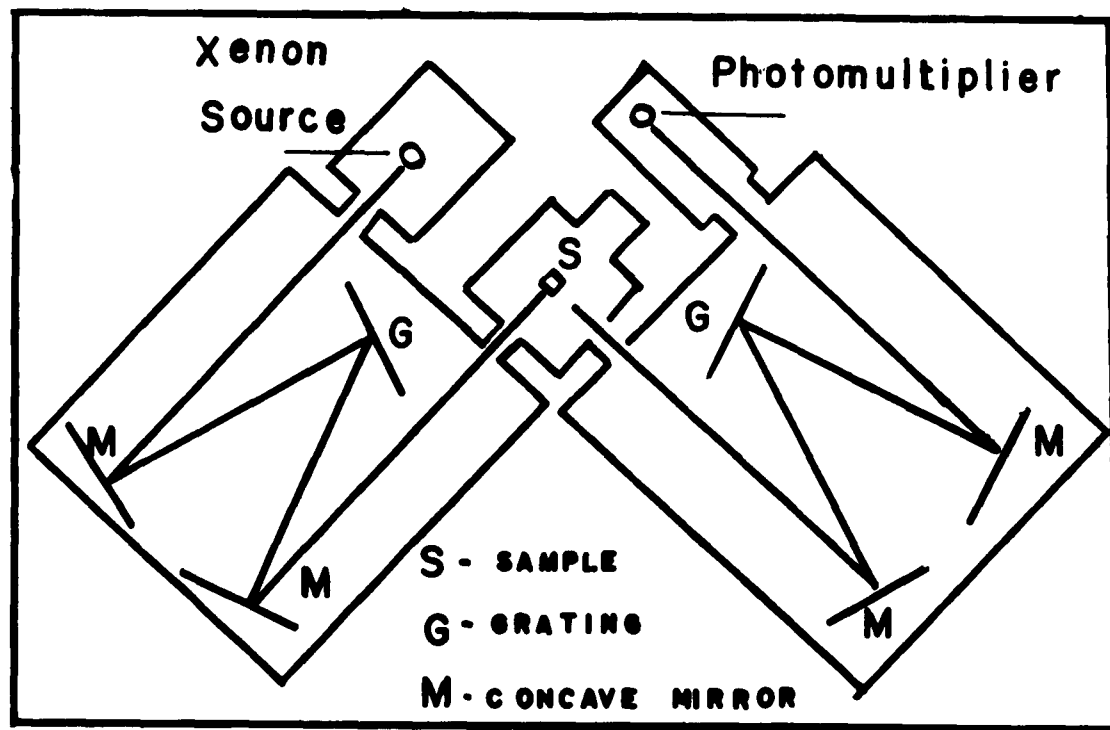

Figure 10. Optical arrangement for emission spectra. By varying the mirror angles by means of calibrated dials, emission spectra at various exciting wavelengths are easily recorded. Crossing ratios are determined by taking the ratio of the intensity of the P band to the F band at their maxima. Intensity is read directly from the photomultiplier output. These ratios are self consistent since the F and P bands of all the tetraphenyls have their maxima at nearly the same wavelengths. However the total response of the instrument was measured using the Xenon light source (standard equipment), a 1P28 photomultiplier and by reflecting the radiation from aluminum foil. It is known that the reflectivity of aluminum does not change by more than 5 per cent between 2400 and 8000Å.

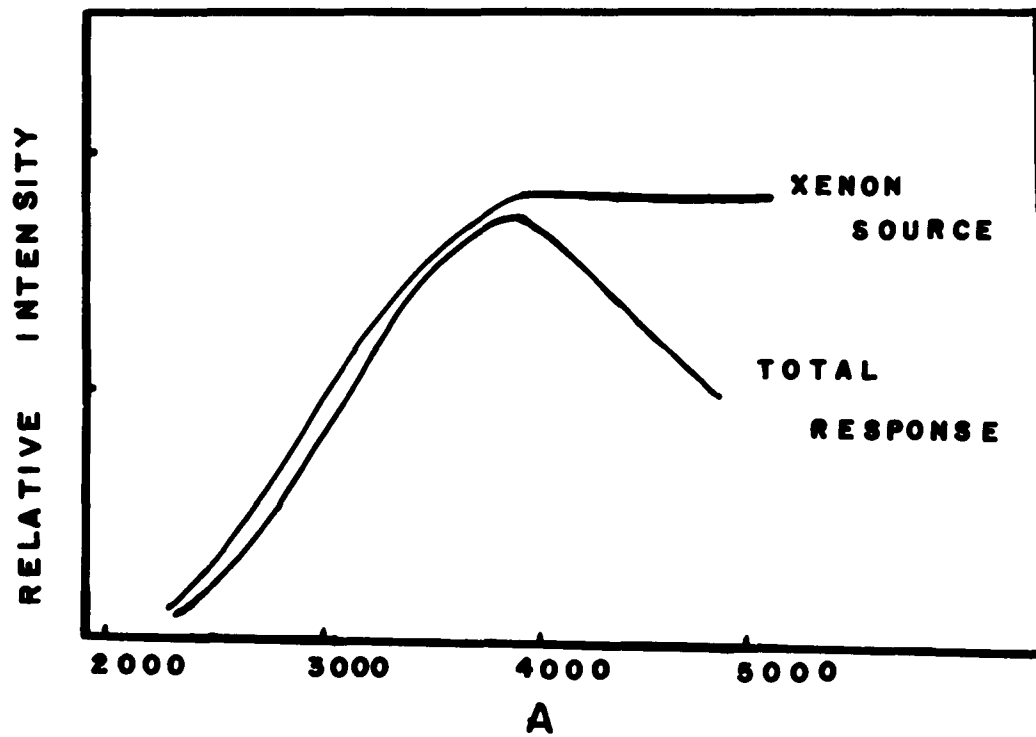

Figure 11. SPF response. Xenon source intensity is obtained from total response by using the wavelength specifications of the 1P28 photomultiplier.

BIBLIOGRAPHY

1. Kasha, M., Radiation Research Supplement, 2, 243, 1960.
2. Sponer, H., Radiation Research Supplement, 1, 558, 1959.
3. Reid, C., Quarterly Review, 3, 205, 1958.
4. Porter, G., Proceedings Chemical Society, p. 291, 1959.
5. Stevens, B., Chemical Reviews, 57, 439, 1957.
6. Kasha, M., Discussions Faraday Society, 9, 14, 1950.
7. Landau, L., Physik Z. Soviet Union, 2, 46, 1932.
8. Zener, C., Proceedings Royal Society, A110, 660, 1933.
9. Teller, E., Journal of Physical Chemistry, 41, 109, 1937.
10. Dexter, D., Journal of Chemical Physics, 21, 836, 1953.
11. Schiff, L. I., Quantum Mechanics, p. 199, McGraw Hill.
12. Robinson, G. W., Journal of Molecular Spectroscopy, 6, 58, 1961.
13. Albrecht, A., Journal of Chemical Physics, 33, 166, 1960.
14. Liehr, A. D., Reviews of Modern Physics, 32, 436, 1960.
15. La Paglia, S. R., Journal of Molecular Spectroscopy (in press).
16. Matsen, F. A., Chemical Applications of Spectroscopy, Interscience Publishers.
17. Matsen, F. A. et al., Journal of American Chemical Society, 72, 5243, 1950.
18. Jaffe, H. H., Journal of Chemical Physics, 22, 1430, 1954.
19. Sponer, H. et al., Spectrochimica Acta, 16, 1135, 1960.
20. Mokeeva, G. and Sveshnikov, B., Optics and Spectroscopy, p. 41, 1960 (English)
21. Livingston, R. and Jackson, G., Ohio State Conference, 1961.
22. Porter, G., Discussions Faraday Society, 27, 18, 1959.
23. Sidman, J., Journal of Chemical Physics, 29, 644, 1958.
24. Hamka, H. and Oosterhoff, L., Molecular Physics, p. 358, 1958.
25. Mizushima, M. and Koida, S., Journal of Chemical Physics, 20, 765, 1952.
26. Clementi, E., Technical Report, 1959-60, University of Chicago.

27. Wilson, E. B., Decius, J. C. and Cross, P. C., Molecular Vibrations, McGraw Hill.
28. McClure, D., Journal of Chemical Physics, 17, 905, 1949.
29. McClure, D., Journal of Chemical Physics, 20, 682, 1952.
30. Slater, J. C., Quantum Theory of Atomic Structure, Vol. I, McGraw Hill.
31. Kanda, Y. and Shimada, H., Spectrochimica Acta, p. 211, 1959.
32. Weissburger, A., Purification of Organic Solvents, Interscience Publishers.
33. Dieke, G. H. et al., Journal of Optical Society of America, 36, 185, 1946.
34. Edgerton, H. and Cathou, P., Review of Scientific Instruments, 27, 821, 1956.
35. Glasoe and Lebacqz, Pulse Generators, (Magnetron Loads), M. I. T. Radiation Laboratory Series, McGraw Hill.
36. Craig, D. et al., Journal of Chemical Physics, 29, 974, 1958.

<p>Aeronautical Research Laboratory, Wright-Patterson Air Force Base, Ohio. INTRAMOLECULAR ENERGY TRANSFER: LUMINESCENCE PHENOMENA IN THE GROUP IV TETRAPHENYLS by S. R. La Paglia, 1/Lt. USAF. December 1961. 28 p. incl. illus. (Project 7013; Task 70346) (ARL 156) Unclassified Report</p> <p>The absorption, emission and excitation spectra, crossing ratios and lifetimes of phosphorescence of the group iv tetraphenyls are presented and discussed from the viewpoint of the theory of intramolecular energy transfer processes.</p> <p>(over)</p>	<p>Aeronautical Research Laboratory, Wright-Patterson Air Force Base, Ohio. INTRAMOLECULAR ENERGY TRANSFER: LUMINESCENCE PHENOMENA IN THE GROUP IV TETRAPHENYLS by S. R. La Paglia, 1/Lt. USAF. December 1961. 28 p. incl. illus. (Project 7013; Task 70346) (ARL 156) Unclassified Report</p> <p>The absorption, emission and excitation spectra, crossing ratios and lifetimes of phosphorescence of the group iv tetraphenyls are presented and discussed from the viewpoint of the theory of intramolecular energy transfer processes.</p> <p>(over)</p>
<p>UNCLASSIFIED</p>	<p>UNCLASSIFIED</p>
<p>UNCLASSIFIED</p>	<p>UNCLASSIFIED</p>
<p>UNCLASSIFIED</p>	<p>UNCLASSIFIED</p>
<p>UNCLASSIFIED</p>	<p>UNCLASSIFIED</p>
<p>UNCLASSIFIED</p>	<p>UNCLASSIFIED</p>