

UNCLASSIFIED

AD 274 351

*Reproduced
by the*

**ARMED SERVICES TECHNICAL INFORMATION AGENCY
ARLINGTON HALL STATION
ARLINGTON 12, VIRGINIA**



UNCLASSIFIED

NOTICE: When government or other drawings, specifications or other data are used for any purpose other than in connection with a definitely related government procurement operation, the U. S. Government thereby incurs no responsibility, nor any obligation whatsoever; and the fact that the Government may have formulated, furnished, or in any way supplied the said drawings, specifications, or other data is not to be regarded by implication or otherwise as in any manner licensing the holder or any other person or corporation, or conveying any rights or permission to manufacture, use or sell any patented invention that may in any way be related thereto.

MARTIN MARIETTA CORPORATION

TITAN II - DYNA SOAR
DESTRUCT TEST AND ANALYSIS REPORT

MR 12269

March 15, 1962

Contract AF 04 (695)-54

Reviewed by:

J. Greichen

Prepared by:

E. Hunter

Approved by:

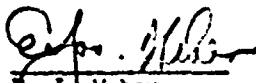
E. J. Weber

E. Lash

MARTIN MARETTA CORPORATION

Page 1

FORWARD

All work was performed in accordance with the following Air Force Contracts:

Titan II Program AFO4(647)-576

Dyna-Soar Step I Program AFO4(647)-610

Titan III Phase I Program AFO4(695)-54

Note: The Dyna-Soar Step I work included in this report was accomplished prior to the termination of the contract. The report and analysis work was accomplished under the Titan III Phase I contract.

ABSTRACT

The use of storable, high energy and hypergolic propellants, Unsymmetrical Dimethyl Hydrazine (UDMH)/Hydrazine and Nitrogen Tetroxide (N_2O_4), in Titan II and Titan III is an advancement in weapon and space systems. However, the intermixing reaction and toxicological properties of these propellants introduced a problem in the design of the destruct system for the booster. The tests that were conducted to develop and verify the booster destruct system with these propellants are described in this report.

MARTIN MARIETTA CORPORATION

Page 111

TABLE OF CONTENTS

	<u>Page</u>
FORWARD	1
ABSTRACT	ii
TABLE OF CONTENTS	111
LIST OF ILLUSTRATIONS	iv
I. INTRODUCTION	1
II. SUMMARY	3
Acknowledgments and References	6
III. TEST METHOD & DESCRIPTION	7
A. Beer Barrel Tests	7
B. Full Scale Stage I - Titan I Without Propellants	12
C. Half Scale Stage II - Titan II With Propellants	15
D. Half Scale Stage I - Titan II With Propellants	30
IV. RESULTS AND CONCLUSIONS	35
A. Beer Barrel Tests	35
B. Full Scale Stage I - Titan I Without Propellants	35
C. Half Scale Stage II - Titan II With Propellants	36
D. Half Scale Stage I - Titan II With Propellants	37

MARTIN MARETTA CORPORATION

Page iv

LIST OF ILLUSTRATIONS

<u>FIGURE</u>		<u>PAGE</u>
1	TYPICAL INSTALLATION OF DESTRUCT CHARGE & BRACKET . . .	14
2	DESTRUCT CHARGE DETONATION OF $\frac{1}{2}$ SCALE STAGE I	16
2a	RESULTS OF BI-DIRECTIONAL CHARGES (WATER-HYPO SPEC) . .	16a
3	STAGE II SPECIMEN	18
4	ORDNANCE ARRANGEMENT	19
5	TEST SITE AT THE LOWRY AIR FORCE BOMBING RANGE	21
6	INSTRUMENTATION ARRANGEMENT	22
7	UDMH/HYDRAZINE LOADING & PRESSURIZATION SYSTEM	24
8	NITROGEN TETROXIDE LOADING & PRESULIZATION SYSTEM	25
9	CAMERA COVERAGE	28
10	STAGE I SPECIMEN	32
11	ERECTION OF STAGE I $\frac{1}{2}$ SCALE SPECIMEN ON THE TEST PAD	33
12	STAGE I SPECIMEN ERECTED ON THE TEST STAND	34
13	FULL SCALE TANK DOME AFTER DESTRUCT	38
14	TEMPERATURE DATA, STAGE II TEST	39
15	PROPELLANT LOADING VEHICLE	40
16	FRAGMENTATION PATTERN, STAGE II TEST	41
17	HALF-SCALE STAGE I AND STAGE II FIREBALL SIZE & RISE	42
18	NITROGEN DIOXIDE CONCENTRATIONS	43
19	FIREBALL SIZE	44
20	FIREBALL RISE	45
21	TEMPERATURE - HALF SCALE STAGE I - TITAN II	46
22	TEMPERATURE - HALF SCALE STAGE I - TITAN II	47
23	FIRE BALL & THERMAL COLUMN RISE	48

MARTIN MARIETTA CORPORATION

Page v

LIST OF ILLUSTRATIONS (cont'd)

<u>FIGURE</u>		<u>PAGE</u>
23a	THERMAL COLUMN RISE	49
24	EXCESS NITROGEN TETROXIDE	50
25	LOCATIONS OF VAPOR EXPLOSIONS	51
26	PAD REMAINS STAGE I	52
27	PAD REMAINS STAGE I	53
28	FRAGMENTATION PATTERN, STAGE I	54
29	SUMMARY OF PRESSURE AND TEMPERATURE DATA, STAGE I	55
30	PRESSURE WAVE FROM VAPOR EXPLOSIONS	56
31	DATA SAMPLE	57

TITAN II - DYNA-SOAR

DESTRUCT TEST AND ANALYSIS REPORT

I. INTRODUCTION

The Titan II Dyna-Soar booster destruct system is completely independent of the other booster systems. The explosive ordnance components used in the destruct system are bi-directional charges. Two units are installed midway between the oxidizer and fuel tank in each stage and are designed to remove 75 to 80 percent of each opposing fuel and oxidizer tank dome to permit intermixing of the propellants.

A series of tests were conducted by the Titan II project to develop and certify the destruct system for flight and to obtain data from the intermixing of various volumes of the storable, hypergolic booster propellants for evaluating the associated explosive and toxicological problems. These tests included intermixing and rupturing specimens containing 1.5 to 292 pounds of propellants. Qualification and acceptance tests were also conducted on the bi-directional or wafer charge.

The Dyna-Soar project joined the Titan II test program to obtain glider environmental data (temperature, over-pressure, debris pattern, etc.) for abort criteria and environmental data (fire ball size, toxicity, debris pattern, etc.) for the mobile service tower and launch complex to develop design criteria and safety requirements.

* Test report on flight certification tests of bi-directional destruct charges, Martin Part No. PB60S0135-001, mfg. Francis Associates Co., Denver 23, Colorado.

MARTIN MARIETTA CORPORATION

Page 2

The joint project tests conducted included a destruct test of a half scale (linear) model of Stage II loaded with 5800 pounds of UDMH/Hydrazine and 10,000 pounds of nitrogen tetroxide, and a half scale test of a Stage I specimen loaded with 21,500 pounds of nitrogen tetroxide and 11,200 pounds of UDMH/Hydrazine.

The Baltimore (M/B) and Denver Divisions (M/D) of the Martin Marietta Corporation, The Denver Research Institute (DRI) of the University of Denver and the United States Bureau of Mines (Bu Mines) provided the personnel who participated in this series of tests with the propellants.

II. SUMMARY

The destruct tests discussed in this report include:

Beer Barrel Destruct Tests

Full Scale Stage I Titan I without Propellants

Half Scale Stage II Titan II with Propellants

Half Scale Stage I Titan II with Propellants

"BEER BARREL" DESTRUCT TESTS

A series of destruct tests were conducted using aluminum beer barrels containing quantities up to 290 pounds of propellants, 112 pounds of UDME/Hydrazine in one barrel and 180 pounds of nitrogen tetroxide in the other.

The objective of these developmental tests was to determine the feasibility of rupturing domes and/or tank walls to provide sufficient intermixing of the propellants for a destruct system.

While simulating both launch and horizontal flight positions, several different destruct arrangements were tested. The results of these tests indicated that the removal of opposing domes was the most effective method for maximum intermixing of the propellants.

MARTIN MARIETTA CORPORATION

Page 4

FULL SCALE STAGE I TITAN I WITHOUT PROPELLANTS

Five methods were considered and tested for opening the opposing domes between tanks - linear shaped charge, primacord, wedge shaped charge, five directional shaped charge and a bi-directional wafer charge. The bi-directional wafer charge was selected because of its effectiveness, cost and safety aspects. It can be handled and installed as a separate unit.

A full-scale test was conducted using the bi-directional destruct system in an airborne Stage I Titan I between tanks specimen. The two bi-directional charges removed 80% of each of the opposing domes.

HALF SCALE STAGE II TITAN II WITH PROPELLANTS

This test consisted of destructing a specimen with 5800 pounds of UDMH/Hydrazine and 10,000 pounds of Nitrogen Tetroxide.

The objectives were to obtain reaction data and NO_2 dispersion from 15,800 pounds of propellant intermixing; to obtain environmental data for the glider, the mobile service tower and the launch complex; and to establish a minimum time delay between glider abort and booster destruct that will not endanger the pilot.

The fireball size was 148 feet in diameter with a maximum recorded temperature of 2400°F. The heat of the fireball caused the NO_2 vapors to rise initially. The maximum concentration of NO_2 recorded 500 feet downwind, was 44 (PPM) parts per million at 60 seconds after destruct initiation. Other values of NO_2 were

MARTIN MARIETTA CORPORATION

Page 5

below 11 PPM before 60 seconds and until 180 seconds after destruct.

HALF SCALE STAGE I TITAN II WITH PROPELLANTS

A specimen containing 11,200 pounds of UDMH/Hydrazine and 21,500 pounds of Nitrogen Tetroxide was destructed for this test.

The objectives were the same as the previous test with 32,700 pounds of propellant intermixing, but the tank sections were bolted and welded in position for maximum propellant and vapor mixing.

The fireball size was 151 feet in diameter with a maximum temperature recorded of 3000°F. The NO₂ cloud rose from the heat and the maximum concentration of NO₂, recorded 700 feet downwind, was 154 PPM at 90 seconds after destruct initiation. Other values of NO₂ were below 1 PPM before 90 seconds and below 1 PPM after 90 seconds until 180 seconds.

The initial pressure recorded from the destruct charge near the specimen was 11 P.S.I. Two significant vapor explosions occurred at 3.1 and 4.2 seconds after destruct. Magnitudes of these were high near the test specimen (5 and 10 P.S.I. respectively); however, their impulses were low. The test set-up remained intact and there was no pressure damage to the test specimen.

Acknowledgments and References

The participation of Frank Gibson, John Murphy and David Burgess of the Bureau of Mines, Explosives Research Laboratory, Pittsburgh, Pennsylvania, in this series of tests was both pleasant and highly professional. Their data is documented in "Bureau of Mines Participation in DYNA-SOAR - TITAN II Destruct Tests" Delivery Order (04-695) 62-2, Reqn. ASD-SSD-62-1 (#127249) or "Evaluation of Radiant Heat Flux and Toxicity in DYNA-SOAR - TITAN II Destruct Tests" Air Force Technical Documentary Report No. ASD-TDR-62-221 of February 1962, and is referenced as (1) in this report. Reference (2) of this report is Rocketdyne's R-2452-4, "Research on the Hazard Classification of New Liquid Rocket Propellants."

III. TEST METHOD AND DESCRIPTION**A. Beer Barrel Destruct Tests**Background:

Late in 1960, a contract was awarded to the Denver Research Institute of the University of Denver to perform a series of tests needed for the study of design parameters of a destruct system in the Titan II booster. Primarily, the objectives were to study the propellants, their intermixing reaction and toxicological properties, and to gather experimental data upon which a destruct system could be designed.

These tests became known as beer barrel tests because the containers used for the propellants were standard commercial aluminum beer barrels. A 16' x 16' concrete pad was constructed on the west range of the University of Denver, and two angle-iron frame assemblies were fabricated for supporting two barrels, twelve inches apart, end to end horizontally or vertically. Flexible linear charges (RFX- 50 grains per foot) were used to rupture the barrels. All the tests were recorded on motion picture film at camera speeds of 24, 400 and 2000 frames per second.

Phase I

Initially, an effort was made to discover the best destruct charge arrangement for maximum intermixing the propellants. The barrels were placed vertically in the frame assembly, filled with 15 gallons of UDMH/hydrazine (112 pounds) and 15 gallons of N_2O_4 (180 pounds) and pressurized to 40 psi.

The destruct system was installed to split the same sides of both barrels. After the destruct, ample intermixing occurred and some propellants burned on the pad.

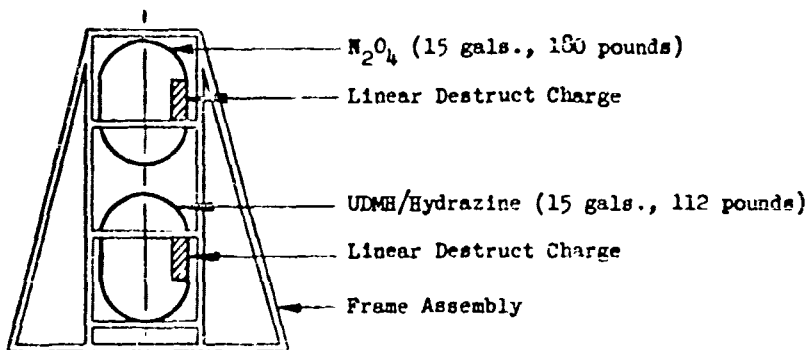

Phase I - Total Propellants - 292 Pounds

Phase II:

The horizontal frame assembly was erected to simulate and investigate how the destruct system would operate in the flight attitude. The barrels were placed horizontally in the frame assembly, filled with $7\frac{1}{2}$ gallons of UDMH/Hydrazine (56 pounds) and $7\frac{1}{2}$ gallons of N_2O_4 (56 pounds), and pressurized to 40 psi. The destruct system was installed to split the top side of each barrel. Some of the propellants were hurled into the air by the linear charge, but three-fourths of the propellants were left in the barrels. After the initial intermixing, the barrel assembly was tipped over to allow the remaining propellants to intermix on the pad.

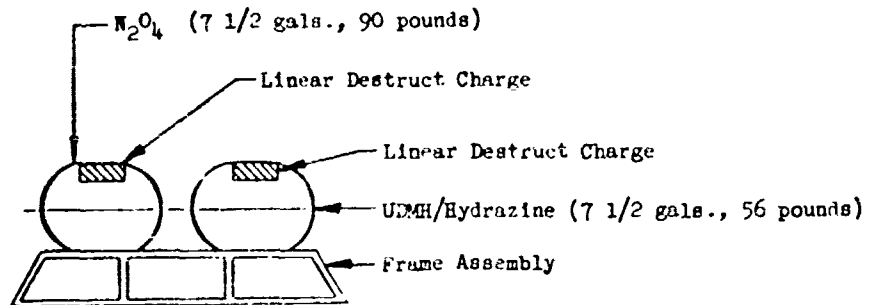

Phase II - Total Propellants - 146 Pounds

Phase III:

The decision was reached to use .056" thick aluminum skirts to enclose the area between the barrels for a simulation of the between-tanks area of the booster. The barrels were again placed horizontally, filled with 7 1/2 gallons of propellants, and pressurized to 40 psi. The destruct system was installed to split the top side of each barrel and the opposing end of each barrel to obtain better propellant intermixing. Greater intermixing did take place with some spillage on the pad, and some propellants remained in the barrels.

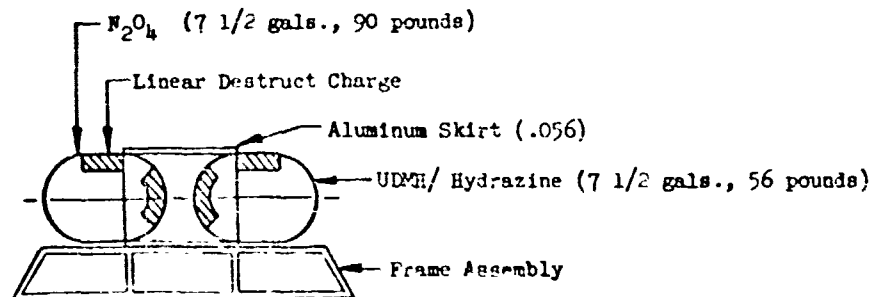

Phase III - Total Propellants - 146 Pounds

Phase IV:

The Phase III test was repeated in the vertical position to simulate the launch pad conditions. The results were considered good because the fireball produced was uniform and the gaseous cloud rose rapidly.

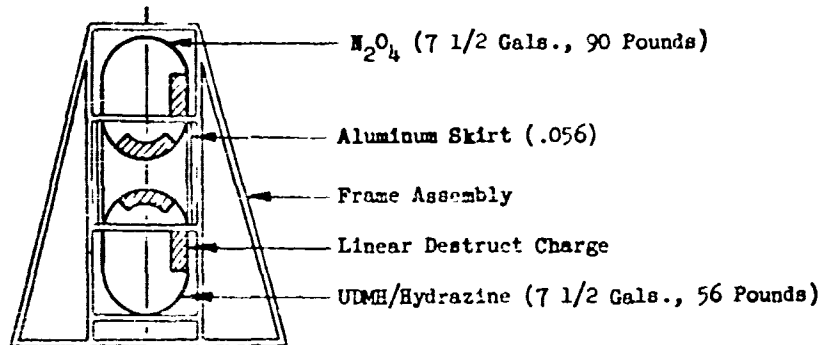

Phase IV - Total Propellants - 146 Pounds

Phase V:

The Phase III test was repeated without the side splitting destruct charges to limit the spillage. The destruct was considered good while some propellants remained and burned in the barrels.

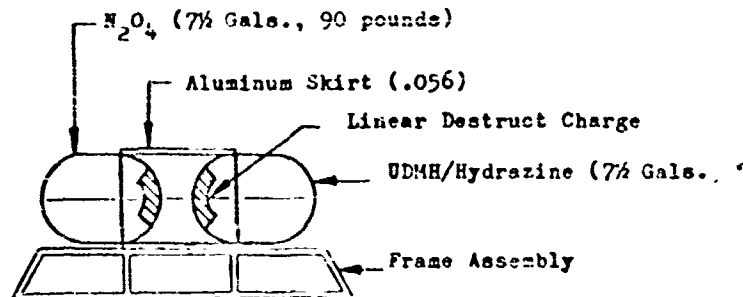

Phase V Total Propellants 146 Pounds

Phase VI:

The Phase V test was repeated in the vertical position. A rapid reaction occurred and the gaseous cloud rose and dissipated quickly. The entire event lasted approximately five seconds with minor reactions that sounded like 30 caliber rifle fire. No propellants remained on the pad after the test.

No severe blast damage resulted. A small commercial tin can filled with water was placed under the barrel and was undamaged after the test.

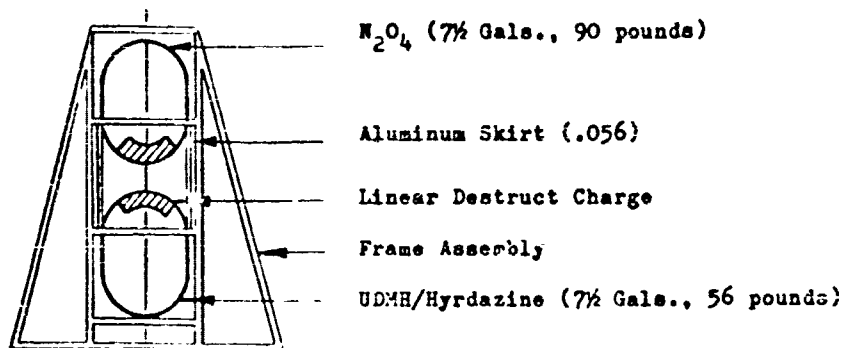

Phase VI Total Propellants 146 Pounds

B. Destruct Test of a Full Scale Portion of Stage I - Titan I Without Propellants**Background:**

Prior to the verification destruct test of a full scale portion of Stage I - Titan I, without propellants, it was necessary to accurately evaluate and demonstrate the effectiveness of the bi-directional destruct charge. Tests were conducted with the destruct charge on 8' x 8' aluminum panels .062" thick and backed up with water. After these evaluation tests were completed a water backed Titan I tank dome was ruptured with the bi-directional charge 20" away from the test specimen. The final test was conducted with the actual destruct system being detonated in the between tanks section of an airborne Titan I missile.

Phase I - Because of the scarcity of available full size tank domes, this test plan was arranged in such a manner as to permit maximum evaluation of the destruct charges against mocked-up target panels. These targets were fabricated from .062" thick 6061-Tb aluminum panels and sized as 8' x 8' floatable panels. These panels were floated on a water surface to simulate the liquid backed condition of a propellant tank dome. (The difference between the flat target panel and the curved tank dome was considered unimportant for purposes of this test.) The destruct charge was located at various distances above the center of the target panel, and oriented so as to produce a destruct action against the center of the panel. Charge effect was evaluated on basis of the degree of damage imparted to the target panel, i.e., (1) maximum hole diameter in target panel caused by destruct charge slug, and (2) maximum tear diameter in target panel caused by

destruct charge blast effect.

Phase II - A subsequent test phase was arranged to permit evaluation of the destruct charge on an actual missile tank dome. A Titan I tank dome was selected for the test specimen. The specimen was oriented to present a water backed tank dome surface to the destruct charge, which was located about 20" away from the dome. This test was considered more realistic for destruct analysis because of the comparable nature of the test specimen to the Titan I tank domes, particularly with respect to the chem-milled dome areas.

Phase III - The final test in this series was planned to permit accurate analysis of a complete destruct system installation. Preceding tests were conducted with one charge at a time. This test set up consisted of two destruct charges mounted on actual installation brackets, along with associated primacord harnesses. The primacord was capped off with crimp-on boosters as in the actual missile installation. This ordnance system was installed in a Titan I Stage I between tanks section structurally integral with a full size fuel tank. The test set up was completed by positioning a full size (10" diameter) Titan I tank dome in its proper orientation atop the between tanks section so that two opposing tank domes were presented to the destruct charges. Water was loaded into the lower tank to approximately 90% capacity, and to a height of about 20' in the upper dome. No tank pressurization was used in the test, in order to establish full capabilities of the destruct charges alone.

(See photographs of the bi-directional destruct charge installation and the results of the charges in figures 1 and 13 on pages 14 and 38.)

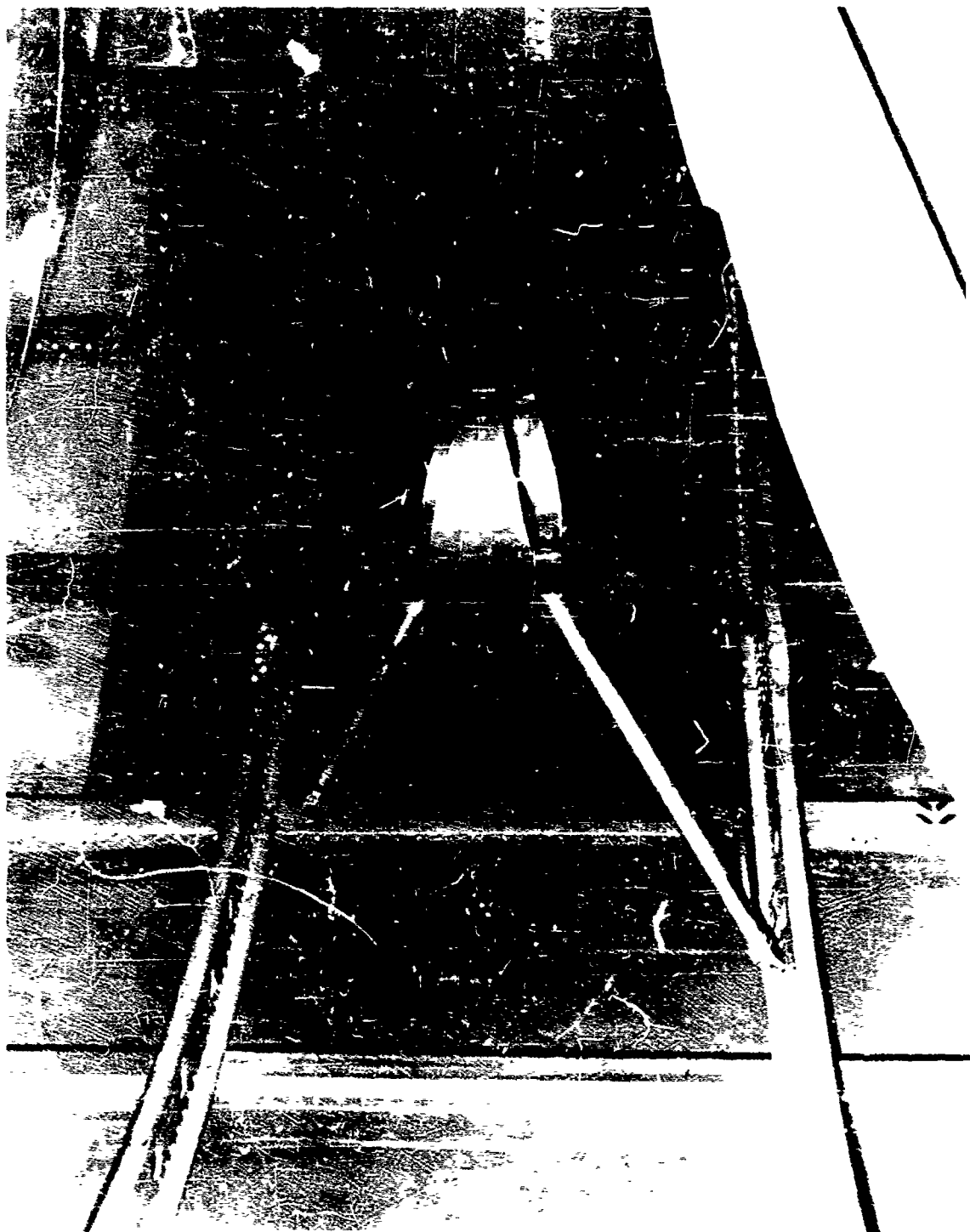

TYPICAL INSTALLATION OF DEBRIS NET ABOVE & BELOW LT

C. Destruct Test of Half Scale Stage II - Titan II With Propellants

Background:

To thoroughly check out the test setup before destructing a model with propellants, a half scale Stage I Titan II test specimen was loaded with water and hypo solution (to simulate the weight of N_2O_4) and pressurized for a structural test. The specimen was then destructed with a bi-directional charge to verify the ordnance installation. (Figs. 2 & 2a, pages 16 & 16a) The hemispherical domes of the test specimen did not rupture in the same manner as the airborne ellipsoidal domes did in Section B of this report. For better simulation of propellant intermixing and to assure removal of 80 percent of each opposing dome in the model, a linear shaped charge was used for the test when the tanks were loaded with propellants.

Since a bi-directional charge was replaced with a linear shaped charge, it was also necessary to conduct the propellant test without bolting the between-tanks sections together. As noted in Section II of this report, the bi-directional charge removes the between-tanks structure. On all previous tests with the bi-directional charge, the tanks separated immediately after the destruct charge was initiated.

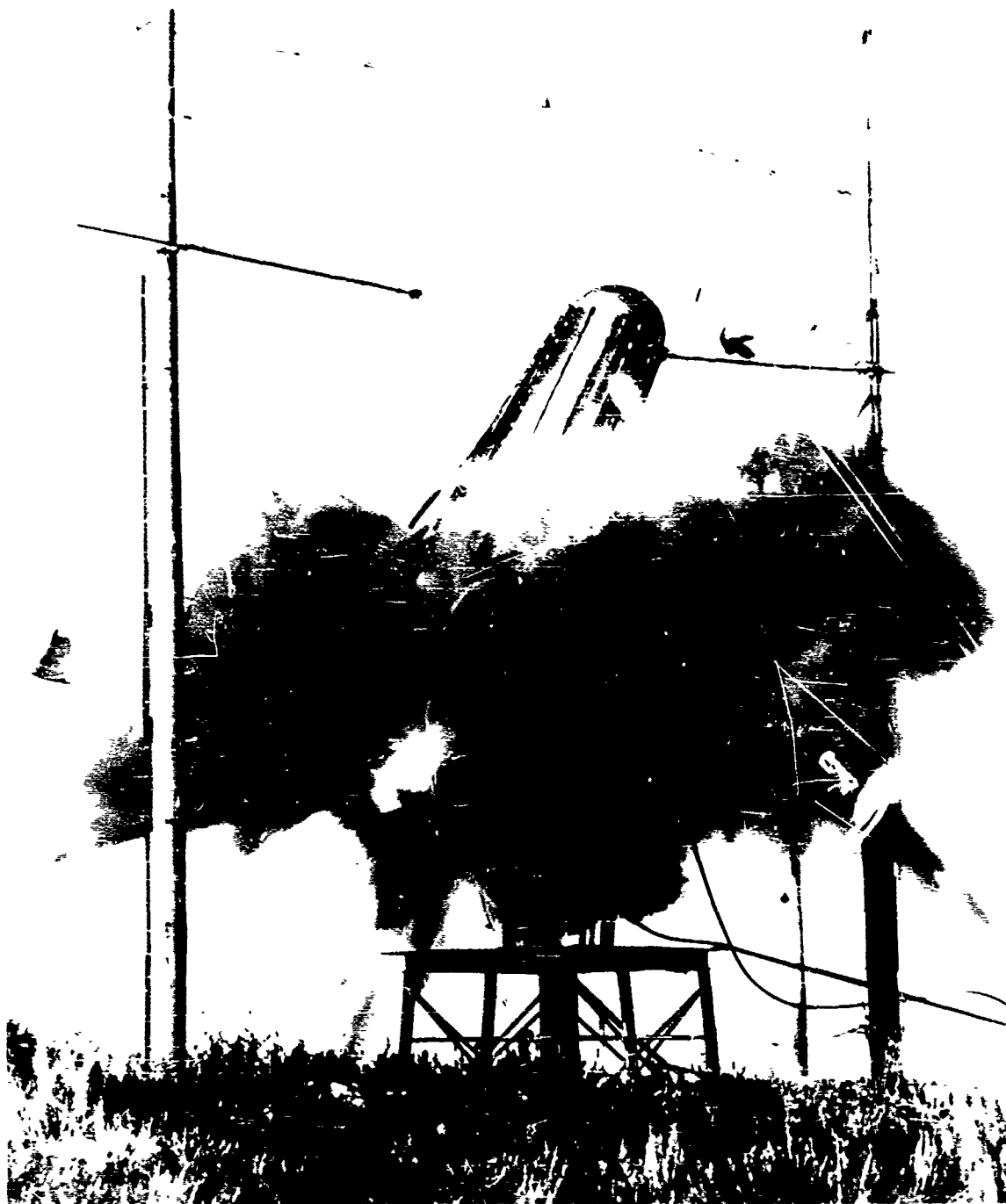

DESTRUCT CHANGE DETONATION OF W SCALE WAC R-17: STAGE 1

Test Conditions:

Time: 2:23 p.m., 4 November 1961

Temperature: 34°F

Atmospheric pressure: 11.7 lbs. per sq. in.

A weak, fast moving Pacific cold front passed the test site at 0610. Brief flurries of snow occurred shortly after the frontal passage. At the time of firing, there were scattered cumulus clouds at an estimated height of 4000 feet. The wind, as measured at the observation point was 40° and 22 mph.

Description of Specimen:

The specimen was an assembly simulating the Stage II propellant tanks of the Titan II booster. The diameter of the specimen was 5 feet. Complete dimensions are shown in Figure 3, page 18. The specimen tank domes were spun aluminum hemispherical domes. The test specimen tank skins were rolled aluminum welded to the tank domes and stiffened by twelve channel stringers welded to the tank at ten inch intervals. The stringers were butted and welded to 1/2" X 5" X 5" diameter flat rings. The upper and lower tank assemblies were placed together, no bolts were used to splice the two assemblies together. Simulated cable bundles were attached across the splice to duplicate those on the actual booster. The between tanks area was covered with 1/2" aluminum skirts and attached by sheet metal screws.

A linear shaped charge (40 grams per foot) destruct system was installed on each of the between tank domes. Styrofoam strips were used between the charge and the tank dome for optimum stand-off. The linear charge pattern was altered on each dome to allow for the propellant fill fittings on the lower UDMH/Hydrazine dome. Each

Figure 3

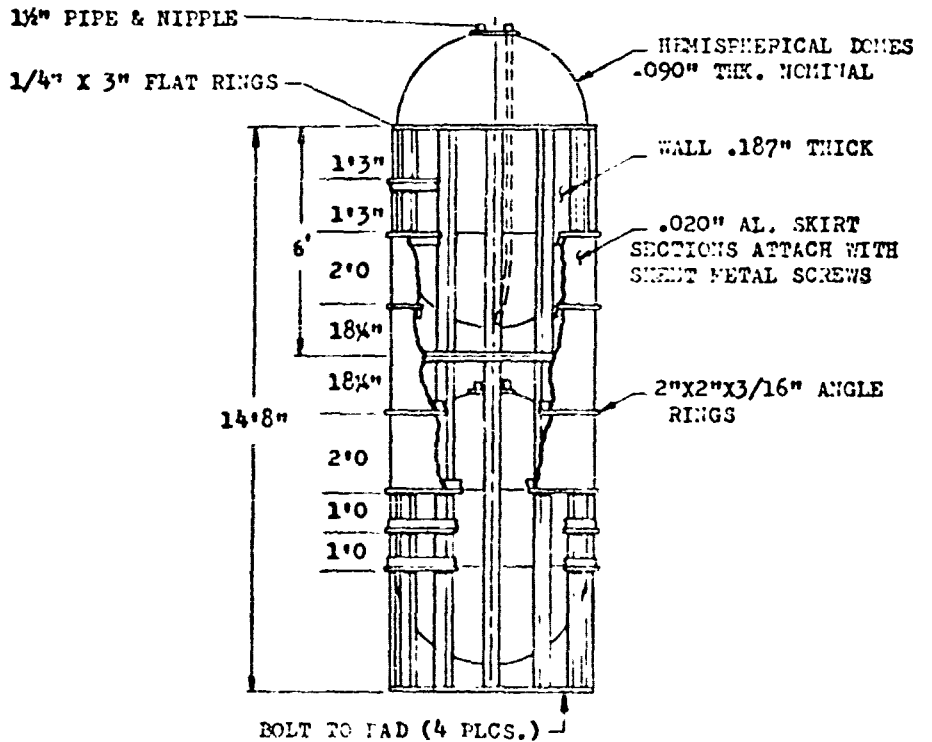
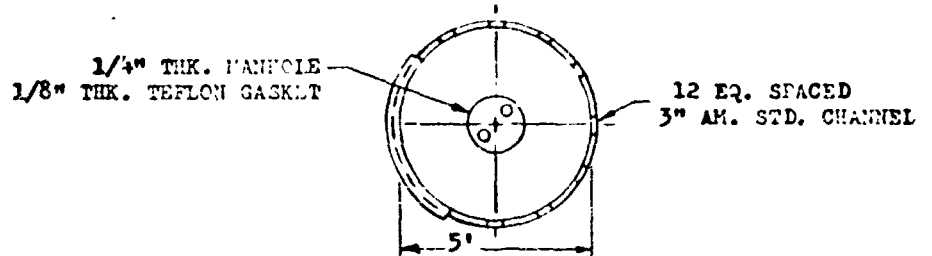

MATERIAL
ALL 6061-T6ALUM. AL.

STAGE II SPECIMEN

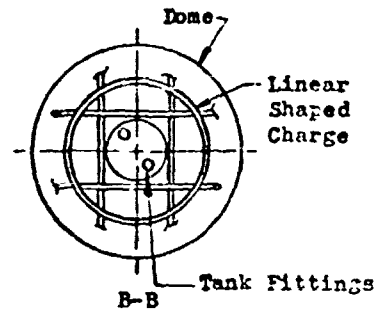
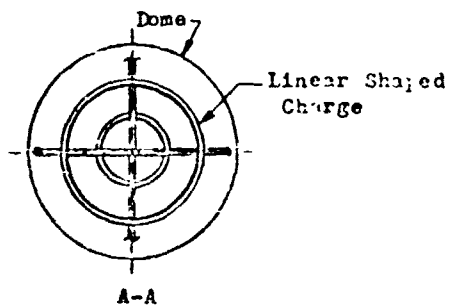
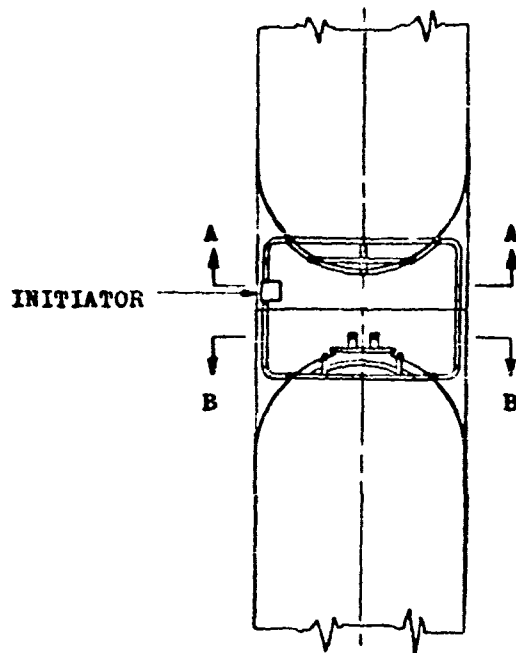

Ordnance Arrangement

Total weight of explosive charge - .49 pounds

MARTIN MARILITA CORPORATION

Page 20

pattern was arranged to cut open a minimum of 75% of the respective dome (See Figure 4, page 19).

Redundant explosive connections were made between the two dome charge installations. In addition, one linear charge from each installation was coupled to the initiator through a pair of booster capped (P-11 Booster M#60E7), 100 grain per foot, primercord strands. A standard Titan I destruct initiator, secured to the between tanks structure, was used to initiate the destruct system.

Explosive bolts were used in the guy line cables to allow the release of the test specimen five seconds prior to the destruct event.

Fixture:

The test specimen was mounted on a stand (Figure 5, page 21) which was ten feet high. The stand consisted of a 10' X 10' platform of steel plate stiffened by 8" channels and supported by six braced steel pipe legs. The stand was bolted to a concrete pad. The pad was 50' X 50' concrete with a curbing 4" wide and 18" high. The pad was situated at a test site on the Lowry Air Force Base bombing range located east of Denver, Colorado. The test site was 6000 feet above sea level, 5.4 miles east of Complex 1A and 3.5 miles north of Complex 1B.

Two wooden telephone poles, 75' high, were erected at the edge of the pad in line with the test stand. Two rods were attached pole to pole 10' and 20' above the specimen. A fifteen foot boom

Figure 6

Position	Type	Range
① ② ③	T/C P/C K HT	2400° F 40 PSI 20 PSI 2400° F
④ ⑤	T/C P/C K HT	2400° F 40 PSI 40 PSI 2400° F
⑥	T/C P/C K HT	2400° F 20 PSI 20 PSI 2400° F

Position	Type	Range
⑦	T/C P/C HT MIKE	1500° F 20 PSI 1500° F 120 db
⑧	T/C SG MIKE HT	1200° F 10 PSI 120 db 1000° F
⑨	(4) SG	

T/C - Thermocouple
P/C - Photocopy Pressure Transducer (static)
K - Kistler Pressure Transducer (dynamic)
HT - Heat Transfer Gage
SG - Strain Gage
Mike - Microphone

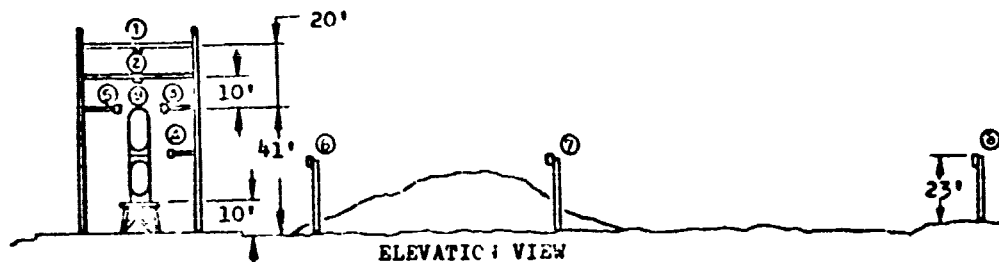
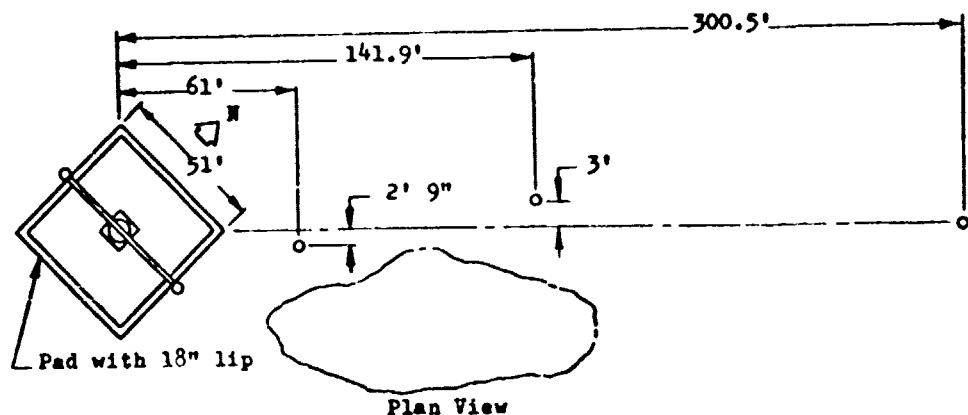

INSTRUMENTATION ARRANGEMENT

was cantilevered from each pole at the top of the specimen, and a ten foot boom was cantilevered from one pole at the between tanks height. Three smaller poles (23' high) were erected at 60', 140', and 300' northeast of the test stand. Instrumentation equipment was mounted to each of these poles. (Figure 6, page 22)

A propellant loading and pressurization system was designed and installed. (Figures 7 & 8, pages 24 & 25)

The firing point was located 3500' southwest of the test pad.

Instrumentation:

A total of 36 channels of instrumentation was installed and calibrated. The instrumentation consisted of eight thermocouples, seven Photocon pressure transducers, six Kistler pressure transducers, eight heat transfer gages, five strain gages and two microphones.

An instrumentation trailer containing the recording equipment was located 400 feet northeast of the test pad.

The Bureau of Mines placed two banks of vapor sensing bottles 500 feet from the test pad. One bank was ten feet above ground and the other was suspended by a crane 60 feet above the ground. The terrain was such that the samplers at 60 feet were at the same elevation as the between tank location of the test specimen.

The pressure transducers K1, K2, K3, K4, K5 and K6 were Kistler piezoelectric Mod. 701 used in conjunction with the Mod. 5.5 amplifier providing a 10MV/pai output with a flat frequency range of .01 to 60,000 cps and an acceleration sensitivity of .02

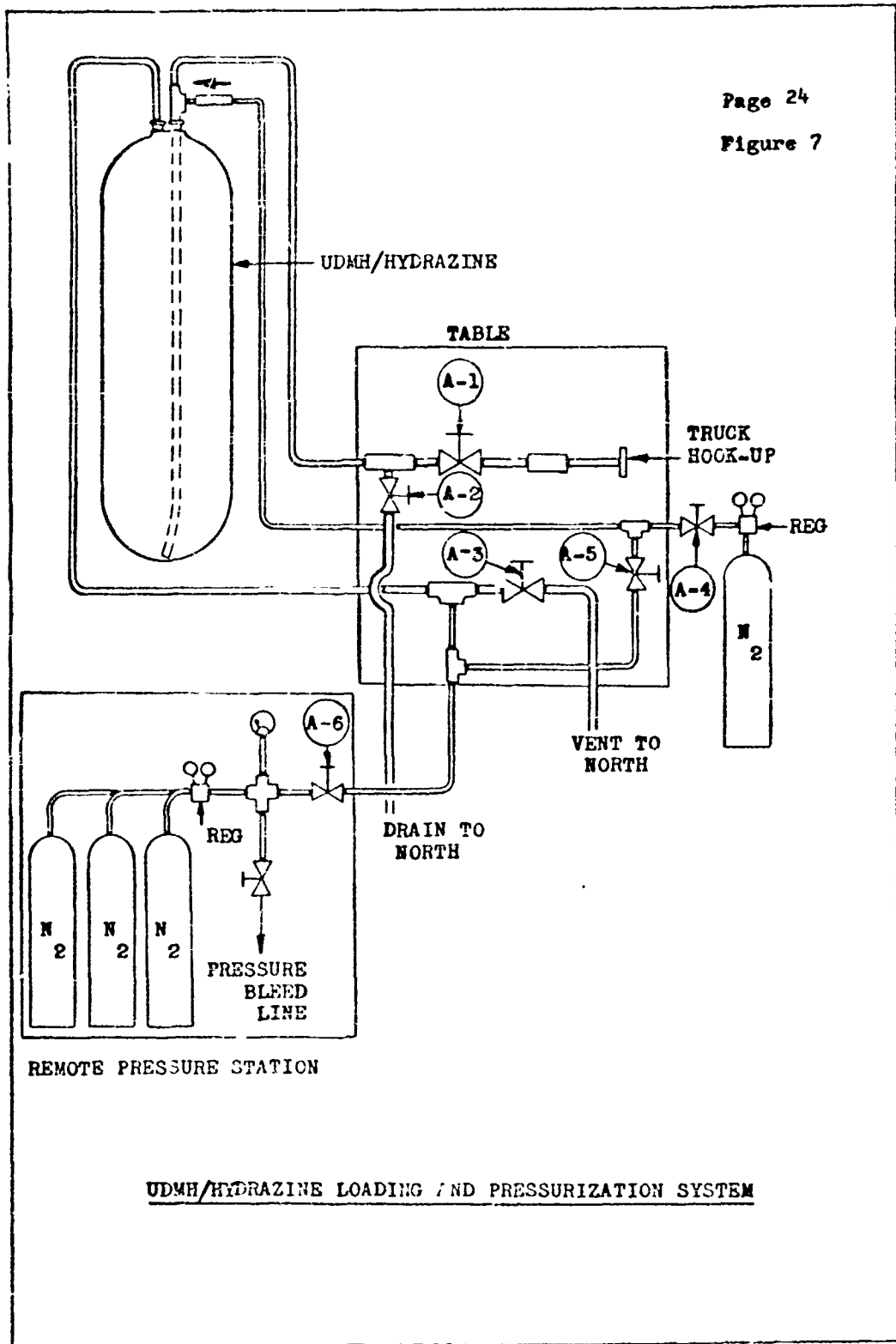

UDMH/HYDRAZINE LOADING AND PRESSURIZATION SYSTEM

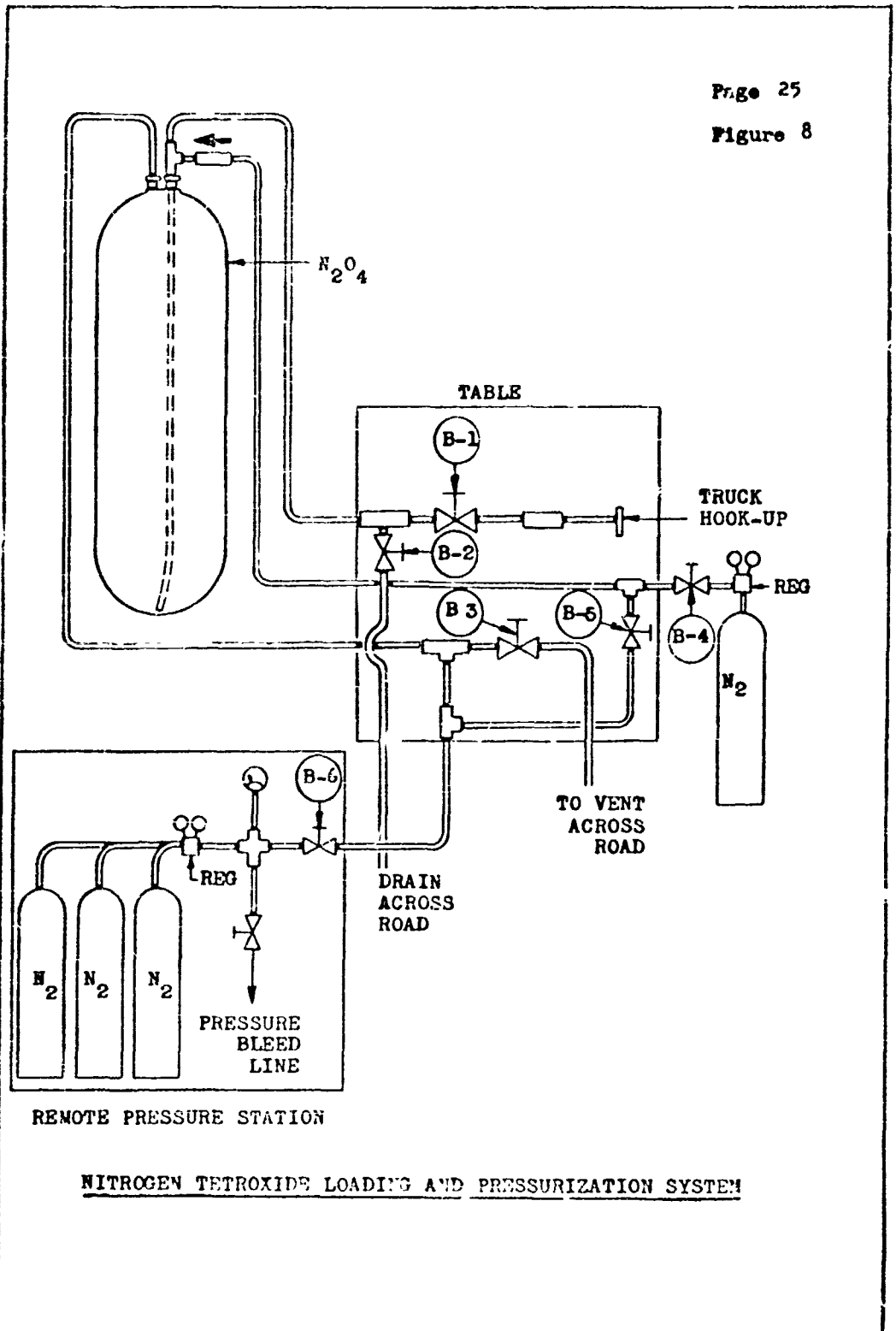

NITROGEN TETROXIDE LOADING AND PRESSURIZATION SYSTEM

MARTIN MARIETTA CORPORATION

Page 26

psi/g. Pressure transducers PC1, PC2, PC3, PC4, PC6, PC7 and PC8 were Photocon capacitance gauges Mod. 352-2170 water cooled, used in conjunction with a DG601-2 Dynagage Amplifier providing 100MV/psi with an essentially flat frequency response from 0-8,000 cps.

The two microphones used as pressure transducers were Altec Lansing 21BR-150 supplying -55 to -65 DB/IV/dyne/cm². The pressure at the last pole, 300 ft. from the blast center was measured with a Statham type PM-131 TC-35045 unbonded strain gage type transducer.

Temperatures (TC1-10) were detected with thermocouples made of 40 ga. chromel alumel thermocouple wire with #24 ga. chromel alumel extension wire. The extension wire terminated in a 150°F ± 1° controlled hot reference junction box. The temperature signal was then carried to the recorder using 18 ga. shielded copper wire. Heat transfer was measured with total heat type calorimeters consisting of a polished gold disk coated with platinum black on the side facing exposure. Forty ga. chromel alumel thermocouple wire was welded to the disk on the backside. This assembly was mounted in a stainless steel housing.

The thermocouple and calorimeter signals were calibrated by means of a voltage substitution using thermocouple/millivolt tables. The Photocon and Kistler pressure signals were stimulus calibrated using actual known pressures applied to the sensing elements. The microphones were calibrated using an Altec Lansing No. 12185 Acoustic Calibrator and the C&C unbonded strain gage transducer

was shunt resistance calibrated.

Strain gages used were TATNALL - 120 ohm, C12-141B with a gage factor of 2.08. Shunt resistance calibrations were performed and the outputs were amplified through KinTel AFill D.C. amplifiers.

All pressure data and strain gage data was recorded on Ampex FR114 Magnetic Tape Recorders. Temperature Data was recorded on a CEC 5-119 oscillograph using 1200 cycle/sec. galvanometers.

Motion picture coverage included 24, 128, 200, 400 frames per second. (Figure 9, page 28)

Procedure

The model was erected on the test stand, and the following functions were performed:

- (a) Both tanks were pressurized to 50 psi while all junctions were covered with a soapy solution to detect leaks.
- (b) All instrumentation was calibrated.
- (c) The ordnance system was installed on the tank domes.
- (d) The lower tank was filled with 5800 pounds (780 gallons) of UDMH/Hydrazine.
- (e) The fuel fill line was purged, and the UDMH/Hydrazine truck withdraw.
- (f) The upper tank was filled with 10,000 pounds (835 gallons) of Nitrogen Tetroxide.
- (g) The temperature during the loading operation varied between 44°F at 0200 hours to 30°F at 0700 hours.

Figure 9

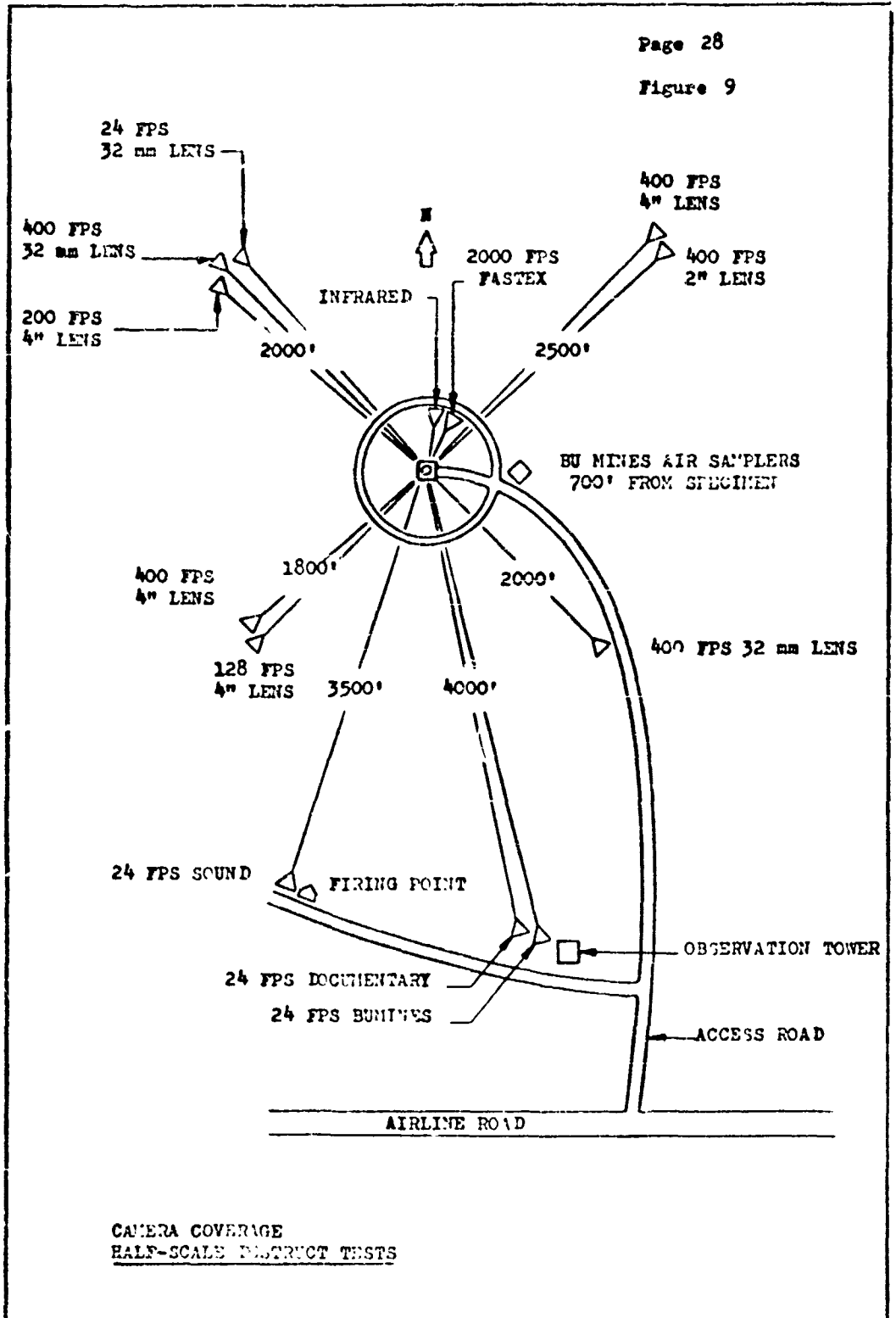

MARTIN MARIETTA CORPORATION

Page 29

- (h) A final check on cameras and instrumentation was completed.
- (i) The Bureau of Mines personnel positioned their equipment.
- (j) Both tanks were pressurized to 40 psi.
- (k) Safety verified an all clear, and the destruct was initiated.

D. Destruct Test of Half Scale Stage I - Titan II With Propellants

Background:

This test was a continuation of the previous test (Section C) using a half scale Stage I test specimen which held a greater amount of propellants (32,700 pounds). The two assemblies of the specimen were welded together at the stringer interface ring to provide for more intermixing of the propellants in their liquid and gaseous states.

Test Conditions:

Time: 12:38 p.m., 22 November 1961

Temperature: 50°F

Wind Velocity: 3 miles per hr.

Wind Direction: 265° from true north

Humidity: 72%

Atmospheric Pressure: 11.7 lbs. per sq. in.

The RAOVS soundings from Appleton Field show that a stable condition existed. There was no low inversion at the time of firing (ref. Martin-Denver IDC to J. E. Greichen from R. H. Bliss, "The Martin Company Meteorologist").

Description of Test Specimen:

The test specimen was an assembly simulating the Stage I propellant tanks and between tanks structure of the Titan II booster. The dimensions and structural components of the specimen are shown in Figure 10, page 32. The aluminum domes were spun to a hemispherical shape and welded to the rolled aluminum

tank barrels. Each tank structure was strengthened by twelve channel stringers welded to the barrel at ten inch intervals and butt welded to flat rings $\frac{1}{2}$ X 5 inches and 5 feet in diameter.

The upper and lower tank assemblies were bolted and welded together to keep the specimen tanks in place after the domes ruptured.

The ordnance installation for this test was the same arrangement as that called out in the previous section. (See page 17).

The fixture and instrumentation arrangement were also the same as that described in the previous section.

Procedure:

The specimen was erected on the test stand, (Figures 11 & 12, pages 33 & 34) functions performed were the same as those in the Stage II procedure (Page 27) except that the Stage I specimen contained 11,200 pounds of UDMH/Hydrazine and 21,500 pounds of nitrogen tetroxide, and both tanks were pressurized to 10 psi.

Camera Coverage:

Sequence camera photographs (8 f/s) were taken in addition to the camera coverage denoted in figure 9, page 28.

12 EQ. SPACED
3" AM. STD. CHANNEL

1/4" THK. MANHOLE
1/8" THK. TEFLON GASKET

Figure 10

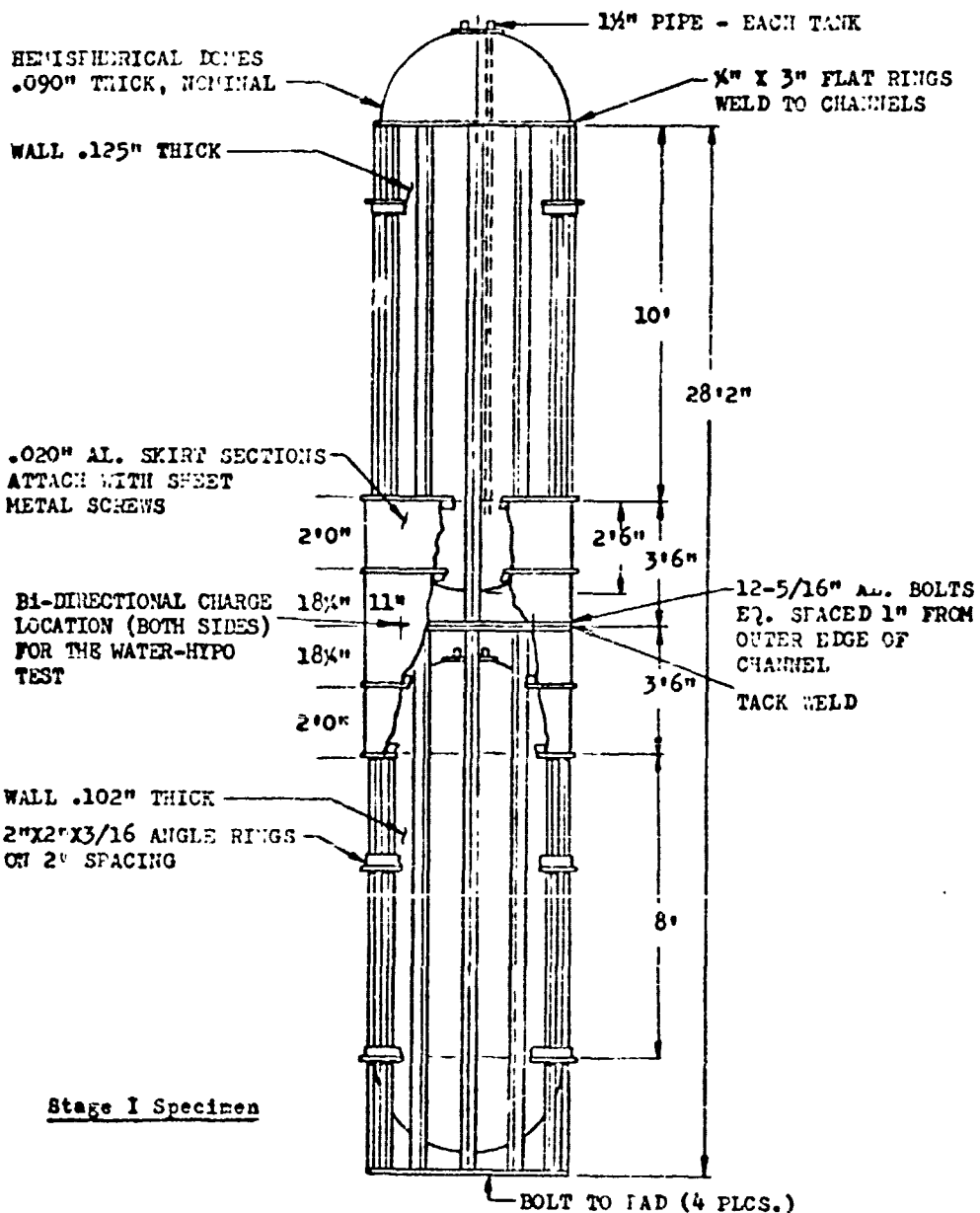

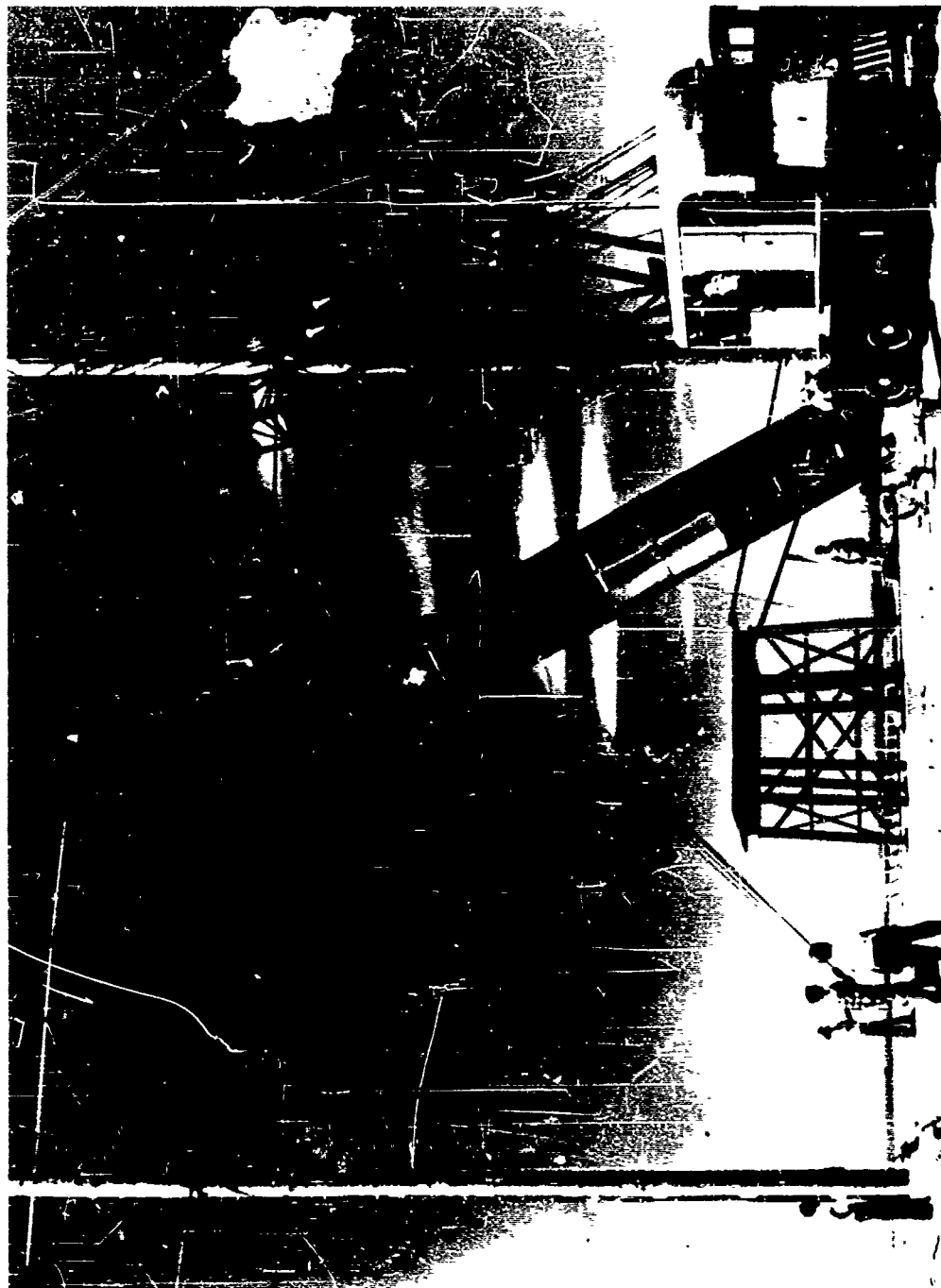

ERECTION OF STAGE I 1/2 SCALE SF CIRCULAR TOWER OF 100 FT

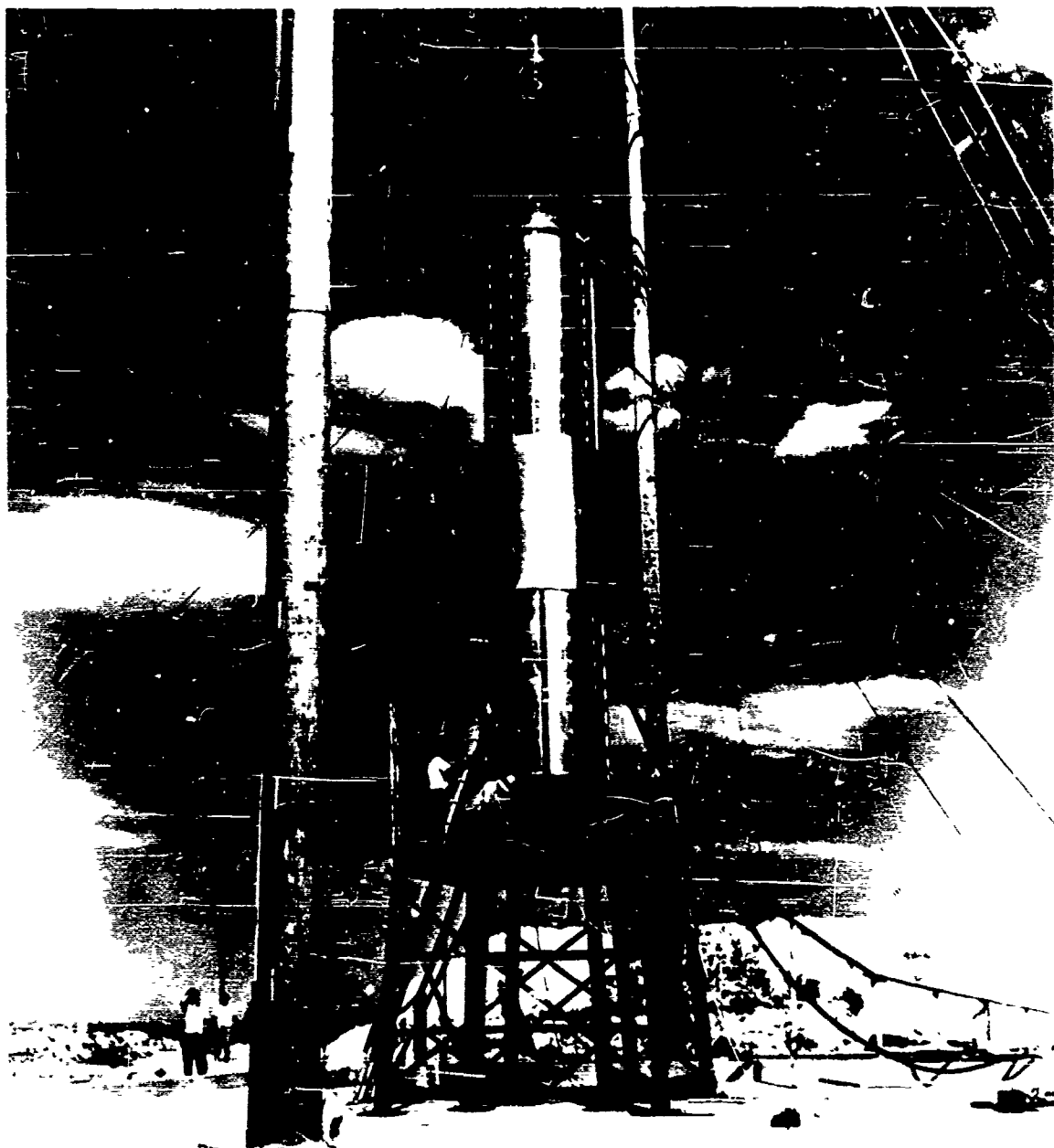

STAGE I SPECIMEN MOUNTED ON THE TEST STAND

IV. Results and Conclusions with Data References:

BEER BARREL DESTRUCT TESTS

- (1) Removal of the opposing domes (oxidizer and fuel) is the most effective method for intermixing the liquid propellants in Titan II and Titan III boosters.
- (2) No significant problems occurred when 292 pounds of propellants were intermixed. The NO₂ cloud rose and dispersed rapidly.

FULL SCALE STAGE I - TITAN I WITHOUT PROPELLANTS

Phase I - Tests With Target Panels

- (1) Performance consistency of the bi-directional destruct charge was demonstrated.
- (2) Target damage patterns justified further investigation of these effects on actual missile domes.

Phase II - Full Scale Dome - Titan I

- (1) Performance consistency of the destruct charge was further verified.
- (2) Destruct charge removed 80% of the dome. (Figure 13, page 38)
- (3) Tears in the dome tended to propagate along the edges of the chem-milled sections.

Phase III Full Scale Between Tank Section of Stage I Titan I

- (1) The destruct assembly was satisfactorily demonstrated.
- (2) More than 75% of both opposing domes were thoroughly destroyed.
- (3) The explosive blast of the two destruct charges ruptured the between tanks skirt assembly and blew the skirt and stringers away from the test specimen.

HALF SCALE STAGE II - TITAN II WITH PROPELLANTS

- (1) Sufficient intermixing of the propellants occurred even though the fuel and oxidizer tanks separated after destruct initiation.
- (2) The fire ball expanded to a maximum size of 148 feet horizontally and 105 feet vertically in 2.3 seconds after destruct initiation. (From 24 fps and 8 fps cameras)
- (3) After reaching a maximum size, the fire ball rose and drifted downwind. At 4.8 seconds after destruct, the bottom of the fire ball was 115 feet above the ground. (From 24 fps camera, Figure 17, page 42)
- (4) The maximum temperature recorded was 2400°F. This occurred at a point at the side of the test specimen 3.2 seconds after destruct initiation. Temperature Data (Figure 14, page 39)
- (5) The total radiant flux at a Thermopile 300 feet from the test specimen was 2.3 joules/cm² (Ref. (1)).
- (6) The rising fire ball and thermal column helped to disperse the NO₂ vapors well above ground level. The cloud rose above 500 feet and dispersed within a mile downwind. Unreacted liquid nitrogen tetroxide vaporized on the pad and this NO₂ vapor drifted toward the sampling units.
- (7) At a distance 500 feet downwind from the pad, air samples were taken from bottles located 10 and 60 feet above ground level. The bottles took samples every 30 seconds over a 3 minute period. Ref (1) or (Figure 18, page 43)

MARTIN MARIETTA CORPORATION

Page 36a

- (8) Personnel one mile downwind from the pad did not detect the presence of NO_2 either by sampling or odor.
- (9) Although no pressures were recorded because of an instrumentation malfunction, there was no pressure damage to the test fixtures; i.e., telephone poles and cross beams above the test specimen. No pressure wave was sensed by personnel at the firing or observation point 4000 feet from the pad.
- (10) Fragments from the between tanks section of the test specimen were blown out horizontally and did not go above the level of the upper tank dome. The upper tank dome remained intact and strain gages on the top of the upper tank dome indicated a compressive load immediately after destruct initiation. Fragmentation pattern is shown on Figure 16, page 41.
- (11) Safety personnel inspected the pad thirty minutes after the test. They were equipped with protective clothing and reported that small amounts of nitrogen tetroxide were still vaporizing. Unprotected personnel inspected the test site sixty minutes after the destruct initiation.

Half Scale Stage I - Titan II With Propellants

- (1) Sufficient intermixing of the propellants occurred at destruct and was similar to the Stage II test. This was due to both test specimens being 5 feet in diameter. Stage II and Stage I fireballs were approximately the same size.
- (2) The fireball expanded to a maximum size of 151 feet horizontally and 111 feet vertically in 2 seconds after destruct initiation. Fig. 17 and Fig. 19.
- (3) After reaching a maximum size, the fireball rose and drifted downwind. At 4.5 seconds after destruct, the bottom of the fireball was 99 feet above the ground. Fig. 17 and Fig. 20.
- (4) The maximum temperature recorded was 3000° F. This occurred adjacent to the test specimen 2.2 seconds after destruct initiation. Fig. 21 and Fig. 22.
- (5) The total radiant flux at a thermopile 275 feet from the test specimen was 3.93 joules/cm² Ref. (1).
- (6) The rising fireball and thermal column helped to disperse the NO₂ vapors well above ground level. However, a volume of unreacted nitrogen tetroxide (larger than Stage II) vaporized on the pad and drifted downwind. Fig. 23.
- (7) An air sample taken 700 feet downwind and 60 feet above ground at 90 seconds after destruct revealed a concentration of 154 parts per million of NO₂. Other air samples taken at six other time intervals up to three minutes recorded less than 1 PPM of NO₂. Ref. (1) and Fig. 18
- (8) Some 30 seconds after destruct a hole burned in the lower fuel tank dome and released unreacted UDMH/hydrazine. This reacted with the nitrogen tetroxide on the pad and reduced the amount of NO₂ vapors. Fig. 24.
- (9) With the UDMH/hydrazine and nitrogen tetroxide tanks being secured together, the vapors from the propellants remained in closer proximity for intermixing.
- (10) A pressure recorded from the destruct charge next to the test specimen was 11 psi. At 3.1 and 4.2 seconds after destruct initiation, two significant vapor explosions occurred and pressures of 5 and 10 psi, respectively, were recorded. Fig. 25. Although the magnitude of these vapor explosion pressures were high, their impulses were low. The test setup remained intact, and there was no pressure damage to the test specimen. Fig. 26 and Fig. 27. Similar vapor explosions were recorded in Ref. (2).
- (11) The skirt between tanks was blown out horizontally from the destruct charge but did not rise above the level of the test specimen. The upper tank dome did not fragment but remained intact.

MARTIN MARIETTA CORPORATION

Page 37 a

- (12) Personnel stationed at the firing point, 3500 feet south southwest of the pad, felt a mild sensation of the snock wave. Figure 30, page 56 shows the snock wave moving outward. The telephone pole gives the illusion of bending as the shock wave passes between the camera and the pole.
- (13) Safety personnel in protective clothing inspected the pad thirty minutes after destruct initiation and reported that small volumes of nitrogen tetroxide were still vaporizing.
- (14) Unprotected personnel inspected the pad sixty minutes after destruct was initiated.
- (15) A sample of the tab run of instrumentation is shown in Figure 31 page 57, and the complete data tabulation is presented in The Martin Company, Denver Division, Report - Dyna-Soar $\frac{1}{2}$ Scale Blast Test of 28 November, 1961.



FULL SCALE TANK DOME AFTER DESTRUCT

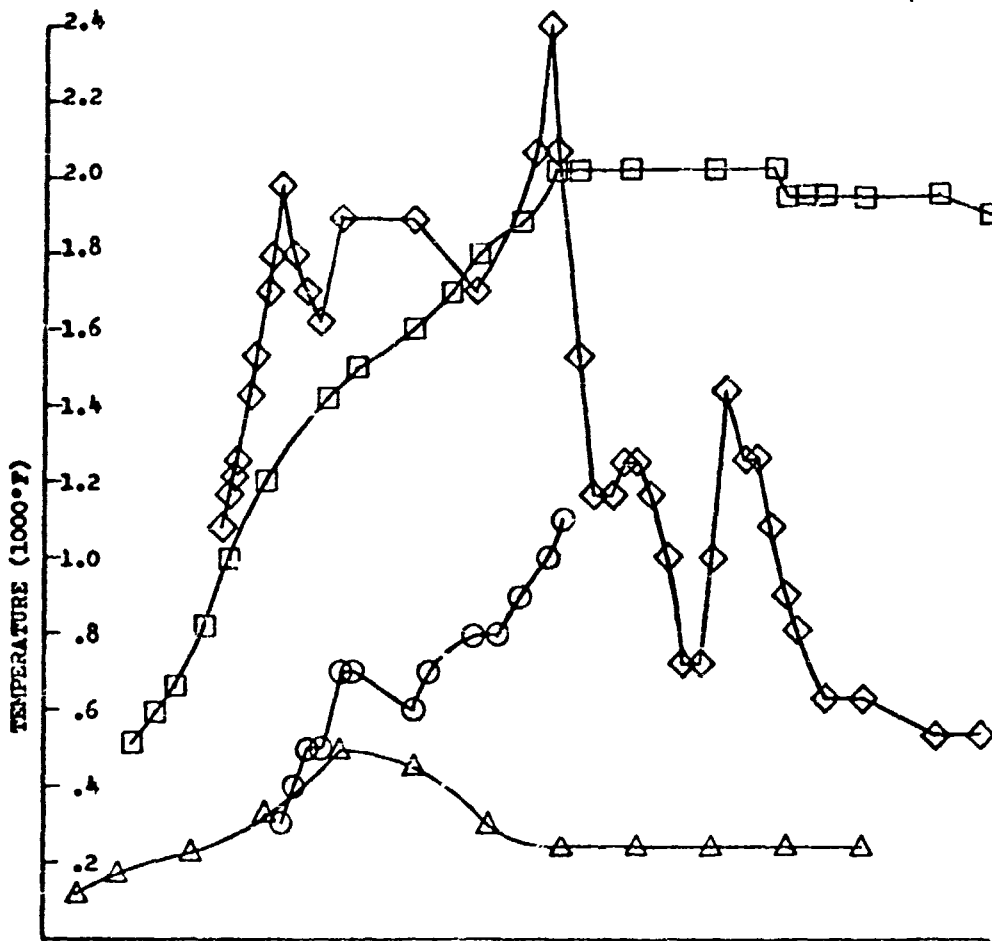

1 SEC

TIME

- - THERMOCOUPLE POSITION NO. 1
- ◇ - THERMOCOUPLE POSITION NO. 3
- - THERMOCOUPLE POSITION NO. 4
- △ - THERMOCOUPLE POSITION NO. 6
- ZERO READING - THERMOCOUPLE POSITION NO. 7

THE THERMOCOUPLE POSITIONS SHOWN
IN FIGURE PAGE

TEMPERATURE
HALF-SCALE STAGE II - TITAN II WITH PROPELLANTS

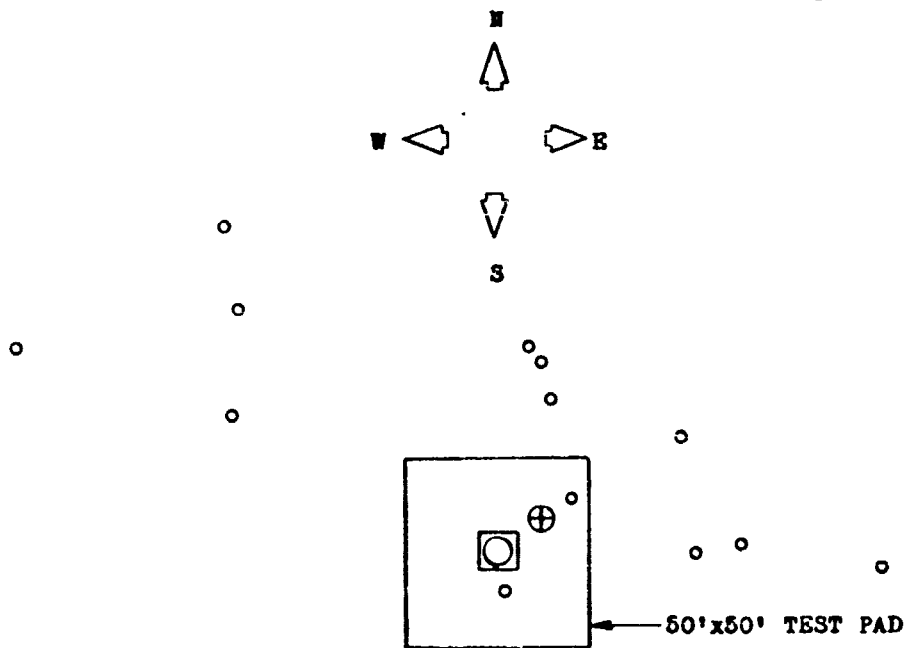

- - UDMH/HYDRAZINE TANK
- ⊕ - N₂O₄ TANK
- - MINIMUM 1 FT. SQ. FRAGMENTS

FRAGMENTATION PATTERN

1/2 scale St. II Destruct Test
with propellants

Scale 1" - 40'

Stage II

Time (seconds)	Horiz. Dia. (feet)	Vertical Dia. (feet)	Rise (feet)
.5	81	47	-
1.0	98	56	-
1.5	127	81	-
2.0	141	95	-
2.33 (max.)	148	105	-
2.83	-	-	9.1
3.33	-	-	13.6
3.83	-	-	32.7
4.33	-	-	59
4.83	-	-	115

Stage I

.5	79.5	43.5	-
1.0	111	73.5	-
1.5	138	93	-
2.16 (max.)	151	111	-
2.56	-	-	20.5
3.06	-	-	32.5
3.56	-	-	49.5
4.06	-	-	73
4.56	-	-	99

Time - seconds after destruct initiation
Rise - measured from bottom of fireball to ground level

Half-scale Stage I and Stage II fireball size & rise

Concentration of NO₂ in
Parts per Million (PPM)

Stage II Test
500 Feet Downwind

Time After Destruct (sec)	Lower Bank (PPM)	Upper Bank (PPM)
5	< 1	3
20	< 1	< 1
30	10	1
60	44	13
90	5	11
120	8	9
180	1	0

Stage I Test
700 Feet Downwind

Time After Destruct (sec)	Upper Bank (PPM)
5	< 1
20	< 1
30	< 1
60	< 1
90	154
120	< 1
130	< 1

Nitrogen Dioxide Concentrations

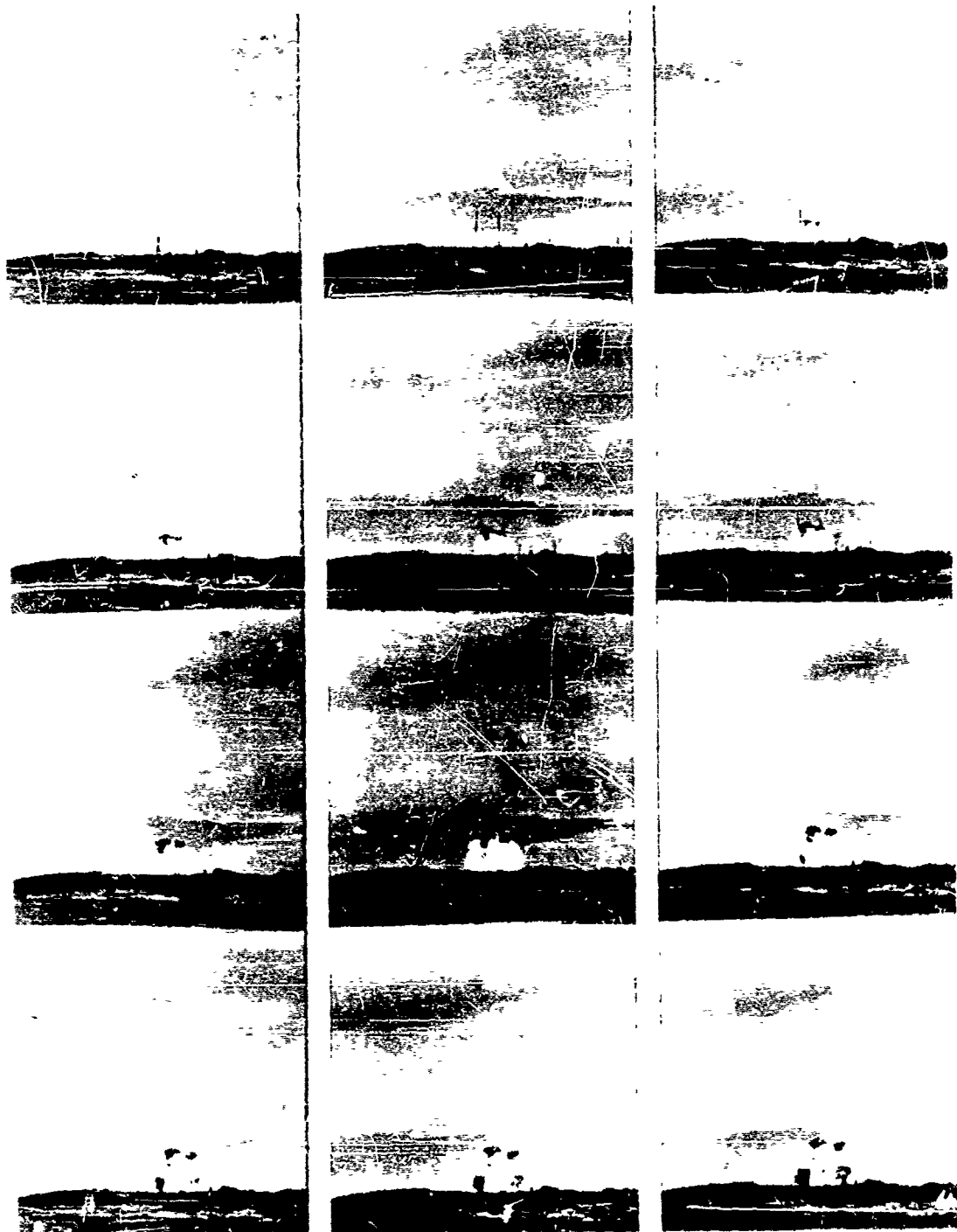

FIREBALL GROWTH

NO. 4 PHOTO WAS TAKEN 1.75 SECONDS AFTER DESTRUCT INITIATION.

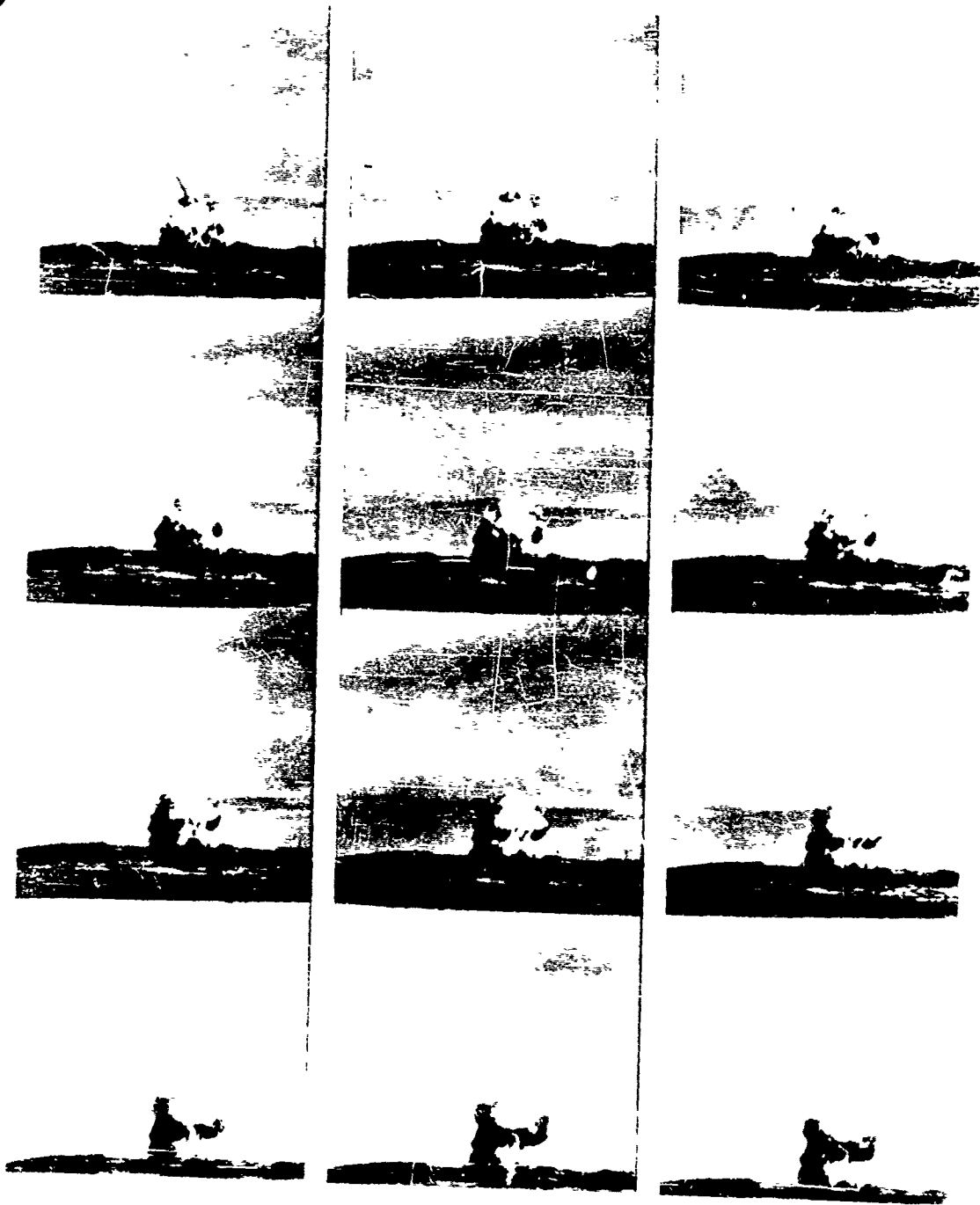

FIREBALL RISE

NO. 5 & NO. 6 PHOTOS TAKEN EARLY 2.7 & 2.75 SECONDS AFTER OBSERVED INITIATION.

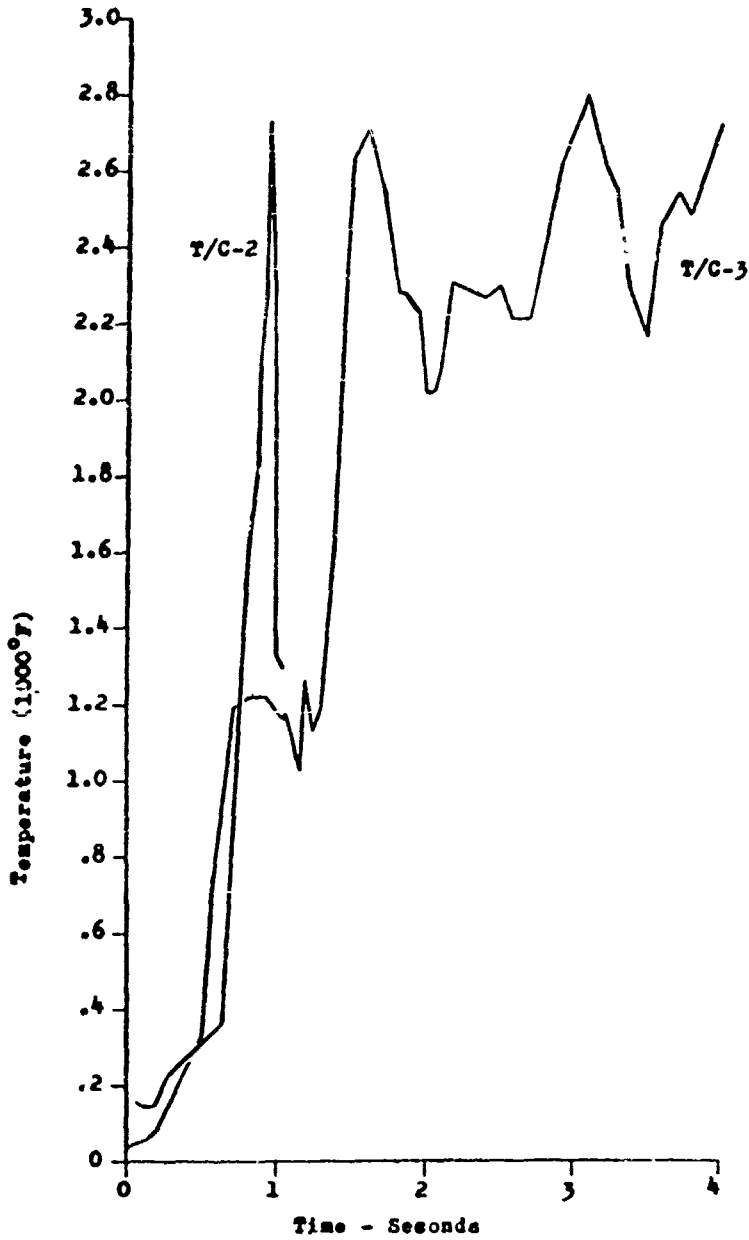

T/C-Thermocouple Position Shown
In Figure Page

Temperature
Half Scale Stage I Titan II With Propellants

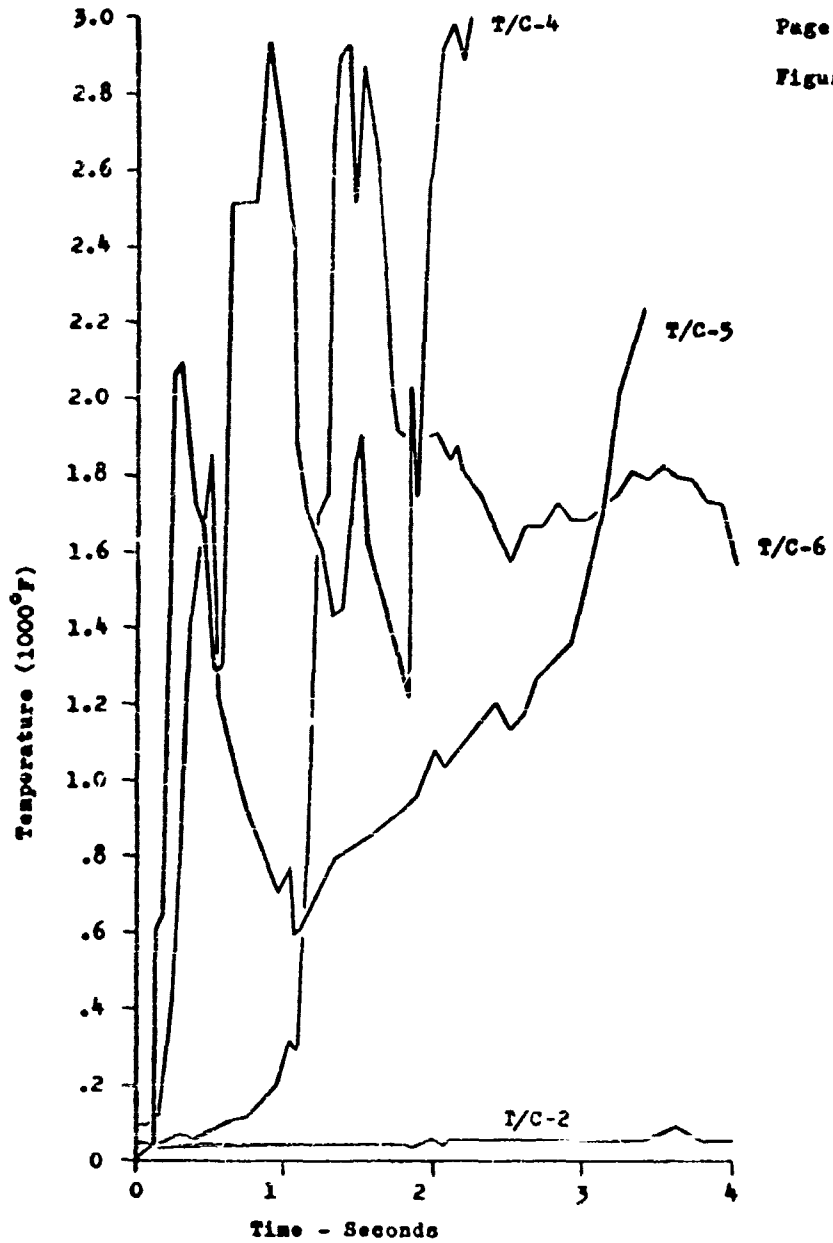

T/C-Thermocouple Positions Shown
In Figure Page

Temperature
Half Scale Stage I Titan II With Propellants

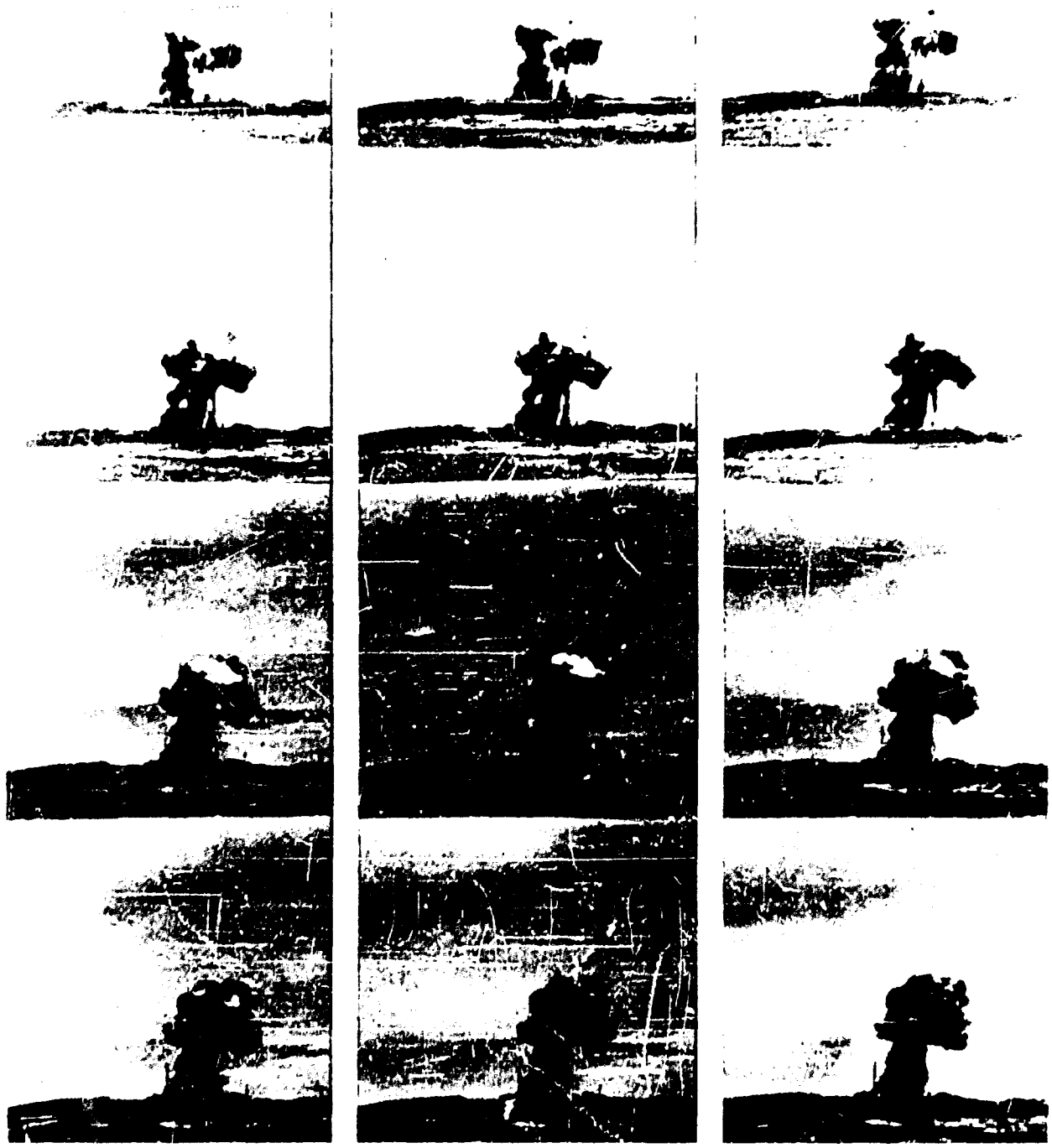

FLAREBALL AND THE MAIN COLUMN RISE

NO. 7 PHOTO WAS TAKEN 4.75 SECONDS AFTER DESTRUCT INITIATION.

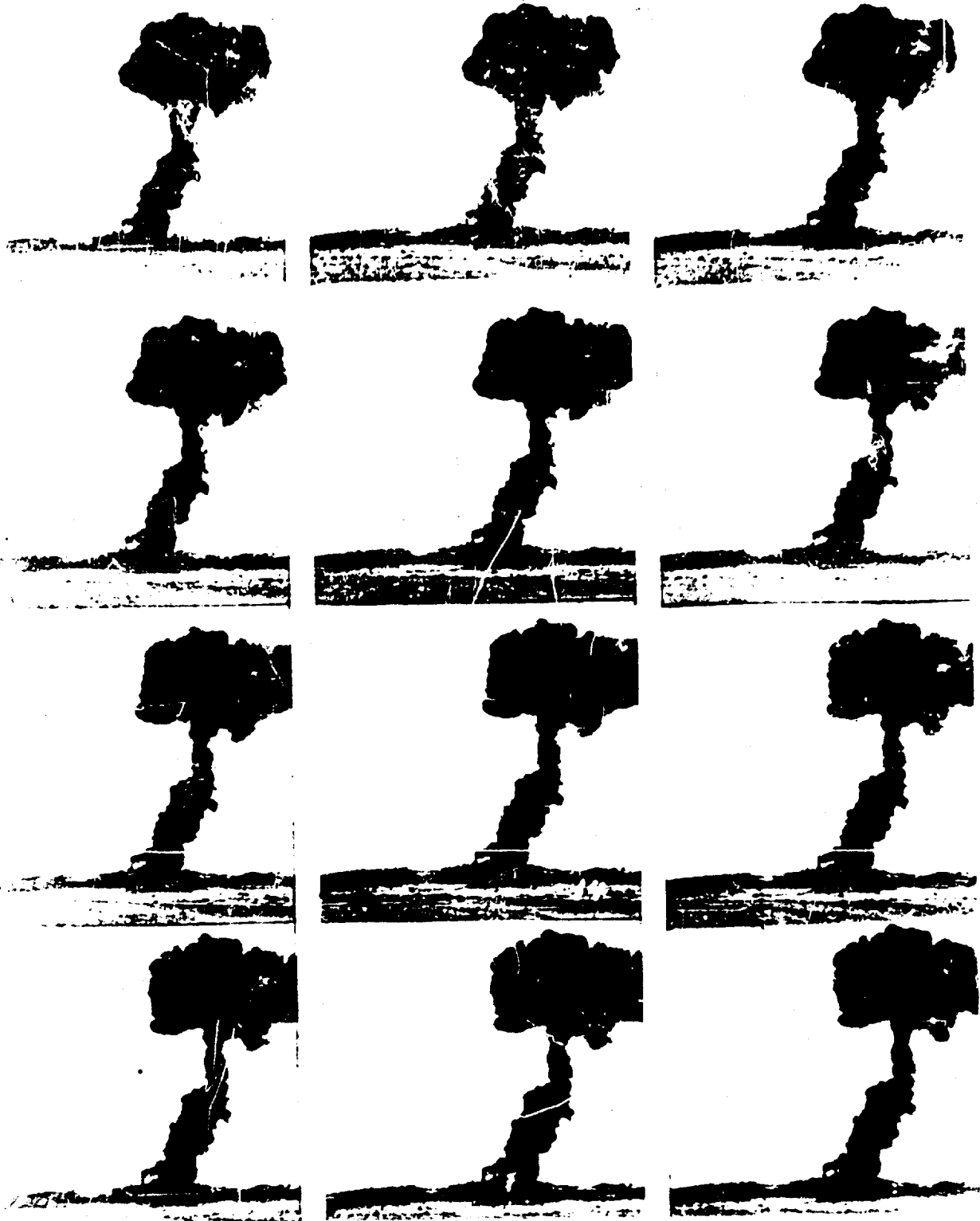

THE CLOUD COLUMN RISE

NO. 13 & NO. 14 PHOTOS TAKEN 10.75 & 11.75 SECONDS AFTER DESTRUCT INITIATION.

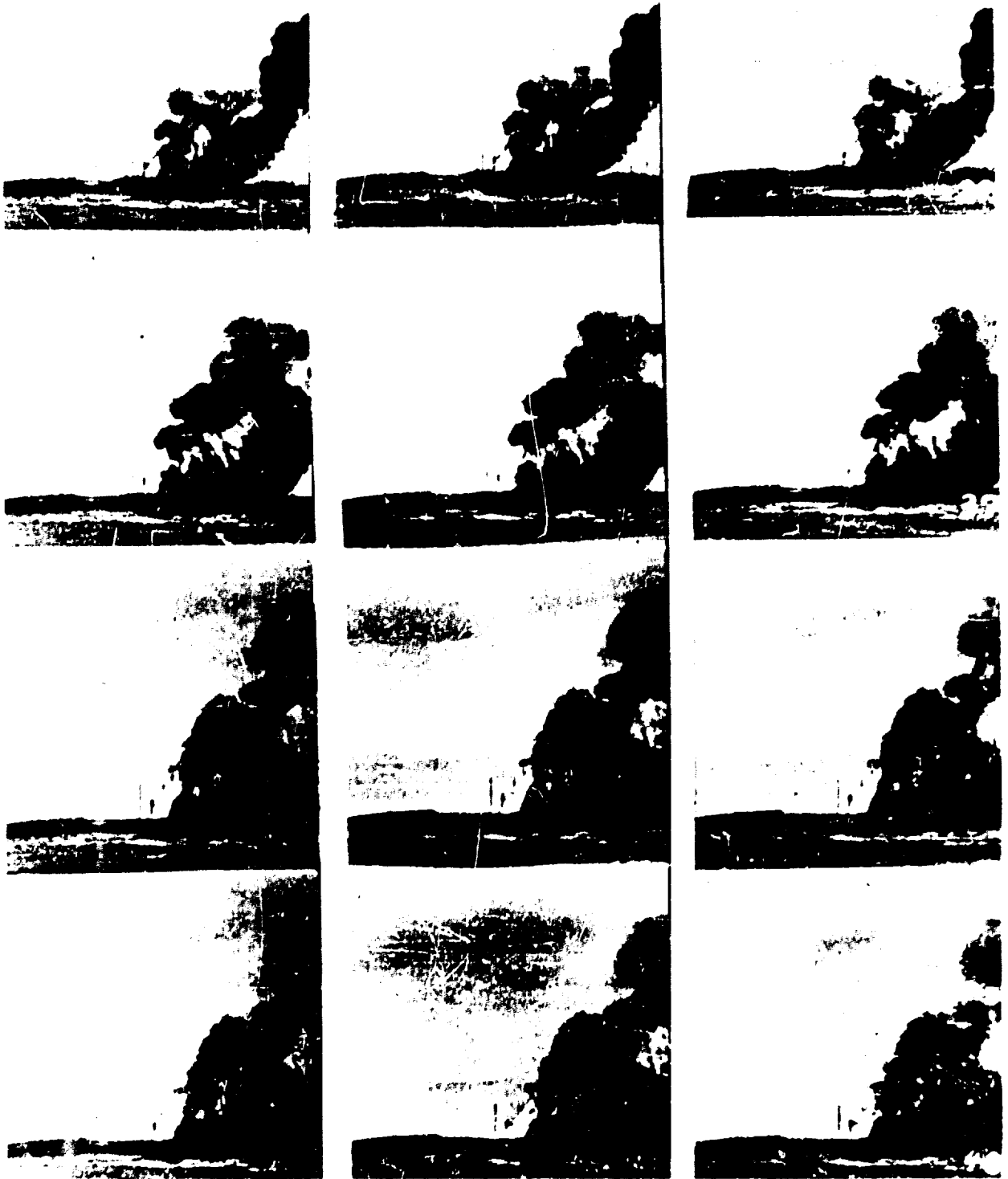

EXCESS NITROGEN TETROXIDE

NO. 29, NO. 37 & NO. 43 PHOTOS ARE PAIR 29.75, 36.75 & 43.75 RECORDS FOR
DETACHMENT UNDER THE ATLAS.

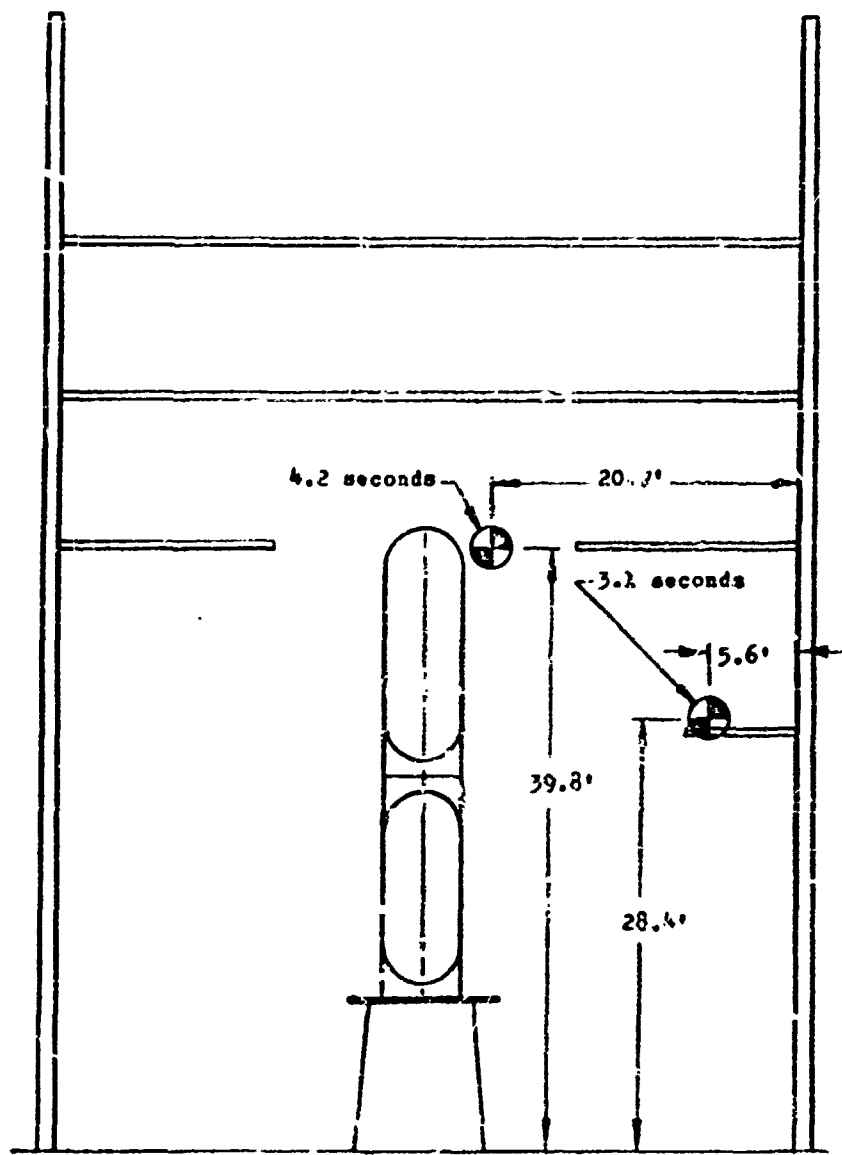

Approximate Center Locations of Vapor Explosions
At 3.1 and 4.2 Seconds After Destruct Initiation
(Measurements are in one plane only)

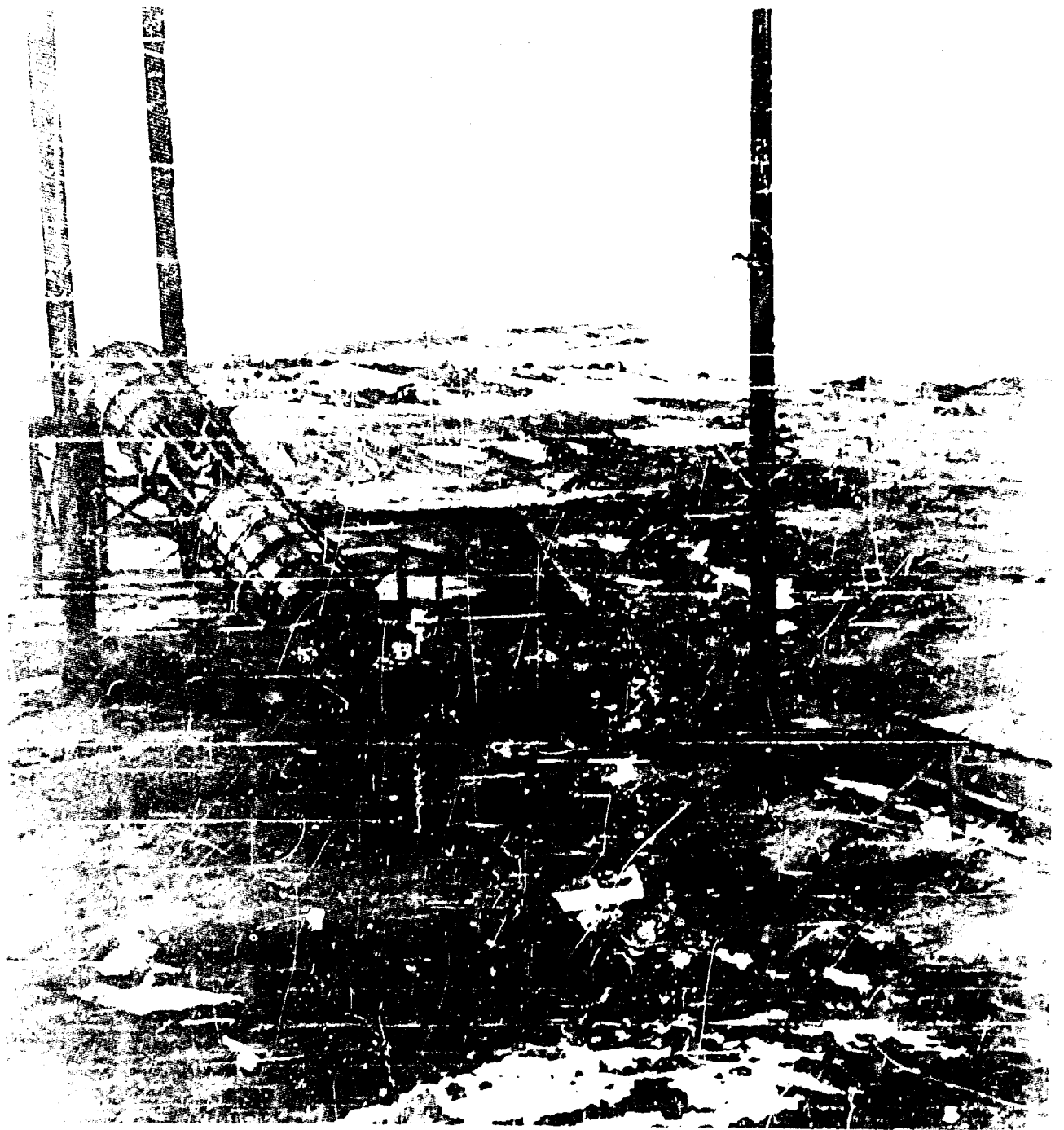

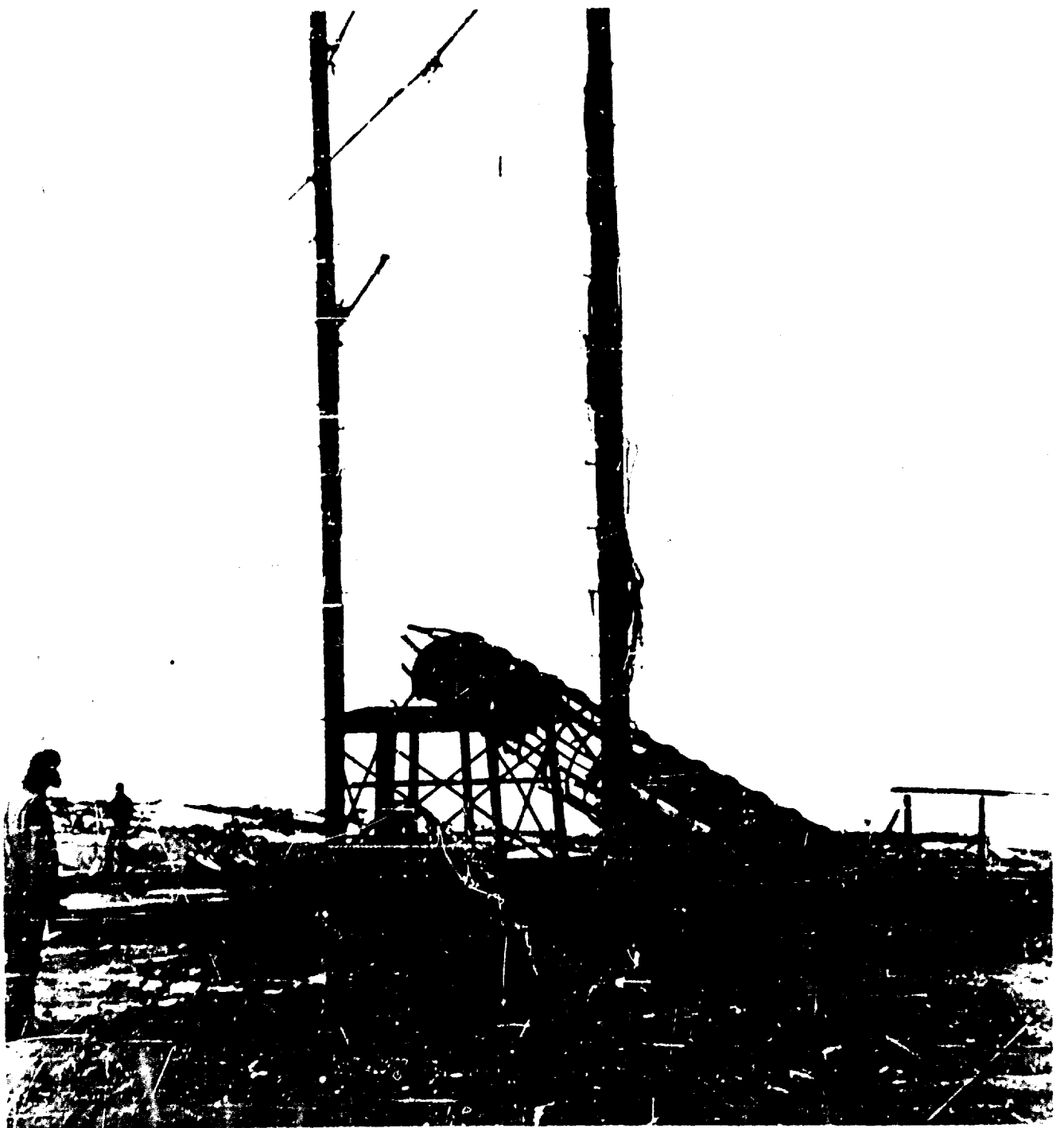

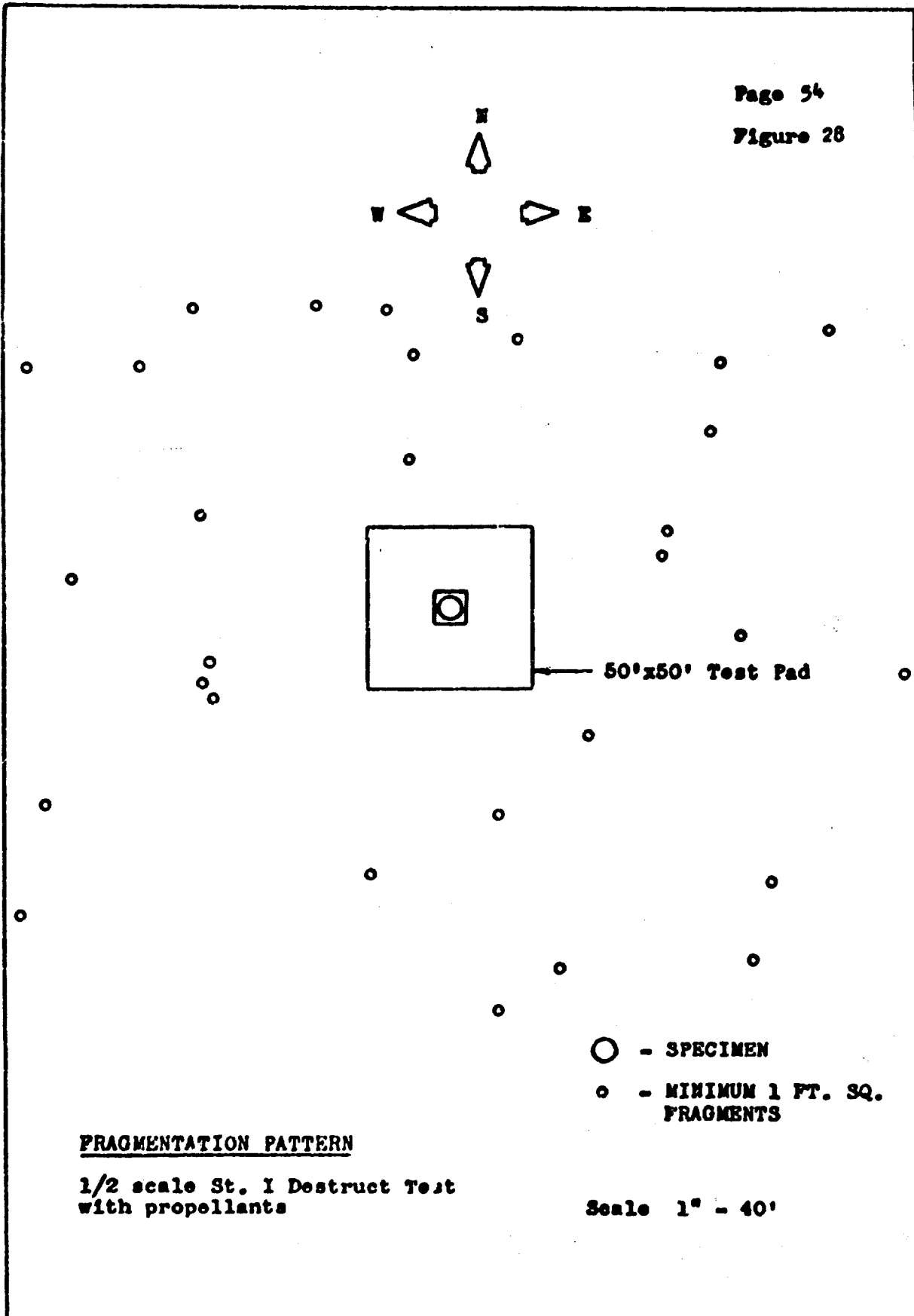

FRAGMENTATION PATTERN

**1/2 scale St. I Destruct Test
with propellants**

Scale 1" = 40'

- - SPECIMEN
- - MINIMUM 1 FT. SQ. FRAGMENTS

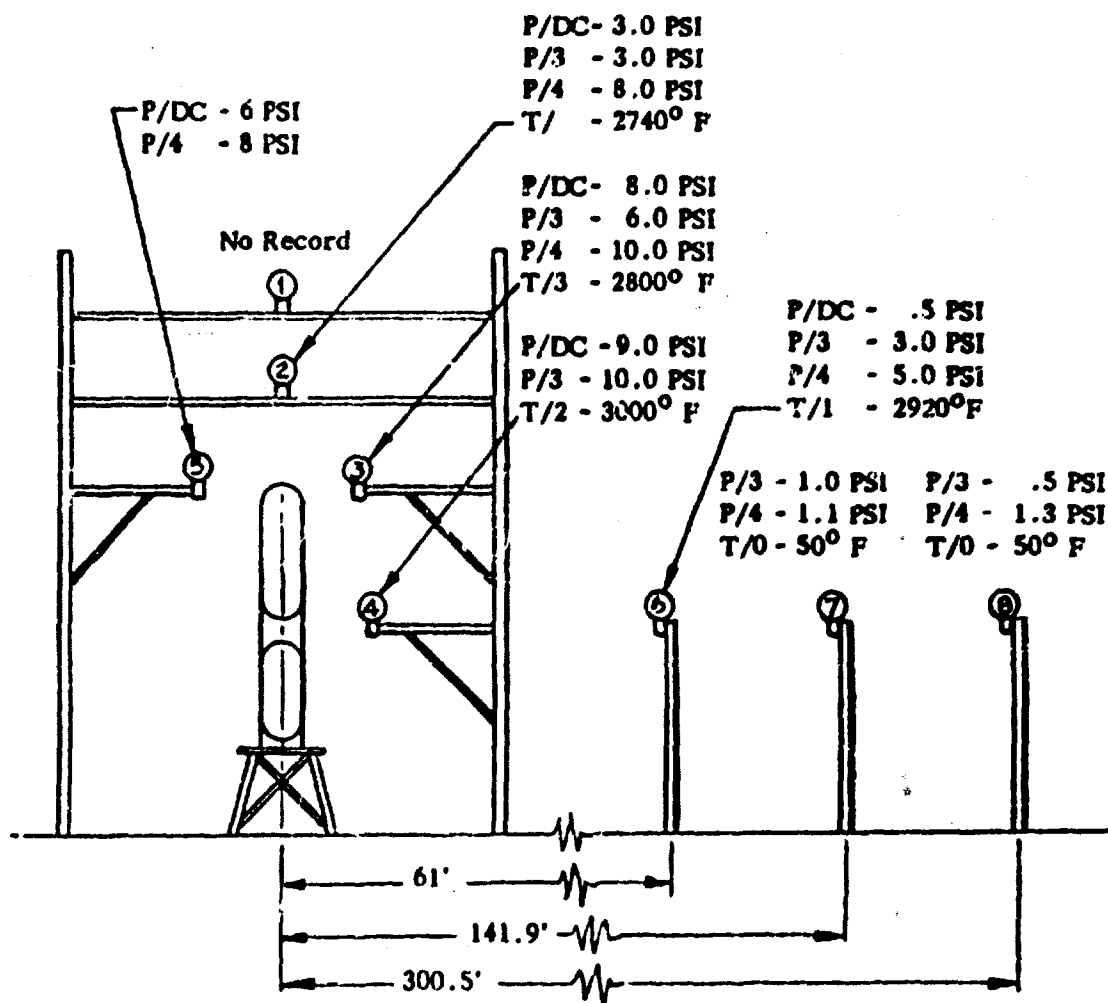

- P/DC - Pressure recorded from destruct charge
- P/3 - Pressure recorded 3.1 seconds after destruct
- P/4 - Pressure recorded 4.2 seconds after destruct
- T/0 - Ambient temperature
- T - Peak temperature recorded 1 second after destruct
- T/1 - Peak temperature recorded 1.4 seconds after destruct
- T/2 - Peak temperature recorded 2.2 seconds after destruct
- T/3 - Peak temperature recorded 3.1 seconds after destruct

SUMMARY OF PRESSURE AND TEMPERATURE DATA
1/2 scale St. I Destruct Test with propellants

PLATE 20

FIGURE 20



RUN ID	MEAS	TIME	BL CTS	FUNCTION VALUE
DYNA--1/2	PC-2	0.033	109	000000.1988
DYNA--1/2	PC-2	0.038	105	000000.1627
DYNA--1/2	PC-2	0.044	105	000000.1627
DYNA--1/2	PC-2	0.047	155	000000.6147
DYNA--1/2	PC-2	0.050	215	000000.1571
DYNA--1/2	PC-2	0.053	160	000000.6597
DYNA--1/2	PC-2	0.055	060	000000.2684-
DYNA--1/2	PC-2	0.059	064	000000.2132-
DYNA--1/2	PC-2	0.069	069	000000.1680-
DYNA--1/2	PC-2	0.072	088	000000.0910
DYNA--1/2	PC-2	0.077	074	000000.0637
DYNA--1/2	PC-2	0.084	109	000000.1780
DYNA--1/2	PC-2	0.089	107	000000.1780
DYNA--1/2	PC-2	0.093	118	000000.2807
DYNA--1/2	PC-2	0.097	165	000000.7051
DYNA--1/2	PC-2	0.101	120	000000.2983
DYNA--1/2	PC-2	0.106	118	000000.2802
DYNA--1/2	PC-2	0.110	139	000000.4700
DYNA--1/2	PC-2	0.115	220	000000.2073
DYNA--1/2	PC-2	0.119	173	000000.7114
DYNA--1/2	PC-2	0.124	168	000000.7322
DYNA--1/2	PC-2	0.127	197	000000.0124
DYNA--1/2	PC-2	0.131	279	000000.7356
DYNA--1/2	PC-2	0.135	188	000000.9130
DYNA--1/2	PC-2	0.139	184	000000.6768
DYNA--1/2	PC-2	0.145	187	000000.9040
DYNA--1/2	PC-2	0.149	167	000000.7232
DYNA--1/2	PC-2	0.156	152	000000.5876
DYNA--1/2	PC-2	0.159	131	000000.3977
DYNA--1/2	PC-2	0.160	175	000000.7955
DYNA--1/2	PC-2	0.170	154	000000.6056
DYNA--1/2	PC-2	0.174	129	000000.3796
DYNA--1/2	PC-2	0.178	112	000000.2260
DYNA--1/2	PC-2	0.182	177	000000.8316
DYNA--1/2	PC-2	0.185	162	000000.6780
DYNA--1/2	PC-2	0.190	169	000000.7412
DYNA--1/2	PC-2	0.195	136	000000.4429
DYNA--1/2	PC-2	0.196	182	000000.8588
DYNA--1/2	PC-2	0.200	151	000000.5785
DYNA--1/2	PC-2	0.203	155	000000.1117
DYNA--1/2	PC-2	0.205	172	000000.7384
DYNA--1/2	PC-2	0.210	072	000000.4409-
DYNA--1/2	PC-2	0.215	106	000000.1717
DYNA--1/2	PC-2	0.219	100	000000.1175
DYNA--1/2	PC-2	0.224	119	000000.2892
DYNA--1/2	PC-2	0.231	072	000000.1409-
DYNA--1/2	PC-2	0.238	121	000000.3073
DYNA--1/2	PC-2	0.243	080	000000.6685-
DYNA--1/2	PC-2	0.248	063	000000.2223-
DYNA--1/2	PC-2	0.256	103	000000.1665
DYNA--1/2	PC-2	0.261	168	000000.8322
DYNA--1/2	PC-2	0.265	127	000000.1164

A SAMPLE TAB RUN OF THE INS SUBSTITUTION