

**UNCLASSIFIED**

---

---

**AD 274 377**

*Reproduced  
by the*

**ARMED SERVICES TECHNICAL INFORMATION AGENCY  
ARLINGTON HALL STATION  
ARLINGTON 12, VIRGINIA**



---

---

**UNCLASSIFIED**

NOTICE: When government or other drawings, specifications or other data are used for any purpose other than in connection with a definitely related government procurement operation, the U. S. Government thereby incurs no responsibility, nor any obligation whatsoever; and the fact that the Government may have formulated, furnished, or in any way supplied the said drawings, specifications, or other data is not to be regarded by implication or otherwise as in any manner licensing the holder or any other person or corporation, or conveying any rights or permission to manufacture, use or sell any patented invention that may in any way be related thereto.

CATALOGED BY AS 114  
AS AD NO. 274377

Cruft Laboratory

---

Harvard University - Cambridge, Massachusetts

AFCRL-62-89

371000

21600

**LINEAR ARRAYS:  
CURRENTS, IMPEDANCES, AND FIELDS, III**

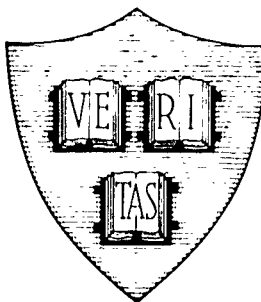

By

Ronold W. P. King and Sheldon S. Sandler

January 25, 1962

Scientific Report No. 12 (Series 2)

Contract AF 19 (604) - 4118      Project 5635, Task 56351

Prepared for

---

Electronics Research Directorate  
Air Force Cambridge Research Laboratories  
Office of Aerospace Research  
United States Air Force - Bedford, Massachusetts

AFCRL-62-89

LINEAR ARRAYS: CURRENTS, IMPEDANCES, AND FIELDS, III

by

Ronold W. P. King and Sheldon S. Sandler

Department of Engineering and Applied Physics  
Gordon McKay Laboratory  
Harvard University  
Cambridge, Massachusetts

Scientific Report No. 12 (Series 2)

Contract AF19(604)-4118

Project 5635 - Task 56351

January 25, 1962

Prepared for

Electronics Research Directorate  
Air Force Cambridge Research Laboratories  
Office of Aerospace Research  
United States Air Force  
Bedford, Massachusetts

Requests for additional copies by Agencies of the Department of Defense, their contractors, and other Government agencies should be directed to the:

ARMED SERVICES TECHNICAL INFORMATION AGENCY  
ARLINGTON HALL STATION  
ARLINGTON 12, VIRGINIA

Department of Defense contractors must be established for ASTIA services or have their "need-to-know" certified by the cognizant military agency of their project or contract.

All other persons and other organizations should apply to the:

U. S. DEPARTMENT OF COMMERCE  
OFFICE OF TECHNICAL SERVICES  
WASHINGTON 25, D. C.

SR12

LINEAR ARRAYS: CURRENTS, IMPEDANCES, AND FIELDS, III

by

Ronold W. P. King and Sheldon S. Sandler  
Gordon McKay Laboratory of Applied Science  
Harvard University  
Cambridge, Massachusetts

ABSTRACT

Further results are given for the curtain array with three-quarter and one-half wavelength elements. Since the general solution assumes an indeterminate form, a special solution is given for arrays with half-wavelength elements. This special solution is obtained from the original Hallén integral equation. Calculations are given for two three-element endfire arrays, for three-quarter and one-half wavelength elements and the base currents specified. The distortion in the distribution of current across the array decreases as the elements approach one-half wavelength. The new quasi zeroth-order theory shows that the conventional assumption of identical current distributions is justified only for the case of half-wavelength elements.

The new array solution is extended to arrays with elements of unequal length. This extension follows from the modification of representations for the coupling terms which appear in the integral equation. Two separate cases are considered: all elements driven by slice generators, and arrays with at least one parasitic element. Numerical calculations of the two-element parasitic couplet confirm the well-known phenomenon that the main radiation beam may be directed by adjusting the length of the parasitic element.

The solution for the array with elements of unequal length is extended to the Yagi array. This solution reduces to a simple form. Numerical results are presented for a representative three-element Yagi array.

6. THE PARTICULAR SOLUTION FOR CURTAIN ARRAYS  
WITH HALF-WAVELENGTH ELEMENTS

The general functional form of the element currents given in 2:52 presents some difficulties for the case  $\beta h = \frac{\pi}{2}$ . A similar difficulty was encountered by King [1, p.S449] for circular arrays. For both circular and curtain arrays the zeroth-order expression for the element current assumes the indeterminate form 0/0 when  $\beta h = \frac{\pi}{2}$ . This indeterminate form for the curtain array case is easily demonstrated by examining 2:52 given by

$$\left\{ I_z(z) \right\} = j \frac{2\pi}{\int_0^h F_0(h) \Psi_{dr}} \left\{ V_0 \right\} \sin \beta(h - |z|) + j \frac{2\pi}{\int_0^h F_0(h) \Psi_{dr}} [\Phi_u]^{-1} [\Phi_v] \left\{ V_0 \right\} (\cos \beta z - \cos \beta h) \quad 6:1$$

From the form of the  $\Psi$  functions at  $\beta h = \frac{\pi}{2}$  it follows that

$$\lim_{\beta h \rightarrow \frac{\pi}{2}} [\Phi_u]^{-1} [\Phi_v] = \lim_{\beta h \rightarrow \frac{\pi}{2}} -[\Psi_{kiu}(h)]^{-1} [\Psi_{kiv}(h)] = -[1] = - \begin{bmatrix} 1 & 0 & 0 & \dots & \dots \\ 0 & 1 & 0 & \dots & \dots \\ \dots & \dots & \dots & \dots & \dots \\ 0 & \dots & \dots & \dots & 1 \end{bmatrix} \quad 6.2$$

The indeterminate form of the element current follows directly, with 6:2 in 6:1, or

$$\left\{ I_z(z) \right\} = j \frac{2\pi \cos \beta z}{\int_0^h \Psi_{dr}} \left\{ V_0 \right\} - j \frac{2\pi \cos \beta z}{\int_0^h \Psi_{dr}} \left\{ V_0 \right\} = \frac{0}{0}, \quad \beta h = \frac{\pi}{2} \quad 6:3$$

The circular array case has been treated by King by differentiating with respect to  $\beta h$  both the numerator and denominator of the one dimensional form of 6:1. This method is too cumbersome for application to the curtain array. For example, this technique requires that each element of the matrix

$[\Phi_u]^{-1}$  be differentiated with respect to  $\beta h$ . A simpler method is presented for the special case  $\beta h = \frac{\pi}{2}$  beginning with the original form of the integral equations given by 2:1, or

$$\begin{aligned} 4\pi\nu_o A_{zk}(z) &= \int_{-h}^h \sum_{i=1}^N I_{zi}(z') K_{ki}(z, z') dz' \\ &= -j \int_{\xi_o}^{\xi_o} \frac{4\pi}{\xi_o} (C_k \cos \beta z + \frac{1}{2} V_{ok} \sin \beta |z|) \end{aligned} \quad 6:4$$

where

$$K_{ki}(z, z') = \frac{e^{-j\beta R_{ki}}}{R_{ki}}, \quad R_{ki} = \sqrt{(z_k - z'_i)^2 + b_{ki}^2} \quad 6:5$$

With  $\beta h = \frac{\pi}{2}$  the vector potential at  $z = h$  is given by 6:4, or

$$4\pi\nu_o A_{zk}(h) = \int_{-h}^h \sum_{i=1}^N I_{zi}(z') K_{ki}(h, z') dz' = -j \int_{\xi_o}^{\xi_o} \frac{4\pi}{\xi_o} (0 + \frac{1}{2} V_{ok}) \quad 6:6$$

The integral equation for the vector potential difference  $W_{zk}(z) = A_{zk}(z) - A_{zk}(h)$  is obtained by subtracting 6:6 from 6:4. This vector potential difference vanishes at  $z = h$  along with the current. The rearranged integral equation is given by

$$\begin{aligned} 4\pi\nu_o W_{zk}(z) &= \int_{-h}^h \sum_{i=1}^N I_{zi}(z') K_{kid}(z, z') dz' \\ &= -j \int_{\xi_o}^{\xi_o} \frac{2\pi}{\xi_o} V_{ok} \left( \frac{2C_k}{V_{ok}} \cos \beta z + \sin \beta |z| - 1 \right) \end{aligned} \quad 6:7$$

where

$$K_{kid}(z, z') = \frac{e^{-j\beta R_{ki}}}{R_{ki}} - \frac{e^{-j\beta R_{kih}}}{R_{kih}} \quad 6:8$$

Note that the form of the right-hand side of 6:7 suggests the leading terms for the current given by King [1, p.S449]. In the general curtain array case the integrals in the rearranged equation 2:6 were separated into two groups depending on the way their leading terms vary as a function of  $z$ . The same separation principle is applied to the special case  $\beta h = \frac{\pi}{2}$ , with one group varying approximately as does  $M_z^h = \sin\beta|z| - 1$ , and the other group as does  $F_z = \cos\beta z$ . The functional forms of the integrals given in 2:12 - 2:14 with 2:10 - 2:11 are applicable to 6:7. The current in each element is separated into two parts in the form

$$I_{zi}(z) = I_{ui}(z) + I_{vi}(z) \quad 6:9$$

where by definition the leading term of the two parts of 6:9 have the forms

$$I_{vi}(z) \sim M_{oz}^h ; \quad I_{ui}(z) \sim F_{oz} \quad 6:10$$

where

$$M_{oz}^h = \sin\beta|z| - 1 ; \quad F_{oz} = \cos\beta z$$

When 6:10 is substituted in 6:7 the integrals that occur may be expressed as follows for all  $k$  and in the range 1 to  $N$ .

$$\int_{-h}^h I_{ui}(z) K_{kid}(z, z') dz' = \Psi_{kidu} I_{ui}(z) - D_{kidu}^h(z) \quad 6:11$$

$$\int_{-h}^h I_{vi}(z) K_{kid}(z, z') dz' = \left(-j \frac{A_i}{B_k}\right) \Psi_{kidv}^h I_{uk}(z) - D_{kidv}^h(z); \quad \beta b_k \geq 1 \quad 6:12$$

$$\int_{-h}^h I_{vi}(z) K_{kidR}(z, z') dz' = \Psi_{kidR}^h I_{vi}(z) - D_{kidR}^h(z); \quad \beta b_{ki} < 1 \quad 6:13$$

$$\int_{-h}^h I_{vi}(z) K_{kidI}(z, z') dz' = \left(-j \frac{A_i}{B_k}\right) \Psi_{kidI}^h I_{uk}(z) - D_{kidI}^h(z); \quad \beta b_{ki} < 1 \quad 6:14$$

As in the general case, it is assumed that the  $\Psi_{ki}^h$  functions are defined such that the differences  $D_{ki}^h(z)$  are small enough that they may be neglected in a solution of quasi-zeroth order. When 6:11 - 6:14 are substituted in 6:7 with only the leading terms retained and the analysis restricted to the case where  $\beta b_{ki} > 1$ ,  $k \neq i$  (cf. 2:21 et seq.), then the following separation into the two groups of equations may be carried out:

$$I_{vk}(z) = -j \frac{2\pi}{\int_0^h \Psi_{dR}^h} V_{oK} M_z^h \quad 6:15$$

$$\sum_{i=1}^N \left\{ \Psi_{kiu}^h + \left(-j \frac{A_i}{B_k}\right) \left[ \Psi_{kidv}^h (1 - \delta_{ik}) + j \Psi_{kidI}^h \delta_{ik} \right] \right\} I_{uk}(z) = -j \frac{4\pi}{\int_0^h} C_k F_z \quad 6:16$$

where

$$\Psi_{dR}^h \equiv \Psi_{kidR}^h \delta_{ik} \quad 6:17$$

For the case  $\beta h = \frac{\pi}{2}$  it follows directly from 6:15 that the leading term in  $I_{vk}(z)$  is always  $M_z^h$  for each value of  $k$ . Similarly, it follows directly from 6:16 that the leading term in  $I_{uk}(z)$  is of the form  $F_z$ . The components of the element current must then be of the form

$$I_{vi}(z) = -j A_i M_z^h, \quad I_{ui}(z) = B_i F_z \quad 6:18$$

or

$$I_{zi}(z) = -jA_i M_z^h + B_i F_z \quad . \quad 6:19$$

Since  $\Psi_{dR}^h$  is real, then from 6:15 it follows that  $A_i$  is real when  $V_{ok}$  is real and from 6:16 that  $B_i \equiv B_{iR} + jB_{iI}$  is complex.

The form of the constant  $C_k$  is given by setting  $z = 0$  in 6:4, or

$$C_k = j \frac{\mathcal{L}_0}{4\pi} \int_{-h}^h \sum_{i=1}^N I_{zi}(z') K_{ki}(0, z') dz' \quad . \quad 6:20$$

The constant  $C_k$  in 6:20 is obtained readily by substituting 6:19 in 6:20 with the result

$$C_k = j \frac{\mathcal{L}_0}{4\pi} \sum_{i=1}^N \left[ -jA_i \Psi_{kiv}^h(0) + B_i \Psi_{kiu}^h(0) \right] \quad 6:21$$

where

$$\Psi_{kiv}^h(0) = \int_{-h}^h M_{z'i}^h K_{ki}(0, z') dz' \quad 6:22$$

$$\Psi_{kiu}^h(0) = \int_{-h}^h F_{z'i} K_{ki}(0, z') dz' \quad . \quad 6:23$$

If 6:21, 6:18 and 6:19 are substituted in 6:15, 6:16 the result in matrix form (cf. 2:34 et seq.) is

$$[ \Phi_u ] \{ B \} = [ \Phi_v^h ] \{ -jA \} \quad 6:24$$

and

$$A_k = \frac{2\pi}{\int_0 \Psi^h dR} V_{ok} \quad 6:25$$

where

$$\Phi_{kiv}^h = \Psi_{kiv}^h (1 - \delta_{ik}) + j \Psi_{kiv}^h \delta_{ik} - \Psi_{kiv}^h(0) \quad 6:26$$

and

$$\Phi_{kidu} = -\Psi_{kidu} + \Psi_{kiu}(0) \quad 6:27$$

Also

$$[\Phi_u] = \begin{bmatrix} \Phi_{11u} & \Phi_{12u} & \dots & \Phi_{1Nu} \\ \Phi_{21u} & \Phi_{22u} & \dots & \Phi_{2Nu} \\ \dots & \dots & \dots & \dots \\ \Phi_{N1u} & \Phi_{N2u} & \dots & \Phi_{NNu} \end{bmatrix} \quad 6:28$$

and

$$[\Phi_v^h] = \begin{bmatrix} \Phi_{11v}^h & \Phi_{12v}^h & \dots & \Phi_{1Nv}^h \\ \Phi_{21v}^h & \Phi_{22v}^h & \dots & \Phi_{2Nv}^h \\ \dots & \dots & \dots & \dots \\ \Phi_{N1v}^h & \Phi_{N2v}^h & \dots & \Phi_{NNv}^h \end{bmatrix} \quad 6:29$$

The  $\Psi$  functions are given by 6:11 - 6:14 and 6:22, 6:23, or

$$\Psi_{dR}^h = -\text{Re} \left\{ \left[ S_b(h, 0) - E_b(h, 0) \right] - \left[ S_b(h, h) - E_b(h, h) \right] \right\} \quad 6:30$$

$$\Psi_{kidI}^h = \text{Im} \left\{ \left[ S_b(h, 0) - E_b(h, 0) \right] - \left[ S_b(h, h) - E_b(h, h) \right] \right\} \quad 6:31$$

$$\Psi_{kidv}^h = \left[ S_b(h, 0) - E_b(h, 0) \right] - \left[ S_b(h, h) - E_b(h, h) \right] \quad 6:32$$

$$\Psi_{kidu}^h = C_b(h, 0) - C_b(h, h), \quad \beta h = \frac{\pi}{2} \quad 6:33$$

$$\Psi_{kiv}^h(0) = S_b(h, 0) - E_b(h, 0) \quad 6:34$$

$$\Psi_{kiu}^h(0) = C_b(h, 0), \quad b \equiv b_{ki} \quad 6:35$$

The quasi-zeroth order form for the element current with  $\beta h = \frac{\pi}{2}$  is given by 6:19 with 6:24, 6:25, with the result

$$\left\{ I_z(z) \right\} = -j \frac{2\pi}{\oint_0 \Psi_{dR}^h} \left\{ V_0 \right\} (\sin \beta |z| - 1) - j \frac{2\pi}{\oint_0 \Psi_{dR}^h} [\Phi_u]^{-1} [\Phi_v^h] \left\{ V_0 \right\} \cos \beta z \quad 6:36$$

The coefficients in 6:36 differ from those given by King [1, p.S449] for the circular array. A numerical comparison will be given for the isolated element with  $\Omega = 10$ . The values of the  $\Psi$  functions for this case are given by 6:30 - 6:35, and it follows from Mack [2] that

$$\Psi_{dR}^h = 6.9087 \quad 6:37$$

$$\Psi_{11dI}^h = 0.3842 \quad 6:38$$

$$\Psi_{11du} = 7.6637 - j0.6331 \quad 6:39$$

$$\Psi_{11v}^h(0) = -7.0754 + j1.0932 \quad 6:40$$

$$\Psi_{11u}^h(0) = 8.3517 - j1.8518 \quad 6:41$$

The above values are substituted in 6:36 to give the quasi zeroth-order current, or

$$I_z(z) = V_o \left\{ 10.0020 \cos \beta z - j \left[ 7.0607 \cos \beta z + 2.4124 (\sin \beta |z| - 1) \right] \right\} \times 10^{-3} \quad 6:42$$

where

$$\Omega = 10, \quad \beta h = \frac{\pi}{2}$$

The comparable result quoted by King [1, p. S450] obtained from the general case is given by

$$[I_z(z)]_o = V_o \left\{ 9.87 \cos \beta z - j \left[ 6.84 \cos \beta z + 2.17 (\sin \beta |z| - 1) \right] \right\} \times 10^{-3} \quad 6:43$$

The input admittance from 6:42 is

$$Y_o = (10.0020 - j4.6480) \times 10^{-3} \text{ mho} \quad 6:44$$

The input admittance from 6:43 is

$$Y_o = (9.87 - j4.67) \times 10^{-3} \text{ mho} \quad . \quad 6:45$$

The second-order theoretical value is

$$Y_o = (9.26 - j4.62) \times 10^{-3} \text{ mho} \quad . \quad 6:46$$

Note that the current distribution 6:42 is in excellent agreement with 6:43 as shown in Fig. 6-1. Also, either current form is in good agreement with the approximate second-order curve given by King [3, p. 116, Fig. 22.9].

The solutions which correspond to Cases I and II are determined readily from 6:24 and 6:25.

Case I.

The N base currents are specified, or

$$I_{zi}(0) = I_{zi}''(0) + jI_{zi}'(0), \quad i = 1, 2, 3, \dots, N \quad . \quad 6:47$$

The N base voltages  $V_{ok}$  are required which maintain these base currents. From 6:19 it follows that at  $z = 0$

$$I_{zi}'(0) = B_{iR} + j(B_{iI} + A_i), \quad \beta h = \frac{\pi}{2} \quad 6:48$$

or

$$I_{zi}''(0) = B_{iR} \quad 6:49$$

$$I_{zi}'(0) = B_{iI} + A_i \quad . \quad 6:50$$

With 6:25 in 6:24 together with 6:49 and 6:50, the driving voltages are given by

$$\left\{ V_o \right\} = \left[ j \frac{2\pi}{\sum_o \Psi_{dR}^h} [\Phi_u] - j \frac{2\pi}{\sum_o \Psi_{dR}^h} [\Phi_v^h] \right]^{-1} [\Phi_u] \left\{ I_z(0) \right\} \quad . \quad 6:51$$

The quasi zeroth-order element current is given by 6:19 with the A coefficient given by 6:25 and the B coefficient given by 6:49 and 6:50 with 6:25.

Case II.

The N base potentials  $V_{ok}$ ,  $k = 1, 2, 3, \dots, N$  are specified, and the values of the base currents  $I_z(0)$  are easily determined from 6:36, with the result

$$\left\{ I_z(0) \right\} = j \frac{2\pi}{\sum_o \Psi_{dR}^h} \left\{ V_o \right\} - j \frac{2\pi}{\sum_o \Psi_{dR}^h} [\Phi_v^h]^{-1} [\Phi_v^h] \left\{ V_o \right\} \quad . \quad 6:52$$

The analysis of the three-element endfire array with quarter-wave spacing,  $\beta h = \frac{\pi}{2}$ ,  $\Omega = 10$ , and specified base currents follows from the results for Case I above. The analysis parallels that given in Chapter 3 for a similar array with  $\beta h = \pi$ . It is expected that the present results will reduce approximately to the conventional case where the distributions are identical. This equivalence is inferred from the similar functional form of  $M_z^h$  and  $F_z$  and the small magnitude of the ratio  $(A_i/B_i)$  for the isolated element. The computations for the driving-point admittances and element currents are given in Appendix VI, and summarized below.

The driving-point admittances are given by VI:13, or

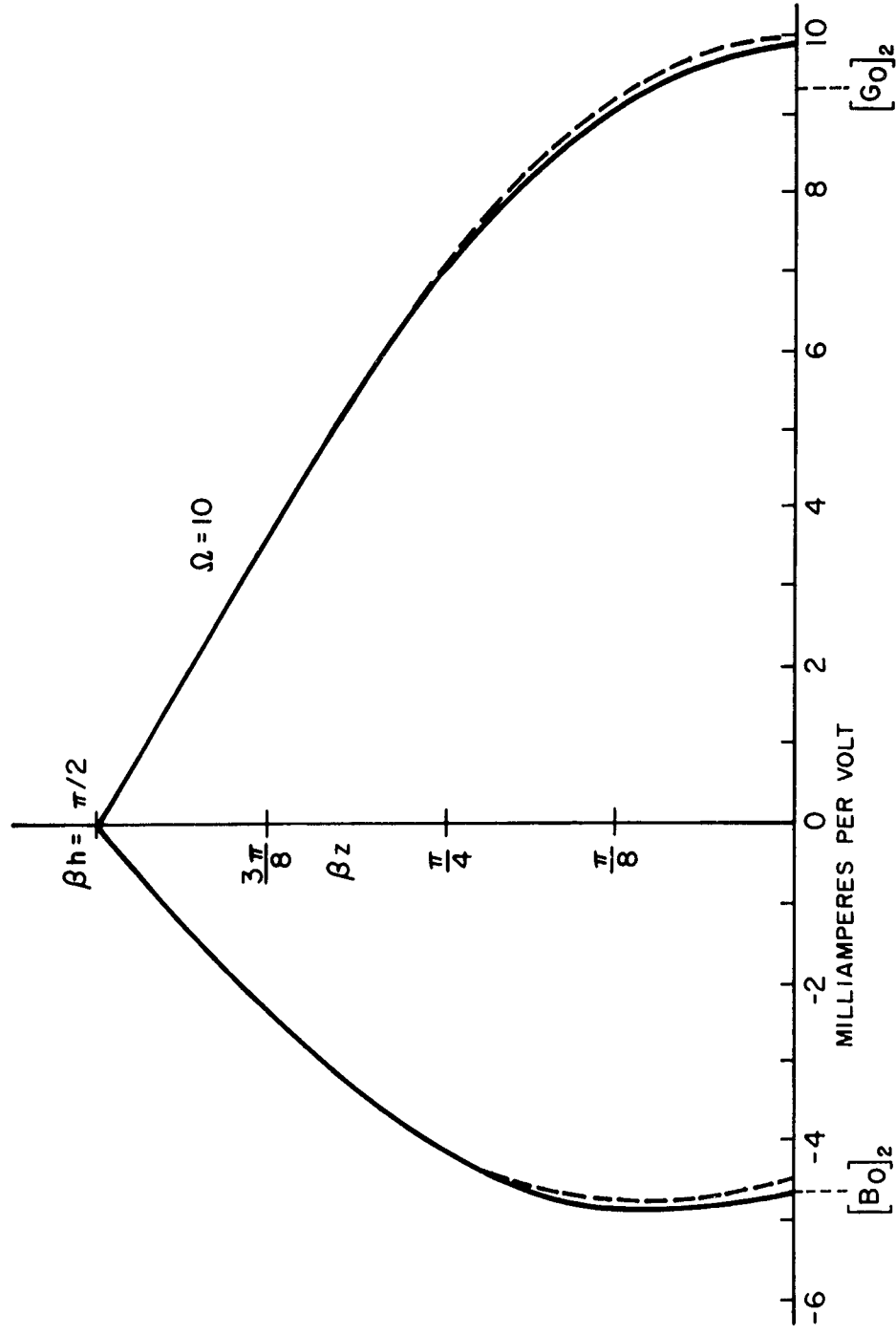

FIG. 6-1 QUASI ZEROth ORDER ELEMENT CURRENT FOR  $\beta h = \pi/2$ ,  $\Omega = 10$

$$Y_{01} = (13.01 - j4.963) \times 10^{-3} \text{ mho}$$

$$Y_{02} = (9.393 - j4.939) \times 10^{-3} \text{ mho} \quad . \quad 6:53$$

$$Y_{03} = (4.322 - j3.560) \times 10^{-3} \text{ mho}$$

The three-element currents are given with respect to the individual driving voltages in VI:14 and with respect to  $V_{02}$  in VI:16. They are

$$I_{z1}(z) = 10^{-3} V_{01} \left\{ 13.01 \cos \beta z - j \left[ 7.375 \cos \beta z + 2.4124 (\sin \beta z - 1) \right] \right\}$$

$$I_{z2}(z) = 10^{-3} V_{02} \left\{ 9.393 \cos \beta z - j \left[ 7.351 \cos \beta z + 2.4124 (\sin \beta z - 1) \right] \right\} \quad 6:54$$

$$I_{z3}(z) = 10^{-3} V_{03} \left\{ 4.322 \cos \beta z - j \left[ 5.972 \cos \beta z + 2.4124 (\sin \beta z - 1) \right] \right\}$$

$$I_{z1}(z) = 10^{-3} V_{02} \left\{ \left[ 1.826 (\sin \beta z - 1) + 6.765 \cos \beta z \right] - j \left[ 0.2193 (\sin \beta z - 1) - 9.177 \cos \beta z \right] \right\}$$

$$I_{z2}(z) = 10^{-3} V_{02} \left\{ \begin{array}{l} 9.393 \cos \beta z - j \left[ 2.4124 (\sin \beta z - 1) + 7.351 \cos \beta z \right] \end{array} \right\}$$

$$I_{z3}(z) = 10^{-3} V_{02} \left\{ \begin{array}{l} -4.4759 (\sin \beta z - 1) - 9.412 \cos \beta z - j \left[ 0.9309 (\sin \beta z - 1) + 10.32 \cos \beta z \right] \end{array} \right\} \quad 6:55$$

The element currents 6:54 and 6:55 are shown in Fig. 6-2. The element currents, with respect to the individual driving voltages, decrease in both the real and imaginary parts from element one to element three. This is the effect due to the interaction between the individual element currents in the array. Note that the general shape of both parts of the element current are similar in all three elements since  $M_z^h$  and  $F_z$  both have maxima at  $z = 0$  and decrease with increasing  $z$ . When the element currents are drawn with respect to  $V_{02}$ , the distribution of the current on all three elements is almost identical. Hence, the quasi zeroth-order result is almost identical to the conventional result for this special case.

## 7. EXAMPLES OF THE GENERAL THEORY:

THE INTERMEDIATE CASE, THE THREE-ELEMENT ENDFIRE ARRAY  
WITH  $\beta h = \frac{3\pi}{4}$ , AND QUARTER-WAVELENGTH SPACING

The three-element array with  $\beta h = \pi$  has been covered in the preceding sections. When the base currents are specified for this array, the shifted cosine currents are automatically determined. However, since the sinusoidal component of the element current is zero at the driving point, it is not affected by the specification of the base current on each element. The situation is somewhat different for a similar array with  $\beta h = \frac{3\pi}{4}$ , since both the sinusoidal and shifted cosinusoidal components of the element contribute to the base current. The general analysis for this case follows a similar presentation for the full wavelength array.

The relationship between the specified base currents and the driving voltages is given by 2:50. The numerical calculations are carried out in Appendix VII, and the results for the array having quarter-wavelength spacing,  $\Omega = 10$ , and the main beam in the endfire position, are summarized below.

The driving-point impedances and admittances are

$$\begin{aligned} Z_{01} &= 357.6 + j293.7 \text{ ohms} , & Y_{01} &= (1.6706 - j1.3744) \times 10^{-3} \text{ mho} \\ Z_{02} &= 374.3 + j402.0 \text{ ohms} , & Y_{02} &= (1.3324 - j1.2402) \times 10^{-3} \text{ mho} \quad 7:1 \\ Z_{03} &= 546.8 + j488.5 \text{ ohms} , & Y_{03} &= (1.0183 - j0.9198) \times 10^{-3} \text{ mho} . \end{aligned}$$

The element currents are given with respect to the individual driving voltages from VII:13, or

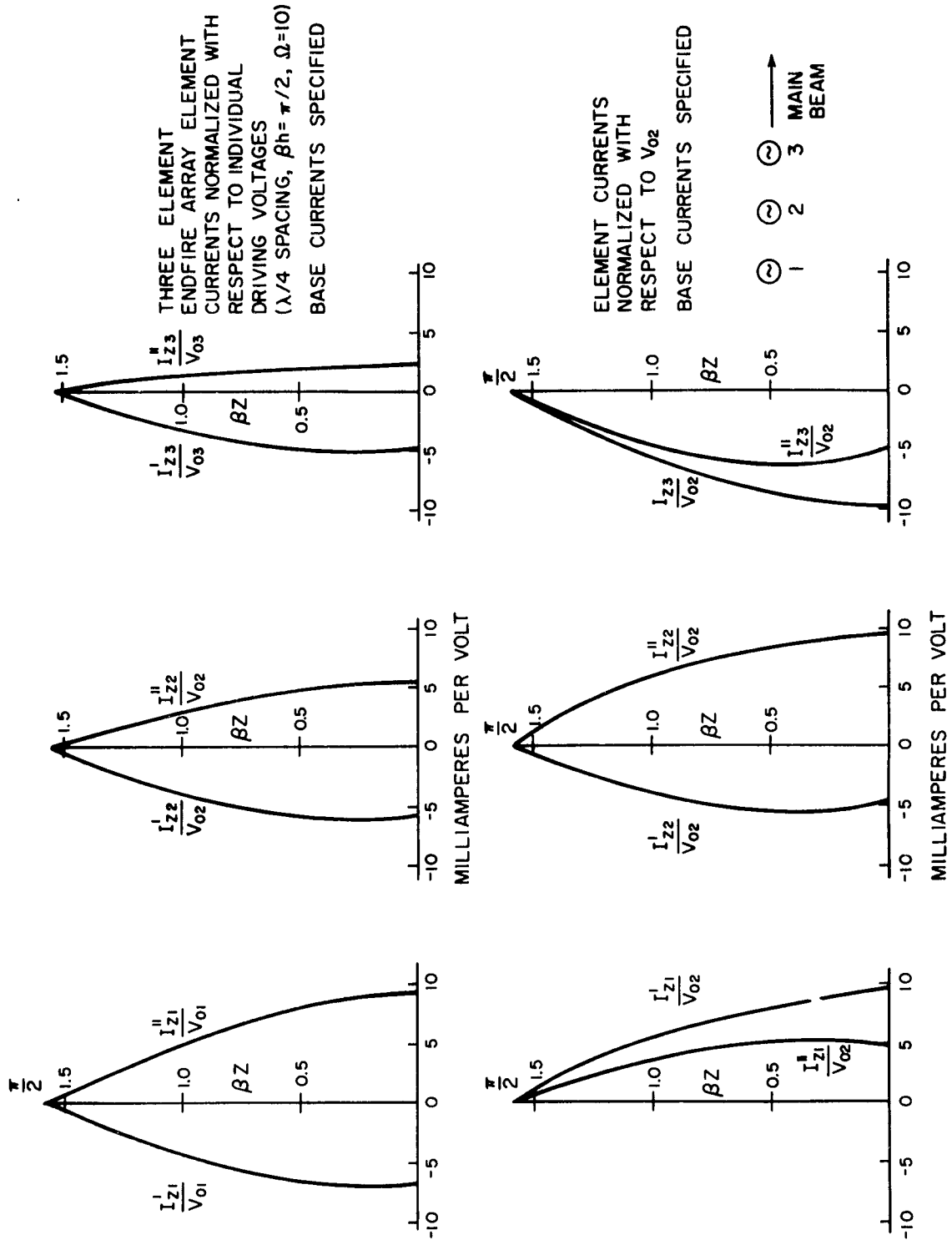

FIGURE 6-2

$$I_{z1}(z) = V_{01} [0.9786F_{oz} - j(3.3219M_{oz} - 0.5708F_{oz})] \times 10^{-3}$$

$$I_{z2}(z) = V_{02} [0.7805F_{oz} - j(3.3219M_{oz} - 0.6495F_{oz})] \times 10^{-3} \quad 7:2$$

$$I_{z3}(z) = V_{03} [0.5965F_{oz} - j(3.3219M_{oz} - 0.8371F_{oz})] \times 10^{-3}$$

where

$$M_{oz} = \sin\left(\frac{3\pi}{4} - \beta|z|\right)$$

$$F_{oz} = \cos\beta z - 0.7071$$

7:3

The element currents are given with respect to  $V_{02}$  from VII:16, or

$$I_{z1}(z) = V_{02} [2.7618M_{oz} - 0.3669F_{oz} - j(0.3704M_{oz} - 0.8798F_{oz})] \times 10^{-3}$$

$$I_{z2}(z) = V_{02} [0.7805F_{oz} - j(3.3219M_{oz} - 0.6495F_{oz})] \times 10^{-3} \quad 7:4$$

$$I_{z3}(z) = V_{02} [-4.3902M_{oz} + 1.0378F_{oz} + j(0.3818M_{oz} - 0.8844F_{oz})] \times 10^{-3}$$

The above results are easily interpreted by investigating the behavior of the two components of the element current,  $F_{oz}$  and  $M_{oz}$ . From 7:2 note that the real part of  $F_{oz}$  decreases and the imaginary part increases from element one to element three. This result is identical to the result for the same array with  $\beta h = \pi$  (cf. 3:26 - 3:28). As before, the  $M_{oz}$  component of the element current is proportional to the driving voltage. Note that in 7:2 the imaginary part of the element current will have a decreasing amplitude at  $z = 0$  from element one to element three, since the  $M_{oz}$  component is larger than the  $F_{oz}$  component. This fact explains the difference between the variation of the admittances for the case  $\beta h = \pi$  in 3:20 - 3:22 and the

results in 7:1. That is, the imaginary part of the admittance decreases for this case instead of increasing as in the case  $\beta h = \pi$ .

The element currents are drawn with respect to the individual driving voltages in Fig. 7-1a. There is a mild decrease in the real and imaginary parts of the element current from element one to element three. To compensate for this effect the driving voltages must increase from element one to element three. This increase will affect the sinusoidal current component, since it is directly proportional to the driving voltage. The shifted cosine component of the current will also be affected. However, since this component is small compared to the sinusoidal component, it will not be as effective in changing the current distributions from element to element. The change in the element distributions for the case of specified base currents is shown in Fig. 7-1b, where the currents are all drawn with respect to  $V_{02}$ . Note that the variation in the current distributions across the array are not as drastic as those given for the same array with  $\beta h = \pi$  (cf. Fig. 3-3).

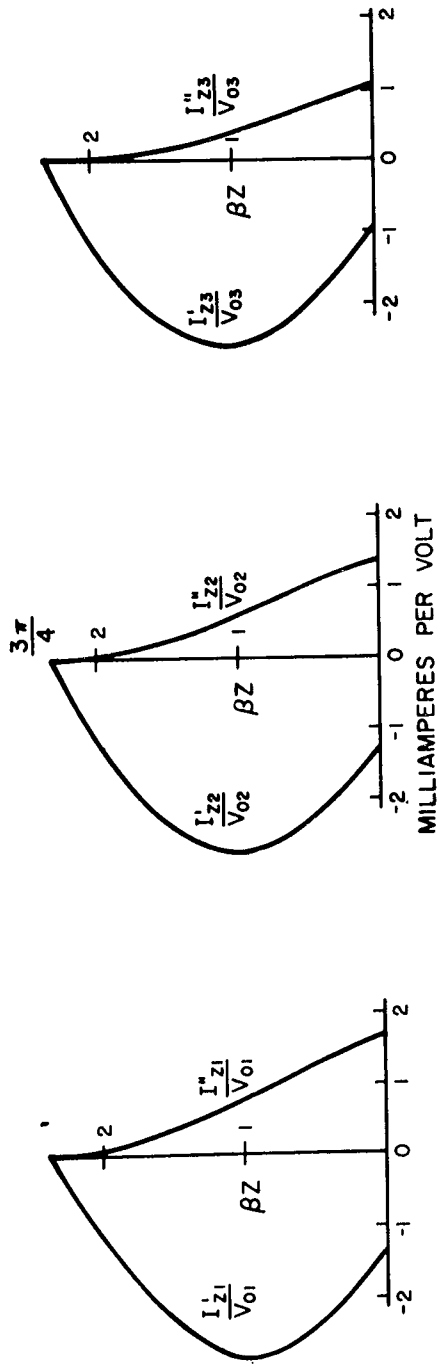

(a) ELEMENT CURRENTS DRAWN WITH RESPECT TO INDIVIDUAL DRIVING VOLTAGES.

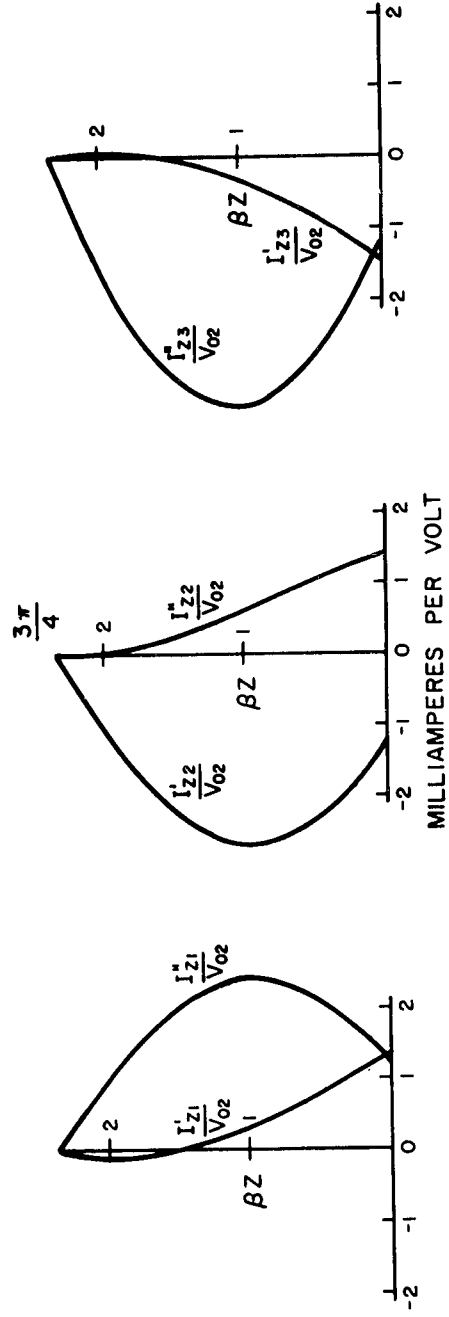

(b) ELEMENT CURRENTS DRAWN WITH RESPECT TO  $V_{02}$ .

FIG. 7-1 THREE ELEMENT ENDFIRE ARRAY BASE CURRENTS SPECIFIED  
 ( $\beta h = \frac{3\pi}{4}$ ,  $\Omega = 10$ ,  $\frac{\lambda}{4}$  SPACING)

## 8. CURTAIN ARRAYS WITH ELEMENTS OF UNEQUAL LENGTH; THE TWO-ELEMENT COUPLET

The problem of determining the driving-point impedance for two elements of arbitrary length and spacing has been carried out by many authors under the conventional assumption of a sinusoidal distribution on each element. A history of this problem will be found in a 1951 article by Chaney [1]. Since the problem of two skew antennas in space leads to many mathematical and experimental difficulties, this discussion will be limited to parallel elements with both elements driven. The solution of this configuration leads not only to the parasitic couplet, but to the practically important case of the Yagi array. The couplet with elements of unequal length is shown in Fig. 8-1 for elements with half lengths  $h_1$  and  $h_2$  separated by a center to center distance of  $b_{12}$ . With the aid of suitable trigonometric approximations, the quasi zeroth-order solution obtained for the curtain array may be extended to include the case of elements of unequal length.

The two integral equations for the currents  $I_{z1}(z_1)$  and  $I_{z2}(z_2)$  in the elements of the array shown in Fig. 8-1 are formally written down from 2:6 with the result

$$\int_{-h}^h I_{z1}(z'_1) K_{11d}(z_1, z'_1) dz'_1 + \int_{-h}^h I_{z2}(z'_2) K_{12d}(z_1, z'_2) dz'_2 = j \frac{4\pi}{\xi_0 F_0(h_1)} (U_{1F_{oz1}} + \frac{1}{2} V_{01} M_{oz1}) \quad 8:1$$

$$-\int_{-h}^h I_{z1}(z'_1) K_{12d}(z_2, z'_1) dz'_1 + \int_{-h}^h I_{z2}(z'_2) K_{22d}(z_2, z'_2) dz'_2 = j \frac{4\pi}{\xi_0 F_0(h_2)} (U_{2F_{oz2}} + \frac{1}{2} V_{02} M_{oz2}) \quad 8:2$$

$$U_k = \sum_{i=1}^2 U_{ki} = \sum_{i=1}^2 -j \frac{\xi_0}{4\pi} \int_{-h_i}^{h_i} I_{zi}(z'_i) K_{ki}(h_k, z'_i) dz'_i \quad 8:3$$

$$F_{\text{Ozi}} = F_{\text{O}}(z_i) - F_{\text{O}}(h_i) = \cos \beta z_i - \cos \beta h_i \quad 8:4$$

$$M_{\text{Ozi}} = F_{\text{O}}(z_i)G_{\text{O}}(h_i) - G_{\text{O}}(h_i)F_{\text{O}}(h_i) = \sin \beta(h_i - |z_i|) \quad 8:5$$

For the array with elements of equal length the currents were conveniently separated into two parts,  $I_z(z) = I_v(z) + I_u(z)$ . The leading term of the  $I_v(z)$  distribution was found to be proportional to  $M_{\text{Oz}} = \sin \beta(h - |z|)$ , and the leading term of the  $I_u(z)$  distribution was proportional to  $F_{\text{Oz}} = \cos \beta z - \cos \beta h$ . With simple sinusoidal and cosinusoidal representations for the element currents, the behavior of the vector potential differences that appear on the left-hand side of the integral equations was easily calculated. The vector potential differences were found to vary approximately in one of two possible ways as a function of  $z$ . One group varied as  $M_{\text{Oz}}$ , and the other group varied as  $F_{\text{Oz}}$ . The two forms for the integrals allowed the original integral equation to be separated into two equations, one for each distribution.

The formal solution for the unequal element case parallels the general solution of the equal element case presented in Chapter 2. However, the solution is complicated by the behavior of certain integrals which appear in 8:1 and 8:2. These integrals behave with  $z$  as does a linear combination of  $M_{\text{Oz}}$  and  $F_{\text{Oz}}$ . The behavior of all the integrals on the left-hand side of the integral equations is first investigated.

The behavior of the integrals in 8:1 and 8:2 with kernels  $I_{z1}K_{11d}$  and  $I_{z2}K_{22d}$  corresponding to the isolated element, was investigated in Chapter 2. The integrals with kernels  $I_{z1}K_{12d}$  and  $I_{z2}K_{21d}$  are concerned with the elements of unequal length and must be investigated for all values of  $\beta b$ . A good example that shows the major effects of coupling between two unequal length elements is the half-and-full-wavelength couplet. (N.B. Since present tables

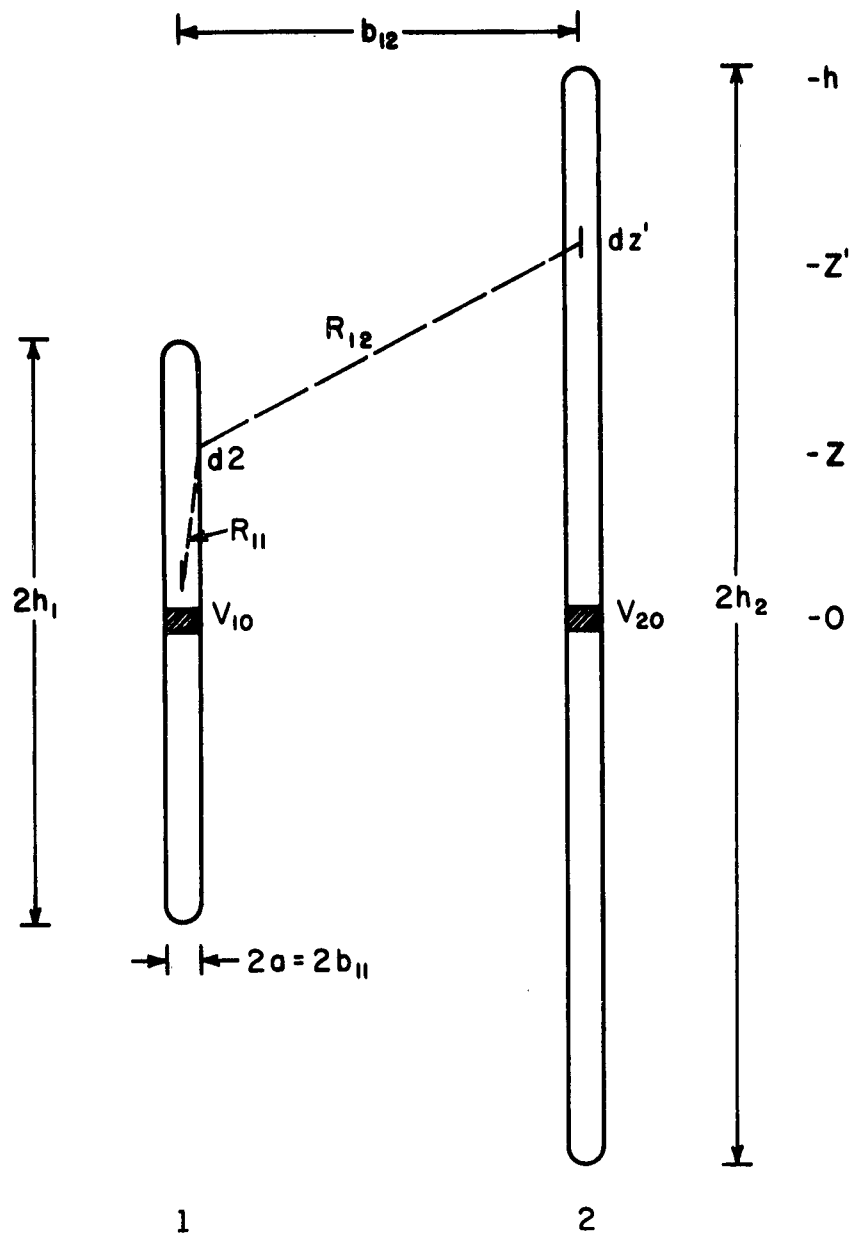

FIG. 8-1 TWO ELEMENT ARRAY WITH ELEMENTS OF UNEQUAL LENGTH.

do not include the values  $h_1 = \lambda/4$  and  $h_2 = \lambda/2$  for all functions, this couplet is approximated in some cases by  $\beta h_1 = 1.6$  and  $\beta h_2 = 3.2$ .) A sinusoidal current is assumed on each element, and the vector potential difference

$W_z(z) = A_z(z) - A_z(h)$  is determined for both  $\beta b$  large and small. Let  $h_1 = \lambda/4$  and  $h_2 = \lambda/2$ ; then the vector potential difference along element one due to a current  $\sin \beta(\frac{\lambda}{2} - |z_2|)$  on element two is given by

$$\int_{-\lambda/2}^{\lambda/2} \sin \beta(\frac{\lambda}{2} - |z_2'|) K_{12d}(z, z_2') dz_2' = S_b(\frac{\lambda}{2}, z_1) - S_b(\frac{\lambda}{2}, \frac{\lambda}{4}) \quad 8:6$$

where

$$0 \leq z_1 \leq \frac{\lambda}{4}, \quad b \equiv b_{ki} \quad 8:7$$

Both the real and imaginary parts of 8:6 are shown in Fig. 8-2. Note that small values of  $\beta b$  are not included, since the behavior of 8:6 for this range is discussed in Chapter 2. Fig. 8-2 shows that 8:6 varies approximately as does  $F_{oz1}$  for  $\beta b \geq 1$  in both the real and imaginary parts. Hence, a simple trigonometric approximation serves for the corresponding integral in 8:1.

The vector potential difference along element two due to a current  $\cos \beta z_1$  on element one is given by

$$\int_{-h_1}^{h_1} \cos \beta z_1 K_{21d}(z_2, z_1') dz_1' = C_b(h_1, z_2) - C_b(h_1, h_2) \quad 8:8$$

where

$$0 \leq \beta z_2 \leq 3.2, \quad \beta h_1 = \frac{\pi}{2} \quad 8:9$$

Tables of the function  $C_b$  are not presently available for the complete range 8:9, and the calculation of 8:8 is based on a representation in terms of more elementary functions [1, p. 77]. The imaginary part of 8:8 is shown in Fig. 8-3 and the real part in Fig. 8-4. The imaginary part of 8:8 behaves like  $F_{oz_2}$  for all values of  $\beta b \geq 1$ . However, the real part has a more complicated behavior for  $\beta b \geq 3.2$ . The reason for this complicated behavior is found in the curvature of the wavefronts near element two. Since at the surface of element two  $z^i I_{z_2}(z) \cong E_z$ , where  $z^i$  is the internal impedance per unit length, some insight into the problem is gained by examining  $E_{z_2}(z_2)$  due to a current  $\cos \beta z$  on element one. The electric field  $E_{z_2}(z_2)$  has been derived by King [2, p. 528] from the scalar and vector potentials, and is given by

$$E_{z_2}(z_2) = -j \frac{I_m \rho_0}{4\pi} \left( \frac{e^{-j\beta R_{1h}}}{R_{1h}} + \frac{e^{-j\beta R_{2h}}}{R_{2h}} \right) \quad 8:10$$

where

$$\beta h_1 = \frac{\pi}{2} \quad 8:11$$

$$R_{1h} = \sqrt{(z_2 - h_1)^2 + b_{12}^2} \quad 8:12$$

$$R_{2h} = \sqrt{(z_2 + h_1)^2 + b_{12}^2} \quad 8:13$$

The magnitude and phase of 8:10 are shown in Fig. 8-5 with respect to the reference value at  $z_2 = 0$ . The  $z$  variation of this magnitude closely resembles that of a shifted cosine for all values of  $\beta b \geq 1.2$ . The phase of  $E_{z_2}$  shows a variation in form as  $\beta b_{12}$  is decreased. For  $\beta b \geq \pi$ , the shape of the phase front is ellipsoidal. When  $\beta b_{12}$  is decreased to  $\beta b_{12} = \pi/2$ , a maximum appears at  $\beta z_2 = \pi/2$ . This distortion is due to the variation in

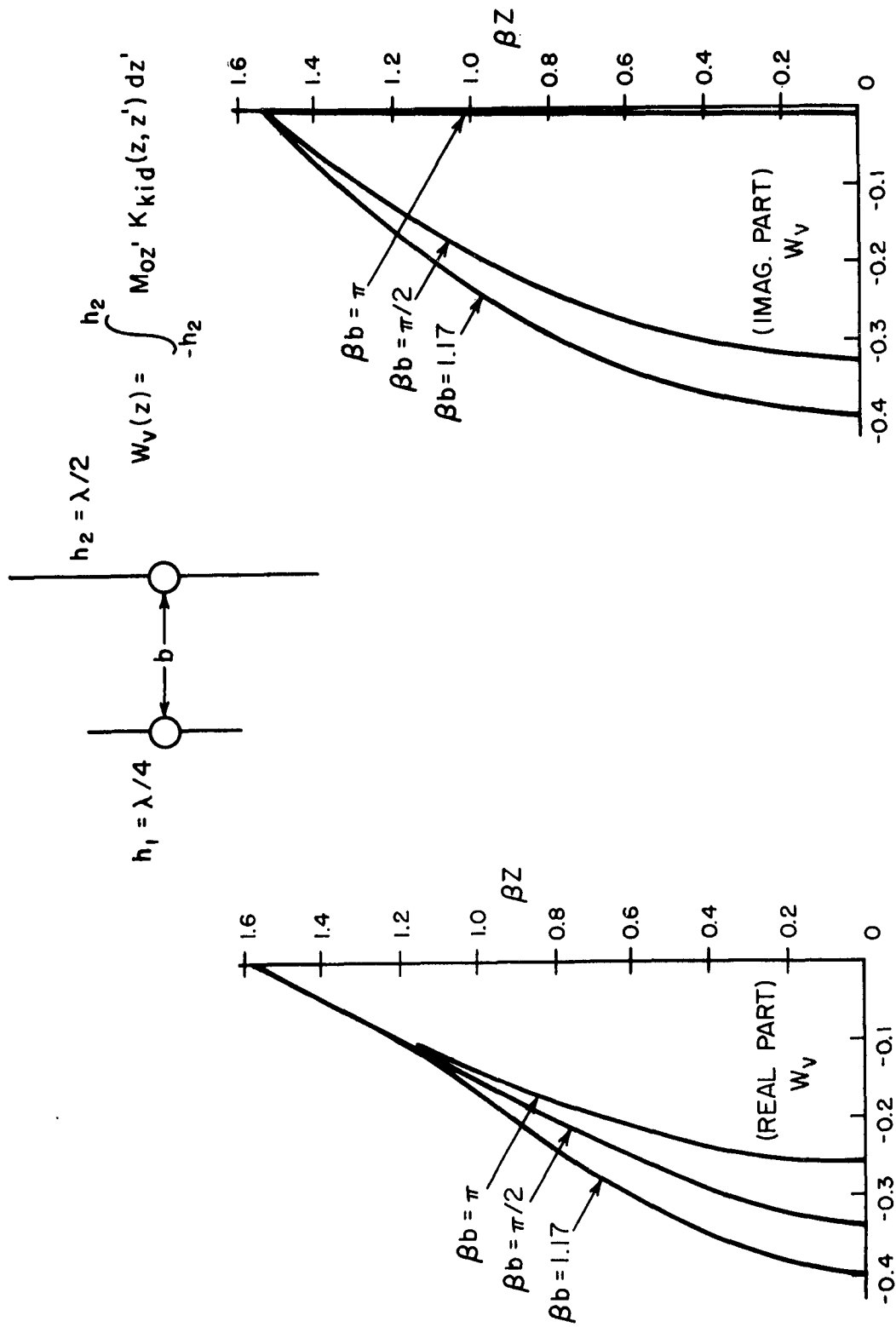

FIG. 8-2 VECTOR POTENTIAL DIFFERENCE ON HALF WAVELENGTH ELEMENT DUE TO SINUSOIDAL CURRENT ON FULL WAVELENGTH ELEMENT.

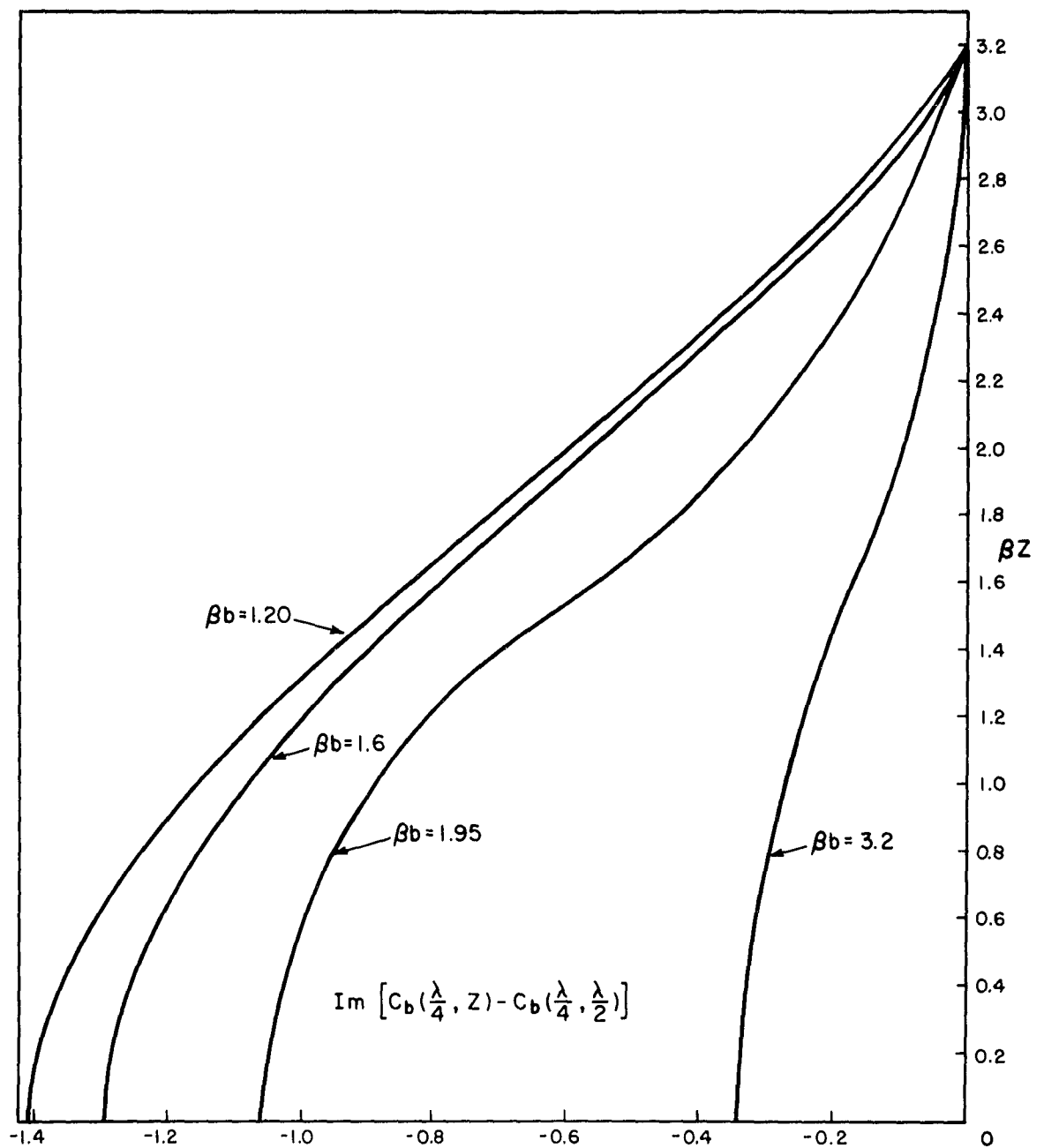

FIG. 8-3 VECTOR POTENTIAL DIFFERENCE ON FULL WAVELENGTH ELEMENT DUE TO HALF WAVELENGTH ELEMENT WITH CURRENT COS.  $\beta Z$  (IMAGINARY PART)

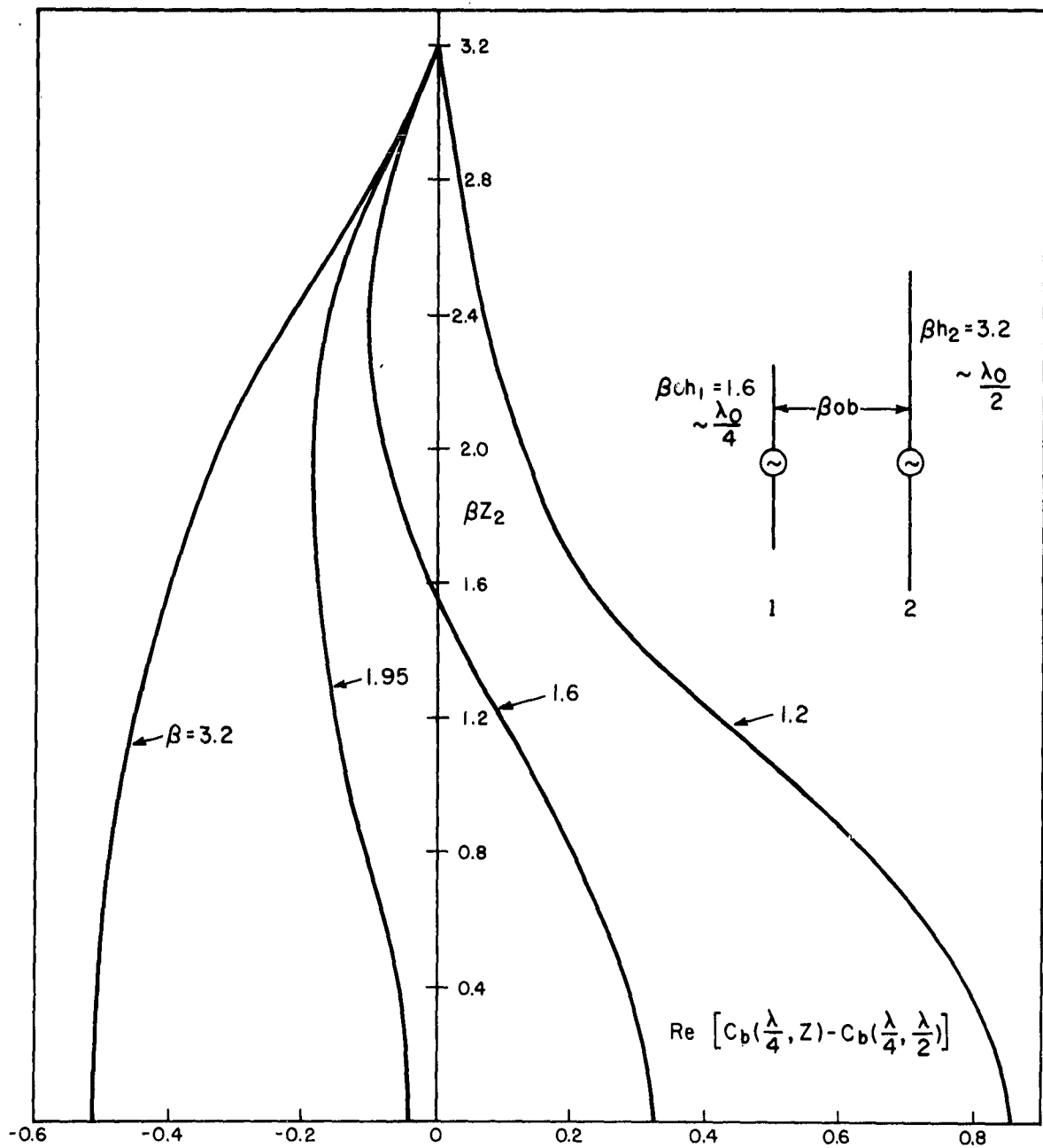
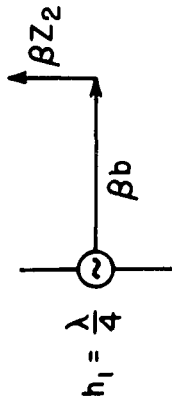

FIG. 8-4 VECTOR POTENTIAL DIFFERENCE ON FULL WAVELENGTH ELEMENT  
 DUE TO HALF WAVELENGTH ELEMENT WITH CURRENT  $\cos. \beta Z$   
 (REAL PART)



$$E_{Z_2}(Z_2) = -j \frac{Im\{Z_0\}}{4\pi} \left( \frac{e^{-j\beta_0 R_{1h}}}{R_{1h}} + \frac{e^{-j\beta_0 R_{2h}}}{R_{2h}} \right)$$

WHERE

$$R_{1h} = \sqrt{(Z_2 - h_1)^2 + b_{12}^2}$$

$$R_{2h} = \sqrt{(Z_2 + h_1)^2 + b_{12}^2}$$

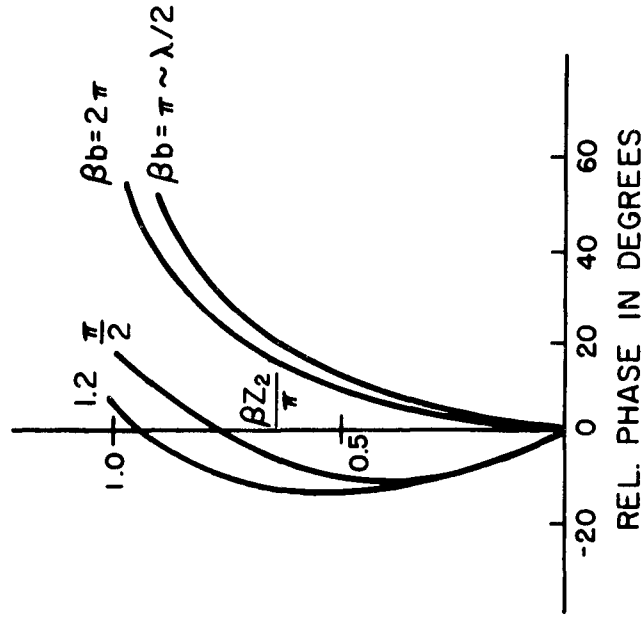
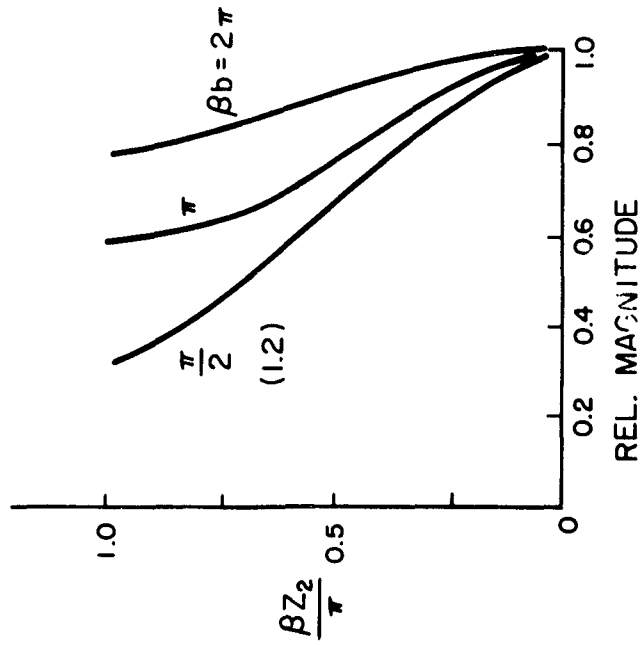

FIG. 8-5 ELECTRIC FIELD ALONG FULL WAVELENGTH ELEMENT DUE TO CURRENT COS.  $\beta Z$  ON HALF WAVELENGTH CURRENT.

phase velocity along the ellipsoidal wavefronts produced by element one. The velocity of propagation is equal to  $v_0 = 3 \times 10^8$  meters per second along the semi-major axis [2, p.540]. However, the velocity of propagation along the semi-minor axis is always greater than or equal to  $v_0$ . For example, with  $\beta h_1 = \pi/2 = \beta b_{12}$  the phase velocity of the wavefront along the semi-major axis is 1.3 times the axial phase velocity. The distortion of the surfaces of constant phase prevents the approximation of the element current  $I_{z_2}(z_2)$  by a single term of form  $T_{oz_2}$ . However, it is possible to approximate 8:8 by a suitable combination of  $M_{oz_2}$  and  $F_{oz_2}$ . Note that for  $\beta b_{12} \geq \pi$  a one term approximation of 8:8 is possible (i.e. in terms of  $F_{oz_2}$ ).

A simple physical explanation serves to demonstrate why it is possible to approximate the vector potential difference 8:8 by a combination of  $M_{oz_2}$  and  $F_{oz_2}$ . Element two is illuminated by a non-linear wave front due to the distributed currents on element one. Crudely, the response of element two must be in terms of its fundamental modes which have sinusoidal and shifted cosinusoidal forms. When  $h_1 = h_2$ , both distributions are present, but the distortion in the illuminating field over the length of the receiving element is small. Hence little of the received power is placed in the sinusoidal mode.

The two term approximation for 8:8 is given by

$$W_u(z_2) = W_u^m \sin \beta(h_2 - |z_2|) + W_u^f (\cos \beta z_2 - \cos \beta h_2) \quad . \quad 8:14$$

The constants  $W_u^m$  and  $W_u^f$  are determined so that a good approximation is given for  $W_u(z_2)$  in 8:14. Although more sophisticated methods are available for the determination of  $W_u^m$  and  $W_u^f$  (e.g. a least mean square fit) a two point approximation for  $W_u(z_2)$  is readily accomplished. Furthermore, the two point approximation includes the true value of  $W_u(0)$ , which is important for the correct value of input power. The functions  $M_{oz_2}$  and  $F_{oz_2}$  have a maximum in the interval  $0 \leq z_2 \leq h_2$ . Hence, the two maximum values

of  $W_u(z_2)$  serve to determine  $W_u^m$  and  $W_u^f$ , or for  $\beta h \geq \pi/2$  it follows that (N.B. For  $\beta h < \pi/2$ ,  $M_{oz_2}$  has a maximum at  $z = 0$ .)

$$W_u(0) = W_u^m \sin \beta h_2 + W_u^f (1 - \cos \beta h_2) \quad 8:15$$

$$W_u(h_2 - \frac{\lambda}{4}) = W_u^m + W_u^f (\sin \beta h_2 - \cos \beta h_2) \quad 8:16$$

Equations 8:15 and 8:16 are solved simultaneously for  $W_u^f$  and  $W_u^m$  with the result

$$W_u^m = \frac{(\sin \beta h_2 - \cos \beta h_2)W_u(0) - (1 - \cos \beta h_2)W_u(h_2 - \frac{\lambda}{4})}{\sin \beta h_2 (\sin \beta h_2 - \cos \beta h_2) - (1 - \cos \beta h_2)} \quad 8:17$$

$$W_u^f = \frac{-W_u(0) + \sin \beta h_2 W_u(h_2 - \frac{\lambda}{4})}{\sin \beta h_2 (\sin \beta h_2 - \cos \beta h_2) - (1 - \cos \beta h_2)} \quad 8:18$$

The excellent agreement between 8:6 and 8:14, with the values given in 8:17 and 8:18, is shown in Fig. 8-6. The approximation 8:14 is quite general, and reduces to the normal one term approximation for 8:6, for  $\beta b_{12} < 1$  and  $\beta b_{12} \geq \pi$ . Before the solution for the original integral equations is obtained, the behavior of the integrals

$$\int_{-h}^h \sin \beta (h - |z'|) K_{kid}(z, z') dz' \quad 8:19$$

and

$$\int_{-h}^h (\cos \beta z - \cos \beta h) K_{kid}(z, z') dz' \quad 8:20$$

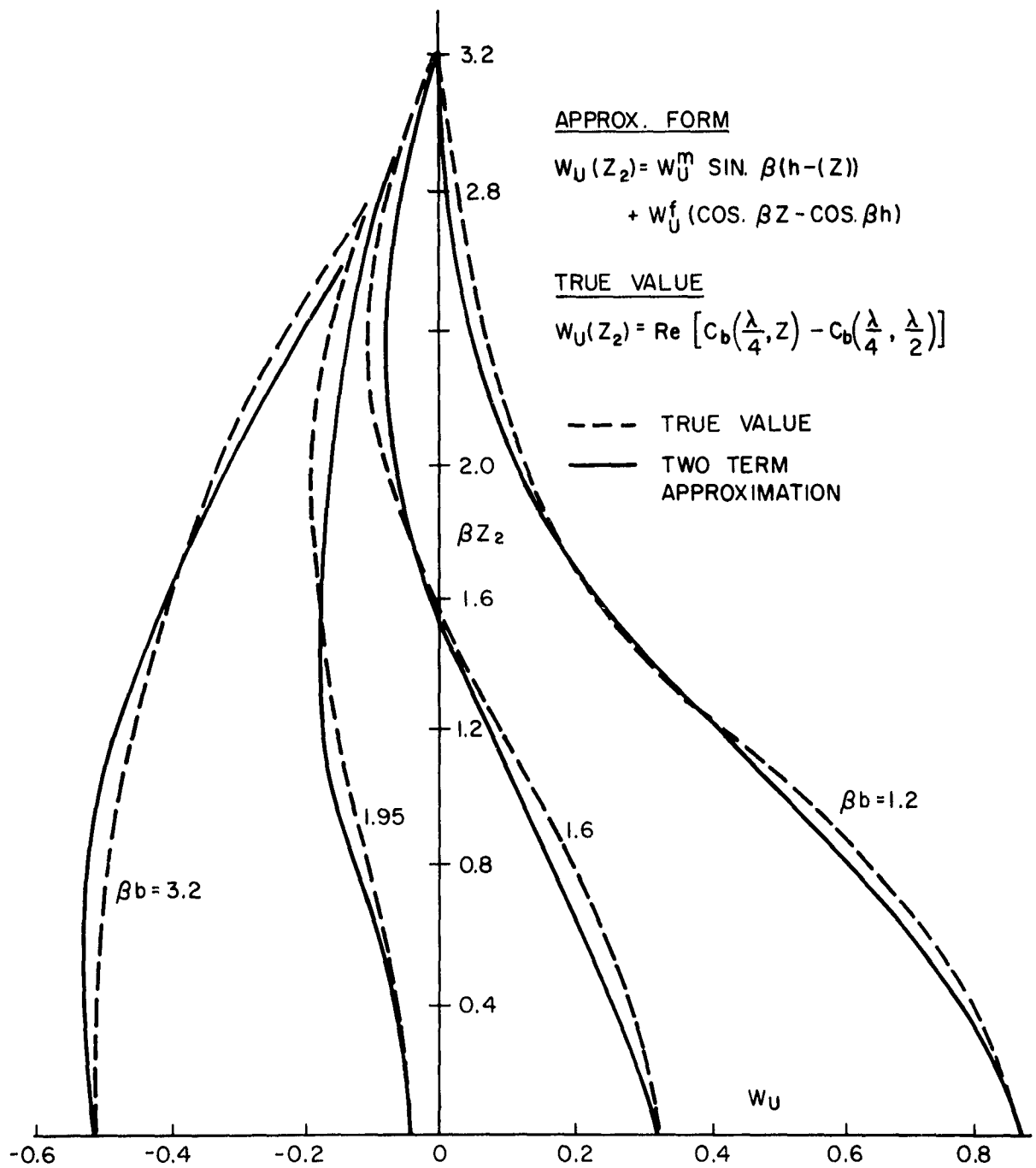

FIG. 8-6 COMPARISON OF TWO TERM APPROXIMATION FOR VECTOR POTENTIAL SHOWN IN FIG. 8-5 WITH TRUE VALUE

is given in Table 8-1 as a function of  $\beta b$ . An inspection of Table 8-1 shows that the only complication arises when  $h_2 > h_1$  for  $\beta b \geq 1$ . In all other cases the behavior of the two integrals is identical to the equal element case.

TABLE 8-1

Integral	Behavior					
	$\beta b < 1$			$\beta b \geq 1$		
	Re	Im	$h_2 < h_1$		$h_2 \geq h_1$	
			Re	Im	Re	Im
$\int_{-h}^h M_{oz'} K_{kid}(z, z') dz'$	$M_{oz}$	$F_{oz}$	$F_{oz}$	$F_{oz}$	$W_v^m M_{oz}$ $+ W_v^f F_{oz}$	$F_{oz}$
$\int_{-h}^h F_{oz'} K_{kid}(z, z') dz'$	$F_{oz}$	$F_{oz}$	$F_{oz}$	$F_{oz}$	$W_u^m M_{oz}$ $+ W_u^f F_{oz}$	$F_{oz}$

The solution for the unequal element case is initiated by separating the current in each element into two parts of the form

$$I_{zi}(z) = I_{vi}(z) + I_{ui}(z) \quad 8:21$$

where by definition the leading terms of the two parts of 8:21 have the forms

$$I_{vi}(z_i) \sim M_{ozi}, \quad I_{ui}(z_i) \sim F_{ozi} \quad 8:22$$

When 8:21 is substituted in 8:1 and 8:2, the following integrals occur (cf. Table 8-1) for  $k = 1, 2$  and  $i = 1, 2$  (N.B. The higher order difference

terms have been neglected.)

$$-\int_{-h}^h I_{vi}(z'_i) K_{kidR}(z_k, z'_i) dz'_i \cong \Psi_{kidR} \left( \frac{A_i}{A_k} \right) I_{vk}(z_k), \quad \beta_{ki} < 1 \quad 8:23$$

$$-\int_{-h}^h I_{vi}(z'_i) K_{kidI}(z_k, z'_i) dz'_i \cong \Psi_{kidI} I_{uk}(z_k) \left( j \frac{A_i}{B_k} \right), \quad \beta_{ki} < 1 \quad 8:24$$

$$-\int_{-h}^h I_{ui}(z'_i) K_{kid}(z_k, z'_i) dz'_i \cong \Psi_{kidu} I_{uk}(z_k), \quad h_k \leq h_i \quad 8:25$$

$$-\int_{-h}^h I_{vi}(z'_i) K_{kid}(z_k, z'_i) dz'_i \cong \Psi_{kidv} I_{uk}(z_k) \left( j \frac{A_i}{B_k} \right), \quad \beta_{ki} > 1 \quad 8:26$$

$$-\int_{-h}^h I_{ui}(z'_i) K_{kidR}(z_k, z'_i) dz'_i \cong \Psi_{kidu}^m \left( \frac{B_i}{jA_k} \right) I_{vk} + \Psi_{kidu}^f \left( \frac{B_i}{B_k} \right) I_{uk}, \quad h_k > h_i \quad 8:27$$

$$-\int_{-h}^h I_{vi}(z'_i) K_{kidR}(z_k, z'_i) dz'_i \cong \Psi_{kidv}^m \left( \frac{A_i}{A_k} \right) I_{vk} + \Psi_{kidv}^f \left( \frac{jA_i}{B_k} \right) I_{uk}, \quad h_k > h_i \quad 8:28$$

$$-\int_{-h}^h I_{ui}(z'_i) K_{kidI}(z_k, z'_i) dz'_i \cong \text{Im} \Psi_{kidu} \left( \frac{B_i}{B_k} \right) I_{uk}(z_k), \quad h_k > h_i \quad 8:29$$

$$-\int_{-h}^h I_{vi}(z'_i) K_{kidI}(z_k, z'_i) dz'_i \cong \text{Im} \Psi_{kidv} \left( \frac{jA_i}{B_k} \right) I_{uk}, \quad h_k > h_i \quad 8:30$$

where  $K_{kidR}$  and  $K_{kidI}$  are defined by 2:10, or

$$K_{kid} = K_{kidR} + jK_{kidI}$$

and where Im and Re are the imaginary and real parts, respectively. Also for  $\beta h_k \geq \lambda/4$

$$\Psi_{kidv}^m = \frac{(\sin \beta h_k - \cos \beta h_k) \operatorname{Re} \Psi_{kidv}(0) - (1 - \cos \beta h_k) \operatorname{Re} \Psi_{kidv}(h_k - \frac{\lambda}{4})}{\sin \beta h_k (\sin \beta h_k - \cos \beta h_k) - (1 - \cos \beta h_k)} \quad 8:31$$

$$\Psi_{kidv}^f = \frac{-\operatorname{Re} \Psi_{kidv}(0) + \sin \beta h_k \operatorname{Re} \Psi_{kidv}(h_k - \frac{\lambda}{4})}{\sin \beta h_k (\sin \beta h_k - \cos \beta h_k) - (1 - \cos \beta h_k)} \quad 8:32$$

The constants  $\Psi_{kidu}^m$  and  $\Psi_{kidu}^f$  are given by 8:31 and 8:32 with  $\operatorname{Re} \Psi_{kidv}$  replaced by  $\operatorname{Re} \Psi_{kidu}$ .

When the integrals on the left-hand side of 8:1 and 8:2 are replaced by their approximate forms from 8:23 - 8:30, and it is assumed that the elements are spaced greater than  $\beta b = 1$ , the following separation into two groups of equations may be carried out:

$$\Psi_{11dR} I_{v1}(z) = j \frac{2\pi}{\int_0^{\infty} F_0(h_1)} V_{01} M_{0z1} \quad 8:33$$

$$\left[ \Psi_{22dR} + \Psi_{21dv}^m \left( \frac{A_1}{A_2} \right) + \Psi_{21du}^m \left( \frac{B_1}{jA_2} \right) \right] I_{v2}(z) = j \frac{2\pi}{\int_0^{\infty} F_0(h_2)} V_{02} M_{0z2}$$

$$\left[ j \Psi_{11dI} \left( \frac{jA_1}{B_1} \right) + \Psi_{12dv} \left( \frac{jA_2}{B_1} \right) + \Psi_{12du} \left( \frac{B_2}{B_1} \right) \right] I_{u1}(z) = j \frac{4\pi}{\int_0^{\infty} F_0(h_1)} U_{1F} \quad 8:34$$

$$\left[ j \operatorname{Im} \Psi_{21dv} \left( \frac{jA_1}{B_2} \right) + j \operatorname{Im} \Psi_{21du} \left( \frac{B_1}{B_2} \right) + \Psi_{22du} + \Psi_{21dv}^f \left( \frac{jA_1}{B_2} \right) + \Psi_{21du}^f \left( \frac{B_1}{B_2} \right) \right] I_{u2}(z) = j \frac{4\pi}{\int_0^{\infty} F_0(h_2)} U_{2F}$$

At this point the simplicity of the quasi zeroth-order solution is clearly

demonstrated, since it follows directly from 8:33 that the leading term in the  $I_{vk}(z)$  is  $M_{ozk}$  for each value of  $k$ . In the same manner, it follows directly from 8:34 that the leading term in  $I_{ui}(z)$  due to all contributions is of the form  $F_{ozk}$ . It is now possible to set

$$I_{vi}(z) = jA_i M_{ozi} ; \quad I_{ui}(z) = B_i F_{ozi} \quad 8:35$$

or

$$I_{zi}(z) = jA_i M_{ozi} + B_i F_{ozi} \quad 8:36$$

Since  $\Psi_{iidR}$  is real, it follows from 8:33 that  $A_1$  is real when  $V_{01}$  is real and  $A_2$  is in general complex. From 8:34 it follows that in general,  $B_1$  and  $B_2$  are complex.

The constant  $U_k$  is obtained readily by substituting 8:36 in 8:3, with the result

$$U_k = \frac{-j\omega_0}{4\pi} \sum_{i=1}^2 \left[ jA_i \Psi_{kiv}(h_k) + B_i \Psi_{kiu}(h_k) \right] \quad 8:37$$

where  $k = 1, 2$  and

$$\Psi_{kiv}(h_k) = \int_{-h}^h M_{oz'k} K_{ki}(h_k, z') dz' \quad 8:38$$

$$\Psi_{kiu}(h_k) = \int_{-h}^h F_{oz'k} K_{ki}(h_k, z') dz' \quad 8:39$$

When 8:37, 8:35, and 8:36 are substituted in 8:33 and 8:34, the result is

$$\left. \begin{aligned} jA_1 \Psi_{11dR} &= j \frac{2\pi}{\oint_0 F_0(h_1)} V_{01} \\ jA_2 \Psi_{22dR} + jA_1 \Psi_{21dv}^m + B_1 \Psi_{21du}^m &= j \frac{2\pi}{\oint_0 F_0(h_2)} V_{02} \end{aligned} \right\} 8:40$$

$$\left. \begin{aligned} \left[ \Psi_{11du} F_0(h_1) - \Psi_{11u}(h_1) \right] B_1 + \left[ \Psi_{12du} F_0(h_1) - \Psi_{12u}(h_1) \right] B_2 &= \left[ \Psi_{11v}(h_1) - j \Psi_{11dI} F_0(h_1) \right] (jA_1) \\ &+ \left[ \Psi_{12v}(h_1) - \Psi_{12dv} F_0(h_1) \right] (jA_2) \\ \left[ (\Psi_{21dv}^f + j \text{Im} \Psi_{21du}) F_0(h_2) - \Psi_{21u}(h_2) \right] B_1 + \left[ \Psi_{22du} F_0(h_2) - \Psi_{22u}(h_2) \right] B_2 &= \\ \left[ \Psi_{21v}(h_2) - (\Psi_{21dv}^f + j \text{Im} \Psi_{21dv}) F_0(h_2) \right] (jA_1) + \left[ \Psi_{22v}(h_2) - j \Psi_{22dI} F_0(h_2) \right] (jA_2) \end{aligned} \right\} 8:41$$

Note that the physical situation is somewhat different from the equal element case since both the A and B coefficients contribute to the sinusoidal distribution of current on element two.

Equation 8:41 may be written in matrix form with the following substitutions:

$$[\Phi_u^u] = \begin{bmatrix} \Psi_{11du} F_0(h_1) - \Psi_{11u}(h_1) & \Psi_{12du} F_0(h_1) - \Psi_{12u}(h_1) \\ (\Psi_{21du}^f + j \text{Im} \Psi_{21du}) F_0(h_2) - \Psi_{21u}(h_2) & \Psi_{22du} F_0(h_2) - \Psi_{22u}(h_2) \end{bmatrix} \quad 8:42$$

$$[\Phi_v^u] = \begin{bmatrix} \Psi_{11v}(h_1) - j \Psi_{11dI} F_0(h_1) & \Psi_{12v}(h_1) - \Psi_{12dv} F_0(h_1) \\ \Psi_{21v}(h_2) - (\Psi_{21dv}^f + j \text{Im} \Psi_{21dv}) & \Psi_{22v}(h_2) - j \Psi_{22dI} F_0(h_2) \end{bmatrix} \quad 8:43$$

With 8:42 and 8:43 in 8:41 it follows that

$$[\Phi_u^u] \{B\} = [\Phi_v^u] \{jA\} \quad 8:44$$

Equation 8:44 resembles the result 2:39 for the equal element case. However, the relation between the driving voltages and the A coefficients is more complicated. The A coefficients are related to the driving voltages by introducing 8:40 into 8:44, that is, by substituting the value of A from 8:40 given in terms of  $B_1$  and  $V_o$  into 8:44. The value of A is given by 8:40, or

$$\{jA\} = \frac{j2\pi}{\xi_o} [\Phi_t]^{-1} \left\{ \frac{V_o}{F_o(h)} \right\} - [\Phi_t]^{-1} [\Phi_c] \{B\} \quad 8:45$$

where

$$[\Phi_t] = \begin{bmatrix} \Psi_{11dR} & 0 \\ \Psi_{12dv}^m & \Psi_{22dR} \end{bmatrix} \quad 8:46$$

$$[\Phi_c] = \begin{bmatrix} 0 & 0 \\ \Psi_{12du}^m & 0 \end{bmatrix}$$

With 8:45 in 8:44, the B coefficients are given in terms of the driving voltage by the matrix equation

$$[\Phi_u^u] \{B\} + [\Phi_v^u] [\Phi_t]^{-1} [\Phi_c] \{B\} = \frac{j2\pi}{\xi_o} [\Phi_v^u] [\Phi_t]^{-1} \left\{ \frac{V_o}{F_o(h)} \right\} \quad 8:47$$

or

$$\{B\} = \frac{j2\pi}{\zeta_0} \left[ [\Phi_u^u] + [\Phi_v^u][\Phi_t]^{-1}[\Phi_c] \right]^{-1} [\Phi_v^u][\Phi_t]^{-1} \left\{ \frac{V_0}{F_0(h)} \right\} \quad 8:48$$

The solution of the array problems which correspond to Cases I and II for the array of unequal lengths may be obtained in the same manner as shown in Chapter 2.

9. CURTAIN ARRAYS WITH ELEMENTS OF UNEQUAL LENGTH;  
THE TWO-ELEMENT COUPLET, SPECIAL CASES

The special form for the element currents in a curtain array for the special case  $\beta h = \pi/2$  is given in Chapter 6. Thus, from 6:9 and 6:10

$$I_{zi} = -jA_i M_{oz}^h + B_i F_{oz} \quad 9:1$$

where

$$\beta h_i = \frac{\pi}{2}, \quad M_{oz}^h = \sin \beta |z| - 1, \quad F_{oz} = \cos \beta z \quad 9:2$$

The special form of the element current in 9:1 was obtained by examining the original integral equation for the currents, 2:1, with the value of  $\beta h$  set equal to  $\pi/2$ . Since curtain arrays with at least one element of half length  $\beta h = \pi/2$  are quite common in practise, it is important to investigate this case in detail. Consider the two-element array shown in Fig. 9-1, with one element of half length  $\beta h_1 \neq \pi/2$  and another with  $\beta h_2 = \pi/2$  driven by potential differences  $V_{01}$  and  $V_{02}$ . The two integral equations for this couplet may be written directly from 2:6 and 6:7. Thus

$$\int_{-h_1}^{h_1} I_{z1}(z'_1) K_{11d}(z_1, z'_1) dz'_1 + \int_{-h_2}^{h_2} I_{z2}(z'_2) K_{12d}(z_1, z'_2) dz'_2 = j \frac{4\pi}{\zeta_0 F_o(h_1)} (U_1 F_{oz1} + \frac{1}{2} V_{01} M_{oz1}) \quad 9:3$$

$$\int_{-h_1}^{h_1} I_{z1}(z'_1) K_{21d}(z_2, z'_1) dz'_1 + \int_{-h_2}^{h_2} I_{z2}(z'_2) K_{22d}(z_2, z'_2) dz'_2 = -j \frac{2\pi}{\zeta_0} (\frac{2C_2}{V_{02}} F_{oz2} + M_{oz2}^h) \quad 9:4$$

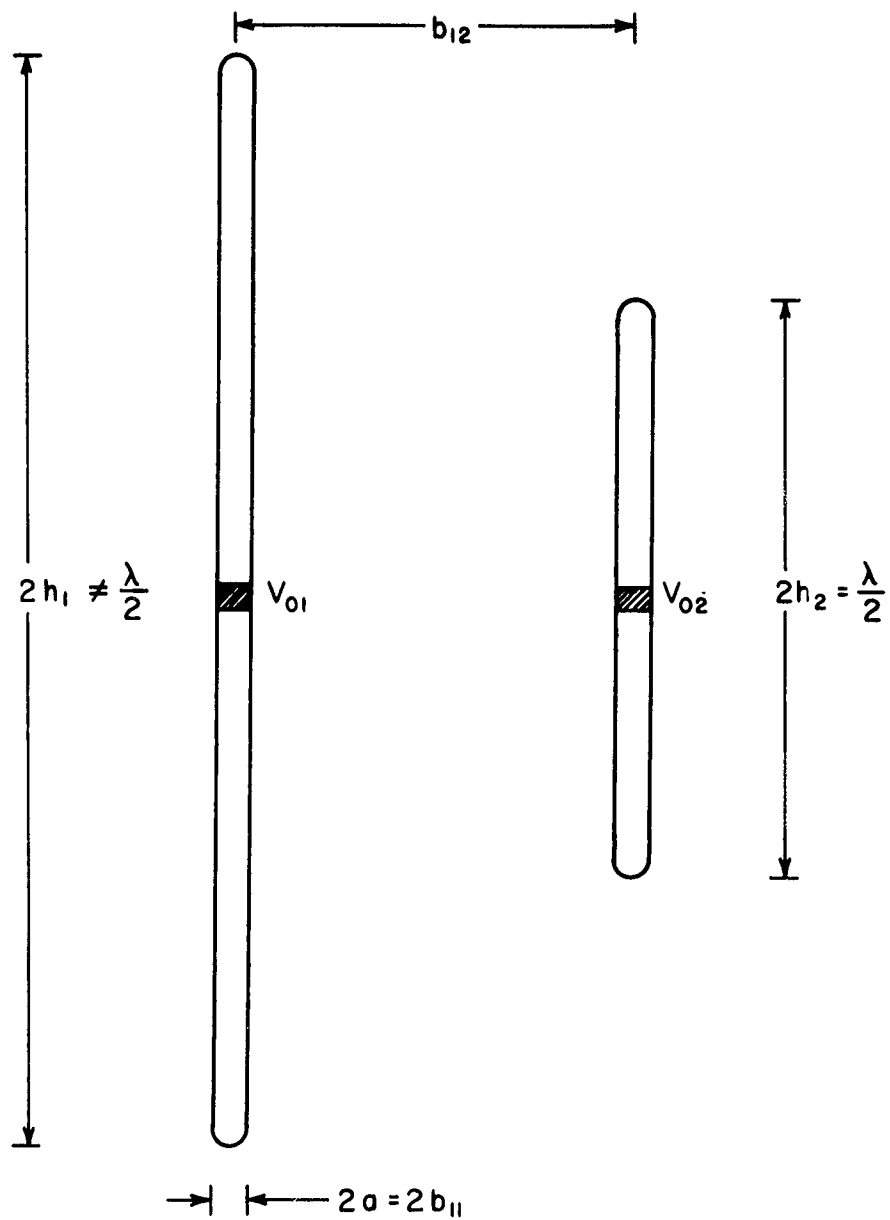

FIG. 9-1 TWO ELEMENT ARRAY  
 ( $\beta h_1 \neq \pi/2$ ,  $\beta h_2 = \pi/2$ )

where

$$U_1 = \sum_{i=1}^2 -j \frac{Z_0}{4\pi} \int_{-h_i}^{h_i} I_{zi}(z'_i) K_{1i}(h_1, z'_i) dz'_i \quad 9:5$$

$$C_2 = \sum_{i=1}^2 j \frac{Z_0}{4\pi} \int_{-h_i}^{h_i} I_{zi}(z'_i) K_{2i}(0, z'_i) dz'_i \quad 9:6$$

$$K_{kid}(z, z') = \frac{e^{-j\beta R_{ki}}}{R_{ki}} - \frac{e^{-j\beta R_{kih}}}{R_{kih}} \quad 9:7$$

Before the behavior of the various integrals in 9:3 and 9:4 is investigated, it is useful to give a qualitative description of the self and mutual terms. With no coupling, the current on element one is given by  $I_{z1}(z) = jA_1 M_{oz1} + B_1 F_{oz1}$  and  $I_{z2}(z) = -jA_2 M_{oz2}^h + B_2 F_{oz2}$  for element two. When these two driven elements are placed in proximity, currents are induced on each element from the opposite member. Two cases may be distinguished:  $\beta h_1 < \pi/2$  and  $\beta h_1 > \pi/2$ . For  $\beta h_1 < \pi/2$  a current proportional to  $F_{oz1}$  is produced due to both parts of the current on element two. A more complicated behavior is exhibited for the current induced on element two due to the current on element one. Due to the distorted wavefront which illuminates element two, an induced current is produced which contains a term proportional to  $F_{oz2}$  plus a term proportional to  $M_{oz2}$ . For the case  $\beta h_1 > \pi/2$  the behavior of the individual elements is reversed. The induced current on element one contains terms which are proportional to  $F_{oz1}$  and  $M_{oz1}$ . However, on element two, a current proportional to  $F_{oz2}$  is produced by  $I_{z1}(z)$ . For both cases, it is the larger element which exhibits a complex behavior while the smaller acts like a receiving element in a uniform field.

The current on each element is first separated into two parts of the form

$$I_{zi}(z) = I_{vi}(z) + I_{ui}(z) \quad i = 1, 2 \quad 9:8$$

where by definition the leading terms of the two parts have the forms

$$I_{v1}(z) \sim M_{oz1} ; \quad I_{u1}(z) \sim F_{oz1} \quad 9:9$$

$$I_{v2}(z) \sim M_{oz2}^h ; \quad I_{u2}(z) \sim F_{oz2} \quad 9:10$$

When the above current forms are substituted in 9:3 and 9:4, the following integrals occur and may be expressed as shown in Chapter 8 (c.f. 8:23 - 8:32), where the higher order differences have been neglected:

$$\int_{-h}^h I_{v1}(z'_1) K_{11dR}(z_1, z'_1) dz'_1 \cong \Psi_{11dR} I_{v1}(z_1), \quad \beta b_{11} < 1 \quad 9:11$$

$$\int_{-h}^h I_{v1}(z'_1) K_{11dI}(z_1, z'_1) dz'_1 \cong \Psi_{11dI} \left( \frac{jA_1}{B_1} \right) I_{u1}(z_1), \quad \beta b_{11} < 1 \quad 9:12$$

$$\int_{-h}^h I_{u1}(z'_1) K_{11d}(z_1, z'_1) dz'_1 \cong \Psi_{11du} I_{u1}(z_1) \quad 9:13$$

$$\int_{-h}^h I_{v2}(z'_2) K_{12d}(z_1, z'_2) dz'_2 \cong \begin{cases} \Psi_{12dv}^h \left( \frac{-jA_2}{B_1} \right) I_{u1}(z_1), & h_1 < h_2 \\ \text{Re} \left[ \Psi_{12dv}^m \left( \frac{-A_2}{A_1} \right) I_{v1}(z_1) + \Psi_{12dv}^f \left( \frac{-jA_2}{B_1} \right) I_{u1}(z_1) \right] + \text{Im} \left[ \Psi_{12dv}^h \left( \frac{-jA_2}{B_1} \right) I_{u1}(z_1) \right] & h_1 > h_2 \end{cases} \quad 9:14$$

$$\int_{-h}^h I_{u2}(z'_2) K_{12d}(z_1, z'_2) dz'_2 \cong \begin{cases} \Psi_{12du} \left( \frac{B_2}{B_1} \right) I_{u1}(z_1), & h_1 < h_2 \\ \operatorname{Re} \left[ \Psi_{12du}^m \left( \frac{B_2}{jA_1} \right) I_{v1}(z_1) + \Psi_{12du}^f \left( \frac{B_2}{B_1} \right) I_{u1}(z_1) \right] + \operatorname{Im} \left[ \Psi_{12du} \left( \frac{B_2}{B_1} \right) I_{u1}(z_1) \right], & h_1 > h_2 \end{cases} \quad 9:15$$

$$\int_{-h}^h I_{v1}(z'_1) K_{21d}(z_2, z'_1) dz'_1 \cong \begin{cases} \operatorname{Re} \left[ \Psi_{12dv}^m \left( \frac{-A_1}{A_2} \right) I_{v2}(z_2) + \Psi_{12dv}^f I_{u2}(z_2) \right] + \operatorname{Im} \left[ \Psi_{12dv} \left( \frac{jA_1}{B_2} \right) I_{u2}(z_2) \right], & h_1 < h_2 \\ \Psi_{12dv} \left( \frac{jA_1}{B_2} \right) I_{u2}(z_2), & h_1 > h_2 \end{cases} \quad 9:16$$

$$\int_{-h}^h I_{u1}(z'_1) K_{21d}(z_2, z'_1) dz'_1 \cong \begin{cases} \operatorname{Re} \left[ \Psi_{12du}^m \left( \frac{B_1}{-jA_2} \right) I_{v2}(z_2) + \Psi_{12du}^f \left( \frac{B_1}{B_2} \right) I_{u2}(z_2) \right] + \operatorname{Im} \left[ \Psi_{12du} \left( \frac{B_1}{B_2} \right) I_{u2}(z_2) \right], & h_1 < h_2 \\ \Psi_{12du} \left( \frac{B_1}{B_2} \right) I_{u2}(z_2), & h_1 > h_2 \end{cases} \quad 9:17$$

$$\int_{-h}^h I_{v2}(z'_2) K_{22dR}(z_2, z'_2) dz'_2 \cong \Psi_{22dR}^h I_{v2}(z_2), \quad \beta_{b22} < 1 \quad 9:18$$

$$\int_{-h}^h I_{v2}(z'_2) K_{22dI}(z_2, z'_2) dz'_2 \cong \Psi_{22dI}^h \left( \frac{-jA_2}{B_2} \right) I_{u2}(z_2), \quad \beta_{b22} < 1 \quad 9:19$$

$$\int_{-h}^h I_{u2}(z'_2) K_{22d}(z_2, z'_2) dz'_2 \cong \Psi_{22du}^h I_{u2}(z_2) \quad 9:20$$

where

$$\Psi_{12du}^m = \frac{0.7071 \operatorname{Re} \Psi_{12du}(0) + 0.2929 \operatorname{Re} \Psi_{12du} \left( \frac{\pi}{2} \right)}{-0.4142} \quad 9:21$$

$$\Psi_{12du}^f = \frac{-\text{Re} \Psi_{12du}(0) - \text{Re} \Psi_{12du}(\frac{\pi}{4})}{-0.4142} \quad 9:22$$

For  $\Psi_{12dv}^m$  and  $\Psi_{12dv}^f$ , replace  $\Psi_{12du}$  by  $\Psi_{12dv}$  in 9:21 and 9:22. The two term approximation for the real part of  $\Psi_{12du}$  is obtained from a two point approximation at  $\beta z_2 = 0$  and  $\beta z_2 = \pi/4$  (c.f. 8:14 et seq.).

The integrals on the left-hand side of 9:3 and 9:4 are replaced by the approximate forms given in 9:11 - 9:20, and for  $\beta b_{12} > 1$  the following separation into two groups of equations may be carried out for  $h_1 < h_2$ . (N.B. Higher order terms have been neglected.)

$$\Psi_{11dR} I_{v1}(z) = j \frac{2\pi}{\xi_o F_o(h_1)} V_{01} M_{oz1} \quad 9:23$$

$$\left[ \Psi_{22dR}^h + \Psi_{21dv}^m \left( \frac{-A_1}{A_2} \right) + \Psi_{21du}^m \left( \frac{B_1}{-jA_2} \right) \right] I_{v2}(z) = -j \frac{2\pi}{\xi_o} V_{02} M_{oz2}^h \quad 9:24$$

$$\left[ \left( \frac{jA_1}{B_1} \right) j \Psi_{11dI} + \left( \frac{-jA_2}{B_1} \right) \Psi_{12dv}^h + \left( \frac{B_2}{B_1} \right) \Psi_{12du} \right] I_{u1}(z) = j \frac{4\pi}{\xi_o F_o(h_1)} U_{1} F_{oz1} \quad 9:25$$

$$\left[ (\Psi_{21dv}^f + j \text{Im} \Psi_{21dv}) + (\Psi_{21du}^f + j \text{Im} \Psi_{21du}) + \left( \frac{-jA_2}{B_2} \right) \Psi_{22dI}^h + \Psi_{22du} \right] I_{u2}(z) = -j \frac{4\pi}{\xi_o} C_2 F_{oz2} \quad 9:26$$

It follows directly from 9:23 that the leading term for  $I_{v1}(z)$  is proportional to  $M_{oz1}$  and from 9:24 that the leading term for  $I_{v2}(z)$  is proportional to  $M_{oz2}^h$ . Similarly, it follows from 9:25 that the leading term for  $I_{u1}(z)$  is proportional to  $F_{oz1}$  and from 9:26 that  $I_{u2}(z)$  is proportional to  $F_{oz2}$ . Hence, it is now possible to set

$$I_{v1}(z) = jA_1 M_{oz1}; \quad I_{u1}(z) = B_1 F_{oz1} \quad 9:27$$

$$I_{v2}(z) = -jA_2 M_{oz2}^h; \quad I_{u2}(z) = B_2 F_{oz2} \quad 9:28$$

or

$$I_{z1}(z) = jA_1 M_{oz1} + B_1 F_{oz1} \quad 9:29$$

$$I_{z2}(z) = -jA_2 M_{oz2}^h + B_2 F_{oz2} \quad 9:30$$

Since  $\Psi_{11dR}$  is real, it follows from 9:23 that  $A_1$  is real when  $V_{01}$  is real. However, 9:24 shows that  $-jA_2$  is in general complex. From 9:25 and 9:26, it follows that in general,  $B_1$  and  $B_2$  are complex.

The constants  $U_1$  and  $C_2$  are given by substituting the element currents given by 9:29 and 9:30 into 9:5 and 9:6, with the result

$$U_1 = -j \frac{\mathcal{L}_0}{4\pi} \left[ jA_1 \Psi_{11v}(h_1) + B_1 \Psi_{11u}(h_1) \right] - j \frac{\mathcal{L}_0}{4\pi} \left[ -jA_2 \Psi_{12v}^h(h_1) + B_2 \Psi_{12u}(h_1) \right] \quad 9:31$$

$$C_2 = j \frac{\mathcal{L}_0}{4\pi} \left[ jA_1 \Psi_{21v}(0) + B_1 \Psi_{21u}(0) \right] + j \frac{\mathcal{L}_0}{4\pi} \left[ -jA_2 \Psi_{22v}^h(0) + B_2 \Psi_{22u}(0) \right] \quad 9:32$$

With 9:31 and 9:32 substituted in 9:23 - 9:26, the result is

$$jA_1 \Psi_{11dR} = j \frac{2\pi}{\mathcal{L}_0 F_o(h_1)} V_{01} \quad 9:33$$

$$jA_1 \Psi_{21dv}^m + B_1 \Psi_{21du}^m - jA_2 \Psi_{22dR}^h = -j \frac{2\pi}{\mathcal{L}_0} V_{02}$$

$$\begin{aligned}
\left[ F_o(h_1) \Psi_{11du} - \Psi_{11u}(h_1) \right] B_1 + \left[ F_o(h_1) \Psi_{12du} - \Psi_{12u}(h_1) \right] B_2 &= \left[ \Psi_{11v}(h_1) - jF_o(h_1) \Psi_{11dI} \right] (jA_1) \\
&+ \left[ \Psi_{12v}^h(h_1) - F_o(h_1) \Psi_{12dv}^h \right] (-jA_2) \\
\left[ (\Psi_{21du}^f + j\text{Im} \Psi_{21du}) - \Psi_{21u}(0) \right] B_1 + \left[ \Psi_{22du} - \Psi_{22u}(0) \right] B_2 &= \left[ \Psi_{21v}(0) - (\Psi_{21dv}^f + j\text{Im} \Psi_{21du}) \right] (jA_1) \\
&+ \left[ \Psi_{22v}^h(0) - j\Psi_{22dI}^h \right] (-jA_2)
\end{aligned} \tag{9:34}$$

Equations 9:33 and 9:34 are easily written in matrix form as follows:

$$[\Phi_t] \{jA\} + [\Phi_c] \{B\} = j \frac{2\pi}{Z_o} \left\{ \frac{V_o}{F_o(h)} \right\} \tag{9:35}$$

and

$$[\Phi_u] \{B\} = [\Phi_v^u] \{jA\} \tag{9:36}$$

where

$$[\Phi_t] = \begin{bmatrix} \Psi_{11dR} & 0 \\ \Psi_{21dv}^m & \Psi_{22dR} \end{bmatrix} \tag{9:37}$$

$$[\Phi_c] = \begin{bmatrix} 0 & 0 \\ \Psi_{21dv}^m & 0 \end{bmatrix} \tag{9:38}$$

$$[\Phi_u^u] = \begin{bmatrix} F_o(h_1)\Psi_{11du} - \Psi_{11u}(h_1) & F_o(h_1)\Psi_{12du} - \Psi_{12u}(h_1) \\ (\Psi_{12du}^f + j\text{Im}\Psi_{21du}) - \Psi_{21u}(0) & \Psi_{22du} - \Psi_{22u}(0) \end{bmatrix} \quad 9:39$$

$$[\Phi_v^u] = \begin{bmatrix} \Psi_{11v}(h_1) - jF_o(h_1)\Psi_{11dI} & \Psi_{12v}^h(h_1) - F_o(h_1)\Psi_{12dv}^h \\ \Psi_{21v}(0) - (\Psi_{21dv}^f + j\text{Im}\Psi_{21dv}) & \Psi_{22v}^h(0) - j\Psi_{22dI}^h \end{bmatrix} \quad 9:40$$

The result comparable to 9:35 and 9:36 for the case  $h_1 > h_2$  has the following values for the component matrices

$$[\Phi_t] = \begin{bmatrix} \Psi_{11dR} & \Psi_{12dv}^m \\ 0 & \Psi_{22dR} \end{bmatrix} \quad 9:41$$

$$[\Phi_c] = \begin{bmatrix} 0 & \Psi_{12du}^m \\ 0 & 0 \end{bmatrix} \quad 9:42$$

$$[\Phi_u^u] = \begin{bmatrix} F_o(h_1)\Psi_{11du} - \Psi_{11u}(h_1) & F_o(h_1)(\Psi_{12du}^f + j\text{Im}\Psi_{21du}) - \Psi_{12u}(h_1) \\ \Psi_{12du} - \Psi_{21u}(0) & \Psi_{22du} - \Psi_{22u}(0) \end{bmatrix} \quad 9:43$$

$$[\Phi_v^u] = \begin{bmatrix} \Psi_{11v}(h_1) - jF_o(h_1)\Psi_{11dI} & \Psi_{12v}^h - F_o(h_1)(\Psi_{12dv}^f + j\text{Im}\Psi_{21dv}) \\ \Psi_{21v}(0) - \Psi_{21dv} & \Psi_{22v}^h(0) - j\Psi_{22dI}^h \end{bmatrix} \quad 9:44$$

The matrix equations for the couplet given by 9:35 and 9:36 are coupled. That is, both the A and B current coefficients appear in both equations. When both elements are equal in length, the coupling disappears and the sinusoidal current coefficient  $jA_1$  again is proportional to the driving voltage. For example, one matrix equation is given for the B coefficients in terms of the driving voltage by combining 9:35 and 9:36, or

$$\{B\} = j \frac{2\pi}{\xi_0} \left[ [\Phi_u^u] + [\Phi_v^u][\Phi_t]^{-1}[\Phi_c] \right]^{-1} [\Phi_v^u][\Phi_t]^{-1} \left\{ \frac{V_o}{F_o(h)} \right\} \quad 9:45$$

Consider the practical case where it is desired to constrain the driving voltages and determine the corresponding element currents. The B coefficients of the element currents are given by 9:45 in terms of the two driving voltages  $V_{01}$  and  $V_{02}$ . The sinusoidal current coefficients are given by 9:35 with 9:45. The current on each element follows directly from 9:1.

10. CURTAIN ARRAYS WITH ELEMENTS OF UNEQUAL LENGTH:  
THE PARASITIC CASE, EXAMPLES OF THE THEORY

The preceding analysis has been concerned with all elements driven by separate generators. When the elements are equal in length, the sinusoidal current on each element is proportional to the driving voltage. This is the result of the quasi zeroth-order approximation. The situation is somewhat changed for the case of unequal length elements. The more complicated behavior of the coupling terms in the integral equations requires sinusoidal current as well as shifted-cosinusoidal currents for a good approximation to the actual behavior of the integrals. The fundamental approach used in the quasi zeroth-order solution is a separate iteration for both the sinusoidal and cosinusoidal currents in the array. Hence, for the array with elements of unequal length, the sinusoidal currents in the coupling terms are determined by suitably modifying the equations which normally account for self-induced sinusoidal currents. The modification involves an adjustment of the driving voltages, which in turn compensates for the effect of the sinusoidal currents in the coupling terms.

The quasi zeroth-order theory implies that the sinusoidal current on an element in an array vanishes if the driving voltage is zero. This result is easily seen from 8:33 or 9:23 - 9:24 with  $V_{oi} = 0$ ,  $i = 1, 2$ . This is only an approximation, since the simplification is made that certain integrals in 2:1 vary only with  $M_{oz}$ . This leads to a discontinuity in the approximate form of the integral at  $z = 0$ , whereas this discontinuity does not exist in the original integral. However, since the trigonometric approximations for the integrals are made at the point of maximum current, the approximation should be quite good except near  $z = 0$ . One method of checking the validity of assuming  $M_{ozk} = 0$  when  $V_{ok} = 0$  is to compare the approximate result with a more rigorous solution given by King [1] using a symmetrical component solution with  $N = 2$ . The solution of the couplet array with one parasitic element is given as a super-

position of two separate coupler problems, each with prescribed driving voltages. First, both elements are driven in phase with voltages

$$V_{01} = V_0/2 = V_{02}, \text{ and then driven in phase reversal with } V_{01} = V_0/2 = -V_{02}.$$

The superposition of the currents for these two cases yields the required coupler with  $V_{01} = V_0$  and  $V_{02} = 0$ . An interesting case to compare the approximate and rigorous solutions for the two-element coupler is  $\beta h = 3\pi/4$  and  $\beta b = \pi/4$ . The calculations are given in Appendix VIII. The result which follows from the quasi zeroth-order theory, where it is assumed that  $V_{02}$  is zero, is given in VIII:15, or

$$\begin{aligned} I_{z1}(z) &= 10^{-3} V_{01} [0.8030 F_{oz} - j(3.3219 M_{oz} - 0.7282 F_{oz})] \\ I_{z2}(z) &= 10^{-3} V_{01} [0.4732 F_{oz} + j0.1604 F_{oz}] \end{aligned} \quad \begin{array}{l} 10:1 \\ 10:1 \end{array}$$

The corresponding result based on a rigorous solution in terms of symmetrical components is given by VIII:21, or

$$\begin{aligned} I_{z1}(z) &= 10^{-3} V_{01} [0.9368 F_{oz} - j(3.3219 M_{oz} - 0.6789 F_{oz})] \\ I_{z2}(z) &= 10^{-3} V_{01} [0.6067 F_{oz} + j0.1075 F_{oz}] \end{aligned} \quad \begin{array}{l} 10:2 \\ 10:2 \end{array}$$

The element currents 10:1 and 10:2 are illustrated in Fig. 10-1 for both the real and imaginary parts.

The error at  $\beta h = 3\pi/4$  should be nearly maximum. This may be deduced by examining the cases  $\beta h = \pi/2$  and  $\beta h = \pi$ . At  $\beta h = \pi/2$  the element current is almost entirely composed of one component, the  $F_{oz}$  distribution. At  $\beta h = \pi$  the parasitic coupling is extremely weak, as shown by [King 1, p S454]. Hence, for both these extreme cases the error should be less than for the case  $\beta h = 3\pi/4$ .

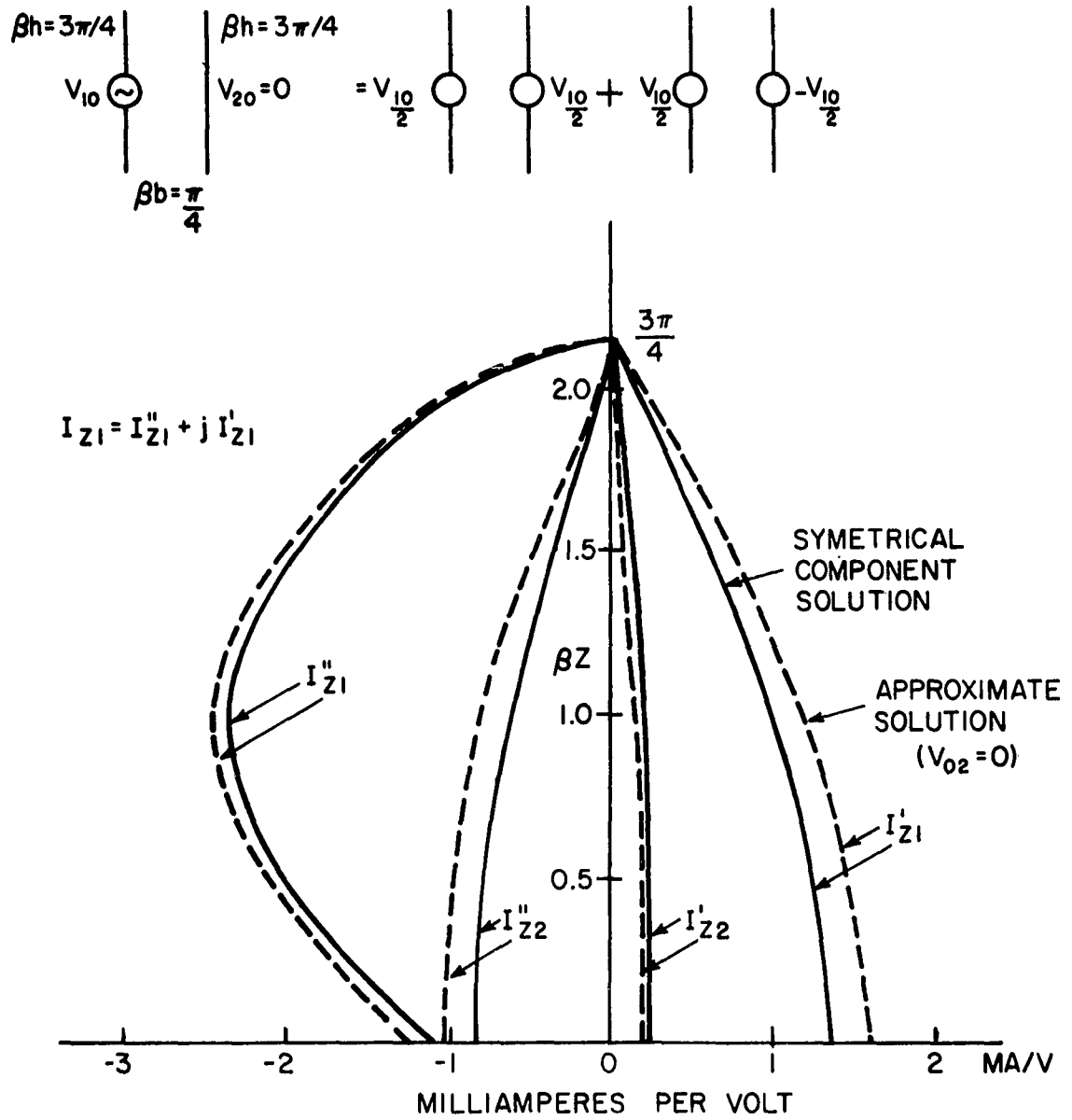

FIG. 10-1 TWO ELEMENT ARRAY WITH  $\beta h = 3\pi/4$ ,  $\beta b = \pi/4$ , ONE ELEMENT PARASITIC, ELEMENT CURRENTS.

A well-known phenomenon discussed in the literature [2] is that for a fixed spacing it is possible to direct the main beam in either direction with respect to the parasite. This directional property is accomplished by adjusting the length of the parasitic element, with the driven element fixed near  $\beta h = \pi/2$ . This effect has been verified experimentally as well as theoretically by an approximate solution due to King [1]. However, the approximate solution is restricted to small changes in the length of the parasitic element near  $\beta h = \pi/2$ . The present theory is not restricted with respect to the length of the parasitic element.

The first example is the couplet with  $\beta h_1 = 1.4$ ,  $\beta h_2 = \pi/2$ ,  $V_{01} = 0$ ,  $V_{02}$ . The complete calculations for the element currents are carried out in Appendix IX, with the result given by IX:28 and IX:29, or

$$I_{z1}(z) = 10^{-3} V_{02} (-20.78 + 17.81) F_{oz1} \quad 10:3$$

$$I_{z2}(z) = 10^{-3} V_{02} [(-0.6554 - j2.468) M_{oz2}^h + (14.06 - j25.39) F_{oz2}] \quad 10:4$$

The element currents are shown in Fig. 10-2, drawn with respect to  $V_{02}$ . The driving-point admittance and impedance of element two is given by 10:4, evaluated at  $z = 0$ .

$$\frac{I_{z2}(0)}{V_{02}} = Y_{02} = 10^{-3} (14.72 - j22.92) \text{ mho} \quad 10:5$$

$$Z_{02} = \frac{1}{Y_{02}} = (19.84 + j30.89) \text{ ohms} \quad 10:6$$

The radiation field in the equatorial plane is given by

$$E_{\theta}^r(\Phi) = K[C_1 + C_2 e^{j\beta b \cos \Phi}] ; \quad \theta = \frac{\pi}{2} \quad 10:7$$

where

$$\left. \begin{aligned} C_1 &= B_1 G_m \left( \frac{\pi}{2}, 1.4 \right) = 0.7475 B_1 \\ C_2 &= -j A_1 H_m \left( \frac{\pi}{2}, \frac{\pi}{2} \right) + B_1 G_m \left( \frac{\pi}{2}, \frac{\pi}{2} \right) = -j A_1 (-0.5708) + B_1 \\ H_m \left( \theta, \frac{\pi}{2} \right) &= \frac{\sin \theta - \sin \left( \frac{\pi}{2} \cos \theta \right)}{\sin \theta \cos \theta} \end{aligned} \right\} 10:8$$

With 10:3, 10:4 and 10:8 in 10:7 the numerical value of the radiation field reduces to

$$E_{\theta}^r(\Phi) = K[(-1.553 + j1.331) + (1.443 - j2.398)e^{j\cos \Phi}] \quad 10:9$$

where

$$\begin{aligned} \beta b &= 1 \\ \theta &= \frac{\pi}{2} \end{aligned} \quad 10:10$$

The radiation pattern is plotted in Fig. 10-3, and the back to front ratio is given by 10:9, or

$$\frac{|E(\zeta)|}{|E(\pi)|} = \frac{|1.245 + j1.249|}{|-2.791 - j1.179|} = 0.5822 \sim -4.7 \text{ db} \quad 10:11$$

Note that for this case, the main beam is directed toward the parasite. The numerical value for the back to front ratio is close to the experimental value

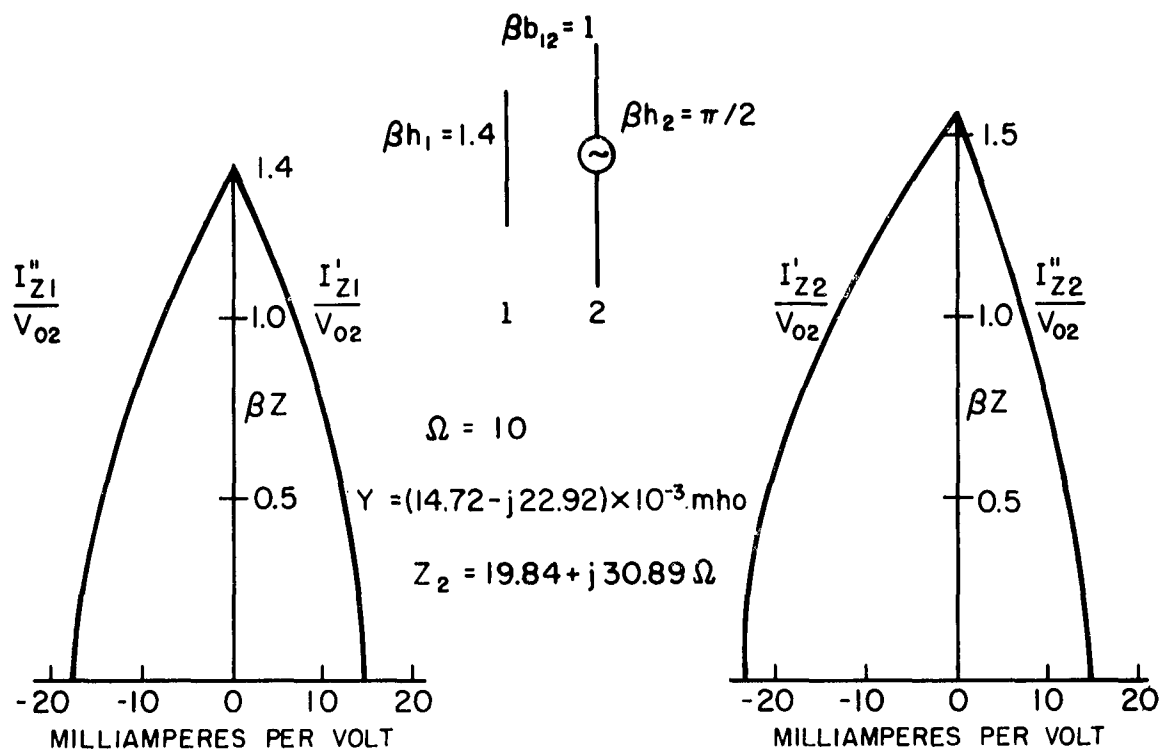

FIG. 10-2 ELEMENT CURRENTS FOR PARASITIC COUPLET WITH  $\beta h_1 = 1.4$ ,  $\beta h_2 = \pi/Z$ ,  $\beta b = 1$ ,  $V_{01} = 0$

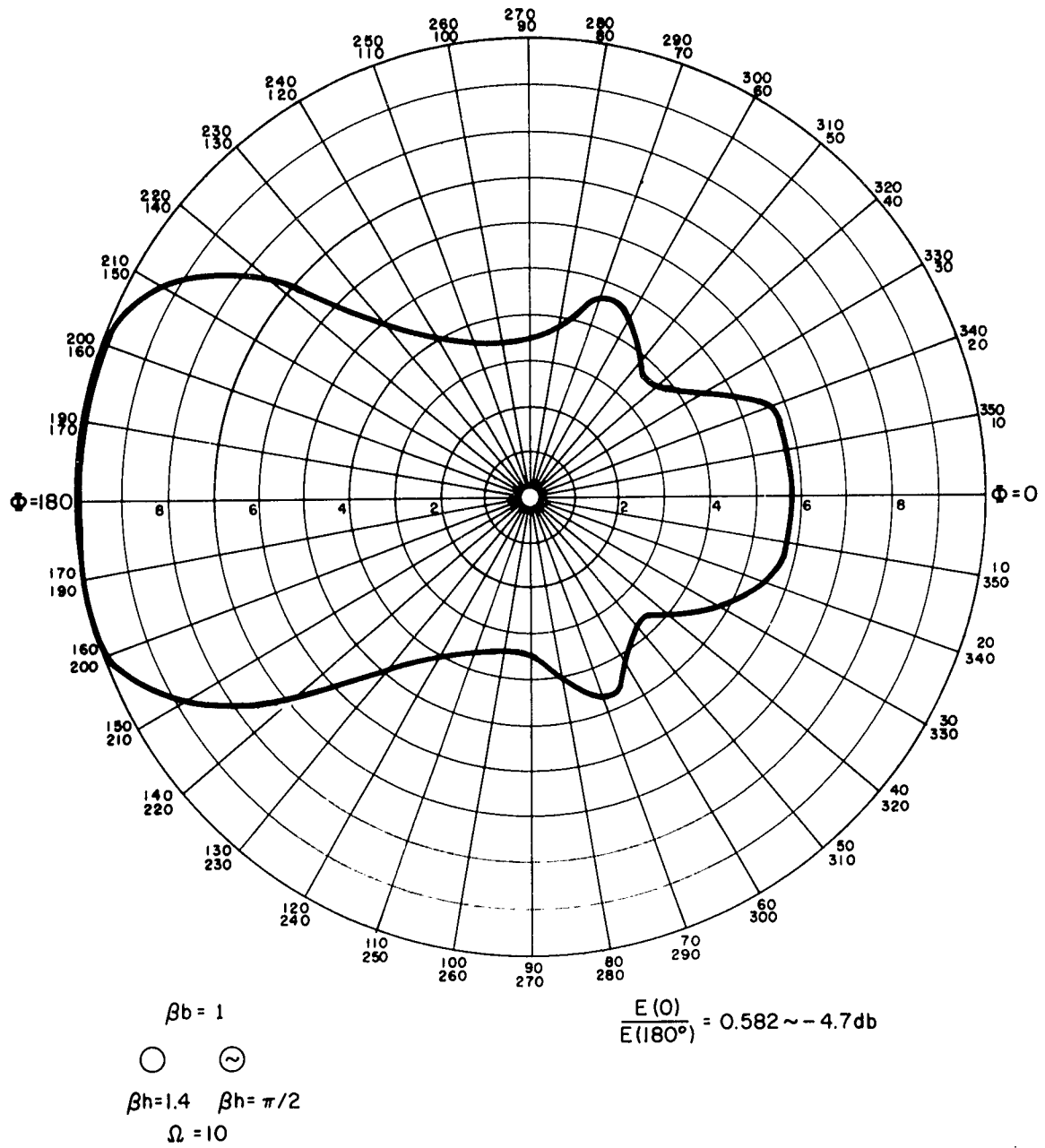

FIG. 10-3 FIELD PATTERN FOR PARASITIC COUPLET,  $\beta_{h_1} = 1.4$ ,  $\beta_{h_2} = \pi/2$ ,  $\beta_b = 1$ ,  $\Omega = 10$

of -6 db. given by Starkey and Fitch [3].

The second example is the couplet with  $\beta h_1 = 1.8$ ,  $\beta h_2 = \pi/2$ ,  $V_{01} = 0$ , and  $V_{02}$ . The calculations for the element currents are carried out in Appendix IX. The results are

$$I_{z1}(z) = 10^{-3} V_{02} (0.5701 + j4.6794) F_{oz1} \quad 10:12$$

$$I_{z2}(z) = 10^{-3} V_{02} [-j2.4124 M_{oz2}^h + (7.178 - j8.865) F_{oz2}] \quad 10:13$$

The element currents are shown in Fig. 10-4, drawn with respect to  $V_{02}$ . The driving-point admittance and impedance of element two are given by 10:13, or

$$Y_{02} = \frac{I_{z2}(0)}{V_{02}} = 10^{-3} (7.178 - j6.453) \text{ mho} \quad 10:14$$

$$Z_{02} = 77.05 + j69.26 \text{ ohms} \quad 10:15$$

The radiation field in the equatorial plane is given by

$$E_{\theta}^r(\Phi) = K(C_1 + C_2 e^{j\beta b \cos \Phi}) \quad 10:16$$

where

$$C_1 = B_1 G_m\left(\frac{\pi}{2}, 1.8\right) = 1.3837 B_1 \quad 10:17$$

$$C_2 = -jA_1 H_m\left(\frac{\pi}{2}, \frac{\pi}{2}\right) + B_1 G_m\left(\frac{\pi}{2}, \frac{\pi}{2}\right) = -jA_1 (-0.5708) + B_1 \quad 10:18$$

With 10:12, 10:13, 10:17 and 10:18 in 10:16, the numerical value of the radiation field in the equatorial plane is given by

$$E_{\theta}^r(\Phi) = K[(0.7888 + j6.475) + (7.178 - j7.489)e^{j\beta b \cos \Phi}] \quad . \quad 10:19$$

The front to back ratio is easily calculated from 10:19:

$$\frac{|E(\Phi = 0)|}{|E(\Phi = \pi)|} = \frac{|10.97 + j8.469|}{|-1.634 - j3.611|} = \frac{14.21}{3.965} = 3.584 \quad . \quad 10:20$$

The ratio  $|E(0)| / |E(\pi)|$  in 10:20 corresponds to a front to back ratio of 11.1 db. Note that in this case (Fig. 10-5), the main beam is directed away from the parasite. The front to back ratio of 11.1 db compares favorably with a value of 11 db given by McPetrie and Saxton [4].

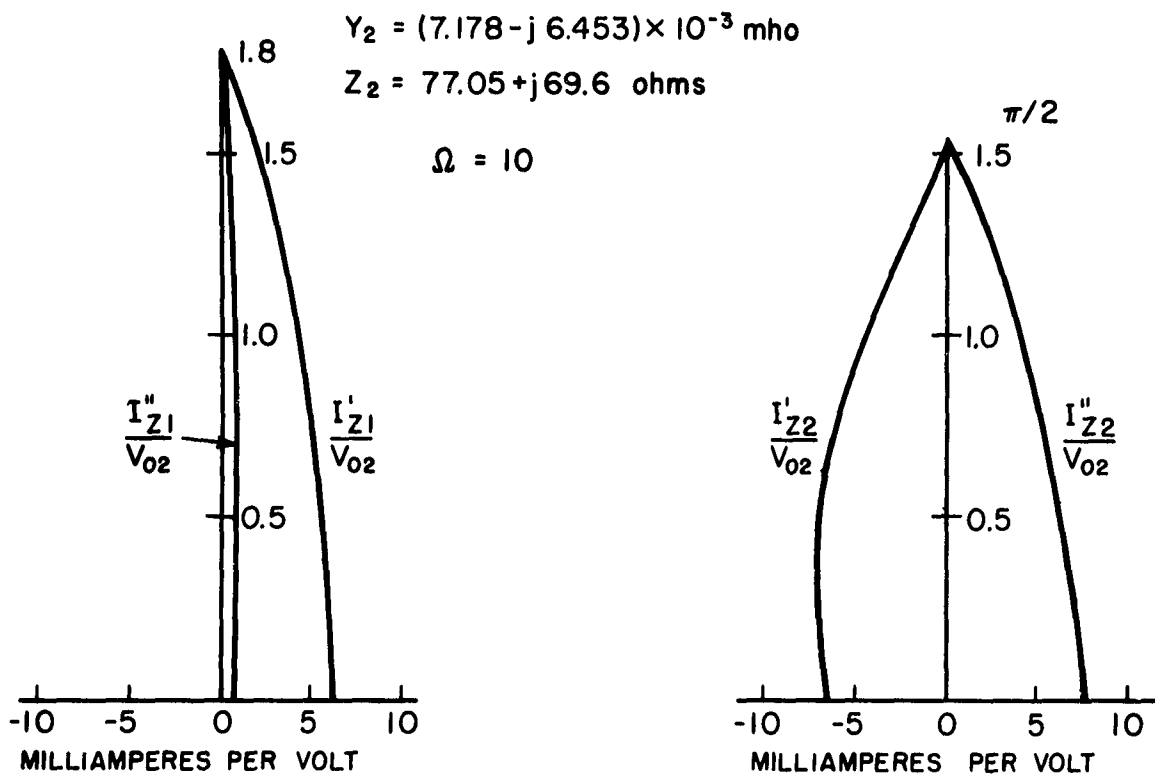

FIG. 10-4 ELEMENT CURRENTS FOR PARASITIC COUPLET,  
 $\beta h_1 = 1.8, \beta h_2 = 1.4, \beta b = 1$

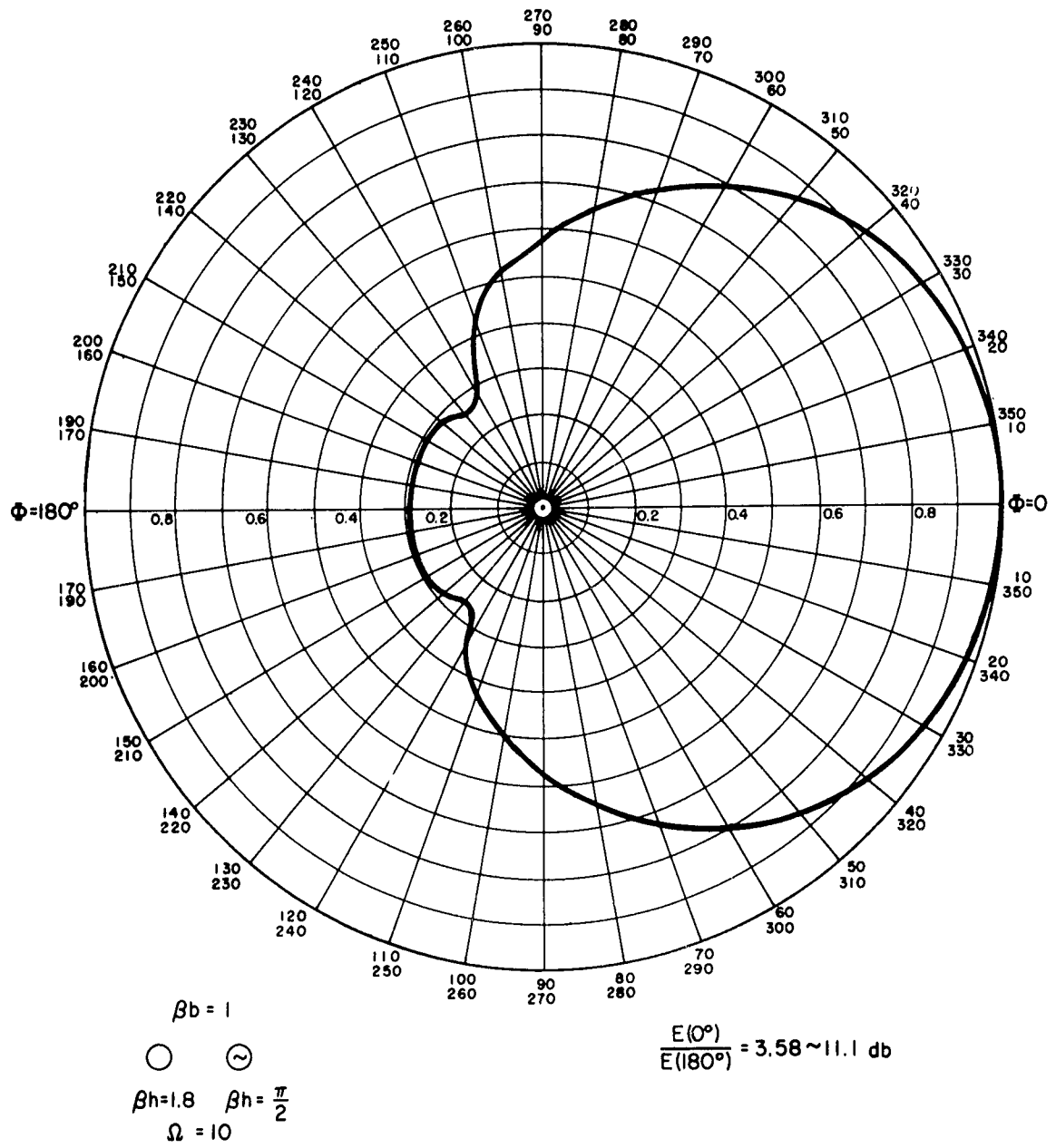

FIG. 10-5 FIELD PATTERN FOR PARASITIC COUPLER  $\beta_{h_1} = 1.8$ ,  $\beta_{h_2} = \pi/2$ ,  $\beta_b = 1$

## 11. THE YAGI ARRAY

The general Yagi array problem is considered by King [1, Ch. VI, Sect. 5]. The N element Yagi array normally consists of one driven element, usually a half-wave dipole, one reflector of half length  $\beta h \geq \pi/2$ , and N-2 directors of half length  $\beta h < \pi/2$ . Since the array has only one driven element, it has an advantage over the conventional endfire array, wherein all elements must be driven in the correct time phase. A six-element Yagi array is shown in Fig. 11-1.

For convenience the driven element is chosen to be of half length  $\beta h = \pi/2$ , and the reflector (element one) of half length  $\beta h > \pi/2$ . The integral equations for this array easily follow from the results for the couplets of unequal length

$$\sum_{i=1}^N \int_{-h_i}^{h_i} I_{zi}(z'_i) K_{1id}(z_1, z'_i) dz'_i = j \frac{4\pi}{\int_0^{\infty} F_o(h_1)} U_1 F_{oz1} \quad 11:1$$

$$\sum_{i=1}^N \int_{-h_i}^{h_i} I_{zi}(z'_i) K_{2id}(z_2, z'_i) dz'_i = -j \frac{2\pi V_{02}}{\int_0^{\infty} F_o} \left( \frac{2C_2}{V_{02}} F_{oz2} + M_{oz2}^h \right) \quad 11:2$$

$$\sum_{i=1}^N \int_{-h_i}^{h_i} I_{zi}(z'_i) K_{3id}(z_3, z'_i) dz'_i = j \frac{4\pi}{\int_0^{\infty} F_o(h_3)} U_3 F_{oz3} \quad 11:3$$

.....

$$\sum_{i=1}^N \int_{-h_i}^{h_i} I_{zi}(z'_i) K_{Nid}(z_N, z'_i) dz'_i = j \frac{4\pi}{\int_0^{\infty} F_o(h_N)} U_N F_{ozN} \quad 11:4$$

The reflector and directors in the Yagi array have half-lengths which are near  $\beta h = \pi/2$  in order to achieve the correct directive properties. With this in mind, it is possible to make certain simplifying approximations for

the case where the elements are spaced a distance greater than  $\beta b = 1$ . For elements of half lengths near  $\beta h = \pi/2$ , it is assumed that all induced currents are proportional to  $F_{oz}$ . That is, it is assumed that only the individual element produces a current which is proportional to  $M_{oz}$ . The validity of this assumption is easily seen by noting that near  $\beta h = \pi/2$  the  $M_{oz}$  and  $F_{oz}$  distributions are similar in form. Furthermore, calculations of the element currents for the couplets of Chapter 10 show that the corrections for not assuming certain integrals proportional to  $F_{oz}$  are quite small, actually of the order of a few per cent.

An example of the order of magnitude of the correction term is given in IX:27 and IX:29 for the couplet with  $\beta h_1 = 1.4$ ,  $\beta h_2 = \pi/2$ ,  $\beta b = 1$ .

The reduction of the original integral equations for the Yagi array 11:1 - 11:4 to a solution of quasi zeroth-order follows directly from the preceding analysis for the two-element couplet in Chapters 8, 9 and 10. The final result is similar to 9:35 and 9:36, and with the simplifying assumption of only  $F_{oz}$  type currents for the coupling terms, the element currents are given by the solution of the following equations:

$$jA_2 = j \frac{2\pi}{\sum_o F_o(h_o) \Psi_{22} dR} V_{02} \quad 11:5$$

$$jA_k = 0 \quad k = 1, 3, 4, 5, \dots$$

$$[\Phi_u^u] \{B\} = [\Phi_v^u] \{jA\} \quad 11:6$$

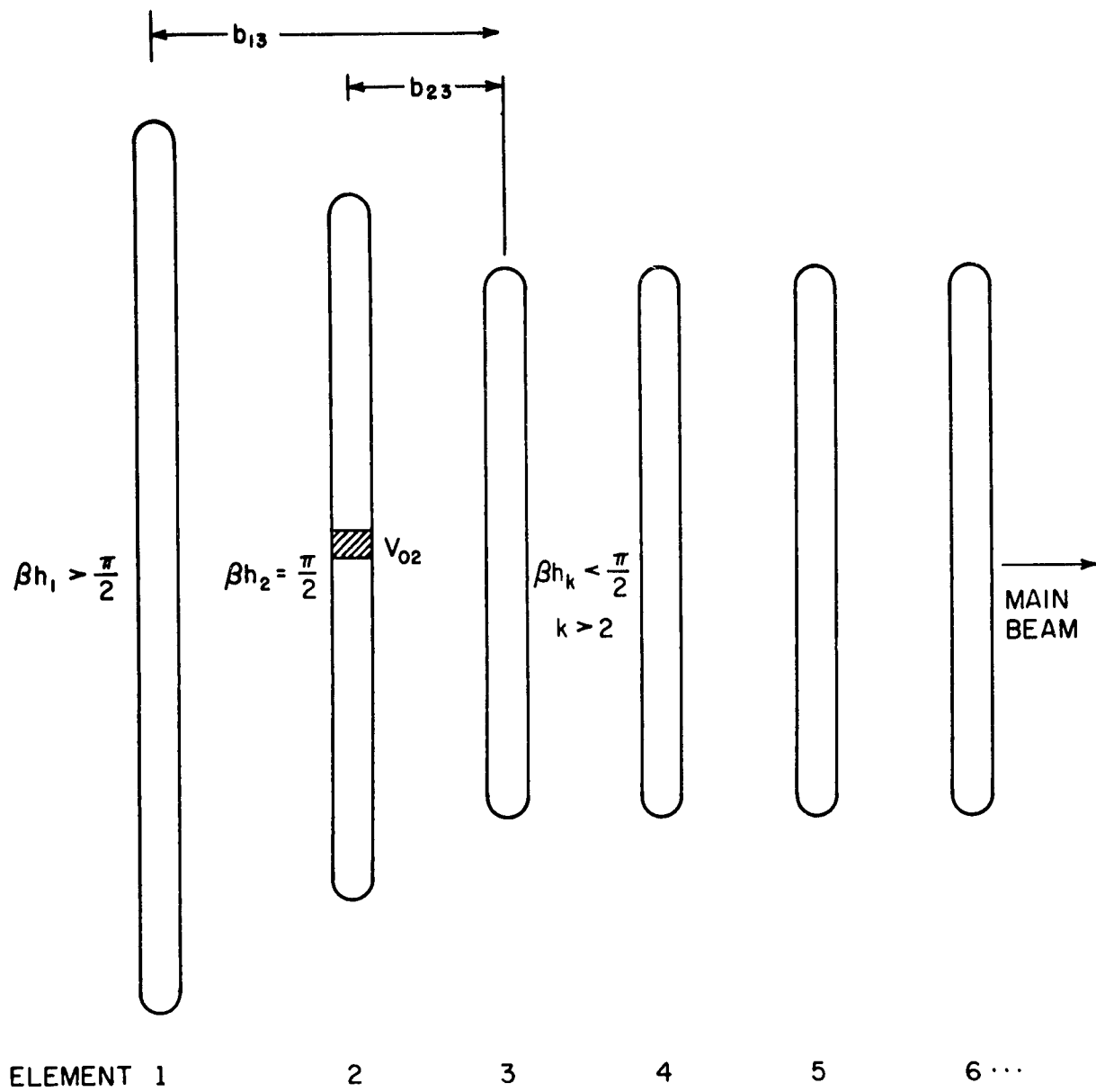

FIG. 11-1 A SIX ELEMENT YAGI ARRAY

where

$$[\Phi_u^u] = \begin{bmatrix} \Phi_{11u}^u & \Phi_{12u}^u & \dots & \Phi_{1Nu}^u \\ \Phi_{21u}^u & \Phi_{22u}^u & \dots & \Phi_{2Nu}^u \\ \dots & \dots & \dots & \dots \\ \Phi_{N1u}^u & \Phi_{N2u}^u & \dots & \Phi_{NNu}^u \end{bmatrix} \quad 11:7$$

$$[\Phi_u^u] = \begin{bmatrix} F_o(h_1)\Psi_{11du} - \Psi_{11u}(h_1) & F_o(h_1)\Psi_{12du} - \Psi_{12u}(h_1) & \dots & F_o(h_1)\Psi_{1Ndu} - \Psi_{1Nu}(h_1) \\ \Psi_{21du} - \Psi_{21u}(0) & \Psi_{22du} - \Psi_{22u}(0) & \dots & \Psi_{2Ndu} - \Psi_{2Nu}(0) \\ F_o(h_3)\Psi_{31du} - \Psi_{31u}(h_3) & F_o(h_3)\Psi_{32du} - \Psi_{32u}(h_3) & \dots & F_o(h_3)\Psi_{3Ndu} - \Psi_{3Nu}(h_3) \\ \dots & \dots & \dots & \dots \\ F_o(h_N)\Psi_{N1du} - \Psi_{N1u}(h_N) & F_o(h_N)\Psi_{N2du} - \Psi_{N2u}(h_N) & \dots & F_o(h_N)\Psi_{NNdu} - \Psi_{NNu}(h_N) \end{bmatrix} \quad 11:8$$

$$[\Phi_v^u] = \begin{bmatrix} \Psi_{11v}(h_1) - jF_o(h_1)\Psi_{11dI} & \Psi_{12v}^h(h_1) - F_o(h_1)\Psi_{12dv}^h & \dots & \Psi_{1Nv}(h_1) - F_o(h_1)\Psi_{1NdI} \\ \Psi_{21v}(0) - \Psi_{21dv} & \Psi_{22v}^h(0) - j\Psi_{22dI}^h & \dots & \Psi_{2Nv}(0) - \Psi_{2NdI} \\ \Psi_{31v}(h_3) - F_o(h_3)\Psi_{31dv} & \Psi_{32v}^h(h_3) - F_o(h_3)\Psi_{32dv}^h & \dots & \Psi_{3Nv}(h_3) - F_o(h_3)\Psi_{3NdI} \\ \dots & \dots & \dots & \dots \\ \Psi_{N1v}(h_N) - F_o(h_N)\Psi_{N1dv} & \Psi_{N2v}^h(h_N) - F_o(h_N)\Psi_{N2dv}^h & \dots & \Psi_{NNv}(h_N) - jF_o(h_N)\Psi_{NNdI} \end{bmatrix} \quad 11:9$$

Note that the formal result 11:5 and 11:6 for the Yagi array is identical to that for the N-element curtain array. Also note that since only  $V_{02}$  is non-zero, the second column of 11:8 enters into the calculations for the

element currents.

A representative three-element Yagi array is shown in Fig. 11-2, with  $\beta h_1 = 1.8$ ,  $\beta h_2 = \pi/2$ ,  $\beta h_3 = 1.4$  and  $\beta b = 1$  spacing. The calculations for the driving impedance and element currents are given in Appendix XI.

The element currents are given by XI:9, or

$$I_{z1}(z) = 10^{-3} V_{02} [ (0.7355 + j6.4421) F_{oz1} ] \quad 11:9$$

$$I_{z2}(z) = 10^{-3} V_{02} [ -j2.4124 M_{oz2}^h + (13.19 - j25.55) F_{oz2} ] \quad 11:10$$

$$I_{z3}(z) = 10^{-3} V_{02} [ (-19.36 + j14.08) F_{oz3} ] \quad 11:11$$

where

$$M_{oz2}^h = \sin \beta |z| - 1 \quad 11:12$$

$$F_{ozk} = \cos \beta z - \cos \beta h_k$$

The driving-point admittance and impedance are given by 11:10 evaluated at  $z = 0$ . Thus

$$Y_{02} = (13.19 - j23.14) \times 10^{-3} \text{ mho} \quad 11:13$$

$$Z_{02} = 18.59 + j32.62 \text{ ohm} \quad 11:14$$

The radiation pattern for this array is shown in Fig. 11-3. The front to back ratio of 10.1 db is less than optimum for this array and is nearly equal to the corresponding ratio for the two-element parasitic couplet with

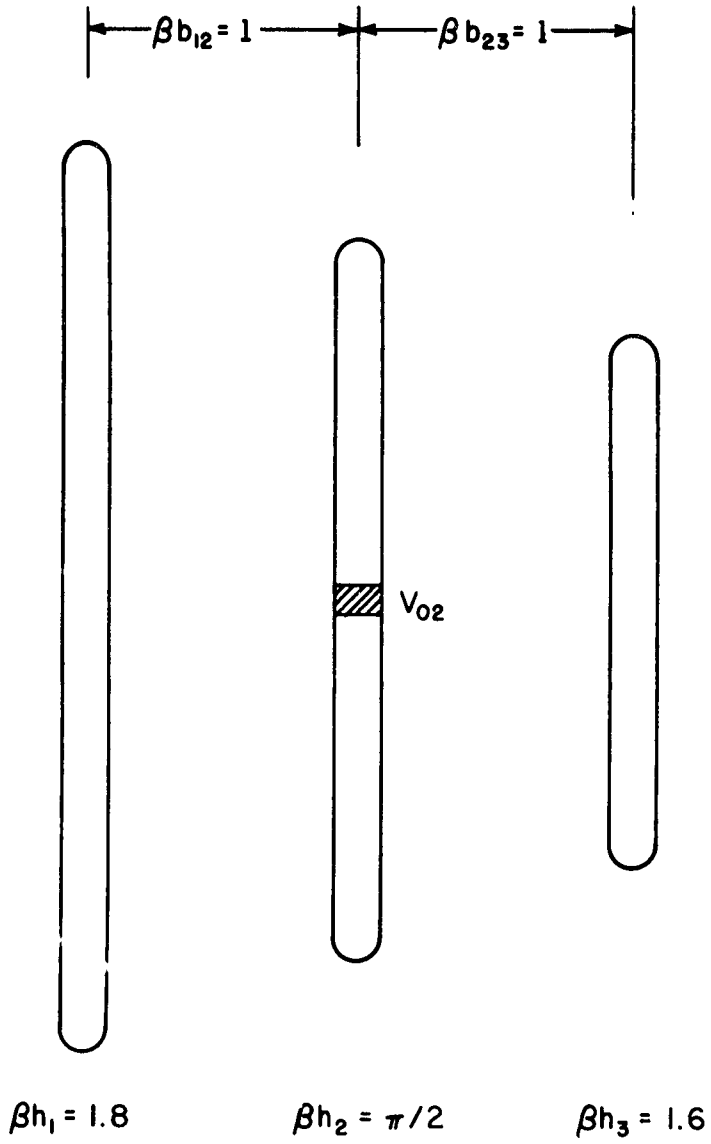

$\Omega = 10$  FOR ALL ELEMENTS

FIG. 11-2 THREE ELEMENT YAGI ARRAY

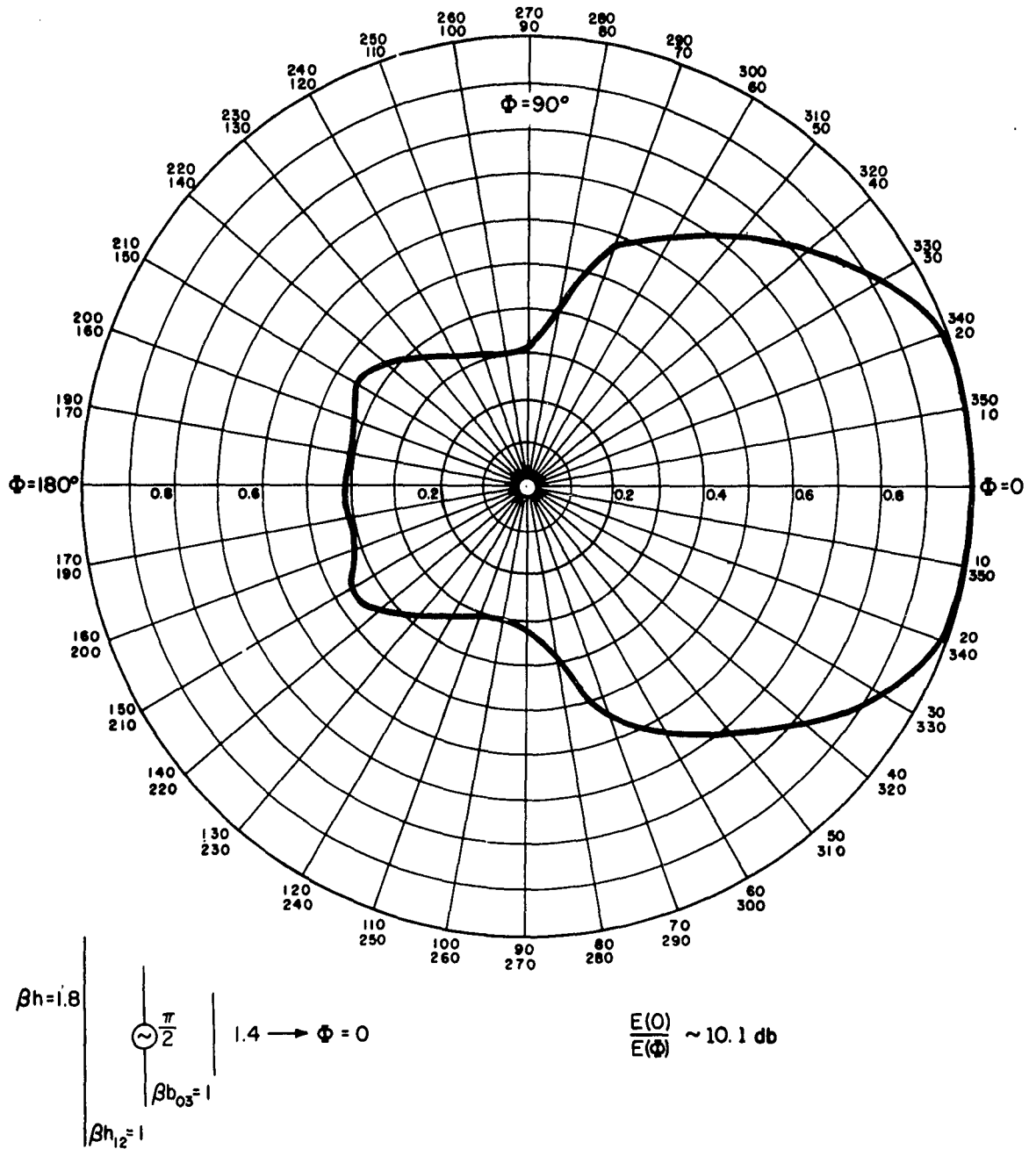

FIG. II-3 THREE ELEMENT YAGI, WITH REFLECTOR & DIRECTOR

$\beta h_1 = 1.8$ ,  $\beta h_2 = \pi/2$ . Hence, for maximizing the front to back ratio of the three-element Yagi, the relative positions of the director and reflector must be changed.

A further theoretical simplification is available for the Yagi array, since

$$(\Phi_{22v}^u)^2 \gg (\Phi_{N2v}^u)^2 \quad . \quad 11:15$$

For example, in the three-element array of Fig. 11-2

$$\Phi_{12v}^u = 0.0739 + j0.5621$$

$$\Phi_{22v}^u = -7.075 + j0.7090 \quad . \quad 11:16$$

$$\Phi_{32v}^u = 0.1605 + j0.5787$$

The relation between the A and B current coefficients is reduced to the following form

$$[\Phi_u^u] \{B\} = -jA_2 \begin{Bmatrix} 0 \\ \Phi_{22v}^u \\ 0 \end{Bmatrix} \quad 11:17$$

or

$$\{B\} = -jA_2 \Phi_{22v} \begin{Bmatrix} \Phi_{21u} \\ \Phi_u \\ \Phi_{22u} \\ \vdots \\ \Phi_{2Nu} \\ \Phi_u \end{Bmatrix} \quad 11:18$$

where  $\Phi_u^{2iu}$  is the element in the second column and  $i^{\text{th}}$  row of  $[\Phi_u^u]^{-1}$ .

With the simplification offered by 11:18, the element currents are recalculated in Appendix XI, with the result

$$I_{z1}(z) = 10^{-3} V_{02} [ (1.292 + j6.737) F_{0z1} ] \quad 11:19$$

$$I_{z2}(z) = 10^{-3} V_{02} [-j2.4124 M_{0z2}^h + (11.11 - j27.22) F_{0z2} ] \quad 11:20$$

$$I_{z3}(z) = 10^{-3} V_{02} [ (-17.88 + j18.28) F_{0z3} ] \quad 11:21$$

The validity of assuming that all  $\Phi_{kiv}^u$  are negligible except  $\Phi_{22v}^u$  is seen by comparing 11:19 - 11:21 with 11:9 - 11:11.

## REFERENCES

Chapter 6. The Particular Solution for Curtain Arrays with Half-Wavelength Elements

1. R. King, "Linear arrays: currents, impedances, and fields, I," *Trans. I. R. E.*, AP-7, S440 (December 1959).
2. R. Mack and E. Mack, "Tables of  $E(h, z)$ ,  $C(h, z)$ ,  $S(h, z)$ ," Cruft Laboratory Technical Report No. 331, Harvard University (November 1960).
3. R. W. P. King, Theory of Linear Antennas, Harvard University Press (1956).

Chapter 8. Curtain Arrays with Elements of Unequal Length: the Two-Element Couplet

1. J. G. Channey, "On the generalized circuit theory as applied to antennas and radiating lines," U.S. Naval Postgraduate School Research Paper No. 1, Annapolis, Md. (March 1951).
2. R. W. P. King, Theory of Linear Antennas, Harvard University Press (1956).

Chapter 10. Curtain Arrays with Elements of Unequal Length: the Parasitic Case, Examples of the Theory

1. R. King, "Linear arrays: currents, impedances, and fields, I," *Trans. I. R. E.*, AP-7, S440 (December 1959).
2. R. King, "A dipole with a tuned parasitic radiator," *Proc. Inst. Elec. Engrs.*, 57, Pt. III (January 1952).
3. B. J. Starkey and E. Fitch, "Mutual impedance and self-impedance of coupled parallel aeriials," *J. Inst. Elec. Engrs.*, 97, Pt. III, 129 (1950).
4. J. S. McPetrie and J. A. Saxton, "Some experiments with linear aeriials," *Wireless Engineer*, 23, 107 (1946).

Chapter 11. The Yagi Array

1. R. W. P. King, Theory of Linear Antennas, Harvard University Press (1956).

## APPENDIX VI

For convenience, the relation between the base currents and the driving voltages for  $\beta h = \pi/2$  is repeated below, or, from 6:51

$$\begin{Bmatrix} V \\ 0 \end{Bmatrix} = \left[ j \frac{2\pi}{Z_0 \Psi_{dR}^h} [\Phi_u] - j \frac{2\pi}{Z_0 \Psi_{dR}^h} [\Phi_v^h] \right]^{-1} [\Phi_u] \begin{Bmatrix} I_z(0) \end{Bmatrix} \quad \text{VI:1}$$

The three-element array with quarter-wavelength spacing and the main beam in the endfire direction has the following relationship for the base currents:

$$\begin{Bmatrix} I_z(0) \end{Bmatrix} = \begin{Bmatrix} I_{z1}(0) \\ I_{z2}(0) \\ I_{z3}(0) \end{Bmatrix} = I_{z1}(0) \begin{Bmatrix} 1 \\ -j \\ -1 \end{Bmatrix} \quad \text{VI:2}$$

The elements of the matrices in VI:1 are given by 6:26 and 6:27 with 6:30 - 6:35, or

$$\left. \begin{aligned} \Phi_{11u} = \Phi_{22u} = \Phi_{33u} &= 0.6880 - j1.2187, \quad \Omega = 10 \\ \Phi_{12u} = \Phi_{21u} = \Phi_{23u} = \Phi_{32u}^h &= -0.4725 - j0.6798, \quad \beta b = \frac{\pi}{2} \\ \Phi_{13u} = \Phi_{31u} &= -0.4988 + j0.2089, \quad \beta b = \pi \end{aligned} \right\} \text{VI:3}$$

$$\left. \begin{aligned} \Phi_{11v}^h = \Phi_{22v}^h = \Phi_{33v}^h &= 7.0754 - j0.7090, \quad \Omega = 10 \\ \Phi_{12v}^h = \Phi_{21v}^h = \Phi_{23v}^h = \Phi_{32v}^h &= -0.2864 - j0.3970, \quad \beta b = \frac{\pi}{2} \\ \Phi_{13v}^h = \Phi_{31v}^h &= -0.2925 + j0.1186, \quad \beta b = \pi \end{aligned} \right\} \text{VI:4}$$

Also

$$-j \frac{2\pi}{\oint_0 \Psi_h} = -j2.4124 \times 10^{-3} \quad \text{VI:5}$$

The inverse matrix on the right-hand side of VI:1 is constructed from the values in VI:3, VI:4 and VI:5. with the result

$$\left[ j \frac{2\pi}{\oint_0 \Psi_h} [\Phi_u] - j \frac{2\pi}{\oint_0 \Psi_h} [\Phi_v^h] \right]^{-1} =$$

$$-j(0.4145) \times 10^3 \begin{bmatrix} (-6.3874-j0.5097) & (-0.1861-j0.2828) & (-0.2063+j0.0903) \\ (-0.1861-j0.2828) & (-6.3874-j0.5097) & (-0.1861-j0.2828) \\ (-0.2063+j0.0903) & (-0.1861-j0.2828) & (-6.3874-j0.5097) \end{bmatrix}^{-1} \quad \text{VI:6}$$

The inverse matrix VI:6 is calculated by the same method employed in Appendix I. First, all the double products of the individual elements of VI:6 are obtained:

$$\left. \begin{array}{ll} \Phi_{11}^2 = 40.5391+j6.5114 & \Phi_{11}\Phi_{12} = 1.0446+j1.9013 \\ \Phi_{12}^2 = -0.0458+j0.1052 & \Phi_{11}\Phi_{13} = 1.3637-j0.4716 \\ \Phi_{13}^2 = 0.0345-j0.0373 & \Phi_{12}\Phi_{13} = 0.0639+j0.0415 \end{array} \right\} \quad \text{VI:7}$$

where

$$\Phi_{11} = -6.3874-j0.5097, \quad \Phi_{12} = -0.1861-j0.2828, \quad \Phi_{13} = -0.2063+j0.0903 \quad \text{VI:8}$$

The complete inverse matrix VI:6 is given by VI:7 and I:3, with the result

$$\left[ j \frac{2\pi}{\omega_0} \frac{1}{dR} \begin{bmatrix} \Phi_u \\ \Phi_v \end{bmatrix} - j \frac{2\pi}{\omega_0} \frac{1}{dR} \begin{bmatrix} h \\ v \end{bmatrix} \right]^{-1} =$$

$$10^2 (0.3664 + j1.5307) \begin{bmatrix} (0.4058 + j0.0641) & (0.0098 - j0.0186) & (-0.0141 + j0.0058) \\ (0.0098 - j0.0186) & (0.4050 + j0.0655) & (0.0098 - j0.0186) \\ (-0.0141 + j0.0058) & (0.0098 - j0.0186) & (0.4058 + j0.0641) \end{bmatrix} \quad \text{VI:9}$$

When VI:9 is multiplied by the matrix  $\begin{bmatrix} \Phi_u \\ \Phi_v \end{bmatrix}$ , and the result substituted in VI:1, it follows that

$$\begin{Bmatrix} V_o \\ \end{Bmatrix} = 10^2 (0.3664 + j1.5307) \begin{bmatrix} (0.3459 - j0.4541) & (-0.1534 - j0.3240) & (-0.2356 + j0.0761) \\ (-0.1639 - j0.3196) & (0.3928 - j0.4443) & (-0.1639 - j0.3196) \\ (-0.2356 + j0.0761) & (-0.1534 - j0.3240) & (0.3459 - j0.4541) \end{bmatrix} \begin{Bmatrix} I_z(0) \\ \end{Bmatrix} \quad \text{VI:10}$$

The specified base currents VI:2 are substituted in VI:10, and after multiplication the result is

$$\begin{Bmatrix} V_{01} \\ V_{02} \\ V_{03} \end{Bmatrix} = (0.3664 + j1.5307) \times 10^2 \begin{Bmatrix} 0.2575 - j0.3768 \\ -0.4443 - j0.3928 \\ -0.9055 + j0.6836 \end{Bmatrix} I_{z1}(0) = 10^2 I_{z1}(0) \begin{Bmatrix} 0.6711 + j0.2561 \\ 0.4385 - j0.8340 \\ -1.3782 - j1.1355 \end{Bmatrix} \quad \text{VI:11}$$

$$= 10^2 \begin{Bmatrix} (0.6711 + j0.2561) I_{z1}(0) \\ (0.8340 + j0.4385) I_{z2}(0) \\ (1.3782 + j1.1355) I_{z3}(0) \end{Bmatrix} \quad \text{VI:12}$$

The driving-point admittances are given directly by VI:12, or

$$\left. \begin{aligned} Y_{01} &= (13.01 - j4.963) \times 10^{-3} \text{ mho} \\ Y_{02} &= (9.393 - j4.939) \times 10^{-3} \text{ mho} \\ Y_{03} &= (4.322 - j3.560) \times 10^{-3} \text{ mho} \end{aligned} \right\} \text{VI:13}$$

The quasi zeroth-order element current is given by 6:19 with the A coefficients given by 6:25, and the B coefficients given by 6:49 and 6:50 with VI:13 and 6:25. With respect to the individual driving voltages, the element currents are

$$\left. \begin{aligned} I_{z1}(z) &= 10^{-3} V_{01} \left\{ 13.01 \cos \beta z - j \left[ 7.375 \cos \beta z + 2.4124 (\sin \beta |z| - 1) \right] \right\} \\ I_{z2}(z) &= 10^{-3} V_{02} \left\{ 9.393 \cos \beta z - j \left[ 7.351 \cos \beta z + 2.4124 (\sin \beta |z| - 1) \right] \right\} \\ I_{z3}(z) &= 10^{-3} V_{03} \left\{ 4.322 \cos \beta z - j \left[ 5.972 \cos \beta z + 2.4124 (\sin \beta |z| - 1) \right] \right\} \end{aligned} \right\} \text{VI:14}$$

The three-element currents are given with respect to a common reference by expressing  $V_{01}$  and  $V_{03}$  in terms of  $V_{02}$  from VI:11, with the result

$$\left. \begin{aligned} V_{01} &= (0.0909 + j0.7569) V_{02} \\ V_{02} &= (1 + j0) V_{02} \\ V_{03} &= (0.3859 - j1.8553) V_{02} \end{aligned} \right\} \text{VI:15}$$

With VI:15 in VI:14, the element currents with respect to  $V_{02}$  are

$$I_{z1}(z) = 10^{-3} V_{02} \left\{ 1.826(\sin \beta|z| - 1) + 6.765 \cos \beta z - j \left[ 0.2193(\sin \beta|z| - 1) - 9.177 \cos \beta z \right] \right\}$$

$$I_{z2}(z) = 10^{-3} V_{02} \left\{ \begin{array}{l} 9.393 \cos \beta z - j \left[ 2.4124(\sin \beta|z| - 1) + 7.351 \cos \beta z \right] \end{array} \right\} \quad \text{VI:16}$$

$$I_{z3}(z) = 10^{-3} V_{02} \left\{ -4.4759(\sin \beta|z| - 1) - 9.412 \cos \beta z - j \left[ 0.9309(\sin \beta|z| - 1) + 16.32 \cos \beta z \right] \right\}$$

## APPENDIX VII

The relation between the specified base currents and the driving voltages is given by 2:50 and repeated below for convenience:

$$\left\{ \begin{matrix} V_o \end{matrix} \right\} = -j \frac{\sum_o F_o(h) Y_{dR}}{2\pi} \left[ \begin{matrix} \Phi_v \\ \Phi_u \end{matrix} \right] + \frac{\sin \beta h}{1 - \cos \beta h} \left[ \begin{matrix} \Phi_v \\ \Phi_u \end{matrix} \right]^{-1} \left[ \begin{matrix} \Phi_u \end{matrix} \right] \left\{ \frac{I_z(0)}{1 - \cos \beta h} \right\}. \quad \text{VII:1}$$

With  $\beta h = 3\pi/4$ , the  $Y_{ki}(z)$  functions in 2:53 - 2:58 are evaluated at  $z = 0$ , except  $Y_{dR}$  which is evaluated at  $z = \lambda/8$ . The  $Y_{ki}$  functions are substituted in 2:34 and 2:35, with the result

$$\left. \begin{aligned} \Phi_{11u} = \Phi_{22u} = \Phi_{33u} &= -5.4121 + j2.5861, \quad \Omega = 10 \\ \Phi_{12u} = \Phi_{21u} = \Phi_{23u} = \Phi_{32u} &= 0.9148 + j1.4058, \quad \beta b = \frac{\pi}{2} \\ \Phi_{13u} = \Phi_{31u} &= 0.9861 - j0.5075, \quad \beta b = \pi \end{aligned} \right\} \text{VII:2}$$

$$\left. \begin{aligned} \Phi_{11v} = \Phi_{22v} = \Phi_{33v} &= 0.3215 - j1.8139, \quad \Omega = 10 \\ \Phi_{12v} = \Phi_{21v} = \Phi_{23v} = \Phi_{32v} &= -0.6472 - j0.9839, \quad \beta b = \frac{\pi}{2} \\ \Phi_{13v} = \Phi_{31v} &= -0.7140 + j0.3625, \quad \beta b = \pi \end{aligned} \right\} \text{VII:3}$$

Also,

$$j \frac{2\pi}{\sum_o F_o(h) Y_{dR}} = -j3.3219 \times 10^{-3}, \quad -j \frac{\sum_o F_o(h) Y_{dR}}{2\pi} = j301.034. \quad \text{VII:4}$$

The inverse matrix on the right-hand side of VII:1 is formed with VII:2, VII:3 and VII:4, or

$$\left[ \begin{bmatrix} \Phi \\ \mathbf{v} \end{bmatrix} + \frac{\sin \beta h}{1 - \cos \beta h} \begin{bmatrix} \Phi \\ \mathbf{u} \end{bmatrix} \right]^{-1} = \begin{bmatrix} -1.9202 - j0.7427 & -0.2683 - j0.4016 & -0.3056 + j0.1523 \\ -0.2683 - j0.4016 & -1.9202 - j0.7427 & -0.2683 - j0.4016 \\ -0.3056 + j0.1523 & -0.2683 - j0.4016 & -1.9202 - j0.7427 \end{bmatrix}^{-1} \quad \text{VII:4}$$

The inverse matrix VII:4 is found by the same method employed in Appendix I. First, all the double products of the individual elements of VII:4 are obtained:

$$\begin{aligned} \Phi_{11}^2 &= 3.1356 + j2.8522 & \Phi_{11}\Phi_{12} &= 0.2169 + j0.9705 \\ \Phi_{12}^2 &= -0.0893 + j0.2154 & \Phi_{11}\Phi_{13} &= 0.6999 - j0.0654 \\ \Phi_{13}^2 &= 0.0702 - j0.0931 & \Phi_{12}\Phi_{13} &= 0.1432 + j0.0818 \end{aligned} \quad \text{VII:5}$$

where

$$\Phi_{11} = -1.9202 - j0.7427; \quad \Phi_{12} = -0.2683 - j0.4016; \quad \Phi_{13} = -0.3056 + j0.1523 \quad \text{VII:6}$$

The final form of the inverse matrix VII:4 is given by VII:5 and I:3, with the result

$$\left[ \begin{bmatrix} \Phi \\ \mathbf{v} \end{bmatrix} + \frac{\sin \beta h}{1 - \cos \beta h} \begin{bmatrix} \Phi \\ \mathbf{u} \end{bmatrix} \right]^{-1} = \begin{bmatrix} -2.3725 - j0.6172 & 0.0821 + j1.0715 & 0.9245 - j0.3517 \\ 0.0836 + j1.0783 & -2.1843 - j0.9847 & 0.0836 + j1.0783 \\ 0.9245 - j0.3517 & 0.0821 + j1.0715 & -2.3725 - j0.6172 \end{bmatrix} \quad \text{VII:7}$$

When VII:7 is multiplied by the matrix  $[\Phi_u]$ , and the result substituted in VII:1 it follows that

$$\begin{Bmatrix} V_0 \end{Bmatrix} = 10^3 (-0.1767 - j0.1044) \begin{bmatrix} -2.3725 - j0.6712 & 0.0821 + j1.0715 & 0.9245 - j0.3517 \\ 0.0836 + j1.0783 & -2.1843 - 0.9847 & 0.0836 + j1.0783 \\ 0.9245 - j0.3517 & 0.0821 + j1.0715 & -2.3725 - j0.6172 \end{bmatrix} \begin{Bmatrix} I_z(0) \end{Bmatrix} \quad \text{VII:8}$$

where for the endfire array

$$\begin{Bmatrix} I_z(0) \end{Bmatrix} = I_{z1}(0) \begin{Bmatrix} 1 \\ -j \\ -1 \end{Bmatrix} \quad \text{VII:9}$$

With the base currents specified by VII:9, the driving voltages are given by VII:8, or

$$\begin{Bmatrix} V_{01} \\ V_{02} \\ V_{03} \end{Bmatrix} = 10^3 (-0.1767 - j0.1044) I_{z1}(0) \begin{Bmatrix} -2.2255 - j0.3476 \\ -0.9847 + j1.9257 \\ 4.3685 + j0.1834 \end{Bmatrix} \begin{Bmatrix} 0.3570 + j0.2937 \\ 0.4020 - j0.3743 \\ -0.5408 - j0.4885 \end{Bmatrix} I_{z1}(0) \quad \text{VII:10}$$

or

$$\begin{Bmatrix} V_{01} \\ V_{02} \\ V_{03} \end{Bmatrix} = 10^3 \begin{Bmatrix} (0.3570 + j0.2937) I_{z1}(0) \\ (0.3743 + j0.4020) I_{z2}(0) \\ (0.5408 + j0.4885) I_{z3}(0) \end{Bmatrix} \quad \text{VII:11}$$

The driving-point impedances and admittances are given by VII:11, thus

$$\begin{array}{ll}
 Z_{01} = 357.0 + j293.7 \text{ ohms} & Y_{01} = (1.6706 - j1.3744) \times 10^{-3} \text{ mho} \\
 Z_{02} = 374.3 + j402.0 \text{ ohms} & Y_{02} = (1.3324 - j1.2402) \times 10^{-3} \text{ mho} \\
 Z_{03} = 540.8 + j488.5 \text{ ohms} & Y_{03} = (1.0183 - j0.9198) \times 10^{-3} \text{ mho}
 \end{array} \left. \vphantom{\begin{array}{l} Z_{01} \\ Z_{02} \\ Z_{03} \end{array}} \right\} \text{VII:12}$$

The quasi zeroth-order current is given by 2:27, 2:45 and 2:47 with 2:40 and VII:11. Hence, with respect to the individual driving voltages, the currents are given by

$$\begin{array}{l}
 I_{z1}(z) = V_{01} [0.9786F_{oz} - j(3.3219M_{oz} - 0.5708F_{oz})] \times 10^{-3} \\
 I_{z2}(z) = V_{02} [0.7805F_{oz} - j(3.3219M_{oz} - 0.6495F_{oz})] \times 10^{-3} \\
 I_{z3}(z) = V_{03} [0.5965F_{oz} - j(3.3219M_{oz} - 0.8371F_{oz})] \times 10^{-3}
 \end{array} \left. \vphantom{\begin{array}{l} I_{z1} \\ I_{z2} \\ I_{z3} \end{array}} \right\} \text{VII:13}$$

where

$$\begin{array}{l}
 M_{oz} = \sin\left(\frac{3\pi}{4} - \beta|z|\right) \\
 F_{oz} = \cos \beta z + 0.7071
 \end{array} \left. \vphantom{\begin{array}{l} M_{oz} \\ F_{oz} \end{array}} \right\} \text{VII:14}$$

The three-element currents are given with respect to a common reference by expressing  $V_{01}$  and  $V_{03}$  in terms of  $V_{02}$  from VII:10, with the result

$$\begin{array}{l}
 V_{01} = (0.1115 + j0.8341)V_{02} \\
 V_{02} = V_{02} \\
 V_{03} = (-0.1148 - j1.3216)V_{02}
 \end{array} \left. \vphantom{\begin{array}{l} V_{01} \\ V_{02} \\ V_{03} \end{array}} \right\} \text{VII:15}$$

With VII:15 in VII:13, the element currents with respect to  $V_{02}$  are

$$I_{z1}(z) = V_{02} [2.7618M_{oz} - 0.3669F_{oz} - j(0.3704M_{oz} - 0.8798F_{oz})] \times 10^{-3}$$

$$I_{z2}(z) = V_{02} [0.7805F_{oz} - j(3.3219M_{oz} - 0.6495F_{oz})] \times 10^{-3} \quad \text{VII:16}$$

$$I_{z3}(z) = V_{02} [-4.3902M_{oz} + 1.0378F_{oz} + j(0.3818M_{oz} - 0.8844F_{oz})] \times 10^{-3}$$

## APPENDIX VIII

The general relation between the base currents and the driving voltages for the N-element array is given by 2:50

$$\left\{ \frac{I_z(0)}{1 - \cos \beta h} \right\} = j \frac{2\pi}{\zeta_0 F_0(h) Y_{dR}} [\Phi_u]^{-1} \left[ \Phi_v + \frac{\sin \beta h}{1 - \cos \beta h} \Phi_u \right] \left\{ V_o \right\} \quad \text{VIII:1}$$

where for the parasitic two-element couplet

$$\left\{ V_o \right\} = \begin{Bmatrix} V_{o1} \\ C \end{Bmatrix} \quad \text{VIII:2}$$

With  $\beta h = 3\pi/4$  and  $\beta b_{12} = \pi/4$  the values of the matrix elements are given in Appendix VII, or

$$[\Phi_u] = \begin{bmatrix} -5.4124 + j2.5861 & 0.9148 + j1.4058 \\ 0.9148 + j1.4058 & -5.4124 + j2.5861 \end{bmatrix} \quad \text{VIII:3}$$

$$\left[ \Phi_v + \frac{\sin \beta h}{1 - \cos \beta h} \Phi_u \right] = \begin{bmatrix} -1.9202 - j0.7427 & -0.2683 - j0.4016 \\ -0.2683 - j0.4016 & -1.9202 - j0.7427 \end{bmatrix} \quad \text{VIII:4}$$

The substitution of VIII:3, VIII:4 and VIII:2 in VIII:1 yields the following result:

$$\left\{ \frac{I_z(0)}{1 - \cos \beta h} \right\} = \frac{-j3.3219 \times 10^{-3} V_{o1}}{23.7461 - j30.5666} \begin{bmatrix} -5.4124 + j2.5861 & -0.9148 - j1.4058 \\ -0.9148 - j1.4058 & -5.4124 + j2.5861 \end{bmatrix} \left\{ \begin{matrix} -1.9202 - j0.7427 \\ -0.2683 - j0.4016 \end{matrix} \right\} \quad \text{VIII:5}$$

where

$$j \frac{2\pi}{\int_0^{\infty} F_0(h) \Psi dR} = -j3.3219 \times 10^{-3} \quad \text{VIII:6}$$

After performing the matrix multiplication in VIII:7, the result is given by

$$\begin{Bmatrix} I_{z_1}(0) \\ 1.7071 \end{Bmatrix} = 10^{-5} V_{01} (6.7773 - j5.2651) \begin{Bmatrix} 12.0044 - j0.2014 \\ 3.2082 + j4.8585 \end{Bmatrix} \quad \text{VIII:7}$$

$$\begin{Bmatrix} I_{z_2}(0) \\ 1.7071 \end{Bmatrix} = 10^{-3} V_{01} \begin{Bmatrix} 0.80299 - j0.64778 \\ 0.47323 + j0.16036 \end{Bmatrix} \quad \text{VIII:8}$$

The two base currents  $I_{z_1}(0)$  and  $I_{z_2}(0)$  are given directly by VIII:8. Thus,

$$\begin{Bmatrix} I_{z_1}(0) \\ I_{z_2}(0) \end{Bmatrix} = 10^{-3} V_{01} \begin{Bmatrix} 1.3708 - j1.1058 \\ 0.8079 + j0.2738 \end{Bmatrix} \quad \text{VIII:9}$$

The B coefficients of the element currents are given by

$$B_i = \frac{1}{1 - \cos \beta h} [I_{z_i}(0) - jA_i \sin \beta h] \quad \text{VIII:10}$$

where

$$-jA_1 \sin \beta h = j2.3489 \quad \text{VIII:11}$$

$$jA_1 = -j3.3219 \times 10^{-3} \quad \text{VIII:12}$$

and

$$jA_2 = 0$$

VIII:13

The element currents are determined from

$$I_{zi}(z) = jA_1 M_{oz} + B_i F_{oz}$$

VIII:14

where the A coefficients are given by VIII:12 and VIII:13, and the B coefficients are given by VIII:10 with VIII:9, whence

$$I_{z1}(z) = 10^{-3} V_{01} \left[ 0.8030 F_{oz} - j(3.3219 M_{oz} - 0.7282 F_{oz}) \right]$$

VIII:15

$$I_{z2}(z) = 10^{-3} V_{01} (0.4732 F_{oz} + j0.1604 F_{oz})$$

The rigorous solution for the same couplet described above follows from the symmetrical component solution, or

$$I_z^m(z) = \frac{j2\pi V_o^m}{\xi_o \Psi_{dR} F_o(h)} (M_{oz} + T^m(h) F_{oz})$$

VIII:16

where for the couplet,  $m = 0$  corresponds to driving both elements in phase, and  $m = 1$  corresponds to the phase reversal case. The  $T^m(h)$  functions are given by

$$T^m(h) = \frac{\Phi_{11v} \pm \Phi_{12v}}{\Phi_{11u} \pm \Phi_{12u}}$$

VIII:17

where the upper sign corresponds to  $m = 0$ , the lower to  $m = 1$ . The numerical

values of the  $T^m(h)$  functions are easily calculated from the  $\Phi$  functions given in Appendix VII, or

$$T^0(h) = -0.2367 + j0.4646$$

. VIII:18

$$T^1(h) = -0.1720 + j0.0994$$

The phase sequence currents are given by VIII:16 with VIII:18:

$$I_{z2}^0(z) = I_{z1}^0(z) = 10^{-3}V^0 [1.5434F_{oz} - j(3.3219M_{oz} - 0.7863F_{oz})]$$

VIII:19

$$-I_{z2}^1(z) = I_{z1}^1(z) = 10^{-3}V^1 [0.3301F_{oz} - j(3.3219M_{oz} - 0.5714F_{oz})]$$

where

$$V^0 = V^1 = \frac{1}{2}V_{01}$$

. VIII:20

The phase sequence currents are combined to give the element currents for the couplet with  $V_{02} = 0$ , thus

$$I_{z1}(z) = \frac{1}{2}I_z^0 + \frac{1}{2}I_z^1 = 10^{-3}V_{01} [0.9368F_{oz} - j(3.3219M_{oz} - 0.6789F_{oz})]$$

VIII:21

$$I_{z2}(z) = \frac{1}{2}I_z^0 - \frac{1}{2}I_z^1 = 10^{-3}V_{01} [0.6067F_{oz} + j0.1075F_{oz}]$$

## APPENDIX IX

The physical dimensions of the couplet are

$$\beta b_{12} = 1, \quad \Omega = 10 = \ln\left(\frac{2h_1}{a_1}\right) = \ln\left(\frac{2h_2}{a_2}\right) \quad \text{IX:1}$$

$$\beta h_1 = 1.4, \quad \beta h_2 = \frac{\pi}{2}$$

and the driving voltages are

$$V_{01} = 0, \quad V_{02} \quad \text{IX:2}$$

The forms of the  $\Psi$  functions which are needed to compute the  $\Phi$  matrices are given below

$$\Psi_{11du} = \frac{1}{1 - \cos\beta h_1} \left\{ [C_a(h_1, 0) - C_a(h_1, h_1)] - \cos\beta h_1 [E_a(h_1, 0) - E_a(h_1, h_1)] \right\} \quad \text{IX:3}$$

$$\Psi_{11v}(h_1) = C_a(h_1, h_1) - \cos\beta h_1 E_a(h_1, h_1) \quad \text{IX:4}$$

$$\Psi_{12du} = \frac{1}{1 - \cos\beta h_1} [C_b(h_2, 0) - C_b(h_2, h_1)] \quad \text{IX:5}$$

$$\Psi_{12u}(h_1) = C_b(h_2, h_1) \quad \text{IX:6}$$

$$\Psi_{21du} = \left\{ [C_b(h_2, 0) - C_b(h_2, h_1)] - \cos\beta h_1 [E_b(h_2, 0) - E_b(h_2, h_1)] \right\} \quad \text{IX:7}$$

$$\Psi_{21u}(0) = C_b(h_2, 0) - \cos\beta h_1 E_b(h_2, 0) \quad \text{IX:8}$$

$$\Psi_{22du} = C_a(h_2, 0) - C_a(h_2, h_2) \quad \text{IX:9}$$

$$\Psi_{22u}^h(0) = C_a(h_2, 0) \quad \text{IX:10}$$

$$\Psi_{12dv}^h = \frac{1}{1 - \cos \beta h_1} \left\{ [S_b(h_2, 0) - S_b(h_2, h_1)] - [E_b(h_2, 0) - E_b(h_2, h_1)] \right\} \quad \text{IX:11}$$

$$\Psi_{12v}^h(h_1) = S_b(h_2, h_1) - E_b(h_2, h_1) \quad \text{IX:12}$$

$$\Psi_{22dI}^h = \text{Im} \left\{ [S_a(h_2, 0) - S_a(h_2, h_2)] - [E_a(h_2, 0) - E_a(h_2, h_2)] \right\} \quad \text{IX:13}$$

$$\Psi_{22v}^h(0) = S_b(h_2, 0) - E_b(h_2, 0) \quad \text{IX:14}$$

$$\Psi_{12du}^m = \frac{0.7071 \text{Re} \Psi_{12du}^h(0) + 0.2929 \text{Re} \Psi_{12du}^h\left(\frac{\pi}{4}\right)}{-0.4142} \quad \text{IX:15}$$

$$\Psi_{12du}^f = \frac{-\text{Re} \Psi_{12du}^h(0) - \text{Re} \Psi_{12du}^h\left(\frac{\pi}{4}\right)}{-0.4142} \quad \text{IX:16}$$

$$\Psi_{22dR}^h = -\text{Re} \left\{ [S_a(h_2, 0) - S_a(h_2, h_2)] - [E_a(h_2, 0) - E_a(h_2, h_2)] \right\} \quad \text{IX:17}$$

The following sine and cosine integral function values are needed to evaluate the preceding  $\Psi$  functions (N. B.  $\Omega = 10$  for both elements.):

$$E_a(h_1, 0) = 9.1108 - j2.5124$$

$$E_b(h_1, 0) = 0.7458 - j2.0968$$

$$E_a(h_1, h_1) = 4.1868 - j1.8321$$

$$E_b(h_1, h_2) = -0.1701 - j1.3249$$

$$E_a(h_2, 0) = 8.8836 - j2.7784$$

$$E_b(h_2, 0) = 0.6950 - j2.3126$$

$$E_a(h_2, h_2) = 4.1786 - j1.8514$$

$$E_b(h_2, h_1) = 0.0413 - j1.6607$$

$$\begin{array}{ll}
C_a(h_1, 0) = 8.6011 - j1.8321 & C_b(h_1, 0) = 0.6670 - j1.5335 \quad \text{IX:18} \\
C_a(h_1, h_1) = 1.4644 - j1.3205 & C_b(h_1, h_2) = -0.1809 - j0.9851 \\
C_a(h_2, 0) = 8.3495 - j1.8514 & C_b(h_2, 0) = 0.6638 - j1.5490 \\
C_a(h_2, h_2) = 0.5737 - j1.1976 & C_b(h_2, h_1) = -0.0431 - j1.1197 \\
S_a(h_2, 0) = 1.8514 - j1.6851 & S_b(h_2, 0) = 0.2278 - j1.3956 \\
S_a(h_2, h_2) = 3.7364 - j1.1549 & S_b(h_2, h_1) = 0.0951 - j1.0247
\end{array}$$

The components of the  $\Phi$  matrices in 9:35 and 9:36 are calculated from 9:37 - 9:40 with IX:2 - IX:18, (N.B. Since  $V_{01} = 0$ , it is not necessary to calculate every member of all the matrices.) with the result

$$\Phi_{22t} = \Psi_{22dR} = 6.9087$$

$$\Phi_{21c} = \Psi_{12du}^m = 0.2179$$

$$\Phi_{11u}^u = F_o(h_1) \Psi_{11du} - \Psi_{11u}(h_1) = 0.5371 + j0.9580$$

$$\Phi_{21u}^u = (\Psi_{21du}^f + j \text{Im} \Psi_{21du}) - \Psi_{21u}(0) = 0.3495 + j0.9295 \quad \text{IX:19}$$

$$\Phi_{12u}^u = F_o(h_1) \Psi_{12du} + \Psi_{12u}(h_1) = 0.1925 + j1.0764$$

$$\Phi_{22u}^u = \Psi_{22du} + \Psi_{22u}(0) = 0.1605 + j0.5784$$

$$\Phi_{22v}^u = \Psi_{22v}^h(0) - j \Psi_{22dI}^h = -7.0754 + j0.7090$$

From 9:33 note that with  $V_{01} = 0$ ,  $jA_1 = 0$  and the value of  $-jA_2$  is given by

$$-jA_2 = -j \frac{2\pi}{\int_0^1 \Psi_{22dR}} V_{02} - \frac{B_1 \Psi_{12du}^m}{\Psi_{22dR}} \quad \text{IX:20}$$

When the value of  $-jA_2$  from IX:20 is substituted into 9:36, the B coefficients are given by the solution of

$$\begin{bmatrix} \Phi_u^u \\ \Phi_u^v \end{bmatrix} \{B\} = \begin{bmatrix} \Phi_v^u \\ \Phi_v^v \end{bmatrix} \left\{ \begin{array}{c} 0 \\ -j \frac{2\pi}{\int_0^1 \Psi_{22dR}} V_{02} - \frac{B_1 \Psi_{12du}^m}{\Psi_{22dR}} \end{array} \right\} \quad \text{IX:21}$$

which may be rearranged in the form

$$\begin{bmatrix} \Phi_{11u}^u + \Phi_{12v}^u \frac{\Psi_{12du}^m}{\Psi_{22dR}} & \Phi_{12u}^u \\ \Phi_{21u}^u + \Phi_{22v}^u \frac{\Psi_{12du}^m}{\Psi_{22dR}} & \Phi_{22u}^u \end{bmatrix} \{B\} = -j \frac{2\pi}{\int_0^1 \Psi_{22dR}} V_{02} \begin{bmatrix} \Phi_{12v}^u \\ \Phi_{22v}^u \end{bmatrix} \quad \text{IX:22}$$

When IX:22 is solved for the B coefficients, the result is

$$\{B\} = -j \frac{2\pi}{\int_0^1 \Psi_{22dR}} V_{02} \begin{bmatrix} \Phi_{11u}^u + \Phi_{12v}^u \frac{\Psi_{12du}^m}{\Psi_{22dR}} & \Phi_{12u}^u \\ \Phi_{21u}^u + \Phi_{22v}^u \frac{\Psi_{12du}^m}{\Psi_{22dR}} & \Phi_{22u}^u \end{bmatrix}^{-1} \begin{bmatrix} \Phi_{12v}^u \\ \Phi_{22v}^u \end{bmatrix} \quad \text{IX:23}$$

The components of the matrices in IX:23 are given by IX:19, or

$$\{B\} = -j2.4124 \times 10^{-3} V_{02} \begin{bmatrix} 0.5422 + j0.9762 & 0.1925 + j1.0764 \\ 0.1263 + j0.9519 & -0.6880 + j1.2187 \end{bmatrix}^{-1} \begin{Bmatrix} 0.1605 + j0.5784 \\ -7.0754 + j0.7090 \end{Bmatrix} \quad \text{IX:24}$$

The inverse matrix on the right-hand side of IX:23 is given by

$$\begin{bmatrix} \Phi_{1lu}^u + \Phi_{12v}^u + \frac{j2du}{22dR} \Phi_{12u}^m & \Phi_{12u}^u \\ \Phi_{2lu}^u + \Phi_{22v}^u + \frac{j2du}{22dR} \Phi_{22u}^m & \Phi_{22u}^u \end{bmatrix}^{-1} = (-1.3231 + j0.7760) \begin{bmatrix} -0.6880 + j1.2187 & -0.1925 - j1.0764 \\ -0.1263 - j0.9519 & 0.5422 + j0.9762 \end{bmatrix} \quad \text{IX:25}$$

With IX:25 in IX:24, the B coefficients are given by

$$\begin{Bmatrix} B_1 \\ B_2 \end{Bmatrix} = \begin{Bmatrix} -20.78 + j17.81 \\ 14.06 - j25.39 \end{Bmatrix} \times 10^{-3} V_{02} \quad \text{IX:26}$$

The coefficient of the  $M_{oz}^h$  current on element two is given by IX:20 with IX:26, or

$$\left. \begin{aligned} -jA_2 &= [-j2.4124 - (20.78 + j17.81)(0.03154)] \times 10^{-3} V_{02} \\ -jA_2 &= (-0.6554 - j2.4686) \times 10^{-3} V_{02} \end{aligned} \right\} \quad \text{IX:27}$$

The current on each element is given by 9:29 and 9:30 with IX:26 and IX:27:

$$\left. \begin{aligned} I_{z1}(z) &= jA_1 M_{oz1} + B_1 F_{oz1} = B_1 F_{oz1} \\ I_{z1}(z) &= (-20.78 + j17.81) \times 10^{-3} V_{02} F_{oz1} \end{aligned} \right\} \quad \text{IX:28}$$

$$I_{z2}(z) = -jA_2 M_{oz2}^h + B_2 F_{oz2}$$

IX:29

$$I_{z2}(z) = [(-0.6554 - j2.468)M_{oz2}^h + (14.06 - j25.39)F_{oz2}] \times 10^{-3}$$

## APPENDIX X

The physical dimensions of the couplet are

$$\beta b_{12} = 1, \quad \Omega = 10 = \ln \frac{2h_1}{a_1} = \ln \frac{2h_2}{a_2}$$

$$\beta h_1 = 1.8, \quad \beta h_2 = \frac{\pi}{2}$$

X:1

The driving voltages are

$$V_{01} = 0, \quad V_{02}$$

X:2

The general forms of the  $\Psi$  functions are given in Appendix IX. The additional values of the sine and cosine integral functions required for this couplet are listed below.

$$C_a(h_1, h_1) = -1.4153 - j1.0279$$

$$E_a(h_1, h_1) = 3.6910 - j1.8219$$

$$C_a(h_1, 0) = 8.1053 - j1.8219$$

$$E_a(h_1, 0) = 8.6050 - j3.0116$$

$$C_b(h_1, h_2) = -0.3508 - j0.5527$$

$$E_b(h_1, h_2) = -0.0448 - j1.6696$$

$$C_b(h_1, 0) = 0.6742 - j1.5254$$

$$E_b(h_1, 0) = 0.6158 - j2.4992$$

$$C_b(h_2, h_1) = -0.2983 - j0.8329$$

$$E_b(h_2, h_1) = -0.2784 - j1.2670$$

$$S_b(h_2, h_1) = -0.0840 - j0.7855$$

$$S_b(h_1, 0) = -0.1496 - j1.5804$$

X:3

Since  $V_{01} = 0$  and  $h_1 > h_2$ , the sinusoidal current on element one is zero, and

$$jA_1 = 0$$

X:4

$$-jA_2 = -j \frac{2\pi}{\int_0^h \Psi_{22dR}^h} V_{02}$$

The elements of the  $\Phi$  matrices for  $h_1 > h_2$  (i.e. 9:41 - 9:44) are given below:

$$\Phi_{11u}^u = F_0(h_1) \Psi_{11du} - \Psi_{11u}(h_1) = -1.3920 + j1.6339$$

$$\Phi_{12u}^u = F_0(h_1) (\Psi_{12dv}^f + j \text{Im} \Psi_{12du}^f) - \Psi_{12u}(h_1) = 0.1722 + j0.9655$$

$$\Phi_{21u}^u = \Phi_{21du} - \Phi_{21u}(0) = 0.3610 + j0.9320$$

X:5

$$\Phi_{22t}^h = \Psi_{22dR}^h = 6.9087$$

$$\Phi_{12v}^u = \Psi_{12v}^h - F_0(h_1) (\Psi_{12dv}^f + j \text{Im} \Psi_{12dv}^h) = 0.0739 + j0.5621$$

$$\Phi_{22v}^u = \Psi_{22v}^h(0) - j \Psi_{22dI}^h = -7.0754 + j0.7090$$

With X:4 in 9:36, it follows that

$$\{B\} = -j \frac{2\pi}{\int_0^h \Psi_{22dR}^h} V_{02} [\Phi_u^u]^{-1} \begin{Bmatrix} \Phi_{12v}^h \\ \Phi_{22v}^h \end{Bmatrix} \quad X:6$$

The inverse matrix on the right-hand side of X:6 is computed from

the values given in X:5, with the result

$$\begin{bmatrix} \Phi_u^u \end{bmatrix}^{-1} = (-0.0176 + j0.2993) \begin{bmatrix} -0.6880 + j1.2187 & -0.1722 - j0.9655 \\ -0.3610 - j0.9320 & -1.3920 + j1.6339 \end{bmatrix} \quad \text{X:7}$$

The inverse matrix X:7 is substituted in X:6, and after matrix multiplication the B coefficients are given by

$$\begin{Bmatrix} B_1 \\ B_2 \end{Bmatrix} = (0.7220 + j0.0425) V_{02} \begin{bmatrix} 1.1671 + j6.4126 \\ 9.1877 - j12.8192 \end{bmatrix} \times 10^{-3} \quad \text{X:8}$$

$$\begin{Bmatrix} B_1 \\ B_2 \end{Bmatrix} = 10^{-3} V_{02} \begin{Bmatrix} 0.5701 + j4.6794 \\ 7.1783 - j8.8649 \end{Bmatrix} \quad \text{X:9}$$

The element currents are given by 9:29 and 9:30 with X:4 and X:9, or

$$I_{z1}(z) = 10^{-3} V_{02} (0.5701 + j4.6794) F_{oz1} \quad \text{X:10}$$

$$I_{z2}(z) = 10^{-3} V_{02} \left[ -j2.4124 M_{oz2}^h + (7.178 - j8.865) F_{oz2} \right]$$

## APPENDIX XI

The relationship between the B and A coefficients for the three-element Yagi array of Figure 11-2 is given by

$$\{B\} = [\Phi_u^u]^{-1} [\Phi_v^u] \begin{Bmatrix} 0 \\ -jA_2 \\ 0 \end{Bmatrix} \quad \text{XI:1}$$

where from 11:7 and 11:8, for  $\beta h_1 = 1.8$ ,  $\beta h_2 = \pi/2$ ,  $\beta h_3 = 1.4$ , and  $\beta b_{12} = 1 = \beta b_{23}$

$$\begin{aligned} \Phi_{11u}^u &= -1.3920 + j1.6339 & \Phi_{21u}^u &= 0.3610 + j0.9320 \\ \Phi_{12u}^u &= 0.1182 + j0.9655 & \Phi_{22u}^u &= -0.6880 + j1.2187 \\ \Phi_{13u}^u &= 0.4326 + j0.3073 & \Phi_{23u}^u &= 0.1323 + j0.9295 \\ \Phi_{31u}^u &= 0.8109 + j0.5728 & \Phi_{12v}^u &= 0.0739 + j0.5621 \\ \Phi_{32u}^u &= 0.1925 + j1.0764 & \Phi_{22v}^u &= -7.0754 + j0.7090 \\ \Phi_{33u}^u &= 0.5371 + j0.9580 & \Phi_{32v}^u &= 0.1605 + j0.5784 \end{aligned} \quad \text{XI:2}$$

The inverse of the  $[\Phi_u^u]$  matrix is symbolically given by

$$[\Phi_u^u]^{-1} = \frac{1}{\Delta} \begin{bmatrix} \Phi^{11} & \Phi^{12} & \Phi^{13} \\ \Phi^{21} & \Phi^{22} & \Phi^{23} \\ \Phi^{31} & \Phi^{32} & \Phi^{33} \end{bmatrix} \quad \text{XI:3}$$

SR12

XI-2

where

$$\Phi^{11} = \Phi_{22}\Phi_{33} - \Phi_{32}\Phi_{23} = -0.5620 - j0.3258$$

$$\Phi^{21} = -\Phi_{21}\Phi_{33} + \Phi_{23}\Phi_{31} = 0.2720 + j0.0372$$

$$\Phi^{31} = \Phi_{21}\Phi_{32} - \Phi_{22}\Phi_{31} = -0.7935 - j0.8143$$

$$\Phi^{12} = -\Phi_{12}\Phi_{33} + \Phi_{13}\Phi_{32} = 0.5941 - j0.1069$$

$$\Phi^{22} = \Phi_{11}\Phi_{33} - \Phi_{13}\Phi_{31} = -2.3836 - j1.0047$$

$$\Phi^{32} = -\Phi_{11}\Phi_{23} + \Phi_{13}\Phi_{21} = 1.5737 + j1.5918$$

$$\Phi^{13} = \Phi_{12}\Phi_{23} - \Phi_{13}\Phi_{22} = -0.2097 - j0.0782$$

$$\Phi^{23} = -\Phi_{11}\Phi_{32} + \Phi_{31}\Phi_{12} = 1.5695 + j2.0344$$

$$\Phi^{33} = \Phi_{11}\Phi_{22} - \Phi_{12}\Phi_{21} = -0.1646 - j3.2792$$

$$\Delta = \Phi_{11}\Phi^{11} + \Phi_{21}\Phi^{12} + \Phi_{31}\Phi^{13} = 1.5035 - j0.1332$$

XI:4

With XI:4 and XI:2 in XI:1, the B coefficients are related to  $-jA_2$  by

$$\begin{Bmatrix} B_1 \\ B_2 \\ B_3 \end{Bmatrix} = -jA_2 \Delta^{-1} \begin{bmatrix} -0.5620 - j0.3258 & 0.5941 - j0.1069 & -0.2097 - j0.0782 \\ 0.2720 + j0.0372 & -2.3836 - j1.0047 & 1.5695 + j2.0344 \\ -0.7935 - j0.8143 & 1.5737 + j1.5918 & -0.1646 - j3.2792 \end{bmatrix} \begin{Bmatrix} 0.0739 + j0.5621 \\ -7.0754 + j0.7090 \\ 0.1605 + j0.5784 \end{Bmatrix} \quad \text{XI:5}$$

The result of the matrix multiplication in XI:5 is

$$\begin{Bmatrix} B_1 \\ B_2 \\ B_3 \end{Bmatrix} = -jA_2 \begin{Bmatrix} -2.6704+j0.3049 \\ 10.5901+j5.4671 \\ -5.9350-j8.0246 \end{Bmatrix} \quad \text{XI:6}$$

where

$$-jA_2 = -j2.4124V_{02} \times 10^{-3} \quad \text{XI:7}$$

With XI:7 in XI:6 it follows that

$$\begin{Bmatrix} B_1 \\ B_2 \\ B_3 \end{Bmatrix} = V_{02} \times 10^{-3} \begin{Bmatrix} 0.7355+j6.4421 \\ 13.1888-j25.55 \\ -19.3585+j14.0764 \end{Bmatrix} \quad \text{XI:8}$$

From XI:8 it follows that the element currents are given by

$$I_{z1}(z) = 10^{-3} V_{02} \left[ (0.7355 + j6.4421) F_{oz1} \right]$$

$$I_{z2}(z) = 10^{-3} V_{02} \left[ -j2.4124 M_{oz2}^h + (13.19 - j25.55) F_{oz2} \right] \quad \text{XI:9}$$

$$I_{z3}(z) = 10^{-3} V_{02} \left[ (-19.36 + j14.08) F_{oz3} \right]$$

When it is assumed that  $\Phi_{22v}^u$  is large compared with  $\Phi_{12v}^u$  and  $\Phi_{32v}^u$ ,

then

SR12

XI-4

$$\begin{Bmatrix} B_1 \\ B_2 \\ B_3 \end{Bmatrix} = -jA_2 \Delta^{-1} \begin{bmatrix} -- & 0.5941 - j0.1069 & -- \\ -- & -2.3836 - j1.0047 & -- \\ -- & 1.5737 + j1.5918 & -- \end{bmatrix} \begin{Bmatrix} -- \\ -7.0754 + j0.7090 \\ -- \end{Bmatrix} \quad \text{XI:10}$$

or

$$\begin{Bmatrix} B_1 \\ B_2 \\ B_3 \end{Bmatrix} = 10^{-3} V_{02} \begin{Bmatrix} 1.2921 + j6.7374 \\ 11.1067 - j27.22 \\ -17.88 + j18.28 \end{Bmatrix} \quad \text{XI:11}$$

The element currents for this case follow from XI:11, or

$$I_{z1}(z) = 10^{-3} V_{02} \left[ (1.2921 + j6.737) F_{oz1} \right]$$

$$I_{z2}(z) = 10^{-3} V_{02} \left[ -j2.4124 M_{oz2}^h + (11.11 - j27.22) F_{oz2} \right] \quad \text{XI:12}$$

$$I_{z3}(z) = 10^{-3} V_{02} \left[ (-17.88 + j18.28) F_{oz3} \right]$$

AFMTC(AFMTC Tech Library-MU-135) Patrick Air Force Base, Florida	ASTIA (TIPAA) [10] Arlington Hall Station Arlington 12, Virginia
AUL Maxwell Air Force Base, Alabama	National Aeronautics and Space Agency 1520 H Street, N. W. Washington 25, D. C. Attn: Library
ASD (ASAPRD-Dist) Wright-Patterson AFB, Ohio	Director Langley Research Center National Aeronautics and Space Administration Langley Field, Virginia
AFOSR (SRGL) Washington 25, D. C.	AFMTC (AFMTC Tech Library-MU-135) Patrick Air Force Base, Florida
RADC (RAYLD) Griffiss AFB, New York Attn: Documents Library	AFMTC (AFMTC Tech Library-MU-135) Patrick Air Force Base, Florida
AF Missile Development Center(MDGRT) Holloman AFB, New Mexico	AFMTC (AFMTC Tech Library-MU-135) Patrick Air Force Base, Florida
ARL(Technical Library) Bldg. 450 Wright-Patterson AFB, Ohio	AFMTC (AFMTC Tech Library-MU-135) Patrick Air Force Base, Florida
Office of Naval Research Branch Office, London [5] Navy 100, Box 39 F. P. O. New York, N. Y.	AFMTC (AFMTC Tech Library-MU-135) Patrick Air Force Base, Florida
Commanding General USASRDL Fort Monmouth, New Jersey Attn: Tech. Doc. Center SIGRA/SL-ADT	AFMTC (AFMTC Tech Library-MU-135) Patrick Air Force Base, Florida
Department of the Army Office of the Chief Signal Officer Washington 25, D. C. SIGRD-4a-2	AFMTC (AFMTC Tech Library-MU-135) Patrick Air Force Base, Florida
Commanding Officer Attn: ORDTL-012 Diamond Ordnance Fuze Labs. Washington 25, D. C.	AFMTC (AFMTC Tech Library-MU-135) Patrick Air Force Base, Florida
Library, Boulder Laboratories National Bureau of Standards [2] Boulder, Colorado	AFMTC (AFMTC Tech Library-MU-135) Patrick Air Force Base, Florida
Mass. Institute of Technology Research Laboratory of Electronics Building 26, Room 327 Cambridge 39, Massachusetts Attn: John H. Hewitt	AFMTC (AFMTC Tech Library-MU-135) Patrick Air Force Base, Florida

\* One copy, unless specified otherwise by number enclosed in brackets.

## AF List K

## DISTRIBUTION LIST\*

ASD(ASRNRE-3, Mr. Paul Springer)  
Wright-Patterson AFB, Ohio

Director  
Evans Signal Laboratory  
Belmar, New Jersey  
Attn: Mr. O. C. Woodyard

Director  
U. S. Army Ordnance  
Ballistic Research Laboratories  
Aberdeen Proving Ground, Maryland  
Attn: Ballistic Measurements Lab.

Commander [2]  
Army Rocket and Guided Missile Agency  
Redstone Arsenal, Alabama  
Attn: Technical Library, ORDXR-OTL

Airborne Instruments Laboratory, Inc.  
Division of Cutler Hammer  
Walt Whitman Road  
Melville, L. I., New York  
Attn: Dr. E. Fubine, Director  
Research and Engineering Division

Stanford Research Institute [2]  
Menlo Park, California  
Attn: Dr. D. R. Scheuch, Asst. Director  
Division of Engineering Research

Bell Aircraft Corporation  
Post Office Box 1  
Buffalo 5, New York  
Attn: Eunice P. Hazelton  
Librarian

Goodyear Aircraft Corporation  
1210 Massillon Road  
Akron 15, Ohio  
Attn: Library, Plant G

Chief of Naval Operation  
Department of the Navy  
Attn: Op-413-B21  
Washington 25, D. C.

Lockheed Aircraft Corporation  
California Division  
Post Office Box 551  
Burbank, California  
Attn: Mr. H. Rempt

Convair, Div. of Gen. Dynamics Corp.  
3165 Pacific Highway  
San Diego 12, California  
Attn: Mr. R. E. Honer  
Head, Electronics Research

Ryan Aeronautical Company  
2701 Harbor Drive  
Lindbergh Field  
San Diego 12, California  
Attn: J. R. Giantvalley

Boeing Airplane Company  
Aero Space Division  
P. O. Box 3707  
Seattle 24, Washington  
Attn: R. R. Barber  
Library Supervisor

General Electric Company  
Electronics Park  
Syracuse, New York  
Attn: Documents Library  
Bessie Fletcher  
Building 3-143A

Director, USAF Project RAND  
Via: AF Liason Office  
The Rand Corporation  
1700 Main Street  
Santa Monica, California

Chu Associates  
Whitcomb Avenue, P. O. Box 387  
Littleton, Massachusetts

Commander  
U. S. N. Air Missile Test Center  
Point Mugu, California  
Attn: Code 366

\*One copy, unless specified otherwise by number enclosed in brackets.

Office of Naval Research (Code 427)  
Department of the Navy  
Washington 25, D. C.

Chief, Bureau of Ordnance  
Department of the Navy [2]  
Attn: Fire Control Branch(Re S4)  
Washington 25, D. C.

Department of the Navy  
Bureau of Aeronautics  
Technical Data Division, Code 4106  
Washington 25, D. C.

California Institute of Technology  
Jet Propulsion Laboratory  
Pasadena 4, California  
Via: District Chief, Los Angeles Ordnance  
District, 55 S. Grand Ave., Pasadena  
California -- Attn: ORDEV-M

University of California [2]  
Department of Engineering  
Berkeley 4, California  
Attn: Antenna Laboratory

Cornell University  
School of Electrical Engineering  
Ithaca, New York  
Attn: Prof. G. C. Dalman

Georgia Technical Research Institute  
Engineering Experiment Station  
722 Cherry Street, N. W.  
Atlanta, Georgia  
Attn: Dr. James E. Boyd

Polytechnic Institute of Brooklyn  
Microwave Research Institute  
55 Johnson Street, Brooklyn, N. Y.  
Attn: Mr. A. E. Laemmel [2]

University of Tennessee  
Ferris Hall, W. Cumberland Ave.  
Knoxville 16, Tennessee

Dr. U. Unz  
University of Kansas  
Electrical Engineering Department  
Lawrence, Kansas

The Johns Hopkins University [2]  
Radiation Laboratory  
1315 St. Paul Street  
Baltimore, Maryland

The Johns Hopkins University [2]  
Applied Physics Laboratory  
8621 Georgia Avenue  
Silver Springs, Maryland

McGill University  
Montreal, Canada  
Attn: Prof. G. A. Woonton, Director  
Eaton Electronics Research

The University of Michigan  
Engineering Research Institute  
Willow Run Laboratories  
Willow Run Airport  
Ypsilanti, Michigan  
Attn: Librarian [2]

New York University  
Institute of Mathematical Sciences  
25 Waverly Place, Room 802  
New York 3, New York  
Attn: Prof. Morris Kline [2]

The Pennsylvania State University  
Dept of Electrical Engineering  
University Park, Pennsylvania

The University of Texas  
Defense Research Laboratory  
Austin, Texas  
Attn: C. W. Horton, Phys. Library

Case Institute of Technology  
Cleveland, Ohio  
Attn: Prof. S. Seeley

Purdue University  
Dept. of Electrical Engineering  
Lafayette, Indiana  
Attn: Dr. Schultz

[The remaining copies to:]  
Hq. AFCRL AFRD (CRRD)  
L. G. Hanscom Field  
Bedford, Massachusetts