

UNCLASSIFIED

AD 274 378

*Reproduced  
by the*

ARMED SERVICES TECHNICAL INFORMATION AGENCY  
ARLINGTON HALL STATION  
ARLINGTON 12, VIRGINIA



UNCLASSIFIED

NOTICE: When government or other drawings, specifications or other data are used for any purpose other than in connection with a definitely related government procurement operation, the U. S. Government thereby incurs no responsibility, nor any obligation whatsoever; and the fact that the Government may have formulated, furnished, or in any way supplied the said drawings, specifications, or other data is not to be regarded by implication or otherwise as in any manner licensing the holder or any other person or corporation, or conveying any rights or permission to manufacture, use or sell any patented invention that may in any way be related thereto.

159 900

California Institute of Technology, Pasadena, California

A Transistorized Multi-Channel Gamma Ray and Neutron Monitor  
with Logarithmic Scale\*

TECHNICAL REPORT\*\*

March 1, 1962

To Office of Naval Research  
Under Contract Nonr-220(18)

ASTIA  
DEC 1962  
APR 27 1962

CATALOGED BY ASTIA  
AS AD NO. 274378

INTRODUCTION

The instrument described in this report is being used to measure the fast neutron and gamma radiation levels around the ONR 10-Mev tandem accelerator at the California Institute of Technology.† It has twelve channels, two for each of six monitoring stations, recording gamma radiation and neutron flux separately. It is wholly transistorized, and features a single logarithmic ratemeter scale and warning system for each channel. Physically it consists of three chassis installed in the control console, one containing the complete power supply unit, the others containing the ratemeters and warning circuits for the neutron and gamma channels. In addition, there are two detector units at each monitoring station housing detector tubes and preamplifiers.

A schematic diagram of the circuit is given in Figure 1. The preamplifiers to the neutron and gamma channels are described in

\* Supported in part by the Joint Program of the Office of Naval Research and the U. S. Atomic Energy Commission.

\*\* Report prepared by Ivo Tamaru, IBM Fellow during the later stages of this work.

† At the time of compiling this report, the complete unit has been in almost continuous operation for over a year. During this period, the instrument has required no replacement of components, or change of circuitry.

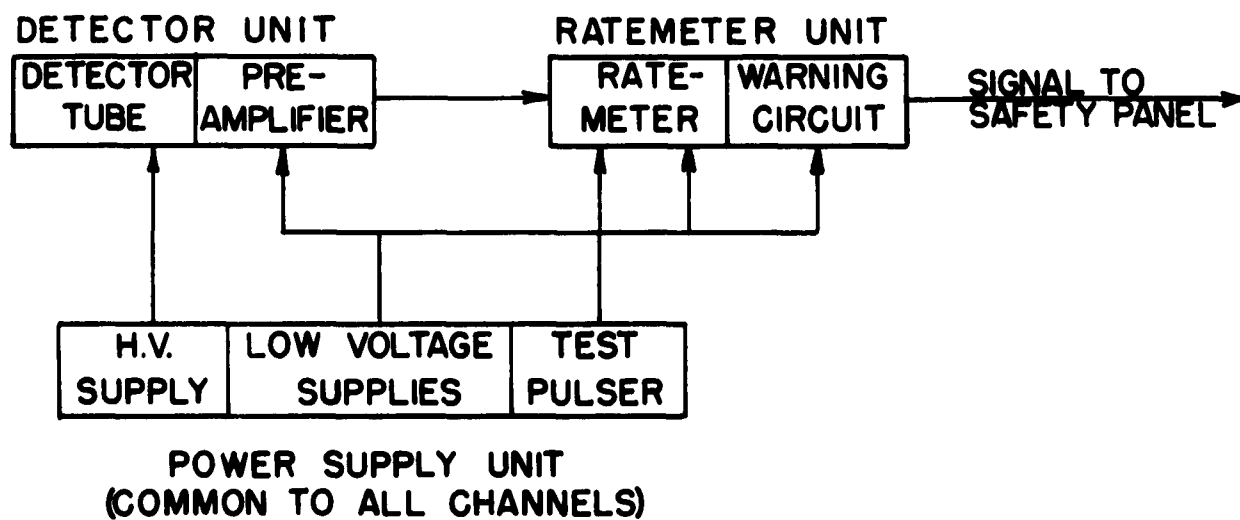

FIG. I. BLOCK DIAGRAM OF ONE CHANNEL

Section 1. Section 2 is devoted to the ratemeter; the trigger circuit is briefly explained, and the integrating circuit is analyzed. The warning circuit and the problem of temperature compensation is discussed in Section 3. A few remarks are made in Section 4 on the built-in check tests of the ratemeter and the warning circuit. The power supply unit, containing dc voltage supplies and a test pulser, is described in Section 5. Dead-time effects are considered in Section 6, and finally, in Section 7, some additional comments are made on the detector units, pertaining to geometrical construction.

## 1. PREAMPLIFIERS

Halogen-quenched geiger tubes are used for monitoring gamma radiation, and  $\text{BF}_3$  proportional counters for monitoring neutrons. The output from the first type of detector tube is of the order of  $10^{-9}$  coul per pulse, and from the second type  $10^{-13}$  -  $10^{-12}$  coul per pulse; both depend somewhat on the applied voltage. The gain requirements of the two types of preamplifiers are thus widely different.

A. PREAMPLIFIER FOR THE GEIGER COUNTER (Fig. 9). A one-transistor amplifier of the emitter-follower type is capable of delivering a 1.5-v pulse into a 90-ohm cable for each geiger event. The transistor, 2N 247, is chosen for its small base-to-collector capacitance (1.7  $\mu\text{mf}$ ).

B. PREAMPLIFIER FOR THE  $\text{BF}_3$  COUNTER<sup>1)</sup> (Fig. 9). The circuit consists of two feedback pairs plus an emitter follower. The first feedback pair (2N 417, 2N 169A) converts a negative pulse from the detector tube into a current signal of fairly long duration (decay time about 40  $\mu\text{sec}$ )

---

<sup>1)</sup> Adapted from F. S. Goulding, Transistorized Radiation Monitors, Chalk River Report CREL-741 (unpublished).

whose amplitude is proportional to the amount of charge in the incoming pulse. The second pair (2N 416, 2N 169A) is a current amplifier. Both feedback pairs have a low input impedance and high output impedance. The input transistors 2N 417 and 2N 416 have relatively low noise and high current gain ( $\beta = 140$  and  $80$  respectively). Because of the feedback, the current signal at the output of the second pair is not much dependent on the current gain of the transistors. Thus, for example, the 2N 417 and the 2N 416 may be interchanged with little or no effect. The gain is approximately proportional to the feedback resistance in the second pair; it is inversely proportional to the feedback capacitance in the first pair and to the un-bypassed emitter load resistances of the 2N 169A transistors.

An emitter-follower stage (2N 508) is added to provide a low-impedance drive for the signal cable. This means of lowering the impedance level is chosen mainly because of its simplicity. It is worth pointing out, however, that such a choice makes the design of the preamplifier as a whole somewhat inconsistent. Whereas the performance of the two feedback pairs is relatively independent of changes in transistor characteristics, the performance of the emitter-follower stage in the present application is strongly dependent on the current gain of the transistor. The choice is justified only because the discrimination level of the ratemeter which follows is sufficiently low. In fact, a pulse height spectrum of the preamplifier output under operating conditions reveals that a change in the amplifier gain by a factor of 2 will change the number of registered pulses by only about 3 per cent.

The total gain of the preamplifier is such that a negative input pulse of  $10^{-13}$  coul will give a negative output pulse of 0.5 - 0.7 v. (The trigger level of the ratemeter is about 0.7 v.) The peak-to-peak noise at the output for an average input transistor in the first feedback pair (either 2N 417 or 2N 416) is about 60 mv, corresponding to an rms input charge of  $3 \times 10^{-15}$  coul.

## 2. RATEMETER

The type of ratemeter which is described here (Fig. 8) was originally developed by Goulding.<sup>2)</sup> The output current, indicated by a meter, is proportional to the logarithm of the pulse rate over a range of nearly two orders of magnitude (Fig. 3).

Two complementary transistors,  $T_1$  and  $T_2$  (Fig. 8), are the active elements in a trigger circuit which is operated by the negative pulses from the preamplifier as follows: In the quiescent state, both transistors are non-conducting because the base of  $T_1$  is negatively biased relative to the base of  $T_2$  by 0.4 v (equal to the sum of the voltage drops in the two 1N 96 biasing diodes). When a pulse drives the base of  $T_2$  more negative than the base of  $T_1$ , the transistors start to conduct. The resulting rise in the collector voltage of  $T_2$  is coupled to the base of  $T_1$  through a coupling capacitor (470  $\mu$ mf). This makes the transistors conduct still harder. As the collector voltage continues to rise, the pump diodes, 1N 482A, begin to conduct, coupling in the charging capacitors  $C_1$  and  $C_2$ , which now deliver additional charge to the base of  $T_1$ . The transistors continue to conduct until the voltage

---

<sup>2)</sup> See reference given in Footnote (1).

across all the capacitors coupling the collector of  $T_2$  to the base of  $T_1$  has been reduced to practically zero.

The pulsed current flowing from the base of  $T_1$  to the collector of  $T_2$ , as the transistor switch closes, is rather high. In order to limit the current peak, the charging capacitors  $C_1$  and  $C_2$  are coupled to the base of  $T_1$  through a 68-ohm resistor. Experimentally, the peak is about 70 ma for a 2- $\mu$ f charging capacitor. The 1N 482A diode is a silicon diode with a low reverse current (0.025  $\mu$ a at 30 v). The trigger level of the circuit is about 0.7 v. It can be lowered by increasing the two 22-kohm resistors biasing the bases of the transistors  $T_1$  and  $T_2$ . With proper biasing arrangement, it is also possible to trigger the ratemeter directly from the high-impedance output of the second feedback pair of the neutron preamplifier, dispensing with the emitter-follower stage, if a direct connection can be made so that the signal current is not loaded by a cable capacity.

The function of the trigger circuit is thus to discharge  $C_1$  and  $C_2$  almost completely each time a pulse is registered. The performance characteristics of the integrating circuit can be obtained from an analysis of the somewhat idealized arrangement of Figure 2. If  $V_c$  is the equilibrium dc voltage across the integrating capacitor  $C$ , and if  $C$  is large enough for the voltage to be very nearly constant, the charge delivered from  $C_1$  and  $C_2$  during an interval  $t$  following a pulse is

$$\begin{aligned} Q(t) &= \int_0^t i(t') dt' = \int_0^t \sum_{i=1}^2 \frac{V-V_c}{R_i} \exp\left(-\frac{t'}{R_i C_i}\right) dt' = \\ &= \sum_{i=1}^2 (V-V_c) C_i \left[ 1 - \exp\left(-\frac{t}{R_i C_i}\right) \right] \end{aligned} \quad (1)$$

The total gain of the preamplifier is such that a negative input pulse of  $10^{-13}$  coul will give a negative output pulse of 0.5 - 0.7 v. (The trigger level of the ratemeter is about 0.7 v.) The peak-to-peak noise at the output for an average input transistor in the first feedback pair (either 2N 417 or 2N 416) is about 60 mv, corresponding to an rms input charge of  $3 \times 10^{-15}$  coul.

## 2. RATEMETER

The type of ratemeter which is described here (Fig. 8) was originally developed by Goulding.<sup>2)</sup> The output current, indicated by a meter, is proportional to the logarithm of the pulse rate over a range of nearly two orders of magnitude (Fig. 3).

Two complementary transistors,  $T_1$  and  $T_2$  (Fig. 8), are the active elements in a trigger circuit which is operated by the negative pulses from the preamplifier as follows: In the quiescent state, both transistors are non-conducting because the base of  $T_1$  is negatively biased relative to the base of  $T_2$  by 0.4 v (equal to the sum of the voltage drops in the two 1N 96 biasing diodes). When a pulse drives the base of  $T_2$  more negative than the base of  $T_1$ , the transistors start to conduct. The resulting rise in the collector voltage of  $T_2$  is coupled to the base of  $T_1$  through a coupling capacitor (470  $\mu\text{mf}$ ). This makes the transistors conduct still harder. As the collector voltage continues to rise, the pump diodes, 1N 482A, begin to conduct, coupling in the charging capacitors  $C_1$  and  $C_2$ , which now deliver additional charge to the base of  $T_1$ . The transistors continue to conduct until the voltage

---

<sup>2)</sup> See reference given in Footnote (1).

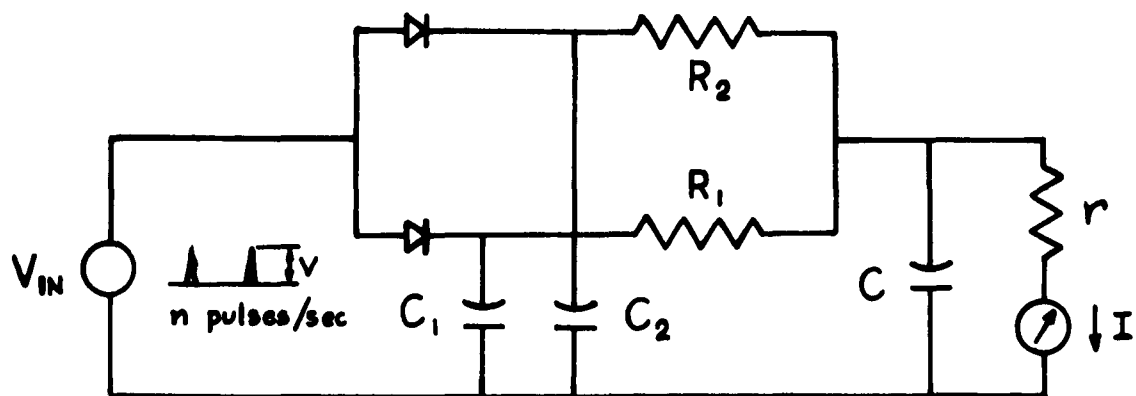

FIG 2. INTEGRATING CIRCUIT

across all the capacitors coupling the collector of  $T_2$  to the base of  $T_1$  has been reduced to practically zero.

The pulsed current flowing from the base of  $T_1$  to the collector of  $T_2$ , as the transistor switch closes, is rather high. In order to limit the current peak, the charging capacitors  $C_1$  and  $C_2$  are coupled to the base of  $T_1$  through a 68-ohm resistor. Experimentally, the peak is about 70 ma for a 2- $\mu$ f charging capacitor. The 1N 482A diode is a silicon diode with a low reverse current (0.025  $\mu$ a at 30 v). The trigger level of the circuit is about 0.7 v. It can be lowered by increasing the two 22-kohm resistors biasing the bases of the transistors  $T_1$  and  $T_2$ . With proper biasing arrangement, it is also possible to trigger the ratemeter directly from the high-impedance output of the second feedback pair of the neutron preamplifier, dispensing with the emitter-follower stage, if a direct connection can be made so that the signal current is not loaded by a cable capacity.

The function of the trigger circuit is thus to discharge  $C_1$  and  $C_2$  almost completely each time a pulse is registered. The performance characteristics of the integrating circuit can be obtained from an analysis of the somewhat idealized arrangement of Figure 2. If  $V_c$  is the equilibrium dc voltage across the integrating capacitor  $C$ , and if  $C$  is large enough for the voltage to be very nearly constant, the charge delivered from  $C_1$  and  $C_2$  during an interval  $t$  following a pulse is

$$\begin{aligned} Q(t) &= \int_0^t i(t') dt' = \int_0^t \sum_{i=1}^2 \frac{V-V_c}{R_i} \exp\left(-\frac{t'}{R_i C_i}\right) dt' = \\ &= \sum_{i=1}^2 (V-V_c) C_i \left[ 1 - \exp\left(-\frac{t}{R_i C_i}\right) \right] \end{aligned} \quad (1)$$

For uniformly spaced pulses of frequency  $n$ , the current  $I$  is given by

$$I = \frac{V_c}{r} = n Q \left( \frac{1}{n} \right) . \quad (2)$$

Eliminating  $V_c$  gives

$$I = \frac{V}{r + \frac{1}{F(n)}} , \quad \text{where}$$

$$F(n) = \sum_{i=1}^2 n C_i \left[ 1 - \exp(-1/nR_i C_i) \right] \quad (3)$$

At low pulse rates, the exponential terms are negligible, so that  $I(n \rightarrow 0) = n(C_1 + C_2)V$ . At high pulse rates, the exponential terms are close to unity, and the current approaches the constant value  $I(n \rightarrow \infty) = \frac{V}{r + R_1 R_2 / (R_1 + R_2)}$ . The values of  $n$  at which the exponential terms are around one-half indicate the regions where each branch is the principal contributor to the logarithmic character of the response. For the neutron channels, for example, where the center of the logarithmic region has been chosen at 8 counts/sec,  $\exp(-1/nR_1 C_1) = 1/2$  for  $n = 3.5$ , and  $\exp(-1/nR_2 C_2) = 1/2$  for  $n = 35$ . Additional RC-branches can be added if it is desirable to extend the logarithmic region further. In the expression for  $F(n)$ , each branch will then add another term of the form  $nC_i \left[ 1 - \exp(-1/nR_i C_i) \right]$ . An attractive feature of the network is that one can easily shift the response curve in frequency by changing the values of  $C_i$ , as is evident from the expression of  $F(n)$ . Thus the gamma channel response has its middle point at 175 pulses/sec, or shifted by a factor of 22, which is very close to the ratio of corresponding capacitors.

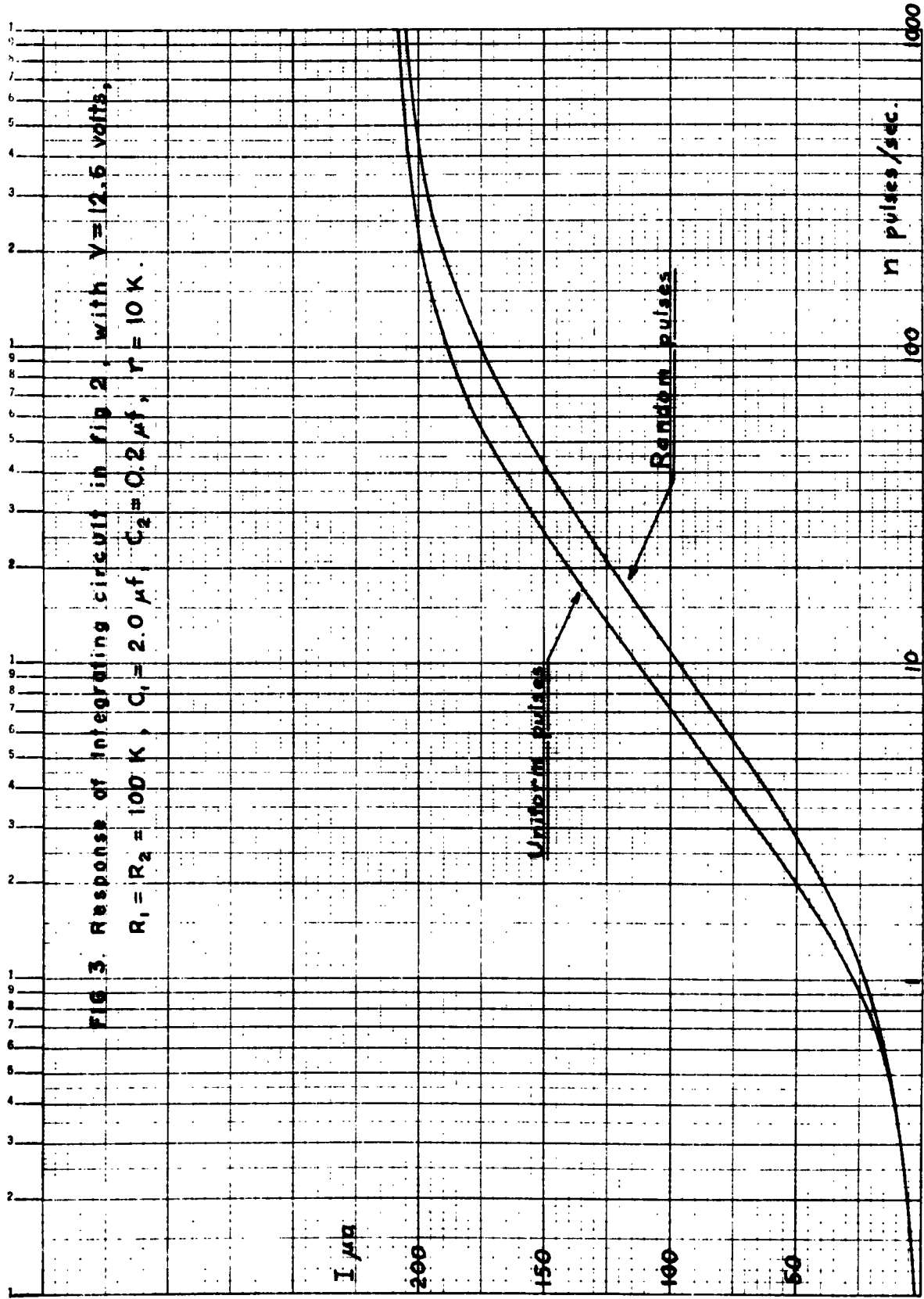

When the input pulses are randomly spaced, rather than uniformly spaced, the output current will be smaller. This is so because the charge delivered by a pulse depends on the length of the time interval between it and the next pulse; the shorter the interval, the smaller the amount of charge. The probability for the time interval to lie between  $t$  and  $t + dt$  is given by  $dP_n(t) = n e^{-nt} dt$ , where  $n$  is the average pulse rate.<sup>3)</sup> Hence, since a short interval is more probable than a long one, the current is smaller for randomly spaced pulses than for uniformly spaced ones. In expression (2) above,  $Q(1/n)$  must now be replaced by

$$\langle Q \rangle_n = \int_{t=0}^{t=\infty} Q(t) dP_n(t) = \sum_{i=1}^2 \frac{(V-V_c) C_1}{1 + n R_i C_1} . \quad (4)$$

Eliminating  $V_c$  as before, the current becomes

$$I = \frac{V}{r + \frac{1}{G(n)}} , \quad \text{where}$$

$$G(n) = \sum_{i=1}^2 \frac{n C_1}{1 + n R_i C_1} . \quad (5)$$

Figure 3 is a plot of (3) and (5) using the values  $R_1 = R_2 = 100 \text{ kohm}$ ,  $C_1 = 2.0 \text{ } \mu\text{f}$ ,  $C_2 = 0.2 \text{ } \mu\text{f}$ , and  $r = 10 \text{ kohm}$ . The value of  $V$  has been chosen to be 12.6 v so as to make the asymptotic value of the current equal 210  $\mu\text{a}$ .

In the actual circuits, the value of  $V$  is in the neighborhood of 15.5 v, being roughly equal to the difference between the 18.2 and 2-v bias supplies. The current reading is calibrated by adjusting a

---

<sup>3)</sup> See, for example, Evans, The Atomic Nucleus (McGraw-Hill, New York, 1955) p. 754.

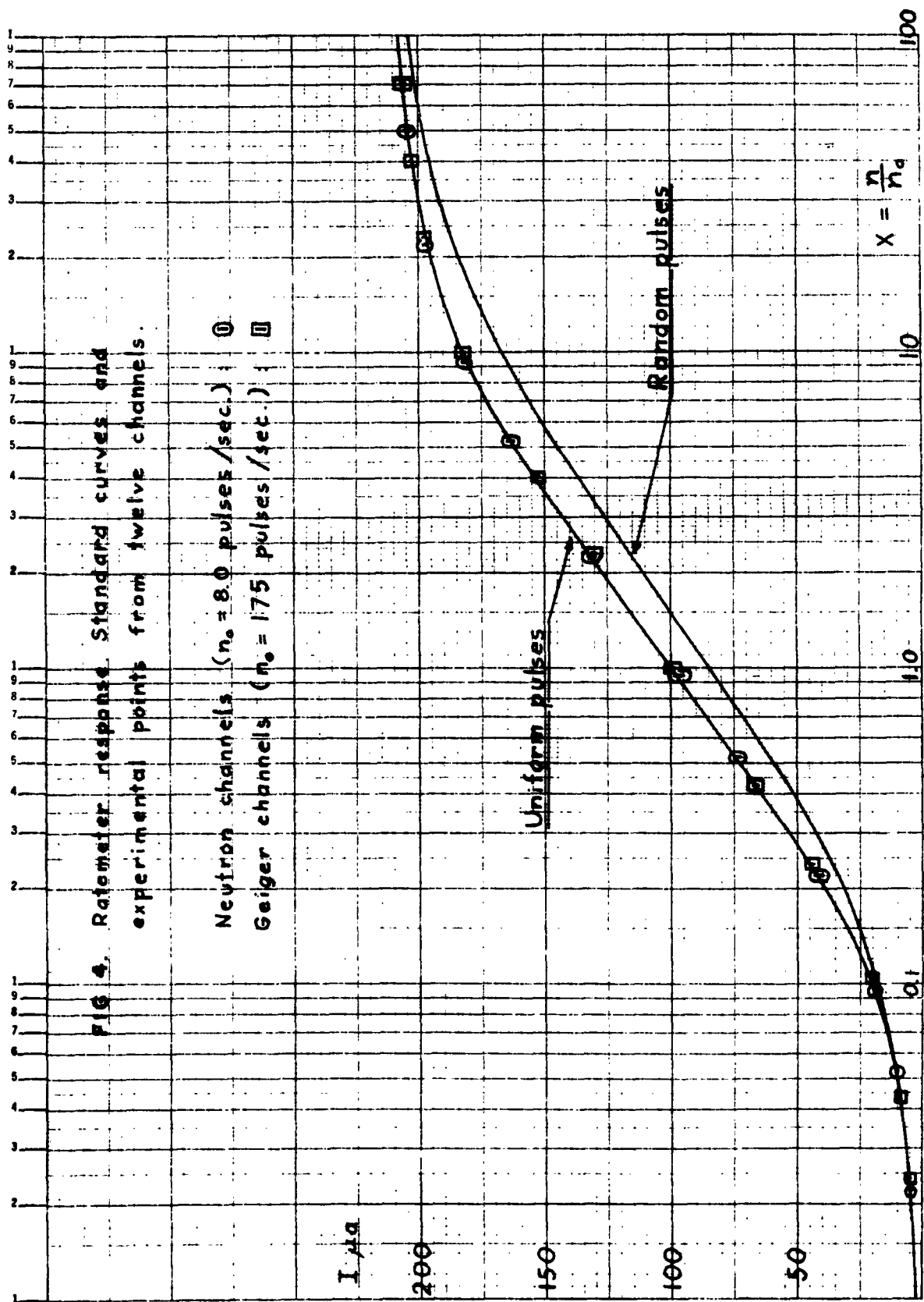

potentiometer in parallel with the meter. If a common asymptotic value is chosen as  $210 \mu\text{a}$ , the middle point of the scale ( $100 \mu\text{a}$ ) corresponds to  $n_0 = 8.0$  pulses/sec for the neutron channels, and  $n_0 = 175$  pulses/sec for the geiger channels. When the theoretical curves for both circuits are plotted against  $x = n/n_0$ , they are almost identical (maximum deviation  $2.5 \mu\text{a}$ ). Figure 4 exhibits the experimental points from twelve channels, and a curve which is the average of the two theoretical curves, shifted by 3 per cent in the direction of increasing  $x$  (this shift would correspond to a uniform decrease in the capacitances by 3 per cent). The response to random pulses can be checked by operating a logarithmic ratemeter and a linear one from a common detector tube. The position and shape of this curve, relative to the response curve for uniformly spaced pulses, is in excellent agreement with theory.

In practice, the calibration is done against the pulser, and is adjusted for each channel so that its response curve has a minimal overall variation from the standard curve. For the neutron channels, the calibration point lies in the region  $176 - 178 \mu\text{a}$  at 60 pulses/sec, for the geiger channels it lies in the region  $85 - 87 \mu\text{a}$  at 120 pulses/sec.

### 3. WARNING CIRCUIT

The warning circuit (Figure 8) consists of a dc current feedback amplifier (2N 169A, 2N 192) and a transistor switch (2N 188A, 2N 241A) operating a 250-milliwatt relay. The performance of the amplifier can easily be calculated if one knows what fraction of the total input current flows into the feedback resistor ( $40 \text{ kohm}$ ). (Note that the

voltage at the input -- the base of the 2N 169A transistor -- is practically constant at about -18.0 v.) If this fraction is written as  $F/(1+F)$ , then  $F$  is sometimes called the feedback factor of the amplifier. In the present case,  $F$  is proportional to the dc current gain of the 2N 169A transistor. For different transistors the gain may vary from 36 to 70 at 1 ma collector current, corresponding to a variation of  $F$  between 13 and 25. The change in output voltage (at the emitter of the 2N 192) is therefore between -37 and -38 mv for 1  $\mu$ a signal current, for a 40-kohm feedback resistor. The state of the switch is controlled by the voltage at the base of the 2N 188A. When this voltage is more positive than "Coil +", both transistors in the switch are non-conducting. When the voltage is driven more negative than "Coil +", the transistors conduct, and the relay becomes energized. The switching action is sharp enough to open and close the relay at the same input current within 3  $\mu$ a, even though the release voltage of the relay is about half the pull-in voltage. The switching point is variable through the "Relay Adjust" potentiometer, which controls the quiescent state of the amplifier. An increase of its resistance will channel more of the current flowing through the feedback resistor into the base of the 2N 169A; this lowers the quiescent output voltage so that less signal current from the ratemeter is needed to reach the switching level.

In most dc-operated transistor circuits, care must be taken to ensure temperature stability. The ratemeter current is practically

temperature independent, but the warning circuit needs to be temperature compensated. Experimentally, the uncompensated warning circuit operates the relay at  $(9 \pm 1.5) \mu\text{a}$  less input current per  $10^\circ\text{C}$  increase in temperature. The shift in switching point is practically linear in the range  $10^\circ\text{C} - 35^\circ\text{C}$ . About three-quarters of the effect comes from the current amplifier, the rest originates in the transistor switch. In the amplifier, the largest contribution is due to the current-gain variation of the 2N 169A, giving rise to a change in both the quiescent output voltage and the amplifier gain. In the switch, the temperature variation of the base-emitter voltages as well as the collector leakage current of the 2N 188A contributes.

In the complete monitor the variation of the supply voltages with temperature must also be taken into account. The reference voltages in the -22.5 and -18.2-v supplies are obtained from Zener diodes which have a temperature coefficient of +0.08 per cent per  $1^\circ\text{C}$ . An increase of the negative reference voltage tends to cut off some of the current flowing in the bias resistor between collector and base of the power transistor. However, this effect is counteracted by the increasing collector leakage current of the first transistor in the regulator amplifier (2N 192 in both supplies). Experimentally, the latter effect dominates, causing the absolute value of the supply voltages to decrease with increasing temperature. The voltage level of "Coil +" is directly determined by the Zener diode in the main supply and becomes therefore more negative with increasing temperature. The supply-voltage variations of the particular circuit that was built is summarized in Table 1. Each variation

causes either an actual change or, in the case of the "Coil +" supply (as far as the switching level is concerned), an equivalent change in the output voltage of the dc amplifier. These voltage changes, translated into equivalent input current signals, are exhibited in the second column of the table.

TABLE 1. Temperature dependence of supply voltages, and the corresponding shift of switching point in terms of input current.

Supply	$V(30^{\circ}\text{C}) - V(20^{\circ}\text{C})$	Equivalent Current Signal
-22.5 v	+ 80 mv	+2 $\mu\text{a}$
-18.2 v	+ 40 mv	-2 $\mu\text{a}$
"Coil +"	-140 mv	-4 $\mu\text{a}$

The total temperature variation of the switching point to be compensated for is thus typically  $(9 - 4)\mu\text{a} = 5 \mu\text{a}$  per  $10^{\circ}\text{C}$ . The compensation is accomplished by a thermistor-resistor branch between the amplifier input and the main supply, chosen in such a manner that the branch current changes by  $+5 \mu\text{a}$  per  $10^{\circ}\text{C}$  increase in temperature. That is, the ratemeter has to supply an additional  $5 \mu\text{a}$  to operate the relay, which is precisely the desired effect. The thermistor that has been selected is made of a material (General Electric grade 1) whose temperature dependence is given by  $R(T) = R(T_0) \exp \left[ \beta(T) \left( \frac{1}{T} - \frac{1}{T_0} \right) \right]$ , where  $T$  is the temperature in degrees Kelvin, and  $\beta \approx 3.9 \times 10^3 \text{ }^{\circ}\text{K}$  in the region  $10^{\circ}\text{C} - 35^{\circ}\text{C}$ . The ratio of the resistance at  $15^{\circ}\text{C}$  and

35°C to its value at 25°C is 1.6 and 0.65 respectively. It so happens that the current flowing through a series thermistor-resistor branch across a constant voltage is a linear function of the temperature in the region 10°C - 35°C if the resistance of the resistor is equal to the resistance of the thermistor at 25°C. If the resistances are 100 kohm, and the voltage is 4.5 v, the current increment is 5 µa for a 10°C increase. For resistances of 50 kohm the increment would be 10 µa, etc. A bias resistor (1.5 meg) between the amplifier input and ground supplies the standing current to the thermistor-resistor branch in order that the possible range of adjustment of the switching point be left undisturbed. A somewhat simpler means of compensation is to replace the thermistor-resistor branch by a suitably selected germanium diode in reverse bias. A rule-of-thumb is that the reverse current of a germanium diode about doubles every 10°C. The current is therefore an exponential rather than a linear function of temperature, but the more limited accuracy of such a compensation may be sufficient for most purposes.

It may perhaps be noted that the use of 1 per cent (Welwyn) resistors in a number of places in the monitor has been preferred for stability against temperature changes and aging rather than for reasons of precision.

#### 4. CHECK TESTS OF RATEMETER AND WARNING CIRCUIT

The monitor has been so designed that check tests of ratemeter and warning circuits can be performed without disturbing the charge on the integrating capacitor. Hence, after a check has been completed, the meter reading will immediately return to its original value.

The ratemeter is calibrated with the pulser (Section 2, last paragraph). A DPDT push-button switch couples the pulser to the input and disconnects the regular integrating capacitor (500  $\mu\text{f}$  or 300  $\mu\text{f}$ ). The mechanical inertia of the meter is high enough to give a steady reading at 60 or 120 pulses/sec, even though the current is pulsed. Since the amplifier output is also pulsed, however, the relay may start to chatter for a certain range of switching points. In the neutron channels, the current is sufficiently steady (within 1  $\mu\text{a}$ ) to avoid this, but in the geiger channels it needs to be smoothed out. A 50- $\mu\text{f}$  integrating capacitor is large enough to bring the variation down to less than 1  $\mu\text{a}$ , yet also small enough to allow a practically instantaneous equilibrium current reading.

The "Relay Check" push-button switch disconnects the ratemeter from the amplifier, connecting in its stead a current-supplying network. The components of this network are so chosen that there is an initial fast rise to a selected current, followed by a slower sweep over the region where the switching point is desired. The network has two parallel branches. One branch has a single resistor, which determines the start of the slow sweep, and the other is an RC-combination, the series resistance of which determines the length of the slow sweep. For values of components as given in the circuit diagram, the slow sweep is approximately between 85 and 115  $\mu\text{a}$ .

The ratemeter calibration should be done before the relay check, because a different calibration will change the switching point as read on the meter.

### 3. POWER SUPPLY UNIT

The power supply chassis contains the main dc supply (-22.5 v), and an auxiliary supply (5 v dc) for the relay coils in the warning system. It also contains the high-voltage supplies (1400 and 900 v dc), additional low-voltage supplies (-2, -12, -18.2 v dc), and a test pulser (60 and 120 pulses/sec), all driven from the main supply.

A. MAIN SUPPLY AND COIL SUPPLY (Fig. 7). Both are regulated supplies with two-stage amplifiers controlling the base-collector voltages of the power transistors (2N 456). The latter are mounted on a common heat sink. Reference voltages are obtained from Zener diodes. The relative bias of the supplies is fixed by connecting the positive side of the coil supply ("Coil +") to the Zener diode (-17.2 v) in the main supply.

The main supply has 10 per cent voltage regulation for 0 - 750 ma output current; its normal operating point is around 250 ma, at which current the low-frequency output impedance is approximately 0.4 ohms and the ripple is less than 10 mv. The coil supply gives 5.3 v output at no load, and 4.8 v with 0.2 v ripple at maximum load (750 ma) when all the relays are activated.

B. HIGH VOLTAGE SUPPLY (Fig. 7). The primary winding of a television flyback transformer (Triad D-133) is part of an oscillator system, which produces (ideally) a square-wave of frequency about 4 kc and peak-to-peak amplitude across the whole primary equal to four times the impressed dc voltage. Two transistors (2N 456) act as switches,

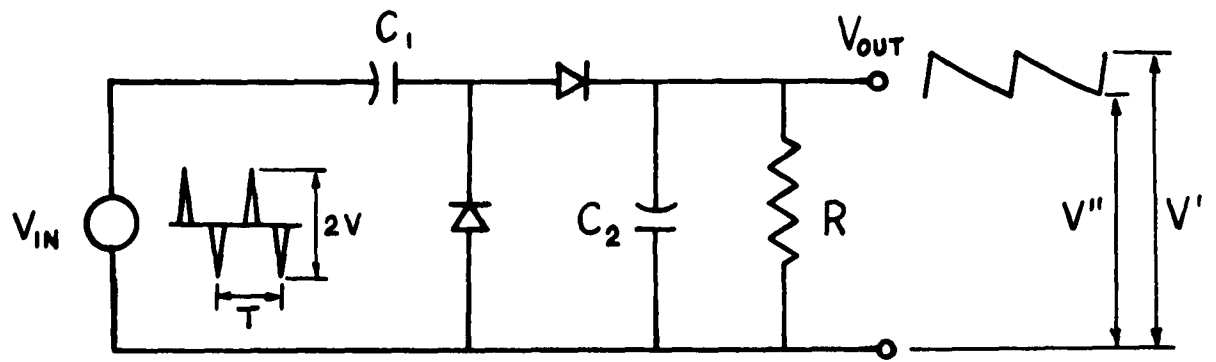

**FIG 5. VOLTAGE DOUBLER**

alternately conducting the current through each half of the primary. Control of the switching action is accomplished by an extra winding (20 turns, center tapped) around the ferrite core of the transformer, which applies a suitable wave form to the transistor bases: The initially conducting transistor is made to conduct harder while the non-conducting transistor gets a larger reverse bias. The build-up of primary current continues until the transformer core saturates, at which point the base signal deteriorates and the current starts to decrease. The voltage in the winding reverses, and is thereafter maintained, while the current changes sign (flowing through the second transistor) and builds up to saturation in the other direction. The two resistors and the capacitor in the oscillator circuit are chosen experimentally for reliability in starting and efficiency of operation.

On the secondary side, the voltage is stepped up by a voltage doubler. An analysis based on the simplified case of Figure 5, with the notation as given, yields

$$V' = 2V \left\{ \frac{C_2}{C_1} \left[ 1 - \exp\left(-\frac{T}{RC_2}\right) \right] + 1 \right\}^{-1}$$
$$V'' = V' \exp\left(-\frac{T}{RC_2}\right) \quad (6)$$

In the present application of the doubler,  $R \approx 10$  meg,  $T \approx 0.25$  msec. If  $C_2 \geq 0.02 \mu f$ , then  $T/RC_2 \leq 10^{-3}$ . Using the approximation  $T/RC_2 \ll 1$ , one gets

$$\frac{V_{\text{ripple}}}{2V} = \frac{V' - V''}{2V} \approx \frac{T/RC_2}{1 + T/RC_1} \approx \frac{T}{RC_2}$$

It is seen that the ripple is strongly dependent on the value of  $C_2$  and almost independent on the value of  $C_1$ . In the actual circuit

$$\frac{V_{\text{ripple}}}{V_{\text{dc}}} = \frac{0.32}{1600} = 2 \times 10^{-4}$$

rather than  $1 \times 10^{-4}$  as predicted with  $C_2 = 0.25 \mu\text{f}$ .

The doubler is followed by voltage regulator tubes (Victoreen corotrons) to give stable dc output for the detector tubes. The 4-ke ripple, however, is practically unattenuated by the corotrons. Each detector tube is therefore preceded by an RC-filter, and in addition there is a filter on the 1400-v supply in the chassis containing the neutron channels.

The number of turns in the secondary, the total primary, and the total base windings are in the approximate ratio 120 : 4 : 1. The standing current in the 1420-v corotron is 80  $\mu\text{a}$ , and in the 900-v corotron it is 95  $\mu\text{a}$ . The power efficiency of the oscillator-transformer-doubler part of the supply is 30 per cent at 200  $\mu\text{a}$  output; it increases if more current is drawn from the doubler.

C. ADDITIONAL LOW VOLTAGE DC SUPPLIES (Fig. 7). The 2 and 18.2-v negative supplies provide bias voltages for the ratemeter circuits. The former is an emitter follower attached to a voltage divider across the main supply; the latter is a regulated supply of the same type as the main supply, which under operating conditions is called upon to deliver 30 - 60 ma. No heat sink is necessary for the power transistor (2N 456). The voltage level, -18.2 v, is adjusted

to be one volt lower than "Coil +" in order to limit the current in the transistor switches operating the relays. The -12 v supply provides the power for the preamplifiers and consists of a Zener diode (1Z 12); its load current is about 20 ma.

D. TEST PULSER (Fig. 8). Negative half sine waves from the rectifier bridge of the main supply are used to drive a Schmitt trigger circuit composed of two complementary transistors. In the quiescent state, both transistors are non-conducting. Letting primed quantities refer to the PNP-type transistor (2N 190) and unprimed to the NPN type (2N 169A), the base voltages are approximately  $V'_B = -6$  v,  $V_B = -10$  v. As a pulse is applied to the base of the PNP-type transistor, both transistors start to conduct when  $V'_B$  becomes more negative than  $V_B$ . The switching-on process is regenerative because a current surge through the transistors raises the collector voltage  $V'_C$ , and hence  $V_B$ , thus turning on more current. The current is a sharp step function, producing a negative step of about 8 v at the collector of the 2N 169A. The circuit returns to the quiescent state when the input wave form drives  $V'_B$  again more positive than  $V_B$ . The output from the trigger circuit goes into an emitter follower and a pulse-shaping network. The final test pulses have a rise time of 2  $\mu$ sec, decay time of 20  $\mu$ sec, and an amplitude of -1.4 v.

## 6. DEAD-TIME EFFECTS

One expects dead-time effects to arise from two sources: a limited time discrimination of the ratemeter, and a finite recovery time of the detector tube. The former source, it turns out, can be ignored completely, although the reason for this is not so straightforward. The minimum discrimination time between two pulses depends very strongly on the state of the charging capacitors  $C_1$  and  $C_2$  just before the arrival of the first pulse. The larger the amount of charge that the trigger circuit has to deliver, the longer the recovery time of the circuit to its "ready state". For evenly spaced pulses, therefore, the time discrimination improves with the pulse rate. Experimentally, the trigger circuit is able to operate on uniform rates over  $10^3$  times the "midpoint rate", that is, where the output current has for all practical purposes reached its asymptotic value. In the case of random pulses one may say, in a loose manner of speaking, that the average time discrimination improves with the average pulse rate. The ratemeter may lose a pulse if, for example, after a long inactive time interval, two pulses arrive close together. But in such a case, the second (lost) pulse would effectively have delivered a very small additional amount of charge in an ideal ratemeter. In practice, we fall back upon experiment, stating that, under conditions where the dead times of the detector tube and the linear comparison ratemeter were negligible, no systematic deviation of the output current from the value predicted theoretically was observed.

The dead time of the neutron detector is not well defined, since the  $\text{BF}_3$ -tube is operated as a proportional counter. However, in view of the relatively low rates that we are interested in, we can neglect its effect altogether. The dead time of the geiger tube is approximately 100  $\mu\text{sec}$ . In relating the output current to a radiation intensity at levels for which the dead time is not negligible, two separate effects have to be considered. The primary effect is that a fraction of all the counts, which would have been registered if the counter tube had been perfect, is lost due to the finite recovery time of the real geiger tube. The secondary effect is that the normal (Poisson) distribution of the pulses is disturbed, since there is a lower limit, equal to the dead time, on the interval between registered pulses. Clearly, the ratemeter current is smaller for the real tube than it would have been for an ideal tube (i.e., one with zero dead time), simply because some pulses are lost. In a sense, however, the secondary effect partly compensates for the primary one, because the counts that are lost would have followed within a short interval of the preceding pulse, and thus effectively contributed a smaller than average amount to the current. To illustrate the magnitude of these effects, we assume a radiation intensity such that an ideal tube would have produced 1750 counts/sec (and thus a ratemeter current of 167  $\mu\text{a}$ ). A corresponding real tube with a dead time of 100  $\mu\text{sec}$  will produce only 1400 counts/sec. If its output had been a Poisson distribution, the ratemeter reading would have been 160  $\mu\text{a}$ . For the actual distribution, a calculation shows that the current will be 164  $\mu\text{a}$ . (The

calculation assumes that the probability of losing two counts in a row is much smaller than the probability of losing one count at a time only.) The overall dead-time correction to the ratemeter curve for the geiger channels is 5 per cent at 155  $\mu$ a, and 25 per cent at 170  $\mu$ a; i.e., at 155  $\mu$ a, for example, the count-rate as read from the uncorrected response curve is 5 per cent lower than the rate from an ideal tube. A current of 170  $\mu$ a, for the real geiger tube, is taken to be the maximum value which can still be reliably related to a radiation intensity.

#### 7. HOUSING OF DETECTOR TUBES

The efficiency of a geiger counter is dependent on the efficiency with which the gamma rays produce secondary electrons that enter the detector tube, because it is the latter which usually trigger a geiger event. It is therefore desirable to provide a shielding arrangement which enhances the electron production probability for those gamma rays, whose energies fall within the particular energy region one is interested in. In a safety monitor it is often desired that the higher energies be weighted more heavily, because high-energy radiation is more damaging to deeper-lying tissue than very low-energy radiation. In the present case, where the region of interest extends up to about 10 Mev, the geiger tube is surrounded by a 0.05-inch-thick brass shield, which will stop electrons having energies up to around 2 Mev. This not only discriminates against very low-energy radiation, by stopping many of the electrons produced by such radiation, but also favors high-energy gamma rays by

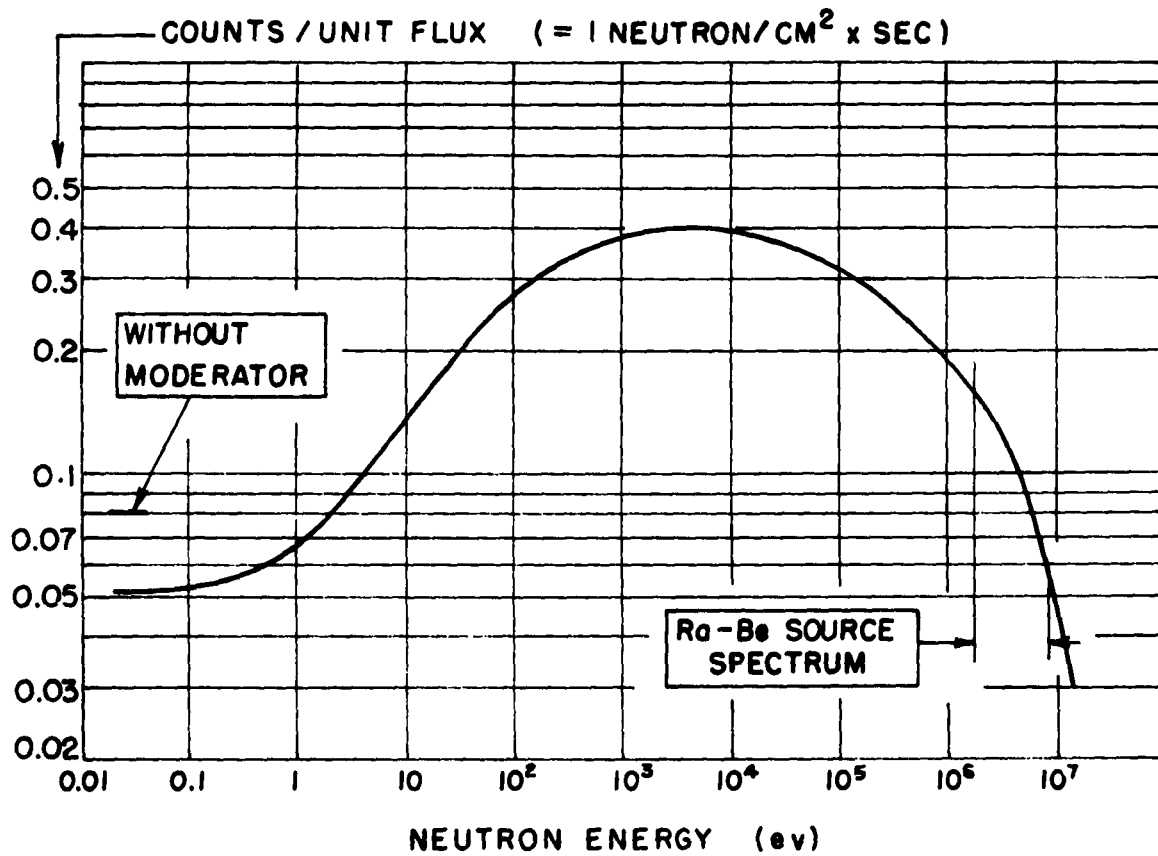

FIG. 6. Detection efficiency of the neutron detector as a function of neutron energy. (Taken from DN-3 Neutron Detector Manual of the Nuclear Chicago Co.)

providing a fair amount of stopping material so as to give a reasonable conversion efficiency at these energies.

The efficiency of the  $\text{BF}_3$ -filled detector tube is much smaller for neutrons with energies of a few Mev than it is for thermal neutrons. Here, as in the geiger case, we want to favor detection of high-energy neutrons relative to thermal and epithermal neutrons. For this purpose, the tube is surrounded by a moderator, which consists of a cylindrical shield of paraffin ( $7/8$  inches wall-thickness), one end of which is closed. This slows down the fast neutrons so that they may be detected with relatively good efficiency. Furthermore, most of the thermal neutrons entering from the outside are stopped by a 25-mil-thick cadmium plate, which is bent around the paraffin cylinder (but does not cover the end). The relative detection efficiency of the unit as a function of neutron energy is shown in Figure 6.<sup>4)</sup> A higher efficiency in the region 1 - 10 Mev would be desirable, but this requires a rather bulky moderator.

#### ACKNOWLEDGMENT

The author wishes to thank Dr. R. K. Bardin for several fruitful discussions, and for a critical reading of the manuscript; and especially Professor C. A. Barnes for his continuous interest and helpful advice during the progress of this work.

Distribution: ONR Technical Report Distribution List.

---

<sup>4)</sup> The detector unit has the same counter tube and very nearly the same geometrical construction as the Nuclear Chicago DN-3 Neutron Detector.

FIG. 7. Main supply, coil supply, high voltage supply.

- Notes:
- ① Triad F-40X
  - ② Triad F-25X
  - ③ Sarkes Tarzian silicon rectifier 20K
  - ④ On heat sink (Delco 7270725)
  - ⑤ On heat sink, common with ④
  - ⑥ Triad television flyback D-13<sup>3</sup> (ferrite core)
  - ⑦ Selenium Rectifier (PIV 2880 v), International  
Rectifier Co.
  - ⑧ Shorting type wafer switch
  - ⑨ Victoreen Corotron

Resistors 10 per cent, 1/2 watt unless otherwise specified.

Electrolytic capacitor notation:

20/25 means 20  $\mu$ f, 25 W.V.D.C.

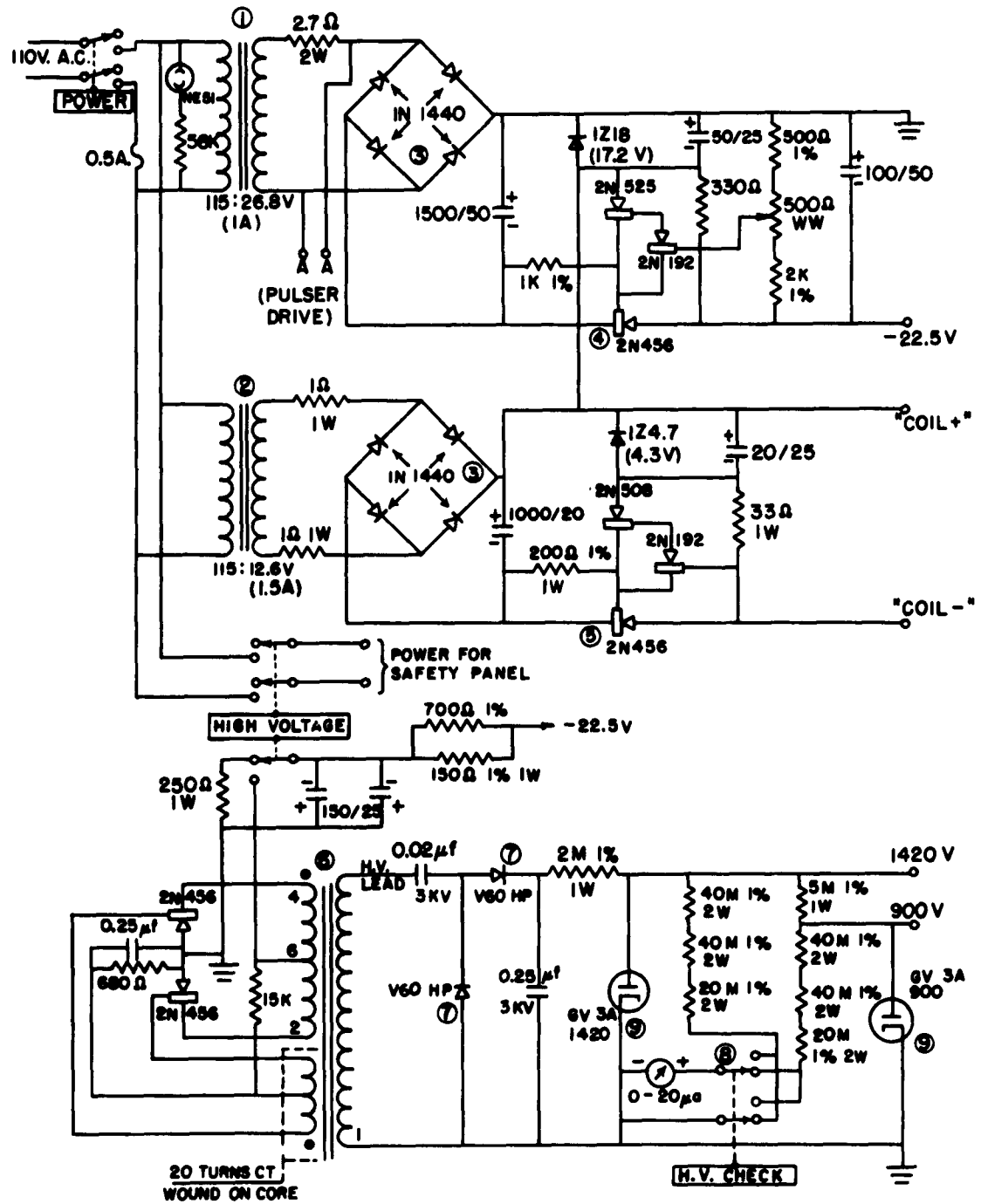

FIGURE 7

FIG. 8. Additional dc supplies, pulser, ratemeter and warning circuit.

- Notes:
- ① Selected with  $I_{CO} < 2 \mu\text{a}$  at 3v
  - ② Adjusted to 1.0 v lower than "Coil +"
  - ③ To rectifier bridge of main supply
  - ④ Sarkes Tarzian silicon rectifier
  - ⑤ Push-button switch (Switchcraft, NF 4006)
  - ⑥ Push-button switch (Switchcraft, NF 4009)
  - ⑦ General Electric thermistor R 051 (100 K at 25°C)
  - ⑧ Potter and Bromfield relay SM5DS (hermetically sealed, 7 pin miniature base)

$\begin{bmatrix} Q_1 \\ Q_2 \end{bmatrix}$  means  $\begin{cases} Q_1 & \text{in neutron channels} \\ Q_2 & \text{in geiger channels} \end{cases}$

1/4 watt resistors may be used in ratemeter and warning circuit.

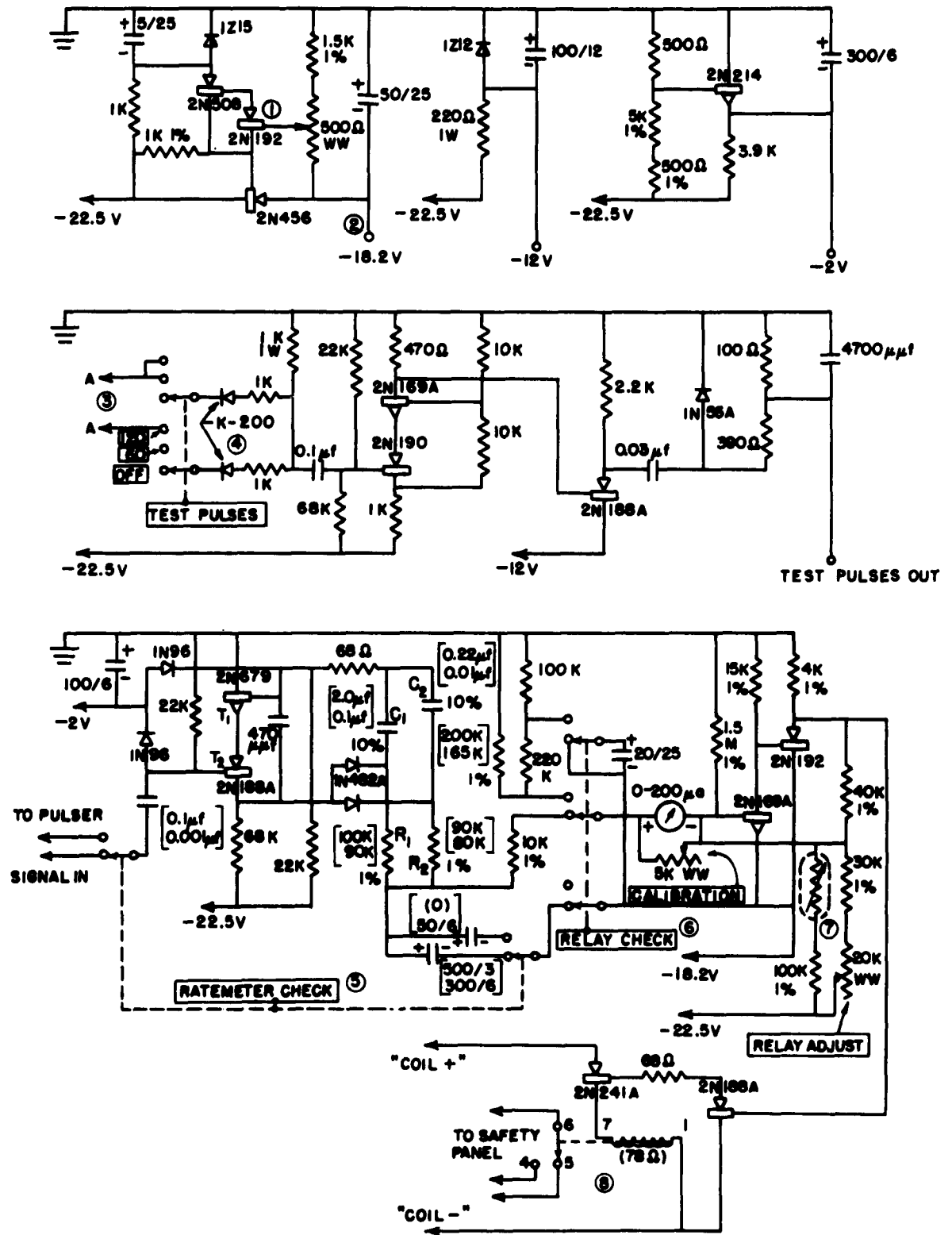

FIGURE 8

FIG. 9. Preamplifiers, chassis filters.

- Notes: ① Nuclear Chicago NC-204  
② Temperature stable (Sprague 10TS-Q25)  
③ Amperex 75 NB 3, 900 v filling

Resistors in preamplifiers are 10 per cent, 1/4 watt unless otherwise specified.

Cables to detector units:

Signal cable: RG-62/U

Cables for low  
and high voltage: Belden 8411

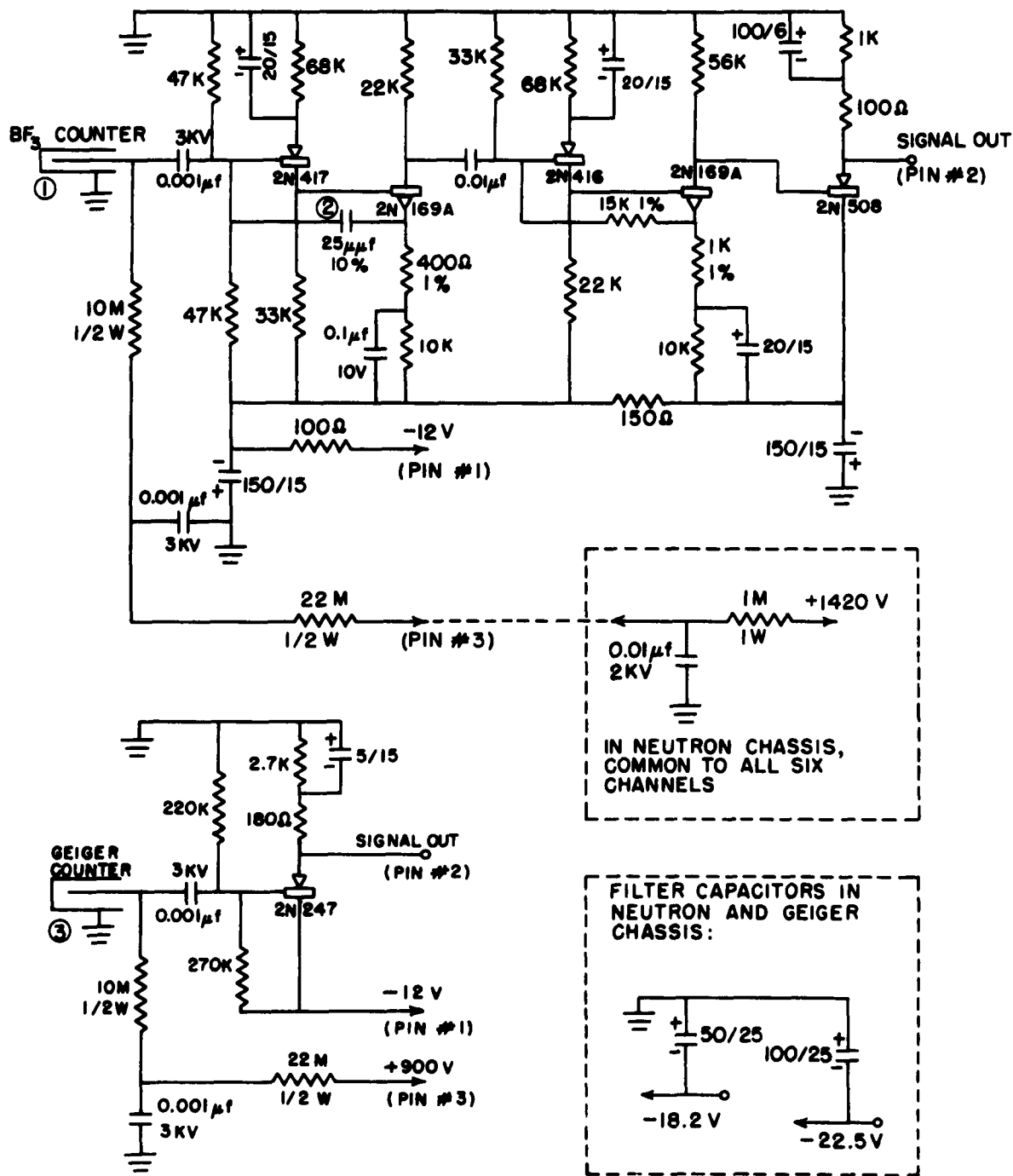

FIGURE 9