

UNCLASSIFIED

AD 275 091

*Reproduced
by the*

**ARMED SERVICES TECHNICAL INFORMATION AGENCY
ARLINGTON HALL STATION
ARLINGTON 12, VIRGINIA**



UNCLASSIFIED

NOTICE: When government or other drawings, specifications or other data are used for any purpose other than in connection with a definitely related government procurement operation, the U. S. Government thereby incurs no responsibility, nor any obligation whatsoever; and the fact that the Government may have formulated, furnished, or in any way supplied the said drawings, specifications, or other data is not to be regarded by implication or otherwise as in any manner licensing the holder or any other person or corporation, or conveying any rights or permission to manufacture, use or sell any patented invention that may in any way be related thereto.

762-3-3

USASRD L Technical Report 2245

NOX

WIND-DATA-ACQUISITION SYSTEM

by

Ronald W. Waite

275 091
275 091
AS
AS

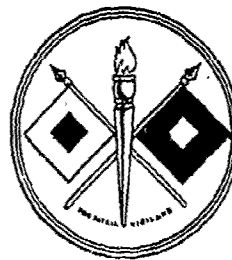

December 1967

ASTIA
100 7177
151

U. S. ARMY SIGNAL RESEARCH AND DEVELOPMENT LABORATORY
FORT MONMOUTH, NEW JERSEY

BEST AVAILABLE COPY

December 1961

USASRDL Technical Report 2245

WIND-DATA-ACQUISITION SYSTEM

Ronald W. Waite

DA Task 3D36-21-004-01

U. S. ARMY SIGNAL RESEARCH AND DEVELOPMENT LABORATORY
FORT MONMOUTH, NEW JERSEY

Abstract

The wind-data-acquisition system is a laboratory, experimental equipment designed to accept wind information from up to 15 dual-channel wind sensors, instantaneously sample and convert this information to digital form, and enter it onto a punched paper tape in a format suitable for entry into an LCP-30 computer.

The results of tests carried out on the equipment indicate that it can be a very valuable research tool for conditions where it is desirable to obtain numerous data samples from various points and act on the data, using digital-data-handling techniques.

CONTENTS

Abstract	1
PURPOSE	1
BACKGROUND	1
DESCRIPTION	11
General	11
Operation	11
Controls	16
TESTS AND RESULTS	16
CONCLUSIONS	20

Figures

1. Front view, showing complete unit	2
2. Rear view, showing complete unit	3
3. Front view, showing punch mechanism	4
4. Front view, showing analog to digital converter section	5
5. Rear view, showing power supply	6
6. Rear view, showing punch mechanism and control panel	7
7. Rear view, showing analog to digital converter	8
8. Rear view, showing logic board and connector panel	9
9. Rear view, showing multiplexing relay section	10
10. Wind Data Conversion System	12
11. LGP-30 Computer Code Used in Messages	13
12. Wind Data Acquisition System Block Diagram (Converter)	14
13. Wind-Data-Acquisition System Message Format	15
14. Front view, showing control panel	17
15. Sample Calibration Run	19

WIND-DATA-ACQUISITION SYSTEM

PURPOSE

The purpose of this report is to describe, and present recommendations for, the use of an analog-to-digital converter and multiplexer which accept multiple inputs from various wind sensors and enter weighted values onto punched paper tape. (Figures 1 through 9 are different views of the system.)

BACKGROUND

In the past, measurements of wind speed and direction were performed by using various types of anemometers as sensors, with voltmeters and recording oscillographs to receive and record the outputs. Using the voltmeter method, only one sensor could be observed at a particular instant in time; and the value received was subject to human as well as equipment error which, in the case of wind gusts, could be considerable. Another method, that of utilizing recording oscillographs, was far better for recording actual instantaneous wind values; however, the system was adequate only for the observation of a single point or at most only a few points in the wind field.

In early 1960, personnel of the Meteorological Division of USASRDL held discussions to determine the feasibility of using digital-data-handling techniques in the acquisition of wind data. It was suggested that these techniques could be used as a substitute for and/or supplement to the present analog techniques. The two features affording the main advantages for using the digital-handling methods would be that instantaneous wind vectors could be obtained for numerous points of a wind field; and the output, instead of having to be manually evaluated, would be in a format compatible to a suitably programmed general-purpose digital computer (in this case, Royal McBee's LQP-30). Thus, by using the digital-handling techniques, a great deal of time could be saved in the tedious evaluation and averaging of wind values from numerous data samples.

It was decided at these discussions to include a digital system in the tests being conducted under the program for low-level winds for missiles. This program includes a series of tests of various types of wind-measuring equipments and evaluation techniques to determine the optimum system to be used in the prediction of a particular surface condition near a missile-launch site. Therefore, using design criteria from this program, technical requirements for a "commercial standard wind-data-handling subsystem," later called "wind-data-acquisition system," were prepared. In July 1960 a purchase order was placed with C. G. Electronics Corp. of Albuquerque, New Mexico (a subsidiary of Gulton Industries), for two such units to be delivered in October 1960. This system was to be used as a backup and supplementary system for a more sophisticated system being built concurrently by Stavid Division of Lockheed Electronics. (The latter system is described in a report entitled, "Converter, Analog to Digital CV-1043()/EM," now being prepared.) The two systems are now in operation at the USASRDL wind range in Belmar, New Jersey.

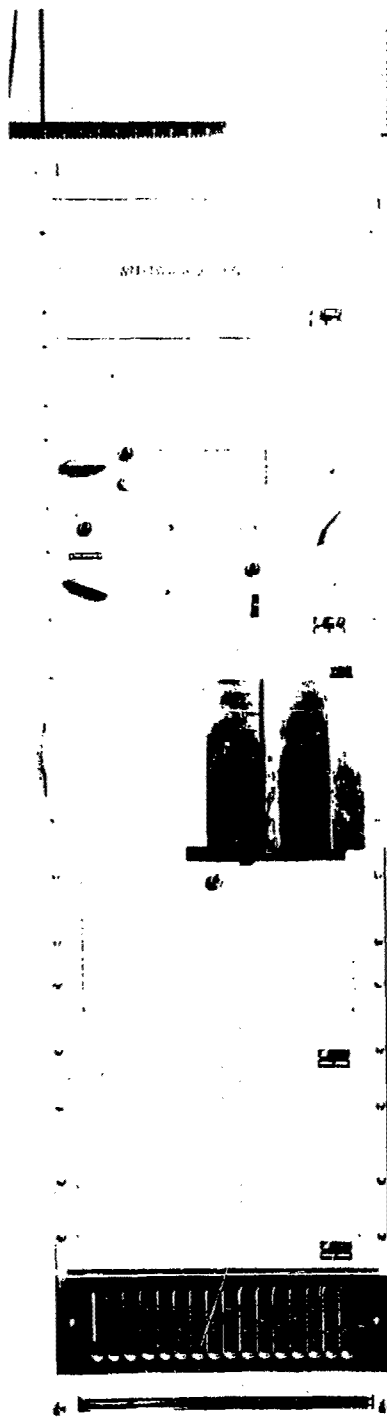

Fig. 1. Wind Data Acquisition System, Front view, showing complete unit.

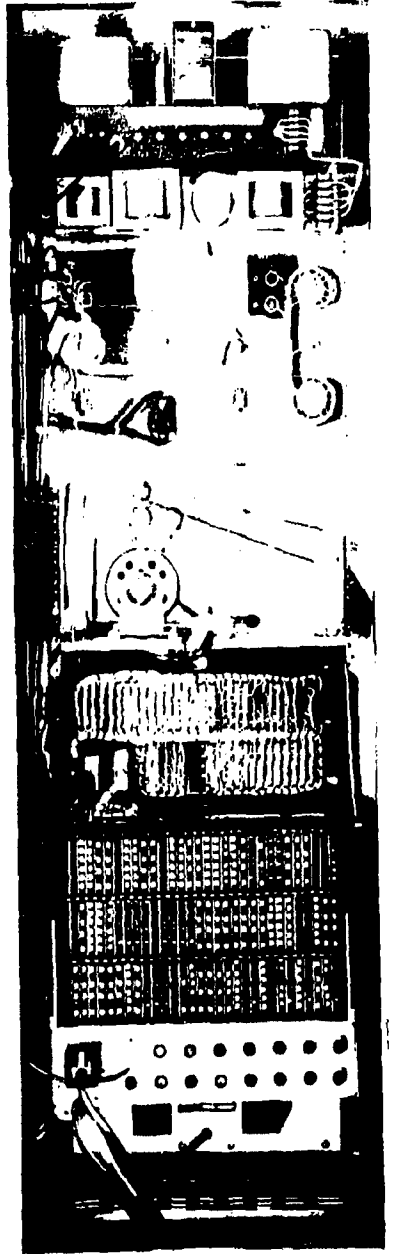

Fig. 2. Wind Data Acquisition System. Rear view, showing complete unit.

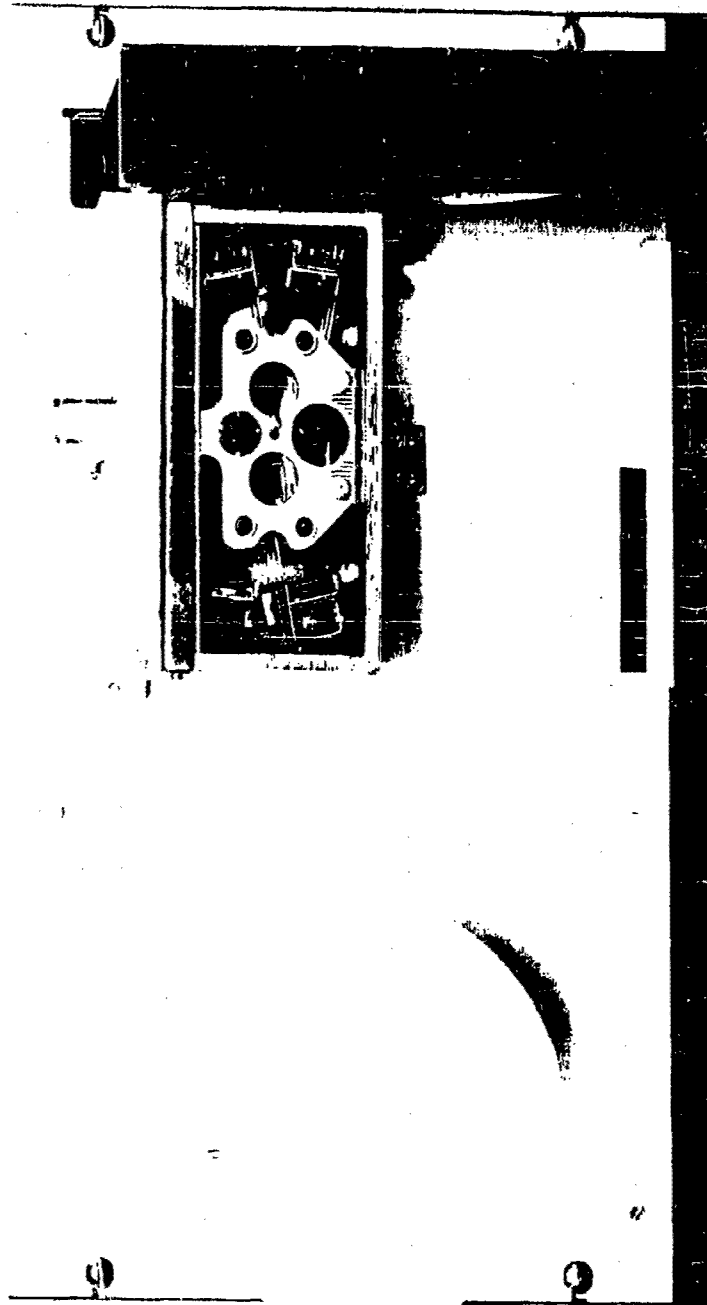

Fig. 3. Wind Data Acquisition System. Front view, showing punch mechanism.

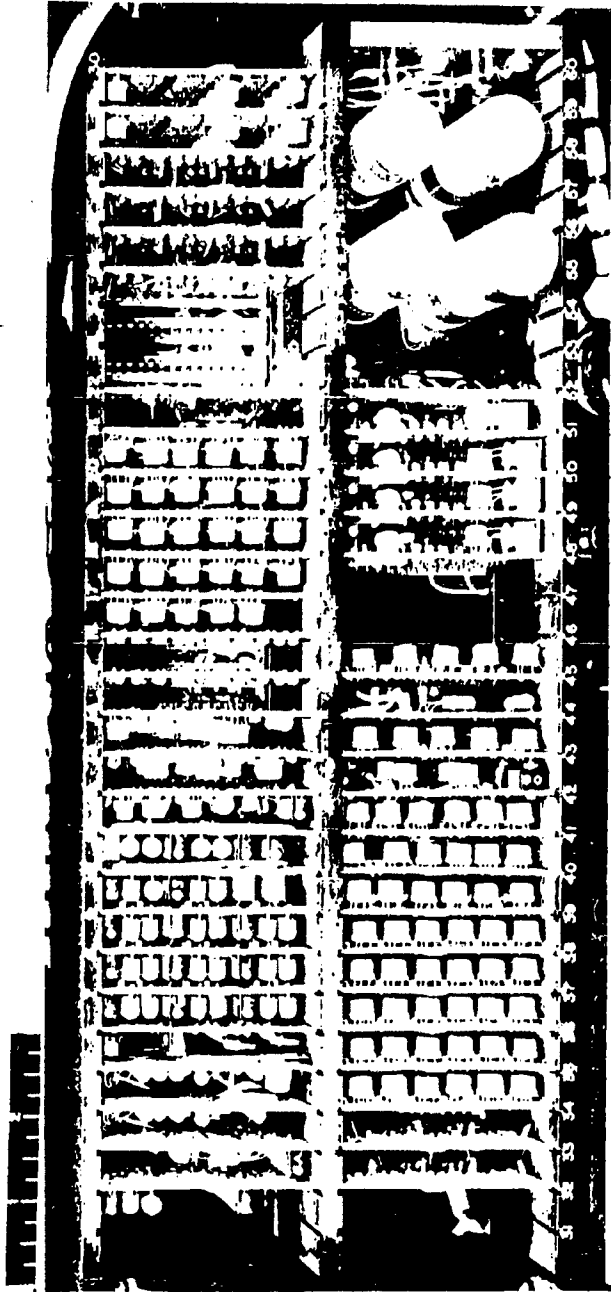

Fig. 4. Wind Data Acquisition System. Front view, showing analog to digital converter section with cover plate removed.

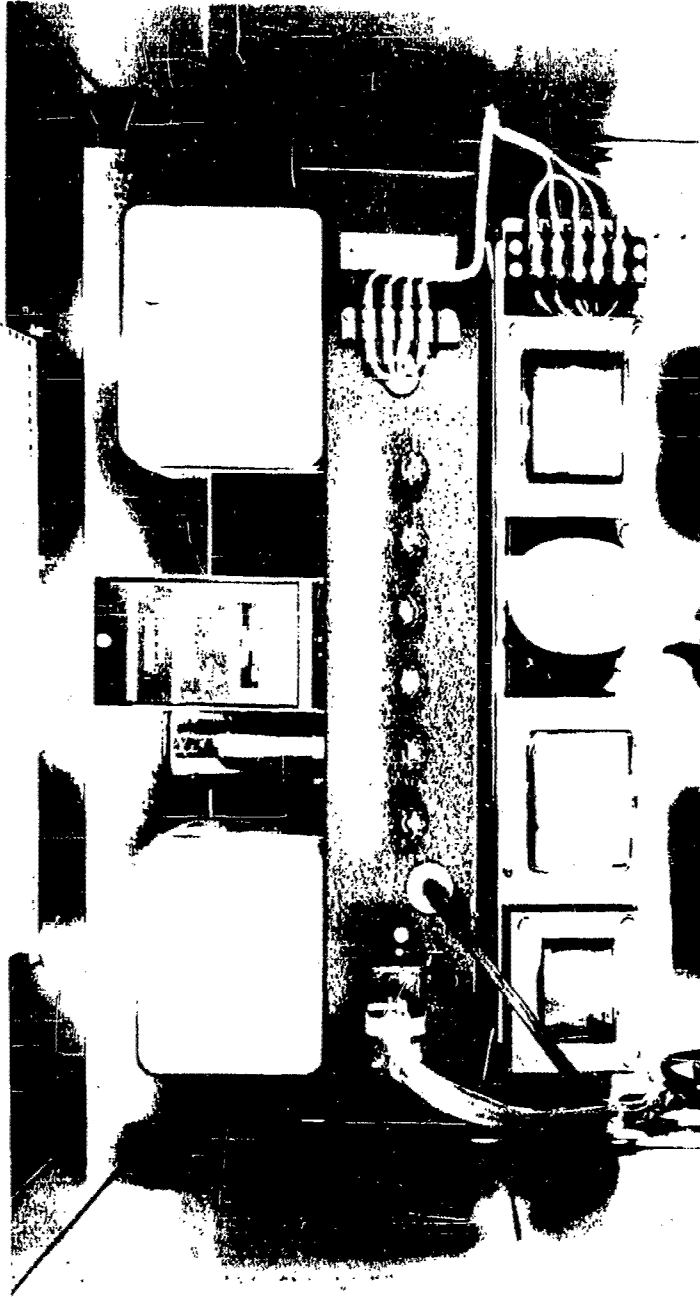

Fig. 5. Wind Data Acquisition System. Rear view, showing power supply.

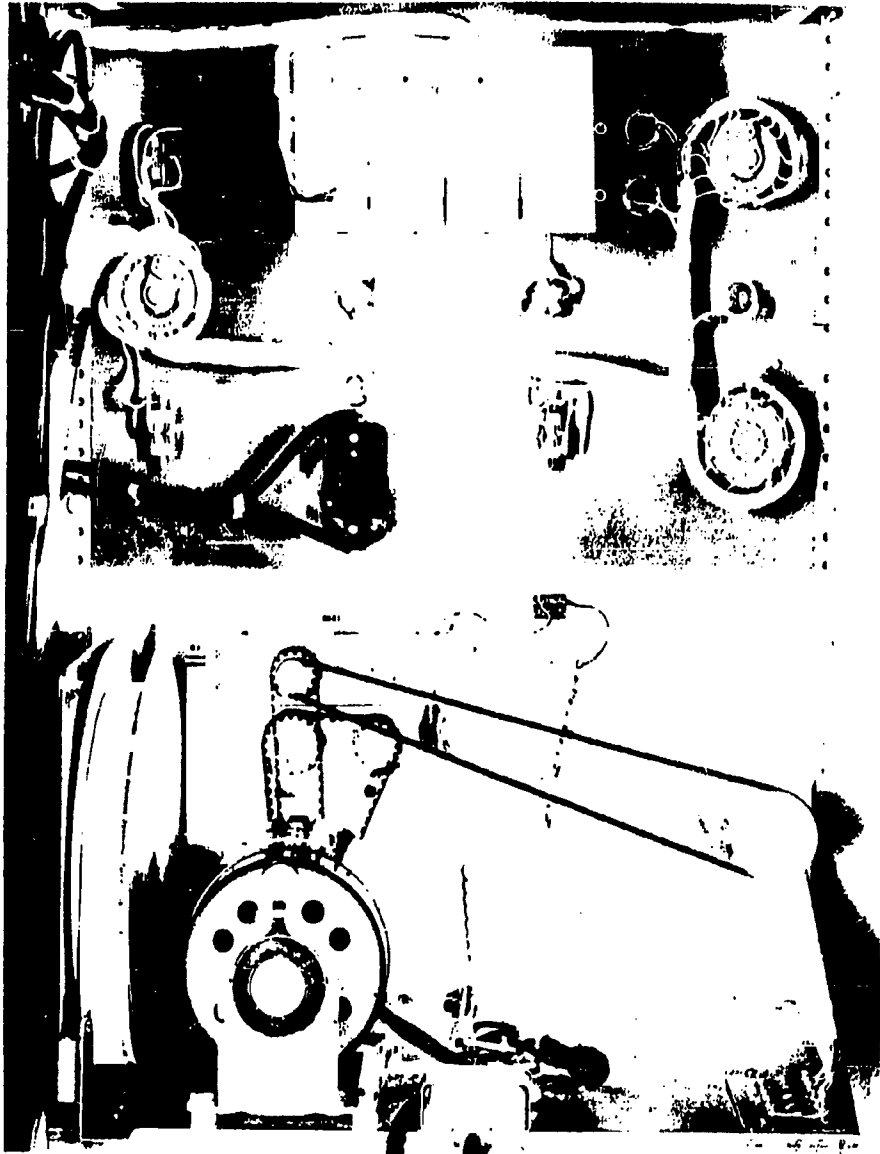

Fig. 6. Wind Data Acquisition System. Rear view, showing punch mechanism and control panel.

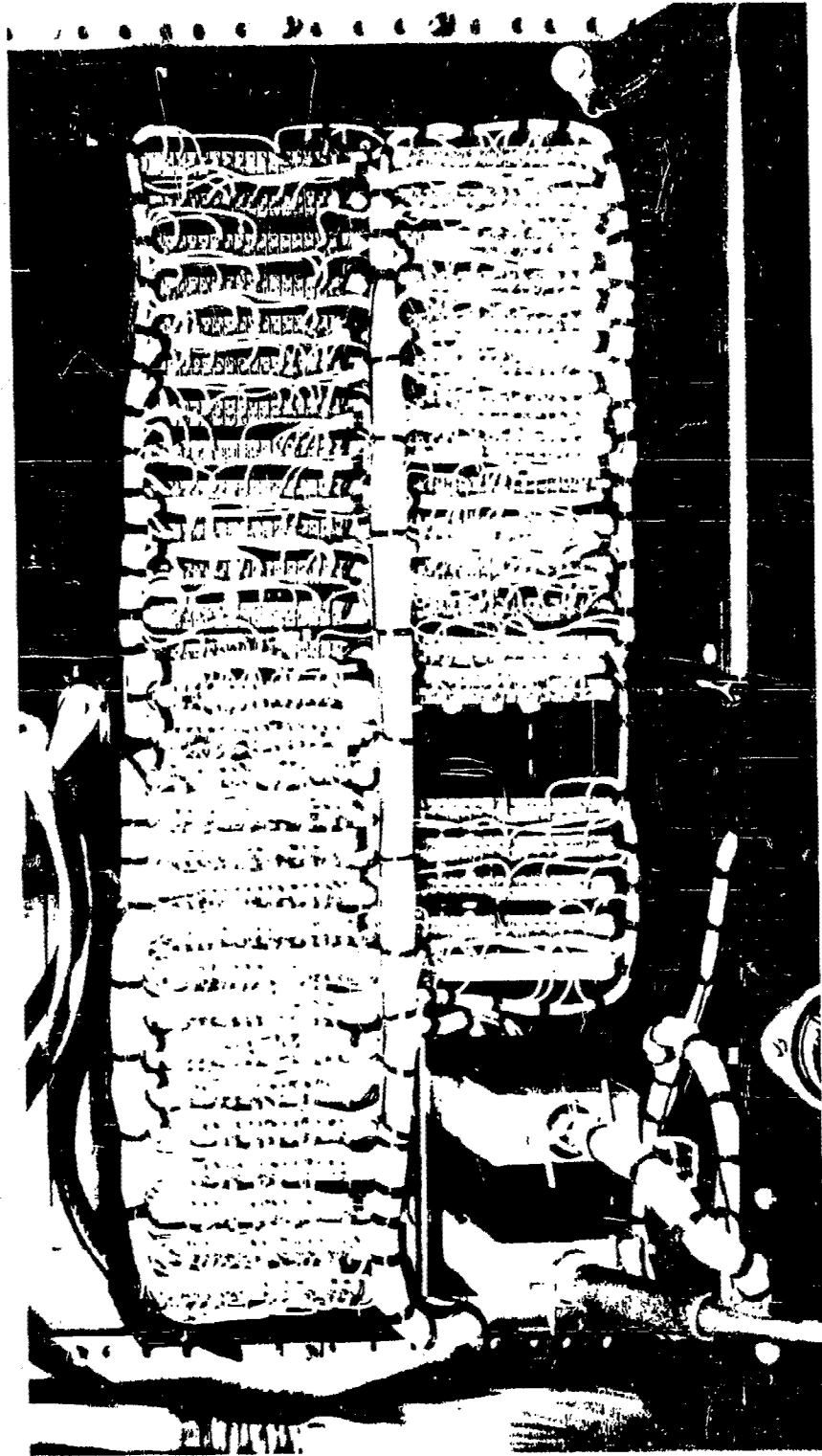

Fig. 7. Wind Data Acquisition System. Rear view, showing analog to digital converter

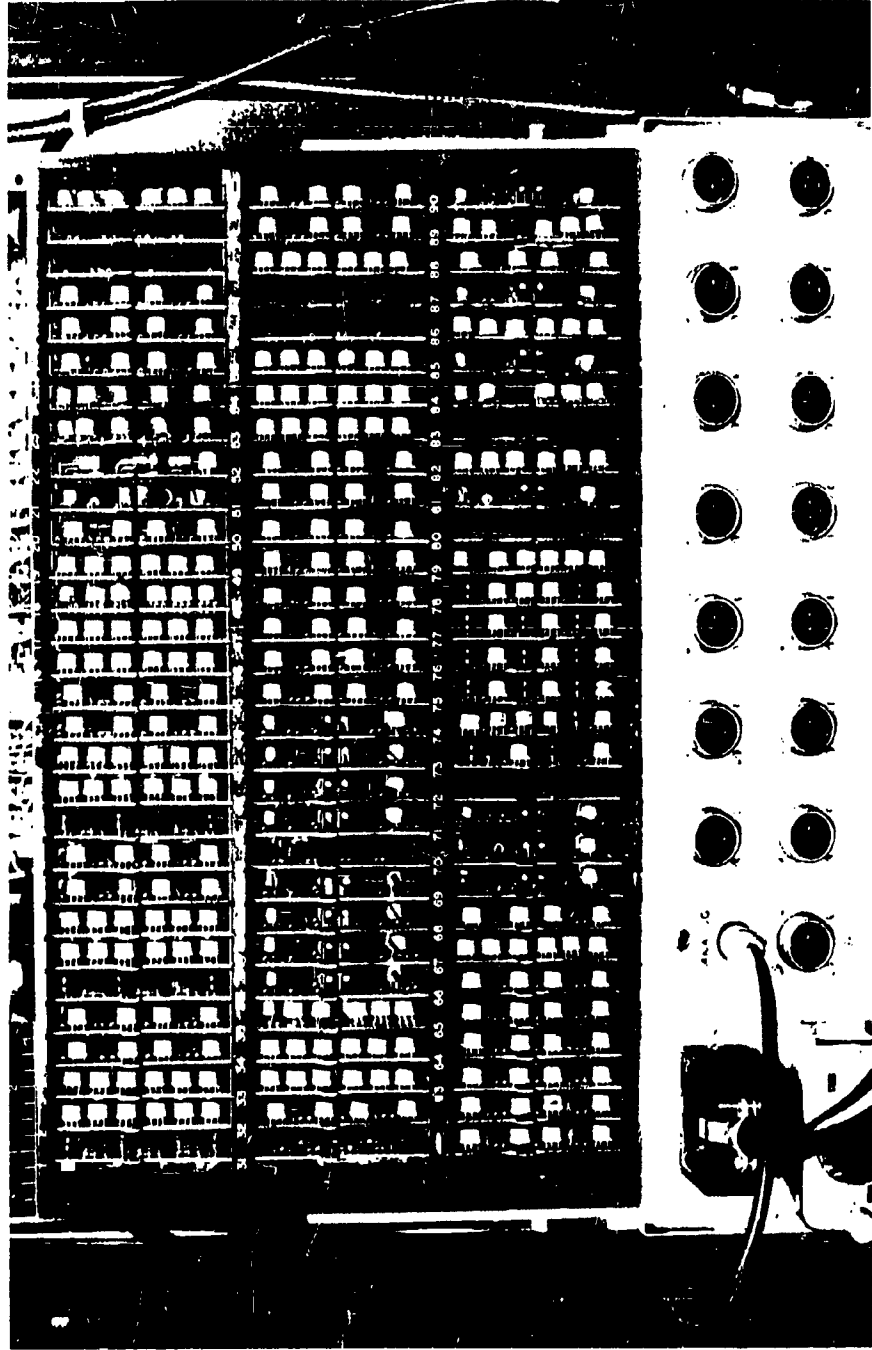

Fig. 8. Wind Data Acquisition System. Rear view, showing logic board and connector panel.

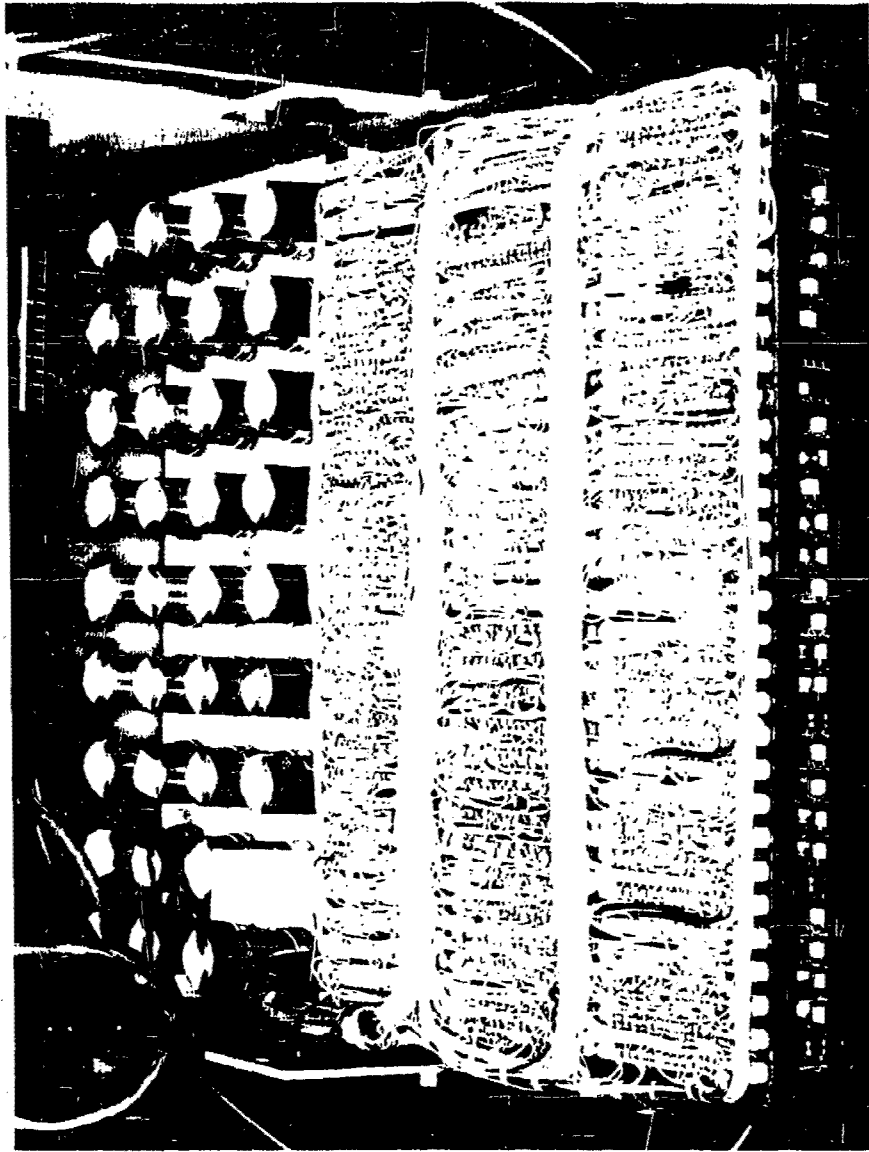

Fig. 9. Wind Data Acquisition System. Rear view, showing multiplexing relay section with logic board panel down.

DESCRIPTION

General

The basic subsystem to be used during the tests consisted of those components shown in Fig. 10. The wind sensor can be any unit that will give a voltage of approximately ± 6 volts per ± 100 miles per hour wind-vector speed. The output tape of the punch is in six-level Flexowriter code. An electric typewriter is both input and output for the LGP-30 computer mentioned previously (Fig. 11).

The wind-data-acquisition system (Fig. 12) is designed to simultaneously sample up to 30 data channels (15 two-channel sensors), and digitize the analog data in serial form. A front-panel switch selects the repetition rate of the messages. The operator may select the number of sensors to be scanned or can select a single channel for observation. The output message is punched on a paper tape by a 60-character-per-second punch. The tape will contain a series of wind-speed values, in miles per hour to the nearest tenth, together with prefix and suffix characters in six-level binary coded decimal form suitable for entry into an LGP-30 general-purpose digital computer. (Figure 13 shows a typical message.) A secondary output is the visual display on the front panel which can monitor the sampled wind vector of any one channel of a sensor.

Operation

The system has two modes of operation: manual and automatic. In the automatic mode the sampling and conversion cycle is initiated by a master timer, while in the manual mode the cycle is initiated by an operator using a front-panel control. The number of sensors to be sampled in any message is limited by the speed with which the punch can operate. In the case of the 60-character-per-second punch, only three sensors can be scanned and recorded every second. The selectable record rate intervals are 1, 2, 3, 6, 12, and 60 seconds per message.

When the system is initiated by the timer (see Fig. 12), a 40-kc oscillator manufactured by Philamon Corporation, the 30 dump relays (mercury-wetted) are closed, allowing data from the 15 sensors to be stored in the sample-and-hold circuits. These circuits consist of an R-C combination having a time constant of ten milliseconds. During this sample time (approximately 100 milliseconds) the prefix characters (Fig. 13) are entered onto the tape by command from the interlock gate. At the end of the sample time, the dump relays are opened, disconnecting the inputs; and the multiplexer relays activate the sample-and-hold circuit of the first data channel. This circuit is then connected to the analog-to-digital converter section through a high impedance, unity gain amplifier. The signal voltage is measured by a voltage comparator in binary decimal coded form. In approximately 100 microseconds the A-D converter has transformed the wind-vector voltage value into a four-level binary coded decimal (B.C.D.) representation of miles per hour to the nearest tenth. Following this function, the four-level B.C.D. code is changed to six-level Flexowriter code by means of a diode coding matrix. Following an appropriate time interval, which is controlled by the single-shot command chain circuit (see Fig. 12), the data are fed to the write gates through buffer storage.

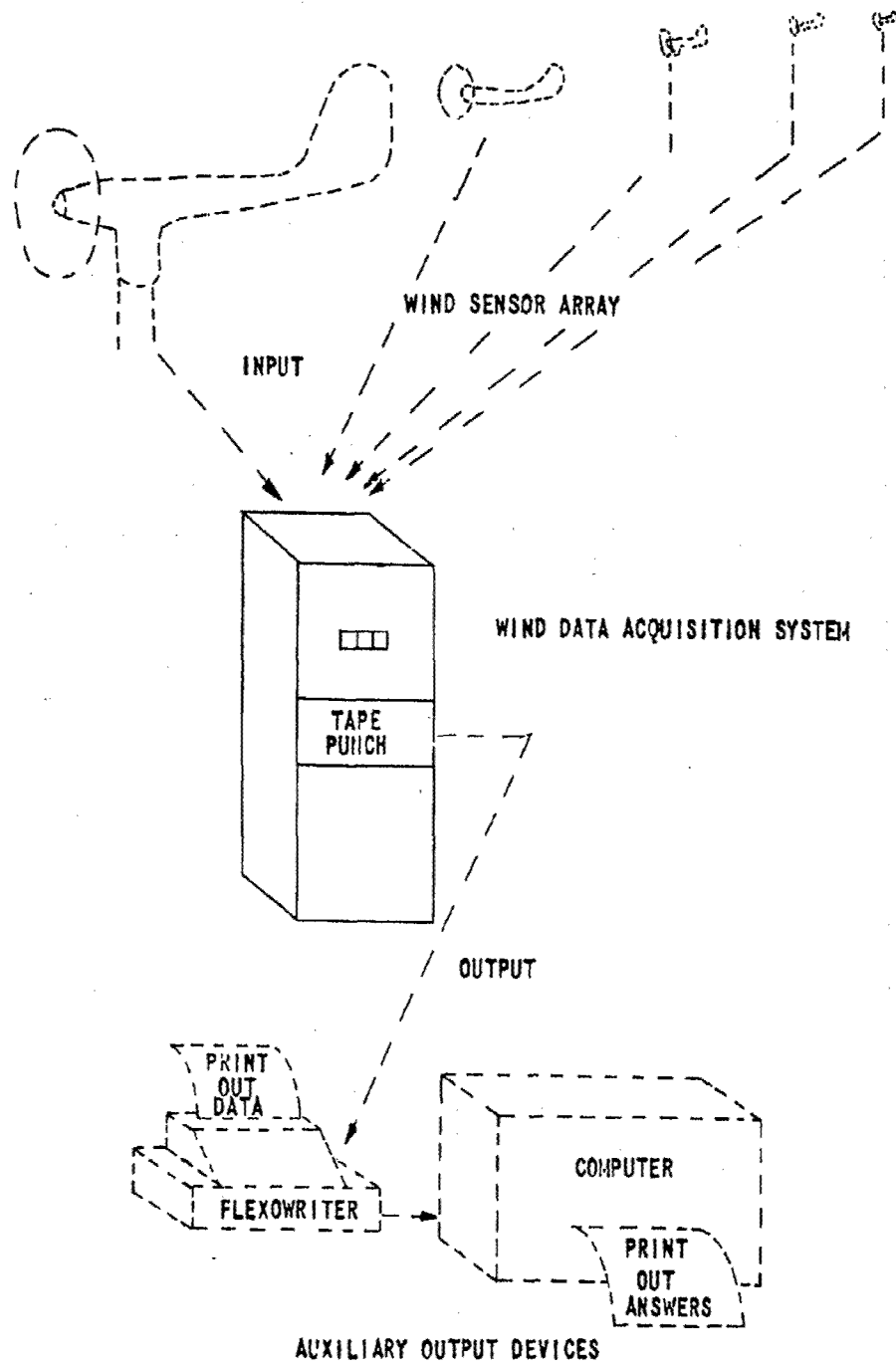

FIG. 10 WIND DATA CONVERSION SYSTEM

<u>Symbol</u>	<u>Code</u> <u>x82 41y</u>
Lower case	000 010
Plus sign	100 101
Minus sign	100 011
Conditional stop	010 000
Space	100 001
Carriage return	001 000
0	000 001
1	000 011
2	000 101
3	000 111
4	001 001
5	001 011
6	001 101
7	001 111
8	010̄ 001
9	010 011

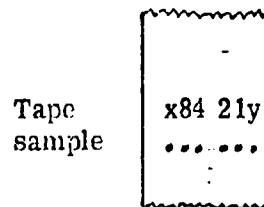

Fig. 11. LGP-30 Computer Code Used in Messages

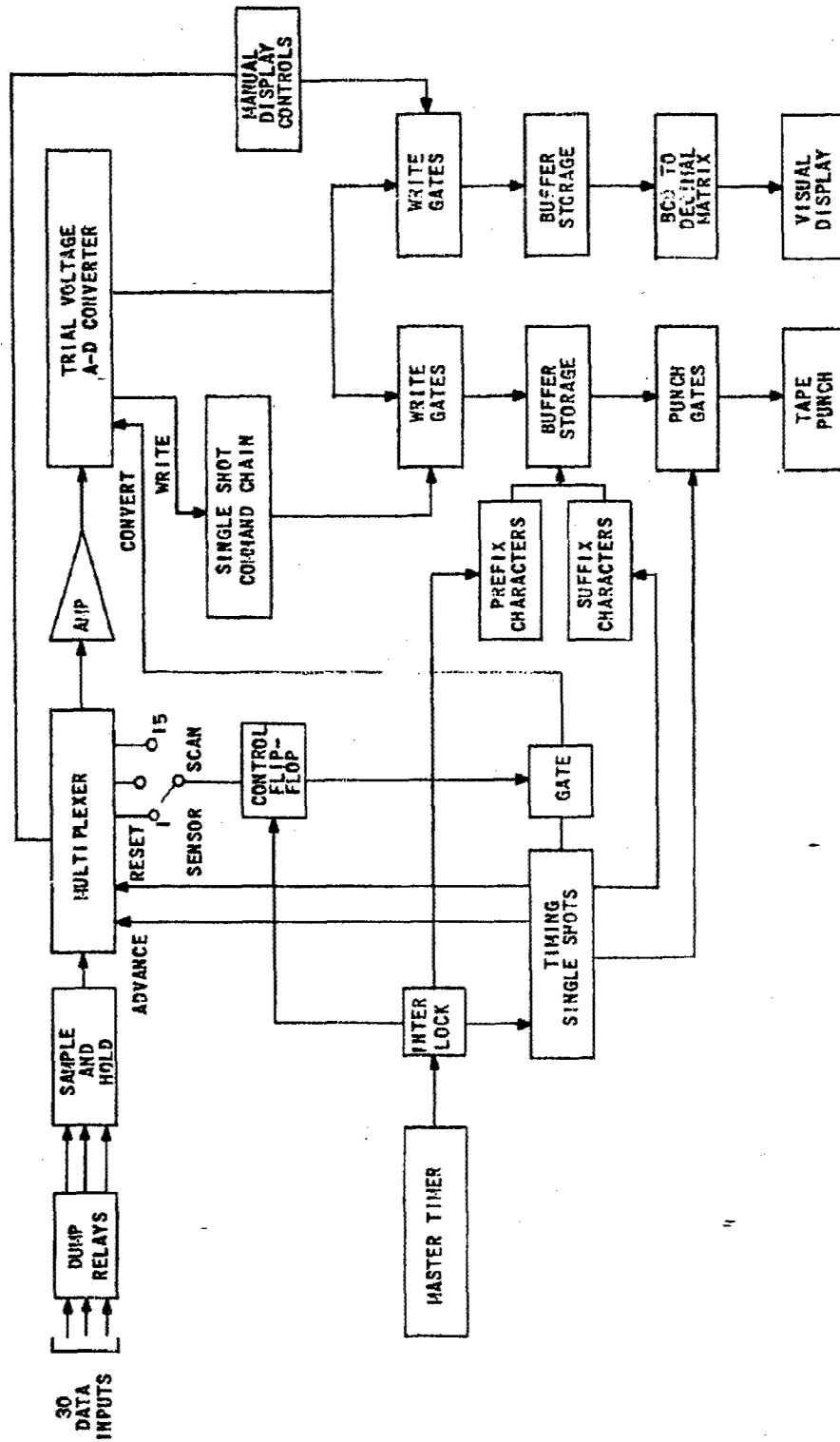

FIG. 12 WIND DATA ACQUISITION SYSTEM BLOCK DIAGRAM

The following is the message format used on the output tape:

	Item	No. of Characters
prefix characters	1. Start of message (lower case)	1
	2. Message count number	4
	3. Data with sign	4 times number of channels sampled
suffix characters	4. Computer control character (conditional stop)	1
	5. Recording rate interval symbol	1
	6. Spare character (space)	1
	7. End of message (carriage return - line feed)	1

The following shows what is included in a typical message of three sensors recorded at two seconds per message:

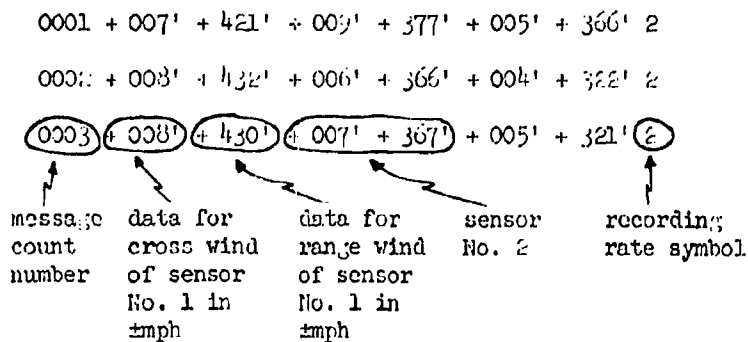

Fig. 13. Wind-Data-Acquisition System Message Format

The numerical values obtained by this process are then punched out in serial form on a paper-tape punch. The multiplexer then steps to the next data channel and the cycle is again repeated. When the final channel is reached, as determined by the sensor selector switch on the front panel, the multiplexer is automatically reset and the coded suffix characters are then gated to the punch gate circuits and onto the paper tape. The system will then remain inactive until another record rate pulse is received from the master timer.

Controls (Fig. 14)

The output can be presented in two modes: the first and primary output mode is through a Tally, model 420, 60-character-per-second tape punch. The second output mode is an in-line numerical display for visual monitoring. This display may be operated in either of two modes: continuous monitoring of the data contained in the message format or displaying the data on command, holding this value indefinitely.

The sensor-scan switch enables the operator to select the desired number of sensors for a particular message.

The time-interval switch determines the rate at which data-recordings take place. The time-interval switch and the sensor-scan switch settings must be compatible with the punch speed. A caution plate is provided to assure this compatibility.

The single-channel-operation switch allows the operator to select one particular channel to be recorded instead of all the channels.

The message-reset button is merely a system-reset button which, among other functions, will reset the message count to 0000.

The manual read-out button, when used in conjunction with the time-interval switch, will allow the operator to initiate the recording cycle.

TESTS AND RESULTS

When the two systems were first received, many deficiencies were found in the output message. These consisted primarily of inconsistent and inaccurate wind values. These deficiencies were alleviated by the contractor by replacing the multiplexing relays with an improved type and by adjustment of the various logic control timing functions. Until these modifications and adjustments were made, consistent or valid test data could not be obtained.

The test procedure to determine the operational accuracy of the wind-data converter consisted of two sections: a static accuracy check and a dynamic operational check.

The static-accuracy check consisted of supplying to the converter various d.c. voltages from ± 0.000 to ± 5.874 volts, using a Kepco, model 5441, precision d.c. voltage supply and a Fluke, model 801, d.c. differential voltmeter. These voltages represented wind speeds from ± 0.0 to ± 99.9 miles per hour. The converter operated on the signal and presented an output message

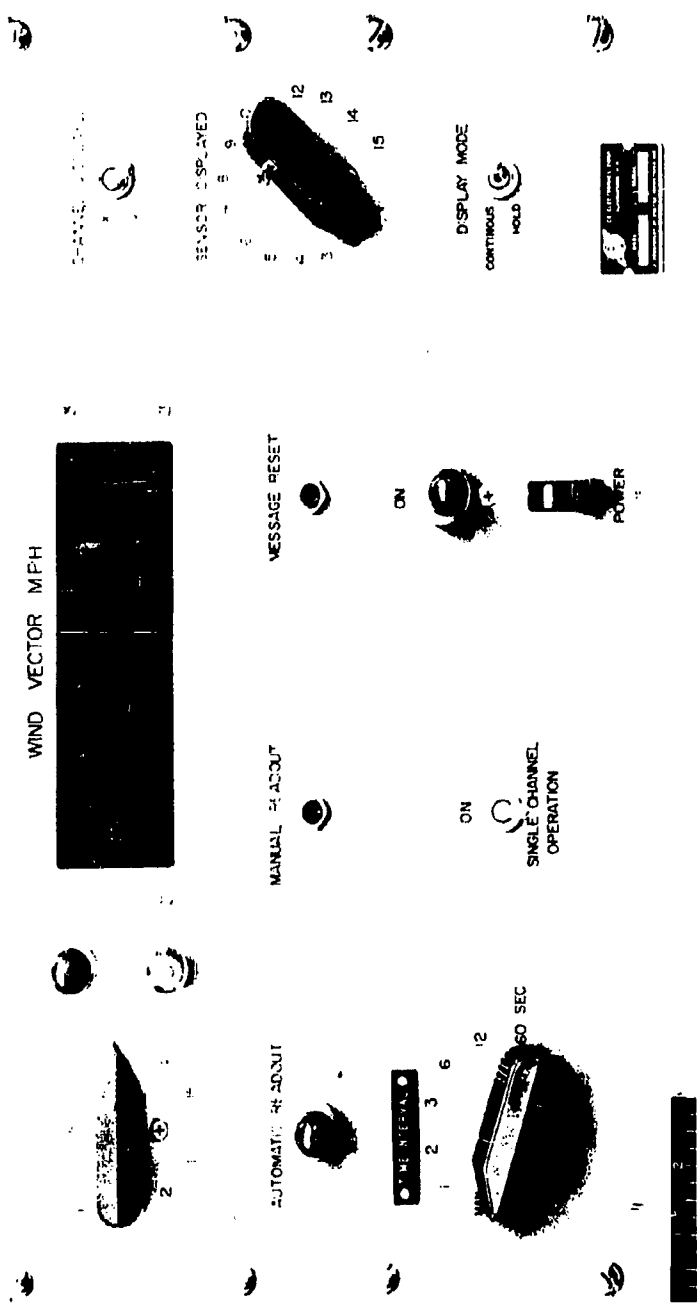

Fig. 14. Wind Data Acquisition System. Front view, showing control panel.

on the paper tape. Calibration voltages were supplied to one connector (one sensor) and subsequently to a number of connectors representing a number of simulated data channels. The simulated data were presented on the punch-paper tape which was reproduced in tabulated numerical form for evaluation.

The system accuracy was found to be dependent on many factors such as different contact-closure times for the multiplexing relays and A-D converter conversion error. The difference in recorded values between one channel and another was due to these factors. The greatest variation from channel 1 to channel 30 per sample was three counts, or 0.3 mph, with the average maximum deviation of about 0.2 mph. Variations in accuracy also occurred with changing input signals. At wind speeds up to ± 40 mph, the variation from one channel of one sample to the next sample was ± 0.1 mph, but these variations occurred infrequently. Above 40 mph the variation still remained at 0.1 mph, but its occurrence from one sample to the next was much more frequent. Another slight variation in accuracy occurs when a negative input voltage is introduced. The maximum deviation for this condition, however, is only -0.1 mph.

Tests were run at 105 volts and 125 volts, with no deterioration of results.

Figure 15 gives an illustration of a calibration-accuracy test run at 115 volts for six different input signals. The data alternate channels, since this gives the maximum change from one channel to the next and thus the greatest chance for error. The input voltages are in proportion to ± 5.874 volts = ± 100.0 miles per hour, as shown below.

<u>Wind speed</u> (mph)	<u>Input voltage</u> (volts)
100.0	5.874
50.0	4.699
40.0	2.350
20.0	1.175
10.0	0.587

These values are true only for an input impedance of 100K ohms.

The dynamic accuracy check consisted of replacing the precision voltage with a set of wind sensors and observing the output message form. The basic reason for this test was to observe the consistency and compatibility of the sensor array and the converter.

Numerous long data samples (200 messages per sample) were observed, and the compatibility of the system was adjudged to be good. The converter gave a true representation of the conditions present at the sensor. The consistency was determined to be good for a digital system with no error-checking or error-correcting circuitry. During the tests both units averaged about one error per 40,000 characters output. The error, when it occurred, was usually a sign or a conditional stop character.

During the tests it was determined, and also suggested by the contractor, that a calibration run should be made on the equipment biweekly, and any

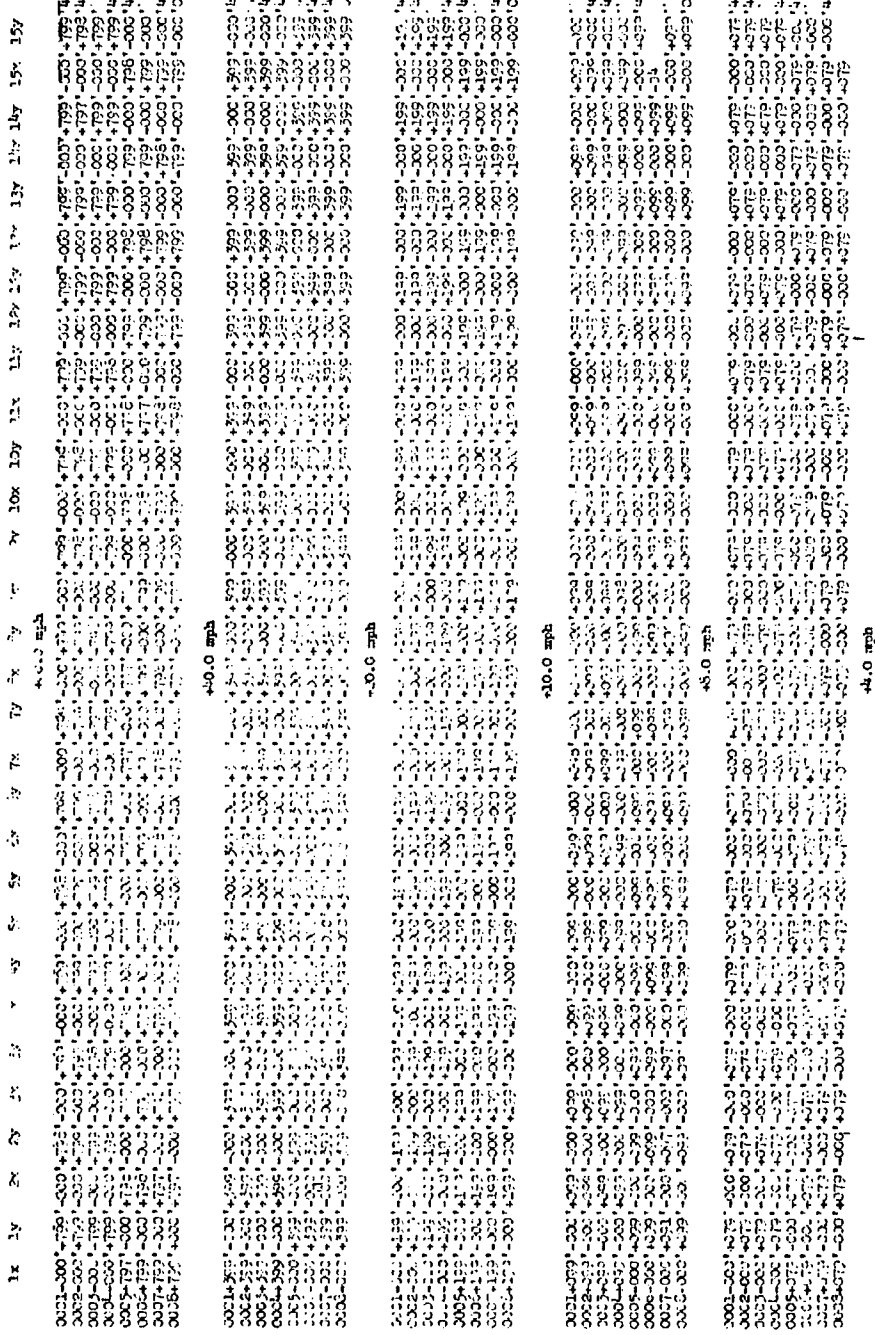

Fig. 15. Sample Calibration Run

conversion adjustments necessary be made at that time. This is necessary because of the normal aging process and the unequal environmental conditions persisting where the equipment is located.

The results of these tests confirmed that the system accuracy is satisfactory, since the errors were well within the applicable tolerance range. In most cases the equipment functioned more satisfactorily than was expected. In any case, the equipment is much more accurate than the wind sensors now in use and so will not add appreciably to the over-all system error.

CONCLUSIONS

The equipment, after the initial adjustment period, gave satisfactory performance. The original accuracy required by the technical characteristics was ± 0.1 mph; however, during the tests it was found that some points fell slightly outside this region. It was felt that since these points were so infrequent and since they fell outside the usual range of measurement (in the 70- to 100-mph range), the equipment met the requirements.

Some trouble has occurred with the 60-characters-per-second tape-punch in one unit; however, this is due to a faulty part supplied by the punch manufacturer. When this part is replaced, the punch will function satisfactorily.

The equipment was turned over to personnel using the USASRDJ wind range in May 1960, and it has been obtaining data since that time. During this period no trouble has been reported, and no maintenance has been performed other than the usual spot-check of conversion accuracy, and adjustment if out of range.

It has been found that the equipment performs more reliably when used frequently, and, after the initial break-in period, the components have aged or adjusted to the circuit in which they are placed.

It should be noted that, although the system operation given in the description is simple, there are a large number of electronic components involved. In the logical-control and analog-to-digital-converter sections, there are 136 circuit boards, each of which contains an average of four transistors with their associated circuits. When these are converted into possible error areas, the reason for the error rate becomes obvious.

DISTRIBUTION	<u>No. of Copies</u>
Chief Signal Officer, ATTN: SIGRD Department of the Army, Washington 25, D. C.	1
Chief Signal Officer, ATTN: SIGPD-8b1 Department of the Army, Washington 25, D. C.	2
U. S. Army Research Office, Research Analysis Division ATTN: Dr. Hoyt Lemons, Arlington Hall Station, Virginia	1
Office of Assistant Secretary of Defense (R and E) ATTN: Technical Library, Room 3E1065, The Pentagon Washington 25, D. C.	1
Chief, United States Army Security Agency ATTN: AC of S, G4 (Technical Library) Arlington Hall Station, Arlington 12, Virginia	1
Commanding General, U. S. Army Electronic Proving Ground ATTN: Meteorological Department, Fort Huachuca, Arizona	1
Commanding General, U. S. Army Electronic Proving Ground ATTN: SIGPG-DCGM, Fort Huachuca, Arizona	2
Commanding General, U. S. Army Electronic Proving Ground ATTN: Technical Library, Fort Huachuca, Arizona	1
Commanding Officer, U. S. Army Signal Missile Support Agency ATTN: SIGMS-MJ, White Sands Missile Range, New Mexico	1
Commanding Officer, U. S. Army Signal Materiel Support Agency ATTN: SIGMS-ADJ, Fort Monmouth, New Jersey	1
Directorate of Intelligence, Hq, United States Air Force ATTN: AFODI-1b1, Washington 25, D. C.	2
Commander, Long Air Development Center ATTN: RALF, Griffiss Air Force Base, New York	1
Commanding General, Hq, Ground Electronics Engineering Installation Agency, ATTN: ROEMS Griffiss Air Force Base N. Y.	1
Commander, Aeronautical Systems Division, ATTN: ASAPRL Wright Patterson Air Force Base, Ohio	1
Commander, U. S. Air Force Security Service ATTN: Directorate of Systems Engineering (ESD) DCS/Communications-Electronics, San Antonio, Texas	1
Commander, Air Force Electronic Systems Division ATTN: CCRR and CCSD, L. G. Hanscom Field, Bedford, Mass.	2

DISTRIBUTION (contd)	<u>No. of Copies</u>
Commander-in-Chief, Strategic Air Command ATTN: DOCEB, Offutt Air Force Base, Nebraska	1
Commander, Air Proving Ground Center ATTN: FGAPI Eglin Air Force Base, Florida	1
Commander, Air Force Cambridge Research Laboratories ATTN: CRO, Laurence G. Hanscom Field, Bedford, Massachusetts	2
Chief of Naval Research, ATTN: Code 427 Department of the Navy, Washington 25, D. C.	1
Bureau of Ships Technical Library ATTN: Code 312, Main Navy Building, Room 1526 Washington 25, D. C.	1
Chief, Bureau of Ships, ATTN: Code 454 Department of the Navy, Washington 25, D. C.	1
Chief, Bureau of Ships, ATTN: Code 686B Department of the Navy, Washington 25, D. C.	1
Director, ATTN: Code 2027 U. S. Naval Research Laboratory, Washington 25, D. C.	1
Commanding Officer and Director, ATTN: Library U. S. Navy Electronics Laboratory, San Diego 52, California	1
Commander, U. S. Naval Ordnance Laboratory White Oak, Silver Spring 19, Maryland	1
Director, U. S. Army Engineer Research and Development Laboratories ATTN: Technical Documents Center, Fort Belvoir, Virginia	1
Commanding Officer, U. S. Army Chemical Warfare Laboratories ATTN: Technical Library, Bldg. 330 Army Chemical Center, Maryland	1
Commander, Armed Services Technical Information Agency ATTN: TIPCR, Arlington Hall Station, Arlington 12, Virginia	10
Signal Corps Liaison Officer, Ordnance Tank Automotive Command U. S. Army Ordnance Arsenal, Detroit, Center Line, Michigan	1
Army Liaison Officer, ATTN: Code 1071 Naval Research Laboratory, Washington 25, D. C.	1
Commander, Air Weather Service (MATS), ATTN: AWSSS/Mr. Hardin Scott Air Force Base, Illinois	1

DISTRIBUTION (contd)

No. of Copies

U. S. Army Signal Liaison Office, Aeronautical Systems Division ATTN: ASDL-9, Wright-Patterson Air Force Base, Ohio	2
Signal Corps Liaison Officer, Massachusetts Institute of Technology Building 26, Room 131, 77 Massachusetts Avenue Cambridge 39, Massachusetts	1
Signal Corps Liaison Officer, Lincoln Laboratory P. O. Box 73, Lexington, Massachusetts	1
Signal Corps Liaison Officer, Rome Air Development Center ATTN: RAOL, Griffiss Air Force Base, New York	1
USASRDL Liaison Officer, Hq, U. S. Continental Army Command Fort Monroe, Virginia	1
USASISMA Liaison Engineer, Signal Section, Eighth U. S. Army APO 301, San Francisco, California	1
Chairman, U. S. Army Chemical Corps Meteorological Committee Fort Detrick, Frederick, Maryland	1
Director, U. S. Army Chemical Corps Operations Research Group Army Chemical Center, Edgewood, Maryland	1
Director, Atmospheric Sciences Program National Science Foundation, Washington 25, D. C.	1
Director, Bureau of Research and Development Federal Aviation Agency National Aviation Facilities Experimental Center ATTN: Technical Library, Bldg 3, Atlantic City, New Jersey	1
Chief, Fallout Studies Branch, Division of Biology and Medicine Atomic Energy Commission, Washington 25, D. C.	1
Chief, Bureau of Naval Weapons (FAME) U. S. Navy Department, Washington 25, D. C.	1
Officer-in-Charge, Meteorological Curriculum U. S. Naval Post Graduate School, Monterey, California	1
Chief of Naval Operations (OPO7) U. S. Navy Department, Washington 25, D. C.	1
Office of Naval Research, U. S. Navy Department Washington 25, D. C.	1
U. S. Naval Research Laboratory, ATTN: Code 7110 Washington 25, D. C.	1

DISTRIBUTION (contd)

No. of Copies

AFSC Liaison Office Naval Air Research and Development Activities Command Johnsville, Pennsylvania	1
Chief of Research and Development, Department of the Army Washington 25, D. C.	2
Marshall Space Flight Center, Aeroballistic Division Aerophysics Branch (Aero-G), ATTN: William Vaughn Huntsville, Alabama	1
Office of U. S. Naval Weather Service U. S. Naval Station, Washington 25, D. C.	1
Officer-in-Charge, U. S. Naval Weather Research Facility U. S. Naval Air Station, Norfolk, Virginia	1
U. S. Army Corps of Engineers Snow, Ice, and Permafrost Research Establishment 1215 Washington Avenue, Wilmette, Illinois	1
U. S. Army Corps of Engineers, Waterways Experiment Station Vicksburg, Mississippi	1
Office of the Chief of Ordnance, Department of the Army Washington 25, D. C.	1
Chief, Aerophysics Branch, Aeroballistics Laboratory Army Ballistic Missile Agency, Redstone Arsenal, Alabama	1
Liaison Officer, LAA U. S. Army Signal Research and Development Laboratory 75 South Grand Avenue, Bldg 13, Pasadena 2, California	1
Commanding Officer, ATTN: Technical Information Section Picatinny Arsenal, Dover, New Jersey	1
Chief, Meteorology Division, U. S. Army Chemical Corps Proving Ground Dugway Proving Ground, Utah	1
USASMSA Liaison Office, Room 4D117, USASRDL	1
Corps of Engineers Liaison Officer, Room 4D123, USASRDL	1
Marine Corps Liaison Officer, Room 4D119, USASRDL	1
U. S. COMARC Liaison Officer, Room 4D115, USASRDL	3
USASRDL Technical Documents Center, Evans Area	1
Mail File and Records, File Unit No. 3, Evans Area	1

DISTRIBUTION (contd)	<u>No. of Copies</u>
Chief, Technical Information Division, Hq, USASRDL	6
Chief Scientist, USASRDL	1
Chief, Atmospheric Physics Branch, Meteorological Division	1
Chief, Meteorological Systems Branch, Meteorological Division	20
Chief, Meteorological Instrumentation Branch Meteorological Division	1
Technical Reports Unit, Meteorological Division	1
Commander 16th Weather Squadron Fort Monroe, Virginia	1
Commanding Officer, Diamond Ordnance Fuze Laboratories ATTN: Library, Room 211, Bldg 92, Washington 25, D. C.	1
Commanding Officer, U. S. Army Signal Research Activity Evans Area	1

