

UNCLASSIFIED

AD 276 219

*Reproduced
by the*

ARMED SERVICES TECHNICAL INFORMATION AGENCY
ARLINGTON HALL STATION
ARLINGTON 12, VIRGINIA



UNCLASSIFIED

NOTICE: When government or other drawings, specifications or other data are used for any purpose other than in connection with a definitely related government procurement operation, the U. S. Government thereby incurs no responsibility, nor any obligation whatsoever; and the fact that the Government may have formulated, furnished, or in any way supplied the said drawings, specifications, or other data is not to be regarded by implication or otherwise as in any manner licensing the holder or any other person or corporation, or conveying any rights or permission to manufacture, use or sell any patented invention that may in any way be related thereto.

DISCLAIMER NOTICE

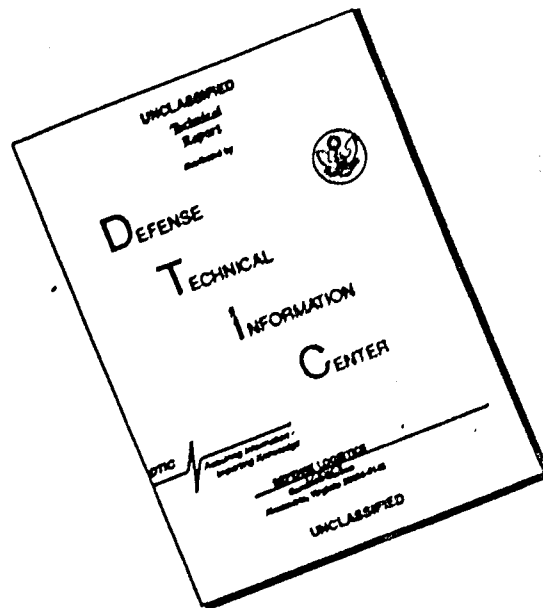

THIS DOCUMENT IS BEST QUALITY AVAILABLE. THE COPY FURNISHED TO DTIC CONTAINED A SIGNIFICANT NUMBER OF PAGES WHICH DO NOT REPRODUCE LEGIBLY.

276 219

CATALOGED BY ASTIA
AS AD NO. 276219

APGC-TDR-62-29



Engineering Evaluation of the F-105 Tow Target System

by Robert J. Tracy, 1stLt, USAF

APGC Technical Documentary Report No. APGC-TDR-62-29

May 1962 • APGC Project No. 6830W1

DEPUTY FOR AEROSPACE SYSTEMS TEST

AIR PROVING GROUND CENTER

AIR FORCE SYSTEMS COMMAND • UNITED STATES AIR FORCE

EGLIN AIR FORCE BASE, FLORIDA



ASTIA
762-305
JUN 14 1962
ASTIA D

Qualified requesters may obtain copies from ASTIA. Orders will be expedited if placed through the librarian or other person designated to request documents from ASTIA.

When US Government drawings, specifications, or other data are used for any purpose other than a definitely related government procurement operation, the government thereby incurs no responsibility nor any obligation whatsoever; and the fact that the government may have formulated, furnished, or in any way supplied the said drawings, specifications, or other data is not to be regarded by implication or otherwise, as in any manner licensing the holder or any other person or corporation, or conveying any rights or permission to manufacture, use, or sell any patented invention that may in any way be related thereto.

Do not return this copy. Retain or destroy.

FOREWORD

This test, APGC Project 6830W1, was conducted under authority of Operational Support Requirement No. 373, dated 5 November 1959. Physical testing was started on 28 August 1961 and was completed on 15 December 1961.

The following personnel were responsible for the testing accomplished under this project and/or for the preparation of this report:

Senior Project Officer	John D. Babinski, Capt, USAF
Project Officer	Robert J. Tracy, 1stLt, USAF
Development Engineer	Ronald E. Jensen, Capt, USAF
Assistant Development Engineer	Earl T. Smith, 1stLt, USAF
335th Tactical Fighter Squadron	
Test Officer	James W. Keeling, Capt, USAF
Project Technicians	Thomas Morton, SSgt, USAF
	Bill A. Donoho, SSgt, USAF
Technical Editor	Gerald D. O'Neill
Technical Illustrator	Melvin H. Fowler, Jr.
Layout and Composition	Phyllis K. Thirsk

Catalog cards may be found at the back of this document.

ABSTRACT

This test consisted of an engineering evaluation of a tow target system designed for use on the F-105 aircraft. The system was designed to provide the Tactical Air Command with a transonic tow target capability for gunnery training.

Missions were conducted to test the tow system for compatibility with the F-105 aircraft, structural integrity, adequacy of the operation of the tow reel under various flight conditions, and operation of the parachute recovery system. In addition, studies were conducted to determine the turnaround capability of the system and to investigate its probable life. Training requirements for introduction of the system into the Tactical Air Command inventory were also determined.

It was concluded from the test that, with certain modifications, the tow system can be satisfactorily used in normal towing operations and that the training requirements can be easily satisfied.

PUBLICATION REVIEW

This technical documentary report has been reviewed and is approved.



ROBERT H. WARREN

Major General, USAF

Commander

CONTENTS

Section	Page
1. INTRODUCTION	1
2. DESCRIPTION	2
General	2
Tow Reel Assembly	2
Parachute Recovery System	5
Target	5
Pylon Adapters	8
Control Panel	8
Associated Wiring	8
3. TEST PROCEDURES	9
4. TEST RESULTS AND DISCUSSION	11
Compatibility of the Tow System with the F-105 Aircraft	11
Structural Integrity of the System	11
Adequacy of Operation of the System	17
Turnaround Capability	19
Estimated Life of the Equipment	21
Training Requirements for Ground Crew Personnel	21
5. CONCLUSIONS	22
6. RECOMMENDATIONS	24
7. ACTION TAKEN	24
Appendix	
I. INSTALLATION PROCEDURES	26
II. PILOTS' OPERATING PROCEDURES	29

ILLUSTRATIONS AND TABLES

Figure

1. Front and Rear Diagonal Views of F-105 Aircraft Showing Tow Target System Installation	3
2. Tow Reel Pod	4
3. Operation of Parachute Recovery System	6

ILLUSTRATIONS AND TABLES (Continued)

Figure	Page
4. Dart Target Installation on F-105 Aircraft	7
5. Tow Target System Control Panel	9
6. Original Tow Reel Spool and Modified Spool Showing Stepped Left End Plate and Increased Weld Area	14
7. Further Modification of Tow Reel Spool Showing Additional Plate Welded on Right End Plate	15
8. Final Configuration of Tow Reel Spool	16
9. Original Recovery Parachute Canister	18
10. Redesigned Recovery Parachute Canister	19
11. Original Recovery Parachute Canister as In- stalled on the F-105 Aircraft	20
12. Installation of Redesigned Recovery Parachute Canister	20
 Table	
1. Mission Summary	12

SECTION 1 - INTRODUCTION

A requirement was established by the Tactical Air Command for a unit-equipped, transonic, gunnery tow target system for the F-105 aircraft. The targets for the system were required to be recoverable for scoring and re-use. An additional requirement was provision for quick removal of the system to make the aircraft combat-ready.

To meet these requirements, the Model 29C2 one-way tow reel assembly, manufactured by Anderson Greenwood and Company, Houston, Texas, and the standard TDU-10/B or modified K-11 dart target utilizing an aerodynamically actuated parachute recovery system were selected.

The purpose of this test was to determine the following:

1. Flight compatibility and structural integrity of the system under conditions of transonic speeds and normal maneuvers.
2. Ability of the tow reel to withstand the structural loads imposed, with the tow cable extended and the target attached, at various altitudes and airspeeds.
3. Adequacy of the tow reel for operation at various altitudes.
4. Adequacy of the tow reel braking system.
5. Operation of the parachute recovery system.
6. Rapid turnaround capability of the system.
7. Estimated life of the equipment.
8. Training requirements for introduction of the system into the Tactical Air Command inventory.

SECTION 2 - DESCRIPTION

GENERAL

The F-105 tow target system (Fig. 1) consists basically of the tow reel assembly mounted on the aircraft centerline pylon by means of a pylon adapter, a TDU-10/B or modified K-11 dart target mounted on either outboard wing pylon by means of a target launcher adapter, and equipment for recovery of the target and the tow cable upon completion of a mission. The tow reel, together with the pod in which it is inclosed, is designed to withstand airspeeds up to mach 1.5 and has a capacity of 3300 ft of 1/8-in. cable or 2100 ft of 3/16-in. cable.* A squib-actuated cable cutter is mounted in the pod behind the reel. A cable cutter switch on the cockpit control panel provided with the system is used to actuate the cutter. Provision is made for recovery of the target and tow cable by means of a parachute packaged in a canister positioned at the aft end of the tow reel pod.

In the original design, the centerline pylon adapter, tow reel pod housing, parachute recovery system, and tow reel loaded with cable weighed approximately 400 lb. As a result of modification of the tow reel during testing, the tow reel weight was increased by approximately 50 lb, making the overall weight of the above items approximately 450 lb. The target launcher adapter and the dart target weigh approximately 275 lb. The lightness of weight of the overall system was achieved through use of aluminum in the fabrication of the tow reel, recovery parachute canister, and sway brace bolts and nuts and use of fiberglass in the construction of the tow reel pod.

The tow system is designed for target deployment at 200 KIAS at 10,000 ft altitude. Maximum allowable airspeed during tow is 475 KIAS or mach 1.1. The system was designed for initiation of parachute recovery at 200 KIAS at an aircraft altitude of 1000 ft above the terrain.

TOW REEL ASSEMBLY

TOW REEL POD. The tow reel pod (Item 2, Fig. 1, and Fig. 2) is approximately 160 in. in length and 18 in. in diameter. It is comprised of a forward section, a center section, and an aft section. A duct is installed in the forward section to provide cooling air for the tow reel installed in the center section. A panel is provided in the bottom of the

* *Armored cable.*

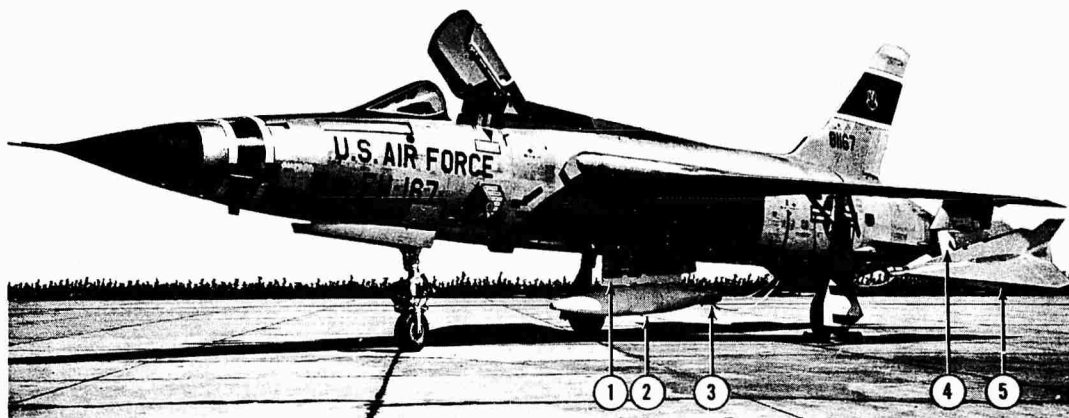

Fig. 1: Front and Rear Diagonal Views of F-105 Aircraft Showing Tow Target System Installation: (1) Centerline Pylon Adapter, (2) Tow Reel Assembly, (3) Parachute Recovery Canister, (4) Target Pylon Adapter, (5) TDU-10/B Target.

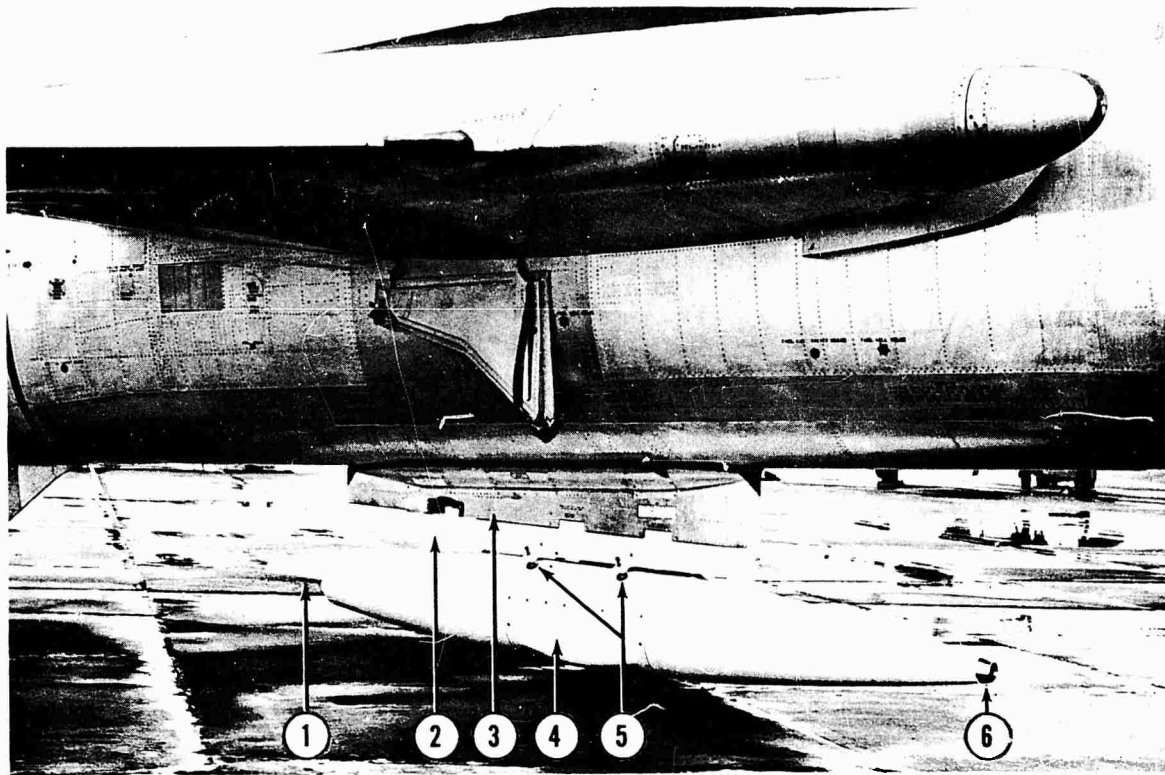

Fig. 2: Tow Reel Pod: (1) Compartment for Installation of Recovery Parachute Canister, (2) Centerline Pylon Adapter, (3) Centerline Pylon, (4) Access Panel, (5) Sway Brace Bolts and Pads, (6) Cooling Air Duct (Intake).

center section to permit access to the tow reel for maintenance or replacement of the reel spool. This section is also provided with lugs for mounting the pod on the aircraft centerline pylon adapter. The aft section of the pod contains an electrically actuated cable cutter and provisions for mounting the parachute recovery system. It also contains provisions for making the required electrical connections between the aircraft and the pod.

TOW REEL. A self-energized inertial brake, actuated by flyweights mounted on the reel drum, controls the payout speed of the tow cable. As the reel rotates, centrifugal force causes the flyweights to exert pressure on the brake discs, thus increasing the friction on the cable reel. When the tow cable is completely reeled out, a "feeler" plug incorporated in the tow reel spool actuates an electrical contact which, in turn, causes a light on the control panel to illuminate. After cable reel-out the cable cannot be reeled in.

PARACHUTE RECOVERY SYSTEM

The parachute recovery system consists basically of a canister (Item 3, Fig. 1) positioned at the aft end of the tow reel pod, a parachute packaged inside the canister, and provisions for release of the parachute from the canister. The system was manufactured by Anderson Greenwood and Company.

The canister is fastened to the tow reel pod by safety wire and serves as a link between the tow reel cable and a 25-ft length of 3/8-in. nylon rope connected to the target to lessen the shock which occurs when the target is launched. A release mechanism is incorporated in the canister lid. The design of the mechanism is such that, upon severance of the tow cable at the tow reel, the cable drags behind the target, causing canister reversal. Aerodynamically actuated levers then separate the lid from the canister. The lid, which is fastened to the top of the parachute, serves as the drogue for deployment of the parachute. The operation of the parachute recovery system is shown in Fig. 3.

During testing, the parachute canister, as originally designed, was determined to be inadequate. The canister was redesigned by the Target Development Laboratory at Eglin AFB and subsequently tested. Details regarding the problems which arose and the improvements which were made are discussed in Section 4, Test Results and Discussion.

TARGET

The TDU-10/B or K-11 target (Item 5, Fig. 1, and Item 4, Fig. 4) is a four-winged cruciform dart, each wing being a triangular plywood frame. The wing sections of both targets are 16 ft long, tapered from an overall width of 5 ft in the TDU-10/B and from a maximum width of 6 ft in the K-11. The plywood frame of each wing encloses a paper honeycomb structure. The wings are covered by an aluminum skin which is glued to the paper honeycomb structure and the wooden frame with a special resin glue. The wings are bolted to an extruded aluminum center section that extends from the nose to the aft edges of the wings. A fiberglass compartment located at the aft end of the target contains a corner radar reflector. In earlier tow systems, this compartment was also used as a container for the recovery parachute.

The TDU-10/B target can be used with the target launcher adapter without modification. The K-11 target, however, must be modified as follows:

1. The metal rails along the edge of each wing must be removed so that the wings will fit into the sway brace channels of the target launcher adapter.

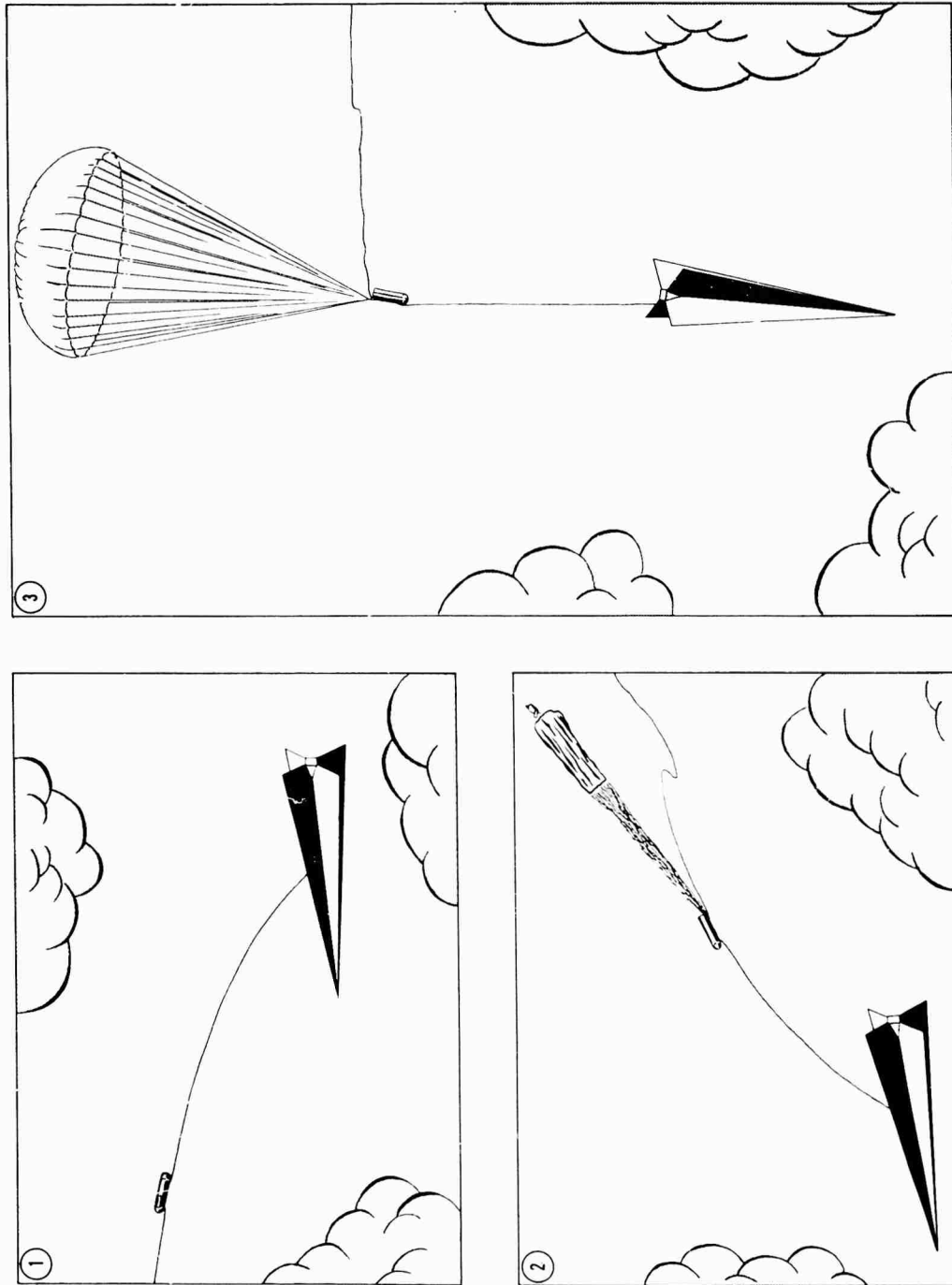

Fig. 3: Operation of Parachute Recovery System: (1) Relative Position of Parachute Canister and Target While Target is Being Towed, (2) Canister Reversal After Severance of Cable, Causing Canister Lid to Separate and Parachute to Deploy, (3) Target Descent.

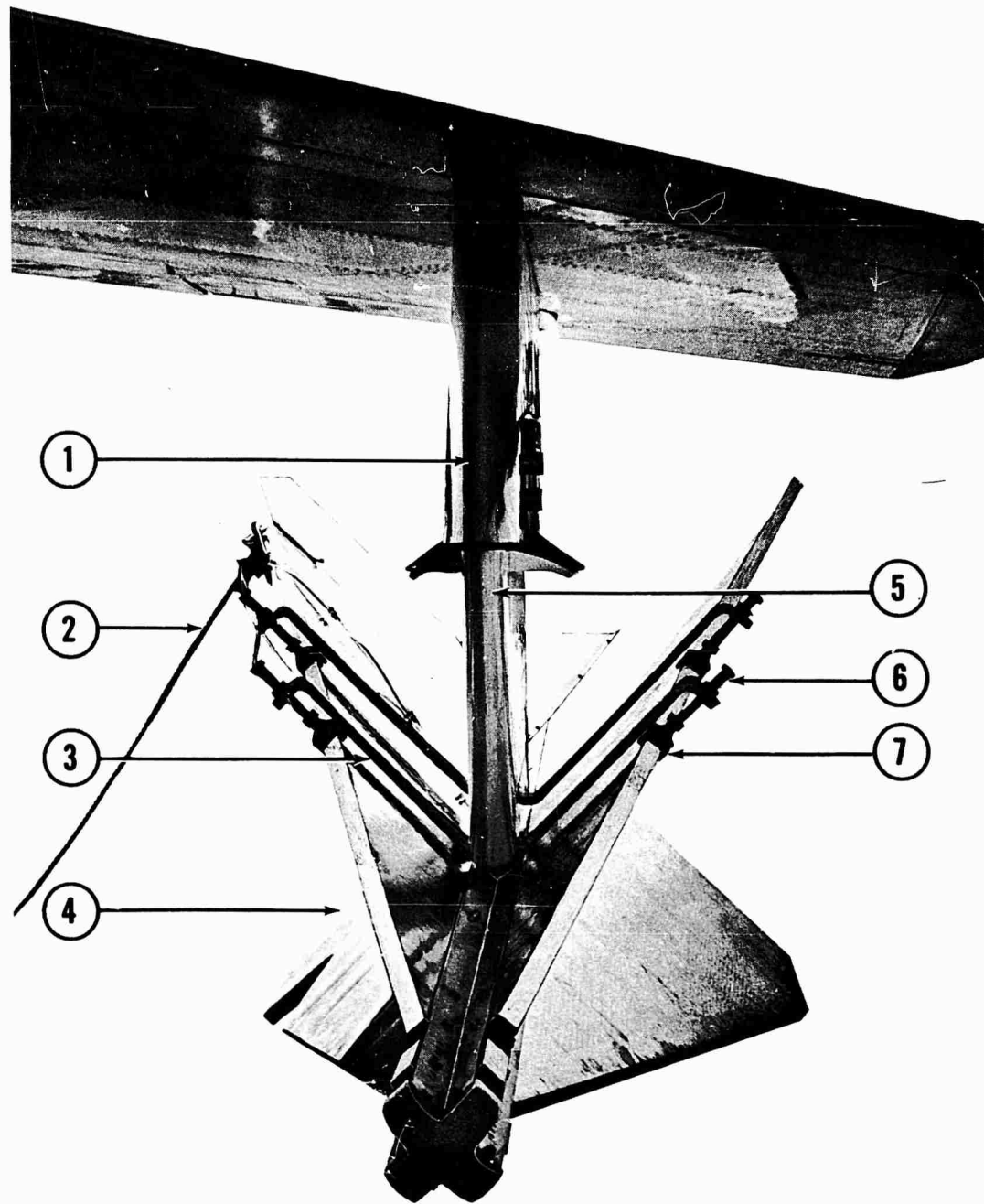

Fig. 4: Dart Target Installation on F-105 Aircraft: (1) Left Outboard Pylon, (2) Nylon Rope, (3) Sway Brace Arms, (4) TDU-10/B Target, (5) Target Launcher Adapter, (6) Sway Brace Bolts, (7) Sway Brace Channels.

2. The top half of the aft V-Block must be inverted in order to obtain the necessary 7 1/2-in. aileron clearance.

PYLON ADAPTERS

CENTERLINE PYLON ADAPTER. The centerline pylon adapter (Item 2, Fig. 2) is used to attach the tow reel assembly to the standard Universal pylon (Item 3) on the centerline of the aircraft. It incorporates sway brace pads (Item 5) to prevent lateral movement of the tow reel assembly. When the MA-4A bomb rack is used, the centerline pylon adapter is not required since this rack is directly compatible with the tow reel assembly.

TARGET LAUNCHER ADAPTER. The target launcher adapter (Item 5, Fig. 4) is used to attach the TDU-10/B or modified K-11 dart target to the standard outboard pylon of the F-105. Sway brace channels (Item 7) are incorporated on this adapter to prevent excessive lateral motion of the target.

CONTROL PANEL

The tow system control panel (Fig. 5) is located below the T-249 panel on the cockpit control console in the position formerly occupied by the buddy refueling system control panel. Included on the control panel are the "Target System Power On" switch which controls power to the panel, the "Release Target" switch which actuates the launch of the target, the "Cut Cable" switch which actuates the squib to cut the tow cable, and the "Cable Payed Out" light which illuminates when the tow cable is entirely reeled out.

ASSOCIATED WIRING

Existing aircraft wiring is used to provide power for the tow system. The bomb arming circuit from the outboard pylon is connected to the existing wiring for the buddy refueling system by a 4-in. jumper wire and provides the necessary power for release of the target. The wiring for the buddy refueling system is also used to supply power to the "Cable Payed Out" light on the control panel and the cable cutting mechanism in the tow reel assembly.

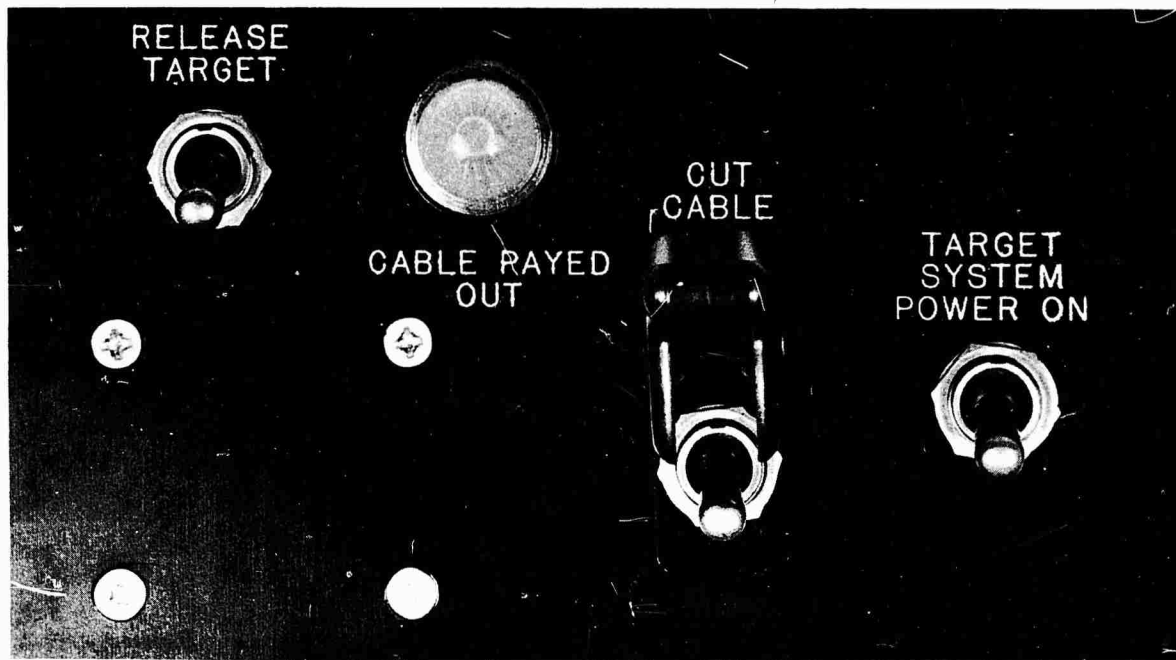

Fig. 5: Tow System Control Panel.

SECTION 3 - TEST PROCEDURES

The test program was divided into two phases. In the first phase, tests were conducted to determine the compatibility of the tow system with the aircraft and the structural integrity of the tow reel assembly and target launcher adapter. Compatibility was established by fit tests and ground checkout of the system circuitry. Structural integrity of the tow reel assembly and target launcher adapter was established by high speed runs and positive acceleration maneuvers at varying altitudes. Motion pictures were taken from a chase aircraft to furnish a photographic record of any flutter or structural failures which might occur. The target was not installed during these operations.

In the second phase of the test, the total tow system was tested to determine structural integrity; characteristics of the target during captive flight, launch, and tow; and the adequacy of the parachute recovery system. Airborne and ground motion picture photography was used to record the condition of the tow system during takeoff roll, target launch and reel-out, normal flight and aerial maneuvers, and target recovery. To record reel-out time, the pilot of the tow aircraft noted the time at

which the target was launched and the time at which the "Cable Payed Out" light appeared. This was correlated with a time check made by the pilot of the chase aircraft.

To supplement the photographic coverage during both phases of testing, comments of the pilots of the chase and tow aircraft were recorded during test operations. During the second phase, additional comments were obtained from pilots of the 335th Tactical Fighter Squadron who were firing on the target. Experienced ground observers were utilized to view the takeoff and parachute recovery operations.

On a typical mission during the second phase, the tow and photo chase aircraft were flown to an altitude of 8000 to 12,000 ft, depending on the weather. The target was flown captive through maneuvers designed to test the limits of the system. During captive operations, the maximum airspeed was 275 KIAS and the maximum load was 2.0 g's. The target was then launched at an airspeed of 195 to 220 KIAS. Reel-out time was noted. The target was then towed at altitudes from 5000 to 45,000 ft in straight and level flight and in maneuvers to test the limits of the system under various conditions. The maximum airspeed attained was mach 1.1 at 32,000 ft. The maximum load imposed was 4.0 g's. The tow aircraft was then flown into the recovery area at an altitude from 1000 to 1500 ft at 200 KIAS for the purpose of target release and test of the parachute recovery system.

During testing, the tow reel braking system was periodically inspected for wear. Methods for reducing the turnaround time of the system and for adequately training personnel were also studied.

Throughout the testing, the tow system was inspected for continued structural integrity in order that an estimate might be made of the tentative life of the equipment. Certain modifications were also performed. These will be discussed in detail in the Test Results and Discussion section.

All missions were conducted using the F-105D model aircraft and 3/16-in. armored cable. The target was always mounted on the left outboard pylon.

SECTION 4 - TEST RESULTS AND DISCUSSION

A summary of all the test missions is presented in Table 1. Included in this summary is the purpose of each mission and the results of the testing conducted. The results of testing as related to the test objectives are discussed in the following paragraphs.

COMPATIBILITY OF THE TOW SYSTEM WITH THE F-105 AIRCRAFT

The ground mount operational checkout of the tow system revealed that the compatibility of the system with the F-105 aircraft was satisfactory with one minor exception. It was found that the tow system control panel designed for installation on the cockpit control console was too large to fit in the position formerly occupied by the buddy refueling system control panel. To provide for the proper fit, approximately 1/2 in. was cut off the top of the panel and new mounting holes for the two top fasteners were drilled.

STRUCTURAL INTEGRITY OF THE SYSTEM

The tow system was determined to be structurally sound except for problems encountered with the tow reel assembly and target launcher adapter. These problems are discussed in the following paragraphs.

At the beginning of the test, using the recovery parachute canister supplied with the system, launch of the target caused the parachute recovery system to actuate. (This problem is discussed in detail under Adequacy of Operation of the System, p. 17.) Upon parachute release and subsequent deployment, the shock of the parachute opening caused the tow cable to bury itself in the reel spool. This exerted side loads which caused the right end plate to separate from the spool. This failure, which occurred on both of the tow reels supplied with the system, indicated a weakness in the spool.

To correct the problem encountered with the tow reel spool, the left end plate was redesigned to incorporate a 3/8-in. stepped-down flange (Item 1, Fig. 6) on which the last three wraps of cable could be wound. This was done to prevent the cable from becoming buried in the reel due to the initial shock at time of target launch. In addition, the weld area at the right of the spool core (Item 2) was increased to insure its being as strong as the parent material.

TABLE 1. MISSION SUMMARY.
 (NOTE: The conditions of flight for the following missions are given on p. 10.)

Mission No.	Purpose of Mission	Target Used		Recovery Parachute Installation			Tow Reel			Target			Launcher			Recovery System			Remarks
		TDU-10/B	Corner Reflector	Parachute Canister	Failure or Determination of End Plate	Satisfactory	Lost on Launch	Other	Satisfactory	Swap Brace Bolts Bent or Lost	Satisfactory	Parachute Opened on Launch	Other	Satisfactory	Other	Other			
1	Fit test of total system	x	-	-	-	-	-	-	-	-	-	-	-	-	-	-	-	x	All components except the control panel fit satisfactorily. Control panel fit when approximately 1/2 in. was cut off top and new mounting holes for top fasteners were drilled. System was flown without target to mach 1, 3 with no adverse effects.
2	Flutter and calibration test of centerline pod and launcher	x	-	-	-	-	-	-	-	-	-	-	-	-	-	-	-	-	Target lost on takeoff roll due to defective target lug. Cable reeled out and was subsequently cut.
3*	Test of total tow system flight characteristics	x	-	-	-	-	-	-	-	-	-	-	-	-	-	-	-	-	Target lost on takeoff roll due to defective target lug. Cable reeled out and was subsequently cut.
4*	Test of total tow system flight characteristics	x	-	-	-	-	-	-	-	-	-	-	-	-	-	-	-	-	Cable reeled out prior to target launch due to insufficient safety wiring of reel spool. The modified "Cut Cable" switch was used to simultaneously launch the target and cut the cable.
5*	Test of total tow system flight characteristics	x	-	-	-	-	-	-	-	-	-	-	-	-	-	-	-	-	Target wing collapsed on takeoff due to excessive air turbulence. Cable was cut and target released by actuating the "Cut Cable" switch. Sway brace bolts lost. System satisfactory.
6	Fit test of TDU-10/B and canister	x	-	-	-	-	-	-	-	-	-	-	-	-	-	-	-	-	Reel failed at weld between spool core and right end plate. This was due to side loads imposed by the cable which buried itself in the reel due to shock caused by parachute opening on launch. Cable broke and target was lost. Same as for Mission 7. Also, sway brace bolts bent and were re-placed.
7	Test of total tow system flight characteristics	x	-	-	-	-	-	-	-	-	-	-	-	-	-	-	-	-	This mission was flown with a modified tow reel spool (stepped left end plate and increased weld area at right of spool core).
8	Test of total tow system flight characteristics	x	-	-	-	-	-	-	-	-	-	-	-	-	-	-	-	-	Parachute deployed on launch and tore. Target was recovered but was not re-usable.
9	Test of total tow system flight characteristics	x	-	-	-	-	-	-	-	-	-	-	-	-	-	-	-	-	Parachute deployed on launch. Parachute broke free when all cable had reeled out. Target was recovered but was not re-usable.
10	Test of total tow system flight characteristics	x	-	-	-	-	-	-	-	-	-	-	-	-	-	-	-	-	Canister lid was safety-wired too tightly and did not separate from canister.
11	Test of total tow system flight characteristics	x	-	-	-	-	-	-	-	-	-	-	-	-	-	-	-	-	Cable cutter squib did not fire. Target was dragged off in trees.
12	Test of total tow system flight characteristics	x	-	-	-	-	-	-	-	-	-	-	-	-	-	-	-	-	9/32 in. deformation of right end plate. This was due to side loads imposed by cable which buried itself in reel due to shock of parachute opening on launch and fully deploying about 10 ft back of aircraft. Cable broke and target was lost. Sway brace bolts bent. Target broke free after about 15 min. of flight. Cable was dropped in recovery zone. No nylon rope with cable. Sway brace bolts bent.
13	Test of total tow system flight characteristics	x	-	-	-	-	-	-	-	-	-	-	-	-	-	-	-	-	Target broke free after about 15 min. of flight. Cable was dropped in recovery zone. No nylon rope with cable. Sway brace bolts bent.
14	Test of total tow system flight characteristics	x	-	-	-	-	-	-	-	-	-	-	-	-	-	-	-	-	Target broke free after about 15 min. of flight. Cable was dropped in recovery zone. No nylon rope with cable. Sway brace bolts bent.
15*	Test of total tow system flight characteristics	x	-	-	-	-	-	-	-	-	-	-	-	-	-	-	-	-	Sway brace bolts bent.
16*	Test of total tow system flight characteristics	x	-	-	-	-	-	-	-	-	-	-	-	-	-	-	-	-	No recovery system used. Target was recovered but was not re-usable. Sway brace bolts bent.
17	Test of total tow system flight characteristics	x	-	-	-	-	-	-	-	-	-	-	-	-	-	-	-	-	No recovery system used. Target was recovered but was not re-usable. Sway brace bolts bent.

18*	Test of total tow system flight characteristics	x	x	x	x	x	x	x	x	x	x	x	x	x	x	x	x	Parachute opened late on target drop. Target was damaged but was re-usable. Cable Payed Out light did not come on due to broken feeler plug on reel spool. Sway brace bolts bent. Previously used target was installed. Cable Payed Out light did not come on due to broken feeler plug on reel spool. Sway brace bolts bent.
19	Test of recovery system	x	x	x	x	x	x	x	x	x	x	x	x	x	x	x	x	5/8 in. NF steel sway brace bolts used. Bolt ends turned down to accommodate aluminum swivel nuts. Speed of mach 1.1 at 25,000 ft attained. Parachute partially out on recovery.
20	Test of recovery system and new sway brace bolts	x	x	x	x	x	x	x	x	x	x	x	x	x	x	x	x	Canister lid did not separate from canister.
21	Test of recovery system and new sway brace bolts	x	x	x	x	x	x	x	x	x	x	x	x	x	x	x	x	Additional wire used to position and safety canister.
22	Test of recovery system and new sway brace bolts	x	x	x	x	x	x	x	x	x	x	x	x	x	x	x	x	Parachute deployed too rapidly on recovery. Nylon rope broke. Target was damaged but was re-usable.
23	Test of recovery system and new sway brace bolts	x	x	x	x	x	x	x	x	x	x	x	x	x	x	x	x	Parachute deployed after target reel-out, tearing panels. Target was recovered and was re-usable. New brake linings installed in tow reel due to wear.
24	Test of recovery system and new sway brace bolts	x	x	x	x	x	x	x	x	x	x	x	x	x	x	x	x	Spool cracked at weld area between core and right end plate. This was due to side loads imposed when cable buried itself in the spool because of shock caused by parachute opening at launch.
25	Test of recovery system and new sway brace bolts	x	x	x	x	x	x	x	x	x	x	x	x	x	x	x	x	No recovery system used. Target was recovered but was not re-usable.
26	Test of tow system	x	x	x	x	x	x	x	x	x	x	x	x	x	x	x	x	Same as for Mission 26.
27	Test of tow system	x	x	x	x	x	x	x	x	x	x	x	x	x	x	x	x	Parachute opened on launch but cable did not break. 335th Tactical Fighter Squadron pilot on target. Target or cable was hit and target was lost.
28	Test of recovery system	x	x	x	x	x	x	x	x	x	x	x	x	x	x	x	x	Same as for Mission 25.
29	Test of recovery system	x	x	x	x	x	x	x	x	x	x	x	x	x	x	x	x	Parachute deployed on launch. No further failures and target recovered. Modified spool with additional right end plate used on this and subsequent missions.
30	Test of recovery system	x	x	x	x	x	x	x	x	x	x	x	x	x	x	x	x	Parachute opened on launch and broke away. Target towed for gunnery practice. Target was recovered but was not re-usable.
31	Test of recovery system	x	x	x	x	x	x	x	x	x	x	x	x	x	x	x	x	Parachute opened on target launch. Spool slightly deformed by cable burying itself in reel. Target lost at launch.
32	Test of recovery system	x	x	x	x	x	x	x	x	x	x	x	x	x	x	x	x	Redesigned canister used on this and subsequent missions.
33	Test of recovery system	x	x	x	x	x	x	x	x	x	x	x	x	x	x	x	x	System satisfactory.
34	Test of recovery system	x	x	x	x	x	x	x	x	x	x	x	x	x	x	x	x	Target lost in trees due to pilot flying too low on approach to drop zone. Recovery system functioned without target when cable was cut.
35	Test of recovery system	x	x	x	x	x	x	x	x	x	x	x	x	x	x	x	x	Should lines of parachute knotted more than 5 ft from canopy. One panel was tore.
36	Test of recovery system	x	x	x	x	x	x	x	x	x	x	x	x	x	x	x	x	System satisfactory.
37	Test of recovery system	x	x	x	x	x	x	x	x	x	x	x	x	x	x	x	x	System satisfactory.
38	Test of recovery system	x	x	x	x	x	x	x	x	x	x	x	x	x	x	x	x	System satisfactory.
39	Test of recovery system	x	x	x	x	x	x	x	x	x	x	x	x	x	x	x	x	System satisfactory.
40	Test of modified tow reel assembly	x	x	x	x	x	x	x	x	x	x	x	x	x	x	x	x	Mission flown with modified tow reel assembly installed on F-86H due to non-availability of F-105 aircraft. Steel reel spool used with thickened one-piece right end plate, stepped left end plate, and slotted spool core. Reinforced sway brace channels and 5/8 in. NF steel sway brace bolts and swivel nuts used. System satisfactory.
41	Test of modified tow reel assembly	x	x	x	x	x	x	x	x	x	x	x	x	x	x	x	x	Same as for Mission 40.

* Due to non-availability of a recovery parachute canister at the beginning of the test, Missions 3, 1, and 5 were conducted with the recovery parachute installed in the corner reflector compartment located at the aft end of the target. Because of difficulties experienced with the canister during the test, Missions 15, 16, and 18 were also conducted with the recovery parachute installed in the corner reflector compartment in order to continue to gather data on other components of the tow system.

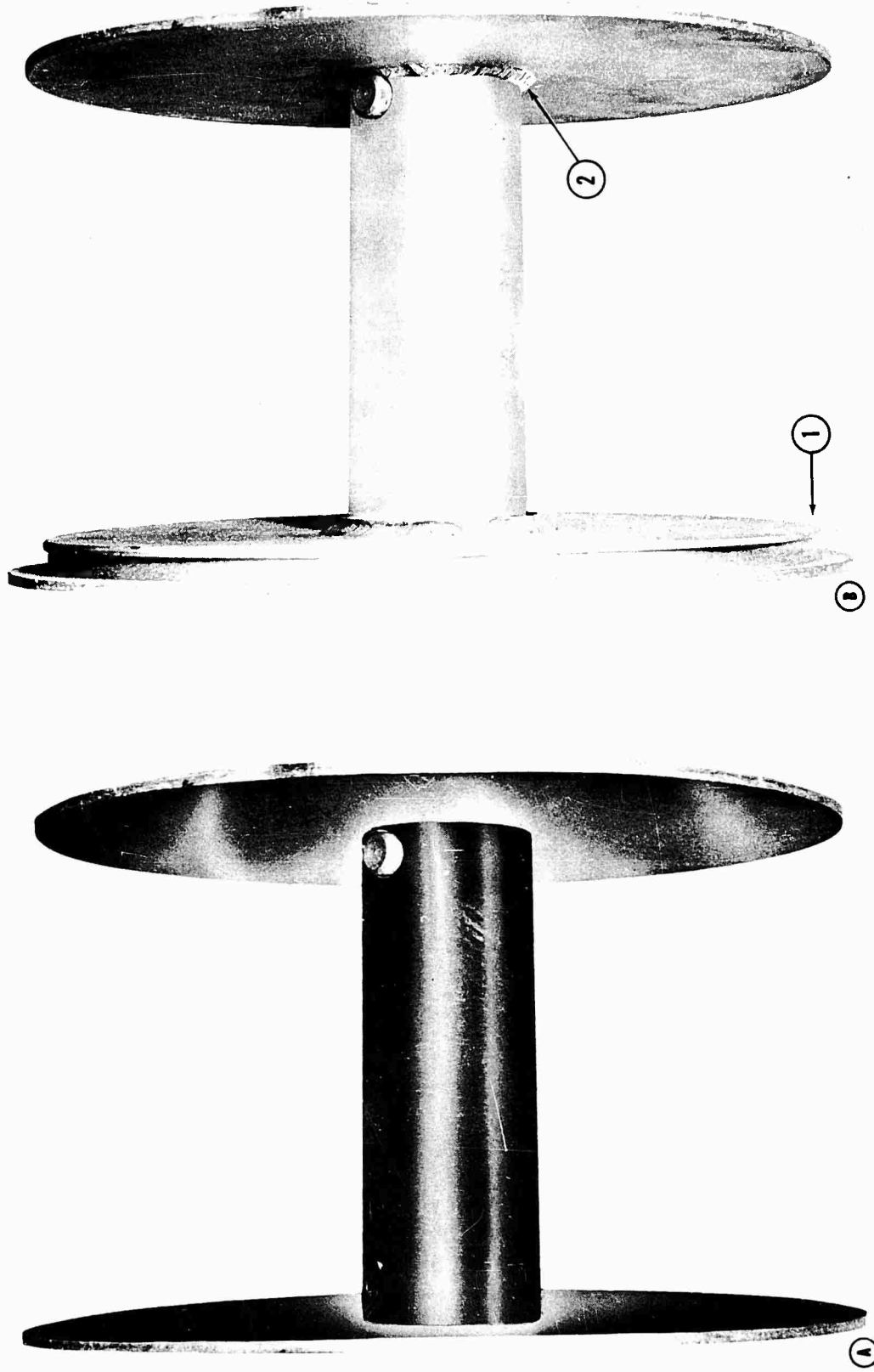

Fig. 6: Original Tow Reel Spool (A) and Modified Spool (B) Showing (1) Stepped Left End Plate and (2) Increased Weld Area.

In further tests the new spool design also presented problems. After the wraps of the cable had come off the step in the left end plate, the cable again buried itself in the reel as a result of the shock of the parachute opening after target launch. This in turn again exerted side loads which caused the right end plate to deform. In one instance the plate cracked at the weld. To further strengthen the tow reel spool an additional plate was welded to the outside of the right end plate. (See Fig. 7.) This modification was sufficient to enable use of the spools in subsequent missions. Although the spools still continued to display slight deformation, the tolerance of 5/16 in. deformation was not exceeded. It was determined that a spool made of 4130 steel would eliminate the bending that occurred with the aluminum spool.

During the test, it was found that the tow cable formed a hump in the area where the cable was knotted to the spool, causing an uneven load on the spool. The spool was modified by fastening a wrap of metal on the spool core so that a slot was formed between the ends of the wrap to accommodate the tow cable knot and the first few inches of cable. (See Item 2, Fig. 8.)

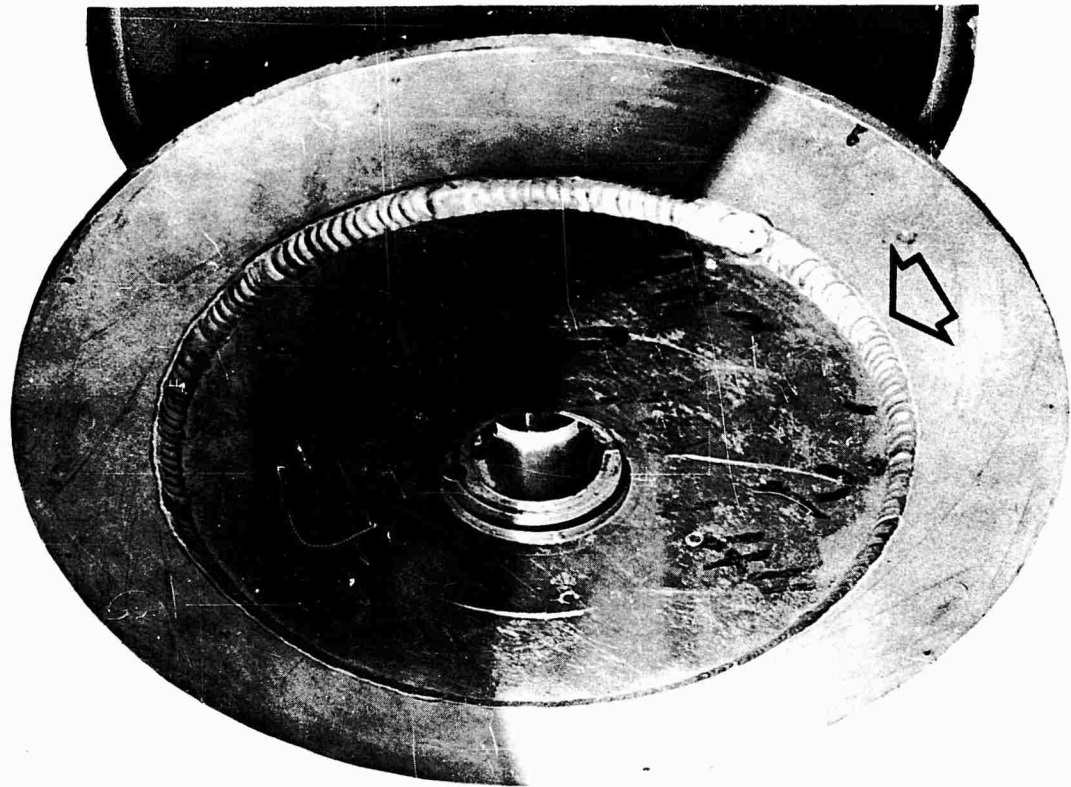

Fig. 7: Further Modification of Tow Reel Spool Showing Additional Plate Welded on Right End Plate.

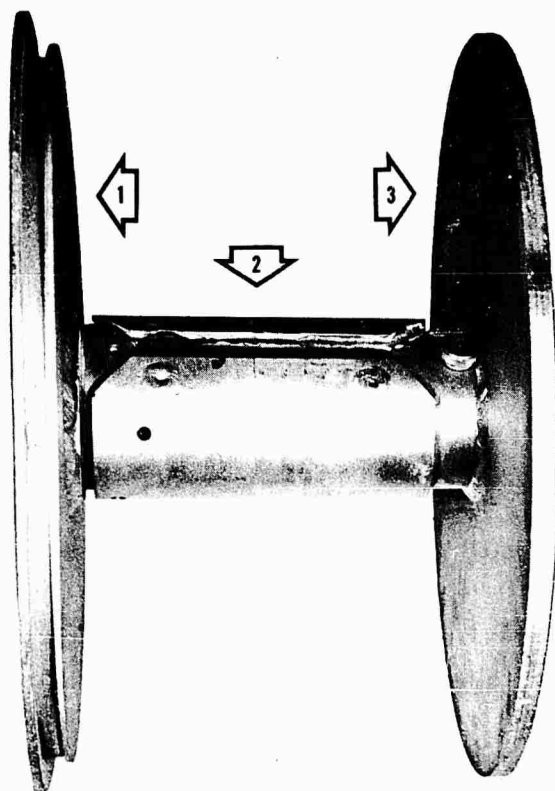

Fig. 8: Final Configuration of Tow Reel Spool: (1) Stepped Left End Plate, (2) Slotted Core, (3) One-Piece Right End Plate of Increased Thickness.

mounted in the sway brace channels. The bolts became deformed on several missions and loosening of the swivel nuts occasionally caused loss of one or more of the sway brace channels. By using NF 5/8-in. steel bolts and nuts, together with reinforced sway braces to provide for a firmer mounting of the nuts in the channels, no further difficulties were encountered.

A spool made of 4130 steel with a 3/4 in. thick right end plate, a stepped left end plate, and a slotted core was incorporated in the system. The tow reel assembly with this spool was flown on two missions on an F-86H aircraft under APGC Project 0041W, "Limited Test of the F-86H Dart Tow System." On both of these missions the target was launched at 200 KIAS at 10,000 ft altitude. During tow, the maximum airspeed was mach 0.81 at 25,000 ft altitude and the maximum load was 4.0 g's. The tow reel spool performed satisfactorily in all phases of operation. The weight increase due to the use of 4130 steel in the fabrication of the reel spool is approximately 50 lb. This increases the total tow system weight to approximately 450 lb. Since the F-105D is capable of carrying a maximum load of six 750-lb bombs at the centerline station, the 50-lb weight increase is considered to be negligible.

Although the target launcher adapter functioned well during the test, difficulties were experienced with the 1/2-in. aluminum sway brace bolts and the swivel nuts

ADEQUACY OF OPERATION OF THE SYSTEM

No difficulties were experienced with the functioning of the total tow system except for the problems associated with the tow reel assembly and the parachute recovery system.

It was found that the difficulty experienced with the parachute recovery system was due to the construction of the canister (Fig. 9). The lid either would separate from the canister during launch of the target or would not separate during the recovery sequence. Several attempts were made to improve the operation of the canisters received with the system; however, these were unsuccessful and it was considered necessary to redesign the canister. The lid (Item 1, Fig. 10) on the new canister was designed so that the vanes (Item 2) do not require strong safetying but are kept in position with a 3 1/8 x 1/8 in. rubber band. The attachment for the tow cable (Item 3) is located farther forward on the canister and also serves as the attachment for the parachute D-ring. The parachute D-ring was formerly secured to the cable which was then attached to the forward eye of the canister (Item 4, Fig. 9). The eye for attaching the nylon rope was replaced by a fastener which is located near the aft end of the canister (Item 4, Fig. 10). The canister is positioned in the recess at the aft end of the tow reel pod by means of two wraps of tow target tape or 0.050-in. safety wire if tow target tape is not available.

The original canister, as installed on the F-105 aircraft, is shown in Fig. 11. The installation of the redesigned canister is shown in Fig. 12.

The final nine missions were flown with the new parachute recovery system and it was found to be satisfactory. During the tests of the system, it was found that the optimum conditions for target drop were with the tow aircraft flying at an altitude of 1000 ft above the terrain at an airspeed of 200 KIAS. This positions the target approximately 500 ft above the ground. It was also found that it is necessary to knot the shroud lines of the parachute 5 ft from the canopy. Knotting the lines closer than this distance will result in too rapid a descent of the parachute and cause excessive damage to the target. Knotting the lines at a greater distance will cause the parachute panels to tear. With the replacement of nose components, as required, the targets can be re-used approximately four or five times if they are not badly damaged from gunfire. The tow cable, however, is generally not re-usable after ground recovery of the target because of kinking and twisting.

In order to improve emergency operations during captive flight, an additional control was incorporated in the "Cut Cable" switch on the

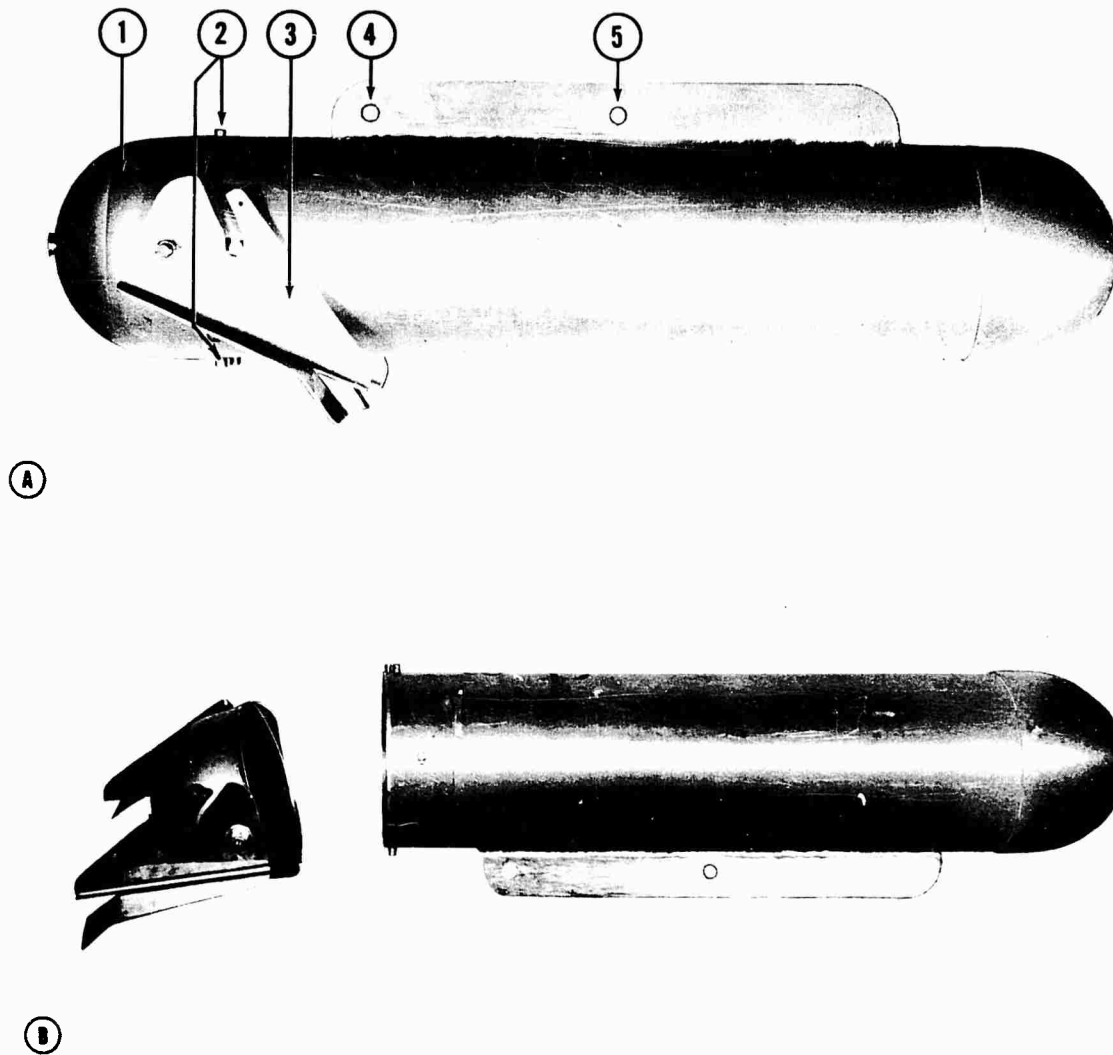

Fig. 9: Original Recovery Parachute Canister: Part A - Intact Unit: (1) Canister Lid, (2) Lid Retaining Pins, (3) Canister Vanes, (4) Tow Cable Attachment Eye, (5) Eye for Attaching Nylon Rope; Part B - Canister with Lid Separated.

cockpit control panel to permit release (jettisoning) of the target simultaneously with cutting of the tow cable. This modification allows both functions to be performed through a single switch operation. On two test missions operational situations arose which required use of the modified switch. It performed satisfactorily on both occasions.

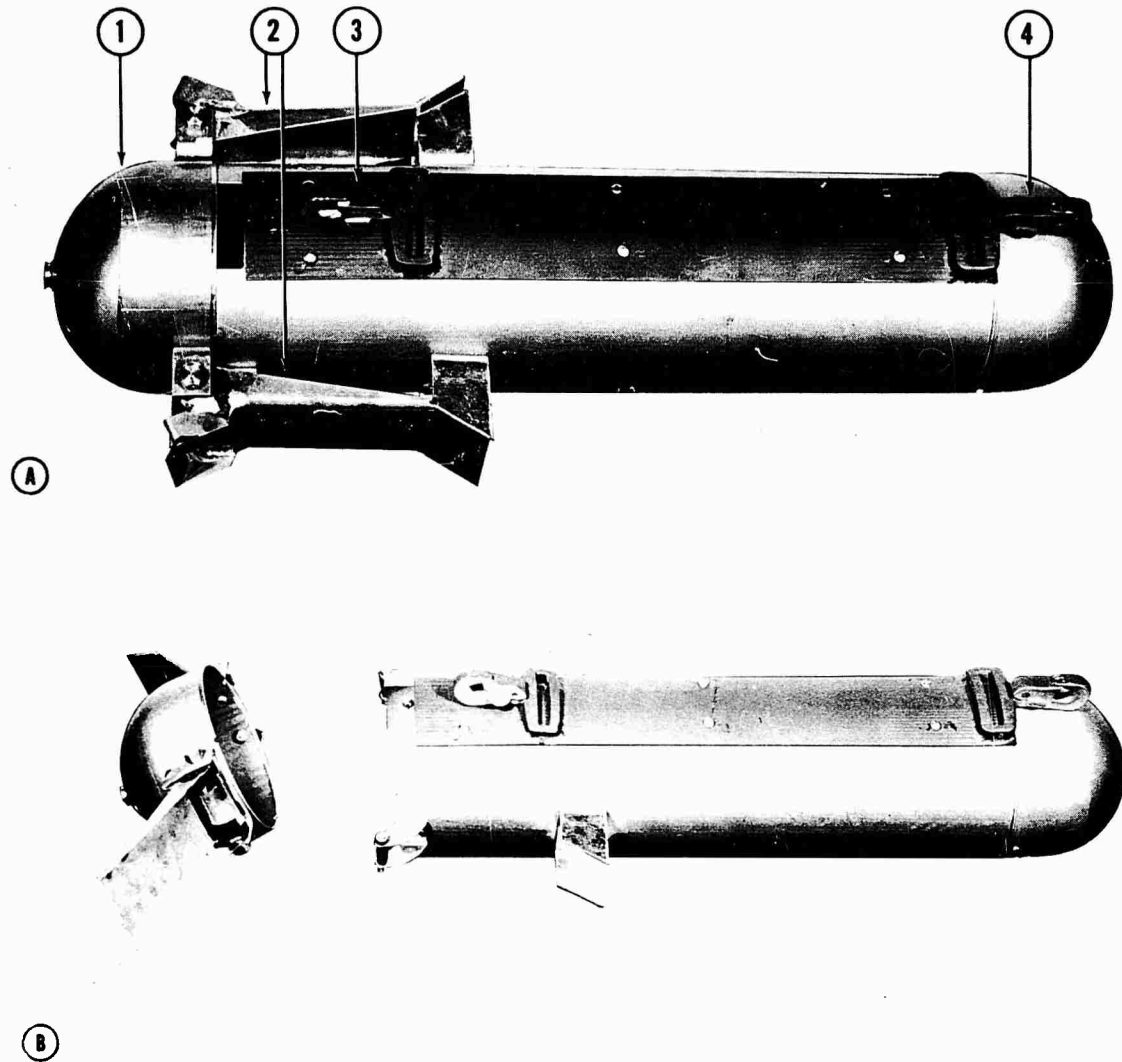

Fig. 10: Redesigned Recovery Parachute Canister: Part A - Intact Unit: (1) Canister Lid; (2) Canister Vanes, (3) Fastener for Attaching Parachute D-Ring and Tow Cable, (4) Fastener for Attaching Nylon Rope; Part B - Canister with Lid Separated.

TURNAROUND CAPABILITY

At the beginning of testing it was estimated that two hours would be required to prepare an aircraft returning from a tow mission to participate in a subsequent tow mission. This estimate pertained to the turnaround time for the tow system only and did not include the time required to attend to aircraft requirements not associated with the tow system. During testing, by having a tow reel spool loaded with cable available prior to the test aircraft landing from a previous tow mission, it was

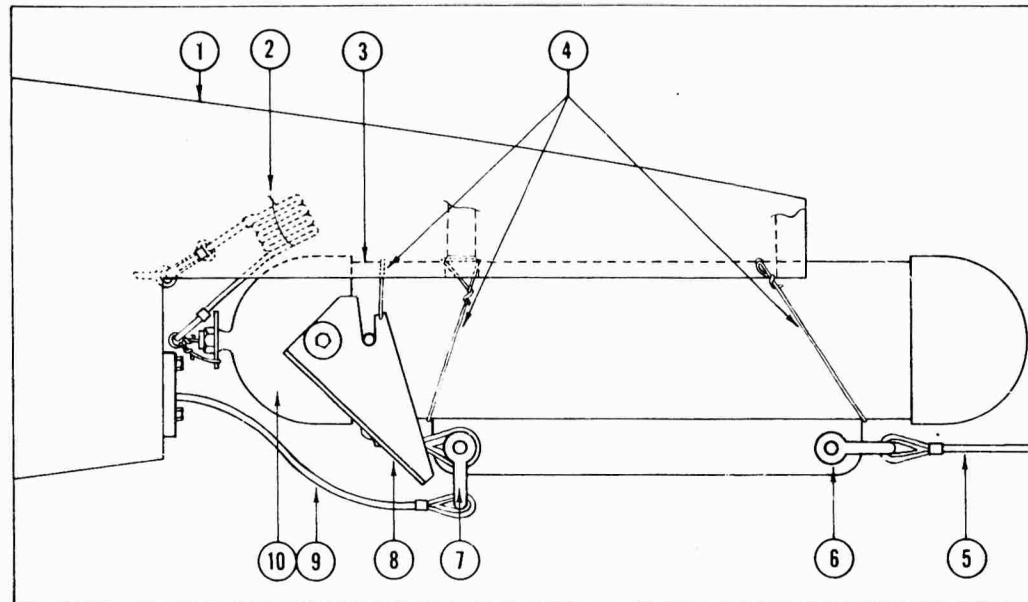

Fig. 11: Original Recovery Parachute Canister as Installed on F-105 Aircraft: (1) Aft End of Tow Reel Pod, (2) Safety Pin Cable, (3) Canister, (4) Safety Wire, (5) Nylon Rope, (6) Aft Shackle, (7) Forward Shackle, (8) Left Canister Vane, (9) Tow Reel Cable, (10) Canister Lid.

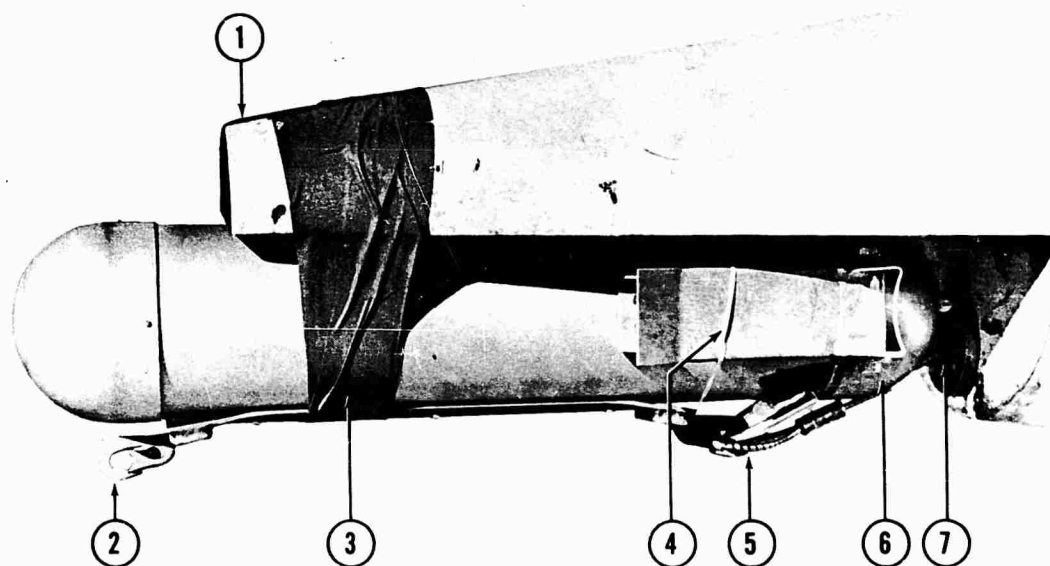

Fig. 12: Installation of Redesigned Recovery Parachute Canister: (1) Aft End of Tow Reel Pod, (2) Fastener for Attaching Nylon Rope, (3) Target Tape, (4) Rubber Band Used to Retain Canister Vanes, (5) Attachment of Tow Cable and Parachute D-Ring, (6) Canister Lid, (7) Tow Cable Exit.

found that turnaround could be accomplished in less than one hour. In an operational environment, with additional time-saving procedures used, it is believed that the turnaround time could be further reduced to less than one-half hour.

ESTIMATED LIFE OF THE EQUIPMENT

At the end of testing, the tow reel pod, tow reel spool, and target launcher adapter were in excellent condition. However, no definite estimate could be made on the probable life of these components since the tow reel pod and target launcher adapter were flown on only 37 missions and the tow reel spool, as finally modified, was flown on only two missions.

The tow reel brake linings were replaced at the end of 22 airborne missions. They could have been re-used for three or four more missions but it is felt that they will have to be replaced after approximately 20 missions during actual operations. The brake linings should be inspected for wear and possible replacement after this number of missions.

The parachute canisters were re-usable from mission to mission unless they were excessively damaged as a result of landing on paved surfaces or excessively hard terrain in the recovery area. The parachutes were re-usable three or four times when the recovery system functioned properly. The life of the targets is difficult to determine. On a non-gunnery mission with target recovery on normal terrain, the targets will be re-usable with replacement of the nose portion. The extent of re-use of the targets, however, is directly dependent on the degree of accuracy of the pilots of the firing aircraft. The targets can be re-used four or five times if they are not badly damaged from gunfire and if the recovery system functions properly, or portions of the targets can be salvaged for use in building up new targets. During this test, due to the accuracy of the 335th Tactical Fighter Squadron pilots, the targets fired upon during gunnery missions were not re-usable.

TRAINING REQUIREMENTS FOR GROUND CREW PERSONNEL

The tow target system was adequately installed and maintained by ground crew personnel after only a briefing by the development and project engineers and by use of the maintenance manual which accompanied the system. Optimum methods for installing and preflighting the system were finalized by armament personnel and the project officer. These are contained in Appendix I of this report and in a training film made at APGC.

SECTION 5 - CONCLUSIONS

1. The tow system, with the TDU-10/B or modified K-11 dart target, is compatible with the F-105 aircraft, provided the tow system control panel is reduced in size to fit the space on the cockpit control console formerly occupied by the buddy refueling system control panel.

2. The structural integrity of the tow system is adequate for normal training missions with the F-105 aircraft, provided the design improvements listed below are made:

a. Strengthening of the tow reel spool to preclude deformation beyond the allowable limits or separation of the end plates from the spool core by:

(1) Use of 4130 steel instead of aluminum in the fabrication of the tow reel spool.

(2) Incorporation of a 3/8 in. stepped-down flange in the left end plate so that the last three wraps of cable can be wound on the step to preclude the cable from becoming buried in the spool due to the initial shock of target launch.

(3) Incorporation of a slot in the core of the tow reel spool so that the tow cable knot can be inserted in the slot and thus eliminate humping of the cable over the knot which, in turn, causes an uneven load on the spool.

(4) Increase of the weld area between the end plates and spool core to provide a structural strength equivalent to that of the parent material.

(5) Increase in the thickness of the right end plate to 3/4 in.

b. Strengthening of the target launcher adapter by:

(1) Use of NF 5/8-in. steel sway brace bolts instead of 1/2-in. aluminum bolts to preclude bending of the bolts.

(2) Use of reinforced sway braces and NF 5/8-in. steel swivel nuts to reduce the possibility of loss of the sway brace channels.

3. With the incorporation of the modifications indicated above, the tow system can be used satisfactorily in gunnery missions at altitudes up to 45,000 ft and at tow speeds up to mach 1.1.

4. The tow reel braking system is adequate for use in the system.
5. The parachute recovery system as redesigned at Eglin AFB is satisfactory; however, the tow cable is generally not re-usable after ground recovery of the target because of twisting and kinking.
6. There is a requirement for a means of quickly jettisoning the captive target in case of an emergency requiring such action.
7. With the availability of a tow reel spool loaded with cable, the turnaround time for the system is less than one hour.
8. Estimates on the tentative life of the system are as follows:
 - a. No estimate could be made of the life of the tow reel pod, as finally modified, because of the limited number of missions conducted.
 - b. The brake shoes will last approximately 20 missions.
 - c. The life of the canister is proportional to the type of surface on which it is dropped.
 - d. If the parachute shroud lines are knotted 5 ft from the canopy, the parachute can be re-used approximately three or four times.
 - e. The life of the targets is a direct function of the accuracy of the pilots of the firing aircraft. With the replacement of nose components, as required, the targets can be re-used approximately four or five times if they are not badly damaged from gunfire.
9. Upon introduction of the system into the Tactical Air Command inventory, training of ground crew personnel can be satisfied by the following:
 - a. Provision of an adequate maintenance manual.
 - b. Adopting as standard the installation procedures presented in Appendix I of this report and shown in a film strip prepared at APGC.

SECTION 6 - RECOMMENDATIONS

It is recommended that:

1. To provide for complete compatibility of the tow system with the F-105 aircraft, the height of the control panel be reduced by 1/2 in. and the top two fasteners be relocated so that the panel will fit on the cockpit control console in the area formerly occupied by the buddy refueling system control panel.
2. The tow reel spool and target launcher adapter be modified as indicated in the Conclusions in order to provide for the required structural integrity.
3. The parachute canister as redesigned at Eglin AFB be incorporated in the recovery system.
4. The "Cut Cable" switch on the control panel be modified such that the cable cutter and target release mechanism can be actuated simultaneously in the event of an emergency requiring jettisoning of the target when it is in the captive position.
5. The tow system installation procedures presented in Appendix I be adopted as standard. It is suggested that the pilots' operating procedures presented in Appendix II also be adopted as standard.
6. The maintenance manual for the system be reviewed by the prime Air Material Area prior to its publication for issuance with the equipment.

SECTION 7 - ACTION TAKEN

The modifications recommended in paragraphs 1 through 4 of Section 6 were incorporated in the design of the F-105 tow system during the course of the test and subsequently included in the production drawings. Future systems procured for the Tactical Air Command will incorporate these changes.

APGC-TDR-62-29

Standardization action for classification of the system as Tentative Standard was approved by Hq AFSC on 2 March 1962. The system has been designated A/A 37U-9, Target System, External Tow, Gunnery.

Category III type testing has been completed by the 4th Tactical Fighter Wing at Seymour Johnson AFB, North Carolina.

APPENDIX I

INSTALLATION PROCEDURES

ELECTRICAL PREFLIGHT AND TOW REEL INSTALLATION

1. Transport the tow reel spool loaded with cable to the aircraft and place it on the MJ-1 hydraulic hoist.
2. Remove the access panel on the tow reel pod.
3. Inform the crew chief that a power-on check is to be accomplished.
4. Cock the launcher rack.
5. Disconnect the cable cutter Cannon plug.
6. Apply power to the aircraft.
7. Apply power to the target system by actuating the "Target System Power On" switch on the control panel in the cockpit. (The control panel is located at the bottom center of the cockpit control console.)
8. Actuate the "Release Target" switch. The launcher should open.
9. Actuate the "Cut Cable" switch. A reading of 28 volts from the cable cutter connector to ground should be obtained.
10. With a screwdriver, create a short across the two terminals for the "Cable Payed Out" light. The light should go out.
11. Turn all power off.
12. With two men holding the tow reel spool in position, line up the splines and insert the shaft. Install the bushing on the right-hand side of the reel, put the bolt through the reel spool, and tighten. (Note: The tow cable should come off the lower side of the spool leading aft.)
13. Thread the tow cable through the cable cutter and out the end of the reel pod.

14. Make a loop in the end of the tow cable using two Nico swedged sleeves.
15. Safety the tow reel spool.

TARGET INSTALLATION

1. Back off the sway braces.
2. With one man at the nose of the target, one at the aft end, and one at the target lugs to guide the lugs into the lug holes, raise the target and position it firmly against the launcher rack to lock the target in place.
3. Torque the sway braces to 25 ft-lb.
4. Safety the manual release on the launcher rack.

PARACHUTE CANISTER HOOKUP

1. Connect the tow cable to the forward eye of the parachute canister.
2. Position the canister at the rear of the tow reel pod beneath the overhang.
3. Secure the canister to the tow reel pod with either 0.050-in. safety wire or two wraps of target tape around the canister and pod.

TARGET HOOKUP

1. Attach the nylon rope to the canister using a thimble.
2. Safety the nylon rope to the forward part of the ventral fin on the fuselage.
3. Run the target harness along the edge of the target wing and safety in position.
4. Attach the nylon rope to the target harness and tape the knot.

STRAY VOLTAGE CHECK AND SQUIB INSTALLATION

1. Check for stray voltage from the pin in the cable cutter connector to ground. Also check pin B to ground in the target launcher.
2. Install the squib and join the connector.

APPENDIX II

PILOTS' OPERATING PROCEDURES

PREFLIGHT OF REEL HOUSING

1. Check the reel housing for security.
2. Check the locking shaft to insure that it is bottomed in the housing.
3. Check that the electrical contact is released from the lock and is against the spool.
4. Check that the cable is cross-wound and that it is fairly tight and taped.
5. Check that the spool is safetied.
6. Check that the cable is connected to the chute canister.
7. Check that the parachute recovery eye is connected to the canister.
8. Check for proper routing of the nylon rope. It should not be too loose.

PREFLIGHT OF TARGET PYLON ADAPTER

1. Check aileron clearance. Minimum clearance is 7 1/2 in. The rear sway brace should be snug against the dart keel.
2. Check that the nylon rope is secured to the target harness. The rope and harness should be taped to the target wing.
3. Apply pressure to the nose of the target to check for excess movement and overall security. Check that all sway braces have been locked.
4. Check that the top wings of the target are not pressed out of line by excessive pressure on the sway braces.

TAKEOFF AND CLIMB

1. After starting the engines, turn the "Target System Power On" switch to the "ON" position.
2. Make normal takeoff.
3. If an emergency occurs which requires simultaneous release of the target and cutting of the cable, actuate the "Cut Cable" switch.
4. Without exceeding 275 KIAS or 2.0 g's, climb to altitude. Speeds in excess of 275 KIAS and loads in excess of 2.0 g's may damage the target.

TARGET LAUNCH

1. Establish 200 KIAS with the aircraft in a straight and level attitude.
2. Check that the "Target System Power On" switch is on.
3. Actuate the "Release Target" switch.
4. Continue at 200 KIAS until the "Cable Payed Out" light appears.
5. During target tow, do not exceed 475 KIAS or mach 1.1. Also, the load factor should not exceed 4.0 g's.

TARGET RECOVERY

1. Achieve an altitude of 1000 ft above ground level at a speed of 200 KIAS. This will position the target approximately 500 ft above the ground.
2. At the target recovery area, actuate the "Cut Cable" switch.

INITIAL DISTRIBUTION

1	Wpns Sys Eval Gp		
1	Hq USAF (AFDRT-GW)	1	4 TAC Ftr Wg (TFM-MONA)
1	Hq USAF (AFORQ-OT)	1	36 TAC Ftr Wg (DCS/O)
1	Hq USAF (AFSSA-AS-5)	1	49 TAC Ftr Wg (DCS/O)
1	Hq USAF (AFORQ-SC/T)	3	7272 AB Wg (DOWT)
1	Hq USAF (AFOOP-SV)	1	7272 AB Wg (DMCM-A&E)
1	Dep IG for Insp (AFIPA)	1	7272 AB Wg (DMCS)
1	AAC (XPR)	1	7272 AB Wg (DCS/O)
1	ADC (MME)	1	Dayton AFD (MDVP)
1	ADC (ADOOP)	1	White Sands Proving Ground
1	ATC (ATTWS)		ORDBS-IRM-RID
4	USAFE, DCS/Ops (OTREQ)	3	4520 C Cr Tng Wg (OFW-TTS)
1	PACAF (PFORQ)	3	Air University Library (9764)
2	TAC (TOD)	1	USAF FWS (TR&D)
2	TAC (TMD)	1	4750 Test Sq (T&AE)
2	TAC (TPL-RQD)	2	Tech Info Sec (Ord Corps)
2	TAC (DORQ-T)	1	ARGMA Tech Lib
2	TAC (TMEM)	1	Commanding General
1	AFMTC (AFMTC Tech Lib/ MU-135)		ABMA (ORDAB-HT)
2	AFSC (SCPPT)	1	Ofc of the Chief of Nav Ops
1	AFSC (SCRA)	1	USNADC
1	AFLC (MCD)	1	BUWEPS (Code RM-46)
1	5 AF (5FCAG-P)	1	NATC (Ord Br, Wpns Sys Test)
1	5 AF (5FOPR-RQ)	3	Fleet Marine Force, Atlantic
1	9 AF (DCS/O)	4	NGB (AFOTT)
1	12 AF (DCS/O)	2	Md ANG
1	13 AF (13ODO)	1	OTS, US Dept of Commerce
4	17 AF (DCS/O)	5	Anderson, Greenwood, & Co
6	ASD (ASZT)	2	Republic Aviation Corp
3	ASD (ASAD-Lib)	15	ASTIA (TIPCR)
1	ASD (ASAT-Index)		APGC
1	MAAMA (MANE)	10	PGWQ
2	MOAMA (MONATE)	2	PGBME
1	OOAMA (OONE)	2	PGAPI
2	OOAMA (OONNRH)	20	ASQTT
2	OOAMA (OONN)	3	PGEH
2	OOAMA (OONNO)	2	PGAPT
2	OOAMA (OONEAT)	2	TAC Liaison Office (TACLO)
4	4 TAC Ftr Wg (DO)		
1	4 TAC Ftr Wg (TFS-F)		
1	4 TAC Ftr Wg (TFM-MT)		
1	4 TAC Ftr Wg (TFAE)		

1. Aircraft, F-105
2. Aerial targets
3. Tow targets
4. TDU-10/B
5. K-11

I. AFSC Project 6830
 II. Tracy, Robert J., 1stLt, USAF
 III. In ASTIA collection

This test consisted of an engineering evaluation of a tow target system designed for use on the F-105 aircraft. The system was designed to provide the Tactical Air Command with a transonic tow target capability for gunnery training. Missions were conducted to test the tow system for compatibility with the F-105 aircraft, structural integrity, adequacy of the parachute recovery system. In addition, studies were conducted to determine the turnaround capability of the system and to investigate its probable life. Training requirements for introduction of the system into the Tactical Air Command inventory were also determined. It was concluded from the test that, with certain modifications, the tow system can be satisfactorily used in normal towing operations and that the training requirements can be easily satisfied.

1. Aircraft, F-105
2. Aerial targets
3. Tow targets
4. TDU-10/B
5. K-11

I. AFSC Project 6830
 II. Tracy, Robert J., 1stLt, USAF
 III. In ASTIA collection

This test consisted of an engineering evaluation of a tow target system designed for use on the F-105 aircraft. The system was designed to provide the Tactical Air Command with a transonic tow target capability for gunnery training. Missions were conducted to test the tow system for compatibility with the F-105 aircraft, structural integrity, adequacy of the parachute recovery system. In addition, studies were conducted to determine the turnaround capability of the system and to investigate its probable life. Training requirements for introduction of the system into the Tactical Air Command inventory were also determined. It was concluded from the test that, with certain modifications, the tow system can be satisfactorily used in normal towing operations and that the training requirements can be easily satisfied.

1. Aircraft, F-105
2. Aerial targets
3. Tow targets
4. TDU-10/B
5. K-11

I. AFSC Project 6830
 II. Tracy, Robert J., 1stLt, USAF
 III. In ASTIA collection

This test consisted of an engineering evaluation of a tow target system designed for use on the F-105 aircraft. The system was designed to provide the Tactical Air Command with a transonic tow target capability for gunnery training. Missions were conducted to test the tow system for compatibility with the F-105 aircraft, structural integrity, adequacy of the parachute recovery system. In addition, studies were conducted to determine the turnaround capability of the system and to investigate its probable life. Training requirements for introduction of the system into the Tactical Air Command inventory were also determined. It was concluded from the test that, with certain modifications, the tow system can be satisfactorily used in normal towing operations and that the training requirements can be easily satisfied.

1. Aircraft, F-105
2. Aerial targets
3. Tow targets
4. TDU-10/B
5. K-11

I. AFSC Project 6830
 II. Tracy, Robert J., 1stLt, USAF
 III. In ASTIA collection

This test consisted of an engineering evaluation of a tow target system designed for use on the F-105 aircraft. The system was designed to provide the Tactical Air Command with a transonic tow target capability for gunnery training. Missions were conducted to test the tow system for compatibility with the F-105 aircraft, structural integrity, adequacy of the parachute recovery system. In addition, studies were conducted to determine the turnaround capability of the system and to investigate its probable life. Training requirements for introduction of the system into the Tactical Air Command inventory were also determined. It was concluded from the test that, with certain modifications, the tow system can be satisfactorily used in normal towing operations and that the training requirements can be easily satisfied.

1. Aircraft, F-105
2. Aerial targets
3. Tow targets
4. TDU-10/B
5. K-11

I. AFSC Project 6830
 II. Tracy, Robert J., 1stLt, USAF
 III. In ASTIA collection

This test consisted of an engineering evaluation of a tow target system designed for use on the F-105 aircraft. The system was designed to provide the Tactical Air Command with a transonic tow target capability for gunnery training. Missions were conducted to test the tow system for compatibility with the F-105 aircraft, structural integrity, adequacy of the parachute recovery system. In addition, studies were conducted to determine the turnaround capability of the system and to investigate its probable life. Training requirements for introduction of the system into the Tactical Air Command inventory were also determined. It was concluded from the test that, with certain modifications, the tow system can be satisfactorily used in normal towing operations and that the training requirements can be easily satisfied.

1. Aircraft, F-105
2. Aerial targets
3. Tow targets
4. TDU-10/B
5. K-11

I. AFSC Project 6830
 II. Tracy, Robert J., 1stLt, USAF
 III. In ASTIA collection

This test consisted of an engineering evaluation of a tow target system designed for use on the F-105 aircraft. The system was designed to provide the Tactical Air Command with a transonic tow target capability for gunnery training. Missions were conducted to test the tow system for compatibility with the F-105 aircraft, structural integrity, adequacy of the parachute recovery system. In addition, studies were conducted to determine the turnaround capability of the system and to investigate its probable life. Training requirements for introduction of the system into the Tactical Air Command inventory were also determined. It was concluded from the test that, with certain modifications, the tow system can be satisfactorily used in normal towing operations and that the training requirements can be easily satisfied.

Air Proving Ground Center, Eglin Air Force Base, Florida
Rpt No. APGC-TDR-62-29, ENGINEERING EVALUATION OF THE
F-105 TOW TARGET SYSTEM. Final report, May 1962, 31p. incl.
illus. table.
Unclassified Report

1. Aircraft, F-105
2. Aerial targets
3. Tow targets
4. TDU-107/B
5. K-11

- I. AFSC Project 6830
- II. Tracy, Robert J., 1stLt, USAF
- III. In ASTIA collection

This test consisted of an engineering evaluation of a tow target system designed for use on the F-105 aircraft. The system was designed to provide the Tactical Air Command with a transonic tow target capability for gunnery training. Missions were conducted to test the tow system for compatibility with the F-105 aircraft, structural integrity, adequacy of the operation of the tow reel under various flight conditions, and operation of the parachute recovery system. In addition, studies were conducted to determine the turnaround capability of the system and to investigate its probable life. Training requirements for introduction of the system into the Tactical Air Command inventory were also determined. It was concluded from the test that, with certain modifications, the tow system can be satisfactorily used in normal towing operations and that the training requirements can be easily satisfied.

Air Proving Ground Center, Eglin Air Force Base, Florida
Rpt No. APGC-TDR-62-29, ENGINEERING EVALUATION OF THE
F-105 TOW TARGET SYSTEM. Final report, May 1962, 31p. incl.
illus. table.
Unclassified Report

1. Aircraft, F-105
2. Aerial targets
3. Tow targets
4. TDU-107/B
5. K-11

- I. AFSC Project 6830
- II. Tracy, Robert J., 1stLt, USAF
- III. In ASTIA collection

This test consisted of an engineering evaluation of a tow target system designed for use on the F-105 aircraft. The system was designed to provide the Tactical Air Command with a transonic tow target capability for gunnery training. Missions were conducted to test the tow system for compatibility with the F-105 aircraft, structural integrity, adequacy of the operation of the tow reel under various flight conditions, and operation of the parachute recovery system. In addition, studies were conducted to determine the turnaround capability of the system and to investigate its probable life. Training requirements for introduction of the system into the Tactical Air Command inventory were also determined. It was concluded from the test that, with certain modifications, the tow system can be satisfactorily used in normal towing operations and that the training requirements can be easily satisfied.

Air Proving Ground Center, Eglin Air Force Base, Florida
Rpt No. APGC-TDR-62-29, ENGINEERING EVALUATION OF THE
F-105 TOW TARGET SYSTEM. Final report, May 1962, 31p. incl.
illus. table.
Unclassified Report

1. Aircraft, F-105
2. Aerial targets
3. Tow targets
4. TDU-107/B
5. K-11

- I. AFSC Project 6830
- II. Tracy, Robert J., 1stLt, USAF
- III. In ASTIA collection

This test consisted of an engineering evaluation of a tow target system designed for use on the F-105 aircraft. The system was designed to provide the Tactical Air Command with a transonic tow target capability for gunnery training. Missions were conducted to test the tow system for compatibility with the F-105 aircraft, structural integrity, adequacy of the operation of the tow reel under various flight conditions, and operation of the parachute recovery system. In addition, studies were conducted to determine the turnaround capability of the system and to investigate its probable life. Training requirements for introduction of the system into the Tactical Air Command inventory were also determined. It was concluded from the test that, with certain modifications, the tow system can be satisfactorily used in normal towing operations and that the training requirements can be easily satisfied.

Air Proving Ground Center, Eglin Air Force Base, Florida
Rpt No. APGC-TDR-62-29, ENGINEERING EVALUATION OF THE
F-105 TOW TARGET SYSTEM. Final report, May 1962, 31p. incl.
illus. table.
Unclassified Report

1. Aircraft, F-105
2. Aerial targets
3. Tow targets
4. TDU-107/B
5. K-11

- I. AFSC Project 6830
- II. Tracy, Robert J., 1stLt, USAF
- III. In ASTIA collection

This test consisted of an engineering evaluation of a tow target system designed for use on the F-105 aircraft. The system was designed to provide the Tactical Air Command with a transonic tow target capability for gunnery training. Missions were conducted to test the tow system for compatibility with the F-105 aircraft, structural integrity, adequacy of the operation of the tow reel under various flight conditions, and operation of the parachute recovery system. In addition, studies were conducted to determine the turnaround capability of the system and to investigate its probable life. Training requirements for introduction of the system into the Tactical Air Command inventory were also determined. It was concluded from the test that, with certain modifications, the tow system can be satisfactorily used in normal towing operations and that the training requirements can be easily satisfied.